

# REPORT DOCUMENTATION PAGE

*Form Approved*  
*OMB No. 0704-0188*

Public reporting burden for this collection of information is estimated to average 1 hour per response, including the time for reviewing instructions, searching existing data sources, gathering and maintaining the data needed, and completing and reviewing this collection of information. Send comments regarding this burden estimate or any other aspect of this collection of information, including suggestions for reducing this burden to Department of Defense, Washington Headquarters Services, Directorate for Information Operations and Reports (0704-0188), 1215 Jefferson Davis Highway, Suite 1204, Arlington, VA 22202-4302. Respondents should be aware that notwithstanding any other provision of law, no person shall be subject to any penalty for failing to comply with a collection of information if it does not display a currently valid OMB control number. **PLEASE DO NOT RETURN YOUR FORM TO THE ABOVE ADDRESS.**

<b>1. REPORT DATE (DD-MM-YYYY)</b> Oct 2006			<b>2. REPORT TYPE</b> Journal Article PREPRINT			<b>3. DATES COVERED (From - To)</b> 2006			
<b>4. TITLE AND SUBTITLE</b> Advanced Space-Based Detector Research at the Air Force Research Laboratory (PREPRINT)						<b>5a. CONTRACT NUMBER</b>			
						<b>5b. GRANT NUMBER</b>			
						<b>5c. PROGRAM ELEMENT NUMBER</b>			
<b>6. AUTHOR(S)</b> P.M. Alsing, D.A. Cardimona, D.H. Huang, T. Apostolova, W.R. Glass, C.D. Castillo						<b>5d. PROJECT NUMBER</b>			
						<b>5e. TASK NUMBER</b>			
						<b>5f. WORK UNIT NUMBER</b>			
<b>7. PERFORMING ORGANIZATION NAME(S) AND ADDRESS(ES)</b> Air Force Research Laboratory Space Vehicles Directorate 3550 Aberdeen Ave SE Kirtland AFB, NM 87117-5776						<b>8. PERFORMING ORGANIZATION REPORT NUMBER</b> AFRL-VS-PS-JA-2007-1003			
<b>9. SPONSORING / MONITORING AGENCY NAME(S) AND ADDRESS(ES)</b>						<b>10. SPONSOR/MONITOR'S ACRONYM(S)</b> AFRL/VSSS			
						<b>11. SPONSOR/MONITOR'S REPORT NUMBER(S)</b>			
<b>12. DISTRIBUTION / AVAILABILITY STATEMENT</b> Approved for public release; distribution is unlimited. (Clearance #VS06-0294)									
<b>13. SUPPLEMENTARY NOTES</b> Authors' final manuscript (article in press), accepted for publication in Infrared Physics & Technology									
<b>14. ABSTRACT</b>  At the Space Vehicles Directorate of the Air Force Research Laboratory we are interested in the use of detectors in space for surveillance and situational awareness missions. Our primary interests are in observations of objects both on earth and in space, each of which has very different background requirements. In addition, the space environment itself is especially demanding of any sensor system that will be expected to work continuously for long periods of time in such a challenging environment. In this talk we will describe some of the requirements for operation in space (low temperatures, long distances, high radiation, etc.), and some of the research we have been performing to address these special issues.									
<b>15. SUBJECT TERMS</b> Space situational awareness; Space surveillance, Optical signal amplification; Frequency agile detection; Optical cooling; Single-pixel polarimeter									
<b>16. SECURITY CLASSIFICATION OF:</b>						<b>17. LIMITATION OF ABSTRACT</b> Unlimited	<b>18. NUMBER OF PAGES</b> 7	<b>19a. NAME OF RESPONSIBLE PERSON</b> Dave A. Cardimona	
<b>a. REPORT</b> Unclassified	<b>b. ABSTRACT</b> Unclassified	<b>c. THIS PAGE</b> Unclassified	<b>19b. TELEPHONE NUMBER (include area code)</b> 505-846-5807						



## Advanced space-based detector research at the Air Force Research Laboratory

P.M. Alsing <sup>\*</sup>, D.A. Cardimona, D.H. Huang, T. Apostolova,  
W.R. Glass, C.D. Castillo

*Air Force Research Laboratory, Space Vehicles Directorate, 3550 Aberdeen Ave., S.E., Kirtland AFB, NM 87117-5776, United States*

---

### Abstract

At the Space Vehicles Directorate of the Air Force Research Laboratory we are interested in the use of detectors in space for surveillance and situational awareness missions. Our primary interests are in observations of objects both on earth and in space, each of which has very different background requirements. In addition, the space environment itself is especially demanding of any sensor system that will be expected to work continuously for long periods of time in such a challenging environment. In this talk we will describe some of the requirements for operation in space (low temperatures, long distances, high radiation, etc.), and some of the research we have been performing to address these special issues.

Published by Elsevier B.V.

*PACS:* 52.70.Kz; 81.07.St; 85.60.Gz

*Keywords:* Space situational awareness; Space surveillance; Optical signal amplification; Frequency agile detection; Optical cooling; Single-pixel polarimeter

---

### 1. Introduction

For Space Situational Awareness (SSA), a satellite would like to detect, track, identify, and determine the status of both cold and hot objects that can be either very near or very far and that could be either sunlit or in eclipse. With this range of requirements, a sensor that has some frequency agility (i.e., is able to detect many different, specific, wavelengths) and has some optical signal enhancement ability would be ideal. In addition, if detailed information about an unknown object becomes desirable, a sensor system that is extremely small and compact, but that still has all the ideal characteristics of frequency agility and high sensitivity would be a major accomplishment.

Earth-based surveillance and reconnaissance missions usually require focal plane arrays (FPAs) operating in

atmospheric “windows” where infrared (IR) transmission is high. The vast majority of applications are in the long-wave IR (LWIR, 7–14  $\mu\text{m}$ ) window with a small number of applications in the midwave IR (MWIR, 3–5  $\mu\text{m}$ ) windows. Space-based surveillance and situational awareness missions call for FPAs operating in many of the same spectral bands as their earth-based counterparts, however, mission and space environment constraints usually make even the most outstanding earth-based FPAs unacceptable for space missions. Space surveillance and SSA often require observation of extremely faint objects against dark backgrounds. These missions call for LWIR or very longwave IR (VLWIR, 14–30  $\mu\text{m}$ ) FPAs to detect cold objects or to increase the detection range. Often, these distant objects form ‘images’ within only one or two pixels – thus requiring extremely uniform arrays for tracking purposes. The dark backgrounds place very stringent requirements on the noise characteristics of the sensor system, resulting in FPAs that must be cooled rather substantially, and the limited satellite power restricts the power consumption

---

<sup>\*</sup> Corresponding author.

*E-mail address:* [paul.alsing@kirtland.af.mil](mailto:paul.alsing@kirtland.af.mil) (P.M. Alsing).

allowed by the cryogenic subsystem. To lower the launch costs, the volume and weight of the sensor should be minimal, and for operation in the harsh environment of space, the sensor must be immune to the radiation found there (protons, gamma rays, etc.). Finally, if we desire to determine the status of an unknown object (is it active or inactive, what is its function, etc.), an SSA sensor system should be able to be placed on a small, maneuverable satellite and should be able to detect a wide range of wavelengths (ultraviolet for improved resolution, visible for optical observation, IR for thermal characteristics, THz for electronics and communications sensing) and other phenomenologies such as: magnetic fields for power generation, gravitational field for mass determination, and polarization for contrast enhancement or shape determination.

Here at the Air Force Research Laboratory's Space Vehicles Directorate we are investigating the possibilities of creating a multi-functional, monolithically-integrated sensor system. We envision a sensor in which each individual pixel has a protection layer, an amplification layer, a detection layer, a solid-state cooling layer; all monolithically grown with the readout electronics and some on-chip data processing capability. This should result in a self-protecting sensor with improved detection efficiency, increased functionality, reduced volume and weight, increased reliability, and reduced cost (both for fabrication and for final launch). As a separate problem, we are also investigating a method of detecting the full polarization vector of an incoming signal within a single pixel of a detector.

## 2. Optical signal amplification

### 2.1. Quantum interference

Quantum well infrared photodetectors (QWIPs) are based on intersubband absorption in III–V semiconductor multi-quantum well heterostructures, and have been rapidly developed to the point where they are now extremely attractive for a growing number of sensor applications. Although considerable progress has been made in QWIPs, their relatively low quantum efficiencies constitute their greatest problem for space-based applications. We are investigating an innovative concept for creating an inversion within the quantum wells that will amplify an incoming infrared signal before sending it into a detector. The proposed device structure will be perfect for monolithic integration with a QWIP or other IR detector.

The prerequisite for creating an IR amplifier in a semiconductor quantum well heterostructure is to obtain a population inversion between the states within the quantum well at which the infrared transition is to occur. The idea we describe here extends the ground-breaking work in field-induced transparency in atoms [1] into the realm of semiconductor QWIPs [2]. The original research performed in atomic physics basically discovered that if you had a three-level atomic system with two excited states each

coupled by a dipole moment to a single ground state, you could tune an applied pump field in such a way as to trap population in the excited states. The coherent excitation of the two closely-spaced upper states creates a quantum mechanical interference between the 2-to-1 transition and the 3-to-1 transition, resulting in a net zero dipole moment for the system. The population then becomes trapped in the excited states, since with a zero dipole moment, the applied field can no longer interact with the system. The system then becomes “transparent” to the applied field. (S.E. Harris studied a related phenomenon and called it “electromagnetically-induced transparency” or EIT [3].)

To extend this idea of population trapping in excited states due to quantum interference into the realm of semiconductor materials, we need to devise a three-level system that can be bandgap engineered. If we sandwich GaAs material between two layers of AlGaAs, the energy band structure becomes shaped like a quantum well, with electrons being trapped energetically within the GaAs well. If the AlGaAs barrier layer is only about 4 or 5 nm thick, and then another GaAs/AlGaAs well/barrier pair are grown, electrons within the two GaAs well layers can interact with each other by tunneling through the barrier layer. When that happens, degenerate energy levels within the two well layers interact and quantum mechanically split into a doublet structure.

With this in mind, we believe that a possible IR amplifier structure should therefore consist of a shallow well with a single bound state separated by a narrow barrier from a deeper well having two bound states, the higher energy state being degenerate with the single state in the other well. The two degenerate states will quantum-mechanically interact through the barrier and split into a doublet state. A coherent pump field at the frequency that will couple the valence band hole state with the doublet of the shallow well induces the transparency effect. This sets up an inversion between the excited state doublet in the deeper well and that well's ground state. An infrared photon at the frequency of the transition between the states of the deeper well should now see amplification. (See Fig. 1) A stack of these structures should produce a cascading multiplication of the incident IR photon. This amplified signal can then be sent into a monolithically-grown detector structure.

### 2.2. Photonic crystals

Photonic bandgap (PBG) materials (also called photonic crystals, or PhCs) are to electromagnetic fields as semiconductor materials are to electrons. Just as semiconductor materials have forbidden energy bandgaps due to the periodic arrangement of many atoms, a material with periodic variations in the dielectric constant can lead to a gap in the frequencies of electromagnetic radiation allowed to exist and propagate in the structured material. The principle of the gap formation is the same in both: Bragg-like diffraction of the electron waves off the atoms in the semiconductor lattice and Bragg scattering of optical waves by the

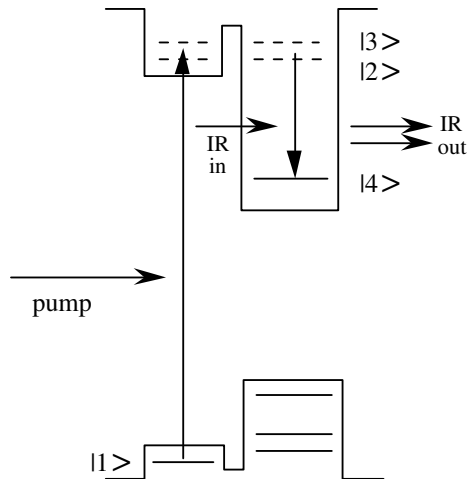

Fig. 1. The semiconductor quantum well structure that is predicted to replicate the coherent population trapping found in the three-level atomic system and allow for an inversion to occur.

dielectric interfaces in the periodically-structured material. Periodic variations in the dielectric constant in one dimension (1D), e.g., planar layers, lead to a PBG for light incident on the material in that dimension. If the variations are in two dimensions (2D), e.g., holes punched in a planar material, then the PBG will manifest for light incident within the plane of the holes. A 3D PhC will consist of dielectric variations in all dimensions, and will produce a PBG for light incident from any direction.

Once a material with a PBG has been created, it is possible to introduce a defect into the material (by subtracting or adding dielectric material at one spot – see Fig. 2 for a 2D example), analogous to acceptor or donor defects in semiconductors. Similar to how these semiconductor defects introduce energy levels into the forbidden bandgap, the defect in a PhC can be designed with any frequency in the PBG, thereby allowing electromagnetic radiation at that frequency to exist and propagate in the crystal. Because the photonic defect is surrounded by a material with a PBG, the field should experience little or no loss,

similar to being in a high- $Q$  cavity. Thus, defects within PBG crystals can be considered microcavities. These microcavities can have extremely long lifetimes, at the same time that they have very small modal volumes. These unique features enable a range of novel applications that take advantage of the emerging field of nonlinear photonic crystals [4]. PhC microcavities have properties that greatly enhance optical nonlinear effects, and show great promise for producing devices for all-optical signal processing. Lengths of these devices can be smaller than the wavelength of light, they can operate with only milliwatts of power, and they can be faster than 10 ps. If the enhancement properties of these PhC microcavities are combined with materials that have extremely large nonlinear responses, then devices of unprecedented optical nonlinear response can be created. In addition, placing a highly dispersive material within one of these cavities will greatly enhance its lifetime. It turns out that materials that can exhibit the phenomenon of EIT will manifest both extremely large nonlinear responses as well as extremely strong dispersion.

We have begun to investigate EIT in semiconductor quantum dots inside photonic crystal cavities. The simplest form of PhC can be created using multilayer films that consist of periodically arranged dielectric materials with alternating high and low indices of refraction. If the thickness of each layer satisfies the Bragg condition, then a well-defined gap in the range of frequencies allowed will form in one dimension. If we further enclose this layered structure with a cylindrical metal mirror through a metal diffusion process in the growth direction, the cavity confinement can be increased, allowing the light to be trapped within the cavity. The ease of fabrication of such structures, and the ease with which a good many quantum dots can be placed on planes between such periodic layers, make these 1D PhCs extremely useful for the study of cavity QED and quantum optics in PBG materials (see Fig. 3).

To obtain higher  $Q$  cavities, we will investigate defect cavities in 2D PhCs (see Fig. 4). The 2D PhC cavity can

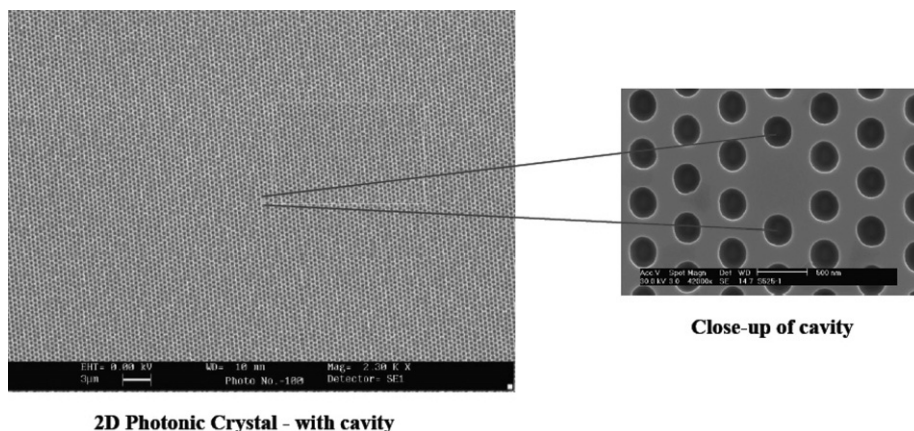

Fig. 2. A 2D photonic crystal fabricated as a regular periodic array of air holes in a high index of refraction material. A 2D cavity is formed by creating a defect, i.e., the absence of a hole.

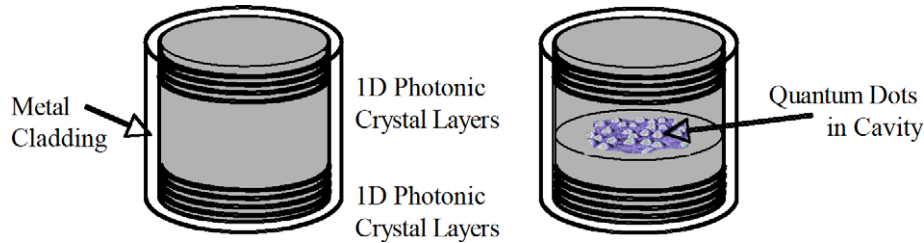

Fig. 3. 1D photonic crystal with cavity (left) and with quantum dots embedded in cavity (right).

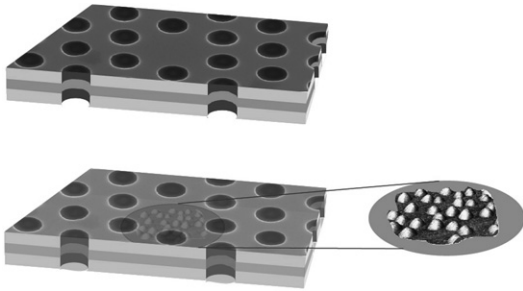

Fig. 4. 2D photonic crystal cavity with embedded quantum dots.

be formed by creating a point defect in the 2D PhC sandwiched between two metal mirrors (cladding layers). The quantum dots inside the 2D PhC cavity can be fabricated using a selective etching technique. The main technical drawback to this geometry will be the small number of quantum dots that will fit into a 2D microcavity. Perhaps an array of such cavities within the 2D PhC will be of more practical use.

For the highest  $Q$ -factor, we will want to investigate a full 3D PhC, which is much more difficult to fabricate. The 3D PhC cavity can be formed by creating a point defect inside it. Colloidal quantum dots might then be fed into the hollow space at the center of the 3D PhC through the Si-wafer bonding technique (see Fig. 5).

### 3. Frequency agile detection

We are also investigating a method for tuning the response of a detector across the IR – using quantum dots and a lateral biasing scheme. We consider an asymmetric double quantum well structure, with doped quantum dots buried in one well tunnel-coupled to the other well. Only

the well without the quantum dots is laterally biased. When the electrons in the dot absorb photons, they are excited to a virtual excited state in the well and then tunnel to the other well. The electrons in the biased well are then swept to the collector region by the lateral bias. When a vertical bias is applied (parallel to the quantum well heterostructure growth direction), there is a shift of the relative energy between the levels in the first well which allows the tuning of the peak wavelength response of the detector (see Fig. 6 for an example without the quantum dot). Since the electrons from the excited level of the first well tunnel to the second well and are then laterally transported, a unit optical gain is expected due to the lack of electron re-capture process. The advantages of quantum dots buried in quantum wells are normal incidence absorption as well as

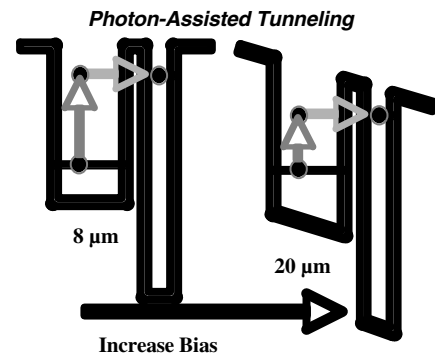

Fig. 6. Example of spectral tuning with an applied bias. In this example, the absorption takes place in the lefthand doped quantum well, rather than from a doped quantum dot buried in the lefthand well as described in the text. A photon is absorbed, taking the electron to a virtual state in the lefthand well. Then the electron tunnels to the state in the righthand well, and is swept out by a laterally-applied bias.

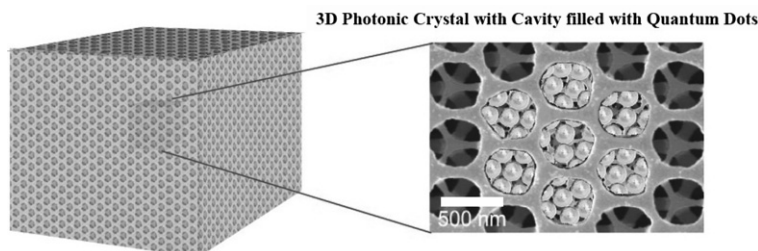

Fig. 5. 3D photonic crystal cavity is formed by creating a point defect within the crystal and filling the resulting hollowed space with colloidal quantum dots.

reduced dark current due to the deep potential well of the doped quantum dots.

#### 4. Quantum electronic refrigeration

For space applications, where the background is very cold and the objects of interest are very far away, infrared FPAs generally need to be cooled. There is, of course, the usual mechanical cooling or merely having the FPA surrounded by cryogenic liquid. However, some new technologies are making sufficient advances that they may soon be considered for space applications. These new technologies utilize quantum electronics, and include: thermoelectric cooling, thermionic cooling, opto-thermionic cooling, and fluorescent (or photoluminescent) cooling. Some of these quantum electronic cooling concepts provide very attractive possibilities for cryogenics-on-a-chip, either including contacts for a current flow under a bias or excluding contacts by replacing the bias with a resonant optical field. Solid state cooling will have many advantages for space-based sensing missions: no moving parts and no vibration, no electronic, magnetic, and electromagnetic noise, very long lifetime, use of low-cost materials and manufacturing, and high reliability. A complete solid-state cryocooler with a cubic centimeter of volume (and in some cases, much less than that) seems possible. This extreme miniaturization could lead to pixel-by-pixel cooling of an FPA.

Laser-induced fluorescent cooling of heavy-metal-fluoride glass doped with trivalent ytterbium ions was first realized in 1995 [5]. A similar technique for cooling semiconductors, photoluminescence cooling, has not yet been observed. In this new technology, a strong laser field first excites electrons from the valence band edge to the conduction band edge. After thermalizing by taking energy from the lattice, electrons recombine with holes and in that process spontaneous photons with energies higher than the input energy of the pump photons can be emitted. As a result, the lattice will be cooled due to the loss of thermal energy to electrons. We have developed a *nonlocal* theory for the laser cooling of semiconductors [6]. Our results indicate that the optimum conditions for cooling of a semiconductor are: (i) have a large bandgap and (ii) have a weak pump laser. It also turns out that the lower the initial temperature is, the slower the cooling will be. A couple of practical issues that must be overcome are: (i) The nonradiative decay must be as small as possible, so that all of the heat is removed from the system by the luminescence. Nonradiative decay will keep the phonon energy within the material. (ii) The index of refraction for semiconductors is quite high, causing total internal reflection to be a problem since we must get that luminescence out of the material.

To observe the effect in quantum wells, we generalized our bulk equations to incorporate quantum well heterostructures. This required introducing a *z*-dependence and phonon diffusion, with cooling taking place within the quantum well layer, and then heat diffusing into that layer from the surrounding barrier layers [7].

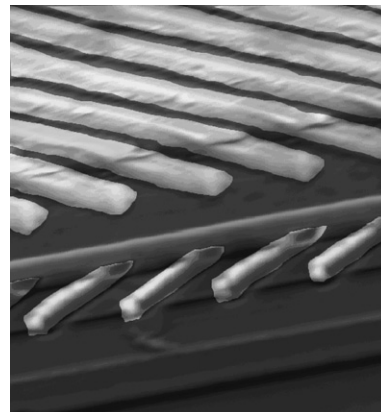

Fig. 7. Two-layer single-pixel polarimeter demonstration structure.

#### 5. Single-pixel polarimeter

One of the drawbacks to quantum well infrared photodetectors (QWIPs) is that they only absorb light that is incident at an angle, i.e., the absorption is polarization-dependent. This tends to reduce the detectivity of such a detector. However, if you actually want to measure the polarization of the incident signal, having a polarization-dependent absorption is required.

Our concept for detecting the full Stokes vector (i.e., the full polarization) within a single pixel utilizes the polarization-dependent absorption of QWIPs. The concept is to place four layers of QWIPs, each with their own grating for turning the incident light, on top of each other, and then read out the photocurrent from each layer separately, just as is now done in multi-color QWIPs (see Fig. 7 for two-layer demonstration structure). Then, due to a combination of the polarization-dependent absorption within each quantum well layer, interference between the multiple reflections at each interface, and mode coupling due to the various angles of the diffraction gratings, the resultant readouts are polarization-dependent, and can be completely predicted once the structure has been calibrated with known polarization signals.

Present polarimeters either determine individual Stokes vector components with four separate detectors or with four separate measurements using a single detector. This procedure leads to spatial or temporal co-registration errors. Our concept will eliminate these errors.

#### 6. Summary

The stringent requirements for use in space often times rule out the use of sensors that are perfectly fine for use with a 300 K Earth background. Developing quantum well or quantum dot detectors that can operate well under these stringent conditions would open up a new realm for these technologies. In addition, reducing the weight and volume of sensor systems is also of interest to us for space situational awareness missions. One concept we have for that is to develop a monolithically-integrated sensor system that

includes protection, optical amplification, tunable multi-color detection, cryogenic cooling, and readout electronics all within each individual pixel.

We are investigating several technologies to amplify incoming signals to a photodetector. This is important for space applications where the objects of interest are often very distant and very dim. The technologies we are looking into involve using: (i) quantum interference effects in quantum-confined structures (such as quantum wells and quantum dots) and (ii) electromagnetic field enhancement in photonic crystal cavities.

Another area of interest for our group is to investigate methods of tuning the spectral response of a photodetector. Presently we are studying a structure that utilizes quantum dots buried in a quantum well tunnel-coupled to another quantum well that is laterally biased.

We are also actively investigating an optical method for on-chip cryogenic cooling of FPAs as well as a method to use the polarization-dependent absorption of quantum wells to detect the full polarization vector within a single pixel.

#### Acknowledgements

This research was supported by the Air Force Office of Scientific Research (AFOSR).

#### References

- [1] D.A. Cardimona, M.G. Raymer, C.R. Stroud Jr., *J. Phys. B* 15 (1982) 55;  
D.A. Cardimona, M.P. Sharma, M.A. Ortega, *J. Phys. B* 22 (1989) 4029;  
D.A. Cardimona, *Phys. Rev. A* 41 (1990) 5016;  
D.A. Cardimona, M.P. Sharma, "Method and Apparatus for Field-Induced Transparency Using Laser Radiation", Patent number 5,196,097, 1993.
- [2] D.S. Lee, K.J. Malloy, *IEEE J. Quant. Electron.* 30 (1994) 85;  
Y. Zhao, D. Huang, C. Wu, *Opt. Lett.* 19 (1994) 816;  
D. Huang, D.A. Cardimona, *J. Opt. Soc. Am. B* 15 (1998) 1578;  
D. Huang, D.A. Cardimona, *Phys. Rev. A* 64 (2001) 013822;  
D.A. Cardimona, D. Huang, *Phys. Rev. A* 65 (2002) 033828;  
P.M. Alsing, D. Huang, D.A. Cardimona, T. Apostolova, *Phys. Rev. A* 68 (2003) 033804.
- [3] S.E. Harris, *Phys. Rev. Lett.* 62 (1989) 1033;  
S.E. Harris, J.E. Field, A. Imamoglu, *Phys. Rev. Lett.* 64 (1990) 1107;  
S.E. Harris, *Phys. Rev. Lett.* 72 (1994) 52.
- [4] M. Soljagic, J.D. Joannopoulos, *Nature Mater.* 3 (2004) 211.
- [5] R.I. Epstein, M.I. Buchwald, B.C. Edwards, T.R. Gosnell, C.E. Mungan, *Nature (London)* 37 (1995) 500.
- [6] D.H. Huang, T. Apostolova, P.M. Alsing, D.A. Cardimona, *Phys. Rev. B* 70 (2004) 033203.
- [7] D.H. Huang, T. Apostolova, P.M. Alsing, D.A. Cardimona, *Phys. Rev. B* 72 (2005) 195308.