



Decision-support Infosphere Services for Collaborative Operations and Virtual Environment Requirements (DISCOVER)

14 Jun 2005
10th ICCRTS



James Milligan
Computer Scientist
AFRL/IFSE

Air Force Research Laboratory

Report Documentation Page

Form Approved
OMB No. 0704-0188

Public reporting burden for the collection of information is estimated to average 1 hour per response, including the time for reviewing instructions, searching existing data sources, gathering and maintaining the data needed, and completing and reviewing the collection of information. Send comments regarding this burden estimate or any other aspect of this collection of information, including suggestions for reducing this burden, to Washington Headquarters Services, Directorate for Information Operations and Reports, 1215 Jefferson Davis Highway, Suite 1204, Arlington VA 22202-4302. Respondents should be aware that notwithstanding any other provision of law, no person shall be subject to a penalty for failing to comply with a collection of information if it does not display a currently valid OMB control number.

1. REPORT DATE 14 JUN 2005	2. REPORT TYPE	3. DATES COVERED 00-00-2005 to 00-00-2005			
4. TITLE AND SUBTITLE Decision-support Infosphere Services for Collaborative Operations and Virtual Environment Requirements (DISCOVER)		5a. CONTRACT NUMBER			
		5b. GRANT NUMBER			
		5c. PROGRAM ELEMENT NUMBER			
6. AUTHOR(S)		5d. PROJECT NUMBER			
		5e. TASK NUMBER			
		5f. WORK UNIT NUMBER			
7. PERFORMING ORGANIZATION NAME(S) AND ADDRESS(ES) Air Force Research Laboratory/IFSE,525 Brooks Road,Rome,NY,13441		8. PERFORMING ORGANIZATION REPORT NUMBER			
9. SPONSORING/MONITORING AGENCY NAME(S) AND ADDRESS(ES)		10. SPONSOR/MONITOR'S ACRONYM(S)			
		11. SPONSOR/MONITOR'S REPORT NUMBER(S)			
12. DISTRIBUTION/AVAILABILITY STATEMENT Approved for public release; distribution unlimited					
13. SUPPLEMENTARY NOTES The original document contains color images.					
14. ABSTRACT					
15. SUBJECT TERMS					
16. SECURITY CLASSIFICATION OF:			17. LIMITATION OF ABSTRACT	18. NUMBER OF PAGES 33	19a. NAME OF RESPONSIBLE PERSON
a. REPORT unclassified	b. ABSTRACT unclassified	c. THIS PAGE unclassified			



Briefing Outline/Purpose



- **Introduction**
 - **What is DISCOVER and why are we doing it**
 - **Background (Joint Battlespace Infosphere and Fuselet Information Transformation Services)**
 - **Goals and objectives**
- **Experimentation Process**
- **System Architecture**
- **Project Status**
- **Preliminary Findings**
- **Next Steps**



What is DISCOVER?



- **DISCOVER is an AFRL project centered on the design and execution of **an experiment****
 - Goal is **to measure the value** and performance impact of a combination of technologies
 - **Joint Battlespace Infosphere (JBI)**
 - **JBI fuselets**
 - **Collaboration and Visualization Software**
 - Operational context focuses on the **dynamic mission re-planning** processes within an Air Operations Center (AOC)



Joint Battlespace Infosphere (JBI)



- A vision for an orchestrated information management system whose services adapt to the operational needs of users and the enterprise for universal access to tailorable, actionable information
 - Information sharing services (publish, subscribe, query)
 - Control services (policy, security, authentication, access control, authorization, QoS)
 - “Service contract” services (*force templates* to facilitate the effective plug-and-play-and-go of operational entities with an instance of an infosphere)
 - **Information transformation** services (*fuselets* which tailor the information space to the needs of the warfighter)

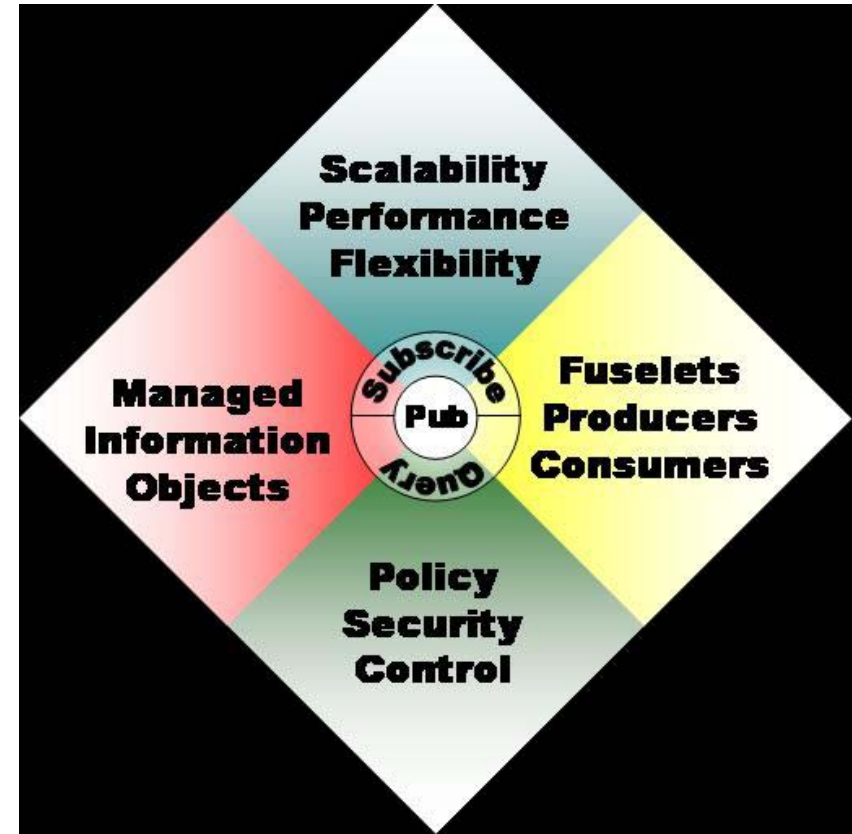

Realizing the Air Force Scientific Advisory Board (SAB) vision as delineated in two SAB summer study reports, Information Management to Support the Warrior (1998) , and Building the Joint Battlespace Infosphere (1999)



Some Related ICCRTS Papers and Presentations from AFRL this Week



- **Joint Battlespace Infosphere: Information Management within a C2 Enterprise**
 - Combs, Hillman, Muccio, McKeel
 - Information Operations/Assurance Track
 - Consulate
 - Day 3, Wednesday, 3:15-3:45
- **A Reference Model for Information Management to Support Coalition Information Sharing Needs**
 - Linderman, Siegel, Ouellet, Brichacek, Hains, Chase, O'May
 - Coalition Interoperability Track
 - Old Dominion
 - Day 4, Thursday, 1:30-2:00



Motivation for Information Transformation: *Lessons Learned from Kosovo, Afghanistan, and Operation Iraqi Freedom*

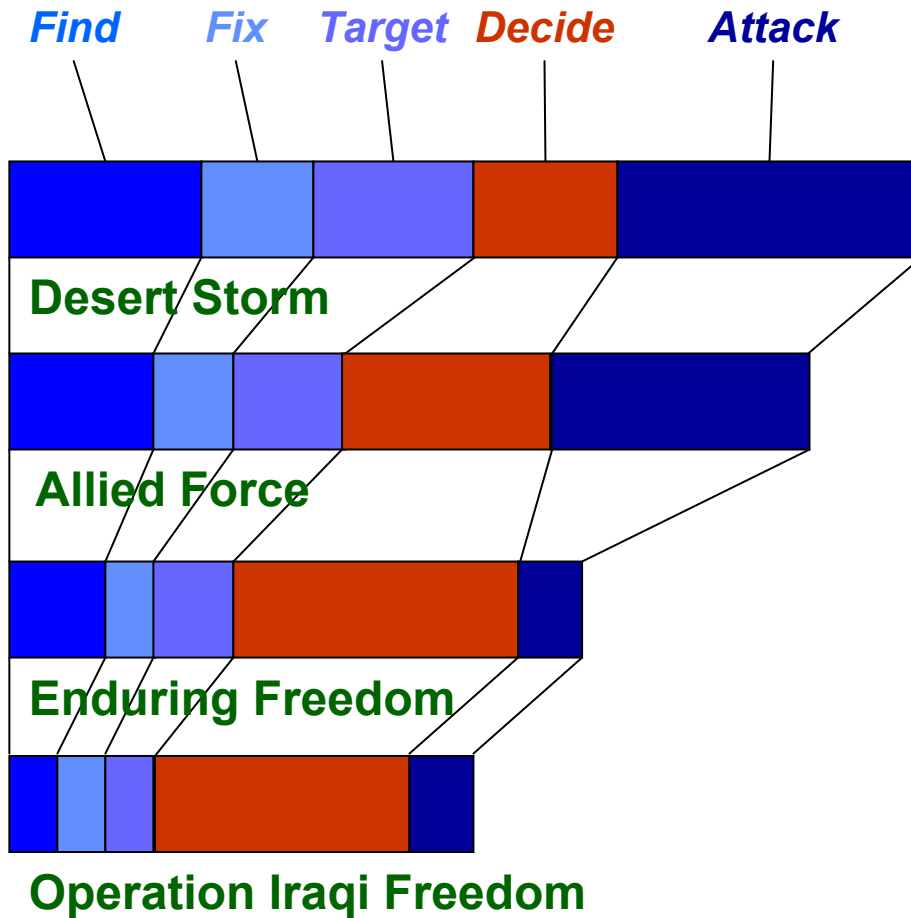

- More intelligence data leads to *information overload*
- Decision time has become the “long pole in the tent”
- Warfighters lack *actionable* information



Problems to be Addressed by Information Transformation



- **Multiple information systems** and sources can produce **duplicate or inconsistent information** that requires **significant human effort** to correlate, integrate and understand
 - Information overload and confusion
 - Inefficient and ineffective decision-making
 - Cumbersome and error-prone migration of information from one system to another (manual data entry often required)
- Current **information systems are difficult to change** to produce information that is tailored to the specific needs and context of end users
 - The information they produce is generally static
 - Application reengineering can be complex, costly and time consuming, potentially leading to significant downtimes



Information Transformation Objectives



- Augment information systems with a **flexible information production capability** that is dynamically responsive to the changing needs of end users and imposes minimal impact to legacy systems
- **Improve the efficiency and effectiveness of decision-making** by correlating duplicative information, resolving inconsistent information, mediating between information sources, and fusing information together into **comprehensible information products**



Fuselet Definition



- **A fuselet is a light-weight, special-purpose JBI client program that provides value-added information processing functions that are under the control of the JBI platform**
 - **These information processing functions take existing information objects as input and manipulate them in some way to produce new information objects**
 - **Light-weight means that they are intended to be easy to build and deploy, relatively modular, usually small in terms of lines of code, amenable to reuse, and utilize a low level of system runtime resources**



Collaboration and Visualization Software



- **We recognized the need to visualize (present) the information produced by fuselets to human operators within an AOC and the need for teams of operators to collaborate over this information**
 - **DISCOVER utilizes portal, messaging, and chat technology to support presentation and collaboration requirements**



AOC Collaborative Decision-Making Support

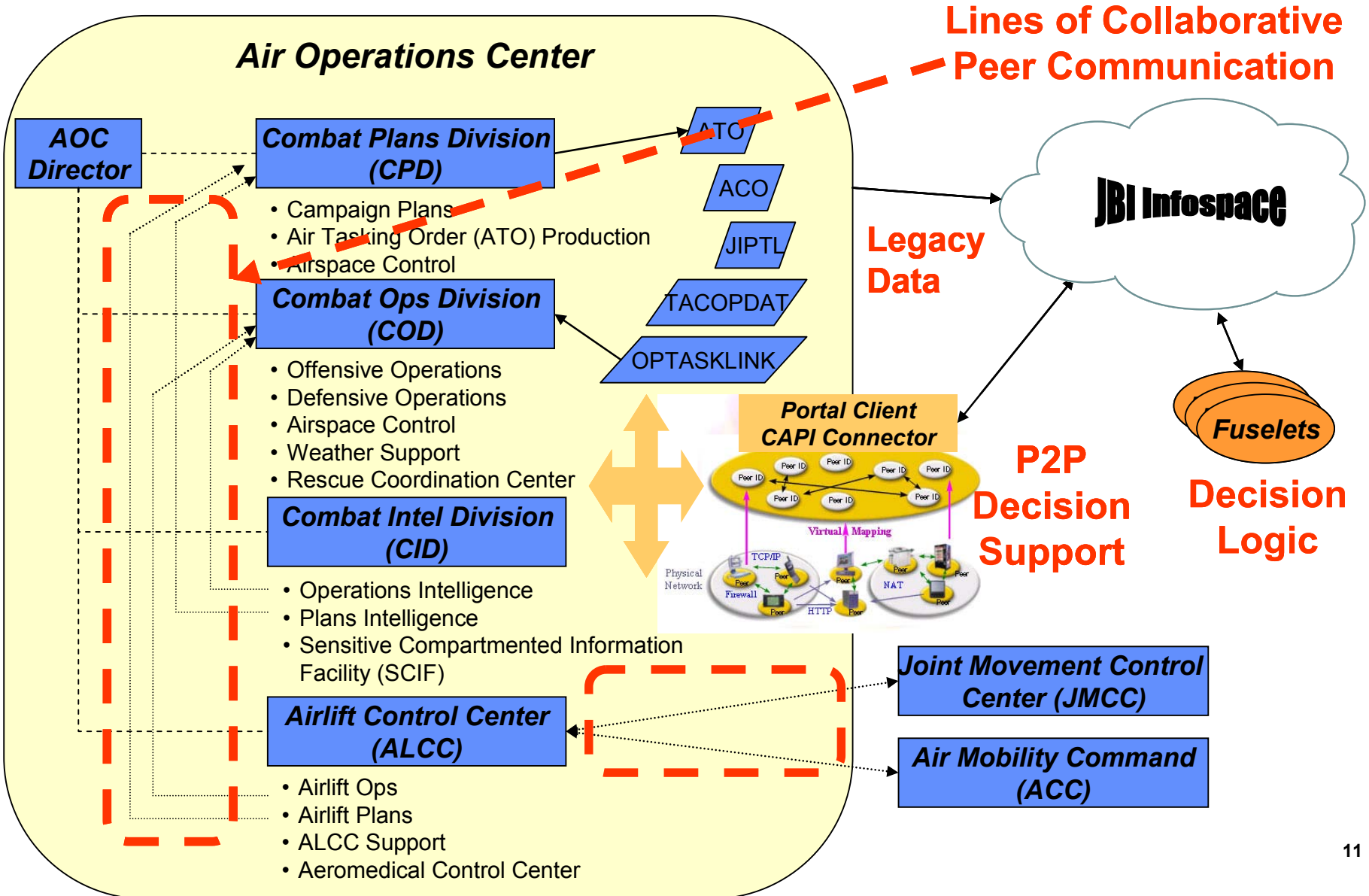



Why DISCOVER?



- **Provide objective experimental evidence** on the value of information management technologies (JBI, fuselets, collaboration)
- **Quantitatively demonstrate** how JBI and fuselets can improve the efficiency and effectiveness of dynamic mission re-planning process in an AOC
- **Identify areas for future R&D** to improve and advance these and other information management, interoperability, and transformation capabilities



DISCOVER – Project Goals



- **Reduce the Footprint [Less People]**
 - Demonstrate how fuselets can perform tedious manpower intensive data collection and processing tasks that are currently done by military personnel
 - Allows the warfighter to focus on warfighting
- **Improve Efficiency [Faster]**
 - Demonstrate how fuselets can increase the speed of decision-making through the production of quality information
- **Improve Effectiveness [Better]**
 - Demonstrate how fuselets can improve the warfighters ability to make better, more optimized decisions



DISCOVER Team

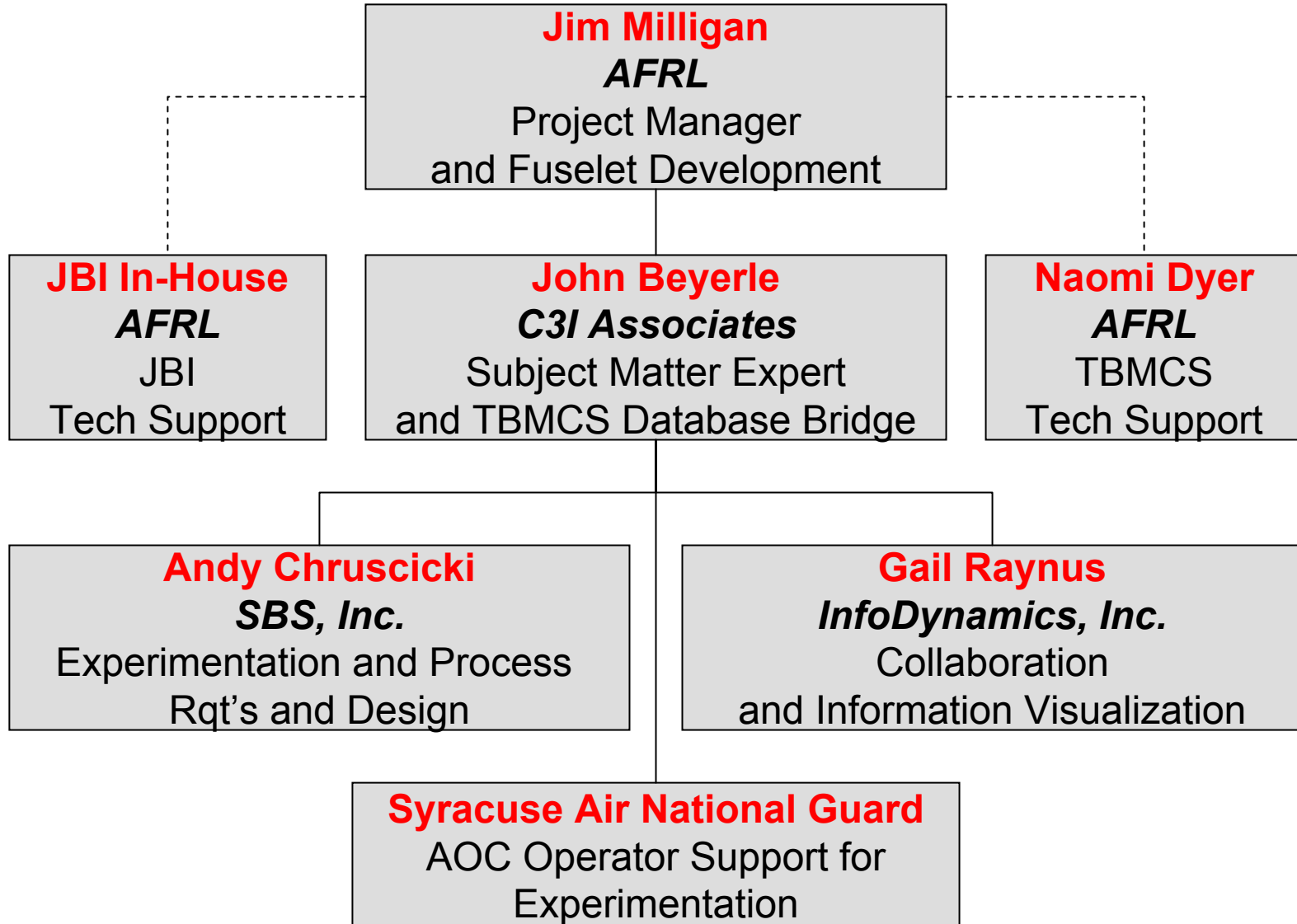



Experimentation Process

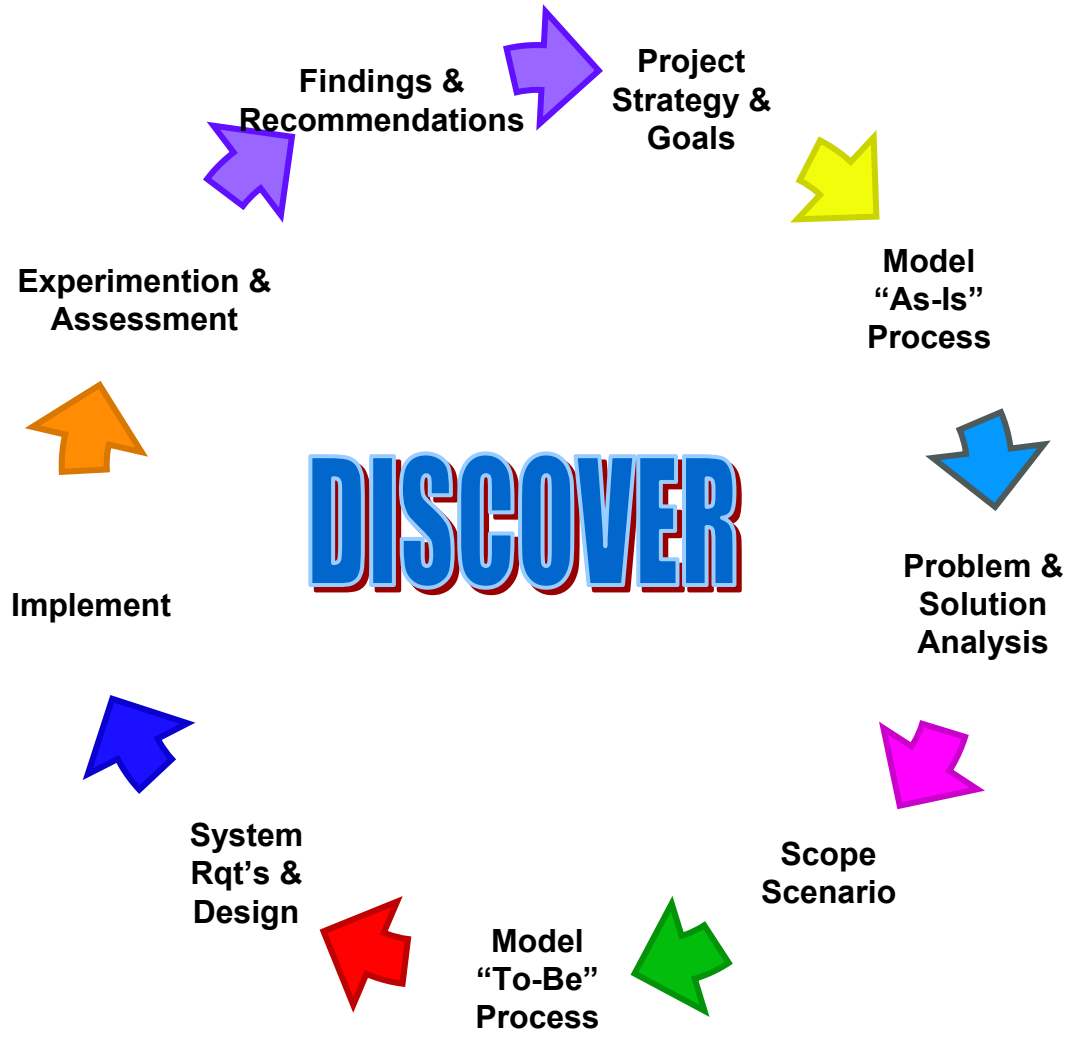



Dynamic Collaborative Mission Replanning Scenario (page 3)

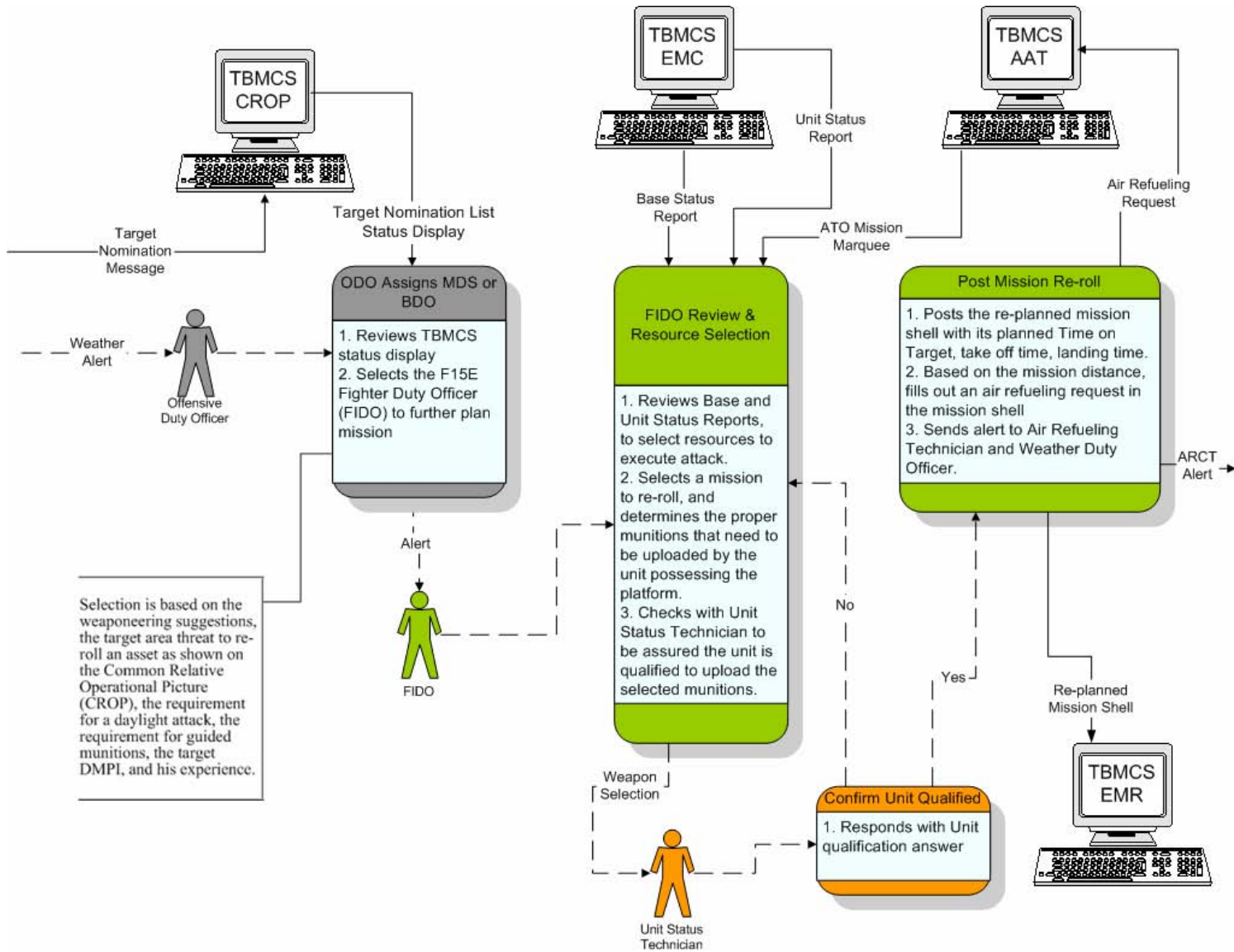



Problem & Solution Analysis



- **Subject Matter Expert (SME) interaction**
- **Operational briefings**
- **Legacy AOC system demonstrations**
- **Documentation review**
- **Legacy system capability analysis and data modeling**
- **As-is scenario analysis**



F15E Fighter Duty Officer (FIDO) Collaborative Decision Making ("As-Is")

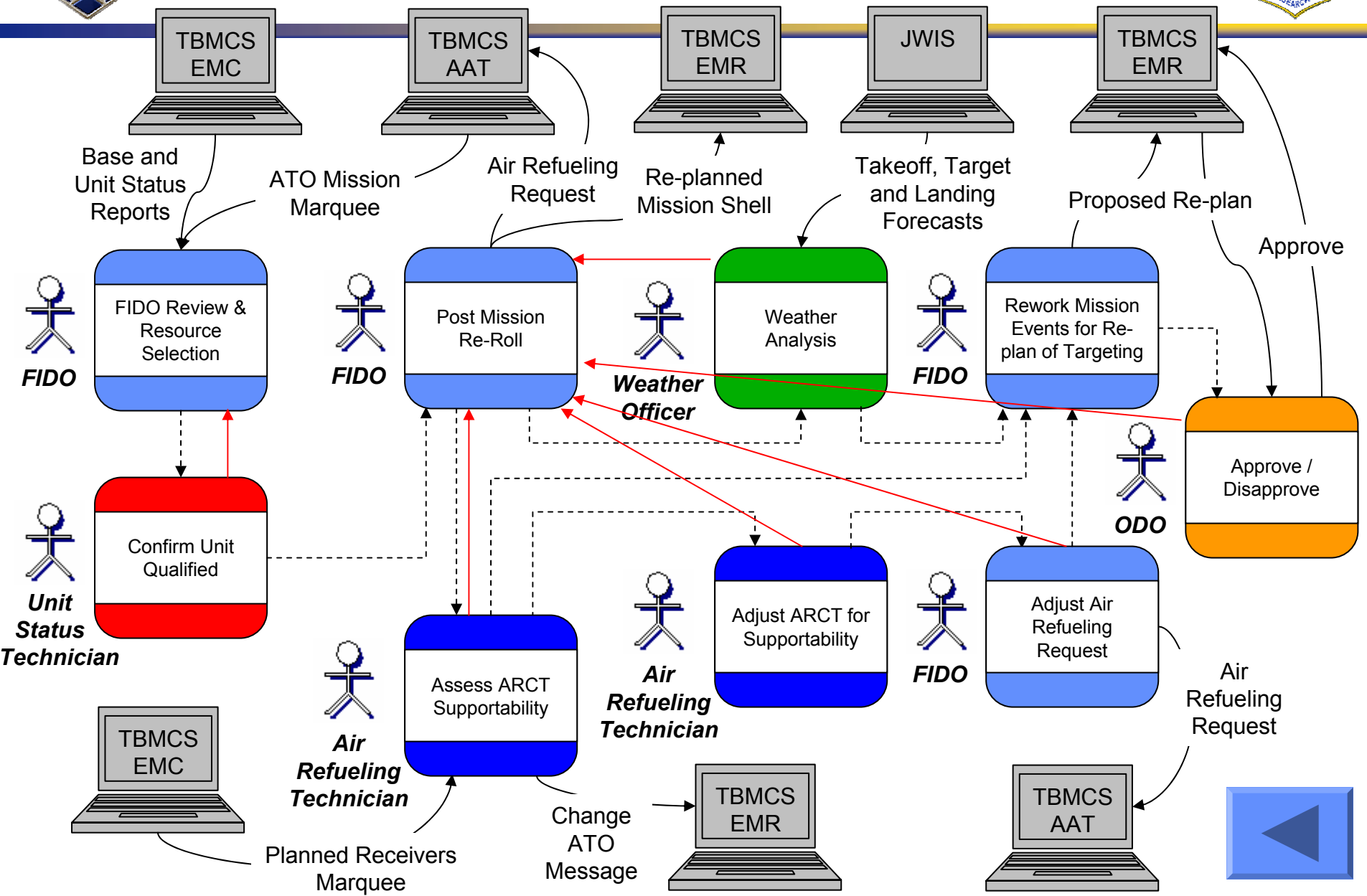



F15E Fighter Duty Officer (FIDO) Collaborative Decision Making (“To-Be”)

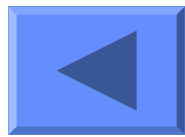
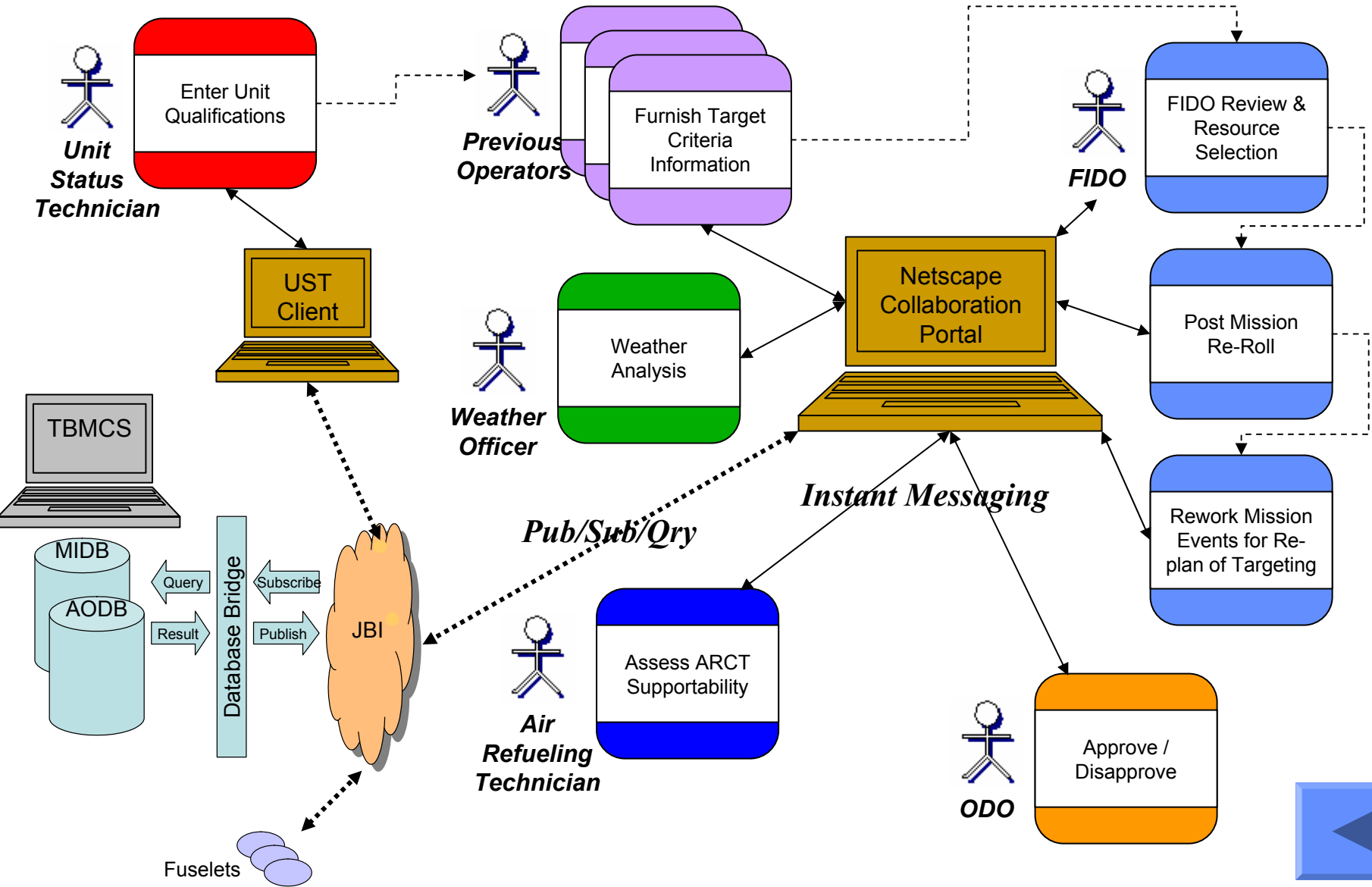



Requirements and Design



- **Information object engineering (XML Schema)**
- **GUI storyboarding (Visio)**
- **Scenario-based use cases (UML)**
- **Sequence diagrams (UML)**
- **Architecture context diagram (UML)**
- **Textual capability requirements specification**

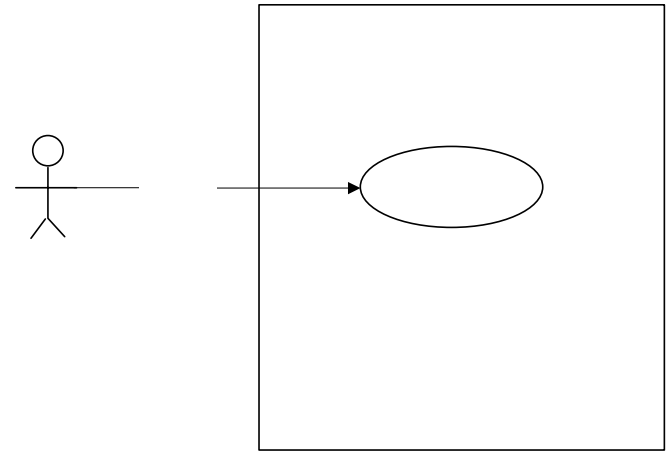





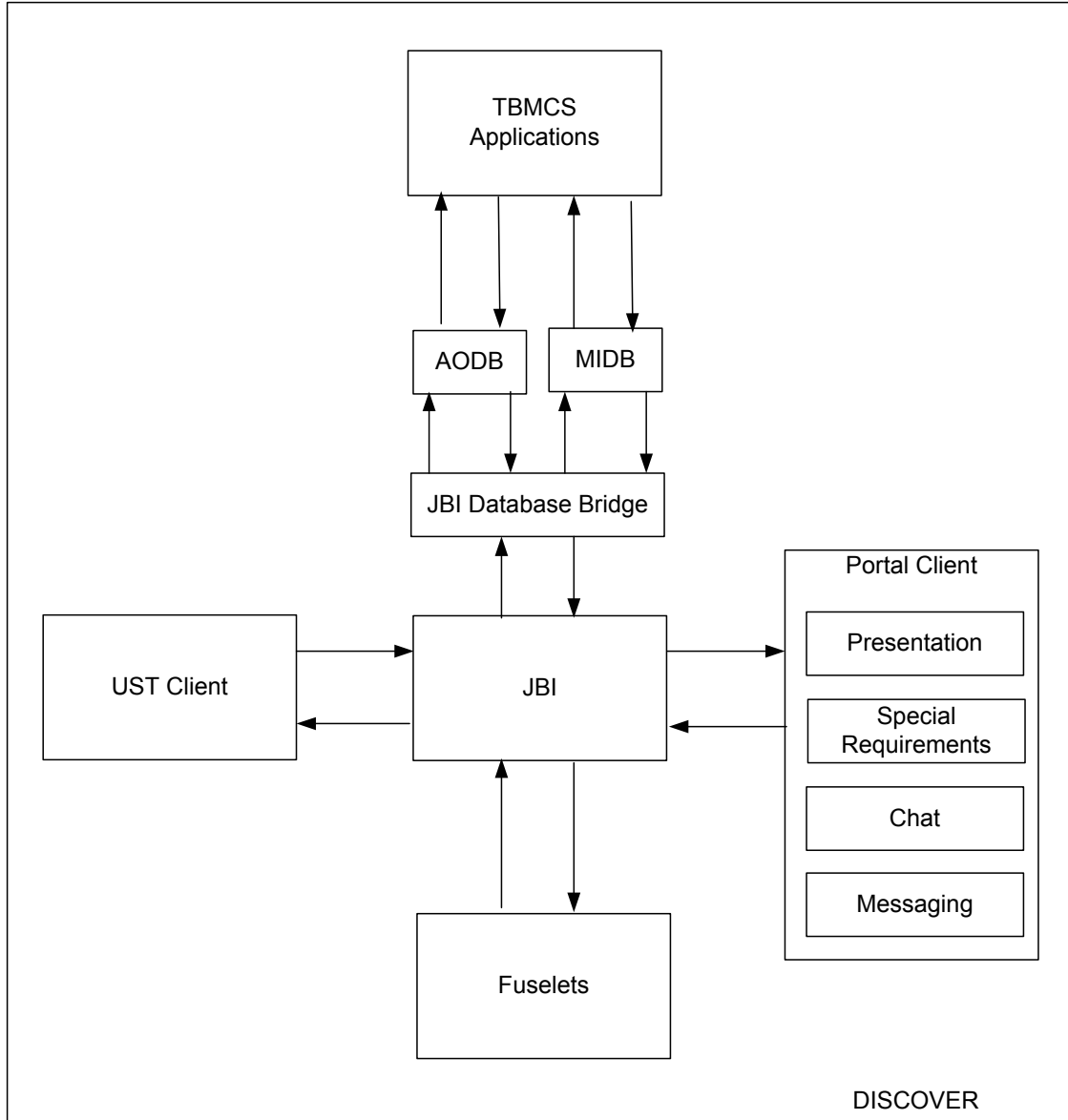

System Architecture





Project Status



-  Legacy / Other
-  Implemented
-  Partially
-  Not Implemented

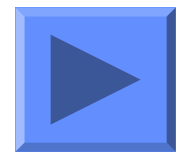
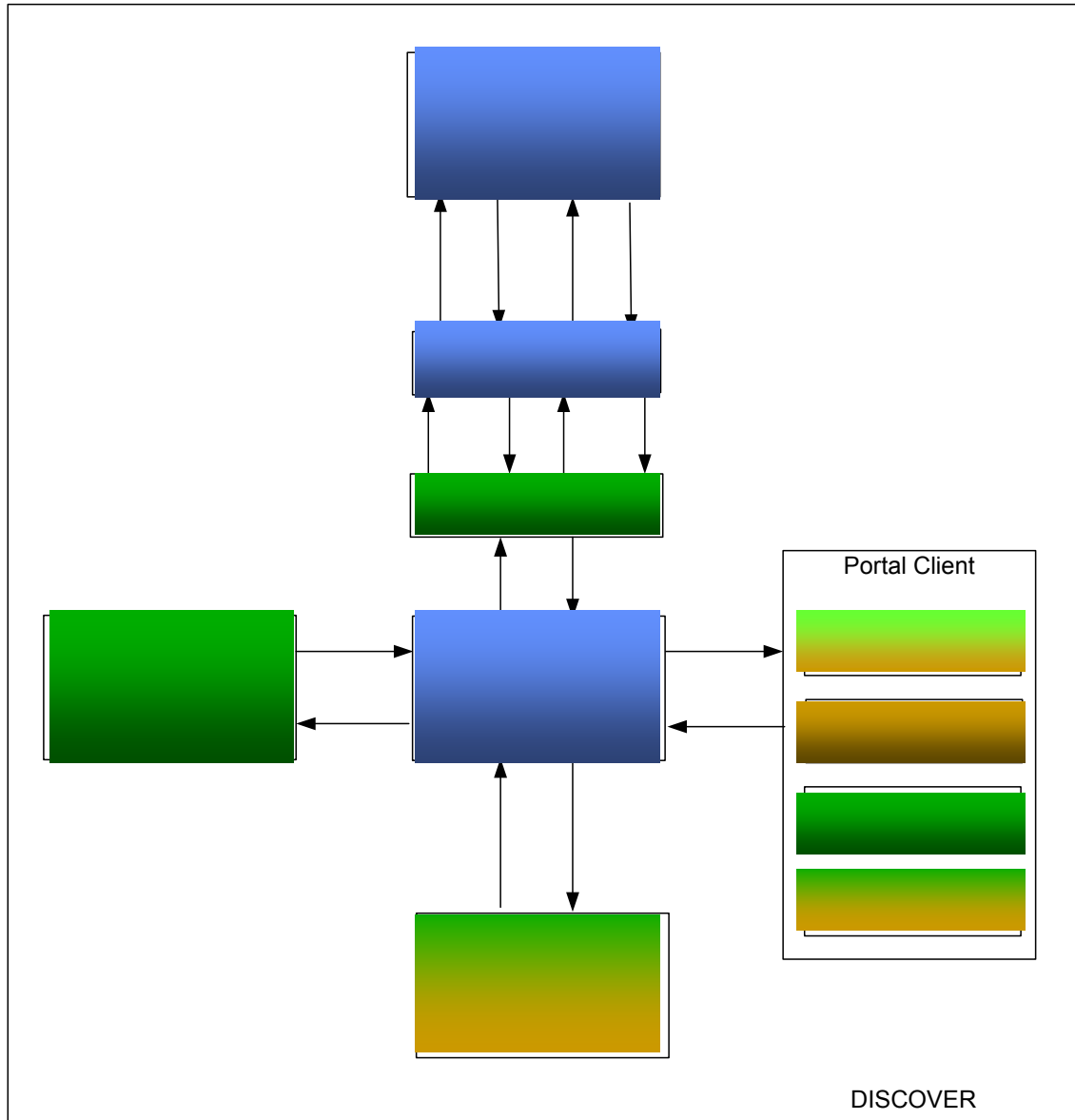



UST Client



UST Client Chat

USTclient

Base Name	Unit	Munition Qualification
Griffiss	AFRL	Toggle the munitions display
Otis AFB	522nd Bomber Wing	Toggle the munitions display
Otis AFB	15th Fighter Bomber Wing	Toggle the munitions display

[Show all munitions](#) | [Hide all munitions](#)

Add/Remove Unit Munition Qualifications

▶ Select Operation (Add/Remove)

Select Unit

Select Munition

Filter by Base: No Filter

Filter by Unit: No Filter





Database Bridge



- Modified to produce the “raw” TBMCS information objects required by the DISCOVER project

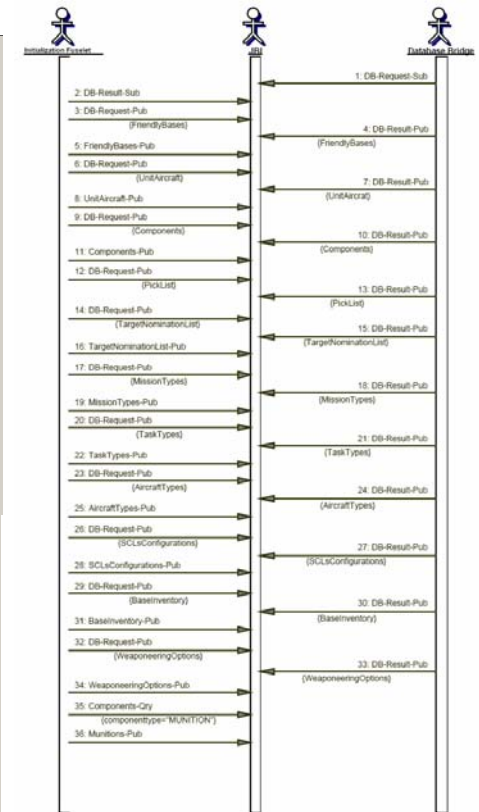
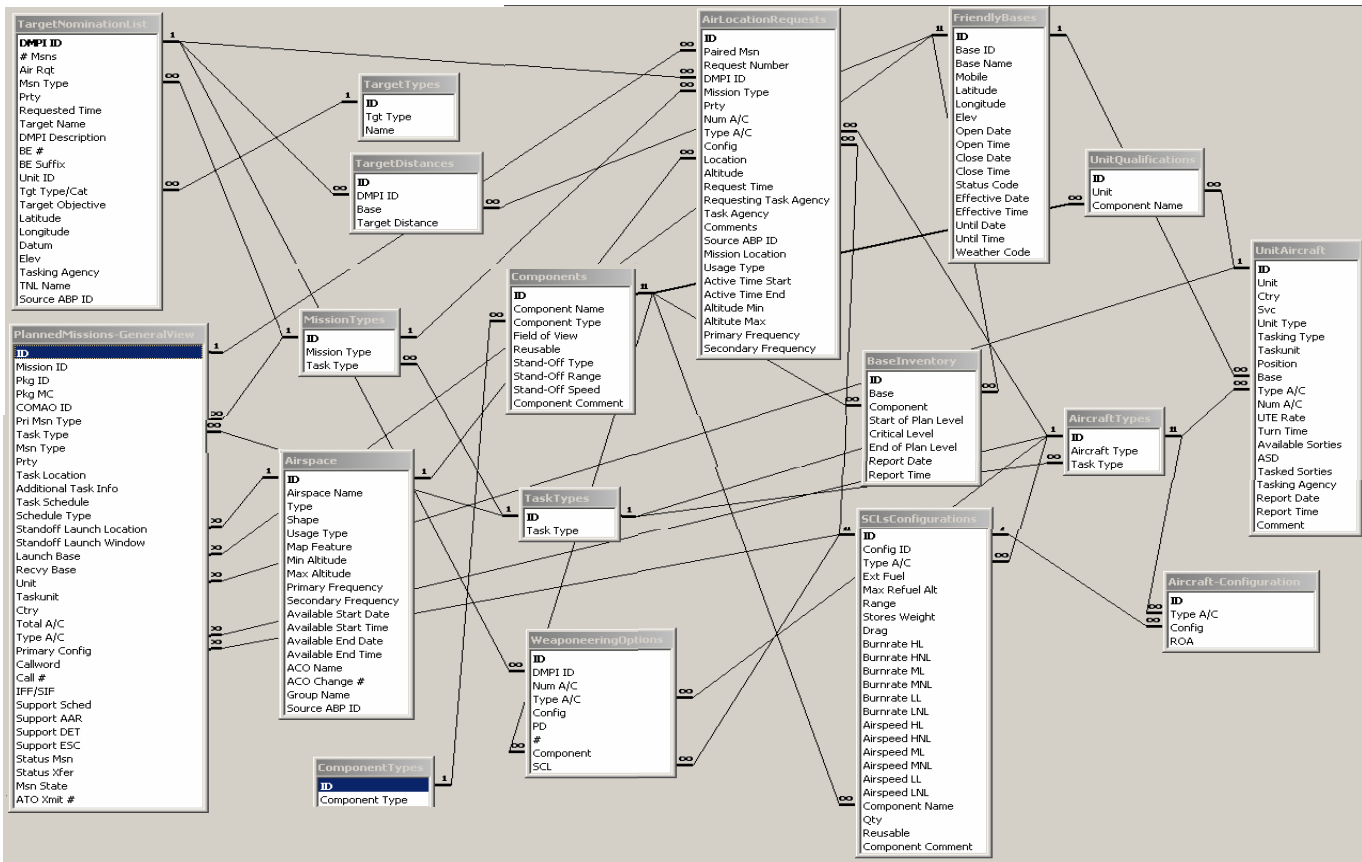



Fuselets

Shared Updatable Knowledge Object (SUKO)

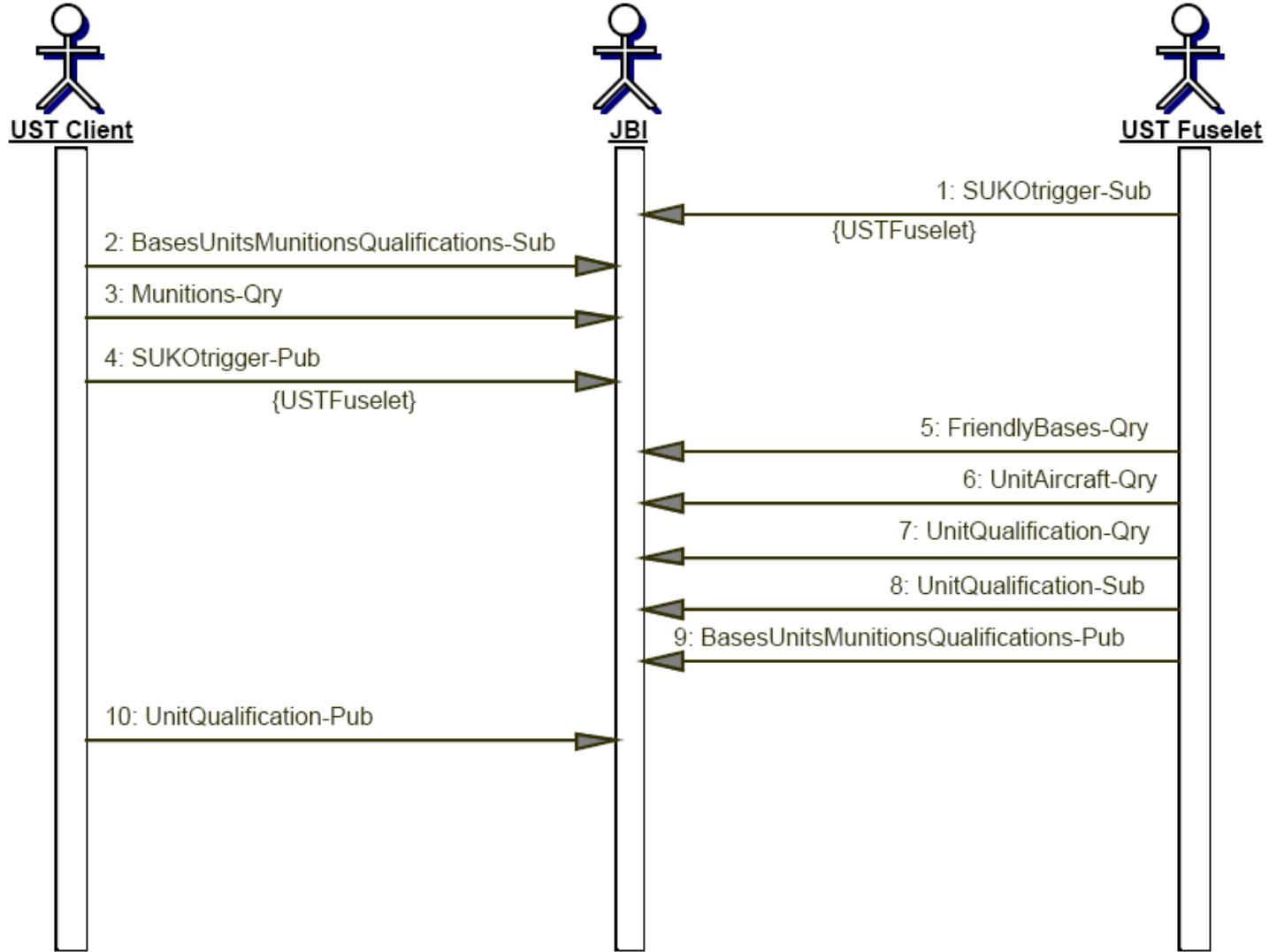



SUKO Publishes Internal State Upon Receipt of a Trigger



```
[ { 'baseid': 525, 'basename': 'Otis', 'unit': '7th Fighter Wing', 'munition': 'MK82' },  
  { 'baseid': 525, 'basename': 'Otis', 'unit': '7th Fighter Wing', 'munition': 'AGM65' },  
  { 'baseid': 525, 'basename': 'Otis', 'unit': '102nd Fighter Wing', 'munition': 'GBU52' } ]
```

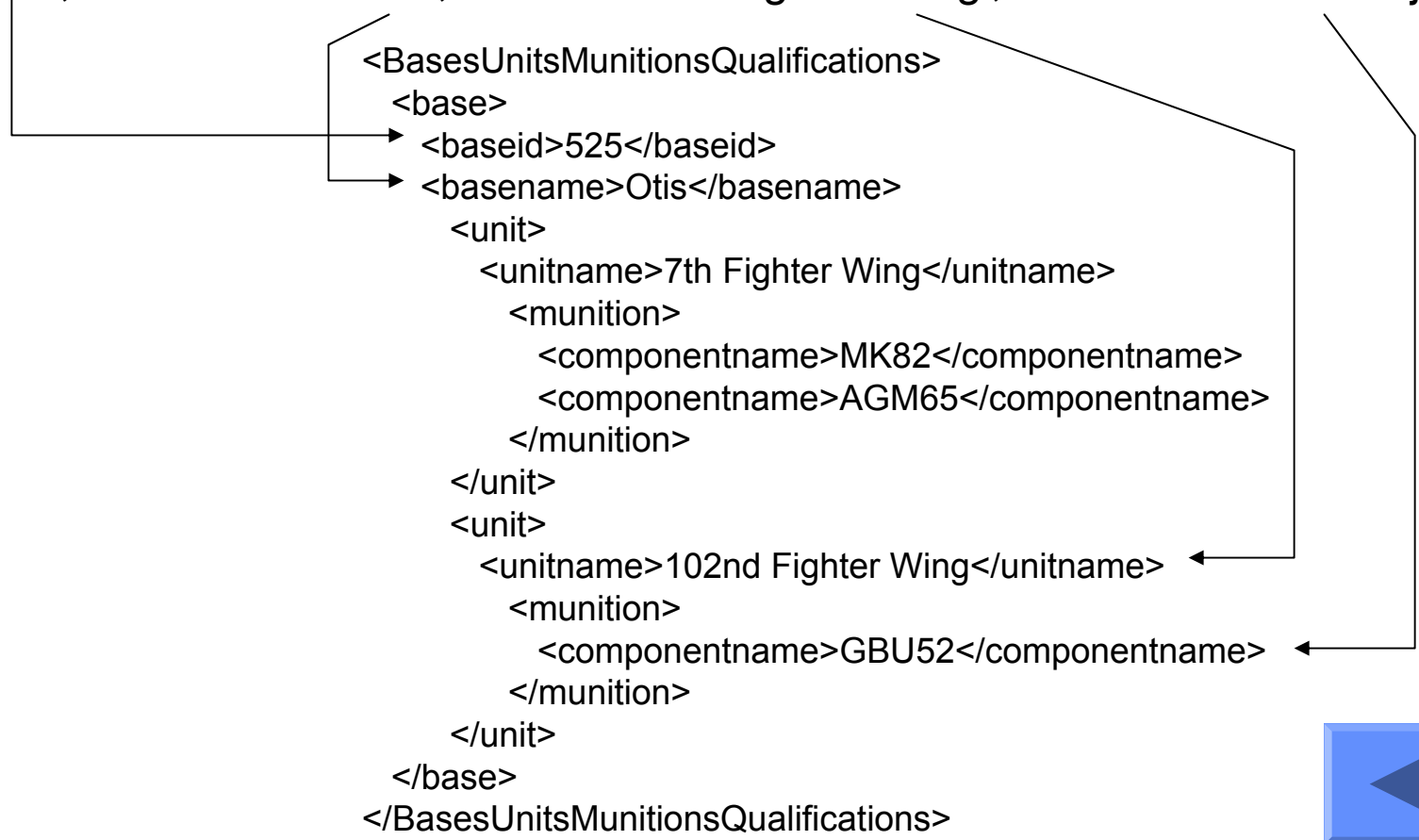



Preliminary Findings

Issues



- **Narrowing the gap between the SME and software developers**
 - **A great deal of application domain knowledge needs to be assimilated before an understanding of problems and the development of potential solutions can be embarked upon**
 - **It seems there will always be is a fairly steep learning curve, either for the fuselet/software developer to understand the problem domain, or for the subject matter expert to learn how to build fuselets and companion clients**
 - **Until we can empower the typical SME in this way, we will always have to employ a problem solving methodology such as we have under DISCOVER to understand and derive solutions to customer problems**



Preliminary Findings

Reducing the footprint



- **It is evident that we can accomplish this by eliminating the need for a Unit Status Technician (UST) to report unit qualifications by capturing this information in the JBI and associating it with the information captured from TBMCS**
- **This in turn leads to better decision-making efficiency and effectiveness...**
 - **Allows the UST to perform other mission-critical tasks**
 - **Makes target-platform-munition-unit-qualification correlation possible by fuselets to provide operators valid options to choose from promoting more efficient and effective decision making**



Preliminary Findings

Improving efficiency



- **Augmenting legacy systems with fuselet technology**
 - One of the problems that we identified is that TBMCS is largely a sophisticated database query-response system
 - Evidence suggests that fuselets can increase the decision-making speed of AOC duty officers by automatically correlating a given target to valid mission re-roll options
 - Fuselets would provide a proactive decision-support capability, as opposed to a reactive one where there is a high potential for no-go decisions where replanning has to back up and repeat itself
- **Distributed collaboration for distributed operations and improved communications**
 - Today, much of the person-to-person communication is done by “tennis shoe” interfaces, which makes distributed AOC operations difficult and centralized operations vulnerable to attack
 - Therefore, automation for collaborative capabilities provided by chat, instant messaging, and portal technology would in theory be beneficial to speeding up communication between operators and enable it to be done in a distributed way



Preliminary Findings

Improving effectiveness



- **Through controlled experimentation we can demonstrate how fuselets improve the warfighters ability to make better, more optimized decisions**
 - **Measure % improvement in missions re-rolled successfully (best selections) in a laboratory setting using realistic data sets**
 - **Do so first without our technology**
 - **Do so second with it**
 - **Compare the results**



Next Steps



- **Complete system/fuselet development**
- **Complete experiment design plan**
- **Execute phased experimentation**
- **Perform data analysis**
- **Document results and provide recommendations**
- **Initiate fuselet security study**
 - **Investigate and report on the operational security implications of JBI fuselet technology, particularly within the operational context of the DISCOVER experiment**
 - **Demonstrate in the DISCOVER prototype a role-based approach for addressing some of the security concerns uncovered by the study**



That's all for now...



- **Thank you.**

– **Questions?**