



Australian Government
Department of Defence
Defence Science and
Technology Organisation

Simulation Activities using Gateway and Tactical Digital Information Links

*Arthur Filippidis, Steve Blandford, Kate Foster
and *Gary Moran*

Air Operations Division
Defence Science and Technology Organisation
***Tactical Information Exchange Integration Office**

DSTO-TR-1918

ABSTRACT

Under the auspices of the Air Platform Connectivity Research Task Air 05/086, novel gateway, Tactical Digital Information Link (TADIL) and Network Centric Warfare simulation activities involving Australian Defence Force (ADF) platforms and Mission System Test-beds (MSTs) are currently in progress in the Air Operations Division. Several recent TADIL activities involve investigations using the Rosetta Data Link Gateway product from the ANZUS Alliance and Northrop Grumman's Dual Link Simulator with Extended Capability. An overview of Airborne Mission System's contribution to the Variable Messaging Format demonstration at the 2005 International Data Link Symposium is also presented.

RELEASE LIMITATION

Approved for public release

Published by

*DSTO Defence Science and Technology Organisation
PO Box 1500
Edinburgh South Australia 5111 Australia*

Telephone: (08) 8259 5555

Fax: (08) 8259 6567

© Commonwealth of Australia 2006

AR-013-755

September 2006

APPROVED FOR PUBLIC RELEASE

Simulation Activities using Gateway and Tactical Digital Information Links

Executive Summary

Network Centric Warfare activities planned by the Australian Defence Force will embrace a “network enabled” approach to warfare that will exploit the effectiveness of linked forces and capabilities in the future battle-space. Some of the key elements of the Air Platform Connectivity Research Task, Air 05/086, focus on the integration of current and future Tactical Data Link (TDL) acquisitions into Airborne Mission Systems, in particular to provide advice to the ADF on:

- (a) New and emerging technologies such as the Rosetta Gateway, which has the potential to solve some of the TDL interoperability and operational issues of using gateways on current and future platforms.
- (b) Network Centric Warfare applications using TDLs to help realise the aspirations of the ADF to establish a coherent and effective Defence Information Environment.

The report also briefly describes Airborne Mission System’s contribution to the Variable Message Format (VMF) demonstration at the International Data Link 2005 Symposium, organised by the Tactical Information Exchange Integration Office (TIE-IO). The overall aim of this demonstration was provide a realistic look at the future VMF and Multi-TDL Battlespace with support from Defence Industry. It also provided an opportunity to demonstrate the Link-11 capability on the Seahawk.

In summary the main aims of this report are to:

1. Investigate data link translator technology which has shown promise for enabling legacy data links to become interoperable with other Australian platforms and useful as a TDL simulator for investigating mission system integration issues.
2. Use of the Dual Link Simulator with Extended Capability (DLS-EC) and Common Connectivity Device (CCD) in pretrial feasibility testing of the Seahawk Helicopter Data Link.
3. Use Rosetta and DLS-EC as part of the TDL subsystem of the AEW&C MST, in preparation for future NCW activities.
4. Evaluate the effectiveness of the Rosetta Gateway technology.
5. Develop simulation activities that will enhance our capability to simulate realistic TDL scenarios in joint environments. This will provide simulations that can :
 - More realistically simulate hardware and software performances in the MSRC.
 - Evaluate different Australian-Coalition Link-16 network designs.
 - Understand the potential benefits of gateways.
 - Develop our knowledge of how ADF platforms fit into the future Global Information Grid with coalition forces.

Authors

Arthur Filippidis

Air Operations Division

Dr Arthur Filippidis obtained his B. Eng. in Electronic Engineering from the University of South Australia. Prior to joining the DSTO in 1996, he worked for Tracker Communications in South Australia, and the Naval Engineering Design section of the Dept. of Defence in Canberra.

While working as a professional officer with DSTO, he received a M. Eng. Sc. degree from the University of Adelaide in 1994, and a Ph.D. degree from the University of South Australia in 1999 in the areas of data fusion, artificial intelligence and automatic target detection. Whilst at DSTO he has authored/co-authored over 40 refereed conferences, journals, book chapters and defence technical reports. As an Adjunct Senior Research Fellow he has participated in the research programs of the Knowledge Based Intelligent Engineering Systems Research Centre, University of South Australia.

In early 2002 he joined the Air Operations Division, and has mainly worked in area of Tactical Communications. Currently he is task manager of the Air Platform Connectivity Task, Air 05/086, in Airborne Mission Systems Branch and has developed the Airborne Systems Connectivity Environment Laboratory to conduct further research in this area.

Steve Blandford

Air Operations Division

Steve Blandford has a BEng (Hons) in Electrical Engineering from the University of SA and has over 23 years experience as a professional working in the field of aerospace related research and engineering. Mr Blandford's career experience includes:-

Fifteen months as a Research Analyst within Airborne Mission Systems Branch of the Air Operations Division at DSTO Edinburgh where he is the current Task Manager for AIR 06/077 – Advanced Technologies for Legacy Mission Systems. Key research areas include; legacy mission systems and methods of treating obsolescence, software

and hardware emulation, advanced data bus, data link connectivity and data link translation.

Ten years experience at the RAAF Aircraft Research & Development Unit as the Senior Avionics Design Engineer. Experience includes electronic design, integration of non standard modifications into military aircraft, programming and computer interfacing in support of aircraft instrumentation and flight test.

Twelve years service within the DSTO at junior design engineer, technical and trades levels including a four year apprenticeship in radio electronics. During this period Mr Blandford performed electronic design, programming, and computer interfacing in support of electro-optical seeker and hardware in the loop system studies.

Kate Foster

Air Operations Division

Dr Kate Foster is a Research Engineer with DSTO's Air Operations Division. Her current work involves support to the AEW&C acquisition, research into the evaluation of component-based software architectures that incorporate middleware, and participation in the Net Warrior initiative to experimentally investigate aspects of network centrality. Kate obtained a Bachelor of Engineering (Electrical/Electronics) (Hons) and a Ph.D. from Swinburne University in Melbourne, Australia.

Gary Moran

Tactical Information Exchange Integration Office

Gary Moran has a background in Mechanical Engineering with a Masters in Engineering Studies from the University of Technology, Sydney.

Gary is the Director of the Tactical Information Exchange Integration Office within the Defence Materiel Organisation of the Department of Defence.

Gary has been with the Department for ten years working in a number of project management roles within Defence's Major Capital Equipment projects and as Chief Executive Advisor to the Under Secretary Defence Materiel.

Previous to this Gary worked in a number of private sector roles within the Australian Defence Sector.

He is a member of the Australian Institute of Company Directors and a Certified Master Project Director with the Australian Institute of Project Management.

He is the current Co-Chair of the International Data Link Society - Australian/New Zealand Chapter.

In 2003 Gary was presented with an Australia Day Medal for outstanding service in introducing an operational Theatre Broadcast Capability for the Australian Defence Force.

Contents

| | |
|---|-----------|
| 1. INTRODUCTION | 1 |
| 2. BRIEF OVERVIEW OF LINKS | 3 |
| 2.1 Overview of Link-11..... | 3 |
| 2.2 Overview of Link-16..... | 4 |
| 2.3 Overview of VMF | 4 |
| 3. OVERVIEW OF TECHNOLOGIES IN THE AIRBORNE SYSTEMS | |
| CONNECTIVITY ENVIRONMENT LABORATORY | 5 |
| 3.1 Rosetta [5], [6]..... | 5 |
| 3.1.1 Text Parsing Engine, Real time Track Database and FROG..... | 5 |
| 3.2 Dual Link Simulator with Extended Capability, | |
| Common Connectivity Device and CIELO Converter..... | 6 |
| 4. AIRBORNE EARLY WARNING & CONTROL MISSION SYSTEM TEST-BED | |
| TADL INTEGRATION..... | 6 |
| 4.1 Track Server Polling..... | 7 |
| 5. SEAHAWK TEST-BED TADIL INTEGRATION..... | 8 |
| 5.1 Seahawk MST..... | 8 |
| 5.2 Overview of AOD's Contribution to the VMF Demonstration | 10 |
| 5.2.1 Systems and Technologies used in the Demonstration..... | 12 |
| 6. NCW SIMULATION ACTIVITIES..... | 13 |
| 6.1 Current Simulation within the Mission System Research Centre using the | |
| DLS-EC & Rosetta..... | 13 |
| 6.2 Future Net Warrior Simulation | 14 |
| 7. SUMMARY AND CONCLUSION..... | 16 |
| 8. ACKNOWLEDGEMENTS..... | 18 |
| 9. REFERENCES..... | 18 |

Acronyms and Abbreviations

| | |
|----------|--|
| ADF | Australian Defence Force |
| AAR | After Action Review |
| ASCEL | Airborne System Connectivity Environment Laboratory |
| AEW&C | Airborne Early Warning and Control Aircraft |
| AOD | Air Operations Division |
| AMS | Airborne Mission Systems |
| ADGESIM | Air Defence Ground Environment Simulator |
| ADFTA | Australian Defence Force Tactical Authority |
| BCSS | Battlefield Command Support System |
| C2PC | Command Control Personal Computer |
| C2CE | Command Control Communication Equipment |
| CCD | Common Connectivity Device |
| CMS | Combat Management System |
| DLS-EC | Dual Link Simulator with Extended Capabilities |
| DTS | Data Terminal Set |
| DIS | Distributed Interactive Simulation |
| DLM | Data Link Modem |
| DLMS | Data Link Management System |
| DROC | Defence Regional Operational Centre |
| FROG | Forwarding Rules Object Gateway |
| HDL | Helicopter Data Link |
| HF | High Frequency |
| IDLS-05 | International Data Link Symposium 2005 |
| I-FACT | Indirect Fire-Forward Air Control Trainer |
| ICS | Interoperable C4I Services |
| JORN | Jindalee Operational Radar Network |
| JTIDS | Joint Tactical Information Distribution System |
| JMMTIDS | JTIDS Moving Map Tactical Information Display System |
| MSRC | Mission System Research Centre |
| MSCT | Multi-Source Correlator/Tracker |
| MST | Mission System Test-bed |
| MIDS | Multifunctional Information Distribution System |
| MIDS-LVT | MIDS- Low Volume Terminal |
| NCW | Network Centric Warfare |
| NCS | Net Control Station |
| NM | Nautical Miles |
| NPG | Network Participation Groups |
| NTDS | Navy Tactical Data System |
| NGS | Naval Gunfire Support |
| OTH | Over The Horizon |
| PU | Participation Units |
| RQL | Real-Time Query Language |
| RAN | Royal Australian Navy |

| | |
|--------|--|
| RAAF | Royal Australian Air Force |
| SLEW | Single Link-11 Waveform |
| SGT | Scenario Generation Tool |
| TADIL | Tactical Digital Information Link |
| TDL | Tactical Data Link |
| TIE-IO | Tactical Information Exchange Integration Office |
| TDS | Tactical Data System |
| TDMA | Time Division Multiple Access |
| TDF | Tactical Display Framework |
| TACP | Tactical Air Control Party |
| UHF | Ultra High Frequency |
| VMF | Variable Messaging Format |
| WAN | Wide Area Network |
| | |

1. Introduction

Network Centric Warfare (NCW) activities planned by the Australian Defence Force (ADF) will embrace a “network enabled” approach to warfare that will exploit the effectiveness of linked forces and capabilities in the future battle-space. The successful conduct of joint and ADF coalition operations requires a secure infrastructure that allows information to be collected, analysed and distributed as timely intelligence to provide friendly forces with superior situational awareness.

Air, ground and sea forces operate concurrently within the same theatre of operations against a wide variety of enemy threats. For today’s war fighter to be successful and avoid engaging friendly forces [1], they need to have the knowledge edge. Each must be aware of its own location and the geographic relationships with friendly and hostile forces in real time. A vital part of achieving mission success is for shared information to be clear, accurate and on time. While seamless networks will provide the necessary links between sensors, engagement systems and decision makers, it is the provision across these links of accurate and timely intelligence, not simply information, that will help commanders to make the right decision at the right time to achieve the desired effects.

Tactical Digital Information Links (TADILs) are a way of passing digital information between platforms of a battle group using netted communications techniques and standard message formats. They can provide the following tactical advantages: increased situational awareness; improved real time weapons coordination among land, surface and airborne units; high integrity communications, navigation and identification; improved data accuracy, throughput and availability; secure jam resistant communications and interoperability with joint and international forces.

There is considerable emphasis within Australian Defence on creating a cohesive Tactical Information Exchange Environment to overcome difficulties that are anticipated, or are currently being experienced, in sharing tactical data across the whole of the joint tactical arena. As part of this thrust, Defence [2] has mandated the use of the “J-series family” of messages (consisting of J-, K-, and F-series message sets), associated with the Tactical Data Link (TDL) networking environment. To accommodate legacy systems, external translation of information formats is one option to allow information to seamlessly flow between the systems. In addition, there may also need to be interfacing of TDL networking environments into other non-TDL networking environments to expand the range of distribution of tactical information, in particular those associated with the F-series or variable messaging format (VMF). An overview of Link-11, Link-16, and VMF are briefly detailed in sections 2.1, 2.2, and 2.3 as they are discussed in some of the applications. Improvements in communication interoperability of legacy systems as discussed above will require the use of gateway technologies such as Rosetta.

In part this report discusses several TADIL activities conducted in the Airborne System Connectivity Environment Laboratory (ASCEL) of the Mission System Research Centre (MSRC) which involve the application of the Rosetta Gateway and the Dual Link Simulator with Extended Capabilities (DLS-EC). The Rosetta Gateway has the potential to

solve some of the TDL interoperability and operational issues on current and future ADF platforms. An overview of Rosetta is detailed in section 3 of the report with applications of this technology reported in section 5 and 6, including reports of any observed deficiencies, advantages and ease of use.

Section 4 describes the application and integration of the Rosetta Gateway and the DLS-EC as part of the TADIL subsystem of the Airborne Early Warning & Control Aircraft (AEW&C) Mission System Test-bed (MST) being developed in the MSRC. In order to achieve the integration of the Rosetta Gateway with the AEW&C MST a Rosetta client is being developed to obtain information from a Rosetta server to populate the MST with track data.

The Seahawk MST, TADIL activity is detailed in section 5. This activity, involves investigation of applicability of data link gateway technology within the Seahawk MST. The purpose is to investigate the feasibility of introducing a modern data link into Seahawk without a rewrite of the aircraft's mission system software. As part of this investigation, a Rosetta module supporting a subset of the existing "Barracuda" Helicopter Data Link (HDL) has been developed.

The DLS-EC currently simulates a tactical display using internally scripted Link-11 and Link-16 network tracks interacting with Link-16 tracks received from an external terminal (simulated using the Northrop Grumman Common Connectivity Device (CCD)).

Section 5.2 briefly describes the DSTO Air Operation Division contribution to the VMF demonstration at the 2005 International Data Link Symposium organised by the Tactical Information Exchange Integration Office (TIE-IO), and lessons learnt through communicating with the other simulation participants using link messages.

Section 6.1 describes the incorporation into the tactical display of AEW&C and Seahawk MST tracks reported as Link-16 and Link-11 tracks respectively, which interact with link messages from internally scripted tracks. These internally scripted tracks may be depicted as surface, air or ground and may be assigned as hostile, friendly or neutral. In the more distant future, the TDL Wide Area Network (WAN) soon to become available to DSTO will allow the above simulation on the DLS-EC to interact in real-time with real ADF platforms using their link networks. This activity also supports a future Net Warrior simulation exercise (in section 6.2) to connect external synthetic environments to the MSTs in the MSRC using the DLS-EC and Rosetta.

2. Brief Overview of Links

2.1 Overview of Link-11

Link-11 (M series), or TADIL-A, was developed as a maritime data link and is currently used on several platforms in the ADF. Link-11 uses a polling protocol and a netted architecture. A net is an ordered conference whose participants have common information needs or a similar function to perform. A net operates under the supervision of a controller, who permits access and maintains circuit discipline. Participation units (PUs) transmit all data for reporting when they are polled by the Net Control Station (NCS) [3]. After transmission, they revert to the receive mode while, one by one, the other PUs transmit their data. This cycle continues until all PUs have transmitted at least once, and then it is repeated. At any given time, a PU is either transmitting or receiving data on a single net.

The Link-11 system [3] has significant operational limitations, lacking in electronic protection, having insufficient tactical message capability, insufficient error detection and correction, and not being able to support a large number of participants. Link-11 is capable of operating in both Ultra High Frequency (UHF) and High Frequency (HF) bands. When operating in the UHF band, the link provides omni-directional gapless coverage to approximately 25 nautical miles (NM) ship-to-ship, or 150 NM ship-to-air. When operating in the HF band, Link-11 provides gapless omni directional coverage of up to 700 NM using Single Link-11 Waveform (SLEW).

A typical Link-11 system configuration, as shown in Figure 1, consists of a computer system called a Tactical Data System (TDS), an encryption device, a Data Terminal Set (DTS), HF or UHF radio, a coupler, and an antenna.

The transmit radio takes data from the TDS, encrypts, converts to multi-frequency modulation, or multiphase and transmits. The receive module demodulates, decrypts and passes the data to the TDS [3]. A frequency standard is required to generate an accurate carrier frequency.

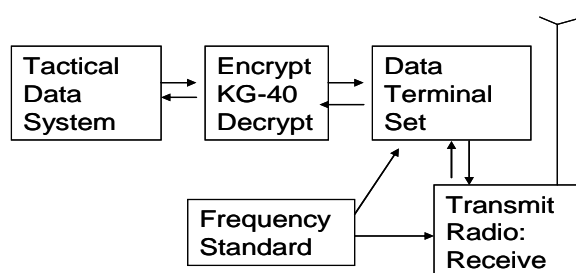

Figure 1. Typical Link-11 signal flow [2]

2.2 Overview of Link-16

Link-16 (J series), which has a message standard designated as TADIL-J, is currently being implemented in the ADF. It provides improvements over Link-11 such as jam resistance, security, increased data rate (throughput), reduced granularity of information exchange, reduced data terminal size allowing installation in fighter and attack aircraft, relative navigation, and precise participant location and identification. Link-16 also uses the principle of Time Division Multiple Access (TDMA) where platforms are pre-assigned sets of time slots in which to transmit their data. TDMA allows users to share the system's nominal 1Mb/sec capacity. Each user is generally limited to 54Kbps which is programmed among a variety of virtual circuits (i.e., Air Control, Electronic Warfare and Voice) called Network Participation Groups (NPGs).

Link-16 uses the Joint Tactical Information Distribution System (JTIDS). JTIDS is the communication component of Link-16 and is gradually being replaced with the Multifunctional Information Distribution System Low Volume Terminal (MIDS-LVT). It encompasses the Class 2 terminal software, hardware, RF equipment, and the high capacity, secure, anti-jam waveform that they generate. In addition to data link programmability Link-16 terminals include a relative navigation function that enables reporting sensor tracks on a very accurate common grid. The Link-16 specification includes data registration rules for track reporting and defines a method for correcting sensor point errors.

TDMA [4] uses time interlacing to provide multiple and simultaneous communications nets. All JTIDS units, or JUs, are pre-assigned sets of timeslots in which to transmit their data and in which to receive data from other units. Multiple nets can be stacked by allowing timeslots to be used redundantly, with the data transmitted in each net on different frequency hop patterns. Each net is assigned a number (127 possible), which has a particular hopping pattern. At any time slot, a unit is either transmitting or receiving on one of a possible 127 nets.

2.3 Overview of VMF

VMF is a bit oriented digital information standard (K message format, based on the J-series). It consists of variable length messages as a common means of exchanging data between combat units at varied organisation levels, with varying requirements for volume and detail of information. VMF provides the user with the flexibility to send only the required information on demand. It is not tied to any specific radio or processor environment and is suitable for near real-time data exchanges in bandwidth constrained combat environments.

3. Overview of Technologies in the Airborne Systems Connectivity Environment Laboratory

The next few sections will provide an overview of the data link technologies and hardware used for the activities conducted in the Airborne Systems Connectivity Environment Laboratory.

3.1 Rosetta [5], [6]

Gateways have been in development for many years and are built on the principle of taking small pieces of information in one link format and translating that information into its equivalent in an alternative data link. As additional data links are added to the system this approach becomes very complex with numerous gateways. Issues such as multiple messages from one data link corresponding to a single message on another link, loss of precision, and alternative location representations further complicate the task.

The technology being used is Rosetta (ANZUS Inc.), which has a client/server architecture, and uses a new approach that consists of a Text Parsing Engine (which interprets data link protocols and messages), a Real-Time Query Language (RQL) database (which manages real-time data in a common format), and a Forwarding Rules Object Gateway (FROG) (which implements information exchange requirements). The Rosetta client/server architecture forms a homogeneous database of data link tracks, commands and simulation data. The JTIDS Moving Map Tactical Information Display System (JMMTIDS) is software capable of running on a Windows based notebook computer that displays, manages and translates a variety of real-time tactical data links. Rosetta can process navigation data and acts as a host for a variety of data links. JMMTIDS and the Scenario Generation Tool (SGT) are both clients of Rosetta. JMMTIDS provides situational awareness by displaying data from a track in a graphical format over maps, charts and imagery. The ability to develop scenarios is provided by SGT.

3.1.1 Text Parsing Engine, Real time Track Database and FROG

Using text parsing technology, ASCII interface control documents (based on MIL-STD documentation) can be used as the basis for interpreting a wide variety of data link message formats and normalising link messages. Link-16, Link-11 and VMF messages are stored in text files that have been parsed from MIL-STD documentation [7]. The RQL Engine was developed as a simple real-time interface to complex data streams such as navigation systems and data links. The Engine performs all data management services and acts as a track server which enables the stored data to be accessed using RQL calls from Rosetta clients through a COM/DCOM interface. RQL can be used to insert, extract, update and delete data stored in the track server. The FROG implements the gateway function of the Rosetta architecture. It can intelligently apply forwarding rules among data links represented in the RQL database. The RQL INSERT statement is used to forward commands and tracks from one data link into another. The architecture relies on a series of

abstraction layers to convert the non-homogeneous Link-11, Link-16 and VMF data to homogeneous data available to a variety of clients.

3.2 Dual Link Simulator with Extended Capability, Common Connectivity Device and CIELO Converter

The Northrop Grumman DLS-EC is a powerful battle space simulator and currently has Link-11 and Link-16 implemented. The system enables realistic battle scenarios to be developed and link messages to be generated and monitored. The system implements Distributed Interactive Simulation (DIS) protocols, enabling participation in geographically distributed exercises, with real and simulated platforms.

The CCD, which is connected to the DLS-EC contains numerous tactical interfaces and protocols (i.e., host, terminal, monitor modes and MIDS-1553) and network interfaces and protocols (i.e., Ethernet TCP/IP, UDP/IP and SIMPLE) acts as a terminal enabling it to translate data among tactical data systems, and communicate with legacy products. It can operate in either host or terminal mode, and can record and playback data for analysis. For example in Link-11 terminal mode the CCD can use the Navy Tactical Data System (NTDS) protocol, which is used in the Seahawk activity. The CIELO converter is used to convert NTDS to Link-11 on UDP (and vice versa) as described in section 5.

4. Airborne Early Warning & Control Mission System Test-bed TADL Integration

The MSRC in Air Operations Division (AOD) has developed an MST for the AEW&C aircraft using the Operational Flight Program running on Solaris workstations. The AEW&C MST (as shown in Figure 2) is used to investigate mission system integration issues. In Figure 2 the Rosetta client in the AEW&C MST interacts with the Rosetta system to obtain track data over Ethernet. The DLS-EC displays the J-series tracks on its link scenario, and the Solipsys Tactical Display Framework (TDF) displays the track as a target track, which can interact with the operator. The Communications Framework is used to transfer data to and from: the Rosetta Client; the Track manager (database); the Track monitor (displays text based track information on a computer screen); and the Track system translator (interface to the TDF).

The Rosetta system has been used in the MSRC to form a TADIL simulator for input into the AEW&C MST. To integrate the Rosetta system with the AEW&C MST, a Rosetta client was required. Two methods to implement the Rosetta client and obtain information from the track server are: (1) polling and (2) streaming. The polling method has been implemented and the streaming method may be implemented in the future.

4.1 Track Server Polling

The polling method involved writing a simple Rosetta client in C++ to query the track server periodically (see Figure 2). The RQL calls SELECT, FROM and SNAPSHOT were used to obtain data fields directly from the track server. The SELECT command was used to gain access to the track server and specified the data fields that were to be obtained (i.e. track number, message number, latitude, longitude, altitude and speed). The FROM clause specified the data source that filled values into the fields from the SELECT list. In this case the data source was a mirror device and the data was broadcast over UDP using the port SIM_MIRROR. For example:

```
SELECT sys.trackno, messageno, track.latitude, longitude, altitude, speed
FROM "mirror, udp\255.255.255.255\SIM_MIRROR"
```

This was followed by calls to SNAPSHOT, which delivered the data fields as they existed at that moment in time.

The resulting ASCII string obtained from the track server was transmitted over Ethernet and parsed to obtain the required information. The Rosetta client then populated the AEW&C MST track manager with this information, which was displayed by the Solipsys TDF.

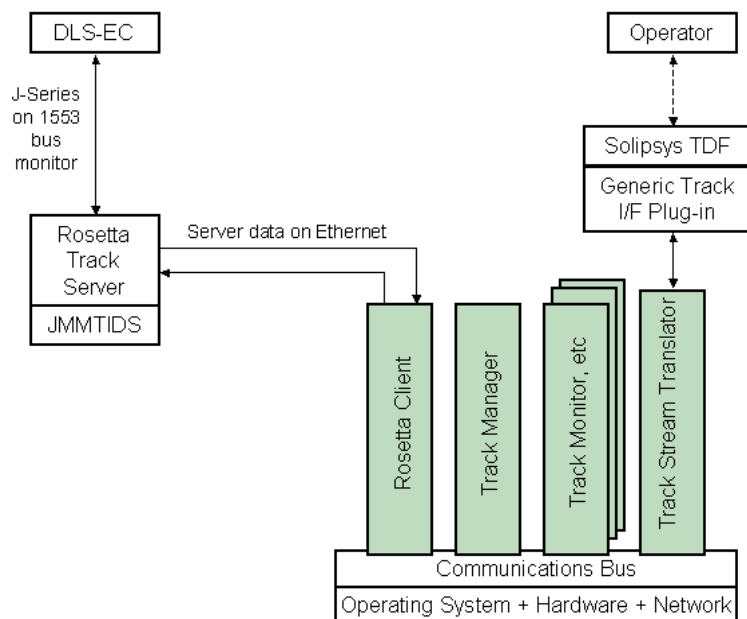

Figure 2. Rosetta client in the AEW&C MST interacts with the Rosetta system to obtain track data over Ethernet.

5. Seahawk Test-bed TADIL Integration

5.1 Seahawk MST

In support of the Project Definition Study for the Seahawk Midlife upgrade, Airborne Mission Systems (AMS) Branch in AOD has developed a Seahawk MST representing part of the Royal Australian Navy (RAN) Seahawk TDS. Feasibility of using a data link translator to introduce a modern link into the existing unique Seahawk Helicopter Data Link (HDL), without a rewrite of the complete system software, is being investigated. As part of this investigation, a module has been written for Rosetta that supports a subset of the existing HDL. As part of future investigations, a live demonstration between the Seahawk MST and either a RAAF AP3-C aircraft or a development environment may be conducted. This section will discuss some of the pre-trial testing aspects of the modified Seahawk MST using Link-11, conducted in the ASCEL using the DLS-EC and CCD. (Note Link-11 is the most likely link to be encountered in theatre of operations in the foreseeable future).

To enable link operations, the Seahawk TDS is connected to a HDL compatible Data Link Modem (DLM), an encryption device and a UHF radio (as shown in Figure 3). The HDL messages are transmitted and received by the UHF radio-transmitter. The DLM does both the message handling and analogue to digital conversion for the actual data transmitted and received by the HDL system. The DLM converts the RF information into data messages which can be understood by the Tactical Display within the aircraft cockpit following encryption and decryption by a crypto device. The situational awareness information is sent to the display units within the aircraft cockpit. The Seahawk MST is stimulated using a commercial flight simulator package such that the system is fooled into thinking it is flying. The flight simulator provides a virtual cockpit for the operators as well as basic flight, navigation and sensor data for the TDS.

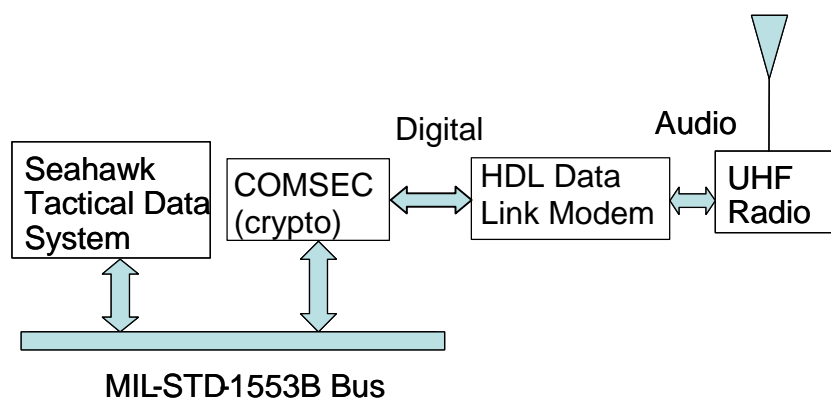

Figure 3. Seahawk HDL Tactical Data Link

The simplified block diagram in Figure 4 summarises the Seahawk Link-11 concept demonstration, as conducted in the ASCEL. The core of the system is the Data Link Management System (DLMS). The DLMS is a Windows based laptop PC running the Rosetta software, whose prime functionality in this case is to provide the translation between HDL and Link-11 messages (other link translation and forwarding can also occur). A typical JMMTIDS screen is shown in Figure 5. Received Link-11 data is converted from NTDS format to Ethernet (via the CIELO converter), where it is passed directly to the PC hosting Rosetta. Information is then converted from Link-11 to HDL and sent to the Seahawk TDS.

The CCD is set up as a Link-11 Network Control Station and a scripted scenario replay unit, to poll and send Link-11 messages to the RAN Seahawk Helicopter TDS respectively. The TDS is capable of transmitting its own ship radar tracks, position and sona-buoy data using the legacy HDL. In the ASCEL, preliminary feasibility tests have demonstrated the Seahawk MST communicating with the CCD using Rosetta to translate the HDL messages to Link-11.

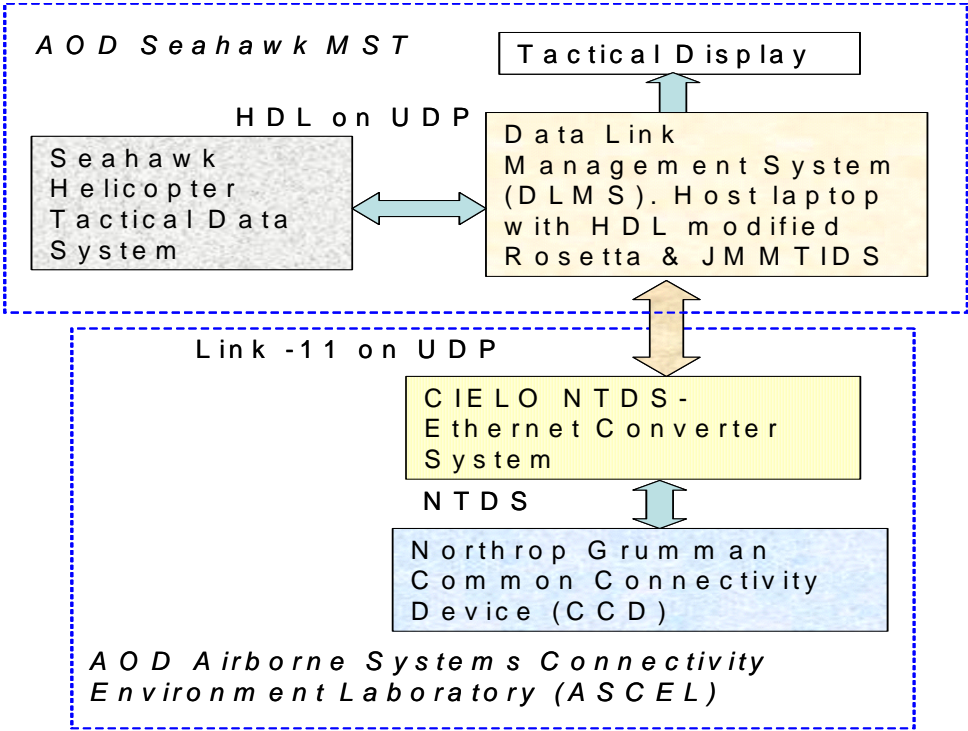

Figure 4. Seahawk Link-11 testing using the Common Connectivity Device

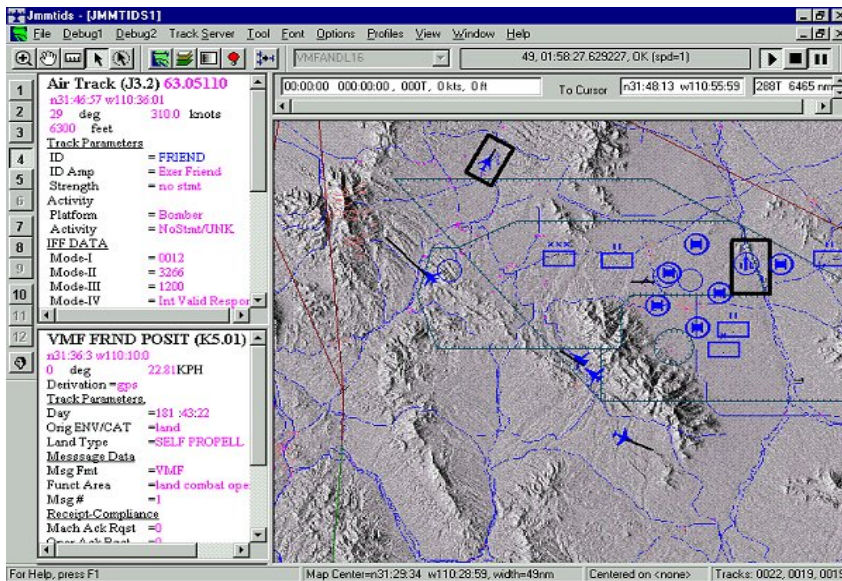

Figure 5. A snapshot of the Data Link Management System (DLMS)

5.2 Overview of AOD's Contribution to the VMF Demonstration

The VMF demonstration at the 2005 International Data Link Symposium (IDLS-05), in Sydney was organised by the Tactical Information Exchange Integration Office (TIE-IO) and Defence Industry. The next few paragraphs will overview AOD's contribution to the VMF demonstration. The Air Platform Connectivity and Seahawk tasks together supported the demonstration providing: integration testing; the use of the CIELO converter, Rosetta Gateway, manning and operational use of the Seahawk MST; and the travel costs and time for several staff to participate in the integration testing and demonstration phases.

VMF in a multi TDL environment is aimed at demonstrating future ADF capabilities in a simulated operational environment (as shown in Figure 6). The demonstration employed a digital slice of the ADF Joint Service environment incorporating the Royal Australian Navy (RAN) Naval Gunfire Support (NGS), Army Field Artillery and Royal Australian Air Force (RAAF) Close Air Support [8]. The demonstration scenario was driven using the Indirect Fire-Forward Air Control Trainer (I-FACT) simulation system to stimulate interaction from participants. Each participant's display, manned by a combination of uniformed (war-fighter) and Industry representatives, executed actions in response to received information or requests for fire support delivery via a VMF deployed backbone [9]. Real systems were used and real data was passed by LAN, but equally could be replaced by other bearers. The operational scenario set on the San Diego coastline, was based around an Australian task force advancing to secure an enemy airfield to establish a forward operating base.

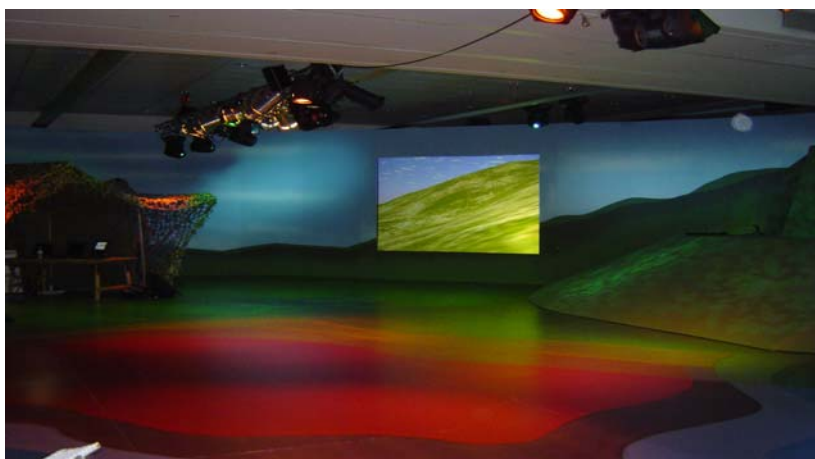

Figure 6. A snapshot of the simulated VMF Environment

The demonstration using the Seahawk MST involved integration and interaction of the Rockwell Collin's DLMS, Northrop Grumman's Command Control PC (C2PC) / Pocket PC Situational Awareness tool (C2CE), Interoperable C4I Services (ICS), SAAB's ANZAC Ship Combat Management System (CMS), the Battlefield Command Support System (BCSS), the Tactical Air Control Party dismount system (TACP) and the I-FACT Simulation System. Section 5.2.1 will overview a few of these systems and technologies.

In terms of the Seahawk involvement, the demonstration provided the first live contact between the new ANZAC CMS and the Seahawk HDL. Figure 7 shows the manned Seahawk MST interacting with the SAAB ANZAC Ship CMS at the IDLS-05 demonstration. Seahawk exchanged its own ship position, tracks and sonobuoy tactical data with ANZAC via Rosetta. The forward observer requested naval gunfire, artillery and close air support to secure the bridge and airfield.

During the integration testing preparations some issues were identified in the developed HDL to SAAB CMS Link-11 interface. It was found that messages passing from the CMS to the HDL were successfully converted from Link-11 to HDL message format. However, messages passing from the HDL to CMS were not successfully converted from the HDL to Link-11. In an effort to provide track information to the CMS and HDL for the purpose of the IDLS-05 VMF demonstration, the messages passing to and from the HDL were converted to Link-16 first and then to Link-11 for the CMS.

Although there were some shortcomings in the Seahawk HDL to SAAB CMS Link-11 interface, most problems were identified and resolved in the AOD ASCEL (together with Rockwell Collins, Anzus, Cielo Pty Ltd., and SAAB) post IDLS. During the testing back in the ASCEL it was then found that the HDL to Link-11 interface on Rosetta was not fully implemented as expected (note it was not tested due to a lack of the CIELO). In summary the collaboration was a good opportunity for AOD to not only participate in this important demonstration but to identify some of the bugs with the HDL system when integrated with other live link systems.



Figure 7. *The manned Seahawk MST and unmanned SAAB CMS at the IDLS-05 VMF Demonstration*

5.2.1 Systems and Technologies used in the Demonstration

The SAAB ANZAC CMS (as shown in Figure 7) enables control of communication, sensors and weapon systems. TADIL information is made available to the operator in the context of part of the tactical picture. The CMS is currently in service with the RAN ANZAC Class Frigates.

The BCSS (in service with the Australian Army since 1999) is a field deployable, real-time tactical and operational command support system offering messaging across a wide range of bearers including Combat Net, Radio, LANs, WANs, satellite and point to point links. BCSS provides GPS based positioning, 2D/3D terrain analysis and military communications.

The I-FACT is designed to train ground controllers in tactics of Joint Close Air Support. The simulator includes: indirect fire, terminal attack and close air support planning, weapon and pilot training and displays and replays exercises for action reviews.

Northrop Grumman's C2CE is a pocket PC situational awareness tool that obtains and displays the common tactical picture through a wireless link to a Command and Control PC (C2PC). It provides land navigation tools for foot soldiers, and calculates range bearings between two points.

6. NCW Simulation Activities

Sections 6.1 and 6.2 describe the current experimental work with the DSL-EC and Rosetta within the ASCEL using scripted platforms together with the MSTs and future connections to external simulators.

6.1 Current Simulation within the Mission System Research Centre using the DLS-EC & Rosetta

To develop our knowledge of the complex simulation equipment within the ASCEL and before any integration with MSTs and external simulators, scenarios are being developed and run on the DLS-EC and CCD. These simulated tracks are given headings and speeds using motion models and classified as being surface, air or ground and assigned as hostile, friendly or neutral. In Figure 8 the DLS-EC is set up as a host to display tactical information from the sensor suite of a particular Command and Control platform and other link information received from any external terminal. It displays both Link-16 and Link-11 incoming tracks (data paths shown in Figure 8). The CCD has been set up as a Link-16 terminal (on another platform) transmitting Link-16 tracks from a prerecorded scenario to the host. Correlation of tracks occurs on the host's tactical display when local and Link-16 tracks from the CCD are determined to be the same using the track reporting rules (outlined in the Military Standards [7]). Figure 9 displays transmit and receive link messages (M and J series shown as AT or AR and JT or JR respectively) and local and external tracks (in the geographic region of South Australia) on the host tactical display. The different symbols shown in Figure 9 represent a target's assigned threat and type of platform. The Link-16 tracks from the CCD are also sent to the Rosetta Gateway via a 1553 connection where it can be translated to a variety of common link types (such as Link-11 or VMF).

Sections 4 and 5, have briefly described some of the integration details required to interface and pass Link-11 and Link-16 messages to and from Rosetta. The next progression (as shown in Figure 8) is to incorporate both the AEW&C and Seahawk MSTs into the simulation. This will enable scripted platforms to interact in a more complex scenario with the MSTs within the MSRC. This will also enable future human in the loop experiments to be conducted flying the Seahawk and AEW&C MSTs interacting together with a variety of simulated platforms passing track messages. These experiments are expected to yield information more conveniently in the laboratory (as opposed to fielding with real platforms) regarding the performance of modifications made to the MSTs such as Seahawk (and other legacy platforms), or to future modifications of software to the AEW&C TADIL sub-system.

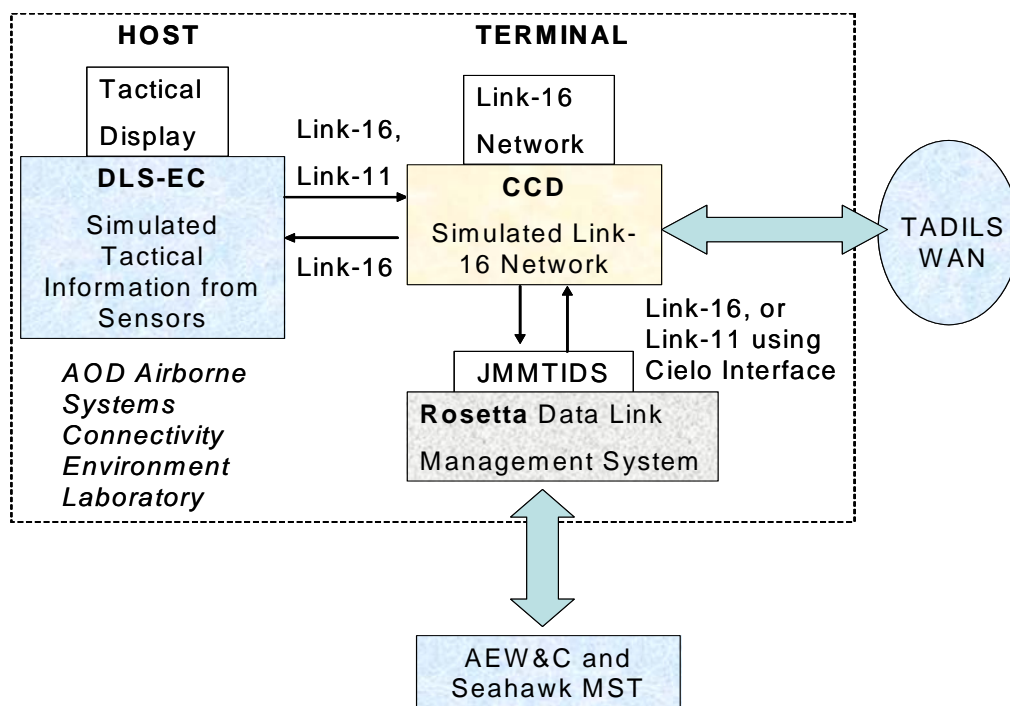

Figure 8. Shows the DLS-EC and CCD simulating the tactical display of one platform and a Link-16 terminal on another platform. Rosetta connects to the MSTs, and the CCD to other external simulators using the TADILs WAN

6.2 Future Net Warrior Simulation

The Net Warrior exercises planned in the future will be based on a joint scenario which includes four internal DSTO research nodes (refer to Figure 10). The nodes are the AEW&C MST, the Future Ship (representing a maritime platform of the future), the Air Defence Ground Environment Simulator (ADGESIM) representing ground based air defence control, and the Defence Regional Operational Centre (DROC) representing EASTROC located at Williamtown.

The DSTO developed simulator ADGESIM [10] is a high fidelity system used by the RAAF for training, and controllers in their operational systems. Figure 10 displays a possible short term (within DSTO) Net Warrior architecture using the ADGESIM software [10] together with the DLS-EC, Rosetta and CCD in the ASCEL interacting using the DIS and J-series networks with the 3 other nodes described above. ADGESIM in this initial architecture consist of a DIS radio, Qantas airline scheduler (which can create way points and schedules), world viewer (showing world entities), After Action Review (AAR) data logger and the Soliypsys Multi-Source Correlator/Tracker (MSCT) and Tactical Display Framework (TDF). The Australian Air Traffic System (TAATS) and Jindalee Operational Radar Network (JORN) Over The Horizon (OTH) simulators developed by Permian monitors the virtual environment on the DIS network and produce J-series messages. In recent tests of this architecture, DIS entities were stored in the AAR logger and successfully sent to the DLS-EC which associated them into corresponding J-series entities, hence demonstrating the first steps in connectivity between ASCEL and the ADGESIM

node. Like the DROC node, full connectivity cannot be demonstrated with the ADGESIM node until J-series messages are successfully received from the MSCT (the equivalent of receiving J-series messages from the Permian applications). In future tests, sending the DIS entities from the logger to the Permian TAATS and JORN simulators should produce J-series messages which can be verified using the DLS-EC via the CCD. This will then lay the groundwork in verifying the connection of the AEW&C node (using the Rosetta and DLS-EC) to the ISRD DROC node which has the Soliypsys MSCT and TDF.

The TDL WAN currently being rolled out by the Australian Defence Force Tactical Authority (ADFTA) is one possible method of connecting the ASCEL (as shown in Figure 8) to external simulators such as ADGESIM. The exercises will aim to comply with the general principles outlined for the future Global Grid [11] and initially mainly use J-series messages.

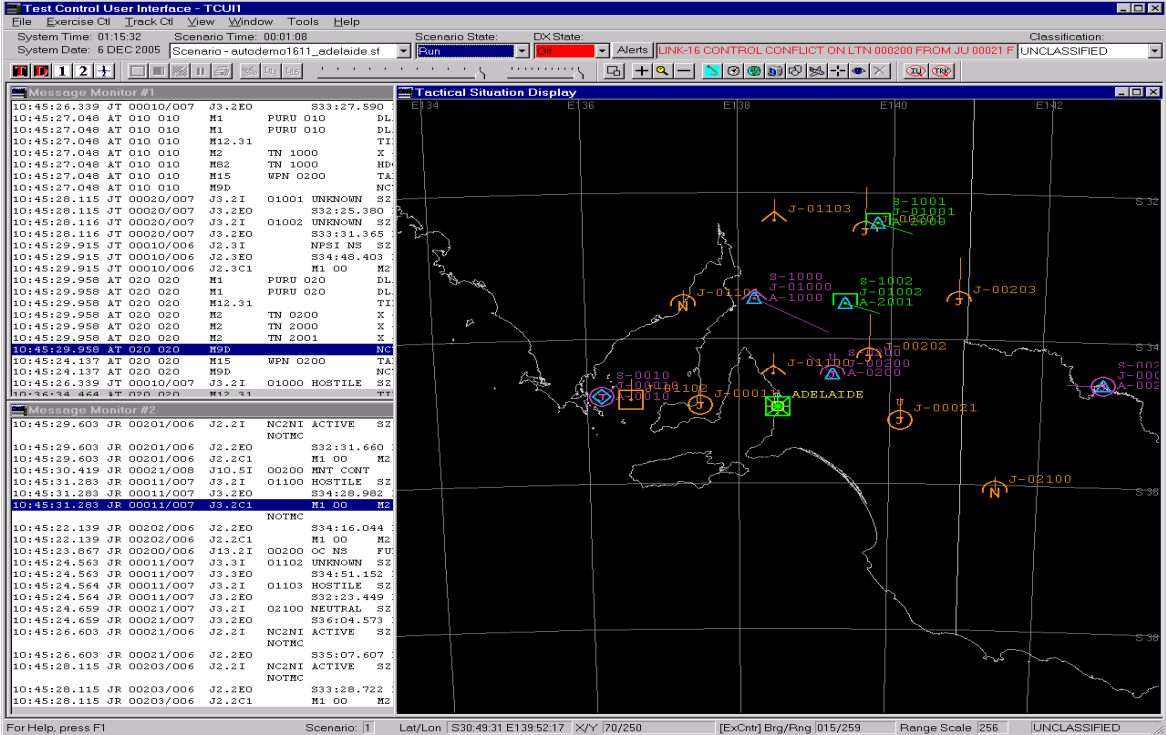

Figure 9. Displays link messages and a variety of local and external tracks received by the DLS-EC set up as a host Tactical display

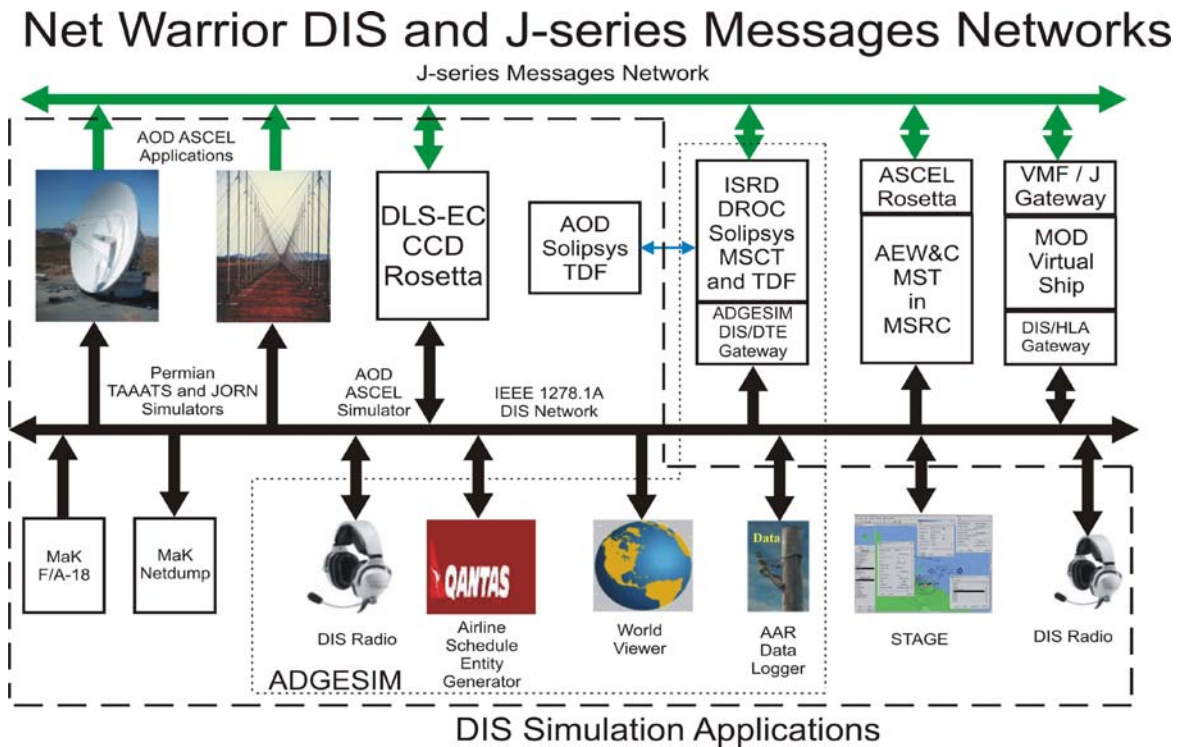

Figure 10. Displays a possible Net Warrior DIS and J-series short term architecture (within DSTO) using the ADGESIM, DLS-EC and CCD in the ASCEL together with several of the external nodes [10]

7. Summary and Conclusion

In summary, link translator technology has shown promise for enabling legacy data links to become interoperable with other Australian platforms. Link translator technology has also proven useful as a TADIL simulator for investigating mission system integration issues. Whilst link translator work in the MSRC has focused on the ANZUS Rosetta product, other link translators will be evaluated in the future.

Limited work on the AEW&C MST has shown the RQL interface to be flexible, as the Rosetta client can be programmed in any computer language that supports the COM/DCOM interface. In the near future the AEW&C MST, like other simulators in the Net Warrior exercises as described in section 6, will be involved with scripted platforms on the DLS-EC by passing link data using Rosetta.

Section 5 described feasibility testing in the ASCEL using Rosetta to translate the Seahawk HDL to Link-11. The advantage of data link translator based solutions is that they do not modify the Seahawk TDS from an operator's point of view, hence there are minimal requirements for re-training or for the production of documentation. Furthermore, inclusion of this technology does not impair the existing HDL capability. An advantage of the gateway system is the wide variety of remote access techniques that are available using

commercial infrastructure. Clients attached to gateways using TCP/IP over satellites, phone lines, Ethernet or tactical radios are feasible leading the way for future Tactical Internet and NCW exercises. In the future, link translators such as Rosetta have the potential to convert HDL to Link-16 or VMF. A Link-16 capability would provide operational advantages over Link-11 for the portrayal of targets, threats and friendly forces on a simple relative position display.

As described in section 5 the simulation architecture in Figure 4 has been useful in the pre-trial testing for the Seahawk HDL. It has helped identify HDL translation issues before any live concept demonstrations. It has also provided the opportunity to evaluate the advantages and disadvantages of the Rosetta Gateway. This information will be of interest to task sponsors and the ADF.

The architecture for the simulation described in Figure 8 has the advantage of being flexible and easy to expand. As described in section 6 the simulation exercise has started with the DLS-EC as a host and the CCD emulating a TADIL terminal simulating a Link-16 network. The simulation can be extended within the MSRC by using the Rosetta Gateway to interface tracks from the Seahawk and AEW&C MSTs. Once again the simulation can be expanded further to include other external simulators and real ADF platforms using the TDL WAN connection through the CCD (as shown in Figure 8). This will allow us to log, monitor, receive and send in real-time TADIL tracks and messages during ADF joint exercises. It will also allow us to monitor link messages for new platforms, such as the AEW&C when delivered, during their evaluation and testing phases (using link messages sent from the East Regional Operational Centre at Williamtown).

During pre-integration testing in Canberra for the IDLS-05 VMF demonstration (as described in section 5.2) it was noticed that there were some shortcomings observed in the Seahawk HDL to SAAB Systems CMS Link-11 interface. As described in section 5.1 these were resolved by us at DSTO together with ANZUS, SAAB, Rockwell Collins and CIELO engineers in the ASCEL in late December during the pre-testing phase of the Seahawk HDL. The problems were due to a combination of not having a fully implemented HDL-Link-11 interface in Rosetta and hardware/firmware problems with the CIELO interface. This highlighted to us the lack of quality control in manufacturing of the CIELO interface before being shipped to DSTO and due to time constraints possibly poor software development practices by ANZUS of the Rosetta HDL to Link-11 interface. These perceived deficiencies were counteracted by the good support given to DSTO by both companies in late December.

The use of the DLS-EC and Rosetta in exercises such as Net Warrior will enhance the capability to simulate realistic TADILs scenarios in joint environments. This will provide simulations that can more realistically simulate hardware and software performances in the MSRC. It will also allow us to evaluate the advantages and disadvantages of different Australian-Coalition Link-16 network designs using different scenarios. Future NCW experiments such as Net Warrior will help us understand the potential benefits of gateways, and how ADF platforms fit into the future Global Information Grid with coalition forces.

8. Acknowledgements

The authors are grateful to Adam Iannos, Norman Lante and Stuart Thompson for the assistance with the AEW&C and Seahawk MSTs. They are also grateful to other members of the AEW&C and Seahawk teams who have been involved in allowing use of the MSTs. The authors also appreciate the time given for comments by the reviewer Dr. John Asenstorfer.

9. References

1. Filippidis, A., Gulley, R. (2003) "Future Tactical Data Link Information Activities in Network Centric Warfare Simulations", Land Warfare Conference, Adelaide Oct. 2003.
2. Australian Defence Force policy paper for Tactical Information Exchanges to support Network Centric Warfare, (2004), Chief Information Officer, Dept. of Defence Canberra, ACT.
3. Understanding Link-11: A guidebook for operators and net managers, Logicon Inc. San Diego, USA, April 1990.
4. Understanding Link-16: A guidebook for operators and net managers, Logicon Inc. San Diego, USA, Sept. 1990.
5. Yanni, P. (2004) "A VMF/Link-16/Simulation Gateway: Addressing the complexity of data link interoperability" ANZUS Inc. 9747 Business Park Ave. San Diego, CA 92131, Paper no. 99S-SIW-068.
6. Yanni, P. (2004) "Rosetta: A High Speed Information Processor for Joint Composite Tracking Network and the Joint Data Network", ANZUS Inc. 9747 Business Park Ave. San Diego, CA 92131, Paper no. 99F-SIW-046.
7. DOD (1999) "Interface Standard TADIL-J MIL STD 6016A", JEBCA Teston VA, 30 April 1999.
8. International Data Link Symposium-2005 program handbook (2005), Sydney Convention and Exhibition Centre Oct. 4, 2005. Consec Symposium co-ordinators PO Box 3127 ACT 2617, Australia.
9. International Data Link Symposium -2005 Demo Brief (2005). Tactical Information Exchange Integration Office, ACT, Fyshwick, Maryborough St.

10. L. Zalcman, J. Blacklock, A. Filippidis, G. Lawrie, "The DSTO Net Warrior Exercise- The ADGSIM Contribution", SimTect Conference, Melbourne May, 29, 2006.
11. Trimble, S. (2004) "Joining the Dots", *Flight International* pp. 34-37, Sept. 2004.

DISTRIBUTION LIST

“As per the Research Library’s *Policy on electronic distribution of official series reports* (<http://web-vic.dsto.defence.gov.au/workareas/library/about/roles&policies/mission.htm>) Unclassified (both Public Release and Limited), xxx-in-confidence and Restricted reports and their document data sheets will be sent by email through DRN to all recipients with Australian defence email accounts who are on the distribution list apart from the author(s) and the task sponsor(s). Other addressees and Libraries and Archives will also receive hardcopies.”

Simulation Activities using Gateway and Tactical Digital Information Links

Arthur Filippidis, Steve Blandford, Kate Foster and Gary Moran

AUSTRALIA

DEFENCE ORGANISATION

No. of copies

Task Sponsor

| | |
|---|----------------------|
| Director Capability Management & Interoperability - Col. Alison Creagh Desk Officer, SO BIE - FLT LT Barry Murray | } 1 shared - printed |
|---|----------------------|

S&T Program

| | |
|---|---------------------------------------|
| Chief Defence Scientist | 1 |
| FAS Science Policy | 1 |
| AS Science Corporate Management | 1 |
| Director General Science Policy Development | 1 |
| Counsellor Defence Science, London | Doc Data Sheet |
| Counsellor Defence Science, Washington | Doc Data Sheet |
| Scientific Adviser to MRDC, Thailand | Doc Data Sheet |
| Scientific Adviser Joint | 1 |
| Navy Scientific Adviser | Doc Data Sheet & Distribution List |
| Scientific Adviser - Army | Doc Data Sheet & Distribution List |
| Air Force Scientific Adviser | 1 |
| Scientific Adviser to the DMO | 1 |
| Deputy Chief Defence Scientist (Platform & Human Systems) | Doc Data Sheet & Executive Summary |
| Chief of Air Operations Division | Doc Data Sheet & Distribution List |
| Research Leader AMS | Doc Data Sheet & Distribution List |
| Head AMS Networking | 1 printed |
| Task Manager: Arthur Filippidis | 2 printed & 1 PDF |

| | |
|--|------------------------------------|
| Author: Steve Blandford, | 1 printed |
| Author: Kate Foster | 1 printed |
| Author: Gary Moran (Director TIE-IO) | 1 printed |
| Brad Tobin | 1 |
| Kevin Pottinger (Director JP2089 TIED) | 1 |
| DSTO Library and Archives | |
| Library Fishermans Bend | Doc Data Sheet |
| Library Edinburgh | 1 printed |
| Defence Archives | 1 printed |
| Library, Sydney | |
| Library, Stirling | |
| Library Canberra | |
| Capability Development Group | |
| Director General Maritime Development | Doc Data Sheet |
| Director General Land Development | 1 |
| Director General Capability and Plans | Doc Data Sheet |
| Assistant Secretary Investment Analysis | Doc Data Sheet |
| Director General Australian Defence Simulation Office | Doc Data Sheet |
| Chief Information Officer Group | |
| Head Information Capability Management Division | Doc Data Sheet |
| Director General Australian Defence Simulation Office | Doc Data Sheet |
| AS Information Strategy and Futures | Doc Data Sheet |
| Director General Information Services | Doc Data Sheet |
| Strategy Executive | |
| Assistant Secretary Strategic Policy | Doc Data Sheet |
| Assistant Secretary International and Domestic Security Policy | Doc Data Sheet |
| Navy | |
| Maritime Operational Analysis Centre, Building 89/90 Garden Island Sydney NSW | Doc Data Sheet & Distribution List |
| Deputy Director (Operations) | |
| Deputy Director (Analysis) | |
| Director General Navy Capability, Performance and Plans, Navy Headquarters | Doc Data Sheet |
| Director General Navy Strategic Policy and Futures, Navy Headquarters | Doc Data Sheet |
| Air Force | |
| SO (Science) - Headquarters Air Combat Group, RAAF Base, Williamstown NSW 2314 | Doc Data Sheet & Executive Summary |
| Staff Officer ARG FEG | Doc Data Sheet & Executive Summary |
| Staff Officer SRG FEG | Doc Data Sheet & Executive Summary |

Army

ABCA National Standardisation Officer

| | |
|---|---------------------------------------|
| Land Warfare Development Sector, Puckapunyal | Doc Data Sheet |
| J86 (TCS GROUP), DJFHQ | Doc Data Sheet |
| SO (Science) - Land Headquarters (LHQ), Victoria Barracks NSW | Doc Data Sheet & Executive Summary |
| SO (Science) - Special Operations Command (SOCOMD), R5-SB-15, Russell Offices Canberra | Doc Data Sheet & Executive Summary |
| SO (Science), Deployable Joint Force Headquarters (DJFHQ) (L), Enoggera QLD | Doc Data Sheet |

Joint Operations Command

| | |
|--|----------------|
| Director General Joint Operations | Doc Data Sheet |
| Chief of Staff Headquarters Joint Operations Command | Doc Data Sheet |
| Commandant ADF Warfare Centre | Doc Data Sheet |
| Director General Strategic Logistics | Doc Data Sheet |

Intelligence and Security Group

| | |
|--|----------------|
| AS Concepts, Capability and Resources | 1 |
| DGSTA , DIO | 1 |
| Manager, Information Centre, Defence Intelligence Organisation | 1 |
| Director, Advanced Capabilities | Doc Data Sheet |

Defence Materiel Organisation

| | |
|--|----------------|
| Deputy CEO | Doc Data Sheet |
| Head Aerospace Systems Division | Doc Data Sheet |
| Head Maritime Systems Division | Doc Data Sheet |
| Program Manager Air Warfare Destroyer | Doc Data Sheet |
| Guided Weapon & Explosive Ordnance Branch (GWEO) | Doc Data Sheet |
| CDR Joint Logistics Command | Doc Data Sheet |

OTHER ORGANISATIONS

| | |
|-------------------------------|---|
| National Library of Australia | 1 |
| NASA (Canberra) | 1 |
| Library of New South Wales | |

UNIVERSITIES AND COLLEGES

Australian Defence Force Academy

| | |
|--|----------------|
| Library | 1 |
| Head of Aerospace and Mechanical Engineering | 1 |
| Hargrave Library, Monash University | Doc Data Sheet |

OUTSIDE AUSTRALIA

INTERNATIONAL DEFENCE INFORMATION CENTRES

| | |
|---|---|
| US Defense Technical Information Center | 1 |
| UK Dstl Knowledge Services | 1 |
| Canada Defence Research Directorate R&D Knowledge & Information Management (DRDKIM) | 1 |
| NZ Defence Information Centre | 1 |

ABSTRACTING AND INFORMATION ORGANISATIONS

| | |
|--|---|
| Library, Chemical Abstracts Reference Service | 1 |
| Engineering Societies Library, US | 1 |
| Materials Information, Cambridge Scientific Abstracts, US | 1 |
| Documents Librarian, The Center for Research Libraries, US | 1 |

INFORMATION EXCHANGE AGREEMENT PARTNERS

| | |
|--|---|
| National Aerospace Laboratory, Japan | 1 |
| National Aerospace Laboratory, Netherlands | 1 |

SPARES 5 Printed

Total number of copies: 42 Printed: 14 PDF: 28

| | | | | | |
|---|------------------------------|-----------------------------|---|---|------------------------------------|
| DEFENCE SCIENCE AND TECHNOLOGY ORGANISATION DOCUMENT CONTROL DATA | | | | 1. PRIVACY MARKING/CAVEAT (OF DOCUMENT) | |
| | | | | | |
| 2. TITLE Simulation Activities using Gateway and Tactical Digital Information Links | | | 3. SECURITY CLASSIFICATION (FOR UNCLASSIFIED REPORTS THAT ARE LIMITED RELEASE USE (L) NEXT TO DOCUMENT CLASSIFICATION) Document (U) Title (U) Abstract (U) | | |
| 4. AUTHOR(S) Arthur Filippidis, Steve Blandford, Kate Foster and Gary Moran | | | 5. CORPORATE AUTHOR DSTO Defence Science and Technology Organisation PO Box 1500 Edinburgh South Australia 5111 Australia | | |
| 6a. DSTO NUMBER DSTO-TR-1918 | | 6b. AR NUMBER AR-013-755 | | 6c. TYPE OF REPORT Technical Report | 7. DOCUMENT DATE September 2006 |
| 8. FILE NUMBER 2006/1073269/1 | 9. TASK NUMBER AIR 05/086 | 10. TASK SPONSOR DCMI | 11. NO. OF PAGES 20 | | 12. NO. OF REFERENCES 11 |
| 13. URL on the World Wide Web http://www.dsto.defence.gov.au/corporate/reports/DSTO-TR-1918.pdf | | | 14. RELEASE AUTHORITY Chief, Air Operations Division | | |
| 15. SECONDARY RELEASE STATEMENT OF THIS DOCUMENT <i>Approved for public release</i> | | | | | |
| OVERSEAS ENQUIRIES OUTSIDE STATED LIMITATIONS SHOULD BE REFERRED THROUGH DOCUMENT EXCHANGE, PO BOX 1500, EDINBURGH, SA 5111 | | | | | |
| 16. DELIBERATE ANNOUNCEMENT No Limitations | | | | | |
| 17. CITATION IN OTHER DOCUMENTS Yes | | | | | |
| 18. DSTO RESEARCH LIBRARY THESAURUS Tactical Digital Information Data Links (TADIL), Link-16, Link-11, Variable Messaging Format (VMF), Simulations, Data Link Gateway | | | | | |
| 19. ABSTRACT Under the auspices of the Air Platform Connectivity Research Task Air 05/086, novel gateway, Tactical Digital Information Link (TADIL) and Network Centric Warfare simulation activities involving Australian Defence Force (ADF) platforms and Mission System Test-beds (MSTs) are currently in progress in the Air Operations Division. Several recent TADIL activities involve investigations using the Rosetta Data Link Gateway product from the ANZUS Alliance and Northrop Grumman's Dual Link Simulator with Extended Capability. An overview of Airborne Mission System's contribution to the Variable Messaging Format demonstration at the 2005 International Data Link Symposium is also presented. | | | | | |