

## **Nuclear, Biological, Chemical (NBC) Reconnaissance Vehicles: Current Achievements and Technology Trends at SPA<sup>1</sup>**

**Alberto Aguilar & Antonio Benítez**

C/ Ingeniero Torres Quevedo, 24  
28022 Madrid  
Spain

[aaguilar@grupospa.com](mailto:aaguilar@grupospa.com)

### ***ABSTRACT***

*Together with the potential use of weapons of mass destruction during military operations, we cannot forget their potential utilisation by terrorist groups. As a consequence of the Prague Conference, a new military concept for defence against terrorism was agreed by NATO nations.*

*Projects at SPA concerning NBC reconnaissance and threat verification are structured in accordance to a pyramid-like concept: From early warning by unmanned vehicles down to thorough detection and identification by manned reconnaissance vehicles down to threat verification and operations command support by the mobile laboratories.*

*The VRAC has been developed by SPA in co-operation with the Spanish MOD. VRAC is probably the most advanced NBC reconnaissance vehicle in operation worldwide. Friendly operation has been achieved: crewmembers (4 people) are not required to be laboratory specialists.*

*Ongoing development projects at SPA include NBC reconnaissance shelters to be carried by light vehicles, mobile laboratories and NBC first response vehicles for security forces.*

*Unmanned vehicles, both Unmanned Ground Vehicles (UGV) and Unmanned Aerial Vehicles (UAV) represent the next step in the technology and business goals for SPA. Technical challenge is to develop reliable, maintainable, miniaturised, modular NBC sensors and associated systems to meet unmanned vehicles' special requirements.*

## **1 THE CURRENT NBC SCENARIO**

### **1.1 The NBC threat**

Together with the potential use of weapons of mass destruction during military operations, we cannot forget that a range of terrorist groups and individuals have explored, or sought to use, NBC materials as terrorist weapons.

---

<sup>1</sup> Servicios y Proyectos Avanzados, S.A. (SPA) was founded in June 1991 by a small group of Spanish professionals with years of experience in defense programs. SPA is located in Madrid, a few kilometers away from Madrid-Barajas international airport. Since the beginning, SPA's strategy has been based on multidisciplinary engineering projects, tailored to each customer needs; basic tool for that has been the capability to manage complex, high technology projects, which usually demand Engineering, Production and Integrated Logistics Support capabilities. This way, turnover has been continuously growing around 20% every year (over 40 M€ in 2004). Human resources have been progressively increased as well (200 people at the moment).

*Paper presented at the RTO SCI Symposium on "Systems, Concepts and Integration (SCI) Methods and Technologies for Defence Against Terrorism," held in London, United Kingdom, 25-27 October 2004, and published in RTO-MP-SCI-158.*

## Report Documentation Page

*Form Approved*  
*OMB No. 0704-0188*

Public reporting burden for the collection of information is estimated to average 1 hour per response, including the time for reviewing instructions, searching existing data sources, gathering and maintaining the data needed, and completing and reviewing the collection of information. Send comments regarding this burden estimate or any other aspect of this collection of information, including suggestions for reducing this burden, to Washington Headquarters Services, Directorate for Information Operations and Reports, 1215 Jefferson Davis Highway, Suite 1204, Arlington VA 22202-4302. Respondents should be aware that notwithstanding any other provision of law, no person shall be subject to a penalty for failing to comply with a collection of information if it does not display a currently valid OMB control number.

|   |                                    |  |                                  |
|---|------------------------------------|--|----------------------------------|
| 1. REPORT DATE<br><b>25 OCT 2004</b>  | 2. REPORT TYPE<br><b>N/A</b>       | 3. DATES COVERED<br><b>-</b>             |                                  |
| 4. TITLE AND SUBTITLE<br><b>Nuclear, Biological, Chemical (NBC) Reconnaissance Vehicles: Current Achievements and Technology Trends at SPAIN</b>  |                                    | 5a. CONTRACT NUMBER                      |                                  |
|   |                                    | 5b. GRANT NUMBER                         |                                  |
|   |                                    | 5c. PROGRAM ELEMENT NUMBER               |                                  |
| 6. AUTHOR(S)  |                                    | 5d. PROJECT NUMBER                       |                                  |
|   |                                    | 5e. TASK NUMBER                          |                                  |
|   |                                    | 5f. WORK UNIT NUMBER                     |                                  |
| 7. PERFORMING ORGANIZATION NAME(S) AND ADDRESS(ES)<br><b>C/ Ingeniero Torres Quevedo, 24 28022 Madrid Spain</b>   |                                    | 8. PERFORMING ORGANIZATION REPORT NUMBER |                                  |
| 9. SPONSORING/MONITORING AGENCY NAME(S) AND ADDRESS(ES)   |                                    | 10. SPONSOR/MONITOR'S ACRONYM(S)         |                                  |
|   |                                    | 11. SPONSOR/MONITOR'S REPORT NUMBER(S)   |                                  |
| 12. DISTRIBUTION/AVAILABILITY STATEMENT<br><b>Approved for public release, distribution unlimited</b>   |                                    |  |                                  |
| 13. SUPPLEMENTARY NOTES<br><b>See also ADM201977, Systems, Concepts and Integration Methods and Technologies for Defence against Terrorism (Systemes, concepts, methodes d'integration et technologies pour la lutte contre le terrorisme),. The original document contains color images.</b> |                                    |  |                                  |
| 14. ABSTRACT  |                                    |  |                                  |
| 15. SUBJECT TERMS   |                                    |  |                                  |
| 16. SECURITY CLASSIFICATION OF:   |                                    |  | 17. LIMITATION OF ABSTRACT       |
| a. REPORT<br><b>unclassified</b>  | b. ABSTRACT<br><b>unclassified</b> | c. THIS PAGE<br><b>unclassified</b>      | <b>UU</b>                        |
|   |                                    |  | 18. NUMBER OF PAGES<br><b>18</b> |
|   |                                    |  | 19a. NAME OF RESPONSIBLE PERSON  |

## Nuclear, Biological, Chemical (NBC) Reconnaissance Vehicles: Current Achievements and Technology Trends at SPA

Chemical, biological, and radiological material as well as industrial agents can be dispensed in the air we breath, the water we drink, or on surfaces we physically contact. Dispersion methods for weapons of mass destruction can be as simple as placing a container in a populated area, or as elaborate as detonating an improvised explosive device.

The key to minimizing impact is early detection and accurate diagnosis. The earlier the detection and diagnosis, the earlier the response to lower the impact.

### 1.2 NATO after Prague: Measures combating new threads

As a consequence of the Prague Conference, a new military concept for defence against terrorism was agreed by NATO nations, with specific action items like implementing a Civil Emergency Planning Action Plan and five defence initiatives:

- Prototype Deployable NBC Analytical Laboratory
- Prototype NBC Event Response team
- Virtual Centre of Excellence for NBC Weapons Defense
- NATO Biological and Chemical Defense Stockpile
- Disease Surveillance System.

As a tangible consequence of the summit, The NATO CBRN Defence Battalion has been launched. Its mission is to provide rapidly a credible NBC capability, primarily to deployed NATO joint forces and commands, in order that Alliance freedom of action is maintained in an NBC threat environment.

## 2 NBC SYSTEMS BY SPA

### 2.1 NBC reconnaissance and threat verification pyramid

SPA, a company based in Spain, is committed to support NATO strategy. The above described scenario and the requirements arising from the CBRN battalion experience are considered as key elements of its own business strategy.

SPA projects concerning NBC reconnaissance and threat verification are structured in accordance to the pyramid-like concept shown in figure 1. From early warning by unmanned vehicles down to threat verification and operations command support by the mobile laboratories, the systems included in the concept are, generally speaking, required means for facing an NBC “incident”. Specific characteristics are engineered for every customer and mission scope.

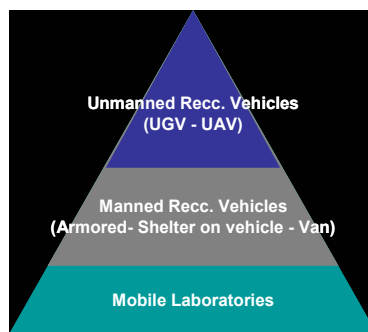

Figure 1: NBC reconnaissance pyramid

SPA, simply because of business evolution and technology availability, has progressed in the development and production of all these systems as explained next.

## 2.2 NBC reconnaissance vehicle (VRAC)

### 2.2.1 General data

The VRAC has been developed by SPA in cooperation with the Spanish MOD. Using a modified combat wheeled vehicle as platform, VRAC is probably the most advanced NBC reconnaissance vehicle in operation worldwide. The selected platform was a BMR armoured vehicle on wheels from Company “Santa Bárbara Sistemas” (General Dynamics). This choice made by the Spanish Army was very much appropriate in order to further extend the operative life of the available BMR fleet (See figure 2).

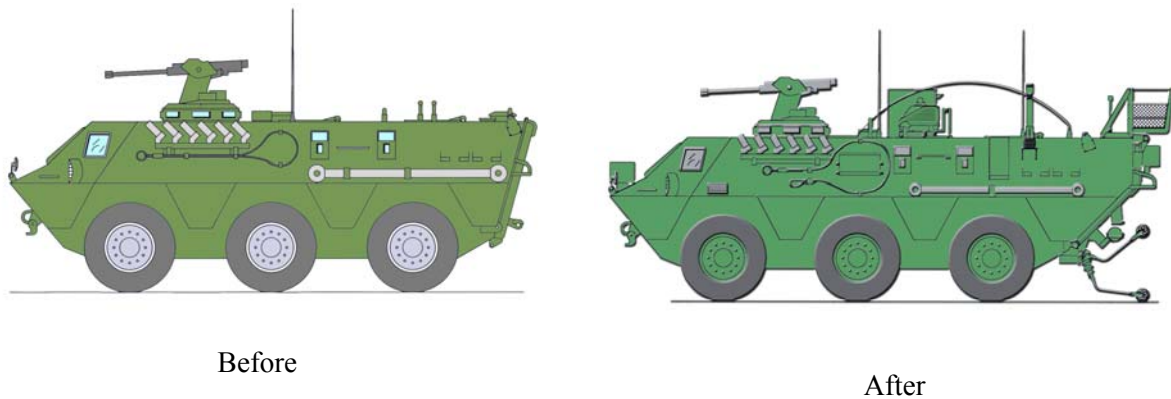

**Figure 2: Schematics of the platform transformation: from BMR to VRAC**

At this moment, 4 units are being evaluated by the Spanish Army (See figures 3 and 4). Series production is starting in 2005.



**Figure 3: VRAC lateral view**



**Figure 4: VRAC rear view**

VRAC represents a state-of-the-art system; modern, reliable instruments from suppliers all over the world have been used to optimize its performance. Its modular, multi-platform concept supports the evolution of its design and operation.

Friendly operation has been achieved by SPA Group’s proprietary management and integration tools. Therefore, VRAC’s crew (4 people) are not required to be laboratory specialists. Figure 5 shows the data flow scheme in VRAC

## Nuclear, Biological, Chemical (NBC) Reconnaissance Vehicles: Current Achievements and Technology Trends at SPA

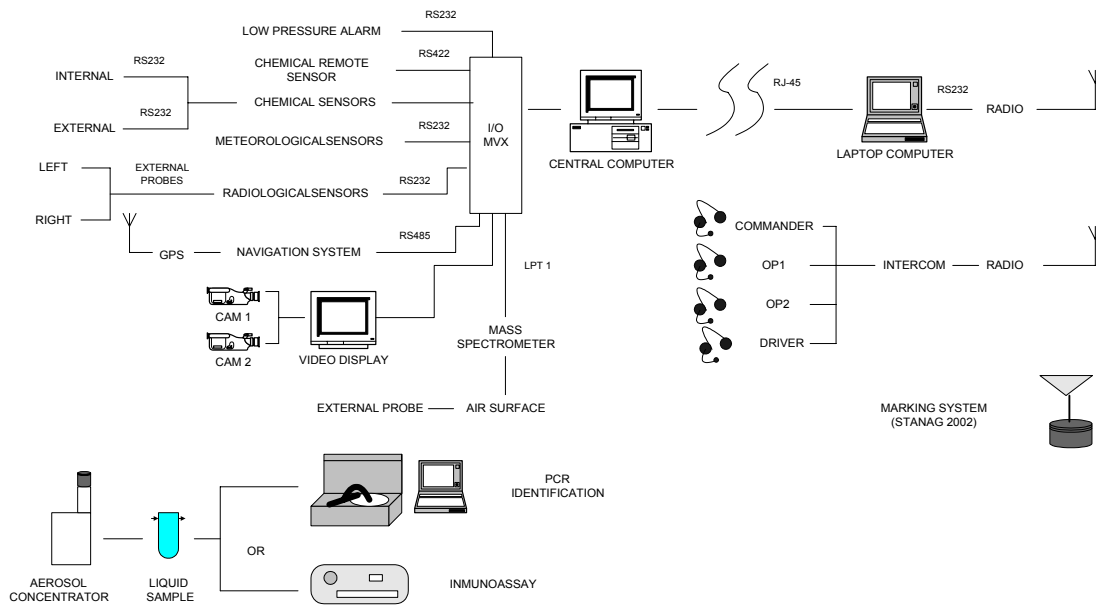

Figure 5: VRAC NBC data flow

### 2.2.2 VRAC mission description

#### a) Scenario

Scenario is basically defined by the following assumptions:

- An attack using weapons of mass destruction in the frame of military operations or large scale terrorist attacks has occurred or it is likely to occur.
- Alternatively, a catastrophic accident has occurred in an industrial site and hazardous substances are likely to have been released to the environment
- The attack can occur in any location, either downtown or in the country side. This can be even overseas from the NBC Unit headquarters.
- Single or combined NBC weapons might be used.
- No preliminary information on the nature of the hazard is available.

#### b) Mission

A set of missions are set for the VRAC:

- NBC surveillance of an assigned GIS defined zone
- To confirm NBC alert on-site, i.e. detection and identification of the thread(s)
- To decontaminate operations area (with limitations)
- To mark the area
- To report comprehensive information on threat and actions. The sensor network provides real-time digitized data to the NBC Center to provide operational NBC situational understanding and detailed hazard analysis.

### 2.2.3 VRAC's key technical features

#### a) Radiation Detection, Warning and Monitoring.

- Vehicle-based measurement of low, medium and high intensity gamma radiation
- Portable device to measure alpha, beta and gamma radiation
- Personal dosimeters for crewmembers

#### b) Chemical Detection, Warning and Identification

- Identification is performed by a high performance mass spectrometer, which can be used as a portable device as well
- Clouds of chemical agents as far as 5 Km away can be detected, even in motion.
- Detection time is less than 30s

#### c) Biological Identification

- PCR technology device together with a thermocycler in combination with a fluorescence monitor is used to identify DNA sequences.

#### d) Sampling

- Telescopic nose with hot tip (liquid samples)
- Silicon wheels (vehicle in motion)
- Agents vapour concentrator (vapour samples)
- Manual pick-up of samples from the interior (liquid and solid samples)
- External refrigerator (4 °C) to store the samples

#### e) Zone marking (STANAG 2002)

- Flags in triangular shape and different colors to announce the existing type of contamination
- The actual marking item consists of a flag; a stick and a semi-spherical heavy base
- Flags are thrown from the VRAC through a dedicated lock.

#### f) Decontamination

- Pressurized tanks with a capacity of 1,5 l of decontaminant liquid
- The area to be decontaminated can be as large as 25 m<sup>2</sup>

#### g) Crew Protection

- A clean environment within a closed down vehicle crew space with filtered, agent-free air is achieved. The occupied area and all the equipment within it remain clean and the crew can operate without individual protection equipment. Air from the NBC filtration system is cooled or heated before being delivered to the vehicle interior.
- Overpressure (8 mbar - 180 m<sup>3</sup>/h) and leak tightness
- EMI/RFI protection improvement
- Individual Protection Equipment (for emergency use only)

## Nuclear, Biological, Chemical (NBC) Reconnaissance Vehicles: Current Achievements and Technology Trends at SPA

---

### h) Weather Station

- Temperature (air & ground)
- % RH and Pressure
- Wind speed & direction

### i) Other features and characteristics

- Localization and Navigation System
- Video cameras for driver assistance

## 2.3 Ongoing development projects at SPA

### 2.3.1 NBC shelter on light vehicle

This project was initiated as a response to various requests for information from several potential customers, who did not consider an armoured vehicle as a suitable platform (see figure 6). However, basic NBC reconnaissance capabilities are as those of the VRAC.

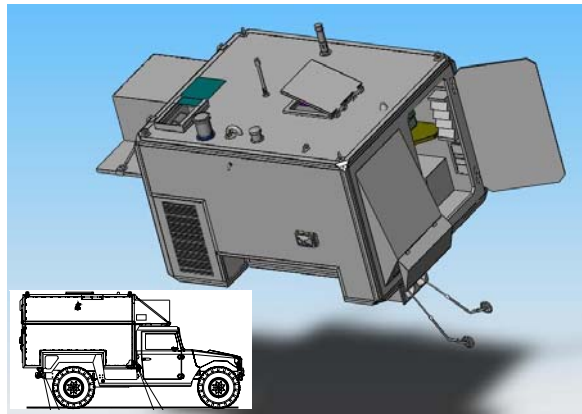

Figure 6: NBC shelter on light vehicle

### 2.3.2 Other ongoing projects

#### a) Mobile laboratories

Extensively equipped mobile field laboratories are used for more comprehensive tasks, e.g. to identify and verify any nuclear, biological or chemical contaminants. These labs permit the measurement of radiation and dangerous substances, the performance of chemical and biochemical analyses and also microbiological investigations. Additionally, some versions of SPA's mobile laboratory systems incorporate EOD features. They are rugged, self-contained laboratories, deployable for worldwide operations.

#### b) Non-military first response vehicles

These are cost-optimized First Response Vehicles based on commercial transport trucks (vans) which have been developed to be used by police and security forces.



### **3.0 NEXT STEP: NBC UNMANNED RECONNAISSANCE VEHICLES**

#### **3.1 Why unmanned?**

A main reason for using unmanned vehicles (UVs) for reconnaissance of potentially NBC contaminated areas is that they can save lives by taking on life-threatening missions, but there might be additional benefits out of it, e.g.: lower (?) operational costs, Easier to be deployed in the battlefield and easier to be decontaminated.

Unmanned vehicles to be used are both unmanned ground vehicles (UGVs) and unmanned air vehicles (UAVs).

UVs must be specified and designed to do what robots can do better (or at lower risk) than humans, rather than trying to imitate what humans already do very well. They are most suitable for undercover surveillance of otherwise unreachable areas. Unmanned vehicles can enter contaminated areas and loiter for extended periods to monitor contamination levels and survey the affected areas. They are to carry out most missions today assigned to manned systems.

A UAV mission with NBC sensor payloads will require sustained operations at lower altitudes based on the capabilities of existing sensor technologies. Detection is targeted at long ranges (30 Km or more) upwind or forward of troop locations. Indications of a potential threat will be communicated to the troop location immediately after detection to provide maximum reaction time to access protective equipment and shelter. The combination of long range and low altitude requirements will affect how the UAV is controlled and deployed.

A family of UVs is required to provide seamless coverage of the operations area. On the other hand, UVs cannot be considered in isolation; they must be integrated into an Integrated Intelligence, Surveillance and Reconnaissance Architecture (IISRA).

#### **3.2 The challenge**

Systems to be incorporated in an UV must be reliable, maintainable, miniaturized and modular.

There is a great deal of promising technologies which might be used for NBC reconnaissance UVs. For detectors, micro-fluidics as well as hyper-spectral technologies and a whole bunch of nanotechnologies show substantial promise; they are typically described as “labs on a chip”. But these are immature technologies and are at least several years away from practical applications.

In the interim, SPA is looking at how to leveraging existing technologies as well as horizontally integrating capabilities with existing systems to achieve more capable, smaller, lighter and cheaper devices. Multi-parametric, optical based sensors for continuous, real time monitoring of different NBC relevant chemical and physical parameters are currently being subjected to assessment. Besides, intrinsic safety of this technology makes it really suitable for the application.

The goal is to develop a compact NBC suit, based on the minimum number of different technologies to achieve the best possible performance vs. weight & volume ratio, based on:

- Homogeneous interfaces, power and environmental requirements, reliability levels, ...
- Single data handling electronics
- Embedding NBC data/command transmission into overall vehicle telecomm means



### Glossary

|                   |   |
|-------------------|---|
| BMR               | Blindado Medio sobre Ruedas   |
| CBRN <sup>2</sup> | Chemical, Biological, Radiological, Nuclear                           |
| IISRA             | Integrated Intelligence, Surveillance and Reconnaissance Architecture |
| MOD               | Ministry of Defense   |
| NBC               | Nuclear, Biological, Chemical   |
| SPA               | Servicios y Proyectos Avanzados, S.A.                                 |
| UAV               | Unmanned Aerial Vehicle   |
| UGV               | Unmanned Ground Vehicle   |
| UV                | Unmanned Vehicle  |
| VRAC              | Vehículo de Reconocimiento de Áreas Contaminadas                      |

### Bibliography

- [1] Adams, Jeffrey A.  
"First Responders Guide to Weapons of Mass Destruction (WMD). Practical Techniques and Procedures for Responding to a Terrorist Incident Involving WMD"  
American Society for Industrial Security, 2002.
- [2] Byrnes, Mark E.  
"Nuclear, Chemical, and Biological Terrorism: Emergency Response and Public Protection"  
Lewis Publishers, 2003.
- [3] Cocciardi, Joseph A.  
"Weapons of Mass Destruction and Terrorism Response: Field Guide"  
Jones and Bartlett, 2004.
- [4] Dunn R.S., McGarry L.P., Meidinger T.  
"NBC Sensors: Feasibility in an Unmanned Aerial Vehicle"  
The Royal Military College of Canada, 2000
- [5] NATO  
"The Prague Summit and NATO's transformation: A reader's guide"  
[<http://www.nato.int/docu/rdr-gde-prg/rdr-gde-prg-eng.pdf>]  
NATO 2003

---

<sup>2</sup> CBRN terminology is nowadays more often used than NBC. However, this last one is still used in this paper for being more widely known to non-experts. Actually CBRNE is already showing up in the literature; "E" meaning explosive.



SCI-158  
Symposium on



**Systems, Concepts and Integration (SCI) Methods and  
Technologies for  
Defence Against Terrorism (DAT)**  
London, October 27, 2004

**Nuclear, Biological, Chemical (NBC)  
Reconnaissance Vehicles:**

**Current achievements and Technology trends  
at SPA**

Authors:

**Alberto Aguilar & Antonio Benítez**

**SERVICIOS Y PROYECTOS AVANZADOS, S.A.**

Ingeniero Torres Quevedo 24 - E-28022 Madrid (Spain)

Phone: (+34) 913 294 455 - FAX: (+34) 913 294 805

e-mail: [spa@grupospa.com](mailto:spa@grupospa.com) - web page: [www.grupospa.com](http://www.grupospa.com)



- **Company data**

- It was founded in June 1991 by a small group of Spanish professionals with years of experience in defence programs
- Multidisciplinary engineering projects
- Turnover around 40 M€ in 2004. 200 people
- SPA is located in Madrid

- **Activities**

- Engineering
- Production
- ILS

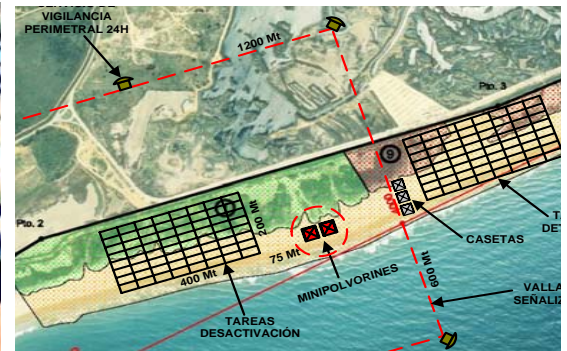



- The NBC threat
  - Chemical, biological, and radiological material as well as industrial agents can be dispensed in the air we breath, the water we drink, or on surfaces we physically contact
  - Dispersion methods can be as simple as placing a container in a heavily used area





- NATO after Prague: Measures combating new threads
  - Prototype Deployable NBC Analytical Laboratory
  - Prototype NBC Event Response team
  - Virtual Centre of Excellence for NBC Weapons Defence
  - NATO Biological and Chemical Defence Stockpile
  - Disease Surveillance System.





Unmanned  
Reconnaissance  
Vehicles

- Unmanned Ground Vehicles (UGV)
- Unmanned Aerial Vehicles (UAV)

Manned  
Reconnaissance  
Vehicles

- Armoured vehicle on wheels
- Shelter on light mil. vehicle
- Civil vehicle (van)

Mobile  
Laboratories

- Shelter on truck





- Developed by SPA under a contract with the Spanish MOD
  - 4 units evaluated by the Spanish Army
  - Series production starting in 2005

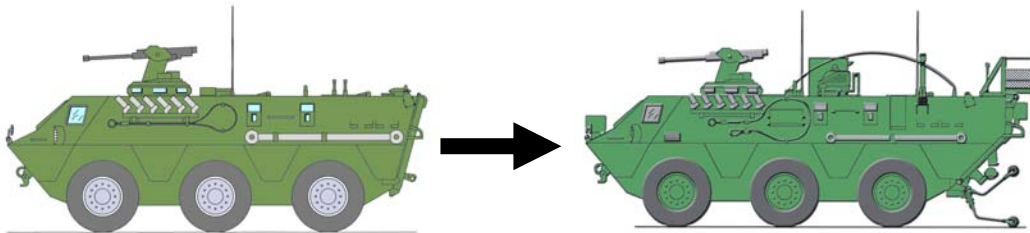

- VRAC represents a state-of-the-art system
  - Based on a retrofitted combat wheeled vehicle
  - Modern, reliable instruments from various suppliers
  - SPA proprietary, friendly software
  - Crewmembers (4) are not required to be lab specialists





- VRAC represents a state-of-the-art system
  - Radiation Detection, Warning and Monitoring
  - Chemical Detection, Warning and Identification
  - Biological Identification
  - Sampling
  - Decontamination
  - Crew Protection
  - Weather Station
  - Navigation





- NBC shelter on light vehicle

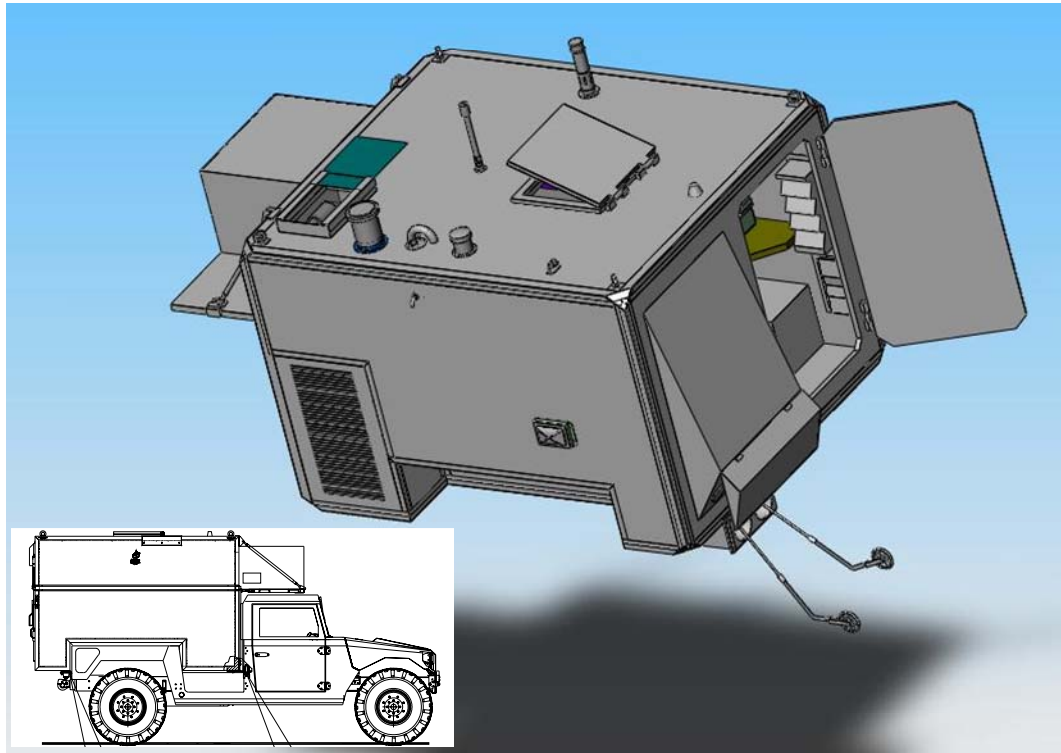

- Mobile laboratories
- Non-military first response vehicles



# Next step: NBC Unmanned Recon. Vehicles



**Non SPA equipment.  
Photos only for  
illustration purposes**

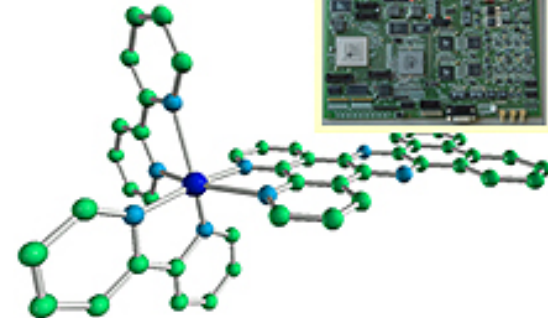

- Why unmanned?
  - They can save lives
  - Other operational advantages
- The challenge
  - Devices to be incorporated must be reliable, maintainable, miniaturized, modular.
  - Optics based sensors are under evaluation at SPA



# Thank you for your attention

**SERVICIOS Y PROYECTOS AVANZADOS, S.A.**

Ingeniero Torres Quevedo 24 - E-28022 Madrid (Spain)

Phone: (+34) 913 294 455 - FAX: (+34) 913 294 805

e-mail: [spa@grupospa.com](mailto:spa@grupospa.com) - web page: [www.grupospa.com](http://www.grupospa.com)