

# Frequency Stabilization Using Matched Fabry-Perots as References

Peter C. Li and Pierre A. Humblet

Massachusetts Institute of Technology  
Laboratory for Information and Decision Systems  
Cambridge, Massachusetts 02139 \*

## Abstract

We propose a matched Fabry-Perot configuration for frequency stabilization where each user locks its laser to a local Fabry-Perot interferometer which is perfectly matched to a master Fabry-Perot. Experimentally, a user Fabry-Perot was matched and locked to a remote master Fabry-Perot.

## Introduction

Frequency-division-multiplexing (FDM) is a potential configuration for broadband fiber-optics communication. One of the key problems is the relative stabilization of center frequencies of transmitting lasers. Various methods have been proposed and

---

\*The authors gratefully acknowledge support for this research from Bellcore, Nynex, NEC and DARPA (grant F19628-90-C-0002)

# Report Documentation Page

Form Approved  
OMB No. 0704-0188

Public reporting burden for the collection of information is estimated to average 1 hour per response, including the time for reviewing instructions, searching existing data sources, gathering and maintaining the data needed, and completing and reviewing the collection of information. Send comments regarding this burden estimate or any other aspect of this collection of information, including suggestions for reducing this burden, to Washington Headquarters Services, Directorate for Information Operations and Reports, 1215 Jefferson Davis Highway, Suite 1204, Arlington VA 22202-4302. Respondents should be aware that notwithstanding any other provision of law, no person shall be subject to a penalty for failing to comply with a collection of information if it does not display a currently valid OMB control number.

1. REPORT DATE <b>APR 1991</b>		2. REPORT TYPE		3. DATES COVERED <b>00-04-1991 to 00-04-1991</b>	
4. TITLE AND SUBTITLE <b>Frequency Stabilization Using Matched Fabry-Perots as References</b>				5a. CONTRACT NUMBER	
				5b. GRANT NUMBER	
				5c. PROGRAM ELEMENT NUMBER	
6. AUTHOR(S)				5d. PROJECT NUMBER	
				5e. TASK NUMBER	
				5f. WORK UNIT NUMBER	
7. PERFORMING ORGANIZATION NAME(S) AND ADDRESS(ES) <b>Massachusetts Institute of Technology, 77 Massachusetts Avenue, Cambridge, MA, 02139-4307</b>				8. PERFORMING ORGANIZATION REPORT NUMBER	
9. SPONSORING/MONITORING AGENCY NAME(S) AND ADDRESS(ES)				10. SPONSOR/MONITOR'S ACRONYM(S)	
				11. SPONSOR/MONITOR'S REPORT NUMBER(S)	
12. DISTRIBUTION/AVAILABILITY STATEMENT <b>Approved for public release; distribution unlimited</b>					
13. SUPPLEMENTARY NOTES					
14. ABSTRACT					
15. SUBJECT TERMS					
16. SECURITY CLASSIFICATION OF:			17. LIMITATION OF ABSTRACT	18. NUMBER OF PAGES <b>7</b>	19a. NAME OF RESPONSIBLE PERSON
a. REPORT <b>unclassified</b>	b. ABSTRACT <b>unclassified</b>	c. THIS PAGE <b>unclassified</b>			

reviewed in [1, 2, 3]. Many focus on the case where a central controller measures the laser frequencies and provides feedback signals.

We are interested in the case of many users that are remotely located. The startup problem and the sheer number of users favor distributed solutions. The proposed method of stabilization is described in (I). The analysis of the system appears in (II). Some experimental results are reported in (III).

## I. System Description

The system configuration is shown in Fig. 1. Each user has a Fabry-Perot interferometer that is used as a local reference and the user Fabry-Perot's are matched to a master Fabry-Perot, providing a global reference system. It is critical that all Fabry-Perot's be perfectly matched, in the sense that their resonance peaks are aligned with each other. We propose to accomplish this by passing light from an LED through a master Fabry-Perot and broadcasting the output spectral pattern to each of the user nodes. A detector measures the power of the LED at the output of each user interferometer. This power exhibits a sharp peak when the user and the master Fabry-Perot's match perfectly. The user Fabry-Perot's are dithered to provide local feedback signals to maintain the match between the user and master Fabry-Perot [4]. Locally the stabilized user Fabry-Perot's serve as reference for laser frequency stabilization.

In practice the LED signal, which has a low spectral density, could be distributed on the fibers used for communication. The LED signal should be modulated (e.g. at 100 kHz) so that a narrowband filter can extract it after the detector.

## II. Analysis

When the user and the master Fabry-Perot's have a normalized length difference of  $y$ , the detected power is proportional to the following approximate expression, which assumes that the spectral density of the LED is uniform between  $\lambda_1$  and  $\lambda_2$ :

$$T(y) = \left(\frac{1-R_1}{1+R_1}\right)\left(\frac{1-R_2}{1+R_2}\right)\left\{1 + \frac{1}{\pi a y} \left[ \tan^{-1}\left(\frac{R_1 R_2 \sin(\pi(2+a)y)}{1-R_1 R_2 \cos(\pi(2+a)y)}\right) - \tan^{-1}\left(\frac{R_1 R_2 \sin(\pi(2-a)y)}{1-R_1 R_2 \cos(\pi(2-a)y)}\right) \right] \right\} \quad [4].$$

The variable  $y$  is equal to  $\left(\frac{1}{\lambda_1} + \frac{1}{\lambda_2}\right)$  times the difference between the Fabry-Perot lengths. The symbols  $R_1$  and  $R_2$  are respectively the power reflectivity of the master and user Fabry-Perot's mirrors, and  $a$  is equal to the normalized bandwidth of the LED,  $2\left(\frac{\lambda_1-\lambda_2}{\lambda_1+\lambda_2}\right)$ . The function  $T(y)$  is displayed in Fig. 3.

The transmission function exhibits many peaks, and it is critical to be able to localize the main peak. It can be seen that the ratio of the second highest peak to the highest peak is approximately  $\frac{2}{aF} \tan^{-1}\left(\frac{aF}{2}\right)$  where  $F = \pi(R_1 R_2)^{1/4}/(1 - \sqrt{R_1 R_2})$ . This is plotted as a function of  $aF$  in Fig. 4. Typical components can easily achieve  $aF > 1$ .

## III. Experiments

The  $T(y)$  function is measured using the setup shown in Fig. 2. Bulk Fabry-Interferometers of Finesse 45 were used, with a free spectral range of 15 GHz. The LED had a 50 nm bandwidth centered at 0.81  $\mu\text{m}$ . The plot of the experimental transmission functions,  $T(y)$ , is also shown in Fig. 3. The power into the user Fabry-Perot was about 500 pW.

To see that the user Fabry-Perot can track the master Fabry-Perot, the length of the master Fabry-Perot was changed in a deterministic manner with a scan signal as shown in Fig. 5. The error was estimated from the feedback voltage to be about 100 MHz; the time constant of the lock-in amplifier was 10 seconds. We believe the error is due mostly to the noise in the high-voltage drive. This may be reduced by using fiber Fabry-Perot's [5, 6] that do not require high control voltages.

The frequency interval where the Fabry-Perot peaks are aligned is checked by measuring the LED spectrum before and after the user Fabry-Perot with a spectrometer set at 5 nm resolution. The ratio of the spectrum is flat over the LED bandwidth, as shown in Fig. 6, indicating that the peaks match. The high out-of-band fluctuations are due to noise.

## References

- [1] M. Ohtsu, "Frequency Stabilization in Semiconductor Lasers", *Opt. and Quantum Electron.*, Vol. 20, pp. 283-300, (1988).
- [2] E. Vezzoni, P. Gambini and M. Puleo, "Laser Frequency Stabilization Techniques for Optical Communications", *Proceedings of ECOC 90, Amsterdam NL*, pp. 943-950, (1990).
- [3] P. A. Humblet and P. C. Li, "A New Frequency Distribution Architecture for Wavelength Division Systems," *Proceedings of Octima, Rome, Jan (1991)*.
- [4] P. C. Li, "A Distributed Frequency Reference System for Optical Fiber Communication," M.S. thesis, Dept. of EECS, Massachusetts Institute of Technology, Cambridge, MA, (in preparation).
- [5] J. Stone and L. W. Stulz, "Pigtailed High-finesse tunable fiber Fabry-Perot interferometers with large, medium and small free spectral ranges," *Electronics Letters*, Vol. 23, pp. 781-783, (1987).
- [6] J. Stone and D. Marcuse, "Ultrahigh finesse fiber Fabry-Perot interferometers," *J. Lightwave Technology*, vol. LT-4, pp. 382-385, (1986).

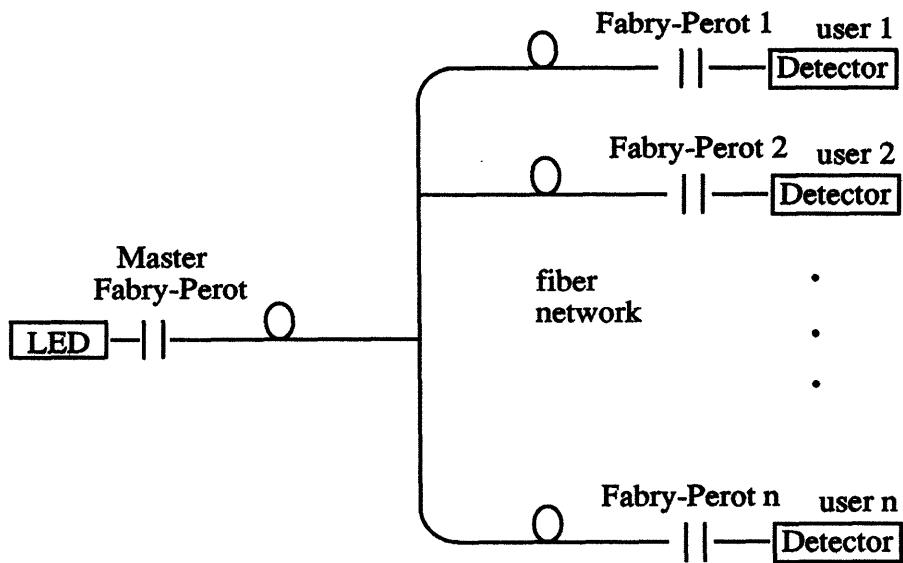

Figure 1: System configuration for frequency stabilization. The user Fabry-Perot's, matched to the master Fabry-Perot, are used as frequency references.

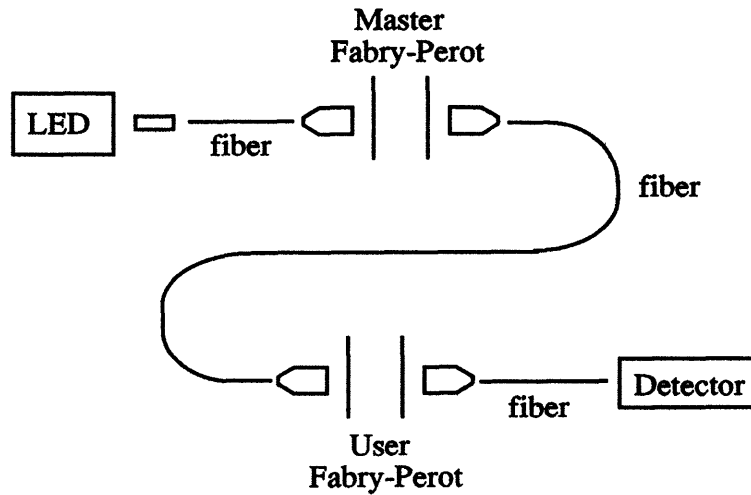

Figure 2: Experimental setup to measure the transmission function  $T(y)$ .

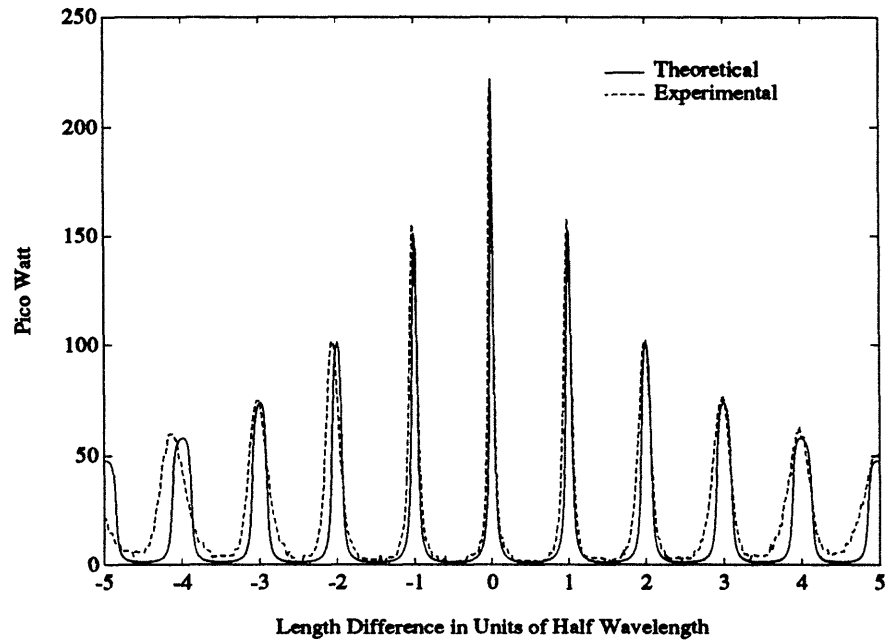

Figure 3: Theoretical and experimental curves for  $T(y)$ . The horizontal axis is the Fabry-Perot length difference where the wavelength is the center wavelength of the LED.

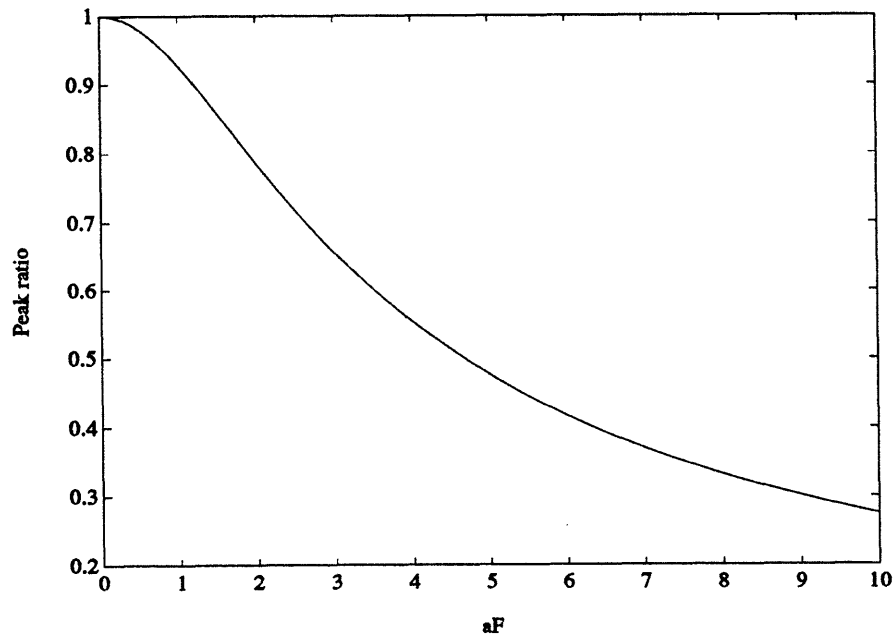

Figure 4: Second highest peak relative to the highest peak as a function of the parameter  $aF$ .

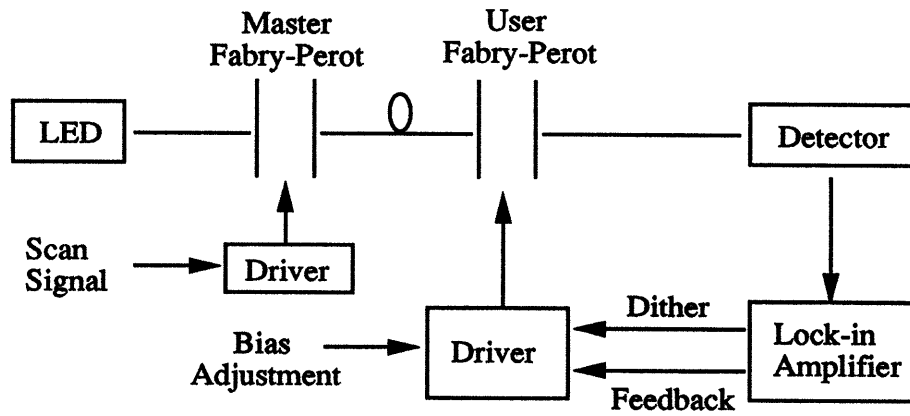

Figure 5: Experimental setup for locking the user Fabry-Perot to the master Fabry-Perot.

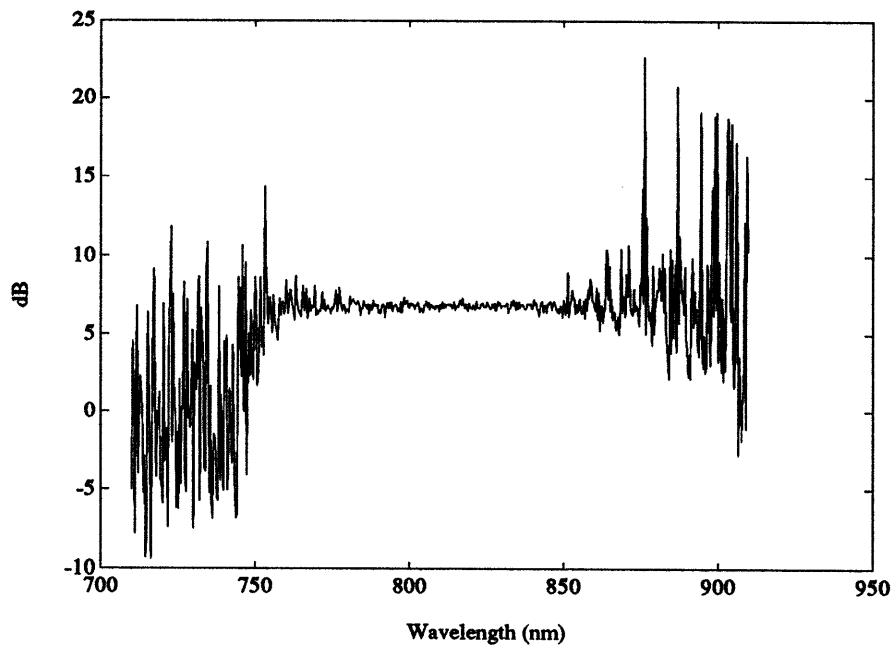

Figure 6: This plot shows the ratio of the output spectrum divided by the input spectrum of the user Fabry-Perot.