

**SHIP PRODUCTION COMMITTEE  
FACILITIES AND ENVIRONMENTAL EFFECTS  
SURFACE PREPARATION AND COATINGS  
DESIGN/PRODUCTION INTEGRATION  
HUMAN RESOURCE INNOVATION  
MARINE INDUSTRY STANDARDS  
WELDING  
INDUSTRIAL ENGINEERING  
EDUCATION AND TRAINING**

September 1991  
NSRP 0340

# **THE NATIONAL SHIPBUILDING RESEARCH PROGRAM**

**1991 Ship Production Symposium  
Proceedings:  
Paper No. VIB-2  
Developing and Using an Expert Sys-  
tem for Planning the Production of  
Structural Piece-Parts**

**U.S. DEPARTMENT OF THE NAVY  
CARDEROCK DIVISION,  
NAVAL SURFACE WARFARE CENTER**

# Report Documentation Page

*Form Approved  
OMB No. 0704-0188*

Public reporting burden for the collection of information is estimated to average 1 hour per response, including the time for reviewing instructions, searching existing data sources, gathering and maintaining the data needed, and completing and reviewing the collection of information. Send comments regarding this burden estimate or any other aspect of this collection of information, including suggestions for reducing this burden, to Washington Headquarters Services, Directorate for Information Operations and Reports, 1215 Jefferson Davis Highway, Suite 1204, Arlington VA 22202-4302. Respondents should be aware that notwithstanding any other provision of law, no person shall be subject to a penalty for failing to comply with a collection of information if it does not display a currently valid OMB control number.

|  |                                    |  |  |
|--|------------------------------------|--|--|
| 1. REPORT DATE<br><b>SEP 1991</b>  | 2. REPORT TYPE<br><b>N/A</b>       | 3. DATES COVERED<br><b>-</b>             |  |
| 4. TITLE AND SUBTITLE<br><b>The National Shipbuilding Research Program, 1991 Ship Production Symposium Proceedings: Paper No. VIB-2: Developing and Using an Expert System for Planning the Production of Structural Piece-Parts</b> |                                    | 5a. CONTRACT NUMBER                      |  |
|  |                                    | 5b. GRANT NUMBER                         |  |
|  |                                    | 5c. PROGRAM ELEMENT NUMBER               |  |
| 6. AUTHOR(S)   |                                    | 5d. PROJECT NUMBER                       |  |
|  |                                    | 5e. TASK NUMBER                          |  |
|  |                                    | 5f. WORK UNIT NUMBER                     |  |
| 7. PERFORMING ORGANIZATION NAME(S) AND ADDRESS(ES)<br><b>Naval Surface Warfare Center CD Code 2230-Design Integration Tools Bldg 192, Room 128 9500 MacArthur Blvd, Bethesda, MD 20817-5700</b>                                      |                                    | 8. PERFORMING ORGANIZATION REPORT NUMBER |  |
| 9. SPONSORING/MONITORING AGENCY NAME(S) AND ADDRESS(ES)  |                                    | 10. SPONSOR/MONITOR'S ACRONYM(S)         |  |
|  |                                    | 11. SPONSOR/MONITOR'S REPORT NUMBER(S)   |  |
| 12. DISTRIBUTION/AVAILABILITY STATEMENT<br><b>Approved for public release, distribution unlimited</b>  |                                    |  |  |
| 13. SUPPLEMENTARY NOTES  |                                    |  |  |
| 14. ABSTRACT   |                                    |  |  |
| 15. SUBJECT TERMS  |                                    |  |  |
| 16. SECURITY CLASSIFICATION OF:  |                                    |  | 17. LIMITATION OF ABSTRACT<br><b>SAR</b> |
| a. REPORT<br><b>unclassified</b>   | b. ABSTRACT<br><b>unclassified</b> | c. THIS PAGE<br><b>unclassified</b>      |  |
| 19a. NAME OF RESPONSIBLE PERSON  |                                    |  |  |

## DISCLAIMER

These reports were prepared as an account of government-sponsored work. Neither the United States, nor the United States Navy, nor any person acting on behalf of the United States Navy (A) makes any warranty or representation, expressed or implied, with respect to the accuracy, completeness or usefulness of the information contained in this report/manual, or that the use of any information, apparatus, method, or process disclosed in this report may not infringe privately owned rights; or (B) assumes any liabilities with respect to the use of or for damages resulting from the use of any information, apparatus, method, or process disclosed in the report. As used in the above, "Persons acting on behalf of the United States Navy" includes any employee, contractor, or subcontractor to the contractor of the United States Navy to the extent that such employee, contractor, or subcontractor to the contractor prepares, handles, or distributes, or provides access to any information pursuant to his employment or contract or subcontract to the contractor with the United States Navy. ANY POSSIBLE IMPLIED WARRANTIES OF MERCHANTABILITY AND/OR FITNESS FOR PURPOSE ARE SPECIFICALLY DISCLAIMED.



# Developing and Using an Expert System for Planning the Production of Structural Piece-Parts

VIB-2

Mark Spicknall, Associate Member, University of Michigan Transportation Research Institute

## ABSTRACT

This paper presents an example of how expert systems can be developed and used for planning structural piece-part production. First, expert systems are briefly and generically described. Then the production processes within a shipyard-like structural piece-part production facility are defined within an expert system "shell"; i.e., the "objects", "attributes", and "rules" describing the production process are established and explained. Then various structural piece-parts are described to the system and the system identifies the required production processes for each described part. The inference process underlying the identification of these processes is described for each of these parts. Finally, potential applications of expert systems to other areas of shipbuilding operations are discussed.

## EXPERT SYSTEMS, A GENERAL DESCRIPTION

The intent of this paper is to build on previous presentations on the application of expert systems in a shipbuilding environment (1)(2) by providing an actual example of a potential expert system application to shipbuilding. But first, a general overview of expert systems is in order.

Expert systems have evolved from within the "artificial intelligence" area of computer science. As the name implies, the intent of an expert system is to emulate the decision-making process of an "expert" within a specific domain, or area of interest. In this way, expert systems differ from traditional computer applications as they lend themselves more toward the resolution of problems with uncertainties in supporting data, and/or with large numbers of exceptions and potential options which would make it virtually impossible to derive singular "optimum" solutions. An expert system is "rule driven" meaning that a "good" solution is derived based on rules and an associated decision-making hierarchy which have been provided by an "expert".

Expert system software tools, called "shells," are created in languages such as "C," but have evolved to the point where users need not be familiar with underlying code. Users are only required to be familiar with an overlying, and fairly straightforward information format and English syntax to describe their domains of interest. Note that the author is not a computer scientist, nor had he any user experience with expert systems until October, 1990.

The representation of a particular domain within an expert system is called a knowledgebase. A knowledgebase is made up of objects, object attributes, attribute values rules and m. An object is any group of information which has meaning. An object can have a name like "ship" and can also have attributes such as "length", "draft", etc. Each attribute can in turn have a value, such as "draft=10 m (33ft)."

Rules are developed to describe how the objects within the domain interrelate. These rules are generally in an "if...then...else..." type of format. For example, a rule could be written to determine which drydock a particular ship can use, as follows: If ship draft  $\geq 10$  m (33 ft) then drydock number is 2. This example assumes that another object called "drydock" has also been defined.

Goals simply establish which object attributes the system is to solve for. In the example above, the goal would be to solve for the object attribute "drydock number."

Modern expert system shells can automatically generate objects and attributes from rules as these rules are defined in the knowledgebase, or the function of object and attribute definition can be independent of rule definition.

A knowledgebase is developed through "knowledge acquisition" and "knowledge engineering": "Knowledge acquisition" is the process of identifying the objects, attributes, values, and rules that represent a domain, in essence identifying as accurately as possible how the domain of interest really works. This is done by interviewing, video taping, and working with the real experts within the working domain. The process of assimilating this domain information

into a system-usable form, and actually creating the knowledgebase is called “knowledge engineering”.

Expert systems become smarter as the domain is defined with greater accuracy and in more detail within the knowledgebase. For example, the rule that was written earlier for determining which drydock a ship can use becomes smarter with the addition of more domain information: If ship draft  $\geq 10$  m (33 ft) and ship length  $\leq 200$  m (656 ft) then drydock number is 2. In this case, another dimensional limitation of the domain has been defined, and the expert system using this rule can infer a smarter solution than it could have using the rule as it was previously written.

### **AN EXAMPLE SHIPYARD DOMAIN: STRUCTURAL PIECE-PART PRODUCTION**

When developing an expert system, it is very important to establish boundaries which limit the scope of knowledgebase development work to a well defined domain. For the purposes of presenting an understandable example within the limitations of this paper, the example presented will be limited to structural piece-part production excluding surface preparation and coating processes, lay-off processes, and assembly processes (the production of “superparts,” which are made up of multiple pieces, is not considered in this example). The fabrication facility and processes in this example are intended to be generic and capable of producing approximately fifty-thousand tons of structural piece parts annually when utilized at a high level.

### **Definition of Production Process Objects, Attributes, and Attribute Values**

Following is a list of the structural piece-part production processes that have been defined as objects in the knowledgebase. The layout of the example facility is shown in Figure 1.

#### Burning Processes:

- . Flame Planer 1, FP1
- . Flame Planer 2, FP2
- . N/C 2-Axis, BR1
- . N/C Plasma, BR2

#### Press Processes:

- . Brake Press, PR1
- . 1500 Ton Press, PR2
- . 37.5 Ton Press, PR3
- . 600 Ton Press, PR4
- . Frame Bender, PR5
- . 250 Ton Press, PR6
- . 60 Ton Cold Press, PR7

#### Roll Processes:

- . 2000 Ton Roll, RL1
- . 12' Roll, RL2

#### Planers:

- . 40' Edge Planer, PL1

#### Drills:

- . plate Drill, DR1
- . Shape Drill, DR2

#### Saws:

- . Band Saw, SW1
- . Hydraulic Band Saw, SW2
- . Contour Band Saw, SW3

#### Shears:

- . Shear, SH1
- . 100 Ton Punch, SH2

The generic processes of “cut”, “edge prep”, and “form” have also been defined within the example knowledgebase. These generic processes and their associated attributes can be inherited by the specific processes listed above based on their capabilities. For instance, the N/C Plasma process can both cut and edge prep. Therefore, this process can inherit the attributes of these two generic processes, and then values relating specifically to the N/C plasma process can be defined for these attributes. Following is a list of the attributes associated with each generic process. For a detailed list of specific process attribute values which define the capabilities of each specific process, refer to the complete object and attribute listing in Appendix A.

#### **Cut:**

- . # of axes
- . # of master cut tools
- . # of slave cut tools
- . angle cut maximum
- . automation level
- . cut accuracy
- . cut configuration
- . cut length maximum
- . cut location
- . cut part depth maximum
- . cut part length maximum
- . cut part width maximum
- . cut routing code
- . hole diameter maximum
- . mat'1 cut thickness maximum

#### Edge Prep:

- . bevel accuracy
- . bevel configuration
- . bevel degrees maximum
- . edge prep length maximum
- . edge prep location
- . edge prep part depth maximum
- . edge prep part length maximum
- . edge prep part width maximum
- . edge prep routing code
- . edge prep thickness maximum

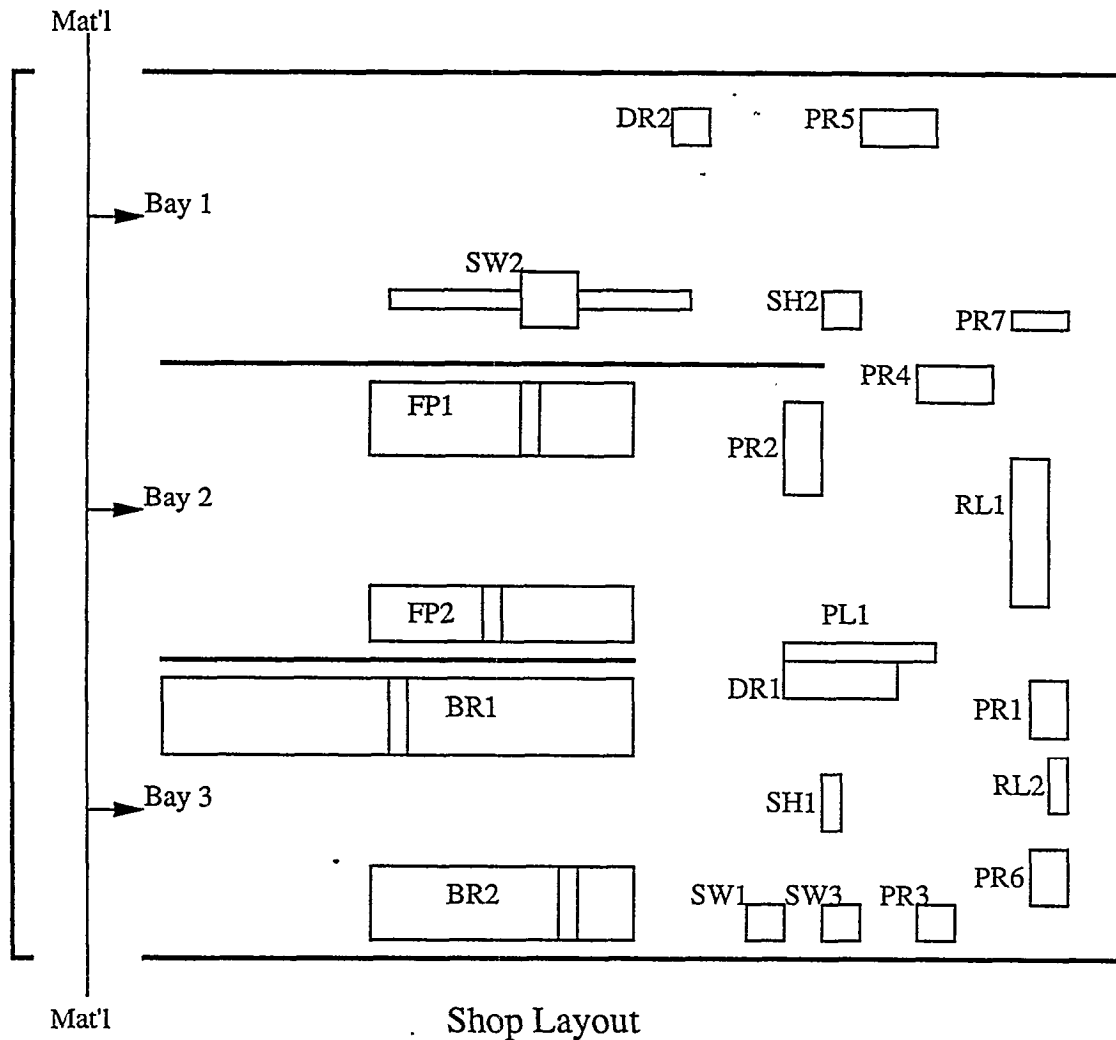

Figure 1

Form.

- . form accuracy
- . forming location
- . forming part depth maximum
- . forming part length maximum
- . forming part width maximum
- . forming routing code
- . outside radius minimum
- . roll degrees maximum
- . section modulus maximum

**Definition of Rules**

Following are the rules which have been established as representative of how the many production processes relate to the fabrication of specific parts. These rules are not intended to represent all of the production relationships within this facility. They represent only basic production relationships to help keep this example simple. Also, the detailed and accurate description of any domain is a continuous,

evolutionary process. As exceptions to the established rules are identified, existing rules are refined or additional rules are defined to address them. In its present state of development, this knowledgebase might, for example, narrow the cut process possibilities for the fabrication of a specific part to two specific processes from the eleven processes with cut capability. If this occurs, the rules established thus far do not provide enough knowledge to allow the system to decide between the remaining two processes; the rules require further refinement, or additional rules are required to address this particular exception.

Rule :  
 IF the part shape is rolled or knuckled,  
 THEN the part process is form process.

Rule :  
 IF the part edge/end preparation is beveled,  
 THEN the part process is edge prep process.

Rule 3:

IF the part size is smaller than stock,  
THEN the part process is cut process.

Rule 4:

IF the part size is stock, and the part mat'l area is less than stock mat'l area (hole cut required),  
THEN the part process is cut process.

Rule 5:

IF the part size is larger than stock,  
THEN the part process is fabricate superpart (joining process).

Rule 6:

IF the part material is aluminum,  
THEN the part thickness aluminum = part material thickness to be cut,  
ELSE the part thickness aluminum = 0, and the part section modulus aluminum = 0.

Rule 7:

IF the part material is steel,  
THEN the part thickness steel = part material thickness to be cut,  
ELSE the part thickness steel = 0, and the part section modulus steel = 0.

Rule 8:

IF the part process is cut process,  
and the part length  $\leq$  cut process cut part length max, and the part width  $\leq$  cut process cut part width max, and the part depth  $\leq$  cut process cut part depth max, and the part cut dimensional accuracy requirement  $\geq$  cut process cut accuracy, and the part thickness steel  $\leq$  cut process material cut thickness steel max, and the part thickness aluminum  $\leq$  cut process material cut thickness aluminum max, and the part hole cut diameter  $\leq$  cut process hole diameter max, and the part angle max variation from 90 degrees  $\leq$  cut process angle cut max, and the part cut configuration is the cut process cut configuration, and the part max cut length  $\leq$  cut process cut length max,  
THEN the part cut method is Object Name <cut process>, and the part cut routing code is the cut process routing code, and the part cut location is the cut process cut location.

Rule 9:

IF the part process is form process,  
and the part length  $\leq$  form process form part length max, and the part width  $\leq$  form process form part width max, and the part depth  $\leq$  form process form part depth max, and the part roll radius accuracy requirement  $\geq$  form process form accuracy, and the part section modulus steel  $\leq$  form process section modulus steel max, and the part section modulus aluminum  $\leq$  form process section modulus aluminum max, and the part outside radius  $\geq$  form process outside radius minimum, and the part roll degrees  $\leq$  form process roll degrees max, and the part web h/t  $\leq$

the form process h/t max,  
THEN the part forming method is Object Name <form process>, and the part forming routing code is the form process routing code, and the part forming location is the form process form location.

Rule 10:

IF the part process is edge prep process,  
and the part length  $\leq$  edge prep process edge prep part length max, and the part width  $\leq$  edge prep process edge prep part width max, and the part depth  $\leq$  edge prep process edge prep part depth max, and the part max bevel angle required  $\leq$  edge prep process bevel degrees max, and the part thickness steel  $\leq$  edge prep process material edge prep thickness steel max, and the part thickness aluminum  $\leq$  edge prep process material edge prep thickness aluminum max, and the part edge prep configuration is the edge prep process edge prep configuration, and the part max edge prep length  $\leq$  edge prep process edge prep length max,  
THEN the part edge prep method is Object Name <edge prep process>, and the part edge prep routing code is the edge prep process routing code, and the part edge prep location is the edge prep process edge prep location.

Rule 11:

IF the part type is plate,  
THEN the part web h/t = 0, and the part material thickness to be cut = part depth.

Rule 12:

IF the part type is shape,  
THEN the part web h/t = part depth \* 0.94 / part web thickness, and part material thickness to be cut = part flange thickness.

As these rules were created, the "part" object and its associated attributes were created automatically by the expert system shell. No values were specified for the part attributes so that the expert system will prompt the user for these values during the inference process. Also, it is clear that some significant generalizations have been made within the rules for the purpose of simplification. These generalizations will probably require further refinement as the user encounters the specific circumstances where the rules do not provide sensible solutions.

A complete list of these rules in system format is provided in Appendix B.

## Definition of Goals

The goals established for this expert system application are to identify the general processes, such as cut, edge prep, and/or form, required to produce a specified structural piece-part, and then to identify the specific shop processes in the defined facility that are required to carry out the general processes in producing the piece-part. In system language, the object attributes that have been identified for solution are:

- part process,
- part cut method,
- part cut routing code,
- part cut location,
- part forming method
- part forming routing code,
- part forming location,
- part edge prep method,
- part edge prep routing code, and
- part edge prep location.

## USING THE EXPERT SYSTEM

Now that a knowledgebase has been created describing the structural piece-part production domain, the expert system can be used to identify production processes for various structural piece-parts based on part descriptions. The expert system will interactively prompt the user for information it does not have, like part characteristics, as the inference process proceeds.

Following are two examples of how the system identifies production processes for structural piece-parts. The inference processes carried out by the expert system for each part are described. Complete system listings of these two inference processes are also provided in Appendix C.

### Part #1

**Inference process.** Part #1 in Figure 2 is a steel rolled T-bar with the toe of the web beveled at 60 degrees, and a part length of about 4.785 m (15.7 ft), which is less than the stock length of 6.096 m (20 ft). The system initially prompts the user for whether the part has shape, whether its edges are beveled, and whether the part is smaller than stock or, if not, whether its area in square feet is less than that of a stock piece. In this way the system can infer whether the part needs to be formed, edge prepped, or cut using Rules 1, 2, 3, 4, and 5. The system then prompts the user for all of the necessary part attribute information that is required to choose the specific shop processes necessary to produce the part using Rules 6-12 (there are too many of these to list individually here; refer to Appendix C for a detailed listing of the complete inference process). In this case, the user has specified that Part #1 requires a high level of accuracy in part length, roll radius, and bevel angle. The entire data entry and system inference process takes approximately 2.5 minutes.

**Solution.** The system properly concludes that Part #1 requires cutting, edge prep, and forming. The system then concludes that the edge prep method should be the edge planer, PLL, in Bay 2, the part cut method should be the hydraulic band saw, SW2, in Bay 1, and the forming process should be the frame bender, PR5, in Bay 1.

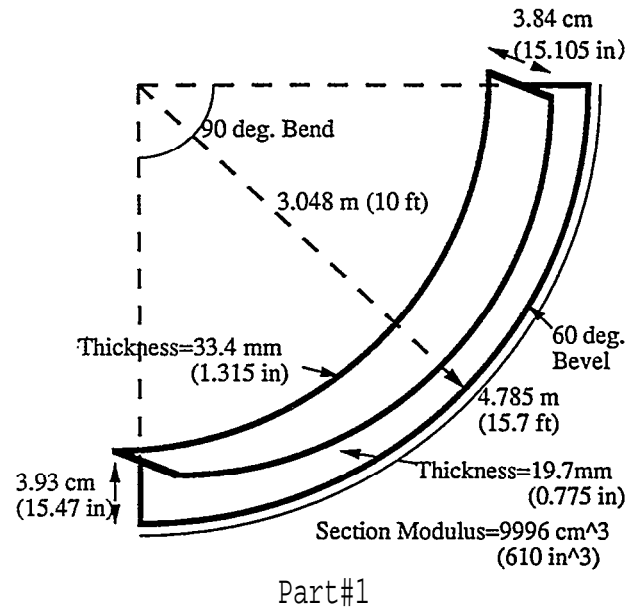

Figure 2

**Comments.** If the inference process provided in Appendix C is examined in detail, it can be seen that when Rule 9 was testing the 1500 ton press as a possible forming process for Part #1, the rule argument was determined to be “false” because of the tight part roll accuracy specified by the user. Had the user required less roll accuracy, the system might have concluded that the part could be formed on either the frame bender or the 1500 ton press, assuming all other part attributes, such as section modulus maximum, roll radius minimum, etc., met the remaining process limitations of the 1500 ton press.

### Part #2

**Inference process.** Part #2 in Figure 3 is a 19 mm (3/4 in) flat steel plate which is stock length of 6.096 m (20 ft) on its long side, 4.877 m (16 ft) long on the opposite side, 2.438 m (8 ft) wide, symmetrical with two non-parallel straight edges, beveled at 45 degrees on all outer edges, with three cut-outs. Again, the system prompts the user for whether the part has shape, whether its edges are beveled, and whether the part is smaller than stock or, if not, whether its area in square feet is less than that of a stock piece to determine whether the part needs to be formed, edge prepped, or cut. The system then prompts the user for all of the necessary part attribute information that is required to choose the specific shop processes necessary to produce the part (again, refer to Appendix C for a detailed listing of the complete inference process). The entire data entry and system inference process again takes approximately 2.5 minutes.

**Solution.** The system properly concludes that Part #2 requires cutting, and edge prep. The system then concludes that the edge prep method could be either the edge planer, PLL, in Bay 2, or



the N/C plasma burning process, BR2, in Bay 3. The system also concludes that the part cut method could be either the N/C 2-axes burning process, BR1, or the N/C plasma burning process, BR2, both in Bay 3.

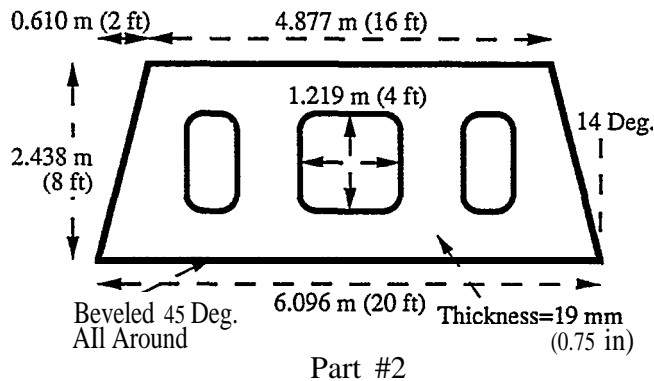

Figure 3

**Comments.** It is only sensible that if a part can be both cut and edge prepped using the same process, in this case the N/C plasma burning process, that process should be the only solution inferred for each of these fabrication needs. In this case, however, the rule necessary to make such a decision has not yet been created by the user. Therefore, the expert system must be refined to address this circumstance.

## CONCLUSIONS

### Expert System Development

**Knowledge Acquisition.** The process of knowledge acquisition is critical to the successful development of any expert system. Accurate and detailed domain information is an absolute necessity. The system can only be as smart as the developer; the old computer adage, "garbage in, garbage out" still applies.

When developing the rules which represent how a domain works, it is important to get beyond "rules of thumb" that are often quoted by the domain experts to the underlying logic of such rules. For instance, in the example presented in this paper, it would be easy to short-cut all of the comparisons of part attributes to process capabilities by simply creating rules that state that parts with certain characteristics are produced by certain specific processes. These type of rules ignore the underlying reasons for the decisions being made, and, if used, potential solution options might be missed simply because they had not been recognized previously by the domain experts.

**Knowledge Engineering.** It takes some practice for a user to learn the language, syntax, and format requirements of a particular expert system shell. However, shells have evolved to the point where anyone can build a functional, if not

elegant, expert system. In fact, some expert system shells today allow a user to create knowledgebases graphically using nodes with associated questions and lines of logical inference between nodes. Knowledge engineering for the example knowledgebase used in this paper took a relatively inexperienced user approximately four man-days.

### Expert Systems Applications

Although the example expert system application presented in this paper is relatively basic, it still provides sensible and usable solutions for the processes required to produce certain structural piece-parts within the shop that has been defined. The next logical step with this particular application would be to refine the system to address exceptions which are identified in its use, and perhaps to expand the system to include manual processes, blast and paint processes, lay-off processes, and superpart fabrication processes.

Some might argue that the role of the expert system application presented in this paper is identical to the role of group technology in a similar manufacturing environment; that is to use part attributes to generate the production processes required to create that part. In an environment where product types and processes are fairly static over time, it may indeed make more sense to utilize group technology for this purpose because of the static, hard-coded nature of a group technology system. In an environment of rapidly changing and/or very different product types and processes, the flexibility that an expert system provides, allowing simple changes to attribute values and rules, may make the use of an expert system more suitable. The two systems might be complimentary in that an expert system could be used to help identify product families and work cells for a group technology system.

Beyond the identification of production processes, process durations and resource requirements could be identified based on part attributes, leading to potential cost estimating, scheduling, and resource management applications.

The cost estimating process would be ideal for expert systems application because of the level of uncertainty involved in the process, and because of the presence of cost estimating domain experts in most shipbuilding environments. The Australian Department of Defense is known to be exploring this potential application to help engineers develop ship configuration costs for comparison during design.

Constrained real-time scheduling, and resource management processes also seem potentially ideal for expert systems application because of the day-to-day uncertainties associated with these processes in a shipbuilding environment. This type of application is

currently being developed and has proven to be very complex because the scheduling and resource management domain is generally very large. If, however, all relevant domain data is available directly from a database in real time, an expert system can theoretically be developed to accomplish much of the scheduling and resource management process.

## **ACKNOWLEDGEMENTS**

The author would like to thank Mr. Chris Tuck and Mr. Steve Kennedy of Emerald Intelligence, Ann Arbor, for their educational support, and Ms. Karla Karinen and Mrs. Kathi Compton of UMTRI for their patience and editorial vigilance.

## **REFERENCES**

1. Bentsen, Charles E., "Index Based Management Information Systems: A Study in Structured Operations," NSRP Ship Production Symposium Proceedings, Milwaukee, Wisconsin, August 1990.
2. Logan, Frank A., "Generative Process Planning By Expert Systems," NSRP Ship Production Proceedings, Williamsburg, Virginia, August 1986.

# APPENDIX A

## System Listing of Objects and Attributes

| OBJECTS ... of Mark's  | HD:Papers:Paper. Exprtsys.Plng:Real.Steel.Fab.7/12.kb/                                      |
|--|---|
| 100 ton punch<br>inherits from:<br>cut process   | (general) (inherited from form process)   |
| (general (inherited from cut process]  | form accuracy (in. radius). (inherited from form process)<br>[Protection]                   |
| # of axes (inherited from cut process]<br>[Protection]   | Values:<br>= .2 (1.00)  |
| values:<br>= 1 (1.00)  | forming location (inherited from form process]<br>[Protection]                              |
| # of master cut tools [inherited from cut process]<br>[Protection]   | values:<br>is bay 3 (1.00)  |
| = 1 (1.00)   | forming part depth max (ln) (inherited from form process]<br>[Protection]                   |
| # of slave cut tools (inherited from cut process]<br>[Protection]  | Values:<br>=6(1.00)   |
| values:<br>= 0 (1.00)  | forming part length max (ft) (inherited from form process]<br>[Protection]                  |
| angle cut max (deg) (inherited from cut process]<br>[Protection]   | values:<br>=25 (1.00)   |
| values:<br>=0(1.00)  | forming part width max (ft) (inherited from form process]<br>[Protection]                   |
| Automation Level (inherited from cut process]<br>[Protection]  | Values:<br>-12 (1.00)   |
| values:<br>= semi (1.00)   | forming routing code [inherited from form process]<br>[Protection]                          |
| cut accuracy (in) (inherited from cut process]<br>v a l u e s :  | Values:<br>is ri2(1.00)   |
| =.01(1.00)   | outsdo radius min (in) (inherited from form process]<br>[Protection]                        |
| cut configuration (inherited from cut process]<br>[Protection]   | Values:<br>-14 (1.00)   |
| Values:<br>is single straight (1.00)<br>is parallel straight (1.00)<br>is non-parallel straight (1.00)<br>is hole (1.00) | Roll Degrees Max [inherited from form process]<br>[Protection]                              |
| cut length max (h)(inherited from cut process]<br>Values:<br>= .75 (1.00)  | Values:<br>- 360 (1.00)   |
| cut location (inherited from cut process]<br>[Protection]  | section modulus max. alum (in <sup>3</sup> ) (inherited from form process]<br>[Protection]  |
| Values:<br>is bay 1 (1.00)   | ..<br>= 157 (1.00)  |
| cut part depth max (in) (inherited from cut process]<br>[Protection]   | section modulus max. steel (in <sup>3</sup> ) (inherited from form process]<br>[Protection] |
| Values:<br>=4 (1.00)   | ..<br>= 54 (1.00)   |
| <b>cut part length max (ft) (inherited from cut process]<br/>[Protection]</b>  | web h/t max (inherited from form process]<br>[Protection]                                   |
| <b>values:<br/>= 40 (1.00)</b>   | ..<br>=0(1.00)  |
| cut part width max (ft) (inherited from cut process]<br>[Protection]   | 1500 Ton Press<br>inherits from:<br>form process  |
| Values:<br>= .75 (1.00)  | (general) (inherited from form process]   |
| cut routing cod.3 (inherited from cut process]<br>v a l u e s :  | form accuracy (in. radius) (inherited from form process]<br>[Protection]                    |
| =sh2(1.00)   | ..<br>- .1 (1.00)   |
| hole diameter max (in) (inherited from cut process]<br>[Protection]  | forming location [inherited from form process]<br>[protection]                              |
| Values:<br>=3(1.00)  | values:<br>is bay 2 (1.00)  |
| marl cut thickness max. alum (in) (inherited from cut process]<br>[Protection]   | toning part depth max (in) (inherited from form process]<br>[Protection]                    |
| Values:<br>=1 (1.00)   | values:<br>= 22 (1.00)  |
| marl cut thickness max. steel (in) (inherited from cut process]<br>[Protection]  | forming part length max (ft) Inherited from form process]<br>[Protection]                   |
| values:<br>=1 (1.00)   | Values:<br>= 35 (1.00)  |
| values:<br>=.375 (1.00)  | forming part width max (ft) (inherited from form process]<br>[Protection]                   |
| 12 Foot Roll<br>inherits from:<br>form process   | values:<br>=1 20 (1.00)   |
|  | forming muting code (inherited from form process]<br>[Protection]                           |
|  | Values:<br>is pr2 (1.00)  |

outside radius min (in) (inherited from form process)  
 [Protection]  
 Values:  
 = 22 (1.00)

Roll Degress Max (inherited from form process)  
 [Protection]  
 =180 (1.00)

section modulus max. alum (in<sup>3</sup>) (inherited from form process)  
 [Protection]  
 values:  
 = 1044 (1.00)

section modulus max. steel (in<sup>3</sup>) (inherited from form process)  
 [Protection]  
 Values:  
 =360 (1.00)

web h/t max (Inherited from form process)  
 [Protection]  
 Values:  
 = 20 (1.00)

2000 Ton Roll  
 inherits from:  
 form process

(general) (inherited from form process)

form accuracy (in. radius) (inherited from form process)  
 [Protection]  
 values:  
 = .1 (1.00)

forming location (inherited from form process)  
 [Protection]  
 Values:  
 is bay 2 (1.00)

forming part depth max (in) (inherited from form process)  
 [Protection]  
 Values:  
 =11 (1.00)

forming part length max (ft) (inherited from form process)  
 [Protection]  
 Values:  
 = 40 (1.00)

forming part width max (ft) (inherited from form process)  
 [Protection]  
 Values:  
 = 45 (1.00)

forming muting code (inherited from form process)  
 [Protection]  
 Values:  
 is rll (1.00)

outside radius min (in) (inherited from form process)  
 [Protection]  
 Values:  
 = 24 (1.00)

Roll Degrees Max (inherited from form process)  
 [Protection]  
 Values:  
 = 180 (1.00)

section modulus max. alum (in<sup>3</sup>) (inherited form form process)  
 [Protection]  
 Values:  
 =4176 (1.00)

section modulus max. steel (in<sup>3</sup>) (inherited from form process)  
 [Protection]  
 = 1440 (1.00)

web h/t mu (inherited from form process)  
 (Protection)  
 Values:  
 = 0(1.00)

250 Ton Press  
 inherits from:  
 form process

(general) [inherited from form process]

form accuracy (in. radius) (inherited from form process)  
 [Protection]  
 values:  
 = .2 (1.00)

forming location (inherited from form process)  
 Values:  
 is bay 3 (1.00)

forming part depth max (in) (inherited from form process)  
 [Protection]  
 Values:  
 = 12 (1.00)

forming part length max (ft) (inherited from form Process)  
 [Protection]  
 Values:  
 = 20 (1.00)

forming part width max (Ft) (inherited from form process)  
 [Protection]  
 Values:  
 =4(1.00)

forming muting code (inherited from form process)  
 [Protection]  
 Values:  
 is pr6 (1.00)

outside radius min (in) (inherited from form process)  
 [Protection]  
 Values:  
 = 17 (1.00)

Roll Degrees Max (inherited from form process)  
 [Protection]  
 Values:  
 = 180 (1.00)

section modulus max. alum (in<sup>3</sup>) (inherited from form process)  
 [Protection]  
 Values:  
 = 52 (1.00)

section modulus max. steel (in<sup>3</sup>) inherited from form process]  
 [Protection]  
 values:  
 = 18 (1.00)

web h/t max (inherited from form process)  
 [Protection]  
 Values:  
 = 22 (1.00)

37.5 Ton Press  
 inherits from:  
 form process

(general) (inherited from form process)

form accuracy (in. radius) (inherited from form process)  
 [Protection]  
 Values:  
 = .1 (1.00)

forming location (inherited from form process)  
 [Protection]  
 is bay 3 (1.00)

forming part depth max (in) (inherited from form process)  
 [Protection]  
 values:  
 =4 (1.00)

forming part length max (ft) (inherited from form process)  
 [Protection]  
 values:  
 = 8 (100)

forming part width max (ft) (inherited from form process)  
 values:  
 =1 (1.00)

forming muting code (inherited from form process)  
 [Protection]  
 values:  
 is pn (1.00)

outside radius min (in) (inherited from form process)  
 [Protection]  
 Values:  
 =4 (1.00)

Roll Degrees Max (inherited from form process)  
 [Protection]  
 =360 (1.00)

Section modulus max. alum (in<sup>3</sup>) inherited from form process)  
 [Protection]  
 = 23 (1.00)

section modulus max. steel (in<sup>3</sup>) [inherited from form process]  
 [Protection]  
 = 8 (1.00)

web h/t max (inherited from form process)  
**[Protection]**  
 = 20 (1.00)

60 Ton Cold Press  
 inherited from:  
 form process

(general) (inherited from form process)

form accuracy (in. radius) (inherited from form process)  
**[Protection]**  
 values:  
 = .15 (1.00)

forming location (inherited from form process)  
**[Protection]**  
 Values:  
 is bay 1 (1.00)

forming part depth max (in) (inherited from form process)  
**[Protection]**  
 Values:  
 = 17 (1.00)

forming part length max. (ft) (inherited from form process)  
**[Protection]**  
 Values:  
 = 20 (1.00)

forming part width max (ft) (inherited from form process)  
**[Protection]**  
 Values:  
 = 5 (1.00)

forming muting code (inherited from form process)  
**[Protection]**  
 Values:  
 is pr7 (1.00)

outside radius min (in) (inherited from form process)  
**[Protection]**  
 Values:  
 = 0 (1.00)

Roll Degrees Max (inherited from form process)  
**[Protection]**  
 Values:  
 =0 (1.00)

section modulus max. alum (in<sup>3</sup>) (inherited from form process)  
**[Protection]**  
 Values:  
 = 35 (1.00)

section modulus max. steel (in<sup>3</sup>) (inherited from form process)  
**[Protection]**  
 values:  
 = 12 (1.00)

web h/t max (inherited from form process)  
**[Protection]**  
 values:  
 =24 (1.00)

600 Ton Press  
 inherits from:  
**form process**

(general) (inherited from form process)

form accuracy (in. radius) (inherited from form process)  
**[Protection]**  
 Values:  
 = .1 (1.00)

forming location (inherited from form Process)  
**[Protection]**  
 Values:  
 is bay 2 (1.00)

forming part depth max (in) (inherited from form process)  
**[Protection]**  
 Values:  
 =15 (1.00)

forming part length max (ft) (inherited from form process)  
**[Protection]**  
 Values:  
 =17 (1.00)

forming part width max (ft) (inherited from form process)  
**[Protection]**  
 Values:  
 = 12 (1.00)

forming routing code (inherited from form process)  
**[Protection]**  
 Values:  
 is pr4 (1.00)

outside radius min (in) (inherited from form process)  
**[Protection]**  
 = 15 (1.00)

Roll Degrees Max (inherited from form process)  
**[Protection]**  
 Values:  
 =180 (1.00)

section modulus max. alum (in<sup>3</sup>) (inherited from form process)  
**[Protection]**  
 values:  
 = 278 (1.00)

**section modulus max. steel (in<sup>3</sup>)** (inherited from form process)  
**[Protection]**  
**values:**  
**= 96 (1.00)**

web h/t max (inherited from form process)  
**[Protection]**  
 values:  
 =20 (1.00)

bandsaw  
 inherits from:  
 cut process

(general) [inherited from cut process]

# of axes [inherited from cut process]  
**[Protection]**  
**= 1 (1.00)**

# of master cut tools (inherited from cut process)  
**[Protection]**  
 Values:  
 = 1 (1.00)

# of slave cut tools [inherited from cut process]  
**[Protection]**  
 = 0 (1.00)

angle cut max (deg) (inherited from cut process)  
**[Protection]**  
 values:  
 = 45 (1.00)

Automation Level [inherited from cut process]  
**[Protection]**  
 values:  
 = semi (1.00)

cut accuracy (in) [inherited from cut process]  
**[Protection]**  
 Values:  
 = .05 (1.00)

cut configuration [inherited from cut process]  
**[Protection]**  
 values:  
 is non-parallel straight (1.00)  
 is parallel straight (1.00)  
 is single straight (1.00)

cut length max (h) (inherited from cut process)  
**[Protection]**  
 Values:  
 =-3 (1.00)

cut location (inherited from cut process)  
**[Protection]**  
 values:  
 is bay 3 (1.00)

cut part depth max (in) [inherited from cut process]  
**[Protection]**  
 Values:  
 =-4 (1.00)

cut part length max (h) (inherited from cut process)  
**[Protection]**  
 Values:  
 = 4 (1.00)

cut part width max (h) [inherited from cut process]  
**[Protection]**  
 Values:  
 =-3 (1.00)

cut routing code [inherited from cut process]  
**[Protection]**  
 Values:  
 is SW1 (1.00)

hole diameter max (in) (inherited from cut process)  
[Protection]  
values:  
-0(1.00)

man cut thickness max, alum (in) (inherited from cut process)  
[Protection]  
values:  
= 3 (1.00)

marl cut thickness max, steel (in) [inherited from cut process]  
[Protection]  
Values:  
=1 (1.00)

Brake Press  
inherits from:  
form process  
(general) (inherited from form process)

form accuracy (in. radius) [inherited from form process]  
[Protection]  
values:  
- .15 (1.00)

f o r m i n g location (inherited from form process)  
Protection  
values:  
is bay 3 (1.00)

forming part depth max (in) (inherited from form process)  
[Protection]  
values:  
-15 (1.00)

forming part length max (h) [inherited from form process]  
[Protection]  
values:  
-35 (1.00)

forming part width max (h) [inherited from form process]  
[Protection]  
values:  
-12 (1.00)

forming routing cods [inherited from form process]  
[Protection]  
values:  
is pr1 (1.00)

outside radius min (In) [inherited from form process]  
[Protection]  
values:  
- 12 (1.00)

Roll Degrees Max [inherited from form process]  
[Protection]  
values:  
- 180 (1.00)

section modulus max. alum (in 3) [inherited from form process]  
(Protection)  
values:  
- 213 (1.00)

Section modulus max, steel (in 3) [inherited from form process]  
[Protection]  
Values:  
-74 (1.00)

web h/t max [inherited from form process]  
[Protection]  
values:  
-20 (1.00)

contour band saw  
inherits from:  
cut process  
(general) (inherited from cut process)

# of axes [inherited from cut process]  
[Protection]  
values:  
-2 (1.00)

# of master cut tools (inherited from cut process)  
[Protection]  
Values:  
-1 (1.00)

# of slave cut tools [inherited from cut process]  
[Protection]  
values:  
- 0 (1.00)

angle cut max (deg) [inherited from cut process]  
[Protection]  
values:  
- 45 (1.00)

Automation Level [inherited from cut process]  
[Protection]  
values:  
- semi (1.00)

cut accuracy (in) [inherited from cut process]  
[protection]  
values:  
= .02 (1.00)

cut configuration [inherited from cut process]  
[Protection]  
Values:  
is contour (1.00)  
is non-parallel staight (1.00)  
is parallel straight (1.00)  
is single straight (1.00)

cut length max (h) [inherited from cut process]  
[Protection]  
values:  
=2(1.00)

cut location [Inherited from cut process]  
[Protection]  
values:  
is bay 3 (1.00)

cut part depth max (in) [inherited from cut process]  
[protection]  
values:  
= 12 (1.00)

cut part length max (ft) [inherited from cut process]  
[Protection]  
Values:  
=8(1.00)

cut part width max (ft) [inherited from cut process]  
[Protection]  
values:  
=2(1.00)

cut routing code [inherited from cut process]  
[Protection]  
values:  
is sw3 (1 .00)

hole diameter max (in) [inherited from cut process]  
[Protection]  
values:  
=0 (1.00)

marl cut thickness max. alum (in) [inherited from cut process]  
[Protection]  
values:  
= 6 (1.00)

marl cut thickness max. steel (in) [inherited from cut process]  
[Protection]  
values:  
= 2 (1.00)

cut process  
is inherited by:  
drill #2  
100 ton punch  
band saw  
contour tend saw  
drill #1  
Flame Plane 1  
Flame Plane 2  
hydraulic tend saw  
N/C 2-Axis  
N/C Plasma  
shear

**(general)**  
#Of axes  
# of master cut tools  
# of slave cut tools  
angle cut max (deg)  
Automation Level  
cut accuracy (in)  
cut configuration  
cut length max (ft)

|  |   |
|--|---|
| cut location   | marl cut thickness max. steel (in) [inherited from cut process] |
| cut part <b>depth</b> max (in)                                 | <b>[Protection]</b>   |
| cut part length max (ft)                                       | <b>values:</b>  |
| cut part width max (ft)  | =6(1.00)  |
| cut routing code   | drill #2  |
| hole diameter max (in)   | inherits from:  |
| marl cut thickness max. alum (in)                              | cut process   |
| marl cut thickness max. steel (in)                             | (general) (inherited from cut process)                          |
| drill #1   | # of axes [inherited from cut process]                          |
| inherits from:   | <b>[Protection]</b>   |
| cut process  | <b>values:</b>  |
| (general) [inherited from cut process]                         | = 1 (1.00)  |
| # of master cut tools [inherited from cut process]             | # of master cut tools [inherited from cut process]              |
| <b>[Protection]</b>  | <b>[Protection]</b>   |
| <b>values:</b>   | <b>values:</b>  |
| =1 (1.00)  | = 1 (1.00)  |
| # of slave cut tools [inherited from cut process]              | # of slave cut tools [inherited from cut process]               |
| <b>[Protection]</b>  | <b>[Protection]</b>   |
| <b>values:</b>   | <b>values:</b>  |
| -1 (1.00)  | = 0 (1.00)  |
| # of slave cut tools (inherited from cut process)              | angle cut max (dog) [inherited from cut process]                |
| <b>[Protection]</b>  | <b>[Protection]</b>   |
| <b>values:</b>   | <b>values:</b>  |
| = 0 (1.00)   | =0(1.00)  |
| angle cut max (deg) (inherited from cut process)               | Automation Level [inherited from cut process]                   |
| <b>[Protection]</b>  | <b>[Protection]</b>   |
| <b>Values:</b>   | <b>Values:</b>  |
| =0 (1.00)  | =semi (1.00)  |
| Automation Level [inherited from cut process]                  | cut accuracy (in) (inherited from cut process)                  |
| <b>[Protection]</b>  | <b>[Protection]</b>   |
| <b>values:</b>   | <b>values:</b>  |
| = semi (1.00)  | = .005 (1.00)   |
| cut accuracy (in) (inherited from cut process)                 | an configuration (inherited from cut process)                   |
| <b>[Protection]</b>  | <b>[Protection]</b>   |
| <b>values:</b>   | <b>values:</b>  |
| = .005 (1.00)  | is hole (1.00)  |
| art configuration (inherited from cut process)                 | cut length max (ft) [inherited from cut process]                |
| <b>[Protection]</b>  | <b>Protection</b>   |
| <b>Values:</b>   | <b>Values:</b>  |
| is hole (1.00)   | = 35 (1.00)   |
| art length max [inherited from cut process]                    | cut location [inherited from cut process]                       |
| <b>[Protection]</b>  | <b>[Protection]</b>   |
| <b>Values:</b>   | <b>values:</b>  |
| =25 (1.00)   | is bay 3 (1.00)   |
| cut location (inherited from cut process)                      | cut part depth max (in) (inherited from cut process)            |
| <b>[Protection]</b>  | <b>[Protection]</b>   |
| <b>values:</b>   | <b>values:</b>  |
| is bay 1 (1.00)  | = 10 (1.00)   |
| cut part depth max (in) [inherited from cut process]           | cut part length max (ft) [inherited from cut process]           |
| <b>[Protection]</b>  | <b>[Protection]</b>   |
| <b>Values:</b>   | <b>values:</b>  |
| = 15 (1.00)  | = 35 (1.00)   |
| cut part length max (ft) [inherited from cut process]          | cut part width max (ft) (inherited from cut process)            |
| <b>[Protection]</b>  | <b>[Protection]</b>   |
| <b>Values:</b>   | <b>values:</b>  |
| = 25 (1.00)  | =12 (1.00)  |
| cut part width max (ft) [inherited from cut process]           | cut routing code [inherited from cut process]                   |
| <b>[Protection]</b>  | <b>[Protection]</b>   |
| <b>values:</b>   | <b>Values:</b>  |
| =3(1.00)   | is dr2 (1.00)   |
| cut muting code [inherited from cut process]                   | hole diameter max (in) [inherited from cut process]             |
| <b>[Protection]</b>  | <b>[Protection]</b>   |
| <b>values:</b>   | <b>values:</b>  |
| is dr1 (1.00)  | =4 (1.00)   |
| hole diameter max (in) [inherited from cut process]            | marl cut thickness max. alum (in) (inherited from cut process)  |
| <b>[Protection]</b>  | <b>[Protection]</b>   |
| <b>values:</b>   | <b>values:</b>  |
| = 3 (1.00)   | =6(1.00)  |
| marl cut thickness max. alum (in) (inherited from cut process) | man cut thickness max. steel (in) [inherited from cut process]  |
| <b>[Protection]</b>  | <b>[Protection]</b>   |
| <b>values:</b>   | <b>values:</b>  |
| =6(1.00)   | = 6 (1.00)  |
| edge planer  | edge prep process   |
| inherits from:   | (general) (inherited from edge prep process)                    |
| edge prep process  |   |

bevel accuracy (deg) (inherited from edge prep process)  
 [Protection]  
 values:  
 = 2 (1.00)

bevel Configuration (inherited from edge prep Process)  
 [Protection]  
 values:  
 is single straight (1.00)  
 is parallel straight (1.00)  
 is non-parallel straight (1.00)

Bevel Degrees Max (inherited from edge prep process)  
 [Protection]  
 values:  
 =80 (1.00)

edge prep length max (ft) (inherited from edge prep process)  
 [Protection]  
 values:  
 =36 (1.00)

edge prep location (inherited from edge prep process)  
 [Protection]  
 values:  
 is bay 2 (1.00)

edge prep PM depth max (in) (inherited from edge prep process)  
 [Protection]  
 Values:  
 = 18 (1.00)

edge prep part length max (ft) (inherited from edge prep process)  
 [Protection]  
 Values:  
 =36 (1.00)

edge prep pan width max (ft) (inherited from edge prep process)  
 [Protection]  
 values:  
 = 20 (1.00)

edge prep routing code (inherited from edge prep process)  
 [Protection]  
 values:  
 is p11 (1.00)

edge prep thickness max. alum (in) (inherited from edge prep process)  
 [Protection]  
 values:  
 =4 (1.00)

edge prep thickness max. steel (in) (inherited from edge prep process)  
 [Protection]  
 Values:  
 =4(1.00)

**edge prep process**  
 is inherited by:  
**Flame Plane 1**  
**N/C Plasma**  
**edge planer**

(general)

bevel accuracy (dog)

bevel configuration

Bevel Degrees Max

edge prep length max (ft)

**edge prep location**

edge pep part depth max (in)

edge prep pan length max (ft)

**edge prep part width max (ft)**

edge prep routing code

edge prep thickness max. alum (in)

edge prep thickness max. steel (In)

Flame Plane:  
 inherits from:  
 cut process  
 edge prep process

**(general) (inherited from edge prep process)**

**(general) (inherited from cut process)**

**# of axes (inherited from cut process)**  
 [Protection]  
 values:  
 = 1 (1.00)

# of master cut mob (inherited from cut process)  
 [Protection]  
 values:  
 = 11 (1.00)

# of slave cut tools (inherited from cut process)  
 [Protection]  
 values:  
 =0(1.00)

angle cut max (deg) (inherited from at process)  
 [Protection]  
 values:  
 =0(1.00)

Automation Level (inherited from cut process)  
 [Protection]  
 Values:  
 is semi (1.00)

bevel accuracy (deg) (inherited from edge prep process)  
 [Protection]  
 values:  
 =2(1.00)

bevel configuration (inherited from edge prep process)  
 [Protection]  
 values:  
 is single straight (1.00)  
 is parallel straight (1.00)

Bevel Degrees Max (inherited from edge prep process)  
 [Protection]  
 values:  
 = 60 (1.00)

cut accuracy (in) (inherited from cut process)  
 [Protection]  
 Values:  
 = .05 (1.00)

cut configuration (inherited from at process)  
 [Protection]  
 values:  
 is parallel straight (1.00)  
 is single straight (1.00)

cut length max (ft) (inherited hum cut process)  
 [Protection]  
 Values:  
 =50 (1.00)

at location (inherited from cut process)  
 [Protection]  
 Values:  
 is bay 2 (1.00)

cut part depth max (in) (inherited from cut process)  
 [Protection]  
 values:  
 = 10 (1.00)

cut part length max (ft) (inherited from cut process)  
 [Protection]  
 Values:  
 = 50 (1.00)

cut part width max (ft) (inherited from cut process)  
 [Protection]  
 Values:  
 = 16 (1.00)

cut routing code (inherited from cut process)  
 [Protection]  
 is S1 (1.00)

edge prep length max (ft) (inherited from edge prep process)  
 [Protection]  
 values:  
 = 50 (1.00)

edge prep location (inherited from edge prep process)  
 [Protection]  
 is bay 2 (1.00)

edge prep part depth max (in) (inherited hum edge prep process)  
 [Protection]  
 Values:  
 - 10 (1.00)

edge prep part length max (ft) (inherited from edge prep process)  
 [Protection]  
 Values:  
 -50 (1.00)

edge prep part width max (ft) (inherited from edge prep process)  
 [Protection]  
 Values:  
 16 (1.00)



edge prep routing code (inherited from edge prep process)  
 [Protection]  
 values:  
 is fp1 (1.00)

edge pep thickness max. alum (in) (inherited from edge prep process)  
 [Protection]  
 values:  
 = 0 (1.00)

edge prep thickness max. steel (in) (inherited from edge prep process)  
 [Protection]  
 values:  
 = 6 (1.00)

hole diameter max. (in) (inherited from cut process)  
 [Protection]  
 values:  
 -0(1.00)

mail cut thickness max. alum (in) (inherited from cut process)  
 [Protection]  
 Values:  
 -0(1.00)

man cat thickness max. steel (in) (inherited from cut process)  
 [Protection]  
 values:  
 -6(1.00)

Flame Plane 2

inherits from:  
 cut process

(general) (inherited from cut process)

# of axes (inherited from cut process)  
 [Protection]  
 values:  
 = 1 (1.00)

# of master cut tool5 (inherited from cut process)  
 [Protection]  
 values:  
 -2(1.00)

x of stave cut tool3 (inherited from cut process)  
 [Protection]  
 Values:  
 -0(1.00)

angle cut max (deg) (inherited from cut process)  
 (Protection)  
 Values:  
 .0(1.00)

Automation Level (inherited from cut process)  
 [Protection]  
 Values:  
 is semi (1.00)

cut accuracy (in) (inherited from cut process)  
 [Protection]  
 Values:  
 -.03 (1.00)

cut configuration (Inherited from cut process)  
 [Protection]  
 Values:  
 is parallel straight (1.00)  
 is single straight (1.00)

cut length max (ft) (inherited from cut process)  
 (Protection)  
 values:  
 - 50 (1.00)

cut location (inherited from cut process)  
 [Protection]  
 values:  
 is bay 2 (1.00)

cu' part depth max (in) (inherited from cut process)  
 [Protection]  
 Values:  
 - 4 (1.00)

cut part length max (ft) (inherited from cut process)  
 [Protection]  
 Values:  
 PM (1.00)

cut part width max (ft) (inherited from cut process)  
 [Protection]  
 Values:  
 = 12 (1.00)

cut routing code (inherited from cut process)  
 [Protection]  
 values:  
 is fp2 (1.00)

hole diameter max (in) (inherited from cut process)  
 [Protection]  
 values:  
 = 0 (1.00)

man cut thickness max. alum (in) (inherited from cut process)  
 [Protection]  
 values:  
 - 0 (1.00)

man cut thickness max. steel (in) (inherited from cut process)  
 [Protection]  
 values:  
 - 4 (1.00)

form process

is inherited by:  
 12 Foot Roll  
 250 Ton Press  
 37.5 Ton Press  
 60 Ton Cold Press  
 600 Ton Press  
 Brake Press  
 1500 Ton Press  
 X100 Ton Roll  
 Frame Bender

(general)

from accuracy (in. radius)

forming location

forming part depth max (in)

forming part length max (ft)

forming part width max (ft)

forming routing code

outside radius min (in)

Roll Degrees Max

section modulus max. alum (in<sup>3</sup>)

section modulus max. steel (in<sup>3</sup>)

web height max

Frame Bender

inherits from:  
 form process

(general) (inherited from form process)

form accuracy (in. radius) (inherited from form process)  
 [Protection]  
 values:  
 - .05 (1.00)

forming location (Inherited from form process)  
 [Protection]  
 values:  
 is bay 1 (1.00)

forming part depth max (in) (inherited from form process)  
 [Protection]  
 values:  
 - 30 (1.00)

forming part length max (ft) (inherited from form process)  
 [Protection]  
 values:  
 - 40 (1.00)

forming part width max (ft) (inherited from form process)  
 [Protection]  
 Values:  
 - 1.5 (1.00)

forming muting code (inherited from form process)  
 [Protection]  
 values:  
 is p5 (1.00)

outside radius min (in) (inherited from form process)  
 [Protection]  
 values:  
 = 60 (1.00)

Roll Degrees Max (inherited from form process)  
 [Protection]  
 values:  
 = 270 (1.00)

section modulus max. alum (in<sup>3</sup>) (inherited from form process)  
 values: [Protection]  
 = 3000 (1.00)

section modulus max. steel (in<sup>3</sup>) (inherited from form process)  
 values: [Protection]  
 = 1000 (1.00)

web h / t (inherited from form process)  
 values: [Protection]  
 124 (1.00)

hydraulic band saw  
 inherits from:  
 cut process

(general) (inherited from cut process)

# of axes (inherited from cut process)  
 values: [Protection]  
 -1 (1.00)

# of master cut tools (inherited from cut process)  
 values: [Protection]  
 - 1 (1.00)

# of slave cut tools (inherited from cut process)  
 values: [Protection]  
 - 0 (1.00)

angle cut max (deg) (inherited from cut process)  
 values: [Protection]  
 - 45 (1.00)

Automation Level (inherited from cut process)  
 values: [Protection]  
 is semi (1.00)

cut accuracy (ii) (inherited from cut process)  
 values: [Protection]  
 - .02 (1.00)

cut configuration (inherited from cut process)  
 values: [Protection]  
 is parallel straight (1.00)  
 is single straight (1.00)  
 is non-parallel straight (1.00)

cut length max (ft) (inherited from cut process)  
 values: [Protection]  
 - 1.5 (1.00)

cut location (inherited from cut process)  
 values: [Protection]  
 is bay 1 (1.00)

cut part depth mu (in) (inherited from cut process)  
 values: [Protection]  
 - 20 (1.00)

cut part length max (ft) (inherited from cut process)  
 values: [Protection]  
 - 40 (1.00)

cut part width max (ft) (inherited from cut process)  
 values: [Protection]  
 - 1.5 (1.00)

cut routing code (inherited from cut process)  
 values: [Protection]  
 is SW2 (1.00)

hole diameter max (in) (inherited from cut process)  
 values: [Protection]  
 - 0 (1.00)

man cut thickness max, alum (in) (inherited from cut process)  
 values: [Protection]  
 - 6 (1.00)

matl cut thickness max. steel (in) (inherited from cut process)  
 values: [Protection]  
 - 3 (1.00)

NIC 2-Axis  
 inherits from:  
 cut process

(general) (inherited from cut process)

# of axes (inherited from cut process)  
 values: [Protection]  
 - 2 (1.00)

# of master cut tools (inherited from cut process)  
 values: [Protection]  
 - 2 (1.00)

# of slave cut tools (inherited from cut process)  
 values: [Protection]  
 - 2 (1.00)

angle cut max (deg) (inherited from cut process)  
 values: [Protection]  
 - 360 (1.00)

Automation Level (inherited from cut process)  
 values: [Protection]  
 - N/C (1.00)

cut accuracy (in) (inherited from cut process)  
 values: [Protection]  
 - .02 (1.00)

cut configuration (inherited from cut process)  
 values: [Protection]  
 is parallel straight (1.00)  
 is non-parallel straight (1.00)  
 is single straight (1.00)  
 is contour (1.00)  
 is hole (1.00)

cut length max (ft) (inherited from cut process)  
 values: [Protection]  
 - 140 (1.00)

cut location (inherited from cut process)  
 values: [Protection]  
 is bay 3 (1.00)

cut part depth max (in) (inherited from cut process)  
 values: [Protection]  
 - 6 (1.00)

cut part length max (ft) (inherited from cut process)  
 values: [Protection]  
 - 140 (1.00)

cut part width max (ft) (inherited from cut process)  
 values: [Protection]  
 - 16 (1.00)

cut routing code (inherited from cut process)  
 values: [Protection]  
 is br1 (1.00)

hole diameter max (in) (inherited from cut process)  
 values: [Protection]  
 - 138 (1.00)

matl cut thickness max. alum (in) (inherited from cut process)  
 values: [Protection]  
 - 0 (1.00)

matl cut thickness max, steel (in) (inherited from cut process)  
 values: [Protection]  
 - 6 (1.00)

NC Plasma  
 inherits from:  
 cut process  
 edge prep process

(general) (inherited from edge prep process)

(general) (inherited from cut process]

# of axes (inherited from cut process)  
[Protection]  
values:  
= 3 (1.00)

# of master cut tools (inherited from cut process)  
[Protection]  
values:  
= 2 (100)

# of slave cut tools (inherited from cut process]  
[Protection]  
values:  
= 2 (1.00)

angle cut max (deg) (inherited from cut process)  
values: [Protection]  
= 360 (1.00)

Automation Level (inherited from cut process)  
[Protection]  
values:  
is N/C (1.00)

bevel accuracy (deg) [inherited from edge prep process]  
[Protection]  
values:  
= .5 (1.00)

bevel configuration (inherited from edge prep process]  
[Protection]  
values:  
is single straight (1.00)  
is parallel straight (1.00)  
is non-parallel straight (1.00)  
is contour (1.00)

Bevel Degrees Max (inherited from edge prep process)  
[Protection]  
values:  
= 70 (1.00)

cut accuracy (in) (inherited from cut process)  
[Protection]  
values:  
= .02 (1.00)

cut configuration (inherited from cut process]  
[Protection]  
values:  
is parallel straight (1.00)  
is single straight (1.00)  
is non-parallel straight (1.00)  
is contour (1.00)  
is hole (1.00)

cut length max (ft) (inherited from cut process)  
values:  
= 50 (1.00)

cut location [inherited from cut process]  
[Protection]  
values:  
is bay 3 (1.00)

**cut part depth max** (in) (inherited from cut process)  
[Protection]  
values:  
= 6 (1.00)

cut part length max (ft) (inherited from cut process)  
[Protection]  
values:  
= 50 (1.00)

cut part width max (ft) (inherited from cut process)  
[Protection]  
values:  
= 18 (1.00)

cut routing code (inherited from cut process)  
[Protection]  
values  
is br2 (1.00)

edge prep length max (ft) (inherited from edge prep process)  
[Protection]  
values:  
= 50 (1.00)

edge prep location (inherited from edge prep process)  
[Protection]  
values:  
is bay 3 (1.00)

edge prep part depth max (in) (inherited from edge prep process)  
[Protection]  
values:  
= 6 (1.00)

edge prep part length max (ft) (inherited from edge prep process]  
[Protection]  
values:  
= 50 (1.00)

edge prep part width max (ft) (inherited from edge prep process]  
values: [Protection]  
= 18 (1.00)

edge pep routing code (inherited from edge prep process)  
[Protection]  
values:  
is br2 (1.00)

edge prep thickness max. alum (in) (inherited from edge prep process)  
values: [Protection]  
= 3 (1.00)

edge prep thickness max. stool (in) (inherited from edge prep process)  
[Protection]  
values:  
= .75 (1.00)

hole diameter max (in) (inherited from cut process)  
values: [Protection]  
= 216 (1.00)

man cut thickness max. alum (in) (inherited from cut process)  
[Protection]  
values:  
= 3 (1.00)

man cut thickness max. steel (in) (inherited from **cut** process)  
[Protection]  
values:  
= .75 (1.00)

part

angle max var. from 90 dog  
[No Auto Values]

area. sq.ft.  
automatic values:  
is less than stock area, sq.ft.

bevel configuration  
automatic values:  
is single straight  
is parallel straight  
is non-parallel straight  
is contour

cut configuration  
automatic values:  
is hole  
is single straight  
is parallel straight  
is non-parallel straight  
is contour  
is non-parallel straight  
is parallel straight  
is single straight

cut dimensions accuracy requirement (in)  
automatic values:  
= .005  
= .01  
= .05  
= .02  
= .03

cut location  
[No Auto values]

cut method  
[No Auto Values]

cut muting code  
[No Auto Values]

depth (in)  
[No Auto Values]

edge prep location  
[No Auto Values]

edge prep method  
[No Auto Values]

edge prep routing code  
[No Auto Values]

**edge/end preparation**  
**automatic values:**  
**is beveled**

**flange thickness (in)**  
forming location [No Auto Values]  
forming method (No Auto Values)

**forming routing code**  
**[No Auto Values]**

hole cut diameter (in) [No Auto Values]

**length (ft)**  
**[No Auto Values]**

man thickness to be cut (in) [No Auto Values]

**material**  
**automatic values:**  
**is alum**  
**is steel**

max bevel angle required [No Auto Values]

max cut length (ft) [No Auto Values]

max edge prep length (ft) (No Auto Values)

**outside radius (in)**  
**[No Auto Values]**

**process**  
**[No Auto Values]**

**roll degrees**  
**[No Auto Values]**

roll radius accuracy requirement (in)  
automatic values:  
= .2  
= .1  
= .15  
= .05

section modulus alum [No Auto Values]

**section modulus steel**  
**[No Auto Values]**

**shape**  
**automatic values:**  
**is rolled**  
**is knuckled**

**size**  
**automatic values:**  
**is smaller than stock**  
**is stock**  
**is larger than stock**

thickness alum [No Auto Values]

thickness steel [No Auto Values]

**type**  
**automatic values:**  
**is plate**  
**is shape**

web h/t [No Auto Values]

web thickness (in)

width (ft) [No Auto Values]

**shear**  
**Inherits from:**  
**cut process**

(general) [inherited from cut process]

**# of AXES** (inherited from cut process)  
(Protection)  
values:  
= 1 (1.00)

# of master cut tools (Inherited from cut process)  
(Protection)  
values:  
= (1.00)

# of slave cut tools (inherited from cut process)  
values: (Protection)  
= 0 (1.00)

angle cut max (deg) (inherited from cut process)  
(Protection)  
values:  
= 0 (1.00)

Automation Level (inherited from cut process)  
values: (Protection)  
= semi (1.00)

**cut accuracy (in)** **[inherited from cut process]**  
**[Protection]**  
**values:**  
**= .03 (1.00)**

cut configuration (inherited from cut process)  
(Protection)  
values:  
is single straight (1.00)  
is parallel straight (1.00)  
is nonparallel straight (1.00)

cut length max (ft) (inherited from cut process)  
(Protection)  
values:  
= 10 (1.00)

cul location (inherited from cut process)  
(Protection)  
values:  
is bay 3 (1.00)

cut part depth max (in) (inherited from cut process)  
(Protection)  
**values:**  
= 6 (1.00)

cut part length max (ft) [inherited from cut process]  
(Protection)  
values:  
= 18 (1.00)

cut part width max (ft) [inherited from cut process]  
values: (Protection)  
= 10 (1.00)

cut routing code (inherited from cut process)  
(Protection)  
values:  
is sh1 (1.00)

hole diameter max (in) (inherited from cut process)  
values: (Protection)  
= 0 (1.00)

man cut thickness max. alum (in) (inherited from cut process)  
(Protection)  
values:  
= 1.5 (1.00)

man cut thickness max. steel (in) (inherited from cut process)  
(Protection)  
values:  
= .5 (1.00)

**\*\*\* OBJECTS \*\*\***

## APPENDIX B

### System Listing of Rules

. \* \* R U L E S . . . of Marks HD:Papers:Paper, Exprt.Sys.Plng:Real.Steel.Fab.7/12.kb . . .

RULE #1 priority 50 -

```
IF -----
(1) the part shape is rolled [threshold 0.20]
(2) or the part shape is knuckled [threshold 0.201]
THEN -----
(1) part process is "form process" [certainty 1.001]
```

RULE #2 priority 50 -

```
IF -----
(1) the part edge/end preparation is beveled [threshold 0.201]
THEN -----
(1) part process is "edge prep process" [certainty 1.00]
```

RULE #3 priority 50 -

```
IF -----
(1) the part size is "smaller than stock" [threshold 0.20]
THEN -----
(1) part process is "cut process" [certainty 1.00]
```

RULE #4 priority 50 -

```
IF -----
(1) the part size is stock [threshold 0.20]
(2) and the part area, sq.ft. is "less than stock area, sq.ft." [threshold 0.201]
THEN -----
(1) part process is "cut process" [certainty 1.00]
```

RULE #5 priority 50 -

```
IF -----
(1) the part size is "larger than stock" [threshold 0.201]
THEN -----
(1) part process is "fabricate superpart (joining process)" [certainty 1.001]
```

RULE #6 priority 50 -

```
IF -----
(1) the part material is alum [threshold 0.20]
THEN -----
(1) part thickness alum = <part 1 mat'1 thickness to be cut (in)> [certainty 1.00]
ELSE -----
(1) part thickness alum = 0 [certainty 1.00]
(2) and part section modulus alum = 0 [certainty 1.00]
```

RULE #7 priority 50 -

```
I F -----
(1) the part material is steel [threshold 0.20]
THEN -----
(1) part thickness steel = <part 1 mat'1 thickness to be cut (in)> [certainty 1.00]
ELSE -----
(1) part thickness steel = 0 [certainty 1.00]
(2) and part section modulus steel = 0 [certainty 1.00]
```

RULE #8 priority 50 -

```
IF -----
(1) the part process is "cut process" [threshold 0.20]
(2) and the part length (ft) <= <cut process 1 cut part length max (ft)> [threshold 0.20]
(3) and the part width (ft) <= <cut process 1 cut part width max (ft)> [threshold 0.20]
(4) and the part depth (in) <= <cut process 1 cut part depth max (in)> [threshold 0.20]
(5) and the part cut dimensions accuracy requirement (in) >= <cut process 1 cut accuracy (in)> [threshold 0.20]
```

- (6) and the part thickness Steel  $\leq$  <cut process | mat'l cut thickness max, steel (in)> [threshold 0.20]
- (7) and the part thickness alum  $\leq$  <cut process | mat'l cut thickness max, alum (in)> [threshold 0.20]
- (6) and the part hole cut diameter (in)  $\leq$  <cut process | hole diameter max (in)> [threshold 0.20]
- (9) and the part angle max var. from 90 deg  $\leq$  <cut process | angle cut max (deg)> [threshold 0.20]
- (10) and the part cut configuration is <cut process | cut configuration> [threshold 0.20]
- (11) and the part max cut length (ft)  $\leq$  <cut process | cut length max (ft)> [threshold 0.20]

THEN

- (1) part cut method is ObjectName(<cut process>) [certainty
- (2) and part cut routing code is <cut process | cut routing code> [certainty 1.00]
- (3) and part cut location is <cut process | cut location> [certainty 1.00]

RULE #9 priority 50 -

IF

- (1) the part process is "form process" [threshold 0.20]
- (2) and the part length (ft)  $\leq$  <form process | forming part length max (ft)> [threshold 0.20]
- (3) and the part width (ft)  $\leq$  <form process | forming part width max (ft)> [threshold 0.20]
- (4) and the part depth (in)  $\leq$  <form process | forming part depth max (in)> [threshold 0.20]
- (5) and the part roll radius accuracy requirement (in)  $\geq$  <form process | form accuracy (in. radius)> [threshold 0.20]
- (6) and the part section modulus steel  $\leq$  <form process | section modulus max, steel (in<sup>3</sup>)> [threshold 0.20]
- (7) and the part section modulus alum  $\leq$  <form process | section modulus max, alum (in<sup>3</sup>)> [threshold 0.20]
- (8) and the part outside radius (in)  $\geq$  <form process | outside radius min (in)> [threshold 0.20]
- (9) and the part roll degrees  $\leq$  <form process | Roll Degrees Max> [threshold 0.20]
- (10) and the part web h/t  $\leq$  <form process | web h/t max> [threshold 0.20]

THEN

- (1) part forming method is ObjectName(<form process>) [certainty 1.001]
- (2) and part forming routing code is <form process | forming routing code> [certainty 1.00]
- (3) and part forming location is <form process | forming location> [certainty 1.00]

RULE #10 priority 50 -

IF

- (1) the part process is "edge prep process" [threshold 0.20]
- (2) and the part length (ft)  $\leq$  <edge prep process | edge prep part length max (ft)> [threshold 0.20]
- (3) and the part width (ft)  $\leq$  <edge prep process | edge prep part width max (ft)> [threshold 0.20]
- (4) and the part depth (in)  $\leq$  <edge prep process | edge prep part depth max (in)> [threshold 0.20]
- (5) and the part max bevel angle required  $\leq$  <edge prep process | Bevel Degrees Max> [threshold 0.20]
- (6) and the part thickness steel  $\leq$  <edge prep process | edge prep thickness max, steel (in)> [threshold 0.20]
- (7) and the part thickness alum  $\leq$  <edge prep process | edge prep thickness max, alum (in)> [threshold 0.20]
- (8) and the part max edge prep length (ft)  $\leq$  <edge prep process | edge prep length max (ft)> [threshold 0.20]
- (9) and the part bevel configuration is <edge prep process | bevel configuration> [threshold 0.20]

THEN

- (1) part edge prep method is ObjectName(<edge prep process>) [certainty 1.00]
- (2) and part edge prep routing code is <edge prep process | edge prep routing code> [certainty 1.00]
- (3) and part edge prep location is <edge prep process | edge prep location> [certainty 1.00]

RULE #11 priority 50 -

IF

- (1) the part type is plate [threshold 0.20]

THEN

- (1) part web h/t = 0 [certainty 1.00]
- (2) and part mat'l thickness to be cut (in) = <part | depth (in)> [certainty 1.00]

RULE #12 priority 50 -

IF

- (1) the part type is shape [threshold 0.20]

THEN

- (1) part web h/t = <part | depth (in)>  $\cdot$  .94 / <part | web thickness (in)> [certainty 1.00]
- (2) and part mat'l thickness to be cut (in) = <part | flange thickness (in)> [certainty 1.00]

## APPENDIX C

### System Listing of Inference Process Part #1

```

- - - backward inference (all goals) - - -
attempting to satisfy goal 'part process'
full testing rule 1 - targets: 'part'
  attempting to satisfy goal 'part shape'
  getting a value from the user for part shape
  attempting to satisfy goal 'part shape'
acting -true- on rule 1
part process is form process [certainty 1.00]
full testing rule 2 - targets: 'part'
  attempting to satisfy goal 'part edge/end preparation'
  getting a value from the user for part edge/end preparation
acting -true- on rule 2
part process is edge prep process [certainty 1.00]
full testing rule 3 - targets: 'part'
  attempting to satisfy goal 'part size'
  getting a value from the user for part size
acting -true- on rule 3
part process is cut process [certainty 1.00]
full testing rule 4 - targets: 'part'
  attempting to satisfy goal 'part size'
acting -false- on rule 4
full testing rule 5 - targets: 'part'
  attempting to satisfy goal 'part size'
acting -false- on rule 5
attempting to satisfy goal 'part edge prep method'
full testing rule 10 - targets: 'part' 'Flame Plane 1'
  attempting to satisfy goal 'part process'
  attempting to satisfy goal 'part length (ft)'
  getting a value from the user for part length (ft)
  attempting to satisfy goal 'Flame Plane 1 edge prep part length max (ft)'
  attempting to satisfy goal 'part width (ft)'
  getting a value from the user for part width (ft)
  attempting to satisfy goal 'Flame Plane 1 edge prep part width max (ft)'
  attempting to satisfy goal 'part depth (in)'
  getting a value from the user for part depth (in)
  attempting to satisfy goal 'Flame Plane 1 edge prep part depth max (in)'
acting -false- on rule 10
full testing rule 10 - targets: 'part' 'WC Plasma'
  attempting to satisfy goal 'part process'
  attempting to satisfy goal 'part length (ft)'
  attempting to satisfy goal 'WC Plasma edge prep part length max (ft)'
  attempting to satisfy goal 'part width (ft)'
  attempting to satisfy goal 'WC Plasma edge prep part width max (ft)'
  attempting to satisfy goal 'part depth (in)'
  attempting to satisfy goal 'WC Plasma edge prep part depth max (in)'
acting -false- on rule 10
full testing rule 10 - targets: 'part' 'edge planer'
  attempting to satisfy goal 'part process'
  attempting to satisfy goal 'part length (ft)'
  attempting to satisfy goal 'edge planer edge prep part length max (ft)'
  attempting to satisfy goal 'part width (ft)'
  attempting to satisfy goal 'edge planer edge prep part width max (ft)'
  attempting to satisfy goal 'part depth (in)'
  attempting to satisfy goal 'edge planer edge prep part depth max (in)'
  attempting to satisfy goal 'part max bevel angle required'
  getting a value from the user for part max bevel angle required
  attempting to satisfy goal 'edge planer Bevel Degrees Max'
  attempting to satisfy goal 'part thickness steel'
  full testing rule 7 - targets: 'part'
    attempting to satisfy goal 'part material'
    getting a value from the user for part material
acting -true- on rule 7
  attempting to satisfy goal 'part material thickness to be cut (in)'
  full testing rule 11 - targets: 'part'
    attempting to satisfy goal 'part type'
    getting a value from the user for part type
  acting -false- on rule 11
  full testing rule 12 - targets: 'part'
    attempting to satisfy goal 'part type'
  acting -true- on rule 12
  attempting to satisfy goal 'part depth (in)'
  attempting to satisfy goal 'part web thickness (in)'
  getting a value from the user for part web thickness (in)
part web h/l is 18.8 [certainty 1.00]
  attempting to satisfy goal 'part flange thickness (in)'
  getting a value from the user for part flange thickness (in)
part material thickness to be cut (in) is 1.315 [certainty 1.00]
part thickness steel is 1.315 [certainty 1.00]
  attempting to satisfy goal 'edge planer edge prep thickness max. steel (in)'
  attempting to satisfy goal 'part thickness alum'
  full testing rule 6 - targets: 'part'
    attempting to satisfy goal 'part material
    acting -false- on rule 6
    part thickness alum is 0 [certainty 1.00]
    part section modulus alum is 0 [certainty 1.00]
    attempting to satisfy goal 'edge planer edge prep thickness max. alum (in)'
    attempting to satisfy goal 'part max edge prep length (ft)'
    getting a value from the user for part max edge prep length (ft)
    attempting to satisfy goal 'edge planer edge prep length max (ft)'
    attempting to satisfy goal 'part bevel configuration'
    getting a value from the user for part bevel configuration
    attempting to satisfy goal 'edge planer bevel configuration'
  acting -true- on rule 10
  part edge prep method is edge planer [certainty 1.00]
  attempting to satisfy goal 'edge planer edge prep routing code'
  part edge prep routing code is P11 [certainty 1.00]
  attempting to satisfy goal 'edge planer edge prep location'
  part edge prep location is bay 2 [certainty 1.00]
  attempting to satisfy goal 'part edge prep location'
  attempting to satisfy goal 'part edge prep routing code'
  attempting to satisfy goal 'part cut location'
  full testing rule 8 - targets: 'part' 'drill #2'
    attempting to satisfy goal 'part process'
    attempting to satisfy goal 'part length (ft)'
    attempting to satisfy goal 'drill #2 cut part length max (ft)'
    attempting to satisfy goal 'part width (ft)'
    attempting to satisfy goal 'drill #2 cut part width max (ft)'
    attempting to satisfy goal 'part depth (in)'
    attempting to satisfy goal 'drill X2 cut part depth max (in)'
  acting -false- on rule 8
  full testing rule 8 - targets: 'part' '100 ton punch'
    attempting to satisfy goal 'part process'
    attempting to satisfy goal 'part length (ft)'
    attempting to satisfy goal '100 ton punch cut part length max (ft)'
    attempting to satisfy goal 'part width (ft)'
    attempting to satisfy goal '100 ton punch cut part width max (ft)'
  acting -false- on rule 8
  full testing rule 8 - targets: 'part' 'band saw'
    attempting to satisfy goal 'part process'
    attempting to satisfy goal 'part length (ft)'
    attempting to satisfy goal 'band saw cut part length max (ft)'
  acting -false- on rule 8
  full testing rule 8 - targets: 'part' 'contour band saw'
    attempting to satisfy goal 'part process'
    attempting to satisfy goal 'part length (ft)'
    attempting to satisfy goal 'contour band saw cut part length max (ft)'
  acting -false- on rule 8
  full testing rule 8 - targets: 'part' 'drill #1'
    attempting to satisfy goal 'part process'
    attempting to satisfy goal 'part length (ft)'
    attempting to satisfy goal 'drill #1 cut part length max (ft)'
    attempting to satisfy goal 'part width (ft)'
    attempting to satisfy goal 'drill #1 cut part width max (ft)'
    attempting to satisfy goal 'part depth (in)'
    attempting to satisfy goal 'drill #1 cut part depth max (in)'
  acting -false- on rule 8
  full testing rule 8 - targets: 'part' 'Flame Plane 1'
    attempting to satisfy goal 'part process'
    attempting to satisfy goal 'part length (ft)'
    attempting to satisfy goal 'Flame Plane 1 cut part length max (ft)'
    attempting to satisfy goal 'part width (ft)'
    attempting to satisfy goal 'Flame Plane 1 cut part width max (ft)'
    attempting to satisfy goal 'part depth (in)'
    attempting to satisfy goal 'Flame Plane 1 cut part depth max (in)'
  acting -false- on rule 8
  full testing rule 8 - targets: 'part' 'Flame Plane 2'
    attempting to satisfy goal 'part process'
    attempting to satisfy goal 'part length (ft)'
    attempting to satisfy goal 'Flame Plane 2 cut part length max (ft)'
    attempting to satisfy goal 'part width (ft)'
    attempting to satisfy goal 'Flame Plane 2 cut part width max (ft)'
    attempting to satisfy goal 'part depth (in)'
    attempting to satisfy goal 'Flame Plane 2 cut part depth max (in)'
  acting -false- on rule 8
  full testing rule 8 - targets: 'part' 'hydraulic band saw'
    attempting to satisfy goal 'part process'
    attempting to satisfy goal 'part length (ft)'
    attempting to satisfy goal 'hydraulic band saw cut part length max (ft)'
    attempting to satisfy goal 'part width (ft)'
    attempting to satisfy goal 'hydraulic band saw cut part width max (ft)'
    attempting to satisfy goal 'part depth (in)'
    attempting to satisfy goal 'hydraulic band saw cut part depth max (in)'
    attempting to satisfy goal 'part dimensions accuracy requirement (in)'
    getting a value from the user for part dimensions accuracy requirement (in)
    attempting to satisfy goal 'hydraulic band saw cut accuracy (in)

```

attempting to satisfy goal 'part thickness steel'  
 attempting to satisfy goal 'hydraulic band saw mart cut thickness max. steel (in)'  
 attempting to satisfy goal 'part thickness alum'  
 attempting to satisfy goal 'hydraulic band saw marl cut thickness max. alum (in)'  
 attempting to satisfy goal 'part hole cut diameter (in)'  
 getting a value from the user for part hole cut diameter (in)  
 attempting to satisfy goal 'hydraulic band saw hole diameter max (in)'  
 attempting to satisfy goal 'pad angle max var. from 90 deg'  
 getting a value from the user for part angle max var. from 90 deg  
 attempting to satisfy goal 'hydraulic band saw angle cut max (deg)'  
 attempting to satisfy goal 'part cut configuration'  
 getting a value from the user for part cut configuration  
 attempting to satisfy goal 'hydraulic band saw cut configuration'  
 attempting to satisfy goal 'part max cut length (ft)'  
 getting a value from the user for part max cut length (ft)  
 attempting to satisfy goal 'hydraulic band saw cut length max (ft)'  
 acting -true- on rule a  
 part cut method is hydraulic band saw [certainly 1.00]  
 attempting to satisfy goal 'hydraulic band saw cut routing code'  
 part cut routing code is sw2 [certainly 1.00]  
 attempting to satisfy goal 'hydraulic band saw cut location'  
 part cut location is bay 1 [certainly 1.00]  
 full testing rule a - targets: 'part N/C 2-Axis'  
 attempting to satisfy goal 'part process'  
 attempting to satisfy goal 'part length (ft)'  
 attempting to satisfy goal 'N/C OAxis cut part length max (ft)'  
 attempting to satisfy goal 'part width (ft)'  
 attempting to satisfy goal 'N/C PAxis cut part width max (ft)'  
 attempting to satisfy goal 'part depth (in)'  
 attempting to satisfy goal 'N/C 2-Axis cut part depth max (in)'  
 acting -false- on rule a  
 full testing rule 6 - targets: 'part N/C Plasma'  
 attempting to satisfy goal 'part process'  
 attempting to satisfy goal 'part length (ft)'  
 attempting to satisfy goal 'N/C Plasma cut part length max (ft)'  
 attempting to satisfy goal 'part width (ft)'  
 attempting to satisfy goal 'N/C Plasma cut part width max (ft)'  
 attempting to satisfy goal 'part depth (in)'  
 attempting to satisfy goal 'N/C Plasma cut part depth max (in)'  
 acting -false- on rule a  
 full testing rule 6 - targets: 'part shear'  
 attempting to satisfy goal 'part process'  
 attempting to satisfy goal 'part length (ft)'  
 attempting to satisfy goal 'shear cut part length max (ft)'  
 attempting to satisfy goal 'part width (ft)'  
 attempting to satisfy goal 'shear cut part width max (ft)'  
 attempting to satisfy goal 'part depth (in)'  
 attempting to satisfy goal 'shear cut part depth max (in)'  
 acting -false- on rule a  
 attempting to satisfy goal 'part cut routing code'  
 attempting to satisfy goal 'part cut method'  
 attempting to satisfy goal 'part forming location'  
 full testing rule 9 - targets: 'part 12 Foot Roll'  
 attempting to satisfy goal 'part process'  
 attempting to satisfy goal 'part length (ft)'  
 attempting to satisfy goal '12 Foot Roll forming part length max (ft)'  
 attempting to satisfy goal 'part width (ft)'  
 attempting to satisfy goal '12 Foot Roll forming part width max (ft)'  
 attempting to satisfy goal 'part depth (in)'  
 attempting to satisfy goal '12 Foot Roll forming part depth max (in)'  
 acting -false- on rule 9  
 full testing rule 9 - targets: 'part 250 Ton Press'  
 attempting to satisfy goal 'part process'  
 attempting to satisfy goal 'part length (ft)'  
 attempting to satisfy goal '250 Ton Press forming part length max (ft)'  
 attempting to satisfy goal 'part width (ft)'  
 attempting to satisfy goal '250 Ton Press forming part width max (ft)'  
 attempting to satisfy goal 'part depth (in)'  
 attempting to satisfy goal '250 Ton Press forming part depth max (in)'  
 acting -false- on rule 9  
 full testing rule 9 - targets: 'part 37.5 Ton Press'  
 attempting to satisfy goal 'part process'  
 attempting to satisfy goal 'part length (ft)'  
 attempting to satisfy goal '37.5 Ton Press forming part length max (ft)'  
 acting -false- on rule 9  
 full testing rule 9 - targets: 'part 60 Ton Cold Press'  
 attempting to satisfy goal 'part process'  
 attempting to satisfy goal 'part length (ft)'  
 attempting to satisfy goal '60 Ton Cold Press forming part length max (ft)'  
 attempting to satisfy goal 'part width (ft)'  
 attempting to satisfy goal '60 Ton Cold Press forming part width max (ft)'  
 attempting to satisfy goal 'part depth (in)'  
 attempting to satisfy goal '60 Ton Cold Press forming part depth max (in)'  
 attempting to satisfy goal 'part roll radius accuracy requirement (in)'  
 getting a value from the user for part roll radius accuracy requirement (in)  
 attempting to satisfy goal '60 Ton Cold Press form accuracy (in. radius)'  
 acting -false- on rule 9  
 full testing rule 9 - targets: 'part 600 Ton Press'  
 attempting to satisfy goal 'part process'

attempting to satisfy goal 'part length (ft)'  
 attempting to satisfy goal '600 Ton Press forming part length max (ft)'  
 attempting to satisfy goal 'part width (ft)'  
 attempting to satisfy goal '600 Ton Press forming part width max (ft)'  
 attempting to satisfy goal 'part depth (in)'  
 attempting to satisfy goal '600 Ton Press forming part depth max (in)'  
 acting -false- on rule 9  
 full testing rule 9 - targets: 'part Brake Press'  
 attempting to satisfy goal 'part process'  
 attempting to satisfy goal 'part length (ft)'  
 attempting to satisfy goal 'Brake Press forming part length max (ft)'  
 attempting to satisfy goal 'part width (ft)'  
 attempting to satisfy goal 'Brake Press forming part width max (ft)'  
 attempting to satisfy goal 'part depth (in)'  
 attempting to satisfy goal 'Brake Press forming part depth max (in)'  
 acting -false- on rule 9  
 full testing rule 9 - targets: 'part 1500 Ton Press'  
 attempting to satisfy goal 'part process'  
 attempting to satisfy goal 'part length (ft)'  
 attempting to satisfy goal '1500 Ton Press forming part length max (ft)'  
 attempting to satisfy goal 'part width (ft)'  
 attempting to satisfy goal '1500 Ton Press forming part width max (ft)'  
 attempting to satisfy goal 'part depth (in)'  
 attempting to satisfy goal '1500 Ton Press forming part depth max (in)'  
 attempting to satisfy goal 'part roll radius accuracy requirement (in)'  
 attempting to satisfy goal '1500 Ton Press form accuracy (in. radius)'  
 acting -false- on rule 9  
 full testing rule 9 - targets: 'part 2000 Ton Roll'  
 attempting to satisfy goal 'part process'  
 attempting to satisfy goal 'part length (ft)'  
 attempting to satisfy goal '2000 Ton Roll forming part length max (ft)'  
 attempting to satisfy goal 'part width (ft)'  
 attempting to satisfy goal '2000 Ton Roll forming part width max (ft)'  
 attempting to satisfy goal 'part depth (in)'  
 attempting to satisfy goal '2000 Ton Roll forming part depth max (in)'  
 acting -false- on rule 9  
 full testing rule 9 - targets: 'part Frame Bender'  
 attempting to satisfy goal 'part process'  
 attempting to satisfy goal 'part length (ft)'  
 attempting to satisfy goal 'Frame Bender forming part length max (ft)'  
 attempting to satisfy goal 'part width (ft)'  
 attempting to satisfy goal 'Frame Bender forming part width max (ft)'  
 attempting to satisfy goal 'part depth (in)'  
 attempting to satisfy goal 'Frame Bender forming part depth max (in)'  
 attempting to satisfy goal 'part roll radius accuracy requirement (in)'  
 attempting to satisfy goal 'Frame Bender form accuracy (in. radius)'  
 attempting to satisfy goal 'part section modulus sleet'  
 full testing rule 7 - targets: 'part'  
 attempting to satisfy goal 'part material'  
 acting -true- on rule 7  
 attempting to satisfy goal 'part marl thickness to be cut (in)'  
 getting a value from the user for part section modulus steel  
 attempting to satisfy goal 'Frame Bender section modulus max. steel (in\*3)'  
 attempting to satisfy goal 'part section modulus alum'  
 attempting to satisfy goal 'Frame Bender section modulus max. alum (in\*3)'  
 attempting to satisfy goal 'part outside radius (in)'  
 getting a value from the user for part outside radius (in)  
 attempting to satisfy goal 'Frame Bender outside radius min (in)'  
 attempting to satisfy goal 'part roll degrees'  
 getting a value from the user for part roll degrees  
 attempting to satisfy goal 'Frame Bender Roll Degrees Max'  
 attempting to satisfy goal 'part web hi?'  
 attempting to satisfy goal 'Frame Bender web M max'  
 acting -true- on rule 9  
 part forming method is Frame Bender [certainly 1.00]  
 attempting to satisfy goal 'Frame Bender forming routing code'  
 part forming routing code is pr5 [certainly 1.00]  
 attempting to satisfy goal 'Frame Bender forming location'  
 part forming location is bay 1 [certainly 1.00]  
 attempting to satisfy goal 'part forming routing code'  
 attempting to satisfy goal 'part forming method'  
 - - - forward inference - - -  
 the part process  
 is cul process [certainly 1.00]  
 is edge prep process [certainly 1.001]  
 is form process [certainly 1.001]  
 the part edge prep method  
 is edge planer [certainly 1.00]  
 the part edge prep location  
 is bay 2 [certainly 1.001]  
 the part edge prep routing code  
 is pll [certainly 1.00]



the part cut location  
 is bay 1 [certainty 1.00]

the part cut routing code  
 is sw2 [certainty 1.00]

the part cut method  
 is hydraulic band saw [certainty 1.001]

the part forming location  
 is bay 1 [certainty 1.001]

the part forming routing code  
 is pr5 [certainty 1.001]

the part forming method  
 is Frame Bender [certainty 1.00]

getting a value from the user for part bevel configuration  
 attempting to satisfy goal 'edge planer bevel configuration'  
 acting-true- on rule 10

part edge prep method is edge planer [certainty 1.00]  
 attempting to satisfy goal 'edge planer edge prep routing code'  
 part edge prep routing code is p11 [certainty 1.00]  
 attempting to satisfy goal 'edge planer edge prep location'  
 part edge prep location is bay 2 [certainty 1.00]  
 full testinagrule 10 - targets: 'part' 'Flame Plane 1'  
 attempting to satisfy goal 'part process'  
 attempting to satisfy goal 'part length (ft)'  
 attempting to satisfy goal 'Flame Plane 1 edge prep part length max (ft)'  
 attempting to satisfy goal 'part width (ft)'  
 attempting to satisfy goal 'Flame Plane 1 edge prep part width max (ft)'  
 attempting to satisfy goal 'part depth (in)'  
 attempting to satisfy goal 'Flame Plane 1 edge prep part depth max (in)'  
 attempting to satisfy goal 'part max bevel angle required'  
 attempting to satisfy goal 'Flame Plane 1 Bevel Degrees Max'  
 attempting to satisfy goal 'part thickness steel'  
 attempting to satisfy goal 'flame Plane 1 edge prep thickness max. steel (in)'  
 attempting to satisfy goal 'part thickness alum'  
 attempting to satisfy goal 'Flame Plane 1 edge prep thickness max. alum (in)'  
 attempting to satisfy goal 'part max edge prep length (ft)'  
 attempting to satisfy goal 'flame Plane 1 edge prep length max (ft)'  
 attempting to satisfy goal 'part bevel configuration'  
 attempting to satisfy goal 'Flame Plane 1 bevel configuration'  
 acting -false- on rule 10

full testing rule 10 - targets 'part' 'N/C Plasma'  
 attempting to satisfy goal 'part process'  
 attempting to satisfy goal 'part length (ft)'  
 attempting to satisfy goal 'N/C plasma edge prep part length max (ft)'  
 attempting to satisfy goal 'part width (ft)'  
 attempting to satisfy goal 'part Plasma edge prep part width max (ft)'  
 attempting to satisfy goal 'part depth (in)'  
 attempting to satisfy goal 'N/C Plasma edge prep part depth max (in)'  
 attempting to satisfy goal 'part max bevel angle required'  
 attempting to satisfy goal 'N/C Plasma Bevel Degrees Max'  
 attempting to satisfy goal 'part thickness steel'  
 attempting to satisfy goal 'WC Plasma edge prep thickness max. steel (in)'  
 attempting to satisfy goal 'part thickness alum'  
 attempting to satisfy goal 'N/C Plasma edge prep thickness max. alum (in)'  
 attempting to satisfy goal 'part max edge prep length (ft)'  
 attempting to satisfy goal 'N/C Plasma edge prep length max (ft)'  
 attempting to satisfy goal 'part bevel configuration'  
 attempting to satisfy goal 'WC Plasma bevel configuration'  
 acting -true- on rule 10

part edge prep method is NE Plasma [certainty 1.00]  
 attempting to satisfy goal 'N/C Plasma edge prep routing code'  
 part edge prep routing code is br2 [certainty 1.00]  
 attempting to satisfy goal 'WC Plasma edge prep lodrion'  
 part edge prep location is bay 3 [certainty 1.00]  
 attempting to satisfy goal 'part edge prep location'  
 attempting to satisfy goal 'part edge prep routing code'  
 attempting to satisfy goal 'part cut location'  
 full testing rule a - targets 'part' 'drill #2'  
 attempting to satisfy goal 'part process'  
 attempting to satisfy goal 'part length (ft)'  
 attempting to satisfy goal 'drill #2 cut part length max (ft)'  
 attempting to satisfy goal 'part width (ft)'  
 attempting to satisfy goal 'drill #2 cut part width max (ft)'  
 attempting to satisfy goal 'part depth (in)'  
 attempting to satisfy goal 'drill #2 cut part depth max (in)'  
 attempting to satisfy goal 'part cut dimensions accuracy requirement (in)'  
 getting a value from the user for part cut dimensions accuracy requirement (in)'  
 attempting to satisfy goal 'drill #2 cut accuracy (in)'  
 attempting to satisfy goal 'part thickness steel'  
 attempting to satisfy goal 'drill #2 man cut thickness max. steel (in)'  
 attempting to satisfy goal 'part thickness alum'  
 attempting to satisfy goal 'drill man cut thickness max. alum (in)'  
 attempting to satisfy goal 'part hole cut diameter (in)'  
 getting a value from the user for part hole cut diameter (in)'  
 attempting to satisfy goal 'drill #2 hole diameter max (in)'  
 acting -false- on rule a

full testing rule 8 - largest 'Part '100 ton punch'  
 attempting to satisfy goal 'part process'  
 attempting to satisfy goal 'part length (ft)'  
 attempting to satisfy goal '100 ton punch cut part length max (ft)'  
 attempting to satisfy goal 'part width (ft)'  
 attempting to satisfy goal '100 ton punch cut part width max (ft)'  
 acting -false- on rule a

full testing rule 8 - targets: 'part' 'band saw'  
 attempting to satisfy goal 'part process'  
 attempting to satisfy goal 'part length (ft)'  
 attempting to satisfy goal 'band saw cut part length max (ft)'  
 acting -false- on rule 8

full testing rule 8 - targets: 'part' 'contour band saw'  
 attempting to satisfy goal 'part process'  
 attempting to satisfy goal 'part length (ft)'  
 attempting to satisfy goal 'contour band saw cut part length max (ft)'  
 acting -false- on rule a

\*\*\*\*\* CONCLUSIONS \*\*\*\*\*

System Listing of Inference Process  
 Part #2

--- backward inference (all goals) ---  
 attempting to satisfy goal 'part process'  
 full testing rule 1 - targets: 'part'  
 attempting to satisfy goal 'part shape'  
 getting a value from the user for part shape  
 attempting to satisfy goal 'part shape'  
 acting -unknown- on rule 1  
 full testing rule 2 - targets: 'part'  
 attempting to satisfy goal 'part edgelen preparation'  
 getting a value from the user for part edgelen preparation  
 acting -true- on rule 2

part process is edge prep process [certainty 1.00]  
 full testing rule 3 - targets: 'part'  
 attempting to satisfy goal 'part size'  
 getting a value from the user for part size  
 acting -true- on rule 3

part process is cut process [certainty 1.001]  
 full testing rule 4 - targets: 'part'  
 attempting to satisfy goal 'part size'  
 acting -false- on rule 4

full testing rule 5 - targets: 'part'  
 attempting to satisfy goal 'part size'  
 acting -false- on rule 5

attempting to satisfy goal 'part edge prep method'  
 full testing rule 10 - targets: 'part' 'edge planer'  
 attempting to satisfy goal 'part process'  
 attempting to satisfy goal 'part length (ft)'  
 getting a value from the user for part length (ft)  
 attempting to satisfy goal 'edge planer edge prep part length max (ft)'  
 attempting to satisfy goal 'part width (ft)'  
 getting a value from the user for part width (ft)  
 attempting to satisfy goal 'edge planer edge prep part width max (ft)'  
 attempting to satisfy goal 'part depth (in)'  
 getting a value from the user for part depth (in)  
 attempting to satisfy goal 'edge planer edge prep part depth max (in)'  
 attempting to satisfy goal 'part max bevel angle required'  
 getting a value from the user for part max bevel angle required  
 attempting to satisfy goal 'edge planer Bevel Degrees Max'  
 attempting to satisfy goal 'part thickness steel'  
 full testing rule 7 - targets: 'part'  
 attempting to satisfy goal 'part material'  
 getting a value from the user for part material  
 acting -true- on rule 7

attempting to satisfy goal 'part matl thickness to be cut (in)'  
 full testing rule 11 - targets: 'part'  
 attempting to satisfy goal 'part type'  
 getting a value from the user for part type  
 acting -true- on rule 11

part web h/t = 0 [certainty 1.00]  
 attempting to satisfy goal 'part depth (in)'  
 part matl thickness to be cut (in) is .75 [certainty 1.00]  
 full testing rule 12 - targets: 'part'  
 attempting to satisfy goal 'part type'  
 acting -false- on rule 12

part thickness steel is .75 [certainty 1.00]  
 attempting to satisfy goal 'edge planer edge prep thickness max. steel (in)'  
 attempting to satisfy goal 'part thickness alum'  
 full testing rule 6 - targets: 'part'  
 attempting to satisfy goal 'part material'  
 acting -false- on rule 6

part thickness alum = 0 [certainty 1.00]  
 part section modulus alum = 0 [certainty 1.00]  
 attempting to satisfy goal 'edge planer edge prep thickness max. alum (in)'  
 attempting to satisfy goal 'part max edge prep length (ft)'  
 getting a value from the user for part max edge prep length (ft)  
 attempting to satisfy goal 'edge planer edge prep length max (ft)'  
 attempting to satisfy goal 'part bevel configuration'



acting -false- on rule 9  
full testing rule 9 - targets: 'part' 'Brake Press'  
  attempting to satisfy goal 'part process'  
acting -false- on rule 9  
full testing rule 9 - targets: 'part' 'Frame Bender'  
  attempting to satisfy goal 'part process'  
acting -false- on rule 9  
full testing rule 9 - targets: 'Part' '1500 Ton Press'  
  attempting to satisfy goal 'part process'  
acting -false- on rule 9  
full testing rule 9 - targets: 'part' '2000 To" Roll'  
  attempting to satisfy goal 'part process'  
acting -false- on rule 9  
- - - forward inference - - -

..... CONCLUSIONS .....

the part process  
  is cut process [certainty 1.00]  
  is edge prep process [certainty 1.00]

the part edge prep method  
  is N/C Plasma [certainty 1.00]  
  is edge planer [certainty 1.00]

the part edge prep location  
  is bay 3 [certainty 1.00]  
  is bay 2 [certainty 1.00]

the part edge prep routing code  
  is br2 [certainty 1.00]  
  is pl1 [certainty 1.00]

the part cut location  
  is bay 3 [certainty 1.00]

the part cut routing cods  
  is br2 [certainty 1.00]  
  is br1 [certainty 1.00]

the part cut method  
  is N/C Plasma [certainty 1.00]  
  is N/C 2-Axis [certainty 1.00]

the part forming location  
(no values)

the part forming routing code  
(no values)

the part forming method  
(no values)

..... CONCLUSIONS .....

Additional copies of this report can be obtained from the  
National Shipbuilding Research and Documentation Center:

**<http://www.nsnet.com/docctr/>**

Documentation Center  
The University of Michigan  
Transportation Research Institute  
Marine Systems Division  
2901 Baxter Road  
Ann Arbor, MI 48109-2150

Phone: 734-763-2465  
Fax: 734-936-1081  
E-mail: [Doc.Center@umich.edu](mailto:Doc.Center@umich.edu)