

SHIP PRODUCTION COMMITTEE
FACILITIES AND ENVIRONMENTAL EFFECTS
SURFACE PREPARATION AND COATINGS
DESIGN/PRODUCTION INTEGRATION
HUMAN RESOURCE INNOVATION
MARINE INDUSTRY STANDARDS
WELDING
INDUSTRIAL ENGINEERING
EDUCATION AND TRAINING

September 1992
NSRP 0383

THE NATIONAL SHIPBUILDING RESEARCH PROGRAM

1992 Ship Production Symposium Proceedings

Paper No. 3A2: The First of a Class - Production of Large Military FRP Displacement Hulls

U.S. DEPARTMENT OF THE NAVY
CARDEROCK DIVISION,
NAVAL SURFACE WARFARE CENTER

Report Documentation Page

Form Approved
OMB No. 0704-0188

Public reporting burden for the collection of information is estimated to average 1 hour per response, including the time for reviewing instructions, searching existing data sources, gathering and maintaining the data needed, and completing and reviewing the collection of information. Send comments regarding this burden estimate or any other aspect of this collection of information, including suggestions for reducing this burden, to Washington Headquarters Services, Directorate for Information Operations and Reports, 1215 Jefferson Davis Highway, Suite 1204, Arlington VA 22202-4302. Respondents should be aware that notwithstanding any other provision of law, no person shall be subject to a penalty for failing to comply with a collection of information if it does not display a currently valid OMB control number.

1. REPORT DATE SEP 1992	2. REPORT TYPE N/A	3. DATES COVERED -	
4. TITLE AND SUBTITLE The National Shipbuilding Research Program, 1992 Ship Production Symposium Proceedings, Paper No. 3A-2: The First of a Class - Production of Large Military FRP Displacement Hulls		5a. CONTRACT NUMBER	
		5b. GRANT NUMBER	
		5c. PROGRAM ELEMENT NUMBER	
6. AUTHOR(S)		5d. PROJECT NUMBER	
		5e. TASK NUMBER	
		5f. WORK UNIT NUMBER	
7. PERFORMING ORGANIZATION NAME(S) AND ADDRESS(ES) Naval Surface Warfare Center CD Code 2230-Design Integration Tools Bldg 192, Room 128 9500 MacArthur Blvd, Bethesda, MD 20817-5000		8. PERFORMING ORGANIZATION REPORT NUMBER	
9. SPONSORING/MONITORING AGENCY NAME(S) AND ADDRESS(ES)		10. SPONSOR/MONITOR'S ACRONYM(S)	
		11. SPONSOR/MONITOR'S REPORT NUMBER(S)	
12. DISTRIBUTION/AVAILABILITY STATEMENT Approved for public release, distribution unlimited			
13. SUPPLEMENTARY NOTES			
14. ABSTRACT			
15. SUBJECT TERMS			
16. SECURITY CLASSIFICATION OF:			17. LIMITATION OF ABSTRACT SAR
a. REPORT unclassified	b. ABSTRACT unclassified	c. THIS PAGE unclassified	
19a. NAME OF RESPONSIBLE PERSON			

DISCLAIMER

These reports were prepared as an account of government-sponsored work. Neither the United States, nor the United States Navy, nor any person acting on behalf of the United States Navy (A) makes any warranty or representation, expressed or implied, with respect to the accuracy, completeness or usefulness of the information contained in this report/manual, or that the use of any information, apparatus, method, or process disclosed in this report may not infringe privately owned rights; or (B) assumes any liabilities with respect to the use of or for damages resulting from the use of any information, apparatus, method, or process disclosed in the report. As used in the above, "Persons acting on behalf of the United States Navy" includes any employee, contractor, or subcontractor to the contractor of the United States Navy to the extent that such employee, contractor, or subcontractor to the contractor prepares, handles, or distributes, or provides access to any information pursuant to his employment or contract or subcontract to the contractor with the United States Navy. ANY POSSIBLE IMPLIED WARRANTIES OF MERCHANTABILITY AND/OR FITNESS FOR PURPOSE ARE SPECIFICALLY DISCLAIMED.

THE NATIONAL SHIPBUILDING RESEARCH PROGRAM

1992 SHIP PRODUCTION SYMPOSIUM

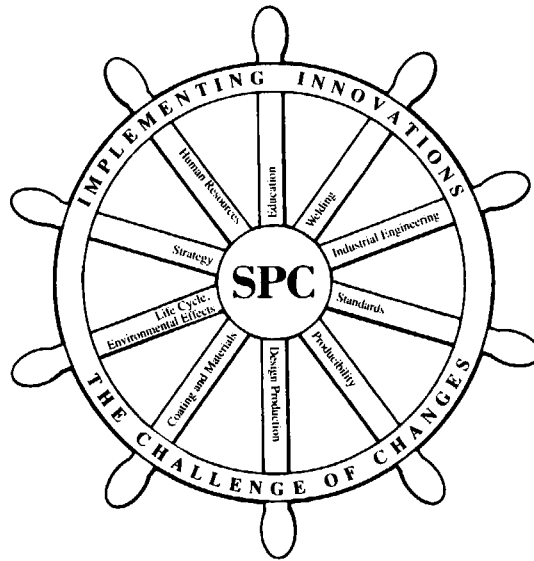

SEPTEMBER 2 - 4, 1992
New Orleans Hyatt Regency
NEW ORLEANS, LOUISIANA

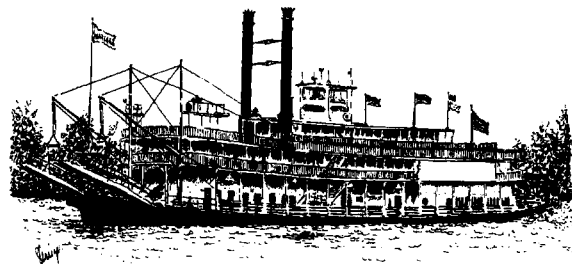

SPONSORED BY THE SHIP PRODUCTION COMMITTEE
AND HOSTED BY THE GULF SECTION OF
THE SOCIETY OF NAVAL ARCHITECTS AND MARINE ENGINEERS



THE SOCIETY OF NAVAL ARCHITECTS AND MARINE ENGINEERS
601 PAVONIA AVENUE, JERSEY CITY, NJ 07306

paper presented at the NSRP 1992 SHIP PRODUCTION Symposium, New Orleans Hyatt Regency, New Orleans, Louisiana, September 2-4, 1992

The First of a Class: Production of Large Military FRP Displacement Hulls

No. 3A-2

Bryant Bernhard, Member, Swiftships Inc.

ABSTRACT

The production of large FRP vessels for military missions is underway in shipyards throughout the United States. These vessels, in many cases, can be built to commercial standards using guidelines already in place. These guidelines are developed through interfaces with private industry and experienced production personnel. By binding the builder to a set of military specifications which detail the entire production process the vessel cost of construction is increased.

Commercial production process are practiced, which may not meet current standard Navy specification requirements, but produce a superior laminate quality. The Navy and industry can work in concert to produce a military procurement process which will allow builders to remain flexible enough in their production processes to continue to improve quality and efficiency. This can be accomplished through eliminating details of processes and parameterizing specifications to focus on laminate result:;

INTRODUCTION

Swiftships, Inc., a builder of primarily aluminum and steel vessels was awarded a foreign military sales contract for the construction of two 29 meter (90 ft) fiberglass reinforced plastic Route Survey Vessels. This contract initiated construction of the first large FRP hulled vessel to be constructed by Swiftships. The major structural attributes of this twin screw trawler type vessel are single skin FRP hull of vinyl ester resin with E-glass reinforcement fitted with aluminum decks and superstructure.

This series of vessels is to be constructed for the Republic of Egypt for use as a Route Survey Vessel (RSV) for recording the underwater

configuration of the coastal routes of Egypt. The contract was awarded with a Navy specification executed by the Supervisor of Shipbuilding, Conversion and Repair of New Orleans, LA.

Historical Development

The basic design of the RSV was established during a design contract prior to the issuance of the construction contract. The hull design and outfitting for ship services were based on the premise that standard commercial practices were to be used in the construction of these vessels to reduce the vessel cost in comparison to a standard Navy, military specification, driven combatant.

In following this idea, a commercial trawler mold was selected for the hull shape. The scantlings were designed to American Bureau of Shipping (ABS) Standards, but mission critical electronics and systems were tightly held to standard military specifications.

Vinyl ester resin was chosen as the FRP matrix with E-glass reinforcement due to its superior resistance to seawater absorption and blistering compared to more widely used polyester resin systems. The upgrade to vinyl ester resin is viewed as a long term quality and longevity investment for the RSV hull and structure which should offset the initial construction cost increase.

Although vinyl ester resins exhibit superior material properties in the laminates than do typical polyester resin systems, these properties were not taken advantage of in the scantling design calculations, as the hull was designed and reviewed based upon polyester resin system material properties as defined by ABS Rules for Building and Classing Glass Reinforced Plastic Vessels (ref. 1). The resulting over design is viewed by the

builder as an increased factor of safety on the hull.

Agenda

The contract was embarked upon in the typical fashion with the exception of one variation. The first order of business was to procure a lamination facility and tools, and obtain personnel to perform the hull layup.

The aluminum portion of the vessel was constructed simultaneously with the hull and joined upon completion of the two parts. A maximum amount of pre-outfitting was performed to minimize the welding around and above the FRP hull and to reduce the production costs.

An experienced subcontractor's crew was retained to perform the actual hull and scantling lamination to minimize the effects of the variables associated with the experience curve typically imposed upon a first time endeavor.

MATERIALS TECHNOLOGY

Material Properties

Due to the nature of vinyl ester resin systems laminated in large panels, as is required to produce a 29 meter (90 ft.) hull, the allowable "quality deficiencies" defined by typical Navy specifications, developed for smaller FRP hulls was not practical. Both the builder and the Navy were taken to task in the start up of the hull lamination process acceptance panels. Although the panels typically exhibited far superior physical strength properties and very low void contents (see Table 1), the panels were rejected due to the following requirement in the specification.

TEST	SPECIFICATION REQUIREMENT	TEST PANEL	PROCESS CONTROL PANEL
FLEXURAL STRENGTH	24 ksi min.	58.8 ksi	59.6 ksi
Flexural Modulus	1x10⁶ psi min.	2.4x10 ⁶	2.5x10⁶
Tensile Strength	22 ksi min.	33 ksi	37 ksi
Interlam. Shear	1.0 ksi min.	6.95 ksi	7.28 ksi
Resin Content	50-60 %	57.1 %	58.7 %
Void Content	Less than 4 %	>0.5 %	>0.5%

TABLE 1

"There shall be no voids extending through more than one ply of laminate.

There shall be no voids larger than 1/2 inch in their greatest dimension.

There shall be no more than one void larger than 1/8 inch in its greatest dimension for each ply of laminate in any 6 inch by 6 inch area; with a maximum of six in any 6 inch by 6 inch area. There shall be no more than three voids larger than 1/8 inch in their greatest dimension for each ply of laminate in any 12 inch by 12 inch area; with a maximum of 20 in any 12 inch by 12 inch area.

Laminate void content shall not exceed four percent."

After testing by the builder and evidence supporting the superiority of a laminate with occasional 1.27 cm (1/2 inch) voids to the requirements of ABS and the Navy, a deviation was accepted to change the allowable void distribution to the following:

"There shall be no voids extending through more than one ply of laminate.

There shall be no voids larger than 1/2 inch in their greatest dimension. Laminate void content shall not exceed four percent."

These revised requirements are more in keeping with standard commercial practices per the intent of the contract.

The second hurdle which confronted the builder was the definition of secondary vs. primary bond. The Navy specification states that the entire hull, excluding doublers and structure, which averages some 16 layers, must be laid up as a primary bond. A primary bond was defined such that the lamination of the subsequent layer must be performed prior to 24 hours elapsed time from the catalization of the previous laminate. This stipulates all exposed layers of the hull, some 464.5 sq. meters (5000 sq. ft.) each, must be laminated upon every 24 hours. Considering the void restrictions from above, all 1.27 cm (1/2 inch) voids and greater on the previously laminated layer must be repaired in the same 24 hour time frame. Continuous hull lamination was virtually impossible, and certainly impractical.

The driving force behind the primary/secondary bond issue was the supposition that after a laminate cure of 24 hours, a subsequent laminate polymer bond would not be initiated with the previous laminate. This

caused a lower interlaminar shear strength value in the final matrix. This phenomena is due primarily to the lack of continuation in the polymer chain reaction exhibited most frequently in general purpose (GP) or polyester resin systems.

In vinyl ester systems, the polymer chains are typically less effected by the cure time from laminate to laminate and will in fact bond very well between laminates laid upon each other after the initial layer has cured and exhibits barcol hardnesses of over 50. Barcol hardness is generally considered an indication of the level of resin cure.

The builder conducted research and testing, with the guidance of Supervisor of Shipbuilding, New Orleans, which exhibited minimal loss in interlaminar shear strength in vinyl ester laminates made with up to seven days elapsed between laminations (See fig. 1). In view of the evidence, the Navy accepted a deviation allowing the definition of secondary bond to be extended from 24 hours to a five day interval.

Interlaminar Shear Bond Test Results

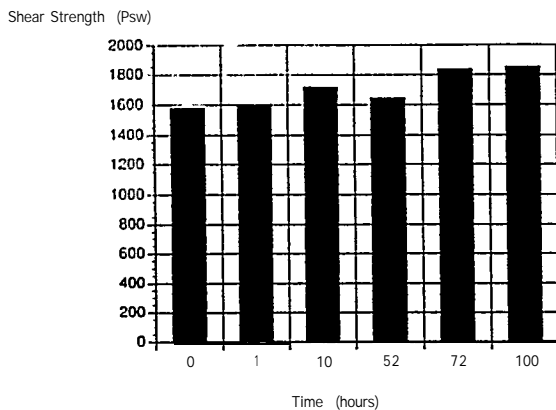

Figure 1

PRODUCTION TECHNOLOGY

Some restrictions present when laminating FRP structures include environmental control (temperature, humidity, and cleanliness) and materials handling and preparation. The environmental issues are taken to a grand scale when a shipyard is required

to control temperature, humidity, and dust in a production facility around and inside a 30 meter (100 ft.) mold.

A single facility was chosen to produce the hull as well as fabricate and assemble all other FRP parts including bulkheads, foundations, battery boxes, etc. The environmental issue was easily solved in the areas of temperature and humidity by the addition of a Heating, Ventilation and Air Conditioning (HVAC) system and insulation in the building. All electrical boxes and tools were made spark proof to eliminate the hazard of explosion during the spraying of polyvinyl alcohol in the mold, to aid in hull release from the mold, or ignition of the styrene vapors omitted during lamination.

The most labor intensive portion of environmental control during production was the elimination of the dust caused during the nightly grinding of the laminate laid during the day. The laminate would be ground nightly to expose voids needing repairs and to assure a smooth, uniform surface for the next laminate. This was necessary to eliminate the possibility of bridging which could be caused by lamination over rough areas. Any evidence of ground fiberglass or resin dust on the surface to be laminated was quickly acted upon by the Quality Assurance (QA) inspectors and resulted in a hold on production until the area could be vacuumed clean of the "foreign matter." The excessive grinding and cleaning was beyond the normal requirements present in a commercial fiberglass facility.

To reduce the surface area which had to be ground nightly, a solution to grinding every layer was required. Laminate production was re-scheduled to lay the boat in sections with a two to three pair "shingle" lay up employed to reduce the cured surface area (See fig. 2). Since all laminate overlaps were to be no less than 5 cm (2 inches), and

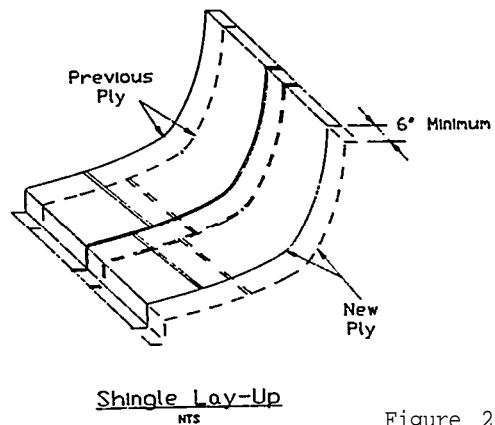

Figure 2

five pairs wet on wet is the maximum wet thickness recommended by the resin manufacturer to avoid excessive exotherm at the promoted level, three pairs wet on wet shingle was the thickest local laminate used.

Tied to the exotherm and number of wet on wet pairs variable was the promotional and catalization levels used to get the gel results from catalyst and promoter. The gel time of the resin used in the impregnator ideally should be long to avoid resin from gelling in the impregnator. Both the gel results and promotional system should be long and cold for the introduction of multiple layers of laminate on the work surface to avoid excessive exotherm. The gel time for lamination on vertical surfaces, which was the majority of a boat hull, should be short to prevent the resin from running out of the material as it stands on the hull sides.

Alternatively, a thixotrope agent can be added to the resin to retard run out, but it has adverse effects on the workability of the resin, again causing voids.

A compromise to the catalyst/promoter/ thixotrope ratio dilemma was reached which allowed the impregnator to keep from gelling up, the resin to adhere to the material until gelling and the laminate build up to be sufficient to reduce the necessary grinding and cleaning.

Education

Education of the builder, Supships and the Navy, in material properties was a great obstacle in the final acceptance of the lamination process prior to production of the first hull. Although the LPD was deemed acceptable by ADS for commercial standards. The Navy was educated in allowable quality characteristics to judge the acceptability of laminates and the material properties of laminates made using the builders production system.

The builder was educated in the fine tuning of resin systems, their catalyst ratios required for the impregnator versus the flow coater, the impregnator settings and speeds to achieve the required glass/resin ratios. Testing was also performed prior to hull layup to determine the material configuration acceptable in receiving rolls of woven roving/mat material so it would properly operate in an impregnator, and finding the proper promotional levels for the resin system in conjunction with various materials.

The impregnator was an indispensable tool to lay up a large vessel and was especially valuable in the lamination of large panels such as decks and bulkheads. The impregnator system has been used very successfully by builders such as Westport Shipyards for hard chine planing craft with few non-developable surfaces and also proved to be quite successful in the

TOOLS AND HARDWARE

The Use of Impregnating Systems

For the hull layup, an impregnator was used to lay a large volume of laminate to meet the primary bond parameters and to create a highly uniform laminate quality. A seven roll impregnator (ref. 2) was used to impregnate the material before it was laid to the mold and rolled and squeegeed into place.

The seven roll impregnator wets the material in the bath then presses the material through a series of rollers to insure proper bundle impregnation. The final set of rollers, with a micrometer clearance adjustment, squeezes the excess resin from the laminate to achieve the proper glass/resin ratio (See fig. 3).

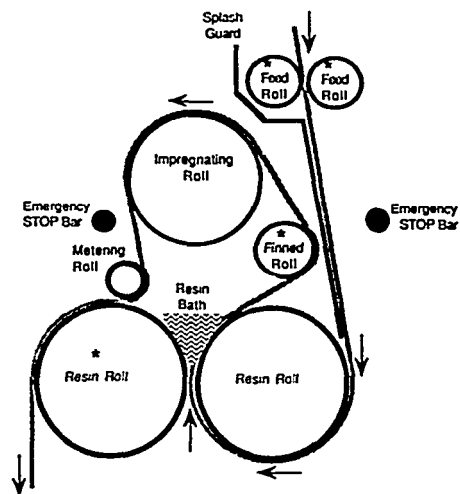

Note: Rolls marked by a * are motor driven.

VENUS-GUSMER'S NEW SEVEN-ROLL IMPREIGNATOR

Figure 3

HULL & SUPERSTRUCTURE PRODUCTION

Mold verification

Since the vessel was constructed using modular ship production techniques, the accuracy of the plans, lines and offsets were paramount. Unfortunately the mold used in the hull production was in existence prior to the RSV conception and the set of lines delivered with the mold were inaccurate. Although the complete contract design package was based upon an inaccurate set of lines, the hydrostatics and arrangements were virtually unaffected. The only portion of the design package that was truly impacted by minor variations in the mold geometry was the interface between modules, such as the hull and deck.

As the unmolded inside surface of the hull was uneven, due to the laps between adjacent layers of laminate, the inside dimension of the hull at deck edge could only be approximated, even after painstaking verification of the mold half breadths. This necessitated a hull/deck joint which would allow the required margins and excess in the deck (ref. 4). The deck joint as defined during the contract design stage was well suited for allowing excess. This joint will be discussed more extensively later.

Mold verification is a very important step in the design spiral and should be performed as early as possible in the production process. Slight variations in lines fairing have much smaller effects on naval architectural and systems engineering endeavors than on production engineering.

Mold & Laminate Materials Preparation

Before beginning the actual hull lamination, the mold had to be leveled both athwartships and longitudinally based upon the design weight and trim estimate. This task was accomplished by shooting the 1 meter (3 feet), 2 meter (6 feet) and 3 meter (9 feet) buttocks with a transit at each of the ten stations. Since the hull consists of only curved surfaces with no hard chines, and the lines were known to be inaccurate, the buttock lines were plotted against the existing lines to determine the actual declivity of the mold as it set on the supports and then leveled symmetrically athwartships.

Several benchmarks were then etched into the mold top and their relative heights, breadths and diagonals were recorded for resetting the mold after removal of the first

hull prior to the lamination of subsequent hulls.

After the mold configuration was verified, the 2.44 meter (8 ft.) waterline was marked with 7.62 cm (3 inch) wax fillets on 3.66 meter (10 ft) centers, and at the port and starboard forward and aft perpendiculars. These fillets would define the hull trim and list when removed from the mold.

Prior to gelcoat the mold surface was prepared in the usual way by applying several coats of wax and a thin coat of Poly vinyl alcohol (PVA).

The laminate materials were kept in a dehumidified storage facility for ten days prior to use to eliminate the risk of moisture contamination affecting the sizing of the laminate. This assured proper resin wetting and bonding. The temperature of the material was kept a minimum of 1°C (2° F) above the ambient temperature at a humidity of less than sixty percent to avoid condensation on the material after removal from dehumidified storage.

During the hull production process preparation of laminate laid prior to subsequent layup included complete sanding of the surface to remove any roughness which could cause bridging and voids. After sounding, repairs were made by grinding out the laminate containing the 1.27 cm (1/2 inch) or greater void using a minimum of twelve to one scarf. The laminate was then replaced with patches sized larger than the scarfed area as required by the Navy Specification.

The problem with this repair technique was that it produced a raised portion of laminate surrounding the perimeter of the ground area and tended to produce voids in the subsequent laminate because of bridging.

There was much speculation concerning the detrimental effects of a void. The Navy specification required repair of voids with their greatest dimensions of 1.27 cm (1/2 inch). These voids were generally only a few thousandths of an inch in depth occurring in a laminate of 6 cm (2 1/2 inch) overall thickness. Many fiberglass experts and consultants believe that the removal of the voids and surrounding laminate, then replacing the removed portion by small patches, causes more disturbance in the matrix and a reduction of strength of the hull than the voids themselves. This belief was based upon the presumption that continuity in the glass fibers was more desirable than the reliance on the interlaminar shear strength of the resin between layers of E-glass.

The impregnator was an indispensable tool to lay up a large vessel and was especially valuable in the lamination of large panels such as decks and bulkheads. The impregnator system has been used very successfully by builders such as Westport Shipyards for hard chine planing craft with few non-developable surfaces and also proved to be quite successful in the lamination of round bilged trawler type hulls as well. Another notable asset of the impregnator is the lack of airborne styrene emissions because the resin is always contained, making for a more comfortable work environment.

Limitations of the impregnator include the lamination of hard to reach and work areas such as the stem and keel. Areas which historically involve high labor intensity to eliminate bridging and resin pools were not good candidates for the impregnator because the time involved to work the areas increased the likelihood of the resin "kicking off" in the bath. This caused a loss of the resin volume in the bath 19 liters (approx. 5 gallons) and the necessity to unload the cloth, dump the bath and clean the impregnator. With only one impregnator in operation, this exercise would completely stop production or necessitate switching to a hand layup technique. Additionally, the length of cloth already wet out during the cleaning operation was lost. This was typically a loss of 4.5 sq.meters (45 sq. ft.) of material.

The impregnator proved to be a high maintenance item with spare parts generally unavailable on a short lead time which necessitated stocking of spares. Great care was exercised in the daily cleaning of the tool as well as preparation prior to use, including charging the resin and catalyst systems and setting the roller micrometers.

Hand Layup Techniques

The only mechanical system used during the construction of the RSV for hand layup situations was a "flow coater".

The flow coater was used to wet out material with resin catalyzed at the gun head, then flowed in a stream, like a shower head as opposed to an atomized mist. As with the impregnator, styrene emissions are low with the flow coater because the airborne resin is not atomized subject to high velocities.

The flow coater was used to laminate the stem and keel as mentioned earlier and to laminate the longitudinal girders and stringers. It is interesting to note that the girders and stringers accounted for roughly one half of the lamination required on the vessel, so the use of efficient hand layup techniques was critical. The layup of the stringers, although accounting for half of the laminate, was the most labor intensive and where the experienced layup crew was the greatest asset.

Laminator Training and Qualifications

A Laminating Process Description (LPD) was prepared prior to start up and revised during the production of laminate qualification panels. The LPD was used as a training tool for the laminators and operators before any lamination took place on the shop floor.

Hours of safety training, including a complete review of the material safety data sheets (MSDS) for all the chemicals used, was conducted for all personnel. A major concern in any fiberglass facility is the cognizance of the fire hazards involved in lamination. Safety was stressed as a high priority throughout the construction process through numerous fire drills and an elaborate styrene evacuation system installed in the mold.

All personnel were required to produce laminate test panels which were then tested to verify the adaptability of the laminators and operators at achieving optimum glass/resin ratios and acceptable void contents.

Throughout the construction process all resin was tested in house prior to promotion for viscosity and after promotion for controlled gel time and temperature to insure proper promotion. Gel cup samples were taken from the mixing gun heads prior to daily production and on the event of 5-10 degree temperature changes in the production facility.

Test panels were laid up daily concurrently with hull lay up and tested in-house for glass/resin ratio, void content, flexural strength and modulus, tensile strength and modulus and shear strength to insure proper laminate quality. Complete testing was done in-house on test coupons from the hull as well as less frequent but regular testing performed by a certified outside laboratory to verify the in-house testing results.

Laminate Quality Requirements

Early in the production process it was established that virtually void free laminate could be achieved even during the lamination of large areas. The trade off for near perfect laminate, of course, was the time required to produce this quality of laminate versus the time required to make repairs.

Figure 4 illustrates that there is not necessarily a well defined relationship between area of laminate produced and number of repairs for a given area. Many variables exist which are not defined in this analysis, including lamination environment or area of the hull.

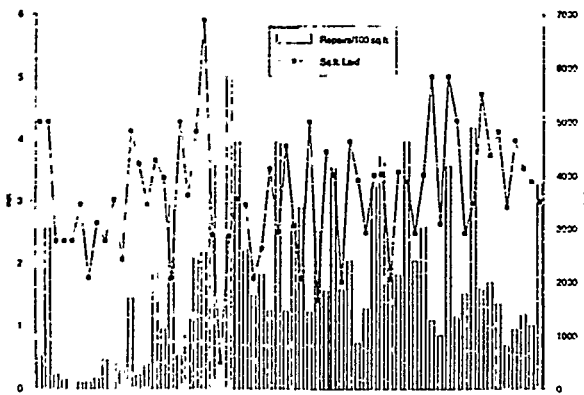

Figure 4

In order to progress the production process, an upper control limit of four repairs per 9.29 Sq. meters (100 sq. ft.) was established, based upon a requirement in the specification limiting the allowable percentage of hull repairs versus the hull surface area. A mean of two repairs per 9.29 sq. meters (100 Sq. ft.) was also established as a target goal. These numbers were conceived mathematically, but not based upon true statistical analysis of the process, because no data was available prior to start-up.

No lower control limit was initially set. The upper control limit was to be adjusted to two standard deviations, plus the mean after data was compiled during production.

After the start of production, however, it was realized that the goal of near perfect laminate, based upon the 1.27 cm (1/2 inch) void specification requirement, was counter-productive. Since the previous laminate was required to be ground anyway, the time required to grind out one or two pairs in a 5.08-7.62 cms (2

or 3 inch) diameter circle to remove a void became negligible. The final method of repair was made by placing the wet out patch on the scarfed area immediately prior to laying the impregnated material of the subsequent laminate. Although the repair process was an added responsibility to the laminators, the real impact was an adverse psychological affect on all of the crew. The attitude of the crew was adjusted to expect some repairs to be made; a lower control limit was determined realizing that some number of voids were acceptable.

Finding voids in laminate which the crew was expecting to be acceptable tended to cast a negative shadow upon the previous days work and built animosity between the production team and the quality assurance personnel. When the attitudes were adjusted to realize the goal was for only two repairs (average) per **9.29 sq. meters (100 sq. ft.)** and to maximize the production output, the tension between the workers and the people checking the work was eased. This resulted in a cohesion among the whole team, including the builder, the lamination subcontractor and Supships, that everyone was working towards an achievable **goal**; to build a high quality boat in an expedient manner.

As an effort to include Total Quality Management (TQM) techniques, high power spotlights were made available on the lamination platforms for the laminators to perform the quality control function on their own work. The laminate quality increased greatly for initial production of acceptance panels to actual hull lamination due to inclusion of quality control at the laminators level.

In the final analysis, based upon two hulls, it is shown in Figure 5 that the common goals of all **players had** been achieved, and a sense of pride in quality workmanship on everyone's part was established.

Installation of Internal Structure

All of the stringers and longitudinal girders were laid up as continuous while the transverse members were intercostal. The sequence of producing the stringers and girders, with the exception of the solid laminate girders in way of the integral fuel tanks, was to fit non-effective structural foam shapes into the hull and laminate some number of layers upon them, secondary bonding the laminate to the hull as bonding angles.

The fitted foam shapes were bonded to the hull with syntactic foam produced by working microspheres,

milled fibers and resin into a putty. Although, the syntactic foam had much better physical properties than the non-effective structural foam used 130 g/cc (eight pound per square foot) polyurethane, the Quality Control Inspectors insisted on a "close and accurate fit" between the foam shapes and the hull, minimizing the use of syntactic foam bedding compound. This interpretation of the Navy specifications caused much work and rework in the fitting of the unlaminated foam shapes in the hull, even though all of the structural integrity and strength was derived purely from the laminate which was to be laid upon the shapes. A more reasonable commercial specification from which the QA inspectors could work from would reduce the labor involved on fitting the foam.

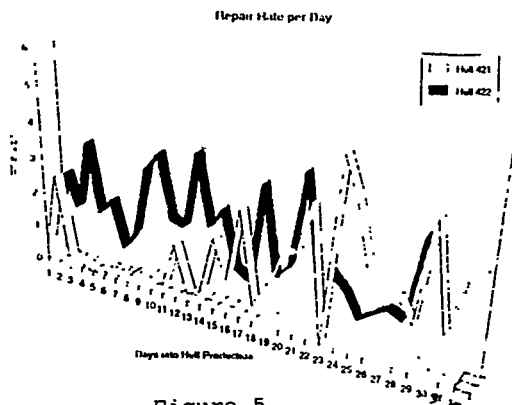

Figure 5

After the lamination of the longitudinal structure, the prefabricated transverse structure was installed and attached using bonding angles.

All prefabricated components were constructed with excess and all joints were designed to allow for some adjustment to be made when the parts were assembled.

An example of joints designed for the assembly of prefabricated parts is the aluminum to FRP main deck to hull joint, detailed in Figure 6.

The 1.27 cm (1/2 inch) thick aluminum shelf was fabricated concurrently with the deck, removed from the deck and attached to the hull. Keeping the frame spacing close and accurate during the shelf installation was painstakingly controlled, but the variances in transverse alignment were not critical because the deck plate could be trimmed to land upon the shelf with the desired overlap.

Experiments were conducted to the satisfaction of the inspectors and engineers to verify the ability to weld

on the aluminum in the proximity of the fiberglass hull without creating thermal damage to the FRP. A source of research (ref. 5) conducted from steel to FRP joints was used for guidance prior to performance of the tests. The pre-outfitted main deck and superstructure was landed on the hull after the below deck level pre-outfitting was accomplished.

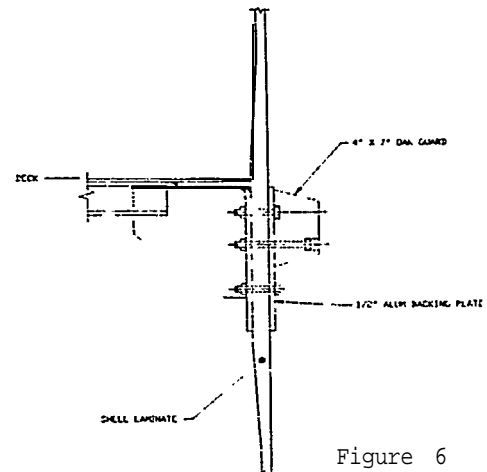

Figure 6

CONCLUSION

Process of Continuous Improvement

Total quality management was practiced throughout both hull lamination processes, and improvements were made on the process, but the inflexible specifications limited the efforts of the builder to produce a quality product at a lower price. Although the specifications can be changed through the use of deviations and waivers, the effort required to bring about the acceptance of the changes is enormous. All specification changes must be reviewed and accepted by at least three governing bodies, Naval Sea System Command (NAVSEA), (Seabat) and Supships.

In lieu of writing a binding set of specifications to define the intricacies of the FRP production process, perhaps an alternative would be to let the builder produce a product which meets minimum parameters in the laminate, such as void content, strength characteristics and glass to resin ratios, with the builders own processes and at the builders own risk as is required by ABS. This scenario would heighten the advantages of using the process of continuous improvement by allowing slight changes in the process based upon real time innovations and techniques. The customer would still receive a product which meets the objective - a hull of sufficient strength and quality to perform the assigned mission.

This would be analogous to the production of an aluminum hull. Instead of the Navy or Supships monitoring and inspecting every phase of the aluminum plate and shape production at the mill, they accept the mill certification as proof that the aluminum has been produced acceptably. Instead of the inspectors overseeing every facet of the hull and deck welding, inspecting every pass being laid down and all areas of the weld prior to local backgouging and weld preparation, the final welds are inspected and sample welds are tested.

Summary

The contract to build the RSV was awarded to the builder for two reasons. The first reason being that the Egyptian Navy required the vessels to perform the assigned mission. The second is the United States of America funding was earmarked for a U. S. yard to help stimulate the U.S. economy.

In essence, the RSV requirements are simply to provide a platform to transport the electronic gear necessary to perform its mission. This platform should be able to move at a specified rate, have all of the necessary safety equipment for any emergency and have the sea keeping ability to provide an environment acceptable to the electronic equipment and survivability in a given sea state. All of the above requirements, with the exception of the speed, are covered through other regulatory body requirements, such as ABS or U.S. Coast Guard.

The Navy specification should include, as a minimum, the parameters required by the mission, speed, sea keeping, approximate vessel size, range and consumption. Commercial regulatory requirements, such as ABS and Coast Guard, should be referenced to assure proper construction of the craft. In lieu of the production processes being defined by committees, production personnel with hands on experience should be responsible and accountable. Commercial standards should be enforced, based upon industry wide acceptance.

This would integrate more fully with the second reason the contract was let, the stimulation of the the U. S. economy by promoting shipbuilding in the U.S..

The premise that U.S. shipbuilders are incapable of producing vessels which are capable of fulfilling military missions without strict guidance of the Navy is limiting the capability of U.S. yards to compete in the world market. These limitations are

due partly to the inflexibility of binding Navy specifications which severely retard the use of the process of continuous improvement and the integration of real time, state of the art technology. The lack of

flexibility of Navy specifications carried from contract to contract over the years are the result of the effects of bureaucracy and its inherent momentum which makes change difficult. The Navy has many sharp minds with helpful ideas to aid builders in becoming leaders in the world shipbuilding market, but the current fixed structure inhibits change.

In the age of shrinking military budgets and increasing social programs to promote business development, the requirements placed upon U.S. shipbuilders to increase yard overhead to support logistics requirements and perform non-essential tasks to comply with sometimes unapplicable specifications are counter productive.

The free enterprise system should be allowed to work in the realm of military spending where tasks are performed to add value to a product rather than exercised to meet specifications.

Both of the objectives of the RSV contract were fulfilled: the Egyptian Navy has the tools required to support their mission and the U.S. economy was stimulated through jobs. The process, however, could be more efficient to allow the production of commercial craft to commercial standards which fit the military mission required throughout the navy procurement process. This would not only ease the burden on taxpayers for the final product, but also streamline production processes for U.S. shipbuilders which would allow them to once again compete in the world market and allow the U. S. to reclaim its position among the premier shipbuilding nations in the world.

LIST OF ABBREVIATIONS

ABS - The American Bureau of Shipping
FRP - Fiberglass reinforced plastics
GP - General Purpose
HVAC - Heating, Ventilation and Air
MSDS - Material Safety Data Sheets
NAVSEA - Naval Sea Systems Command
PVA - Poly Vinyl Alchohol
QA - Quality Assurance
Rsv - Route Survey Vessel
Supships - The Supervisor of
Shipbuilding and Repair
SEABAT - Naval Ship Combat Sciences &
Engineering Services
Conditioning
TQM - Total Quality Management

REFERENCES

1. Rules for Building and Classing Reinforced Plastic Vessels, American Bureau of Shipping, 1978
2. Richard Lee Storch, Colin P. Hammon and Howard M. Bunch, ship Production, Cornell Maritime Press, 1988
3. "Venus Impregnator" Operation Manual, Venus Products, Inc.
4. The National Shipbuilding Research Program, Standards for Excess, U.S. Department of Transportation in cooperation with Todd Pacific Shipyards Corporation, 1982
5. Pat Cahill, "Journal of Ship Production", Composite Materials and Naval Surface Combatants: The Integrated Technology Deckhouse Project, Vol. 8, No. 1, 1992, pp. 1-7

Additional copies of this report can be obtained from the
National Shipbuilding Research and Documentation Center:

<http://www.nsnet.com/docctr/>

Documentation Center
The University of Michigan
Transportation Research Institute
Marine Systems Division
2901 Baxter Road
Ann Arbor, MI 48109-2150

Phone: 734-763-2465
Fax: 734-763-4862
E-mail: Doc.Center@umich.edu