

**AFRL-IF-RS-TR-2006-280**  
**Final Technical Report**  
**September 2006**



# **WEBTAS SOFTWARE LIFE CYCLE DEVELOPMENT**

**Intelligent Software Solutions, Inc.**

*APPROVED FOR PUBLIC RELEASE; DISTRIBUTION UNLIMITED.*

**AIR FORCE RESEARCH LABORATORY  
INFORMATION DIRECTORATE  
ROME RESEARCH SITE  
ROME, NEW YORK**

## **STINFO FINAL REPORT**

This report has been reviewed by the Air Force Research Laboratory, Information Directorate, Public Affairs Office (IFOIPA) and is releasable to the National Technical Information Service (NTIS). At NTIS it will be releasable to the general public, including foreign nations.

AFRL-IF-RS-TR-2006-280 has been reviewed and is approved for publication.

APPROVED: /s/

**BRUCE A. RUBIN**  
Project Engineer

FOR THE DIRECTOR: /s/

**JOSEPH CAMERA**  
Chief, Information & Intelligence Exploitation Division  
Information Directorate

**REPORT DOCUMENTATION PAGE***Form Approved*  
**OMB No. 0704-0188**

Public reporting burden for this collection of information is estimated to average 1 hour per response, including the time for reviewing instructions, searching data sources, gathering and maintaining the data needed, and completing and reviewing the collection of information. Send comments regarding this burden estimate or any other aspect of this collection of information, including suggestions for reducing this burden to Washington Headquarters Service, Directorate for Information Operations and Reports, 1215 Jefferson Davis Highway, Suite 1204, Arlington, VA 22202-4302, and to the Office of Management and Budget, Paperwork Reduction Project (0704-0188) Washington, DC 20503.

**PLEASE DO NOT RETURN YOUR FORM TO THE ABOVE ADDRESS.**

<b>1. REPORT DATE (DD-MM-YYYY)</b> SEP 06		<b>2. REPORT TYPE</b> Final		<b>3. DATES COVERED (From - To)</b> Aug 05 – Mar 06	
<b>4. TITLE AND SUBTITLE</b> WEBTAS SOFTWARE LIFE CYCLE DEVELOPMENT				<b>5a. CONTRACT NUMBER</b> FA8750-04-D-00080010	
				<b>5b. GRANT NUMBER</b>	
				<b>5c. PROGRAM ELEMENT NUMBER</b> 31335F	
<b>6. AUTHOR(S)</b> Marcus Featherston				<b>5d. PROJECT NUMBER</b> 2183	
				<b>5e. TASK NUMBER</b> QR	
				<b>5f. WORK UNIT NUMBER</b> 11	
<b>7. PERFORMING ORGANIZATION NAME(S) AND ADDRESS(ES)</b> Intelligent Software Solutions, Inc. 5450 Tech Center Drive, Suite 400 Colorado Springs Colorado 80919				<b>8. PERFORMING ORGANIZATION REPORT NUMBER</b> N/A	
<b>9. SPONSORING/MONITORING AGENCY NAME(S) AND ADDRESS(ES)</b> Air Force Research Laboratory/IFEB 525 Brooks Rd Rome NY 13441-4505				<b>10. SPONSOR/MONITOR'S ACRONYM(S)</b>	
				<b>11. SPONSORING/MONITORING AGENCY REPORT NUMBER</b> AFRL-IF-RS-TR-2006-280	
<b>12. DISTRIBUTION AVAILABILITY STATEMENT</b> APPROVED FOR PUBLIC RELEASE; DISTRIBUTION UNLIMITED. PA #06-613					
<b>13. SUPPLEMENTARY NOTES</b>					
<b>14. ABSTRACT</b> Under this effort, ISS enhanced the WebTAS Data Gateway to improve the system's ability to maximize generic data access and data mapping across disparate data sources. Additional capabilities included the enhancements to the WebTAS Project Manager function to include features that were previously embedded within the View manager. In addition, there were significant improvements in the functionality and flexibility of the WebTAS Timetable capability to allow the user full control of data aggregation and display techniques, and as a replacement for the User Manager, a much improved WebTAS Security Manager was developed. The contractor completely retooled and updated WebTAS core documentation from WebTAS 2.5.1 to WebTAS 2.5.3 and 3.0 (including User's Guide, Installation and System Administration Manual). Finally, ISS investigated and resolved a number of system performance issues concerning WebTAS core implementation strategies.					
<b>15. SUBJECT TERMS</b> Time line analysis, data access, software security manager					
<b>16. SECURITY CLASSIFICATION OF:</b>			<b>17. LIMITATION OF ABSTRACT</b>  UL	<b>18. NUMBER OF PAGES</b>  30	<b>19a. NAME OF RESPONSIBLE PERSON</b> Bruce A. Rubin
<b>a. REPORT</b> U	<b>b. ABSTRACT</b> U	<b>c. THIS PAGE</b> U			<b>19b. TELEPHONE NUMBER (Include area code)</b>

## Table of Contents

1	Introduction .....	1
2	WebTAS Overview .....	1
3	Technical Achievements .....	4
3.1	Data Gateway .....	4
3.2	WebTAS Timetable Improvements .....	6
3.3	WebTAS Documentation .....	12
3.4	Project Manager Enhancement .....	18
3.5	Security Manager .....	22
3.6	Performance .....	25
4	Outstanding Issues and Discussion .....	25
	Appendix A - Acronyms .....	26

## List of Figures

Figure 1	- WebTAS Architecture .....	2
Figure 2	- Suite of Data Analysis and Visualization Tools .....	3
Figure 3	- Data Gateway High Level Architecture .....	4
Figure 4	- Enterprise Service Bus Platform .....	5
Figure 5	- Timetable Display .....	7
Figure 6	- Timetable Labels with Row Coloring .....	8
Figure 7	- Timetable Data Grouping and Attribute Rollup .....	9
Figure 8	- Timetable Wizard Feature Selection .....	10
Figure 9	- Timetable Timeline Attribute Selection .....	11
Figure 10	- ISS Documentation Central .....	13
Figure 11	- WebTAS 3.0 User's Guide HTML Extract .....	14
Figure 12	- WebTAS 3.0 Quick Reference Card .....	15
Figure 13	- WebTAS 2.5.3 ISAM .....	16
Figure 14	- WebTAS 2.5.3 Domain Editor Guide .....	17
Figure 15	- WebTAS 3.0 Project Manager Tabs .....	19
Figure 16	- WebTAS 3.0 Project Manager Map Control Setup Example .....	20
Figure 17	- WebTAS 3.0 Project Manager Map Control Example .....	21
Figure 18	- Security Manager LDAP Configuration .....	22
Figure 19	- Security Manager Password Control .....	23
Figure 20	- Security Manager Data Driven Constraints .....	24

# 1 Introduction

This document represents the final technical report for contract FA8750-04-D-0008/0010, WebTAS Software Life Cycle Development, for the Air Force Research Laboratory (AFRL) Rome Research Site. Under this effort, ISS enhanced the WebTAS Data Gateway to improve its ability to maximizing generic data access and mapping across disparate data sources. ISS enhanced the functionality of the WebTAS Project Manager to include features that were previously embedded in the View manager. ISS significantly enhanced and improved the functionality and flexibility of the WebTAS Timetable to allow the user full control of data aggregation and display techniques. ISS completely re-tooled and updated WebTAS core documentation from WebTAS 2.5.1 to WebTAS 2.5.3 and 3.0 (including User's Guides, Installation and System Administration Manual, etc.). ISS developed a much improved WebTAS Security Manager as a replacement for the previous User Manager. Finally, ISS investigated and resolved a number of performance issues concerning WebTAS core implementation strategies. Specific technical achievements are expanded upon below.

## 2 WebTAS Overview

WebTAS is a government off-the-shelf (GOTS) suite of data analysis, visualization, situation awareness, and data mining tools that supports the analysis of multisource data. Developed by Intelligent Software Solutions (ISS) for the Air Force Research Laboratory (AFRL), WebTAS and the underlying analysis techniques have over 10 years of proven operational success. The success of WebTAS is due to many factors including:

- Visualization and analysis capabilities that address key mission requirements across a diverse set of application areas ranging from intelligence analysis to air operations planning.
- Easy integration into existing computing environments.
- Maximal use of legacy systems and data sources with minimal cost.
- Program office and contractor team responsiveness to evolving operational needs, onsite support, and problem resolution.

WebTAS supports multiple client/server architectures to allow customization for the unique computing requirements of each organization. Figure 1 is a generic architecture diagram describing the various WebTAS services and interfaces. Written in Java, WebTAS is platform independent and supports a variety of relational database management systems (RDBMS), streaming data feeds, and service-oriented architectures (SOAs). Figure 1 depicts the overall WebTAS architecture.

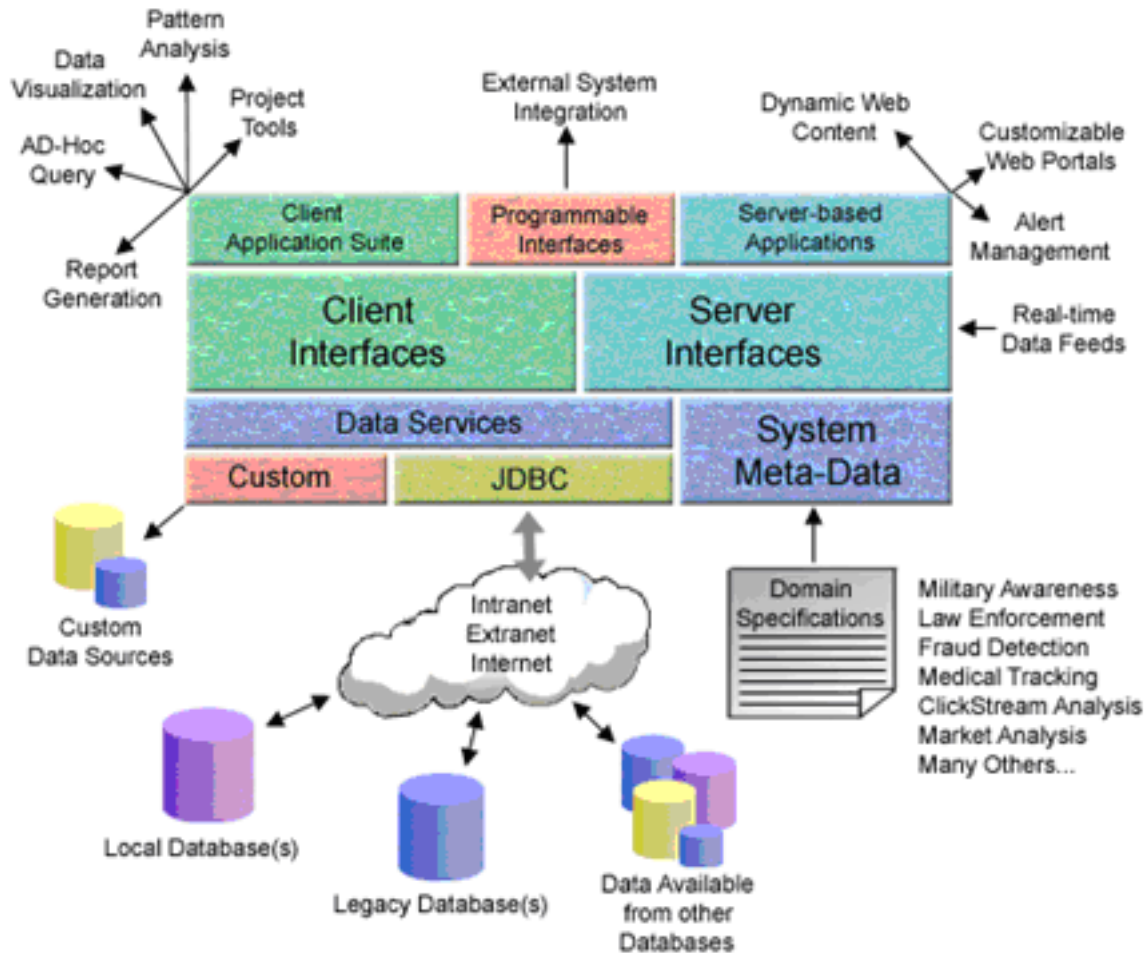

**Figure 1 - WebTAS Architecture**

As shown in Figure 2, WebTAS provides a wide assortment of generic capabilities in both Java client and web browser configurations. Key features include:

- A flexible data infrastructure that exploits and integrates disparate, multisource data from relational databases, real-time streams, and web sources with little or no programming.
- The ability to create new databases on the fly to support evolving data archival and retrieval requirements.
- Sophisticated data query and visualization capabilities that allow users to easily comprehend the complex relationships between large data sets and to perform ad hoc queries against disparate data sources.
- Tools supporting multiple analysis and architecture configurations, including both client applications and browser-based information and management portals.
- A graphics-based knowledge editor for specifying alerts patterns and behavioral models for use in trend and pattern detection activities.

- A verification-based, data-mining component that supports the identification of patterns within historical data sources.
- A near real-time fusion engine that monitors data sources for unfolding situations and develops predictions based on knowledge represented in behavioral models.
- A Java Server Pages (JSP) Tag library that supports web publishing of WebTAS data and displays in custom web pages.

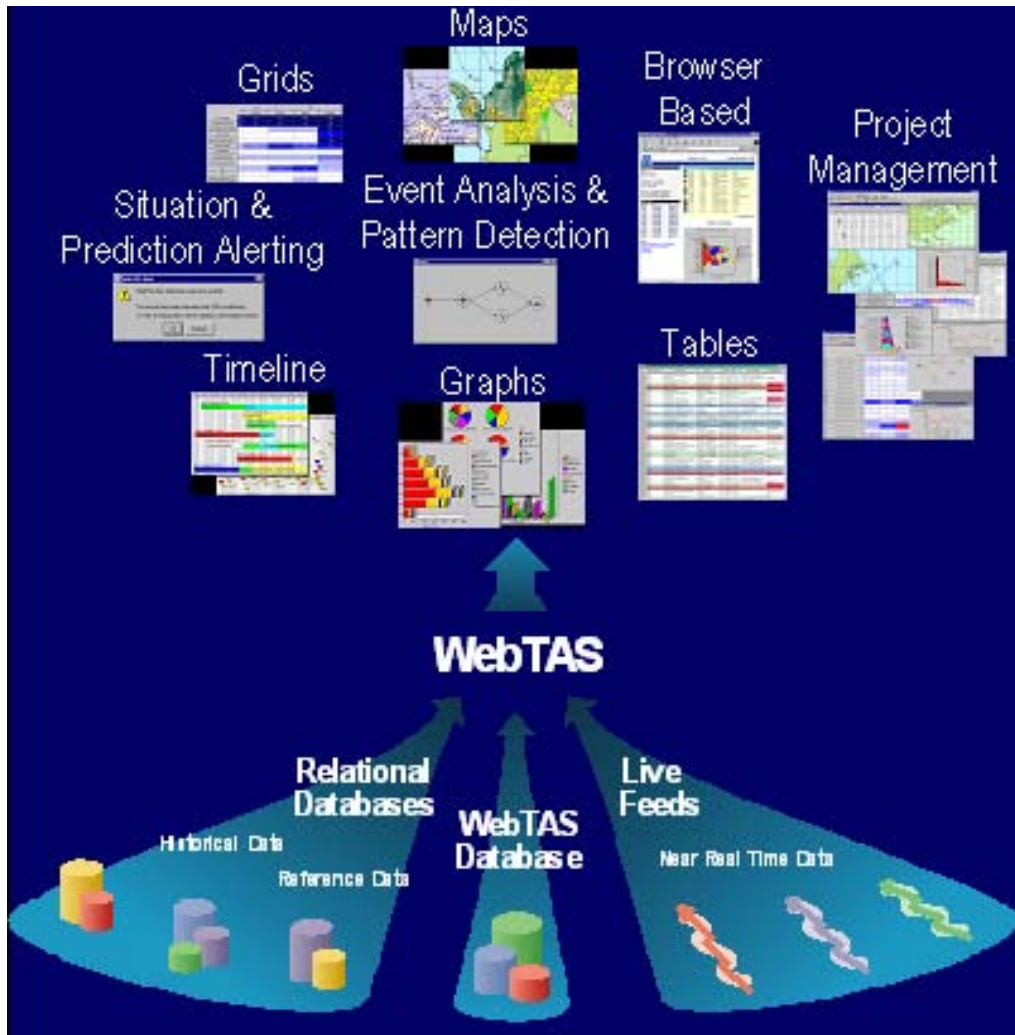

Figure 2 - Suite of Data Analysis and Visualization Tools

### 3 Technical Achievements

#### 3.1 Data Gateway

The Data Gateway is a suite of Web Service API's aimed at allowing secure data access to the WebTAS data model. Figure 3 depicts the high level architecture of the Data Gateway.

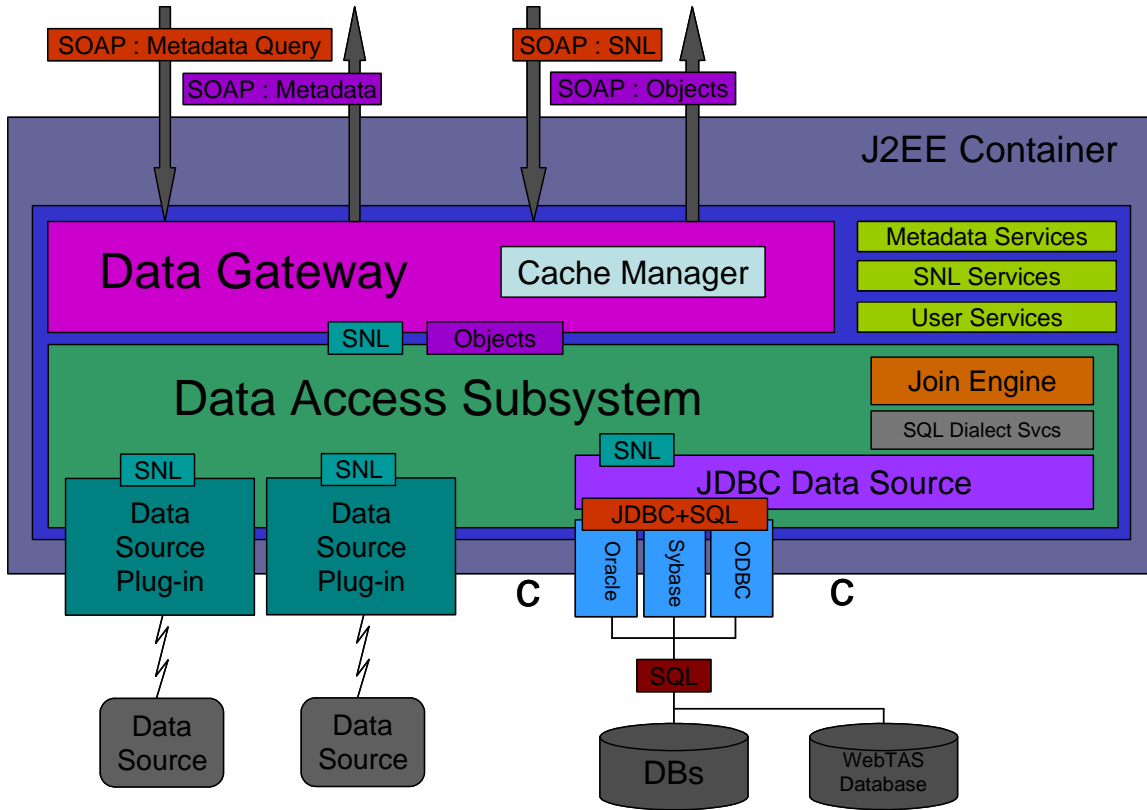
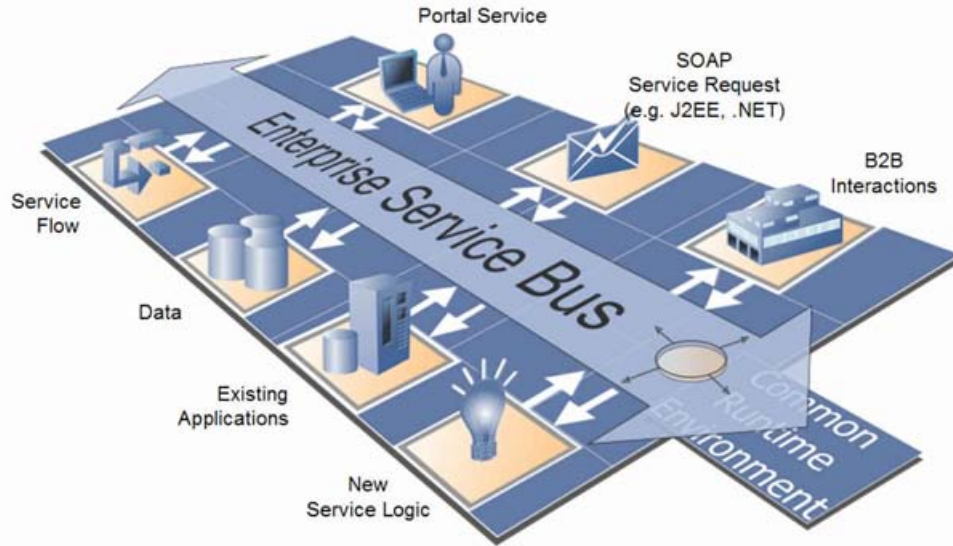

Figure 3 - Data Gateway High Level Architecture

The Data Gateway has been enhanced to leverage key WebTAS technologies to maximize generic data access and mapping across disparate data sources. For example, improvements in the Enterprise Service Bus (ESB) platform were accomplished. The Enterprise Service Bus is a standards-based integration platform that combines messaging, web services, data transformation, and intelligent routing to reliably connect and coordinate the interaction of diverse applications across the extended enterprise. ESB supports synchronous and asynchronous interactions with multi-protocol entry and dissemination points (HTTP, JMS, SMTP, TCP, UDP, XMPP, etc.). Figure 4 depicts the ESB platform as employed in WebTAS.





**Figure 4 - Enterprise Service Bus Platform**

The Data Gateway now takes advantage of the WebTAS user authentication and authorization models via:

- Pluggable authentication to various user stores (i.e. Active Directory).
- The treatment of users as part of groups/roles with data object level access privileges.

The Data Gateway utilizes Web Services Security (WS-Security) to encode user credential tokens into Simple Object Access Protocol (SOAP) messages, resulting in the following advantages:

- Provides for a portable security model which is protocol independent.
- 3<sup>rd</sup> parties do not have to worry about the implementation details of the credential encoding if they use the provided client API.

The Data Gateway continues to improve on its ability to support client interaction via the provision of standardized and easy to use application programming interfaces (APIs), including JAX-RPC, SAAJ, and .NET.

Finally, a Software Development Kit (SDK) was generated which includes:

- Data Gateway client API jar.
- Javadocs of key packages.
- Code samples on how to use the API.
- Data Gateway WSDLs and supporting xsds.
- Supporting documentation, for example, the Data Gateway Functional Description Document.

### **3.2 WebTAS Timetable Improvements**

ISS enhanced the Timetable functionality to include a number of features that significantly enhanced both its flexibility and ease of use. Prior to these enhancements, timetable display/rendering attributes were not accessible to the user. Rather, timetable display characteristics were accomplished at the programmer/engineer level. Now the user has an exceptional amount of control over how WebTAS data is displayed using a timetable. From selecting presentation formats for icons, date ranges, day/night shading, current time line bar, and column shading to specifying what columns (including order) to display, the user is able to tailor a timetable display to meet their specific needs. The user selection of these display options is readily accessible via a timetable wizard which further enhances the ease by which the user is able to select, manipulate and preview options prior to their rendering on a timetable. In addition, since the timetable wizard is accessible via the Project Manager, the user may adjust timetable display settings at any time via selection of the "Edit Properties" button contained in the Project Manager window. Finally, the underlying flexible design structure of the Timetable Wizard supports its extension and modification as WebTAS continues to mature and new display techniques unfold.

The enhancements to the WebTAS Timetable were successfully completed and are now packaged as part of the WebTAS 3.0 baseline. Sample screenshots of the new Timetable features are shown below.

The following screen depicts a simple timetable where the date range associated with the data is displayed. Selection of the start and stop icons is user controlled as well as the date range line. Note also that icons presentation may be data driven (reference the “red” start icon). Finally, in this example, the columns have been colorized to assist in the discrimination of time periods.

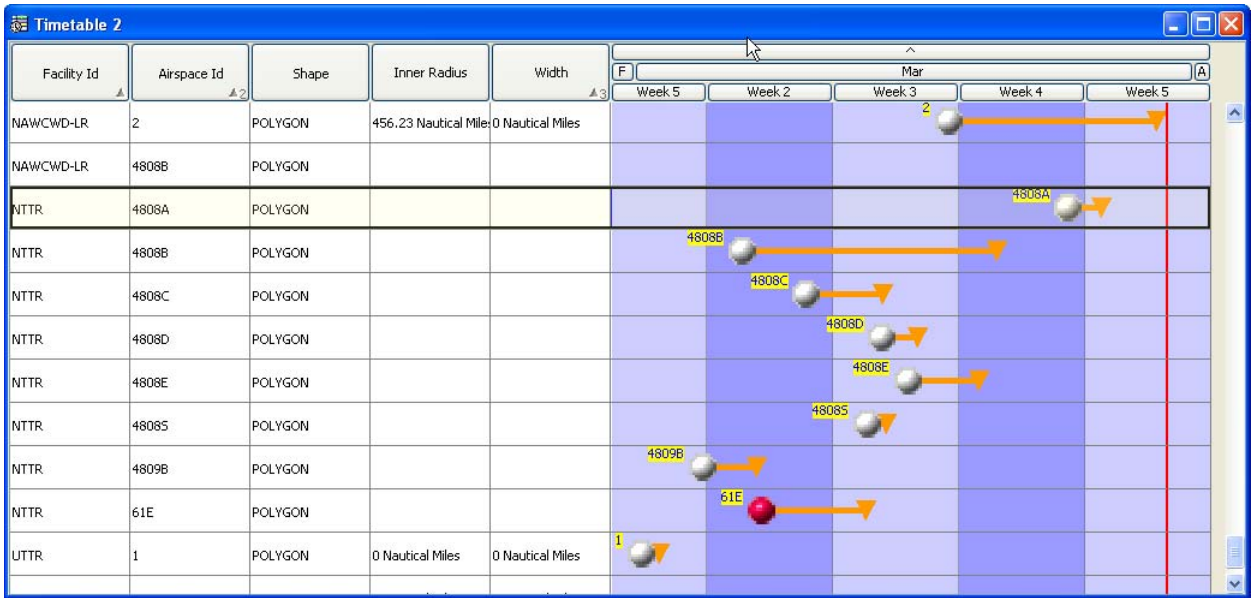

Figure 5 - Timetable Display

This screen images depicts data driven single position icons with labels and row coloring. In this example, all “Storage Tanks” are highlighted in blue. Icons may also be selected and color coded based upon associated data values.

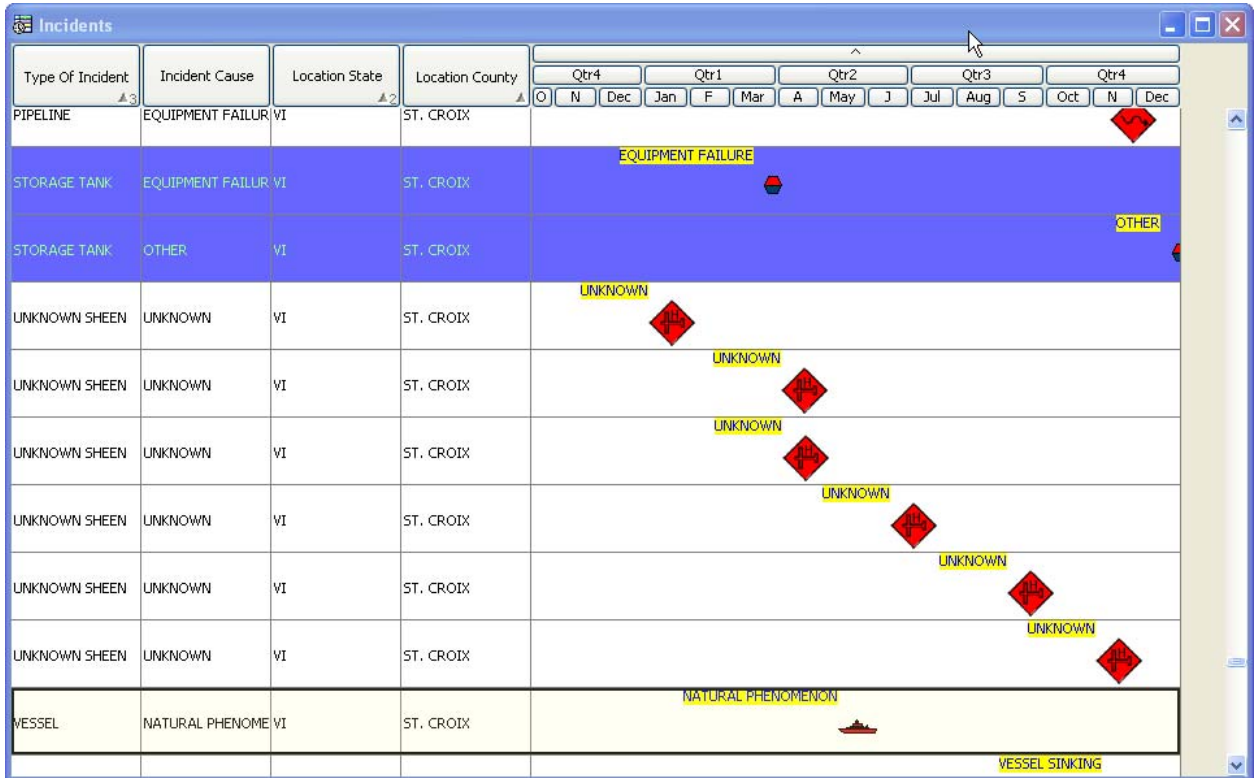

Figure 6 - Timetable Labels with Row Coloring

The following screen image depicts an example of how many results (33,000 in this example) can be grouped for easy navigation. In this example, Coast Guard incidents from 2004 are grouped by Type and State of occurrence. Each 'rollup' row shows the number of objects it contains in parenthesis.

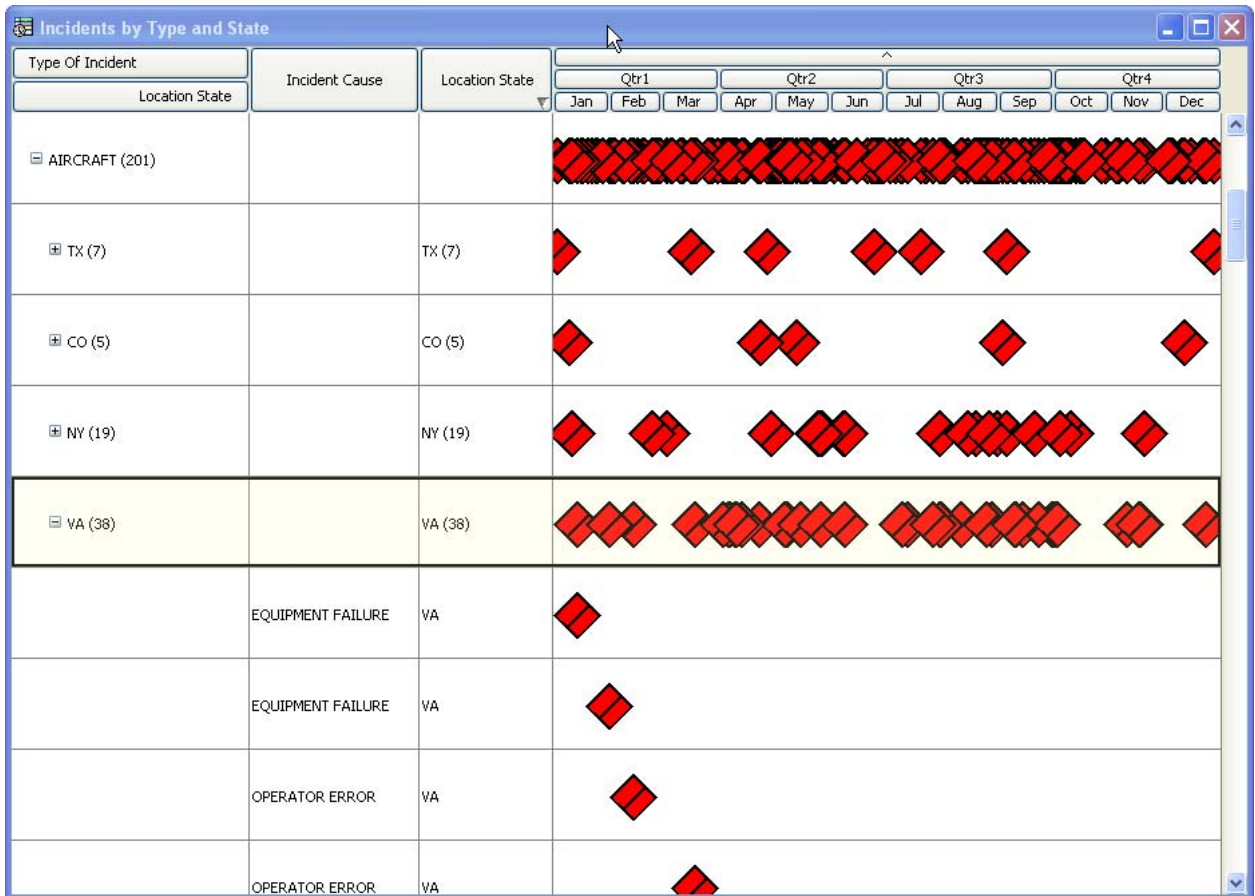

Figure 7 - Timetable Data Grouping and Attribute Rollup

The properties of a timetable are selectable when a timetable is first created and after its creation via the Project Manager “Edit Properties” button. Selections are accomplished via a “Specify Timetable Display Properties” window as shown below. As each available attribute is selected, its display properties are shown in the right hand pane. In the following example, the user selected the “Date Bar with Icon” attribute. As a result, the display properties for a date bar are accessible in the right hand pane. Located at the bottom of the window, a “Preview” of the combined attributes (i.e., current time, date bar, day/night shading and time grid) is displayed.

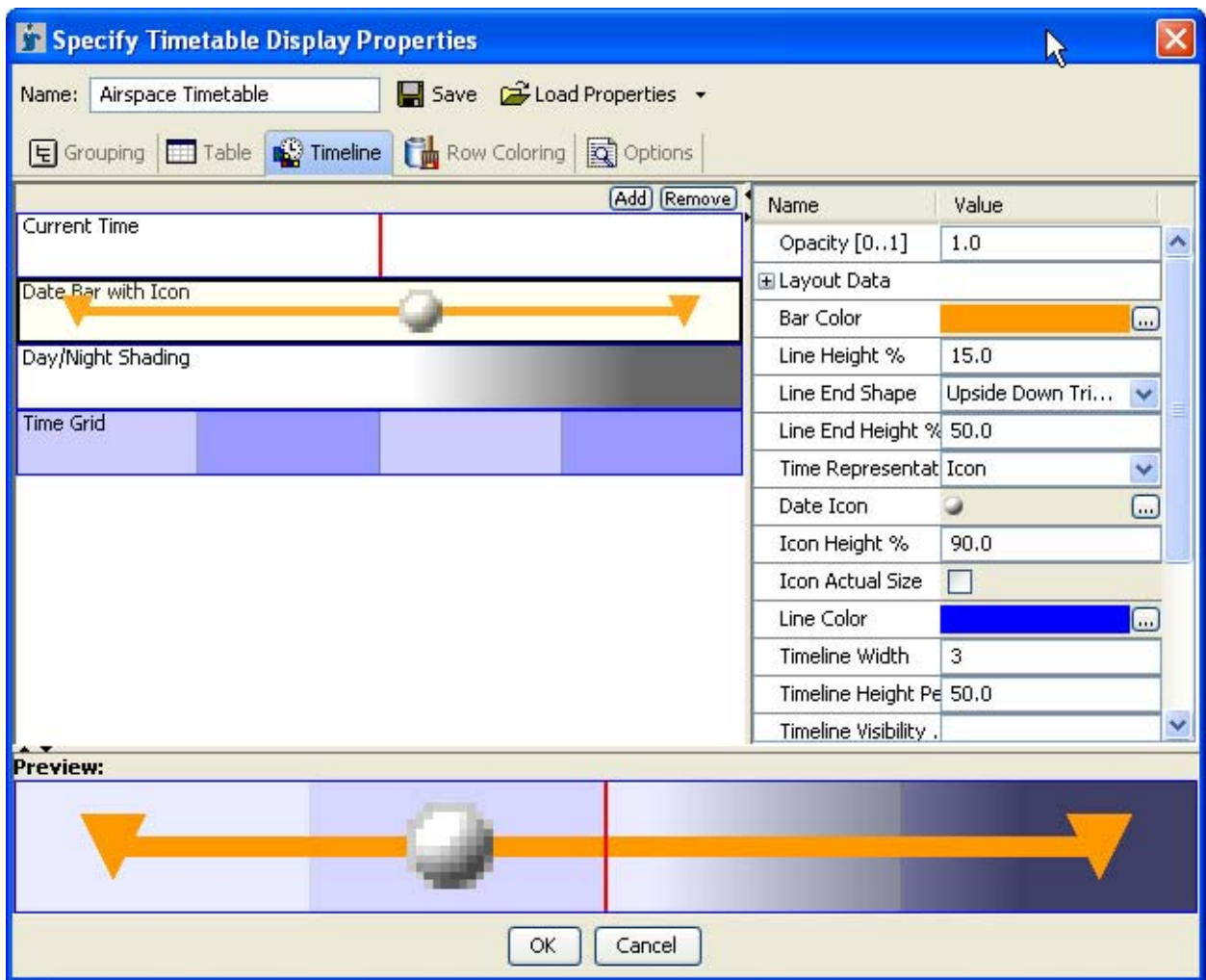

Figure 8 - Timetable Wizard Feature Selection

This screen image depicts the ability of the user to add additional display attributes to the timeline segment of a timetable. In this example, the Timeline attributes current time, date range, day/night shading and time grid have already been selected by the user to be displayed. Selection of the “Add” button results in the display of the “Select Timeline Visual” window. For your reference, in the following screen image, the “Add” button is depicted just slightly above the upper left edge of the “Select Timeline Visual” window. This display allows the user to include an additional attribute (e.g., Text (Formatted)) to the timeline display. Similarly, attributes may just as easily be removed by selecting the “Remove” button that is located to the immediate right of the “Add” button.

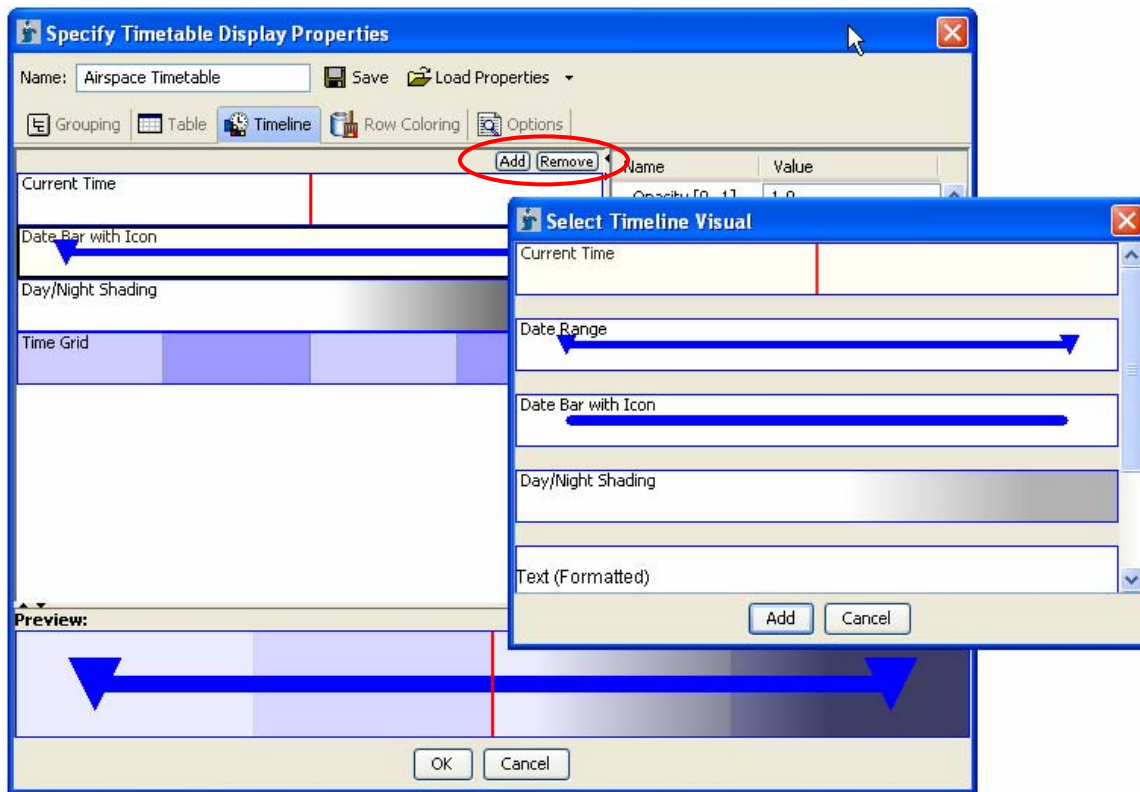

Figure 9 - Timetable Timeline Attribute Selection

### 3.3 WebTAS Documentation

WebTAS documentation has undergone a complete overhaul and transformation. Updated WebTAS documentation is now provided in both Internet browser compatible (html) and static/portable document (pdf) compliant styles. Moreover, the underlying Commercial Off-the-Shelf (COTS) tool suite utilized to generate WebTAS documentation provides all the inherent flexibility and capabilities to maintain a single, well-defined document baseline that may be published in both html and pdf formats via menu selection. Adobe® FrameMaker® 7.1 and Quadralay Corporation WebWorks® Professional 2003 provide the primary COTS components used to generate consistent and well formatted WebTAS documents. In addition, as documents are generated, embedded “markers” are easily added that support context sensitive help during future releases of WebTAS. The use of these tools provide a demonstrably stable, efficient and repeatable publishing environment that allows the WebTAS documentation team to focus on content and presentation versus the mechanics of building and structuring individual documents.

As part of this task, WebTAS 2.5.1 documentation was updated to version 2.5.3. Included was the generation of the WebTAS 2.5.3 Service Pack 5 (SP5) Installation and System Administration Manual (ISAM) that successfully passed DODIIS Certification. Certification To Field (CTF) was issued by DIA ITA March 2006 for PL-2. Testing involved three phases and coordination with three agencies:

- 1) Integration testing involved DIA SERSC members at the integration test lab. ISS supported the installation and integration of WebTAS 2.5.3 in the RSC test environment. This included both Web App and Client installation on JWICS.
- 2) Security testing involved USAF/AFSCO to verify that WebTAS met PL-2 DCID 6/3 requirements.
- 3) Interoperability Testing involved exercising the Functional Test Plan (FTP) and new capabilities/deltas since 2.5.1 including new Web App and new link analysis.

WebTAS 2.5.3 and 3.0 documentation was also generated and updated during this period of performance. Documents included:

Document	HTML Format	PDF Format
WebTAS 3.0 User Guide	X	X
WebTAS 3.0 Quick Reference Guide		X
WebTAS 3.0 Security Manager Guide	X	X
WebTAS 3.0 Version Description Document		X
WebTAS 3.0 Enterprise Functional Description Document		X
WebTAS 2.5.3 User Guide	X	X
WebTAS 2.5.3 ISAM	X	X
WebTAS 2.5.3 Domain Editor Guide	X	X



The backbone of the ISS publishing environment consists of Adobe® FrameMaker® and WebWorks® Publisher Professional 2003. FrameMaker® provides an enterprise-class authoring and publishing solution that combines the simplicity of word processing with the power of XML. WebWorks, with its easy access to FrameMaker® book files, delivers online web documents with a simple point and click.

All of WebTAS documents are accessible internally to ISS developers and users via the “ISS Documentation Central” repository. The ease of access facilitates document review and comment by those who actually use the documents.



Figure 10 - ISS Documentation Central

Sample screenshots from the new suite of WebTAS documents are shown below.

The following extract is taken from the html variant of the WebTAS 3.0 User Guide from the section discussing Timetables. The table of contents and overall look and feel are easily defined and modified using ISS's publishing environment.

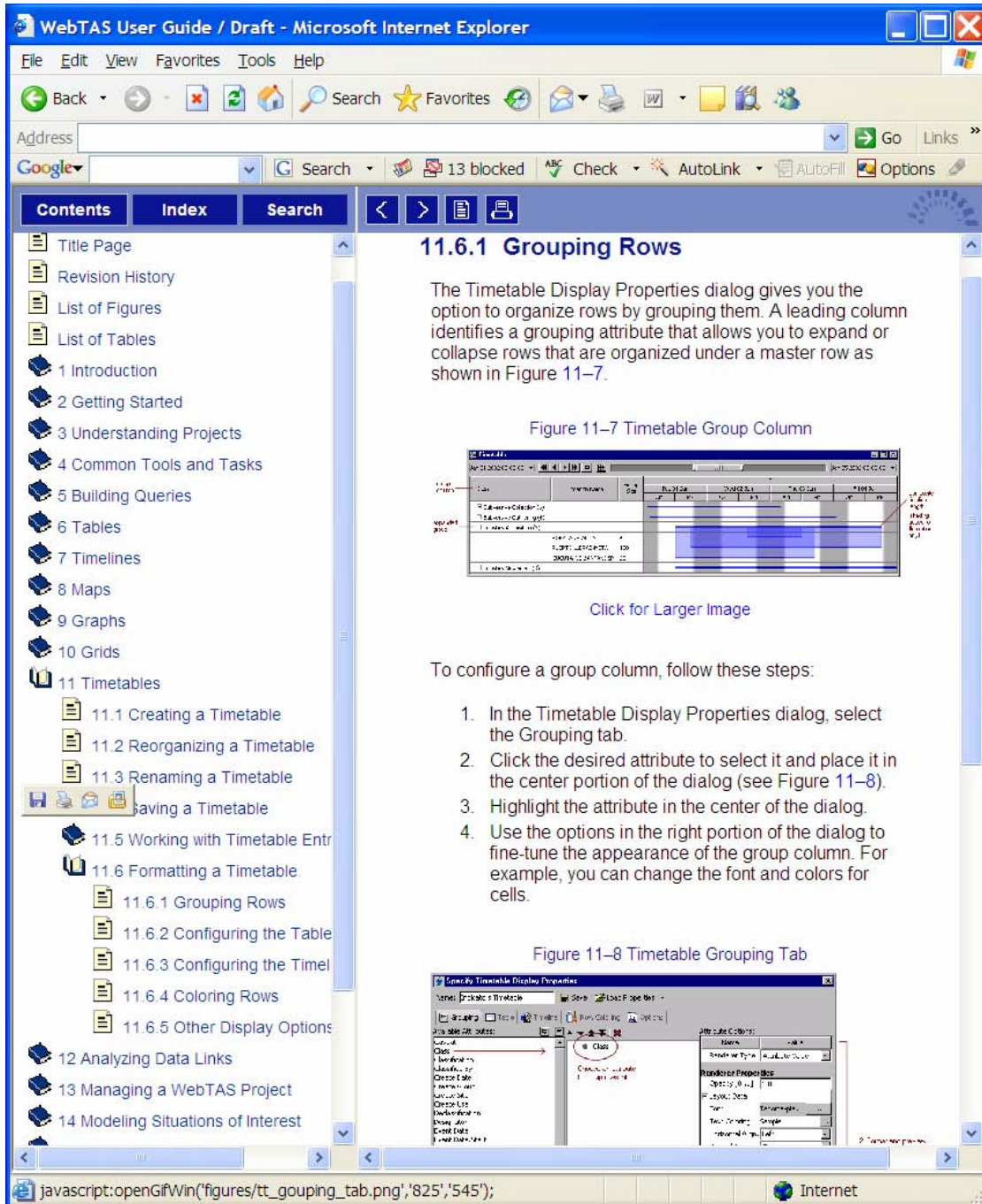

Figure 11 - WebTAS 3.0 User's Guide HTML Extract

The WebTAS 3.0 Quick Reference Card is a new addition that has received notable positive user feedback. This two page, double-side reference card provides the user with a quick reference to the significant features and capabilities of WebTAS. For example, during JEFX 06, this Quick Reference Card could be found at many of the workstations in the AOC area.

























## WebTAS Version 3.0 Quick Reference Card

The Web-enabled Temporal Analysis System (WebTAS) is a multiplatform data visualization and analysis suite. WebTAS lets you work with data from many different sources as if you are looking at one database. In practical terms, this means that WebTAS can compare and contrast a very wide variety of information—and WebTAS displays that information in a virtually unlimited number of custom geographic and temporal combinations.

[www.webtas.com](http://www.webtas.com)

---

### Toolbar

<ul style="list-style-type: none"> <li> Open a WebTAS project</li> <li> Add a new record to the native database</li> <li> Modify a record in the native database</li> <li> Merge records and store the composite in the native database</li> <li> Create a new map view</li> <li> Create a new graph view</li> <li> Create a new table view</li> <li> Create a new model</li> <li> Open the collaboration chat window</li> <li> Pause automatic data refresh</li> <li> Manage existing views by opening the Project Manager</li> <li> Draw directly on a map</li> </ul>	<ul style="list-style-type: none"> <li> Save the current project</li> <li> View a record</li> <li> Delete a record from the native database</li> <li> To support link analysis, modify relationships between records</li> <li> Create a new timeline view</li> <li> Create a new grid view</li> <li> Create a new timetable view</li> <li> Create a new link analysis</li> <li> Populate existing views with refreshed data</li> <li> Resume automatic data refresh</li> <li> Query data sources by opening the Query Panel</li> <li> Highlight coordinates on a map</li> </ul>
--	--



© 2006 Intelligent Software Solutions Incorporated  
[www.issinc.com](http://www.issinc.com)

---

Figure 12 - WebTAS 3.0 Quick Reference Card

The Installation and System Administration Manual (ISAM) for WebTAS 2.5.3 has passed DODIIS Certification. Similar to other ISS documents, the ISAM is thickly hyperlinked and cross-referenced to enhance its usability.

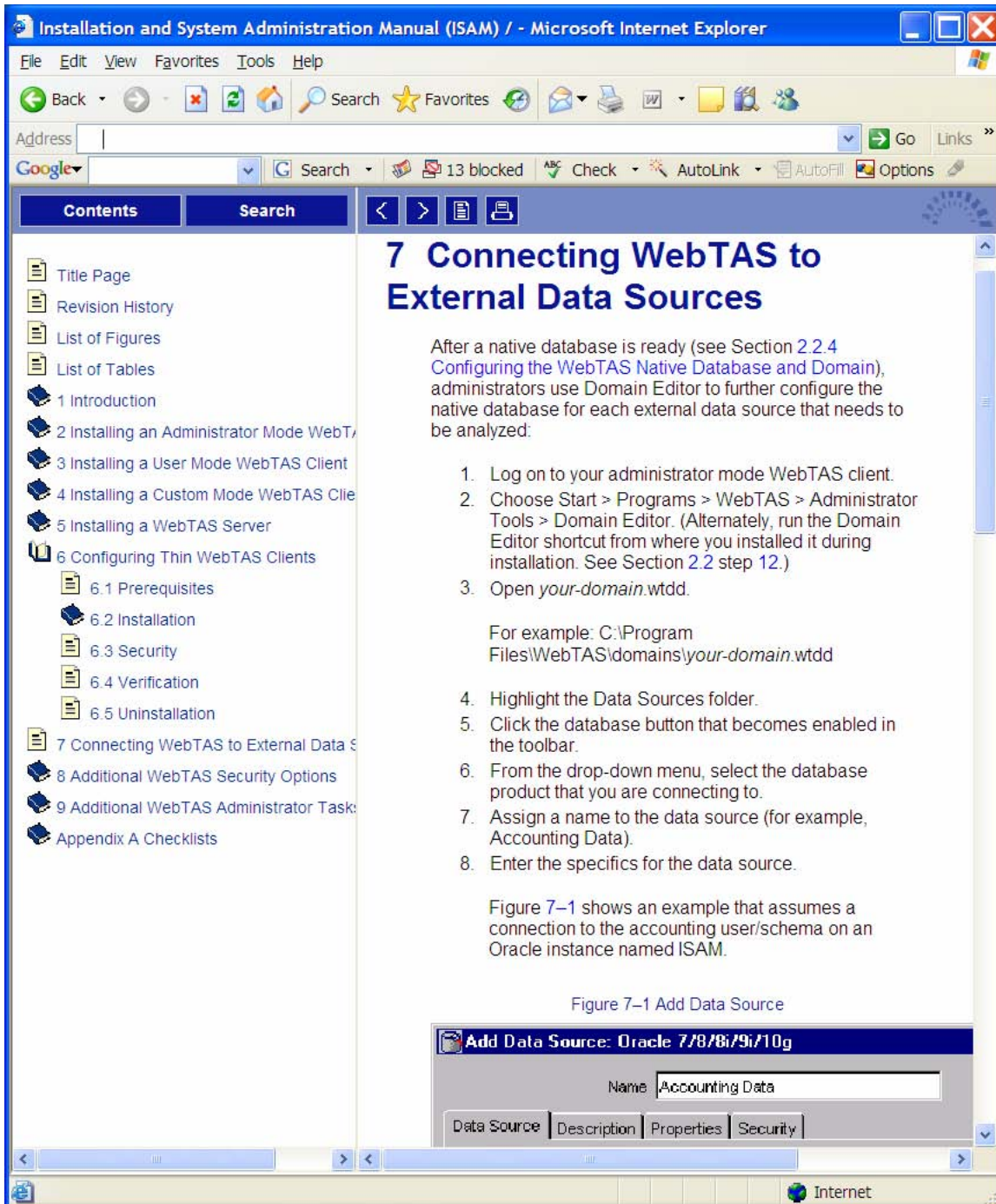



Figure 13 - WebTAS 2.5.3 ISAM

The last example of WebTAS documents generated under this task is the WebTAS 2.5.3 Domain Editor Guide. Although a pdf extract is shown below, this document is also available in an online, browser compatible format. As with its html counterpart, the pdf variant is also complete with hyperlinks and cross-references.

4 Running the Domain Editor  
WebTAS Domain Editor Guide • 1 November 2005

---

## 4.9 Customizing the Graphical User Interface

There are a number of options available for customizing the look and feel of the data entry forms for your Domain. A few of the most common basics are covered in this section.

---

**Note:**

Some GUI features may require advanced planning. You may want to build your Classes and Attributes using the GUI tab view.

---

The toolbar buttons that are used to customize GUI are depicted in Figure 4-19.

**Figure 4-19 Customizing GUI Toolbar Buttons**



Using the example class Arrests, the following sections guide you through customizing the GUI on the data entry forms as shown in Figure 4-20.

Figure 14 - WebTAS 2.5.3 Domain Editor Guide

### **3.4 Project Manager Enhancement**

The WebTAS Project Manager has come “into its own” during this task. As the result of incorporating and enhancing legacy View Manager functions, the Project Manager now serves as a spring board for tailoring query results to meet the needs of the user. For example, the user is able to use Project Manager to manage maps at runtime. In addition, the Project Tool’s internal design now lends itself to incorporating and exposing additional functionality to the user in future releases.

By incorporating View Manager functionality into the Project Manager, it has become the central user interface (UI) component where virtually all aspects of a project can be manipulated, including: displays, queries, display properties, synchronization, and project parameters. The inclusion of two tabs across the bottom of the Project Manager window, titled View Summary and View Detail, provide an intuitive and easy point of access for general project manipulation. All Add, Edit, Remove and Refresh buttons are sensitive to the selected tab as well as the selected object (e.g., map or query).

The underlying design strategy of the enhanced Project Manager is based upon a single ViewManagerComponent (VMC), which is composed of a list of VMC Perspectives. Each VMC Perspective is represented as a tab across the bottom edge of the Project Manager window. Each perspective supports the notion of a current "target" which is an abstract item on the perspective UI that currently has the user's attention. In the case of the view tree, the target is the node in the tree that is currently selected. The VMC Panel that renders the perspective registers itself with the perspective to detect target changes, and update the perspective's supported controls and features accordingly. In particular, if a perspective supports the properties panel feature, then the VMC panel provides a split pane with a placeholder on the right that the current target may populate with its property editing UI.

Sample screenshots of the enhanced WebTAS Project Manager are shown below.

The two current Project Manager Tabs are depicted in Figure 15. Note how the “View Details” tab allows the user to select and drill down to the item/attribute of interest. In this particular example, the user is interested in the general map properties. As the user selects specific map components (e.g., Query Results, Graticule, and Default Drawing Attributes), the content in the right hand pane is context sensitive to the object of interest the user has selected.

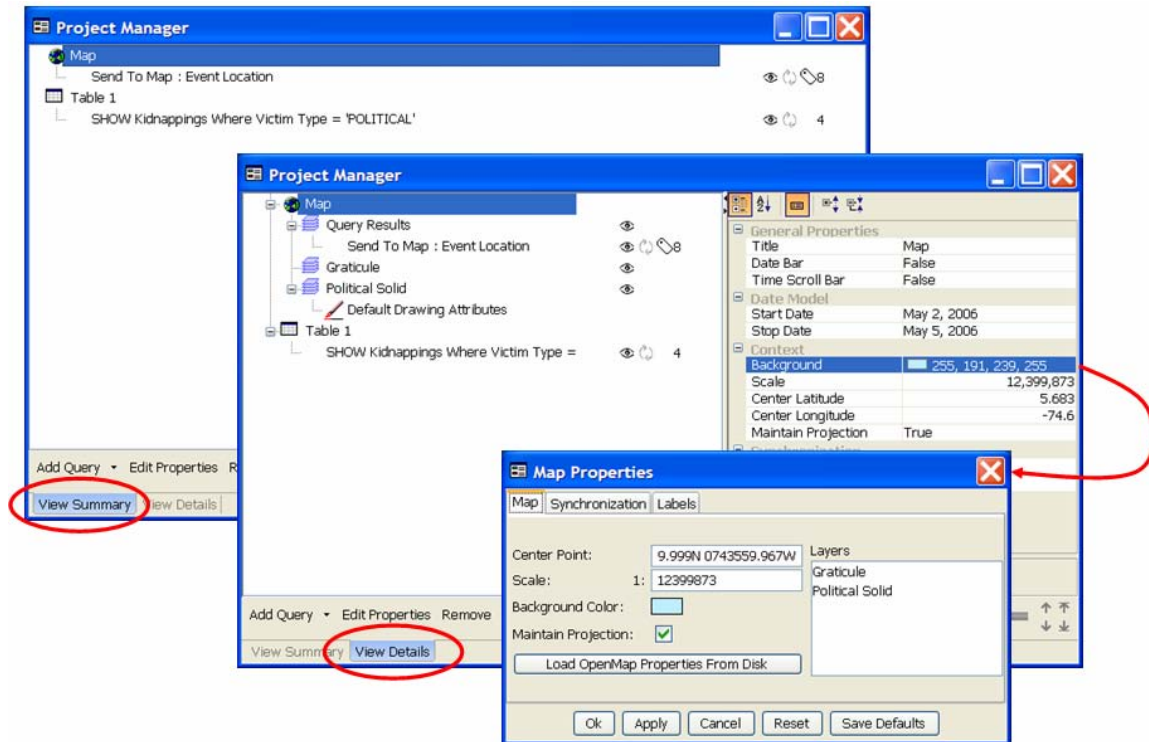

Figure 15 - WebTAS 3.0 Project Manager Tabs

In the following example, the user has displayed on a map kidnappings where the victim type was “Political” in nature. Reference Figure 17 to view an example of the clarity and intuitiveness of the Project Manager window associated with this example query.

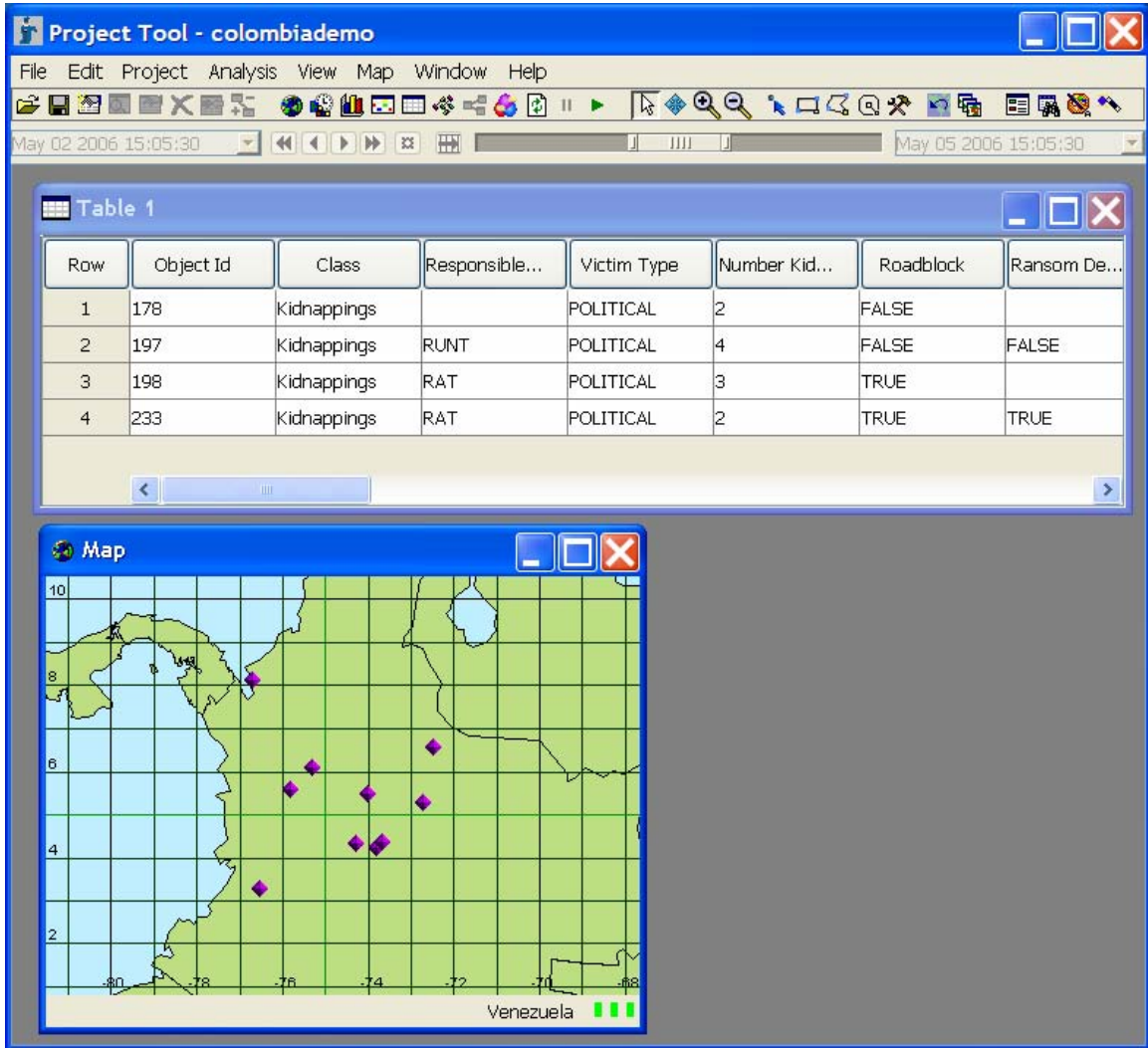

Figure 16 - WebTAS 3.0 Project Manager Map Control Setup Example



The following image depicts the results of viewing the Project Manager associated with the previous example. In this example, the user is interested in modifying map attributes. Specifically, the day/night shading attribute has been set to a light shade of gray with a transparency setting of approximately 50%. The ease, simplicity and directness of the enhanced Project Manager is very evident in this example.

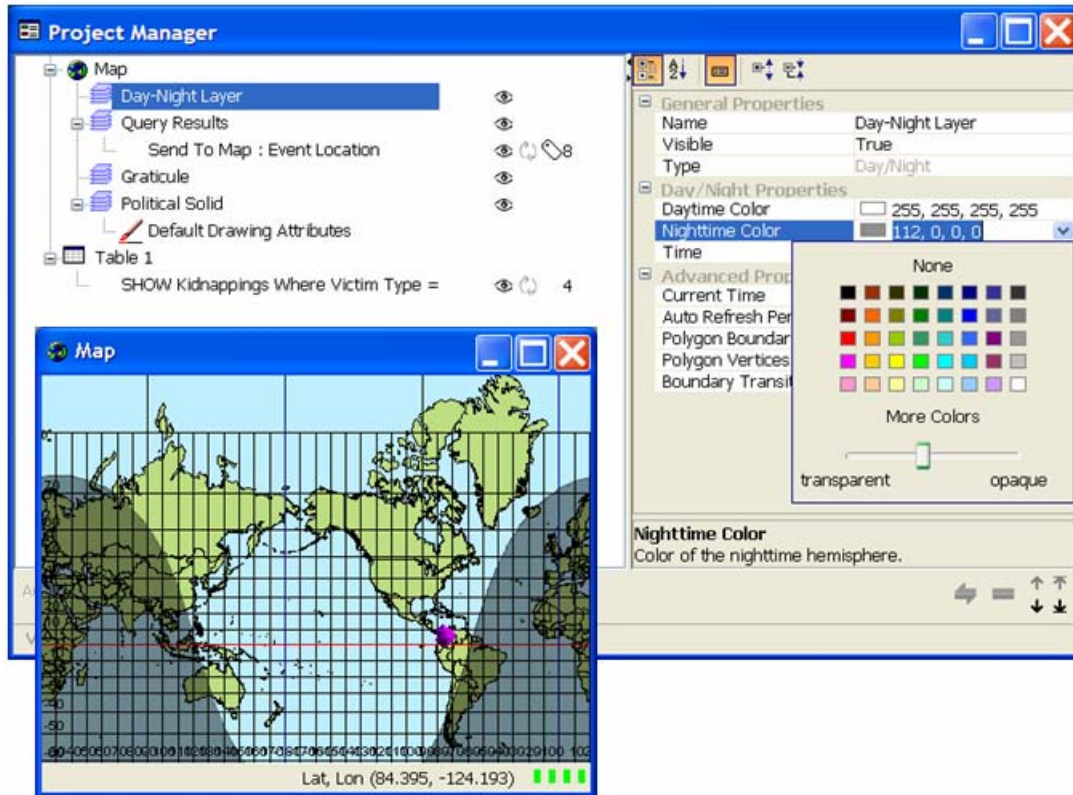

Figure 17 - WebTAS 3.0 Project Manager Map Control Example

### 3.5 Security Manager

During the period of performance for this task, the WebTAS v2.5.\* User Manager has been replaced by WebTAS v3.0 Security Manager. Significant enhancements were made to both the authentication and authorization aspects of the new Security Manager. In addition, the Security Manager's settings can now be exported to and imported from Excel spreadsheets. This provides a means to backup the current settings and to create copies of a domain's settings for import at other installations.

Authentication. The WebTAS v3.0 administrator may now select one of two authentication sources. The first is domain-based authentication, as in previous WebTAS versions. The previous password controls are still available but have been segmented out so that the administrator can select which features are enforced, e.g., passwords can be required to meet a minimum length but not required to be of mixed case, etc.

The second additional authentication source is LDAP-based. When enabled, users can login to Project Tool, Domain Editor, etc., using the same password created for them in their organization's LDAP (Active Directory, etc). All password format and history requirements are controlled by the LDAP. The following figure depicts the "LDAP Configuration" tab associated with the Security Manager "Admin" function.

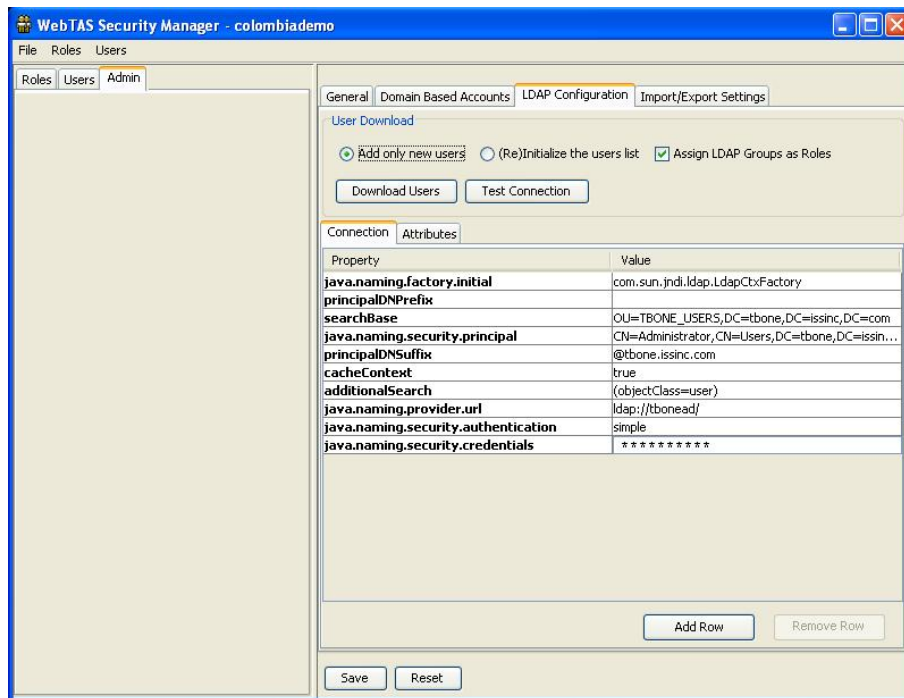

Figure 18 - Security Manager LDAP Configuration

The new authentication system also adheres to standard Java Authentication and Authorization Service (JAAS) technology, which is easily extendable to add options such as X.509 certificates or Kerberos.

Authorization. WebTAS v3.0 now employs a role-based scheme and has expanded the set of data access permissions. Users can be assigned multiple roles, and the permissions set has been expanded to include create, read, update and delete (CRUD). Authorization is the logical OR of the role settings, e.g., read access to a particular class is granted when ANY of the user's assigned roles has read access to the class. The following figure depicts the password features that are selectable in WebTAS v3.0.

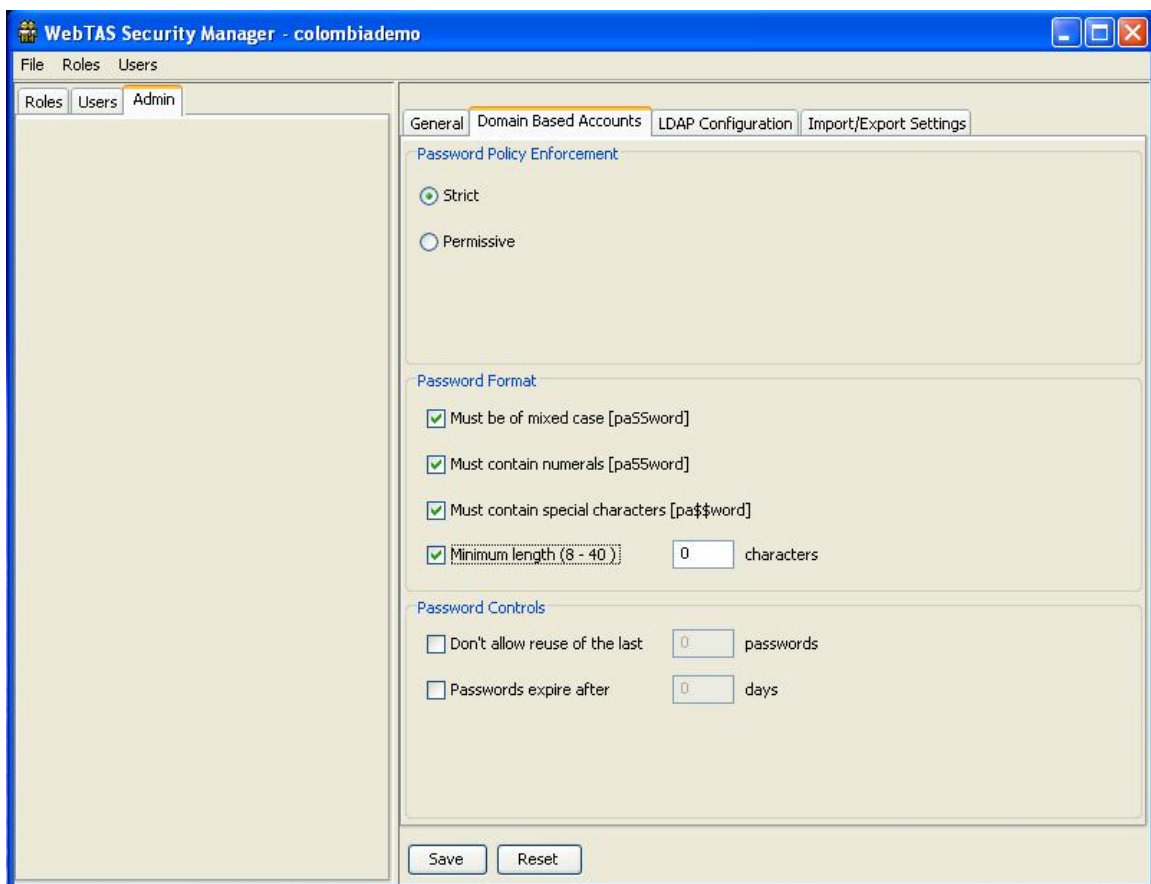
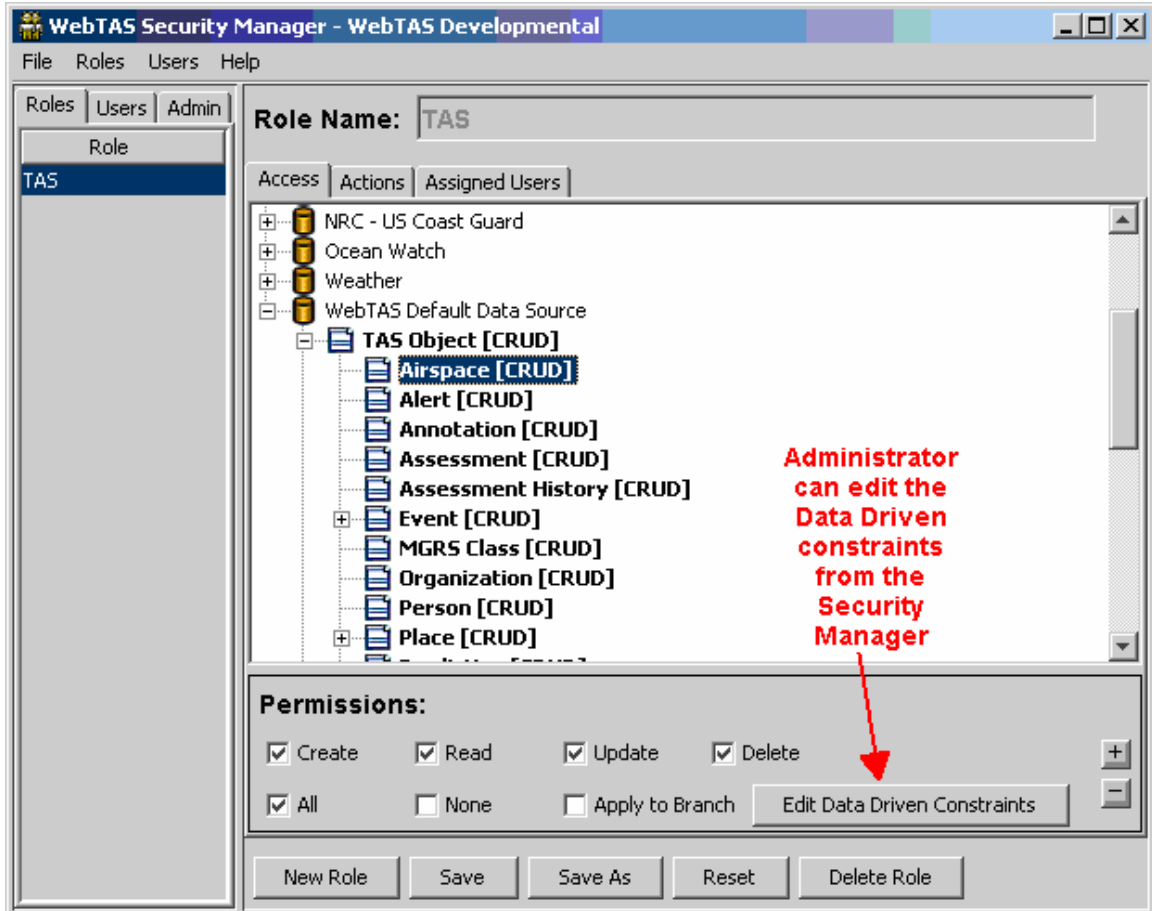

Figure 19 - Security Manager Password Control

In addition, data dependent authorization now allows the WebTAS administrator to specify conditions that restrict or allow access based on the contents of the record. The access to this feature is illustrated in the following image.



**Figure 20 - Security Manager Data Driven Constraints**

Finally, new to WebTAS v3.0 is the ability to control actions (as opposed to just access). Actions are activities that can be performed by the user and are often, but not always, associated with GUI widgets such as menu items. Some actions are pre-defined by the WebTAS core, e.g., “run Project Tool” and the Domain Editor’s “Recreate all tables” action. Permissions can be set to Allow or Deny.

### **3.6 Performance**

The performance of WebTAS core has been addressed on several fronts throughout the execution of this task. For example, the following areas were addressed:

- 1) **Composite Queries:** This internal coding interface allows chaining of multiple Semi-Natural Language (SNL) queries into one. Complex objects that span large parts of the object graph can be built. While this requires multiple queries to the database, it provides immediate performance benefits as well as an abstraction that may lead to fully optimized subquery capability in WebTAS.
- 2) **Surgical Updates:** Progress was made on the ability to update selected attributes of an object instead of replacing the object totally. This has provided major payback on several projects where a common operation such as updating a specific field in a large group of related records has accelerated performance significantly. In one instance performance was accelerated by more than 50 times.
- 3) **Domain Bean Population:** Domain beans are a programming methodology utilizing automatically generated source code representing each object in a WebTAS data dictionary. Changes were made in the query engine so that only the attributes represented by each domain bean are requested from the database server, thus providing an incremental performance benefit without changes to application code.
- 4) **Memory Leak Reduction:** A major profiling effort was conducted and changes made to improve the memory stability of WebTAS applications.
- 5) **Java Message Service (JMS) Transaction Notifications:** This technology provides automatic notification of data changes to other workstations on the network. Optimizations of the WebTAS listeners to these notifications are starting to make this approach practical in a busy environment such as an Air Operations Center (AOC).

## **4 Outstanding Issues and Discussion**

There are no outstanding issues to report.

## Appendix A - Acronyms

Acronym	Definition
AFRL	Air Force Research Laboratory
AFSCO	Air Force Service Certifying Organization
AOC	Air Operations Center
API	Application Programming Interface
B2B	Business to Business
COTS	Commercial Off-the-Shelf
CRUD	Create, Read, Update and Delete
DIA	Defense Intelligence Agency
DCID	Director of Central Intelligence Directive
DODIIS	Department of Defense Intelligence Information System
GOTS	Government Off-the-Shelf
ESB	Enterprise Service Bus
FTP	Functional Test Plan
GUI	Graphical User Interface
html	Hypertext markup language
HTTP	Hyper Text Transfer Protocol
ISAM	Installation and System Administration Manual
ISS	Intelligent Software Solutions
ITA	Information Technology Architecture
J2EE	Java 2 Platform Enterprise Edition
JAAS	Java Authentication and Authorization Service
JAX-RPC	Java API for XML-Based Remote Procedure Call
JDBC	Java Database Connectivity
JEFX	Joint Expeditionary Force Experiment
JMS	Java Message Service
JSP	Java Server Pages
JWICS	Joint Worldwide Intelligence Communications System
LDAP	Lightweight Directory Access Protocol
pdf	Portable document format
RDBMS	Relational database management system
SAAJ	SOAP with Attachments API for Java
SERSC	Southeast Regional Services Center
SMTP	Simple Mail Transfer Protocol
SNL	Semi-Natural Language
SOA	Service-Oriented Architecture
SOAP	Simple Object Access Protocol
TCP	Transmission Control Protocol
UDP	User Datagram Protocol
UI	User interface
USAF	United States Air Force
VMC	ViewManagerComponent
WebTAS	Web-enabled Temporal Analysis System
WS	Web Services
WSDL	Web Services Description Language
X.509	A widely used standard for defining digital certificates
XMPP	eXtensible Message and Presence Protocol
xsd	XML Schema Definition