

STINFO COPY

AFRL-HE-WP-TR-2006-0120

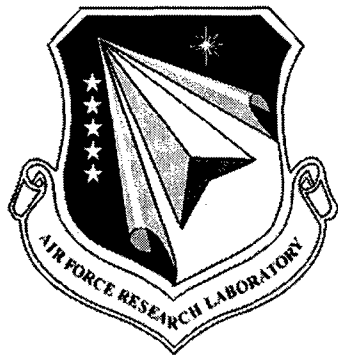

**Logistics Planning for Coalition
Command and Control**

Celestine A. Ntuen

**North Carolina A&T State University
Center for Human-Machine Studies
419 McNair Hall, 1602 E. Market Street
Greensboro, NC 27411**

December 2005

Final Report for June 2004 to December 2005

20061023055

**Approved for public release;
distribution is unlimited.**

**Air Force Research Laboratory
Human Effectiveness Directorate
Warfighter Readiness Research Division
Logistics Readiness Branch
WPAFB OH 45433-7604**

NOTICE

Using Government drawings, specifications, or other data included in this document for any purpose other than Government procurement does not in any way obligate the U.S. Government. The fact that the Government formulated or supplied the drawings, specifications, or other data does not license the holder or any other person or corporation; or convey any rights or permission to manufacture, use, or sell any patented invention that may relate to them.

This report was cleared for public release by the Air Force Research Laboratory Wright Site (AFRL/WS) Public Affairs Office (PAO) and is releasable to the National Technical Information Service (NTIS). It will be available to the general public, including foreign nationals.

National Technical Information Service
5285 Port Royal Road, Springfield VA 22161

Federal Government agencies and their contractors registered with Defense Technical Information Center should direct requests for copies of this report to:

Defense Technical Information Center
8725 John J. Kingman Rd., STE 0944, Ft Belvoir VA 22060-6218

DISCLAIMER

This Technical Report is published as received and has not been edited by the Air Force Research Laboratory, Human Effectiveness Directorate.

TECHNICAL REVIEW AND APPROVAL

AFRL-HE-WP-TR-2006-0120

THIS TECHNICAL REPORT HAS BEEN REVIEWED AND IS APPROVED FOR PUBLICATION.

FOR THE COMMANDER

//SIGNED//

DANIEL R. WALKER, Colonel, USAF
Chief, Warfighter Readiness Research Division
Air Force Research Laboratory

This report is published in the interest of scientific and technical information exchange and its publication does not constitute the Government's approval or disapproval of its ideas or findings.

REPORT DOCUMENTATION PAGE

Form Approved
OMB No. 0704-0188

Public reporting burden for this collection of information is estimated to average 1 hour per response, including the time for reviewing instructions, searching existing data sources, gathering and maintaining the data needed, and completing and reviewing this collection of information. Send comments regarding this burden estimate or any other aspect of this collection of information, including suggestions for reducing this burden to Department of Defense, Washington Headquarters Services, Directorate for Information Operations and Reports (0704-0188), 1215 Jefferson Davis Highway, Suite 1204, Arlington, VA 22202-4302. Respondents should be aware that notwithstanding any other provision of law, no person shall be subject to any penalty for failing to comply with a collection of information if it does not display a currently valid OMB control number. **PLEASE DO NOT RETURN YOUR FORM TO THE ABOVE ADDRESS.**

1. REPORT DATE (DD-MM-YYYY) December 2005		2. REPORT TYPE Final		3. DATES COVERED (From - To) June 2004 - December 2005	
4. TITLE AND SUBTITLE Logistics Planning for Coalition Command and Control				5a. CONTRACT NUMBER FA8650-04-1-6532	
				5b. GRANT NUMBER	
				5c. PROGRAM ELEMENT NUMBER 62202F	
6. AUTHOR(S) Celestine A. Ntuen				5d. PROJECT NUMBER	
				5e. TASK NUMBER	
				5f. WORK UNIT NUMBER 1710D222	
7. PERFORMING ORGANIZATION NAME(S) AND ADDRESS(ES) North Carolina A&T State University Center for Human-Machine Studies 419 McNair Hall, 1602 E. Market Street Greensboro, NC 27411				8. PERFORMING ORGANIZATION REPORT NUMBER Project No: 4-41236	
9. SPONSORING / MONITORING AGENCY NAME(S) AND ADDRESS(ES) Air Force Materiel Command Air Force Research Laboratory Human Effectiveness Directorate Warfighter Readiness Research Division Logistics Readiness Branch Wright-Patterson AFB OH 45433-7604				10. SPONSOR/MONITOR'S ACRONYM(S) AFRL/HEAL	
12. DISTRIBUTION / AVAILABILITY STATEMENT Approved for public release; distribution is unlimited.				11. SPONSOR/MONITOR'S REPORT NUMBER(S) AFRL-HE-WP-TR-2006-0120	
				13. SUPPLEMENTARY NOTES Cleared as AFRL-WS-06-2398, 10/17/2006	
14. ABSTRACT Logistics constitutes a very complex reality that requires a high level of coordination among many different entities. In the military coalition logistics planning environment this problem is amplified because of the differences in command and control (C2) of the participating coalition members. This project develops a decision support model for the military coalition logistics problem. As a short-term goal, this project result can be used to provide a proof-of-concept decision model for shared logistics asset deployment and allocation to achieve a single mission. As a long-term goal, the thesis will demonstrate the capability to use a decision support system (DSS) for logistics process management through a simplified constructive simulation. The proposed model is constructive in that it is parameter driven; reflecting the user's perception of the logistics needs and the likelihood that the resource contribution (input) to the system will lead to the intended goal. The DSS developed is known as COLOPS—an acronym for Coalition Logistics Planning System. The COLOPS model can model the costs associated with the coalition effort. The cost can be the tangible and intangibles logistics costs that are often considered in military transportation and logistics. In the present COLOPS version, we concentrate on planning of coalition resource donations, due dates, cost of late delivery, resource reliability as accounted for by attrition, and coalition readiness and nervous metrics. Future extensions should consider optimizing the logistics throughput by considering maintenance costs and the possibility that coalition members can withdraw their support during a mission.					
15. SUBJECT TERMS Decision Support System, Coalition Logistics Planning, Coalition Readiness					
16. SECURITY CLASSIFICATION OF:			17. LIMITATION OF ABSTRACT SAR	18. NUMBER OF PAGES 44	19a. NAME OF RESPONSIBLE PERSON Edward S. Boyle
a. REPORT UNCLASSIFIED	b. ABSTRACT UNCLASSIFIED	c. THIS PAGE UNCLASSIFIED			19b. TELEPHONE NUMBER (include area code)

THIS PAGE LEFT INTENTIONALLY BLANK

EXECUTIVE SUMMARY

Logistics constitutes a very complex reality that requires a high level of coordination among many different entities. In the military coalition logistics planning environment this problem is amplified because of the differences in command and control (C2) of the participating coalition members. This report develops a decision support model for the military coalition logistics problem. As a short-term goal, this report will provide a proof-of-concept decision model for shared logistics asset deployment and allocation to achieve a single mission. As a long-term goal, the report will demonstrate the capability to use a decision support system (DSS) for logistics process management through a simplified constructive simulation. The developed model is constructive in that it is parameter driven; reflecting the user's perception of the logistics needs and the likelihood that the resource contribution (input) to the system will lead to the intended goal. A decision support tool for coalition logistics planning in the military domain is the product of the research. The model is known as COLOPS, an acronym for COalition LOGistics Planning System. The COLOPS will provide at least three advantages for the military logistics planning. These are:

- (1) provide coordinated multinational logistics information and decision support tools for accurate identification of resource requirements, improved deployment planning, efficient resource sustainment, and rapid logistics re-planning across the full spectrum of operational sectors;
- (2) provide improved logistics command and control (C2) interoperability with coalition partners; and
- (3) provide multinational collaborative logistics analysis capability.

The report has five sections as follows:

Section 1 presents the introduction to coalition logistics to include the domain where coalition logistics may be needed—Coalition Task Force, Joint Task Force, and other collaborative C2 systems that contribute to resource pool management. The project objectives and challenges are identified.

Section 2 presents an anecdotal review of existing related decision support models for coalition logistics planning. They include the Agent-Based Expeditionary Logistics Simulation (ABLS) developed by the Navy; DARPA's Coalition Agent eXperiment (COAX); the Enhanced Logistics Intra-Theater Support Tool (ELIST); the Multi-Agent Logistics Tool (MALT); the Joint Flow and Analysis System for Transportation (JFAST); the Coalition Flow Modeler (CFM); and the Focused Logistics Warfighter (FLOW). These models are context specific and rarely generalized across all military organizations.

Section 3 presents a model for a coalition logistics planning decision support system. The coalition model is assumed to have a mission and a set of objectives that demand specific resources. These resources may be personnel, aircraft, tanks, fuel, munitions, and bulk resupply that occurs at all levels of theater of war. The coalition members, upon assessing their capabilities, are willing to contribute specific resources for the coalition mission. Each resource contributed has a point of staging for logistics, and points of embarkation established by the

coalition command. Different types of costs can be incurred during the process of moving contributed resources from each member nation to the designated logistics assembly point known as point of debarkation. Example costs may include delayed scheduled cost due to missing assembly due date, transportation costs, maintenance and part supply costs, and so on. A set of mathematical models are developed to capture the process. The model also adds some notional extensions to include resource assignment logistics based on sector demands.

Section 4 presents the COLOPS implementation model—including hand calculation examples and the computer software. There are a variety of techniques for modeling logistics processes. These include spreadsheet-based analyses, simulations (both stochastic and deterministic), and application of generalized simulation frameworks (such as Arena). In this project, Visual Basic™ and Microsoft Excel™ spreadsheets are used to implement the models in the previous section.

Section 5 presents the project summary and conclusions, including suggestions for COLOPS extension. Bearing in mind that the current project was to give a proof-of-concept principle, we have developed an architecture in which the COLOPS model can be extended to include the use of Bayesian models to capture coalition member changes in “promise” to donate one or more resources. It is suggested that the model be further refined to “optimize” resource delivery and synchronization by minimizing late delivery costs.

TABLE OF CONTENTS

PAGE NO.

Section 1: Logistics in a Coalition Task Force Operation 1

1.1 Introduction 1

1.2 Coalition Task Force 1

1.3 Coalition Logistics 3

1.4 Project Objective 5

Section 2: An Anecdotal Review of Existing Related Decision Support Models for Coalition Logistics Planning 6

2.1 Agent-Based Expeditionary Logistics Simulation (ABLS) 6

2.2 DARPA’s Coalition Agent eXperiment CoAX) 6

2.3 The Enhanced Logistics Intra-Theater Support Tool (ELIST)..... 6

2.4 Multi-Agent Logistics Tool (MALT) 7

2.5 The Joint Flow and Analysis System for Transportation (JFAST) 7

2.6 Coalition Flow Modeler (CFM) 7

2.7 Focused Logistics Warfighter (FLOW)..... 8

Section 3: Coalition Logistics Planning Decision Support..... 8

3.1 The Rationale 8

3.2 The Proposed Analytical Models in COLOPS 9

3.3 The Decision Support Elements 10

3.4 Model Development and Representation 11

3.5 Resource Delivery Lateness 15

Section 4: The Decision Support Software for COLOPS Implementation 21

4.1 The COLOPS Decision Support Software 21

4.2 The COLOPS User Manual 27

Section 5: Summary and Conclusions 33

5.1 Summary..... 33

5.2 Conclusions 33

References 34

LIST OF EXHIBITS

PAGE NO.

Exhibit 1: The COLOPS Interface 28
Exhibit 2: Coalition Logistics Attrition Worksheet..... 30
Exhibit 3: Coalition Summary Information..... 31
Exhibit 4: Delivery Lateness Cost..... 31
Exhibit 5: Sample Excel Analysis of Delivery Lateness Cost Information 32

LIST OF FIGURES

PAGE NO.

Figure 1: Sample Coalition Task Force	2
Figure 2: Coalition Logistics Network.....	10
Figure 3: The COLOPS Decision Support Model Architecture	11
Figure 4: Coalition Member and Resource Contribution Model	15
Figure 5: Delivery Lateness Model.....	15
Figure 6: Transportation and Maintenance Cost Model	17
Figure 7: Sector Resource Assignment Model	20
Figure 8: Resource Donor Illustration	22
Figure 9: Coalition Effect on Resource Donor	25
Figure 10: Demand-Supply Cost Sample.....	26

LIST OF TABLES

PAGE NO.

Table 1: Sample Resource Information 21
Table 2: Sample Computational Database Representation 22

Section 1: Logistics in a Coalition Task Force Operation

1.1 Introduction

Recent military operations within Afghanistan and Iraq have illustrated the need for incorporating coalition factors in military modeling and simulation. In the new Objective Force structure (<http://www.objectiveforce.army.mil>), effective collaboration is dependent on the reconciliation and integration of multiple operational perspectives across different organizational boundaries, different bodies of staff expertise, different sources of battlespace information, and different resources. Here, the rapid operational tempo of recent operations suggest that coalition members must engage in an almost continuous process of exchange of doctrinal information that extends from the initial development of high-level command intent to the execution of specific attacks and effects against key elements of the adversary's forces and operations. Notably, resource management is a significant part of the process.

With the increasing requirement for coalition forces and their collaboration, there is a need to re-engineer the process of logistics management by considering coalition factors. Coalition factors in military logistics have important implications for coalition warfare, especially on resource planning. For example, questions such as how people of diverse languages, military and political doctrines, socio-economic differences, and affiliation to religious groups share information and reach consensus during courses of action (COA) are important parameters in coalition logistics planning. Also, effective and efficient logistics planning for coalition command and control (C2) depends critically upon orchestrating the collaboration and resource strengths of coalition members to attain the maximum effect against the adversaries.

1.2 Coalition Task Force

With the dimension of asymmetric warfare increasing, there is an increasing reliance on Joint Task Force or Coalition Task Force philosophies. A typical Coalition Task Force (CTF) consists of multinational teams with heterogeneous cultures. Even teams with members from the same country may have cultural differences in the way they set up their operating procedures and doctrines in their various organizations (e.g. Air Force, Marines, Army, etc.). The on-going war in Iraq presents a picture of how a CTF operates. Typically, a single nation leads the coalition process with some understanding on how resources are shared, managed, and coordinated—including the command and control (C2) structure. The CTF led by the USA in the Iraq war is an example. The rising interest in fighting wars with coalition forces creates a need for not only understanding the culture of the coalition members and the enemy, but adds an additional burden on logistics management.

A coalition is usually formed for a focused, limited-scope purpose. A coalition (or network) is a group composed of many different organizations, groups, collectives, and affinity groups. The term "coalition" is derived from the Latin "coalescere," which means "to grow together, to unite or merge into a single body" (Angelis, 1992). Communication is essential in disseminating information in a clear and effective method. Coalitions can be composed of different types of builders that play various roles. One type of a coalition builder is referred to as "the core," which includes key leaders, and others who have an overwhelming sense of mission or something to gain (Angelis, 1992). The second group is interested, helpful, and

supportive and will provide specific resources but is unable to contribute in leadership responsibilities. The third group is composed of individuals who have a passing interest and will come and go. Coalitions can be applied to a plethora of sectors, which includes community-based organizations, health related industries, and emergency relief organizations.

According to the military Coalition Operations Handbook, coalition operations are conducted by forces of two or more nations, which may not be allies, acting together for the accomplishment of a single mission (Coalition Operations Handbook, 2001). Terms such as “multinational,” “work groups” and “alliance” are integrated in the term “coalition.” Forming a coalition involves several steps. For example, the United States pursues national interests through multinational operations to include alliances and coalitions. An alliance is the result of formal agreements (treaties) between two or more nations for broad, long-term objectives that further the common interests of the members (<http://www.army.mil/fm1/chapter3.html>). Alliance members strive to field compatible military systems and establish common procedures. They develop contingency plans to integrate their responses to potential threats. Alliances and coalitions work in conjunction to achieve synchronized actions in mission planning. Unlike alliances, which have an enduring element to them, coalitions are considered ad hoc, short term, and established for a specific objective (Rice, 1997).

Collaboration among military alliances and coalitions to accomplish common goals can be challenging. To implement successful strategies for given missions, collaboration and proper communication are key facets. As a coalition increases in numbers of member nations, conflicting objectives and additional political constraints are added to the pot (RisCassi, 1993). In some cases, the military forces of other nations contribute vital capabilities to the multinational force. In coalition operations, strategy is the level of war where international politics and bodies are coalesced into a unified approach (RisCassi, 1993). Figure 1 shows an example of a coalition of military task force.

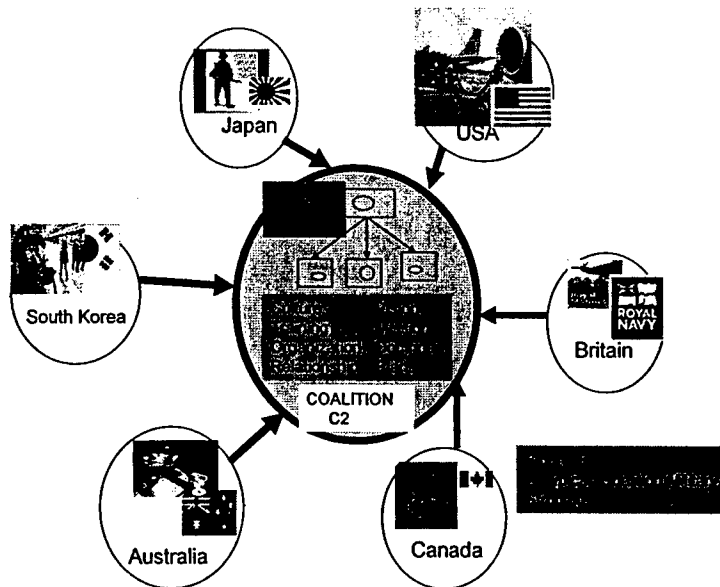

Figure 1. Sample Coalition Task Force

The distributed locations of coalition forces, coupled with team coordination of coalition resources in time and space, provide a significant landscape to research alternative planning models for delivering common logistics, synchronized in time and space, across all echelons of operation command. Current logistics planning systems, particularly for large-scale operations, are generally cumbersome to work with, lack adequate automated capability to prune and select plans, and cannot efficiently handle small changes in initial conditions (e.g., doctrinal conflicts between coalition forces) thus taking a long time to generate high quality plans. In this effort, we have developed models that capture the basic salient parameters of team logistics planning.

1.3 Coalition Logistics

Desimone (1999) notes that military logistics planning is a complex process, involving many calculations, satisfaction of constraints, and cooperation amongst many organizational entities that provide services in order to achieve military logistics goals. Military (operational) logistics planning primarily involves supplying and transporting resources and military assets. These logistics goals are achieved by obtaining services from various organizational entities; for example, obtaining fuel from a fuel supplier, and having a freight company provide the transportation of the fuel from the fuel supplier to its required destination.

Desimone's (1999) organized workshop on coalition logistics identified near-term and long-term problems associated with coalition-planning. The short/medium-term challenges are identified as:

- Defining coalition logistics processes for various mission types
- Developing a shared representation (reflecting culture, doctrine, language issues)
- Defining classes of logistics and deployment assets
- Developing a coalition logistics picture for monitoring execution
- Establishing coalition access (with accredited security model) to information
- Coping with a plethora of logistics systems and databases
- Developing logistics validation models and simulations
- Demonstrating *e-commerce* approach to bidding/brokering for logistics capabilities
- Capitalizing on advanced planning and scheduling technology

The following long-term challenges are identified:

- Demonstrating adaptable, rapidly re-configurable coalition logistics processes
- Developing shared representation (reflecting culture, doctrine, language issues)
- (Essential) tasks, plans capabilities and options
- Identifying agent capabilities (including human roles) and authority chain and process

- Supporting complex logistic planning queries validated by coalition simulations and models at multiple hierarchical levels
- Establishing more flexible security domain models for adaptable, re-configurable coalition logistics planning system

As a short-term goal, this thesis will deal with a proof-of-concept decision model for shared logistics asset information management and allocation required to achieve a single mission. As a long-term goal, the thesis will demonstrate the capability to use a DSS for adaptable, rapidly configurable coalition logistics information management through a simplified constructive simulation. The proposed model is constructive in that it is parameter driven; reflecting the user's perception of the logistics needs and the likelihood that the information input to the system will drive the system towards its intended goal.

There are some challenges associated with the way the model is perceived as parametric simulation-driven. These challenges can be folded into the way logistics is traditionally defined. Logistics can be defined from several perspectives. One example is the business definition of logistics, which defines logistics as a business-planning framework for the management of material, service, information and capital flows. It includes the increasingly complex information, communication and control systems required in today's business environment (Logistics World, 1996). The military defines logistics as, "The science of planning and carrying out the movement and maintenance of forces...those aspects of military operations that deal with the design and development, acquisition, storage, movement, distribution, maintenance, evacuation and disposition of material; movement, evacuation, and hospitalization of personnel; acquisition of construction, maintenance, operation and disposition of facilities; and acquisition of furnishing of services" (Logistics World, 1995). In this instance, logistics can apply to the process of supplying a theater of war with troops, equipment and supplies. One prominent example of logistics is used in the military is the Advanced Logistics Project. This project is under development by DARPA and it advocates focused logistics. Focused logistics is the fusion of logistics and information technologies, flexible and agile combat service support organizations, and new doctrinal support concepts to provide rapid crisis response to deliver precisely tailored logistics packages directly to each level of military operations (Army Vision 2010). In addition, logistics can be categorized in various aspects. According to Logistics World, acquisition logistics, integrated logistics support, and logistics support analysis are some other terms closely associated with the term logistics. The Council of Logistics Management (CLM) has their rendition of logistics. Their definition states, "...that part of the supply chain process that plans, implements, and controls the efficient, effective flow and storage of goods, services, and related information from the point of origin to the point of consumption in order to meet customers' requirements" (Stroh, 2002).

As illustrated by the selected definitions, the proposed thesis will be focused on the coalition aspect of logistics—by investigating how coalition affects the overall resource contribution, integration, and transshipment from points of member donation to points of military deployment.

According to Colonel Patrick J. Dulin, history tells us that "coalition logistics" or "multinational logistics" is essential (Dulin, 2002). Interoperability functions rely on coalition logistics to allow an effortless flow of logistics planning. Multinational partners must remain on a common ground to effectively organize logistical support for military decisions. Coalition

logistics is applied in forming global relationships and developing global partnerships. Developing global partnerships can be cumbersome and challenging; especially within limited time constraints. Some benefits of coalition logistics include cultural insights and skills provided by global coalitions that the United States cannot provide. Coalition members can often present redundant logistical solutions when a common agreement cannot be met in restricted time situations. According to the existing studies that focus on coalition logistics (Dulin, 2002), there is no uniform solution for resolving conflicting issues among coalitions or coalition members. However, there are some ideas that have been proposed to alleviate some of these friction points in coalition logistics. For example, it has been recommended that the regional commanders-in-chief (CINCs) assume the role of interoperability advocates for potential coalition partners within the acquisition logistics process. To implement this recommendation, the regional CINCs need a mechanism that will empower them to discharge an advocacy role (Dulin, 2002). A decision support system will be required to support such effort.

Military logistics involves supplying and transporting resources and military assets (Perugini, et al, 2003). The majority of military logistics planning is not centralized due to its autonomous elements such as various suppliers, transportation entities, and diverse coalition members. Separate geographical locations for the supply and transportation entities are involved in order to achieve specific logistics goals. Each entity has its own assigned task or plan to achieve the logistic goal. Since logistics goals, organizational capabilities, beliefs, and decisions are constantly changing throughout the planning stages, the logistics domain can be considered dynamic. Additionally, organizations or members may withdraw from the system at any time (Perugini, et al, 2003), requiring the DSS to be adaptive and able to tolerate uncertainties.

1.4 Project Objective

The major objective of this project is to develop a decision support tool for coalition logistics planning in a military domain. The model is known as COLOPS, an acronym for COalition LOGistics Planning System. The COLOPS will provide at least three benefits for the military logistics planning tasks. These are:

- (1) provide coordinated multinational logistics information and decision support tools for accurate identification of resource requirements, improved deployment planning, efficient resource sustainment, and rapid logistics re-planning across the full spectrum of operational sectors;
- (2) provide improved logistics command and control (C2) interoperability with coalition partners; and
- (3) provide multinational collaborative logistics analysis capability.

The COLOPS decision support model will be developed with Microsoft Visual Basic™ and Microsoft Excel™. The model will be parametric-driven, i.e., the user will specify the parameters required to generate input for the COLOPS environment. This will be discussed in detail in Section 3 of this paper. In developing the COLOPS model, user-interface issues will be taken into consideration as well as the validation of the model. The COLOPS model will

also consider the costs associated with the coalition effort. The cost will be the tangible and intangibles logistics costs that are often considered in military transportation and logistics.

Section 2: An Anecdotal Review of Existing Related Decision Support Models for Coalition Logistics Planning

In this section, a summary of existing DSSs for military logistics planning is presented. It should be noted that there are many logistics planning models however, the ones presented here have some similar applications for the model to be proposed.

2.1 Agent-Based Expeditionary Logistics Simulation (ABLS)

The ABLS is a logistics simulation developed for Navy logistics management needs. It has the capability to conduct future naval logistics analysis, war-gaming, and training exercises in a dynamic, unpredictable environment. ABLS is an adaptive and dynamic logistics modeling and simulation (M&S) capability that uses agent-based modeling technology. The key capability of ABLS is the ability to model dynamic and uncertain environments. (<http://www.atl.external.lmco.com/overview/programs/IS/ABLS.html>)

2.2 DARPA's Coalition Agent eXperiment (CoAX)

The CoAX project is aimed at demonstrating the utility of agents for coalition planning (Allsopp, et al, 2002). Some 20 organizations from the USA, UK and Australia were involved. The Coalition Agents eXperiment (CoAX) aimed to show that multi-agent systems are an effective way of dealing with the complexity of real-world problems, such as agile and robust coalition operations and enabling interoperability between heterogeneous components to include legacy and actual military systems. CoAX is an international collaboration carried out under the auspices of DARPA's Control of Agent-Based Systems (CoABS) program. Building on the CoABS Grid framework, the CoAX agent infrastructure groups agents into domains that reflect real-world organizational, functional, and national boundaries, such that security and access to agents and information can be governed by policies at multiple levels.

2.3 The Enhanced Logistics Intra-Theater Support Tool (ELIST)

The ELIST project (<http://www.tea.army.mil/tools/elist.htm>) is a transportation forecasting simulation that predicts the arrival of troops, equipment and re-supplies cargo from ports of debarkation or theater origins to final destinations or tactical assembly areas. It simulates organic and external lift movements over a detailed model of the infrastructure with constrained transportation assets. Key features of ELIST include:

- A knowledge base that captures the expertise of planners and logisticians,
- Simulations that expedite time-phased planning,
- Object-oriented databases of transportation infrastructure,
- Heuristic algorithms, and
- User interface that integrates maps, data, reports, and model results.

The knowledge base within ELIST is a repository for standard operating procedures, doctrine, and data, including qualitative criteria, and planner's "rules of thumb." The system is interactive, having a stop-start capability. During simulation, the user can pause, affect changes in infrastructure capabilities, modify lift asset availability, and then continue the simulation. ELIST allows planners to evaluate the operational transportation feasibility of a movement plan. ELIST identifies infrastructure constraints, lift asset constraints, and projects closure trends. This allows for rapid course of action development with quantitative analysis. ELIST runs in a stand alone mode. It also can accept input from strategic deployment models, such as the Joint Flow and Analysis System for Transportation or the Model for Inter-theater Deployment by Sea and Air. ELIST can be used in a planning, training, or exercise context, and has the potential to "feed" combat models with realistic deployment and sustainment information

2.4 Multi-Agent Logistics Tool (MALT)

Multi-Agent Logistics Tool (Perugini, et al, 2003) is being developed using agent technology, where agents represent the organizations within the logistics domain and model their logistics functions, processes, expertise, and interactions with other organizations. Agents in MALT cooperate with each other in order to form a distributed logistics plan (services from various organizations) to meet their logistics goals. The input for MALT is a logistics goal, and the output is an executable logistics plan.

2.5 The Joint Flow and Analysis System for Transportation (JFAST)

The JFAST is a multimodal transportation analysis model designed for the U.S. Transportation Command (USTRANSCOM) and the Joint Planning Community. JFAST is used to determine transportation requirements, perform course of action analysis, and project delivery profiles of troops and equipment by air, land, and sea. JFAST operates on a wide variety of desk-top and laptop computers. The configuration is primarily determined by how large the plan is to analyze and how fast the analysis is required (<http://www.defensesystemsgroup.com/jfast.htm>).

2.6 Coalition Flow Modeler (CFM)

The CFM model was developed by the U.S Air Force Advanced Concept Technology Demonstration (ACTD)'s Coalition Theater Logistics (<http://www.coalitiontheaterlogistics.org/product/product.htm>). The CFM tracks the movement of military units from their installations to their airports and seaports of debarkation within the theater of operations. The CFM routes trucks, trains, buses, convoys, aircraft, and ships over appropriate networks to forecast potential congestion points within the transportation network, determine lift requirements, and project force closures. The CFM has the capability of executing multiple plans simultaneously, identifying where there is competition for common resources such as port throughput. CFM was developed specifically for military transportation planning, and is designed for the action officer as a PC desktop tool. CFM is intended to provide as complete an environmental picture as possible in which to develop and analyze

military deployments from the perspective of defense transportation. The CFM environment includes the necessary reference files and editors, requirements builders and editors, transportation asset managers, multi-modal flow models, reporting tools and system administration functions, all integrated into a common environment.

2.7 Focused Logistics Warfighter (FLOW)

The FLOW model is an innovative logistics assessment tool used by military analysts to examine logistics capabilities of joint and combined forces employed over the full spectrum of operations. The FLOW system was developed by Systems Planning and Analysis, Inc, Alexandria, VA (<http://www.spa.com/jwad.htm>). The FLOW process is a unique approach facilitating assessments of new technology, current and proposed joint logistics doctrine, and current and future Desired Operational Capabilities (DOCs) required to meet Joint Vision 2020 Focused Logistics Challenges. FLOW assessments are based upon a scenario involving U.S. and multinational forces operating in a globally engaged posture, punctuated by specifically designed events to purposefully stress the logistics system. The whole process is focused on developing joint solutions for identified shortfalls and redundant capabilities and on emphasizing innovation over resource-intensive answers. A major benefit also includes increasing awareness, understanding, and sharing of logistics practices and capabilities among the Services, federal agencies, and allies.

Section 3: Coalition Logistics Planning Decision Support

3.1 The Rationale

Coalition logistics goals are achieved by obtaining services from various organizational entities; for example, obtaining fuel from a fuel supplier, and having a freight company provide the transportation of the fuel from the fuel supplier to its required destination. The organizations, which primarily include supply, transportation and force element organizations, are geographically distributed and must cooperate in order to achieve the logistics goals. Each coalition member's organizations have their own logistics business processes in order to perform their particular logistics functions (services) required to achieve logistics goals. The logistics domain is also decentralized; not because it is geographically distributed, but because coalition members exhibit a strong notion of autonomy, with characteristics such as making their own decisions (i.e. not controlled by others); and being reluctant to release information (e.g. because it may be proprietary or classified). The logistics domain is also dynamic, where logistics goals, organizations' capabilities (the type and availability of services they can provide) and beliefs are continually changing throughout the planning process, as well as open, where organizations may enter or leave the system at any time.

Models used in logistics systems analysis can be classified into deterministic analytical models, stochastic analytical models, economic models, and simulation models (Beamon 1998). A deterministic analytical model is one in which the variables are known and specified, and the goal is to achieve a closed-form analytical solution through mathematical programming techniques. These models provide prescriptive solutions under certain assumptions, but are limited to static system representation. A stochastic analytical model is one in which at least

one of the variables is unknown, and is assumed to follow a particular statistical distribution - for example, logistics models including maintenance of repairable items. Here, some known probability distributions are used to model the behavior of item failures or behaviors of the inventory system. These models embody more realistic features of a supply chain in the form of stochastic representations however; they are not dynamic because they do not account for real time updates of the entities and interactions of the system. Examples of stochastic models include a heuristic stochastic model developed by Lee and Billington (1993) for managing material flows on a site-by-site basis. Simulation models use computer representations to model the real-world description of the phenomenon of interest. For example, in military logistics, a simulation model will include the command and control structure, the mission statement, and the multiple objectives of managing logistics in an agile and dynamic fashion to cope with battle situations.

To add to the complexity, logistics planning requires many interactions between organizations, many calculations, and satisfaction of many constraints (e.g. to ensure that casualties are delivered to the appropriate medical facilities in time). As a result of logistics planning complexities, there is typically a trade off between the time to form the logistics plans and the quality of the logistics plans formed.

3.2 The Proposed Analytical Models in COLOPS

As previously described, military logistics is a complex system with all the randomness often associated with such complexity. Logistics, in the military coalition domain, can be described as follows: The coalition has a mission and a set of objectives that demand specific resources. These resources may be personnel, aircraft, tanks, fuel, munitions, and bulk resupply that occurs at all levels of theater of war. The coalition members, upon assessing their capabilities, are willing to contribute specific resources for the coalition mission. Each resource contributed has a point of staging for logistics, and points of embarkation established by the coalition command. Different types of costs can be incurred during the process of moving contributed resources from each member nation to the designated logistics assembly point known as the point of debarkation. Example costs may include delayed scheduled cost due to missing assembly due date, transportation cost, maintenance and part supply cost, and so on. Further, attrition of the resources can occur due to natural or enemy disruption. Figure 2 shows the overall conceptual logistics network.

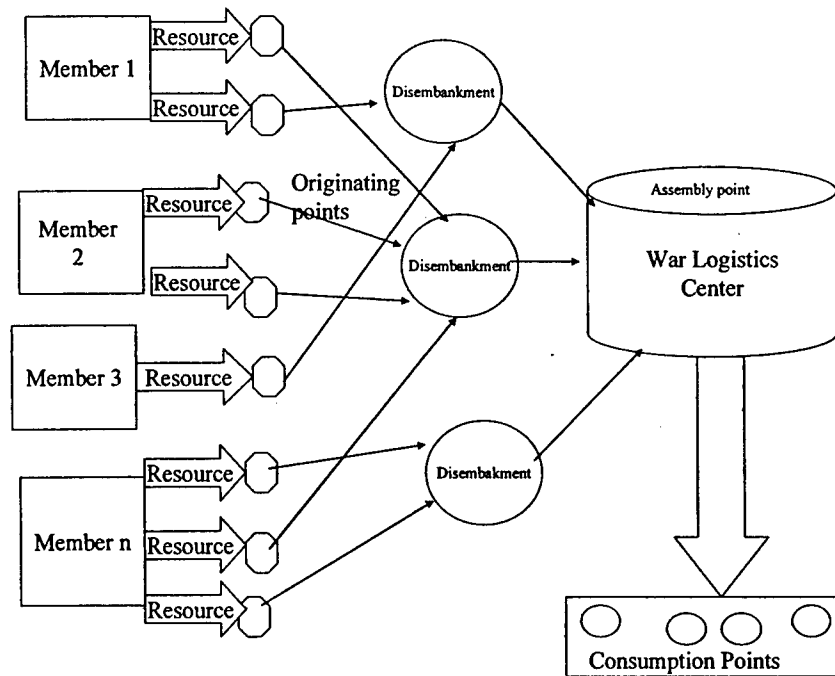

Figure 2. Coalition Logistics Network

As shown in Figure 2, each coalition member donates specific resources with known capacities, and designates a location where the resource will be staged for logistics and transportation to a point of debarkation. Note that these resources are non-homogenous assets that may require disassembly and/or assembly. The fictitious “War Logistics Center” represents the military’s logistics command and control (C2) center.

3.3 The Decision Support Elements

A decision support system (DSS) is a class of computer-based models that are designed to support the human with decision and judgment tasks. Some observed characteristics of a DSS that have evolved from the work of Alter and others (Alter, 1977) include:

- they tend to be aimed at less well structured, underspecified problems that upper level managers typically face;
- they attempt to combine the use of models or analytic techniques with traditional data access and retrieval functions; and
- they specifically focus on features which make them easy to use by non-computer experts in an interactive mode.

A typical, well-designed DSS would allow the decision makers to explore the dimensions of “what if” possibilities in a problem situation. This is often achieved by embellishing a simulation model within the DSS (Desimone, 1999). In addition, a DSS can provide support in managing complex information through information deduction and fusion algorithms.

The COalition LOGistics Planning System (COLOPS) model proposed here, views the DSS at two macro levels: Mission Requirements and Logistics Synchronization. This is illustrated in Figure 3.

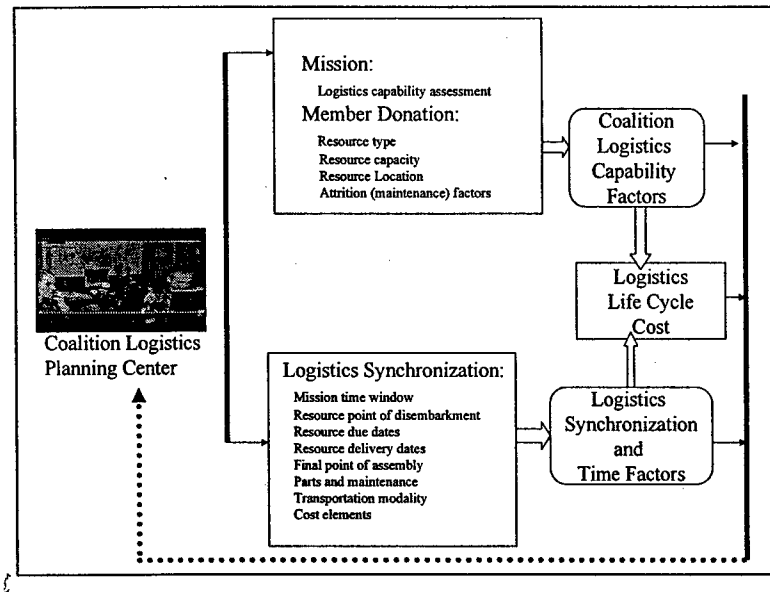

Figure 3. The COLOPS Decision Support Model Architecture

At the Mission level, the COLOPS will provide the user with the overall Coalition Logistics Capability Factor by combining inputs from the database of the member's resource donation list. A typical resource will include its capacity, type, location, and attrition or maintenance factors. At the Logistics Synchronization level, the COLOPS will analyze and produce performance assessments on achieving resource synchronization and meeting due dates. The input to this process consists of the planning time window, information on points of resource delivery, expected due date, optimistic delivery date, final point of use or assembly, transportation modality, and associated cost elements. By combining the information at the two levels, a logistics life cycle cost can be calculated. The calculated parameters are displayed to the Coalition Logistics Planning Center for review. With this information, the COLOPS will provide a user-friendly interface that will be tested for usability.

3.4 Model Development and Representation

This section provides a glossary of terms associated with the coalition logistics models to be presented.

a_{ij} = lateness delivery cost of resource j denoted by i

A_{ij}^{km} = the arrival time of resource j from donor i staged at depot k to be delivered to location k

$$b_{jk}^i = \begin{cases} 1, & \text{if resource } j \text{ denoted by } i \text{ is staged at point } k \\ 0, & \text{else} \end{cases}$$

B_{ij}^{km} = the cost of transporting resource j denoted by donor i from staging depot k to delivery point m

D_{ji}^{km} = expected delivery due date of resource j donated by i , from staging point k to delivery point m

D_p = the plan window, i.e., the coalition established due date for all resources to be delivered to their respective destinations

d_{jn} = the unit cost of part n used by resource j

L_{ij}^{km} = the total lateness of resource j from donor i , originating from staging point k to final destination m

TL_{ij} = the total lateness (time) of resource j denoted by i

LC_{ij} = the total lateness cost of resource j denoted by i

LLC_j = the total lateness cost attributed to resource j

RAL = total resource assembly lateness at the final destination

$RALC$ = total assembly lateness cost

V_m^j = lateness cost of resource j to its final destination m

$$Z_{ij}^{km} = \begin{cases} 1, & \text{if resource } j \text{ is donated by } i \text{ is staged at } k \text{ and moved to } m \\ 0, & \text{else} \end{cases}$$

r_{ij} = the quantity of resource j donated by i

$$X_{ij} = \begin{cases} 1, & \text{if resource } j \text{ is donated by } i \\ 0, & \text{else} \end{cases}$$

TQ_j = the total quantity of resource j denoted

P_{jn} = part type n required by resource j

NP_j = the total number of parts required by resource j

U_{jn} = the quantity of part n required by j (part kit)

TC = the total cost of transportation of resources to their respective final points

q_{jn} = the probability of part n failure from resource type j

$$0 \leq q_{jn} \leq 1$$

NR = the number of resource types in the planning horizon

I = the number of donors

$j = 1, 2, 3, \dots, NR$

$i = 1, 2, 3, \dots, I$

K = the number of staging points

$k = 1, 2, 3, \dots, K$

M = the number of final destinations

$m = 1, 2, 3, \dots, M$

MC_j = total maintenance cost of parts associated with resource j

TMC = total maintenance cost of all parts required by all resources

R_j^k = the total units of resource j at staging point k

QR_j = the total quantity of resource j donated

NQ = the total volume of resources (in units) donated

α_{ij} = percentage of attrition of resource j denoted by i

$0 \leq \alpha_{ij} \leq \alpha^*$, $\alpha^* = [0.2]$, this is estimated by the experts

β_{ij} = percentage loss of resource j donated by i due to latent logistics problems

$$0 \leq \beta_{ij} \leq \alpha_{ij}$$

Λ_j = total loss of resource j due to attrition and logistics problems

Ψ = an integrated decision factor that measures the overall coalition resource strength

$bel(i,j)$ = a subjective rate value by donor i about the sufficiency of resource j

$$0 \leq bel(i,j) \leq 1$$

R_j^{\min} = the perceived minimum requirement of resource j

R_j^{\max} = the perceived maximum requirement of resource j

τ = a normalized constant to convert bel(i,j) values to a probability equivalent

W_{js} = The fraction of resource j assigned to demand sector s

$$\lambda_{js} = \begin{cases} 1, & \text{if resource } j \text{ is needed at sector } j \\ 0, & \text{else} \end{cases}$$

SR_{js} = the total demand of resource j at sector s

Δ_j^- = unsatisfied demand of resource j

Δ_j^+ = excess inventory of resource j

c_j^+ = unit cost of carrying excess inventory of resource j

c_j^- = penalty cost of unsatisfied demand of resource j

SC = total sector cost of inventory and penalty cost

LCC = total logistics life cycle cost up to final stage points

TCC = total life cycle cost of logistics operation

In the next sections of this paper, diagrams and cases will be used to illustrate the model derivation. In Figure 4, a sample network of resources donation and logistics information flow is illustrated.

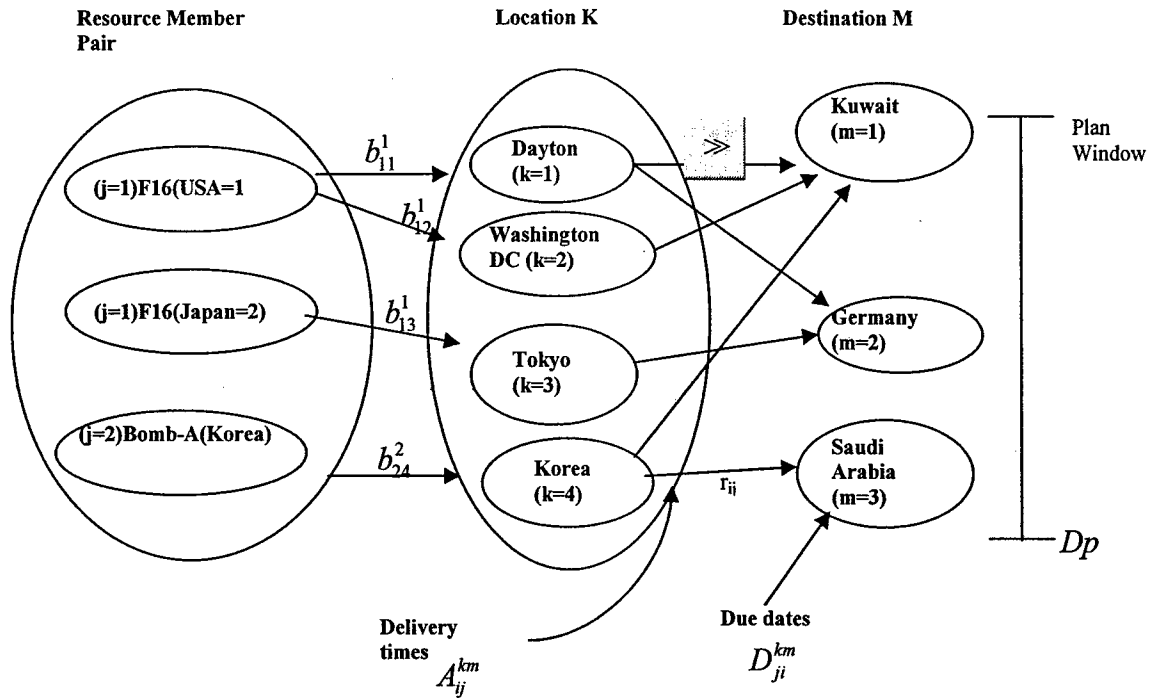

Figure 4. Coalition Member and Resource Contribution Model

As shown in Figure 4, each donor (i) contributes to resources (j=1,2, ..NR). The contributed resources are located at k (k=1,2,...K). The resource assembly (final destination) point is denoted by m=1,2,...M. The coalition planning window (D_p) gives the expected due date for all resources denoted to reach their respective destinations. The delivery times vector (A) and due date's vector of each resource (D) and resource contribution (r_{ij}) are indicated.

3.5 Resource Delivery Lateness

Realistically, resources that are shipped from location k to final point m may arrive late, i.e., they do not satisfy the stipulated due dates. In this case, a lateness cost is incurred. Figure 5 is used to illustrate this.

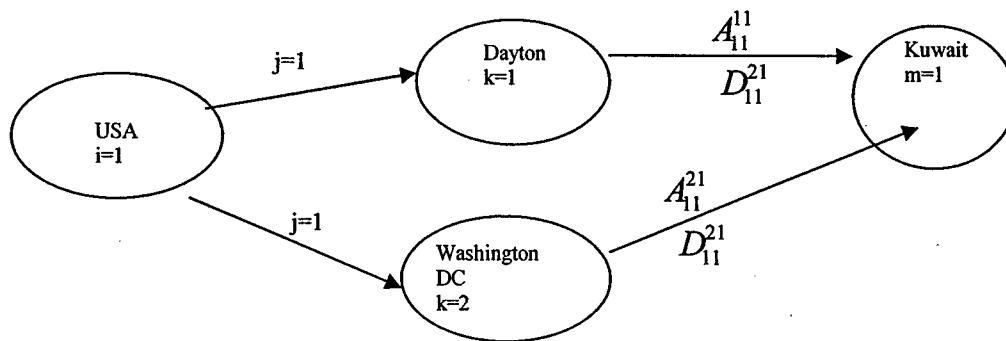

Figure 5. Delivery Lateness Model

As an example, the lateness of resource $j=1$ denoted by member $i=1$, moved from location $k=1$ (Dayton) to final point $m=1$ (Kuwait) is determined by:

$$L_{11}^{11} = \max(0, A_{11}^{11} - D_{11}^{11})$$

Similarly, $L_{11}^{21} = \max(0, A_{11}^{21} - D_{11}^{21})$

The total lateness of resource $j=1$ from member $i=1$ is:

$$L_{11}^{11} + L_{11}^{21}$$

In general, the total lateness is:

$$TL_{ij} = \sum_k \sum_m b_j^k \max(0, A_j^{km} - D_{ij}^{km}) Z_{ij}^{km} \quad (1)$$

Resource Delivery Lateness Cost

By using the lateness model in equation 1, the total cost of lateness can be estimated by:

Lateness cost = Penalty cost per unit time * lateness time

For example: $LC_{11} = a_{11} * TL_{11}$

In general,

$$LC_{ij} = a_{ij} \sum_k \sum_m b_{jj}^k [Z_{ij}^{km} \max[0, A_{ij}^{km} - D_{ij}^{km}]] \quad (2)$$

The total lateness cost attributed to resource j is:

$$LLC_j = \sum_i L_{ij} \quad (3)$$

The lateness cost against the system planning due date can be calculated in a similar manner.

$$RALC = \sum_m V_m^j \max(0, \max[A_{ij}^{km}] - D_p) \quad (4)$$

Here, lateness is determined against individual resource expected delivery date and the planning horizon due date (D_p). The total lateness is defined by equation (5).

The total cost, RALC, is:

$$RALC = \sum_m V_m^j \max(0, \max[A_{ij}^{km}] - D_p) \quad (5)$$

Transportation Cost

Transportation cost is an unavoidable cost in a logistics system. Here, we compute the total cost of transporting the resources from location m to its final point k. This is given in equation (6).

$$TC = \sum_i \sum_j \sum_k \sum_m Z_{ij}^{km} B_{ij}^{km} r_{ij} x_{ij} \quad (6)$$

Parts and Maintenance Cost

It is assumed that a given resource j will need parts and maintenance. Further, it is assumed that each part type requires a part kit with some estimated quantities; some quantities of these parts have a probability of failure. This is shown in Figure 6.

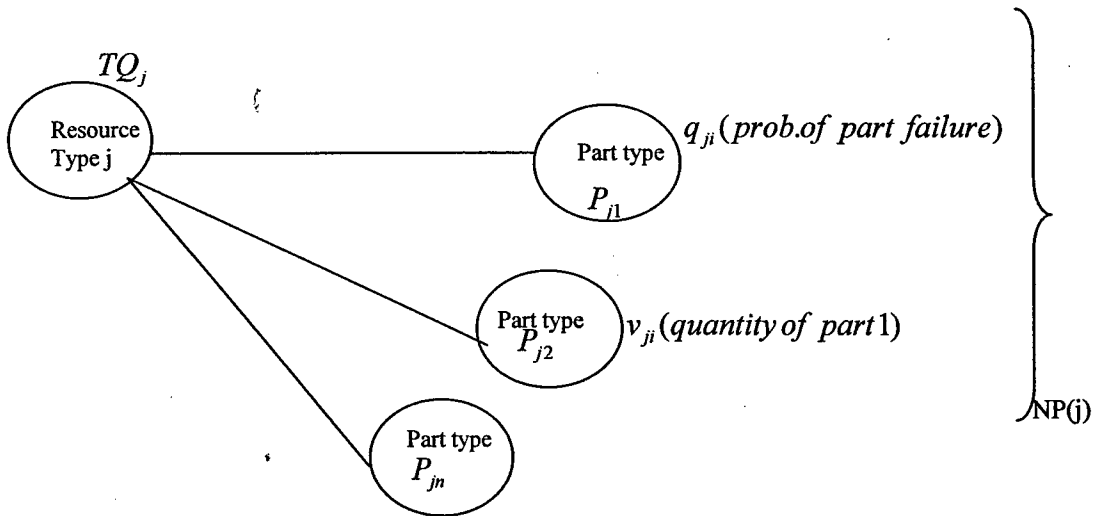

Figure 6. Transportation and Maintenance Cost Model

To estimate parts and maintenance cost, the following equations are used (7-9b):

$$TQ_j = \sum_i \sum_j b_{ji}^k r_{ij} \quad (7)$$

$$MC_j = \sum_{n=1}^{NP(j)} q_{jn} u_{jn} d_{jn} \quad (8)$$

$$TMC = \sum_j^{NR} MC_j \quad (9a)$$

$$TMC = \sum_j^{NR} \sum_{n=1}^{NP(j)} q_{jn} u_{jn} d_{jn} \quad (9b)$$

Coalition Logistics Readiness Factor

Coalition logistics readiness factor is an index to measure the readiness (nervousness) of resources available for the mission. This index can be determined as the ratio of expected discounted resource denoted to expected resource needs. The following equations are used to determine this.

The total inventory resource j at location k is defined by:

$$R_j^k = \sum_i X_{jk}^i b_{ij}^k r_{ij} \quad (10)$$

The total resource volume contributed by coalition members is calculated as follows:

$$NQ = \sum_j \sum_k R_j^k \quad (11)$$

The total volume discounted against attrition and loss is:

$$DNQ = \sum_j \sum_k \sum_i b_{ij}^k (1 - \alpha_{ij} \beta_{ij}) r_{ij} X_{ij} \quad (12)$$

$$ERN = \sum_j Q_j \quad (13)$$

Resource j Attrition

$$\Lambda_j = \sum_k \sum_i b_{ij}^k (\alpha_{ij} \beta_{ij}) (r_{ij} X_{ij}) \quad (14)$$

The coalition logistics readiness factor Ψ is calculated by

$$\Psi = \frac{DNQ}{NQ} \quad (15)$$

The logistics reliability factor R_L is calculated by

$$R_L = \frac{DNQ}{NQ} \quad (16)$$

Logistics Plan Index (LPI)

The LPI is determined as the ratio of expected resource donation against expected resources needed for the mission.

$$LPI = \frac{\Psi}{R_L} = \frac{NQ}{ERN} \quad (17)$$

Coalition Effect on Logistics Model

Let $Bel(i, j)$ hold the opinion to which member i believes that resource j contributed is adequate or sufficient for the mission. Further, let the coalition belief be established in the range defined by the minimum and maximum resource adequacy established by the coalition as defined by:

$$R_j^{\min} \ \& \ R_j^{\max}$$

The $Bel(i, j)$ rating is an arbitrary and a positive real number, $Bel(i, j) \rightarrow R^+$. We can convert the $Bel(i, j)$ to a probability vector (Pearl, 1988) by estimating the normalizing factor τ .

$$\tau \sum_i bel(i, j) = 1 \quad (18)$$

$$\tau = \left[\sum_i bel(i, j) \right]^{-1} \quad (19)$$

We want the total resource j contribution to satisfy the expected demand constraints.

$$R_j^{\min} \leq \sum_i \tau Bel(i, j) \cdot X_{ij} r_{ij} \leq R_j^{\max} \quad (20)$$

Resource Assignment

We now consider a model for distributing resources to "sectors of action." To do this, first the total resource contributions are calculated across the final assembly points. Second, the resources are distributed to sectors based on their probability of needs. Figure 7 illustrates this.

$$\lambda_{js} = \begin{cases} 1 & \text{if resource } j \text{ is needed at sector } s \\ 0 & \text{else} \end{cases}$$

W_{js} = probability of resource j demanded at sector s

$$\sum_j W_{js} = 1$$

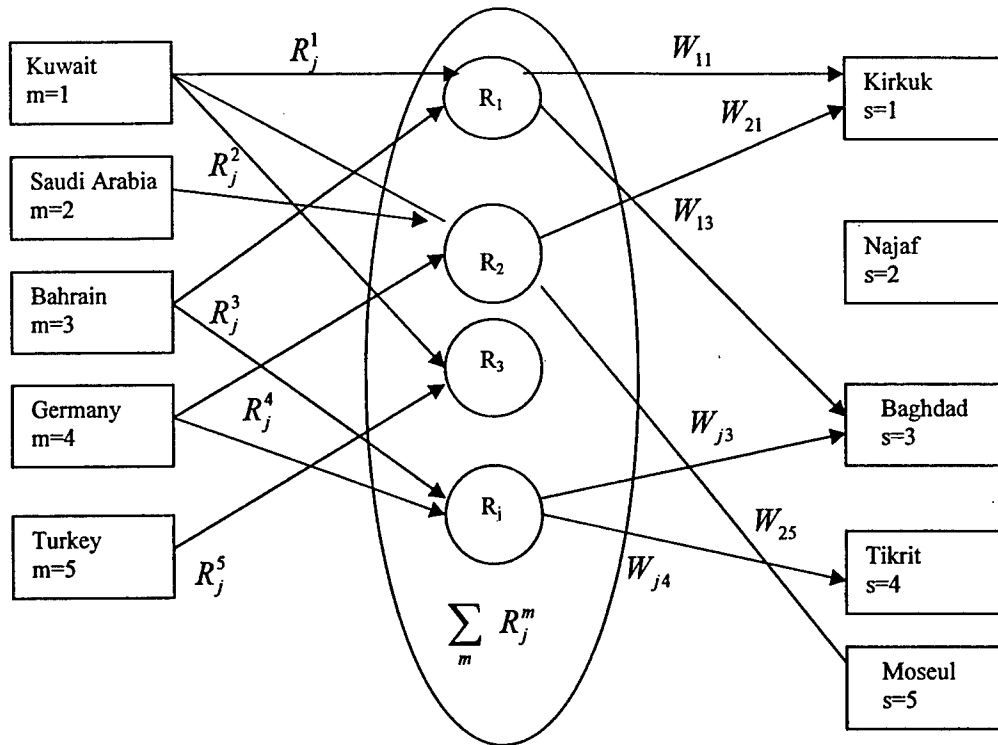

Figure 7. Sector Resource Assignment Model

Every assignment to the sectors must satisfy resource j availability. This is given in equation (21).

$$\sum_s W_{js} \lambda_{js} S R_{js} \leq R_j \quad (21)$$

where $S R_{js}$ is the total demand of resource j at sector s .

Demand-Supply Cost

The demand-supply penalty cost is defined by:

SC = Shortage Cost + Inventory Cost

Based primarily on the resource assignment to demand sectors, costs of inventory and shortage can be estimated. Equation (22) is used to capture this.

$$SC = \sum_j \Delta_j^+ c_j^+ + \sum_j \Delta_j^- c_j^- \quad (22)$$

where,

$$\sum_s w_{js} \lambda_{js} SR_{js} - R_j = \begin{cases} \Delta_j^- & \text{if demand of resource } j \text{ from all sectors is greater resource availability} \\ \Delta_j^+ & \text{if demand of resource } j \text{ from all sectors is less than resource availability} \\ 0, & \text{else} \end{cases} \quad (23)$$

If the solution of the equation $\sum_s w_{js} \lambda_{js} SR_{js} - R_j$ is Δ_j^- , then we have a shortage, incurring a shortage of c_j^- ; if the solution is Δ_j^+ , we have inventory on resource j , incurring inventory cost of c_j^+ per unit.

Life Cycle Cost Model

The total planning life cycle cost and the total cost of logistics with resource assignments are given in equation (24) and (25) respectively.

$$LCC = RALC + TC + TMC + TRLC \quad (24)$$

$$TLCC = LCC + SC \quad (25)$$

Section 4: The Decision Support System for COLOPS Implementation

4.1 The COLOPS Decision Support Software

There are a variety of techniques for modeling logistics processes. These include spreadsheet-based analyses, simulations (both stochastic and deterministic), and application of generalized simulation frameworks (such as Arena). In this project, Visual BasicTM and Microsoft ExcelTM spreadsheets are used to implement the models in the previous section. First, hand calculated examples will be used to illustrate the application of the models. Consider the following sample database in Table 1.

Table 1. Sample Resource Information

Country	Resource	Location	Quantity	Destination	Delivery Times	Due Date	Cost	Sector
(i)	j	k	r_{ij}	m	A	D_{ij}		
USA	AC-130	WPAFB	10	Kuwait	5	5	1.5	Kirkuk
USA	C-141	Colorado	5	Kuwait	7	5	2	Najaf
Japan	AC-130	Tokyo	3	Saudi Arabia	3	5	2	Baghdad
Korea	H-60	Seoul	3	Kuwait	5	5	1.5	Baghdad
USA	F-16	Washington D.C.	10	Bahrain	2	5	1	Tikrit
Britain	F-16	London	5	Bahrain	10	5	3	Najaf
Britain	C-141	Ireland	5	Germany	5	5	1.5	Moseul

USA	H-60	WPAFB	8	Germany	2	5	2	Tikrit
Britain	TC-135	London	10	Kuwait	1	5	1	Baghdad
Korea	B-1	Seoul	2	Turkey	5	5	4	Najaf
Japan	B-1	Tokyo	5	Turkey	3	5	3	Baghdad
Australia	B-52	Adelaide	5	Saudi Arabia	2	5	4	Moseul

Following the notations of Figure 8 and glossary definitions, we obtain Table 2.

Table 2. Sample Computational Database Representation

Country i	Resource j	x_{ij}	r_{ij}
i=1 USA	J=1(AC-150)	1	10
i=1 USA	J=2(C-141)	1	5
i=1 USA	j=5(F-16)	1	10
i=1 USA	j=4(H-60)	1	8
i=2 Japan	j=3(AC-130)	1	3
	j=8(B-1)	1	5
i=3 Korea	j=4(H-60)	1	3
	j=8(B-1)	1	2
i=4 Britain	j=5(F-16)	1	5
	J=2(C-141)	1	5
	J=7(T-135)	1	10
i=5 Australia	J=9(B-52)	1	5

We can use USA as a donor ($i=1$) to illustrate some of the calculations. Figure 8 is used to illustrate this.

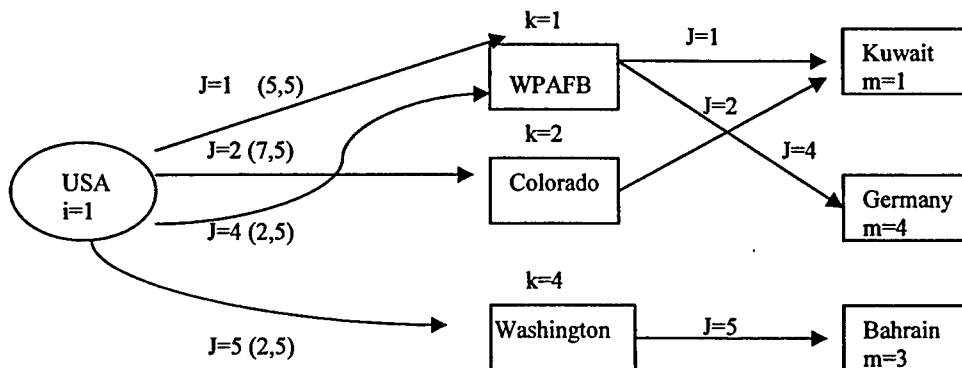

Figure 8. Resource Donor Illustration

$$L_{11}^{11} = \max(0, 5 - 5) = 0 \quad (Z_{11}^{11} = 1)(b_{11}^1 = 1)$$

$$L_{14}^{14} = \max(0, 2 - 5) = 0 \quad (Z_{14}^{14} = 1)(b_{14}^1 = 1)$$

$$L_{12}^{21} = \max(0, 7 - 5) = 2 \quad (Z_{12}^{21} = 1)(b_{12}^2 = 1)$$

$$L_{15}^{43} = \max(0, 2 - 5) = 0 \quad (Z_{15}^{43} = 1)(b_{15}^4 = 1)$$

Assume the lateness cost vector:

$$[a_{11}, a_{14}, a_{12}, a_{15}] = [2, 1, 0.5, 1]$$

The total lateness cost of all resources attributed to USA as a donor is

$$\text{TRLC} = 0(0.2) + 0(1) + 2(0.5) + 0(1) = 1$$

Resource Assembly Lateness Cost

This cost is a result of violating the coalition strategic due date required to assemble all assets at their respective points defined by m . In general, the coalition strategic due date can be defined heuristically in many ways that include the following:

a. Average due date estimation

At any final delivery point m , calculate the average due dates of all resources. This is defined by:

$$DD_m = \frac{\sum_i \sum_k Z_{ij}^{km} \cdot D_{ij}^{km}}{\sum_i \sum_k Z_{ij}^{km}} \quad (26)$$

For example, at node $m=1$ of USA donation network of Figure 8.

$$DD_1 = \frac{D_{11}^{11}(1) + D_{12}^{21}(1)}{1 + 1}$$

$$DD_1 = \frac{5 + 5}{2} = 5$$

b. Maximum of all due dates at delivery node

$$DD_m = \max \{Z_{ij}^{km} D_{ij}^{km}\} \text{ for all } i, j, k$$

In the above example,

$$DD_1 = \max(D_{11}^{11}(1), D_{12}^{21}(1))$$

$$= \max(5, 5) = 5$$

c. Probabilistic Estimate defined by equation 27

$$D_p = \bar{D} + g\sigma \quad (27)$$

Where \bar{D} is the average of expected due dates of all resources, σ is the standard deviation and $g=0,1,2,\dots$ finite number.

As an example in the simple network for USA as a donor,

$$\bar{D} = \frac{5+5+5+5}{4} = 5$$

if any of the due dates are changed, say

$$D_{11}^{11} = 3; \quad \bar{D} = \frac{5+5+5+3}{4} = 4.5$$

$$\sigma = 0.867$$

$$D_p = 4.5 + 0.867g$$

we can calculate the resource assembly lateness cost by using equation 5 by assuming the cost vector V_m^j as $[V_1^1, V_1^2, V_4^4, V_3^5] = [1, 4, 3, 4]$

At node $m=1$:

$$1 * \max[0, \max(5, 5) - 5] + 4 * \max(0, 7 - 5) = 8$$

At node $m=4$:

$$3 * \max[0, 5 - 5] = 0$$

At node $m=3$:

$$4 * \max[0, 2 - 5] = 0$$

$$\text{Total resource assembly lateness cost} = 8 + 0 + 0 = 8$$

Calculation of Transportation Cost

By using the same sample network in Figure 5, we have

$$TC = Z_{11}^{11} B_{11}^{11} \cdot x_{11} r_{11} + Z_{12}^{21} B_{12}^{21} \cdot x_{12} r_{12} + Z_{14}^{14} B_{14}^{14} x_{14} r_{14} + Z_{15}^{45} B_{15}^{45} x_{15} r_{15}$$

$$Z_{11}^{11} = Z_{12}^{21} = Z_{14}^{14} = Z_{15}^{45} = 1$$

$$x_{11} = x_{12} = x_{14} = x_{15} = 1$$

$$r_{11} = 10, r_{12} = 5, r_{14} = 8, r_{15} = 10$$

$$B_{11}^{11} = 2, B_{12}^{21} = 3, B_{14}^{14} = 0.5, B_{15}^{45} = 5$$

$$TC = (1)(2)(1)(10) + (1)(3)(1)(5) + (1)(0.5)(1)(8) + (1)(5)(10)(1)$$

$$TC = 20 + 15 + 4 + 50 = \underline{89 \text{ units}}$$

Parts and Maintenance Cost

Consider the fictitious part information for the USA donated items:

$$mc_1 = \sum_{n=1}^3 q_{1n} u_{1n} d_{1n}$$

$$mc_1 = (0.1)(5)(2) + (0.05)(10)(1) + (0.1)(20)(2) = 1 + 0.5 + 4 = 5.5$$

similarly,

$$mc_2 = (0.01)(16)(1) + (0.2)(24)(1.5) = 7.36$$

$$mc_4 = (0.15)(30)(5) = 22.5$$

$$mc_5 = (0.1)(5)(2) + (0.01)(20)(1) = 1.2$$

$$TMC (\text{From USA}) = 5.5 + 7.36 + 22.5 + 1.2 = \underline{36.56}$$

To illustrate the effect of a coalition, consider the donation of resource $j=5$ (F-16's) by USA and Britain. The total donated unit is 15 (10 from USA and 5 from Britain). This is shown in Figure 9. USA believes that under the current mission, 10 units of F-16's will be adequate 90% of the time, while Britain believes that at least a minimum of 5 units of F-16's will be needed with a confidence of 75%.

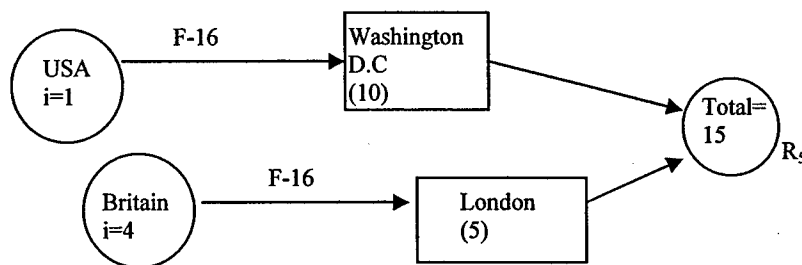

Figure 9. Coalition Effect on Resource Donor

Here, $Bel(1,5) = 90\%$, $R_5^{\max} = 10$

$$\text{Bel}(4,5) = 75\%, R_5^{\min} = 5$$

$$\text{Total rating} = 0.90 + 0.75 = 1.65$$

$$\text{The normalized constant } (\tau) = \frac{1}{1.65} = 0.606$$

$$\sum_i \tau \text{Bel}(i,5) x_{i5} r_{i5}$$

$$= (0.606)(.9)(1)10 + (0.606)(.75)(1)(5) = 7.7265 \sim 8 \text{ units}$$

In this example, the total units of resource R_j is calculated as the expected value derived from the individual donor belief factors. This method is often used in coalition information aggregation (Piketty, 1999).

Consider the above example with 15 F-16's available. Let the demand information on each of the sectors requesting F-16's be shown in Figure 10.

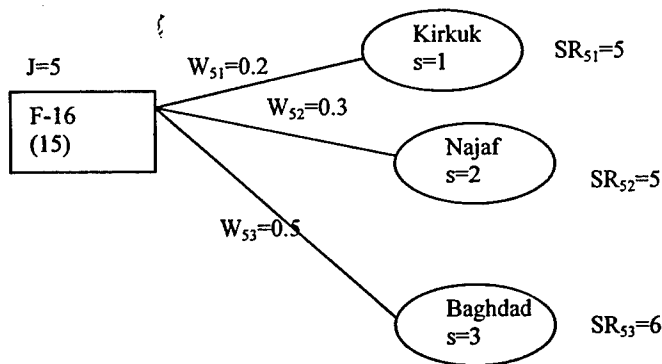

Figure 10. Demand-Supply Cost Sample

We want the condition to hold:

$$\sum_s W_{s_s} \lambda_{s_s} SR_{s_s} \leq R_5$$

$$(0.2)(1)(5) + (0.3)(1)(5) + (0.5)(1)(6) = 5.5$$

$$R_5 = 15; \text{ expected demand} = 5.5$$

$$\text{Inventory} = 9.5 = \Delta_5^+$$

$$\text{Let } c_5^+ = \$1.1$$

$$\text{Inventory cost} = \$1.1 (9.5) = \$10.45.$$

Suppose now that the demands at each sector are changed: $SR_{51}=15(0.5)$, $SR_{52}=15(0.4)$, and $SR_{52} = 20(0.1)$; we have the expected demand =15.5. The demand is greater than the supply of F-16's; $\Delta_5^- = 0.5$. Let $c_5^- = 2.5$, the shortage penalty cost = $2.5(.5) = \$1.25$.

4.2 The COLOPS User's Manual

4.2.1 Software Installation

Hardware Requirement:

To use the Military Logistics Application Software (MLAS), you need the following:

1. PC with Pentium IV processor
2. Windows 2000 or XP operating system
3. 64MB RAM or higher
4. The PC must have access to the internet.

Software Requirement:

The following application software needs to be installed on the PC in order to successfully run the Military Logistics Application Software:

1. Microsoft XP professional operating system
2. Microsoft Visual Basic 6.0TM with service pack 6

4.2.2 Installation of the COLOPS Software

We recommend that the COLPS be copied to a thumb drive and be used as a stand alone software at this time. However, it may be copied to the hard drive.

Running COLOPS:

To run the application software, follow the following directions:

1. Click the <START> button on your desktop
2. Select Programs
3. Select Visual Basic 6.0TM
4. Once the VB 6.0 program loads, select the FILE from the menu bar
5. Select the menu option OPEN project
6. Navigate to the drive where the thumb drive is, select the form the COLOPS folder and click <OPEN> button. The COLOPS interface opens (Exhibit 1).
7. Now you are ready to use the COLOPS.

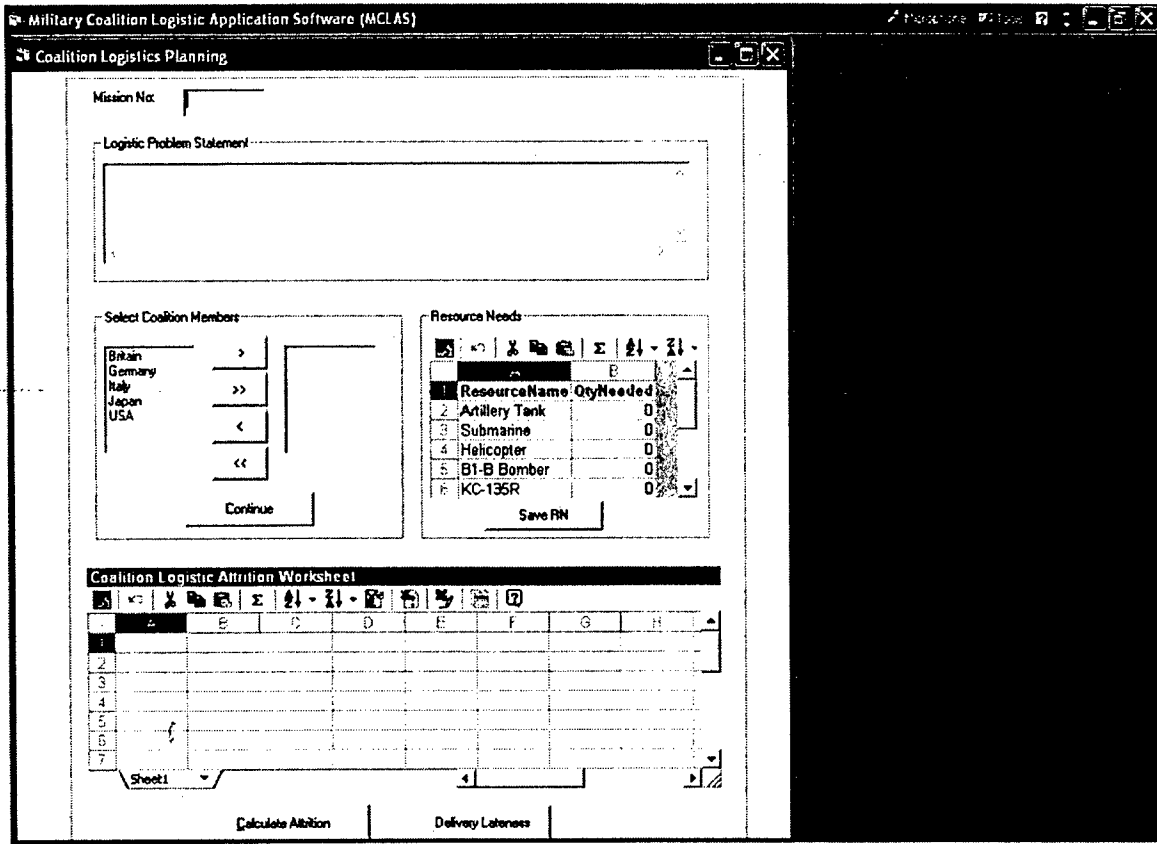

Exhibit 1. The COLOPS Interface

4.2.3 Getting Started

The COLOPS interface consists of the following parts:

- Mission ID
- The logistics problem statement
- Selection of the coalition members participating in the mission
- Appropriations of the coalition resources needed to accomplish the mission.
- The coalition logistic attrition worksheet

Mission ID

The Mission ID is the identification number of the current mission. It is a number and must be supplied by the user.

The logistics problem statement

The logistics problem statement is a precise description of the current logistics situation. All issues regarding coalition logistics are defined in the section.

Selection of the coalition members participating in the mission

Participating coalition members are selected for a mission. To select a member, click on the member then use the buttons below to select or deselect a member or all members.

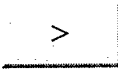
 Selects one coalition member one at a time

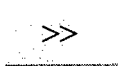
 Selects all the coalition members

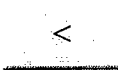
 Deselects a member from the coalition

 Deselects all members from the coalition

Once all the coalition members have been selected, **press** the continue button.

Appropriations of the coalition resources needed to accomplish the mission

In this section, the quantity for each resource needed for a mission is specified. The assumption is that all the resources will be needed therefore, the quantity must be greater than or equal to one. Once the resource needs have been specified, the <SaveRN> button must be clicked to save values.

The coalition logistic attrition worksheet

This worksheet provides the all the resources and the quantity on hand for each of the participating coalition members. The quantity of each resource donated by the participating coalition members are entered in the column, "Qty Supplied." The column **must** be filled in in order to calculate the attrition (Exhibit 2).

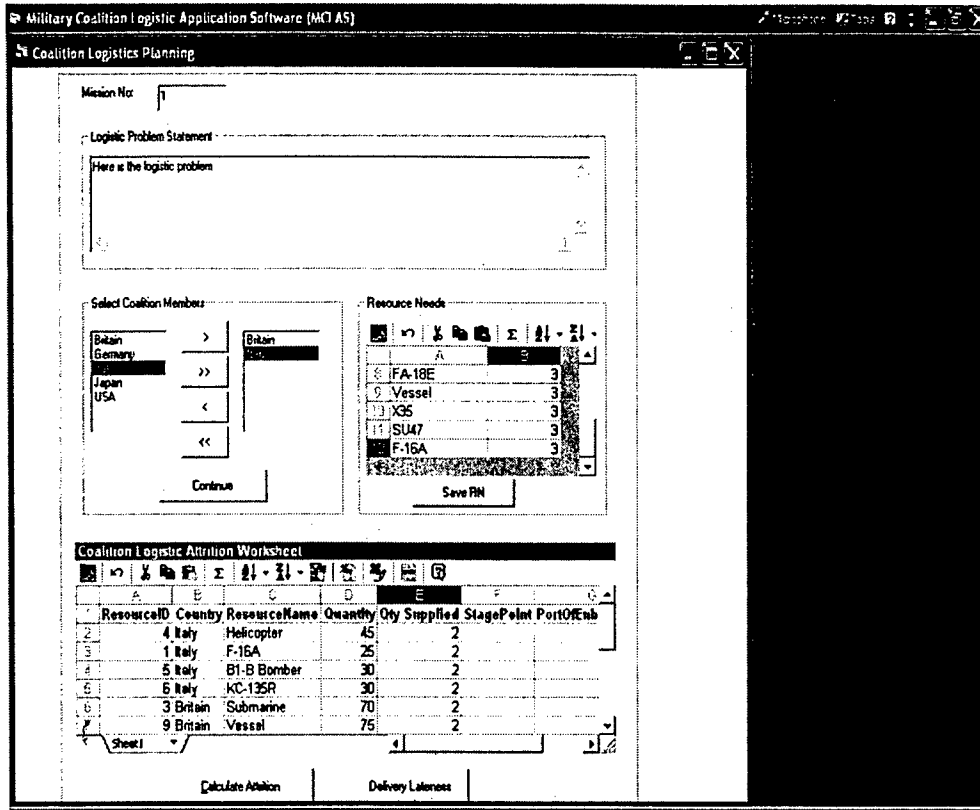

Exhibit 2. Coalition Logistics Attrition Worksheet

The staging point and point of embarkation for each resource are also entered in this worksheet. Once these three columns have been filled in, you click on the <Calculate Attrition> button. The Coalition Summary Information screen (Exhibit 3) is displayed. Clicking on the <Delivery Lateness> button will present you with the worksheet associated with calculating the delivery lateness (Exhibit 4).

Military Coalition Logistic Application Software (MCLAS)

Coalition Logistic Information Summary

Coalition Summary Information

Mission ID: 1

Logistic Problem Statement: Here is the logistic problem

Coalition Members: Britain Italy

Logistics Summary:

ResourceID	ResourceName	QtyNeeded	QtySupplied	QtyReceived	ResourceRel
1	F-16A	3	4	3.60	
2	Artillery Tank	3	2	1.90	
3	Submarine	3	4	3.17	
4	Helicopter	3	4	3.35	
5	B1-B Bomber	3	4	3.43	
6	KC-135R	3	4	3.28	
7	SU-35	3	2	1.67	

Total Resource Volume (NQ): 32

Discounted Volume (DNQ): 28

Logistic Readiness (Pa): 0.875

Logistic Reliability (RL): 0.848484848484849

Logistic Plan Index (LPI): 1.03125

Save

Print

Exhibit 3. Coalition Summary Information

Military Coalition Logistic Application Software (MCLAS)

Calculate Delivery Lateness Cost

Delivery Lateness Cost

Country	ResourceName	DeliveryDueDate	DeliveryDate	LatenessCost
Italy	Helicopter	12/1/2005	11/30/2005	0
Italy	F-16A	12/1/2005	12/15/2005	14266
Italy	B1-B Bomber	12/1/2005	10/31/2005	0
Italy	KC-135R	12/1/2005	11/25/2005	0
Britain	Submarine	12/1/2005	11/30/2005	0
Britain	Vessel	12/1/2005	12/15/2005	14266
Britain	X35	12/1/2005	10/31/2005	0
Britain	SU47	12/1/2005	11/25/2005	0
Britain	F-16A	12/1/2005	11/30/2005	0

Calculate Lateness Cost

Lateness Cost By Resource

ResourceID	ResourceName	Delay Cost
1	F-16A	14266
2	Artillery Tank	14266
3	Submarine	0
4	Helicopter	0
5	B1-B Bomber	0
6	KC-135R	14266
7	SU-35	0
8	FA-18E	0
9	Vessel	14266

Exhibit 4. Delivery Lateness Cost

The worksheets contain tools for additional analysis. If you are experienced with Microsoft Excel™, these tools will be familiar to you. The worksheets can be copied to an MS Excel™ worksheet; filtered and sorted in ascending or descending order. More analysis can be done, such as plotting graphs, calculating totals and average costs, etc. (Exhibit 5).

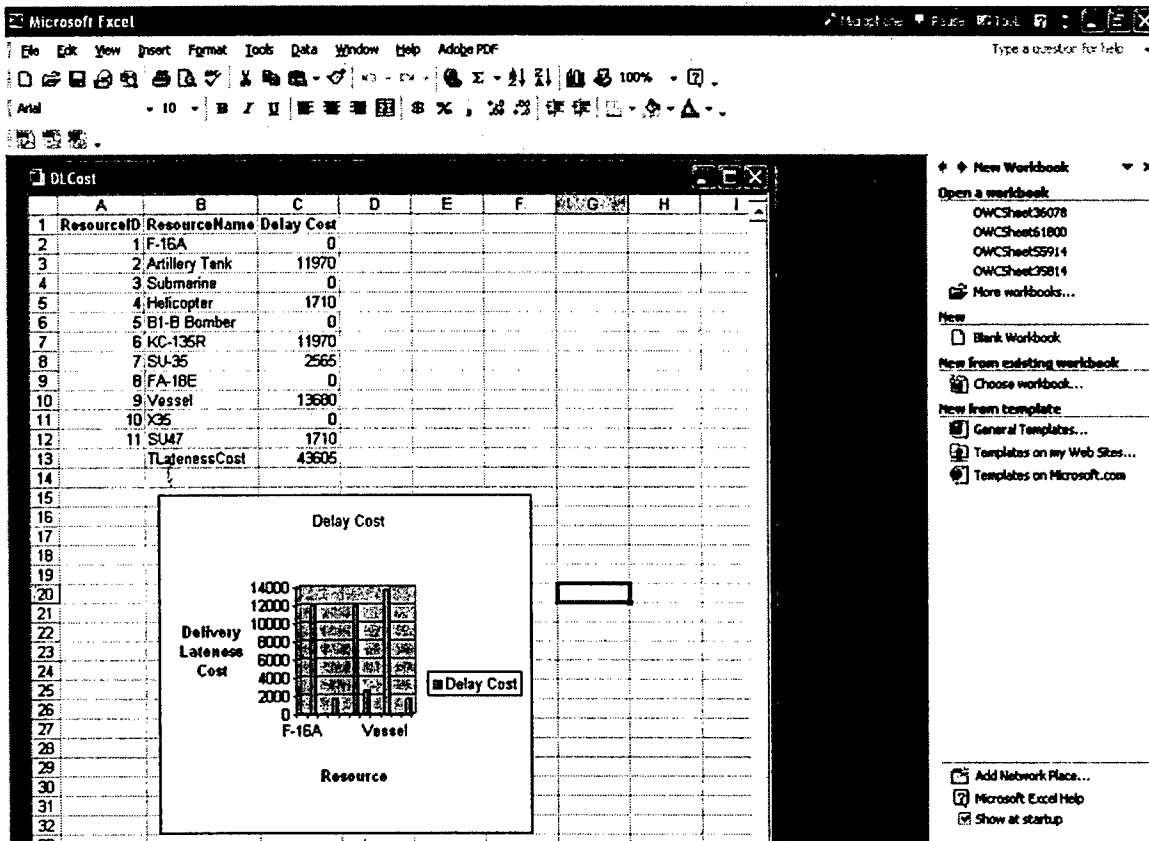

Exhibit 5. Sample Excel Analysis of Delivery Lateness Cost Information

Delivery Lateness

By clicking on the <Delivery Lateness> button from the Coalition Logistic Attrition worksheet, the Delivery Lateness Worksheet is presented (Exhibit 4). In this worksheet, the delivery due date and the actual delivery date of each resource are entered. After this has been done, click on <Calculate Lateness Cost> button. The lateness cost for each resource is calculated. The lateness cost summary by resource is also presented.

Section 5: Summary and Conclusions

5.1 Summary

This technical report has focused on developing a decision support system for coalition logistics planning. This report proposes a decision support model for the military coalition logistics problem. As a short-term goal, this report provides a proof-of-concept decision model for shared logistics asset deployment and allocation to achieve a single mission. As a long-term goal, the report demonstrates the capability to use a decision support system (DSS) for logistics process management through a simplified constructive simulation. The developed model is constructive in that it is parameter driven; reflecting the user's perception of the logistics needs and the likelihood that the resource contribution (input) to the system will lead to the intended goal. The COLOPS provides at least three advantages for the military logistics planning. These are:

- Provide a coordinated multinational logistics information and decision support tool for accurate identification of resource requirements, improved deployment planning, efficient resource sustainment, and rapid logistics re-planning across the full spectrum of operational sectors,
- Provide an improved logistics command and control (C2) interoperability with coalition partners, and
- Provide a multinational collaborative logistics analysis capability.

5.2 Conclusions

The COLOPS decision support model was developed with Microsoft Visual Basic™ and Microsoft Excel™. The model is parametric-driven, i.e., the user specifies the parameters required to generate input for the COLOPS environment. In developing the COLOPS model, user-interface issues have been taken into consideration as well as the validation of the model. The COLOPS model also considers the costs associated with the coalition effort. The costs may be tangible or intangibles logistics costs that are often considered in military transportation and logistics. In the present COLOPS version, we concentrated on planning of coalition resource donations, due dates, cost of late delivery, resource reliability as accounted for by attrition, and coalition readiness and nervous metrics.

The following are suggested for the future expansion of the COLOPS decision support model:

1. Include a maintenance model in the COLOPS calculation and logistics process.
2. Consider optimizing the logistics throughput by incorporating the Bayesian update logic to capture the possibility that coalition members can withdraw their support during a mission.
3. Include the logistics distribution and sector assignments based on demands and resource availability—i.e., from the point of universal resource assembly to points in which the resources are used for the intended mission.

REFERENCES

Allsopp, David N. et al. (2002). Coalition Agents Experiment: Multiagent Cooperation in International Coalitions. *IEEE Intelligent Systems*, 17(3), pp. 26-35.

Alter, S. L. (1977). A Taxonomy of Decision Support Systems. *Sloan Management Review*, 19(1), Fall, pp. 39-56.

Angelis, Jane (1992). *Creating Intergenerational Coalitions: Bottom Up - Top Down Strategies*. Carbondale: Southern Illinois University.

Army Vision 2010 (1996). Retrieved from: <http://www.army.mil/2010/>

Beamon, Benita M. (1998). Supply Chain Design and Analysis: Models and Methods. *International Journal of Production Economics*, 55(3), pp. 281-294.

Coalition Operations Handbook (2001). Retrieved from: (<http://www.abca-armies.org/>).

Desimone, R. (1999). *Report of the Working Group on Coalition Logistics*, DERA Malvern, UK, 10-11th May. Retrieved from: <http://www.aiai.ed.ac.uk/project/coalition/ksco/ksco-1999/PROCEEDINGS/Coalition-Logistics-WG.html>

Dulin, Patrick J. Colonel (2002). Finding the Friction Points in Coalition Logistics. *Army Logistician*, 34(2), March-April, pp. 8-12.

Lee, H. L. & Billington, C. (1993). Material Management in Decentralized Supply Chains. *Operations Research*, 41(5), pp. 835-847.

Logistics World (1995 and 1996). Retrieved from: <http://www.logisticsworld.com/>

Pearl, Judea (1988). *Probabilistic Reasoning in Intelligent Systems: Networks of Plausible Inference*. San Mateo, CA: Morgan Kaufmann.

Perugini, D., Wark, S., Zschorn, A., Lambert, D., Sterling L. & Pearce, A. (2003). Agents in Logistics Planning - Experiences with the Coalition Agents Experiment Project. In *Agents at Work: Deployed Applications of Autonomous Agents and Multi-agent Systems, a Workshop at the Second International Joint Conference on Autonomous Agents and Multiagent Systems (AAMAS 2003)*, Melbourne, Australia, 2003.

Piketty, T. (1999). The Information Aggregation Approach to Political Institutions. *European Economic Review*, 43, pp. 791-800.

Rice, Anthony J. (1997). Command and Control: The Essence of Coalition Warfare. *Parameters*, Spring, pp. 152-167.

RisCassi, Robert W. (1993). Principles for Coalition Warfare. *JFQ: Joint Forces Quarterly*, Summer, pp. 58-71.

Stroh, Michael B. (2002). What is Logistics? Retrieved from:
<http://www.logistics.ws/whatislogistics.htm>