



**FACTORS AND INTERACTIONS THAT
AFFECT AIR FORCE C-17 AIRCRAFT
MISSION CAPABLE RATES**

THESIS

Scotty A. Pendley, Captain, USAF

AFIT/GLM/ENS/06-12

**DEPARTMENT OF THE AIR FORCE
AIR UNIVERSITY**

AIR FORCE INSTITUTE OF TECHNOLOGY

Wright-Patterson Air Force Base, Ohio

APPROVED FOR PUBLIC RELEASE; DISTRIBUTION UNLIMITED.

The views expressed in this thesis are those of the author and do not reflect the official policy or position of the United States Air Force, Department of Defense, or the United States Government.

AFIT/GLM/ENS/06-12

FACTORS AND INTERACTIONS THAT AFFECT AIR FORCE
C-17 AIRCRAFT MISSION CAPABLE RATES

THESIS

Presented to the Faculty
Department of Operational Sciences
Graduate School of Engineering and Management
Air Force Institute of Technology
Air University
Air Education and Training Command
In Partial Fulfillment of the Requirements for the
Degree of Master of Science in Logistics Management

Scotty A. Pendley, BS

Captain, USAF

August 2006

APPROVED FOR PUBLIC RELEASE; DISTRIBUTION UNLIMITED

FACTORS AND INTERACTIONS THAT AFFECT
AIR FORCE C-17 AIRCRAFT MISSION CAPABLE RATES

Scotty A. Pendley, BS
Captain, USAF

Approved:

//signed//
Dr. Alan W. Johnson (Chairman)
Associate Professor of Logistics Management

date

//signed//
Kirk A. Patterson, Major, USAF (Member)
Assistant Professor of Logistics Management

date

Abstract

Given the high demand for mission capable airlift aircraft and considering increasing budget pressures, Air Mobility Command decision makers need a better understanding of mission capable (MC) rate-related factors and their interactions for mobility aircraft. This is needed to comprehend how issues such as airlift funding, current and future force reductions, and manning and experience levels may impact future MC rates for air mobility assets. Existing tools do not incorporate several key variables that the literature suggests are related to MC rates.

Using a longitudinal approach, this thesis combines C-17 aircraft data with a structural equations modeling approach to evaluate relationships between MC rates and selected variables. The research addresses linkages between several areas not addressed in prior research and currently used models, and provides recommendations for both existing tools and for further research.

Acknowledgments

First, I can't say thank you enough to my wife and daughter, my girls. They amaze me more everyday and I have truly missed too many special moments with them during this and previous assignments. My daughter is growing faster than I could have ever imagined and is destined for great things in life. My wife manages to balance the daily chaos, her own important career, and our family needs with a tireless energy that I truly admire. She shoulders more of the load and sacrifices more than anyone should have too, especially while I toiled away those many hours in the "castle" upstairs during this AFIT tour, and she still gets things done. I love you both more than you will ever know.

I have to thank the rest of my family, particularly my father, for not just telling me about things such as integrity, honesty, and the value of hard work, but by being a living example of all of these things and more. My father is the best man I know. I love you Dad.

I must also thank my advisor Lt Col Arostegui and my reader Dr. Alan Johnson for their guidance, advice, and above all else, their patience. I truly appreciate the help they gave me as I was "grinding" along on this journey.

Finally, I could not have made it through AFIT without my classmates. You are a special group and your help and advice in and out of class were tremendous. Your friendship is priceless.

Scotty A. Pendley

Table of Contents

	Page
Abstract.....	iv
Acknowledgments.....	v
List of Figures.....	ix
List of Tables.....	xi
I. Introduction.....	1
Background.....	1
Mission Capable Rate	2
Problem Statement	4
Research Question	5
Investigative Questions	6
Outline of Remaining Chapters	6
II. Literature Review.....	8
Chapter Overview	8
MC Rate Standards	8
MC Rate Factors	11
Events of Recent Years.....	17
Organizational Change	17
AEF Cycle Changes	18
OPTEMPO and PERSTEMPO	20
Personnel Changes	23
Funding.....	30
C-17 Aircraft.....	33
History	33
C-17 Flexible Sustainment Strategy.....	34
AMC Mission and National Strategy.....	37
Overview of Next Chapter	38
III. Methodology.....	38
Introduction.....	39
Data Sources and Collection.....	39
Reliability and Maintainability Information System (REMIS)	39
Multi-Echelon Resource and Logistics Information Network (MERLIN)	42
Secondary Items Requirements System (SIRS) (D200A)	43

	Page
Personnel Data System	47
PERSTEMPO Data	49
Funding Data	50
Structural Equations Modeling (SEM)	50
SEM Basics	50
SEM Assumptions and Limitations	53
Analysis of Moments Structures (AMOS) Software	56
Model Building and Specifications	57
Research Assumptions and Limitations.....	61
Overview of Next Chapter	62
 IV. Analysis and Results.....	 63
Chapter Overview	63
Structural Equations Model Development.....	63
Initial SEM Models and Variables.....	63
SEM Model 2.....	63
SEM Model 3.....	63
SEM Model 4	71
Overview of Next Chapter	79
 V. Conclusions and Recommendations	 80
Chapter Overview	80
Problem Statement and Research Questions.....	80
Lessons Learned and Limitations.....	82
Recommendations for Future Research	83
 Appendix A: REMIS Variables and Snapshots	 84
Appendix B: Secondary Items Requirements System (SIRS).....	87
Appendix C: C-17 Enlisted/Officer MX AFSCs and Authorized vs. Assigned Data	88
Appendix D: PERSTEMPO Snapshot.....	91
Appendix E: AMOS Output for SEM Model 4	94
Appendix F: Analysis of Variables.....	101
Appendix G: Personnel Related Variables	104
Appendix H: Stepwise Regression Data and Models	107
Bibliography.....	109

	Page
Vita	115

List of Figures

	Page
Figure 1. Air Force Overall Aircraft Trends 1994 - July 2005 (MERLIN, 2005).....	12
Figure 2. Airlift Rates August 04 to July 05 (MERLIN, 2005).....	123
Figure 3. Total U.S. Troop Deployments 1950 to 2004 (DIOR, 2005).....	21
Figure 4. Percentage of U.S. Troops Deployed 1950 to 2004 (DIOR, 2005).....	21
Figure 5. Deployments Per Air Force Component September 2001 to June 2003.....	23
Figure 6. C-17 Flying Hours and Sorties FY93 - FY05 (MERLIN, 2005)	24
Figure 7. C-17 MC Rates January 1997 - December 2005 (MERLIN, 2005).....	24
Figure 8. Historical Air Force Active Duty End Strength (Air Force Handbook, 2005).	25
Figure 9. DOD Active Duty Strength Levels 1950 - 2004 (DOD SMS, 2004).....	27
Figure 10. Air Force Enlisted Retention Rates for FY97 - FY03 (AFPC, 2004).	28
Figure 11. Growth in Depot Maintenance Public-Private Partnerships.....	35
Figure 12. How TNMCM Data is Reported (Bell, 2000:5).....	40
Figure 13. Requirement Management System (RMS) Subsystems (Towell, 2004).....	43
Figure 14. SIRS (D200A) Interfaces (Towel, 2004).....	445
Figure 15. Requirements Determination Systems Flow (Towell, 2004).	46
Figure 16. Initial MC Rate Factors Model (SEM Model 1)	58
Figure 17. Maintenance Experience Construct Initial Model (SEM Model 2).....	67
Figure 18. Initial MC Rate Factors & Fleet Health Construct Model (SEM Model 3) ...	70
Figure 19. MC Rate Factors with All Lvl's Combined (SEM Model 4).. ..	72
Figure 20. SEM Model 4 with Unstandardized Estimates.....	75
Figure 21. SEM Model 4 with Standardized Estimates.....	76

	Page
Figure 22. Original REMIS Status Hours and Counts Data Partial Snapshot	85
Figure 23. Original REMIS MC Rate Data Partial Snapshot	86
Figure 24. D200A Snapshot.....	87
Figure 25. AFPC Personnel Data System Authorized vs. Assigned Snapshot.....	90
Figure 26. PERSTEMPO Variables and Calculations.....	93
Figure 27. SEM Model 4 Variables Partial Spreadsheet	101
Figure 28. Bivariate Analysis of C-17 MC Rate by TNMCS/5.....	102
Figure 29. Bivariate Fit of C-17 MC Rate by TNMCM/5.....	103
Figure 30. AMC Maintenance AFSCs Quarterly Retention Percentages 1997 to 2005	105
Figure 31. AMC Maintenance AFSCs Yearly Retention Percentages 1997 to 2005	105
Figure 32. Stepwise Regression Variables Partial Spreadsheet.....	107
Figure 33. JMP Screenshot Normality Check Example	107
Figure 34. Constant Variance Checks - JMP Analysis Examples	108

List of Tables

	Page
Table 1. Increasing Air Force Fleet Age (SecDef Annual Report, 2005:65)	16
Table 2. Potential Factors Affecting MC Rates (Wall, 2004).....	17
Table 3. Goodness of Fit Specifications	59
Table 4. SEM Model 4 Goodness of Fit Comparisons	74
Table 5. REMIS Variables.....	84
Table 6. SIRS (D200A Variables).....	87
Table 7. C-17 Enlisted/Officer Maintenance AFSCs	88
Table 8. All AMC AFSCs PERSTEMPO Snapshot.....	91
Table 9. AMC Maintenance Specific AFSCs PERSTEMPO Snapshot	92
Table 10. SEM Model 4 - Goodness of Fit Measures.....	94
Table 11. SEM Model 4 - Variable Summary	95
Table 12. SEM Model 4 - Notes for Group and Model.....	95
Table 13. SEM Model 4 – Normality Assessment	96
Table 14. SEM Model 4 – Check for Outliers (partial table)	97
Table 15. SEM Model 4 – Estimates	98
Table 16. SEM Model 4 – Modification Indices	100
Table 17. Personnel Data Variables.....	104
Table 18. Retention Percentages Calculation Example – AMC Avionics AFSCs	106

UTILIZING STRUCTURAL EQUATIONS MODELING TO EXAMINE FACTORS
AND CONSTRUCTS AFFECTING AIR FORCE C-17 AIRCRAFT MISSION
CAPABLE RATES

I. Introduction

Background

Since the events of September 11, 2001 and the subsequent increase in demand on airlift assets brought about by the buildup to and continuing support of Operation Enduring Freedom and Operation Iraqi Freedom, as well as tsunami, hurricane, and earthquake relief missions, the Air Force is under even greater pressure than before to provide and maintain mission capable mobility aircraft that can successfully complete the mission anywhere anytime. The need to understand factors related to providing mission ready aircraft becomes even greater when we consider the relatively recent wing-level reorganization and current and predicted future budget constraints which may continue to pull money away from the personnel, operations and sustainment arenas. In addition, the ongoing base realignment and closure (BRAC) process and the quadrennial defense review (QDR) will continue to shape our force and intensify the necessity of understanding the various determinants of aircraft mission capability rates, as well as the observed and unobserved interactions of these factors. Any one of the organizational changes, resource constraints, or process reviews just mentioned are stressful enough, but in combination, they create a stressful situation indeed. Regardless, the Air Force and the

air mobility mission must continue to succeed. In order to do this, the Air Force relies on mission capable aircraft.

Mission Capable Rate

One of the most referenced indicators of combat readiness for Air Force aircraft is the mission capable (MC) rate. The MC rate is an expression of the set percentage of the fleet available on any given day which is necessary to carry out the mission, whether a real-world mission or local training sortie in support of the flying hour program (Metrics Handbook, 2001). The MC rate is probably the best known measurement for unit performance although it is categorized as a *lagging* type indicator. Typically, a unit will compare its MC rate against established MAJCOM standards. Or, a unit may compare its MC rate with the rates of other units that possess the same type of aircraft. Units who suffer through a period of low MC rates when compared with the standard or with other units will use this as an indicator to start looking for something (e.g., a process, a resource) that may be negatively influencing the MC rate.

The MC rate is also a composite metric which implies that it is an indicator of several processes and metrics and relates the percentage of possessed hours that an aircraft is partially or fully mission capable (AMC Metrics Handbook, 2005). Crucial to remember is that repairing aircraft correctly and completely is more important than repairing them quickly. The MC rate calculation is shown in equation 1 below.

$$\text{MC \%} = \frac{\text{FMC Hours} + \text{PMCB Hours} + \text{PMCM Hours} + \text{PMCS Hours}}{\text{Possessed Hours}} \times 100 \quad (1)$$

(Metrics Handbook, 2001)

The MC rate calculation shown in equation 1 includes the terms fully mission capable (FMC) , partial mission capable for both maintenance and supply (PMCB), partial mission capable for maintenance (PMCM), and partial mission capable for supply (PMCS).

Additionally, another factor used in classifying whether or not an aircraft is FMC, not mission capable (NMC), or PMC, is the Air Force's Minimum Essential Subsystems List (MESL). The MESL defines the system and subsystems that must be operational for an aircraft to do its assigned missions (Balaban and others, 2000). So, while the MC rate is a number which is easy enough to calculate when you have the required data, it is not as easy to understand how many different factors bear on the end result, and the interactions of these factors is probably even less understood.

For Air Mobility Command (AMC), the AMC Directorate of Logistics is responsible for ensuring AMC aircraft are available to accomplish the mission. The Directorate has initiated the development of a Mobility Aircraft Availability Forecast (MAAF) simulation model designed to identify alternatives and associated impacts on aircraft availability, manpower, and cost. AMC also utilizes an Aircrew/Aircraft Tasking System (AATS) to determine the number of available C-17 aircraft to the Tactical Airlift Control Center (TACC) on a monthly basis (Huscroft, 2004). But, the AATS is a process and not a tool for predicting aircraft availability.

In addition, the Air Force also currently uses several models and techniques in one fashion or another to forecast mission capable rates as well as aircraft availability. The Air Force uses the Funding/Availability Multi-Method Allocator for Spares (FAMMAS) forecasting model to forecast the MC rate for each mission design series

(MDS) aircraft in the inventory (Oliver, 2001). This model uses an exponential smoothing algorithm to predict overall MC rates using past, present, and future spares funding levels and the last three years of historical total not mission capable for supply (TNMCS) and total not mission capable for maintenance (TNMCM) rates for each respective aircraft. While the FAMMAS model has done a good job forecasting MC rates, it still does not consider several important variables which can and do affect MC rates. Because the FAMMAS model does not incorporate other factors such as manning levels, break rates, fix rates, spares parts issues, funding and other variables, the model possesses limited effectiveness and by itself is not enough (Oliver, 2001).

Several research efforts previously conducted used various aspects of regression analysis in an effort to determine factors significant in forecasting MC rates. These previous efforts are discussed in more detail in chapter 2.

Problem Statement

The attacks on 9/11/2001 showed that threats to U.S. security can now come from any number of terrorist groups, at any number of locations, and in wholly unexpected ways. As a result, the Department of Defense (DOD) is shifting to a new defense strategy focused on dealing with uncertainty by acting quickly across a wide range of combat conditions. In regard to mobility requirements, the Joint Staff, Office of Secretary of Defense, and Air Mobility Command are reviewing mobility requirements in light of the new National Military Strategy and the Global War on Terrorism (USAF Posture Statement, 2005).

One key ingredient of the new strategy is the availability of aircraft to carry out their missions (GAO 03-300, 2003:31). Key measures of this availability are the MC and FMC rates. With increased demand for mission capable aircraft, particularly airlift, and also considering recent Air Force organizational changes and increasing budget constraints, decision makers at AMC need a better understanding of MC rate related factors and their interactions. This is needed in order to relate how actions such as current and future force reductions and manning and experience levels may impact future MC rates for air mobility assets. Tools such as the FAMMAS model are good; however, it does not incorporate several key variables that the literature suggests are related to MC rates.

Using a longitudinal approach, this research seeks to utilize C-17 associated data and a structural equations modeling (SEM) approach to evaluate relationships between MC rates and several observed variables, as well as hypothesized constructs and possible interactions between the variables and or the constructs themselves. The research strives to provide linkages between several areas not previously addressed in other research and currently used models and seeks to resolve shortfalls in these currently used predictor's abilities in order to bridge a gap toward a more effective planning tool.

Research Question

Several studies have linked various factors such as variables in the area of reliability and maintainability, funding, leadership, and personnel to mission capable rates. The research question serving as motivation for this project is "What are the interactions between these factors and their impact on aircraft readiness as evidenced by

mission capable rates?” Once identified, these interactions will be evaluated using SEM theory to test a hypothesized causal model of possible interactive factors.

Investigative Questions

- 1) What factors have a significant impact on aircraft mission capable rates?
- 2) Of the factors identified in investigative question one, what changes have taken place in the last decade, especially since 9/11, that have an impact on aircraft mission capable rates?
- 3) For the factors identified in investigative question one, what type of theoretical model best estimates the impact of these factors on mission capable rates?
- 4) What latent constructs, if any, have a significant relationship with aircraft mission capable rates and what are these relationships?

Outline of Remaining Chapters

Chapter II: Literature Review – Chapter II first provides a background discussion regarding the MC rate. Next, factors affecting MC rates and previous research in this area are discussed. Next, recent events and AF organizational changes are reviewed. Particular aspects of airlift operations and unique C-17 aspects including support agreements are then included. Lastly, the chapter includes a discussion of existing models currently used in MC rate forecasting.

Chapter III: Methodology – Chapter III begins by describing the method of data collection as well as data sources used during data retrieval. The research paradigm is

also discussed as well as the use of SEM techniques and the theoretical model building methodology.

Chapter IV: Findings and Analysis – Chapter IV presents the results of the initial model and subsequent revisions. Difficulties and issues arising during analysis are discussed.

Chapter V: Conclusions and Recommendations – Chapter V reviews the research results and the relevance of the research effort is presented. Lastly, recommendations for future research and a summary are provided.

II. Literature Review

Chapter Overview

This chapter provides a review of literature relevant to the current research endeavor. The chapter begins with a discussion of how MC rates are initially established. Then, previous research and commentary regarding various factors that can influence MC rates are examined. Next, a review is provided of events and organizational changes in recent years that affect how aircraft are maintained and utilized. Since data specific to the C-17 aircraft was chosen for use in this research, the chapter then focuses on particular aspects of AMC airlift operations and unique C-17 support agreements.

MC Rate Standards

As defined in Joint Publication 1-02, the term mission-capable as related to aircraft is defined as the “Material condition of an aircraft indicating it can perform at least one and potentially all of its designated missions. Mission-capable is further defined as the sum of full mission-capable (FMC) and partial mission-capable (PMC)” (Joint Publication 1-02, 2005:353). For the C-17, the Air Force MC rate standard is 87.5. This is the goal units strive for at a minimum. So the definition of the MC rate is clear enough, but exactly how are MC rate standards originally determined?

As noted in DOD Instruction (DODI) 3110.5, all military services are required to establish quantitative availability goals and corresponding condition status measurements for aircraft and other mission essential systems and equipment. The goals

established must estimate the maximum aircraft performance that is achievable on the basis of the aircraft's design characteristics, especially reliability and maintainability, and planned peacetime usage. In this instance, assumptions include full funding and optimal operation of the peacetime manpower and logistic support systems (DODI 3110.5, 1990:2). The instruction also specifically identifies MC, FMC, and other specific capabilities as measures the services must maintain. However, the instruction does not identify any specific goals that must be established.

DODI 3110.5 also provides little guidance on the methodology to be used in setting the goals. The instruction gives no details on the issue of whether it is appropriate to use historical trends of similar aircraft in determining the goals as opposed to a more analytical approach using actual requirements. The instruction also does not provide an answer on whether the aircraft availability goals should vary on the basis of the aircraft's deployment posture. Moreover, unlike one 2003 United States General Accounting Office (GAO) report, it includes no requirement for the services to identify the readiness and cost implications of setting the goals at different levels (GAO 03-300, 2003:4).

It appears that the historical approach to reviewing the standards can sometimes perpetuate relatively low standards because it simply accepts the low funding levels and other problems which may lower MC rates without focusing on actual mission needs. The new approach attempts to factor in wartime operational requirements, peacetime flying hour requirements for pilot training, and other such requirements. A mix of both approaches is currently used by the commands to review the goals.

Some officials believe that actual funding levels for personnel, spare parts inventories, and other key resources should be factored into the goal setting process since

full funding has not been provided for years (GAO 03-300, 2003:31). Similarly, the instruction provides little organizational structure for the goal-setting process in DOD. For example, it does not require the services to identify one office as the coordinating organization for goal-setting and other related activities.

Also according to the same 2003 GAO report, the Air Force was the only service that routinely conducted formal reviews of its goals and that “Air Force officials also told us that they generally try to keep the goals high because it is difficult to stop the goals from dropping further once they begin to be lowered” (GAO 03-300, 2003:15).

Interestingly, the report also noted that Air Force officials could not explain exactly how initial MC and FMC goals for their aircraft were originally established. In particular, Air Combat Command (ACC) reported that they could find no historical record of the process used to establish most of the goals.

Additionally, the same GAO report iterated that AMC officials reported that AMC was formed in 1992 and did not know how the previously existing commands had established the MC rate goals. It seems each of the major commands that operate aircraft and other major weapon systems in the Air Force is responsible for establishing its own MC rate goals, and no one has published a standardized methodology to use. Moreover, some of the documentation related to the goals was lost when the Military Airlift and Strategic Air Commands were deactivated (GAO 03-300, 2003:28).

Another factor is that DODI 3110.5 dates back to the 1970s when readiness concerns had reached a high point. The focus was on getting the services to set benchmark readiness goals. The instruction was revised in 1990 but still does not reflect the current environment we live and fight in today. In 1997 and 1998, the two Air Force

Commands began to develop so-called requirements-based analyses to review the standards. Regardless of exactly how MC rates for various airframes are set, the MC rate is still one of the most visible markers used to judge aircraft capability and readiness. Therefore, we must understand what factors interact to ultimately affect MC rates.

MC Rate Factors

In some respects, the MC rate concept is simple. The higher the MC rate, the more hours aircraft are available to fly. But what really drives an MC rate? There are many factors, both observed and some possibly unobserved, that play a part. Total non-mission capable due to maintenance (TNMCM) time and total non-mission capable due to supply (TNMCS) time encompass two major observed factors that affect MC rates. “TNMCM is affected by such factors as maintenance manpower availability and experience and by the prioritization of maintenance actions, including scheduled inspections. TNMCS rates are affected by the availability of aircraft parts and supplies” (Thaler, 2002:20). Figure 1 illustrates annual MC, TNMCM, TNMCS, and aircraft parts cannibalization (CANN) rates for Air Force aircraft aggregated from 1994 to July 2005. It appears the overall Air Force MC rate is trending down during this timeframe. Figure 2 highlights the previous year’s rates for airlift aircraft specifically. This shorter term view exhibits a relative stable MC rate. TNMCM and TNMCS rates are two of the major factors influencing an MC rate. But, there are several other underlying factors that

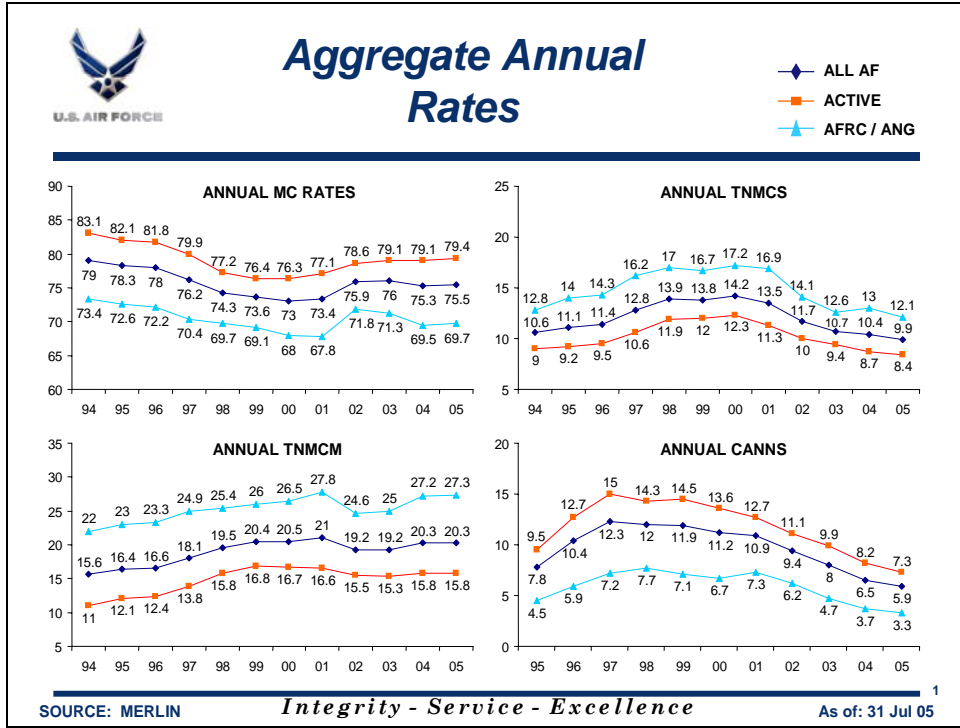

Figure 1. Air Force Overall Aircraft Trends 1994 - July 2005 (MERLIN, 2005).

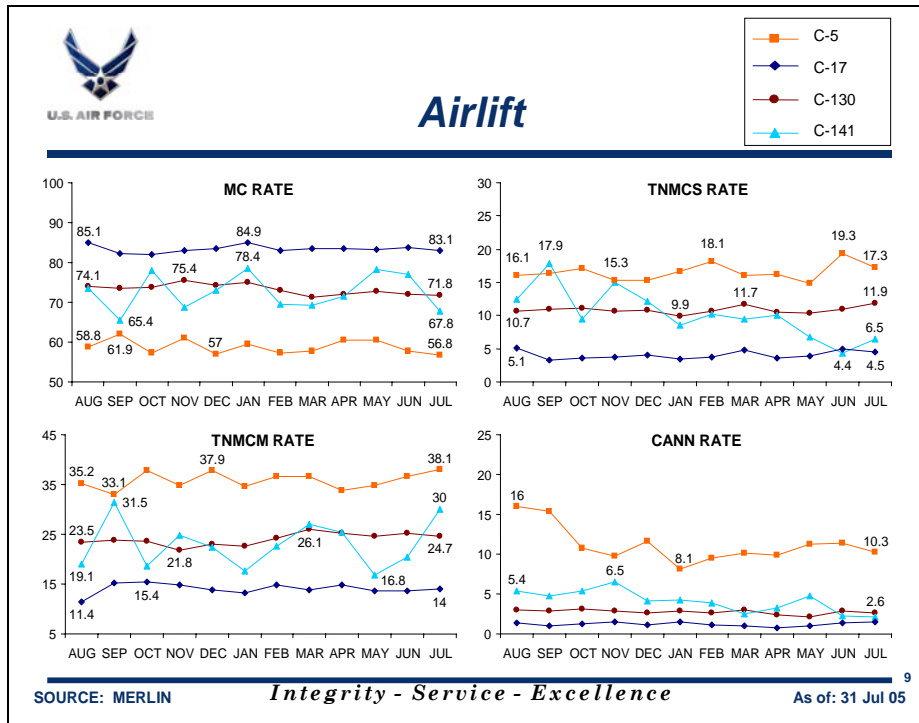

Figure 2. Airlift Rates August 04 to July 05 (MERLIN, 2005)

contribute to TNMCM and TNMCS, thus affecting MC rates. In addition to the effect of overall TNMCM and TNMCS rates, it is well documented that MC rates are affected by numerous combinations of interrelated logistical and operational factors with no dominating single problem (GAO 03-300, 2003:16). Many previous research projects have been conducted in an effort to identify factors that correlate to MC rates in an effort to identify important relationships and in some instances build more robust forecasting models. Much of this previous work also concentrated on fighter type aircraft data. Also, historically, regression analysis is the most common technique utilized to determine possible relevant factor models, along with the use of surveys and questionnaires to get a feel for which factors to include in initial data gathering and analysis. Examples of previous research related to MC rates and contributing factors include:

- Research utilizing questionnaires completed by deputy commanders for maintenance (DCM) and maintenance chiefs which identified 13 initial variables. Regression analysis was then conducted resulting in the cannibalization rate, delayed discrepancies (DD) (particularly awaiting maintenance (AWM) DD's), and average possessed aircraft as negatively, negatively, and positively correlated respectfully to MC rates (Gilliland, 1990).

- Analysis resulting in the idea that aggregate level research may not be applicable but analysis at possibly a particular aircraft level may be appropriate (Jung, 1991).

- Other research has also found that organizational structure is a key determinate of performance and also identified NMCS, aircraft hourly utilization (UTE)

rate, aircraft sortie UTE rate, and abort rate as factors to use at a non-aggregated level (Davis and Walker, 1992).

- Another research project summarized work up to the point it was completed in 1993. At that time, 53 independent and dependent variables had been analyzed. Both regression models developed in that particular research portrayed DDs as important factors (Gray and Ranalli, 1993).

- One Naval Postgraduate School thesis, again using regression analysis, identified a significant negative correlation with the number of consumable requests, percentage of items sent to the depot for repair, the number of cannibalizations, and the greater interaction between cannibalizations and sorties. This particular thesis also identified a positive correlation with the number of sorties and the percentage of consumable requests filled in one to two days from the time of placing the request (Moore, 1998).

- Additional research also concluded that there are many determinants of the MC rate and that you can not isolate it to just three or four variables (Stetz, 1999).

- More recent work identified many relevant factors we would expect to make up TNMCM and TNMCS, the ratio of maintainers per aircraft, the number of inexperienced personnel (number of 3-level training status personnel and personnel assigned in the grade of E-3) assigned, and the heavier weighting of some Air Force Specialty Codes. First term and career airmen reenlistments, the overall reenlistment rate, and the crew chief retention rates also displayed high correlations to MC rates (Oliver, 2001).

- Jon Ramer, in a 2002 article published in the Air Force Journal of Logistics (AFJL), also stated the “Analysis of current data trends suggests there is a correlation

between customer wait time (time elapsed from placing an order for a part until it is received) and MC rates” (Ramer, 2002:1).

In addition to these numerous projects, the GAO more recently reported such MC rate factors as the complexity of an aircraft, aircraft age and usage (aircraft age being accelerated by frequent deployments and high operating rates), shortages of spare parts, and even implications related to fleet size in addition to other factors previously noted in this chapter (GAO 03-300, 2003:16). With regard to the age of our fleet, on any given day, an estimated 2,000 of our approximately 6,000 Air Force aircraft are under various flight restrictions, usually related to aircraft age (Kitfield, 2005). Air Force Chief of Staff General T. Michael Mosley recently noted that currently “We have the oldest aircraft fleet in the history of the Air Force...the average age of the fleet has gone from 8.5 years in 1967 to 23.5 years old today” (Moseley, 2005). Additionally, the average age of the fleet will increase to 25 years in 2007 and to 30 years by 2020. Table 1 provides an example of increasing fleet average age for various airframe types in the coming years.

This increasing average fleet age will continue to add pressure in many areas, particularly maintenance and budget, especially considering a Congressional Budget Office 2001 report. The report estimated that spending for operations and maintenance for aircraft increases by one to three percent for every additional year of age (GAO, 2003:23-24). According to another source, the Air Force would need to buy an average of 170 aircraft per year to reverse the ongoing age trend and prevent readiness decay (Lopez, 2001).

Table 1. Increasing Air Force Fleet Age (SecDef Annual Report, 2005:65)

AVERAGE AGE OF AIR FORCE SYSTEMS (as of 18 Feb 05) 2004 to 2011		
MISSION	AVERAGE AGE 2004	AVERAGE AGE 2011
Fighter/Attack	17	21
Bombers	30	35
Tankers	41	46
Strategic Lift	17	16
Tactical Lift	25	25
Operational Support Airlift	23	28
C4&ISR	23	21

Table 2 lists several possible factors affecting MC rates. These factors are grouped into six main areas based on past history and research. While not totally inclusive, these factors present a very good starting point for researchers trying to study the interactions of variables that affect MC rates. Also well documented is the fact that most of these, as well as other potential factors, are relatively easy to quantify and include in possible predictive forecasting models. Other factors are more challenging to analyze quantitatively and there may be some overarching constructs comprised of variables not directly observed that should also be considered. With this in mind, and in addition to the research by Davis and Walker, more recent research also found that organizational structure can affect MC rates (Barthol, 2005). But, our Air Force structural changes are only one of several events which have occurred in recent years that affect how we conduct operations and thus affect our capability, readiness, and MC rates.

Table 2. Potential Factors Affecting MC Rates (Wall, 2004)

Personnel	Environment	Reliability & Maintainability	Funding	Aircraft Operations	Logistics Operations
Personnel Assigned or Authorized	OPS Tempo Factors	TNMCM Hours	Replenishment Spares Funding	Aircraft Utilization Rates	TNMCS Hours
Personnel in Each Skill Level	PERS Tempo Factors	Maintenance Downtime and Reliability	Repair Funding	Possessed Hours	Base Repair Order Time
Personnel in Each Grade	Number of Deployments	MTBF & MTTR	General Support Funding	Average Sortie Duration	Order and Ship Time
Maintenance Personnel in Various Air Force Specialty Codes	Policy Changes	Code 3 Breaks	Contractor Logistics Support Funding	Flying Hours	Level of Serviceable Inventory
Maintenance Personnel by Skill Level per AFSC	Contingencies	8-Hour Fix Rate	Mission Support Funding	Sorties	Level of Unserviceable Inventory
Maintenance Personnel by Grade per AFSC	Vanishing Vendors	Reparable Item Failures	O & M Funding	Flying Scheduling Effectiveness	Supply Reliability
Retention Rates for Maintenance Personnel	Weather	Cannibalization Hours and Actions	Initial Spares Funding	Type of Mission	Supply Downtime
Personnel per Aircraft Ratios	Aircraft Age	Repair Actions and Hours	Acquisition Logistics Funding	Airframe Hours	Depot Repair Cycle Time
Maintenance Officers Assigned or Authorized	Aircraft Mission	Maintenance Man Hours			Maintenance Scheduling Effectiveness

Events of Recent Years

Organizational Change

The 1990's were a busy time for the Air Force. The Objective Wing was instituted, Air Combat Command was formed, the Expeditionary Air Force (EAF) concept was implemented, and Gulf War I was fought and won. The centralized

intermediate repair facility (CIRF) and regional supply squadrons (RSS) were also created. Additionally, the Air Force changed from a three-level maintenance approach to a two-level approach.

The Air Force continued to evolve as the 21st century began by introducing concepts such as the Expeditionary Logistics for the 21st Century (eLog21) in February 2003. Before eLog21, the Combat Wing organizational structure replaced the Objective Wing concept in 2002 with the intent of better meeting the needs of the 10 Aerospace Expeditionary Force (AEF) packages (George, 2004:37) and to improve fleet health by bringing aircraft maintenance under the lead of the senior maintainer in the wing, the Maintenance Group (MXG) Commander. This is a great responsibility considering there are currently 65 active duty Air Force aircraft and missile maintenance groups (DOD Fact Book, 2005). Recent research into the effects of this latest organization change resulted in at least one conclusion that it was effective in attaining its proposed outcomes (Barthol, 2005). Obviously, the late 20th and early 21st centuries saw many changes, but the events of September 11, 2001 served as a major catalyst for change. The very nature of our AEF and the cycle by which it operates were ultimately affected.

AEF Cycle Changes

The Expeditionary Aerospace Force (EAF) concept is how the Air Force organizes, trains, equips, and sustains itself by creating a mindset and cultural state that embraces the unique characteristics of aerospace power – range, speed, flexibility, and precision – to meet the national security challenges of the 21st Century. The concept has two fundamental principles: first, to provide trained and ready aerospace forces for national defense and second, to meet national commitments through a structured approach which enhances Total Force readiness and sustainment (AFI 10-244, 2002:4).

Expeditionary Aerospace Force refers to the overall concept of operations while Air and Space Expeditionary Force (AEF) refers to the particular units that will deploy. Originally implemented by January 2000, AEFs were designed to reduce operation tempo and provide predictability and stability for airmen. The concept was intended as a response to the increasing number of contingencies calling for worldwide deployments. The Air Force is divided into 10 AEFs and an enabler force to support and sustain global expeditionary operations. Capabilities are immediately available via two AEFs continually postured for rapid deployment. The remaining eight are in various states of training, rest, redeployment, or redeployment training but can surge if needed (Air Force Posture Statement, 2005).

The original concept was, with the exception of major surge operations, for airmen to be either on call or deployed for 90 days every 15 months and airmen would know in advance when their time in *the bucket* was scheduled. General Moseley stated in March 2004 that during the peak of Operation Iraqi Freedom the Air Force had eight of our 10 AEFs deployed, but that two deployed at any one time during a steady state environment was the goal (C. Lopez, 2004). In September 2004, the deployment length of the AEF cycle changed to 120 days every 20 months in an effort to increase stability for commanders and reduce transportation requirements. Recently, the possibility of increasing deployments to 180 days as the new standard was posited. Part of the reason for changes to our AEF flow is the need to adapt to an increased tempo of operations our personnel and aircraft are striving to sustain, especially since the Global War on Terrorism began.

OPTEMPO and PERSTEMPO

OPTEMPO (Operation Tempo) measures a weapon system's or unit's activity level, deployed or at home station. PERSTEMPO is one aspect of OPTEMPO and measures the number of days a military unit or an individual service member operates away from home station. "PERSTEMPO attempts to capture all the time individuals are deployed away from their normal residence" (SecDef Annual Report, 2005:73). In its simplest definition, PERSTEMPO is the number of days per 12-month period a member is TDY away from his or her permanent duty station. In a broader sense, PERSTEMPO is the short and long term impact on a member, a member's unit, and his or her family of satisfying the needs of the Air Force. In this respect, all TDY and PCS assignment policies and procedures are PERSTEMPO sensitive (AFI 36-2110, 2005). Figure 3 depicts total U.S. troops deployed through 2004.

Obviously after the events of 9/11 our personnel and airframes got even busier, especially in support of Operation Enduring Freedom, and then for Operation Iraqi Freedom in 2003 as displayed in Figure 4. In a February 2005 speech to the Air Force Association, former Acting Air Force Secretary Peter B. Teets stated:

We ended 2004 with nearly 31,000 Airmen in Southwest Asia including 5,000 Air National Guardsmen and 2,500 Air Force Reservists flying over 200 sorties a day over Iraq and Afghanistan. To date they've flown over a quarter of a million sorties for intelligence, surveillance and reconnaissance, close air support, aerial refueling, aeromedical evacuation and airlift. And that's just in the theater.
(Teets, 2005)

The cost to sustain such operations is not cheap either. From September 30, 2001 through April 30, 2005, the DOD spent over \$19 billion in transportation costs in support of the Global War on Terrorism. Of this \$19 billion, \$9.5 billion was spent on airlift

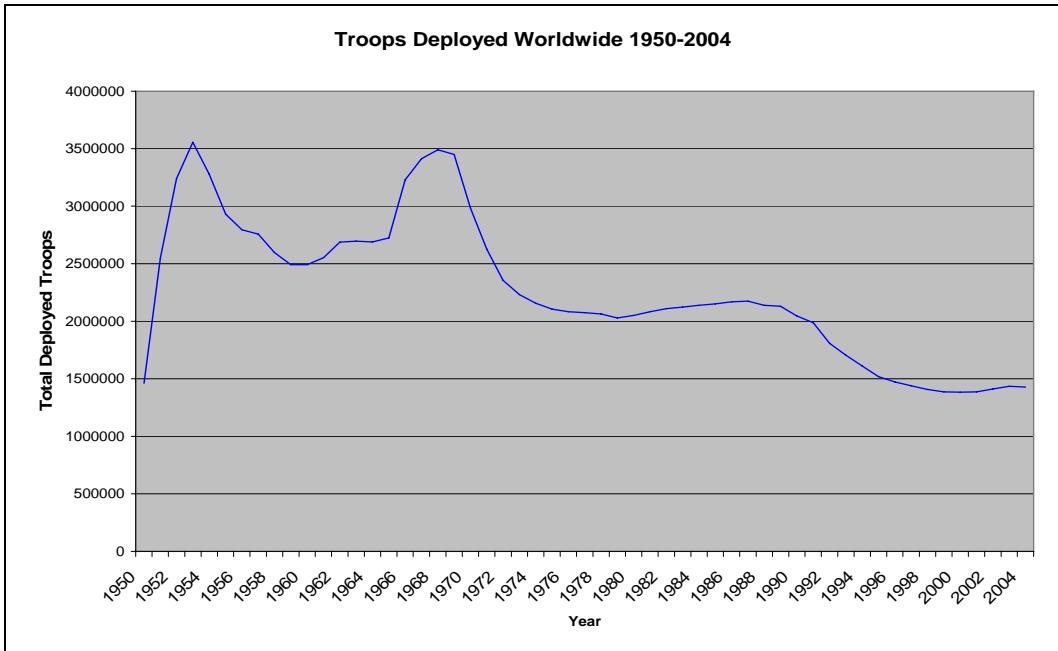

Figure 3. Total U.S. Troop Deployments 1950 to 2004 (DIOR, 2005).

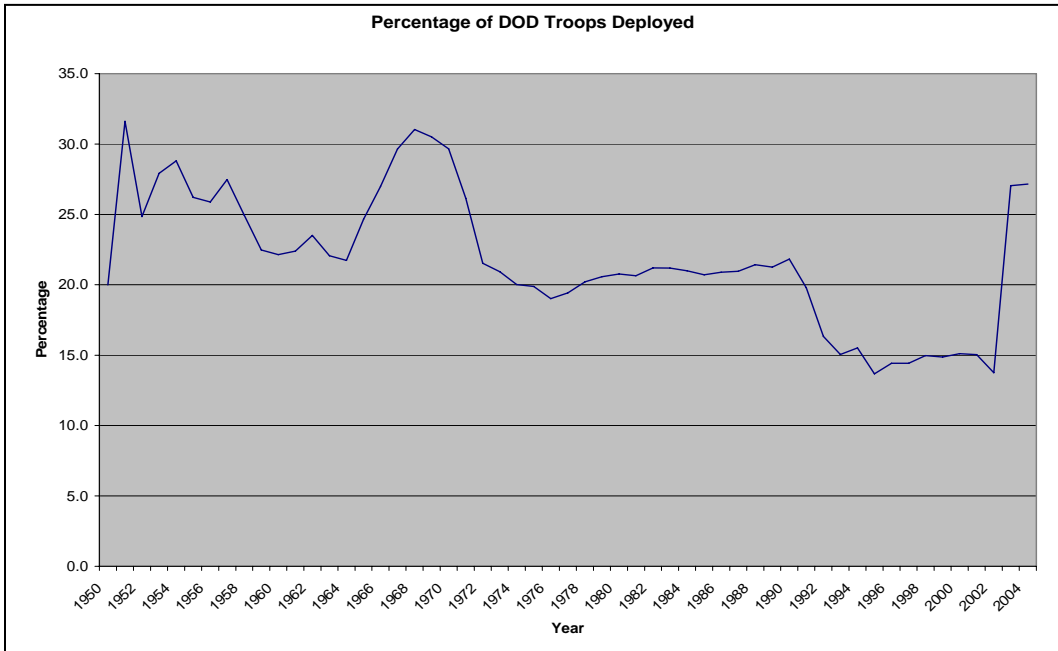

Figure 4. Percentage of U.S. Troops Deployed 1950 to 2004 (DIOR, 2005).

alone (GAO 05-819, 2005:1). Regardless, getting the mission done is most important. Air Force doctrine states that meeting mission needs is the primary objective of AMC, with efficient use of airlift capacity as a secondary goal (GAO 05-819, 2005:1).

In addition to mission objectives, operational readiness and sustainment training allow military forces to be prepared for various types of contingency operations and provide for the primary means of protection and defense of United States national security interests. Readiness and sustainment training have suffered due to increased OPTEMPO and PERSTEMPO due to the rigors of missions and everyday operations, and complications brought on by budget, environmental, and infrastructure constraints, but the mission must continue.

On any given day the Air Force has around 310 aircraft deployed flying over 60 missions a day in Afghanistan and nearly 180 a day over Iraq. There are actually over 200,000 active-duty airmen supporting the combatant commander every day (Geren, 2005). In reality, since hostilities began in Operation Desert Storm in January 1991, we have been in non-stop combat ever since, but even busier since 9/11. Figure 5 gives a snapshot of deployment numbers by component from September 2001 to June 2003 and the increased numbers associated with the buildup and start of Operation Iraqi Freedom is easily visible. In conjunction with increased demands on personnel, the demand on aircraft, particularly airlift, has also increased in recent years.

The Boeing C-17 Globemaster III is just one aircraft in greater demand since the Global War on Terrorism (GWOT) began. Figure 6 displays the C-17 aircraft's flying hours and sorties since its introduction into the Air Force fleet in 1993. Important

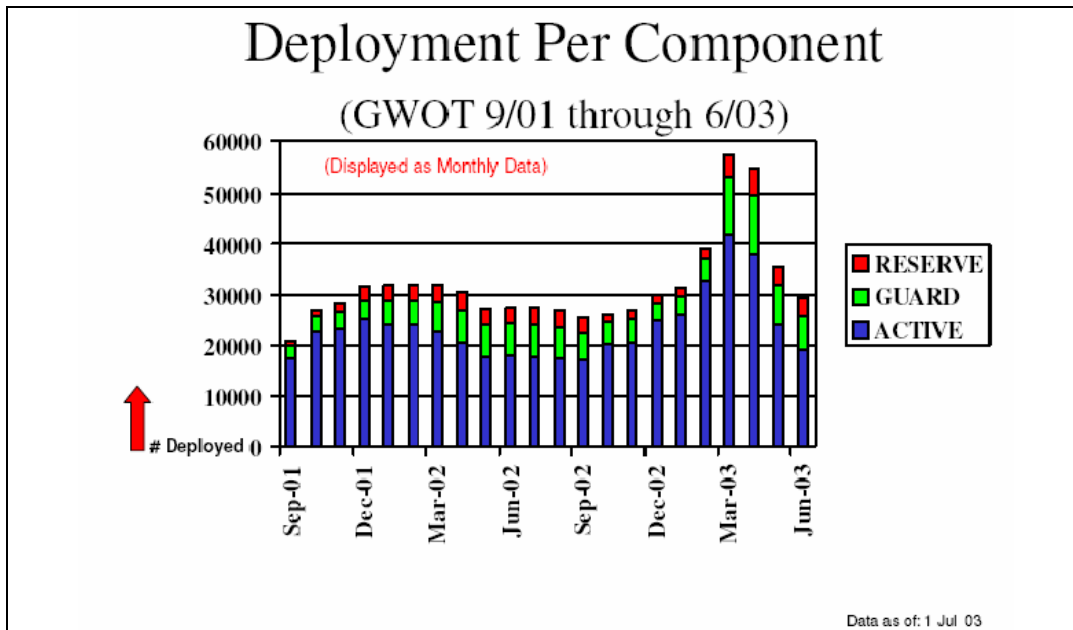

Figure 5. Deployments Per Air Force Component September 2001 to June 2003

(HQ USAF/DPM, August 2004:13)

to keep in mind for Figure 6 is that the total number of C-17 aircraft steadily increased over this same time frame which is consistent with an increase in flying hours. Even so, the dramatic increased demand for airlift that took place after 9/11 is evident. This increased OPTEMPO is possibly one factor driving the slight overall linear decline in C-17 MC rates shown in Figure 7, although the coefficient of determination (R^2) value of the trend line is only 0.06 serving as an indication that the slope is not statistically significant. In addition to the organizational, AEF, OPTEMPO, and PERSTEMPO changes in recent years, the number and makeup of personnel in uniform continues to change as well.

Personnel Changes

Congress controls manpower by authorizing end strength troop levels. Since manpower is a large part of the annual Air Force budget approved by the Congress, the

Air Force is obligated to accomplish the mission “using the minimum levels of manpower needed to effectively and efficiently execute missions” (AFPD 38-2:1).

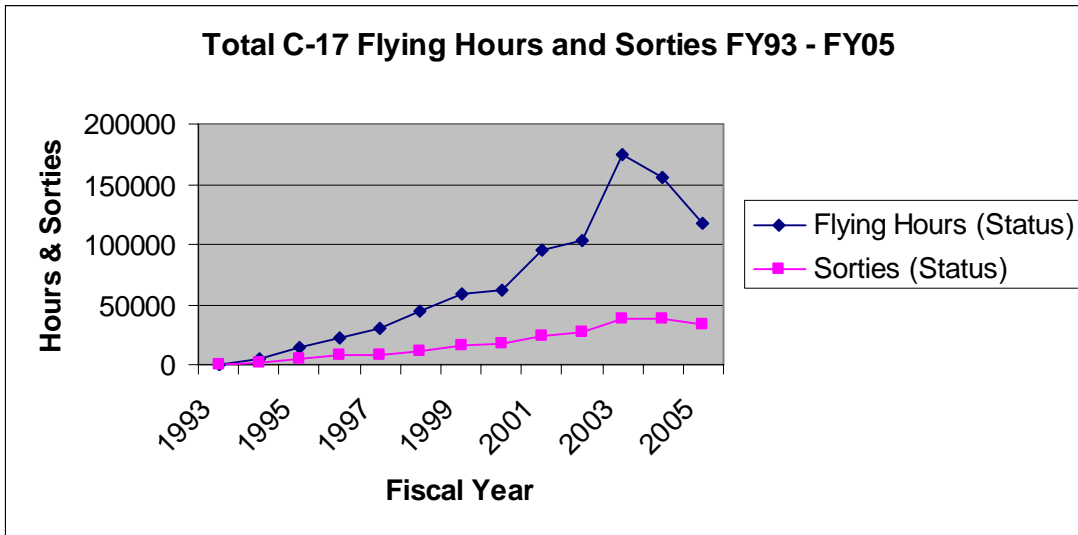

Figure 6. C-17 Flying Hours and Sorties FY93 - FY05 (MERLIN, 2005)

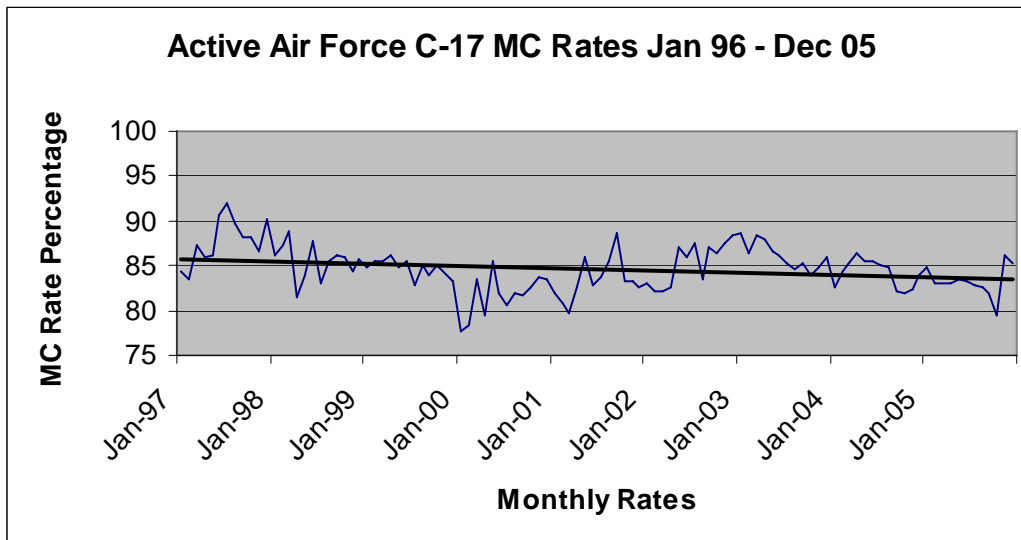

Figure 7. C-17 MC Rates January 1997 - December 2005 (MERLIN, 2005).

Figure 8 charts historical Air Force active duty end strength. The continual overall decline is obvious with declines in enlisted personnel particularly evident in the 1990’s when the force began the post Cold War drawdown. During the 1990’s, Air Force

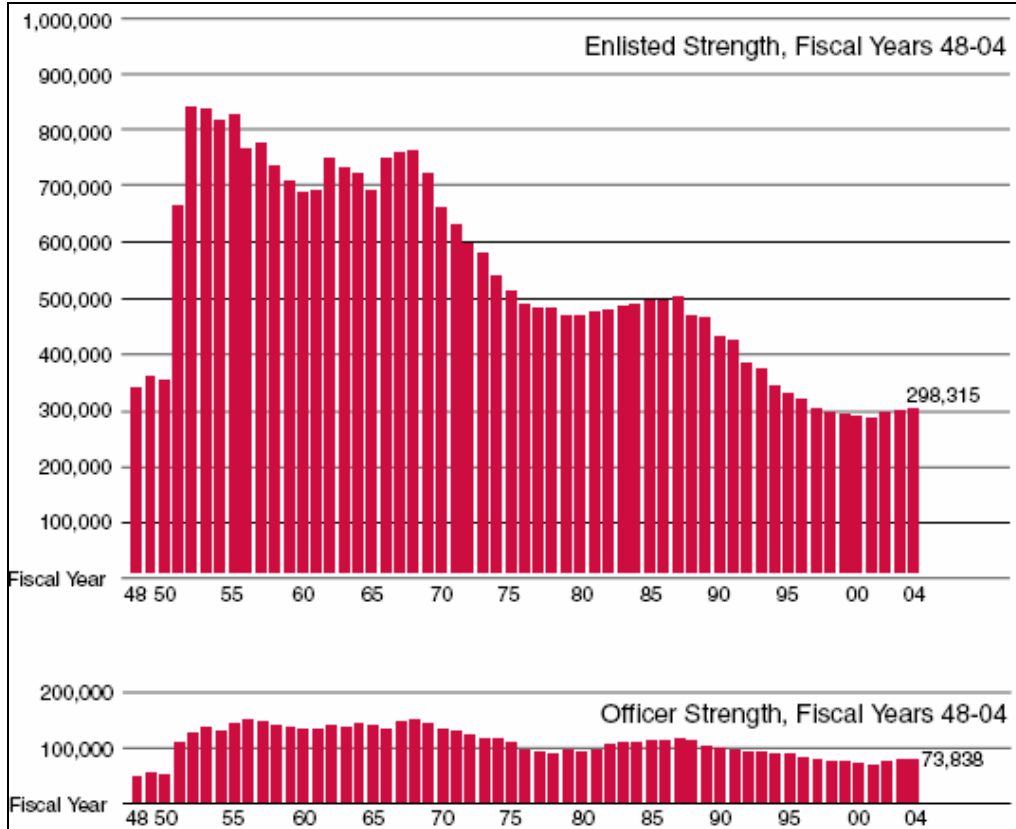

Figure 8. Historical Air Force Active Duty End Strength (Air Force Handbook, 2005).

end strength declined 40 percent from 608,000 to 375,000 while the force was still engaged at a higher rate than at any time during the Cold War (Roggero, 2004). Even with reduced numbers, the Air Force exceeded authorized end strength levels during the early years of the GWOT. This was allowed because the Secretary of Defense has the authority to increase the services' end strengths by up to two percent above active-duty authorized levels for a given fiscal year if such action is deemed to serve the national interest. In addition, the President may waive end strength authorization levels for a particular fiscal year if he declares a national emergency such as he did after 9/11 (GAO, February, 2005:5). This allowed the Air Force to exceed their authorized end strengths

by more than three percent in fiscal years 2003 and 2004 due to the GWOT. The Air Force also had better than expected recruiting and retention during this time. But with recent force reductions, active duty end strength is now below mandated levels with 349,369 personnel at the end of FY 2005. Apparently though, that number is not low enough. The Air Force plans to continue drawing down its total end strength over the next several years in order to balance the books.

In May 2005, then Chief of Staff Gen. John Jumper reported impending personnel reductions estimated at 10,000 airmen. By 13 December 2005, new Chief of Staff Gen. T. Michael Moseley and new Air Force Secretary Michael Wynne announced the Air Force would have to cut some 40,000 military and civilian positions. Only two weeks later Program Budget Decision 720, dated 28 December 2005, outlined personnel cuts totaling over 57,000. Those include more than 33,000 active duty troops with the remaining cuts coming from guard, reserve, and civilian positions through 2011 in order to realign resources (Colarusso, 2006). The anticipated savings from this realignment, with associated improved process efficiencies, as well as personnel and aircraft reductions, will help finance other programs including the latest goal of purchasing 183 F-22A Raptor fighters. However, it is not just the Air Force that has reduced personnel numbers over the years. Figure 9 shows the overall decline in all military branches. Interestingly, after a nearly 40 percent reduction in personnel in the early

**DoD ACTIVE DUTY MILITARY PERSONNEL STRENGTH LEVELS
FISCAL YEARS 1950-2004**

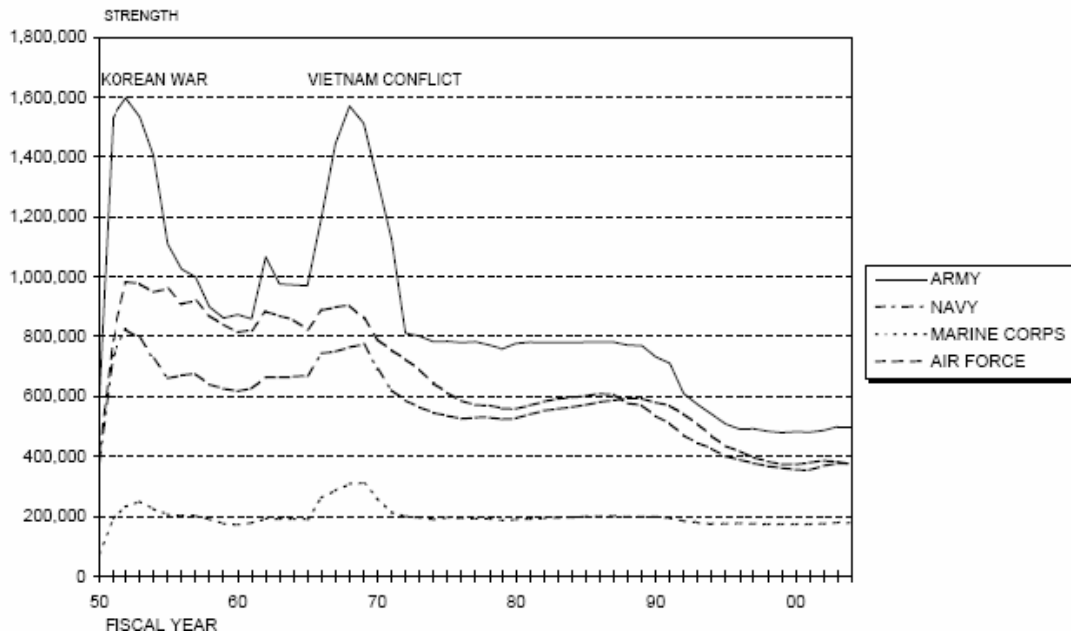

Figure 9. DOD Active Duty Strength Levels 1950 - 2004 (DOD SMS, 2004).

1990s, the Air Force has maintained a total force of about 6,300 aircraft to meet our military's goals (Pyles, 2003:1). During the busy 1990s, many operations and contingencies stretched our capabilities and our personnel resources. Specifically, by 1998 the Air Force deployed four times as often as it did to start the decade. This with a third less people, 66 percent fewer overseas bases, and 40 percent fewer fighter squadrons (HQ USAF/DPM, 2004:12-13). This increased tempo had a direct impact on the formulation of the AEF concept.

The AEF concept provided additional planning and deployment stability to the force and this was needed after the declining retention rates during much of the 1990s. As noted in Figure 10, the FY02 retention rates were higher but this was due to stop loss. A stop loss policy was implemented after 9/11 and so these rates can not be directly

compared to retention rates during years when stop loss was not in place. This is because a stop loss action prevents most airmen from either separating or retiring from the Air Force. Stop loss was later rescinded but was reinstated effective 2 May 2003. This version affected 43 officer and 56 enlisted specialties. Another initiative to improve retention of enlisted personnel's skills was a change to the high year tenure (HYT) limits. The HYT changes took effect on 1 January 2003 and added two additional years to the maximum most ranks are allowed to serve on active duty.

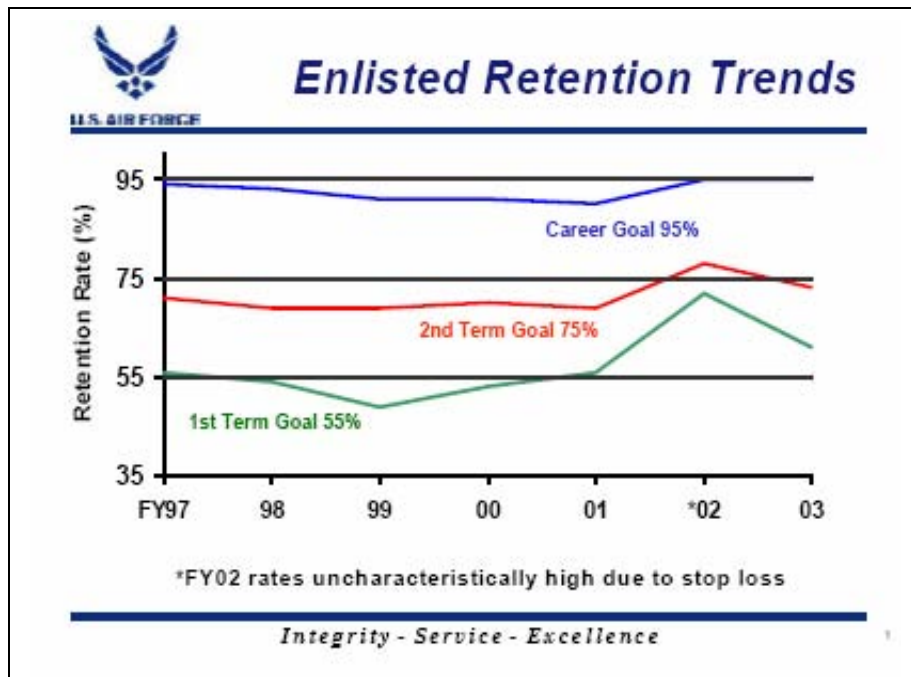

Figure 10. Air Force Enlisted Retention Rates for FY97 - FY03 (AFPC, 2004).

Looking back at the personnel end strength and retention rate declines of the 1990s, some resulted from economic conditions but many were a result of deliberate policy, especially during the post-Cold War drawdown. Regardless, by the late 1990s the trends had become worrisome with the Air Force missing its recruiting goal in 1999, the first time since 1979. There were also concerns about the quality of recruits and retention

of junior and mid-career officers in some key areas. Changes in military pay were seen as one area to take action to counter these trends.

Over the past two decades, entry-level military pay has grown more competitive with civilian wages for those just starting in the work place. The increases in military pay were instituted in response to the decline of both military recruiting and retention in the 1990s. To ensure this pay growth, Congress enacted a formula in 1999 which mandated annual military pay raises set at 0.5 percentage points above annual civilian wage increases. The increased pay formula expired with the most recent pay raise of 3.1 percent on 1 January 2006. This strategy brought the so-called pay gap between military pay and private sector wages to just 4.4 percent. Also during the period 2000-2004, the DOD utilized targeted pay raises for personnel within particular ranks and years of service. Even with the recent pay formulas and targeted raises to improve the pay gap, and in some way maybe help compensate for the increased tempo since the beginning of the GWOT, the Army in particular is still suffering from recruiting problems.

The Army missed its recruiting goal of 80,000 last year by more than 6,600 recruits. This was the first time the Army missed its target goal since 1999 and the largest shortfall since 1979 (Baldor, 2006). In fact, “for FY 2005, 5 of 10 components—the Army, Army Reserve, Army National Guard, Air National Guard, and Navy Reserve—missed their recruiting goals by 8 to 20 percent” (GAO, February, 2005). The ongoing GWOT and the associated increased OPTEMPO and PERSTEMPO are seen as direct causal factors for such recruiting shortfalls. Along with these recruiting shortfalls, the Associated Press also reported “the number of personnel leaving the military

each year has increased from 8.7 percent in 2002 to 10.5 percent in 2005” (Mendoza, 2006). One tool used to reduce recruiting shortfalls is military pay including enlistment and reenlistment bonuses, but how military pay stacks up in the future remains to be seen. Beginning in 2007, troops are due raises that only equal the average private-sector increase. This will result in a 2.2 percent raise in basic and drill pay on January 1, 2007, unless a different amount is approved by Congress and the White House. Pay and benefits are a motivator, but money for personnel and related benefits also compete with the needs of operations and maintenance.

Funding

From 2010 to 2030, an estimated 30 million Americans will pass the age of 65 but only 10 million new workers will enter the workforce. This looming increase in retirements as well as other factors including the national deficit and rising health care costs are affecting the Defense Department’s budget (Colarusso, 2006). But, personnel costs may be the biggest factor of all. According to Maj. Gen. Frank Faykes, deputy assistant Air Force secretary for budget, personnel costs have risen over 51 percent in the last ten years. Additionally, O&M costs have risen 87 percent during this same time frame (Colarusso, 2006). So, as the largest discretionary account, defense spending could come under intense pressure to meet future entitlement demands. Excluding funding for military operations, the proposed FY06 budget represents a 1.9 percent real (inflation adjusted) increase from the level provided for national defense through regular, annual appropriations in FY 2005 and a 32 percent increase from FY 1998, when funding for defense reached its post-Cold War low point. From 2002 to 2004, the defense budget

grew at about 10 percent per year but this is expected to decrease to a growth rate of only about 3 percent per year in the coming years (Kosiak, 2005).

DOD budgets, and particularly the Air Force's portion, affect funding which in turn ultimately affect spares inventories which directly impacts the cannibalization (CANN) rate. Although criticized by many as a poor use of logistics resources, cannibalization, which is the selective removal of serviceable parts from inoperable weapon systems to make others operable, can be a cost-effective and mission-enhancing practice, at least according to one study from the Logistics Management Institute (LMI). An LMI study revealed that cannibalization activity, which consumes less than 1 percent of available maintenance labor hours, can increase weapon system MC rates more than 17 percent and cost less than 1 percent of the alternative, which is buying additional spares (LMI, 2005). This is contrary to traditional thinking regarding cannibalizations. Typically, cannibalizations are seen as doubling the maintenance workload due to the effort required to remove (CANN) a serviceable part coupled with the time required to replace the part and then operationally check the aircraft it was removed from (Bosker, 2000). Cannibalizations also increase the possibility of breaking a serviceable part through the process of removing and replacing the part itself. This can in turn affect spares availability. Regardless, CANN rates are impacted by adequate spares funding.

The 2006 Operations and Maintenance (O&M) Overview released by the Secretary of Defense contained more information on recent budget changes. For FY06, logistics program changes include \$35.1 million to support the new Expeditionary Combat Support System (ECSS), which provides near real-time worldwide visibility of assets allowing the war-fighter to pinpoint the location of mission critical weapon

systems and confirm availability of resources to the area of responsibility. Program decreases include Depot Maintenance (-\$28.5 million) and Depot Maintenance Software (-\$25.6 million) (SecDef, O&M Overview, 2005:44). The FY06 Training and Recruiting program of \$3.0 billion includes a \$122.9 million price increase driven by higher fuel costs, but an overall actual program reduction of -\$23.9 million.

Also, the FY06 budget request includes a \$0.6 billion transfer into Air Force O&M funds from procurement funds for C-17 transition from Interim Contractor Support (ICS) to Contractor Logistics Support (CLS) per the C-17 Globemaster III Sustainment Partnership (GSP) program (SecDef, O&M Overview, 2005:8). The FY06 Mobilization Forces budget of \$4.0 billion includes a \$232.6 million price increase driven by increased fuel costs. This particular portion of the budget also supports engine overhauls, spares, electrical upgrades, paint, and indepth inspections over FY05 levels. The overview also points out other programs which are experiencing a decrease in FY06 funding including flying hours (-\$60.0 million), facility restoration and modernization (-\$33.8 million), base support programs (-\$27.3 million), and war reserve materiel (WRM) (-\$12.2 million). While WRM funding can also impact spares levels, the O&M overview states that funding levels are consistent with required sustainment levels (SecDef, O&M Overview, 2005:41).

As evidenced in the literature review, the MC rate is influenced by many factors and their complex interactions. The research effort here focuses on several of these factors and utilizes C-17 aircraft related data specifically. The C-17 was chosen because it is in high demand, is expected to increase in importance to our strategic airlift and national strategies, and it possibly lacks some of the confounding variables associated

with other airlift airframes. In addition, an airlift asset was chosen for this research in part because fighter aircraft have more often served as data sources in previous research relating to MC rates. Before starting an analysis of the C-17 and factors possibly related to MC rates, a brief background of the C-17 itself, a review of its role in AMC and national strategy, and a discussion of some unique C-17 program elements are provided.

C-17 Aircraft

History

Billed as the future of Air Force airlift, the C-17 is manufactured by the McDonnell Douglas Corporation in Long Beach, California. In 1997, McDonnell Douglas merged with and is now a wholly-owned subsidiary of the Boeing Company. The C-17 made its maiden flight on September 15, 1991, and the first production model was delivered to Charleston Air Force Base June 14, 1993. The first squadron of C-17s was declared operationally ready January 17, 1995 (Air Force Factsheet, 2005). Initially, only 40 aircraft were ordered with further orders pending corrections to early production cost and production inefficiencies. After subsequent successful evaluations in 1995, the Air Force ordered another 80 aircraft with the last scheduled delivery in November 2004. Then in 2002, the Air Force decided to purchase 60 more C-17s with estimated delivery completion by 2008. As of mid December 2005, 139 C-17s had been delivered to the Air Force at an estimated cost of \$200 million each. C-17s are currently stationed at Charleston, McChord, McGuire, Altus, Hickam, and Edwards Air Force bases as well as March Air Reserve Base and Thompson Field Mississippi Air National Guard base.

Elmendorf, Travis, and Dover Air Force bases are scheduled to receive C-17s in the near future.

At one time U.S. Transportation Command identified a requirement for 42 more C-17s which would bring the total fleet to 222 aircraft. However, on 13 December 2005, Air Force Secretary Michael Wynne stated that the Air Force accepts the results of the recent mobility capabilities study which leaves the final airlift inventory at 500 C-130s, 180 C-17s, and 112 C-5s (Bloomberg News, 2005). The C-17s success to date no doubt played a role in the studies' results and this success does not come without hard work by everyone involved with the C-17 program, whether in the areas of procurement, operations, or maintenance. The literature also attributes this success to the C-17's somewhat unique sustainment approach.

C-17 Flexible Sustainment Strategy

The C-17 has proven to be a workhorse since its inception and continues to maintain high readiness rates. The literature points to the C-17s performance-based logistics (PBL) program as a key to current success. The C-17 PBL program is just part of an overall increasing trend in public-private partnerships for aircraft depot maintenance as shown in Figure 11.

Performance based logistics basically equates to purchasing a defined level of performance and or sustainment over a defined time period at a fixed cost to the government, or in this case the Air Force. In January 1998, Boeing and the Air Force entered into a Flexible Sustainment contract which was a public-private partnership utilized to support the C-17 as part of a Flexible Sustainment strategy. This strategy gave

Boeing total sustainment responsibility while the aircraft was still in production (Huxsoll, 1999). The initial plan called for a yearly performance evaluation from 1998 to 2000.

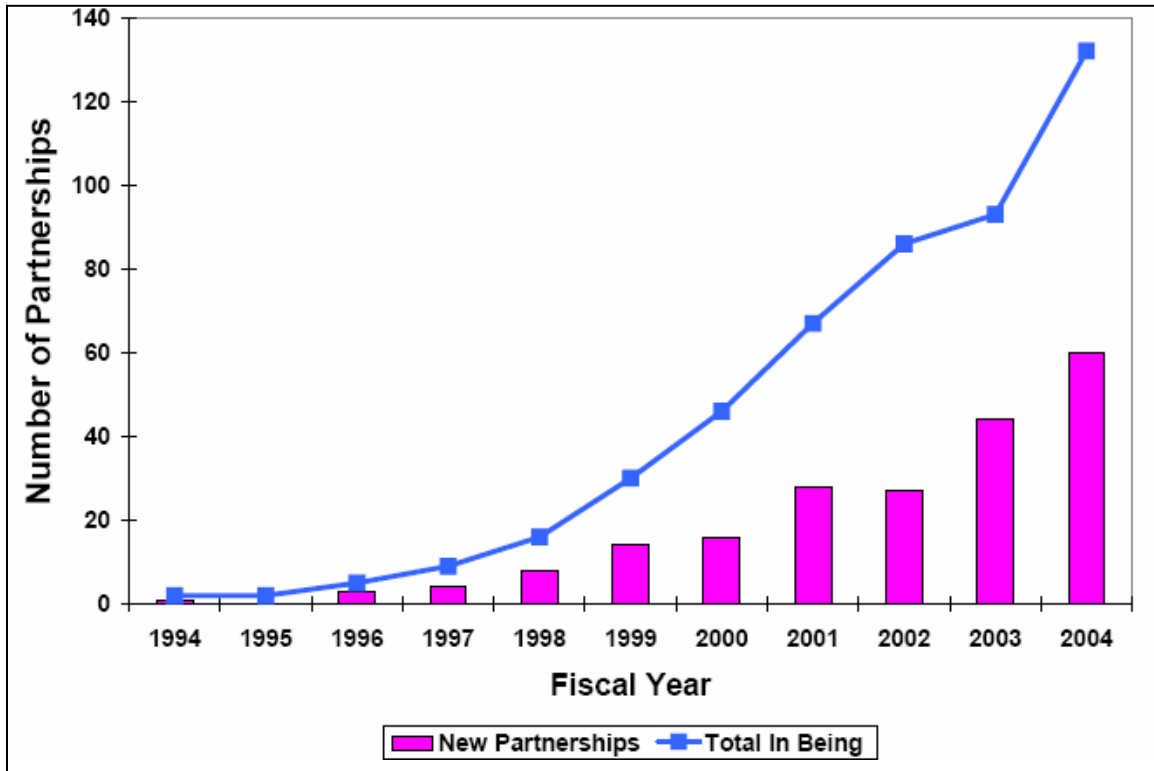

Figure 11. Growth in Depot Maintenance Public-Private Partnerships.

(DOD Maintenance Fact Book, 2005)

As part of the shift of material management responsibilities to Boeing during this time frame, in October 1999 Boeing began assuming logistics management responsibility for C-17 peculiar items from the Defense Logistics Agency (DLA). The buyout of these items was incrementally funded and concluded in 2002. The FY00 buyout included 1,400 national stock numbers (NSNs). These stock numbers were assigned a source of supply code of F77 so that Boeing, now the contractor, could appear as the DOD source for the older legacy computer systems (WR-ALC, 2000). By taking on this

responsibility, Boeing became the Contractor Integrated Materiel Manager (CIMM) to procure, stock, store, and issue C-17 peculiar support items, which also made them the inventory control point for C-17 managed items. Also during 1998 to 2000, depot maintenance was incrementally shifted to Boeing. Eventually, a full-up evaluation was conducted in 2001 and 2002.

In 2003, the Secretary of the Air Force approved a long term PBL C-17 contract with Boeing which was performance based and included award fees. The contract also included Boeing investments in the Air Force Air Logistics Centers (ALC) over the next five years. This program was named the C-17 Globemaster III Sustainment Partnership (GSP). Thus, Boeing assumed total sustainment responsibility for the C-17 and shouldered the performance risk to provide sustainment support as continuously raised benchmark levels. Since the C-17 was designed to operate without the typical periodic (depot) maintenance concept, C-17 long term maintenance is performed via a concept known as the Global Reach Improvement Program (GRIP). The GRIP is a unique program which includes the planning and execution of annual maintenance, retrofit, and any required C-17 modifications or block upgrades. This is all accomplished through the use of Boeing contract field teams (CFT), analytical condition inspections (ACI) completed by Boeing, and aircraft paint programs. The contract field teams are currently located at Charleston, McChord, Altus, and McGuire AFBs with additional teams planned for March and Travis AFBs in FY06 and FY07 respectively. Analytical condition inspections are inspections conducted by Boeing personnel to validate C-17 fleet health by sampling a selected portion of the fleet. The first aircraft completed GRIP at Warner Robbins ALC in April 2003.

The PBL approach for the C-17 evolved into a product support concept and is now part of a larger construct called the Logistics Transformation Initiative within the DOD. With compelling factors including defense infrastructure downsizing, leading commercial companies supply chain efficiencies, and our expeditionary force's need for agile logistics support, the Air Force realized it needed to leverage the benefits of the public sector together with our own organic maintenance capabilities as part of a new way to maximize our capabilities (Orr, 2005). These maximized capabilities are crucial to meet the requirements placed on airlift in today's increasing global environment.

AMC Mission and National Strategy

The C-17 is a vital asset used by AMC as part of the command's mission to provide airlift, aerial refueling, special air missions, and aeromedical evacuation to U.S. forces in support of the our nation's defense strategy. Since the early 1990s, our national strategy has been based on a two-war formula which was built around the need to fight and win two near simultaneous major regional conflicts. This strategy was part of a larger construct consisting of defending the homeland, deterring aggression in four theaters, and fighting and winning the two near simultaneous conflicts (Sherman, 2005). The literature suggests the impending change to a new construct which gives equal weight to homeland defense, GWOT, and conventional campaigns is the result of the global environment we now operate within as well as shrinking defense budgets.

The Quadrennial Defense Review (QDR) report was due to Congress 6 February 2006. Although the overall report was slated to remain classified, portions of the upcoming report were discussed publicly by senior defense officials. While speaking to the Joint Civilian Orientation Conference, Secretary of Defense Rumsfeld discussed how

the QDR focuses on capabilities rather than quantities and how current warfighting models don't work effectively against terrorism (Miles, 2006). Regardless of the reasons, any changes in national strategy directly impacts how personnel are trained and deployed, and in turn ultimately affect how many personnel are left to carry out all of our nation's military missions. Of course, all of the areas discussed in this chapter including personnel levels, retention, funding, personnel and operations tempo, even organizational structure can and do bear on how we conduct aircraft maintenance, which in turn drives aircraft MC rates.

Overview of Next Chapter

Chapter three describes the methodology utilized in this research and begins with a discussion of the data sources used in this research effort. The chosen methodology is outlined and includes a general discussion of structural equations modeling (SEM), analysis of moment structures (AMOS), and particular aspects of SEM as it applies to this research effort. Strengths and weaknesses of SEM are also reviewed as well as assumptions and limitations of this research.

III. Methodology

Introduction

Frequently, fighter aircraft have served as the data source for previous research regarding MC rates and various factors that influence them. Many prior research endeavors also used multiple regression techniques to analyze possible non-causal models of the relationships among these proposed variables. The methodology for this research attempts a different approach in that it incorporates Structural Equations Modeling (SEM) techniques, specifically utilizing analysis of moment structures (AMOS) 4.0 software, and the use of C-17 data in order to evaluate potential factors and interactions within proposed MC rate causal models. The proposed structural equations models will include previously identified factors and their associated variables as well as newly proposed latent constructs. Before proposing the specific methodology and potential models, data sources for this research are discussed.

Data Sources and Collection

Reliability and Maintainability Information System (REMIS)

REMIS is the primary Air Force data system for collecting, validating, editing, processing, integrating, standardizing, and reporting equipment maintenance data, including reliability and maintainability data. REMIS also provides authoritative information on weapon system availability, reliability and maintainability, capability, utilization, and configuration. REMIS interfaces with many different Air Force and

contractor systems with much of the data input to REMIS coming from the Core Automated Maintenance System (CAMS), the Comprehensive Engine Management System (CEMS), and the CAMS for Mobility system GO81.

Although REMIS is a comprehensive data base, it is not without flaws and is subject to the same *garbage in, garbage out* dilemma as any other military or commercial database. This problem relates to the concept of dirty data which can result from the fact that many people input data into CAMS and other systems daily. If data integrity standards are not strictly followed, data fed into these systems can be corrupt. This data, accurate or not, in turn feeds REMIS. REMIS data is then used by other systems and users. Figure 12 provides a graphical overview of how a typical variable, in this case TNMCM time, flows through the system when requested by, in this example, someone at HQ USAF/ILM.

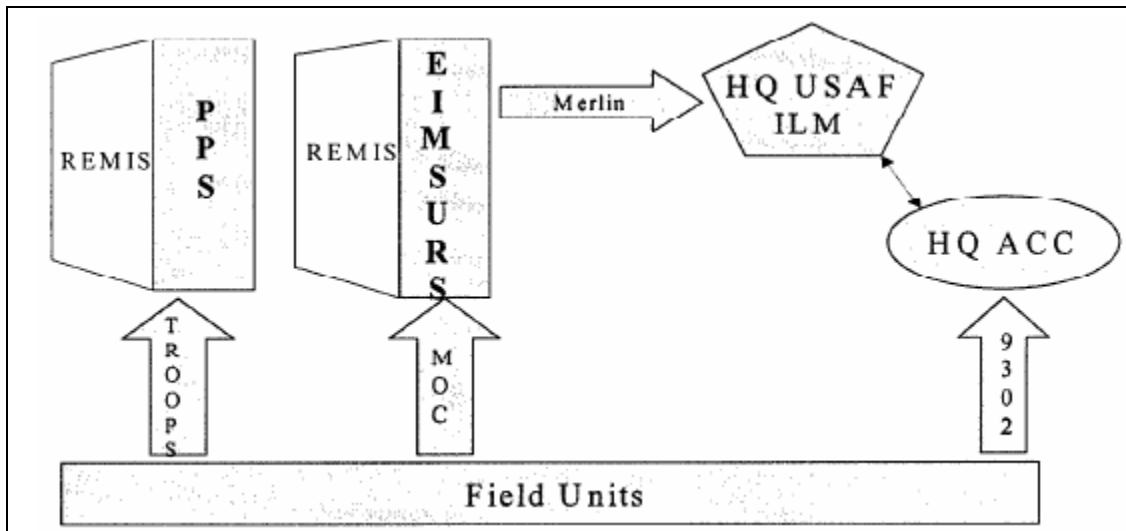

Figure 12. How TNMCM Data is Reported (Bell, 2000:5).

As illustrated in Figure 12, data is originally input from the field by troops in the various maintenance squadrons into the Product Performance Subsystem (PPS) subsystem of REMIS and into the Equipment Inventory, Multiple Status, Utilization Reporting System (EIMSURS) subsystem by personnel located in the Maintenance Operations Centers (MOC) at operational wings. If personnel at HQ USAF/ILM desire TNMCM information, they extract their data from the Multi-Echelon Resource and Logistics Information Network (MERLIN) system. Unfortunately, this information is not as in-depth as REMIS data. One cause for possible disagreement is the fact that the PPS data is not visible to MERLIN users because PPS and EIMSURS data is not shared or consolidated. This data can also vary from MAJCOM available data. A 2000 AFLMA report detailed several other reasons for data mismatches including single status reporting by MOCs and status reporting using aggregated two digit work unit codes (WUC) versus the full five digit WUCs (Bell, 2000). As a result, data integrity sometimes comes into question with databases such as this, but many researchers and agencies, both within and outside the Air Force, continue to use REMIS and other Air Force databases as a valid source for aircraft fleet health data. Thus, REMIS was chosen as a primary data source for this research.

For this research, the REMIS program management office was contacted for assistance and the e-mail address is included Appendix A. REMIS is also accessible through the Air Force Portal after access is granted from the program management office. REMIS program management personnel extracted the requested C-17 data for this research. The original REMIS data was provided in a text file format with monthly data points. An example snapshot of a text file and the list of REMIS related variables used in

this research are also included in Appendix A. The data was subsequently transferred to Microsoft Excel® files for manipulation and more in-depth analysis. The newly developed variables are also located in Appendix A.

Multi-Echelon Resource and Logistics Information Network (MERLIN)

The MERLIN system mentioned in the previous section is a web-enabled, integrated reporting and analysis software tool that provides access to a variety of logistics data similar to REMIS. MERLIN differs from REMIS in some ways however. MERLIN contains metrics for generating information on the logistic health of the Air Force's weapons systems and enables multi-weapon system as well as specific weapon system views. MERLIN also captures historical data and funding profiles and MERLIN can also identify trends and has some forecasting capability. MERLIN can also provide the ability for a quick comparison, analysis, and graphic output. Additionally, and seemingly in contrast due to differences in data output from REMIS discussed in the previous section, the United States General Accounting Office has certified MERLIN as the trusted source for Air Force logistics information (Air Force Portal, 2005).

Access to the MERLIN database is granted from the application owner. They were contacted via the Air Force Portal at their e-mail address at merlin@drc.com. MERLIN data was used in this research as an initial source for historical C-17 sorties and flying hours comparisons as well as some graphics output of these and similar variables for both C-17 specific and Air Force aircraft at aggregated levels. During the course of this research, disparities were seen between REMIS reported data and MERLIN reported data for variables such as the MC rate. This is no doubt caused by some of the factors previously discussed in the REMIS section of this chapter.

Secondary Items Requirements System (SIRS) (D200A)

Replenishment spares are vital to mission success and directly impact aircraft mission capable rates. One source for data related to asset order and ship times, base and depot repair cycle times, serviceable and unserviceable inventory levels, and component failures is the Air Force's Requirements Management System (RMS). The RMS is actually composed of several major subsystems as shown in Figure 13. The subsystem providing specific data for this research effort is the Secondary Items Requirements (SIRS) which also has the data system designator D200A (AFMCMAN 23-1, 2005:33). The SIRS provides for the automation of inventory tracking and increases the accuracy and efficiency of the requirements computational processes for recoverable items.

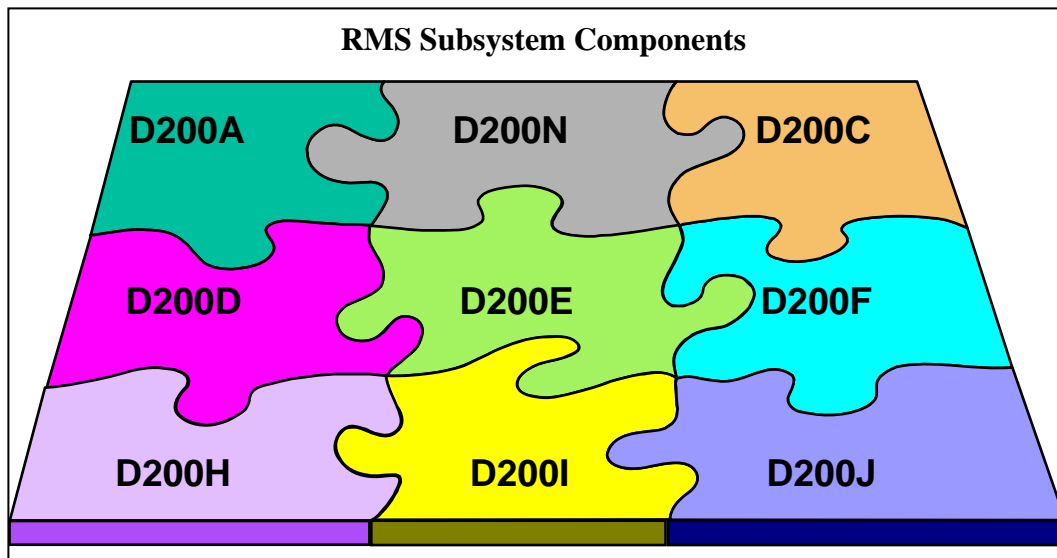

Figure 13. Requirement Management System (RMS) Subsystems (Towell, 2004).

This subsystem utilizes the Aircraft Availability Model (AAM) to develop Peacetime and Wartime requirements. SIRS computations involve a relatively complex process. Figure

14 provides an illustration of the 16 systems that feed data into the SIRS and the 22 systems plus contractors that receive data from the SIRS.

SIRS replaces the previously used D041 system and uses historical failure and program data for each item to determine a failure rate to be applied to a future program.

The system computes buy, repair, excess, and termination requirements for

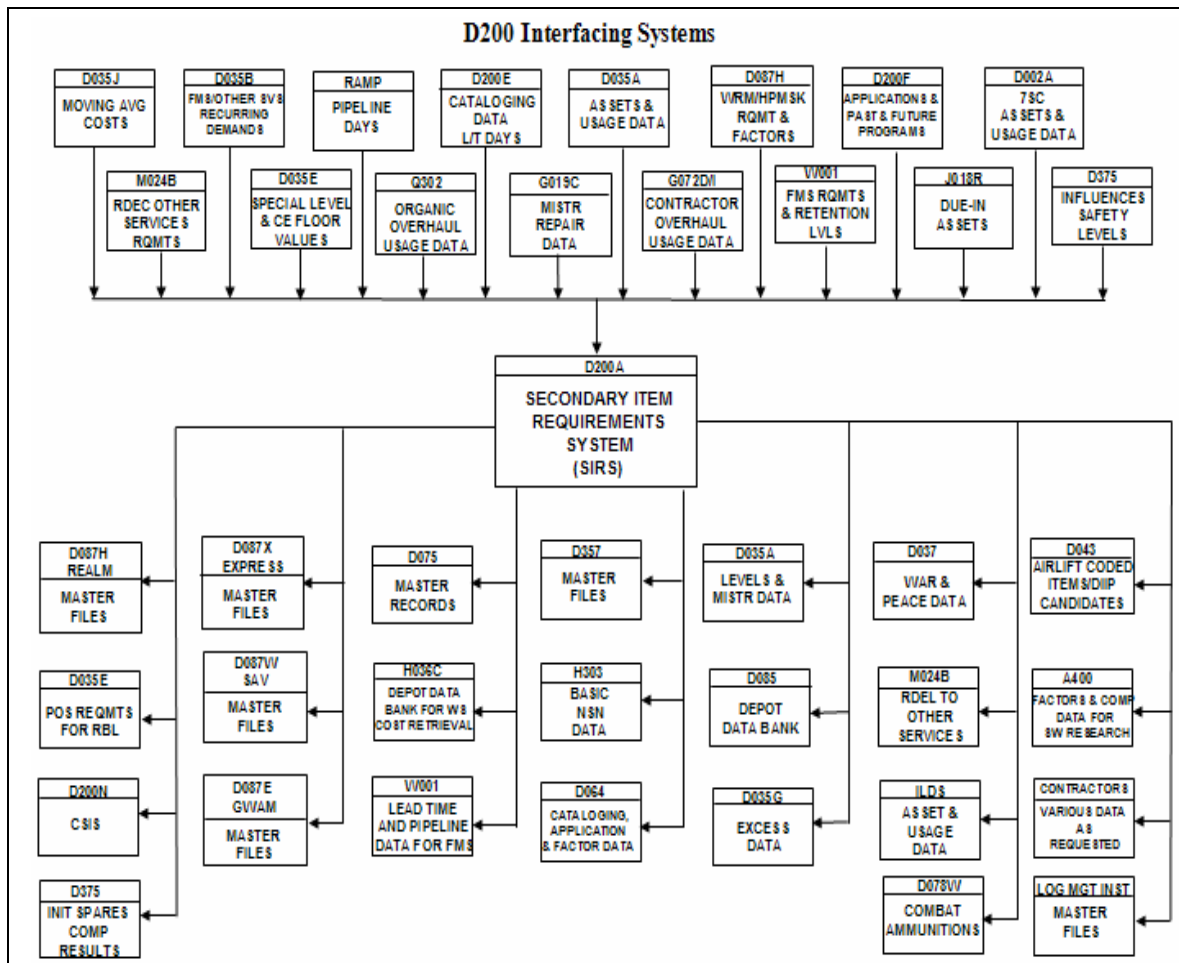

Figure 14. SIRS (D200A) Interfaces (Towel, 2004).

approximately 150,000 secondary items, both recoverable and consumable, with Expendability, Recoverability, Reparability Category (ERRC) codes C, T, N, and P. Basically, SIRS tracks world wide replenishment spares requirements for secondary

items (Towell, 2004). For SIRS, the term *spare*s imply that installed parts are not reflected in the individual asset balances. Also, the term secondary item refers to the fact that these particular assets lose their identity when they are installed on the next higher assembly, i.e., an aircraft.

Lastly, recoverable items represent a line replaceable unit (LRU), components, etc, that are economically feasible to repair at the depot level. Consumable items are usually not economical to repair or are consumed during use. According to AFMCMAN 23-1, when an item's unit repair cost exceeds 75 percent of its actual unit price it should be considered consumable instead of repairable and treated as a throw-away item. The responsible engineer should also consider changing the ERRC to reflect this as well (AFMCMAN 23-1, 2005:33). Recoverable items were previously managed in the DO41 system and consumable or expendable items were previously managed in the DO62 system. The consumable items were also sometimes called Economic Order Quantity (EOQ) items.

The SIRS requirements computation is conducted quarterly using data that are current on the last day of each calendar quarter (March, June, September and December). For each of these four cycles, the SIRS computation is actually run three times with an initial, final, and summary computation conducted. Then, the results of the summary computation are passed to the Central Secondary Item Stratification (CSIS) (D200N) for stratification and summarization of results (Towell, 2004). These results of this process, shown graphically in Figure 15, eventually conclude in the requirement which is included in the budget which is sent to congress. These requirements are computed for two

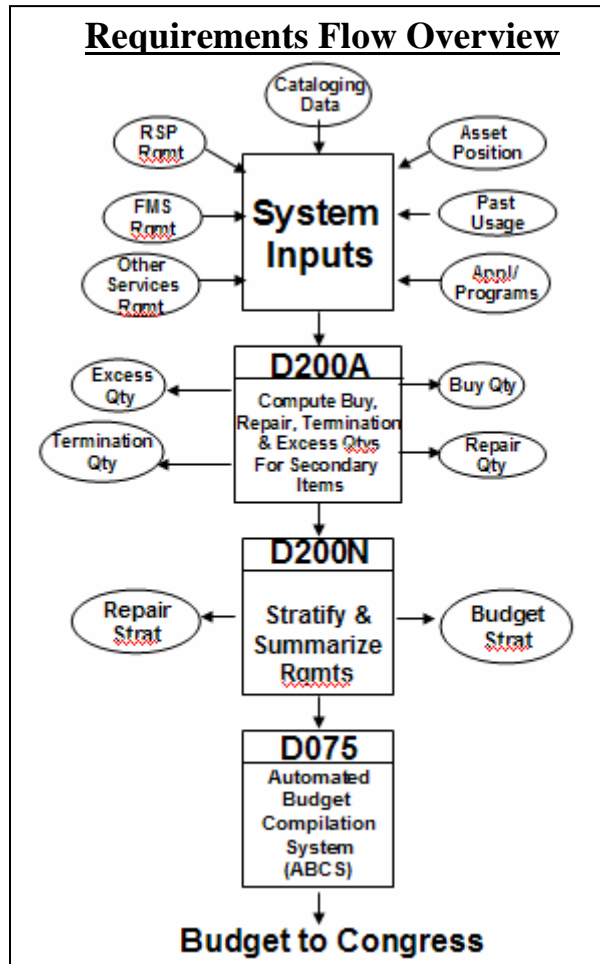

Figure 15. Requirements Determination Systems Flow (Towell, 2004).

categories of programs: Organizational Intermediate Maintenance (OIM) for base activities and Depot Level Maintenance (DLM) for depot activities. HQ AFMC/LGYR, specifically contractors from Dynamics Research Corporation employed with the Requirements Interface Process Improvement Team (RIPIT), wrote the data retrieval programs for C-17 related historical supply data from SIRS. Data was retrieved for the March 1997 to March 2005 timeframe for C-17 reparable common items pipeline, asset, and usage data. Pipeline data included order and ship days, base repair cycle days, and depot repair cycle days. Asset data included serviceable and unserviceable asset data. Usage data contained base reparable generations and depot reparable generations.

The data extraction resulted in a national stock number (NSN) specific database containing 481 C-17 common item NSNs managed by the Air Force. The term common item relates to the fact that each NSN has a system management code (SMC) assigned which identifies what application, i.e., airframe, equipment, etc, that the particular item is used with. If a single airframe such as the C-17 has 96 percent of a particular assets usage, the SMC would be coded as C-17. Otherwise, the asset is treated as a common item used by various airframes and coded with an SMC beginning with 999 or another variation (Towell, 2005). The original data retrieved from SIRS was in quarterly format and converted into several new variables via Microsoft Excel® spreadsheets for use in the analysis. Appendix B provides a snapshot of the spreadsheet data retrieved from the SIRS, both the initial data as well as the newly derived supply related variables.

An important note is that C-17 peculiar assets are managed by Boeing item managers as part of the Global Sustainment Partnership (GSP) discussed in chapter two. Therefore, historical data related to Boeing managed supply assets is directly applicable to analysis related to C-17s. Unfortunately, this particular data was not obtained by this researcher in the given timeframe for this project. Therefore, only C-17 common asset historical data obtained from the D200A system was used in this research and is a limitation. Overall limitations are discussed more at the end of this chapter.

Personnel Data System

Personnel retention, experience levels, and career field manning levels have all been documented as important factors which affect aircraft MC rates (Oliver and others, 2004). In order to obtain aircraft maintenance personnel data for this research, a request for data was submitted to the Air Force Personnel Center's (AFPC) Data Retrieval

Section at HQ AFPC/DPAFDT for data retrieval from the Personnel Data System (PDS). Since this research is sponsored at the Air Mobility Command (AMC) level, access to AMC level data was granted by AFPC. After the command-level data request was approved, personnel from the AFPC Force Management and Analysis Division conducted the actual data retrieval.

For this research, data was extracted for AMC authorized versus assigned active duty personnel in C-17 aircraft maintenance related enlisted (2AXXX) control AFSCs as well as aircraft maintenance officer (21AX) primary AFSCs for 1995 through 2005. A list of typical AFSCs assigned to C-17 maintenance units and used in this research is given in Appendix C. This AFSC list was derived after reviewing AFMAN 36-2108 for enlisted classifications, AFMAN 36-2105 for officer classifications, consulting with previous and current C-17 maintenance unit leadership, and reviewing AMC's recurring health of the fleet presentations which included tracking of C-17 maintenance manning combined 5/7 levels in particular 2AXXX career fields.

The Personnel Data System is updated primarily by base-level personnel and in addition to the authorized versus assigned data, the system contains information related to skill level upgrades, personnel assignment histories, and many other types of personnel data, both current and historical. As a military shared database utilizing inputs from many different personnel at numerous locations, the Personnel Data System is subject to the same potential errors and delays related to databases previously discussed in this report. In the case of the Personnel Data System, this can occasionally result in skewed data in areas such as the number of personnel assigned at particular skill-levels, particularly from the 3 to 5 skill-level, due to input and processing delays.

The requested historical data for the number of personnel authorized versus assigned was only available in fiscal year format. This yearly data was then converted into quarterly estimates using increases or decreases from the previous year and spreading the associated changes over the four quarterly periods. Any personnel in student, trainee, or personal holdee status are not counted in the normal authorized versus assigned totals. Incidentally, those in personal holdee status include prisoners and personnel in long term medical patient status. Also of note, there are no manpower authorizations below the rank of Airman First Class (A1C). This results in Airman Basic (AB), Airman (AMN), and A1C all grouped together as far as authorizations versus assigned are concerned.

For aircraft maintenance personnel retention data, the AFPC Data Retrieval Section at HQ AFPC/DPAFDT also extracted AMC-level data for 2AXXX career fields via the Requirements Applications Website (RAW) database. The RAW database is also available to individuals via the interactive reports menu on the AFPC Personnel Statistics webpage which is provided by AFPC's Directorate of Assignments. An individual account can be established by completing the registration process via the AFPC website. This account then allows the user limited access to a number of applications.

PERSTEMPO Data

Personnel Tempo (PERSTEMPO) data was extracted from the AFPC secure web page, AFPC secure main menu, PERSTEMPO tab. The PERSTEMPO site main menu supports data retrieval through the selection of various parameters including a specific component such as active duty, different level views including action officer, the data source timeframe, a search level set at the Air Force or major command level, and the

type of display such as by AFSC. PERSTEMPO data was also only available in one year snapshots. Data for all enlisted 2XXXX AFSCs and logistics officer AFSCs were only available in one year increments and data was retrieved for the March 1997 – October 2005. All non-aircraft maintenance related PERSTEMPO data was removed and the applicable data subdivided into quarterly data estimates. A copy of an example initial spreadsheet and also an aircraft maintenance filtered PERSTEMPO spreadsheet from the AFPC site is included in Appendix D.

Funding Data

Many DOD and Air Force level budgets, various literature and previous research projects were reviewed in search of a source of funding information at a disaggregated level which would best represent a realistic factor for use in the comparison of variables which interact with MC rates for the purpose of this research. Specific disaggregated data was not uncovered during this research, therefore, in an attempt to model the relationship between funding and MC rates, Air Force Total Obligation Authority (TOA) for operations and maintenance (O&M) during the 1997 to 2005 timeframe was considered as the funding variable during model development.

Structural Equations Modeling (SEM)

SEM Basics

The structural equations modeling (SEM) family is considered one of the most inclusive statistical procedures used in the behavioral sciences, the area where it is applied most often (Kline, 2005:14). Evidence of this inclusiveness is the fact that

analysis of variance (ANOVA) is a special case of multiple regression. Both ANOVA and multiple regression are in turn part of what is known as the general linear model (GLM), and the GLM itself is a special case of SEM (Kline, 2005:14). When compared to regression and factor analysis, SEM is a relatively young field which gained ground with work relating to sociology and econometric-type models in the late 1960s and early 1970s (Bollen, 1989:7). The advancement of SEM software, which included the ability to analyze problems graphically as well as by explicitly developing the actual equations greatly assisted the growth of SEM usage. SEM is also referred to as covariance structure analysis, covariance structural modeling, analysis of covariance structures, and another term often used for SEM is causal modeling.

SEM is set apart from other multivariate procedures by several aspects. SEM consists of a series of multiple structural (i.e., regression) equations and all equations are fitted simultaneously. These structural relations can also be modeled graphically in SEM. This graphical representation enables a different and usually more user friendly conceptualization of the problem under study (Byrne, 2001:3). SEM is an a priori technique where intervariable relationships are specified initially and these specifications thus reflect the researcher's hypothesis. This fact contributes to why SEM is often considered confirmatory versus exploratory (Kline, 2005:10).

SEM also includes several types of variables for use in modeling scenarios. Independent variables, assumed to be measured without error, are called exogenous variables. Changes in these variables are not explained by the model. Dependent variables, also called mediating variables, are referred to as endogenous variables and these are influenced by the exogenous variables either directly or indirectly. SEM

variables are also defined as observed and latent. Observed variables are directly measured by the researcher and are usually continuous. They serve as indicators of the underlying construct they are supposed to represent. Latent variables are unobserved variables which are not directly measured but are inferred by the relationships or correlations among the observed variables in the analysis. Latent variables are continuous. The distinction between latent and observed variables also provides a way to account for imperfect score reliability and can assist with a more realistic quality to the analysis, although this can not compensate for gross flaws in model design (Kline, 2005:12).

Covariance is the basic statistic of SEM. Intuitively, covariance is the measure of how much two variables vary together. Covariance becomes more positive for each pair of values which differ from their mean in the same direction and more negative with each pair of values which differ from their mean in opposite directions. A covariance is sometimes referred to as an unstandardized correlation because it has no bounds, unlike a correlation coefficient which limited to the range of -1 to +1. Correlation is also a dimensionless measure of linear dependence. This enables covariance to convey more information than a correlation, as a single number statistic (Kline, 2005:13). In SEM, tests can be done to determine whether or not variables are interrelated through a set of linear relationships by examining the variances and covariances of the variables.

A typical approach to SEM analysis includes specifying a model based on theory, determining how to measure constructs, collecting data, and imputing the data into an SEM software package. The basic SEM model typically consists of two components: a measurement model and a structural model (Byrne, 2001:12). The measurement model

defines the relationships between the observed and unobserved variables which in turn provides the link between the measuring instrument and the underlying constructs. The structural model then defines the relationships between the unobserved or latent variables. Data input can be in the form of a covariance matrix, correlation matrix, or matrix of covariances and means but typically the researcher inputs raw data into the software and the program converts the data into covariances and means for use. The software then attempts to fit the data to the model and produces results including overall model fit statistics and parameter estimates. In order to provide successful results, the SEM software program requires certain assumptions to be met and as with all modeling software, SEM does have limitations.

SEM Assumptions and Limitations

Like any statistical method, SEM includes several assumptions. SEM requires a reasonable sample size. Sample sizes of less than 100 are considered small and are usually too small to utilize unless a very simple model is evaluated. A sample size between 100 and 200 subjects is considered medium and sample sizes over 200 cases are considered large (Kline, 2005). Some authors also recommend at least a ratio of five to one for the number of data points to the number of free parameters to be estimated in a model (Kline, 2005). SEM program errors are calculated under the assumption of large sample sizes. SEM also assumes the endogenous variables are distributed with multivariate normality. An additional requirement is that each equation be properly identified. "Identification is demonstrated by showing that the unknown parameters are functions only of the identified parameters and that all these functions lead to unique solutions" (Bollen, 1989:88). This means there is a unique solution for each parameter

estimate in the SEM model when all parameters are identified. All of the assumptions just discussed come into play while using any one of several core SEM techniques.

SEM core techniques include path analysis (PA), confirmatory factor analysis (CFA), and structural regression (SR). Path analysis is considered when there is only one measure of each theoretical variable and also utilizes a researcher's existing hypothesis regarding causal relationships of these variables (Kline, 2005:66). Path analysis can be used in place of multiple regression in instances where a variable cannot be represented as both a predictor and as a criterion.

Unlike path analysis, confirmatory factor analysis is capable of multiple indicator measurement. This is important considering that it is probably unrealistic to think that a single indicator could adequately measure a hypothetical construct. Confirmatory factor analysis analyzes a priori measurement models where both the number of factors and their correspondence to the indicators are explicitly specified (Kline, 2005: 71). In path analysis, path coefficients are the statistical estimates of direct effects. In confirmatory factor analysis, the corresponding term is factor loading and these represent regression coefficients and may be in standardized or unstandardized form. Confirmatory factor analysis estimates only unanalyzed relationships among factors, not direct causal effects. The results of a confirmatory factor analysis include loadings of the indicators on respective factors, amount of unique variance for each indicator, and estimates of covariance between the factors.

Lastly, a structural regression model is the most general kind of basic SEM. A structural regression model is the combination of a structural model and a measurement model (Kline, 2005:75). Unlike path analysis, structural regression models can test

hypotheses about direct and indirect causal effects including those involving latent variables. Structural regression models also contain a measurement component which represents observed variables as indicators of underlying constructs, similar to confirmatory factor analysis. Again, even when all the assumptions are met, SEM, like any statistical method, has its limitations.

As previously mentioned, the preferred mode of analysis uses raw data input into the programs. If there is incomplete data, there are four general categories of methods for dealing with missing observations and these are discussed in detail in Rex Kline's 2005 book (Kline, 2005). Causality is another limitation of SEM and other techniques. Just because a given set of data is consistent with a model does not imply that the model corresponds to reality, and statistical tests can only disconfirm models, they can never prove a model or the causal relations in it (Bollen, 1989). Ultimately, correlation does not imply causation.

When evaluating a model, at least two broad questions are relevant: Is the model consistent with the data and is the model consistent with the real world? SEM typically tests the first question explicitly and implicitly addresses the second. SEM entails some uncertainty and thus the requirement for explicit model specification. Even so, and similar to regression models, SEM models can never be fully accepted, they can only fail to be rejected. Models that fit the data well can be provisionally accepted while models that fail to fit the data can be absolutely rejected. Additionally, SEM assumptions and limitations are common across the various software programs in use today including the AMOS software chosen for use with this research.

Analysis of Moment Structures (AMOS) Software

AMOS software is a product of SPSS Inc. AMOS version 4.0 was utilized for the structural equations modeling in this research due to its availability, flexibility, powerful graphical interface, its comparability to other structural equations modeling techniques currently in use, and numerous goodness of fit indices provided in the AMOS output (Byrne, 2001). However, AMOS 4.0 requires data for the variables to be input via one of several older formats and Excel 5.0 was chosen for this research. AMOS was developed within the Microsoft Windows interface but allows the user to choose from two approaches to model specification: AMOS graphics and AMOS basic (Byrne, 2001).

AMOS graphics utilizes the common SEM technique of the path diagram. A path diagram is similar to a flow chart and incorporates various symbols and types of lines to represent different variable types and the directions of causal flow. Observed variables are drawn as boxes and latent variables are drawn as circles or ellipses. Error terms are drawn as latent since errors are estimated and not measured directly. All independent variables have lines with arrows pointing toward the dependent variable and the weighting (path) coefficient is placed above the arrow if required by the model specification. A curved two-headed arrow connecting two variables in the diagram represents covariance between the two variables. AMOS also operates on the principle of what you see is what you get. If a covariance path is not specified in the path diagram, that parameter will not be estimated, but if a parameter is included, AMOS will attempt to estimate a value for the parameter (Byrne, 2001:33).

To use AMOS basic, the researcher specifies the model using an equation format versus graphical representation. In the case of larger models or for batch-oriented results,

AMOS basic may be the better approach (Byrne, 2001: 15). Differences also exist between AMOS graphics and AMOS basic in regard to parameter covariance default rules. For AMOS basic, instead of what you see is what you get operations of AMOS graphics, unique latent variables are considered to be correlated with each other and with all exogenous variables. Also, all observed exogenous and latent variables are presumed to be correlated with each other (Byrne, 2001: 33-34).

Model Building and Specifications

For this research, the structural regression SEM model shown in Figure 16 serves as the initial conceptual model of MC rates, influencing factors, and possible interactions. This model is proposed based on previous research discussed in chapter two, discussion with various aircraft maintenance personnel, and personal experience. Models are seldom if ever perfect and all encompassing, so this initial model serves as just one example of the possibilities. Small portions of this overall model will be initially tested using AMOS graphics and analysis. Based on initial results, the smaller models may require modification and retest in order to compare and ultimately build to the best representative model of how aircraft MC rates, hypothesized constructs, and factors theoretically interact.

The initial conceptual model includes several directly observable and well known factors such as sorties, flying hours, etc. The model also includes the four latent constructs of OPSTEMPO, maintenance experience, maintenance capability, and fleet health. OPSTEMPO is a well known factor but is composed of more than one aspect so it in itself is not directly observable. Maintenance experience in this model consists of

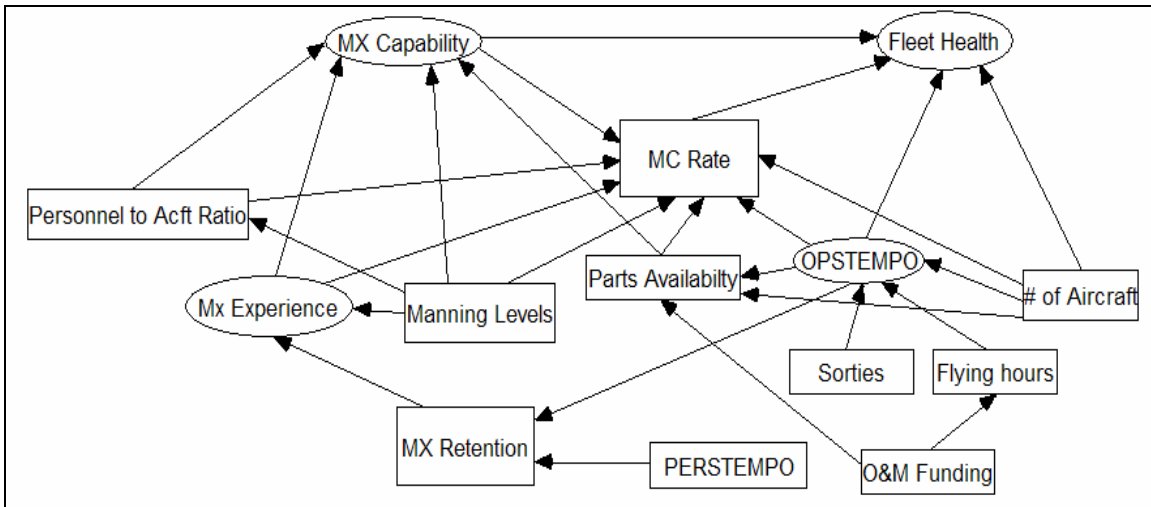

Figure 16. Initial MC Rate Factors Model (SEM Model 1)

a combination of the levels of maintenance manning assigned versus authorized and also retention levels for aircraft maintenance personnel. The maintenance capability construct represented in this model is an often talked about quantity but again, not directly observable itself. In the context of this research, it comprises several variables including personnel to aircraft ratio, maintenance experience, manning levels, and parts availability. Finally, the fleet health construct is another frequently mentioned concept and is theoretically comprised of several factors. In this conceptual model, fleet health is affected by the number of C-17 aircraft labeled “# of Aircraft”, OPSTEMPO, MC rates, and maintenance capability.

The primary interest in structural equations modeling is the extent to which a hypothesized model fits, i.e., describes the sample data. As previously mentioned, AMOS provides many model goodness of fit indices. For the purposes of this research, the measurements in Table 3 will be used to assess the fit of the model and the preset significance level will be .05. The first goodness of fit measurement is the p-value for the chi-square (χ^2) statistic. The p-value is the probability of getting as large a discrepancy as

occurred with the present model under appropriate distributional assumptions and assuming a correctly specified model (Arbuckle, 1999).

Table 3. Goodness of Fit Specifications

Measure	Indication of Good Fit
<i>p</i> -value (χ^2)	> .05
GFI	> .90
CFI	> .90
RMSEA	< .10
TLI	> .90

The χ^2 stat for a just-identified (model degrees of freedom = zero) model equals zero and has no degrees of freedom. So, the model χ^2 tests the null hypothesis that the overall model is correct. If the model perfectly fits the data, then $\chi^2 =$ zero. Failure to reject the null hypothesis supports a researcher's theory. The higher its value, the worse the model fits the data (Kline, 2005). A statistically non-significant χ^2 ($p > .05$) is favorable and indicates a good model fit (Byrne, 2001). However, χ^2 is sensitive to sample size. If the sample is small the χ^2 test will show that the data are not significantly different from quite a wide range of very different theories. χ^2 is also sensitive to the size of correlations with larger correlations typically leading to higher χ^2 values. χ^2 values also tend to be too high if the distributions are severely nonnormal. Due to these and other problems with χ^2 as a fit index, other indices were also considered.

The goodness of fit (GFI) index belongs to the class of absolute fit indexes and basically compares the researcher's model with no model at all (Byrne, 2001). It is analogous to a squared multiple correlation (R^2). It ranges from 0-1.0 and a GFI > .90 may indicate a good fit (Kline, 2005).

The comparative fit index (CFI) ranges from 0-1.0 and belongs to the class of incremental fit indexes. It assesses the relative improvement of the researcher's model compared to a baseline model in which the covariances among population variables are assumed to equal zero. Generally, CFI values greater than .90 may indicate a reasonably good fit of a researcher's model (Kline, 2005).

Root mean square error of application (RMSEA) is a parsimony-adjusted index that favors the simpler of two models (Kline, 2005). The RMSEA measures the error of approximation which concerns the lack of fit of a researcher's model to the population covariance matrix. A value of zero indicates the best fit with values $< .10$ suggesting a reasonable error of approximation.

The last goodness of fit measurement used in this research is the Tucker-Lewis Index (TLI). The Tucker-Lewis Index compares a proposed model's fit to a baseline or null model. Additionally, this index measures parsimony by assessing the degrees of freedom from the proposed model to the degrees of freedom of the null model. The typical range is 0-1.0 with a TFI $> .90$ indicative of good model fit (Byrne, 2001).

In addition to evaluating the fit of an overall model, the individual parameters estimated by the model must be evaluated also. The first step in assessing individual parameters in a model is to determine the viability of their estimated values. The estimates should indicate the correct sign and size and be consistent with the theory underlying the hypothesized model (Byrne, 2001). Estimates that fall outside an admissible range signal the model may be wrong or that possibly the sample size is too small. AMOS also provides standard errors for the parameters. This standard error value is akin to a standard deviation for an approximately normally distributed random

variable. If the standard errors are excessively large or small it is another sign of poor model fit, although there is no definitive criterion for what constitutes large or small. Also, the statistical significance of these parameter estimates is measured by the critical ratio. This value represents the parameter estimate divided by the standard error and it operates as a z statistic for testing that the estimate is statistically different from zero (Byrne, 2001). Based on the chosen significance level of .05 for this research, the test stat will need to be $> \pm 1.96$ before the hypothesis that an estimate equals zero can be rejected. An important note is the fact that nonsignificant parameters can also be an indication of small sample sizes.

Research Assumptions and Limitations

Assumptions and limitations in this research include:

1. All data from the Personnel Data System, the Reliability and Maintainability Information System, the Secondary Items Requirements System, PERSTEMPO database, and the Multi-Echelon Resource and Logistics Information Network are assumed accurate and complete. Although subject to flaws previously discussed in this report, these systems and databases provide data for leaders and researchers both within and outside the Air Force and are considered valid, reliable sources.
2. Any period where no retention activity occurred, i.e., no one was eligible for reenlistment, was treated as a 100 percent retention data point.
3. The number of aircraft maintenance personnel serving in various roles within maintenance such as production supervisor, quality assurance, etc, is not

separated within the retrieved data and thus can possibly skew the relationships between personnel to aircraft ratios, etc, and MC rates, and is a research limitation.

4. The number of aircraft maintenance personnel in each C-17 related AFSC used for this research are representative of maintenance personnel assigned in a typical C-17 maintenance organization. Many AFSCs are also assigned to maintain other airframes within AMC and this fact creates a limitation.
5. The data extracted from the Secondary Items Requirements System consisted of C-17 common depot (XD) and field (XF) condemnation level coded components. Since C-17 specific assets are managed by Boeing through a performance based logistics contract, the common item data retrieved for this research is limited in its ability to reflect actual C-17 supply item variations.

Overview of Next Chapter

Chapter IV provides a detailed account of the structural equations MC rate model building process and the associated results. First, a simple MC rate model is proposed and the related variables analyzed. Subsequent models are then developed and tested and the results presented.

IV. Analysis and Results

Chapter Overview

The previous chapters outlined the problem statement, presented research questions, reviewed previous literature of research methods and results related to MC rates and influencing factors, and proposed the methodology utilized in this study. This chapter discusses the analysis of structural equations models developed in this research as well as other statistical techniques utilized.

According to author Rex Kline (Kline, 2005), there are typically six steps of basic structural equations modeling and his approach was utilized in this research to the extent possible:

1. Specify the model – expresses the researcher’s hypothesis in the form of a structural equations model.
2. Determine whether the model is identified – this means that it is theoretically possible for the computer program to derive a unique estimate of all model parameters.
3. Select measures and collect, prepare, and screen the data.
4. Use an SEM computer program to estimate the model – this involves evaluating model fit, interpreting the parameter estimates, and considering equivalent models.
5. If necessary, respecify the model and evaluate the revised version with the same data.

6. Describe the analysis as accurately and completely as possible in a written report.

Structural Equation Model Development

Initial SEM Model and Variables

There are so many potential causal variables mentioned in the literature that it is virtually impossible to include all of them in any one model. In most cases, a researcher must rely on his or her own judgment to determine what they believe to be crucial variables (Kline, 2005). As previously stated, SEM Model 1 serves as one example of a theoretical big picture model representing MC rates and possible factors and a model of this level of complexity is the ultimate end goal of this research.

However, before a model of such complexity is attempted, simpler models are hypothesized and tested to build confidence in the proposed measurements as well as enhance the researcher's ability to construct, test, and analyze potential structural equations models. Unlike many examples of previous research in different areas of the behavioral sciences, no previous examples of structural equations modeling used with aircraft mission capable rates and factors were found during the literature review. This is another reason simple models were built initially with the intent to build upon small successes.

Another aspect of model complexity is the limit on how many parameters can be represented. A parameter is some particular characteristic of a population and is estimated with a sample statistic. The number of parameters that can be estimated is limited by the number of observations, with observations being the variances and

covariances among the observed variables. The calculation for the number of observations in a model is shown in equation 2.

$$\text{Number of model observations} = v(v+1)/2 \quad (2)$$

(Kline, 2005)

In equation 2, v equals the number of variables in the model. The number of observations remains the same regardless of sample size so adding cases does not increase the number of observations, only adding variables will do that. There are also two types of parameters, free parameters and fixed parameters. Free parameters are estimated by SEM software using the sample data. A fixed parameter is specified to equal a constant and the software program accepts this value as the estimate of the parameter regardless of the sample data. With all these factors in mind, simpler models were proposed and tested.

SEM Model 2

SEM Model 2 shown in Figure 17 is a less complex initial model hypothesizing only a maintenance experience construct. Even though SEM Model 2 is only a portion of the overall factors represented in SEM Model 1, it is easy to see how attempting to model with even small portions of the overall MC rate model can be complicated. In SEM Model 2, there are three primary latent variables represented by the large ovals: overall maintenance experience, overall maintenance manning levels, and overall maintenance personnel retention. The small circles linked with each observed variable and the primary constructs represent possible error in the measurement and serve to absorb random variation in the variable's data and systematic components for which no suitable predictors were provided. The number "1" associated with the error terms and also with

some of the directional arrows assists with model identification and also serves to scale the latent variables.

Again, for a model to be identified there must be at least as many observations as free parameters (model degrees of freedom \geq zero). Additionally, every latent variable must be assigned a scale. This is because for unobserved variables, there is no way to specify a measurement unit. Assigning an arbitrary value indirectly chooses a unit of measurement for error (Arbuckle, 1999). This assignment of a number (the default for AMOS is the number one) allows for the SEM software to solve for the error variance because otherwise the software can not simultaneously solve for both the regression weight and the error variance.

The observed variables, represented by rectangles in the model, consist of manning and retention aggregated data variables for maintenance personnel in five areas including crew chiefs, avionics, structures, engines, and systems. For example, the systems variables include personnel in career fields such as hydraulics, electrical systems, etc. The other four variables consist of personnel with AFSCs similar to others in their particular subset of maintenance. Data for the C-17 related AFSCs in each of these five areas were combined to create these specific variables and a list of C-17 AFSCs used in this research is located in Appendix C. Each of these five groups of maintenance personnel were separated into airman (AMN), non-commissioned officer (NCO), and senior non-commissioned officer (SNCO) authorized versus assigned variables. These variables are labeled as CC A/A NCO for crew chief authorized versus assigned non-commissioned officers, etc, in the model.

MX Experience Construct Initially Proposed Model

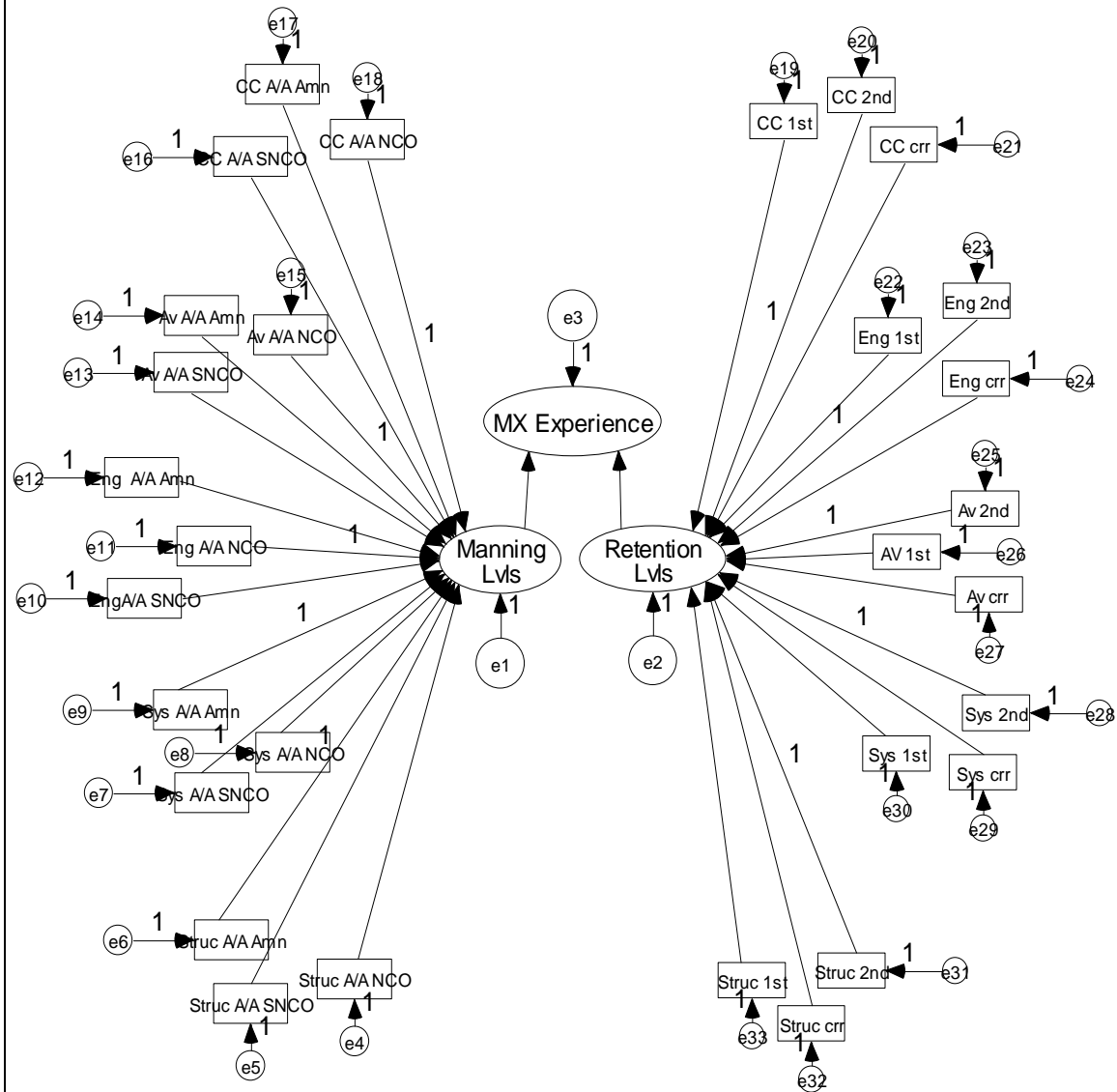

Figure 17. Maintenance Experience Construct Initial Model (SEM Model 2)

The five maintenance variables groups are also separated into retention variables for each group of personnel including crew chief 1st term retention labeled CC 1st in the model, crew chief 2nd term retention labeled CC 2nd in the model, etc. Another item of note for this model is that all arrows in SEM Model 2 are unidirectional and indicate the direction of causality. Each single-headed arrow also represents a regression weight. For example, all of the AMN, NCO, and SNCO A/A variables listed on the left side of the model drive the overall manning level construct, labeled Manning Lvl in the model.

For SEM Model 2, the Maintenance Experience Construct Model, there are 98 total parameters, 55 free parameters, 465 observations (listed as sample moments in AMOS), and 410 degrees of freedom. As previously mentioned, one question to ask about any model is whether or not the model in question represents the real world. For SEM Model 2, the model assumptions and directionality appear realistic. However, using the conservative five to one rule for the number of cases per number of parameters, this model really needs a sample size of 275 in order to properly estimate the parameters.

Using personnel retention data which was only available in yearly increments from the Personnel Data System, only 36 quarterly estimates were possible. For the assigned versus authorized personnel data, using the annual data retrieved from the Personnel Data System and the monthly C-17 inventory totals from REMIS, a total sample size of 129 data points was possible. For consistency, quarterly estimates were calculated for the assigned versus authorized variables in order to match the number of data points for the retention variables. Although theoretically limited by the 36 quarterly estimates for all variables, an initial attempt was still made to test the model.

Unfortunately, the model did not achieve a minimum solution and AMOS generated error messages stating the model's sample moment matrix was not positive definite. This indicates the program estimated one or more of the model's observed variables to have negative variances and also means the program can not generate maximum likelihood estimates for the given model parameters. The later is one indication of a sample size which is too small for AMOS to successfully evaluate the proposed model. Due to these results, a smaller model was proposed and tested. This slightly smaller model is SEM Model 3 and is shown in figure 18.

SEM Model 3

SEM Model 3 is the MC Rate Factors and Fleet Health Construct Initial Model. The model consists of interacting variables and factors affecting MC rates including the same Fleet Health, OPSTEMPO, and Personnel to Aircraft Ratio constructs from SEM Model 1. However, SEM Model 3 also includes observed variables for personnel to aircraft ratios for 3, 5, and 7 skill-levels for maintenance personnel in the five aggregated groups previously discussed, and observed variables for MC Rate and C-17 Average Inventory.

Additionally, the model also contains the four observed variables TNMCM/5, TNMCS/5, Sorties/5, and Flying Hours/5. These four variables were all divided by five in order to reduce each of their variances by a factor of 25. This is in response to a potential problem known as ill scaled covariance matrices (Kline, 2005). An ill scaled matrix can cause problems with SEM iterative estimation techniques and possibly result in estimates that fail to converge to stable values. An ill scaled matrix can result when the ratio of the largest to the smallest variance is greater than 10. Rescaling a variable by

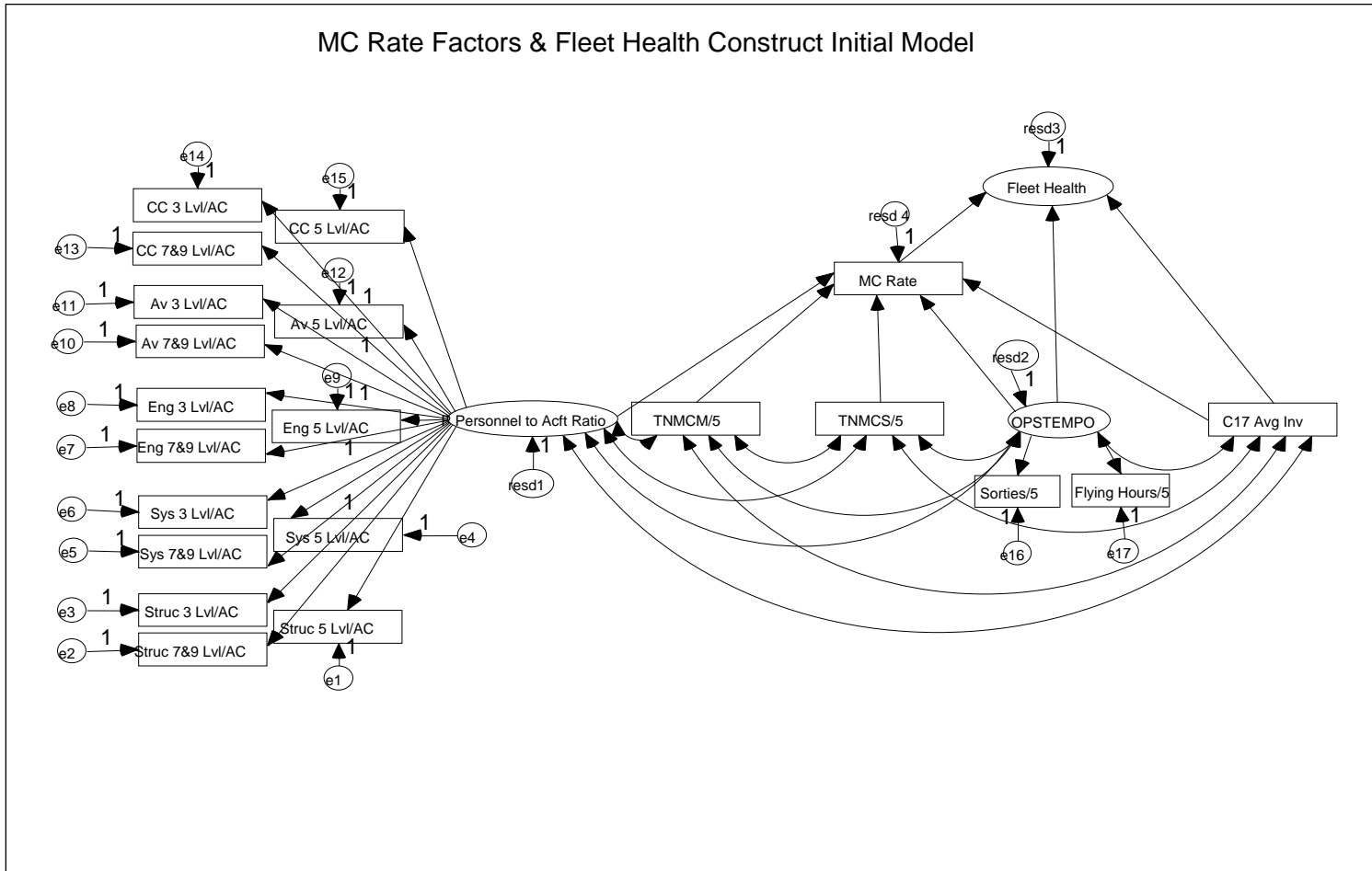

70

Figure 18. Initial MC Rate Factors & Fleet Health Construct Model (SEM Model 3)

division in this case changes the variables mean and variance but not its correlation with other variables.

SEM Model 3 hypothesizes that personnel to aircraft ratios, total non mission capable for maintenance time, total non mission capable for supply time, operations tempo, and the C-17 average inventory all interact to affect MC rates. SEM Model 3 also hypothesizes that operations tempo, the average inventory of C-17 aircraft, and MC rates affect the latent construct of Fleet Health. SEM Model 3 contains 80 total parameters, 54 free parameters, 231 sample moments, and 177 degrees of freedom. Again, the available sample size of 129 is less than the 270 data points theoretically needed using the five to one rule. Even with the small sample size, an attempt was again made to test the model with AMOS. Not surprisingly, as with SEM Model 2, AMOS generated error messages indicating the covariance matrix was not positive definite which again can be an indication of a sample size which is too small. Failure of AMOS to successfully achieve a minimum solution can also result if an out-of-bounds correlation is part of the covariance matrix. In a continuing attempt to demonstrate the possible utility of structural equations modeling in a non-behavioral science environment such as aircraft mission capable rates and theoretical related factors, an even more condensed SEM model was proposed.

SEM Model 4

SEM Model 4, shown in Figure 19, is the MC Rate Factors for All Levels Combined Model. In this model, the data for maintenance manning per aircraft variables for all separate qualification levels of 3, 5, and 7 and 9-levels were combined into total manning data points over the same time frame for each of the five general maintenance

AFSC areas of structures, systems, engines, avionics, and crew chiefs. In addition, based on a high correlation between flying hours and sorties, aircraft flying hours was chosen to represent OPSTEMPO in this particular model. This was done to further simplify the model. For the same reason previously discussed in regards to TNMCM and TNMCS, aircraft flying hours were divided by five to reduce the variance of the data points. The Fleet Health construct was also removed in an effort to simplify the model. Otherwise, the same variables used in SEM Model 3 were included.

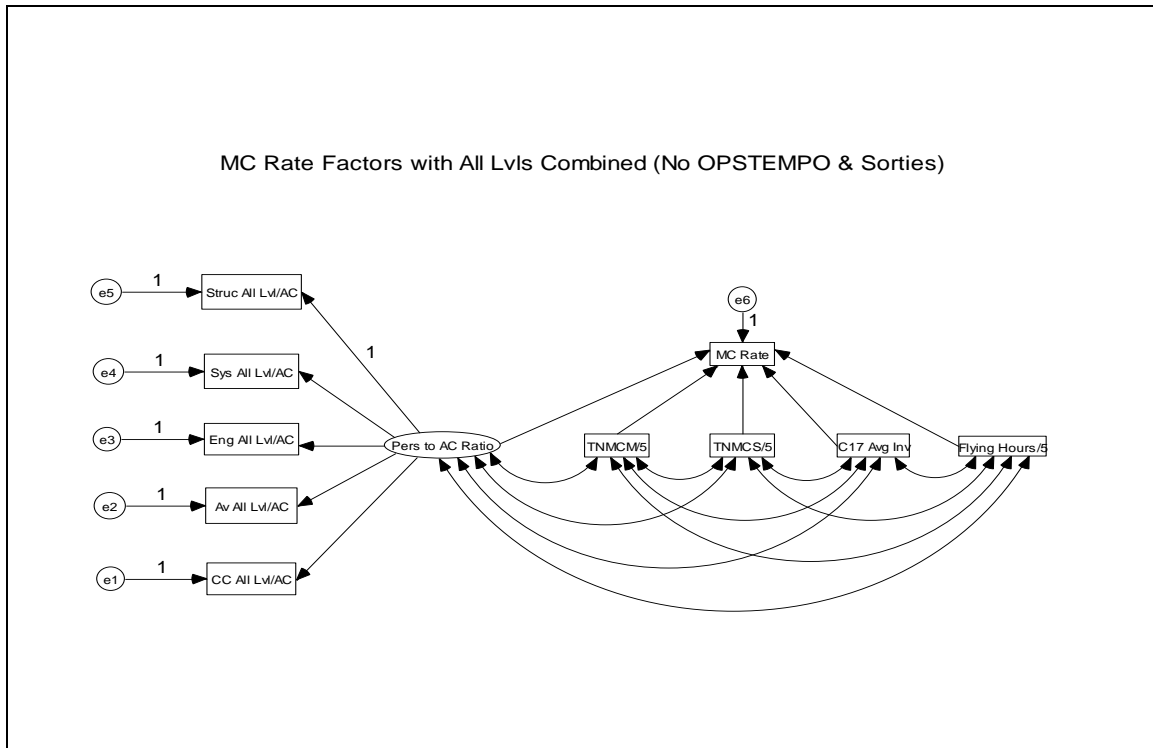

Figure 19. MC Rate Factors with All Lvl's Combined (SEM Model 4)..

SEM Model 4 is a recursive model which includes 17 variables, 11 exogenous and 6 endogenous. The model also contains 37 total parameters, 30 free parameters, 55 sample moments, and 25 degrees of freedom. Using the five to one rule, the model requires 150 data points. The 129 available data points are much closer to the theoretical

minimum required than in previously proposed models so AMOS was once again used to test the model. For SEM Model 4, AMOS achieved a minimum solution. As a reminder, this indicates AMOS successfully fitted SEM Model 4 to the given data set. Various AMOS outputs for SEM Model 4 is located in Appendix E. In particular, table 13 lists the variable's normality assessment data. All values were within an acceptable range of +/- 1 for skew and kurtosis with a few exceptions. The variables representing engine and structural personnel were slightly out of tolerance for skew. Also, the variables for flying hours/5 and TNMCM/5 were slightly out of tolerance for kurtosis. A logarithmic transformation was conducted on these variable's data sets but only served to increase kurtosis in every case. Therefore, in the interest of maintaining the variable's original metric, the variables in this model were assumed to possess univariate normality.

Table 14 also includes the result of AMOS calculations for what is known as Mardia's coefficient of multivariate kurtosis. In the case of SEM Model 4, the value of Mardia's coefficient has a critical ratio of 0.897. Utilizing an alpha value of 0.05 as previously discussed, the value of 0.897 is less than 1.96 and thus not considered significant. This supports an assumption of multivariate normality for the data set.

Table 4 lists a portion of the goodness of fit measures for SEM Model 4. A complete listing is located in table 11 in appendix E. These five specific fit measures were explained in chapter 3. The entire goodness of fit table is located in Appendix E. As shown in table 4, none of the fit measures for SEM Model 4 meet the limitations previously defined, although some are close to the generally accepted criteria. However, the proposed model, listed by AMOS as the default model in table 4, is a better fit than either of the two other models tested by AMOS. These two model are listed as the

saturated and independence models. The saturated model has no constraints on the population moments and is the most general model possible. It theoretically fits any data set. On the other extreme is the independence model. This model is severely constrained with all correlations equal to zero and so the independence model is generally expected to have a poor fit. Of the three possible models for this AMOS comparison, the proposed model provided the best fit.

Table 4. SEM Model 4 Goodness of Fit Comparisons

<u>Fit Measure</u>	<u>Default model</u>	<u>Saturated</u>	<u>Independence</u>	<u>Macro</u>
P	0.000		0.000	P
Discrepancy / df	25.980		94.108	CMINDF
GFI	0.648	1.000	0.150	GFI
Tucker-Lewis index	0.732		0.000	TLI
RMSEA	0.442		0.853	RMSEA

For this model the AMOS check for potential outliers was also selected. Table 15 in Appendix E gives a partial snapshot of the entire table of data points and their Mahalanobis distances. Mahalanobis distances take into account the correlation structure of the data as well as individual scales. Based on a p value < 0.001 as the conservative level of statistical difference (Kline, 2005), only data point number 1 is listed as a potential outlier.

Based on the majority of other AMOS outputs and estimates, SEM Model 4 appears realistic in terms of the proposed relationships between variables. The calculated regression weights, also listed in Appendix E, are all significant based on their associated critical ratios being greater than 1.96 in absolute value and the associated p-value are very low or equal to zero in most cases. The positive or negative sign of the estimates

agree with past research and practical logic with the exception of one estimate. The value of the regression weight for the effect of the personnel to aircraft ratio construct on MC rate has the opposite sign, a negative, than expected. The standard logic is that as the ratio of maintenance personnel to aircraft increases, the MC rate should also increase or improve. It is not immediately clear why AMOS calculated this negative regression weight estimate.

Both the unstandardized and standardized parameter estimates are displayed in the context of the model in Figures 20 and 21 respectively.

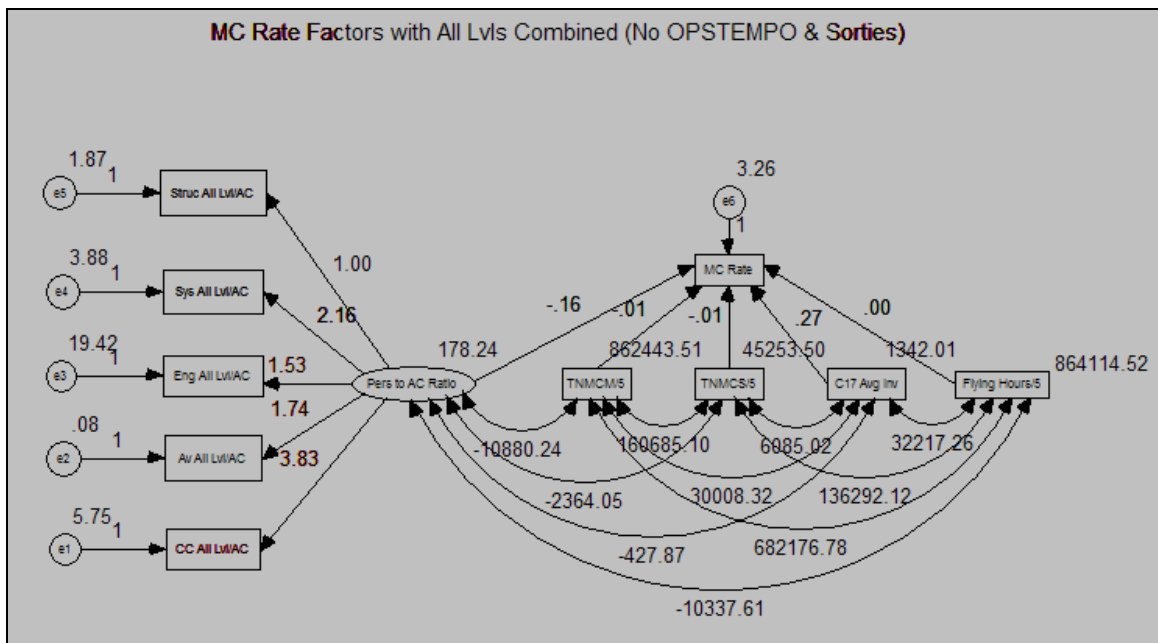

Figure 20. SEM Model 4 with Unstandardized Estimates

The estimates displayed in figure 20 represent covariances and unstandardized regression weights. Unstandardized values are not limited to a particular range and the value does change if the scale of either variable changes. All covariance estimates appear logical based on them possessing the expected positive or negative sign as well as their

critical ratio and p-values. The critical ratios and p-value are listed in table 16. However, the relationship between flying hours and the personnel to aircraft ratio latent variable is not supported in the literature. This particular relationship was included in SEM Model 4 as dictated by the AMOS software for identification purposes during model setup. Based on this researcher’s personal experience, there is no practical real-world relationship between an increase in flying hours and a reduction in personnel to aircraft ratios as indicated by the negative covariance estimate generated by AMOS.

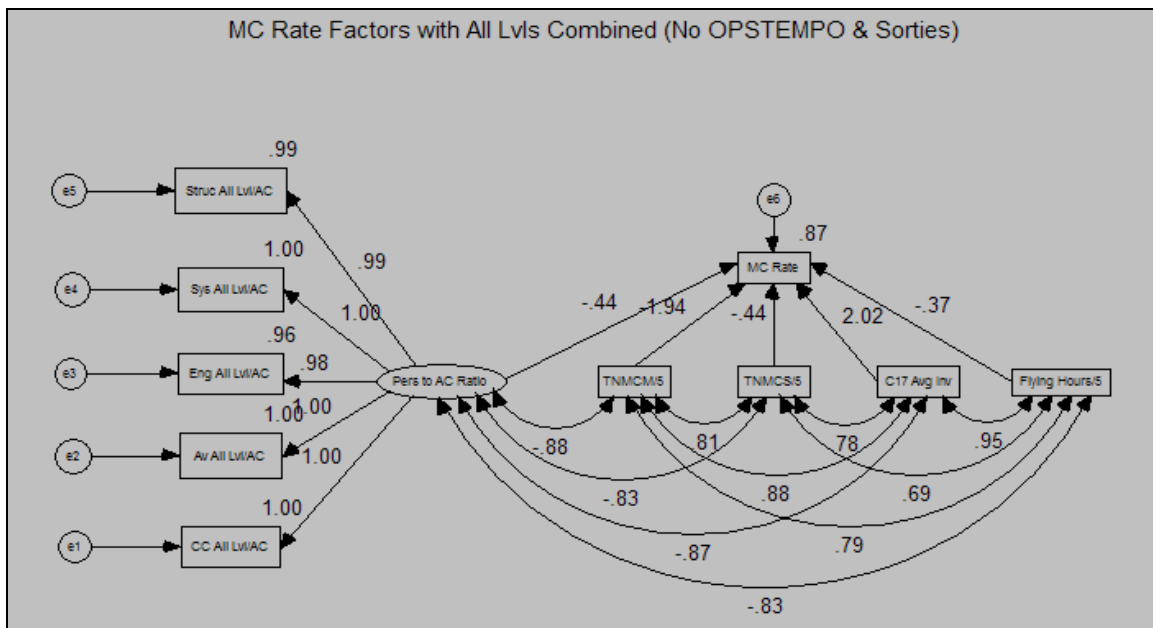

Figure 21. SEM Model 4 with Standardized Estimates

The standardized estimates generated by AMOS are shown in figure 21. These values represent standardized regression weights and correlations between variable. The correlations can also be considered the same as standardized regression coefficients. These values indicate the expected difference on variable Y in standard units, given an increase on variable X of one full standard deviation. Standardized estimates are

unaffected by the scale of either the X or Y variable. Squared multiple correlation (R_{smc}) values are also shown in figure 21. Based on the AMOS calculations, the R_{smc} for the MC Rate equals 0.868. This indicates that in SEM Model 4, as proposed, almost 87 percent of the variance in the MC Rate is accounted for by its predictors. As mentioned previously, AMOS is a powerful tool with many more options not yet mentioned.

If the option is selected on the AMOS analysis properties box, AMOS also computes a modification index for each parameter that is fixed at a constant value and for each parameter that is required to equal some other parameter. The modification index for a parameter is an estimate of the amount by which the discrepancy function would decrease if the analysis were repeated with the constraints on that parameter removed. The actual decrease that would occur may be much greater (Byrne, 2001).

Amos also computes modification indices for paths that do not appear in a model, giving the approximate amount by which the discrepancy function would decrease if such a path were introduced. There are, however, two types of nonexistent paths for which Amos does not compute a modification index. First, Amos does not compute a modification index for a nonexistent path which, if introduced, would convert an exogenous variable into an endogenous variable. Second, Amos does not compute a modification index for a nonexistent path that, if introduced, would create an indirect path from a variable to itself where none already exists. In particular, Amos does not compute a modification index for a nonexistent path that, if introduced, would convert a recursive model to a nonrecursive one.

Each time Amos displays a modification index for a parameter, it also displays an estimate of the amount by which the parameter would change from its current,

constrained value if the constraints on it were removed. Specifying a small value for threshold can result in the output of a large number of modification indices. The default threshold setting is four. In the case of SEM Model 4, the default setting was used and the modification index output is located Appendix E table 17. After reviewing the AMOS suggested changes, none made substantive sense from a representative real-world model standpoint and the proposed changes were not considered worthy of inclusion in a subsequently specified model.

One additional item of note for SEM Model 4 is the relationship between TNMCM, TNMCS, and MC rates. Based on the given formula, the MC rate is a linear combination of these two variables. However, the bivariate analysis of both TNMCS and TNMCM with C-17 MC rates, shown in Appendix G, failed to totally support this expected strong linear relationship, at least with the given data set. This less than expected relationship also appears in the correlation estimate between TNMCM/5 and TNMCS/5. For SEM Model 4, AMOS calculated the correlation between these variables to equal only 0.813. While still a relatively strong correlation, this value is less than might normally be expected, especially when compared to other calculated estimates such as the correlation of C-17 average inventory to flying hours. The estimated correlation for these variables equaled 0.946 which is not surprising.

Given the available data set and lack of real success while utilizing smaller and smaller proposed models to this point, the continued use of structural equations modeling becomes exploratory at best but is definitely no longer confirmatory. It is apparent that even with respecification the overall model and targeted parameters would not be substantively meaningful. So, due mainly to a smaller than adequate data set, another

technique besides SEM is needed to continue the analysis of the C-17 data in hand and the possible relationships to MC rates. Stepwise regression techniques were selected for this task.

An attempt was made to aggregate all the available data used in the research to this point in order to generate a common set of variables over the given time frame. In order to compare similarly constructed variables, the available data was consolidated into nine data points, one for each year 1997 to 2005, for many of the variables. 159 variables were originally created and an attempt was made to construct a multiple regression equation utilizing stepwise regression techniques that would best represent and explain relationships between mission capable rates and related variables. Unfortunately, with only nine data points to work with, such a complex model was not possible. So, while the stepwise regression method did generate a model with realistic statistical values, the model was too simple to be of any practical use.

Overview of Next Chapter

Chapter V first provides a reminder of the reasons behind this research effort and then conclusions, lessons learned, and recommendations for future research.

V. Conclusions and Recommendations

Chapter Overview

This chapter discusses the work accomplished in the previous chapters as well as the findings related to the research questions. The limitations of this research effort are also discussed as well as recommendations for future research.

Problem Statement and Investigative Questions

This research was begun in response to the need for our nation to maintain mission ready aircraft in the face of a newly developing strategy for a changing world. One key ingredient of this new strategy is the availability of aircraft to carry out their missions. A key measures of this availability are the MC and FMC rates. This research was pursued in order to provide new linkages between several areas not previously addressed in other research and currently used aircraft availability and mission capability predictive models. The research also sought to resolve shortfalls in these currently used predictor's abilities in order to bridge a gap toward a more effective planning tool. The investigative questions guiding this research were:

- 1) What factors have a significant impact on aircraft mission capable rates?
- 2) Of the factors identified in investigative question one, what changes have taken place in the last decade, especially since 9/11, that have an impact on aircraft mission capable rates?

3) For the factors identified in investigative question one, what type of theoretical model best estimates the impact of these factors on mission capable rates?

4) What latent constructs, if any, have a significant relationship with aircraft mission capable rates and what are these relationships?

For question number one, a thorough review of previous research as well as past and present models was conducted. It should come as no surprise that there are many previous research efforts related to mission capable rates and related models. If there is any consensus, it is that there are numerous factors which can influence mission rates. The literature review highlighted many of these factors.

Research question two was also answered during the literature review phase of this project. In the years since 9/11, our world and our Air Force have witnessed many changes in how we are structured, organizational changes, how many fewer personnel we have remaining, tighter budget demands, and the many influences brought about with the global war on terror.

For research question three, a different approach from the often used multiple regression method was attempted. Although typically used in the behavioral sciences environment, the intent of this research was to apply structural equations modeling techniques in an attempt to model multiple hypothesized constructs and interactions between different factors that affect mission capable rates. Although not completely successful in developing a full scale model representative of aircraft and how we support them in our daily environment, this project hopefully introduced future researchers to a new or at least different approach and provided some mileposts for those looking for different methods of modeling aircraft fleet health and related factors.

Related to the discussion regarding model development and research question three, the answers for research question four were also not completely answered. Structural equations modeling provides the capability to analyze latent variables but at least in this case, the smaller than required data set did not allow for modeling at a depth needed in order to fully analyze proposed latent variables and their relationships to mission capable rates.

Lessons Learned and Limitations

This experience provided an opportunity to gain insight and experience into the larger overall process of performing research. Many lessons were learned and will not soon be forgotten. One important lesson is that the research methodology is the foundation. It directs and drives the whole research effort and the research methodology must be thoroughly considered up front. The purpose and goals of the research must be clear. What is the reason, the catalyst, for the amount of work that will be required to achieve the end goals? The methodology must be clearly understood before data gathering begins in earnest. If the requirements of the chosen methodology are not fully understood in the early stages, many hours will surely be wasted researching and gathering data that may not be appropriate or extensive enough to generate adequate solutions.

There are some limitations to the conclusions of this research. The data set used in this research was similar to those used in similar projects using multiple regression. However, it was not adequate for use with the structural equations techniques used in this project. Also, the C-17 aircraft was chosen with the thought that some confounding

variables that apply to other air frames could be avoided. In hindsight, the C-17 is a unique airframe in many regards and possesses some confounding factors of its own. The fact that it is still a new airframe and the overall fleet size is not yet stabilized is one. It also utilizes a different support approach than many other airframes. These and other factors contributed to difficulties of their own.

Recommendations for Future Research

Although not wholly proven with this research, I believe structural equations modeling could still be used in the context purposed with this research with positive returns. I recommend future researchers attempting to utilize SEM techniques in a similar environment chose an airframe that is more stabilized in regard to the size of the overall fleet and possibly with a larger fleet size. Also an older airframe would provide a larger data set which is crucial for SEM techniques.

If the C-17 aircraft is chosen for future research using SEM techniques, I would recommend concentrating on data from specific C-17 bases first, and build from successes at that level. This would serve to remove possible ambiguity in the data set by focusing on very specific C-17 maintenance personnel, etc, versus the necessary assumptions due required when using a larger data set such as that for the entire Air Mobility Command.

Appendix A: REMIS Variables and Screen Shots

Table 5. REMIS Variables

Variable	Description
TNMCM Hours	Number of hours recorded for aircraft not being mission capable for maintenance reasons (does not include partially mission capable for maintenance hours)
TNMCS Hours	Number of hours recorded for aircraft not being mission capable for supply reasons (does not include partially mission capable for supply hours)
MC Hours	Number of hours recorded for aircraft being fully mission capable or partially mission capable
MC Rate	MC hours/possessed hours X 100
Possessed Hours	Number of hours aircraft is possessed
Flying Hours	Number of flying hours recorded for aircraft
Sorties	Number of flights recorded for aircraft
Average Sortie Duration	Average sortie duration per aircraft
Aircraft Utilization Rate	Average number of sorties flown per aircraft
Manhours Expended	Number of manhours expended on both on and off equipment WUCs
Repair Hours Expended	Number of repair hours expended on both on and off equipment WUCs
Repair Actions Conducted	Number of repair actions performed on both on and off equipment WUCs
Cannibalization Hours	Number of hours expended on cannibalization actions per WUC
Cannibalization Actions	Number of cannibalization actions performed per WUC
Manhours per Sortie	Total manhours/total sorties
Manhours per Flying Hour	Total manhours/total flying hours
Flying Hours Per Sortie	Total flying hours/total number of sorties
Average Inventory	Average number of aircraft possessed by the Air Force

Information from the REMIS program management office, Dayton Ohio. They can be contacted at OSSG.LRXUserAdmin@wpafb.af.mil.

Status Month Year (Historical)	Work Unit Code (WUC) (Historical)	WUC Description (Historical)	NMCM Hours (Historical)	NMCM Count (Historical)
199501	01000	GROUND HANDLING, SERVICING AND RELATED TASKS	144	4
199501	03000	LOOK PHASE OF SCHEDULED INSPECTIONS	121	2
199501	04199	SPECIAL INSPECTION NOT OTHERWISE CODED	5	2
199501	11A99	NOC	25	1
199501	11ACA	JAMB STOPS, TROOP DOOR	12	1
199501	11AUA	DOOR ASSEMBLY, STRUCTURE, SIDE EQUIPMENT ACCESS	0	0
199501	11B00	CARGO DOOR AND RAMP	3	1
199501	11BBC	SEAL ASSEMBLY, CARGO DOOR	68	1
199501	11BJA	DOOR ASSEMBLY, PRESSURE VENT	4	1
199501	11DCA	DOOR, MLG, FORWARD INBOARD	24	1
199501	11DFA	DOOR, MLG, AFT OUTBOARD	67	2
199501	11HA0	RADOME, NOSE	0	0
199501	11HC0	WING TO FUSELAGE FILLETS	5	1
199501	11HCX	PANEL, WING TO FUSELAGE, NO 19	49	3
199501	11HEE	PANEL, MLG POD	30	1
199501	11R99	NOC	52	1
199501	11RQ0	WING ACCESS COVERS	71	2
199501	11RQA	COVER, UPPER WING FUEL TANK ACCESS	31	1
199501	11RQF	COVER, FUEL PUMP ACCESS	1	1
199501	11RSE	COVER, NO 2 FLAP HINGE FWD LOWER ACCESS	56	1
199501	11RTD	PANEL ASSY, NO 3 FLAP SUPPORT FWD INBOARD	23	2
199501	11UFD	ACCESS COVERS	0	0
199501	11UFB	DOOR, FIXED LEADING EDGE LOWER ACCESS	13	1
199501	11V00	WING TRAILING EDGE	13	1
199501	12A00	CENTER ROW CARGO HANDLING SYSTEM-ADS	0	0
199501	12E00	TROOP AIRDROP SYSTEM	0	0
199501	12HA0	TOW RELEASE ASSY	0	0
199501	13000	LANDING GEAR SYSTEM	3	1
199501	13EAA	SHOCK STRUT ASSY.	15	1
199501	13GA0	LANDING GEAR CONTROL	9	1
199501	13GBA	VALVE ASSY, LANDING GEAR CONTROL	12	1
199501	13HA0	MLG WHEEL & TIRE ASSY	44	9
199501	13HAB	MLG TIRE	4	1
199501	13HB0	NOSE WHEEL & TIRE ASSEMBLY	15	6
199501	13JGA	NTRL UNIT, ANTISKID-BRAKE TEMP MONITOR(DCK-277/A24U-	3	1
199501	13L00	POSITION AND WARNING	12	1
199501	13LAY	CONNECTOR	2	1
199501	14000	FLIGHT CONTROL SYSTEM	10	1
199501	14AFA	ACTUATOR, ELECTRO-MECHANICAL, ROTARY (ATK-114/A37G-1	3	1
199501	14CDA	MODULE, INTEGRATED FLIGHT CONTROL - ELEVATOR	4	1
199501	14E00	FLAP SUBSYSTEM	1	1
199501	23000	ENGINE	14	1
199501	23A00	ENGINE, BASIC (F117-PW)	13	1
199501	23AE0	HPC GROUP	330	3

Figure 22. Original REMIS Status Hours and Counts Data Partial Snapshot

C_YEAR	C_MONTH	FLYING_HRS	POSS_HOURS	MC_HOURS	MC_RATE	TNMC_HOURS	TNMC_RATE	C-17 AVG INV
1995	1	659.8	13,392	9,374.00	70	4,018.00	30	18
	2	833.1	12,360	9,845.00	79.65	2,515.00	20.35	18.39
	3	1,184.20	14,136	11,777.00	83.31	2,359.00	16.69	19
	4	879.8	14,088	11,007.00	78.13	3,081.00	21.87	19.57
	5	1,229.00	14,880	10,793.40	72.54	4,086.60	27.46	20
	6	1,045.00	14,688	11,038.60	75.15	3,649.40	24.85	20.4
	7	2,118.90	15,648	13,117.70	83.83	2,530.30	16.17	21.03
	8	1,432.50	16,368	13,844.00	84.58	2,524.00	15.42	22
	9	1,276.20	15,888	12,325.70	77.58	3,562.30	22.42	22.07
	10	1,340.90	17,112	14,482.80	84.64	2,629.20	15.36	23
	11	1,458.20	16,800	13,548.10	80.64	3,251.90	19.36	23.33
	12	1,958.60	17,856	14,483.00	81.11	3,373.00	18.89	24
1996	1	1,792.40	18,000	15,513.00	86.18	2,487.00	13.82	24.19
	2	1,800.70	17,400	14,769.20	84.88	2,630.80	15.12	25.89
	3	2,204.70	18,600	16,176.00	86.97	2,424.00	13.03	25
	4	2,164.20	18,000	15,319.00	85.11	2,681.00	14.89	25
	5	1,642.20	19,320	17,197.80	89.02	2,122.20	10.98	25.97
	6	1,446.30	18,720	16,493.30	88.11	2,226.70	11.89	26
	7	1,774.10	20,040	17,453.00	87.09	2,587.00	12.91	26.94
	8	1,778.50	20,088	16,969.90	84.48	3,118.10	15.52	27
	9	1,787.20	19,440	16,986.60	87.38	2,453.40	12.62	27
	10	1,915.50	20,088	16,154.60	80.42	3,933.40	19.58	27
	11	1,942.20	20,064	17,383.10	86.64	2,680.90	13.36	27.87
	12	1,777.50	21,168	18,713.00	88.4	2,455.00	11.6	28.45
1997	1	1,844.10	21,648	18,068.00	83.46	3,580.00	16.54	29.1
	2	1,980.10	20,160	16,243.00	80.57	3,917.00	19.43	30
	3	2,260.20	22,440	19,206.90	85.59	3,233.10	14.41	30.16
	4	1,862.90	22,320	18,672.00	83.66	3,648.00	16.34	31
	5	2,214.20	23,808	19,729.80	82.87	4,078.20	17.13	32
	6	2,427.80	23,040	20,526.20	89.09	2,513.80	10.91	32

Figure 23. Original REMIS MC Rate Data Partial Snapshot

Appendix B: Secondary Items Requirements System (SIRS) Variables

Table 6. SIRS (D200A Variables)

D200A Variables	
<u>Variable</u>	<u>Description</u>
Order and Ship Time	Amount of time (days) it takes for an item to be received by the customer from the time the order is place
Base Repair Cycle Time	Amount of time (days) to repair an unserviceable item at base level (for those items authorized base-level repair)
Depot Repair Cycle Time	Time it takes (days) for depot to repair an unserviceable item
Serviceable Inventory Level	Quantity of serviceable items (per NSN) on the shelf
Unserviceable Inventory Level	Quantity of unserviceable items (per NSN) awaiting repair
Failures	Total number of failures (per NSN) at each level of maintenance

Pipeline Data:												10.55882353		
SGNSN	IINSGM	ALC	IMS	ERRC	ITEM_CAT	SMC	NOUN	URC_MAR05	UP_MAR05	FUP_MAR05	BASE_ORDER_SHIP_DAY_MAR97	BOSD_SRC_MAR97		
432000490742UC	00490742A	WR	AM4	T			410Z PUMP,ROTARY	\$1,439.00	\$9,610.00	\$9,659.86	11	S		
1660015098023BO	015098023	OC	ECK	T			9999 REGULATOR,OXYGEN,DI	\$4,655.64	\$6,207.83	\$6,207.83				
1660008998380BO	008998380	OC	ECK	T			9999 CONVERTER,LIQUID OX	\$4,669.89	\$11,116.66	\$11,261.18	11	E		
5821010620986	010620986	WR	C4M	T			F16Z CONTROL,RADIO SET	\$400.00	\$2,139.00	\$2,485.52	5	E		
5835011287757CX	011287757	WR	N4D	T			484L RECORDER,SOUND	\$1,436.00	\$7,215.00	\$8,383.83	6	A		
1650012931480JY	012931480	OC	EPU	T			999Z SERVOCYLINDER	\$2,808.00	\$18,457.00	\$19,638.25	11	S		
5985012775627BY	012775627	WR	C4G	T			999C COUPLER,ANTENNA	\$2,624.00	\$35,310.00	\$35,310.00	11	S		
1650010833522JY	010833522	OC	EPU	T			999Z SERVOCYLINDER	\$1,898.00	\$4,112.15	\$7,697.94	11	S		
5810004490154CA	004490154	SA	TE7	T			190K KY-58-1	\$1,683.64	\$2,820.37	\$4,106.46	10	A		
5826014626002	014626002	WR	N4T	T			C17A RECEIVER,RADIO NAVI	\$18,128.00	\$86,653.41	\$93,412.38				
5826012416889	012416889	WR	N4G	T			9999 RECEIVER,RADIO	\$3,399.00	\$12,524.00	\$12,686.81	6	A		
5841011942452	011942452	WR	N4O	T			9999 RECEIVER-TRANSMITTE	\$6,476.06	\$39,324.18	\$40,346.61	11	E		
5989012894620CW	012894620	WR	N4O	T			9999 CIRCUIT CARD ASSEMB	\$1,009.00	\$1,025.20	\$1,114.39	11	S		
5895014145895EW	014145895	WR	B6P	T			NIM5 SENSOR,OPTICAL	\$7,615.00	\$13,842.00	\$13,842.00	11	S		
5985012026261CW	012026261	WR	N4O	T			9999 ANTENNA	\$8,459.00	\$48,007.00	\$50,167.32	7	A		
5895013190509	013190509	WR	C4G	T			999C CONTROL,RECEIVER-TR	\$3,025.00	\$17,713.00	\$19,395.74	6	A		
5989013760040CW	013760040	WR	N4O	T			C17A BACKPLANE ASSEMBLY	\$5,461.67	\$14,867.77	\$17,618.31	11	S		
5989012363794CX	012363794	WR	N4G	T			9999 CIRCUIT CARD ASSEMB	\$269.01	\$486.00	\$727.06	5	A		
5821013063385	013063385	WR	C4H	T			9999 RECEIVER-TRANSMITTE	\$5,382.00	\$27,697.00	\$27,697.00	5	A		
5895012509557CS	012509557	SA	TE1	T			190K CONVERTER,MODEM,SI	\$7,903.81	\$23,400.00	\$29,273.40	12	A		
5895012301284CW	012301284	WR	N4H	T			9999 CONVERTER,SIGNAL,DA	\$2,848.24	\$10,538.17	\$13,752.31	6	A		
6220013129348BY	013129348	WR	C4H	T			9999 PANEL,INDICATING,LI	\$382.00	\$1,188.00	\$1,550.34	11	S		
5826013590056LZ	013590056	WR	N4K	T			C17A INTERROGATOR SET	\$5,313.00	\$14,422.00	\$16,123.80	11	S		
5821012866543	012866543	WR	C4G	T			9999 RECEIVER-TRANSMITTE	\$3,345.00	\$25,434.00	\$28,994.76	6	A		
5841013014588	013014588	WR	N4H	T			9999 RECEIVER-TRANSMITTE	\$5,040.00	\$38,115.00	\$39,105.99	6	A		
5841014708036CX	014708036	WR	N4X	T			999Z PROCESSOR,RADAR,DAT	\$12,798.32	\$54,675.00	\$58,174.20				
5821014715507	014715507	WR	C4G	T			9999 PROCESSOR,SIGNAL,DA	\$3,749.00	\$31,725.00	\$32,137.43				
5826012368622	012368622	WR	N4G	T			9999 RECEIVER,RADIO	\$1,886.00	\$11,923.00	\$13,055.69	5	A		
1660009271996BO	009271996	OC	ECK	T			9999 REGULATOR,OXYGEN,DE	\$1,943.28	\$2,591.17	\$2,591.17	11	E		
5821010774298	010774298	WR	C4M	T			9999 RECEIVER SUBASSEMBL	\$929.05	\$2,168.42	\$2,638.97	11	E		
5826012201387	012201387	WR	N4G	T			410A CONTROL	\$1,234.00	\$1,647.00	\$2,149.34	11	S		
5826014767784CX	014767784	WR	N4A	T			999C CONTROL,RADIO SET	\$7,150.09	\$26,142.00	\$26,481.85				
5895013123507	013123507	WR	C4H	T			9999 CONTROL,FREQUENCY'S	\$3,758.00	\$9,273.00	\$9,570.83	11	S		
5821014130123	014130123	WR	C4G	T			999C PROCESSOR,SIGNAL,DA	\$3,267.00	\$20,242.00	\$22,164.98	11	S		
5841014428402CW	014428402	WR	N4O	T			C17A PROCESSOR,RADAR,DAT	\$14,425.05	\$100,734.00	\$103,263.08	11	S		
5821010546424	010546424	WR	C4H	T			9999 SELECTOR,ANTENNA	\$377.00	\$1,445.00	\$1,463.79	3	A		
6130012562085BY	012562085	WR	C4H	T			9999 POWER SUPPLY	\$889.00	\$1,515.00	\$1,534.70	6	A		
5810010269624CS	010269624	SA	TE7	T			190K Z-AHO,INTER,ASSY	\$493.98	\$852.08	\$1,204.84	11	A		
5835014770137CX	014770137	WR	N4D	T			999C RECORDER,SOUND	\$3,260.84	\$8,700.00	\$8,813.10				
6645013889100RK	013889100	OC	ECK	T			9999 CLOCK,PANEL	\$948.49	\$1,375.00	\$1,436.88	11	S		
1660001952729BO	001952729	OC	ECK	T			9999 REGULATOR,OXYGEN,DI	\$2,864.23	\$4,250.00	\$4,250.00	9	A		
7625013120060EW	013120060	WR	B6P	T			NIM5 PROCESSOR,CENTRALC	\$9,355.50	\$35,464.00	\$35,464.00	11	S		
6605012700306CW	012700306	WR	N4O	T			9999 STABILIZER,GYRO	\$2,433.00	\$3,244.16	\$3,244.16	11	S		
5810010508115CA	010508115	SA	TE7	T			190K KY-58-2	\$1,507.32	\$2,600.00	\$3,676.40	14	A		

Figure 24. D200A Snapshot

Appendix C: C-17 Enlisted/Officer Maintenance AFSCs and Authorized vs. Assigned Data

Table 7. C-17 Enlisted/Officer Maintenance AFSCs

Enlisted AFSC	Enlisted AFSC Duty Title (FY97 – FY05)
2A0X1B	Avionics Test Station & Component, Avionics Systems, Helicopters & Aircraft (Except F-15)
2A190	Avionics Superintendent till 30 April 2004
2A090	Avionics Superintendent
2A000	Avionics System Manager (CEM) (Thru Oct 03, then changed to 2A600)
2A5X1D	Aerospace Maintenance, C-17 (Helper & Apprentice)
2A551J	Aerospace Maintenance, C-17 (Journeyman)
2A5X1	Aerospace Maintenance (Craftsman)
2A590	Aerospace Maintenance Superintendent
2A300	Aircraft Chief Enlisted Manager (CEM for crew chiefs and avionics personnel)
2A1X2	Avionics Guidance & Control (Backshop, combined into 2A5X3B starting in 2002)
2A1X3	Avionics Communication & Navigation (Backshop, combined into 2A5X3A starting in 2002)
2A4X0	Aircraft Avionics Superintendent
2A4X1	Avionics Guidance & Control Systems (Combined into 2A5X3B starting in 2003)
2A4X2	Avionics Communication & Navigation Systems (Combined into 2A5X3A starting in 2003)
2A5X3A	Integrated Avionics Systems; Communication, Navigation, & Mission
2A5X3B	Integrated Avionics Systems; Instruments & Flight Controls
2A5X3C	Integrated Avionic Systems, Electronic Warfare
2A6X1C	Aerospace Propulsion (Helper & Apprentice, F-117 Engine)
2A6X1A	Aerospace Propulsion (Journeyman & Craftsman, Jet Engines)
2A691	Aerospace Propulsion Superintendent
2A600	Aircraft Systems (CEM for various aircraft systems including fuels, hydraulics, electro/environmental, egress, also engines)
2A6X2	Aerospace Ground Equipment
2A6X4	Aircraft Fuel Systems
2A6X5	Aircraft Hydraulic Systems
2A6X6	Aircraft Electrical and Environmental Systems
2A690	Aircraft Systems Superintendent

Enlisted AFSC	Enlisted AFSC Duty Title (FY97 – FY05)
2A790	Aircraft Fabrication Superintendent
2A7X1	Aircraft Metals Technology
2A7X2	Nondestructive Inspection
2A7X3	Aircraft Structural Maintenance
2A7X4	Survival Equipment
2W0X1	Weapons (Not included in this analysis)
2P0X1	Precision Measurement Equipment Lab (Not included in this analysis)
Officer AFSC	Officer AFSC Duty Title (FY97 – FY05)
21AX	Aircraft Maintenance Officer (Flightline {X=3} and Staff {X=4})

1 ACTIVE AIR FORCE ENLISTED 2 MANNING a/c OFFICER EXTRACT 3 - EDM SEPTEMBER 2005 4 (AUTH and ASGN do NOT include 5 STP numbers) 6 Enlisted 2 Digit AFSC = 2AXXX and 7 MAJCOM = AIR MOBILITY 8 COMMAND (IL)							
		PERM PARTY	PERM PARTY	%	ST	INVENTORY	END FY PROJ
8	AFSC7	GRAD					
9	2A031B	AMN	6	4	66.67	0	4
10		TOTAL	6	4	66.67	0	4
11	2A051B	GRAD					
12		SRA	3	8	266.7	0	8
13		SSG	10	17	170	0	17
14		TOTAL	13	25	192.3	0	25
15	2A071B	GRAD					
16		TSG	5	7	140	0	7
17		MSG	3	3	100	0	3
18		TOTAL	8	10	125	0	10
19	2A071C	GRAD					
20		TSG	0	2	.	0	2
21		TOTAL	0	2	.	0	2
22	2A090	GRAD					
23		SMS	1	1	100	0	1
24		TOTAL	1	1	100	0	1
25	2A300	GRAD					
26		CMS	61	55	90.16	0	55
27		TOTAL	61	55	90.16	0	55
28	2A312	GRAD					
29		TSG	0	2	.	0	2
30		TOTAL	0	2	.	0	2
31	2A332	GRAD					
32		TSG	0	1	.	0	1
33		TOTAL	0	1	.	0	1
34	2A351B	GRAD					
35		SSG	0	1	.	0	1
36		TOTAL	0	1	.	0	1
37	2A352	GRAD					

Figure 25. AFPC Personnel Data System Authorized vs. Assigned Snapshot

Appendix D: PERSTEMPO Snapshots

Table 8. All AMC AFSCs PERSTEMPO Snapshot

		AMC Data for Nov 97-Oct 98															
MAJCOM	AFSC	AFSC TITLE	120+	90-119	60-89	< 60	Nbr	Total	Total	Manning	Total	TDY	Avg	Avg	Assigned	Assigned	Avg Days
			Days	Days	Days	Days	of	TDYs	Days	TDY	Days	Rate	Days	Days	%	%	Per
			TDY	TDY	TDY	TDY	People				Available		>120	> 60	>120	> 60	Traveler
AMC	20CX	LOGISTICS CMDR	0	0	0	30	30	101	513	29	10585	5	0	0	0	0	17
AMC	21AX	ACFT MAINT & MUNI	8	28	23	251	310	758	11118	263	95995	12	152	99	3	22	36
AMC	21AXA	ACFT MAINT & MUNI	0	0	0	1	1	3	28	0	0	0	0	0	0	0	28
AMC	21GX	LOGISTICS PLANS	0	2	3	39	44	115	1259	41	14965	8	0	88	0	12	29
AMC	21LX	LOGISTICIAN	1	3	6	148	158	608	3723	119	43435	9	158	88	1	8	24
AMC	21MXA	SPACE & MSL MAIN	0	0	0	1	1	2	7	1	365	2	0	0	0	0	7
AMC	21SX	SUPPLY	2	1	3	40	46	89	1025	64	23360	4	126	97	3	9	22
AMC	21TX	TRANSPORTATION	8	8	11	159	186	512	6339	193	70445	9	138	100	4	14	34
AMC	2A0X0	AVIONICS SYS CEM	0	0	0	1	1	2	8	3	1095	1	0	0	0	0	8
AMC	2A0X1B	ATSC F16,F117,A10.	0	0	0	15	15	37	226	47	17155	1	0	0	0	0	15
AMC	2A1X0	AVIONIC SUPT	1	1	1	6	9	29	441	13	4745	9	176	117	8	23	49
AMC	2A1X1	AVIONIC SENSORS	0	0	0	8	8	19	215	12	4380	5	0	0	0	0	27
AMC	2A1X2	AV GUID&CON SYS	0	0	0	29	29	55	406	64	23360	2	0	0	0	0	14
AMC	2A1X3	COMM & NAV SYS	0	0	1	19	20	36	398	77	28105	1	0	61	0	1	20
AMC	2A1X7	ELEC WAR SYS	17	11	9	69	106	194	6158	135	49275	12	157	119	13	27	58
AMC	2A3X0	AIRCRAFT CEM	1	2	4	107	114	324	2306	101	36865	6	123	90	1	7	20
AMC	2A3X2A	F16 AV SYS ACS	1	0	0	1	2	5	185	1	365	51	150	150	100	100	92
AMC	2A3X2B	F16 AV SYS IFCS	0	0	1	0	1	1	66	1	365	18	0	66	0	100	66
AMC	2A3X3B	TAM F-16/F-117	2	0	1	5	8	24	449	0	0	0	122	102	0	0	56
AMC	2A3X3J	TAM CFMN GENERA	0	0	0	5	5	5	83	14	5110	2	0	0	0	0	17
AMC	2A4X1	ACFT GUID&CON	36	75	84	387	582	1481	28146	747	272655	10	141	97	5	26	48
AMC	2A4X2	ACFT COM&NAV SY	33	75	122	471	701	1812	33595	894	326310	10	140	91	4	26	48
AMC	2A5X0	AEROSPACE MAINT	2	9	20	135	166	496	5852	169	61685	9	126	86	1	18	35
AMC	2A5X1	AEROSP MAINT	44	84	102	707	937	2812	37141	1243	453695	8	137	96	4	19	40
AMC	2A5X1A	AERO MAINT HELP	2	6	2	140	150	332	3071	268	97820	3	125	100	1	4	20
AMC	2A5X1B	AERO MAINT HELP	6	20	10	30	66	151	4450	110	40150	11	148	101	5	33	67
AMC	2A5X1C	AERO MAINT HELP	3	6	7	123	139	219	3694	357	130305	3	132	98	1	4	27
AMC	2A5X1D	AERO MAINT HELP	6	10	14	88	118	475	4961	271	98915	5	150	99	2	11	42
AMC	2A5X1G	AERO MAINT HELP	22	30	38	118	208	743	12077	325	118625	10	135	99	7	28	58
AMC	2A5X1H	AERO MAINT HELP	2	15	37	136	190	478	7465	264	96360	8	150	84	1	20	39
AMC	2A5X1J	AERO MAINT JNMN	98	169	150	865	1282	4892	62339	1734	632910	10	144	103	6	24	49
AMC	2A5X1L	AERO MAINT JNMN	110	122	147	390	769	3665	50560	843	307695	16	149	105	13	45	66
AMC	2A5X2	HELICOP MAINT	0	0	0	19	19	25	387	61	22265	2	0	0	0	0	20
AMC	2A5X2A	HEL MAINT MH-53	1	0	0	0	1	1	136	0	0	0	136	136	0	0	136
AMC	2A5X3B	BAS HELP I&FCC	0	0	1	0	1	3	61	1	365	17	0	61	0	100	61
AMC	2A6X0	SYSTEMS CEM	3	1	9	56	69	160	2183	69	25185	9	145	92	4	19	32
AMC	2A6X1	AERO PROPUL	0	0	1	19	20	56	435	26	9490	5	0	87	0	4	22

Table 9. AMC Maintenance Specific AFSCs PERSTEMPO Snapshot

		AMC Data for Mar 97-Feb 98															
MAJCOM	AFSC	AFSC TITLE	120+ Days TDY	90-119 Days TDY	60-89 Days TDY	< 60 Days TDY	Nbr of People	Total TDYs	Total Days TDY	Manning	Total Days Available	TDY Rate	Avg Days >120	Avg Days > 60	Assigned % >120	Assigned % > 60	Avg Days Per Traveler
AMC	2A0X0	AVIONICS SYS CEM	0	0	0	4	4	6	28	4	1460	2	0	0	0	0	7
AMC	2A0X1B	ATSC F16,F117,A10,B1	0	0	0	3	3	3	10	42	15330	0	0	0	0	0	3
AMC	2A1X0	CONVENT AVION SUPT	0	0	1	6	7	17	146	12	4380	3	0	65	0	8	21
AMC	2A1X2	AV GUID&CON SYS	0	0	2	24	26	48	398	79	28835	1	0	72	0	3	15
AMC	2A1X3	COMM & NAV SYS	0	0	0	25	25	42	375	81	29565	1	0	0	0	0	15
AMC	2A4X0	ACFT AVIONICS SUPT	0	2	1	15	18	62	525	17	6205	8	0	91	0	18	29
AMC	2A4X1	ACFT GUID&CON	34	80	83	413	610	1486	29499	794	289810	10	149	98	4	25	48
AMC	2A4X2	ACFT COM&NAV SYS	39	81	108	475	703	1805	33413	953	347845	10	143	96	4	24	48
AMC	2A6X1	AERO PROPUL	0	0	2	16	18	60	454	23	8395	5	0	76	0	9	25
AMC	2A6X1A	AERO PROPULSION - JET EN	25	52	87	524	688	1781	25693	914	333610	8	136	90	3	18	37
AMC	2A6X1C	AERO PR TF33JET	2	3	12	47	64	154	2477	205	74825	3	238	94	1	8	39
AMC	2A6X0	SYSTEMS CEM	1	3	7	72	83	210	2043	87	31755	6	123	83	1	13	25
AMC	2A6X2	AEROSP GRD EQUIP	40	50	47	320	457	763	21073	745	271925	8	136	102	5	18	46
AMC	2A6X4	ACFT FUEL SYS	3	16	36	189	244	469	8195	319	116435	7	136	83	1	17	34
AMC	2A6X5	ACFT HYDRAULIC SYS	36	60	96	462	654	1659	29389	885	323025	9	144	95	4	22	45
AMC	2A6X6	ACFT ELECT&ENVIR SYS	27	77	90	516	710	1827	30972	952	347480	9	138	94	3	20	44
AMC	2A7X0	ACFT FABRIC SUPT	1	0	1	8	10	13	280	17	6205	5	130	106	6	12	28
AMC	2A7X1	ACFT METALS TECH	6	4	2	44	56	79	2285	109	39785	6	137	116	6	11	41
AMC	2A7X2	NONDESTR INSP	5	2	2	33	42	65	1521	103	37595	4	129	110	5	9	36
AMC	2A7X3	ACFT STRUCT MAINT	6	15	26	176	223	374	7432	460	167900	4	132	91	1	10	33
AMC	2A7X4	SURV EQUIP	2	4	2	49	57	109	1657	173	63145	3	134	105	1	5	29
AMC	2A3X0	AIRCRAFT CEM	1	1	7	111	120	332	2718	116	42340	6	121	83	1	8	23
AMC	2A5X0	AEROSPACE MAINT SUPT	2	4	14	132	152	405	4579	153	55845	8	122	83	1	13	30
AMC	2A5X1D	AERO MAINT HELP C-17	3	4	12	65	84	235	2905	259	94535	3	134	86	1	7	35
AMC	2A5X1J	AERO MAINT JNMN	99	159	157	849	1264	4990	60392	1883	687295	9	140	101	5	22	48
AMC	21AX	ACFT MAINT & MUNITIONS	3	18	26	263	310	681	9335	269	98185	10	146	90	1	17	30

AFSC MDS LD- HD	AFSC- TITLE MAJCOM	120+ DAYS TDY	90-119 DAYS TDY	60-89 DAYS TDY	1-59 DAYS TDY	NBR OF PEOPLE TDY	TOTAL TDYS	TOTAL DAYS TDYS	(Manning) ED STRENG (TH)	DAYS AVAILAB LE	TDY RATE	AVG DAYS > 120	AVG DAYS > 60	ASSIGNE D % > 120	ASSIGNE D % > 60	AVG DAYS PER TRAVELE R
Note 1	Note 2	Note 3	Note 4	Note 5	Note 6	Note 7	Note 8	Note 9	Note 10	Note 11	Note 12	Note 13	Note 14	Note 15	Note 16	Note 17
Note 1	AFSC = 4 OR 5 DIGIT OFFICER OR ENLISTED AFSC. PREFIXES ARE NOT USED IN THESE REPORTS															
	MDS (MISSION DESIGN SERIES)= THE AIRCRAFT TYPE, AND IN SOME CASES THE MODEL NUMBER (IE. F-15 vs. F-15E)															
	LD-HD (LOW DENSITY/HIGH DEMAND)= MDS' OR SPECIALIZED CAPABILITY DESIGNED BY DOD AS THOSE WHERE YOU WOULD EXPECT A HIGH OPSTEMP/PERSTEMPO															
Note 2	AFSC-TITLE = CLEAR TEXT DESCRIPTION OF AN AIR FORCE SPECIALTY CODE AS SHOWN ON AFVAs 36-211 and 36-212.															
	MAJCOM = MAJCOM NAME THAT OWNS THE MDS OR LD-HD															
Note 3	120+ DAYS TDY or # Over 120 = TOTAL NUMBER OF PEOPLE WITHIN THE GROUP SHOWN THAT HAVE ACCUMULATED 120 OR MORE TDY DAYS DURING THE WINDOW OF TIME SHOWN ON THE REPORT															
Note 4	90-119 DAYS TDY = TOTAL NUMBER OF PEOPLE WITHIN THE GROUP SHOWN THAT HAVE ACCUMULATED 90-119 TDY DAYS DURING THE WINDOW OF TIME SHOWN ON THE REPORT															
Note 5	60-89 DAYS TDY = TOTAL NUMBER OF PEOPLE WITHIN THE GROUP SHOWN THAT HAVE ACCUMULATED 60-89 TDY DAYS DURING THE WINDOW OF TIME SHOWN ON THE REPORT															
Note 6	1-59 DAYS TDY = TOTAL NUMBER OF PEOPLE WITHIN THE GROUP SHOWN THAT HAVE ACCUMULATED 1 - 59 TDY DAYS DURING THE WINDOW OF TIME SHOWN ON THE REPORT															
Note 7	NBR OF PEOPLE TDY = TOTAL NUMBER OF PEOPLE (INDIVIDUAL SSNs) WITHIN A SELECTED GROUP (AFSC, MDS, UNIT ETC) THAT PERFORMED TDY DURING THIS ONE YEAR WINDOW OF TIME. ONE PERSON CAN BE COUNTED MORE THAN ONE TIME IF THEY HELD DIFFERENT DUTY AFSCS OR WERE TDY FROM MORE THAN ONE UNIT DURING THIS ONE YEAR WINDOW. (FOR EXAMPLE, DURING THIS YEAR TSGT SMITH GOES TDY FROM SPANGDAHLEM AB GERMANY, SUBSEQUENTLY GOES PCS TO MOODY AFB, GA, AND WHILE AT MOODY GOES TDY. IN THIS PROGRAM THE TDYs THAT TSGT SMITH ACCUMULATED ARE CREDITED INDIVIDUALLY TO BOTH SPANGDAHLEM AB AND MOODY AFB). IF YOU WANT TO SEE HOW MUCH TIME TDY TIME TSGT SMITH ACCUMULATED DURING THIS PERIOD, YOU MUST USE THE "SEARCH BY INDIVIDUAL" FEATURE.															
Note 8	TOTAL TDYS = TOTAL TDYS ON THE TDY HISTORY FILE FOR A SELECTED GROUP (AFSC, MDS, UNIT, etc) DURING THIS ONE YEAR WINDOW OF TIME.															
Note 9	TOTAL DAYS TDY = SUM OF ALL TDY DAYS FOR EACH PERSON WITHIN A SELECTED GROUP FOR THE WINDOW OF TIME SHOWN OF THE REPORT															
Note 10	Note 10. MANNING OR ASSIGNED STRENGTH = TOTAL NUMBER OF PERSONNEL ASSIGNED WITHIN THE SELECTED AFSC, MDS, MAJCOM, UNIT etc. MANNING OR ASSIGNED STRENGTH IS A ONE DAY SNAPSHOT AND IS NOT ACCUMULATED DURING THIS ONE YEAR PERIOD.															
Note 11	TOTAL DAYS AVAILABLE = NUMBER ASSIGNED * NUMBER OF DAYS SPECIFIED IN THE REPORT (USUALLY A ONE YEAR PERIOD) (IE. 100 ASSIGNED * 365 DAYS = 36500 DAYS AVAILABLE)															
Note 12	TDY RATE = PERCENT OF TDY TIME DIVIDED BY THE TOTAL DAYS AVAILABLE															
Note 13	AVG DAYS > 120 = AVG OVER 120 DAYS FOR THOSE WITH MORE THAN 120 TDY DAYS ACCUMULATION															
Note 14	AVG DAYS > 60 = AVG OVER 60 DAYS FOR THOSE WITH MORE THAN 60 TDY DAYS ACCUMULATION															
Note 15	ASSIGNED %> 120 DAYS = % OF PEOPLE WITHIN THE SELECTED GROUP WITH 120 OR MORE TDY DAYS ACCUMULATED															
Note 16	ASSIGNED %> 60 DAYS = % OF PEOPLE WITHIN THE SELECTED GROUP WITH 60 OR MORE TDY DAYS ACCUMULATED															
Note 17	AVERAGE NBR TDY DAYS PER TRAVELER = AVG TDY DAYS FOR EVERYONE WITHIN THE SELECTED GROUP THAT TRAVELED DURING THE WINDOW OF TIME SHOWN (TOTAL DAYS TDY / NUMBER OF PEOPLE TDY)															

Figure 26. PERSTEMPO Variables and Calculations

Appendix E: AMOS Ouput for SEM Model 4

Table 10. SEM Model 4 - Goodness of Fit Measures

<u>Fit Measure</u>	<u>Default model</u>	<u>Saturated</u>	<u>Independence</u>	<u>Macro</u>
Discrepancy	649.505	0.000	4234.864	CMIN
Degrees of freedom	25.000	0.000	45.000	DF
P	0.000		0.000	P
Number of parameters	30.000	55.000	10.000	NPAR
Discrepancy / df	25.980		94.108	CMINDF
RMR	183.667	0.000	97010.381	RMR
GFI	0.648	1.000	0.150	GFI
Adjusted GFI	0.227		-0.038	AGFI
Parsimony-adjusted GFI	0.295		0.123	PGFI
Normed fit index	0.847	1.000	0.000	NFI
Relative fit index	0.724		0.000	RFI
Incremental fit index	0.852	1.000	0.000	IFI
Tucker-Lewis index	0.732		0.000	TLI
Comparative fit index	0.851	1.000	0.000	CFI
Parsimony ratio	0.556	0.000	1.000	PRATIO
Parsimony-adjusted NFI	0.470	0.000	0.000	PNFI
Parsimony-adjusted CFI	0.473	0.000	0.000	PCFI
Noncentrality parameter estimate	624.505	0.000	4189.864	NCP
NCP lower bound	545.146	0.000	3979.897	NCPLO
NCP upper bound	711.281	0.000	4407.086	NCPHI
FMIN	5.074	0.000	33.085	FMIN
F0	4.879	0.000	32.733	F0
F0 lower bound	4.259	0.000	31.093	F0LO
F0 upper bound	5.557	0.000	34.430	F0HI
RMSEA	0.442		0.853	RMSEA
RMSEA lower bound	0.413		0.831	RMSEALO
RMSEA upper bound	0.471		0.875	RMSEHI
P for test of close fit	0.000		0.000	PCLOSE
Akaike information criterion (AIC)	709.505	110.000	4254.864	AIC
Browne-Cudeck criterion	715.146	120.342	4256.745	BCC
Bayes information criterion	864.377	393.932	4306.488	BIC
Consistent AIC	825.300	322.290	4293.463	CAIC
Expected cross validation index	5.543	0.859	33.241	ECVI
ECVI lower bound	4.923	0.859	31.601	ECVILO
ECVI upper bound	6.221	0.859	34.938	ECVIHI
MECVI	5.587	0.940	33.256	MECVI

Table 11. SEM Model 4 - Variable Summary

Your model contains the following variables		
MC Rate	observed	endogenous
Struc All Lvl/AC	observed	endogenous
Sys All Lvl/AC	observed	endogenous
Eng All Lvl/AC	observed	endogenous
Av All Lvl/AC	observed	endogenous
CC All Lvl/AC	observed	endogenous
TNMCM/5	observed	exogenous
Flying Hours/5	observed	exogenous
C17 Avg Inv	observed	exogenous
TNMCS/5	observed	exogenous
Pers to AC Ratio	unobserved	exogenous
e5	unobserved	exogenous
e4	unobserved	exogenous
e3	unobserved	exogenous
e2	unobserved	exogenous
e1	unobserved	exogenous
e6	unobserved	exogenous
Number of variables in your model:		17
Number of observed variables:		10
Number of unobserved variables:		7
Number of exogenous variables:		11
Number of endogenous variables:		6

Table 12. SEM Model 4 - Notes for Group and Model

The model is recursive.
Sample size = 129
Computation of degrees of freedom
Number of distinct sample moments = 55
Number of distinct parameters to be estimated = 30
Degrees of freedom = 55 - 30 = 25
Minimum was achieved
Chi-square = 649.505
Degrees of freedom = 25
Probability level = 0.000

Table 13. SEM Model 4 – Normality Assessment

Assessment of normality	min	max	skew	c.r.	kurtosis	c.r.
TNMCS/5	43.4	1019.2	-0.101	-0.466	-0.433	-1.004
C17 Avg Inv	18	140	0.411	1.906	-1.1	-2.549
Flying Hours/5	131.96	3442.14	0.515	2.388	-1.064	-2.468
TNMCM/5	305.3	3447.98	0.016	0.075	-1.267	-2.937
CC All Lvl/AC	18.571	205.389	0.893	4.14	-0.34	-0.788
Av All Lvl/AC	13.014	100.833	0.908	4.21	-0.263	-0.611
Eng All Lvl/AC	6.436	87.5	1.331	6.173	0.834	1.933
Sys All Lvl/AC	13.888	125.867	0.992	4.598	0.055	0.127
Struc All Lvl/AC	5.714	55.944	1.134	5.257	0.283	0.656
MC Rate	66.93	91.32	-0.372	-1.724	-0.434	-1.007
Multivariate					2.446	0.897

Table 14. SEM Model 4 – Check for Outliers (partial table)

Observations farthest from the centroid (Mahalanobis distance)			
Observation Number	Mahalanobis d-squared	p1	p2
1	34.98	0.000	0.016
5	24.872	0.006	0.163
3	20.072	0.029	0.716
74	19.86	0.031	0.559
128	19.414	0.035	0.48
99	19.13	0.039	0.381
62	18.586	0.046	0.38
26	18.466	0.048	0.272
2	18.079	0.054	0.257
101	17.769	0.059	0.231
87	16.266	0.092	0.652
25	16.085	0.097	0.607
122	15.931	0.102	0.555
95	15.412	0.118	0.668
61	14.897	0.136	0.778
6	14.807	0.139	0.728
88	14.768	0.141	0.653
22	14.416	0.155	0.721
7	14.286	0.16	0.693
100	14.255	0.162	0.618
10	14.072	0.17	0.619
8	13.732	0.186	0.704
97	13.176	0.214	0.865
27	13.106	0.218	0.837
82	13.047	0.221	0.801
31	12.853	0.232	0.822
123	12.593	0.247	0.866
4	12.07	0.28	0.958
104	11.958	0.288	0.956
129	11.946	0.289	0.936
17	11.904	0.292	0.918
73	11.829	0.297	0.906
30	11.708	0.305	0.907
12	11.421	0.326	0.947
13	11.338	0.332	0.942
80	11.315	0.333	0.922
57	11.287	0.336	0.898
117	11.254	0.338	0.873
98	11.167	0.345	0.866
77	11.077	0.352	0.86

Table 15. SEM Model 4 – Estimates

Regression Weights			<u>Estimate</u>	<u>S.E.</u>	<u>C.R.</u>	<u>P</u>
MC Rate	<-	TNMCM/5	-0.01	0	-23.376	0.00
MC Rate	<-	Pers to AC Ratio	-0.163	0.031	-5.213	0.00
MC Rate	<-	Flying Hours/5	-0.002	0.001	-3.366	0.001
MC Rate	<-	C17 Avg Inv	0.274	0.019	14.551	0.00
MC Rate	<-	TNMCS/5	-0.01	0.001	-7.015	0.00
Struc All Lvl/AC	<-	Pers to AC Ratio	1			
Sys All Lvl/AC	<-	Pers to AC Ratio	2.157	0.023	91.854	0.00
Eng All Lvl/AC	<-	Pers to AC Ratio	1.534	0.032	47.458	0.00
Av All Lvl/AC	<-	Pers to AC Ratio	1.741	0.016	109.6	0.00
CC All Lvl/AC	<-	Pers to AC Ratio	3.83	0.038	100.398	0.00

Standardized Regression Weights			<u>Estimate</u>
MC Rate	<-	TNMCM/5	-1.943
MC Rate	<-	Pers to AC Ratio	-0.437
MC Rate	<-	Flying Hours/5	-0.366
MC Rate	<-	C17 Avg Inv	2.018
MC Rate	<-	TNMCS/5	-0.441
Struc All Lvl/AC	<-	Pers to AC Ratio	0.995
Sys All Lvl/AC	<-	Pers to AC Ratio	0.998
Eng All Lvl/AC	<-	Pers to AC Ratio	0.978
Av All Lvl/AC	<-	Pers to AC Ratio	1
CC All Lvl/AC	<-	Pers to AC Ratio	0.999

Covariances			<u>Estimate</u>	<u>S.E.</u>	<u>C.R.</u>	<u>P</u>
C17 Avg Inv	<-->	TNMCS/5	6085.019	873.919	6.963	0.00
TNMCM/5	<-->	TNMCS/5	160685.1	22508.38	7.139	0.00
TNMCM/5	<-->	C17 Avg Inv	30008.32	4009.659	7.484	0.00
Flying Hours/5	<-->	C17 Avg Inv	32217.26	4143.517	7.775	0.00
Flying Hours/5	<-->	TNMCS/5	136292.1	21227.88	6.42	0.00
TNMCM/5	<-->	Flying Hours/5	682176.8	97251.89	7.015	0.00
Pers to AC Ratio	<-->	Flying Hours/5	-10337.6	1430.738	-7.225	0.00
Pers to AC Ratio	<-->	C17 Avg Inv	-427.87	57.568	-7.432	0.00
Pers to AC Ratio	<-->	TNMCS/5	-2364.05	327.322	-7.222	0.00
TNMCM/5	<-->	Pers to AC Ratio	-10880.2	1461.358	-7.445	0.00

Correlations				<u>Estimate</u>
C17 Avg Inv	<-->	TNMCS/5		0.781
TNMCM/5	<-->	TNMCS/5		0.813
TNMCM/5	<-->	C17 Avg Inv		0.882
Flying Hours/5	<-->	C17 Avg Inv		0.946
Flying Hours/5	<-->	TNMCS/5		0.689
TNMCM/5	<-->	Flying Hours/5		0.79
Pers to AC Ratio	<-->	Flying Hours/5		-0.833
Pers to AC Ratio	<-->	C17 Avg Inv		-0.875
Pers to AC Ratio	<-->	TNMCS/5		-0.832
TNMCM/5	<-->	Pers to AC Ratio		-0.878

Variances				
	<u>Estimate</u>	<u>S.E.</u>	<u>C.R.</u>	<u>P</u>
TNMCM/5	862443.51	107805.44	8	0
Pers to AC Ratio	178.243	22.513	7.917	0
Flying Hours/5	864114.52	108014.32	8	0
C17 Avg Inv	1342.005	167.751	8	0
TNMCS/5	45253.502	5656.688	8	0
e5	1.871	0.239	7.824	0
e4	3.875	0.523	7.416	0
e3	19.424	2.436	7.973	0
e2	0.082	0.12	0.684	0.494
e1	5.752	0.93	6.187	0
e6	3.26	0.408	7.998	0

Squared Multiple Correlations	
	<u>Estimates</u>
CC All Lvl/AC	0.998
Av All Lvl/AC	1
Eng All Lvl/AC	0.956
Sys All Lvl/AC	0.995
Struc All Lvl/AC	0.99
MC Rate	0.868

Table 16. SEM Model 4 – Modification Indices

Modification Indices			<u>M.I.</u>	<u>Par Change</u>
<u>Covariances:</u>				
-				-
e1	<-->	TNMCS/5	6.785	61.986
e1	<-->	C17 Avg Inv	21.614	8.629
e1	<-->	Flying Hours/5	12.008	-208.2
e1	<-->	TNMCM/5	20.323	-353.905
e4	<-->	C17 Avg Inv	4.521	-3.184
e4	<-->	Flying Hours/5	5.057	109.022
e4	<-->	Pers to AC Ratio	6.017	2.219
e4	<-->	TNMCM/5	14.645	242.412
e4	<-->	e1	25.766	-2.217
e5	<-->	C17 Avg Inv	7.012	2.733
e5	<-->	Pers to AC Ratio	44.198	4.145
e5	<-->	TNMCM/5	6.668	112.719
e5	<-->	e1	23.346	1.455
e3	<-->	Pers to AC Ratio	22.978	9.582
e3	<-->	TNMCM/5	19.145	612.325
e3	<-->	e1	10.856	3.182
e3	<-->	e5	98.085	5.319
e2	<-->	C17 Avg Inv	11.593	-2.229
e2	<-->	Pers to AC Ratio	26.037	-2.011
e2	<-->	e4	11.685	0.472
e2	<-->	e5	26.333	-0.518
e2	<-->	e3	27.375	-1.761
<u>e13</u>	<u><--></u>	<u>e4</u>	<u>14.412</u>	<u>-1.211</u>
e13	<-->	e2	4.024	0.279
<u>Variances:</u>			<u>M.I.</u>	<u>Par Change</u>
<u>Regression Weights:</u>			<u>M.I.</u>	<u>Par Change</u>
CC All Lvl/AC	<--	MC Rate	9.629	0.137
Sys All Lvl/AC	<--	MC Rate	13.673	-0.131
Struc All Lvl/AC	<--	C17 Avg Inv	15.029	0.013
Struc All Lvl/AC	<--	Flying Hours/5	12.316	0
Struc All Lvl/AC	<--	TNMCM/5	8.649	0
Struc All Lvl/AC	<--	Eng All Lvl/AC	4.33	0.012
Eng All Lvl/AC	<--	C17 Avg Inv	4.489	0.023
Eng All Lvl/AC	<--	TNMCM/5	7.518	0.001
Eng All Lvl/AC	<--	MC Rate	7.418	-0.214

Appendix F: Analysis of SEM Related Variables

	A	B	C	D	E	F	G	H	I	J	K	L	M	N
1	CYEAR	CMONTH	MC Rate	Flying Hours	Sorties	TNMCM	TNMCS	C17 Avg Inv	Struc All LwWAC	Sys All LwWAC	Eng All LwWAC	Av All LwWAC	CC All LwWAC	TNMCM5
2	1995	1	70	659.8	246	3,032.00	1,572.00	18	55.94444444	125.867284	87.5	100.8333333	205.3888889	606.4
3		2	79.65	833.1	319	1,978.00	823	18.39	54.75802066	123.1557745	85.64437194	98.6949429	201.0331702	395.6
4		3	83.31	1,184.20	381	2,130.00	393	19	53	119.1412742	82.89473684	95.52631579	194.5789474	426
5		4	78.13	879.8	394	2,913.00	437	19.57	51.45631068	115.6195192	80.48032703	92.74399591	188.9115994	582.6
6		5	72.54	1,228.00	376	3,984.60	217	20	50.35	113.0975	78.75	90.75	184.85	796.92
7		6	75.15	1,045.00	444	3,342.40	548	20.4	49.3627451	110.8482314	77.20588235	88.97058824	181.2254902	668.48
8		7	83.83	2,118.90	513	2,414.30	275	21.03	47.88397527	107.4815115	74.89300999	86.30527917	175.7964812	482.86
9		8	84.58	1,432.50	418	2,333.00	249	22	45.77272727	102.6797521	71.59090909	82.5	168.0454545	466.6
10		9	77.58	1,276.20	475	3,039.30	958	22.07	45.62754871	102.3497752	71.36384232	82.23833258	167.5124604	607.86
11		10	84.64	1,340.90	464	2,472.20	4615	23	43.7826087	98.15879017	68.47826087	78.91304348	160.7391304	494.44
12		11	80.64	1,458.20	473	2,954.60	918.6	23.33	43.16330904	96.75297439	67.50964423	77.79682812	158.4654951	590.92
13		12	81.11	1,958.60	893	2,553.00	1,443.50	24	41.95833333	94.01909722	65.625	75.625	154.0416867	510.6
14	1996	1	86.18	1,782.40	790	1,844.00	954	24.19	36.66804465	79.42024359	57.46176106	70.56634973	143.3650269	368.8
15		2	84.88	1,800.70	679	2,100.50	1,261.30	25.89	34.26033217	74.14146758	53.68868289	65.93279258	133.9513326	420.1
16		3	86.97	2,204.70	647	1,564.00	1,072.00	25	35.48	76.8144	55.6	68.28	138.72	312.8
17		4	85.11	2,164.20	591	2,254.20	1,223.00	25	35.48	76.8144	55.6	68.28	138.72	450.84
18		5	89.02	1,642.20	645	1,960.20	844.5	25.97	34.15479399	73.91028628	53.52329611	65.7296881	133.5386985	392.04
19		6	88.11	1,446.30	534	1,659.70	788	26	34.11538462	73.8239645	53.46153846	65.85384615	133.3846154	331.94
20		7	87.09	1,774.10	583	2,140.00	975	26.94	32.92501856	71.21773536	51.59613957	63.36302895	128.7305122	428
21		8	84.48	1,778.50	583	2,446.10	1,700	27	32.85185185	71.05761317	51.48148148	63.22222222	128.4444444	489.22
22		9	87.38	1,787.20	630	1,890.10	1,079.20	27	32.85185185	71.05761317	51.48148148	63.22222222	128.4444444	378.02
23		10	80.42	1,915.50	680	2,881.40	2,336.00	27	32.85185185	71.05761317	51.48148148	63.22222222	128.4444444	576.28
24		11	86.64	1,942.20	607	2,138.20	1,420.20	27.87	31.82633656	68.81418921	49.87441694	61.24885447	124.4348762	427.64
25		12	88.4	1,777.50	536	1,526.50	1,232.60	28.45	31.17750439	67.39564061	48.85764499	60	121.8980668	305.3
26	1997	1	83.46	1,844.10	626	2,466.00	1,464.00	29.1	31.44328987	81.89768536	39.48453688	67.83505155	130.9965636	493.2
27		2	80.57	1,980.10	538	3,054.60	1,986.40	30	30.5	79.22333333	38.3	65.8	127.0666667	610.92
28		3	85.59	2,260.20	673	2,240.10	1,755.40	30.16	30.33819629	78.79905755	38.09681698	65.45092838	126.3925729	448.02
29		4	83.66	1,862.90	593	3,009.40	1,565.60	31	29.51612903	76.64412071	37.06451613	63.67741935	122.9677419	601.88
30		5	82.87	2,214.20	690	3,103.20	2,148.00	32	28.59375	74.22753906	35.90625	61.6875	119.125	620.64
31		6	89.09	2,427.80	652	1,832.10	1,506.20	32	28.59375	74.22753906	35.90625	61.6875	119.125	366.42
32		7	91.32	2,875.10	773	1,759.30	856.2	32.98	27.74408733	72.00269491	34.83829654	59.85445725	115.5852032	351.86
33		8	89.08	2,712.10	738	2,210.00	965	33	27.72727273	71.95867769	34.81818182	59.81818182	115.5151515	442
34		9	88.01	2,903.40	673	2,220.90	1,155.60	33.98	26.92760447	69.86583875	33.81400824	58.09299588	112.1836374	444.18
35		10	86.35	3,394.20	861	2,809.10	1,590.10	34.97	26.16528453	67.87171389	32.85673434	56.44838433	109.0077209	561.82
36		11	86.06	2,899.10	756	2,468.80	2,046.30	35.55	25.73839662	66.75544636	32.32067511	55.52742616	107.2292546	493.36
37		12	88.6	2,904.60	771	2,768.50	970.5	36.31	25.18966951	65.34715406	31.64417516	54.36518885	104.9848527	553.7
38	1998	1	84.38	3,151.00	785	3,438.00	1,849.30	37	23.16216216	60.76406136	29.32432432	50.54054054	96.18918919	687.6
39		2	86.56	3,736.50	822	2,899.50	977.5	37.9	22.6121372	59.31092098	28.62796834	49.34036939	93.90501319	579.9
40		3	88.31	3,999.60	975	2,777.30	1,198.50	38.89	22.03651324	57.79068032	27.89920288	48.08434045	91.51452816	555.46
41		4	79.77	3,573.90	845	4,685.40	2,145.40	39.51	21.69071121	56.87786785	27.46140218	47.32978993	90.07846115	937.08

Figure 27. SEM Model 4 Variables Partial Spreadsheet

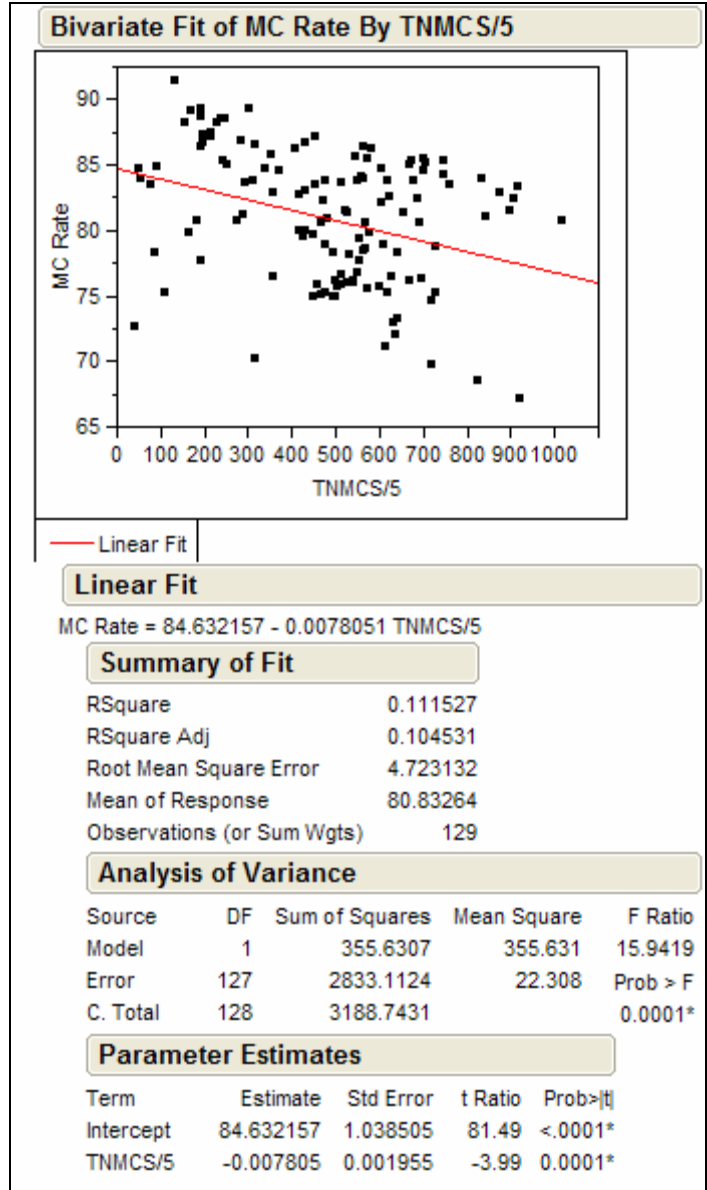

Figure 28. Bivariate Analysis of C-17 MC Rate by TNMCS/5

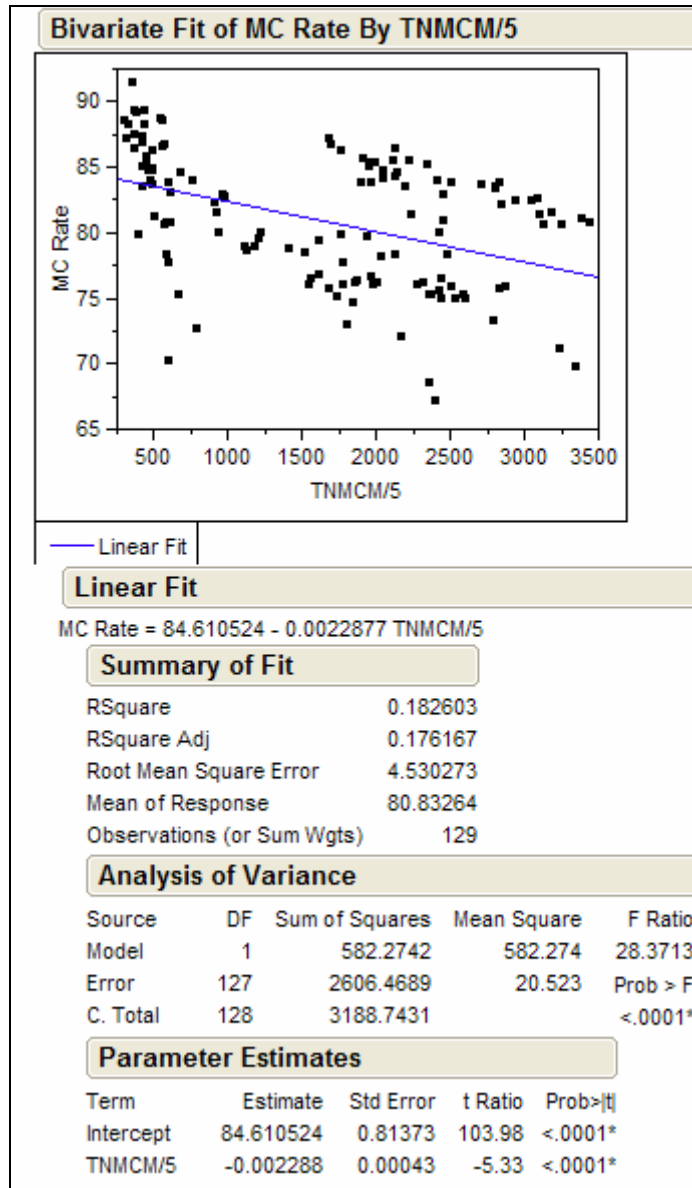

Figure 29. Bivariate Fit of C-17 MC Rate by TNMCM/5

Period	AV 1st	Av 2nd	Av crr	Eng 1st	Eng 2nd	Eng crr	CC 1st	CC 2nd	CC crr	Sys 1st	Sys 2nd	Sys crr	Struc 1st	Struc 2nd	Struc crr
1997 Q1	45.71	64.22	95.86	66.67	73.75	96.30	57.14	76.84	95.26	62.67	67.46	97.75	76.09	70.83	93.24
1997 Q2	45.71	64.22	95.86	66.67	73.75	96.30	57.14	76.84	95.26	62.67	67.46	97.75	76.09	70.83	93.24
1997 Q3	45.71	64.22	95.86	66.67	73.75	96.30	57.14	76.84	95.26	62.67	67.46	97.75	76.09	70.83	93.24
1997 Q4	45.71	64.22	95.86	66.67	73.75	96.30	57.14	76.84	95.26	62.67	67.46	97.75	76.09	70.83	93.24
1998 Q1	41.03	60.91	92.59	45.12	69.74	93.97	60.38	71.81	97.30	48.02	62.84	91.96	41.79	68.63	88.89
1998 Q2	41.03	60.91	92.59	45.12	69.74	93.97	60.38	71.81	97.30	48.02	62.84	91.96	41.79	68.63	88.89
1998 Q3	41.03	60.91	92.59	45.12	69.74	93.97	60.38	71.81	97.30	48.02	62.84	91.96	41.79	68.63	88.89
1998 Q4	41.03	60.91	92.59	45.12	69.74	93.97	60.38	71.81	97.30	48.02	62.84	91.96	41.79	68.63	88.89
1999 Q1	54.55	76.32	91.16	15.38	70.37	94.21	50.72	68.07	93.87	47.03	61.44	97.65	57.45	75.00	93.83
1999 Q2	54.55	76.32	91.16	15.38	70.37	94.21	50.72	68.07	93.87	47.03	61.44	97.65	57.45	75.00	93.83
1999 Q3	54.55	76.32	91.16	15.38	70.37	94.21	50.72	68.07	93.87	47.03	61.44	97.65	57.45	75.00	93.83
1999 Q4	54.55	76.32	91.16	15.38	70.37	94.21	50.72	68.07	93.87	47.03	61.44	97.65	57.45	75.00	93.83
2000 Q1	42.25	72.38	93.37	78.95	83.08	94.78	52.33	75.57	93.53	51.46	76.98	95.14	44.05	63.64	97.59
2000 Q2	42.25	72.38	93.37	78.95	83.08	94.78	52.33	75.57	93.53	51.46	76.98	95.14	44.05	63.64	97.59
2000 Q3	42.25	72.38	93.37	78.95	83.08	94.78	52.33	75.57	93.53	51.46	76.98	95.14	44.05	63.64	97.59
2000 Q4	42.25	72.38	93.37	78.95	83.08	94.78	52.33	75.57	93.53	51.46	76.98	95.14	44.05	63.64	97.59
2001 Q1	44.74	48.21	89.44	65.45	71.01	89.80	46.35	76.79	93.48	53.60	77.03	96.41	55.74	43.90	93.90
2001 Q2	44.74	48.21	89.44	65.45	71.01	89.80	46.35	76.79	93.48	53.60	77.03	96.41	55.74	43.90	93.90
2001 Q3	44.74	48.21	89.44	65.45	71.01	89.80	46.35	76.79	93.48	53.60	77.03	96.41	55.74	43.90	93.90
2001 Q4	44.74	48.21	89.44	65.45	71.01	89.80	46.35	76.79	93.48	53.60	77.03	96.41	55.74	43.90	93.90
2002 Q1	51.22	58.54	92.70	71.74	80.00	98.89	67.24	80.80	96.97	73.56	131.60	97.21	67.21	85.71	98.80
2002 Q2	51.22	58.54	92.70	71.74	80.00	98.89	67.24	80.80	96.97	73.56	131.60	97.21	67.21	85.71	98.80
2002 Q3	51.22	58.54	92.70	71.74	80.00	98.89	67.24	80.80	96.97	73.56	131.60	97.21	67.21	85.71	98.80
2002 Q4	51.22	58.54	92.70	71.74	80.00	98.89	67.24	80.80	96.97	73.56	131.60	97.21	67.21	85.71	98.80
2003 Q1	49.40	71.43	93.71	68.75	77.78	98.88	61.29	69.05	97.34	58.11	72.84	96.72	54.55	76.47	93.75
2003 Q2	49.40	71.43	93.71	68.75	77.78	98.88	61.29	69.05	97.34	58.11	72.84	96.72	54.55	76.47	93.75
2003 Q3	49.40	71.43	93.71	68.75	77.78	98.88	61.29	69.05	97.34	58.11	72.84	96.72	54.55	76.47	93.75
2003 Q4	49.40	71.43	93.71	68.75	77.78	98.88	61.29	69.05	97.34	58.11	72.84	96.72	54.55	76.47	93.75
2004 Q1	56.07	57.89	95.58	51.06	81.82	100.00	51.65	73.21	99.14	50.00	75.00	95.37	73.53	76.92	96.43
2004 Q2	56.07	57.89	95.58	51.06	81.82	100.00	51.65	73.21	99.14	50.00	75.00	95.37	73.53	76.92	96.43
2004 Q3	56.07	57.89	95.58	51.06	81.82	100.00	51.65	73.21	99.14	50.00	75.00	95.37	73.53	76.92	96.43
2004 Q4	56.07	57.89	95.58	51.06	81.82	100.00	51.65	73.21	99.14	50.00	75.00	95.37	73.53	76.92	96.43
2005 Q1	21.79	47.06	99.35	62.20	46.43	96.00	22.67	35.42	95.63	46.25	53.85	96.45	78.43	72.73	93.62
2005 Q2	21.79	47.06	99.35	62.20	46.43	96.00	22.67	35.42	95.63	46.25	53.85	96.45	78.43	72.73	93.62
2005 Q3	21.79	47.06	99.35	62.20	46.43	96.00	22.67	35.42	95.63	46.25	53.85	96.45	78.43	72.73	93.62
2005 Q4	21.79	47.06	99.35	62.20	46.43	96.00	22.67	35.42	95.63	46.25	53.85	96.45	78.43	72.73	93.62

Figure 30. AMC Maintenance AFSCs Quarterly Retention Percentages 1997 to 2005

Period	AV 1st	Av 2nd	Av crr	Eng 1st	Eng 2nd	Eng crr	CC 1st	CC 2nd	CC crr	Sys 1st	Sys 2nd	Sys crr	Struc 1st	Struc 2nd	Struc crr
1997	45.71	64.22	95.86	66.67	73.75	96.30	57.14	76.84	95.26	62.67	67.46	97.75	76.09	70.83	93.24
1998	41.03	60.91	92.59	45.12	69.74	93.97	60.38	71.81	97.30	48.02	62.84	91.96	41.79	68.63	88.89
1999	54.55	76.32	91.16	15.38	70.37	94.21	50.72	68.07	93.87	47.03	61.44	97.65	57.45	75.00	93.83
2000	42.25	72.38	93.37	78.95	83.08	94.78	52.33	75.57	93.53	51.46	76.98	95.14	44.05	63.64	97.59
2001	44.74	48.21	89.44	65.45	71.01	89.80	46.35	76.79	93.48	53.60	77.03	96.41	55.74	43.90	93.90
2002	51.22	58.54	92.70	71.74	80.00	98.89	67.24	80.80	96.97	73.56	131.60	97.21	67.21	85.71	98.80
2003	49.40	71.43	93.71	68.75	77.78	98.88	61.29	69.05	97.34	58.11	72.84	96.72	54.55	76.47	93.75
2004	56.07	57.89	95.58	51.06	81.82	100.00	51.65	73.21	99.14	50.00	75.00	95.37	73.53	76.92	96.43
2005	21.79	47.06	99.35	62.20	46.43	96.00	22.67	35.42	95.63	46.25	53.85	96.45	78.43	72.73	93.62

Figure 31. AMC Maintenance AFSCs Yearly Retention Percentages 1997 to 2005

Table 18. Retention Percentages Calculation Example – AMC Avionics AFSCs

Avionics AFSC Totals									
	1st Term			2nd Term			Career		
	Eligible	Reenlist	%	Eligible	Reenlist	%	Eligible	Reenlist	%
1996									
1997	175.00	80.00	45.71	109.00	70.00	64.22	169.00	162.00	95.86
1998	117.00	48.00	41.03	110.00	67.00	60.91	189.00	175.00	92.59
1999	99.00	54.00	54.55	114.00	87.00	76.32	147.00	134.00	91.16
2000	213.00	90.00	42.25	105.00	76.00	72.38	166.00	155.00	93.37
2001	152.00	68.00	44.74	56.00	27.00	48.21	161.00	144.00	89.44
2002	82.00	42.00	51.22	41.00	24.00	58.54	178.00	165.00	92.70
2003	83.00	41.00	49.40	28.00	20.00	71.43	143.00	134.00	93.71
2004	107.00	60.00	56.07	38.00	22.00	57.89	113.00	108.00	95.58
2005	156.00	34.00	21.79	34.00	16.00	47.06	155.00	154.00	99.35
	1184.00	517.00	43.67	635.00	409.00	64.41	1421.00	1331.00	93.67

Appendix H: Stepwise Regression Data and Models

Year	C-17 Avg Inventory	C-17 MC Rate	O&M TOA \$\$	Maintenance Officers Assigned	Maintenance Officer A/A %	Structure Amn A/A %	Structure NCO A/A %	Structure SNCO A/A %	Structure 3-Lvl A/A %
1997	32.59	86.37	22,795,000	282	130.56	92.48	107.52	184.75	105.00
1998	41.13	82.21	25,131,000	265	118.83	87.40	104.08	172.88	110.70
1999	51.67	76.44	27,068,000	294	134.86	85.57	97.24	140.98	109.73
2000	63.43	75.71	27,299,000	272	128.30	71.71	105.47	135.00	100.57
2001	74.51	75.36	30,072,000	281	133.81	68.42	94.77	136.21	80.11
2002	88.25	77.79	34,294,000	316	151.92	60.88	94.35	143.86	74.63
2003	105.33	85.12	43,262,000	385	150.98	79.75	93.84	127.12	142.35
2004	121.85	83.19	39,539,000	344	139.84	94.82	109.51	113.56	154.01
2005	134.78	82.17	34,288,000	363	150.62	97.57	93.55	104.76	129.11

Figure 32. Stepwise Regression Variables Partial Spreadsheet

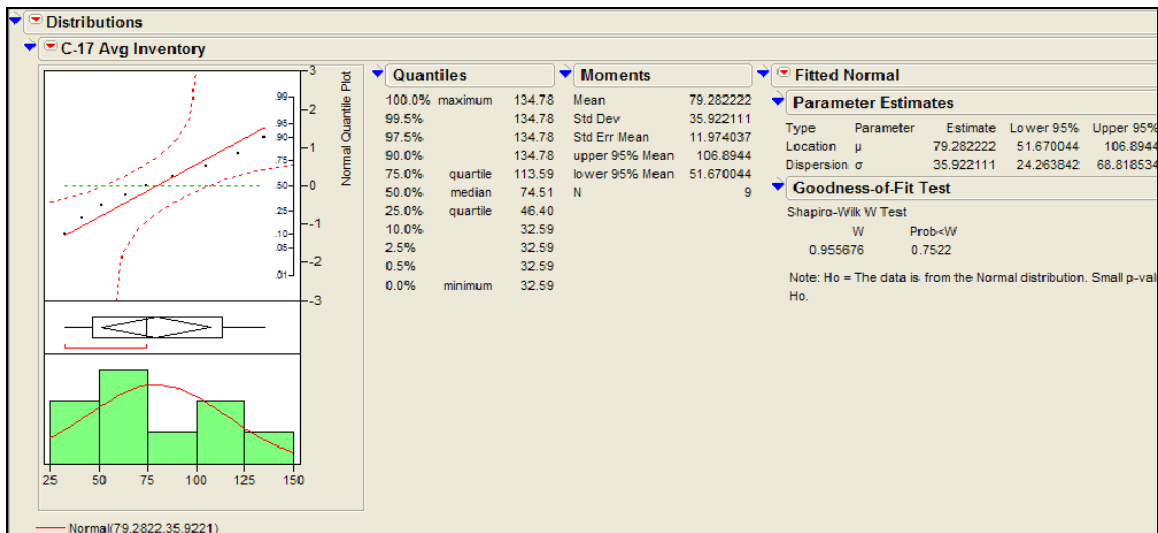
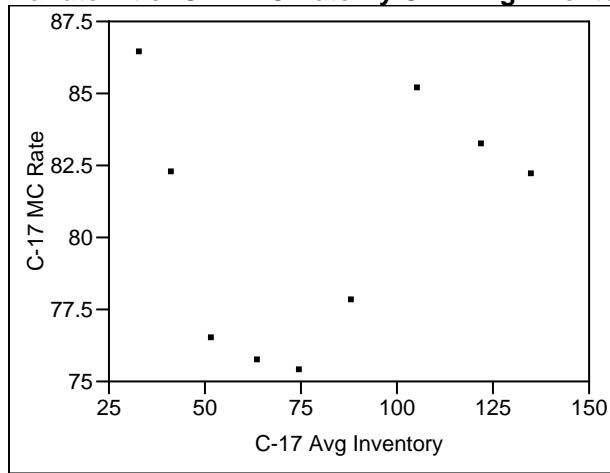

Figure 32. JMP Screenshot Normality Check Example

Fit Y by X Group
Bivariate Fit of C-17 MC Rate By C-17 Avg Inventory



Bivariate Fit of C-17 MC Rate By O&M TOA \$\$

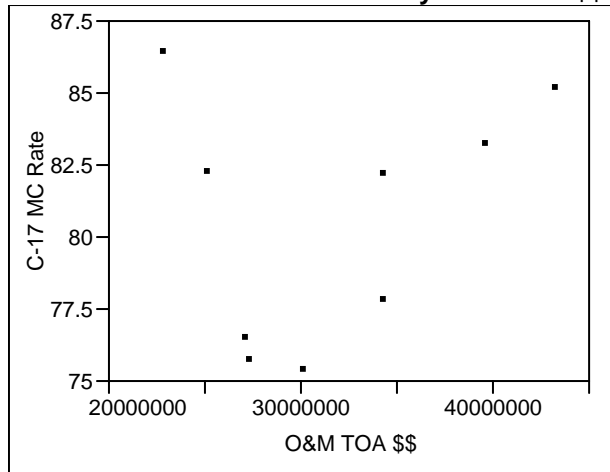

Figure 33. Constant Variance Checks - JMP Analysis Examples

Bibliography

- Air Force Factsheet. C-17 Globemaster III. 20 December 2005
<http://www.af.mil/factsheets/factsheet.asp?id=86>.
- Air Force Handbook for the 109th Congress. Washington: HQ USAF, 2005. 20 August 2005 <http://www.af.mil/library/posture/2005handbook.pdf>.
- Air Force Material Command (AFMC). *Requirements for Secondary Items (D200A & D200N)*. AFMCMAN 23-1. Dayton: HQ AFMC, 16 March 2005.
- Air Mobility Command (AMC). *Metrics Handbook for Mobility Air Forces*. Scott AFB: HQ AMC, April 2005.
- Air Mobility Command (AMC). AMC Enlisted Retention 2005. Scott AFB: HQ AMC/A15PA, 2005.
- Air Force Portal. Applications web page, MERLIN application details. n. pag. <https://www.my.af.mil/afp40/USAF/ep/index.do?command=application>
- Air Force Portal. Applications web page, REMIS application details. n. pag. <https://www.my.af.mil/afp40/USAF/ep/index.do?command=application>
- Arbuckle, James L. and Werner Wothke. *AMOS 4.0 User's Guide*. Chicago: SmallWaters Corporation, 1999.
- Balaban, Harold S. and others. "A Simulation Approach to Estimating Aircraft Mission Capable Rates for the United States Air Force," *Proceedings of the 2000 Winter Simulation Conference*. 1035-1042. 2001.
- Baldor, Lolita C. "Rumsfeld Says Military Not Overextended." Associated Press. n. pag. 25 January 2006 <http://news.yahoo.com>.
- Barthol, Derrick R. *An Analysis Into the Effectiveness of Aircraft Maintenance Under the Combat Wing Structure*. MS Thesis, AFIT/GLM/ENS/05-02. School of Systems and Logistics, Air Force Institute of Technology (AU), Wright-Patterson AFB OH, March 2005 (ADA431553).
- Bell, John, and Richard Hardemon. *Total Not Mission Capable for Maintenance (TNMCM) Study*. Air Force Logistics Management Agency (AFLMA) Final Report LM199934800. Maxwell AFB, AFLMA. December 2000.
- Bollen, Kenneth A. *Structural Equations With Latent Variables*. New York: John Wiley & Sons, 1998.

Bosker, A.J. "Air Force Continues to Reverse Spare Parts Shortfall." Excerpt from Air Force Print News Article. n. pag. 27 July 2000.

Byrne, Barbara M. *Structural Equations Modeling with AMOS: Basic Concepts, Applications, and Programming*. Mahwah, New Jersey: Lawrence Erlbaum Associates, 2001

Colarusso, Laura M. "Budget Boost Won't Stop Manpower, Aircraft Cuts." Excerpt from unpublished article. n. pag. 10 February 2006 <http://airforcetimes.com>.

----. "The Deepest Cuts," *The Air Force Times*, 23 January 2006: 14.

Davis, Wesley C. and Sanford Walker. *A Comparison of Aircraft Maintenance Organizational Structures*. MS Thesis, AFIT/GLM/LSM/92S-16. School of Systems and Logistics, Air Force Institute of Technology (AU), Wright-Patterson AFB OH, September 1992 (ADA260158)

Department of the Air Force. *Reporting Status of Aerospace Expeditionary Forces*. AFI 10-244. Washington: HQ USAF, 19 February 2002.

Department of the Air Force. *Officer Classification*. AFMAN 36-2105. Washington: HQ USAF, 31 October 2004.

Department of the Air Force. *Enlisted Classification*. AFMAN 36-2108. Washington: HQ USAF, 31 October 2004.

Department of the Air Force. *Assignments*. AFI 36-2110. Washington: HQ USAF, 20 April 2005.

Department of the Air Force. *Manpower and Organization*. AF Policy Directive 38-2. Washington: HQ USAF, 2 March 1995.

Department of the Air Force. *Posture Statement*. Washington: HQ USAF, 2005.

Department of the Air Force. "USAF Report on Reducing Stress on the Force." Report compiled by Deputy Chief of Staff, Personnel, HQ USAF/DPM, Washington D.C. August 2004.

Department of Defense. *Dictionary of Military and Associated Terms*. Joint Publication 1-02. Washington: Joint Staff, Amended through 31 August 2005.

Department of Defense. "Selected Manpower Statistics" (SMS). Washington: Washington Headquarters Services, Information Technology Management Directorate (WHS/ITMD). 2004. 15 October 2005
<http://www.dior.whs.mil/mmid/mmidhome.htm>.

- Department of Defense. SMS. Washington: Washington Headquarters Services, Information Technology Management Directorate (WHS/ITMD). 2005. 17 October 2005 <http://www.dior.whs.mil/mmid/military/history/309hist.htm>.
- Department of Defense. *DOD Maintenance Fact Book*. Washington: Department of Defense, Deputy Undersecretary of Defense, Logistics and Material Readiness, 2005.
- Department of Defense. *Material Condition Reporting for Mission-Essential Systems and Equipment*. DOD Instruction 3110.5. Washington: Department of Defense, 14 September, 1990.
- George, David, Kristen F. Lynch, Robert S. Tripp, and John G. Drew. "Maintenance Organization: A Historical Perspective," *Air Force Journal of Logistics*, 28, Number 4: 27-38 (Winter 2004).
- Geren, Pete, Acting Secretary of the Air Force. "State of the Force – 2005." Keynote address to the Air Force Association's Air and Space Conference, Washington D.C. 12 September 2005. 10 October 2005 www.af.mil/library/speeches/speech.asp?id=116.
- Gilliland, Billy J. *Productivity Measurement in Aircraft Maintenance Organizations*. MS Thesis, AFIT/GLM/LSM/90S-20. School of Systems and Logistics, Air Force Institute of Technology (AU) Wright Patterson AFB, OH, September 1990 (ADA229239).
- Gray, Mark A. and Margaret M. Ranalli. *An Evaluation of Aircraft Maintenance Performance Factors in the Objective Wing*. MS Thesis, AFIT/GLM/LA/93S-22. School of Systems and Logistics, Air Force Institute of Technology (AU) Wright-Patterson AFB, OH, September 1993 (AAK8728).
- Huscroft, Joseph R. *A Demand Side Requirements Model to Forecast C-17 Mobility Aircraft Availability*. MS Thesis, AFIT/GLM/ENS/04-06. School of Systems and Logistics, Air Force Institute of Technology (AU) Wright-Patterson AFB, OH, March 2004 (ADA422881).
- Huxsoll, Dave. "AF, Boeing Sign Unique Work Contract," *Hilltop Times*. Aeronautical Systems Center Public Affairs, Wright Patterson AFB, OH. 14 October 1999. 17 October 2005 <http://www.hilltoptimes.com/archieve/19991014/AF.html>.
- Kline, Rex B. *Principles and Practice of Structural Equations Modeling* (2nd Edition). New York: The Guilford Press, 2005.
- Kitfield, James. "Losing Altitude," *Government Executive*, 37: 69-70 (August 15, 2005).

- Kosiak, Steven M. "COMPARISON OF THE FY 2006 HOUSE AND SASC DEFENSE AUTHORIZATION BILLS," Center for Strategic & Budget Assessments. 5 October 2005.
- Jung, Charles R. *Determining Production Capability in Aircraft Maintenance: A Regression Analysis*. MS Thesis, AFIT/GLM/LSM/91S-35. School of Systems and Logistics, Air Force Institute of Technology (AU) Wright-Patterson AFB, OH, September 1993 (ADA246720).
- Leedy, Paul D. and Jeanne Ellis Ormrod. *Practical Research: Planning and Design*. Upper Saddle River, New Jersey: Prentice-Hall, 2001.
- Logistics Management Institute (LMI). Information contained on LMI home page, Readiness link. n. pag. 26 October 2005. 12 November 2005
<http://www.lmi.org/logistics/logisticsreadiness.aspx>.
- Lopez, C. Todd. "Moseley: Airman Doing Tremendous Work." Excerpt from Air Force Print News Article. n. pag. 10 March 2004. 18 October 2005
<http://www.af.mil/news/story.asp?storyID=123007178>.
- Lopez, Ramon. "Short Supply, U.S. Air Force Low Combat Readiness," *Flight International*, 34 (September 25, 2001).
- McClave, James T., P. George Benson, and Terry Sincich. *Statistics for Business and Economics* (9th Edition). Upper Saddle River, New Jersey: Pearson Prentice Hall, 2005.
- Mendoza, Martha. "Enlisted Strength Declines." n. pag. Excerpt from unpublished article. 16 January 2006 <http://airforcetimes.com>.
- MERLIN Database. Air Force Portal. <https://www.my.af.mil/merlinprod>.
- Miles, Donna. "QDR Provides Vectors for Force Transformation." Armed Forces Press Service, Armed Forces Information Service (AFIS). n. pag. 27 January 2006
http://afisnews_sender@DTIC.MIL.
- "Modernization Effort on C-17 Globemaster III Flight Control System Observes Two Milestones," *Forbes*, n. pag. (June 2005). USAF Aim Points. 10 June 2005
<http://aimpoints.hq.af.mil/display.cfm?id=4239>.
- Moore, Patricia B. *Analysis of Predictive Factors for Fully Mission Capable Rates of Deployed Aircraft*. MS Thesis, Department of Operations Research, Naval Post Graduate School, Monterey, CA, September 1998 (ADA355707).

- “Moseley: Future of the Air Force,” *Air Force Policy Letter Digest*, n. pag. (September/October, 2005). 17 November 2005
http://www.af.mil/library/policy/letters/pl2005_10.html.
- Oliver, Steven A. *Forecasting Readiness: Using Regression to Predict the Mission Capability of Air Force F-16 Fighter Aircraft*. MS Thesis, AFIT/GLM/ENS/01M-18. School of Systems and Logistics, Air Force Institute of Technology (AU), Wright-Patterson AFB, OH, March 2001 (ADA391223).
- Orr, Ronald L, Assistant Deputy Chief of Staff, Logistics, HQ USAF. Speech on 19 Aug 2005. 20 October 2005 <http://www.acq.osd.mil/log/lpp/productsupport/orr6.htm>.
- Pyles, Raymond A. *Aging Aircraft: USAF Workload and Material Consumption Life Cycle Patterns*. RAND Project Air Force. Contract F49642-01-C-0003. Santa Monica CA: RAND, 2003.
- Ramer, Jon V. “Focused Logistics and Combat Capability: Support Plans for the Future – Logistics Support,” *Air Force Journal of Logistics*, 26, Number 4: 29-32, 46 (Winter 2002).
- Roggero, B. Gen. Frederick F. “Adaptive Warfighting: Defending America in an Asymmetric World.” *Air Force Policy Letter Digest*, n. pag. February 2004.
- Secretary of Defense (SecDef). Operation and Maintenance Overview: FY06 Budget Estimates. February 2005. 17 September 2005
<http://www.dod.mil/comptroller/defbudget/fy2006/index.html>.
- Secretary of Defense (SecDef). Annual Report to the President and Congress. 2005. 20 September 2005 <http://www.defenselink.mil/execsec/adr2005.pdf>.
- Stetz, Larry J. *An Ex Post Facto Analysis of E-3 Maintenance Indicators in the 552nd Air Control Wing Since Reorganization Under an Aircraft Generation Squadron Concept*. MS Thesis, AFIT/GLM/LAL/99S-10. School of Systems and Logistics, Air Force Institute of Technology (AU), Wright-Patterson AFB, OH, September 1999 (ADA369595).
- Teets, Peter B., Acting Secretary of the Air Force. Excerpt from Speech to the Air Force Association in February 2005. *Air Force Policy Letter Digest*. n. pag. 20 December, 2005. 30 August 2005
http://www.af.mil/library/policy/letters/pl2005_03.html.
- Thaler, David E. and Carl J. Dahlman. *Assessing Unit Readiness: Case Study of an Air Force Mobility Wing*. Documented Briefing. Santa Monica CA: RAND, 2002.

Towell, Joe. Dynamics Research Corporation. Air Force contractor, HQ Air Force Material Command/LGYR. Class handout, LOG 260, Fundamentals of Supplying an Expeditionary Aerospace Force (EAF). School of Systems and Logistics, Air Force Institute of Technology, Wright-Patterson AFB OH, November 2004.

----. Personal Interview. 19 September 2005.

United States General Accounting Office. *Military Readiness: DOD Needs a Clear and Defined Process for Setting Aircraft Availability Goals in the New Security Environment*. Report Number 03-300, April 2003.

United States General Accounting Office. *Defense Inventory: Air Force Plans and Initiatives to Mitigate Spare Parts Shortages Need Better Implementation*. Report Number 03-706, June 2003.

United States General Accounting Office. *Military Personnel: DOD Needs to Conduct a Data-Driven Analysis of Active Military Personnel Levels Required to Implement the Defense Strategy*. Report Number 05-200, February 2005.

United States General Accounting Office. *Defense Transportation: Air Mobility Command Needs to Collect and Analyze Better Data to Access Aircraft Utilization*. Report Number 05-819, September 2005. (ADA438360)

United States General Accounting Office. *Military Personnel: DOD Needs Action Plan to Address Enlisted Personnel Recruitment and Retention Challenges*. Report Number 06-134, November 2005.

United States Air Force (USAF). "Fact Sheet – C-17 Globemaster III." n. pag. Excerpt from unpublished article. 10 October 2005
<http://www.af.mil/factsheets/factsheet.asp?fsID=86>.

Wall, David B. *Theoretical Models for Aircraft Availability: Classical Approach to Identification of Trends, Seasonality, and System Constraints in the Development of Realized Models*. MS Thesis, AFIT/GLM/ENS/04-20. School of Systems and Logistics, Air Force Institute of Technology (AU), Wright-Patterson AFB OH, March 2004 (ADA423009).

Warner Robins Air Logistics Center (WR-ALC). "WR-ALC FY00 Annual History," n. pag. Warner Robins AFB, Public Affairs. 26 October 2000. 15 September 2005
<http://www.robins.af.mil/HISTORY/PublicFY00/Chapter%204%20-%20Final.htm>.

"180 C-17s enough, Air Force Says," *Bloomberg News*, n. pag. USAF Aim Points, 14 December 2005. 14 December 2005 <http://aimpoints.hq.af.mil>.

Vita

Captain Scotty A. Pendley graduated from Lynn High School in Lynn, Alabama. He enlisted in the Air Force in 1992 and was an honor graduate of both basic training and technical training school. His only enlisted assignment was as a Guidance and Control Systems Specialist on the MH-53J Pave Low III helicopter at Hurlburt Field, Fl. While enlisted, he was promoted to Senior Airman Below-the-Zone, was squadron Airman of the Year, and was also an Airman Leadership School John Levitow Honor Graduate.

Captain Pendley graduated with a Bachelor of Science degree in Professional Aeronautics from Embry-Riddle Aeronautical University in 1997. After completing Officer Training School at Maxwell AFB, Alabama, in August 1998, he completed technical training as an aircraft maintenance and munitions officer at Sheppard AFB, Texas, where he was a distinguished graduate. He was then assigned to the 436th Airlift Wing, Dover AFB, Delaware, in January 1999. While at Dover, he served in various positions within the logistics group and also led the wing's maintenance team for AMC Rodeo 2000.

Captain Pendley was then assigned to the 1st Fighter Wing, Langley AFB, Virginia, in January 2002. While there, he served as the 71st Aircraft Maintenance Unit Officer in Charge and deployed to King Faisal Air Base, Saudi Arabia, during Operation Iraqi Freedom. Capt Pendley also served as the Maintenance Operations Officer for the 1st Component Maintenance Squadron. In August 2004, he entered the Graduate School of Engineering and Management, Air Force Institute of Technology. Upon graduation, he will be assigned to the Air Force Logistics Management Agency at Maxwell AFB, Gunter Annex, Alabama. Captain Pendley is married and has one daughter.

REPORT DOCUMENTATION PAGE

Form Approved
OMB No. 074-0188

The public reporting burden for this collection of information is estimated to average 1 hour per response, including the time for reviewing instructions, searching existing data sources, gathering and maintaining the data needed, and completing and reviewing the collection of information. Send comments regarding this burden estimate or any other aspect of the collection of information, including suggestions for reducing this burden to Department of Defense, Washington Headquarters Services, Directorate for Information Operations and Reports (0704-0188), 1215 Jefferson Davis Highway, Suite 1204, Arlington, VA 22202-4302. Respondents should be aware that notwithstanding any other provision of law, no person shall be subject to a penalty for failing to comply with a collection of information if it does not display a currently valid OMB control number.

PLEASE DO NOT RETURN YOUR FORM TO THE ABOVE ADDRESS.

1. REPORT DATE (DD-MM-YYYY) 01-09-2006		2. REPORT TYPE Master's Thesis		3. DATES COVERED (From - To) Sept 2004 - Sept 2006	
4. TITLE AND SUBTITLE Factors and Interactions That Affect Air Force C-17 Aircraft Mission Capable Rates				5a. CONTRACT NUMBER	
				5b. GRANT NUMBER	
				5c. PROGRAM ELEMENT NUMBER	
6. AUTHOR(S) Pendley, Scotty, A., Captain, USAF				5d. PROJECT NUMBER	
				5e. TASK NUMBER	
				5f. WORK UNIT NUMBER	
7. PERFORMING ORGANIZATION NAMES(S) AND ADDRESS(S) Air Force Institute of Technology Graduate School of Engineering and Management (AFIT/EN) 2950 Hobson Way WPAFB OH 45433-7765				8. PERFORMING ORGANIZATION REPORT NUMBER AFIT/GLM/ENS/06-12	
9. SPONSORING/MONITORING AGENCY NAME(S) AND ADDRESS(ES) HQ AMC/A44A Attn: Col Gerald J. Frisbee 402 Scott Drive, Unit 2A2 Scott AFB, IL 62225 DSN: 779-3005				10. SPONSOR/MONITOR'S ACRONYM(S) HQ AMC/A44A	
				11. SPONSOR/MONITOR'S REPORT NUMBER(S)	
12. DISTRIBUTION/AVAILABILITY STATEMENT APPROVED FOR PUBLIC RELEASE; DISTRIBUTION UNLIMITED.					
13. SUPPLEMENTARY NOTES					
14. ABSTRACT Given the high demand for mission capable airlift aircraft and considering increasing budget pressures, Air Mobility Command decision makers need a better understanding of mission capable (MC) rate-related factors and their interactions for mobility aircraft. This is needed to comprehend how issues such as airlift funding, current and future force reductions, and manning and experience levels may impact future MC rates for air mobility assets. Existing tools do not incorporate several key variables that the literature suggests are related to MC rates. Using a longitudinal approach, this thesis combines C-17 aircraft data with a structural equations modeling approach to evaluate relationships between MC rates and selected variables. The research addresses linkages between several areas not addressed in prior research and currently used models, and provides recommendations for both existing tools and for further research.					
15. SUBJECT TERMS Mission Capable Rates, Structural Equations Modeling, Mobility Aircraft, Aircraft Maintenance, C-17 Aircraft, Readiness					
16. SECURITY CLASSIFICATION OF:			17. LIMITATION OF ABSTRACT UU	18. NUMBER OF PAGES 128	19a. NAME OF RESPONSIBLE PERSON Dr. Alan W. Johnson, AFIT/ENS
REPORT U	ABSTRACT U	c. THIS PAGE U			19b. TELEPHONE NUMBER (Include area code) (937) 255-3636, ext 4703; e-mail: alan.johnson@afit.edu