

A DEMONSTRATION OF
INTERACTIVE INSTRUCTION
FOR TRAINING SHIPYARD TRADE SKILLS

Prepared for
NATIONAL SHIPBUILDING RESEARCH PROGRAM
SP-9 EDUCATION AND TRAINING PANEL

Prepared by
Ship Analytics, Incorporated
North Stonington Professional Center
North Stonington, Connecticut 06359
(93-U-042)

September 1993

TaskNo. N9-90-2

Report Documentation Page

Form Approved
OMB No. 0704-0188

Public reporting burden for the collection of information is estimated to average 1 hour per response, including the time for reviewing instructions, searching existing data sources, gathering and maintaining the data needed, and completing and reviewing the collection of information. Send comments regarding this burden estimate or any other aspect of this collection of information, including suggestions for reducing this burden, to Washington Headquarters Services, Directorate for Information Operations and Reports, 1215 Jefferson Davis Highway, Suite 1204, Arlington VA 22202-4302. Respondents should be aware that notwithstanding any other provision of law, no person shall be subject to a penalty for failing to comply with a collection of information if it does not display a currently valid OMB control number.

1. REPORT DATE SEP 1993		2. REPORT TYPE N/A		3. DATES COVERED -	
4. TITLE AND SUBTITLE A Demonstration of Interactive Instruction for Training Shipyard Trade Skills				5a. CONTRACT NUMBER	
				5b. GRANT NUMBER	
				5c. PROGRAM ELEMENT NUMBER	
6. AUTHOR(S)				5d. PROJECT NUMBER	
				5e. TASK NUMBER	
				5f. WORK UNIT NUMBER	
7. PERFORMING ORGANIZATION NAME(S) AND ADDRESS(ES) Naval Surface Warfare Center CD Code 2230 - Design Integration Tower Bldg 192 Room 128 9500 MacArthur Blvd Bethesda, MD 20817-5700				8. PERFORMING ORGANIZATION REPORT NUMBER	
9. SPONSORING/MONITORING AGENCY NAME(S) AND ADDRESS(ES)				10. SPONSOR/MONITOR'S ACRONYM(S)	
				11. SPONSOR/MONITOR'S REPORT NUMBER(S)	
12. DISTRIBUTION/AVAILABILITY STATEMENT Approved for public release, distribution unlimited					
13. SUPPLEMENTARY NOTES					
14. ABSTRACT					
15. SUBJECT TERMS					
16. SECURITY CLASSIFICATION OF:			17. LIMITATION OF ABSTRACT SAR	18. NUMBER OF PAGES 159	19a. NAME OF RESPONSIBLE PERSON
a. REPORT unclassified	b. ABSTRACT unclassified	c. THIS PAGE unclassified			

******* USE OF THIS REPORT *******

This report documents and was written to accompany an interactive multimedia delivery system and lesson developed by the Education and Training Panel of the National Shipbuilding Research Program (NSRP). The interactive lesson, "Fundamentals of Arc Stud Welding," was designed, and the delivery system assembled, to demonstrate to shipyard management and training personnel the capabilities of interactive instruction, and how interactive instruction can be used to train shipyard trade skills.

The report is a valuable source of information even without the delivery system. Its contents provide an excellent example of how shipyard training departments can create their own interactive instruction programs and can develop interactive lessons using off-the-shelf hardware components and commercially-available authoring systems.

******* USE OF THE DELIVERY SYSTEM *******

The NSRP interactive multimedia system consists of six subsystems, all which have been integrated to provide complete interactive videodisc (IVD) instruction. These subsystems are as follows:

1. IBM-compatible Personal Computer (Gateway 486SX/25) with keyboard and mouse
2. Touchscreen color monitor (Goldstar monitor/Elographics touchscreen)
3. Laser Videodisc Player (Sony Lasermax LDP-1450)
4. Amplified-speaker Unit (Realistic MINIMUS-0.4)
5. Multimedia Interactive Control System (VideoLogic MIC Systems I and II) consisting of a digital video adapter circuit board (DVA-4000) installed in the PC, and all operating software.
6. Interactive Multimedia Authoring System (TenCORE Producer) for the development and production of interactive instruction lessons

Certain of these subsystems can be operated independently for test or demonstration purposes, but are otherwise always operated as a single lesson development or instruction device.

DELIVERY SYSTEM OPERATION

The delivery system contains at least one interactive lesson on the "fundamentals of Arc Stud Welding". Other lessons may be added over time. This lesson was designed and developed specifically to demonstrate how interactive instruction can be used to train shipyard trade skills. To take this lesson, follow the instructions labeled "TO TAKE THE LESSON" that accompany the delivery system.

If instead of taking the arc stud welding lesson, you would like to review how it was authored or how it can be changed, follow the instructions labeled "TO AUTHOR THE LESSON. "

If you would like to operate the videodisc player independent of the lesson or authoring system, follow the instructions labeled "TO OPERATE THE LASERDISC PLAYER."

If you would like to demonstrate, test, or calibrate the touchscreen independent of the lesson or authoring system, follow the instructions labeled "TO OPERATE THE TOUCHSCREEN. "

DELIVERY SYSTEM AVAILABILITY

Use of the interactive multimedia system and lesson will enable you to appreciate the benefits of interactive instruction and determine how it could be integrated into your shipyard's trades' training program. The system will also provide you with the opportunity to experience the ease with which interactive lessons can be developed, and to investigate the subject matter to which they can best be applied.

The interactive multimedia delivery system and accompanying "Fundamentals of Arc Stud Welding" lesson are available for self-demonstration by qualifying shipyards and organizations. To obtain more information about the self-demonstration program, contact the National Shipbuilding Research Program.

LESSON DISCLAIMER

Neither the National Shipbuilding Research Program, NAVSEA Shipyard Instructional Design Center, Ship Analytics, Inc., nor any other party who has been involved in the design, manufacture, assembly, testing, distribution, or circulation of the delivery system or interactive lesson, "Fundamentals of Arc Stud Welding, shall be liable for any direct, indirect, incidental, special, or consequential damages (including damages for loss of profit, revenue, or business and the like) in any way related to the the project. The foregoing language cannot be waived, modified, or supplemented in any manner whatsoever.

ABSTRACT

The report describes the development and contents of an interactive videodisc (IVD) lesson that was produced by the National Shipbuilding Research Program (NSRP) to demonstrate interactive multimedia as an effective technology for teaching shipyard trade skills.

Interactive instruction evokes the active involvement of the trainee in his or her own computer-controlled, audio-visual instruction. Through a desk-top PC, the instruction exchanges information with the trainee on a personal basis; processes the trainee's responses to generate appropriate rewards or remediation; and measures, evaluates and documents the trainee's learning performance. An earlier study by NSRP surveyed American shipyards to investigate their experiences with interactive multimedia for trades' training, and to determine if American shipyards would participate in a demonstration of interactive instruction for that purpose.

Findings of the survey led NSRP to sponsor the development of an interactive lesson titled, "Fundamentals of Arc Stud Welding." This lesson (1) demonstrate the capabilities and benefits of interactive instruction for training shipyard skilled trade tasks, (2) shows how interactive multimedia can be used for both tutorial and simulation instruction, (3) illustrates the ease with which interactive courseware can be developed by shipyards, and (4) provides an interactive lesson for instructing the fundamentals of arc stud welding. The development process and contents of the interactive lesson are thoroughly described in the report.

FOREWORD

This document is the second of two reports published by the National Shipbuilding Research Program (NSRP) to describe and promote the use of interactive instructional technologies to meet shipyard training needs. The earlier report, "Recommendations on the Use of Interactive Instruction for Training Shipyard Trade Skills" (NSRP 0334/UMTRI 82210), provides information to shipyards on the use of interactive multimedia for training trade skills, and recommends that NSRP develop and make available to American shipyards an interactive lesson to demonstrate this training technology. The early report contains an overview of current interactive instructional technologies, reviews available interactive courseware and authoring systems as of the date of publication, provides recommendations for the application and integration of interactive instruction into existing shipyard training programs, and describes in detail the factors that influence the cost-effectiveness of interactive instruction.

The present report, "A Demonstration of Interactive Instruction for Training Shipyard Trade Skills," describes (1) the integration of hardware components and an authoring system into an interactive multimedia system, (2) the selection of arc stud welding as an appropriate topic for interactive instruction, and (3) the development of the lesson, "Fundamentals of Arc Stud welding," to demonstrate both the benefits of interactive instruction in training and the ease with which interactive lessons can be produced.

ACKNOWLEDGMENTS

The authors wish to thank the Technical Coordinator, Mr. Terry J. Reel, Director of the NAVSEA Shipyard Instructional Design Center, and Mr John W. Hartigan, Past Director of Shipyard Training for NAVSEA, under whose direction and guidance the project was conceived and Implemented. The authors are also grateful to the past and present chairmen of the Education and Training Panel SP-9, Dr. Howard Bunch and Ms. Joanna M. Jones, for their continued support and encouragement during the project.

A sincere thanks is extended to all members of the SP-9 Panel for appreciating the value and potential of the project, and to the following individuals who took significant time to provide information and guidance so essential to the project:

Mr. Mike Ambrose, Supervisor of Welding, Norfolk Naval Shipyard
Mr. Jeff Fields, Department of Training, Bath Iron Works Corporation
Mr. Jeff Jacobs, Welding Engineering, Bath Iron Works Corporation
Ms. Pat McCarron, Department of Training, Bath Iron Works Corporation
Mr. Marc Nguyen, Coordinator, National Steel and Shipbuilding Company

A SPECIAL THANKS to the entire staff of the NAVSEA Shipyard Instructional Design Center for their keen interest and involvement in testing and demonstrating the system, and particularly the quick turn-around and exceptionally high quality video that they provided for the project.

TABLE OF CONTENTS

	<u>Page</u>
FORWARD	i
ACKNOWLEDGMENTS	iii
EXECUTIVE SUMMARY	ES-1
1 INTRODUCTION TO THE PROJECT	1-1
1.1 Background	1-1
1.2 Purpose of the Demonstration	1-2
1.3 Benefits of Interactive Instruction	1-2
1.4 General Approach	1-3
1.4.1 Technical Approach	1-4
2 SELECTION OF A LESSON TOPIC	2-1
2.1 Candidates for the Lesson	2-1
2.1.1 Alternative Candidates	2-1
2.2 Selection of the Demonstration Lesson	2-2
2.2.1 Criteria for Demonstrating the Simulation Capability	2-2
2.2.2 Criteria for Demonstrating the Tutorial Capability	2-2
2.2.3 Criteria for Selecting the Lesson Topic	2-3
2.2.4 The Selected Topic	2-4
3 SELECTION OF A DELIVERY SYSTEM	3-1
3.1 Components of the Delivery System	3-1
3.2 Hardware Selection	3-2
3.3 Authoring System Selection	3-2
4 DEMONSTRATION FEATURES	4-1
4.1 Features of Interactive Multimedia	4-1
4.2 Tutorial and Simulation Features	4-1
4.2.1 Tutorial	4-2
4.2.2 Simulation	4-2
4.3 Unit Design Features	4-3
4.3.1 Unit Identification	4-3
4.3.2 Instructional Features	4-9
4.3.3 Design Criteria	4-18
4.4 Feedback and Remediation	4-18
4.4.1 Simple Feedback Loop	4-18
4.4.2 Re-test Loop	4-18
4.4.3 Re-presentation Loop	4-20
4.4.4 Special Presentation Loop	4-20
4.5 Motivation and Evaluation	4-20

TABLE OF CONTENTS (continued)

		<u>Page</u>
5	LESSON DEVELOPMENT	5-1
5.1	Methodology	5-1
5.2	Lesson Objectives	5-1
5.3	Modules	5-1
5.4	Unit Descriptions	5-4
5.4.1	Lesson Flow	5-4
5.5	Unit Review	5-5
6	RECOMMENDATIONS FOR USE	6-1
6.1	Continued Lesson Development	6-1
6.2	Demonstration of Interactive Instruction	
6.3	Demonstration of Authoring Capabilities	6-1
6.4	Continued SP-9 Promotion	6-2
	References	R-1
Appendix A	OBJECTIVES OF THE LESSON	A-1
Appendix B	LESSON UNIT DESCRIPTION	B-1
Appendix C	SCREEN DESIGN CRITERIA	c-1

LIST OF TABLES

<u>Table</u>		<u>Page</u>
4-1	Simulation of Welding Equipment Adjustment - Unit Flow	4-4
4-2	Unit Design Objective	4-10

LIST OF FIGURES

<u>Figure</u>		<u>Page</u>
4-1	Definition of the Unit Identification Number	4-8
4-2	Some Examples of Inter-module Feedback and Remediation	4-19
5-1	The Interactive Courseware Development Process	5-2
5-2	Modules of the Arc Stud Welding Lesson	5-3

EXECUTIVE SUMMARY

The National Shipbuilding Research Program (NSRP) is a cooperative effort of the U.S. Navy, the American shipbuilding industry, the Maritime Administration, and selected academic institutions. It is dedicated to assisting the shipbuilding and ship repair industry in improving its productivity. This project was sponsored by the Education and Training Panel SP-9 of NSRP. The purpose of the project is to demonstrate, to shipyard management and training department personnel, the value and ease of using interactive instruction to teach shipyard trade skills.

This project is the follow-up to a study conducted by NSRP in 1991 which indicated that most American shipyards, while they have very knowledge of interactive instruction, would be grateful for an opportunity to experience interactive instruction and to evaluate it for use in their trades' training program. The study concluded that this experience could best be gained by providing to the shipyards, free of charge, an interactive multimedia delivery system and an interactive lesson specifically designed to demonstrate the many capabilities of interactive instruction for trades' training.

As a result, NSRP undertook to select and purchase a complete interactive videodisc (IVD) delivery system and interactive courseware authoring system; and selected, from among many proposed candidates, the instruction of Arc Stud Welding as the subject matter for a demonstration lesson.

The goals of the project are to (1) demonstrate to shipyard training departments and personnel the use and benefits of interactive instruction for training shipyard trade skills, (2) demonstrate how interactive instruction can be used for both tutorial and simulation lessons, (3) demonstrate to shipyard training departments and personnel the ease and low cost with which interactive instruction courseware can be developed and produced in-house, (4) provide an interactive lesson to teach the fundamentals of arc stud welding, and (5) provide the Shipyard Instructional Design Center and other shipyard training departments with experience in the development of interactive instruction courseware.

The "Fundamentals of Arc Stud Welding" interactive lesson was developed jointly by Ship Analytics, Inc. and NAVSEA'S Shipyard Instructional Design Center (SIDC), Norfolk Naval Shipyard. The lesson was produced using a popular commercially-available authoring system, TenCORE Producer. This authoring system, and the hardware used to support it, was selected after a thorough review of the various types and capabilities of authoring systems, and the different multimedia technologies associated with interactive instruction. Most favorable for the selected authoring system was its ease of operation, capacity for expansion, relatively low cost, and overall popularity among interactive courseware developers. There are other authoring systems available that would have been equally acceptable and many additional ones continue to appear on the market.

The hardware selected for the delivery system consists of a U.S. manufactured IBM-compatible PC, a "Gateway 2000" with a 80486 processor operating at 25MHz. Computer speed is important when re-drawing interactive multimedia displays. The computer is equipped with Super VGA, a surface acoustic wave (SAW) touchscreen color monitor, a VideoLogic DVA-4000 adapter board for overlaying graphics on top of a video picture, and a Sony LDP-1450 Lasermax videodisc player. Functionally equivalent hardware for IVD systems available on the commercial market for approximately \$7,000. similar-capability authoring systems are available for less than \$2,000. Cost of the 3M-manufactured Alpha Videodisc is less than \$500. This means that a complete interactive instruction system can be purchased for under \$10, 000, and can be used in shipyards to develop and teach hundreds of interactive lessons.

Production of the demonstration lesson followed the traditional interactive courseware development process. This process requires the publication of Lesson Objectives; construction of a flow diagram; the publication of Unit Descriptions (also called "storyboards") that contain complete screen text, narration, video, and graphics; and a video shot list to guide the video production. The Lesson Objectives for the "Fundamentals of Arc Stud Welding" are presented in Appendix A of the report. The Unit Descriptions for the lesson are presented in Appendix B.

The "Fundamentals of Arc Stud Welding" lesson uses text, graphics, animation, digital bitmaps, still and motion video, and sound to stimulate learning. It uses a touchscreen to accept trainee responses, and it illustrates self-pacing through a variety of different types of testing, feedback, and remediation branches. Trainees are automatically screened with a pre-test just as they would be in traditional training, and their performance is verified and documented at the end of each lesson. Answer analysis and student management, routinely conducted during training, are also performed by the system.

One additional goal of the demonstration is to illustrate different presentation and feedback techniques, specifically tutorial and simulation. These techniques are demonstrated on many occasions within the lesson. The lesson carefully balances "demonstration" with the requirement for good instructional design which is to maintain display and interaction consistency throughout the lesson.

The "Fundamentals of Arc Stud Welding" contains eight modules, each addressing a specific topic in arc stud welding and each demonstrating a unique capability of interactive instruction. The title and purpose of the modules are as follows:

Module 1 ABOUT THE LESSON - Contains introduction video and explains how to operate the lesson.

Module 2 THEORY - Demonstrates simple animation synchronized to the audio.

- Module 3 STUDS AND FERRULES - Pages of "text" demonstrate a simple Computer Based Training (CBT) presentation. Demonstrates the trainee's own control of presented information.
- Module 4 WELDING EQUIPMENT - Demonstrates various types of touch responses to answer questions and identify parts of the stud gun.
- Module 5 WELDING PROCEDURES - Demonstrates simulated set-up of the arc welding system. Describes how to read graphs and tables to adjust arc welding equipment. Demonstrates the use of color, timing, and audio to simulate welder's operational cues.
- Module 6 INSPECTIONS AND TESTS - Presents stud weld defects and their causes. Demonstrates touch responses to identify stud weld defects.
- Module 7 PRACTICE - Simulates shot studs that require visual evaluation of the weld, and adjustment of equipment by the trainee to improve the weld.
- Module 8 EXAMINATION - Final examination (10 questions without feedback) designed to demonstrate different types of trainee interaction.

A more detailed description of what is demonstrated within each module is presented in Section 4 of the report.

In addition to demonstrating the applications and benefits of interactive instruction in shipyard skilled trades' training, the system is also designed and configured to demonstrate to shipyard training personnel how easy it is to develop interactive courseware in-house. To this end, the TenCORE Producer authoring system is resident in the hard drive of the delivery system and may be used by participants either to modify the existing lesson or to develop one or more new lessons.

The project will benefit the shipbuilding/repair industry by proving the existence of more effective and less costly alternatives to classroom instruction and by proving that off-line practice of shipyard production tasks can be made cost-effective. The project will demonstrate the ability of advanced training technologies to satisfy training needs common to all shipyards, large and small, construction and repair, public and private. A corollary benefit will be the project's demonstration to shipyard management and training personnel that interactive courseware can be developed in-house both easily and inexpensively by personnel knowledgeable of traditional instructional design.

Section 1
INTRODUCTION TO THE PROJECT

1.1 Background

In June 1991, The National Shipbuilding Research Program (NSRP) published a report, "Recommendations on the Use of Interactive Instruction for Training Shipyard Trade Skills" (reference 1). This document was the result of 'a year-long study to investigate the feasibility of using interactive instructional technologies to meet shipyard training needs. The study performed a survey of American shipyards to determine if and how the shipyards were using interactive instruction for training purposes; reviewed the interactive multimedia industry to document what new technology, authoring systems, and interactive courseware were available; and analyzed shipyard skilled trades to determine if and how interactive instruction could be effectively integrated into existing trades' training programs.

The report indicated that although very few American shipyards have used it or are familiar with it, interactive multimedia does have great potential as a low-cost, effective method for training the skilled trades. The report presented an overview of current interactive instructional technologies, listed off-the-shelf commercial courseware and authoring systems, provided recommendations for the application and integration of interactive instruction into existing training programs, and described factors that influence the cost-effectiveness of its use.

In addition to this information, the report also recommended that NSRP develop, and make available to American shipyards, an interactive lesson that would demonstrate the capabilities and benefits of interactive instruction. This interactive lesson would

- a. demonstrate to shipyard management and training departments the characteristics and instructional features of an interactive instruction system,
- b. demonstrate how interactive instruction can be used for both tutorial and simulation lessons,
- c. demonstrate to shipyard training departments and personnel the ease with which they can develop their own interactive courseware, and
- d. provide an interactive lesson on the fundamentals of arc-drawn stud gun welding.

These recommendations led the Education and Training Panel SP-9 of NSRP to sponsor the development of an interactive demonstration to accomplish all of the above objectives. The demonstration combines computer graphics, animation, still and motion video, sound, and touchscreen interaction to demonstrate the broad spectrum of the interactive multimedia technology.

The subject material selected for the lesson which is arc stud welding, is particularly well suited to both tutorial presentation and simulation. The lesson uses a popular, commercially-available authoring system to illustrate ease of courseware development, and it was designed using the instructional development process for interactive courseware.

1.2 Purpose of the Demonstration

"Interactive multimedia" is the result of technology's ability to bring together, in a low-cost computer environment, new forms of visual and auditory stimuli, and allow human operators to interact with them in ways never before possible. Faster yet smaller processors, large capacity desk-top storage, life-like color motion and high-resolution display capabilities, and a variety of new interface technologies produce highly effective exchanges of information between the media and its user. Interactive multimedia has become the platform from which ambitious applications of instructional technology are being launched worldwide.

"Interactive instruction," as the name implies, uses interactive multimedia for education and training. It requires the trainee to become an integral part of the overall educational process. Interactive instruction links an audio/visual presentation to a microcomputer through the use of computer software specifically designed to react to each trainee's individual needs. It establishes a personal relationship between the trainee and the subject matter to be learned. The combination of sight, sound, personal interaction, and computer control provides a highly effective learning environment.

The purpose of the demonstration lesson described in this report is to enable shipyard management and training personnel to actually use an interactive instruction system at no cost to the shipyard, and to permit them to operate and evaluate the authoring system that was used to develop the lesson. This demonstration will provide American shipyards with the opportunity to witness many of the different capabilities and characteristics of interactive instruction. Personnel will also be able to formulate in their own minds how the technology could be applied to their own requirements.

1.3 Benefits of Interactive Instruction

Interactive instruction has acquired, and continues to acquire accolades for its achievements in cost-effective training. Industry, government, and the academic community attribute this to the way the multimedia is designed and, equally important, to the way it is applied. Studies (references 2 and 3) compiled over the past two decades have found that computer-aided instruction significantly reduces training time.

This is due to the instructional method of "self-pacing" that directs the most efficient path of learning, the use of auditory cues and narration to reinforce text and pictures, the immediacy of feedback to augment trainee actions, and the computer's "capacity" to adapt to personalized styles to maximize learning efficiency.

The major cost of interactive instruction lies in its initial production, not its distribution or use. Cost-per-trainee is reduced as more trainees use the same program. Also important, interactive instruction does not have "bad" days, or tire toward the end of a session. Instruction is delivered consistently and reliably. With interactive instruction, trainees are free to ask questions and explore ideas that might otherwise cause embarrassment. Interactive instruction encourages trainees to persevere and review materials until real mastery is achieved. Unlike traditional training, interactive instruction does not present new material until current material is mastered. This ensures that trainees have strong foundations for continued learning.

Trainees can explore potentially hazardous subjects or dangerous activities without risk to equipment or themselves. In addition, one-to-one interactive instruction focuses the trainee's attention, thereby reducing distraction or disruption. Individual involvement is highly motivating to the trainee and instills a sense of responsibility. The portability of delivery systems can establish a training environment in locations where trainee populations would not otherwise support full-time instructors or where qualified instructors are not available. Interactive instruction also makes "any time" training a reality. This is extremely important in a production environment that operates round-the-clock.

Trainees who use interactive instruction take greater control and responsibility for their own learning process. As they become more accomplished learners, they become fully active participants in the learning process, not just passive recipients of instruction. As a result, the training "sticks."

Interactive instruction is particularly effective in the shipyard environment, where worker proficiency must be proven and documented, and where trainees vary in experience, learning ability, reading ability, or language. The low-cost and portability of the delivery system is a significant benefit where there are many trainees distributed over time or in different locations. Also, the use of multimedia and computer-based training, and the operation of PCs are familiar to most shipyard training personnel.

1.4 General Approach

The demonstration lesson was developed and produced jointly by Ship Analytics, Inc. and the NAVSEA Shipyard Instructional Design Center (SIDC), Norfolk Naval Shipyard. The lesson was produced using TenCORE Producer, a popular commercially-available authoring system. This authoring system and the hardware used to support it was selected after a thorough review of the various types and capabilities of authoring systems, and the different multimedia technologies available to interactive instruction. Most favoring TenCORE Producer was its ease of operation, capacity for expansion to the TenCORE Authoring Language, relatively low cost, and overall popularity among interactive courseware developers. There are many other authoring systems available that would have been equally acceptable, and additional ones continue to appear on the market.

The hardware used for the SP-9 demonstration lesson consists of a U.S. manufactured IBM-compatible 80486 computer, touchscreen color monitor, graphics overlay board for displaying graphics on top of video pictures, and a laser videodisc player. This hardware is described in Section 3.

1.4.1 Technical Approach

The technical approach to the project was as follows:

- a. Selection of a Lesson Topic. A list of criteria was published that enabled the Education and Training Panel SP-9 to select the topic for the interactive lesson. The lesson, developed for delivery on interactive videodisc (IVD) media, was designed to be administered in approximately one hour for the slowest learner and less than 30 minutes for the fastest learner. It makes maximum use of narration, video motion and still pictures, graphics, animation, and textual presentation within this period of time.

Parts of the lesson demonstrate the tutorial method-of imparting knowledge of procedures, operations, and activities that are performed by a shipyard trade. Other parts of the lesson demonstrate the use of simulation to practice procedures, operations, and activities that are performed by a shipyard trade.

The lesson also demonstrates instruction capabilities that include student/computer interface through such devices as touchscreen, mouse, and keyboard; student screening (pre-test and post-test); branching for remediation, reward, and simulated response; performance measurement; and student management. Video and narration is limited to one side of the laserdisc only.

The lesson is designed to demonstrate the flexibility and capabilities of interactive multimedia. It carefully balances this objective with the requirement of a good interactive lesson which is to maintain consistency throughout.

- b. Selection of a Delivery System. The selection of an authoring system and hardware platform was recommended to the SP-9 panel based upon pre-established criteria. Both were purchased and retained by Ship Analytics for the period of courseware development, then were transferred to SIDC where video integration was performed. The system remained at SIDC for final testing and verification before being presented for demonstration to the shipyards.
- c. Courseware Development. Instructional developers and trade instructors developed training objectives, performance measures, lesson flow diagrams, and storyboards for the demonstration lesson. From the storyboards a video production shot list was generated that described in detail the requirements of the courseware video. This video was shot and edited by a SIDC video production crew at the same time that Ship Analytics' instructional designers authored the courseware.

Upon completion of the editing and review process, the video tape was converted to a 12-inch Alpha Laser disc. This disc is of production quality. It can be duplicated for distribution from the original Betacam SP tape that resides at SIDC.

- d. Reporting of Results. This technical report was published to describe how the demonstration lesson was developed, document its contents, and to provide recommendations on its use.

A technical paper, "Fundamentals of Arc Stud Welding: An Interactive Multimedia Lesson for Shipyard Training," was presented at the 1993 Ship Production Symposium. It describes the project and important features of the interactive lesson.

Section 2
SELECTION OF A LESSON TOPIC

2.1 Candidates for the Lesson

Section 9.2 of NSRP'S 1991 report (reference 1) identified seven lessons as "most recommended" candidates for the demonstration of interactive instruction to shipyards. These lessons were selected based upon the criteria described in the report. The lessons are as follows:

- a. WIRE FLAME SPRAY PROCESS
- b. ARC STUD WELDING -
- c. PLASMA ARC CUTTING AND GOUGING
- d. MECHANICAL FLANGE JOINT and/or UNION JOINT MAKE-UP
- e. RIGGING
- f. MATERIAL HANDLING EQUIPMENT OPERATION and/or MAINTENANCE
- g. STAGE AND SCAFFOLD BUILDING

2.1.1 Alternative Candidates

An additional 21 lessons were also identified in the report as candidates for the demonstration in the event one of the "more recommended" lessons could not be used. These lessons are as follows:

- a. FLUOROCARBON and/or NITROGEN HANDLING PROCEDURES
- b. SHIP 'S NOMENCLATURE
- c. FIBER-OPTICS INSTALLATION
- d. RIP-OUT AND RE-ENTRY CONTROL
- e. SYSTEM INSPECTION AND GROOMING
- f. OPERATING CREW TRAINING
- g. FUEL LOADING
- h. FLAME CUTTER BASIC TRAINING
- i. HYDRAULICS
- j. RESPIRATORS
- k. REMOVAL OF POTENTIALLY CONTAMINATED PAINTS
- l. LEAD AND MERCURY HANDLING
- m. WETTED CARBON STEEL PIPING
- n. BLASTING
- o. NON-DESTRUCTIVE TESTING (NDT)

- p. NON-NUCLEAR TEST EQUIPMENT
- q. VALVES, TUBES, AND FITTINGS
- r. SPECIAL HULL TREATMENT
- s. TURRET LATHE OPERATION
- t. BURNING MACHINES
- u. PROPERTIES OF COLOR

All candidates are listed here as a suggestion to shipyards of the types of topics that are well suited for interactive instruction.

2.2 Selection of the Demonstration Lesson

In November 1990, SP-9 polled those shipyards who had earlier indicated a willingness to participate in the demonstration, to determine which of the above topics would make the best demonstration of interactive instruction. This survey was conducted informally by telephone to the various training departments and SP-9 representatives in the shipyards.

2.2.1 Criteria for Demonstrating the Simulation Capability

Simulation is the training method whereby the pictorial replication of a real object or device is made to change in direct response to the trainee's action, just as it would in the real-world. The change illustrates the results of the action whether it is "correct" or "incorrect," and requires the trainee to determine this "correctness." The trainee thereby learns by experiencing the consequences of his or her action.

The topic for simulation must be a potentially complex procedure, one which requires knowledge of how to proceed based upon decisions derived after interpretation and analysis of conditions, i.e., cause and effect. Some examples of simulation are nozzle, arc, or flame adjustment; mirror or lens alignment; and equipment operator control functions.

2.2.2 Criteria for Demonstrating the Tutorial Capability

Tutorial presentation is the training method whereby material is presented in a methodical, progressive manner such that the information imparted is easy to retain and apply. A tutorial lesson is used for knowledge training.

The topic for a tutorial presentation must be one that requires competence in recognition (locating/identifying), procedures and processes, analysis, interpretation, decision making, communications, etc. Such training is conventionally taught by lecture, reading, audio/video tape, etc. However, interactive instruction adds the element of "self-pacing" through continuous testing, feedback, and branching. A tutorial lesson may also instruct by using the actual piece of equipment, tool, or document; although this feature was not considered practical for the proposed demonstration.

2.2.3 Criteria for Selecting the Lesson Topic

The following criteria were used in selecting the topic for the demonstration lesson. Many of these criteria are based upon the requirement of the lesson to demonstrate interactive instruction features to management and other non-welder personnel.

- a. The lesson should be one that, if taught in the traditional method, would require no more than a one hour session.
- b. The lesson should be basic enough so that participants in the demonstration can comprehend the material and answer most of the questions correctly. Correct answers will encourage the participants to continue and will ensure completion of the demonstration. Incorrect answers would be selected intentionally to demonstrate feedback and branching. The lesson should be able to be completed by all participants without prior experience or knowledge of the skill.
- c. The lesson should contain only material that can be learned and tested without additional aids such as calculators, tools, mock-ups, reference documents, etc. There will be no opportunity to use these aids during the demonstration.
- d. Throughout the entire lesson, the material should be relatively consistent in terms of complexity and prerequisite knowledge. The learning of new material should not rely extensively upon previously learned material. This will make it possible to demonstrate the lesson to management and non-welder personnel.
- e. The lesson should be on a topic that (1) is of true interest to the demonstration participants; (2) is, or could be, used in their shipyard; and (3) is inviting to them to learn even though they may never need the skill. The objective of the lesson should be to try to teach each participant something, while at the same time demonstrating many of the capabilities of interactive instruction. The topic should be of a new or high technology that the participant may have heard or read about, but that he or she knows little about.
- f. The topic should be relatively easy to shoot on video with respect to "opportunity" and the ease with which it can be shot. If intended for the simulation lesson, it must be possible to shoot many different equipment configurations and many different modes of operation including defects, failures, emergencies, contingencies, different environments, etc.
- g. The topic should be capable of being presented, in part, using graphics and animation. This would include both overlays on the video and stand-alone graphics. Suggestions include graphs, histograms, or color coding to illustrate such things as rise in temperature, speed, pressure, etc., and the use of animation to

focus, expand, simplify, clarify, etc., on an object or component in the video.

- h. The topic should be one that is important to shipyards in terms of (1) criticality of the task to quality and production, (2) the requirement for qualification or certification, and (3) the number of employees that need to perform it. Other factors include the consequences if the task is done improperly or incorrectly, the cost (time, materials, and personnel) of teaching the topic using conventional methods, and its use where trainee abilities and motivations vary extensively.

2.2.4 The Selected Topic

Based upon the results of the the shipyard survey and the application of above criteria, it was determined that the fundamentals of ARC STUD WELDING would be the most suitable topic for a lesson to demonstrate interactive instruction to shipyard management and training department personnel.

Section 3
SELECTION OF A DELIVERY SYSTEM

3.1 Components of the Delivery System

The components of interactive instruction are as fluid as the computer industry that produces them. Their functions, however, remain consistent; that is to stimulate, to evaluate, and to communicate. Technological advancements such as Digital Video Interactive (DVI), Compact Disc Interactive (CD-I), and CD-ROM do much to enhance the learning environment and are being rapidly accepted in the instruction role. Interactive videodisc (IVD), however, continues as the most popular media for interactive motion video, and it is the platform that is used in this project. These technologies are described in detail in Section 9.3 of NSRP'S 1991 report (reference 1).

The IVD platform consists of the following six essential components, although others can be added to expand the multimedia capability.

- a. A desk-top personal computer (PC) that initiates all the instructional features, processes and evaluates trainee responses, and provides lesson management.
- b. A color monitor for the presentation of visual information from the computer and video player.
- c. Interaction devices, such as a touchscreen that signals the computer when and where the screen is touched, and a keyboard for answering questions with numbers or text.
- d. A graphics overlay board that permits the combined display of motion video and computer graphics on the monitor.
- e. A laser disc player that instantly retrieves video imagery and audio information from a 12-inch optical disc. The retrieved information is controlled by the computer. Videodiscs, unlike video tape, provide the ability to access any portion of a video program instantly. This allows the computer to "branch" to other video segments, skip ahead, or repeat.
- f. IVD courseware which includes the software that manages and administers the training program, and a laser videodisc that contains the video and narration portion of the lesson. The computer program that controls the lesson is created through the use of an authoring system. This authoring system is a "user-friendly" computer program that permits the courseware developer to design screens; causes the multimedia to operate; specifies lesson flow through trainee interaction and branching; questions, evaluates, and scores trainee responses; and manages the production of lessons for multiple distribution.

3.2 Hardware Selection

Section 9.5 of NSRP'S 1991 report (reference 1) presents a recommended rationale and methodology for selecting hardware components of the demonstration delivery system. While cost was a major consideration, it was also an objective of the project to procure the most up-to-date technology and a system that had the greatest potential for future multimedia expansion. The hardware for the demonstration lesson was selected using this criteria and the recommendations of the NSRP report.

The demonstration hardware consists of a U.S. manufactured IBM-compatible desk-top computer, a Gateway 2000 with an Intel 80486 processor operating at 25MHz. Computer speed is important when re-drawing interactive multimedia displays. The computer is equipped with Super VGA, a surface acoustic wave (SAW) touchscreen color monitor, a VideoLogic DVA 4000 graphics overlay board for displaying graphics on top-of video pictures, and a Sony LPD-1450 Laser videodisc player. This hardware was purchased on the commercial market for less than \$7,000.

3.3 Authoring System Selection

Section 9.4 of NSRP's 1991 report (reference 1) provides a brief treatise on the selection of authoring systems and identifies additional sources of information that may be used for this purpose. Many authoring systems are available on the commercial market that would have accommodated the requirements of the study. The selection of TenCORE Producer authoring system was based primarily on the overall popularity of the system, its relatively low cost, its ease of operation, and yet its potential for expansion and increased capability by the addition of TenCORE Language Authoring System, TenCORE Toolkit, and other TenCORE products.

The TenCORE authoring system and similar-capability systems can be purchased for less than \$2,000. This means that complete interactive instruction development systems can be obtained for well under \$10,000, and can be used in shipyards to develop and teach hundreds of interactive lessons.

Section 4

DEMONSTRATION FEATURES

The "Fundamentals of Arc Stud Welding" interactive lesson uses text, graphics, animation, photographs, still and motion video, and sound to stimulate learning. It uses a touchscreen to accept trainee responses, and it illustrates self-pacing through a variety of different types of remediation and feedback loops. Trainees are automatically screened with a pre-test just as they would be in traditional training, and their performance is verified and documented at the end of each lesson. Answer analysis and student management, routinely conducted during training, are also performed by the system. Some flow sequences are designed to produce tutorials, while others provide simulation.

4.1 Features of Interactive Multimedia

Learning arc stud welding from interactive multimedia is an experience not to be missed. From the very start, the sights and sounds of multimedia provide a continuous challenge, requiring the trainee to identify arc welding components by touching them and making simulated adjustments to operate them. The multimedia teaches welding theory through animation, workstation set-up and initial adjustment through graphic representation, inspection of welds through pictures, and permits practice through simulation. Duration of the lesson depends upon the learning ability of the trainee. If all branches are viewed, the lesson will last approximately one hour. A fast learner can take the entire lesson in less than half that time.

Upon being seated at the interactive workstation, a trainee begins by typing his or her name into the lesson management data base. This ensures that the trainee is approved for the course, and a file for recording the trainee's progress is created. By touching the screen, the trainee is guided through a series of still and motion videos, animation, graphics, text, and narrations. Each module ends with a series of questions that must be answered. The lesson makes extensive use of simulation to describe procedures and encourage practice. Some questions require either a 'point-to' or 'button-press' response from the trainee. The accuracy of these responses is used to determine whether the trainee should receive additional instruction; and, if so, what type of remediation it should be. If warranted, the trainee receives a special remedial branch, or in some cases the original presentation is simply repeated. In all cases, the responses of the trainee are used to determine whether the lesson was completed satisfactorily. The end result is that the trainee becomes aware of his or her own capabilities, and management receives assurance that safe, cost-effective stud gun welding will be performed.

4.2 Tutorial and Simulation Features

A major objective of the SP-9 lesson is to demonstrate that interactive multimedia is extremely effective at providing both tutorial and simulation instruction. Since cognitive skills (those requiring mental processing of

facts) are best taught through the tutorial process, and stimulus-response (trial and error) skills are best taught through simulation; it was decided to select a complex shipyard trade task that would benefit from both types of learning. Portable electric arc stud welding was determined to be such a task.

4.2.1 Tutorial

"Fundamentals of Arc Stud Welding" as a tutorial, presents the material to be learned in a methodical, progressive manner such that the information imparted to the trainee is easily understood, easy to remember, and easy to apply. The subject material requires competence in recognition and interpretation, knowledge of procedures and processes, ability to analyze and make decisions, and the ability to communicate. Such training is traditionally taught by lecture, reading, and audio/video tape. This lesson, however, adds the elements of motivation and self-pacing through sensory stimulus, physical interaction, continuous testing, feedback, and branching.

4.2.2 Simulation

"Fundamentals of Arc Stud Welding" also permits practicing skills and rehearsing complex procedures through simulation. Training a skill such as arc stud welding, that requires extensive trial and error coordination and the rehearsal of procedures for equipment adjustment and inspection of welds, is an excellent application "of" simulation. For this application, pictures of actual equipment are shown. The trainee touches the picture to simulate handling or adjusting equipment, and the picture changes in response to the action. The trainee is thereby guided through both equipment set-up and operating tasks, and can experience the consequences of his or her actions. The trainee can also practice procedures over and over before being tested.

Three different simulations are provided in the demonstration lesson. The first is a simulation for connecting the components of a stud welding system when setting up the workstation. This simulation shows the trainee a cable that is connected only at one end. It requires the trainee to touch on the screen where the other end of the cable should be connected. Upon touching the correct destination for the cable, the cable becomes connected.

The second simulation presents the colored "flashes" of an electric arc along with an arc sound and asks the trainee to identify which "flash" most likely produced the best weld. While it can be argued that these cues are of limited value to a stud welder during actual welding, the sequence does demonstrate how interactive multimedia can be used for sensory stimulation and tasks requiring basic perception.

The third simulation presents pictures of welded studs with varying degrees of defects and nonconformity. The trainee is required to identify what adjustments should be made to the equipment to improve the weld and then is shown, in the next picture, the results of this adjustment. The simulation permits the trainee to make most adjustments required of the arc

stud welding system, and to experience the consequences of this action. This simulation is provided immediately before the final examination, and only after all other lesson material has been presented. The simulation also requires trainees to be able to identify a good weld if and when they produce one. Trainees receive simple remediation when they make the wrong choice twice in a row. They receive detailed remediation when their response is grossly in error, or they request it.

Table 4-1 shows the unit flow for simulating the adjustment of welding equipment. This simulation occurs in Module 7 of the demonstration lesson. It provides the trainee with opportunities for correcting a cold weld, extremely cold weld, hot weld, extremely hot weld, short plunge weld, hang-up weld, poorly aligned weld, arc blow weld, and contaminated weld. The table describes the weld that is pictured in the unit, the equipment adjustments available to the trainee, and the type of weld that results when the trainee makes the adjustment.

Of particular importance is the cost savings realized by having the trainee learn procedures and practice skills without **using actual** equipment. Interactive instruction eliminates the need to take equipment out of service for training purposes, and significantly reduces the risk of injury to personnel or damage to equipment.

4.3. Unit Design Features

"Fundamentals of Arc Stud Welding" consists of approximately 150 units, although the number of units in multimedia can be endless. A "unit" is the authoring system's term for an independent, unique display or a display that transforms to a different presentation depending upon the trainee's response. This means the trainee has many opportunities to receive information and to interact with the system. The fastest learner will receive the same amount of information from significantly fewer units than the slowest learner.

4.3.1 Unit Identification

Units are identified in the authoring system and documentation by a Unit Identification Number. This number is unique to each unit and, in the case of the arc stud welding lesson, contains a code to identify the type of unit (i.e., menu, presentation, question, and remediation) and the module in which the unit is located.

Figure 4-1 defines the code used in the demonstration lesson. In interactive multimedia, any scheme can be used to assign Unit Identification Numbers, but no two numbers can be the same.

Table 4-1 Simulation of Welding Equipment Adjustment - Unit Flow

<u>Unit #</u>	<u>Picture/Text</u>	<u>Adjustment Choices</u>	<u>Results of Adjustment</u>	<u>Next Unit</u>
7Q1	<u>Cold Weld</u>	DECREASE CURRENT INCREASE TIME DECREASE LIFT IT IS GOOD	extremely cold weld good weld extremely cold weld cold weld w/ text	7Q2 7R1 b 7Q2 7R1 a QUIT 7M1 b
7R1 a	"No, too cold"	DECREASE CURRENT INCREASE TIME DECREASE LIFT I DON'T KNOW	extremely cold weld good weld extremely cold weld - presentation	7Q2 7R1 b 7Q2 7P1 QUIT 7M1 b
7R1 b	<u>Good Weld</u>	DECREASE CURRENT INCREASE TIME DECREASE STICKOUT IT IS GOOD	cold weld hot weld short plunge	7Q1 7Q3 7Q5 7M1 a QUIT 7M1 a
7P1	- presentation describing the causes of a cold weld (same as 6P6)			previous
7M1 a	"Correct, good weld"	MORE PRACTICE FINAL EXAM		7Q3 8Q1 QUIT IG2
7M1 b	"Not shot good weld"	MORE PRACTICE FINAL EXAM		7Q3 8Q1 QUIT IG2
7Q2	<u>Extremely Cold Weld</u>	DECREASE CURRENT INCREASE TIME INCREASE LIFT IT IS GOOD	- presentation cold weld cold weld ext. cold weld w/ text	7P1 7Q1 7Q1 7R2 QUIT 7M1 b
7R2	"No, extremely cold"	DECREASE CURRENT INCREASE TIME INCREASE LIFT I DON'T KNOW	- presentation cold weld cold weld - presentation	7P1 7Q1 7Q1 7P1 QUIT 7M1 b
7Q3	<u>Hot Weld</u>	INCREASE CURRENT DECREASE TIME INCREASE LIFT IT IS GOOD	extremely hot weld good weld extremely hot weld hot weld w/ text	7Q4 7R3b 7Q4 7R3a QUIT 7M3b
7R3a	"No, too hot"	INCREASE CURRENT DECREASE TIME INCREASE LIFT I DON'T KNOW	extremely hot weld good weld extremely hot weld - presentation	7Q4 7R3b 7Q4 7P3 QUIT 7M3b

Table 4-1 Simulation of Welding Equipment Adjustment (continued)

<u>Unit #</u>	<u>Picture/Text</u>	<u>Adjustment Choices</u>	<u>Results of Adjustment</u>	<u>Next Unit</u>
7R3b	<u>Good Weld</u>	INCREASE CURRENT DECREASE TIME DECREASE STICKOUT IT IS GOOD	hot weld cold weld short plunge	7Q3 7Q1 7Q5 7M3a QUIT 7M3a
7P3	- presentation describing the causes of a hot weld (same as 6P7)			previous
7M3a	'Correct, good weld'	MORE PRACTICE FINAL EXAM		7Q5 8Q1 QUIT IG2
7M3b	"Not shot good weld"	MORE PRACTICE FINAL EXAM		7Q5 8Q1 QUIT IG2
7Q4	<u>Extremely Hot Weld</u>	INCREASE CURRENT DECREASE TIME DECREASE LIFT IT IS GOOD	- presentation hot weld hot weld ext hot weld w/ text	7P3 7Q3 7Q3 7R4 QUIT 7M3b
7R4	"No, extremely hot"	INCREASE CURRENT DECREASE TIME DECREASE LIFT I DON'T KNOW	- presentation hot weld hot weld - presentation	7P3 7Q3 7Q3 7P3 QUIT 7M3b
7Q5	<u>Short Plunge Weld</u>	INCREASE CURRENT DECREASE TIME INCREASE STICKOUT IT IS GOOD	short plunge short plunge good weld short plunge w/ text	7Q5 7Q5 7R5b 7R5a QUIT 7M5b
7R5a	"No, short plunge"	INCREASE CURRENT DECREASE TIME INCREASE STICKOUT I DON'T KNOW	short plunge short plunge good weld - presentation	7Q5 7Q5 7R5b 7P5 QUIT 7M5b
7R5b	<u>Good Weld</u>	INCREASE CURRENT DECREASE TIME DECREASE STICKOUT IT IS GOOD	hot weld cold weld short plunge	7Q3 7Q1 7Q5 7M5a QUIT 7M5a
7P5	- presentation describing the causes of a short plunge weld (same as 6P3)			previous
7M5a	"Correct, good weld"	MORE PRACTICE FINAL EXAM		7Q7 8Q1 QUIT IG2

Table 4-1 Simulation of Welding Equipment Adjustment (continued)

<u>Unit #</u>	<u>Picture/Text</u>	<u>Adjustment Choices</u>	<u>Results of Adjustment</u>	<u>Next Unit</u>
7M5b	"Not shot good weld"	MORE PRACTICE FINAL EXAM		7Q7 8Q1 QUIT IG2
7Q7	<u>Hang-up Weld</u>	RE-ALIGN FOOT ASSEMBLY RE-TIGHTEN CONNECTORS INCREASE CURRENT IT IS GOOD	good weld hang-up w/ text hang-up w/ text hang-up w/ text	7R7b 7R7a 7R7a 7R7a QUIT 7M7b
7R7a	"No, hang-up"	RE-ALIGN FOOT ASSEMBLY RE-TIGHTEN CONNECTORS INCREASE CURRENT I DON'T KNOW	good weld - presentation - presentation - presentation	7R7b 7P7 7P7 7P7 QUIT 7M7b
7R7b	<u>Good Weld</u>	INCREASE TIME DECREASE STICKOUT DECREASE LIFT IT IS GOOD	hot weld short plunge cold weld	7Q3 7Q5 7Q1 7M7a QUIT 7M7a
7P7	- presentation describing the causes of a hang-up weld (same as 6P4)			previous
7M7a	"Correct, good weld"	MORE PRACTICE FINAL EXAM		7Q8 8Q1 QUIT IG2
7M7b	"Not shot good weld"	MORE PRACTICE FINAL EXAM		7Q8 8Q1 QUIT IG2
7Q8	<u>Poor Alignment Weld</u>	INCREASE CURRENT INCREASE STICKOUT CONCENTRATE ON ALIGN IT IS GOOD	extremely hot weld long plunge good weld poor align w/ text	7Q4 7Q6 7R8b 7R8a QUIT 7M8b
7R8a	"No, poor alignment"	INCREASE CURRENT INCREASE STICKOUT CONCENTRATE ON ALIGN I DON'T KNOW	extremely hot weld long plunge good weld - presentation	7Q4 7Q6 7R8b 7P8 QUIT 7M8b
7R8b	<u>Good weld</u>	DECREASE CURRENT DECREASE STICKOUT INCREASE LIFT IT IS GOOD	extremely cold weld short plunge hot weld	7Q2 7Q5 7Q3 7M8a QUIT 7M8a
7P8	- presentation describing causes "of a poor alignment weld (same as 6P5)			previous

Table 4-1 Simulation of Welding Equipment Adjustment (continued)

<u>Unit #</u>	<u>Picture/Text</u>	<u>Adjustment Choices</u>	<u>Results of Adjustment</u>	<u>Next Unit</u>
7M8a	"Correct, good weld"	MORE PRACTICE FINAL EXAM		7Q9 8Q1 QUIT IG2
7M8b	"Not shot good weld"	MORE PRACTICE FINAL EXAM		7Q9 8Q1 QUIT IG2
7Q9	<u>Arc Blow Weld</u>	INCREASE CURRENT SHORTEN CABLE RE-TIGHTEN CONNECTORS RESET GROUND CABLE	text only text only text only text only	7R9 7R9 7R9 7R9 QUIT 7M9
7R9	"Arc blow weld. You should do all."	TOUCH ANYWHERE		7Q10 QUIT IG2
7M9	"Not shot good weld"	MORE PRACTICE FINAL EXAM		7Q10 8Q1 QUIT IG2
7Q10	<u>Contaminated Weld</u>	RE-TIGHTEN CONNECTORS INCREASE TIME RE-CLEAN WORKPIECE IT IS GOOD	contaminated w/ text contaminated w/ text good weld contaminated w/ text	7M10b 7M10b 7M10a 7M10b QUIT 7M10b
7M10a	"Correct, good weld"	MORE PRACTICE FINAL EXAM		7Q2 8Q1 QUIT IG2
7M10b	"No, this is a contaminated weld. To eliminate weld contamination, re-clean the workpiece."	MORE PRACTICE FINAL EXAM		7Q2 8Q1 QUIT IG2

Unit Identification Number

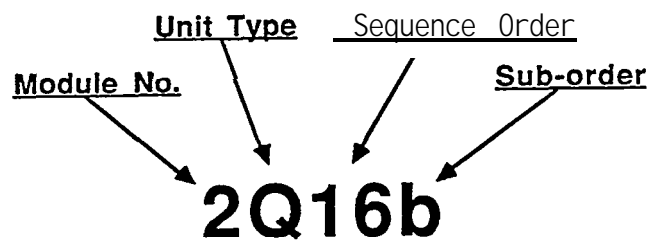

Module No.

- 1 Initialization
- 1 About the Lesson
- 2 Theory
- 3 Studs and /Ferrules
- 4 **Welding** Equipment
- 5 Welding Procedures
- 6 Inspections and Tests
- 7 Practice
- 8 Examination

Unit Type

- | | |
|----------|--------------|
| M | Menu |
| P | Presentation |
| Q | Question |
| R | Remediation |

Figure 4-1 Definition of the Unit identification Number

4.3.2 Instructional Features

The large number of units in the arc stud welding lesson provides the opportunity to demonstrate many different instructional features. The instructional features demonstrated in the modules of the lesson are listed below. Table 4-2 details the instructional design objectives of individual units within these modules.

<u>Title Module</u>	<u>Demonstrated Feature</u>
ABOUT THE LESSON	- Contains introduction video and explains how to operate the lesson.
THEORY	- Demonstrates simple animation synchronized to audio.
STUDS AND FERRULES	- Pages of "text" demonstrate a simple Computer Based Training (CBT) presentation. - Demonstrates trainee-controlled information.
WELDING EQUIPMENT	- Demonstrates various types of touch responses to answer questions and identify parts of the stud gun.
WELDING PROCEDURES	- Demonstrates simulated set-up of the arc welding system. - Describes how to read graphs and tables to adjust arc welding equipment. - Demonstrates the use of color, timing, and audio to simulate welder's operational cues.
INSPECTIONS AND TESTS	- Presents stud weld defects and their causes. - Demonstrates touch responses to identify stud weld defects.
PRACTICE	- Simulates shot studs that require visual evaluation of the weld, and adjustment of equipment by the trainee to improve the weld.
EXAMINATION	- Final examination (10 questions without feedback) designed to demonstrate different types of trainee interaction.
QUIT THE LESSON	- A means of exiting the lesson.

Table 4-2. Unit Design Objective

<u>Unit ID Number</u>	<u>Unit Design</u>
IP1	Demonstrates a good title screen. It is colorful, has dimension, and contains only the essential information to identify the lesson. The screen contains simple directions for the trainee's first interactive operation.
IP2	Demonstrates a menu for initial branching. The menu enters either into a lesson for experienced (re-qualifying) welders or into a lesson for new welders. The screen contains two text buttons. "Operating instructions appear within the text.
IQ1-IQ3	Demonstrates three multiple-choice screening questions. Answers are made with next-to-text buttons. The format is identical for all questions.
IM2	Demonstrates a master menu with 3-dimensional buttons for the selection of any module within the lesson. This menu appears only in the re-qualifying welder's lesson.
IP1	Demonstrates a full-screen, full-motion video to introduce the lesson. Text is displayed directly on the picture as when it presented in the narration. The narration describes the next required operator interaction.
1P3 Series	Demonstrates instructions on how to operate the interactive lesson. Narration is used, along with arrows pointing to the actual buttons, to describe the system's operation.
2P1	Demonstrates complex animated graphics to illustrate the basic theory of arc stud welding. This is the most complex graphic in the lesson. It makes use of a series of individual animations, the sequential presentation of text, and strategic pauses to synchronize the graphics and text with the narration.
2Q1	Demonstrates a multiple-choice question with large font text buttons for trainee answers. The unit provides simple "correct" and "not correct" feedback responses.

Table 4-2 Unit Design Objective (continued)

Unit ID Number	Unit Design
2Q2	Demonstrates an alternate-choice question with large font text buttons for trainee answers. This unit also provides simple "correct" and "not correct" feedback responses.
3P1-3R11	Demonstrates the appearance of printed text on a white page without narration. Highlighted words are red or gray. Interactions, when required, are provided through text buttons, system flow buttons, and by touching the actual text. Feedback for INCORRECT answers is a simple repeat of the presentation.
3P1, 3P3, 3P10	Demonstrates opportunities for trainees to select additional information on their own.
3P3a	Demonstrates a simple bitmap drawing with text overlay provided by the authoring system.
4P1	Demonstrates full-screen still video with narration and text identifying many components within the picture.
4P2	Demonstrates still video with narration and a text window describing only one component within the picture.
4P3	Demonstrates a simple attention-getting statement with text and narration
4P4	Demonstrates a graphical illustration of the arrangement and relationships between components within the welding system.
4P5	Demonstrates the pause capability within a motion video sequence.
4Q7	Demonstrates a multiple-choice question with text buttons for answers. Feedback for INCORRECT answers is discussion that addresses all possible answers. Feedback for CORRECT answers is simple large-font positive response.
4P8	Demonstrates large font directly on the video picture at the top and bottom of the screen.

Table 4-2 Unit Design Objective (continued)

Unit ID Number	Unit Design
4P9	Demonstrates large font directly on the video picture in the center of the screen.
4P10	Demonstrates a list of small-character text that is sequentially displayed from top-to-bottom of the screen when it is presented in the narration.
4P11	Demonstrates a shaded drawing of a stud gun with its parts sequentially identified by text when they are described in the narration. Fifteen parts of the stud gun are identified.
4P11a	Demonstrates the ability of the trainee to interact with a drawing or picture by touching the screen and receiving information about the area (or part) touched. In this case the name of the stud gun part is displayed when it is touched. The name extinguishes when another part is touched.
4Q11 Series	Demonstrates how trainees can be questioned to identify certain areas (or parts) by touching the screen. In this case the question asks the trainee to touch a certain part on the stud gun. Feedback for INCORRECT answers states that the answer is INCORRECT and then identifies the part that was touched. Feedback for CORRECT answers acknowledges the CORRECT answer and sequences to another question.
4P11b	Demonstrates a simple motivational/instruction statement.
4M12	Demonstrates the use of a menu to enable trainees to obtain additional information on their own.
4P12	Demonstrates the use of large white font on a gray background with single color highlighting.
4P13, 4P14	Demonstrates the use of large white font on gray background with multiple color highlighting.
5P1	Demonstrates full-screen still video with narration and text identifying many components within the picture.

Table 4-2 Unit Design Objective (continued)

Unit III Number	Unit Design
5Q2	Demonstrates trainee interaction with a still video picture by touching items within the picture.
5P2 Series	Demonstrates simple text statements to re-enforce narration.
5R2 Series	Demonstrates positive and negative feedback using text with high color and brightness contrast.
5P2a	Demonstrates the use of three lines of text in motion.
5P2b	Demonstrates the use of two lines of text in motion with a different font.
5P2C	Demonstrates the use of a single line of text in motion with a different font.
5P2d	Demonstrates the use of text with a highly saturated color.
5P2d	Demonstrates the use of text with a pale color.
5P7	Demonstrates the use of text windows on motion video at the top and bottom of screen.
5P7a	Demonstrates the use of full-screen, large text with narration.
5P9	Demonstrates the use of full-screen, mixed-size text with narration.
5P10	Demonstrates the use of all upper-case shadowed text.
5Q10	Demonstrates the use of color to indicate the importance of text.
5P11 Series	Demonstrates the ability of interactive multimedia to simulate actual equipment set-up. This series of units simulates the connection of electrical cables by showing a disconnected cable and requiring the trainee to touch the component where the cable should be connected. Feedback to a CORRECT answer (touching the CORRECT component)

Table 4-2 Unit Design Objective (continued)

Unit ID Number	Unit Design
5P11 Series (continued)	<p>produces a unit with the cable properly connected. Feedback to an INCORRECT answer (touching the wrong component) informs the trainee that the connection is INCORRECT and permits the trainee to try again.</p> <p>This series concludes with all cables of the stud gun system connected.</p>
5P12	<p>Demonstrates a motion video close-up view of an operation with narration, but without any text.</p>
5P13	<p>Demonstrates a bitmap-generated graph with animation to illustrate how the graph is read, and how the required value for which it is used, is determined.</p>
5Q13 Series	<p>Demonstrates a multiple-choice question that requires the trainee to read and interpret the graph previously demonstrated. Feedback for an INCORRECT answer is a remedial unit that demonstrates, differently than the original presentation, how to read the graph. Feedback for a CORRECT response provides the trainee with opportunity to determine another value using the same graph, or to continue the lesson.</p>
5P14 Series	<p>Demonstrates a bitmap-generated <u>table</u> with animation to illustrate how the graph is read, and how the required value for which it is used, is determined.</p> <p>Demonstrates a multiple-choice question that requires the trainee to read and interpret the table previously demonstrated. Feedback for an INCORRECT answer is a remedial unit that demonstrates, differently than the original presentation, how to read the table. Feedback for a CORRECT response provides the trainee with opportunity to determine another value using the same table, or to continue the lesson.</p>
5P15	<p>Demonstrates a method for presenting dimensions of an object on the screen.</p>
5P17-18	<p>Demonstrates video only, with narration.</p>

Table 4-2 Unit Design Objective (continued)

Unit ID Number	Unit Design
5P19	Demonstrates text only, with identical narration.
5P20	Demonstrates the ability of interactive multimedia to simulate equipment operation monitoring. This series of units simulates the sound, color, duration, and brightness of an arc flash for the purpose of instructing trainees in the monitoring of weld operations. Following four "flashes," the trainee is required to identify by touching a text button, which of the flashes most likely produced the best weld. For each INCORRECT answer, the cause of the flash is described and the four flashes are repeated. For the CORRECT response, positive re-enforcement is provided and the lesson continues.
6P1	Demonstrates motion video within in a framed picture. Text is presented at the bottom of the frame when it is discussed in the narration.
6P2-6P8	Demonstrates a framed, still video picture with narration and with text. Each unit presents a unique weld condition. The condition is described at the top of the frame, and the cause of the condition is listed at the bottom of the frame.
6P8 Series	Demonstrates a bitmap-generated drawing of six studs caused by different weld conditions. The trainee is asked to touch the stud that was caused by a unique weld condition. Feedback for an INCORRECT answer is a brief text description, above the touched area, that describes its cause. Feedback for a CORRECT response is a positive text statement and request to touch another stud.
6P9	Demonstrates an attention-getting, brightly colored screen with narration and special-effects text.
6P10-6P12	Demonstrates motion video with text windows. The text windows are arranged in different locations on the screen and are of different sizes and shapes to demonstrate special effects.

Table 4-2 Unit Design Objective (continued)

Unit ID Number	Unit Design
6P13-6P15	Demonstrates different character styles and sizes (fonts), and colors on a fixed-color background.
Module 7	<p data-bbox="546 431 1339 712">Demonstrates the ability of interactive multimedia simulate actual equipment operation. This series of units presents still video pictures of studs that were produced under different weld conditions. To the right of the still video picture are touch buttons for the trainee to select an adjustment to the welding equipment that would improve the weld condition pictured.</p> <p data-bbox="546 746 1339 970">No CORRECT or INCORRECT responses are provided for the trainee's answer. Instead, upon selection of an adjustment, the picture changes to a weld that would be produced by the selected adjustment. The lesson thereby simulates what would result from the trainees action if this action were taken on real equipment.</p> <p data-bbox="546 1004 1339 1419">On some units, one of the text buttons provides the opportunity for the trainee to select "GOOD WELD . NO ACTION OR ADJUSTMENT NECESSARY. " On others, a text button appears that permits the trainee to select "I DO NOT KNOW." Selection of the "I DO NOT KNOW" button produces the complete presentation that originally explained the causes of the weld condition displayed. In the even the "GOOD WELD , NO ACTION NECESSARY" button is selected when a good weld is not pictured, an additional text window is presented explaining that the weld is not good and what is wrong with it.</p> <p data-bbox="546 1453 1339 1734">Ten different weld conditions, including the good weld are simulated. It is expected that the trainee will practice making "equipment" adjustments until a good weld is both achieved and is recognized. When a good weld has been both attained and acknowledged, the trainer is given the opportunity to continue practicing adjustments or the trainee may begin the Final Examination.</p>

Table 4-2 Unit Design Objective (continued)

Unit ID Number	Unit Design
Module 8	Demonstrates ten examination questions whose answers are scored and recorded for review and analysis at the end of the lesson. Questions are timed only to ensure that the lesson is completed, not to test the trainee's reaction time.
8Q1	Demonstrates a multiple-choice question with answers that use text buttons.
8Q2	Demonstrates a multiple-choice question with answers that use next-to-text buttons.
8Q3	Demonstrates a touch-in-a-drawing question.
8Q4	Demonstrates an alternate-choice question with answers that use text buttons.
8Q5	Demonstrates a touch-in-a-video picture question.
8Q6	Demonstrates a touch-in-a-graphic question.
8Q7	Demonstrates a touch-in-a-bitmap drawing question.
8Q8	Demonstrates a question whose answer requires the trainee to enter a number via the keyboard.
8Q9	Demonstrates a question whose answer requires the trainee to enter a word via the keyboard.
8Q10	Demonstrates a question whose answer requires the trainee to press a certain button on the keyboard.

4.3.3 Design Criteria

Design of the arc stud welding lesson complies with human engineering design criteria, which include simplicity of format, limiting the variety of color in text, attention to font and character size, prudent application of sound and motion, and avoiding unnecessary trainee interaction. The first module provides a brief description of how to operate the lesson. This knowledge is subtly expanded throughout the lesson so that the trainee can eventually perform relatively complex interactions.

Appendix C contains the human engineering design criteria used during the lesson's design.

4.4 Feedback and Remediation

An additional objective of the arc stud welding lesson is to illustrate different feedback and remediation techniques that are available through interactive instruction.

The form and timing of feedback to the trainee is the strength of interactive instruction. This feedback results from the trainee's response to a question or required action, and provides the immediate re-enforcement so vital to the learning process. Many forms of feedback may be used in an interactive lesson. Most authoring systems, TenCORE Producer included, contain provisions for automatic feedback.

A wide variety of remediation techniques are also demonstrated. Most authoring systems provide simple remediation capabilities within individual units, or the ability to branch to other units for more complex remediation. Feedback and remediation are the important ingredients of interactive instruction, and are well demonstrated by the project.

Figure 4-2 illustrates some of the feedback and remediation loops used in the arc stud welding lesson.

4.4.1 Simple Feedback Loop

Simple feedback issues a positive "correction" statement following a trainee's incorrect answer, and continues to the next material without re-testing (at least at this time) to determine whether the correction was learned. A sample response to a correct answer might be, "You are correct! This is a cold weld." A sample response to an incorrect answer might be, "No, this is a cold weld."

4.4.2 Re-test Loop

A re-test feedback loop also issues a simple positive "correction" statement following a trainee's incorrect answer, but it immediately re-tests the trainee to determine whether the correction was learned. The same question may be used or it may be arranged or worded differently.

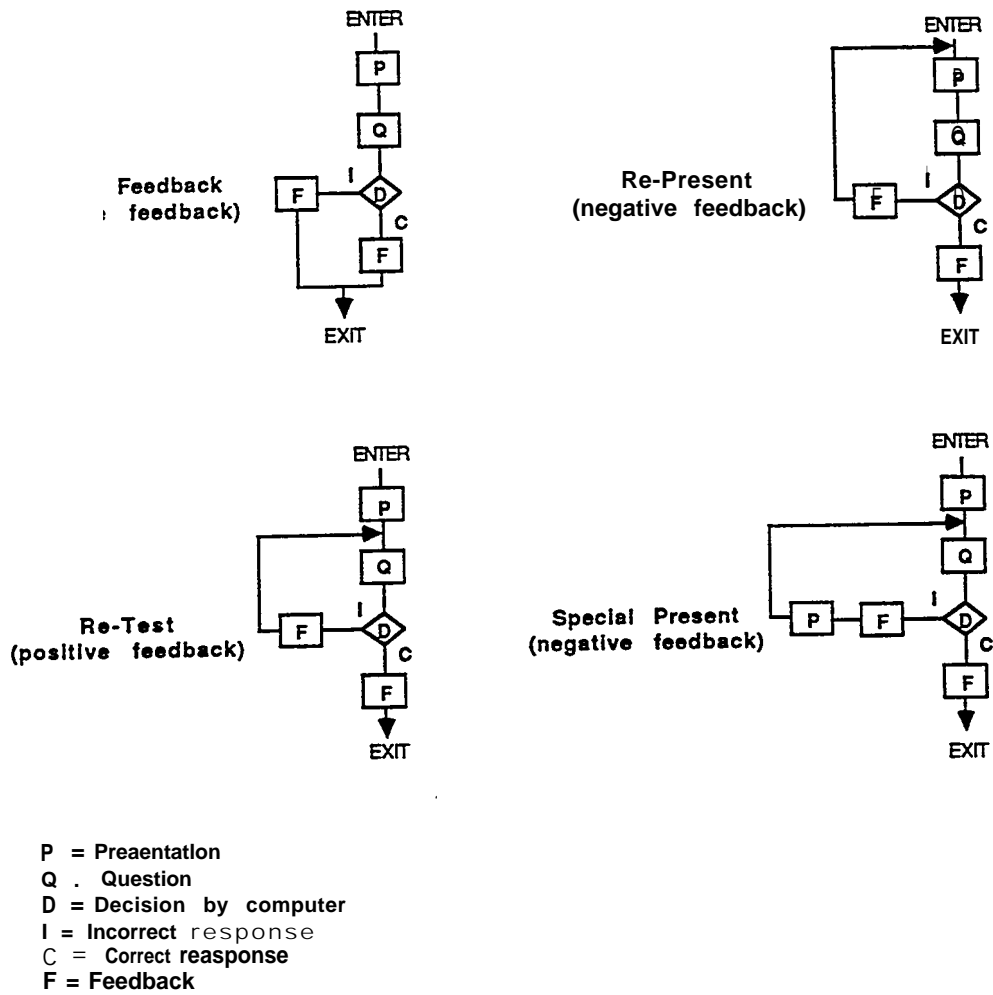

Figure 4-2 Some Examples of Inter-module Feedback and Remediation

4.4.3 Re-presentation Loop

The re-present loop issues a negative "correction" statement, followed by a replay of the original presentation. A sample response to a correct answer might be, "You are correct! This is a cold weld." A sample response to an incorrect answer might be, "No, that is incorrect. It is not a hot weld."

4.4.4 Special Presentation Loop

The special present loop also issues a negative "correction" statement, but immediately follows it by a new presentation usually structured at a different instructional level or using a different instructional approach. The trainee is then immediately re-tested using the same or differently arranged question. This is the preferred loop for critical material or when the material is complex or difficult to explain.

4.5 Motivation and Evaluation

Motivation and verification are "built-in" to all aspects of the lesson. The trainee is constantly motivated through positive and negative feedback statements, both spoken and printed. The lesson is structured to continuously challenge the trainee through the use of rewards and critiques. Both positive and negative feedback are included in the lesson.

At the end of the "Fundamentals of Arc Stud Welding" lesson the trainee is administered ten questions, each with only one correct response that must be answered within a defined period of time. Although response time can also be used to test trainee reaction time, in this lesson the time element is used only to ensure that the lesson proceeds to the end. The method of trainee response is unique for each examination question. This enables the lesson to demonstrate ten different response techniques: specifically multiple-choice buttons, multiple-choice text, multiple-choice pictures, alternate-choice true/false or yes/no, pointing in a graphic, pointing in a picture, pointing in a video, numeric keyboard entry, text keyboard entry, and press-a-key. Questions are weighted differently in their contribution to the final score.

After the final question, all trainees are congratulated and invited to view their final score, which is derived from question criticality and other data. The instructor receives a full performance report, including a description of which questions were answered incorrectly.

Section 5

LESSON DEVELOPMENT

5.1 Methodology

Development of the demonstration lesson followed the traditional process for developing interactive multimedia instruction. This process is illustrated in Figure 5-1. The process required the publication of enabling and terminal objectives, a flow diagram, and a detailed description of each unit within the lesson (the storyboard). The Lesson Unit Description was published so that the software for the lesson could be authored at the same time the video was being shot. Ship Analytics used text and graphics information from the Lesson Unit Description to author the lesson. The NAVSEA Shipyard Instructional Design Center used narration and video information from the Lesson Unit Description to produce the supporting video.

5.2 Lesson Objectives

Enabling and terminal objectives for the "Fundamentals of Arc Stud Welding" are presented in Appendix A. These objectives are the required first step in the development of an interactive training course. They define what the trainee is expected to know or be able to do upon satisfactory completion of the course. They also define the examination requirements for the course.

For this project a single "Terminal Objective" was stated for the lesson. This lesson would be only one of many that comprise a comprehensive welding course.

Individual "Enabling Objectives" were then listed which, when fulfilled, would lead to total compliance with the stated Terminal Objective. The Enabling Objectives were then arranged in a logical order to accommodate the instruction process. This led to the creation of modules for the lesson.

5.3 Modules

Lesson modules usually contain independent issues or subjects about the topic, or they may represent a unique instructional technique. In the "Fundamentals of Arc Stud Welding," module design is intended to demonstrate both of these. The arrangement of modules within the lesson is illustrated in Figure 5-2.

Modules are arranged such that all of them are administered to new trainees, while experienced trainees or those who are receiving refresher or re-qualification training, can randomly access any or all of them in any order. The examination must be taken by all trainees.

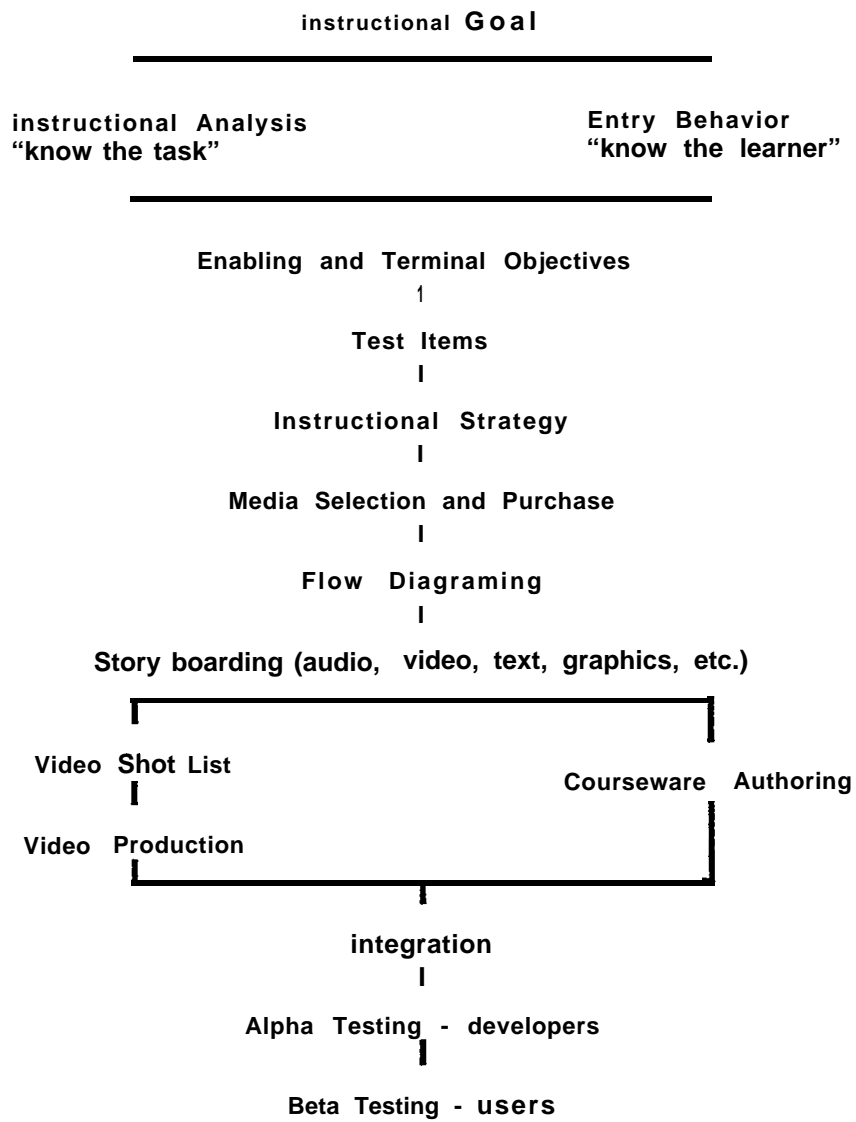

Figure 5-1 The Interactive Courseware Development Process

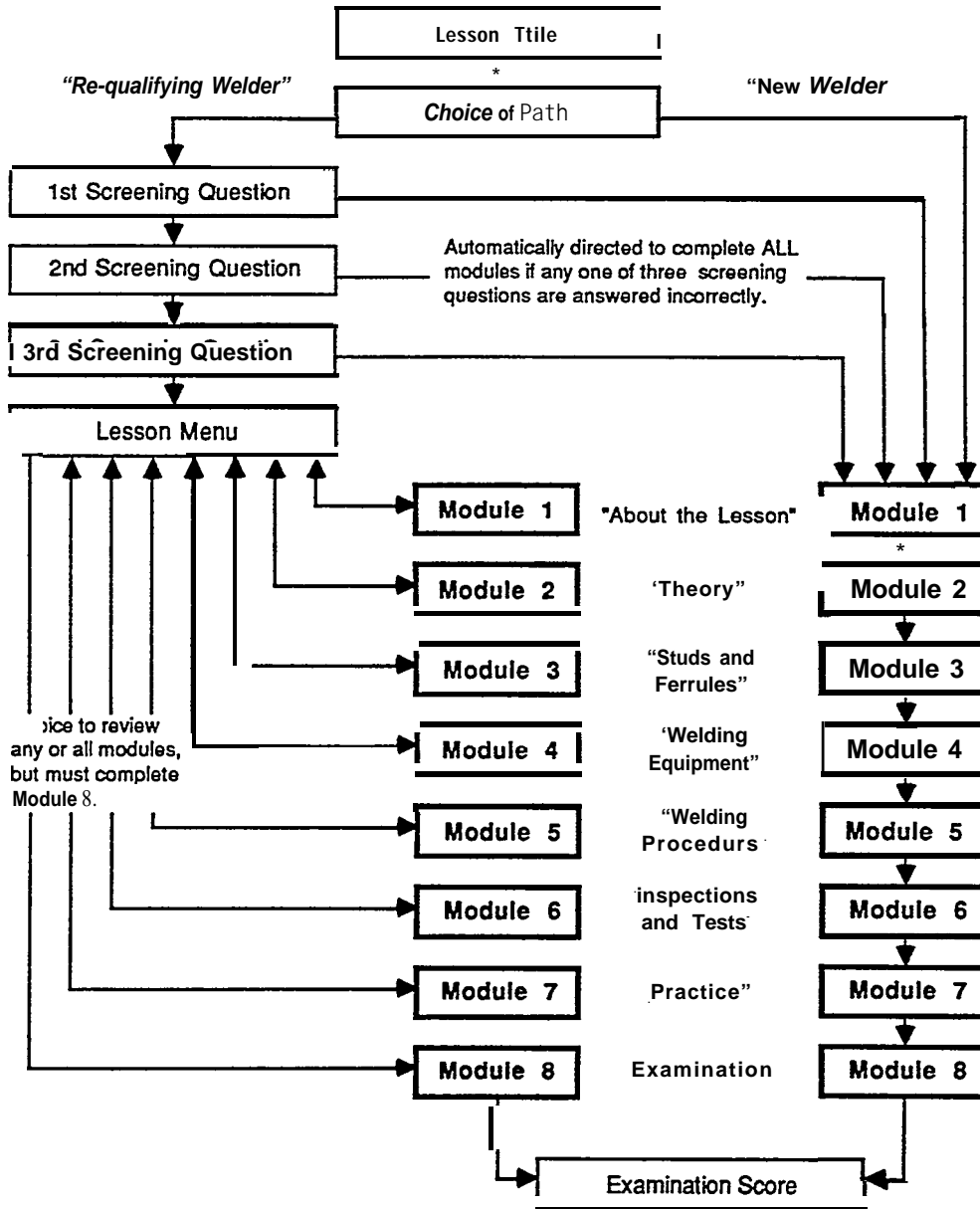

Figure 5-2 Modules of the Arc Stud Welding Lesson

5.4 Unit Descriptions

Storyboards for the "Fundamentals of Arc Stud Welding" interactive lesson were constructed in the form of "lesson unit descriptions." These descriptions are presented in Appendix B of the report. The descriptions provide guidance and instructions to all participants in the courseware development process. They address text, narration, video, graphics, and overall screen design requirements as well as lesson flow characteristics.

Specifically, the Lesson Unit Description contains all lesson units listed in the order in which they appear in the lesson. These units are identified by Unit Identification Number (reference Figure 4-1) and are grouped by module. The text is shown as it appears on the screen. Formatting, arrangement and other appearance characteristics of the text screen are not defined in the Lesson Unit Description. This work was performed by the instructional designer directly through the authoring system. In the event that authoring is done by someone other than the instructional designer, it is recommended that a more detailed and descriptive storyboard be used.

Video was shot under the supervision of a shipyard welding instructor. The action in each unit was staged to coincide with the material presented in the narration. Narration was then produced verbatim from the Lesson Unit Description script by a narrator. Pauses and inflections were inserted at the narrator's discretion to match the video action.

Graphics and animation were produced during the authoring process with appropriate pauses to achieve the required effects. Narration for graphics was also produced verbatim from the Lesson Unit Description script by the narrator, with pauses and inflections inserted to match the animation.

5.4.1 Lesson Flow

Lesson flow in TenCORE Producer can occur in many different ways. Lesson flow is the sequencing between displays or between screens within displays such that the information is changed or the interaction is changed. Although the mechanics of flow varies extensively in TenCORE Producer, the lesson is designed to make this difference transparent to the trainee. In other words, the arc stud welding lesson demonstrates many different methods of unit flow and achieves a variety of different results. All, however, are seen by the trainee as part of the normal instruction and interaction process.

The following flow methods are demonstrated in the arc stud welding lesson:

SYSTEM FLOW BUTTONS. Up to four buttons at the bottom of the screen that, when touched, cause the sequence to proceed forward to the next unit (NEXT), backup to a previous unit (BACK), stop within the unit (PAUSE), or return to the title unit (QUIT). All or none of these buttons may be present on the screen at the same time, depending upon the interaction desired for the unit.

CUSTOMIZED BUTTON. Any button on the screen (other than a System Flow Button) that permits the trainee to interact with the system and cause the system to sequence. These buttons appear with or without text, in two or three dimensional configuration, and of varying sizes, shapes, and colors.

TOUCH AREA. An area on the display which when touched, causes the system to sequence. This area may include text, or an object within a still or motion picture, drawing, diagram, table, or text.

TIME PAUSE . A delay of predetermined duration before the next unit appears.

END OF NARRATION OR VIDEO. Sequencing to the next unit upon completion of a required narration or video play.

It should also be recognized that in many cases the above flow methods can be combined to provide additional options to the trainee and therefore increase the opportunity for interaction.

5.5 Unit Review

The use of Appendix B together with the interactive lesson operating in the "Edit" mode, provides an excellent behind-the-scenes review of lesson flow and other features available from interactive instruction. The "Edit" mode of operation permits all units to be observed in the same order that they appear in the Lesson Unit Description.

Note that in the "Edit" mode of operation, permanent changes can accidentally be made to the original lesson that is loaded on the hard drive. For this reason, first copy the original lesson using the "LESSON OPTIONS" screen and give this new lesson a unique, personal name. Use this "personal" lesson to perform the review. You may then make any changes and experiment with the authoring system without affecting the original lesson.

Always delete your "personal" lesson from the hard drive when you have completed your review. Use the "LESSON OPTIONS" screen for this also. Be careful not to delete the original lesson.

Complete directions for entering the lesson in the "Edit" mode or the "lesson" mode are attached to the delivery system.

CAUTION

Do not use the touchscreen to operate the authoring system in the "Edit" mode. If the touchscreen is activated, return to the : tpr21 " prompt and type "elo/d" to disconnect the touchscreen. You will then be able to use the mouse and cursor.

Section 6

RECOMMENDATIONS FOR USE

At the time this report was published, "Fundamentals of Arc Stud Welding" had been viewed only by project personnel involved in its development. The major test of this interactive lesson will come during the next year and beyond when shipyard management and training departments begin to use it, evaluate its benefits, possibly improve upon it, and develop similar lessons of their own.

Results of the earlier NSRP report, "Recommendations on the Use of Interactive Instruction for Training Shipyard Trade Skills," (reference 1) revealed that while most American shipyards are not completely familiar with interactive instruction, most would be willing to participate in its demonstration. This interactive lesson provides that demonstration. It is intended that the lesson will enable American shipyards to better understand what interactive multimedia is, how the shipbuilding industry can benefit from it, and how interactive instruction can contribute to higher quality, cost-effective production in an ever-increasing competitive market.

6.1 Continued Lesson Development

Provisions have been made to maintain a baseline of the original "Fundamentals of Arc Stud Welding" lesson. This means that individual users can make temporary changes to the lesson within the delivery system. If the changes improve upon the lesson's design and it is determined by NSRP that the changes should be incorporated into the baseline, then such modification is possible and is encouraged.

It is also possible for participants in the program to develop interactive courseware for their own use and to accompany the delivery system for continued demonstration. The addition of such lessons to the delivery system are also encouraged.

The demonstration system is not intended as a platform for the production of commercial (for sale) interactive lessons by individual shipyards. Such commercial production of interactive courseware may be undertaken only by shipyards that purchase the authoring system and the "runtime" development license that accompanies it.

6.2 Demonstration of Interactive Instruction

Participating shipyards are encouraged not only to review the interactive lesson resident on the delivery system, but also to make use of it in the actual training environment.

Criticisms of the lesson may be communicated back to NSRP. However, the intent of the demonstration is to encourage shipyards to make necessary improvements to the lesson themselves, thereby gaining experience in the critique and development of interactive instruction and becoming confident in their ability to do so.

6.3 Demonstration of Authoring Capabilities

Participating shipyards are encouraged to use the authoring system and instructional design process described in this report to produce new interactive lessons for their own demonstration purposes. Such lessons may use frames on the laser videodisc that accompanies the delivery system, or the shipyard may produce its own videodisc.

NSRP'S desire for shipyards to develop their own new interactive lesson using this delivery system is based upon the conclusion that the best way to learn and appreciate interactive instructional technology is to create such a lesson from the ground-up.

6.4 Continued SP-9 Promotion

This report recommends that the delivery system be given as wide a circulation as possible throughout American shipyards, and for a period of time within each shipyard that will permit training department-personnel to evaluate the existing lesson and create at least one new one. A minimum of 60 days in each shipyard is recommended.

It is also strongly suggested that some type of initial guidance be provided that will familiarize the shipyard's personnel with the characteristics and applications of interactive instruction, the courseware development process, screen and interaction design, capabilities of the delivery system, and operation of the authoring system. This could be performed with a one-time briefing upon delivery of the system to the shipyard, or by periodic consultations with the shipyard throughout the demonstration period.

Finally, the components of the delivery system were specifically selected to permit significant expansion in its interactive multimedia capabilities. It is recommended that NSRP continue to upgrade and expand this system so that it will always be capable of demonstrating the state-of-the-art multimedia spectrum. Such additions might include a CD-ROM player, a sound board, another authoring system or the TenCORE Authoring Language as a supplement to TenCORE Producer, an alternative video device (in addition to the videodisc player), a digital audio capability, or additional graphics, art, or animation software.

Serious consideration should also be given to the purchase and demonstration of commercial off-the-shelf interactive courseware that is applicable to skilled trade tasks in American shipyards. A significant amount of this courseware exists (reference 1) and it provides both varied and excellent examples of the benefits of interactive instruction for training shipyard trade skills.

REFERENCES

1. "Recommendations on the Use of Interactive Instruction for Training Shipyard Trade Skills," Education and Training Panel, SP-9, National Shipbuilding Research Program (NSRP 0334/UMTRI 82210). 1991.
2. Fletcher, J.D., Effectiveness and Cost of Interactive Videodisc Instruction in Defense Training and Education, IDA Paper P-2372, Institute for Defense Analyses, Alexandria, VA. 1990.
3. Urlansky, J. and J. String, Cost Effectiveness of Computer-Based Instruction in Military Training, IDA Paper P-1375, Institute for Defense Analyses, Alexandria, VA. 1977.

APPENDIX A
OBJECTIVES OF THE LESSON

Appendix A

Objectives of the Interactive Lesson "Fundamentals of Arc Stud Welding"

PRE-REQUISITES FOR THE LESSON

Before receiving this lesson, the trainee must have a demonstrated knowledge of:

- A. Welding safety procedures and precautions
- B. Basic arc welding theory
- C. Basic arc welding terminology
- D. Identification of materials (metals)
- E. Measurements and the use of stud measurement instruments

TERMINAL OBJECTIVE OF THE LESSON

The objective of this lesson is to instill and verify trainee knowledge of the arc stud welding process, specifically (1) the basic principles and terminology of arc stud welding; (2) the identification and preparation of materials to be welded; (3) the selection, set-up, and initial adjustment of arc stud welding equipment; (4) the performance of trial welds; (5) the inspection and testing of trial welds; (6) the re-adjustment of equipment based upon this inspection; and (7) securing the workstation.

ENABLING OBJECTIVES

Module I - Initialization. This module will provide the mechanics to:

1. Start the lesson from a title screen.
2. Determine whether to direct the lesson through a 'new welder' training path or 're-qualifying welder' refresher path.
 - a. Selected by trainee
 - b. Determined by answers to 3 screening questions
3. Permit the 're-qualifying welder' to select modules from a menu for refresher training and the examination.

Module 1 - About the Lesson. Upon satisfactory completion of this module, the trainee will:

1. Be familiar with different types of stud welding.
 - a. Resistance
 - b. Friction
 - c. Percussion
 - d. Electric arc
 - 1) Common shielded metal arc welding
 - 2) Capacitor discharge stud welding
 - 3) Arc stud welding
2. Be familiar with the general meaning of 'arc stud welding.'
 - a. Arc stud welding defined
3. Know the purpose of this lesson, what it teaches, and how it is operated.
 - a. Lesson flow control
 - 1) Start - touch screen anywhere
 - 2) Continue - 'NEXT'
 - 3) Repeat - 'BACK'
 - 4) Freeze - 'PAUSE'
 - 5) Exit - 'QUIT'
 - b. Question answering
 - 1) Touch on screen
 - 2) Keyboard entry

Module 2 - Theory. Upon satisfactory completion of this module, the trainee will:

1. Be able to describe the basic theory of arc stud welding.
 - a. Workpiece
 - b. Stud
 - c. Ferrule
 - d. Touch
 - e. Lift and arc
 - f. Plunge

Module 3 - Studs and Ferrules. Upon satisfactory completion of this module, the trainee will:

1. Be familiar with the types of studs that can be arc welded.
2. Know the limitations of arc welded studs.
 - a. Weld one end only
 - b. Size and shape must accommodate ferrule
 - c. Cross section within power range
 - d. Size and shape must accommodate chuck
3. Be able to describe the effects of different stud materials on the welding process.
4. Be able to describe the cause of stud length reduction.
5. Be able to describe the cause of fillet size and shape.
6. Be able to describe the function of flux.
7. Be able to describe the effects of different base materials on the welding process.
8. Be able to describe the visual effects of insufficient heat or too much heat.
 - a. Small, irregular fillets
 - b. Not enough length reduction
 - c. Large, irregular fillets
 - d. Too much length reduction
 - e. Splatter
9. Be able to describe the location of the ferrule.
 - a. Placement of ferrule
10. Be able to describe the purpose of the ferrule.
 - a. Concentrate heat
 - b. Restrict air flow
 - c. Confine molten metal

- d. Prevent charring of adjacent materials
 - e. Shields operator
11. Be familiar with two types of ferrules and their uses.
- a. Expendable ferrules
 - b. Semi permanent ferrules

Module 4 - Welding Equipment. Upon satisfactory completion of this module, the trainee will:

1. Be able to identify the major components of an arc stud welding system.
 - a. DC power source
 - b. Control unit
 - c. Stud gun
 - d. Cables and connectors
2. Be able to describe common sources of arc stud welding power.
 - a. Transformer-rectifier
 - 1) Sampson Stud Drawer
 - 2) Six-pak grid system
 - b. Motor generator
 - c. Batteries
3. Be familiar with high current, short duration requirements.
4. Be able to describe common stud welding power source ratings.
 - a. 1000 amperes
 - b. 50 volts
 - c. 1 second
5. Be able to describe the purpose of the controller.
 - a. Timing device
 - 1) Interrupts welding current
 - b. Connected in series between gun and DC power source
 - c. Variations in controls, indicators, and connectors

6. Be able to describe the function of the controller.
 - a. Time control
7. Be able to read, understand and apply a simple, generic controller Set-up Chart.
 - a. Time duration settings (seconds)
 - b. Weld current (amperes)
 - c. Stud size (base diameter) and material
 - d. Workpiece material
 - e. Gun lift (inches)
8. Be familiar with the purpose and use of combination power source machines.
 - a. Three phase and single phase
 - b. Solid state control circuits
9. Be able to describe causes and cures of power fluctuation.
 - a. Possible causes
 - 1) Current too high
 - 2) Duration too long
 - 3) Other welders
 - 4) Cables too long
 - 5) Cables or connections are defective
 - b. Possible cures
 - 1) Time-compensating controller
 - 2) Repair or replacement of cable or connector
10. Be able to identify electrical connectors and their function.
 - a. Welding cable connections
 - 1) Two at power source
 - 2) Two on controller
 - 3) One on gun
 - b. Gun control cables
 - 2) One on controller
 - 3) One on gun
 - c. Ground connection on workpiece

11. Be able to describe characteristics of good connections.
 - a. Clean
 - b. Tight
 - c. In good repair
12. Be familiar with important characteristics of the stud gun.
 - a. Portable and hand-held, resembles a pistol
 - b. Contains potentially hazardous parts
 - 1) Moving parts
 - 2) Exposed electrical conductors
 - c. Made of high impact plastic
 - d. Weighs from 4 to 9 pounds
 - e. Small guns for studs up to 5/8 inch
 - f. Large guns for studs up to 1 1/4 inch
 - g. Best to use small, light-weight gun for small studs
13. Be able to identify all the major parts of the stud gun.
 - a. Foot assembly
 - 1) Foot - holds ferrule grip and ferrule, and aligns stud
 - 2) Ferrule grip - holds ferrule in place
 - 3) Ferrule grip set screw - holds ferrule grip in foot
 - 4) Leg - supports foot, connects it to gun
 - 5) Leg set screw - controls 'stick-out' of stud beyond ferrule
 - b. Chuck assembly
 - 1) Chuck - holds and aligns stud
 - 2) Chuck adapter - holds and aligns chuck
 - c. Gun adjustments
 - 1) Lift adjustment - controls lift of stud, arc length
 - 2) Plunge damper adjustment - buffers force of stud plunge
 - 3) Trigger - operator's control of shot
14. Be able to describe the purpose of the stud gun.
 - a. Purpose of stud gun
 - 1) Securely support stud and ferrule
 - 2) Enable operator to align stud and ferrule on workpiece
 - 3) Make electrical contact
 - 4) Lift stud, thereby creating arc
 - 5) Plunge stud into molten metal on workpiece

15. Be able to describe the operation of the stud gun.
- a. Stud held in specifically designed chuck
 - 1) May need to change chucks when changing type of stud
 - 2) Condition of chuck important to weld quality
 - b. Lifting mechanism
 - 1) Solenoid - controls lift
 - 2) Clutch
 - 3) Mainspring
 - c. Lift is consistent for all studs
 - 1) 1/32 to 1/8 inch
 - d. Ferrule held in specifically designed ferrule grip
 - 1) May need to change grips when changing type of ferrule
 - 2) Condition and seating of ferrule important to weld quality
 - e. Steps during gun operation
 - 1) Touch
 - 2) Lift and arc
 - 3) Interrupt
 - 4) Plunge

Module 5 - Welding Procedures. Upon satisfactory completion of this module, the trainee will:

1. Be able to describe welding safety requirements and procedures.
- a. Self-protection precautions
 - 1) Head - hard hat
 - 2) Eyes - safety glasses, possibly #3 filter lenses
 - 3) Face - shield
 - 4) Body - protective clothing, leather apron
 - 5) Hands - gloves
 - 6) Feet - safety shoes
 - b. Remove fire hazards from welding area
 - c. Notify nearby workers
 - d. Ensure there is a firewatch
 - e. Inspect for damaged or incomplete equipment
 - 1) Report damage or missing components to supervisor
 - 2) Do not attempt repair without checking with supervisor

- f. Avoid water or wetness
 - 1) Do not stand in water
 - 2) Prevent rain or snow from workpiece
 - 3) Keep equipment out of water
 - g. Never look at arc, even if shielded by ferrule
 - h. Always follow your company's welding safety procedures
2. Be able to describe workstation set-up procedures.
- a. Prepare to shoot, inspect, and test 5 practice welds
 - 1) Always, before shooting any production studs
 - 2) Whenever stud type or material changed
 - 3) Whenever workpiece material changed
 - 4) Beginning of day or work period
 - 5) Whenever environmental conditions or quality of welds changes
 - b. Obtain adequate supply of studs and ferrules
 - c. Prepare workpiece
 - d. Obtain, inspect, and connect equipment
 - e. Make initial settings and adjustments
 - 1) Power source
 - 2) Controller
 - 3) Stud gun
 - f. Insert stud and ferrule into gun
 - g. Align and shoot first stud onto practice workpiece
3. Be able to describe the selection of studs.
- a. As specified in work instructions, drawing, or by supervisor
 - b. Verify size with rule before shooting
 - 1) Original base diameter
 - 2) Original length
 - c. Size and composition of stud may be marked on stud container
4. Be familiar with the importance and identification of workpiece material.
- a. Verify workpiece material from drawings or markings
5. Be able to describe the selection of ferrules.
- a. Ferrule shape and size must match stud base shape and size
 - 1) Must fit snugly over stud
 - 2) Must fit snugly in ferrule grip

- b. Must not be deformed or broken
 - c. Must not be wet or damp
 - d. Ferrule remains behind after shot
 - 1) Removed by breaking with slag hammer
6. Be able to describe surface preparation.
- a. Use standard metal cleaning procedures
 - b. Importance of removing all contaminants
 - 1) Dirt
 - 2) Rust
 - 3) Grease
 - 4) Moisture
 - 5) Paint, most primers
 - c. Check with supervisor when workpiece is primed
 - d. Must be free of moisture
 - e. Workpiece temperature must be above 60 degrees F
7. Be able to describe the importance of preheating.
- a. Reference company procedures before preheating
 - 1) Preheat when base material below 60 degrees F
 - 2) Preheat to above 120 degrees F
 - b. Use of soaking preheat most desirable
 - 1) Allows all of base material to reach preheat temperature
8. Be able to describe the set-up of stud welding equipment.
- a. The selection of equipment and cables
 - 1) Power source drawer
 - 2) Controller
 - 3) Hand-held stud gun
 - 4) Two-conductor welding cable
 - 5) Single-conductor welding cable
 - 6) Single-conductor ground cable
 - 7) Two-conductor control cable
9. Be able to describe how to make stud gun welding system connections.
- a. Cable connections
 - 1) Two-conductor welding cable from power source to controller
 - 2) Single-conductor welding cable from controller to gun
 - 3) Single-conductor ground cable from controller to workpiece
 - 4) Two-conductor control cable from gun controller to gun

10. Be able to describe the selection and installation of the chuck.
 - a. Make sure power is off at power source
 - b. Select proper size chuck and ferrule grip
 - c. Remove foot assembly from gun
 - 1) Loosen leg screw with special tool
 - d. Replace proper size ferrule grip on foot
 - Loosen, tighten grip set-screw with special tool
 - 2) Visually inspect ferrule grip
 - e. Replace proper size and shape chuck in chuck adapter
 - 1) Pull old chuck directly from adapter
 - 2) Push new chuck into adapter
 - 3) Visually inspect newly installed chuck
 - f. Re-install foot assembly on gun
 - 1) Do not immediately tighten leg screw
 - 2) Adjust for 1/8 to 1/4 inch 'stick-out' of stud from ferrule
 - 3) Measure with rule
 - 4) Tighten leg screw and re-measure 'stick-out'
 - g. Observe that all gun adjustments are complete except for the lift adjustment
11. Be able to describe the initial set-up of equipment controls.
 - a. Use of tables for determining initial adjustments and control settings
 - b. Make initial setting for gun lift in inches
 - 1) Example using a generic 'initial set-up' table
 - c. Make initial setting for weld current in amperes
 - 1) Example using the 'Weld Current vs. Weld Time' curve
 - 2) Example using a generic 'initial set-up' table
 - d. Make initial setting for weld time in seconds
 - 1) Example using the 'Weld Current vs. Weld Time' curve
 - 2) Example using a generic 'initial set-up' table
12. Be able to describe how to energize the controller.
 - a. Carefully rest gun on work area
 - b. Turn on power source
 - c. Pick up gun by pistol grip
 - d. Keep finger off trigger

13. Be able to describe how to locate and align studs for shooting.
 - a. Factors effecting location accuracy
 - b. Use of templates
 - c. Use of center punch marks
14. Be able to describe stud gun operation.
 - a. Set point of stud into center punch mark
 - b. Hold gun perpendicular to work surface
 - 1) Both hands
 - 2) Avoid interfering with moving parts
 - c. Prepare to hold steady for several seconds
 - d. Squeeze trigger to shoot stud
 - 1) Do not trigger again
 - e. Note appearance of light and sound of arc
15. Be able to describe stud gun removal from the stud.
 - a. Hold gun in position until red glow disappears
 - b. Draw gun directly off top of stud
 - 1) Do not twist
 - 2) Do not bend

Module 6 - Inspections and Tests. Upon satisfactory completion of this module, the trainee will:

1. Be able to describe the sight and sound of a good arc stud weld.
 - a. Consider what is seen and heard during the shot
 - 1) Brightness of arc
 - 2) Color of arc
 - 3) Sound of arc
 - b. Four simulated examples of arc stud weld brightness, color, and sound.
 - 1) Bright blue-white with the normal buzz
 - 2) Long, dim blue-white with a hiss
 - 3) Brief, dim blue-white with a pop
 - 4) Bright yellow-orange with a crackle

2. Be able to describe the visual characteristics of good welds.
 - a. Visually inspect stud
 - 1) Free from nicks and burrs
 - 2) Threads undamaged, if any
 - 3) Discoloration on base of stud only
 - b. Visually inspect workpiece
 - 1) Star pattern well defined with evenly distributed points
 - 2) Discoloration on workpiece in weld area only
 - c. Visually inspect fillet
 - 1) Evenly distributed around base of stud
 - 2) Shiny surface with smooth serrations around edge
 - d. Measure length of stud
 - 1) $1/8$ to $3/16$ inch less than original length
 - 2) If smaller, too much heat
 - 3) If longer, not enough heat or plunge needs adjustment
 - e. Example of good shot with good length and good fillet formation
3. Be able to describe the visual characteristics of poor welds.
 - a. Short plunge - SHOW EXAMPLE
 - 1) Stud too long
 - 2) Irregular shaped: possibly partially missing fillet
 - b. Hang-up - SHOW EXAMPLE
 - 1) Stud too long
 - 2) Irregular shaped, possibly partially missing fillet
 - c. Poor alignment - SHOW EXAMPLE
 - 1) Bent or angled stud, not perpendicular to workpiece
 - 2) Stud too long
 - 3) Irregular shaped, possibly partially missing fillet
 - d. Cold weld - SHOW EXAMPLE
 - 1) Stud too long
 - 2) Fillet small and possibly irregular
 - 3) Fillet gray in color with grainy surface texture
 - 4) May look satisfactory but will fail mechanical test
 - e. Too hot weld - SHOW EXAMPLE
 - 1) Stud too short
 - 2) Large, irregularly shaped fillet
 - 3) Splatter around and beyond fillet
 - f. Arc blow - SHOW EXAMPLE
 - 1) Stud burned off on one side
 - 2) Irregularly shaped, possibly partially missing fillet

4. Be able to describe how poor welds can be corrected.
 - a. Short plunge - CORRECT PREVIOUS EXAMPLE
 - 1) Re-adjust legs of gun but do not exceed 1/4 inch 'stick-out'
 - 2) Correct mechanical malfunction or restricted movement on gun
 - b. Hang-up - CORRECT PREVIOUS EXAMPLE
 - 1) Re-align components of gun to ensure freedom of movement
 - 2) Loosen and reset lift adjustment
 - c. Poor alignment - CORRECT PREVIOUS EXAMPLE
 - 1) Concentrate on perpendicular alignment during next shot
 - 2) Continue shooting practice shots without equipment re-adjustment
 - d. Cold weld - CORRECT PREVIOUS EXAMPLE
 - 1) First, check ground and all other connections. If proper, slightly increase weld time at controller and re-shoot weld.
 - 2) Second, check lift setting on gun. If proper, slightly increase welding current at power source or controller and re-shoot weld.
 - 3) Third, further increase weld time and re-shoot weld.
 - e. Too hot weld - CORRECT PREVIOUS EXAMPLE
 - 1) First, check to see if current and lift settings are proper. If so, slightly reduce weld time at the controller and re-shoot weld.
 - 2) Second, slightly decrease current and re-shoot weld.
 - 3) Third-slightly decrease the lift adjustment and re-shoot weld.
 - 4) Fourth, further decrease weld time and re-shoot weld.
 - f. Arc blow- CORRECT PREVIOUS EXAMPLE
 - 1) Check ground and all other connections
 - 2) Check proper operation of power source
 - 3) If problem persists, call supervisor
5. Be familiar with the requirement for mechanical testing of arc stud welds.
 - a. Two types of mechanical testing
 - 1) Bend testing
 - 2) Torque testing
 - b. Destructive testing
 - 1) Bend-test or torque-test all practice shots
 - 2) Production studs that are bend-tested must be removed and replaced
 - 3) Follow company procedures for bend and torque testing

6. Be able to describe how the best method of bend testing is performed.
 - a. Bend to 15 degrees from perpendicular for ferrous studs
 - 1) Strike with hammer
 - 2) Bend with pipe or bending tool
 - 3) Any direction
 - 4) Return to perpendicular
 - b. Bend to 10 degrees from perpendicular for aluminum studs
 - c. Bend flat studs in direction of flat side
 - d. Visually inspect stud, fillet, and workpiece
 - 1) Any tears in fillet indicate a failed test
 - 2) Tears in stud or workpiece material are no cause for rejection
7. Be able to describe how the alternate method of bend testing is performed.
 - a. Bend to 90 degrees from perpendicular or parallel to workpiece
 - 1) Strike with hammer
 - 2) Bend with pipe or bending tool
 - 3) Any direction
 - 4) Do not return to perpendicular
 - b. Bend flat studs in direction of flat side
 - c. Visually inspect stud, fillet, and workpiece
 - 1) Any tears in fillet indicate a failed test
 - 2) Tears in stud or workpiece material are no cause for rejection
8. Be familiar with torque testing of studs and how it is performed.
 - a. May be used instead of bending test for some applications
 - 1) Only with threaded studs
 - 2) Company procedures will specify when torque testing is required
 - b. Performed by tightening down on stud to specified torque on nut
 - 1) Torque wrench
 - 2) Nut
 - 3) Washer
 - 4) Sleeve

- c. Torque specifications
 - 1) MIL-STD-686
 - 2) Company standards
 - d. Failure indications same as for bending test
9. Be familiar with the need for stud repair.
- a. Not covered in this lesson
 - 1) Contact supervisor if necessary for your job
 - b. Never attempt repair of production stud without proper training
10. Be familiar with the need for stud removal or replacement.
- a. Not covered in this lesson
 - 1) Contact supervisor if necessary for your job
 - b. Never attempt removal or replacement of production stud without proper training
11. Be able to describe disassembly, inspection, and stowage of arc stud welding equipment.
- a. Possible special company procedures for disassembly
 - 1) Log of equipment settings
 - 2) Notification of problems
 - b. Visual inspection during disassembly
 - 1) Cables
 - 2) Connectors
 - 3) Components
 - c. Handle electro-mechanical equipment with due care
 - 1) Keep clean
 - 2) Keep dry
 - 3) Keep in good repair

Module 7 - Practice. Upon satisfactory completion of this module, the trainee will:

- 1. Have demonstrated, through the use of simulation, how to visually inspect arc stud welds.
- 2. Have demonstrated, through the use of simulation, the proper re-adjust of equipment to improve arc stud welds.

Module 8 - Examination. Upon satisfactory completion of this module, the trainee will:

1. Have answered ten questions on information presented in Modules 1 through 7.
 - a. Multiple choice (touch 1 of 5 text bars)
 - b. Multiple choice (touch 1 of 4 adjacent buttons)
 - c. Multiple choice (touch 1 of 4 picture windows)
 - d. Alternate choice (touch true/false yes/no)
 - e. Pointing choice (touch object in bitmap or 'clip')
 - f. Pointing choice (touch object in graphic)
 - g. Pointing choice (touch object in still video)
 - h. Keyboard entry (type number answer)
 - i. Keyboard entry (type word answer)
 - j. Keyboard entry (type Function Key or answer code)

Performance Report. Upon satisfactory completion of Module 8 (Examination), trainee performance results will be automatically provided by the TenCORE Producer authoring system.

APPENDIX B
LESSON UNIT DESCRIPTIONS

Appendix B

LESSON UNIT DESCRIPTIONS

Text, Narration, Video, and Graphics
for the
Fundamentals of Arc Stud Welding
Interactive Lesson

Prepared for

NATIONAL SHIPBUILDING RESEARCH PROGRAM
EDUCATION AND TRAINING PANEL SP-9

Prepared by

Ship Analytics, Inc.
North Stonington Professional Center
North Stonington, Connecticut 06359
(93-U-034)

September 1993

Sample Graphics Unit

Unit Identification Number.

Defines text written on screen by TenCORE Producer.

Defines verbal narration on videodisc.

5P11a

T: - Power source
- Controler
- Stud gun
- Welding
- **Welding Control**
- Welding

Power
to workpiece
to controler
to gun
to gun

N: This diagram-shows the set-up and connection of equipment for the arc stud welding of steel. Review it carefully, because you will next be asked to make the connections yourself. Touch "next" when you think you know all the cable connections.

G: Diagram with text overlay of arc stud welding system with all cables connected and all components identified [im5P11]

19550-20

[NEXT] 5Q11a [BACK] 5P11 [] [QUIT] 1G2

Defines graphic presentation on screen.
May be a bitmap drawing, animation, or TenCORE produced "image."
(Pull down "Edit" and open "Qbjects" to verify destination)

Defines flow buttons and "go-to" units.c
(Pull down "set" and open "Elow" to verify destination)

Sample Video Unit

1 P2

T: Arc stud Welding

N: Arc stud welding, also called "arc-drawn" stud welding uses direct current power to produce an electric arc similar to manual shielded arc welding. The stud, which is held in a stud gun, is positioned by the operator on the workpiece and shot by pressing the trigger. The weld usually takes less than a second. The gun is then removed from the stud for visual inspection and testing of the weld, and to "re-load" for the next weld.

Arc stud welding is safe and fast, and produces high-quality welds providing the procedures are closely followed. This lesson describes these procedures at the end, permits you to simulate practice welds by touching the screen.

Touch "next" to continue.

V: Motion medium view with text overlay zoomed to close-up of arc stud welder loading gun, welding studs, and reloading gun

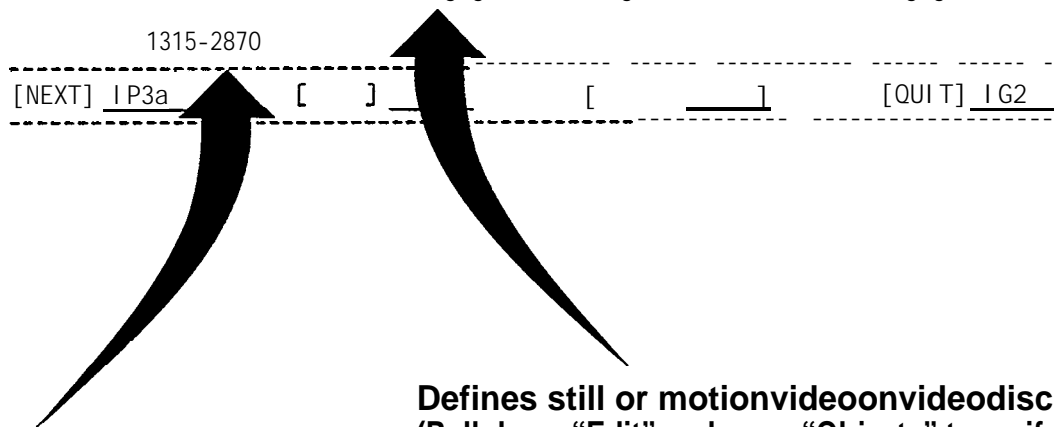

**Defines still or motion video on videodisc.
(Pull down "Edit" and open "Objects" to verify narration and/or video)**

Defines videodisc frame numbers.

Sample Response Unit

- 4M12 T: - Touch to find out more about
- The chuck [4P12J]
 - The ferrule grip [4P14]
 - The lifting mechanism [4P13]
 - To continue the lesson [IM21]
 - [IG1]

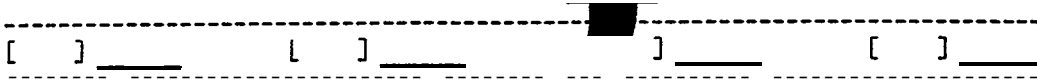

Defines response area and "go-to" unit.
(Pull down "Response" and open selected option to verify destination)

- 1 P3a T: - To quit - touch "QUIT"
- N: If you do not wish to continue the lesson at this point, touch the "quit" button at the bottom of the screen. If at any other time during the lesson you wish to leave the lesson, touch "quit."
- G: Arrow to flow button when text and narration are presented [im1P3]
- [2/1P3b]

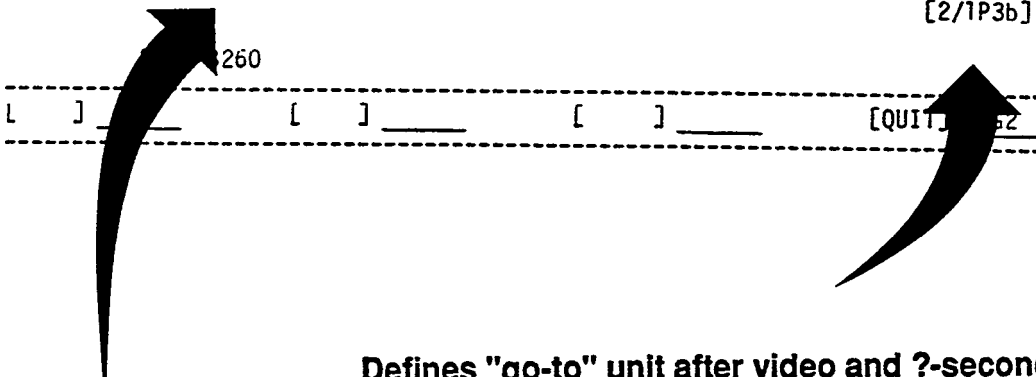

Defines "go-to" unit after video and ?-second pause.

Identifies the "image" that is imported.

"Fundamentals of Arc Stud Melding" Unit Descriptions

Module I - Initialization.

I T: - Module I lead-in unit

[NEXT] next [J _____ [1 _____ [QUIT] end

IP1 T: - Fundamentals of Arc Stud welding
- Touch screen to begin. [IM1]

[J _____ [] _____ [] _____ [] _____

IM1 T: - Touch here if you are training to become an arc stud
welder. [IP1]
- Touch here if you are re-qualifying as an arc stud welder.
[IG1]

[J _____ [] _____ [] _____ [] _____

KEY:

Unit Identification Number as indicated
G = General Comment or Video Pause unit
M = Menu unit
P = Presentation unit
Q = Question unit
R = Remediation unit

T: = Text presented on the screen. Format unspecified.
N: = Narration accompanying motion video, still video, or masked video.
v: = Video - still or motion; wide angle, medium or close-up view; with
overlay identified and content as specified.
G: = Graphics, bitmap or clip - still, moving or animated; with overlay
identified and content as specified.

Numbers immediately above dashed lines identify videodisc frame numbers.
Brackets inside dashed lines identify TenCORE flow buttons that are active.
Identification following brackets indicates flow button destination.

I01 First screening question. Multiple choice with no feedback.

T: - What is not found on the stud gun?
- Touch one

- Chuck adapter [IP1]
- Ferrule grip [IP1]
- Weld time adjustment [IQ2J]
- Lift adjustment [IP1]
- [IG1]

Four TenCORE buttons adjacent to text

[] _____ [] _____ [] _____

I02 Second screening question. Multiple choice with no feedback.

T: - A weld that causes the stud to be too short, with a large irregularly shaped fillet and splatter on the workpiece could possibly be corrected by
- Touch one

- Changing the weld current from 600 to 700 amperes [IP1]
- Changing the weld time from .35 to .40 seconds [IP1]
- Changing the gun lift from 1/16 to 3/32 inch [IP1]
- None of the above [IQ3]
- [IG1]

Four TenCORE buttons adjacent to text

[] _____ [] _____ [] _____ [] _____

I03 Third screening question. Multiple choice with no feedback)

T: - Which of the following statements is false?
- Touch one

- Stick-out should not exceed 1/4 inch. [IP1]
- Studs that are bent to 90 degrees for mechanical testing must be returned to the perpendicular. [IM2]
- Length reduction caused by the weld should not exceed 3/16 inch for most studs. [IP1]
- Lift height for most studs is between 1/32 and 1/8 inch. [IP1J]
- [IG1]

Four TenCORE buttons adjacent to text

[] _____ [] _____ [] _____ [] _____

IM2 T: - Touch the box to review the topic
About the lesson [1P1]
Theory [2P1]
Studs and ferrules [3P1]
Welding equipment [4P1]
Welding procedures [5P1]
Inspections and tests [6P1]
Practice [7G1]
Examination [8Q1]
Quit the lesson [1G1]

Nine custom buttons arranged as a menu

[] _____ [] _____ [] _____ [] _____

IG1 T: - Touch one of the buttons

[2/previous]

[] _____ [] _____ [] _____ [] _____

IG2 T: - Are you sure you want to exit the lesson?
- Touch one!
- Yes [1P1]
- No [previous unit]
- [1G1]

Two TenCORE panel buttons

[] _____ [] _____ [] _____ [] _____

IG3 T: - That is correct!

[2/previous]

[] _____ [] _____ [] _____ [] _____

IG4 T: - That is NOT correct. Try again!

[2/previous]

[] _____ [] _____ [] _____ [] _____

IG5 T: - Touch one of the studs!

[2/previous]

[] _____ [] _____ [] _____ [] _____

Module 1 - About the Lesson.

IP1 T: - Resistance
- Friction
- Percussion
- Electric Arc

N: "Stud welding" is the process of joining a metal stud to a metal workpiece. There are many different types of stud welding: resistance welding, friction welding, percussion welding, and electric welding.

This lesson teaches you the electric process called "arc stud welding."

Another electric process called "capacitor discharge stud welding" is not covered in this lesson. If you are taking this lesson only to learn capacitor discharge welding call your instructor or touch the "quit" button at the bottom of the screen.

Otherwise, touch the button labeled "next" to continue the lesson.

V: Motion wide-angle view with text overlay of arc stud welder performing production work

0001-1310

[NEXT] 1P2 [] _____ [] _____ [QUIT] IP1

IP2 T: Arc stud Welding

N: Arc stud welding, also called "arc-drawn" stud welding uses direct current power to produce an electric arc similar to manual shielded arc welding. The stud, which is held in a stud gun, is positioned by the operator on the workpiece and shot by pressing the trigger. The weld usually takes less than a second. The gun is then removed from the stud for visual inspection and testing of the weld, and to "re-load" for the next weld.

Arc stud welding is safe and fast, and produces high-quality welds providing the procedures are closely followed. This lesson describes these procedures at the end, permits you to simulate practice welds by touching the screen.

Touch "next" to continue.

V: Motion medium view with text overlay zoomed to close-up of arc stud welder loading gun, welding studs, and reloading gun

1315-2870

[NEXT] 1P3a [] _____ [QUIT] IG2

IP3a T: - To quit - touch "QUIT"

N: If you do not wish to continue the lesson at this point, touch the "quit" button at the bottom of the screen. If at any other time during the lesson you wish to leave the lesson, touch "quit."

G: Arrow to flow button when text and narration are presented
[imlP3]

[2/1 1P3b]

2880-3260

[] _____ [] _____ [] _____ [QUIT] IG2

- 1P3b**
- T: - To quit - touch "QUIT"
 - To repeat - touch "BACK"
 - N: If you wish to replay or repeat part of the lesson, touch "back." Try it now!
 - G: Arrow to flow button when text and narration are presented
[imlP3]

3270-3520

[] _____ [BACK] 1P3c [] _____ [QUIT] 1G2

- 1 P3c
- T: (Use same text as 1P3b)
 - N: (Use same narration as 1P3b)
 - G: (Use same graphic as 1P3b)

3530-3680

[NEXT] 1P3d [BACK] 1P3c [] _____ [QUIT] 1G2

- 1P3d**
- T: - To quit - touch "QUIT"
 - To repeat - touch "BACK"
 - To stop - touch "PAUSE"
 - N: If at anytime during the lesson you wish to stop or freeze the action, touch "pause."
 - G: Arrow to flow button when text and narration are presented
[im]

[2/1P3e]

3760-3960

[] _____ [BACK] 1P3d [PAUSE] 1P3d [QUIT] 1G2

IP3e

- T: - To quit - touch "QUIT"
- To repeat - touch "BACK"
- To stop - touch "PAUSE"
- To continue the lesson - touch "NEXT"

N: To continue the lesson touch "next." Or if a Question is asked, touch the screen to answer the question. '

Listen carefully and read all of the information on the screen. If the lesson stops and will not continue, call your instructor.

Now, touch "next."

G: Arrow to flow button when text and narration are presented [implP3]

4010-4610, Seamless: 4610

 [NEXT] IM2 [BACK] IP3a [PAUSE] IG3 [QUIT] IG2

IG3 Video Pause unit ("Still Frame" set to "Current")

 [NEXT] IM2 [BACK] IP3a [PAUSE] IP3e - [QUIT] IG2

Module 2 - Theory.

- 2P1 T: - Stud Gun Chuck
- Stud
- Workpiece
- Ferrule

N: In portable arc stud welding, the stud is held in place by the chuck of the stud gun and is manually aligned on the workpiece by the operator.

At the base of the stud is attached a small ceramic shield called a "ferrule." The ferrule surrounds the stud to contain the molten metal, and shield the arc from the operator.

When the stud is shot, electric current is applied between the stud and workpiece, and an arc is produced as the stud is lifted away from the workpiece. The amount of current, the distance of the lift, and the duration of the arc must be carefully controlled to produce the proper amount of heat.

When the temperature is reached and the metal has melted, the gun automatically plunges the stud into the molten pool on the workpiece.

The stud is allowed to cool for a moment before the gun is withdrawn. Eventually the ferrule is broken away, leaving behind a high quality arc welded stud.

Touch "BACK" if you would like to see the process again.

G: Animated graphics with text overlay to enhance and better illustrate the basic theory of arc welding [im2PIa thru im2PIe]

4635-6620

[NEXT] 2Q1 [BACK] 2P1 [] _____ [QUIT] IG2

- 2Q1 T: - Heat for the weld is created by an electric arc between
- The stud and the ferrule? [IG4]
- The ferrule and the workpiece? [IG4]
- The stud and the workpiece? [2RIa]
- [IG1]

[] _____ [] _____ [] _____ [] _____

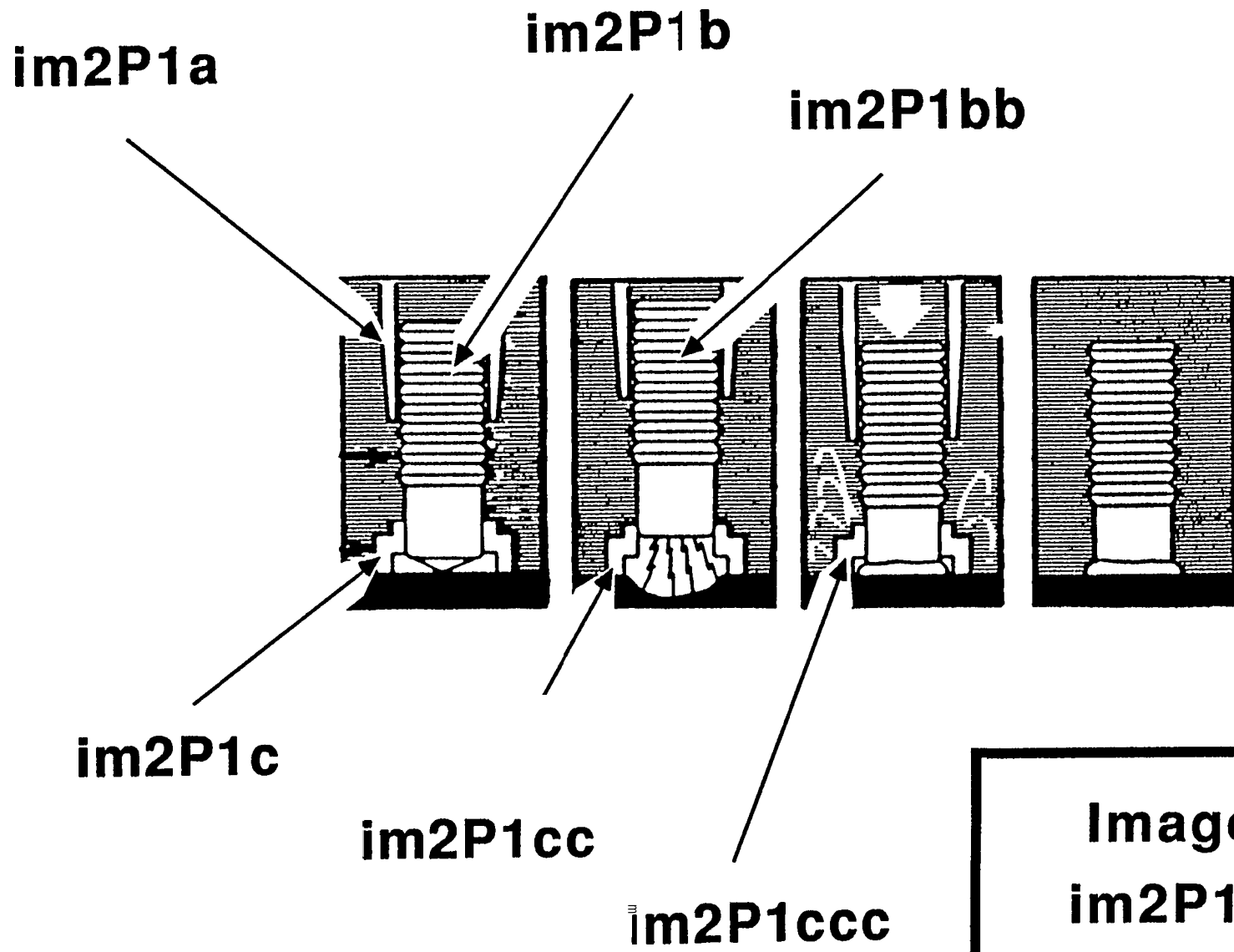

2R1 a T: - That is correct!

[2/202]

[] _____ [] _____ [] _____ [] _____

2Q2 T: - The heat of the weld is determined by the duration of the arc, the length of the arc, and the amount of electric current in the arc.
- True? [2R2a]
- False? [2R2b]
- [IG1]

[] _____ [] _____ [] _____ [] _____

2R2a T: - That is correct!

[2/IM2]

[] _____ [] _____ [] _____ [] _____

2R2b T: - No, that is NOT correct.

[2/2PI]

[] _____ [] _____ [] _____ [] _____

Module 3 Studs and Ferrules.

- 3P1 T: - Stud fasteners come in many sizes, shapes, and materials. If you are not familiar with the different types of studs and how to identify them, check with your instructor.
- To see some different types of studs, touch here: [3P1a]
 - To continue, touch here! [3P2]

[] _____ [] _____ [] _____ [QUIT] IG2

- 3P1a v: Still medium to close-up view close up of various different types of studs arranged on a flat surface.

6630

[NEXT] 3P2 [BACK] 3P1 [] _____ [QUIT] IG2

- 3P2 T: - Always know the material of the stud you are welding.
- The most common materials for arc welded studs are
 - Low carbon steel
 - Stainless steel
 - Aluminum.
 - Aluminum studs require different welding equipment than steel studs. If you are taking this lesson only to weld aluminum studs, check with your instructor before continuing.

[NEXT] 3P3 [BACK] 3P1 [] _____ [QUIT] IG2

- 3P3 T: - Low carbon steel and stainless steel welding requires the use of flux.
- These studs usually have a granular, coated, or solid flux permanently attached to their base. The flux deoxidizes the weld metal and helps stabilize the arc.
 - To see some flux-tipped studs, touch here: [3P3a]
To continue, touch here: [3P4]

[] _____ [BACK] 3P2 [] _____ [QUIT] IG2

3P3a G: Bitmap of flux-tipped studs [im3P3a]

[NEXT] 3P4 [BACK] 3P3 [] _____ [QUIT] 1G2

3P4 T: - Workpiece or "base" material also plays an important part in the arc welding process. Because different metals melt at different temperatures, it is necessary to know both the stud material and the base material to make equipment settings.

[NEXT] 3P5 [BACK] 3P3 [] _____ [QUIT] 1G2

3P5 T: - When a stud is plunged into the pool of molten metal, its overall length is reduced. This is called "length reduction."
- Length reduction varies depending upon the diameter of the stud and the quality of the weld.
- A 3/16 to 1/2 inch diameter stud with a good weld will be reduced in length by 1/8 inch
- A 5/8 to 7/8 inch diameter stud with a good weld will be reduced in length by 3/16 inch
- A 1-inch or larger diameter stud with a good weld will be reduced in length by 3/16 to 1/4 inch
- To determine a good weld, measure length reduction with a rule, "go/no go" gauge, or by holding a new unwelded stud beside the welded stud.

[NEXT] 3Q5 [BACK] 3P4 _____ [QUIT] 1G2

3Q5 T: - What should be the length reduction of a 1/2-inch diameter stud?
- 1/8" length reduction [3R5]
- 3/16" length reduction [3P5]
- 1/4" length reduction [3P5]

[] _____ [BACK] 3P5 [] _____ [QUIT] 1G2

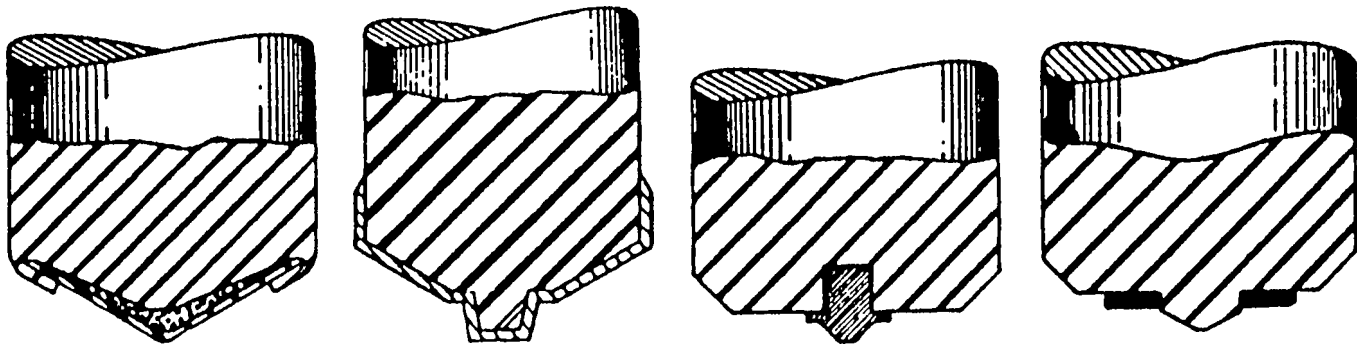

**Image
im3P3a**

3Q5a T: - No. Read this again!

2/3P5

[] _____ [] _____ [] _____ [] _____

3R5 T: - That is correct! Remember
- A 5/8" to 7/8" diameter stud will be reduced by 3/16"
- A 1" or larger diameter stud will be reduced by up to 1/4"

[NEXT] 3P6 [BACK] 3Q5 [] _____ [QUIT] 1G2

3P6 T: - During the weld, molten metal expelled from the pool creates a "fillet" at the base of the stud. A fillet that is the proper size and is evenly distributed at the base of the stud suggests a good weld.

- Although appearance alone is not sufficient evidence to accept or reject a weld. Always visually inspect it before shooting the next one.

[NEXT] 3P10 [BACK] 3P5 [] _____ [QUIT] 1G2

3P10 T: - Ferrules are small ceramic shields placed over the weld end of the stud and held in position by a grip on the stud gun. They are used only once then broken away from the stud with a slag hammer.

- The ferrule
- Concentrates the heat of the arc in the weld area
- Restricts the flow of air into the weld to control oxidation
- Confines the molten metal to the weld area
- Prevents charring of adjacent non-metallic materials
- Shields the welder from the arc

- To see some different types of ferrules, touch here! [3P10a]
- To continue, touch here! [3Q11]

[] _____ [BACK] 3P6 [] _____ [QUIT] 1G2

3P10a V: Still medium to close-up view of various shaped ferrules arranged on a flat surface.

6665

[NEXT] 3Q11 [BACK] 3P10 [] _____ [QUIT] 1G2

3Q11 T: - Touch the sentence that is NOT correct.

- Aluminum studs require different welding equipment than steel studs. [3R11b]
- Flux may be permanently attached to the base of a stud. [3R11c]
- When arc welded, all studs are reduced in length by the same amount. [3R11a]
- Fillet appearance is one indicator of the quality of the weld. [3R11d]
- Ferrules confine the molten metal to the weld area. [3R11e]

[] _____ [] _____ [] _____ [QUIT] 1G2

3R11a T: - Very good! You are now familiar with studs and ferrules.
- Touch NEXT to continue.

[NEXT] 1M2 [BACK] 3Q11 _____ [QUIT] 1G2

3R11b T: - Always know the material of the stud you are welding.

- The most common materials for arc welded studs are
 - Low carbon steel
 - Stainless steel
 - Aluminum.
- Aluminum studs require different welding equipment than steel studs. If you are taking this lesson only to weld aluminum studs, check with your instructor before continuing.

[NEXT] 3Q11 [] _____ [] _____ [QUIT] 1G2

- 3R11c T: - Low carbon steel and stainless steel welding requires the use of flux.
- These studs usually have a granular, coated, or solid flux permanently attached to their base. The flux deoxidizes the weld metal and helps stabilize the arc.

[NEXT] 3Q11 [] _____ [] _____ [QUIT] IG2

- 3R11d T: - During the weld, molten metal expelled from the pool creates a "fillet" at the base of the stud. A fillet that is the proper size and evenly distributed around the base usually indicates complete fusion, and a weld that is free of contaminants and pores.

- Always visually inspect your weld!

[NEXT] 3Q11 _____ [] _____ [QUIT] IG2

- 3R11e T: - Ferrules are used mostly for steel studs. The ferrule is placed over the stud at the weld end, and is held in position by a grip on the stud gun.

- The ferrule
 - Concentrates the heat of the arc in the weld area
 - Restricts the flow of air into the weld to control oxidation
 - Confines the molten metal to the weld area
 - Prevents charring of adjacent non-metallic materials
 - Shields the welder from the arc

[NEXT] 3Q11 [] _____ [] _____ [QUIT] IG2

Module 4 - Welding Equipment.

- 4P1 T: - Components of a portable arc stud welding system
- DC power source
- Control unit
- Stud gun
- Cables and connectors
- N: Arc stud welding equipment consists of a DC power source, control unit, a-hand held stud gun, and all necessary cables and connectors.
- V: Still wide-angle view of all components laid out but not connected

[4P2]

6720-7060

[] _____ [] _____ [] _____ [] _____

- 4P2 T: - The power source
- Motor generator
- Transformer-rectifier
- N: DC power for arc stud welding is usually provided from the same source that is used for manual shielded arc welding.
- V: Zoom up to front panel on power source

[4P3]

7070-7500

[] _____ [] _____ [] _____ [] _____

- 4P3 T: - A 1000-amp power source provides 1000 amps at 50 volts for 1 second

[NEXT] 4P4 [BACK] 4P1 [] _____ [QUIT] IG2

P 4

T: T: -The controller

N: The control unit or "controller" consists of a timing device and an electrical contactor that interrupts the welding current after a set period of time. To interrupt the current, the controller must be connected in series between the stud gun and the power source.

G: Simple diagram with text showing controller between gun and power source [im5P11]

[4P5]

7510-8090

[] _____ [] _____ [] _____ [] _____

4P5

N: Before you connect a controller to a power source, become familiar with its controls, indicators and connections.

The most important part of the controller is the "Weld Time Control." This control permits you to chose the proper time duration of the arc.

A chart is provided to help you set up to shoot the first weld. Following the first shot, inspect and test the weld to determine if the time setting was proper.

Time settings will be different for different size studs. In general, once the correct time setting has been made for a stud; many of the same type of studs can be shot very consistently. It is important to take time to shoot good practice welds before beginning production work.

V: Motion medium view showing the operator using a chart to set the time control on the controller, shooting a stud, visually examining the stud, re-adjusting the time control, shooting another stud, inspecting it, and shooting another stud and inspecting it.

8100-9535, Seamless: 9535

[NEXT] 407 [BACK] 4P5 [PAUSE] 4G5 [QUIT] IG2

4G5

Video Pause unit ("Still Frame" set to "Current")

[NEXT] 407 [BACK] 4P5 [PAUSE] 4P5 - [QUIT] IG2

4Q7 T: - Some control units automatically compensate for changes in electrical power. Unexpected fluctuations in power may occur when

- Current is too high [4R7]
- Weld times are too long [4R7]
- Other welders are operating on the system [4R7]
- Cables are too long [4R7]
- Connectors are loose or defective [4R7]
- Any or all of these [4R7a]
- [IG1]

 [] _____ [] _____ [] _____ [] _____

4R7 T: - 1. Current is high
 - 2. Weld times are long
 - 3. Other welders are operating on the system
 - 4. Cables are too long
 - 5. Connectors are loose or defective
 - 6. Any or all of these

N: Power fluctuations in the power line can occur wherever current is high, weld times are very long, cables are very long or defective, or many users are on the same power source. Some controllers are designed to provide the proper amount of heat required for the weld regardless of these power fluctuations. This equipment automatically increases or decreases weld time whenever there are changes in power.

9540-10430

 [NEXT] 4P8 [BACK] 4Q7 [] _____ [QUIT] IG2

4R7a T: - Very goods! 2/4P8

 [] _____ [] _____ [] _____ [] _____

4P8

- T: - Connectors for welding cables
- Connectors for control cables
- All must be
 - Clean
 - Tight
 - In good repair
- Correct size and length

N: Every power source, controller, and stud gun has connectors for welding cables and control cables. The controller may also require 110-volt operating power.

Be sure to make all connections. They must be clean, tight, and maintained in good repair. Many arc stud welding problems are caused by poor connections. Two common faults are worn contact surfaces and twist-lock connectors that are not fully rotated to the locked position. Check these when setting-up the system.

Cable size and length are also very important. Power loss may be caused by cables that are either too small or too long. Current to the gun can be reduced by as much as one half if you select the wrong cables.

V: Motion close-up view with text overlay of operator stringing cable, visually inspecting connectors, and making connections to equipment and workpiece

10440-12060, Seamless 12060

 [NEXT] 4P9 [BACK] 4P8 [PAUSE] 4G8 [QUIT] 1G2

4G8 Video Pause unit ("Still Frame" set to "Current")

 [NEXT] 4P9 [BACK] 4P8 [PAUSE] 4P8 - [QUIT] 1G2

- 4P9 T: - Small guns for studs up to 5/8 inch
 - Large guns for studs up to 1 1/4 inches
 - Whenever possible use small gun for small studs
- N: The heart of the portable arc stud welding system is the hand-held stud gun. It resembles a pistol and is made of high impact-strength plastic. It weighs from 4 1/2 to 5 pounds.
- Small stud guns are used for up to 5/8-inch diameter studs. Larger guns are used for studs up to 1/4 inches. When small diameter studs are being shot, it is best to use the small, light-weight gun.
- V: Motion medium view with text overlay of welder holding a large gun in one hand and a small gun in the other. Zoom to close-up view of gun (whichever) that will be illustrated next.

12070-12510, Seamless: 12510

 [NEXT] 4P10 [BACK] 4P9 [PAUSE] 4G9 [QUIT] IG2

4G9 Video Pause unit ("Still Frame" set to "Current")

 [NEXT] 4P10 [BACK] 4P9 [PAUSE] 4P9 - [QUIT] IG2

- 4P10 T: - Support stud and ferrule
 - Touch to make electrical contact
 - Align stud perpendicular to workpiece
 - Lift stud to produce electrical arc
 - Plunge stud into molten metal on workpiece

[3/4PI 1]

 [] _____ [] _____ [] _____

4P11 T: - Stud
 Ferrule
 Foot
 Ferrule grip
 Ferrule grip set screw
 Leg
 Leg set screw
 Plunge damper
 Chuck
 Chuck adapter
 Lift adjustment
 Trigger
 Weld cable connector
 Control cable connector
 When you think you know all the parts, touch "NEXT."

N: This is the stud gun loaded with a "stud" and "ferrule." The "foot" of the gun contains the "ferrule grip" and "ferrule grip set screw." The ferrule grip holds the ferrule in place until the stud is shot. The foot is attached to the gun by two "legs." Stick-out of the stud beyond the ferrule is adjusted with the "leg set screws" located near the "plunge damper."

The "chuck" is connected to the gun at the "chuck adapter" and holds the stud securely in place. The "lift adjustment" controls how high the stud is raised when it is shot.

This is the "trigger." The "weld cable" and "control cable" connect at the base of the hand grip.

G: Bitmap or clip of stud gun clearly showing all parts above, with parts identified when they are described in the narration. [im4P11]

12520-13840

 [NEXT] 4P11a [] _____ [] _____ [QUIT] 1G2

4P11a N: Name the part, then touch it to see if you are correct. Touch "quit" when you know all the parts of the stud gun.

G: Bitmap or clip of stud gun clearly showing all parts listed on 4P11. Use TenCORE alternating feedback to provide opportunity for trainee to practice identifying parts [im4P11]

13850-14110

 [] _____ [] _____ [] _____ [QUIT] 4P11b

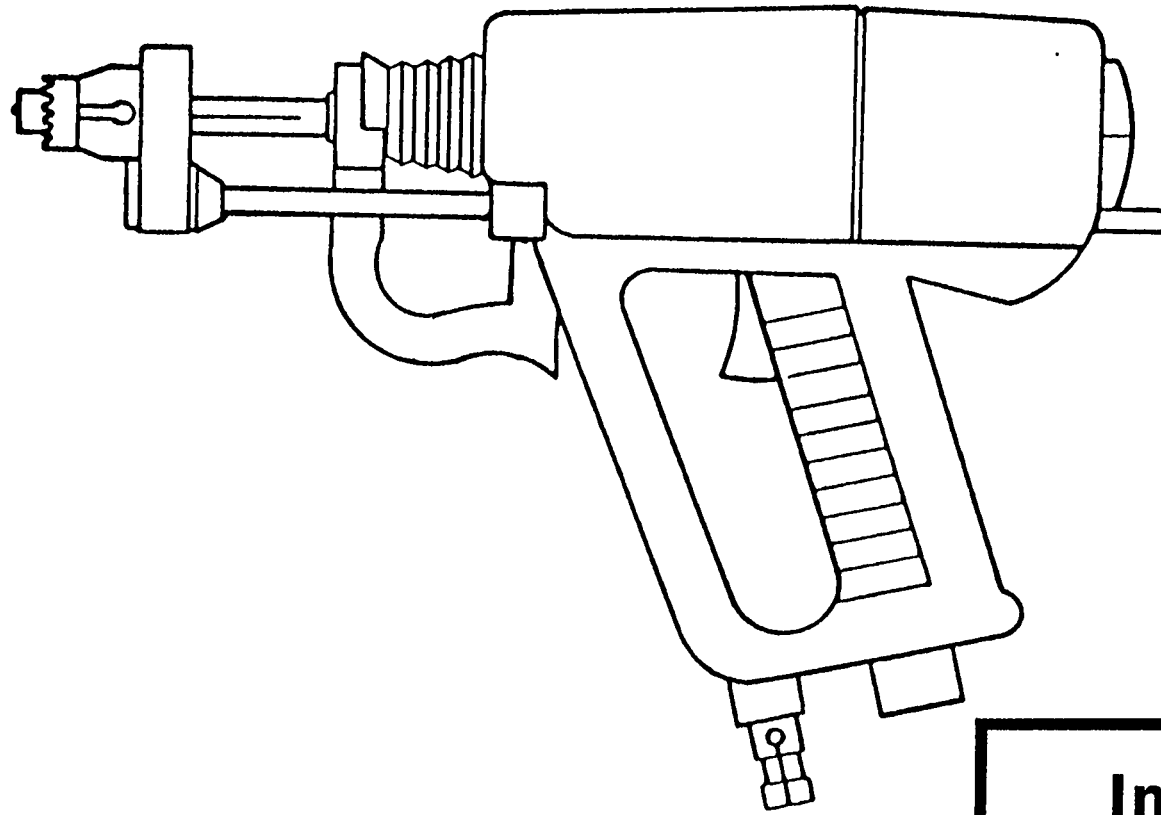

**Image
im4P11**

4P11 b T: - Now you show me: [2/4Q11a]

[] _____ [] _____ [] _____ [] _____

4Q11 a T: - Touch the Ferrule [4Q11 b]
- [4G11]
G: Bitmap or clip of stud gun clearly showing all parts [im4P11]

[] _____ [BACK] 4P11 [] _____ [QUIT] IG2

4Q11 b T: - Touch the Chuck. [4Q11 c]
- [4G11]
G: Bitmap or clip of stud gun clearly showing all parts [im4P11]

[] _____ [BACK] 4P11 [] _____ [QUIT] IG2

4Q11 c T: - Touch the lift adjustment [4Q11 d]
- [4G11]
G: Bitmap or clip of stud gun clearly showing all parts [im4P11]

[] _____ [BACK] 4P11 [] _____ [QUIT] IG2

4Q11 d T: - Touch the plunge damper adjustment [4M12]
- [4G11]
G: Bitmap or clip of stud gun clearly showing all parts [im4P11]

[] _____ [BACK] 4P11 [] _____ [QUIT] IG2

4M12 T: - Touch to find out more about
- The chuck [4P12]
- The ferrule grip [4P14]
- The lifting mechanism [4P13]
- To continue the lesson [IM2]
- [IG1]

[] _____ [] _____ [] _____ [] _____

4G11 T: - That is not correct. Try another part of the gun.
[2/previous]

[] _____ [] _____ [] _____ [] _____

4P12 T: - You may need to change the chuck when you change the type of stud you are using.
- Always inspect the condition of the chuck.

[] _____ [BACK] 4M12 [] _____ [] _____

4P13 T: - The lifting mechanism on-the gun consists of
- A solenoid
- A clutch
- A mainspring
- The lift height for all studs is between 1/32 and 1/8 inch

[] _____ [BACK] 4M12 [] _____ [] _____

4P14 T: - You may also need to change the ferrule grip when you change the type of stud you are using
- Always inspect the ferrule grip to make sure it holds the ferrule securely.

[] _____ [BACK] 4M12 [] _____ [] _____

Module 5 - Welding Procedures.

- 5P1 T: - Hard hat
- Safety glasses
- Protective clothing, leather apron
- Gloves
- Safety shoes

N: Before setting up the arc stud welding workstation, there are safety precautions that must be observed. Follow all safety procedures that are required by your company.

As in all welding processes, protect your head, eyes, and face with a properly fitting hard hat, safety glasses; and face shield if your company requires it. Protect your body from weld splatter with protective clothing such as properly fitting coveralls, leather apron, gloves, and safety shoes. Always wear your gloves when handling metal.

V: Still window of each item or welder wearing all items

[5Q2]

14120-15225

[] _____ [] _____ [] _____ [] _____

- 5Q2 T: - Touch the safety violation. [5R2a]
- There are no safety violations [5R2b]
- [5R2b]

V: Still wide-angle view of welder shooting studs without gloves.

15240

[] _____ [] _____ [] _____ [] _____

- 5R2a T: - That is correct. Gloves must always be worn when shooting studs .

[3/5P7]

_____ [] _____ [] _____ [] _____

5R2b T: - The welder is not wearing gloves. Always wear gloves when shooting studs.

[3/5P2a]

[] _____ [] _____ [] _____ [] _____

5P2a T: - Remove potential fire hazards (im5P2a1)
- Notify nearby workers (im5P2a2)
- Ensure there is a firewatch (im5P2a3)

N: Before starting any work, remove all potential fire hazards from the welding area and notify nearby workers that you are beginning work. Be sure there is a firewatch in the area.

[5P2b]

15265-15640

[] _____ [] _____ [] _____ [] _____

5P2b T: - Inspect for damaged or missing equipment (im5P2b1)
Check with supervisor before attempting repairs (im5P2b2)

N: Do not weld with damaged or incomplete equipment. Never repair stud welding equipment without first checking with your supervisor.

[5P2c]

15650-15940

[] _____ [] _____ [] _____ [] _____

5P2c T: - Keep dry (im5P2c)

N: Do not stand in water while stud welding. Do not weld when work is exposed to rain or snow. Do not allow controller, cables, or stud gun to become wet.

[5P2d]

15950-16350

[] _____ [] _____ [] _____ _____

5P2d T: - Never Look at arc (im5P2d)

N: Although it is mostly shielded by the ferrule, never look directly at the welding arc.

[5P2e]

16360-16560

[] _____ [] _____ [] _____ [] _____

5P2e T: - Always follow company procedures (im5P2e)

N: Always follow your company's welding safety procedures.

[5P7]

16570-16705

[] _____ [] _____ [] _____ [QUIT] 1G2

5P7 T: - Shoot 5 practice welds

- Before shooting any production studs
- At the beginning of each work period
- Whenever stud type or material is changed
- Whenever workpiece material is changed
- When changing from downhand to a vertical surface
- Whenever the quality of welds changes

N: Now that you are familiar with arc stud welding theory and arc stud welding equipment, you are ready to set up a workstation and shoot five practice welds.

Five practice welds must always be shot, inspected, and tested each time arc stud welding equipment is set up; whenever the type of stud or workpiece material is changed; when you change from downhand to a vertical surface; or when the quality of the weld changes.

All five practice studs must be the same type that will be used for production. The practice "baseplate" must also be the same-material as the production workpiece.

V: Motion medium view of shooting five good practice studs (onto a baseplate) without any adjustments to equipment

16715-17940, Seamless: 17940

[] _____ [BACK] 5P7 [PAUSE] 5G7- [QUIT] 1G2

5G7 Video Pause unit ("Still Frame" set to "Current")

[] _____ [BACK] 5P7 [pAUSE] 5P7 - [QUIT] 1G2

- 5P7a T:
- Select studs and ferrules
 - Prepare workpiece
 - Obtain, inspect, connect equipment
 - Select and install chuck and ferrule grip
 - Make initial adjustments and settings
 - Insert stud and ferrule into gun
 - Align and shoot

[3/5P9]

[] _____ [] _____ [] _____ [] _____

- 5P9 T:
- No dirt (in 5P9)
 - No rust
 - No grease
 - No moisture
 - No paint - no primer

N: Clean the work surface where the stud is to be welded using standard metal cleaning procedures. It is important to remove all contaminants which could effect the quality of the weld. The weld location must be free of dirt, "rust," grease, moisture, and all traces of paint.

Studs can be shot through some primer coatings. Check with your supervisor if the workpiece is primed.

[5P10]

17950-18730

[] _____ [] _____ [] _____ [] _____

5P10 T: - Determine the temperature of the base material?
 - Preheat when below 60 degrees F
 - Preheat to above 120 degrees F
 - Use soaking preheat

N: Determine the temperature of the base material. Your company's procedures may require that when the base material falls below 60 degrees Fahrenheit, preheat must be applied and the temperature raised to 120 degrees before arc stud welding can occur. The use of a "soaking" preheat is desirable. It allows all of the base material to reach preheat temperatures.

18740-19540

 [NEXT] 5Q10 [BACK] 5P7a [] _____ [QUIT] IG2

5Q10 T: - When should preheat be applied to the base material?
 When it is damp. [no]
 When it is above 120 degrees F [no]
 - When it is painted or primed [no]
 When it is below 60 degrees F [5R10]
 - [IG1]

Use TenCORE feedback

 [] _____ [] _____ [] _____ [] _____

5R10 T: - Good! [2/5PIIa]

 _____ [] _____ [] _____ [] _____

- 5P11a T: - Power source drawer
 - Controller
 - Stud gun
 - Welding cable to workpiece
 - Welding cable to controller
 - Control cable to gun
 - Welding cable to gun

N: This diagram shows the set-up and connection of equipment for the arc stud welding of steel. Review it carefully, because you will next be asked to make the connections yourself. Touch "next" when you think you know all the cable connections.

G: Diagram with text overlay of arc stud welding system with all cables connected and all components identified [im5P11]

19550-20090

 [NEXT] 5Q11a [BACK] 5P11 [] _____ [QUIT] IG2

5Q11a N: Touch where to connect the other end of this welding cable.

G: Diagram with one end of welding cable connected to positive terminal on power source [im5P11]

20100-20260

 [] _____ [] _____ [] _____ [] _____

5Q11b N: Touch where to connect the other end of this welding cable.

G: Diagram with one end of welding cable connected to negative terminal on power source [im5P11]

20270-20390

 [] _____ [] _____ [] _____ [] _____

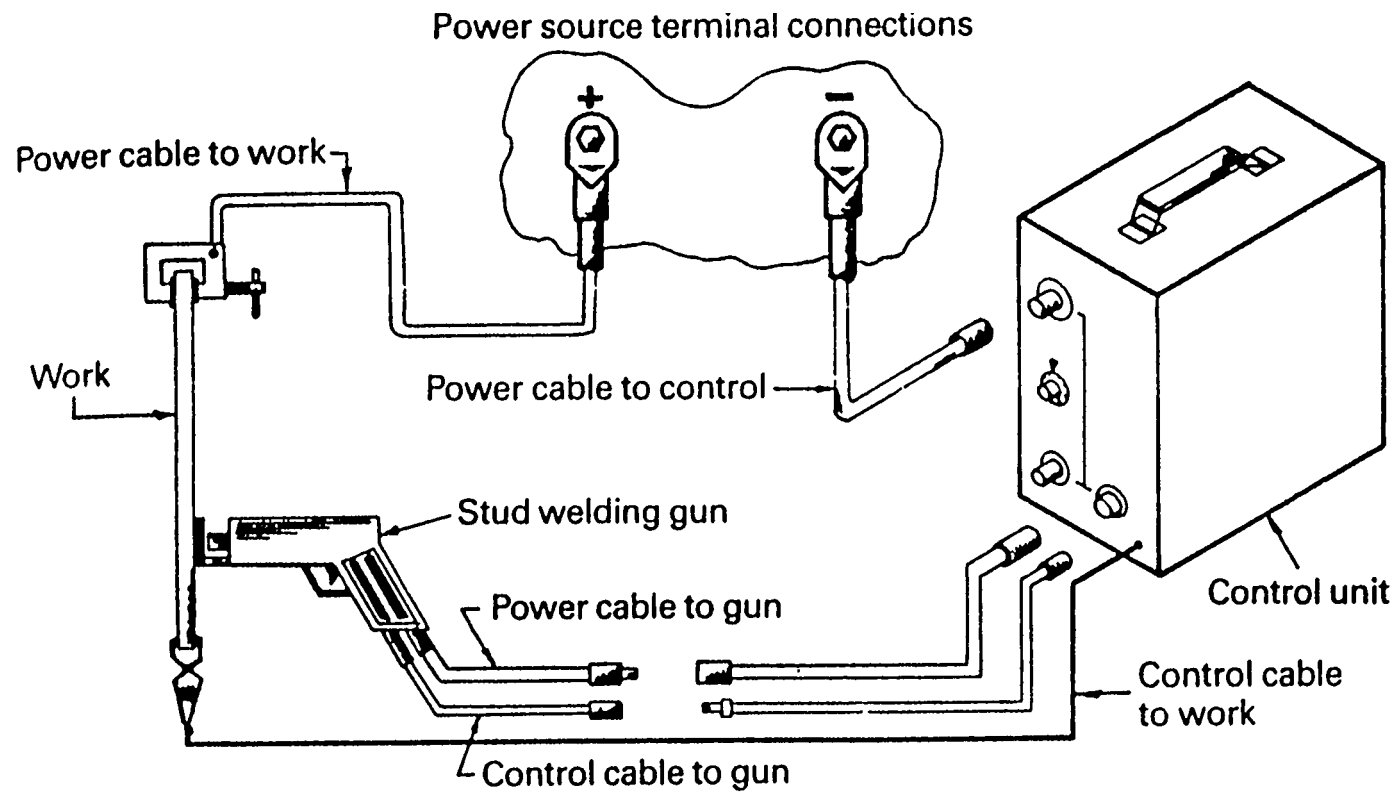

**Image
im5P11**

5Q11 c N: Touch where to connect the other end of this control cable.

G: Diagram with one end of control cable connected to controller
[im5P11]

20570-20685

[] _____ [] _____ [] _____ [] _____

5Q11 d N: Touch where to connect the other end of this welding cable.

G: Diagram with one end of welding cable connected to the gun
[im5P11]

20440-20560

[] _____ [] _____ [] _____ [] _____

5Q11 e T: - Good job! you're all set up.

[2/5P12]

[] _____ [] _____ [] _____ [] _____

5P12

- T: - Power off
- Adjust for 1/8 to 1/4 inch 'stick-out'

- N: Now that you have connected the power equipment, you need to make some important adjustments to the gun.

First, make sure the power source and controller are both off. Select the proper size chuck and ferrule grip for your stud and ferrule. Loosen the leg adjustment with an "L" wrench, and remove the entire foot assembly.

Loosen the ferrule set screw on the foot and replace the ferrule grip. Pull the chuck directly off the gun to remove it. Replace it with the proper size chuck. Make sure the new chuck is tightly seated into the tapered chuck adapter. Inspect both the ferrule grip and chuck to make sure they are not broken, bent, or worn.

Re-install the foot assembly but do not tighten the set screws. Place a stud in the chuck, and a ferrule in the grip. Make sure both are securely seated. Inspect the ferrule to make sure it is not deformed or broken. Use only dry ferrules.

Holding the gun with one hand, adjust the foot assembly with the other so that the weld end of the stud extends 1/8 to 1/4 inch beyond the ferrule. Use a rule to measure it. Also, make sure the ferrule is exactly concentric to the stud. This will prevent the stud from getting hung up on the ferrule when it is shot.

Tighten the foot assembly set screws and re-check the 1/8 to 1/4 inch "stick-out."

Except for one more adjustment, the "lift adjustment," the stud gun is now set-up and ready to shoot studs. Leave the stud and ferrule installed in the gun for your first practice shot.

- V: Motion close-up view of chuck and ferrule grip replacement, and stud and ferrule installation with text overlay. Try to follow steps in narration closely with video or modify narration as required.

20695-23990, Seamless: 23990

[NEXT] 5P13 [BACK] 5P12 [PAUSE] 5G12 [QUIT] 1G2

5G12 Video Pause unit ("Still Frame" set to "Current")

[NEXT] 5P13 [BACK] 5P12 [PAUSE] 5P12 - [QUIT] IG2

- 5P13 T: - Using the "Weld Current vs. Weld Time" curve, set
- Weld current - amperes
- Weld time - seconds
- N: Estimates for initial equipment settings appear on diagrams provided by your company or the equipment manufacturer. One type of diagram may look like this.

The first setting is for welding current. This adjustment is usually made at the power source, but on some systems it may be made at the controller.

The curve shows that a 5/8 steel stud will require a welding current of between 1400 and 1000 amps depending upon the weld time. If we set our power source to deliver 1200 amps, then we must set the weld time on the controller to 0.6 seconds.

- G: The "Weld Current vs. Weld Time" curve with moving arrows corresponding to description in narration. [im5P13]

24000-25220

[NEXT] 5Q13 [BACK] 5P13 [] _____ [QUIT] IG2

- 5Q13 T: - What weld time is needed to shoot a 3/8 inch stud at 600
amps of weld current?
- Less than 0.2 seconds [5R13b]
 - Between 0.3 and 0.4 seconds [5R13a]
 - 0.3 seconds only [5R13b]
 - Between 0.5 and 0.8 seconds [5R13b]
 - [IG1]

- G: The same 'Weld Current vs. Weld Time' curve without arrows
[im5P13]

_____ [] _____ [] _____ [QUIT] IG2

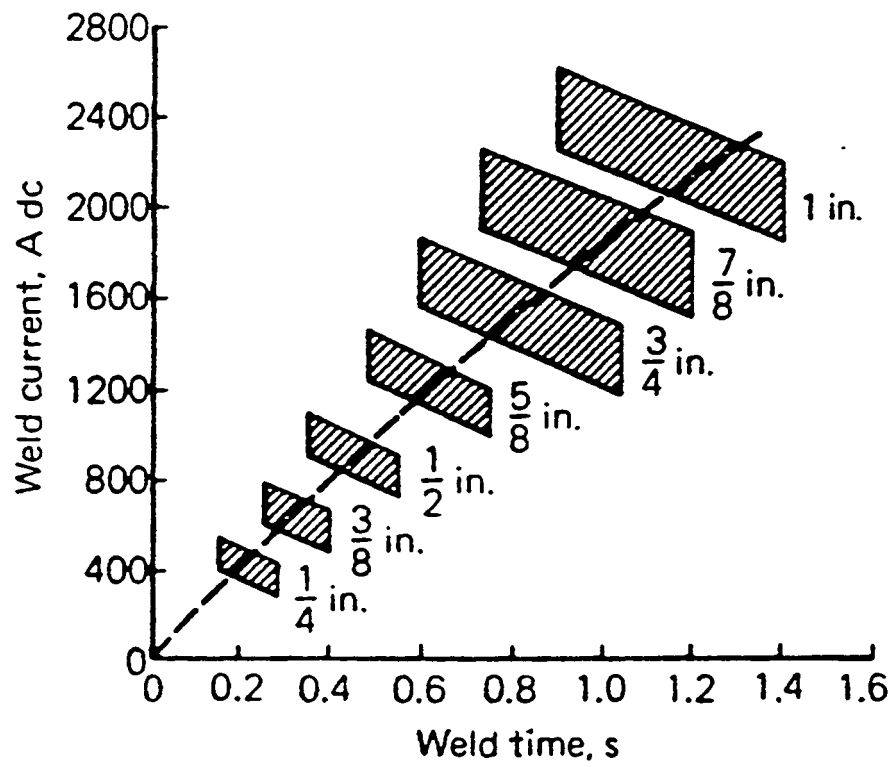

**Image
im5P13**

5R13a T: Good job: Would you like to try another?

- Try another [5Q13a]
- Continue lesson [5P14]
- [IG1]

[] _____ [] _____ [] _____ [QUIT] IG2

5R13b N: That is NOT correct. The curve shows that a 3/8 inch steel stud shot at 600 amps will require between 0.3 and 0.4 seconds weld time.

Draw a line from 600 amps to the shaded area labeled "3/8 in." Draw a line from the beginning of the shaded area and the end of the shaded area down to "Weld Time." The weld time setting can be anywhere between 0.3 and 0.4 seconds.

G: The "Weld Current vs. Weld Time" curve with moving arrows corresponding to description in narration [im5P13]

25230-26190

[NEXT] 5Q13a [BACK] 5R13b [] _____ [QUIT] IG2

5R13c N: That is NOT correct. The curve shows that a 3/4 inch steel stud shot at 1200 amps will require exactly 1.05 seconds weld time.

Draw a line from 1200 amps to the shaded area labeled "3/4 in." Draw a line from the shaded area down to "Weld Time." weld time setting can only be 1.05 seconds.

G: The "Weld Current vs. Weld Time" curve with moving arrows corresponding to description in narration [im5P13]

26200-27060

[NEXT] 5P13 [BACK] 5R13c [] _____ [QUIT] IG2

5R13d T: - That is correct. You've got it!

[2/5P14]

[] _____ [] _____ [] _____

- 5Q13a T: - What Weld Time is needed to shoot a 3/4 inch stud if only 1200 amps of weld current is available?
- Exactly 1.05 seconds [5R13d]
 - Between 0.6 and 1.0 seconds [5R13c]
 - 10 seconds [5R13c]
 - None of the above [5R13c]
 - [IG1]

G: The same 'Weld Current vs. Weld Time' curve without arrows [im5P13]

 [] _____ [] _____ [] _____ [QUIT] IG2

- 5P14 T: - Using a different kind of "set-up" table, set
- Weld current - amperes
 - weld time - seconds
 - Gun lift - inches

N: This is a different kind of diagram, but it contains the same information and is used for the same purpose. It is more like the type you will find with your equipment. It also contains a third setting which is "gun lift."

Using this table, determine the proper "weld amps," "time seconds," and "gun lift" for a 5/16 "base diameter" stud.

The initial weld amps setting is made at the power source or controller. It would be 600 amps.

The initial time setting is made on the controller. It would be .3 seconds.

The initial lift setting is made on the gun. It would be 1/16 inch.

G: The "set-up table" with moving arrows corresponding to description in narration [im5P14]

27070-28390

 [NEXT] 5Q14 [BACK] 5P14 [] _____ [QUIT] IG2

PARAMETERS FOR STEEL (DOWNHAND)

Thread Size (Inches)	Base Diameter Inches	Weld Amps	Time Sec.	Gun Lift
3/16	3/16	600	.2	1/16
1/4	.215	600	.2	1/16
	1/4	600	.2	1/16
5/16	.275	600	.3	1/16
	5/16	600	.3	1/16
3/8	.330	600	.35	1/16
	3/8	600	.4	1/16
1/2	.448	900	.45	1/16
	1/2	900	.45	1/16

**Image
im5P14**

- 5Q14 T: - Using this same table, determine what welding current, welding time, and gun lift adjustment should be set to shoot a 1/2 inch steel stud.
- 600 amps, .4 seconds, 1/16 inches [5R14]
 - 900 amps, .35 seconds, 1/2 inches [5R14]
 - 900 amps, .45 seconds, 1/16 inches [5P15]
 - 900 amps, .45 seconds, 1/2 inches [5R14]
 - [IG1]

G: The. same 'generic set-up table' without arrows [im5P14]

 [] _____ [] _____ [] _____ [QUIT] IG2

- 5R14 N: That is NOT correct. The table shows that a 1/2 inch steel stud should be shot at 900 amps for .45 seconds with a 1/16 inch gun lift.

Draw a line from the 1/2 inch stud base diameter, directly across the chart and read the values.

G: The "Weld Current vs. Weld Time" curve with moving arrows corresponding to description in narration [im5P14]

28400-29040

 [NEXT] 5Q14a [BACK] 5R14 [] _____ [QUIT] IG2

- 5Q14a T: - This time determine what welding current, welding time, and gun lift adjustment should be set to shoot a 1/4 inch steel stud.

- 600 amps, .2 seconds, 1/16 inches [5P15]
- 600 amps, .35 seconds, 1/16 inches [5 R14a]
- 600 amps, .2 seconds, 1/4 inches [5 R14a]
- 900 amps, .2 seconds, 1/16 inches [5 R14a]
- [IG1]

G: The same 'generic set-up table' without arrows [im5p14]

 [] _____ [] _____ [] _____ [QUIT] IG2

T: Not quite. Try once more!

[2\5Q14a]

[] _____ [] _____ [] _____ [] _____

V5P15 N: Very good! Remember that the base diameter is often less than the diameter at the threads. For example, even if it is called a 5/8-inch stud; if it has a 1/2-inch base, the arc stud welding equipment should be set up for a 1/2-inch stud.

G: Graphic of "5/8-inch stud, illustrating 5/8" diameter threads and 1/2" diameter base.

29050-29575

[NEXT] 5P17 [BACK] 5P15 [] _____ [QUIT] IG2

5P17 T: - Shallow centerpunch mark
- Template

N: The method of positioning a stud depends upon how accurately it must be located. A common procedure for positioning studs is to lay out and centerpunch their locations either directly on the workpiece or through a template.

Use caution to avoid deep punch marks. These will cause the fluxing action to be lost, and the stud will "rim-fire."

V: Motion medium shot of operator energizing the system. Zoom to hand holding gun with finger away from trigger, then to close-up view of gun aligning on a centerpunch mark.

29585-30350

[NEXT] 5P18 [BACK] 5P17 [] _____ [QUIT] IG2

5P18 N: Align the gun perpendicular to the work surface. The ferrule should be firmly seated against the workpiece. Hold the gun with both hands being careful not to interfere with moving parts of the gun. Prepare to hold the gun steady for about one second.

Press the trigger and release it. Do not trigger again. Do not look directly at the weld, but make a mental note of the intensity of the light and the sound that it produces.

Hold the gun in position until the red glow from welding has disappeared, then remove the gun from the stud by drawing it directly off the top of the stud. Be careful not to twist or bend the stud with the gun.

After the stud is shot and the gun is removed, the ferrule remains behind on the stud. It is broken away with a slag hammer.

V: Continued previous motion close-up view of shooting stud, removing gun, and breaking away the ferrule.

[NEXT] 5P19 [BACK] 5P18 [] _____ [QUIT] 1G2

5P19 T: As in all arc welding processes, much can be learned about the quality of the weld by the brilliance of the arc and its sound. The proper stud welding arc should produce a bright blue-white light and a relatively loud cracking sound for the full duration of the weld. If the light is dim and yellowish, or sounds like a hiss or a pop, the weld is probably defective.

[NEXT] 5P20 [] _____ [] _____ [QUIT] 1G2

5P20 N: The screen has now darkened. You will see 4 simulated flashes of light and hear 4 sounds of actual arc stud welds. After you have heard them, you will be asked which one; the first, second, third, or fourth you think produced the best arc stud weld.

Touch the screen when you are ready. [5P21a]

32120-32840

[] _____ [] _____ [] _____ [] _____

5P21a G: Flood screen with long (.8 second) dim blue-white color in synchronization with crackle [crackle]

V: Sound of a hot weld.

[.8/5P21b]

32880-32915



5P21b G: Flood screen with short (.1 second) dim gray-white color in synchronization with pop [pop]

V: Sound of a hang-up weld.

[.1/5P21c]

33055-33085



5P21c G: Flood screen with normal (.3 second) bright yellow-orange color in synchronization with hiss [hiss]

V: Sound of a cold weld.

[.3/5P21d]

33185-33205



5P21d G: Flood screen with normal (.3 second) bright blue-white color in synchronization with buzz [buzz]

V: Sound of a good weld.

[.3/5P21e]

33305-33335



5P21e G: Black screen for 5 second pause [no image]

[5/5021]



5Q21 T: - Which flash and sound *do you* think produced **the best weld**.

- 1st [5R21c]
- 2nd [5R21b]
- 3rd [5R21a]
- 4th [5R21d]
- [IG1]

N: Which flash and sound do you think produced **the best weld**?
The first, second, third or the **fourth**?

Text overlay and question/answer format after all four flashes and sounds are presented.

33400-33690

[] _____ [] _____ [] _____ [] _____

5R21a T: - No, that was a hot weld. Try again; [crackle]

[NEXT] 5P20 [] _____ [] _____ [] _____

5R21 b T: - No, that was a hang-up weld. Try again! [pop]

[NEXT] 5P20 [] _____ [] _____ [] _____

5R21c T: - No, that was a cold weld. Try again! [hiss]

[NEXT] 5P20 [] _____ [] _____ [] _____

5R21d T: - Correct! That was probably a good weld, but it still needs
close visual inspection and a mechanical test [buzz]

[NEXT] IM2 [BACK] 5P20 [] _____ [QUIT] IG2

Module 6 - Inspections and Tests.

- 6P1 T: - Stud free from nicks and burrs
- Threads undamaged
- Discoloration on base of stud only
- On Workpiece
- Star pattern well defined with even points
- No splatter or berries
- Inspect fillet
- Measure length reduction

N: After you have shot your first practice stud and lifted the gun straight off the stud, break away the ferrule with your slag hammer and visually inspect the weld.

The stud should be standing perpendicular to the workpiece. It should be free of nicks and burrs, and the threads should be undamaged. There may be some discoloration of the stud near the base, but it should not extend all the way up the stud. There may also be some discoloration on the workpiece near the weld.

Look at the "star" pattern on the workpiece. This is caused by the "blow out" of gases during the weld. The star should be well defined, indicating that the ferrule was securely and properly placed, and the "points" of the star should be evenly distributed and shaped all the way around the base of the stud. There should be no splatter berries or stringers leading from the vent holes in the ferrule.

Closely examine the fillet at the base of the stud.

v: Motion zoom to still close-up view of each item with text overlay at the same time the item is described in the narration.

33700-35520

[NEXT] 6P2 [BACK] same [] _____ [QUIT] IG2

- 6P2 T: - Good weld
- N: On a good weld, the fillet is evenly distributed all the way around the base of the stud. The fillet has a shiny surface with smooth serrations around the edge. The stud measures 1/8 to 3/16 inch less than before it was welded. It must still be tested, however.
- This shows a good weld with good stud length and fillet formation. If you shoot this weld with your first practice shot, continue to shoot four more practice studs.
- V: Still close-up view of "good weld" stud. Picture must show a stud with the correct length, a proper size and shaped fillet with shiny surface and smooth serrations, and a uniform star pattern with no splatter on the workpiece. Text overlay, "good weld," at beginning of narration only.

35670-36695

 [NEXT] 6P3 [BACK] previous [] _____ [QUIT] 1G2

- 6P3 T: - Short plunge
- Re-adjust legs. Less than 1/4 inch 'stick-out'
 - Correct malfunction or restricted movement
- N: This shows a stud weld in which the plunge is too short. It is marked by a "long" stud and an irregular shaped, partially missing fillet. Re-adjust the legs of the gun so that the stud extends a little further beyond the ferrule. However, do not allow the stud to extend more than 1/4 inch beyond the ferrule. If that is necessary, there is another problem.
- V: Still close-up view of "short plunge" stud. Picture must show a stud that is too long with an irregular shaped, partially missing fillet. Text overlay, "short plunge," at beginning of narration only.

36705-37475

 [NEXT] 6P4 [BACK] previous [] _____ [QUIT] 1G2

6P4 T: - Hang-up
- Re-align components
- Loosen and reset lift adjustment

N: This illustrates a "hang-up." The stud did not plunge into the weld pool although a satisfactory weld pool was created. The condition may be corrected by realigning the foot assembly on the gun to ensure the stud's freedom of movement during lift and plunge. Arc length may also require some adjustment. If neither of these solutions solve the problem, the gun may be inoperative and should be replaced.

V: Still close-up view of "hang-up" stud. Picture must show a stud that is too long with an irregular shaped, partially missing fillet. Text overlay, "hang-up," at beginning of narration only.

37485-38355

[NEXT] 6P5 [BACK] previous [] _____ [QUIT] IG2

6P5 T: - Poor alignment
- Concentrate on perpendicular alignment
- Continue practice shots

N: This stud shows poor alignment which may have been caused by not positioning the stud gun perpendicular to the workpiece. Shoot four more practice welds, paying special attention to gun alignment.

v: Still close-up view of "poor alignment" stud. Picture must show a stud that is too long, bent or angled not perpendicular to the workpiece, and with an irregular shaped partially missing fillet. Text overlay, "poor alignment," at beginning of narration only.

38365-38820

[NEXT] 6P6 [BACK] previous [] _____ [QUIT] IG2

6P6

T: - Too cold

- 1st - Check ground and all other connections. If proper, slightly increase weld time at controller and re-shoot weld.
- 2nd - Check lift setting on gun. If proper, slightly increase welding current at power source or controller and re-shoot weld.
- 3rd - Further increase weld time and re-shoot weld.

N: This stud shows the results of too low weld power or too short welding time. The stud may be too long, and the fillet may be small and irregular. The fillet will be gray with a grainy surface texture. Cold welds are more difficult to detect visually but they will most certainly fail the mechanical test that follows.

For a suspected cold weld, first check all ground and cable connections. If they are secure, increase welding time slightly. It may also be necessary to increase welding current or the lift setting on the gun. It may be necessary to shoot several studs, making minor adjustments between each shot, before a satisfactory weld is achieved.

V: Still close-up view of "cold weld" stud. Picture must show a stud that is too long, with a small and irregularly shaped fillet that is gray in color and has a grainy surface texture. Text overlay, "cold weld," at beginning of narration only.

38830-40255

[NEXT] 6P7

[BACK] previous

[] _____

[QUIT] IG2

6P7

T: - Too hot

- 1st - Check to see if current and lift settings are proper. If so, slightly reduce weld time at the controller and re-shoot weld.
- 2nd - Slightly decrease current and re-shoot weld.
- 3rd - Slightly decrease the lift adjustment and re-shoot weld.
- 4th - Further decrease weld time and re-shoot weld.

N: This stud shows the results of too much heat. The stud is short, it has a large irregular shaped fillet, and there may be splatter or stringers on the workpiece.

This was likely caused by too much weld power or too long a welding time. The gun lift may also be too high. First check to see if the current and lift settings are what you intended, then slightly reduce arc time on the controller. If that fails, decrease current first; then decrease lift.

V: Still close-up view of "hot weld" stud. Picture must show a stud that is too short, with a large and irregularly shaped fillet, and with splatter around and beyond the fillet. Text overlay, "hot weld," at beginning of narration only.

40265-41284

[NEXT] 6P8 [BACK] previous [] _____ [QUIT] IG2

6P8

T: - Arc blow

- Check ground and other connections
- Check for other welders in the area

N: If the stud appears burned off on one side only, this may be caused by "arc blow." Arc blow results from insufficient current or when welding near strong magnetic fields. Check for other welders nearby, or that the weld is near the edge of the plate. Call your supervisor if the problem persists.

Most of the weld problems you will see while arc stud welding can be easily corrected by minor adjustments.

V: Still close-up view of "arc blow" stud. Picture must show a stud that is burned off on one side, with an irregularly shaped and partially missing fillet. Text overlay, "arc blow," at beginning of narration only.

41290-42205

[NEXT] 6Q8a [BACK] previous [] _____ [QUIT] IG2

6Q8a T: - Touch the cold weld [6Q8b, #2]
- [IG5]

G: Bitmap of six stud welds [im6Q8a]

Use TenCORE feedback to identify item incorrectly touched.

[] _____ [] _____ [] _____ [QUIT] IG2

6Q8b T: - Correct: Now touch the hot weld [6Q8c, #6]
- [IG5]

G: Bitmap of six stud welds [im6Q8a]

Use TenCORE feedback to identify item incorrectly touched.

[] _____ [] _____ [] _____ [QUIT] IG2

6Q8c T: - Very Good. Touch the hang-up weld [6Q8d, #3]
- [IG5]

G: Bitmap of six stud welds [im6Q8a]

Use TenCORE feedback to identify item incorrectly touched.

[] _____ [] _____ [] _____ [QUIT] IG2

6Q8d T: - Excellent: Now touch the good weld [6Q8e, #1]
- [IG5]

G: Bitmap of six stud welds [im6Q8a]

Use TenCORE feedback to identify item incorrectly touched.

[] _____ [] _____ [] _____ [QUIT] IG2

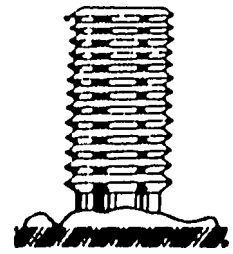
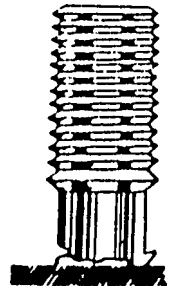
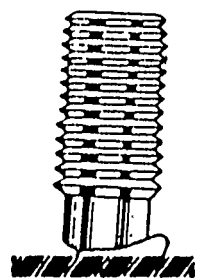
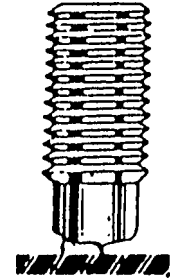
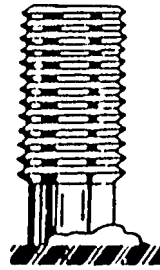
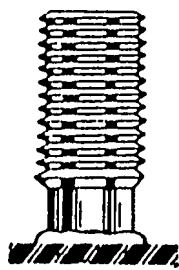

**Image
im6Q8a**

6Q8e T: - OK: Which was caused by poor alignment? [6Q8f, #4]
- [IG5]

G: Bitmap of six stud welds [im6Q8a

Use TenCORE feedback to identify item incorrectly touched.

[] _____ [] _____ [] _____ [QUIT] IG2

6Q8f T: - Good job. Touch the result of a short plunge. [6Q8g, #5]
- [IG5]

G: Bitmap of six stud welds [im6Q8a

Use TenCORE feedback to identify item incorrectly touched.

[] _____ [] _____ [] _____ [QUIT] IG2

6Q8g T: - Good job!

[2/6P9]

[] _____ [] _____ [] _____ [] _____

6P9 T: - Two types of mechanical testing
- Bend testing
- Torque testing

N: After you have visually inspected each weld, made adjustments to the equipment, and shot five good practice studs, you are ready to perform the mechanical test.

Two types of mechanical testing are "bend testing" and "torque testing."

[6P10]

42220-42715

[] _____ [] _____ [] _____ [] _____

6P10

- T:
- Bend 15 degrees from perpendicular for ferrous studs
 - Bend 10 degrees from perpendicular for aluminum studs
 - Return to perpendicular
 - Tears in fillet indicate a failed test
 - Tears in stud or workpiece are no cause for rejection

N: The bending test may be done either by striking the stud with a hammer, or by bending the stud with a piece of pipe or a "bending tool." One method is to bend the stud in any direction from the perpendicular. 15 degrees if it is a steel stud or 10 degrees if it is an aluminum stud. Then return the stud to its original perpendicular position. A flat stud must be bent in the direction of its flat side.

Remove the pipe or bending tool and visually inspect the weld zone. Any evidence of tears in the fillet indicate a defective weld and therefore a failed test. Tears in the stud material or workpiece, however, are not cause for rejection.

V: Motion close-up view of bending the stud to 15 degrees with a hammer and/or bending tool and returning it to perpendicular. Zoom out to medium view of operator visually inspecting the weld.

42725-44175, Seamless: 44175

[NEXT] 6P11 [BACK] 6P10 [PAUSE] 6G10 [QUIT] IG2

6G10 Video Pause unit ("Still Frame" set to "Current")

[NEXT] 6P11 [BACK] 6P10 [PAUSE] 6P10 - [QUIT] IG2

6P11 T: - Bend to 90 degrees from perpendicular, parallel to workpiece
- Do not return to perpendicular
- Tears in fillet indicate a failed test
- Tears in stud or workpiece are no cause for rejection

N: An alternate bending test is to hammer over each stud ninety degrees or parallel to the workpiece surface. With this method, the stud is not returned to the perpendicular. As in the other bending test, flat studs are bent in the direction of the flat side.

Visually examine the weld for tears within the weld zone only. Failure of the base material or stud shank outside the weld zone is not cause for rejection.

V: Motion close-up view of bending the stud to 90 degrees with a hammer and/or bending tool without **returning it to** perpendicular. Zoom out to medium view of operator visually inspecting the weld.

44185-45110, Seamless: 45110

[NEXT] 6P12 [BACK] 6P11 [PAUSE] 6G11 [QUIT] 1G2

6G11 Video Pause unit ("Still Frame" set to "Current")

[NEXT] 6P12 [BACK] 6P11 [PAUSE] 6P11 - [QUIT] 1G2

6P12 N: For studs that fail either of the bending tests just described, re-adjust your stud welding equipment, shoot new studs, and perform the same bending test again. It may not be easy to determine what adjustments to make to correct the failure. The simulation at the end of this lesson will enable you to try different solutions to different types of weld problems.

V: Motion medium view of an operator shooting a weld, bend testing it, re-adjusting the time setting on the equipment, and shooting another weld.

45115-45885, Seamless: 45885

[NEXT] 6P13 [BACK] 6P12 [PAUSE] 6G12 [QUIT] 1G2

6G12 Video Pause unit ("Still Frame" set to "Current")

[NEXT] 6P13 [BACK] 6P12 [PAUSE] 6P12 [QUIT] 1G2

6P13 T: Torque testing to company or military standards

N: A second method of mechanically testing a stud is the "torque test." This test may be used instead of the bending test, but it can only be performed on threaded studs. Torque tests are performed by tightening a nut on the stud over a sleeve and washer such that the stud is pulled away from the workpiece. After achieving a specified amount of torque on the nut, as measured with a torque wrench, the nut washer and sleeve are removed and the weld is visually inspected.

Arc welds that fail the torque test appear similar to welds that fail the bend test. Use the same solutions to obtain acceptable welds before beginning production work. Consult your company's stud testing procedures or military standard 1686 before performing a torque test.

V: Close up motion of complete torque test of a stud

45890-47580, Seamless: 47580

[NEXT] 6P14 [BACK] 6P13 [PAUSE] 6G13 [QUIT] 1G2

6G13 Video Pause unit ("Still Frame" set to "Current")

[NEXT] 6P14 [BACK] 6P13 [PAUSE] 6P13 [QUIT] 1G2

6P14 T: - Stud repair
- Stud removal or replacement

N: Stud repair, removal, or replacement is not covered in this lesson but may be necessary for your job. Contact your instructor to determine what you need to know about stud repair. Never attempt to repair, remove, or replace a production stud without being trained in proper stud repair procedures.

47590-48265

[NEXT] 6P15 [] [] [QUIT] 1G2

- 6P15 T: - Follow company procedures for disassembly of workstation
 - Visually inspect connectors, cables and components
 - Handle electro-mechanical equipment with due care
 - Keep clean
 - Keep dry
 - Keep in good repair

N: Before disassembling your arc stud welding equipment at the end of the day or at the end of the job, be sure you have completed all necessary procedures. Some companies require that you test the last production studs that you shot. Some require that you log the settings of your equipment or complete a checklist.

When disassembling the arc stud welding system, visually inspect all connections and the condition of cables and components, including the stud gun and controller. If equipment is damaged, immediately notify your supervisor. This could be the cause of poor welds in production work.

Finally, return all arc stud welding equipment to its storage location. Always handle electro-mechanical equipment with due care. Keep it clean, dry, and in good repair and it will serve you well in the future.

V: Motion wide-angle view of operator disassembling workstation.
 Text overlay on still frame at end

48275-49970, Seamless: 49970

 [NEXT] 1M2 [BACK] 6P15 [PAUSE] 6G15 [QUIT] 1G2

6G15 Video Pause unit ("Still Frame" set to "current")

 [NEXT] 1M2 [BACK] 6P15 [PAUSE] 6P15 - [QUIT] 1G2

Module 7 - Practice.

7G1 T: - Touch the box that best describes what action you would take to improve the quality of the weld. To end practice and return to the lesson, touch "quit."

N: You may now practice inspecting welds and making equipment adjustments to improve the welds. Touch the box that best describes what action you would take to improve the quality of the weld. To end practice and return to the lesson, touch "quit."

[7Q1]

49985-50525

[] _____ [] _____ [] _____ [] _____

7Q1 T: - Decrease current [7Q2, "extremely cold weld"]
- Increase time [7R1b, "good weld"]
- Decrease lift [7Q2, "extremely cold weld"]
- Good weld: No adjustment or action necessary [7R1a]
- [IG1]

v: Still close-up view of stud weld.
- Cold weld

Four panel buttons in the periphery of the display describing possible adjustments or actions to improve the weld.

50550

[] _____ [] _____ [] _____ [QUIT] 7MI b

7RI a T: This is not a good weld. It was too cold. What would you do to improve it?
- Decrease current [7Q2, "extremely cold weld"]
- Increase time [7RI b, "good weld"]
- Decrease lift [7Q2, "extremely cold weld"]
- I do not know. [7P1]
- [IG1]

v: Still close-up view of stud weld.
- Cold weld

Four panel buttons in the periphery of the display describing possible adjustments or actions to improve the weld.

50550

i [[] _____ [] _____ [] _____ [QUIT] 7M1 b

7RI b T: - Decrease current [7Q1, "cold weld"]
- Increase time [7Q3, "hot weld"]
- Decrease stick-out [7Q5, "short plunge weld"]
- Good weld! No adjustment or action necessary [7M1 a]
- [IG1]

v: Still close-up view of stud weld.
- Good weld

Four panel buttons in the periphery of the display describing possible adjustments or actions to improve the weld.

50840

[] _____ [] _____ [] _____ [QUIT] 7M1a

7P1 T: (Use same text as 6P6)

N: (Use same narration as 6P6)

V: (Use same video as 6P6)

[NEXT] previous [BACK] previous [] _____ [QUIT] previous

- 7M1a T: - You are correct! That was a good weld.
 - If you would like more practice, touch "MORE PRACTICE."
 - More practice [7Q3]
 - If you are ready to begin the final examination, touch
 "FINAL EXAMINATION."
 - Final examination [8Q1]
 - [IG1]

Two panel buttons

 [] _____ [] _____ [] _____ [QUIT] IG2

- 7M1b T: - You still have not shot a good weld.
 - Touch "MORE PRACTICE" to try other adjustments.
 - More practice [7Q3]
 - Touch "FINAL EXAMINATION" if you think you are ready for
 the test.
 - Final examination [8Q1]
 - [IG1]

Two panel buttons

 [] _____ [] _____ [] _____ [QUIT] IG2

- 7Q2 T: - Decrease current [7P1]
 - Increase weld time [7Q1, "cold weld"]
 - Increase lift [7Q1, "cold weld"]
 - Good weld: No adjustment or action necessary [7R2]
 - [IG1]
- v: Still close-up view of stud with weld that would result from
 previously selected adjustment or action
 - Extremely cold weld

50590

 [] _____ [] _____ [] _____ [QUIT] 7MI b

- 7R2 T: This is not a good weld. It was very cold. What would you do to improve it?
- Decrease current [7P1]
 - Increase weld time [7Q1, "cold weld"]
 - Increase lift [7Q1, "cold weld"]
 - I do not know. [7P1]
 - [IG1]
- v: Still close-up view of stud with weld that would result from previously selected adjustment or action
- Extremely cold weld

50590

 [] _____ [] _____ [] _____ [QUIT] 7M1b

- 7Q3 T: - Increase current [7Q4, "extremely hot weld"]
- Decrease time [7R3b, "good weld"]
 - Increase lift [7Q4, "extremely hot weld"]
 - Good weld' No adjustment or action necessary [7R3a]
 - [IG1]
- v: Still close-up view of stud with weld that would result from previously selected adjustment or action
- Hot weld

50660

 [] _____ [] _____ [] _____ [QUIT] 7M3b

- 7R3a T: This is not a good weld. It was too hot. What would you do to improve it?
- Increase current [7Q4, "extremely hot weld"]
 - Decrease time [7R3b, "good weld"]
 - Increase lift [7Q4, "extremely hot weld"]
 - I do not know. [7P3]
 - [IG1]
- v: Still close-up view of stud with weld that would result from previously selected adjustment or action
- Hot weld

50660

 [] _____ [] _____ [] _____ [QUIT] 7M3b

- 7R3b T: - Increase current [703, "hot weld"]
 - Decrease time [701, "cold weld"]
 - Increase stick-out [705, "short plunge weld"]
 - Good weld No adjustment or action necessary [7M3a]
 - [IG1]
- V: Still close-up view of stud with weld that would result from previously selected adjustment or action
 - Good weld

50840

[] _____ [] _____ [] _____ [QUIT] 7M3a

- 7P3 T: (Use same text as 6P7)
 N: (Use same narration as 6P7)
 V: (Use same video as 6P7)

[NEXT] previous [BACK] previous [] _____ [QUIT] previous

- 7M3a T: - You are correct! That was a good weld.
 - If you would like more practice, touch "MORE PRACTICE."
 - More practice [705]
 - If you are ready to begin the final examination, touch "FINAL EXAMINATION."
 - Final examination [801]
 - [IG1]

Two panel buttons

[] _____ [] _____ [] _____ [QUIT] IG2

- 7M3b T: - You still have not shot a good weld.
 - Touch "MORE PRACTICE" to try other adjustments.
 - More practice [705]
 - Touch "FINAL EXAMINATION" if you think you are ready for the test.
 - Final examination [801]
 - [IG1]

Two panel buttons

[] _____ [] _____ [] _____ [] _____ [QUIT] IG2

7Q4

- T:
- Increase current [7P3]
 - Decrease time [7Q3, "hot weld"]
 - Decrease lift [7Q3, "hot weld"]
 - Good weld: No adjustment or action necessary [7R4]
 - [IG1]

- v:
- Still close-up view of stud with weld that would result from previously selected adjustment or action
 - Extremely hot weld

50630

[] _____ [] _____ [] _____ [QUIT] 7M3b

7R4

- T: This is not a good weld. It was extremely hot. What would you do to improve it?
- Increase current [7P3]
 - Decrease time [7Q3, "hot weld"]
 - Decrease lift [7Q3, "hot weld"]
 - I do not know. [7P3]
 - [IGL]

- v:
- Still close-up view of stud with weld that would result from previously **selected** adjustment or action
 - Extremely hot weld

50630

[] _____ [] _____ [] _____ [QUIT] 7M3b

7Q5

- T:
- Increase current [7Q5, "short plunge weld"]
 - Decrease weld time [7Q5, "short plunge weld"]
 - Increase stick-out [7R5b, "good weld"]
 - Good weld: No adjustment or action necessary [7R5a]
 - [IGI]

- v:
- Still close-up view of stud with weld that would result from previously selected adjustment or action
 - Short plunge weld

50690

[] _____ [] _____ [] _____ [QUIT] 7M5b

- 7R5a T: This is not a good weld. The plunge was too short. What would you do to improve it?
- Increase current [7Q5, "short plunge weld"]
 - Decrease weld time [7Q5, "short plunge weld"]
 - Increase stick-out [7R5b, "good weld"]
 - I do not know. [7P5]
 - [I GI]
- v: Still close-up view of stud with weld that would result from previously selected adjustment or action
- Short plunge weld

50690

 [] _____ [] _____ [] _____ [QUIT] 7M5b

- 7R5b T: - Increase current [7Q3, "hot weld"]
- Decrease weld time [7Q1, "cold weld"]
 - Decrease stick-out [7R5a, "short plunge weld"]
 - Good weld' No adjustment or action necessary [7M5a]
 - [I GI]
- v: Still close-up view of stud with weld that would result from previously selected adjustment or action
- Good weld

50840

 [] [] _____ [] _____ [QUIT] 7M5a

- 7P5 T: (Use same text as 6P3)
- N: (Use same narration as 6P3)
- v: (Use same video as 6P3)

 [NEXT] previous [BACK] previous [] _____ [QUIT] previous

- 7M5a T: - You are correct! That was a good weld.
 - If you would like more practice, touch "MORE PRACTICE."
 - More practice [7Q7]
 - If you are ready to begin the final examination, touch "FINAL EXAMINATION."
 - Final examination [8Q1]
 - [IG1]

Two panel buttons

 [] _____ [] _____ [] _____ [QUIT] 1G2

- 7M5b T: - You still have not shot a good weld.
 - Touch "MORE PRACTICE" to try other adjustments.
 - More practice [7Q7]
 - Touch "FINAL EXAMINATION" if you think you are ready for the test.
 - Final examination [8Q1]
 - [IG1]

Two panel buttons

 [] _____ [] _____ [] _____ [QUIT] 1G2

- 7Q7 T: - Re-align foot assembly on gun [7R7b, "good weld"]
 Clean and re-tighten connectors [7R7a]
 - Increase current [7R7a]
 - Good weld! No adjustment or action necessary [7R7a]
 - [IG1]
- V: Still close-up view of stud with weld that would result from previously selected adjustment or action
 - Hang-up weld

50730

 [] _____ [] _____ [] _____ [QUIT] 7M7b

7R7a T: This is not a good weld. It is a hang-up weld. What would you do to improve it?

- Re-align foot assembly on gun [7R7b, "good weld"]
- Clean and re-tighten connectors [7P7]
- Increase current [7P7]
- I do not know. [7P7]
- [IGI]

V: Still close-up view of stud with weld that would result from previously selected adjustment or action

- Hang-up weld

50730

 [] _____ [] _____ [] _____ [QUIT] 7M3b

7R7b T: - Increase weld time [7Q3, "hot weld"]

- Decrease stick-out [7Q5]
- Decrease lift [7Q1]
- Good weld! No adjustment or action necessary [7M7a]
- [IGI]

V: Still close-up view of stud with weld that would result from previously selected adjustment or action

- Good weld

50840

 [] _____ [] _____ [] _____ [QUIT] 7M7a

7P7 T: (Use same text as 6P4)

N: (Use same narration as 6P4)

V: (Use same video as 6P4)

 [NEXT] previous [BACK] previous [] [QUIT] previous

- 7M7a T: - You are correct! That was a good weld.
 - If you would like more practice, touch "MORE PRACTICE."
 - More practice [7Q8]
 - If you are ready to begin the final examination, touch "FINAL EXAMINATION."
 - Final examination [8Q1]
 - [IG1]

Two panel buttons

 [] _____ [] _____ [] _____ [QUIT] IG2

- 7M7b T: - You still have not shot a good weld.
 - Touch "MORE PRACTICE" to try other adjustments.
 - More practice [7Q8]
 - Touch "FINAL EXAMINATION" if you think you are ready for the test.
 - Final examination [8QL]
 - [IG1]

Two panel buttons

 [] _____ [] _____ [] _____ [QUIT] IG2

- 7Q8 T: - Increase current [7Q4, "extremely hot weld"]
 - Increase stick-out [7Q6, "long plunge weld"]
 - Concentrate on aligning gun during shot [7R8b, "good weld"]
 - Good weld! No adjustment or action necessary [7R8a]
 - [IG1]
- V: Still close-up view of stud with weld that would result from previously selected adjustment or action
 - Poor alignment weld

50750

 [] _____ [] _____ [] _____ [QUIT] 7M8b

7R8a T: This is not a good weld. It is was caused by poor alignment.
 What would you do to improve it?
 - Increase current [7Q4, "extremely hot weld"]
 - Increase stick-out [7Q6, "long plunge weld"]
 - Concentrate on aligning gun during shot [7R8b, " good weld"]
 - I do not know. [7P8]
 - [IGI]

v: Still close-up view of stud with weld that would result from
 previously selected adjustment or action
 - Poor alignment weld

50750

 [] _____ [] _____ [] _____ [QUIT] 7M8b

7R8b T: - Decrease current [7Q2, "extremely cold weld"]
 - Decrease stick-out [7Q5, "long plunge weld"]
 - Increase lift [7Q3, "hot weld"]
 - Good weld! No adjustment or action necessary [7M8a]
 - [IGI]

V: Still close-up view of stud with weld that would result from
 previously selected adjustment or action
 - Good weld

50840

 [] _____ [] _____ [] _____ [QUIT] 7M8a

7P8 T: (Use same text as 6P5)
 N: (Use same narration as 6P5)
 V: (Use same video as 6P5)

 [NEXT] previous [BACK] previous [] _____ [QUIT] previous

- 7M8a T: - You are correct! That was a good weld.
 - If you would like more practice, touch "MORE PRACTICE."
 - More practice [7Q9]
 - If you are ready to begin the final examination, touch "FINAL EXAMINATION."
 - Final examination [8Q1]
 - [I G1]

Two panel buttons

 [] _____ [] _____ [] _____ [QUIT] IG2

- 7M8b T: - You still have not shot a good weld.
 - Touch "MORE PRACTICE" to try other adjustments.
 - More practice [7Q9]
 - Touch "FINAL EXAMINATION" if you think you are ready for the test.
 - Final examination [8Q1]
 - [I G1]

Two panel buttons

 [] _____ [] _____ [] _____ [QUIT] IG2

- 7Q9 T: - Increase current [7R9]
 - Shorten welding cable [7R9]
 - Clean and re-tighten connectors [7R9]
 - Reset ground connection on workpiece [7R9]
 - [I G1]
- V: Still close-up view of stud with weld that would result from previously selected adjustment or action
 - Arc-blow weld

50780

 [] _____ [] _____ [] _____ [QUIT] 7M9

- 7R9 T: - This is an arc-blow. To eliminate arc-blow you should try all of those things.
 - Touch the screen anywhere to make more improvements [7Q10]

 [] _____ [] _____ [] _____ [QUIT] IG2

- 7M9 T: - You still have not shot a good weld.
- Touch "MORE PRACTICE" to try other adjustments.
 - More practice [7Q10]
 - Touch "FINAL EXAMINATION" if you think you are ready for the test.
 - Final examination [8Q1]
 - [IG1]

Two panel buttons

 [] _____ [] _____ [] _____ [QUIT] IG2

- 7Q10 T: - Clean and re-tighten connectors [7M10b, "contaminated fillet"]
- Increase weld time [7M10b, "contaminated fillet"]
 - Re-clean workpiece [7M10a, "good weld"]
 - Good weld! No adjustment or action necessary [7M10b]
 - [IG1]

- V: Still close-up view of stud with weld that would result from previously selected adjustment or action
- Contaminated fillet weld

50810

 [] _____ [] _____ [] _____ [QUIT] 7M10

- 7M10a T: - You are correct! That was a good weld.
- If you would like more practice, touch "MORE PRACTICE."
 - More practice [7Q2]
 - If you are ready to begin the final examination, touch "FINAL EXAMINATION."
 - Final examination [8Q1]
 - [IG1]

Two panel buttons

 [] _____ [] _____ [] _____ [QUIT] IG2

- 7M10b T: - You still have not shot a good weld.
- Touch "MORE PRACTICE" to try other adjustments.
 - More practice [702]
 - Touch "FINAL EXAMINATION" if you think you are ready for the test.
 - Final examination [801]
 - [IG1]

Two panel buttons

[] [] [] [QUIT] IG2

Module 8 - Examination.

801 Multiple choice question (touch 1 of 5 text panels)

T: - The fillet is grainy and has a cold gray appearance. Check for:

- Welding current set too low
- Arc time set too short
- Poor ground connection
- Incorrect "stick-out"
- All of the above [ok]

- There are 9 questions remaining.

Text on five panel buttons

[] _____ [] _____ [] _____ [] _____

802 Multiple choice question (touch 1 of 5 buttons adjacent to text)

T: - What piece of safety equipment is not normally required for arc stud welding?

- Safety glasses
- Respirator [ok]
- Gloves
- Leather apron
- Safety shoes

- There are 8 questions remaining.

[] _____ [] _____ [] _____ [] _____

803 Pointing choice question (touch object in bitmap or clip)

T: - Touch the weld that was caused by poor alignment. [ok]

- There are 7 questions remaining.

G: Bitmap or clip diagram of 6 satisfactory and unsatisfactory arc stud welds [im6Q8a]

[] _____ [] _____ [] _____ [] _____

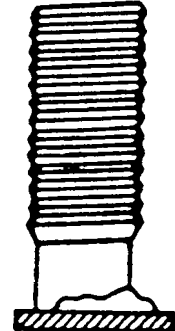
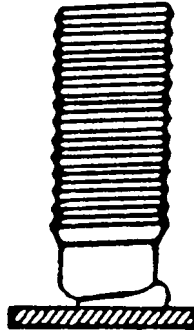
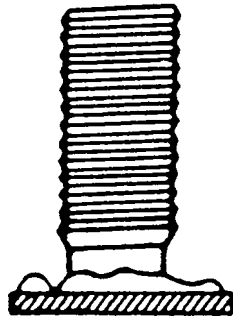
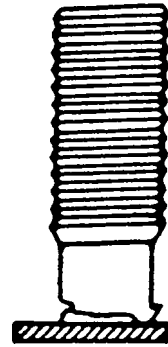
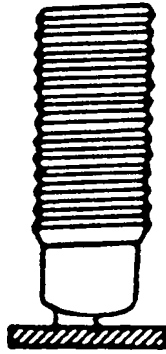
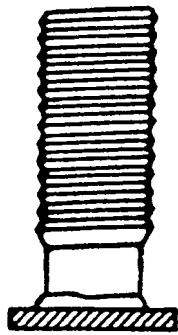

Image
im8Q3

804 Alternate choice question (touch true/false text panel)

T: - A faint spark and no weld can be caused by improper lift adjustment on the gun.

- True [ok]
- False

- There are 6 questions remaining.

[] _____ [] _____ [] _____ [] _____

805 Multiple choice question (touch 1 of 4 picture windows)

T: - Touch the good weld. [ok]

- There are 5 questions remaining.

V: Still close-up views of welded studs in four picture windows (hot weld, cold weld, hang-up, and good weld)

50870

[] _____ [] _____ [] _____ [] _____

806 Pointing choice question (touch object in graphic)

T: - Touch the most likely location of the Weld Time Control [ok]

- There are 4 questions remaining.

G: Graphic diagram of all system components connected together but not identified [im803]

[] _____ [] _____ [] _____ [] _____

807 Pointing choice question (touch object in still video)

- T: - Touch the chuck. [ok]
- There are 3 questions remaining.

G: Still close-up view of stud gun clearly showing the chuck
[im807]

[] _____ [] _____ [] _____ [] _____

808 Keyboard entry question (keyboard entry of number answer)

- T: - What should the Time Control be set to on the controller for shooting a 3/8-inch diameter stud, using a 600 amp power source and 1/16-inch gun lift?
_____ seconds [.4 ok]
- Use the keyboard to type your answer on the line above. Be sure to type the decimal point and push the RETURN key after you have entered your number.
- There are 2 questions remaining.

G: Graphic representation of an Initial Settings Table [im5P14]

[] _____ [] _____ [] _____ [] _____

809 Keyboard entry question (keyboard entry of word answer)

- T: - What is the name of the small ceramic piece that fits over the end of the stud, that is gripped by the stud gun foot, and that shields the arc during welding.
- _____ [ferrule ok]
- Use the keyboard to type your answer on the line above. You may use lower case or upper case letters, but be sure to push the RETURN key when you are finished.
- There is 1 question remaining.

[] _____ [] _____ [] _____ [] _____

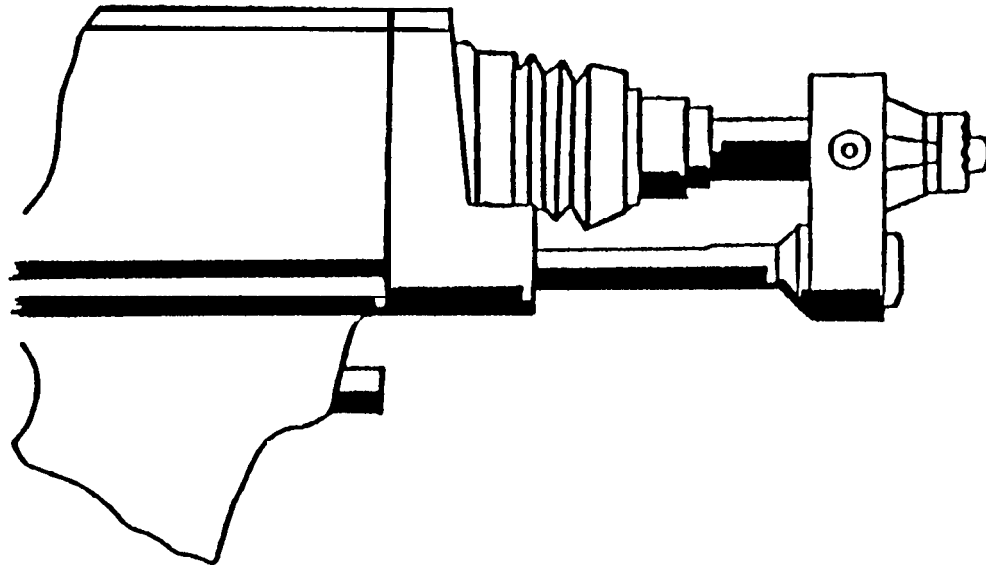

**Image
im8Q7**

8Q10 Keyboard entry question (Function Key entry)

- T: - Type the number on your keyboard to select the best answer.
- 1 Ferrous studs bent 90 degrees must be returned to perpendicular for visual inspection
 - 2 Tears in the stud or workpiece are cause for rejecting the weld
 - 3 Both the bending test and torque test must be performed on all 5 practice welds before starting production
 - 4 A hammer is an accepted substitute for the bending tool [ok]
 - 5 The bending test should be performed on all production studs
- This is the last question.

[] _____ [] _____ [] _____ [] _____

LAST T: - Congratulations! You have completed the basic course on arc-drawn stud welding. Touch anywhere on the screen to see your score, than call your instructor or push the ESC key on the keyboard to exit the lesson.

N: Congratulations! You have completed the basic course on arc-drawn stud welding. Touch anywhere on the screen to see your score, than call your instructor or push the "ESC" key on the keyboard to exit the lesson. []

50895-51400

[] _____ [] _____ [] _____ [] _____

APPENDIX C
SCREEN DESIGN CRITERIA

Appendix C

HUMAN ENGINEERING DESIGN OF INTERACTIVE INSTRUCTION SCREENS (Condensed from Roy Strauss of Commodore International and Bernard Luskin of Philips International)

1. General Screen Design

The two most important factors in screen design are (1) usability and (2) aesthetics. They are interrelated. A screen that may initially please the eye will not do so for long if the user gets frustrated using it. Likewise, a screen that is not visually appealing will be a "turn-off," no matter how easy it is to use.

1.1 Usability

The user must be able to quickly figure out what to do and how to do it without prior instruction or guidance.

1.2 Aesthetics

The screen must have visual appeal, be pleasing to the eye and have artistic qualities that are appropriate to the application.

2. Screen Layout

Screen layout has a major influence on esthetics, but is only one of many influences on usability. Such things as the design of off-screen **controls, system operation**, presentation content, and **design of the workstation** also affect usability.

2.1 Scanning Patterns

The observer always scans from top-down and left-to-right on a screen. Put initial and orienting information at top-left. Put "continue on" or "next" information at lower-right. Operating information and controls therefore occur at the top or bottom.

2.2 Zones and Regions

Content information and content interaction (questions and answers) appear in the central area of the screen.

Because of the scan pattern, it is best if the screen is arranged in horizontal zones of commonality rather than vertical zones. This enables the user to detect, identify, or select on the left-side; and define, interpret, or obtain information on the right-side. Somewhat akin to the format of an outline.

For example, the top zone might contain the title of the screen, the second zone a picture, the third zone a text description of the picture, and the bottom zone a row of control buttons.

2.3 Grids

Grids are necessary during screen design to balance the screen and produce a visually pleasing layout. It ensures consistency of style, format, placement, size, location, etc. It also ensures an adequate border-around proper spacing.

The grid should remain constant across all screens. It is essential to maintain the zones and regions described above.

3. Eye Attraction

The eye is always attracted to the area on the screen with (1) motion, (2) color, and (3) high contrast.

3.1 Motion

Motion is produced by animation, video, blinking, color cycling, etc. Motion will both attract the eye (flashing button) and direct the eye (bouncing ball).

Motion that is not used for this purpose distracts from the remainder of the screen. "Decorative" motion should be avoided.

Text that is moving or flashing is difficult to read and should be avoided, however one or two short words may be slow-flashed. If the text requires attention, a border around it should be flashed.

HOWEVER, it is also said that some activity on the screen is preferable at all times.

Every lesson should have some amount of linear-motion. This is best used in the introduction to orient the user to the lesson content, but may also be used in the summary to "recoup" and "refresh" the content. The "how-to" obviously will also serve this purpose.

3.2 Color

"Hotter" colors (reds, yellows, pinks, etc.) attract the eye and are perceived to be closer to the viewer ("come forward"). "Cooler" colors (blues, greens, browns, etc.) do not attract the eye and are perceived to be further from the viewer ("recede").

The lighter and more saturated the color, the more strongly it will attract the eye. This means a cool color can be made to overcome a hot color by brightness and saturation, however, the result is viewer "tension" due to the eye's "fight" between colors on the screen. Such an example is brilliant blue text on a muted red screen.

3.3 Contrast

The eye is attracted to the area of highest contrast on the screen. This includes both color and brightness contrast. If a screen is divided with one half a hot and bright color and the other half a cool and dull color, the area where these two colors intersect will be the area of strongest attraction.

Therefore to attract attention to a large area, a background of stripes, dots, or speckles could be used.

Contrasting colors are clearer from 8-10 feet.

3.4 Background/Foreground

Always select the background and foreground colors very deliberately and carefully to achieve a specific purpose. A receding background should be olive green, grey, blue, brown, dark purple or black. A foreground color should be lemon yellow, pink, orange, or red.

Multiple depths (layers) and third dimension can be achieved using combinations hot and cool colors and brightness, with the hottest and brightest on top (at the front) and the coolest and duller on the bottom (at the back). Good examples are boxes, buttons, pages, etc.

Uncluttered backgrounds are better for image clarity and assimilation (comprehension).

3.5 Color Coordination

Visual appeal is determined in large part by "colorfulness." Colorfulness refers to selection of color, not amount of color. No more than three hues (pure colors) should ever be used on a screen. Brightness variation (shades) should be used instead of additional hues.

The most attractive screens use only two or three hues and many shades of these hues. Hues and shades should be selected to achieve a stated goal. This will ensure proper selection color and consistency of its use on all screens.

3.6 Color Blindness

8% of the adult male population is red/green color blind. Avoid the use of these colors, particularly if they are **at** the same brightness.

4. Text Readability

The use of easily read text is essential to screen design. Text that is hard to read will not only annoy and frustrate the user, but will very significantly reduce the impact of the lesson.

Sentences must be short and seriously edited. **"Wordsmithing"** is **One** of the most important functions of the author.

Highlight, with a colored box or strip, text that is overlaid on a multicolored graphic or video presentation.

4.1 Initial Caps vs. Upper Case

Words in upper and lower case are easier to read than words in all uppercase. Initial capitals should be minimized as much as possible (used only in titles, at start of sentences, and for proper nouns and names).

4.2 Flicker

"Interlacing flicker" is extremely distracting and objectionable and must be avoided. Interlacing flicker appears on the screen in thin, high contrast lines and often at the edge of the screen in the viewer's periphery. This flicker can be prevented by using (1) anti-aliasing, **(2)** drop-shadows, or (3) avoiding single pixel lines.

Anti-aliasing is the process of inserting transitional colors or shading at high contrast edges to minimize flicker and reduce eye strain. Usually only one pixel line of this transitional color or shade is required.

Transitional colors can also be used to produce a drop-shadow either "off-set" or directly "under" each character in a text. This helps pull the characters out away from the background and eliminates flicker. The off-set itself, however, must be carefully designed not to be distracting.

4.3 Color Selection

In selecting color, variations between different types and color adjustments of monitors must be considered. Red, for example, is very hue and brightness critical and small difference between monitors and monitor adjustments can produce very different appearing displays.

Fades to black are not effective. Fading to the background **color or to another** screen improves the "seamlessness of the presentation.

Another major consideration is whether the European PAL system or the American NTSC system will be used to display **the screen. Both brightness and** hue vary extensively between these two systems.

4.4 Font Selection

Size is the most important factor in selecting a font. Recommendations for font size vary, and depend upon the content or purpose of the text and the distance of the viewer from the screen. Font that is too large can be as difficult to read **as** font that is too small. Large font should be used sparingly, for individual words or short phrases (such as titles), and only to achieve a specific purpose.

Fonts must be large and clear and readable from 8-10 feet away.

No more than two different fonts should be used on a screen without specific purpose. Instead use different sizes and weights of the same font to achieve different meanings.

Use wide borders around text, especially when it is boxed. Always use recommended space between lines of text. Too little space makes reading difficult and too much space is distracting and confusing.

5. Consistency

"Consistency" is best defined as a common look and feel across various screens within a single application or series of applications. This is particularly important for instructional screens where the student is relying upon every detail of the presentation for information.

5.1 Consistency as a Rule

Consistency is an extremely important factor in the user's perception of the overall system. From an esthetic standpoint, a system that is consistent in terms of color, style, and layout is perceived as "high quality." From a functional standpoint, a system that maintains tight consistency gives the user a feeling of unity and overall vision of design. This lends a valuable sense of credibility and integrity to the application.

Lack of consistency requires continuous re-orientation by the user thereby detracting from the subject content. It is usually faster and easier to develop screens that are consistent in their design. Everything from fonts, font sizes, button designs, and button placement; to colors, background textures, and screen format (layout) should be consistent unless there is a specific reason to deviate from the consistency.

Consistency also applies to the operation of the system. Similar appearing buttons (or other controls) must all have the same function; similar button functions must all operate the same way; and similar operations must all occur in the same sequence, at the same speed, and with the same feedback or response.

5.2 Exceptions to Consistency

Consistency of screen style usually, but not always, leads to consistency in the system's ease-of-use. Since ease-of-use is most important, there are times when the rules of consistency for style must be "bent." Such is the case when it is intended to draw particular attention to the fact that the presentation or control is not consistent with others, or when it is intended to show that there are other ways of achieving the same presentation or control. Even this, it can be argued, is being consistent.

6. Narration and Music

Narration should be conversational with significant voice modulation. Dull and boring documentary style is not sufficiently engaging.

Scripts should be written and spoken using proper language; avoiding slang and overuse of contractions, abbreviations, and acronyms (unless they are part of the instruction content).

Music heightens the user's emotion and energy of participation.

7. Content

Too much information in a lesson, or lessons that are too rigorous, may be easy to "sell" but will not be effective. Many times, "less is more."

Each lesson must instill a sense of completion and accomplishment to create a sense of satisfaction within the user. That means it must have a well defined purpose, start point, end point, and leave the user with a clear understanding of whether or not material was learned.

LOOK, FEEL, STRUCTURE, CONTENT, ART DIRECTION, and FUNCTIONALITY are aspects of each lesson that should be addressed and evaluated separately.

Every lesson should have a good "how to."

8. Control

A program should never take control away from the user. This breaks concentration and implies that the program "knows" more than the user.

Keep the numbers of buttons or icons to a minimum. Too many are confusing.

Dead ends in navigation create confusion and frustration.

Display only controls that are usable.

8.1 Navigation

"Transparency" is the ability of the user to operate the system without being aware of the mechanics or purpose of each operation. This is particularly important in controlling and navigating between screens. For example, when a remediation branch is activated, the user should not know that it is "remediation," but should think that it is part of the normal instruction. Similarly, when multiple still-frames are used to simulate motion, the user should not be aware that individual frames are used to produce the effect. Such lack of transparency is extremely distracting and will detract from the efficiency of the instruction.

9. General

The primary criteria for good design are that the system must (1) be easy to use, (2) catch the user's interest, (3) make navigation intuitive.

The personalized "you-attitude" is essential for motivation and to maintain attention. This is reflected in all aspects of the presentation, but particularly the script (narration and text) and user interaction (operator interface design).

Additional copies of this report can be obtained from the National Shipbuilding Research Program Coordinator of the Bibliography of Publications and Microfiche Index. You can call or write to the address or phone number listed below.

**NSRP Coordinator
The University of Michigan
Transportation Research Institute
Marine Systems Division
2901 Baxter Rd.
Ann Arbor, MI 48109-2150
Phone: (313) 763-2465
Fax: (313) 936-1081**

**SHIP PRODUCT
FACILITIES II
OUTFITTING AND
INDUSTRIAL ENGINEER
SHIPBUILDING
DESIGN / PRODUCT
COMPUTER AIDS
SURFACE PREPARA
ENVIRONMEN
TECHNOLOG
WEI
RE**