

Long-Term Storage of the Solar Arrays for the Defense Meteorological Satellite Program (DMSP) 5D3 Spacecraft

(6.3) Environmental Testing and Space Systems

10 February 2006

Prepared by

E. J. SIMBURGER
Electronics and Photonics Laboratory
Laboratory Operations
The Aerospace Corporation

W. L. BUNSELMEYER
Lockheed Martin Space Systems Company
Sunnyvale, CA 94088

Prepared for

SPACE AND MISSILE SYSTEMS CENTER
AIR FORCE SPACE COMMAND
2430 E. El Segundo Boulevard
Los Angeles Air Force Base, CA 90245

Engineering and Technology Group

APPROVED FOR PUBLIC RELEASE;
DISTRIBUTION UNLIMITED

This report was submitted by The Aerospace Corporation, El Segundo, CA 90245-4691, under Contract No. FA8802-04-C-0001 with the Space and Missile Systems Center, 2430 E. El Segundo Blvd., Los Angeles Air Force Base, CA 90245. It was reviewed and approved for The Aerospace Corporation by B. Jadaszliwer, Principal Director, Electronics and Photonics Laboratory; and P. H. Mak, Principal Director, Meteorological Satellite Systems. Lt. Col. John Varljen, Chief, Satellite systems Division, was the cognizant officer for the program.

This report has been reviewed by the Public Affairs Office (PAS) and is releasable to the National Technical Information Service (NTIS). At NTIS, it will be available to the general public, including foreign nationals.

This technical report has been reviewed and is approved for publication. Publication of this report does not constitute Air Force approval of the report's findings or conclusions. It is published only for the exchange and stimulation of ideas.

Lt. Col. John Varljen
SMC/WXS

20 Apr 06

REPORT DOCUMENTATION PAGE

Form Approved
OMB No. 0704-0188

Public reporting burden for this collection of information is estimated to average 1 hour per response, including the time for reviewing instructions, searching existing data sources, gathering and maintaining the data needed, and completing and reviewing this collection of information. Send comments regarding this burden estimate or any other aspect of this collection of information, including suggestions for reducing this burden to Department of Defense, Washington Headquarters Services, Directorate for Information Operations and Reports (0704-0188), 1215 Jefferson Davis Highway, Suite 1204, Arlington, VA 22202-4302. Respondents should be aware that notwithstanding any other provision of law, no person shall be subject to any penalty for failing to comply with a collection of information if it does not display a currently valid OMB control number. PLEASE DO NOT RETURN YOUR FORM TO THE ABOVE ADDRESS.

1. REPORT DATE (DD-MM-YYYY) 10-02-2006			2. REPORT TYPE		3. DATES COVERED (From - To)	
4. TITLE AND SUBTITLE Long-Term Storage of the Solar Arrays for the Defense Meteorological Satellite Program (DMSP) 5D3 Spacecraft					5a. CONTRACT NUMBER FA8802-04-C-0001	
					5b. GRANT NUMBER	
					5c. PROGRAM ELEMENT NUMBER	
6. AUTHOR(S) E. J. Simburger and W. L. Bunselmeyer					5d. PROJECT NUMBER	
					5e. TASK NUMBER	
					5f. WORK UNIT NUMBER	
7. PERFORMING ORGANIZATION NAME(S) AND ADDRESS(ES) The Aerospace Corporation Laboratory Operations El Segundo, CA 90245-4691					8. PERFORMING ORGANIZATION REPORT NUMBER TR-2006(1550)-1	
9. SPONSORING / MONITORING AGENCY NAME(S) AND ADDRESS(ES) Space and Missile Systems Center Air Force Space Command 2450 E. El Segundo Blvd. Los Angeles Air Force Base, CA 90245					10. SPONSOR/MONITOR'S ACRONYM(S) SMC	
					11. SPONSOR/MONITOR'S REPORT NUMBER(S) SMC-TR-06-09	
12. DISTRIBUTION/AVAILABILITY STATEMENT Approved for public release; distribution unlimited.						
13. SUPPLEMENTARY NOTES						
14. ABSTRACT Lockheed Martin built the United States Air Force's DMSP 5D-3 Spacecraft. The satellite was designed for a mission that consists of two years of ground storage and 45 days of prelaunch checkout, followed by 3-1/2 years of operational life. The 5D-3 spacecraft will operate in a circular, sun-synchronous orbit with an inclination of 98.7° at an altitude of 458 nmi. The build of five 5D-3 spacecraft was completed in 1997. The first 5D-3 satellite, designated F-16, was launched on October 18, 2003 after six years of storage. The next 5D-3 DMSP, designated F-17, is scheduled to be launched in 2006. The remaining three satellites will be launched roughly every two years to maintain the two-satellite DMSP constellation. The final DMSP satellite may not be launched until 2012, after 16 years of storage! Thus, the Air Force is concerned about the age of the DMSP spacecraft hardware and possible age-related degradation of the hardware. This report examines how well the solar arrays for the 5D-3 spacecraft withstood the extended storage at the Lockheed Martin plant located in Sunnyvale California.						
15. SUBJECT TERMS Solar arrays, Silicon photovoltaic technology, Space systems, Long-term storage						
16. SECURITY CLASSIFICATION OF:			17. LIMITATION OF ABSTRACT	18. NUMBER OF PAGES	19a. NAME OF RESPONSIBLE PERSON Ed Simburger	
a. REPORT UNCLASSIFIED	b. ABSTRACT UNCLASSIFIED	c. THIS PAGE UNCLASSIFIED				8

Contents

1. Description of the 5D-3 Solar Arrays	1
2. Results of I-V Testing of the DMSP S-17 Solar Array	5
3. Conclusions	7

Figures

1. Photo of deployed solar array for DMSP S-17 spacecraft.....	1
2. Artist's rendition of DMSP 5D-3 spacecraft on orbit with deployed solar array.	1
3. DMSP 16-20 peak solar array capacity in June at the end of five years on orbit.	2
4. DMSP 16-20 peak solar array capacity in December to the end of five years on orbit.	2
5. Sample schematic for each of 70 solar array circuits.	3
6. I-V Curves for Circuit 4 Panel A1.	5
7. I-V Curve for Circuit 4A Panel A1	6
8. I-V Curve for Circuit 4B Panel A1	6

Table

1. Summary of I-V Characteristic Test Results Summary.....	5
--	---

1. Description of the 5D-3 Solar Arrays

The solar array includes ten flat structurally identical solar cell panels. The ten panels are assembled into two five packs that are attached to the solar array boom. When deployed, the two five packs are positioned into a single plane symmetrical around the solar-array boom, as shown in Figure 1.

The solar-array boom can be canted with respect to the +Z axis of the spacecraft from 12° to 42° in 5° increments. The cant is set prior to launch and cannot be changed once the spacecraft is on orbit. Thus, the Solar Array for the DMSP 5D-3 Spacecraft is a single-axis tracking system. The single axis of tracking is accomplished by rotating the solar array around the boom once per orbit. The rotation of the solar array is such that the solar array is essentially motionless in inertial space. Figure 2 is an artist's rendition of the DMSP satellite on orbit. Figure 3 provides the peak solar array capacity as a function of sun angle with optimal cant angle for the each sun angle for the month of June after five years on orbit. Figure 4 is for the month of December after five years on orbit.



Figure 1. Photo of deployed solar array for DMSP S-17 spacecraft.

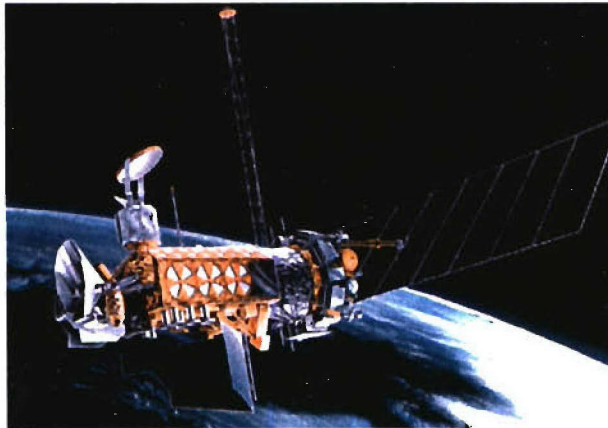

Figure 2. Artist's rendition of DMSP 5D-3 spacecraft on orbit with deployed solar array.

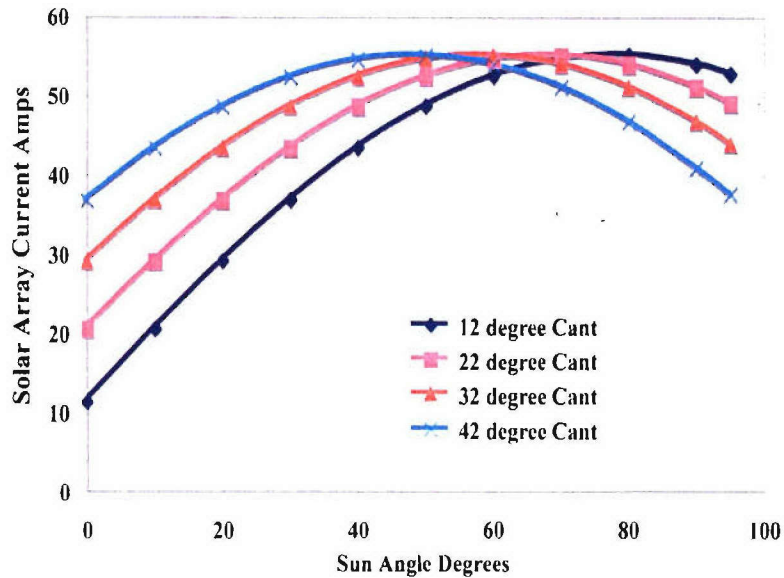

Figure 3. DMSP 16-20 peak solar array capacity in June at the end of five years on orbit.

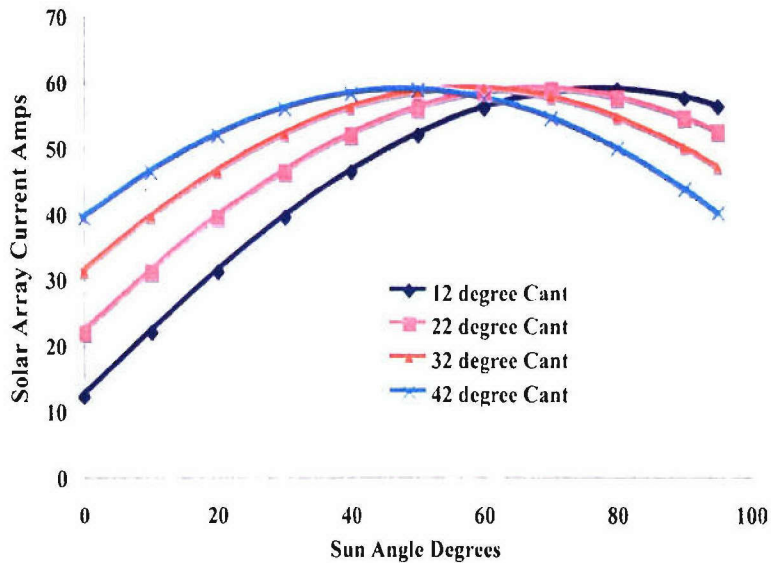

Figure 4. DMSP 16-20 peak solar array capacity in December to the end of five years on orbit.

The phasing of the solar array normally is such that the plane of the array, neglecting the cant angle, is normal to the sun. However, the array can be oriented at an offset angle (with respect to normal tracking of the sun) with a ground command. This feature has been used in the past to allow the solar array to provide shading of the batteries from the sun on Flight F-16. This was desired at low sun angles where the vehicle is in full sun.

Each of the ten solar array panels has seven circuits, which consist of three cells in parallel with 89 or 90 cells in series. The cells are 4.04- x 2.02-cm high-efficiency N-on-P silicon with backside reflec-

beginning of life power rating of 2207 W. Each of the ten panels is 107.5 by 24.3 in. and weighs 19.9 lb. Each panel has seven shunt circuits (one for each solar array circuit) and is configured as shown in Figure 5.

The wiring harness of the solar array has individual wires, positive, negative and tap points, for each solar array circuit, which are brought out to the harness connector for a Five Pack. Thus, it is possible to obtain the Current-Voltage (I-V) Characteristic for each circuit of three cells in parallel by 89 or 90 cells in series. In addition, the I-V characteristic of the 32 series cells (CKT A) and 58 or 58 series cells (CKT B) can be obtained.

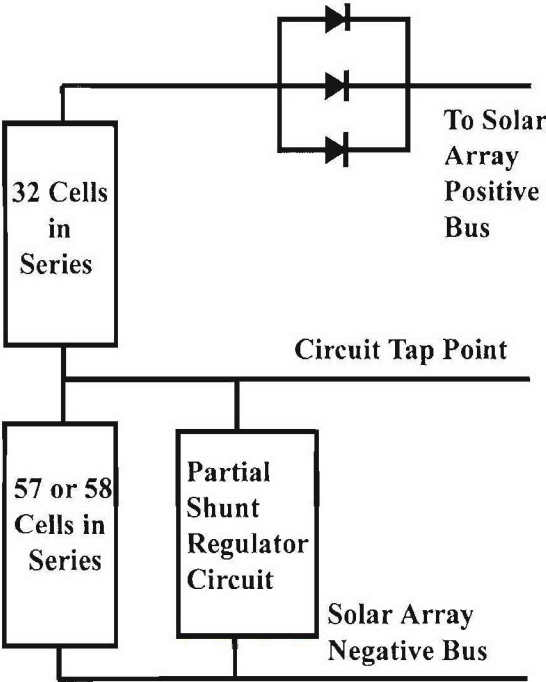

Figure 5. Sample schematic for each of 70 solar array circuits.

2. Results of I-V Testing of the DMSP S-17 Solar Array

The I-V curves were obtained for each circuit and subcircuit for the DMSP S-17 spacecraft when the arrays completed the manufacturing process in 1997 after rework to correct a shorting of the shunt circuit wiring in 1999 and prior to installation on the spacecraft during launch processing operations in 2005. Table 1 provides a summary of the results of these tests for a representative solar cell circuit. The data presented in Table 1 includes the Voltage Open Circuit (VOC), Current Short Circuit (ISC), Maximum Power Point (Pmax), Voltage at Maximum Power Point (Vmax), Current at Maximum Power Point (Imax), Fill Factor (FF), and temperature at which the data was taken.

Figures 6, 7, and 8 provide the actual I-V characteristics for Circuit 4 Panel A1, Circuit 4A Panel A1, and Circuit 4B Panel A1.

Table 1. Summary of I-V Characteristic Test Results Summary

Circuit 4 Panel A1							
Date	VOC	ISC	Pmax Watts	Vmax	Imax	FF	Temp. C
8/22/97	53.14	0.9692	40.48	44.39	0.9118	0.786	28
1/14/99	52.94	0.986	40.93	44.16	0.9268	0.784	28
1/28/05	53.2	0.9995	41.32	44.4	0.931	0.777	28
Circuit 4A Panel A1							
8/22/97	18.91	0.9802	14.49	15.73	0.9215	0.782	28
1/14/99	18.9	0.9832	14.5	15.7	0.9237	0.78	28
1/28/05	18.87	1.001	14.73	15.7	0.938	0.779	28
Circuit 4B Panel A1							
8/22/97	34.36	0.9753	26.3	28.66	0.9176	0.785	28
1/14/99	34.22	0.9779	26.37	28.53	0.9241	0.788	28
1/28/05	34.25	0.989	26.53	28.57	0.929	0.783	28

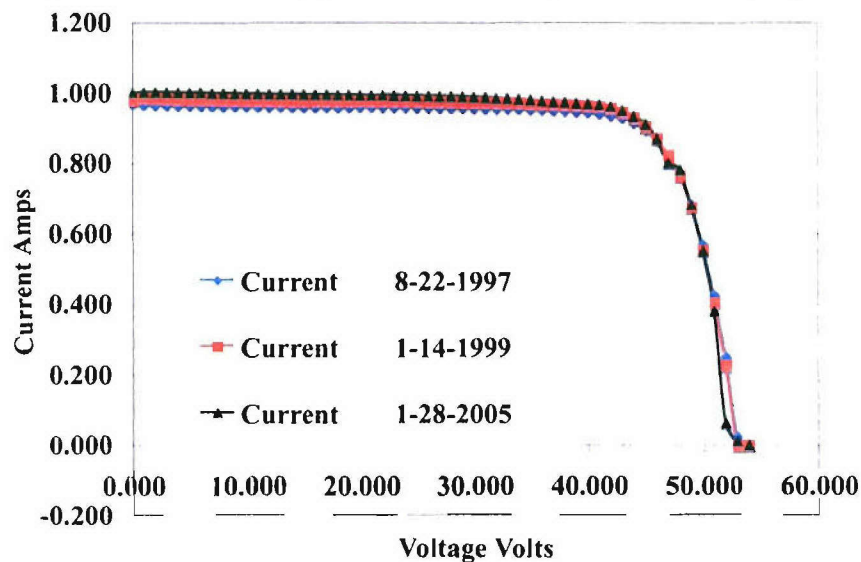

Figure 6. I-V Curves for Circuit 4 Panel A1.

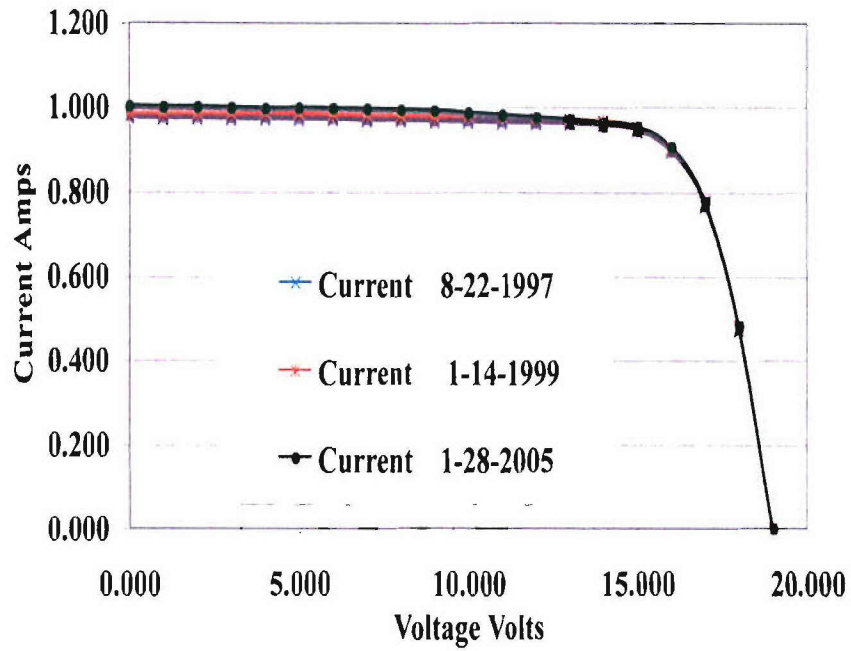

Figure 7. I-V Curve for Circuit 4A Panel A1.

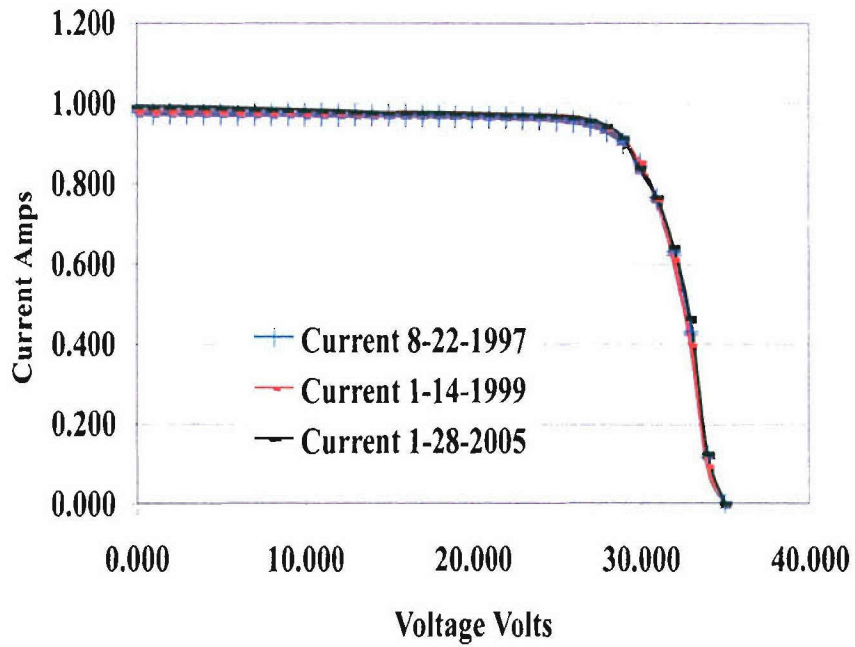

Figure 8. I-V Curve for Circuit 4B Panel A1.

3. Conclusions

The tests performed to date on the DMSP S-17 solar array do not show any degradation over the period of time that the array was in storage. A method has been demonstrated whereby I-V curves of the individual 70 circuits taken over the period of time in storage are compared to determine the health of the solar arrays after extended storage periods.

LABORATORY OPERATIONS

The Aerospace Corporation functions as an “architect-engineer” for national security programs, specializing in advanced military space systems. The Corporation's Laboratory Operations supports the effective and timely development and operation of national security systems through scientific research and the application of advanced technology. Vital to the success of the Corporation is the technical staff's wide-ranging expertise and its ability to stay abreast of new technological developments and program support issues associated with rapidly evolving space systems. Contributing capabilities are provided by these individual organizations:

Electronics and Photonics Laboratory: Microelectronics, VLSI reliability, failure analysis, solid-state device physics, compound semiconductors, radiation effects, infrared and CCD detector devices, data storage and display technologies; lasers and electro-optics, solid-state laser design, micro-optics, optical communications, and fiber-optic sensors; atomic frequency standards, applied laser spectroscopy, laser chemistry, atmospheric propagation and beam control, LIDAR/LADAR remote sensing; solar cell and array testing and evaluation, battery electrochemistry, battery testing and evaluation.

Space Materials Laboratory: Evaluation and characterizations of new materials and processing techniques: metals, alloys, ceramics, polymers, thin films, and composites; development of advanced deposition processes; nondestructive evaluation, component failure analysis and reliability; structural mechanics, fracture mechanics, and stress corrosion; analysis and evaluation of materials at cryogenic and elevated temperatures; launch vehicle fluid mechanics, heat transfer and flight dynamics; aerothermodynamics; chemical and electric propulsion; environmental chemistry; combustion processes; space environment effects on materials, hardening and vulnerability assessment; contamination, thermal and structural control; lubrication and surface phenomena. Microelectromechanical systems (MEMS) for space applications; laser micromachining; laser-surface physical and chemical interactions; micropropulsion; micro- and nanosatellite mission analysis; intelligent microinstruments for monitoring space and launch system environments.

Space Science Applications Laboratory: Magnetospheric, auroral and cosmic-ray physics, wave-particle interactions, magnetospheric plasma waves; atmospheric and ionospheric physics, density and composition of the upper atmosphere, remote sensing using atmospheric radiation; solar physics, infrared astronomy, infrared signature analysis; infrared surveillance, imaging and remote sensing; multispectral and hyperspectral sensor development; data analysis and algorithm development; applications of multispectral and hyperspectral imagery to defense, civil space, commercial, and environmental missions; effects of solar activity, magnetic storms and nuclear explosions on the Earth's atmosphere, ionosphere and magnetosphere; effects of electromagnetic and particulate radiations on space systems; space instrumentation, design, fabrication and test; environmental chemistry, trace detection; atmospheric chemical reactions, atmospheric optics, light scattering, state-specific chemical reactions, and radiative signatures of missile plumes.



2350 E. El Segundo Boulevard
El Segundo, California 90245-4691
U.S.A.