

December 1995
NSRP 0415

SHIP PRODUCTION COMMITTEE
FACILITIES AND ENVIRONMENTAL EFFECTS
SURFACE PREPARATION AND COATINGS
DESIGN/PRODUCTION INTEGRATION
HUMAN RESOURCE INNOVATION
MARINE INDUSTRY STANDARDS
WELDING
INDUSTRIAL ENGINEERING
EDUCATION AND TRAINING

THE NATIONAL SHIPBUILDING RESEARCH PROGRAM

Benefit Analysis of SPC Panel SP-10 Projects

U.S. DEPARTMENT OF THE NAVY
CARDEROCK DIVISION,
NAVAL SURFACE WARFARE CENTER

in cooperation with
National Steel and Shipbuilding Company
San Diego, California

Report Documentation Page

Form Approved
OMB No. 0704-0188

Public reporting burden for the collection of information is estimated to average 1 hour per response, including the time for reviewing instructions, searching existing data sources, gathering and maintaining the data needed, and completing and reviewing the collection of information. Send comments regarding this burden estimate or any other aspect of this collection of information, including suggestions for reducing this burden, to Washington Headquarters Services, Directorate for Information Operations and Reports, 1215 Jefferson Davis Highway, Suite 1204, Arlington VA 22202-4302. Respondents should be aware that notwithstanding any other provision of law, no person shall be subject to a penalty for failing to comply with a collection of information if it does not display a currently valid OMB control number.

1. REPORT DATE DEC 1995	2. REPORT TYPE N/A	3. DATES COVERED -			
4. TITLE AND SUBTITLE The National Shipbuilding Research Program, Benefit Analysis of SPC Panel SP-10 Projects		5a. CONTRACT NUMBER			
		5b. GRANT NUMBER			
		5c. PROGRAM ELEMENT NUMBER			
6. AUTHOR(S)		5d. PROJECT NUMBER			
		5e. TASK NUMBER			
		5f. WORK UNIT NUMBER			
7. PERFORMING ORGANIZATION NAME(S) AND ADDRESS(ES) Naval Surface Warfare Center CD Code 2230 - Design Integration Tower Bldg 192 Room 128 9500 MacArthur Blvd Bethesda, MD 20817-5700		8. PERFORMING ORGANIZATION REPORT NUMBER			
		10. SPONSOR/MONITOR'S ACRONYM(S)			
9. SPONSORING/MONITORING AGENCY NAME(S) AND ADDRESS(ES)		11. SPONSOR/MONITOR'S REPORT NUMBER(S)			
		12. DISTRIBUTION/AVAILABILITY STATEMENT Approved for public release, distribution unlimited			
13. SUPPLEMENTARY NOTES					
14. ABSTRACT					
15. SUBJECT TERMS					
16. SECURITY CLASSIFICATION OF:			17. LIMITATION OF ABSTRACT		
a. REPORT unclassified	b. ABSTRACT unclassified	c. THIS PAGE unclassified	SAR	18. NUMBER OF PAGES 304	19a. NAME OF RESPONSIBLE PERSON

DISCLAIMER

These reports were prepared as an account of government-sponsored work. Neither the United States, nor the United States Navy, nor any person acting on behalf of the United States Navy (A) makes any warranty or representation, expressed or implied, with respect to the accuracy, completeness or usefulness of the information contained in this report/manual, or that the use of any information, apparatus, method, or process disclosed in this report may not infringe privately owned rights; or (B) assumes any liabilities with respect to the use of or for damages resulting from the use of any information, apparatus, method, or process disclosed in the report. As used in the above, "Persons acting on behalf of the United States Navy" includes any employee, contractor, or subcontractor to the contractor of the United States Navy to the extent that such employee, contractor, or subcontractor to the contractor prepares, handles, or distributes, or provides access to any information pursuant to his employment or contract or subcontract to the contractor with the United States Navy. ANY POSSIBLE IMPLIED WARRANTIES OF MERCHANTABILITY AND/OR FITNESS FOR PURPOSE ARE SPECIFICALLY DISCLAIMED.

December 1993
NSRP 0415

**NATIONAL
SHIPBUILDING
RESEARCH
PROGRAM**

**Benefit Analysis of SPC Panel
SP-10 Projects**

U.S. DEPARTMENT OF THE NAVY
DAVID TAYLOR RESEARCH CENTER

National Steel and Shipbuilding Company
San Diego, California

FINAL REPORT

✘ ✘ ✘

BENEFIT ANALYSIS OF SPC PANEL SP-10 PROJECTS

✘ ✘ ✘ ✘ ✘

Prepared by
Robinson-Page-McDonough and Associates, Inc.
Post Office Box 9
Greenland, New Hampshire 03840
(603) 436-7762

For
NATIONAL STEEL AND SHIPBUILDING COMPANY
Harbor Drive and 28th Street
Post Office Box 85278
San Diego, California 92186-5278

In Behalf Of
SNAME SPC PANEL SP-10
on
FLEXIBLE AUTOMATION

Under the
NATIONAL SHIPBUILDING RESEARCH PROGRAM

✘ ✘ ✘ ✘ ✘

December 1993



Dedicated to the memory of

JAMES BARNES ACTON

October 14, 1926 - August 26, 1990



Only Chairman of SPC Panel SP-2
on
Flexible Automation



PREFACE

The National Shipbuilding Research Program has been sponsored during the past 20 years by the Maritime Administration United States Department of Transportation, and by the United States Navy toward improving productivity in shipbuilding. The Program is operated through several Panels of the SNAME Ship Production Committee. During 1988 a survey was conducted in behalf of SPC Panel SP-3 on Surface Preparation and Coatings to determine (1) the benefit value that had accrued from the research projects sponsored by that Panel during the previous 15 years, and (2) how the management and administration of the Panel itself- meetings, discussions, activities - was seen by the using community. The report of this survey (NSRP 0303, July 1989) was well received. It was therefore decided to conduct a similar survey for each of the other active SPC Panels. In addition available information on now inactive Panels SP-2 (Outfitting and Production Aids) and SP- 10 (Flexible Automation) would be reported if it appeared that such information might be helpful to the active Panels.

The modified survey of SPC Panel SP-10 on Flexible Automation is reported herein. The purpose of this survey was to gather and present user opinions and comments on the projects sponsored by Panel SP-10 toward better utilization of this research information.

The Task was conducted by Rodney A Robinson, Vice President of Robinson-Page-McDonough and Associates, Inc. Personal interviews were conducted with several members of the shipyard Flexible Automation community to gain the necessary information. Conclusions and recommendations based on analysis of the findings are included in the report. The work under NASSCO Purchase Order No. MU171117-D, began in October 1991 and was completed in December 1993.

EXECUTIVE SUMMARY

This Task has investigated the benefits derived from the projects sponsored by SNAME Ship Production Committee Panel SP-10 on Flexible Automation during the 4 year period when this Panel was active under the National Shipbuilding Research Program. It has found that Panel SP-10 was actively addressing the potential advantages to the shipyard community of flexible automation equipment and techniques known during that time frame. Much important research was accomplished, but only minimal shipyard application of it has since been achieved. Avoiding a major financial investment in equipment may have caused the low implementation rate. Flexible automation depends on “big ticket” items, which the shipyard community simply has not accepted as essential to staying in business. Since the foreign shipyards that currently dominate the international commercial market seem to have a different opinion, this position may need closer examination in the immediate future.

This Task also identified a problem common to all SPC Panels, but particularly acute for those Panels that are no longer active. Attempts to assemble copies of meeting minutes, attendance rosters, and other material associated with the meetings of SPC Panel SP- 10 from several shipyard contacts were not productive. After only six years of inactivity, the density of such documents has become so thin that locating this information was nearly impossible. The only Chairman of Panel SP-10, James B. Acton passed away some three years after the last Panel meeting. Fortunately, his personal NSRP records were made available to this survey by his Widow. Much of that information is included herein as Appendices B through M. This area of concern still exists for the other Panels, however. Documents of this type are typically thrown out when their immediate purpose has been satisfied. For the active Panels, the problem of obtaining these documents is less severe because recent attendees have them handy. However, the recovery difficulty increases for the earlier meetings, some of which were attended by people no longer on the NSRP scene. Clearly, deliberate steps are needed to preserve such material for future reference. A recommendation to correct this situation is contained in this report.

SPC Panel SP-10 was quite active during its 4-year existence. Much important research was being addressed by this group, but funding uncertainties and the 3 to 4 year project cycle time eventually combined to erode the interest level of Panel participants. As our shipyard community now endeavors to gain a competitive posture in the international commercial market, the research accomplished by Panel SP-10 definitely should be included in deliberations aimed at improving our performance. Even though some of the SP-10 activity took place over a decade ago, the information generated clearly is still relevant. A modest amount of effort to study this information and merge it with the progressive attitudes currently emerging in some of our shipyards could pay substantial dividends.

TABLE OF CONTENTS

	<u>PAGE</u>
BACKGROUND	1
BENEFIT ANALYSIS OF PROJECTS SPONSORED BY SPC PANEL SP-10	7
Detailed Discussion of Individual Projects	7
CONCLUSIONS FROM THE FINDINGS	12
RECOMMENDATIONS FROM THE CONCLUSIONS	13
APPENDICES	
A - Project Benefit Analysis Worksheet, SPC Panel SP-10	
B - Minutes of SPC Panel SP-10 Meeting No. 1 held on Jun 14-15, 1983	
C - Minutes of SPC Panel SP-10 Meeting No. 2 held on Nov 15-17, 1983	
D - Minutes of SPC Panel SP-10 Meeting No. 3 held on Mar 20-21, 1984	
E - Minutes of SPC Panel SP-10 Meeting No. 4 held on Jul 17-18, 1984	
F - Minutes of SPC Panel SP-10 Meeting No. 5 held on Nov 27, 1984	
G - Attendees at SPC Panel SP-10 Meeting No. 6 held on Mar 20, 1985	
H - Minutes of SPC Meeting Sep 10, 1985 where SP-10 Meeting No. 7 was held	
I - Attendees at SPC Panel SP-10 Meeting No. 8 held on Nov 7-8, 1985	
J - Minutes of SPC Panel SP-10 Meeting No. 9 held on Mar 18-19, 1986	
K - Attendees at SPC Panel SP-10 Meeting No. IO held on Jul 8-9, 1986	
L - Minutes of SPC Panel SP-10 Meeting No. 11 held on Nov 20-21, 1986	
M - Minutes of SPC Panel SP-10 Meeting No. 12 held on Apr 28, 1987	

FINAL REPORT



BENEFIT ANALYSIS OF SPC PANEL SP-10 PROJECTS

BACK GROUND

General Discussion

This Project was designed to investigate the benefits that may have resulted from SPC Panel SP-10 Flexible Automation projects carried out during the 4 year period when this Panel was in active operation. The Project would consist of interviews with members of the Flexible Automation community to gain information on these matters. The interviews would be on-site and face-to-face, to yield the most meaningful results. Analysis of findings would be published for principal consumption by the members of other active SPC Panels toward better utilization of this research information by the shipyard community.

This project was a direct follow-on to a similar project conducted in 1989 in behalf of SPC Panel SP-3 to (1) explore the benefits that may have resulted from the projects sponsored by that Panel during the previous 15 years, and (2) to evaluate how the management of Panel SP-3 itself was seen by the using community. The report on that project (NSRP 0303, July 1989) was well received, prompting the development of this current project, which consists of the same kind of analyses for all other active SPC Panels, as well as an update on the projects of Panel SP-3 since the original report. It was also decided to add a modified survey of currently inactive Panels SP-2 (Outfitting and Production Aids) and SP-10 (Flexible Automation) toward better utilization of their research findings. The report presented herein covers the area of projects sponsored by SPC Panel SP-10 on Flexible Automation.

Overview

Information on project benefits was gained through personal and anonymous interviews with 3 members of the Flexible Automation community from 3 different shipyard locations. The interviews were conducted during the months of April and May, 1993. The survey would have benefited from interviews with a larger number of people, but difficulty was encountered in finding shipyard representatives who were still knowledgeable of SP-10 matters after the six years of Panel inactivity. Out of the 200+ people contacted for this survey (which involved all SPC Panels), only these 3 individuals were able to provide specific information on the projects sponsored by Panel SP-10.

Records of Panel SP-10 activities also were difficult to locate in the shipyard community. Fortunately, however, the personal records of the Chairman of Panel SP-10 were obtained, and they yielded important information. These records are now located in the NSRP Program Office at NASSCO. Panel SP-10 held a total of twelve meetings over four years. A matrix of the attendees at each of the twelve meetings, and their company affiliations, appears on pages 3 through 6. The minutes of nine meetings have been located. These minutes are included as appendices to this report.

Several questions were designed to explore the aspects of this survey. The worksheets for gathering information on the benefits of individual projects are contained in Appendix A.

A detailed discussion of the findings is presented below. Those associated with the benefit analysis of panel projects begin on page 7. Conclusions reached from the findings are on page 12. The recommendations drawn from these conclusions are on page 13.

ATTENDEE	COMPANY AFFILIATION	DATE - LOCATION											
		JUN '83 - LONG BEACH, CA	NOV '83 - ARLINGTON, VA	MAR '84 - MYSTIC, CT	JUL '84 - MENLO PARK, CA	NOV '84 - ANAHEIM, CA	MAR '85 - CAMBRIDGE, MA	SEP '85 - LONG BEACH, CA	NOV '85 - WASHINGTON, DC	MAR '86 - BETHESDA, MD	JUL '86 - ARLINGTON, TX	NOV '86 - NEW ORLEANS, LA	APR '87 - CHICAGO, IL
ACTON, JAMES B.	TODD PACIFIC S/Y/S CORP - LA	X	X	X	X	X	X	X	X	X	X	X	X
AGEE, MARVIN H.	VIRGINIA POLYTECHNIC INST	X	X	X	X	X							
AJALIA, SOLO	INTRICATE MACHINE & ENGR'G			X									
ALBUS, J.	NATIONAL BUREAU OF STANDARDS							X					
ARRISON, JOHN C.	MASS INST OF TECHNOLOGY						X						
BERGER, HOWARD	ROBOTIX CORP.	X				X							
BLAIS, DAVE	BATH IRON WORKS	X		X				X					
BUTLER, W. J.	NAVSEA								X				X
BYLER, ERIC	ADVANCED MARINE ENTERPRIZES		X										
CAMERON, JAMES	GENERAL DYNAMICS/EB DIV	X	X	X	X		X	X	X	X			
CANTRELL, J.	GENERAL DYNAMICS/EB DIV								X				
CARSTENS, JEFF	UNITED TECHNOLOGIES						X						
CHRISTENSEN, WALTER	NAV IND RES SUPP ACTIVITY											X	
CORDEIRO, ROD	GENERAL DYNAMICS/EB DIV			X									
CUNNINGHAM, MAURICE	BATH IRON WORKS						X	X					
DALLAS, ANDREW	U. MICHIGAN				X								
DAVIS, O. J.	INGALLS SHIPBUILDING DIVISION											X	
EVERETT, BART	NAVSEA		X						X				
FALLICK, JON	NAVSEA				X			X					
FEOLI, ROBERT	INTRICATE MACHINE & ENGR'G			X									
FODOR, M. M.	TODD PACIFIC S/Y/S CORP - LA	X											
FRENCH, WILLIAM	AVONDALE INDUSTRIES, INC.	X	X	X									
FUNKHOUSER, OREN	TODD PACIFIC S/Y/S CORP - LA	X											
GALIE, THOMAS R.	NAVSES		X	X	X		X						
GOODWIN, K.	NATIONAL BUREAU OF STANDARDS							X	X	X	X		
GUASTINI, ROBERT	GENERAL DYNAMICS/QUON POINT			X									
HAYNES, NICK V.	BETHLEHEM STEEL - SPARROWS PT	X	X		X	X	X		X				
HENSON, FRED	MARE ISLAND NAVAL S/Y	X		X	X								
HILL, RAYMOND	INTRICATE MACHINE & ENGR'G			X									
HOCKETT, RONALD E.	NEWPORT NEWS SHIPBUILDING			X									
HOLLIDAY, LAWRENCE	NEWPORT NEWS SHIPBUILDING	X		X									
HUBER, D.	MACHINE INTELLIGENCE	X											
JENKINS, ROBERT	DAVID TAYLOR RES'CH CENTER	X	X	X	X		X	X	X	X		X	X
JESSUP, JOHN	U. MICHIGAN - TRANS RES'CH INST												X
JONES, MARILYN	VIRGINIA POLYTECHNIC INST				X								
JUSTICE, JAMES F.	SCIENCE APPLICATIONS, INC.	X			X		X		X	X			
KELLY, RONALD	GENERAL DYNAMICS/DSD					X	X						
KLICK, A. M.	GENERAL DYNAMICS/EB DIV								X				
KNOWLES, H.	DAVID TAYLOR RES'CH CENTER												X
KREMERS, JAN	SRI INTERNATIONAL				X								
LASH, R.	AEROSPACE CORP	X											
LEVINE, SEYMOUR S.	ROBOTIC VISION SYSTEMS, INC.	X											
LEWIS, C.	METCO, INC.	X											
LORMER, M.	OPTIMATION									X			X

SPC Panel SP-10
Meeting Attendees
Alphabetical by Last Name

ATTENDEE	COMPANY AFFILIATION	DATE - LOCATION											
		JUN '83 - LONG BEACH, CA	NOV '83 - ARLINGTON, VA	MAR '84 - MYSTIC, CT	JUL '84 - MENLO PARK, CA	NOV '84 - ANAHEIM, CA	MAR '85 - CAMBRIDGE, MA	SEP '85 - LONG BEACH, CA	NOV '85 - WASHINGTON, DC	MAR '86 - BETHESDA, MD	JUL '86 - ARLINGTON, TX	NOV '86 - NEW ORLEANS, LA	APR '87 - CHICAGO, IL
LUNDY, M.	OPTIMATION										X		
MACIEL, J.	TODD PACIFIC S/Y S CORP - LA	X											
McEACHRAN, J.	ROBOTICS INTERNATIONAL OF SME	X											
MEYER, CLIFF	GENERAL DYNAMICS/QUON POINT			X									
MILLER, BERNARD	CONTRAVES-GOERZ CORP.				X								
NELSON, M.	LONG BEACH NAVAL S/Y						X						
NEVENS, JIM	CHARLES STARK DRAPER LABS		X		X	X	X			X	X		
NITZAN, DAVID	SRI INTERNATIONAL				X								
O'BRIEN, T. P.	MACHINE INTELLIGENCE	X											
OAKES, WILLIAM S.	NASSCO		X		X	X	X		X				
PAYNE, KENNETH	GENERAL DYNAMICS/QUON POINT			X									
PETERSEN, EDWIN J.	TODD PACIFIC S/Y S CORP - LA	X						X					
PHILLIPS, JOSEPH R.	BATH IRON WORKS						X	X					
PRICE, RICHARD A.	AVONDALE INDUSTRIES, INC.							X					
RICHARD, JOEL	MARITIME ADMINISTRATION								X	X	X	X	
RINEHART, VIRGIL	MARITIME ADMINISTRATION								X	X			X
RIVAS, JIM	LONG BEACH NAVAL S/Y	X	X	X		X							
ROME, DALE	INGALLS SHIPBUILDING DIVISION											X	X
SAPPINGTON, STEPHEN	BETHLEHEM STEEL - SPARROWS PT		X	X									
SCHAFFRAN, ROBERT	DAVID TAYLOR RES'CH CENTER	X	X	X	X		X	X	X	X			
SCULLY, K.	DAVID TAYLOR RES'CH CENTER									X	X		
SIZEMORE, JOHN	INGALLS SHIPBUILDING DIVISION	X	X	X	X				X	X	X	X	X
SLAUGHTER, ROBERT H.	INGALLS SHIPBUILDING DIVISION								X	X			
STEPHANS, OREN	DAVID TAYLOR RES'CH CENTER									X			
STAPIEN, T.	CHARLES STARK DRAPER LABS								X				
TANNER, MARK	NEWPORT NEWS SHIPBUILDING	X		X				X					
THAYER, WILLIAM	GENERAL DYNAMICS/EB DIV			X									
VISAGE, J. R.	MARE ISLAND NAVAL S/Y					X							
VIVIAN, L. D.	LONG BEACH NAVAL S/Y								X				
WALLEN, REX	NEWPORT NEWS SHIPBUILDING								X	X			
WATSON, H.	PENNSYLVANIA STATE UNIV.												X
WELLS, ROY	NAVSEA	X	X	X	X						X		
WHITNEY, DANIEL E.	CHARLES STARK DRAPER LABS			X						X			X
WITZ, J.	AEROSPACE CORP	X											
WOLLAM, W.	SOUTHWEST RES'CH INST							X					
WYSK, Dr. R. A.	VIRGINIA POLYTECHNIC INST	X											

SPC Panel SP-10
Meeting Attendees
Alphabetical by Last Name

ATTENDEE	COMPANY AFFILIATION	DATE - LOCATION											
		JUN '83 - LONG BEACH, CA	NOV '83 - ARLINGTON, VA	MAR '84 - MYSTIC, CT	JUL '84 - MENLO PARK, CA	NOV '84 - ANAHEIM, CA	MAR '85 - CAMBRIDGE, MA	SEP '85 - LONG BEACH, CA	NOV '85 - WASHINGTON, DC	MAR '86 - BETHESDA, MD	JUL '86 - ARLINGTON, TX	NOV '86 - NEW ORLEANS, LA	APR '87 - CHICAGO, IL
BYLER, ERIC	ADVANCED MARINE ENTERPRIZES		X										
LASH, R.	AEROSPACE CORP	X											
WITZ, J.	AEROSPACE CORP	X											
FRENCH, WILLIAM	AVONDALE INDUSTRIES, INC.	X	X	X									
PRICE, RICHARD A.	AVONDALE INDUSTRIES, INC.							X					
BLAIS, DAVE	BATH IRON WORKS	X		X					X				
CUNNINGHAM, MAURICE	BATH IRON WORKS							X	X				
PHILLIPS, JOSEPH R.	BATH IRON WORKS							X	X				
HAYNES, NICK V.	BETHLEHEM STEEL - SPARROWS PT	X	X		X	X	X			X			
SAPPINGTON, STEPHEN	BETHLEHEM STEEL - SPARROWS PT		X	X									
NEVENS, JIM	CHARLES STARK DRAPER LABS		X		X	X	X			X	X		
STEPIEN, T.	CHARLES STARK DRAPER LABS								X				
WHITNEY, DANIEL E.	CHARLES STARK DRAPER LABS			X						X			X
MILLER, BERNARD	CONTRAVES-GOERZ CORP.				X								
JENKINS, ROBERT	DAVID TAYLOR RES'CH CENTER	X	X	X	X		X	X	X	X		X	X
KNOWLES, H.	DAVID TAYLOR RES'CH CENTER												X
SCHAFFRAN, ROBERT	DAVID TAYLOR RES'CH CENTER	X	X	X	X		X	X	X	X			
SCULLY, K.	DAVID TAYLOR RES'CH CENTER									X	X		
STEPHANS, OREN	DAVID TAYLOR RES'CH CENTER									X			
KELLY, RONALD	GENERAL DYNAMICS/DSD					X	X						
CAMERON, JAMES	GENERAL DYNAMICS/EB DIV	X	X	X	X		X		X	X	X		
CANTRELL, J.	GENERAL DYNAMICS/EB DIV									X			
CORDEIRO, ROD	GENERAL DYNAMICS/EB DIV			X									
KLICK, A. M.	GENERAL DYNAMICS/EB DIV									X			
THAYER, WILLIAM	GENERAL DYNAMICS/EB DIV			X									
GUASTINI, ROBERT	GENERAL DYNAMICS/QUON POINT			X									
PAYNE, KENNETH	GENERAL DYNAMICS/QUON POINT			X									
MEYER, CLIFF	GENERAL DYNAMICS/QUON POINT			X									
DAVIS, O. J.	INGALLS SHIPBUILDING DIVISION												X
ROME, DALE	INGALLS SHIPBUILDING DIVISION											X	X
SIZEMORE, JOHN	INGALLS SHIPBUILDING DIVISION	X	X	X	X				X	X	X	X	X
SLAUGHTER, ROBERT H.	INGALLS SHIPBUILDING DIVISION								X	X			
AJALIA, SOLO	INTRICATE MACHINE & ENGR'G			X									
FEOLI, ROBERT	INTRICATE MACHINE & ENGR'G			X									
HILL, RAYMOND	INTRICATE MACHINE & ENGR'G			X									
NELSON, M.	LONG BEACH NAVAL S/Y							X					
RIVAS, JIM	LONG BEACH NAVAL S/Y	X	X	X		X							
VIVIAN, L. D.	LONG BEACH NAVAL S/Y								X				
HUBER, D.	MACHINE INTELLIGENCE	X											
O'BRIEN, T. P.	MACHINE INTELLIGENCE	X											
HENSON, FRED	MARE ISLAND NAVAL S/Y	X		X	X								
VISAGE, J. R.	MARE ISLAND NAVAL S/Y					X							
RICHARD, JOEL	MARITIME ADMINISTRATION								X	X	X	X	
RINEHART, VIRGIL	MARITIME ADMINISTRATION								X	X			X

SPC Panel SP-10
Meeting Attendees
by Company Affiliation

ATTENDEE	COMPANY AFFILIATION	DATE - LOCATION											
		JUN '83 - LONG BEACH, CA	NOV '83 - ARLINGTON, VA	MAR '84 - MYSTIC, CT	JUL '84 - MENLO PARK, CA	NOV '84 - ANAHEIM, CA	MAR '85 - CAMBRIDGE, MA	SEP '85 - LONG BEACH, CA	NOV '85 - WASHINGTON, DC	MAR '86 - BETHESDA, MD	JUL '86 - ARLINGTON, TX	NOV '86 - NEW ORLEANS, LA	APR '87 - CHICAGO, IL
ARRISON, JOHN C.	MASS INST OF TECHNOLOGY						X						
LEWIS, C.	METCO, INC.	X											
OAKES, WILLIAM S.	NASSCO		X		X	X	X		X				
ALBUS, J.	NATIONAL BUREAU OF STANDARDS								X				
GOODWIN, K.	NATIONAL BUREAU OF STANDARDS								X	X	X	X	
CHRISTENSEN, WALTER	NAV IND RES SUPP ACTIVITY											X	
BUTLER, W. J.	NAVSEA									X			X
EVERETT, BART	NAVSEA		X							X			
FALLICK, JON	NAVSEA				X				X				
WELLS, ROY	NAVSEA	X	X	X	X						X		
GALIE, THOMAS R.	NAVSES		X	X	X		X						
HOCKETT, RONALD E.	NEWPORT NEWS SHIPBUILDING			X									
HOLLIDAY, LAWRENCE	NEWPORT NEWS SHIPBUILDING	X		X									
TANNER, MARK	NEWPORT NEWS SHIPBUILDING	X		X				X					
WALLEN, REX	NEWPORT NEWS SHIPBUILDING								X	X			
LORMER, M.	OPTIMATION										X		X
LUNDY, M.	OPTIMATION										X		
WATSON, H.	PENNSYLVANIA STATE UNIV.												X
LEVINE, SEYMOUR S.	ROBOTIC VISION SYSTEMS, INC.	X											
McEACHRAN, J.	ROBOTICS INTERNATIONAL OF SME	X											
BERGER, HOWARD	ROBOTIX CORP.	X					X						
JUSTICE, JAMES F.	SCIENCE APPLICATIONS, INC.	X			X		X			X	X		
WOLLAM, W.	SOUTHWEST RES'CH INST						X						
KREMERS, JAN	SRI INTERNATIONAL				X								
NITZAN, DAVID	SRI INTERNATIONAL				X								
ACTON, JAMES B.	TODD PACIFIC S/SYS CORP - LA	X	X	X	X	X	X	X	X	X	X	X	X
FODOR, M. M.	TODD PACIFIC S/SYS CORP - LA	X											
FUNKHOUSER, OREN	TODD PACIFIC S/SYS CORP - LA	X											
MACIEL, J.	TODD PACIFIC S/SYS CORP - LA	X											
PETERSEN, EDWIN J.	TODD PACIFIC S/SYS CORP - LA	X						X					
DALLAS, ANDREW	U. MICHIGAN				X								
JESSUP, JOHN	U. MICHIGAN - TRANS RES'CH INST												X
CARSTENS, JEFF	UNITED TECHNOLOGIES						X						
AGEE, MARVIN H.	VIRGINIA POLYTECHNIC INST	X	X	X	X	X							
JONES, MARILYN	VIRGINIA POLYTECHNIC INST				X								
WYSK, Dr. R. A.	VIRGINIA POLYTECHNIC INST	X											

SPC Panel SP-10
Meeting Attendees
by Company Affiliation

BENEFIT ANALYSIS OF PROJECTS SPONSORED BY SPC PANEL SP-10

General Discussion

This section contains information on all of the SP-10 projects investigated, including a description of each project, the pertinent information surrounding that project, and an analysis of the benefit value gained from that project to date. The NSRP Number is that assigned to each report in the NSRP Bibliography of Publications 1973-1992, published (now annually) by the University of Michigan for the National Shipbuilding Research Program. The projects investigated are those listed in this specific publication (1973-1992). The analysis portion has been drawn from the comments offered by those interviewed, and is intended to provide a general indication of how the project has been received by the shipyard industry. Appendix A was the worksheet used during the interviews.

For each of the active SPC Panels covered by this survey, a section was included at this location in each Final Report to provide a rapid visual idea of the relative benefit value that has been gained from the projects of each Panel that were investigated. Each Project was assigned a number of *'s (from 1 to 9) to indicate the relative benefit value gained from that project; the more *'s, the larger the benefit value gained. While these ratings were recognized as surely subjective, they were intended to represent the general opinions of those interviewed as a reflection of the overall industry attitude surrounding these projects.

In view of the small number of interview inputs available for Panel SP-10 projects, however, there was an insufficient basis for the assignment of *'s to these projects. The comments offered by those interviewed have been included below, and do provide at least some indication of project benefits.

Detailed Discussion of Individual Projects

Each of the individual projects investigated are discussed below in the chronological order in which they were carried out. Included is: NSRP Number, *TITLE*; *AUTHOR*; *DATE*; *COST* (where available); ABSTRACT and BENEFIT ANALYSIS.

NSRP 0081

TITLE: Technology Survey of Major U. S. Shipyards

AUTHOR: Marine Equipment Leasing, Inc.

DATE: 1978

COST: (Not available)

ABSTRACT: This is a report on a technology survey of 13 major U. S. shipyards and 16 of the best comparable foreign shipyards. A standard procedure is followed in assigning one of four technology levels to a broad range of shipbuilding operations and processes in each shipyard. The results are presented in terms of comparisons among U. S. shipyards and between U. S. and foreign shipyards. (300 p. approx.)

BENEFIT ANALYSIS: This project established a starting point for consideration of flexible automation in the shipyard community. It did not intend much else, and so was not "applied" in the sense of directly affecting the way in which shipyard work is earned out. It was, however, a good assessment of technology conditions in U. S. shipyards and in several foreign shipyards in the 1978 time frame, which might be useful as a baseline for present-day studies associated with the entry of U. S. shipyards into the international commercial market.

NSRP 0131

TITLE: Robotics in Shipbuilding Workshop Proceedings with Executive Summary.

AUTHOR: Todd Pacific Shipyards, Los Angeles Division (TPLA)

DATE: October 1981

COST: (Not available)

ABSTRACT: This report summarizes a three-day workshop held by MARAD and TPLA to initiate the shipbuilding industry into the field of Robotics. It assesses industry needs which could be potentially met by robots. A number of problems were identified, some preliminary projects specified, and an industry direction for developing a program was established. The attendees recommended increased promotion of robotics technology and its application; development of a program led by the industry to apply robotics technology; and establishment of a SNAME/SPC panel to take action on recommendations and continue the work of the workshop. (133 p.)

BENEFIT ANALYSIS: This workshop launched SPC Panel SP-10 as an industry voice in the flexible automation area. This gathering was a seed-planting opportunity which produced considerable interest in flexible automation activities. The first meeting of Panel SP-10 followed in June, 1983, at Long Beach CA. Eleven additional meetings of Panel SP-10 were held, the last one in April, 1987, in Chicago, IL This particular report did not precipitate any direct application of flexible automation ideas, but one shipyard representative cited the introduction of a robotics shape processor at his shipyard in this general time frame which he felt could well have been a follow-on from the initial impetus produced during this workshop.

NSRP 0267

***TITLE:* Implementation Plan for Flexible Automation in U.S. Shipyards.**

AUTHOR: The Charles Stark Draper Laboratory, for Todd Pacific Shipyards, Los Angeles.

DATE: February 1987

COST: \$221,047.

ABSTRACT: This implementation plan surveys current design and building practice in the shipbuilding industry and recommends a systematic approach to productivity improvement through flexible automation. Flexible automation in this context, covers any technique that can deal with a class of similar jobs. It can be applied to associated automation opportunities in design production planning, outfit planning, measuring, data analysis, process improvement, and other crucial areas that support fabrication, account for a large part of construction cost, and can benefit from automation. (268 p.)

BENIFIT ANALYSIS: This project report was referred to by one shipyard representative as “a scholarly piece with a good message that should be read by many other people”. A second shipyard representative admitted that his shipyard did not have much in the way of flexible automation, and so he “suspected that the report was not too persuasive”, at least in the case of his shipyard. This report addresses the one and only flexible automation research effort that was sponsored by Panel SP-1 O and was subsequently published under the NSRP. Several other items of research were addressed by Panel SP-10 (as discussed briefly below), but none of them reached the point of being published.

NOTE: Review of the Panel SP-10 meeting minutes, which have been included herein as Appendices, will reveal several other projects that were in various stages of completion when the Panel was disbanded. Notable among these projects are the following:

- **Marking Plate Cut by CNC Burning Machines, Phase I.** This project suffered a stop work order in the midst of the research. It had a high technical risk and required a high capital investment. This research would have been useful to a shipyard having a high volume of plate being cut with CNC burning machines.

- **Design Production Integration for Robotics Ship Manufacture.** This project attempted to design a class of components as a rationalized parts family for group manufacture on flexible automated production equipment. It also would design a flexible automatic production system incorporating operational capabilities specifically aligned with the manufacturing task requirements of the component class. The project also suffered a stop work order following the collapse of Todd LA who was serving as the research contractor. It might have been directed to another contractor, but finding problems developed and the project was abandoned.

- **Manufacture, Inspection and Repair of Welding Cable Using Flexible Automation.** This project was pursued for several months, but was stopped in mid-stream. The variety of cables and connectors and the variety of damages were found to be so great that programming and tooling was viewed as too complicated and expensive. The shipyards did not agree on what was the “right” welding cable. Any one company investment in hand tooling for one variety of connectors could be done so cheaply, and without the involvement of other shipyards, that it would become a proprietary advantage for them. Broad cooperative research was therefore of no interest.

- **Project Funding.** One other commentary on the general nature of Panel SP-10 projects during this time frame is included to describe (1) the finding queue facing the Panel, and (2) the uncertainty of project application due to the length of time needed to gain meaningful project results. The finding cycle at that time consumed 2 to 3 years. As one shipyard representative put it, “No self-respecting SP-10 project could ever realistically be accomplished in less than one year.” The net result was that even with good ideas, it was 3 to 4 years before the research could be accomplished and reported. Ideas were often overtaken by other events, and “The Panel could not keep up the interest level of the participants”. This situation is surely not confined to Panel SP-10 some 6 years ago; it still exists today with the active SPC Panels who watch this condition erode many promising items of research. One possible solution would be to “commit money to a GOAL, rather than to a specific project. Then the researchers could be turned loose to accomplish the GOAL” on a shorter time frame than would be required to complete an entire project.

CONCLUSIONS FROM THE FINDINGS

Three principal conclusions have been drawn from this survey, as follows:

1. Panel SP-10 research findings have not been applied effectively in U. S. shipyards.

Analysis of the responses offered by those interviewed, and informal discussions with several other people generally aware of SP-10 matters and currently close to the NSRP and the activities of other active SPC Panels, suggest that the few projects sponsored by SPC Panel SP-10 were directed at areas where improvements in U. S. shipyards are still needed. In analyzing comments on why so few of the Flexible Automation findings have been applied in U. S. shipyards, it appears that avoiding a major financial investment in equipment may have caused the low implementation rate. U. S. shipyards simply have not found it necessary to utilize flexible automation techniques in order to stay in business. This position may have to be examined in some depth however, as the foreign shipyards that currently dominate the international commercial market seem to have a different opinion.

Since there is a large amount of potentially helpful information contained in the material generated by Panel SP-10, consideration should be given to the study and understanding of this material as it relates to the transition of U. S. shipyards from Government customers to an active role in the international commercial market. SPC Panels SP-1 , SP-4, and SP-8 all share interest in this general area, and should consider a deliberate effort to build on the baseline of information that was produced by Panel SP-10.

2. Information on the meetings and activities of SPC Panel SP-10 is not widely available.

During this survey attempts to assemble information on the meetings and associated activities of Panel SP-10 were modestly successful, but only after the personal records of the Chairman were made available by his Widow following his unexpected passing. Many contacts were made with people who attended one or more of the Panel meetings, but rarely were copies of the minutes or a listing of attendees found. As time goes on, even less information is likely to survive. It is for this reason that the existing meeting minutes have been included as appendices to this report.

There appears to be no single location where meeting minutes and reports on related activities of any SPC Panel can be found. For active Panels, the problem of obtaining such material is greatly lessened, because recent attendees still have the documents handy, although it is still a challenge to obtain older material. For inactive Panels, once this information disappears it cannot be reconstructed.

Consideration should be given to a deliberate arrangement whereby a copy of each and every set of SPC Panel meeting minutes, roster of attendees, and selected support information (enclosures, appendices, attachments, etc.) is placed in a permanent file at a published location. It

is common for major changes in operations, facilities, flexible automation capabilities, vendor relationships, and other aspects of shipyard life to consume many years of effort before they become reality. The valuable history of these issues, as contained in the meeting minutes and associated documents, often can greatly assist the process. Although the usage traffic for such a file would undoubtedly be quite low, the guaranteed availability of this information would surely be worth the modest expense of such an arrangement.

3. The Project Funding Queue was Long and Uncertain.

During the period when Panel SP-10 was in fill operation, the project finding cycle regularly consumed 2 to 3 years and was fraught with uncertainty. When this finding queue was coupled with a nominal one year project performance period, the time from idea conception to research results was 3 to 4 years. In addition the equipment needed to support research in the Flexible Automation area usually included "big ticket" items which were not readily available. In this atmosphere the Panel could not keep up the interest level of the participants, which contributed to the eventual demise of Panel activities.

RECOMMENDATIONS FROM THE CONCLUSIONS

The following recommendations have been drawn from the conclusions:

1. Efforts should be directed toward understanding and utilizing the research information produced by SPC Panel SP-10. In particular, Panels SP-1, SP-4, and SP-8 each should examine this material and see that it is applied during active projects involving or interfacing with flexible automation techniques or equipment.

2. Arrangements should be made to have one copy of every set of SPC Panel meeting minutes, roster of attendees, and selected support information placed on permanent file at a published location that will be conveniently available to the shipyard community. This location could be SNAME, the office of the respective NSRP Program Manager, the Chairperson of each Panel, NSWC - Carderock Division, the NSRP Library at the University of Michigan, or some other suitable place. This arrangement should be made promptly, as much of the information currently in existence will soon disappear.

3. Those managing the financial affairs of the NSRP should consider finding the desired research by GOALS, rather than by projects. This approach could allow the research to proceed on a shorter time frame than that obligated by a fill project. This would make the research results available sooner, and should strengthen industry interest in supporting the overall Program.

APPENDIX A

Project Benefit Analysis Worksheet

SPC Panel SP-10

SP-10 PROJECTS LISTING

NSRP	KEY	REMARKS
0-081	Technology Survey of Major U.S. Shipyards 1978	
0131	Robotics in Shipbuilding Workshop Proceedings with Executive Summary 1981	
0267	Implementation Plan for Flexible Automation in U.S. Shipyards 1987	

KEY RATING DESCRIPTION

- 0 No knowledge/no interest
 - 1 Interested; will look at information
 - 2 Have information; considering it
 - 3 Have studied information; no application intended
 - 4 Information looks useful; application planned
 - 5 Applied once; no further application seen
 - 6 Have applied on limited scale; may apply again
 - 7 Have applied substantially; information useful
 - 8 Constant application on-going; information valuable
 - 9 Need more information; wider application
-

RATING SYSTEM FOR NSRP PROJECTS EVALUATION

APPENDIX B

**Minutes
of
SPC Panel SP-10 Meeting No. 1**

**held at
Long Beach, CA
on June 14-15, 1983**

**with
Enclosures 1 through 13**

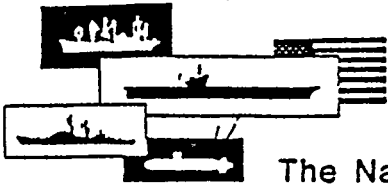

The National Shipbuilding Research Program
Panel SP-10 Flexible Automation

JBA:NSRP:002/83

July 6, 1983

The initial meeting of the panel was held June 14-15, 1983 at the Hyatt Regency Hotel in Long Beach, California. It was a productive meeting for which the attendees deserve special praise for their participation. The minutes are attached for your retention and use; please contact me if you have any questions or comments.

Special thanks go to Mr. E. J. Petersen, the new Chairman of the SPC for his attendance and opening remarks. The challenge of the future which he presented to us will be an exciting time for the panel.

I hope to see all the panel members at the IREAPS symposium in Boston, August 23, for a "mini" meeting to firm up our FY '84 budget proposals. Those of us who accepted the task are working on project briefs which I will distribute as soon as they are completed.

Very truly yours,

J. B. ACTON
Chairman and
Program Manager
SP-10

JBA:els

Attachments

SNAME/SPC PANEL SP-10 FLEXIBLE AUTOMATION
Minutes of the Meeting 1
Hyatt Regency Hotel
Long Beach, California
Tuesday & Wednesday, JUNE,14-15, 1983 - 8:30 a.m.

PRESIDING : Mr. J. B. Acton - Panel Chairman

ATTENDEES : [see enclosure (1)]

GENERAL

1. The first meeting of this panel was convened by the Panel Chairman/Program Manager, James B. Acton at 8:30 a.m. in the Hyatt Regency Hotel. Twenty-eight (28) people were in attendance representing seven private and two Naval shipyards, three consulting firms, four "artificial intelligence" vendors, one university, plus MARAD and the Navy. A modified agenda is forwarded as enclosure (2).

2. The panel was honored by the presence of the new Chairman of the Ship Production Committee, Mr. Edwin J. Petersen of Todd Pacific Shipyards Corporation, Los Angeles Division, who welcomed the panel into the National Shipbuilding Research Program and the attendees to the meeting. His remarks are included as enclosure (3).

PANEL ESTABLISHMENT

1. The attendees then undertook the task of establishing the panel. Panel Chairman Acton started by stating the definition of Flexible Automation as:

"The combination of reprogrammable single and multi-functional manipulators and fixed function machines integrated with conventional fabrication and assembly techniques for optimizing the performance of the manufacturing process".

He then provided the following proposed charter:

The Flexible Automation Panel has the responsibility to act for the industry in coordinating a cooperative technical program with the Maritime Administration and the Navy to:

- a. Develop a "road map" for transferring existing and developing/applying new flexible automation technology;
- b. Establish a consensus priority list of high cost driver areas for target applications of this technology;
- c. **Solicit** and review proposed research projects which address problem areas;
- d. Coordinate the efforts of other SNAME panels proposing flexible automation applications;
- e. Maintain an up-to-date awareness of flexible automation technology as it applies to shipbuilding technology;
- f. Publish and disseminate research results to the industry; and
- g. Maintain a flexible program with redirection capability to address new problems/technology as they arise.

This was discussed at length and agreed upon with the following significant points emphasized:

- o There will be a considerable overlap between SP-10 and other panels such as SP-7, therefore requiring close coordination between panels rather than duplication of their efforts. Thus, the substantive requirements of each flexible automation project must be analyzed in order to determine the lead panel.
- 0 This panel should be prepared more than any other to provide service to other panels.
- 0 Progress of projects should be carefully monitored by the entire panel with those failing to show accomplishment cancelled and the remaining budget applied elsewhere.

2. The subject of membership was reviewed and the following categories designated:

- a. Regular (voting members) -
 - (1) Participating private shipyards (open to all member yards of SPC);
 - (2) U.S. Naval Shipyards
(if invitation by SPC Chairman for their active participation accepted by NAVSEA);
- b. Associate (non-voting) members -
 - (1) MARAD
 - (2) **Navy** offices, bureaus and research activities
 - (3) Membership-approved education and research institutions
 - (4) Professional associations
- c. Guest Members
 - (1) Consulting firms (in appropriate field)
 - (2) Private research firms
- d. Voting regulations were then established as follows:
 - (1) One vote per participating shipyard on technical matters
 - (2) One vote per organization on organizational and policy matters
 - (3) Vote will be by members present at a regularly announced meeting

3. A discussion of project control mechanisms resulted in the adoption of the rules governing the following extrapolated procedure:

a. Project Preparation

- (1) Following the decision to pursue a project, a member will be tasked with preparing a project brief, as outlined in enclosure (4), to be forwarded to the Program Manager at least one month prior to the next scheduled meeting.
- (2) The Program Manager shall send a copy of the project brief and a review sheet to each member with the meeting announcement.
- (3) Members should prepare comments and bring them to the meeting or, if not attending, mail them to the Program Manager in time for them to be discussed at the meeting.
- (4) Members present will review the comments and determine -
 - (a) whether or not to pursue the project
 - (b) the priority of the project, and
 - (c) its potential procurement sources (e.g. shipyard, consultant, etc.)

b. Project Assignment

- (1) Following receipt of the approved budget, the Program Manager will notify all members of the projects available and request detailed proposals from those interested shipyards and/or other approved sources.
- (2) Copies of completed proposals will be forwarded to all members for comment and consideration.
- (3) Members should prepare comments and bring them to the next regular meeting or mail them to the Program Manager in time for discussion by the attending members.
- (4) Members present will review the comments and decide to whom the project will be awarded.

c. Project Reporting

- (1) Either the panel member or a project representative shall present a project progress report to the panel at each regular meeting. (This report should be in writing so that it may be accurately repeated to absent members).
 - (2) Upon completion, each project will be reviewed by the panel.
 - (3) Reports on projects approved by the panel shall be submitted "camera ready" to the Program Manager for printing and distribution.
4. Related discussion on the use of the panel as a forum resulted in the consensus that members should present progress reports on related projects (MANTEC, IMIP, etc.) at each meeting.
5. John McEachran of RI/SME described the organization and the benefits that becoming a member accrue to panel members. He solicited the panel's cooperation to working on a joint project to develop a seminar for application of Robotics in the shipbuilding industry. The idea was generally approved but the consensus was that the idea is premature.

INDUSTRY PROJECT REPORTS

1. Robotic Arc-Welding Evaluation Project (MARAD Panel SP-7)

J. B. Acton - Todd Los Angeles Division
[see enclosure (5)]
2. Development of a Prototype Robotic Arc-Welding Station (MANTEC)

M. M. Fodor - Todd Los Angeles Division
[see enclosure (6)1
3. Evaluation of Unimation "Apprentice" Portable Welding Robot (MARAD Panel SP-7)

J. Maciel - Todd Los Angeles Division
[see enclosure (7)1

4. CNC/Robotic Shapes Processing System - phase I - R&D (MANTEC)

D. Blais -Bath Iron Works
[see enclosure (8)]

5. Flexible Manufacturing System for Submarine Propellers (MANTEC)

R. Wells - NAVSEA
[see enclosure (9)]

6. Overview of Navy Programs

R. Jenkins - David Taylor Navy R&D Center
[see enclosure (10)]

7. Other Plans & Programs

R. Holliday reported that NNS has established a new department called "Advance Technology." The department is working on several aspects of advanced technology problems; his responsibility includes MANTEC and flexible automation. NNS is examining several potential projects for commencement later this year.

CURRENT BUSINESS

1. Robotic Welding Cable Manufacture, Inspection and Repair

N. Haynes - Bethlehem Steel, Sparrows Pt.
[see enclosure (11)]

2. Plan for Implementing Flexible Automation in the Shipbuilding Industry

J. B. Acton - Todd Los Angeles Division

This will be a project utilizing a consulting firm to assist the panel in developing a plan for introducing the concepts of Flexible Automation to and implementing them in the shipbuilding industry. The Panel Chairman will develop a bid specification for approval by the panel at the IREAPS meeting in August.

NEW BUSINESS

New business consisted of developing potential projects, selecting the most desirable for development as FY '84 proposals, and designating a panel member to prepare abstracts for review by the panel prior to the IREAPS meeting in August.

1. Robotic Thermal Spray Facility - (Spraying aluminum onto steel for corrosion protection).
 - a. Discussion
 - (1) This project will require major involvement of panels SP-7 and 023-1 with SP-10 leading. Potential support "spin-off" projects include changed weld procedures to take advantage of the aluminum as a "weld through" coating. This would permit coating plates and shapes prior to fabrication.
 - (2) The facility size should accommodate parts up to 12' x 40' (plate) and shapes (angles, tees) of equal length.
 - (3) METCO (vender) is interesting in helping develop the specifications and the project.
 - b. Todd Los Angeles will prepare the abstract.

2. Marking of Plate Cut by CNC Burning Machines
 - a. Discussion
 - (1) Explore various marking devices such as laser, and the Ishikawajima-Harima Heavy Industries (IHI) Co., Ltd. "Z-marking" system.
 - (2) All identification data should be included.
 - (3) Should be generated along with the cutting information (CAD-DNC, tape, etc.)
 - b. Ingalls will prepare the abstract.

3. Electric Cable Preparation from a CAD Data Base
 - a. Discussion

All panel members agreed that this potential project has merit.
 - b. Ingalls will prepare the abstract.

4. Procure and Evaluate an Existing 3-D Vision System

a. Discussion

- (1) R. Wells of NAVSEA and S. Levine of Robotic Vision Systems, Inc. presented the capabilities of the "two-pass" system developed for the "Flexible Manufacturing System for Submarine Propellers".
- (2) The potential availability of other systems demonstrated at Robot VII need to be explored.
- (3) The panel agreed on the need for reaching the objective of off-line teaching but wants more information on other available systems.
- (4) The suggestion was made that we consider combining inspection with the welding vision analysis system.

b. Todd Los Angeles will prepare a report on available systems.

5. RI/SME Seminars

a. Discussion

Reference was made to earlier discussion (see sub-paragraph 5 under PANEL ESTABLISHMENT).

b. Further consideration deferred until FY' 85 planning.

6. Flange Forming

[see enclosure (12)]

a. Discussion

This item was included as part of the National Shipbuilding Five-Year Productivity Plan. It is contingent upon a system now being tested at BIW for Navy acceptance.

b. Deferred pending results of BIW tests.

7. Robots for Assembling Sub-Blocks

[see enclosure (13)]

a. Discussion

This item was submitted as part of the Five-Year Plan. The panel concluded that:

- (1) The proposed schedule is too ambitious;
- (2) The scope is greater than should be attempted as a first year project for the panel;
- (3) Each goal is a major project;
- (4) The estimated cost is totally inadequate.

b. Deferred for consideration as part of FY'85 proposal.

8. Walking Robots (ODETICS, Inc.)

a. Discussion

This is a prototype, tele-operated machine that has yet to be adapted to a specific task. It represents an advancement in the technology of joint configuration but requires a "brain" to be assigned to a robotic task.

b. Deferred as being insufficiently removed from basic R&D to be of practical interest to the industry at this time.

CONCLUSION

1. The next meeting will be a short "spin-off" at the IREAPS symposium in Boston during the period 23-26 August 1983.

2. The next regular meeting will be held in approximately 4 months; the tentative location is Crystal City. Firm location and exact dates will be forwarded by the Program Manager as soon as arrangements are completed (Program Manager's note: agenda items will be solicited prior to being formalized).

3. **The** meeting was adjourned at noon of June 15, followed by a tour of Todd Pacific Shipyards, Los Angeles Division.

ATTENDANCE LIST - PANEL SP-10 FLEXIBLE AUTOMATION
JUNE 14-15, 1983 HYATT REGENCY HOTEL - LONG BEACH, CA.

J. B. ACTON
Todd Los Angeles Division
710 Front Street
San Pedro, CA 90733
(213) 832-3361

M. H. AGEE
Virginia Polytechnic Inst. &
State University
Blacksburge, VA 24061
(703) 961-6978

H. BERGER
Robotix Corp.
23717 Hawthorne Blvd.
Suite #306
Torrance, CA 90505
(213) 373-6383

D. BLAIS
Bath Iron Works
700 Washington Street
Bath, Maine 04530
(207) 443-3311

J. CAMERON
General Dynamics
Electric Boat Division
Eastern Pt. Road
Groton, Connecticut 06340
(203) 446-5960

N. M. FODOR
Todd Los Angeles Division
710 Front Street
San Pedro, CA 90733
(213) 832-3361

W. FRENCH
Avondale Shipyard
P. O. Box 50280
New Orleans, LA 90150
(504) 436-2121

O. FUNKHOUSER
Todd Los Angeles Division -
710 Front Street
San Pedro, CA 90733
(213) 832-3361

F. HANSON
Mare Island Naval Shipyard
Vallejo, CA 94592
(707) 646-2164

N. HAYNES
Bethlehem Steel Co.
Sparrows Point Shipyard
Sparrows Point, ND 21219
(301) 388-3000

L. HOLLIDAY
Newport News Shipbuilding
4101 Washington Avenue
Newport News, VA 23607
(804) 380-3226

D. HUBER
Machine Intelligence
3395 Cane La Veta
San Clemente, CA 92672
(714) 625-7937

R. JENKINS
David Taylor Naval Ship R&D Center
Bethesda, MD 20084
(202) 227-1363

J. JUSTICE
Productivity System Inc.
21999 Farmington Road
Farmington, MI 48024
(313) 474-5454

R. LASH
The Aerospace Corp.
2350 East El Segundo Blvd.
El Segundo, CA 90245
(213) 648-7028

SEYMOUR S. LEVINE
Robotic Vision Systems, Inc.
536 Broadhollow Rd.
Xelville, NY 11747
(516) 694-8910

C. LEWIS
METCO Inc.
518 No. Western Avenue
Los Angeles, CA 90004
(213) 469-6281

J. MACIEL
Todd Los Angeles Division
710 Front Street
San Pedro, CA 90733
(213) 832-3361

J. McEACHRAN
Robotics International of SME
One SME Drive
P. O. Box 930
Dearborn, MI 48128
(313) 271-1500

T. P. O'BRIEN
Machine Intelligence
3395 Cane La Veta
San Clemente, CA 92672
(714) 625-7937

E. J. PETERSEN
Todd Los Angeles Division
710 Front Street
San Pedro, CA 90733
(213) 832-3361

J. RIVAS
Long Beach Naval Shipyard
Long Beach, CA 90733
(213) 547-7466

R. SCHAFFRAN
Maritime Administration (MARAD)
Office of Adv. Ship Dev.
400 7th Street S.W.
Room 4107
Washington, D.C. 20590
(202) 382-0446

J. SIZEMORE
Ingalls Shipbuilding/Litton Ind.
P. O. Box 149
Pascagoula, MI 39567
(601) 935-1122

M. TANNER
Newport News Shipbuilding
4101 Washington Avenue
Newport News, VA 23607
(804) 380-3226

R. WELLS
NAVAL SEA SYSTEMS COMMAND (NAVSEA)
SEA 070
Bldg. One, Room 6E06
Washington, D.C. 20362
(202) 692-3580

J. WITZ
The Aerospace Corp.
2350 East El Segundo Blvd.
El Segundo, CA 90245
(213) 648-7028

R. A. WYSK (PhD), Asso.Prof.
Virginia Polytechnic Inst. &
State University
Room 154, Hittmore Hall
Blacksburge, VA 24061

SPC PANEL SP-10 FLEXIBLE AUTOMATION
 HYATT REGENCY HOTEL - LONG BEACH, CALIFORNIA
 JUNE 14-15, 1983

A G E N D A

TUESDAY, JUNE 14

8:30 a.m.	Call to Order Chairman's Comments	J.B. Acton (TPLA)
8:45 a.m.	SPC Chairman Remarks	E.J. Petersen (TPLA)
9:00 a.m.	Establish Panel Organization Membership (and categories) Operating Rules RI/SME	J.B. Acton
10:00 a.m.	BREAK	
10:30 a.m.	Industry Project Reports Robotic Arc-Welding (Panel SP-7) Robotic Vision (Navy MANTEC) Apprentice Robot (Panel SP-7) Robotic Structural Shape Processing (Navy MANTEC) Flexible Manufacturing System for Submarine Propellers Oveview of Navy R&D Programs	J.B. Acton M.M. Fodor (TPLA) J.Maciel (TPLA) D.Blais (BIW) R.Wells (NAVSEA) R. Jenkins (David Taylor Navy R&D Ctr.)
11:30 a.m.	LUNCH	

1:00 p.m.	Current Business	
	Robotic Welding Cable Mfg. Inspection & Repair	Nick Haynes (Bethlehem Steel)
	Plan for Implementing Flexible Automation in the Shipbuilding Industry	J. B. Acton
	- Establish Bid Specification	
2:30 p.m.	BREAK	
3:00 p.m.	New Business	
	Round Table for Potential Projects	
5:00 p.m.	ADJOURN	

WEDNESDAY, JUNE 15

8:30 a.m.	New Business	
	FY 84 Budget	
	Deferred to FY 84	
11:30 a.m.	LUNCH	
1:00 p.m.	Tour of Todd	
2:00 p.m.	ADJOURN	

E. J. PETERSEN REMARKS
SPC CHAIRMAN
VICE PRESIDENT-TODD L.A.

As the new Chairman of the Ship Production Committee of the Society of Naval Architects and Marine Engineers, it is a special privilege for me to welcome you to the first meeting of the newest SPC panel, SP-10 Flexible Automation.

I hope that both our Southern California weather and our Southern California hospitality can combine to get this panel off to a running start towards its goal of working with the other eight SPC Panels to initiate and implement projects that will materially improve productivity in the U.S. ship construction and repair industry.

To bring you up-to-date, I took over the Ship Production Committee Chairmanship from Ellsworth Peterson effective May 9. In Ellsworth's more than eight years at the helm, a great deal was accomplished and he left a mark on our industry that will last for some time to come. This mark is an imprint called "HOPE" in an otherwise rather depressing sea of gloom, for shipbuilding, repairing and operating are currently in a severe state of depression worldwide, as you know. The hope stems from the unpretentious but solid accomplishment of SPC over the past several years in its technical management of the National Shipbuilding Research Program under Ellsworth's leadership. Impressive results have already been achieved and further progress is being made in many areas of ship construction and repair. To name a few:

- o Reorganization of work for greater production efficiency utilizing the principles of group technology;
- 0 Welding technology, including introduction of both fixed-base and portable welding robots;
- o Long-range facilities planning;
- 0 Modeling techniques including photogrammetric and computer modeling methods;
- 0 Shipbuilding standards;
- 0 Application of Industrial Engineering concepts;
- 0 Improvements in surface preparation and coating;
- 0 Better integration of design and planning with production;
- 0 Education and training of our industry's most important and indispensable asset - its human resources

The National Shipbuilding Research Program (NSRP) is a cooperative technical venture among the Ship Production Committee of SNAME, representing most of the nation's major private shipyards; the U.S. Maritime Administration; the U.S. Navy; educational institutions; and ship design firms. The U.S. Coast Guard, American Bureau of Shipping and other regulatory agencies, research

institutions and technical societies have also provided support when needed. During the twelve years since it was instituted, the National Shipbuilding Research Program has been recognized to be one of the most effective government sponsored research programs in the United States in terms of achievements per dollar invested.

Typically, annual budgets have been in the range of \$4 million, which includes both the government and private industry contribution - a relatively modest amount for a nationwide program encompassing all shipbuilding and ship repair firms that choose to participate. The principal strength of the National Shipbuilding Research Program lies in its emphasis on implementation. There are no interminable studies; no "pie-in-the-sky" research. The main thrust of the program has been and should continue to be: investigate what is available now; determine what is needed to use it in U.S. shipbuilding; analyze the cost and benefits of its use the best that can be determined ahead of time; develop guidance or instructions needed for its use; and then TRY IT!

I might mention that during the past year, a comprehensive Five-Year Productivity Improvement Plan was developed through a *truly* national effort. More than 40 knowledgeable people representing at least thirty different organizations contributed to this effort, and the draft plan has received the endorsement of most major shipyards. After resolution of a few relatively minor issues and technicalities, I expect the Plan to be issued within a few months and to serve as a more formal framework for National Shipbuilding Research Program accomplishments for many years to come.

At this point, we *are* ready to take our next step towards putting better tools in the hands of the shipbuilding industry in order for us to continue our drive to build better ships at lower cost and in less time. That step is to activate this new panel on flexible automation. This panel will have as its ultimate goal the development of automation tools - such as robots - that, when coupled with the activities of the other panels, will fully implement group technology in the U.S. shipbuilding industry. What is needed is better management of all the resources that go into the product - manpower, material, facilities, and time. That is what group technology is all about, and with this panel in operation, the nine panels of the Ship Production Committee will cover all those bases.

I sincerely appreciate the interest and attendance at this opening session of so many distinguished experts both within and outside of the marine community.

Once again, on behalf of both the Ship Production Committee and Todd Pacific Shipyards Corporation, the sponsor of this new panel, I'd like to extend a warm welcome. Here's hoping that together we can turn a new ^{corner} ~~corner~~ toward making the United States a world leader once again in ship construction and repair.

Thank you and have a good week!

Prepared By: _____ (Name)

(Company Name)

Per agreement in SP-10 Panel Meeting

(Date of the Meeting)

SNAME PANEL SP-10

ABSTRACT FOR PROPOSED PROJECT ENTITLED AS SHOWN BELOW

Title:

BACKGROUND:

OBJECTIVES OF THE PROJECT:

TECHNICAL APPROACH TO THE PROJECT:

RESULTS AND DELIVERABLES TO BE EXPECTED FROM THE APPROACH:

BENEFITS WHICH THE INDUSTRY CAN REASONABLY EXPECT TO DERIVE FROM
THESE RESULTS:

SCHEDULE BREAKDOWN:

ESTIMATED COST:

EVALUATION OF A ROBOTIC ARC-WELDING STATION
A MARAD PROJECT UNDER SNAME/SPC PANEL SP-7
- J. B. ACTON - TODD L.A. DIVISION -

The overall task was to evaluate a Cincinnati Milacron T3 (CM-T3) computer-controlled pedestal-mounted robot performing arc-welding tasks. This was a participatory project in which MARAD funded the lease of the robot for 18 months and TODD assumed all other costs, including associated equipment: an Aronson model 60cs 6000 lb. positioning table and Hobart RC 650 RVS welding power supply with Bernard #3500 water cooler. The evaluation commenced October 16, 1981. Objectives of the CM-T3 evaluation included:

- o Design and analyzing an arc-welding robot welding station;
- o Testing the results of the robotic welding performance;
- o Identifying acceptable candidate parts for welding on the robot;
- o Establishing minimum batch size vs. teach time that is practical to produce on the robot;
- o Determining whether or not sufficient eligible parts are available to make the robot an economical industry tool; and
- o Recommending technology necessary to make robotic welding more economical.

The robot was installed in a location where all utilities, material handling equipment and material access were available, yet it could be isolated and bypassed when necessary. The first objective was achieved after several layouts were evaluated and a second positioning table was added to optimize productivity.

As the final report will show, the robot can more consistently and more productively produce high quality welds than can be achieved manually. However, this does require that close tolerance be maintained in fit-up and positioning which requires more sophisticated and expensive tooling than is commonly used in the shipbuilding industry.

For evaluation, TODD elected to utilize the CM-T3 to weld fairly complex aluminum and steel subassemblies produced for the Navy FFG-7 class ship. A review of welded structures indicated that foundations constituted the largest potential source of candidate parts for the project. These parts are not suitable for fixed automation; they constitute a variety of geometries and are all fillet-welded. By controlled tests, TPLA established the limitations for accessibility for such items as minimum joint angle and clearance. These limitations were used as a final screening for candidate parts.

Seven hundred **thirty** (730) prints of foundations falling within the size criteria were reviewed; 675 emerged as candidate parts. These were examined for the number of pieces comprising each part. Eight-seven percent (87%), (588 parts) were constituted of 2 to 19 pieces, the remainder (20-162 pieces) were considered too complex for robot production at this time. Four hundred

forty-one (441) parts require only one each per ship; 128 require two each, 11 require three each, seven require four each, and one requires six.

Teaching the robot (teach time) was quickly confirmed as the most significant factor limiting the productivity of flexible automation machines in small batch manufacturing operations. The constraint was determined to be whether or not teach time plus total set-up and run time for each batch is more economical than current methods such as manual or semi-automatic welding. Since that can frequently be several times the actual arc-time, it is apparent that the small batch size for an individual ship requires other factors, such as quality of work circumstances, be considered for justifying an on-line taught robot in the shipbuilding industry. The ability to record a taught path for reuse at a future time does partially alleviate this constraint if multiple ship contracts are available; however, insufficient data has been developed to establish the number. Statistical data on various batch sizes and part configurations from a Todd facility project will be developed over the next six months. These results should provide some indication of that number and be available in November 1983.

An extension of that project to develop statistical back-up to the teach vs. run time has been requested. However, the conclusions drawn from data collected to this point indicate the need for:

- (1) Interim technology enabling the robot to be "taught" off-line;
- (2) Ultimate "artificial intelligence" which will locate, track and adjust for the variables in root gap and allow a direct CAD/CAM link, and
- (3) With any robotic welding application, more attention to tooling and fixturing.

"DEVELOPMENT OF A PROTOTYPE ROBOTIC ARC-WELDING STATION",
SUBCONTRACT NO. C10599 TO SRI INTERNATIONAL; U.S. NAVY
MANTEC CONTRACT NO. NO0024-82-C-5320

- MAGDA M. FODOR - TODD L.A. DIVISION -

The project objectives were:

PHASE I

(1) Development and evaluation of the Fast Manual" Programming
System;

(2) Development of the vision system for the robot.

PHASE 11

Implementation of the vision system in the shipyard environment.

PHASE I

Completed on 31 March 1983. SRI demonstrated the feasibility of their
vision system for the robot, and Todd demonstrated the use of the fast
manual programming system with the pendant-mounted joystick in the pro-
duction environment.

BACKGROUND

SRI installed in October 1982 at Todd their control system for the CM-T3
robot and presented their programming techniques with:

- o pendant-mounted joystick;
- o robot-mounted force sensor;
- o combination of the robot-mounted force sensor and teach probe.

Each of these programming techniques was compared to the time and quality of welding with the standard (push-button) CM-T3 system.

CONCLUSION

The conclusion of this feasibility study was based on a very ambitious schedule of four months of testing and evaluation. The results were as follow:

- o The pendant-mounted joystick significantly (40%-50%) reduced the programming and welding time;
- o The force sensor did not improve the programming time. In addition, the "manual walk through the welding path: is not desired. Also, the force sensor was viewed as a potential safety hazard.
- o The teach probe was not operational during the testing and evaluation, however, based on the principles of its use, the same applies as for the force sensor. In addition, the shipbuilding industry does not have suitable parts, which would justify the use of the force sensor or the teach probe.

A few hardware and software modifications were recommended in order to improve the system's reliability, and subsequently to improve the potential use of the robotic technology available today for the shipbuilding industry.

EVALUATION OF UNIMATION APPRENTICE ROBOT
A MARAD PROJECT UNDER SNAME/SPC PANEL SP-7
- J. MACIEL - TODD L.A. DIVISION -

The official start date for the Unimation Apprentice Robot was December 1982. The initial step was procurement of the power source and wirefeeder from Union Carbide, Linde Division. In the interim period while waiting for welding equipment delivery, a wheeled carriage/cart was fabricated.

A positioning table was fabricated to facilitate positioning of the test assemblies which would be welded to accomplish operator training and procedure qualification. During testing, it was determined that the 1" diameter teach wheel supplied with the robot was unsatisfactory due to accessibility limitations which prevented proper manipulation of the teach probe in tight corners of fillet welded assemblies. A 1/2" diameter wheel was ordered, received and tested successfully.

During the initial stages of testing, numerous problems were experienced with software. The initial problems were experienced on the Linde power supply at a very early stage in testing. Once corrected, additional problems continued with both hardware and software on the Unimation products. Factory representatives from Unimation have corrected several conditions and are still in the process of debugging.

Overheating of Unimation equipment software is a probable limitation. Equipment operating time has not been sufficient to date for conclusive evidence that overheating has been a major problem. Additional equipment operating time is required in order to justifiably make this determination.

A *maximum* of 15 programmable steps is also considered a limitation, in that, complex parts having numerous welds must be programmed in several teach and weld stages rather than one. Further testing is required to determine the limitations/accuracy of the total working envelope.

Puget Sound Naval Shipyard has been testing a similar robot and have indicated similar problems with software and hardware. They have not had any problems with the welding power supply or the wirefeeder. It is not known how extensive their testing program has been.

It has been determined that the robot supplied to Todd has an old model number and continual updating of software/hardware has occurred and will continue.

The portability of the robot on the wheeled cart mount carriage is not practical for shop use at present. The cart mount carriage limits the robot to small tables or edge of table working areas only. An overhead gantry mount carriage is planned to extend the working area of robot to cover an entire table top (10' x 19'). This should allow larger parts to be welded along with easier and faster access in welding small parts.

D. BLAIS REPORT - BATH IRON WORKS

CNC\ROBOTIC STRUCTURAL SHAPES
PROCESSING SYSTEM
PHASE I - RESEARCH AND DEVELOPMENT
PROJECT SUMMARY

NAVSEA Contract No. N00024-82-C-5317

BATH IRON WORKS CORPORATION

April 20, 1983

CNC/ROBOTIC STRUCTURE SHAPESPROCESSING SYSTEMEXECUTIVE SUMMARY

The processing of ship structural shape parts is a low technology, highly labor intensive activity. The CNC Robotic Structural Shape Processing System (RSPS) has been conceived as a solution to this high cost driver. The RSPS will marry Computer Aided Design capability with robotic technology and sophisticated material handling equipment for a complete CAD\CAM system. The N/C control data necessary to drive the robots in 3D plasma arc cutting and various marking activities will be generated automatically directly from the ship CAD data base. This is seen as a significant new development in robotic application.

The project is to be implemented in two distinct phases. Phase I - Research and Development, has been concluded. It has shown that robotic 3D plasma arc cutting of structural shapes is technically feasible. In addition, the technical requirements of a DNC interface with a Computer Aided Design system have been defined. The final technical report and system specification, deliverables under Phase I, will be used as a foundation for the Phase II effort.

The goal of the Phase II - Implementation effort will be the installation of a prototype RSPS at Bath Iron Works Corporation fabrication facility. A production demonstration for industry will be held at the successful conclusion of Phase II. The technology developed under the project will be made available for dissemination to the industry.

It is estimated that implementation of the RSPS will reduce labor costs in shapes processing by 50% and significantly reduce material waste and rework.

CNC\ROBOTIC STRUCTURAL SHAPESPROCESSING SYSTEMProblem

The processing of ship structural shapes is a low technology, highly labor intensive activity. In the current method, processing starts in the lofting department where engineering drawings are used to determine the information required to produce ship parts. This information, which includes end cut configuration, dimensions, material type, bend line marks, fit-up marks, as well as the part numbers, is manually transferred to sketches, called control cards. The control cards are released to the layout department as required by the production schedule.

Structural shape parts are processed in separate areas according to type. Steel parts destined for ship structural components such as decks and bulkheads, are processed in the shape shop. Steel foundation parts, which are characterized by more complex cuts and smaller size, are handled in an area adjacent to the foundation assembly area. Aluminum parts are processed in an area which has equipment capable of cutting aluminum. The layout process is essentially identical for all areas.

parts are manually laid out according to the control cards, utilizing a variety of tools and templates. Steel parts are manually cut using oxy-fuel torches; aluminum parts are cut using a variety of saws. Material handling between work stations is accomplished by means of overhead cranes.

Proposed Solution

The CNC Robotic Structural Shapes Processing System (RSPS) has been conceived as a solution to the high cost of producing ship structural parts. The system will marry a Computer Aided Design (CAD) system with robotic technology to perform all cutting and marking of steel and aluminum structural shapes. The ability to program the robotic processing center directly from the CAD data base is considered to be a significant development in manufacturing technology. The Robotic Processing Center will consist of one or more Robotic Processing Cells. Each cell will be comprised of a robot and two conveyerized cutting stations. The robot will be equipped with a plasma arc cutting torch and tools for making fit-up marks and parts identification marks. Material will be transported in and out of the cell by a powered conveyor which will be engineered to serve as the cutting surface. The system will also be used to generate production control documents, such as materials lists and parts lists, to aid production management in scheduling work through the system;

Implementation

The RSPC is being developed and implemented under the Navy's Manufacturing Technology/Shipbuilding Technology Program. The project is being accomplished in two distinct phases as outlined below:

● Phase I - Research and Development

This effort has included the validation of the technical feasibility of the system, the preparation of a detailed system specification, and the presentation of an end-of-contract demonstration.

● Phase II - Implementation & Production Demonstration

The goal of Phase II is the complete development and implementation of a prototype Robotic Structural Shapes Processing System, at the Bath Iron Works Corporation fabrication plant. At the conclusion of Phase II, BIW will conduct an industry demonstration of the working system.

Phase I has been successfully completed. The results of the feasibility study and system specification will be utilized in the Phase II implementation of the system.

Project Responsibility

BIW was responsible for primary project management for Phase I and will retain this responsibility for the Phase II effort. Automatix, Inc. was selected to perform the Phase I effort based on their expertise in CAD/CAM technology and capability in robotics applications. Automatix elected to retain Total Transportation Systems, Inc. to define the material handling aspects of the system.

Shipping Research Services, the developers of the AUTOKON '79 CAD/CAM system, worked closely with BIW to define the requirements for interfacing the Robotic Processing Center with the AUTOKON data base.

System Benefits

The Robotic Structural Shapes Processing System will benefit both the shipbuilding industry and the Navy. Benefits to industry are in the areas of:

- Efficiency - The RSPS is estimated to reduce labor requirements by 50%.
- Accuracy The RSPS will be capable of cutting parts **to an accuracy of $\pm 1/32$ " or better.** This increased accuracy will make subsequent operations of assembly and installation easier and faster.
- Errors The automatic programming of parts is expected to significantly reduce the number of lofting and layout errors.
- Material Material utilization will be improved through more efficient nesting and through a reduction of rework.
- Capacity Shop capacity will be increased due to decreased cycle times and reduced in-process storage.
- Planning Production planning and scheduling will become more flexible and responsive due to the increased throughput and shorter cycle times made possible by the system.

Benefits to the Navy include the following:

- Lower Procurement Cost - Ship production cost will be reduced owing to the increased efficiency of the RSPS, improved accuracy of parts, and reduction of costly rework.
- Follow-On Use - The RSPS will be fully documented for dissemination throughout industry.
- Strengthened Industrial Base - The defense industrial base will be strengthened due to the increased capacity of the shipbuilding industry. This will serve to improve the defense posture of the Navy.

Conclusion

The Robotic Structural Shape Processing System has been proven technically feasible by the Phase I effort. The benefits which can be realized by employing the system indicate that full development and implementation under Phase II of the project is highly desirable.

ENCLOSURES

- 1 PROPOSED SHAPE PROCESSING FACILITY
- 2 CONCEPTUAL SKETCH OF ROBOTIC PROCESSING CELL
- 3 CARTESIAN ROBOT AND WORK ENVELOPE
- 4 TEE BAR END CUTS
- 5 ANGLE BAR END CUTS
- 6 FLAT BAR END CUTS
- 7 DOT MATRIX PAINTING HEAD

PROPOSED CNC ROBOTIC STRUCTURAL SHAPES PROCESSING PROJECT .

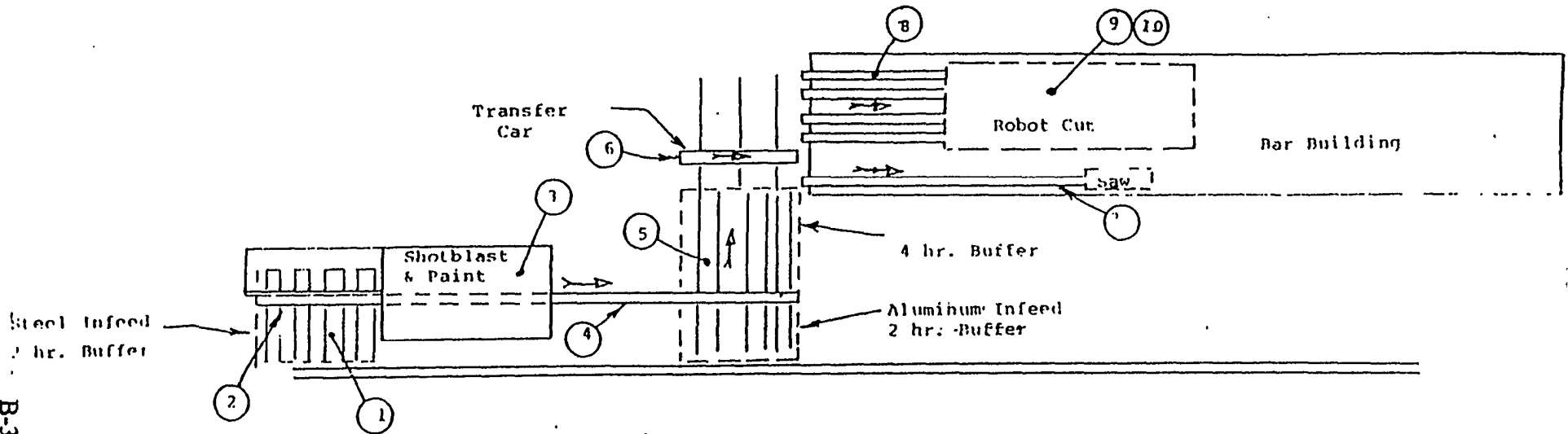

TTS Components:

1. Steel Infeed Transfer Table
2. Steel Infeed Conveyor
3. Shotblast & Paint System
4. Steel Outfeed Conveyor
5. Buffer Transfer System
6. Transfer Car
7. Saw Conveyor
8. Robot Roller Conveyors (4)
9. Robot Slat Conveyors (4)
10. Slat Conveyor Clamping Systems (4)

REV	DESCRIPTION	DRFT	APP

D
C
A
F
A

B-36

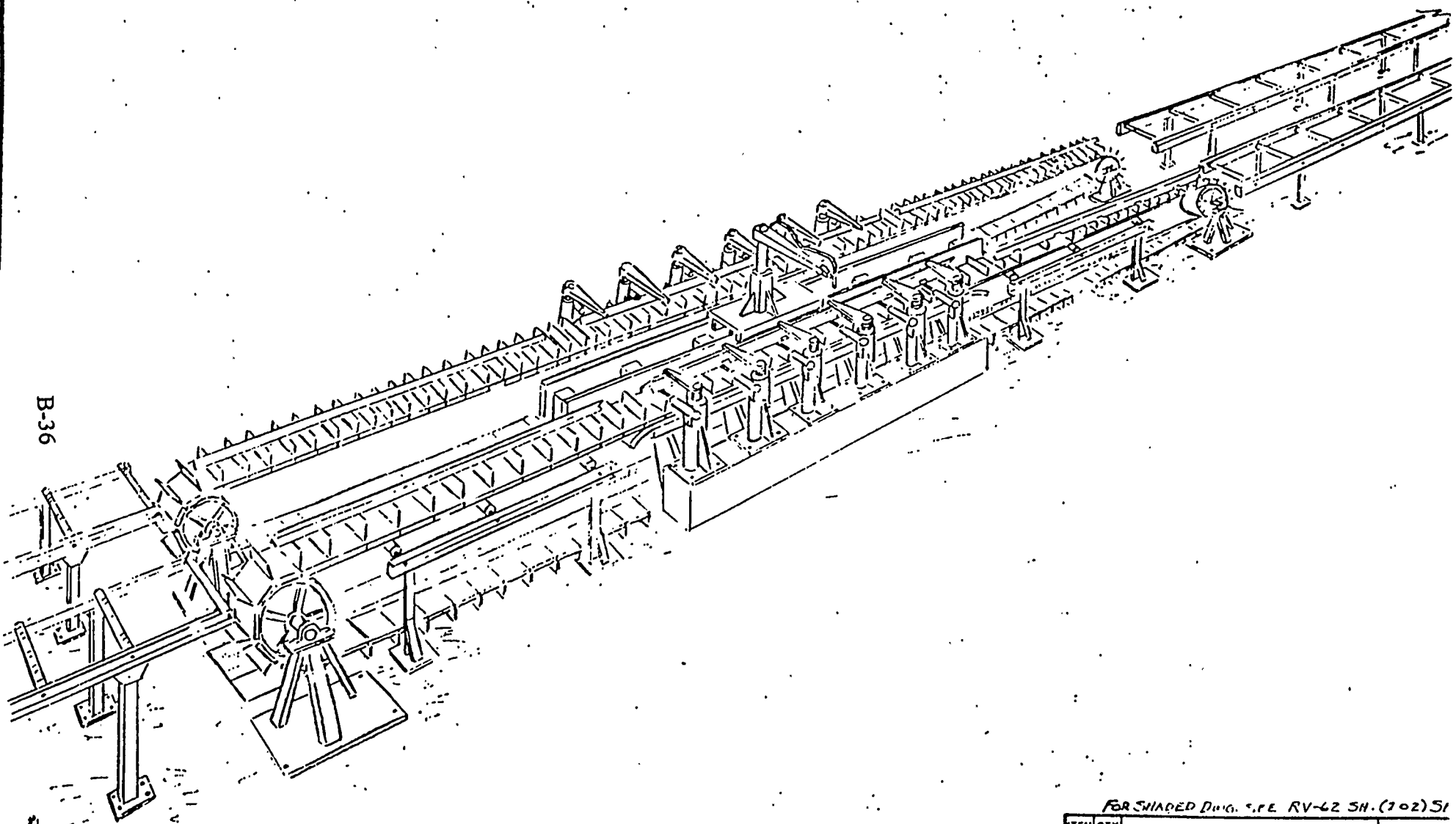

FOR SHAPED DRG. S.P.E. RV-62 SH. (102) S1

ITEM	QTY	DESCRIPTION	PART
TOLERANCES UNLESS OTHERWISE SPECIFIED		DRG. BY: McMillen	1000 TECH PAP
DECIMAL		CHK	BILLERICA, MA
XX	± .	ENG	U S A
XXX	± .	MFG	TITLE BATH IRON WORKS
XXXX	± .	ISSUED	ROBOTIC SHAPES PROCESS
FRACT.	±	SCALE:	CENTER
ANGLES	±	DO NOT SCALE DRAWING	
MAT'L		CODE	SIZE CODE - DRAWING NUMBER
FINISH		10691	C C - RV-62

NET	APP
-----	-----

Work Envelope

B-37

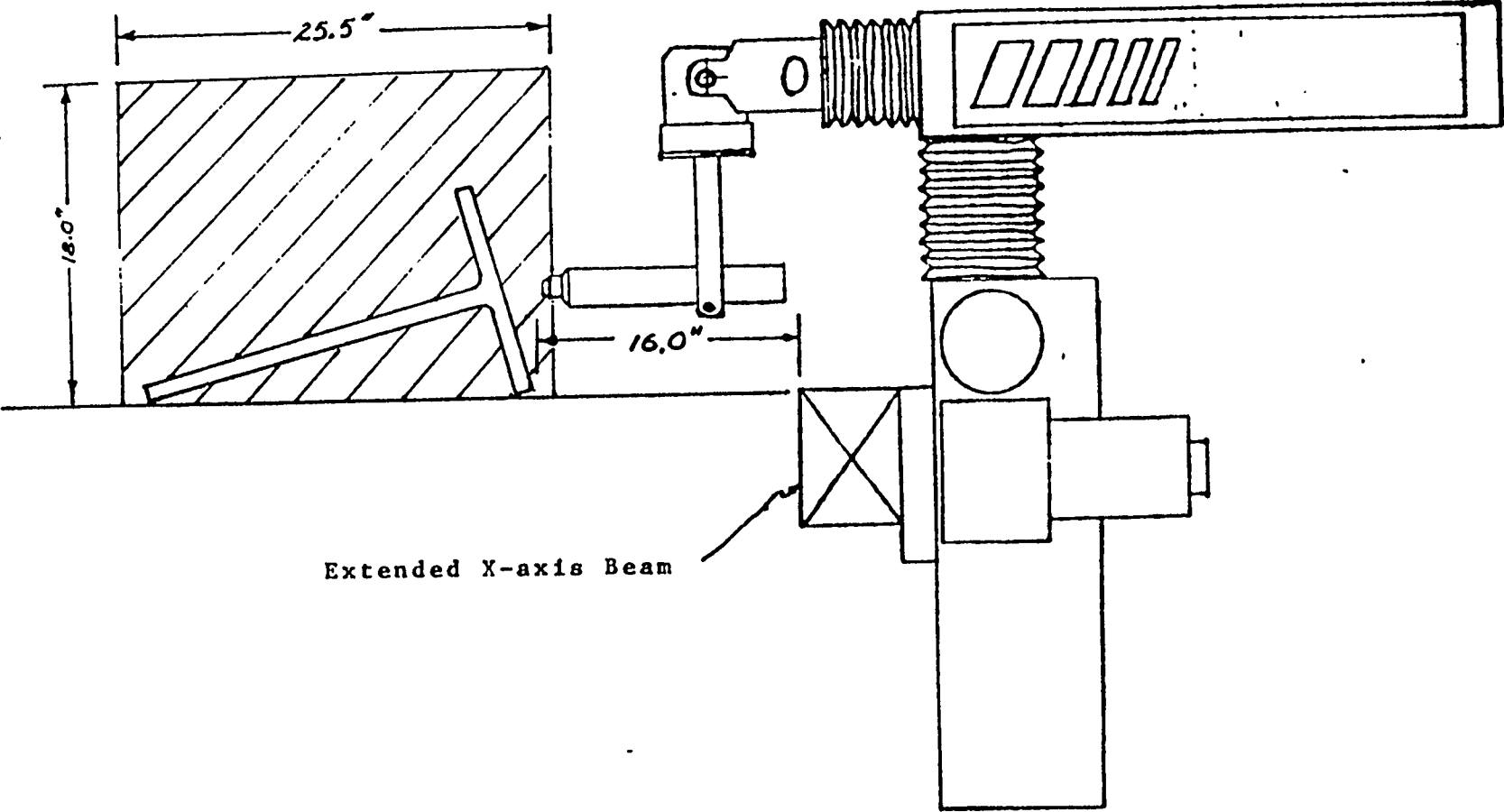

Cartesian Robot, showing work envelope and typical stock orientation

TEE JOINT WORKING

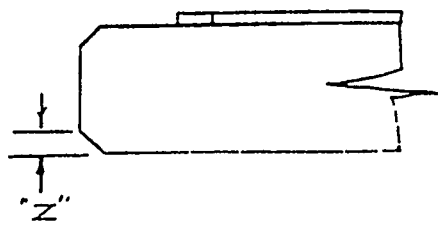
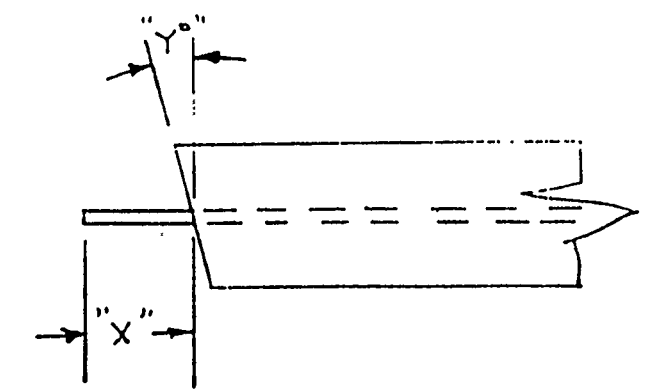
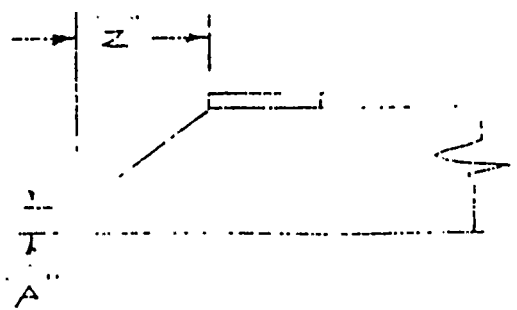
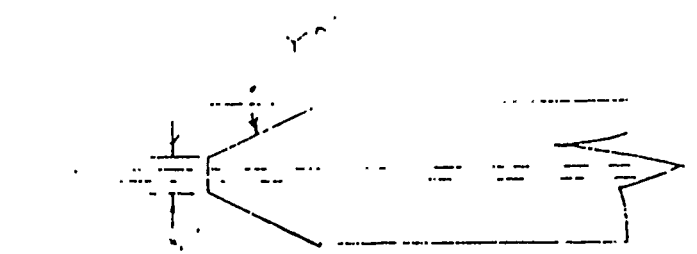
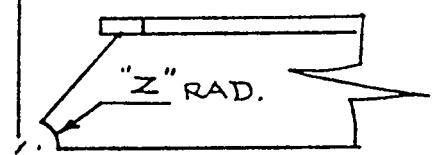
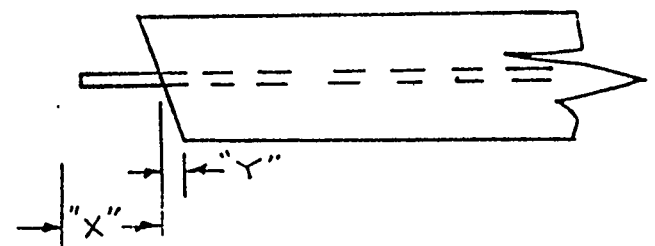
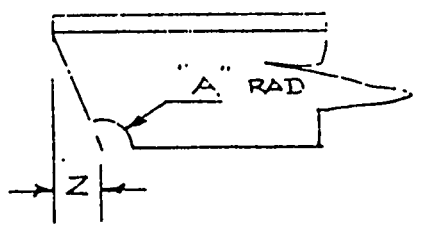
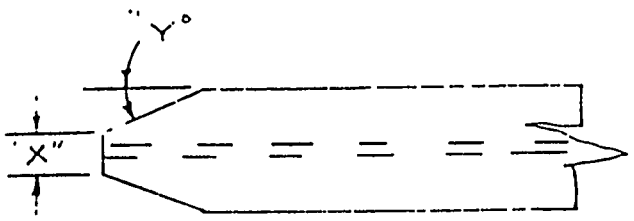

B-38

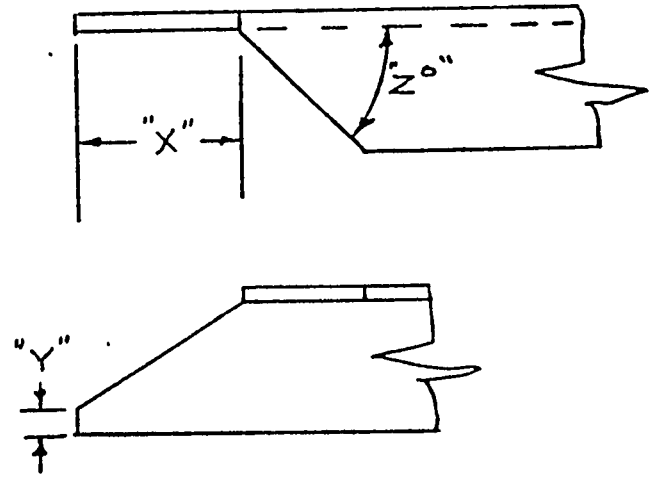
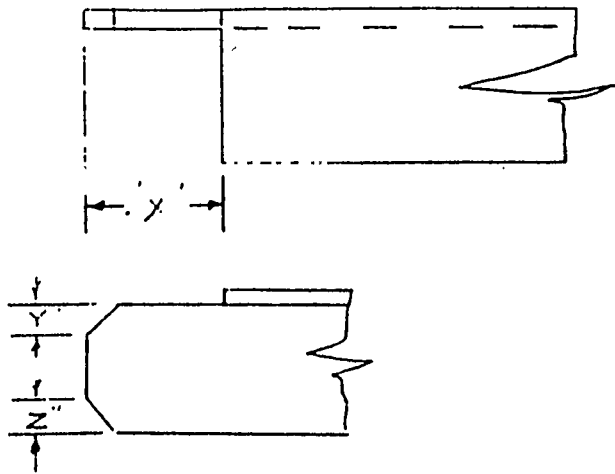

B-39

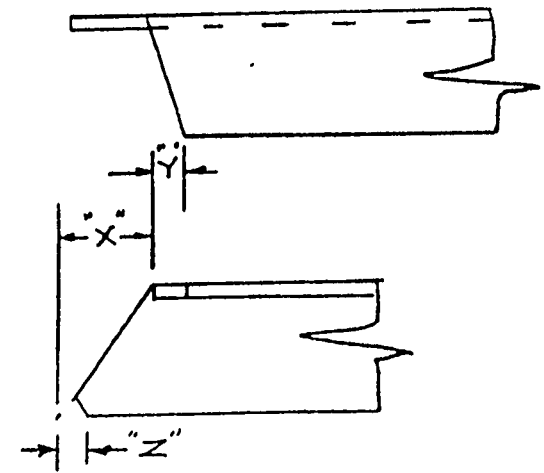
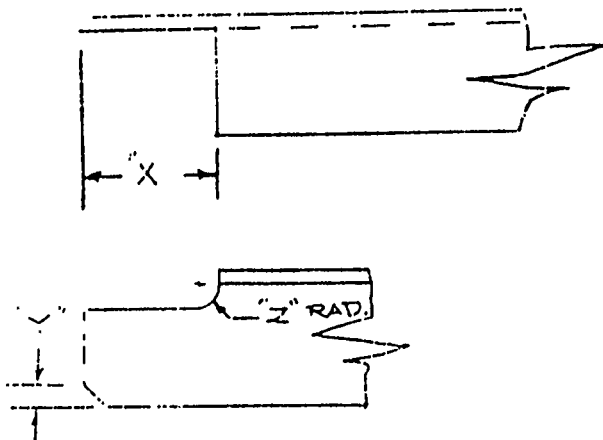

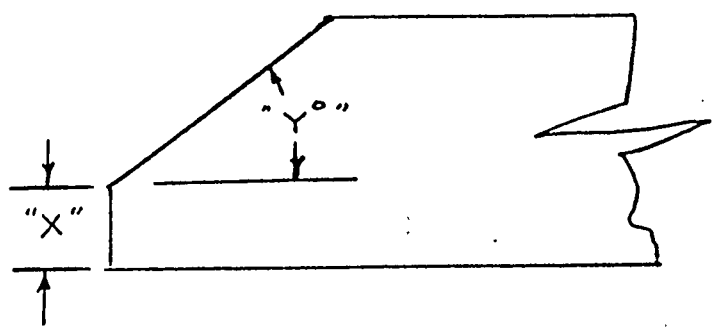
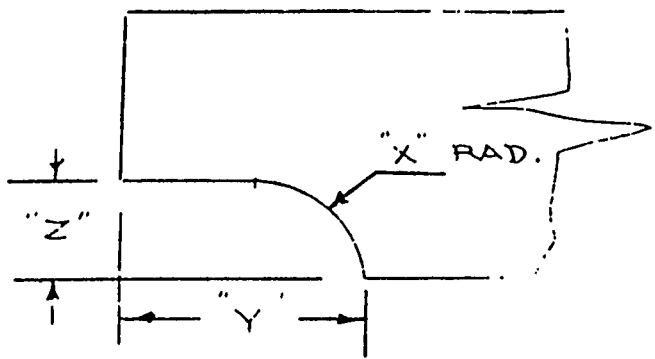

B-40

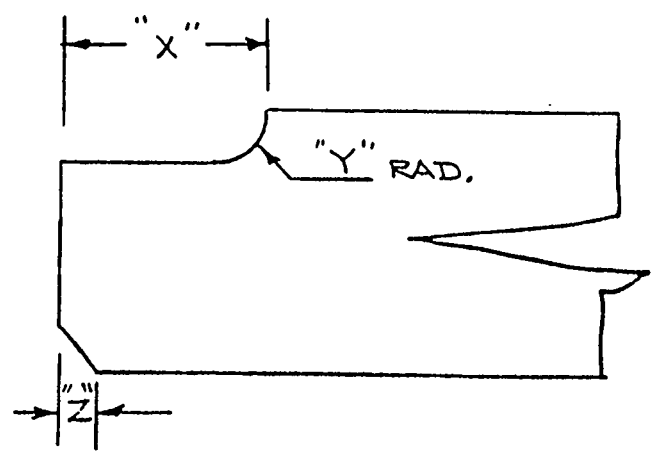
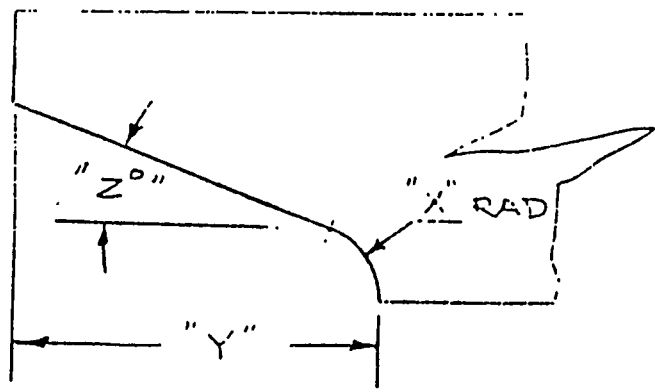

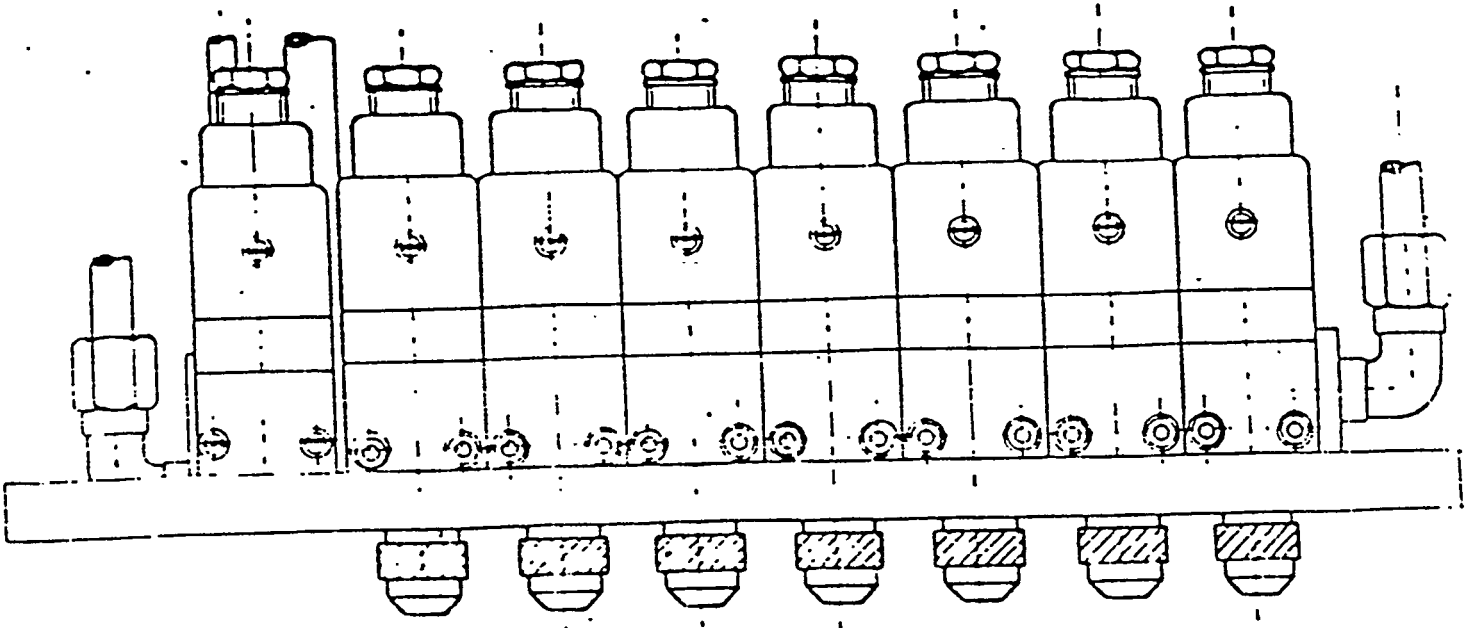

FIGURE 1

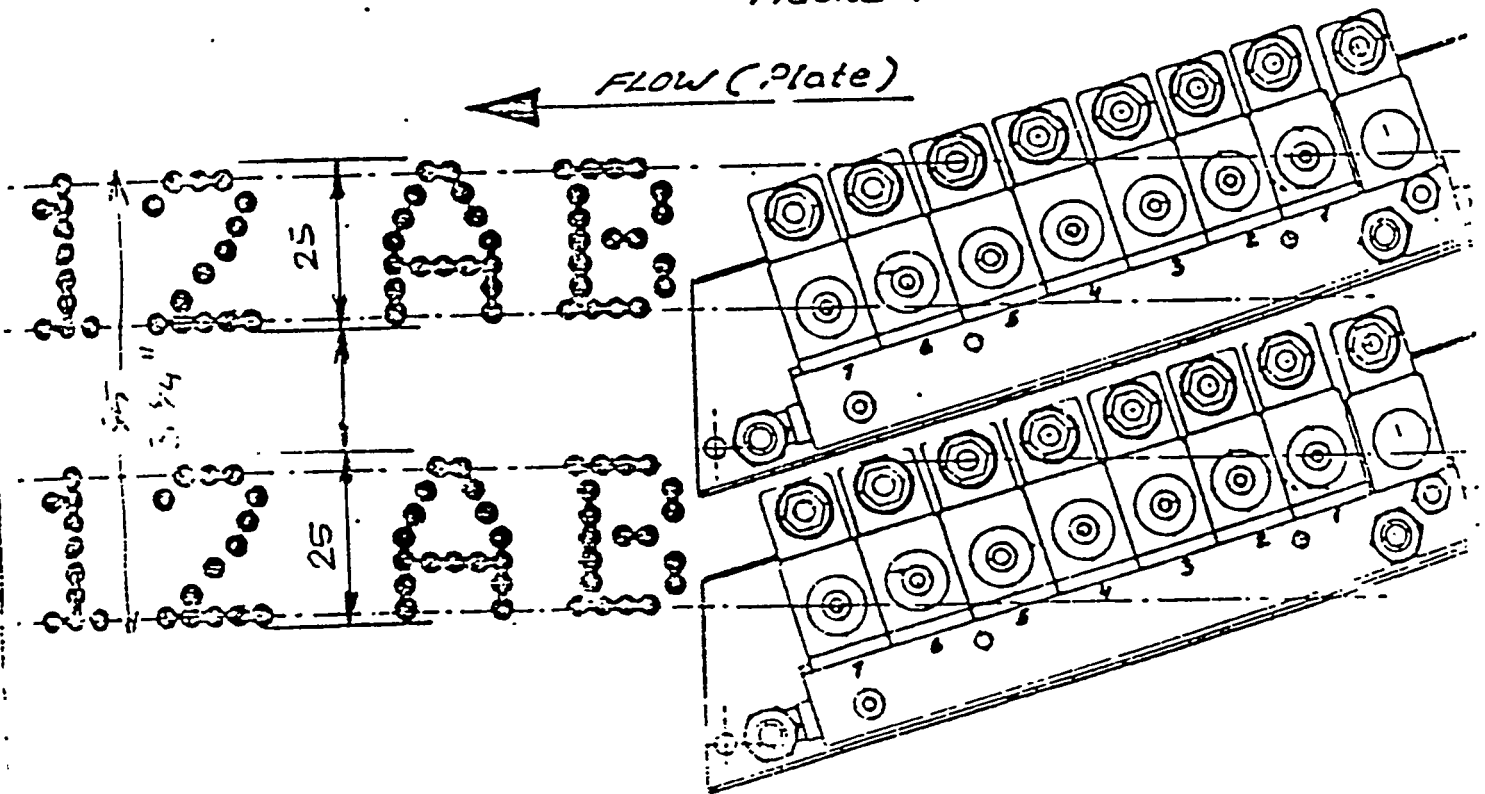



FIGURE 2

<p>B-41</p>	 <p>MAGNEMAG[®] COPENHAGEN DENMARK</p>	<p>TJ</p>
	<p>TWO LINE MARKING SECTION</p>	<p>BIW TECH.</p>

AUTOMATION IN PROPELLER MANUFACTURE & REPAIR
Roy N. Wells, Jr.
Manager of Manufacturing Technology Program
U.S. Naval Shipyards
NAVAL SEA SYSTEMS COMMAND SEA 070

The need for improving the manufacturing methods of propellers has existed since the inception of powered combatant ships and submarines. Except for relatively recent innovations, such as NC machining, there has been little improvement in the manufacturing process since the turn of the century. The basic manufacture and measurement operations had always been performed manually. The machinist, chipper, grinder and polisher who hand-sculptured what many called "works of arts". The dimensional quality of the finished propeller was determined by the use of manually-applied sheet metal gauges or templates, with the final decision on the quality of the propeller left to the interpretations of the inspector applying those "hand-made" sheet metal gauges.

Today's ship propellers have become more sophisticated in design and must be manufactured to greater accuracy than ever before to meet the stringent performance requirements dictated by the combat environment.

The need to improve the efficiency and quality potential in propeller manufacturing has thus become critical. These factors have prompted NAVSEA to undertake a program to modernize propeller manufacturing methods through the use of available technologies, including 3-D measurement systems, robotic and/or machine automation and sophisticated computer processing and control. The technical

keystone of the various subsystems involved in the overall approach is the use of adaptive control of the shaping equipment via feedback from the 3-D measurement equipment. This closing of the measurement-shaping loop will reduce manufacturing time and cost while assuring that the desired final shape configuration is achieved to the accuracies required. The program which is being pursued will address and improve the methods of measurement, machining, welding, bending and grinding both for new builds as well as repairs.

R. JENKINS REMARKS - DAVID TAYLOR NAVY R&D CENTER

I can't discuss details of projects related to Flexible Automation because I haven't had time to have the presentations cleared for release. Basically I want to *talk* about two activities - one is robotics and the other data management.

In the robotics area, Jim has arranged to have you see a presentation of some of the Navy part of the work - Navy-funded work. So I'm going to take a different approach; I'm going to tell you a little about Cmdr. Everett in NAVSEA and what he is assigned to do.

Cmdr. Everett graduated from post graduate school in Monterey last year. His Master's thesis was in robotics with a corresponding *project* in which he built a home safety robot that is drawing a certain amount of publicity, including an article in Wall Street Journal. At about the same time, Adm. Fowler (Commander-NAVSEA), decided that he needed to do something about robotics in NAVSEA so he brought Cmdr. Everett on-board as special assistant in robotics because of his background. What he is trying to do is to establish (in NAVSEA) a coordinated robotics program. He is looking at three separate categories - flexible automation (or industrial automation) which can be a typical manufacturing technology type project; fleet support which is repair maintenance and overhaul; and futuristic applications. To date, most of his activities involve gathering data from existing and planned

Navy projects and surveying the industry developments to get a program going this year in terms of existing state-of-the-art. You can well imagine the complexity of the task that he is undertaking. I guess what I'm really saying is that any input that this panel might have to give Cmdr. Everett will be appreciated. I think that one of the things that we really need to have is some communication between industry and the Navy and to what area of the Navy we should be concentrating on.

The other area that I think would be of interest to all of you is data management. I think most everybody would agree that to keep flexible automation viable, you have to have a proper data and the proper format to provide the instructions to the machine - and that turns out to be one of the key thrusts of the Navy Manufacturing Technology programs which is being headed by Jack McGinnis of NAVMAT. As part of that, he has just this year started planning the NASA IPAD projects. This is basically a research program in data and data management. IPAD operates through a contract with Boeing and under IPAD Technology Advisory Group called ITAB which is open to industrial representation. The Navy is asking NASA to include tasks to determine data requirements for design and manufacture of Navy aircraft weapon systems and on the ships. I think that since we are beginning to provide support to IPAD on that area that it would be advantageous that we can get some shipyard representation into that IPAD advisory group. The next IPAD meeting is scheduled August 2nd in Seattle. The board consists of something like 20 voting companies and maybe a hundred observers and you are all welcome to participate in that activity.

Another related area is a project called NAVCIM (Navy Computer Integrated Manufacturing) which is being developed at the National Bureau of Standards. That program is basically *looking at* developing the system of architecture for control of flexible manufacturing systems that addresses the problem of transferring the data from one make of machine to another driven by different kinds of computers.

ROBOTIC WELDING CABLE MANUFACTURE, INSPECTION
AND REPAIR
- N. HAYNES - BETHLEHEM STEEL-SPARROWS POINT -

SCOPE

This project will be directed to the development and installation of a robotic controlled system for the manufacture and repair of welding cable. Beth. Ship's Sparrows Point Shipyard will enlist the technical assistance of Virginia Tech. for this project.

OBJECTIVE

The proposed system will perform the following functions:

1. Take new cable from a reel, cut it to the desired length, and attach the male and female cam locks to the ends.
2. Take used welding lines and inspect them for damage; and from predefine parameters, identify what kinds of repairs are necessary.
3. Perform the following repairs as required:
 - replace the male and/or female cam locks
 - cut out damaged areas and splice the remaining pieces together
 - tape over minor damages to the insulation
 - perform no repairs on undamaged lines
 - perform no repairs on lines having too many damaged areas, but feed them into a discard bin.

TASK AREA OUTLINES

The total project is subdivided into the following tasks:

1. Initial task analysis
2. Identification of operational requirements
3. Preparation of functional specifications
4. Inquiries and discussions with potential vendors
5. Placement of purchase order
6. Layout, design, and overall site preparation
7. Installation
8. Testing
9. Evaluation and modification.

Virginia Tech will assume primary responsibility for tasks 1 through 3.

Sparrows Point Shipyard will assume primary responsibility for tasks 5 through 8.

Responsibility for tasks 4 and 9 will be equally shared.

Throughout the project, Sparrows Point Shipyard will be the prime contractor, and Virginia Tech will be a subcontractor to the Shipyard.

SCHEDULE

Tasks 1 through 4 will be completed during the first 12 months of the project. If funding is available, task 5 will also be completed and task 6 will be in progress.

Assuming a purchase order placement by the end of the 10th month and a 6-month delivery period, it is estimated that the project will be completed within an approximate 24-month period.

POTENTIAL SAVINGS

The savings from this project will result from the Shipyard's increased capability to adequately supply its workforce with quality welding lines. This will significantly reduce the amount of **lost** time incurred while welders or tackers are either searching for usable lines, or exchanging damaged lines for good lines, or repairing lines. It is expected also that the costs associated with the repair of copper inclusions in the steel will be greatly reduced, as there will be fewer such inclusions. Additionally, there will be a savings resulting from a decrease in the manpower currently utilized to repair welding lines.

Keeping in mind that any savings must be reduced by installation and maintenance costs, it is conservatively estimated that Sparrows Point Shipyard can realize annual savings of \$600,000. It is not difficult to see that larger shipyards can realize proportionately greater savings.

FUNDING REQUESTED

The "order of magnitude" funding request **will** be approximately \$300,000.

"FLANGE" FORMING

Objective:

At least three machines have recently become available for hot or cold upsetting of pipe ends in order to utilize loose flanges (similar to a Van stone flange for copper pipe years ago). The process is inherently productive because pipe-piece fitting, welding, and finished stages are eliminated as well as the need to provide accurate bolt-hole positioning of flanges. Bath Iron Works is testing a system for Navy acceptance. Because both hot and cold forming methods are available and because of the multiplicity of pipe materials and sizes employed in both naval and commercial ships, a process approval program is needed.

Plan of Action:

- Subtask 1. Obtain the results of previous pertinent testing programs. Also, obtain the table of pipe-piece families organized in the order of increasing difficulty regarding problems imposed by their manufacture, which will be produced by the FY84 project "Pipe Piece Family Manufacturing for Naval Ship Construction." Combine the latter information with similar such information in the National Shipbuilding Research Program publication "Pipe Piece Family Manufacturing - March 1982" and establish the numbers of pipe pieces required per ship classified by problem areas (sizes and materials included) that could be produced more productively by use of loose flanges.
- Sub task 2. Based on the foregoing, obtain Navy and ABS prerequisites for approvals.
- Sub task 3. Obtain, preferably from organizations who already have machines installed, representative samples of upset pipe ends and conduct metallurgical and dimensional examinations.
- Sub task 4. Prepare a booklet advising of Navy and ABS approval criteria and how to submit requests for process approvals. The booklet shall also advise of the availability of such machines and their relative costs.

End Product:

A booklet describing Navy and ABS process approval **criteria** and the mechanics for seeking approvals. In addition, the availability and cost of required equipment will be covered.

Schedules

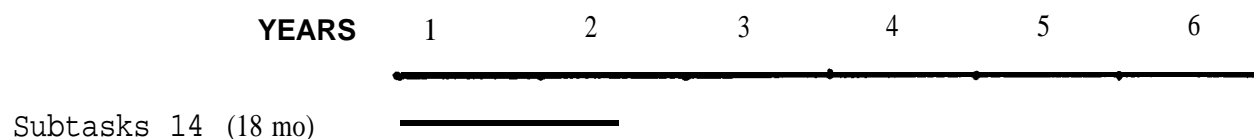

Estimated :

Labor: 2000 hours at \$50/hr	\$100,000
Material:	20,000
Administrative:	<u>20,000</u>
	\$140,000

ROBOT FOR ASSEMBLING SUB-BLOCKS

Objective :

Optimum accuracy of sub-blocks when consistently achieved, significantly contributes to producing optimally accurate blocks. Assembly of both account for approximately 50% of hull construction man-hours. Typically, sub-blocks are required for a ship in many varieties and in varying quantities. However, in accordance with the principles of Group Technology, many sub-blocks can be contrived so that they impose the same problems in their manufacture and have about the same work content. Thus, a robot which can 'see' can perform all required work, i.e., layout, fittings welding, and distortion removal uniformly and productively. In consideration of sub-block sizes and their variations, a specifically designed robot is required for both handling and manufacturing functions.

Plan of Action:

- Task I. Conduct inquiries for pertinent robotic technology and identify problem areas in which the greatest numbers of sub-blocks for naval and commercial ships would be assigned. Plan Task II in detail.
- Task II. Procure, adapt, and/or develop a discriminating robot which can "recognize" different sub-block panel shapes and perform layout, fitting, welding, and distortion removal. Develop software routines. Demonstrate the process.

End Product:

A practical robot for manufacturing the majority of sub-blocks required for a ship regardless of sub-block differences.

Schedule:

	YEARS	1	2	3	4	5	6
Task I (6 mo)		—					
Task II (36 mo)			—————				

Estimated Coats

Labor: 5000 hours at \$50/hr	\$250,000
Material:	300,000
Administrative:	<u>50,000</u>
	\$600,000

APPENDIX C

**Minutes
of
SPC Panel SP-10 Meeting No. 2**

**held at
Arlington, VA
on November 15-17, 1983**

**without
Attachments 1 through 4**

SNAME/SPC PANEL SP-10 FLEXIBLE AUTOMATION
Minutes of the Meeting 2
Quality Inn-Pentagon City
Arlington, Virginia
Tuesday, Wednesday, Thursday, November 15-17, 1983

PRESIDING	:	Mr. J. B. Acton	Todd Pacific Shipyards-L.A.
ATTENDEES	:	LCDR Bart Everett	NAVSEA 90
		Thomas R. Galie	NAVSSSES
		Roy Wells, Jr.	NAVSEA 070
		Jim Rivas	L.B. Naval Shipyard Code 385.4
		William Oakes	NASSCO, San Diego
		Bob Jenkins	David Taylor Naval Ship R&D Center
		John Sizemore	Ingalls Shipbuilding
		William French	Avondale
		Bob Schaffran	Maritime Administration
		Jim Cameron	GD/Electric Boat
		Marv in Agee	Virginia Polytechnic & State U.
		Nick Haynes	Bethlehem Steel, Sparrows Pt.
		Stephen Sappington	Bethlehem Steel, Sparrows Pt.
		Jim Nevins	Draper Labs, Cambridge
		Eric Byler	Adv. Marine Ent., Crystal City

The meeting was chaired by J. B. Acton, Panel Chairman and Program Manager.

OPENING REMARKS

Bill Oakes of NASSCO was asked to be Recording Secretary of the Panel and to prepare the minutes for this meeting.

This SP-10 meeting inadvertently conflicted with the AUTOFACT 5 Conference and Exposition in Detroit and several SP-10 panel members went there. The conference was sponsored by the Computer and Automated Systems Association of the Society of Manufacturing Engineers (CASA/SME). Other panel members may want to join CASA/SME.

Todd LA has submitted a proposal to the Navy for a MANTEC project to investigate lasers as a heat source for heat line fairing. They plan to work with MIT (Prof. Masubuchi) on this project.

year, the SPC plans to join with SNAME, New York Metropolitan Section for their September 27-28, 1984 symposium; call for papers will be sent to all persons on the IREAPS mailing list.

The announcement of the SNAME 1984 Star Symposium was circulated.

The call for papers for the SNAME 1985 Star Symposium was distributed.

Appreciation and "Thank You" were expressed to Roy Wells for arranging facilities.

PANEL PROJECT REPORTS

- o Robotic Welding Cable Manufacturing Inspection and Repair.
See Attachment(1).
- o Plan for Implementing Flexible Automation in the Shipbuilding Industry (Hand RFP) .

Jim Acton presented the draft of an RFP to invite consulting firms to put together a proposal for the SP-10 panel to introduce flexible automation in the shipbuilding industry. The SPC has approved this approach.

Considerable discussion ensued with different groups wanting consideration for the design aspect, the construction aspect, and repair considerations written in to the RFP. There was a wide difference of opinion as to what Phase I, Proof of Concepts should consider. Bob Schaffran was concerned that most consultants would take a long time to learn the shipbuilding industry constraints, leaving little time to perform the project.

LCDR Bart Everett of NAVSEA offered to assist in rewriting the RFP with Navy interests in the total design, constructions, and life cycle included in the proposal.

The final decision was for TPLA to rewrite the RFP in more general language to enable the panel to evaluate competing vendors overall capability in the areas rather than response to very specific work statements.

PANEL RELATED PROJECT REPORTS

- o Dave Blais of Bath Iron Works was absent and did not report on the CNC Robotic Structural Shape Processing (MANTEC). This is a system to plasma-cut the standard endings for T-Bar, Angle Bar, and Flat Bar,

and then automatically mark the shapes with one-inch high characters. It is in the implementation phase now which will include a production demonstration to the shipbuilding industry. BATH estimates a 50% labor savings in this type of work.

- o Roy Wells of NAVSEA described a project using a flexible machining system for precise accurate work on a submarine propeller. This project is being done by Robotics Vision Systems Inc., using their 3-D vision sensor and data processing technology. This company is also developing systems for 3-D vision control of MIG seam arc welding for the General Motors Corporation. Right now, Wells says he is looking for propeller to demonstrate with next February 1984, Attachment (2).

NAVY PROGRAMS

- o LCDR Bart Everett of NAVSEA described some of their programs:

Several yards are working on blasters for cleaning marine growth and paint from the sides of submarine and other Naval vessels. Puget Sound has one for Trident subs built by Wheelabrator-Fry. Jim Cameron said that Quonset Point was going to a closed cycle system for blasting.

The blaster of current interest is the "SANDROID", a unit built by Hockett Systems of Florida, Inc., 5103 South West Shore Blvd., Tampa, Florida 33611. They have taken a Simon "cherry picker", fitted the end of the boom with a set of six blasting nozzles and control the unit by a "tele-operator", Potentially, sensors and/or NC will be added to this control unit to automatically control this function. Some discussion was generated with comments about using this system (in smaller form) to blast compartments and bilges of ships.

A NAVSEA Robotics Council has been established, with LCDR Everett named coordinator. NAVSEA hopes to get maximum value of their robotics investment by merging common problems into one project.

Adaptive MIG welding. There a number of manufacturers involved in 3-D and other vision systems for seam-tracking automatic welders. There are also a number of Navy installations interested in this technology including Dr. John Silva at the Navy Ocean Systems Center in San Diego.

The Navy's use of robotics will be characterized by low lot size, small market, special projects like handling unexploded ordnance, underwater surveillance, and high risk operations. The Navy will sponsor these programs.

Tom Galie of the Navy NAVSSES mentioned that robotics is rapidly becoming a critical technology. There probably will be limits placed on overseas information distribution.

Breakdown of Robotic Applications

Manufacturing

This is the first area that they are heavily involved with and have existing funds by way of MT programs and already have some projects ongoing.

Maintenance and Repair

Not much is being done in this area. There are piece studies underway but mostly in air system command than in the NAVSEA. This area is of major significance to the Navy because they are much more involved in maintenance and repair than they are in manufacturing.

Operational or Tactical

This involves mobile applications and to some extent autonomous applications, considered a much more futuristic category.

REPORT ON SPC MEETING, OCTOBER 25-26, 1983

The Panel Chairman discussed the SPC meeting and results, which are contained in the attached copy of the Executive Control Board minutes, Attachment (3).

WEDNESDAY, NOVEMBER 16, 1983

Mr. Jim Nevins from Draper Laboratories, Cambridge, Massachusetts, described his organization, the former MIT Instrument Lab. They have 2,000 people and offer outside design service and consulting. He distributed a 3-sheet outline describing their approach to systems application development, Attachment (4). Draper is a possible responder to the SP-10 RFP on a plan to implement Flexible Automation into the shipbuilding industry.

Minutes of the Meeting
Panel SP-10 Flexible Automation
November 15-17, 1983
Page Five

SP-10 will be developing a 5-year plan with the number of projects limited until the systems concepts have been worked out. There are a lot of fundamental changes (on-block construction, etc.) going on in all shipyards right now which will influence flexible automation projects.

The consensus of the panel members was that a meeting plan of three (3) times per year with the possibility of plant visits and demonstrations would be the best. The next meeting was tentatively set for March 20, 1984 in the Boston area.

Adjournment for the day at 4:30 p.m.

THURSDAY, NOVEMBER 17, 1983

Most of the panel assembled at the National Bureau of Standards facility in Gaithersburg, Maryland to view the new Automated Manufacturing Facility. This facility, which concentrates on a system to control standard "off the shelf" machine tools and transporters, is funded by the Congress, \$3M per year from the Navy, some from the Air Force and contribution from private industry.

The basic approach to their system is to use readily available components and operate with small batches--an approach of interest to the shipyard production engineers.

Adjournment upon completion of tour.

JAMES B. ACTON
Chairman
SNAME PANEL SP-10

SNAME/SPC PANEL SP-10 FLEXIBLE AUTOMATION
QUALITY INN-PENTAGON CITY - ARLINGTON, VIRGINIA
NOVEMBER 15-16, 1983
AND
NATIONAL BUREAU OF STANDARDS, GAITHERSBURG ROAD
NOVEMBER 17, 1983

A G E N D A

Tuesday, November 15

8:30 a.m.	CALL TO ORDER CHAIRMAN'S REMARKS	J. B. Acton
8:45 a.m.	PANEL PROJECT REPORTS	J. B. Acton
	o Robotic Welding Cable Manufacturing Inspection and Repair	N. Haynes Bethlehem Steel
	PLAN FOR IMPLEMENTING FLEXIBLE AUTOMATION IN THE SHIPBUILDING INDUSTRY (HAND RFP)	J. B. Acton
10:00 a.m.	BREAK	
10:30 a.m.	INDUSTRY PROJECT REPORTS	
	o Robotic Structural Shape Processing (MANTEC)	D. Blais Bath Iron Works
	o FMS For Submarine Propellers	R. Wells NavSea
	o Overview of Navy Programs	LCDR B. Everett NavSea
12:00 Noon	LUNCH	
1:30 P.M.	INTRODUCTION AND REMARKS BY VISITORS	J. B. Acton
3:00 p.m.	BREAK	
3:30 p.m.	REPORT ON SPC MEETING EXECUTIVE CONTROL BOARD MEETING FY '84 BUDGET	J. B. Acton
5:00 p.m.	ADJOURNMENT	

Agenda - SP-10
Quality Inn-Virginia
November 15-16, 1983 & NBS November 17
Page Two

Wednesday, November 16

8:30 a.m.	DISCUSSION AND APPROVAL OF FY '83 PROJECT RFP FOR INDUSTRY IMPLEMENTATION and FY '84 FOLLOW-ON REQUIREMENTS	J. B. Acton
10:00 a.m.	BREAK	
10:30 a.m.	DISCUSS REMAINDER OF FY '84 PROJECTS	J. B. Acton
11:30 a.m.	LUNCH	
1:00 p.m.	FIVE-YEAR PLAN	
1:30 p.m.	DISCUSSION OF HANDOUTS	
2:30 p.m.	ADJOURNMENT	

Thursday, November 17

10:30 a.m.	ASSEMBLE AT NATIONAL BUREAU OF STANDARDS (NBS)	
11:00 a.m.	TOUR NBS AUTOMATED MANUFACTURING RESEARCH FACILITY	
12:00 noon	ADJOURNMENT	

SF-10 Meeting

Name	Affiliation
Jim Acton Chairman	Toda LA
LCDR Bart Everett	NAVSEA 90
John Sizemore	Ingalls Shipbuilding
William B French	Acadiale SHIPYARDS INC.
Bob Schaffran	Marad
JIM CAMERON	GD/Electric Boat
Marvin Agree	VA. Polytechnic Institute & State U.
Nick Haynes	Beth. Steel, Sparrows Point Yard
Stephen Sappington	Beth Steel, Sparrows Pt. Yard.
Thomas A Galie	NAVSES
Roy Wells, Jr	NAVSEA 070
Jim Rivas	Long Beach Naval Shipyard, Code 38
Bill Oaker	NASSCO. San Diego

APPENDIX D

Minutes
of
SPC Panel SP-10 Meeting No. 3

held at
Mystic, CT
on March 20-21, 1984

with
Enclosures 1 through 5

SNAME/SPC PANEL SP-10-ELEXIBLE AUTOMATION
Minutes of the Meeting 3
Ramada Inn, Mystic, Connecticut
March 20-21, 1984

PRESIDING : J. B. Acton, Chairman-SP-10
Todd Pacific Shipyards Corp.

ATEENDEES : Dave Blais Bath Iron Works
Bill French Avondale Shipyards
Tom Galie NAVSSES
Fred Henson Mare Is. Naval Shipyard
Steve Sappington Bethlehem Steel
Lawrence Holliday Newport News Shpbldg.
Robert Jenkins David Taylor Naval R&D Center
James Rivas Long Beach Naval Shipyard
Mark Tanner Newport News Shpbldg.
R. E. Hockett Newport News Shpbldg.
Robert Schaffran Maritime Administration
John Sizemore - Ingalls Shipbuilding
Roy Wells - Naval Sea Systems Command
Marvin Agee Virginia Tech.
Daniel E. Whitney Draper Labs

Intricate Machine & Eng'g. - Massachusetts

Solo Ajalia, President
Raymond Hill, Project Manager
Robert Feoli, NDST

General Dynamics - Quonset Points

Cliff Meyer
Kenneth Payne
Robert Guastini

General Dynamics - Groton, Connecticut

James Cameron
William Thayer
Rod Cordeiro

OPENING REMARKS

The meeting was called to order by Panel Chairman, Mr. J. Acton. Mr. James Cameron introduced some of the people from General Dynamics--Groton and Quonset Point Shipyards. Mr. Walter Lord, Assistant General Manager, Quality, from General Dynamics said a few words of welcome to all the attendees. Mr. Cameron then provided details on the tour the following day. Mr. Acton apologized for the problem of late delivery of meeting notices by UPS delivery and assured the group that he would make sure that this won't happen again (by not using UPS). He then thanked General Dynamics, particularly Mr. Cameron, for hosting the meeting and making all the arrangements. Self introductions of all the attendees followed.

APPROVAL OF THE MINUTES OF PREVIOUS MEETING

The minutes of the December meeting were approved as corrected in Enclosure 1.

PANEL PROJECT REPORTS

A) Robotic Welding Cable Manufacturing

Mr. Marvin Agee, subcontractor to Bethlehem Steel for this project, made the presentation (Enclosure 2).

A handout, the compilation of the questionnaires sent to naval and commercial shipyards, was distributed. He commented on the commercial shipyards being very cooperative and the naval shipyards quick to respond; however, some of the answers in some cases did not compute well.

Mr. Agee mentioned their developing a software program to select a preferred robot model. The panel asked him to send some reading materials or brochures for attachment to the minutes (Enclosure 3).

In response to an inquiry of plans after completion of the questionnaire, he stated that they are not planning additional input since what they already collected is sufficient.

Mr. Acton commented that at the last meeting, Mr. Agee indicated he has moved directly from welding cable only into electrical cable preparation and that this issue would be taken up in the July meeting and also how to convert this project at that point in time.

one of the issues discussed was the problem with filling out the questionnaire. It was stated that most of the time, questionnaires sent just get buried and nothing done about it. In some cases, the person who received it was sort of hesitant to fill it out for fear of the damage it would do the company and the benefit to the competitor. Mr. Acton said that if the question somewhat pertains to sensitive area, that it should be specified. The answers should be documented so the person filling it out should be assured that it is safe to give out that information. He also said that Mr. Edwin Petersen, Chairman of the Ship Production Committee, would probably contact the chief operating officers of the shipyards to give them assurance with regards to questionnaires.

Mr. Agee ended his presentation by informing the group that this phase of project would be complete by July 15, 1985.

NOTE : Status report on the above project is attached as Enclosure 4.

B. Plan for Implementing Flexible Automation in the Shipbuilding Industry - J. B. Acton

Mr. Acton reported that not much progress had been made since the last meeting because of his many commitments and different turn of events.

He reiterated the importance that the Executive Control Board of the Ship Production Committee has assigned to this task. Various consultants have been reviewed but most of them have limited capability for what is needed. The resulting problem is that the panel would need to monitor the various consultants as each would be performing a specific portion of the project. This would create a problem of complexity that could degrade the final results.

He then proposed that the panel develop a request for various organizations to submit to the panel a presentation of their capability of performing this project, the presentation to be based upon a statement from the panel similar to an RFP, to put the problem in front of the organization and how to resolve it without responding to a specific work statement.

Mr. Acton requested the panel to submit ideas to modify or change entirely the draft RFP that was put out in December to determine the approach that they should take.

Mr. Acton also mentioned that Phase 1 and Phase 2 could overlap which would result in the time span being less. The two phases, hopefully, would give the Ship Production Committee the deliverables that they are looking for: namely, to develop a plan to implement flexible automation in the shipbuilding industry that would improve productivity and reduce costs.

In the discussion that followed, it was the consensus that since the members are mostly from shipyards, they don't have the expertise within the panel (SP-10) to draw from experience outside of the shipyards (like the automobile industry) for them to put a plan together, hence the need for a consultant or contractor. To assist the panel in developing a plan, the consultant-to-be should have that broad overview to give the panel the advantage to come up with an intelligent plan.

He also informed the group of the desirability to issue the subcontract before the next meeting and to get a presentation from the selected organization at that meeting in July. This would be funded from the FY '84 and FY '85 budgets.

He ended the update on the Flexible Automation by repeating to the group that he would appreciate receiving comments on how to put out a plan; he will then prepare the invitation for the potential vendors in the next few weeks, depending on his schedule in the office.

Other matters were discussed too, such as:

Manufacturing Technology Projects

Mr. Acton informed the group that Increments 1-3 projects were considered to be under the Manufacturing Technology Program, were submitted to Mr. Jack McInnis for possible funding for FY '85. He asked them that if they have projects that fall under that category to send it to him for inclusion for the next batch of projects under Increment 4.

Five-Year Plan

The original title was changed to National Shipbuilding Research Program Long-Range Plan. Changes were made and will be ready for reissuance soon.

PANEL RELATED PROJECT REPORTS

A) CNC Robotic Structural Shape Processing (MANTEC)-Dave Blais

Mr. Blais first described the project; it is two-phased, with Phase I completed in April 1983 with a demonstration. The demonstration addressed the feasibility of arc-plasma type using a robot and some of the problems and potential solutions to linking a robot to a CAD system. BIW had already completed a test on the feasibility of plasma cutting using a robot. They used off-line programming at that demonstration to build a library of end cuts of steel and aluminum of what the standard end cuts would be. He said that it is a feasible program that would have economic advantages not only at BIW but also in the other shipyards.

Mr. Blais gave the following update on progress after the demonstration in April 1983:

- 0 Submitted final report to the Navy--hoped that this would be their basis for approving Phase II of the project which is the actual implementation, but to-date BIW has not received the RFP yet. They anticipate to receive this before the end of Fiscal Year '84 (September 30, 1984).
- 0 To prepare for Phase II, they wrote to some vendors for proposals. Out of the 3 vendors they sent letters to, only one responded and sent proposal based on the concept they have on Phase I.

Mr. Blais said BIW is still looking for someone to provide them with cost and maybe another concept. Westinghouse sent in a proposal for a very unique manipulator Model 6000, track-mounted unit that rotates that does more things than the present AUTOMATIX robot they have. Only problem with Westinghouse is that theirs is very weak in the off-line programming and control unlike AUTOMATIX which has the expertise or lead on the software side (which is the most important factor to make the system successful).

As for Cincinnati Milacron, they don't want to get into the system aspect of the project--integrated material handling linking to the CAD system, etc.--no interest at all.

As for General Electric, they told BIW how great their automation was, but until now they have not sent in their response.

Another company, NUCOR from Michigan, deals primarily with the automotive industry but with the decline in the auto industry, they are looking for a new market and shipbuilding is one of those they are looking at. NUCOR is going to send them a proposal for both the material handling system. This is a unique company and rather expensive but they have great innovative ideas. Mr. Blais said that he was very positive they can deliver the goods.

Mr. Acton told Mr. Blais of a company which is doing plasma cutting. He said that this company is interested in the process of arc welding and is also a well-known robot manufacturer.

Mr. Blais told the group that even though they are looking for another subcontractor for better hardware, he thinks that AUTOMATIX is still the best bet with regards to software and he informed them too that AUTOMATIX is looking for other manipulators, much larger.

Discussion followed after his presentation.

B) Laser Line Heating Project - J. B. Acton

This project, Mr. Acton reported, is a new project; still in its infancy stage. This project basically will go through the same series of experiments and proofs that Japanese went through to establish oxyacetylene as a heat source for shaping and heat line fairing.

He continued to say that this project would basically be confined to shaping rather than fairing due to difficulty in manipulating a 15K laser around the shipyard. The present technique which was developed by the Japanese is either to use a torch with a man holding it or use it in a gantry format and using sight-line templates to bring your steel into shape. This requires some degree of "art form" in accomplishing this task. It is also restricted to mild steel because of the surface degradation effect to HY 80 and HY 100.

This project is Todd-sponsored with MIT doing most of the work, data reduction and analysis, and using the Navy Research Lab laser. This is truly a joint industry-academia-Navy project.

The objective of the project is to ultimately develop a machine to pass the laser heat source over the steel plate and have it bent to exactly the shape wanted as defined in a CAD data base, utilizing a continuous feedback system that would make it a self-adaptive machine.

If Phase I is successful (completion by January 1985), Phase II would be to develop the specifications for the Facility itself - cost, design, specifications, etc.. Phase III will be the installation of that facility in a shipyard.

The first series of experiments on this project will be later part of March; second series first or second week of May and will continue through the fourth series.

This project proves to be a fairly exciting concept in that it fully supports the line heating manual that was published under the SNAME Panel SP-2.

UPDATE ON NAVY PROGRAMS - PRESENTED BY R. JENKINS FOR
LCDR. B. EVERETT

LCDR Everett gave Mr. Jenkins a carousel of slides to present to the panel for the update on the Navy program.

Following were just a few of the important areas that were presented:

- o Navy labs involved in the robotics projects: NOSC, NSWC, NRL, DTNRDC.
- o NavSea robotic interim or potential Navy applications: manufacturers applications, maintenance and repair applications tactical or operations applications.
- o Manufacturing Technology - 6 of the programs that are underway:
 - CNC Robotic Structural Shape Processing
 - Integrated Computer-Aided Manufacturing of Propeller
 - Articulating Robot for Laser Assistance Metalworking
 - Vision Assisted Robotic Welding
 - Vision Assisted in Adaptive Mig Welding
 - Robot Assisted Preparation and Painting
- o Sandroid Sandblaster - A slide of the Sandroid was shown. John Sizemore said that Ingalls is the only shipyard who has this machine in operation. The major disadvantage of this is its being in an open air system. Also, the operator of this machine must really be skilled or he'll spend a lot of time spraying in the open air.

Slides with detailed info on the 6 MT programs followed.

After Mr. Jenkins finished his presentation, Mr. Acton informed the group that the final report on the CM-T3 project has been sent out. The report was about existing technology and the SRI technology.

FY '85 PROJECTS AND LONG-RANGE PLAN

Mr. Acton asked the group to have the FY '85 project proposals before the July meeting for submission in September or October. He told them to include a project abstract for each project, and also to break those projects into two phases, to bring it down small enough to submit and get funded. The projects must have something that would catch the eye of the industry--sort of prove to them that the panel is doing something exclusively within the category.

He mentioned that he offered to write a project abstract for taking a robot--does not have to be the T3--utilize the existing system to make one accurate and go into a project for off-line programming and down loading from a CAD data base. If it is approached in that context, Mr. Acton thinks that the panel will have moved into an area which is rightfully theirs and still will be utilizing existing technology (not going into Manufacturing Technology development type projects).

He also reported to the group about the Manufacturing Technology projects that have been submitted and of the tie-in the ManTech program it is going to have with the NSRP including the requirement that only ManTec projects recommended by the Ship Production Committee will be funded.

He suggested to have the meeting at Palo Alto on July 17 and 18 and a tour of the SRI.

Also, Mr. Acton requested that whoever is making a presentation or report to the panel to send a copy in the mail before the meeting for inclusion in the minutes.

OTHER MATTERS

A) CONTRAVES Presentation - Bernie Miller

Detailed account of his presentation attached as Enclosure 5.

Mr. Acton informed the group that as a result of the conversation with Mark Tanner and Bernie Miller, he is considering proposing as an FY '85 SP-10 project? to develop a system for off-line programming of welding robot. He told Mr. Tanner that it stands a better chance on being in an SP-10 project than SP-7 because of their (SP-7) present backlog of projects.

B) Marine Robot

Mr. Acton informed the group that the Marine Underwater Robot, developed by a French shipyard, was designed primarily to clean ship's hulls, but could possibly be adopted to other operations if desired. They (NORMED) have asked Todd to enter into an Independent Research and Development project with them to evaluate the ability of this robot to work on Navy ships.

SP-10 Meeting 3
March 20-21, 1984
Page Ten

The marine robot is programmed similar to other robots, comes in 3 modules--the robot, the controller, and the director. The plan is for Todd to lease the robot from them to perform the evaluation then jointly recommend whether or not it will do what they have advertised. The project is scheduled for later this year to be completed within six months.

There will be a paper published on this at ROBOTS VIII.

There being no other matters to discuss, the Chairman reminded the group about the tour and the time they have to be at the lobby the following day.

The meeting adjourned at 5:30 p.m.

Evelina L. Sequerth
EVELINA L. SEQUERTH
Recorder

J. B. ACTON
Chairman, SNAME/SP-10

SPC PANEL SP-10 FLEXIBLE AUTOMATION
General Dynamics-Electric Boat Division
Groton, Connecticut
March 20-21, 1984
Meeting No. 3

A G E N D A

TUESDAY, MARCH 20, 1984

8:30 - 8:45 a.m.	CALL TO ORDER/ OPENING REMARKS	J. B. Acton
8:45 - 9:15 a.m.	APPROVAL OF MINUTES OF PREVIOUS MEETING November 15-17, 1983 PANEL PROJECT REPORTS	
9:15 - 9:45 a.m.	o Robotic Welding Cable Manufacturing, Inspection and Repair	N. Haynes
9:45 - 10:45 a.m.	o Plan for Implementing Flexible Automation in the Shipbuilding Industry	J. B. Acton
10:45 - 11:00 a.m.	COFFEE BREAK PANEL RELATED PROJECT REPORTS	
11:00 - 11:30 a.m.	o CNC Robotic Structural Shape Processing (MANTEC)	D. Blais
11:30 - 12:00 noon	o Laser Line Heating Project	J. B. Acton
12:00 - 12:30 p.m.	UPDATE ON NAVY PROGRAMS	LCDR B. Everett
12:30 - 1:30 p.m.	LUNCH BREAK	
1:30 - 3:00 p.m.	FY '85 PROJECTS AND LONG RANGE PLAN	All
3:00 - 3:15 p.m.	COFFEE BREAK	
3:15 - 4:00 p.m.	OPEN SESSION	
4:00 p.m.	ADJOURNMENT	

Agenda
Meeting 3
Page Two

WEDNESDAY, MARCH 21, 1984

8:00 a.m.	Assemble at Hotel Lobby for tour of General Dynamics-Electric Boat Division
11:00 a.m.	LUNCH BREAK
12:00 noon	Leave for tour of Quonset Point
4:00 p.m.	ADJOURNMENT

Minutes of the Meeting
Panel SP-10 Flexible Automation
November 15-16, 1983
Page Three

and then automatically mark the shapes with one-inch high characters. It will be in the implementation phase soon which will include a production demonstration to the shipbuilding industry. BATH estimates a 50% labor savings in this type of work.

- o Roy Wells of NAVSEA described a project using a flexible machining systems for precise accurate work on a submarine propeller. This project is being done by Robotics Vision Systems, Inc., using their 3-D) visiion sensor and data processing technology. This company is also developing systems for 3-D vision control of MIG seam arc welding for the General Motors Corporation. Right now, Wells says he is looking for propeller to demonstrate with next February 1984, Attachment (2).

NAVY PROGRAMS

- o LCDR Bart Everett of NAVSEA described some of their programs:

Several yards are working on blasters for cleaning marine growth and paint from the sides of submarine and other Naval vessels. Puget Sound has one for Trident subs built by Wheelabrator-Fry. Jim Cameron said that Quonset Point was going to a closed cycle system for blasting.

The blaster of current interest is the "SANDROID", a unit built by Hockett Systems of Florida, Inc., 5103 South West Shore Blvd., Tampa, Florida 33611. They have taken a Simon "cherry picker", fitted the end of the boom with a set of six blasting nozzles and control the unit by a "tele-operator". potentially, sensors and/or NC will be added to this control unit to automatically control this function. Some discussion was generated with comments about using this system (in smaller form) to blast compartments and bilges of ships.

A NAVSEA Robotics Council has been established, with LCDR Everett named coordinator. NAVSEA hopes to get maximum value of their robotics investment by merging common problems into one project.

Adaptive MIG welding. There are a number of manufacturers involved in 3-D and other vision systems for seam-tracking automatic welders. There are also a number of Navy installations interested in this technology including Dr. John Silva at the Navy Ocean Systems Center in San Diego.

Table 1A. Questionnaire Summary on Manufacture/Repair of Manual Arc Welding Cable - Commercial Shipyards.

Shipyard	1	2	3	4	5	6
Mfg. or Buy Cable Sections?	mfg.	mfg.	both	mfg.	buy	mfg.
Formal Make vs. Buy Analysis?	no	no	yes	yes	yes	no
Cable Coded?	no	no	no	yes	yes	no
How Coded?	N/A	N/A	N/A	number	---	N/A
Max. Distance From a Connector to a Splice?	NP*	10'	NS**	NP	NP	25'
Use Heat Shrink Tubing?	yes	no	no	no	yes	yes

*NP = No policy

**NS = No splices, do cut off damaged ends

D-14

Table 1B. Questionnaire Summary on Manufacture/Repair of Manual Arc Welding Cable - Navy Shipyards.

Shipyard	1	2	3	4	5	6	7
Mfg. or Buy Cable Sections?	mfg.	mfg.	mfg.	mfg.	both	mfg.	mfg.
Formal Make vs. Buy Analysis?	no	yes	no	no	no	no	no
Cable Coded?	yes	yes	yes	no	some	no	no
How Coded?	color	number	color	N/A	number	N/A	N/A
Max. Distance From a Connector to a Splice?	NS	NP	NP	NS	NP	NS	15'
Use Heat Shrink Tubing?	NS	no	no	NS	no	NS	yes

D-15

Table 2A. Questionnaire Summary on Manufacture/Repair of Manual Arc Welding Cable - Commercial Shipyards.

Shipyard	1	2	3	4	5	6
Total No. of Welders	300	---	2500	761	623	190
Std. Length of Cable Sections	75', 55'	50'	100'	125'	100'	100', 50'
Max. No. of Sections Joined	NP	3	NP	2	---	2
Sections Mfg. per Year	700	830	60+ (?)	320	100	1200
Max. No. of Splices	NP	3	0	6	1 per 25'	1 per 50'
Full-time Persons Involved in Mfg.	0.25	0.15	1.0	2.0	N/A	0.5
Full-time Persons Involved in Repair	0.75	1.0	1.0	0.1	1.0	---

D-16

Table 2B. Questionnaire Summary on Manufacture/Repair of Manual Arc Welding Cable - Navy Shipyards.

Shipyard	1	2	3	4	5	6	7
Total No. of Welders	350	317	665	37.	580	575	300
Std. Length of Cable Sections	50'	50',100'	50'	50'	50'	70'	50'
Max. No. of Sections Joined	4	0	NP	0	NP	0	4-6
D-17 Sections Mfg. per Year	300	240	100	10	400	850	275
Max. No. of Splices	0	NP	5	0	NP	0	2
Full-time Persons Involved in Mfg.	0.1	1.5	2	0.02	0.12	0.78	1.0
Full-time Persons Involved in Repair	0.5	1.5	2	0	0.12	0	1.0
Avg. Time to Mfg. Cable (min.)	30	30	30	60	30	5	20
Avg. Time to Splice (min.)	N/A	15	15	N/A	15	N/A	15

Enclosure (2)
Sheet 4 of 22

Table 3A. Questionnaire Summary on Manufacture/Repair of
Manual Arc Welding Cable - Commercial Shipyards.

Shipyard	1	2	3	4	5	6
Male Connector	CAMLOCK B-34	Lincoln 516315-1	CAMLOX A20036-1	LC40 HD Lenco	Class M cooper 34AWG Neoprene	Lenco LC-40HD
Female Connector	CAMLOK B-36	Lincoln 516314-1	CAMLOX A20036-19	LC40 HD Lenco	Black Anaconda Tweco male and female ends	Lenco LC-40HD
Sleeve	RSD-12		JSCF500 A200040-1		boot cover with band-it jr. clamp	
D-18 Vendor	Roto Mfg.		J.B. Nottingham			
Cable Sizes	2/0	2/0,4/0	2/0	2/0,4/0	1/0,2/0	3/0,4/0
Amps (max)	285	300,900	225	300,600	300,300	300,400
Single or Double Insulation?	D	S	S	D,S	D	S
Insulation Type	85 Mil Elexar 20 mil Estane Polyurethane	neoprene	neoprene	neoprene	neoprene	neoprene or rubber

Table 3B. Questionnaire Summary on Manufacture/Repair of Manual Arc Welding Cable - Navy Shipyards.

Shipyard	1	2	3	4	5	6	7
Male Connector	taperscrew lock connector with copper sleeve	MCC-4 MCC-12 MCC-201	E1018-13	Jackson Quik-Trik disconnect ONB-2	Lektralink	Palm-gren	E1027-13
Female Connector		FCC-12 FCC-201	E1018-62		P/N 31016		E1027-62
Sleeve		SMC-201 SFC-201		Neoprene			brass
Vendor		CAMLOK	CAMLOK		CAMLOK	Roto Mfg.	CAMLOK
Cable Sizes	6,1,2/0,4/0	3,1,2/0	1/0,2/0	1,1/0	3	1/0	2/0
Amps (max)	180,300, 800,900		150,600	200,400	300	300	500
Single or Double Insulation?	D,S,S,S	S,S,S	S,S	S,S	S	S	D
Insulation Type	neoprene	polychloroprene	neoprene	neoprene	neoprene	neoprene, rubber	neoprene

D-19

Table 4. Questionnaire Summary on Salvage/Scrap
 Procedure - Commercial and Navy Shipyards.

	Navy Yards	Commercial Yards
Salvage Connectors?	4	6
Make Pigtails?	6	6
Sell Cable "as is"?	3	5
Strip Insulation?	1	1

D-20

General Notes on Questionnaire Responses

1. All shipyards purchase cable in either 500' or 1000' spools.
2. Except for one commercial and one navy shipyard, all have a central facility to manufacture and repair welding cable.
3. Only one shipyard (Navy) has individual welders make major repairs to welding cables. {A small yard - 37 welders}.
4. Only four shipyards use heat shrink tubing in making a cable splice.
5. Four shipyards test repaired cable for continuity; one shipyard gives a "strain" test.

Connector Classification Parameters

The following is a listing of parameters that can be used to distinguish one welding cable connector from another.

1	Connector Gender	(male, female)
2	Connector Size	(1/0, 2/0, ...)
3	Connector Length	(inches)
4	Connector Material	(brass, ...)
5	Depth of Cable Opening	(inches)
6	Width of Cable Opening	(inches)
7	Connector End Type	(flanged, straight)
8	Connector Fastening	(crimp, set screw)
9	Connector Screw Type	(hex, slot)
10	Number of Connector Screws	(1, 2, ...)
11	Connector Symmetry	
12	Connector Shape	(round, ...)
13	Connector Tip Type	(slotted, notched, ...)
14	Length of Tip	(inches)
15	Width of Tip	(inches)
16	Connector Opening Type	(slotted, notched, ...)
17	Depth of Connector Opening	(inches)
18	Width of Connector Opening	(inches)
19	Degree Radius of Turn	(30, 180, ...)
20	Cable Covering	(bare, copper shim, ...)
21	Cover Type	(molded, slip over, ...)
22	Cover Material	(rubber, rigid plastic, ...)
23	Cover Reinforcing	(none, steel, ...)
24	Cover Fastening	(friction, pin, screw, ...)
25	Cover Screw Type	(hex, slot, ...)
26	Number of Cover Screws	(1, 2, ...)
27	Fastener Depth	(through cover-into connector, through cover-through connector, ...)
28	Cover Alignment	(yes, no)
29	Insertion of Difficulty	(low, medium, high)
30	Complexity of Assembly	(low, medium, high)
31	Salvageability	(reusable, one time use, ...)
32	Tools for Assembly	(hex wrench, crimp tool, ...)
33	Manufacturer	
34	Part Number	
35	cost	
36	Yard Name in Use	
37	Notes	

Electrical Cable Classification Parameters

One hundred and fourteen different parameters have been identified which are needed to define a particular electrical cable. These have been identified by researching the Military Specifications, MIL-C-915E, for electrical cable and cord for shipboard use; Also, a publication by Seacoast Electric Supply on U.S. Navy-approved cables was reviewed. The parameters may be classified into two major groups: General and Material Properties. A sample of parameters in each major group is given below:

General

1. Classification Name (watertight, non-flexing, etc. - Sec. 1.2)
2. Classification Use (power and lighting, etc. - Sec. 1.2)
3. Conductor Material (copper, aluminum, etc. - Sec. 3.3.1)
4. Conductor Type (solid, stranded, etc. - Sec. 3.3.1)
5. Number of Strands
6. Strand Diameter (inches or mm.)
7. Weight (lbs./1000 ft.)
8. Current Capacity (amps)
(Conductor)
9. Current Capacity (amps)
(Cable)
10. Insulation Material (silicone rubber, polyester, etc.) -
Section 3.4.3)

Material Properties

1. Abrasion Resistance - (Sec. 4.8.1)
2. Bending Endurance - (Sec. 4.8.4)
3. Crack Resistance - (Sec. 4.8.14)
4. Flammability - (Sec. 4.8.16)

Material Properties (Cont'd.)

- | | |
|-----------------------------|-------------------|
| 5. Tensile Strength, Jacket | - (Sec. 4.8.22.3) |
| 6. Elongation, Insulation | - (Sec. 4.8.22.3) |
| 7. Capacitance | - (Sec. 4.9.2) |
| 8. Conductor Resistance | - (Sec. 4.9.4) |
| 9. Pulse Response Time | - (Sec. 4.9.7) |
| 10. Max. Voltage Withstand | - (Sec. 4.9.8) |

The Section numbers refer to MIL-C-915E sections.

Table 5. Bill of Materials for Ship A - Electrical Cable.

Cable Type	No. of Conductors	Conductor Strands	AWG or Navy Std. Size	Voltage	Max. Amps Per Cond. @ 40° C	Max. Cable O. D. (in.)	Weight lbs./1000 ft.	Total Length Used (ft.)
DSGB- 4	2	7	#14	1000	22	.427	170	127000
DSGB- 9	2	7	#11	1000	44	.544	265	20300
DSGB- 14	2	7	# 9	1000	60	.670	350	1700
DSGB- 23	2	7	# 7	1000	78	.815	475	100
DSGB- 50	2	19	# 3	1000	126	.911	770	200
DSGB- 75	2	37	# 1	1000	168	1.074	1075	100
DSGB-100	2	61	#1/0	1000	199	1.167	1300	200
DSGB-200	2	61	#4/0	1000	308	1.583	2200	300
TSGB- 4	3	7	#14	1000	18	.449	200	49000
TSGB- 9	3	7	#11	1000	39	.575	315	12000
TSGB- 14	3	7	# 9	1000	51	.720	465	5800
TSGB- 23	3	7	# 7	1000	69	.870	605	10000
TSGB- 50	3	19	# 3	1000	110	.969	1090	4800
TSGB- 75	3	37	# 1	1000	148	1.134	1410	1500
TSGB-100	3	61	#1/0	1000	174	1.266	1780	1500
TSGB-150	3	61	#3/0	1000	235	1.515	2590	3300
TSGB-200	3	61	#4/0	1000	271	1.669	3150	1400
TSGB-300	3	91	300	1000	348	1.957	4460	5200
TSBG-400	3	127	400	1000	435	2.203	5850	4800
FSGB- 4	4	7	#14	1000	18	.513	255	17000
FSGB- 9	4	7	#11	1000	39	.630	380	150
FSGB- 75	4	37	# 1	1000	148	1.240	1700	50
FSGB-150	4	61	#3/0	1000	235	1.625	3120	50

D-25

Enclosure (2)
Sheet 12 of 22

Table 5. Bill of Materials for Ship A - Electrical Cable. (Continued)

Cable Type	No. of Conductors	Conductor Strands	AWG or Navy Std. Size	Voltage	Max. Amps Per Cond. @ 40° C	Max. Cable O. D. (in.)	Weight lbs./1000 ft.	Total Length Used (ft.)
MSCB- 7	7	7	#18	1000	12/8	.484	210	9100
MSCB- 10	10	7	#18	1000	12/8	.622	300	5100
MSCB- 14	14	7	#18	1000	12/8	.668	355	6700
MSCB- 19	19	7	#18	1000	12/8	.738	430	2000
MSCB- 24	24	7	#18	1000	12/6	.855	540	1350
MSCB- 30	30	7	#18	1000	12/6	.901	610	900
MSCB- 37	37	7	#18	1000	12/6	1.002	715	4500
MSCB- 44	44	7	#18	1000	12/5	1.114	860	300
MSCB- 61	61	7	#18	1000	12/4.5	1.250	1100	4200
MSCB- 91	91	7	#18	1000	12/4	1.480	1530	1500
TTRSB- 2	4	7	#20	300	--	.680	200	1400
TTRSB- 4	8	7	#20	300	--	.740	245	4250
TTRSB- 6	12	7	#20	300	--	.880	335	100
TTRSB- 16	32	7	#20	300	--	1.190	640	250
TTSB-1.5	3	7	#22	300	--	.330	78	10300
TTSB- 3	6	7	#22	300	--	.450	140	2400
TTSB- 5	10	7	#22	300	--	.540	195	2500
TTSB- 10	20	7	#22	300	--	.675	295	400
TTSB- 15	30	7	#22	300	--	.800	375	600
TTSB- 20	40	7	#22	300	--	.870	445	300
2SWB- 14	28	7	#22	--	--	.860	540	300
3SWB- 3	9	7	#18	--	--	.650	290	700
3SWB- 7	21	7	#18	--	--	.840	520	600
7SGB- 4	7	7	#14	1000	26/14	.595	305	200
2SB- 7	14	7	#22	--	--	.660	205	1300
DSS- 3	2	7	#16	600	--	.500	160	200

D-26

Table 6. Bill of Materials for Ship A - By Electrical Cable Type (Example).

<u>Cable Type</u>	<u>No. of Conductors</u>	<u>Conductor Strands</u>	<u>AWG or Navy Std. Size</u>	<u>Voltage</u>	<u>Max. Amps Per Cond. @ 40° C</u>	<u>Max. Cable O. D. (in.)</u>	<u>Weight lbs./1000 ft.</u>	<u>Total Length Used (ft.)</u>
DSGB- 4	2	7	#14	1000	22	.427	170	127000
DSGB- 9	2	7	#11	1000	44	.544	265	20300
DSGB- 14	2	7	#9	1000	60	.670	350	1700
DSGB- 23	2	7	#7	1000	78	.815	475	100
DSGB- 50	2	19	#3	1000	126	.911	770	200
DSGB- 75	2	37	#1	1000	168	1.074	1075	100
DSGB-100	2	61	#1/0	1000	199	1.167	1300	200
DSGB-200	2	61	#4/0	1000	308	1.583	2200	300

D-27

Table 7. Electrical Cable for Ship A - Sorted by Diameter.

Cable Type	No. of Conductors	Conductor Strands	AWG or Navy Std. Size	Voltage	Max. Amps Per Cond. @ 40°C	Max. Cable O. D. (in.)	Weight lbs./1000 ft.	Total Length Used (ft.)
TTSB-1.5	3	7	#22	300	---	.330	78	10300
DSGB- 4	2	7	#14	1000	22	.427	170	127000
TSGB- 4	3	7	#14	1000	18	.449	200	49000
TTSB- 3	6	7	#22	300		.450	140	2400
MSCB- 7	7	7	#18	1000	12/8	.484	210	9100
DSS- 3	2	7	#16	600	--	.500	160	200
FSGB- 4	4	7	#14	1000	18	.513	255	17000
TTSB- 5	10	7	#22	300	--	.540	195	2500
DSGB- 9	2	7	#11	1000	44	.544	265	20300
TSGB- 9	3	7	#11	1000	39	.575	315	12000
7SGB- 4	7	7	#14	1000	26/14	.595	305	200
MSCB- 10	10	7	#18	1000	12/8	.622	300	5100
FSGB- 9	4	7	#11	1000	39	.630	380	150
3SWB- 3	9	7	#18		--	.650	290	700
2SB- 7	14	7	#22	---	--	.660	205	1300
MSCB- 14	14	7	#18	1000	12/8	.668	355	6700
DSGB- 14	2	7	# 9	1000	60	.670	350	1700
TTSB- 10	20	7	#22	300	--	.675	295	400
TTRSB- 2	4	7	#20	300	--	.680	200	1400
TSGB- 14	3	7	#9	1000	51	.720	465	5800
MSCB- 19	19	7	#18	1000	12/8	.738	430	2000
TTRSB- 4	8	7	#20	300	--	.740	245	4250
TTSB- 15	30	7	#122	300	--	.800	375	600
DSGB- 23	2	7	17	1000	78	.815	475	100
3SWB- 7	21	7	#18	---	--	.840	520	600

D-28

Table 7. Electrical Cable for Ship A - Sorted by Diameter. (Continued)

<u>Cable Type</u>	<u>No. of Conductors</u>	<u>Conductor Strands</u>	<u>AWG or Navy Std. Size</u>	<u>Voltage</u>	<u>Max. Amps Per Cond. @ 40° C</u>	<u>Max. Cable O. D. (in.)</u>	<u>Weight lbs./1000 ft.</u>	<u>Total Length Used (ft.)</u>
MSCB- 24	24	7	#18	1000	12/6	.855	540	1350
2SWB- 14	28	7	#22	--	--	.860	540	300
TSGB- 23	3	7	# 7	1000	69	.870	605	10000
TTSB- 20	40	7	#22	300	--	.870	445	300
TTRSB- 6	12	7	#20	300	--	.880	335	100
MSCB- 30	30	7	#18	1000	12/6	.901	610	900
DSGB- 50	2	19	# 3	1000	126	.911	770	200
TSGB- 50	3	19	# 3	1000	110	.969	1090	4800
MSCB- 37	37	7	#18	1000	12/6	1.002	715	4500
DSGB- 75	2	37	# 1	1000	168	1.074	1075	100
MSCB- 44	44	7	#18	1000	12/5	1.114	860	300
TSGB- 75	3	37	# 1	1000	148	1.134	1410	1500
DSGB-100	2	61	#1/0	1000	199	1.167	1300	200
TTRSB- 16	32	7	#20	300	--	1.190	640	250
FSGB- 75	4	37	# 1	1000	148	1.240	1700	50
MSCB- 61	61	7	#18	1000	12/4.5	1.250	1100	4200
TSGB-100	3	61	#1/0	1000	174	1.266	1780	1500
MSCB- 91	91	7	#18	1000	12/4	1.480	1530	1500
TSGB-150	3	61	#3/0	1000	235	1.515	2590	3300
DSGB-200	2	61	#4/0	1000	308	1.583	2200	300
FSGB-150	4	61	#3/0	1000	235	1.625	3120	50
TSGB-200	3	61	#4/0	1000	271	1.669	3150	1400
TSGB-300	3	91	300	1000	348	1.957	4460	5200
TSGB-400	3	127	400	1000	435	2.203	5850	4800

D-29

Table 8. Electrical Cable for Ship A - Sorted by Weight.

Cable Type	No. of Conductors	Conductor Strands	AWG or Navy Std. Size	Voltage	Max. Amps Per Cond. @ 40° C	Max. Cable O. D. (in.)	Weight lbs./1000 ft.	Total Length Used (ft.)
TTSB-1.5	3	7	#22	300	--	.330	78	10300
TTSB-	3	7	#22	300	--	.450	140	2400
DSS-	3	7	#16	600	--	.500	160	200
DSGB-	4	7	#14	1000	22	.427	170	127000
TTSB-	5	10	#22	300	--	.540	195	2500
TSGB-	4	3	#14	1000	18	.449	200	49000
TTRSB-	2	4	#20	300	--	.680	200	1400
2SB-	7	14	#22	--	--	.660	205	1300
MSCB-	7	7	#18	1000	12/8	.484	210	9100
TTRSB-	4	8	#20	300	--	.740	245	4250
FSCB-	4	4	#14	1000	18	.513	255	17000
DSGB-	9	2	#11	1000	44	.544	265	20300
3SWB-	3	9	#18	--	--	.650	290	700
TTSB-	10	20	#22	300	--	.675	295	400
MSCB-	10	10	#18	1000	12/8	.622	300	5100
7SGB-	4	7	#14	1000	26/14	.595	305	200
TSGB-	9	3	#11	1000	39	.575	315	12000
TTRSB-	6	12	#20	300	--	.880	335	100
DSGB-	14	2	# 9	1000	60	.670	350	1700
MSCB-	14	14	#18	1000	12/8	.668	355	6700
TTSB-	15	30	#22	300	--	.800	375	600
FSCB-	9	4	#11	1000	39	.630	380	150
MSCB-	19	19	#18	1000	12/8	.738	430	2000

D-30

Table 8. Electrical Cable for Ship A - Sorted by Weight. (Continued)

Cable Type	No. of Conductors	Conductor Strands	AWG or Navy Std. Size	Voltage	Max. Amps Per Cond. @ 40° C	Max. Cable O. D. (in.)	Weight lbs./1000 ft.	Total Length Used (ft.)
TTSB- 20	40	7	#22	300	--	.870	445	300
TSGB- 14	3	7	# 9	1000	51	.720	465	5800
DSGB- 23	2	7	# 7	1000	78	.815	475	100
3SWB- 7	21	7	#18	--	--	.840	520	600
MSCB- 24	24	7	#18	1000	12/6	.855	540	1350
2SWB- 14	28	7	#22	--	--	.860	540	300
TSCB- 23	3	7	# 7	1000	69	.870	605	10000
MSCB- 30	30	7	#18	1000	12/6	.901	610	900
TTRSB- 16	32	7	#20	300	--	1.190	640	250
MSCB- 37	37	7	#18	1000	12/6	1.002	715	4500
DSGB- 50	2	19	# 3	1000	126	.911	770	200
MSCB- 44	44	7	#18	1000	12/5	1.114	860	300
DSGB- 75	2	37	# 1	1000	168	1.074	1075	100
TSGB- 50	3	19	# 3	1000	110	.969	1090	4800
MSCB- 61	61	7	#18	1000	12/4.5	1.250	1100	4200
DSGB-100	2	61	#1/0	1000	199	1.167	1300	200
TSGB- 75	3	37	# 1	1000	148	1.134	1410	1500
MSCB- 91	91	7	#18	1000	12/4	1.480	1530	1500
FSGB- 75	4	37	# 1	1000	148	1.240	1700	50
TSCB-100	3	61	#1/0	1000	174	1.266	1780	1500
DSGB-200	2	61	#4/0	1000	308	1.583	2200	300
TSCB-150	3	61	#3/0	1000	235	1.515	2590	3300
FSGB-150	4	61	#3/0	1000	235	1.625	3120	50
TSGB-200	3	61	#4/0	1000	271	1.669	3150	1400
TSGB-300	3	91	300	1000	348	1.957	4460	5200
TSGB-400	3	127	400	1000	435	2.203	5850	4800

D-31

Table 9. Electrical Cable for Ship A - Sorted by Total Length Used.

Cable Type	No. of Conductors	Conductor Strands	AWG or Navy Std. Size	Voltage	Max. Amps Per Cond. @ 40° C	Max. Cable O. D. (in.)	Weight lbs./1000 ft.	Total Length Used (ft.)
DSGB- 4	2	7	#14	1000	22	.427	170	127000
TSGB- 4	3	7	#14	1000	18	.449	200	49000
DSGB- 9	2	7	#11	1000	44	.544	265	20300
FSCB- 4	4	7	#14	1000	18	.513	255	17000
TSGB- 9	3	7	#11	1000	39	.575	315	12000
TTSB-1.5	3	7	#22	300	--	.330	78	10300
TSGB- 23	3	7	# 7	1000	69	.870	605	10000
MSCB- 7	7	7	#18	1000	12/8	.484	210	9100
MSCB- 14	14	7	#18	1000	12/8	.668	355	6700
TSGB- 14	3	7	# 9	1000	51	.720	465	5800
TSGB-300	3	91	300	1000	348	1.957	4460	5200
MSCB- 10	10	7	#18	1000	12/8	.622	300	5100
TSGB-400	3	127	400	1000	435	2.203	5850	4800
TSGB- 50	3	19	# 3	1000	110	.969	1090	4800
MSCB- 37	37	7	#18	1000	12/6	1.002	715	4500
TTRSB- 4	8	7	#20	300	--	.740	245	4250
MSCB- 61	61	7	#18	1000	12/4.5	1.250	1100	4200
TSGB-150	3	61	#3/0	1000	235	1.515	2590	3300
TTSB- 5	10	7	#22	300	--	.540	195	2500
TTSB- 3	6	7	#22	300	--	.450	140	2400
MSCB- 19	19	7	#18	1000	12/8	.738	430	2000
DSGB- 14	2	7	# 9	1000	60	.670	350	1700
MSCB- 91	91	7	#18	1000	12/4	1.480	1530	1500
TSGB-100	3	61	#1/0	1000	174	1.266	1780	1500
TSGB- 75	3	37	# 1	1000	148	1.134	1410	1500

D-32

Table 9. Electrical Cable for Ship A - Sorted by Total Length Used. (Continued)

Cable Type	No. of Conductors	Conductor Strands	AWG or Navy Std. Size	Voltage	Max. Amps Per Cond. @ 40° C	Max. Cable O. D. (in.)	Weight lbs./1000 ft.	Total Length Used (ft.)
TTRSB- 2	4	7	#20	300	--	.680	200	1400
TSGB-200	3	61	#4/0	1000	271	1.669	3150	1400
MSCB- 24	24	7	#18	1000	12/6	.855	540	1350
2SB- 7	14	7	#22	--	--	.660	205	1300
MSCB- 30	30	7	#18	1000	12/6	.901	610	900
3SWB- 3	9	7	#18	--	--	.650	290	700
3SWB- 7	21	7	#18	--	--	.840	520	600
TTSB- 15	30	7	#22	300	--	.800	375	600
TTSB- 10	20	7	#22	300	--	.675	295	400
2SWB- 14	28	7	#22	--	--	.860	540	300
TTSB- 20	40	7	#22	300	--	.870	445	300
MSCB- 44	44	7	#18	1000	12/5	1.114	860	300
DSGB-200	2	61	#4/0	1000	308	1.583	2200	300
TTRSB- 16	32	7	#20	300	--	1.190	640	250
DSS- 3	2	7	#16	600	--	.500	160	200
7SGB- 4	7	7	#14	1000	26/14	.595	305	200
DSGB-100	2	61	#1/0	1000	199	1.167	1300	200
DSGB- 50	2	19	# 3	1000	126	.911	770	200
FSGB- 9	4	7	#11	1000	39	.630	380	150
TTRSB- 6	12	7	#20	300	--	.880	335	100
DSGB- 75	2	37	# 1	1000	168	1.074	1075	100
DSGB- 23	2	7	# 7	1000	78	.815	475	100
FSGB-150	4	61	#3/0	1000	235	1.625	3120	50
FSGB- 75	4	37	# 1	1000	148	1.240	1700	50

D-33

Table 10. Summary of Electrical Cable for Ship A.

Diameter Range (inches)	Weight Range (lbs./1000 ft.)	Number of Cables	Total Ft. Used	Percent of Footage	Percent of Cables
0.330 - 0.500	78 - 210	6	198,000	56.250	10.345
0.513 - 0.969	195 - 1090	27	100,750	28.622	46.552
1.002 - 1.480	640 - 1780	10	14,100	4.006	17.241
1.515 - 1.957	2200 - 4460	5	10,250	2.912	8.621
2.203	5850	1	4,800	1.364	1.724

NOTE: Total of 58 cables, 352,000 ft. No data on 9 cables accounting for 24,100 ft., or 6.847% of footage and 15.517% of cables.

D-34

CABLE FAULT LOCATING TECHNIQUES

- (1) CABLE FAULT DETECTION DEVICES USING 60 HZ.
- (2) CORONA DETECTORS
- (3) DETECTORS USING AUDIO TONES
- (4) CABLE INSTRUMENTS USING RF
- (5) EDDY CURRENT TESTERS
- (6) INDUCED SIGNALS ON CABLES
- (7) X-RAY EQUIPMENT
- (8) CABLE SHIELD EFFICIENCY DEVICE
- (9) TIME DOMAIN REFLECTOMETRY
- (10) PARTIAL BREAK LOCATER
- (11) INSULATION RESISTANCE RATIO FOR OPEN CIRCUITS
- (12) CAPACITANCE RATIO FOR OPEN CIRCUITS
- (13) VOLTAGE DROP RATIOS FOR SHORTS AND GROUNDS
- (14) RESISTANCE LOOP BALANCE FOR SHORTS AND GROUNDS
- (15) STANDING WAVE DIFFERENCE METHOD
- (16) CAPACITANCE IMPULSE METHOD
- (17) INFRARED THERMOMETER
- (18) **AC/DC** BREAK DOWN AND LEAKAGE TESTING

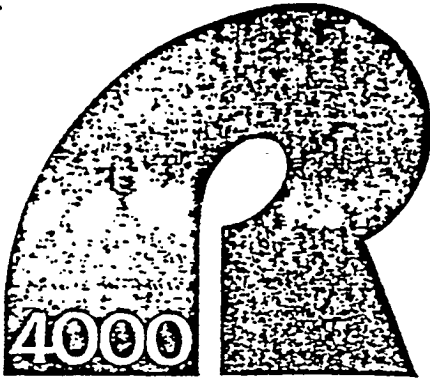

R:BASE SERIES 4000
RELATIONAL DATABASE
MANAGEMENT SYSTEM

R:base Relational Database Management System is a powerful, yet easy to use software tool for managing information on your microcomputer.

As a relational database management system, R:base organizes your data into two-dimensional tables of rows and columns. These tables or relations can be compared, combined and manipulated to meet the needs of a broad range of users in business, financial, engineering and scientific applications.

With R:base, all defining, *editing*, querying and report writing steps progress logically, relating similarly to the way people think.

Even first-time users will find the plain-English command structure and prompted screens make for easy interaction with the system.

R:base even lets you "draw" on the screen to create any form you're used to using for data entry or reporting. In addition, on-line HELP texts give you detailed information on every command and process required to master R:base operations.

And, as your requirements change and grow, R:base moves ahead with you. It is the only relational DBMS that lets you transport your data and your applications between micros, minis and mainframes without modification.

EXTENDED REPORT
WRITER

This output formatting utility is an optional software package designed for use with Microrim's R:base Series 4000 database management system.

It goes beyond the basic reporting and computational capabilities provided in the base product to generate complex and detailed reports from R:base files.

With the Extended Report Writer, you can retrieve data from multiple relations, perform calculations based on ranges of values, and define line and page breaks to occur when a specified field changes in value.

New or non-technical users can take advantage of prompted screens or on-line HELP text to create customized report formats. You can even conditionally print reports within a *report* to meet a broad range of formatting requirements.

TUTORIAL

The R:base Series 4000 Tutorial lets you experience the full relational power of R:base.

A demo diskette and tutorial guide take you step-by-step through an actual business application of R:base.

You learn firsthand how to build a data-base and use plain-English commands to make data inquiries and format reports.

The approach is thorough, yet easy to follow. When you have finished, you will have sampled the system's major features and seen how complex data management problems can be simply solved using R:base.

1.4 Specifications

Operating System Requirements

MS-DOS™ Release 1.1 (or higher)
PC-DOS™ Release 1.1 (or higher)
CTOS™ Release 8.0 (or higher)
BTOS™ Release 8.0 (or higher)

MAIN MEMORY:

R:base 4000 requires 256K bytes of memory for execution under MS-DOS.

DISK TYPES:

R:base 4000 is provided on a diskette compatible with each operating system. Your database files may reside on any disk supported by your system.

PRINTER. (Optional)

Any 80 or 132 column ASCII printer compatible with your system.

Database Specifications

Maximum number of files (relations)	
per database:	40
Maximum number of fields (attributes)	
per database:	400
Maximum record (row) size.	1530 characters
Maximum records per file (rows per relation):	2.5 billion
Maximum records per database	100 billion
Maximum command line input:	1600 characters

or limited by the file size of your operating system

Data Types

DATE: Represented as mm/dd/yy or in any order
you specify.

TIME: hh:mm:ss representing hours, minutes,
and seconds.

DOLLAR: Range of \pm **\$99,999,999,999.99**

INTEGER. Range of \pm 999,999,999

REAL: Range of 0 to $10 \pm^{38}$. 6-7 place accuracy.
Scientific or decimal point notation.

TEXT: 1 to 1500 characters:

STATUS REPORT - ROBOTIC WELDING CABLE MANUFACTURING

Dr. Marv Agee of Virginia Polytechnic Inst. Of Technology, the subcontractor to Bethlehem Steel, gave the following status report on the above-mentioned project. The report included the following main points:

1. Responses to Questionnaire on Welding Cable

Questionnaires were mailed to nine commercial and eight naval shipyards last fall. To date, six commercial and seven naval yards have responded. The three non-responding commercial yards have been contacted several times by phone over the past months. With one exception, the naval yards made a rapid response to the questionnaire. A summary of the responses is given in Tables 1A-4, Enclosure 2.

2. Advantages/Disadvantages of Different Types of Welding Cable Connectors

The various cable connectors used by the shipyards are being accumulated and analyzed. The Final Report on the project will include a discussion of the advantages/disadvantages of each connector type from the perspective of ease of automatic assembly to the cable unit cost, ease of damage, etc. Further, a recommendation on the preferred type of connector will be made.

panel SP-10 members suggested to Dr. Agee that the recommendation include two connector standards: one standard based on commercially available connectors, and one standard based on "ideal characteristics".

A listing of 35 parameters that can be used to distinguish one welding cable from another is attached, Enclosure 2.

3. Classification of Electrical Cable Parameters

Up to the processing step of attaching connectors, the procedure for manufacturing electrical cable (unspooling, metering, cut-off, repooling) is the same as for manufacturing welding cable. Thus, handling and processing equipment should be the same or similar. The project team is therefore investigating certain electrical cable as well.

For electrical cable defined by the Military Specification MIL-C-915E, 114 parameters (or attributes) have been identified which are needed to define a particular electrical cable. (Not all of these are relevant to determining specifications for handling and processing equipment.) The parameters may be

grouped into two major categories: General and Material Properties. A sample of these parameters is attached, Enclosure 2.

4. Electrical Cable Bill of Materials Summary

For two types of commercial ships, the Bill of Materials for electric cable (covered by MIL-C-915E specifications) have been analyzed. A computer program has been developed to sort the cable parameters in various ways. Sorting the cable by total footage used, cable diameters and cable weight can provide information to specify the type of handling and processing equipment required to manufacture electrical cable.

This study is not complete and information on shipping method and shipping weights must be collected. An example of Bill of Materials analysis for Ship A is given in Tables 5-10, Enclosure 2.

5. Welding Cable Test Equipment Study

It was reported that automating the testing and repair of used welding cable is a much more difficult task than automating the manufacture of welding cable. It is unlikely that such automation will be economically feasible and, in fact, may not be technologically feasible.

An extensive literature review on cable fault (defect) locating techniques is ongoing. Further, several manufacturers of test equipment and electrical cable have been contacted. Of 18 techniques identified thus far, no single technique seems capable of detecting both the type and location of faults in used welding cable.

A list of the 18 techniques is attached to these minutes.

6. Computerized Robot Selection Model

A software program to select a preferred robot model from a data base of commercial robots is being developed for the IBM PC (microcomputer). The software will consist of a commercially available data base management package and a developed BASIC program. The commercial data base software purchased is called R:BASE SERIES 4000, a relational data base management system. It is available from:

MICRORIM, INC.
1750 112th Avenue, N.E.
Bellevue, WA 98004
(1-800-547-4000 Dept. 819)

The manufacturer's quoted price is \$495, but the software was purchased for \$349 from:

COMPUTER RESOURCES COMPANY
1437 Gordon Street
P. O. Box 1770
Allentown, PA 18102
(215-776-2100)

7. Summary

Data collection on the manufacture of welding cable at the sponsoring yard is virtually complete, and that on the repairs of welding cable is almost complete. Data collection on production downtime due to defective cable is ongoing. These data will permit an analysis of economic feasibility. It is expected that this analysis will be completed by the next SP-10 meeting. Also, the tasks mentioned above will be either completed or near completion by then.

MARVIN H. AGEE

CONTRAVES CORP. PRESENTATION - BERNIE MILLER

Mr. Miller briefed the panel about his company, which specializes in the motion simulation business; they build very high accuracy test equipment for testing inertia guidance systems.

"Hardware-in-the-loop" is a technique that has been used to improve the whole development cycle in testing either missile or airplane. It has the capability of simulating either the air dynamics of an air frame or a missile scenario including the whole guidance tracking lock on and destroy scenarios. In the hardware-in-the-loop facility, the first step is to simulate all of the various components. As you begin to actually design and develop the individual devices, you then substitute the real device back in the system for verification of the test performance. As the system evolves, you'll soon have the entire real hardware in the system and you can then simulate the mission or the aerodynamics or interference. This whole operation is called hardware-in-the-loop.

The facility is actually for testing missiles. In order to actually check the tracking of the missile, it is necessary to have a target simulator. The target simulator can represent the infrared from the airplane or whatever pattern it can emit in a particular area in a particular volume. As the mission scenario is played out, the target is moved to the range and the simulator attracts the missile and what they do is test how accurately the missile tracks the target.

In order to do this, they needed a large working volume and a very accurate robot; that was why they selected and modified the CM-T3 robot.

In order to provide the kind of missile accuracy they needed, they were not able to live with the normal kind of tolerances that are specified by standard industrial robot such as the Cincinnati Milacron. Second major requirement was that they should be able to program this off-line because the entire mission scenario is simulated by an overall computer. So the two requirements are--they have to be able to simulate the entire mission of off-line and they have to be able to move the robot very accurately within free space.

The procedure selected was to remove the transducers that give the angular orientation of each joint and also to instrument each of the actuators to provide true differential pressure signals across each of the actuators. They took the Cincinnati control and literally put it off to the side and built a brand-new control. They now have the ability to command the robot to particular point in space in accurate precision in order of ± 5000 in and are able to say that it is the position in the true absolute sense. They can also control the robot through a mission scenario with very little change due to changes in the external loading on the robot. In other words, the control is truly not only absolute and accurate but also has a lot of dynamic capability *in* this range. It also uses a control which is based on an "Intel" system which has a fairly standard language which enabled them to program this entirely off-line.

Mr. Miller said that they have just finished testing the system but not sure what the commercial implications are of what they have done. His reason for attending the meeting was to essentially explore to what utility they can put both the control system and the fact that they can modify a hydraulic T3 robot to enhance its performance substantially.

He commented that the limitations on off-line programming and down loading from a CAD data base has always been the accuracy and the positioning repeatability of the robot. The CAD system is getting much better; people are putting more and more of their drawing information in CAD bases and it is only a matter of time until robot manufacturers are going to be forced to increase their performance based on the demand of industry. He said that he thinks that the robot manufacturers, in some respect, have been able to sell their standard robot over the years to people who have been fairly forgiving about their shortcoming but he thinks that the users now are getting more sophisticated and he really believed that this is going to put more and more pressure on this whole field of off-line programming and the enhanced accuracy of robots. He was not sure whether it will be in a year or in five years, but it will come because it will offer tremendous cost savings to people who use robot.

Mr. Miller said that there is one other aspect of off-line programming that appeals to him. In order to program the CM-T3 robot by the standard means, it is necessary for the operator to lead it through point-by-point and in many cases

gethis head within inches of the end of the robot. Unfortunately, engineers are the biggest offenders of all the safety rules and he thinks that they have been fortunate that very few people have gotten hurt by this. Therefore, one of the aims, again, is to try to get programming to the point where it can be entirely from a terminal or from data base from a large computer and eliminate the need for the operator to be exposed within the operating envelope of the robot.

* * *

APPENDIX E

Minutes
of
SPC Panel SP-10 Meeting No. 4

held at
Menlo Park, CA
on July 17-18, 1984

with
Enclosure 2 only
(Enclosures 1, 3, and 4 not available)



the Society of Naval Architects and Marine Engineers

ONE WORLD TRADE CENTER, SUITE 1369 NEW YORK, N. Y. 10048 • 212 432-0310

COMMITTEE CORRESPONDENCE

August 8, 1984

FROM : Chairman, SNAME/SPC Panel SP-10
TO : All Members, SNAME/SPC Panel SP-10
SUBJECT : MINUTES OF MEETING NO. 4, JULY 17-18, 1984,
SRI INTERNATIONAL, MENLO PARK, CALIFORNIA

Attached are minutes and enclosures of the previous meeting held at SRI International, July 17-18, 1984. I am also forwarding some reading materials that might be of interest to you.

please note that Enclosure 1 is not attached as this handout was distributed to all the members present.

J. B. ACTON
Chairman
SNAME/SPC Panel SP-10

JBA:els

Attachments

SNAME/SPC PANEL SP-10 FLEXIBLE AUTOMATION
Minutes of the Meeting 4
SRI International, Menlo Park, California
July 17-18, 1984

PRESIDING : J. B. Acton, Chairman, SP-10
Todd Pacific Shipyards Corporation

ATTENDEES : Marvin Agee Virginia Polytechnic
James Cameron General Dynamics-EB
Andrew Dallas - University of Michigan
Jon Fallick NavSea
Thomas R. Galie - NAVSSES
Nick Haynes Bethlehem Steel Co.
Fred C. Henson Mare Island Shipyard
Robert L. Jenkins - DTNSRDC
Marilyn Jones Virginia Polytechnic
James F. Justice - Science Applic., Inc.
Jan Kremers SRI International
Bernard Miller Contraves-Goerz Corp.
James L. Nevins - Charles Stark Draper Labs
David Nitzan SRI International
William Oakes NASSCO
Robert W. Schaffran - Maritime Administration
John Sizemore Ingalls Shipbuilding
Roy Wells NavSea

ABSENTEES : Dave Blais Bath Iron Works
Howard Berger Robotix Corp.
Dale Cheatham Lockheed Shipbldg.
William French Avondale Shipyards, Inc.
Arthur Gutenberg University of California
Lawrence Holliday Newport News Shipbuilding
Ronald Kelly General Dynamics
John McEachran RI/ SME
James Rivas Long Beach Naval Shipyard
Paul V. Williams Tacoma Boat

OPENING REMARKS

The meeting was called to order at 8:45 a.m. by the Panel Chairman, J. B. Acton. Mr. David Nitzan of SRI International welcomed the panel to his facilities and gratefully outlined the tour planned for the second day. Mr. Acton, in turn, thanked Mr. Nitzan for hosting the meeting.

SP-10 Minutes 4

July 17-18, 1984

Page Two

The Panel Chairman announced to the panel that Mr. E. J. Petersen was stepping aside as Chairman of the Ship Production Committee due to his new assignment at Todd and the new Chairman will be Mr. Jess Brasher of Ingalls Shipbuilding Division. He also informed the panel that the Ship Production Committee Directory has been completely revised, is ready for printing, and will be distributed in the near future.

The Panel Chairman reported that the Industrial Modernization Incentive Program has made significant progress into the shipbuilding industry with a Memorandum Agreement now being executed between Newport News Shipbuilding and the Navy.

APPROVAL OF THE MINUTES OF THE PREVIOUS MEETING

The minutes of the meeting of March 20-21 were revised and approved with the following corrections:

- 1) Mr. Tom Galie of NAVSSES was not in attendance.

PANEL PROJECT REPORTS

- 1) Flexible Automated System for Welding Cable Manufacture/Repair - by Bethlehem Steel, Sparrows Point and Virginia Polytechnic Institute

The report was given by Dr. Marvin Agee and is included as Enclosure 1. A by-product of this project was the development of a robot selection program using an IBM Personal Computer. A demonstration of this program was

given to the panel with several shipyards requesting the disks for the program. It was determined that the program write-up and the disks will be distributed to all panel members upon request and through the SP-9 panel library with a charge covering the cost of reproducing the disk for all others.

2) Plan for Implementation of Flexible Automation In U. S. Shipyards - J. B. Acton, Todd Pac. Shipyards Corp.

The Panel Chairman read the C. S. Draper Laboratories proposal to assist the panel in developing the Plan. The provisions of the proposal and controls to be exercised by the panel were discussed at length. It was the consensus of the panel that reports should be made to the panel at each meeting and that the proposal be modified to include audit points at which the panel can make go/no go decisions on continuing the project. The panel then voted unanimously to accept the CSDL proposal with the previously stated modifications. It was also decided to delay execution of a contract until FY 84 funds are received so that the project could be funded as a single vice two-phased project.

NOTE: A copy of the revised proposal is included with these minutes as Enclosure 2.

SP-10 Minutes 4

July 17-18, 1984

Page Four

PANEL RELATED PROJECT REPORTS

1) Laser Line Heating

This is a Manufacturing Technology Project being managed by Todd and performed by MIT.

The results of the Series II experiments were discussed; a summary of these results is included as Enclosure 3.

2) Ship Production Journal

Andrew Dallas from the University of Michigan presented the new SNAME Ship Production Journal to the panel and requested papers for future publications.

NAVY PROGRAMS

1) Automated Propeller Optical Measurement System (APOMS)

The "End-of-Contract" demonstration was successfully conducted on April 3, 1984. Attendance was the largest of any ManTec demonstration to date. The manufacturing cell is pictured in Enclosure 4. The next demonstration will be on the project phase for drilling and grinding operations.

2) New Programs - Roy Wells

There are three new Manufacturing Technology programs being conducted under SEA 05; they are:

- a) Flexible Welding System
- b) Welding Seam Tracker
- c) Propeller Shaft/Rudder Handling Equipment

3. Structural Shapes Processing - BIW

In the absence of Dave Blais from BIW, Bob Jenkins of David Taylor Naval Research Development Center reported that there are two years more of effort remaining on this project.

4. Robotic Surface Preparation System

Tom Galie of NAVSSES reported that Ingalls Shipbuilding Division is currently working on a feasibility study; he anticipates a five-year project with a prototype to be developed from available commercial components.

5. Ship Production Committee Involvement in the Navy Manufacturing Technology Program

Tom Galie addressed the key issues of the changes taking place in submission of Manufacturing Technology project proposals by the shipyards. The key issues are:

- a) The need for a method to transfer technology into the shipbuilding industry.

- b) The need for an advisory committee, and
- c) The implementation of projects.

In addressing these key issues, it has been decided that the Ship Production Committee will be the advisory committee and will provide screening of projects and a consensus on the prioritizing of those projects. This will include identifying good project proposals, review of the projects by the panels and the Ship Production Committee, and the monitoring, by the panels, of the progress of the various projects. The mechanisms for implementing these changes are being worked out and formal directions will be forthcoming. In the interim, all projects submitted to date have been reviewed and endorsed by the Chairman of the Ship Production Committee and are being evaluated by the Navy. There have been a number of rough spots and a lot of informal liaison will be required to produce good results for FY '85 final proposals. Proposals that are submitted subsequent to this date should be sent to the Chairman of the Ship Production Committee where they will be held temporarily until the next SPC meeting (September 1984) at which time they will be incorporated into the overall Ship Production Committee plan. It is unlikely that formal submission to the Navy will be made until guidelines have been issued.

FISCAL YEAR '85 PROJECTS

Only four new projects for FY '85 were submitted. Two of these came from Bath Iron Works, one from the University of Michigan, and one from Contraves Corporation. Bernard Miller of Contraves Corporation gave a brief summary of his proposal for off-line programming of welding robots and Andrew Dallas of University of Michigan summarized his proposal for "Investigation Into the Technology and Application of Digital Imaging Processing." In the absence of Dave Blais of Bath Iron Works, their two projects were not discussed. The Panel Chairman proposed that no decision be made at this time and that he would prepare project abstracts and a ballot which would include these projects, plus the residual projects submitted but were not budgeted in FY 84 to be mailed to all members within the next two weeks for return by mid-August.

NOTE: Subsequent to the meeting, Bethlehem Steel Sparrows Point submitted a project abstract for an expanded scope of the Flexible Automated System for Welding Cable Manufacture and Repair that would develop the detail specifications for an automated identification system to track materials in a shipyard from the warehouse to the point of final use; this abstract will be included in the potential FY '85 package.

ADJOURNMENT FOR THE DAY

The meeting adjourned at 5:15 p.m. to be reconvened at 8:30 am on Wednesday, July 18.

SP-10 Minutes 4

July 17-18, 1984

Page Eight

WEDNESDAY, JULY 18

The meeting was reconvened at 8:30 a.m. by the Panel Chairman. At this time, he used a video tape, prepared by NORMED Shipyards, on the Underwater Marine Robot which TPLA is evaluating. This was followed by a presentation by David Nitzan of the work in the field of flexible automation being accomplished by SRI International. This presentation was followed by a tour of the pertinent SRI facilities.

ADJOURNMENT

The meeting was adjourned at 12:00 noon.



J. B. ACTON
Chairman
Panel SP-10

JULY 30, 1984



the Society of Naval Architects and Marine Engineers
SHIP PRODUCTION COMMITTEE
PANEL SP-10 - FLEXIBLE AUTOMATION

A G E N D A

July 17. Tuesday

8:45 - 9:00 a.m.	Opening Remarks
9:00 - 9:15 a.m.	Approval of Minutes of Previous Meeting
9:15 - 10:45 a.m.	Panel Project Reports
10:45 - 11:00 a.m.	BREAK
11:00 - 12:00 noon	Panel Related Project Reports
12:00 - 1:00 p.m.	LUNCH
1:00 - 1:30 p.m.	Update on Navy Programs
1:30 - 3:30 p.m.	FY '85 PROJECTS

JULY 18. Wednesday

8:30 a.m.	Assemble at SRI
9:00 - 12:00 noon	Tour of SRI Facilities
1:00 p.m.	ADJOURNMENT

SNAME/SPC Panel SP-10 Meeting
RI International, Menlo Park, California
July 17-18, 1984

James B. Acton
Manager, R&D, Naval Tech. Div.
TODD PACIFIC SHIPYARDS CORP.
710 Front Street
San Pedro, CA 90733
(213) 832-3361, Ext. 4571

Marvin Agee
VIRGINIA POLYTECHNIC INSTITUTE
290 Whittemore Hall
Blacksburg, VA 24091

James Cameron
Manager, Welding & Mat. Eng.
Electric Boat Division
GENERAL DYNAMICS
Department 341
Eastern Point Road
Groton, CT 06340

Andrew Dallas
Transportation Research Inst.
UNIVERSITY OF MICHIGAN
2901 Baxter Road
Ann Arbor, MI 48109
(313) 763-2465

J. Fallick
Department of the Navy
NAVAL SEA SYSTEMS COMMAND
SEA 05H2
Washington, DC 20362
(202) 692-0143

Tom Galle
Senior Project Manager
Philadelphia Naval Base
NAVSES
Philadelphia PA 19112
(215) 952-7365

Nick Haynes
Marine Construction Division
BETHLEHEM STEEL CO.
Sparrows Point, MD 21219

Fred Henson
P. O. Box 4285
Vallejo, CA 94590

Robert L. Jenkins
Program Director, Automated Mfg.
DAVID TAYLOR NAVAL SHIP R&D CENTER
Code 1853
Bethesda, MD 20084
(202) 227-1363

Marilyn Jones
LEOR Department
VIRGINIA POLYTECHNIC INSTITUTE
Blacksburg, VA 24061
(703) 961-5363

James F. Justice
SCIENCE APPLICATIONS, INC.
604 Sunset Drive
Milford, MI 48042

Jan Kremers
Senior Computer Scientist
SRI INTERNATIONAL
333 Ravenswood Avenue, EJ235
Menlo Park, CA 94025
(415) 859-2337

Bernard Miller
CONTRAVES-GOERZ CORPORATION
610 Epsilon Drive
Pittsburgh, PA 15238
(412) 967-7297

James L. Nevins
CHARLES STARK DRAPER LABS
555 Technology Square
Cambridge, MA 02139
(617) 258-1347

David Nitzan
Director, Robotics Laboratory
SRI INTERNATIONAL
333 Ravenswood Avenue, EJ254
Menlo Park, CA 94025
(415) 859-2575

William Oakes
Senior Industrial Engineer
NATIONAL STEEL & SHIPBLDG. CO.
Harbor Drive & 28th, M/S 11
P. O. Box 89278
San Diego, CA 92138
(619) 696-7806

Robert W. Schaffran
Manager, Shipbldg. Res. Prog.
Office of Adv. Ship. Dev.
Department of the Navy
MARITIME ADMINISTRATION
400-7th st., SW, Room 4100
Washington, DC 20590
(202) 382-0444

John Sizemore
Senior Engineer, Adv. Tech.
INGALLS SHIPBUILDING
P. O. Box 149, MS 1020-08
Pascagoula, MS 39567

Roy Wells
Industrial Specialist
Department of the Navy, SEA 070
NAVAL SEA SYSTEMS COMMAND
Building One, Room 6E06
Washington, DC 20362
(202) 692-3580

A PLAN FOR IMPLEMENTATION OF FLEXIBLE AUTOMATION
IN UNITED STATES SHIPYARDS

I. BACKGROUND

This proposal was written as an outgrowth of a Draper Laboratory representative attending a recent meeting of the Flexible Automation Panel (SP-10) of the Ship Production Committee (SPC). The SPC, as part of the Society of Naval Architects and Marine Engineers (SNAME), is acting on behalf of the U.S. shipbuilding industry, advising the U.S. Maritime Administration and the U.S. Navy, who are cooperating on the development and implementation of a long range plan to modernize U.S. shipyard equipment and methods. At this meeting it became clear that SP-10 needs its own plan for implementation of flexible automation in shipyards. This proposal is for a 16-month, approximately 15 man-months study to aid SP-10 in formulating this plan. Due to the diversity of the participating shipyards (large, small, civilian ships, military ships), the plan will necessarily emphasize methodology to aid shipyards in identifying and prioritizing flexible automation opportunities. Generic opportunities will also be explicitly identified in the final report, along with several case studies and data that illustrate the methodology.

11. STATUS OF SHIPBUILDING TECHNOLOGY AND ITS RELATION TO
FLEXIBLE AUTOMATION

Shipbuilding is one of the oldest arts, and its methods have deep traditions. Ships have evolved from being just hulls, to hulls plus superstructure plus masts plus propulsion plus weapons etc. The materials and technologies in these categories have changed but the categories themselves have remained the same, The final ship is an aggregation -- often confused and crowded -- of these basic entities. Traditional organizational lines in design, fabrication, assembly, test, certification, subcontractors, and even customers' organizations have grown up for each category.

This end-item oriented structure does not favor efficiency in manufacture. In fact, it is only in the last 25 years that ship construction has been looked at anew as a true manufacturing problem. Not surprisingly, it is the Japanese who took this approach, by applying and advancing the mass production techniques developed by Kaiser and other U.S. shipyards during World War II. The way they make ships looks very familiar to anyone who knows about their manufacturing methods in autos, watches, and semiconductors. The latter items are commodities with much similarity between product units and large production volume. Ships are the reverse: little similarity from one unit to the next and low production volume.

Yet the Japanese created efficient shipyards capable of producing a one-of-a-kind tanker ship from keel laying to sea trials in eight months. The key ingredients of the method seem to be:

1. breaking the ship conceptually into finer and finer -- subdivisions, with the finer divisions having less and less identity as members of any particular traditional category or system.
2. identifying groups of parts or subassemblies that require similar processing steps, and making them together using mechanization, bulk processing, single setups, and other economies of scale.
3. determining the accuracy with which each part must be made and suitable assembly sequences? jigs, and fixtures so that assembled units will come out the right size and shape.
4. great attention to detail when planning the above and great volumes of information exchange during its execution.

In sum,

- planning
- grouping

- measuring
- talking
- integrating.

From this point of view, design becomes merely a subset of planning, sequencing, and scheduling. The idea of a ship is restructured, along with the boundaries between items and subassemblies, to suit efficient manufacture. Only after assembly is finished at the module or block level do the original systems emerge. At this point they can be tested. After modules and blocks are built, any systems wholly contained within them can be tested. Only after blocks are connected to make the ship can systems that span several blocks be tested completely. Much interlock assembly (predominantly electric wiring) exists, too, especially in combat ships.

In traditional U.S. shipbuilding, all design and production is controlled on a system basis. Drawings are made, schedules issued, work orders and purchase orders sent, work done, parts installed, shops and work crews organized, all along traditional system lines, In this way, the status of each system can be tracked but at the cost of pure job shop manufacturing methods with all their inefficiencies. Traditional automation has no foothold here, only the opportunity to automate the flow of information or decision support systems.

The Ship Production Committee and the participating shipyards recognize these problems as well as the opportunities that automation could bring. But even given that all the organizational revolutions were in place, one must recognize that automation will be limited in its effectiveness unless it is understood and carefully applied.

Automation takes many forms and has several distinguishing characteristics. True mass production can be accomplished only on millions of identical, usually small parts or items per year. By contrast, ships' parts are few, large, and different in enough details that customary fixed automation is inappropriate.

The above discussion makes it clear that modern shipbuilding is data-driven, with the data comprising part shapes, size tolerances, process control parameters, and assembly or test instructions.

Modern flexible automation is also data-driven, comprising well understood processes and careful control structures for managing those processes. Only processes having these properties can be automated with the confidence that the output will be reproducible enough to meet the accuracy requirements.

Flexible automation means more than a single robot here or there, however. That is a piecemeal approach that gradually mechanizes parts of a traditionally organized shop without

changing the basic way work is done. It is unlikely to be economically attractive because too much of the old inefficient methods, part definitions, and small order quantities survive.

Instead, effective flexible automation requires combination of related process steps (such as cut, clean, bevel, mark) into integrated systems. In traditional manufacture, the Japanese have shown that to do this requires fundamental product redesign. New part shapes, boundaries, fastening methods, inventory controls, vendor relations and so on are forced into being as a result. This describes their approach to shipbuilding as well.

Thus the true ingredients of flexible automation are reproducible processes integrated into systems to operate on redesigned products.

The combined necessary elements are:

Organization

Automation

planning

process specifications

grouping

reconfigurable machine system design

measuring

instrumentation and control

talking

data flow and decision support systems

integrating

To make flexible automation work in modern ship-building (see Figure 1) requires carefully planning the ship's design and construction so that meaningful quantities of appropriate work are created for properly configured flexible automation systems. The plans must include data and process specifications in numerical form for transfer to the systems. If planning techniques do not exist to allow a ship to be disaggregated effectively? then they must be created. If processes are not well enough understood to allow process specifications to be written, then R&D is needed to bring those processes under control. If applicable, controllable, and reproducible process equipment does not exist, then it must be designed, economically justified, and tested.

III. PHASED APPROACH STRATEGY

The SPC hopes to spur modernization of U.S. shipyards over a five year period. It is clear that the best use of flexible automation will come after completion of new planning systems that release properly configured group technology work orders. Until that time, flexible automation can and should be introduced in stages. Such staged implementations should thoroughly test either the suitability of the technology or the potential of the application area.

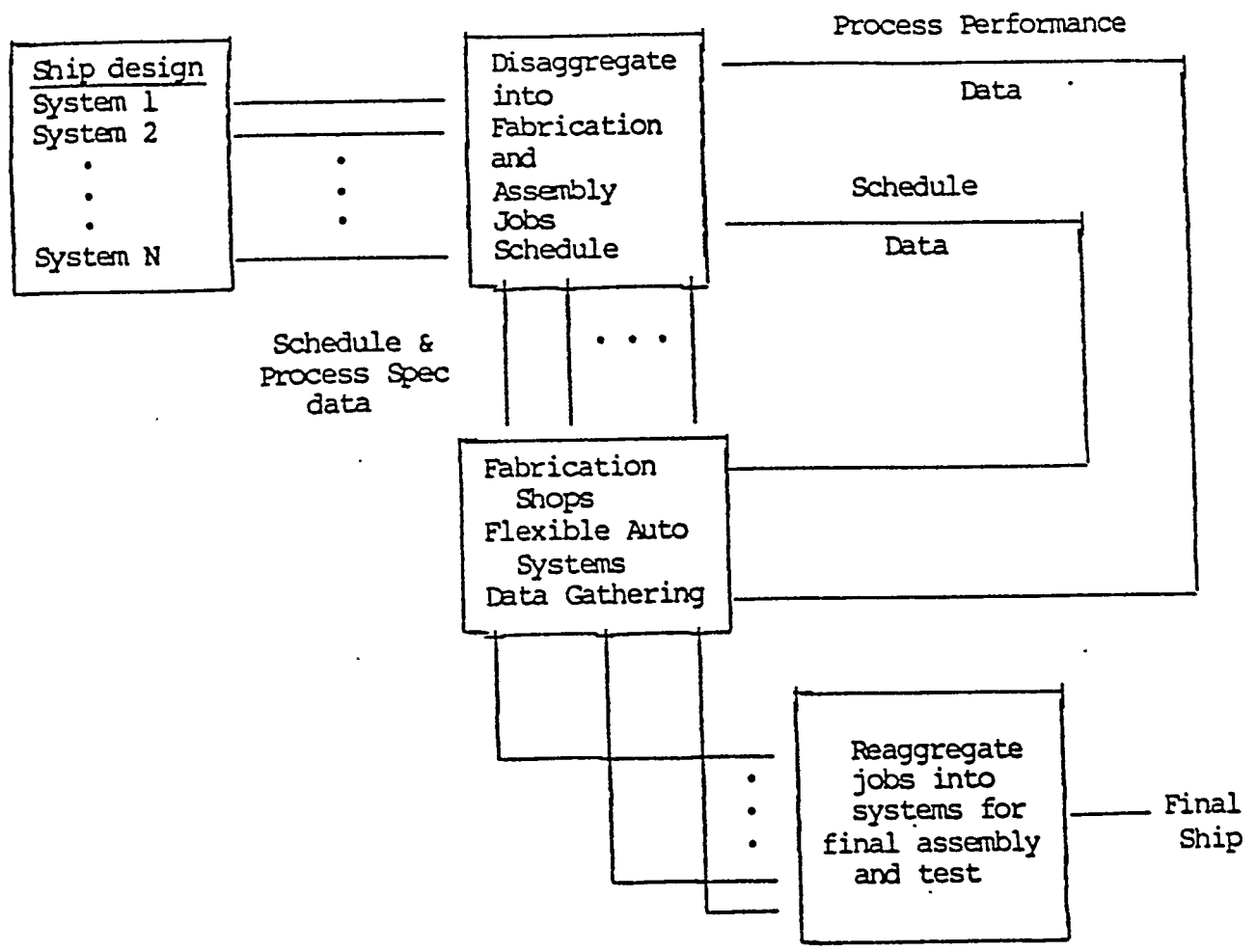

Figure 1
Schematic of Data-Driven Ship Construction

If a yard makes no attempt to redo its planning methods and organization, then little can be done except to automate a few isolated operations or increase the efficiency of information flow. The overall yard efficiency can be raised a little with better scheduling of facility use. At the other extreme might be a yard that is fortunate enough to make relatively simple or uniform shape vessels like tankers *or* bulk cargo carriers. For these ships the disaggregation requires less intellectual effort. Technologically they are simpler as well. Here it will be sufficient to break the job out into generic pieces of plate or vent duct and to determine the design specifications for ambitious machines to make or assemble them.

In between are yards with military shipbuilding jobs. These ships are less uniform from bow to stern, contain special materials, odd shape compartments, and many complex systems. Here the intellectual effort to create efficient plans will be great. Again, it will be relatively easy to find individual islands to automate but it may be more difficult to create large integrated flexible systems. The constraints of the product may be too specific.

An important output of this study must therefore be to assess the limits of applicability of flexible automation to each of these different situations and to show how each yard can grow into fuller use of flexible automation. For example, a single robot station probably will work on small workplaces. Starting

out this way means learning gradually how to deal with large workplaces. Doing so will undoubtedly lead two ways: either systems of robots or, more likely, totally different types of flexible machines specifically designed to suit properly planned large scale work. Thus job design, part design, and automation system design can all be expected to evolve and influence each other.

The proper design of flexible automation systems and the appropriate design of suitable products is a topic familiar to the Charles Stark Draper Laboratory. In the next section this method is briefly described.

IV. DRAPER LABORATORY APPROACH TO AUTOMATION OPPORTUNITIES

Draper Laboratory has engaged in automation opportunity assessments for over a dozen industrial firms in the last several years. The topic is usually flexible assembly but can extend into processes like cutting, welding, grinding and measuring. The approach has these main parts.

- assessment of the customer's objectives
- analysis of the product, both function and assembly issues
- product redesign recommendations to reduce part count, create useful subassemblies, improve quality, or speed production flow

- 1 automation system configuration synthesis, plus economic analysis of feasible alternatives
- 1 key experiments to test recommendations or resolve difficult issues
- 1 detailed system design, implementation and evaluation (currently we are building our third system)

In some cases a customer will ask us to focus on a particular product. More frequently, we will be asked to focus on a factory or product line and pick a likely candidate product for detailed study. Actually, the shipyard automation question is like the second situation because it involves identifying automation candidates among a field of manual processes. A step by step elimination procedure narrows the search to products with limited access directions, well defined size and style variations, and opportunity to benefit from careful process control. The needed improvements in product design, assembly methods, and process definition are identified, and candidate solutions are evaluated technically and economically. Concept designs are created for the most promising ones.

Attached to this proposal, are two Appendices which go into detail on this procedure. Appendix I is a paper titled "Applying Robots in Industrial Assembly," which describes the approach and *lists the* computer tools developed for such work. Appendix II is titled "Phase I: Methods and Initial Questionnaire," which is given to each new customer in preparation for our first intensive

plant visit. The questions show that our method extends well beyond the local details of assembling the product, probing into the global issues of product marketing plans and factory institutional constraints.

The next Section shows how this approach will be applied in shipyards.

v, PROGRAM PLAN AND DELIVERABLES

The objective of this project is to create a plan with the SPC, SP-10, and the participating shipyards to help identify and prioritize research and development needs for flexible automation in shipbuilding. Draper will approach this as it has the previous projects it has undertaken in this area (see the Appendices). That is, the work will be job, product, or process driven. It will not consist of our seeking applications for any particular technology, such as currently available robots.

There are several constraints on a study of this type. They are the diversity of work at different yards and the different degree of modernization, i.e., the degree to which Japanese or similar methods have been adopted. Also, the study has limited resources. These constraints mean that a major study output must be the transfer of the methodology itself to the participating yards so they can carry it on themselves in more detail, focussed

on their type of work. No one set of recommendations will serve all yards.

Second, the study cannot assume that yards will wait until they have completely modernized their methods before trying flexible automation, even though the best opportunities for flexible automation will occur only after modernization. At intermediate stages, the yards can use limited flexible automation projects to learn new technology and, more important, to learn the impact and potential benefits that technology brings to the modern organization itself.

The method Draper proposes to follow is:

1. Travel to visit several yards, followed later by selection of two or three for more detailed study.
2. Tutorial lectures to us by the resident Japanese and yard personnel at host yards to explain the reorganization going on, plus its status at each yard.
3. Case studies of selected areas at two or three yards, such as measuring or fabrication methods, stock handling, particular items like masts and antennas, sheet metal fabrication; pipe or cable joining, or information handling problems like data base design or group technology selection methods.

4. To support each study, Draper will ask each yard to designate a prime contact person. One of this person's most important services will be to provide Draper with economic and technical data that show statistical distributions of job types, plate sizes, weld lengths, pipe diameters, and so on, so that the potential for grouping jobs and the variation between jobs can be assessed.

5. Consultants may be utilized by Draper to fill in some areas of expertise. These include welding and ship design faculty from the MIT Ocean Engineering Department as well as project management faculty from the MIT Sloan School of Management. Additional consulting may be sought from engineering firms such as Stone and Webster who have experience running large construction projects.

6. project progress will be reported to SP-10 at regular panel meetings, or about 4-month intervals. At the 8-month point, there will be a written report and SP-10 will make a go/no go decision on continuing the project. There will be a final written report and a presentation of the results. The report will contain a prioritized list of action areas if data can be mustered to support firm recommendations. If such data can not be obtained, projects will be recommended that have data and insight as prime outputs. Recommendations will also be made as to what analysis and computer tools should be developed, a) to help identify further opportunities, and b) to alter design methods so as to foster opportunities.

APPENDIX F

**Minutes
of
SPC Panel SP-10 Meeting No. 5**

**held at
Anaheim, CA
on November 27, 1984**

**with
Attachments**



the Society of Naval Architects and Marine Engineers

ONE WORLD TRADE CENTER, SUITE 1369, NEW YORK, N. Y. 10048 • 212 432- 0310

COMMITTEE CORRESPONDENCE

December 19, 1984

FROM : Chairman, Panel SP-10-Flexible Automation
TO : All Members SP-10-Flexible Automation
SUBJECT: MINUTES OF THE MEETING NO.5, NOVEMBER 27, 1984

Attached are the minutes and pass-outs of the subject meeting held at the Anaheim Hilton Hotel, Anaheim, California. Your attention is particularly invited to Section 111.3 and the attached project abstracts. You will note significant changes in the off-line programming of welding robots. For those representative: submitting the abstracts accepted for FY 85, I again remind you of the July meeting deadline for detail proposals.

ROBOTS WEST which was held the three days following the meeting, was a success by anyone's measure. The target was for 300 attendees--over 350 registered for the conference sessions. The combined exhibits drew over 16,000 people. Since this was the first regional robot conference by SME, those of us in the planning and advisory committee were extremely pleased with our success. Next year, the regional conference will be ROBOTS EAST and I wouldn't be surprised if some of you were requested by the Society to participate. If so, I urge you to accept as it is an exciting challenge and one from which you end up learning and receiving more than you give.

As you will note from the attendance listing, a significant number of members were absent from this meeting and several have missed a number of consecutive meetings. I can't emphasize too strongly the need for panel members to attend the meetings. You are the governing board for panel activities, representing both the technical expertise and the areas of interest for the shipbuilding industry. Therefore, your first-hand knowledge, input, and participation in the discussions and decision-making at the meetings are vital in assuring a well-run organization that can provide significant benefits to the shipbuilding

F-1

and ship repair industry. As a manager in my own organization, as well as panel chairman, I fully realize the heavy demands upon your time in your own organization; I also understand the need for austerity at this time. In fact, those are precisely the reasons that the National Shipbuilding Research Program has been created and the panels exist--to improve productivity in the shipyards. All of you are members of the panel because your management has opted to participate in the program and have appointed you to represent them in the best interest of your company. You can accomplish this only by full participation in panel activities. If, after all alternatives--including the designation of an alternate--have been exhausted and you still are experiencing difficulties in obtaining travel budget, etc., please let me know and I will bring it to the attention of the Chairman of the Ship Production Committee, your Ship Production Committee representative, and if necessary appropriate members of your management. The simple fact is, I need you to help make this panel a success.

NEXT MEETING: Draper Labs has generously offered to host our next meeting at their facility in Cambridge, Massachusetts and to provide us an extensive tour of their laboratories. The meeting will be held March 20-21, 1985; further details will be forthcoming prior to 1 February.

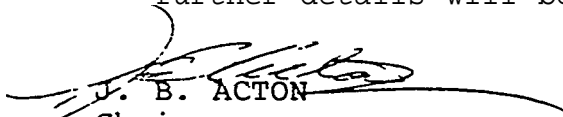
J. B. ACTON
Chairman
Panel SP-10
Flexible Automation

JBA:els
Attachments

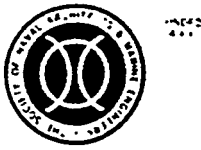

the Society of Naval Architects and Marine Engineers

ONE WORLD TRADE CENTER, SUITE 1369, NEW YORK, N. Y. 10048 · 212 432-0310

COMMITTEE CORRESPONDENCE

SNAME/SPC PANEL SP-10 FLEXIBLE AUTOMATION
Minutes of the Meeting 5
Carmel Room, Anaheim Hilton, Anaheim California

PRESIDING : J. B. Acton, Chairman, SP-10
Todd Pacific Shipyards Corporation

ATTENDEES : M. Agee Virginia Polytechnic
H. Berger Robotix Corp.
N. V. Haynes Bethlehem Steel
R. Kelly Gen.Dynamics/DSD
J. Nevins CSDL
W. Oakes NASSCO
J. Rivas LBNSY
J. R. Visage Mare Is.Nav.Shipyard

ABSENTEES : D. Blais Bath Iron Works
J. Cameron General Dynamics-EB
D. Cheatham Lockheed Shipbuilding
A. Dallas Univ. of Michigan
J. Fallick NavSea
W. French Avondale Shipyards, Inc.
T. R. Galie NAVSSES
A. Gutenberg University of California
F. Henson Mare Island Shipyard
L. Holliday Newport News Shipbldg.
R. Jenkins DTNSRDC
J. McEachran RI/SME
R. Schaffran MarAd
J. Sizemore Ingalls Shipbuilding
R. Wells NavSea
P. V. Williams - Tacoma Boat

-1-

F-3



SNAME/SPC PANEL SP-10-FLEXIBLE AUTOMATION
Carmel Room, Anaheim Hilton, Anaheim, California

TUESDAY, NOVEMBER 27, 1984

- | | |
|-------------------------|---|
| 9:00 a.m. - 9:15 a.m. | OPENING REMARKS
-J. B. Acton |
| 9:15 a.m. - 9:30 a.m. | APPROVAL OF MINUTES OF PREVIOUS MEETING
(1st page - Change Automatrix to Robotix) |
| | PANEL PROJECT REPORTS |
| 9:30 a.m. - 10:00 a.m. | a. Robotic Welding Cable Mfg.
Inspection and Repair
- M. H. Agee |
| 10:00 a.m. - 10:30 a.m. | b. Plan for Implementing Flex. Auto.
in the Shipbuilding Industry
- J. B. Acton |
| 10:30 a.m. - 11:00 a.m. | COFFEE BREAK |
| | PANEL RELATED PROJECT REPORTS |
| 11:00 a.m. - 11:30 a.m. | a. Laser Line Heating
- J. B. Acton |
| 11:30 a.m. - 12:00 noon | b. Ship Production Journal
- J. B. Acton |
| 12:00 noon - 1:00 p.m. | LUNCH BREAK |
| 1:00 p.m. - 2:00 p.m. | FY '85 PROJECTS |
| | OTHER MATTERS |
| 2:00 p.m. - 3:00 p.m. | a. Call for Papers |
| 3:00 p.m. - 4:00 p.m. | b. Long-Range Productivity
Improvement Plan |
| 3:30 p.m. - 4:00 p.m. | c. SP-10 Panel Charter |
| 4:00 p.m. - | ADJOURNMENT |

OPENING REMARKS :

The meeting was called to order at 9:00 a.m. by the Panel Chairman, J. B. Acton. After welcoming the attending members to the meeting and to the ROBOTS WEST conference, he made the- following announcements.

1. Due to conflicting schedules of the Manufacturing Technology Advisory Group meeting and this panel meeting, the NavSea and other Washington Navy representatives were unable to attend;
2. The purpose of this meeting is to review the status of ongoing projects and to inform the panel of the FY 85 program plans;
3. The Panel Chairman provided passes to the ROBOTS WEST EXPOSITION for all panel members who had not registered as conference attendees;
4. The next meeting of the panel is tentatively scheduled to be held at Draper Labs/MIT in March 1985--this will be confirmed by January 1985.

APPROVAL OF THE MINUTES OF THE PREVIOUS MEETING

The minutes of the meeting of July 17, 1984, with corrected page 1, were approved.

PANEL PROJECT REPORTS

1. Flexible Automated System for Welding Cable Manufacture/
Repair--by Bethlehem Steel, Sparrows Point and Virginia
Polytechnic Institute.

Nick Haynes reported that the project is almost complete with the final report due to be submitted in December. The final report will consist of 4 volumes as follows:

Volume I

- o Questionnaires
- o Cable Connectors
- o Economic Analysis
- o Management Practices
- o Methods Engineering

Volume II

- o Robot Selection Model
- o Software

Volume III

- o Fault Detection Study

Volume IV

- o Electrical Cable Study

Marvin Agee then gave an abbreviated report on the project for the benefit of members who had not heard or seen the detailed report made for the July meeting.

Copies of all four volumes of the report, including the floppy disks for the robot selection model, will be automatically distributed to all panel members. Additional copies can be obtained from the SP-9 panel at the University of Michigan for a nominal charge; this service is described in more detail below.

Following the report, discussion was conducted concerning competing commercial systems, benefits anticipated from the report, the reasons for selecting the R-Base 4000 and type of decision model for the robot selection program.

2. Plan for Implementing Flexible Automation in the Shipbuilding Industry - C. S. Draper Labs Laboratories

The Panel Chairman reported that the justification for awarding this project to C. S. Draper Laboratories has been submitted to the Maritime Administration with early approval anticipated. All efforts will be made to have

a contract to C. S. Draper Laboratories by early January 1985.

Jim Nevins provided a discussion of the approach C. S. Draper Laboratories plans to take and conducting this project for the benefit of members unfamiliar with the background. Details of this approach can be found in the minutes of the July meeting.

The Panel Chairman emphasized to the panel that the results of this project will form the basis for the panel's long-range plan, therefore active participation by panel members during the study phase of the project is highly encouraged.

PANEL RELATED PROJECT REPORTS

1. Laser Line Heating

The Panel Chairman, as Project Manager for this project, reported that Series III experiments have been conducted, but that the subsequent analysis have not been completed. As a result of the availability schedule of the Naval Research Laboratory laser, which delayed the conduct of the Series III experiments, the overall project has been extended with

the final report of Phase I being due by 1 March 1985. A detailed report on the project is planned for the panel at the March meeting.

2. SNAME Journal of Ship Production

Chairman Acton, a member of the editorial board of this new publication, reported that the first issue will be in February 1985. Distribution of the first issue will be automatic to all SNAME members; further issues will be by subscription at the same rates as the Journal of Ship Research. The initial articles for the Journal will be drawn from the papers presented at the last IREAPS conference held in Boston in August of 1983. Future articles will initially be drawn from the papers being presented at the Annual National Shipbuilding Research Program Symposium and papers submitted by readers--both domestic and foreign. All articles will be screened by the editorial board and will be limited to those dealing with ship production and productivity as opposed to ship design and other more exotic research.

The Panel Chairman urged all members of the panel to become members of SNAME, as that is the parent organization for the National Shipbuilding Research Program (and the panels)

and provides a forum for broadening our experience base.

3. Microfiche Library

The Panel Chairman reported that Prof. Howard Bunch, Chairman of Panel SP-9, Education and Training, had announced the completion of the microfiche library containing all previously-published NSRP reports. A catalogue of these available reports has been distributed to all shipyards; and they are available for a nominal charge. Future project reports will be microfiched as soon as they are published and, in fact, initial distribution of all reports will include copies to Panel SP-9 for this purpose. It is to be noted that this is the first time that a single repository of copies of all project reports has existed.

FY 85 PROJECTS

1. The panel ranking of the six potential projects for FY '85 are listed below (weighting--1=6 pts., 2=5 pts . . .6=1 pt.)

<u>Project Title</u>	<u>Points</u>
Plate Marking/CNC Burning Mach.Ph.II	45
Off-Line Programming-Welding Robot-Ph.I	37
Families of Parts Robot Welding Cell,Ph.I	31
Automated Identification System for Tracking Materials	30
Robotic Welding Cell	13
Digital Image Proc.Cell	8

The Panel Chairman expressed his appreciation for the responses by the panel--particularly those members who submitted comments in addition to the ranking of the projects.

2. Because of the known limitations of the FY 85 available budget, the following projects were submitted for the SP-10 program:

<u>Title</u>	<u>\$(000)</u>
o Marking of Plates, Ph. II	\$190
o Families of Parts Robotic Welding Cell, Ph. I	85
o Off-Line Programming of Welding Robots, Ph. I	50
o Program Management	\$100
TOTAL	\$525

At the Program Managers' meeting, September 21, an analysis of various projects from all the panels was made and it was determined that Marking of Plates, Ph. II, should be submitted as a Manufacturing Technology Project rather than a National Shipbuilding Research Program Project. The Panel Chairman agreed to this change with the stipulation that the panel be funded for a substitute unnamed project (or projects) totalling \$90,000 and leaving a total submitted program for FY 85 of \$325,000. This was subsequently approved by the Ship Production Committee on September 25. John Sizemore was notified of this decision and indicated that he would be submitting a Manufacturing Technology project proposal for Ph. II of the Plate Marking Project.

3. Copies of the abstracts of the 3 projects submitted are attached to these minutes. Shipyards submitting the project abstracts are requested to have detailed proposals with the optional form 60 (Cost Proposal) prepared for submission not later than the July meeting.

OTHER MATTERS

1. Call for Papers for NSRP Annual Symposium September 9-12, 1985. The attention of the panel was directed to the Call for Papers which had previously been mailed to all panel members, with the request that each member consider the advantages of presenting a paper at this Symposium.
2. The Panel Chairman announced that the NSRP Long-Range Productivity Improvement Plan has been completed and is in the process of being sent to all shipyards. As noted earlier, the Long-Range Plan for this panel will not be truly reflective of industry need until the completion of the project for implementing flexible automation is complete.
3. The Panel Chairman distributed the copies of the charter as it was established at the first panel meeting. (A COPY

is attached to these minutes for information of those members who were absent) . The reason for publishing the charter is a requirement by SNAME to comply with anti-trust guidelines which they have established for all technical committees and panels. A copy Of these guidelines will be made available to any panel member upon request.

OPEN FORUM

1. Bill Oakes described a panel SP-1 project on Group Technology for which he is Project Manager at NASSCO. He requested any inputs/assistance from panel members to enable him to better reflect an industry position in preparing his final report on this project.

NOTE : Please direct any inquiries you may have regarding this project directly to Bill Oakes at NASSCO.

2. The Panel Chairman reported to the panel on the progress being made by NAVSEA to incorporate the Ship production Committee and panels into the Manufacturing Technology program for shipbuilding. In summary, a draft plan has been made and presented to the Ship Production Committee--as well as selected individual within NAVSEA--and some of

the details are being worked out. Essentially, this would bring all projects, regardless of funding source, into the same group for prioritizing and committing. Among the adjustments that must be considered will be the change in ManTech funding to include participative contracts similar to current NSRP contracts. This would eliminate any competition for funding source and would extend the financing capability to a larger number of projects. Target amounts being considered for Government funding of the combined programs will exceed \$15 million a year in the near-term as opposed to approximately \$4 million today. The panel will be kept advised as to the progress of these types of changes in programs.

ADJOURNMENT

There being no further business, the meeting was adjourned at 5:30 p.m.

Respectfully submitted,



J. B. ACTON
Panel Chairman/
Program Manager
SNAME/SPC Panel
SP-10

SNAME/SPC PANEL SP-10 FLEXIBLE AUTOMATION
Minutes of the Meeting 4
SRI International Menlo park, California
Y 17-18, 1984

PRESIDING : J. B. Acton, Chairman, SP-10
Todd Pacific Shipyards Corporation

ATTENDEES : Marvin Agee Virginia Polytechnic
James Cameron General Dynamics-EB
Andrew Dallas University of Michigan
Jon Fallick NavSea
Thomas R. Galie - NAVSSES
Nick Haynes Bethlehem Steel Co.
Fred C. Henson Mare Island Shipyard
Robert L. Jenkins - DTNSRDC
Marilyn Jones Virginia Polytechnic
James F. Justice - Science Applic. , Inc.
Jan Kremers SRI International
Bernard Miller Contraves-Goerz Corp.
James L. Nevins - Charles Stark Draper Labs.
David Nitzan SRI International
William Oakes NASSCO
Robert W. Schaffran - Maritime Administration
John Sizemore Ingalls Shipbuilding
Roy Wells NavSea

ABSENTEES : Dave Blais Bath Iron Works
Howard Berger ~~Robotix Corp.~~
Dale Cheatham ~~Lockheed Shipbldg.~~
William French Avondale Shipyards, Inc.
Arthur Gutenberg - University of California
Lawrence Holliday - Newport News Shipbuilding
Ronald Kelly General Dynamics
John McEachran RI/SME
James Rivas Long Beach Naval Shipyard
Paul V. Williams - Tacoma Boat

OPENING REMARKS

The meeting was called to order at 8:45 a.m. by the Panel Chairman, J. B. Acton. Mr. David Nitzan of SRI International welcomed the panel to his facilities and gratefully outlined the tour planned for the second day. Mr. Acton, in turn, thanked Mr. Nitzan for hosting the meeting.

NATIONAL SHIPBUILDING RESEARCH PROGRAM

STATUS REPORT

Program Title : Flexible Automation
Contract Number : DTMA 91-83-C-30028
Lead Yard : Todd Pacific Shipyards Corp., L.A. Division
Period Covered : 07/15/84-11/30/84
Work Accomplished
(by project) :

FY 83 PROJECTS

1. Manufacture, Inspection & Repair of Welding Cable Using Flexible Automation
Bethlehem Steel Corp., Sparrows Point Yard

Work combined on all four volumes of the final report. Completion is anticipated by mid December, 1984. Projected expenditures indicates that a residual of 30-35% of committed funds will remain at project completion. This is due to the determination that the original objectives of the project would not be cost-effective thus resulting in a final report consisting of four volumes of study data that can be of help to the shipyards.

2. Plan for Implementing Flexible Automation in the Shipbuilding Industry
- Charles S. Draper Laboratories (Proposed)

Final proposed work statement was accepted by the panel; it included the restriction that the project could not be performed in two phases thus requiring the receipt of FY 84 funds before proceeding with subcontract award. Upon receipt of those funds 10/84, the proposal and contractor justification data was forwarded to MARAD for approval. Approval and subcontract award is anticipated in early January 1985.

FY 84 PROJECTS

1. Marking Plate Cut by CNC Burning Machines, Phase I
- Ingalls Shipbuilding Division of Litton Industries, Inc.
(Proposed)

Currently awaiting detailed Work Statement and Cost Proposal from Ingalls. Anticipated start date is 02/01/85.

2. Plan for Implementing Flexible Automation, etc.
(See write-up under FY 83 projects)

3. Potential New Projects

Upon formal completion of FY 83 project no. 1, approximately \$110,000 will be available for additional projects. Selection should be made at the panel meeting in March 1985.

Project Status: See attached milestone charts (by FY)

Funding Status:

FY 83 Funds Authorized	\$560,000
FY 83 Funds Committed	399,347
FY 84 Funds Authorized	340,000
FY 84 Funds Committed	-0

CHARTER
SNAME / SPC Sp-10
FLEXIBLE AUTOMATION

1. AUTHORIZATION

Creation of this panel as part of the National Shipbuilding Research Program (NSRP) was approved by the Ship production Committee of the Society of Naval Architects and Marine Engineers (SNAME) June 23, 1982. Todd Pacific Shipyards Corporation, Los Angeles Division, was awarded sponsorships of the panel by the U. S. Maritime Administration (MARAD) in August 1983.

II. RESPONSIBILITY

- A. Develop the plan for transferring existing and developing/applying new Flexible Automation technology;
- B. Establish a consensus priority list of high cost driver areas for target applications of this technology;
- C. Solicit and review proposed research projects which address problem areas;
- D. Coordinate the efforts of other SNAME panels proposing Flexible Automation applications;
- E. Maintain an up-to-date awareness of Flexible Automation technology as it applies to shipbuilding technology;
- F. Publish and disseminate research results to the industry; and
- G. Maintain a flexible program with redirection capability to address new problems/technology as they arise;
- H. Monitor progress of projects carefully, cancelling those failing to show accomplishment and applying the remaining budget on more promising projects.

III. MEMBERSHIP

- A. As part of the NSRP, no dues are required of members; however, all expenses of attending meetings are their responsibility. Membership in SNAME is encouraged but is not mandatory. The following classes of membership have been established:
1. Regular (Voting Members)
 - a. Participating private shipyards (open to all member yards of SPC);
 - b. U. S. Naval shipyards (open to all).
 2. Associate (non-voting) Members
 - a. Maritime Administration (MARAD);
 - b. Navy offices, bureaus and research activities;
 - c. Membership-approved education and research institutions;
 - d. Professional associations (societies).
 3. Guest Members
 - a. Consulting firms (in appropriate field);
 - b. Private research firms.
- B. Voting regulations are established as follows:
1. One vote per participating shipyard on technical matters;
 2. One vote per organization on organizational and policy matters;
 3. Vote will be by members present at a regularly announced meeting.

Iv. MEETINGS, AGENDA AND MINUTES

The panel will normally meet three times per year at a time and place designated by the Chairman. A written agenda will be presented to the members prior to, or at the beginning of, each meeting and will be attached to the minutes. Minutes will be distributed to all members and other interested parties; program progress reports will be made as part of the minutes.

v. PROJECT CONTROL

A. Project Preparation

1. Following the decision to pursue a project, a member will be tasked with preparing a project brief, as outlined in enclosure (4) , to be forwarded to the Program Manager at least one month prior to the next scheduled meeting.
2. The Program Manager shall send a copy of the project brief and a review sheet to each member with the meeting announcement.
3. Members should prepare comments and bring them to the meeting or, if not attending, mail them to the Program Manager in time for them to be discussed at the meeting.
4. Members present will review the comments and determine -
 - a. whether or not to pursue the project;
 - b. the priority of the project, and
 - c. its potential procurement sources (e.g. shipyard, consultant, etc.)

B. Project Assignment

1. Following receipt of the approved budget, the Program Manager will notify all members of the projects available and request detailed proposals from those interested shipyards and/or other approved sources.

2. Copies of completed proposals will be forwarded to all members for comment and consideration;
3. Members should prepare comments and bring them to the next regular meeting or mail them to the Program Manager in time for discussion by the attending members.
4. Members present will review the comments and decide to whom the project will be awarded.

c. Project Funding

project funding will be in accordance with NSRP guidelines, utilizing shipyards providing shared funding or non-profit organizations wherever feasible.

D. Project Reporting

1. Either the panel member or a project representative shall present a project progress report to the panel at each regular meeting. (This report should be in writing so that it may be accurately repeated to absent members) .
2. Upon completion, each project will be reviewed by the panel.
3. Reports on projects approved by the panel shall be submitted "camera ready" to the Program Manager for printing and distribution.

VI. USE OF PANEL AS A FORUM

Because of the advanced and rapidly changing state-of-the-art associated with Flexible Automation, a portion of each panel meeting shall be made available for presenting related pertinent information to the panel members. These shall include, but not limited to:

Charter - SP-10 - Flexible Automation

1. progress reports by panel members on related projects (Manufacturing Technology, Industrial Modernization Improvement Program, etc) ;
2. presentation by guest experts in the field;
3. Tours of advanced research activities (e.g. National Bureau of Standards, major university research labs and major research institutions);
4. Tours of nationally-recognized exhibition; and
5. End-of-contract demonstration at shipyards.

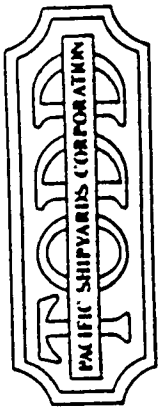

PROGRAM MANAGEMENT

<u>ITEM</u>	<u>AMOUNT (X1000)</u>
DIRECT LABOR	70
TRANSPORTATION AND LODGING	12
MEETING EXPENSE	8
PRINTING, PUBLISHING AND MAILING	<u>10</u>
TOTAL	100 =====

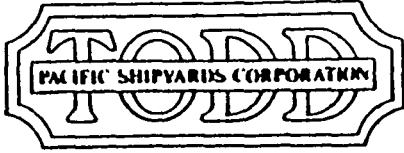

PROGRAM MANAGEMENT

F-25

<u>ITEM</u>	<u>AMOUNT (X1000)</u>
DIRECT LABOR	70
TRANSPORTATION AND LODGING	12
MEETING EXPENSE	8
PRINTING, PUBLISHING AND MAILING	<u>10</u>
TOTAL	<u>100</u> =====



PROPOSED FY 85 PROGRAM SUMMARY

F-26

<u>PROJECT TITLE</u>	<u>A M O U N T (X1000)</u>			
	<u>Funded</u>	<u>Requested</u>	<u>Future</u>	<u>Total</u>
1. Marking of Plate Cut by CNC Burning Machine, Phase II	\$ 150	(\$ 290)*	(\$ 0)	(\$ 440)
2. Families-of-Parts, Robotic Welding Cell, Phase I	0	85	25	110
3. Off-Line Programming of Welding Robots, Phase I	0	50	300	350
Sub-Total for Projects		135		
Program Management		100		
TOTAL PROGRAM		235		

*-Phase II being submitted as MANITEC Project.

SNAME/SPC PANEL SP-10, FLEXIBLE AUTOMATION

PROPOSED FY '85 PROGRAM

<u>Project Title</u>	<u>Amount (X1000)</u>			
	<u>Funded</u>	<u>Requested</u>	<u>Future</u>	<u>Total</u>
1. Marking of Plate Cut by CNC Burning Machine, Phase II	\$ 150	\$ 290	\$ 0	\$ 440
2. Families-of-Parts, Robotic Welding Cell, Phase I	0	85	25	110
3. Off-Line Programming of Welding Robots, Phase I	0	<u>50</u>	TBD	TBD
Sub-Total for Projects		\$ 325		
Program Management		<u>100</u>		
TOTAL PROGRAM		<u>\$ 425</u> =====		

NATIONAL SHIPBUILDING RESEARCH PROGRAM

SPC TECHNICAL PANEL SP-10

PROJECT ABSTRACT

PROJECT TITLE:

Marking Plate Cut by Computer Numerically Controlled (CNC) Burning Machines, Phase II

TECHNICAL OBJECTIVE:

The technical objective of this project shall be a device to automatically mark part identification data and reference lines on plate cut by CNC burning machines. The device shall produce marks of high legibility, permanence, and correct geometric registration to the part edge. The speed of marking shall be compatible with the cutting rate of the burning machine.

CURRENT :METHOD:

currently, Part identification data are manually painted onto plate cut by CNC burning machines. The individual parts are identified by referring to a hard copy of cutting plan. Where the part identification data must survive a post fabrication abrasive blast cleaning, the data are manually letter punched onto sheet metal tags welded to the plate. These are labor intensive tasks and are subject to such errors as misidentified parts, missing or misplaced characters and illegibility due to poorly drawn characters.

Reference marks on plate cut by CNC burning machines are currently drawn as a series of punch marks made by a power driven punch mounted on the burning machine carriage. Operation of the punch is considerably slower than the maximum travel speed of the carriage resulting in an operating bottleneck during the marking sequence. In addition, some shipyards have reported difficulty in making these marks with an adequately high profile in hard materials such as HY80. Difficulty in maintaining the punch geometrically indexed to the cutting torch has also been reported.

PROPOSED METHOD:

It is proposed to utilize high speed marking technologies to automatically produce part identification data and reference line marks on plates cut by CNC burning machines. The marking equipment will be mounted on an auxiliary carriage to accomplish the marking cycle independent from and in approximately the same the frame as the cutting cycle. The marking operation will be accomplished parallel with the cutting cycle.

APPROACH :

Phase I (FY 84)

- o Study and evaluate various high speed marking technologies. Consideration shall be given to the problems of flexible automation and to present an anticipated shipyard marking requirements. Accomplish the demonstration required to establish the suitable candidate marking technologies.
- o Establish the system operational characterization, and define a system design concept.
- o Develop a preliminary engineering design for the selected system design concept. This shall include the preparation specifications for the procurement of major equipment.
- o Evaluate the system control software requirements and prepare a specification for the required development.
- o Define the system economic justification.

Phase II (Proposed)

- o Procure the selected system equipment.
- o Develop the required system control software.
- o Fabricate necessary hardware items and assemble the system.
- o Initiate system operation and eliminate any difficulties encountered.
- o Evaluate the productivity increment achieved with operation of the system.
- o Conduct system demonstrations.

BENEFITS:

The principal benefit from the automation of plate marking will be an approximately 20% increase in the amount of plate cut by the burning machine. This benefit is derived from the parallel operation of the cutting and marking equipment.

The automated marking system will not be subject to such manual marking errors as misidentification of parts, missing, misplaced or illegibly drawn characters.

All of the plate markings can be made with sufficient permanence to survive a post-fabrication abrasive blast cleaning.

Direct labor to accomplish plate marking will be reduced by approximately 0.25 layout men per burning machine.

COST :

The cost for accomplishing the project will be approximately as follows:

Phase I (Funded for FY 84)

0.7 man-year labor @ \$30/hour	\$ 42,000	
Marking Equipment Suitability Demo.	33,000	
sys. Cont. Software Eval. Spec. & Initial Development	45,000	
Travel & Miscl. Direct Cost	<u>30,000</u>	\$ 150,000 YEAR :

Phase II

0.8 man-year labor @ \$30/hour	\$ 48,000	
Marking Equipment	117,000	
Control Equipment	105,000	
Travel & Miscl. Direct cost	<u>20,000</u>	\$ 290,000 YEAR :

TOTAL SYSTEM COST, HARDWARE & DEVELOPMENT -----		\$ 440,000 =====
---	--	---------------------

SCHEDULE:

The period of performance for Phase I of this project will be approximately 8 months.

The period of performance for Phase II of this project will be approximately 7 months.

DELIVERABLES :

1. Progress in the accomplishment of the project shall be reported in a series of deliverable documents and demonstration of the operation system.
2. Technical reports shall be prepared at the completion of each phase describing the work accomplished.
 - a. Appendices to the final technical report shall set forth the system engineering design, equipment specifications~ and an explanation and listing of the system control software.

- b. An audio-visual presentation shall be Prepared to illustrate the final technical report.
 - The presentation visual aids shall De prepared as 35mm slides.
 - TWO copies of the presentation shall be submitted.
- 3. The operating modes and capabilities of the system to increase the productivity of plate machine cutting operations shall be demonstrated.

NATIONAL SHIPBUILDING RESEARCH PROGRAM

SNAME Technical Panel SP-10

PROJECT ABSTRACT

PROJECT TITLE:

Families-of-Parts Robotic Welding Cell

TECHNICAL OBJECTIVE:

To install and demonstrate a robotic welding cell equipped with artificial vision which will have the capability to process families of parts. Families of parts are defined as parts which are similar in form but differ in size, such as spools and penetrations. This system would also incorporate software fixturing and adaptive robotic controls to make extensive hardware fixturing and accurate positioning unnecessary.

CURRENT METHOD:

Shipyards have been generally unable to take advantage of robotic welding of small parts because of the low volume of identical parts and the corresponding high cost of fixturing and robot programming for each part. While there is not a high volume of identical parts, there is a high volume of families of parts. Traditional methods of robotic programming of weld paths and the need for precise positioning has kept robotic welding of these parts from being cost-effective. These parts are currently being welded by manual means.

PROPOSED METHOD:

The family of parts robotic welding cell is conceived as a stand-alone processing cell capable of welding families of parts. A part would be secured to a work table within the work envelope of the robot. An artificial vision system would locate and measure the part. System software would use this information to modify a pre-existing welding procedure to suit the specific part being processed. Precise positioning would be unnecessary as long as the part remained within the work envelope. This ability is termed software-fixturing and is the major development software needed to enable this project.

APPROACH:

Phase I

Identify components as candidates for family of parts processing and prepare a preliminary system specification. Develop pilot software and part holding devices and validate performance of demonstration at the manufacturer's site.

Phase II

Install system in shipyard, train operators and monitor performance and reliability over a three-month period.

BENEFITS:

Software fixturing eliminates the need for precise fixturing and positioning through hardware. Software fixturing is prerequisite to family-of-parts capabilities. Full implementation of the cell would greatly expand the applicability of robotic welding of ship components. This has the potential to reduce the labor cost of welding these components by an estimated 40% while significantly improving quality.

COST :

Year 1	\$85,000
Year 2	\$25,000

SCHEDULE:

Year 1	9 months
Year 2	3 months

DELIVERABLES :

1. Report documenting the development and testing of the system, summary of significant findings/benefits, and recommendations for further development.
2. Presentation materials consisting of 2 sets of 35mm slides and associated briefing materials.

NATIONAL SHIPBUILDING RESEARCH PROGRAM

SNAME Technical Panel SP-10

PROJECT ABSTRACT

PROJECT TITLE:

Off-Line Programming of Welding Robots

TECHNICAL OBJECTIVE:

Reduce or eliminate lost arc time of a welding robot now being used for point-to-point teaching.

Modifying a Cincinnati Milacron T-3 Robot to be much more accurate and building a set of controls able to accommodate off-line programming of the robot from an external source or an existing data base.

CURRENT METHOD (PROBLEM):

Todd Pacific Shipyards is presently using a Cincinnati Milacron T3 Robot to successfully weld fairly complex aluminum and steel subassemblies. However, the robot is programmed by teaching each individual point using a hand-held pendant. This programming method has become the single most significant factor limiting the productivity of the robotic system. This limitation is not unique to robotic welding, but is generally a significant factor in limiting the productivity of flexible automation equipment for small batch manufacturing operations. Longer range, as manufacturing activities become more automated, the limitations imposed by hand-held teaching will become intolerable.

PROPOSED METHOD (SOLUTION):

This project proposes to supplement the existing Todd Pacific robotic welding system with a welding robot which can be programmed "off-line". In addition, the new robot will be sufficiently accurate and repeatable so that the part information in a data base can eventually be used to correctly command the robot to produce the required motions.

Off-line programming will significantly improve the overall productivity of the welding system by eliminating the "down-time" required for the point-to-point teaching.

APPROACH:

PHASE I

1. Evaluate the state-of-the-art development for:
 - a. improved versatility robot control software and hardware;
 - b. systems for procedures to calibrate mechanical variances between robot arms which otherwise would position different arms using identical programm in different places;
 - c. Graphics systems which can be used for teaching a robot arm path and which allow graphic manipulation of a test robot;
 - d. Software that will allow CAD data to be downloaded to the test robot.
2. a. Develop detailed specification for installing these features on an operational welding robot.
 - b. Prepare a plan for Phase II which will include revised cost and cost justification.

PHASE II

1. Procure and install selected equipment on an operational welding robot, e.g. the CM-T3 at Todd Los Angeles.
2. Evaluate the performance and perform an industry demonstration.

BENEFITS:

1. In the short term, off-line programming will improve the up-time or arc-time of the welding robot. Longer range, newer applications should open up as the impact of computer-integrated manufacturing becomes more widespread. Production economies will be realized as the number of shop drawing are gradually reduced and the number of tools and fixtures are reduced or even eliminated.
2. Overall safety is improved. The programmer will no longer have to be near the robot to do the teaching.

COSTS :

Phase I	--	\$50,000
Phase II	--	\$300,000 (Est.)

SCHEDULE:

Phase I	--	10 months
Phase II	--	12 months

DELIVERABLES :

1. Control hardware and software as required.
2. Demonstration of off-line/alternate input programming of robot.
3. Technical manuals for all equipment.
4. Phase I written report including items in Phase 2.
5. Final written report documenting the changes and results.
6. Presentation materials including 2 sets of 35mm slides and associated briefing materials.

APPENDIX G

**List of Attendees
a t
SPC Panel SP-10 Meeting No. 6**

**held at
Cambridge, MA
on March 20,1985**

**without
Minutes**

ATTENDANCE LIST

WEDNESDAY, MARCH 20, 1985

<u>Name</u>	<u>Company's Name</u>	<u>Signature</u>
1. J. B. Acton	Todd Pac. Shipyards	Present
2. M. Agee	Virginia Poly.	
3. J. Arrison	MIT	
4. D. Blais	Bath Iron Works	<i>[Signature]</i>
5. H. Berger	Robotix Corp.	
6. H. Bunch	UMTRI	
7. J. Cameron	General Dynamics	
8. D. Carico	INFAC	<i>[Signature]</i>
9. J. Carstens	United Technologies	
10. D. Cheatham	Lockheed	<i>[Signature]</i>
11. M. Cunningham	Bath Iron Works	
12. A. Dallas	UMTRI	<i>[Signature]</i>
13. B. Everett	NAVSEA	
14. J. Fallick	NAVSEA	
15. W. French	Avondale Shipyards	
16. T. Galie	NAVSSSES	<i>[Signature]</i>
17. A. Gutenberg	USC	
18. N. Haynes	Bethlehem Steel	<i>[Signature]</i>
19. L. Holiday	Newport News	
20. R. Jenkins	DTNSRDC	
21. J. Justice	SAI	<i>[Signature]</i>
22. L. Kamm	Mobot	<i>[Signature]</i>
23. R. Kelley	General Dynamics	
24. J. McEachran	RI/SME	<i>[Signature]</i>
25. J. Nevins	CSDL	
26. M. Nelson	LBNSY	<i>[Signature]</i>
27. W. Oakes	NASSCO	<i>[Signature]</i>
28. J. R. Phillips	Bath Iron Works	
29. R. Price	Avondale Shipyards	<i>[Signature]</i>
30. R. W. Schaffran	MARAD	
31. J. Sizemore	Ingalls Shipbuilding	<i>[Signature]</i>
32. James R. Visage	Mare Island	
33. Roy Wells	NAVSEA	
W. Woelam	Southwest Research Inst.	<i>[Signature]</i>

APPENDIX H

**Minutes
of
SPC Meeting**

**held at
Long Beach, CA
on September 10, 1985**

**where
SPC Panel SP-10 Meeting No. 7
was held**

(separate minutes for SP-10 meeting not available)

minutes

the Society of Naval Architects and Marine Engineers

ONE WORLD TRADE CENTER, SUITE 1369, NEW YORK, N. Y. 10048 • 212 432-0310

SHIP PRODUCTION COMMITTEE

4:00 P.M.

Time

SEPTEMBER 10, 1985

Date

HYATT REGENCY HOTEL
LONG BEACH, CA

Location

MEMBERS PRESENT

Mr. Jesse W. Brasher, Chairman
Mr. James B. Acton
Mr. Frederick B. Barham, Jr.
Prof. Howard M. Bunch
Mr. Louis D. Chirillo
Mr. Conway D. Davis
Mr. Malcolm Dick
Mr. Jan Erikson
Mr. Ben C. Howser
Mr. Edward S. Karlson
Mr. Norman W. Lemley
Prof. Richard P. Neilson
Dr. T. Francis Ogilvie
Mr. Thomas M. O'Toole
Mr. James Palmer
Mr. Wesley D. Payne
Mr. Edwin J. Petersen
Mr. Joseph R. Phillips
Mr. Richard A. Price
Mr. R. W. Schaffran
Mr. Mark I. Tanner
Mr. Richard W. Thorpe, Jr.

OTHERS PRESENT

Mr. Robert Behr, Bethlehem Steel
Mr. Samuel Bevins, Newport News Shipbuilding
Mr. Noel M. Brehant, General Dynamics
Mr. Maurice Cunningham, Bath Iron Works
Mr. Joseph Getz, Bethlehem Steel
Mr. Robert Jenkins, David W. Taylor NSRDC
Mr. Trevor Lewis-Jones, SNAME
Mr. George A. Uberti, NASSCO
Mr. D. A. Washburn, PBI
Mr. J. R. Wilkins, Avondale Shipyard

MEMBER(S) ABSENT

Mr. Kenneth S. Amer
Mr. Ralph F. Mselmi
Mr. Richard E. Blackinton
Mr. Kristian K. Christensen
Capt. A. D. Clark, USN
Mr. Louis W. Frank, Sr.
Mr. Robert B. Geary
Mr. James A. Higgins
Mr. Rockwell Holman
Mr. Peter E. Jacquith
Mr. Francis J. Long
Mr. Peter M. Palermo
Dr. Michael G. Parsons
Mr. John W. Peart
Mr. Feite Posthumus
Prof. David T. Pratt
Mr. George J. Trausch
Mr. David Watson
CDR William D. Whiddon, USN
Mr. Joseph E. Wise

I. INTRODUCTION

Mr. Brasher opened the meeting by having everyone introduce themselves around the table. It was moved, seconded and passed that the minutes of the previous meeting be approved.

II. 1986 SHIP PRODUCTION SYMPOSIUM

Mr. Brasher announced that the "Call for Papers" has gone out, and that while the method of papers selection is somewhat different from the previous symposia, the SPC program managers are member\$ of the selection committee and can ensure that the selection is appropriate. The next meeting is scheduled for November 14, 1985 in New York at the SNAME Annual Meeting.

Mr. Brasher said the Executive Control Board recommended and the SPC concurred, that 1987 is too early to go back to New York and so turned down the offer of the New York Metropolitan Section to host the 1987 SPC Symposium. The plans for 1987 have yet to be firmed up, however, a West Coast or Gulf Coast location was preferred.

III. PANEL SP-6

Mr. J. R. Phillips' petition that panel 5p-6 change its name from Standards and Specification to Marine industry Standards was approved by the Committee.

Mr. Phillips led a rather lengthy discussion on the standards program, and proposed an ad hoc committee built especially to interface with the Navy on standards production, an effort similar to the CAD/CAM ad hoc group already in place. Mr. Phillips said that this would supplant the present system, which can never amount to more than a small pilot project.

Mr. Brasher backed this plan, saying he felt that high level shipyard and USN support is slowing growing for standards improvements. The ad hoc group would include Navy members, hopefully giving the program more Navy support.

Mr. Phillips planned to discuss the matter with members of the ASTM F-25, Committee. Mr. Phillips also suggested that each yard set up a standards committee to provide input and to expedite the review/revision process.

IV. FISCAL 1986 PROJECTS

The plan now is for the Executive Control Board to meet in January and place all the projects into priority for SPC approval. Mr. Schaffran said there was a hold-up at the Secretary of Transportation level but this has now been waived by OMB. (Tentatively this ECB-p.m. meeting will be in Pascagoula.)

The full SPC review and approval of the projects is scheduled for February 1986. (Tentatively this meeting is set for Washington, DC at the Maritime Administration.) Thus, the project approval will be in February and the letter request from the Chairman to MarAd and the Navy Department around March 1, 1986, and the actual contracting with the yards by the first month of FY 1987 (October 1).

v. CAD/CAM INTERFACE WITH NAVY

The names on this ad hoc group are:

Malcolm Dick
Jake Lindgren
Edwin Petersen
James Palmer
James Wilkins

H-3

A "strawman" has been prepared, and after rework being done by Mr. Baxter Barham and Mr. Vander Schaff, the ad hoc group will again meet with cognizant members of NAVSEA. (This meeting is now set for the 24th or 25th of October, 1985.

VI. This-brief meeting concluded with a discussion on the Navy Manufacturing Technology Program and the Brasher-Acton. testimony before the House Merchant Marine and Fisheries Committee. There is an "Effectiveness Report" regarding the Man-Tech Program which Mr. Acton will provide to those interested.

VII . NEXT MEETING AND ADJOURNMENT

The next meeting will be at MarAd in Washington, February, 1986. The date will be announced by Mr. Brasher.

The meeting adjourned at 5:15 p.m.

Respectfully submitted,

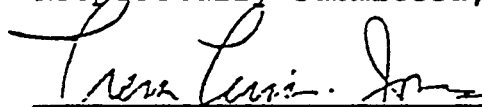

Trevor Lewis-Jones, Manager
Publications and Technical Program

Approved

Jesse W. Brasher, Chairman

TL - J / b t
9/26/85
10/16/85

APPENDIX I

**List of Attendees
at
SPC Panel SP-10 Meeting No. 8**

**held at
Washington, DC
on November 7-8, 1985**

**without
Minutes**

MEETING MINUTES

SHANE/SPC PANEL SP-10 FLEXIBLE AUTOMATION
MEETING NO. 8
MARAD HEADQUARTERS
WASHINGTON, D.C.
NOVEMBER 07 - 08, 1985

PRESIDING: J. B. Acton

TODD PACIFIC SHIPYARDS CORPORATION

ATTENDEES:

J. B. Acton	Todd Shipyards
J. Albus	Nat'l Bureau of Stds
D. Blais	Bath Iron Works
J. Cameron	General Dynamics-Electric Boat
J. Fallick	NAVSEA 05M2
K. Goodwin	Nat'l Bureau of Stds.
R. Jenkins	DTNRDC, Code 1853
W. Oakes	NASSCO
V. Rinehart	MARAD
J. Richards	MARAD
R. Schaffran	MARAD
J. Sizemore	Ingalls
R. H. Slaughter	Ingalls (SP-11)
T. Stepien	Draper Labs
L.D. Vivian	Long Beach NSY
R. Wallen	NNS

ABSENTEES:

R. Price	Avondale
M. Agee	VPI
H. Berger	Robotix Inc.
W. Christensen	NAVMAT
B. Everett, LCDR, USN	NAVSEA
W. French	Avondale
T. Galie	NAVSES, Phila.
A. Gutenberg	A.W. Gutenberg, Inc.
C. Gummic	Lockheed
N. Haynes	Beth. Steel, Sparrows Pt.
J. Justice	Morrisson-Knudson
R. Kelly	General Dynamics-Quonset Point
D. Lick	GE-CALMA
J. McEachran	RI/SME
J. Visage	Mare Island NSY
R. Wells	NAVSEA (07)
P. Williams	Tacoma Boatbuilding
W. Wollam	SwRI
C. White	NAVSEA (070)

APPENDIX J

**Minutes
of
SPC Panel SP-10 Meeting No. 9**

**held at
Bethesda, MD
on March 18-19, 1986**

**with
Appendix I through V
and
Panel Charter**

MEETING MINUTES

SNAME/SPE PANEL SP-10 FLEXIBLE AUTOMATION

MEETING NO. 9

DAVID TAYLOR NAVAL SHIP RESEARCH & DEVELOPMENT CENTER

BETHESDA, MARYLAND

MARCH 18-19, 1986

PRESIDING: J.B. Acton
TODD PACIFIC SHIPYARDS CORPORATION

ATTENDEES:

J.B. Acton	Todd Shipyards
W.J. Butler	NAVSEA
J. Cameron	General Dynamics - Electric Boat
J. Cantrell	General Dynamics - Electric Boat
B. Everett, LCDR, USN	NAVSEA
K. Goodwin	National Bureau of Standards
N. Haynes	Bethlehem Steel - Sparrows Point
R. Jenkins	DTNSRDC
J. Justice	MK Ferguson
A.M. Klick	General Dynamics - Electric Boat
J. Nevins	C.S. Draper Labs.
J. Richard	MARAD
V. Rinehart	MARAD
R. Schaffran	DTNSRDC
K. Scully	DTNSRDC
J. Sizemore	Ingalls Shipbuilding
R.H. Slaughter, Jr.	Chairman, SNAME/SPC Panel SP-11
O. Stephans	DTNSRDC
R. Wallen	Newport News Shipbuilding (alternate)
D. Whitney	C.S. Draper Labs.

ABSENTEES:

R. Price	Avondale
M. Agee	Virginia Polytechnic Inst.
D. Blais	Bath Iron Works
W. Christensen	NAVSUPP
J. Fallick	NAVSEA
W. French (alternate)	Avondale
T. Galie	NAVSES
L. Holiday	Newport News
D. Lick	GE-CALMA
W. Oakes	NASSCO
J. Rivas	Long Beach NSY
L. Vivian	Long Beach NSY
R. Wells	NAVSEA (07)
W. Wollam	Southwest Research Inst.
C. White	NAVSEA (070-A)

OPENING REMARKS

The meeting was called to order by panel chairman, J.B. Acton at 0910 March 18, 1986. He welcomed the members and guests attending then thanked and introduced the host, Mr. Robert Schaffran.

WELCOME ADDRESS

After welcoming the attendees, Mr. Schaffran described the function of the new group he heads and introduced the members of his staff who were present. He indicated his desire that his group continue to work with the NSRP in the future.

APPROVAL OF MINUTES OF PREVIOUS MEETING

Dan Whitney requested that the reason for rejecting project No, 7 (November minutes) be changed to read, "lack of technical data" vice "lacking of technical merit." The panel agreed and the minutes were approved as modified.

ECB/SPC MEETINGS AND PROGRAM STATUS

Virgil Reinhart repeated and updated the report given to the ECB and SPC meetings regarding the future of the NSRP. He stated funding problems do exist, but some interest is now being shown at high levels in the administration, MARAD funding for FY 87 is extremely doubtful, but some remaining FY 86 funds will be utilized to stretch out the program long enough to complete currently approved projects. He expects the Navy portion of FY 85 funds to be forthcoming soon, which will allow contracting for all approved projects. His opinion, regardless of funding, is that the panel structure should be maintained and a new financial sponsoring agency (or program) be found.

His proposed solution(s) would be:

- o extension of time of contracts;
- o tag onto "Build & Charter" legislation;
- o develop other legislation; or
- o obtain sponsorship through the Navy overhaul branch (Sea 07).

FY 86 & 87 BUDGET

Financial Report

Included as Appendix I

Approved Projects for FY 87

Included as Appendix I I

Status

FY 85 - 60% funds received; remainder awaiting Navy transfer;

FY 86 - Only token amount available from MARAD surplus;

FY 87 - Funding doubtful.

Project in lieu of Off-Line Programming

The panel approved the use of these funds for Phase O of the Stabilized Platform Crane Robot (#2 ranked project in November minutes)

Sub-Contractor approval - FY 87 projects

Ingalls was designated by the panel as the proposed sub-contractor for both projects approved by the ECB.

Disposition of Abstracts

A vote of thanks was extended to all who submitted abstracts for consideration in FY 87. Proposing individuals should revise and resubmit them - if appropriate - for FY 88.

Extension of Contract Period

The FY 86 funds being provided by MARAD are for use in "program administration" to cover the period through June, 1988.

PANEL ROJECT REPORTS

Plan for Implementing Flexible Automation

- D. Whitney, Draper Labs

Included as Appendix III

Following the presentation, J. Cameron suggested that Shipyard CE Officers be given a formal presentation. The panel concurred with the idea, but lack of available funding makes this impractical at this time.

Marking of Plate Cut by CNC Burning Machines

- J. Sizemore, Ingalls

included as Appendix IV.

Families of Parts in Robotic Welding Cell

- J. Acton, Program Manager

As of the meeting, Todd Los Angeles had not provided a work statement for performing this project. J. Cameron made a motion that an RFP be issued to participating shipyards. The motion was seconded and approved.

PANEL RELATED PROJECT REPORTS

Navy Programs

- R. Jenkins, DTNSRDC

No significant milestones have been reached in current Navy programs that would be related to this panel.

Laser Line Heating

- K. Scully, DTNSRDC

Phase II is essentially on schedule. Significant experiment results should be available for the July meeting.

RECESS

The meeting was recessed at 1640; reconvening time was set at 0830 March 19.

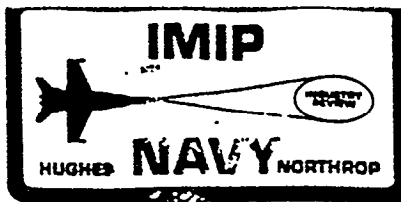

NOTES NOTES NOTES NOTES NOTES NOTES NOTES NOTES NOTES

ATTENDANCE - FOR MINUTES OF 03/18-19/86 MEETING

R.H. SLAUGHTER JR	INGALLS SHIPBUILDING / SP-11	(601) 935-4611
John Sizemore	INGALLS Shipbuilding SP-10	601 935 2558
KEN GOODWIN	NAT'L BUR. of STANDARDS	301 921-2381
Jim Nevins	Charles Stark Draper Lab	617-258-2901
Dan Whitney	" "	2917
Bob Jenkins	DTNSRDC 1853	202-227-1363
JAY CANTRELL	GENERAL DYNAMICS, ELECTRIC BOAT	701-268-2555
Anthony M Klick	General Dynamics, Data Systems Div	401-268-2201
Tim Justice	MK FERRELL	216/523-5923
Vick Haynes	Beth Steel	301-388-7600
REX WALLEN	NEI-PORT NEWS SHIPBUILDING	404 380-3513
Bob Schaffran	DTNSRDC	(202) 227-1365
VIRGIL RINEHART	MARAD	(202) -382-0353
Jim Cameron	Electric Boat	203) 446-3111
JOEL RICHARD	MARITIME ADMINISTRATION	(202) 382-0444
Kevin Scully	DTNSRDC	202 227-1365
J. J. BUTLER	NAVSEA	202 692 608
Barrett Everett		
Bill STEPHENS	DTNSRDC	

Initials Date
 Prepared By JWL 4/8/86
 Approved By

TADD BRISTLE SHIPYARDS CONSTRUCTION NAVAL TECHNOLOGY DIVISION
 05519-VMEANS @ 4/8/86

Page #1

ITEM	DESCRIPTION	BUDGET By PROGRAM MANAGER	PURCHASE ORDER			Cost Control Paid To Date By EMPLOYEE	PAID TO DATE TAG RUN	Booked ON	7/8/79 TAG Run @	OPEN COMMITMENT
			NUMBER	PO DATE	PO COMMITMENT					
01	<u>DIRECT MATERIALS</u>									
01200	<u>Subcontracts</u>									
01201	BATHURSTON STEEL (WELDING CABLE)		PL 45753	11-14-83	518,231	218,794-	10,799-	226,789-	108,247	
01202	DUMPER LADS (PLAN FRM INT)		PL 75064	1-30-85	226,047	153,546-	7,207-	161,283-	67,501	
01203	INGOALS (PLATE MARKING)		PL 74760	10-26-85	169,165	-0-	-0-	-0-	168,164	
						369,539-	18,474-	382,006-	337,912	
03	<u>DIRRECT LABOR</u>		N/A	N/A	N/A	143,743.95	35,412.57	179,312.42	-0-	
07	<u>TRAVEL</u>									
07000			N/A	N/A	N/A	7,174.95	252.48	7,531.63	-0-	
07100	TRANSPORTATION		N/A	N/A	N/A	5,182.77	257.14	5,442.91	-0-	
07200	SUBSISTANCE		N/A	N/A	N/A	18,992.18	412.82	18,973.34	-0-	
08	<u>CONSULTANTS</u>									
08100			N/A	N/A	N/A	1138.00	52.90	1134.90	-0-	
08200			N/A	N/A	N/A	1,022.98	44.47	1,068.95	-0-	
						2,160.98	111.87	2,338.75	-0-	
09	<u>OTHER DIRECT COSTS</u>		N/A	N/A	N/A	7,444.27	1211.80	2,213.13	176.85	
TOTAL COMMITMENT						577,298.22	55,827.64	603,747.84	338,108.85	

Initials Date
 Prepared By 11/2 3/4/82
 Approved By

TODD INERTIC SHIPMENTS OPERATIONS - NAVAL TECHNOLOGY DIVISION
 06519 - VARIOUS 4/8/82

		Budget Established	ATT HOURS	THY HOURS	LABOR	REL COST	TOTAL LABOR 6.7:8	Material	Booked P/H	TOTAL	Other Commitment
03	<u>DIRECT LABOR</u>										
03010	Program Manager		2477.6	2152.3	51,004.53	35,491.28	86,622.01	-	17,977.47	104,403.48	NA
03020	Panel Chairman		447.0	412.0	10,340.00	8,225.42	18,945.42	-	3,961.28	18,926.70	NA
03030	Clerical		1868.5	2122.9	112,362.09	16,544.16	31,094.25	252.00	11,428.32	45,772.57	NA
03040	Support labor		480.0	480.0	50,933.51	3,648.05	8,754.56	1,151.61	3,803.50	12,118.27	NA
			5273.1	5607.4	85,977.93	52,369.31	142,342.24	1,404.21	35,472.57	179,214.42	NA
09	<u>Other Direct Costs:</u>										
09000			-	-	-	-	-	2,992.62	149.63	3,142.25	NA
09010	MEETING EXPENSE		-	-	-	-	-	1,416.16	281.82	1,912.77	NA
09020	PRINTING, Publishing, MAILING		38.5	38.5	3211.96	172.83	514.79	2,602.62	160.04	10,288.66	176.85
09030	OFFICE EXPENSE & SUPPLIES		-	-	-	-	-	3,751.87	209.41	3,977.45	NA
09040	CONFERENCE		2.0	2.0	27.80	17.37	45.17	2,000.00	100.00	2,100.00	NA
90000	SUPPORT OF OTHER SHIPMENT CHARGES		-	-	-	-	-	-	-	-	176.85
			38.5	38.5	3249.76	210.20	559.96	17,441.27	1,211.90	21,213.13	176.85

SHIP PRODUCTION COMMITTEE

PANEL SF-10

FLEXIBLE AUTOMATION

FISCAL YEAR 1986 PROPOSED PROJECTS

SF-10-86-01	Design Production Integration for Robotic Ship Manufacture	300,000
SF-10-86-02	Analysis/Synthesis of Robotic Ship Component Manufacturing Systems	50,000
FM	Program Management	100,000

	TOTAL	450,000

NATIONAL SHIPBUILDING RESEARCH PROGRAM
SHIP PRODUCTION COMMITTEE PANEL SP-10

SP-IO-86-01

PROJECT ABSTRACT

PROJECT TITLE

Design production Integration for Robotic Ship Manufacture

TECHNICAL OBJECTIVE

Design a class of components as a rationalized parts family for group manufacture on flexible automated production equipment. Design a flexible automatic production system incorporating operational capabilities specifically aligned with the manufacturing task requirements of the component class.

CURRENT METHOD

Current ship structural and fittings components design practice is tradition based. These components are often designed with considerable geometric complexity. The variety of these components is great. Because of minimal similarity among individual members, production groupings of ship components must often encompass very broad parts families. Only small numbers of like components are required for a given ship. Tool access and material handling are secondary considerations in current ship design practice. The geometric complexity also greatly increases the complexity of orientation sensitive processes such as welding. Finally, the scale and the tolerances common to ship components are beyond the capabilities of commercially available robotic equipment.

PROPOSED METHOD

This describes the first phase of a project to promote robotic manufacture of ships integrating design for production principles with the inherent requirements of robot utilization. The project is proposed for co-joint sponsorship by Ship Production Committee Panel SP-4 and Panel SP-10.

Traditional ship structure and fittings components are geometrically complex and highly varied in detail. Commercial robotic machines have limited flexibility and working envelope capabilities. These are major detracting factors to implementing flexible automation in ship manufacture. It is not sufficient to develop new ways to produce traditional ship components. New designs must be developed to accomplish the function of existing components without performance degradation. These designs must be specifically conceived to support group manufacture on

flexible automatic production equipment, Coincident with these new component designs flexible automatic production systems incorporating capabilities particularly suited to group manufacture of these components must be developed.

ship production Committee Panel SP-10 is presently preparing a plan for implementing flexible automation in the shipbuilding industry. The plan will address the technical doctrines and methodologies necessary for successful application of robotics and flexible automation to the manufacture and repair of ships. Design production integration for robotic ship manufacture builds upon the plan. It demonstrates by example the practicality of the technical doctrines and methodologies of the plan applied to the manufacture of a specific class of ship component.

The project objective will result in complementary modification of ship structural and fittings components and to robotic machines designed for ship manufacture. The first phase will examine the design and manufacture of a class of ship components. The ship component class selected will be in accordance with the recommendation of Panel SP-10' plan for implementing flexible automation in the shipbuilding industry, The selected class of ship component will be studied using the technical doctrines and methodologies of the plan. Designs and specifications for a selected class of ship component and robotic production equipment necessary for a shipyard feasibility demonstration will be prepared. The new component class design will comprise a rationalized parts family for use throughout a ship and will support group manufacture on flexible automatic production equipment. The organization of the rationalized parts family will be consistent with the group technology parts classification and coding system developed by Ship Production Committee Panel SP-4

This work will include design simplification of the selected component class, enhanced tool access, automation of a limited number of well-defined processes, accommodation of tolerances, rational division of labor between craftsmen and fixed and robotic tools, and synthesis of production machines specifically appropriate for this work. Computer analysis models and visual mockups will be utilized as appropriate. The modified design for the selected component class will be examined for qualification under Navy and classification society rules. The economic consequences of proceeding will be estimated.

The first phase of the project is partitioned into subphases to facilitate tracking progress of accomplishment. These subphases are identified in the Approach statement below.

It is anticipated that the second phase of the project will consist of constructing and physically testing. The second phase of the project will also consist, as necessary, of demonstrating technical feasibility of flexible automatic production system

controller and unique mechanism features. Subsequent phases of the project will accomplish shipyard demonstration of shipyard feasibility and extend the project objective to additional

APPROACH

Phase 1A - Synthesis Alternative Design Approaches

A class of ship components will be identified for further study in accordance with the recommendation of Panel SP-10 Flexible Automation Implementation Plan. The factors determining the design and manufacture of the selected component class and the potential for improvement will be examined. On the basis of this examination, alternative design approaches to achieving the functions of the selected component class will be synthesized and studied. The study of alternative approaches will emphasize design simplification and rationalized part family grouping enhanced tool access? utilization of more highly defined processes. and reduced numbers of processes, accommodation of tolerances and rational division of labor between craftsmen and fixed and robotic tools. Computer analysis models and visual mockups will be utilized as appropriate.

Phase 1B - Identify Manufacturing Task Primitives

The manufacturing tasks required by the alternative approaches will be subdivided into primitive operations. Using these task primitive operations, labor will be rationally divided and appropriate characteristics for the necessary flexible automatic production system machinery identified.

Phase 1C - Component Class Detail Design

One of the alternative design approaches will be selected for detail development. The selected design approach will be analyzed for structural competence and shock and vibration performance over the parameter range common to the component class. The selected design approach and the analysis will be codified as a new design standard for the component class.

Phase 1D - Develop Design standard

A detail design and specifications will be prepared for an illustrative example component in accordance with the new design standard. The impact of the new design standard upon a future ship will be evaluated for a variety of conditions including joining to adjacent structure penetrations for distributed systems, and personnel access. Qualification of the design under Navy and classification society rules will be examined.

Phase 1E - Design Flexible Automatic Production System

A flexible automatic production system including robotic tools will be designed specifically incorporating capabilities suited to group manufacture of the new form of the selected component class. Specifications will be prepared for the production system.

Phase 1F - Economic Studies

Economic studies of current practice will be made. Projections of costs and productivity using the new production system will be prepared. The economic consequences of proceeding with the project will be estimated.

BENEFITS

It is anticipated that the project will result in productivity gains for the selected class of ship component in excess of the requirement to economically justify development and capital costs. The resulting robotic manufacturing system will serve as an illustrative example of applying this technology to ship construction. Operation of the robotic manufacturing system will promote further implementation of robotic manufacture to ship construction.

COST

\$300,000

Phase 1A: Synthesize Alternative Design Approaches	25,000
Phase 1B: Identify Manufacturing Task Primitives	50,000
Phase 1C: Component Class Detail Design	60,000
Phase 1D: Develop Design Standard	75,000
Phase 1E: Design Flexible Automatic Production Systems	70,000
Phase 1F: Economic Studies	20,000

SCHEDULE

One (1) year.

DELIVERABLES

Progress of work will be periodically reported to Panel SP-4 and Panel SP-10. A report of the work accomplished will be prepared, including the designs and specifications developed and the results of the economic studies. The report will also include evaluation of utilizing the design on a future ship and of qualification under Navy and classification society rules.

NATIONAL SHIPBUILDING RESEARCH PROGRAM
SHIP PRODUCTION COMMITTEE PANEL SP-10

SP-10-86-02

PROJECT ABSTRACT

PROJECT TITLE

Analysis/Synthesis of Robotic Ship Component Manufacturing Systems

TECHNICAL OBJECTIVE

This project prepares personal computer software to support robotic ship component manufacturing system configuration and tradeoff study decisions. The software will synthesize and analyze multiple alternatives representative of generalized shipyard conditions. These models will accommodate variability between individual members of a component family utilizing a design recall group technology code. Generalized models of various production resources and automation technologies will be provided. The software will provide for the rational division of labor between system elements and manual operators, and for the development of optimum system parameters. The software will be menu-driven. Provision will be made to tailor the models and constraints to individual shipyards.

CURRENT METHOD

Identification of appropriate ship construction operations for flexible automation and development of the system parameters involves consideration of a very large number of contributing factors. Decision theory and operations research hold the computation tools necessary for the rational accomplishment of these tasks. Because of the number of factors involved, manual computation of these decision aids is very complex and cumbersome. In the absence of computer implementation of these decision aids, the remaining options are intuition and engineering judgment, using inappropriate accounting results, and trusting third parties who do not understand the constraints inherent to ship construction.

PROPOSED METHOD

Develop software to implement generalized task analysis and ship component manufacturing system parameter tradeoff studies computation tools on a personal computer.

APPROACH

Develop cost and constraint models representative of generalized shipyard conditions. Develop a design recall group technology code consistent with the group technology parts classification and coding system developed by Ship Production Committee Panel SP-4. Develop generalized models of various production resources. Prepare the robotic ship manufacturing systems analysis/synthesis software as a menu-driven application on an existing personal computer relational database.

BENEFITS

The proposed development will provide shipyard production engineers integrated computational tools in a convenient and accessible form for identification and parameter development of flexible automation projects.

COST

\$50,000

SCHEDULE

Twelve (12) months.

DELIVERABLES

Progress of the development of the models, constraints, design recall group technology code, and the preparation of software will be periodically reported to Panel SP-10. A final report will be prepared identifying the models and decision theory implemented and explaining application to ship construction flexible automation projects. Software installation instructions will be provided. The software will be delivered on 5-1/4" floppy disks and hard copy listings.

IMPLEMENTATION PLAN FOR FLEXIBLE AUTOMATION

PROGRESS REPORT

MARCH 18, 1986

D.E. WHITNEY

C.S. DRAPER LABORATORY

J-16

APPENDIX III



ACTIVITIES SINCE NOVEMBER MEETING

YARD VISITS
TODD SEATTLE (TEDD HANSEN)
DEC. 3-4
BATH (DAVE BLAIS)
DEC. 17-18
INGALLS (JOHN SIZEMORE)
JAN. 7-8, 1986
AVONDALE (RICHARD PRICE)
JAN. 28

J-17

OTHER VISITS AND CONSULTATIONS

L.D. CHIRILLO DEC. 4

PROF. DAVE WIDDON, MIT

FRED SAAVEDRA, NAVSEA

HOWARD GORDON, SOUDRONIC, INC.

FRED SHEVELO, SPIRO-AMERICA

MAIN ACTIVITY HAS BEEN WRITING FINAL REPORT AND PAPER FOR MARINE COMPUTERS CONFERENCE



SP-10 IMPLEMENTATION PLAN FOR

FLEXIBLE AUTOMATION

HIGHLIGHTS OF DRAFT CONCLUSIONS AND RECOMMENDATIONS

MARCH 18, 1986

J-18



GENERAL CONCLUSIONS

COMPETITIVE SHIPBUILDING IS INTENSELY COMPLEX

- HEAVY RELIANCE ON PLANNING
- NEED FOR RATIONALIZATION OF DESIGNS, PROCEDURES, TOLERANCES

EXPERIENCE BASE MAY BE STRONG BUT SCIENCE BASE IS WEAK

- EXPERIENCE-BASED IDEAS DIFFICULT TO CHANGE
- SCIENCE BASE (COST DATA, MEASUREMENT DATA, PROCESS MODELS) OFFER FIRM BASIS FOR CHANGE

19

RATIONALIZATION/AUTOMATION OPPORTUNITIES EXTEND BEYOND FABRICATION

- PLANNING, SCHEDULING, MODULE DEFINITION, OTFIT SEQUENCING
- MEASURING, DATA ANALYSIS, PROCESS IMPROVEMENT

AUTOMATION/RATIONALIZATION EFFORTS WILL HAVE MORE IMPACT WHEN FAB AND NON-FAB STEPS ARE INTEGRATED -- WILL HAVE LESS IMPACT AS SEPARATE ROBOTS OR MACHINES WEDGED INTO EXISTING DESIGNS, METHODS OR SHOPS



GENERAL CONCLUSIONS (CONTINUED)

FLEXIBLE AUTOMATION REQUIRES A SUITABLE ENVIRONMENT TO BE SUCCESSFUL

- GOOD PROCESS MODELS THAT LEAD TO CLEAR SPECS FOR MACHINES
- SIMPLE PART SHAPES AND SUBASSEMBLY DESIGNS THAT ENCOURAGE FLOW-SHOP METHODS
- AWARENESS OF TOLERANCES AND MEASUREMENT BY YARD PERSONNEL
- AWARENESS OF PRODUCIBILITY ISSUES BY CONTRACT AND DETAIL DESIGNERS

THE BEST OPPORTUNITIES FOR FLEXIBLE AUTOMATION ARISE FROM COMBINING FABRICATION WITH DESIGN, INFORMATION TRANSFER, AND MATERIAL CONTROL

J-20

- ESTABLISH SENSIBLE SHAPES, SIZES, TOLERANCES
- DEFINE WORK CONTENT
- PREDICT PERFORMANCE: TIME, DIMENSIONS, DISTORTION
- EXPLOIT CAPABILITIES OF FLEXIBLE AUTOMATION TO DEFINE WORK PACKAGES, ENFORCE ADHERENCE TO SPECS AND SCHEDULES, OR INSPIRE NEW TYPES OF DESIGNS OR FAB METHODS
- A TWO-WAY FLOW: GOOD DESIGN ALLOWS AUTOMATION AND AUTOMATION ALLOWS BETTER DESIGN



STATUS OF AUTOMATION IN U.S. YARDS NOW

AUTOMATION LIMITED TO DESIGN AND FIRST PROCESSING STEPS ON SINGLE WORKPIECES

- CUT-OUT AUTOMATED
- SHAPE-CHANGE AND JOINING MOSTLY MANUAL AND EXPERIENCE-BASED
- TRANSITION DESIGN, WORK PACKAGE DEFINITION, OUTFIT PLANNING, SCHEDULING, MEASUREMENT
SPC ALL ARE MOSTLY MANUAL AND EXPERIENCE-BASED
- BETTER SCIENCE BASE AND NEW DESIGN/FAB CONCEPTS NEEDED TO EXTEND AUTOMATION TO LATER
PROCESSING STEPS

FABRICATED COMPONENTS ARE DESIGNED TO BE BUILT UP FROM RAW STOCK

J-21

- RESULTS IN MANY PIECES
- PIECES HAVE BIG RATIO OF PERIMETER TO AREA
- RESULTS IN LOTS OF MEASUREMENTS, MANY JOINING OPERATIONS
- AUTOMATION IS DIFFICULT
- NEW DESIGN/FAB CONCEPTS ARE NEEDED

HEAT-INDUCED DISTORTION IS A SERIOUS PROBLEM

- TIME TO CORRECT IT IS LARGE
- FITUP TIME SIGNIFICANT COMPARED TO JOINING TIME, SO JOINING AUTOMATION MAY NOT BUY
MUCH
- NEW DESIGN/FAB/COMPENSATION/CORRECTION CONCEPTS NEEDED



DESIGN AND PRODUCTION ISSUES

SHIPYARDS LACK COST AND TECHNICAL PERFORMANCE DATA AND TECHNIQUES FOR EVALUATING SUCH DATA

- COST AND TIME TRACKING
- MATERIAL TRACKING
- TOLERANCE PERFORMANCE
- DATA GATHERING METHODS, COST-CAPTURING, AND DECISION AIDS ARE NEEDED

LACK OF RELIABLE DATA MAKES IT DIFFICULT TO DETECT, RECOGNIZE, AND JUSTIFY AUTOMATION, DESIGN, OR PROCESS IMPROVEMENTS

J-22

IN MANUFACTURING, COST OR PRODUCTION IS DETERMINED MOSTLY BY PRODUCT DESIGN

IN SHIPBUILDING, COST OF PRODUCTION IS DETERMINED BOTH BY DESIGN AND BY PLANNING

WHO HOLDS THE HANDLES?

CUSTOMER: CONTRACT DESIGN -- FRAMING, MACHINERY GROUPS, LARGEST MODULES, STANDARDS

YARD: DETAIL DESIGN --THOUSANDS OF DETAILS (COLLARPLATES, PIPE JOINT TYPES AND LOCATIONS, VENT DUCT CONTORTIONS...)

YARD: PLANNING -- WORK PACKAGE DEFINITIONS, ZONE DESIGN/FAB/OUTFIT STRATEGIES, WORKERS' JOB INSTRUCTIONS



RECOMMENDATIONS: "MISSIONS"

CUSTOMER - MUST EXTEND PAST EFFORTS TO INVOLVE YARDS IN DESIGN

- MUST RETHINK SPECS AND TOLERANCES
- MUST CREATE DESIGNS, FUNDING METHODS, AND STANDARDS THAT ENCOURAGE YARDS TO RATIONALIZE SHIPBUILDING
- MUST ESTABLISH CENTRALIZED MECHANISM FOR EVALUATING PROCESS IMPROVEMENTS

J-23

YARDS - MUST MAKE THE MOST OF THE OPTIONS ALLOWED BY EXISTING STANDARDS

- MUST EXERT MORE CONTROL WHERE THEY HAVE IT NOW
 - * DETAIL DESIGN
 - * PLANNING
 - * DATA GATHERING, ANALYSIS, DECISIONS
- MUST IDENTIFY AND THOROUGHLY JUSTIFY IMPROVED DESIGNS OR FAB OPTIONS AND PRESENT THEM FORCEFULLY

EDUCATORS AND RESEARCHERS - MUST MAKE PRODUCIBILITY A HIGH PRIORITY



SPECIFIC IMPLEMENTATION RECOMMENDATIONS

GRAFT FLEXIBLE AUTOMATION ONTO PRODUCT-ORIENTED SHIPBUILDING PHILOSOPHY

- INTERIM PRODUCT CONCEPT
- SIMILAR PROBLEM AREAS
- CLASSIFICATION AND CODING

WORK TO BROADEN SCOPE OF SIMPLE PROBLEM AREAS AND NARROW THE DIFFICULT ONES

IDENTIFY INTERIM PRODUCTS WITH SIMILAR-ENOUGH PROBLEMS AND WRITE PROCESS SPECS, GET TIME/COST/TOLERANCE DATA

J-24

USE HIGH COST, HIGH REWORK, EXCESSIVE X-BAR OR R, DANGER OR STRAIN AS JUSTIFICATIONS

FOCUS ON TASKS WHERE DESIGN DATA AND MATERIAL HANDLING/TRACKING CAN BE PROFITABLY COMBINED WITH FABRICATION:

- STRUCTURAL DETAILS
- PIPE ASSEMBLY
- FOUNDATIONS
- VENT DUCT
- STRUCTURAL JOINTS





AUTOMATED MARKING OF PLATE

CUT BY

COMPUTER NUMERICALLY CONTROLLED BURNING MACHINES

**SHIP PRODUCTION COMMITTEE
PANEL SP-10**

J-25

APPENDIX IV

OBJECTIVE

SYSTEM TO AUTOMATE MARKING OF PLATE OFF LINE FROM
COMPUTER NUMERICALLY CONTROLLED BURNING MACHINES,
INCLUDING FACILITY TO AUTOMATE PROGRAMMING OF THE
BURNING MACHINES AND ALIGNING THE CUTTING PROGRAM
WITH THE POSITION OF A PLATE ON THE PLATEN

PHASE 1: REQUIREMENTS DEFINITION, SPECIFICATION
PREPARATION, ECONOMIC JUSTIFICATION

CURRENT PLATE MARKING METHOD

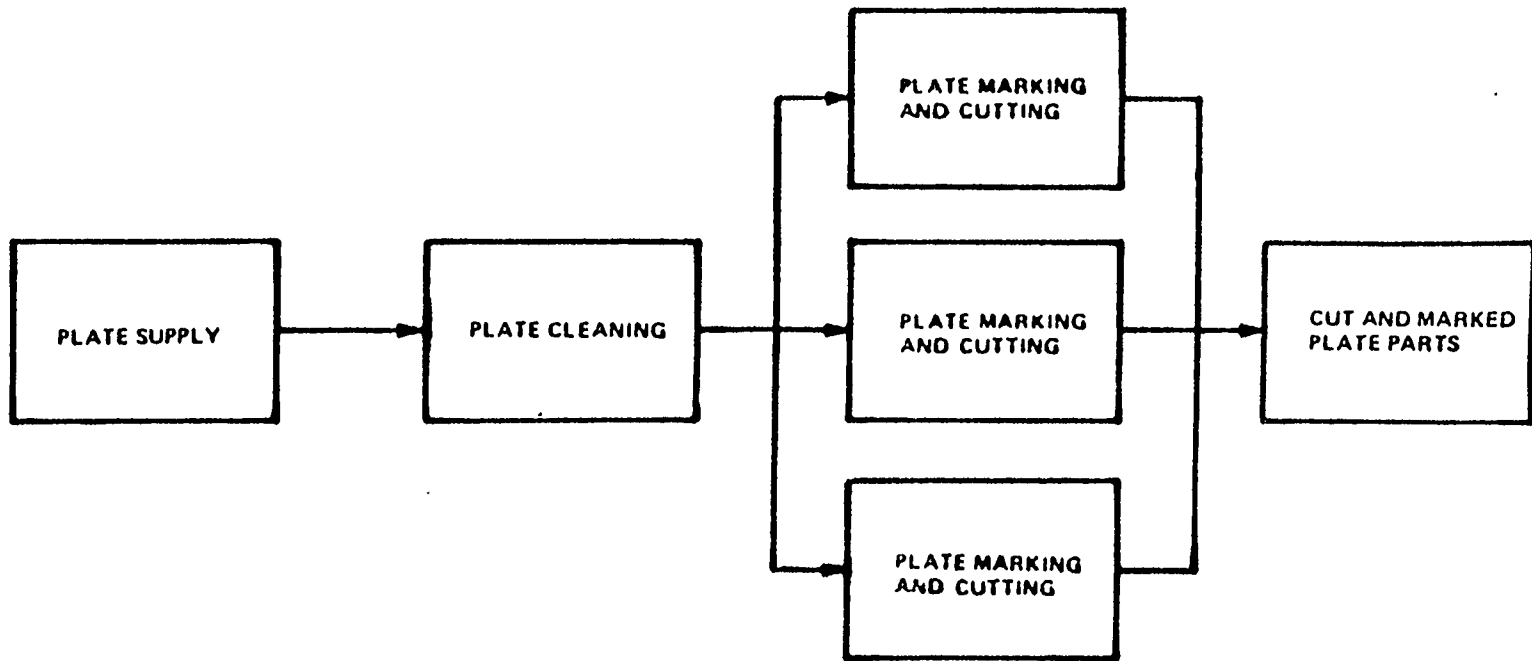

PROPOSED PLATE MARKING METHOD

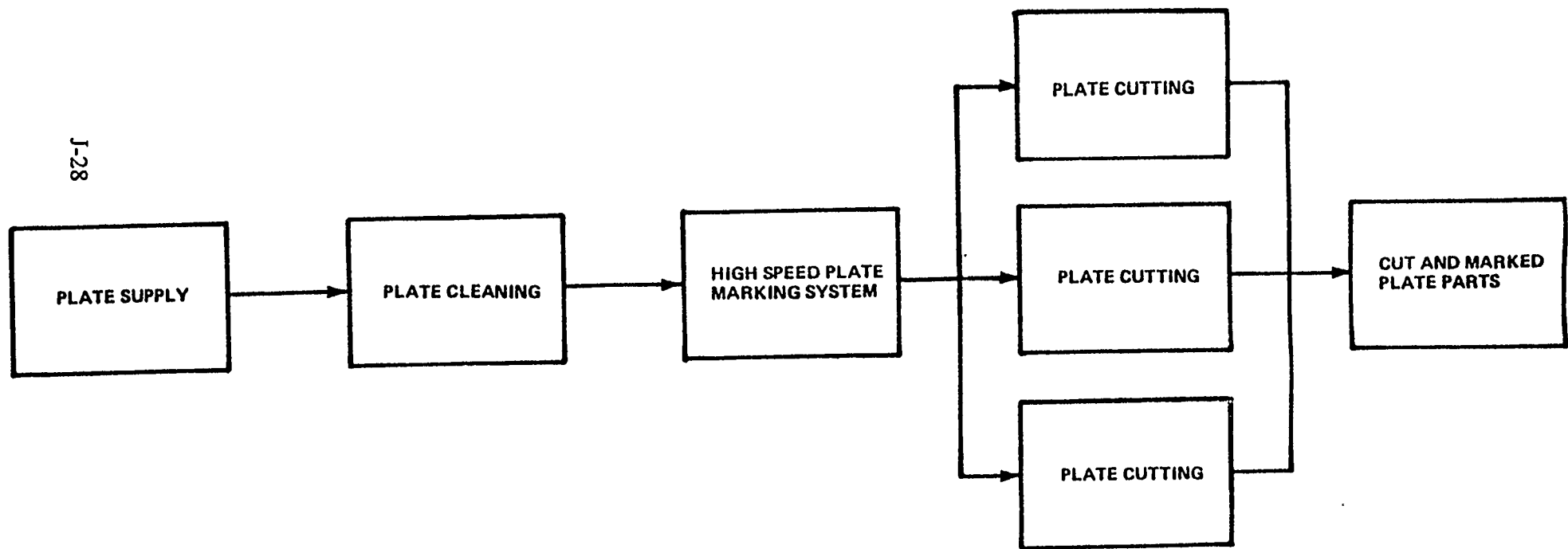

APPROACH

PHASE I

- CHARACTERIZE PROCESS LANE REQUIREMENTS
- STUDY MARKING TECHNOLOGIES
- SYNTHESIZE SYSTEM DESIGN CONCEPT
- ANALYZE ECONOMIC JUSTIFICATION

ALTERNATIVE MARKING TECHNOLOGIES

J-30

- PAINT JET

ZINC POWDER

LASER ENGRAVING

ROTARY ENGRAVING

PNEUMATIC PIN PUNCH

MOTOR DRIVEN MULTIPLE
WHEEL LETTER PUNCH

PLATE MARKING STUDY

131

TRAFFIC MARKING in FEET

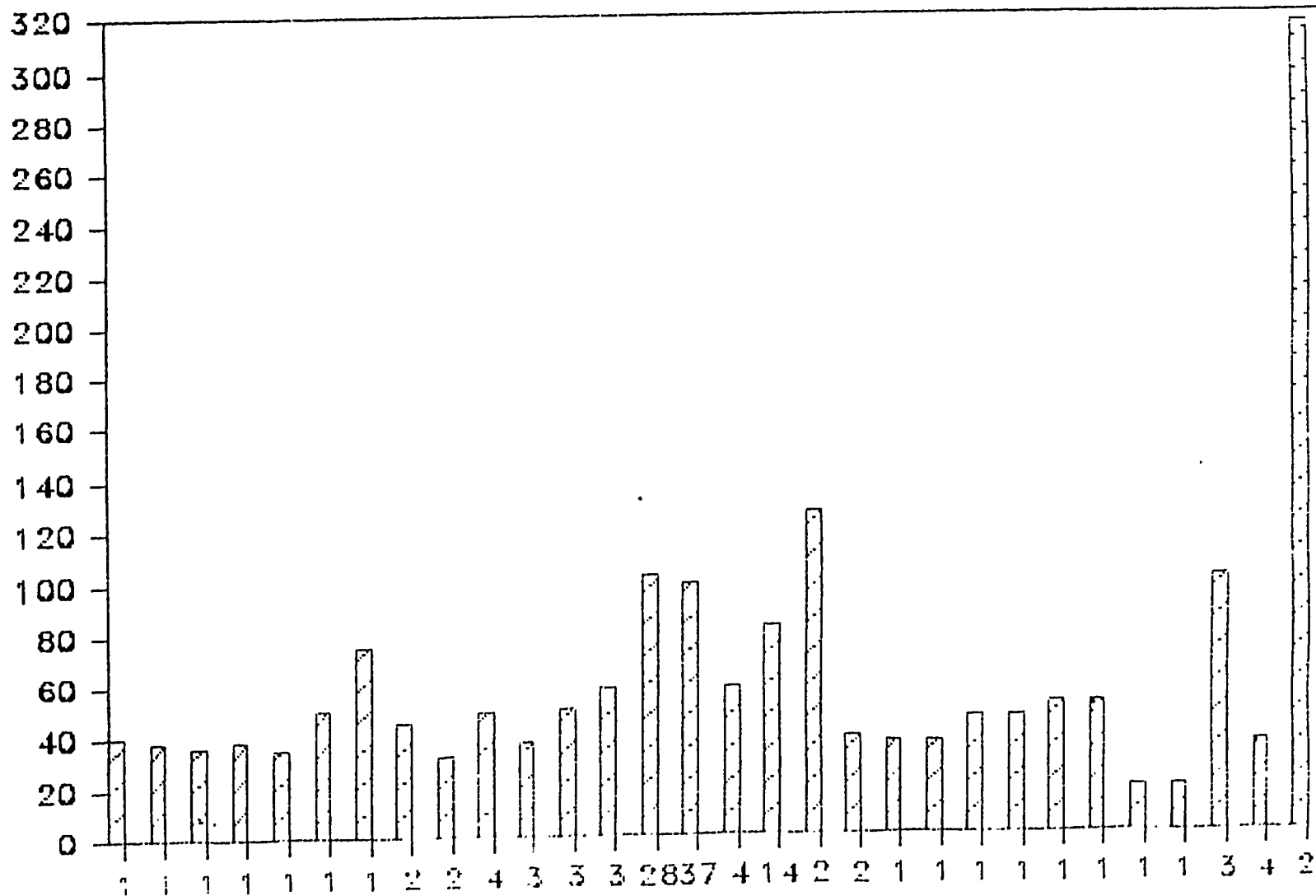

BENEFIT

J-32

- **REDUCED DIRECT LABOR**
- **INCREASED BURNING MACHINE THROUGHPUT**

PANEL SP-10
FLEXIBLE AUTOMATION

PANEL CHARTER

(Revised Jun 11, 1986)

Panel SP-10 of the Ship Production Committee of the Society of Naval Architects and Marine Engineers is chartered to perform research and development tasks to the advancement of shipbuilding, conversion and repair technology and methodology. Its goal is to develop and initiate implementation of integrated flexible manufacturing technology which will result in American shipbuilding taking its rightful and competitive place in the maritime interests of America.

Panel SP-10 will take its general guidance from the *Strategic Long Range Productivity Improvement Plan* of the Ship Production Committee, and will augment its efforts through information obtained from the Panel members, based on their individual experiences and knowledge.

Panel SP-10 will diligently research new industrial methods, not necessarily being used in shipbuilding and investigate means to adapt them to this industry.

Panel SP-10 will, when appropriate, join efforts with other panels to produce a common project product.

Panel SP-10 is, by its charter, challenged to perform tasks including, but not limited to, the following areas:

- o Planning, developing, testing, and/or combining technologies to maximize the implementation of integrated cellular and Flexible Manufacturing Systems (FMS) into the shipbuilding process.
- o Developing and maintaining plans for transferring existing and new flexible automation technology
- o Establishing a consensus priority list of high cost driver areas for target applications of this technology.
- o Soliciting and reviewing proposed research projects which address problem areas.
- o Publishing and disseminating research results to the industry.

- o Coordinating the efforts of other of Society of Naval Architects and Marine Engineers Panels proposing flexible automation technology as it applies to shipbuilding, conversion and repair.
- o Maintaining a flexible program with redirection capability to address new problems and technologies as they arise.
- o Developing an annual plan of projects related to the improvement of application of flexible automation to the shipbuilding, conversion and repair industry.
- o Coordinating the project plan and results thereof with other panels to ensure the maximum benefit derivable.

Panel SP-10 shall compose itself of capable individuals of shipbuilding, design and academic expertise who are versed in the current and future concepts of shipbuilding, conversion and repair, to the extent that the members are knowledgeable of problems extant and the need for their resolution. The members should be characterized by their ability to penetrate deeply the existing shipbuilder problems and by innovative resolution of such problems. They should investigate the methods of others, where such methods are obviously effective, accepting those which are transferable and rejecting those that are the converse. No dues are required of members, however all expenses of attending meetings are their responsibility. The following classes of membership are hereby established:

- o Regular Members

Participating private shipyards (open to all member yards of the Ship Production Committee)

U.S. Naval Shipyards (open to all)

- o Associate Members

- Maritime Administration

- Navy offices, bureaus and research activities

Membership-approved education and research institutions

Professional societies/associations with direct involvement in the industry

- o Guest Members

 - Consulting firms (in the appropriate fields)

 - Private research firms

Voting regulations are established as follows:

- o One vote for each regular member's organization on policy matters
- o One vote for each regular and associate member (or his alternate) on technical matters
- o Vote will be by members (or alternates) present at a regularly scheduled meeting.

Panel SP-10 shall conduct plenary meetings, at least semi-annually, in convenient locations - preferably near the sites of installations where field visits can be conducted and where the current processes of design, construction, conversion, repair or training can be observed.

Projects selected should be undertaken considering the probability of imminence of implementation.

Results of the panel's activities will be shared with the industry in the expectation that, by such altruistic action, the industry will realize synergistic results.

RECONVENE

The meeting was reconvened at 0830 March 19 by Chairman Acton. The business meeting was resumed.

PANEL CHARTER

All panel charters were revised by Mr. R. Slaughter, Chairman of panel SP-11 to establish consistency and standardization between the panels. The panel reviewed the revised charter and, after directing certain changes, approved the revised edition - which is included as Appendix V.

The chairman will reissue procedural items contained in the old charter as *Panel Procedures*. NOTE: Pending reissue, procedural items in the old charter will remain in effect.

The chairman reported that a number of panel members had not attended a meeting in excess of one year and had not responded to the request in the November meeting-notice to indicate their desire to remain on the panel. He requested, and was granted permission by the panel to terminate their membership.

TOUR OF DTNSRDC

From 0930 until 1130, the panel was given an in-depth tour of DTRSRDC facilities.

MEETING VRAP-UP AND ANNOUNCEMENTS

- o The next panel meeting will be hosted by the Engineering Department of the University of Texas at Arlington 8-9 July.
 - o Future meeting sites will include ARO corporation 21-22 October and (tentatively) GM Tech Center in March, 1987.
 - o The panel members were encouraged to attend the following meetings:
 - Robots 10, Chicago, April 21-24;
 - NSRP Symposium, Williamsburg, VA, 27-29 August;
 - ULTRATEC 86, Long Beach, 22-25 Sept;
 - 1987 NSRP Symposium, New Orleans, 23-25 Sept, 1987; and
- ~ Appropriate *End of Contract Demonstrations*.

ADJOURNMENT

There being no further business, the meeting was adjourned at 1200.

Prepared and Approved by:

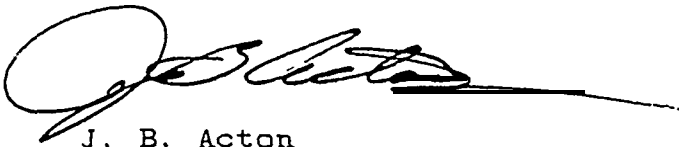
A handwritten signature in black ink, appearing to read "J. B. Acton", with a long horizontal flourish extending to the right.

J. B. Acton
Panel Chairman

PANEL SP-10
FLEXIBLE AUTOMATION

PANEL CHARTER

Panel SP-10 of the Ship Production Committee of the Society of Naval Architects and Marine Engineers is chartered to perform research and development tasks to the advancement of shipbuilding technology and methodology. Its goal is to develop and initiate implementation of processes which will result in American shipbuilding taking its rightful and competitive place in the maritime interests of America.

Panel SP-10 will take its general guidance from the Strategic Five Year Plan of the Ship Production Committee, and will augment its efforts through information obtained from the Panel members, based on their individual experiences and knowledge.

Panel SP-10 will diligently research new industrial methods, not necessarily being used in shipbuilding, and investigate means to adapt them to this industry.

Panel SP-10 will, when appropriate, join efforts with other panels to produce a common project product.

Panel SP-10 is, by its charter, challenged to perform tasks including, but not limited to, the following areas:

- o Planning, developing, testing, and/or combining technologies to maximize the integration of cellular and flexible manufacturing systems (FMS) into the shipbuilding process, defined as a group of manual operations, conventional or numerically controlled machines dedicated to the production of a family of parts.
- o Developing and maintaining plans for transferring existing and new flexible automation technology.
- o Establishing a consensus priority list of high cost driver areas for target applications of this technology.
- o Soliciting and reviewing proposed research projects which address problem areas.
- o Publishing and disseminating research results to the industry.
- o Coordinating the efforts of other Society of Naval Architects and Marine Engineers Panels proposing flexible automation technology as it applies to shipbuilding.

2 January 1986 (4: 10PM)

- o Maintaining a flexible program with redirection capability to address new problems and technologies as they arise.
- o Develop an annual plan of projects related to the improvement of application of flexible automation to the shipbuilding industry.
- o Coordinate the project plan and results thereof with other panels to ensure the maximum benefit derivable.

Panel SP-10 shall compose itself of senior individuals of shipbuilding design, and academic expertise who are versed in the current and future concepts of shipbuilding, to the extent that the members are knowledgeable of problems extant and the need for their resolution. The members should be characterized by their ability to penetrate deeply the existing shipbuilder problems and by innovative resolution of such problems. They should find acceptable the methods of others where such methods are obviously effective, rejecting those that are the converse.

Panel SP-10 shall conduct plenary meetings, at least semi-annually, in convenient locations, preferably near the sites of installations where field visits can be conducted and where the current processes of design/construction or training can be observed.

Projects selected should be undertaken with consideration of the probability of imminence of implementation.

Results of the panel's activities will be shared with the industry in the expectation that, by such altruistic actions the industry will realize synergistic results.

APPENDIX K

**List of Attendees
at
SPC Panel SP-10 Meeting No. 10**

**held at
Arlington, TX
on July 8-9, 1986**

**without
Minutes**

M E E T I N G M I N U T E S
SNAME/SPC PANEL SP-10 FLEXIBLE AUTOMATION

Meeting No. 10
UNIVERSITY OF TEXAS AT ARLINGTON
ARLINGTON, TEXAS
JULY 8-9, 1986

PRESIDIHG: J,B. Acton, Chairman & Program Manager

ATTENDEES:

J.B. Acton	Todd Shipyards
J. Cameron	General Dynamics - Electric Boat
K. Goodwin	National Bureau of Standards
J. Justice	M.K. Ferguson
M. Lormer	Optimation
M. Lundy	Optimation
J. Nevins	C.S. Draper Labs.
J. Richard	MARAD
K. Scully	DTNSRDC
J. Sizemore	Ingalls Shipbuilding
R. Wells	NAVSEA (07)

ABSENTEES:

D. Blais	Bath Iron Works
W. Christensen	Nav Ind Res Supp Activity
LCDR B. Everett, USN	NAVSEA (90M)
A. Dallas	U of Mich - Trans Res Inst
J. Fallick	NAVSEA (05M2)
W, French (alternate)	Avondale
T, Galie	NAVSYSENGSTA
N. Haynes	Beth Steel - Sparrows Pt
L. Holliday	Newport News Shipbuilding
R. Jenkins	DTNSRDC
A. Klick	General Dynamics - Data Systems
D. Lick	General Electric - CALMA
R. Price	Avondale
V. Rinehart	MARAD
J. Rivas	Long Beach Naval Shipyard
J. Ruecker	NASSCO
R. Schaffran	DTNSRDC
R. Slaughter	Ingalls
L. Vivian	Long Beach Naval Shipyard
R. Wallen (alternate)	Newport News Shipbuilding

APPENDIX L

**Minutes
of
SPC Panel SP-10 Meeting No. 11**

**held at
New Orleans, LA
on November 20-21, 1986**

**with
Appendix I
and
Panel Membership Listing**



the Society of Naval Architects and Marine Engineers

ONE WORLD TRADE CENTER- SUITE 1369. NEW YORK n. y. 10048 (212) 432-C310

COMMITTEE CORRESPONDENCE
SPC PANEL SP-10 * FLEXIBLE AUTOMATION

TODD PACIFIC SHIPYARDS CORPORATION - NAVAL TECHNOLOGY DIVISION

ISO West Seventh Street. San Pedro. CA 90731 * 213 832-3361

Jan 27, 1987

To: Distribution

Subj : Minutes of meeting #11, November 20-21, 1986

Attached are the minutes of subject meeting held at the New Orleans Hilton. Please contact me if you have any questions, comments or corrections.

Your attention is invited to the NOTE on page 3; please respond with your suggestions as soon as possible.

It is my sincere hope that the 1987 schedule will enable more of the panel members to attend meetings - a function that is vital to the successful operation of the Program. Remember, the program is still very much alive and with the "low bidder wins" philosophy it is vital that the tenets of Flexible Automation be implemented.



J. B. Acton
Panel Chairman

L-1

M E E T I N G = M I N U T E S
SNAME/SPC PANEL SP-10 FLEXIBLE AUTOMATION
MEETING NUMBER 11
NEW ORLEANS HILTON RIVERSIDE
NEW ORLEANS, LA
NOVEMBER 20-21, 1986

PRESIDIHG: J.B. Acton, Chairman & Program Manager

ATTEEDEES:

J.B. Acton	Todd Shipyards
W.H. Christensen	Nav Ind Res Supp Activity
O.J. Davis	Chairman, Panel SP-7
K. Goodwin.	National Bureau of Standards
R. Jenkins	DTNSRDC
Leo Plonsky (visitor)	Nav Ind Res Supp Activity
J.C. Richard	MARAD
D. Rome	Ingalls Shipbuilding
J. Sizemore	Ingalls Shipbuilding

ABSENTEES:

D. Blais	Bath Iron Works
J. Cameron	GD-Electric Boat
O.E. Edwards	Lockheed Shipbuilding
LCDR Bart Everett, USN	NOSC
J. Jessup	Univ of Mich-TRI
J. Fallick	NAVSEA (05M2)
W. French	Avondale
N. Haynes	Beth Steel-Sparrows Pt
L. Holliday	Newport News Shipbuilding
J.F. Justice	M.K. Ferguson
A.M. Klick	GD-Data Systems Div
D.E. Lick	GE-CALMA
J.L. Nevins	C.S. Draper Labs
V.W. Rinehart	MARAD
J.R. Ruecker	NASSCO
R. Schaffran	DTNSRDC
L.D. Vivian	Long Beach Naval Shipyard
R. Wallen (alternate)	Newport News Shipbuilding
R. Wells	NAVSEA (07)
W.E. Woolam	Southwest Research Institute

OPENIEG REMARKS:

The meeting was called to order by panel chairman Acton at 1305 November 20, 1986. After passing out the AGENDA, he welcomed the members, guests and visitors. He then outlined the objective of the meeting: to affirm resubmission of the FY 87 budget proposal, or to propose new projects.

APPROVAL OF MINUTES OF PREVIOUS MEETING

The minutes of the meeting of July 8-9, 1986 were approved as published.

PROGRAM STATUS

Joel Richard reported on the status of the program and made recommendations to the panel for assisting in keeping the program alive and well.

Funding

- o FY 85 - Except for Panel SP-6 - which has been fully funded, the Navy's \$1,5M share, last expected by late July, has not been transferred to MARAD. Therefore, this panel is still \$88K short, and a substitute project for *Off-line Programming of Welding Robot* can not be made.
- o FY 86 - \$60K for "Technology Transfer and Direction" to mid-1988 has been made to the panel. Unless *new funding is received for proposed projects, this will end government participation in the program!*
- o FY 87 - UNFUNDED
- o FY 88 - MARAD has a shipbuilding research line item in the budget proposal, BUT we in the program need to lobby "The Hill" to retain it.

ALSO, the Navy has a line item to cover program funding.

Program Summary

Avondale Shipyard has opted to discontinue sponsorship of the Facilities & Environmental Effects Panel (SP-1); proposals from other shipyards have been requested.

NOTE: As of the publication of these minutes, a new sponsoring shipyard has not been selected.

Joel urged all panel members to increase their level of participation in the program; not only to conduct technical and administrative business, but also to *promote the program.*

- o to their own organization (especially shipyards);
- o to the customer - particularly the U.S. Navy; and
- o to other shipyards.

In addition, he has asked the Program Managers to assist the panel members in justifying the necessary travel to attend meetings. Therefore, future MEETIEG NOTICES will contain a justification paragraph and can be attached to your trip request to assist you in obtaining approval.

NOTE. I will appreciate your suggestions as to the contents of this justification that will satisfy the requirements of your management.

PAHEL PROJECT REPORTS

Families of Parts, Robotic Weld Cell

- J.E. Actan, Todd

Todd-L. A. has been selected to perform this project, and sub-contractor approval has been requested from MARAD. Funds from the canceled project, *Off line Programming of Welding Robot*, will be utilized to complete the \$84,611 required for this project; it will be awarded as soon as approval is received.

NOTE: As of the publication of these minutes, sub-contractor approval has been received and the award will be made for work to commence not later than 01/31/87.

Plan for Implementing Flexible Automation

- J.B. Acton, Program Manager

The project has been completed and camera ready manuscript submitted for review. Some revisions have been requested, and some of the graphics need to be re-drawn prior to publication. Due to the workload of the Program Manager and Todd's Graphics kdepartment, publication is anticipated during January, 1987.

Panel members discussed distribution of the report and the report summary; the conclusion was to add to the normal list as follows:

- o Pete Palermo for distribution to Navy Program Managers;
- o Ron Kiss for Navy Design Codes(50);
- o Admiral Horn for Naval Shipyards;
- o Manufacturing Studies board of the NRC (Bob White, National Academy of Educ);
- o Marine Studies Board (Charlie Bookman);
- o House Subcommittee on Merchant Marine; and

- o Professional Societies, e.g.

AIIE
SME
ASNE
SNAKE
Etc.

Plate Marking CNC Burning Machines

- J, Sizernore, Ingalls

This report is summarized on the viewgraph copies included as Appendix I.

PANEL RELATED PROJECT REPORTS

All Navy Projects

- R. Jenkins, DTNSRDC

All Navy projects are winding down due to funding cuts, This has resulted in the suspension of follow-on phases for a number of the projects closely related to the NSRP program.

APOMS is now being installed in the Philadelphia Naval Shipyard. Future installations are pending.

RAWS is on hold due to limited funding. The future of the project is now problematical.

3-D Weld Seam Tracking System is now proceeding independently and is to be installed in Puget Sound Naval Shipyard as soon as completed.

PROSHAPS (Robotic Structural Shapes) - a BIW/Westinghouse project - is almost complete, with an end-of-contract demonstration planned for August, 1987.

FY 88 PROJECTS AM) PROPSAL

Since the FY 87 proposal was deleted from the budget, the panel re-examined the projects that were submitted and concluded that they continue to be the most desirable for the panel to work. There was one new project submitted, however, it dropped out when the screening criteria was applied to it. Therefore, it was the decision of the panel to re-submit the FY 87 proposal with new justification in accordance with the screening criteria promulgated by the Executive Control Board in August; the Draper Report will be used as the baseline for the new justification.

MEETING WRAP-UP AND ANNOUNCEMENTS

1. The panel discussed the location of future meetings, and agreed that, due to limited travel funds, it would be desirable to schedule them to coincide with major events that panel members would most likely be attending. The schedule agreed upon (announced in the Panel Chairman's letter of Dec 04, 1986) is as follows:

Next meeting - April 28 in Chicago (during ROBOTS 11)

2nd meeting - Early August at BIW (with end-of-contract demo on PROSHAPS), or

- August 25 in New Orleans (during the annual NSRP Symposium)

3rd meeting - November 10 in Detroit (during AUTOFACT 87),

2. Panel members were invited to comment on panel events; the universal concern was the *perception of funding* that exists in the minds of many shipyard managers. The recommended solution was to publish the Draper study ASAP and then develop a long range plan for this panel. This will be explored further in future meetings.
3. Members and guests were encouraged to submit abstracts for papers for the 1987 NSRP Symposium.

ADJOURNMENT

There being no further business, the meeting was adjourned at 1200, November 21, 1986.

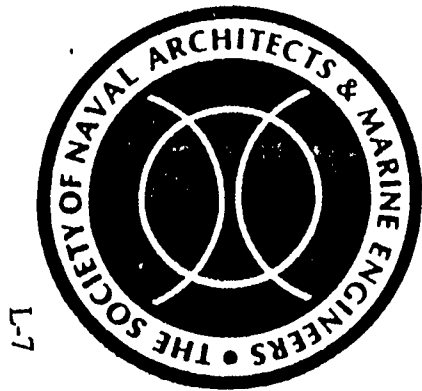

**AUTOMATIC MARKING
OF PLATE CUT BY**

DIRECT NUMERICAL CONTROL BURNING MACHINES

SHIP PRODUCTION

COMMITTEE

PANEL SP-10

APPENDIX I

OBJECTIVES

- **IMPROVE THROUGHPUT**
- **REDUCE TOUCH LABOR**
- **IMPROVE GEOMETRIC FIDELITY**
- **MINIMIZE HUMAN ERROR SOURCES**
- **ENHANCE MARK CHARACTERISTICS**
- **WORK STATUS REPORTING CAPABILITY**

CONCEPT DEVELOPMENT

- **ELEMENTS**

- **MARKING TECHNOLOGY CAPABILITIES**
- **REQUIREMENTS DEFINITION**
- **STRUCTURED EVALUATIONS**
- **FEASIBILITY DEMONSTRATIONS**
- **PRELIMINARY DESIGN AND SPECIFICATIONS**
- **ECONOMIC JUSTIFICATION**

SYSTEM REQUIREMENTS DEFINITION

- **ELEMENTS**
 - **CHARACTERIZATION OF MARKS REQUIRED**
 - **CHARACTERIZATION OF PROCESS LANE REQUIREMENTS**
 - **CHARACTERIZATION OF AVAILABLE DATA RESOURCES**

CHARACTERIZATION OF MARKS

- **BASIS**
 - **NAVY DRAWING STUDY**
 - **SHOP OBSERVATIONS**
- **PARAMETERS**
 - **NUMBER AND PLACEMENT OF ALPHANUMERICS**
 - **ORIENTATION AND LENGTH OF LINES**
 - **NUMBER AND PLACEMENT OF FIDUCIALS**
 - **DEGREE OF PERMANENCE**

CHARACTERIZATION OF PROCESS LANE REQUIREMENTS

- **BASIS**

- NAVY DRAWING STUDY
- SHOP OBSERVATIONS
- INTERVIEWS

- **PARAMETERS**

- CHARACTERIZATION OF PLATE SPECTRA
- CHARACTERIZATION OF SHIPYARD EQUIPMENT
- CHARACTERIZATION OF MARKING CYCLE TIME
- CHARACTERIZATION OF SYSTEM ENVELOPE CONSTRAINTS
- CHARACTERIZATION OF CURRENT AND ANTICIPATED PLATE VOLUME

CHARACTERIZATION OF A VAILABLE DATA RESOURCES

- **BASIS**

- **INTERVIEWS**

- **EQUIPMENT SPECIFICATIONS**

- **PARAMETERS**

- **CHARACTERIZATION OF RESOURCES AVAILABLE FOR GENERATION OF
ALPHANUMERIC CHARACTERS**

- .* **LINES AND ARCS**

- BAR CODES**

- FIDUCIALS**

- **CHARACTERIZATION OF DATA FORMATS AND TYPES**

- **CHARACTERIZATION OF TRANSMISSION PROTOCOLS**

- **CHARACTERIZATION OF COMPATIBILITY WITH INDUSTRY STANDARDS**

STRUCTURED EVALUATIONS

- **TOPICS**
 - **PROCESSES**
 - **MANIPULATION MECHANISMS**
 - **SYSTEM ARCHITECTURES**

PROCESSES *CONSIDERED*

- **CONTACT MARKING DEVICES**
 - **IMPRESSION STAMPING**
 - **ROTARY ENGRAVING**
- **NONCONTACT MARKING DEVICES**
 - **ZINC-OXIDE POWDER**
 - **INK-JET PRINTING**
 - **WATER-JET ENGRAVING**
 - **LASER ENGRAVING**

PROCESS EVALUATION

- **PRIMARY CRITERIA**

- **GEOMETRIC FIDELITY**
- **APPLICATION SPEED**
- **REQUIRED ENVELOPE**
- **LEGIBILITY AND PERMANENCE OF MARKS**
- **SAFETY IMPACT**
- **SURFACE PREPARATION IMPACT**
- **EQUIPMENT ACQUISITION COST**
- **OPERATING COST**
- **MAINTENANCE COST**

MANIPULATION MECHANISMS CONSIDERED

- **STATIC PLATE**

- **ARTICULATED ARMS**

- **DYNAMIC BRIDGE AND CARRIAGE**

- **DYNAMIC PLATE**

- **ARTICULATED ARMS**

- **DYNAMIC BRIDGE AND CARRIAGE**

- **DYNAMIC CARRIAGE ON STATIC BRIDGE**

- **MANIFOLD TOOL ON STATIC BRIDGE**

MANIPULATION MECHANISM EVALUATION

L-18

- **CRITERIA**
 - **FEASIBILITY**
 - **MECHANICAL COMPLEXITY**
 - **CONTROL COMPLEXITY**
 - **UTILITY**

SYSTEM ARCHITECTURE ALTERNATIVES

- **SYNTHESIS OF AN EXHAUSTIVE SET OF ARCHITECTURES**

- **SYMBOLIC NOTATION**

- BOUNDS**

- * **MUST BEGIN AFTER PLATE STOWAGE**
 - * **MUST COMPLETE BEFORE PART ASSEMBLY**
 - * **FIXED SERIAL RELATIONSHIPS**

- **CONSTRAINTS**

- * **BUFFERS OR QUEUES NECESSARY FOR MISMATCHED MATERIAL FLOW**
 - * **SINGLE DESTINATION CONVEYORS**
 - * **MUST MEET SYSTEM ECONOMIC OBJECTIVES**

SYSTEM ARCHITECTURE EVALUATION

- **CRITERIA**
 - **FEASIBILITY**
 - **PRACTICALITY**
 - **UTILITY**

ARCHITECTURE PRACTICALITY

L-21

- **CRITERIA**
 - **ENVELOPE**
 - **ACQUISITION COST**
 - **OPERATING COST**
 - **PRODUCTIVITY**

ARCHITECTURE UTILITY

- **CRITERIA**

- **ADJACENT PROCESSES**

- .. **IMPACT OF**

- .. **IMPACT ON**

- .. **END PRODUCT SUITABILITY**

- **MARKING TOOL MANIPULATION**

- .. **EMBODIMENT**

- .. **NUMBER OF MARKING TOOLS REQUIRED**

- .. **EMBODIMENT SPECIFIC ACQUISITION COST**

- .. **OPERATING COST**

- **POWER AND EXPENDABLES**

- **MAINTENANCE AND RELIABILITY**

DETERMINATION OF MARKING RESOURCE GEOMETRY

- **OBJECTIVES**
 - **MINIMIZE REQUIRED ENVELOPE**
 - **MINIMIZE REQUIRED SUBRESOURCES**
 - **SIMPLIFY BEAM DELIVERY**

L-24

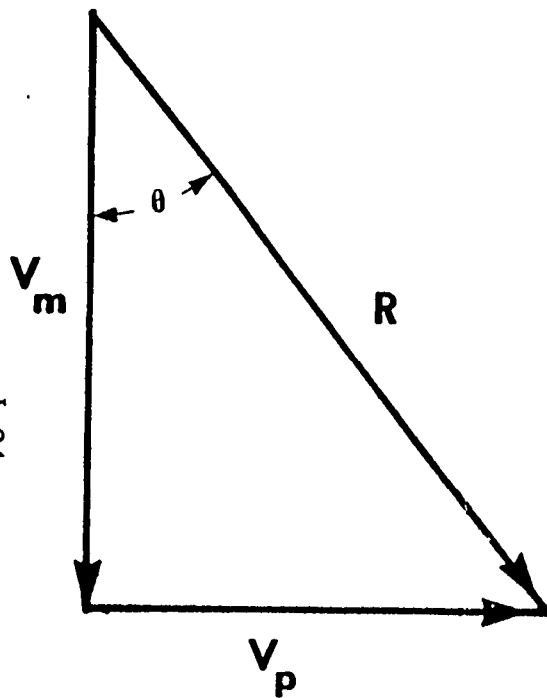

W_m : = Maximum marking speed 300 inches per minute

V_p : = Maximum plate travel speed; 240 inches per minute

R = Plane boundary of accessible areas which can be marked by Transverse Resources

θ = Angle R makes to the plates leading edge

R : = $(300^2 - 240^2)^{0.5} = 384$ inches per minute.

θ = $\text{Tangent}^{-1}(240/300) = 38.66$ degrees

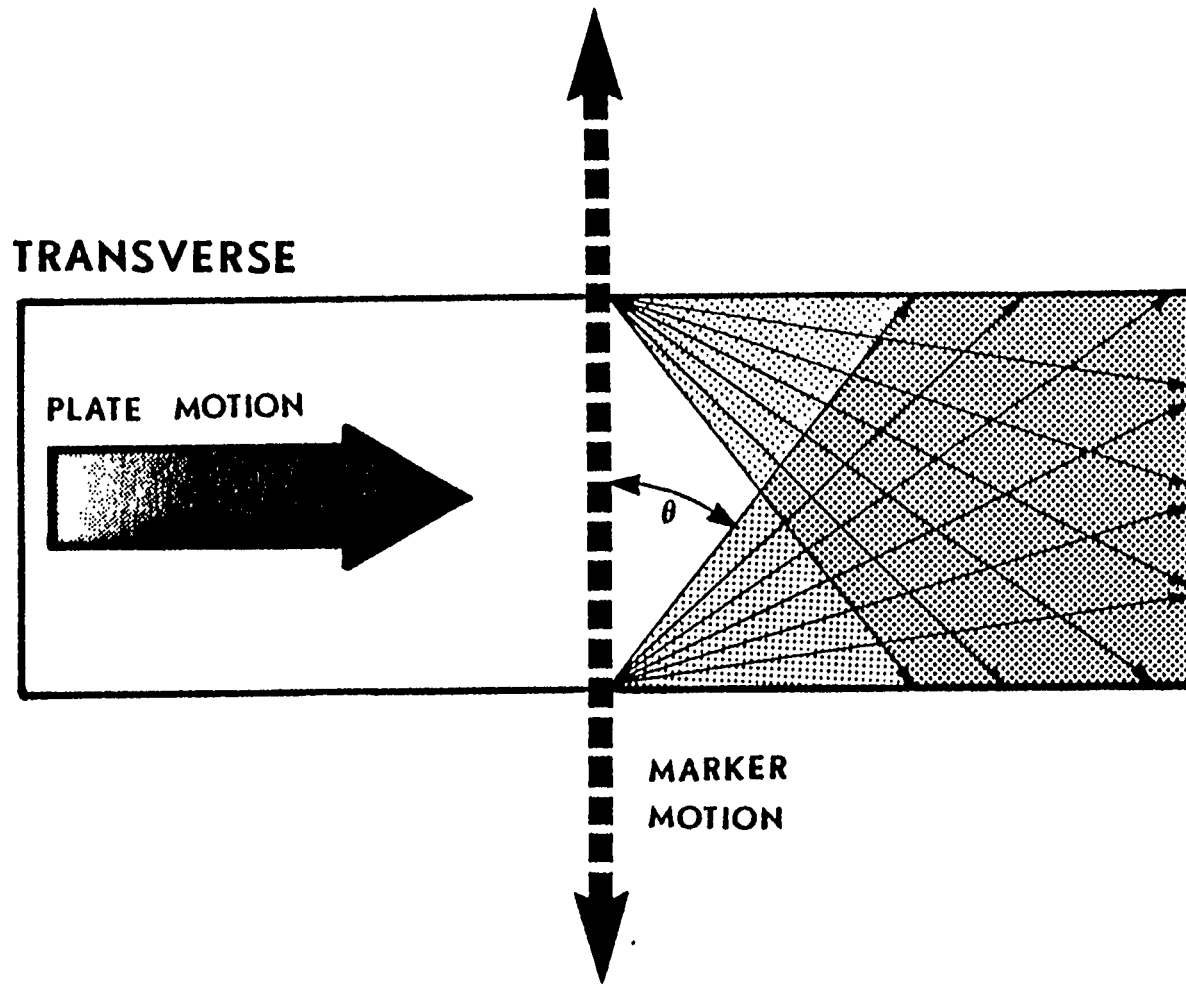

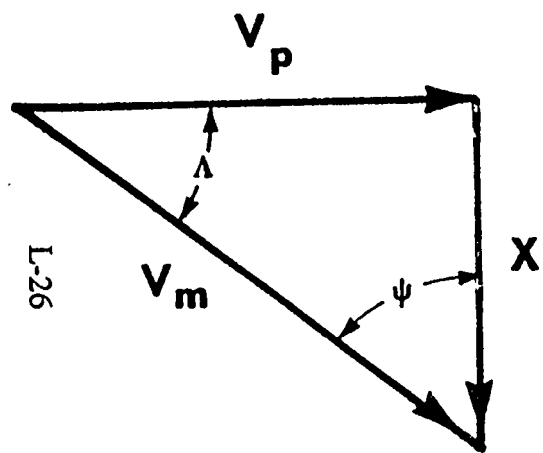

$$X = (300^2 - 240^2)^{0.5} = 180 \text{ inches per minute.}$$

This is > 160" = Maximum
Plate width and leads to the
limiting angle of:

$$\Lambda = \text{Tangent}^{-1}(180/240) = 36.87 \text{ degrees}$$

$$\psi = 90 - 36.87 = 53.13 \text{ degrees}$$

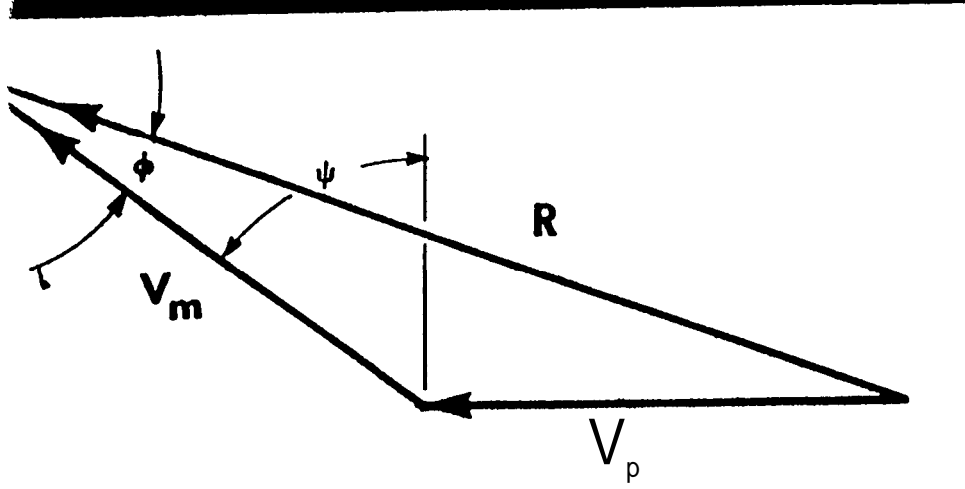

L-27

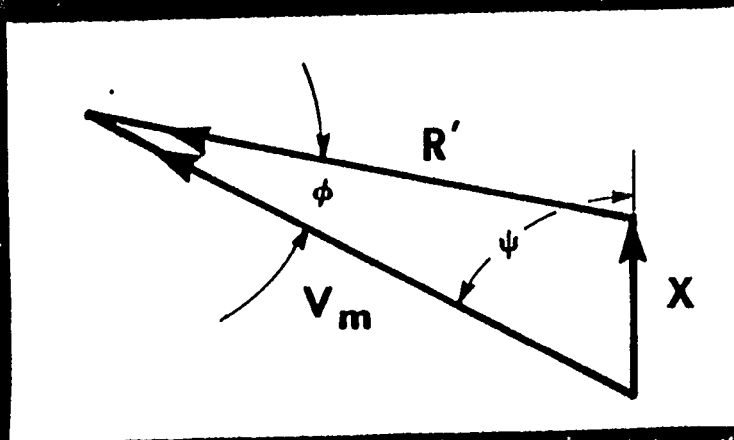

Using the Law of cosines.

$$|V_m| = 300 \text{ inches per minute.}$$

$$|V_p| = 240 \text{ inches per minute.}$$

$$|R| = (300^2 + 240^2 - 2(300)(240) \text{ Cosine}(143.14))^{1/2}$$

$$= 512 \text{ inches per minute.}$$

Using the law of sines.

$$\phi = \text{Sine}^{-1} [240 \text{ Sine}(143.13) / 512]$$

$$= 16.33 \text{ degrees.}$$

The maximum length of transverse mark that can be accomplished with a single resource traveling in the direction can be determined.

$$X = 300 \text{ Sine}(16.33) / \text{Sine}(180 - 53.13 - 16.33)$$

$$= 90 \text{ inches} < 160 \text{ inches.}$$

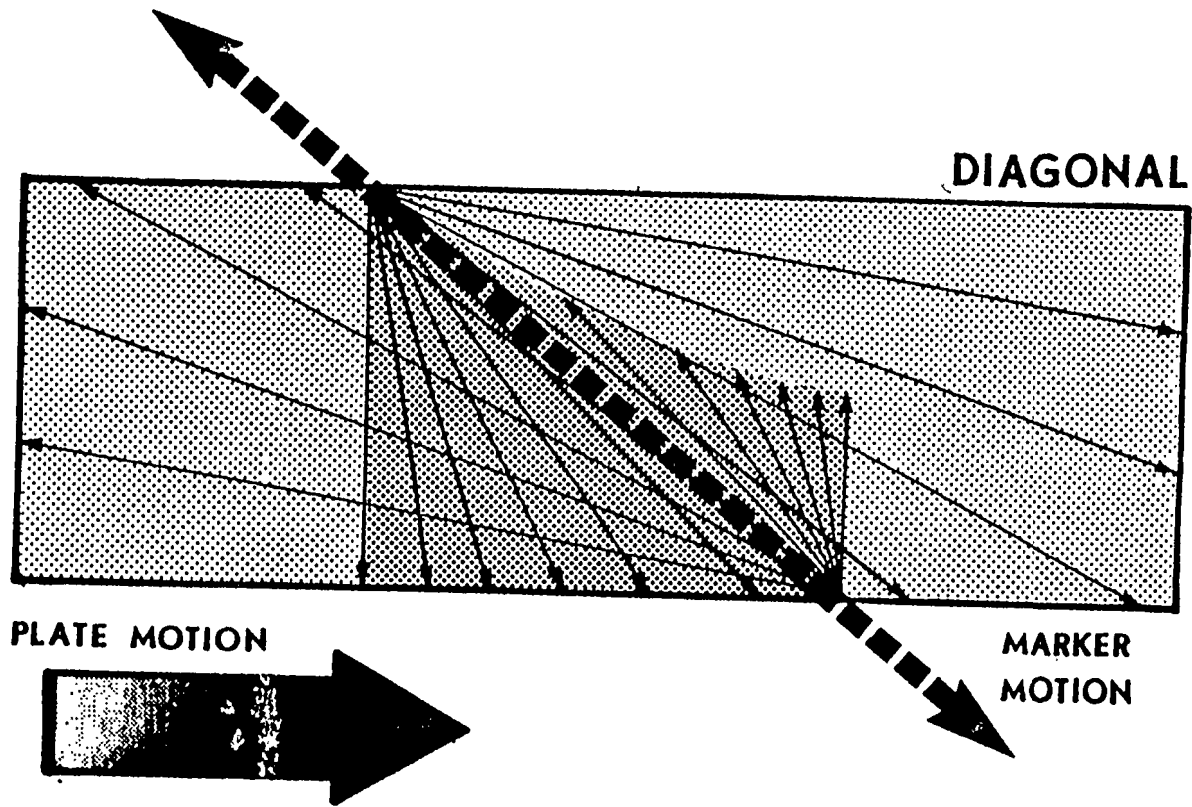

REMAINING WORK

L-29

- » ASIBILITY DEMONSTRATIONS
- Ž PRELIMINARY DESIGN
- ECONOMIC JUSTIFICATION

FEASIBILITY DEMONSTRATIONS

- CENTRAL CONTROL ISSUES
 - RESOURCE ALLOCATION
 - TRAJECTORY GENERATION
- LASER ENGRAVING PARAMETERS
 - INSTANEOUS POWER
 - COVER GAS
 - MARKING SPEED
 - DEPTH OF FOCUS
- FIDUCIAL MARK SENSING
 - MARK IMAGE ACQUISITION
 - LOCATION DETERMINATION

10

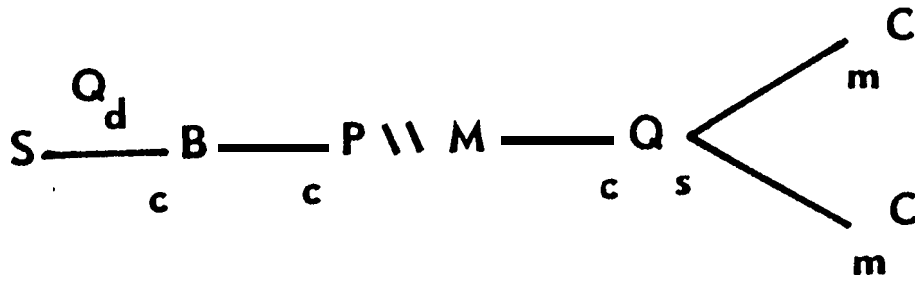

Infeasible

13

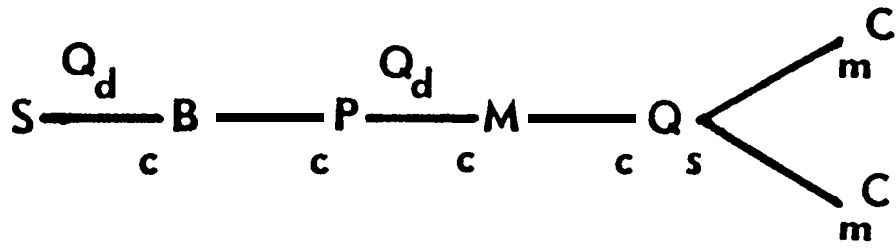

Impractical

41

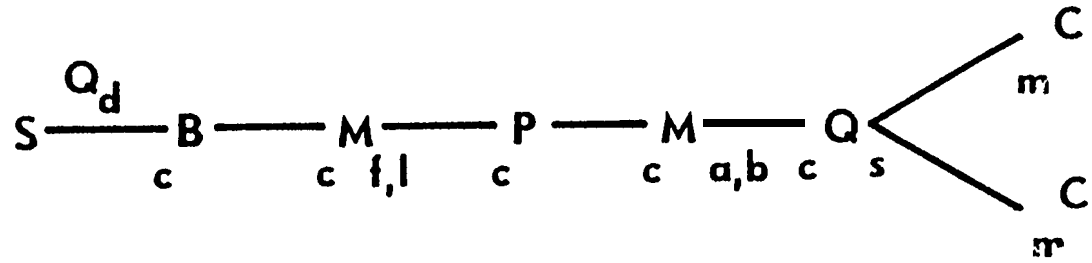

Selected

PRELIMINARY DESIGN

L-34

- **EXPAND LAYOUT DETAIL**
- **BUDGETARY DESIGN OF SELECTED COMPONENTS**
- **DEVELOPMENT AND PROCUREMENT SPECIFICATIONS**

ECONOMIC JUSTIFICATION

L-35

- **OBTAIN QUOTATIONS UNDER SPECIFICATION REQUIREMENTS**
- **REFINE PRODUCTIVITY MODEL**

ECONOMIC JUSTIFICATION

LABOR

THROUGHPUT

GEOMETRIC FIDELITY, LEGIBILITY

WORK STATUS

FLEXIBILITY

PLATE FABRICATION PROCESS LANES

L-37

- **CURRENT PRACTICES**
 - **AUTOMATED AND MANUAL MARKING ON CUTTING PLATENS**
 - **MANUAL MARKING ON CUT PARTS**
 - **MANUAL ALIGNMENT OF PLATE**
- **PROPOSED PRACTICE**
 - **AUTOMATED MARKING OF STOCK IN PLATE PREPARATION LINE**

L-38

DISTRIBUTION ,NONBURN % OF BURN .TIME

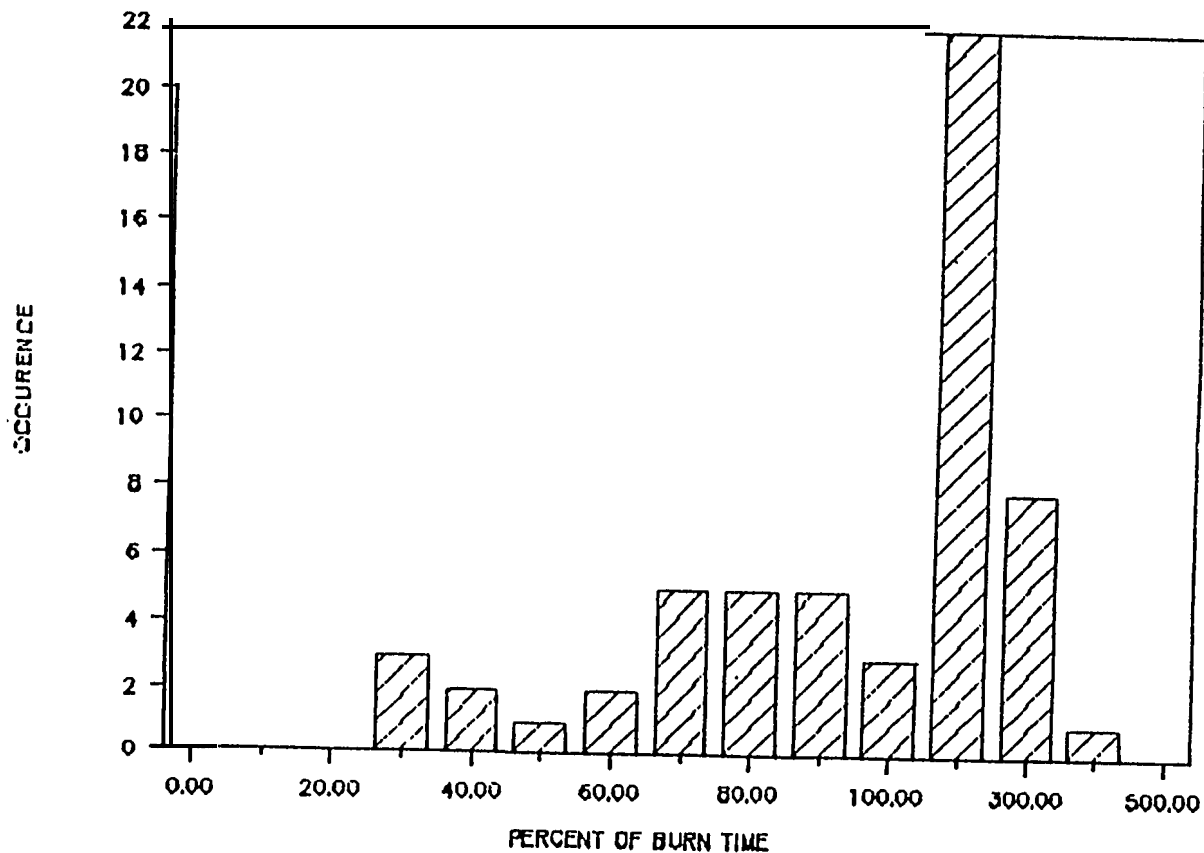

SHIP PRODUCTION COMMITTEE
PANEL SP-10, FLEXIBLE AUTOMATION

CURRENT TO Nov 13, 1986

David Blais Manager, IE, Manufacturing Technology BATH IRON WORKS CORPORATION 100 Washington Street Bath, ME 04530	(207) 443-3311
James Cameron Manager welding & Materials Engineering GENERAL DYNAMICS - ELECTRIC BOAT DIV Eastern Point Road Groton, CT 06340	(203) 441-8483
Walter Christensen NAVSEA coordinator DEPARTMENT OF THE NAVY Naval Ind. Resources Support Activity Philadelphia PA 19112-5078	(215) 897-6684
H E Edwards Manager, Program Production & Planning LOCKHEED SHIPBUILDING COMPANY 3529 131 tenth Avenue S.W. Seattle WA 98134	(206) 292-6731
LCDR Bart Everett, USN Assistant for Robotics (SEA 90M) DEPARTMENT OF THE NAVY Naval Sea Systems Command, Room 906 Washington, D C. 20362	(202) 692-6118
Jon Jessup Marine Systems Division UNIVERSITY OF MICH.-Trans. Res. Inst. 2901 Baxter Road Ann Arbor, MI 48109	(313) 763-2465

Jon Fallick (202) 692-0205
Supervisor, NDE Welding Engineering
DEPARTMENT OF THE NAVY
Naval Sea Systems Command (SEA 05M2)
Washington D.C. 20362

William French (504) 436-2121
Manufacturing Engineer
AVONDALE SHIPYARDS, INC.
P O Box 50280 - Station #78
New Orleans, LA 70150

Thomas R. Galie (215) 952-7424
Branch Head
Code 051B
NAVAL SEA SYSTEMS ENGINEERING STATION
Philadelphia, PA 19112

Ken Goodwin (301) 921-2381
Deputy Chief, Robot Systems Div.
Metrology Building, Room B-124
NATIONAL BUREAU OF STANDARDS
Gaithersburg, MD 20899

Nick Haynes (301) 388-7600
Industrial Products Sales Manager
BETHLEHEM STEEL CORPORATION
Sparrows Point Shipyards
Sparrows Point, MD 21219

Lawrence Holliday (804) 380-3283
Program Manager, Adv. Mfg. Tech.
NEWPORT NEWS SHIPBUILDING
4101 Washington Avenue
Newport News, VA 23607

Robert Jenkins (202) 227-1363
Program Director, Automated Mfg.
DAVID TAYLOR NAVAL SHIP R & D CENTER
Code 1853
Bethesda, MD 20084

James F. Justice (215) 523-5913
THE M. K. FERGUSON COMPANY
A Morrison-Knudsen Company
One Erieview Plaza
Cleveland, OH 44114

Anthony M. Flick (401) 368-2101
Chief, CAD/CAM
GENERAL DYNAMICS - DATA SYSTEMS DIV.
Quonset Facility
North Kingstown, RI 02852

David E. Lick (800) 672-0023
Consultant (301) 982-0130
GENERAL ELECTRIC - CALMA
6411 Ivy Lane, Suite 300
Greenbelt, MD 20770

James L. Nevins, M.S.IE (617) 258-2901
Div. Leader, Robotics & Assy. Svs. Div. -2905
CHARLES STARK DRAPER LABORATORIES
555 Technology Square
Cambridge, MA 02139

Joel Richard (202) 366-1941
Program Manager
U.S. MARITIME ADMINISTRATION
400 Seventh St. SW, Room 7330
Washington, D.C. 20590

Virgil W. Rinenart (202) 366-1941
Director, Office of Adv. Ship Dev.
U.S. MARITIME ADMINISTRATION
400 Seventh St. SW, Room 7330
Washington, D.C. 20590

James R. Fuecker (619) 544-7780
Chairman, SNAME/SFC Panel SP-3
NATIONAL STEEL & SHIPBUILDING CO.
P O. Box 80278 - Mail Stop 04
San Diego, CA 92138

Robert Schaffran (202) 227-1368
Head, Shipbuilding Technology Division
DAVID TAYLOR NAVAL SHIP R & D CENTER
Code 185
Bethesda, MD 2084-5000

John Sizemore (601) 935-2553
Coordinator, Adv. Mfg. Systems Dev.
INGALLS SHIPBUILDING
P. O. Box 149 - Mail Station 1020-08
Pascagoula, MS 39568-0149

R. H. Slaughter, Jr. (601) 935-4511
Chairman, SNAME/SPC Panel SP-11
INGALLS SHIPBUILDING
P.O. Box 149, Mail Station 1020-08
Pascagoula, MS 39568-0149

Lawrence D. Vivian, P.E., MBA (213) 547-6071
Production Engineering Superintendent -7134
Production Engineering Division
LONG BEACH NAVAL SHIPYARD
Long Beach, CA 90822

R. Vallen (804) 380-3513
Project Engineer
NEWPORT NEWS SHIPBUILDING
4101 Washington Avenue
Newport News, VA 23607

Ray Wells (202) 692-3082
Manager, Manufacturing Technology
DEPARTMENT OF THE NAVY
Naval Sea Systems Command, Code 070A
Washington, D.C. 20362

William E. Woolam (703) 979-0500
Director, Washington Office
SOUTHWEST RESEARCH INSTITUTE
1235 Jefferson Davis Highway #1406
Arlington, VA 22202-3283

SUPPLEMENTARY DISTRIBUTION

*****-NOT PANEL MEMBERS-*****

Project managers
Vendors
Guests
Other non-members

Dr. Daniel E. Whitney
Sect. Chief, Robotics & Assv. Svs. Div.
CHARLES STARK DRAPER LABORATORIES
555 Technology Square
Cambridge, MA 02139

(617) 258-2917

W. J. Butler
t i t l e #
DEPARTMENT OF THE NAVY
Naval Sea Systems Command, Room # 906
Washington, D.C. 20362

(202) 692-6118

J. Cantrell
t i t l e #
GENERAL DYNAMICS - ELECTRIC BOAT DIV
Eastern Point Road
Groton, CT 06340

(401) 268-2555

Kevin Sculiv
Automated Ship Technology
DAVID TAYLOR NAVAL SHIP R & D CENTER
Code 1853
Bethesda, MD 20084

(202) 227-1365

D Stehans
Automated Ship Technology
DAVID TAYLOR NAVAL SHIP R & D CENTER
Code 1853
Bethesda, MD 20084

William Oakes
Consultant
NASSCO
1130 Crest Road
Del Mar CA 92014

(619) 755-8030

Mike Lormer
Optimization
2301 E. Missouri
Suite 17
Las Cruces, N.M. 88001

(505) 522-3303

LCDR Mark O'Hare, USN
Head, Hull Expansion Program
DEPARTMENT OF THE NAVY
Philadelphia Naval Shipyard, Code 201
Philadelphia, PA 19112-5087

Richard A. Price
President
RAVERNA TECHNICAL SERVICES
4331 McArthur Blvd.
New Orleans, LA 70114

(504) 394-5814

John Peart
Consultant
JPCo
P. O. Box 1002
Harvey, LA 70059

(504) 362-5293

APPENDIX M

**Minutes
of
SPC Panel SP-10 Meeting No. 12**

**held at
Chicago, IL
on April 28, 1987**

**with
Appendix I and II
(Appendix III and IV not available)**



the Society of Naval Architects
and Marine Engineers

601 PAVONIA AVENUE. JERSEY CITY. NEW JERSEY 07036 * 201 798-4800

COMMITTEE RESPONSIBILITIES

SPC PANNEL SP-10 * FLEXIBLE AUTOAMATION
AC TON ASSOCIATES

10 Box 8938. Chule Visla. California 92012-8930 * 619 426-1150

Jun 19, 1987

To: Distribution

Subj: Minutes of meeting #12, April 28, 1987

Attached are the minutes of subject meeting held at the Chicago Hilton. Please contact me if you have any questions, comments or corrections.

It is apparent that most of you either do not read the minutes, are too busy to respond to requests, or simply don't care. I have requested input from the last two meetings and have received exactly 0 comments. I know how busy you all are, and am acutely aware of the limited funds for travel to meetings. But membership on the panel does have the obligation of participation, and simply dropping me a note or picking up the telephone should not be an excessive burden. I do not want to run this panel alone, so please send me your thoughts and input. This panel has a significant contribution to make to the industry - and to your organization - and together we can make it more impacting.

J. B. Acton
Panel Chairman

M E E T I N G M I N U T E S
SNAME/SPC PANEL SP-10 FLEXIBLE AUTOMATION
SNAME/SPC PANEL SP-10 FLEXIBLE AUTOMATION
MEETING NUMBER 12
CHICAGO HILTON
APRIL 28, 1987

PRESIDING: J.B. Acton, Chairman and Program Manager

ATTEHDEES:

J.B. Acton	Todd Shipyards
W.J. Eutler	NAVSEA
R. Jenkins	DTNSRDC
J. Jessup	Univ of Mich
V. Rinehart	MARAD
J. Sizemore	Ingalls
M. Lormer	Optimation
P. Rome	Ingalls
D. Whitney	C.S. Draper Labs
H. Knowles	DTNSRDC
V. Mangold(guest)	Kohol
H. Watson	Penn State Univ

ABSENTEES:

D. Blais	Bath Iron Works
J. Cameron	GD-Electric Boat
w. Christensen	Nav Ind Res Supp Activity
O. Edwards	Gulfport Marine
LCDR B. Everett, USN	NOSC
J. Fallick	NAVSEA (05M2)
K. Goodwin	NBS
N. Haynes	Beth Steel-Sparrows Pt
L. Holiday	NNS
A. Klick	GD-Data Systems
D. Lick	GE-Calma
J. Nevins	C.S. Draper Labs
J. Richard	MARAD
L. Vivian	Long Beach NSY
R. Wells	NAVSEA (070A)
W. Woolam	Southwest Research Inst

OPENING REMARKS:

The meeting was called to order by panel chairman Acton at 1010 April 28, 1987. After passing out the minutes, he welcomed the members, guest and visitors following which each introduced himself.

ADIMINISTRATIVE ITEMS

The minutes of the November 20-21 meeting were approved as published.

The Financial Report was made to the panel; a copy is attached as Appendix I.

Chairman Acton announced that he would be leaving Todd, but would continue to represent them as Panel Chairman and Program Manager for this panel as a sub-contractor. The formal announcement with address and telephone number will be made as soon as the dates are firm.

Note: The announcement was made by memorandum to all panel members and guests on May 15, 1987.

Other announcements included the departure from Todd Los Angeles of General Manager, Mr. Len Thorell and Naval Technology Division Manager, Kr. Ed Petersen.

A letter from the Chairman of Panel SP-4 (Appendix II) to the Chairman of the SPC concerning the FY 88 budget submittal was read to the panel. After discussion, the panel concurred with the contents of the letter and directed the Chairman to support that position.

NOTE: At the Ship Production Committee meeting in Philadelphia on May 27, this was done, and the decision was made in favor of the position taken in the letter. This will be discussed further at the next panel meeting.

PROGRAM STATUS

Virgil Rinehart reported on the status of the NSRP:

- o Joel Richard is moving to another assignment within the DOT and will be replaced by Fred Siebold as COTR for MARAD contracts.

NAVSEA (05) has agreed to transfer \$500K in FY 87 funds to support selected projects from the FY 87/88 proposal. One significant reason for this is the report documenting savings to the Navy from implementing NSRP projects that was prepared by Vern Stortz and presented to the Assistant Secretary of the Navy.

NOTE: *Update-- the funds have been transferred, and \$75K has been allotted to this panel for a Phase I effort on the proposed project, Design Production Integration for Robotic Ship Manufacture. In addition, SEA 07 has*

*transferred \$504K to support other selected projects.
Funds were included for projects in all panels.*

- 0 It appears that shipyard interest in the program is declining; for example, Bath Iron works has indicated that they no longer desire to sponsor panels SP-6 and SP-8 and SP-1 has been transferred from Avondale to NASSCO since our last meeting, therefore, they need continuing motivation to restore their interest levels and participation. One of the suggested ways is for the Program Managers to visit shipyards more frequently and present the results of projects to the CEO's and other yard personnel.
- o For future project proposals, the strategy should be on short term, quick pay-off projects benefiting ship repair in favor of ship construction.
- o One identified need is an education program aimed first at the Navy (Crystal City complex), then to other "customers" and yard users. One way to commence this program is for each panel to schedule one meeting each year in the Crystal City area.
- o Senator Pete Wilson (CA) has proposed new legislation that would be of benefit to the Industry and (indirectly) to this program; it would (1) establish a cargo preference, (2) require the president to obtain agreement with MARAD and the Navy for a cargo-type ship that would satisfy the Navy in wartime and could be leased to a commercial operator in peace time and (3) allow the shipyards to obtain loans to modernize production facilities,

PANEL PROJECT REPORTS

Families of Parts, Robotic Weld Cell
- J.B. Acton, Todd

Due to internal problems which have resulted in extensive personnel reductions and reassignments, Todd has been unable to commence work on this project. As of this meeting, I am negotiating with Todd management to recall my (now) former assistant, Ed Southern, from layoff for the purpose of accomplishing this assignment. The prospects are good that they will do so. If not, it will be recalled and assigned to the next higher bidder, Ingalls.

Plan for Implementing Flexible Automation
- J.B. Acton/D. Whitney

The basic project has been completed and copies distributed; each panel member should have received it by now. Dan Whitney is working on the presentation for the NSRP Symposium in August.

Plate Marking - CNC Burning Machines
- J. Sizemore, Ingalls

In order to reduce the complexity of a long title, this project has been renamed *AUTOMARK SYSTEM*. Discussion on progress is included as Appendix III.

PANEL RELATED PROJECT REPORTS

NANTEC/Navy Projects
- R, Jenkins, DTNSRDC
- H. Watson, Penn State

As reported in November, Navy projects have also suffered from lack of funding. However, it is anticipated that some \$14M in MANTEC funds is forthcoming, and most of them will be restarted.

PROSHAPS (Robotic Structural Shapes) - a BIW/Westinghouse project - is expected to be ready for End of Contract demonstration in late August.

RAWS (Robotic Arc Welding Systems) is still on hold due to funding limitations.

Laser Line Heating has been completed, the final report submitted to the COTR and is in review.

LARS (Laser Articulated Welding Systems) and *IRIS* (Intelligent Robotic inspection System) are scheduled for End of Contract Demonstration May 6 and 7 in Minneapolis.

FY 88 PROJECT PROPOSAL AND PRIORITIES

The Program Managers presented their FY 88 budget proposals to the Executive Control Board of the SPC on 18 March. The results of their prioritization are included as Appendix IV, While the rating system is far from perfect, it does demonstrate to the Navy that the SPC is looking at the total program.

NOTE: *some of these projects were selected by the Navy for work on the funds transferred; therefore panels will have to re-look at their proposals and a new set of priorities will have to be established. I will report more on this at the next meeting.*

MEETING WARP-UP AND) ANNOUNCEMENTS

- o The 1967 NSRP Symposium is scheduled for 26-28 August in New Orleans. Announcements will be in the mail soon.
- o The 1988 NSRP Symposium is being planned for August in Seattle,

- 0 *The next meeting of this panel will be in New Orleans on the 24th or 25th of August - preceding the NSRP Symposium. I will promulgate the exact date with the MEETING NOTICE as soon as the symposium planners have us scheduled for a date/time/room.*

- 0 *Ways to improve attendance/participation were discussed. Some of the suggestions:
Program Manager promotion by travel to the yards.
[Use of panel meetings as a "Workshop", with subjects such as the "Draper report", having SP-9 assist in setting up the curricula.
Try to select meeting sites that have more common interests to members.
I would appreciate your written or telephone suggestions on this PLEASE.*

ADJOURNMENT

There being no further business, the meeting was adjourned at 1715, April 28, 1987.

CTR D'NA 91-93-C-30028	PROJECT	ST/DT	CP/DT	OBLIG	OMTD	EXPD	OPN	OMT	UNCMTD	% REM	% CPL
Contract Summary	99-10/0005	09/83	07/88	1,051	1,070	783	266	21	307	==	
Program Management	01200/TTBD	05/87	03/88	44	44	0	44	0	44	==	
TELA TT & D	4060	09/83	05/87	275	275	275	0	0	0	100	
Robotics - Mig Insp. & Pac	01207/83-01	12/83	12/84	210	210	210	0	0	0	100	
Flex Automation Plan	01202/83-02	04/85	09/87	243	243	228	15	0	15	35	
Automated Marking	01203/84-01	10/85	06/87	168	168	104	64	0	64	80	
Part Families- Robot weld Cell	01331/85-01	02/87	03/89	55	55	0	54	0	54	5	
Unspecified	85-00	0	0	44	0	0	0	44	44	NA	

CTR D'NA 94-11989	PROJECT	ST/DT	CP/DT	OBLIG	OMTD	EXPD	OPN	OMT	UNCMTD	% REM	% CPL
CONTRACT SUMMARY	BASIC	09/86	11/88	50	50	4	55	0	55	==	
TELA TT & D	MISC	09/86	05/87	4	4	4	0	0	0	100	
Program Management	01200/TTBD	05/87	11/88	56	56	0	55	0	55	==	



FOUNDED
1897

APPENDIX II

the Society of Naval Architects and Marine Engineers

ONE WORLD TRADE CENTER, SUITE 1369, NEW YORK, N. Y. 10048 · 212 432-0310

COMMITTEE CORRESPONDENCE

April 16, 1987

Mr. J. W. Brasher
Chairman Ship Production Committee
Ingalls Shipbuilding Division
P. O. Box 149
MS 1011-01
Pascagoula, MS 39568-0149

Subject: Ship Production Committee Program for Fiscal Year 1988

Dear Mr. Brasher:

During the course of the Panel SP-4 meeting on April 9, 1987, it was reported that the sum of the Ship Production Committee (SPC) panel programs proposed to the Executive Control Board (ECB) at its meeting on March 17, 1987, would require funding of approximately \$4,500,000. It was further reported that the ECB's action was to apply the project priority system and to recommend to the SPC a total program requiring only about \$2,500,000.

Panel SP-4 requested that I as panel chairman and their representative on the SPC, relay to you and the SPC the panel's opposition to the ECB recommendation. The panel agreed that it is proper to prioritize the projects in accordance with an approved and established prioritization plan, but objects to the recommendation limiting the total program to those projects that may be covered by \$2,500,000.

Panel SP-4 recommends that the entire program of projects as identified by the various panels, and as prioritized via the accepted prioritization program, be submitted to the government with a request for funding. To do otherwise would suggest that the \$2,500,000 program is all that the NSRP feels is needed in the coming year, and this is not so! To do otherwise would also limit the government's visibility to only the ECB selected projects. The Panel feels such limitations should be avoided in that an omitted project may well address some government activity's special need (as well as industry's need, and qualify for unique funding.

M-8

please give the above comments your careful consideration and bring them to the attention of the ship Production Committee. If I can be of any assistance in this matter, please advise.

Sincerely,

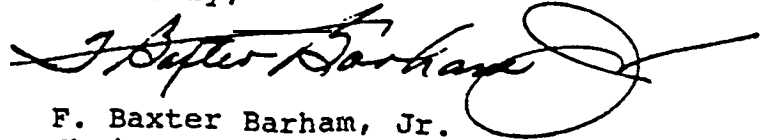
A handwritten signature in cursive script, appearing to read "F. Baxter Barham, Jr.", with a large, decorative flourish at the end.

F. Baxter Barham, Jr.
Chairman, Panel SP-4

FBB : dsc

Copies to:

Panel SP-4
SPC Panel Chairman

Additional copies of this report can be obtained from the
National Shipbuilding Research and Documentation Center:

<http://www.nsnet.com/docctr/>

Documentation Center
The University of Michigan
Transportation Research Institute
Marine Systems Division
2901 Baxter Road
Ann Arbor, MI 48109-2150

Phone: 734-763-2465
Fax: 734-936-1081
E-mail: Doc.Center@umich.edu