

January, 1995
NSRP 0439

SHIP PRODUCTION COMMITTEE
FACILITIES AND ENVIRONMENTAL EFFECTS
SURFACE PREPARATION AND COATINGS
DESIGN/PRODUCTION INTEGRATION
HUMAN RESOURCE INNOVATION
MARINE INDUSTRY STANDARDS
WELDING
INDUSTRIAL ENGINEERING
EDUCATION AND TRAINING

THE NATIONAL SHIPBUILDING RESEARCH PROGRAM

1995 Ship Production Symposium

Paper No. 16: Automated Blasting & Recovery of Coatings Removed From Ship Hulls

U.S. DEPARTMENT OF THE NAVY
CARDEROCK DIVISION,
NAVAL SURFACE WARFARE CENTER

Report Documentation Page

Form Approved
OMB No. 0704-0188

Public reporting burden for the collection of information is estimated to average 1 hour per response, including the time for reviewing instructions, searching existing data sources, gathering and maintaining the data needed, and completing and reviewing the collection of information. Send comments regarding this burden estimate or any other aspect of this collection of information, including suggestions for reducing this burden, to Washington Headquarters Services, Directorate for Information Operations and Reports, 1215 Jefferson Davis Highway, Suite 1204, Arlington VA 22202-4302. Respondents should be aware that notwithstanding any other provision of law, no person shall be subject to a penalty for failing to comply with a collection of information if it does not display a currently valid OMB control number.

1. REPORT DATE JAN 1995		2. REPORT TYPE N/A		3. DATES COVERED -	
4. TITLE AND SUBTITLE The National Shipbuilding Research Program, 1995 Ship Production Symposium: Paper No. 16: Automated Blasting & Recovery of Coatings Removed From Ship Hulls				5a. CONTRACT NUMBER	
				5b. GRANT NUMBER	
				5c. PROGRAM ELEMENT NUMBER	
6. AUTHOR(S)				5d. PROJECT NUMBER	
				5e. TASK NUMBER	
				5f. WORK UNIT NUMBER	
7. PERFORMING ORGANIZATION NAME(S) AND ADDRESS(ES) Naval Surface Warfare Center CD Code 2230 - Design Integration Tower Bldg 192 Room 128 9500 MacArthur Blvd Bethesda, MD 20817-5700				8. PERFORMING ORGANIZATION REPORT NUMBER	
9. SPONSORING/MONITORING AGENCY NAME(S) AND ADDRESS(ES)				10. SPONSOR/MONITOR'S ACRONYM(S)	
				11. SPONSOR/MONITOR'S REPORT NUMBER(S)	
12. DISTRIBUTION/AVAILABILITY STATEMENT Approved for public release, distribution unlimited					
13. SUPPLEMENTARY NOTES					
14. ABSTRACT					
15. SUBJECT TERMS					
16. SECURITY CLASSIFICATION OF:			17. LIMITATION OF ABSTRACT	18. NUMBER OF PAGES	19a. NAME OF RESPONSIBLE PERSON
a. REPORT unclassified	b. ABSTRACT unclassified	c. THIS PAGE unclassified			

DISCLAIMER

These reports were prepared as an account of government-sponsored work. Neither the United States, nor the United States Navy, nor any person acting on behalf of the United States Navy (A) makes any warranty or representation, expressed or implied, with respect to the accuracy, completeness or usefulness of the information contained in this report/manual, or that the use of any information, apparatus, method, or process disclosed in this report may not infringe privately owned rights; or (B) assumes any liabilities with respect to the use of or for damages resulting from the use of any information, apparatus, method, or process disclosed in the report. As used in the above, "Persons acting on behalf of the United States Navy" includes any employee, contractor, or subcontractor to the contractor of the United States Navy to the extent that such employee, contractor, or subcontractor to the contractor prepares, handles, or distributes, or provides access to any information pursuant to his employment or contract or subcontract to the contractor with the United States Navy. ANY POSSIBLE IMPLIED WARRANTIES OF MERCHANTABILITY AND/OR FITNESS FOR PURPOSE ARE SPECIFICALLY DISCLAIMED.

1995 SHIP PRODUCTION SYMPOSIUM

Commercial Competitiveness for Small and Large North American Shipyards

Seattle, Washington
The Westin Hotel
January 25-27, 1995

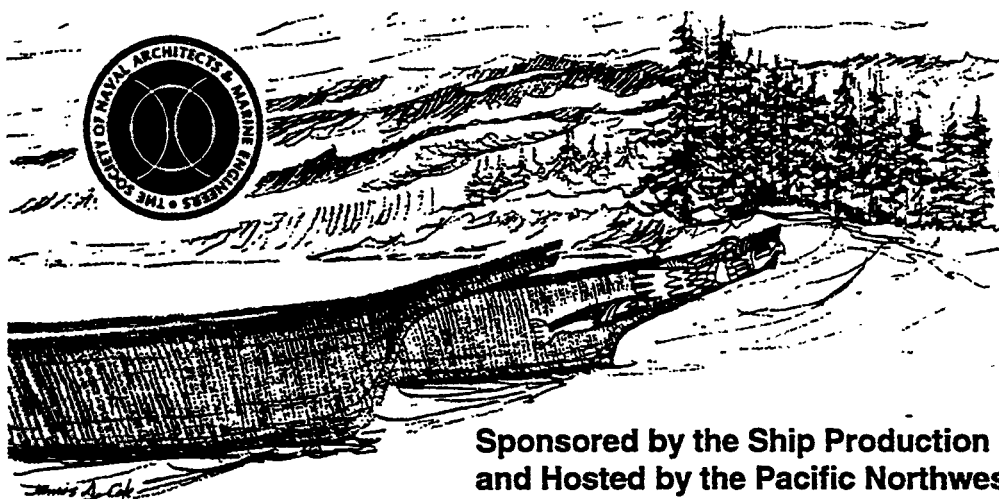

**Sponsored by the Ship Production Committee
and Hosted by the Pacific Northwest Section of
The Society of Naval Architects and Marine Engineers**

601 Pavonia Avenue
Jersey City, New Jersey 07306
Phone (201) 798-4800
Fax (201) 798-4975



Automated Blasting and Recovery of Coatings
Removed From Ship Hulls
Gary K Sweet (M), Sandroid Systems, Inc., U.S.A.

ABSTRACT

The environment and open air blasting are in conflict today. An economical coating removal system which recaptures the blast media, debris and dust at the substrate and recycles for reuse is now available.

The current method of hull blast cleaning is open blasting. This creates major air and water pollution problems from abrasive residue as well as paint and anti-foulant residues. Most drydock areas are not conducive to abrasive recovery and recycling; therefore, the abrasive residue falls into the drydock where it contaminates equipment, interferes with movement of equipment and is a potential health hazard to unprotected workers. There is considerable cost involved in clean-up and disposal of the spent abrasive and, if it is contaminated with hazardous paints, the spent abrasive must be disposed of as 'hazardous waste. Disposal costs of hazardous waste can run as high as \$550 per metric ton (\$500 per short ton), greatly increasing the cost of blast cleaning.

With a properly designed containment system, the adverse environmental impact of blast cleaning can be essentially eliminated. The containment device should be flexible enough to conform to the configuration of the ship hull and allow the blaster to work unimpeded. Incorporated in the containment system should be an abrasive

recovery and recycling system to collect and clean the spent abrasive and then return the reusable abrasive to the blast cleaning operation.

The containment system would eliminate the air pollution problems and maintain a clean environment at the job site. Reclaiming and recycling spent abrasive would allow the use of recyclable abrasive that will reduce hazardous waste disposal costs and provide additional savings in material handling costs or abrasive movement and clean-up.

This abstract introduces a revolutionary flexible abrasive blasting and recovery containment system which permits the use of recyclable abrasive and prevents air and water pollution.

INTRODUCTION

The current method of hull blast cleaning is open blasting. This creates major air and water pollution problems from abrasive residue as well as paint and anti-foulant residues. Most drydock areas are not conducive to abrasive recovery and recycling; therefore, the abrasive residue falls into the drydock where it contaminates equipment, interferes with movement of equipment and is a potential health hazard to unprotected workers. There is considerable cost involved in clean-up and disposal of the spent abrasive, and if it is contaminated with hazardous paints, the spent abrasive must be disposed of as hazardous waste. Disposal costs of hazardous wastes can run as high as \$550 per metric ton, greatly increasing the cost of blast cleaning.

Recently passed Federal regulations and many new state mandates make it necessary for the surface preparation contractor to devise a means of recovering those undesirable after-products which have been labeled as hazardous.

The problems associated with containment are well known: major increases in operating costs for erection and movement of a containment structure; devising a collection system; and the increased strain on workers due to the more confined, hostile environment, as well as use of protective clothing. Additionally, the design of the containment must be carefully engineered, lest there be damage to the ship, with the attendant liability risk.

With a properly designed containment system, the adverse environmental impact of blast cleaning can essentially be eliminated. The containment device must be flexible enough to conform to the configuration of a ship's hull and allow a blaster to work unimpeded. Incorporated in the containment system

should be an abrasive recovery and recycling system to collect the spent abrasive. The abrasive should be cleaned and returned to the blast cleaning operation.

A containment system eliminates the air pollution problems and maintains a clean environment at the job site. Reclaiming and recycling abrasive allows the use of recyclable abrasive which reduces hazardous waste disposal costs by about 99.5%. There are additional savings in material handling costs in abrasive movement and clean-up.

When properly effected, containment requires substantial capital investment in the design and fabrication of the containment structure, and the ventilation and collection equipment, to meet appropriate EPA standards. Since containment increases operating costs, one might view this capital expenditure as an investment that has a negative return.

Such a situation gives impetus to an engineering method of stripping that meets the environmental concerns, but at the same time is operationally cost effective, with an appropriate return on any capital investment that is required.

ROBOTIC BLASTING SYSTEM

A multi-process, severe environment, ecologically safe, computer-controlled robotic blaster is now being manufactured. Accompanying the robotic blaster are completely integrated support trailers that provide abrasive grit blasting, both wet and dry, high-pressure water jetting, and electrical power for continuous operation.

The robotic blaster is mobile and equipped with a robotic controller having a modular open architecture microprocessor-

based computer that uses a hierarchical control scheme. Self-diagnostic capabilities, the modular arrangement and use of standard components enhance maintainability.

The robotic blaster is equipped with a vacuum recovery and reclassification system that source recovers and recycles after-blast material of abrasive grit and water blast procedures to meet or exceed local environmental protection guidelines by virtually eliminating fugitive emissions, drydock floor contaminants and reducing burden on landfills.

SEE FIGURE(S) 1,2, & 3

Process Capability

Automatic programmable control process paths, with the ability to work within 20 cmm (8 inches) of edges, comers and protrusions. “ The ability to operate, over flat or curved surface areas with a minimum radius of 90 cmm (3 feet). Blasts a minimum of 45 square meters (500 square feet) of ship hull surface area per hour. Accommodates different end effecters (dry abrasive blasting, water blasting and painting).

Recovery and Reclassification System

Recovers virtually all abrasive cleaning material and the airborne particles that are a result of abrasive blasting. Recovers, classifies, and cleans reusable abrasive material and discharges surface residue into an appropriate container for disposal on a continuous basis.

Reclaims up to 95% of the abrasive media for reuse, depending on the condition of the surface being prepared.

Recovers virtually 100% of water blast after-blast products.

Computer System Operations

Controls the robotic blaster operations from a computer control console.

Monitors the equipment functions while the system is in operation.

Operates the robotic blaster operations in three modes; Manual, Teach and Automatic.

Emergency Stop button overrides all system operations and immediately shuts down the blaster in an orderly fashion.

Collision sensing devices interrupt system for the protection of hardware.

End effector sensors track surface contours, automatically adjusting distance and pose of end effecters to obtain optimum performance.

Justification

Meets local environmental protection requirements for air and water quality in the coating removal process. Reduces burdens on landfills.

Reduces personnel exposure to the hazardous abrasive blasting work environment.

Reduces man-hours and increases productivity in surface preparation. High productivity is possible since the blaster is operational three (3)

SANDROID WITH GRIT PROCESS TRAILER

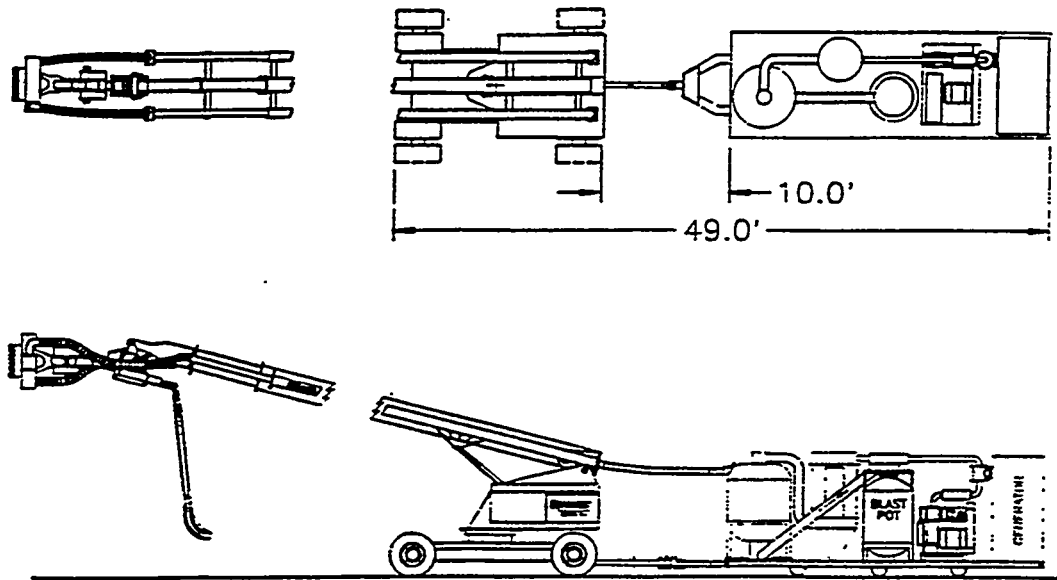

72,000 lbs

Figure 1

AIR PROCESS TRAILER

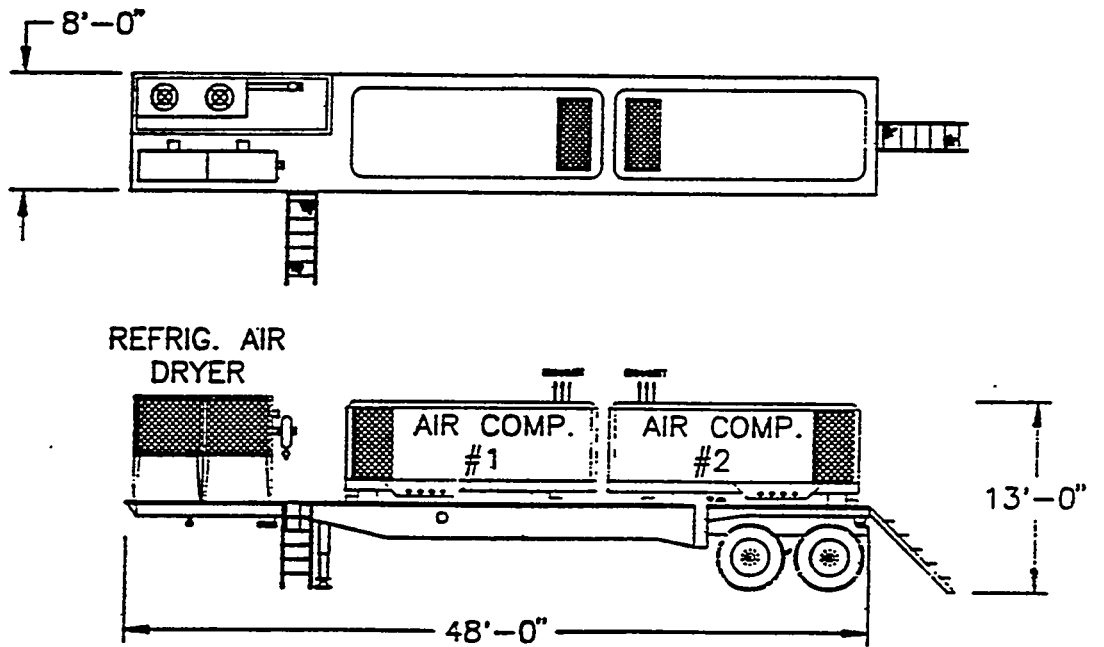

58,700 lbs

Figure 2

CONTROL AXES

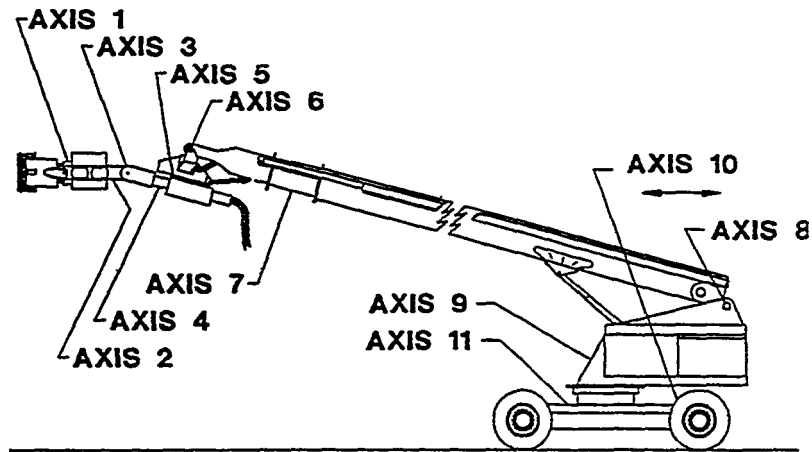

- Axis 1 -100 Degrees of Movement
- Axis 2 -100 Degrees of Movement
- Axis 3 -180 Degrees of Movement
- Axis 4 -360 Degrees of Rotation
- Axis 5 -280 Degrees of Rotation
- Axis 6 -110 Degrees of Movement
- Axis 7 - Boom Extension
- Axis 8 - Boom Lift
- Axis 9 - Boom Rotation
- Axis 10- Forward And Reverse
- Axis 11- Steer Left and Right

Figure 3

shifts per day.

1 A minimum crew of three (3) people can operate and control the entire robotic operation.

1 Scaffolds, tenting and aerial lift platforms required for abrasive blasting and surface preparation work are reduced or eliminated.

1 Dramatically reduces worker compensation and other employee fringe costs.

Control Axes

The robotic blaster has eleven (11) axes of control to position the blast nozzles and vacuum recovery head. All axes can be controlled by the operator in the Manual and Teach Modes of operation. In the Automatic Mode, nine (9) of the axes move in unison to the pre-programmed coordinates of the surface area.

Vacuum Principles

The patented vacuum recovery head is able to maintain a constant fluid seal on a ship hull surface area by controlling the volume of air introduced into the recovery head, and the displacement of air, abrasive, and surface blast residue from the recovery head through the outlets.

Air is injected at a determined volume into air casters to each of the seal elements that make up the flexible outer rim of the recovery head. Air and abrasive is forced through the blast nozzles at a constant rate, regulated by metering control devices on the blast pot.

A vacuum system provides the required air suction to collect the air, abrasive and surface blast residue from the head and transport them through an abrasive recovery and reclassification

system for collection, cleaning, storage and disposal.

SEE FIGURE(S) 4 & 5

Surface Types

The vacuum head lowers on a cushion of air that provides for a smooth flowoverflat, convex, and concave surface areas on a ship's hull. The vacuum head is capable of maintaining a seal with a minimum radius of three feet.

Sensors on the vacuum head send signals to the controller for needed seal element adjustments to follow the contour of the ship surface. The computer, in turn makes adjustments for the pitch, roll, yaw and stand-off distance of the end effector.

The design ensures the full recovery of abrasive and blast residue. Dry Abrasive Blasting

Surface preparation is accomplished with a specially designed venturi-style supersonic nozzle at high pressure ratings, and four times higher volumes of abrasive than is normally found in manual blasting operations.

The system uses end effector technology to direct the media particles to achieve a uniform particle distribution within the blast pattern. Control of the overlap from sparsely distributed particles in fringe areas maintains the uniform particle distribution from one pass to the next.

The air and abrasive are channeled through hose assemblies that are placed in the articulator's exoskeletal structure. The hose assemblies eliminate leaking couplings, screw punctures, washer wear and many of the other field maintenance problems of traditional abrasive hose equipment that results in down-time.

VACUUM RECOVERY HEAD

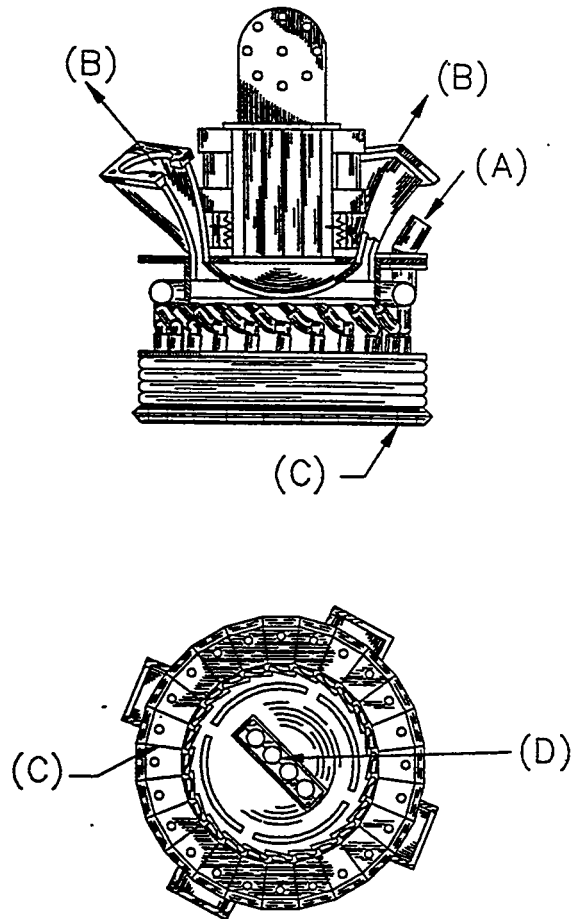

- (A) Air introduced into recovery head
- (B) Blast residue exits through torreds
- (C) Seal elements on Outer Rim
- (D) Blast Nozzles

Figure 4

VACUUM RECOVERY HEAD (VRH)

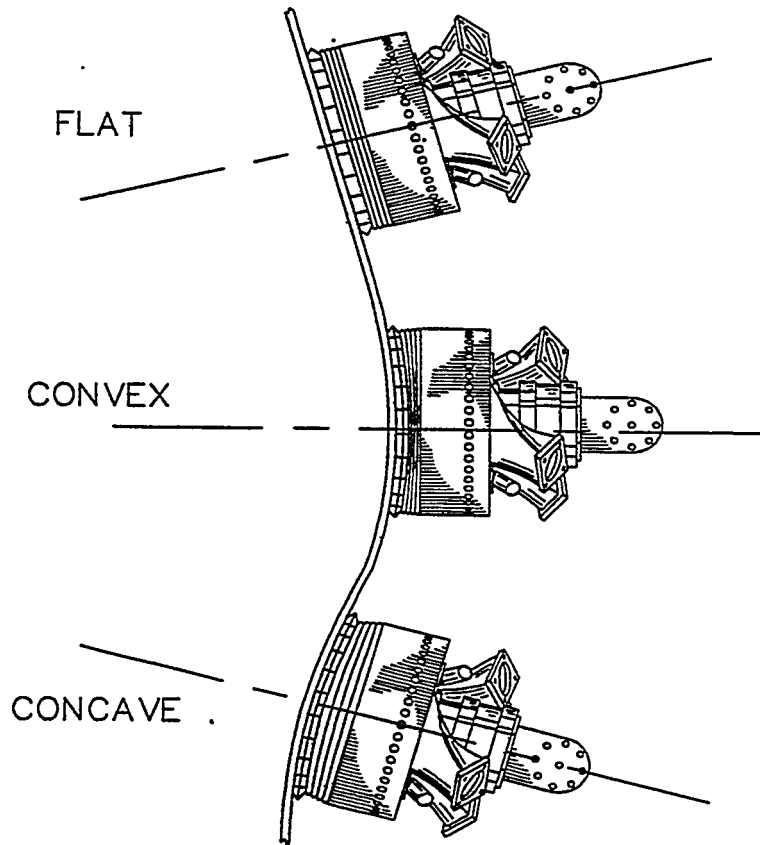

The VRH glides on a cushion of air that provides for a smooth flow over flat, convex or concave surface areas

Figure 5

Abrasive Recovery and Reclassification System

A closed cycle vacuum recovery system removes residual surface material and reclaims after-blast products in both abrasive grit blasting and in water blasting processes. The abrasive recovery and reclassification system is comprised of components to perform recovery, grit and debris separation, blast media reclassification, "grit washing" and recycling on a continual basis.

The system reduces costs and increases productivity. This is achieved through the engineering design to:

- 1 Recover and process dry abrasive material for reuse, recovery and containerization of surface coating residue in a continuous process.
- 1 Reclaim up to 95% of the dry abrasive media for reuse, depending on the condition of the surface.
Provide a dust free work environment and reduce personnel exposure in the handling of hazardous abrasive blasting material.
Meet the local environmental protection requirements while blasting and performing other surface preparation of ship hulls.
- 1 Recover and collect water blast, water and residue for recycling.

Abrasive Blast Pot Equipment

The abrasive handling equipment consists of a blast pot unit, blast nozzles and blast hose assemblies. The blast pot unit is computer controlled to allow working pressure and air/media mixture to be precisely regulated.

The blast pot unit is design with double chambers to permit automatic or manual filling for continuous uninterrupted operation; an ASME coded tank certified for 125 psi maximum operation pressure; an access man-way; a bottom clean-out plug; six 5 cmm (2 inch) bottom outlets and remote control choke and metering controls.

Blast Nozzle End Effecters

The venturi style blast nozzle is designed for high production; the nozzle is manufactured with an extended wear liner, providing abrasion wear resistance. Water blast nozzles are available for operation with water blast pumps of 10,000 psi and 30,000 psi processes.

Blast Hose Assemblies

The blast hoses use 4-ply" static dissipating hose, structurally bonded to a nozzle holder using a reusable, unbreakable copolymer coupling assembly. The design features of the blast hose assemblies result in less field maintenance and therefore increased productivity.

Recovery and Reclassification Equipment

The system is capable of recovering and processing material resulting from abrasive blast and water blast processes in a continuous system.

Reusable abrasive, from dry abrasive blasting, is separated from the removed coatings chips and abrasive fines. Recovered abrasive media is "washed" in an air aspirator and then returned to the **blast pot on a continuing basis.**

Fines and coating particles are separated and transferred into environmentally approved waste disposal containers.

The recovery and reclassification equipment consists of:

- 1 Vacuum system
- 1 Vacuum recovery head
- 1 Cyclone separators and classifiers that separate abrasive media from airborne particles and material fines.
- 1 Fitter units that filter the fines from the return air; collect and transfer the fines to waste disposal containers on a continuous basis.
- 1 Multi-Aspirators to clean the recovered abrasive media for reuse.

HOSTILE ENVIRONMENT PROTECTION SYSTEM

The system is designed to work in hostile environment job-site applications and engineered for the protection of vital components. Although designed specifically for abrasive blasting applications, this package works for all airborne particulate contaminants found in a shipyard.

Design Features

- 1 Boom wiper seals create a close bond and a snug fit by sealing the open areas between boom sections.
- 1 Chrome plated telescopic cylinder rod is for longer life; this manufacturing process acts as a barrier to cylinder rod contaminants.
- 1 Electronic equipment and computer boards are housed in waterproof,

temperature controlled compartments. Electronic boards easily slide out

The Sandroid hostile environment protection results in extended equipment life and reduced downtime, thus ensuring greater productivity.

SUMMARY

A standard byproduct of most sand-blasting operations is a large cloud of dust. Spent abrasive and the removed coating litter the work area and often must be handled as hazardous waste. A system that collects its own spent grit and blast debris saves money, time and the environment.

The "Robotic Blaster" from Sandroid Systems, Inc. does that and a whole lot more. its blast head conforms to both flat surfaces and curved surfaces with a minimum radius of three feet. It includes the air-and abrasive- delivery system, as well as a vacuum-recovery system to collect blast residue. When blasting ship hulls, the robot covers a minimum of 500 sq ft per hour.

The blasting head operates at the end of a telescoping boom and manipulator assembly with a reach of 90 ft. A total of eleven axes permit positioning the head against virtually any surface within its reach. Integrated support trailers carry the air compressors, dryers, generator, the grit-handling apparatus, and the residue-reclassification system.

All phases of blaster operation are under computer control. One or more resolvers at each axis report axis positions

which are displayed on the operator console. Sensors in the vacuum-recovery head read the contour of the work surface, permitting the computer to maintain the optimum distance and angle to the work surface. The computer regulates working pressure and air/media mixture as well as the two pump hydraulic system. 'It constantly checks for errors or out-of-tolerance operation and shuts down the system if it detects problems.'

Two modes of control are available. In the manual mode, the operator maneuvers each axis through toggle switches on the control console. Once the head is about 18 inches away from the work surface, the operator switches to joystick/robotic control. For this method, the operator controls direction and speed with the joystick. The robotic control adjusts the axes to maintain the pose and stand-off distance of the end effector.

In automatic, the operator defines a

work-window size (width and height). Next the operator moves the end effector to about 18 inches from the work surface. Computers then maneuver the blasting head over the work area within eight inches of edges, comers, and projections. Collision sensors interrupt the system to protect the hardware. End effector sensors track surface contours and adjust stand-off distance and pose for optimum performance. An emergency stop button overrides all system operations to shut the blaster down in an orderly fashion.

After recovering its grit and the debris removed from the work surface, the reclassification system sorts and cleans abrasive, recovering as much as 95% of it for reuse. In addition, the system separates the surface residue and discharges it into appropriate disposal containers. The systems uses different end effecters for high pressure water blasting and painting.

Additional copies of this report can be obtained from the
National Shipbuilding Research and Documentation Center:

<http://www.nsnet.com/docctr/>

Documentation Center
The University of Michigan
Transportation Research Institute
Marine Systems Division
2901 Baxter Road
Ann Arbor, MI 48109-2150

Phone: 734-763-2465
Fax: 734-936-1081
E-mail: Doc.Center@umich.edu