

NASA TECHNICAL NOTE



NASA TN D-3014

NASA TN D-3014

AMPTIAC

DISTRIBUTION STATEMENT A
Approved for Public Release
Distribution Unlimited

EXTRUSION AT TEMPERATURES APPROACHING 5000° F

by Charles A. Gyorgak
Lewis Research Center
Cleveland, Ohio

20060516183

NASA TN D-3014

EXTRUSION AT TEMPERATURES APPROACHING 5000⁰ F

By Charles A. Gyorgak

Lewis Research Center
Cleveland, Ohio

NATIONAL AERONAUTICS AND SPACE ADMINISTRATION

For sale by the Clearinghouse for Federal Scientific and Technical Information
Springfield, Virginia 22151 - Price \$1.00

~~EXTRUSION AT TEMPERATURES APPROACHING 5000° F~~

by Charles A. Gyorgak

Lewis Research Center ~~EXTRUSION~~

SUMMARY

Development of refractory metal alloys having high strength at temperatures in excess of 3000° F requires methods of ingot breakdown or working at temperatures much higher than the use temperatures. Extrusion generally has been the most successful method. However, extrusion containers and other tooling melt in the temperature range 2400° to 2600° F and since maximum retention of billet temperature is desired, special handling methods are necessary. Accessories to permit extrusion at ultrahigh temperatures have been developed for a 1020-ton vertical extrusion press. These include a high-temperature atmosphere furnace, a rapid billet transfer device, an extrusion straightener, and an eight-tube extrusion retriever. The furnace permits heating for extrusions in either inert gas or hydrogen atmospheres to 5000° F. The rapid billet transfer device currently permits an average extrusion time from furnace opening until extrusion is completed of 5 seconds. The straightener enables extrusions of refractory metals to be made with deviations of less than 1/4 inch from straightness over an 8-foot length. An extrusion retriever facilitates the removal of extrusions from the extrusion pit.

Effects of various lubricants on extrusion quality have been observed but have not been definitely determined. The best quality extrusions have been obtained by the use of a calcium graphite grease for an extrusion temperature range of 1500° to 2300° F. For an extrusion temperature range of 3000° to 5000° F, glass cloth impregnated with tungsten disulphide was best. Although extrusion quality has not been consistently good with these lubricants, a good yield of acceptable experimental materials has been obtained. end

~~INTRODUCTION~~

Start Technological advances in alloy development have produced experimental refractory metal materials which possess high strength at temperatures greater than 3000° F.]

These experimental materials, produced by both powder metallurgy and advanced melting techniques, require working to break up the as-cast structure and to develop fully their strength potential. The primary working of these materials has been most successfully accomplished by the use of the hot-extrusion process. However, the great inherent strength of these experimental refractory metal products at high temperatures imposes difficulties in the extrusion process.

The major problem area is associated with the 4000^o to 5000^o F working temperature range for these newer alloys. These alloys, being oxidation prone, must be heated in either neutral or reducing atmospheres. High heat loss encountered in small billets, 2 or 3 inches in diameter, necessitates short handling time from furnace to extrusion press. Protection for extrusion tooling must be provided when the average billet temperature is approximately 1.7 times the melting temperature of the tooling (4500^o and 2450^o F, respectively). In alloy development, the amount and type of deformation is closely controlled in order that the effect of working parameters can be determined. To minimize deformation variables, straight extrusions are desired so that postextrusion straightening will not be required and the metal deformation present in all straightening operations can be eliminated.

This report explains how a 1020-ton, three-stage vertical-forging extrusion press has been adapted for extrusions at temperatures to 5000^o F by incorporating a high-temperature furnace and a rapid billet loader into the press tooling and how the incorporation of an extrusion straightener eliminated the necessity of postextrusion straightening operations. Also described is the press instrumentation for recording extrusion speeds and pressures, temperature measurement and temperature control of billets heated for extrusion, and handling of the extruded product. Lubricants used for extrusion and their relative merits are also discussed.] to p. 11

When almost every extrusion is a new composition, systematic investigations of extrusion variables for each of these materials are not possible; therefore, the information presented herein does not prove the advantage of a particular innovation such as a new lubricant but rather reports what has tended to work well and thus may be useful in similar programs.

EXTRUSION PRESS

The vertical press (fig. 1) is a three-stage combination extrusion-forging press with a maximum capacity of 1020 tons. A water hydraulic system powers the press by means of an accumulator bottle. The maximum working pressure of the accumulator bottle is 3600 pounds per square inch, although lesser pressures down to 2500 pounds per square inch can be used. The operating specifications of the press are given in table I.

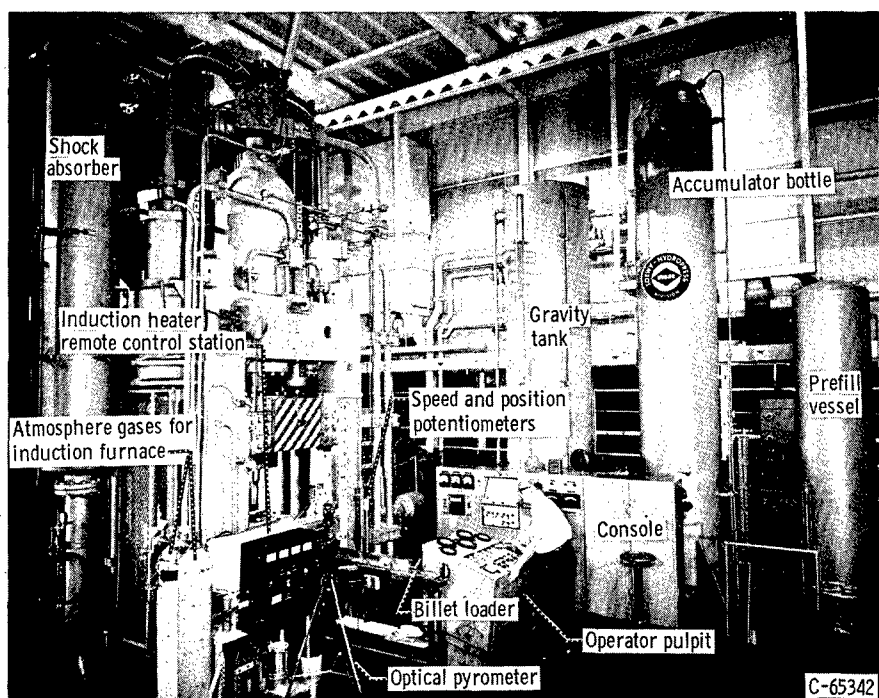

Figure 1. - 1021-Ton water hydraulic extrusion-forging press.

The three-stage design is advantageous because it makes the press a multitonnage press in which three distinct extrusion-force levels can be developed without changing the pressure in the accumulator bottle; this arrangement results in operating advantages beyond the scope of this report. These three force levels are produced by introducing the working fluid on various ram areas by means of proper valving. A simplified hydraulic diagram (fig. 2) shows how this is accomplished. When high-pressure (3600 psi) water is introduced into the two side cylinders (first-stage rams), the press produces a force of 340 tons. High-pressure (3600 psi) water introduced into the main cylinder only (second-stage ram), produces a force of 680 tons, and when all three cylinders are pressurized simultaneously (third-stage ram combination), a force of 1020 tons is developed. These are the maximum tonnages which may be developed; however, by decreasing the pressure in the accumulator bottle from 3600 to a minimum of 2500 pounds per square inch, forces of 237.5, 475, and 712.5 tons, respectively, can be developed. Thus, discrete forces can be developed between a minimum of 237.5 tons and a maximum of 1020 tons by varying the accumulator bottle pressure and ram cylinder areas.

The extrusion-stem speed during extrusion is rated at 16.7 inches per second when the resistance to deformation is 880 tons. The maximum stem speed obtained from an empty press was recorded at 18.0 inches per second, and the actual maximum speed recorded during an extrusion with a force of 311 tons was 15.2 inches per second against a resisting force of 210 tons. Generally, extrusion speeds on this press are kept to values ranging from a minimum of 0.5 to a maximum of 6.0 inches per second in order

TABLE I. - WATER HYDRAULIC
PRESS SPECIFICATIONS

[Cylinder capacities at 3600 lb/sq in.
maximum working pressure.]

Ram force, tons	
Side (first power stage)	340
Main (second power stage)	680
Main and side (third power stage)	1020
Return	100
Container (hold down)	140
Container (stripping)	100
Maximum travel, in.	
Main and side rams	36
Container	22
Maximum speed, in./sec	
Main and side rams	
Advance	16.7
Extrusion (with 880-ton resisting force)	16.7
Return	13.3
Container	
Lowering cycle	4
Raising cycle	5
Tank capacity, gal	
Prefill tank (working)	110
Gravity tank (working)	1210
Accumulator bottle (working)	124
Oil power unit	30
Water pump capacity, gal/min	70
Air compressor capacity, cu ft/min	17.5

to maintain a good surface finish on the extruded product. Experience with this press has shown that the slowest speed possible to complete the extrusion produces the best surface.

The press is erected over a 16-foot-deep pit. The maximum length of extrusion that can be made presently is 13 feet because an eight-tube retriever has been placed into the pit to facilitate handling of the completed extrusions.

The forging features of the press with respect to forces available are the same as those available for extrusion. Two forging cycles are obtainable with the valving of the press, a normal forging cycle and a fast forging cycle. The normal forging cycle is used when long strokes are required. In this operation, the hammer (upper tool) approaches the ingot by the use of water from the prefill vessel (low pressure), and the penetration (deformation) stroke is accomplished by the use of water from the accumulator bottle (high pressure). The fast forging cycle is employed when short planishing strokes in rapid sequence or hammer-like action is required. The planishing or hammering action

is accomplished by the use of high-pressure water (accumulator bottle) only. The water capacity of the accumulator bottle and a pumping capacity of 70 gallons per minute permit 60 planishing strokes per minute through a distance of 1/2 inch for a continuous operation.

Tooling

Containers. - To obtain versatility from the multistage press, two containers are available for use: one container for the extrusion of 2-inch-nominal-diameter billets and another container for 3-inch-nominal-diameter billets. Either container can be incorporated into the press in a housing as shown in figure 3.

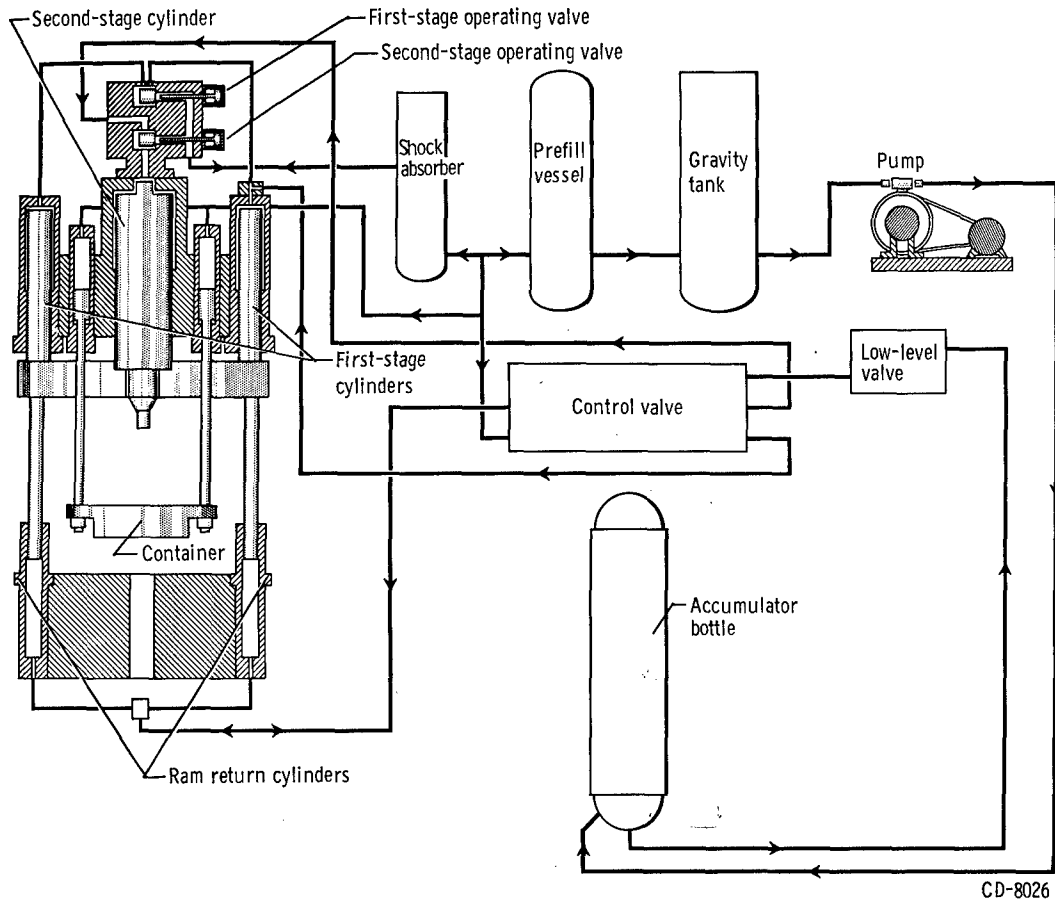

CD-8026

Figure 2. - Hydraulic diagram for 1020-ton extrusion press.

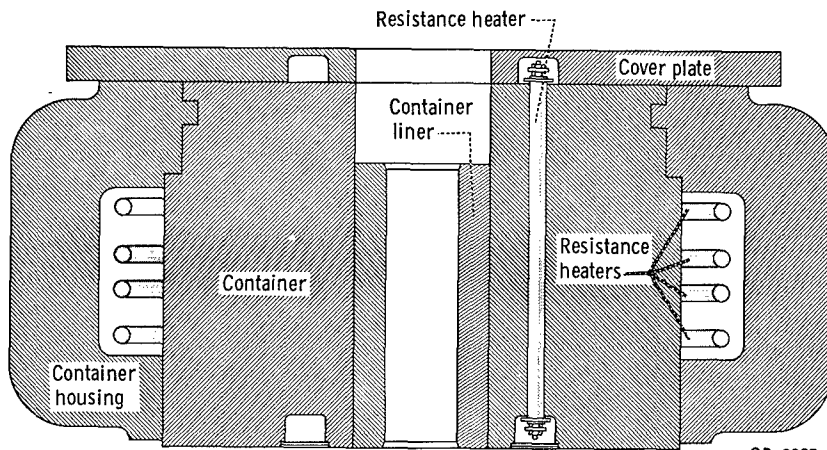

CD-8025

Figure 3. - Schematic drawing of container assembly used in extrusion.

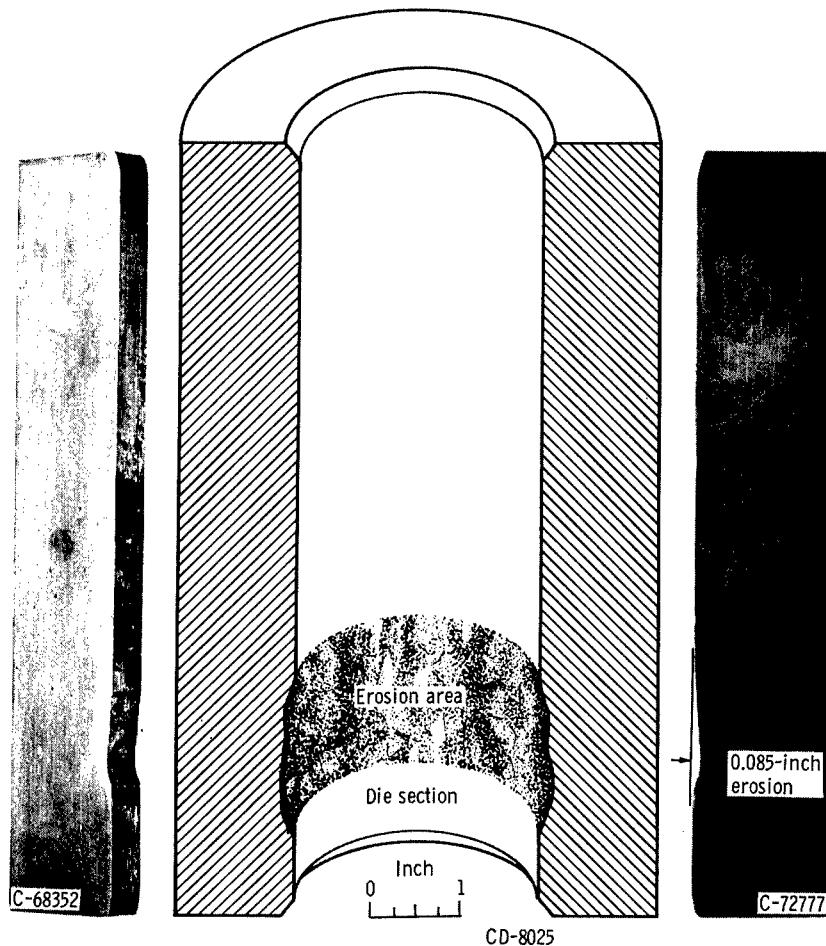

Figure 4. - Nominal 2-inch-diameter container liner number 6 eroded 0.085 inch at juncture of billet and die after 106 high-temperature extrusions.

The function of the container is to constrain the billet laterally while the extrusion stem forces the billet through the die, which produces the shape of the extrusion.

In usual practice, the container is protected from damage (such as abrasion, melting, or widening) during extrusion by a relatively thin metal sleeve (AISI H-12 tool steel) known as a container liner (fig. 3). During extrusion, the liner is subjected to the temperature of the billet, supplies the lateral constraint necessary for extrusion, and erodes or wears away, particularly when lubrication fails.

For extrusion at elevated temperatures (i. e., appreciably greater than room temperature), the container is heated to minimize cooling of the billet and thus decreases the compressive force required for extrusion and improves the surface finish of the extruded product.

The containers are heated by two interconnected sets of resistance-heating elements. Container temperature could be maintained as high as 1000⁰ F; however, the present procedure is to hold the temperature at 600⁰ F to obtain the best compromise

between container-liner life and extrusion-surface finish.

Container-liner life (number of extrusions per liner) appears to be a function of container temperature, billet temperature, pressure required for extrusion, and lubrication. Container-liner life is judged by both the appearance of the liner wall and the surface quality of the extrusions obtained from the liner. Experience indicates that, as the liner wall deteriorates, the required extrusion pressure tends to rise and the surface of the extrusion becomes rough and sometimes tears. The rough and torn extrusion surfaces resulting from liner failure decrease the yield of extruded material that has not been canned or clad; however, no loss of billet material has occurred in canned or clad extrusions. More will be mentioned of canning, subsequently.

Generally, the portion of the liner immediately above the die erodes excessively during the extrusion of refractory alloys. The magnitude of this erosion may be noted in figure 4.

The life of container liners is given in table II. Initially, the container temperature was varied between 700° and 900° F in an attempt to determine the optimum container temperature for extrusion. After the first three liners failed (two by welding to the billets and one by erosion in only 75 extrusions), the container temperature was decreased to 400° F. Container-liner life appeared to improve at this temperature (400° F); however, the quality of the extruded product was adversely affected. It was reasoned that a container temperature of 400° F chilled the billet excessively and that the resultant billet temperature was too low to produce proper viscosity of the glasses (table III, p. 15) used for lubrication. Increasing the container temperature to the currently used temperature of 600° F improved extrusion quality but apparently decreased liner life from that obtained at 400° F (table II). An attempt to improve liner life by increasing the Rockwell C hardness from the commonly used values of 44 to 48 to values of 52 to 54 (table II) did not appear to have any noticeable effect on liner life.

Extrusion stems. - Extrusion stems are made from wrought AISI H-12 hot-work tool steel, heattreated to a Rockwell C hardness of 52 to 54. Stems hardened to the recommended value of 44 to 48 bend or break during the extrusion of some experimental refractory alloys when stressed at 190 000 pounds per square inch. Since the extrusion of experimental alloys are of prime importance and tooling life is secondary, the press conditions are set so the stems can be stressed to a maximum of 200 000 pounds per square inch. Some new alloys being made today appear to resist extrusion at a billet temperature of 4800° F and maximum stem loads of 200 000 pounds per square inch. Apparently, stem materials of the future will have to withstand unit loadings greater than 250 000 pounds per square inch during the extrusion of the newer high-strength refractory materials being produced at this Center.

Dies. - Dies are generally fabricated from AISI H-12 or H-21 hot-work tool steel heattreated to a Rockwell C hardness of 48 to 54. Die configuration depends on the

TABLE II. - LIFE OF CONTAINER LINERS USED IN EXTRUSION OF VARIOUS REFRACTORY METALS AND ALLOYS AT VARIOUS EXTRUSION TEMPERATURES AND WITH DIFFERENT LUBRICANTS

Container	Hole diameter at preheat temperature, in.	Rockwell C hardness	Container preheat temperature, °F	Number of extrusions	Remarks
1	2.2	44 to 48	700 to 900	13	Billet welded to liner
2			700 to 900	75	Excessive erosion of liner
3			700 to 900	10	Billet welded to liner
4			400	71	Excessive erosion of liner
5			400	11	Liner forced from container during stripout of an unextruded billet
6			400	88	Excessive erosion of liner after total of 106 extrusions
			600	18	
7			600	26	Excessive erosion of liner
8			600	64	Excessive erosion of liner
9	600	42	Liner still in use		
10	3.13	44 to 48	700 to 900	46	Excessive erosion of liner after total of 85 extrusions
			400	21	
			600	18	
11	3.13	52 to 54	600	46	Liner slightly eroded, removed for start of new alloy series.

material being extruded and the desired shape of the extruded product.

The simplest configuration is a straight round hole through the center of the die with the entrance and exit ends of the hole normal to the face of the die (a flat faced or 180° die).

Entrance cones leading into the orifice of the dies (fig. 5) may be varied from 60° to 180°. At the Lewis Research Center, the most commonly used entrance cone is 90°. Entrance cones of 60°, 100°, 120°, and 150° are also used. The effect of included die angles of 60°, 90°, and 120° on other extrusion parameters associated with refractory metals has been studied (ref. 1), and the results show that both the 60° and the 90° included-angle dies require approximately equal deformation loads, which are much

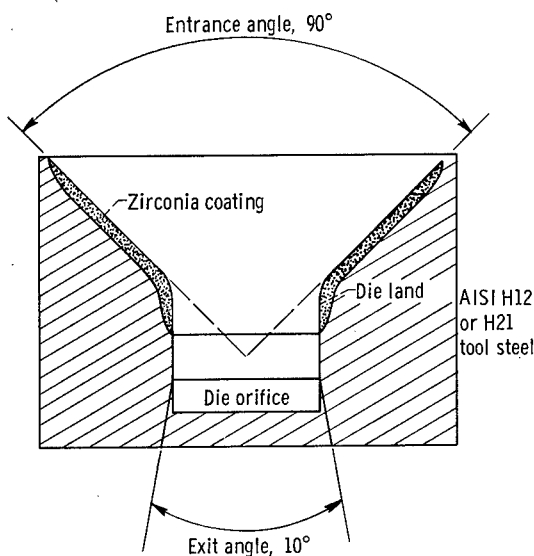

Figure 5. - Cross section of coated extrusion die.

lower than for 120° dies.

In extrusion practice, the entrance cone is generally blended into the straight section of the orifice with a radius. This radius may be varied over a wide range of values from under 0.10 inch to approximately 0.5 inch, with a commonly accepted radius of approximately 0.25 inch. The straight section of the die orifice, the die land, also can be varied, but the commonly used length is approximately 0.25 inch. Relief to the land is provided in instances where the land length is greater than desired. This die relief on round dies is another cone having an included angle of approximately 10°.

Figure 5 shows a cross section of a zirconia-coated die typical of those used at this Center for the extrusion of refractory metals.

In the subject press, dies employed for materials extruded below 2500° F are made of AISI H-12 or H-21 steel and are oxidized so that a thin oxide film covers the entire surface and then are coated with colloidal graphite in mineral oil. For materials extruded at temperatures ranging between 2500° and 3000° F alumina-coated, flame-sprayed dies are used. For extrusion temperatures above 3000° F, dies coated with zirconia (flame or plasma sprayed) are employed. To date, no appreciable difference in die life or extrusion quality has been noted between the flame and the plasma sprayed zirconia coatings.

Dummy and follower blocks. - In the design of extrusion tooling, provisions have been made to protect the stem from coming in contact with the hot billet (so as not to temper the stem) or with the die after the press is closed (so that intimate contact of stem and die does not occur). This is accomplished by having a 2½-inch-long space between the end of the stem and the top of the die when the empty press is closed. Two inches of this space are utilized by an AISI H-12 tool-steel spacer or dummy block which protects the stem from the high temperature of the billet by means of its thermal resistivity. The short length of time the tooling is in contact with the hot billet also serves to limit stem temperature. The dummy block cools the billet during contact; therefore, to minimize cooling, dummy blocks may be heated. The maximum temperature to which the block is heated is a function of its tempering characteristics and is usually below 1000° F.

The remaining 1/2 inch of space produces an extrusion butt (unextruded portion of the billet). This butt usually prevents the formation of an extrusion defect (extrusion

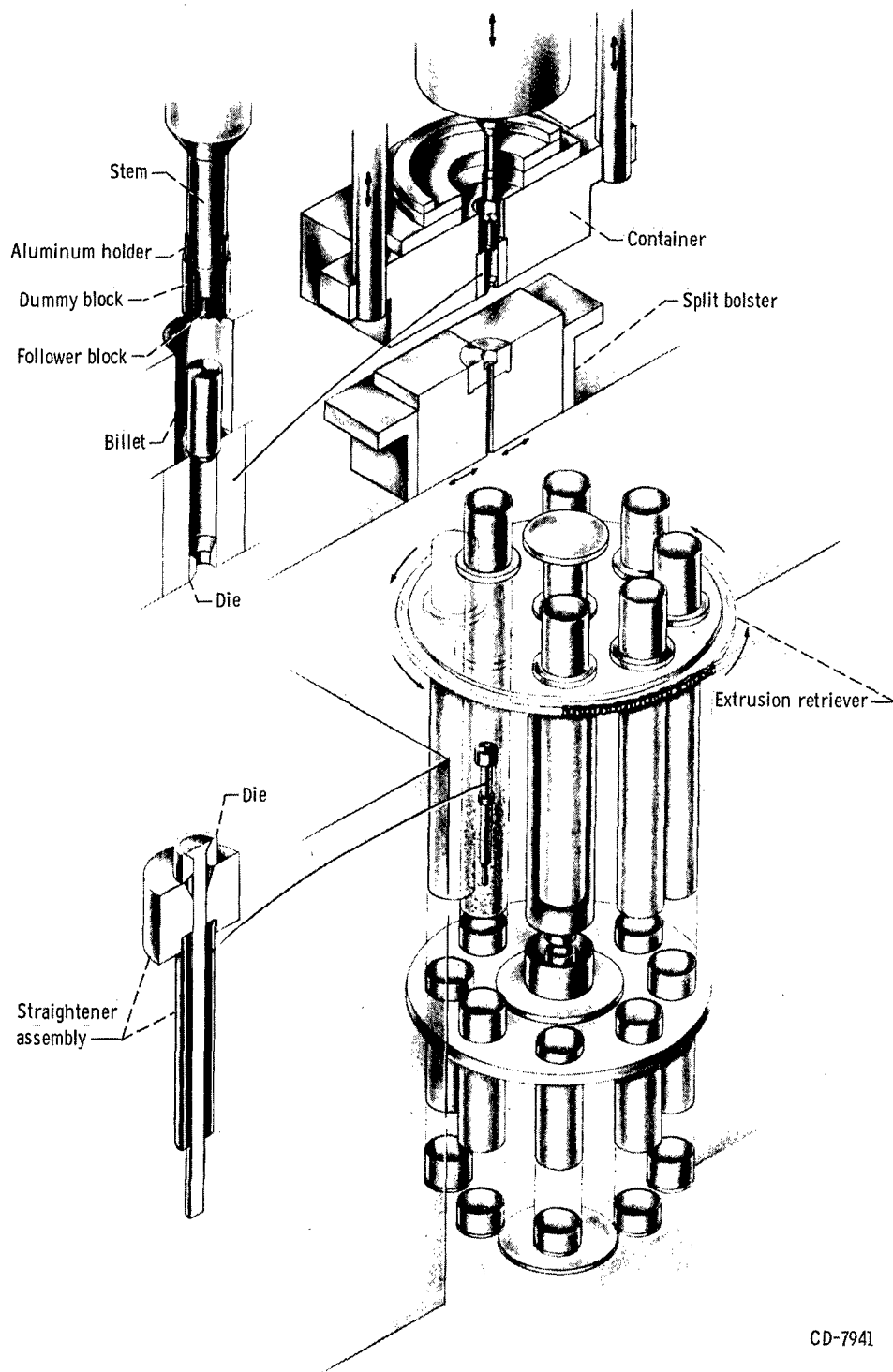

CD-7941

Figure 6. - Extrusion-tooling alinement.

pipe) at the end of the billet. However, some usable material is sacrificed by the retention of a 1/2-inch-long butt.

To decrease the loss of billet material, the 1/2-inch space can be filled with a spacer of extrudable material. This spacer, or follower block, is made from graphite, copper, or mild steel. The height of the block used depends on the length of butt desired. If a complete extrusion (one without a butt) is desired, a follower block of sufficient height to force the entire billet through the die is used.

To minimize the handling of dummy blocks and spacers and to decrease the extrusion cycle time, the block and spacer are connected to the extrusion stem by an aluminum or brass holder as shown in the tooling arrangement of figure 6. The time saved by using a preassembled follower block assembly on the stem decreases the dwell time of the hot billet in the relatively cool (600° F) container and facilitates the process in two ways. First, the heat loss from the billet is lessened so that the extrusion is accomplished at a higher temperature than would result from a slower method, and second, the short dwell time of the hot billet in the container minimizes the temperature rise of the container wall and thus minimizes the possibility of melting the container.

Press Innovations

Billet loader. - The average heat loss in the center of a $1\frac{3}{4}$ -inch-diameter, 3-inch-long refractory alloy billet heated to 4000° F (when power was shut off and timing started) was 42° F per second over a 10-second interval. This heat loss is sufficiently great to cause concern about the extrusion cycle time, the time from opening the furnace until the billet is extruded. To minimize the extrusion cycle time, a rapid billet loader was made an integral part of the extrusion tooling.

The billet loader and its position relative to the press are shown in figure 7. The loader consists of a retractable billet slide, a pneumatic billet loader, a bottom-loading, induction-heated atmosphere furnace, and a billet pusher.

The billet slide is positioned so that it bridges the distance between the furnace and the container. In this position, the furnace-loading port aligns with the opening of the atmosphere furnace, and a container-loading port aligns with the container bore. The billet is positioned on the pneumatic billet loader, and when the loader is energized, the billet is inserted into the furnace.

After the billet has been heated to the desired temperature, the billet loader is again energized to extract the hot billet from the furnace. At this point in the process, the furnace operator pushes the hot billet down the billet slide to the container port, where the billet falls into the container. When the billet falls into the container, the press operator moves the extrusion stem to the press position. Simultaneously with the

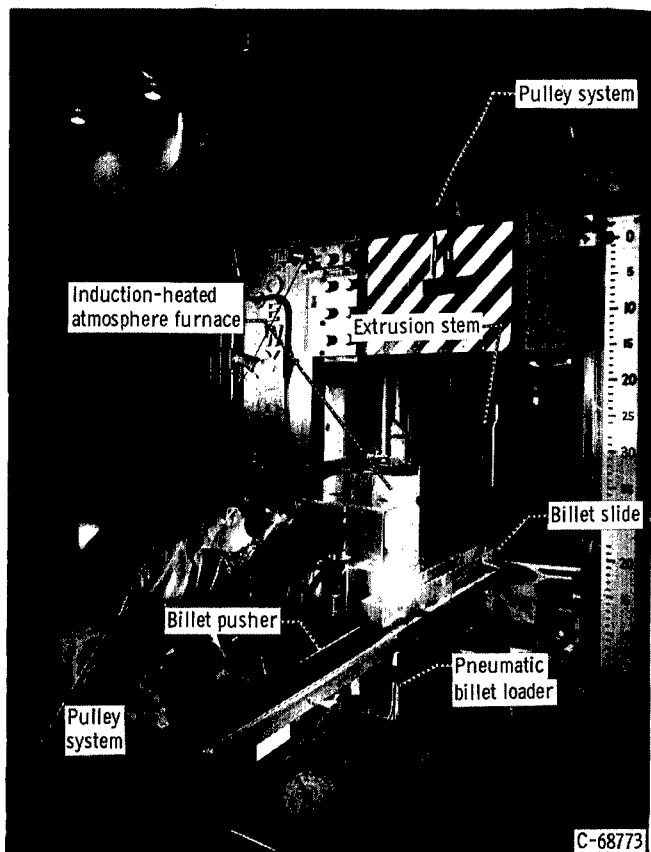

Figure 7. - Lowering of billet from furnace into rapid billet loader device.

movement of the extrusion stem, the telescoping section of the billet slide is retracted from beneath the moving cross head by means of a cable and pulley system.

The installation of this system has cut the extrusion cycle time from 10 to 15 seconds (when done manually) to an average time of less than 5 seconds. The shortest extrusion cycle time obtained by this process has been 2.5 seconds. This system is being further automated by the addition of an automatic billet pusher, and a significant decrease (approx 2.5 sec) in average extrusion cycle time will be obtained.

Extrusion straightener. - To maintain the straightness of extruded material and thus eliminate the additional heating cycles and the metal working required in a postextrusion straightening operation, a straightener (an extru-

sion guide) has been made an integral part of the extrusion tooling. The straightener consists of sections of steel pipe or tubing attached to a die backer as shown in figure 6.

For materials extruded at temperatures in excess of 2500° F, the pipe is lined with either asbestos or graphite sleeves which protect the pipe against melting. For materials extruded at temperatures below 2500° F, unlined pipe is used. This technique has produced straight extrusions in all materials irrespective of extrusion temperature and/or extrusion speed. The straightness tolerances maintained by this method are discussed in the section Surface quality (p. 19).

Extrusion retriever. - To permit extrusion of eight billets in rapid succession and to facilitate the handling of the extrusions in the 16-foot-deep pit, an eight-tube extrusion retriever has been installed. The location of the extrusion retriever with respect to the press can be seen in figure 6. The retriever is designed so that a protective inert gas atmosphere can be maintained on the extruded product during cooling if desired. The retriever may also be used as a quench bath for the extruded product if quenching is desired. The retriever limits the extrusion length to a maximum of 13 feet.

To unload the retriever, the receiving tube located under the extrusion port of the press bedplate is rotated through a chain-drive mechanism until the tube is positioned

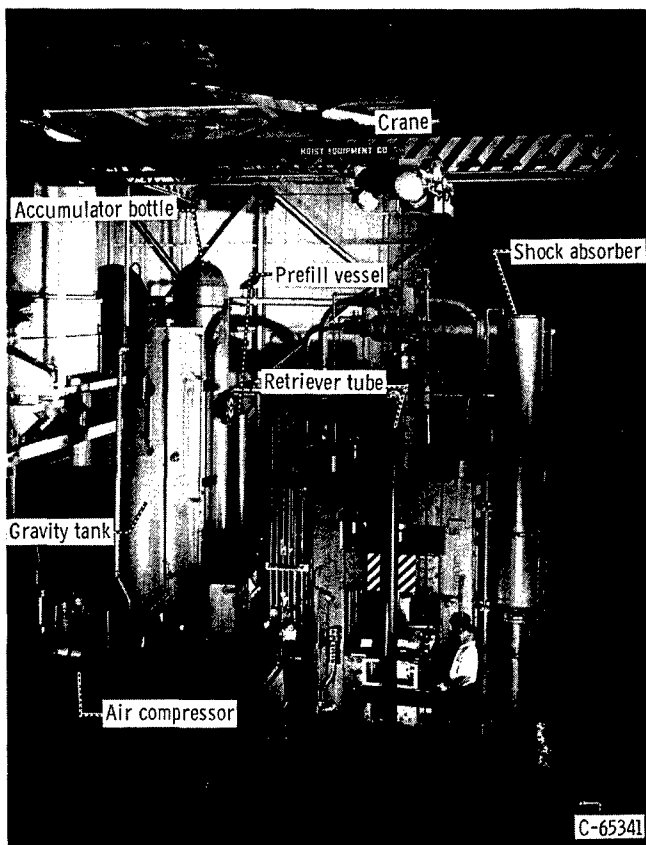

Figure 8. - Rear view of press with retriever retracted from extrusion pit.

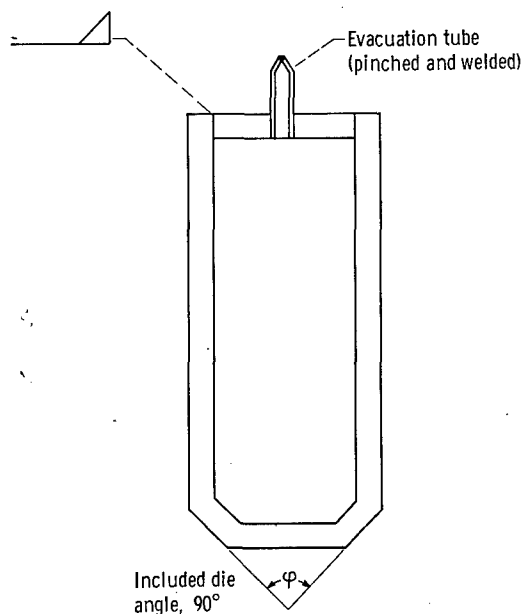

Figure 9. - Schematic drawing of canned billet. Type of canning material, as required by billet.

at the back of the press. From this position the tube is extracted from the retriever with the aid of the crane shown in figure 8.

Lubrication

Lubrication practice varies with the material being extruded and the extrusion temperature. For cold (room temperature) extrusions, either mineral oil or mineral oil and colloidal graphite is employed. The lubricant is simply swabbed on the inside of the container and on the extrusion die.

For aluminum and copper being extruded at their respective maximum extrusion temperatures, oil dag is usually employed. For steel, a calcium graphite grease is swabbed onto the container and die, and in addition, some of the lubricant (in a plastic bag) is placed on the back end of the billet immediately prior to the closing of the press. This additional lubricant (approx 50 cc) has been found to facilitate the extrusion by decreasing the pressure required and to improve the surface finish of the extruded product considerably.

Occasionally, experimental alloys must be protected from contamination by lubricants used in the extrusion process. Contamination is most prone to occur during working of low-density powder-metallurgy products. To minimize contamination and to aid lubrication, materials may be canned as shown in figure 9. A wide choice of canning

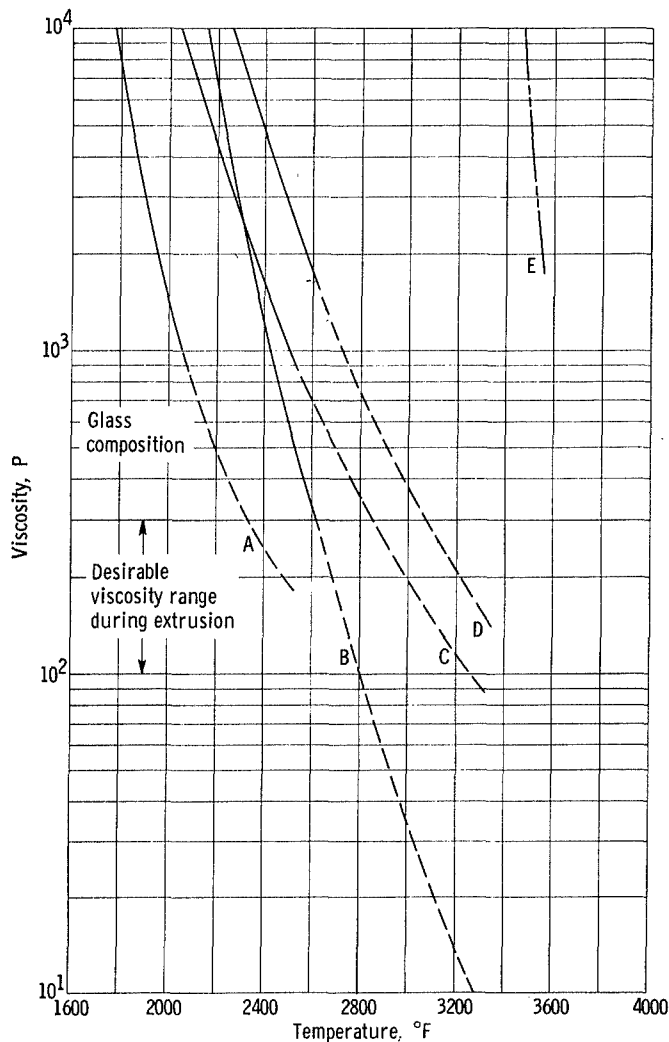

Figure 10. - Viscosity of various glasses as a function of temperature. (Data from ref. 2.)

materials which are metallurgically compatible with the experimental alloys or powder products are available. However, the choice of canning material should be guided not only by compatibility of the composite extrusion but also by the extrusion characteristics of the can. In many instances the canning material may act as a lubricant and facilitate the extrusion of the composite.

Lubrication practices for extrusion of refractory metals and alloys at temperatures ranging from 3000° to 5000° F have run through a gamut of materials and conditions. Coated dies are always used for these extrusions, and the lubricants have varied from plain greases through complex powdered glass and powdered metal formulations. A list of lubricants used is given in table III.]

Lubrication is partly a function of viscosity, and it has been determined that glass lubricants having a viscosity range of 100 to 300 poises are optimum for extruding metals at elevated tem-

peratures. Some glass formulations exhibit these viscosities in certain temperature ranges. Figure 10 shows the effect of temperature on the viscosity of some of the glasses currently being used in the extrusion process.

To date, the most effective lubricant used at this facility has been glass cloth impregnated with tungsten disulphide in an epoxy or similar carrier. The cloth is coated with a slurry of carrier and tungsten disulfide and cured at approximately 250° F for about 10 minutes. The cured cloth is cut into proper sizes to cover the entire length of the billet and to lap the container bore with a single thickness.

The temperature range between 2300° and 3000° F has not been sufficiently explored for extrusion to warrant any comment on the effects of lubricants.]

118

all
TABLE III. - LUBRICANTS USED FOR EXTRUSION OF REFRACTORY METALS AND ALLOYS

Lubricant	Method of application	Use temperature, °F	Remarks
8 Parts grease 1 Part glass 1/2 Part powdered copper 1/2 Part powdered molybdenum (thinned with light mineral oil to swabbing consistency)	Container swabbed	3000 to 3400	Lubricant failed during extrusion; extruded surfaces range from good to poor
7.5 Parts grease 1 Part glass 1/2 Part powdered copper 1/2 Part powdered molybdenum 1/2 Part powdered talcum	Container swabbed	3000 to 3800	Provided adequate lubrication; extruded surfaces range from excellent to fair
7.5 Parts grease 1.0 Part glass 1/2 Part powdered molybdenum 1/4 Part molybdenum disulfide 1/4 Part copper 1/2 Part powdered talcum	Container swabbed	3000 to 3800	Addition of molybdenum disulfide improved surface finishes of extruded products; however, consistently good surface finishes could not be obtained
Powdered glasses in caropol carrier	Billet coated by spatulation	3000 to 3400	Glass coating softened and flowed off billet; reaction occurred between billet and glass
Powdered glasses in sodium silicate carrier	Billet spray coated	3000 to 3600	Glass coating softened and flowed off billet; reaction occurred between billet and glass
Powdered glass, nose pads, and polyvinyl alcohol binder	Die coated	3000 to 4500	Glass was forced through die causing loss of lubrication
Powdered glass, nose pad, and follower	Die and dummy block coated	3000 to 4500	Adequate lubrication provided but not consistently; made stripping difficult
Graphite cloth cemented to copper sheet	Lubricant inserted into container	3000 to 4200	Poor surfaces obtained; copper melted; carbon may have reacted with billet
Glass cloth and various binders as stiffeners	Lubricant inserted into container	3000 to 4500	Provided adequate lubrication; surfaces were not consistently good
Glass cloth and tungsten disulfide	Lubricant inserted into container	3000 to 4500	Produced best extruded surfaces to date
Graphite cloth, glass cloth, and tungsten disulfide	Lubricant inserted into container	3000 to 5000	Produced best extruded surfaces to date

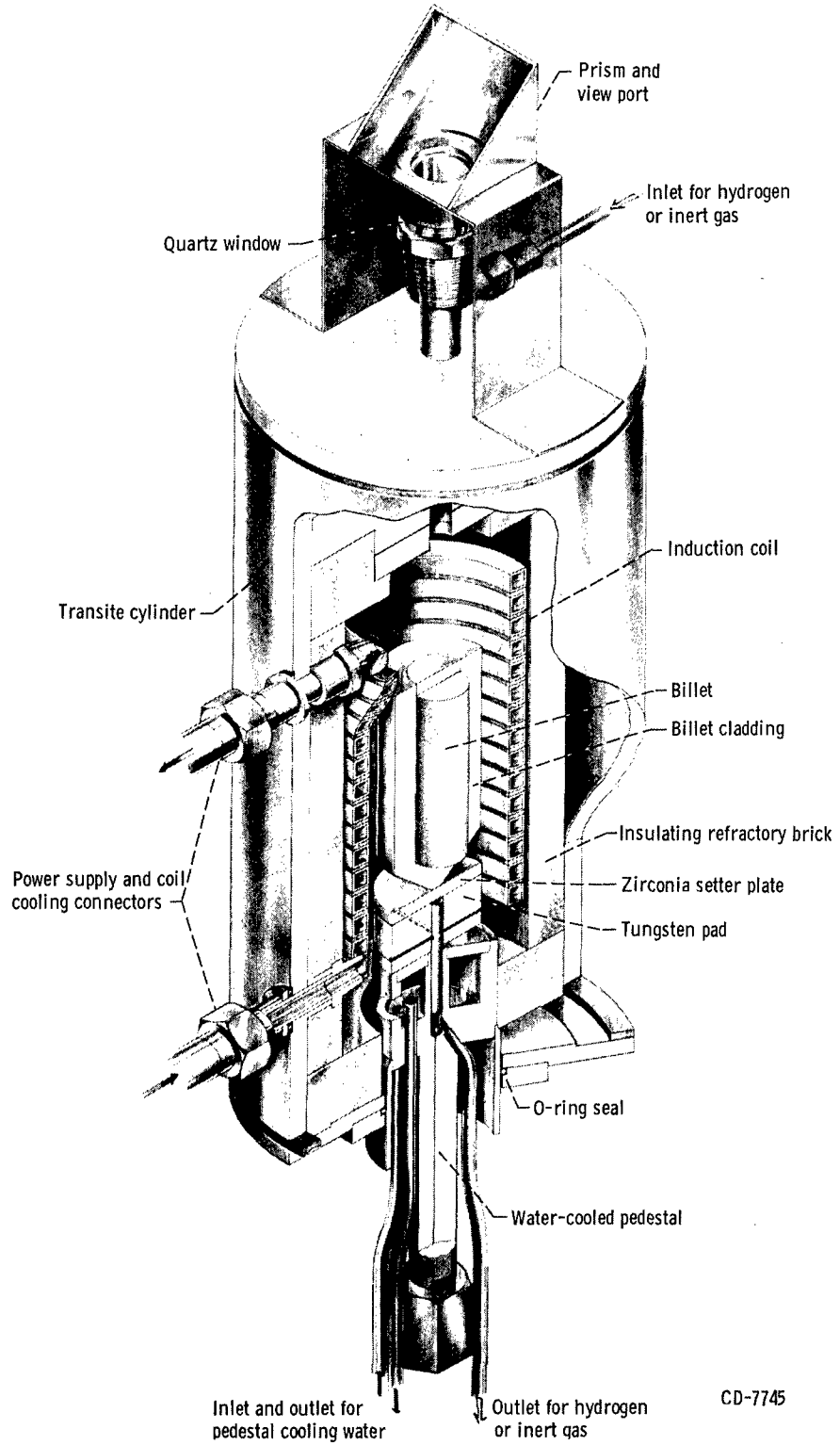

Figure 11. - High-temperature, hydrogen atmosphere, extrusion preheat furnace.

Auxiliary Equipment

Billets may be heated in any one of three furnaces; the choice of furnace is governed by the extrusion temperature and the type of atmosphere required for the billet. The furnaces are as follows: a full muffle, silicon carbide heated, 8- by 11 $\frac{3}{4}$ - by 48-inch hearth, controlled atmosphere, flame-curtain furnace, capable of maintaining a temperature of 2400^o F; a semimuffle, silicon carbide heated, 6- by 8- by 16-inch hearth furnace capable of maintaining a temperature of 3000^o F (which has been adapted for argon or inert gas atmosphere); and an induction furnace (fig. 11) capable of maintaining temperatures up to 5000^o F in a 2-inch-diameter, 4 $\frac{1}{2}$ -inch-long billet in either a hydrogen or an inert-gas atmosphere. The induction furnace is powered by either a 50- or a 75-kilowatt 10-kilocycle-per-second motor generator. The induction furnace is bottom loaded and is made an integral part of the rapid billet loader device shown in figure 7.

Instrumentation

Temperature control. - The temperatures in the two resistance-heated furnaces are controlled and monitored by electronic strip chart recorder-controllers. In the induction furnace the billet temperature is manually monitored and controlled, under blackbody conditions, with an optical pyrometer. The blackbody conditions are produced by drilling a small hole in the butt end of the billet. The depth of the hole is at least five times the diameter. Hole diameters range from 0.080 to 0.130 inch depending on the machinability of the alloys and the tooling available. The small-diameter holes are usually produced in the less machinable alloys.

Temperature determinations are made by sighting the pyrometer on the blackbody hole by means of a 45^o prism through a quartz window (fig. 11). The window is kept clear by clean atmosphere gas continuously sweeping over it, which prevents deposition of any particles that would affect the accuracy of the temperature determination.

The pyrometer has been calibrated against a standard lamp with both the quartz window and the prism in the system, and the observed temperature has been plotted as a function of true (standard lamp) temperature. The accuracy of pyrometric temperature determinations made on billets in this induction furnace has been checked against calibrated tungsten - tungsten-26-percent rhenium thermocouples to 4300^o F. It has been found that the pyrometer readings agreed with the thermocouple readings to within $\pm 5^{\circ}$ F to 4000^o F. At temperatures greater than 4000^o F, large, inconsistent variations in temperature readings between the pyrometer and the thermocouple existed. These variations in temperature were attributed to a reaction between the thoria thermocouple

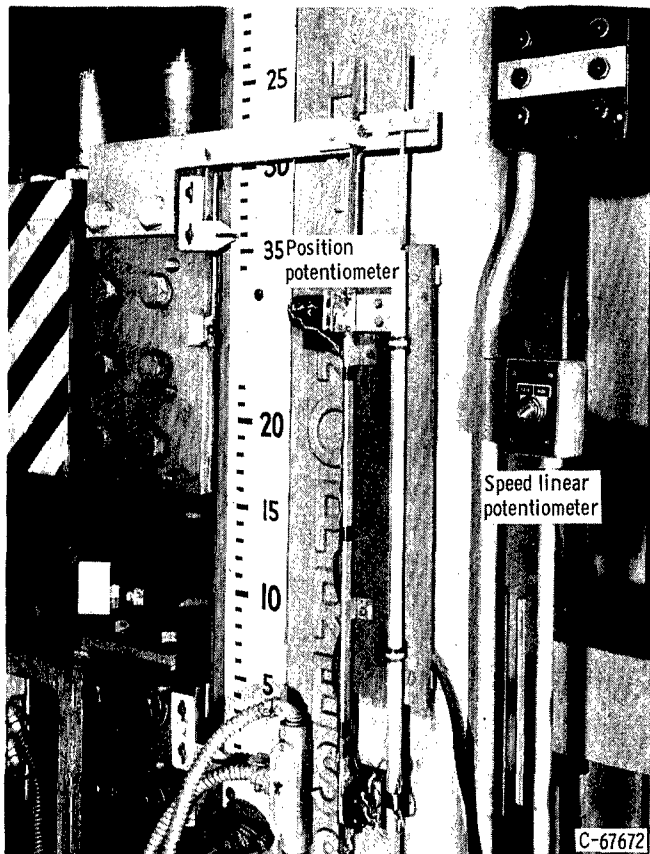

Figure 12. - Stem position and velocity potentiometers.

recorded by an X-Y-Y plotter having a full-scale deflection speed of 0.5 second. Pressure is plotted as a function of distance of stem travel (or stem position) instead of time.

Stem position. - Stem position during the extrusion cycle is determined through the use of a 10-turn, 10 000-ohm potentiometer (fig. 12). The potentiometer is operated by a gear and rack assembly. The rack is fastened directly to the moving crosshead. The potentiometer is electrically connected to the X-axis of the plotter. One inch of stem (crosshead) travel is equal to 1.5 inches of distance on the plotted graph.

Speed determinations. - The speed of the stem is determined through the use of a 20-inch-long linear potentiometer (fig. 12). Speed is also recorded as a function of distance traveled or position. Thus, speed and pressure can be determined for any portion of the billet extruded.

The linear potentiometer has been calibrated against time for speeds to 20 inches per second and determined to be accurate to within ± 1 percent of the actual speed.

insulators and the thermocouple wire. The accuracy of readings of temperatures between 4000° and 5000° F obtained in the induction furnace is impractical to ascertain at the present time. However, it is presumed, from our best judgment, that the optical pyrometer readings taken on billets heated to 5000° F are correct within $\pm 30^{\circ}$ F.

Pressure measurement. - Extrusion pressures are determined by the use of strain-gage load cells mounted in the valve blocks, which admit the water into the stem actuating cylinders. The pressure pickups have been calibrated against known pressures developed by a controlled pressure pump unit. The pump pressure is read from a Bourdon tube pressure gage which has been calibrated against a dead-weight tester. The pressure is re-

Extrusion Alloys and Extrusion Quality

Extrusion alloys. - The materials extruded in the press range from elemental

TABLE IV. - EXTRUSION CHARACTERISTICS OF REFRACTORY TUNGSTEN ALLOYS
 EXTRUDED AT ELEVATED TEMPERATURES IN 1020-TON PRESS

Alloy composition	Nominal billet diameter, in.	Overall reduction ratio	Extrusion temperature, °F	Stress on external stem, psi	Material recovery, percent
Tungsten - 0.5 weight percent zirconium - 15 weight percent tantalum ^a	2.0	12:1	4400	199 600	60
Tungsten ^b - 4 weight percent hafnium	3.0	8:1	4200	177 000	90
Tungsten - 8 volume percent hafnium carbide ^a	2.0	8:1	4200	197 600	50
Ultrafine tungsten ^a	2.0	8:1	4200	200 000	40
Tungsten - 4 volume percent thoria ^a	2.0	12:1	4000	185 000	60
Tungsten - 5 weight percent hafnium - 0.5 weight percent boron - 0.05 weight percent carbide - 0.05	3.0	8:1	4000	144 000	90

^aPowder-metallurgy sintered.

^bArc melted.

metals through complex alloy systems, primarily restricted to the tungsten alloy family. Extrusions have been made of ferrous alloys, nonferrous alloys, dispersion-strengthened nickel and nickel-base alloys, powder-metallurgy tungsten, vacuum-arc-melted and electron-beam-melted tungsten and tungsten alloys, and dispersion-strengthened tungsten and tungsten-base alloys. Some successful preliminary extrusions have also been made on pure and mixed carbides. These carbides have been most difficult to extrude even at extrusion temperatures approaching 5000° F. Table IV gives some extrusion characteristics for some tungsten alloys that are difficult to extrude which have been tried in the 1020-ton press. Material recovery for these materials ranged from 40 to 90 percent.

Surface quality. (- The surface finish obtained on extrusions has been primarily a function of the material being extruded. Excellent surfaces have been produced on aluminum, copper, steel, and some tungsten products.)



C-52610

(a) From conventional extrusion press.

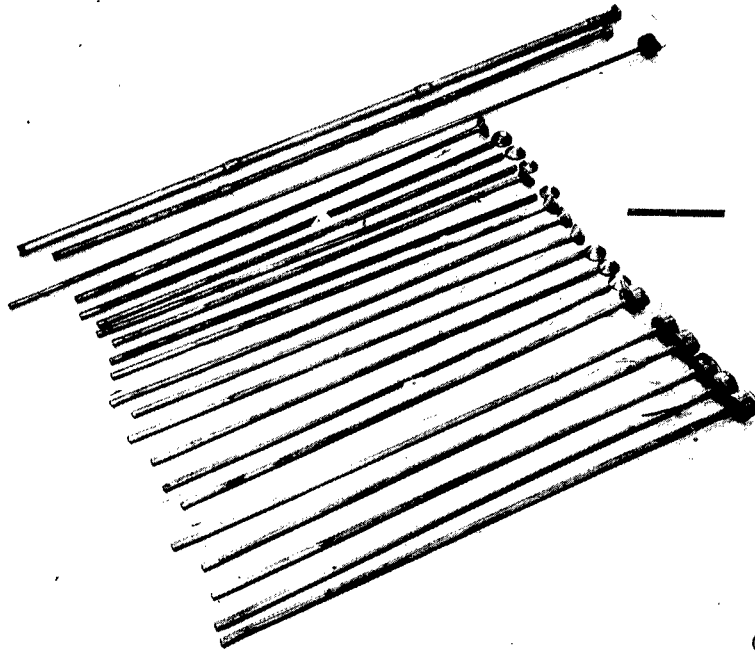

C-63645

(b) From press with straightener incorporated.

Figure 13. - Typical extrusions obtained in extrusion processes.

[Other tungsten products, irrespective of the method of billet fabrication, show extrusion defects that are generally associated with lubrication failure, in that torn and/or striated surfaces are obtained. Yet visual inspection of these extrusions indicate the presence of lubricant along the entire extruded length, and dimensional checks of the extrusion show little or no die wear. Attempts to eliminate these extrusion defects by varying lubrication techniques, canning materials, and extrusion temperatures have met with little success to date.]

Straightness. - Prior to the employment of the extrusion straightener, extrusions would twist and bend. The degree of twist or bend depended on the reduction ratio, lubricant, die configuration, billet temperature, and extrusion speed. Typical extrusions produced without the straightener are shown in figure 13(a). With the straightener incorporated into the tooling setup, straight extrusions have been obtained (fig. 13(b)).

However, the straightness is a function of the clearance between the extrusion and the wall of the straightener, and exceptionally straight extrusions can be obtained when close tolerances are held. In a series of extrusions where the straightener was used, the extrusions, with the exception of the nose end, were straight along the remainder of the length (up to 8 ft) within 1/4 inch (fig. 13(b)). The use of the straightener eliminates the need for subsequent straightening and the introduction of additional processing variables.

CONCLUSIONS

Experience gained while operating a three-stage vertical extrusion press at temperatures approaching 5000° F during the past several years has resulted in a relatively good yield of acceptably extruded experimental materials and has also shown that

1. Billets inductively heated in an atmosphere furnace can be controlled within $\pm 5^\circ$ F of the desired temperature to 4000° F with the use of an optical pyrometer. The accuracy of temperatures greater than 4000° F has not been ascertained, but it is felt that optical pyrometer determinations of temperature at 5000° F are correct within $\pm 30^\circ$ F.

2. An average extrusion cycle time, the time from the opening of the furnace until completion of the extrusion of less than 5 seconds can be obtained by making a rapid billet loader an integral part of the extrusion tooling. The time can further be reduced to 2.5 seconds by the addition of an automatic billet pusher.

3. Straight extrusions (to within 1/4 in. over an 8-ft length) can be obtained by incorporating an extrusion straightener into the tooling mechanism, and thus postextrusion straightening operations can be eliminated.

4. While the effects of the various lubricants used in the extrusion of metals have not been fully evaluated, the best quality extrusions have been obtained by using a calcium graphite grease for extrusion temperatures in the range 1500° to 2300° F and an epoxy or resin bonded glass cloth impregnated with tungsten disulfide for extrusion temperatures ranging from 3000° to 5000° F. The extrusion temperature range between 2300° and 3000° F has not been sufficiently explored to determine the effect of lubrication on extrusion quality.

5. Life of container liners is relatively short when they are used in extruding refractory materials at temperatures greater than 3800° F.

Lewis Research Center,
National Aeronautics and Space Administration,
Cleveland, Ohio, July 16, 1965.

J
and

REFERENCES

1. Carnahan, D. R.; and DePierre, V.: The Primary Working of Refractory Metals. Rept. No. AFML-TR-64-387, Westinghouse Electric Corp., Nov. 1964.
2. Anon.: Properties of Selected Commercial Glasses. Brochure No. B-83, Corning Glass Works, Corning (N. Y.), 1959.