

NASA CONTRACTOR
REPORT

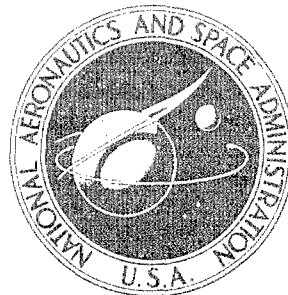

NASA CR-1021

NASA CR-1021

AMPTIAC

DISTRIBUTION STATEMENT A
Approved for Public Release
Distribution Unlimited

DESIGN HANDBOOK
UMBILICAL LOCKING MECHANISM
DEVELOPMENT PROGRAM

by David L. Cusick

20060516263

Prepared by

CHRYSLER CORPORATION

Huntsville, Ala.

for George C. Marshall Space Flight Center

~~B072213~~

NASA CR-1021

DESIGN HANDBOOK
UMBILICAL LOCKING MECHANISM
DEVELOPMENT PROGRAM

By David L. Cusick

Distribution of this report is provided in the interest of information exchange. Responsibility for the contents resides in the author or organization that prepared it.

Prepared under Contract No. NAS 8-20649 by
CHRYSLER CORPORATION
Huntsville, Ala.

for George C. Marshall Space Flight Center

NATIONAL AERONAUTICS AND SPACE ADMINISTRATION

For sale by the Clearinghouse for Federal Scientific and Technical Information
Springfield, Virginia 22151 - CFSTI price \$3.00

DESIGN HANDBOOK
LOCKING MECHANISMS

By

David L. Cusick

Electrical Systems and GSE Engineering Department
Chrysler Corporation Space Division
Huntsville, Alabama

ABSTRACT

This handbook presents the techniques, developed in an intensive testing program, for use in designing ball-lock mechanisms for use on space vehicle umbilicals. In addition to the general design of this locking device and its component parts, this handbook covers the effects of component surface conditioning, temperatures from ambient to minus 196 degrees Centigrade ($^{\circ}\text{C}$), materials and material hardness, and forces on the locking device up to 5000 pounds.

For the convenience of the reader, the final test report under this contract is included as an addendum to this report.

DESIGN HANDBOOK
LOCKING MECHANISMS

SUMMARY

The information presented in this handbook is the product of a test program conducted by Chrysler Corporation Space Division, Huntsville Operations under Contract Number NAS8-20649.

The locking devices investigated in this program were limited to two types, ball-locks and collet-locks. The ball-lock mechanism (Illustration 1, Appendix A) consists of two basic parts, a vehicle half or ball race and a ground half that performs the mechanics of locking or unlocking. The ground half of the ball-locking mechanism houses the balls and the release pin that is mechanically or pneumatically actuated to accomplish the locking or unlocking function.

The collet-lock mechanism (Illustration 2) investigated in this test program, like the ball-lock, consists of a vehicle half or seat and a ground half that performs the mechanics of locking or unlocking. The ground half of the collet-lock mechanism is a one-piece, segmented, cantilever configuration fabricated from a spring material such as beryllium copper. The release pin in the collet-lock mechanism may also be mechanically or pneumatically actuated.

The testing program indicated that the ball-lock mechanism is to be greatly preferred over the collet-lock mechanism. The degree of effort involved in the design of collet-lock mechanisms is too involved and too time consuming for the end result. The ball-lock mechanism will more than adequately perform the locking function and is more easily designed and manufactured. For these reasons this handbook is limited to the design of ball-lock mechanisms only.

→ p. 7

SECTION I. INTRODUCTION

This handbook covers the design of ball-lock mechanisms for use on space vehicle umbilicals. The design information presented in this handbook is the product of a test program conducted by the Electrical Systems and GSE Engineering Department, Chrysler Corporation Space Division, Huntsville Operations.

In addition to the general design of this locking mechanism and its components, the effects of component surface conditioning, temperatures from ambient to minus 196°C, materials and material hardnesses, and forces (pre-loads*) on the locking device up to 5000 pounds are presented.

This information was compiled to aid in the future design of umbilical locking mechanisms. The use of this information will increase hardware reliability and life and by standardizing umbilical lock designs will increase the interchangeability of parts among umbilical locks of different vehicles and vehicle stages.

This handbook is limited to the design of the components of the ball-lock that actually perform the locking function and does not include the pneumatic cylinder or mechanical system that supplies the force for lock release.

* For the purpose of this handbook pre-loads refer to those forces that are applied to the locking mechanism to maintain contact between both halves of the umbilical and those forces on the locking mechanism that result from vibration, umbilical weight, wind effects, vehicle sway, etc.)

SECTION II. DESCRIPTION

CONFIGURATION

A. ENVELOPE

The first consideration in the design of umbilical locking mechanisms is that of size, available space, or envelope that is allowed for the lock. Coupled with this consideration is the pre-load on the umbilical or that force trying to separate the two halves of the umbilical while the lock is engaged. These two parameters, size and pre-load, must be considered together to achieve an optimum design. In general, the lock should be designed to the largest size that is practical from a weight and configuration standpoint. In the case of ball-locks of optimum designs, tests where three sizes were investigated (Ref. figure 1, Appendix B), 1.056 inches, 1.358 inches, and 1.810 inches in diameter, demonstrated that each sized lock functioned reliably with few differences in release characteristics up to 5000 pounds pre-loading. (The ball-lock sizes refer to the diameter of the ball retainer tip (Ref. illustrations 3 through 5). In collet-lock tests, 1.00 inch diameter hardware in most cases released with reasonable success at pre-loads up to 5000 pounds force while collets of 0.50 inches in diameter failed (fractured) consistently at pre-loads between 3000 and 4000 pounds (see illustrations 2, 6 and 7). It can be noted, therefore, that locks of the 1.00 to 2.00-inch diameter size range which incorporate optimum design features are generally acceptable for umbilicals where pre-loads no greater than 5000 pounds are present.

B. COMPONENT DESIGN

1. General. The general ball-lock configuration should be capable of relatively smooth operation and coupling and should be sufficiently sturdy to withstand some abuse. It should also, of course, be of sufficient size and critical surface area to withstand the applied tension forces within the limits of the materials used for manufacture. A typical example is shown in illustration 1. One of the first basic considerations in component design is the number of balls to be used. The number of balls is directly related to the maximum system stress under a given applied force. An optimum configuration will contain some optimum number of balls that aids in reducing the overall system stress to a minimum. This optimum ball configuration may be theoretically calculated using Hertzian contact stress equations* and simple geometric relationships. The optimum number of balls will be independent of ball and ball retainer size. For detailed calculations of optimum ball configurations refer to Appendix C, Examples I, II, and III. The results of these calculations should be considered along with certain practical aspects before making the final determination of an optimum ball configuration. Ease of manufacture, ball size, availability of hardware and tolerancing are

* Kents Mechanical Engineers Handbook, Design and Production Volume, Twelfth Edition, Page 8-36.

some of these additional considerations. Based on these considerations and the above mentioned calculations, the ideal number of balls to be used for any sized ball-lock of the type applicable for space vehicle umbilicals has been determined to be four.

The next basic consideration in component design is that of relative component size. With the ideal number of balls established at four, the relative size of the ball-lock components (the balls, the ball-retainer, the release pin, and the ball race) must be determined based on the space limitations for this hardware. The sizing of the ball race depends on the pre-loading of the lock as well as the space limitations. If the pre-loading is extremely high, up to 5000 pounds, the race should be designed to the maximum envelope allowed with the inner diameter (I.D.) of the race in the range of one to two inches. Tests have proven that ball-locks of optimum configurations in this size range are capable of reliable performance under pre-loads of 5000 pounds. With an approximate value established for the race I.D., an approximate value for the outside diameter (O.D.) of the ball retainer may be established as these values will be equal except for tolerance differences (see illustration 8). The ball size based on the ball retainer size may now be calculated from equations formulated from the geometric relationships of the components. These equations, shown in Example III, determine the maximum ball size for a given retainer size in a four-ball configuration. This calculated value of ball diameter may then be compared with vendor size listings of ball bearings to select a ball size that can be purchased as a "stock" item. When the proper ball is selected, a more exact determination of the ball retainer O.D. and the race I.D. can be made utilizing the calculations discussed previously.

2. Race. The general size and configuration of the race has been established by the envelope and calculations discussed in the previous section. The race angle must now be determined (Ref. illustration 8). When a load is applied to the lock, the balls bear directly on the race angle which transmits a resultant force to the release pin. The size of the race angle will determine the resultant force value on the release pin. As the race angle size increases the load on the pin decreases. The load on the pin is directly related to the force required to actuate the lock. As the load on the pin becomes greater, the balls will indent farther into the pin and more brinelling or galling of the pin will occur during the unlocking operation. As a general rule the race angle should be as large as possible within the limits of practicality. Tests have supported this by showing that as the race angle size is increased the release force decreases (Ref. figure 2). However, the size of the race angle will be limited by certain physical aspects connected with the manufacturing and assembly of the locking mechanism. It has been determined in actual practice that as the size of the race angle is increased the difficulty of fabrication and assembly becomes greater. The problem is primarily one of ball retention by staking the retainer versus ball position relative to the race angle; i.e., as the race angle is increased,

the balls must be allowed to protrude farther out of the ball retainer to maintain full contact on the race. The farther the balls protrude relative to the retainer, the more difficult it becomes to sufficiently stake the ball retainer to permanently hold the balls. As the ball retainer size decreases, as in the case of smaller ball-locks, the problem becomes greater, in that there is a definite limit to the race angle that may be used. Illustration 9 graphically illustrates this effect. In the testing discussed above, 75 degree race angles were used in two-inch ball-lock assemblies with relative ease whereas, in other tests on one-inch ball-locks, it was necessary to limit the race angle to sixty-five degrees. To reiterate, the theoretically desirable race angle which minimizes the resultant force on the release pin will not be practical for all ball-lock sizes, however, the largest practical angle should be determined. The physical limit of the race angle or the maximum race angle may be calculated by the equation shown in Example IV. This equation relates the variables discussed above: The ball-retainer size, ball-size, tolerance between the race I.D. and the ball-retainer O.D., the corner radius of the race I.D., ball position relative to the race angle and staking depth. The retainer and ball sizes have been established from the previous section (Ref. Paragraph II.B.1) and the tolerance between the race I.D. and the ball retainer O.D. may be established according to normal tolerancing practices. The corner radius of the race I.D. should be as small as possible (approximately 0.03 inches or less) to maintain as much surface area on the race angle as possible. The staking depth and the ball position relative to the race are nebulous values that must be assumed. The ball position relative to the race, the Y dimension shown in Example IV, is the vertical distance from the top of the corner radius of the race I.D. to the ball and race contact point. This dimension will depend on the diameter of the ball brinell or indentation in the race that occurs when the lock is loaded. For the purposes of design, this value may be assumed to be from 0.03 to 0.04 inches. The staking depth will vary depending on the tool and the personnel performing this operation. As a starting point, a value of 0.032 inches may be used for this value but a larger value would be more desirable. If minimum values are chosen for the staking depth, the ball position, the corner radius, and the tolerance; the equation in Example IV will yield the maximum possible angle that may be used for this configuration. If possible this maximum angle value should be reduced somewhat to "loosen up" on the variables in question. Although the equation mentioned above may not provide an absolute value for the race angle, it will provide a good approximation and starting point for further evaluation.

3. Release Pin. The release pin is basically a cylinder with a small tip tapered up to a larger diameter which initiates the lock mechanics by pushing the balls out in the locking operation (Ref. illustration 10). The purpose of the small tip on the end of the pin is to retain the balls when the mechanism is in the unlocked position. The overall length of the release pin and tip will depend on the travel of the pneumatic piston or actuating mechanism of the lock. However, this travel should be limited to approximately 1.00 inch or less. The

pin travel relative to the ball and the pin taper should be held to a maximum of approximately 0.25 inches (Ref. illustration 10). The pin and tip diameters may be calculated from the equation in Example V after the variables discussed in previous sections have been established.

In the case of this type of pin (single point contact), severe stressing on the ball and pin contact surface may be present due to the small surface area of contact in a ball-on-cylinder configuration. This high stressing will cause some brinelling of the pin during the unlocking operation. The severity of brinelling will of course vary with the resultant load on the pin. As previously discussed, this resultant force will increase as the race angle decreases and in the case of relatively low race angles (i.e. 45 degrees) the force may be very high. In this case the pin brinelling can be extremely severe. This pin damage can possibly influence the force required to release the lock. To increase the surface area between the ball and pin and thus decrease the contact stress at any one point, two other types of pins, the two point contact pin and the line contact pin, may be used (Ref. illustration 11). Tests were performed on pins of both types, however, and no reduction of release force was experienced when tested in hardware with 70 degree race angles even though the overall pin damage was very light. Although tests were not performed with low race angle configurations, pins of these type may have applications where low race angles are required. For this reason, these designs merit consideration dependant on the specific set of conditions encountered.

C. TOLERANCING

In most cases the tolerances encountered in designs of this nature should conform to standard tolerancing practices.* Tolerance stack-up should be considered and minimum and maximum tolerances on all dimensions should be reflected in the equations discussed previously. Two critical areas of tolerancing are: (1) the holes in the ball retainer housing that retain the balls and (2) the bore through the center of the ball retainer that houses the release pin (Ref. illustration 8). The release pin bore should be maintained concentric with the outside diameter of the ball retainer to achieve equal ball protrusion from the retainer. The holes in the retainer that retain or house the balls should be held to a close tolerance with the diameter of the ball to maintain line contact with the ball and to decrease the depth of staking required. These holes should also be maintained in the same plane to achieve even bearings on the race angle.

Tolerances that affect the installation into the umbilical housing and cause angular misalignments between the ground and vehicle halves of the locking mechanism should be held to a minimum. If an angular misalignment is present, the release force will be affected. Tests have shown that as the degree of misalignment is increased, the force required to release the lock will increase (see figure 3). At low lock pre-loads this effect is negligible but at extremely high loads a failure of the lock to release could result.

* Reference - MSFC Engineering Drafting Manual, Section 06, Tolerancing

MATERIALS

A. GENERAL

In the selection of materials for locking mechanism components, two of the most important considerations are pre-load or stressing and environment. In applications of this type where contact stresses are present and pre-loads are high, extremely high stresses will be experienced. In most cases, materials are not available that will withstand this high stressing without some damage. Stresses of several hundred thousand pounds per square inch on ball-lock components can be expected when pre-loads of 5000 pounds or more are applied to the lock. However, in contact stressing only the surface of the part is stressed and only surface damage will result. This surface damage must be held to a minimum to maintain release forces at a reasonable level and, therefore, very strong materials must be used. In most cases harder materials effect the best results in applications of this type. In addition, surface damages must be restricted to certain areas in the locking device. For example, if the balls were made of a very soft material, they would deform or flatten out under high loads and release would be greatly affected. Generally, it is preferable if the balls are maintained as the hardest components in the ball-lock assembly and the surface damage limited mainly to the race and release pin.

Environment is also an important factor in the selection of materials. All materials used must be compatible with the environment to which they are exposed. In space vehicle applications, materials may be subjected to a corrosive environment, a liquid oxygen (LOX) environment, extreme temperature environments, etc. It may be required that the materials be compatible with all of these conditions.

Stainless steels are best suited for applications of this type because of their high strength and corrosion resistance. Stainless steel, type 440C ^{SS} is an excellent ball material and can be heat treated to a very hard condition (Rockwell C (R_C) 58 or harder). Since this material is a standard ball bearing material, balls can be readily purchased in all sizes. All 400 series stainless steels, however, become extremely brittle at low temperatures and may not be desirable for cryogenic applications. Although in all tests performed in the associated test program (nearly 4000 tests in all) at temperature as low as minus 196°C using 440C balls, no failures, fractures or serious damage occurred due to the ball material. Since contact stresses result in stressing on the component surface only and a ball configuration does not readily lend itself to fracture, it is felt that the use of 440C stainless steel as a ball material will not result in any serious problems at reduced temperatures.

300 series stainless steels such as 304 ^{SS} and 303 ^{SS} can be used for other component materials (race, release pin, ball retainer). Stainless steel type 304 has exceptionally good low temperature properties. However, all 300 series steels must be purchased in a prehardened condition by cold working and are not readily

available in very hard conditions. The hardness limit is approximately Rc 35 and is very difficult to obtain. 17-4 PH stainless steel is an age hardenable stainless steel and can be purchased in various hardness conditions. This material is recommended when a 300 series stainless steel is not available at a desired hardness level. Eighteen percent (18%) nickel maraging steel is an ultra-high strength material which can be heat treated to a hardness of approximately Rc 50 and an ultimate strength of approximately 250,000 pounds per square inch. This material performs very well as a component material in a ball-lock assembly. However, this material at the present time is comparatively expensive and is not corrosion resistant. A protective coating or plating would be required for use in a corrosive atmosphere. For these reasons this material would not be recommended unless very high strengths are required due to excessive pre-loads on the ball-lock. Various other materials may be applicable but they should be selected to be compatible with the specific set of conditions under which they will be used. *end*

B. MATERIAL HARDNESS

In ball-lock design, the material hardness is generally more important than the type of material in so far as the unlocking operation or force required to unlock is concerned. As previously stated, very high surface stresses may be encountered in the use of ball-locks and to minimize surface damage, hard materials are required. Tests have shown that as the material hardness increases, the force required to release the lock decreases (Ref. figure 4). In addition the release force data obtained in tests of this type was much less scattered and more reproducible when harder materials were tested. In cryogenic temperature applications, soft materials become harder and release forces become comparable with those where hard materials are used. However, based on past experience, the most favorable results will be achieved when the hardness of the race, release pin and ball retainer is maintained above Rc 25 and the ball material is maintained above Rc 50. The exact hardness level required will depend on the specific service conditions, primarily the overall load on the lock. When the pre-load does not exceed 5000 pounds the above hardness recommendations will apply.

C. HARDWARE LIFE

Hardware life will basically be affected by material hardnesses. Since ball-lock components will suffer some surface damage, repeated use of the same hardware may cause some problems if the materials used are too soft. When life cycle tests, shown in figures 5 and 6, were performed on ball-lock assemblies with components of two hardnesses, the data was more consistent where the harder material was tested. No failures to release, however, were experienced in either test series of 250 cycles. When lower race angles than the 70-degree angles used in these tests are required, the release forces are likely to be more inconsistent and the possibility of failure after repeated cycling will be greater. Basically, the use of the hardest materials available that are practical for this application and can be acquired both readily and economically will increase the overall reliability of the locking mechanism.

SURFACE CONDITIONING

A. SURFACE FINISH

To achieve an optimum ball-lock design, the proper surface finish must be selected for each component of the assembly. Since the bearing surfaces of the race and release pin even in an optimum configuration will receive moderate damage during the unlocking operation, the difference in the effect of surface finishes of 8 root mean square (rms) to 32 rms on these components is negligible as release force is concerned (see figure 7). In addition, only slightly higher release forces will be obtained when surface finishes as high as 125 rms are used. A 32 rms finish is recommended for the bearing surfaces of the above hardware since it is easily achieved by normal machine shop procedures and is quite acceptable from a release standpoint. The surface finish of the balls on the other hand should be maintained as low as possible. Past experience has shown that the surface condition of the balls will greatly affect the release characteristics of the lock such that it may be required that the balls be replaced frequently during repeated use. Standard precision grade bearing balls conforming to Military Standard MS 9461 can be purchased economically with a 2 rms surface finish and are recommended for this application due to past performances. Even when using balls of this type a transfer of material from the release pin to the balls under high loads may occur that will require replacement of the balls for continued use of the lock assembly.

B. PLATING

A protective plating on lock hardware will be required when materials that are not corrosion resistant are required for applications where a corrosive atmosphere is present. A plating of this type will not affect the overall operation of the lock. Tests have supported that release forces are neither reduced nor increased due to plating effects when optimized ball-lock designs are used. When less than optimum designs are used and loads on the plated parts are sufficient to cause severe surface damage, the reliability of the lock may be affected due to flaking of the plating material. In situations where the lock is required to undergo an excessive number of release cycles, the reliability of the lock may also be affected due to plating damage.

C. LUBRICATION

Ball-locks of an optimum design do not require lubrication on the bearing surface to function reliably. However, the use of certain types of lubricants will significantly affect the release characteristics of the lock such that very little force is required to release the lock. This was demonstrated in tests where the effect of lubrication was investigated and the results compared with data where lubrication was not used (see figure 8). These tests also demonstrated that only dry film type or spray film type lubricants showed any improvements over unlubricated systems for this type of application. The data from the tests where grease type lubricants were used was only comparable to and in some cases higher than the test data where no lubrication was used.

As in the case of material selection, lubricants must be compatible with the environment to which they are exposed. When the lock assembly is subject to cryogenic temperatures, dry film type lubricants produce the best results. When exposed to liquid oxygen (LOX), the lubricant must of course be compatible with LOX. The lubricant which produced the lowest release forces in the previously discussed test program, Electrofilm Lubri-Bond A, was not LOX compatible and, therefore, could not be used for most space vehicle applications. Other lubricants of the same type are available which will conform to the necessary requirements. As stated before, however, lubrication is not necessary unless very low release forces are desired.

APPENDIX A - ILLUSTRATIONS

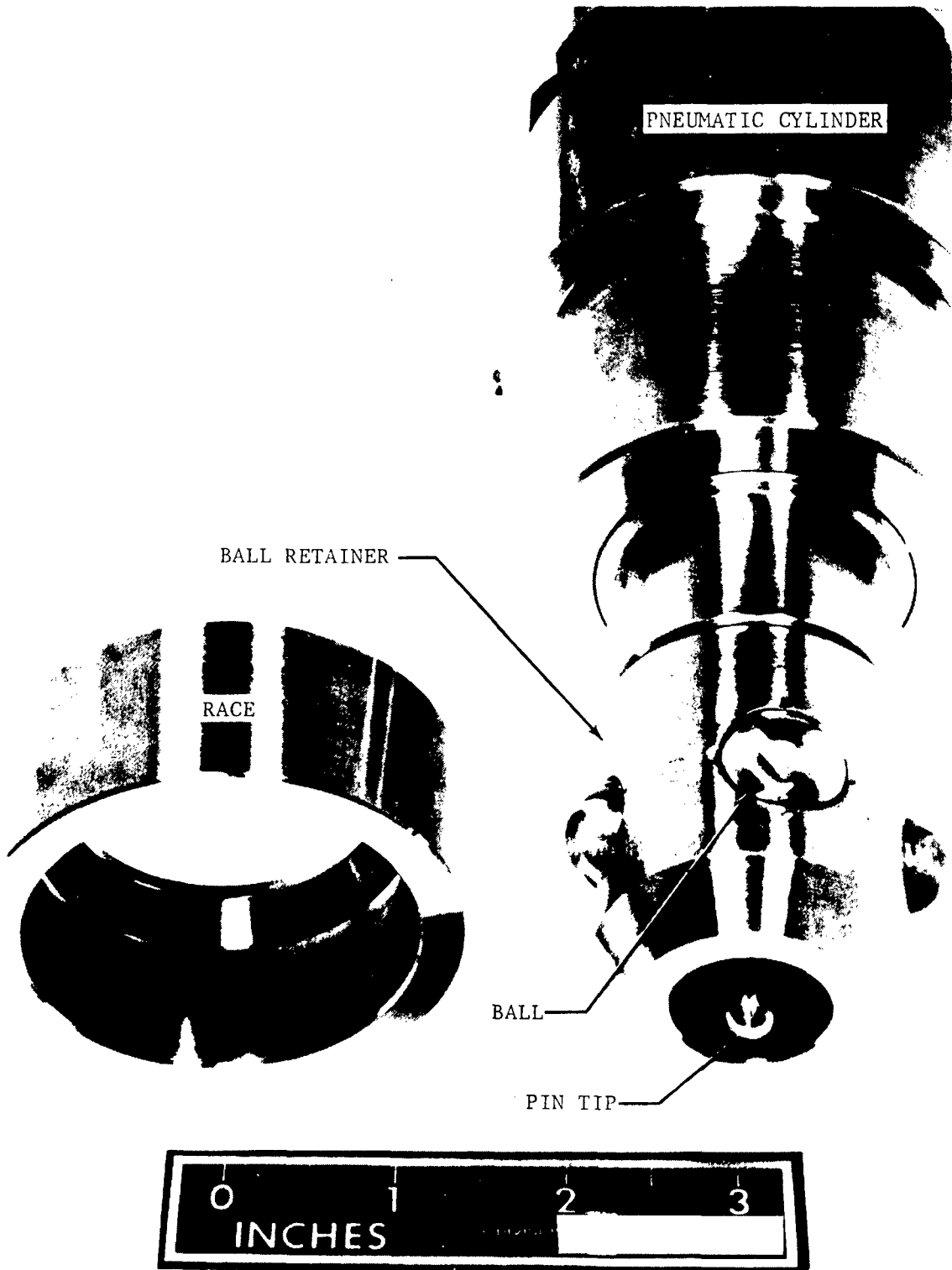

ILLUSTRATION 1. BALL-LOCK (2 INCH)

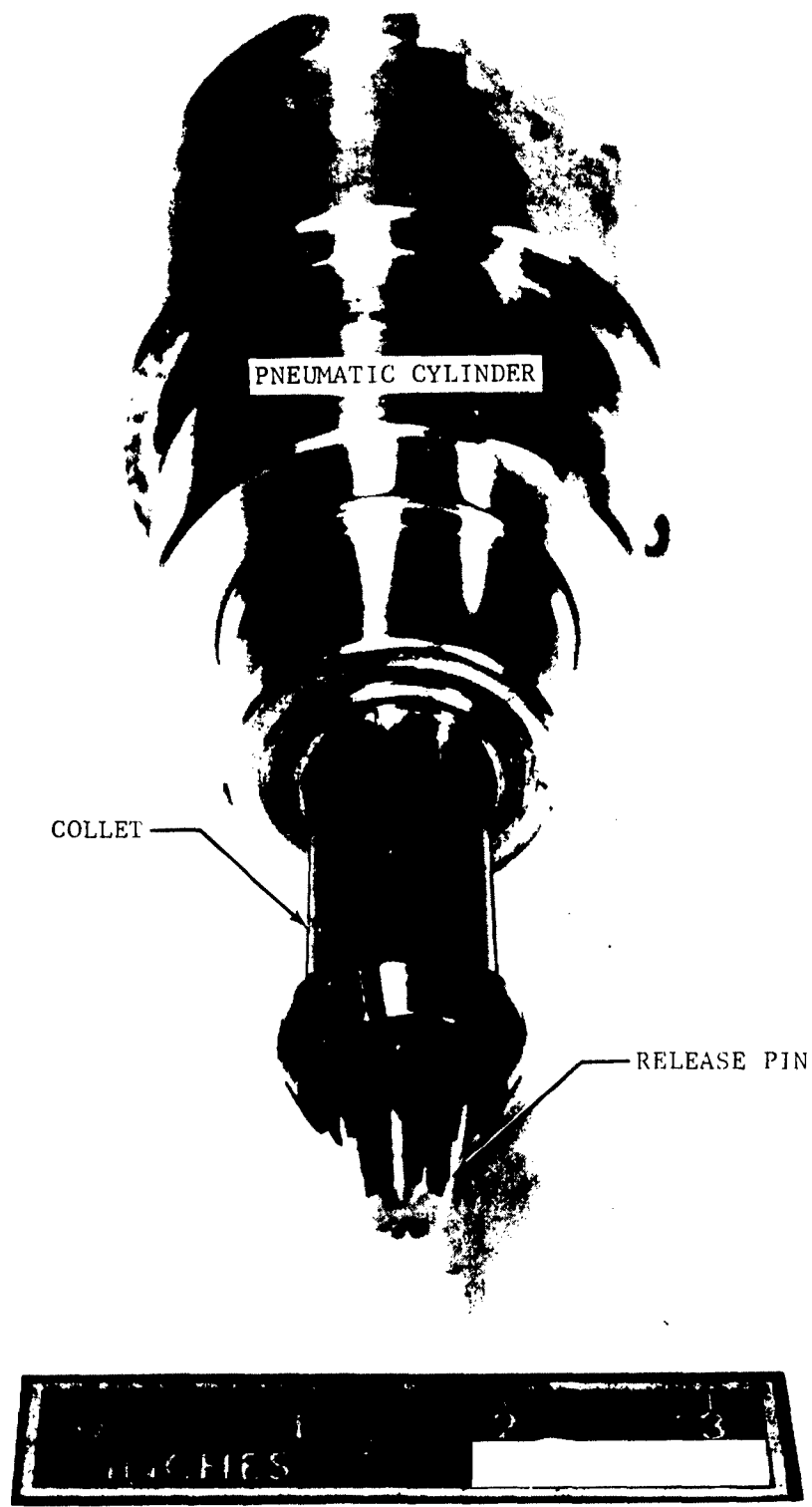

ILLUSTRATION 2. COLLET-LOCK (1 INCH)



ILLUSTRATION 3. BALL-LOCK (1 1/2 INCH)

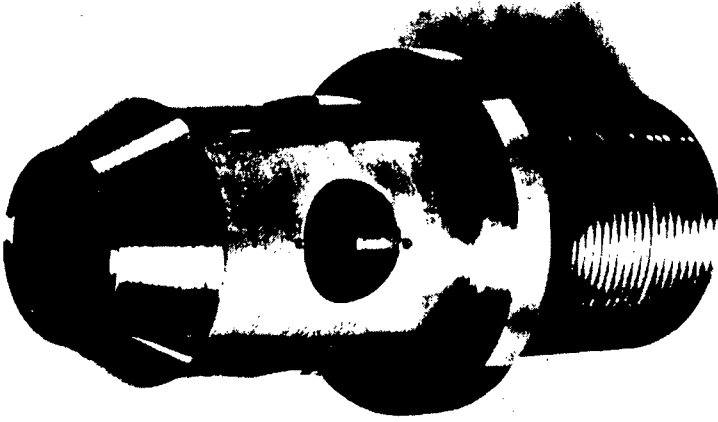

ILLUSTRATION 4. BALL-LOCK (1 INCH)

1.810"O.D. (2" LOCK)



1.358"O.D. (1 1/2" LOCK)



1.056"O.D. (1" LOCK)

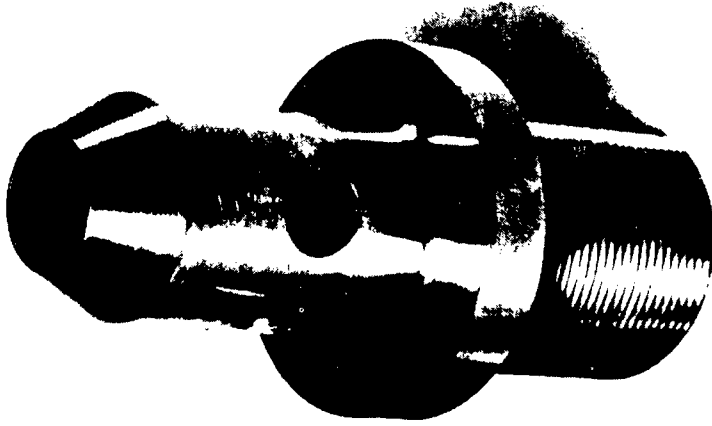

ILLUSTRATION 5. BALL-LOCK SIZE COMPARISON

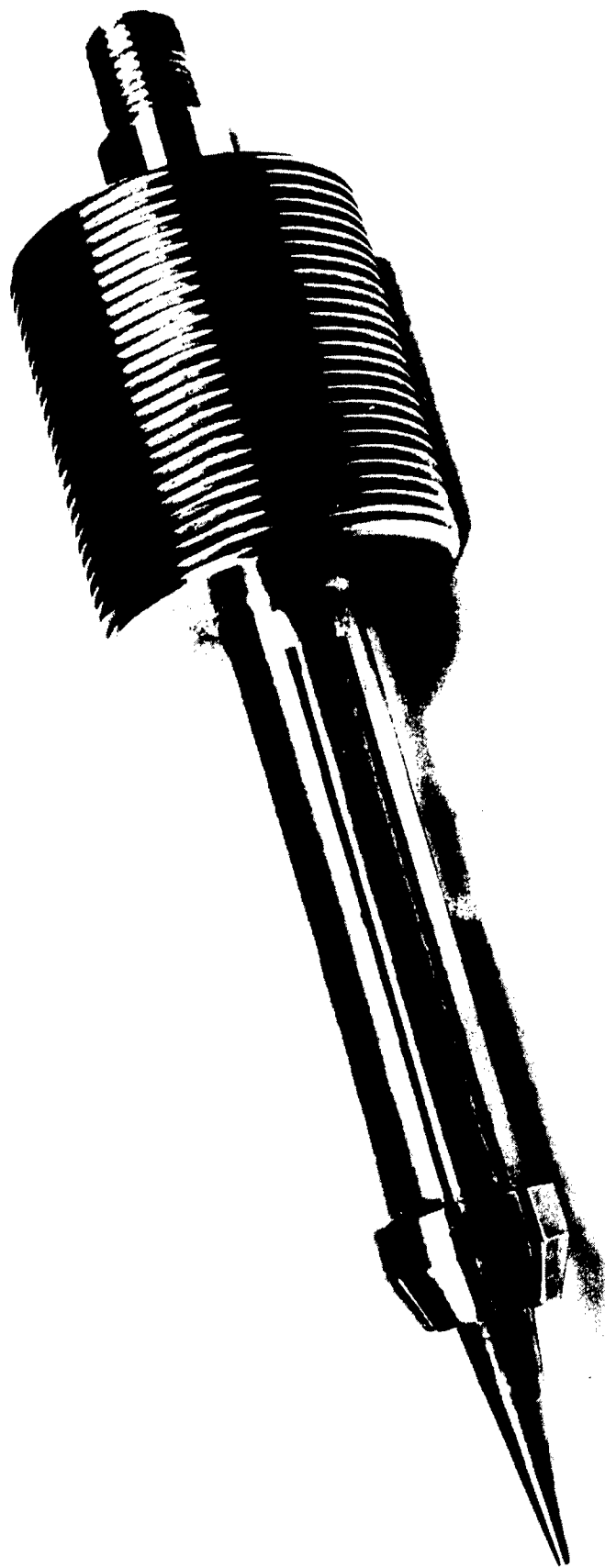

ILLUSTRATION 6. COLLET-LOCK (1/2 INCH)

.980"O.D. (1" LOCK)

.630"O.D. (1/2" LOCK)

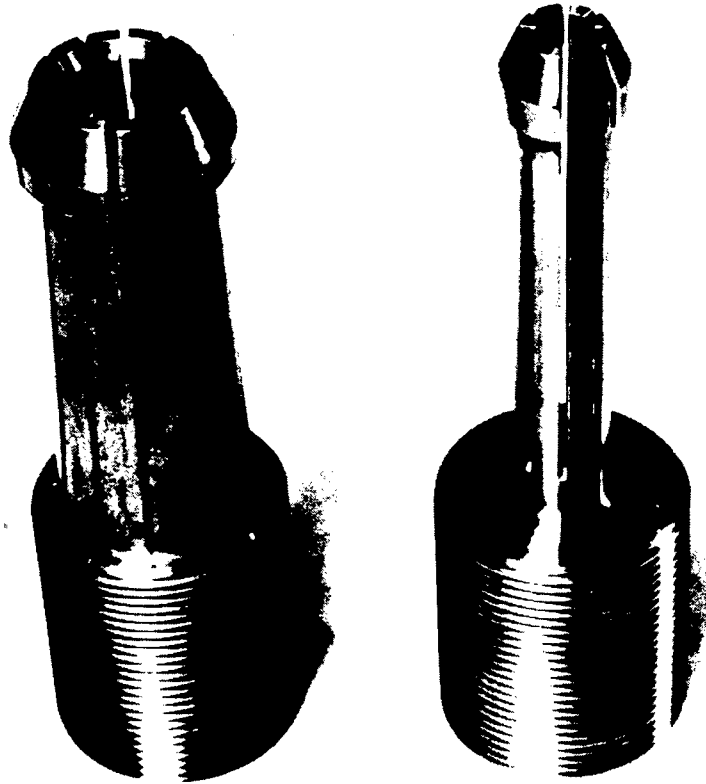

ILLUSTRATION 7. COLLET-LOCK SIZE COMPARISON

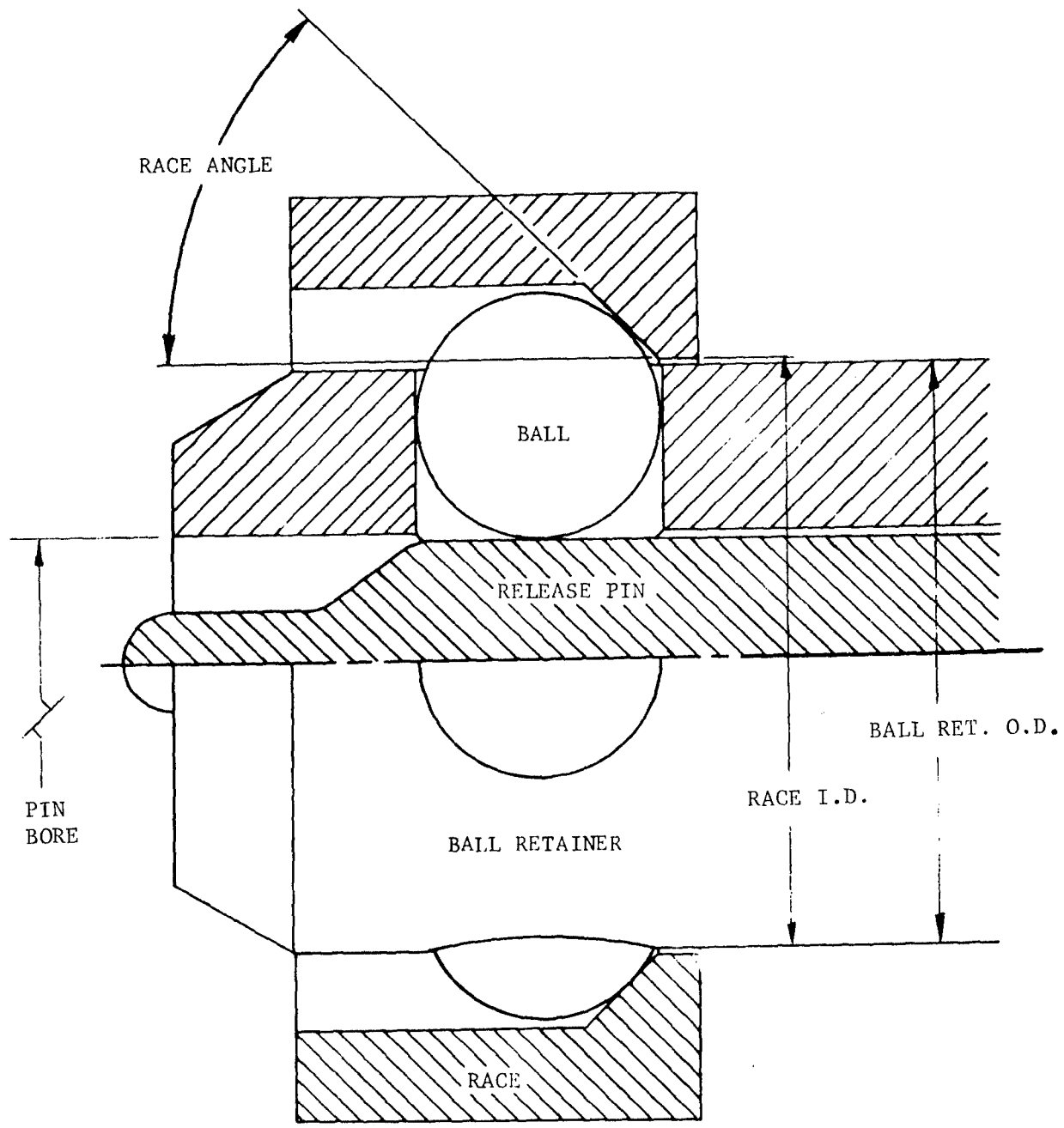
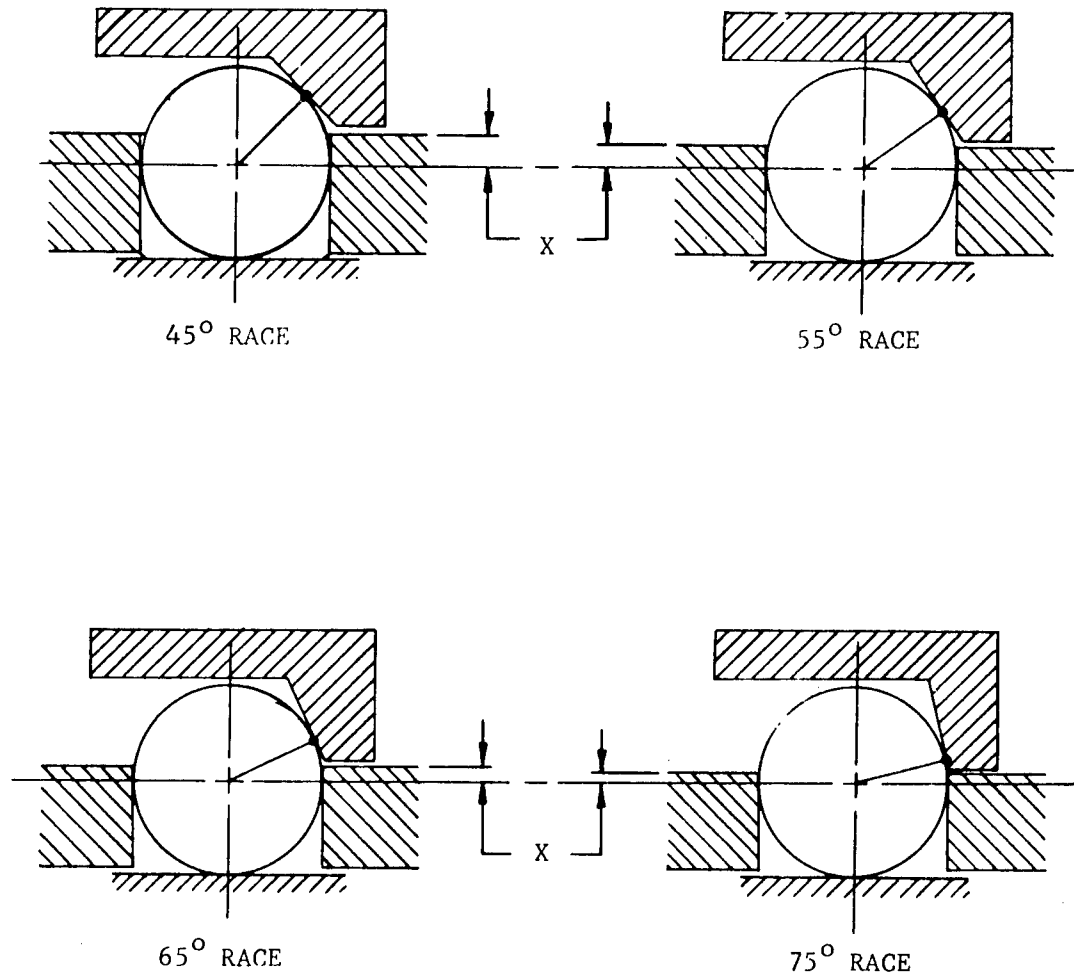

ILLUSTRATION 8. BALL-LOCK RACE ANGLE MEASUREMENT



- POINT OF CONTACT
- X MATERIAL ALLOWANCE FOR STAKING

(REFER TO ILLUSTRATION 8 FOR ORIENTATION & PART IDENTIFICATION)

ILLUSTRATION 9. RACE ANGLE SIZE VERSUS BALL RETENTION

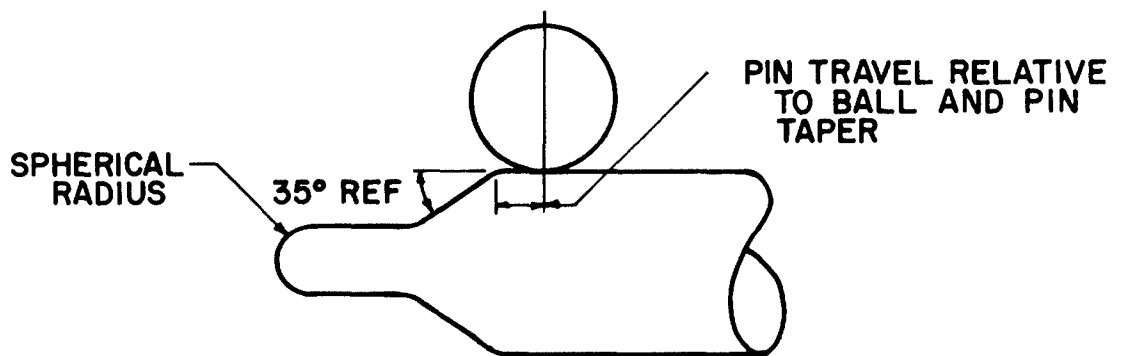
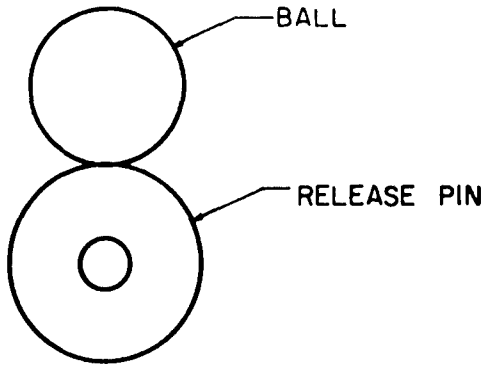
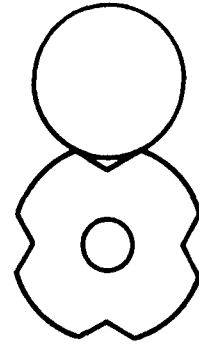

ILLUSTRATION 10. BALL-LOCK RELEASE PIN



SINGLE POINT CONTACT



TWO POINT CONTACT

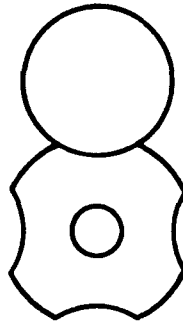

LINE CONTACT

ILLUSTRATION II. BALL-LOCK PIN DESIGN

APPENDIX B - GRAPHS

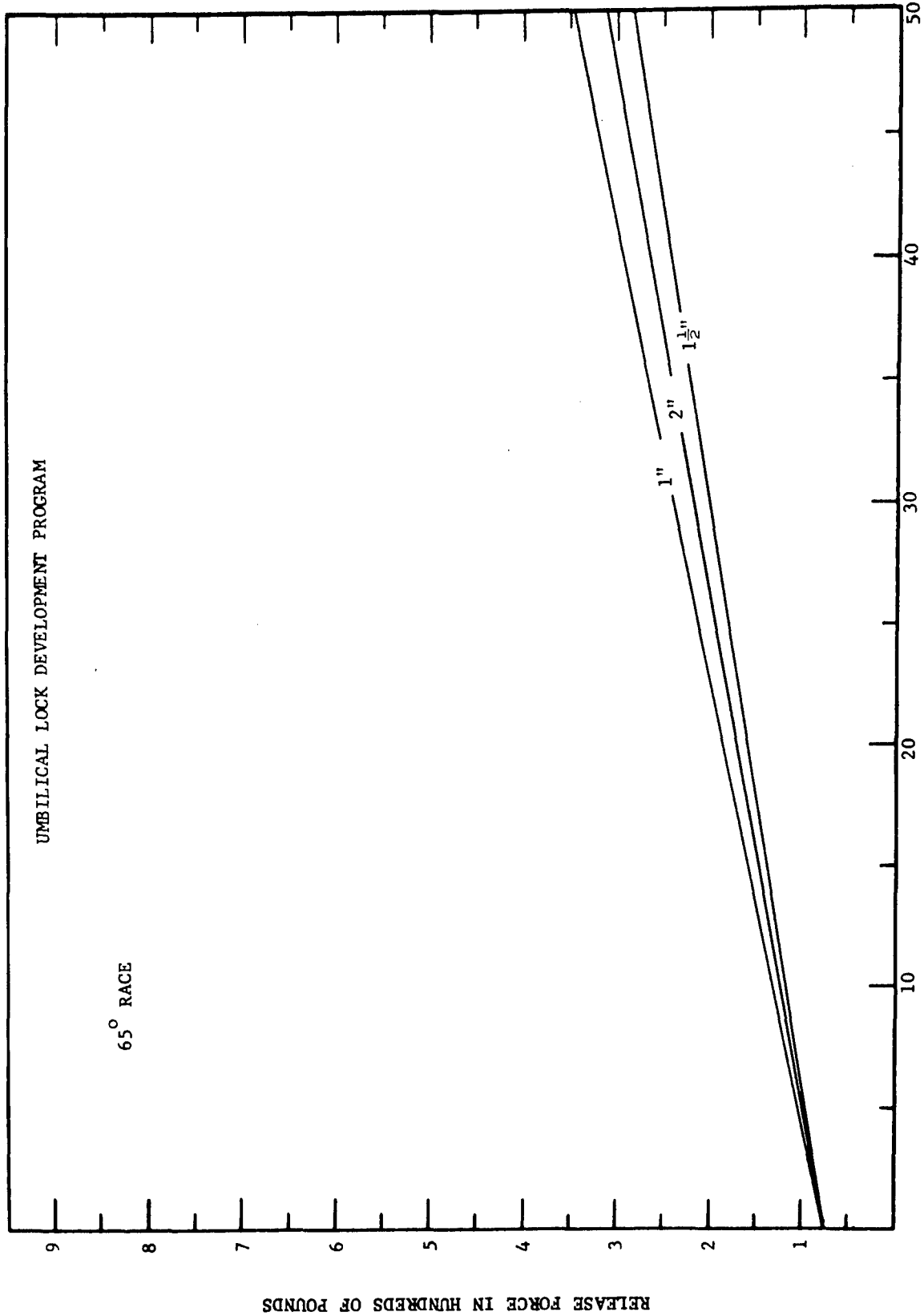

UMBILICAL LOCK DEVELOPMENT PROGRAM

65° RACE

PRE-LOAD IN HUNDREDS OF POUNDS

FIGURE 1. BALL-LOCK SIZE COMPARISONS

UMBILICAL LOCK DEVELOPMENT PROGRAM

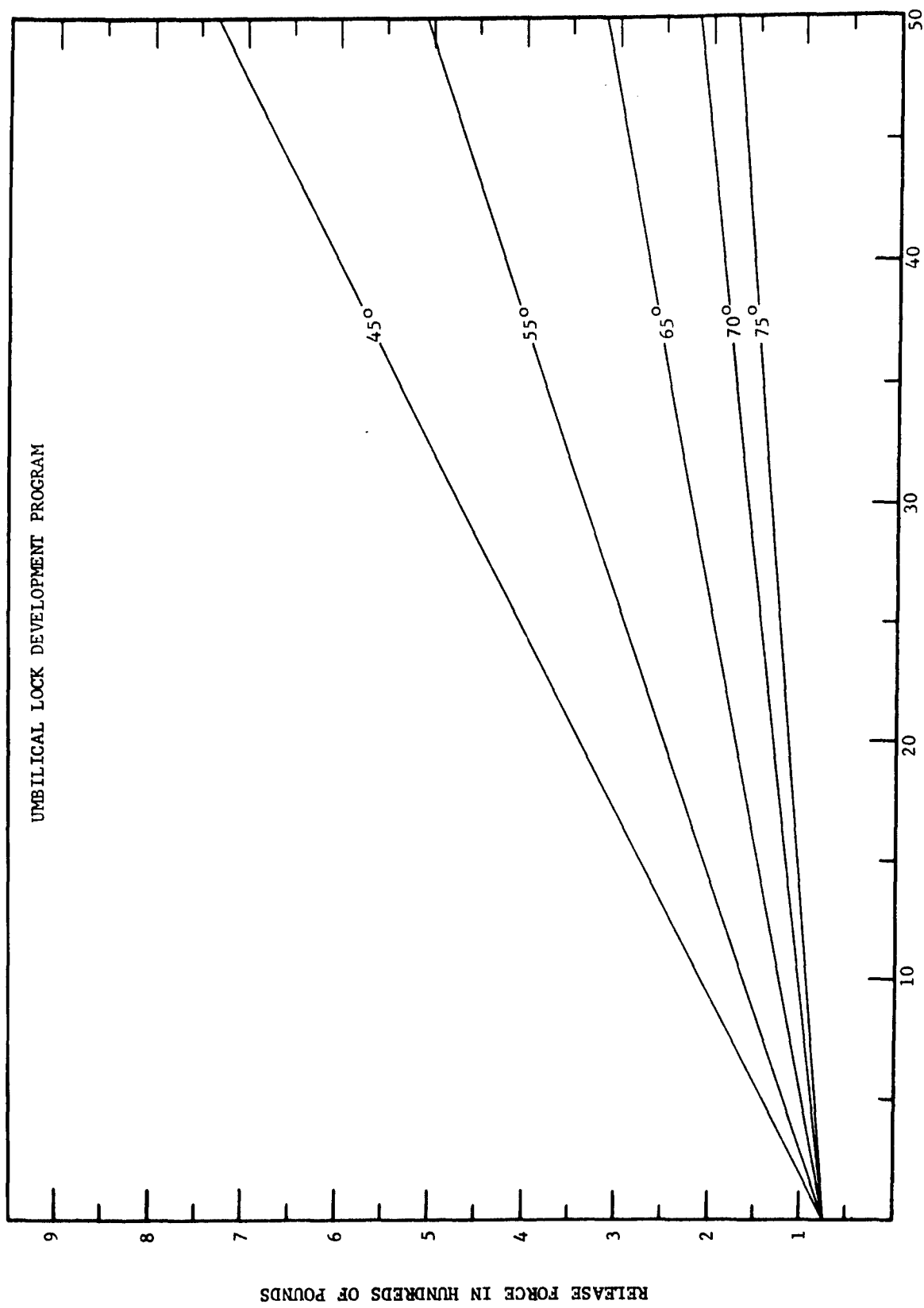

PRE-LOAD IN HUNDREDS OF POUNDS
FIGURE 2. BALL-LOCK RACE ANGLE COMPARISONS

RELEASE FORCE IN HUNDREDS OF POUNDS

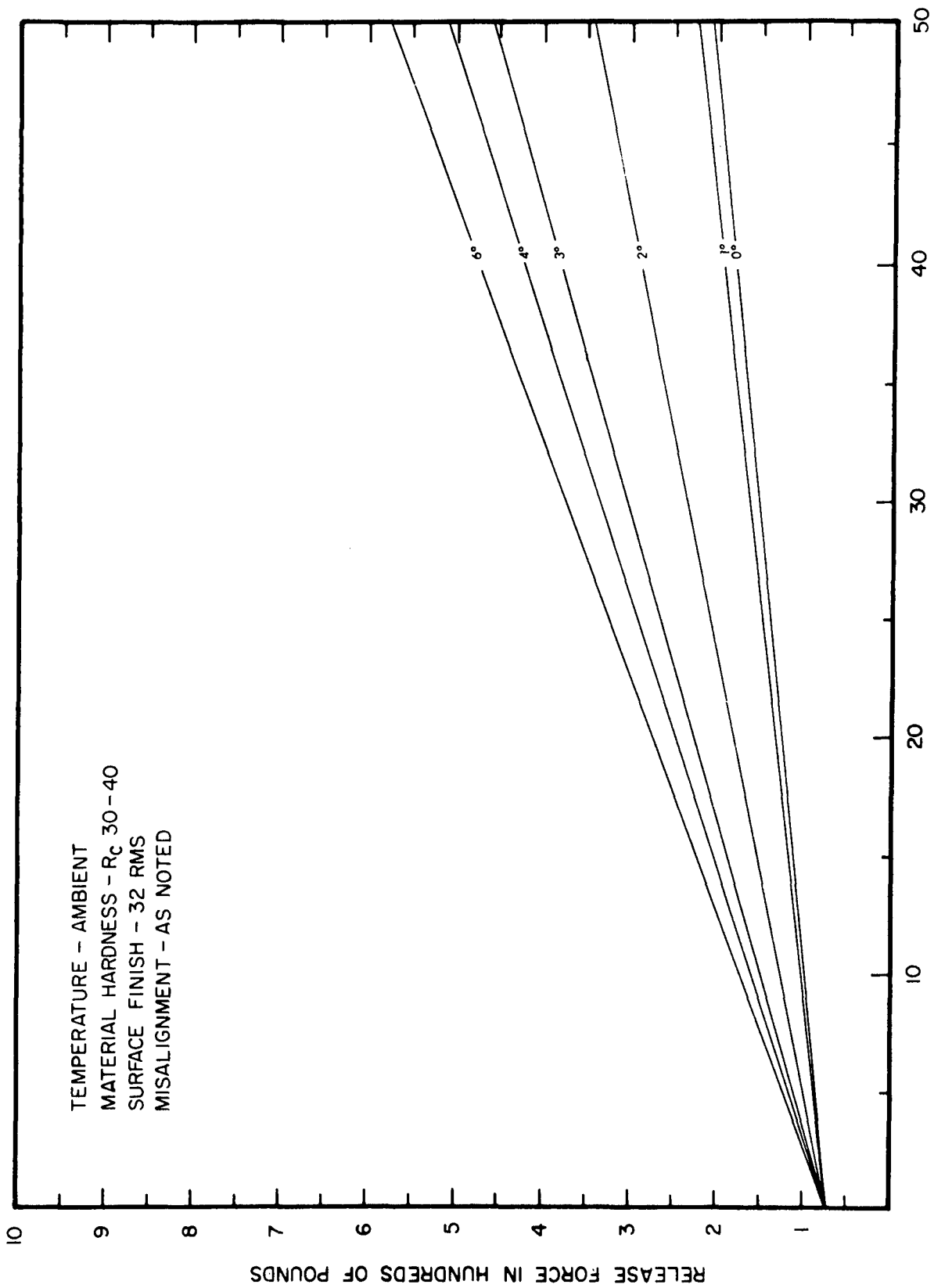

PRE-LOAD IN HUNDREDS OF POUNDS
 FIGURE 3. BALL-LOCK ALIGNMENT INVESTIGATION

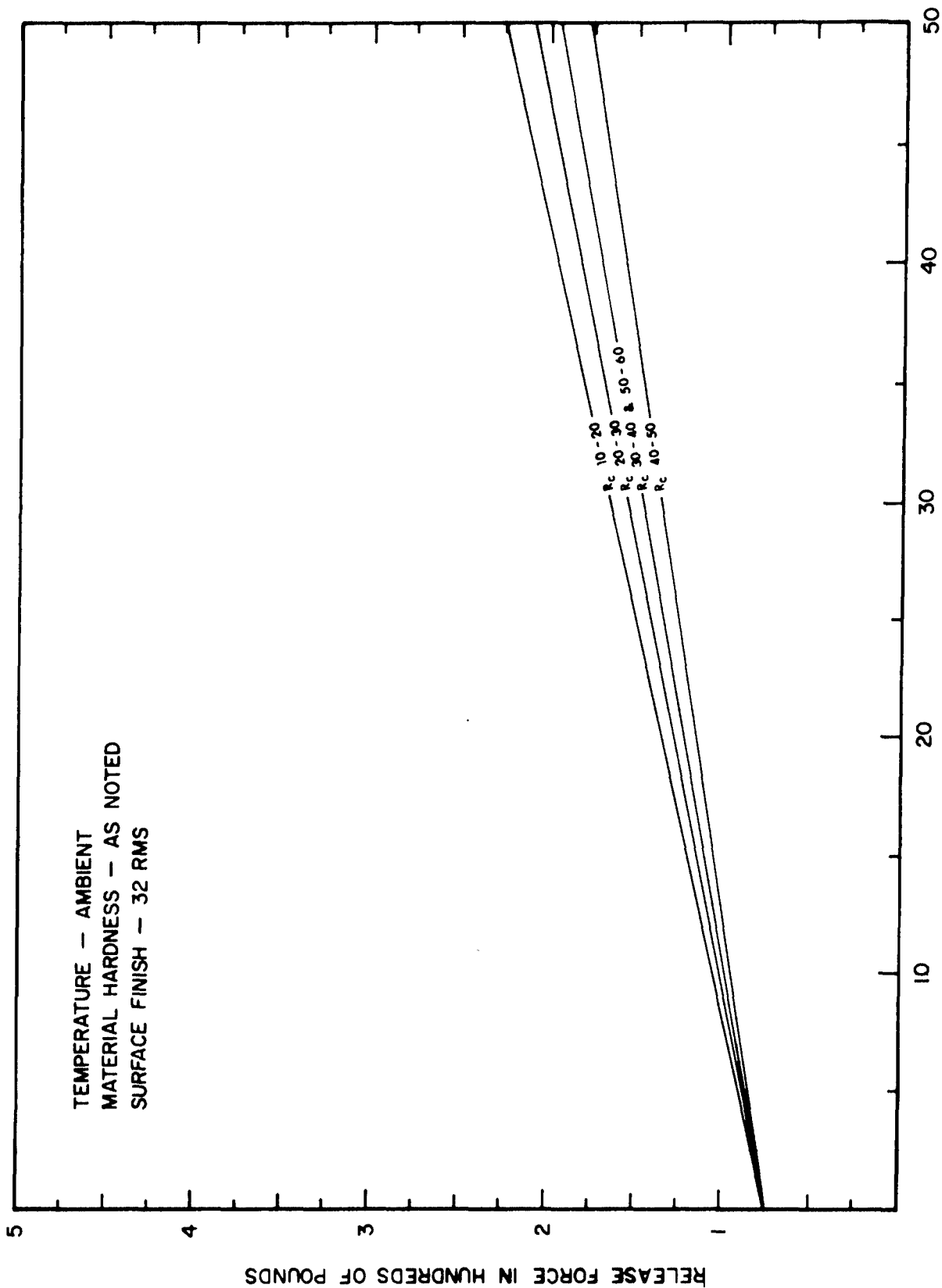

PRE-LOAD IN HUNDREDS OF POUNDS

FIGURE 4. BALL-LOCK HARDNESS INVESTIGATION

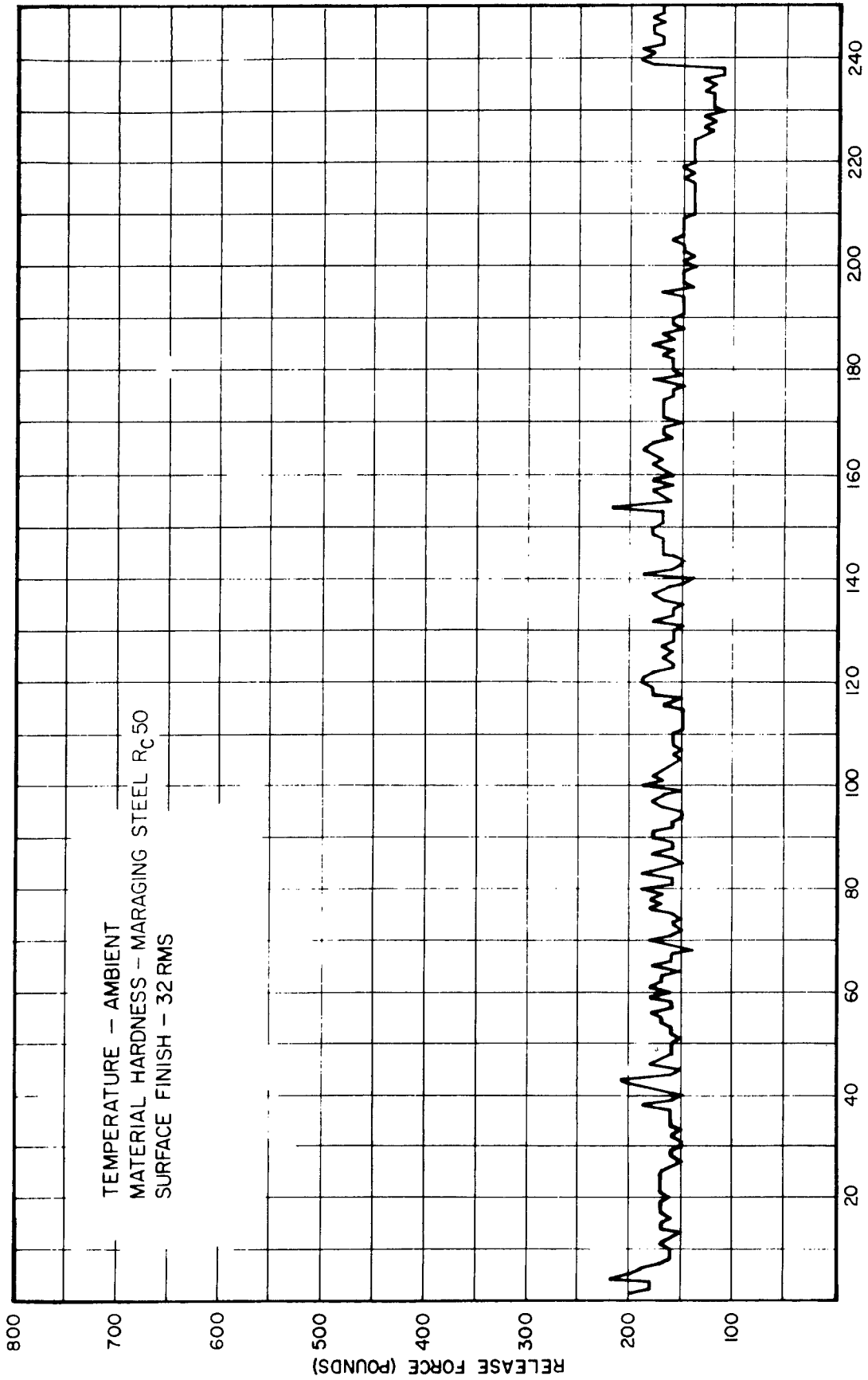

FIGURE 5, BALL-LOCK LIFE CYCLE INVESTIGATION

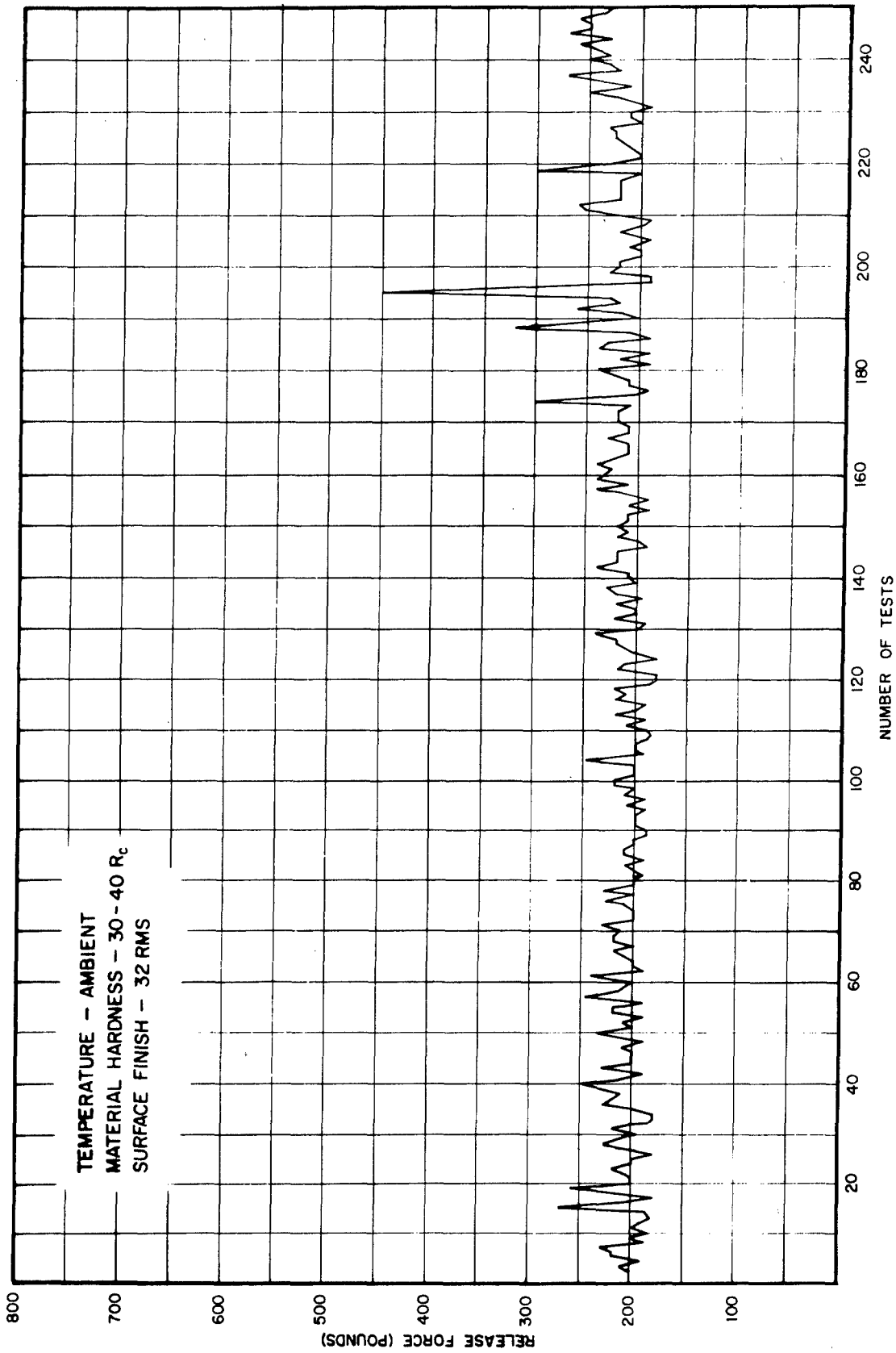
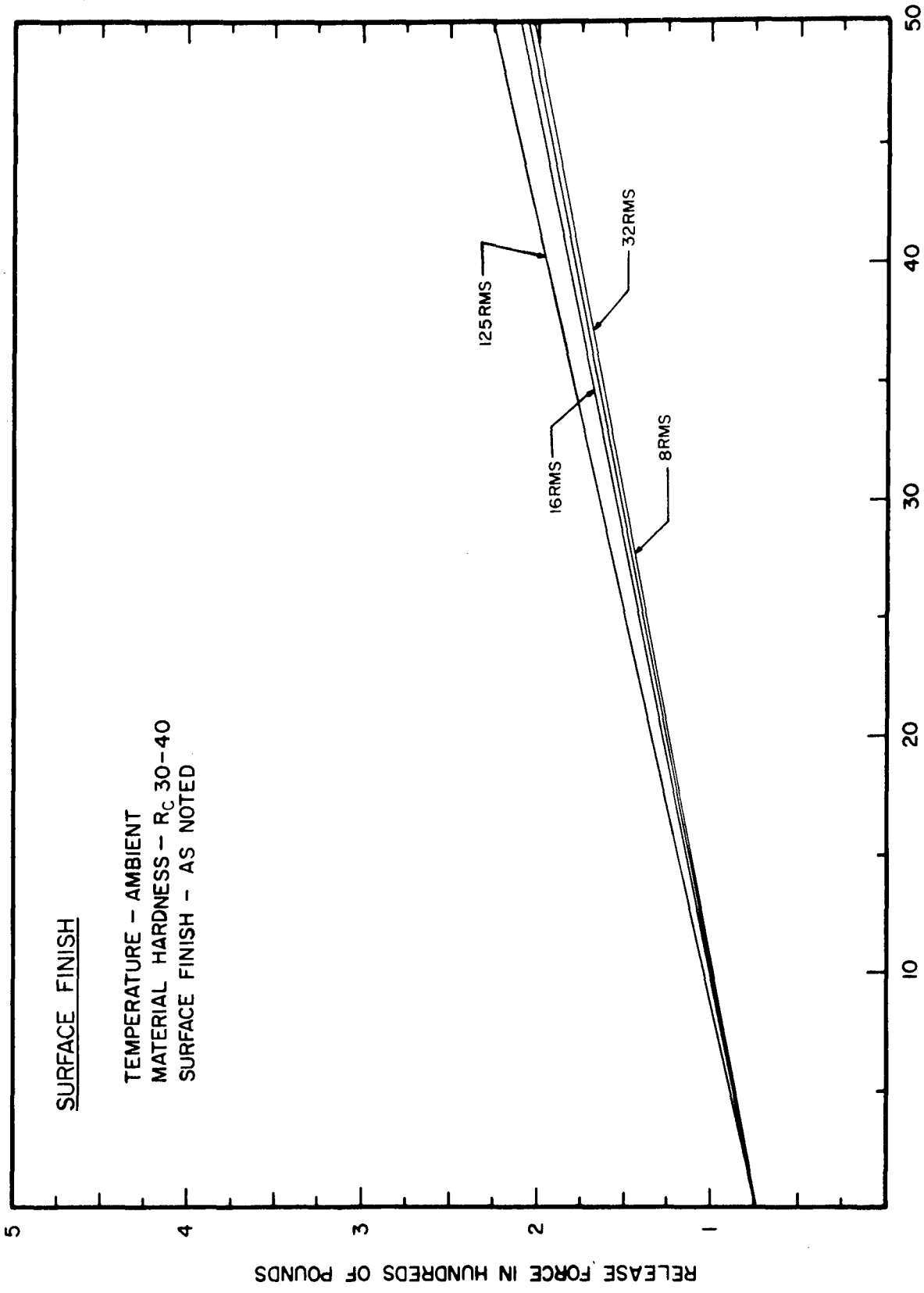

FIGURE 6. BALL-LOCK LIFE CYCLE INVESTIGATION



SURFACE FINISH

TEMPERATURE - AMBIENT
 MATERIAL HARDNESS - R_C 30-40
 SURFACE FINISH - AS NOTED

RELEASE FORCE IN HUNDREDS OF POUNDS

PRE-LOAD IN HUNDREDS OF POUNDS

FIGURE 7. BALL-LOCK SURFACE CONDITION INVESTIGATION

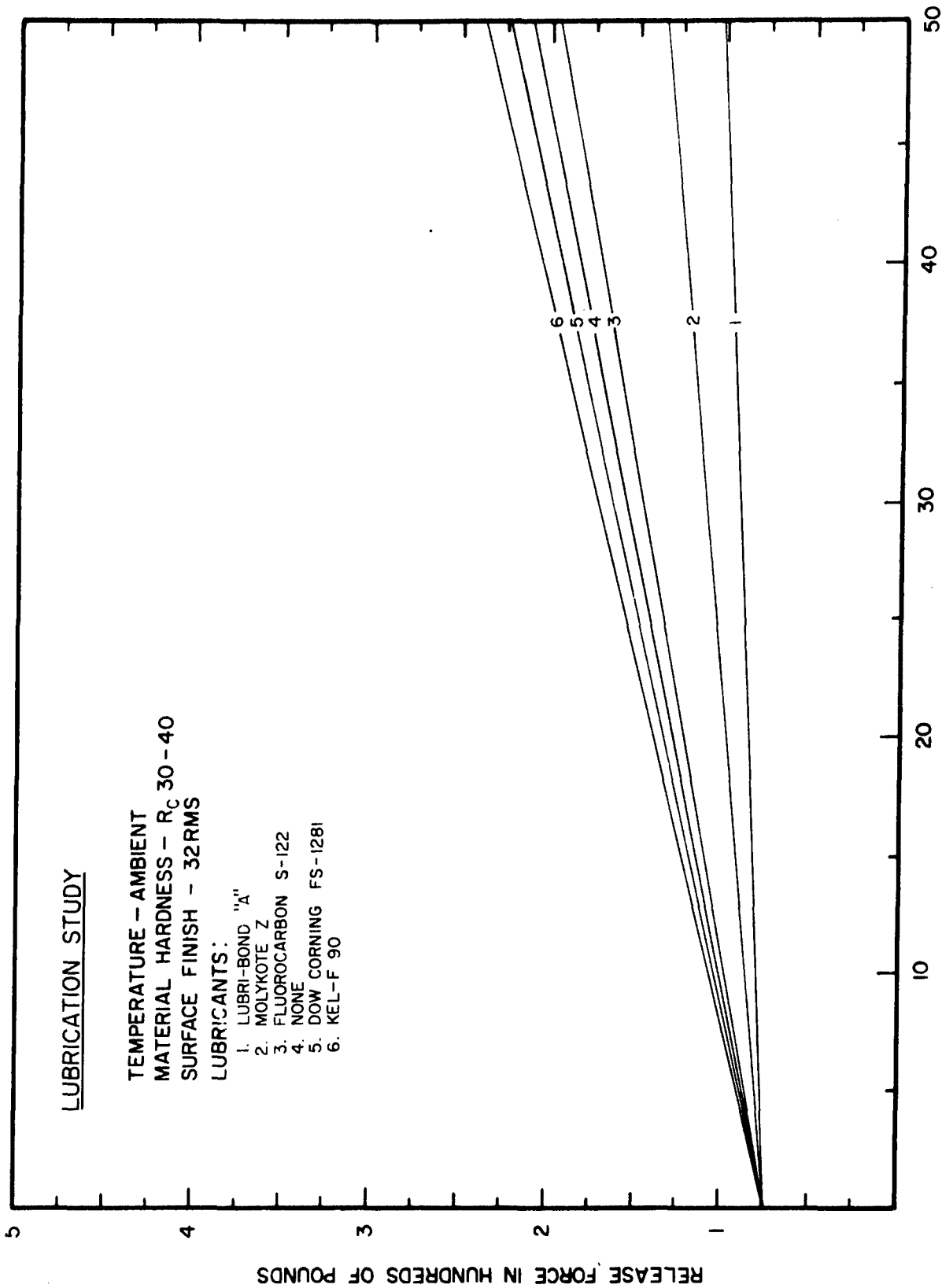

PRE-LOAD IN HUNDREDS OF POUNDS

FIGURE 8. BALL-LOCK SURFACE CONDITION INVESTIGATION

APPENDIX C - CALCULATIONS

The basic equation developed by H. Hertz for determining contact stress in a sphere-on-plane configuration is as follows:

$$S = 0.616 \sqrt[3]{\frac{PE^2}{d^2}}$$

Where:

S = Stress
P = Load
E = Modulus of Elasticity
d = Sphere diameter

(Reference: Kent's "Mechanical Engineers' Handbook", Design & Production, Twelfth Edition, pages 8-36)

Or:

$$S = 0.616 \sqrt[3]{\frac{P_r E^2}{4r_1^2}} \quad \text{Equation (1)}$$

Where:

P_r = Force on Ball-Lock Race
 r_1 = Radius of Ball

From the force diagram: (See page C-4)

$$P_r = \frac{F_t A_1}{N} \quad \text{Equation (2)}$$

Where:

F_t = Total load on Ball-Lock
N = Number of Balls
 A_1 = Constant

EXAMPLE I. OPTIMUM BALL NUMBER DETERMINATION.

From the ball and ball retainer relationship: (See page C-6)

$$r_1 = aR \quad \text{Equation (5)}$$

Where:

R = Ball retainer radius

and:

$$a = \frac{\sin\left(\frac{\pi}{N}\right)}{1 + \sin\left(\frac{\pi}{N}\right)} \quad \text{Equation (4)}$$

Substituting from Equations (2) and (5) in Equation (1)

$$S = 0.616 \sqrt[3]{\frac{A_1 F_t E^2}{4Na^2 R^2}} \quad \text{Equation (6)}$$

Letting A_1 , E , F_t and R be Constants:

$$S = K_1 \sqrt[3]{\frac{1}{Na^2}} \quad \text{Equation (7)}$$

Where:

K_1 = Accumulated Constants

Thus indicating that stress(s) is minimum when Na^2 is maximum

And letting A_1 , E , S and R be Constants:

$$F_t = K_2 Na^2 \quad \text{Equation (8)}$$

Where:

K_2 = Accumulated Constants

Thus indicating that, for a given stress(s), the total force on the lock (F_t) will be maximum when Na^2 is maximum.

EXAMPLE I. (Continued)

Solving for a and Na^2 for various numbers of balls (N) results in the following table:

(Ref: Equation 4)

<u>N</u>	<u>a</u>	<u>Na^2</u>
2	0.5000	0.500
3	0.4640	0.6459
4	0.4142	0.6864
5	0.3701	0.6850
6	0.3333	0.6667
7	0.3026	0.6412
8	0.2767	0.6128
9	0.2548	0.5841
10	0.2360	0.5570
12	0.2055	0.5064
14	0.1819	0.4364

Therefore:

When the number of balls is four, the Na^2 value is maximum and from Equation (7) the stress on the race will be minimum.

EXAMPLE I. (Concluded)

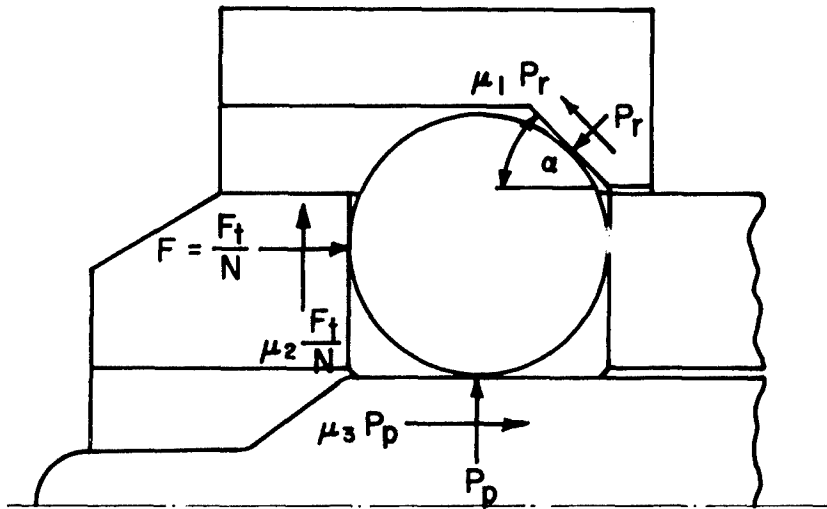

FORCE DIAGRAM

- F = Applied force on each ball
- F_t = Total applied force on lock
- N = Number of balls
- P_r = Resultant force on race
- P_p = Resultant force on pin
- $\mu_1 \mu_2 \mu_3$ = Coefficient of friction on respective surfaces
- $F = \frac{F_t}{N}$

ΣF_x

$$F = -\mu_3 P_p + P_r \sin \alpha + \mu_1 P_r \cos \alpha$$

Or:

$$P_p = \frac{F - P_r \sin \alpha - \mu_1 P_r \cos \alpha}{-\mu_3}$$

EXAMPLE II. FORCE DIAGRAM

ΣF_y

$$P_p = -\mu_2 F - \mu_1 P_r \sin \alpha + P_r \cos \alpha$$

$$\therefore \frac{F - P_r \sin \alpha - \mu_1 P_r \cos \alpha}{-\mu_3} = -\mu_2 F - \mu_1 P_r \sin \alpha + P_r \cos \alpha$$

Or:

$$\frac{P_r}{F} = \frac{1 - \mu_2 \mu_3}{\sin \alpha (1 + \mu_1 \mu_3) + \cos \alpha (\mu_1 - \mu_3)}$$

Let:

$$A_1 = \frac{1 - \mu_2 \mu_3}{\sin \alpha (1 + \mu_1 \mu_3) + \cos \alpha (\mu_1 - \mu_3)}$$

And:

$$\frac{P_r}{F} = A_1 \quad \text{Or:} \quad P_r = F A_1$$

Or:

$$P_r = \frac{F A_1}{N} \quad \text{Equation (2)}$$

EXAMPLE II. (Concluded)

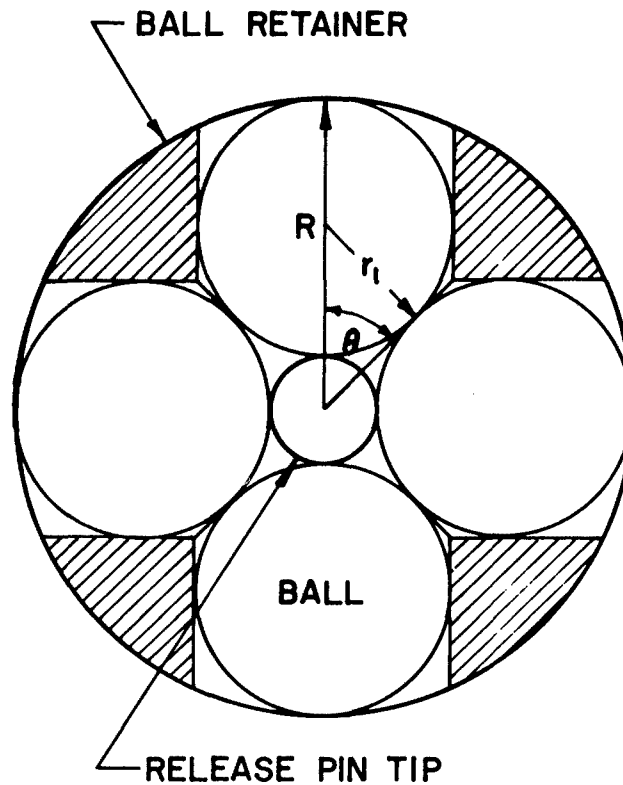

N = Number of balls

R = Radius of ball retainer

r_1 = Radius of ball

θ = Angle formed by the intersection of the line drawn through the ball and ball retainer centers and the line drawn through the ball retainer center tangent to the ball.

$$\sin \theta = \frac{r_1}{R - r_1}$$

$$\theta = \frac{180^\circ}{N} = \frac{\pi}{N}$$

$$\therefore \sin\left(\frac{\pi}{N}\right) = \frac{r_1}{R - r_1}$$

EXAMPLE III. BALL & BALL-RETAINER SIZE RELATIONSHIPS

Or:

$$r_1 = \frac{R \sin\left(\frac{\pi}{N}\right)}{1 + \sin\left(\frac{\pi}{N}\right)} \quad \text{Equation (3)}$$

Let:

$$a = \frac{\sin\left(\frac{\pi}{N}\right)}{1 + \sin\left(\frac{\pi}{N}\right)} \quad \text{Equation (4)}$$

$$\therefore r_1 = aR \quad \text{Equation (5)}$$

EXAMPLE III. (Concluded)

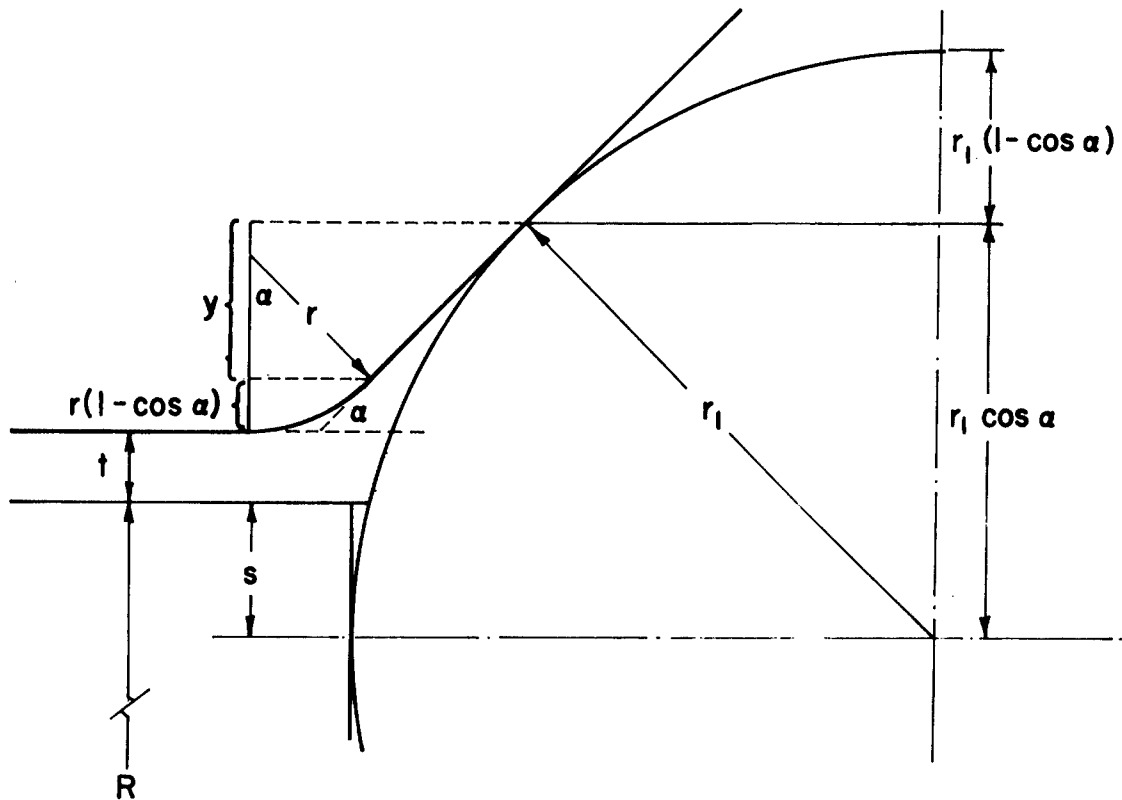

- R** = Ball retainer radius
r₁ = Ball radius
r = Corner radius on race I. D.
t = Tolerance between race I.R. and ball retainer O.R.
s = Staking depth or distance from ball \mathcal{C} to ball retainer O.D.
y = Vertical distance from top of the race I. D. corner radius to the ball and race contact point

$$r_1 = s + t + r(1 - \cos \alpha) + y + r_1(1 - \cos \alpha)$$

Or:

$$\cos \alpha = \frac{r + s + t + y}{r + r_1} \quad \text{Or: } \alpha = \arccos \left[\frac{r + s + t + y}{r + r_1} \right]$$

EXAMPLE IV. RACE ANGLE SIZE DETERMINATION

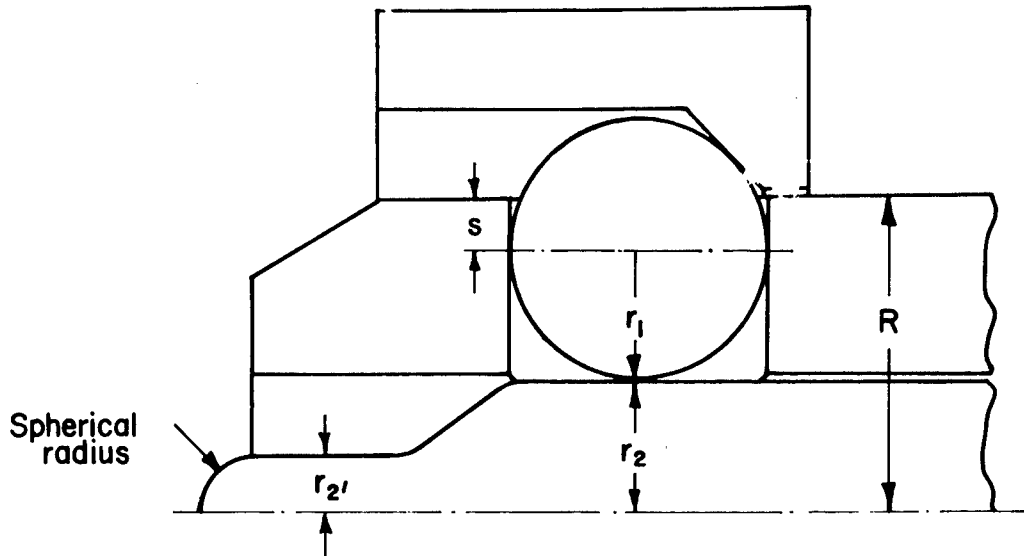

- R = Ball retainer radius
- r_1 = Ball radius
- s = Staking depth
- r_2 = Release pin radius
- $r_{2'}$ = Pin tip radius

$$R = r_2 + r_1 + s$$

Or:

$$r_2 = R - r_1 - s$$

And:

$$R = r_{2'} + 2r_1$$

Or:

$$r_{2'} = R - 2r_1$$

EXAMPLE V. RELEASE PIN SIZE DETERMINATION

ADDENDUM

FINAL TEST REPORT OF
UMBILICAL LOCKING MECHANISM
DEVELOPMENT PROGRAM

29 MARCH 1967

PREPARED FOR
THE GEORGE C. MARSHALL SPACE FLIGHT CENTER
NATIONAL AERONAUTICS AND SPACE ADMINISTRATION
HUNTSVILLE, ALABAMA

TEST REPORT
CONTRACT NUMBER - NAS8-20649
REQUEST NUMBER - DCN 1-6-51-01183 (1F)

PREPARED BY
DAVID L. CUSICK

ELECTRICAL SYSTEMS AND GSE ENGINEERING DEPARTMENT
CHRYSLER CORPORATION SPACE DIVISION
1312 NORTH MERIDIAN STREET
HUNTSVILLE, ALABAMA 35807

TABLE OF CONTENTS

Paragraph	Title	Page
1.0	INTRODUCTION	1
2.0	SUMMARY	2
2.1	Material Hardness Investigation	2
2.2	Surface Condition Investigation	2
2.3	Pin Design Investigation	3
2.4	Alignment Investigation	3
2.5	Life Cycle Investigation	3
3.0	TEST HARDWARE	4
3.1	General	4
3.2	Ball-Lock	4
3.3	Collet-Lock	4
4.0	DISCUSSION	5
4.1	Ball-Lock Testing	5
4.2	Collet-Lock Testing	8

APPENDIX A - ILLUSTRATIONS

Illustration

1	Ball-Lock (2 Inch)	A-1
2	Ball-Lock Size Comparison	A-2
3	Collet-Lock (1 Inch)	A-3
4	Ball-Lock Race Angle Measurement	A-4
5	Collet-Lock Angle Measurement	A-5
6	Ball-Lock Pin Design	A-6

APPENDIX B - GRAPHS

Figure

1-3	Ball-Lock Hardness Investigation	B-1/B-3
4-10	Ball-Lock Surface Condition Investigation	B-4/B-10
11-13	Ball-Lock Pin Design Investigation	B-11/B-13
14-15	Ball-Lock Alignment Investigation	B-14/B-15
16-17	Ball-Lock Life Cycle Investigation	B-16/B-17
18	Collet-Lock Hardness Investigation 75° Angle	B-18
19	Collet-Lock Material Hardness Investigation	B-19
20-26	Collet-Lock Surface Condition Investigation	B-20/B-26
27	Collet-Lock Alignment Investigation	B-27
28-29	Collet-Lock Life Cycle Investigation	B-28/B-29

1.0 INTRODUCTION

This report covers the results of Phase II of a test program conducted for the Umbilical and Disconnects Section of the Propulsion and Vehicle Engineering Laboratory of Marshall Space Flight Center, Huntsville, Alabama, under Contracts NAS8-4016, Mod. 206 and NAS8-20649. The purpose of the program is to establish the criteria necessary in the design, the selection, and the acceptance of locking mechanisms applicable for space vehicle umbilical carriers. Tests were performed on two basic types of locking mechanisms to determine the effect of certain significant parameters on release force and reliability. In Phase I of the program, conducted and reported under Contract NAS8-4016, Mod. 206, the parameters investigated were: (1) race angle, (2) lock size, (3) materials, (4) material hardness, and (5) temperature. Phase II of the program was concerned with: (1) additional investigation in the areas of materials and material hardness, (2) surface conditioning, (3) release pin design, (4) alignment, and (5) hardware life. In both phases of the program experimental hardware was tested at loadings up to 8000 pounds and temperatures as low as minus 196 degrees centigrade (°C).

This report is limited to the results of the testing accomplished in Phase II of this program. All curves and data comparisons shown in this report were statistically generated from the raw data obtained in this test program. All data was transposed to the same zero point for ease of comparison and should be used for comparison purposes only.

2.0 SUMMARY

2.1 MATERIAL HARDNESS INVESTIGATION

Ball-lock and collet-lock component material hardnesses in the ranges of Rockwell C (R_c) 10-20, 20-30, 30-40, 40-50, and 50-60 were investigated. The materials used to obtain these hardness levels were 304 stainless steel, 17-4PH stainless steel, 18% nickel maraging steel, and beryllium copper. Collets of beryllium copper at three hardness levels (Rockwell B (R_b) 60, R_b 75, and R_c 45) have also been tested. In most cases, the lowest release forces were obtained where the harder materials were used.

2.2 SURFACE CONDITION INVESTIGATION

2.2.1 Surface Finish

Ball-lock and collet-lock configurations with component surface finishes of 8, 16, 32 and 125 root mean square (rms) were tested. The resulting release forces were directly proportional to the surface finish with the highest release forces resulting in the 125 rms tests, however, the only significant differences in release forces were obtained in the collet-lock tests.

2.2.2 Lubrication

Five lubricants were tested on both ball-lock and collet-lock configurations. These lubricants were Molykote Z, a dry powder; Electrofilm Lubri-Bond A, a molybdenum disulfide spray film; Fluorocarbon S-122, a teflon spray film; Dow Corning FS 1281 grease; and KEL-F No. 90 grease. These lubricants were selected for their liquid oxygen (LOX) compatibility and/or low temperature properties. Release forces were always reduced where the spray type lubricants were used. The lowest release forces were obtained in the tests using the Lubri-Bond A lubricant.

2.2.3 Plating

In these tests the effects of a hard chrome plate on the release pins of ball-lock and collet-lock assemblies were investigated. The plating of the pin did not have any significant affect on the release characteristics of the locks. The release forces obtained in these tests were comparable with the results of tests performed where no plating was used. However, no flaking or extreme damage to the chrome plate was observed in these tests.

2.3 PIN DESIGN INVESTIGATION

Two types of ball-lock release pins, a two point contact design and a line contact design, were tested. When compared to the results of tests where a conventional release (single point contact) pin was used, the release forces obtained in these tests proved to be high. Considering this along with the additional problems involved in the manufacture of pins of these types, it is felt that these designs do not merit any further consideration.

2.4 ALIGNMENT INVESTIGATION

Angular misalignments of one, two, three, four, six and eight degrees in ball-lock and collet-lock test set-ups were investigated. A misalignment greater than eight degrees cannot be tested as that is the largest angle at which the two halves of the lock may be coupled together. In the ball-lock tests, the resulting release forces increased in direct proportion with the degree of misalignment. Although release forces above 550 pounds occurred in the six-degree tests, no failures to release occurred. In the collet-lock tests, however, no pattern was detected in the comparison of the results, and the release forces in general were lower than those obtained in the ball-lock tests. One collet, however, fractured during the six-degree tests.

2.5 LIFE CYCLE INVESTIGATION

Two life cycle test series of 250 tests each were performed on both ball-lock and collet-lock configurations. In the ball-lock tests, the two series were performed with hardware of two hardnesses, R_c 35 and R_c 50. When compared, the R_c 50 tests resulted in generally lower release forces and less data scatter than did the R_c 35 tests. In one collet-lock test series, a fracture occurred on test number 180. Another collet-lock, however, successfully completed 250 cycles. Lubrication was used in both collet-lock test series.

3.0 TEST HARDWARE

3.1 GENERAL

The locking devices tested in this program were pneumatically released by means of a piston-cylinder arrangement with Buna-N "O" ring seals. The effective surface area of the piston was one square inch. Removable tips as shown in illustration 2, Appendix A, allowed the pneumatic cylinder to be used in testing either the ball-lock or collet-lock configuration. System pre-loads were applied hydraulically and measured with load cell instrumentation. All temperatures were measured and recorded with potentiometric recording equipment. With the exception of the lubrication study tests and some collet tests, no lubrication was used on the locking surfaces. Although various types of lubrication were used on the pneumatic cylinder depending on the temperature of the test environment no attempt will be made to evaluate the performance of this hardware.

3.2 BALL-LOCK

The ball-locks tested in this phase of the program were four-ball configurations with a ball retainer tip diameter of 1.810 inches. Of the three ball-lock sizes investigated in Phase I of the program, this size was selected for Phase II testing due to past experience with locks of this size. (Ref. illustrations 1 and 2). A race angle of 70 degrees established in Phase I testing as optimum for ball-locks in this size range, was used exclusively in all Phase II testing. (Ref. illustration 4). The ball-retainer was fabricated from 304 stainless steel, condition B (hardness R_c 35), in accordance with Specification QQ-S-763. In all tests 440C stainless steel balls, full hard (R_c 58), were used. The materials for race and release pin fabrication were varied in order to achieve various hardness conditions. These materials included 304 stainless steel, 17-4PH stainless steel, 18 per cent nickel maraging steel, and beryllium copper.

3.3 COLLET-LOCK

One-inch diameter collet-locks of a one-piece, twelve segment, cantilever configuration were selected for use in this phase of the program. This configuration is identical to that used in most of Phase I testing (Ref. illustration 3). The collet angle and race angle used in Phase II testing was 75 degrees. This was the angle value that was optimized in Phase I of the program (Ref. illustration 5). All collets were fabricated from beryllium copper in accordance with Specification QQ-C-530 and heat treated to an HT condition (hardness R_c 45). As in the case of ball-lock hardware, the collet races and release pins were fabricated from varied materials which include 304 stainless steel, 17-4PH stainless steel, 18 per cent nickel maraging steel, and beryllium copper. Lubrication of the collet locking surfaces was performed in some sections of the program.

4.0 DISCUSSION

4.1 BALL-LOCK TESTING

4.1.1 Material Hardness Investigation

This investigation was a continuation of a study originally initiated in Phase I of the program. In this phase, races and release pins of hardnesses in the ranges of R_c 10-20, 20-30, 30-40, 40-50 and 50-60 were tested in standard ball-lock configurations. A test series was performed for each hardness range where both a race and pin of the hardness under investigation were incorporated into a test lock assembly. In each series, tests were conducted at various pre-loads up to 5000 pounds and at three temperatures: ambient, minus 80°C, and minus 196°C. 304 and 17-4 PH stainless steel, purchased in pre-hardened conditions, were used for hardware at hardnesses from R_c 10-40 while beryllium copper and 18 per cent nickel maraging steel were used where hardnesses above R_c 40 were required.

The results of the testing in this investigation are shown graphically in figures 1 through 3, Appendix B. A temperature affect of some significance can be seen from this data as the lowest release forces resulted in the tests at minus 196°C. Therefore, a comparison of the results of the various hardness tests was made for each test temperature. In the tests at minus 196°C some of the softer materials actually produced the lowest forces. However, it can be stated that any variation in the release force data over this hardness range is insignificant for practical purposes since the release forces ranged from a maximum of approximately 240 pounds to a minimum of approximately 120 pounds.

4.1.2 Surface Condition Investigation

4.1.2.1 Surface Finish

This study was concerned with the effects of various surface finishes on ball-lock locking component surfaces. Four finishes, 8, 16, 32 and 125 rms, were selected for investigation. These finishes were limited to the bearing surfaces of the race and release pin of a standard ball-lock configuration. All tests were conducted at ambient temperature without lubrication on the locking surfaces. A comparison of the results of these tests are shown in figure 4. These curves were statistically derived from the raw data resulting from the tests. It can be seen that no significant differences in the release forces due to surface finish were disclosed by these tests. Based on these data, a finish of 32 rms was selected for all future testing.

4.1.2.2 Lubrication

All tests in Phase I and II of this program prior to this series were performed without the benefit of lubrication on the lock bearing surfaces. This series of tests demonstrate the effects of lubrication. Five lubricants were selected for their LOX compatibility and/or low temperature properties. These lubricants were as follows:

1. Electrofilm Lubri-Bond A - A molybdenum disulfide spray film - not compatible with LOX.
2. Molykote Z - A molybdenum disulfide dry powder - good low temperature and LOX compatibility properties.
3. Fluorocarbon S-122 - A teflon spray film - good low temperature and LOX compatibility properties.
4. Dow Corning FS1281 - A grease - good low temperature properties to minus 80 degrees Fahrenheit (°F) requires batch testing to assure LOX compatibility.
5. KEL-F-#90 - A grease - LOX compatible - freezes at extremely low temperatures.

These lubricants were applied to the bearing surfaces of the release pin and race only. The results of this study are shown graphically in figures 5 through 7. Tests were conducted at three temperatures, ambient, minus 80°C and minus 196°C, and a comparison of the data was made at each temperature. In figure 5, a comparison at ambient temperature, it can be seen that no improvements in release force resulted except where the film type lubricants were used. The release forces occurring in the tests where the two greases were used were actually higher than those occurring in tests where the system was unlubricated. However, the data comparison at minus 196°C, figure 7, shows that all lubricants improved the releasing characteristics of the lock although both the greases froze at that temperature. In all cases the lowest release forces resulted in tests using the Electrofilm Lubri-Bond A.

4.1.2.3 Plating

In these tests the effects of a hard chrome plate on the release pin were investigated. Release pins fabricated from basic materials of two hardnesses, R_C 20 and R_C 51, were plated with a hard chrome, 0.002 of an inch thick. The basic finish on the pin bearing surface was 32 rms and the pins were tested in the as received condition after plating. Tests were conducted at three temperatures, ambient, minus 80°C and minus 196°C. Figures 8 through 10 show the results of these tests. The release forces obtained in these tests compared in magnitude to the resulting forces in tests where unplated hardware was used. No flaking or extreme damage to the chrome plate was observed in these tests. It would be possible, however, for a chrome plated pin to experience severe damage at loadings on the order of 5000 lbs if low race angles (i.e., 45 degrees) were used where extreme resultant forces on the pin are present.

4.1.3 Pin Design Investigation

In the case of a conventional ball-lock release pin or single point contact pin, severe surface stressing on the pin and ball contact surface is present due to the small surface area of contact in a ball-on-cylinder configuration. This high stressing causes some brinelling of the pin during the unlocking operation. The severity of brinelling will of course vary with the resultant load on the pin. Where high race angles are used (i.e., 70 degrees) the brinelling is relatively light. Where low race angles are used (i.e., 45 degrees) and the resultant force on the pin is very high, the pin brinelling can be extremely severe. This pin damage will greatly influence the release force of the lock. In an effort to reduce the releasing force by increasing the contact surface area of the pin, two new types of release pins, the two point contact and the line contact pins, were designed and tested (ref. illustration 6). These tests were conducted on hardware with a hardness of R_c 35 and a race angle of 70 degrees. The results of this test series are shown in figures 11 through 13. A comparison of the release forces obtained in single point contact, two point contact and line contact pin tests is shown in figure 13. As can be seen by these data, no reduction of the release force magnitude was achieved. In fact, the release forces were higher in the two point and line contact tests than in the single point contact tests. In the manufacture of pins of this type, the alignment of the pin grooves in relation to the ball positions is very critical and a slight misalignment could account for the increase in release force. However, based on these data and the manufacturing problems involved, it is felt that these new designs do not merit any further consideration with the exception of possible applications where low race angles are used.

4.1.4 Alignment Investigation

In space vehicle umbilical applications, some degree of angular misalignment may be present between the ground and vehicle halves of the locking mechanism. It was felt that misalignments depending on the degree could greatly affect the releasing characteristics of the lock. Therefore, tests were performed on standard ball-lock hardware with varying degrees of misalignment incorporated in the test set-up. Angular misalignments of one, two, three, four, six and eight degrees were investigated. Misalignments greater than eight degrees could not be tested as that was the largest angle at which the two halves of the lock could be coupled together. All tests were conducted at ambient temperature and with hardware with a hardness of R_c 35. Figure 14 shows a comparison of the results of these tests for each degree of misalignment. The eight-degree tests are not shown in this comparison due to the extreme amount of data scatter occurring in this series (ref. figure 15). However, up to and including the six-degree tests, the release forces increase in direct proportion with the degree of misalignment. Although release forces above 500 pounds were experienced in the six- and eight-degree tests, no failures to release occurred in this series.

4.1.5 Life Cycle Investigation

Life cycle test series were performed on ball-lock hardware with races and release pins of two hardnesses, R_c 35 and R_c 50. Each configuration was cycled at least 250 times at 5000 pounds pre-load. These tests were conducted at ambient temperature on conventional 70 degree ball-lock test assemblies. A finish of 32 rms was used on the bearing surfaces in both cases. The results of these tests can be seen in figures 16 and 17. The R_c 50 tests resulted in generally lower release forces and less data scatter. No failures to release occurred during either series.

4.2 COLLET-LOCK TESTING

4.2.1 Material Hardness Investigation

This investigation was also a continuation of a study originally initiated in Phase I of the program. Phase I testing was limited to variation of the collet hardness only. In that test series, shown in figure 18, the collet hardness was varied from R_b 60, annealed condition, to R_c 44, heat treated condition. In Phase II testing, the hardness of the race and pin was varied while the collet hardness was held within the range of R_c 40 - 45. Five race and pin hardness ranges were selected for investigation, R_c 10-20, 20-30, 30-40, 40-50 and 50-60. A 75 degree collet test assembly was used and tests were conducted at three temperatures, ambient, minus 80°C and minus 196°C. No lubrication was applied to the lock bearing surfaces. The same materials used in the ball-lock program were used to obtain the various hardness requirements (ref. paragraph 4.1.1). The results of this testing are shown in comparison form in figure 19. It can be seen that all of the data obtained in this series of tests was relatively high when compared to Phase I collet-lock test data. Since the collet design was identical to that used in Phase I testing no specific reasons can be given for the general increase in release force. Since all of the data was consistently high, it can be used to show the general relationship between the various hardness tests. In later tests where lubrication was investigated, the results obtained were more consistent with Phase I test data. These findings indicate that lubrication is mandatory in a collet-lock assembly where pre-loads on the order of 5000 pounds are present.

A temperature affect of any practical significance, as seen in the ball-lock data, did not occur in these collet tests. Therefore, a comparison of the data was made neglecting temperature. As can be seen in this comparison, shown in figure 19, the release forces decreased as harder component materials were tested except for the R_c 50-60 material. The R_c 50-60 tests were the only tests in this series in which the release pin material was harder than the collet material (R_c 40-50). A great amount of material transfer from the beryllium copper collet to the maraging steel pin and galling of the collet was observed in these tests. In all other tests of this series no excessive amount of material transfer was noticed. Based on this reasoning, therefore, it is surmised that the collet galling contributed to the release force increase. In all succeeding tests release pins of a softer material than the collet were used.

4.2.2 Surface Condition Investigation

4.2.2.1 Surface Finish

The effects of component surface finishes of 8, 16, 32 and 125 rms on release force were investigated in this series of tests. Each finish under investigation was limited to the bearing surfaces of the race, release pin and collet. All tests were conducted at ambient temperature on hardware with a hardness in the range of Rc 30 to 40. Two test series were performed. In the first series no lubrication was used and the data obtained was relatively high and inconsistent. Problems experienced in the material hardness investigation were similar to those experienced in these tests. A second series of tests was performed where the hardware was lubricated with Electrofilm Lubri-Bond A. The results of these tests shown in figure 20 were much improved over the unlubricated test data. Therefore, these data were used for the surface finish effects comparison. As shown in figure 20 the release forces obtained in these tests increased in direct proportion to the surface finish. Unlike the ball-lock surface finish results, the release forces in the collet test series were significantly higher in the 125-rms tests than in all others. The release force at 5000 pounds pre-load in the 125-rms tests was approximately 600 pounds compared to approximately 300 pounds in 32-rms tests and 200 in the 8-rms tests. Only minor differences were noted between the results of the 8- and 16-rms tests. For this reason and manufacturing considerations the 16-rms finish was selected for all future testing.

4.2.2.2 Lubrication

Lubricants of the same type used in the ball-lock lubrication tests were selected for this series also. The lubricants were Electrofilm Lubri-Bond A, Molykote Z, Fluorocarbon S-122, Dow Corning FS1281, and KEL-F-#90. Component hardware in the hardness range of Rc 30-40 with a surface finish of 16 rms was used and tests were conducted at three temperatures, ambient, minus 80°C and minus 196°C. The results of these tests are shown in figures 21 to 23. A comparison of the data was made for each test temperature. As in the ball-lock lubrication study, the film type lubricants provided the best results. The tests where the two greases were used resulted in higher release forces than unlubricated tests and as the temperature decreased the release forces increased greatly. The Molykote Z test data compared with the unlubricated test data at ambient temperature and minus 80°C but was much lower at minus 196°C. Also as in the ball-lock tests, the lowest release forces were experienced in the tests where Electrofilm Lubri-Bond A was used.

Based on the results of these tests, all remaining testing in the collet-lock phase of the program was performed with Electrofilm Lubri-Bond A applied to bearing surfaces in order to achieve more consistent data. Furthermore, it is recommended that a spray film lubricant of some type be used in all applications where collet type locking mechanisms are in use.

4.2.2.3 Plating

In some applications in an corrosive environment, hardware of a corrosive nature could be used if the hardware was plated with a passive material. In this test series, the effects of plating on the release characteristics of the lock were investigated. A hard chrome was selected as a representative plating material. The chrome was coated to a thickness of 0.005 of an inch on release pins in the hardness range of R_c 30-40. The lock bearing surfaces were lubricated with Electrofilm Lubri-Bond A. Tests were conducted at ambient temperature, minus 80°C and minus 196°C. The results of these tests, shown in figures 24 through 26, were compared with results where unplated hardware was tested. A comparison was made at each test temperature. It can be seen that the plating did not significantly affect the release force of the test assembly. However, like the ball-lock plating tests, no severe damage to or flaking of the chrome plate was experienced in this test series.

4.2.3 Alignment Investigation

As in the ball-lock program, angular misalignments between the two halves of the locking mechanism of one, two, three, four, six and eight degrees were investigated in collet hardware test set-ups. The results of these tests, shown in figure 27, were quite different, however, from the results of the ball-lock alignment investigation. The data did not conform to any sort of pattern and the release forces were relatively low throughout the entire series. Although one set of hardware successfully completed tests up to eight degrees of misalignment, another set of hardware fractured during six-degree tests. It is surmised that when the pre-load is applied to the test hardware the collet tip and pin actually bend when not aligned properly and tend to attempt self-alignment. This action cannot happen in the ball-lock assembly since the ball-lock tip is of sufficient structural strength to withstand bending. This bending of the collet tip would tend to reduce release force values but would increase the overall system stress and increase the possibility of failure. It can be generally stated, therefore, that the force required to release a collet-lock that was not properly aligned would be less than that required in a similar ball-lock set-up but the chance of premature failure would be greater.

4.2.4 Life Cycle Investigation

Life cycle test series were performed on two sets of collet-lock hardware. The race and pin hardness, R_c 35, was the same for both sets of hardware. Both series were conducted at ambient temperature with lubrication on the lock bearing surfaces. In one case the lubricant used was Electrofilm Lubri-Bond A, while in the other series Fluorocarbon S-122 was used. The results of these tests are shown in figures 28 and 29. In the first series, a fracture occurred on release number 180 although the release forces up to that point were very low and consistent. In the other series the collet assembly successfully completed 250 cycles. Due to type and nature of the collet design, it appears as though it will be subject to severe fatigue stressing when exposed to a great number of cycles which may result in a fracture of the collet during release.

APPENDIX A
ILLUSTRATIONS

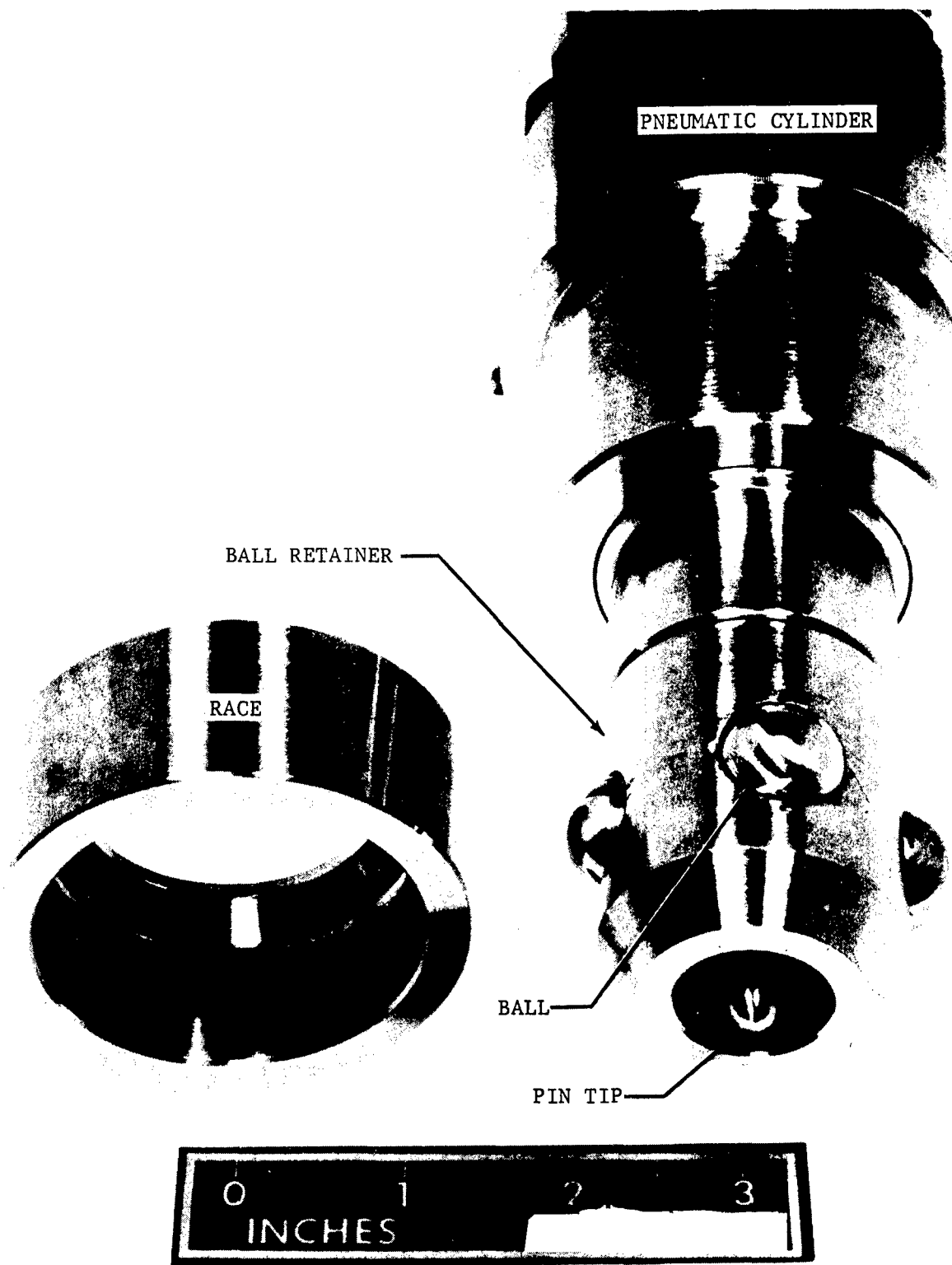
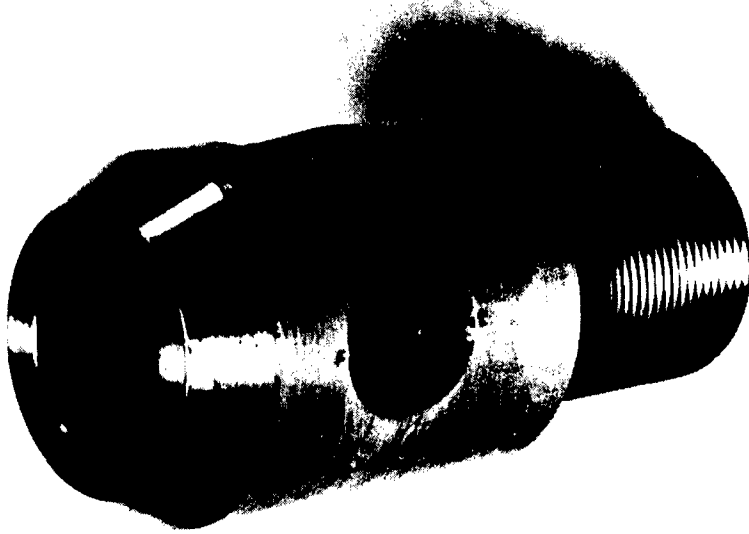
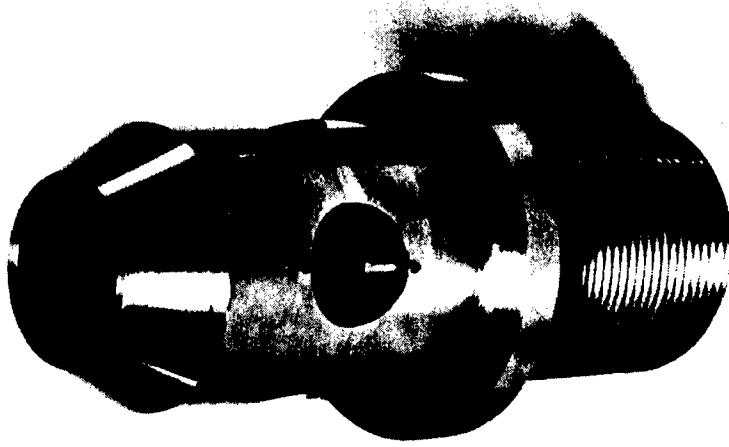

ILLUSTRATION 1. BALL-LOCK (2 INCH)

1.810"O.D. (2"LOCK)



1.358"O.D. (1 1/2" LOCK)



1.056"O.D. (1"LOCK)

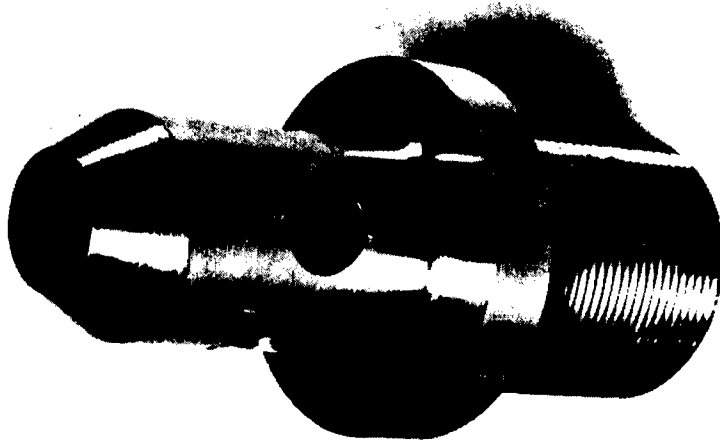

ILLUSTRATION 2. BALL-LOCK SIZE COMPARISON

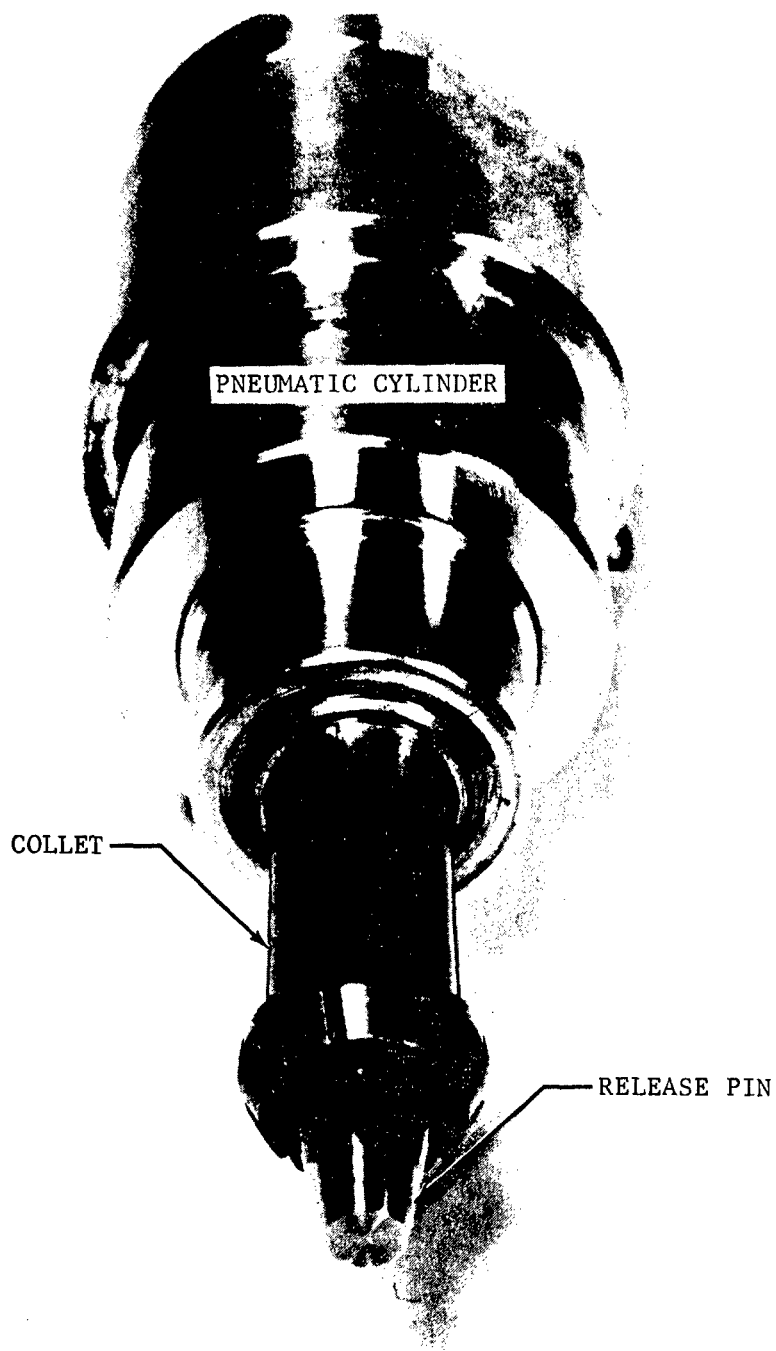

ILLUSTRATION 3. COLLET-LOCK (1 INCH)

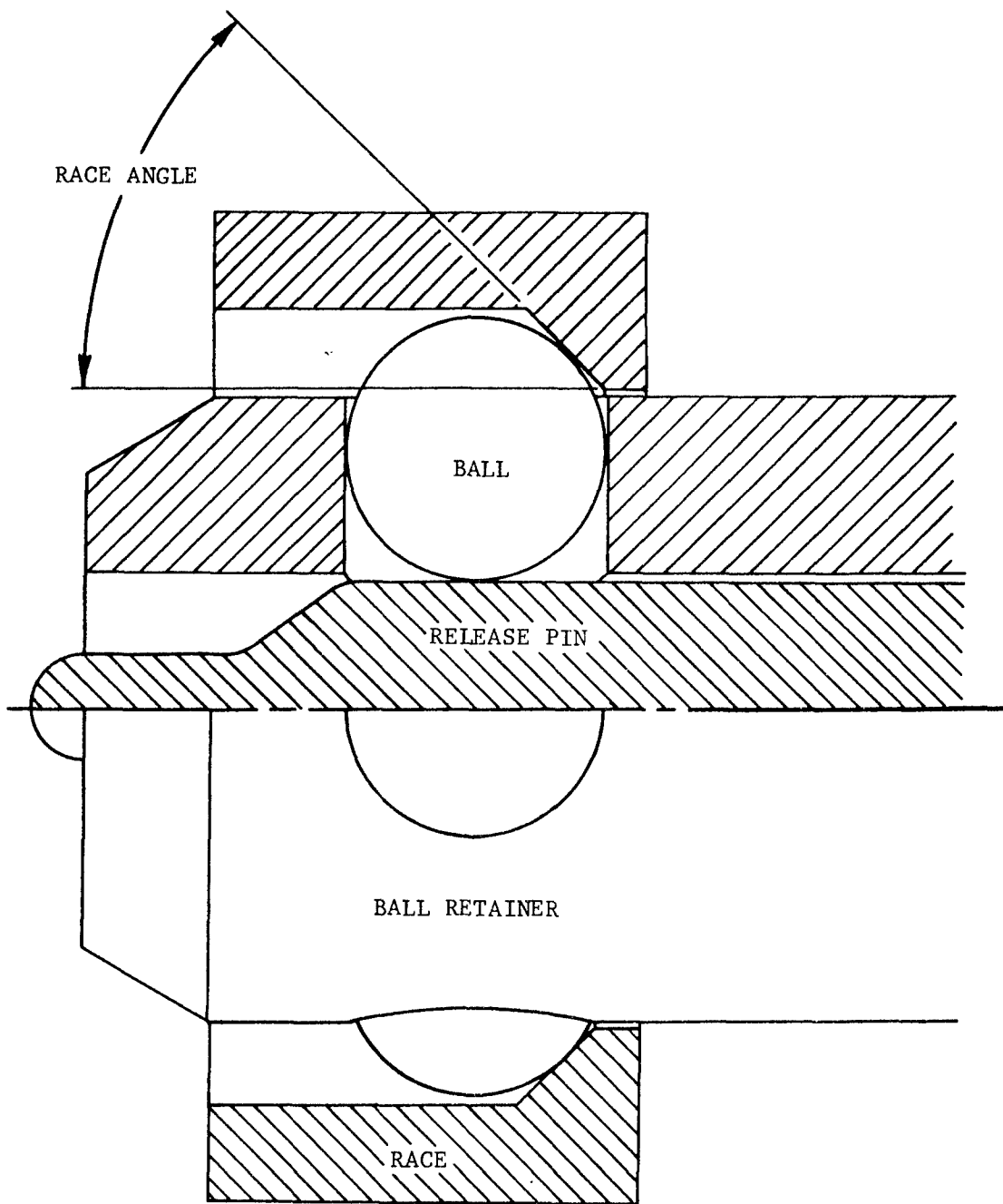

ILLUSTRATION 4. BALL-LOCK RACE ANGLE MEASUREMENT

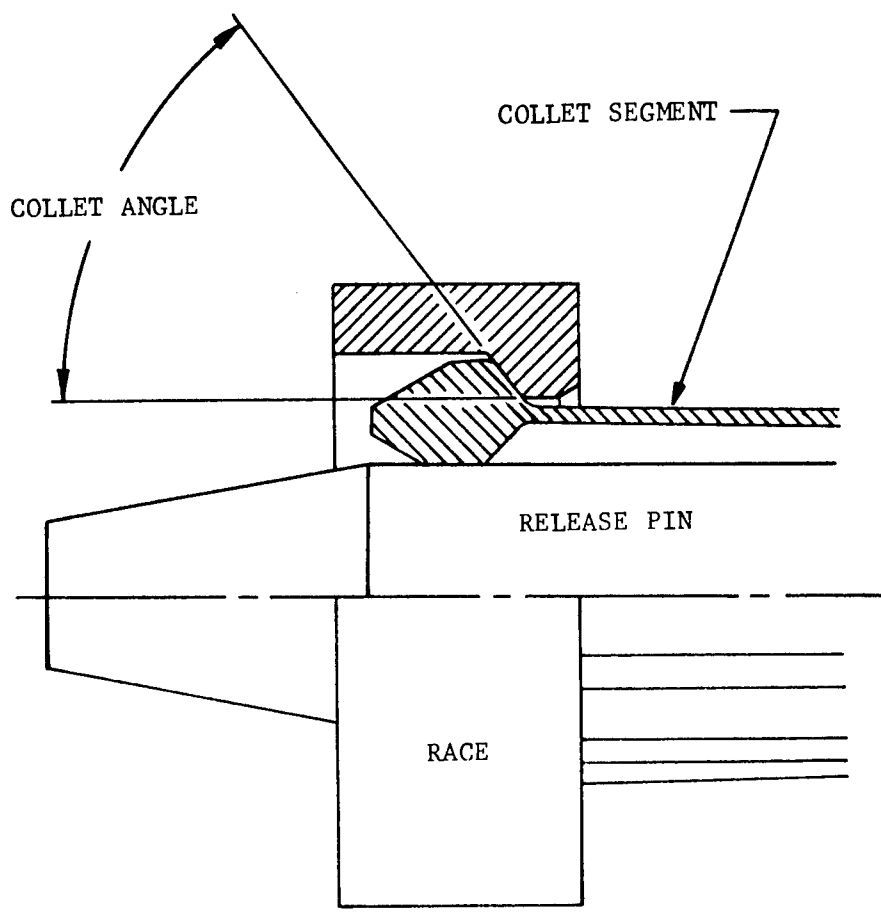
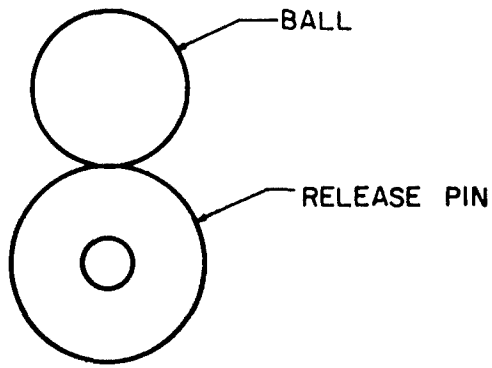
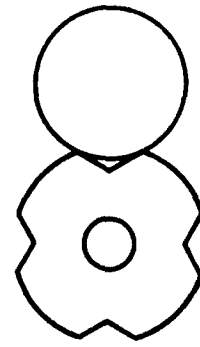

ILLUSTRATION 3. COLLET-LOCK ANGLE MEASUREMENT



SINGLE POINT CONTACT



TWO POINT CONTACT

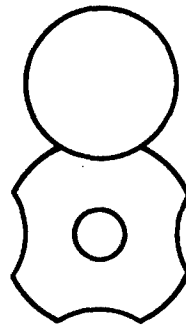

LINE CONTACT

ILLUSTRATION 6. BALL-LOCK PIN DESIGN

APPENDIX B

GRAPHS

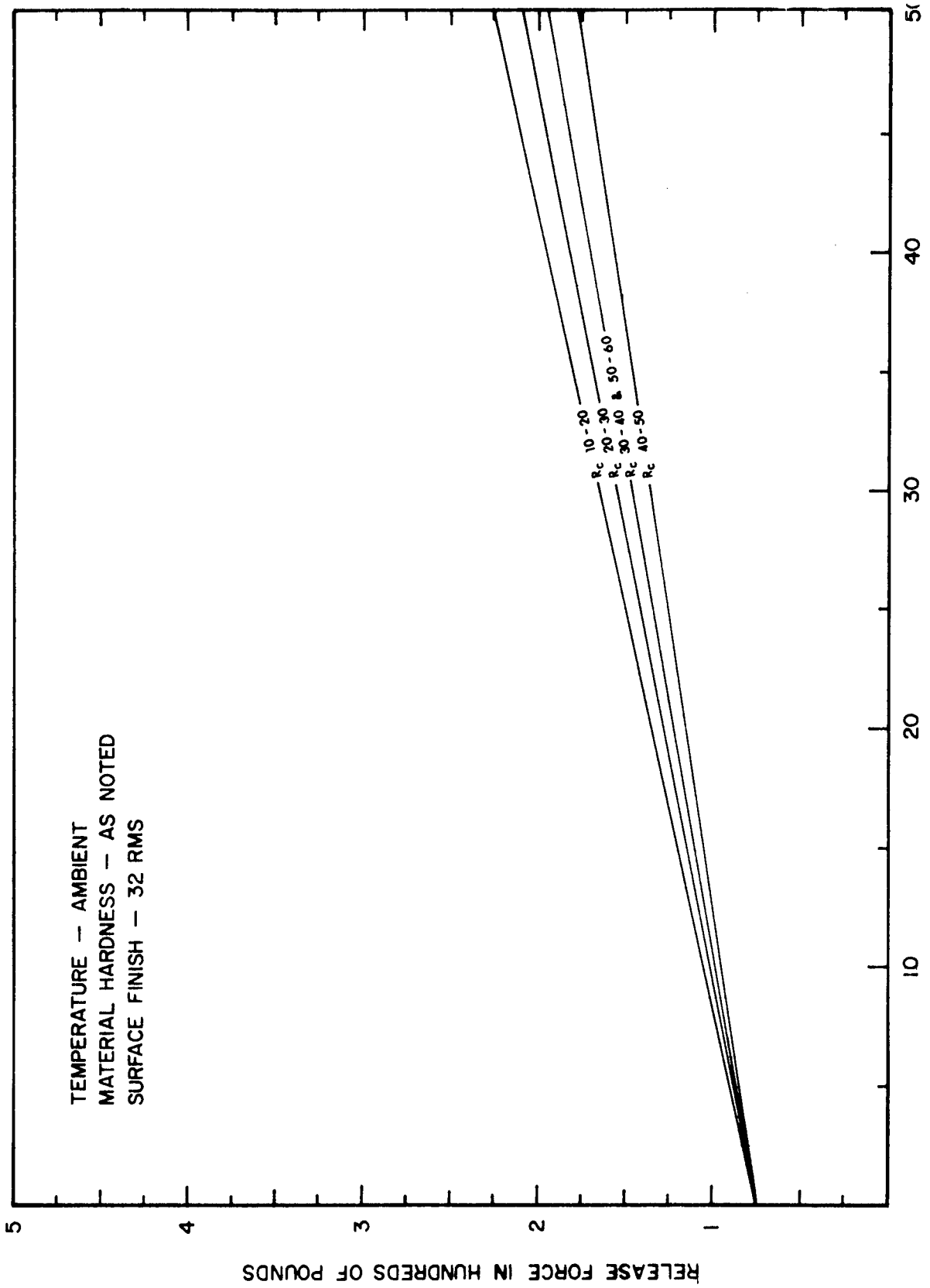

PRE-LOAD IN HUNDREDS OF POUNDS
 FIGURE 1. BALL-LOCK HARDNESS INVESTIGATION

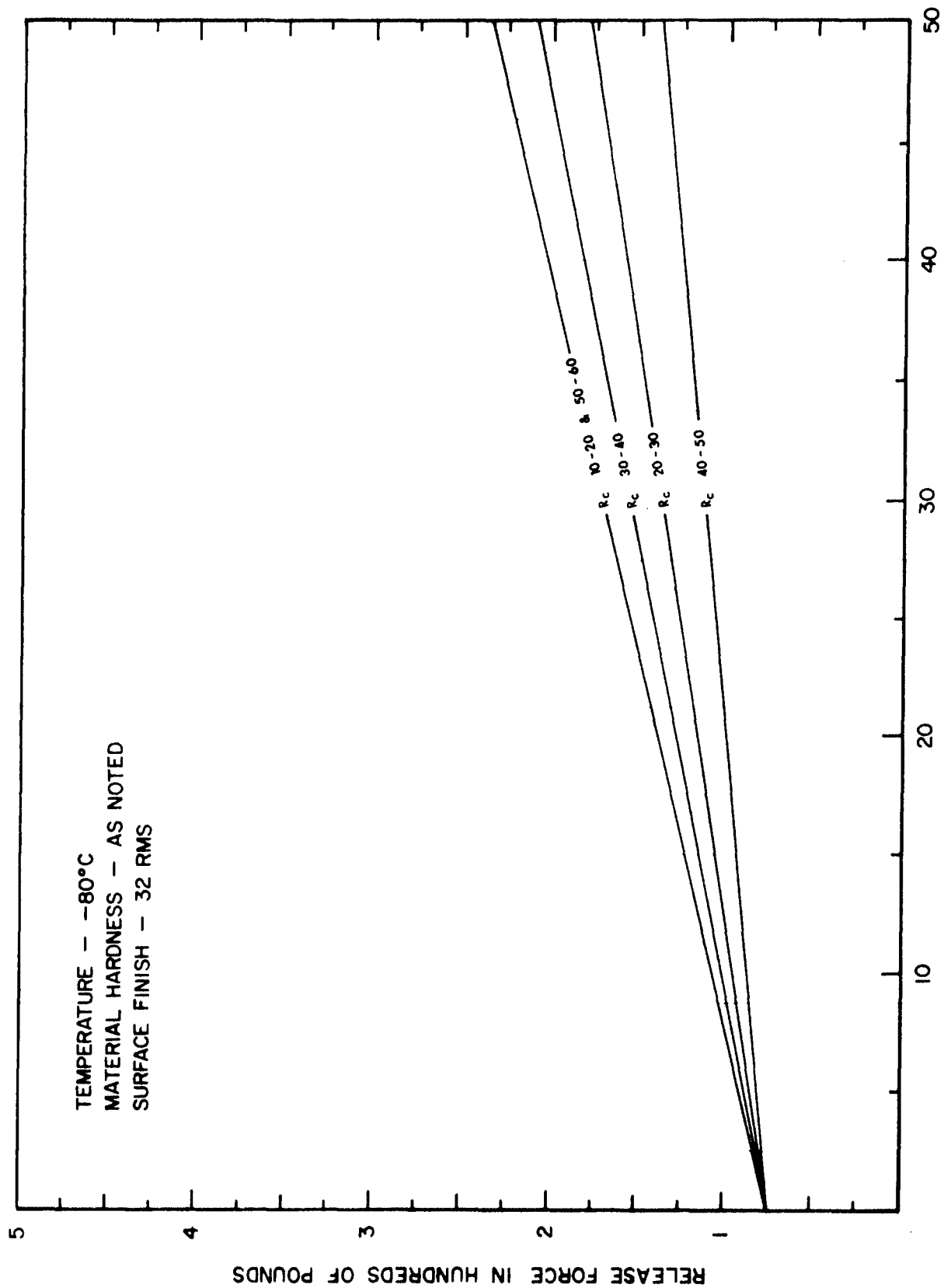

PRE-LOAD IN HUNDREDS OF POUNDS
 FIGURE 2. BALL-LOCK HARDNESS INVESTIGATION

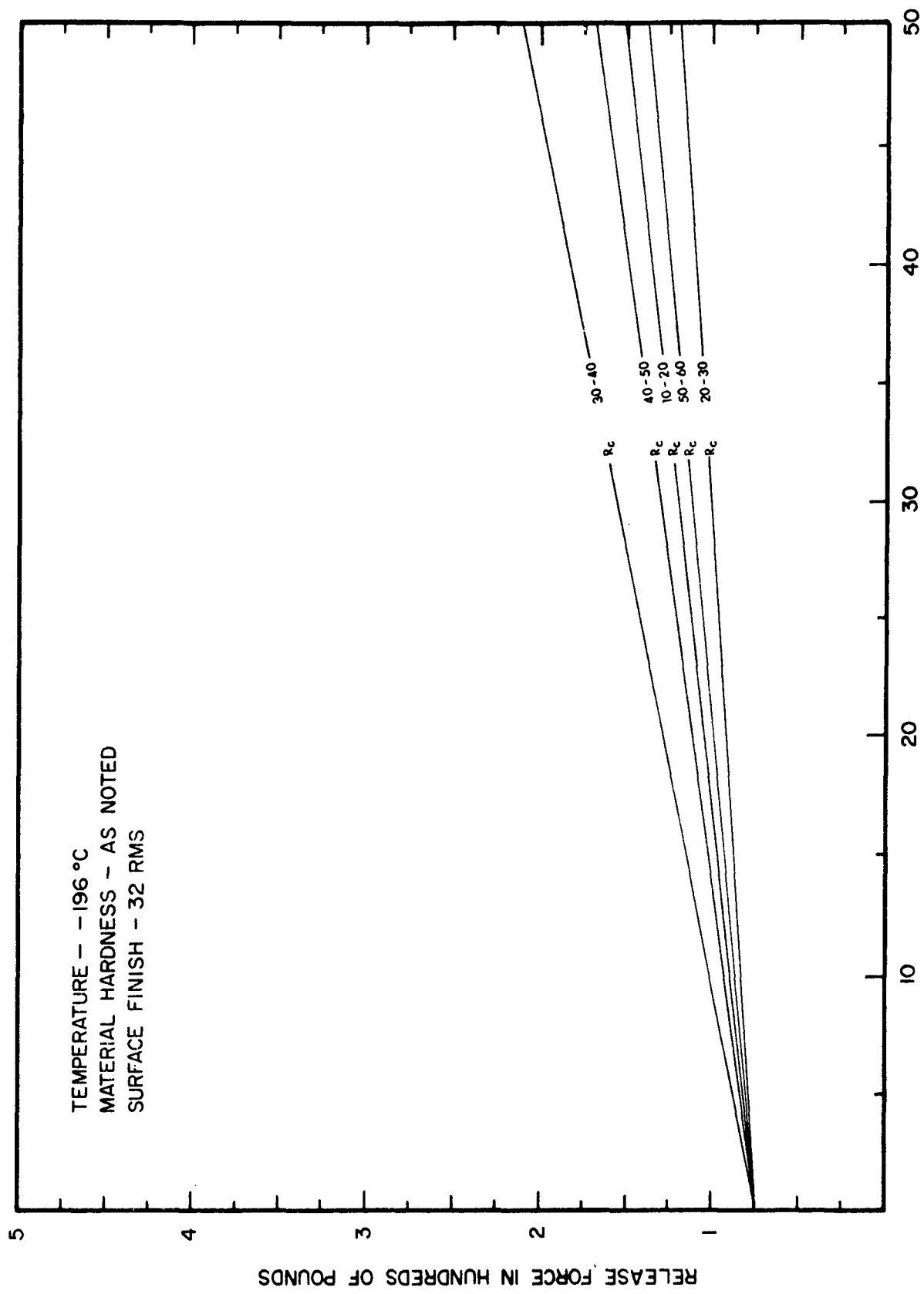

PRE-LOAD IN HUNDREDS OF POUNDS
 FIGURE 3. BALL-LOCK HARDNESS INVESTIGATION

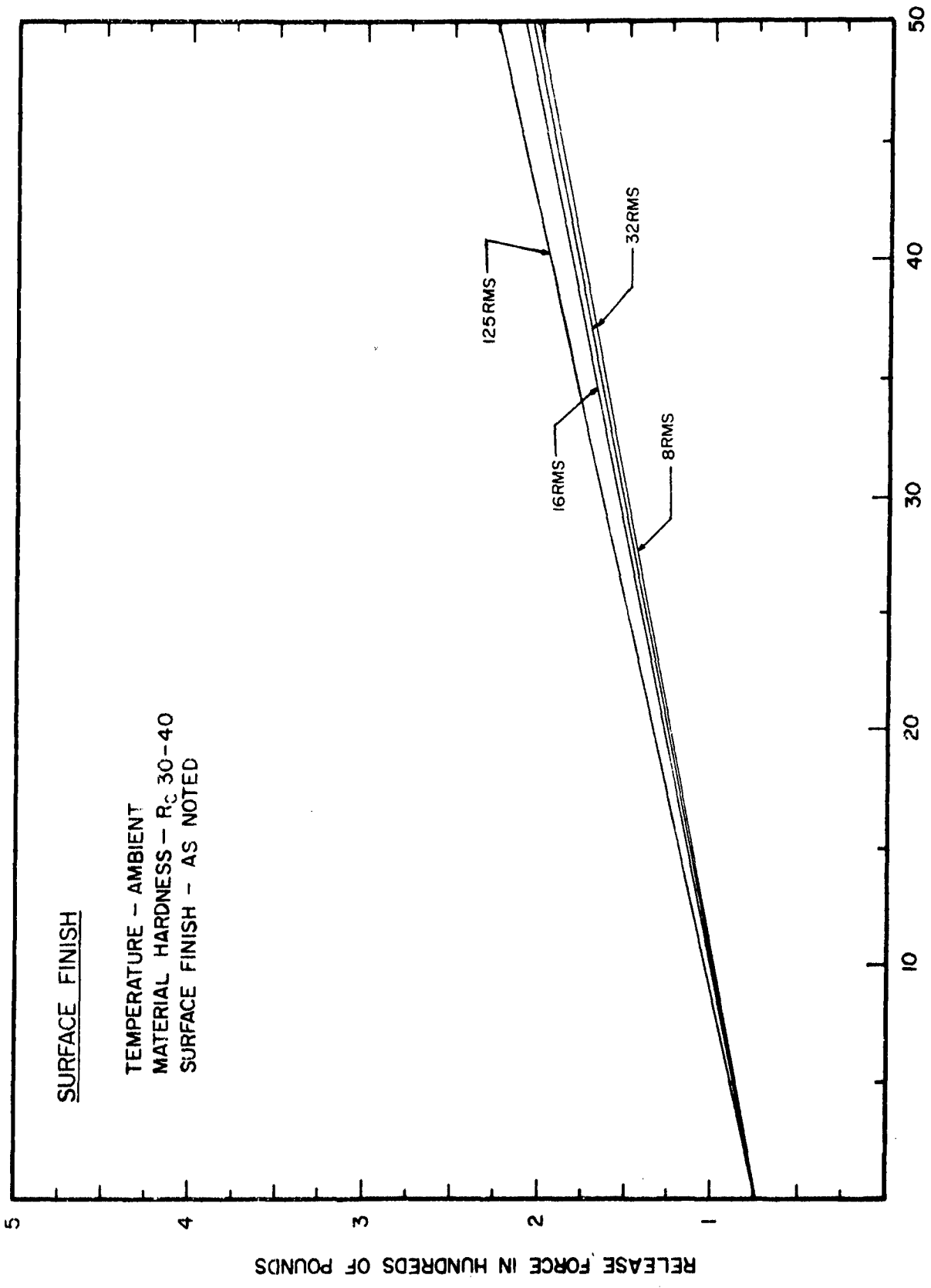

PRE-LOAD IN HUNDREDS OF POUNDS

FIGURE 4. BALL-LOCK SURFACE CONDITION INVESTIGATION

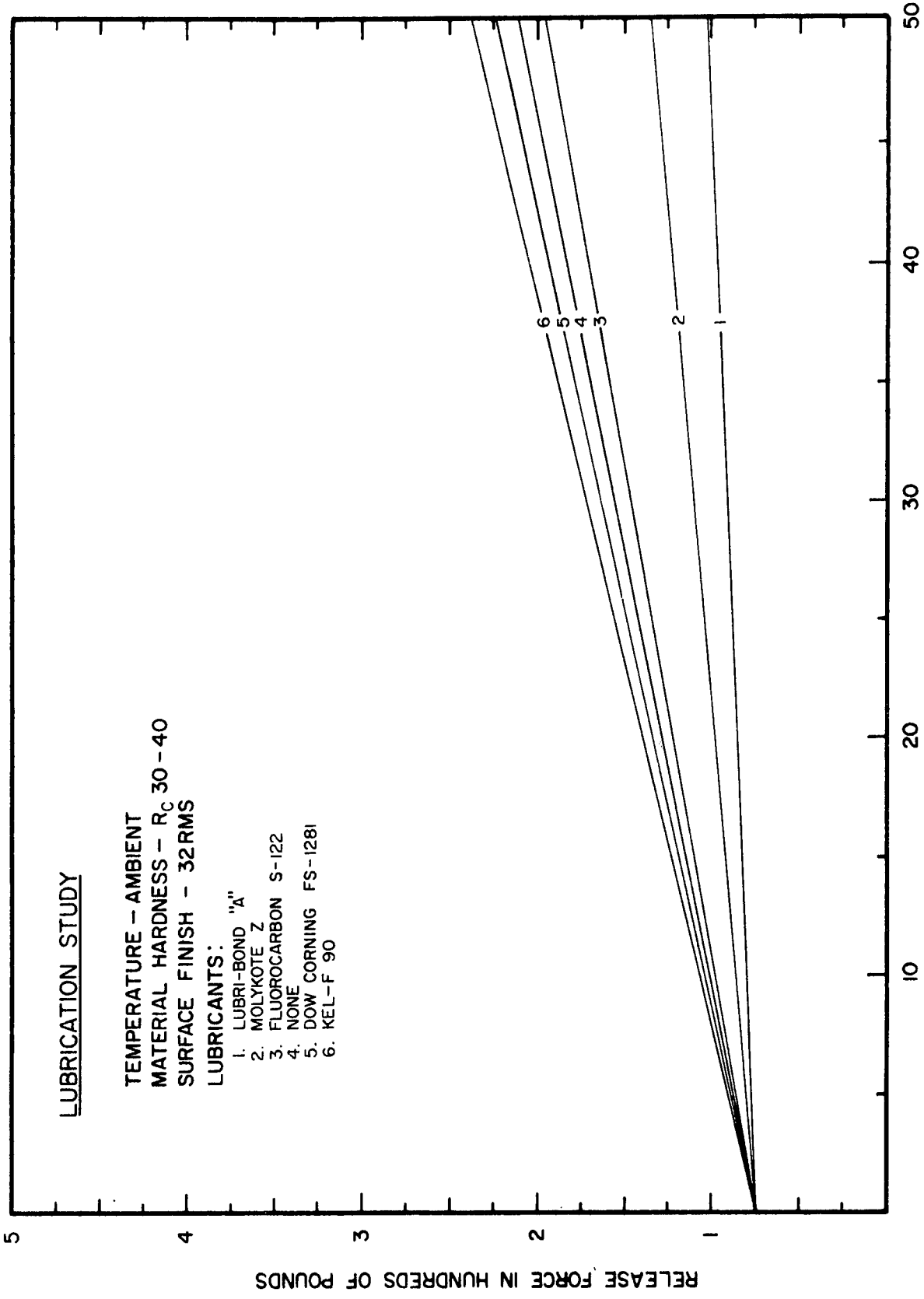

PRE-LOAD IN HUNDREDS OF POUNDS

FIGURE 5. BALL-LOCK SURFACE CONDITION INVESTIGATION

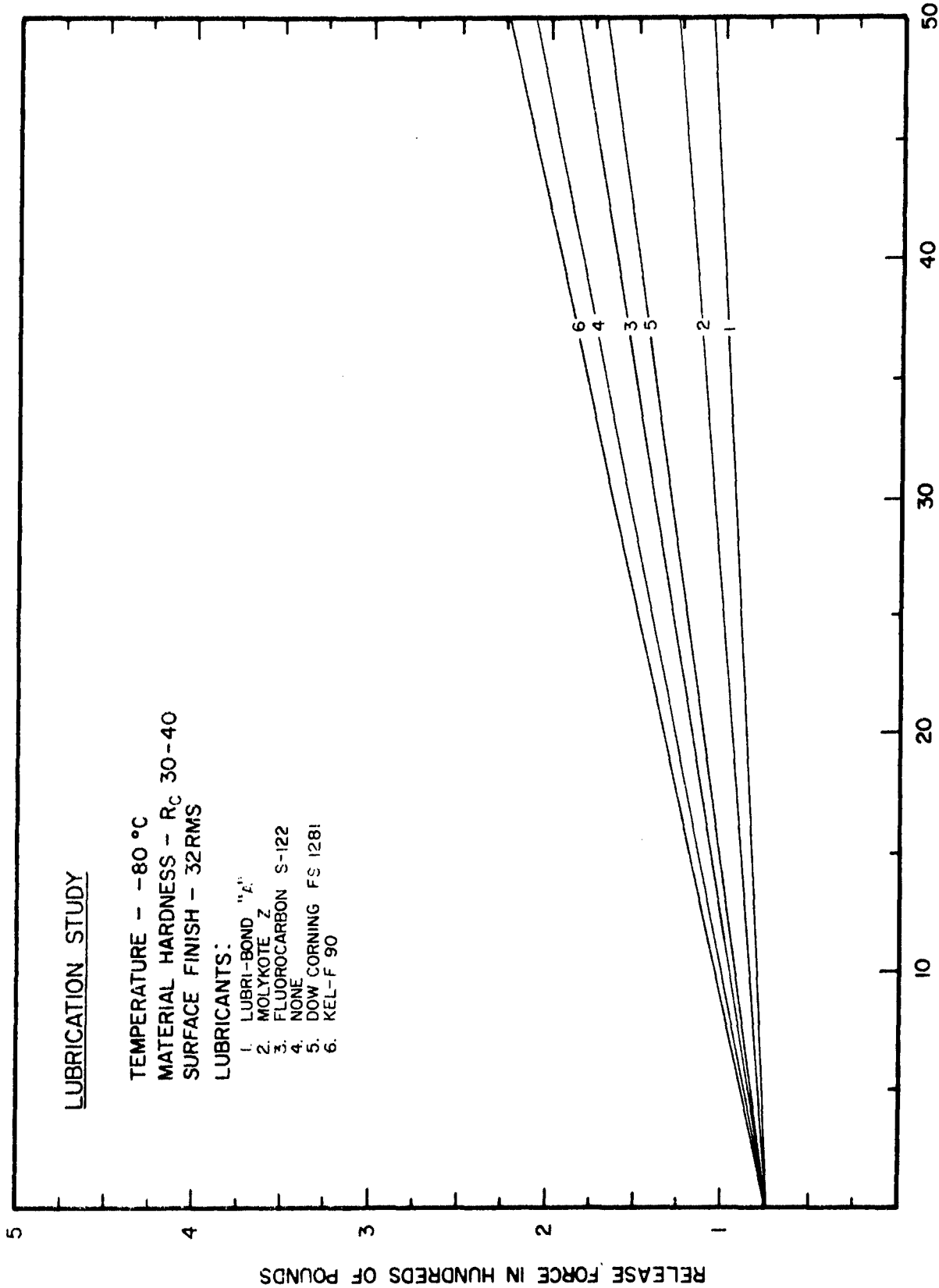

PRE-LOAD IN HUNDREDS OF POUNDS

FIGURE 6. BALL-LOCK SURFACE CONDITION INVESTIGATION

LUBRICATION STUDY

TEMPERATURE - -196 °C
MATERIAL HARDNESS - R_C 30 - 40
SURFACE FINISH - 32 RMS

LUBRICANTS:

1. LUBRI-BOND "A"
2. MOLYKOTE Z
3. FLUOROCARBON S-122
4. NONE
5. DOW CORNING FS-1281
6. KEL-F 90

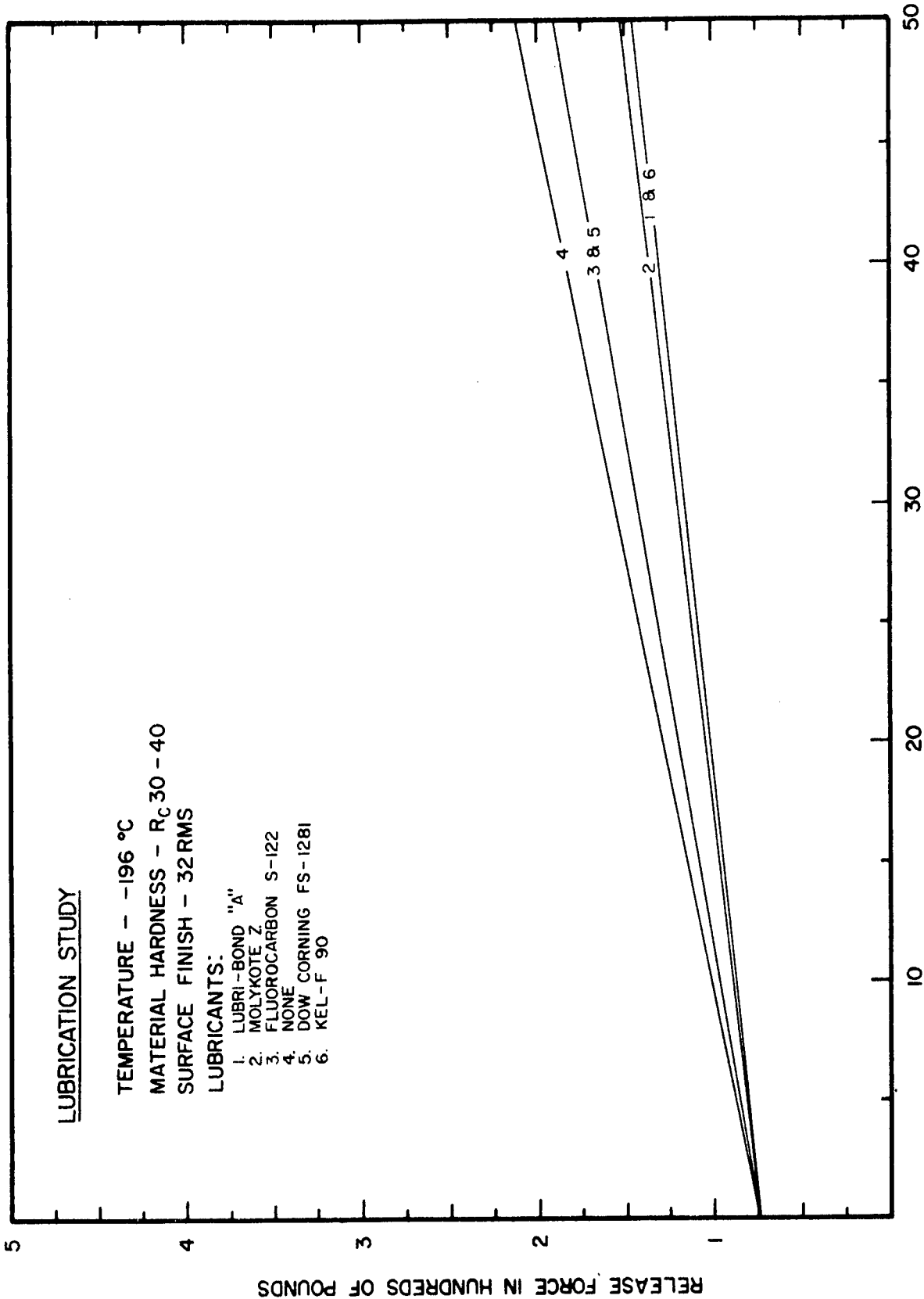
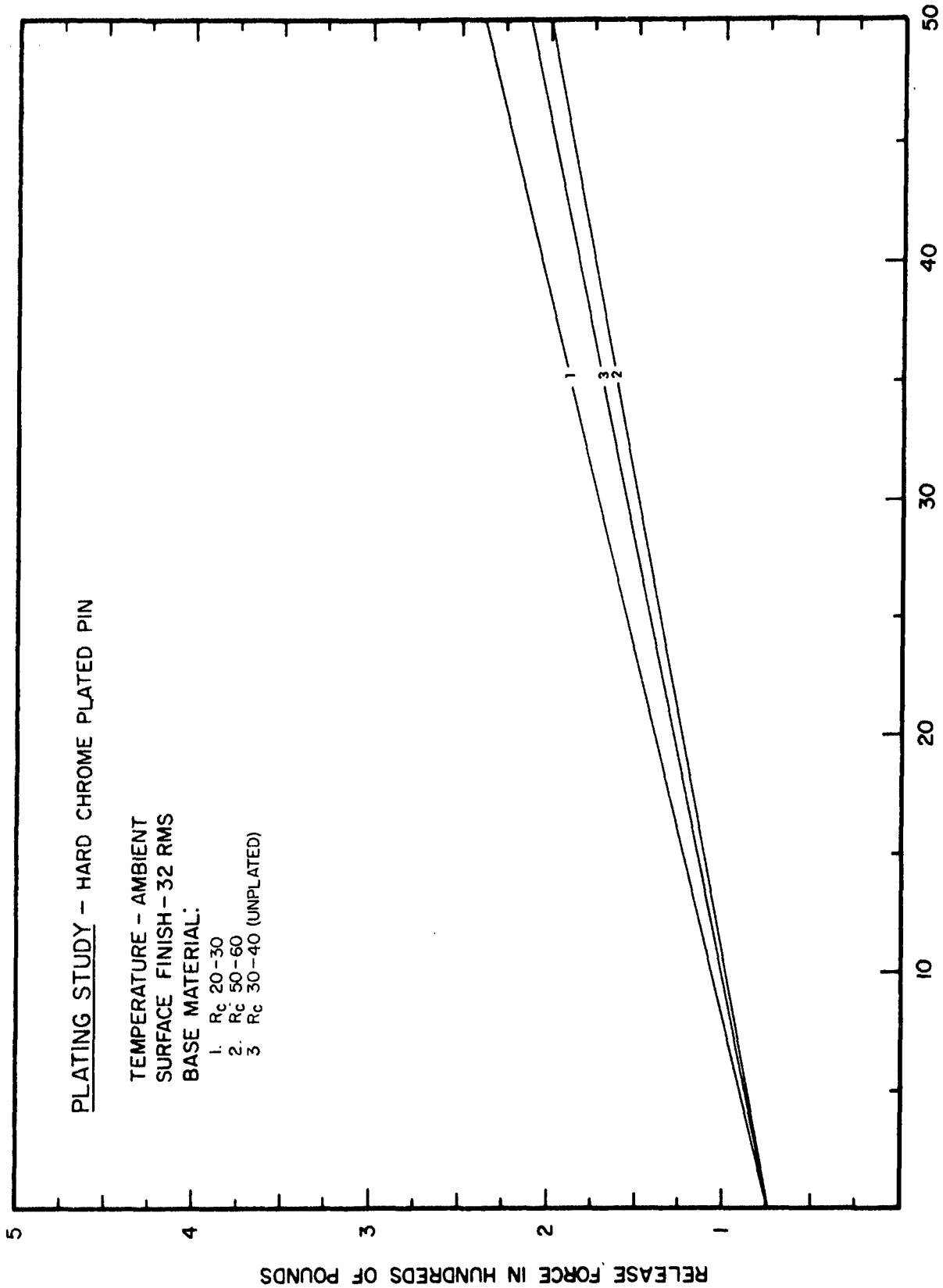
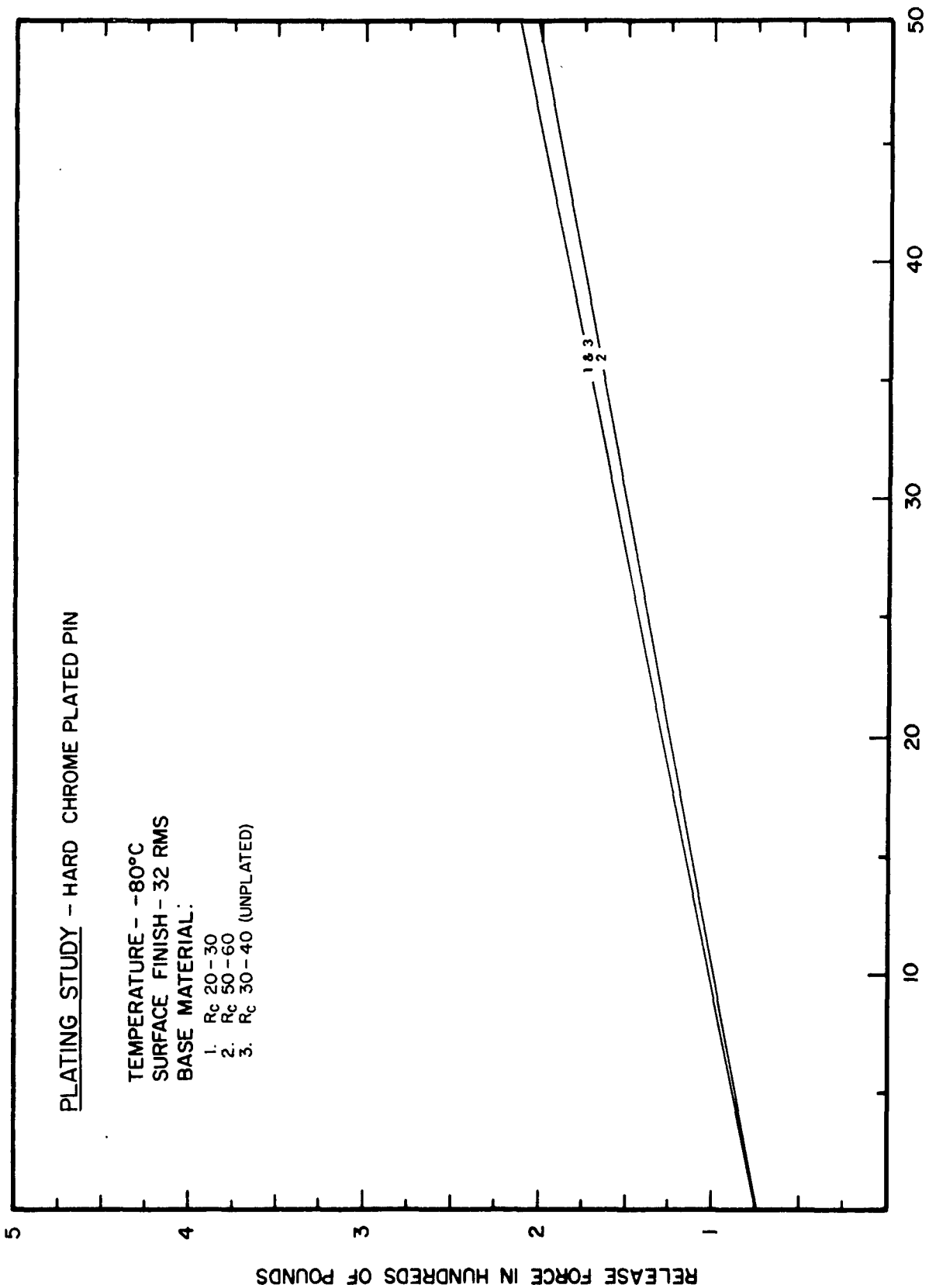

FIGURE 7. BALL-LOCK SURFACE CONDITION INVESTIGATION



PRE-LOAD IN HUNDREDS OF POUNDS

FIGURE 8. BALL-LOCK SURFACE CONDITION INVESTIGATION



PRE-LOAD IN HUNDREDS OF POUNDS

FIGURE 9. BALL-LOCK SURFACE CONDITION INVESTIGATION

PLATING STUDY - HARD CHROME PLATED PIN

TEMPERATURE - -196 °C
SURFACE FINISH - 32 RMS

BASE MATERIAL:

- 1. Rc 20-30
- 2. Rc 50-60
- 3. Rc 30-40 (UNPLATED)

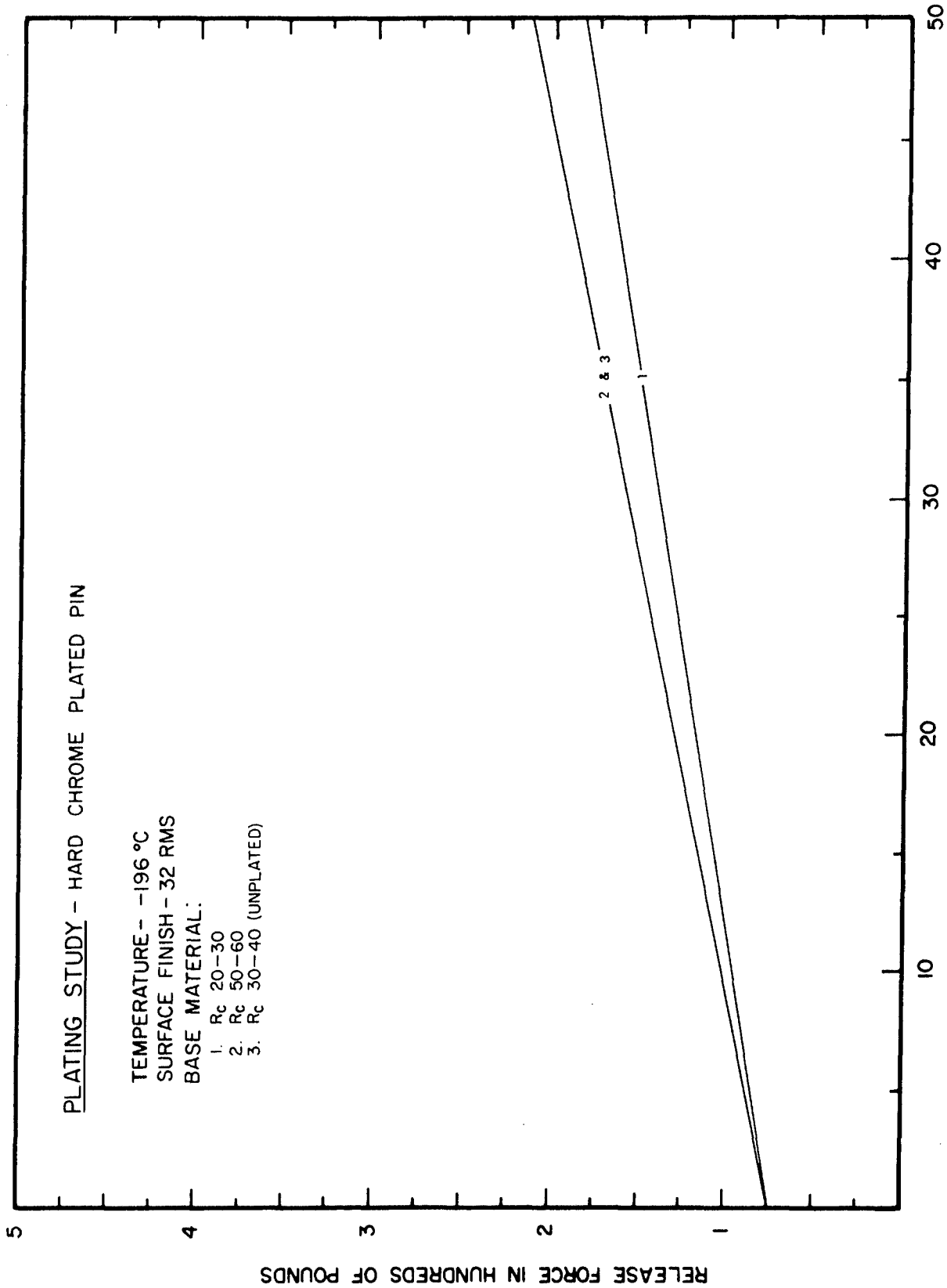

PRE-LOAD IN HUNDREDS OF POUNDS

FIGURE 10. BALL-LOCK SURFACE CONDITION INVESTIGATION

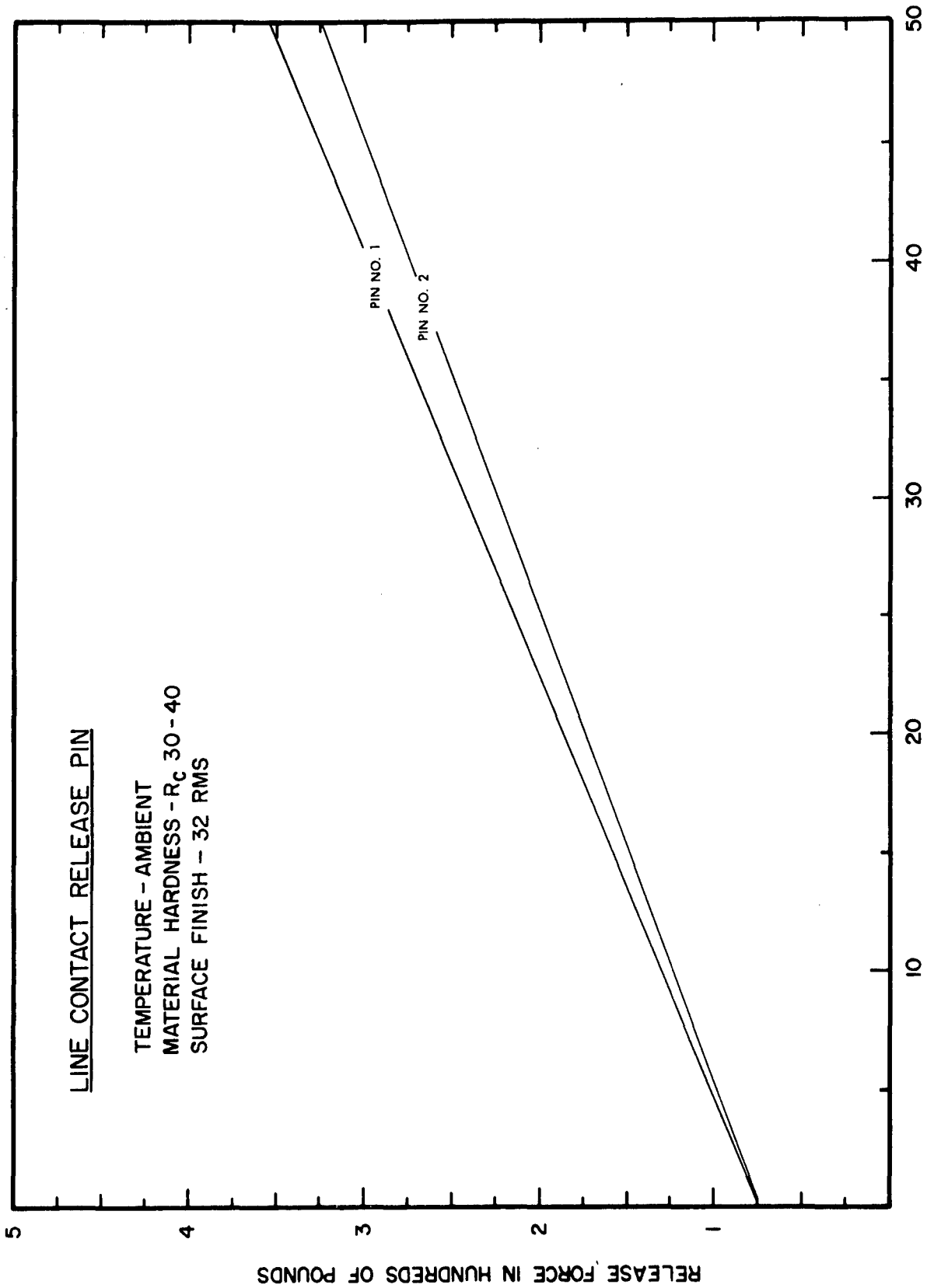
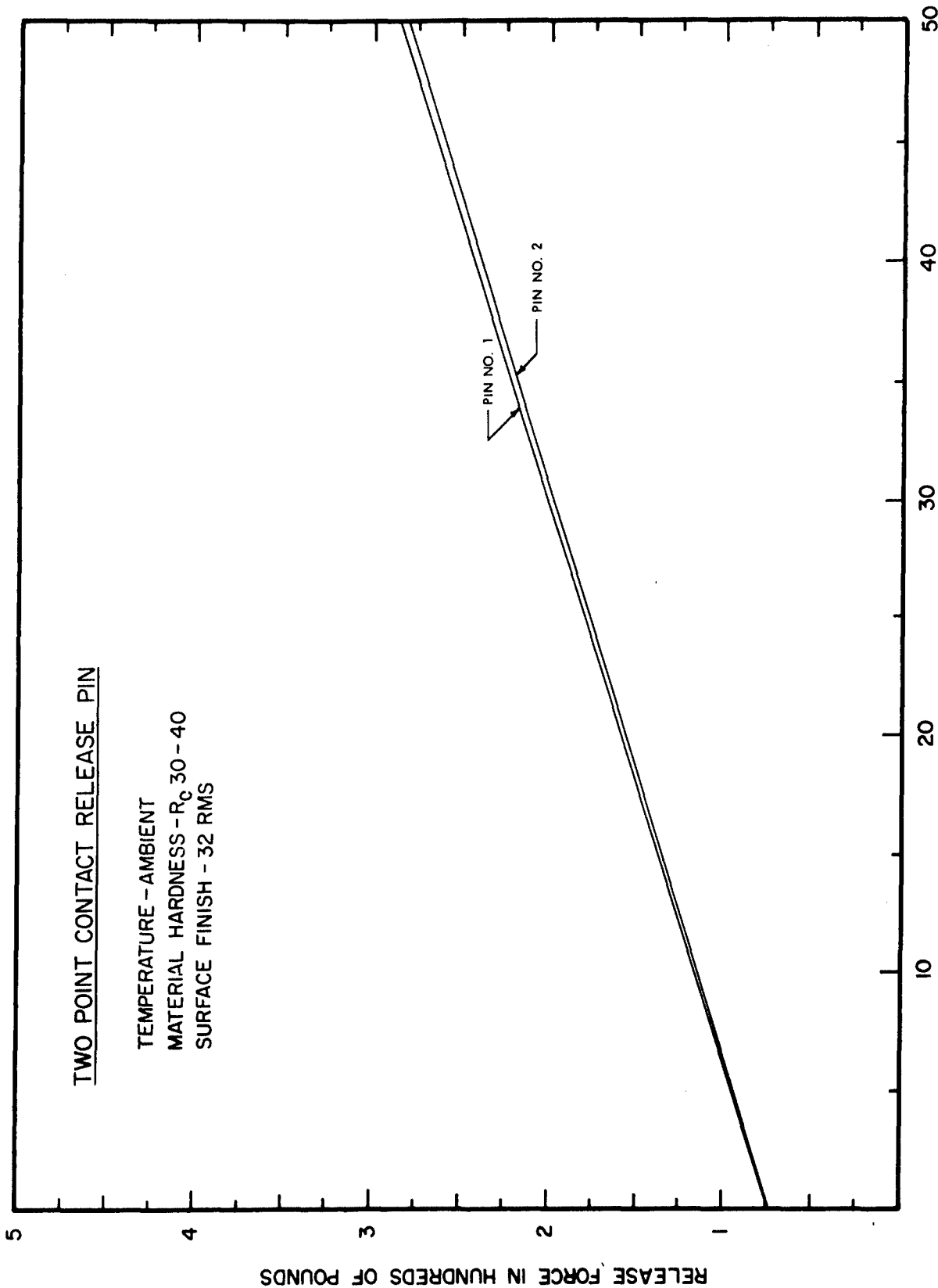

FIGURE 11. BALL-LOCK PIN DESIGN INVESTIGATION



PRE-LOAD IN HUNDREDS OF POUNDS

FIGURE 12. BALL-LOCK PIN DESIGN INVESTIGATION

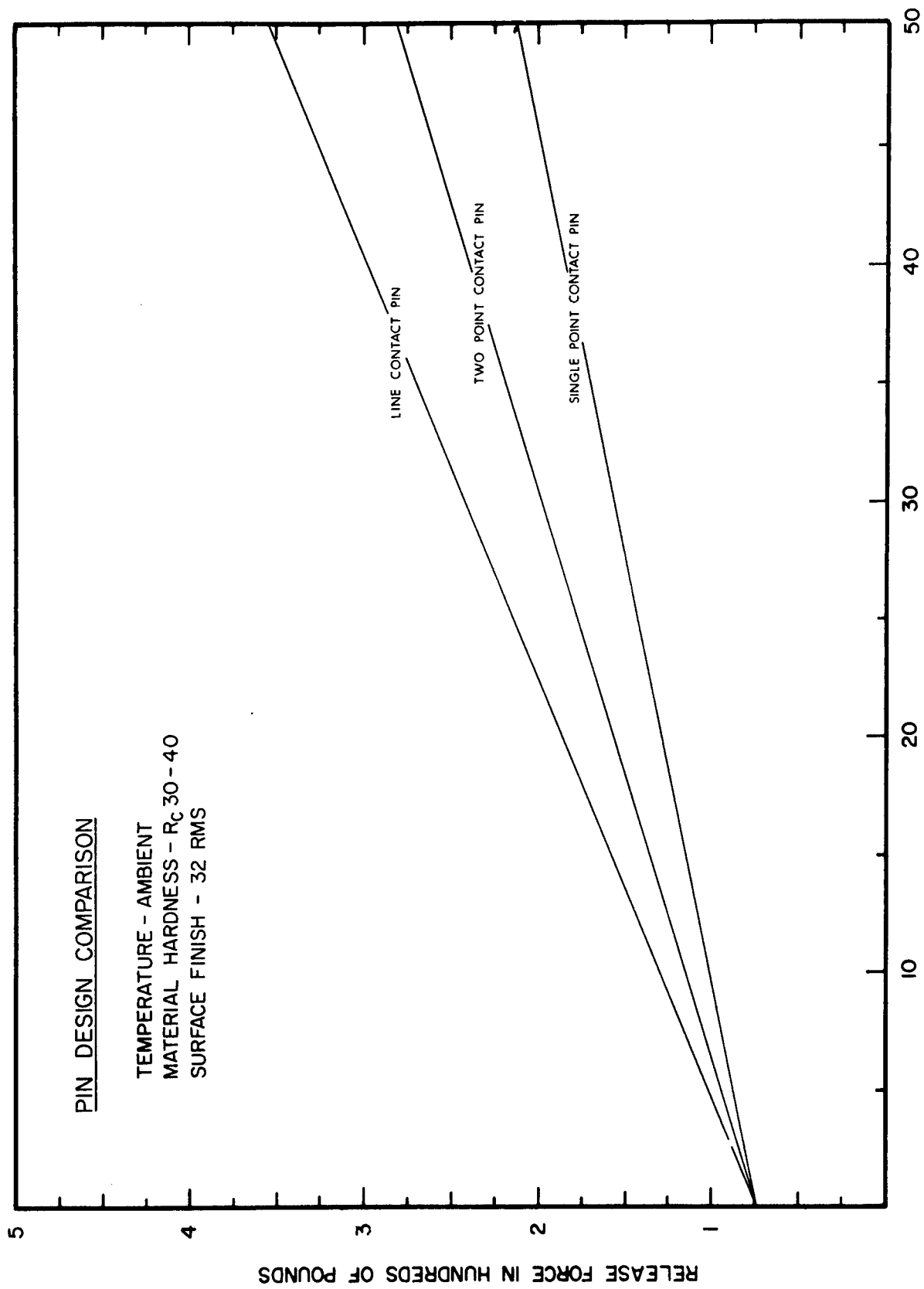
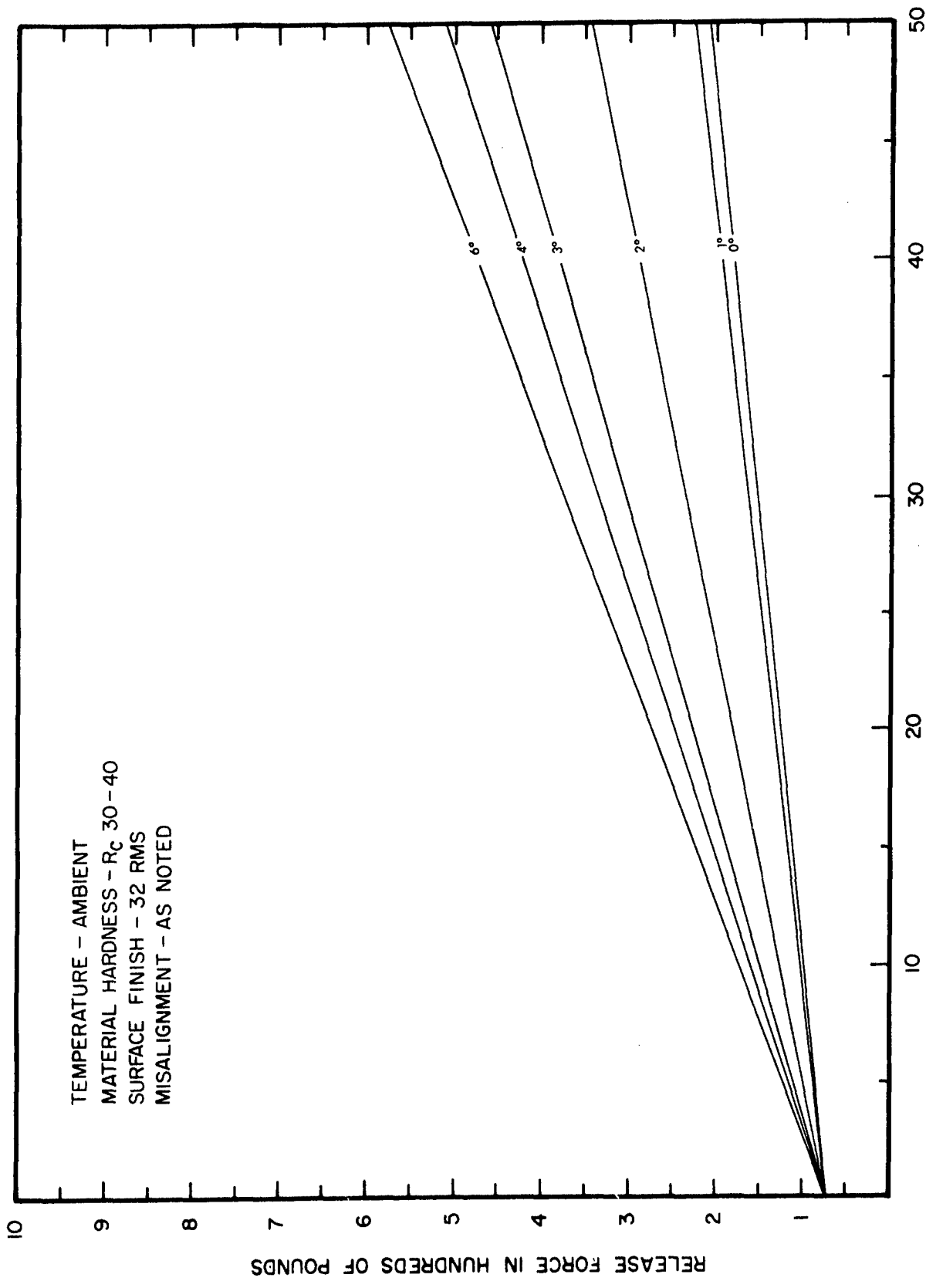
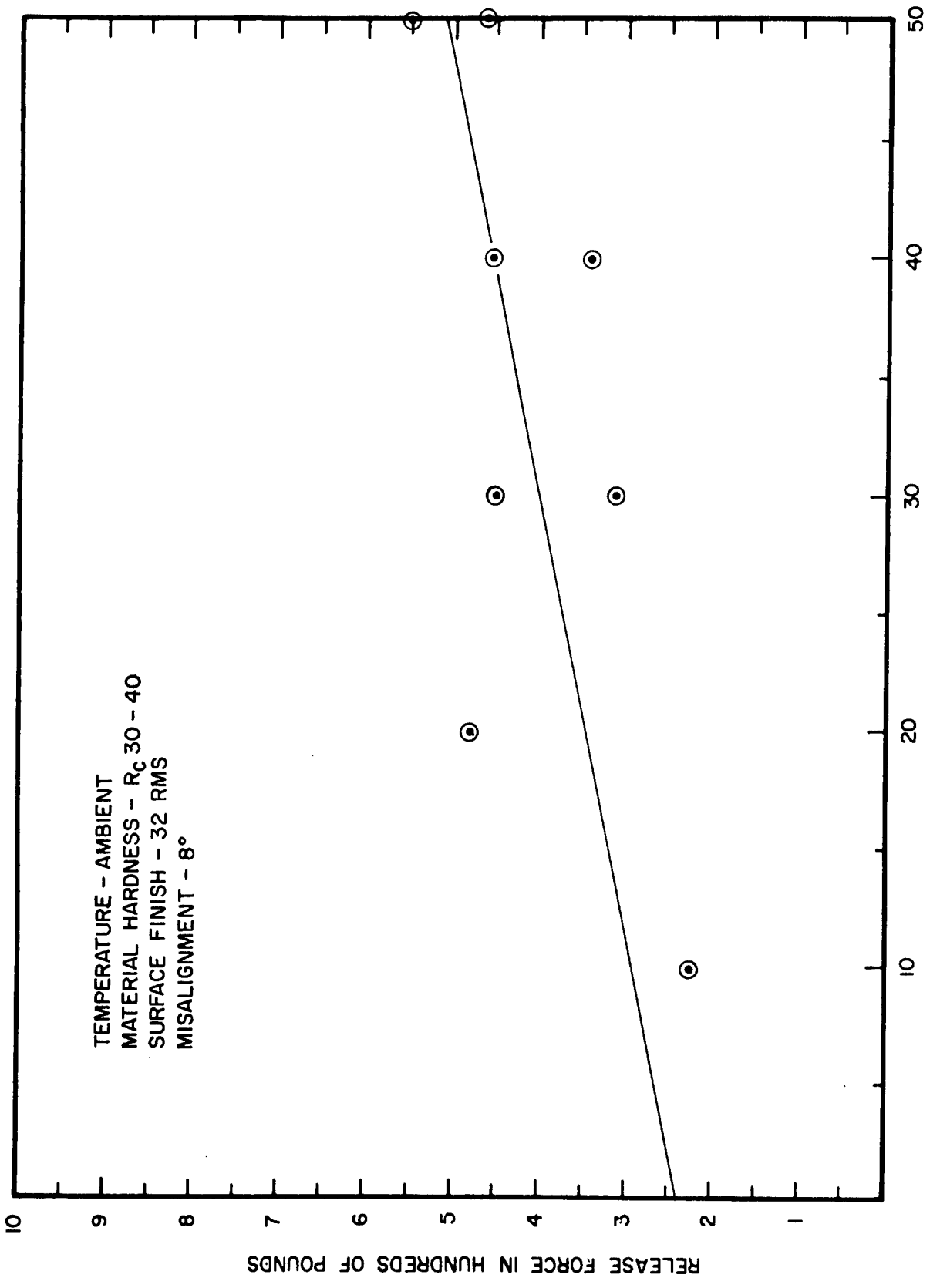

FIGURE 13. BALL-LOCK PIN DESIGN INVESTIGATION



PRE-LOAD IN HUNDREDS OF POUNDS
 FIGURE 14. BALL-LOCK ALIGNMENT INVESTIGATION



PRE-LOAD IN HUNDREDS OF POUNDS
 FIGURE 15. BALL-LOCK ALIGNMENT INVESTIGATION

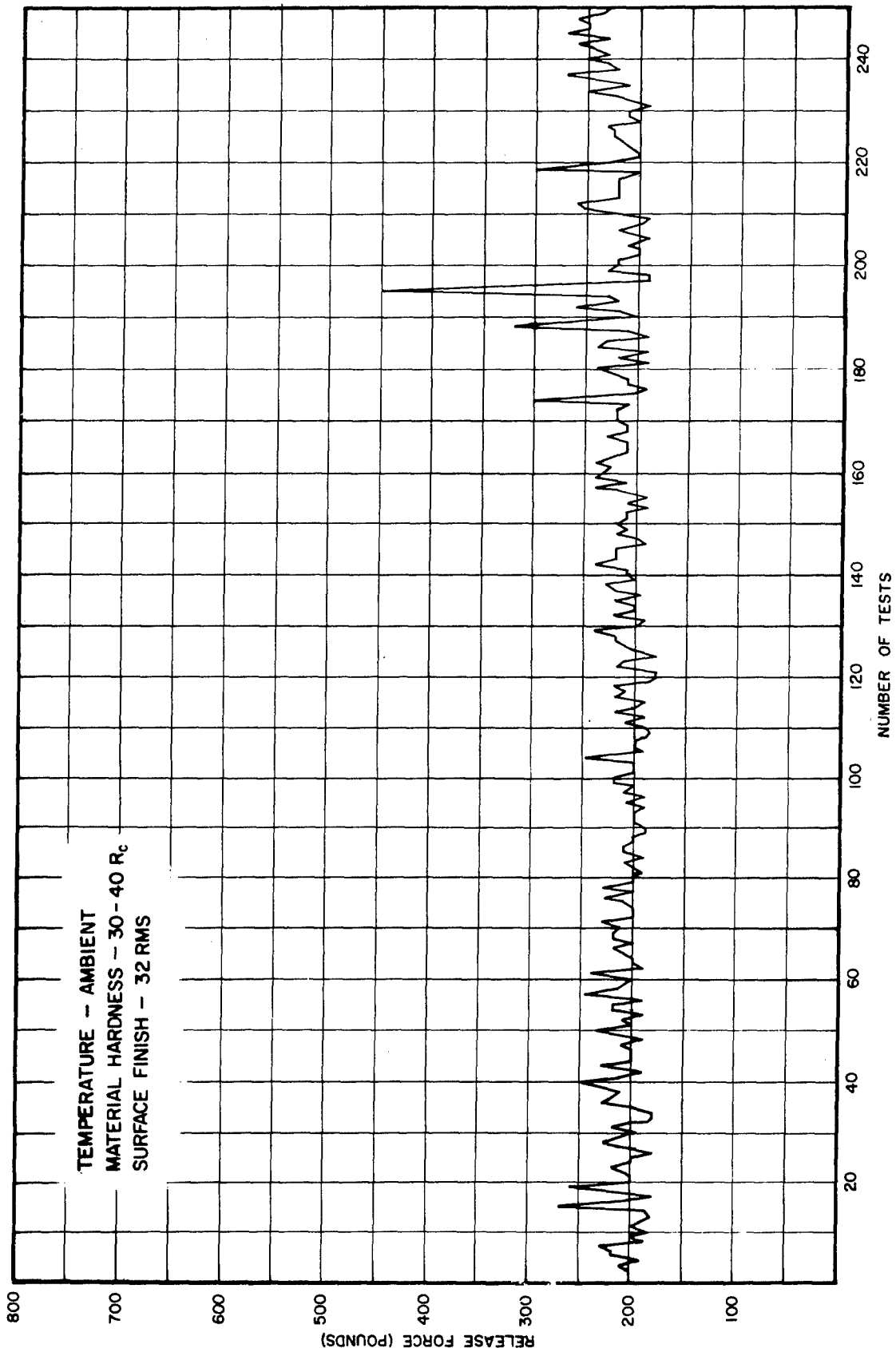

FIGURE 16. BALL-LOCK LIFE CYCLE INVESTIGATION

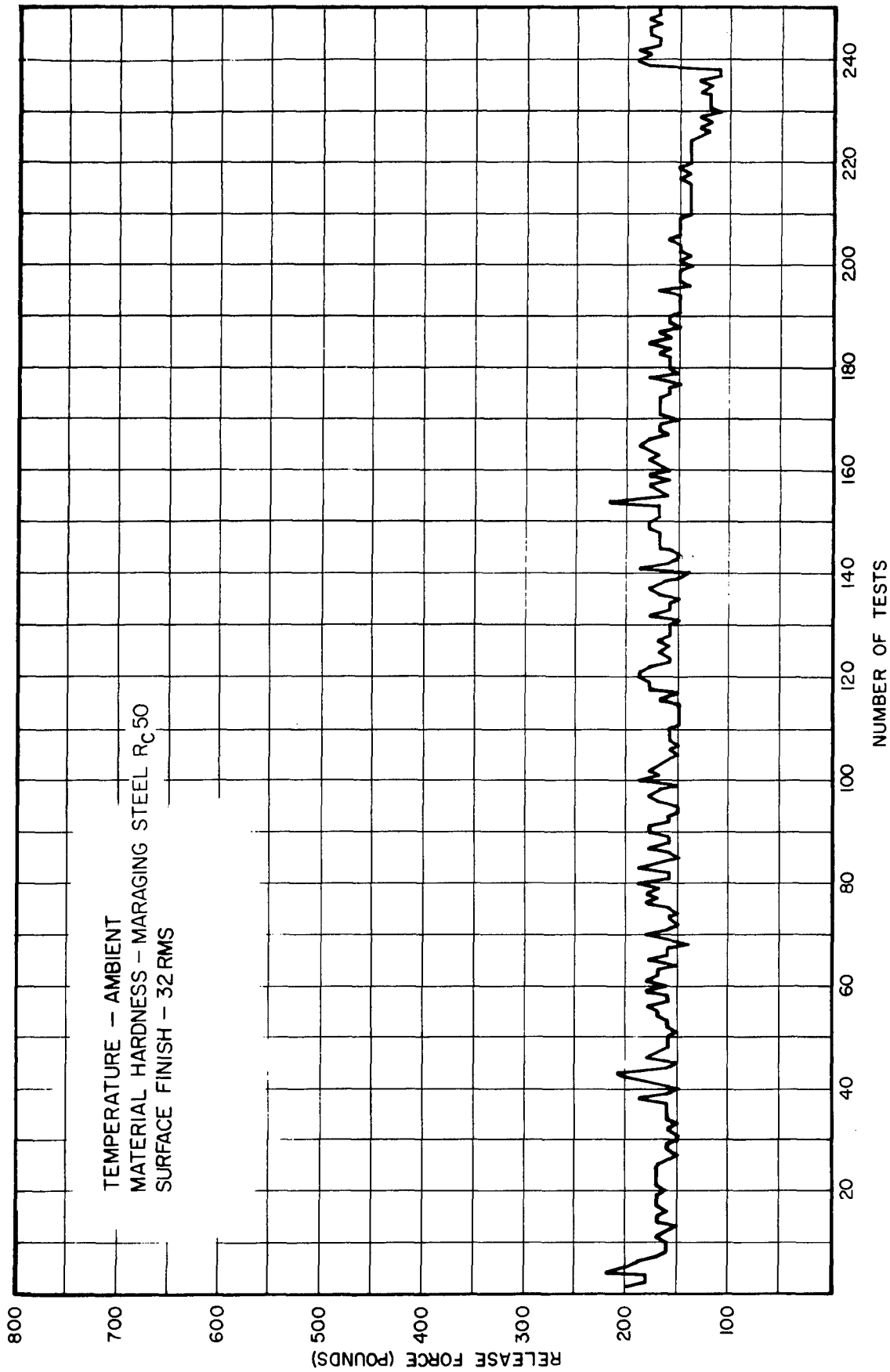

FIGURE 17. BALL-LOCK LIFE CYCLE INVESTIGATION

UMBILICAL LOCK DEVELOPMENT PROGRAM

CONDITION	HARDNESS
A	Rb 60
H	Rb 75
HT	Rc 44

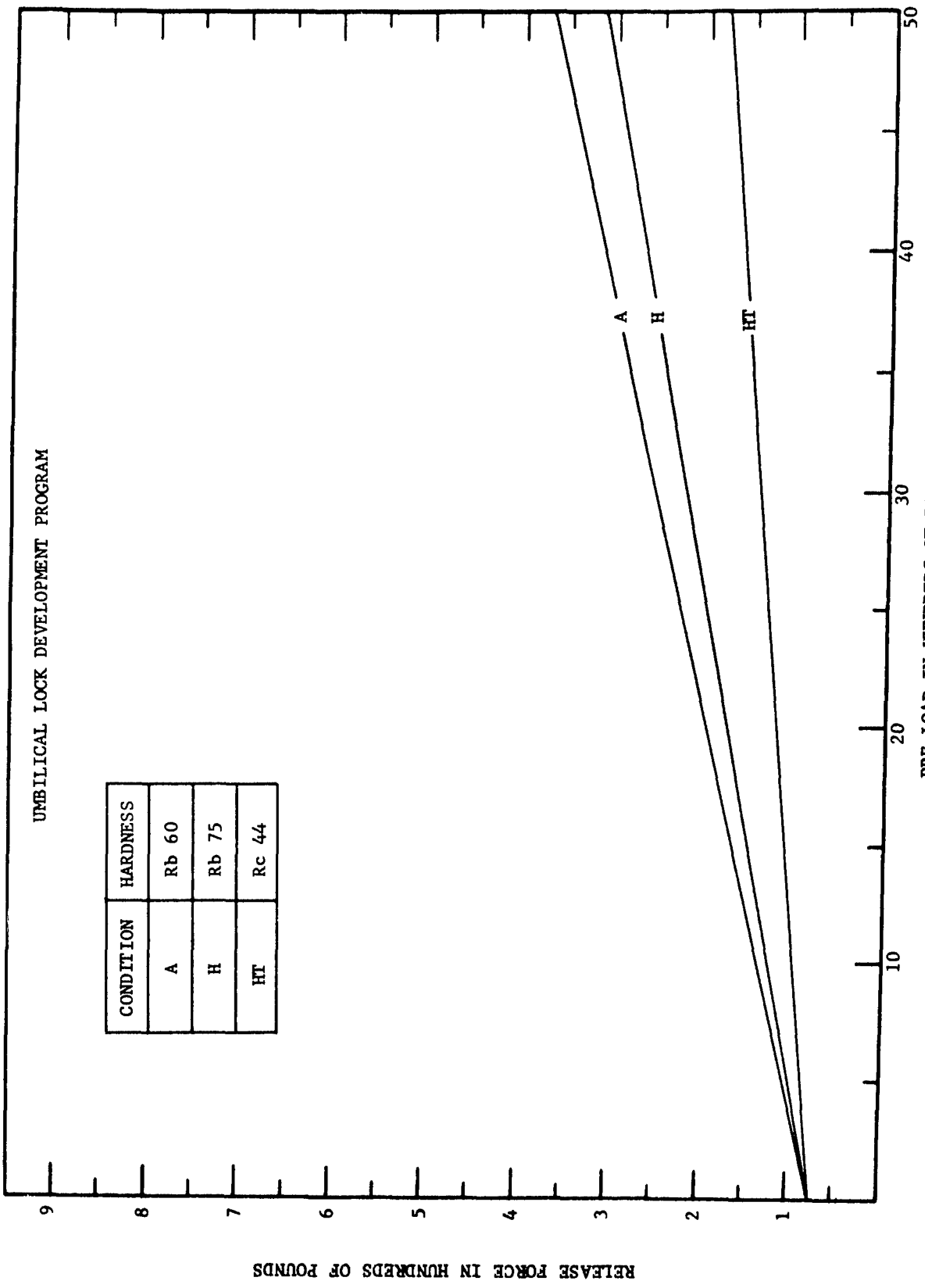
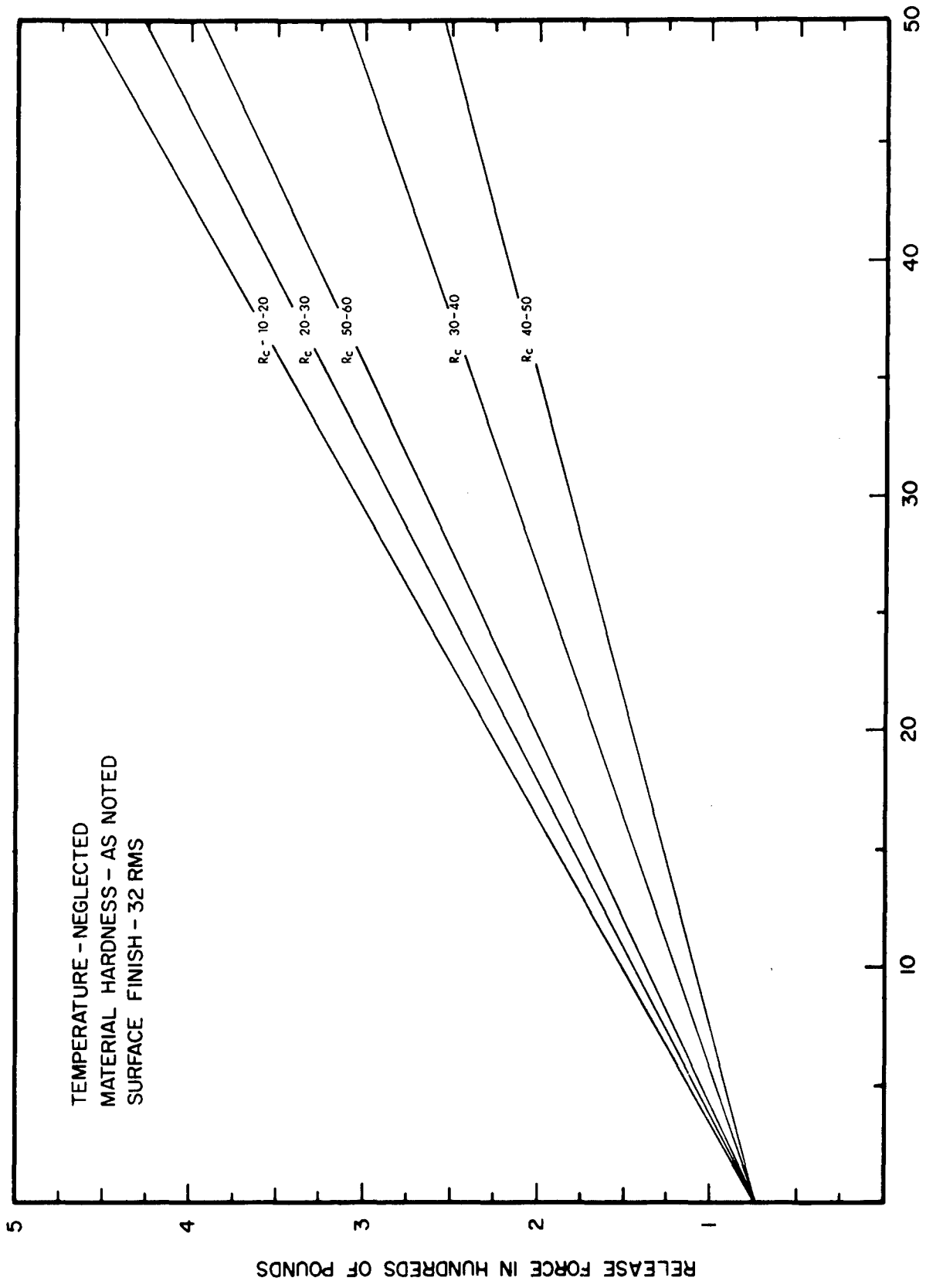
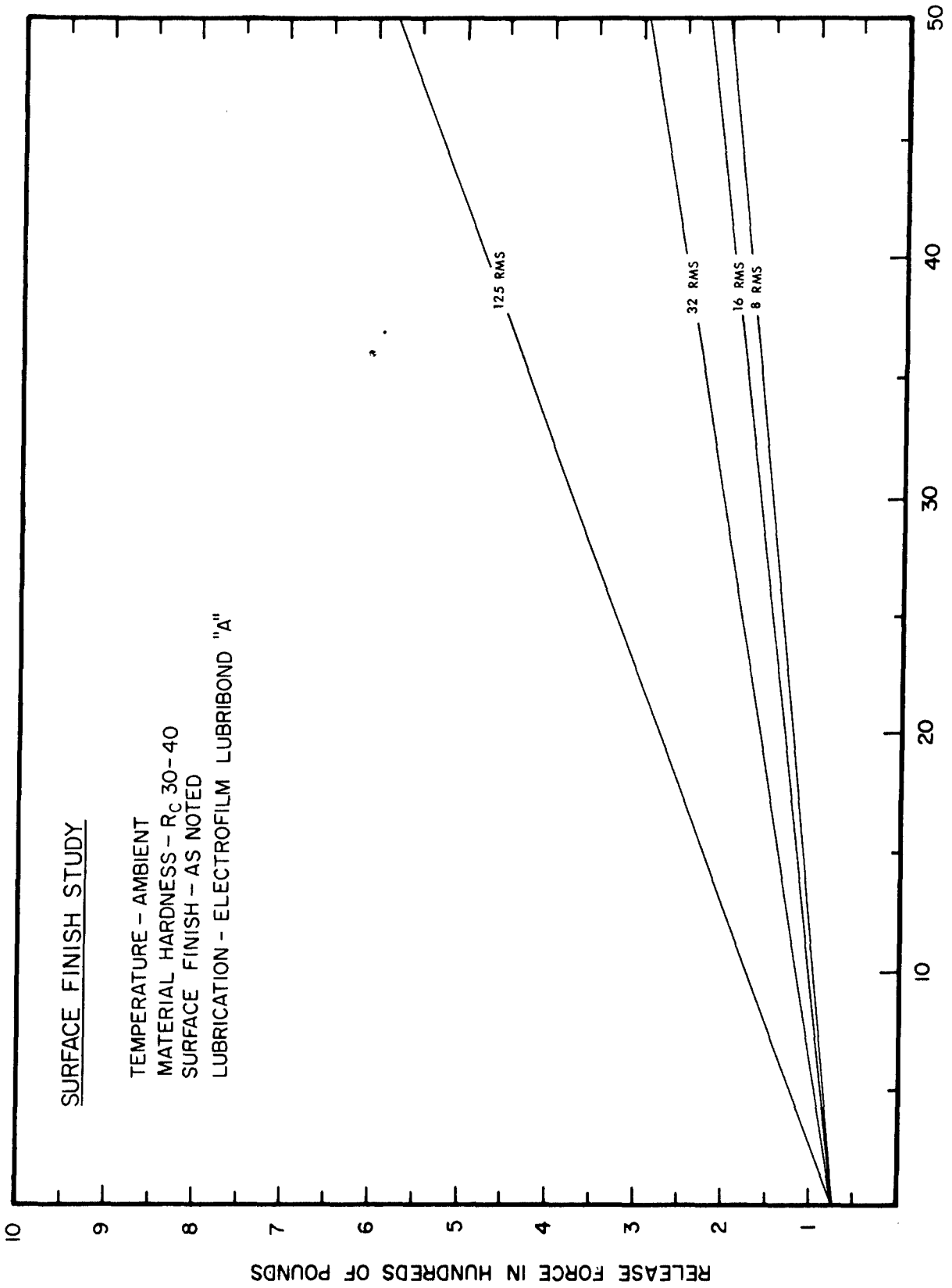

FIGURE 18. COLLET-LOCK HARDNESS INVESTIGATION 75° ANGLE



PRE-LOAD IN HUNDREDS OF POUNDS

FIGURE 19. COLLET-LOCK MATERIAL HARDNESS INVESTIGATION



PRE-LOAD IN HUNDREDS OF POUNDS

FIGURE 20. COLLET-LOCK SURFACE CONDITION INVESTIGATION

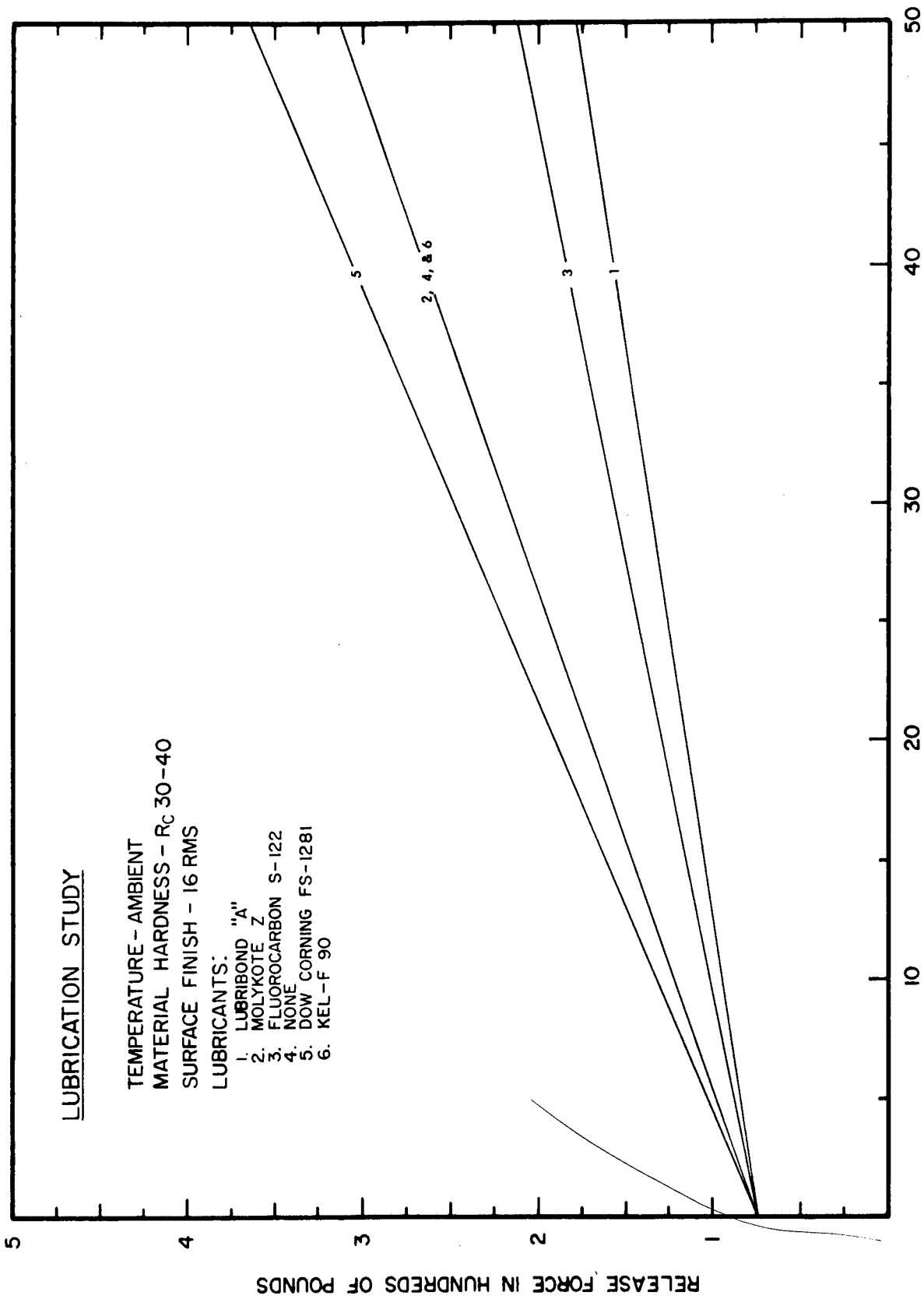

PRE-LOAD IN HUNDREDS OF POUNDS

FIGURE 21. COLLET-LOCK SURFACE CONDITION INVESTIGATION

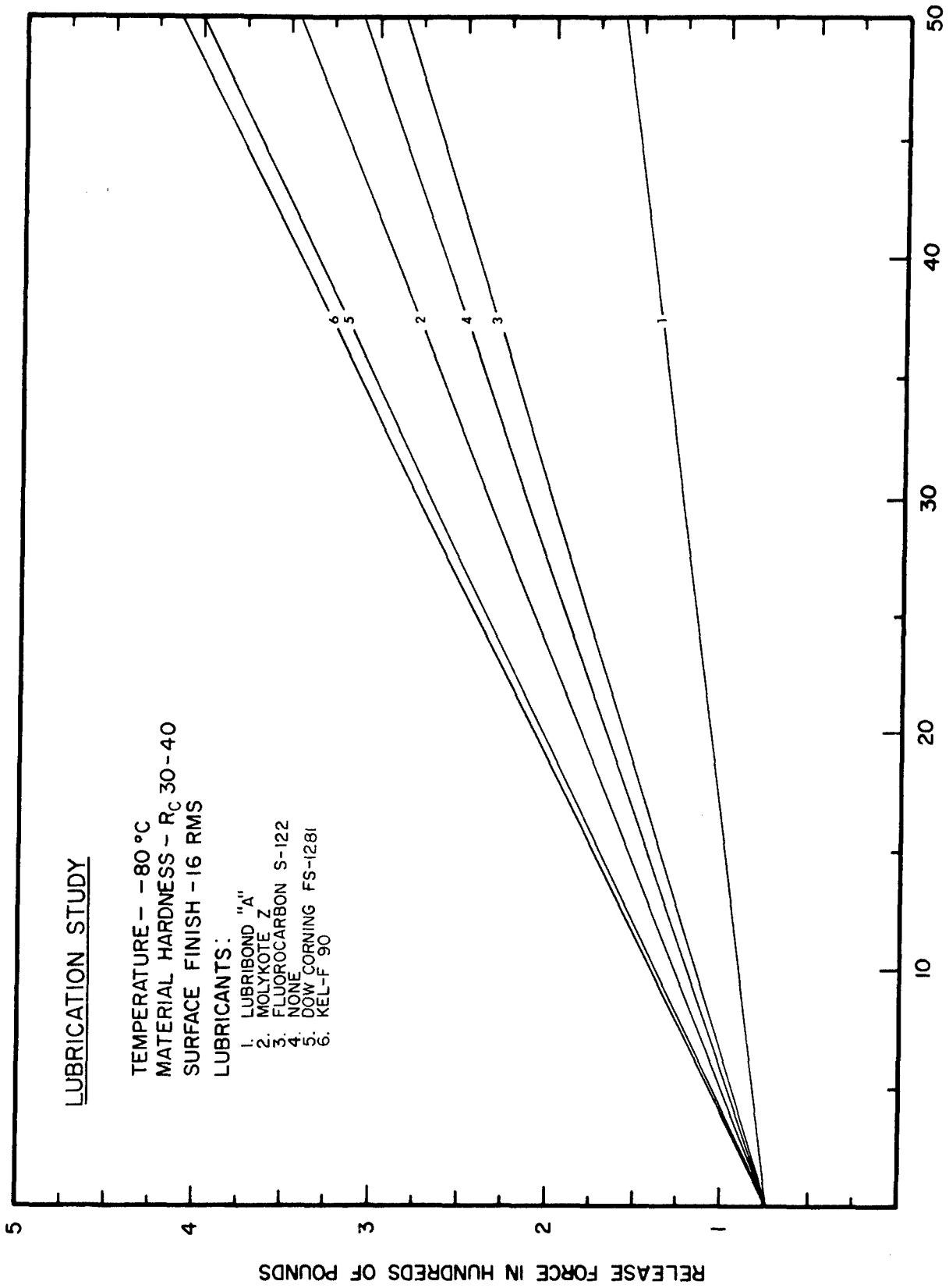

PRE-LOAD IN HUNDREDS OF POUNDS

FIGURE 22. COLLET-LOCK SURFACE CONDITION INVESTIGATION

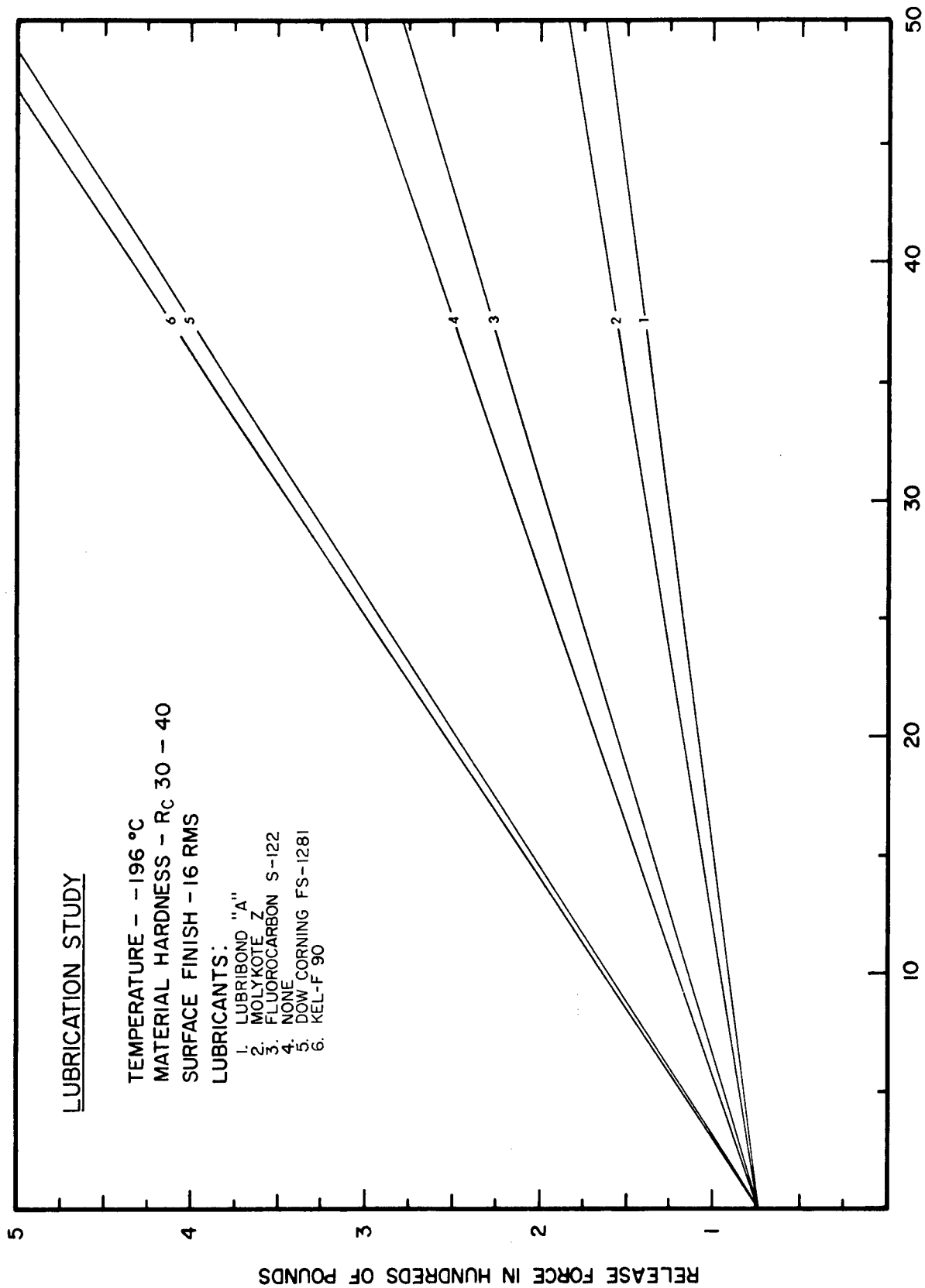
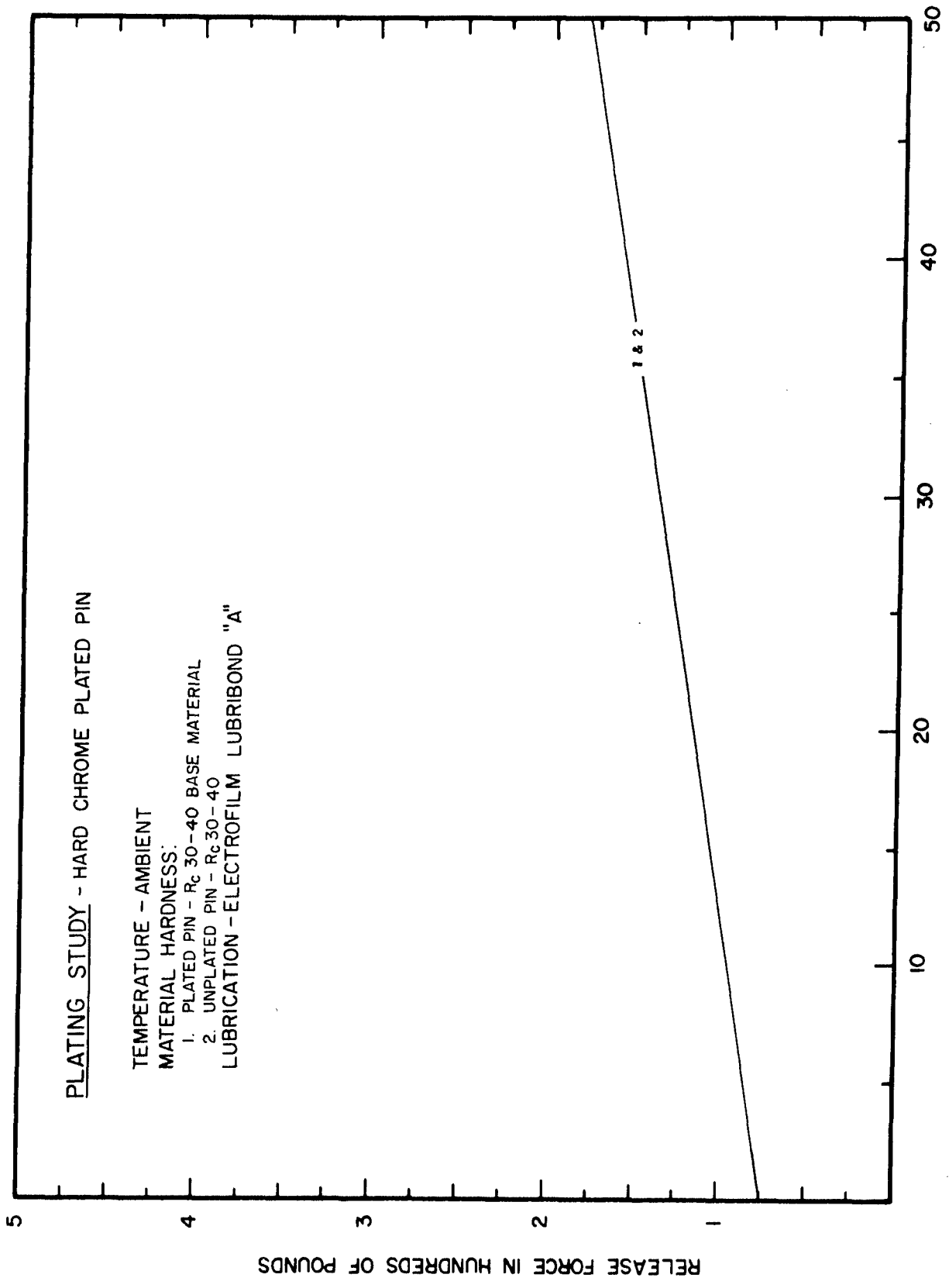

FIGURE 23. COLLET-LOCK SURFACE CONDITION INVESTIGATION



PRE-LOAD IN HUNDREDS OF POUNDS

FIGURE 24. COLLET-LOCK SURFACE CONDITION INVESTIGATION

PLATING STUDY - HARD CHROME PLATED PIN

TEMPERATURE - -80 °C

MATERIAL HARDNESS:

1. PLATED PIN - R_c 30 - 40 BASE MATERIAL
2. UNPLATED PIN - R_c 30 - 40

LUBRICATION:- ELECTROFILM LUBRIBOND "A"

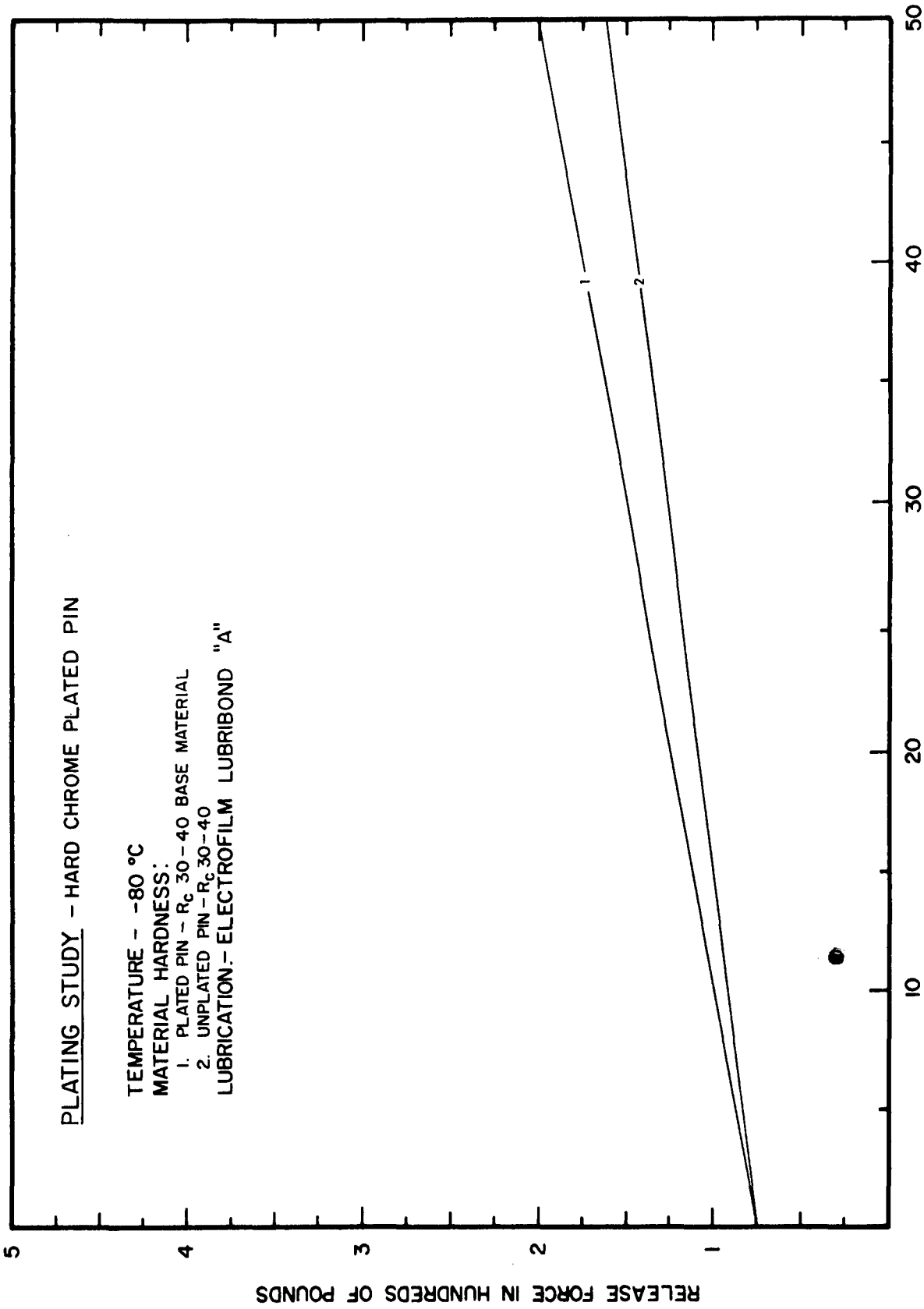

PRE-LOAD IN HUNDREDS OF POUNDS

FIGURE 25. COLLET-LOCK SURFACE CONDITION INVESTIGATION

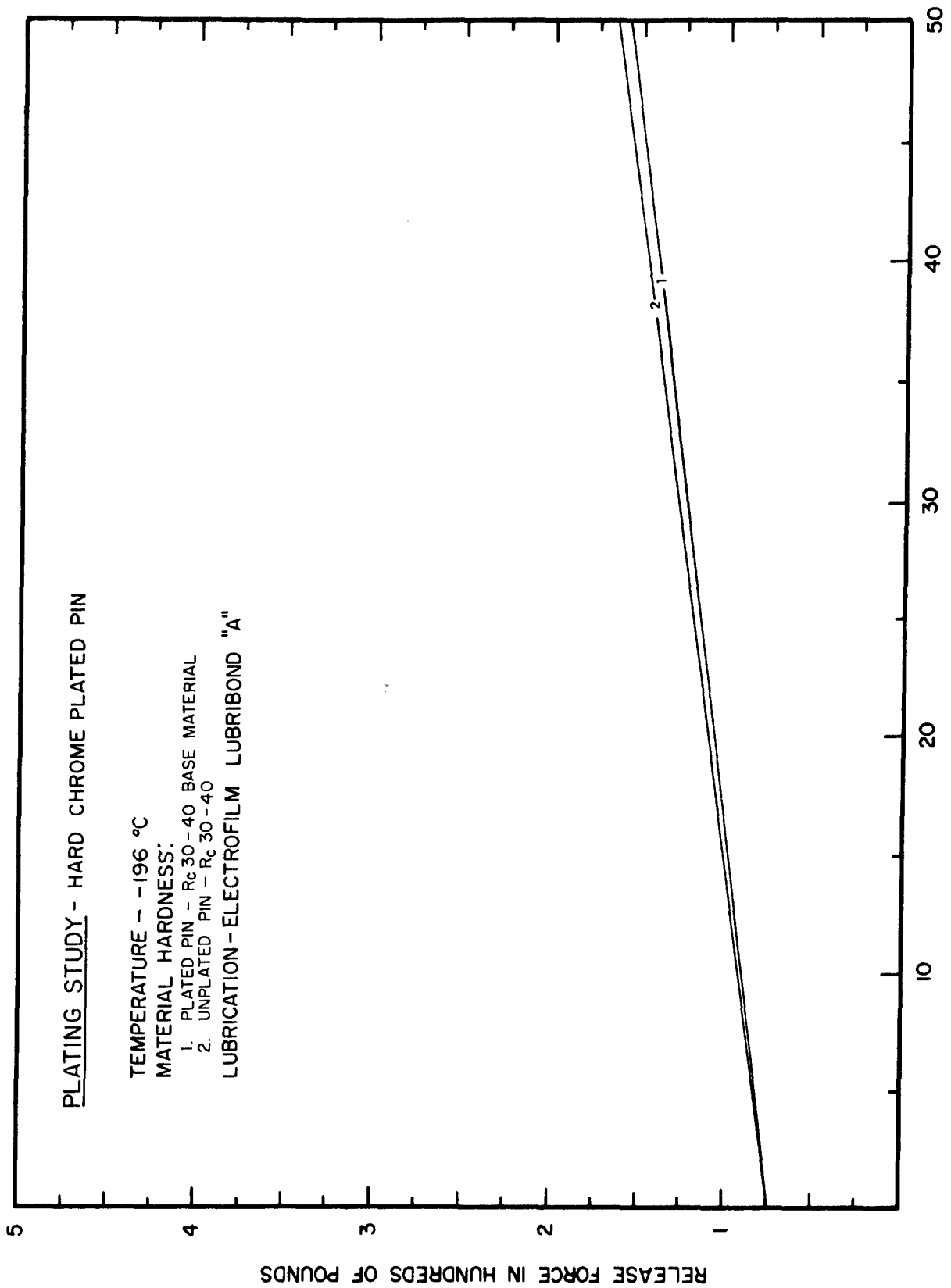

PRE-LOAD IN HUNDREDS OF POUNDS

FIGURE 26. COLLET-LOCK SURFACE CONDITION INVESTIGATION

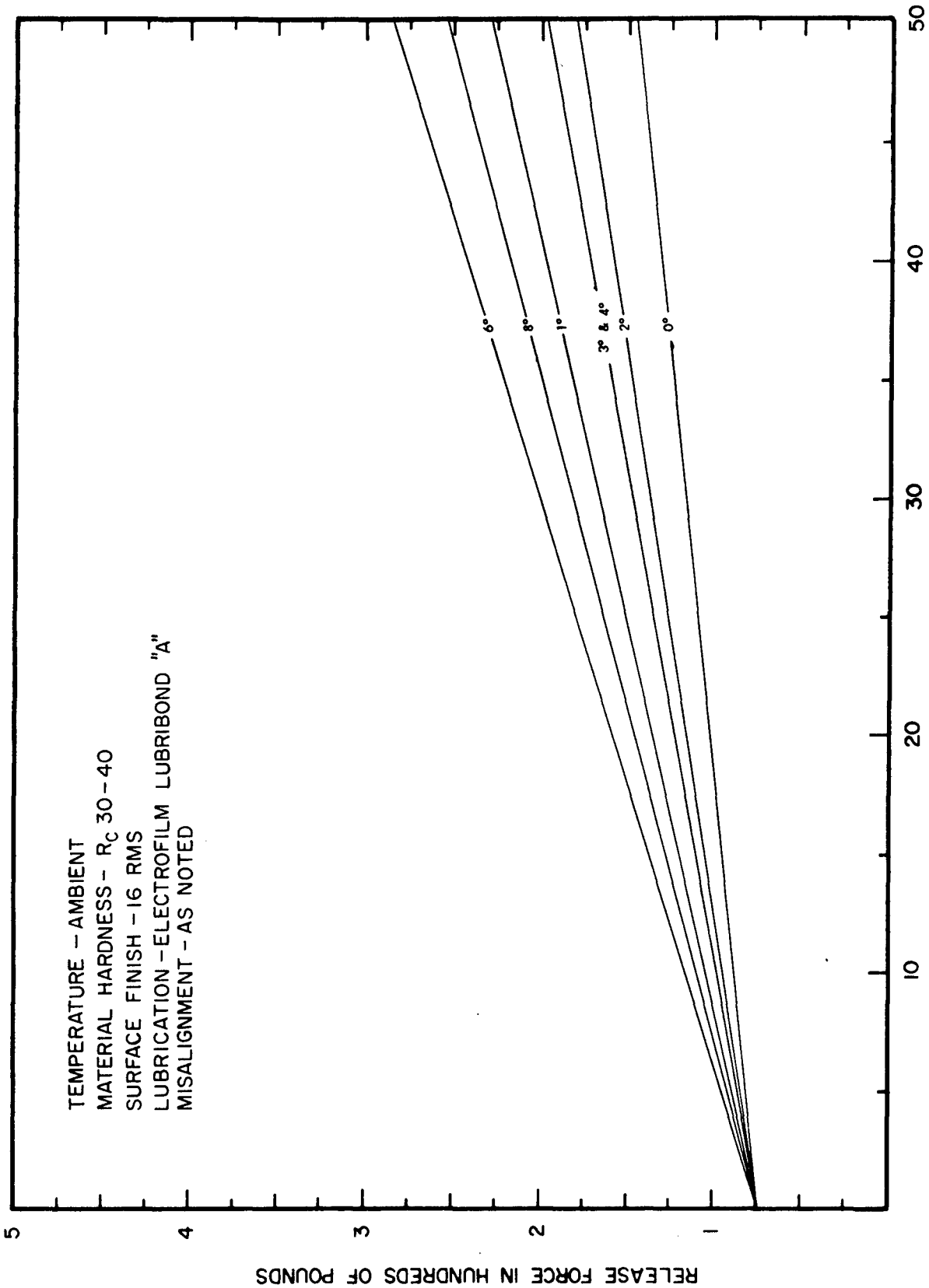

PRE-LOAD IN HUNDREDS OF POUNDS

FIGURE 27. COLLET-LOCK ALIGNMENT INVESTIGATION

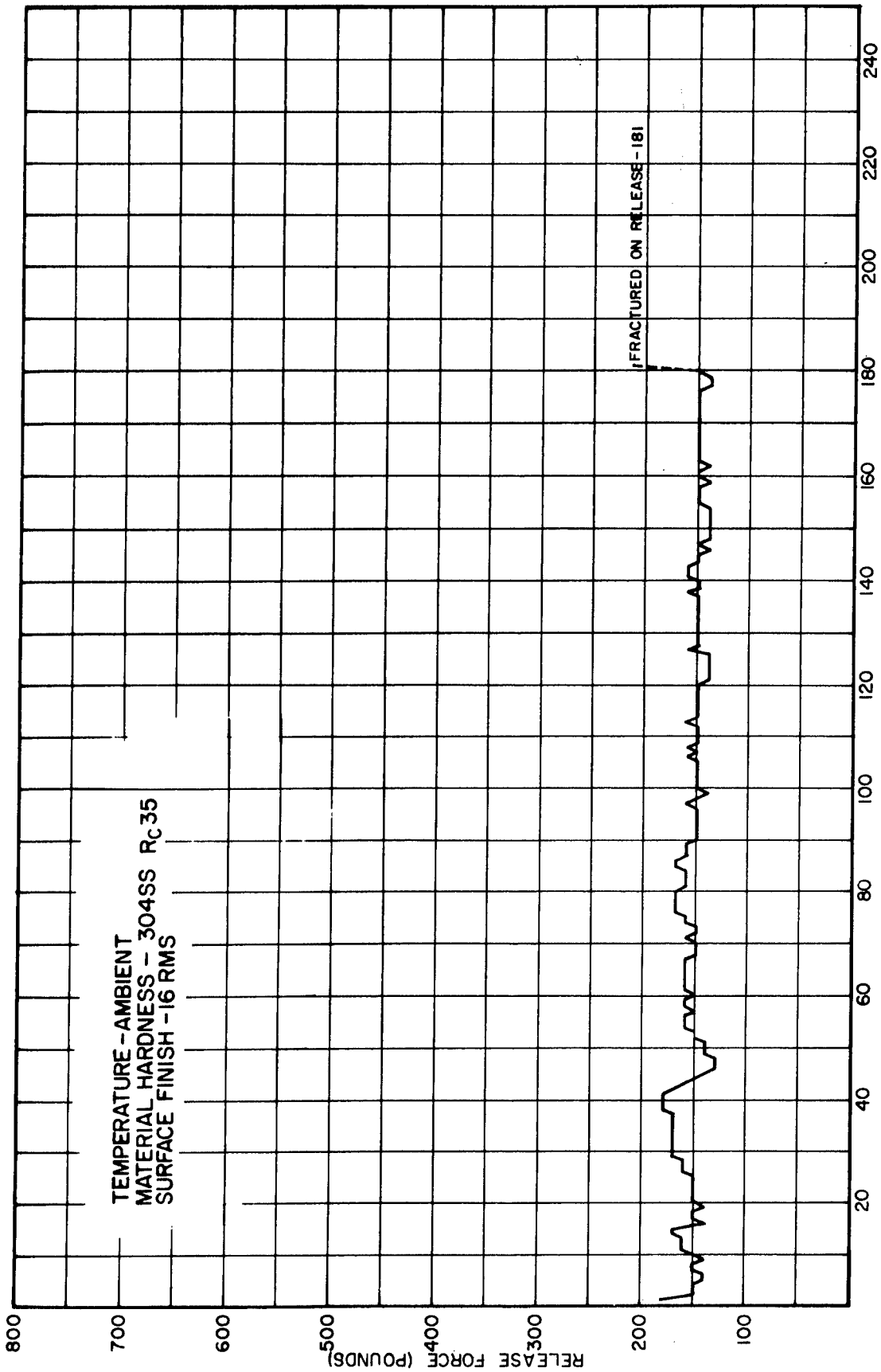

FIGURE 28. COLLET-LOCK LIFE CYCLE INVESTIGATION

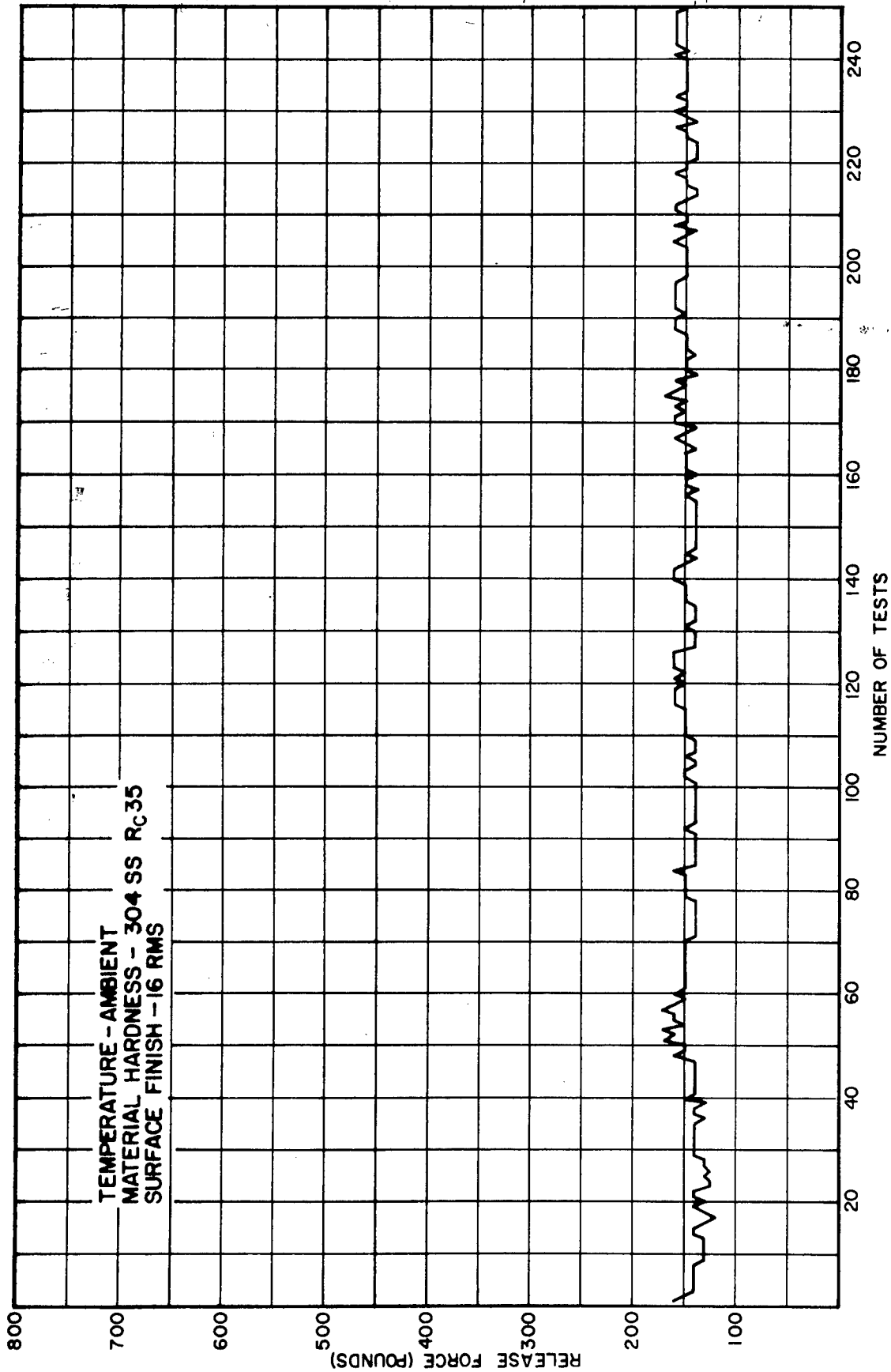

FIGURE 29. COLLET - LOCK LIFE CYCLE INVESTIGATION