

SHIP PRODUCTION COMMITTEE  
FACILITIES AND ENVIRONMENTAL EFFECTS  
SURFACE PREPARATION AND COATINGS  
DESIGN/PRODUCTION INTEGRATION  
HUMAN RESOURCE INNOVATION  
MARINE INDUSTRY STANDARDS  
WELDING  
INDUSTRIAL ENGINEERING  
EDUCATION AND TRAINING

September 1989  
NSRP 0310

# **THE NATIONAL SHIPBUILDING RESEARCH PROGRAM**

## **1989 Ship Production Symposium**

### **Paper No. 8: Flexible Standards: An Essential Innovation in Shipyards**

U.S. DEPARTMENT OF THE NAVY  
CARDEROCK DIVISION,  
NAVAL SURFACE WARFARE CENTER

# Report Documentation Page

*Form Approved*  
*OMB No. 0704-0188*

Public reporting burden for the collection of information is estimated to average 1 hour per response, including the time for reviewing instructions, searching existing data sources, gathering and maintaining the data needed, and completing and reviewing the collection of information. Send comments regarding this burden estimate or any other aspect of this collection of information, including suggestions for reducing this burden, to Washington Headquarters Services, Directorate for Information Operations and Reports, 1215 Jefferson Davis Highway, Suite 1204, Arlington VA 22202-4302. Respondents should be aware that notwithstanding any other provision of law, no person shall be subject to a penalty for failing to comply with a collection of information if it does not display a currently valid OMB control number.

1. REPORT DATE <b>SEP 1989</b>		2. REPORT TYPE		3. DATES COVERED <b>00-00-1989 to 00-00-1989</b>	
4. TITLE AND SUBTITLE <b>The National Shipbuilding Research Program. 1989 Ship Production Symposium, Paper No. 8: Flexible Standards: An Essential Innovation in Shipyards</b>				5a. CONTRACT NUMBER	
				5b. GRANT NUMBER	
				5c. PROGRAM ELEMENT NUMBER	
6. AUTHOR(S)				5d. PROJECT NUMBER	
				5e. TASK NUMBER	
				5f. WORK UNIT NUMBER	
7. PERFORMING ORGANIZATION NAME(S) AND ADDRESS(ES) <b>Naval Surface Warfare Center CD, Code 2230 -Design Integration Tower, 9500 MacArthur Blvd Bldg 192 Room 128, Bethesda, MD, 20817-5700</b>				8. PERFORMING ORGANIZATION REPORT NUMBER	
9. SPONSORING/MONITORING AGENCY NAME(S) AND ADDRESS(ES)				10. SPONSOR/MONITOR'S ACRONYM(S)	
				11. SPONSOR/MONITOR'S REPORT NUMBER(S)	
12. DISTRIBUTION/AVAILABILITY STATEMENT <b>Approved for public release; distribution unlimited</b>					
13. SUPPLEMENTARY NOTES					
14. ABSTRACT					
15. SUBJECT TERMS					
16. SECURITY CLASSIFICATION OF:			17. LIMITATION OF ABSTRACT	18. NUMBER OF PAGES <b>14</b>	19a. NAME OF RESPONSIBLE PERSON
a. REPORT <b>unclassified</b>	b. ABSTRACT <b>unclassified</b>	c. THIS PAGE <b>unclassified</b>			

## DISCLAIMER

These reports were prepared as an account of government-sponsored work. Neither the United States, nor the United States Navy, nor any person acting on behalf of the United States Navy (A) makes any warranty or representation, expressed or implied, with respect to the accuracy, completeness or usefulness of the information contained in this report/manual, or that the use of any information, apparatus, method, or process disclosed in this report may not infringe privately owned rights; or (B) assumes any liabilities with respect to the use of or for damages resulting from the use of any information, apparatus, method, or process disclosed in the report. As used in the above, "Persons acting on behalf of the United States Navy" includes any employee, contractor, or subcontractor to the contractor of the United States Navy to the extent that such employee, contractor, or subcontractor to the contractor prepares, handles, or distributes, or provides access to any information pursuant to his employment or contract or subcontract to the contractor with the United States Navy. ANY POSSIBLE IMPLIED WARRANTIES OF MERCHANTABILITY AND/OR FITNESS FOR PURPOSE ARE SPECIFICALLY DISCLAIMED.

# THE NATIONAL SHIPBUILDING RESEARCH PROGRAM 1989 SHIP PRODUCTION SYMPOSIUM

NSRP  
0310

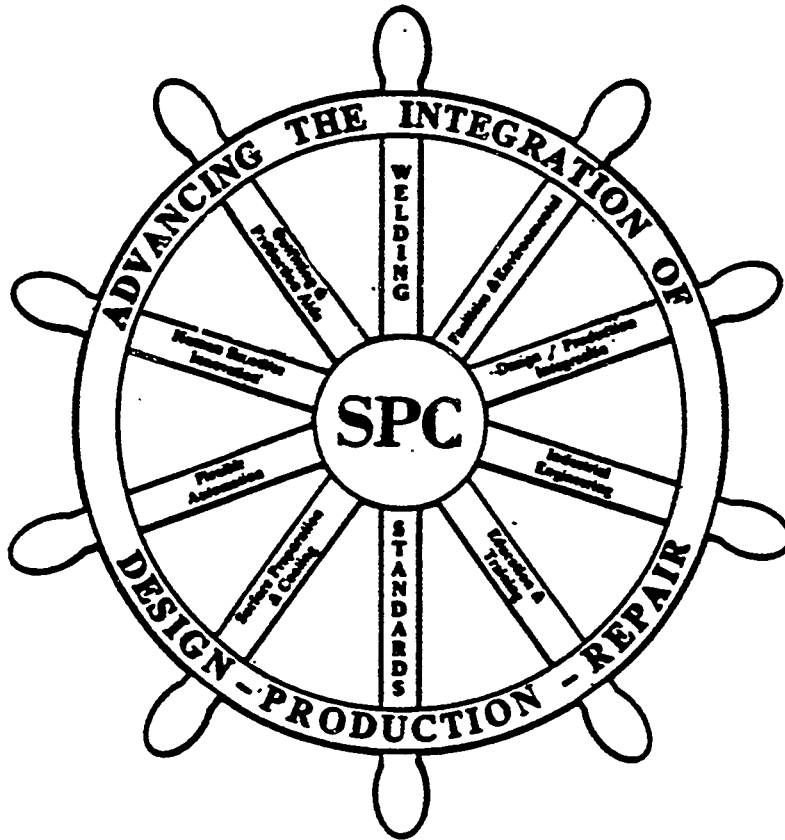

SEPTEMBER 13-15, 1989  
SHERATON NATIONAL  
Arlington, Virginia

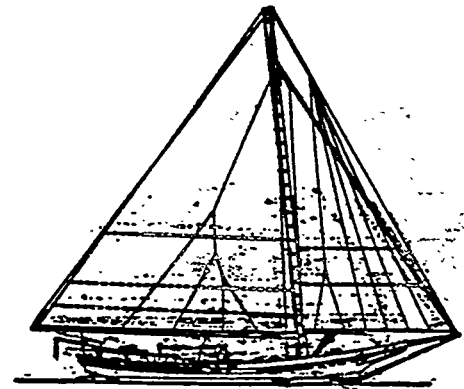

DIRECTED BY  
HOSTED BY

IN COOPERATION WITH  
THE CHESAPEAKE SECTION OF  
THE SOCIETY OF NAVAL ARCHITECTS AND MARINE ENGINEERS

SPONSORED BY THE SHIP PRODUCTION COMMITTEE  
AND HOSTED BY THE CHESAPEAKE SECTION OF  
THE SOCIETY OF NAVAL ARCHITECTS AND MARINE ENGINEERS



# Flexible Standards: An Essential Innovation in Shipyards

Louis D. Chirillo, Member,  
L.D. Chirillo Associates, Bellevue, WA

## ABSTRACT

Following a pattern established by Japan after World-War II, a number of other Asian countries are encouraging labor-intensive shipbuilding as means to develop their economies. For them, low-cost labor abounds. As a consequence, established shipbuilders elsewhere in the world market cannot be competitive for ordinary ships including multiple such ships of the same type. Their only alternative is to develop an organization that routinely ferrets out and solves new problems arising from custom-designed ships and different products other than ships, regardless of quantities, i.e., flexible-system production.

An indispensable feature of effective flexible-system production is a file of standards which can be adapted to changing requirements, including requirements for modernizing naval ships, while at the same time permitting reapplication of significant corporate experience. This paper addresses such flexible standards and their significance.

## INTRODUCTION

Where the word "standard" is mentioned in the presence of traditional shipyard managers, they immediately fantasize about a material paradise. Regardless of manufacturing sources, all valves of the same type and nominal size would be geometrically identical, pumps for a specific service of a particular capacity would have the same foundation interfaces and the same nozzle locations, and so on. For the purpose of completing their dream, they envision standardized work methods to match a marketplace in which only their designs for runs of standard-series ships would be in demand. That's Tara. If it ever existed, it's gone with the wind.

Some traditionalists compound their self-celusion with the expressed intent to continue to build, convert, and overhaul just ships. This narrow focus, actually a rigid standardization of

corporate purpose, has caused shipyards to close or go into bankruptcy. Years ago one such firm turned away from an opportunity to focus on development of its construction process and to direct it wherever markets dictated. More recently, a manager in a private shipyard which has just Navy work, addressed the need to diversify by saying, "The door is always open." That inadequate response infers continued dependence on just the Navy and no intent to market elsewhere.

Despite profound changes in our economic world, by the 1973 Oil Shock and already by the growing influence of glasnost, traditionalists on both sides of the disintegrating iron curtain continue to associate security with stability. For free nations, security is inherent in flexibility, i.e., the abilities of industry managers to quickly shift from making plowshares to swords. For modern industrialists, security is also inherent in flexibility, i.e., regardless of what is being produced, constantly developing their manufacturing systems. No one has made this solution clearer and provided better pertinent definitions than Robert B. Reich in a paper appropriately titled "The Next American Frontier":

"Flexible-system production is rooted in discovering and solving new problems; high volume, standardized production basically involves routinizing the solutions to old problems. Flexible system production requires an organization designed for change and adaptability; high volume, standardized production requires an organization geared to **stability.**" [1]

Flexibility in this context does not mean the absence of standardization. But, the word "standard" in flexible system production is dynamic; it means more than the usual dictionary definition, "something established by authority, custom or general consent." In

modern industrial systems the word "standard" must be thought of, paradoxically, as something subject to continuous change. The word should be used as if it was set off in quotation marks because what is meant is a standard of the moment. As soon as something better is detected, a new or revised standard is adopted!

For most matters for which standards are useful, there is no time for achieving general agreement. A modern manufacturing system features unrelenting analyses which constantly identify even minute improvements. Authority, custom or general consent applies to acceptance of the system for constant improvement and not to the improvements per se. The latter are automatically incorporated in the forever changing standards.

### **FLEXIBLE MATERIAL STANDARDS**

Traditionalists are right when they first think of material when standards are mentioned. But the need for material standardization transcends traditional concerns. Materials are tangible and thus comprise the soundest basis for production control. The most effective shipbuilders equate material volume to work volume. Using statistical methods they have, for work package after work package of the same problem category, identified some physical characteristic of material that varies directly with man-hours. Thus, as designers define and refine material requirements, a solid basis emerges for estimating required production man-hours. Moreover, the man-hours are expressed statistically, i.e., for each category of work, with a mean value and standard deviations so as to reflect real-world variation.

As long as the distribution of the variations approximates a normal curve, man-hour allocations and scheduling are based on the premise that jobs will probably go over or under in accordance with a prescribed variation pattern. But, the operational words in the foregoing paragraph are "same problem category", an aspect of group technology. Thus, if a drain pump of a specific type was included in an outfitting work package, it would not matter if a drain pump of a different type was substituted provided it had equivalent capacity and provided the problems inherent in associated work remain unchanged. The pumps' foundation interfaces as well as suction and discharge piping could differ significantly without changing the work classification.

Having appreciation of the foregoing, the most effective shipbuilders have over the years built computer files of so-called standards. In one case, the files are based on as many as four stan-

dard machinery arrangements which anticipate four different main-engine types. For each auxiliary-machine position in an arrangement two or three different vendors' catalog items are certified as shipyard standards. The items are functionally equivalent but physically different. Moreover, the auxiliary-machinery market is constantly monitored. When better buys are discovered, based on evaluations of the effects on required shipyard man-hours as well as on price, new vendor catalog items displace old ones in the files.

For the purpose of declaring vendors' equipments as shipyard standards, preference is given to those vendors who each produce machines of the same basic design for a range of capacities. Thus, each standard machinery arrangement for a particular main-engine type can expand or contract with engine horsepower. As any of two or more vendors' equipments can be employed for each auxiliary-machine position without impact on the normal performance of work, What could be more flexible and at the same time practical?

When during contract negotiations the customer agrees on the selection of one of the four main-engine engine types and usage of the flexible material standards, the shipyard simultaneously knows all auxiliary-machinery requirements as well as requirements for large valves, strainers, etc. which are treated the same way. Upon contract award or very soon thereafter, the definition is narrowed down to two, or some other reasonable number of vendors' products for each requirement.

Limiting prospective bidders to reasonable numbers makes it practical to maintain critically-needed material histories and material codes in a shipyards computer file. In some shipyards this includes design details, approval records, price and delivery histories vendors' prior agreements with procurement terms and conditions, and vendors' guarantee performances. Thus, in the moment of action sparked by contract signing, for each requirement only two steps remain for a procurement decision-issuing requests for bids which asks only for price and delivery, and evaluating a limited number of vendor responses. Three responses, perhaps one or two more for certain equipments, are judged to be optimum for balancing need for competition against a yard's capacity to maintain required material information in a computer file.

Instead of investigating, some managers quickly respond, "Neat! But, we can't use such standards. We're building warships; the government would not permit us to limit the list of bidders. One shipbuilder who so responded took a

second look, initiated a survey, and discovered that there were over a thousand material items in three different warships for which specifications were separately written and for which only one supplier responded with the same product. How many thousands more are there for which there are only two or three suppliers? Thus defacto standardization exists and few, if any, exploit it. The most significant problem for some of those items is not how to limit the bidders list. Instead, it is one of creating a second or third source, something the U.S. Navy's office of Competition Advocate General has been doing on a much larger scale.

The former Competition Advocate General, Rear Admiral Stuart F. Platt, U.S. Navy (Retired) recently offered pertinent advice:

"Getting up to date on computerized information systems is the greatest single barrier to continued gains in efficiency in the procurement process. The fact that we still rely to a large degree on a paper-based procurement system is ludicrous. Internal automation is the most attractive automation opportunity we have here. It will begin paying off almost immediately, in reduced overhead, faster and better decision making, and higher quality goods and services."

Elsewhere in the same article Admiral Platt advised:

"There are no fast fixes. Improvements will best be made from a disciplined inspection of the system's fundamentals. Common sense calls for a procurement process that is prompt, equitable, and administered with a firm hand that allows room for good judgement." [2]

Thus, U.S. shipyard managers including those in naval shipyards, should investigate how their material management systems support their operations. They would find that they have justification to change how government procurement regulations are being implemented. Traditional material managers should be pressed to identify and test the specific procurement regulations that are believed to inhibit productivity in the work place. If they are proven barriers to implementing flexible standards as thus far described, managers should be unrelenting in their pursuit of pertinent regulation changes. Nothing can facilitate promptness more than flexible material standards.

Good judgement dictates that equitability should not apply only to Suppliers. A vendor's sales practices, credibility and after-delivery services

usually impact more on a yard's productivity than the vendor's price. Thus, equitability should be interpreted as meaning benefit for all, i.e., designers, buyers, suppliers and production workers through manifest increases in productivity and quality. It is for this reason that Dr. W. Edwards Deming insists that U.S. industry must learn to deal with fewer suppliers for productivity reasons! It is for the same reason that in the most effective shipyard in Japan, the purchasing department reports to the production control manager. There, material, man-hour allocations and scheduling are inextricably linked. The linkage is the substance of corporate experience which becomes ineffective when too many suppliers are involved. The linkage is applied in a more profound way than can be surmised from just understanding flexible material standards.

#### FLEXIBLE STANDARD ARRANGEMENTS AND DETAILS

Eleven-years ago, Mr. Y. Ichinose presented a paper which disclosed how standards, including flexible standards, were organized and employed by Ishikawajima-Harima Heavy Industries Co., Ltd. (IHI) of Japan. This insightful paper advised:

"It is obvious that a comprehensive computerized design system, consistent from design through production, could not be effectively realized without standards or modules."

Conversely the paper also advised:

"Standards and modules show their greatest advantage when integrated with a comprehensive computer system."

Mr. Ichinose, then president of IHI Marine Technology, Inc., concluded:

"In the 80s it is hoped that the...demand for new ship construction will increase. Although the major demands may still concentrate on conventional ship designs, it is foreseeable that modern technology and sophistication in Ship design may require more complexity in various ship's systems. This complexity can still be solved by refining the standards and modules to cope with the state of the art of the future era, so we remain convinced that shipbuilding can be changed to a mass-production industry without losing the ability to provide sufficient 'tailor made' features to satisfy the individual demands of ship owners." [3]

In the context of Mr. Ichinose's fore-

---

[1] Reich, Robert B., "The Next American Frontier," The Atlantic Monthly, March 1983.

[2] Platt, Stuart F., "Busting the Navy 'Trusts'" U.S. Naval Institute Proceedings, May 1989, pp. 120-125.

[3] Ichinose, Yoshinobu, "Improving Shipyard Production with Standard Components and Modules," Proceedings SNAME Spring Meeting/STAR Symposium, April 26-29, 1978; Paper No. 10.

[4] Sasaki, H., "IHI's Experience of Technical Transfer and Some Considerations on Further Productivity Improvement in U.S. Shipyards," National Shipbuilding Research Program Ship Production Symposium, August 26-28, 1987; Paper No. 2.

[5] The Society of Naval Architects of Japan recorded in its 1967 English-language annual report of shipbuilding developments that, "Statistical control 'epoch makingly' improved quality, laid the foundation of modern ship construction methods and made it possible to extensively develop automated and specialized welding." There is urgent need to repeat this statement until the last traditionalist succumbs.

[6] "Japanese shipbuilding Quality Standard (Hull Part)" periodically updated and published by the Research Committee on Steel Shipbuilding, The Society of Naval Architects of Japan.

[7] The Commission on Merchant Marine and Defense, Third Report of the Commission on Merchant Marine and Defense: Armendices, U.S. Government Printing Office, September 30, 1988, p. 214.



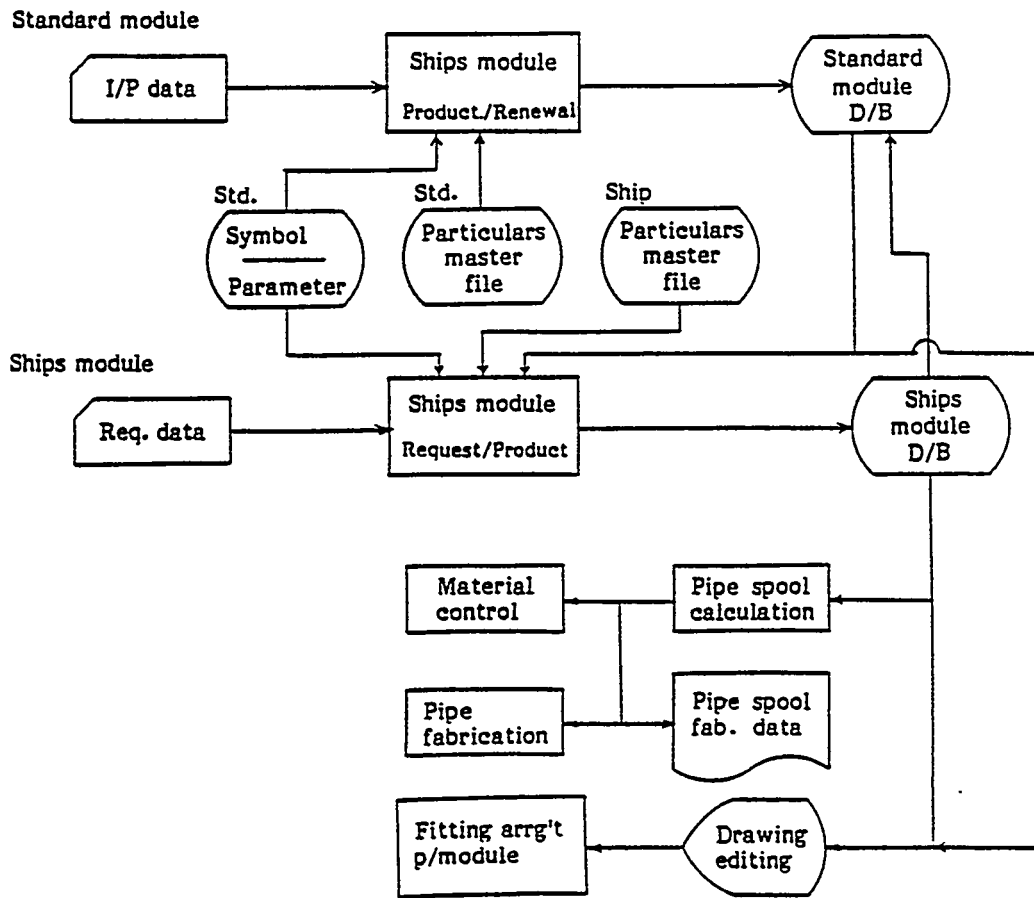
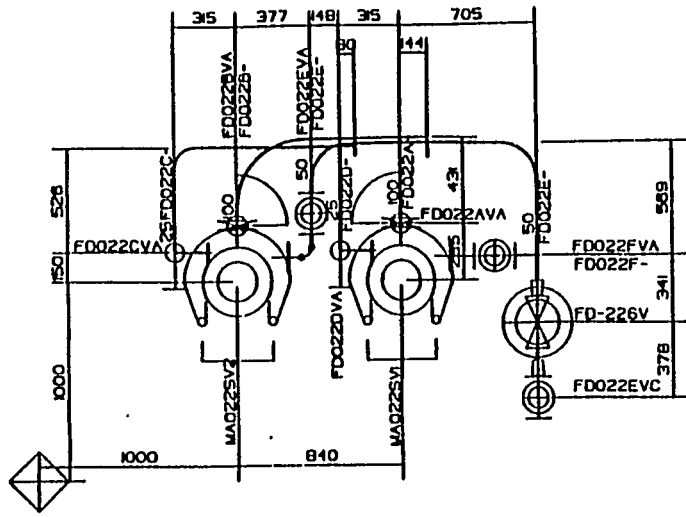
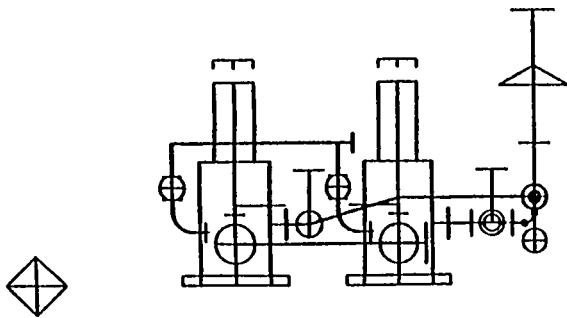

FIGURE 1: FRESCO-F Process Flow



WPL100



WSR100

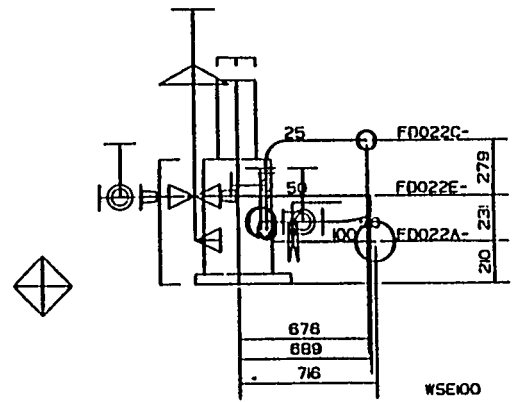

WSE100

FIGURE 2: Condensate Pump Unit

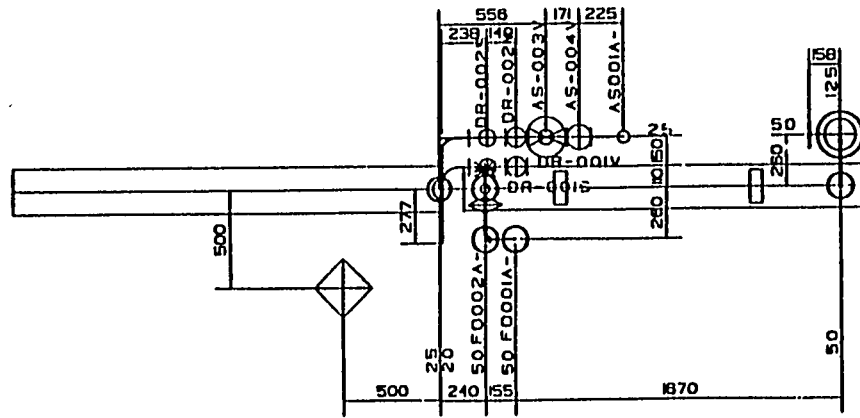
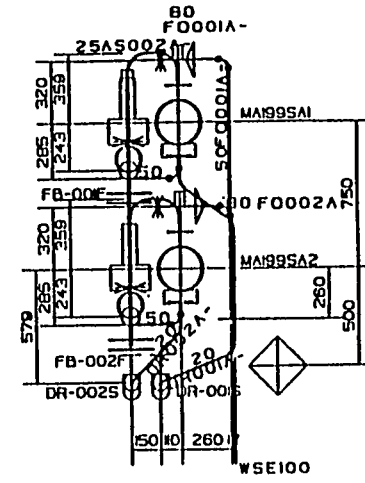
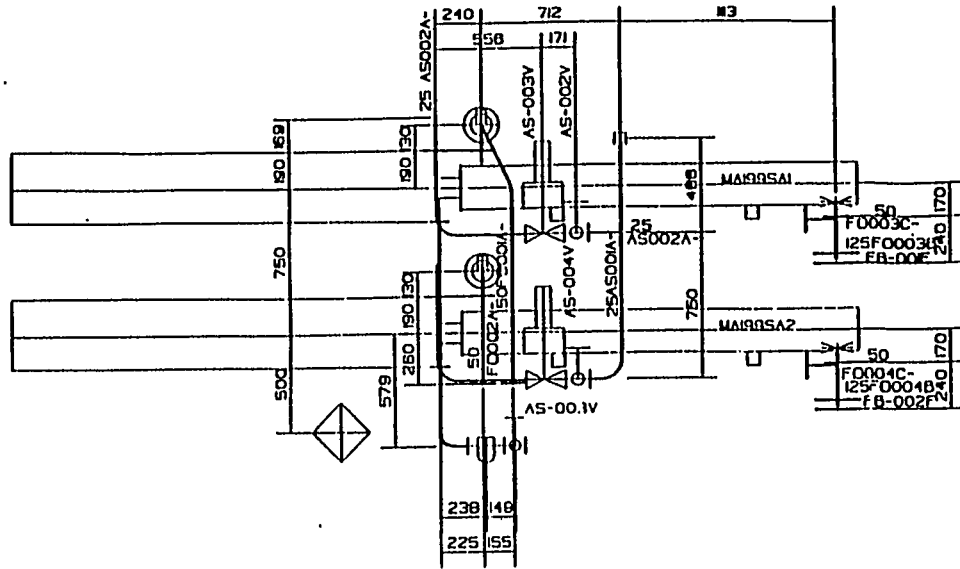

FIGURE 3: Purifier H.F.O. Heater Unit



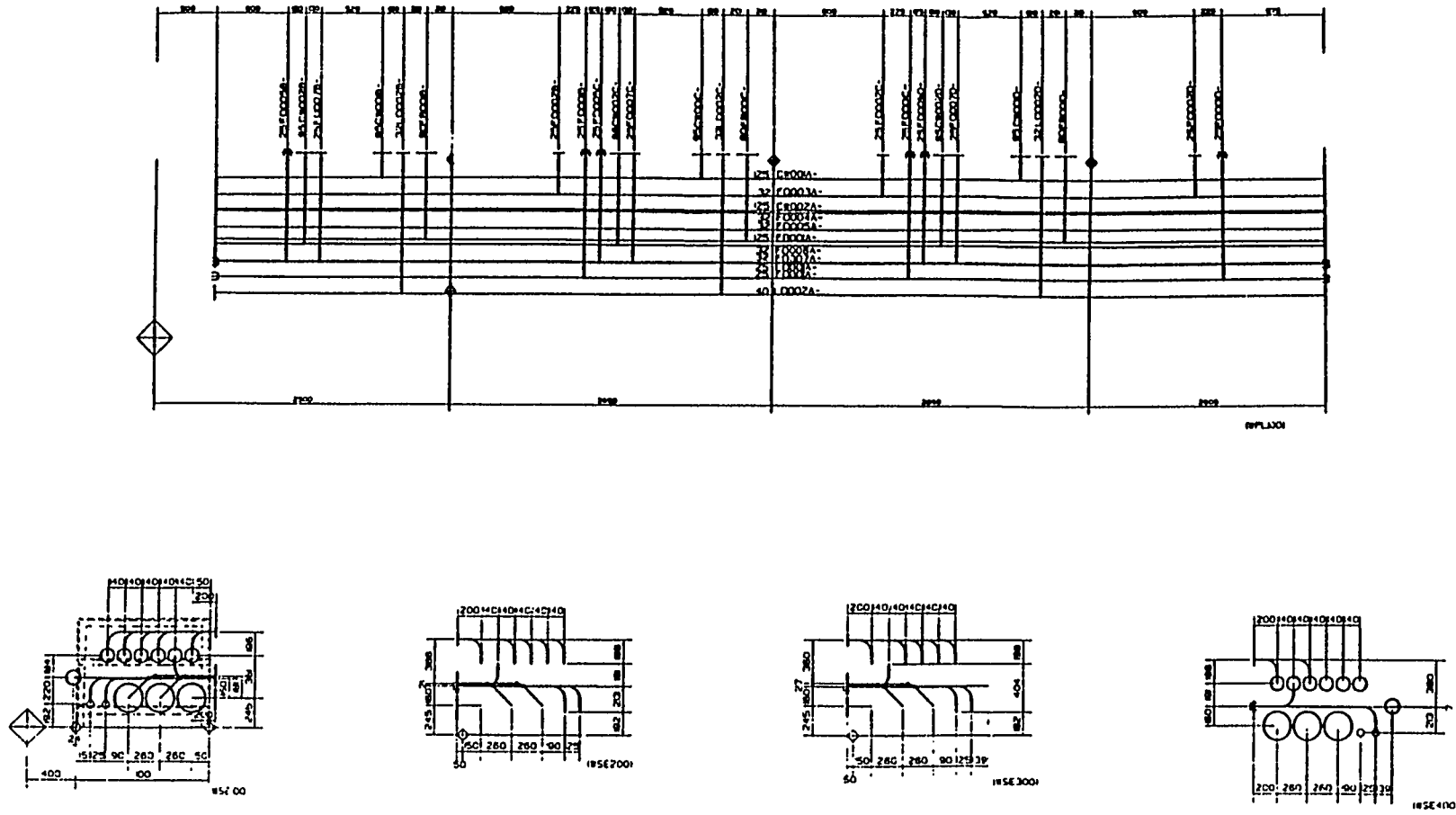

FIGURE 5: Lower E.R. Flat Unit (near D.G.)

TABLE 1: Typical Performance Indicators (circa 1983-1984)

Hull Construction:

$$\text{Steel Yield Rate} = \frac{\text{Net Weight}}{\text{Invoice Weight}} \times 100 = > 93\%$$

Pipe Fitting:

Man-Hours/Ton	Fabrication	27.5 mh/t
" " "	Installation	40.0 mh/t
Man-Hours/Piece	Fabrication	1.6 mh/pc
" " "	Installation	2.3 mh/pc

$$\text{Pipe Piece Refab Rate} = \frac{\text{Refabrication Number}}{\text{Total Number Fabricated}} \times 100 = < 2\%$$

Electrical:

Man-Hours/Meter for Total Cable Length 0.18 mh/m

Painting:

Man-Hours/Square Meter	Zone 1	0.10 mh/m <sup>2</sup>
" " " "	" 2	0.12 "
" " " "	" 3	0.10 "
" " " "	Total	0.11 "

Material Marshaling

$$\text{Pallet Completion} = \frac{\text{Lost Line Items}}{\text{Total Line Items}} \times 100 = < 1.8\%$$

TABLE 2: Principal Dimensions of Three FFG-7 Class Frigates

Differences from Design Principal Dimensions (in inches)

Deviations Beyond Allowed Tolerances (in inches)

	Shipyard X	Shipyard Y	Shipyard Z
Length overall	-13 <sup>1</sup> / <sub>4</sub>	-6 <sup>1</sup> / <sub>4</sub>	-7 <sup>1</sup> / <sub>8</sub>
Length between perpendiculars	-3 <sup>1</sup> / <sub>8</sub>	-3 <sup>1</sup> / <sub>4</sub>	-1 <sup>1</sup> / <sub>8</sub>
Beam (midship, main deck)	-1 <sup>1</sup> / <sub>2</sub>	-2 <sup>1</sup> / <sub>4</sub>	-1 <sup>1</sup> / <sub>2</sub>
Beam (midship, design waterline)	-2 <sup>7</sup> / <sub>8</sub>	-4 <sup>1</sup> / <sub>4</sub>	-1 <sup>1</sup> / <sub>8</sub>
Depth (midship, main deck)	-1 <sup>1</sup> / <sub>8</sub>	+2	-1 <sup>1</sup> / <sub>8</sub>

	Shipyard X	Shipyard Y	Shipyard Z
Length overall	-8 <sup>3</sup> / <sub>4</sub>	-1 <sup>3</sup> / <sub>4</sub>	-2 <sup>3</sup> / <sub>8</sub>
Length between perpendiculars	accept.	accept.	accept.
Beam (midship, main deck)	-1 <sup>1</sup> / <sub>2</sub>	-1 <sup>3</sup> / <sub>8</sub>	accept.
Beam (midship, design waterline)	-1 <sup>7</sup> / <sub>8</sub>	-3 <sup>1</sup> / <sub>4</sub>	-1 <sup>1</sup> / <sub>8</sub>
Depth (midship, main deck)	-1 <sup>1</sup> / <sub>8</sub>	+1	-1 <sup>1</sup> / <sub>8</sub>

Additional copies of this report can be obtained from the  
National Shipbuilding Research and Documentation Center:

**<http://www.nsnet.com/docctr/>**

Documentation Center  
The University of Michigan  
Transportation Research Institute  
Marine Systems Division  
2901 Baxter Road  
Ann Arbor, MI 48109-2150

Phone: 734-763-2465  
Fax: 734-763-4862  
E-mail: [Doc.Center@umich.edu](mailto:Doc.Center@umich.edu)