

**SHORT COURSE  
O N  
IMPLEMENTATION  
OF ZONE TECHNOLOGY  
IN THE REPAIR AND  
OVERHAUL  
ENVIRONMENT**

**COURSE NOTES**

[VERSION 4/96]

A TRAINING INITIATIVE  
OF  
THE UNIVERSITY OF MICHIGAN  
FOR  
THE NATIONAL SHIPBUILDING RESEARCH PROGRAM

# Report Documentation Page

Form Approved  
OMB No. 0704-0188

Public reporting burden for the collection of information is estimated to average 1 hour per response, including the time for reviewing instructions, searching existing data sources, gathering and maintaining the data needed, and completing and reviewing the collection of information. Send comments regarding this burden estimate or any other aspect of this collection of information, including suggestions for reducing this burden, to Washington Headquarters Services, Directorate for Information Operations and Reports, 1215 Jefferson Davis Highway, Suite 1204, Arlington VA 22202-4302. Respondents should be aware that notwithstanding any other provision of law, no person shall be subject to a penalty for failing to comply with a collection of information if it does not display a currently valid OMB control number.

1. REPORT DATE <b>1996</b>		2. REPORT TYPE <b>N/A</b>		3. DATES COVERED <b>-</b>	
4. TITLE AND SUBTITLE <b>Short Course on Implementation of Zone Technology in the Repair and Overhaul Environment</b>				5a. CONTRACT NUMBER	
				5b. GRANT NUMBER	
				5c. PROGRAM ELEMENT NUMBER	
6. AUTHOR(S)				5d. PROJECT NUMBER	
				5e. TASK NUMBER	
				5f. WORK UNIT NUMBER	
7. PERFORMING ORGANIZATION NAME(S) AND ADDRESS(ES) <b>Naval Surface Warfare Center CD Code 2230-Design Integration Tower Bldg 192, Room 128 9500 MacArthur Blvd Bethesda, MD 20817-5700</b>				8. PERFORMING ORGANIZATION REPORT NUMBER	
9. SPONSORING/MONITORING AGENCY NAME(S) AND ADDRESS(ES)				10. SPONSOR/MONITOR'S ACRONYM(S)	
				11. SPONSOR/MONITOR'S REPORT NUMBER(S)	
12. DISTRIBUTION/AVAILABILITY STATEMENT <b>Approved for public release, distribution unlimited</b>					
13. SUPPLEMENTARY NOTES					
14. ABSTRACT					
15. SUBJECT TERMS					
16. SECURITY CLASSIFICATION OF:			17. LIMITATION OF ABSTRACT <b>SAR</b>	18. NUMBER OF PAGES <b>393</b>	19a. NAME OF RESPONSIBLE PERSON
a. REPORT <b>unclassified</b>	b. ABSTRACT <b>unclassified</b>	c. THIS PAGE <b>unclassified</b>			

NATIONAL SHIPBUILDING RESEARCH PROGRAM

THREE DAY SHORT COURSE  
ON  
IMPLEMENTATION OF ZONE TECHNOLOGY IN THE REPAIR  
AND OVERHAUL ENVIRONMENT

COURSE BOOK CONTENTS

AGENDA

SHIP REPAIR AND OVERHAUL REVIEW

WHAT IS ZONE TECHNOLOGY?

ZONE TECHNOLOGY BENEFITS

IS ZONE TECHNOLOGY APPLICABLE TO SHIP REPAIR AND OVERHAUL?

PRODUCTIVITY EXERCISE

CASE STUDY 1

ORGANIZATION FOR ZONE TECHNOLOGY

DESIGN FOR SHIP REPAIR AND OVERHAUL ZONE TECHNOLOGY

PLANNING AND SCHEDULING FOR SHIP REPAIR AND OVERHAUL ZONE  
TECHNOLOGY

SCHEDULING EXERCISE

PRODUCTION AND MATERIAL CONTROL FOR SHIP REPAIR AND OVERHAUL ZONE  
TECHNOLOGY

CASE STUDY 2

CASE STUDY 3

CASE STUDY 4

ATTENDEE FORMS

# AGENDA - FIRST DAY

## MORNING

- |                 |                                 |
|-----------------|---------------------------------|
| 8.00- 8.30AM    | INTRODUCTIONS                   |
| 8.30 - 9.30AM   | SHIP REPAIR AND OVERHAUL REVIEW |
| 9.30 - 9.45AM   | BREAK                           |
| 9.45 - 10.30AM  | WHAT IS ZONE TECHNOLOGY         |
| 10.30 - 11.30AM | ZONE TECHNOLOGY BENEFITS        |
| 11.30 - 12.30PM | LUNCH                           |

## AFTERNOON

- |                |   |
|----------------|---|
| 12.30 - 1.30PM | IS ZONE TECHNOLOGY APPLICABLE TO SHIP PAIR AND OVERHAUL |
| 1.30 - 2.00PM  | PRODUCTIVITY EXERCISE                                   |
| 2.00 - 2.15PM  | BREAK   |
| 2.15 - 3.30PM  | CASE STUDY 1  |

# AGENDA' - SECOND DAY

## MORNING

- |                  |  |
|------------------|--|
| 8.00 - 8.30AM    | FIRST DAY REVIEW   |
| 8.30 - 9.30AM    | ORGANIZATION FOR ZONE TECHNOLOGY                                     |
| 9.30 - 9.45AM    | B R E A K  |
| 9.45 - 10.30AM   | DESIGN FOR SHIP REPAIR AND OVERHAUL ZONE TECHNOLOGY                  |
| 10.30 - 11.30 AM | PLANNING AND SCHEDULING FOR SHIP REPAIR AND OVERHAUL ZONE TECHNOLOGY |
| 11.30 - 12.30PM  | LUNCH  |

## AFTERNOON

- |                |   |
|----------------|---|
| 12.30 - 1.00PM | SCHEDULING EXERCISE   |
| 1.00 - 2.00    | PRODUCTION AND MATERIAL CONTROL FOR SHIP REPAIR AND OVERHAUL ZONE TECNOLOGY |
| 2.00 - 2.15PM  | BREAK   |
| 2.15 - 3.30PM  | CASE STUDY 2  |

# AGENDA - THIRD DAY

## MORNING

- |                 |                     |
|-----------------|---------------------|
| 8.00 - 8.30AM   | SECOND DAY REVIEW   |
| 8.30 - 9.45AM   | CASE STUDY 3        |
| 9.45 -10.00AM   | BREAK               |
| 10.00 - 11.15AM | CASE STUDY 4        |
| 11.15 - 11.30AM | SUMMARY AND WRAP-UP |

**PLEASE TAKE TIME TO COMPLETE THE  
COURSE EVALUATION FORM IN THE BACK OF  
YOUR COURSE BOOK**

NATIONAL SHIPBUILDING RESEARCH PROGRAM

**SHIP REPAIR  
AND  
OVERHAUL  
REVIEW**

IMPLEMENTATION OF ZONE TECHNOLOGY IN REPAIR & OVERHAUL ENVIRONMENT

## **U.S. SHIP REPAIR AND OVERHAUL**

- . THE REDUCTION IN SIZE OF U.S. FLEET AND DIMINISHING NAVAL WORK, AND THE ENTRY OF SOME SHIPBUILDERS INTO REPAIR, HAS FORCED U.S. SHIP REPAIRERS TO SEEK INTERNATIONAL BUSINESS.**
- . FOR A WHILE THE FOREIGN EXCHANGE RATE WAS FAVORABLE TO THIS EFFORT WITH U.S. PRICES LESS THAN FOREIGN, BUT RECENT IMPROVEMENT IN THE FOREIGN EXCHANGE RATE WILL MAKE IT MORE DIFFICULT**
- . THERE ARE CURRENTLY OVER 200 PRIVATELY OWNED SHIP REPAIRERS IN THE U.S., 31 OF WHICH CAN DRYDOCK SHIPS GREATER THAN 400 FEET WITH 41 FLOATING DOCKS AND 31 GRAVING DOCKS**
- THE TAKE OVER OF EX NAVY SHIPYARDS HAS ADDED TO THE PRIVATE REPAIR CAPABILITY**
- SHIP REPAIRERS SEE INCREASING WORK DEMAND**



## **U.S. SHIP REPAIR AND OVERHAUL (CONTINUED)**

- . REST OF THE WORLD SEE INCREASING OVERCAPACITY ESPECIALLY AS U.S. IS INCREASING ITS PRESENCE**
- . BETHSHIP UPGRADE ITS FLOATING DOCK TO HANDLE LARGER CRUISE SHIPS**
- . NEWPORT NEWS WILL MAKE ITS GAINT AIRCRAFT CARRIER BUILDING DOCK AVAILABLE TO REPAIR LARGE SHIPS**
- . TWO SHIP REPAIRERS HAVE VASTLY INCREASED THEIR CAPABILITY BY TAKING OVER PARTS OF THE CHARLESTOWN NAVAL SHIPYARD**
- NEW SHIP REPAIR COMPANIES ARE SPRINGING UP ALL AROUND OUR COASTLINE**
- ALL AREAS ARE ACTIVE AND EXPECT TO INCREASE THEIR INVOLVEMENT**
- . THE PACIFIC NW IS BENEFITTING FROM RUSSIAN BUSINESS**

## **U.S. SHIP REPAIR AND OVERHAUL (CONTINUED)**

- **MEANWHILE, THE REST OF THE WORLD SEES LESS WORK AROUND AND PRICES UNDER PRESSURE. WITH SHIPPING STILL UNDER GREAT PRICE PRESSURE, SHIP OWNERS ARE STILL DELAYING REPAIR**
- **EUROPE, WITH ITS HIGH LABOR COSTS IS ESPECIALLY VULNERABLE. SOME COMPANIES HAVE RECENTLY CLOSED THEIR SHIP REPAIR FACILITIES AND MORE CLOSURES ARE PLANNED**
- **OTHER EUROPEAN SHIPBUILDING YARDS ESPECIALLY IN SCANDINAVIA AND GERMANY HAVE CHANGED OVER TO REPAIR**
- **SINGAPORE WILL INCREASE ITS SHIP REPAIR DOCKING CAPACITY BY OVER 30% BY THE END OF THIS YEAR**
- **FINALLY, MANY SHIP OWNERS ARE TAKING ADVANTAGE OF SAILING REPAIR CREWS AND “REPAIR IN ANY PORT” ROVING COMPANIES**

## **U.S. SHIP REPAIR AND OVERHAUL (CONTINUED)**

- **AT ONE TIME SHIP REPAIR FACILITIES PARTICIPATED IN THE DEACTIVATION AND SCRAPPING OF SHIPS. THIS BECAME SPECIALIZED AND THEN WENT OFFSHORE AS ENVIRONMENTAL LAWS MADE IT IMPRACTICAL IN THE U.S.**
- **REPAIR, OVERHAUL AND CONVERSION JOBS VARY WIDELY IN SCOPE AND COMPLEXITY AND EACH JOB HAS DIFFERENT NEEDS FOR FACILITIES AND MANAGEMENT**
- **THERE ARE BOTH SIMILARITIES AND DIFFERENCES BETWEEN SHIPBUILDING. AND SHIP REPAIR AND OVERHAUL**
- **SIMILARITIES INCLUDE FACILITIES, EQUIPMENT, TOOLS AND MANUFACTURING PROCESSES. DIFFERENCES INCLUDE UNCERTAINTY OF WORK SCOPE AND TIME TO PREPARE FOR IT AND PERFORM IT**
- **SHIP REPAIR AND OVERHAUL MUST ACCOMPLISH A MIX OF KNOWN AND UNKNOWN WORK ON AN EXISTING SHIP WHILE MINIMIZING OUT-OF-SERVICE TIME**

## **U.S. 'SHIP REPAIR AND OVERHAUL (CONTINUED)**

- **THREE PRIMARY CUSTOMERS IN THE SHIP REPAIR AND OVERHAUL MARKET ARE:**
  - COMMERCIAL SHIP OWNERS**
  - NAVY AND USCG**
  - GOVERNMENT OWNED COMMERCIAL SHIPS**
- **THE COST OF SHIP MAINTENANCE AND REPAIR IS GREATER THAN THE ACTUAL COST TO HAVE THE WORK DONE. THE TOTAL IMPACT MUST BE CONSIDERED**
- **THE OUT-OF-SERVICE TIME COSTS ARE OFTEN THE MOST IMPORTANT AND INCLUDE:**
  - LOSS OF DEPENDABILITY BY SHIPPERS**
  - LOSS OF INCOME AND NEW BUSINESS**
  - DAMAGE TO ON-BOARD CARGO**
  - UN-DEFRAYED OVERHEAD COSTS**
- **THUS REPAIR DECISIONS ARE A COMPLICATED BALANCING OF COMPETING NEEDS**

## **U.S. SHIP REPAIR AND OVERHAUL (CONTINUED)**

- **THE SHIP REPAIR AND OVERHAUL INDUSTRY WORKS ON SHIPS THROUGHOUT THEIR LIVES TO:**
  - MAINTAIN THE SHIP AND ITS EQUIPMENT IN GOOD AND SAFE OPERATING CONDITION**
  - REPAIR VOYAGE AND OTHER DAMAGE AND BROKEN EQUIPMENT**
  - CONDUCT CLASS INSPECTIONS**
  - CHANGE SHIP TO PERFORM BETTER OR NEW JOBS (CONVERSION AND MODIFICATION)**
- **THE TIMING OF THESE ACTIONS AND THEIR SCOPE OF WORK IS DETERMINED BY:**
  - CLASSIFICATION SOCIETY RULES AND COUNTRY LAWS**
  - SHIOWNER'S MAINTENANCE APPROACH**
  - SAFETY, MARKET AND ECONOMIC CONSIDERATIONS**

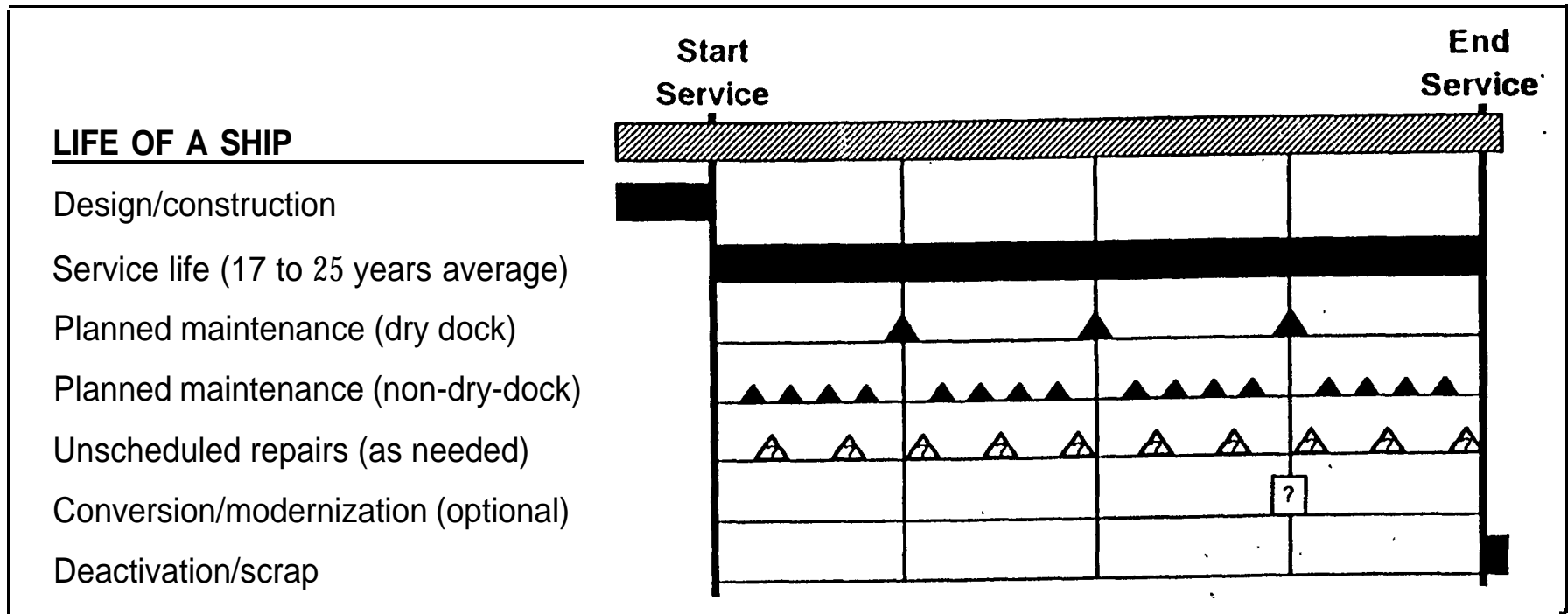

**Fig. 9-1. Maintenance/repair life of a ship.**

## **U.S. SHIP REPAIR AND OVERHAUL (CONTINUED)**

- **MOST SHIPOWNERS HAVE PLANNED MAINTENANCE PROGRAMS TO TAKE CARE OF ROUTINE MAINTENANCE**
- **MAINTENANCE REQUIRED BY CLASSIFICATION AND REGULATORY AGENCIES MUST BE DONE IN ACCORDANCE WITH THE RULES AND LAWS**
- **FOR OTHER MAINTENANCE AND REPAIR, SHIPOWNERS GENERALLY PREPARE WORK LISTS AND NEGOTIATE WITH A NUMBER OF SHIP REPAIRERS BASED ON THESE LISTS**
- **WHILE THE REPAIR WORK IS BEING DONE THE SHIOWNER WILL HAVE A PORT ENGINEER OR REPRESENTATIVE AT THE REPAIR FACILITY TO LOOK OUT FOR THE SHIOWNER'S INTERESTS**
- **FOR CONVERSIONS THE SHIOWNER WILL HAVE A TEAM IN THE SHIPYARD**
- **SOME SHIPOWNERS USE MAINTENANCE & REPAIR CONSULTANTS**

## **U.S. SHIP REPAIR AND OVERHAUL (CONTINUED)**

- THE U.S. NAVY REPAIR AND MODERNIZATION BUSINESS IS LARGE AND HIGHLY COMPETITIVE, FOR U.S. COMPANIES. IT IS RESTRICTED TO U.S. COMPANIES UNLESS IT IS IMPRACTICAL TO RETURN SHIP TO U.S. OR WHERE U.S. NAVY HAS LARGE FOREIGN BASES
- PRIVATE SHIPYARDS AND REPAIRERS COMPETE WITH THE NAVY FACILITIES FOR THE WORK, WITH MORE AND MORE GOING TO PRIVATE COMPANIES AS THE NAVY YARDS ARE CLOSED
- THE U.S. NAVY ESTABLISHES A PLANNED MAINTENANCE PROGRAM FOR EACH CLASS OF MAJOR SHIP
- PLANNING YARDS ARE SET UP FOR EACH CLASS OF MAJOR SHIP
- REPAIR/CONVERSION WORK IS IDENTIFIED BASED ON ESTABLISHED REQUIREMENTS FOR THE SHIP CLASS AND EXTENSIVE RECORD KEEPING, INSPECTION AND ENGINEERING ANALYSIS PROGRAM



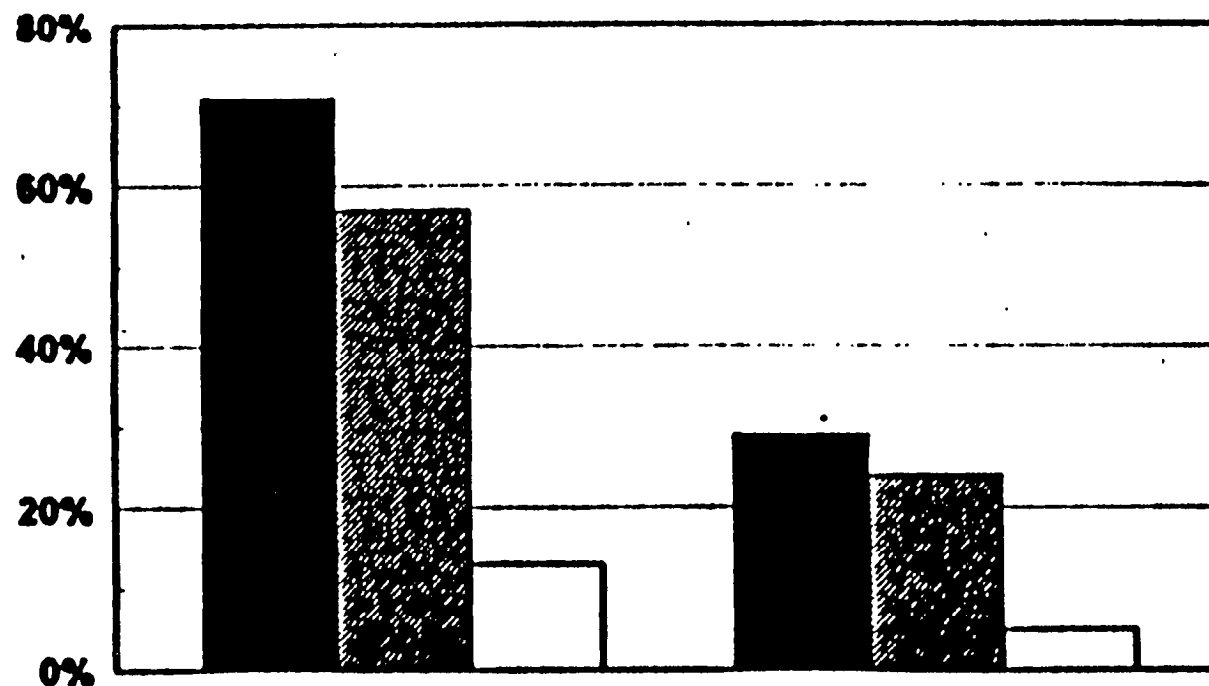

Repair Market	Military	Commercial
Total <span style="display: inline-block; width: 1em; height: 1em; background-color: black; vertical-align: middle;"></span>	71%	29%
Repairs <span style="display: inline-block; width: 1em; height: 1em; background: repeating-linear-gradient(45deg, transparent, transparent 2px, black 2px, black 4px); vertical-align: middle;"></span>	57%	24%
Conversions <span style="display: inline-block; width: 1em; height: 1em; border: 1px solid black; vertical-align: middle;"></span>	13%	5%

Fig. 9-2. Breakdown of U.S. ship repair market  
(From *Conference of Manufacturers*, June 1987)

<b>U.S. Navy Repair and Modernization Budgets of Active and Reserve Ships, FY 1990-94</b> (in millions of dollars)					
<b>Item</b>	1990	1991	1992	1993	1994
Public Yards	2,913.8	2,521.9	2,719.1	2,390.3	1,595.8
Private Yards	1,734.5	1,310.8	1,339.3	1,104.3	802.1
Competition	(*)	(*)	(*)	(*)	393.5
<b>Total</b>	<b>4,648.3</b>	<b>3,832.7</b>	<b>4,058.4</b>	<b>3,494.6</b>	<b>2,791.4</b>
* Data included in public and private yard budget numbers. NOTE: Does not include other program costs. SOURCE: U.S. Department of the Navy, based on FY 1994 Congressional Budget.					
<b>Navy Shipbuilding and Repair Budgets, FY 1990-94</b> (in millions of dollars)					
<b>Item</b>	1990 (1)	1991 (1)	1992 (1)	1993 (1)	1994 (2)
Shipbuilding & Conversion	11,541.2	8,751.2	6,713.2	5,853.2	4,294.7
Ship Repair & Modernization	4,648.3	3,832.7	4,058.4	3,494.6	2,791.4
<b>Total</b>	<b>16,189.5</b>	<b>12,583.9</b>	<b>10,771.7</b>	<b>9,347.8</b>	<b>7,086.1</b>
(1) Appropriated. (2) Requested. SOURCE: U.S. Department of the Navy, based on FY 1994 Congressional Budget.					

Fig. 9-4. U.S. Navy shipbuilding and repair budgets.

## **U.S. SHIP REPAIR AND OVERHAUL (CONTINUED.)**

- **THE WORK REQUIREMENTS ARE CONVERTED INTO TWO STANDARD SPECIFICATION STANDARDS, ONE FOR NAVY SHIPYARDS AND ONE FOR SUPSHIPS TO USE TO OBTAIN A BID FROM PRIVATE COMPANIES.**
- **NAVY REPAIR/CONVERSION SPECIFICATIONS AND CONTRACT LANGUAGE ARE EXTENSIVELY STANDARDIZED AND. THEREFORE KNOWN BY EXPERIENCED PEPAIRERS**
- **NAVY'S CURRENTLY USES 35 PRIVATE COMPANIES AND 5 NAVY SHIPYARDS TO PERFORM THEIR REPAIR/CONVERSION NEEDS. HOWEVER, THEIR NEEDS ARE CONTRACTING AND THE OUTLOOK IS FOR MORE CLOSURES AND GREATER COMPETITON**
- **PRIVATE COMPANIES MUST PRE-QUALIFY AND FOR WORK ON LARGER, MORE COMPLEX SHIPS MUST RECEIVE A MASTER SHIP REPAIR AGREEMENT**
- **TO OFFSET THIS PRIVATE SHIP REPAIRERS HAVE TO SEEK WORK FROM OTHER MARKETS**

## **U.S. SHIP REPAIR AND OVERHAUL (CONTINUED)**

- **THE GOVERNMENT OWNED COMMERCIAL SHIPS ARE MAINTAINED AND REPAIRED TO COMMERCIAL REQUIREMENTS**
- **THE MILITARY SEALIFT COMMAND SHIPS AND THE MARAD NATIONAL DEFENSE READY FLEET MAKE UP MOST OF THIS MARKET WITH OVER 150 SHIPS EACH**
- **THE U.S. ARMY ALSO OWNS A NUMBER OF SHIPS**
- **THE OTHER TWO OWNERS ARE THE NATIONAL OCEANIC AND ATMOSPHERIC ADMINISTRATION (NOAA) AND THE NATIONAL SCIENCE FOUNDATION**
- **THIS MARKET SEGMENT IS DRIVEN BY GOVERNMENT CONTRACTION AND FIXED PRICE LOWEST BID AWARDS**

## **U.S. SHIP REPAIR AND OVERHAUL (CONTINUED)**













- **SHIP REPAIR AND OVERHAUL ARE CLASSIC CASES OF THE “JOB SHOP” FORM OF MANUFACTURING**
- **THEY ARE HIGHLY LABOR AND SKILL INTENSIVE WITH LITTLE POTENTIAL FOR AUTOMATION**
- **MOST OF THE WORK IS DONE ON BOARD THE EXISTING SHIP, THUS THE PROBLEM OF SPACE AND TRADE CONGESTION MUST BE OVERCOME**
- **THE JOB SHOP ENVIRONMENT AND THE SHORT PERFORMANCE TIME DICTATE THAT MANY REPLACEMENT PARTS BE MANUFACTURED BY THE REPAPERER INSTEAD OF PURCHASING THEM FROM ORIGINAL EQUIPMENT MANUFACTURERS**

## **U.S. SHIP REPAIR AND OVERHAUL (CONTINUED)**





- **EACH REPAIR JOB IS UNIQUE (EXCEPT FOR NAVY CLASS)**
- **THE BEST APPROACH TO EACH CASE DEPENDS ON THE COMBINATION OF:**
  - J O B S I Z E**
  - J O B C O M P L E X I T Y**
  - F A C I L I T Y R E Q U I R E M E N T S**
  - M A N A G E M E N T R E Q U I R E M E N T S**
- **LARGER, MORE COMPLEX JOBS GENERALLY REQUIRE MORE EXTENSIVE FACILITIES, OVERALL PLANNING AND MANAGEMENT ORGANIZATIONS**
- **SMALLER, LESS COMPLEX JOBS CAN BE ACCOMPLISHED WITH MINIMUM FACILITIES, ON-THE-JOB PLANNING AND SIMPLE MANAGEMENT**

## **U.S. SHIP REPAIR AND OVERHAUL (CONTINUED)**

- **A FULL-SERVICE SHIP REPAIR AND OVERHAUL FACILITY IS VERY SIMILAR TO THAT OF A NEW CONSTRUCTION SHIPYARD**
- **THE PRIMARY DIFFERENCES INVOLVE THE UTILIZATION OF THE FACILITIES. IN A SHIPYARD, STEEL MANUFACTURING FORMS THE CORE AROUND WHICH OTHER PROCESSES ARE ORGANIZED, WHEREAS IN SHIP REPAIR AND OVERHAUL STEEL IS ONLY ONE OF MANY NEEDS. OUTSIDE MACHINE AND ELECTRICAL SHOPS BECOME THE PRIORITY**
- **SERVICES TO DOCKS AND PIERS ARE MORE IMPORTANT BECAUSE OF THE NEED TO SUPPORT, SHIP'S SERVICES TO STAY ON LINE DURING THE WORK AS WELL AS THE NEEDS OF THE WORKERS**

	<u>Size</u>	<u>Complexity</u>	<u>Facilities</u>	<u>Planning Approach</u>	<u>Management Approach</u>
Repair & overhaul					
Unscheduled repairs			Varies	Sys to Zone	Varies
Planned maintenance			Shops/Pier/DD	Sys to Zone	Function to Project
Overhaul			Shops/Pier/DD	Zone	Project/Matrix
Conversion/modernization			Full Service SY	Zone	Project/Matrix
Deactivation			Shop/Pier	Zone & Sys	Project
Scrap			Pier/DD/Staging	Zone	Project

<b>Legend:</b>	 Least	 Least to midrange	 Least to greatest	 Midrange to greatest	 Greatest
----------------	---	---	--	--	--

**Fig. 9-3. Nature of the industry.**



## **U.S. SHIP REPAIR AND OVERHAUL** (CONTINUED)

- **FULL SERVICE SHIP REPAIR AND OVERHAUL FACILITIES WILL HAVE:**

TECHNICAL DEPARTMENT

PLANNING AND SCHEDULING DEPARTMENT

PURCHASING DEPARTMENT

PRODUCTION DEPARTMENT

TEST DEPARTMENT

DRYDOCKS

PIERS

OVER-SIDE CRANES

TEMPORARY HOLDING TANKS FOR SHIP'S FUEL, ETC

WASTE TANKS FOR OFF LOADING SHIP'S WASTE

SHOPS FOR - STEEL

ENGINES

PIPE

MACHINING

SHEET METAL

ELECTICAL

BLAST AND PAINT EQUIPMENT

SPECIAL TOOLS, JIGS AND FIXTURES

TEST EQUIPMENT

## **U.S. SHIP REPAIR AND OVERHAUL (CONTINUED)**

- **SMALLER SHIP REPAIR FACILITIES MAY ONLY CONSIST OF PIER SPACE, MOBILE (CRAWLER) CRANES, SOME STORAGE SPACE AND AN OFFICE**
- **ALMOST ALL OF THE WORK WILL BE PERFORMED ON BOARD THE SHIP**
- **AS PREVIOUSLY MENTIONED, THERE ARE SHIP REPAIR COMPANIES THAT PROVIDE ON BOARD SAILING REPAIR CREWS AND OTHERS THAT SEND COMPLETE REPAIR CREWS TO ANY PORT IN THE WORLD TO PERFORM REPAIRS. ROVING IN PORT REPAIR COMPANIES OFTEN HAVE STANDING CONTRACTS WITH SHIP REPAIR COMPANIES IN THE PORTS TO USE THEIR FACILITIES WHEN REQUIRED**

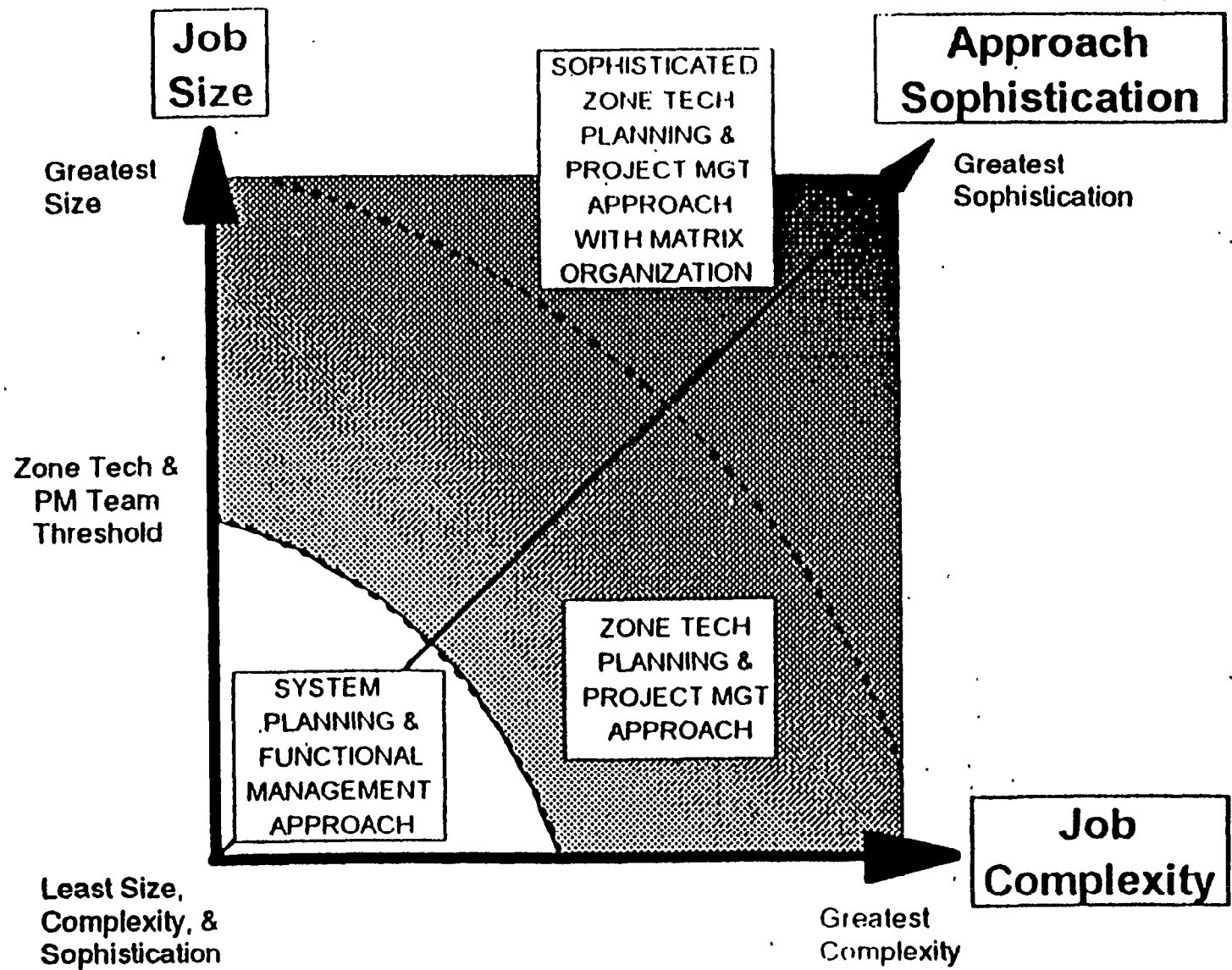

**Fig. 9-5. Approach selection criteria.**

## Analysis of Vessels Broken Up in 1992

(Developing countries are in the lead)

	<b>T o t a l</b>		<b>Tankers</b>		<b>Dry Bulkers</b>		<b>Gen. Cargo Ships</b>	
	No.	dwt (‘000)	No.	dwt (‘000)	No	w t ( ‘ 0 0 0 )		(‘000)
China	36	3,187	15	2,442	12	666	9	79
India	109	2,733	32	1,528	13	420	64	785
Bangladesh	34	1,727	12	1,370	3	113	19	243
Pakistan	20	1,715	13	1,472	4	214	3	29
Turkey	7	1 8 5	2	106	2	41	3	38
Thailand	1	15	—	—	—	—	1	15
Mexico	1	13	—	—	—	—	1	13
Spain	2	5	—	—	—	—	2	5
Peru	1	3	—	—	—	—	1	3
Greece	1	3	—	—	—	—	1	3
Portugal	1	2	—	—	—	—	1	2
Denmark	2	2	—	—	—	—	2	2
Japan	2	1	—	—	—	—	2	1
Netherlands	1	1	—	—	—	—	1	1
Germany	1	1	—	—	—	—	1	1
United Kingdom	1	1	—	—	—	—	1	1
<b>TOTAL</b>	<b>220</b>	<b>9,593</b>	<b>74</b>	<b>6,919</b>	<b>34</b>	<b>1,453</b>	<b>112</b>	<b>1,221</b>

Source: Lloyd's Shipping Economist. Research files. London.

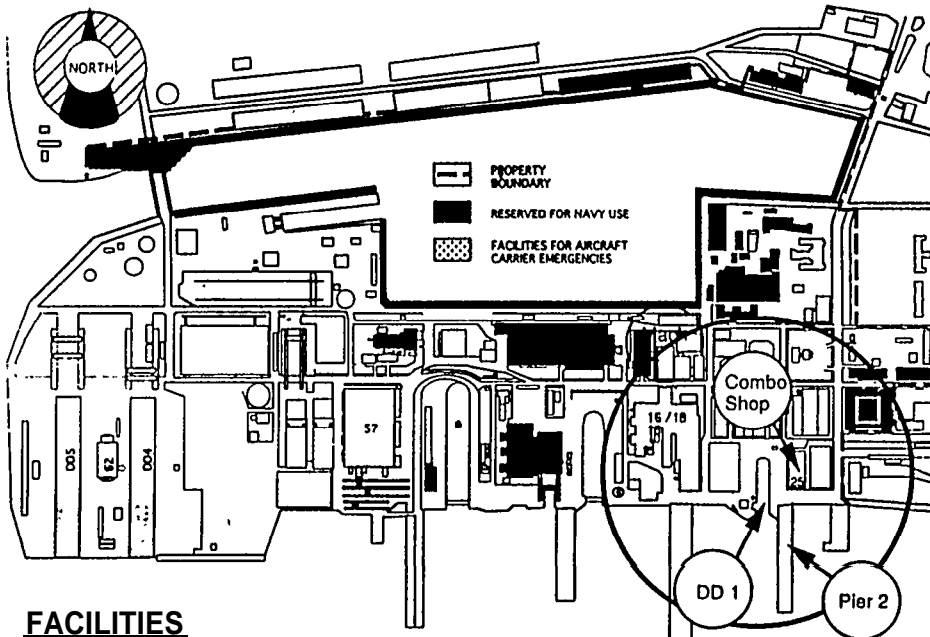

SMALL REPAIR YARD

ORGANIZATION

Executive	1
Administrative'	3
Business Development'	1
Design/Engineering	1
Production Support'	4
Production Management	3
Production	50

Manpower requirements will be approximately double for military work.

FACILITIES

Requirement	PNSY Facility	Size	Max Crane	Available
Piers	Pier No. 2	894ft	60T	1993 (RF)
Dry Docks	Dry Dock No.1	442ft	60T	1993
<b>Shops :</b>				
Machine	Bidg 25-Rigging	53k sf		1995
Pipe	(Use for all			
Electrical	Functions in a			
Fabrication	Combined Shop)			
Outfitting				
Sheet Metal				

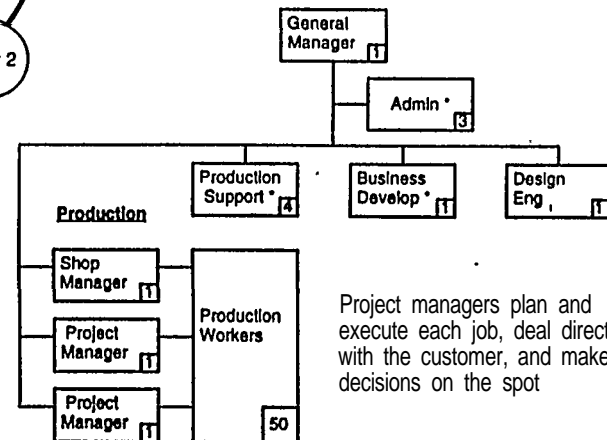

Project managers plan and execute each job, deal directly with the customer, and make decisions on the spot

Legend: ○ = Small ● = Medium ① = Combined shop functions RF = Tentatively obligated to Reserve fleet (NISMF)

Fig. 9.6. Representative layout for a small repair yard.

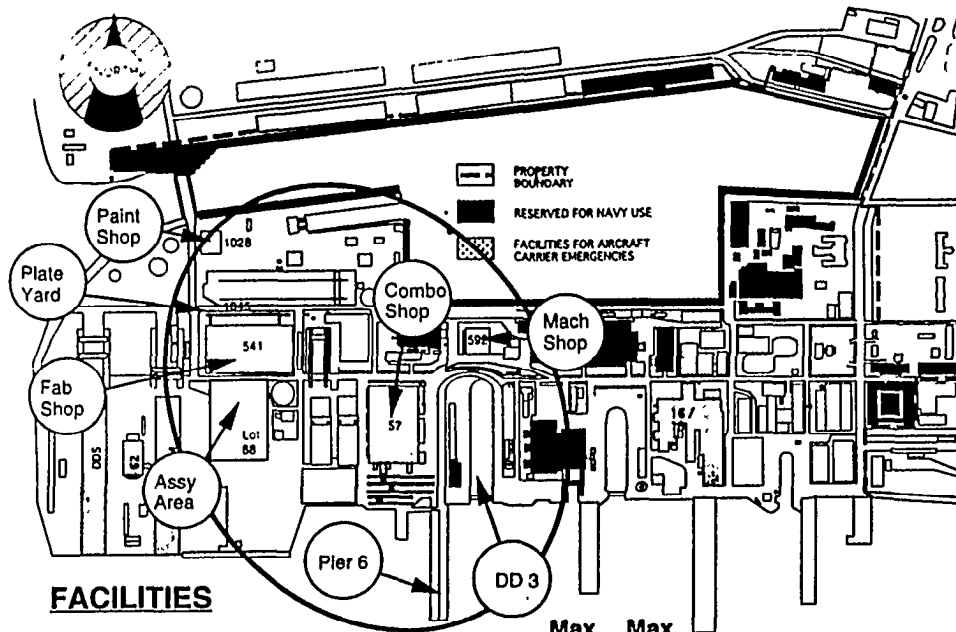

**CONVERSION YARD FOR LARGE & MEDIUM SHIPS**

**ORGANIZATION**

Executive	3
Administrative*	10
Business Development*	2
Design/Engineering	4
Production Support*	12
Production Management	12
Production	150

\* Manpower requirements will be approximately double for military work.

**FACILITIES**

Requirement	PNSY Facility	Max Size	Max Crane	Available
Piers	● Pier 6	970 ft	50T	1996 (RF)
Dry Docks	● Dry Dock 3	1011 ft	50T	1994
Shops: Machine	① Bldg 592-Mach	81k sf	60T	1993
Pipe	④ Bldg 57-Combo	307k sf	60T	1996 (A/C)
Electrical	④ Bldg 57-Combo	307k sf	60T	1996 (A/C)
Fabrication	① Bldg 541-Part	316k sf	60T	1995/96
Outfitting	① Bldg 57-Combo	307k sf	60T	1996 (A/C)
Boiler	② Bldg 57-Combo	307k sf	60T	1996 (A/C)
Sheet Metal	① Bldg 57-Combo	307k sf	60T	1996 (A/C)
Plate Yard	○ Bldg 1045	68k sf	60T	1996
Assembly	① Lot 88-Part	300k sf	Mobile	1994-Partial
Blast & Paint	● Bldg 1028-B/P	13k sf	---	1995

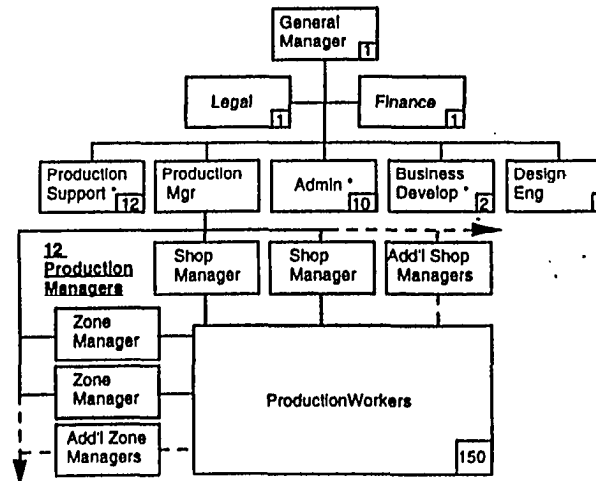

Legend: ○ = Small ● = Medium ● = Large ① = Combined shop functions Tentatively obligated. RF = Reserve fleet (NISMf) A/C = Aircraft carrier emergency

Fig. 9-7. Representative layout for a larger repair/conversion shipyard.

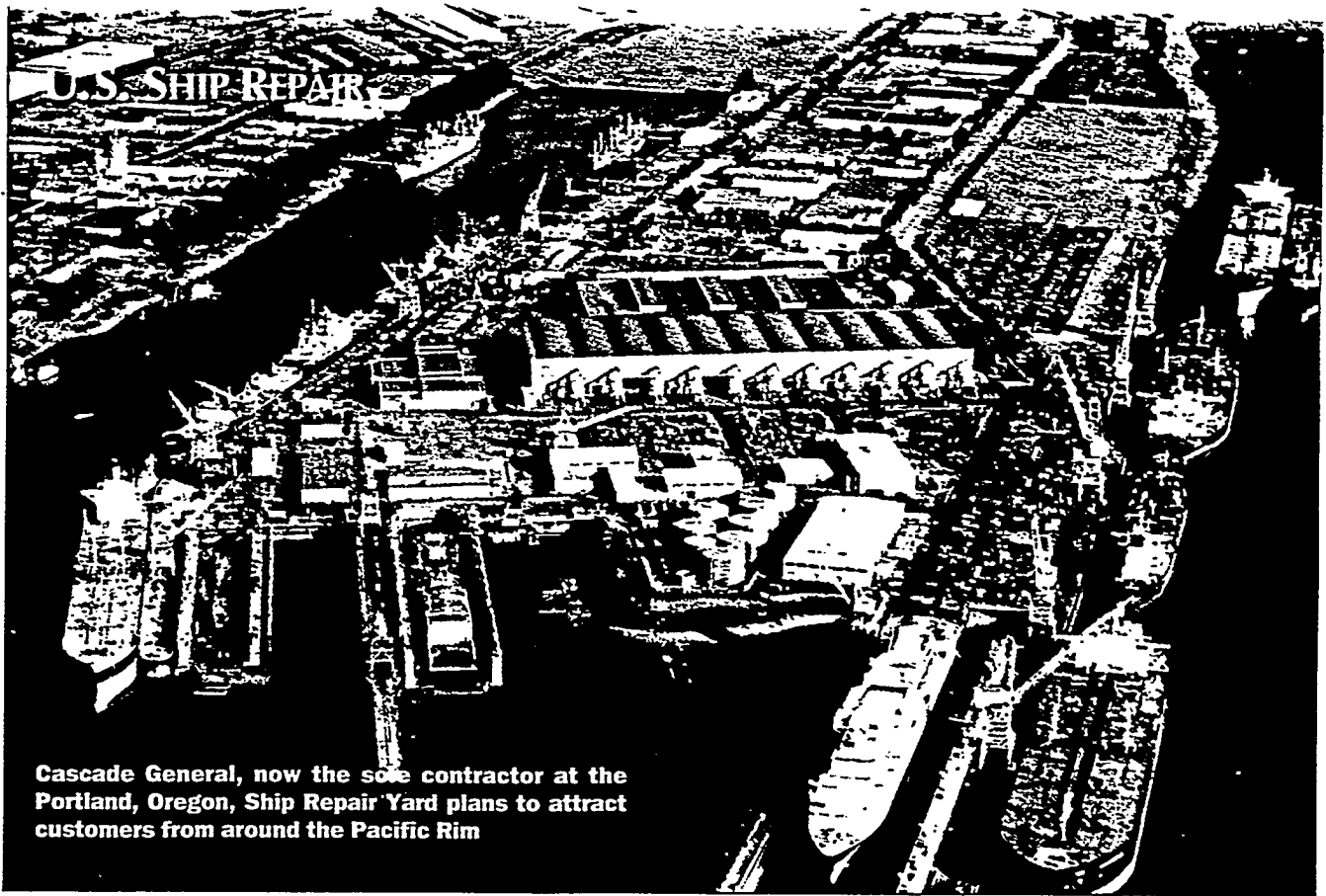

## U.S. repairers woo the world market

*Competitive labor rates and a soft dollar are helping American yards to persuade more foreign-flag operators into their dry docks*

**A**n eroding U.S.-flag oceangoing fleet and a reduced Navy budget have demanded a shift in marketing focus by U.S. ship repair yards whose international competitiveness has been sharpened by a favorable exchange rate for the dollar and labor costs below those in many other countries.

"What I hear from our members is that we are very competitive on labor rates with all of the European and Japanese yards," says Robert O'Neill, vice president of the Shipbuilders Council of America. "And, when I say 'competitive,' I mean that in most cases their prices are lower."

In the U.S., there are currently more than 200 privately owned ship repair firms, 31 of which are capable of drydocking vessels of 122 m or more and have channel depths of 3.7 m and up, according to the Maritime Administration. For ships of this size, the U.S. shipbuilding and repair industry is currently operating a total of 43 floating dry docks, 31 graving docks, and two marine railways.

Some of the graving docks, however, are committed to new construction.

A poll by MARINE LOG indicates that over the next six to 12 months, many yards expect to increase their presence in the foreign-flag vessel repair business. They also expect to see a continued upward trend in the coastal tug and barge repair activity. Offshore rig conversions are also seen as likely to increase. A number of yards plan to invest in new technology and equipment that will enable continued productivity and quality enhancements.

### ONE COLLISION: TWO REPAIR CONTRACTS

A double repair performed by Bender Shipbuilding & Repair Co., Inc., Mobile, Ala., following the collision of two cargo ships off the coast of Louisiana last July, was one of the most memorable repair projects of 1995. It also underlined U.S. yards' increasing ability to deliver quality and timely repairs to international customers at the right price.

In the collision incident, the 725 ft x 106 ft Greek-owned *Alexia* sustained considerable damage to its bow, while the 515 ft x 72 ft *Enif* damaged its port side, aftmost kingpost and cargo gear.

According to Robert A. Beckmann, vice president of repair for Bender Shipbuilding and Repair Co., Inc., Mobile, Ala., prior to the arrival of the *Alexia* on July 10, Bender had dispatched a sales representative to New Orleans to assist the owner's representative and view the magnitude of the damages and resultant repair work. At that time, available drawings and technical information were gathered to facilitate detailed planning and engineering of the repairs.

When the *Alexia* arrived, work commenced immediately at wet dock with the vessel ballasted to raise its bow as high as possible. To speed repairs, new frames, bulkheads, floors, etc., were lofted and N.C.-burned for fabrication and installation, while the damaged hull sections were being scrapped out.

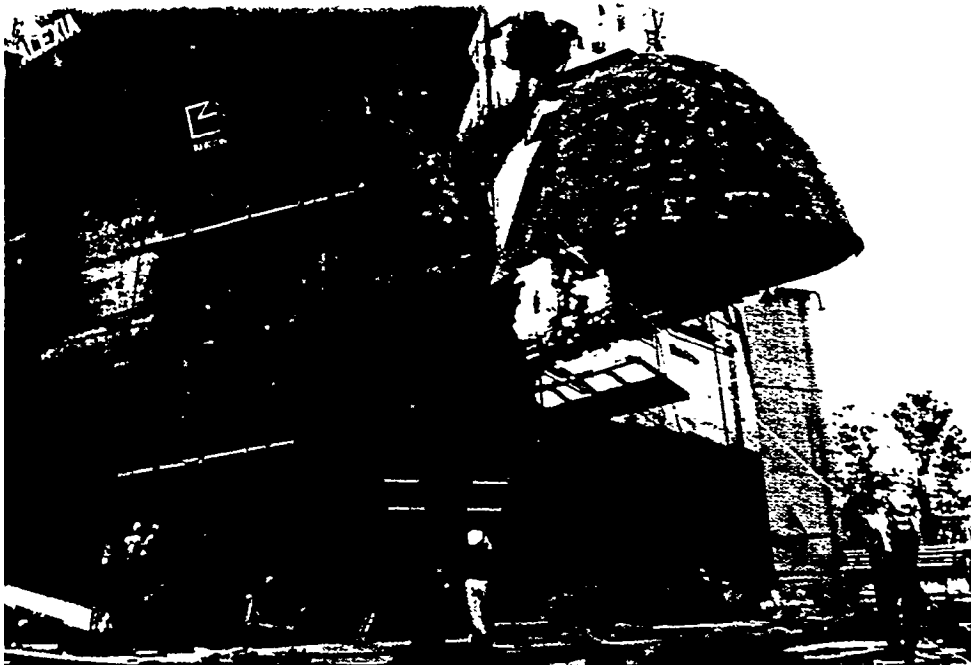

Repairs by Bender to collision-damaged *Alexia* included rebuilding and refitting the bulbous bow

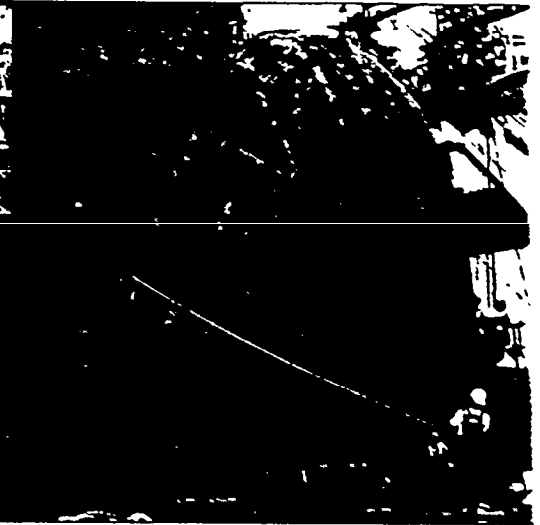

The severely damaged bulbous bow was removed ashore. It was set vertically under a fabrication shed for re-manufacture as work continued on board, minimizing the vessel's required time in the dry dock. Installation of steel on the hull above the waterline continued until the dry dock became available on July 27.

Once the vessel was drydocked, Bender was able to assess the full extent of bottom damage. The damaged areas were then repaired with new plates.

Following the replacement of the structure immediately aft of the bulbous bow, the re-manufactured bow was lifted in two sections and refit to the hull.

The repairs were tested for the classification society while on dry dock, with the owner taking advantage of the opportunity to take care of some other repair items not related to the casualty.

In all, when the *Alexia* sailed complete on August 17, Bender had renewed about 273,000 lb of steel.

The *Enif*, which arrived on July 29, needed more complex repairs. On arrival in Mobile, divers and a shore-side crane removed as much cargo (steel coils) as possible from the ship's flooded No. 3 cargo hold.

The vessel was then drydocked at Atlantic Marine for removal of the balance of the cargo, survey and installation of a cofferdam. Once the survey was completed, negotiations were conducted with the owner's on-site representative and Bender was awarded the permanent repairs.

The vessel was refloated and berthed at Bender Yard No. 5. Removal of damaged structures began

while the vessel was afloat.

A new 140 ft long side shell module with main deck and tweendecks was fabricated and the mast house and boom, damaged in the accident, were remanufactured ashore.

*Enif* was drydocked on August 21 and the cofferdam and remaining damaged structure were removed. The new side shell module was then put in place by a 600-ton Bisso floating derrick.

The vessel was being re-classed to Germanischer Lloyd while in dry dock. This involved additional steel work on the hull as well as the usual survey items and application of new bottom coating systems.

After undocking, topside work included re-installation of the mast house and kingpost. All electrical, hydraulic and piping systems were also restored, flushed, and tested as necessary.

New MACOR main deck and tweendeck hatch covers (purchased by the owner) were installed, while other covers that suffered relatively minor damage were repaired by and integrated with new panels.

By the time it sailed from the yard on November 24, *Enif* had had about 530,000 lbs. of steel replaced (excluding the new hatch covers).

At their peak, the *Alexia* and *Enif* projects were running simultaneously, generating employment for about 250 workers.

The two vessels were among 80 docked last year in Bender's two floating dry docks and Beckmann reports that the yard is already off to a robust

start in 1996, expecting to dock 11 vessels in February alone. During the rest of the year, the yard anticipates increased repair activity to be generated by the coastal and barge trade. As to future foreign-flag business, Beckmann says the *Enif* project was one of Bender's first from German). Since then it has had a number of inquiries from potential German customers.

#### FIERCE INTERNATIONAL COMPETITION

In going after international work, American yards are entering a tough league. Robert A. Fiorelli, manager, business development and sales for BethShip, Sparrows Point, Md., sees foreign flap work increasing. But "prices are extremely competitive for available work," he notes. "International competition from the U.K., Spain, Portugal and the Mediterranean is fierce. Oversupply of repair capacity is still a problem. Work volume shows signs of increasing due to IACS enhanced surveys."

In the coming months, Fiorelli also sees BethShip's percentage of government work increasing due to the award of the *El Paso* and *Mobile* conversions, as well as other Military Sealift Command (MSC) contracts.





Recent projects at the yard have included the renewal of 1,000 tons of double-bottom plating on the barge *Adelaide* for Blue Circle Cement, 400 tons of cargo hold and tank steel renewals for the *Energy Enterprise (ex-Energy Independence)* for Central Gulf Lines, and the drydocking of 10 cruise ships, including a Lido deck extension on the *Royal Princess* and a grounding repairs to the *Royal Majesty*.

BethShip last year upgraded its floating dry dock to handle larger cruise ships and added new numerically-controlled machining equipment. Plans for 1996 include investment in new hydro- and abrasive-blasting equipment.

#### HAMPTON ROADS

A considerable proportion of U.S. ship repair capacity is concentrated in the Hampton Roads region, where the largest repairer is Norshipco, whose facilities include its huge floating dock, *Titan*.

Competition in the region intensified in 1992 when Tenneco's Newport News Shipbuilding re-entered the commercial repair market. The yard now has a very healthy backlog of commercial newbuilding work. Nonetheless, having repaired over 60 ships since re-entering the commercial arena, it is committed to staying in the repair business. Most of its current repair work is for repeat customers, trading to the East Coast and

Gulf, including cruise and containership owners. These are operators, says Ed Waryas, director of commercial marketing, "to whom quality and getting the ship out on time are major factors." And, in addition to the yard's newbuilding and Navy commitments, "we've been very successful in matching up work for these customers with our dry dock availabilities."

Waryas, who recently assumed responsibility for commercial repairs in addition to newbuilding, says that besides meeting the needs of its established customers, Newport News is "always looking to broaden our customer base."

One sector of the repair market Newport News could well pursue is the

new generation of post-Panamax vessels. Its graving dock, the largest in the Western Hemisphere, has been extended. This has given the yard added flexibility to carry out commercial repair, as well as newbuilding, in parallel with Navy work.

Another of the area's repairers, Colonna's Shipyard, Inc., Norfolk, Va., is in the midst of an evolution, following its successful emergence from Chapter 11.

An ability to deal with everything from tugs and barges to oceangoing ships up to 18,000 tons has helped Colonna's to carve out a niche for itself, says vice president J. Douglas Forrest. "We've handled a plethora of foreign-flag ships, tugs, barges, and some FFG-7s," states Forrest. "Every year for the last five years we have increased our market share in commercial work." In the past year, Colonna's has repaired about 80 vessels, including repairs to the cable-layer USNS Zeus and the drydocking and overhaul of the *Export Patriot* for, Farrell Lines.

A resurgence in the tug and barge market leads Forrest to see increased activity in that sector over the next six months, as owners catch up on repairs that they deferred while the market was in a lull. Other possibilities could include some midbody conversions on containerships.

"I think other shipyards will have to undergo the same evolution we did," says Forrest. He expects the yard to invest in technology to

increase productivity. Colonna's has already added a 30,000 lb/in<sup>2</sup> high pressure water blasting system.

#### CHARLESTON NAVY FACILITIES

According to Rich R. Wilcox, manager of planning and estimating, Braswell Services Group will expand its repair capabilities by leasing part of the former Charleston Naval complex, which will enable it to handle ships up to 600-700 ft in length. At present, Braswell can drydock ships up to 220 ft in length and repair those up to 350 ft alongside at its Charleston facility. It is also establishing ship repair facilities in Brunswick, Ga. In 1995, military and government work accounted for about 90% of the company's repair workload at its U.S. facilities. Braswell's main contestant in the commercial and foreign-flag arena is its Balboa, Panama, facility, which expects to increase its business.

Detyens Shipyards, Inc., Mt. Pleasant, S.C., is also active in Charleston, where it has taken over operation of portions of the Navy yard, where facilities include three graving docks (the largest being 741 ft x 110 ft), over 7,000 ft. of piers and 220,000 ft<sup>2</sup> of shop space.

Detyens plans to continue to operate two floating dry docks at its Mt. Pleasant and Charleston, S.C., facilities, for smaller vessels.

During the first four months of fiscal '96, reports Gerald L. Mosher, vice president and chief estimator, commercial work accounted for approximately 25% of the company's repair workload. He expects the trend to continue through the rest of the year.

#### GULF COAST

Repair work is an increasingly important part of the business mix at America's bustling Gulf Coast shipyards. William Round, vice president of repair at Avondale Industries, New Orleans, reports a high level of inquiries from foreign owners. "There appears to be interest from foreign-flag owners in possibly doing more of their drydockings in the U.S.," he says. "With the rise in prices around the world, it is certainly more economically viable to drydock here, when you consider the down time and long voyage, possibly without cargo, to a foreign repair yard].

A healthy sign for ship repair is that the industry is attracting new entrants. One recent start-up, Runyan Industries, Inc., in Pensacola, Fla., is performing conversion work on

## Goltens boosts crankshaft capabilities

**D**iesel repair specialist Goltens-New York recently enhanced its crankshaft grinding capability at its Brooklyn, N.Y., shop. Goltens has been doing crankshaft grinding in-shop and in dry dock for more than 50 years, according to Norman Golten, the company's president. The purchase of a new state-of-the-art crankshaft grinder will enable the firm to handle crankshafts as large as 4.3 m long with a swing of 1,200 mm.

At press time, Goltens was reworking the rams and yokes of the steering gear of the MV Vitorandis. The original manufacturer of the steering gear is out of business and with the needed parts no longer being available, it could have taken many

months to manufacture a new steering gear. But with Goltens Involvement. "the ship should be sailing in six to seven days," Norman Golten reports. Another interesting recent job for the firm involved the M/V Rio Enco, which was docked in Norfolk, Va., in need of a new crankshaft. Golten engineers went to Norfolk to disassemble the engine and move the crankshaft from the ship. The entire process of removing the old crankshaft and replacing it with a new one took 26 days. "This short amount of time would normally be expected if the Job was carried out in a local port," says Norman Golten. "However, it was done out of town, on a bid competing with local shops."

one offshore gaming vessel and preparatory work on another, according to president Harry Bell. The conversion involves inserting a 77 ft x 48 ft midbody into a 130 ft aluminum former research catamaran. The second project involves some removal and preparatory work on a SWATH vessel that had been working in the oil patch.

Bell sees offshore gaming ships as only a temporary niche for the yard, noting that "it was easy for us to get this type of work because most of our team has casino experience." Bell expects the company to branch out into Coast Guard, Navy, and commercial work-particularly coastal freighters working the Caribbean-as well as new construction. The yard

already has a repair contract for two U.S. Coast Guard patrol boats.

## FORTY PERCENT FOREIGN

International Ship Repair & Marine Services, Inc., Tampa, Fla., derived 40% of last year's repair business from foreign flag ships, reports William S. Russell, company vice president of administration. International Ship Repair has the capability to drydock vessels up to 700 ft in length and conduct alongside repairs to vessels of up to 950 feet in length.

## MORE DRY DOCKS FOR BOLLINGER

Marking its 50th anniversary, Bollinger Machine Shop & Shipyard, Inc., drydocked about 850 vessels last year at its seven Louisiana, according to spokesman Scott Theriot. The company controls 17 dry docks, the largest handling vessels up to 6,000 tons. Last summer it acquired 20 acres of McDermott Shipyard's Amelia, La., facility, as well as various assets, including three dry docks.

Now the company is planning to build two more dry docks with a minimum 2,000-ton capacity (more likely 3,700 to 4,000 ton) to handle the new

## Vancouver Shipyards

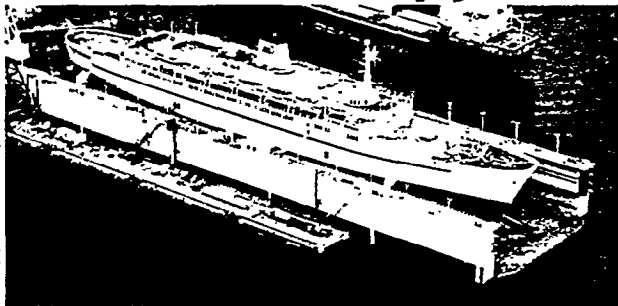

### FOR PACIFIC SHIP REPAIR AND SERVICE

- A century of experience
- Vessels up to 100,000 DWT
- A winning combination of technology, facilities and experience
- Competitive pricing and quick turn-around

 **Vancouver Shipyards**

50 Pemberton Ave., North Vancouver, B. C., Canada, V7P 2R2  
Tel. (604) 988-6361 • Fax (604) 984-1651 • Telex 04-352532 • Seaspan VCR

# PROOF POSITIVE!

**Corrozeal converts rust to magnetite and primes metal for painting in just one easy application!**

Independent research proves...

- CORROSEAL bonds with all major top coats without the high cost of grit blasting.
- CORROSEAL is nonflammable, emits no explosive fumes, is nontoxic, earth-friendly and VOC compliant.

Discover for yourself why owners and crews are saying,

**"We won't paint another vessel without Corrozeal!"**

**800-237-1573**

Call for the distributor nearest you and ask for free samples of Corrozeal Rust Converter & Corrozyme Paint Prep Enzyme Cleaner

**CORROSEAL, INC.**  
MARINE & INDUSTRIAL COATINGS



Corrozeal and Corrozyme are Registered Trademarks of Corrozeal, Inc.

generation of cargo boats (220 ft x 54 ft). says Theriot. "From what I hear, I don't think we're through adding yards either," he comments.

#### SHAVE AND HAIRCUT IN NEW ORLEANS

One of 21 shipyards in the Trinity Marine Group, New Orleans-based Trinity-Gulf Repair, located on the site of the former American Marine Corporation, recently drydocked, repaired and repainted the 600-passenger *John James Audubon* for New Orleans Steamboat, Inc. The "shave and haircut" included routine maintenance on the vessel as well as repairing holes in a tank, repacking stuffing boxes, servicing sea valves, removing rope wrapped around the propeller shaft and repainting the vessel's bottom.

Trinity-Gulf Repair also recently won a contract to drydock a five-deck Iowa riverboat casino for its Coast Guard required five-year inspection, and some refurbishment work.

On the Mermentau River in Jennings, La., Leevac Shipyards, Inc., recently finished repair work on a couple of tank barges for Higman

Towing, according to sales manager Charles Burrell. "There seems to be quite a bit of activity in the Gulf," says Burrell. Other current work at the yard includes an engine refit on a 102 ft tugboat for Point Comfort Towing Co. During the eight-week job, the tug will have two rebuilt 12-cylinder 64532 diesel engines inserted in place of a pair of Fairbanks Morse engines.

#### OFFSHORE RIG CONVERSIONS

"Our primary focus has been on MODUs and in the near future will be on floating oil storage platform systems," says Ned Hastings of AMFELS, Brownsville, Texas. In addition to new construction projects, recent work at AMFELS has included repairs and upgrades on three Arethusia rigs—the *Neptune*, *Saratoga* and *Lexington*, as well as leg repairs on the *Glomar High Island II*. It has also been upgrading two jack-ups, is bidding on two similar rig projects and expects as many as a dozen others to be bid for upgrade or repairs.

Texas Drydock Incorporated, Orange, Texas, operates five marine repair yards for barge, inland and offshore vessel repair. The company

recently purchased the interest of Bethlehem Steel Corporation in the BethShip, Sabine Yard at Port Arthur. Operated under a long-term lease agreement with the Port Arthur Navigation District Industrial Development Corporation, the Sabine Yard repairs and inspects mobile offshore drilling rigs and ships, and includes a 64,000-ton-capacity floating dry dock that can accommodate various size vessels and semi-submersible, mat-supported and independent leg jackup rigs, submersibles and drillships.

#### PORTLAND TURNAROUND

In the Pacific Northwest, Cascade General, Inc., now has exclusive use of the Portland Ship Yard, following the signing of a lease agreement in the summer of 1995 with the Port of Portland, according to Andrew G. Rowe, company executive vice president. The company's business strategy, says Rowe, has been to focus on the consolidation and management of the 94-acre facility and the diversification of its customer base.

"Before, we were strictly a Jones Act yard. If you look at our business now, three-quarters is coming from

The  
Gulf Coast's  
best bet for  
ship repair  
is now  
even better.

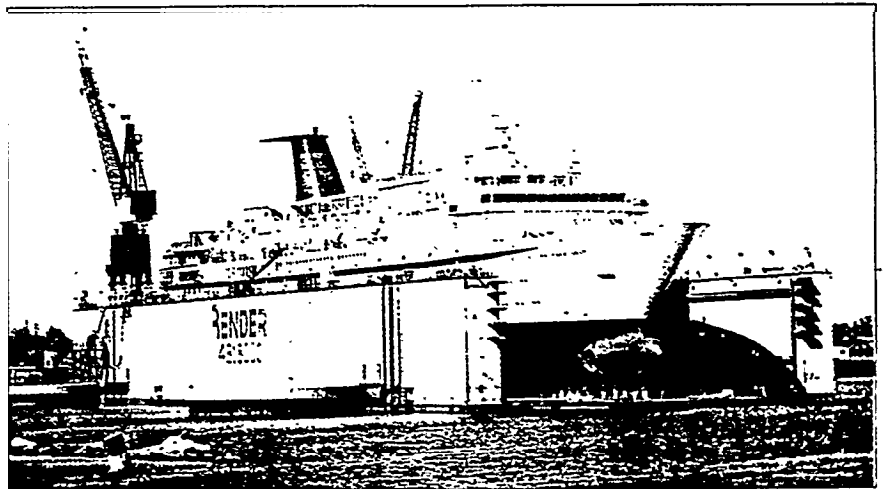

For more than 70 years, Bender has been the leading ship repair facility on the central Gulf of Mexico. Now, we're even better. Along our 7,000 feet of deep water frontage, we've built new yards and wet docks, improved equipment, and added dry docks to raise lifting capacities to 20,000 tons. These modern Panamax facilities and an around-the-clock workforce put muscle behind our promise of fast, reliable ship repair. Now, more than ever, Bender is your best bet for ship repair on the Gulf of Mexico.



**BENDER**  
HIPBUILDING & REPAIR CO., INC.

265 South Water Street • Mobile, Alabama 36603 USA • P.O. Box 42 • Mobile, Alabama 36601 USA • (205) 431-8000 • FAX (205) 432-2260 • Telex 505457

Write 44 on Reader Service Card

M A R I N E L O G

non-traditional customers. And certainly while there is a well defined U.S.-flag fleet-it's finite. We need to access the foreign flag fleets. We want to transform ourselves into a major player in the foreign flag market."

Rowe sees the yard capitalizing on three rapidly growing business segments-the expansion of trade with the Pacific Rim and Northern Europe and the booming Alaska summer cruise market. In recent months, Cascade General has docked three Holland America cruise ships-the *Staatendam*, *Rotterdam*, and *Ryndam*. The yard is also bidding on a number of other cruise ship drydockings for the fall.

With Dry Dock 4-the growing business for AMFELS

largest on the Pacific Rim at 351 m x 5.5 m-in its arsenal, Cascade General has set its sights on attracting Japanese and Far East customers.

"With the increase in Pacific Rim trade, we believe that the foreign flag segment represents about 75% of the

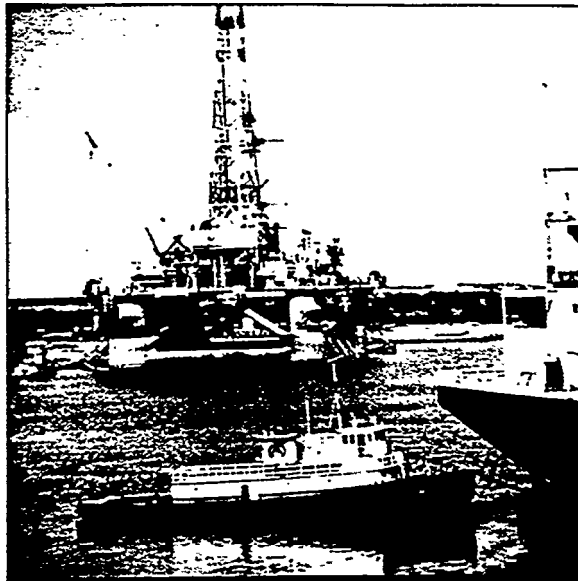

Repairs and conversions to MODUs are providing the tankers in the Alaskan oil

market potential." declares Rowe.

Rowe also points to penetration into the tug and barge trade, as well as a \$1.5-million overhaul of the Corps of Engineers hopper dredge *Essayons*.

Cascade General recently landed its first major Navy ship repair contract-the 84.4-million overhaul of the USS *Ingram* (FFG-61), which it expects to complete in April, and has also performed repair work on two Military Sealift Command's T-AO oilers.

Other projects have include a winch modification on the *Igrim*, a vessel that hauls crude out of Alaska to the Russian Far East, the overhaul of the Mattson containership *Nanukaar* and work on Red River's Buffalo *Soldier*, an ammunition ship under charter to MSC.

In its traditional repair areas, Cascade General still probably handles about 80% of the tankers in the Alaskan oil trade, says Rowe. Typical of its tanker repair jobs is the recently-completed 85 million overhaul of the *BT Alaska* for Marine Transport Lines, involving steel and piping renewal, blasting and coating, machinery work, shaft and rudder work, shaft bearing jobs, and electrical work.

*Proteus Engineering*

*flagShip*

Visit us at AISE Booth #421

Design Software for:  
Hullform  
Stability  
Powering  
Structures  
Estimating

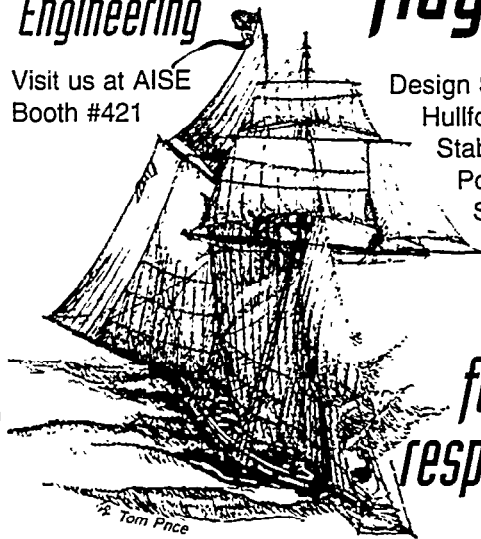

*fast and responsive...*

The *Lawrence*, a fine example of the Baltimore Clipper ships, was built in 1813 in Maryland, near the offices of Proteus Engineering. She was noted to be especially fast and responsive, and had a successful career as a privateer during the War of 1812 with Great Britain. In one encounter with a convoy escorted by a brig-of-war, she captured eight vessels.

**Proteus Engineering** tel +1 (410) 643-7496  
301 Pier One Road, Suite 200 fax +1 (410) 643-7535  
Stevensville, MD 21666 USA flagship@cc.atinc.com  
<http://www.access.digex.net/~proteus/>

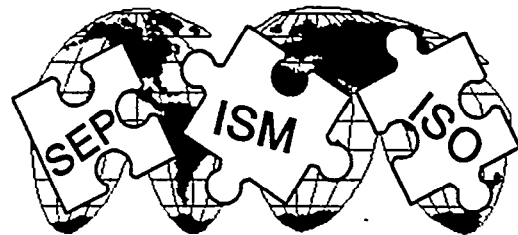

**As the pieces come together . . .**

LET P AND H PROVIDE HANDS-ON BENEFITS FOR

- ✓ RULES, STANDARDS, AND CODE COMPLIANCE
- ✓ PERSONNEL ORIENTATION AND TRAINING
- ✓ DOCUMENT PLANNING AND DEVELOPMENT
- ✓ COMPLETE SOM SYSTEM IMPLEMENTATION

OUR NEW *SMART SHIPS* PROGRAM INCORPORATES A DETAILED ANALYSIS OF YOUR SHIPBOARD SAFETY AND QUALITY MANAGEMENT SYSTEM, INSPECTIONS OF EQUIPMENT AND PROCEDURES, AND SOM SYSTEM TRAINING FOR ALL VESSEL PERSONNEL.

THE AUDIT YOUR SHIPS WILL ASK YOU FOR

P AND H MARINE  
ASSOCIATES, INC  
PO Box 561  
WOLFEBORO FALLS NH  
USA 03896  
1-800-876-8969  
TEL 603-569-6081  
FAX 603-569-1912



P AND H MARINE  
AUSTRALASIA, PTY., LTD  
4 / 10 PITT WAY  
MYAREE WA  
AUSTRALIA 6154  
TEL : 61-9-317-1103  
FAX: 61-9-317-1103

Rowe is extremely optimistic about 1996 and expects the shipyard's revenues to grow 50% over last year's. "Certainly it's not all roses and daisies, but because of the rise in the value of the yen versus the dollar, we are extremely cost competitive with the Japanese. Prices are also rising in Korean and other Asian yards. Quality is what will keep customers coming back."

#### THE RUSSIANS ARE COMING

As a result of the opening of the Soviet bloc, there has been an influx of fishing vessels, freighters, break-bulkers, RO/ROs looking for repairs on the West Coast, according to Jim Hitch, director of market development for Todd Pacific Shipyards, Inc., Seattle, Wash.

"There are very few places these vessels can go on their return trip or in Vladivostok," says Hitch. With the sustained trade between the West Coast and the Far East and Soviet Union, he sees Todd picking up additional foreign flag repair business. "The yards in Malaysia and Japan are too far to go. There is certainly a time-saving factor docking the vessel right here in Seattle. It's more cost-effective."

Todd Pacific drydocked a FESCO ship last-summer, recently completed generator repairs to a Russian vessel and is bidding on repair work for two other Russian ships, according to Hitch.

Other Pacific Northwest shipbuilders have also conducted extensive repairs for the Russian fishing fleet. Tippett Marine Services, located on Seattle's Lake Union, recently completed its 25th contract with a Russian-registered ship.

The company's most recent project involved the 65-meter trawler/processor *Sterkoder*. Over a six-week period, Tippett performed electrical motor and pump repairs, re-certified all rigging, and accomplished a variety of miscellaneous repairs to the crew quarters, factory area, hydraulics, and boilers. At the same time, main engine overhauls were completed by Trans Marine of Seattle and dry dock work was carried out at Lake Union Drydock.

"We've developed a good rapport with Russian vessel operators," says Tippett president Billie Adams, "and this milestone is a tribute to the way our people have learned to meet their needs on a repeat basis."

Jerry Tilley, operations manager for Marine Resources Company Inter-

national (MRCI), Seattle, which manages more than 20 Russian-registry fishing vessels, agrees. "We've handled 35 Russian vessel refits," Tilley says, "and 22 of those have been done at Tippett. A lot of yards call us for bids on these jobs, but Tippett outperforms the others. They understand the elements of time, quality and price, and they know exactly what to do." Tippett anticipates similar projects in the future, both for vessel conversion and return visits for systems upgrades and voyage repairs.

"At this point, we've scheduled four projects for 1996," says Adams, "and we're negotiating more."

While it has a continuing Navy contract for the phased maintenance of two AOE ships, Todd Pacific draws about 70% of its work from the commercial sector. Recent U.S. customers include Matson, APL, Sea-Land and TOTE. The company will also have the opportunity to bid on a couple of cruise ship drydockings this fall.

#### LIFE EXTENSION IN SAN DIEGO

Southwest Marine, Inc., San Diego, Calif., which operates a network of West Coast repair yards, recently began the mid-life extension of the research vessel *New Horizon*, operated by the University of California. San Diego Scripps Institute of Oceanography. Under the package, SWM will drydock the vessel, inspect its shafting and rudders, install a new thruster tunnel, modify the deckhouse, install a new fathometer, and conduct piping modifications.

In addition, the yard is also performing routine maintenance on the recovery vessel *Laney Chouest*, began regular haul-out, routine maintenance, and ABS inspection on the *MSRC Barge 320* for the Marine Spill Response Corporation in January, and completed voyage repairs to the research vessel *Atlantis II* for Woods Hole Oceanography.

SWM is also bidding on the refurbishment of a tuna boat.

Through its lease of facilities at Ingleside, Tex., from Braswell Services Group, SWM has begun to build a presence in the Gulf market and "compete successfully in an increasingly competitive and shrinking ship repair market." Engel, SWM president and chief operating officer.

The SWM Ingleside yard will provide phased maintenance to four MCM Class ships home ported at Naval Station Ingleside under an \$11.5-million contract. ML

## STRAINERS, FILTERS TRANSFER VALVES TRANSFER PUMPS

Rugged Construction—Cast Iron, Steel, Stainless, Bronze and Other Alloys. Flanged, Threaded or Weld-End.

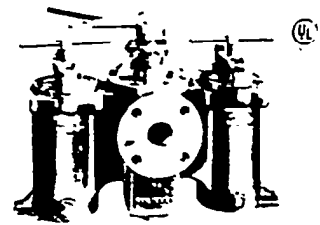

**Model 72**  
**Simplex & Duplex Strainers**

For fuel oil, lube oil, cooling water or any fluid service. Protects pumps, nozzles, meters, heat exchangers and process lines. Size 1/4" to 12" and larger. High pressure/temperature special designs available.

**Model 73**  
**Sea-View**  
**Strainers**  
**Simplex-**  
**Duplex**

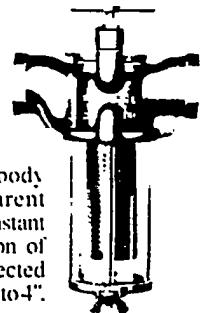

Cast bronze body with transparent sump permits instant visual inspection of flow and collected debris. Sizes 1" to 4".

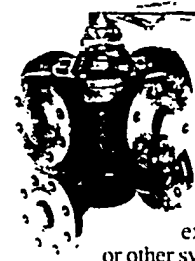

**Model 72A-**  
**Transfer**  
**Valves**

Six (6) port plug valve for duplexing two tanks, heat exchangers, filters, or other systems with minimum piping and space. Easy 1/4 turn, one stroke plug valve operation switches flow from one side to the other. Sizes 3/4" to 8" and larger. High pressure/temperature special designs available.

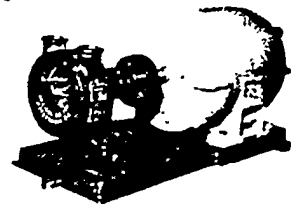

**Model 60 Pumps**

General line of cast iron fuel and lube oil pumps—direct connected for light oils, reduction drives for heavy oils. High temperature special designs available. Sizes 3/8" to 2".

**KRAISSL CO**

303 Williams Avenue., Hackensack, N.J. 07601  
Tel: (201) 342-0008 • Fax: (201) 342-0025

## WORLD SHIP REPAIR

# Repairers are keeping



Full floating docks at Poland's Gdanska Stocznia Remontowa. Polish yards have emerged as an attractive, competitively-priced option for many owners—helping to keep the pressure on prices throughout northern Europe

*While some observers see shipowners continuing to defer all the repairs they can, their leeway to do so is inhibited by a tougher regulatory climate. At the same time, high newbuilding prices are encouraging more owners to look at conversions of existing tonnage. These and other factors are helping to create continuing demand for ship repair services. But that doesn't mean that operating a dry dock has become a license to print money. Established ship repair centers—notably Singapore—have been adding capacity and new, lower-cost contenders continue to enter the arena. Our Annual Survey of World Ship Repair takes a region-by-region look at what's happening.*

### NORTHERN EUROPE

**P**rice levels remained under pressure last year in Northern Europe as a result of stiff competition between regional repairers. Verolme Botlek reports. This judgement is confirmed by other Netherlands repairers. "There's a lot of competition in our region and abroad. Prices are under pressure. [There is] less work around," notes F.H. van Velsen, marketing manager of the Scheldepoort Repair Yard in Vlissingen. And Hans P.M. Stoop of Shipdock Amsterdam says yards face "fierce competition from low cost countries."

Verolme Botlek is the largest repairer in the Rotterdam area. Its

by Doug Woodyard  
International Editor

three graving docks include a 405 m x 90 m unit that can accommodate VLCCs and which is one of the few in northern European broad enough to accept semi-sub and jack-up rigs and crane vessels. Operational flexibility is enhanced by an intermediate movable wall which can be arranged as a divider at any described position to allow work to proceed simultaneously on short- and long-term projects.

Another large facility in Rotterdam, Wilton-Fijenoord, offers docking for ships up to 160,000 dwt as well as repair services throughout the port. A completely covered 40,000 dwt capacity graving dock is also available.

Niehuis & Van den Berg operates five floating docks in Rotterdam capable of handling ships of up to 28,000 dwt. The yard is a specialist in serving dredges, reefer vessels, RO/RO ships and chemical carriers.

Despite the competition, Shipdock Amsterdam increased its vessel throughput last year. It repaired a total of 144 ships. 73 of them in dry dock. The yard can drydock vessels up to Panamax size and can accommodate ships up to 150,000 dwt alongside. Around 70% of its business is foreign-flag.

Work last year included conversion and upgrading of a cutter suction dredge and refitting the propulsion gears on a series of eight reefers. Conversions will be a focus of future marketing efforts.

The Scheldepoort Repair Yard can drydock vessels up to 90,000 dwt and accommodate ships up to 350,000 dwt alongside. Over 90% of its work is for foreign customers.

Significant contracts last year included collision damage and engine room repairs to Yang Ming Line's *Ming Fortune*. Some 135 tons of steel was renewed.

### FRENCH YARDS

Northern France is well served by major repairers operating in Dunkerque, Le Havre and Brest. Ships of up to 160,000 dwt can be handled by Arno Dunkerque whose workshops are located close to four graving docks accepting vessels with dimensions up to 290 m x 44 m and

two floating docks (the largest accommodating vessels up to 215m x 30m).

Siren targets tonnage calling at its home base of Le Havre or at Rouen and elsewhere in Normandy. The Le Havre dry dock complex embraces four graving docks (the largest measuring 219 m x 38 m x 14 m) and a 310 m x 53 m x 11.50 m floating dock. A full range of specialist services-including main engine repairs and overhauls, tank cleaning, slop removal, propeller repairs and polishing-are available from Siren and associated companies.

Brest-based Sobrena Shipyard deploys three docks with widths ranging from 27 m to 80 m and can repair ships of up to 550,000 dwt; offshore rigs and production platforms can also be accommodated (no height limitation is reported). Last year the yard completed its largest-ever contract, the 5% month conversion of the Rasmussen Offshore-owned accommodation platform *Polycastle*.

#### EAST VS. WEST IN GERMANY

In Germany, Blohm + Voss, Hamburg, continues to enhance its reputation as one of the world's leading specialists in conversion. However, HDW in Kiel closed its merchant vessel repair division at the end of last year. In repair and conversion, as in new-building, the inevitable question is the extent to which the focus of German shipyard activity will shift towards facilities in the lower-cost former East Germany, where the industry has benefited from substantial, subsidized modernization.

Thus, the former Neptun new-building yard, now a member of Germany's Vulkan group, is dedicated to repair and conversion projects. Substantial steel fabrication and outfitting resources support the yard's three floating docks, which offer lifting capacities of 2,700 tons; 8,000 tons and 23,000 tons. The smallest docks are based at Restock while the larger facility is in Warnemünde. The yard has already established a reputation for major conversions. Its credits include the transformation of the RO/RO freight carrier *Sharm el-Sheikh* into the car/passenger ferry *Dahab* with a high standard of accommodation and amenities.

#### POLISH PRESSURE

Elsewhere in eastern Europe, Polish yards are demonstrating their competitiveness. Remontowa Gdansk Shiprepair Yard, for example, plans continuing investment to strengthen its status as one of north Europe's

## MARINE BEARING ENVIRONMENTS DEMAND POLLUTION-FREE RELIABILITY

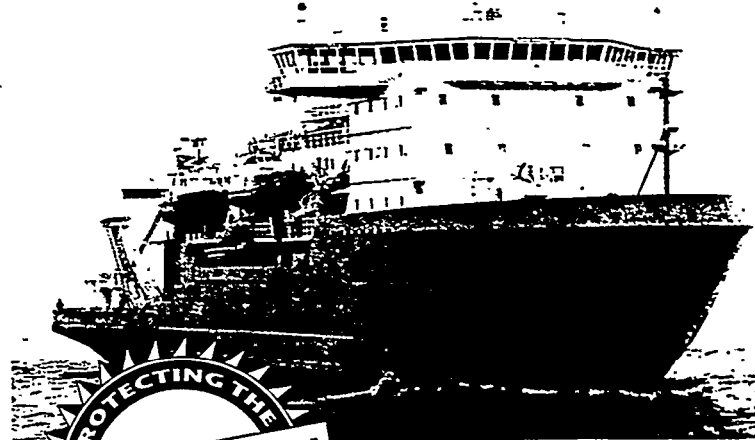

*Working in the world's most ecologically sensitive environment, the Antarctic icebreaker and research vessel, Nathaniel B. Palmer relies on 6-40 mm (25") Thor-Lube stem tube bearings for pollution free reliability. The ship is also equipped with Thordon rudder and thruster bearing systems.*

Today's environmental challenges and government regulation demand a move from traditional oil lubricated stem tube systems to pollution-free alternatives.

The Thor-Lube bearing system combines proven Thordon XL bearings with Thor-Lube: a water soluble, environmentally friendly lubricant to deliver pollution-free performance. wear life is comparable to conventional oil-lubricated systems and the system is considered equivalent to oil-lubricated by most Classification Societies.

Higher operating efficiencies can be expected with the Thor-Lube system. Operating friction is lower, particularly at start-up and higher shaft speeds. Similar in size to oil-lubricated bearings,

Thor-lube bearings can be as easily integrated into conversion projects as new build.

For pollution-free reliability in your marine bearing application contact Thordon Bearings Inc. or your local Thordon distributor (located in over 55 countries around the world).

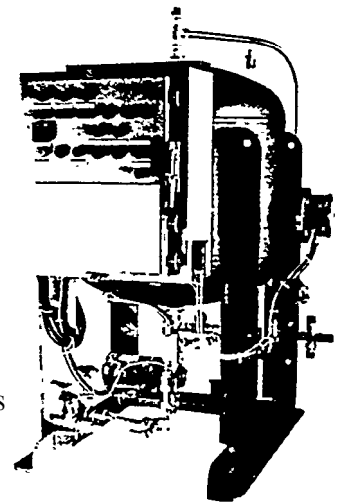

# THORDON

Thordon Bearings Inc., 4225 Mainway Drive, Burlington, Ontario L7M 1A6  
Telephone (905) 335-1440 Fax (905) 335-4033

## THORDON BEARINGS ARE AVAILABLE THROUGH THESE THORDON DISTRIBUTORS

Electro-Watt Utility Services, Inc.  
464 Chardonnay Drive  
Fremont, CALIFORNIA 94539-7776  
Telephone/Fax (SIO) 770-1653

pacific Marine & Industrial  
2005 Palo Verde Ave., Suite 112  
Long Beach, CALIFORNIA 90815  
Telephone: (800) 248-3579

Coppedge Marine Inc.  
4972 River Point Road, P.O. Box 5636  
Jacksonville, FLORIDA 32207  
Telephone: (904) 398-9586  
Telefax: (904) 398-4333

Maquire Bearing Co.  
1919 Hau Street  
Honolulu, HAWAII 96819  
Telephone: (808) 847-3331  
Telefax: (808) 842-1889

Marine Industries Corp.  
601 East Riverside Drive  
Clarksville, INDIANA 47130  
Telephone (800) 733-3130  
Telefax: (812) 283-9628

Johnson Packings &  
Industrial Products, Inc.  
One Industrial Way, Unit 9  
Portland, MAINE 04103  
Telephone: (207) 797-9212  
Telefax: (207) 797-9158

Johnson Packings &  
Industrial Products, Inc.  
1434 Memorial Avenue, West Springfield  
MASSACHUSETTS 01089  
Telephone: (413) 733-7861  
telefax (413) 732-2210

Argo International  
13477 SE Johnson Road  
Milwaukie, OREGON 97222-1237  
Telephone: (503) 794-9686  
Telefax (503) 794-8336

Hampton Sales Inc.  
P.O. Box 492, 361B North York Road  
Willow Grove, PENNSYLVANIA 19090  
Telephone (215) 784-0390  
Telefax: (215) 784-0392

Pacific Marine Equipment Inc.  
3307, Preemont Ave. N. Bldg G  
Seattle, WASHINGTON 98103  
Telephone: (206) 548-0334  
Telefax (206) 548-0468

Avalon Marine Ltd.  
44 Coventry Lane  
Dartmouth, NOVA SCOTIA B2V 2K2  
Telephone: (902) 456-1381  
Telefax: (902) 462-1004

P.D.L. Kenscott  
9653 Clement Street  
Lasalle, QUEBEC H8R 4B4  
Telephone (514) 364-0808  
Telefax (514) 364-0454

Thordon Offices:  
2106 Old Farm Road  
Bakersfield, CALIFORNIA 93312  
Telephone/Fax (805) 589-7161

1140 Ft. 2094, #106  
Clear Lake Shores, TEXAS 77565  
Telephone (713) 334-6118  
Telefax: (713) 538-1924

For International Distributors- Contact

Thordon Bearings Inc.  
3225 Mainway  
Burlington, ONTARIO L7M 1A6  
Telephone (905) 335-1440  
Telefax (905) 335-4033

# THORDON

major repairers. The yard typically candles around 200 ships annually with earnings of around \$100 million. It has five floating dry docks with respective lifting capacities of 6,400, 1,000, 11,000, 25,000 and 33,000 t, allowing ships up to 120,000 dwt to be accommodated.

Remontowa Gdansk's hull and cargo hold blasting operations average 1,360 m<sup>2</sup>/day, with top rates often reaching 4,500 m<sup>2</sup>/day. Steel replacement performance now averages 20 tons/day per ship but 35 tons/day has been exceeded.

The investment program will focus on new welding, blasting, coating and transport systems. Huge canvas covers are planned to cover the docks in the fall-winter period to limit the impact of ambient conditions on the yard's productivity.

An interesting contract underway at press time at another Polish yard, Morska Stocznia Remontowa, was rebuilding of a 1965-built, 2,996 dwt tanker for a Swedish owner. Work included renewal of the whole cargo section with a 54 m section weighing 600 tons.

### U.K. YARDS GO AFTER WIDER MARKETS

U.K. ship repairers have been busy lately. The A&P group reported record business at its Tyne facility in the closing months of last year and also had a broad mix of ships stemmed at its Falmouth and Southampton facilities. Ferries are a seasonal market that always helps the U.K. industry, but there are indications that some yards are now looking further afield.

With the largest graving dock in the British Isles, Northern Ireland's Harland and Wolff Shiprepair, is stepping up efforts to attract more business from North America. The Belfast yard is well placed to serve tonnage trading between the U.S., Canada and northern Europe, and can accept ships up to 215,000 dwt. Keppel Marine Agencies, Inc., of New Providence, N.J., has been appointed agent for the U.S. and Canada, and will also be responsible for marketing the yard in Bermuda and Costa Rica.

The yard has considerable experience with tankers and recently completing a major repair contract for Mobil on Waneta, the second of two 81,283 dwt sisterships. Also being eyed is the offshore sector, where H&W offers expertise and resources for converting tankers into floating production and storage vessels. Ferry

and cruise liner repair and conversion projects are another speciality.

Across the Irish Sea, in Birkenhead, the Cammell Laird yard offers dry docks up to 298 m x 42 m, extensive fabrication, engineering and outfitting workshops plus comprehensive design capabilities. It is now targeting the conversion market.

### SCANDINAVIA

Sweden's Gotarerken Cityvarvet extended its specialities early last year by taking over the propeller repair and reconditioning activities formerly handled in Gothenburg by Cisery. The associated tools are now installed in the yard's engineering shops. A swift start-up was smoothed by the transfer of skilled Cisem personnel to Gotarerken Cityvarvet, ensuring the maintenance of a high quality service. In addition, a co-operation agreement with Lips has secured access to that company's expertise in propellers and propeller repairs.

Russian business is considered vital for the Kvrerner Kimek yard at Kirkenes in the far north of Norway whose new shiplift and hall complex, part of an overall investment of \$35 million in modernization, was officially opened last March.

The 117 m long x 24 m wide shiplift can handle vessels weighing up to 5,000 t while the 80 m x 35 m ship hall offers a maximum height to crane hook of 33 m (crane capacity is 50+10 t). A transport system links the lift with the hall, behind which is a 24 m x 24 m welding shop. Repairs to smaller ships can thus be effected under cover while in-water projects are performed at a 280 m long quay with a water depth of 5.5-8 m.

The yard's services are targeted at the fishing sector, maintenance of semi-sub and jack-up rigs and the construction of offshore modules. Russia has typically accounted for 70-80% of Kimek's revenues in recent years but projects have been small in comparison with the yards ambitions.

### TANKER CONVERSION AT TURKU

In Finland, Kvaerner Masa-Yards' Turku facility earned a credit in the offshore tanker conversion sector last summer with a contract to install a new type of bow loading system on Neste's 91,000 dwt Futura. The new Submerged Turret Loading system, patented by Norway's Statoil, allows oil to be loaded directly from a production platform even in rough seas and in Arctic conditions.



## SOUTHERN EUROPE

**A** high level of business has slowed plans by Portugal's Lisnave to phase out all activity at its Margueira yard in Lisbon and transfer it to the former Setenave facility further south at Setubal, now designated as Mitrena. The volume of bookings is such that both sites are in demand and the deadline for the closure of Margueira has been put back from late 1996 to 1998 at the earliest.

Margueira might well survive until the turn of the century since work has yet to start on the construction of another dock at Mitrena, considered essential for flexibility.

Lisnave's combined throughput at both yards in 1994 totaled 174 ships with an aggregate tonnage of 13 million dwt, yielding an average per ship of 14,000 dwt and maintaining its leadership in Europe and position among the world's top three repairers. The performance was sustained into 1995, the group budgeting for 83 ships in the first six months, but actually handling 103 ships with an aggregate tonnage of 7.3 million dwt.

A strong flow of contracts at a higher price (a rate rise of around 15% is desirable) would steer Lisnave into healthy profitability. More extensive tanker conversion projects are also being sought to boost returns. New managing director Joao Manuel de Mello Franco is keen to enhance the skills and flexibility of his managers and the 2,200-strong workforce through training programs at Margueira and Mitrena.

Upgrading of the Mitrena yard proceeds, the investments including an extensively reconstructed tank cleaning station. The increasing importance of the facility is reflected in its average load-sharing trend with the Margueira yard which at end-1994 was 43/57%. In first quarter 1995, the balance changed in favor of Mitrena which repaired 55.5% of the

54 ships handled by the two yards. The trend was maintained in the second quarter with Mitrena handling 53% of the workload.

Mitrena was assigned last summer to carry out the jumboization of two Swedish Orient Line 13,050 dwt multipurpose RO/RO cargo ships, *Thebeland* and *Tyrusland*. There are options for similar conversions for four other ships of the class. The project called for the insertion of a 1,200 ton midbody section between frames

totalling 758 m in length.

Up to mid-October last year the yard completed repairs and/or conversions on 39 vessels with an aggregate tonnage of just under 600,000 dwt. Some 33 of this total were drydocked, the remainder being repaired alongside. Tanker tonnage-including chemical, gas, asphalt and wine carriers-accounted for over a third of the throughput.

Astander's conversion credits were extended during the year with the

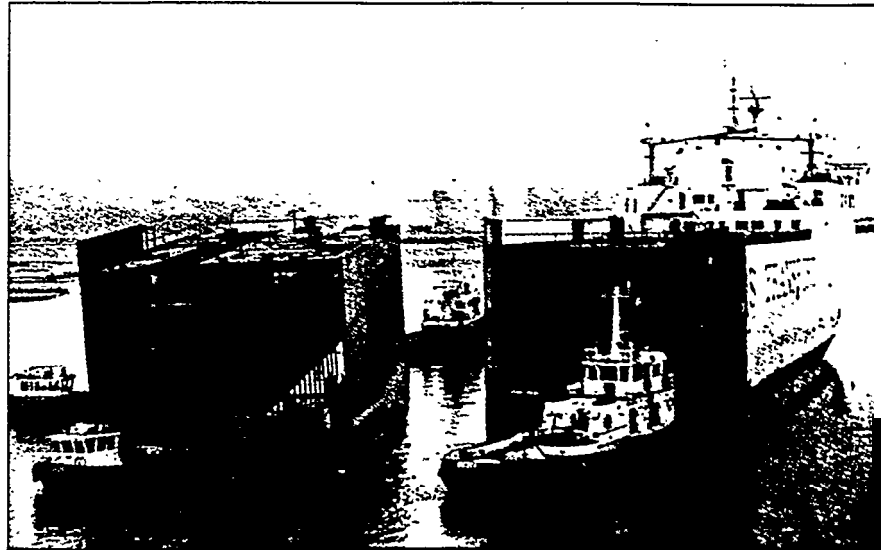

Jumboizing the DFDS RO/RO Dana Maxima at Spain's Astilleros de Santander

116 and 117, measuring 25.2 m long x 25.5 m wide x 8.25 m deep. A new shelterdeck was also fabricated and installed aft of the accommodation superstructure to stow 58 empty containers.

### SPANISH YARDS

In the north of Spain, major conversions and tank coating projects continue to be booked by the Astilleros de Santander (Astander) yard, strategically located on the Bay of Biscay. Astander has two dry docks, the largest accepting ships up to 50,000 dwt, and repair quays

jumboization and upgrading of the DFDS RO/RO freight vessel *Dana Maxima*. The Danish owner's specification sought to make the 1978-built vessel more suitable for the North Sea trade by increasing the cargo capacity to 2,800 lane-m or 210 trailers. The overall length was stretched to 176.20 m by inserting a new 31.5 m long hull section weighing some 1,000 tons. Deadweight capacity was raised to 8,546 dwt.

Barcelona-based Union Naval de Levante (UNL) is well located to target a wide range of business, including regular callers to the busy port-

QUALITY-ASSURANCE  
ISO 9002  
GL-certified

**Service  
Center  
Hamburg**

5 414 211

MAN B&W Diesel AG, Service Center Werk Hamburg, Rossweg, D-20457 Hamburg, Telephone (+49) 74090

Factory-owned quay in the port of Hamburg for ships up to 90,000 tdw. Repairs, overhauls and modernisation of MAN B&W and other engines, boiler and turbine plants as well as of industrial and power plants.

General contractor for shipbuilding work. Spare parts supply and depot.

Reconditioning and exchange service for engine

parts. Turbocharger service. Materials test-

ing station. Technical service. Trouble-

shooter-service round the clock.



Write 26 on Reader Service Card

tugs, ferries, bulkers, car carriers, container ships and cruise vessels—as well as attracting tonnage trading to or via the Mediterranean.

The yard benefited from a major upgrading in 1992 which injected fully computerized administration and production systems. UNL has since gained ISO 9002 quality assurance certification.

A 24-hour seven-day operation and a flexible labor agreement back the yard's ability to offer an Express Docking Service, responding to short-notice requests for repair and maintenance projects. A docking redelivery in four days is possible depending on the complexity of the project. UNL also promises fixed rates, with any extras quoted and agreed beforehand.

Facilities center on a 215 x 35 m graving dock and a 4,500 t-lift floating dock, backed by two fully equipped repair berths, each 250 m in length. The past year has seen the docks well-utilized, a healthy level of bookings partly boosted by the port of Barcelona's record commercial traffic. A new joint venture agreement with Sistemar allows UNL to offer a package deal to owners wishing to retrofit the Spanish designer's fuel-saving CLT propeller. The work can be executed during a drydocking at no additional expense.

In Cartagena, Bazan Carenas can drydock vessels up to 230,000 dwt and accept those up to 400,000 dwt alongside. Currently, about 40% of its business is military, but it expects its commercial work to increase. General manager Jose Luis Moya notes that Singapore has increased its prices, with the result that more ships are reverting to Europe for repair. Interesting work at Bazan last year included installation of special new blisters on a semisubmersible to increase stability. The total steel weight involved in the job was some 320 tons.

Astilleros Espaiioles' large repair facility in Cadiz has lately been focusing primarily on large conversions as



## From products tanker to Class chemical carrier

In a first-of-its-kind operation, Lisnave recently converted Latvian Shipping Company's 20,000 dwt products tanker *Dzintari* into a full Class 3 chemical tanker.

As part of the upgrade, the vessel's cargo tanks and piping were lined with MarineLine, a coating developed by Advanced Polymer Sciences, Inc., Avon, Ohio. MarineLine is based on a patented multi-functional polymer that reacts with a catalyst to form a very dense, highly cross linked molecular structure. It is resistant to all solvents and to 98% of all chemicals.

Latvian Shipping Company had already had good experience with the coating. At the end of 1994, the tanks of its 28,400 dwt tanker *Indra* were coated with MarineLine to enable it to operate in the the methanol trade—where it is earning 50% more a day.

part of the group's Strategic Competitiveness Plan. Its most recent contract (*MARINE LOG*, January, p.9) will see it convert a drilling platform into a production platform for operation in Brazilian Basin waters more than 3,000 m deep.

Across the frontier, Kværner Gibraltar last year handled 126 ships, drydocking 55 of them. The yard has made a considerable com-



One of *Dzintari's* 14 cargo and slop tanks after coating with MarineLine

*Dzintari* has been upgraded to enable it to carry phosphoric acid. The job involved applying MarineLine to a total surface area of some 30,000 m<sup>2</sup>.

mitment to training to improve staff skills and is planning to at least break even by the end of this year.

### FRENCH MEDITERRANEAN

France's most important repair center on the Mediterranean coast is the 10 dry dock complex owned by the Port of Marseilles. The largest is a 700,000 dwt unit with a usable length and breadth of 465 m x 85 m.

## Service Center Frederikshavn

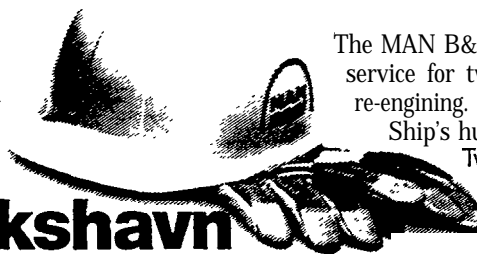

The MAN B&W Service Center in Frederikshavn, Denmark offers full service for two and four-stroke engines - maintenance, repair and re-engining. Gear and propeller equipment-overhaul and refurbishing. Ship's hull and deck equipment - general repairs and conversions. Two slipways and a pier length of 600 metres.

Turbocharger service.

Technical consulting.

Engineering service round the clock.

MAN B&W Diesel, Service Center Fredenkshavn, Langerak 74, DK-9900 Frederikshavn. Tel. (-45)962041 00



Write 30 on Reader Service Card

Among repairers using the complex are CMR, Marine Technologies, Travofer and SPT Phocenne de Travaux. CMR's commitments this year have included six gas tankers, among them the Algerian-owned LNG carriers *Mostefa Ben Boulaid* and *Hassi R'Mel* which were redelivered in August and mid-October after extensive upgrading projects.

#### ITALY

In Italy, work at INMA in La Spezia last year included the \$60 million complete rebuilding of the *Lee-ward*, now based in Miami, and the \$20 million rebuilding of the *Regal Voyager*, managed by ISP of Miami. About 60% of the yard's business is repair and conversion and this is expected to increase due to new SOLAS stability rules.

Newbuilding resources at the Fincantieri group's Palermo yard in Sicily enhance its capability to execute conversions involving major steelwork, notably jumboizations—a speciality reflected in the recent and projected workload at the yard.

Considerable docking flexibility is derived from three graving docks (20,000 dwt, 150,000 dwt and 400,000 dwt) and two floating docks (19,000t and 52,000 t-lift capacities). The 150,000 dwt capacity graving dock is a recent addition to the facilities. Current investment is focused on new steel fabrication machinery and a new subassembly workshop.

In the year to October, the Palermo yard repaired 43 ships, of which 24 were drydocked. The most significant project called for the renewal of around 1,000 tons of steel on a 35,000 grt containership which had suffered grounding damage. Maintaining its jumboization speciality, the yard extended a car carrier by inserting a 32 m long midbody section and was booked to lengthen two RO/RO vessels with 35 m sections.

Company managers report that increased competition—notably from

yards newly targeting western business—has driven down prices and made the repair market tougher for established contenders.

#### CONFIDENCE IN CROATIA

An active year, underwriting confidence in the future, is reported by Croatia's Viktor Lenac Shipyard whose facility at Rijeka near the Italian border is claimed to be the largest repair yard on the Adriatic Sea and the most competitive in the region.

Since the beginning of 1993 the yard has been registered as a joint stock company owned 100% by the private sector. Its own workforce of 650 personnel is supported by 500 workers available locally when required from subcontractors. Staff skills and facilities reportedly allow any type of repair and conversion project to be handled, including ship lengthenings.

The yard's prime resources are three floating docks with respective lifting capacities of 5,500, 12,000 and 24,000 tons, allowing ships up to 65,000 dwt to be targeted. Afloat-repairs on ships up to 125,000 dwt can be undertaken at berths totaling 1,200 m in length.

In the year to end-September Viktor Lenac docked 40 ships, renewed around 1,200 tons of steel and completed some 60,000 m<sup>2</sup> of sophisticated epoxy and zinc tank coating work, as well as around 85,000 m<sup>2</sup> of cargo hold and hatch cover treatment. August was particularly busy, with 825 tons of steel renewal executed. Facility development investments aim at enhancing work quality and environmental protection.

#### BLACK SEA YARD WITH KEEN PRICES

Romania's privatized Black Sea Shipyard, located in Midia Harbour near Constantza, claims to offer a range of alongside and clocking repair services at competitive prices attracting increasing business from West European, Russian, Ukrainian,

Cuban and domestic operators. Yard management is making efforts to expand bookings from the international market for docking facilities based on two 10,000 t lift floatin docks and a 20,000 t lift floating dock, ships of up to 65,000 dwt can be handled at repair quays.

#### FAR EAST

One-third more docking capacity will be in place in Singapore by mid-1996, taking the total Singapore capacity to around 3.85 million dwt. An investment program totaling around S\$580 million will deliver, between 1994 and end-1996, two more VLCC/ULCC docks, a Panamas dock and two handy-sized docks. In addition, the republic's yards will be able to tap extra repair berthage and upgraded workshops.

Keppel will exploit a new 360,000 dwt graving dock at its Tuas yard (the group's eighth dock in Singapore).

Jurong Shipyard has committed S\$150 million for the construction of a 400,000 dwt graving dock, a new quay at Tanjong Kling, quay extensions at Pulau Samulum and general facility upgradings. The new ULCC dock, scheduled for completion by mid-1996, will increase the yard's capacity by around 60%.

Singmarine Dockyard & Engineering, the medium-sized repair arm of the Keppel group, has built a 14,000 t-lift dock (190m x 33m) to replace the facility damaged in the *Belorussiya* cruise ship accident.

Jurong Shipyard's aim of providing a "one-stop total service" for all owners influenced its acquisition of a 25% stake in Atlantis Engineering & Construction, the medium-sized newbuilding/repair subsidiary of Neptune Orient Lines. The associated Tuas Road-based Atlantis Shipyard has hitherto operated with a 25,000 dwt capacity floating dock and repair

QUALITY ASSURANCE  
ISO 9002  
Lloyd's Register certified

**Service  
Center  
Singapore**

MAN B&W Diesel, Service Center Singapore, 29 Tuas Avenue 2, Singapore 2263, Telephone (-) 8 621401

The MAN B&W Service Center in Singapore covers the whole of South East Asia, offering the widest range of genuine MAN B&W spare parts outside Europe. Services comprising engine and turbocharger repairs, reconditioning and a parts exchange service, consulting activities on modernizing and maintenance.

Own workshop and training facilities.  
Trouble-shooter service round the clock.



Write 38 on Reader Service Card

berths able to accommodate seven vessels up to 200 m length. A second dock, bought from Russia, was due for service early last year, offering a lifting capacity of 4,500 t. The yard is under the management of Jurong Shipyard, which may spell a larger financial stake and further expansion of resources. Joint marketing and purchasing permits repair and conversion projects involving ships from 500 dwt to ULCCs to be targeted.

Sembawang Corporation (formerly Sembawang Shipyard) is investing heavily in upgrading and rationalizing its own facilities as well as improving infrastructural support. Sembawang operates five docks with a total capacity of 740,000 dwt and claims to be southeast Asia's largest repair yard in a single location. Its largest dock can accept ships of up to 400,000 dwt. Apart from tankers and other mainstream cargo tonnage, the yard has established a reputation in the refurbishment and upgrading of high class passenger ships.

Singapore Shipbuilding & Engineering has invested around S\$80m in the phased development of its new yard at Tuas, a 28,000 t-lift floating

dock being completed last year to handle tonnage of Panamax size.

Own-built floating dry docks have extended the resources of Tuas-based Pan-United Shipyard, which reports that competition in Singapore remains intense and margins low. Pan-United recently strengthened its reputation in conversion projects with the lengthening and re-engining of a large Philippines inter-island ferry.

#### **LOCK ON THE MARKET, OR OVER AMBITION?**

Will all this expansion strengthen Singapore's lock on a sizeable chunk of the international repair market? The republic's Big Four—Hitachi Zosen, Jurong Shipyard, Keppel and Sembawang—already control some 25% of the world's drydocking capacity and are also estimated to account for around 40% of the world VLCC repair market.

Their confidence has been buoyed by an expected surge in demand, both in volume and revenue terms, for repair and life extension work from 1993-96; particularly third and fourth special surveys for large tankers, the staple diet of Singapore's majors.

Yard chiefs also anticipate a recovery in the world economy and the continuing growth of trade and shipping in the Asia-Pacific region.

Nonetheless, some analysts are questioning whether the boom can go on for ever. A recent report from Schroders Singapore sees the repair market strengthening in the second half of this year, with average revenues from repairs also rising. But it notes that Singapore's dominant position is being eroded by competition from the Arab Gulf and China. It also notes that the world VLCC fleet is shrinking, so that even if Singapore maintains its share of this repair market at its current 40% the number of VLCCs available for the yards will drop. One response the Singapore majors have taken to meet low-cost competition is to invest in repair facilities outside Singapore. The overseas interests of the major groups reportedly already contribute some 15% of Singapore's total repair revenue. This injection is primed to grow in the years ahead. Another step taken by some of the majors has been to lower their dependence on repair revenues. Thus, at press time, Keppel



## **EXPERIENCED VESSEL CONVERSION PROFESSIONALS**

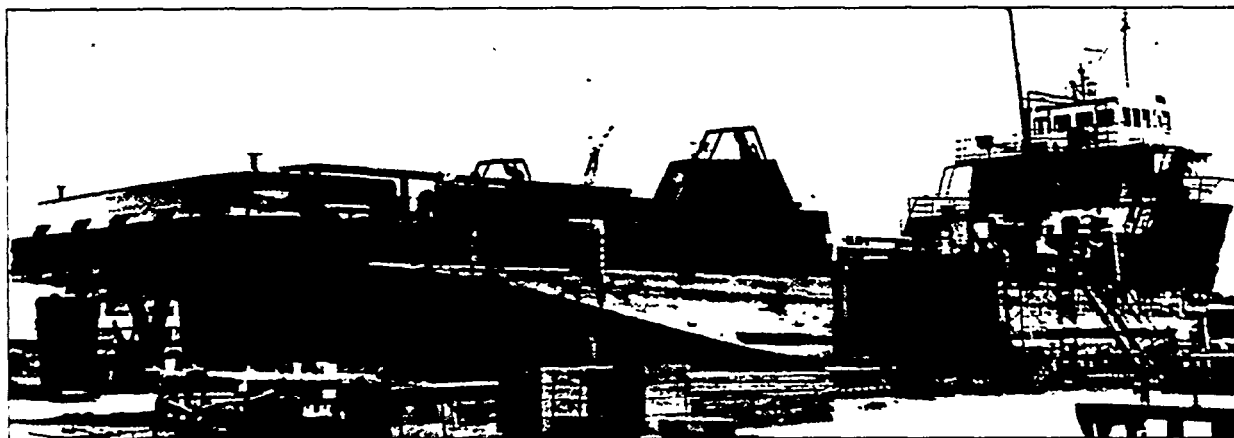

**WHEN IT'S TIME TO CONVERT YOUR VESSEL TO IMPROVE DECK CARGO AND LIQUID CARGO CAPACITY, YOU WANT A SHIPYARD WITH EXPERIENCE, FULL SERVICE DESIGN AND ENGINEERING CAPABILITIES AND THE PROVEN ABILITY TO TURN-KEY YOUR CONVERSION TO QUICKLY RETURN YOUR BOAT TO SERVICE. WHY TURN TO ANYONE ELSE?**

SERVICE MARINE INDUSTRIES, INC.  
P.O. BOX 3606  
MORGAN CITY, LA 70380  
(504) 631-0511 / FAX (504) 631-2933

**SHIPYARD AT:**  
MILE 88.5 WEST INTRACOASTAL WATERWAY  
606 FORD INDUSTRIAL RD.  
AMELIA, LA 70340

was predicted to announce higher 1995 net profits. But only 40% was expected to come from ship repair. What's more, 'we expect shipyard earnings. once the lynch pin of the group, to be very weak,' said analyst Foo Jou Min of Crosby's She attributed this to shipowners doing minimal dry dock work due to low freight rates and to stiff competition from both domestic and international rivals. However, she expected subsidiary Singmarine Industries, which repairs medium size ships, to report increased 1995 earnings as a result of a 12 month contribution from its new dock. Meanwhile, analysts polled by the *Singapore Business Times* were expecting gloomy FY 1995 results from another of the Big Four. Sembawang, including a "letdown in the shipyard sector in 1995's second half."

#### EXPANSION AT MSE

Just over the border from Singapore. Malaysia Shipyard & Engineering (MSE) now has more docking capacity after the installation of a 48,000 dwt capacity 110-hoist Syncro-lift formerly operated at Todd Shipyards' Los Angeles yard. MSE's repair division had hitherto been based around 450,000 dwt and 140,000 dwt dry docks. Two quays have been extended to allow the berthing of VLCCs and two new quays built for repairing smaller ships, supported by new craneage and three workshops for painting, piping and machining.

#### MAJOR CONTRACTS FOR HMD

In Korea. Hyundai Mipo Dockyard (HMD) continues to land significant contracts. It has recently been completing a seven ship contract involving Sea-Land 2.472 TEU class containerships. Work reportedly included removal of tin-free antifouling and their replacement with tin-based products for longer service life. HMD has also been active in the conversion

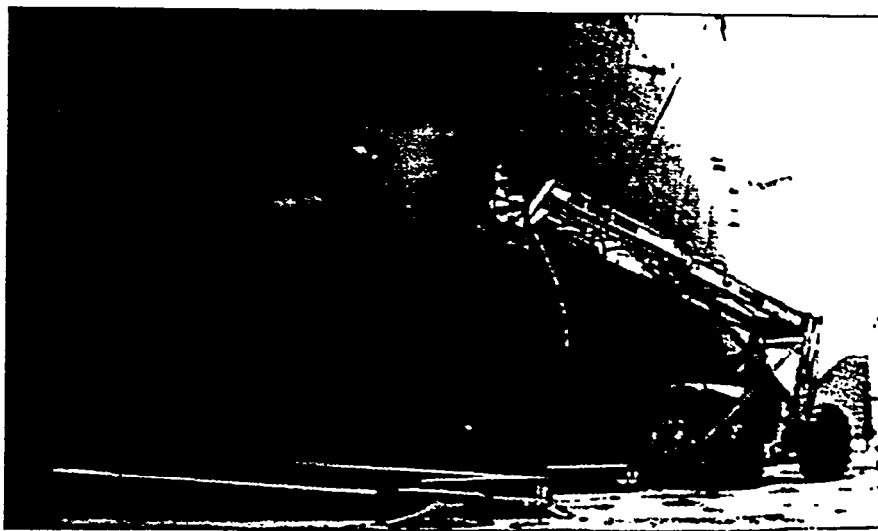

Hull coating at Vietnam's Pha Rung. Canada's Montreal Tankers Repairs is now marketing a service to international shipowners backed by the yard's facilities

market. recent contracts including one from South Africa's Safmarine for conversion of a 37,425 dwt bulker into a specialized liquid carrier.

#### CHINESE YARDS LOOK OVERSEAS

The obvious big new player in Far East ship repair is likely to be China. Though much of its capacity is committed to supporting the domestic fleet. China is keen to secure more overseas business for its widespread repair industry. The Shanghai Machinery Import & Export Corporation alone represents a region with over 10 yards and 15 docks targeting ships up to 150,000 dwt. More than 30 repair/service stations are also located in and around Shanghai.

Next year, of course, Chinese repair capacity will include that in Hong Kong. Confidence in the future of Hong Kong as a repair center under mainland rule is underlined by the investment commitments and plans of Hongkong United Dockyards (HUD) and Yiu Lian Dockyards.

Capacity at HUD was boosted last

year by a new 40,000 t-lift floating dry dock from Singapore's Far East Levingston yard. The 290 m long x 46 m internal breadth GVA-designed facility has an operational width of 40 m, enabling it to handle current and future generations of large post-Panamax containerships.

China Merchants Holdings' subsidiary Yiu Lian Dockyards has expanded facilities in Hong Kong and is also committed to development on the South China mainland. Space restrictions on berth expansion and floating dock moorings in Hong Kong led Yiu Lian to develop a repair yard at Shekou in South China's booming Shenzhen special economic zone.

#### NEW CHALLENGERS

Poised to become another competitive challenger in southeast Asia. Thailand's Unithai Shipyard & Engineering (UTSE) was started up in early 1992 with Hong Kong Chinese and Japanese investment. Senior yard management and technical staff were drawn from the U.K., Japan, Singa-



MAN B&W Diesel and Turbocharger Service day and night in Argentina, Australia, Austria, Bahrain, Bangladesh, Belgium, Brazil, Canada, Chile, Columbia, Croatia, Cuba, Curaçao, Denmark, Ecuador, Egypt, Finland, France, Germany, Great Britain, Greece, Hong Kong, Iceland, India, Indonesia, Iran, Ireland, Italy, Japan, Kuwait, Latvia, Lebanon, Luxemburg, Malta, Mexico, Morocco, Netherlands, New Zealand, Norway, Oman, Pakistan, Peru, Philippines, Poland, Portugal, Saudi Arabia, Singapore, South Africa, South Korea, Spain, Sri Lanka, Sweden, Taiwan, Thailand, Tunisia, Turkey, Russia, Ukraine, United Arab Emirates, Uruguay, USA, Venezuela, and Zimbabwe.



Write 47 on Reader Service Card

pore, Hong Kong, Malaysia, Taiwan, China and the Philippines.

UTSE is adjacent to the deepwater container and bulk handling port of Laem Chabang, 120 km southeast of Bangkok. The yard operates a 40,000 t-lift floating drydock measuring 282 m x 47 m and allowing 150,000 dwt vessels to be stemmed. Strengths are claimed in steel renewals and hold blasting/coating projects. Blasting is performed by Thai Clavon, a joint venture between UTSE and Jurong Shipyard.

Vietnam is also seen as offering considerable potential. The Pha Rung Shipyard at Haiphong City, whose facilities include a 156 m x 26 m dry dock and a repair pier, claims to handle a full range of hull, machinery and propeller repairs. Specialties include in-situ reconditioning of crankshafts. Pha Rung is soon likely to become better known to the international community. It is in partnership with Canada's Montreal Tankers Repairs, Inc. in Asian Star Shipyards. The joint venture uses Pha Rung's facilities to offer ship repair services to international merchant ships transiting to Vietnam, specializing in refits and emergency repairs.

## MIDDLE EAST

Middle East yards' overall capacity, range of facilities and expertise—particularly in the Arab Gulf—have matured in the past 10 years to earn a leading international status. The main contenders are based in Bahrain, the United Arab Emirates (UAE) and Kuwait but yard facility developments proceed in Iran, Saudi Arabia and elsewhere. The region's potential is reflected in the local participation of major Singaporean repair groups, through shareholdings, yard management and co-operation agreements.

ULCCs, VLCCs, other large tankers and combination carriers calling at Arab Gulf oil terminals have traditionally provided a business baseload. But investment has been made in new docking facilities and afloat-repair services to support a diverse range of tonnage: support vessels, bulk carriers, product tankers, containerhips, general cargo vessels, gas carriers, vehicle carriers and live-stock vessels.

Another investment objective has been to boost competitiveness

through faster turnarounds and through higher quality—with the region's leading repairers already boasting or pursuing ISO 9002 certification. As a result, Gulf repair yards are giving the Singapore industry a run for its money.

ASRY chairman Shaikh Daij Bin Khalifa Al-Khalifa has always believed that his Bahrain yard could compete with and eventually out-perform Singapore rivals. Independent studies, he suggests, have confirmed that ASRYs efficiency and price levels are now on a par with Singapore yards.

Dubai Dry-docks claims a slight price advantage over Singapore, not least due to the strength of Singapore's currency. A number of oil majors, such as Shell, have switched some business to Dubai at the expense of Singapore.

Owners are now more prepared to accept that repair work can proceed in the Gulf during the hot summer months without productivity suffering. Tank coating projects at ASRY are facilitated by refrigerated dehumidifiers which allow tank steel temperatures to be lowered to a level

## Kvaerner Masa Marine Inc.

Naval Architects and Marine Consultants

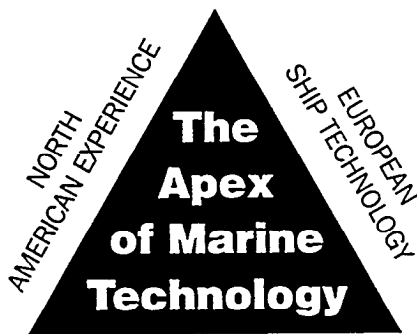

INNOVATIVE & RELIABLE SOLUTIONS



KMM's knowledge base is backed up by the advanced technologies of the Kvaerner Shipbuilding Group, derived from decades of ship design and construction experience.

Power Technology Center  
201 Defense Highway, Suite 202  
Annapolis MD U.S.A. 21401  
Tel: (301) 970-2226  
Fax: (301) 970-2230

1525 West 8th Avenue, Suite 207  
Vancouver BC Canada V6J 1T5  
Tel: (604) 736-8711  
Fax: (604) 738-4410

Email [kmm@mindlink.bc.ca](mailto:kmm@mindlink.bc.ca)

KVAERNER

Write 48 on Reader Service Card

## Bite Through RUST, SCALE & PAINT

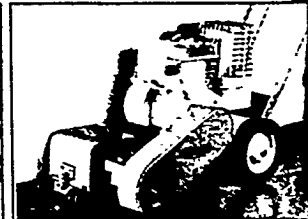
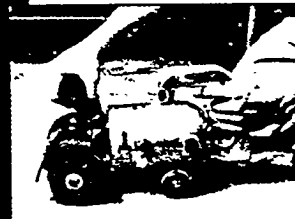

There is an AURAND tool that's  
right for EVERY job!

Aurand's patented cutting teeth bite right through tough accumulations on ANY hard surface. On decks, walls, or ship hulls, on tanks, pipelines or boilers, results like sandblasting are yours. Aurand's unique Centrif-Clean® action quickly peels off build-up. Adjustable depth settings protect the underlying surface and prevent overloading, stalling and excessive cutter wear.

- LIGHTWEIGHT
- ADJUSTABLE DEPTH SETTINGS
- EASY TO USE
- SAVES HOURS OF WORK

### AURAND

1210 ELLIS STREET • CINCINNATI, OHIO 45223-1843

PHONE: (513) 541-7200

FAX: (513) 541-3065

MADE IN  
USA

TOLL FREE: 1-800-860-2872



Write 29 on Reader Service Card

favoring optimum adhesion of coatings. Experienced local subcontractors compete for the business.

ULCCs and VLCCs inspired the creation of the UAE's Dubai Drydocks complex and have consistently fed its 1 million dwt, 550,000 dwt and 350,000 dwt graving docks. In 1994-1995, the number of VLCCs docked increased from 35 to 38, helping Dubai Drydocks to claim a 30% share of the global VLCC/ULCC repair market.

The prime customer base has traditionally been independent tanker owners operating west-bound tonnage.

But a drive to secure more business from oil majors (at the expense of Singapore yards) has reportedly proved fruitful. Tonnage has been committed in the past year by Shell, Mobil and Texaco; Saudi Arabia's Vela has also stemmed tankers on a regular basis at Dubai Drydocks.

Meanwhile, the growing potential for business from smaller tonnage

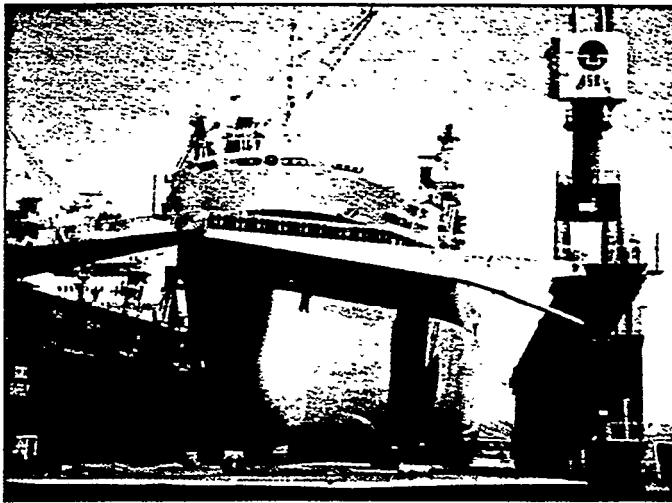

Floating docks have given ASRY, Bahrain, an added flexibility

encouraged the yard to build its own 15,000 t lift capacity floating dock. Nominally, this unit is limited to ships up to 40,000 dwt, but vessels handled last year included the 42,600 dwt Indian bulk carrier Matru Kripa. It was docked for hull renovation, bow collision damage repairs and cargo hold blasting and painting.

Bahrain's Arab Shipbuilding and

Repair Yard (ASRY) last year logged net repair revenues of \$73.6 million, a gain of 10.8% over 199-1 and the highest achieved since the OAPEC-owned facility opened its 500,000 dwt graving dock for business in 1977. Yard directors said the results were achieved "in a climate of intense competition and low repair -prices worldwide, most notably in the FarEast."

The success will stimulate ASRY's plans for further significant investment following the \$62 million spent on two second hand floating docks

and supporting infrastructure commissioned in 1992. The 80,000 dwt and 120,000 dwt capacity docks gave the yard a much needed extra flexibility.

ASRY's latest development plan, representing an investment of \$87 million, seeks to expand the yard's berthing space. The \$ 19 million first phase calls for dredging a channel to

## Proven power transmission solutions for large ships

At Philadelphia Gear, we have consistently demonstrated our ability to provide innovative solutions for ship propulsion requirements. Count on us to deliver rugged, cost-effective gear drives for your large ship requirements.



philadelphia gear corporation

181 S. Gulph Road  
King of Prussia, PA 19406 U.S.A.  
Tel: 610-265-3000 • Fax: 610-337-5637

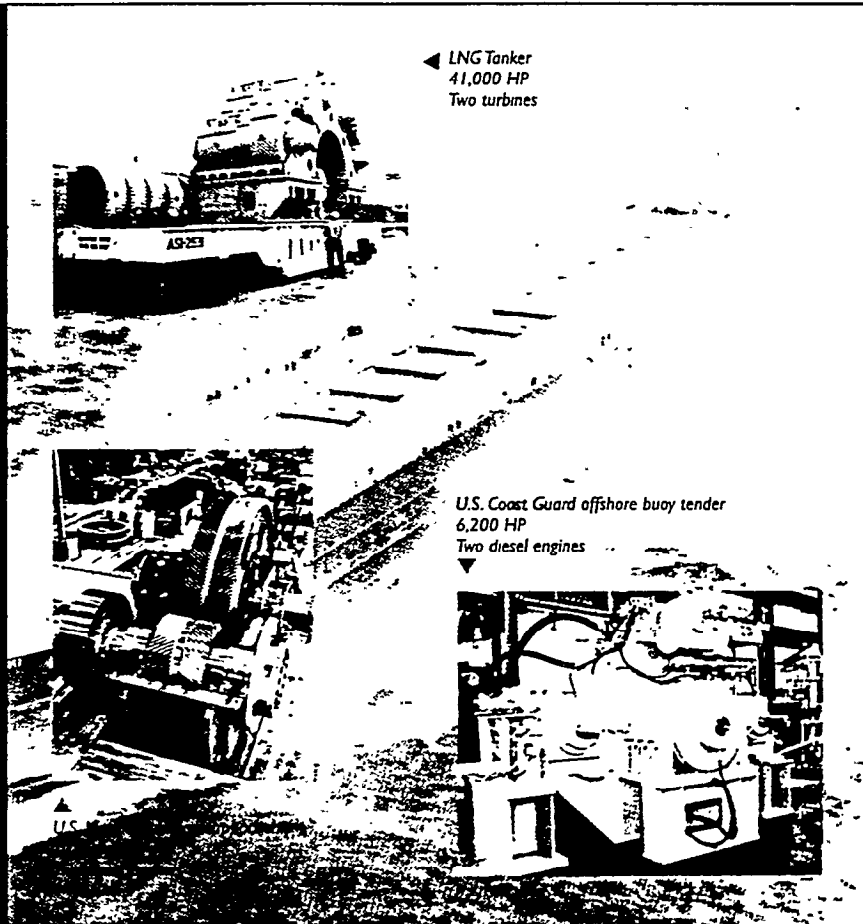

Write 28 on Reader Service Card

a 10 m minimum depth and building a new quay and wall to accommodate VLCCs. The 400 m long x 250 m wide quay would be provided with a 15 t capacity travelling crane and electrical/compressed air services.

The 868 million second and third phases call for extension of the quay to 700 m and then 1,100 m, and the dredging of an 110 x 250 m channel. A second large traveling crane and other shoreside installations and workshops would be added. Plans for a second large graving dock are still on hold. The go-ahead for the investment of 8120 million awaiting justification from market demand and ASRY's financial resources.

In addition to ASRY and Dubai Drydocks, the Arab Gulf is served by over 70 companies offering repair services. For example, a wide range of repair and maintenance work is targeted by the Bahrain Ship Repairing and Engineering Company (Basrec). The yard can stem ships up to 6 000 dwt in its floating dock, while two 80 m shipways can handle vessels up to 1,000 t. Two 30 t capacity tower cranes have been installed to cover the dock and slipways.

Opportunities for Bahrain-based in-water service business have been widened by government regulations making the Bahrain anchorage available to ships for a one-off payment of 300 Dinars (around \$800), irrespective of the tonnage or length of stay.

A broad mix of vessels is served by Kuwait Ship Repair Yard. Recent visitors have included three multipurpose general cargo ships in the 23,000 dwt size range owned by United Arab Shipping Co., a 6,769 dwt Malaysian chemical tanker and a Greek owned bulker

## OTHER OPTIONS

**I**n this survey we've concentrated on the major repair centers. But shipowners continue to find other options opening up.

Sri Lanka's Colombo Dockyard is benefiting progressively from Japanese investment, management and training-Onomichi Dockyard is now its majority owner. Elsewhere in the region, the ship repair potential of the Indian subcontinent remains largely untapped. That could change. The pool of skilled labor at compara-

tively low cost is attracting interest from overseas repairers and facility investment is under way at several yards.

Goa's Western India Shipyard Ltd (WISL) at Mormugao Port enhanced its resources last year with a new floating dock from Pan-United Shipyard, Singapore. The 20,000 t-lift facility can accept ships up to 230m long x 34m wide x 7.7m draft. The yard is jointly managed and operated by senior personnel from Lisnave.

Another area where ship repair business appears to be picking up is South Africa. Thus Globe Engineering, in Cape Town, which has been expanding its capabilities, has been awarded the drydocking of three Mitsui OSK vessels operating on the African west coast and reports that Cape Town's 40 m wide Sturrock dry dock "is almost fully booked for 1996."

In Latin America, Tsakos Industrias Navales, S.A., Montevideo, Uruguay, is expecting to increase its repair volume this year. Besides an increase in overall business, it will bring a second floating dock for smaller vessels-mostly fishboats-into operation this year. M L



## Cameroon Shipyard and Industrial Engineering LTD

Head Office: Zone Amont - Port de Douala - BP 2389 Douala-Cameroun-Central Africa  
Tel: (237) 40-15-60; 40-34-88; 40-47-71 • Fax: (237) 40-61-99; Telex: 5479 KN

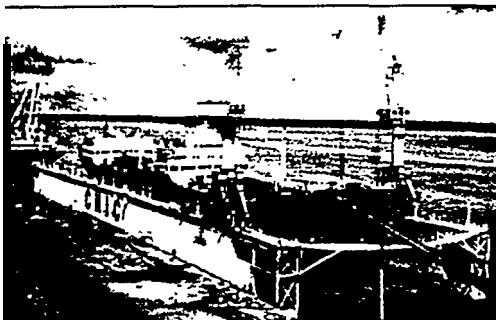

Hull clearing with HP water of a Greek tanker

### Main Mission

- Shiprepair and Shipbuilding
- Onshore-and Offshore industrial engineering activities
- General engineering
- Maintenance and Manufacture of Containers

### Our Facilities

- 3 floating dry docks with the following lifting 500T: 1000T: 10 000T
- A floating crane with a lifting capacity of 120T
- An area of 5000 m2 of covered workshops equipped with modern machinery.
- Repair berths for afloat work.

**Chantier Naval et Industriel du Cameroun s.a.**  
Cameroon Shipyard and Industrial Engineering LTD





# All is not quiet on the shiprepair front

*Bill McConnell gives a containership operator's view of shiprepair*

I propose to lay down some pointers that will lead to closer cooperation between owners' representatives and shiprepair yards. For too long there has been a fundamental lack of understanding of each other's priorities. It is hoped that as we rapidly approach the 21st century the demands and pressures of our industry can be more widely understood and the difficulties therefore more easily overcome. This is seen as an opportunity to dispel some widely held myths and to develop a greater degree of confidence amongst our friends on the other side of the business.

P&O Containers operates a wide and varied fleet of 27 container ships trading worldwide, with particular interests in Europe, the Far East, Australia, New Zealand, South Africa and more recently between the Indian Subcontinent, the Arabian Gulf via the Mediterranean to the US East Coast and the Gulf of Mexico.

The age profile of the fleet ranges from among the earliest fully cellular container ships of 1969 vintage to the most modern ship, delivered from the builders in April 1995. To support our commitment to the industry there are also larger and faster ships on the drawing board, but more about those later.

P&O Containers developed out of OCL (Overseas Containers Limited) and is an independent operator within the P&O group of companies, with its own Commercial, Financial and Fleet Management divisions. OCL was formed in the mid-sixties from a number of the old traditional shipping companies closely associated with the Europe-Australia service. Apart from P&O these included Furness Withy, British & Commonwealth

and the Ocean Steamship Co. The first ship on the trade was *Encounter Bay*, delivered by Howaldtswerke Deutsche Werft, Hamburg in February 1969. She carries just under 1600 20-foot boxes and was powered by a 32 000 SHP Stal Laval turbine. You will notice a subtle change of tense in that last sentence because the ship is still in service but the steam plant was replaced in the early eighties with a slow-speed two-stroke diesel engine, as the oil crisis began to bite and fuel prices took off.

Over the intervening 26 years the company has developed into a major global player operating ships up to maximum Panamax size capable of lifting well over 4000 20-foot units.

At the time of writing P&O are well up the league table of container operators and the intention is to maintain or improve on that position. We are currently talking to shipbuilders about significantly increasing our tonnage, mindful of the fact that the world does not stand still and that there are no viable alternatives to the very large drycargo carriers - not even in the minds of the prophets and soothsayers.

## Operating philosophy

In simple terms, what a modern container operator requires is a ship that arrives in and out of port as if by clockwork. It should dock on a preset day at a fixed time, preferably at 07.30 to start cargo work at 08.00, with sailing time arranged for 15 minutes after the end of the day shift. Minor problems like repairs, damages and any out-of-service activities just do not figure in the planning. Even technical people understand that modern trading patterns demand minimum downtime. Our Europe/Far



**Bill McConnell**

East trade operates a nine-ship string with a 60-day round voyage per ship with 16 port calls plus MO Suez Canal transits. Average port time is about 12 hours with an occasional maximum of 30 hours. There is always the uncertainty of scheduling, weather, port movements, gantry breakdowns and strikes in all trades. Australian wharfies have been known to withdraw their labour on some pretext or other.

It is therefore incumbent on technical superintendents to dovetail the necessary repairs, breakdowns, storing, surveys, statutory obligations and bunkering into this restricted port time.

In many ports in the world *there* are immobilisation restrictions laid down by the port authorities where main engine work is not permitted while the ship is alongside a container terminal. Consequently a further opportunity to keep on top of even routine engine maintenance is denied.

Another peculiarity of the box business is the constant overlap of import and export cargoes. There will always be cargo on board. Loading and discharge take place simultaneously, even in the same hold, to maximise on port rotation time. This makes underdeck work very difficult and hazardous. There are added complications with the blown-air reefer ships, particularly on the Australia/New Zealand and South African trades, where access to fans, couplings coolers and insulation for basic repairs and cleaning can be compromised by stowage patterns.

Urgent work therefore needs a good excuse and tough negotiating with the terminal operators. Technical delays do not go down well with cargo planners, being on a par with selling their children into slavery.

In short, between major, planned out-of-service periods of 10 running days every 30 months and 15 days every five years there is little available time for other than running maintenance.

What to do?

Having defined some of the difficulties, what are the options open to the operators?

---

*Minor repairs can be made at sea*

---

## 1. Travelling squads

*These* fit in well for certain types of repair, like superficial steelwork, generator maintenance, cleaning and painting. In other words, fairly selective activities. Cargo areas are not usually accessible owing to the possibility of damage, fire, taint or where there are high-risk commodities. On-deck painting must be kept clear of reefer air-change vents or hazardous areas. It can be seen that choices are limited.

## 2. Stopping at sea

In order to keep up with engine maintenance, selective stoppages on passage can be beneficial. However, certain factors need to be considered: time available, increased fuel consumption to make up schedules, weather conditions and the safety factor. In order to make best use of the time available it may be necessary to carry additional labour for a limited period, with its associated costs.

It is clear that shiprepair firms need to understand the pressures under which liner-trade vessels are operating. Realistically the repair firm must provide a service that fits in with the limited time available. Initially this requires commitment because the market and opportunity are there for those with the resources and a dedicated approach with a fair number of unsociable hours thrown in: Planning and regular

dialogue with the owner's technical superintendent are essential.

Everyone is aware of the necessary attributes needed: quality, reliability and efficiency - all matched to a realistic cost. But what is a realistic cost? As always, this means different things to different people. So let us be clear where we stand. Cost is important to both parties in any transaction but it rates a poor second place to a job well done within a given time.

Over the years many shipowners have experimented with their own repair labour and workshop facilities with mixed results. If this is thought out and planned correctly with a sensible level of investment and a dedicated full-time management team, it could be made to work. If nothing else, it gives the shipowner/operator a taste of the problems the shiprepair industry has to face.

A sponsored repair yard on, say, a biannual fixed time contract with a minimum guaranteed work load could also be attractive.

## The green scene

One of the big topics facing every strand of shipping in the late 20th century is the environment and its associated implications. It encompasses smoke pollution, oil waste and garbage disposal, plastics and the colourful issue of paint. Both shipyards and owners are facing increasing and damaging legislation covering many aspects of painting.

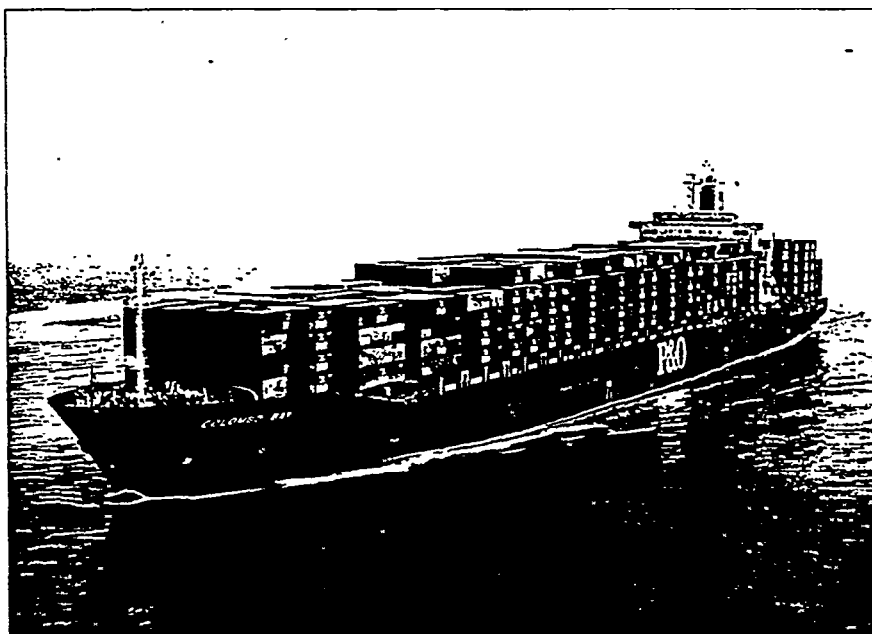

P&O Containers

Due care must be exercised with blasting preparations, the application and the type of paint itself, and not forgetting the disposal of all waste. Collectively this represents a huge cost to both parties, most of which will be picked up by the owner.

In practical terms tin-free anti-fouling has got to be just that - anti-fouling - and it has to be effective for up to five years and be a substitute for the well proven self-polishing product it replaces. There is not yet a suitable alternative on the market. We know the paint companies are spending a lot of money on research in trying to overcome this problem but with legislation years ahead of reality the industry ends up not solving one problem but creating a further two. At present there is a tin-free anti-fouling that seems actively to encourage the growth of sea grass. The result is that both slip and fuel consumption increase and at the same time the main engine emits a larger volume of airborne pollutants into the atmosphere.

All sections of the marine industry are committed to improving the world which supports us. Scientists, engineers and chemists will find solutions to some of the intractable problems that currently exist. Nature can give us many clues. If only we could harness the material that makes the dolphin's outer shell so smooth and the blue whale's power plant so clean and powerful.

The marine industry gets a bad press but at least it makes a serious attempt to clean up its act. It is a pity a few more industries don't follow suit.

Softly, softly; cleanly, cleanly  
The container ship on liner trades is worked hard in a demanding and hostile environment with a minimum of slack time. This says a great deal for the

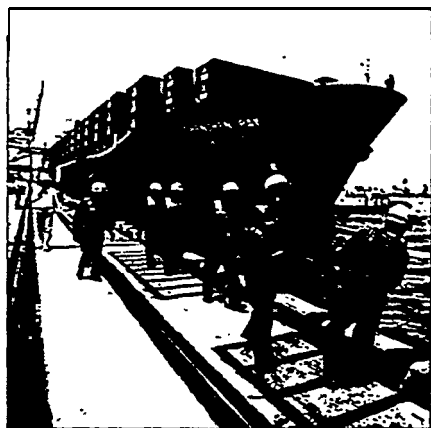

slow-speed two-stroke engine whose development has mirrored the trades that it has geaced with its ability to cope with operating abuse, constantly deteriorating residual fuel, minimum maintenance and the ever increasing demands of an insatiable commercial world.

The main area of concern is reliability. Traditionally, operating maintenance has been undertaken by the ship's own staff. But as plant gets larger and crew numbers decrease the repair equation ceases to balance.

Fuel-injection equipment increasingly needs the support of specialists who understand the business and are close to the engine builder and who don't charge outlandish prices for an indifferent service.

The ability of an engine to breathe correctly cannot be overstated. Turbochargers and air coolers need to be in the peak of condition in order to maximise on engine output within respectable operating temperatures.

It is necessary to be able to purchase spare parts on a worldwide market. Many licensees do their own thing, whereby company A provides a part that does not fit company B's engines. This situation is just not acceptable.

The average turbo charger, operating at the top of its range, tends to go off the boil at around 15 000 hours, or about every two years.

This means that in a multi-cylinder engine with three or possibly four blowers, they will all require attention at the same time. This job cannot be phased, on account of engine balance. One this voyage and another the next isn't feasible. Very few, if any, repair firms are geared up to dismantle three blowers simultaneously. The best solution is to complete the work over a number of coastal ports, creating something of a logistical headache.

### Yards ahead

With the present trend towards longer periods between dockings, out-of-service periods for maintenance become more critical. The operator must make maximum use of this valuable opportunity and the key for both yard and owner is planning.

several factors influence an owner's selection or preference for a particular yard: ability, confidence, available time, the current work load of the yard, the position of the yard relative to the ship's scheduled ports and finally cost are all relevant.

Ability and confidence go hand-in-glove and are usually the result of a good working relationship over many years. Major repair problems and emergencies successfully overcome form the basis of such a relationship.

Time and the yard's work load are also important factors. It makes no sense for a container ship to be competing for labour and services with a high-profile passenger or cruise ship. The butter will only spread so far. Using several valuable days steaming to and from a yard for a tight-scheduled docking is not a good idea and benefits no one.

Dealing with the cost aspect, no one objects to a fair price for good-quality work. The owner's superintending staff understands the internal problems that put undue pressure on the shipyard and of course all owners think their ship is the priority job.

The attending superintendent must always have a handle on the day-today running costs and the level of extras. Regular daily meetings between the shipmanager, his estimator and the owner's representative are essential. There has to be a constant update on costs. Perceived problems need to be ironed out and progress towards the final completion date firmly fixed in everyone's mind.

There are numerous elements that contribute to the final overall costs. Arriving at a fair and amicable settlement can be achieved by approaching the project as a whole in a structured manner. Once the owner has selected the yard and a realistic quote has been presented based on a clear and concise specification, the relevant parties must meet and plan a workable strategy, thus setting the foundation for a firm and honest working relationship.

Initially priorities have to be established. Time is a major element. The redelivery date has to be fixed and the work content planned to suit. A critical path must be set and modified as necessary on a daily basis as the overall work pattern changes.

---

**Swift port operations are unperative**

## Yard

Planning of labour  
Flow of materials  
Control of subcontractors  
Safety in all forms  
Environmental issues  
Co-ordination of trades  
Interpretation of the owner's specification

## Owner

Redelivery date  
Quality of work  
Overall cost  
Safety in all forms  
Environmental issues  
Preparation of the plant for sea  
Translating the specification for the benefit of the yard managers'

### What comes first?

The repair yard and owner have quite separate priorities, not necessarily in this order (see table above.)

### Extras

By definition this is a very delicate subject. The realistic view is that they are impossible to avoid and difficult to reconcile particularly with the 'bean counters' back home, who cannot understand how these jobs missed the original specification.

The yards see extras as nuisance-value, particularly if there is a shortage of labour, although most yards build in a provision for up to a 30 per cent extra work load within the original time scale. It is also a great opportunity for the unscrupulous yards to increase their profit margins, providing a variety of excuses that the unsuspecting superintendent can only wonder at.

### Price negotiations

This is a specialised and delicate subject which needs to be approached in a firm and honest manner. The superintendent has a fixed-budget price in mind, beyond which he is reluctant to stray without good reason. It is always difficult to sell an overspend to the respective trade manager who is already running on a tight shoe-string budget. The technical manager isn't a lot of help either, because his main interest is the bottom line, but he may be a little more forgiving as long as there is a plausible explanation or a credible story to defend.

As long as both sides stick to the ground rules and have consistently agreed on prices throughout, the exercise becomes academic. There has to be give and take on both sides. It is in no one's interest for bad feelings or serious conflict

to prevail. We may need each other again next year or even next week.

P&O Containers has never felt that legally binding contracts have served its side of the industry very well. With a large operation, there are too many loopholes and get-out clauses. It should also be noted that should a serious rift develop between yard and owner, the curtain will fall on a beautiful friendship. That 'you're only as good as your last job', is a true and apt concept. Involving the legal profession in what should be, at worst, a family squabble is never totally satisfactory.

### Conclusions

This paper is an effort from our side of the fence to open up our hearts and present a case for closer cooperation. We need each other probably more now than ever and although the ships are getting bigger, they are fewer and much more is demanded of them. There are fewer repair facilities today and many of those are struggling to exist.

Many technical problems often stem from the original concept. Too often the operating side of the business has little or no input into the design and layout of new tonnage and so-called state-of-the-art equipment sadly lacks sufficient in-service development or operational experience.

We appreciate that repair yards love complicated ships and machinery which requires constant attention located in inaccessible and hostile corners. Engines are required to run at their maximum operating power to compensate for cargo and port delays. All these factors mean limited port time, more labour and therefore higher repair costs.

If the operating superintendent had a friend in heaven he would dearly request:

1. Proven equipment;
2. Adequate main and auxiliary power; and
3. Access for maintenance; but above all
4. Simplicity.

With the advent of bigger ships, smaller crews and tighter schedules the average seafarer has to concentrate his time and efforts on basic routines, safe passage and keeping the vessel on the move, not forgetting company and statutory regulations that are increasing all the time.

A word about the seafarer of the late 20th century. As a manager closely involved with a big company running many and varied ships operating throughout the world, we depend on these people as never before. We pile more and more work, responsibilities and stress on to fewer and fewer shoulders, and what do we do to help them? We give them satellite communications so that we can breathe down their necks. We also give them computer networking covering every area imaginable and then, when they get the hang of it, we uprate and change the system.

My sincere hope for the future is that operators and repair yards can move closer together for their mutual benefit and that coexistence can be both rewarding and interesting for all within this industry.

*Bill McConnell is fleet technical manager at P&O Containers based in London. He joined Overseas Containers Limited in 1981 as a fleet superintendent. OCL was absorbed into the P&O Group in 1986 and renamed P&O Containers. He is responsible for the overall technical operation of the current container fleet and has an advisory role in the selection and design of new tonnage,*

*He served a traditional mechanical apprenticeship in shiprepair before joining Alfred Holt & Co as a junior engineer in 1957. He remained with the Ocean Group under its many names and was appointed chief engineer in 1972.*

*This paper was delivered at shiprepair and Conversion 95. A full volume of the papers delivered is available at £10 from BML Business Marketing Limited. Fax: +44 1923 777209.*

# **WHAT IS ZONE TECHNOLOGY?**

# **WHAT IS ZONE TECHNOLOGY?**

- **ZONE TECHNOLOGY IS A MANAGEMENT METHODOLOGY BASED ON ORGANIZING WORK BY ZONE RATHER THAN BY SYSTEM**
- **ZONE TECHNOLOGY RELIES AS MUCH ON WHO DOES PLANNING, SCHEDULING AND CONTROL AS THE ACTUAL TOOLS AND TECHNIQUES FOR ORGANIZING THE WORK**
- **THE INTENT OF BREAKING THE SHIP DOWN INTO ZONES IS TO REDUCE THE MANAGEMENT TASKS IN SIZE BY BEING “PRODUCT-ORIENTED” RATHER THAN SYSTEM-ORIENTED**

## **WHAT IS ZONE TECHNOLOGY? (CONTINUED)**

- **ZONE TECHNOLOGY USES THE CONCEPTS OF THE BLOCK AND ZONE OUTFITTING APPROACH**
- **ZONE OUTFITTING USES THE ADVANCED OUTFITTING APPROACH**
- **ZONE OUTFITTING IS A SHIPBUILDING APPROACH WHICH ORGANIZES OUTFITTING WORK BY ZONE AND STAGE INTO “ON-UNIT”, “ON-BLOCK” AND “ON-BOARD” WORK**
- **FOR COMPLETENESS THE ADVANCED OUTFITTING PRESENTATION FROM THE EARLIER SHORT COURSE ON DESIGN FOR PRODUCTION INTEGRATION IS ATTACHED**

## 1.12 **Advanced Outfitting**

1.12.1 **WHAT IS ADVANCED OUTFITTING.** Advanced outfitting can be regarded simply as the fitting to ship structure, before and after it is erected on the building berth, of outfit items at a significantly earlier time in the building sequence than is traditional.

Advanced outfitting is normally subdivided into three types, namely:

- OnUnit
- On Block
- On Board

“On-unit” advanced outfitting consists of constructing packages of equipment or bundles of pipe and other systems on a common foundation. The work is usually performed in a shop environment instead of onboard the ship. The packages incorporate unitized foundations and/or support bases, equipment, small tanks, pipe, fittings, controllers, electric cable, etc., and are completely painted except perhaps for a touchup coat. Where required and possible, the package is tested before installation “on block” or “on board.” Typical examples of “on-unit” advanced outfitting are shown in Figures 1.1.127 and 1.128.

“On-block” advanced outfitting consists of installing “units” (equipment modules), pipe bundles, foundations, etc., on a structural assembly or module before it is erected on the building berth. Structural assemblies may be erected as assemblies or joined to other assemblies or modules to form an “erection module.” Typical examples of “on-block” advanced outfitting are shown in Figures 1.129 and 1.130.

“On-board” advanced outfitting consists of installing “units” or individual pieces of equipment, pipe, etc., into the ship as it is on the building berth or once it is afloat. Typical examples of “on-board” advanced outfitting are shown in Figures 1.131 and 1.132. A special approach to “on-board” advanced outfitting is “open deck” or “blue sky” advanced outfitting. In this approach a complete compartment such as a machinery space is left open (deck off) until all the equipment is installed. It is normally used by shipyards which have covered building berths, especially for warship (frigate and destroyer) construction as shown in Figure 1.133.

1.12.2 **WHY USE ADVANCED OUTFITTING.** Traditionally, shipbuilding engineering attempts to complete all design and material procurement before commencing actual construction. In the past, shipbuilding companies in Japan and Europe had large order books, and were able to do this. This approach is illustrated in Figure 1.134(a). This has generally not been possible in most U.S. shipyards due to both commercial and naval ship procurement methods. It is quite usual for a U.S. shipyard to obtain a new ship construction order with no other ongoing work in the yard. The objective then is to get production started as soon as possible, and this causes an overlap of design, material procurement, and production activities, as shown in Figure 1.134(b). It is this overlap coupled with the traditional approach to both design and production which causes the extensive rework and equipment delay problems normally experienced in U.S. shipbuilding.



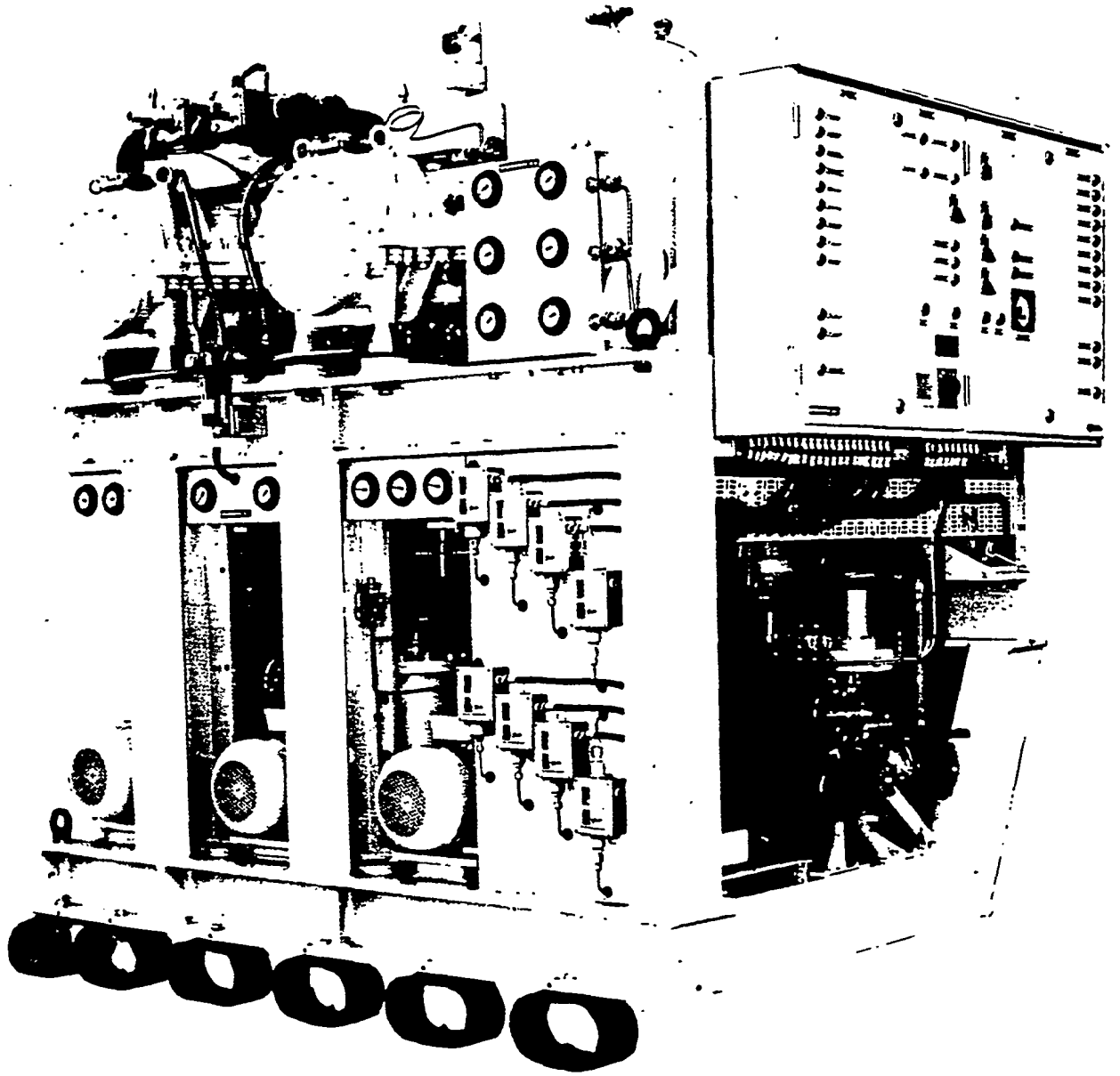
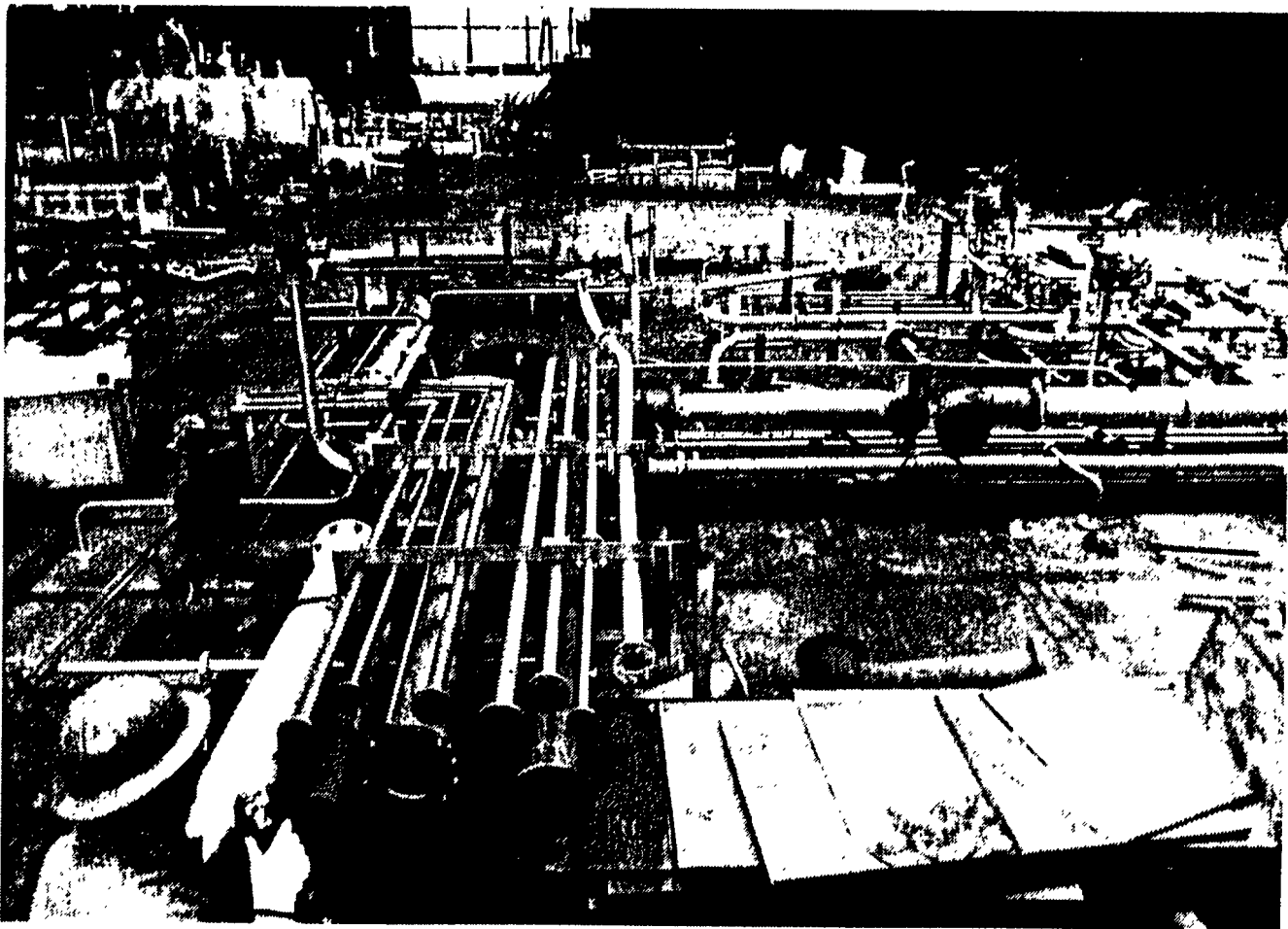
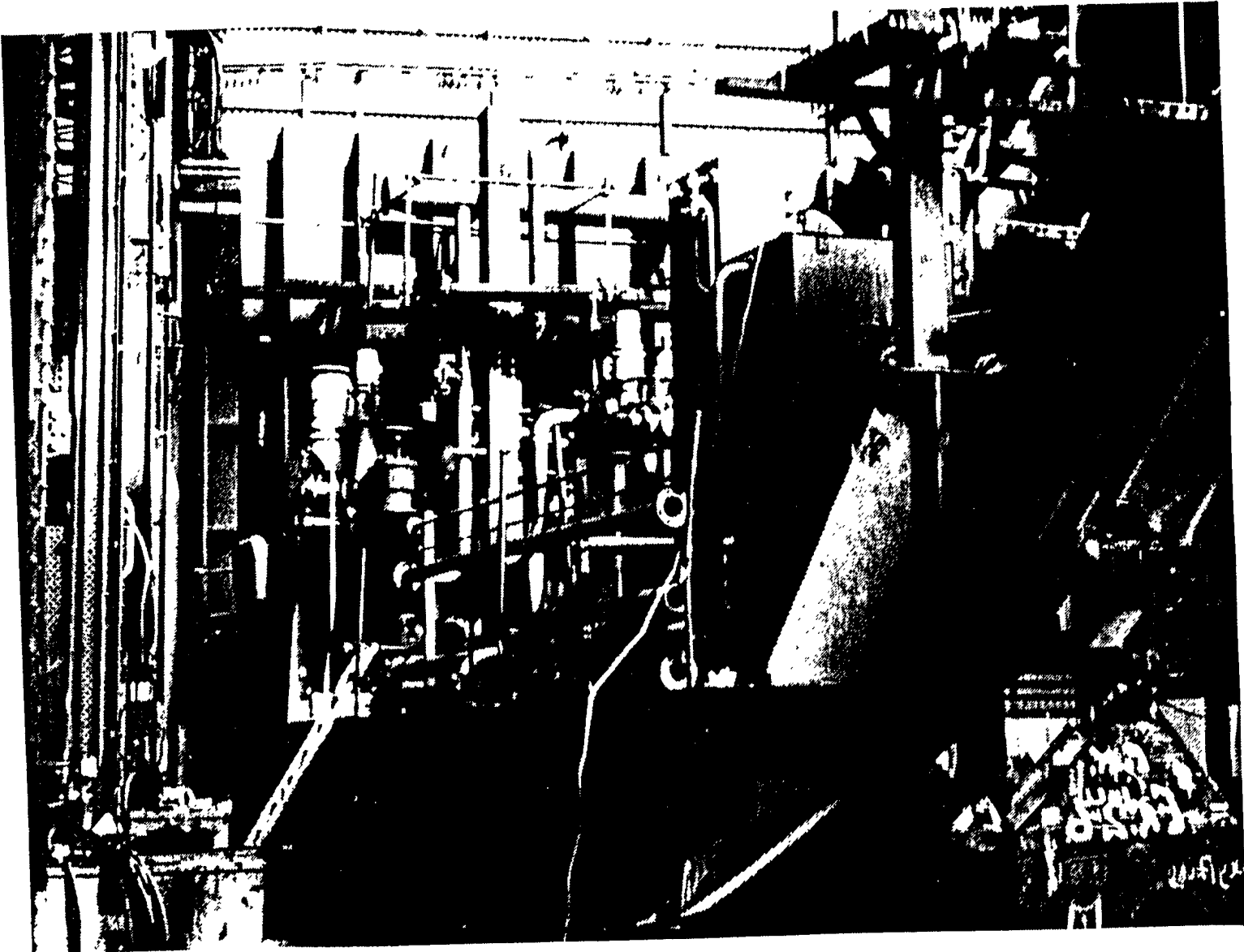

FIGURE 1.127 Typical "on-unit" advanced outfitting.



**FIGURE 1.128** Piping bundle “on unit” under construction.



.FIGURE 1.129 "On-block" advanced outfitting.

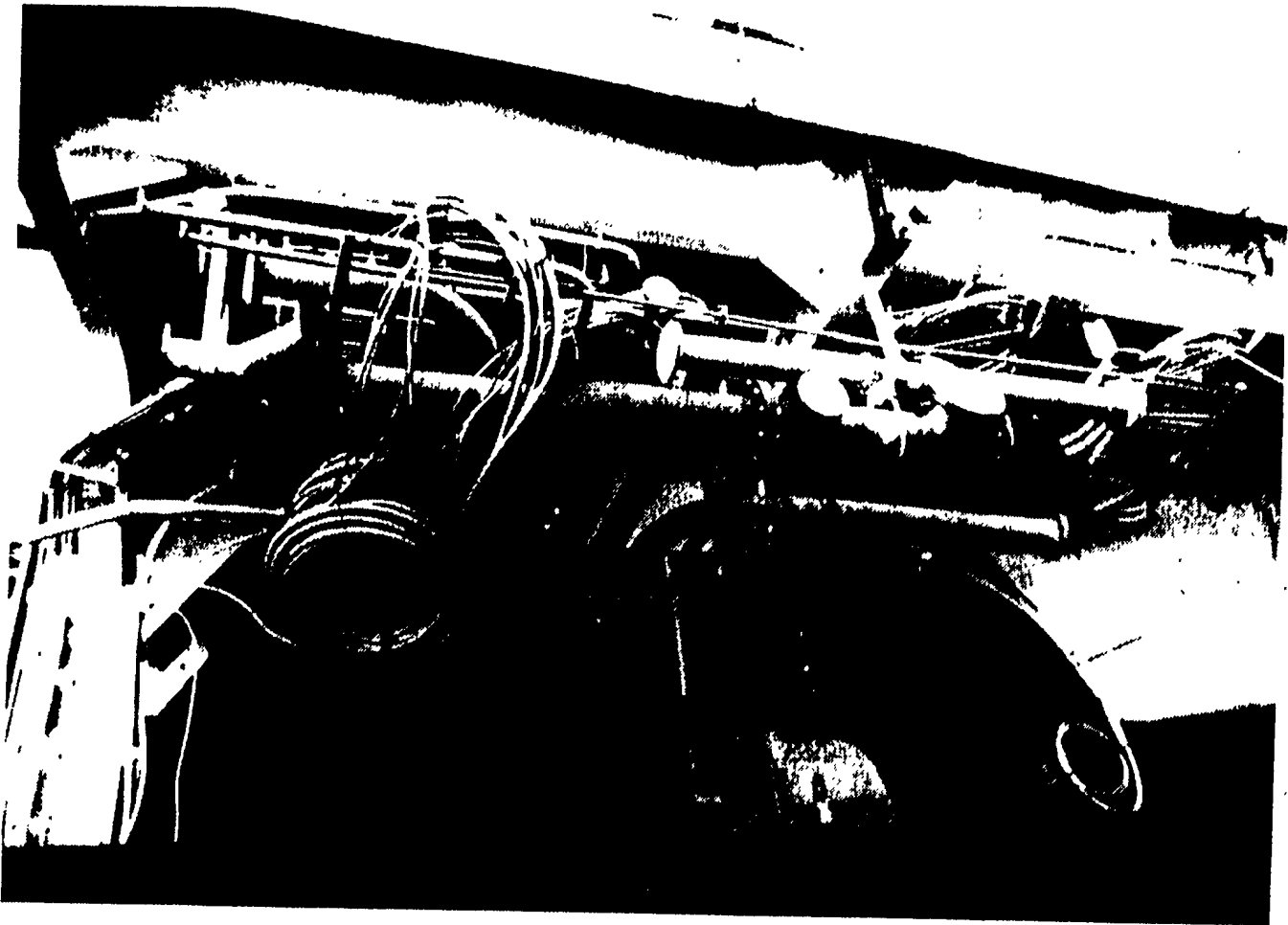

**FIGURE 1.130** “On-block” advanced outfitting.

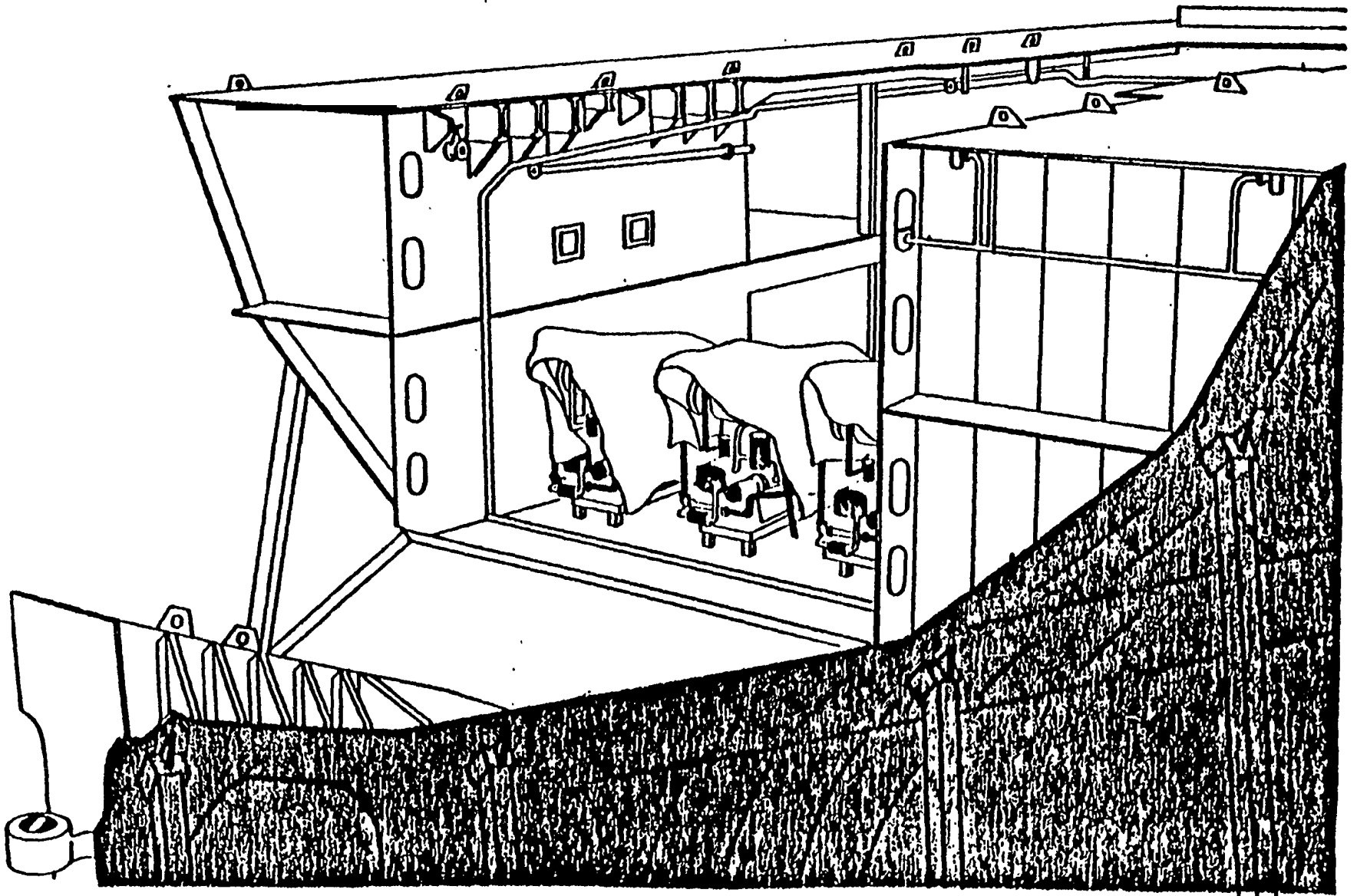

FIGURE 1.131 "On-board" advanced outfitting.

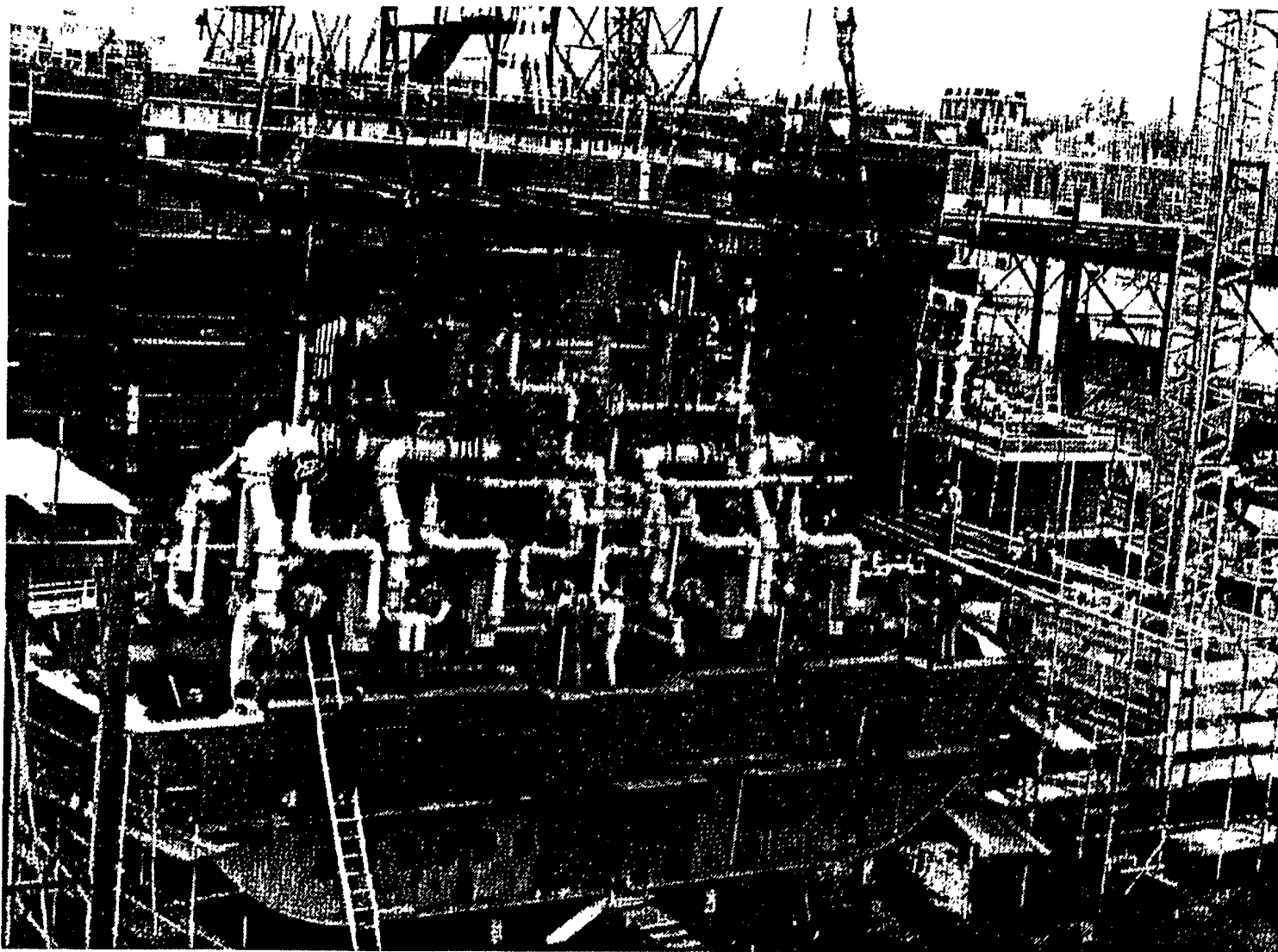

FIGURE 1.132 "On-board" advanced outfitting.

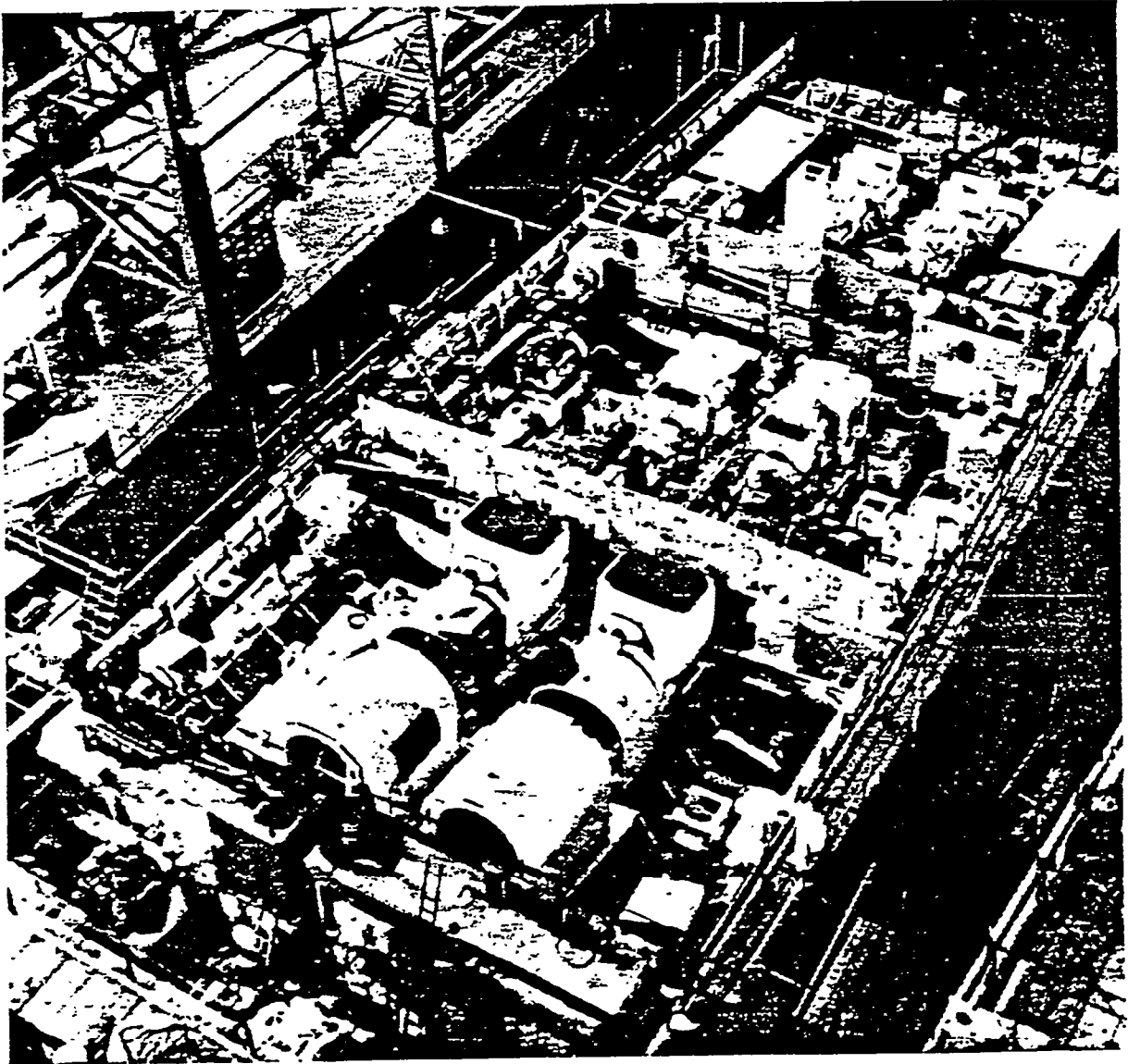
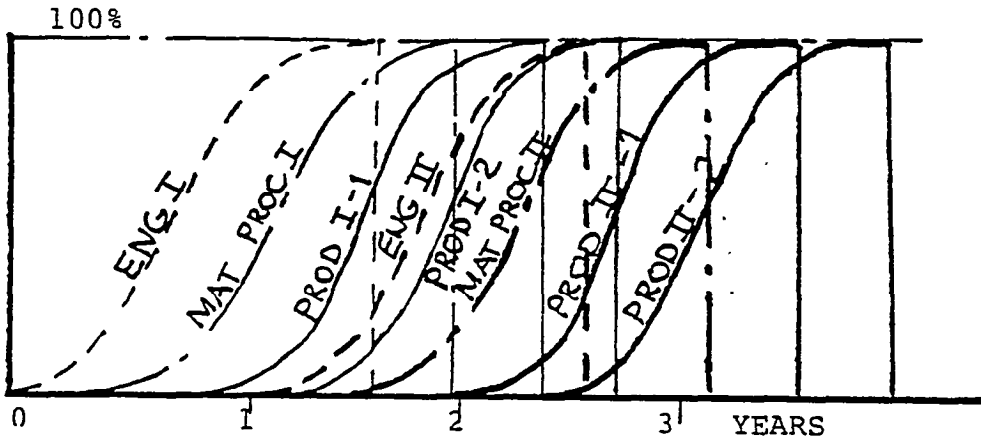
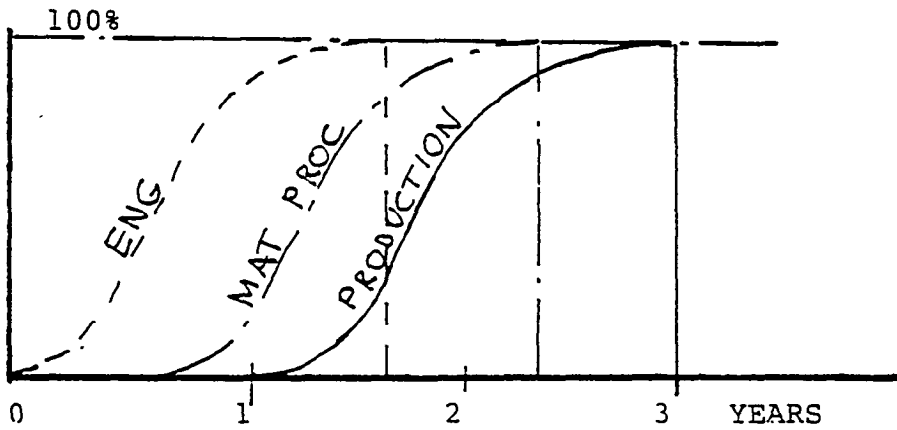

FIGURE 1.133 “Blue-sky” or “open-air” advanced Outfitting.



[A] LARGE ORDER BOOK FOREIGN SITUATION



[B] TYPICAL U.S. SHIPYARD SITUATION

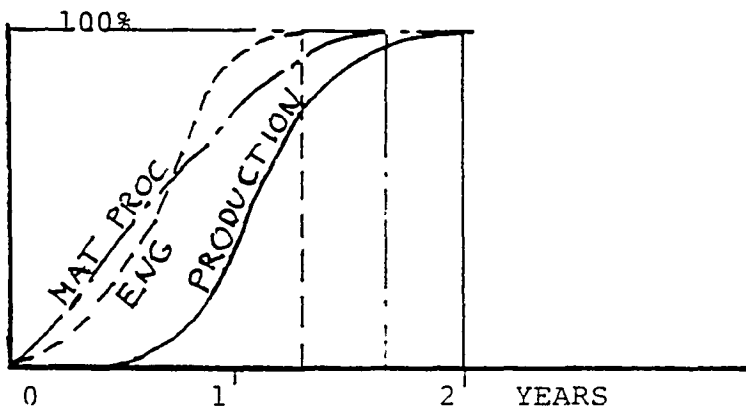

[C] FUTURE U.S. SHIPYARD REQUIREMENT

FIGURE 1.134 Required change in contract performance time.



In today's competitive shipbuilding situation, it is not enough to make the existing overlap work successfully. It is necessary to reduce the performance time, and at the same time increase productivity. Obviously, any reduction in performance time increases the overlapping of the activities as shown in Figure 1.134(c). This has been successfully done by a number of foreign shipyards, and they have presented the requirements based on their experience to accomplish both reduced contract performance time and increased productivity. The essential requirements are:

- A completely integrated planning function
- A planning, scheduling, and control system which is adequate for the task
- Maximum practical use of advanced outfitting
- Maximum use of industry standards for equipment
- Maximum use of company standards for system design and fabrication details
- An engineering approach that is compatible with production requirements, and the way the ship will actually be constructed
- A material procurement approach which is compatible with production schedule. This requires ordering and receiving material on a zone basis

The direct benefits of advanced outfitting are increased productivity and shorter building schedules. Increased productivity is possible as the workers' efficiency for "On-unit" versus "on-block" and "on-board" advanced outfitting is one half and one quarter, respectively. This can be seen from Figure 1.135 which is taken from NSRP publication, *Product Work Breakdown Structure*. This results from the following benefits:

- Earlier start to outfit fabrication and *installation*,. thus better utilization of outfit crafts throughout the duration of construction rather than the heavy concentration near the end
- Logical sequencing of work
- Improved worker safety throughout easier access, better ventilation, better lighting, easier material delivery, etc.
- Simpler outfit planning and scheduling
- Installation of outfit in the best position and worker attitude
- Shop environment allowing cleaner work and better quality (less rework)

Figure 1.136 gives an overview of the goals and benefits of advanced outfitting as modified from a similar figure in the National Shipbuilding Research Program publication, *Outfit Planning*.

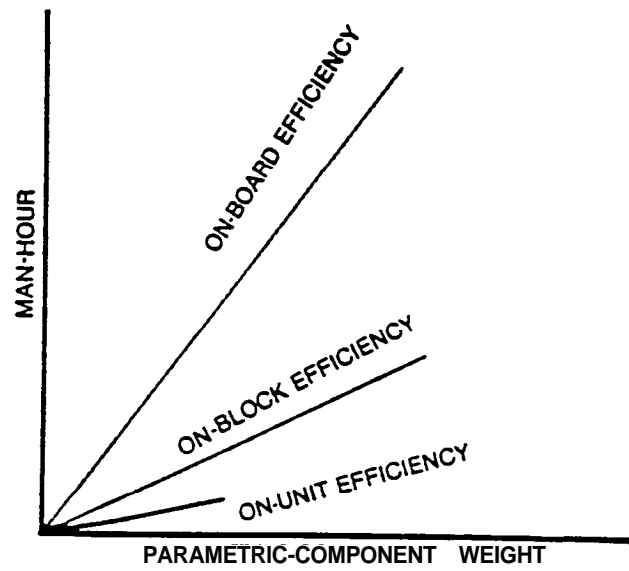

FIGURE 1.135 Productivity improvement through advanced outfitting.

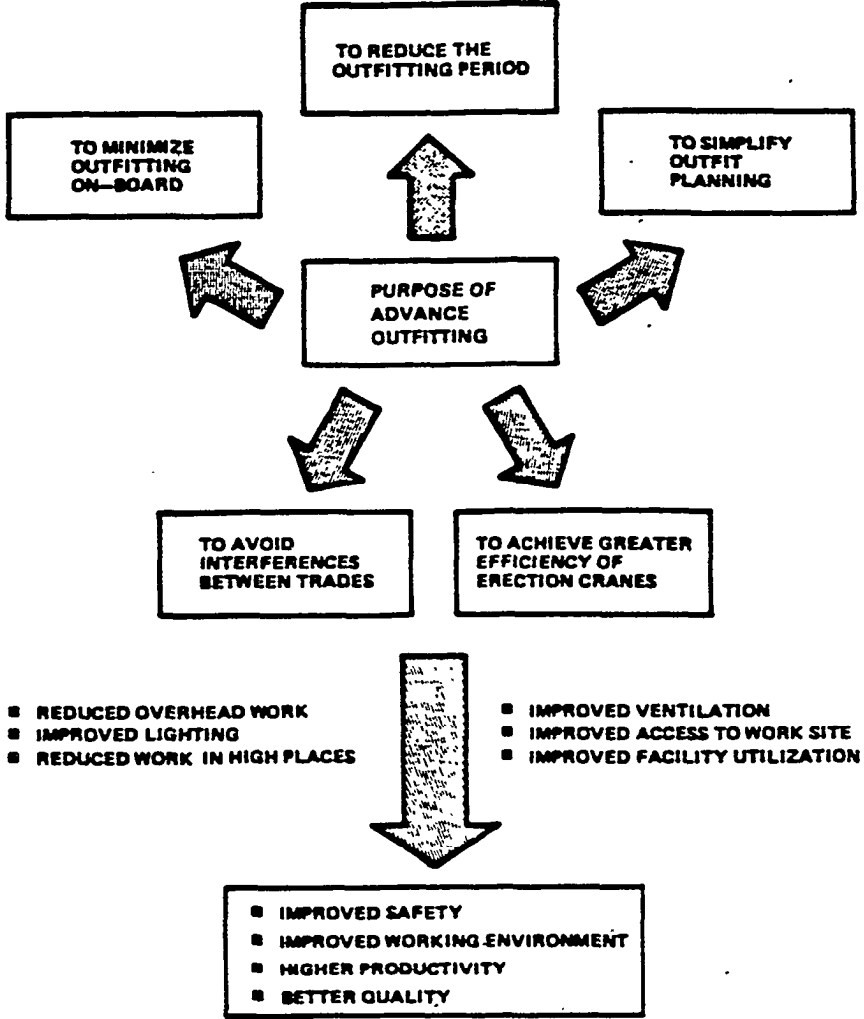

FIGURE 1.136 Goals and benefits of advanced outfitting.

**NATIONAL SHIPBUILDING RESEARCH PROGRAM**

# **ZONE DEFINITION EXERCISE**

**IMPLEMENTATION OF ZONE TECHNOLOGY IN REPAIR & OVERHAUL ENVIRONMENT**

**NATIONAL SHIPBUILDING RESEARCH PROGRAM**

**ZONE  
TECHNOLOGY  
BENEFITS**

**IMPLEMENTATION OF ZONE TECHNOLOGY IN REPAIR & OVERHAUL**

# **ZONE TECHNOLOGY BENEFITS**

**USE OF ZONE TECHNOLOGY APPROACH HAS RESULTED IN SIGNIFICANT OVERALL PERFORMANCE IMPROVEMENT BY:**

- REDUCING WORK PACKAGE SIZE AND SCOPE, BY FOCUSING ON ZONES RATHER THAN THE SHIP, TO A MORE MANAGEABLE LEVEL THAT AN INDIVIDUAL IS CAPABLE OF UNDERSTANDING AND MANAGING**
- FORCING ALL DEPARTMENTS TO PAY ATTENTION TO THE PLANNING AND INTERFACES IN WHICH THEY ARE INVOLVED**
- FORCING PRODUCTION TO TAKE AN ACTIVE ROLE EARLY IN THE PROJECT DEVELOPMENT**
- PROMOTING THE USE OF MULTI-SKILLED TEAMS**
- ENGINEERING PROVIDING TECHNICAL DOCUMENTATION THAT SUPPORTS THE ZONE TECHNOLOGY APPROACH**
- MORE REALISTIC AND RELIABLE SCHEDULING**

## **ZONE TECHNOLOGY BENEFITS (Continued)**

- **IMPROVED SCHEDULING BY EARLY INVOLVEMENT BY ALL DEPARTMENTS**
- **MATCHING DESIGN AND PLANNING WITH THE ACTUAL WAY WORK IS PERFORMED. THAT IS ACCROSS SYSTEMS AND TRADES**
- **MOST OF THE WORK IS PERFORMED IN A MORE ACCESIBLE, SAFER, BETTER LIGHTED AND VENTILATED WORK PLACE**
- **ALL THE MATERIALS AND TOOLS ARE DELIVERED 'AND AVAILABLE WHEN NEEDED**
- **ALL INTERFACING WORK IS CONSIDERED AND PROPERLY SEQUENCED**
- **PRODUCTION EFFICIENCY IS IMPROVED BY PERFORMING ALL WORK WHICH CAN BE DONE BY THE SAME WORKERS AT THE SAME TIME AT THE SAME LOCATION**

**INTERNATIONAL SHIPBUILDING RESEARCH PROGRAM**

**IS ZONE  
TECHNOLOGY  
APPLICABLE TO  
SHIP REPAIR AND  
OVERHAUL  
ENVIRONMENT?**

**IMPLEMENTATION OF ZONE TECHNOLOGY IN REPAIR & OVERHAUL ENVIRONMENT**



# **IS ZONE TECHNOLOGY APPLICABLE TO SHIP REPAIR AND OVERHAUL?**

- U.S. NAVY SHIPYARDS HAVE ACHIEVED SIGNIFICANT PRODUCTIVITY AND SCHEDULE IMPROVEMENTS BY APPLYING ZONE TECHNOLOGY APPROACH TO ALL TYPES OF REPAIR AND OVERHAUL PROJECTS**
- FORTUNATELY FOR US, THEY HAVE BEEN KEEN TO SHARE THESE OUTCOMES WITH THE REST OF THE SHIPBUILDING/REPAIR INDUSTRY**
- RATHER THAN RE-WRITE THE STORY, A NUMBER OF THE PAPERS ON THE APPROACH ARE ATTACHED, INCLUDING THE CLASSIC BY MOEN**
- IT IS SUGGESTED THAT PRIVATE SHIP REPAIR AND OVERHAUL COMPANIES COULD ACHIEVE SIMILAR BENEFITS BY APPLYING THE APPROACH**

**APPLICATION OF ZONE LOGIC  
AND OUTFIT PLANNING CONCEPTS  
TO OVERHAUL. MODERNIZATION.  
AND REPAIR OF U.S. NAVY SHIPS**

**PREPARED BY: DENNIS MOEN  
PUGET SOUND NAVAL SHIPYARD  
FEBRUARY 1985**

# APPLICATION OF ZONE LOGIC AND OUTFIT PLANNING CONCEPTS TO OVERHAUL, MODERNIZATION, AND REPAIR OF U.S. NAVY SHIPS

## ABSTRACT

This paper presents the experience of Puget Sound Naval Shipyard in applying zone logic and outfit planning concepts to the overhaul, modernization, and repair of an aircraft carrier, three cruisers, and a submarine. Procedures were developed to involve design, production, testing, and material personnel in the overhaul process from preplanning through completion of the production phase, with the resulting synergism and open communication. The systems approach was replaced with tone by stage sequenced work packaging with as much work as possible done off the ship. Computer Aided Design (CAD) and photogrammetry were applied to enhance preplanning and off-ship work.

Puget Sound Naval Shipyard's application of zone logic is drawn from the research managed by the Maritime Administration's National Shipbuilding Research Program which has introduced the highly successful scientific shipbuilding systems developed in Japan. In brief, this concept represents a shift in logic from system to zone orientation.

## INTRODUCTION

Historically, all outfitting work in naval shipyards has been planned, scheduled, executed, and tested on a system by system basis. This method has developed for several valid reasons which include:

- Cost estimating and accounting
- Material estimating
- Ship operation and identification of problem areas
- System testing

While this method is acceptable and necessary for some shipyard functions it is recognized that when repair work is actually accomplished it is not done solely on a system by system basis. Examination of any ship repair effort will show that work accomplishment is based on several criteria, one of which is the functional system. Other considerations must include:

- Physical location of work
- Manpower requirements
- Other work required in the same location
- Similar work required in other areas
- Availability of material

These parameters are currently being considered and resolved by trade general foremen, with decisions made on a trade by trade basis when the work is actually started. Typically, the general foremen are faced with making these day to day decisions without knowledge or understanding of the overall plan *for* completion of the overhaul. This often causes items to be installed in an improper sequence which results in unnecessary rework.

Additionally, manufacturing and installation of numerous outfitting components have traditionally been postponed until the hull is available to the trades to determine their construction requirements. This process has resulted in relegating outfitting to a successor function completely dependent on hull constraints, with the natural effect of requiring peak manning and confined outfitting schedules.

Through the application of system oriented logic to actual work accomplishment, there is no allowance for an

objective, analytical examination of the best possible way to perform work, nor does it provide a method of feedback to increase the corporate knowledge of the shipyard. With the various systems being considered separately, trades often occupy space and compete for access simultaneously which minimizes the effect of production scheduling and control, and creates strained channels of communication.

In looking at how outfitting **work** is actually performed, it is found that products are produced by procuring and/or manufacturing parts and joining them together to create subassemblies. These subassemblies are progressively combined to produce a completed operational product. It becomes clear that the ideal way to subdivide ship repair and overhaul work is to focus on the needed parts, or interim products, that **pre-occupy** the worker. Zone outfitting logic provides a scheme by which work is subdivided with interim products as the focal point.

Outfit planning addresses all outfitting components within a defined 3-dimensional space, and frees outfitting as much as possible from hull dependence and ship systems control. This provides the basis for grouping work into classes or problems so that common solutions can be applied regardless of product configuration and location, and planning installations in a logical sequence. The result of this scheme is that it permits most outfitting work to be accomplished earlier, and away from the ship to where it is safer, cleaner, and **resources** can be delivered to the worksite more economically. Overhaul durations can be reduced because of simultaneous accomplishment and coordination of outfitting and hull work which will minimize total shipboard construction time.

A zone is any subdivision of the planned work which best serves for

organizing information needed to support outfitting at a particular stage of an overhaul. A zone might be a compartment or a portion of a compartment; it could include an entire superstructure or a component subassembly. The principle aspect of a zone is that it represents a means of dividing a ship's overhaul package into manageable, trackable blocks. Zone outfitting features three basic stages: on-unit, on-block, and on-board, coordinated by the "master bill of erection sequence."

### On-Unit

On-unit outfitting is the assembly of an interim product consisting of manufactured and purchased equipment (components). It includes all but a final coat of paint. A unit is composed exclusively of outfitting materials (pumps, motors, mechanical and electrical interfaces, and a common foundation including false floor ribbing, etc. ). The on-unit outfit planning is separate from the main hull structure. Units can be categorized as (a) functional, (b) geographical, or (c) combination.

Functional units consist mainly of components necessary for the operation of something, e.g., a heat exchanger assembly. It is generally associated with one system (potable water and freshwater units, water distilling unit, F. O. purifier unit, refrigeration plant unit, etc. ).

Geographical units provide passage(s) for systems. Such units are assembled together to insure that they will fit onboard (pipe, HVAC, or wireway passage(s) on deck unit, accommodation unit, engine room unit, etc. ).

Combination units include more than one system built together and lifted to installation site (pipe/HVAC/wireway/machinery/associated foundations, grating/false floor attachments, handrails, etc. ).

On-unit outfitting **should be given** the highest priority even though there is some impact on hull construction progress because assembly is performed in shops which provide ideal climate, lighting, and access. Shop work **increases** the opportunity **for** improved safety and higher productivity. Outfitting **on-unit** has less impact on the progress of hull structure as opposed to on-block outfitting.

### On-Block

On-block outfitting is the installation of outfit components, or even a unit, onto a hull structural assembly or "block" prior to its erection. It is the next best alternative to outfitting on-unit. It includes all painting except a final coat and that paint omitted to anticipate welding of butts and seams. On-block outfitting requires coordination between hull, mechanical, ventilation, and electrical systems supported by material (supply), planning and estimating, and scheduling. A "master bill of erection sequence," developed by engineering, production, planning and estimating, and supply is controlled by scheduling (via work order task assignment). This identifies the sequential road map in which systems are installed. Engineering lists systems and components to be involved on-block and provides the work package; production assists in the design planning stage designating the construction envelope and supports engineering on preferred design applications; planning and estimating defines the work packages by crafts and sequences the construction flow by landing dates; and material (supply) has the integral task of coordinating the material flow based on the "master bill of erection sequence" and only stages the identified materials required to support production flow.

### On-Board

On-board outfitting includes, and ideally should be limited to, the connection of units and/or outfitted

blocks, final painting, and test and trials. It necessarily includes some installation Of outfit Components, in a hull at a building position or outfitting pier, which cannot be productively incorporated "on-unit" or "on-block."

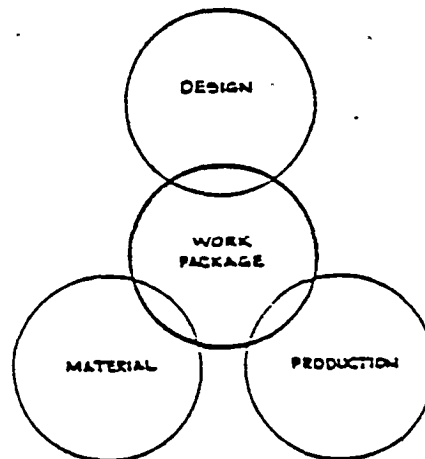

Figure 1

The work package acts as a common link to integrate work requirements.

One method used to organize information to support outfit planning is the work package concept. This is a conceptual approach that allows information from design, material, and production to integrate so that the various shipyard departments have a common understanding of how the ship will be overhauled. A work package is the common link to communicate a "build strategy" so that a definite increment of work with all located resources needed to produce a defined interim product is identified. A work package is also a definition of components of the various functional systems in a particular zone at a specified time of repair. This concept is extremely beneficial for staging material for delivery to a work-site.

Preoutfitting should not be confused with zone outfitting. Preoutfitting is usually planned by all locating resources to activities associated with ships'

systems in related large structural sections. Access is improved over conventional outfitting but components are still installed on a systems basis with great dependence on hull availability. Trades still compete for time and space, using unchanged methods, and material flow to the worksite is not optimized. Savings in total mandays and overall building period are limited because the only real difference between preoutfitting and conventional outfitting is where the work takes place. Preoutfitting of a very large structural assembly can be equivalent to outfitting a small ship of equal tonnage by conventional methods. Zone outfitting takes the additional step of freeing outfitting from hull dependence and systems control.

Puget Sound Naval Shipyard began its experiment with outfit planning by sponsoring two-day training seminars to all shipyard upper and middle level managers in May of 1982 and January of 1983. These seminars provided the necessary background to gain the shipyard-wide support needed to successfully carry out test cases for outfit planning. In February of 1983, while understanding that zone outfitting logic applied to new construction, the shipyard Planning Officer and Production Officer (with the support of the Shipyard Commander) called for the establishment of an Outfit Planning Group *to* determine if and how zone outfitting logic might be applied to the type of repair/overhaul work accomplished at Puget Sound Naval Shipyard.

## OUTFIT PLANNING GROUP

Host shipyards that have adopted zone logic have completely restructured their organizations to reflect the concept. Since this was an exploratory project for Puget Sound Naval Shipyard, and because of its potential far reaching impact *on* the methods and procedures used within the shipyard, it was determined that an Outfit Planning Group with

representation from all shipyard departments was necessary to ensure tot evaluation. This type of approach ga the shipyard the best opportunity assure familiarity with all problem and solutions, and gets all department involved in the planning and sequencing of all operations from issue of planning documents through completed installation testing.

The Outfit Planning Group formed a Puget Sound Naval Shipyard consisted a representation from the following departments:

- Combat Systems
- Design
- Overhaul Superintendent
- Planning and Estimating
- Plant Engineering
- Production
- Progress
- Scheduling
- Supply
- Test Engineering

With this cross section of ship repair departments, the integration of outfit planning to ship repair receive overall review to assure organizational coordination and' agreement. The Outfit Planning Group became the forum by which the technical requirements and practical applications are integrated *to* develop a common "build strategy."

As shown in Figure 2, a *core* group evolved which had more direct involvement in the daily function of accomplishing repair work, and *was in* an optimum position to analyze the affect: of zone logic on individual and shipyard methods. The core group interacted among themselves, and within their own departments, to examine, resolve, and promote the application of new approaches developed from *zone* logic. Corroboration with the periphery departments is maintained when their special ties are involved and at periodical verification reviews. This process proved to be reliable by allowing the smaller group to efficiently operate

and still sustain total shipyard involvement. This forum is at all times tasked to be creative in the analysis of the technical and manufacturing processes to stimulate smarter approaches during the project evolution.

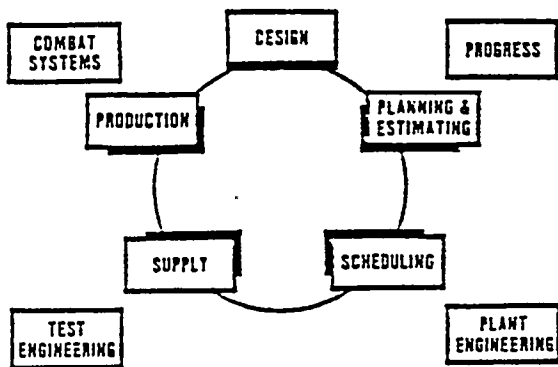

Figure 2  
Outfit Planning Group

The Outfit Planning Group uses a unique dual management posture which reflects the work emphasis shift from the planning phase to the production execution phase, and the direct link between design requirements and production applications. These two leadership positions are represented by the Design Division (chairman) and Production Department (zone manager). With the influence of design requirements paramount in the early planning process, the chairman leads the Outfit Planning Group's efforts in defining work zone parameters. When the work is identified, the zone manager then takes the lead to direct the group's sequencing to reflect production needs; During the transition period between defining and sequencing, both work together to adjudicate the exchange of information between the various departments such that a fully integrated, zone oriented build strategy is proceeding. With zone logic in mind, the chairman is responsible for providing production with a sequenced work package, and the zone manager is responsible for executing the work package. Both are responsible for

assuring all the requirements and methods are coordinated and supported.

In order, for the Outfit Planning Group to assimilate and associate all the information to implement zone logic concepts, a process framework was prepared to operate with. The following procedure organizes all input related to the project and generates the master bill of erection sequence.

- Systems drawing preparation
- Composite drawing preparation
- Composite/system drawing analysis
- Work package identification
- Work package sequence
- Work package instruction

**System Drawing Preparation.** In accordance with current policy, traditional systems drawings are prepared and provided to the installing activity.

**Composite Drawing Preparation.** Using the data from the various systems drawings, a composite drawing is prepared to delineate all components to be installed within the defined zone boundaries, and existing shipboard components to be interfaced. Depending upon the complexity of the systems in the zone, the composite drawing will consist of plan views at various levels, and elevation views of particularly congested areas. This drawing provides a means to identify and correct potential interference items while still in the planning phase. **More** importantly, it is used as a tool by the Outfit Planning Group to trunk systems for the simplest fabrication and installation sequence.

**Composite/System Drawing Analysis.** The Outfit Planning Group performs a detailed analysis of the drawings to form an overall profile of the task. The analysis includes such items as:

- System requirements
- Trade involvement
- Material requirements
- Testing
- Facility impact
- Certification requirements

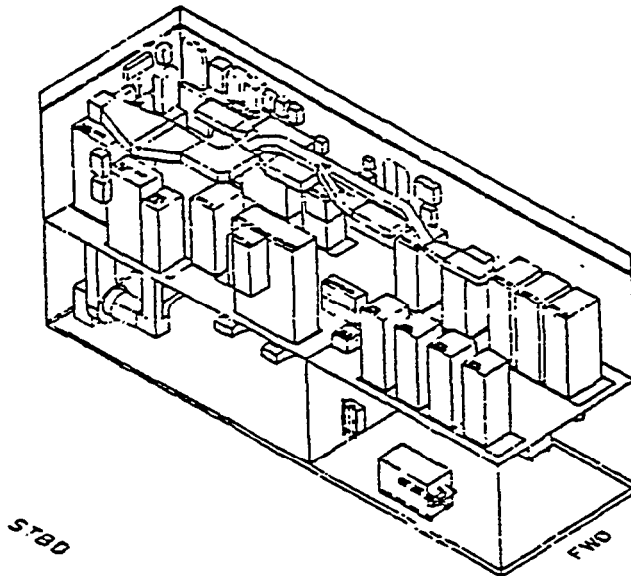

Figure 3  
 CAD composite depicting layering of equipment  
 and air conditioning within hull block.

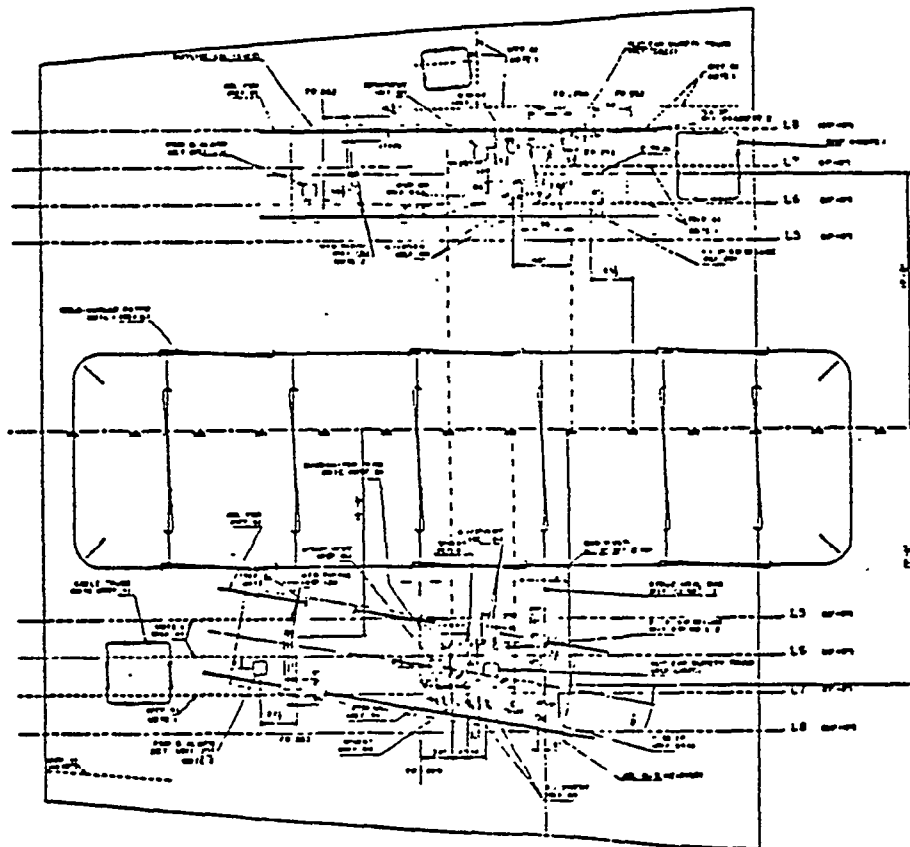

Figure 4  
 Composite view identifying common work procedure  
 for onboard site preparation.



Work Package Identification. During this phase, the Outfit Planning Group divides the task into segments of work in order to focus on the coordinated interface between planning and production requirements. It is at this time that the various trades provide input as to their particular methods of accomplishing specified tasks. These various inputs are coordinated and incorporated through an iterative process to accom-

modate decisions and commitments reached to form a final work package definition.

Work Package Sequence. The Outfit Planning Group arranges the work packages into a 'logical FLOW of work which represents the project build strategy. While this function is separate from work -package identification, it is an integral element of the iterative decision making process to arrive at a final work package.

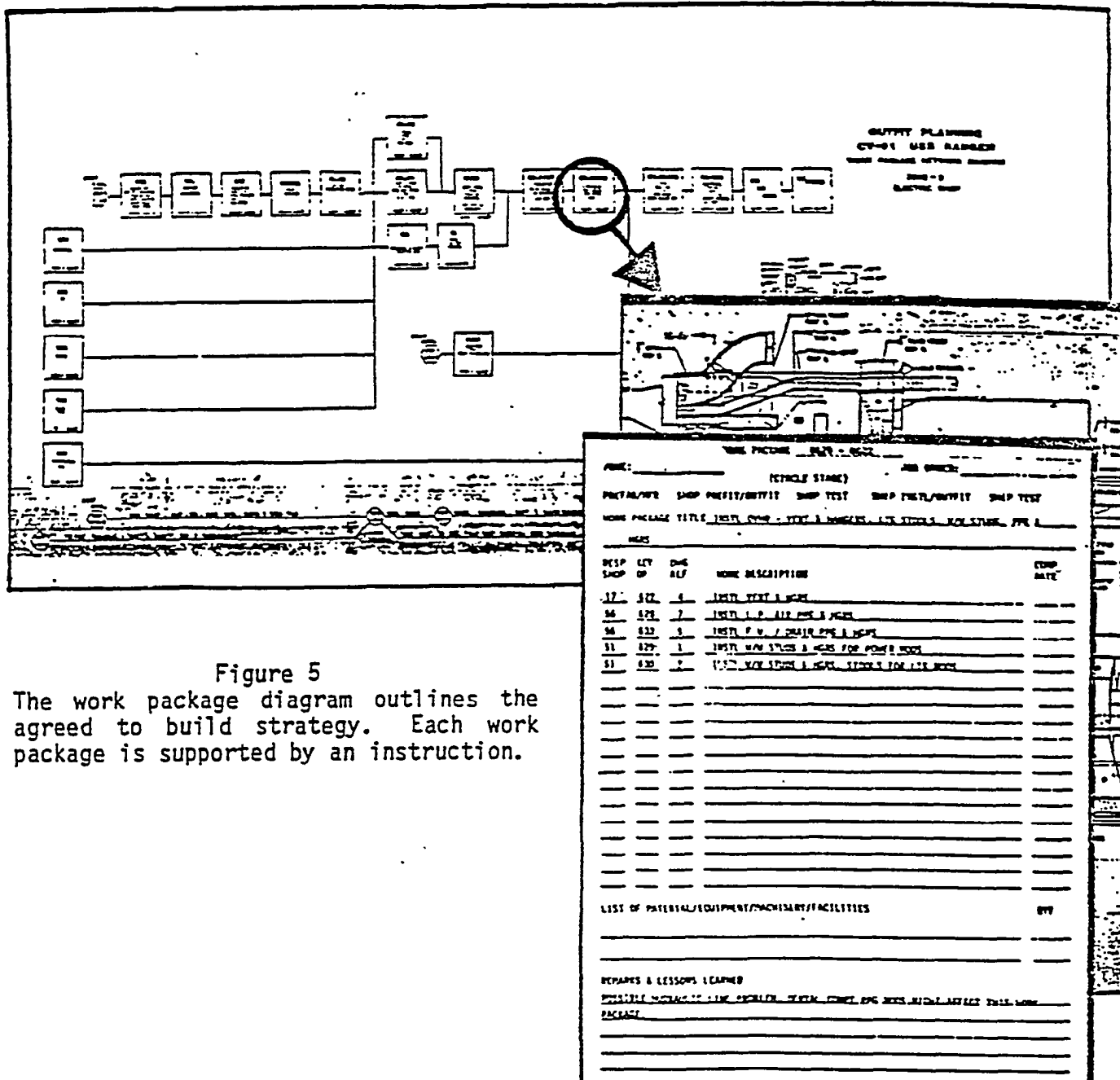

Figure 5  
The work package diagram outlines the agreed to build strategy. Each work package is supported by an instruction.

Work Package Instruction. Once the work packages are identified and sequenced, the Outfit Planning Group prepares an instruction for each work package. This instruction is a synopsis of the work required to accomplish the work package and includes such information as:

- Work description
- Key shop
- Job order and key op
- Needed resources
- Highlighted sketch

These sheets are assembled into a book, and issued to the zone manager and involved trade foremen to be used as a tool to manage the project resources, aid the waterfront decision making process, and measure project progress.

#### CASE NO. 1: USS RANGER (CV 61)

The complex overhaul of the aircraft carrier USS Ranger (CV 61) provided the first opportunity for Puget Sound Naval Shipyard to determine how zone outfitting concepts could be adopted. Two shipalt packages were targeted *for anal* - ysis. The areas selected furnished excellent opportunities to examine a good mix of systems work in two typical, but divergent types of overhaul tasks. The first task involved the construction and installation of a new deckhouse which closely resembles *new* construction processes (on-unit and on-block) ; while the second task accomplished complete reoutfitting of an existing space which represents typical overhaul work (on-board).

In order to concentrate on zone logic concept application and provide reasonable data for evaluation, the Outfit Planning Group limited it's focus to the specific compartments involved, and did not attempt to sequence work once a

system exited the defined *zone*. On other hand, any non-related system "passing through" the zone was includ in the build strategy.

With all the design, planning, production work being accomplished Puget Sound Naval Shipyard, the oppc tunity to open cross communication between the various departments k taken. Production Department concer and needs were expressed to the desi division so that documents could enhanced to aid production methods. the same time, design requirements we being explained to production personn to aid their understanding of the pr jects. In a few cases, producti personnel *were* loaned to the Desi Division to prepare the drawings whi were to be used for these tasks.

When the projects were ready, production to begin, a meeting of a' involved trades was called to expl the build strategy. General foremen and mechanics were represented so that' all parties would have the sar understanding of how work was to I accomplished. Each was also encourage to provide input that would improve work sequencing analysis methods for future work.

#### Zone 1: Close-In Weapon System Decl house

This project consisted of fabri cating, outfitting, and attaching a new 24'x26'x8' 26-ton deckhouse to the out board side of the existing island t accommodate a new defensive weapon suite. It required the coordination and sequencing of 14 various systems and integrating these systems with the hull block construction. Preparatic of the shipboard site was an additional major element to be incorporated int the build strategy.

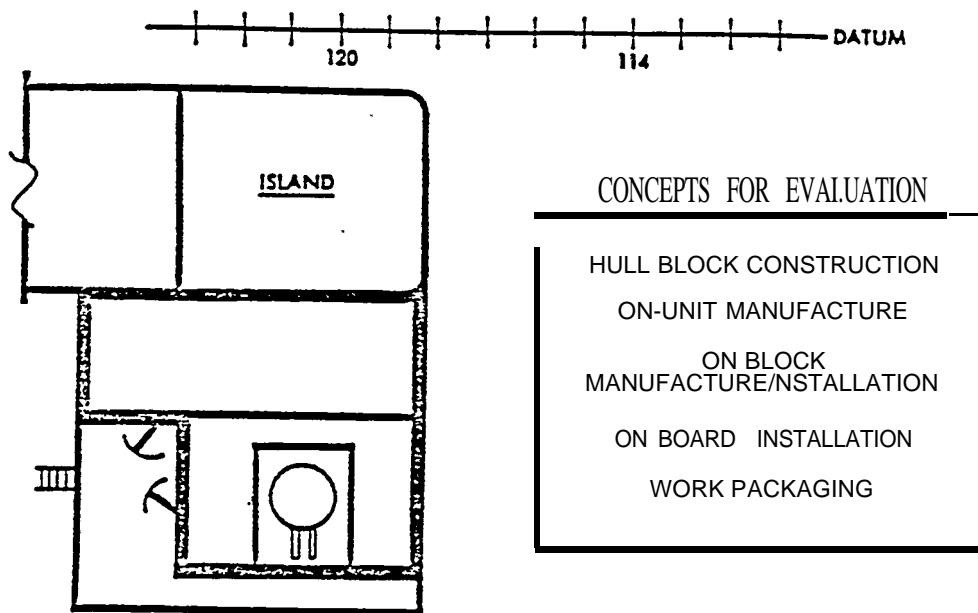
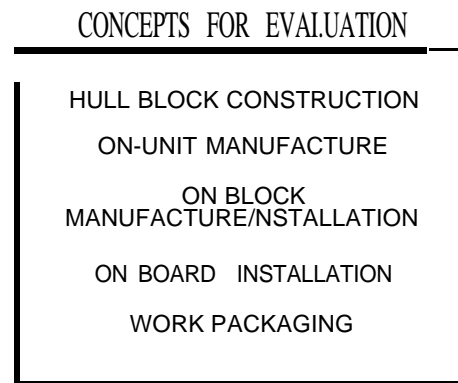

Figure 6  
USS Ranger Close-In Weapon System

Through the use of the composite drawing, the hull block/outfitting interface areas were identified and incorporated in the structural construction phase of the deckhouse to support subsequent outfitting installations. All system penetrations and underdeck foundation stiffening in the new structure were detailed on the structural prefabrication drawing so that they could be included during the initial construction of the deckhouse. This process allowed for accomplishing common work procedures regardless of the particular system and independent of when that system is to be installed.

As the hull block was being constructed, the required manufactured



components were being fabricated in the shops using the appropriate system drawings for details. This opened up the idea of accomplishing outfit component manufacture simultaneous with and independent from structural fabrication.

Space was provided in the structural shop to place the deckhouse for outfitting and on-site material laydown during the on-block phase. In order to coordinate hanger locations, the trades used a "put-up/take-down" technique to install hangers so that all welding could be completed and clear access provided for thermal insulation application. The deckhouse was then ready for installation of the components to proceed according to the sequence developed.

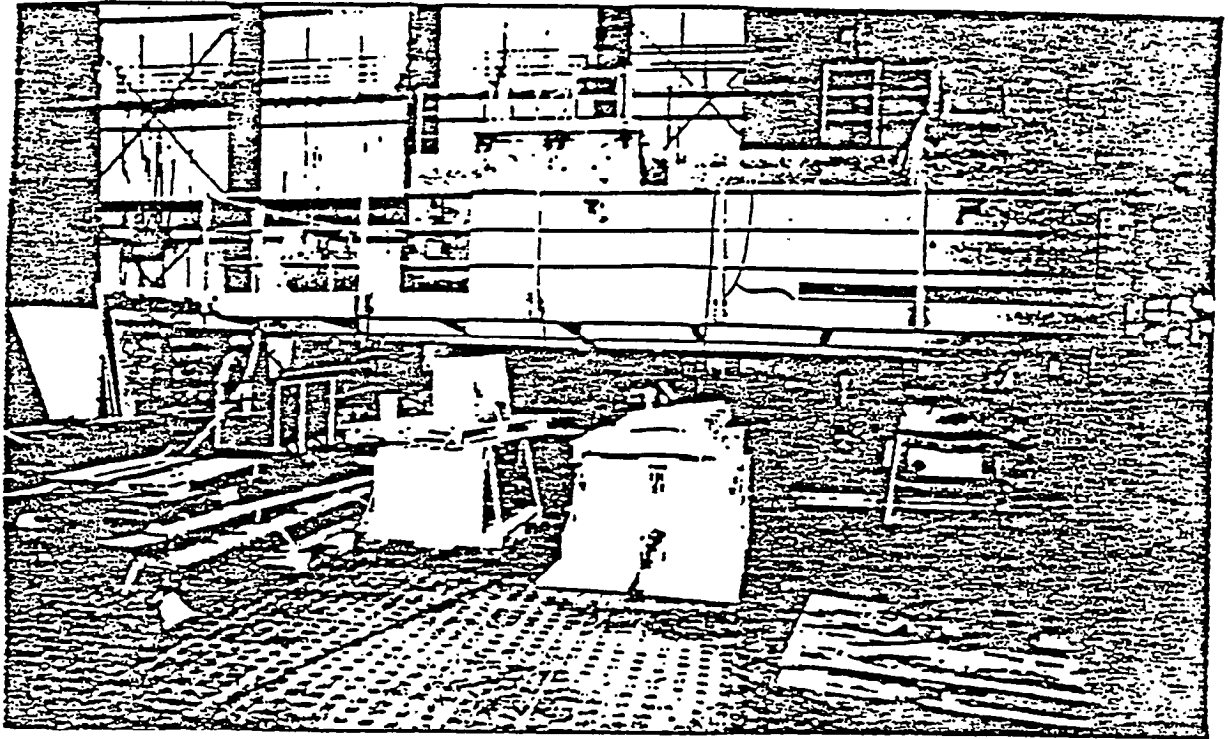

Figure 7  
On-block outfitting of USS Ranger close-in weapon system deckhouse.  
Components staged and accessible to trades.

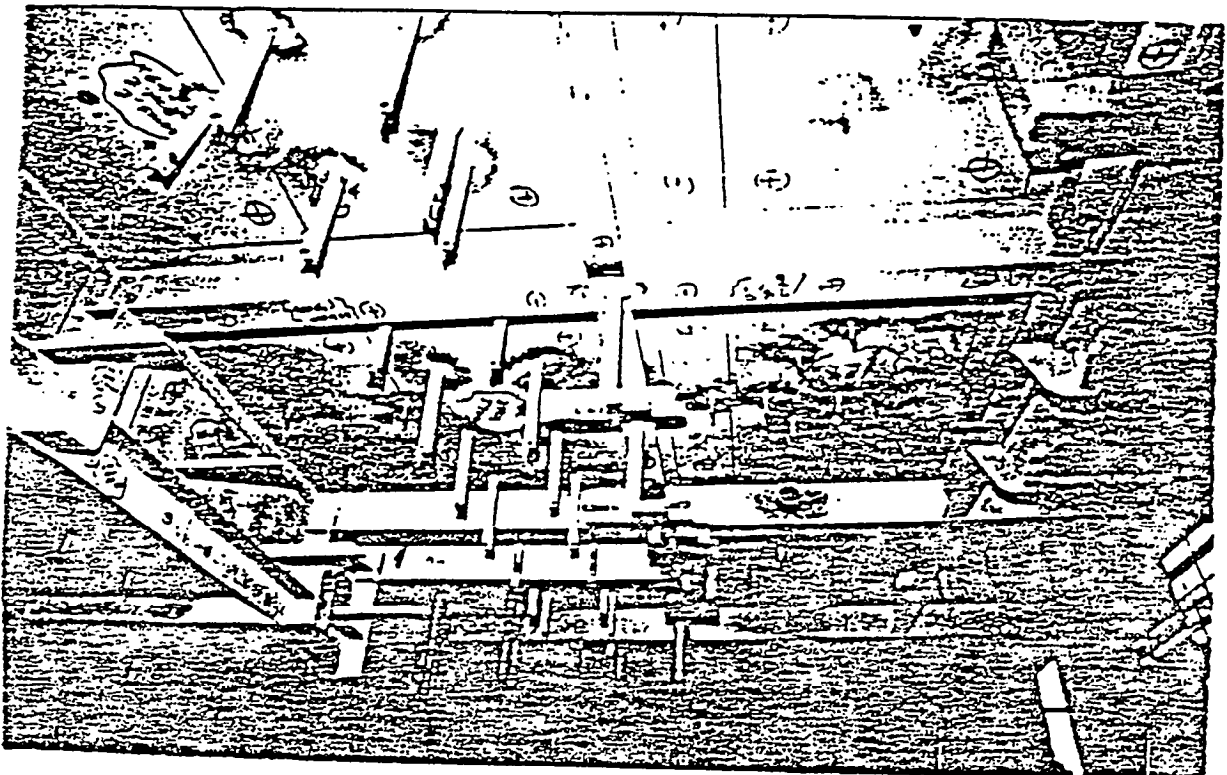

Figure 8  
Hangers, brackets, and foundations located and installed.  
Structure accessible for insulation application.

It should be noted that the deckhouse outfitting was 50 percent complete prior to ship arrival. This illustrates the impact that outfit planning can have on overhaul durations. One major factor that precludes complete outfitting of a new structure away from the ship is the allowance necessary for attachment to the existing structure. For the CV 61 deckhouse, a 24" strip around the attachment plane was left empty to allow clearance for welding when the house was attached to the ship.

At the ship's arrival the site preparation phase was accomplished in which the existing surface was cleared of interferences and prepared for accepting the new structure. To support the concept of accomplishing as much work in the shop as possible, photogrammetry was used to define the contour of the prepared island enclosure bulkhead. The data from the computer readout was transferred to the mating edge of the new deckhouse which allowed the structure to be trimmed while still in the shop.

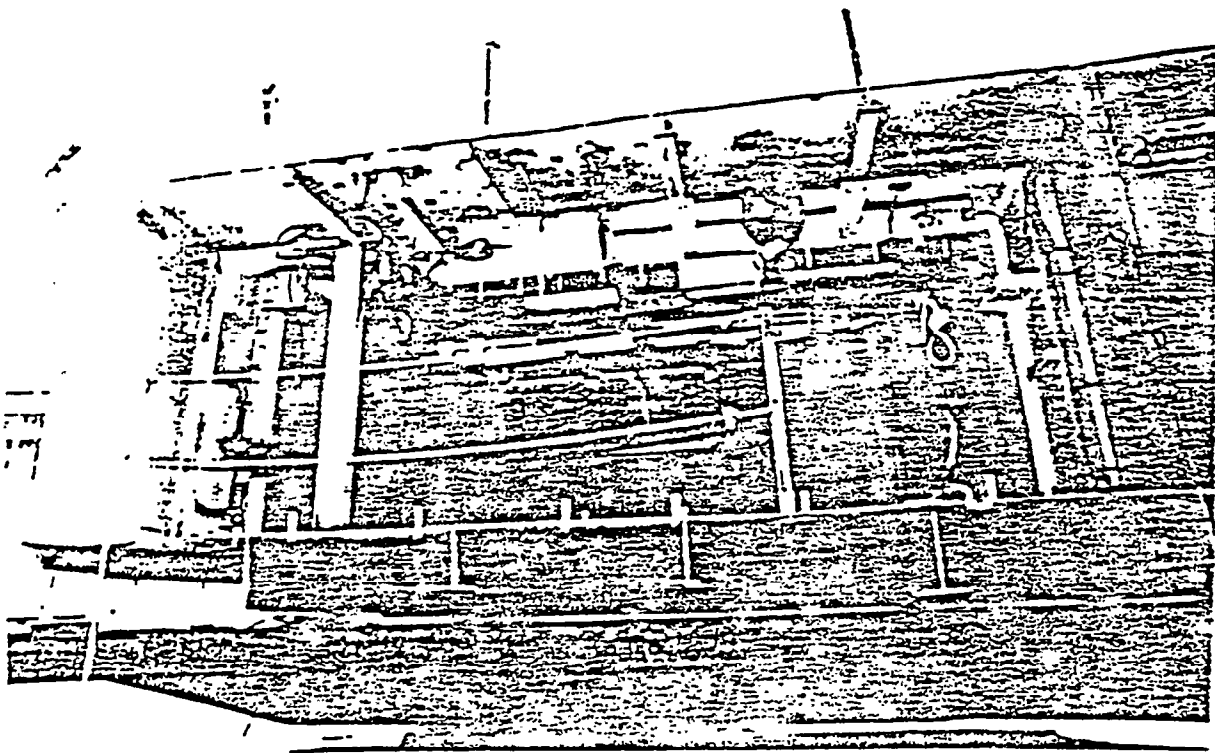

Figure 9

USS Ranger deckhouse transferred to site with outfitting 80 percent complete and mating edge trimmed. A 24" strip around the mating edge is left clear to facilitate site installation hot work.

Forty-four days after the ship's arrival, the new deckhouse, with 80 percent of the outfitting components installed, was attached to the existing ship. The fit-up interface between the new and existing structures averaged  $\pm 1/16$ " which allowed production welding to begin within hours after the initial lift, and tied up pierside cranes for only four hours.

After the structure was welded in place, the remaining outfitting components were installed and interfaced with systems transiting the zone boundary.

### Zone 2: Electrical Shop Upgrade

This project involved the complete reoutfitting of the existing Electrical Shop with updated equipment to improve shipboard electrical repair capability. The shop is located on the third deck centerline and represented the most typical type of overhaul work encountered by a repair facility. Interfacial on-unit concepts with existing shipboard conditions provided the peculiar challenge of this project. It requires the sequencing of nine different systems to be modified, and coordination of the affects of these on the existing systems.

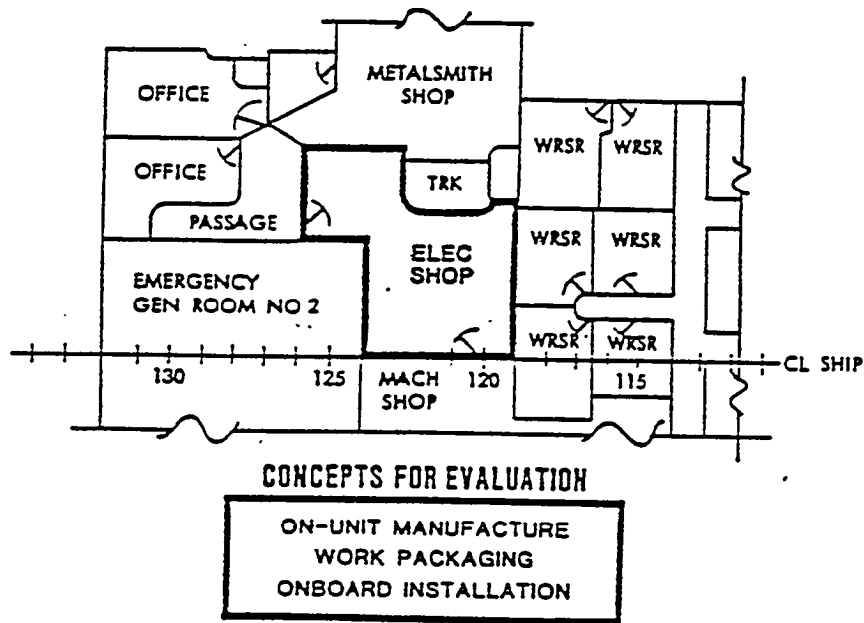

Figure 10  
USS Ranger Electric Shop

With this project, the composite drawing was used to identify the inter-relationship between the new components being installed, and the existing components being either removed, modified, or remaining. Preparation of the composite required extensive effort to correctly delineate the existing system location and configuration. With the aid of the composite, a number of system components that would have normally been fabricated and routed onboard were

designated for manufacture in the shop prior to the ship's arrival.

The concept of on-unit fabrication of the components was modified by permitting key piece trim allowance to accommodate final interface alignment with existing components. This procedure allowed for 90 percent of the particular run to be fabricated in the shop, with the remaining 10 percent to be fitted onboard.

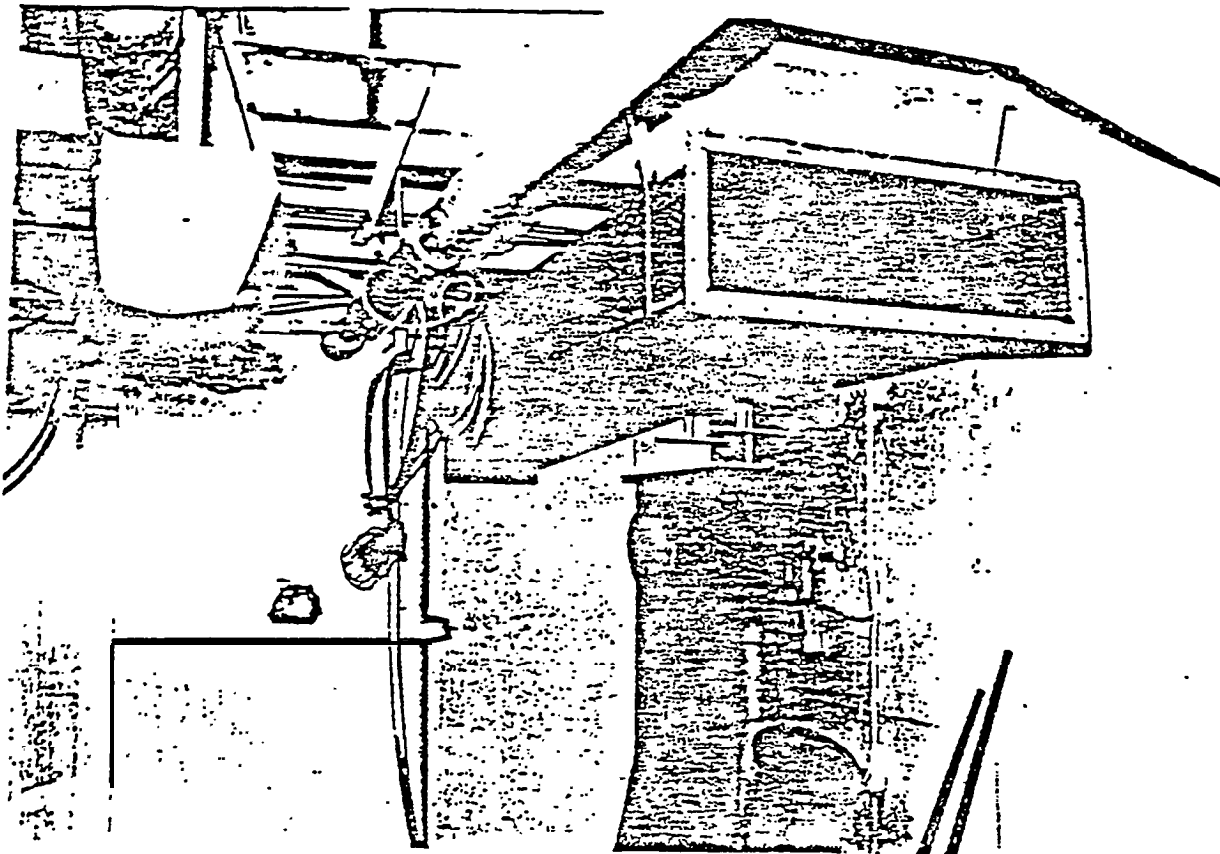

Figure 11  
Integration of new components with existing systems  
requires extensive coordination.

The Electric Shop task concentrated on the on-unit and onboard work concepts of zone logic and emphasized the trade coordination necessary to support the planned sequence of removal and installation. This task had a number of problems related to Government Furnished Equipment (GFE), but the 'shipyard was in a much better position to identify impact and coordinate solutions because it had a definite planned approach. for the production effort.

CASE NO. 2: USS ARKANSAS (CGN 41)

A selected restricted availability for the cruiser USS Arkansas (CGN 41) provided an excellent opportunity for Puget Sound Naval Shipyard to expand on the outfit planning concepts initiated on USS Ranger. The planned availability is to be a short duration overhaul primarily for the purpose of installing Tomahawk weapon capability. This provided the opportunity to use the zone

logic application to a complete ship alteration and it's affect on the entire ship.

Other variances from the Ranger task to be considered and evaluated are the use of systems drawings prepared by another design agent, and the use of computer aided design (CAD) to prepare the composite drawings. Incorporating these variances into the zone oriented planning process previously discussed represents a significant step forward for Puget Sound Naval Shipyard's application of outfit planning.

The Tomahawk project consisted of fabrication, outfitting, and installation of a 40'x12-1/2'x16' 40-ton equipment module below the main deck; installation of armored box launchers on the main deck; and, modification of various electronic control throughout the ship. This task Profile offered the ability to expand on new construction and existing space modification techniques began on USS Ranger.

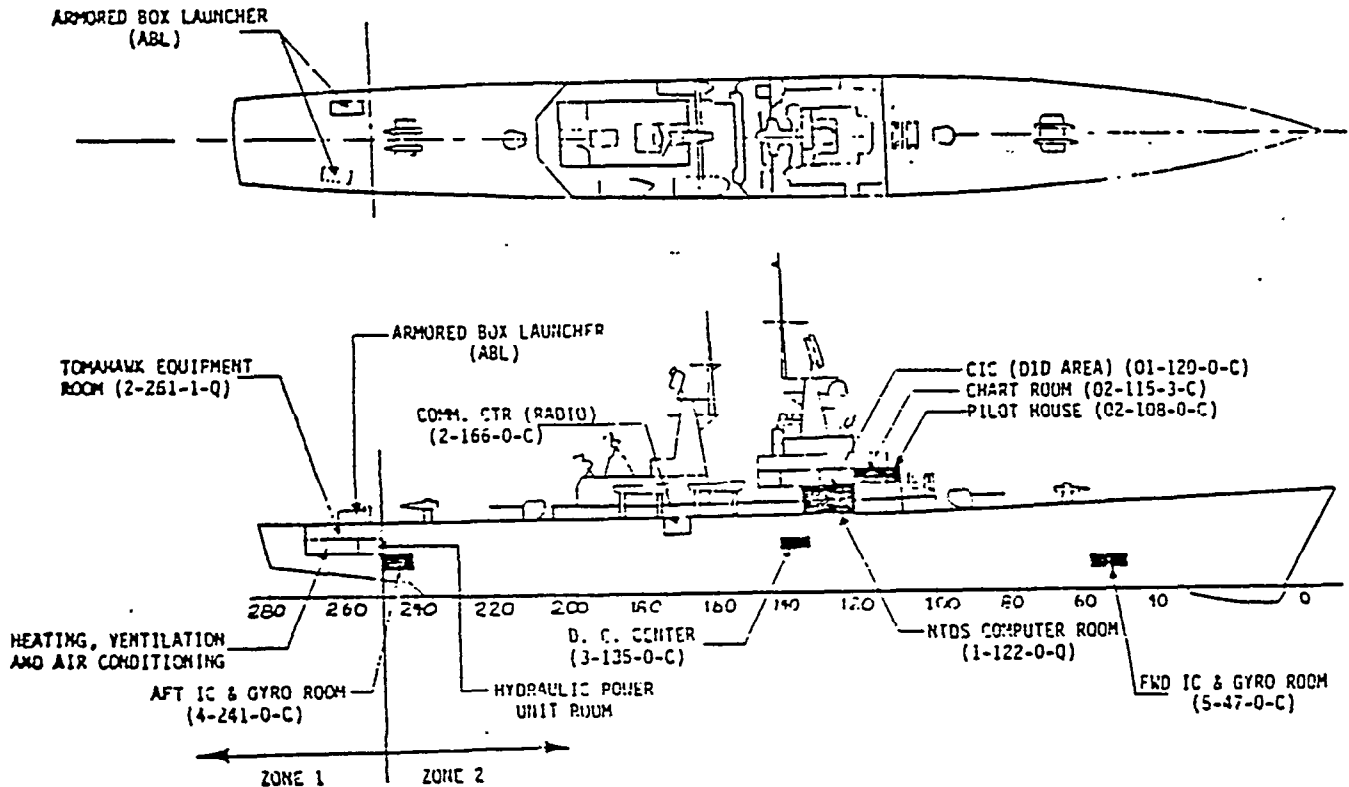

Figure 12  
USS Arkansas Tomahawk Installation



Employing systems drawings prepared by design agents for use by other shipyards' production department is a situation that will be contended with *more* frequently in the future. The constraints of this condition on outfit planning application is a prime area of evaluation for the USS Arkansas project. Methods of introducing production input to these documents *are* being examined to allow timely response and substantial familiarity of the project for the installing activity. The Arkansas Outfit Planning Group was able to have some input to the structural prefabrication drawings, but drawing and production schedule compression precluded the Group's attempt to influence component systems drawings to provide a totally interrelated drawing package reflecting the build strategy.

The composite drawings used by the USS Ranger Outfit Planning Group were prepared by hand which was labor intensive and time consuming. In order to reduce cost and time for composite drawing preparation, the USS Arkansas Outfit Planning Group initiated the use of CAD for this effort. Not only was time reduced, but because of the "layering" capabilities of CAD, the flexibility of the composite drawing was greatly enhanced to allow view rotation, enlargement, and highlighting.

Based upon common work and schedule problems, the USS Arkansas Tomahawk project was divided into two zones. The first *zone* incorporates all work from the main deck down to the first platform at the aft end of the ship which is comprised of the equipment module and launcher installation. The second zone was the interface with the remainder of the ship and focused on the electronic spaces being modified.

Fabrication, outfitting, and installation of the Tomahawk equipment module Zone 1, once again offers opportunity to examine the complete on-unit, on-block onboard outfitting cycle exemplifying new construction. The process of reviewing drawings and involving trade and technical personnel to determine a common build strategy resulting in the issue of a work package instruction, was continued. On-block outfitting of the module was completed, along with phase one and two testing, and ready for installation when the ship arrives. Other on-unit components were also completed and staged for installation. After shipboard site preparation is completed, the module and new outfitting components can be installed, tested, and turned over to the ship within the four-month time frame allotted.

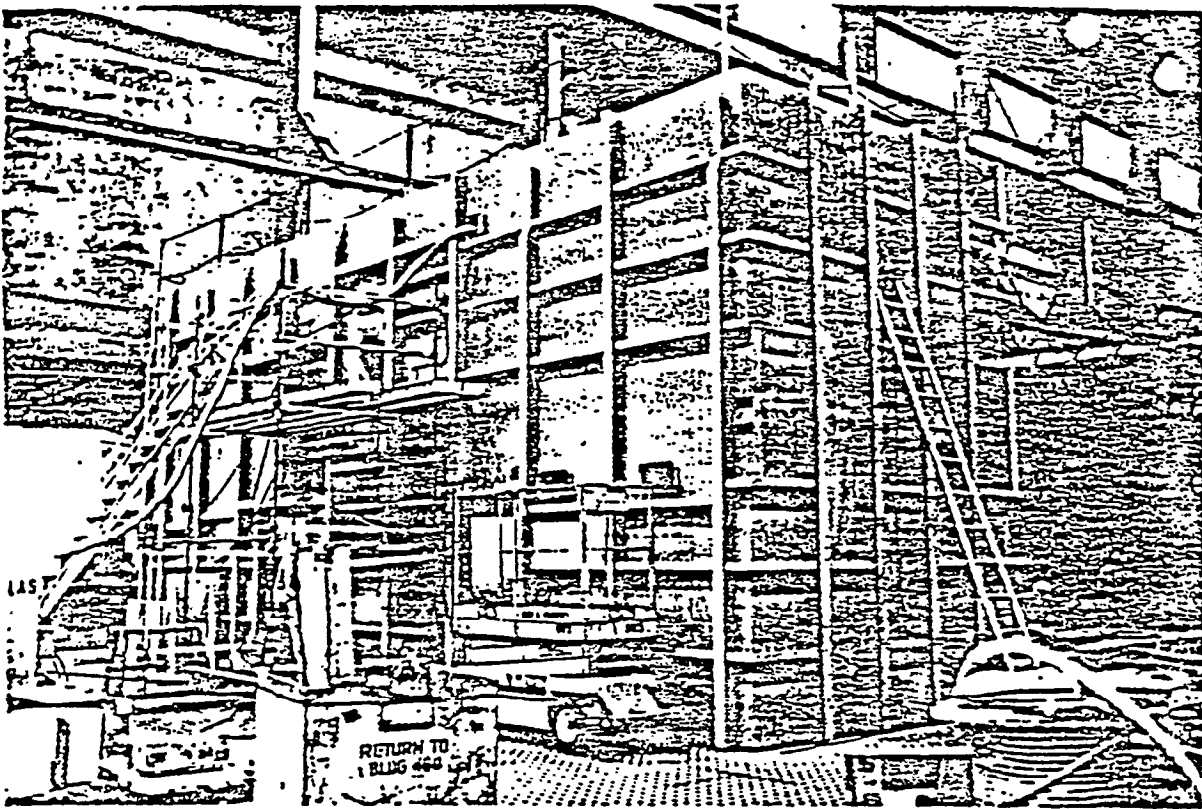

Figure 13  
USS Arkansas Tomahawk module in construction.  
Structural related outfitting requirements are incorporated.

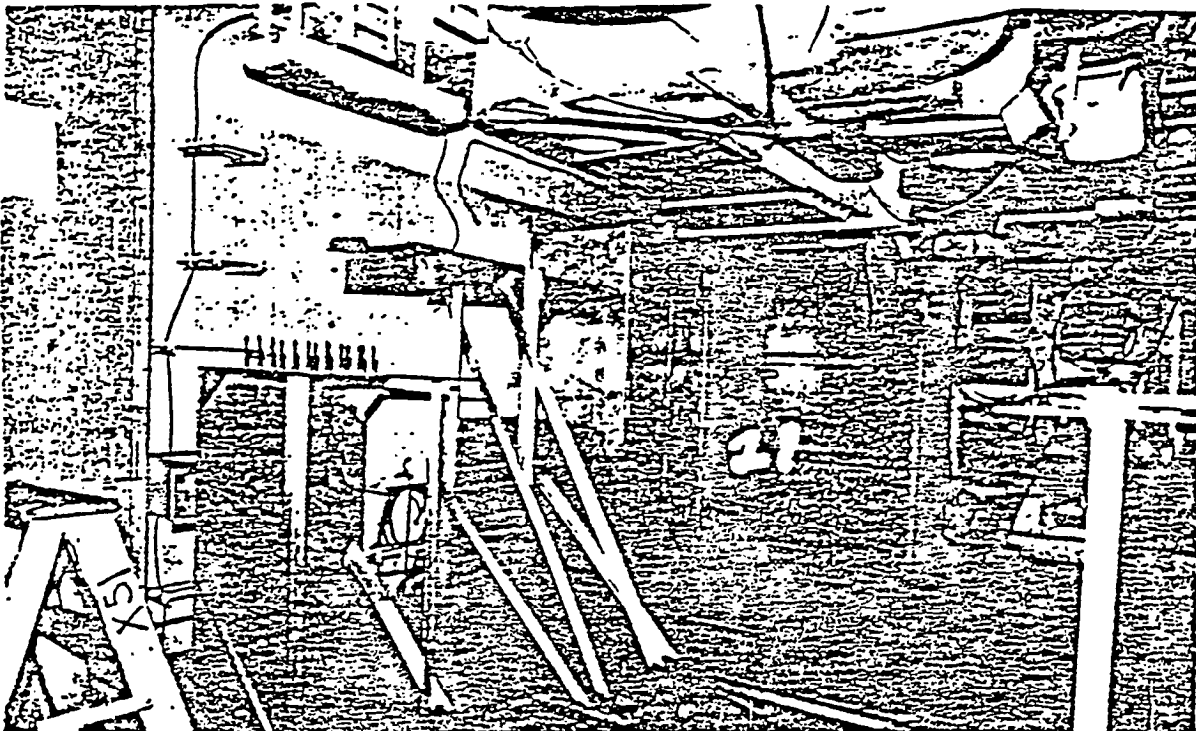

Figure 14  
On-block outfitting of USS Arkansas module allowed for equipment  
testing ready for installation at ship's arrival.

The "spread out" nature of Zone 2 is typical of overhaul/repair work normally accomplished by the shipyard. In order to deal with this situation, Zone 2 was divided into subzones to be able to concentrate on each compartment as separate but interrelated products. Since work in these dispersed compartments was limited to installation of peripheral electronic equipment to sup-

port the Tomahawk module, composites were not prepared for these subzones. The use of compartment cards was introduced as a method of packaging work for each of the compartments. These cards list all equipment and material requirements, material source or location, and sequencing information to be used in conjunction with the work package instruction.

1348 PSNS 4317/08 (Rev. 10-67)

COMPARTMENT MATERIAL SUMMARY CARD

01-120-0-C		1 OF 3		01-120-0-C		COMBAT INFORMATION CENTER			
CGN 41		USS ARKANSAS		AREA NO		LOCATION 01-120-0-C			
DWC - WORK ORDER - MATERIAL DESCRIPTION	NAME PLATE	MATERIAL		TYPE	NS NO	MATERIAL SOURCE	QTY.	MATERIAL STATUS	
		QUANTITY	REQ'D						
1 405-4735607/30041-72191-694									
2 OPERATOR INTERACTIVE DIS TERM				O.I.D.T.	EX9M000	GFE	5		
3 GRAPHICS CONTROL CENTER				HCU	EX7M000	GFE	1		
4 CABLE -- ORDERED ON TOMAHAWK COMPUTER & EQUIP				ROOM CABLE					
6 401-4735211/30041-72191-676									
6 COOLING FAIL ALARM PANEL						RAYTHEON	1		
7 SWITCH SNAP 15R2C4A-2						RAYTHEON	2		
10 401-4735224/30041-72191-690									
11 ALARM SWITCHBOARD IC/SM-2						RAYTHEON	1		
12 INTRUSION ALARM RELAY PANEL						RAYTHEON	1		
13 RESISTOR 6.2K Ω 2W						RAYTHEON	11		
14 DOOR OPER SWITCH TYPE S-193A						RAYTHEON	3		
16 NAMEPLATES						RAYTHEON	4		
16 CABLE DSCN-3						PSNS	15		
17 CABLE MSCN-7						PSNS	50		
18 CABLE TTSU-1 1/2						PSNS	130		
22 401-4735221/30041-72191-682									
22 SWITCHBOX SOCKET				A-19A	6201-7409	JPL 41221236	1		
23 SELECTOR SWITCH 16 POS				A-26A	1-74295	41221235	4		
24 HANDSET						41221237	4		
25 TERMINAL BOX - 60 T						41221241	1		
26 HOLDER HANDSET.					6201-7445	41221238	4		

Figure 15  
Compartment card used to interface material requirements in various compartments.

CASE NO. 3: SUBMARINE TANK REPAIR

Repair of submarine tanks presents the opportunity to apply zone logic to a work process that usually does not involve installation of new equipment. The evolution of tank repair work during a typical submarine overhaul includes the opening, sandblasting or cleaning, painting, repair of damage, testing, and closing of as many as 50 tanks. The full extent of work necessary is not known until these tanks are available for inspection, which eliminates the use of the on-unit and on-block concepts of outfit planning. However, through the analysis of the typical repair cycle, identification and coordination of common onboard work processes can be accomplished.

By taking advantage of the input from production, design, planning and

estimating, supply, test engineering, and scheduling the sequencing of work is achieved which provides for the proper resources being at the right place at the designated time. Through this group approach, the task resultant of sequencing tank repairs is:

- Identification of repairs early in the overhaul period
- Avoiding trade interference
- Minimizing rework
- Reducing duration of the tank repair process

It is being demonstrated that through the communication and cooperation of the Outfit Planning Group, the efficiency of the submarine tank repair process is improving and will culminate in a much improved standard approach which can be applied to any submarine.

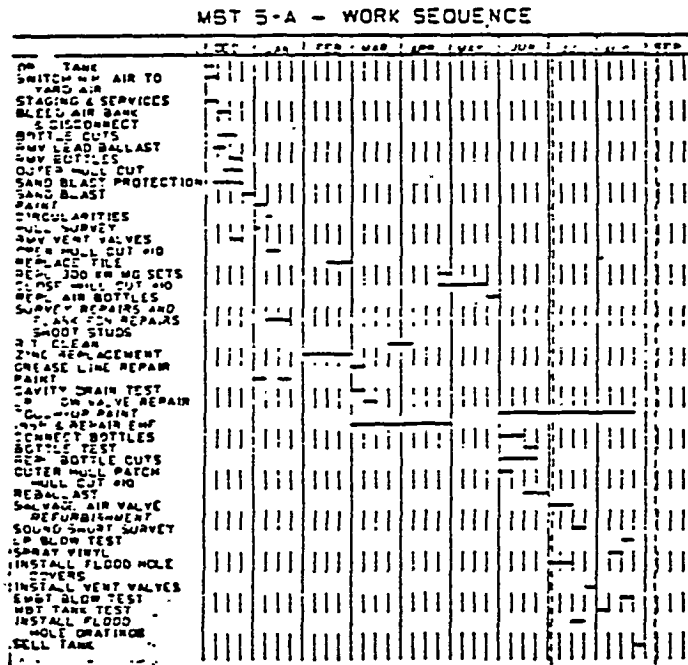

Figure 16  
Bar chart used to coordinate work within submarine tank.  
A similar bar chart sequences all tanks to be repaired.

#### CASE NO. 4: USS LONG BEACH (CGN 9)

The selected restrictive availability of the cruiser USS Long Beach presented a new challenge to Puget Sound Naval Shipyard's outfit planning experiment. With less than two months between receipt of off-station prepared systems drawings and arrival of the ship to begin installation of Tomahawk systems, the Long Beach Outfit Planning Group was faced with developing an overhaul strategy within a very short time frame. Based on the experiences of the USS Ranger and USS Arkansas efforts, the Long Beach Outfitting Planning Group recognized that the shipyard was not yet ready to develop a full Tomahawk overhaul strategy within the extremely limited preplanning window given. However, with the attitude that *zone* logic could be still applied, even if only to a small portion of the project, the results would be of beneficial.

The group's efforts quickly focused on the crew living area directly below the Tomahawk launcher locations. Because of considerable structural changes required to support the launchers, all of the systems mounted to the overhead needed to be either replaced - or modified. Because of the heavy congestion in this area, a composite was prepared by the design agent to aid the design effort.

In order to provide a viable sequence of onboard work, the group enhanced the use of existing composite drawings by the following process.

- Developed a structural panel drawing (SPD) depicting the new structural configuration of the crew living space' overhead at 1-1/2" = 1'-0" scale.
- Gave a reproducible copy of the SPD to each trade that had work to accomplish in this area, to delineate their particular system on the drawing based on

systems drawing provided. The trades also identified their prefabrication requirements.

The marked SPD's were collected and combined into a single overlay composite to accurately resolve interferences. Zone logic was used to identify construction installation advantages.

The resolved composite was then used by all trades to coordinate hanger locations, which allowed the hangers to be installed without having system components available.

with the installation sequence thus developed and agreed to, the Composite became the tool by which the zone manager could control the outfitting installation onboard.

#### CASE NO. 5: USS TEXAS (CGN 39)

The complex overhaul of the cruiser USS Texas is furnishing the shipyards outfit planning experiment with the opportunity to expand the work package instruction process into a zone prefab work package related to a master bill of erection sequence. Building on the experiences of the previous outfit planning projects, the Texas Outfit Planning Group is making significant inroads on the way technical information is to be given to production personnel.

This project involves the installation of Tomahawk missile capability similar in scope, but different *in* detail from the USS Arkansas project. Attention is being placed on the prefabrication and outfitting of a 46'x20'x19' 125ton magazine/launcher module, and reconfiguration of two electronic control rooms. The electronic control room portion is designated as Zone 2, and will use a compartment card and composite drawing

combination to provide the basic tools for work analysis, sequencing, and instruction. The procedures used will be similar to those previously discussed as enhanced by the appropriate findings of the following process.

Major emphasis for the USS Texas project is on the magazine/launcher module, Zone 1, to deliver a more comprehensive work instruction to the mechanic in the form of a zone prefab work package. This document will consist of numerous individual work instructions prepared from a complete CAD model of the module being built using a sequenced panel method.

The CAD model is being developed from system drawings provided by another design agent, and by using the layering capability of the CAD, each identified system is easily accessible individually or collectively. Systems input into the layered CAD files is being accomplished through a joint effort between design and production personnel. Where system rerouting may take advantage of using common hangers or improve manufacturing methods, hand layouts are being prepared by design personnel for review by the Outfit Planning Group. Once the

rerouting is firm, production personnel will locate the required hangers. This new data is then entered into the CAD to form an optimized CAD composite from which the graphic portion of the work instruction is developed.

The work package instruction is being enhanced by relating work to a sequenced panel erection process whereby each structural surface that makes up the zone is individually developed to reflect not only the structural members but also the outfitting components. These components are further identified as prefabricated pieces and tracked through the ordering, fabrication, and installation processes. With each piece being identified and tracked, control of the erection sequence is more manageable. This method provides for tracking of a piece from the original drawing, to locating the material required, where it is staged; when it is to be fabricated, which panel it is a part of, when it is to be installed, and how it is to be sequenced into the overhaul strategy. The work instructions are scheduled and sequenced in the zone prefab work package to reflect similar work processes and common manufacturing methods.

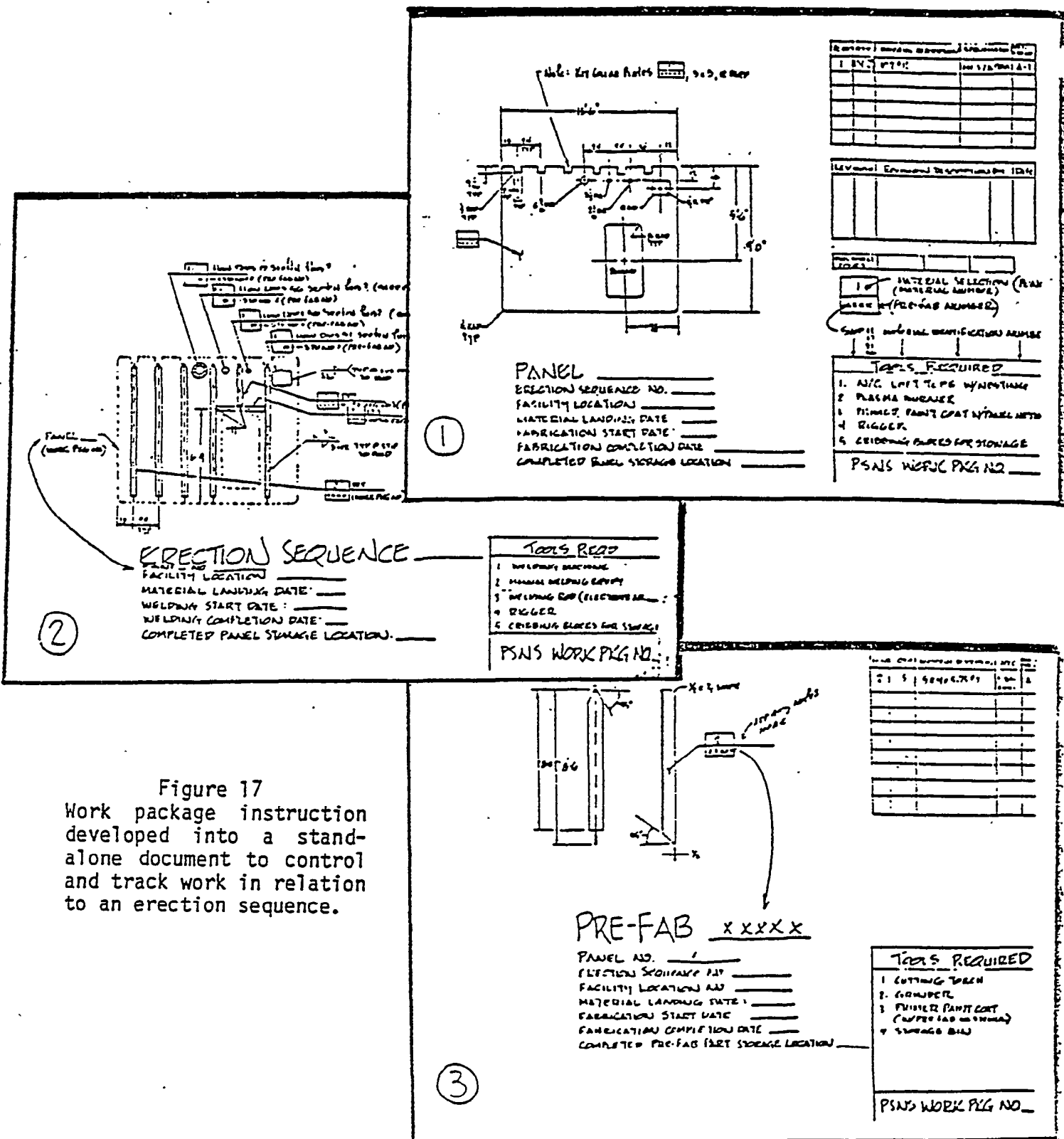

Figure 17  
 Work package instruction  
 developed into a stand-  
 alone document to control  
 and track work in relation  
 to an erection sequence.

## CONCLUSION

Adoption of zone logic concepts, developed for new construction projects, into the naval ship overhaul /repair process is continually proving its benefits. Unlike new construction, overhaul /repair work adds the necessity of dealing with existing entities that must be accounted for when planning new work. This results in gathering definitive data reflecting existing conditions installed by traditional system by system thinking, and integrating into it new work planned with zone logic concepts. Because of this added complexity factor and the potential organizational impact of zone logic, it was determined, that *an* evolutionary process of small projects would best serve Puget Sound Naval Shipyard's venture.

The key factor to the continuing success of outfit planning at the shipyard is the establishment of interdepartmental groups to examine, develop, apply, and evaluate zone logic concepts for the various overhaul projects. By concentrating knowledgeable shipyard resources into one group and providing the forum for departmental interaction, levels of mutual respect and trust are reached which allows the channels of communication to open, and helps all members to understand how each is interfaced in the total ship overhaul process.

A large portion of the outfit planning projects have been aimed at prefabrication and outfitting of large modules being added to the ships. These types of projects represent a small portion of a normal ship overhaul while the majority of overhaul /repair work takes place within the existing hull. These hull modules have been emphasized during these early stages of the outfit planning experiment because they represent a common link between new construction and overhaul of existing ships, which provides the opportunity to become

familiar with zone logic ideas. However, because of the mix of projects undertaken thus far, it is evident that the majority of future routine overhaul / repair work will concentrate on the coordinated sequence of on-unit and on-board outfitting concepts.

By taking advantage of applying the shipyard's knowledgeable resources to analyzing work requirements, developing an overhaul strategy, and accomplishing as much work as possible before the ship arrives, a number of actual and potential benefits are being realized.

- Identifying and coordinating common trade requirements to reduce *or* eliminated accomplishing similar work in the same area at different times.
- Performing component fabrication and assembly under better, safer conditions in the shop rather than onboard the ship where competition for space hinders productive efforts.
- Work sequencing coordination which minimizes *rework*.
- Dedicated material staging areas and tracking methods to have components available when and where they are needed.

Introduction of advanced technology procedures such as the use of photogrammetry and computer aided design.

Perhaps the most significant benefits realized are the involvement of the Production Department during the planning phase, and the development of the work package instruction. By participating in planning shipchecks and interacting with design personnel, the Production Department gains an improved understanding of the overall task requirements. Through this process the



Planning Department can provide improved instructions to support production methods. This interaction promotes a technical /trade teamwork approach to resolving problems on an equal basis.

In its development from the USS Ranger project to the USS Texas project, the work package instruction has become a powerful tool in using zone logic. The work package has evolved into a document that not only stands al one for the mechanic to accomplish his work but it has become the tool by which other related shipyard functions can be tracked. Items such as. manning, scheduling, material, budget, progressing, historical data, and quality assurance can now have a common

vehicle through which overhaul project can be managed to reflect actual world requirements.

Puget Sound Naval Shipyard's experiences with outfit planning have both been positive and progressive; The change in thinking of identifying and accomplishing work by application of zone logic has met resistance with those who have "grown up", with the traditional systems approach; however, as each project has progressed, response has become much more favorable as the benefits are recognized. Step by step, as more people accept and participate in this logic change, more ideas are being injected to improve the shipyard's method of doing business.

## MODERN SHIP REPAIR TECHNOLOGY APPLIED TO NAVAL VESSELS

James H. Shoemaker  
Project Leader, Production Control Branch  
Norfolk Naval Shipyard  
Portsmouth, Virginia

Mr. Shoemaker is presently in charge of implementation, of an automated planning and scheduling technique at Norfolk Naval Shipyard. This technique is based on outfit planning and product ~~work~~<sup>work</sup> breakdown structure methods developed under the National Shipbuilding Research Program.

Mr. Shoemaker has over twenty years shipbuilding experience in both new construction and repair. Major assignments have included new design work on CVN class reactor plants, and Q.A. engineering in a repair environment. He holds a Bachelor of Science degree in engineering technology from Old Dominion University.

### ABSTRACT

During the past several years the Maritime Administration has sponsored the National Shipbuilding Research Program (NSRP). The primary thrust of this program has been to identify those techniques which have enabled the Japanese to become world leaders -in shipbuilding.

To date, the NSRP has been directed primarily toward new construction. However, in the Fall of 1981, Norfolk Naval Shipyard embarked on a program to adapt these techniques to the repair of naval ships. This effort is based on the Outfit Planning and Product Work Breakdown Structure methodology presented in the NSRP publications.

Further, a mini-computer system has been installed at Norfolk which allows schedules to be produced in a real-time manner. This system allows the shipyard to take full advantage of the NSRP techniques.

A further problem with the system by system approach is that the overall plan for completion of the overhaul is known, and fully understood only by a few individuals. Typically, these individuals are not the foremen and general foremen who are making the day to day waterfront decisions. For example, pipefitter and outside machinist foremen should not be expected to know all of the work to be performed in a given space. However, their decisions may directly impact upon the electrician's work. This often causes items to be installed in an improper sequence which results in unnecessary rework.

*Intendit  
9/20/2001*

## 2.2 Zone Orientation

The work required for any large construction (or repair), project must be subdivided in order to be readily analyzed and managed. Any such subdivision scheme is a work breakdown structure.<sup>1</sup>

In order to subdivide repair work the "Zone Outfitting" and "Product /Work Breakdown Structure" techniques published by the Maritime Administration have been closely examined. These techniques allow a repair yard to plan, schedule, execute and test production work in the manner in which it is actually performed i.e. across system and across trade boundaries. The work is broken into manageable blocks or zones which cross system and trade boundaries; and zone size may vary to suit the work at hand. A zone may be a single component or the entire ship. The zone concept of planning and scheduling allows the day to day decisions presently being made by waterfront foremen to be made at an earlier time in the overhaul, in a more objective manner. System by system planning is not eliminated by the zone technique. Indeed, sorting of work by system is in fact made easier and more meaningful when Zone Orientation is used.

*, oriented*

## 2.3 Mini-Computer

As one explores the subdivision of a ship alteration/repair package beyond the traditional system by system approach, it becomes apparent that there is a significantly larger amount of information to be dealt with when using the PWBS technique. Unlike new construction, repair work must not only consider the production work and testing sequence, but must also consider those systems (or portion of systems) which must remain on-line throughout the overhaul.

In order to manage this large amount of information the need for a computer becomes readily apparent. Norfolk is attempting to use a relatively small mini-computer system for this effort. Our system is known as "PROMPT," an acronym for production oriented management planning technique, was developed by Science Applications, Inc., of La Jolla, California. The present hardware configuration includes a DEC PDP 11/44 processor with six CRT stations and a Printronix printer. PROMPT allows the sorting of detailed schedule information into various management reports. It further provides a graphics capability which enables us to produce automated PERT schedules. We are presently using the PROMPT system to create working schedules at Norfolk.

## 3. PERTINENT TERMINOLOGY

3.1 Group Technology. Group technology applied to ship overhauls is the systematic grouping of similar repair processes to match common labor skills. Work is grouped by production process rather than by ship's systems.

**3.2 Conventional Outfitting.** Conventional outfitting is system by system outfitting. It is typified by allocations of resources to ship's systems and does not generally recognize interim subassembly of products, or the common production processes between systems.

**3.3 Zone Outfitting.** Zone outfitting is a technique which allows augmentation of the production process by classes of problems in order that common solutions can be applied to common problems. It is a means of organizing the work for better control and execution.

**3.4 Zone.** A zone is any subdivision of a ship which best serves for organizing information needed to support the ship at any stage of the overhaul.

**3.4.1 Functional Zone.** A functional zone is a subdivision of the ship which includes all equipment associated with a particular system or component. For example, a functional zone might include all piping and pumps associated with a particular tank, as well as the tank itself.

**3.4.2 Geographical Zone.** A geographical zone is a physical segment of the ship such as a complete deckhouse, a compartment, or portion of a compartment.

**3.4.3 Variable Zone.** A variable zone is a combination of functional zone and geographical zone which organizes the work by process. It is the zone in which the work is to be done and may include more than one functional and geographical zone. It is also known as a work zone.

**3.5 Pallet as a Work Package.** Literally a pallet is a portable platform upon which materials are stacked for storage or transportation. The term pallet is also used to indicate a work package. It represents a definite increment of work with allocated resources needed to perform the defined overhaul activity. A pallet is therefore organized by work zone and stage of the overhaul.

**3.6 Palletizing.** Palletizing is the creation of a work package including job definition, location, software, resource definitions and material definition. It includes integration of zones and processes to achieve an optimum flow of people past the required work.

**3.7 Stage.** A stage is a band of time during an overhaul in which specific production processes take place. Examples include:

- . Prearrival planning/engineering
- . Prefabrication
- . Disassembly (ripout)
- . Open and inspect (replanning)
- . Repair
- . On-unit assembly
- . On-block assembly
- . On-board assembly
- . Test

**3.8 Problem Area.** A problem area is an aspect of a particular job which is unique, and therefore requires special categorization. A specialty within a trade is the most common example. However, problem area may also be due to

quantity (large or small) of similar operations, location of the operation, or type of operations (i.e., manufacturing vice assembly).

#### 4. PRODUCT/WORK BREAKDOWN STRUCTURE

**4.1 General.** The work required for any large repair project must be subdivided in order to be effectively analyzed and managed.' Traditionally, this subdivision has been by ship's functional systems. System orientation is desirable for estimating and early planning. However, system orientation for production planning, scheduling, and execution is inappropriate since it does not reflect the way the work is actually performed. Product Work Breakdown Structure (PWBS) provides a scheme to subdivide the repair/overhaul tasks in the manner in which they are actually conducted.

*hand-drawn  
by  
new-time*

#### 4.2 System Vice Zone Orientation

**4.2.1 Schedules.** Historically, schedules at NNSY have been drawn on a system by system basis. This technique results in a series of parallel lines which, in theory, are interconnected at each system interface. In practice, the interfaces are insufficient either because they are not properly thought out originally; or because they are lost during revisions to the schedule. Therefore, the end product is a series of parallel lines indicating activities which may, or may not, be interdependent.

In order to resolve this problem the shipyard has turned to PERT type schedules which clearly show interfacing activities. However, the complexity of creating and revising hand drawn PERT schedules is overwhelming. Therefore, it becomes necessary to have a system for creating and/or revising a PERT schedule using ADP equipment.

**4.2.2 Job Orders/Work Orders.** Job orders, work orders, and procedures, i.e., the paper by which the trades do work, are also written on a system by system basis. A further breakdown usually identifies the job to a lead or cognizant trade. The paper does not usually identify similar work taking place on the same ship, or adjacent/interface work. This results in the real Production Department decisions, such as which tasks to perform together., and when to perform the tasks, being made by each individual trade. While trade supervisions attempt to be objective, it is not unusual for work to be performed on a "first one in" basis. This often results in trade conflicts such as ripout of newly installed items.

#### 4.3 PWBS for Overhaul/Repair

**4.3.1 PWBS Decisions.** To date, PWBS techniques have been applied only to new construction. Figure 4-1 has been developed to provide a guide for making PWBS decisions in an overhaul environment. Figure 4-1 allows the work to be subdivided categorically by zone, problem area (specialty) and stage. Each category is then examined in relation to other two. Using this technique it is possible to create a virtual flowlane for the required work. A virtual flowlane may be thought of as an assembly line in which people flow by the work. The virtual flowlane optimizes use of production time by minimizing set up time between jobs of similar skill, and by ensuring that the best possible environment exists when the cognizant trade arrives at the job site. The environment created will provide a safe workplace in which all needed materials are on hand, and all interfacing work has been considered and properly sequenced.

*T /*

*PERT*

2T IN RC 40 SUPPLY - 1.1 <sup>1.1</sup> ~~1.1~~ by ABC

**4.3.2 Productivity Measurement.** Upon completion of the PWBS analysis described in section 4.3.1 it becomes apparent that one is able to assign a productivity value, or product resource value, to each of the defined tasks. This value will be categorized under the general heading of one of the following?

Material, to be used for production, either direct or indirect, e.g., steel plate, machinery, cable, oil, etc.

Manpower, to be charged for production, either direct or indirect, e.g., welder, gas cutter, fitter, finisher, rigger, material arranger, transporter, etc.

ABC . Facilities, to be applied for production, either direct or indirect, e.g., docks, machinery, equipments, tools, etc.

Expenses, to be charged for production, either direct or indirect, e.g., designing, transportation, sea trials, ceremonies, etc.

Upon assignment of the product resource value it is possible to analyze the availability of resources for each category and determine the impact on the overall performance of work.

## 5. PROMPT SCHEDULING SYSTEM

Scheduling  
needs to  
be RT

5.1 General. In order to effectively apply the PWBS technique it is highly desirable to have a real time, interactive scheduling system. Norfolk Naval Shipyard is using the PROMPT system to meet this need. PROMPT was developed by Science Application, Inc. (SAI) of La Jolla, California. To develop this system SAI drew upon hardware and software from similar government applications, and combined these with additional software to provide a dynamic, interactive scheduling system. The system provides integrated schedules at various levels of detail, and allows information to be updated, progressed or modified as required via an on-line interactive terminal.

The present system at NNSY consists of a DEC PDP 11/44 mini-computer with six CRT terminals. The system is operated on a day-to-day basis by scheduling section personnel, and is presently used to create and/or modify PERT chart schedules at various levels of detail.

5.2 Hierarchical Schedules. Shipyard production schedules form the framework for the flow of information between various shipyard functions. Moreover, schedules are the control mechanisms by which planned work packages are conveyed to the work force.<sup>2</sup> In order to be meaningful to the intended user, the schedule should generally be presented at the level of detail which corresponds to the user's responsibility. For example, the major key event schedule of an overhaul may be interesting to a first line waterfront foreman; however, his real need is a day-to-day sequence of the tasks he must accomplish.

In order to meet the needs of senior management, middle management, and first line supervision NNSY has chosen a top down method of scheduling. Schedules are developed by determining the ship availability dates, the major

milestones, key events and so forth. This process is carried to the lowest level necessary which may be a list of jobs, or a list of tasks within a specific job.

The PROMPT system allows six levels of schedules. Schedules are linked between levels through individual activities. Each of the networks in this hierarchical arrangement is a sub-network which relates to the overall repair plan.

**5.3 Schedules by Zone.** In order to be meaningful, schedules must indicate the sequence in which work is to be accomplished. The schedule must show all system and trade interdependencies. These fundamental requirements have resulted in three scheduling zones at NNSY. These zones form the basic framework by which the scheduling decisions are made.

**5.3.1 Functional Zone.** This level of schedule depicts the system functional requirements as they relate to the jobs required to be performed. This schedule creates the basic "windows" in which work may be performed. These windows reflect which systems, or portions of systems, are required to be on line during the overhaul.

**5.3.2 Geographical Zone.** The geographical zone is simply the physical location of the job aboard ship. Ideally, the jobs are indicated on a composite drawing. However, since composite drawings are generally not available to an overhaul yard, a "make do" composite is created from the ship's arrangement drawing. There is presently some interest at NNSY in creating composite drawings using photogrammetry. However, this interest has not yet been developed to the prototype stage.

**5.3.3 Variable Zone.** The variable zone may be thought of as the work zone. It is a union of the functional zone and the geographical zone by the process to be performed.

**5.4 Test Schedule.** Traditionally, the schedule for testing of ship's systems has been independent from the production schedule. Using the PROMPT system, it is desirable to integrate system tests with production work to the maximum extent possible. This allows testing to take place in the earliest possible window established by the functional zone.

**5.5 Progress Reporting/Rescheduling.** In order for a real time scheduling system to be effective throughout an overhaul it must have the capability to reflect the status of each job in a timely manner. PROMPT allows the user to enter job progress on a periodic basis (the time period is selected by the user). Upon entry of progress, it is possible to determine impact on the remainder of the network being progressed; and, on networks of a higher level. This feature enables the user to reschedule work as the situation changes. Moreover, impact of late finishes or earlier finishes of events may be immediately analyzed and the "best path" to job completion determined.

The real time capability of PROMPT allows the shipyard to perform "what if" studies in a much easier manner than previously possible. However, yard management has found that while this increased capability is a great advantage, projects must be thoroughly examined prior to initiation in order to efficiently utilize PROMPT resources.

**5.6 Management Reports.** With the large amount of data stored in PROMPT it is possible to develop many different management **reports**. These reports include the following which are adequately described by their title:

Milestone Report  
Schedule Report  
Work Status and Progress Report  
List of Active Projects

**Additional reports include:**

a. Bar Graph Report or Gantt Chart which graphically illustrates the scheduled duration of each work item, a Precedence Report which lists all work items in the network and identifies each preceding work item, a Calendar Report which provides a calendar of the network period including those days which the user has declared as holidays, and a Master File Report which is a printout of PROMPT created scheduling files.

6. **EXAMPLE**

**6.1 General.** The best method to illustrate the concepts previously presented is with an example. Figure 6.1 shows a plan view of the hypothetical ship to be overhauled. Figure 6.2 shows the same ship, with a functional zone representing the Firemain System in the forward portion of the ship. Figure 6.3 shows the first cut at geographical zoning which includes the port Auxiliary Machinery Room, and one half of the Main Machinery Room. The variable zone, or work zone, is shown in Figure 6.4. This work zone has been determined by analyzing all work in the machinery space using the PWBS system.

**6.2 Specific Jobs.** For the purpose of this example assume that the following specific jobs are to be performed in the variable zone shown in Figure 6.4.

**JOB ORDERS**

1. Replace 9'-0 level grating
2. Replace firemain piping FR 100-102
3. Replace demineralized water pump and motor
4. Calibrate gauges system 1
5. Calibrate gauges system 2
6. Calibrate gauges system 3
7. Add light frame 103-104 S/A 1000
8. Renew pipe and valve main feed system FR 100-102
9. Add vent duct S/A 2000
10. Open/inspect/repair valves system 1
11. Open/inspect/repair valves system-2
12. Open/inspect/repair valves system 3
13. Open/inspect/repair valves system 4
14. Open/inspect/repair valves system 5
15. Add shock support and modify demin water pump foundation S/A 3000

**6.3 Tasks Required.** In order to accomplish the jobs listed in section 6.2 the tasks shown below must be performed. These tasks have been organized by stage; i.e., Planning and Engineering, Procurement, Open and Inspect, Secondary



Procurement, Repair, On Unit Assembly, On Board Assembly. This has been done by proceeding through the PWBS process as outlined in Figure 4.1, which results in the breakdown of:

#### **PLANNING AND ENGINEERING**

Define jobs from customer.  
Perform production planning.  
Write job orders or procedures.  
Define material  
Schedule work

#### **PROCUREMENT**

Procure material and fabricate demin water pump foundation.  
Procure material and fabricate main feed system pipe.  
Procure material and fabricate fire main system pipe.  
Procure material and fabricate vent duct.  
Procure material and fabricate light assembly.

#### **RIPOUT**

Remove insulation  
Remove demineralized water pump and motor  
Remove MN feed pipe assy  
Remove 9'-0 level grating and demin water pump FND  
Remove AUX salt water PPG  
Remove fire main  
Remove gauges  
Remove 6' demin water pipe FR 100-103  
Install temp staging @ 9'-0 LVL  
Cut temp access

#### **OPEN AND INSPECT**

Open/inspect system 1, 2, 3 valves, flow path A  
Open/inspect system 1, 2, 3 valves, flow path B  
Open/inspect system 1, 2, 3 valves, flow path C  
Open/inspect system 4 & 5 flow path B  
Open/inspect. system 4 & 5 flow path C

#### **SECONDARY PROCUREMENT AND REPAIR**

Procure material identified by open and inspect stage.

#### **REPAIR/ALTERATION**

Perform all repairs and alteration work aboard ship and off ship such as valve lapping, component maintenance, etc.

## ON UNIT

### Assemble demineralized water pump unit

## ON BOARD

Reassemble system 1, 2, 3 valves flow path A  
Reassemble system 1, 2, 3 valves flow path B  
Reassemble system 1, 2, 3 valves flow path C  
Reassemble system 4 & 5 valves flow path B  
Reassemble system 4 & 5 valves flow path C  
Reinstall system 1 gauge, flow path A  
Reinstall system 1 gauge, flow path B  
Reinstall system 1 gauge, flow path C  
Install vent duct  
Install MN feed pipe assy  
Install fire main piping assy  
Reinstall ASW piping  
Install demin water pump unit and connect pipe  
Remove staging Clean and paint bilge  
Install 9'-0 LVL grating  
Close access cuts  
Install light  
Relag MN FD and demin water PPG ABV 9'-0 LVL  
Clean and paint 9'-0 LVL to 22' LVL

Once the PWBS technique has been completed a PERT schedule for the tasks is generated, a portion of which is shown in Figure 6.5. The schedule is then progressed, and tasks are rescheduled as necessary, as work progresses.

## 7. EXPECTED PRODUCTIVITY IMPROVEMENTS

**7.1 Current Improvements.** Presently, the PROMPT system is in use for planning and scheduling of a complex overhaul of the propulsion plant on a CGN. Schedules have been produced with the computer which have resulted in a significant savings in the manual drafting time previously required to produce a schedule. However, greater savings have been achieved when it has become necessary to revise PROMPT schedules. A revision with PROMPT takes only minutes, where the hand drawn revision would take days.

**7.2 Expected Improvements.** While there have been productivity improvements in scheduling, the greatest improvement is expected in the Production Department waterfront trades. The virtual flow lanes created by the PWBS process will produce an efficient use of trade resources in that work will be performed in an orderly manner which has been thought through objectively prior to arrival of the cognizant trade at the job site.

1. "National Shipbuilding Research Program - Product <sup>priority</sup> Work Breakdown Structure" U.S. Dept. of Commerce, Maritime Administration
2. "National Shipbuilding Research Program - Outfit Planning" U.S. Department of Commerce, Maritime Administration

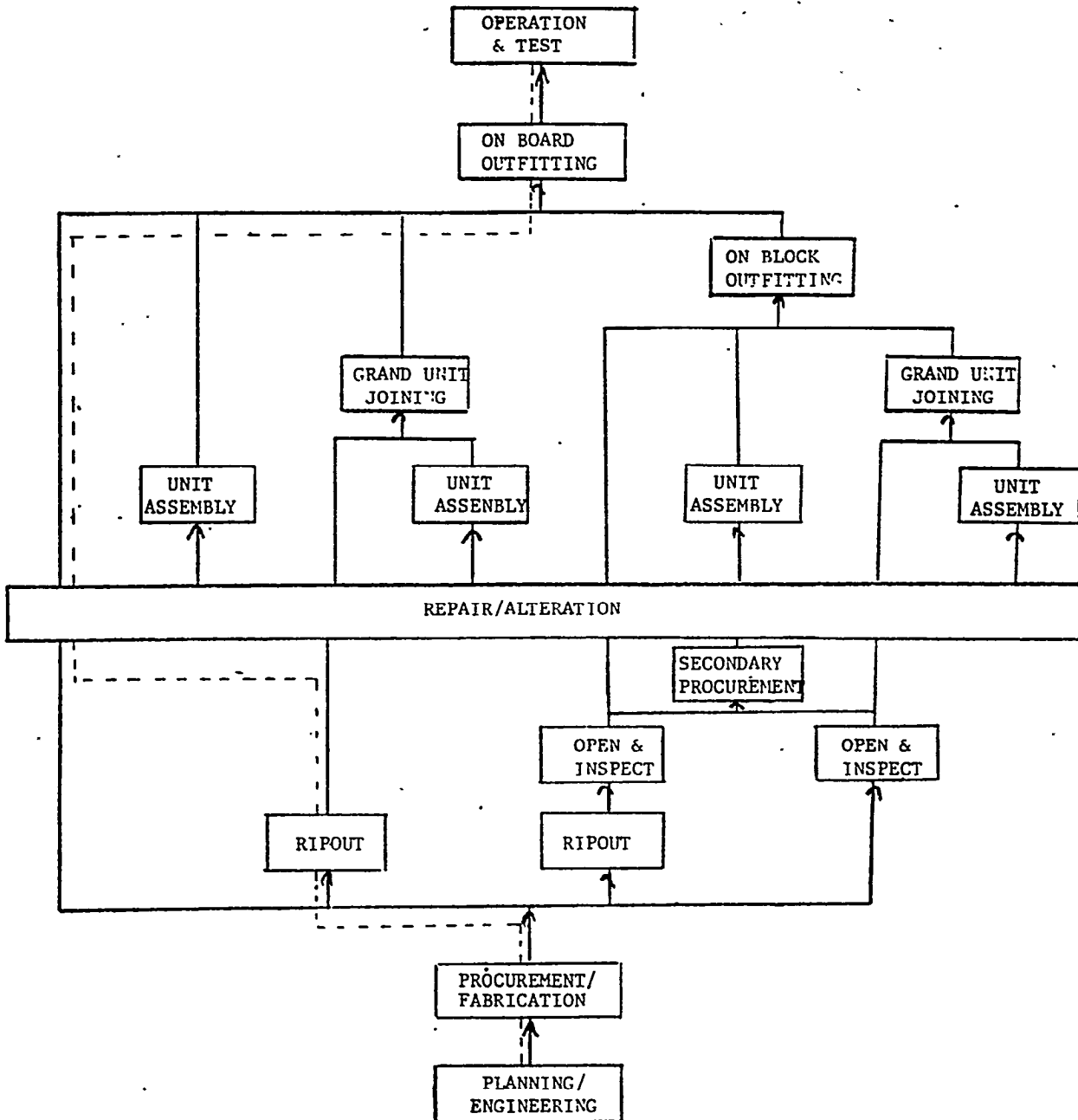

FIGURE 4.1  
SHI

PRODUCT ASPECTS							
ZONE	PROBLEM AREA					STAGE	
SHIP	DECK	ACCOM.	MACH	NUCLEAR	ELECT.	ELEX/WEAP	OPERATION & TEST
ON BOARD DIVERSION	SIMILAR WORK IN SML VOL.	SIMILAR WORK IN LRG VOL.	SIMILAR WORK IN HIGH SKILL				REASSEMBLY
BLOCK	COMPONENT IN LARGE QUANTITY		COMPONENT IN SMALL QUANTITY				REASSEMBLY
GRAND UNIT	LARGE UNIT						WELDING
							UNIT JOINING
UNIT	LARGE SIZE UNIT		SMALL SIZE UNIT				WELDING
						ASSEMBLY	
COMPONENT	LARGE/SMALL QUANTITY	SPEC-IALTY	INTER-FACES				
ON BOARD DIVERSION	BY SPEC-IALTY		ITEMS IN LARGE/SMALL QUANTITY				INSPECT/REPORT
							DISASSEMBLY
ON BOARD DIVERSION	BY SPEC-IALTY		ITEMS IN LARGE/SML QUANTITY		INTERF.		SORTING (DEPALLETIZING)
COMPONENT	IN HOUSE MANUFAC	OUTSIDE MANUFAC	BUY	REQ. FROM STOCK			PALLETIZING
							MANUFACTURING
							MAT'L REQ. DEFINITION
SHIP	DECK	ACCOM.	MACH	NUCLEAR	ELECT	ELEC/WEAPS	PREARRIVAL INSP. REPORT
							SHIPALTS
							TECH WORK DOC.

FIGURE 4.1  
SH 2

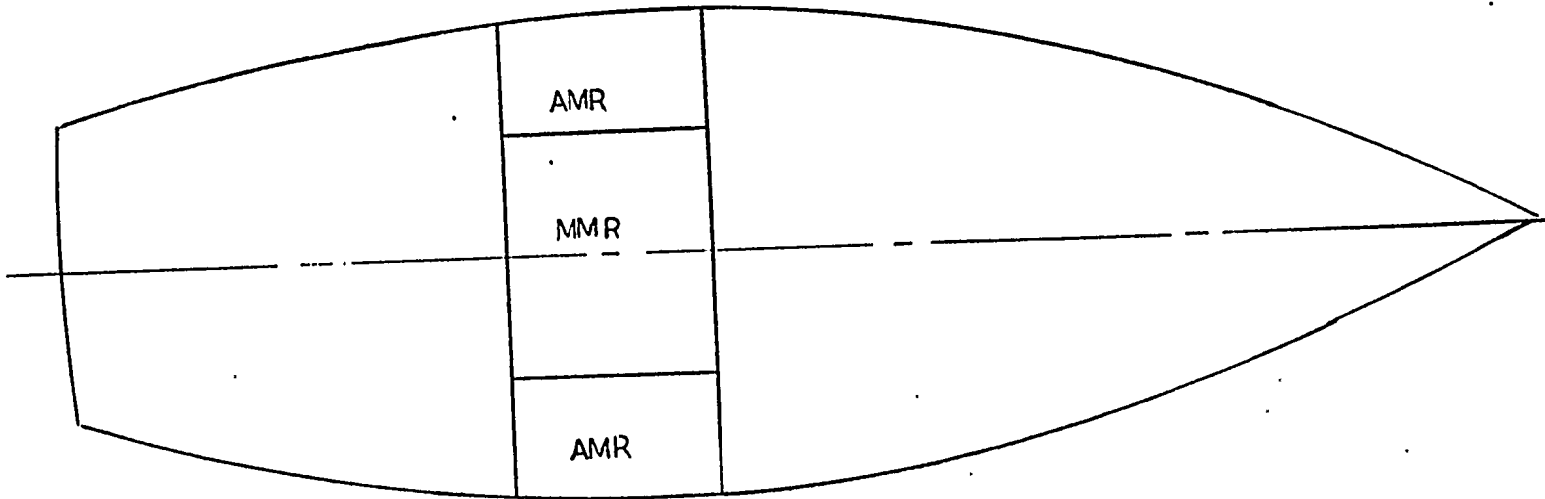

FIGURE 6.1

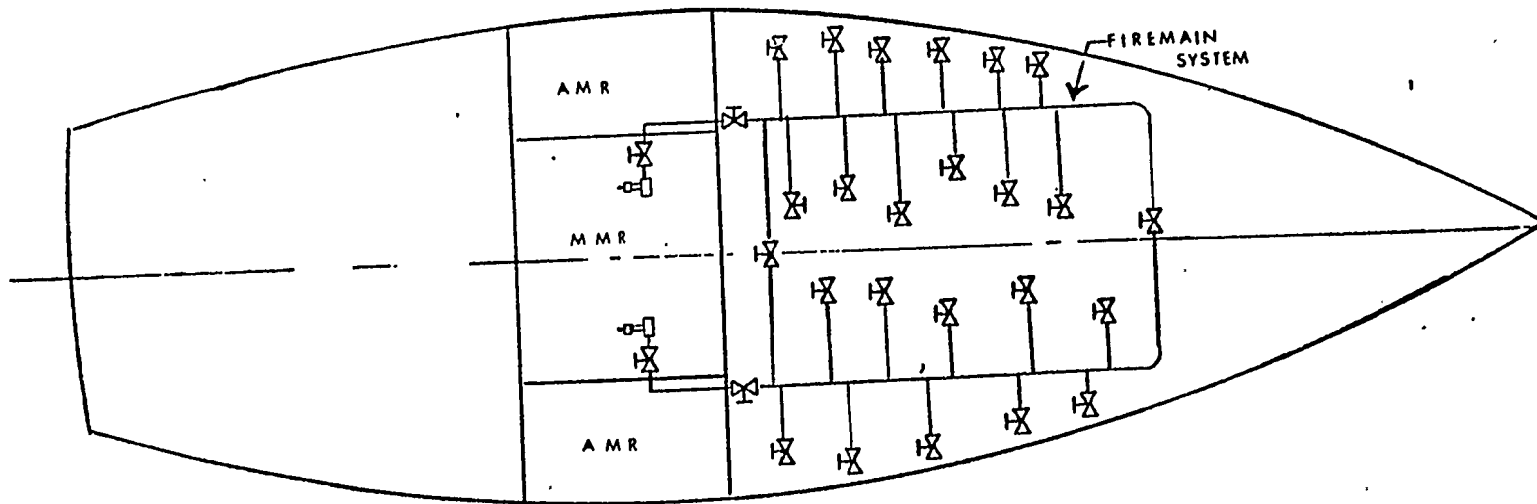
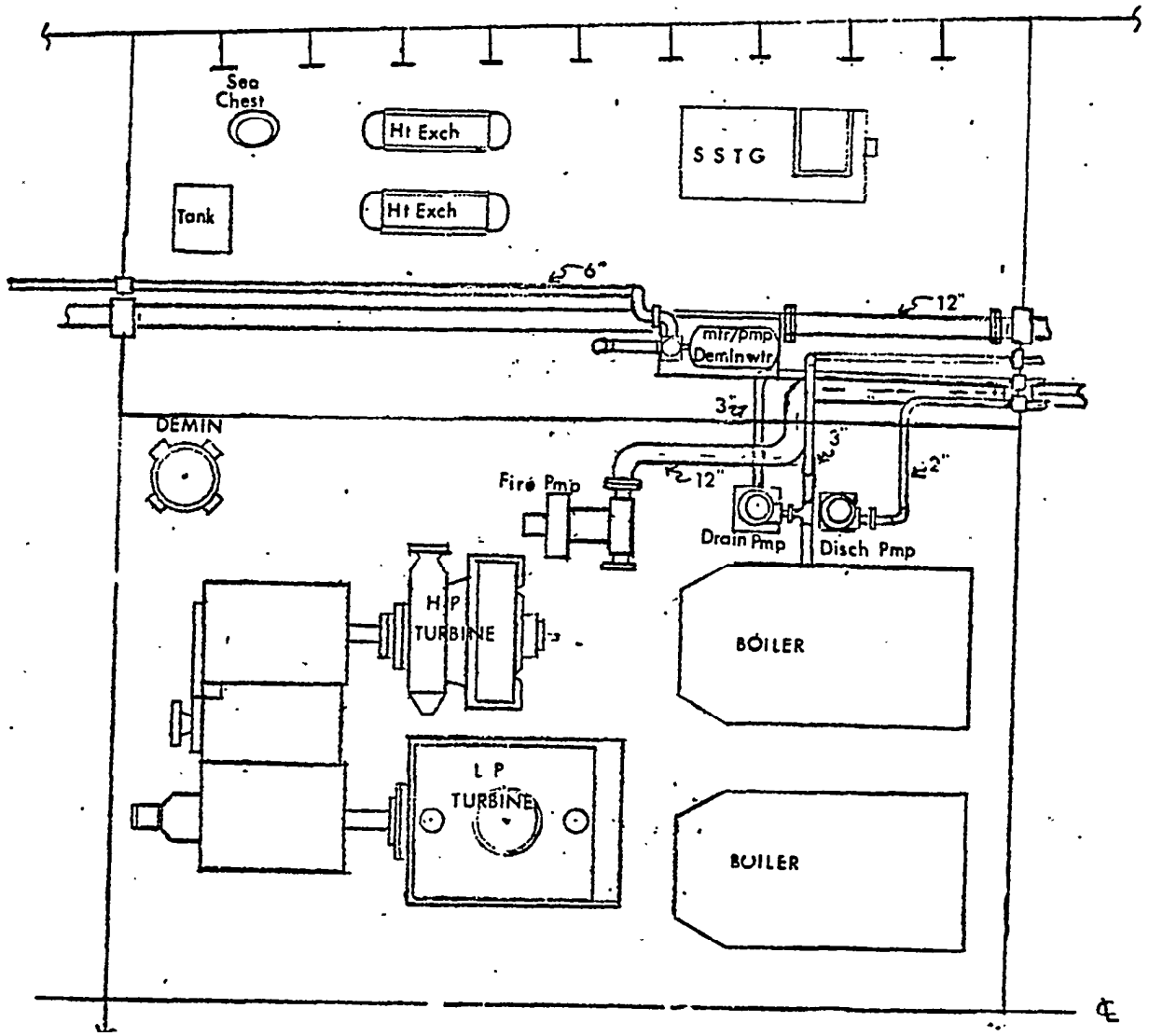

FIGURE 6.2



**FIGURE 6.3**

P L A N

FWD

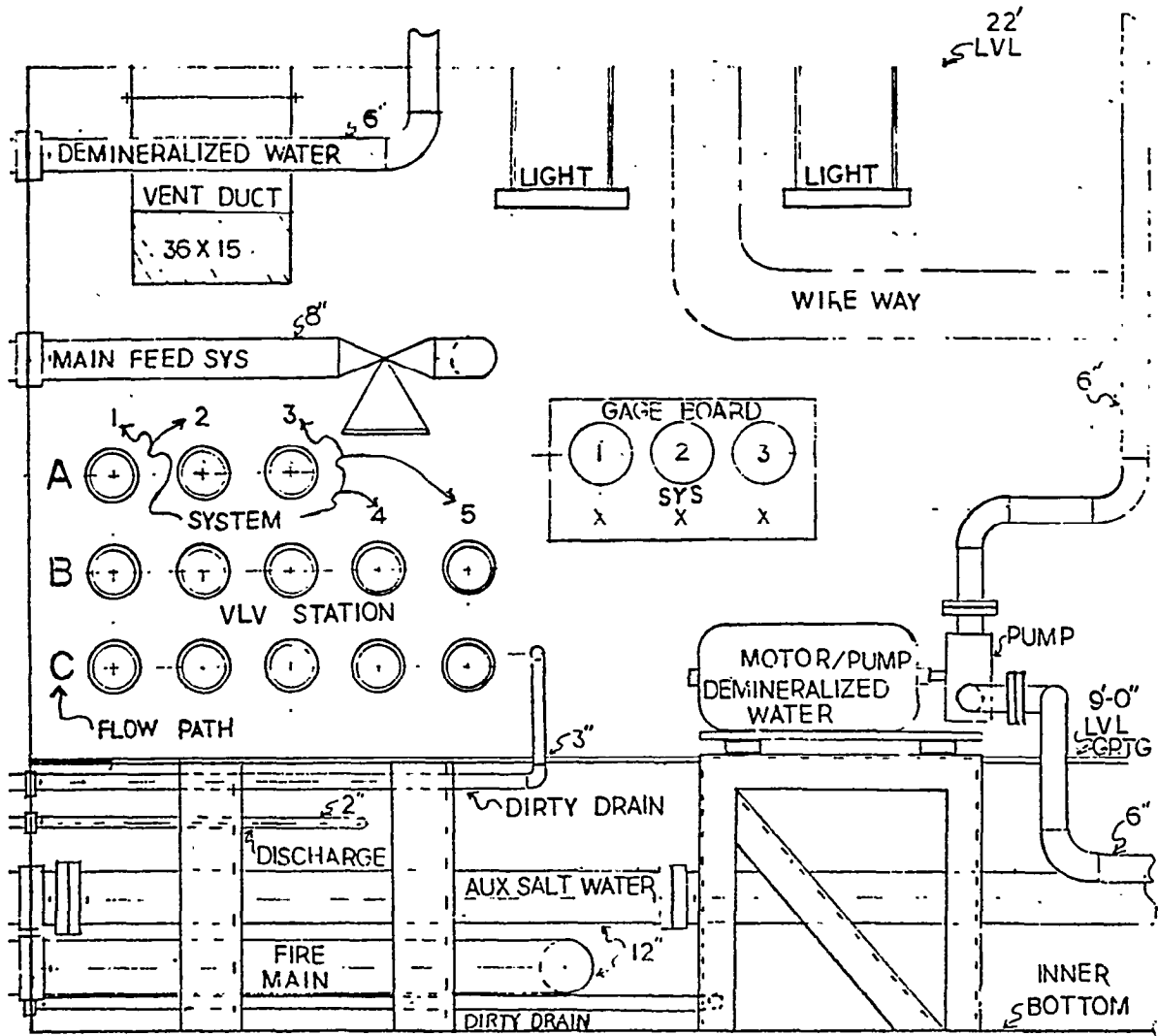

ELEVATION (LKG INBD)

FIGURE 6.4

FR  
00

FR  
101

FR  
102

FR  
103

FR  
104

FR  
105

THR 20	FRI 21	SAT 22	SUN 23	MON 24	TUE 25	WED 26
-----------	-----------	-----------	-----------	-----------	-----------	-----------

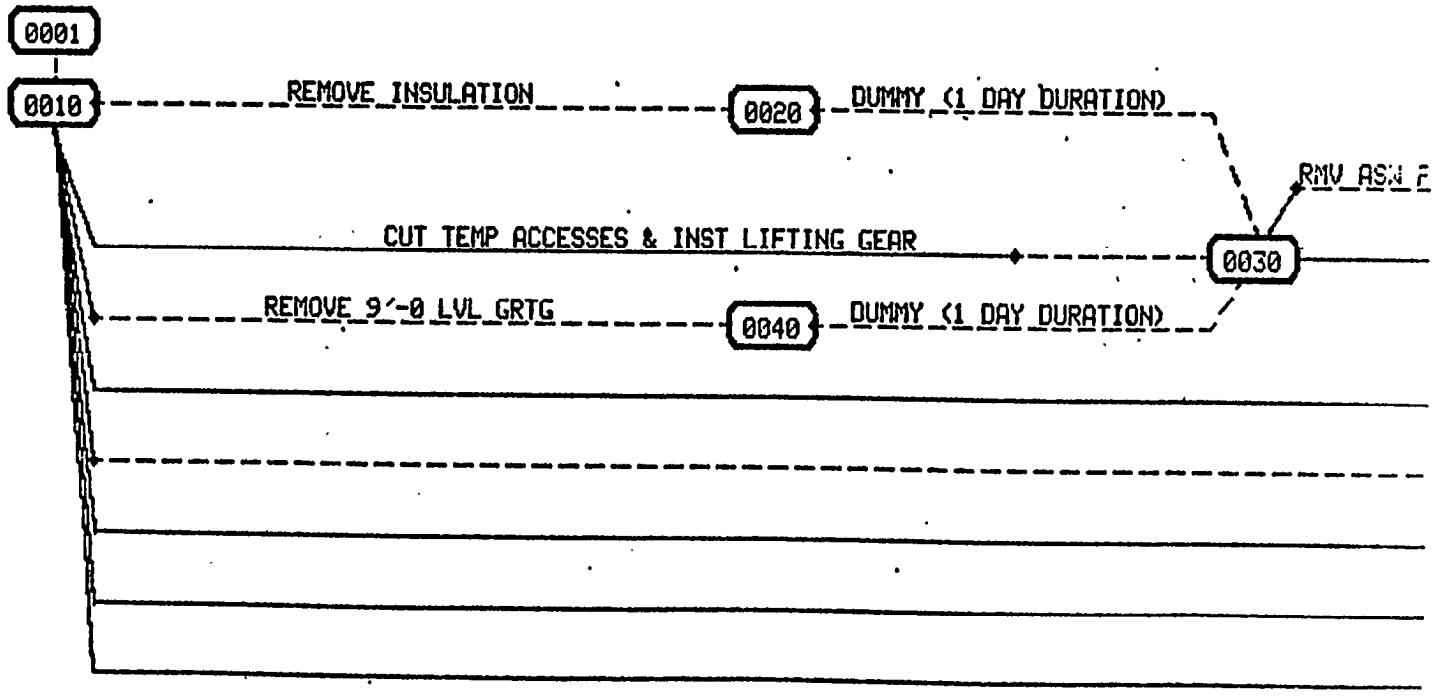

FIGURE 6.5



## Unit Work Guide for Zone Outfitting in Repair and Overhaul

Shel Kjerulf

This paper compliments *one* previously published to describe Puget Sound Naval Shipyard (PSNS) progress in substituting zone for system logic for alteration, **overhaul** and repair of U.S. Navy ships. More specifically, progress is tracked through development of a different way of grouping information to facilitate zone by stage implementation of work [1]. The zone logic was extracted from a series of National Shipbuilding Research Program (NSRP) publications. Understanding by shipyard managers was enhanced by seminars followed by the July 26, 1983 presentation to the management luncheon by L. D. Chirilo, chairman of SNAME Ship Production Panel SP-2 and the program manager for the outfitting and production aids category of the NSRP. The NSRP publications particularly exploited are given in references [24].

### Introduction

UNIT WORK GUIDE (UWG) is the term applied by PSNS for the new way of grouping all required information for a discrete amount of work to be accomplished in a particular zone during a series of stages. Instructions, graphics, material lists, special tool requirements, work locations, material landing dates, and specific amounts of time to complete stages are all included. The *system* for utilization of UWG's is referred to as Zone Outfitting in Repair and Overhaul (ZORO).

Success is manifested in the gradual sophistication of UWG's and their extension to more complicated work situations as described herein.

The July 26, 1983 presentation to the PSNS management luncheon crystallized certain facts of life for a sufficient management nucleus:

Except for combining shops under Group Superintendents, there is no significant difference in the way naval shipyards were organized thirty years ago. Certainly ships have changed. Overhauls now undertaken in naval shipyards are foremost industrial challenges by any measure. Yet, there have been no significant organizational changes commensurate with the problems now encountered."

Currently, there is no significant public support for building commercial ships causing private shipyards to lobby for more naval ship overhauls." For public shipyards, "the . . . only real security is *constant* improvement in productivity." There is plenty of pertinent precedent but, PSNS is ". . . now the bell-wether for ship overhauls."

At the time, because of participation in SNAME Panel SP-2 activities by a PSNS Design Division representative, *manual* grouping of information by zone/stage for building a deckhouse containing a Close In Weapon System (CIWS) for upgrading, including overhaul, of a relatively inaccessible electric shop in the USS *Ranger* (CV 61) was already in progress.

Computer-aided design (CAD) was not employed because

the idea of using CAD as a tool for developing work packages had not yet surfaced. Perhaps the absence of CAD was fortunate because it proved that CAD is not mandatory for successful zone/stage grouping of information as some traditionalists believe.

At that time, utilization of CAD was basically limited to automated drafting and storage of great amounts of information on magnetic disks. Thus, justification for CAD is questionable.

Utilization of zone logic for the CIWS sharply focused Design and Production people on the relationships of systems to each other and the installation problems which would be encountered *beforehand*. Design changes were made accordingly which significantly diminished rework normally encountered. This unique foresight facilitated composites, inherent in zone orientation, that led to simplified distributive system runs in subsequent applications. The simplification is making it easier to apply CAD.

Thus, early experiences disclosed that zone logic was both justifying and facilitating the use of CAD.

Greater use of CAD and further use of UWG's proceeded rapidly for subsequent work. Design people who had introduced UWG's were being driven by Production people to extend the grouping of work instructions per zone logic. Mechanics were the first to realize and appreciate that a strategy for overhaul and/or modernization conceived by Production people was, for the first time, dictating the sequence for design and material marshalling efforts. With system orientation, they were often frustrated by Design and material people being preoccupied with portions of systems that were far downstream in the Production scheme.

Of course, the simplicity and all-encompassing work instructions which characterize UWG's were immediately appreciated by *mechanics*. It is not likely that mechanics will ever want to return to cumbersome system arrangement and detail drawings referenced on system-oriented job orders.

The most complete application of UWG's was for building, outfitting, painting, and testing a four-compartment module (grand block) containing numerous components for a new weapons system on the USS *Texas* (CGN-39). This effort differed from that for the USS *Arkansas* (CGN-41), previously

<sup>1</sup>Outfit Planning coordinator, Puget Sound Naval Shipyard, Bremerton, Washington.

<sup>2</sup>Numbers in brackets designate References at end of paper. Presented at the Ship Production Symposium, Williamsburg, Virginia, August 27-29, 1986.

<sup>3</sup>The acronym CAD does not imply usage for planning. CAP for "computer-aided planning" makes more sense because design can be rationalized as an aspect of planning but planning cannot be rationalized as an aspect of design. Among U.S. shipyards, only naval shipyard organizations correctly reflect design as an aspect of planning.

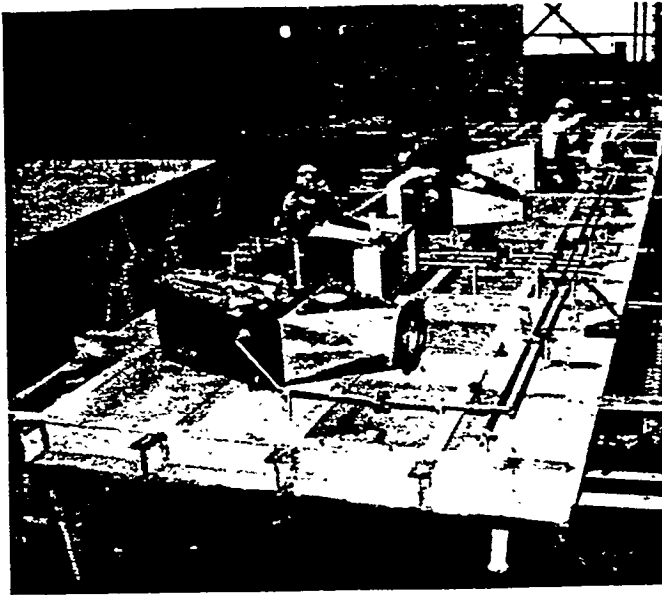

Fig. 1 Outfitting work on grand block panel

reported, in that a fair amount of outfitting, including insulation, was performed on-block before blocks were assembled into the grand block. See Figs. 1, 2, and 3.

The apprehension of traditionalists prevented complete outfitting of overheads when blocks were upside down. None the less, the amount accomplished proved to all concerned that PSNS riggers and shipfitters definitely have the skills to handle and assemble outfitted blocks into grand blocks just as effectively as their counterparts in the most effective Japanese shipyards.

Workers, particularly welders and insulators, who previously worked with their arms stretched over their heads, had to have wondered why work on such overheads was not performed downhand before. Similarly, workers who previously-when responding to a system-oriented work package-competed for access to work, had to wonder why the zone/stage concept was not used before.

### Outfit Planning Group

For the application of zone logic, PSNS employs decentralization manifested in the Outfit Planning Group (OPG), which transcends the traditional organizational divisions. The Groups' title is derived from the first NSRP publication, issued in December 1979, which introduced zone logic in U.S. shipyards. The Group reports for administrative and financial control as shown in Fig. 4.



Fig. 2 Grand block panel lift



Fig. 3 Grand block being transported to ship. (Does it matter where the ship is??? Can we look forward to government-furnished manufacturing?)

OPG composition touches every facet of every operation needed to produce a specific product. It is product-oriented! Its responsibilities include coordination of logistics and facilities as well as material handling and progressing.

OPG core members include Design, Production, Supply (material), Scheduling, and Planning and Estimating personnel. Satellite members may include quality assurance and testing people, riggers, progressmen, painters, sandblasters, insulators, ect., as needed for a specific product.

The OPG is chaired by a Project Engineer during nearing development. Selection by Design management based on experience in the predominant function associated with an assigned product and leadership ability. Responsibilities of the chair include defining the makeup of the OPG leading Group strategy sessions, assigning tasks to Group members, reports of task accomplishments to the regular shipyard management, coordination, resolution of problems pertaining to specification adherence, and compliance with regulatory requirements. In a way, an OPG leader is an additional Project Engineer sharply focused on a particular product, for example, an outfitted and painted grand block as needed for a ship alteration or overhaul of a very congested space on a submarine.

At the end of an assigned effort, the OPG chair is also responsible for a detailed report that represents corporate knowledge. Lessons Learned and recommendations for improvements in future such work are included. The context of the report contrast vividly with resolution of problems mechanics responding to system-by-system work package. So many variables are involved that, while individuals collect useful experience, relatively little can be reduced practical corporate knowledge.

During initial formation of an OPG, someone from Production is selected as a Zone (product) Manager to assume leadership upon issue of a UWG. In reality, the leaders from Design and Production share chair responsibilities. Prerequisites for selection of a Zone Manager are appreciable knowledge of all manufacturing and overhaul processes in addition to knowledge of the shop regularly assigned and of course, leadership ability.

A Zone Manager's responsibilities include:

- Identifying like processes that can be effectively accomplished during the same stage regardless of systems rep-

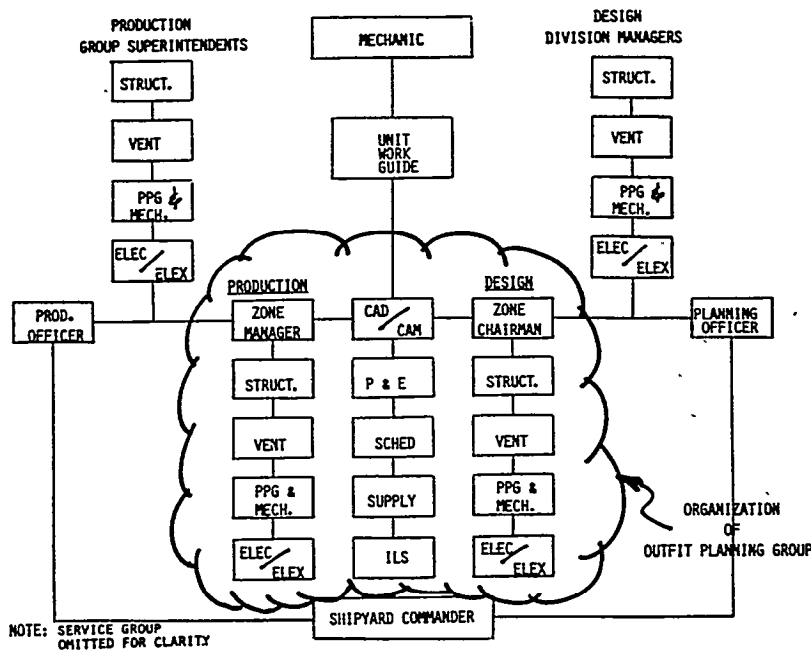

Fig. 4 OPG flow chart. Any process that does not support the mechanic should be terminated

resented and traditional craft responsibilities (for example, having all hot work to take place at one time),

- designating work for on-unit, on-block, and on-board outfitting, and
- sequencing work so to comprise a build strategy which achieves uniform work flow.

average, each OPG meets once per week for about one hour. During these meetings, a build strategy and schedule are finalized, Progress reports are reviewed, remedial efforts are applied, etc. Each OPG is charged with identifying and solving problems. The regular shipyard management is approached only for resources.

An OPG's reporting system consists of minutes of weekly meetings which are distributed to the regular shipyard management.

### Unit Work Guide

An Outfit Planning Group's (OPG) tool to accomplish its tasks is a Unit Work Guide (UWG). Design people provided training and assistance to the structural shop's loftsmen who now routinely produce UWG graphics. A team, supplemented by Design people assigned to the loft, combine the graphics with work instructions and precautions as necessary to produce completed UWG's.

The composition of a UWG is in four phases:

- Planning Phase—who, what, where, and when (including structured material lists and special tools).
- Manufacturing and/or Procurement Phase—like manufacturing processes and, eventually, just-in-time procurement.
- Assembly Phase—like assembly processes.
- Installation Phase—sequentially scheduled to support even manloading and the overhaul strategy.

Each UWG is a complete document that does **not** have to be supplemented by reference documents. Each stands alone! It is a simple, user-friendly work instruction prepared in

an 8 1/2-by-11-in readily reproducible format. Each identifies the sequence of stages needed to produce a particular product. Some UWG's which provided the work instructions for the grand block (shown in Figs. 1,2, and 3) are provided as an Appendix-Figs. 5 through 17.

The UWG format includes: key operation **numbers** (funding); authorization job order number; ship/project number; title of project; unit work guide number; work center number, CAD/CAM text file number, material landing date, start date; completion date; estimated man-hours; signature blocks for the preparer, Zone Manager, and Shop Planner, and space for the mechanic to sign after task completion. At the bottom of the UWG cover sheet there is a check-off block for indicating how many copies have been issued and to whom. In the main body of the UWG cover sheet, there is space for sequence identity to indicate where this specific UWG fits into the entire product process.

An important aspect of the UWG is the in-process quality control capability. By having the ability to break down the tasks into manageable increments of work, quality assurance check points can be established for inspection during the production process without generating additional documents. This circumvents inspection after the fact, which creates an enormous amount of rework and schedule slippage.

The UWG's are powerful tools which enhance management reporting systems without burdening middle management and floor supervisors with additional reporting systems. Each UWG stands **alone** as a published sequence for events that are tied to time, space, and manning. It is also an excellent vehicle for a feedback loop that insures that problems encountered and their resolutions are captured as corporate experience. For this purpose, each zone/stage portion of a UWG is supplemented with a questionnaire, Table 1, designed to solicit actual experiences so that work instructions can be constantly improved. "The obligation to improve never ceases (W. Edwards Deming)."

Table 1 UWG typical question

Shop	UWG Cont. Sheet	Key Op No.	UWG No.	023
1. List all Material that was used on this Unit Work Guide that was not called out on the List of Material.				
2. List any additional tools that were used on this Unit Work Guide that was not called out on the List of Material.				
3. List any additional Steps that were used on this Unit Work Guide that was not called out.				
4. Recommendations/Comments on how to improve this Unit Work				
5 Did feel that the work package was beneficial to you as a				

### Conclusion

The UWG (zone/stage product oriented) approach simplifies work instructions and constantly drives engineers to design for producibility in the most practical way. The approach provides for assimilation of numerous ideas generated by everyone, particularly mechanics. While no one idea may result in a breakthrough, collectively they always have great value.

### Acknowledgments

The author desires to hut cannot list all of the individuals who were critical **in bringing** about this change in the way we do business. He would like to mention a few, however, who "stood on the windy corner"-the others know who you are.

For insight and leadership: Mr. Tom Rosebraugh and Mr. Mahlon Wixson. For the first Unit Work Guide: Mr. Jim Van Antwerp, Mr. Glenn Shock and Mr. Jerry Davis. To the USS Texas Zone Chairman and Zone Manager: Mr. Glenn Shock and Mr. Bert Esau. To my counterpart in Production: Mr. Ted Anderson. And finally, for her professional secretarial support: Mrs. June Loveless.

### References

- 1 Moen, D., "Application of zone Logic and Outfit Planning Concepts to Overhaul, Modernization, and Repair of U.S. Navy Ships" *JOURNAL OF SHIP PRODUCTION*. Vol. 1, No. 4, Nov. 1985, pp. 238-248.
- 2 "Outfit Planning," National Shipbuilding Research Program, Dec. 1979.
- 3 "Product Work Breakdown Structure," National Shipbuilding Research Program, Nov. 1980; revised Dec. 1982.
- 4 "Design for Zone Outfitting," National Shipbuilding Research program, Sept. 1983.

*(Appendix follows, pages 99 through 105)*

*(Discussion follows Appendix)*



THE SOCIETY OF NAVAL ARCHITECTS AND MARINE ENGINEERS  
601 PAVONIA AVENUE, JERSEY CITY, NJ 07306

Paper presented at the NSRP 1968 shop production symposium.  
Edgewater Inn, Seattle, Washington, August 24-26, 1988

# Initial Implementation of IHI Zone Logic Technology at Philadelphia Naval Shipyard

N O . 7 8

Koichi Baba, Visitor, Takao Wada, Visitor, Soichi Kondo, Visitor, Ishikawajima-Harima Heavy Industries Co., Ltd. (IHI), Tokyo, Japan, LCDR M. S. O'Hare, USN, Visitor, Philadelphia Naval Shipyard, Philadelphia, PA, and James C. Schaff, Member, George G. Sharp, Inc., New York, NY

## ABSTRACT

Group Technology or Zone Logic Technology has been successfully implemented in several U.S. shipyards for new ship construction. This technology was originally conceived in the U.S. It was greatly refined by the Japanese and recently (beginning in 1979) reimported to the U.S. The technology replaces traditional system-by-system work with work organized zone-by-zone and by grouping similar work together with zones. This grouping of jobs enhances efficiency.

Those yards in Japan where Zone Logic is an everyday way of working, find that this technology is very effective in large scale overhaul and modernization projects covering both alterations as well as repairs. The traditional approach of working by systems is difficult to manage with the degree of difficulty being proportional to the size of the project. Work performed utilizing the principles of Zone Logic provides a more effective management method. The application of Zone Logic to Ship Overhaul, as advanced by Zone Logic advocates, has actually been made in small isolated cases on some U.S. Naval Ship Overhauls.

Philadelphia Naval Shipyard's application of Zone Logic to ship overhaul is neither small nor isolated. PNSY started its implementation of Zone Logic in the late fall of 1986, targeting the Service Life Extension Program (SLEP) for USS Kitty Hawk (CV-63) as the initial application. The technical services of Ishikawajima-Harima Heavy Industries Co. Ltd. (IHI), Japan were contracted to assist in this transition. This implementation on the Kitty Hawk is not a trial effort but involves about one third of the production mandays and covers over one-half of the compartments on the ship.

The actual SLEP production work on Kitty Hawk began in January 1988. Even though it is early in the three (3)

year SLEP, Zone Logic already is proving its worth. This paper explains the Zone Logic methods and methodology applied at PNSY on Kitty Hawk. It also discusses the future of Zone Logic at PNSY and its continued application.

## INTRODUCTION

The establishment of the National Shipbuilding Research Program (NSRP) in the early 1970's and the reintroduction of Group Technology as refined by Ishikawajima-Harima Heavy Industry Co., Ltd. (IHI), started U.S. Shipbuilders on the road to modern shipbuilding practices. Ref. (1)

The continuing ebbing of merchant ship construction and the high cost of construction in the U.S. have the surviving yards looking to the only work available; i.e., U.S. Navy construction and repair work. Thus, ferocious competition has private yards searching for every possible means to be more productive. Most of the surviving yards have implemented Zone Logic for new construction as the means of improving production. Many of them have consulted or contracted with IHI to make the transition to Zone Logic.

Increased productivity in new ship construction using Zone Logic principles is now a well accepted fact. These same principles can increase productivity in large scale overhaul/modernization and repair work. The Japanese yards practicing these concepts have demonstrated its value. The use of Zone Logic in U.S. Navy repair/modernization field, may be contested by American traditionalists even though its value may be immediately apparent to Demming type believers and industrial engineers. Those who do not completely understand Zone Logic concepts may not draw the same conclusions regarding the advantages of Zone Logic for repair/modernization projects. These people must spend time studying and working with Zone Logic concepts to really understand their benefits. With Zone Logic being embraced by the private

sector for. its new construction, it is only a matter of time before they take the natural step of employing these concepts in large scale repair work.

Decreasing work the Marine Industry always fans the flames of the age-old question of Private vs Public Shipyards. Public yards are needed for national security, but are they cost competitive with private yards? This question becomes even more controversial in the case of the non-nuclear yards. Some feel that the public yards' very existence depends on their ability to remain cost effective in the ever increasing competitive environment.

Some public yards, however, have gotten the jump on the private sector. They are beginning to implement Zone Logic for repair work in limited way-s. These implementation5 have been assisted by American Consultants and the NSRP Publications. However, Philadelphia Naval Shipyard is the first. to contract with IHI, the innovators of this greatly refined technology. Many factors precipitated PNSY management to initiate Zone Logic on USS Kitty Hawk (CV-63) Service Life Extension Program (SLEP), Ref.(P). The initial implementation was in support of the Hull Expansion project; but due to high risk factors associated with this work on Kitty Hawk, the work was eventually cancelled. Nevertheless, PNSY's management was determined to embrace Zone Logic. Therefore, alternate work of the same magnitude was ear-marked for Zone Logic implementation.

A brief overview of Zone Logic is helpful to the understanding of the details that follow. First of all, there seems to be universally accepted term to describe this technology. It has been called IHOP (Integrated Hull Construction, Outfitting and Painting) by NSRP, Group Technology by Mr. Chirillo, Ref.(3); and Zone Logic Technology by the Naval Shipyards. IHI does not have a single term to express these concepts, so for this paper we will simply call it Zone Logic.

The name Zone Logic implies one of the concepts embraced; i.e., work by zones. But this expression sometimes causes misunderstanding, because it implies that all work must be done by zone. However, in a shipbuilding or overhaul project, there still exists some exceptional type jobs, such as through-ship cable installation, tests, etc., which should be performed by system. It should be noted that working by zone is a tool to increase production efficiency. Working with

Zone Logic principles should be understood as a comprehensive effort for the achievement of this purpose.

A test book definition for Zone Logic is a scheme by which work is subdivided with interim products as the focal point. Thus, it is the logical arrangement and sequencing of all facets of company operations in order to bring the benefits of mass production to highly varied and mixed quality production. This term in industry is also known as Product Orientation, Zone-Technology or Family manufactory and is a detailed industrial engineering scheme for field as well as shop work.

This paper explains the initial implementation of Zone Logic at PNSY in support of USS Kitty Hawk SLEP project, evaluation of that implementation and where PNSY (and perhaps the entire Navy yard community) should go from here.

ZONE LOGIC AS APPLIED TO USS KITTY HAWK SLEP

#### Zone Logic Application In SLEP

SLEP intends to add 15 years to a ships' service life after approximately 30 years of service. This requires not only repairs and overhaul but also extensive alterations and modernization to keep the aircraft carrier in top fighting shape during this extended life. The massive scope of work consists of approximately 1.2 million mandays of production work over a 37 month period allocated for this program.

Initially the Hull Expansion Project, with approximately 350,000 production mandays, was to serve as the impetus to establish Zone Logic in PNSY. As the total scope of the Hull Expansion Project was analyzed, it was found to impact some thirty (30) percent of the already identified SLEP work package. Therefore, not only would the Hull Expansion Project be done by Zone Logic principles, but the other effected SLEP work as well. Once the shipyard started planning this work there would be no turning back to traditional methods. To revert later would cost millions of dollars in rework and adversely effect the overall SLEP schedule. Thus, when the Hull Expansion Project was cancelled, the other work had proceeded to the point where it would have been to costly to revert back to traditional methods to accompany the work. Proceeding with Zone Logic implementation was also consistent with PNSY management philosophy. It was also decided to apply these principles only to a portion of the SLEP considering the following:

- It was required that the Zone Logic

Project show actual cost saving and not be just a trial effort.

- Design and planning for the SLEP had been going on for a year prior to shifting to the Zone Logic concept and obtaining IHI support beginning in January 1987. By this time it was too late to change the procedures and products of design, planning and estimation, job orders, material procurement, reporting, etc. The work of Zone Logic was to rearrange the system oriented drawings, Job Order Progress Cards (JOPC'S), Supplements, Key Operations and Material Lists produced by the existing organization in the traditional manner. Such a translation process had to be limited considering availability of personnel for the project and benefit in budget savings as a result of Zone Logic application.

- SLEP on Kitty Hawk is only a part of PNSY activities. PNSY carries out repairs and overhauls on other ships simultaneously. It was strongly felt that too much confusion would be generated by changing the whole system of the shipyard without enough preparation and training.

**Areas For Zone Logic**

Figure 1 shows the arrangement of 10 Major Zones used to divide the

entire ship from the viewpoint of Zone Logic. Four of these zones were chosen for application of Zone Logic principles. The main compartments or areas in the 10 Zones are as follows:

- Zone 1:** Tanks and Voids (fourth deck and below), underwater hull, rudders, anchors and anchor chains.
- Zone 2:** Four (4) Main Machinery Rooms, compartments on fourth deck just above these machinery rooms, shaft alleys, uptakes, propellers and shafts.
- Zone 3:** Two (2) Auxiliary Machinery rooms, compartments on fourth deck just above these machinery rooms.
- Zone 4:** Magazines and weapons elevators.
- Zone 5:** Seven (7) pump rooms, Three (3) emergency generator rooms, Two (2) steering gear rooms, Two (2) steering motor rooms, air conditioning machinery rooms, refrigerating chambers and various other storerooms below third deck. (compartments below the third deck not covered in Zones 1 thru 4).

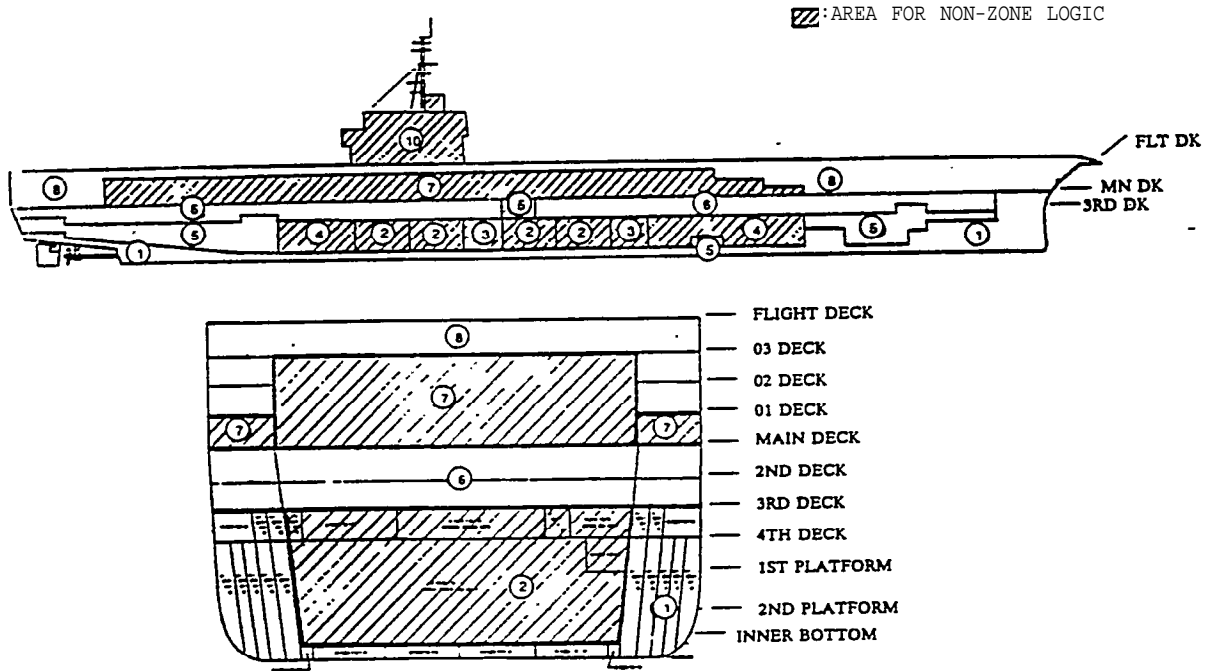

FIG.1 ZONE LOGIC IMPLEMENTATION ON USS KITTY HAWK SLEP

- Zone 6: Habitability on the second and third deck.
- Zone 7: Hanger Bay and the offices and storerooms related to Hanger Bay, aircraft elevators and the related machinery rooms.
- Zone 8: Habitability, offices and electronic rooms from the main deck to the flight deck, excluding compartments in Zones 2, 4 and 7.
- Zone 9: Flight deck, catapults and the related machinery rooms, catapult troughs with wing voids, arresting gears and the related machinery rooms and jet blast deflectors and the related machinery rooms.
- Zone 10: Island and other structures above the flight deck.

After close investigation, Zones 1, 5, 6 and 8 were the zones selected for Zone Logic application. The production work in these zones amounts

to about 400,000 mandays, approximately one-third of the total production mandays for SLEP.

Detail specifications of the zone boundaries are as described in Table 1. The boundaries are basically defined by deck level except the following:

- In case the compartment is continuous between decks, the whole space belongs to the lower zone.
- Vertical watertight trunks belong to the zone where the lowest access is located.

Determining the zones to which each compartment belongs though is not enough. It is equally important to clarify which zone controls the boundary. In principle, the zone which completes work earliest at the boundary, controls the boundary. But, in Kitty Hawk's case, exceptions to the boundaries rule were made for boundaries between a Zone and Non-Zone Logic area. In these cases the boundary is controlled by Zone Logic. This is done because of more positive control and detail scheduling associated with Zone Logic.

TABLE I BOUNDARY DETAILS AND SPECIFIC RESPONSIBILITIES

ZONE	ADJACENT ZONE	ITEMS AT BOUNDARIES	INCLUDED IN (Responsible For)	LOCATION OF INTERFACE	HOOKED-UP & TESTED AT INTERFACE BY	INITIATIVE ON MILESTONES TAKEN BY
①	②&③	INNER BOTTOM PLATING BULKHEAD PLATING STIFFENER, WEB, FOUNDATION, FITTING: RELATED TO BOUNDARY PLATING REPAIR RELATED TO OTHERS (SHIPALT, ETC) PIPING CABLING INSULATION RELATED TO THE ABOVE	① ① ① ②&③ ②&③	MANIFOLD/JOINT IN ②&③ JUNCTION IN ①	② ③	①
	④	INNER BOTTOM PLATING BULKHEAD PLATING STIFFENER, WEB, FOUNDATION, FITTING: RELATED TO BOUNDARY PLATING REPAIR RELATED TO OTHERS (SHIPALT, ETC) PIPING CABLING INSULATION RELATED TO THE ABOVE	② ② ② ④ ④	MANIFOLD/JOINT IN ④ JUNCTION IN ①	④ ④	①
	⑤	INNER BOTTOM PLATING/PLATFORM PLATING BULKHEAD PLATING STIFFENER, WEB, FOUNDATION, FITTING PIPING CABLING INSULATION RELATED TO THE ABOVE	⑤ ⑤ ⑤ ⑥ ⑥	MANIFOLD/JOINT IN ⑤ JUNCTION IN ①	⑤ ⑤	①
	⑥	DECK PLATING BULKHEAD PLATING STIFFENER, WEB, FOUNDATION, FITTING PIPING CABLING INSULATION RELATED TO THE ABOVE JOINERS RELATED TO THE ABOVE	⑥ ⑥ ⑥ ⑥ ⑥ ⑥	JOINT IN ⑥ JUNCTION IN ①	⑥ ⑥	⑥ RETW 59&205 ① IN OTHER SPACES
	⑦	3RD DECK PLATING (DK ELEV MACHY RM) STIFFENER, WEB, FOUNDATION, FITTING PIPING CABLING	⑦ ⑦ ⑦	JOINT IN ⑦ JUNCTION IN ①	⑦ ⑦	⑦



TABLE I BOUNDARY DETAILS (Continued)

ZONE	ADJACENT ZONE	ITEMS AT BOUNDARIES	INCLUDED IN (Responsible For)	LOCATION OF INTERFACE	HOOKED-UP & TESTED AT INTERFACE BY	INITIATIVE ON MILESTONES TAKEN BY
⑤	②&③	BULKHEAD PLATING STIFFENER, WEB, FOUNDATION, FITTING: RELATED TO BOUNDARY PLATING REPAIR RELATED TO OTHERS (SHIPALT. ETC) PIPING CABLING DUCT INSULATION RELATED TO THE ABOVE	⑤ ⑤ ②&③ ②&③	— — JOINT IN ②&③ JUNCTION IN ②&③ JOINT IN ②&③	— — ⑤ ②&③ ②&③	⑤ ③ ②&③ ⑤
		④ 2ND PLATFORM PLATING BULKHEAD PLATING STIFFENER, WEB, FOUNDATION, FITTING: RELATED TO BOUNDARY PLATING REPAIR RELATED TO OTHERS (SHIPALT. ETC) PIPING CABLING INSULATION RELATED TO THE ABOVE	⑤ ⑤ ③ ④ ④	— — — MANIFOLD/JOINT IN ④ JUNCTION IN ④ —	— — — ④ ④ —	⑤ ⑤ ③ ④ ⑤ ⑤
		⑥ DECK PLATING BULKHEAD PLATING STIFFENER, WEB, FOUNDATION, FITTING PIPING CABLING DUCT INSULATION RELATED TO THE ABOVE JOINERS RELATED TO THE ABOVE	⑥ ⑥ ⑥ ⑥ ⑥ ⑥	— — — JOINT IN ⑥ JUNCTION IN ⑥ JOINT IN ⑥ —	— — — ⑥ ⑥ ⑥ —	⑥ ⑥ ⑥ ⑥ ⑥ ⑥
⑥	②&③	3RD DECK PLATING TRUNK/UPTAKE WALL ABOVE 3RD DECK STIFFENER, WEB, FOUNDATION, FITTING: RELATED TO BOUNDARY PLATING REPAIR RELATED TO OTHERS (SHIPALT. ETC) PIPING CABLING DUCT INSULATION RELATED TO THE ABOVE	⑧ ②&③ ⑧ ②&③ ②&③	— — — JOINT IN ②&③ JUNCTION IN ②&③ JOINT IN ②&③	— — — ②&③ ②&③ ②&③	⑧ ⑧ ⑧ ⑧ ⑧
		④ 3RD DECK PLATING WPN/BOMB ELEV TRUNK STIFFENER, WEB, FOUNDATION, FITTING: RELATED TO BOUNDARY PLATING REPAIR RELATED TO OTHERS (SHIPALT. ETC) PIPING CABLING DUCT INSULATION RELATED TO THE ABOVE	⑧ ④ ④ ④ ④	— — — JOINT IN ④ JUNCTION IN ④ JOINT IN ④	— — — ④ ④ ④	⑧ ④ ④ ④ ④
	⑦	⑦ MAIN DECK PLATING BULKHEAD PLATING (DK EDGE ELEV M RM) STIFFENER, WEB, FOUNDATION, FITTING: RELATED TO BOUNDARY PLATING REPAIR RELATED TO OTHERS (SHIPALT. ETC) PIPING CABLING DUCT INSULATION RELATED TO THE ABOVE JOINERS RELATED TO THE ABOVE	⑧ ⑦ ⑧ ⑦ ⑦ ⑦	— — — JOINT IN ⑦ JUNCTION IN ⑦ JOINT IN ⑦ —	— — — ⑦ ⑦ ⑦	⑧ ⑦ ⑧ ⑦ ⑦ ⑦
		⑧ MAIN DECK PLATING CAT PIPING TRUNK PIPING CABLING DUCT INSULATION RELATED TO THE ABOVE JOINERS RELATED TO THE ABOVE	⑧ ⑧ ⑧ ⑧ ⑧	— — — JOINT IN ⑧ JUNCTION IN 1 ⑧ JOINT IN ⑧ —	— — — ⑧ ⑧ ⑧	⑧ ⑧ ⑧ ⑧ ⑧
⑥	②	② UPTAKE WALL ABOVE MAIN DECK STIFFENER, WEB, FOUNDATION, FITTING: RELATED TO BOUNDARY PLATING REPAIR RELATED TO OTHERS (SHIPALT. ETC) PIPING CABLING INSULATION RELATED TO THE ABOVE	⑧ ⑧ ② ②	— — — JOINT IN ② JUNCTION IN 1 ②	— — — ② ②	⑧ ⑧ ⑧ ⑧
		④ WPN/BOMB ELEV TRUNK STIFFENER, WEB, FOUNDATION, FITTING PIPING CABLING DUCT INSULATION RELATED TO THE ABOVE	④ ④ ④ ④	— — — JOINT IN ④ JUNCTION IN ④ JOINT IN ④	— — — ④ ④ ④	④ ④ ④ ④

TABLE I BOUNDARY DETAILS (Continued)

ZONE	ADJACENT ZONE	ITEMS AT BOUNDARIES	INCLUDED IN (Responsible For)	LOCATION OF INTERFACE	HOOKE-UP & TESTED AT INTERFACE BY	INITIATIVE ON MILESTONES TAKEN BY
⑧ (cont.)	⑦	OS LEVEL DECK PLATING BULKHEAD PLATING/WALL STIFFENER, WEB, FOUNDATION, FITTING: RELATED TO BOUNDARY PLATING REPAIR RELATED TO OTHERS (SHIPALT. ETC) PIPING CABLING DUCT INSULATION RELATED TO THE ABOVE JOINERS RELATED TO THE ABOVE	⑧ ⑧ ⑦ ⑦ ⑦ ⑦	— — — JOINT IN ⑦ JUNCTION IN ⑦ JOINT IN ⑦	— — — ⑦ ⑦	⑧
	⑨	FLIGHT DECK PLATING OS LEVEL DK PLATING/WALL OF ROOM FOR ARST GR/BARRICADE/CAT/DK EDGE ELEV PIPING CABLING DUCT INSULATION RELATED TO THE ABOVE JOINERS RELATED TO THE ABOVE	⑨ ⑨ ⑨ ⑨ ⑨	— — — JOINT IN ⑧ JUNCTION IN ⑧ JOINT IN ⑧	— — — ⑧ ⑧	⑨

Organization

A project with the magnitude of the Hull Expansion would normally have been assigned to the executing shipyard three (3) to four (4) years ahead of a scheduled start date. However, in order to be able to execute the Hull Expansion Project in conjunction with USS Kitty Hawks' SLEP, a special project team was established. Under this project team an aggressive plan of action along with milestones was developed to meet the short fused time table PNSY had to execute the Hull Expansion Project. This plan of action called for a reorganization of the shipyards normal working procedures. In development of this plan of action, a world wide tour/investigation and analysis of many major U.S., Canadian, British and Japanese shipyard practices was conducted. Also, numerous key members of the National Shipbuilding Research Program (NSRP) of the Society of Naval Architects and Marine Engineers (SNAME) were consulted in order to learn state of the art technology being used in todays shipbuilding and repair environment.

The project team was established with key members from all the shipyard's major departments/branches; Planning, Production, Supply and Design. After Hull Expansion cancellation, the project team continued with the newly defined Zone Logic work. The shipyards existing Planning and Estimating branch made adjustments in their normal issuing of Work practices to support the Zone Logic efforts. Similarly, the shipyards Design branch established a Zone Logic design team whereby all Zone Logic efforts are coordinated.

The outstanding results of Design and Planning and Estimating branches are worth a paper alone and will be only addressed briefly here. Also an additional work packaging group called the Outfit Planning team was established. The primary mission of the Outfit Planning team is to package work by zone, product and problem category as well as to schedule this work. As the project developed a production group dedicated to do all production work under the Zone Logic concept was established.

As general foremen, foremen and the mechanics were brought in to start work in the Zone Logic Production Group and under the new concepts of Zone Logic, they received lectures and training for a better understanding of these concepts and procedures. Figure 2 depicts a line diagram of how these groups are structured and the interrelation with each other.

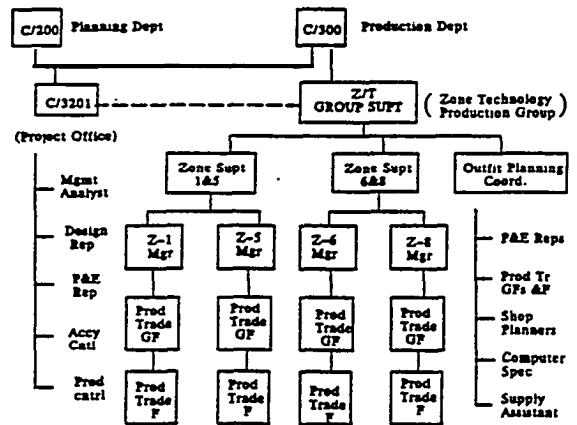

FIG.2 ZONE LOGIC PROJECT TEAM

**Zone Logic Work Breakdown Structure**

The historical work definition method at PNSY uses a JOPC and work center system. JOPC's define work on a system-by-system level; key or lead production shop are defined along with assist shops to accomplish needed work. As with the work statement (the JOPC), design direction and information (drawings), are produced on a system level. Because of the reasons stated above (the advance stage of design and work definition already accomplished, and the portion Zone Logic work represent5 in the overall shipyard workload), Zone Logic work would use the existing JOPC and systems drawings to develop work instruction for Zone Logic production. Since the current work packaging method did not efficiently support Zone Logic production, development of a new work issuing and identification system was necessary. This new work breakdown structure is called a Unit of Work or "Unit Work". Each Unit Work describes three components of the work:

Where the work is located (Zone),

What category or type of work it is (Phase),

Who will do the work (Product Trade).

**Zone.** A hierarchical structure was used to break the ship down into Zones, Intermediate Zones and Sub-zones. Major zone breaks were based on the function performed within that zone. The four major zones selected for application of Zone Logic were tanks and voids, pump room and miscellaneous auxiliary machinery spaces, and the upper and lower habitability spaces. These selected zones were then broken down to Intermediate zones. Work defined by Intermediate Zones was utilized for long term scheduling, setting priorities and planning. Sub-zones were the most detailed level and used to define Unit Work. Sub-zone breaks were carried out considering the work environment such work accessibility, route for material movement, configuration of compartment, etc. For the Kitty Hawk, Zone Logic work was broken down into:

- 4 - - - - - Major Zones
- 117 - - - - - Intermediate Zones
- 388 - - - - - Sub-zones

Phase Six phases or catagories were set to define the work.

- Pre-Overhaul Test/Inspection
- Ripout/Remove
- Shop fabrication/Shop repair
- Repair/Install
- Test
- Rework/Grooming/Titivation

**Trade.** There are fourteen (14) production shops and 147 work centers in PNSY. The traditional shipward Job Order system is to break down the work by each 'shop and work center. This, procedure is extremely ineffective for sequencing, scheduling and p r o p e r management. A *Product Trade System* was devised to simplify and make production more manageable.

Each Product Trade consists of multiple shop mechanics capable of accomplishing a series of work. To realize this concept, as mentioned earlier, the Production organization for Zone Logic was modified. The responsibility to accomplish each Unit of Work is given to a single foreman who manages multiple shop mechanics including part time assist trades. Nine Product Trades were set up:

- Steel work (with shipfitters and welders),
- Pipe work (with pipefitters and welders),
- Paint work (with blasters and painters),
- Tank cleaning work (with cleaners and gas free people),
- Joiner work (with sheetmetal men, welders, insulators and woodworkers),
- Electric/Electronic work (with electricians and electronic technicians),
- Machine work (with machinists and riggers),
- Scaffolding work (with staggers, riggers and welders),
- Assist/specialty work for assisting other Product Trades and performing special work.

A numbering system was designed during the definition of the Unit Work system or Zone Logic work breakdown structure. This numbering system fit within the structure of the shipyard Management Information System (MIS). Means were also devised whereby charges to Units of Work would be automatically

allocated back to their original system defined work for funding and reporting purposes. The five (5) digit Job Order field is used to indicate Zone, Intermediate-Zone and Sub-zone. The three (3) digit Keyop field is used to indicate Phase and Product Trade. Figure 3 shows the structure of this numbering scheme.

Certain categories of the work such as thru-ships cabling and system tests should not be defined by above mentioned Sub-zone levels. This work is better defined at higher zone levels such as Intermediate, major or multiple zones, depending on the nature and scope of work.

- Sub-zone number
- Phase number
- Trade number
- Job description
- Budget hours
- Parent Job Order number
- Supplement number
- Drawing number

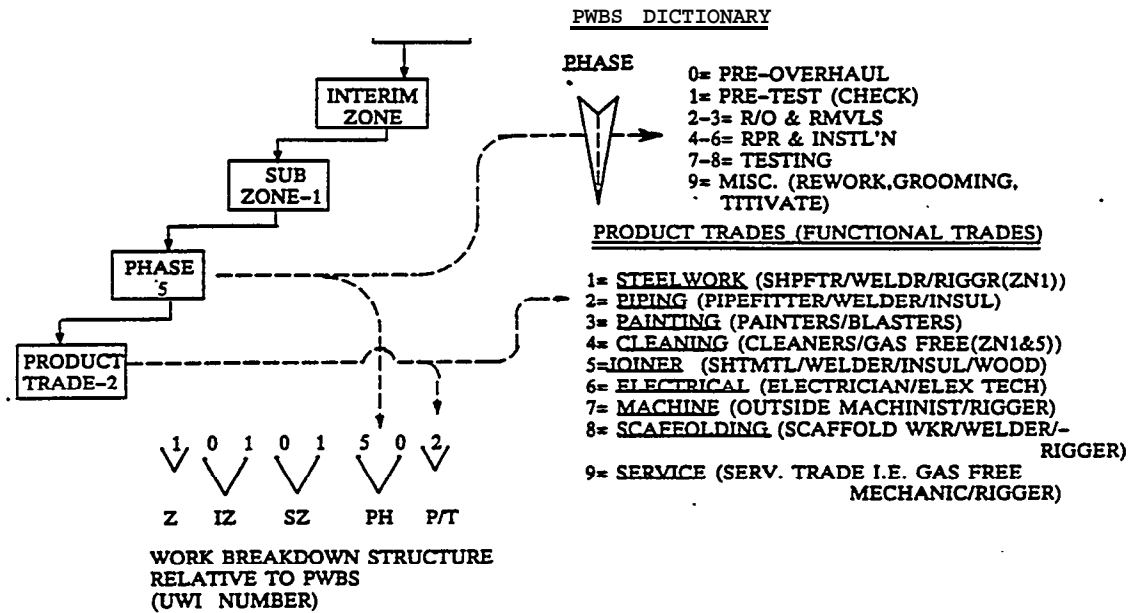

**FIG.3 ZONE LOGIC PRODUCT WORK BREAKDOWN STRUCTURE (PWBS)**

Unit Work Definition

The process used in re-defining Zone Logic work in accordance with the structure described above is labor intensive and time consuming. Figure 4 depicts this two-step process. First, each JOPC received which described work on the system approach, was analyzed in conjunction with applicable system level drawings. Each line item on each JOPC was allocated by zone Logic Planners to Sub-zone, Phase and Product Trade. Gathering of various pieces from various JOPC's for specific Sub-zone, Phase and Product Trade produced a specific Unit of Work. The initial procedure for gathering information was done by hand. This gathering process is now being handled by PNSY's new Zone Logic Data Base Management System. (Ref.2) Each line item of every JOPC will be entered into this computer system. The data to be entered is:

At a certain point in time the computer will sort the data by Sub-zone, Phase and Trade. A determination is then made that:

- all line items can be done at the same time,
- interference with other work does not exist,
- total budget man-hours is less than 800.

If the above criteria are met, this group of work is defined as one Unit of Work. If not, the work will be separated into two or more Units of Work using sequential phase numbers. The 800 man-hour limit per Unit of Work was established for ease of managing and controlling the work.

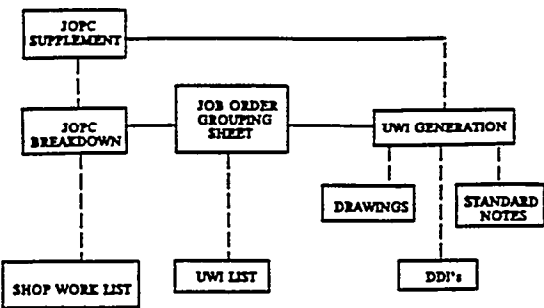

FIG.4 UWI GENERATION PROCESS

### Unit Work Instructions

The second step is to write a Unit Work Instruction (WI) for each Unit of Work. This is the only document needed to accomplish a Unit of Work. It contains all the information necessary by production and consists of:

- Work location
- Budget hours
- Source information
- General notes
- Job description
- Drawings
- Material List

In making each UWI, parts of drawings are extracted and portions of material lists are used so only applicable information is supplied in each UWI. Specific job descriptions are extracted from the JOPC reviewed. General notes are established for each Product Trade. When all the pieces of each UWI are assembled, the package then contains all the information needed by production to accomplish that specific Unit of Work. This is a key to the success of Zone Logic. No longer must first line supervisors research references or look thru multiple sheet drawings for a single lieu applicable to the work being performed. All this is now done with the UWI.

Admittedly, this is a time consuming process. However, it is necessary for Zone Logic Implementation. Initially the WI engineers did all this work by hand, and 60 man months of effort were required to define 3000 Units of Work, and to write 1300 UWI's which contained 560,000 man-hours of production work. This labor intensive process is being automated by PNSY as much as possible. Plans are also being formulated to structure future planning and design

work to better support Zone Logic Product Breakdown Structure without losing sight of funding and reporting requirements necessary at system levels.

### Scheduling And Manning

More realistic and reliable schedules can be produced through Zone Logic Techniques. Under the existing method of system-by-system Job Orders,.. it is virtually impossible to sequence work to be performed in a specific location. This results in scheduling work only within a time frame which includes time "float". No exact start and completion dates are scheduled. This method leaves too much for production workers to decide. They must decide work sequence, trade sequence, level loading and manning. In most cases under the traditional system, production workers will start work that can be done at the moment. This produces duplication of work and excess movement in the field. To combat this problem Zone Logic effort concentrates on:

- More detailed and exact schedules,
- Work flow charts,
- Definite schedule dates without float,
- Work schedules reviewed and revised against manning,
- Continuous review of work and schedule updates,
- Monitor Work Progress and Productivity.

'Zone Logic philosophy is to start and complete work zone-by-zone rather than allowing random starts anywhere. Zone-by-zone work is vastly more manageable than random system-by-system work. Zone-by-zone schedule is initially done on an Intermediate Zone basis, considering estimated work volume in the Intermediate Zones and the Key Milestone Schedule for the ship. Critical work takes first priority and this Intermediate Zone Schedule is the overall plan to be followed. This plan also used to make more detailed schedules which are issued on a four (4) month basis. The procedures and process of Schedule and Manning are shown in Figure 5.

Flow charts are made for Intermediate zones prior to making detailed four (4) month work schedules. These flow charts show the sequence of the work within Intermediate zones, independent of Trade or Phase. The scheduler during this process looks at all UWI's to understand all the work to

FD pin

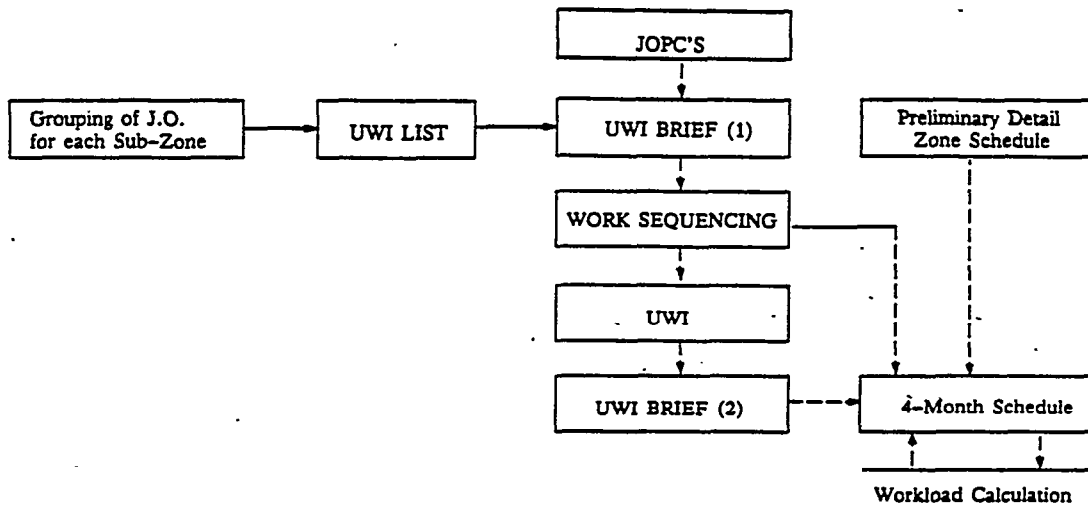

- NOTES:
1. The purpose of UWI Brief (1) and (2) to prepare for work sequencing and the 4-Month Schedule respectively.
  2. UWI Brief (2) is a refinement of (1) because of:
    - a) Issuance of additional JOPC's.
    - b) Grouping or dividing UWI considering both contents and amount of work.

FIG.5 ZONE LOGIC SCHEDULING AND MAN LOADING PROCESS

be carried out in a particular area. For instance, there are vent ducts, pipes, joiner bulkheads and furniture to be installed in one compartment; which is first? The sequence is checked and determined during this process. During this process the scheduler may find some Units of Work which interrupt other Units of Work. Such Units of Work are divided and/or rearranged to suit the production sequence.

- Definitive start and completion dates are given each Unit of Work considering the flow chart, budget hours and numbers of mechanics which are allocated to each Unit of Work. Allocation of mechanics is done considering not only the total manning of Zone Logic work, but also the appropriate size of the work force for each Unit of Work. These dates are used to generate a Bar Chart Schedule. Bar charts are used in place of the customary digital information because they are more pictorial and convenient for production to use in managing the work.

An obviously important factor in scheduling is to ensure the work can be accomplished with the available mechanics during the period of time being scheduled. Equally important is that the schedules produced make the workload as level as possible.

Additionally a total projected manhour accumulative curve for the entire period of the program is prepared based on total budgeted manhours. Specifically scheduled Units of Work are compared to the total manpower curve to show overall progress of the program towards completion.

An ideal condition exists when all the details of- all the work are known in advance and schedules from beginning to end can be made. However, when performing repairs, it is almost impossible to know the total scope of the work in advance. Huge amounts of work come out continuously after the start of work because repairs are discovered when inspections are performed. With work definition changing, long range detail scheduling cannot be done. The only overall plan which can be made is the Intermediate Zone Schedule discussed above. Even so, Detail Unit Work Schedules must be done for level loading of production work. For the SLEP, these detailed schedules are set up for a four (4) month period. Unit Work schedules and manning plans show a four (4) month window based on the latest job information as shown in UWI's. The last month is overlapped by the next four (4) month schedule, i.e. a new schedule is issued every three (3) months. If changes are great the schedule is updated once a month.

Finally, work is monitored using the "Cost/Schedule Control System" (C/SCSC). Expended manhours and progress percentage of each Unit of Work is reported weekly by production. The c/scsc system figures out performance measurements based on budget data and schedule dates which come from the four (4) month schedules. Only firm data on work to be executed in the following four (4) month window is used because broad data pertaining to future work is not detailed enough for reliable reporting of production performance. Long-range forecasting of overall performance is accomplished by comparing actual accumulative manhours expended and the Budget Cost of Work Performed on an accumulative basis, with the projected manhour accumulative curve. This projected manhour accumulative curve is **for** overall project based on the Intermediate Zone Schedule discussed above.

**EVALUATION OF ZONE LOGIC IN SLEP**

Merit of Applying Zone Logic Techniques to SLEP

The major merits in the implementation of Zone Logic in Kitty Hawk SLEP, are as follows:

- Efficiency is enhanced by performing all phased work which can be done by the same people, at the same time, in the same location, (Phased work pertains to work of like nature, i.e., ripout, repair, installation, test, etc. )
- Work sequencing problems are resolved by organizing workers into Product Trades and scheduling each Unit of Work,
- Work efficiency is enhanced and level-loading achieved by following the realistic schedule prepared by Unit of Work.

The first of the major merits and the original aim of Zone Logic in overhaul projects is the concept of the same people, same type of work and same location. This corresponds to Product Trade, Phase and Sub-zone being used on Kitty Hawk SLEP. The reason why this causes increased efficiency are self evident.

Planning and managing the huge amount of work included in a large scale overhaul project is not easy when thousands of Job Orders are produced for various shops. Work sequencing by shops is indeed one of the most difficult things to plan in such a project. This is especially true if the work is described system-by-system.

Work described by system is almost impossible to efficiently plan when trying to consider the work sequence of the various shops. Therefore, production schedules have normally been issued with should be or must complete dates and possible start dates. The Job Orders are issued and scheduled with float, not the exact date when a particular Job Order should be performed. Scheduling by this method leaves planning to production and it is easy to see why production people have difficulty in managing this way. Interference of work between shops is the result, and many of the jobs tend to start at the end of the scheduled time frame. The result is a tremendously high backlog of work as the scheduled completion date of the project comes close.

In Zone Logic, on the other hand, Unit Work Instruction are issued by Product Trade, and each Unit of Work is carefully scheduled with definite start and completion date. Unit Work Schedules do not contain float and indicate what is the most efficient timing for each Unit of Work.

Organizing by Product Trade simplified and solved the trade sequencing problem. Unit Work Schedules are developed considering work sequence. This is not difficult because sequencing is done by Product Trades, not system Job Orders. The only thing left to production is detail sequencing within Product Trade on a daily basis.

Level-loaded work schedules are one of the major factors in keeping productivity high. The traditional method, of course, takes into account this level-loading in setting up events, but the scheduling with float allows postponement of work until the scheduled completion date approaches. This tendency makes a "bow wave" in manpower loading, which is obviously undesirable from the work efficiency point of view. In Zone Logic, schedules are developed based on both work sequence and level loading. Therefore, if the schedule is followed the bow wave does not appear and work efficiency will remain high. Unit Work Schedules are Four (4) Month duration for Kitty Hawk SLEP.

Other Merits

Beside the three (3) major merits above, several others follow the implementation of Zone Logic.

Overall Project Schedule Adherence

Traditional system definition of work and scheduling- with float may cause an extremely high bow wave as the project approaches completion. The extent of this wave may be so great as to

12

Origin of SLEP Zone

→ Zone Logic → End of  
 Shop work diff. with 11/3/61

jeopardize the completion of the project on time.

**Manhour Reduction by Carefully Arranging of Work.** Scaffolding in Tank & Void for Kitty Hawk was planned for use by both piping and painting work. Such planning physically decreases the amount of scaffolding required.

Beside the enhancement of efficiency in direct work stated above, the indirect support work of temporary services can be reduced by providing the services from many job orders to the same sub-zone, same trade and same phase. This means that services are rigged fewer times than in a system approach.

**Rework is Reduced.** Rework is basically unavoidable in the traditional method because production people cannot know whether or *not* there exists other similar type of job when they receive a Job Order. Generally, several pieces of similar work at the same location are routed separately and consequently implemented separately. In Zone Logic this problem is greatly reduced.

**Wait Time is Greatly Diminished.** Zone Logic organizes production into Product Trades to more efficiently manage the work. The mechanics of necessary disciplines are within the group managed by each foreman. Because of this, lost time due to waiting for other trades will be remarkably reduced.

**Information Availability.** In the traditional method various reference information is shown in the Job Order. Production people need to collect the information before commencing the job. Unit Work Instruction includes all of this information. Unit Work Instruction also shows only the work associated with that Unit of Work as sketches or portions of drawings. These sketches and drawings are provided in a convenient size for field use. This makes it much easier for production to comprehend the work content of the Unit of Work.

**Better First Line Supervision.** Because of the Product Trade Organization and the form of the UWI, first line supervisors do not need to spend as much time arranging for support work or gathering reference material. They are able to devote more time to actual supervision.

#### **Issues Raised During Implementation**

The implementation of Zone Logic at PNSY has proceeded fairly well. Management has supported this change

and those working on the implementation have accepted and are enforcing the concepts diligently. As with any change, some areas and issues have proven to be troublesome. The following have created the major implementation problems:

#### **Timely Availability of Information.**

The policy established for Kitty Hawk's Zone Logic was to develop Unit Work Instructions without changing upstream information such as drawings, Job Orders, etc. Job Orders were issued system-by-system, one-by-one, the information became firm, not as total packages of work. Issuing work in this manner makes it extremely difficult for Zone Logic implementation. Consequently as Unit Work Instructions were being generated, it was not known whether all the information was received or whether more information was coming. This often caused the revision of Unit Work Instructions as additional information was received. Zone Logic becomes almost the same as the traditional method of work if many Unit Work Instructions are issued for each combination of Sub-zone, Product Trade and Phase. Many UWI's will result if the information is not diligently gathered for each Sub-zone, Product Trade and Phase.

The solution to this problem is to establish priorities for the issuance of all upstream information. This will ensure the availability of the needed information when developing a specific Unit Work Instruction. This priority should be in the same order as production intends to perform the work. In order to establish these priorities an overall production plan must be established much in advance of what is currently being done. In addition to this prioritization, a Master Schedule for all activities of the project should be established. Every organization, Design, Planning, Procurement, etc., in the shipyard should abide by this schedule.

#### **Information Flow of Repair Work.**

SLEP work is divided into two (2) basic categories: Ship Alterations and Repair. Ship Alterations (Shipalts) are in a sense, similar to new construction and the initial design work for both Zone Logic and traditional approaches are the same. Initial design must be made on system level. Zone Logic takes a different step in the transition of initial design to production design. Traditional design remains at a system level. Zone Logic, through the Transition Design Stage, develops production design on a Zone-by-Zone basis.

Repair information basically originates in a zone-by-zone form



because the repair requirements occur in a specific part of a system or at a specific location. The traditional method requires the information to be transformed into system-by-system package for funding and authorization. In Kitty Hawk's case, it was necessary to transform this information back into zone packages for developing the Unit Work Instructions. It should be obvious that this information flow is very inefficient and should be simplified.

A solution for this problem might be to ensure the original zone information be retained when developing system repair packages for funding purposes. It would then be an easy machine process to reorganize the repair information back into zone packages to issue in accordance with the Priority List and Master Schedule discussed above.

**Sub-zone Breakdown.** Sub-zone definition in Kitty Hawk SLEP are in *some cases* to be too small. This was caused by Sub-zone definition being made early before the geometrical distribution of work was well known. Experience shows that if the amount of work for a particular Sub-zone is too small, it is more efficient to make that Sub-zone larger. Sub-zones should be defined when a good understanding of Work distribution is known. Intermediate zones may be used for planning purposes before the Sub-zones are defined.

#### **FUTURE APPLICATION**

Zone Logic is being applied on about one-third of the total Kitty Hawk SLEP work, while minimizing the change to traditional shipyard operation. This policy was made because of the large amount of the upstream information which had been completed by the time Zone Logic Implementation started. However, in order to make Zone Logic more effective, it will be essential for many of the upstream activities in the shipyard to generate information more suitable for Zone Logic use. Some ideas for these changes are:

o Assign each piece of work as it is identified to the appropriate Intermediate zone. Prioritize major work within intermediate zones and prioritize iniermediate zones.

o Prepare a Master Schedule for the entire project from initial planning to completion, using the information above.

o Prepare a Design Schedule based on this Master Schedule. Issue drawings in accordance with this design schedule.

Develop Unit Work Instructions directly based on the drawings and information above without first generating a system level JOPC.

The above procedure will streamline the information flow for Zone Logic. It will eliminate duplicated work and provide information at the appropriate time. Without a doubt it is a key to-the success of. Zone Logic that every organization in the shipyard, from Design (upstream) to Production (downstream), follow the carefully established Master Schedule of the entire project. Abiding by the Master Schedule will maximize production efficiency.

#### **CONCLUSION**

This paper reports on the initial implementation of Zone Logic in Kitty Hawk SLEP project. It has been found that Zone Logic is highly effective in a large-scale overhaul project, especially when an enormous amount of alteration work is included. Thus, it is the writers wish that the entire Kitty Hawk project will be completed with successful results; that the Zone Logic portion of the work will show the savings known to be available by these techniques; and that Zone Logic Implementation at PNSY and in the Navy as well will continue and be widely applied in other projects and in other U.S. Navy shipyards.

#### **REFERENCES**

1. "IHI's Experience of Technical Transfer and Some Considerations on Further Productivity Improvement in U.S. Shipyards". Hiroshi Sasaki, Member, Ishikawajima-Harima Heavy Industries Co., Ltd. (IHI), Japan The Society of Naval Architects and Marine Engineers, August 26-28 1987
2. "An Integrated CAD/CAM Network for Work Packaging Development and Database Management". M.S. O'Hare, Zone Technology Project Director and M.J. Anderson, Zone Technology Assistant Project Officer Philadelphia Naval Shipyard, Philadelphia, Pennsylvania
3. "A Product Work Breakdown Approach for Ship Overhauls". The Society of Naval Architects and Marine Engineers Pacific Northwest Section, 12 March 1988 L. D. Chirillo, Bellevue, Washington



## Zone Logic Applications for Submarine Overhauls

Ernest D. Ellsworth, Visitor, and H. Bruce Bongiomio, Associate Member, Portsmouth Naval Shipyard, Kittery, ME

N o . 5 8

### Abstract

Japanese shipbuilding methods have typically been applied in new ship construction. As new buildings decline, the ship repair market has become more competitive and shipyards have started to apply some of these principles to ship repair. Public shipyards have been the most active in this technology development. This paper addresses some of the history and problems that have been encountered at Portsmouth Naval Shipyard in the application of zone outfitting methods.

### Introduction

Interest in zone outfitting methods has *grown* as the Navy deals with reduced budgets and increasing costs. Portsmouth Naval Shipyard is one of several public shipyards that has recently started to use zone outfitting methods in the overhaul environment (specifically nuclear submarines). In this paper we will present our efforts in the hope that our experiences will add to the existing body of knowledge.

Portsmouth Naval Shipyard is located in Kittery, Maine on Seavey Island which is positioned on the border between Maine and New Hampshire. Unlike the other Navy shipyards, Portsmouth deals exclusively in repair, overhaul, and refueling of submarines. Application of zone outfitting methods to submarine work must be integrated with stringent quality control and documentation requirements that are not found in work on surface ships.

In efforts to reduce costs in maintaining and modernizing the fleets, the Navy has adopted a series of policies consistent with the Carlucci Initiatives (reference 1). These are:

- a) Implement increase competition
- b) Implement economic production rates
- c) Reduce time to procure
- d) Reduce apparent <sup>cost</sup> growth
- e) Improve reliability through specification

- f) Improve schedule realism
- g) Provide more apparent design-to-cost goals

Detailed goals and actions for putting these policies into place were identified in a study performed by Coopers and Lybrand on contract to the Secretary of the Navy.

### Efforts at other shipyards

With the stage set by the Carlucci Initiatives and the Coopers and Lybrand report, public shipyards are beginning to adopt appropriate Japanese methods and new technologies. Significant among these are zone management methods similar to those practiced in new construction.

*Puget Sound Naval Shipyard* in Bremerton, Washington, has been very active in the implementation of zone outfitting methods (reference 1).

In most of these projects, no cost tracking was reported so benefits were recognized qualitatively. However, in one of these projects a reduction of 35% of total estimated cost and schedule performance improvement of 45 days was quantitatively documented.

Subsequently, Puget has applied zone outfitting to the structural work for ShipAlts on the forward end of SSN637 class submarines. On three submarines, traditional methods were used and on four zone outfitting was used. Final cost accounting reported an average savings of about 10% in man hours of which nearly half was overtime when zone outfitting was applied.

Technology transfer has not been limited to just zone outfitting methods. Pearl Harbor Naval Shipyard has begun a program they call Total Quality Management (reference 2). This program is dedicated to constant process improvement and, thereby, quality improvement. zone outfitting and work packaging are parts of this more general management

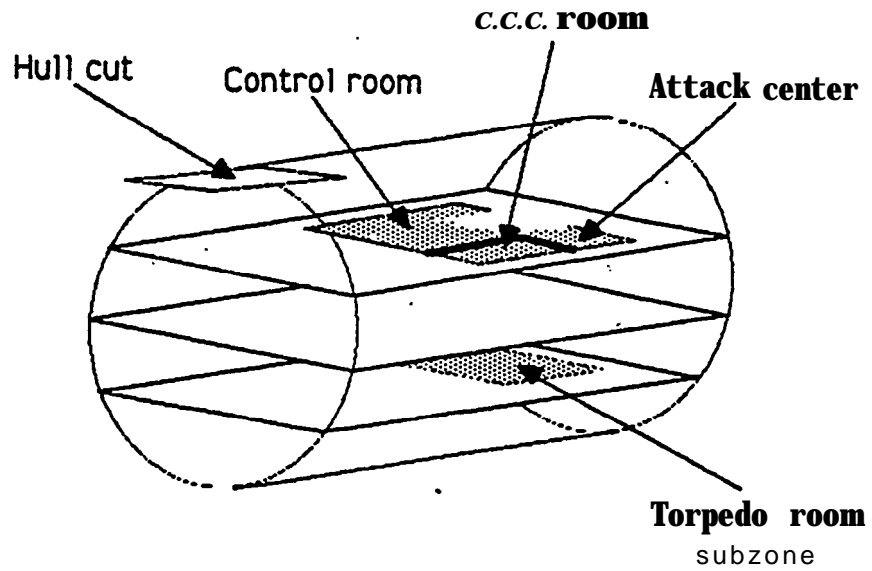

figure 1 - USS Bluefish Pilot Project

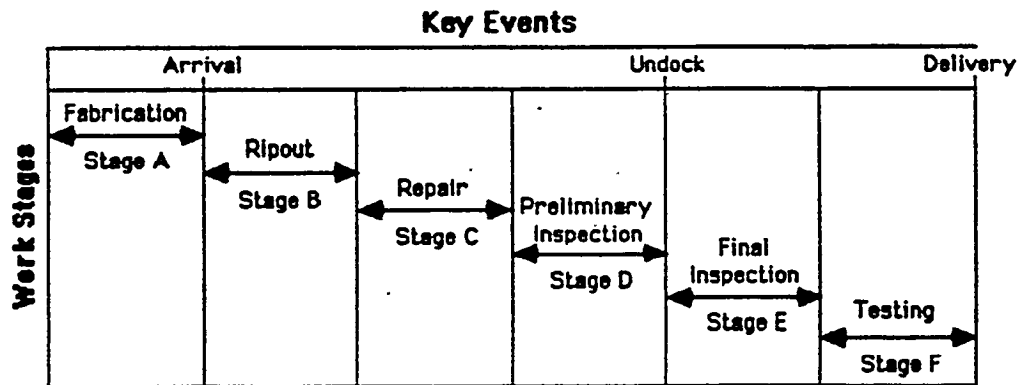

figure 2 - USS Bluefish Work Stages

philosophy. As did Puget Sound, Pearl Harbor has reported significant improvements in work performance on submarine modernization projects.

Philadelphia Naval Shipyard has retained consultants from Ishikawajima-harima Heavy Industries to help apply zone outfitting methods to the SLEP (Service Life Extension Program) of the USS Kitty Hawk. Although no papers have been published regarding these efforts, review of documentation provided to us shows that there is a high degree of schedule and resource visibility. The resulting control of the project will undoubtedly improve the overhaul performance.

#### Efforts at Portsmouth

In November 1985, Portsmouth Naval Shipyard management established the Adhoc Committee on Work Packaging to investigate methods to increase productivity through improved work instructions and better means of providing mechanics resources they need. The Major conclusions from their investigation were that significant improvements in cost and schedule performance could be realized by:

1. Developing detailed sequencing of work by geographic zone on the ship.
2. Grouping like work by zone in a set of work instructions.
3. Providing self-contained work instructions that cover events in a 1 to 3 week time horizon while minimizing support from assist trades
4. Palletizing material to support the work instructions and schedule.

Since these findings were consistent with concepts from the National Shipbuilding Research Program (NSRP), transfer of these technologies became the committee's recommendation. Subsequent to the committee presenting its findings, an assistant to the Planning Officer was assigned to facilitate implementation. His task was to identify pilot project opportunities and determine to what extent Portsmouth management should attempt to implement the committee's recommendations. The intent has been to gain experience with the technologies and management approaches and to best determine the path for transition.

#### Zone Outfitting on the USS Kamehameha

The overhaul of the USS Kamehameha was selected as the first opportunity to try zone outfitting concepts. The pilot project in this case was limited to sequencing component rip-out and reinstallation by zone. The ship was divided into geographic zones associated with common access cuts. Ship-checking of the areas identified major interferences in

the rip-out Paths in those zones and these were considered in determining rip-out sequences. A strategy was developed for the rip-out sequence and a schedule was then created to control events and measure progress.

The project Management Team reported that the rip-out and reinstallation went smoother than on previous overhauls. Trade tasks were better integrated with less lost time, manning levels were lower than normal practice, and scheduled completion dates were met. This approach to organizing work was expanded in the next pilot project on the overhaul of the USS Bluefish.

#### Zone Outfitting on the USS Bluefish

Portsmouth developed a pilot project on the overhaul of the USS Bluefish. The intention of this pilot project has been to explore the technical, management, and organizational issues involved in evolving from a system-oriented philosophy to a zone-oriented approach to overhaul work.

Applying zone concepts to repair and overhaul and involved the following:

- a) Division of the ship into geographic work zones
- b) Division of the overhaul period into work stages
- c) Detailed sequencing of work in the zones
- d) Scheduling of the work by zone considering manpower resources and work space constraints

The above efforts have been supported by:

- a) providing detailed work instructions (Unit Work Procedures) such that no reference materials will be required by the mechanics
- b) palletizing of material for mechanics based on Unit Work Procedures
- c) participation of production personnel in the planning process

The pilot project has included all the authorized work within the zones shown in figure 1. The primary work has been ShipAlt (ship alteration) 1929 (K), CCS MK 01 MOD 0 Installation, an upgrading of the torpedo fire control system. Work from other ShipAlt's and regular overhaul work requirements in the scope of zone planning.

The original zones were defined as:

- zone 101- attack center
- zone 102- control room, aft end
- zone 103- central computer complex
- zone 104- passage
- zone 304- torpedo room forward center

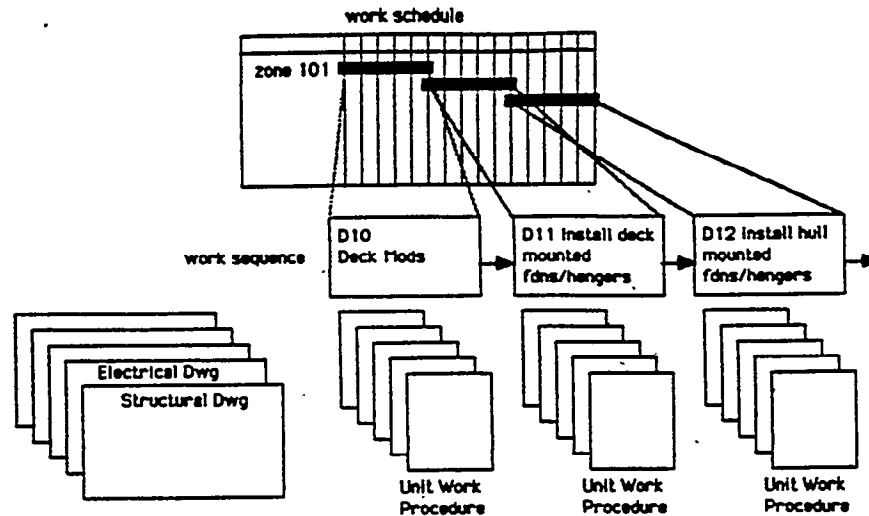

figure 3 - Diagram of Unit Work Procedure Development

Work stages were defined as shown in figure 2:

- A - fabrication
- B - rip-out
- C - repair
- D - preliminary installation
- E - final installation
- F - systems testing and completion

The methods described above were applied to the structural and electrical work. Unit work procedures were not generated for mechanical, piping, and ventilation. However, this work was included in work sequencing and scheduling.

Prior to the start of the overhaul, the decision was made to expand the project to include the operations compartment. This work involved extensive cabling modifications in zone 105, the sonar room, and zone 107, the radio room.

Major work included in the project was to upgrade sonar, radio, and navigation equipment in addition to upgrading of the fire control systems. This required extensive structural, as well as cabling modification. Changes were also required in several piping systems. All of these activities had an impact on insulation and painting.

Testing requires system orientation, that is, tests are conducted as systems are completed. Testing of systems in the zones was not part of the pilot project, but was taken into account in the scheduling system completion dates to support the integrated test schedule were taken as zone completion milestones.

### Unit Work Procedures

Unit Work Procedures were developed for this project similar in format and content to what was done at Puget Sound Naval Shipyard and discussed in reference 1. This process involves converting information that was presented by system into a package that presents it organized according to the ship's geographic zones and consistent with process sequences (figure 3).

Each package contained the information that a mechanic needed to perform the scheduled tasks. This included isometric diagrams of the components to be removed or installed, detailed work instructions, safety information, and a list of required material.

The Unit Work Procedures also provided the necessary signature documentation for verification of work completion, work quality control, and accountability. All of this information is critical to insuring the safety of the submarine and satisfying the quality control audit requirements.

CAD modeling and use of a database program have been transition planning efforts. CAD modeling of structural work was used to provide graphics for Unit Work Procedures in the same way as has been done at Puget Sound Naval Shipyard and documented in reference 2. However, what proved to be equally useful in the grouping of work was using a commercial database program on a personal computer. Using an appropriate coding scheme, the database program allowed retrieval of information to form work packages and identify similar work to be performed in a zone. This was used extensively for electrical work.

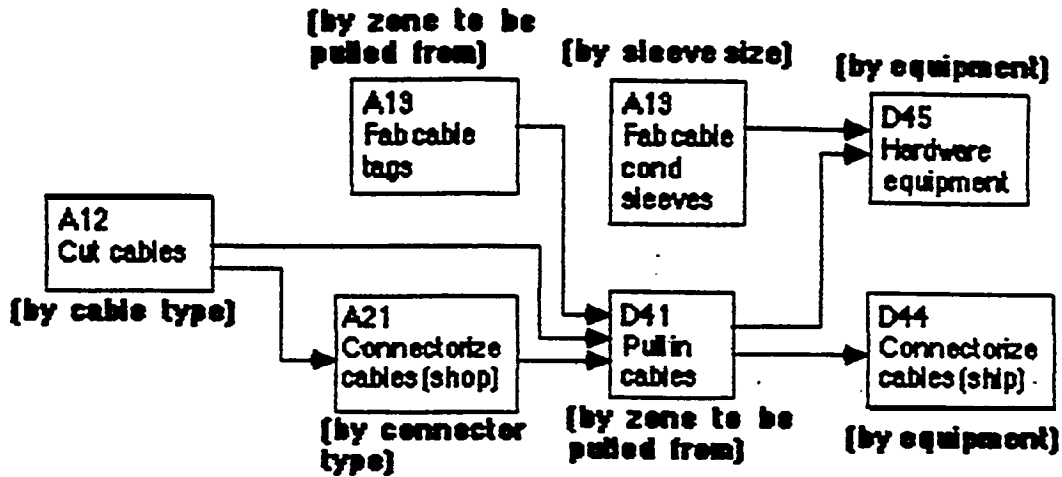

figure 4 - Organization of Unit Work Procedure Information to Facilitate Use of Group Technology in Electric Cable Fabrication/Installation Process

In developing the PC coding scheme for effective retrieval of information, processes were defined and a coding system was established to identify interim products. The database could be sorted for selected features to facilitate application of group technology and development of Unit Work Procedures. This is shown in figure 4.

**Organizational correlates**

Zone outfitting is a management technology relying as much on who does the planning, scheduling, and control as the actual tools for organizing the work. The intent of breaking the ship down into zones is to reduce the management tasks in size by being product-oriented rather than by system. This allows the zone manager to integrate and control predecessor/successor events and resource allocation. In this case the resources are manpower, material, and calendar time.

The Bluefish pilot project used two organizational concepts to support zone methods. The first involved designating a Zone Manager whose responsibilities were to direct work in the zones and integrate trade efforts.

The second was creating a Zone Planning Team. Core members were representatives from Design Division and production shop personnel. Representatives from the Planning and Estimating department, scheduling, combat systems, and additional shop personnel were added as needed.

The Zone Planning Team gathered in a series of meetings for the purpose of

grouping and sequencing work. The meetings were chaired by the zone manager. Deliverables from these meetings were integrated work sequences for the zones.

Another responsibility of the core Zone Planning Team was to participate in the CAD modeling efforts and the development of the Unit Work Procedures. These tasks represented near full-time assignments for the shop personnel involved.

**Lessons learned**

Although the project is still in progress, several lessons have been learned that are worthy of sharing. The project significantly deviated from the normal methods of planning work and managing execution. Consequently the project could not be Sully integrated into the Shipyard "system". The confusion this would cause during execution was not Sully anticipated and has detracted from the successes achieved.

The Unit Work Procedures provided instructions to mechanics but did not replace the traditionally prepared Key Ops in the management system. This approach caused extra work for foremen in reporting costs and progress as well as preventing accurate UWP cost tracking. Since the UWPs did not replace key ops, they did not fully address trade requirements. This limited their usefulness as a manpower planning tool. In the next project, UWPs will be Sully integrated.

Although material lists were included on UWPs, the material was not linked with ordering numbers in the

Shipyard MIS. This, also, caused considerable confusion and extra work. This will be corrected in the next project.

The zone manager, by virtue of his position outside the traditional Shipyard project management structure and with limited control over resources, had difficulty performing the trade Integration function. His role was further weakened when schedulers with systems background had difficulty developing zone schedules that integrated all work. The credibility of the zone manager, however, has significantly improved since the early stages of the project with apparent corresponding work efficiency Improvements.

The use of a relational data base manager for grouping like work and providing input to work Instructions when graphics Is not required has proven successful as a work management tool during execution of this work.

The mixing of engineering and production personnel In the zone planning team has proven to be an education to both groups. They enjoyed learning from each other. Some engineers have commented that this approach is their first realization that engineering should be concerned with execution cost effectiveness. A large scale and continuous sharing of knowledge between these groups has apparent potential to significantly improve shipyard performance.

#### The Depot Modernization Period

Portsmouth Naval Shipyard is scheduled to perform one of the first Depot Modernizations of a 688 class attack submarine. The philosophy of the Depot' Modernization Period (DMP) is to reduce maintenance costs by going from time-based repairs and upgrading of systems' to condition- based, fix-only-what-is-broken, repairs and upgrading of systems. The objective Is to perform upgrading of systems within a rigid time frame and with a minimum of disruptive emergent work.

Portsmouth Management recognizes that such a concept Is very different from past work that has been performed at the yard. Consequently, they recognize that a unique project management approach must be developed. Such management concepts require decentralization of decision making and rapid response to problems since no schedule slippage can be allowed.

Plans for the first DMP involve using a zone Identification code with the cost collecting numbers (Key ops). This will allow collection of work content Information by zone. This

Information can then be used to Create zone schedules that integrate trade efforts.

Part of the management approach on latter DMP's will be to more fully incorporate zone outfitting concepts. Although It has not been decide when a fully developed zone management organization will be used, pilot projects are being defined in areas of greatest potential benefit. These projects will provide additional experience to facilitate Implementation on following D M P ' s .

In particular, work to be performed In the after end of the engine room and the associated main ballast tanks Is being considered as a zone technology project. The scope of this application would include all shipalt and repair work. Unit Work Procedures would be developed and a more flexible scheduling system similar to that used at Philadelphia Naval Shipyard would be used to control work.

#### Conclusion

As a result of our pilot projects at Portsmouth, we have concluded that zone outfitting methods can be effective In Improving performance on submarine overhaul and repair work. The Shipyard will continue to Implement zone methods on a selective basis. It Is likely to continue to be refined and expanded In areas where It has the greatest potential benefit. However, factors unique to the nature of Portsmouth Naval Shipyard's work may prevent realization of the full potential improvements from shipyard-wide application of zone technology.

#### References

1. W.L. Christensen, "Benefits of the National Shipbuilding Research Program to the Navy and the Industrial Base: Part 3 - Navy Perspective," Journal of Ship Production, November, 1986.
2. Gerry A. Damon, "Implementation of Total Quality Management at Pearl Harbor Naval Shipyard," Ship Production Symposium, 1987.
3. Shel Kjerulf, "Unit Work Guide for Zone Outfitting In Repair and Overhaul," Journal of Ship Production, May 1987.



# IHI Zone Logic Application to Electrical Outfitting on Highly Sophisticated Ships

Shuji Sato, Visitor and Shizuo Suzuki, Visitor,  
Ishikawajima-Harima Heavy Industries Co., Ltd. (IHI), Tokyo, Japan

## ABSTRACT

Outfitting electrical cable in highly sophisticated ships, such as, research vessels, patrol boats, etc., has significant impact on every aspect of ship construction, modernization, overhaul and repair. In other words, cost, schedule adherence and quality for very sophisticated ships are fully dependent on the performance of electrical work. Ishikawajima-Harima Heavy Industries, Co., Ltd. (IHI) has been exploiting zone logic, also recognized as group technology, for construction of virtually all ship types. But, the extensive cable footage in sophisticated ships requires special considerations and techniques. This paper presents practical design and production processes for zone outfitting electric cable.

## Special focus is on:

- 1) functional and detail design,
- 2) conversion of system-oriented design data to zone-oriented work packages called pallets, and
- 3) work methods currently employed in IHI - shipyards.

## INTRODUCTION

Significant advances are being made in North American shipyards to reduce cost and LO assure schedule adherence by applying zone logic, for construction, and also for modernization, overhaul and repair of ships. Everyone so involved acknowledges that much more needs to be done. But, most do not yet understand how to include electric-cable work within the zone approach for integrated hull construction, outfitting and painting.

Traditionalists regard electric-cable work as incompatible with zone logic. They insist that most cables must be installed on board because, "cables extend over several ship compartments and/or zones." Where traditionalism has prevailed, cable work has taken a back seat while full-scale applications of zone logic are achieving unprecedented productivity increases for other types of work. Two different build strategies are underway at the same time. Unavoidably, cable installations then proceed rather haphazardly under

old-fashion control which relies on each supervisor's experience and intuition while other work proceeds in a much safer and productive manner. Moreover, system-oriented work does not yield the corporate experience needed for constant analysis and constant improvement in design details and work methods.

Also, continuing the system-by-system approach for installing electric cables while hull construction, other outfitting and painting are zone oriented, increases the probability of unsafe work situations, cable damage, and rework even for the other types of work. Any combination of these conditions could lead to a deterioration in quality and catastrophic confusion in attempting to implement a work schedule for a ship as a whole.

Obviously, the solution lies in integrating the installation of cables with other types of work. In this connection, design data which are originally generated in a system-oriented manner must be rearranged in accordance with zone-oriented classification criteria. Cables have to be grouped for both material and production control in accordance with problems inherent in their installation. Thus, group technology (GT) has an important role in the advanced techniques for installing cable.

The exploitation of GT for cable work is firmly established in IHI and is now regarded as indispensable, particularly for the most sophisticated ships. This advanced process has brought about a remarkable outcome for every aspect of electrical outfitting. An electric-cable length is regarded as a fitting every bit the equivalent of a single pipe piece. The approach has made it possible to adopt the "Cable Pre-cut Method" which is essential for making cable-installation work safer, more productive, and susceptible to production control commensurate with other outfitting work.

Cable grouping is performed in the Production Department as a major part of production planning and given to the Design Department for completion of the last stage of detail design. The data base and processing system for cables, called CLIP (Cable List Program) is an important tool that is applied from functional design through production.



Emphatically, the design, planning and production methods for electric-cable installation work described throughout this paper are routinely applied in every IHI shipyard for the construction of highly sophisticated ships.

such as: cable lengths, cable-tray widths, Penetration-piece requirements and material lists. From the Outset, CLIP was developed and applied for the Construction of sophisticated ships.

The engineering procedure consists of the following processes:

### OVERALL ENGINEERING PROCEDURE

Figure 1 shows the paths for information flow from the beginning of functional design to production. The relationships to material procurement functions are also shown. CLIP, which dominates the figure, is a very efficient tool for receiving the system-oriented data base generated by system diagrams as well as for creating information groups that are most appropriate for installing cable. The program also produces production control information of various kinds,

#### 1) Design

- a. Functional Design - Major work typically includes generation of wiring diagrams, equipment arrangement, basic design data, and construction of a data base in CLIP.
- b. Detail Design - This stage specifically defines cable lengths, cable routings, cable trays, penetration pieces, etc. as well as the CLIP data base.

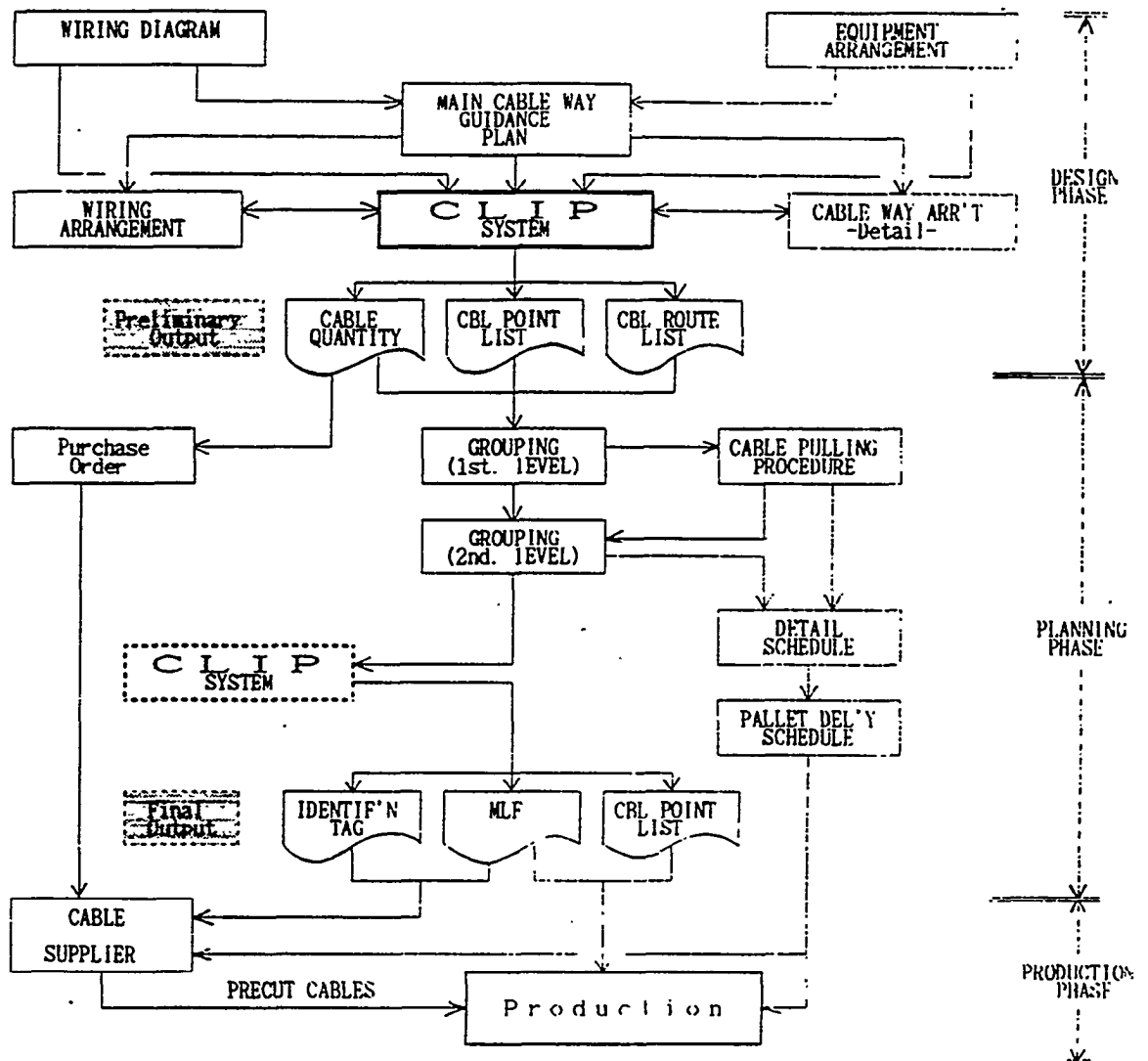

FIGURE 1 INFORMATION FLOW PATHS

2) Production Planning - This is the most important phase because it converts the system-oriented information that was generated during functional design into zone-oriented information. The work includes definition of cable-installation sequences and methods. The output of this phase is processed by CLIP to automatically produce required information such as material lists and cable-cutting instructions. Other work such as preparation of the manning plan, cable-installation scheduling, and setting pallet-delivery dates, are also performed during this phase.

Design and production planning are further described in the next parts of this paper.

## DESIGN

In addition to the role CLIP plays as a tool for grouping work, it has remarkable merit for reducing required detail-design man-hours.

The development of an electric-wiring arrangement (EWA) accounts for a significant part of a detail-design effort. Before CLIP was introduced, an EWA was the only drawing developed for cable-installation work and pertinent purchasing-data generation. The preparation of EWA then required a high degree of skill; each cable was superimposed to 1/25 scale on hull structural drawings. The process was extremely time consuming and required a huge manpower investment. As an EWA shows all cable routes, it thereby indicates cable lengths cable-tray dimensions, penetration-piece sizes, and comprises the basis for placing purchase orders. EWAs are also used for installing cables at the production site. CLIP succeeded, not only in simplifying EWA formats, but also, in substantially reducing man-hours and the time required for their preparation.

The design phase consists of:

- 1) Prerequisites - The following are required before-starting data input into CLIP:
  - a. Wiring Diagrams - These are prepared per circuit. Ten-digit circuit numbers, the names of terminal equipments, and the types of cable to be used are identified.
  - b. Equipment Arrangement - The positions of electrical equipments in the context of a general arrangement, machinery arrangement, cabin arrangement, etc., are shown.
  - c. Main Cable-Way Guidance Plan - This is needed to determine locations for main-cable trays. As a general rule cable ways are superimposed on an equipment arrangement. This plan presents the distances from nearest hull structure to each cable way and also gives the positions and numbers of cable index points. The latter are used to determine routes, calculate cable lengths, establish cable-tray sizes, etc.

2) Data Input - CLIP requires the following data input during the design phase:

- a. Cable-Standard Master - The outside diameters and unit weights for all types of cables to be used are required. Note should be made that much of these data are common to many ships. Therefore, much is retained in the master file that is common to other ships. The work required to input data for a specific ship is usually negligible.
  - b. Circuit Data - The circuit numbers, the names of terminal equipments and the zones they are located in, are inputted. Since these data are conserved from previous ships' files, the actual volume to be inputted for a specific project is reduced substantially.
  - c. Cable Route Data - The index numbers alongside the route of each circuit runs, and the distance from the terminal equipment to the nearest index point on the route, are inputted. Margins at both ends of each cable to be precut are taken into consideration at this time.
  - d. Cable-Way Data - The distances between all index points on the main cable way guidance plan are inputted. These data in combination with cable-route data used to calculate cable lengths.
- 3) Preliminary CLIP output - CLIP preliminarily outputs the following informations after processing the data inputted during the design phase.
- a. Cable route list - The circuit number, the type of cable, the names of the terminal equipments, the index points through which the circuit pass, and the cable cutting length are outputted for every circuit in the form of a list.
  - b. Cable point list - By each index point, the circuit numbers of all cables pass through are outputted in the form of a list. The sum of outer diameters of all cables, that determines the cable tray width, is also provided.
  - c. Cable quantity - The required cable length is summed up for each cable type and the purchase order is forwarded to the cable supplier.
  - d. Fittings information - Sizes and required quantities of penetration pieces, "Multi Cable Transit"s (MCTs) and glands are outputted, and thereby the fabrication details are developed. Another computer system which is capable of on-line processing being connected to SLIP determines the arrangement of MCT elements in a frame.

Aforementioned outputs are next processed in a production planning phase for determining the best sequences and methods and for converting system-oriented information into zone-oriented information.

## PRODUCTION PLANNING

Production planning work consists of the following processes:

- 1) **Zone Designation** - Figure 2 shows typical zone designations. In this example the ship is divided into five zones: forward, midships less the engine room, aft, engine room and superstructure. Each cable is assigned to the zone or zones through which it runs. Thus a cable may be assigned to one or as many as five zones. Cable in common zones are grouped by problems inherent in their installation. Then, they are broken down to the pallet (work package) level. A pallet is the smallest unit for the sake of controlling material and is determined in accordance with two levels of grouping;
- 2) **First-Level Grouping** - The cables assigned to each zone are first grouped, in accordance with factors, such as, time to be installed, cable way to share, and locations of terminal equipments. This grouping is also used to determine the fundamental work procedure which will have a significant impact on the success of subsequent planning and installation work. Therefore, the grouping is performed by the same production engineer who will be in charge of work for electrical outfitting on block and on board.

**First level classifications are:**

- a. **Lighting-Gable Group** - This work is given top priority because the ship's lighting fixtures will be used for illumination during construction. Since 80% of the cables in this group will be installed on upside-down blocks before hull erection, the work to be completed on board consists mostly of uncoiling cable ends and pulling them across erection joints:

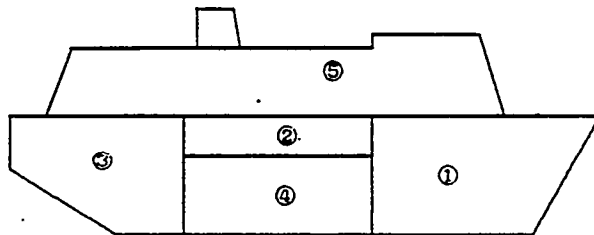

- b. **Interzone-Cable Group** - These cables run across several zones. They are further broken down according to the zones where terminal equipments are located.
- c. **Intercompartment-Cable Group** - These cables run through several compartments within one zone.
- d. **Local-Gable Group** - These cables run exclusively inside a single compartment.
- e. **Coiled-Cable Group** - These are cables that are to be pulled into position except for their ends. The ends are temporarily coiled at a bulkhead or at a block erection joint pending being able to pull them into position during a latter work stage.
- f. **Other-Cable Group** - These are cables that do not fit into the aforementioned groups- Usually they are cables that cannot be installed until after certain equipments are blue-sky landed or after certain blocks are erected, e.g., a main engine and the engine-room closing block.

After such formal classification of cables, the most appropriate cable installation procedure is developed and documented as shown in Figure 3. Immediately thereafter, the production engineer who performed first-level grouping interact with engineers for other work in order to avoid unintentionally having troubles by doing different kinds of work in the same zone during the same stage. As a consequence of the interaction, all groups usually have to make some adjustments in their proposed schedules. An electrical master schedule is formulated simultaneously.

- 3) **Second-Level Grouping** - At this level, there is a further break down in order to generate pallets (work packages). Detail scheduling, setting pallet delivery dates, and identifying pallet-interface problems are part of second-level grouping responsibilities.

Second-level grouping is carried out by the supervisors who will be in charge of the actual cable-installation work. They are supervised by the engineer in charge of first-level grouping

- (1) FWD Zone
- (2) Midship Zone Less Engine Room
- (3) AFT Zone**
- (4) Engine Room Zone
- (5) Superstructure Zone**

FIGURE 2 ZONE DESIGNATIONS

For each of the zones shown in Figure 2, an assistant foreman or a worker having sufficient experience and skill, would be in charge. As a matter of course, the foreman who coordinates electrical outfitting will give advice when need exists.

- a. Second-Level Breakdown - Each first-level group is further broken down by taking into account such factors as terminal equipments, compartments in which equipments are located, cable trays shared, locations of penetration pieces, etc. As a consequence of this process the groups which are identified, -each containing 30 to 40 cables, are regarded as pallets.
- b. Implementation Schedule and Pallet-Delivery Dates - The electrical master schedule, formulated simultaneously with the cable installation procedure, is updated by making use of most recent planning information. Thereby, the

implementation schedule is formulated by breaking it down into activities which are the equivalents of pallets. Pallet-delivery dates are set based upon this latest activity.

- c. Color Marking - Cables are positioned and strapped as soon as possible after they are pulled. Thus, despite extra length provided as a margin and correct precutting, a cable that is not pulled completely into its designed position could cause rework or even scrapping of the cable. The potential is greater when terminal points are located outside the working zone. In order to assist workers in pulling cables into their designed positions, the precut cables are marked before they are pulled with colored vinyl tape at key points such as one which corresponds to a bulkhead penetration. planning for such marking points is part of the second-level grouping activity.

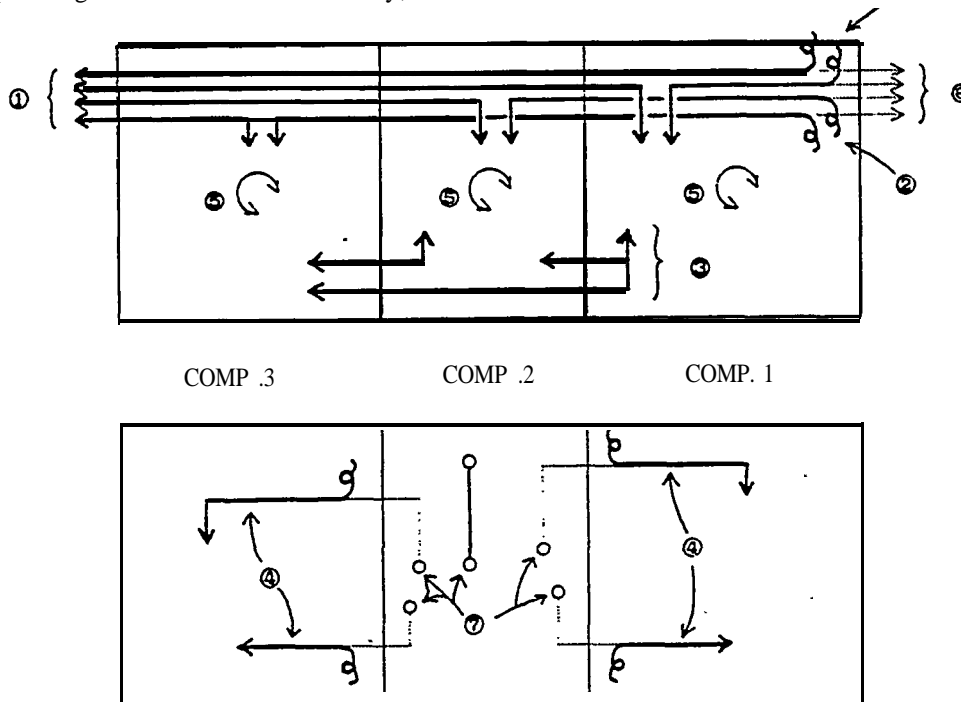

- (1) Engine Room Zone -> AFT Zone : Inter zone Cable
- (2) Engine Room Zone -> FWD Zone : Coiled Cable  
(Coiled at FWD BHD until FWD Zone is Ready)
- (3) Compartment 1 -> 2.3 / 2 -> 3 : Inter compartment Cable
- (4) Engine Room Zone -> Superstructure Zone : Coiled Cable  
via Closing Block  
(Coiled at Erection Joint)
- (5) Local Cable within each Compartment : Local Cable
- (6) Uncoiling (2) (To FWD Zone)
- (7) Uncoiling (4) (To Superstructure Zone)

- Engine Room Zone -  
FIGURE 3 CABLE INSTALLATION PROCEDURE

- d. **Interface Problems** - At this level potential pallet-interface problems are identified in detail. They are organized as a check list to insure that they are addressed, solved and verified during the production phase. It goes without saying that this activity improves coordination efficiency and minimizes losses that would otherwise occur during construction.

The refined planning that results from second-level grouping is incorporated in CLIP.

- 41 **Final CLIP Output** - CLIP's refinement of preliminary planning yields the following:
  - a. **Material List of Fittings (MLF)** - Each MLF is a bill of material by pallet and represents a refinement achieved by some rearrangement of the CLIP-produced cable-route list during design phase. MLFs are used for production-control purposes, including by cable suppliers for precutting and assembling cable-lengths into pallets.
  - b. **Cable-Point List** - This is an updated version of the preliminary cable-point list.
  - c. **Identification Stickers** - These stickers are needed for the purpose of identifying precut cables during warehousing and installation. They are fixed to both ends of each cable and identify circuit number, pallet number, names of terminal equipments, and color-marking specifications.

MLFs and identification stickers are delivered to cable suppliers. MLFs and the cable-point list are sent to production.

## PRODUCTION METHODS

The following work methods which support zone-oriented cable installation are noteworthy:

- 1) **Cable Precutting** - Precutting virtually all cable is most important for implementing zone-oriented cable installation work. Each pallet consists of many types of cables that have common problems inherent in their installation. Systems to be served and cable types are not relevant. Therefore, bringing reels for many types of cable on board, as in traditional shipbuilding, is impractical and unsafe. They needlessly clutter working environments and, if not sufficiently secured, could be very dangerous on cambered decks or on decks that are inclined due to list, trim, etc.

All except very small-diameter cables, e.g., lighting-circuit cables, are precut. The supplier delivers precut cables pallet by pallet complete with identification stickers and color marking per MLF cutting and other instructions furnished by the shipyard.

- 2) **Lighting Cable** - In order to secure trafficability and workability on board, and sometimes even on block, a ship's lighting fixtures should be put into use as soon as a space is enclosed. The majority of lighting cable and fixtures are fitted on block when blocks are upside down, so that they can be lit immediately after block **erection**.

Usually, lighting cable pulled from reels comprises about 5% of total cable length required.

- 3) **On-Block Outfitting** - In addition to lighting cable and fixtures, cable trays, foundations, and supports, penetration pieces, associated with electrical systems, are also outfitted on block. This accounts for about 85% of required electrical fittings.
- 4) **Bundled Wiring** - Pulling several together, applies to cables that are relatively straight over long runs and that pass together through the same MCTs. If care is taken to avoid abrading cable insulation during the pulling process, manpower savings are realized by using small pneumatic winches and pulleys.

## CABLE PROCUREMENT

Figure 4 shows a flow diagram for cable procurement processes. First, and initial purchase order is placed, based on preliminary quantity by cable type as produced by CLIP. Generally, the order is placed 90 or more days before the earliest pallet delivery date. A specific pallet delivery instruction, complete with MLF, cutting, identification and marking information, is issued 45 or more days before each required pallet-delivery date. For the purpose of assessing about when pallets should arrive, Figure 5 shows typical expected progress for cable installation work relative to key dates.

As a consequence of purchasing cable already precut, palletized and designated for just-in-time delivery by pallet, there is a great reduction in shipyard man-hours, space required for material handling, and in the total amount charged (interest) for the money used to purchase cable. Shipyard personnel are freed from reception and storage of hundreds of reels, precutting cables in warehouses or on board, and from other material marshaling chores.

Suppliers benefit also because demand on them does not fluctuate as much and their remuneration is greater because of the additional services they render. As long as they maintain sufficient supplies to assure shipyard deliveries on time, they have more freedom in serving other customers compared to having huge stocks in a shipyard warehouse, perhaps on consignment, that are not needed by the shipyard for quite some time.

Although supplier precutting, identifying and marking increases cable unit costs, the cost benefit from improved material and production control surpasses, by far, the cost increases. The result is unquestionably advantageous.

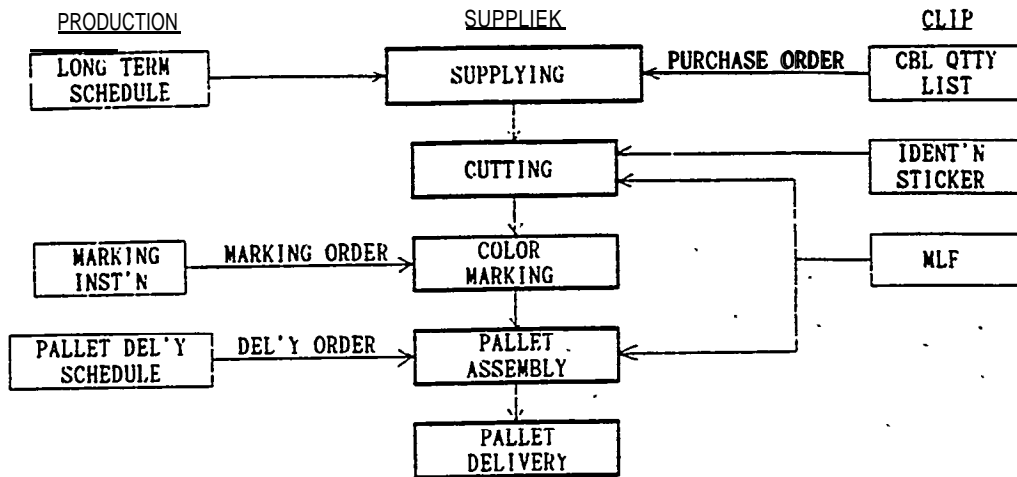

FIGURE 4 CABLE PROCESSES

Even if a cable supplier cannot be found to provide the increased services at reasonable added cost, precutting, identifying, marking and palletizing cable should be performed within a shipyard before cable is released to production. **There** is no question about it; there will be justifying savings resulting from improved production control through control of material.

EVALUATIONS

The various effects brought about in IHI shipyards by the approach described in this paper are:

- 1) There were substantial improvements in both design and production productivity. Accurate tracking of cable-pulling work progress was greatly facilitated. All that has to be done is "cross off" on cable-point and route lists as work progresses. As the work is classified by problem category per GT logic, productivity indicators such as men-hours per cable-length pulled, became very accurate and became sound bases for budgeting and scheduling for the normal performance of work, in a statistical sense. Thus, trends toward schedule lapses were immediately detected before they became of serious consequence. With prompt and appropriate remedial actions, unexpected delays were completely eliminated.
- 2) More efficient coordination was achieved between cable-pulling work and other types of work because interface problems were identified advance. Such potential problems were discussed and priority countermeasures were incorporated during the planning and/or scheduling for all types of work involved.
- 3) The beneficial results of using group leaders to perform production planning, who were later to be in charge of cable installation work, were conspicuous during the production phase.

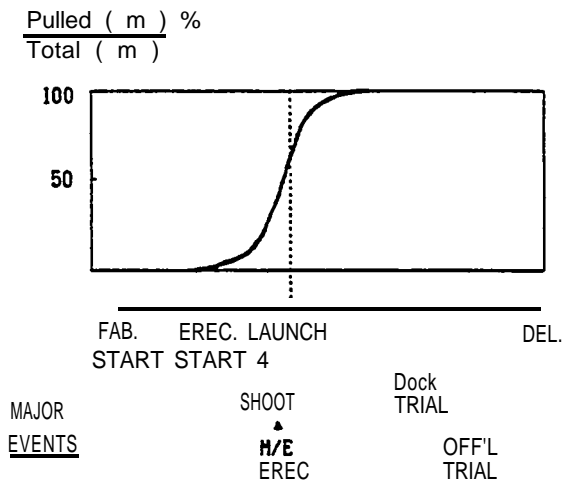

FIGURE 5 CABLE INSTALLATION PROGRESS

Besides what they contributed to planning documents, every small unwritten detail that they had detected while performing production planning, was recalled and applied by them, as they supervised cable installations, to manifestly further improve efficiency.

- 4) CLIP significantly streamlined design work. Noteworthy simplification was realized in the wiring arrangement which before, required many man-hours, skilled designers and large drafting tables. The skilled designers and saved man-hours are now applied for more sophisticated design duties. The CLIP processing system and data base are absolutely indispensable for transforming data by system to data by zone. The application of zone logic to facilitate cable installations is impractical without a processing system like CLIP and an appropriate data base. Moreover, CLIP made it practical to precut cable because of its reliability when calculating cable lengths.

- 5) Since all cable information for a ship are conserved in the CLIP data base, design data so filed can be easily reapplied when building different ships of the same type. Moreover, because all significant aspects of cable usage are captured as corporate data that is readily recallable, cost estimating with a high degree of accuracy has become practical. In addition, the conserved data base has also proven to be very useful for modernizing, overhauling and repairing ships.

## CONCLUSIONS

Cable installation work was once always regarded as the most difficult to plan and control with zone logic. But, after CLIP made it practical to transform system-oriented data to zone-oriented work packages, zone logic has been successfully applied and reapplied for installing cable in ships. The zone approach is now routine in IHI shipyards.

Improvement in coordination with other trades during the busiest stage of cable installation, is still being realized. The improvement process is not likely to stop.

Emphatically, the more complex that a ship is, the more CLIP is essential for cost, scheduling and quality matters. The fact that CLIP is applicable and effective for modernization, overhaul and repair work, in addition to construction work, is reiterated.

While cable installation work is generally held to be very important, **its** importance is increasing with the increasing density of cables required for the seemingly unlimited sophistication of numerous electric and electronic equipments of every kind, that are now being fitted in ships. CLIP is being improved to keep up with this extraordinary demand.

The addition of computer-aided design (CAD) functions for automatic design and drafting of fittings, and automatic determination of cable routes, are regarded as priority subjects to be dealt with in the future. But, at the same time, IHI is also applying priority efforts **for** the development of fiber-optic systems and multiplexed communication systems, for the purpose of reducing cable requirements.



# Strategizing and Executing the implementation and Utilization of Zone Technology at Philadelphia Naval Shipyard

LCDR Larry D. Burrill, USN, Visitor, LCDR Bany S. Munro, 'CF, Visitor, LCDR Mark S. O'Hare, USN, Member, Philadelphia Naval Shipyard. Philadelphia PA, Koichi Baba, Visitor, Ishikawajima-Harima Heavy Industries Co., Ltd. (IHI), Tokyo, Japan

## ABSTRACT

The fundamental philosophies of Group Technology or Zone Logic Technology are accepted practices in Japanese Shipyards. The ideologies, originally conceived in the U.S. ironically, were considerably refined by the Japanese Shipbuilding and Repair Industry and since 1978, have been reimported to the U.S. The traditional system-by-system approach to work has been replaced by a zone oriented product work breakdown structure, Zone Logic Technology. This grouping of jobs if executed properly, has the potential to significantly enhance efficiency and productivity.

Numerous documented articles published by the National Shipbuilding Research Program (NSRP) and the Society of Naval Architects and Marine Engineers (SNAME) have explained in detail how the U.S. time-honored shipbuilding methods (post WWII) are slowly being replaced by the more efficient and analytical procedures of Zone Logic Technology. These concepts dictate that work be planned and executed under a priority scheme:

- 1) Divide work into geographical zones carefully considering the nature of the problems that are involved,
- 2) Develop a zone oriented product and interim product work breakdown structure,
- 3) Properly sequence the work to be accomplished by stage and area,
- 4) Plan final systems tests as necessary.

To date, the application of Zone Logic Technology in new ship construction is commonplace. On the other hand, its use in the ship repair, overhaul and conversion environment has been relatively small in scope and isolated in application in both private and public shipyards.

However, the application at the Philadelphia Naval Shipyard (PNSY) has greatly overshadowed all other U.S. shipyards' efforts combined. PNSY started its implementation of Zone Logic Technology in the late fall of 1986, targeting the Service Life Extension Program (SLEP) for the USS KITTY HAWK (CV-63) for its initial application.

This paper will discuss the strategy in the development and implementation of Zone Logic Technology at PNSY. Frank disclosure of the valuable lessons learned and current status will also be presented. Equally as important is what the future has in store for Zone Logic Technology at PNSY, which will also be described.

This paper provides a candid presentation of the experiences in the implementation of Zone Logic Technology in a demanding repair environment.

## INTRODUCTION

PNSY is nearly half way through the 37 month USS KITTY HAWK SLEP. After approximately 30 years of operational service, a SLEP is expected to add 15 years to a Carrier's life, Ref. 1. It is this project that enticed Senior Shipyard Management to consider Zone Logic Technology (ZLT).

The implementation strategy developed as a result of Shipyard Management taking bold Innovative steps to accomplish the Hull Expansion Project planning for the USS Kitty Hawk. Though this project was eventually canceled, the planning effort was so intricately woven into the overall SLEP project that it gave rise to alternate implementations of ZLT at PNSY. In scope, the Zone Logic Technology application on USS KITTY



HAWK encompasses approximately one-third (over 400,000 mandays) of the total production effort, three years of work, and Involves over half of the ship's compartments.

A game plan was devised after having had visited several shipyards worldwide (Japan, US, Canada and Europe) to investigate any prospective productivity enhancements that would help PNSY meet the immediate short term requirement of the Hull Expansion Project.

The ultimate goal was to improve our overall productivity to meet the Navy's operational fleet repair and conversion requirements. As a consequence, PNSY entered into a contract with Ishikawajima-Harima Heavy Industries (IHI) Co., Ltd., Japan, in January of 1987 to assist the shipyard in implementing Zone Logic Technology. Just twelve months prior to the start of the SLEP project with the planning processes well underway, the decision was made to implement ZLT.

In view of this, the implementation procedure necessitated the use of several products from the traditional planning processes (such

as Job Order Progress Cards), and then adapt these products to ZLT. The system orientated outputs were reduced and re-assembled into Product Work Packages in the form of unit Work Instructions (CWI). UWL's marked the departure from the traditional systems approach to planning work. This new method took various types of work in discrete areas and treated it as a work package in direct support of products' and interim products as discussed in Ref. 2. This is a very important aspect of ZLT and worthy of reemphasis here.

A UWI is the compilation of all production work by phase of a particular discipline/trade intended in a specific location/subzone. This package included all support services. Further, a UWI could be a grouping of work for a unit/system/area which are inherent or unique to that item. The UWI'S were then provided to the Production Department. The Data Based management System designed to support the Technical publishing process used in the development of Unit work Instructions is discussed in Ref. 2. The flow chart, represented here in Fig. 1. outlines the process from source documentation to final product.

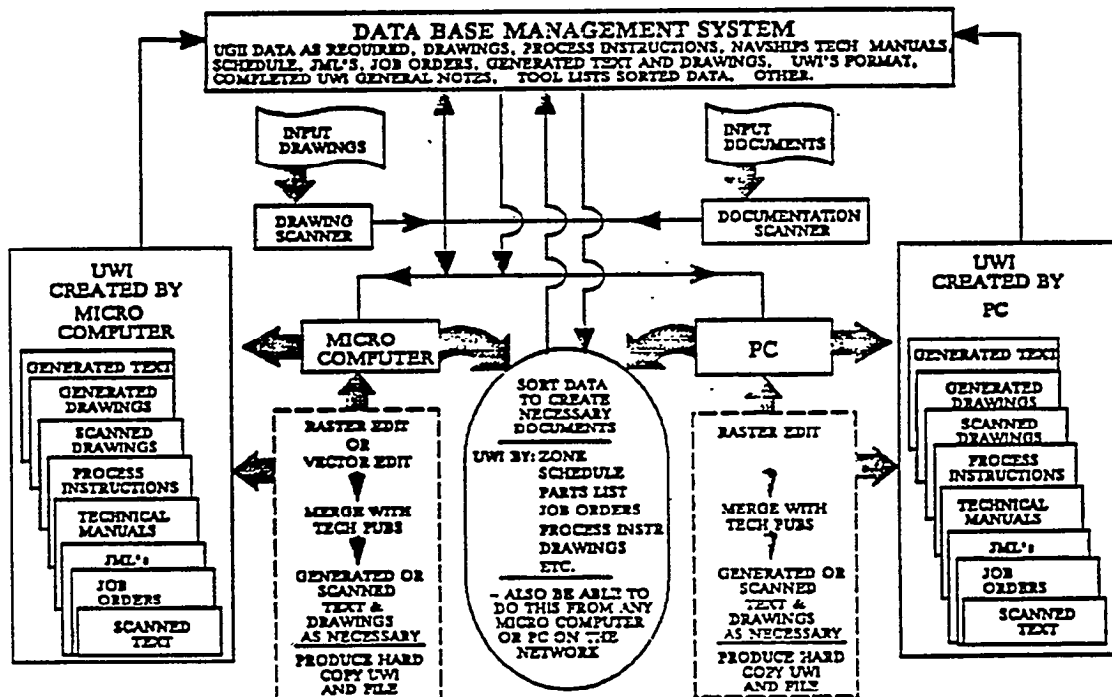

Fig. 1. ZLT System Process Requirements

The Production Department was re-organized to accomplish all zone work with separate Zone Technology Production Group (see Fig. 2). This group drew its cadre from the existing Production Groups (i.e., structural, machinery, electrical, piping and service) to assemble nine Product Trades. These Product Trades were then organized into four Production Shops to perform the work.

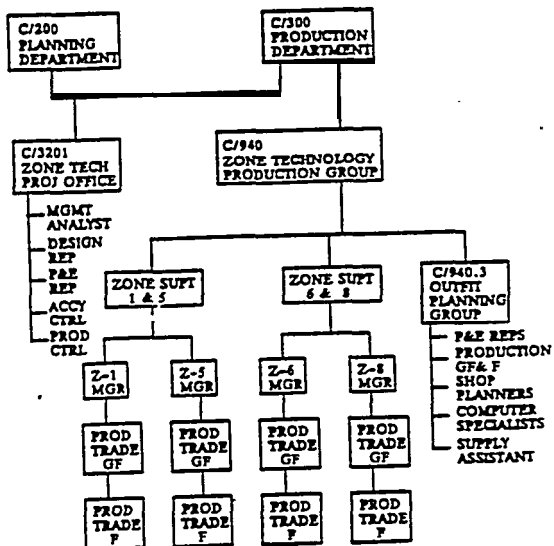

Fig. 2. ZONE LOGIC PROJECT TEAM

In a continuation of Ref. 2, this paper will consider two principal areas:

- 1) Detail the lessons learned during the USS KITTY HAWK SLEP, provide the current status, and outline the mid course corrections applied,
- 2) Describe the strategy intended for the continuation of ZLT applications at PNSY.

CURRENT STATUS OF ZONE LOGIC TECHNOLOGY IMPLEMENTATION

The broad scope of ZLT implementation at PNSY may best be broken down into three phases at this point:

- 1) Initial planning and the first year of execution in the USS KITTY HAWK SLEP, (Fall of 1986 - January 1989),
- 2) The planning phase for the USS CONSTELLATION SLEP and the final two years of execution of USS KITTY HAWK SLEP, (February 1989 - February 1991),
- 3) The execution of the USS CONSTELLATION SLEP in conjunction with other complex overhauls and other availabilities, (June 1990 - Future).

With the majority of planning complete, the USS KITTY HAWK was drydocked on November 25, 1987, though January 28, 1986, officially marked the start of her SLEP. Of the projected 1.2 million mandays to be completed during SLEP, the current physical progress is calculated to be 417%. of the approximately 400,000 mandays to be accomplished by ZLT, over 230,000 have been completed (data date-of 2 June 1989). Over the first 8 - 10 months of the project, a cost savings of approximately 1.8 million dollars was realized in the tank package alone. Although these preliminary 'results were encouraging., other developments within the shipyard in relation to ZLT were significantly impacting the overall potential for success. One alarming affect was the increasingly disharmonious working relationship developing between the Zone Technology Production Group and the Non-Zone Production Groups. The net result being a "Two Shipyard Syndrome". In conjunction with this was the growing appearance that anticipated productivity enhancements were not being realized. Consequently, in December 1988, the ZLT organization was changed to that reflected in Fig. 3. This action essentially dissolved the Zone Technology Group (Code 940) and reassigned the four shops (42, 44, 46 and 47) to the Structural Group Superintendent (Code 920).

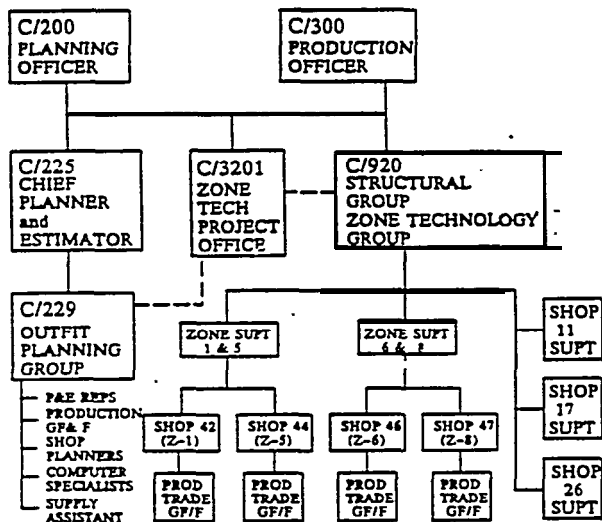

Fig. 3. CURRENT ZONE TECHNOLOGY ORGANIZATION

Further, the Outfit Planning Group (Code 940.3) was re-assigned as Code 229 to the Planning and Estimating Division, although remaining in the same location and performing the same function. The Zone Technology Project Office was not affected.

The basis For using A Group Approach To Problem Solving (GAPS),

The existence of a problem between zone and non-zone oriented employees became particularly apparent late in 1988. The Shipyard Commander took the first step by dissolving the Code 940 group. Then, recognizing the need to clearly identify the hurdles preventing PNST's ZLT efforts from succeeding as planned and define positive action to eliminate them, he directed that a GAPS team be assembled. The team consisted of select personnel associated with the planning and implementation of ZLT. The team was comprised of the following individuals:

<u>POSITION</u>	CODE
o Group Superintendent (Team Leader)	970
o Production Superintendent (Deputy Team Leader)	917
o Chief Planner and Estimator	225
o Assistant Repair Officer.	331
o ZT Project Director	3201
o Zone Manager	9 4 4
o Zone Manager	942
o Supervisory Planner (Recorder)	970.03
o Head, Employee Division (Facilitator)	180

GAPS is a unique problem identification and resolving, and process improvement study.

For obvious reasons, it is initiated by managers. Though its approach is tailored to suit the intended purpose, it is also staged in way of problem/process discussion, brainstorming, cause and effect diagramming (fishboning), parieto diagramming, the gathering of information and/or data and the effective compilation of same for accurate analysis of the findings. Further, it addresses the implementation of positive corrective action and finally as a follow-up measure, the provision of a plan to monitor the improvements instituted. A GAPS team is expected to maintain the initiating authority- attuned to their activities by way of regular project team meeting reports. The culminating activity of this GAPS team was a formal presentation of findings to the Shipyard Commander and members of his executive staff.

Over a period of four months the group met and conducted a series of interviews and surveys to investigate the implementation of ZLT. Initially, there were personal interviews conducted by the Team Leader and Deputy Team Leader. These were followed by other interviews with the entire GAPS Team with such personnel as ZLT Production Superintendents, Ship Superintendents, and representatives from Material Receipt and Inspection, Combat Systems, Hull, Mechanical and Electrical testing and the Supply Department.

<p><b>I UNIT WORK INSTRUCTION ISSUES</b></p> <p>1) DO YOU LIKE THE UNIT WORK INSTRUCTIONS? YES ___ NO ___</p> <p>A) IF YOU DISLIKED THE UNIT WORK INSTRUCTIONS DID YOU EVER INDICATE SO ON THE FEEDBACK SHEET? YES ___ NO ___</p> <p>B) IF YOU DISLIKED THE UNIT WORK INSTRUCTIONS, TO WHOM DID YOU BRING YOUR OBJECTIONS? YES ___ NO ___</p> <p>CO WORKER _____</p> <p>FOREMAN _____</p> <p>GENERAL FOREMAN _____</p> <p>ZONE SUPT _____</p> <p>GROUP SUPT _____</p> <p>OUTFIT PLANNING _____</p> <p>C) WHAT DIDN'T YOU LIKE ABOUT THE UNIT? CLARITY OF DRAWING _____</p> <p>JOB DESCRIPTION _____</p> <p>JOB REFERENCES _____</p> <p>INSUFFICIENT ALLOCATED FUNDS _____</p> <p>THE FACT THAT IT WAS ONLY A PLACE OF THE TOTAL SYSTEM PICTURE _____</p> <p>HOW YOU CHARGE PRODUCT TRADE/ASSIST TRADE BAD MATERIAL LIST _____</p> <p><b>II MISCHARGING/COST SCHEDULE AND CONTROL (C/SCS)</b></p> <p>1) DO YOU KNOW WHO IS RESPONSIBLE TO CHARGE/TRACK ASSIST MANHOURS ON A UNIT? YES ___ NO ___</p> <p>2) PLEASE PUT A CHECK NEXT TO WHO YOU BELIEVE IS RESPONSIBLE TO ENSURE ACCURATE CHARGES FOR THE ASSIST WORK ON THE UNIT YES ___ NO ___ OTHER ___</p> <p>ZONE MANAGER _____</p> <p>PRODUCT TRADE FOREMAN _____</p> <p>PRODUCT TRADE GENERAL FOREMAN _____</p> <p>LEAD MECHANIC _____</p> <p>3) HOW MANY HOURS OF COST SCHEDULE AND CONTROL (C/SCS) TRAINING HAVE YOU HAD? _____</p>	<p>4) TO WHAT DEGREE DO YOU FEEL THAT MISCHARGING IS OCCURRING IN ZONE TECH WORK? NONE _____</p> <p>MINOR _____</p> <p>MAJOR _____</p> <p>OUT OF CONTROL _____</p> <p>5) IF YOU FEEL THAT MISCHARGING IS OCCURRING, WHAT DO YOU ATTRIBUTE THIS TO? CONFUSED AS TO WHAT JOB TO CHARGE _____</p> <p>DID NOT HAVE ANOTHER JOB/UNIT TO CHARGE TO OTHER (SPECIFY) _____</p> <p><b>III SCHEDULE ISSUES</b></p> <p>1) TO WHAT DO YOU ATTRIBUTE THE MAJOR REASON FOR NOT KEEPING ON SCHEDULE? PRIORITYZ FROM 1 TO 6</p> <p>WORKSITE AVAILABILITY _____</p> <p>LACK OF MATERIAL _____</p> <p>LACK OF MANNING _____</p> <p>POOR SCHEDULE _____</p> <p>POOR QUALITY UNIT _____</p> <p>QUALITY OF MECHANICS _____</p> <p>TECHNICAL ISSUES _____</p> <p>POOR SUPERVISOR DIRECTION _____</p> <p>OTHER (SPECIFY) _____</p> <p><b>IV MATERIAL ISSUES</b></p> <p>1) TO WHAT DEGREE DO YOU FEEL THAT LACK OF MATERIAL IS CAUSING A PRODUCTION HOLDUP? NONE _____</p> <p>MINOR _____</p> <p>MAJOR _____</p> <p>OUT OF CONTROL _____</p> <p><b>V GENERAL COMMENTS</b></p> <p>1) PLEASE PROVIDE ANY GENERAL COMMENTS, BOTH GOOD AND BAD, THAT AFFECT YOUR PRODUCTIVE EFFORTS UNDER ZONE TECH, FEEL FREE TO USE THE BACK OF THIS QUESTIONNAIRE</p>
---	--

Fig. 4. GAPS TEAM QUESTIONNAIRE

1 CONTRIBUTION TO PROBLEM SITUATION

<u>COMMUNICATIONS</u>	<u>METHODS</u>	<u>MANPOWER</u>
LACK of Manior management InPut Lack of ongoing communications Limited senior management support Lack of ourside support	Too big a work package Scheduling process-4 months Full workload forecast not available Too rigid implementation	wrong personnel assignments Lack of prior practical experience undistributed mandays Lack of training for first line supervisors

11 IMPORTANT TO CORRECT AT THIS STAGE

<u>COMMUNICATIONS</u>	<u>METHODS</u>	<u>MANPOWER</u>
Lack Of senior management input Lack of ongoing communications limited senior management input Lack Of outside support Failur to follow face plan	Improper sequencing of work Full workload forecast not available Scheduling process-1 months Lack of accurate monitoring system Failure to follow game plan	Wrong personnel assignments Lack of training for first line supervisors undistributed mandays Lack of prior practical experience

111 POSSIBILITY TO CORRECT IN SHORT ORDER

<u>COMMUNICATIONS</u>	<u>METHODS</u>	<u>MANPOWER</u>
Lack of senior management input Limited senior management input Lack Of outside Support Lack of ongoing communications failur to follow game plan	fill workload forecast not available Scheduling process-4 months Errors in bays and means of charging implementation Deviations from established work plan	wrong persnnal assignments Undistributed mandays Lack of training for first line supervisors

THE MAJOR CONTRIBUTOR TO THE PROBLEM SITUATION  
UNANIMOUS CONCLUSION DRAWN: FAILURE TO PROVIDE FOR SENIOR MANAGEMENT INPUT.

Fig. 5. GAPS TEAM FINDING

Formal surveys were also conducted by the GAPS Team. The survey questionnaire (Fig. 4), was distributed to all First and Second Line Supervisors in the ZLT Production Group. The table in Fig. 5 summarizes the findings of the GAPS Team with the single largest contributor being the "failure to provide for senior management input".

(1.4%) with poor graphics (column B) and 11 (1.2%) with poor quality drawings (column C). Production personnel found 30 (3.2%) with poor graphics (column D) and they considered the written work instructions of 44 (4.8%) too vague (column E).

In addition, a survey was conducted by the Outfit Planning Group (OPG). Responses were retrieved via feedback sheets that accompanied each UWI. Of the UWI'S issued and completed, a random sample of 924 which represented approximately 20% of those held on file at that time, were assessed for this study. The results are presented in Fig. 6. Column A shows the number assessed. The Planner; who wrote the UWI's found 13

Since the effort to produce the UWI's was such a large part of the ZLT implementation procedure, a great deal of attention was focused on their acceptance and quality. Shown graphically, the UWI product was very good. However, much effort has been expended to attend to the recognized deficiencies..

Lessons Learned

Prior to addressing the lessons 'learned, it is important to pause and review the more salient points to appreciate the gravity of the monumental task faced by PNSY. The decision to implement ZLT on the USS KITTY HAWK SLEP was made just twelve months prior to a 1.2 million manday availability. Of' this, 400,000 MD's were allocated for ZLT. In addition to the tremendous administrative task posed by this decision, much of the traditional planning processes were complete or not economically feasible to alter. The majority of the shipalt drawings were complete as was much of the scoping of authorized work. Conseauently, the fundamental concepts of ZLT could not be strictly adhered to. Rather, many compromises had to be negotiated several of which were not necessarily in the best interest of ZLT. The application of the concept on the USS KITTY HAWK proved to be a valuable learning environment.

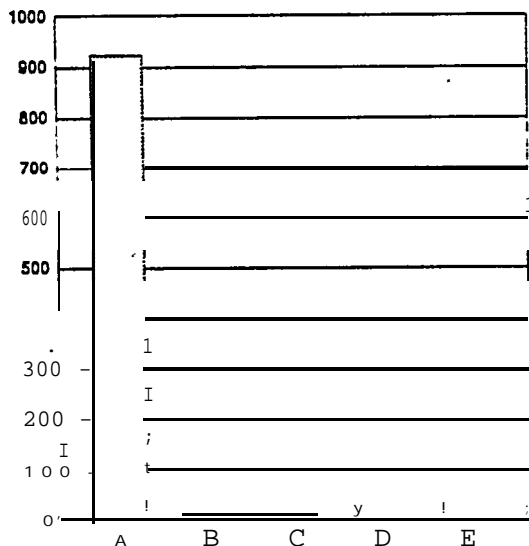

Fig. 6. COMPLETED UWI AUDIT

The following reflects a summary of the more important lessons learned:

1) The Zone Technology work Package was not initially networked into the overall ships scheduled network. As a result, Shipyard Management governing the availability had to refer to two sources of information to review the project's disposition. This meant administratively managing the project via two distinct parameters which was awkward at best, caused much confusion and was an additional burden. Ergo, it should be networked as soon as possible,

2) The ZLT work package was set up to work in four month windows. Only the work scheduled for that four month period was issued. Though this was not a popular decision and certainly not ideal, it was a necessary compromise. Four month schedules were used because there simply was not enough work available for issue to justify anything lengthier. In traditional fashion, the Planners and Estimators wrote job orders by phase and authorized work as the information was made available without requisite consideration given to all of the work to be accomplished in a zone/area. No guidance was provided them regarding the prioritization of this work. It should be appreciated that any one area could (and often did) have a number of Planners issuing work in it for a variety of different jobs which they progressed independently and in no delineated priority. As a consequence, the Outfit Planning Group found it extremely difficult if not altogether impossible to ascertain if absolutely all work in a particular zone, intermediate or subzone had been issued from P&E. There always existed an element of doubt. Ideally of course, all work would have been issued at the start of the availability. If that were the case, there would have been no doubt about adhering to the fundamental concepts of ZLT. But such was not the case and a schedule had to be provided to Production. Four month schedules (originally three month) were considered a reasonable compromise,

3) The unions representing the various trades and codes must be actively involved and thoroughly supportive from the outset. This is important considering the novel Product Trade concept,

4) The cultural issues involving the people and personnel surrounding this effort were/are/will continue to be by far the most important concern of all. They must be dealt with from the outset to the maximum extent possible.

it should be obvious that the items noted above are not all unique to the implementation of ZLT.

#### **FUTURE APPLICATIONS OF ZONE TECHNOLOGY**

Despite the concerns previously discussed, senior PNSI Management remain committed to the continuation of ZLT. A reflection of this commitment is exhibited in the decision to undertake the entire USS CONSTELLATION SLEP via ZLT. major efforts are currently underway to analyze and apply the lessons learned from the USS KITTY HAWK throughout the pre-planning phases of the USS CONSTELLATION. A meticulous review of the processes required is ongoing and will result in their thorough clarification. These processes are being utilized in the planning for the Docking Selected - Restricted Availability (DSRA) of the USS SPRUANCE, DD 963, as well. It is the intent of Senior Management to test out these processes on the USS SPRUANCE as a precursor to the execution of USS CONSTELLATION SLEP. Although the manday package on the USS SPRUANCE is small, (approximately 11,000) exercising ZLT concepts on this project should prove invaluable in validating the entire PNSY process.

#### **Integrated Strategies**

The work of the Planning Department is thorough advanced planning in preparation for the customer, in this case Production. Chronologically then, this means that the zones and intermediate zones must be clearly defined and this information distributed as early in the planning process as possible. Secondly, it is necessary to accurately determine the scope of the work to be accomplished in each zone. Given this and the first cut (initial proposal) of the Production Schedule, the zones can be effectively prioritized. This first cut Production Schedule considers the area, work to be accomplished in it, identifies the most logical time frame (phase/sequence) to do it in (on a global sense) and hoc; it is proposed that this be done. This iterative process to be regularly reviewed and updated. Not to belabor the obvious but in a work environment of this magnitude, concurrent activity is expected.

This prioritization of zones and intermediate zones is then provided to the Supply, Design and Planning and Estimating Divisions for the sole purpose of positive and consistent guidance with respect to what aspects to pursue first. As an example, if

Supply had 10,000 Job Material Lists to process, the guidance would provide the approach to acquisition priorities driven by need dates to meet the Production Schedule. The same could be said of drawings from Design and of job orders from P&E. Herein marks one of the most significant departures from traditional shipyard management, that is "Integrated Planning for Production"!

In an attempt to address the issues identified above, a multi-tiered Zone Technology Steering Group, was founded. The tiers are:

- 1) Senior Executive Zone Logic Technology Steering Group,
- 2) Zone Logic Technology Steering Committee,
- 3) Zone Logic Technology Steering Subcommittees.

The Senior Executive ZLT Steering Group, chaired by the Shipyard Commander, consists of the following individuals:

- 0 Planning Officer
- o Production Officer
- o Chief Design Engineer
- o All Production Group Superintendents
- o Chief Planner and Estimator
- o Chief Combat Systems Engineer
- 0 Supply Officer
- 0 Comptroller
- o SLEP Project Officer
- o Zone Technology Project Officer

This committee meets bi-weekly to discuss all aspects of ZLT implementation and planning. It is meant to monitor and discuss the overall progress in implementing ZLT, furnish a vehicle for important decisions when warranted, and provide guidance and direction to the other levels.

The ZLT Steering Committee is chaired by the Zone Technology Project Officer. It consists of division head level managers from various shops and codes across the shipyard management team. Its charter is to implement the second phase of ZLT. It assigns, oversees, and approves of the various subcommittees' activities involved in delineating the details of all aspects of ZLT implementation. This committee serves as the main conduit of information, administrative and strategic developments with respect to all issues involving ZLT.

ZLT Steering Subcommittees are chaired by designated steering committee members and consist of both members of the steering committee as

well as representatives from various trades and codes in the shipyard as required. There are currently three subcommittees:

- 1) Integrated Strategy and Scheduling,
- 2) Material Support,
- 3) Training.

The flow chart (Fig. 7) reflects the completion of the first task of the integrated Strategy and Scheduling.. (ISSI) Subcommittee. Though initially generated for the CV SLEP Program, the availability strategy chart has been modified here significantly for the USS SPRUANCE. It shows the varied and complex interrelationships that exist in planning an availability. This may be considered as the simplified model of the SLEP version, which by virtue of sheer volume and complexity, would represent the most detailed of all availabilities.

The follow on task assigned to the ISS Subcommittee is to clearly define the implementation processes of a Master Schedule (center, Fig.7). The issue of a Master Schedule has been an integral part of the ship repair and conversion environment for some time. It is perhaps the singular most important aspect of an integrated repair/conversion strategy through the implementation of ZLT. As defined here, the Master Schedule draws the following schedules together in one data base.

- o Drawing,
- o Material Procurement Sequence,
- o Test Development,
- o Production,
- o Tiger Team.

It should be emphasized that Master Schedule as used here is the culmination of many cycles iterative process beginning at the Proposed Planning and Production Strategy. (center, left Fig. 7).

The Material Subcommittee is responsible for delineating the material Management System to support ZLT and specifically, the "kitting" effort planned for USS CONSTELLATION SLEP. Zone Technology has as one of its attributes, the fundamental requirement that a particular package of work be accomplished during a precise period of time, by a specific trade or product trade. Having this requirement, it is even more critical that an effective material management system be in place and fully capable of supporting the work packages and schedule by providing all of the required material. The material Subcommittee has reviewed the complete material support cycle from definition

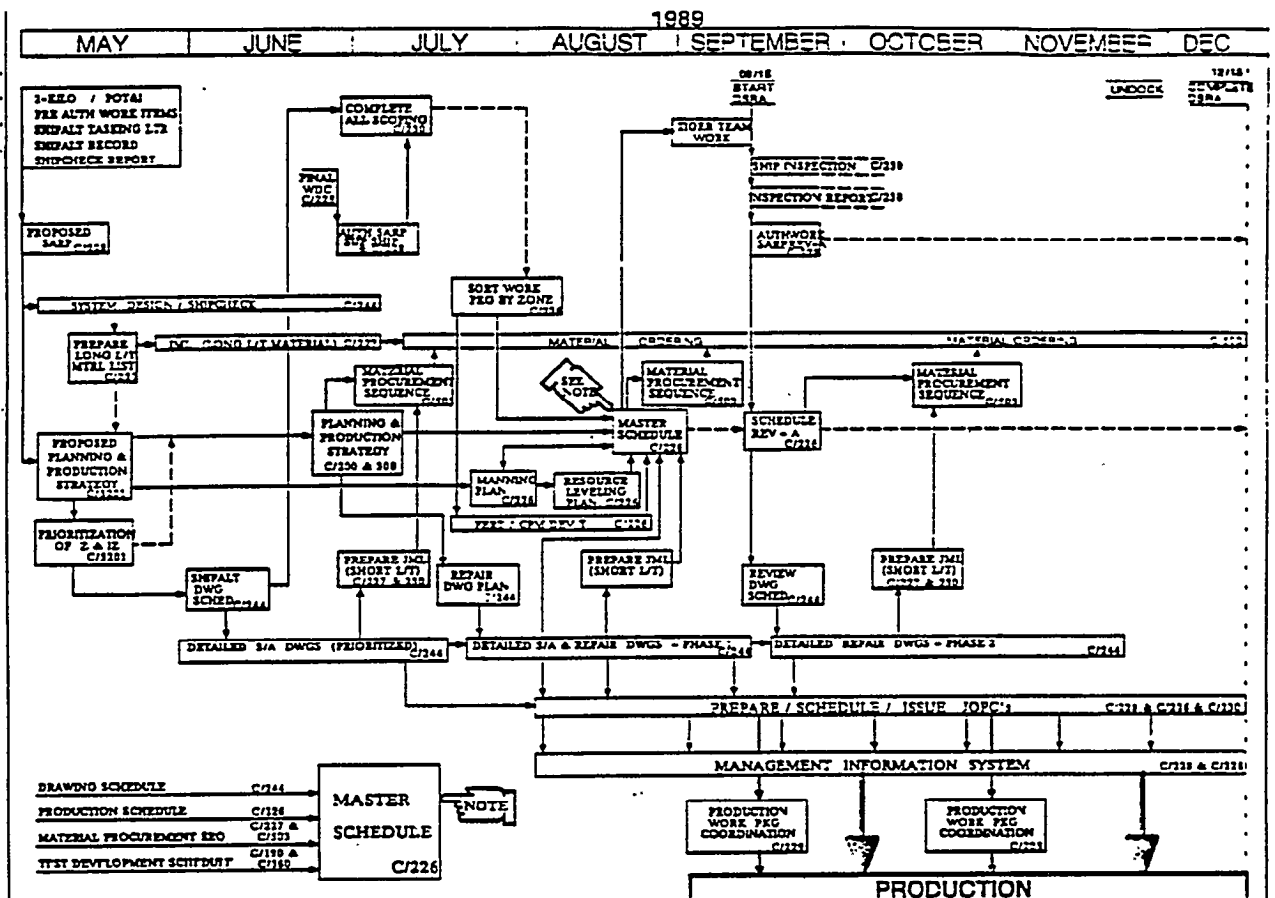

Fig. 7. USS SPRUANCE (DD-963) DSRA STRATEGY

Zone Logic Technology In Scheduling

of a requirement to the turnover of that material to Production. A kit may be appreciated to be all of the material required to accomplish that unit of work when the schedule calls for it.

The Training Subcommittee is tasked with developing a training Plan as well as training modules. These modules will be tailored to address departmental concerns and at a minimum, will answer the following questions.

- a) What exactly is it that we- are trying to do?
- b) Why are we trying to do it? Why change?
- c) IS this expected to be a temporary or permanent change?
- d) What part does each employee have to play?
- e) What part does the Union/Military have to play?
- f) Why is it so important?
- g) What lessons have we learned from the USS KITTY HAWK?
- h) Where does ZLT fit into Philadelphia Quality Process?
- i) What sort of education needs do we have?
- J) Who needs to be educated and who will do it?
- k) How and when will we educate everyone?
- l) What time frame are we adhering to?

The issue of a Master Schedule was previously discussed. The natural offspring to it is the development of a short term Detailed Production Schedule. This schedule will be a product of the Production Scheduling Branch in league with the Outfit Planning Group. Owing the breakdown and identification of work by area done by the Design and P&E Divisions, the Overall Event Level Schedule must be developed by zone. This can be accomplished via the Event Management System currently in place within the shipyard. The scheduled event (or "C" event) will strictly correspond to a particular intermediate zone. In support of having a particular unit of work accomplished by a specific group of people during a precise period of time, the "C" event will have many key operations (keyops) assigned to it. Appropriately then, all keyops will be packaged and entered into the short term Detailed Production Schedule. As a "C" event may span a full four month time frame, the Detailed Production Schedule will be a reasonably flexible tool to meet shorter periodicities.

Ultimately, **as** ZLT concepts become firmly established practices of the planning process, all work will be issued in accordance with the availability strategy previously outlined.

This would support the development of detailed and accurate weekly schedules. The obvious consequence of this would be better schedule adherence, positive project management and equally as important, more desirable control of their work on behalf of the waterfront personnel.

### Zone Technology In Design

Due to the time frame to implement ZLT on the USS KITTY HAWK, the Design Division Integrated Drawing Development effort was limited to two spaces; specifically, air conditioning machinery room number three and four and pump room number five.

The Design Team is fittingly called "Design for Production". Their mandate was to generate an integrated Design Work Package for each space, where practical, either by actual onboard shipchecks or by the use of Computer Aided Design (CAD) equipment. However, the actual method remains viable and is as outlined below:

- 0 Shipcheck the compartments for systems that remain after shipalts are accomplished,
- 0 Shipcheck for greater detail to support pre-fabrication accuracy,
- 0 Develop composite drawings integrating new shipalt drawings with existing configurations,
- 0 Perform interference checks,
- 0 Review composite drawings for quality producibility for the purpose of pre-fabrication, pre-outfitting, providing detailed assemblies and conformance to standardizations.

CAD is a very dynamic method of accomplishing the same task. An example of a piping composite drawing for Pump Room number five as generated by CAD is shown in Fig. 8. This drawing is then supported by the requisite number of detailed drawings required for the actual system fabrication and assembly. On this particular work package alone, twenty Interference Control Memorandums were sent to various Design Codes highlighting interference problems. This number does not include the number of informal corrections initiated while working with the preliminary drawings. The benefits of CAD are:

- o A detailed and accurate document to accomplish installation (easier/safer).
- o Advanced production techniques eliminating interferences to a fine point of detail,
- o provide consistent base line model supporting multiple Design Engineers to use and thus eliminating repetitive efforts,
- o automated interference control eliminates guesswork and constant communication between Design Engineers,
- o incorporates the most logical integrated installation configuration of all items within the space and supports ease of maintainability,
- o accommodates computer interface with CAM for prefabrication and preoutfitting capabilities and accuracy of same,
- o accurate computer model available for future availability advance planning efforts.

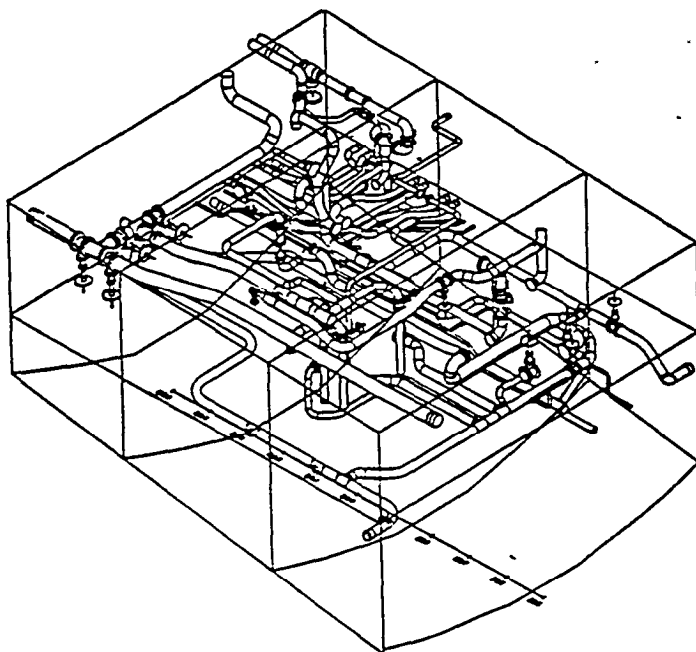

Fig. 8. PUHP ROOM PIPING COMPOSITE BY CAD



For the USS CONSTELLATION SLEP more than twenty-five complex compartments will have an integrated Design work Package. These may involve many of the extensive and complex ship alterations which include:

- o Weapons Magazines,
- o Catapult Accumulator Spaces,
- o Rotary Retract Machinery Spaces,
- o Combat Information Center,
- o Two Air Conditioning Machinery Spaces,
- o All three. Arresting Gear Engine Spaces,
- o NSSMS Control Space,
- o Two Radar Rooms and associated Pump Rooms,
- o All five Pump Rooms.

Additionally, all drawings for the USS CONSTELLATION SLEP are being developed by intermediate zone. AS discussed In Ref. 2, the entire ship is broken down, by area/zone whereby these zones reflect the products and interim products required to complete the availability. These zones are then further broken down into intermediate zones and then again to sub-zones. The generic zone breakdown for the USS CONSTELLATION in Fig. 9 shows the intended Zone Manager responsibilities of Production, Design and P&E. An example of intermediate zone in zone 9 would be, both forward catapults and a sub-zone might be #1 catapult. In addition, a potential cohesive advantage of grouping work by product and zone/area exists.

c/230 c/240 c/300  
 C/970 ZONE 0: SERVICES DOCK WORK AND MISCELLANEOUS  
 C/920 ZONE 1: ALL TANK WORK (CLEANING, PAINTING, STRUCTURAL FITTING, TESTING) TANK TOPS AND HULL STRUCTURAL  
 C/930 ZONE 2: ALL WORK ASSOCIATED WITH SHAFT ALLEYSWAYS INCLUDES MAIN MACHINERY SPACES EXCEPT FOR TANK TOP STRUCTURAL REPAIRS  
 & 960  
 C/960 ZONE 3: ALL WORK ASSOCIATED WITH AUXILIARY MACHINERY SPACES ( EXCEPT TANK TOP REPAIRS )  
 C/950 ZONE 4: ALL MAGAZINE WORK EXCEPT TANK TOP  
 C/930 ZONE : ALL PUMP ROOM WORK EMERGENCY GENERATION, AC SPACES, RUDDER WORK  
 O/920 ZONE 6: SPACES FROM 3rd DECK TO MAIN DECK  
 C/930 ZONE 7: HANGAR DAY  
 C/950 ZONE 1: MAIN DECK TO FLIGHT DECK PLUS ISLAND  
 C/930 ZONE 9: FLIGHT DECK

**Fig.9. GENERAL CV-64 ZONE BREAKDOWN**

**Zone Logic Technology In Planning**

As a natural succession to the intermediate zone drawing development, the P&E Division is producing all initial job scoping information by intermediate zone or sub-zone as applicable. Owing to the sheer size of an aircraft carrier, some areas present unique problems. For esample, consider one of four main machinery

spaces as an Intermediate zone (Fig. 9. zone 2). The volume of concentrated effort to be accomplished within a main machinery space during a SLEP is absolutely immense, and since there area no geographic boundaries es to speak of in the space. it is not at all practical to further divide it into subzones. After all, the work is very nearly in every case entirely contained within that geographic area. Another example but not as complex is the hull blasting and painting sequence. It is treated as an intermediate zone of itself. and is not divided into subzones. On the other hand, consider the catapults (four in number, which do spread out amongst a wide variety of compartments and geographic locations. in this case, the subdivision into subzones is imperative to the success of the work packaging and execution.

This is a significant departure from what was done on the USS KITTY HAWK SLEP in the sense that unit Work Instructions were developed from the traditionaliy written system ) job orders. Now that scoped work data is available by area, the information can be collated (via automated data processing) by phase and area to be packaged for Production. These packages in many cases will be supported by the integrated Design work Packages as previously described. Because of not being able to collect detailed work area information on USS KITTY HAWK, the UWI had to be developed. It required an enormous duplication of efforts to the degree outlined in Ref. 2. Efforts are now underway that will enable the Outfit Planning Group to package' work as before without having to actually duplicate the traditional job order-s. This should result in significant cost saving improvements in the processes used for the USS KITTY HAWK.

Realize that it is the Production Schedule that drives the integrated efforts of the Planners, Schedulers, Material Suppliers and Outfit Planning Group. After receiving the detailed job order from the PCE codes and ascertaining the scheduled start date of the work, the Outfit Planning Group will be required to liaise with the Material Suppliers to determine if all of the required material is available and properly kitted. If so. they then prepare and issue the work package to Production.

The OPG may be considered as the final check point of all planning efforts. Though the case described above is ideal, there may be exceptions to it. For example, perhaps there may be an item or two of

the material that is not yet available; it may or may not have an expected delivery date and it may or may not be a problem that the Shipyard can control; there may be a plan or a shipalt drawing that is not yet available. In these cases, the OPG will assess the whole of the work package and make a conscientious decision with respect to whether it is or in not issued without this particular aspect of the package. The Production Schedule would be affected and administrative action would have to be initiated to deal with the problem. They may decide not to issue the package which would also have direct ramifications on the Production Schedule. Therefore, they must take positive steps to fill the void with practical alternatives.

The intent is to maximize the most efficient flow of work to accommodate the established Production Schedule. The corollary being, minimize incomplete work packaging. However, this piece of information (the OPG not able to prepare/issue a work package for whatever reason) is particularly important as it provides a valuable impact analysis. That is, the impact on the Production Schedule caused by unavailable material; the impact (or snowball effect) of any one division not adhering to established need dates provided in the zone and intermediate zone prioritization; the impact on the ships availability by significant growth in the authorized work package.

Only achievable work packages will be issued the likes of which will include:

- 0 Cover sheet,
- 0 Verification sheet,

- 0 All keyops that support the event work package,
- 0 All technical references (plans, drawings, test procedures and standards, etc.) required to accomplish the work instructions,
- 0 Job material list at the keyop level,
- 0 work completion verification card,
- 0 Customer feedback sheet.

**Zone Technology In Production**

The work is then in the hands of Production. It is imperative that they execute the plans explicitly in strict adherence to the schedule. Common sense must still prevail and constructive feedback must be strongly encouraged if not altogether demanded to continually strive to improve upon the quality of the process.

The lessons learned from the USS KITTY HAWK SLEP precipitated the changes in the Production Department organization as detailed previously. As expected, the results of the surveys conducted through GAPS indicated the unanimous approval of the Product Trade concept. First Line Supervisors found this extremely beneficial in developing an efficient work flow. To enhance this process during future availabilities Yet maintain parent shop identity, modifications will be made to the Production organization. That proposed for the USS CONSTELLATION SLEP is shown in Fig. 10. As indicated, there will be Zone Managers who will have production responsibilities for a zone and will report directly to their respective Group Superintendent. There will also be SLEP Superintendents who will report to Group Superintendents and will provide a direct interface between zones.

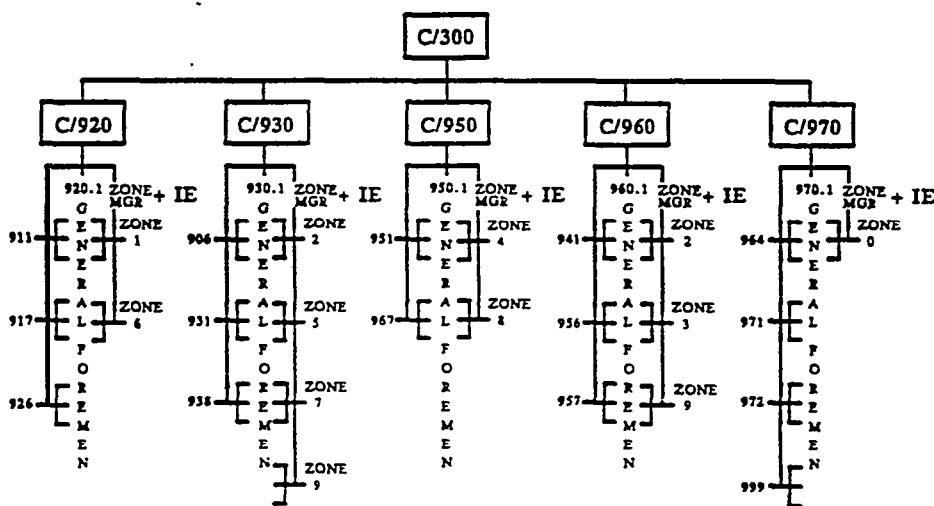

Fig.10. PNSY PRODUCTION DEPARTMENT

By identifying work by area; producing drawings by area; preparing work packages by area; scheduling by area, and accomplishing work by area, the cohesive potential is again gainfully exploited to improve productivity, that is "Integrated Planning for Production-.

Finally the involvement of Industrial Engineers in the daily Production Management team organization is planned to further foster the objectives of Zone Managers. The immediate benefit will be the detailed evaluation of all work processes. More importantly though, will be the direct interface (feedback) with other support codes such as Scheduling, Design, Testing, P&E and OPG.

### Summary

The concepts of ZLT are being modestly applied to the USS KITTY HAWK SLEP with some administrative difficulties. In the past, these efforts were, in general, outside the traditional realm of shipyard organizational procedures. In subsequent availabilities and overhauls, ZLT will be applied much sooner in the planning process. The DSRA of the USS SPRUANCE is evidence of this and will prove to be the test case of all associated processes. The more important proposals are:

- 0 Standardization of zone and intermediate zone principles applied to all classes of USN ships ultimately leading to standardization of zones and intermediate zones within each class of ship,
- 0 Identify work by item in the work authorization document,
- 0 Provide for electronic distribution of work instructions together with their supporting technical documentation (i.e. enhanced use of Automated Data Processing),
- 0 Increased emphasis on the provision of and adherence to short term Detailed Production Schedules in direct support of the First Line Supervisors.

### CONCLUSIONS

Much has been accomplished in the name of Zone Logic Technology at the Philadelphia Naval Shipyard. This paper has outlined the experiences and reactions to the problems encountered throughout this process. ZLT continues to be a part of the future at PNSY as the Senior Shipyard Executive Management are committed to its approach. They are convinced that ZLT is the vehicle to improve productivity. It has much to offer PNSY in the way of improving our quality and hence, our competitive edge. The motivation here is survival in an extremely competitive industrial environment by fundamentally changing the way we do business.

In general, the applications of ZLT are being infused into a greater part of the traditional shipyard organizations. As these organizations take on the new methods and procedures, it is essential that the fundamental precepts of Zone Logic Technology are maintained and used to guide the improvement efforts.

### REFERENCES

1. LCDR M.S. O'Hare, USN and LT. M.J. Anderson, USN, "An Integrated CAD/CAM Network for Work Packaging Development and Database Management", SNAME, 1988 NSRP Symposium, Seattle, Washington
2. K. Baba, et al, "Initial Implementation of IHI Zone Logic Technology at Philadelphia Naval Shipyard", SNAME, 1988 NSRP Symposium, Seattle, Washington

0383



**THE SOCIETY OF NAVAL ARCHITECTS AND MARINE ENGINEERS  
601 PAVONIA AVENUE, JERSEY CITY, NJ 07306**

Paper presented at the NSRP 1992 Ship Production Symposium, New Orleans Hyatt Regency, New Orleans, Louisiana, September 2-4, 1992

# Corporate Repair Philosophy and Measuring for Continuous Improvement at Philadelphia Naval Shipyard

No. 4B-1

Lcdr. Lawrence R. Baun, USN, Visitor, and Robert G. Gorgone, Visitor, Philadelphia Naval Shipyard

## ABSTRACT

**Initial zone** technology implementation at the Philadelphia Naval Shipyard (PNSY) in 1986 set the stage for one of the most significant shifts in culture and repair philosophy ever witnessed at a public naval shipyard. Attempting to fundamentally change the way that the shipyard conducted business forced senior and middle management to completely understand the dynamic and interrelated processes that were utilized to perform depot level work. Through the Philadelphia Quality Process (PQP), this understanding was achieved and changes that were necessary to shift from a Ship Work Breakdown Structure (SWBS) to a Product Work Breakdown Structure (PWBS) began.

As all quality processes will point out, measurement is the key to obtaining the necessary data to make corporate decisions. As the zone technology model was refined from 1987 through 1991, the understanding of "how we do work" continued to improve. Attacking processes that are sluggish, manual and not responsive enough to support the manufacturing process is the direct result of meaningful measurement focusing management attention. The purpose of this paper is to point out that the emphasis of the shipyard is now on the total "manufacturing process" rather than just "odds and ends" of planning and production. The utilization of zone technology provided the environment and attitude that supported improvements from within. Shipyard goals remain constant: improve producibility, reduce cost, and maintain quality. Continuous measurement, analysis and action to improve the shipyard's manufacturing process has been the mechanism used to achieve those goals.

## ACRONYMS AND DEFINITIONS

AOE: Auxiliary, Oil and Explosives. The Navy letter designation for a combination oiler-ammunition ship.

AVT: Aircraft Carrier, Fixed Wing, Training. The Navy letter designation of a training aircraft carrier.

BB: The Navy letter designation for a battleship.

CAD: Computer Assisted Design. Design drawings and models produced utilizing computers.

CkO: Closed KEOP. A key operation which is completed.

COB: Complex Overhaul. The Navy term for an extended overhaul period where major repairs and alterations are conducted.

CPI: Cost Performance Index. The (CS)<sup>2</sup> term representing the ratio of expenditures vs. physical progress on completed work and work in progress.

(CS)<sup>2</sup> Cost/Schedule Control System. Shipyard computerized system to track expenditures and physical progress vs. budget and time allocations for authorized work..

CT: Carrier, Fixed Wing. The Navy letter designation for an attack aircraft carrier.

DD: The Navy letter designation for a destroyer.

DSR: Design Service Request. The formal method where production shops request engineering assistance from the design division.

DSRA: Docking Selected Restricted Availability. The Navy designation for a planned, short-term, drydocking shipyard availability.

EDD: Estimated Delivery Date. Normally used when discussing material delivery requirements.

FF: The Navy letter designation for a frigate.

**FON:** Fiber Optic Network. A specific type of LAW utilizing fiber optics as the physical link between stations.

**HP&A:** Hull, Propulsion and Auxiliary. The acronym used to identify work as being part of the hull, propulsion or auxiliary systems on a ship.

**IDP:** Integrated Design Package. A three dimensional CAD drawing which overlays all systems in a given area to assure that no interferences exist.

**JOPC:** Job order Process Card. The document used to specify work to be accomplished on an equipment or system and identify shops and budgets allowed.

**KEOP:** Key Operation. The lowest level non-trade unique, work instruction.

**LAN:** Local Area Network. The term used to describe the hardware and software link between computer systems and workstations.

**NIIP:** Navy Industrial Improvement Program. A program sponsored by the Secretary of the Navy which had the goal of improving processes and products of Navy depot-level activities.

**P&E:** Planning and Estimating. The shipyard office responsible for job planning, estimating and scheduling.

**PF:** Performance Factor. The ratio of expenditures vs. allowances (normally on completed KEOPs).

**PQP:** Philadelphia Quality Process. The Philadelphia Naval Shipyard's version of Total Quality Leadership/Management.

**PWBS:** Product Work Breakdown Structure. The identification scheme used to identify ship work by products, normally by a geographic area.

**RDD:** Required Delivery Date. Normally used when discussing material delivery requirements.

**SARP:** Ship Authorized Repair Package. The contract between the shipyard and the customer concerning the repair and overhaul of a specific ship.

**SLEP:** Service Life Extension Program. An overhaul program designed to increase the service life of conventionally powered aircraft carriers by 15 years.

**SLQ-32:** An electronic warfare system installed on most U.S. Navy combatants.

**SWBS:** Ship Work Breakdown Structure. The identification scheme used to identify ship work by system.

**TQL:** Total Quality Leadership. The U.S. Navy's management program which strives to assure continuous improvement in all productive processes.

**WMT:** Waterfront Management Team. A group of production, planning, supply and other department personnel directly supporting the execution of a ship overhaul.

## INTRODUCTION

As the management team of a non-nuclear public shipyard operating in an increasingly competitive environment, Philadelphia Naval Shipyard senior managers have understood that a strategic plan, commitment to quality and a corporate repair philosophy were needed in order to ensure the viability of the shipyard. In 1988 the shipyard entered a program of quality education designed to a fundamental attitudes concerning quality at the shipyard. This process, known as the Philadelphia Quality Process (PQP) has been accepted as the method for assuring continuous improvement in shipyard processes. In 1989, shipyard senior managers, with the assistance of the Navy Industrial Improvement Program (NIIP) began a series of discussions which centered on the development of a shipyard five-year strategic plan. The strategic plan provided the focus, utilizing PQP as a vehicle to assure continuous improvement, and the necessary communication required to "make it work" form the foundation of Total Quality Leadership (TQL) (figure 1)

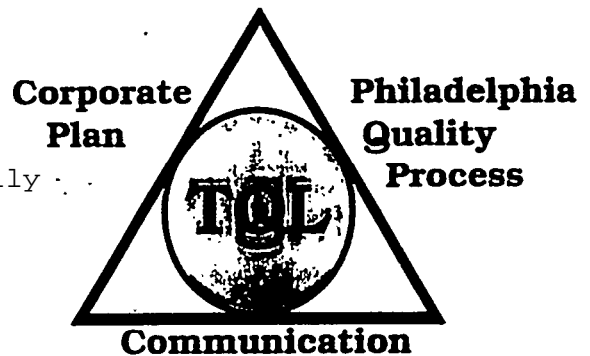

Fig. 1 TOTAL QUALITY LEADERSHIP

As a means of improving its competitive posture, the shipyard has made a fundamental shift from a systems-oriented approach to ship repair and modernization to a product-oriented overhaul management philosophy. This product-oriented overhaul philosophy, also known as zone logic technology has

become the accepted means of planning and executing work at the shipyard and is the foundation of the shipyard's corporate repair philosophy.

The introduction of zone logic technology at the shipyard actually began in 1986 with the Service Life Extension Program (SLEP) of the USS Kitty Hawk (CV-63). This initial phase of zone logic implementation was conducted approximately 35% of a 1.7 million manday, 37 month duration project. The methods and organizational structure used for zone logic on the Kitty Hawk SLEP have been discussed in detail by Baba, et al (1). While evidence of many potential improvements in ship repair practices were apparent, the shipyard experienced considerable difficulty in having zone logic accepted by all shipyard management and workforce. Prior to entering the planning stages for the USS Constellation (Cv-64) SLEP in 1988, shipyard management evaluated the pros and cons of zone technology and made the decision to continue using zone technology as the method to planning and executing ship overhauls. Burrill, et al (2) summarize the methodology used on Kitty Hawk SLEP and the process of applying lessons learned to uss Spruance (DD-963) Drydocking Selected Restricted Availability (DSRA) and subsequently, USS Constellation SLEP. Petersen-Overton (3)

discussed numerous changes made in the planning and production organizations prior to USS Constellation SLEP and reported on the initial results from this project as well as the results of zone technology implementation on smaller availabilities.

The SLEP of the USS Constellation is now at 80% completion. This presentation studies the current status of the Constellation SLEP and evaluates the results of changes made in the shipyard's corporate repair philosophy including zone technology implementation, project management and the quality process used to measure and improve on this project; In addition, numerous other changes and improvements in the way of planning and executing a complex ship repair and alteration project have been made at the shipyard. These changes and their effect on productivity on the Constellation SLEP are discussed.

#### STATUS OF ZONE TECHNOLOGY IMPLEMENTATION

As zone technology implementation extends into its seventh year, the shipyard is entering a new phase in the implementation plan. Petersen-Overton (3) described this as a four-phase plan. Figure 2 illustrates the zone technology implementation plan and its current status.

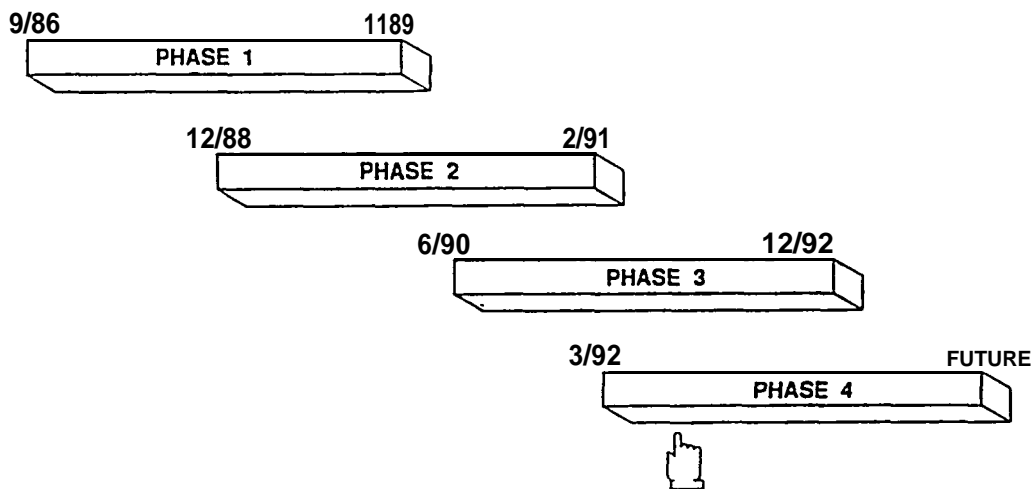

- PHASE 1:- INITIAL IMPLEMENTATION INCLUDING THE FIRST YEAR OF EXECUTION ON KITTY HAWK
- PHASE 2:- PLANNING PHASE FOR USS CONSTELLATION SLEP, COMPLETION OF USS KITTY HAWK SLEP AND EXECUTION OF USS SPRUANCE AND USS HEWES
- PHASE 3:- EXECUTION OF USS CONSTELLATION SLEP IN CONJUNCTION IN CONJUNCTION WITH OTHER COMPLEX OVERHAULS / AVAILABILITIES
- PHASE 4:- PLANNING AND EXECUTION OF USS FORRESTAL AND USS JOHN F. KENNEDY COMPLEX OVERHAULS

Fig. 2 ZONE TECHNOLOGY IMPLEMENTATION PHASES

With the Constellation SLEP nearing completion, and advanced planning started on the USS Forrestal (AVT-59) and USS John F. Kennedy (CV-67) Complex Overhauls (COH), the shipyard is entering Phase IV of the plan. Numerous internal audits of the yard's zone technology planning and production processes and a review of measurements used have been conducted. Phase IV will consist of the application of lessons learned on the Constellation SLEP to the Forrestal and Kennedy COHs. In addition to aircraft carrier overhauls, zone technology continues to be used on other types of ships repaired at the shipyard. Table I lists projects completed or planned using zone logic technology.

**Integrated Planning for Production**

- an organized, thought out approach to planning and executing the project.

**Work Packaging using Zone**

**Technology** - specifically the Packaging of work into "doable" work packages that are to be executed by trade, by phase, by geographic area.

**Measurement for Continuous**

**Improvement** detailed analysis is conducted on a continuing basis of all in-process work hold-ups and to identify systematic problem areas.

<b>PROJECT</b>	<b>PRODUCTION MANDAYS</b>	<b>STATUS</b>
USS KITTY HAWK (CV-63)	<b>550,000</b>	COMPLETE
USS HEWES (PF-1078)	15,000	COMPLETE
USS SPRUANCE (DD-963)	15,000	COMPLETE
USS CONSTELLATION (CV-64)	806,000	IN PROGRESS
USS DETROIT (AOE-4)	35,100	COMPLETE
USS WISCONSIN (BB-64)	30,000	COMPLETE
HS KIMON (D-218)	25,000	COMPLETE
USS SEATTLE (AOE-3)	35,000	MAY 1992
USS FORRESTAL (AVT-59)	275,000	SEPT 1992
USS JOHN F. KENNEDY (CV-67)	700,000	SEPT 1993

Table I ZONE TECHNOLOGY PROJECT STATUS

USS CONSTELLATION STATUS

At the 80% point of completion in the USS Constellation SLEP, the shipyard is experiencing a significant improvement in the cost performance of its production shops when compared with previous SLEPs. Figure 3 shows the completed work (closed KEOP) performance factor (actual cost of work performed divided by budgeted cost of work performed) on all five SLEPs to date. The performance factor is plotted against the percentage of time expired. The gains in efficiency indicated at this point in the overhaul shows an average 11% improvement as compared to the previous four SLEPs at the 80% point.

It is generally accepted that the improvements realized are a combined result of several changes made in the way of doing business. These changes represent the corporate repair philosophy and are described below.

**Project Management implementation**

- this enables experienced, shipyard production managers to be removed from the daily administrative burdens of running a group or shop and concentrate on project management.

**waterfront Management Team**

- this has enabled a team of planning and production project managers to work in the same location, physically near the worksites. Communication and efficiency in handling changes has been vastly improved as the Project Manager has on his team members of all offices required to support the project.

**Increased use of Integrated Design**

**products** - Areas of the ship which require extensive renovation or

alteration have individual systems designs integrated in a three dimensional Computer Assisted Design (CAD) format. Interference control and resultant work stoppages are drastically reduced.

Increased use of Design Aids for productivity - use of initiatives such as photogrammetry for shipchecks and automated thru-ship cable routing instructions have vastly improved the accuracy and control of work packages provided to production shops.

CORPORATE REPAIR PHILOSOPHY

Integrated Planning for Production

It is no secret that emphasis placed on up-front planning will result in a smoother-flowing, better executed availability. But what should this planning consist of? It is not enough for a planning department to issue job orders, issue a schedule, issue drawings, order material and hope that production shops can carry it all out. The shipyard strategized the execution of the Constellation SLBP through an integrated planning and production schedule. This schedule was described briefly by Burrill, et al (2). When the advanced planning for USS Constellation SLEP

began, managers decided that if zone technology were to be successfully applied to Constellation, a total review of the shipyard planning and production process was required. Managers initially drew up a strategy chart which incorporated their individual experience of the ship overhaul planning and execution process. What resulted was somewhat disjointed and lacked direct responsibility for the many sub-processes. The managers, using training received in the quality process, then developed process model worksheets identifying products, requirements, and customers in each step of the overhaul process. Through this customer-product relationship, the individual processes were better defined with deliberate relationships identified and clear lines of responsibility spelled out. A "master schedule" was developed which identified the requirements of the shipyard's customer, incorporated experience from four previous SLEPs and took into account long-lead time material delivery schedules. This "master schedule" was used to identify an intermediate product, a production schedule. Through the integrated planning and production schedule, all "suppliers" or support offices were given the requirement to provide their products to support this schedule. These products include material deliveries and receipt inspection, job order and drawing development, test

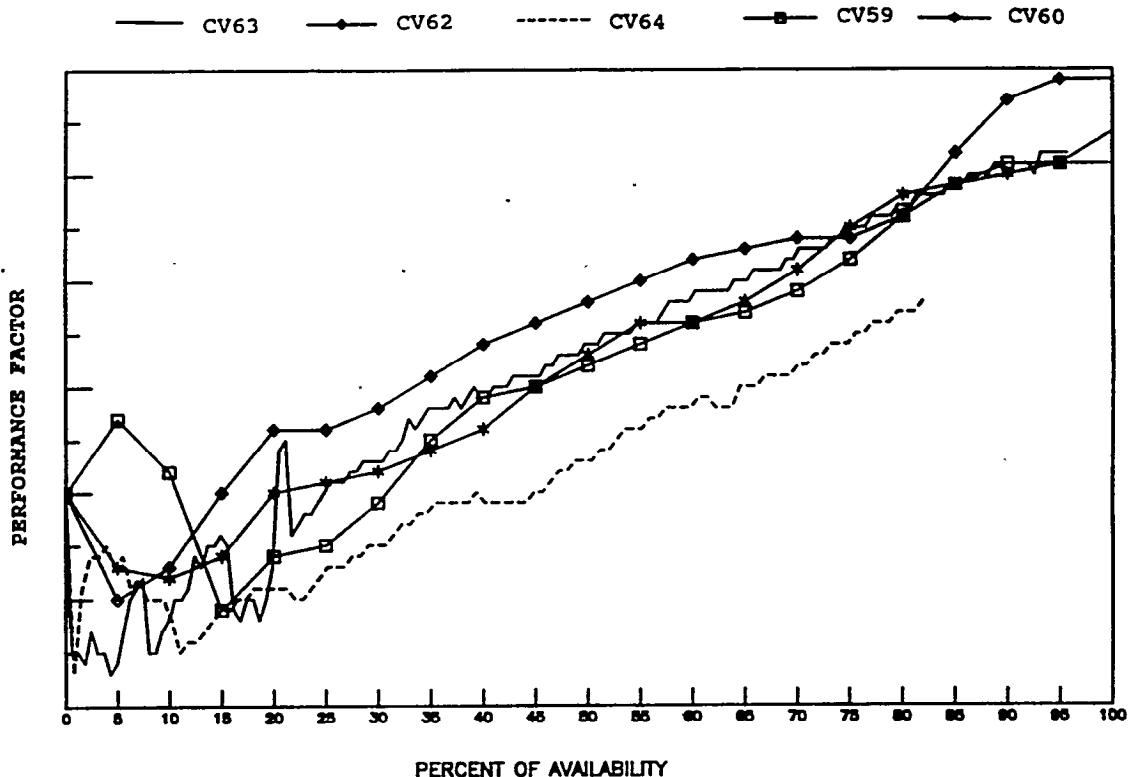

Fig. 3 CLOSED KEOP PERFORMANCE ON CV-SLEP



specification writing and work package issuance. The end result is the CV-64 "availability strategy" shown in Figures 4a and 4b. This "availability strategy" has been used as the tool to have all

schedules driven by the production schedule. The sub-processes which support this availability strategy are, then measured to assure conformance to the schedule and continuous improvement.

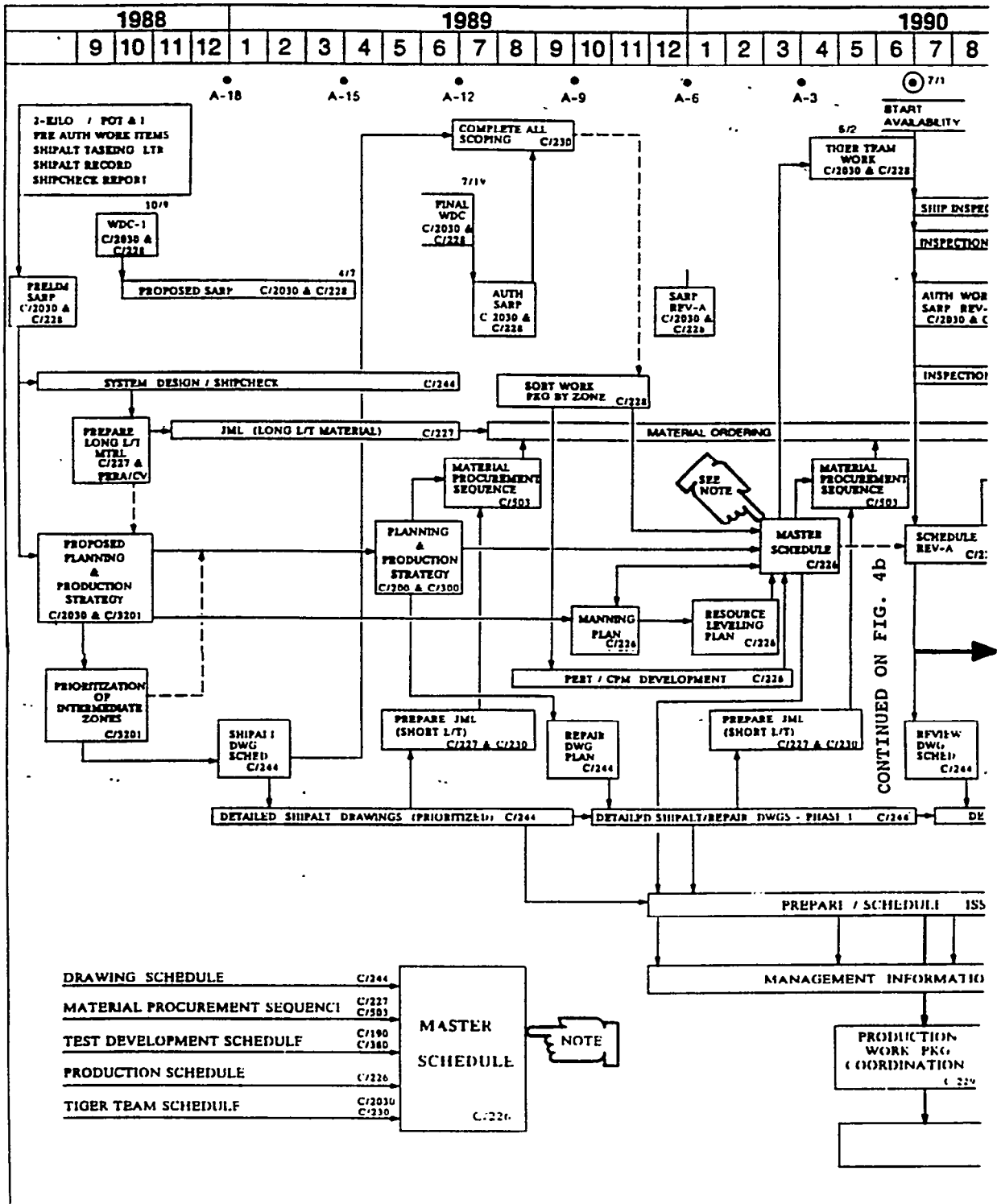

Fig. 4a USS CONSTELLATION AVAILABILITY STRATEGY

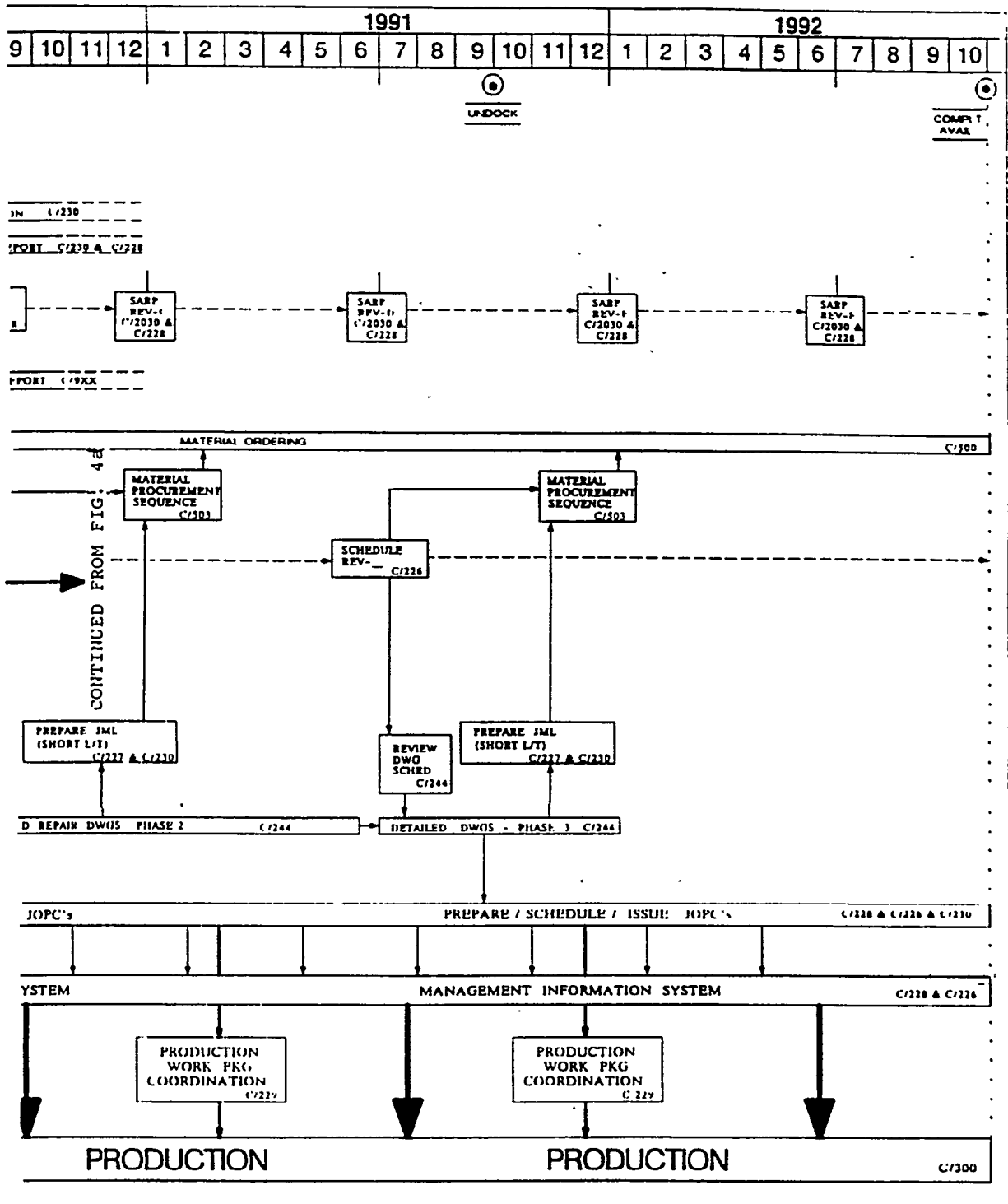

Fig. 4b USS CONSTELLATION AVAILABILITY STRATEGY

Work Packaging Utilizing Zone Logic

In order to simplify and organize the number of products which were being provided to production shops, a work

packaging group has been established. Baba, et al (1) and O'Hare, et al (4) discuss the methodology used by the work packaging group. This group has two main functions listed below.

- 1) Organize the work according to the production schedule and grouping it using zone technology principles, that is: by phase. by trade. by area.
- 2) Provide to production all of the assets which production shops require to complete a job on schedule

The difference in philosophy from "traditional" means of providing products to the shops to the "zone technology method" is illustrated by Figures 5 and 6.

The work packaging group "product," the work package, combines all of the information, authorization and material required of a shop to execute work. This includes scanned-in sections of process instructions, scanned-in portions of drawings, material lists including the location of the material, test specifications and, of course the job order process cards (JOPCs) which are the work authorizations and descriptions of work on specific KEOPs contained within the work package. The job order process cards and the accompanying information/documentation is grouped and scheduled together to assure that a work package consists of similar work which

is carried out by phase. by trade and are in the same geographic area. In order to assure that the product (work package) is delivered to production shops in sufficient time to execute, the work packaging group schedules individual work packages to be compiled and issued at least 90 days prior to the scheduled start date of that work package. The ability, or inability to deliver the product on schedule is measured as shown in Figure 7.

As a "customer," work packaging receives "products" from their "suppliers" which make up the work package. These products may vary with the specific work package but, in general, they are:

- test specifications,
- material lists,
- Job Order Process Cards,
- material inspection certifications,
- drawings or design instructions, and/or
- other sources of information.

The ability of the work packaging "suppliers" to meet their requirements is measured as a number of non-conformances which prohibit timely issue of work to production. Examples of these measures are discussed in the following sections.

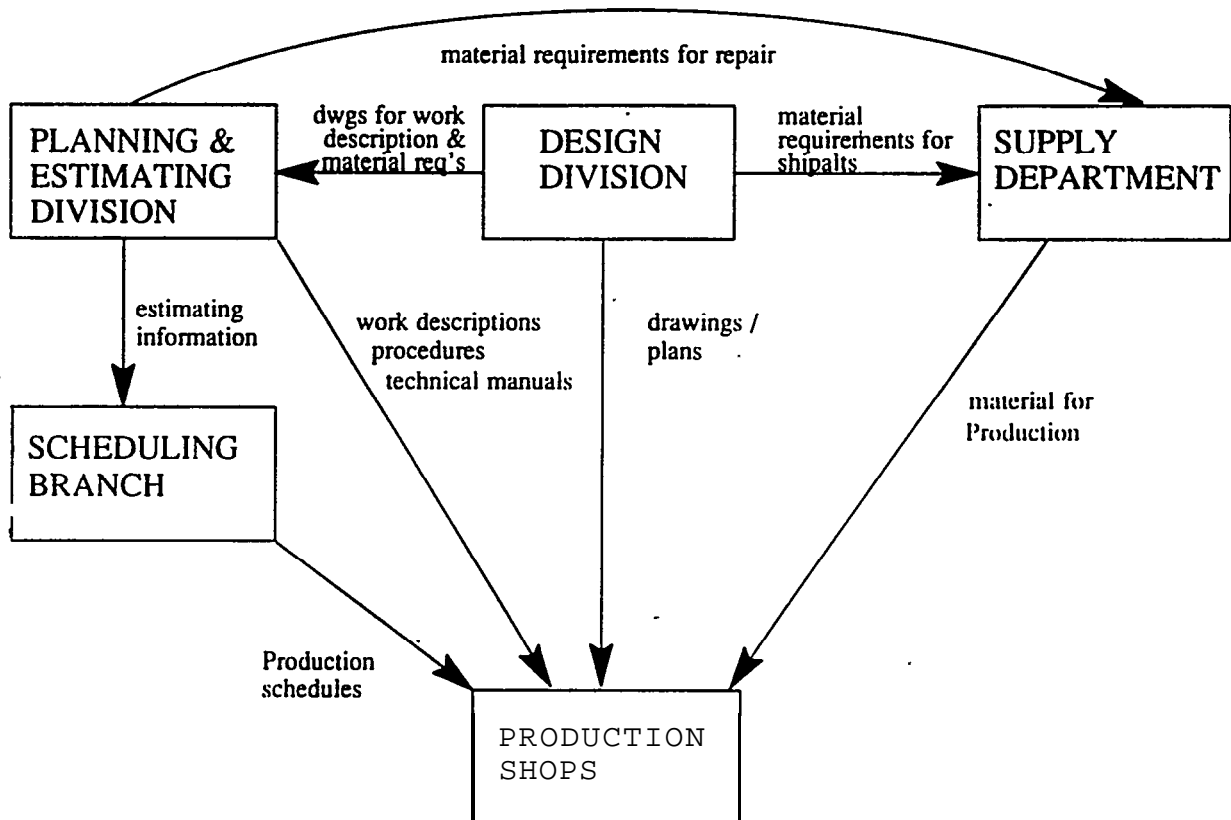

Fig. 5 "TRADITIONAL" PLANNING PROCESS

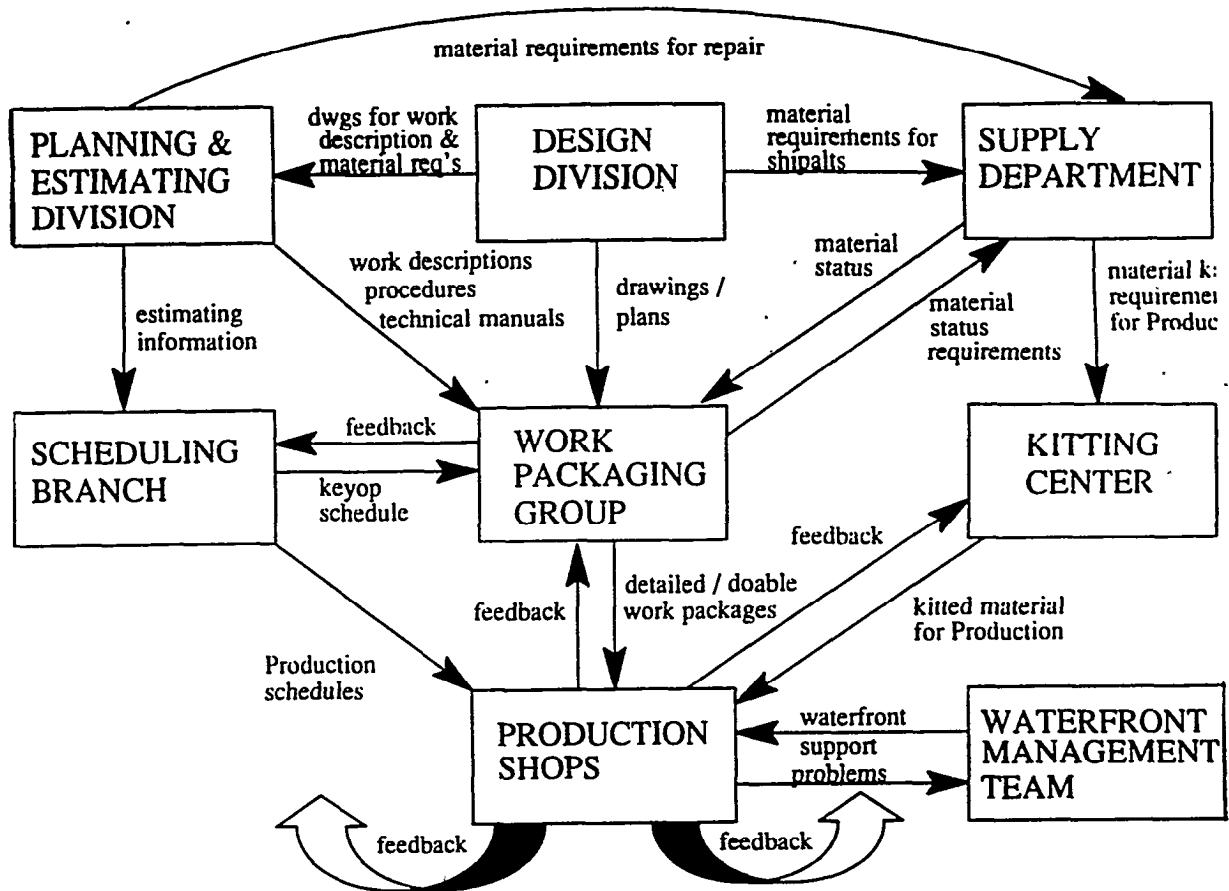

Fig. 6 ZONE TECHNOLOGY PLANNING PROCESS

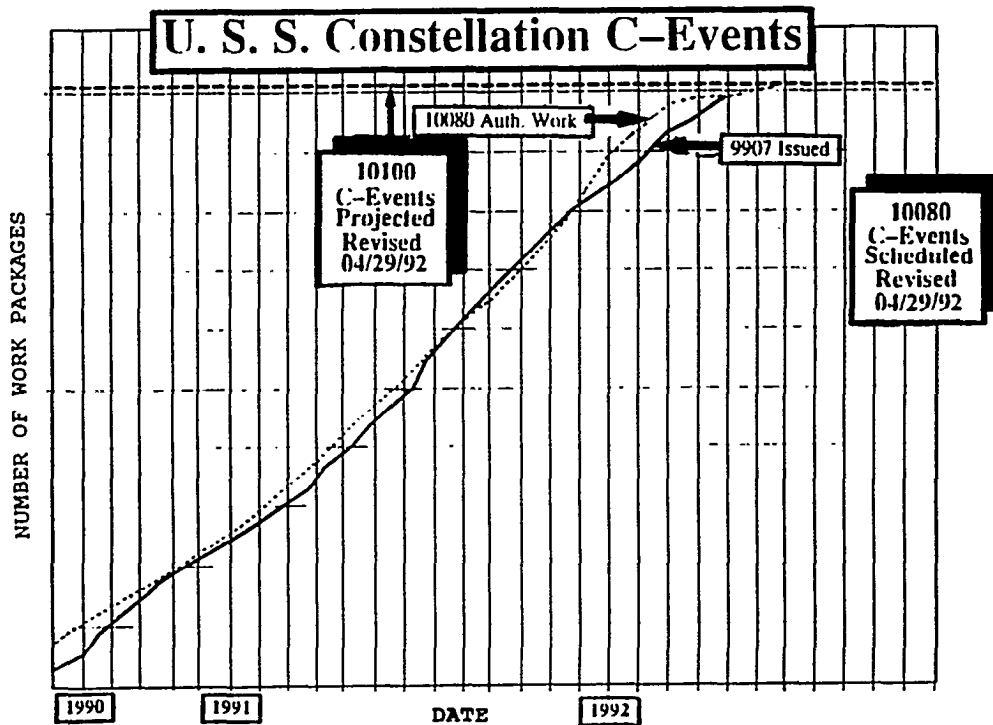

Fig. 7 WORK PACKAGE SCHEDULE ADHERENCE

Test Specifications. The issuance of test specifications is required at least 150 days prior to the scheduled start of that test. This lead time allows planning adequate time to identify any additional repairs or materials required to allow the test specification to be met satisfactorily the first time. Figure 8 shows a number of non-conformances to this 150 day requirement on the part of the Hull, Propulsion and Auxiliary (HP&A) test writing branch. Here, non-conformances are measured against calendar time and indicate an improving trend.

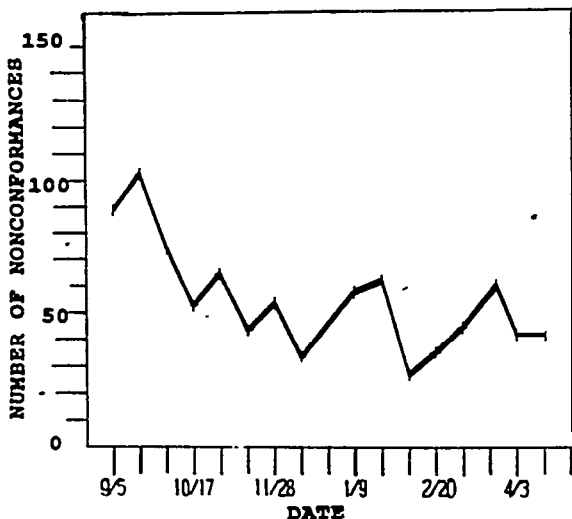

Fig. 8 TEST SPECIFICATIONS ISSUED MEASUREMENT

Material Dues. Through adherence to the integrated planning and production schedule and zone technology principles, all material ordered is assigned a specific job order and key operation (KEOP). This makes it possible to assign latest required delivery dates (RDDs) of all material ordered based on the date the work is scheduled to start. This allows the shipyard material ordering branch and supply department to know precisely when material is required. The RDD will not change unless the schedule should change. Since material orderers, purchasers and expeditors know in advance when production requires the material, the "crisis management" approach to expediting material through the various steps of the procurement process has been significantly reduced. In order to identify potential material problems early on, a 120 day window has been selected to measure "material dues". Figure 9 shows a sample of this material dues measurement. Here, the solid bar indicates the number of material line items due with RDDs past due or RDDs

within 120 days. The asterisks and connecting line indicates the number of material dues within this window which have a "bad" estimated delivery date (EDD), that is the EDD is after the RDD. The cross-hatched bar indicates the number of material dues which are assigned to KEOPs which are closed (completed) or canceled. Material dues on closed or canceled work are reviewed to determine if these orders should then be canceled.

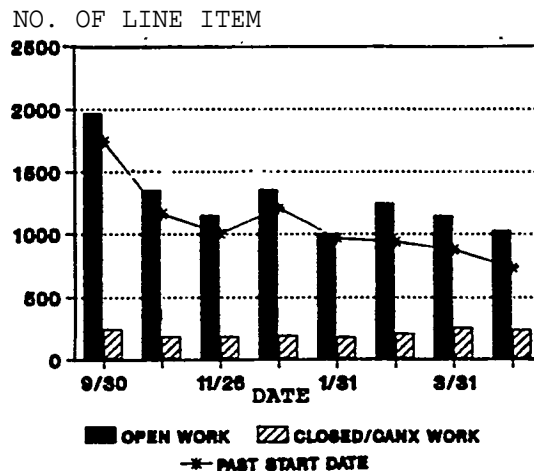

Fig. 9 MATERIAL DUES MEASUREMENT

Material Inspection. Among the lessons learned from the Kitty Hawk SLEP is that receipt inspection for quality assurance was frequently a bottleneck in getting material to production. Since RDDs were not tied to each material line item ordered, it was impossible for the receipt inspection branch to know in advance what material was needed immediately on the waterfront and what should have gone into temporary storage pending need. The priority of receipt inspections are now tied to XEOP and work package start dates. Receipt inspection is measured by viewing a 75 day window prior to the work package start date. All material requiring inspection for work packages past its start date or scheduled to start within the next 75 days are measured. Figure 10 shows a sample graph of receipt inspection measures. Here, the inspections pending are categorized as:

- 1) material not yet received in the shipyard,
- 2) material received but not on-site for inspection,
- 3) material in inspection backlog, or
- 4) material lost.

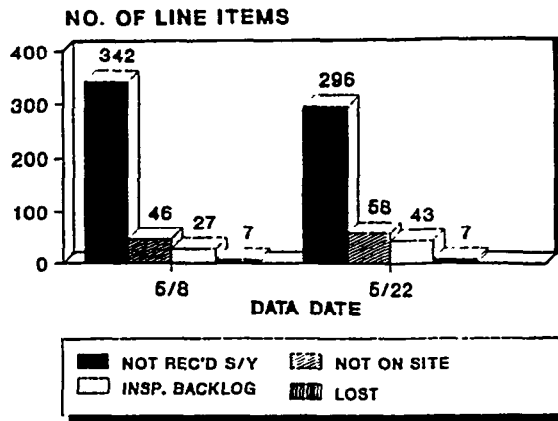

Fig. 10 MATERIAL INSPECTION MEASUREMENT

Work Package Hold-Ups. As previously discussed, the work packaging branch has requirement of issuing work to production at least 90 days prior to the start date of that work package. In order to measure the non-conformances which are preventing issuance of complete work packages, the work packaging branch measures non-conformances and categorizes according to reason for hold-ups. These hold-ups are presented to responsible codes on a weekly basis for action, and are discussed by senior management on a bi-weekly basis. The categories of hold-ups and examples of causes are shown below:

- 1) Production Shops - due to late submission of an as-found condition report;
- 2) Type Desk - due to late release of reservation or funding by the customer for identified work;
- 3) Planning/Estimating - due to late issuance of an authorized job order;
- 4) Design - due to late issuance of design instructions or plan revisions;
- 5) Combat Systems Office- due to late issuance of test specifications; and
- 6) Hull, Propulsion & Auxiliary (H, P&A) - due to late issuance of test specifications.

Figure 11 gives an example of work package hold-up measures.

Measurement for Continuous Improvement

Thus far, measurements of the planning process have been discussed. Numerous other issues can cause work stoppages. Through the principle of measurement for continuous improvement, roadblocks and bottlenecks which delay the manufacturing process once production shops start work are identified, analyzed and corrected.

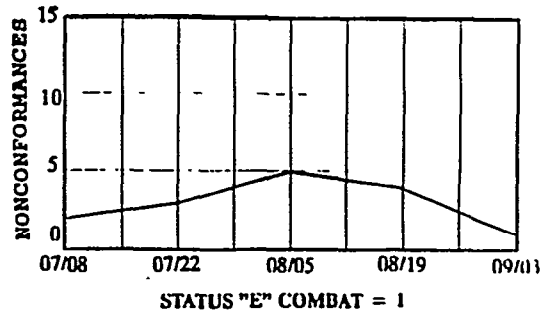

Fig. 11 MEASUREMENT FOR WORK PACKAGING HOLDUPS (COMBAT SYSTEMS DIVISION)

Some of the measures used in this analysis are:

- 1) reschedule action analysis;
- 2) shop report analysis; and
- 3) Design Service Request (DSR) analysis.

Reschedule Action Analysis. When work packages cannot be completed on schedule, a rescheduling may be justified. Shipyard management requires that each reschedule action be clearly categorized by cause for the reschedule. Causes are then studied to identify and correct systematic problems. Typical categories for rescheduling are:

- 1) production shops - worksite not available due to pre-requisite work not completed, sufficient manning or equipment not available;
- 2) planning - work package not issued;
- 3) supply - material not in yard; or
- 4) sequence - work improperly scheduled.

A sample measurement of reschedule actions is shown in Figure 12.

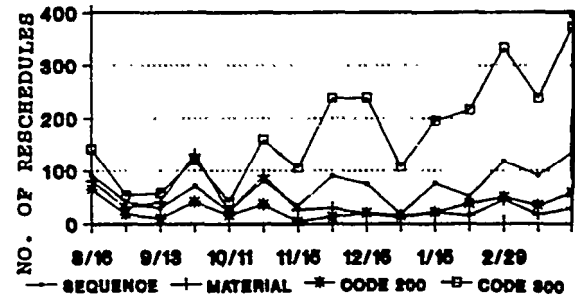

Fig. 12 RESCHEDULE CAUSE MEASUREMENT

Shop Report Measurement. Shop reports are used to identify as-found conditions or to identify inconsistencies

in planning documentation. Total number of shop reports outstanding and the shipyard office responsible for answering are reported weekly. Managers are advised of outstanding actions they have and corrective action required. Figure 13 shows by office, where the outstanding shop reports are for action. Typical categories are:

- Code 214 (Type Desk): requires authorization of work:
- Code 300 (Production Shops): solicited shop report overdue for submission:
- Code 503 (Supply): missing or incorrect material problem:
- Code 225 (Planning and Estimating): requires estimate or routing of work: and
- Code 244 (Design): requires engineering analysis.

Design Service Request Analysis. As many Design Service Requests indicate a work stoppage in a given job, design division is measured on its ability to satisfactorily answer DSRs in a timely fashion. Any DSR which is determined to be "urgent" or a work stoppage requires a 24-hour turnaround.

Project Management

Petersen-Overton, (3) discussed the project management organization developed for USS Constellation SLEP. Project management at the shipyard has since evolved to the point that the production department has divided into two separate departments. These are the production resources department (Code 300) and the operations department (Code 3300). This reorganization is a natural one given the emphasis and responsibility placed on project managers. The Operations Officer now reports directly to the Shipyard Commander on matters relating to the execution of projects at the shipyard. Each project is assigned a project superintendent, a senior group superintendent level or shop head level civilian manager. Assistant project superintendents each have several zones assigned as their areas of responsibility. Due to the size of the SLEP work package, zone managers are assigned to manage individual zones and report to an assistant project superintendent. Military or civilian ship superintendents are also assigned to each project. The role of the ship superintendent is essentially unchanged from that described by Petersen-Overton as the individual responsible for interface of shipyard work to ship's force work. Figure 14 illustrates the project management organization.

CV64 SHOP REPORT  
OUTSTANDING ACTION

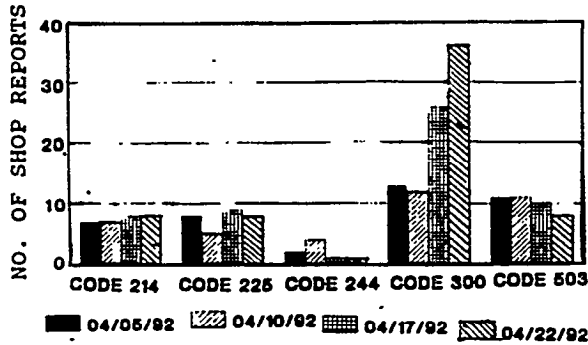

Fig. 13 SHOP REPORT MEASUREMENT

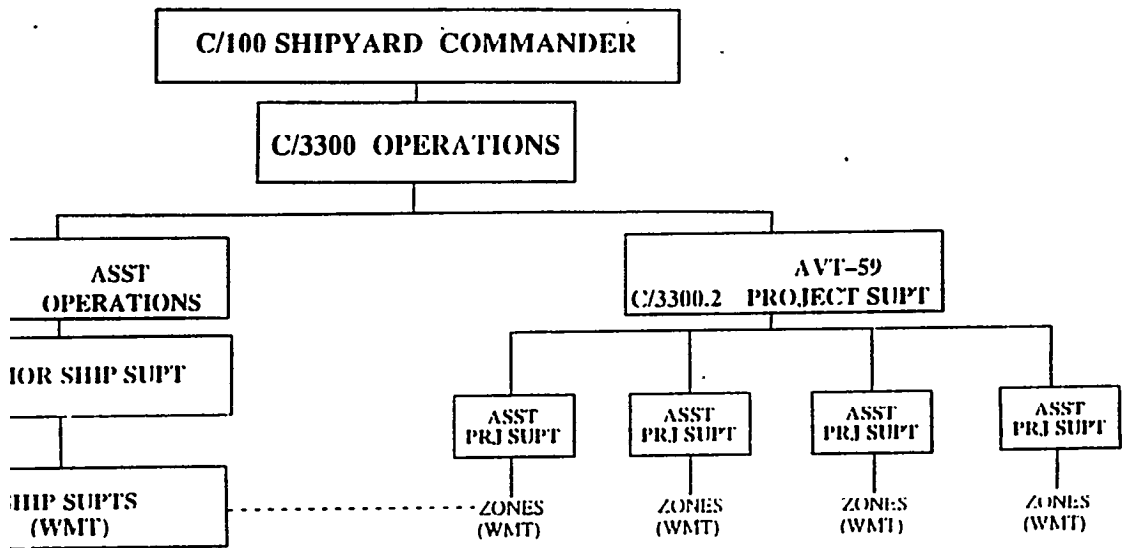

Fig. 14 TYPICAL PROJECT MANAGEMENT ORGANIZATION (AVT-59 COH)

The former production office (Code 300), now the production resources office, also reports directly to the Shipyard Commander and is responsible for providing manpower and equipment to the project superintendents for their use. The production resources organization is shown in Figure 15.

It has been recognized that the project management approach to ship overhauls is much more efficient than the previous approach because it allows the senior civilian and military managers to focus on the project at hand. A senior civilian project superintendent will no longer have to be pre-occupied with the myriad of administrative duties which are time consuming and prevent him/her from spending the time needed the project execution. The project superintendents responsibilities are considerable: execution of the project within cost and schedule constraints. There-organization is proving to be the tool he/she needs to succeed. The project management organization discussed above is generic and is tailored for any sized project.

**Waterfront Management Team**

The philosophy of manning and outfitting complete Waterfront Management Team (WMT) to assist the project superintendent in his duties is unique. The WMT is staffed by members of all shipyard offices and departments which are required to keep the project flowing smoothly. While staffing a WRT may be more expensive than the "traditional" work out of the home office

approach, the benefits in improved communication are enormous. It is nearly impossible to measure the efficiency gains made by staffing WMTs but it is accurate to say that, after going through 80% of a SLEP and numerous shorter availabilities with the WMT concept, no manager or office at the shipyard would be willing to operate without them. Each WMT works out of a common trailer or office situated as close as possible to the worksite. These offices are fully outfitted with the required ADP equipment, Local Area Network (LAN) fiber-optic connections, FAX machines, etc. to operate as autonomously as possible. The intangible benefit of the WMT has proven to be the improved communications made possible by the closer working relationship. WMT members, due to their close proximity to the worksite, are also able to spend much more time at the worksite, anticipating and solving problems as they arise. Response time to problems has been greatly reduced as most of shop questions can be answered on the spot rather than waiting for phone calls, calling meetings, etc. Petersen-Overton, (3) has explained in detail, the duties and responsibilities of the individual WMT members. Increased use of computer-aided management tools has proven to be a time-saver for WMT members. Currently, the LAN allows on-line cost/schedule and material information, on-line daily status reporting and automation of routine reports. These all serve to allow the project superintendents and WMT member6 to spend more time "on the deckplates" solving and anticipating problems.

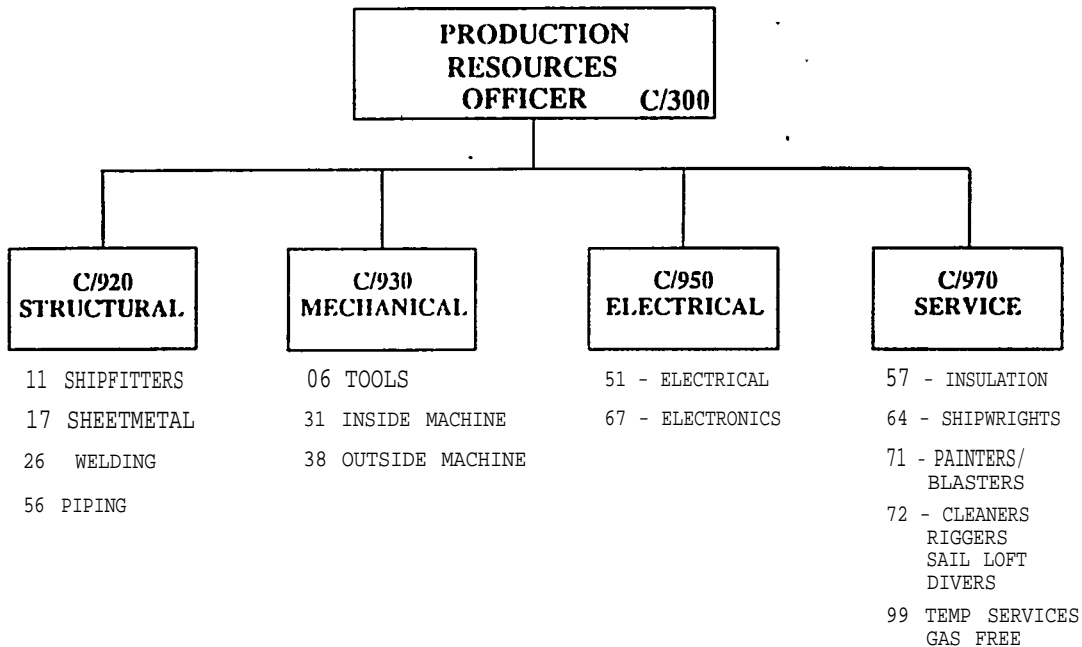

Fig. 15 PRODUCTION RESOURCES ORGANIZATION



## Increased Use of Integrated Design Packages

Arguto, et al, (5) discuss the use of Computer-Aided Design (CAD) tools to provide Integrated Design Packages (IDP). These products have served to noticeably decrease the amount of interferences and resultant rework in those areas of the ship which are undergoing large scale renovation or re-design. As seen in Table II, there has been a dramatic increase in the use of IDP from CV-63 SLEP to CV-64 SLEP.

### **INTEGRATED DESIGN**

#### USS KITTY HAWK (CV-63)

Pump Room #5  
A/C Machry Rm #3 & 4

#### USS CONSTELLATION (CV-64)

Pump Room #5  
A/C Machry Rm #1  
A/C Machry Rm #3 &4  
Weapons Magazine  
CAT Accum Rm #1  
CAT Accum Rm #2  
CAT Accum Rm #3 &4  
TAS MK 23 Eqpt Rm  
TAS Clg Eqpt Rm  
Air Terminal Office  
Radar Rm #5 (SPN-46)  
Radar Rm #9 (SPN-46)  
A / G M a c h r y R m # 1 & 2  
A/G Machry Rm #3  
A/G Machry Rm #4  
AN/SPS-48E Clg Eqpt Rm  
Radar Rm #6  
Fan Rm  
Radar Rm #8  
RRE Machry Rm #1  
RRE Machry Rxn #2  
RRE Machry Rm #3 &4  
EW Eqpt Rm #1  
EW Eqpt Rm #2  
NTDS/ASWM CIC  
NTDS/ASWM Cmptr Rm  
NTDS/ASWM Aux Rdr Rm

Table II. INTEGRATED DESIGN ON  
CV-63 VS. VC-64

## Increased Use of Design Aids for Producibility

Photogrammetry. CV-64 SLEP has represented an increase in use of photogrammetry for shipchecks and fabrication information. Sparacino, et al (6) discuss in detail some of the photogrammetry applications and methods used on CV-63 and Cv-64 SLEP. Table III shows total usage on CV-64 SLEP compared to Cv-63 SLEP. The use of photogrammetry has increased the number of first time fits and significantly reduced the amount of field fitting and welding required on structural modifications.

### PHOTOGRAMMETRY

#### USS KITTY HAWK (CV-63)

Bow Section Repair  
Arresting Gear Bolt Holes  
Terrier Missile Sponson  
Jet Blast Deflector #2

#### USS CONSTELLATION (CV-64)

Arresting Gear Bolt Holes  
Pump Room #5 Shipcheck  
SLQ-32 Deckhouse  
Jet Blast Deflector #4  
Wet Accumulator Fnd #3 &4  
Wet Accumulator Fnd #1  
Wet Accumulator Fnd #2  
Flight Deck Extension  
A/C Plant #4 &5 Shipcheck

Table III. PHOTOGRAMMETRY USAGE  
on CV-63 vs. CV-64

Automated Cable Routing Instructions. USS Constellation SLEP was the first shipyard project to use automated cable routing. Approximately 260,000 m. (850,000 ft.) of new cable is being installed on CV-64 using nearly 9000 local and thru-ships cable runs. Previous methods provided production only with termination points of cabling. The shops determined routing of the cables, resultant interference control, etc. This method did not conform to zone technology and resulted in excessive cost. By identifying specific compartments which cables are routed through, planning is able to provide for production not only more accurate cable length information but, more importantly, details on where and what size penetrations are to be installed and optimize cable hanger requirements. By establishing a separate job order to cover through-ship cable installations and cable collar installations, zone logic is applied to through-ship cabling and rework is significantly reduced.

RESULTS

Design Cost Improvements

Certainly, use of IDP, photogrammetry and automated cable routing represents increased up-front costs, but this investment is more than paid off in improved efficiencies. As an example, Figure 16 shows the level of activity of DSR submission on CV-63 SLEP and CV-64 SLEP. Since the CV-63 workpackage was larger than the CV-64 workpackage (1.7 million vs. 1.375 million mandays), the CV-64 numbers have been normalized. Recognize that every DSR submitted represents a problem, or perceived problem identified by production shops which may cause work to stop, and always requires design division investigation and answer. As Figure 16 indicates, approximately 2600 (normalized) DSRs fewer have been submitted at the 80% point of CV-64 SLEP when compared to CV-63 SLEP. Using the conservative figure of four mandays, as discussed by Burrill, et al, (2) to investigate and answer each DSR, this represents a 10,400 manday savings by design division alone! This 10,400 manday figure does not include all of the "rippling effects" of a DSR submittal such as work stoppage, Planning and Estimating (P&E) time to issue new work and material orders if required. This improvement cannot be totally attributed

to increased use of IDP, photogrammetry and automated cable routing but these changes represent a significant portion of overall project efficiency gains.

Production Cost Performance

As discussed earlier, Figure 3 shows cost performance information on all five cv SLEPS. In Figure 3, closed KEOP performance factor (CKO PF) is plotted against time \*expired. As previously discussed, the CKO PF is a measure of actual charges divided by budgeted charges on all KEOPs which are Completed. At the 80% point a significant 11% improvement is indicated by CV-64 SLEP when compared to CV-60, CV-59, CV-62 and CV-63. The CKO PF chart shown in Figure 3 represents production costs only, non-production costs such as design division are not shown.

Production schedule Performance

Figure 17 shows the percent of planned work accounted for in completed KEOPs plotted against time expired. Here, CV-64 data is compared with like data for CV-62 and CV-63. The percentage of work in CKO at 80% is slightly less-for CV-64 when compared to CV-63 at its 80% point in 1989 (approximately 67% vs. 70%) and equal to CV-62 at its 80% time expired point in 1987. A portion of the lag which developed at the 55% point was due to an

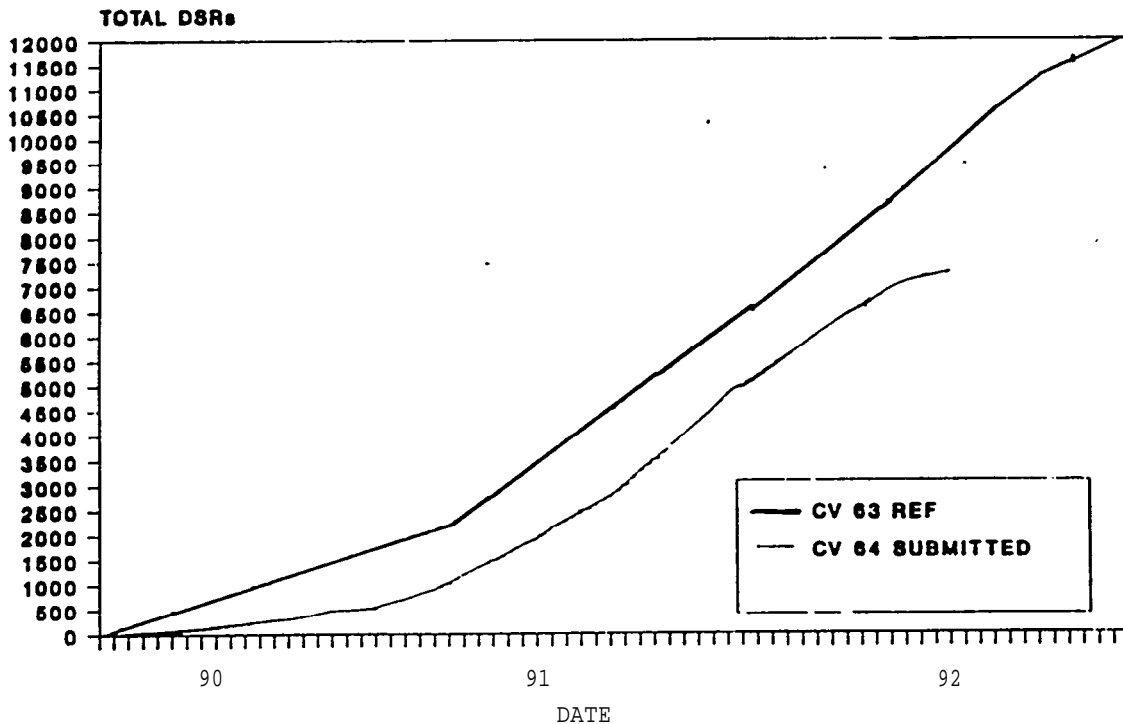

Fig. 16 DSR COMPARISON CV-64 vs. CV-63 (NORMALIZED)

increase in funding and subsequent increase in authorized work by 100,000 mandays. This increase represents a nearly 10% increase in the scheduled work for the CV-64 SLEP. It is not yet known what effect an increase of this magnitude will have on the final performance factor of the CV-64 SLEP. Generally, work picked up late in the scheduled availability is considered high risk and "costs" 10-20% more to execute. This may partially offset gains in efficiency which have been made.

#### Rework

Rework is measured by totalling mandays charged to established rework job orders. Figure 18 shows non-normalized curves for rework accomplishment on USS Independence (CV-62) SLEP, USS Kitty Hawk SLEP and USS Constellation SLEP to date. At the 80% point, the USS Constellation rework performance is encouraging and indicates additional payoffs as a result of zone logic and the corporate repair philosophy.

#### CONCLUSIONS

Utilizing a carefully developed strategic plan, an established quality process, and zone logic technology as a corporate repair philosophy, the shipyard has exhibited significant gains in the cost of doing business. Zone technology has become the accepted way of planning and performing work and, together with numerous improvements in the planning and production process is beginning to pay dividends. There are always improvements to be made, however, and evaluation and changes to the manufacturing process must be continuous. As planning is currently underway for the USS Forrestal and USS John F. Kennedy COHs, "lessons learned" are being applied which will continue to streamline the manufacturing process and complete the shift to logical availability strategies, product-oriented work packaging and successful project execution.

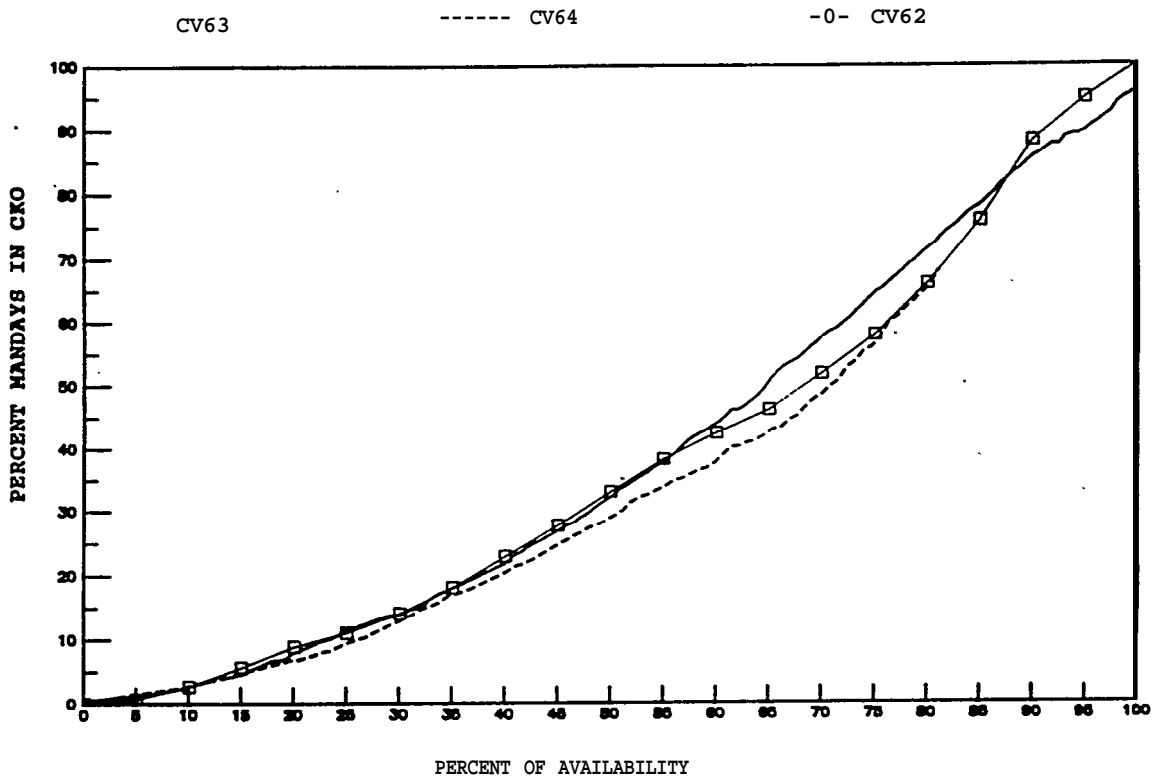

Fig. 17 CV-BLEP PERCENT OF WORK IN CLOSED KEOPS

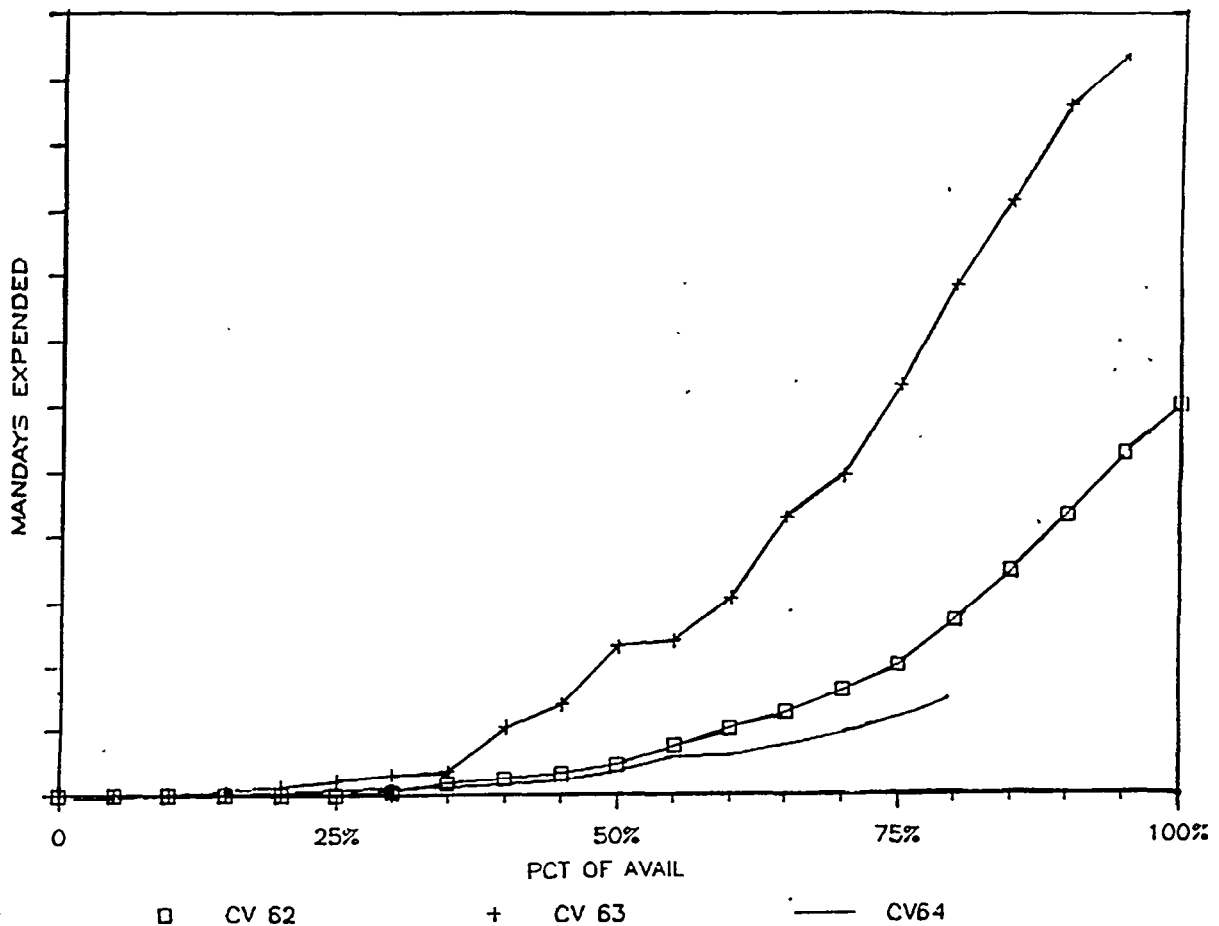

Fig. 18 MANDAYS EXPENDED ON REWORK, CT-64 vs. CV-62 and CV-63

REFERENCES

1. K. Baba, et al, "Initial Implementation of IHI Zone Logic Technology at Philadelphia Naval Shipyard", SNAME, 1988 NSRP Symposium, Seattle, Washington
2. LCDR L.D. Burrill, USN, et al, "strategizing and Executing the Implementation and Utilization of Zone Technology at Philadelphia Naval Shipyard", SNARE, 1989 NSRP Symposium, Arlington, Virginia
3. LCDR M.D. Petersen-Overton, USN, "Zone Technology Implementation at Philadelphia Naval Shipyard - Phase III", SNAME, 1991 NSRP Symposium, San Diego, California
4. LCDR M.S. O'Hare, USN, "An Integrated CAD/CAM Network for Work Packaging Development and Database Management", SNAME, 1988 NSRP Symposium, Seattle, Washington
5. w. Arguto, "Integrated Design Packages, the Link to Manufacturing, Production and Design Instructions", SNAME, To be presented at 1992 NSRP Symposium, New Orleans, Louisiana
6. P.L. Sparacino, et al, "Photogrammetry, Shipcheck of uss Constellation (CV-64) Arresting Gear Engines", SNAME, 1990 NSRP Symposium, Milwaukee, Wisconsin

NATIONAL SHIPBUILDING RESEARCH PROGRAM

# **PRODUCTIVITY EXERCISE**

IMPLEMENTATION OF ZONE TECHNOLOGY IN REPAIR & OVERHAUL ENVIRONMENT

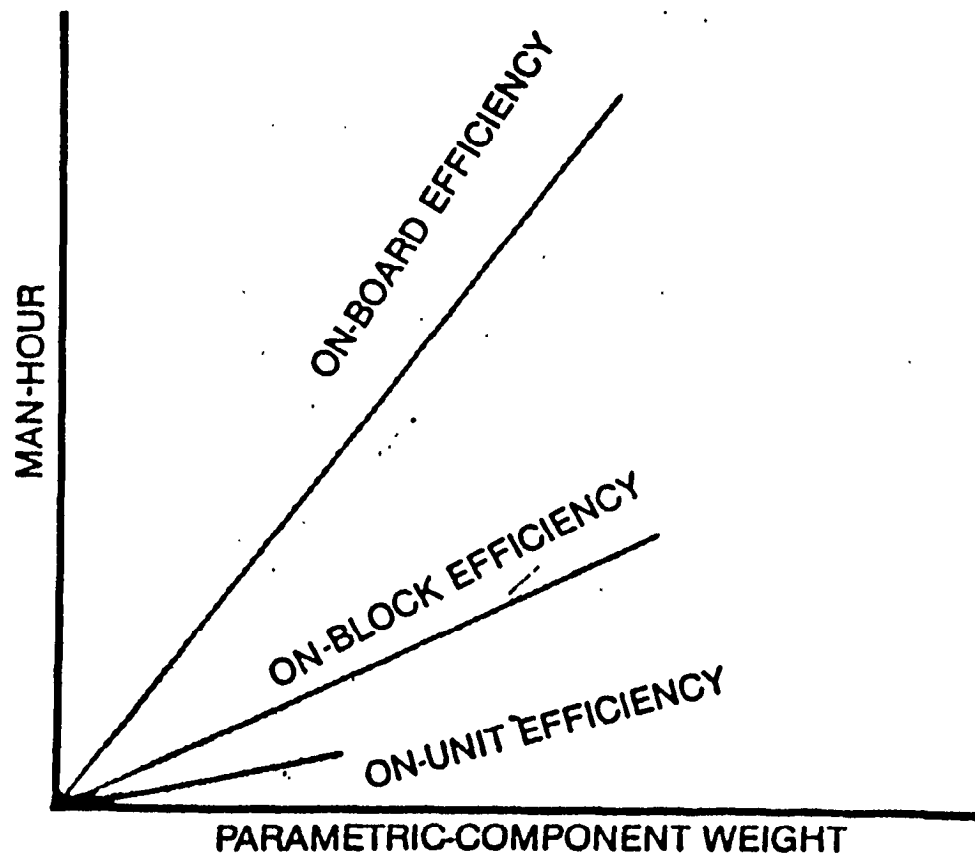

FIGURE 1.2.9 - PRODUCTIVITY IMPROVEMENT THROUGH ADVANCED OUTFITTING

# ZONE TECHNOLOGY EXERCISE

- PRODUCTIVITY BENEFIT OF ADVANCED OUTFITTING**

ACTIVITY	TRADITIONAL OUTFITTING <small>PERCENTAGE X MH/TON = PHASE MH/TON</small>	ADVANCED OUTFITTING <small>PERCENTAGE X MA/TON = PHASE MH/TON</small>
BEFORE BLOCK ERECTION	10 X	50 X
ON UNIT OUTFITTING	0 X	30 X
ON BOARD OUTFITTING	90 X	20 X

**TOTAL OUTFITTING MH/TON**

**NATIONAL SHIPBUILDING RESEARCH PROGRAM**

# **CASE STUDY 1**

**IMPLEMENTATION OF ZONE TECHNOLOGY IN REPAIR & OVERHAUL ENVIRONMENT**



NATIONAL SHIPBUILDING RESEARCH PROGRAM

# **CASE STUDY 1**

## **“USS PROVIDENCE”**

### **QUESTIONS**

1. What made this effort to improve different from other attempts in NSYs?
2. What are the strengths, weaknesses, opportunities and threats for CNSY?
3. How can CNSY management use the threats to improve the weaknesses?
4. What did CNSY Commander do right, what did he do wrong?
5. Why do you think Navy let the 8 NSYs approach implementing change for improvement in their own and different ways?
6. Why do you think there was no noticeable improvements from previous attempts? Why could they not break the “business as usual” attitude?
7. What was the challenge accepted by the team?
8. What was the team attitude/activity that had to be constrained at the beginning of the job?
9. What were the three basic philosophies adopted by the execution team?
10. With all their success, why do you think CNSY was still closed?

NATIONAL SHIPBUILDING RESEARCH PROGRAM

**ORGANIZATION  
FOR  
ZONE  
TECHNOLOGY**

IMPLEMENTATION OF **ZONE** TECHNOLOGY IN REPAIR & OVERHAUL ENVIRONMENT

## **ORGANIZATION FOR ZONE TECHNOLOGY**

- . THE TRADITIONAL APPROACH TO SHIP REPAIR MANAGEMENT HAS BEEN BY FUNCTION.**
- . THIS WAS BASED ON SYSTEM IDENTIFICATION OF WORK DEFINITION, DESIGN, ESTIMATING, PURCHASING, PLANNING, PRODUCTION AND TESTING**
- . A FURTHER PROBLEM WITH THE SYSTEM APPROACH IS THAT THE OVERALL PLAN FOR THE REPAIR OR OVERHAUL IS KNOWN AND UNDERSTOOD BY ONLY A FEW INDIVIDUALS. THESE ARE TYPICALLY NOT THE PEOPLE WHO MAKE THE DAY TO DAY DESIGN, PURCHASING, PLANNING AND WATERFRONT DECISIONS**
- . THE U.S. NAVY APPLICATION OF ZONE TECHNOLOGY TO SHIP REPAIR AND OVERHAUL QUICKLY IDENTIFIED THE NEED FOR ORGANIZATIONAL CHANGES TO FACILITATE IT**
- . BOTH CROSS-FUNCTIONAL MANAGEMENT AND CROSS-FUNCTIONAL TEAMS WERE FOUND TO BE NECESSARY**

## **ORGANIZATION FOR ZT IN R & O (CONTINUED)**

- IN FACT THE NAVY APPROACH WAS CLOSER TO THE INTEGRATED PRODUCT AND PROCESS DEVELOPMENT AND INTEGRATED PRODUCT TEAM APPROACHES THAT ARE CURRENTLY THE FOCUS OF THE U.S. NAVY AND SOME U.S. PRIVATE SHIPYARDS
- WHILE THE FUNCTIONAL APPROACH CAN STILL BE USED EFFECTIVELY FOR SMALL JOBS, ITS USE ON LARGER, MORE COMPLEX JOBS IS INEFFECTIVE AS PROVEN BY EXPERIENCE
- SOME RESEARCHERS SUGGEST THAT THE “PROJECT” OR MATRIX FORM OF ORGANIZATION IS BEST FOR THE LARGER, MORE COMPLEX JOB
- NAVY EXPERIENCE SUGGESTS THAT THE INTEGRATED PRODUCT TEAM APPROACH IS BEST
- ORGANIZING FOR ZONE TECHNOLOGY IN REPAIR AND OVERHAUL IS VERY SIMILAR TO SHIPBUILDING AND THE ATTACHED EXERT FROM A PAPER EXPLAINS THE NEEDS

## 1.0 Introduction

When interviewed by the Washington Post in April 1983, Dr. H. Shinto, perhaps the foremost shipbuilding authority in Japan, noted that when he first visited America in the early fifties he observed that college-educated engineers pervaded the workshops. "The engineers knew the production program, and they knew how to use machine tools. Because they knew the production process in detail, they were able to get greater productivity and high quality. "He added that during his visit to the U.S. in 1980, he "...didn't find the same kind of intelligence in the workshop." [1]

This paper began as a report on the management development program of Ishikawajima-Harima Heavy Industries (IHI) of Japan. Dr. Shinto's emphasis on the role of middle management in the shipyard was the impetus. However, research soon disclosed that another, related but much wider topic needed to be addressed: shipyard organizational structure and design.

Between 1950 and 1970, an extraordinary change occurred among the U.S. Fortune 500 companies. In 1950

---

[1] Dr. H. Shinto, former President of Ishikawa jima-Harima Heavy Industries of Japan, is now President of Japan Telegraph and Telephone Corporation.

just 20.3% of them were product organizations while as many as 62.2% were in functional organizations. As shown in Figure 1, within two decades, 75.9% of the Fortune 500 had adopted product organizations while the number retaining functional organizations plunged to 11.2%. [2]

In the middle of the same time frame, i.e., the early sixties, shipbuilders in Japan abandoned functional and adopted product organizations based on a Product Work Breakdown Structure (PWBS). In contrast, no such revolution occurred in the U.S. shipbuilding industry. [3]

## 2.0 Functional and Product Organizations

The two basic forms of organization are functional and product. All other forms, such as matrix, are hybrids.

A functional structure groups resources into common activities. Engineers are organized per function and production people are organized per function. A product structure is based on a PWBS and Group Technology which permits diversification, i.e., a multi-

---

[2] Richard P. Rumelt, "Strategy, Structure and Economic Performance", Division of Research, Harvard Business School, Boston, 1974, p.65.

[3] Y. Okayama and L.D. Chirillo, "Product Work Breakdown Structure - Revised December 1982", for the National Shipbuilding Research Program (NSRP).

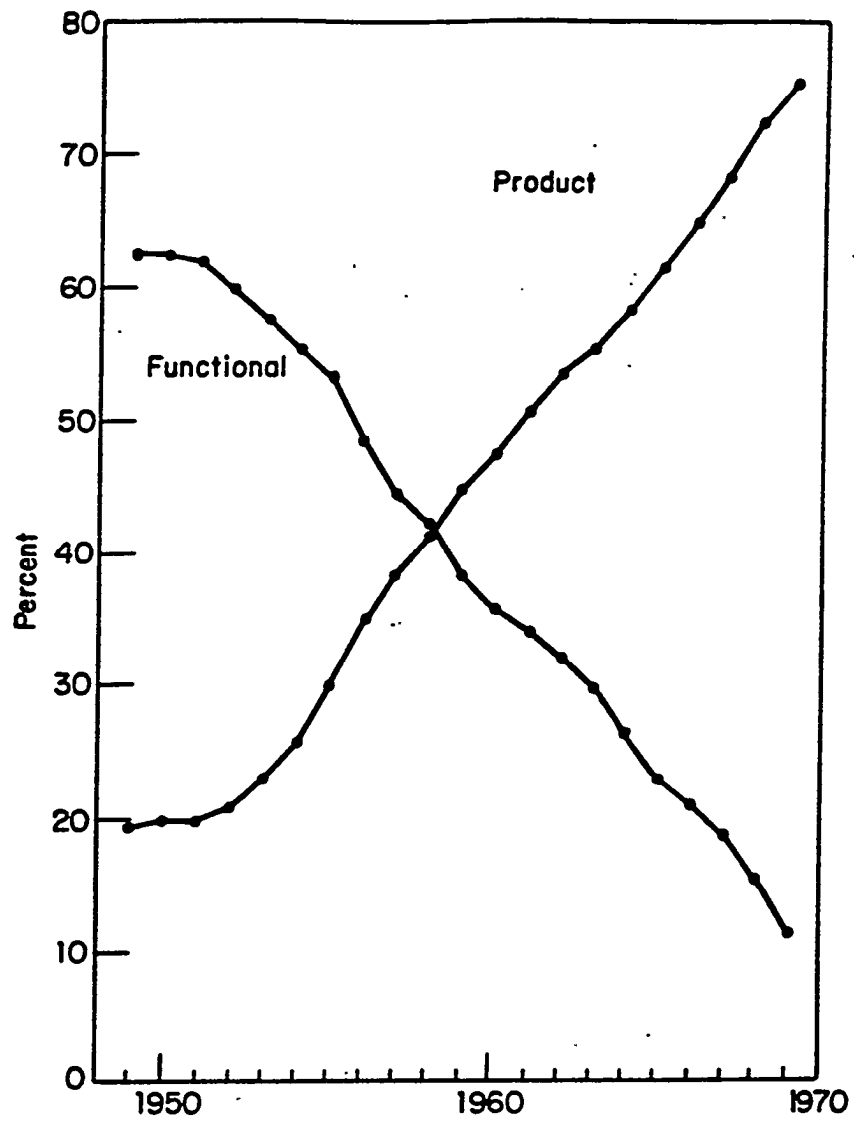

FIGURE 1 : Transformation of Fortune 500 companies from functional to product organizations between 1949 and 1970. From Richard P. Rumelt. "Strategy, Structure and Economic Performance," Division of Research, Harvard Business School. Boston, 1974. p. 66.

product line. Design and production are organized in the same way, both aimed at the same products, in the case of shipbuilding, interim products.

Functional organization, as an organization type, is best when a firm makes only one or a few products and where technology does not change. Traditionalists in shipbuilding look simplistically at the entire ship as the end product of a shipyard. Modern shipyard managers, however, "...break down an envisioned end product into interim products, i.e., parts and tiers of subassemblies, which are contrived to facilitate creation of larger assemblies and which are assigned for manufacture to the most specialized and cost effective producers, in-house or elsewhere. Such advanced shipbuilding is said to be product (interim product) oriented and is primarily an assembly process." [4]

The ship as an end product becomes incidental as the end product could be other than a ship, i.e., bridge, chemical plant, power plant, etc. Whatever the end product, modern shipyard managers are designers and producers of many interim products. This focus on interim product makes it possible for large firms, like IHI, -to better cope with technological change and multiple markets.

---

[4] "Product Oriented Material Management - June 1985", NSRP.



### 3.0 Two Levels of General Management

"The product structure implies the existence of at least two levels of general management and an increase in the number of general management roles over that of a functional structure." [5]

In a study of the 'development of 70 large American corporations, the impact of the change from functional to product organization was described as creating two levels of general management which,

"...removed the executives responsible for the destiny of the entire enterprise from the more routine operational activities and so gave them time, information and even psychological commitment for long-term planning and appraisal. Conversely, it placed the responsibility and necessary authority for the operational administration in the hands of the general managers of the multifunction divisions." [6]

Having more than one enterprise, the two tier management concept is exploited to the utmost by IHI. In each shipyard, although the title "general manager!" is used, the incumbent has less responsibilities than a typical American general manager and more responsibilities than are generally associated with the title "operations manager". For the purpose of maintaining a

---

[5] Richard P. Rumelt, Ibid, p.33.

[6] Alfred D. Chandler, Jr., "Strategy and Structure", Doubleday and Company, Garden City, N.Y., 1962, p.382.

distinction, the title "principal operating manager" (POM) is used hereinafter.

POM responsibilities include the following functions of the management cycle that applies for all industrial processes:

- o planning (design and material definition are aspects of planning),
- o scheduling, and
- o executing (includes material procurement and marshalling as well as production).

Regarding design, the POM is responsible for all aspects except basic design when a central basic design office exists.

Further, a POM is not distracted by business affairs such as accounts payable or receivable. Above all, a POM is concerned only with matters that are internal to the shipyard which directly affect production and is not involved in external matters, e.g., sales, business acquisitions, and lobbying..Another way to characterize the role of POM vis-a-vis top management is that POM is concerned with current return on investment while growth through investment in new products and businesses is the role of top management.

NATIONAL SHIPBUILDING RESEARCH PROGRAM

**DESIGN FOR SHIP  
REPAIR AND  
OVERHAUL ZONE  
TECHNOLOGY**

IMPLEMENTATION OF ZONE TECHNOLOGY IN REPAIR & OVERHAUL ENVIRONMENT

# **DESIGN FOR SHIP REPAIR AND OVERHAUL ZONE TECHNOLOGY**

- THE TASK OF PREPARING ZONE-ORIENTED DESIGN TECHNICAL DOCUMENTATION FOR SHIP REPAIR AND OVERHAUL IS BECOMING EASIER AS MORE AND MORE ORIGINAL NEW SHIP DESIGN IS PREPARED FOR BLOCK CONSTRUCTION AND ZONE OUTFITTING
- EVEN WHERE THE ORIGINAL TECHNICAL DOCUMENTATION IS NOT ZONE-ORIENTED, IT IS ESSENTIAL THAT THE SHIP REPAIR AND OVERHAUL DOCUMENTATION BE PREPARED TO SUIT ZONE OUTFITTING
- THE TECHNICAL DOCUMENTS FOR SHIP REPAIR AND OVERHAUL ZONE TECHNOLOGY SHOULD BE INTEGRATED WORK PACKAGES FOR EACH ZONE OR SUB-ZONE
- IF A CAD MODEL IS AVAILABLE IT WILL SIMPLIFY THE PROCESS

## **DESIGN FOR SR&O ZT (CONTINUED)**

- **ALL OF THE PRINCIPLES OF DESIGN FOR PRODUCTION/ MANUFACTURING/ASSEMBLY/MAINTENANCE/ETC APPLY TO SHIP REPAIR AND OVERHAUL. IN SOME CASES IT IS EVEN MORE NECESSARY DUE TO INSTALLATION ACCESS AND TIME CONSTRAINTS. THUS PRODUCTION (OR INDUSTRIAL) ENGINEERING IS AN ESSENTIAL INGREDIENT THAT, UNFORTUNATELY, IS USUALLY MISSING (SEE ATTACHED PAPER ON INDUSTRIAL ENGINEERING)**
- **SHIP CHECKS ARE A VERY IMPORTANT PART OF DESIGN FOR SHIP REPAIR AND OVERHAUL**
- **IF SHIP CHECKS ARE INADEQUATE THEN REWORK WILL PROBABLY BE REQUIRED. THIS WILL REDUCE PRODUCTIVITY AND ADD TO THE SCHEDULE**
- **ALL AVAILABLE METHODS TO OBTAIN SHIP CHECK DATA IN EASILY USABLE AND COMPUTER COMPATIBLE FORMAT SHOULD BE CONSIDERED, SUCH AS THE USE OF VIDEO CAMERAS, CAMCORDERS AND TODAY THEY SHOULD BE DIGITAL TO FACILITATE DIRECT ACCEPTANCE BY THE CAD SYSTEM**

## **DESIGN FOR SR&O ZT (CONTINUED)**

- TECHNICAL DOCUMENTATION FORMAT IS EQUALLY, IF NOT MORE SO IMPORTANT IN SHIP REPAIR AND OVERHAUL AS IT IS IN NEW SHIP CONSTRUCTION
- LARGE DRAWINGS HAVE NO PLACE ON A SHIP. TECHNICAL DOCUMENTATION SHOULD BE PRESENTED IN BOOKLETS SUITABLE FOR DIRECT INCORPORATION INTO THE WORK PACKAGES. BOOKLET SIZE SHOULD BE LESS THAN 17 BY 14 INCHES
- ISOMETRICS SHOULD BE USED AS MUCH AS POSSIBLE AS THEY ARE EASIER TO UNDERSTAND
- MARKED-UP PHOTOGRAPHS CAN BE EFFECTIVE TECHNICAL DOCUMENTATION
- BOOKLET DRAWINGS SHOULD SHOW ALL THE WORK TO BE DONE BY THE SAME WORKERS AT THE SAME TIME IN THE SAME LOCATION



THE SOCIETY OF NAVAL ARCHITECTS AND MARINE ENGINEERS  
601 Pavonia Avenue, Jersey City, NJ 07306

Paper presented at the NSRP 1988 Ship Production Symposium.  
Edgewater inn. Seattle, Washington, August 24-26.1988

## Revitalization of Industrial Engineering in the Naval Shipyards

No. 5A

Roy M. MacGregor, Member, Naval Sea Systems Command, Washington, D.C.

### ABSTRACT

Recent developments in the ship repair industry have focused attention on the operation of the naval shipyards. The loss of commercial ship construction work to foreign nations and the declining commercial ship repair work market have resulted in aggressive competition among private shipyards for naval ship repair work. The naval shipyards have come under increasing pressure and scrutiny to become more productive and cost effective. This paper examines the impact of these factors on the naval shipyards, specifically with respect to the industrial engineering functions. The paper describes the initiatives taken to revitalize industrial engineering in the naval shipyards and summarizes some of the successes achieved in reducing costs. The paper concludes with a prognosis for the future and describes efforts to institutionalize the strengthened role of industrial engineering.

### INTRODUCTION

There are 8 naval shipyards, 4 on each coast (considering Pearl Harbor as a West Coast shipyard), located as shown. (Fig. 1) Although they all share a common mission of repair and overhaul of US Navy ships, each shipyard has unique capabilities and specific mission assignments. Portsmouth and Mare Island perform work principally on nuclear submarines; Philadelphia does work on non-nuclear

surface ships, including the Service Life Extension Program (SLEP) on non-nuclear aircraft carriers: Norfolk and Puget Sound repair nuclear submarines and surface ships, including nuclear aircraft carriers: Charleston works on nuclear submarines and surface combatants, (excluding aircraft carriers); Long Beach does work on non-nuclear surface combatants; and Pearl Harbor repairs all ship classes homeported in Hawaii. Although each shipyard is unique, they all pride themselves in delivering ships back to the navy after repair and modernization in fighting trim, and fully capable of performing their assigned mission. Quality of work has always been the hallmark of the naval shipyards. The naval shipyards are vital to our strategic defense. Maintenance of the skilled labor core and shipyard facilities are critical to our ability to respond in time of national mobilization as well as perform our peace-time mission.

### BACKGROUND

The naval shipyards have a long history of serving the fleet; the oldest shipyard, Norfolk, was constructed prior to the Revolutionary War; the newest, Long Beach, was erected during World War II. Total employment levels have varied with a peak in 1943 of about 350,000 at the then 11 naval shipyards: currently

FIGURE 1:

## NAVAL SHIPYARDS



about 70,000 are employed at the 8 shipyards. Up until the late 1960's, the naval shipyards were involved in shipbuilding as well as repair; today their mission is confined to the overhaul, modernization, and repair of naval ships; all ship construction being performed by the private sector.

Organizationally, the naval shipyards are a holdover from the early days of the Industrial Revolution, when the master craftsmen were the dominant force in directing productive efforts and in determining work methods. The shops in a naval shipyard, organized by trade, are to this day managed by former mechanics who, by demonstrating proficiency in their craft, have been promoted to the level of shop superintendent, or shop master as the position is still occasionally referred to. Cultural change comes hard in the naval shipyards; the long standing traditions of organizing work by trade boundaries are not easily changed - one reason why we have been slow to adopt newer work methods, such as zone

outfitting. Engineers have traditionally been cast in support roles, called upon to resolve problems, but not expected to play much of a role in establishing productive efficiencies or determining optimum work methods. In fact, since supervisory pay has historically been tied to the size of the work unit, there has been little incentive for shop managers to look for more efficient methods. Frequently, the reward for being productive has been the loss of resources in the form of budget or manpower. Additionally, the staggering number of constraining rules and regulations, particularly in the personnel management area, has fostered a defeatist attitude with respect to change. Furthermore, the emphasis in naval shipyards has historically been placed on meeting schedules, frequently at the expense of cost efficiency.

### INDUSTRIAL ENGINEERING IN THE NAVAL SHIPYARDS

Industrial engineers are not new



to the naval shipyards. In 1946 the Bureau of Ships issued a directive to all the shipyards defining the responsibilities of the Reads of Departments and Divisions [1]. The Industrial Engineering Officer was described as the Head of the Management, Planning and Review Division, responsible for conducting studies and preparing reports for shipyard management, "in order to improve and simplify organization, administration, procedures, and utilization of manpower and facilities throughout the Naval Shipyard". A pretty broad charter, but without any teeth in it. Over the years the organization became known as the Management Engineering Office and they still provide reports and support to shipyard managers as well as staff support to the Shipyard Commander in broad areas with little direct control over shipyard operations. The Industrial Engineering identity has gradually disappeared and in recent years, only the Production Engineering Divisions of the shipyards have had much involvement with classical Industrial Engineering functions, and those mostly relegated to the development of engineered labor standards and facilities development.

As early as 1950 a major finding of a study conducted by a Management Engineering consultant firm was that "the navy must assemble a group of trained industrial engineers and appoint in the production shops experienced workmen to develop standards of performance under the technical guidance of industrial engineers" [2]. Although many of the recommendations of that study were disregarded, the Navy did establish a standards program, which has survived to this day albeit with limited success in controlling shipyard costs. The reasons for the failure of the standards program are varied; an underlying cause is the complexity and variability of the ship repair business. In addition, over the years many of the standards have been eroded through adjustment for contingencies, projected growth, personal bias, or specific problems, resulting in standards which have reduced credibility and effectiveness. Even when credible standards have been developed, they may or may not have been accurately reflected in the job estimates, which in turn have been frequently disregarded by those doing the work.

In 1904 another study of the naval shipyards (along with other industrially-funded activities of the Navy) was conducted, this time by Coopers and Lybrand [3]. Once again

they found that the shipyards lacked a directed cohesive industrial engineering program. Among their recommendations; "increase the size and involvement of the shipyard industrial engineering organization in all aspects of shipyard operations". The impact of this far-reaching recommendation was diluted by other findings and recommendations which focused on the need to reduce costs, particularly in the overhead area. As a result, although it was generally conceded by shipyard managers that there were inadequate industrial engineering resources-in-the shipyards, there was a wide spread perception that we couldn't afford to increase the industrial engineering staffs; that if anything, these staffs should be reduced. In number along with other overhead functional areas. In fact, during 1985, several shipyards did reduce the number of people in their Production Engineering Divisions, straining the limited industrial engineering resources to an even greater extent.

Fortunately, during the same time frame (1985) NAVSEA headquarters support for and understanding of the important role which industrial engineers could play in improving shipyard efficiency was increasing. Under the leadership of the newly appointed Deputy Commander for Industrial and Facility Management,,.

RADM Roger Horne, additional impetus was given to enhancing the role of industrial engineering in the naval shipyards. Largely due to his personal interest and guidance, the stage was set to revitalize the industrial engineering function with the ultimate objective of bringing down shipyard costs. During this time period, it was becoming increasingly clear that the naval shipyards would have to reduce costs. Shipyards in the private sector were increasingly dependent upon Navy work, and as a result, were stepping up their efforts to get a larger share-of the Navy workload. A decision was made in the 1984-85 time frame to compete some ship availabilities between the public and private sectors. A decision was also made to reduce the 1987 ship maintenance budget for the naval shipyards by \$500 million while keeping the workload constant, a 17 percent gain in productivity. At this time also, the federal deficit was getting increased visibility and interest - all factors which clearly showed the need for improved efficiency in the naval shipyards.

#### THE PLAN OF ACTION

In late 1985 RADM Horne asked that we identify the actions necessary to develop a strong and effective - industrial engineering function in the naval shipyards.

In order to answer his request, a group of the shipyard Production Engineering managers was assembled for a two day brain-storming session. The result was a one hour brief to the Admiral, during which the following points were made;

1) The industrial engineering function should remain within the Production Departments of the shipyards since the primary focus of industrial engineering improvement efforts is with the production systems and processes.

2) In order to develop the industrial engineering role, many of the ancillary functions being performed by the Production Engineering groups, such as equipment maintenance support, tool engineering, manufacturing engineering, design of industrial support equipment, rigging engineering, and others, should be reassigned or minimized.

3) Additional industrial engineering resources will be required - both from reassignment of personnel from within the shipyards as well as recruitment of engineering talent from outside the shipyards.

4) Existing resources need to be better utilized, through leveraging of engineers as project team leaders, better training of engineers and technicians, and better screening and prioritization of work.

5) Shipyard management needs to be "sensitized" to the role and potential for industrial engineering in meeting the challenge to reduce costs and become more efficient in doing work.

6) NAVSEA headquarters needs to be more supportive and provide stronger leadership of industrial engineering than it has in the past.

The reaction from RADM Horne was generally favorable to the groups recommendations and we were tasked to "make it happen".

#### IMPLEMENTATION OF THE PLAN

One of the first things we did was largely symbolic, although very important; that was to change the name of our organization in NAVSEA from the Facilities and Equipment Division, to the Industrial Engineering and Planning Division. Simultaneously, we reorganized by establishing two principal subdivisions or "offices" - one for industrial engineering and the other for capital investments; each headed by a senior level manager.

In addition, we transferred people into the industrial engineering branch, gradually increasing the staffing to its current level of four engineers and four technicians.

Early in 1983 a group had been established which gained stature and importance as a result of the renewed emphasis on industrial engineering. The group, called the NAVSEA Industrial Engineering Steering Group, or "NIESG", was comprised of the shipyard Production Engineering Division Directors and the Director of the then Facilities and -- Equipment Division of NAVSEA. The purpose of this group was to facilitate the transfer of information among the shipyard Production Engineers and NAVSEA as well as to provide a forum to discuss policy issues of common concern. Initially, despite the name of the group, most of the issues discussed were not related to industrial engineering; they primarily focused on facilities and equipment issues.

When the industrial engineering challenge was recognized in late 1985, the NIESG was a natural vehicle to use in developing a strategy and action plan for the enhancement of industrial engineering. During a December 1985 NIESG meeting at Charleston Naval Shipyard, the NIESG was briefed on the presentation made to RADM Horne and his favorable reaction. At the following meeting, in April 1986, in Monterey California, the group discussed plans and progress being made at the individual shipyards to execute the recommendations approved by RADM Horne. We discovered that many of the Production Engineers were having difficulty in getting shipyard management support for some of the initiatives that they were attempting, such as the reassignment of functions. A RADM Horne policy letter had been signed out in March 1986 to help overcome the obstacle, but little impact had been observed in April [4]. The March letter reiterated the need for naval shipyards to become more cost effective and pointed out that investment in industrial engineering resources should yield favorable returns. Shipyards were strongly encouraged to increase their capability in the industrial engineering area.

1986 was a busy year for everyone involved in the industrial engineering enhancement efforts. At NAVSEA headquarters we began numerous initiatives to foster and encourage expansion of the function in the naval shipyards. One of the problems identified early on was a lack of shipyard management understanding of the industrial engineering function.

Several concurrent actions were undertaken to address this concern. A contract was established with a prominent consultant to teach an introductory industrial engineering course, aimed at Production Department managers who had received little previous exposure to the subject. To date, this course has been presented 10 times, at seven of the eight naval shipyards, and at NAVSEA headquarters. The success of this endeavor has been confirmed by an increasing demand on the part of production shop managers for industrial engineering support.

In August 1986, the NIESG members paid a visit to the headquarters of the Institute of Industrial Engineers (IIE) in Atlanta, Georgia to discuss ways in which the IIE could help to support our efforts. One outcome of the visit was that in October 1986 a Senior Manager from IIE addressed the shipyard production officers during a meeting at Mare Island Naval Shipyard, and described some of the favorable results being achieved in private industry through the application of industrial engineering techniques. Industrial engineering has continued to be an agenda topic for the Production Officers in each of their meetings held since October 1986, resulting in increased awareness of the potential benefits to be achieved through the use of industrial engineers, and support on their part for hiring additional industrial engineers.

In September 1986, the NIESG met in Sturgeon Bay, Wisconsin and visited Peterson Shipbuilders to observe the positive results being achieved by their aggressive industrial engineering efforts including active participation in SP-8. RADM Horne attended the two day meeting and shared with the group his vision of what industrial engineering should encompass in the naval shipyards; ranging from development of an overhaul strategy to the analysis of high cost jobs to effect improvements.

A significant outcome of the September meeting was the establishment of a subcommittee tasked to define the ideal naval shipyard industrial engineering system and to address short and long term implementation strategies. The final report of the subcommittee was issued in August 1987 [5]. Several of the findings and recommendations contained therein were significant and will be discussed in more detail later in this paper.

Also during 1986a program was initiated for the NIESG to Visit private industry corporations recognized for their active industrial

engineering programs and achievements. Companies visited to date include Dana Corporation, Caterpillar Tractor, 3M Corporation, Rockwell International, and the Quonset Point Division of Electric Boat. These visits have proven especially beneficial in helping to identify industrial engineering techniques which are effective in the private sector and which can be adopted to the public sector. Caterpillar Tractor for example, has recently gone through an adjustment period of dealing with a new competitor, requiring cost reductions. The approach they used in identifying potential efficiencies has direct applicability to the naval shipyards- In some cases these visits have resulted in a continuing dialog between our shipyard industrial engineering managers with their private sector counterparts, to their mutual benefit.

During 1986 a formal work sampling program was established at the naval shipyards. In May 1986 NAVSEA tasked the shipyards to begin conducting the studies and provided guidance with respect to the measuring of productive, ancillary, and non-productive activities

[6] The purpose of these studies which are to be conducted at least quarterly, are two-fold. First they can provide statistically reliable data to identify problem areas where corrective action will be cost effective. Secondly, work sampling studies provide shipyard management with information and indicators on productive levels and effectiveness of actions taken. NAVSEA has established a corporate objective of improving shipyard worker productivity by 20% - the work sampling studies results are an indicator of the success achieved in meeting that goal.

Finally in 1986, the Industrial Engineering and Planning Division became actively involved in the National Shipbuilding Research Program (NSRP). The Division Director is designated as RADM Horne's representative to both the Ship Production Committee and the Executive Control Board of the NSRP, and the Division also administers a portion of the NAVSEA funds provided to support the NSRP.

The hoped-for gains to be achieved through this active involvement in the NSRP include continuation of the development of shipbuilding and ship repair technologies generally fostered by the NSRP, as well as providing a vehicle for the interchange of information between the private and public shipyard communities in various areas of common interest, including industrial engineering.

## INCREASING THE VISIBILITY OF INDUSTRIAL ENGINEERING

During 1987 the tempo picked up. In January 1987 the shipyard commanders were briefed on several industrial engineering topics, including the potential for effecting cost-savings through the application of industrial engineering resources, and the important issue of hazardous waste minimization to be achieved through analysis of industrial processes. Follow on briefings in these and other industrial engineering initiatives have been given at each of the shipyard commanders conferences since. These briefings were successful in building support for the industrial engineering revitalization efforts and facilitated the achievement of two of the recommendations made by the Production Engineering Managers. Additional staffing was provided during 1987 and some suboptimal functions were reassigned within the shipyards.

Concurrently, an effort was made to sensitize the shipyard commanders of the future. A briefing was presented to the Engineering Duty Officers attending a seven week Basic Course at the Engineering Duty Officer School at Mare Island Naval Shipyard in January 1987, and has been repeated during each session of the course since that time: four times per year. Finally, other shipyard managers, particularly those in the Production departments, have also been briefed on industrial engineering applications in the naval shipyards in order to build a consensus of support for the efforts being undertaken.

In addition to increasing staffing, the Production Engineering Divisions within many of the shipyards reorganized and established Industrial Engineering Branches to give added visibility to the function. Personnel in these Branches were charged to conduct methods and process analyses, and to identify potential areas of cost savings. Several of the shipyards set targets for their engineers of 5 times their salaries in savings to be identified each year. Additionally, industrial engineers were assigned to work directly in the Production Shops, using industrial engineering techniques to analyze problem areas and develop recommendations for improvements to lower costs. The results of these efforts have been impressive and will be described later.

In mid 1987 NAVSEA issued a corporate business plan for the naval shipyards [7]. Specific reference to enhancing the industrial engineering

functions was as follows:

"More emphasis needs to be given to and by the industrial engineering functions to continuously seek ways of improving work processes to optimize resource effectiveness, reduce the volume/toxicity of hazardous waste generation, reduce incidents of rework and generally improve the output of the mechanic...."

Furthermore, application of industrial engineering techniques and resources is an inherent part of many of the goals and objectives in the plan.

The shipyards responded by developing their own business plans showing the actions to be taken to meet the targets established by NAVSEA including the enhancement of industrial engineering. In order to assure the desired level of attention on industrial engineering functions, NAVSEA subsequently tasked the shipyards to develop a specific strategic plan for increasing their industrial engineering efforts with the ultimate objective of reducing costs and within the context of ten specific target areas [8].

A related issue also addressed by the NAVSEA corporate business plan is in the area of capital investments. Shipyards were tasked to take steps to ensure optimum use of their limited investment funds, based on economic analyses of their projects. Minimum acceptable thresholds of 15% internal rate of return, and 7 year payback were established. NAVSEA issued instructions for the performance of economic analyses to assure consistency and credibility of these calculations [9]. shipyards were notified that they would have to defend their savings projections and show how and where they were effected through budget reductions. Industrial engineering analysis of capital investment projects were thereby emphasized and in fact, required for successful project development.

### SUBCOMMITTEE REPORT

The report of the subcommittee established by the NIESG, referred to earlier in this paper, was issued in August 1987. The recommendations of the subcommittee were focused in five areas; organization, training, marketing plan, resources, and applications.

The principal organizational recommendation was that the Production Engineering Division be renamed the Industrial Engineering Division, still located in the Production Department, but with primary mission and objectives oriented around industrial engineering

functions and organized to support those functions. Earlier this year, in January 1988, NAVSEA formalized this recommendation by issuing specific guidance to the shipyards directing the redesignation of Production Engineering as the Industrial Engineering Division.

The second area of subcommittee concern: training, was addressed by short-term (1-6 months), mid-term (6-18 months) and long term recommendations. Short term recommendations included internal shipyard industrial engineering training and shipyard participation at IIE conferences. Although there has been some increase in shipyard activity in these areas, the subcommittee recommendations have not been fully met. Mid term recommendations included conducting IE workshops with customers and utilization of outside training resources such as SP-8 and the Army Management Engineering Training Activity (AMETA). To date these resources have not been used as much as we would like, although some shipyards have AMETA qualified instructors to provide this training locally. The long term recommendations include the development of a IE training curriculum by NAVSEA, and institutionalization of IE training in shipyard apprentice, supervisory, and officer training programs. Our principal focus to date has been on officer training, as discussed earlier. We in NAVSEA are however pursuing the establishment of additional training designed to refresh and enhance specific skills of our engineers and technicians.

The sub committee felt that an aggressive marketing plan would significantly enhance the chances of success of the industrial engineering organization. About half of the shipyards have developed such a plan and have been successful in building customer support through the use of briefings, presentations, and publicity in the shipyard newsletter. The other shipyards are gradually moving in this direction.

Resource recommendations were of two types: the more efficient utilization of existing resources, and the aggressive recruitment of additional resources. Steps have been taken at all eight shipyards in both these areas, but we consider that continuing attention and efforts will be required to assure optimum resource use.

Finally, the subcommittee

concluded that implementation of the recommendations in the areas described above would result in the successful application of IE principles in achieving real cost savings. Their recommendation was that each shipyard develop and implement a strategic plan to assure continued improvement and achievement of results. As discussed earlier, NAVSEA subsequently issued specific direction to the shipyards with respect to the development of such a plan.

## RESULTS

Up to this point, the content of this paper has been largely descriptive of the initiatives -taken to strengthen the industrial engineer's role. This was not however considered to be an end unto itself, the real underlying objective of all this effort was to achieve cost reductions. Although many of the actions taken are long term and will only show results over the long term, there have been improvements which we feel confirm that we are on the right track.

Such things as the consolidation of tank watches from up to 6 people to 1 person; the use of ultrasonic cleaning vice manual cleaning for certain valve components; in place air flask seal testing vice removing the flasks from the ship and transporting them to the inside machine shops; elimination of 55,000 gallons of industrial waste water through the use of an improved ventilation air scrubber design; are all examples of improvements that have been identified as a result of our renewed reliance on industrial engineers. The savings from the four examples cited above are estimated in excess of one million dollars per year and these are a small percentage of the successes we are recording. Industrial engineers are also playing an active role in adopting the use of zone outfitting techniques at some of our shipyards. Projected savings resulting from this innovative approach to ship repair are in excess of \$500,000 per ship. Adaptation of techniques and technologies from other industrial applications have yielded additional savings. The use of enzyme/bacteria culture for cleaning of sanitary tasks, previously cleaned by manual labor; expanded use of swaged marine fittings in certain piping systems, are but two more examples of the progress we are making.

Success breeds success, and as positive results are being recorded by our industrial engineers, the enthusiasm and support for increasing the numbers of industrial engineers

has been growing. We feel that it is vital to the success of our efforts to publicize the good things being done by industrial engineers in the shipyards. To this end, earlier this year, in March, we held an Industrial Engineering Symposium in Washington DC, inviting papers from naval shipyard industrial engineering personnel. The two day symposium included 12 papers on topics ranging from successful hazardous waste minimization efforts, to the use of group technology as a means of improving productivity.

Senior headquarters and shipyard managers, including shipyard commanders as well as members of SP-8, were invited to attend, and the large turnout confirmed the level of interest in these industrial engineering topic areas. We plan on holding symposia of this kind on a yearly basis as a means of providing continuing visibility and reinforcement to the efforts of our young engineers and technicians.

#### THE FUTURE

Where do we go from here? How do we continue to build the momentum achieved from our efforts to date? Most importantly, how can we institutionalize the use of industrial engineering resources and techniques so that it becomes an inherent part of the way of doing business at the naval shipyards, and does not languish from lack of interest as has occurred in the past? As stated previously, successes breed success. It is important to continue to highlight the real productivity improvements that are being identified and achieved through the efforts of the shipyard industrial engineering community. It is also important that we establish a process by which advances achieved at one shipyard can be shared with the other shipyards. To this end, the NIESG established a subcommittee at the January 1988 meeting at Philadelphia Naval Shipyard: tasked to investigate the sharing of information and develop recommendations as to the most effective means of achieving this. The results of this study will be available before the NSRF symposium and will be reported at that time.

We recognize that it takes time to institute change. We are trying to modify a culture and mind-set which has developed over many years in the naval shipyards. Not until an entirely new set of managers who have grown up with the idea of the importance of industrial engineering are in place, can we truly expect

full acceptance of the role of industrial engineering in the naval shipyards. Our shipyard military and production shop managers are a product of their environment, which has not fully recognized the advantages to be realized through the use of industrial engineering resources and techniques. In fact, our industrial engineers themselves are not having an easy time breaking out of the stereotype they have been cast in. Many of our engineers still think of themselves as waterfront problem solvers and developers of engineered standards. We must continue to focus on providing training, both for orientation of our managers, and for skills development of our industrial engineers. Finally, we must continue to develop our ties with our counterparts in private industry, through involvement in IIE and SP-8, and visits to private industry leading companies.

There are still many untapped opportunities for our industrial engineering efforts. Areas that we are looking forward to increasing involvement include design for production and industrial planning. Our ship designs have rarely given adequate consideration to maintainability - our industrial engineers have the necessary skills to identify changes which can be made in ship design to improve access and repairability, without compromising the system technical requirements. It is becoming increasingly apparent that investments made in the planning phase of ship availabilities yield high returns in the more efficient execution of work. Our industrial engineers need to assure a more proactive role in the planning function. Finally, industrial engineers must become more involved in the strategic planning of our shipyards. - Decisions concerning-trade mix, work sequencing, and other overhaul strategy issues have historically been made by managers based on their best intuition and have been frequently driven by workforce considerations. We need to manage our workforce to support our strategy rather than vice versa. Industrial engineering techniques should provide shipyard management with the information they need to make these strategic decisions'.

#### SUMMARY

In conclusion, we are in the midst of exciting and demanding times at our shipyards. Increasing attention on reducing cost and competitiveness is here to stay. We have embarked on a process to increase and enhance our industrial engineering resources as one way to deal with these issues. We

have come a long ways from the days when industrial engineers were primarily used for work measurement and the development of standards. We have a long ways to go before we make full use of this valuable resource. I have a vision of the day when our naval shipyards are recognized as the standards for efficient and effective accomplishments of ship repair and modernization. My vision has the industrial engineers as an inherent part of the shipyard management process, continuously striving for improvement, and continuously achieving results.

#### REFERENCES

1. "U.S. Naval Shipyards - Internal Organization and Functions and Duties of the Various Departments and Divisions" - Bureau of Ships letter NY/A3-1 (701)EN25/A2-11, 7 February 1946.
2. "Performance Control Techniques - U.S. Naval Shipyards", Cresap, McCormick and Paget - Management Engineers, New York, April 1950.
3. "Management Analysis of the Navy Industrial Fund Program - shipyard Review Report - Draft", Coopers and Lybrand, New York, August 1985.
4. "Industrial Engineering in the Naval Shipyards", Commander Naval Sea Systems command letter 5240 Ser 0704/60, 20 March 1986.
5. "Industrial Engineering (IE) Improvement Plan for Naval Shipyards", Naval Industrial Engineering Steering Group (NIESG) Industrial Engineering Subcommittee letter 5200 Ser 380/52, 4 August 1987.
6. "Work Sampling Studies for, Shipyard Efficiency Improvement", Commander, Naval Sea Systems command letter 5240 Ser 0704/90, 6 May 1986.
7. "Naval Shipyard Corporate Business Strategy and Plan", Naval Sea Systems command, Industrial and Facilities Management Directorate, 1 May 1987.
- a. "Shipyard' Industrial Engineering Improvement Plan", Commander Naval Sea Systems Command Letter 5240 Ser 07/183 of 9 October 1987.
9. "Procedures for Preparing Economic Analysis of Capital Investment Projects", Naval Sea Systems Command, Wash, D.C., 19 June 1987.
10. "Naval shipyard Industrial Engineering Organization", Commander Naval Sea Systems command letter 5240 Ser 070/02 of 29 January 1988.

# WHERE IS THE PRODUCTION ENGINEERING?

EXTENT OF PRODUCTION-ORIENTED TECHNICAL DOCUMENTATION

MINIMUM

MAXIMUM

PREPARED  
BY

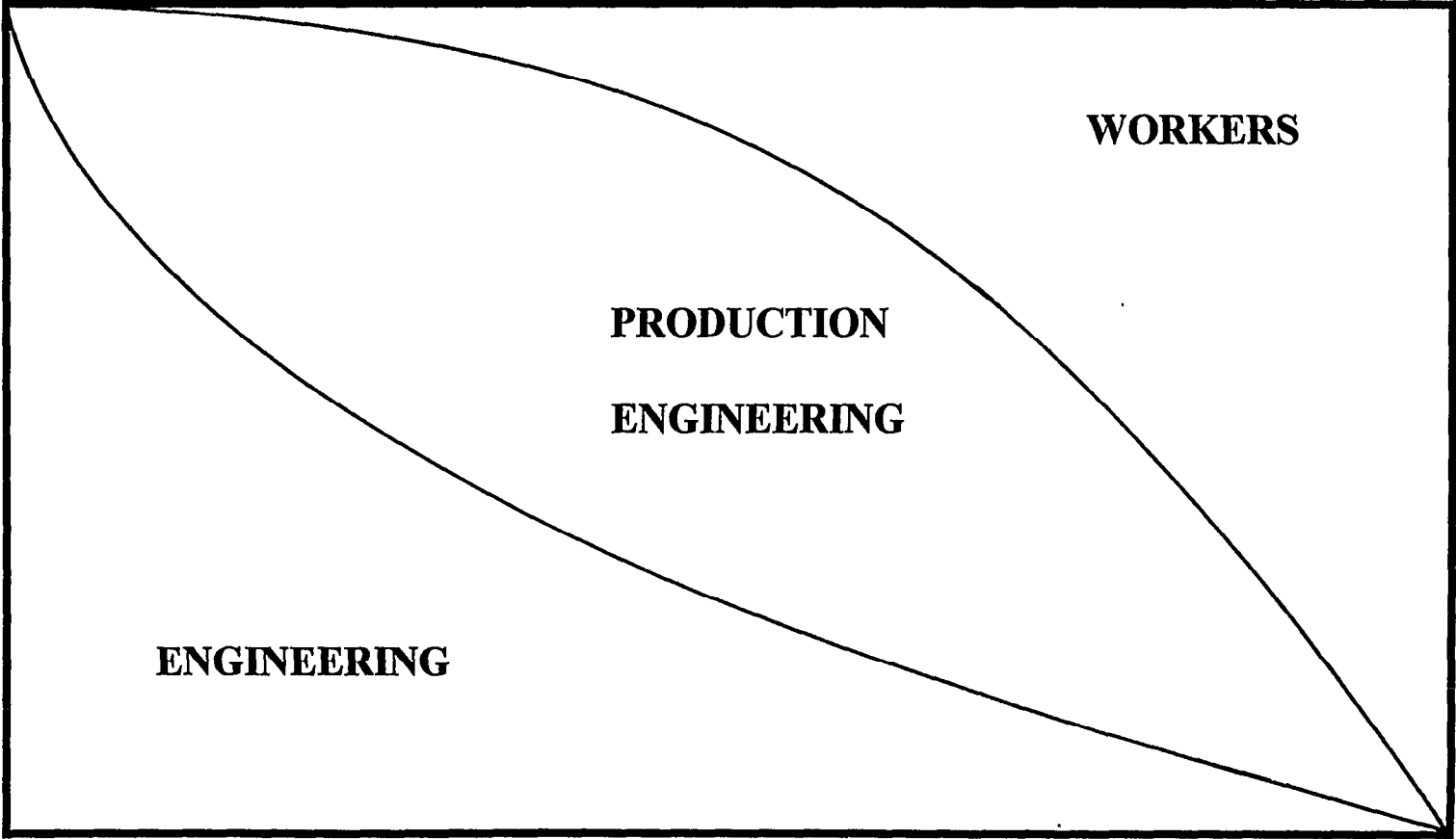

MAXIMUM



NATIONAL SHIPBUILDING RESEARCH PROGRAM

**PLANNING AND  
SCHEDULING FOR  
SHIP REPAIR AND  
OVERHAUL ZONE  
TECHNOLOGY**

IMPLEMENTATION OF ZONE TECHNOLOGY IN REPAIR & OVERHAUL ENVIRONMENT

# PLANNING AND SCHEDULING FOR SR & O ZONE TECHNOLOGY

- PLANNING IS THE “HOW”. SCHEDULING IS THE “WHEN”
- PLANNING FOCUSES ON THE FUTURE, WHAT IS TO BE ACCOMPLISHED AND WHEN
- THE PLANNING FUNCTION INCLUDES THOSE MANAGERIAL ACTIVITIES THAT DETERMINE OBJECTIVES FOR THE FUTURE AND THE APPROPRIATE MEANS FOR ACHIEVING THEM
- PLANNING OCCURS AT ALL LEVELS IN AN ORGANIZATION
- THERE ARE THREE LEVELS OF PLANNING; STRATEGIC, TACTICAL AND DETAILED (OPERATIONAL)
- TOP MANAGEMENT HANDLES THE STRATEGIC PLANNING, MIDDLE MANAGEMENT THE TACTICAL PLANNING AND THE DETAILED PLANNING SHOULD BE HANDLED AT THE LOWEST APPROPRIATE LEVEL IN THE ORGANIZATION

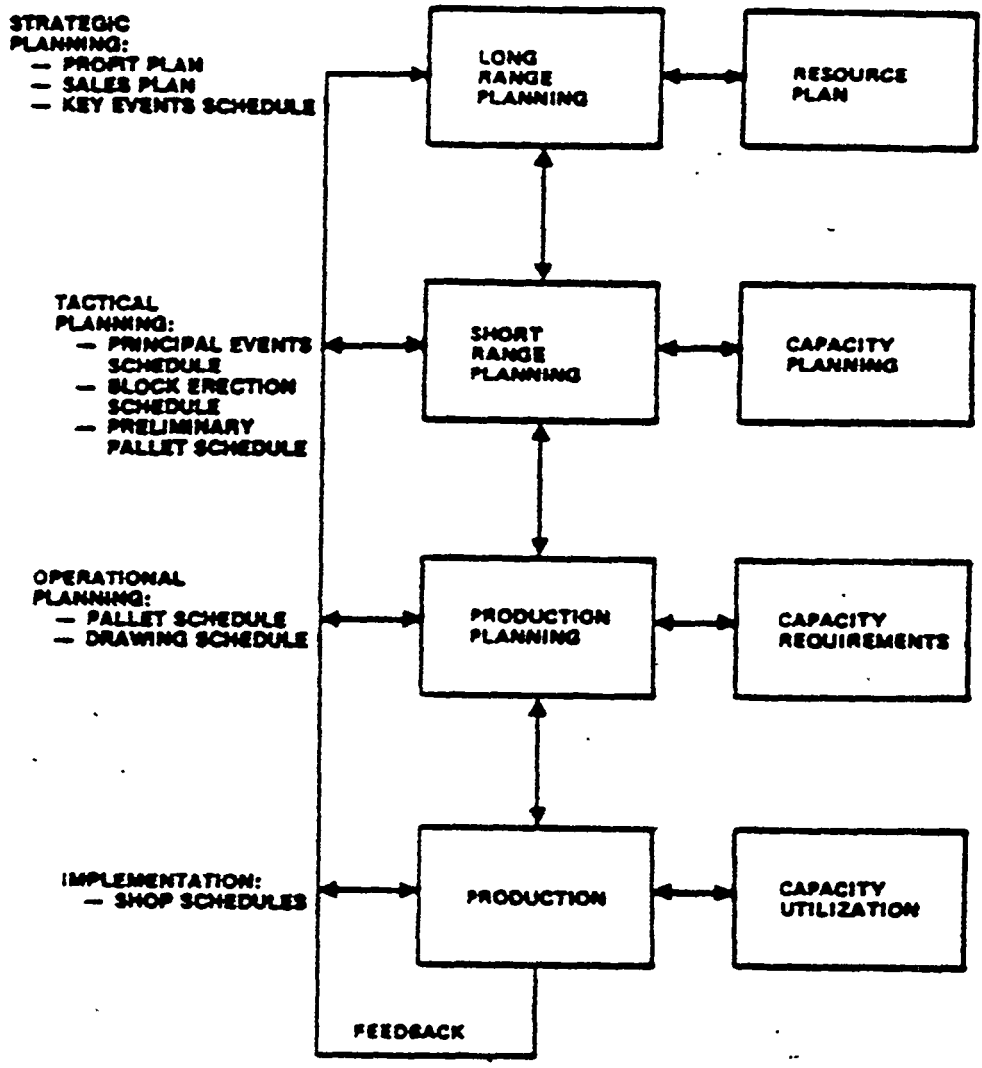

Fig. 7-6. Different levels of detail in planning.

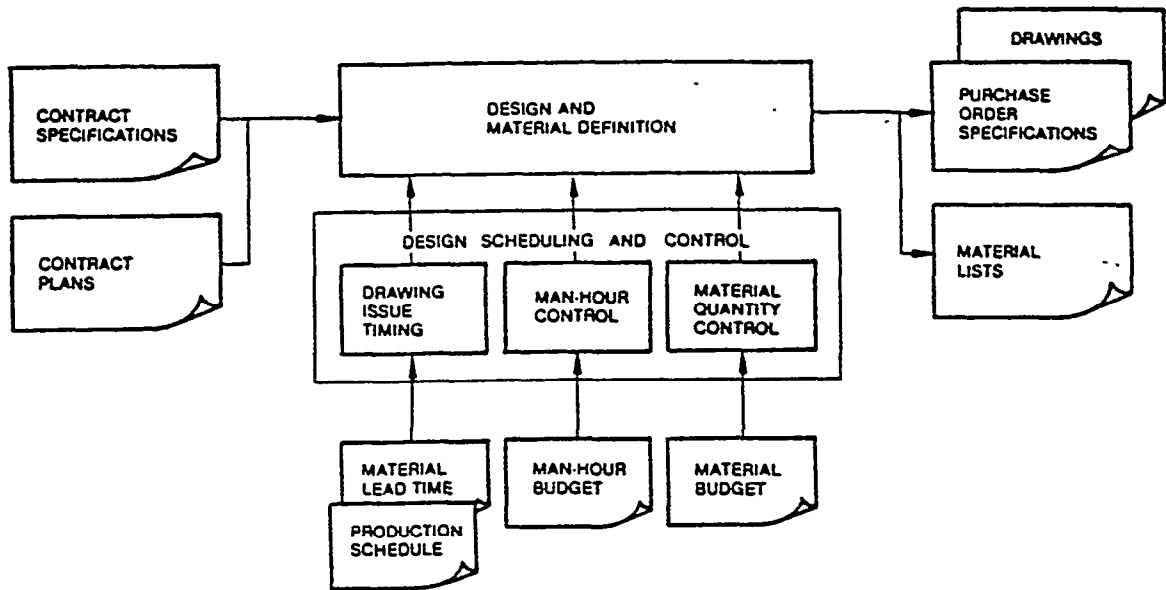
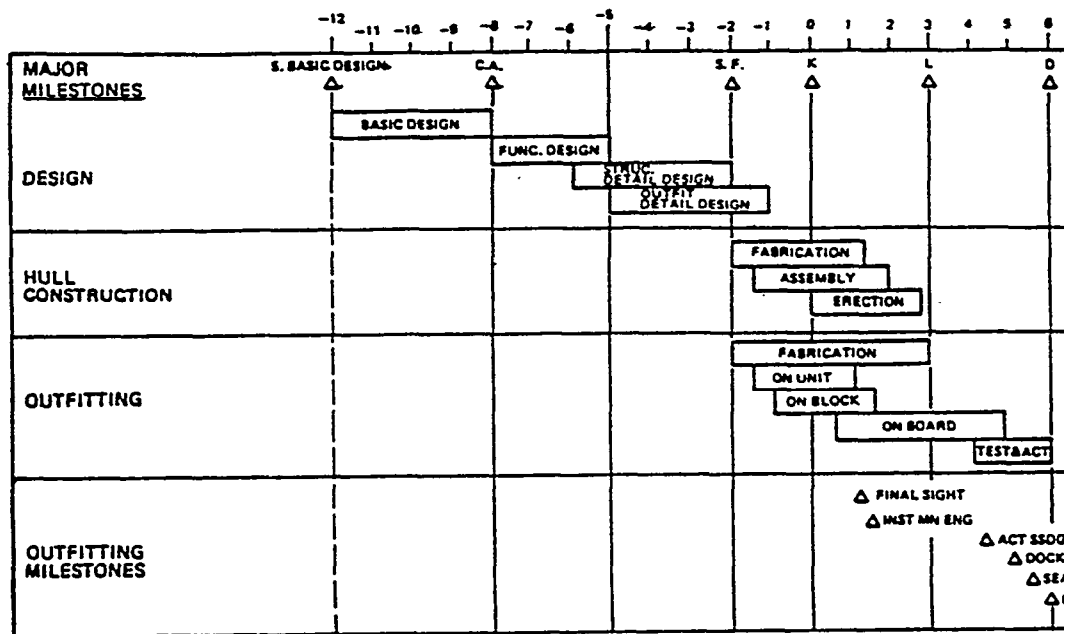

Fig. 7-9. Scheduling objectives for design and material definition.



NOTES: TYPICAL WITH MINOR ADJUSTMENTS FOR A NON-STANDARD CARGO. BULK. CONTAINER, OR AO/RO SHIP.

Fig. 7-10 Shipbuilding master schedule.

# **PLANNING AND SCHEDULING FOR SR & O ZONE TECHNOLOGY (CONTINUED)**

- SCHEDULING ALSO FOCUSES ON THE FUTURE, BUT ON WHEN THE ACTIVITIES MUST BE PERFORMED
- OPERATING SCHEDULES START AT THE TOP OF AN ORGANIZATION IN THE FORM OF THE INTEGRATING “MASTER OR KEY EVENT SCHEDULE” AND CASCADE DOWN THROUGH THE ORGANIZATION TO EACH DEPARTMENT, SECTION, GROUP AND TEAM
- OPERATING SCHEDULES RANGE FROM THE SIMPLE TO THE COMPLEX, EACH BEING SUITABLE FOR SPECIFIC APPLICATIONS
- POINT TO POINT SCHEDULES ARE SUITABLE FOR TASKS TO BE PERFORMED IN SEQUENCE

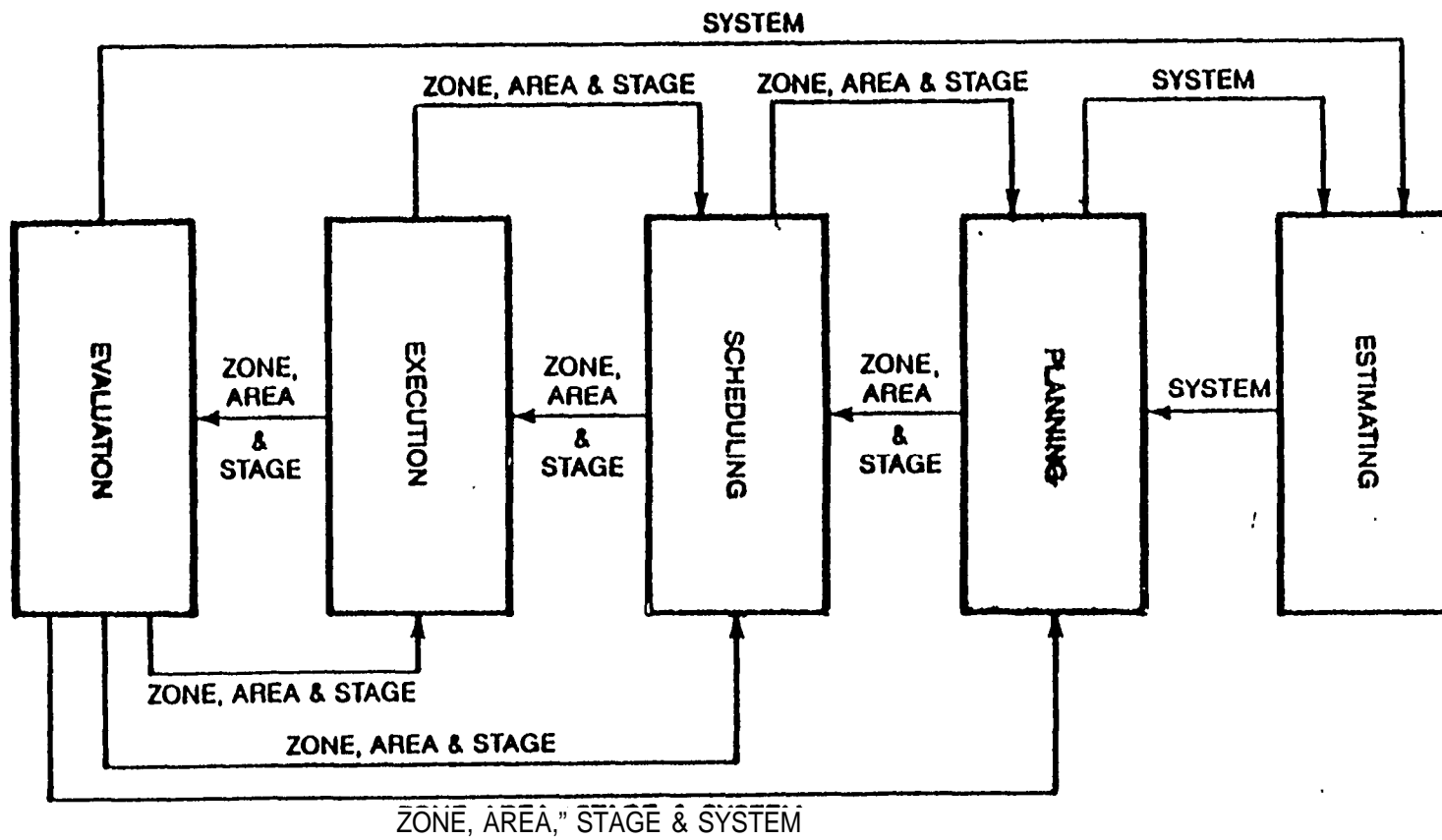

Fig. 7-1. The management cycle.

# **PLANNING AND SCHEDULING FOR SR & 0**

## **ZONE TECHNOLOGY** (CONTINUED)

- ALL BUT THE SMALLEST AND SIMPLEST REPAIR JOBS CAN BENEFIT FROM A ZONE-ORIENTED APPROACH TO PLANNING AND SCHEDULING BECAUSE OF THE WAY ZONE TECHNOLOGY FACILITATES THE COORDINATION OF DIFFERENT TYPES OF WORK IN RESTRICTED SPACES ON BOARD A SHIP (SEE ATTACHED FIGURE 9-5)
  - ZONES ARE THE ON BOARD INTERIM PRODUCTS THAT ARE WORKED ON AND COMPLETED DURING THE REPAIR/OVERHAUL PROCESS. THEY ARE ACTUAL PHYSICAL ENTITIES
- 1 THERE ARE TWO PRIMARY TYPES OF ZONES TO CONSIDER IN PLANNING AND EXECUTING ON BOARD WORK:

FUNCTIONAL ZONES

GEOGRAPHIC ZONES

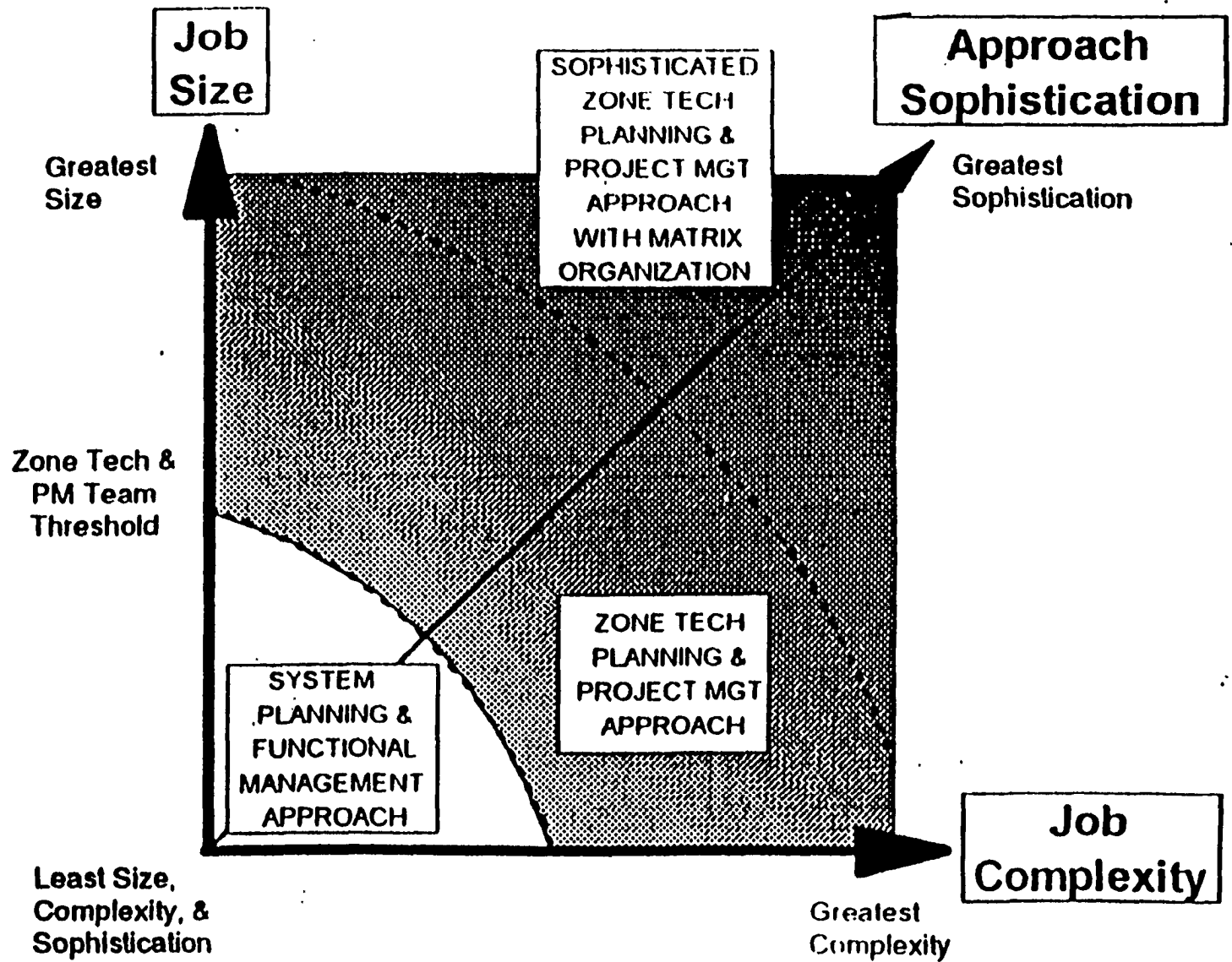

Fig. 9-5. Approach selection criteria.



# **PLANNING AND SCHEDULING FOR SR & O ZONE TECHNOLOGY (CONTINUED)**

- . OVERLAP OR PARALLEL SCHEDULES ARE SUITABLE FOR TASKS THAT MUST BE PERFORMED AT THE SAME TIME OR PORTIONS OF THE SAME TIME
- . FINALLY, NETWORK SCHEDULES ARE SUITABLE FOR COMPLEX TASKS WHERE BOTH SEQUENCE AND PARALLEL APPROACHES ARE NEEDED
- . PERT/CPM IS THE BEST KNOWN NETWORK SCHEDULING APPROACH (SEE ATTACHED ARTICLES ON PERT/CPM)
- . A “GANT” CHART IS A GRAPHIC SCHEDULEING TECHNIQUE. IT CAN BE USED FOR THE SIMPLE SEQUENCE OR PARALLEL TASKS OR THE OUTCOME OF THE PERT/CPM APPROACH ONCE THE NETWORK HAS BEEN DEVELOPED

# 10

---

## ***Project Management: PERT/CPM***

---

In many situations managers assume the responsibility for planning, scheduling, and controlling projects that consist of numerous separate jobs or tasks performed by a variety of departments, individuals, etc. Often these projects are so large and/or complex that the manager cannot possibly keep all the information pertaining to the plan, schedule, and progress of the project in his/her head. In these situations the techniques of PERT (Program Evaluation and Review Technique) and CPM (Critical Path Method) have proved to be extremely valuable in assisting managers in carrying out their project management responsibilities.

PERT and CPM have been used to plan, schedule, and control a wide variety of projects, such as

1. Research and development of new products and processes
2. Construction of plants, buildings, highways
3. Maintenance of large and complex equipment
4. Design and installation of new systems

In projects such as these, project managers must schedule and coordinate the various jobs or activities so that the entire project is completed on time. A complicating factor in carrying out this task is the interdependence of the activities; for example, some activities depend upon the completion of other activities before they can be started. When we realize that projects can have as many as several thousand specific activities, we see why project managers look for procedures that will help them answer questions such as the following:

1. What is the total time to complete the project?
2. What are the scheduled start and finish dates for each specific activity?
3. Which activities are "critical" and must be completed exactly as scheduled in order to keep the project on schedule?
4. How long can "noncritical" activities be delayed before they cause a delay in the total project?

As you will see, PERT and CPM can be used to help answer the above questions.

While PERT and CPM have the same general purpose and utilize much of the same terminology, the techniques were actually developed independently. PERT was introduced in the late 1950s specifically for planning, scheduling, and controlling the Polaris missile project. Since many jobs or activities associated with the Polaris missile project had never been attempted previously, it was difficult to predict the time to complete the various jobs or activities. Consequently, PERT was developed with an objective of being able to handle uncertainties in activity completion times.

On the other hand, CPM was developed primarily for scheduling and controlling industrial projects where job or activity times were considered known. CPM offered the option of reducing activity times by adding more workers and/or resources, usually at an increased cost. Thus a distinguishing feature of CPM was that it enabled time and cost trade-offs for the various activities in the project.

In today's usage the distinction between PERT and CPM as two separate techniques has largely disappeared. Computerized versions of the PERT/CPM approach often contain options for considering uncertainty in activity times as well as activity time-cost trade-offs. In this regard modern project planning, scheduling, and controlling procedures have essentially combined the features of PERT and CPM such that a distinction between the two techniques is no longer necessary.

## 10.1 PERT/CPM NETWORKS

The first step in the PERT/CPM project scheduling process is to determine the specific jobs, or activities, that make up the project. As a simple illustration involving the process of buying a small business, consider the list of four activities shown in Table 10.1. The development of an accurate list of activities such as this is a key step in any project. Since we will be planning the entire project and estimating the project completion date based on the list of activities, poor planning and omission of activities will be disastrous and lead to inaccurate schedules. We will assume that careful planning has been completed for the example problem and that Table 10.1 lists all activities for the small business project.

**TABLE 10.1**  
**Activity list for the Example Project of Buying a Small Business**

Activity	Description	Immediate Predecessors
<i>A</i>	Develop a list of sources for financing	–
<i>B</i>	Analyze the financial records of the business	–
<i>c</i>	Develop a business plan (e.g., sales projections, cash flow projections, etc.)	<i>B</i>
<i>D</i>	Submit a proposal to a lending institution	A, C

Note that Table 10.1 contains additional information in the column labeled immediate predecessors. The immediate predecessors for a particular activity are the activities that, when completed, enable the start of the activity in question. For example, the information

in Table 10.1 tells us we can start work on activities *A* and *B* anytime, since neither of these activities depends upon the completion of prior activities. However, activity *C* cannot be started until activity *B* has been completed, and activity *D* cannot be started until both activities *A* and *C* have been completed. As you will see, immediate predecessor information must be known for each activity in order to describe the interdependencies among the activities in the project.

In Figure 10.1 we have drawn a network that not only depicts the activities listed in Table 10.1 but also portrays the predecessor relationships among the activities. This graphical representation is referred to as the PERT/CPM network for the project. The activities are shown on the branches, or arcs, of the network. The circles, or nodes, of the network correspond to the beginning and ending of the activities. The completion of all the activities that lead into a node is referred to as an event. For example, node 2 corresponds to the event that activity *B* has been completed, and node 3 corresponds to the event that both activities *A* and *C* have been completed.

**FIGURE 10.1**  
*PERT/CPM Network for the Example Project Of Buying a Small Business*

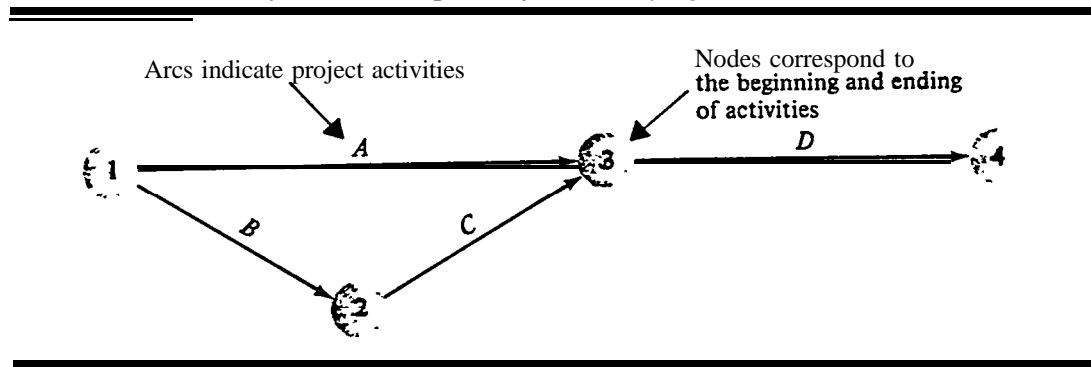

Let us now attempt to develop the network for a project having the following activities and immediate predecessors:

Activity	Immediate Predecessors
<i>A</i>	-
<i>B</i>	-
<i>c</i>	<i>B</i>
<i>D</i>	<i>A, C</i>
<i>E</i>	<i>c</i>
<i>F</i>	<i>C</i>
<i>G</i>	<i>D, E, F</i>

A portion of the PERT/CPM network that could be used for the first four activities is as follows:

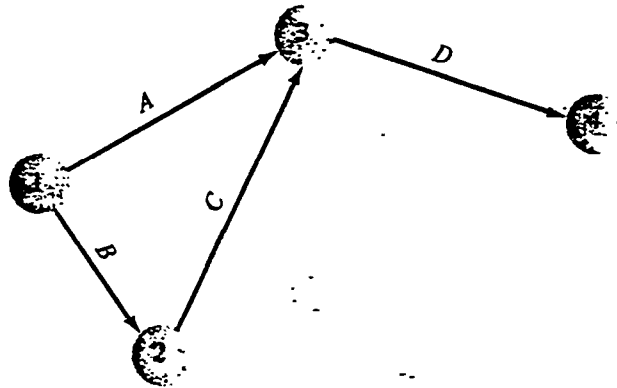

This portion of the network causes no particular problem for activity D, since it shows activities A and C as the correct immediate predecessors. However, when we attempt to add activity E to the network, we encounter a problem. At first we might attempt to show activity E beginning at node 3. However, this indicates that both activities A and C are the immediate predecessors for activity E, which is incorrect. Referring to the original activity schedule for the project, we see that activity E only has activity C as its immediate predecessor.

We can avoid the above problem by inserting a *dummy activity*, which, as the name implies, is not an actual activity but rather a fictitious activity used to ensure that the proper precedence relationships among the activities are depicted in the network. For example, we can add node 5 and insert a dummy activity, indicated by a dashed line, from node 5 to node 3 forming the network shown below.

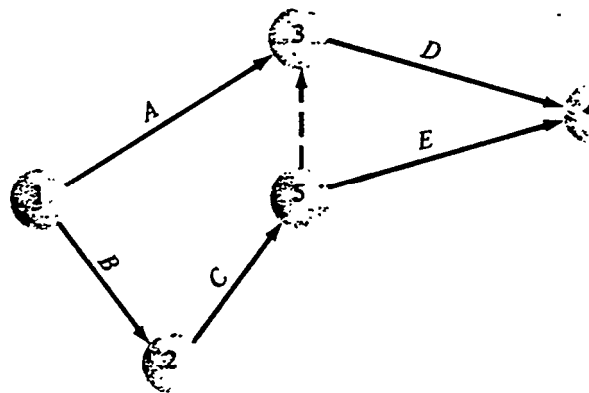

With this change in the network, activity E starting at node 5 has the correct predecessor of only activity C. The dummy activity does not have a time requirement but is merely used to maintain the proper precedence relationships in the network. Note that the insertion of the dummy activity also correctly shows activities A and C as the immediate predecessors for activity D.

Completion of the seven-activity network could be shown as follows:

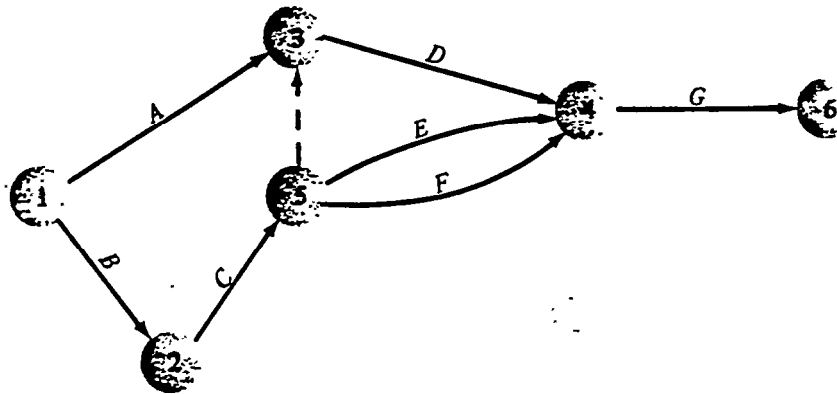

Note how the network correctly identifies activities D, E, and F as the immediate predecessors for activity G. However, note that activities E and F *both start* at node 5 and end at node 4. This situation causes problems for certain computer programs that use starting and ending nodes to identify the activities in a PERT/CPM network. In these programs the computer procedure would recognize activities E and F as *the same* activity since they have the same starting and ending nodes. When this condition occurs, dummy activities can be added to a network to make sure that two or more activities do not have the same starting and ending nodes. The use of node 7 and a dummy activity as shown below eliminates this problem for activities E and F.

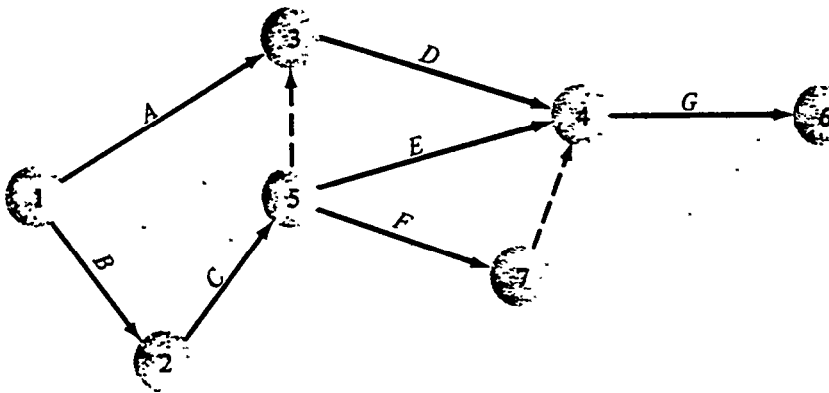

Dummy activities can be used to identify precedence relationships correctly as well as to eliminate the possible confusion of two or more activities having the same starting and ending nodes. Although dummy activities may not be required for all PERT/CPM networks, larger and/or more complex projects may require many dummy activities in order to depict the project network properly.

## 10.2 PROJECT SCHEDULING WITH PERT/CPM

---

The owner of the Western Hills Shopping Center is considering modernizing and expanding the current 32-business shopping complex. Financing for the expansion has been arranged through a private investor. If the expansion project is undertaken, the owner hopes to add eight to 10 new businesses or tenants to the shopping complex.

The specific activities that make up the expansion project are listed in Table 10.2. Note that the list includes the immediate predecessor for each activity as well as the number of weeks required to complete the activity. The PERT/CPM network for the project is shown in Figure 10.2. Check for yourself to see that the network does in fact maintain the immediate predecessor relationships shown in Table 10.2.

**TABLE 10.2**  
*Activity List for the Western Hills Shopping Center Expansion Project*

Activity	Activity Description	Immediate Predecessor	Completion Time (Weeks)
A	Prepare architectural drawings of planned expansion	-	5
B	Identify potential new tenants	-	6
C	Develop prospectus for tenants	A	4
D	Select contractor	A	3
E	Prepare building permits	A	1
F	Obtain approval for building permits	E	4
G	Construction	D, F	14
H	Finalize contracts with tenants	B, C	12
I	Tenants move in	G, H	2
			Total 51

**FIGURE 102**  
*PERT/CPM Network for the Western Hills Shopping Center Expansion Project*

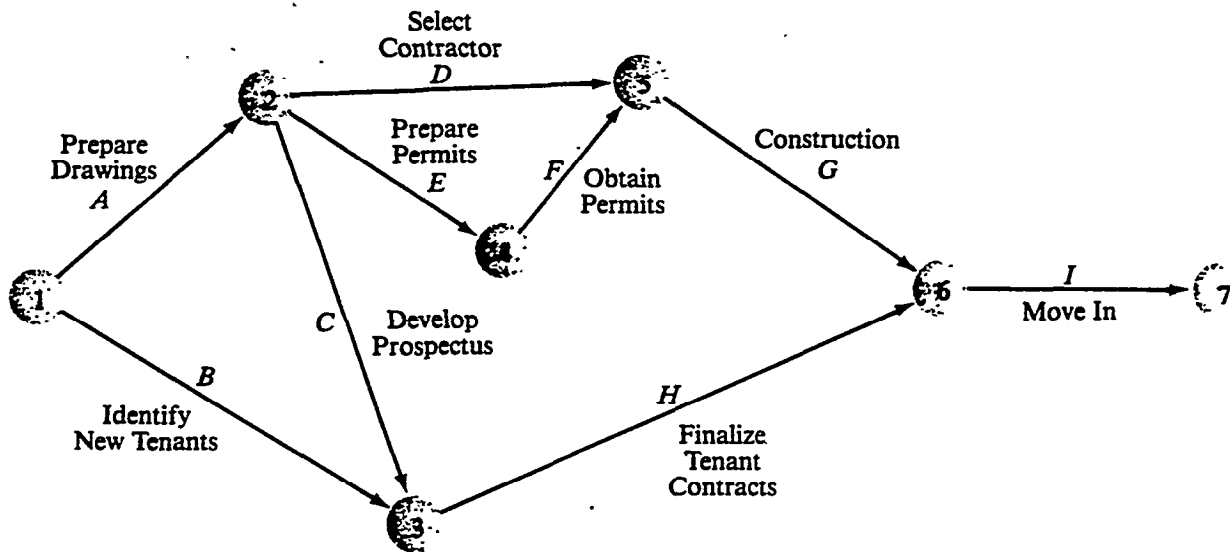

Information in Table 10.2 indicates that the total time required to complete all activities in the shopping center expansion project is 51 weeks. However, we can see

from the network (Figure 10.2) that several of the activities can be conducted simultaneously (A and B, for example). Being able to work on two or more activities at the same time will shorten the total project completion time to less than 51 weeks. However, the required project completion time is not directly available from the data in Table 10.2.

In order to facilitate the PERT/CPM computations that we will be making, the project network has been redrawn as shown in Figure 10.3. Note that each activity letter is written above and each activity time is written below the corresponding arc.

**FIGURE 103**  
*Western Hills Shopping Center Project Network with Activity Times*

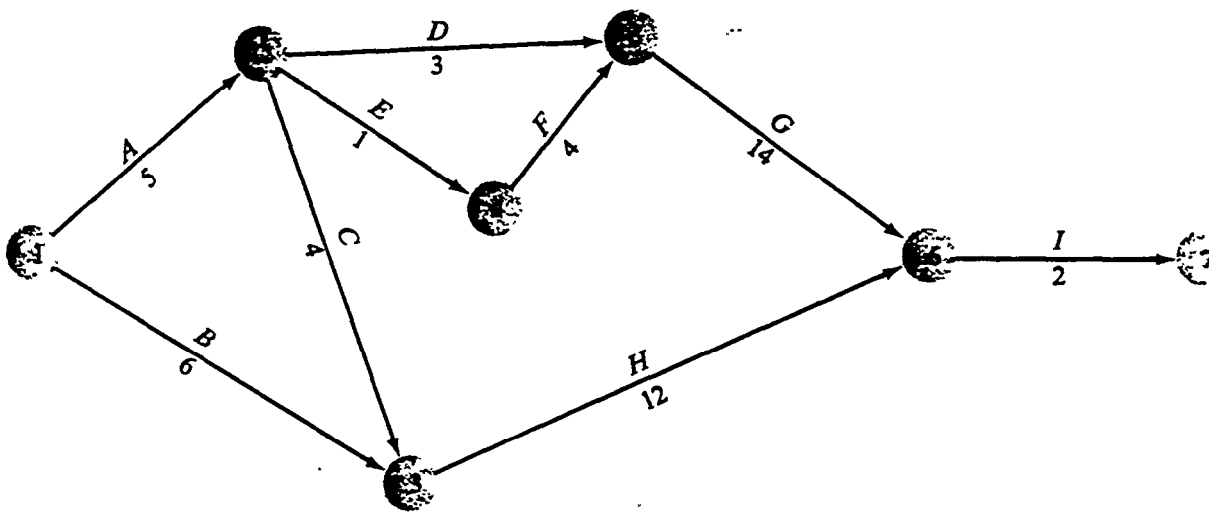

### *The Critical Path*

Once we have the project network and the activity times, we are ready to proceed with the calculations necessary to determine the total time required to complete the project. In addition, we will use the results of the calculations to develop a detailed start and finish schedule for each activity.

In order to determine the project completion time we will have to analyze the network and identify what is called its *critical path*. A *path* is a sequence of connected activities that leads from the starting node (1) to the completion node (7). The connected activities defined by nodes 1-2-3-6-7 form a path consisting of activities A, C, H, and I. Nodes 1-2-5-6-7 define the path associated with activities A, D, G, and I. Since *all* paths must be traversed in order to complete the project, we need to analyze the amount of time the various paths require. In particular, we will be interested in the longest path through the network. Since all other paths are shorter in duration, the longest path determines the total time or duration of the project. If activities on the longest path are delayed, the entire project will be delayed. Thus the longest path activities are the *critical activities* of the project and the longest path is called *the critical path* of the network. If managers wish to reduce the total project time, they will have to reduce the length of the critical path by shortening the duration of the critical activities. The following discussion



presents a step-by-step procedure or algorithm for finding the critical path of a project network.

Starting at the network's origin (node 1) and using a starting time of 0, compute an earliest start and earliest finish time for each activity in the network. Let

- ES = earliest start time for a particular activity
- EF = earliest finish time for a particular activity
- t = expected activity time for the activity

The following expression can be used to find the earliest finish time for a given activity:

$$E F = E S + t \quad (10.1)$$

For example, for activity A, ES = 0 and t = 5; thus the earliest finish time for activity A is EF = 0 + 5 = 5.

We will write the earliest start and earliest finish times directly on the network in brackets next to the letter of the activity. Using activity A as an example, we have

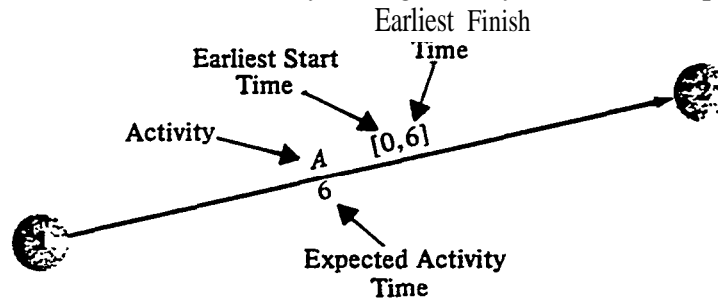

Since activities leaving a node cannot be started until all immediately preceding activities have been completed, the following rule can be used to determine the earliest start times for activities:

**Earliest Start Time Rule:**  
 The earliest start time for an activity leaving a particular node is equal to the largest of the earliest finish times for all activities entering the node.

In applying this rule to a portion of the network involving activities A, B, C, and H, we obtain the following:

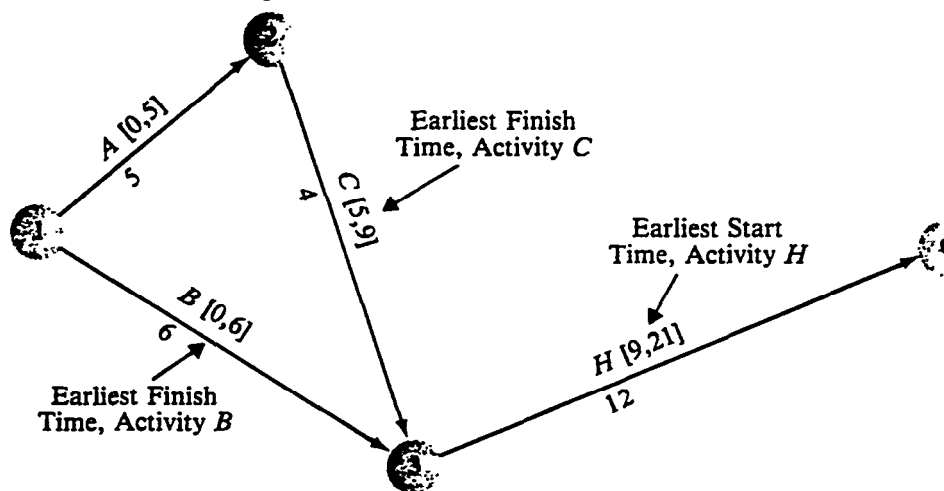

Note that in applying the earliest start time rule for activity C, which leaves node 2, we first recognized that activity A is the only activity entering node 2. Since the earliest finish time for activity A is 5, the earliest start time for activity C is 5. Thus the earliest finish time for activity C must be  $EF = ES + t = 5 + 4 = 9$ .

The above diagram also shows that the earliest finish time for activity B is 6. Applying the earliest start time rule for activity H, we see that the earliest start time for this activity must be equal to the largest of the earliest finish times for the two activities that enter node 3, activities B and C. Thus the earliest start time for activity H is 9, and the earliest finish time is  $EF = ES + t = 9 + 12 = 21$ .

Proceeding in a forward pass through the network, we can establish the earliest start time and then the earliest finish time for each activity. The Western Hills Shopping Center PERT/CPM network, with the ES and EF values for each activity, is shown in Figure 10.4. Note that the earliest finish time for activity I, the last activity, is 26 weeks. Thus the completion time for the entire project is 26 weeks.

**FIGURE 10.4**

**Western Hills Shopping Center Project with Earliest Start Times and Earliest Finish Times Shown Above the Activity Arcs**

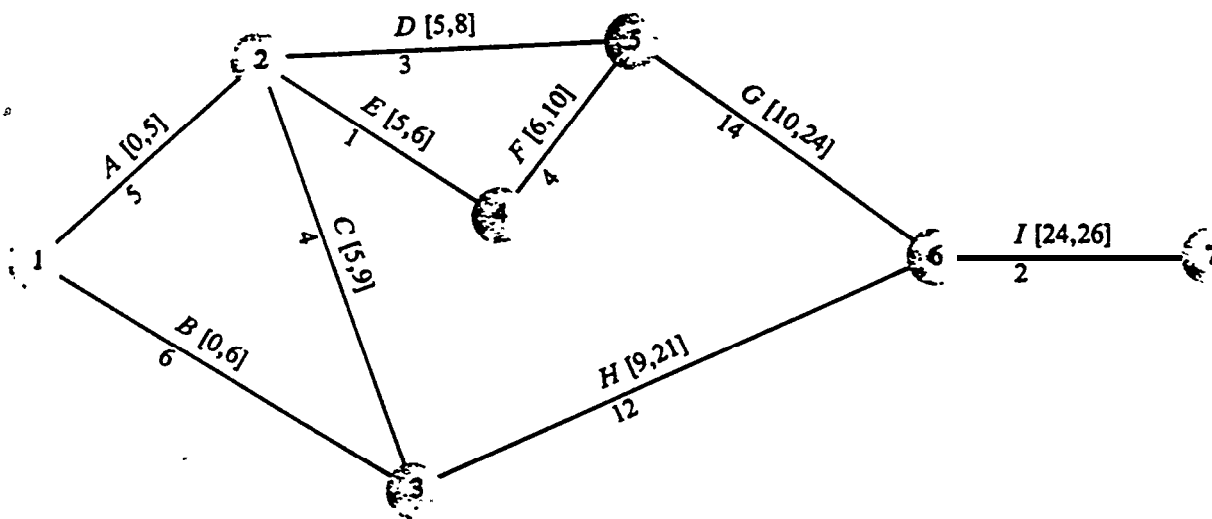

We now continue the **algorithm** for finding the **critical** path by making a backward pass calculation. Starting at the completion point (node 7) and using a latest finish time of 26 for activity I, we trace back through the network computing a latest start and latest finish time for each activity. Let

LS = latest start time for a particular activity

LF = latest finish time for a particular activity

The following expression can be used to find the latest start time for a given activity:

$$LS = LF - t \quad (10.2)$$

Given  $LF = 26$  and  $t = 2$  for activity I, the latest start time for this activity can be computed as  $LS = 26 - 2 = 24$ .

The following rule is necessary in order to determine the latest finish time for any activity in the network:

**Latest Finish Time Rule:**  
 The latest finish time for an activity entering a particular node is equal to the smallest of the latest start times for all activities leaving the node.

Logically the above rule states that the latest time an activity can be finished is equal to the earliest (smallest) value for the latest start time of following activities. The complete network with the LS and LF backward pass calculations is shown in Figure 10.5. The latest start and latest finish times for the activities are written in brackets directly under the earliest start and earliest finish times.

**FIGURE 10.5**

Western Hills Shopping Center Project with Latest Start Times and Latest Finish Times Shown Below the Activity Arcs

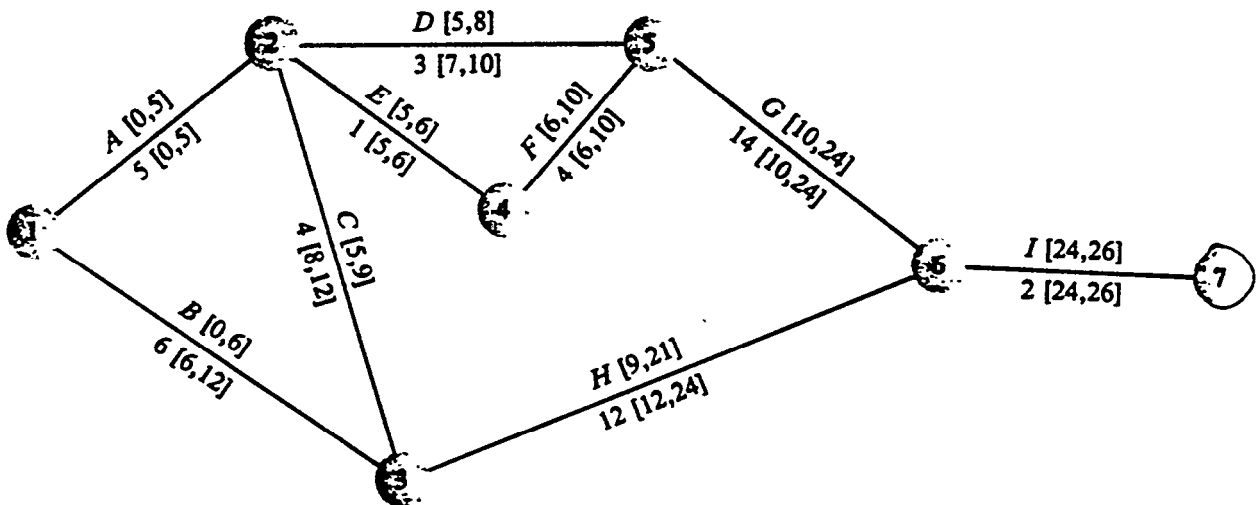

Note the application of the latest finish time rule for activity A, which enters node 2. The latest finish time for activity A (LF = 5) is the smallest of the latest start times for the activities that leave node 2; that is, the smallest LS value for activities C (LS = 8), E (LS = 5), and D (LS = 7) is 5.

After obtaining the start and finish activity times as summarized in Figure 10.5, we can find the amount of slack or free time associated with each of the activities. Slack is defined as the length of time an activity can be delayed without affecting the completion date for the entire project. The amount of slack for each activity is computed as follows:

$$\text{Slack} = \text{LS} - \text{ES} = \text{LF} - \text{EF} \quad (10.3)$$

For example, we see that the slack associated with activity C is  $LS - ES = 8 - 5 = 3$  weeks. This means that activity C can be delayed up to 3 weeks (start anywhere between weeks 5 and 8) and the entire project can still be completed in 26 weeks. Thus activity C is not a critical activity and is not part of the critical path. Using (10.3), we see that the slack associated with activity E is  $LS - ES = 5 - 5 = 0$ . Thus activity E has no slack time and must be held to the 5-week start time schedule. Since activity E cannot be delayed without affecting the entire project, it is a critical activity and is on the critical path; in general, the critical path activities are the activities with zero slack.

The start and finish times shown on the network in Figure 10.5 provide a detailed schedule for all activities. That is, from Figure 10.5 we know the earliest and latest start and finish times for the activities. Putting this information in tabular form provides the activity schedule shown in Table 10.3. Note that by computing the slack associated with each activity, we see that activities A, E, F, G, and I each have zero slack; hence these activities form the critical path in the shopping center expansion network. Note that Table 10.3 also shows the slack or delay that can be tolerated for the noncritical activities before these activities will cause a project delay.

**TABLE 103**

Activity Schedule for the Western Hills Shopping Center Expansion Project

Activity	Earliest Start (ES)	Latest start (LS)	Earliest Finish (EF)	Latest Finish (LF)	Slack (LS-ES)	Critical Path?
A	0	0	5	5	0	Yes
B	0	6	6	12	6	
C	5	8	9	12	3	
D	5	7	8	10	2	
E	5	5	6	6	0	Yes
F	6	6	10	10	0	Yes
G	10	10	24	24	0	Yes
H	9	12	21	24	3	
I	24	24	26	26	0	Yes

### Contributions of PERT/CPM

Previously we stated that project managers look for procedures that will help answer many important questions regarding the planning, scheduling, and controlling of projects. Let us reconsider these questions in light of the information the PERT/CPM network and critical path calculations have provided about the Western Hills Shopping Center expansion project.

1. What is the total time to complete the project?  
*Answer:* PERT/CPM has shown that the project can be completed in 26 weeks if the individual activities are completed on schedule.
2. What are the scheduled start and completion times for each activity?  
*Answer:* PERT/CPM has provided the detailed activity schedule that shows the earliest start, latest start, earliest finish, and latest finish times for each activity (Table 10.3).

3. Which activities are “critical” and must be completed exactly as scheduled in order to keep the project on schedule?

*Answer:* PERT/CPM has identified the five activities-A, E, F, G, and I-as the critical activities for the project.

4. How long can “noncritical” activities be delayed before they cause a delay in the completion time for the project?

*Answer:* PERT/CPM has identified the slack time available for all activities as shown in Table 10.3.

In the management of any project the above information is important and valuable. While larger projects may substantially increase-the time required to draw the PERT/CPM network and to make the necessary calculations, the procedure and contributions of PERT/CPM to larger projects are identical to those observed in the shopping center expansion project. Furthermore, computer packages exist that carry out the steps of the PERT/CPM procedure. Figure 10.6 shows the activity schedule for the shopping center expansion project developed by The Management Scientist computer software package. Input to the program included the activities, their immediate predecessors, and the expected activity times. Only a few minutes were required to input the information and generate this critical path and activity schedule information.

**FIGURE 10.6**

Activity Schedule for the Western Hills Shopping Center Expansion Project Developed using the Management Scientist<sup>®</sup>

<i>Activity</i>	Earliest Start (ES)	Latest start (LS)	Earliest Finish (EF)	<b>Latest Finish (LF)</b>	slack (LS-ES)	Critical Path?
<i>A</i>	0	0	5	5	0	Yes
<i>B</i>	0	6	6	12	6	
<i>C</i>	5	8	9	12	3	
<i>D</i>	5	7	8	10	2	
<i>E</i>	5	5	6	6	0	Yes
<i>F</i>	6	6	10	10	0	Yes
<i>G</i>	10	10	24	24	0	Yes
<i>H</i>	9	12	21	24	3	
<i>I</i>	24	24	26	26	0	Yes

The critical path is **A-E-F-G-I**.  
The project completion time is 26.

### Summary of the PERT/CPM Critical Path Procedure

Before leaving this section, let us summarize the PERT/CPM critical path procedure that can be used to plan, schedule, and control projects.

- Step 1 Develop a list of activities that make up the project.
- Step 2 Determine the immediate predecessor activities for each activity in the project.
- Step 3 Estimate the completion time for each activity.
- Step 4 Draw a network depicting the activities and immediate predecessors listed in steps 1 and 2.
- Step 5 Using the network and the activity time estimates, determine the earliest Start time and the earliest finish time for each activity by making a forward pass through the network. The earliest finish time for the last activity in the project identifies the completion time-for the entire project.
- Step 6 Using the project completion time identified in step 5 as the latest finish time for the last activity, make a backward pass through the network to identify the latest start time and latest finish time for each activity.
- Step 7 Use the difference between the latest start time and the earliest start time for each activity to identify the slack time available for the activity.
- Step 8 The critical path activities are the activities with zero slack.
- Step 9 Use the information from steps 5 and 6 to develop a detailed activity schedule for the project.

### 1 0 3 PROJECT SCHEDULING WITH UNCERTAIN ACTIVITY TIMES

---

In this section we consider the details of project scheduling for a problem involving the research and development of a new product. Because many of the activities in this project have never been previously attempted, the project manager wants to identify and account for the uncertainties in the activity times. Let us show how project scheduling can be conducted with uncertain activity times.

#### ***The Daugherty Porta-Vac Project***

The H. S. Daugherty Company has manufactured industrial vacuum cleaning systems for a number of years. Recently a member of the company's new-product research team submitted a report suggesting the company consider manufacturing a cordless vacuum cleaner that could be powered by a rechargeable battery. The vacuum cleaner, referred to as a Porta-Vac, could contribute to Daugherty's expansion into the household market. Management hopes that the new product can be manufactured at a reasonable cost and that its portability and no-cord convenience will make it extremely attractive.

Daugherty's management would like to initiate a project to study the feasibility of proceeding with the Porta-Vac idea. The end result of the feasibility study will be a report recommending the action to be taken for the new product. In order to complete the feasibility study, information must be obtained from the firm's research and development (R&D), product testing, manufacturing, cost estimating, and market research groups. How long do you think this feasibility study project will take? When should we tell the product testing group to schedule its work? Obviously, we do not have enough information to answer these questions at this time. In the following discussion we will learn how to answer these questions and provide the complete schedule and control, formation for the project.

processes (such as the mass production of a product or the periodic reorders of inventory for which management has past experience, standards, and costs), historical data are not available for nonrepetitive projects. However, each task in a one-of-a-kind program must be performed on time and be of the necessary quality, just as with routine work. In other words, management must still plan and control nonroutine operations. PERT is extremely helpful in such situations because it enables a manager to think through a project in its entirety. As such, it usually results in a more optimum utilization of resources.

### Specific Applications of PERT

PERT (and variations of it) is probably one of the most widely used production planning models. It was developed through the cooperation of the U.S. Navy and the management consulting firm of Booz Allen & Hamilton Inc. Introduced by the Special Projects Office of the U.S. Navy in 1958 on the Polaris missile project, PERT was widely credited with helping to reduce by two years the time originally estimated for the completion of the engineering and development programs for the missile. By identifying the longest paths through **all** of the tasks necessary to **complete** the project, it enabled the program managers to concentrate efforts on those tasks that vitally affected the total project time. PERT has spread rapidly throughout the defense and space industries. Today, almost every major government agency involved in the space program utilizes PERT. In fact, **many** government agencies require contractors to use PERT and other network models in planning and controlling their work on government contracts.

While the aerospace business faces peculiar problems, one-of-a-kind development work is also an important element in many other kinds of organizations and industries. In addition to developing space vehicles and putting a man on the moon, PERT has also been utilized successfully in:

1. Constructing new plants, buildings, and hospitals.
2. Designing new automobiles.
3. Coordinating the numerous activities (production, marketing; and so forth) involved in managing a new product or project<sup>18</sup>
4. Planning and scheduling space probes.<sup>19</sup>
5. Managing accounts receivable.<sup>20</sup>
6. Coordinating the installation of large-scale computer systems.
7. Coordinating ship construction and aircraft repairs.

In addition to engineering-oriented applications, PERT has been used to coordinate the numerous activities associated with mergers and acquisitions and with economic planning in underdeveloped countries. The technique has also contributed to planning large conventions and meetings. The Management Focus describes PERT's application to a special type of a convention: the Olympics.

### Examples of Production Planning with PERT

Using PERT and other network models involves two fundamental steps (1) constructing the network and (2) estimating activity time requirements.

## **MANAGEMENT Focus**

### **PERT Goes to the International Olympics**

History does not record much about the first Olympiad. However, if Hercules had attempted to coordinate over 30,000 activities—food, security, transportation, assistants, and medical backup for thousands of competitors—relating to the 1988 Winter Games in Calgary, Canada, he might have cried uncle. A company named Project Software and Development, however, rose to the Olympian task. Employing PERT-based software developed for the

space shuttle, PSD broke down the games into 15-minute segments. PSD also developed an integrated computer network to monitor the Olympic activities. Although a few glitches occurred, the games were completed in a manner that would have pleased Hercules.

*Adapted from Nell Margolis, "Software Firm Tackles Olympian Project Management Task," Computerworld, February 22, 1988, pp. 85ff.*

### **Constructing the Network**

PERT networks are developed around two key concepts: activities and events. An activity is the work necessary to complete a particular event. An event is an accomplishment at a particular point in time and consumes no time. In PERT diagrams, an event is designated with a circle and an activity as an arrow connecting two circles. These two concepts are shown in Figure-18-3.

Before a PERT network can be constructed, the activities and events that will be represented on the diagram must be identified. Table 18-2 describes the activities and events required to manufacture a prototype aircraft engine.

The information from Table 18-2 is represented by the network model shown in Figure 18-4. Examination indicates that event 1 is the network beginning event since there are no activities leading to it and event 8 is the network ending event since there are no activities leading away from it. Note also that event 2 is the beginning event for two activities and event 6 is the ending event for two activities as well as the beginning event for one activity.

PERT emphasizes identifying events and activities with enough precision so that it is possible to monitor accomplishment as the project proceeds. There are four basic phases in constructing a PERT network:

1. Define each necessary activity.
2. Estimate how long each activity will take.
3. Construct the network.
4. Find the critical path—that is, the longest path, in time, from the beginning event to the ending event.

All events and activities must be sequenced in the network under a strict set of logical rules (e.g., no event can be considered complete until all predecessor



FIGURE 18-3

**Two Events and One Activity**

*The basic building blocks of PERT are events (circles 1 and 2) and activities (arrow)*



**TABLE 18-2**

**Description of PERT Activities and Events for Manufacturing of Prototype Aircraft Engine**

*The effectiveness of PERT depends on accurate determination of all events and activities.*

Activity		Event	
Arrow	Description	Prerequisite Circle	Description
1-2	Develop engineering specifications.	2	Specifications completed.
2-3	Obtain test models.	1-2	3 Test models obtained.
2-4	Locate suppliers of component parts.	1-2	4 suppliers located.
3-5	Develop production plans.	2-3	5 Plans completed.
5-6	Begin subassembly 1.	3-5	6 Subassembly 1 completed
4-6	Place orders for component parts and await receipt	2-4	6 Component parts received
6-7	Begin subassembly 2.	5-6 and 4-6	7 Subassembly 2 completed
7-8	Begin final assembly.	6-7	8 Engine completed

FIGURE 18-4

**PERT Network for Information in Table 18-2**

*A PERT network chart enables managers to perceive complex problems in relatively simple graphic form.*

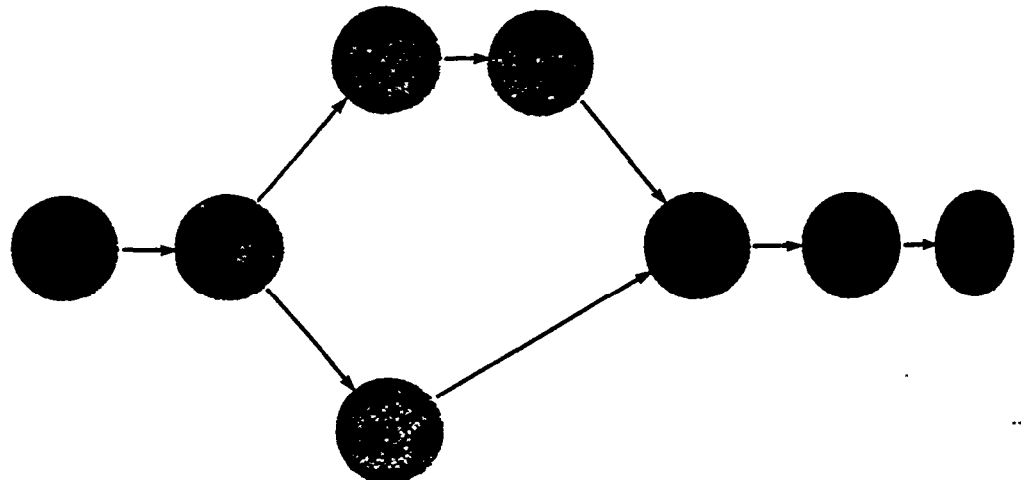

time requirements  
 mental part of doing  
 ss. A hot, tasty pizza  
 pead on it.



events have been completed) that allows for the determination of the critical path.<sup>21</sup>

The paramount variable in a PERT network is time.<sup>22</sup> Estimating how long each activity will take is extremely difficult, since the manager may have no experience on which to rely.

### **Estimating Activity Time Requirements**

Since PERT projects are usually unique, they are subject to a great deal of uncertainty. PERT is designed to deal specifically with the problem of determining time estimates.

For example, assume you are trying to estimate how long it will take to complete a term 'project for your management class. You know that one activity will be to collect certain information. If all goes well, you believe that you could complete this one activity in eight weeks. However, if you encounter numerous obstacles (dates, parties, illness, material not available in the library), this one activity will take much longer to complete. Estimating the time needed to complete your term project becomes a complex process when you try to account for the delays that might occur,

For PERT projects, three time estimates are required for each activity. The individual or group chosen to make each time estimate should be that individual or group most closely connected with and responsible for the particular activity under consideration. The three time estimates needed are:

Optimistic time (a): The time in which the activity can be completed if everything goes exceptionally well and no obstacles or problems are encountered.

Most likely time (m): The most realistic estimate of how long an activity might take. This is the time we would expect to occur most often if repeated numerous times.

Pessimistic time (b): The time that would be required if everything goes wrong and numerous obstacles and problems are encountered. -

It is extremely difficult to deal simultaneously with the optimistic time, the most likely time, and the pessimistic time. Fortunately a way has been developed to arrive at one time estimate. An expected time ( $t_e$ ) can be estimated satisfactorily for each activity by using the following formula:

$$t_e = \frac{a + 4m + b}{6}$$

Note that in the formula for computing the expected time ( $t_e$ ), the weight that is given to the most likely time (m) is much greater than the weight given to the optimistic and pessimistic times, since each of them has only a small chance of occurring. Also note that optimistic and pessimistic time each receive the same weight.

To illustrate the use of this formula, recall the prototype-engine project described in Table 18-2. Suppose you estimate that three weeks is the most likely completion time (m) for the activity of developing engineering specifications. However, you feel that there is a small chance that the activity might be completed in one week. Therefore, the optimistic time (a) is 1. You also feel there is a slight chance things could go wrong and it would take eight weeks to develop specifications. Therefore, the pessimistic time (b) is 8.

To compute the expected time from the three time estimates, we must determine at what time there is a 50-50 chance of completing the activity. The expected time formula provides that figure. The time estimates are as follows:

Optimistic time (a) = 1 week

Most likely time (m) = 3 weeks

Pessimistic time (b) = 8 weeks

Substituting these time estimates into the formula yields:

$$\text{Expected time} = t_e = \frac{1 + 4(3) + 8}{6} = 3.5$$

Thus, there is a 50-50 chance that the engineering specifications can be developed in 3.5 weeks.

The expected time may be either longer or shorter than the most likely time, depending on the three time estimates. To illustrate an expected time shorter than the most likely time, assume the following three time estimates for developing engineering specifications:

Optimistic time (a) = 3 weeks

Most likely time (m) = 4 weeks

Pessimistic time (b) = 10 weeks

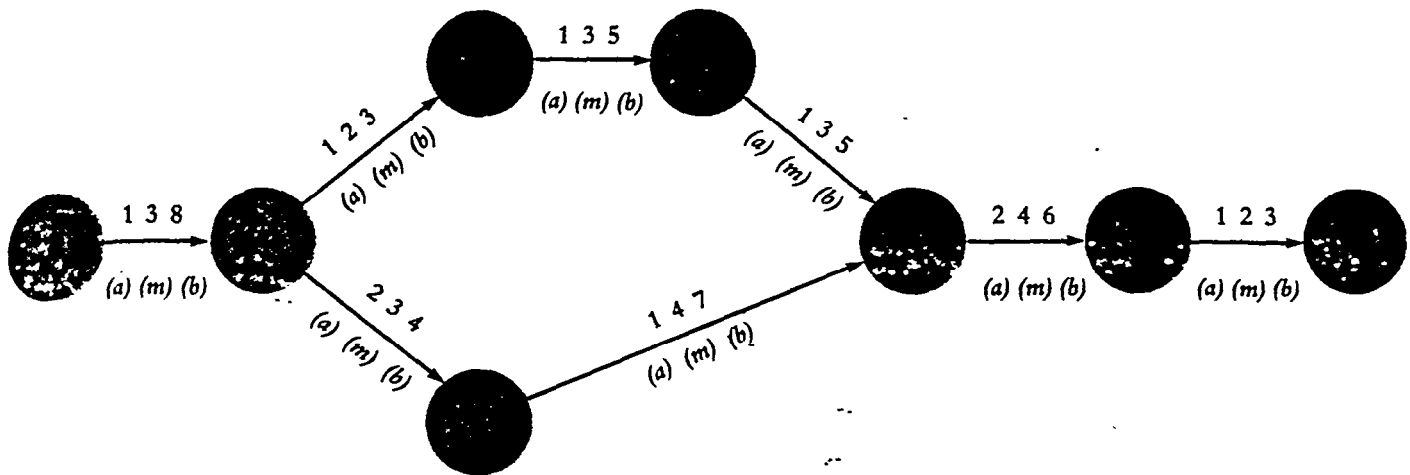

FIGURE 18-5

**PERT Network: Time Estimates for Each Activity**

PERT networks become more complicated when time estimates are included.

Substituting these values into the formula yields:

$$\text{Expected time} = t_e = \frac{3 + 4(4) + 10}{6} = 4.83$$

In this case, the expected time of 4.83 weeks is longer than the most likely time of 4 weeks.

When there is a great uncertainty in a project, this three-way time estimate is an important advantage of PERT. While it does introduce a complicating feature, it recognizes realities that can cause problems in planning for the future. The three-way time estimate usually results in a greater degree of honesty and accuracy in forecasting time. If nothing else, it provides the manager with the opportunity to be aware of and to evaluate the degree of uncertainty involved, especially along the critical path.

The completed PERT networks for the aircraft engine prototype project are shown in Figures 18-5 and 18-6. Figure 18-5 shows the three time estimates for each of the eight activities. Figure 18-6A shows the expected time for each activity. Obviously, expected times are only estimations. But if carefully constructed, they form a solid base for subsequent management decisions.

**Critical Path**

The critical path is the most time-consuming sequence of activities from the beginning event to the ending event.<sup>23</sup> Therefore, the most crucial calculation in a PERT network is for the critical path.<sup>24</sup> Using two steps, we can calculate the critical path for the network shown in Figure 18-6A. First, we must identify each discrete path from beginning to end. In Figure 18-6B, two paths are shown. Second, we must sum the expected times for each discrete path. Path 1 is expected to be completed in 17.5 weeks (3.5 + 2 + 3 + 3 + 4 + 2); path 2 is expected to be completed in 16.5 weeks (3.5 + 3 + 4 + 4 + 2). Path 1, which takes 17.5 weeks, is the critical path.

Path 1 is critical because any delay in the completion of its activities delays the total project. Yet, a delay of up to one week can occur on path 2, and the project can still be completed in 17.5 weeks. Path 1 is critical for another reason. If the project must be completed sooner than the expected 17.5 weeks.

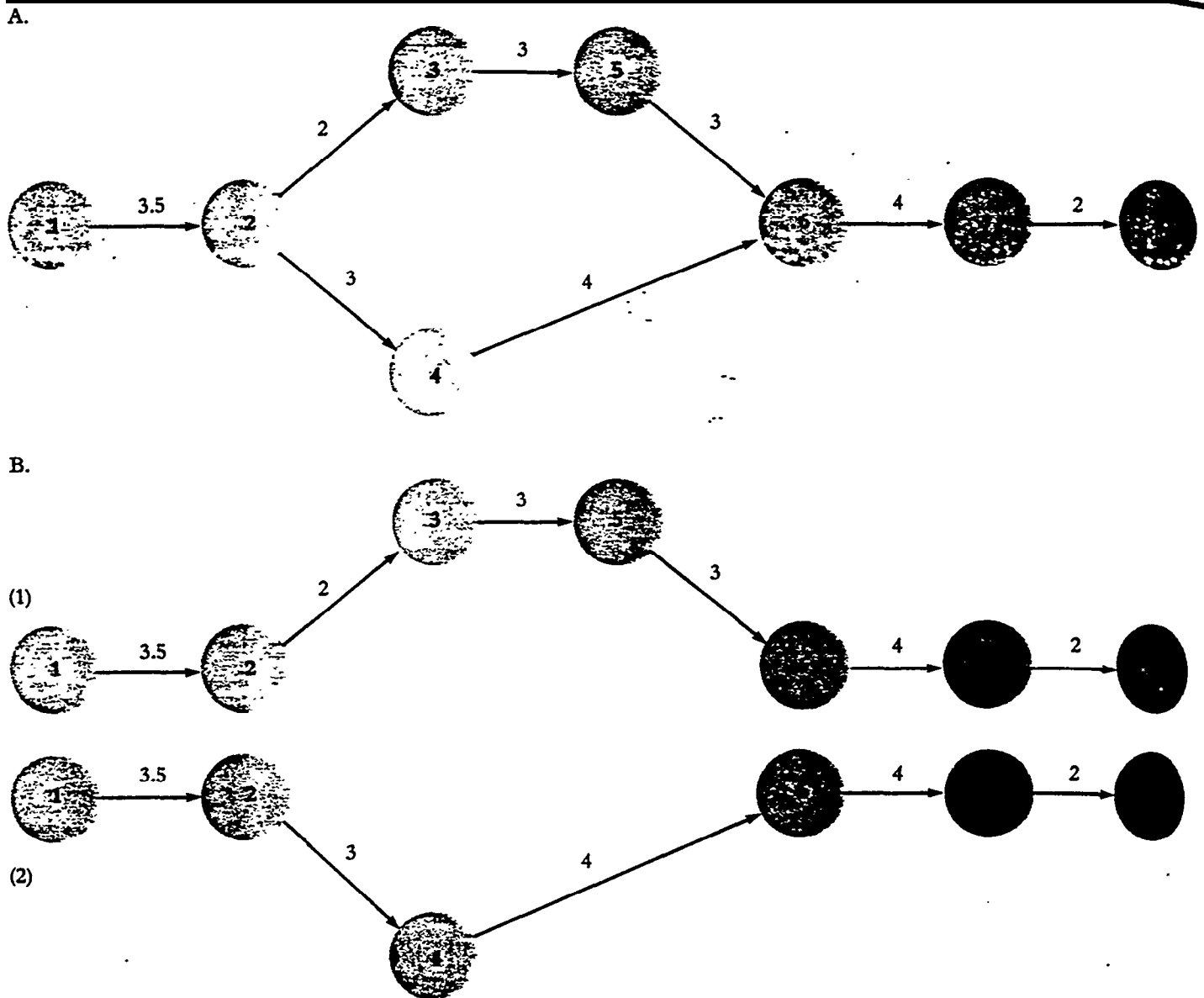

FIGURE 18-6

**Expected Time ( $t_e$ ) for Each Activity**

*Calculating the expected time for each activity helps managers identify ways to reduce the time it takes to complete the project.*

management can see that additional resources must be allocated to it rather than to path 2.

In this example, the project network is rather simple; it has only two paths, and the critical path is readily identifiable. Real-world problems are seldom so simple.<sup>25</sup> As projects become more complex, the development of PERT networks also becomes more complex. In fact, were it not for developments in computer programming, the use of PERT would be seriously hampered.<sup>26</sup>

**The Value of PERT**

Properly constructed, PERT and other network models provide direct aid to managers in two important areas:<sup>27</sup>

### **Improved Planning**

Network models help managers handle the uncertainties involved in projects where no standard cost and time data are available. Because it shows the manager the interconnections of tasks and provides estimated times, PERT increases the manager's ability to plan an optimum schedule before starting work.<sup>28</sup> In other words, while a project is still in the planning stage, management can take a number of steps to reduce the total time needed to complete the project. Time reductions can be brought about in a number of ways:

1. By reducing the 'expected time on the longest path through the network (the critical path) by transferring resources or additional funds from those activities that can afford it since they do not take as long to complete.
2. By eliminating some part of the project that previously might have been considered desirable but not necessary.
3. By adding more resources-men or machines.
4. By purchasing a component if the time required to produce the component is too long.
5. By changing some work to parallel activities that had previously been planned in a series.

### **Better Control-A Major Advantage**

The planning necessary to construct the network contributes significantly to the definition and ultimate concurrent control of the project. In the case of PERT, the construction of the network is a very demanding task that forces the planner to visualize the number, different kinds, and sequence of all the necessary activities. This kind of thinking cannot help but be a benefit in and of itself in most cases.

Throughout the early days of space exploration, Goddard Space Flight Center (GSFC) made extensive use of PERT as its principal schedule planning and control tool in flight projects<sup>29</sup> Each project was assigned a schedule team of from two to four PERT analysts to draft and update PERT networks. However, budget and personnel reductions forced Goddard to reduce the size of schedule teams and the use of PERT. Goddard was forced to substitute less detailed methods of schedule planning and control. One result was a loss of monitoring information necessary for controlling key activities in a project.

In the early 1970s, a number of computer graphic programs became available. These programs have the capability of producing high-quality and accurate PERT network drawings in a few hours. PERT analysts simply sketch out a network, put the information in a proper format, submit the data for computer processing, and in a few hours receive a complete, finished network. The critical paths are identified and highlighted in the computer-produced network, and any subsequent updates or corrections can be quickly processed.

Since the development of computer-graphic programs, the use of PERT has exceeded its use in the early 1960s. The time-consuming aspects of PERT have been virtually eliminated. A PERT analyst can now handle five times more PERT networks than was possible using manual methods. The availability of computer software has increased the applicability of PERT to any organization that can afford a personal computer as noted in the Management Focus

# PLANNING AND SCHEDULING FOR SR & O

## ZONE TECHNOLOGY (CONTINUED)

- FUNCTIONAL ZONES CAN BE EITHER THE TOTAL PURPOSE OF THE SPACE OR, AS USUAL IN THE CASE OF PLANNING THE INDIVIDUAL SHIP SYSTEMS ON WHICH FINAL SYSTEM TESTING WORK IS TO BE PERFORMED. ANY PARTICULAR FUNCTIONAL ZONE MAY CROSS AND INCLUDE MANY COMPONENTS WITHIN SEVERAL GEOGRAPHIC ZONES. (SEE ATTACHED FIGURE 9.7)  
EXAMPLES ARE: FUEL OIL SYSTEM  
POWER DISTRIBUTION SYSTEM  
FIRE MAIN SYSTEM
- GEOGRAPHIC ZONES ARE THE PHYSICAL SPACES ON BOARD A SHIP IN/ON WHICH ON BOARD PRODUCTION WORK CAN BE LOGICALLY PERFORMED. MANY SYSTEMS CAN BE INCLUDED WITHIN A GEOGRAPHIC ZONE OR IT MAY CONTAIN ONLY A SINGLE SYSTEM (SEE ATTACHED FIGURE 9.8)

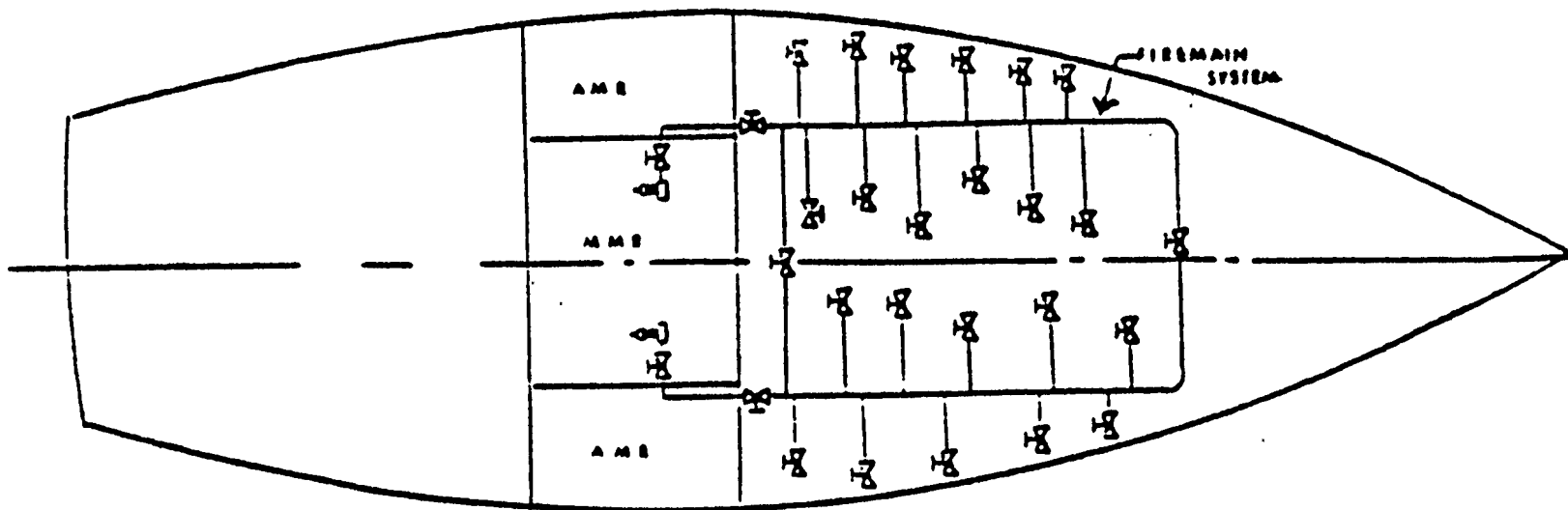

Fig. 9-7. Functional zone representation.



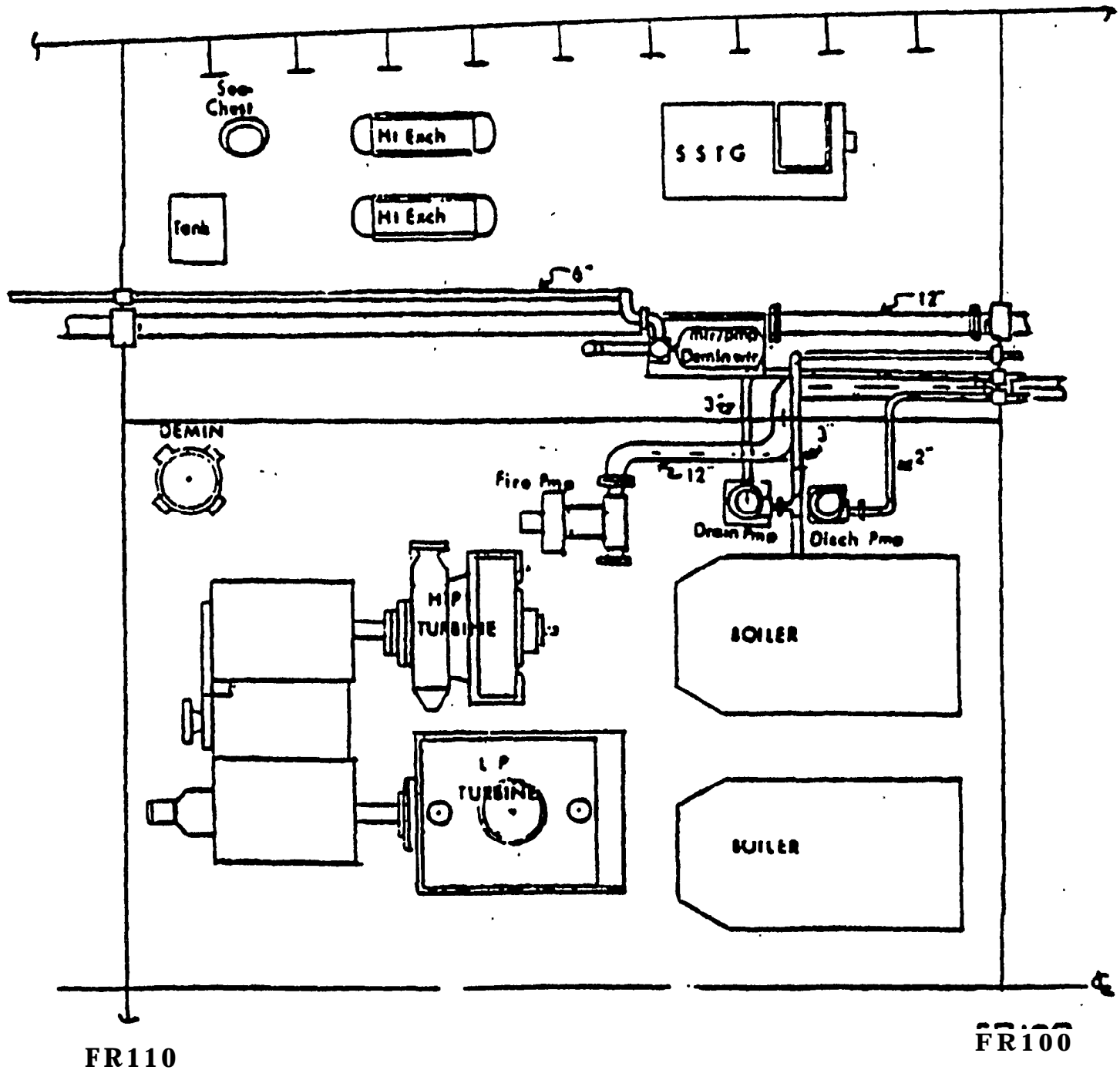

Fig: 9-8. Geographic zone representation.

# **PLANNING AND SCHEDULING FOR SR & O**

## **ZONE TECHNOLOGY (CONTINUED)**

- THE FIRST STEP IN THE REPAIR/OVERHAUL PLANNING PROCESS IS TO IDENTIFY THE SYSTEMS/FUNCTIONAL ZONES ON WHICH THE WORK WILL BE PERFORMED (SEE ATTACHED FIGURE 6)
- NEXT THE SPECIFIC WORK AND ASSOCIATED MATERIAL AND EQUIPMENT IS IDENTIFIED
- THERE IS USUALLY TIME TO PREPARE THIS PLANNING FOR OVERHAULS BUT MOST LIKELY LITTLE TIME IN THE CASE OF REPAIR
- SO OVERHAUL PLANNING CAN BE MORE FORMAL INVOLVING EQUIPMENT MANUFACTURERS' RECOMMENDATIONS, HISTORICAL DATA ON SIMILAR EQUIPMENT, SHIP SPECIFIC MAINTENANCE RECORDS, INSPECTION OF SHIP AND ANALYSING CURRENT SYSTEM DATA

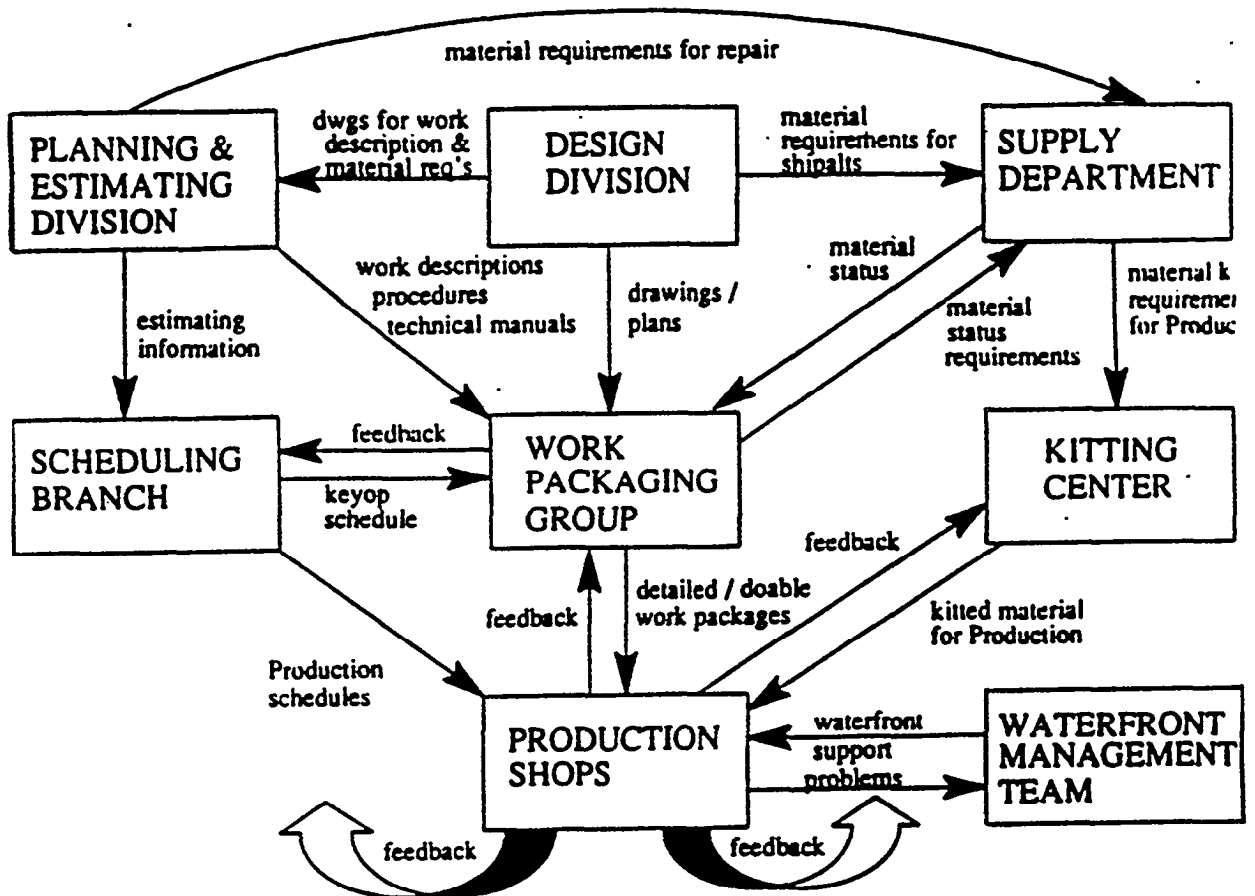

Fig. 6 ZONE TECHNOLOGY PLANNING PROCESS

## **PLANNING AND SCHEDULING FOR SR & O ZONE TECHNOLOGY (CONTINUED)**

- FOR REPAIR, THE PLANNING MUST BE CARRIED OUT QUICKLY AND ON A MORE AD-HOC WATERFRONT BASIS
- NEXT THE GEOGRAPHIC ZONES IN WHICH THE WORK WILL OCCUR ARE IDENTIFIED
- THE WORK IN EACH GEOGRAPHIC CAN THEN BE CLASSIFIED BY TYPE. THEN EACH TYPE OF ON BOARD WORK CAN BE LOGICALLY SEQUENCED IN EACH GEOGRAPHIC ZONE TO PREVENT OVERCROWDING AND WORK INTERFERENCES
- HAVING COMPOSITE (MULTI-SYSTEM) DRAWINGS,  
• PHOTOGRAPHS OR COMPUTER REPRESENTATION OF THE GEOGRAPHIC ZONES GREATLY FACILITATES THIS PLANNING

# **PLANNING AND SCHEDULING FOR SR & 0 ZONE TECHNOLOGY (CONTINUED)**

- . AN IMPORTANT PART OF THE PLANNING PROCESS IS TO MOVE WORK FROM ON BOARD THE SHIP TO THE PRODUCTION SHOPS TO BENEFIT FROM ADVANCED OUTFITTING
- IN ORDER TO HAVE AN ORDERLY AND LOGICAL BREAKDOWN OF THE WORK A ZONE TECHNOLOGY-ORIENTED WORK BREAKDOWN STRUCTURE SHOULD BE USED TO DEFINE THE INTERIM PRODUCTS AND THE PROCESSES THAT THEY USE (SEE FIGURE 4.1 AND ATTACHED PAPER ON PWBS IN REPAIR)
- THE INDIVIDUAL WORK ELEMENTS AND THEIR WORK SEQUENCES, ALONG WITH RESOURCE AND MATERIAL REQUIREMENTS AND AVAILABILITY, ARE THEN ENTERED INTO A PROJECT MANAGEMENT SYSTEM AND AN INTEGRATED PRODUCTION PLAN AND COST DEVELOPED

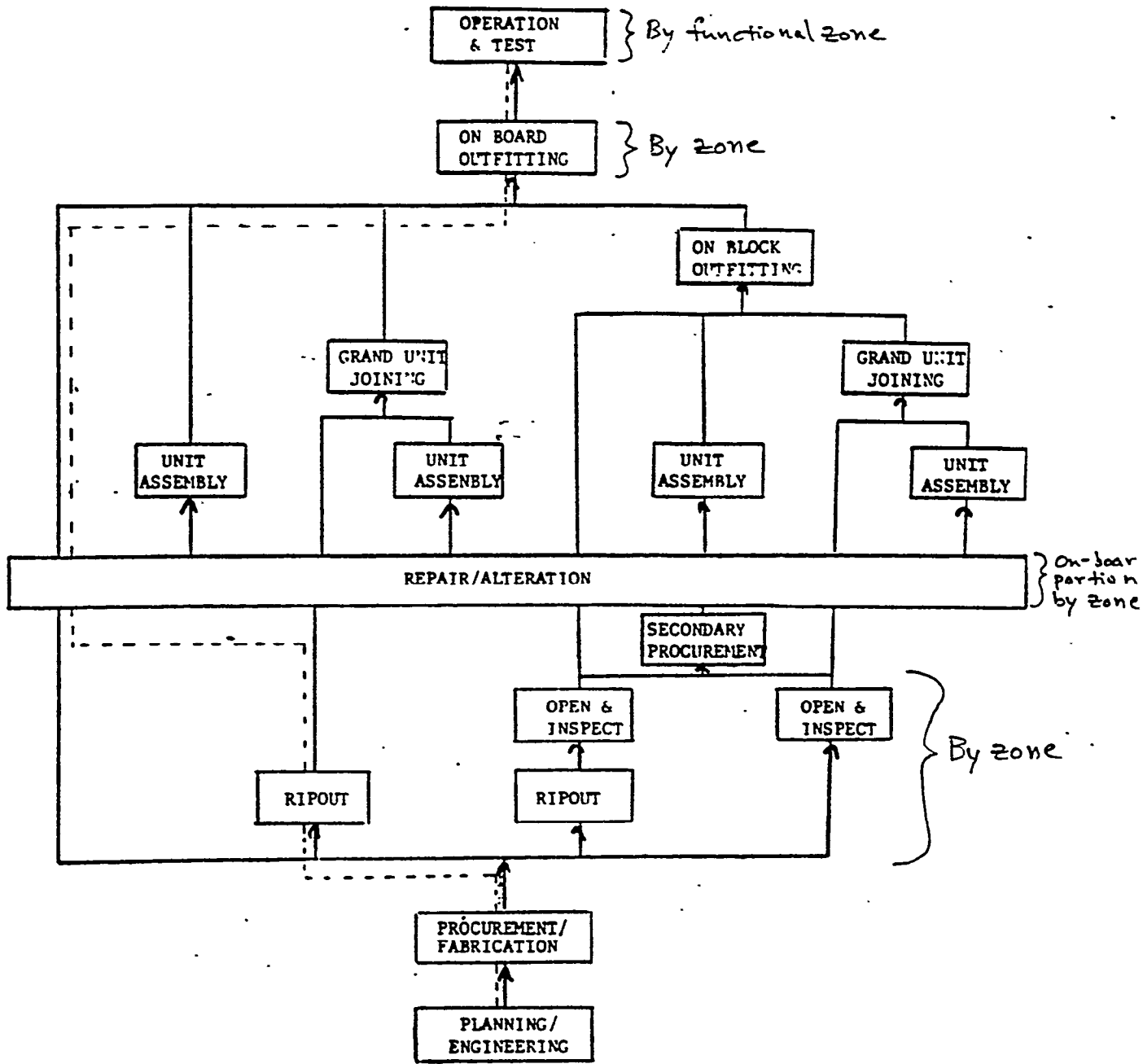

FIGURE 4.1  
SHI

## **PLANNING AND SCHEDULING FOR SR & O ZONE TECHNOLOGY (CONTINUED)**

- **THIS IS AN AREA WHERE SIMULATION AND COMPUTER AIDED PROCESS PLANNING CAN BE OF GREAT BENEFIT (SEE ATTACHED NSRP REPORT)**
- **THE SUCCESSFUL BUSINESS PLAN → SHIPBUILDING POLICY → BUILD STRATEGY APPROACH CAN BE APPLIED TO SHIP REPAIR AND OVERHAUL (SEE ATTACHED MARRED UP DESCRIPTION OF THE APPROACH)**
- **SENSITIVITY OR “WHAT-IF” ANALYSIS CAN NOW BE PERFORMED TO DETERMINE ALTERNATIVES THAT MAY OFFER IMPROVEMENT IN PRODUCTIVITY OR SCHEDULE. IT MAY BE NECESSARY TO DO SO BECAUSE OF LATE MATERIAL OR UNEXPECTED REPAIRS.**

THE APPLICATION OF COMPUTER-AIDED PROCESS PLANNING  
TO SHIP MODERNIZATION, OVERHAUL AND REPAIR

SHIP PRODUCTION COMMITTEE

PANEL SP-4

DESIGN/PRODUCTION INTEGRATION



## TABLE OF CONTENTS

1.	Foreword . . . . .	i
2.	Abstract . . . . .	ii
3.	The Plight of U.S. Shipbuilding/Ship Repair . . . . .	1
4.	The Forces of Competition . . . . .	6
5.	Traditional Work Package Preparation . . . . .	12
6.	The Waterfront Supervisor . . . . .	18
7.	Process Planning . . . . .	24
8.	The Philadelphia Experiment . . . . .	35
9.	Product-Oriented Work Packages . . . . .	45
10.	The Navy's Advanced Industrial Management Program . . . . .	57
11.	Conclusions . . . . .	63

## FIGURES

1.	Traditional Planning Process . . . . .	20
2.	Product Work Breakdown Structure . . . . .	38
3.	Information Flow in a Product Oriented Work Structure . . . . .	43
4.	Integrated Planning for Production . . . . .	53

## TABLES

1.	Core Shipyards in the United States. . . . .	5
2.	Comparison of U.S. Ship Operating Companies, 1970 and 1980 . . . . .	5

## APPENDICES

A.	Sources of Information . . . . .	68
----	----------------------------------	----

## FOREWORD

This report is the product of the National Shipbuilding and Research Program (NSRP) project "The Application of Computer-Aided Process Planning to Ship Modernization, Overhaul and Repair", MARAD contract DTMA 91-84-C-41043, conducted under the auspices of the Ship Production Committee's Design and Production Integration Panel (SP-4) of the Society of Naval Architects and Marine Engineers. The purpose of this study is to investigate and evaluate the use of Computer Aided Process Planning in the extension of Group Technology concepts to ship repair and modernization.

Conducted by CDI Marine Company, this study was performed by RADM H.L. Young, USN (Ret), former Chief Engineer of the Navy and CAPT M.R. Gluse, USN (Ret), former Commander, Norfolk Naval Shipyard.

Appreciation is expressed to Mr. Frank J. Barbarito, Chief Design Engineer, Philadelphia Naval Shipyard, for his unfailing support and review of portions of the manuscript. Mr. Barbarito's pioneering work in Zone Technology relative to the repair and modernization of surface ships undergirds much of this study effort.

Appreciation is also expressed to CDR Larry D. Burrill, Zone Technology Project Officer, Philadelphia Naval Shipyard, for his insight relative to the fine points of Zone Technology and how they relate to the ship repair and modernization process, and to RADM W.C. Wyatt, USN (Ret) for his review of a portion of the manuscript.

## ABSTRACT

To be truly competitive, the U.S. ship repair industry must divorce itself from the entrenched, archaic practices that impede the productive work effort and stymie personal initiative. The industry is married to a 50 year old systems-oriented work culture that has failed to reap the benefits of a product-oriented work structure. The application of new construction experience to repair work, specifically, group technology and zone logic, has been limited. Pockets of excellence do exist in the repair industry but, overall, progress has been excruciatingly slow. Where change is taking place, it is more a testimony to individual leadership and initiative than stated Government policy.

Industry experience has demonstrated that when computer-aided process planning (CAPP) is applied to a zone-based, product-oriented work structure, significant cost savings can be realized. CAPP exploits the principles espoused by Dr. W.E. Deming that improvement in any industrial operation is achieved by the constant, bit-by-bit refinement of the process by which work is accomplished. A system or functional approach to work execution does not provide that opportunity. Nor does it allow the creative talents of the work force to be synergistically joined.

Repair yards are captive customers of a depressed market that is essentially Government-sponsored. In a repair industry that is heavily controlled by Navy-induced, systems-oriented policies and practices, there is little stimulus for change. Initiatives are underway by the Navy to optimize work execution at the component level, but solid linkage with zone technology and computer-aided process planning is required if meaningful, cost-effective results are to be realized. Effective change can only come by joint government and industry involvement, a conclusion emphasized in the 1988 report by the Presidential Commission on Merchant Marine and Defense. The time is ripe to develop and execute a truly integrated build and repair strategy. The re-assessment of our sealift capabilities, a necessary fallout of Operation Desert Shield and Operation Desert Storm, can provide the catalyst for change.

## THE PLIGHT OF U.S. SHIPBUILDING/SHIP REPAIR

Hidden within the appendices of the comprehensive 1988 "Report of the Commission on Merchant Marine and Defense" are some very prophetic words, which, to date, have gone largely unheeded:

. . .Although U.S. shipyard management is well aware of the modern production organization methods of process lane work flow and zone/area/stage outfitting, actual conversion of the management process to take advantage of the productivity enhancing concepts has been very slow...if an infusion of federal capital is employed to fund a renewed commercial cargo vessel construction effort...as recommended...the opportunity to revolutionize U.S. shipbuilding operational management should be an integral part of the program... [1]

In very direct terms, the Commission's statement addresses much of what plagues the U.S. shipbuilding and repair industry today. Without a swift reversal in our thinking, led by strong Maritime Administration and Navy Department policy direction at the corporate level, U.S. shipbuilding will continue its downward spiral. Just as world events serve to shape the fabric of society, those same forces can change the way we do business. The Iraqi invasion of Kuwait, followed by the build-up of U.S. Forces in Saudi Arabia and the ensuing conflict, can be that window of opportunity. Virtually concurrent with the announcement by General H. N. Schwarzkopf III, Chief of the U.S. Central Command, that Operation Desert Shield was being impacted by an inadequate sealift capability, Transportation Secretary S.K. Skinner advised that he was considering asking for a revival of government subsidies to the

U.S. Maritime industry to meet future mobilization needs. The time is ripe for change. [2]

What is being advocated in that statement is a transformation of the U.S. shipbuilding and ship repair base from one that polarizes around the systems of the ship (functional orientation) to one that concentrates on the products indigenous to those systems. The principles of Group Technology (GT) and Zone Technology (ZT) provide a vehicle for such a transformation.

The principles of GT are not new to the U.S., and were described as far back as 1925 by an American, R.E. Flanders. The productivity benefits of the technology have been emphatically demonstrated by foreign shipbuilders, but it has not been widely accepted in this country. In general terms, GT is the operational alignment of production resources, including people, equipment and work products., into self-contained groups, each of which share common characteristics in the manufacture of components, either at the final or interim product level. Zone technology and zone logic - the terms are used interchangeably - refers to the geographic or area control of work when GT principles are applied to a shipboard environment. While a general lack of understanding of GT does prevail, when all is said and done, a leadership vacuum has thwarted the recognition of its merits.

Admiral Frank B. Kelso II, Chief of Naval Operations, in his remarks to Shipyard Commanders at the 31 July 1990 NAVSEA conference on industrial management, addressed the challenges that must be met if our Navy is to maintain its preeminent role as a viable instrument of U.S. foreign policy. Unlike many speeches, the gloves were taken off when he singled out the areas that need immediate attention if the trends of the past years are to be reversed: (1) the need for a competitive environment; (2) the importance of finding new ways to manage in detail; (3) that total improvement can only be realized by constant improvement of the process by which work is accomplished, with a direct reference to Dr. W. Edwards Deming and his principles of statistical quality control; and (4) that leadership, not the worker, is at the root of much of what is wrong in U.S. shipyards.

The salvos directed by Admiral Kelso could not have been more on-target, but they fell short in one vital area: his remarks were directed at an audience whose primary concerns were that of ship repair. Shipyard leadership by itself will not achieve the results required, particularly in ship repair. In a very fundamental sense, a product-oriented work culture demands a change in both the style and structure of operational management. Herein lies the problem. Change requires a recognition that the systems-oriented work structure that has been cultivated over the years has run its course, and that it is time to adapt to more innovative approaches to work execution. That can happen only within an atmosphere

conducive to change. To many leaders in the ship repair industry, today's challenge is one of sustaining employment levels in an era of diminishing workload. When survival is at stake, there is little time to experiment with "new ideas" when quick returns are not in the offing. To others, there is no need for change, when repair work that is predominately government-sponsored is routinely allocated under the guise of mobilization base requirements, and new ship awards are competitively limited to a select few. In a repair industry that is heavily controlled by government-induced, systems-oriented policies and practices, the impetus for effective change can only come by joint government and industry involvement. The seeds for change can be sown at the working levels, but a full harvest requires direction from the top. The Commission foresaw this need for joint action in its Finding No. 22:

In the past, many government programs have addressed only parts of the maritime problem. Coordinated action is now even more essential. To avoid wasting private and public funds, and to address the situation effectively, government leadership (underscoring added) is required to ensure active and constructive cooperation among government, business and labor to make the U.S. maritime industries more productive and cost-competitive in world trade. [3]

In a recent report on the U.S. shipbuilding industry, the Naval Sea System Command reported that the capability of shipyards to build large ships was now about 50% of what it was in the early 1980's. [4] Tables 1 and 2, which follow, are derived from data available in the Commission's report and graphically illustrate the precipitous decline in our maritime capability.

Table 1. Core' Shipyards in the United States.

	1982		1988	
	Shipyards	Production Workers	Shipyards	Production Workers
Largest Private	5	57,500	5	57,600
Naval	8	39,500	8 <sup>2</sup>	33,000
Remaining Core	67	46,800	44	23,900
Total	80	143,800	57 <sup>3</sup>	114,500

<sup>1</sup>Core shipyard defined as "full service", with ability to build or drydock a ship 400 ft. long and 68 ft. in beam.

<sup>2</sup>As of Sept. 1990, under review was the closing of one or more Naval Shipyards, with the downsizing of all eight Naval Shipyards another option under consideration.

<sup>3</sup>As of Aug. 1988, four core shipyards were operating under Chapter 11 bankruptcy protection.

Table 2. Comparison of U.S. Ship Operating Companies, 1970 and 1980

	1970	1987	% Change
Liner Companies	21	14	-33%
Number of Ships	458	137	-70%
Tanker Companies	68	48	-29%
Number of Ships	299	238	-20%
Dry-bulk Companies	21	16	-24%
Number of Ships	32	26	-18%

Comments: (1) 69 commercial ships were on order in 1980. One ship, the first commercial ship ordered since 1984, is now on order.

(2) U.S. shipbuilding is oriented almost entirely to government work, mostly Navy, with 95% of that new construction concentrated in five private shipyards. [4]



## THE FORCES OF COMPETITION

The devastating impact of foreign competition on U.S. shipyards has been well-documented over the past decade. And while out-dated arguments are still being put forth that lower labor rates in foreign shipyards have been the true cause of the demise of U.S. shipbuilding and repair work, those same arguments-fly in the face of the, productivity gains being realized by shipyards actively pursuing a product-oriented management philosophy. Where changes have taken place, competitive pressures have been a central forcing function. Increasingly, new construction shipyards in the U.S., particularly those involved in major Navy shipbuilding programs, are shifting to zone construction and outfitting. In the process, they have also come to realize that Group Technology can ameliorate the impact of skills shortfalls in many areas. But the full embrace of a product-oriented work structure has been painstakingly slow. In a limited sense, the Navy has given tacit endorsement to group technology by its incorporation of modular drawings into the deliverables package of some shipbuilding contracts. However, this is little more than a short-term step on the part of the Navy, with the expectation that final construction costs will be lower. Furthermore, there has been no tangible spillover of these actions onto the ship repair side of the house.

These same forces of competition do not come into play for repair work. Private repair shipyards find themselves being

captive to a depressed market, and one that is heavily - dependent on government sponsored work. And over the years, Navy policies and practices associated with a systems-oriented maintenance strategy have steadily, but consistently, influenced the operational management structure in place at each of those shipyards. This is not an unusual situation. When a company has one primary customer, the administrative practices that evolve frequently tend to parallel or mirror those of the customer, if only to facilitate the work flow process. With many of the shipyards already operating on the margin, there is little stimulus for change, particularly when those changes represent an upfront investment that cannot be quickly recouped when executed by individual yards. This point comes home in dramatic fashion in situations where there is minimal rollover in work package commonalities applicable to follow-on availabilities. Competition is not a forcing function for change in the public sector either. With the preponderance of available Navy repair work allocated to the eight Naval Shipyards based on mobilization requirements, true competition does not exist in the public sector. Competition sheds the insulation that surrounds the inefficiencies of an industry, and the costs of operations - true costs - are basic to that principle. The Navy Industrial Fund provides little support for that axiom in the public sector.

The Navy Industrial Fund, in excess of \$14 billion, is a revolving fund designed to free more than 50 Navy designated

industrial and commercial activities from annual appropriations. Established in 1977, it functions in a "buyer-seller" environment, and is directly comparable to the corporate profit center concept that prevails in the private sector. But the parallel stops there. Stabilized manday rates (SMDRs) were developed principally to ease the budget preparation process so that the customer could plan, budget, and execute without worrying about cost escalation. This allows the seller, the shipyard, to recover losses or return prior year gains at the end of the fiscal year periods by virtue of an activity group payback feature in the corpus. But SMDRs, set approximately two years prior to execution, do little to strengthen fiscal accountability. And where is the incentive for improvement by an individual activity when losses from poor performance are routinely recovered from the corpus and gains for good performance are paid into that corpus for subsequent distribution to other activities operating on the margin or in a loss mode? The creation of the SMDR, in sum, has removed all vestiges of any competitive influence on performance.

In his efforts to streamline the management of Naval Shipyards, Secretary of the Navy John Lehman, in 1985, directed a series of actions designed to incrementally dismantle the SMDR at the activity level, but leaving intact the stabilized rate concept at the NAVCOMPT/DOD interface and at the fleet level. It was a forceful action designed to give visibility to the true costs of

industrial operations in the public sector. But with his departure in April 1987, full implementation of the initiatives was stymied.

Interestingly, this same issue of accurate cost accounting was raised in 1984 by the National Research Council's Committee on U.S. Shipbuilding Technology, when it concluded that the Navy's performance measurement requirements did not lend themselves to modern shipbuilding methods. While the basic problem was patently different from the problems inherent in the SMDR structure imposed on public shipyards, the underlying issue of conformance to DODINSTR 7000.2 was the same. At issue was the Navy's instructions associated with the Ship Work Breakdown Structure (SWBS) for weight and cost programs to account for product-oriented work and management methods. That Committee also concluded that an expanded work breakdown structure could be developed to accommodate system-related cost and progress reporting (such as functional design and system testing), as well as interim product and product zone-oriented reporting. An extended system would allow efficient use of current computerized product-oriented management systems and, more importantly, it would bring current cost, schedule and progress reporting requirements into closer compliance with the intent and purpose of DODINSTR 7000.2. This point appears to have been lost on the financial community, for meaningful progress in this direction is not in evidence.

The fact that public shipyards polarize around the people aspects of the organizational structure, rather than the institutional process itself, helps explain why the transition to a product or zone-oriented management base has been so slow in ship repair. There are a few pilot programs in existence but, with the exception of Philadelphia Naval Shipyard, the public shipyards have merely nibbled at the fringes of a product-oriented work culture. And where progress has been demonstrated, it has been more a testimony to that shipyard's leadership and initiative, rather than any stated Navy policy so necessary to nurture it to full maturity. It is the nature of bureaucracy that sharp or sudden moves be minimized. When change is in the wind, the risk-free option of a pilot program is always an avenue that creates the illusion of action. But where is the risk in a management concept that has been time-proven by such shipbuilding giants as Ishikawajima-Harima Heavy Industry Co., Ltd. (IHI), in Japan, and to use a non-shipyard example, our own IBM? The proof is in performance, and that has been demonstrated by IHI's construction and overhaul of more than 3000 ships and other major end products using ZT principles. IBM needs no introduction.

To gain a fuller appreciation of the benefits of a product-oriented work structure, there must be a recognition at the outset that you win or lose the performance battle on the waterfront, not in the recesses of any hierarchical structure remote from the day-to-day fray. All of that becomes mere window-dressing to the more

exacting toll of what is going on at the deckplate level. Even the presence of a learning curve as a demonstration of achievement is insufficient. As Dr. W. E. Deming's principles of statistical control have so aptly demonstrated - principles embraced and revered by Japanese shipbuilders - examination of processes at the macro-level, i.e., system or functional level, obscure product and process similarities that exist at the micro level. Complacency is but a short step to failure, and any organization that views its current performance as "good enough" is doomed to fail. Dr. Deming is the enemy of the status quo. Central to his 14 principles of management is that improvement in the production process comes by constant, bit-by-bit refinement of the individual pieces or products that constitute the whole. Only by a constant, iterative effort that concentrates on improving each product, whether the basic process by which the product is achieved or the design of the product itself, can productivity be improved, costs lowered and the overall learning curve be pressed further downward.

## TRADITIONAL WORK PACKAGE PREPARATION

The quality of traditional, systems-oriented process planning in public shipyards is weighted heavily-by the experience level of the lead planner. In the main, planners are ex-tradesmen. Regardless of how well-intentioned, they are products of their background, with new methods and new processes essentially limited to those that have been gleaned from their waterfront experience. It is also a fact that some managers resist the use of new time and labor-saving technologies, such as computers, due partly to the fear of the technology, but mostly to the fear that technology can replace people. As with all work, personal motivation also enters into the picture. Without a direct and genuine interest by the planner as to what really is happening at the shop floor or deckplate levels, the quality of planning will suffer. The dynamics of change are real in ship repair, and the planner must be intimately familiar with the job's constraints and the problems being encountered by the trades. All too frequently, however, planners are satisfied with solely a desktop planning effort, rather than verifying the adequacy of their software product at the worksite itself.

In this discussion, it is important to understand that planning is not the responsibility of any one functional code. A lead planner may have overall responsibility and final sign-off authority on a job order, but that work document should be viewed

as the coordinated actions of engineering, planning and estimating (P&E), scheduling and material procurement. This required interaction is vividly illustrated in the series of action steps leading to material procurement. Direct material accounts for 25% or more of the final repair costs in any availability. Based on working drawings developed by engineering (design), generalized bills of material are provided to P&E. Planning and estimating translates those material requirements into material specifications, including National Stock Numbers (NSNs), manufacturer's part numbers for purchase specifications, and job order material listings that allow material codes to do their job within a specified timeframe. But when each functional area acts in series, based on the information it has been provided, the potential for error is high. Buyers should not be consulting engineering codes solely in response to vendor inquiries concerning non-conformance to specifications, nor should engineering be assisting P&E on an "as-called" basis. Rather, all parties need to work in concert from the outset since inadequate technical data is the leading cause of incorrect repair parts and components being delivered to the waterfront, a fact borne out by the large number of job material listings (JMLs) that are returned for additional information. A systems-oriented approach to job order preparation, moreover, treats each of these issues in isolation, negating a standard solution to what is really a common problem.



Planners are also victims of the management policies that have been imposed. The fact that some shipyards strive to meet the artificial goal of having all known work issued to the trades at the start of an availability further detracts from the quality of the planning. Once used as one of many management indicators to evaluate the "readiness to start" an availability, this rush to put paper in the hands of the waterfront trades, frequently months in advance of actual need, now only leads to sloppy planning and poor work execution. (The 1985-86 Coopers & Lybrand Naval Industrial Fund review of the eight public shipyards found that, on the average, some 20% of the material ordered for overhauls and repair work was not used [5]. Against a Direct Material Inventory (DMI) and shop stores inventory of in excess of \$500 million, this is certainly not an insignificant figure. Unfortunately, some shipyards view excess material as merely the price of doing business in a line of work beset with unknowns. But the impact of excess material transcends the simple dollar value of the material held. The tasks of ordering, expediting, inspecting and warehousing material that is not needed ultimately equates to more people being required to do the work.)

Once issued, moreover, job orders tend to remain as written, unless the work scope is changed by the customer, or the work content is challenged by the trades as being either impractical, ambiguous or technically incompatible with the work at hand. And it would not be unusual to find three variations of the same job

if written by three different planners. The degree to which similar work on follow ships is refined and improved is frequently dependent on the extent to which job order history files - the "lessons learned" - are utilized. As a simple check of how golden promises can turn to dross, shipyards need only to check the number of job order revisions issued and the number/frequency of design liaison action requests. And as that planning experience base is diluted, the learning process starts all over again. Job order reserves, including the application of contingency allowances or J-factors to allotted hours, are a function of planner experience and operating style, with shop performance factors swinging in the balance. (In public shipyards, "J-factors" come in various forms and can include allowances for in-scope growth, contingency factors to cover potential shipyard errors and performance inefficiencies by non-production direct labor. In some shipyards, contingency factors even cover situations for design and planning and estimating errors, as well as rework. Those practices lend little to a credible estimating system.)

The paper empire that has resulted from this scenario defies description. The two to three page job order of the 1950's - early 1970's timeframe has been supplanted by all-encompassing documents that can reach thirty or more pages in length, with an equal number of references, as the originator seeks to cover all bases and to anticipate all circumstances that might arise at the worksite. More, rather than less, becomes the rule of the day. A recently-

completed review of one highly-specialized area of ship repair work, for example, revealed that work requirements had undergone a three-fold increase in the 1955-1990 timeframe. Given the tight controls placed on this work and the stringent review that it receives, it is highly likely that other ship repair areas have realized a substantially higher increase in the paper demands associated with their work. Environmental and safety requirements generated over this past decade, by themselves, do not account for this avalanche of paper. And when in doubt as to who should receive a copy of the work instructions, all too often the solution is to simply expand the distribution.

If the Navy runs the risk of being over-whelmed by its own paper, the need for accurate technical documentation is even more pressing. The existing Navy technical data repository is based on film or copy data with little automation. The manual steps of indexing, storage, retrieval, cross-referencing, updating, and refiling,, by themselves, are highly error-prone and frequently culminate with the mechanic, responsible for the work, being the recipient of drawing packages that are incomplete, outdated or unreadable. It goes without saying that the costs associated with this manual process are staggering. The fact that in excess of 6 million drawings are maintained in the central files of Norfolk Naval Shipyard alone illustrates the size of the problem. And Norfolk Naval Shipyard, like all shipyards, is not classified as one of the Navy's eight primary engineering drawing repositories.

The issue is so acute that more than one shipyard shop has attempted to establish its own data files, in the shortsighted belief that it would solve their compelling need for accurate technical documentation.

For repair yards, help, hopefully, is on the way in the form of EDMICS (Engineering Data Management Information and Control System). EDMICS, a subset of the Computer-aided Acquisition and Logistics Support (CALs) initiative, is moving to automate the Navy's engineering drawing repositories using optical disk storage technology. As of February 1991, Operational Test and Evaluation (OT&E) of the first site (Naval Ordnance Station, Louisville) was essentially complete, with Major Automated Information System Review Council (MAISRC) scheduled for the near future. When implemented, it portends a quantum leap in the ability of shipyard operations to support the productive effort. Funding remains a major obstacle. For the present, however, plan vault operations remain virtually on the same plateau as has existed over the past 40 years - labor intensive, slow response to system needs and prone to inaccuracies and lost data.

But the fortunes of any shipyard are ultimately determined by what transpires at the production worksites. At this point in the discussion, it is important to gain an insight into the environment in which the waterfront supervisor is expected to do his job when operating within this systems-oriented management structure.

## THE WATERFRONT SUPERVISOR

In any complex endeavor involving disparate disciplines, there is the real and constant potential for a mismatch between the job assigned and the resources required to accomplish the objective. Ship repair is no exception. The sheer magnitude and complexity of blending the efforts of 8,000 or more people into a cohesive structure, one that synchronizes the accomplishment of work detailed frequently at the 8-10 manhour level, can defy comprehension by even those intimately familiar with the process. Like new construction, the repair of ships is characterized by an overlap of functional responsibilities, with each shipyard department susceptible to the pressures of its own internal priorities, work constraints and imperfections.

And when those disparate work efforts finally come into congruence at the job site itself, any bottleneck can create disruption and even chaos, particularly when pressures mount to meet key events. Mismatches between work assigned and the resources provided come in a variety of forms, whether it be required material not in hand, inadequate or confusing technical instructions, a skills shortfall for the process described, or the basic challenge of work space competition with other tradework that is in progress. Up until this point, each organizational entity believes it has done its job, at least within the constraints under which it functions. For them, it is time to move on to the next

problem. Placing order into the process - aggregating the pieces provided, managing the exceptions and integrating those elements into some orderly semblance of work progression - becomes the responsibility of the lead shop assigned the work. And in the center of this vortex stands the first line supervisor, the individual charged with actually doing the work. Jockeying multiple revisions of a drawing, frequently laden with inconsistent data baselines, along with multiple copies of the same data, can be a thankless job. In public shipyards, as well as many private yards, drawings are not routinely issued by the Planning Department with the job order that references it. It is not unusual to have drawings, applicable technical manuals, and other documentation acquired separately by the mechanic doing the work. Figure 1 is representative of the traditional planning process used in most repair yards. It is, in effect, a series operation with the final product reflecting all the shortcomings of the process that produced it.

The first line supervisor is expected to resolve those shortfalls and merge them into a doable work package. Blindly expecting that the sanctity of the job order will transcend all problems, that the aforementioned "mismatches" will magically dissolve, ignores reality. As a minimum, the traditional system-oriented documents must be broken down by the physical location of where the work is to be accomplished, material must be segregated by location and manpower allocated for the work areas available.

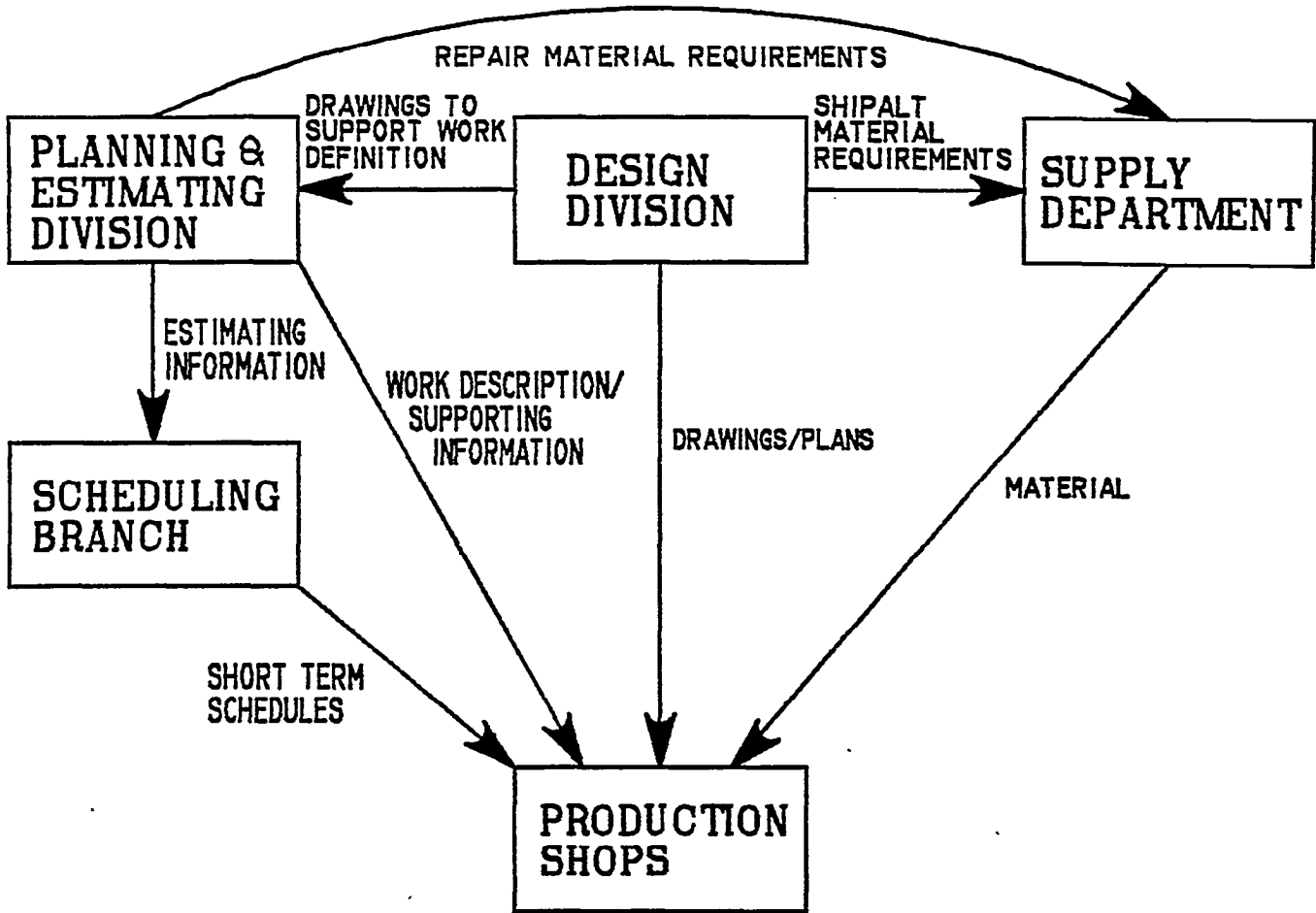

FIGURE I.  
TRADITIONAL WORK PLANNING PROCESS

The fact that this same supervisor must coordinate system line-ups, establish work boundaries, schedule support services, and may be required to resolve ships force interface issues, is of secondary consideration. At this juncture, then, the supervisor must function as both traffic cop and referee, with success determined by his personal ingenuity, initiative and experience.

Over time, solutions to each perceived symptom have been put in place, each equipped with its own charter of authority, each addressing its own discrete portion of the overall problem and, in the process, each making its own contribution to the paper morass that ultimately masks personal responsibility. Material expeditors, shop planners and design liaison engineers are the immediate examples that come to mind. This should not be construed as a reflection on those who have valiantly labored long and hard within those organizations. Rather, it is an indictment of the system that fostered the need for this degree of specialization. The authors themselves were reared in an era when exhortations such as "think shipyard" and "work smarter, not harder" were but some of the common terms in the repertoire of shipyard folklore, along with "put production on the windy corner" and "put the engineers on the deckplates". Each such pronouncement had its purpose and, backed up by policy decrees and strategy sessions, they undoubtedly served a useful purpose for the circumstances that prevailed at the time. But the sporadic performance of both public and private shipyards over the past 30 years suggests that the successes



achieved were more the product of leadership and personal charisma than any other factor. And to that same supervisor on the waterfront, they had a hollow ring, for nothing was drastically changed - at least not with any degree of permanency. Planning the job, in a fashion that met the needs of the production trades, still required that a disproportionate amount of the details be worked out on the waterfront before the start of work.

But isn't planning defined as the detailed formulation of an action program to achieve a given objective? Shouldn't the basic purpose of planning be one of simplifying work execution to increase productivity? And shouldn't the planning process be engineered to the extent that facilities and shipboard producibility and procedural constraints are routinely weighed and work shifted to earlier manufacturing stages for ease of fabrication and off-hull outfitting? And when all is said and done, doesn't it really mean that the waterfront supervisor can minimize the downtime of his work group, and exit the starting blocks, at the scheduled time, knowing that he is playing with a full deck? A serendipitous attitude by the functional codes will not achieve that objective. The extent to which these questions are satisfactorily answered rests with how well design engineers, planners, production engineers and the trades have worked in concert before the job is released for execution. In an interview concerning the challenges that U.S. industry faces in the 1990's, Mr. J. Welch, CEO, General Electric Corporation, summarized the

interaction that will be required when he stated that "... we no longer have the time to climb over barriers, such as engineering, or between people; that geographic barriers must evaporate." [6] Explicit in this interview was the need to move faster, communicate more clearly, and to involve everyone in an effort to serve ever-demanding customers in an era of technological change and intense competition. Management cannot package and distribute self-confidence, but it can foster it by removing institutional barriers and giving people a chance to win. Achieving that interaction, on a sustained basis, is a fundamental characteristic inherent to the zone technology management process. Computer-aided process planning (CAPP) is the management tool that forces this horizontal integration of work effort.

## PROCESS PLANNING

Process planning, the determination of how the authorized work is to be accomplished, can be the single-most dominating factor influencing the cost of production work. In a macroscopic sense, shipyards are similar to any industrial operation that produces a product, whether it be automobiles, airplanes or television sets. In totality, each final product is the summation of the pieces, parts and components that make up the delivered product. The repair of ships is no different in that it represents the assembly of component parts. Unlike many of its industrial counterparts, however, a shipyard may be involved with hundreds of thousands of parts in the repair and assembly process. While literally thousands of individual processes are involved in ship repair, the vast majority are repeated over and over again, whether it be on different ships or different components. Circumstances can vary, but those processes remain basically constant. By careful examination of each step in those processes - how many people required, what material needed, how long the work will take - a reasonably accurate determination can be made of the-work required to perform that process. When this information is captured in one data repository that will be used for all planning efforts associated with that process, the foundation has been laid for future improvement in that particular area. Herein lies the benefits of a computer-aided process system, for it is at this point that the Deming principles of statistical quality control can

be brought to fruition. (Increasingly, industry is also learning that safety is intertwined with quality, for safety is dependent on understanding the processes being used. The Aluminum Company of America (ALCOA), for example, has determined that a major cause of accidents is the deviation from an approved process plan: i.e., a shortcut. But that accident is not necessarily indicative of negligence on the part of the worker, for analyses have concluded that, in far too many situations, that accident is merely identifying an inefficient process or inadequate tooling.)

In all process planning, the need for accurate information is basic to successful application, for the overall objective must be predictable performance if improvement is to be achieved. All work measurement standards stem from this premise. When the waterfront supervisor is spending a disproportionate amount of time off the worksite collecting information needed to do his job, subsequent variance analysis of planned versus actual expenditures are routinely misleading as to the underlying reasons for that performance. If nothing else, this lost motion can readily mask the root causes. Product-oriented work packages that stand on their own, however, allow meaningful analysis. But predictable performance is also not possible when the estimating base is either inconsistent or distorted by the application of a myriad of contingency factors. This mandates that those associated with a given work process share a common data file. When work is defined to the lowest practical level of detail, moreover, the entire

estimating process is greatly enhanced in that estimates are not mired in a web of competing factors so common with systems-oriented work packages. With the restructuring of work to a product-oriented format, the majority of existing engineered standards, in the main, may be found lacking without a major rewrite. Achieving the elusive objective of predictable performance requires the capturing of all relevant data germane to the work package under consideration. That should include relevant data from engineered or estimated standards, as well as data elements that may be available from existing methods and standards. The planning process seldom reaches a steady state, and only by a constant awareness of what the work entails, who is to do it, and how and ~~when~~ it is to be accomplished, can reasonable performance predictions be made. Predictable performance is central to realistic schedules. There are commercially-available automated time standards (ATS) that can be linked-to the process-planning system. These cost calculation modules make it possible to predict the cost of finished parts at the shop floor level within a 5-8% accuracy range. By themselves, these cost modules can assist the planners (and others) in realizing the cost implications of their decisions. At the outset, that is until meaningful benchmark performance standards have been established, just the simple step of performing comparative analyses of like-processes at the macro level can produce tangible savings.

Computer-aided process planning (CAPP) capitalizes on the strength of computers to manipulate the literally thousands of data elements associated with production work. Just the step of eliminating the manual labor required to write or type each process plan can increase planning efficiencies by 20% or more. When

applied to the preparation of work packages, CAPP is the sorting tool that organizes, refines and electronically transmits production data in the format and sequence in which work is actually accomplished on the waterfront. By inputting all pertinent design and manufacturing data associated with the product into a common data repository, and making that data accessible via a mainframe hookup, all information and changes are given immediate visibility to the users. It is, then, a communication tool designed to meet realtime needs and which, depending on the degree of sophistication desired, can be linked to different computer-, -aided design and computer-aided manufacturing (CAD/CAM) systems. There are other applications as well. This incorporation of add-on features, however, illustrates the importance for shipyards to have a strategic plan for the use of computers, particularly when access to the mainframes is a prerequisite. Without a prioritizing of needs, both as to value added and their relationship to the predominate objective of supporting the productive effort, shipyards will routinely face the dilemma of system saturation and slow response. The constant demand for, and proliferation of, redundant or unnecessary status reports, by themselves, can quickly overwhelm a system's capacity to respond and relegate CAPP to a

secondary function. Many shipyards are already encountering lock-out periods in the futile effort to ration mainframe availability and still serve all customers.

A classification and coding system is obviously needed if data is to be retrieved and analyzed, and that includes relevant design, production and other features of the parts or products involved. But one system will not meet the needs of all departments, for each requires different types of information. Design, for example, may be interested in coding drawings into families (groups) of parts with similar manufacturing features that use common processes, but Production and Purchasing may not. Successful classification and coding systems can be developed in-house but, in some instances, it may be more cost-effective to use commercial software.

Zone logic increases the productivity of design and production work by taking advantage of the underlying similarities in the products or subassemblies, those common characteristics classified by both design and production attributes. ZT is, in effect, the integration of many of the same common principles, tasks, and problems that find their way into job history files or are retained in the little "black books" maintained by lead planners. The goal is standardization, not only to eliminate unnecessary duplication, but to also determine the optimal utilization of material, time and personnel. Work packages, then, should reflect an accumulation of experience, and every available data base should be tapped for

inclusion in a data repository that can be routinely updated. The potential for applying new construction experience to repair work, particularly from those building yards utilizing modular or sectional construction drawings (SCDs), should be obvious.

Standardization of work content for common products or interim products is achieved by requiring planners and designers to share a common data base. The discipline associated with information retrieval, by itself, imparts a more structured approach to the development of work package content, and provides the means for the constant, iterative micro-improvement steps espoused by Dr. Deming. This classification and coding system should be based on characteristics that are product-independent, wherever possible. A centrifugal fire pump, for example, is a centrifugal fire pump. The manufacturers may vary, their capacities differ, and their parts be of different sizes, but the process by which they are overhauled remains essentially the same. (Analyses performed by one centrifugal pump manufacturer, for example, revealed that, of the 50,000 - 55,000 parts used in its various models, only some 1,000 of those parts, such as gears, spindles and other similar components, represented different shapes requiring different manufacturing processes.) If customized to specific products, the work packages are of limited value on different ship types. It is not recommended, however, that a menu of prestored sequences of operations for given processes be developed, for this approach can accommodate only a limited number of variables before it becomes



top-heavy. Regardless of differences in functional systems, comparable work packages for different ships of the same type can be readily modified if product independent characteristics are used.

New construction yards have recognized that the preponderance of their production costs are associated with joining things together; i.e, plate or piping joints. While the dollars associated with cutting plate are relatively small, the cost-savings associated with precise or "neat" cuts are high, particularly when weld preparation time can be minimized. Can sufficient dimensional accuracy be maintained to specify neat cuts? Castings are typically cheaper than forgings and weldments, particularly where small quantities and complex configurations are involved. Which way should the shipyard go? The features of joints, the materials used, their configuration and their ease of fabrication, are just some of the critical elements in the overall cost equation. Butt joints may be lighter and cheaper to buy, but socket joints are easier to produce. What are the cost trade-offs? If series 300 CRES is specified, is it cheaper to use 316 CRES rather than 304L? How does it impact the trades? By proper engineering at the outset, adhering closely to the tenets of form, fit, and function, and not over-engineering the product, significant cost-savings are being realized as the more cost-effective options with broad applications are identified. In somewhat loose terms, this upfront sorting function - looking for

commonalities at the product or interim product levels to lower manufacturing costs - is analogous to the process that any good new construction purchasing department, exercises in the procurement of material. By sorting, grouping, and aggregating the material control numbers assigned to the parts lists on the hundreds of drawings involved, smart bulk-buy or make-buy decisions can be executed.

This same upfront design and engineering effort can be applied to repair work, but, at this point in time, it remains an opportunity waiting to be exploited. There have been some isolated exceptions, however. In one such example, Mare Island Naval Shipyard examined the drawings associated with 300 parts that had been recently manufactured in its machine shop [7]. More than 60% of the parts exhibited significant similarities to one another, permitting the grouping of specific manufacturing steps to improve tool utilization and reduce costs. Seven percent were either identical or close enough to share identical manufacturing processes. This action would have been greatly facilitated had a product-oriented classification and coding system been in place, with the requirement that Design routinely sort drawings to identify common products or interim products to like manufacturing processes. The elimination of the work effort for just a few duplicate parts, whether they are the final products or interim products, can result in significant savings. By minimizing design duplication, as well as the costs associated with the preparations

for manufacture (which includes the process plan itself and the set-up time for jigs and fixtures), a simple, flexible retrieval system can readily yield savings in the 5-10% range. And, in some cases, there is no need for shipyards to develop their own computer software. Off-the-shelf modules are readily available on the commercial market to address many numerically-controlled manufacturing processes. If necessary, they can be tailored to a company's practices and made more user-friendly.

When engineering and planning tasks are treated in isolation, as is so prevalent in a functional or systems-oriented structure, the across-the-board, quantum leap forward is not possible. If the Navy is searching for the means to interject this product-oriented approach into the design and engineering functions associated with ship repair, a logical jumping-off point is in the design of ship alterations. By routinely requiring planning yards, particularly those with Expanded Planning Yard (EPY) responsibilities, to engineer the ship alteration drawings in a zone logic format, the influence of those techniques will realize significant cost-savings. Not only is the SHIPALT process itself enhanced, but it allows the overhaul yard the capability to integrate the repair work package with the SHIPALT effort, thereby optimizing installation planning, execution and manning.

The level of detail required for the planning of product-oriented work directly influences the accuracy of material buys.

On older ships, configuration control is acknowledged as a serious problem impacting material procurement. Yet, it is not unusual to find re-buy rates in the 5-6% range or lower when effective horizontal integration of engineering and planning codes has been achieved in a product-oriented work structure. Philadelphia Naval Shipyard, in fact, has demonstrated the practicality of that step in its preparation of an LPH ship alteration package, one that was successfully executed by a private shipyard. And in those situations where a building yard, already using zone technology, also has EPY responsibilities, much of the informational grouping and analyses required would have already been accomplished.

There is a very subtle but powerful reason in having EPY's "prime the PWBS pump," and that is in the area of producibility - optimizing the manner in which work is done at the production level. The concept of designing for production is usually not an option that receives serious consideration in the development of an acquisition strategy. This is partly due to the perception that it might give the winning shipyard an unfair competitive advantage: but certainly the fear of losing control, or just not understanding the procedures by which work is or can be accomplished, enters into the decision process. The vast majority of Navy shipbuilding programs are rigidly controlled by the specifications invoked, with new production methods and processes developed within the constraints of those requirements. Production innovations that fall outside those boundaries are subjected to the tortuous rigors

of the contract change process. When designs are controlled by the shipyard, particularly at the preliminary design stage, that shipyard can directly influence the methods and processes by which the work is done. The development of ship alterations presents such an opportunity. There are standards that must be followed in the development of ship alterations, but sufficient specification latitude does exist to allow meaningful producibility changes. By specifically tasking Planning Yards to develop SHIPALTS using a product-oriented work structure, and making producibility an inherent part of that tasking, two noteworthy objectives could be met. There would be no fear of giving any shipyard a competitive edge, since SHIPALTS are but one part of a total work package that is competitively awarded. More importantly, it would start the slow transition to an across-the-board adoption of a repair methodology that would be product-oriented.

## THE PHILADELPHIA EXPERIMENT

In those instances where repair yards have started the transformation to a product-oriented work base, the central focus has been on the ship itself. None, for example, have matured to the extent that products or interim products are routinely classified into groups (families) according to the production processes by which they are produced. As stated earlier, application within the shops has been limited. And this is understandable. Changing the attitudes and thinking of people who have been reared in a traditional functional organization is difficult. Despite the major strides Philadelphia Naval Shipyard has made in the application of zone logic to repair work, it was recognized at the outset that the change represented a cultural shock to many and that institutional barriers had to be overcome. Under these circumstances, it is not practical to eat the elephant at one sitting unless you are inviting chaos. It is far better to put in place the basic product-oriented work structure and fine-tune the operation once the initial barriers have been overcome.

Zone technology is relatively easy to understand, but fighting resistance to change is not an easy chore, and it certainly can't be viewed as a short term effort. Only a top-down management approach, with strong leadership involvement throughout, will nurture its development. The first step must be one of getting the workforce on board. Without that action, entrenched interests will

undermine its progress. That step must be close-coupled with the gradual, but steady, introduction of systems-oriented data into the product work breakdown (PWBS) structure that fuels zone technology. Absent that gradual transition, people will be overwhelmed by masses of data in different forms. It is a case of starting small, but keeping the ultimate objective constantly in sight, with the speed of development tied directly to the leadership capabilities" of the individuals in charge. And it should not be implemented in the expectation of significant near term savings. Industry reviews, supported by Dr. Deming, suggest a 3-5 year timeframe before major payback is realized.

At Philadelphia Naval Shipyard, indoctrination into the principles of zone logic started with special briefing sessions for all senior managers, followed in sequence by the middle managers and design engineers. Zone technology experts from the Ishikawajima-Harima Heavy Industry Co., Ltd. (IHI) were brought in on a consultant-basis to accelerate the training and to facilitate the implementation steps required. In many instances, one-on-one discussions were held to ensure that there were no misunderstandings as to the course and speed the shipyard was embarking on, and that each recognized the importance of the initiative. First line supervisors and union leaders were similarly briefed. (As a point of record, production trade unions were not in direct opposition to the changes being advocated. Resistance to change should not be confused with a valid need to

know and understand the reasons behind management policies, particularly when they represent a radical shift in the way work is accomplished. Mr. Paul J. Burnsky, President of Metal Trades Department, AFL-CIO, properly expressed this point in his July 1988 statement before the Commission on Merchant Marine and Defense, when he stressed that "Shipyard labor has proven again and again our willingness to modify traditional work patterns to help achieve mutually advantageous production objectives". [8] A climate of openness, fostered by shipyard management, facilitated this cooperation.) Special training sessions were conducted for the 800 trade personnel who were assigned to the **USS KITTY HAWK** (CV-63) zone technology pilot project. These trade personnel were assigned to one of the nine product trades that were established, with each product trade representing a functional work group capable of multiple tasks. See Figure 2. To some, this smacked of cross-crafting, rather than the establishment of functional work groups. In reality, it was an extension of the same horizontal integration of work effort being applied to work planning. Assigned to one foreman, these multi-talented product trades not only improved trade coordination, but they reduced the time lost waiting on assist trades. A 10-person Zone Technology Office (C3201), with direct access to senior shipyard management, was established and charged with resolving all execution problems. The code number assigned clearly indicated that it was the bridge between the Production Department (C300) and Planning Department (C200) in the resolution of all interface issues.



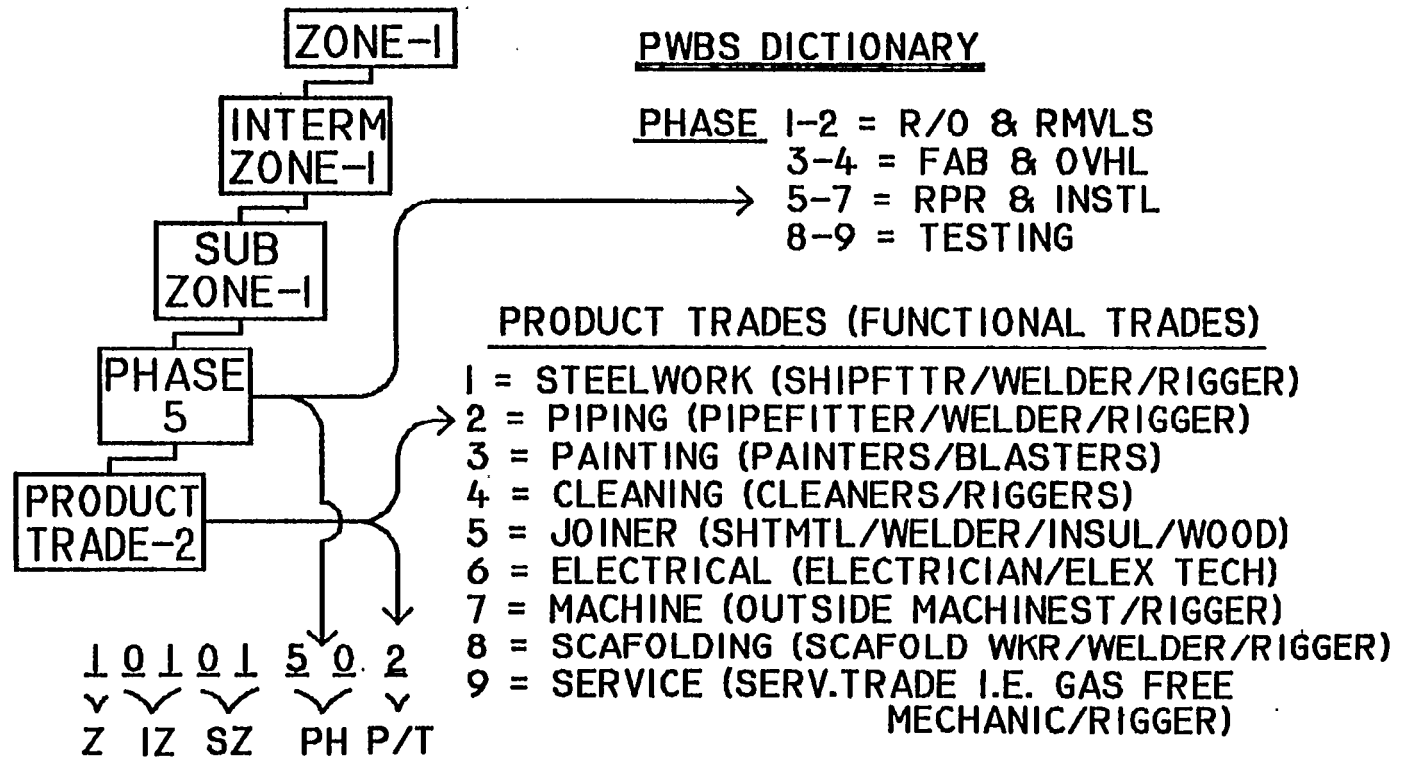

WORK BREAKDOWN STRUCTURE  
 RELATIVE TO PWBS  
 (UWI NUMBER)

FIGURE 2.

PRODUCT WORK BREAKDOWN SYSTEM CLASSIFICATION AND CODING SYSTEM

Weekly progress meetings, chaired by senior management, were instituted to demonstrate that this was not a one-shot infusion of time and effort being devoted to an initiative that had a short half-life. Zone technology was, in fact, there to stay. To further foster an atmosphere of teamwork, copies of the Shipyard Corporate Plan, which included an overview of zone technology and the shipyard's competitive strategy, were sent to the homes of each employee. The shipyard has one major objective in sight: to apply zone technology to all ships in 1991.

What transpired at Philadelphia Naval Shipyard was the labor-intensive and arduous chore of manually realigning the way in which work would now be executed at the shipyard. The details of this effort have been fully described at the 24-26 August 1988 Ship Production Symposium in Seattle, Washington [9], and in subsequent publications. But the magnitude of the task warrants touching upon, if only to underscore the challenges that the shipyard overcame. For the initial plunge, yard management focused their attention on a 400,000 manday segment of work that represented one third of the total USS KITTY HAWK (Cv-63) Service Life Extension Program (SLEP). It required that the traditional system-oriented job order system, which broke the work down by 14 production shops, as well as 147 work centers, be analyzed and transformed into a product-oriented format aligned to the geographical areas or zones where the work would be performed on the ship. In order to

accommodate the level of detail planned for each individual work package, KITTY HAWK was divided into four major zones - which were further divided into 117 intermediate and 338 subzones. WS-17 zone managers, with line authority over the product trades, were designated for each major zone.

For planning purposes and to establish work priorities, work was initially defined at the intermediate zone level. Detailed work packages would follow, and would be dependent on final work definition. As part of that detailed planning, each work item was reviewed against its applicable system drawing and those portions required for the accomplishment of the work extracted. Each work package was sequenced and issued on a product trade basis. As a basic objective, there would be no random work starts as is prevalent in a system by system approach to work accomplishment. Work would be scheduled with zero float and would be completed on a zone by zone basis, thereby allowing tighter management control. The underlying thrust of this total effort was to use the same people (product trade) to do the same type of work (work phase) in the same location (subzone). The glue that held this massive realignment effort together was the product work breakdown (PWBS) necessary for accountability and reporting of production work. The classification and coding system that evolved employed a 5-digit job order field to indicate location and a 3-digit Key Operation (KeyOp) field to specify the work phase and product trade. See Figure 2. While manhour allowances and other performance

indicators were predicated primarily on historical KeyOp data extracted from existing systems-related files, that was appropriate. The important task was to set in place the basic structure, with refinement to come later. Comparable classification and coding systems can be developed to support design work, particularly when the emphasis is on the grouping of like manufacturing processes, with the production and design systems interactive at the first tier document level for common products.

And important to this entire project, a minor revolution of sorts was taking place: increasingly, the use of computers was being applied to labor-intensive efforts of sorting, arranging and refining of the mountains of data required to formulate the work packages required. A primary focus of the initial automation efforts was to provide direct correlation between the traditional 50-year old Navy Ship (Systems) Work Breakdown Structure (SWBS) and the new Product Work Breakdown Structure (PWBS) classification and coding system.

Experience has shown that an operational management structure that serves only the perceived needs of the financial community does not necessarily support the needs of production trades, and, when carried to extremes, is doomed to failure over the long term. What evolved in this case, however, was a work format that supports the way in which production does the work, yet provides the

financial community the tools to account for costs accrued. With the maturing of the shipyard's Zone Logic Data Base Management System, each line of work is now entered into the computer system, with the data sorted by zone number, phase number, trade number, job description, budget hours, parent job order number, supplement number and drawing number. Subsequent sorting by subzone, phase, and trade is dependent on sequencing in accordance with the master schedule. Figure 3 is a schematic of this information flow process. For Philadelphia Naval Shipyard, development of a cost accounting system to accommodate product-oriented work processes has been a case of playing with the cards it has been dealt. Improvisation has imposed an added administrative burden, but it is functional.

Now comes the more demanding challenge of sustaining those gains and putting in place the infrastructure that will ensure its future growth. More than 1500 additional personnel have since been trained, and the introduction of zone technology workshops lends credence to the belief that the Shipyard does not intend to rest on its laurels. By constantly sensing the pulse of day-to-day execution of ZT, including formal presentations to the Shipyard Commander and other senior managers, the cultural barriers are being rapidly demolished. No transition of this magnitude is without its problems, but by steady and consistent attention by senior management, each issue is amenable to solution. The issue of the zone manager having line authority over personnel from

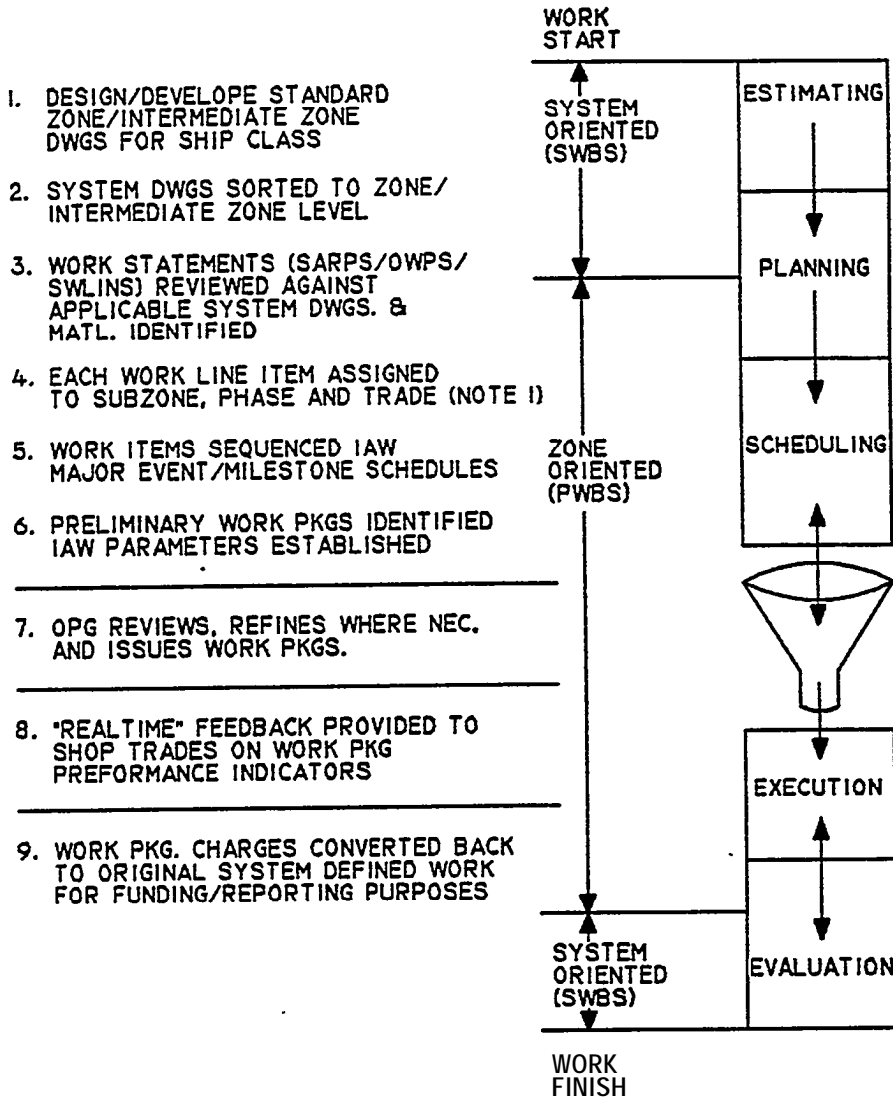

THE TOTAL SCOPE OF REPAIR WORK IS ROUTINELY NOT KNOWN AT THE START OF AN AVAILABILITY WITH A LARGE PORTION OF THE UNKNOWNNS DEPENDENT ON INSPECTIONS. ACCORDINGLY, THE INITIAL ASSIGNMENT IS TO THE INTERMEDIATE ZONE, FOLLOWED BY ADJUSTMENT TO THE SUBZONE LEVEL AS WORK IS DEFINITIZED.

**FIGURE 3.**

INFORMATION FLOW IN A PRODUCT-ORIENTED WORK STRUCTURE

different shops, for example, was perceived by some as undermining the traditional authority of the shop head. Like so many issues that represent a cultural change, this problem could not be allowed to fester. In this case the solution came from the Group superintendents. Traditional responsibilities for in-shop work would remain unchanged, but Group Superintendents have been given specific zone assignments, and that includes work that crosses all trade lines within the assigned zones.

The introduction of a product-oriented work structure is the management of change in the classic sense of the term. The USS CONSTELLATION (CV-64) SLEP, in its initial phases at this writing, is the part of this evolutionary process. While the basic techniques are similar, the breadth of the undertaking has increased dramatically. Engineering and production both drive the zone strategy. Design, P&E, Supply and Production - right down to the details of work packaging - are moving into an era of total integrated planning for production. Subsequent reviews will attest to its success.

## PRODUCT-ORIENTED WORK PACKAGES

Where shipyards have made the transition to a product-oriented work structure, there is general agreement that the format and specificity of the work instructions are critical elements in the successful application of group technology, or its derivative, zone technology. Philadelphia Naval Shipyard refers to this step as "outfit planning", while other shipyards appear to be more comfortable with the term "detailed planning". Regardless of terminology, they all share the common objective of avoiding the single greatest loss that plagues all industrial efforts: worker downtime, the lost motion that delays work execution and escalates the cost of doing business.

Computer-aided process planning, conducted within a product-oriented work structure, provides the tools and data repositories to eliminate the vast majority of these work instruction problems. Whether they are called Unit Work Procedures (UWPs), Unit Work Instructions (UWIs), C-Events (as at Philadelphia Naval Shipyard), Component-Oriented Technical Work Procedures (COTWPs) or just work packages (and there is a collage of other terms in use by the shipyard community), all share some very fundamental, yet common, characteristics when repair work is accomplished by zones:

1. The work instructions are self-sufficient, meaning that the work package is a stand-alone document with no supplemental



data needed to accomplish the work specified. The work package includes drawings of the component(s) to be worked, including amplifying sketches where necessary, detailed instructions for the accomplishment of the work, trade responsible for each line item, pertinent safety information, material listings, allocated hours, as well as required verification documentation. Wherever practical, only those portions of drawings depicting the actual component to be worked are incorporated, rather than burdening the trades with unwanted paper. That step forces the planner to review drawings for applicability. The conversion of systems-oriented data into a product-oriented format, extracting portions of drawings and material lists applicable to specific areas or intermediate zones on the ship, is admittedly labor-intensive upfront. Planners therefore cannot lose sight of the fact that standardization - repeatability - is the goal. If work packages are restricted in application, the opportunity for grouping common manufacturing steps has been lost. The objective of zone logic is to subdivide the ship into subsets of interim products or products that can be grouped according to similar manufacturing processes, with each grouping (family) identified to the trade or shop responsible.

2. The work can be accomplished in a reasonably short period, usually in three weeks or less. When the timespan for a work package is excessive, effective performance measurement is not possible and the risk of mischarging is real. This means that a

single job order to unship, open/inspect, shop repair, reinstall and test a high pressure air compressor - repair work that can cover as much as four or more months of elapsed time - has been replaced by separate, detailed work instructions for each phase. Zone logic, moreover, dictates that each of these phases, as a minimum, be treated as interim products. Each of these phases represents a discreet amount of value that has been added to the final end product and must be treated separately, thereby providing the opportunity for the statistical analysis so important for improvement. Wherever possible, the work packages must be structured for assignment to a single supervisor to permit clear accountability for costs incurred and schedule adherence. Broad KeyOp coverage, particularly those depicting work centers responsible for discrete line items of work independent of each other, must be minimized. It goes without saying that these individual line items must be scheduled upfront, rather than being left to the lead shop to coordinate. By defining the work in small, digestible chunks, the identification of problems impacting work execution can be brought into sharp focus.. In this same vein, accurate progress reporting is greatly simplified and supervisory lines of responsibility and accountability are reinforced. Progressive improvement is keyed directly on the ability to isolate problems to their fundamental root cause. This requirement to plan work at the lowest practical level of detail applies to assist trade work as well. All too frequently, assist trade hours are allotted in eight hour or four hour increments. This practice may

facilitate the accounting system in place, but it does little to accurately determine the true cost of doing the work.

3. The work can be accomplished within a manhour allocation that allows efficient supervisory control of resources. It is not uncommon to find the average work package falling in the 160-200 manhour range, with some work packages containing only two to four KeyOps. (For the KITTY HAWK SLEP, on the order of 10,000 work packages were issued.) The upper limit is about 800 manhours, but that is restricted to special work scopes. The nature of the work, including its criticality and physical constraints, obviously influences work package sizing. (One illustration of the extremes would be the repair of in-line valves versus hull sandblasting.) The ultimate objective is to plan and schedule the work to the lowest practical level of detail. By that action, greater visibility is given to assist hours, "borrowed" hours among waterfront supervisors are minimized, and greater accuracy is achieved in tracking expenditures. For those shipyards accustomed to the ritual of planners handwriting job orders, clerks typing up the input, and then transmitting the work task by teletype, the workload suggested by this approach can be overwhelming. By utilizing the capability of the computer, coupled with a disciplined structure for accessing the existing data repository, the need for this archaic practice is negated.

4. When more than one component is defined in the work scope, none of the work items are mutually-exclusive in their execution. Properly planned, there is no need for competing trades to work in the same physical area. All work can either be accomplished in the assigned area at the same time or within the period of performance specified. Similarly, there is no interference with other on-going trade work. By going to this level of planning detail, parallel as well as series work can be achieved. Under a systems-oriented approach, the main and vital hydraulic work for a submarine overhaul can be scheduled for an overall duration of six to seven months in order to cover system pumpdown, component repairs, final assembly and testing. To expect such conflicts with other trade work to be resolved at the deckplate level, as routinely occurs with system-oriented job orders, is both costly and unrealistic.

5. Instructions for the work are released approximately two weeks before its scheduled start. Late release ignores the realities of the work place. The waterfront supervisor needs a reasonable amount of time to become familiar with the upcoming work and to assemble needed tooling and material. And there are frequently manning problems, equipment failures and ships force interface issues to be resolved before work starts. Conversely, premature issuance is an open invitation for labor charging in many shipyards, in order to account for personnel assigned to the work crew. New construction yards, especially those associated with

lead ship design efforts, have found that releasing the work instructions as little as two weeks before scheduled work start minimizes the disruption caused by design changes. But repair yards must also contend with changing work scopes and new work directed by the customer. By delaying the release of work packages to the last practical moment, work performance measurement is greatly strengthened. There is little need to add scheduling contingency factors (float) to account for disruption caused by late changes to work content or to account for the uncertain status of other work in the area, for the unknowns impacting work start are coming into rapid convergence at this point in time. Zero float, meaning firm start and completion dates, should be the objective. Work schedules issued in two-week snapshots, and updated on a weekly basis, provide both the flexibility and control required. Even though data is maintained in electronic format until the last practical moment, functional codes should have the capability to access data (Read Only access mode) contained in the mainframe repository, for work content can change based on evolving situations at the worksite.

Development of product-oriented work instructions usually entails a two or three-step tiered process, depending on the nuances of the shipyard's organizational structure, with each step iterative as to the degree of refinement. Some private shipyards prefer a three-step process that melds the efforts of three separate divisions, Advance Planning, Detail Planning and

Production Control. Working against the Master Construction Schedule or Strategic Plan, Advance Planning determines the most logical breakout of work, including long-lead time material ordering, work to be subcontracted ("make or buy" decisions) and workload allocations in-yard. The Detail Planning Division prepares the work packages based on this breakdown and initial planning and, using the master schedule for work sequencing, defines the specific work to be performed, including the hardware and software necessary to accomplish it. About two weeks prior to scheduled work start, Production Control calls out the work package and pre-kitted material is positioned by the Material Department. As work progresses, feedback from Production Control permits variance analysis as to hours expended and elapsed time, along with any refinement that may be necessary in the technical data repository. Some shipyards have reached the stage where discrete action steps in the work package are bar-coded, thereby allowing real-time input as to work status and the timing of support services such as Quality Control checkpoints. Staffed with personnel representing all required disciplines, particularly engineering and individuals with either current or recent trade experience, personnel are shifted among the three divisions as workload dictates and to provide cross-training.

Under the Outfit Planning Group concept at Philadelphia Naval Shipyard, the iterative process leading to a detailed work package (called a C-Event) starts with inputs from Planning and Estimating

(P&E) , Design and Scheduling. Working with the major event (A-Event) and milestone (B-Event) schedules, and the predetermined ship zones or area boundaries, P&E describes the work authorized and provides the required procedures and technical manual extracts to the Outfit Planning Group. Design furnishes selective portions of plans and drawings-that pertain to the work in the prescribed areas. Based on P&E estimates of work scopes, Scheduling provides KeyOp scheduling information, as well as any supplemental data that may be germane to the task at hand. A typical flow diagram of this integrated planning process is shown in Figure 4. It could be rationalized that the Outfit Planning Group has merely assumed the role of the shop planning groups, but such is not the case. Planning and Estimating, Design and Scheduling, working from systems-oriented source documents, have provided the initial cut at providing product-oriented data and, in the process, have benefitted the entire iterative planning process by their individual perspectives, expertise and experience. No functional code works in isolation, and by the cross-fertilization of data and ideas, each step is a refinement of data developed during earlier stages. And while everyone tends to view a job from a different perspective, the user reigns supreme throughout. The Outfit Planning Group (OPG), staffed with shopwise engineers and planners, as well as former senior shop planners and production foremen, proofs, collates and provides the necessary final refinement to ensure that each work package stands on its own and is, in fact, the most appropriate way in which to accomplish the work. If shop

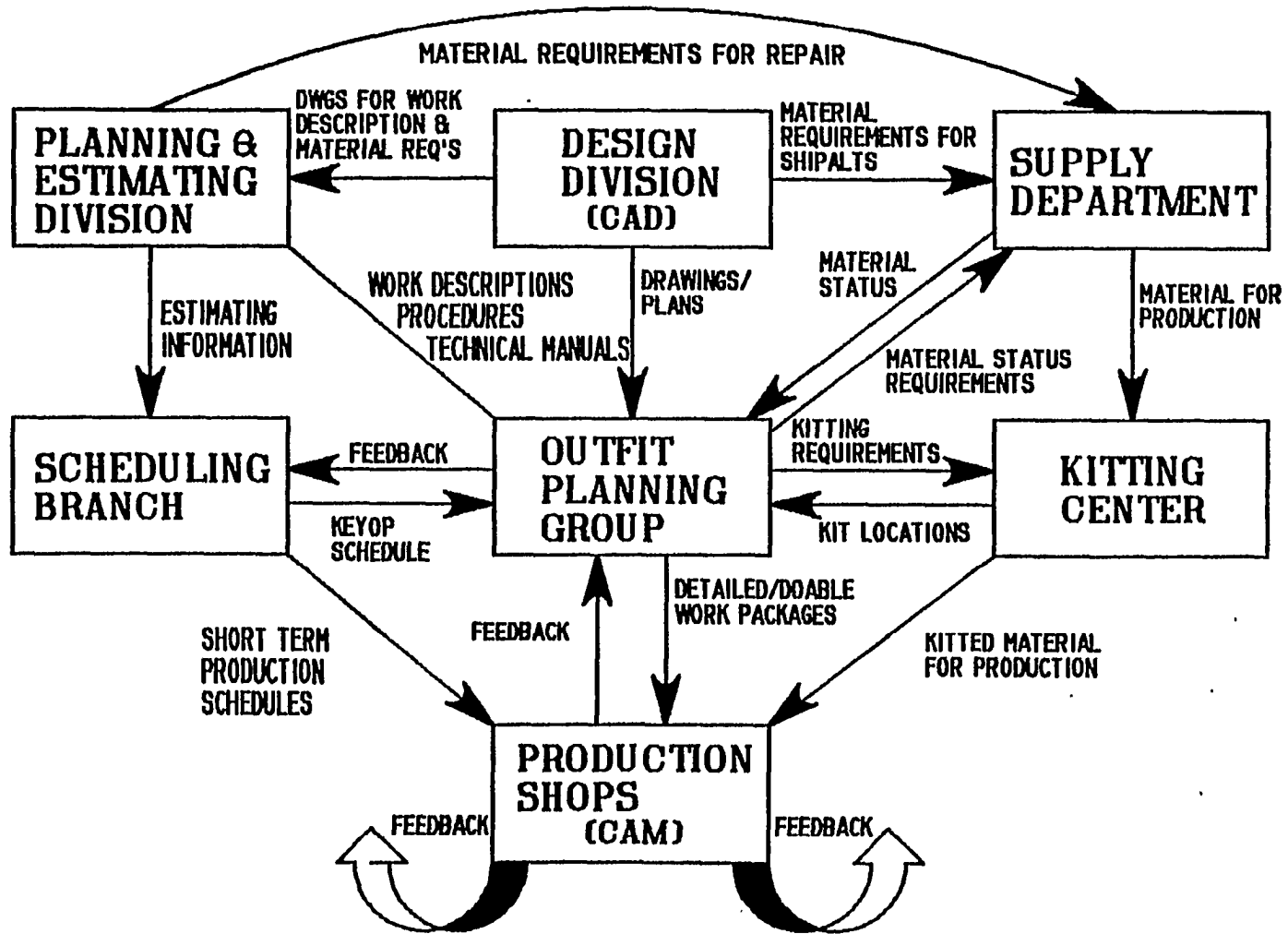

**FIGURE 4.**  
**INTEGRATED PLANNING FOR PRODUCTION**  
 (COURTESY OF PHILADELPHIA NAVAL SHIPYARD)



repair, rather than in-place repair, for example, is deemed the most appropriate way to accomplish the work, that decision is made by the OPG. One priority function is the provision of quality drawings to support the task assigned, a common problem on older ships. By the use of a variable density, Versatec Acris II aperture card scanner and a high resolution laser printing system, sub-standard blueprints are reviewed, edited and image-enhanced where necessary. The use of six 19" viewing screens minimizes the need for excessive scrolling. To provide added assurance that the OPG is not isolated from the realities of the waterfront, and to allow prompt resolution of any emerging problems, a waterfront management team, staffed with combat systems, design and industrial engineers, provides prompt feed back to the OPG of any execution problems encountered.

The parallelism in the approaches used by Philadelphia Naval Shipyard and some private shipyards is striking. At the chokepoint of shipyard operations, a position comparable to functioning at the neck of a funnel, a multi-talented organization selectively integrates data elements from a myriad of sources and formulates doable work packages, as seen through the eyes of the trades that will do the work. Explicit in this integration effort is that everyone knows what has to be done, that the work is transmitted in a language understood by the individuals doing the work and it is scheduled in a sequence that is compatible with the way that the work is actually accomplished. The synergism that can result from

the horizontal integration of interdepartmental disciplines is remarkable. Probably one of the more important benefits derived from having one central clearing house for work package issuance is the realism that can be brought to bear on the scheduling of events. Based on the sharp exchanges that have been witnessed between schedulers and production supervisors at this juncture of the planning process, it certainly raises questions as to the actual need for a separate scheduling section at many shipyards.

Uncertain at this point is whether Philadelphia Naval Shipyard can afford to retain "one central clearinghouse" for work packages as it moves to apply zone technology to all assigned work. About 30 people are currently assigned to the Outfit Planning Group and, absent an augment in resources, some adjustments in responsibility will be required as the workload increases. Some OPG functions could be shifted to P&E, for example, but that decision is predicated on their full acceptance of the new work methodology. Job order structuring may be one such candidate. A quasi-cellular organizational structure, one that solidifies the horizontal integration of functional disciplines, is another option. Another factor concerns itself with the data repository, and the progress made towards standardization. If the stored data permits little repetitive action, the shipyard is faced with the task of building each work package essentially from scratch.

Regardless, when the rules of engagement" are precise and only that documentation necessary to do the assigned task provided, there is no need for the mechanic to sort through an endless listing of references and superfluous drawings before starting the job. Precise work identification means that broad, generalized drawing notes, such as "structure welding will be accomplished IAW MIL-STD 1689", are replaced by the specific portions directly applicable to the work at hand. Only the portions of drawings applicable to the job are provided, and they are shown in exploded view with amplifying details or sketches, if needed. (How many times has it been jokingly suggested that mechanics should be equipped with over-sized suitcases to carry the library of job order references and blueprints to the worksite?) The lead production trades must be involved throughout the planning process, rather than being required to sort out all the issues once the pieces are received on the waterfront.

In any shipyard, you win or lose on the waterfront. This forced integration of designers, engineers, planners and trade supervisors has been cited as the most significant benefit to be derived from product-oriented work execution [10]. But it really goes beyond that. It is a lesson in ownership; that problems do not end when the paper is passed into the outgoing basket. It is a synergistic effort, one where everyone involved in the process owns a piece of the action until the final product is satisfactorily completed. In sum, teamwork.

## THE NAVY'S ADVANCED INDUSTRIAL MANAGEMENT PROGRAM

The random application of zone logic by the shipyards, regardless of how successful, does not mean that it will shortly become standard policy for all repair work. Pockets of excellence do exist at the individual activity level, but the absence of a corporate repair strategy, one that endorses the concept of zone technology, and provides the focus and support needed, continues to be the major contributory factor to its excruciatingly slow incorporation into repair work. Current Navy maintenance philosophy, allied to a systems-oriented work methodology, is the singular most significant impediment to change. Only Navy action at the corporate level can rectify that.

There are initiatives underway by the Navy, however, that could both facilitate zone technology efforts already in progress, and accelerate the across-the-board adoption of a product-oriented work process. But they will require adjustments in thrust and purpose if that is to occur. The Naval Sea Systems Command Advanced Industrial Management (AIM) Program is one such example. This program would concentrate on accurate technical documentation to support the work authorized and the use of standalone work packages at the component level. As described at the March 1990 ASNE Logistics Symposium, the Advanced Industrial Management Program would consist of two basic elements: (1) Advanced Technical Information Support (ATIS) and (2) Advanced Planning and Packaging

support (APPS). ATIS is a digitized and integrated technical information base, linking component technical documentation (such as technical manuals and drawings) with 3-D models via the Ship Configuration and Logistics Support Information System (SCLISIS). APPS would optimize job packaging methodology, and quoting from implementing directives, "... may be based on skills, physical ship zones (zone logic technology), schedule milestones, ship systems or other criteria" (sic).

With the exception of physical ship zones (zone technology), the practicality of "Optimizing" job packaging methodology around the other polarizing factors is questionable at best. Job packaging by schedule milestones, for example, might answer the question as to when specific tasks are to be accomplished, but it ignores the realities of how the work is done. Unless there is an upfront analysis of related tasks, in the form of manageable productive units of work that balance the demands of multi-trade coordination, we're back to business as usual. Expecting the schedule to be the forcing function to pull events together after-the-fact, and that is what will happen, represents no change at all. It is possible to control by divisions in time, but the most effective way is to meld time with zone control.

Job packaging under the AIM program, however, would not be based on traditional, system-oriented key operations. Under this program, the central technical source document for repair

activities would be the Component-Oriented Technical Work Procedure (COTWP) . This procedure could be retrieved from either a local ATIS repository or a master digital database, and it would permit work tasks to be executed on a stand-alone basis. The ultimate objective of the AIM Program, then, would be to provide the shipyard users with accurate, real-time, digitally-based data and tool repositories, eliminating the onerous administrative burden inherent in today's paperwork process. In effect, it is envisioned as the industrial counterpart to the much espoused "Paperless" ship of the year 2000. Nothing in that objective contradicts the purpose of computer-aided process planning.

Accurate technical documentation and improved work package methodology are worthy objectives, and both are essential to the successful application of computer-aided process planning. But process planning goes far beyond those two steps. It is the analyses of the Processes by which work is accomplished that achieves lower assembly and manufacturing costs. Zone logic, using computer-aided process planning as its forcing function, derives its strength from its ability to subdivide the authorized work into subsets of interim products and products that can be grouped according to similar manufacturing/assembly processes. Improvement comes by constant refinement of those individual processes. It is this upfront sorting of common principles, tasks and problems, made possible by a product-oriented classification and coding system, that makes this possible. While AIM is silent on these factors, it

wouldn't take a major change in purpose to move the very promising COTWP initiative into the full realm of process planning possibilities.

AIM's casual reference to zone technology, however, is disturbing, and would suggest that the lessons and experience of building yard group technology, specifically its linkage to repair yard zone logic, are either not understood or they are not appreciated. Component-Oriented Technical Work Procedures (COTWPs) should be viewed as a subset of zone logic techniques. To view zone logic as merely performing a sorting function for the execution of COTWPs is fallacious reasoning. The programmatic controls inherent in zone logic serve to strengthen the integration of work documents treated in isolation. Work execution is not the simple aggregation and sequencing of individual work tasks, it is the grouping of like processes that leads to efficient work execution. Therein lies a key element in the success of the zone logic process that is lacking in the COTWP initiative as currently structured. With minor adjustments, COTWPs can form the basis for the grouping of like processes.

The procedure by which work packages are assembled and scheduled is central to realizing the savings that detailed planning offers under zone logic. Unless COTWPs are assembled into units of work that recognize the interrelationships of specific tasks within the area where the work is to be performed, as well

as the similarities of the processes by which work is done at the component or interim product level, that potential will not be fulfilled. Treated in isolation, COTWPs run the risk of becoming a refinement of Technical Repair Standards (TRS), but with a different veneer. Standardization of work requirements (specifications) does have merit, but when efforts are made to standardize the method by which work is accomplished, the flexibility needed to improve the process has been lost, in other words, producibility. Already the COTWP concept of standardized component work procedures, announced in March 1990, has seen re-direction. It was found that the method - the process - of work execution varies among shipyards, and that the COTWPs were not directly usable in each shipyard on a routine basis. Similarly, in the effort to also standardize the quality requirements for each COTWP, there was found to be a wide variation among shipyards as to what constitutes Objective Quality Evidence (OQE).

The preponderance of funding being committed to implement AIM in FY 90/91 is directed towards the submarine force. While the reasonably good configuration baseline afforded by these ships may appear to be a logical starting point, this concentration of funding to one segment of the Navy means that public and private shipyards doing repair work must continue to cope with two management structures, one product-oriented, the other the traditional systems approach to doing work. For shipyards with a mixed workload, the structure becomes particularly cumbersome.



More importantly, it does little to fuse a meaningful link between new construction and repair yards. With CALS (Computer-aided Acquisition and Logistics Support), along with the continuing emphasis on CAD, the new construction yards will be determining and defining the components that will populate the delivered ship. This build strategy forms the logical basis for a repair and modernization strategy.

As an integral part of the NAVSEA Corporate Operating Strategic Plan (COSP), AIM has the potential for fulfilling the need for total integration of all planning efforts in the execution of production work. When married to Computer Aided Process Planning (CAPP) within a zone logic structure, the significant cost savings of a product-oriented work environment can be realized. The technical information provided by ATIS is directly transferable to on-going CAPP efforts. But the APPS subset of AIM requires modifications if COTWP work packages are to be effectively blended into a zone logic work environment.

## CONCLUSIONS

The belief, shared by many, that ship repair is little more than a job-shop operation, offering few opportunities for the application of computer-aided process planning to the overhaul and modernization of ships, is a feckless opinion at best. It certainly runs counter to the productivity gains being realized by virtually every industry that has made the transformation to a product-oriented work base. Ship repair presents unique challenges, but each is amenable to solution by the corporate talent that resides in the shipyard community. Nurtured within a group technology (zone logic) framework, computer-aided process planning has the potential for revolutionizing a shipbuilding and ship repair industry that is mired in the archaic policies and practices of a systems-oriented work culture.

Shifting to a work structure oriented around computer-aided process planning, however, represents an attitudinal challenge, rather than achieving any scientific breakthrough. It requires adherence to a discipline that no single unit of work is the product of one individual, but that the work instructions represent the collective, albeit disparate, talents of many shipyard disciplines. Component design obviously impacts manufacturing costs, but production costs are directly determined by the process by which work is accomplished. It is here that the horizontal integration of tooling, skills levels and manufacturing methods

come into play - the "how" rather than the "what". But with experienced process planning in short supply, that experience will be lost unless captured. A CAPP-based data repository permits that.

Process planning is more than word processing. With a group technology based system, one utilizing classification and coding at the design and production levels, code numbers allow the retrieval of existing and preferred manufacturing information, with preferred being the optimal method based on experience and tools available. Standardized process plans permit preferred shop routings for component/part families, with this same GT breakout reducing the cost and time in the preparation of numerically-controlled tapes in both micro and macro format. Detailed knowledge of work requirements and work processes is required if the full benefits of computer-aided process planning are to be realized. But change will not be easy, nor will it be quickly achieved. At the outset, transformation of the U.S. ship repair industry to a product-oriented work base requires a strategic plan that is close-coupled to modern shipbuilding methods. The interconnectivity between ship construction and ship repair must form the central fabric of that overall plan. Just the step of exploiting that linkage and eliminating many of the duplicative and redundant planning efforts will result in significant cost-savings. But this integrated build and repair strategy transcends simple savings in repair yard engineering services, for the ultimate

objective should be to restore this country's maritime base to its former position of preeminence.

Specific action steps that will start this transition process include:

1. For financial and progress reporting purposes, expand the current Ship Work Breakdown Structure (SWBS) to account for product-oriented work and management methods. Standardization of requirements, in conformance with DODINST. 7000.2, will preclude the need for individual activities to devise alternate systems, and it will ensure greater consistency of Defense Contract Audit Agency (DCAA) auditing actions.

2. Expanded Planning Yards (EPYs) should be tasked to prepare Ship alteration drawings in zone format for assigned classes. In the initial phases, close liaison with repair activities is mandatory, for the zone strategy utilized must allow repair yards the flexibility to combine or further refine the zones to accommodate varying work packages and to allow repair and ship alteration integration. Depending on the size and complexity of the alterations, this approach by the EPYs would also permit the pre-sorting (grouping) of associated drawings to identify component parts amenable to similar manufacturing processes. It would, in effect, be the initial entry into a CAPP-oriented data repository.

3. New construction drawings showing zone and intermediate zone designations should be routinely provided, on a ship class basis, to all activities involved in repair package planning, including Planning Yards and PERAs. Using data already available from new construction yards employing group technology, this step would obviate the need for repair yards to duplicate some of the administrative steps associated with ship zoning. Admittedly, new construction zones may not be directly transferable to repair and modernization zone strategy on a "one for one" basis in all instances, but the mechanics of integrating build and repair strategies would be afforded the opportunity to start their gestation process.

4. The electronic distribution of technical documentation at the component level, and this includes that available in CALS, EDMICS and CAD data repositories, needs to be made readily available to repair activities. Work instructions, such as COTWPs, should also be part of this data package, but they need to be restricted to the applicable component requirements (the ~~what~~), with the method of accomplishment (the how), determined by each individual repair activity. By making many of these elements part of the Contract Data Requirement List (CDRL) deliverables package, and providing them in digital-optical format, repair planning can be greatly streamlined (particularly when CAPP is utilized) and many of the startup costs associated with data verification and compilation could be eliminated.

5. Maintenance procedures need to be modified to accommodate product-oriented work, and that should include the identification of work location at the zone/intermediate zone level by activities involved in the planning efforts associated with Ship Alteration and Repair Packages (SARPs) and Overhaul Work Packages (OWPs). This upfront sorting would preclude the need for the same work effort by each activity involved. Preliminary review also indicates that the first four to five digits in a Product Work Breakdown Structure (PWBS) could be standardized on a class basis to identify the component and area (zone). This would permit a generic breakdown of the work item, with unique identification or "customizing" done at the repair activity level.

Both the time and opportunity for change is present. Practical, hands-on experience from the shipyards that have demonstrated the merits of zone technology, melded within a corporate framework that can provide course, rudder and speed changes as the entire integrated process unfolds, would inject a sense of National priority that, heretofore, has been seriously lacking.

## SOURCES OF INFORMATION

- [1] "Third Report of the Commission on Merchant Marine and Defense: Appendices". U.S. Government Printing Office, Sept. 30, 1988. Pg. 214.
- [2] Washington Post, September 11, 1990, pg. A12; and September 13, 1990, pg. A1.
- [3] "Third Report of the Commission on Merchant Marine and Defense: Findings of Fact and Conclusions". Sept. 30, 1988, Pg. 3.
- [4] "Report on the United States Shipbuilding Industry" promulgated by Naval Sea Systems Command, July 1990.
- [5] Coopers & Lybrand/American Management Systems Navy Industrial Fund Project, Shipyard Review Report, June 1986
- [6] Fortune Magazine, 26 March 1990.
- [7] D. Davison, "Applying GT to Increase Productivity in a Job-Shop Environment", Journal of Ship Production, Vol. 6, No. 1, Feb 1990.
- [8] "Public Hearings Before the Commission on Merchant Marine and Defense, May 1988 and July 1988", pg. 582.
- [9] "Initial Implementation of IHI Zone Logic Technology' at Philadelphia Naval Shipyard", Journal of Ship Production, Vol. 5, No. 2, May 1989.
- [10] L.D. Chirillo, "Product Work Breakdown Structure: An Essential Approach for Ship Overhauls", Journal of Ship Production, Vol. 5 Number 3, August 1989



THE SOCIETY OF NAVAL ARCHITECTS AND MARINE ENGINEERS  
601 Pavonia Avenue, Jersey City, NJ 07306  
paper presented at the NSRP 1988 ship production symposium  
Edgmont Inn, Seattle, Washington, August 24-26, 1988

## Product Work Breakdown: An Essential Approach for Ship Overhauls

No. 6B

L. D. Chirillo, Member, L. D. Chirillo Associates, Bellevue, WA

### ABSTRACT

Some North American shipyard managers have successfully adopted a product work breakdown structure for ship construction. Adoption by those who would compete is inevitable. But, none have applied the same product-oriented approach for ship overhauls. Yet, significant such progress is being made by a naval shipyard.

In yards which accept both challenges, continuing to employ a system work breakdown structure for overhauls while applying a product work breakdown structure for construction, doesn't make sense. Two different management information systems are required.

Thus, this paper identifies how the same product-oriented logic successfully applied to improve construction productivity, also applies for overhauls.

### INTRODUCTION

Many are familiar with or at least aware of the logic revolution irreversibly established in some North American shipyards. Basically, information that had been grouped only by system, e.g., as on a system arrangement and detail drawing, is now grouped in the design process to exactly anticipate the parts, subassemblies, and assemblies, i.e., the interim products, required to build ships. In each case, the build strategy which guides designers in 80 grouping information, is imposed before contract design starts!

When the interim products are grouped by the problems inherent in their manufacture, even for different ships being built simultaneously, production lines can be organized which are just as effective as counterparts in the automobile manufacturing industry. This approach which examines required interim products with different eyes so to speak, looks for manufacturing commonalities and ignores differences in design details. The organization of

alike work in this manner is called Group Technology (GT). GT is the most ideal way to process interim products of different designs in varying quantities as required for ships and for many end products other than ships. [2]

For certain interim products, production lines sometimes constitute real work flows wherein materials conveyed from work station to work station. In contrast, when a team of workers is moved from site to site and the work category at each site remains the same, the effort is regarded as virtual work-flow. The impact on people is the same as if they were at fixed work stations and a conveyor was transporting the materials being worked. The objective of work flows, both real and virtual, is to avoid the greatest single loss in any industrial endeavor, i.e., people waiting for work.

Rationalizing virtual work flows is extremely important because they are means for effectively organizing very much of the ship production effort, particularly outfitting and painting, and because they are the means for bringing unprecedented order to nearly all shipboard overhaul activities. Whereas, traditional methods which feature system-by-system work packages assigned to different supervisors are always issued with the inferred management cop-out, "Somehow coordinate among yourselves."

As work on one system conflicts with work on other systems in an infinite number of ways, traditional supervisors are preoccupied with reacting to day-to-day changing circumstances. Such disruption is significantly reduced with the product-oriented (also called zone-oriented) approach because all work of one type, say gas cutting, is planned to be performed in a specific zone during a specific stage. No two work teams doing different types of work are unintentionally scheduled to be in the same zone at the same time.



In the absence of conflicts, productivity indicators, such as, man-hours per weight of material ripped out or man-hours per lineal feet of gas cutting, become very meaningful. Work performance becomes predictable. This association of man-hours with a discrete product is essential for true compliance with the U.S. Department of Defense cost/schedule control systems criterion for a work breakdown structure to "...define the product to be produced as well as the work to be accomplished..." 131

Equally important, each envisioned interim product, i.e., what is to be worked in a specific zone during a specific stage; becomes a focal point for organizing prerequisite work instructions, materials, and manpower. Already, some overhaul strategies are being expressed in terms of Zones/stages. As a consequence, the preparation of work instructions and the procurement and marshaling of materials, including material overhauled in yard shops, proceed in accordance with the exact same strategy to be applied by production people on board for each unit of work.

Also, because their system-oriented work packages are usually large and scheduled for implementation over relatively long periods, traditional supervisors become skilled at retaining unspent budgeted man-hours from one system in order to charge them to another system for which they would otherwise have a budget overrun. Usually, their intent is not deceit. More often, they want to avoid having to make explanations when they are preoccupied with reacting to more unforeseen problems. The consequence is experience vested in supervisors only; i.e., inadequate corporate experience.

The most important thing in any industrial enterprise is how to analyze. Corporate experience is crucial for accurately estimating future overhauls, for budgeting man-hours based on workers performing normally in a statistical sense, for scheduling with certainty based on mean values and standard deviations, and for constantly setting targets for improvement. As overhauls become more complicated, particularly overhauls of warships, their successful implementation with traditional system-by-system grouping of people, information and work, is becoming impossible. Adequate corporate experience can only be derived from a product work breakdown structure with people and information grouped accordingly. Work organized by zone/stage which is also classified by problem area per GT logic, is susceptible to statistical analysis. When work is so organized, Dr. W. Edwards Deming's fourteen points for management become alive even for overhauls.

Some traditionalists will remain skeptical. "Overhauls are different from construction!", they will say and they are right. In two very significant aspects, overhauls are much easier. Most overhauls are not encumbered with having to integrate structural work to the degree encountered in construction. Also, management, supervision, and the workforce as an entity, knows an infinite amount more about a ship due to arrive for overhaul than does an organization awarded a shipbuilding contract know about the ship to be built. More often than not, an overhaul activity has previously overhauled a ship of the same type if not of the same class.

"What about open and inspect work?," traditionalists will counter. The lack of definitive information upon contract award is what both construction and overhauls have most in common. In the world's most effective shipyard, contract design is part of the shipbuilding process. With just preliminary design input, production engineers document a build strategy which will guide subsequent design stages. Before, the contract protected only the owner's ship performance characteristics. Now, with incorporation of a build strategy in the contract design, the yard's manufacturing system is also protected. This vigilance guarantees that the manufacturing system will retain its flexible nature and, through management by target, will continue to improve. Without such flexibility and constant improvement, competitiveness is jeopardized. The yard's very existence is at stake. A major production engineering effort, i.e., planning well before the fact, must commence with less information than is usually available when a contract is awarded for overhaul work. Devising an overhaul strategy in terms of zones/stages for a known ship type is much easier.

As shown in Figure 1, the design process for construction is organized in phases. The first, contract design, is preceded by a product-engineered build strategy. As the progress of contract design makes more information available, production engineers refine the build strategy in time to guide the next design phase, i.e., functional design, and so on. By the time the last design stage is reached, the information being produced by the production-engineering effort is tactical in nature, e.g., it advises designers where to show on sketches of hull blocks, the reference points and lines needed to facilitate hull erection, it includes specific instructions for drilling and tapping fillet welds in portions of blocks that will form oil-tight bulkheads so that such welds may be air tested in the shop, it includes instructions for dividing material lists in order to obtain

work packages of about 40 man-hours each, etc.

In the process depicted by Figure 1, information is first grouped in a large-frame sense, then in an intermediate-frame sense, and thereafter in a small-frame sense corresponding to work packages. In other words data always exists for the entire construction effort but in different degrees of refinement as time goes by. The process is the same for large overhaul endeavors as shown in Figure 2.

The boxes and flows shown in Figures 1 and 2 are identical only for discussion purposes. Open-and-inspect on board and open-and-inspect in shops does not occur in distinct phases as shown in Figure 2. They occur bit by bit as various equipments are opened regardless of their locations. But, the effect is the same as in construction projects. Information describing required work is being refined as time goes by.

Overhaul traditionalists will persist, "What about materials? We don't know what is needed until open-and-inspect takes place" To the Uniformed it would seem that similar overhauls have never been accomplished before and that contingent work cannot be planned and schedule.

#### CONTROL THROUGH CONTROL OF MATERIAL

One of the neatest things about a product work breakdown is that it facilitates production control through control of material. Man-hours required are always related to some physical characteristic of material regardless of whether something is to be ripped out, overhauled, fabricated, or reinstalled. With obsessive focus on identifying all material including contingent material at the bid stage, with rough assessment of where in the ship and when materials are to be processed, and with productivity indicators which reflect corporate experience, man-hours required are obtained and schedules are derived. The initial man-hour budgets and schedules so obtained do not make sense unless they are in a large-frame sense commensurate with the grouping of information available. As the materials to be processed become more definitive, the man-hour budgets and schedules are refined accordingly. At first some materials can be counted from an Overhaul work list and from a list of ship alterations (shipalts). Other requirements have to be estimated per material Classification, e.g., so many lineal feet of medium-diameter pipe.

What is required is a more effective material management approach which recognizes that material procurement and marshaling are production control func-

tions equivalent to man-hour budgeting and scheduling. It is for this reason that in the world's most effective shipyard, the material procurement manager reports to the production control manager and the production control manager is Subordinate only to the general manager. Further, a prerequisite for being a production control manager is having been a production department manager. With procurement so drawn into production control, a much greater sense of urgency emerges about material.

With such emphasis it becomes clear why the most effective shipyard managers regard the computer program which maintains the material required status as the most important computer program, that for payroll notwithstanding. For all Projects underway, i.e., shipbuilding, overhaul, and other, the computer assimilates all material requirements which are the result of counts of some items and estimates of others. As work is more definitized by open and inspect reports and the development of shipalt detail assign drawings, a Sorting and collating function immediately asks:

- 0 "Were materials just designated anticipated in the initial material assessment in Sufficient Quantities?", if not
- 0 "Are they long lead-time materials, materials that must be fabricated either in-house or by a subcontractor, or are they Short lead-time materials?"

If any material are newly discovered, management is immediately alerted to the fact that the current man-hour budget and schedule are incorrect. If long lead-time materials are newly discovered, management is immediately alerted for procurement action commensurate with the problem.

An essential technique not generally employed by managers outside of Japan is use of a third material classification to supplement allocated material (often called "direct material") and stores stock. The third classification is called allocated-stock because it combines features of the first two classifications. Allocated-stock pertains to relatively expensive long-lead-time materials which are required in at least moderate quantities. Too many of them are required to conveniently regard them as allocated material and they are too expensive to be treated as stores stock.

The requirements for each item of allocated-stock are assessed periodically, usually monthly and for all contracts underway at the same time (ship overhaul, Ship construction and other) Per allocated-stock item, questions that are answered each month are:

- o How many are in the yard's warehouse today?
- o How many are on order that are expected to be received in the coming month?
- o How many new requirements Surfaced in the past month due to open and inspect reports, design development and/or change orders?
- o How many are scheduled for issue during the coming month?

When the net requirement is determined, a margin is added by the production control organization as an allowance to offset unforeseen needs, loss, damage, defects, etc., as determined from the yard's experience with that particular item. A purchase Order amendment is issued accordingly, usually to an open-end purchase order which specifies a bulk quantity estimated when information existed in a larger-frame sense. Reduced to logic, the process is similar to that traditionally applied by shipyard managers for ordering structural steel. A mill reservation is placed based on bulk tonnage and as the design develops, the mill is instructed regarding specific-size plates and shapes and delivery dates.

Another necessary material practice includes limiting the number of Suppliers to two or three for each item, i.e., just enough to maintain competitive pricing while keeping a practical limit on the amount of data to be maintained in a computer data bank regarding suppliers' products and past performances. Each such supplier's catalog item becomes, in a sense, a shipyard standard. In the absence of such "standards" with which to guide the people performing material definition, effective sorting and collating as material requirements are refined and management of allocated-stock, are elusive. In the absence of "standards", the use of computers for material management is inherently impractical.

If similar great emphasis on material was Suddenly applied for complete overhauls of U.S. Navy ships. the first thing to emerge would be general awareness that planners are adversely handicapped. For each overhaul, they necessarily focus on the officially described ship configuration (list of components in a ship) for the purpose of ascertaining needs for technical manuals, replacement parts, and test equipments. The problem is that each official configuration intentionally lists only about 70% of what is purported to be in a Ship. of the 70%, reportedly, as much as 30% of the component<sup>8</sup> listed are incorrect even for submarines. In other words, the basic records which planners rely on are both incomplete and inaccur-

ate. In traditional functional organizations which characterize most public and private shipyards outside of Japan, problems of this nature do not demand resolution commensurate with their adverse impact on productivity. In product organizations which control through control of material and focus on cost per product, the disciplines imposed would contribute to correcting this grave situation while clearly identifying the nature and scope of the problem with the utmost sense of urgency.

## PRODUCT ORGANIZATIONS.

People who have acquired overhaul experience only in traditional functional organizations will have a hard time accepting all of the foregoing. There are prerequisites for success that are unknown to them. One is a product organization in which people specialize differently. Another, is greater investment in the planning effort where planning consists of both production engineering and design engineering for integrated hull construction, outfitting, and painting. Production engineering becomes more professional, ultimately, with college graduates or people having equivalent ability to think analytically, assigned as generalist<sup>8</sup> in all levels of the production organization and design becoming literally an aspect of planning.

Much is written in Worth American college textbooks about product organizations. Their great advantage is their obsession with cost per product, or more clearly in shipyards, per interim product. Initiatives by Panel SP-2 of the Society of Naval Architects and Marine Engineers for the National Shipbuilding Research Program, disclosed reliance on product organizations by Ishikawajima-Harima Heavy Industries Co., Ltd. (IHI) of Japan for ship construction, overhaul, and other work in order to maintain leadership as the world's most effective manager of shipyards.

At the time of the disclosures, IHI people concerned with outfitting in both design and production were grouped in accordance with the following specialties for both construction and overhaul work deck, accommodation, machinery and electrical. For Warships a fifth specialty was added: weapons. Thus, all disciplines required to perform work in a machinery space, for example, were under a common boss. The earnings applied to the other specialties with deck designating all spaces that were not accommodation, machinery or weapons spaces. At that time electrical was still functionally organized but electrical outputs mere product oriented.

Design people were so organized in counterpart organizations. Each design

speciality and its counterpart in production was only concerned with costs per parts, subassemblies, and assemblies for the region for which it was responsible. The analogous organizational divisions for hull construction except for erection work, applied to flat-panel blocks, curved-panel blocks and superstructure blocks with all further subdivided in both design and production by parts fabrication, subassembly, and block assembly. The distinct products of each group were identifiable. This is product orientation. A separate product-oriented group in design and its counterpart in production were concerned with the virtual work flows needed for effective hull erection.

Recently, in response to unprecedented pressure to become more productive, IHI'S Kure Shipyard shifted to a purer form of product organization. For example, its Hull Fabrication Shop is still responsible for producing all hull blocks. But, the Hull Fabrication Shop is now also responsible for outfitting and painting all forebody blocks. Thus for merchant-ship forebodies the Hull Fabrication Shop now specializes by blocks which represent perfectly integrated hull construction, outfitting and painting. Outfitters (people who work with stick welders and spanner wrenches), electricians, and painters are assigned to the Hull, Fabrication Shop accordingly. Already shipfitters and painters are being trained to perform outfitting. This is one of the strengths of a product organization. When work is organized differently, labor will adjust to suit just as predicted by the head of the AFL-CIO Metal Trades Department a few years ago. [4]

A simultaneous initiative resulted in a target to reduced the total number of components to be purchased and parts to be fabricated for a very-large crude carrier (VLCC) from more than 70,000 to less than 40,000. In the first 10 months the number was reduced to less than 60,000. Now, square-steel tubing which doubles as ventilation duct is used in place of H-beams for support of engine-room flats. In many cases separate flanges have been eliminated by extending webs and forming flanges by bending. Wherever possible, holes are punched in the flanged surfaces before bending to accommodate U-bolts so as to eliminate need for separate pipe hangers. (Note: Reportedly, there are approximately 1,150,000 separate pipe hangers in a Nimitz-class aircraft carrier.)

The initiative to reduce the total number of components combined with the purer form of product organization will eventually force designers to reorganize as that in the future, the same people performing detail structural

design for forebody blocks will be simultaneously producing the forebody outfit details. Not only is there an analogy for overhaul work, the analogy is well underway in the U.S.

#### APPLICATION IN KITTY HAWK

Following precedent established by at least eight private U.S. shipyards to acquire benefits by either retaining IHI consultants or having floating drydocks built by IHI, the Philadelphia Naval Shipyard retained IHI to assist in planning a major portion of the Ship Life Extension Program (SLEP) overhaul of the aircraft carrier KITTY HAWK. As a consequence, about 400,000 man-days of work are being controlled by a product work breakdown. The areas being so controlled exclude the carrier's island, hanger deck, main machinery spacer and magazines. Included are pump rooms, air-conditioning machinery rooms, electronic spaces, storerooms, accommodation spaces, tanks, voids, steering-engine room, anchor-windlass room, chain locker, etc. The application is purposely limited commensurate with resources available.

The Specialities designated are faithfully in accordance with GT but are necessarily different from what IHI has applied to-date for merchant-ship and destroyer construction and overhaul work is shown in Figure 3 the specialists in design with counterpart specialists in production, are for:

- o electronic and accommodation spaces between the flight deck and the hangar deck,
- o accommodation spaces below the hangar deck,
- o pump rooms, air-conditioning machinery rooms, storerooms, etc., and
- o tanks and Voids.

Two specialities involve accommodation spaces because work in those between the hangar deck and the flight deck has to be carefully coordinated with work in various electronic spaces, including the combat information center, which are located in the same region. The same problem does not exist for accommodation spaces below the hangar deck.

The grouping of miscellaneous spaces, such as pump rooms, storerooms, etc. into a single specialty illustrates something that people do not at first understand. Product orientation is often called zone orientation and perhaps for this reason traditionalist immediately envision major divisions of a complete ship that usually coincide with transverse bulkheads. They then contemplate subdivisions that coincide with compartments. But, per GT logic separations are

different because they are by problem category. It doesn't matter where in a ship work of the same problem Category is located for organizing virtual work flows. Thus, as shown in Figure 3, the spaces that are assigned to each speciality do not comprise neat geographical divisions of the ship. In fact, the spaces for the miscellaneous speciality are not even contiguous with each other. Treating them as a single -group is like gerrymandering in politics. Geographical boundaries, grouping of classes of problems and needed horizontal communication were a11 factor8 in developing the specialities for KITTY HAWK in addition to applying the basic GT principle, i.e., matching classes of problems to sets of solutions.

An additional concept that is hard for the uninitiated to understand is the nature of zone/stage. It is possible to control by diViSiOns in geography, i.e., by zones. It is also possible to control by divisions in time, i.e., by stages. But, the most effective and flexible may be to control large industrial endeavors is by combinations of both. Thus if a particular zone scheme is optimum at one point in time, as soon as time changes it can be abandoned for a different zone scheme that is more opportune. For example, planners are entirely free to organize an on-board zone/stage work package that straddles a bulkhead during hot work on the bulkhead, knowing full well that later in time, zones that coincide with the compartments on both sides of the bulkhead make more sense for painting. Zone/stage designations are synonymous with opportunities. The greater degree of control afforded should be extremely attractive to people involved in nuclear submarine overhauls because specific systems must remain active during certain stages and because work durations must be limited in the vicinities of certain active systems.

Just as designers in IHI's Kure Shipyard are now focusing on all requirements of merchant-ship forebody blocks. Philadelphia Naval Shipyard planners focus on all requirements for Overhaul work in each space within their assigned speciality. In one case the product is conversion of a pump room that needs overhaul to one that is overhauled. In other words, value added is synonymous with designation of an interim product. With such focus it became immediately apparent that 80% of the pump-room's components had to be ripped out. After evaluating various overhaul strategies, the team consisting of designers and people performing production engineering, determined that the most productive option was to redesign the pump room as as to facilitate zone/stage reassembly.

Because of the team's prudent decision, the redesign is likely to combine

some foundations, show some pipe runs in parallel under walkways sharing common supports, have a greater percentage of straight pipe pieces, limit a greater percentage of pipe bends to 90 and 45 degrees, and increase average pipe-piece length. All such features enhance productivity. [5]

Significantly, the output of the design process now includes preparation of detail part drawings eliminating the need for such effort by production people. This is a clear example of a major design effort being geared to support production overhaul work. The benefits expected are assembly and painting of many outfit packages in shops, a significant reduction in rework, and perhaps less volume occupied and less weight in the overhauled pump room. On-board man-hours and the overall duration required should be much less than that for the traditional system-by-system approach. Based on first-time experiences observed elsewhere, the associated production man-hours should drop by about 30%.

Another example of significant benefit being obtained arises from focus on the replacement bulbous now as a distinct interim product by a team formed to integrate production and design engineering. Line heating was adopted for Curving she11 plates so as to reduce the number of separate Shell pieces from 14 to 9. This action caused a 30% reduction in seams and butts to be welded. Significant savings should be reported, including savings in fitting, weld-inspection, and distortion-removal man-hours. As a further indication of more investment in planning, the team exploited a photogrammetric survey to insure accurate fit of the bulbous bow to the as-built, ship.

Virtual work flows can be more readily visualized in the speciality for the more than 900 tanks and voids shown in Figure 3 than in any other speciality. About five different piping systems have to be ripped out and replaced. The zone/stage work package8 by types of work are controlling the different teams like rolling waves one after another in the following sequence: tank cleaning, ripping out all pipe, blasting, holding-coat painting, inspecting structure, ripping out structure, replacing structure, touch-up blasting and undercoat painting, outfitting, and final painting. Each zone/stage work package consists of 6 or 7 sheets of 8-1/2" x 11" or 8-1/2" x 17" paper that are readily reproduced on photo-copy machines. Typically, that for tank cleaning conveys to a work team:

0 location of the zone in the ship,

0 safety instructions,

- o job description,
- o a sketch showing the locations of tank manholes,
- o routing instructions for temporary services.

No other drawings or references are required.

For the work involving reinstallation of piping, all fittings including pipe pieces regardless of system are fitted in a zone during one stage. The pertinent work instruction contains composite arrangement and detail sketches and an applicable material list limited to the zone. Shop personnel are relieved from all bother such as associated with hold-ups and revisions. Such problems are absorbed during the interaction of production engineers and design engineers.

For the product-oriented approach to the SLEP Overhaul of KITTY HAWK, a project office has been created to direct, monitor, and expedite implementation of the overall strategy by all facets of the hierarchy in Philadelphia Naval Shipyard. The production part is shown in Figure 4. A-group superintendent, 1.8, the highest-level Civilian manager second only to the Production Officer, has been assigned. The product for which he is responsible is converting spaces that need overhaul and modernization into spaces that are overhauled and modernized within the boundaries of the four specialities shown in Figure 3. Because the workload is so great, about 400,000 man-days, he is assigned two assistants called zone Superintendents, one of whom has charge of the two specialities with accommodation spaces and the other having cognizance of the miscellaneous specialty and the tanks and voids specialty. This grouping reflects some commonalities in work problems and the proximity of the specialities for resolution of interface problems.

At the third level there are four zone managers, each of whom is assigned a speciality. Each is assisted by as many as five general foremen per-product trade. The teams of foremen and Workers that report to the general foremen are made up of mixed crafts as required to produce specific products. People, information and work are grouped in the same product-oriented manner. Throughout the hierarchy all managers and supervisors are generalists equivalent to factory managers for the products assigned. As maintaining the coordination of all work flows is of ultimate importance, every level has been delegated authority to transfer manpower as required. The degree of such authority is of course commensurate with the level.

Already, as has happened in IHI shipyards and as predicted by the head of the AFL-CIO Metal Trades Department, people of different trades are beginning to assist one another toward common objectives. For the first time they have something that is realistically measurable, i.e., cost per product. Now, much of the managerial advice expounded by Peter F. Drucker is coming into focus in Philadelphia Naval Shipyard.

Shipyards with less resources are well advised to venture into product orientation in a more modest way. The course taken by some other naval shipyards, so far mostly for Shipalts, is also good guidance. Applications were purposely limited. Puget sound Naval Shipyard employed an-ad-hoc product teams as shown in Figure 5. The figure indicates the maximum number of possible incumbents, but positions are only filled commensurate with the needs of the product being contemplated.

On the production Side, the team members were the actual general foremen who were to immediately manage the work. In a one hour meeting each week, they conveyed a strategy to the designers and constantly refined their strategy as designers were able to make information available through design development. The results were dramatic. One case involved seven electronics shipalts in a confined region of a submarine which had been implemented in other submarines with traditional system-by-system work packages.

The shift to product orientation focused on everything in each zone at once, caused the different foundation requirements to be combined, and resulted in multi-system foundations that were completely fabricated, machined and drilled ashore. In one case, for a job on the critical path, the duration for on-board foundation work was reduced from seven weeks to three work shifts in one day! While the overall saving in man-hours was not reported, it is likely to be at least 30%. Really, all that has been applied is just Common sense. That is, for the detail design and arrangement of anything that is part of a complex, everything in the vicinity should be considered regardless of the system it is part of. Similarly, for efficient implementation of on-board work, all work of one type in a region should be accomplished at the same time regardless of the different Systems represented.

#### **PERTINENT EXPERIENCES**

Review of some experiences in U.S., U.K., and Canadian shipyard which have successfully shifted to product orientation for construction work and those which have not, is helpful for applying product orientation to overhauls. Most

problems to be overcome are people problems.

Only three types of managers have succeeded:

- 0 those who are practical, have a solid production background, and are confident enough to refrain from appeasement of traditional middle managers,
- 0 those who have financial/business educations and experience who regard how to analyze as the most important aspect of any industrial endeavor, and
- 0 those who have engineering degrees, but whose educations are not limited to applied engineering, who appreciate manufacturing as a system and who accept the obligation to constantly develop the manufacturing system while producing end products.

All employed IHI consultants to accelerate the transitions to product orientation. [6]

Others, have been either disappointed with progress made or have failed completely. In one case a manager whose predecessor was deposed for insufficient tact in an attempt at more formal organization for the purpose of obtaining useful corporate data, overreacted with cancellation of everything his predecessor invoked. This was followed by a directive which exempted the structural shop from effective material control. Both acts were politically motivated as they were concessions to hard-nosed traditional middle managers. The shipyard was committed to a downhill course from which it has yet to recover.

Elsewhere the first application was extremely large in scope and was soon overlapped by an even greater application. At the same time another revolution use being attempted to computerize the design process. Had the first attempt at product orientation been limited to one complicated space, the affect on all management information systems would have become known without people being overwhelmed by masses of data in different formats. Other Achilles' heels were the failure to shift to a product organization commensurate with the transformation being attempted and both inadequate build strategies and insufficient standardization for the purposes of directing designers in grouping information and defining materials.

In still another case, a manager listened to a different drummer for at least two critical years before making a concerted attempt to shift into a product-oriented mode. IHI consultants were retained to assist in accelerating

the transition. But the investment was too little too late. A contract critical for the shipyard's survival was lost. A competitor had discovered the same need three years earlier and at that time made a far greater investment in IHI services. The message is loud and clear. It is not enough to be managing a transition to product-oriented methods with focus on constantly developing the manufacturing system, a firm must be making such progress ahead of its competitors!

In more than one instance, top managers were obsessed with acquiring expensive facilities as means to improve productivity without first developing product-oriented manufacturing systems. The corporate data produced by the latter would have provided a sounder basis for making decisions and would have resulted in less costly, if any, facility investments. Relative to competitors, they assumed increased overhead costs while losing valuable time for manufacturing-system development.

The most pitiful experience occurred in a shipyard where the top manager seems to have been preoccupied with other matters. The move toward product orientation was sparked by a few middle managers. Although applications were limited, significant amounts of assembly and painting work were organized zone per stage and performed in an orderly fashion in shops. Traditionally, the work would have been done on board with people assigned to various systems competing with each other for access to work. But, the yard's archaic management information system did not report all savings. When common sense should have prevailed because people were obviously working smarter and savings were manifest, the absence of pertinent interest from the top permitted die-hard traditionalists to wipe out the move toward modern management. Impact on the morale of those who dared to innovate, van devastating. Traditionalists in power might just as well have said to the innovators, "How dare you improve productivity?"

"The innovator has for enemies all those who have done well under the old conditions." [7]

In a category by itself, is the shipyard management team which rapidly and successfully abandoned its traditional methods in favor of a product work breakdown approach. Impressive command of integrated hull block construction, zone outfitting, and zone painting has been clearly manifest for more than one shipbuilding program. But, the same group has not adopted statistical accuracy control applied for production control purposes. With regard to levels of technology development, they have reached a plateau. Their manufacturing

system will never acquire the characteristic of constant self development until the statistical approach is appreciated and adopted.

Regardless of the nature of work, e.g., overhaul work of the same problem category in a virtual work flow or construction of multiple ships of the same class, demonstration of a learning curve by itself is no longer an impressive achievement nor is it sufficient for survival. What is required now is bit-by-bit constant improvement which has the effect of constantly displacing the learning curve downward for product after product as shown in Figure 6.

For the benefit of people who have yet to appreciate the significance of statistical accuracy control, the advice of the world's most effective shipyard managers is reiterated:

"Statistical control epoch makingly improved quality. laid the foundation of modern-ship construction methods and made it possible to extensively develop automated and specialized welding." [8]

Overhaul specialists in considering the foregoing should dwell on the problems they encounter with disassembly and reassembly of high-pressure pipe systems, particularly in submarines. The use of large-capacity chain falls to make up such pipe joints is common. Because of locked-in stresses they are more susceptible to failure during high-impact shock and are dangerous to disassemble. Statistical accuracy control applied for manufacture of new and replacement pipe pieces would greatly minimize such problems.

Regarding middle managers, not all having had only traditional experience were obstructionists when their yards began to transform. Some found that, despite the erudite terminology and the different organizations of people, information and work, a great undercurrent of common sense is inherent in product orientation. The many photographs published of IHI people working smarter not harder appealed to them. Some of these middle managers fitted in quickly and graciously. Others wanted very much to participate but had never been educated in how to shift gears.

Second to no other problem are the dyed-in-the-wool traditional middle managers and design engineers. Advising of them cannot be better stated than in the following:

... management must make commitments necessary to make it work. Commitments must transcend management hierarchy, trade boundaries, curators of ivory towers and traditionalists who

balk at new concepts. Failure to attend these considerations make it fairly easy for a single disbelieving or disinterested person or group to scuttle successful utilization. "[9]

#### SUCCESSFUL ACTIONS

The implementation actions which follow are the most effective of those employed in U.S., U.K., and Canadian shipyards which have successfully shifted to product orientation for construction work and, more recently, for overhaul work.

Top managers, including a naval shipyard commander, made some judgement calls. Are shipyard operations, particularly for modern naval ships, now so complicated that they overwhelm traditional system-by-system based management? Does a management information system based only on a system work breakdown structure produce accurate enough corporate data and does it truly comply with the U.S. Department of Defense cost/schedule control systems criterion for a work breakdown structure to "...define the product to be produced as well as the work to be accomplished..."? Are competitors benefiting enough from product-oriented approaches to threaten traditionally operated shipyards? If so, is there time to self-develop a product-oriented approach or should special assistance be obtained to accelerate transition as has been done, or is being done by a number of private yards and Philadelphia Naval Shipyard?

After deciding to shift to modern product-oriented operations, the most effective top manager worked persistently on implementation. Senior and middle managers were advised of his decision and were then indoctrinated in basic logic and principles. Afterwards, each was interviewed separately so that the top manager could identify:

- the majority that was willing to cooperate and was capable of cooperating,
- those who were sincere in their willingness but who needed special assistance to make the transformation, and those few individuals who had to be weeded out because they were disbelievers, disinterested, dyed-in-the-wool traditionalists, or curators of ivory towers who constituted a threat to successful implementation.

When the management team was so conditioned, a second indoctrination effort was directed at people who perform design engineering. Similar interviews were conducted for the same purposes.

With assurances thus obtained, only then were workers' immediate supervisors



and union leaders indoctrinated in pertinent logic and principles. They were also advised of the progress made by competitors in applying product-oriented methods for constructing and overhauling ships of all types and sizes and various end products other than ships. Thus, workers were not exposed to how people could work smarter before management was fully prepared to follow through. Part of the preparations addressed trade-union leaders concerns even when they were expected to be just political in nature.

The managers who determined that they had to rapidly move ahead of their competition in commanding more effective methods, retained IHI consultants. Their common objective was to supplement their resources with people having extensive pertinent experience. This assistance is especially needed by designers when a "computer" revolution is undertaken simultaneously with the logic revolution, i.e., the shift from system to product orientation.

In one case where time was not critical and only modest resources were available, the first application was limited per advice proffered by Dr. H. Shinto, former President of IHI. For the first attempt he suggested selecting a single complicated space such as a tanker pump room within which product orientation would be applied exclusively. He further recommended relying on advice from everyone involved in that experience to suggest how fast and where else to expand the product approach. People were not overwhelmed by the limited size of the first such challenge and at the same time were obtaining knowledge of how all aspects of the yard's management information system were being affected. The experience instilled confidence and the people involved wanted to expand product orientation to all work as soon as possible. Those in the work force who were not involved wanted to work the new easier way.

For a few additional applications, continued employment of ad-hoc product teams is reasonable. But, each top manager has to watch carefully because traditional managers who are unsure of their abilities to become more generalized can be expected to try to preserve their roles as functional specialists regardless of the top manager's objective. Thus, changing the entire organization to a product organization should be planned and scheduled just as for key events during any overhaul or construction project; i.e., in the context of the shipyard's master schedule. If not a high-priority concern to the top manager, the transition, if effected at all, will be agonizing for many people and unnecessarily prolonged.

## CONCLUSION

Obstructionists should be informed that in the U.S., abandonment of functional organizations by many successful non-shipyard firms, e.g., IBM and Exxon, started about 40-years ago. By 1960, IHI was actively managing a logic revolution and in 1963 started operations in the world's first shipyard rationalized to exploit product orientation for both construction and overhaul work. For many shipyards elsewhere, the time for adopting product organizations is long overdue. [10]

In North American shipyards, only one top manager provided thorough continuing education in the logic and principles of product orientation to his managerial staff, design engineers, first-line supervisors and union leaders. He retained IHI consultants to accelerate what turned out to be a very successful transformation. He weeded out uncompromising traditionalists. When asked why he personally attended all of the many pertinent seminars, he replied, "I want everyone in this yard to know how important this subject is to me!" Any commitment less than that will not suffice.

[1] The logic and principles of what is described herein reflect the very effective management system employed by Ishikawajima-Harima Heavy Industries Co., Ltd. (IHI) of Japan as published by L.D. Chirillo Associates, P.O. Box 953, Bellevue, Washington 98009, U.S.A., in a series of booklets for the National Shipbuilding Research Program (NSRP). Some of the material so published is incorporated in "Ship Production" by Storch, Hammon, and Bunch; Cornell Maritime Press, Centreville, Maryland (ISBN 0-87033-357-7), Chapters III, IV, VI, VII, and VIII. Other pertinent booklets based on IHI methods and published for the NSRP by L.D. Chirillo Associates are: Precontract Negotiation of Technical Matters - December 1984, Product Oriented Material Management - June 1985, Shipyard Organization and Management Development - October 1985, (Reprinted in the May 1986 issue of The Society of Naval Architects and Marine Engineers' Journal of Ship Production, pp. 74-79.). Flexible Production Scheduling system - April 1986, Product Oriented Safety and Health Management - May 1986, Analytical Quality Circles - September 1986, and Flexible Production Indices - April 1987.

[2] In U.S. naval shipyards the term "Zone Logic Technology" is sometimes used in place of "Group Technology". The latter is preferred because of its general use in literature.

[3] U.S. Department of Defense Instruction 7000.2.

[4] Responding to a shipyard manager's statement that labor imposed trade separations impeded productivity advances, Paul J. Burnsky, President of the AFL/CIO Metal Trades Department said in effect, "We are not your problem. If you do not like the way we are organized, change the way you organize work. If you do, you will cause problems for people like me, but we will get to where you want to go. It won't be as fast as you want, but we will get there. Management infers leadership so act like leaders, take the first step."

[5] There is also great opportunity to achieve such benefits during ship construction. In at least four countries, frigates are currently being built in follow yards with less productivity than is achievable because the lead-ship design was not developed in the context of a product-oriented build strategy. Two such follow shipbuilders are using the product approach for other shipbuilding projects while having to revert to a corruption of the product approach in order to achieve some productivity increase for the frigates. To say the least, they are frustrated. There is much to be gained from a policy of constantly enhancing productivity by design changes in follow ships. Naval administrators should work to create practical approval procedures which would encourage follow shipbuilders to submit proposals that would, in ship after follow ship, constantly result in more combined foundations, more pipe runs in parallel, more straight pipe pieces, etc. Such benefits are achievable with nominal changes in machinery arrangements, focus on piping runs, and without changing any components which require apart provisioning.

[6] The consultants were made available to U.S. and Canadian shipyards by IHI Marine Technology, Inc. of New York

[7] Machiavelli.

[8] The Society of Naval Architects of Japan, 1967.

[9] Similar resistance to change was also noted by John F. Kenefick, JFK Inc., Indianalantic, Florida, in-"Transfer of Photogrammetric Technology to the U.S. Shipbuilding Industry"Ta presentation to the U.S. Naval Shipyards' Structural Group Superintendents Workshop, 3-5 November 1987. Paradoxically, in certain shipyards photogrammetric surveys are being beneficially applied in more and more repair and ship-alteration situations while in other yards which have identical work-

loads, there is no such response. Managers are well advised to investigate the motives of their people who do not pursue opportunities to exploit innovations that have been proven elsewhere. Some of the latest such photogrammetric surveys are for creating accurate data for manufacturing replacement gravity davits for which existing as-built drawings are useless, dimensioning foundation bolt-hole locations in rebuilt arresting-gear engines (about 6' x 50') before they are landed in aircraft carriers, and determining required interface dimensions of as-built multi-leg masts before new mast tops are fitted.

[10] See "Shipyard Organization and Management Development". R.D. Chirillo. I. Inuki, and I. Kobayashi, SNAME Journal of Ship Production, May 1986,

FIGURE 1: A build strategy starts the shipbuilding process. Contract design describes the ship with information grouped in a large-frame sense. Functional design describes the ship system by system, i.e., with information grouped in an intermediate-frame sense. Transition design groups information zone/stage for the purpose of preparing work instructions, i.e., information grouped in the smallest-frame sense.

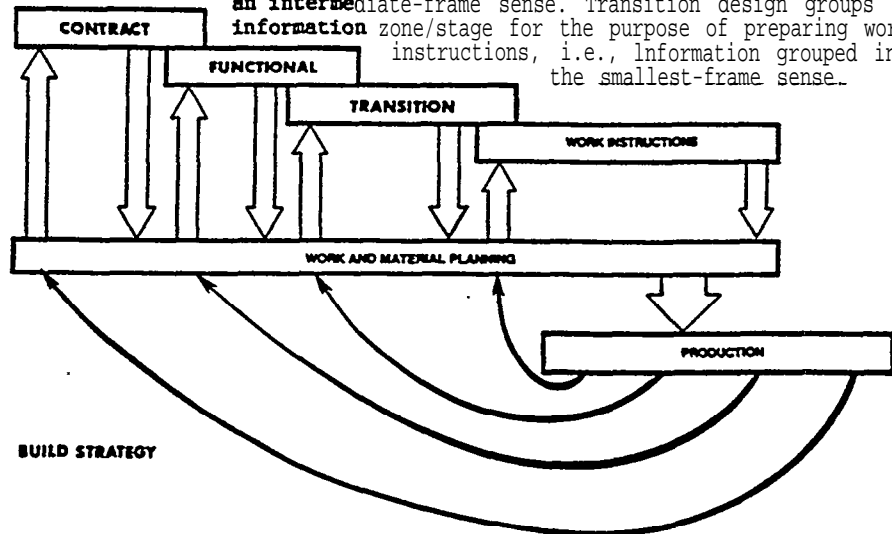

FIGURE 2: An overhaul strategy starts the overhaul process. While the information development phases are not as distinct as in shipbuilding, the effect is the same. As more becomes known due to open-and-inspect reports, information is refined until it is the form of work instructions, i.e., in the smallest-frame sense.

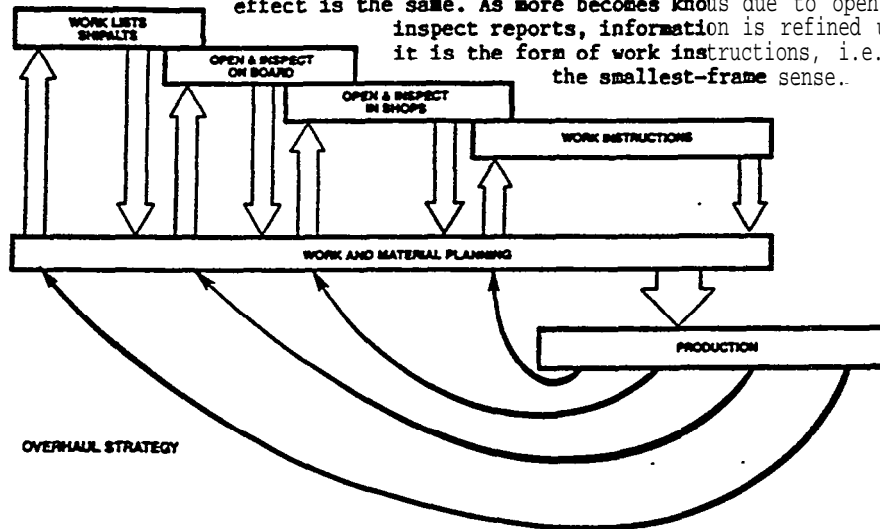

FIGURE 3: Specialities applied by Philadelphia Naval Shipyard for overhaul of the aircraft carrier KITTY HAWK are: (1) Electronic and Accommodation Spaces, (2) Accommodation Spaces, (3) Pump Rooms, Air-Conditioning Machinery Rooms, Storerooms, etc., and (4) Tanks and Voids.

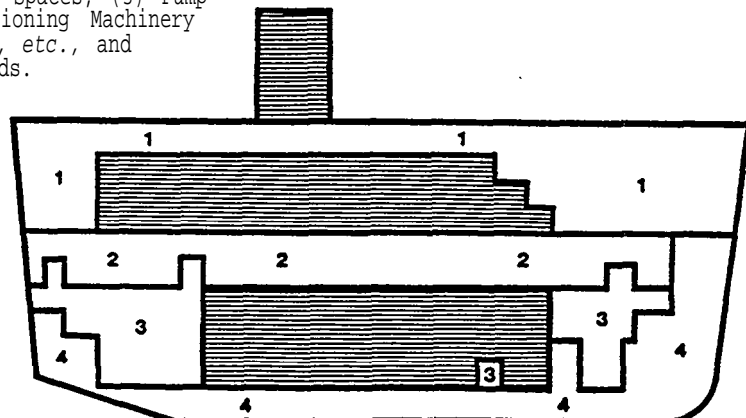

FIGURE 4: Product-Oriented Production Organization applied by Philadelphia Naval Shipyard for overhaul of the aircraft carrier KITTY HAWK.

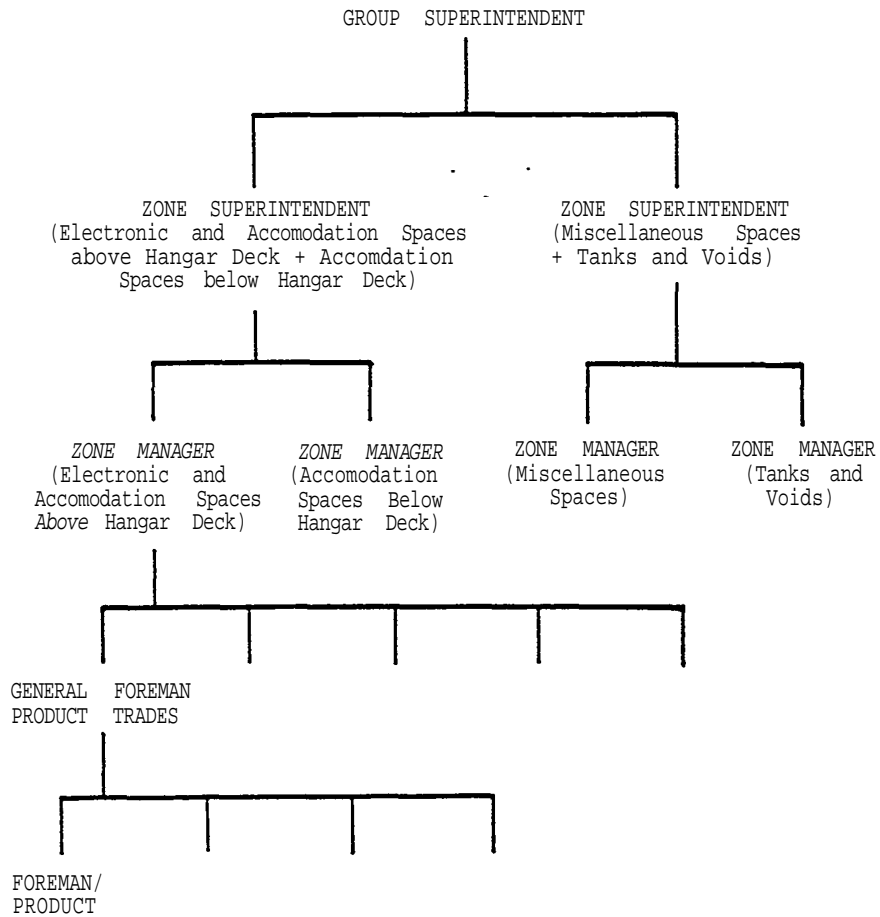

FIGURE 5: Ad-Hoc Product Team applied by Puget Sound Naval Shipyard for alterations, e.g., a close-in weapons system in the aircraft carrier RANGER, an outfitted and painted grand block for a Tomahawk-missile system in the cruiser TEXAS, and modification of electronic systems in 637-class submarines.

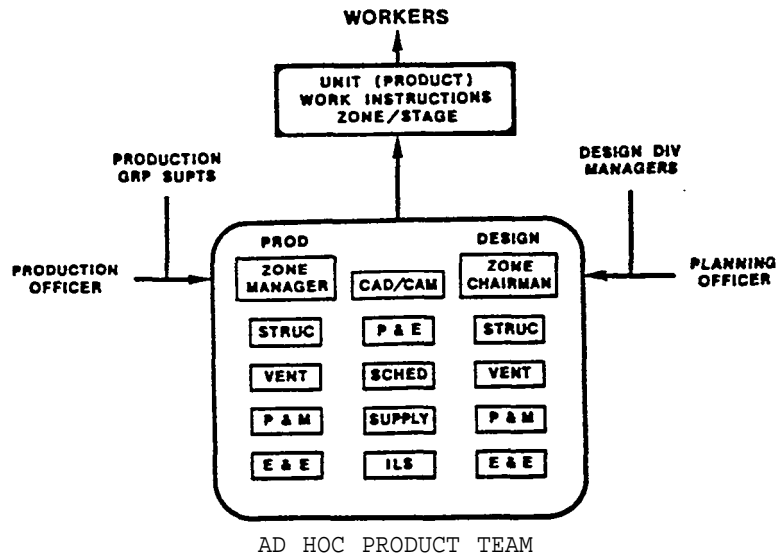
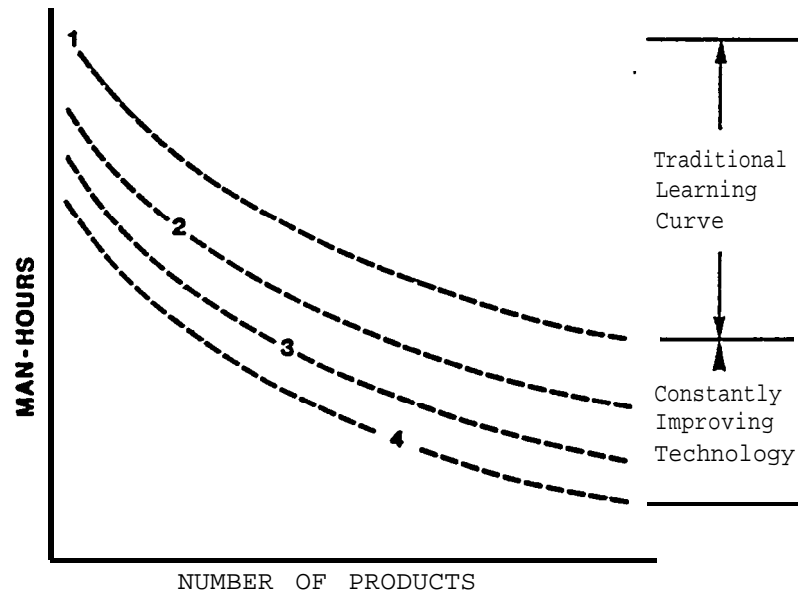

FIGURE 6: Modern manufacturing systems supplement learning-curve benefits with savings derived from constant improvements in technology. The effect is constant displacement of the learning curve downward. Per Dr. W. Edwards Deming, "The obligation to improve the system never ceases."



## **PLANNING AND SCHEDULING FOR SR & O ZONE TECHNOLOGY (CONTINUED)**

- **MANY SYSTEMS HAVE BUILT IN “MONTE CARLO SIMULATION THAT CAN BE USED TO DETERMINE STATISTICALLY BASED CONFIDENCE LEVELS, FOR SELECTED PROBABILITY DISTRIBUTIONS (SEE ATTACHED PAPER ON GT APPROACH TO MASTER SCHEDULING)**
- **AS ADDITIONAL REPAIR WORK EMERGES (AS IT ALWAYS DOES IN REPAIR AND OVERHAUL JOBS) IT IS NECESSARY TO ITERATE THROUGH THE ABOVE STEPS TO FIT IT IN WITH MINIMUM IMPACT ON SCHEDULE**
- **THE RESULTING PLAN AND SCHEDULE IS THEN USED AS THE BASIS FOR PRODUCTION AND MATERIAL CONTROL**
-



REPAIR & O/CUMM PRODUCT RANGE

OWNERS REQUIREMENTS
<del>-TYPE</del>
<del>-SIZE</del>
<del>-CAPACITY</del>
<del>-CREW</del>
<del>-SPEED</del>
<del>-PORTS</del>
<del>-MAINTENANCE</del>
<del>-E.R.</del>

- SHORT OUT OF SERVICE TIME
- QUALITY REPAIR WORK

REPAIR SHIPBUILDING POLICY

DESIGNS

REPAIR WORK SPECIFICATION SCOPE

PRELIMINARY REPAIR STRATEGY

REPAIR

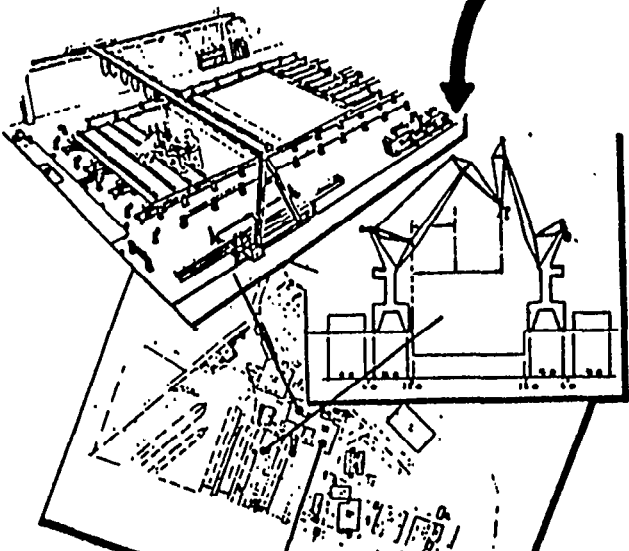

SHIPYARD REPAIR FACILITIES

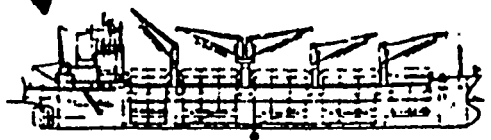

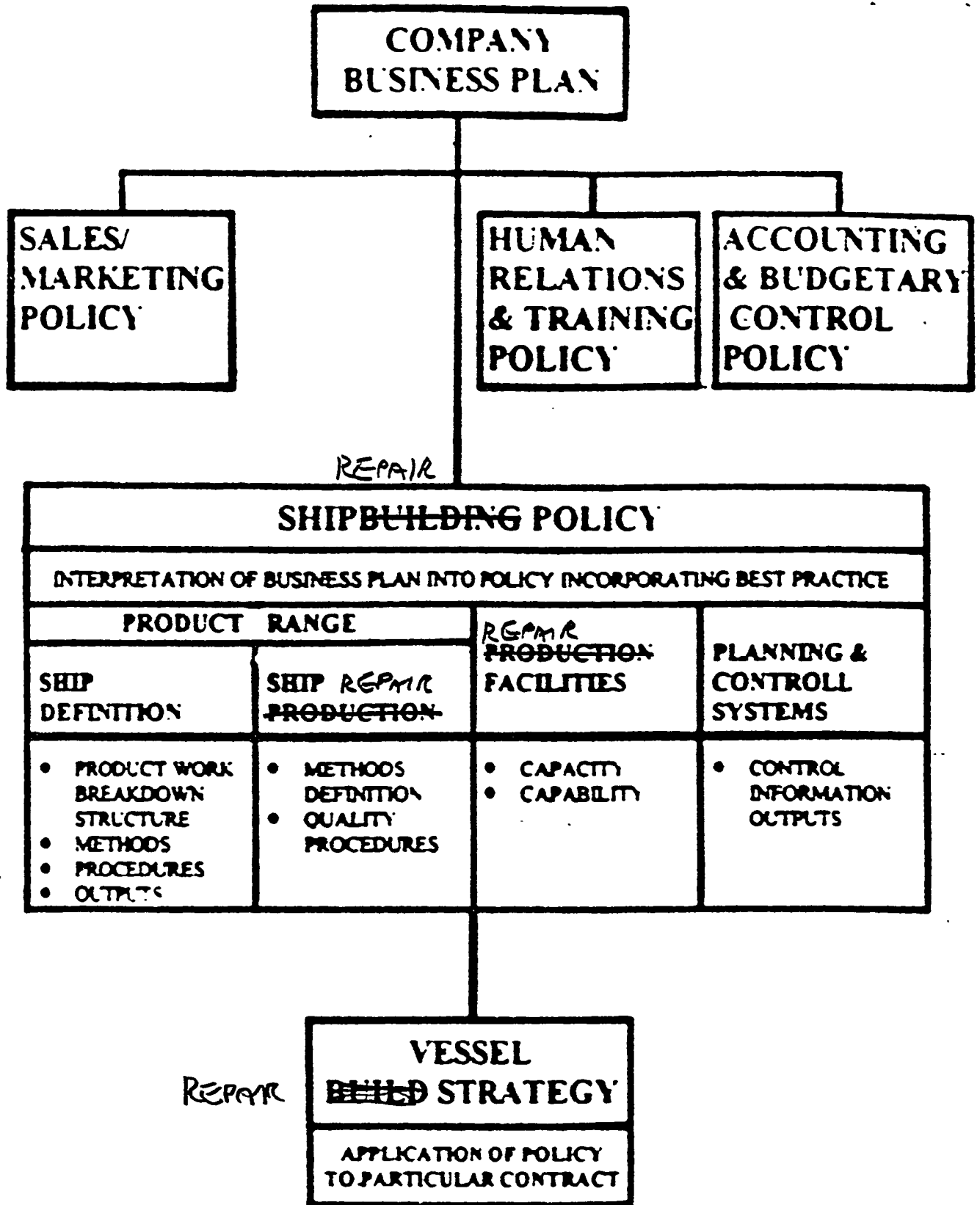

Figure 1 - *REPAIR* ~~Build~~ Strategy and *Repair* ~~Shipbuilding~~ Policy





# Repair Build Strategy Development

John Clark (V), A & P Appledore International Ltd., U.K., and Thomas Lamb (FL), Textron Marine & Land Systems: U.S.A.

## ABSTRACT

The 1985 NSRP-Design For Production Manual' (SP-4.1986) describes the use of a Build strategy as a basis for improved shipbuilding performance through front end involvement of all and better communication. A number of U.S. shipbuilders are known to have used the approach. However, the extent of its use and the experience of the users was unknown.

To remedy this situation the SP-4 Panel conceived a project to determine (1) how widely the Build strategy approach was known and used by U.S. shipbuilders, and (2) a suitable Build Strategy framework with examples of its use for two typical ship types.

This paper summarizes performance of the project and briefly describes the findings of the U.S. and foreign shipyard surveys and visits, the required prerequisites for use of a Build Strategy and benefits from its use. It also includes the contents list for the proposed Build Strategy framework.

## INTRODUCTION

Shipbuilders plan how they will build their ships. The plan may be only in someone's head or a detailed and documented process involving many people. Often different departments prepare independent plans which are then integrated by a Master Plan/Schedule.

Repair

A Build Strategy is much more than the normal planning and scheduling and a description of how the Production Department will build the ship.

Many shipbuilders use the term "Build Strategy" for what is only their Production Plan. In terms of this project, this is incorrect. The term "Build Strategy" as used throughout this paper has a special, specific meaning. It is also recognized that some shipbuilders have a process very similar to the Build Strategy approach but do not call it such.

Repair

Repair  
What is the meaning by the term Build Strategy for this project? Before specifying this, the aims of a Build Strategy are briefly discussed.  
Repair

It:

- applies a company's overall shipbuilding policy to a contract, Repair
- 1 provides a process for ensuring that design development takes full account of production requirements,
- 1 systematically introduces production engineering principles that reduce ship work content and cycle time,
- 1 identifies interim products and creates product-oriented approach to engineering and planning of the ship,
- determines resource and skill requirements and overall facility loading,
- identifies shortfalls in capacity in terms of facilities, manpower and skills,
- 1 creates parameters for programming and detail planning of engineering, procurement and production activities
- 1 provides the basis on which any eventual production of the product may be organized including procurements dates for "long lead" material items,
- 1 ensures all departments contribute to the strategy,
- 1 identifies and resolves problems before work on the contract begins, and
- ensures communication, cooperation, collaboration and consistency between the various technical and production functions.

In summary:

Repair

A BUILD STRATEGY IS AN AGREED DESIGN, ENGINEERING, MATERIAL MANAGEMENT, PRODUCTION AND TESTING PLAN. PREPARED BEFORE WORK STARTS, WITH THE AIM OF IDENTIFYING AND INTEGRATING ALL NECESSARY PROCESSES.

FOR THE REMAINDER OF THE PAPER REPLACE "BUILD" WITH "REPAIR" AND "SHIP BUILDING" WITH "SHIP REPAIR"  
6-1

## BACKGROUND

It was A&P Appledore that conceived and developed the formal Build Strategy approach in the early 1970's. It developed from the ideas and processes generated to support the A&P Appledore associated "Ship Factories" at Sunderland and Appledore. The detailed work breakdown formalized work sequencing and very short build cycles associated with these ship factories required the communication, coordination and cooperation that are inherent in the Build Strategy approach.

British Shipbuilders adopted the Build Strategy approach for all their shipyards (Vaughan, 1983)\* and A&P Appledore consulting group continued to develop the approach as a service to their clients.

The Build Strategy approach was introduced into the U.S. by A&P Appledore's participation in IREAPS conferences, as well as through presentations to how the individual shipbuilders and the SP4 Panel (Craggs, 1983; A&PA 1983; and A&PA, 1984).

A&P Appledore consulting to NORSHIPCO, Lockheed shipbuilding company and Tacoma Boat introduced the use of the Build Strategy approach to U.S. shipbuilding projects. Finally, the Build Strategy approach was described in the DESIGN FOR PRODUCTION Manual, prepared by A&P Appledore for the SP4 Panel (SP4.1986).

The concept of the Build Strategy has existed for a number of years, and there has been an ongoing development of the concept in those shipyards which have adopted the Build Strategy approach. During this time, shipyards in Britain and other countries have had considerable experience in applying this **technology**, and it was appropriate to update the **original Build Strategy approach** in the light of this **experience**.

It is a known fact but unfortunately, a not an often practiced approach that the performance of any endeavor will be improved by improvements in communications, cooperation and collaboration. A Build Strategy improves all three. It communicates the intended total shipbuilding project to all participants. This communication fosters improved cooperation as everyone is working to the same plan. It improves collaboration by involving most of the stakeholders (interested parties) in its development.

**Why was this project necessary? It was perceived** by some shipbuilders and the U.S. Navy that the formal documental Build Strategy approach had not been enthusiastically embraced by U.S. shipbuilders

\* See REFERENCES

**If the Build Strategy approach is thought to be such a good idea and/or shipbuilding improvement tool, it is surely worthwhile to try to find out if this is the case, and, also to find out why it is not being used by U.S. shipyards.**

## PREREQUISITES FOR A BUILD STRATEGY

A Build Strategy could be produced as a stand alone document for any ship to be built by a shipyard but it would be a great deal thicker and would take a lot more Strategy effort if certain other documents had not (83)\* and been prepared earlier.

**The first of these documents would be the shipyard's Business Plan, which will probably exist in most shipyards. A Business Plan sets out the shipyard's ambitions for a period of years and describes how the shipyard aims to attain them.**

Next a Shipbuilding Policy should be in place. The policy defines the product mix which the shipyard intends to build plus the optimum organization procedures will allow it to produce efficiently. The shipbuilding Policy Will also include methods for breaking the ships in the product mix into standard interim products by applying a Product Work Breakdown Structure. Areas in which the interim products will be produced and the tools and procedures to be used will also be defined.

Ideally, a Ship Definition Policy will also exist. This specifies the format and content that the engineering information will take in order to support the manner in which the ships will be built.

If any of these documents do not exist, then the information relevant to a particular contract that would have been in them will have to be produced and included in the Build Strategy.

## RELATIONSHIP BETWEEN SHIPBUILDING POLICY AND BUILD STRATEGY

A Shipbuilding Policy is the definition of the optimum organization and build methods required to produce the product mix contained within the company's shipbuilding ambitions, as defined in the Business Plan. The Shipbuilding Policy is aimed primarily at design rationalization and standardization together with the related work organization to simulate the effect of times construction. This is achieved by the application of group technology and a product work breakdown which leads to the formation of interim product families.

A Shipbuilding Policy is developed from a company's Business Plan which usually covers a period of five years and includes such topics as:

- the product range which the shipyard aims to build,
- 1 shipyard capacity and targeted output
- **targets for costs, and**
- **pricing policy.**

The product range is identified, usually as a result of a market study.

The relationship between a Business Plan, Shipbuilding Policy, and Build Strategy is shown in Figure 1.

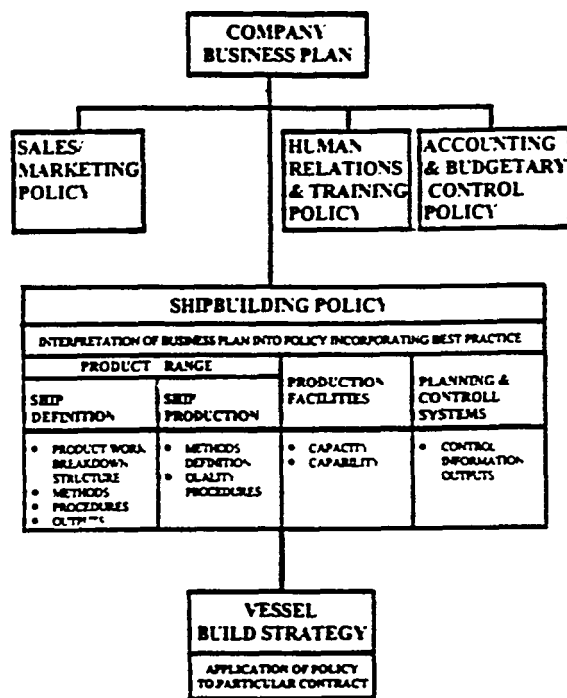

Figure 1 - Build Strategy and Shipbuilding Policy

The Business Plan sets a series of targets for the technical and production part of the organization. To meet these targets, a set of decisions is required on:

- facilities development
- productivity targets,
- make, buy or subcontract and
- technical and production organization.

These form the core of the Shipbuilding Policy. The next level in the hierarchy defines the set of strategies by which this policy is realized, namely the Build Strategy.

In essence, the Shipbuilding Policy comprises a set of standards, which can be applied to specific ship contracts. The standards apply at different levels:

- Strategic, related to type plans, planning units, interim product types, overall facility dimensions, and so on; applied at the Conceptual and Preliminary Design stages.
- Tactical, related to analysis of planning units, process analysis, standard products and practices, and so on; applied at the Contract and Transition Design stages.
- Detail, related to work station operations and accuracy tolerances; applied at the Detail Design stage.

Because shipbuilding is dynamic, there needs to be a constant program of product and process development. Also, the standards to be applied will change over time with product type, facilities, and technology development.

The Shipbuilding policy is therefore consistent, but at the same time will undergo a structured process of change in response to product development, new markets, facilities development, and other variations.

The policy has a hierarchy of levels which allow it to be applied in full at any time to a particular contract

Therefore, to link the current policy with a future policy, there should be a series of projects for change which are incorporated into an overall action plan to improve productivity. Since facilities are a major element in the policy, a long term development plan should exist which looks to a future policy in that area. This will be developed against the background of future business objectives, expressed as a plan covering a number of years.

These concepts are summarized and illustrated in Tables I and II.

Work at the Strategic level provides inputs to:

- the conceptual and preliminary design stages,
- contract build strategy,
- facilities development
- **organizational changes, and**
- the tactical level of shipbuilding policy.

At the strategic level, a set of documents would be prepared which address the preferred product range. For each vessel type, the documents will include:

- definition of the main planning units,
- development of type plans, showing the sequence of erection, and
- 1 analysis of main interim product types.

**TABLE 1  
ELEMENTS OF SHIPBUILDING  
POLICY**

**POLICY OVERVIEW**

**Policy** Based on Business Plan Objectives  
Sets Objectives for Lower Levels

**CURRENT PRACTICE**

Existing Standards  
"Last Best" Practice  
Procedures to be Applied to Next Contract

**PRODUCTIVITY ACTION PLAN**

Covers Next Twelve Months  
Plans Improvements in Specific Areas  
Is a Set of Projects

**FUTURE PRACTICE**

Developed from Current Practice  
Incorporates Outcome of Action Plan  
Procedures to be Applied to Future Contracts

**LONG TERM DEVELOPMENT PLAN**

Covers Facilities Development  
Covers a Five Year Period

**TABLE 2  
TYPICAL LIST OF CONTENTS IN A  
DETAILED SHIPBUILDING POLICY  
DOCUMENT**

**1.0 OVERVIEW**

1.1 Objectives  
1.2 Purpose and Scope  
1.3 Structure

**2.0 PRODUCT RANGE**

2.1 Product Definition  
2.2 Outline ~~Build~~ **Repair** Methods

**3.0 OVERALL PHILOSOPHY**

3.1 Outline  
3.2 Planned Changes and Developments  
3.3 Related Documents

3.4 Work Breakdown Structure  
3.5 Coding  
3.6 Technical Information  
3.7 Workstations  
3.8 Standards  
3.9 Accuracy Control

**4.0 PHYSICAL RESOURCES**

4.1 Outline  
4.2 Planned Changes and Developments  
4.3 Related Documents  
4.4 Major Equipment  
4.5 Steel Preparation and Subassembly  
4.6 Outfit Manufacture  
4.7 Steel Assembly  
4.8 Outfit Assembly  
4.9 Pre-outfit Workstations  
4.10 Berth/Dock Area  
4.11 Engineering Department Resources

**Repair**

**5.0 SHIP PRODUCTION METHODS .**

5.1 Outline  
5.2 Planned Changes and Developments  
5.3 Related Documents  
5.4 **Standard Interim Products, Build Repair** Methods,  
5.5 Critical Dimensions and Tolerances  
5.6 Steel Preparation  
5.7 Steel Assembly  
5.8 Hull Construction  
5.9 Outfit Manufacture  
5.10 Outfit Assembly  
5.11 Outfit Installation  
5.12 Painting  
5.13 Services  
5.14 Productivity Targets  
5.15 Subcontract Work

**6.0 SHIP DEFINITION METHODS**

6.1 Outline  
6.2 Planned Changes and Developments  
6.3 Related Documents  
6.4 Ship Definition Strategy  
6.5 Pre- **B**  
6.6 ~~Post-Tender Design~~

7.0 PLANNING FRAMEWORK
7.1 outline
7.2 Planned Changes and Developments
7.3 Related Documents
7.4 Strategic Planning
7.5 Tactical Planning
7.6 Detail Planning
7.7 Performance Monitoring and Control
8.0 HUMAN RESOURCES
8.1 Outline
8.2 Planned Changes and Developments
8.3 Related Documents
8.4 Organization
8.5 Training
8.6 safety
9.0 ACTION PLAN
9.1 Outline
9.2 Projects and Time scales

The strategic level will also address the question of facility capability and capacity.

Documentation on the above will provide input to contract the conceptual design stage except, of course, in those cases where a design agent is undertaking the design work and the builder has not been identified.

Documentation providing input to the preliminary design stage will include:

- 1 preferred raw material dimensions.
- 1 maximum steel assembly dimensions.
- 1 maximum steel assembly weights.
- 1 material forming capability, in terms of preferred hull configurations.
- 1 "standard" preferred outfit assembly sizes.
- 1 configuration and weights, based on facility capacity/capability, and
- 1 "standard preferred service routes.

At the tactical level standard interim products and production practices related to the contract and transition design stages, and to the tactical planning level will be developed. All the planning units will be analyzed and broken down into a hierarchy of products.

The policy documents will define preferences with respect to:

- standard interim products,
- standard product process and methods.
- standard production stages.
- **installation practices,**
- **standard material sizes, and**
- 1 standard piece parts.

The capacity and capability of the major shipyard facilities will also be documented.

For the planning units, sub-networks will be developed which define standard times for all operations from installation back to preparation of production information. These provide input to the planning function.

At the Detail level, the policy provides standards for production operations and for detail design.

The documentation will include:

- 1 workstation descriptions.
- **workstation capacity,**
- 1 workstation capability,
- **design standards,**
- **accuracy control tolerances,**
- **welding standards, and**
- **testing requirements.**

Reference to the standards should be made in contracts, and relevant information made available to the design, planning and production functions.

As with all levels of the Shipbuilding policy, the standards are updated over time, in line with product development and technological change.

A ship definition is a detailed description of the procedures to be adopted, and the information and format of that information to be produced by each **department developing technical information within a**. **The description must ensure that the** information produced by each department is in a form suitable for the users of that information.

These users include:

- ship owners or their agents,
- shipyard management,
- classification societies,
- government bodies,
- other technical departments:
  - design and drawing offices.
  - CAD/CAM center.
  - lofting,
  - planning,

production engineering  
production control  
material control.  
estimating  
procurement and  
production departments

Preferably the ship under consideration would also be of a type which has been identified in the Shipbuilding Policy as one which the shipyard is most suited to build

The next best scenario would be that the ship being designed was of a type for which a build strategy exists within the shipyard.

#### BENEFITS OF A BUILD STRATEGY TO U.S. SHIPBUILDERS

If mass production industries, such as automobile manufacture, are examined, there is no evidence of the use of build strategies.

Some shipyards, which have a very limited product variety, in terms of interim and final products, integral generally speaking, also have no need for build strategies, due to their familiarity with the products. If such shipyards, which are amongst the most productive in the world, do not use build strategies, then why knowledge should the U.S. industry adopt the build strategy approach?

The answer lies in the differences in the commercial environments prevalent and the gearing of operating systems and technologies to the product mix procure and marketing strategies. In a general sense, the most productive yards have identified market niches, developed suitable standard ship designs, standard interim products and standard build methods. By various means, these yards have been able to secure sufficient orders to sustain a skill base which has **become familiar with those standards. As the degree of similarity in both interim and final products is high,** there has been no need to re-examine each vessel to produce detailed build strategies, but many of them do as they find the benefits greatly outweigh the effort.

It is most likely that the U.S. shipbuilding industry's re-entry into major commercial international markets will begin with one-offs or at best very limited series contracts. Furthermore, as many U.S. shipyards believe that it will be most effective to concentrate on complex vessels, the build strategy approach will be a key factor in enabling the yards to obtain maximum benefit from the many advanced technologies, most of which have been made available through the work of the NSW Ship Production Panels. Also, the Build

**Strategy approach will ensure that the way they are to be applied is well planned and communicated to all involved.**

Most shipyards will have elements of a Build Strategy Document in place. However, without a formalized Build Strategy Document the lines of communication may be too informal and variable for the most effective strategy to be developed

A well organized shipyard will have designed its facilities around a specific product range and standard production methods which are supported by a variety of technical and administrative functions that have been **developed according to the requirements of production,** and detailed in a Shipbuilding Policy. In this case, when new orders are received only work which is significantly different from any previously undertaken needs to be investigated in depth in order to identify possible difficulties.

Where it has not been possible to minimize product variety, such investigations will become crucial to the effective operation of the shipyard. The outcome of these investigations is the Build Strategy Document

A Build Strategy is a unique planning tool. By integrating a variety of elements together, it provides a holistic beginning to end perspective for the project development schedule. It is also an effective way of capturing the combined design and shipbuilding knowledge and processes, so they can be continuously improved, updated, and used as training tools.

A Build Strategy effectively concentrates traditional in the meetings that bring all groups involved, together to evaluate and decide on how the ship will be designed, procured, constructed, and tested before any tasks are commenced or any information is "passed on".

The objectives of the Build Strategy Document are as follows:

- 1 To identify the new vessel.
- 1 To identify the design and features of the new vessel.
- 1 To identify contractual and management targets.
- 1 To identify departures from the shipyard's shipbuilding Policy.
- To identify constraints, based on the new vessel being designed/constructed particularly with reference to other work underway or envisaged
- 1 To identify what must be done to overcome the above constraints.

The last objective is particularly important as decisions taken in one department will have

implications for many others. This means that effective interdepartmental communication is vital.

The very act of developing a Build Strategy will have benefits due to the fact that it requires the various departments involved to communicate, and to think rationally about how and where the work for a particular contract will be performed. It will also highlight any potential problems and enable them to be addressed well before the 'traditional' time when they strength will arise.

If a Shipbuilding Policy exists for the company, then its should be examined in order to ascertain if a man Ship of the type under consideration is included in the delivery preferred product mix If such a ship type exists then certain items will already have been addressed.

These items include:

- 1 outline build methods,
- 1 workbreakdown structure,
  - . coding
  - . workstations,
  - **standard interim products,**
  - **accuracy control,**
  - . ship definition method&
  - . planning framework,
  - . Physical resources at shipyard, and
  - . human resources.

One thing which is unique to any new ship order is how it fits in with the ongoing work in the shipyard-The current work schedule must be examined in order to fit the ship under consideration into this schedule. Key dates, such as cutting steel, kell laying, launch and delivery will thus be determined.

**Using the key dates other events can be planned. These events are:**

- 1 key event program
  - resource utilization,
- 1 material and equipment delivery schedule,
- 1 material and equipment ordering schedule,
  - **drawing schedule,**
  - . schedule of tests and trial, and
- 1 stage payment schedule and projected cash flow.

Once the major events and schedules arc determined,they can be examined in detail to expand the information into a complete build strategy. For example. the key event program can be associated with the work breakdown to produce planning units and master schedules for hull. blocks. zones. equipment units, and systems.

is that The Build Strategy Document should be used by all of the departments listed above, and a formal method of feedback of problems *and/or* proposed changes must be in place so that agreed procedures cannot be Changed without the knowledge of the responsible person. Any such changes must then be passed on to all holders of controlled copies of the Build Strategy.

The Build Strategy is used to facilitate and strengthen the communication links. It should bring up front and be used to resolve, potential conflicts between departments in areas of design details, manufacturing processes, make/buy decisions, and **delivery goals.**

A Build Strategy can be used as an effective people empowerment tool by giving participants the opportunity to work out all their needs together in advance of performing the tasks.

The intent of a Build Strategy is to disseminate the information it contains to all who can benefit from knowing it Throughout this report it is described as a hard copy document, but today it could well be electronically stored and disseminated through local area network work stations.

Producing a Build Strategy Document will not guarantee an improvement in Productivity, although as stated earlier, the process of producing the document will have many benefits. Full benefits will only be gained if the strategy is implemented and adhered to.

Positive effects of the Build Strategy approach are two-fold:

- . During production, managers and foremen have a guidance document which ensures that they are fully aware of the construction plan and targets, even those relating to other **departments. This reduces the likelihood of** individuals making decisions which have adverse effects in other departments. Although often quoted by shipyards as being the reason for a Build Strategy, the benefits accruing from this are not major.
- 1 Prior to production. the use of the Build Strategy approach ensures that the best possible overall design and production philosophy is adopted. Crucial communication between relevant departments is instigated early enough to have a significant influence on final costs. It is therefore the structured, cross-discipline philosophy which provides the downstream reductions in costs. and this is the major benefit

A yard which develops a strategy by this method will gain all the advantages, whether or not a single

Build Strategy Document is produced. However, the imposition of the requirement for a single document should ensure that the development of the strategy follows a structured approach.

Perhaps the single most beneficial aspect of a Build Strategy is, that by preparing one, the different departments have to talk to each other as a team at the right time. A Build Strategy is a "seamless" document. It crosses all traditional department boundaries. It is an important step in the direction of the seamless enterprise. The most evident benefit is improved communication brought about by engaging the whole company in discussion about project goals and the best way to achieve them. It eliminates process/rework problems due to downstream sequential hand-over of tasks from one department to another by defining concurrently how to ship will be designed and constructed

Some of the advantages mentioned by users of the Build Strategy approach are:

- help prioritize work,
- serves as an effective team building tool
- requires that people share their viewpoints because they need to reach a consensus
- places engineers face to face with the customers - purchasing production, test etc..
- expands peoples view of the product (ship) to include such aspects as maintenance, customer training support service. etc..
- fosters strong lateral communication
- saves time through concentration on parallel versus sequential effort,
- facilitates resolution of differences and misunderstandings much earlier.
- greatly improves commitment ("buy in") by participants and the effectiveness of the hand-over later,
- serves as a road map that every one can see and reference as to what is happening.
- facilitates coordinated communication and
- develops a strong commitment to the process and successful completion of the project.

There are a few disadvantages mentioned by users, such as:

- 1 effort and time to prepare the formal Build Strategy document.
- 1 total build cycle appears longer to some participants due to their earlier than normal involvement.

- **cross functional management is not the norm** and most people currently lack the skills to make it work.
- experts who used to make independent decisions may have difficulty sharing these decisions with others in developing the Build Strategy, and
- a Build Strategy describes the complete technology utilized by a shipyard and if given to a competitor, it could negate any competitive advantage.

**However, the users felt that the advantages greatly outweigh the disadvantages.**

## PERFORMANCE OF THE PROJECT

Although it was known that a number of U.S. shipbuilders have utilized Build Strategies, it was not known how many and how effective they were.

A number of shipyards and the U.S. Navy believed in the benefit of the Build Strategy approach and this project was undertaken to accomplish the following objectives:

- To determine for a number of U.S. shipyards involved in building the selected ship types, capabilities and limitations, and to classify them into common U.S. industry criteria.
- To determine how many U.S. shipbuilders currently use formal documented Build strategies.
- To - U.S. shipbuilding personnel with the Build Strategy approach requirements and benefits.
- To determine U.S. shipyard perceived need for a formal Build Strategy.
- To prepare a generic Build Strategy that can be used by U.S. Navy program office during concept, preliminary, and contract design, as well as U.S. shipyards, as the basis for the Build Strategy for a specific project
- 0 To prepare specific examples of the use of the generic Build Strategy for two selected ship types-
- 0 To provide a final report on the findings of the shipyard survey on the use of formal Build Strategies, the perceived requirements shipyard capabilities and limitations and how they were used/incorporated into the generic Build Strategy.



## SELECTION OF SHIP TYPES

Four ship types were offered as potential examples to the Panel Project Team, namely.

- Destroyer.
- Fleet Oiler.
- RORO, and
- Container.

The Team selected the fleet oiler and the container ship in January 1993. As the project developed and the industry interest shifted even more from military to commercial ships, a number of sources recommended that the fleet oiler example be changed to a product tanker. Therefore, the final examples that were parts selected to demonstrate the use of the Build Strategy Development framework were a 42,400 tonne DWT included Product Tanker and a 30,700 tonne DWT Container/RORO ship.

Attempts to get ship design information from U.S. sources, for ships of these types recently designed and/or constructed, were unsuccessful. Therefore, an A&P Appledore design for a product tanker and the MarAd PD-337 commercial cargo ship (non-enhanced) design were used for the examples.

## QUESTIONNAIRES

BUILD STRATEGY and SHIPYARD CAPABILITIES AND LIMITATIONS questionnaires were prepared for distribution to U.S. and Canadian shipbuilders. Their purpose was to determine current understanding and use of the Build Strategy approach and to determine current capabilities and limitations regarding building of selected ship types so that common capabilities and limitations could be developed and used in the two Build Strategy examples.

Both questionnaires were sent to 22 private and Navy shipyards. Questionnaires were received back from three shipyards. The Build Strategy Questionnaire was completely filled out in all three cases. The Ship capability and Limitation Questionnaire was only completely filled out by one shipyard with the other shipyards completing from 30 to 50 percent. Only one of the shipyards that responded to the questionnaires was willing to meet with the project team. Two other shipyards agreed to a team visit: during telephone calls to solicit support for the project. The Build Strategy Questionnaires were also completed for two shipyards that were visited but had not completed the questionnaires.

**All five shipyards responding to the Build Strategy Questionnaire** were familiar with the Build strategy approach. Only one had never prepared a Build Strategy document, although even that shipyard did prepare many of the listed content components and was of the opinion that it was not worth the effort to produce a single Build Strategy document.

There were wide differences in the need for many of the listed content components to be in the Build Strategy document. However, 18 out of 51 components were identified by at least four shipyards, and another 11 components by at least three shipyards. These 29 components were identified as Build Strategy **"recommended" components**. **Two components in the Construction Data group, namely, Number of Plate Parts and Number of Shape parts, were considered unnecessary by all five shipyards.** They will not be included in the Build Strategy Document. The **remaining 20 components were identified as "optional"**.

The lack of response made it impossible to determine common capabilities and limitations. However, the following findings are presented:

- Two shipyards have existing Marketing **which are involved in Market Research. Interestingly, they both have only** been involved in Navy or government contracts during the past decade.
- One shipyard has a central planning and scheduling department; the others have a Master Planning Group that integrates the planning and scheduling of the various **departments.**
- Two shipyards have separate Material Planning/Control Groups and all three shipyards that responded to the questionnaire use material coding MRP II or similar **systems.**
- Only one shipyard has a complete in-house engineering capacity. Both the other shipyards subcontract most of their engineering to marine design agents.
- Two shipyards use CAD concurrent engineering, production oriented drawings, standard engineering procedures and engineering standard details.
- All three shipyards have complete in-house lofting capability that are part of the engineering department.
- Two shipyards have Manufacturing industrial Engineering groups that are part of the Production Department.

- Engineering in all three shipyards is functionally organized into the traditional hull, machinery and electrical although their work is prepared for block construction and Zone outfitting.
- Two shipyards use self-elevating, self-propelled transporters up to 250 ton capacity, and both self and non-elevating trailers from 50 to 80 ton capacity. Fork lift trucks from 1 to 14 ton capacity are used for general material handling.
- All three shipyards claim to use block construction, Zone outfitting and packaged machinery units. They all claim to use Accuracy Control for structure and one shipyard uses sit for piping ventilation and electrical components.
- All three shipyards have state of the art painting capabilities.

#### U.S. SHIPYARD VISITATION

The project team visited BethShip, Avondale The Shipyards and NASSCO. Each visit lasted a minimum of four hours with one taking six hours. A proposed agenda was sent to each shipyard prior to the meetings along with a number of additional questions which would be asked during the visit. The project team first presented background information on the project, such as description, objectives, and approach. Then the **purpose of the meeting was presented, which was to discuss face to face the questionnaire responses and clarify any questions.** It was also to see what each shipyard had done, and was doing with regard to Build Strategy. In addition the Shipbuilding Technology Office of the Naval Surface Warfare Center at Carderock, Maryland was visited. The purpose of this visit was to learn about the Generic Build Strategy activity being worked on for the Mid Term Fast Sealift Ship (MTFSS) program. The purpose the meeting was to determine how the two projects could and should interact. The Navy reported that there was considerable confusion in the industry because of identical project titles, and concern regarding the relationship of the SP-4 Panel Build Strategy project and the U.S. Navy's Mid Term Fast Sealift Ship program. Questions being asked ranged from "Are they connected?" to "How are the two projects going to be differentiated?" There is no contractual connection. The MTFSS program is interested in using the Build Strategy approach for one specific ship in a number of shipyards to reduce the time taken from contract award to delivery of the ship.

The SP-4 project is interested in showing many shipyards how to use the Build Strategy approach for any ship type. The visit was most beneficial in determining this difference and resulted in agreement that it was necessary to differentiate between the two projects to the maximum extent possible. It was mutually decided to rename the SP-4 project and further, to concentrate entirely on commercial shipbuilding and ship types. It was decided to clearly differentiate between the two projects by changing the title of the SP-4 project to BUILD STRATEGY DEVELOPMENT.

All shipyards and the Shipbuilding Technology Office were very cooperative and generous in the giving of their time and sharing of their experiences and information.

All three shipyards were familiar with the Build Strategy approach and had prepared a number of Build Strategies in preparation of bids. Ship types involved were container ship and product tanker. Two had used Build Strategies for at least one complete design/build cycle. Ship types involved were container sealift conversion and T-AGS.

The departments having the major responsibility for the Build Strategy Development were under Production in two shipyards and part of Advanced Product Planning and Marketing in the other shipyard.

All three shipyards were committed to using the Build Strategy approach in continuing greater scope. This was entirely based on their own perceived needs/benefits and was not being driven by external demands or pressure.

The project team was able to review recent Build Strategies at each shipyard and was impressed by the level at which they were being used. Build Strategy size ranged from 100 to 300 pages.-- Typical effort ranged from 400 to 2000 man hours. However, it was pointed out that most of the effort would be required in any case. It simply was being performed earlier, up front, in a formal and concurrent manner. Based on this, the additional effort to prepare a Build Strategy is likely to be about 400 hours. Obviously, the first time it is done, the additional effort may be considerably more as the new approach must be learned in a team environment and many traditional barriers broken down.

By this review and discussion of the Build Strategies, it was possible to determine the items which were considered by the shipyards to be essential, which items were optional, and what should not be included in the Build Strategy document.

The project team emphasized that it was necessary for each shipyard to have a documented Shipbuilding Policy on which to base their Build Strategies.

otherwise, each Build Strategy must contain the required policy components.

The shipyards had a number of concerns and capacity emphasized the following requirements:

- Build Strategy document should not be structured that it discourage innovation or the introduction of improved methods or facilities.
- It should not attempt to tell shipyards how to prepare drawings, build ships, define or limit block size or dictate required production information
- It should incorporate need for design for producibility and be a guide for continuous improvement and TQM.
- The Build Strategy document and examples of its use should be based entirely on commercial ships of the type likely to be built in the U.S. in the foreseeable future.
- 0 It should not address military ships of any type.
- 0 The Build Strategy document must treat all components of the design build and test process with equal attention. So often the "simpler" or "better known" front end design and production decisions are more than adequately treated, but the back end processes, such as system tests and compartment check off, are given minimum consideration in a Build Strategy.
- 0 The two examples of the Build Strategy document use should emphasize the ship type major differences and their impact on the Build Strategies.
- 0 The project should emphasize the benefits of the formal Build Strategy approach. In doing this an attempt should be made to determine which world class shipbuilders use the Build Strategy or similar approaches.
- 0 The project should also clearly describe the pre-requisites that a shipyard should have or develop before undertaking a Build Strategy to ensure the best chance of an effective Build Strategy being developed and implemented.
- 0 The use of preliminary and detailed Build Strategies should be clearly described.
- 0 The project should provide documentation that is suitable for use as an educational tool.

Because of the reluctance of most shipyards that were contacted to share the detailed information requested by the Shipyard Capabilities and Limitations Questionnaire, no renewed attempt was made to obtain this information during the the. instead. each

shipyard visited was asked what were their two or three major limitation. All thru shipyards mentioned crane capacity. They would all like to erect larger blocks than currently possible. One shipyard would like to increase crane capacity throughout the fabrication and assembly shops. as well as for block erection on the ways or in the dock. Another shipyard would like to have more covered (out of the weather) buildings for assembly and block construction. Finally, one shipyard mentioned that its major limitation was timely engineering.

#### U.S. SHIPYARD COMMON ATTRIBUTES

As previously mentioned due to lack of response to the shipyard capabilities and Limitations Questionnaire, it was not possible to determine U.S. shipyard common attributes which could be used in the Build Strategy Document In order to have a basis on which to prepare the project Build Strategy Document and examples of its use, a hypothetical shipyard was defined by the project team. The hypothetical shipyard represents no existing U.S. shipyard but rather attempts to reflect some of the facilities and capabilities of a typical U.S. shipyard that would be interested in competing in the world commercial ship market It does not reflect the lowest common capabilities.

#### FOREIGN SHIPYARD VISITATION

Eight foreign shipyards were contacted, but only four responded and three of them agreed to a visit

Visits to the three foreign shipyards were made in June and July, 1993. The shipyards were Ferguson's in Port Glasgow, Scotland, a successful small shipbuilder. Odense Steel Shipyard in Denmark a successful large shipbuilder reputed to be one of the best shipbuilders in the world today, and Astilleros Espanoles in Spain. another successful large shipbuilding group which has utilized many of the NSRP project publications to assist them in their improvement program

All shipyards visited gave outstanding support in time and effort to the team, and their hospitality was exceptional. They were most open in showing and describing their facilities, process, goals, and problems, and all stated that their willingness to participate in projects to help the U.S. shipbuilding industry improve was based on the belief that everyone benefits from an open exchange of technology, a sharing of problems. and the development of solutions for their resolution.

Ferguson's does prepare a Build Strategy for each contract. They cover most of the recommended items in the study proposed Build Strategy Document List. Most of the optional items are omitted, although they do include budgets. Build Strategy with budgets are given restricted distribution. The production Engineering Group has the responsibility to prepare the Build Strategies with input from other groups/departments.

Ferguson's Build Strategy is relatively simple (that's how they like it), but even with their small size they still see and achieve benefits from using the Build Strategy approach. Ferguson's uses previous Build Strategies as the basis for new Build Strategy.

Ferguson's approach was to accept mid-1980 facilities and to concentrate on using the people more effectively through integrated processes.

Odense Steel Shipyard (OSS) has excellent facilities with up to date equipment and processes. They have an extensive ongoing facilities improvement program. They are not satisfied with any phase of the operation and are always seeking continuous improvement. They are currently today building today what they did in the past with 40% of man hours. OSS believes productivity is the key to future success in global shipbuilding. They have a goal of 6% annual productivity improvement.

Typical build cycle is 12 month with 3 month in the building dock, one month outfitting and 3 weeks deck trials and sea trials. Sea trials are normally 3 days and once the ship leaves the shipyard for sea trials it does not return to shipyard.

OSS does not use the Build Strategy approach, but has a planning system that covers most of the Build Strategy components and recognizes the need to communicate this information in a formal manner to the many users in shipyard. OSS was not aware of the Build Strategy approach. However, the way they prepare and formally document and distribute their planning documents achieves some of the same strategy objects. OSS does have a long term business plan and the Phase I part of their planning process is similar to the shipbuilding Policy. Their planning is totally integrated. OSS has always used standard processes and standard details to the maximum extent. They are an effective part of OSS high productivity in all departments and processes. OSS has very up to date capabilities and is in the fortunate position of having no known limitations for the foreseeable future.

Astilleros Espanola is a grouping of diverse shipyards covering all sizes of commercial ships and offshore vehicles/rigs. They have a central office in Madrid. This central group performs much of the business planning and setting of each shipyard policy. However, at the meeting with representatives of all

shipyards in the group, and at meetings at Sestau and Peurto Real Shipyards, the enthusiasm of individual managers for continuous improvement, including the use of a Build Strategy approach was very clear.

Each shipyard has its own 5 year plan covering goals, productivity, ship tugs and employees. A major point in their use of Build Strategy is the development of a catalog of interim products for a shipyard. Build Strategies were reviewed in two shipyards. They covered most of the recommended items in the study proposal Build Strategy Contents List. In addition, they added interesting information about the ship owner, his existing fleet and operations. The study proposed Build Strategy Contents List was modified to **incorporate this additional item as an option.**

Astilleros Espanoles shipyards cover the range from old shipyards to relatively new facilities, but in all cases they have had significant modernization in the last few years, some of which is still underway. One shipyard acknowledged any limitations, and that was the clear width of a bridge through which its ships had to pass to get to the sea.

All of the shipyards visited stated that improvement in productivity was the key to survivability and future success in the global shipbuilding market place.

## BUILD STRATEGY DOCUMENT CONTENTS LIST

A contents list, shown in Table III, was developed for the Build Strategy Document from the questionnaire responses, as well as from shipyard visit discussion. The actual Build Strategy Document and the two examples followed this contents list. An introduction outlining the purpose of the Build Strategy Document, its suggested distribution in a shipyard and the prerequisites for a successful Build Strategy was also provided.

**TABLE III** *Repair*  
**PROPOSED BUILD STRATEGY**  
**DOCUMENT CONTENTS**

*Repair*

<b>R IS RECOMMENDED</b>			
<b>O IS OPTIONAL</b>			
<b>1: INTRODUCTION</b>			
1.1 Purpose of Document	R		
1.2 <del>Build</del> Strategy Document Prerequisites	R		
1.3 Distribution	R		
1.4 Summary	R		
<b>2: VESSEL DESCRIPTION</b>			
2.1 General Description & Mission	R		
2.2 Principal Particulars	R		
2.3 Special Characteristics & Requirements	R		
2.4 Comparisons/Differences From Previous Vessels	R		
2.5 Applicable Regulations & Classification	O		
2.6 Owner Particulars			
2.6.1 Background	O		
2.6.2 Fleet	O		
2.6.3 Past Relationship	O		
2.6.4 Competition	O		
<b>3: CONTRACTUAL</b>			
3.1 Contractual Dates & The Constraints	R		
3.2 Payment	O		
3.3 Liquidated Damages & Penalties	R		
3.4 Cancellation	O		
3.5 Drawing Approval	O		
3.6 Construction Inspection	O		
3.7 Trials	O		
3.8 Quality	R		
<b>4: DESIGN &amp; ENGINEERING</b>			
4.1 Strategy & Scope			
4.1.1 General	R		
4.1.2 Changes to Ship Definition Strategy	R		
4.1.3 Modeling & Composites	R		
4.2 Key Drawings	R		
4.3 Production Information requirements			
4.3.1 CAM Information	R		
4.3.2 Manufacturing information	R		
4.3.3 Parts Listings	R		
4.3.4 Installation Drawings	R		
4.3.5 Installation Procedures	R		
4.4 Design & Engineering Schedule			
4.4-1 Schedule	R		
4.4.2 Resourcing & Utilization	O		
4.4.3 VFI Schedule	R		
4.5 Datum's & Molded Definition	O		
4.6 Design Standards	R		
4.7 Functional Space Allocations	R		
4.8 Detail Design Guidelines			
4.8.1 Steelwork	O		
4.8.2 Machinery	O		
4.8.3 Pipework	O		
4.8.4 Electrical	O		
4.8.5 Joinerwork	O		
4.8.6 Paintwork	O		
<b>5: PROCUREMENT</b>			
5.1 Master Material List	O		
5.2 Master Equipment List	O		
5.3 Material Procurement Strategy	O		
5.4 Procurement Schedule	R		
5.5 Critical/Long Lead Items	R		
<b>6: PLANNING &amp; PRODUCTION</b>			
6.1 Strategic Planning			
6.1.1 Key Event Program	R		
6.1.2 Resourcing & Utilization	O		
6.1.3 Changes to Shipbuilding Policy	R		
6.1.4 Required Facility, Tooling & Equipment Upgrade	R		
6.2 Work Breakdown			
6.2.1 Work Breakdown Structure	R		
6.2.2 Coding	R		
6.3 List of Planning Unit			
6.3.1 Hull Blocks	R		
6.3.2 Zones	R		
6.3.3 Equipment Units	R		
6.3.4 Systems	R		
6.4 Master Schedules			
6.4.1 Hull Blocks	R		
6.4.2 Zones	R		
6.4.3 Equipment Units	R		
6.4.4 Systems	R		

6.5 Hull Production Strategy	
6.5.1 Preliminary Process Analysis	0
Integration of Outfit	
Process Analysis By Block	
6.5.2 Non Standard Interim Products	0
6.5.3 Build Location & Launch Condition	R
6.5.4 Erection Schedule	R
6.6 Machinery Space Outfit Strategy	
6.6.1 Equipment Units	R
6.6.2 On Block Outfitting	R
6.6.3 On Board outfitting	R
6.7 Accommodation Outfit Strategy	R
6.8 Cargo & Other Space Outfit Strategy	
6.8.1 On Block Outfitting	R
6.8.2 On Board Outfitting	R
6.9 Painting Strategy	
6.9.1 Outline Paint Specification	0
6.9.2 Pre-Painting	R
6.9.3 Primer Repair Strategy	R
6.9.4 Unit/Block Painting Strategy	R
6.9.5 Zone Painting Strategy	R
6.9.5.1 Machinery Spaces	
6.9.5.2 Outside Shell and Decks	
6.9.6 Special Considerations	R
6.10 Sub-Contract Requirements	
6.10.1 Bought-In Items	R
6.10.2 Use of On-Site Sub-Contractors	R
6.11 Productivity	
6.11.1 Productivity Targets	R
6.11.2 Comparison&Differences From	
Previous Vessels	R
<b>6.12 Temporary Services</b>	
6.12.1 staging Plan	R
6.12.2 Access & Escape Plan	0
6.12.3 Power & Lighting	0
6.12.4 Weather Protection	0
<b>7: ACCURACY CONTROL</b>	
<b>MANAGEMENT PLAN</b>	
7.1 System Critical Dimensions & Tolerances	R
7.2 Interim Product Critical Dimensions &	
Tolerances	R
7.3 sampling Plan	0
7.4 Special Procedures	0
7.5 Jigs & Fixtures	0

7.6 Hot Work Shrinkage	
<b>7.6.1 Use of Extra Stock</b>	0
<b>7.6.2 Shrinkage Allowances</b>	0
7.6.3 Distortion Control	0
<b>8: TEST &amp; TRIALS</b>	
8.1 Test Planning	
8.1.1 Strategy	R
8.1.2 Schedule (High Level)	R
8.2 Pre-Completion Testing	
<b>8.2.1 Pre-Survey &amp; Dry Survey</b>	0
<b>8.2.2 Pipe Pre-Testing</b>	0
<b>8.2.3 Equipment Unit Pre-Testing</b>	0
<b>8.3 Tank Test Schedule</b>	R
8.4 Equipment Unit Test Schedule	R
<b>8.5 Pipe Unit Test Schedule</b>	R
<b>8.6 Zone Close-Out Strategy</b>	R
<b>8.7 Principal Trials Items</b>	R
<b>9: PERSONNEL</b>	
9.1 Industrial Relations Aspects.	
9.1.1 Design	0
9.1.2 Sub-Contract	0
9.2 Training	0
9.3 Project Organization	
9.3.1 Shipyard Organization Charts	R
9.3.2 Client's Organization Charts	R
<b>10: WEIGHT CONTROL</b>	
10.1 General	
10.2 Outline Procedure	R
10.3 Departmental Responsibilities	R

## ACKNOWLEDGMENTS

This paper is based on a report prepared jointly by A&P Appledore International Ltd. and Thomas Lamb, and covers the preparation, distribution and analysis of the responses to the Build Strategy and Shipyard Capabilities and Limitations Questionnaires; a summary of the visits to both U.S. and foreign shipyards; the attempt to develop U.S. shipyard Common Attributes prerequisites for the use of Build Strategies; the Build Strategy Document and the examples of its use.

Both questionnaires were jointly developed by A&P Appledore International Ltd and Thomas Lamb. However, without the participation of the shipyards who took the time to respond to the questionnaires and those that agreed to allow the project team to visit and discuss the subject further, this report would have no value. Their contributions are acknowledged with appreciation.

The project was funded by the National Shipbuilding Research Program Design/Production Integration Panel (SP-4), at the time chaired by J. Getz of Bethlehem Steel Shipyard.

## REFERENCES

Presentations to Norfolk Shipbuilding by A&P Appledore in 1983, and to Lockheed Shipbuilding and Tacoma Boatbuilding in 1984

Presentation by A&P Appledore to SP-4 Panel on "Productivity Improvement" in Sturgeon Bay, Wisconsin, July 1984

Craggs, J. D. F., "Build Strategy Development" SPC/IREAPS Technical Symposium, 1983

DESIGN FOR PRODUCTION MANUAL. NSRP Report. December 1986

Vaughan R. 'Productivity In Shipbuilding' NECIE&S, December, 1983



THE SOCIETY OF NAVAL ARCHITECTS AND MARINE ENGINEERS  
601 Pavonia Avenue, Jersey City, NJ 07306

paper presented at the NSRP 1968 Ship Production Symposium,  
Edgewater Inn, Seattle, Washington, August 24-26, 1968

# A Group Technology Approach to Master Scheduling of Shipbuilding Projects

No. 8B

Jon Gribskov, Associate Member, Rain Bird Sprinkler Manufacturing Corp., Glendora, CA

This paper describes the current Master scheduling approach used at National Steel and Shipbuilding Company (NASSCO) in San Diego. Master schedule<sup>8</sup> at NASSCO focus on key interim products involved in ship construction: units, blocks, (on-board) zones, and tests. Network scheduling algorithms (i.e. Critical Path) are used. Each interim product has an associated subnet. Categorization by type is used to simplify the task of developing and maintaining activity lists, dependencies (predecessor/successor relationships) and duration<sup>8</sup> for the thousand<sup>8</sup> of activities. Manual level-loading of critical resources is incorporated into and supported by the overall scheduling process. The paper includes some discussion of problems encountered in the implementation of this scheduling approach.

## NOMENCLATURE

The following definitions are provided to clarify usage within the body of this paper. They reflect common usage within National Steel and Shipbuilding, San Diego. Definitions provided are not intended to imply industry standard practice.

The definition of interim products is somewhat circular. The intent behind defining interim products is to focus attention on a deliverable units of work among common process characteristics. In the spirit of the definition of Group technology given below.

**Block** -- a structural assembly which will be erected singly or as part of a grand-block;

**group Technology** -- organization of work to take advantage of common process characteristics, while accommodating minor differences in material, geometry and size, in order to bring the advantage of made production to high-activity, mixed quantity production;

**Interim Product** -- an assembly or portion of work which can be logically scheduled and managed as though it were a deliverable product; e.g., unit, block, subzone, system test, etc. ;

**Pallet** -- subdivision of a workpackage; a unit of work which has common work characteristics (process, tooling or material), and which can be performed lay a single crew in a reasonably short period of time while working in a defined work area;

**Subzone** -- a geographic volume within a ship; typically bounded by watertight bulkheads fore and aft, decks above and below, and shell plating to port and starboard;

**Unit** -- Piping unit; an erectable assembly composed both of structural component<sup>8</sup> (structural framework, common foundations, floor plates and gratings) and outfitting components (e.g., pumps, motors, piping, gauges) and which is not an integral part of the ship structure;

**Workpackage** -- all work within a given stage of construction, of a given type of work (e.g.; piping, vent. etc. ), and for a given interim product (unit, block, subzone, . etc. ).

## INTRODUCTION

This paper describes a method of developing the portion of the Master Production Schedule (MPS) associated with the assembly, outfitting and erection of hull blocks. The method discussed:

- 0 uses information available very early in the contract cycle
- 0 can accommodate some inaccuracy in available information
- 0 is sufficiently detailed to, insure workable schedule<sup>8</sup>
- 0 Integrates the Scheduling or engineering, material procurement, detail planning and production activities
- 0 uses Group Technology concepts and PC-based Project Management software to maximize efficiency of the scheduling process



The method discussed can, by extension, be applied to other portions of the Master Production Scheduling process.

#### MASTER PRODUCTION SCHEDULE

The American Production and Inventory Control Society dictionary defines the Master Production Schedule as follows:

...the anticipated build schedule for those selected items assigned to the master scheduler....

The master Production Schedule for an individual ship or contract must take into account the contractual requirements, existing or anticipated backlog, availability of drawings and material, availability of manpower and capacity, and management objectives. The Master Production Schedule must therefore include or incorporate information from:

- o Milestone/Key Event \*Schedules
- o Procurement Master Schedule
- o Engineering Master Schedule
- o Manpower Curves and Capacity Plans

The Master Production Schedule integrates the efforts of different functional areas (production, engineering, materials as well as various production sub-organizations (steel fabrication, assembly and erection, outfitting shops, on-block and on-board outfitting, test and trials, and subcontractors, etc.). Different parts of the organization require different information. The shop requires a Set of need dates, together with design and material availability dates. On-block outfitting requires steel assembly complete dates, design and material (purchased and fabricated) availability dates, and erection dates. The MPS provides the sets of dates necessary to do this, while allowing area managers flexibility to schedule within the required constraints. The responsibility to manage must rest with the manager, not the scheduler.

The Master Production Schedule becomes the basis of more detailed scheduling of engineering work, material procurement, manpower planning, training schedules, and capacity planning. Development of the Master Production Schedule therefore assumes a degree of urgency once a contract is awarded.

Methods must be developed which provide reasonable accuracy of schedule even when based on preliminary and incomplete information. Later changes to the MPS which result in earlier requirements for material or engineering products are difficult or impossible to accommodate. On the other hand, schedules which

introduce unnecessarily early requirements on engineering and material procurement work may result in higher costs for those functions.

#### GROUP TECHNOLOGY AND INTERIM PRODUCTS

The concepts of Group Technology are central to much of the modernization of shipbuilding production management methods and procedures. Application of these concepts within the shipbuilding environment has been well-documented within the shipbuilding literature.

Group technology (GT) has been defined as:

GT is a technique for manufacturing small to medium lot size batches of parts of similar process, of somewhat dissimilar materials, geometry and size, which are produced in a contained small cell of machines which have been grouped together physically, specifically tooled, and scheduled as a unit.?

While such a definition works well in a machine shop environment, a modified definition is required for effective application to shipbuilding. The following definition by G. M. Ranson is suitable:

The logical arrangement and sequence of all facets of company operation in order to bring the benefits of mass production to high variety, mixed quantity production.

Ranson's definition broadens the scope of application of the central concept of Group Technology: focusing on similarities in process, while accommodating differences in materials, geometry and size. This broader definition encompasses such of the work that has been done in applying GT to the shipbuilding environment. The key to successful application of Group Technology in shipbuilding is a focus on "interim product."

Ship construction is characterized by a single, deliverable end product. The ship is assembled from a number of major assemblies (structural hull blocks, main engines, shafting, piping units, etc.) supplied by the shipyard and by outside vendors. These in turn are composed of smaller assemblies and purchased components. The bill of materials explosion of a ship being built using modern shipbuilding technology would have levels similar to those shown below

ship

major assemblies  
(e.g., blocks, units, subzones, main engines, shafting)

minor assemblies  
(e.g., manifolds, structural panels, pumps, vent fans)

fabricated and purchased parts and components

(e.g., pipe spools, vent pieces, valves, connection boxes)

raw stock material  
(e.g., plate, angle, pipe, cable)

At the middle levels of the ship assembly process, a variety of interim products can be defined. For example, at the major assembly level these include: piping units, outfitted structural blocks, outfitted subzones and tanks, shafting installation, etc. (Terminology varies somewhat within the shipbuilding industry.) Focusing on these interim products is the key to application of Group Technology to the shipbuilding process.

This article will focus on the scheduling of a particular interim product at the major assembly level: assembly, outfitting and erection of structural hull blocks, including the design and material need dates for each block. The scheduling approach discussed is applicable with minor modifications to other interim products at the major assembly level.

#### HULL BLOCK SCHEDULING ELEMENTS

Scheduling of all work associated with structural hull blocks was done using Project Management software running on an IBM AT computer. A project network was built for the purpose which included:

- 0. engineering activities
- 0 material identification, procurement and receipt
- 0 detail planning activities
- 0 all related production activities

The purpose was to integrate schedules at a level of detail sufficient to assure a workable schedule.

Building the scheduling network involved merging several pieces of information:

- 0 a scheduling network for a typical block which integrated the engineering, materials, planning and production activities associated with the block
- 0 a hull block breakdown showing the location of the structural breaks between blocks

- 0 an erection schedule showing erection dates for all outfitted structural blocks
- 0 tables of scheduling offset and schedule durations for those activities and relationships which vary according to block type or individual block

These elements, from which the overall network schedule is built, will be discussed in turn.

#### Hull Block Network

The hull 'block network includes known scheduling information common to all blocks. Dependencies among and between engineering, materials, planning and production activities are incorporated. Desired lag period between activities are included. Schedule durations which are standard for all blocks are incorporated. The activities and relationships represent the flow of materials and information, movement of the interim product through various processes and stages, and intervals of time provided for completion of activities not shown explicitly. Figure 1 shows a typical block network. Note that the network is not to scale since some activities shown may vary for given blocks.

Developing the network involves the balancing of several factors. Every activity or relationship in the individual network will be duplicated a number of times in the project network. For example, a 40 activity network used with 300 structural blocks will result in a project network of 12,000 activities. Excessive detail can lead to problems with file size, software constraints, processing time, report sizes, and so on. Activities that should be included are those which are required to establish schedule dates, schedule durations, utilization of critical resources, and those activities whose schedule will need to be tracked as the project proceeds.

Standard durations which exceed normal operational times for a given set of activities provide a means of absorbing delays, uncertainty in work content and work rate, correction of minor material problems, etc. Given the uncertainties which often prevail in the shipbuilding environment, this conservative approach makes sense for an area facing significant material problems, unplanned work, or uncertainties in work scope or sequence. It provides a means of minimizing the schedule impact of deviations from the plan, and works in conjunction with an iterative approach to planning.

Standard durations which exceed operational times also have several

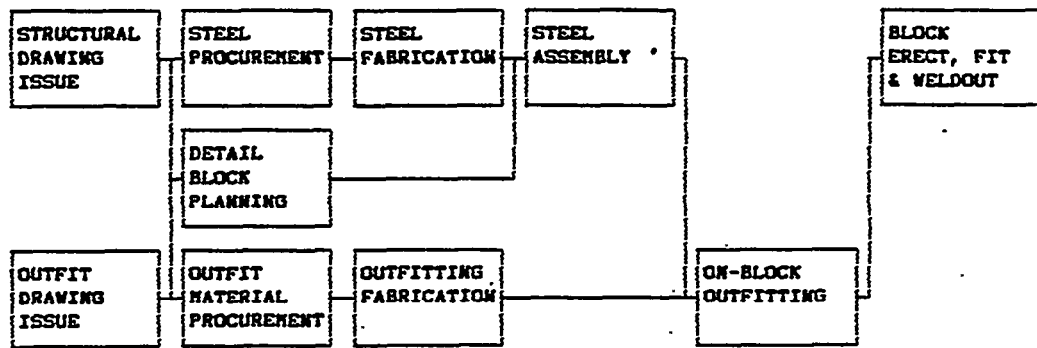

Fig. 1: Typical block scheduling network (precedence diagramming method)

disadvantages. First, line of balance scheduling of critical resources must be done separately using planned operation durations. Line of balance scheduling assumes that a crew moves from one job to the next, maintaining a smooth flow of work. Schedule durations which exceed the time required to perform the work will result in a delay between completion of one job and starting of the next if the jobs were scheduled end-to-end.

Second, longer overall program schedules may result. If the duration of an activity which is on the critical path exceeds the actual duration required, then the schedule based on that path will be longer than necessary. This can have local and/or global impacts on the project schedule. For example, if limited pin Jig laydown area exists for assembly of curved shell blocks, the total time required to assemble all curved shell blocks will depend on how long each block must remain on the pin jig. This may or may not affect the overall ship construction project schedule.

Third, conservative scheduling durations imply acceptance of a certain level of schedule uncertainty. Variances in actual durations and schedule performance are hidden. Underlying problems which cause the variances are accommodated. The urgency of correcting such problems is thus reduced.

A pragmatic approach is needed to balance these considerations. Conservative (longer) scheduling durations can be used where required. If the resulting schedule does not appear optimal from any standpoint, shorter durations can be substituted and the schedule recalculated.

#### Hull Block Breakdown

The hull block breakdown established the list of blocks, their numbering, and location of the erection breaks. This

information can be used in conjunction with contract guidance or other drawings in establishing block types and estimates of work content. These estimates can be used to define schedule durations and offsets for those activities and relationships which are non-standard and depend on the individual Characteristics of the block.

#### Hull Block Erection Schedule

The hull block erection schedule establishes the need dates for the end assemblies, the outfitted structural blocks. This schedule is the backbone of that portion of the production schedule related to hull blocks. Any change to the erection date for an individual block is likely to affect every other activity for that block.

The erection schedule can either be in the form of a table of dates or can itself be a form of network. Figure 2 shows a portion of an erection schedule in network form. If the erection schedule is in tabular form (with no dependencies between erection of individual blocks) then the final project network will be composed of a series of independent subnets, one for each block.

#### Table of Schedule Offsets and Schedule Durations

The table of schedule offsets and schedule durations captures all of the non-standard features of the individual block networks. For example, assembly durations may vary by block type (flat deck or bulkhead vs. curved shell block) and/or by work content (tonnage or weld footage). Outfitting durations and routing may depend on the point requirements and outfitting work content. A table of values matching block number with the particular values will be used to tailor the standard block network to the requirements of the specific block.

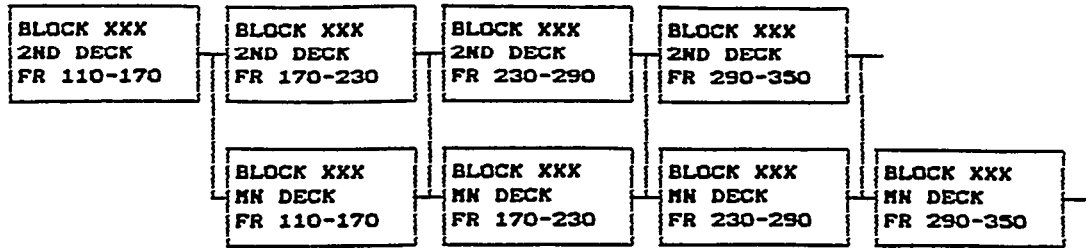

Fig. 2: Portion of an erection schedule (precedence diagramming method)

Group Technology can be used to advantage by defining families of blocks by type. For durations and offsets which are a function of some categorization by block type, the duration or offset can be provided for each block type in a separate table. The type associated with each individual block is then indicated in the block table. This encourages standardization, with the usual benefits.

#### BUILDING THE PROJECT MODEL

An integrated scheduling network is constructed from the elements discussed above. The network is created through the following series of steps:

- o make a copy of the block network for each individual block
- o incorporate constraining factors such as erection date into the individual block networks
- o incorporate block parameters which are unique or which depend upon some categorization into the individual block networks
- o introduce the relationships which represent dependencies within the erection schedule
- o add other activities and relations which form portions of the total project network

Each of these steps will be discussed in more detail.

Copies of the typical block network form the bulk of the overall schedule. Making the copies is straightforward with most project management software packages. It is also usually very tedious and time-consuming if more than a few copies need to be made. First, one or a group of block networks are copied. Next, the copied activities are renamed or renumbered so that all activities and relations are uniquely identified. Finally, copies are merged into a larger project network.

Many project management software packages allow definition of "hammocks." A hammock is a group of activities and relations which form a sub-network having single entry (start activity) and exit (complete activity) points.

Hammocks can be incorporated in the project network by establishing a relation to these entry and exit points.

The hammocking feature of the software can sometimes be used for incorporating standard sub-networks (such as the block subnet discussed above) into the project network. In some software packages, however, hammocks are represented by a single activity. In this case, it is not possible to tie a relation to an activity internal to the hammock. More flexible methods of incorporating standard subnets are sometimes required.

The next step in building the project network is to incorporate any necessary constraints into the project network. For example, each block has an erection or grand-block erection date. If the erection schedule has been developed by hand off-line, the erection date is a fixed date. This implies that other activities for that block (e.g., steel assembly, on-block outfitting) should be scheduled to complete in time to support the scheduled erection date. The erection date could then be represented as a milestone date for the block, as the late start of an activity (erect, fit and weldout), or as the late complete date of an activity (erection).

At this point the project file is composed of individual block networks, each of which may have a constraining start or complete date on at least one activity. The next step is to tailor the individual block networks to account for known differences. These differences may be due to individual characteristics of the block, or to characteristics common to a family of blocks. For example, the erection date is different for each block. In the case of individual differences, use values from a table of schedule dates, durations, or offsets.

Characteristics may also vary according to block type. Sets of blocks may be organized into "families" or "groups" based on some common characteristic. As an example, all blocks built in a particular jig may form a family having identical assembly durations. In this

case, one needs a table that identifies which blocks are members of the family, and another table which identifies the assembly duration for that family.

Relations which represent the predecessor-successor dependencies within the erection schedule can now be introduced. If the erection schedule is typically developed by hand, this step may be unnecessary. However, introduction of the computer as a scheduling support tool may provide opportunities for further refinement of schedules. This will be discussed later.

The last step in the process is to merge the completed block network with networks which represent other portions of the project. For example, it may be useful to include landing of major equipment and installation of key components in the overall project network. The installation schedule for propulsion machinery and shafting is directly related to the erection schedule and also to the critical path of the project. Including these relations within the scheduling network insures that they are not ignored when schedule changes are being considered.

#### SCHEDULING AND RESOURCE SCHEDULING

The network is at this point complete and can be scheduled. For the purpose of this discussion, critical path scheduling will be done using the Precedence Diagramming Method (PDM). Those not familiar with the concepts and techniques discussed are referred to the many excellent texts in the field.

Project start and complete dates, scheduled milestones, and planned activity start and complete dates are the constraints which limit the schedules for other activities. Most current software packages employ a two-pass scheduling approach. During the forward pass, successors of already scheduled activities are in turn scheduled, with the dates stored in the early start and early finish date fields. During the backward pass, predecessors of scheduled activities are themselves scheduled, and the dates stored in the late start and finish date fields.

Each activity then has early and late start dates, and early and late finish dates. Activities cannot be started prior to the early start, or later than the late start without either violating the project network logic, or affecting the overall project schedule. The early and late dates thus define the schedule "window" within which an activity can be worked without affecting the overall project. Each activity has float, which measures how much the activity schedule

can move within the schedule window without affecting the overall project.

If resource and capacity constraints are ignored, the late start and complete dates provide a workable schedule produced by back scheduling. This is similar to the schedule which results from scheduling back from end assembly completion dates down through a till or materials explosion, taking proper account of duration and lead times.

The typical shipbuilding practice of back scheduling produces a schedule where every activity is on the critical path. This is equivalent to the situation that exists when the early and late start dates are the same -- there is zero float. Assuming durations are accurate, a one day delay in starting an activity will result in a one day delay in every successor activity. Given the unpredictability and frequent delay which exist in a shipyard, a more conservative approach to scheduling is useful.

Taking into account resource and capacity constraints, neither the early or late schedules are optimal. Neither results from any consideration of resource availability or levelling. High labor content and expensive shipyard facilities demand something more. Typically, some resources are critical, and constrain other schedules. Utilization of steel assembly facilities and manpower normally require careful levelling.

Many current project management software packages allow levelling of resources. One of two different algorithms is usually involved. The first is schedule constrained. Activities are progressively scheduled based on some assignment of priority (e.g. amount of remaining float for the activity). When this would result in starting an activity later than its late start date, the date constraint takes precedence and the activity is scheduled to start. This may result in resource utilization in excess of resource availability.

The second method also proceeds progressively scheduling activities based on priority. Resource requirements are matched against resource availability curves. When a resource required by an activity is unavailable, the activity is delayed until the resource becomes available. Project completion dates will not be met if the start of an activity is delayed past its late start date. Scheduling proceeds staying within the bounds of the resource availability curve at the expense of schedule.

The resource scheduling features of project management software can be used to limit use of critical shipyard resources to within a capacity constraint or planned resource availability. The steel assembly schedule is a prime example. Manpower availability curves can be used to schedule steel assembly to maintain planned levels. If a special jig is to be used, a jig availability curve can be added to the resource file. steel assembly records for those blocks to be built in the Jig have the Jig resource requirement added. If there is one Jig, and it can hold only one block at a time, the resource file must show that one Unit Of resource "jig" is available, and the block file must show that one unit of resource jig 16 required. Pan jig areas can be divided up into a number of unit squares, and the number of unit squares required for the assembly of any given block or block type loaded to the project file. The total amount of available pin Jig area can then be Used to control the scheduling of assembly work through the area.

Once the critical resources have been scheduled, the resulting schedules should be examined carefully. Project management software is a scheduling aid, not a replacement for good planning. The software facilitates balancing of a large number of schedule and resource constraints, and examination of resulting schedules from a number of perspectives. Resource utilization curves should be examined closely. A sampling of the block schedules should be done to insure accuracy, and that the results make sense.

If problems are identified with the schedules and resource curve6 that resulted, adjustments can be made by hand to the schedule, and the schedules recalculated. "What-if" games can be played using copies of the network. The result should be a schedule which is logically consistent and Which makes glad use of key resources.

#### GENERAL COMMENTS

Existing project management software typically forces the user to work in a bottom-up fashion. Building a project network for a large shipbuilding project tecemel a significant clerical effort. One loses Eight Of the overall project in the process of entering and maintaining 10,000 activity records, with associated predecessor-successor relations and resource requirements.

building the project schedule should be a mizture of bottom-up and top-down scheduling techniques. Bottom-up scheduling can be employed to develop

those portions of the scheduling network for which a good history is not available, portions for which the available history does not meet current objectives, or portions which are known to be critical to the overall program schedule. Top-down techniques can be used where schedule6 have already been developed, where good historical information exists, or where the detailed schedule will not effect the overall program schedule.

The network will never completely model reality. The project management team must find the level at which the model is most useful in relation to the effort required to construct and maintain the model. The Group Technology approach outlined above rraplifie6 the problem to one of standard families of assemblies, and instenece6 of the standard. In addition, several strategies exists to make the effort more productive:

- o focus attention on activities which are Critical to the overall project, scheduling that are driver6 of other schedules, and resources that are bottlenecks
- o avoid inclusion of activities for which schedules can be easily derived as Offsets from the other schedules, and which are not themselves schedule driver6
- o be relentless in identifying standard durations, sequences, and categorier -- look for families of components at all level6 in the product hierarchy
- o develop a library of standard subnets
- o keep the project model as simple as possible, avoid unnecessary detail in the network, look for ways to reduce the Size and complexity
- o Where repeatability or predictability of schedule is low, more conservative scheduling approaches should be used -- longer durations to minimize impact of schedule delay6
- o engineering and materials schedule6 can be frozen after initial development by copying the appropriate date6 into the planned start and complete fields, or by keeping a copy of "the baseline" from which to run report6

The job of managing the network can become very unwieldy. if one has only 20 activities for each of 300 steel assemblies or other interim products, one ha6 a network of 6000 activities (20 activities/product x 300 products = 6000 activities), plus the associated relations between activities. For some

packages which run on personal computers, networks of 5,000 or more activities can stretch the limits of available disk storage, and result in very long run times (30 minutes or more) for the scheduling operation. The network should contain only those activities necessary to preserve the schedule relationships and the Offsets between activities.

Another method for reducing complexity in scheduling is to choose an appropriate time frame. Most project management software allows scheduling at a daily or even hourly level. But a weekly schedule may be more meaningful because it focuses attention at the proper level of detail. Scheduling by week can be done by setting durations and lag periods in multiples of 5, ignoring holidays, and setting all fixed start dates on Mondays, all fixed completion dates on Friday.

The scheduling network can also be simplified through reducing the number of relations. If the supervisor in the field will exercise his own discretion in the scheduling of an activity between two milestone dates, then the only relations needed for that activity are those which tie it to the milestones. There is no need to add additional relations to the network to constrain the timing of the activity. Also, if simple finish-to-start relations will establish the desired work sequence, there is no need to establish a complex pattern of start-to-start and finish-to-finish relations and associated lag periods.

The schedules produced using project management software are dynamic. A single small change has the potential of changing the entire project scheduling if it lies on the critical path. Once the initial schedule has been developed, it may be desirable to lock in certain schedule dates. Changes to engineering and material schedule may cause unnecessary disruption and may impact vendors and subcontractors.

Several techniques are available to stabilize portions of the project schedule. The project schedule can be archived, and the archived dates used for scheduling selected activities. Schedule changes which conflict with the archived dates can then be handled on an exception basis. Some software packages allow preservation of the initial dates as baseline dates for each activity. The baseline dates can be used where desired, and reports produced to indicate activities having dates which are in conflict with the baseline dates. A third alternative is to copy the desired dates into the planned start and planned complete fields. When the project is rescheduled, activities whose

dates conflict with these planned dates will be shown as having negative float.

## CONCLUSION

This paper outlines a method for developing the Master Production Schedule for a shipbuilding project using PC-based project management software. Currently available software offers functionality, power and flexibility to PC users. The techniques outlined - here balance use of top-down and bottom-up scheduling techniques. They are designed to facilitate effective use of Project Management software in the shipbuilding environment.

## ACKNOWLEDGEMENTS

Thanks are due to National Steel and Shipbuilding Company for providing providing me the opportunity to develop these ideas. Particular thanks to Andy Parikh for for many hours of stimulating discussion and for giving me the freedom to apply these concepts on a new contract.

## REFERENCES

1. Wallace, Thomas F., ed., APICS Dictionary, Fifth Edition, American Production and Inventory Control Society, Falls Church, VA, 1984.
2. Hyde, William F., Improving Productivity by Classification, Coding and Data Base Standardization, Marcel Dekker, Inc., New York, H.Y., 1981.
3. Ranson, G.M., Group Technology, McGraw-Hill Book Company, Ltd., London, 1972.

**NATIONAL SHIPBUILDING RESEARCH PROGRAM**

# **SCHEDULING EXERCISE**

**IMPLEMENTATION OF ZONE TECHNOLOGY IN REPAIR & OVERHAUL ENVIRONMENT**



5

Pert and The Space Landing Vehicle Project

~~Task Questions worth 6 points~~

**The situation:** Suppose you are a project manager for the MLZ Aerospace firm. You have just been told that the company is going to embark on the design and construction of a space-landing vehicle. While MLZ has been active in the space program, it has never been involved with a project quite like this. You have virtually no experience with landing vehicles, but the company has successfully produced other equipment which is similar but still substantially different enough so that you, as a manager, feel somewhat uncertain about how long such a project will take.

The network in **Figure 18-1** reflects the nine major events in the production process. **Table 18-1** reflects the nine major events in the production process. **Table 18-1** provides the basic time estimates needed to compute the expected time for each of the 10 activities.

Figure 18-1: Basic PERT Network for Space-Landing Vehicle Project

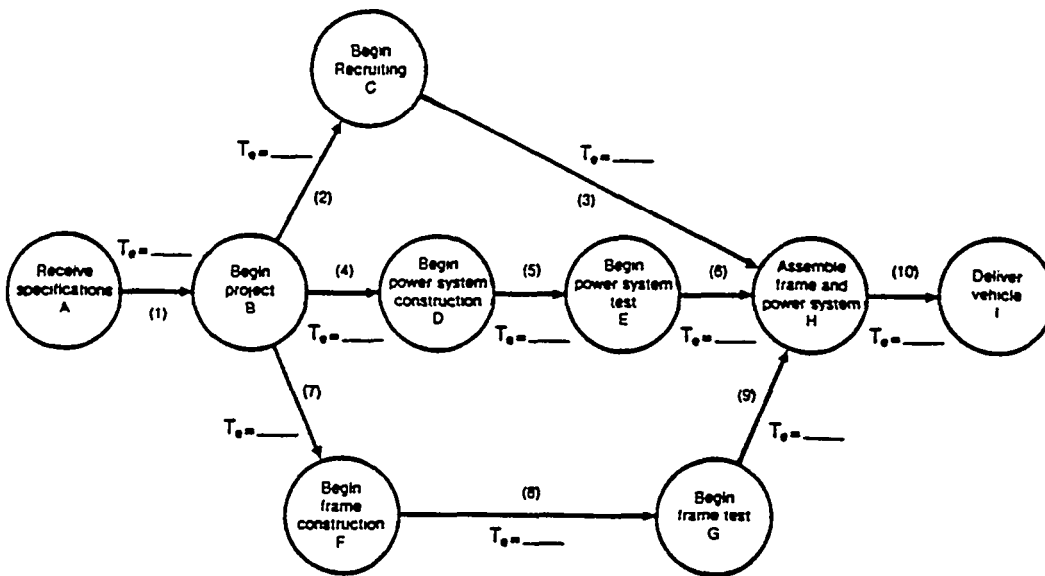

A . . . I Denotes events  
1 . . . 10 Denotes activities

Table 18-1  
Activity Time Estimates (in weeks)

Activities	Optimistic	Most Likely	Pessimistic	Activity Time Estimated (t <sub>e</sub> )
	(a)	(b)	(c)	
1. Approve specifications	2	2.5	6	
2. Develop recruiting plans	1	3	5	
3. Hire work force	3	4.5	9	
4. Design power system	4	5.5	10	
5. Build power system	8	11	14	
6. Test power system	4	6	8	
7. Design frame	3	4.5	9	
8. Build frame	9	9.5	13	
9. Test frame	1	3	5	
10. Assemble and test vehicle	4	6	8	

Instructions: Determine the critical path by completing the following steps.

1. Compute the expected time ( $t_e$ ) for activities 1-10 and transfer the computed  $t_e$  times to the appropriate arrow in the PERT network shown in Figure 18-1.

2. Identify all the possible paths between the starting point (event A) and the ending point (event 1). Place the appropriate letters in the circles. Sum the times associated with each path.

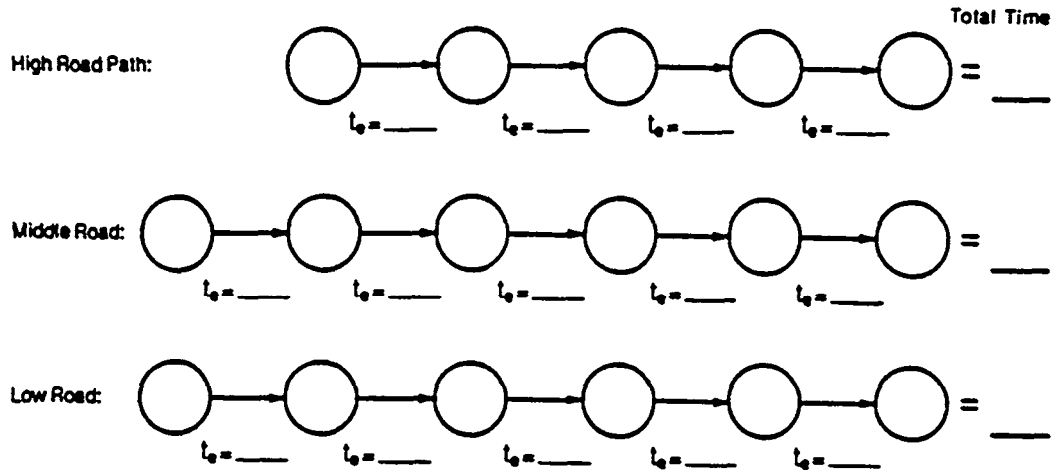

3. The times associated with each path are:

High road total time:

Middle road total time:

Low road total time:

The critical path is:

NATIONAL SHIPBUILDING RESEARCH PROGRAM

**PRODUCTION AND  
MATERIAL  
CONTROL FOR  
SHIP REPAIR AND  
OVERHAUL ZONE  
TECHNOLOGY**

IMPLEMENTATION OF ZONE TECHNOLOGY IN REPAIR & OVERHAUL ENVIRONMENT

# **PRODUCTION AND MATERIAL CONTROL FOR SR & 0 ZONE TECHNOLOGY**

- **PRODUCTION CONTROL CONSISTS OF CONTINUOUS ADJUSTMENTS WHICH ARE REQUIRED TO ACCOMPLISH THE PLAN AND INFERS THE EXISTANCE OF:**
  1. **AN INFORMATION SYSTEM BY WHICH THE ACTUAL STATE OF THE ACTIVITIES IS COMPARED TO THE PLANNED STATE**
  2. **A FEED BACK SYSTEM BY WHICH ADJUSTMENTS CAN BE MADE TO THE PRODUCTION PLANNING STAGE**

**(SEE ATTACHED PAPER ON SHIP CONVERSION PROJECT MONITORING)**
- **PRODUCTION CONTROL DEPENDS UPON PROCESSING ADEQUATE AMOUNTS OF ACCURATE AND TIMELY INFORMATION REGARDING CURRENT STATUS OF THE PRODUCTION PLAN, THE WORK IN PROCESS; INVENTORIES; HUMAN, FACILITY AND MATERIAL RESOURCES; AND REQUIREMENTS PROJECTIONS**

## **PRODUCTION AND MATERIAL CONTROL FOR SR & OZONE TECHNOLOGY (CONTINUED)**

- **PRODUCTION CONTROL BEGINS WITH TECHNIQUES FOR ORGANIZING AND CONCEPTUALIZING INFORMATION ABOUT THE PLAN AND THE CURRENT STATUS OF EVENTS PURSUING THE PLAN**
- **IN MANY REPAIR COMPANIES, PRODUCTION CONTROL IS RESPONSIBLE FOR THE ISSUANCE OF THE WORK PACKAGES AND MATERIAL RELEASE DOCUMENTS**
- **TOOLS USED BY PRODUCTION CONTROL INCLUDE INVENTORY MODELING, QUEUING THEORY, MATERIAL & RESOURCE PLANNING AND PERT/CPM**
- **PRODUCTION CONTROL AND MATERIAL CONTROL ARE SO CLOSELY INTERTWINED THAT MANY ORGANIZATIONS COMBINE THEM**

# **PRODUCTION AND MATERIAL CONTROL FOR SR & O ZONE TECHNOLOGY (CONTINUED)**

- **MATERIAL CONTROL (MC) IS OFTEN CALLED MATERIAL MANAGEMENT**
- **MC STARTS WITH A BILL OF MATERIAL FOR A GIVEN PRODUCT, USUALLY DEVELOPED BY ENGINEERING AND MANIPULATED BY PRODUCTION PLANNING TO SORT INTO REQUIRED SEQUENCING AND DELIVERY DATES**
- **MC THEN INVOLVES PROCURING, RECEIVING, WHAREHOUSING, HANDLING, DELIVERING WITHIN THE REPAIR YARD, PLUS ALL THE INFORMATION MANAGEMENT REQUIRES FOR THE SUCCESSFUL OPERATION OF THE ABOVE ACTIVITIES**
- **MC TOOLS INCLUDE INVENTORY CONTROL AND MATERIAL REQUIREMENTS PLANNING, SOMETIMES REFERRED TO AS MRPI**

## **PRODUCTION AND MATERIAL CONTROL FOR SR & OZONE TECHNOLOGY (CONTINUED)**

- **AGAIN, MATERIAL CONTROL AND PRODUCTION CONTROL ARE SO CLOSELY INTERTWINED THAT MANY COMPANIES COMBINE THEM, ESPECIALLY IF THEY USE MRPII WHICH CAN HANDLE BOTH IN AN INTEGRATED DATABASE**
- **TO SUPPORT ZONE TECHNOLOGY THE COST COLLECTION SYSTEM FOR THE LABOR AND MATERIAL MUST BE BASED ON A ZONE TECHNOLOGY-ORIENTED WORK BREAKDOWN STRUCTURE**
- **USING THE ABOVE TOOLS THE PROJECT PERFORMANCE MUST BE MONITORED CONTINUOUSLY AND CHANGES MADE TO MAINTAIN THE BUDGETS AND SCHEDULES**
- **MANAGEMENT MUST BE PROVIDED ACCURATE AND TIMELY REPORTS ON PROJECT PERFORMANCE**
- **P&MC MUST BE THE COMPANY'S FOCUS FOR CONTINUOUS PROCESS IMPROVEMENT**

**What we need:**

- o 'A smart number" system that starts -in Engineering and gives us a part number through all review processes, through all manufacturing processes and through all accountability processes.**
- o A-system that can be accessed through work stations in any user location.**
- o A system that uses a common data base with our Financial, Work Control, CAD, and Work Scheduling systems.**
- o A system that lends itself to labor saving through standardization where standardization is possible.**

**To be concise-**

**A material Control System that is an element of a larger Management Information System**



The elements of material control are:

- (a) A procedure.
- (b) A means of tracking and monitoring.
- (c) A material identification function.
- (d) A material requisitioning function.
- (e) A material requisitioning review function.
- (f) A material ordering scheduling function.
- (g) A material ordering function.
- (h) An expediting function.
- (i) A budget control function.
- (j) A receipt function.
- (k) A warehousing function.
- (l) A material staging function.

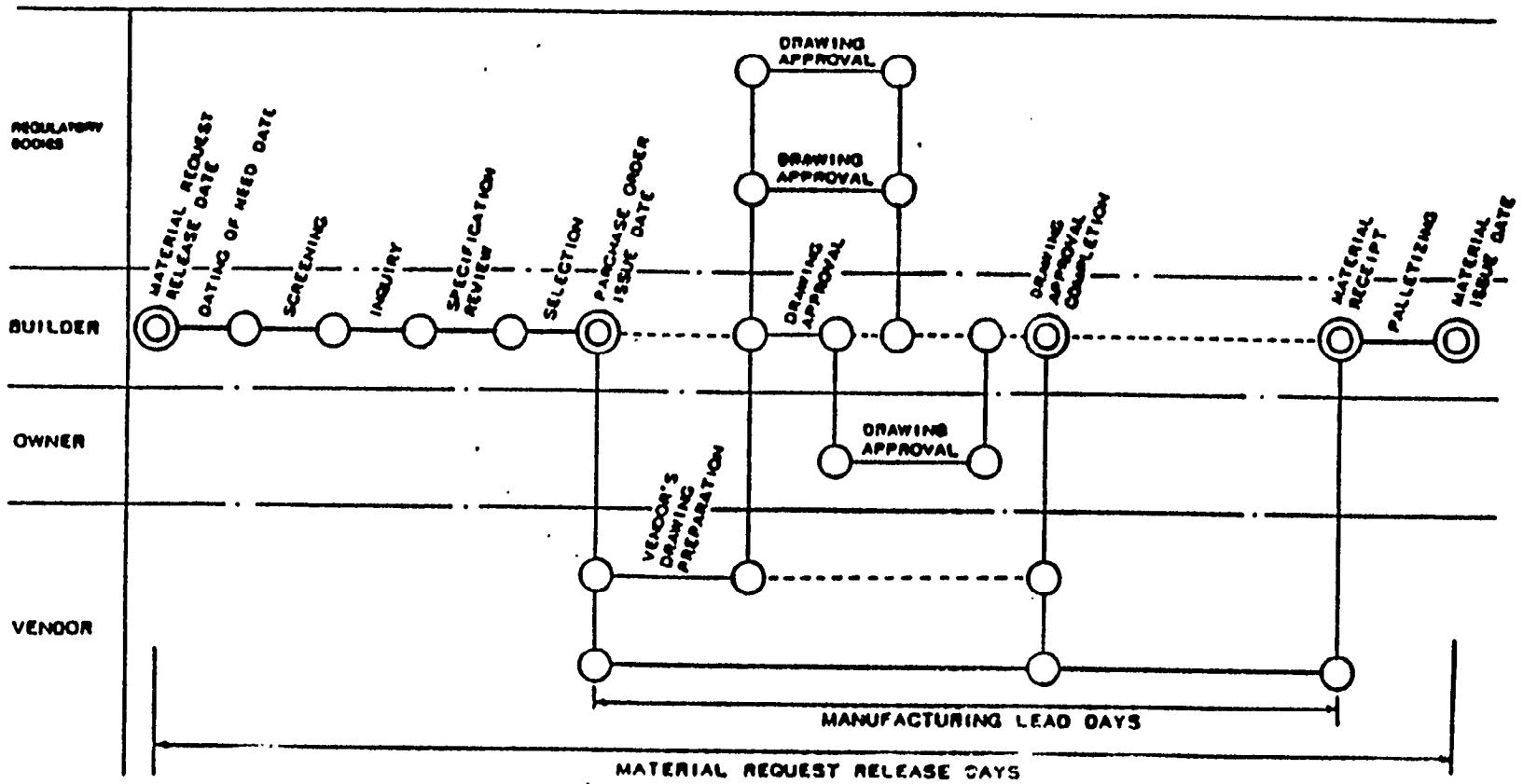

Fig. 7-46. Critical path model of material lead times.



THE SOCIETY OF NAVAL ARCHITECTS AND MARINE ENGINEERS  
601 Pavonia Avenue, Jersey City, N.J. 07306

Paper presented at the 1991 Ship Production Symposium.  
The Pan Pacific Hotel, San Diego, California, September 3-6, 1991.

# Ship Conversion Project Monitoring - From the Customer's Viewpoint

Edward S. Karlson, Member, Maritime Administration

## ABSTRACT

Over the past ten years, the Maritime Administration (MARAD) has awarded and administered contracts for the major conversion of 15 vessels. Each of these projects involved vessel reactivation as well as conversion, and each contract was awarded on a fixed price basis.

The combination of fixed pricing and vessel conversion/reactivation creates a challenge to shipyards bidding for the contract in that price competition is intense while, at the same time, an unknown level of growth work can be expected in the vessel reactivation portion of the project. Moreover, the project being bid, inclusive of anticipated growth work, must be integrated into the overall orderbook within the shipyard. The need for careful planning by the shipyard from the beginning of bid preparation through the end of the performance period is clearly evident.

This SNAME paper, however, addresses not shipyard planning but continuing project monitoring and progress evaluation by the shipyard's customer. Such monitoring includes ongoing comparisons between the shipyard's planned and actual performance with respect to resource application and schedule adherence. From a technical standpoint, it involves compliance with contract and specification requirements. And finally, from a financial standpoint, it includes project progressing to provide the basis for periodic payments to the shipyard for completed work.

## INTRODUCTION

The shipyard's plan for completing a major conversion/reactivation project on time and within budget involves integration of the project into other orderbook work, timely accomplishment of necessary engineering, timely procurement and receipt of material,

allocation of facilities and financial resources, and time-phased allocation of labor resources.

The customer's plan for monitoring a major conversion/reactivation project, on the other hand, must be essentially complete before the project is even bid because the solicitation must include all of the project monitoring considerations which the shipyard will be required to comply with. Fundamental among these considerations is the requirement for submission of specified information by the shipyard to the customer prior to contract award and throughout the contract period. This paper focuses on these information requirements without which effective contract monitoring and progress evaluation cannot be accomplished, even though inspection of in-process work may be satisfactory.

Successful completion of a major conversion/reactivation project in accordance with contractual provisions is a team effort. It is important that both the shipyard's plan and the customer's plan be accommodated within this effort.

## PRECONTRACT CONSIDERATIONS

### Pro Forma Contract Provisions

MARAD includes a pro forma contract in its bid solicitation which includes several basic requirements to assist in project monitoring and progress evaluation. Among these requirements are:

Inspection. The shipyard is required to provide specified facilities, materials and services necessary for the safe and convenient on-site administration of the contract. A MARAD Construction Representative is assigned the responsibility and authority to conduct ship and work site inspection and to accept shipyard work. All workmanship and materials, and all shipyard operational practices, are

## References

1. National Advisory Committee on Oceans and Atmosphere (NACOA), Shipping, Shipyards and Sealift: Issues of National Security and Federal Support, 1985.
2. U.S. Department of the Navy/Maritime Administration, Shipyards Mobilization Base Study (SYMBA), 1984.
3. Naval Sea Systems Command - Code 034, United States Shipbuilding Industry - 1990, annual report prepared for the Office of the Assistant Secretary of the Navy (OASN), 1990.
4. Ralph M. Doggett, The Economic Impact of the U.S. Shipbuilding Industry, prepared for Shipbuilders Council of America and the Maritime Administration, 1982.
5. "1988 Review of Global Shipbuilding Requirements to 2000", Association of West European Shipbuilders, as reprinted in the Shipbuilders Council of America, 1988 In Review - Ship Construction Report, 1989.
6. Howard M. Bunch, "Comparison of the Construction Planning and Manpower Schedules for Building the PD214 General Mobilization Ship in a U.S. Shipyard and in a Japanese Shipyard", Journal of Ship Production, February 1987.
7. Congressional Budget Office, U.S. Shipping and Shipbuilding: Trends and Policy Choices prepared for Senate Armed Services Committee (SASC), 1984.
8. Robert W. Kesteloot, "Sealift After The Storm", Seapower, June 1991.
9. Hastings and Jenkins, The Battle for the Falkland Islands, New York, W.W. Norton & Company, 1983.
10. Jay Carson, Prospects for Improving Competitiveness of the U.S. Shipbuilding Industry, prepared for Shipbuilders Council of America Marketing Seminar, January 1990.
11. "IDEF Modeling Part I: Pinpointing Needs Worth the Effort?", CIM Strategies, November 1989.
12. Daniel Rasmus, "Redesigning the Corporation with IDEF's Help", Manufacturing Systems, December 1988.
13. Richard C. Berry, Industrial Marketing for Results, London, Addison-Wesley Publishing Company, 1980.
14. Frank Paine, The Financing of Ship Acquisitions, London, Fairplay Publications, 1989.
15. Gerald R. Jantscher, Bread Upon the Waters: Federal Aids to the Maritime Industries, Washington, Brookings Institution, 1975.
16. Clinton H. Whitehurst, Jr., The U.S. Shipbuilding Industry - Past, Present, and Future, Annapolis, MD, Naval Institute Press, 1986.
17. M.I.T. Commission on Industrial Productivity, Made in America: Regaining the Productive Edge, Cambridge, MA, MIT Press.
18. Robert B. Harris, Precedence and Arrow Networking Techniques for Construction, New York, John Wiley & Sons, 1978.
19. J.J. Moder, C.R. Phillips, E.W. Davis, Project Management with CPM, PERT, and Precedence Diagramming, third edition, New York, Van Nostrand Reinhold Company, 1983.

required to be in accordance with the requirements of specified regulatory and other rule-making bodies. The vessel must be fully certified by the U.S. Coast Guard and the American Bureau of Shipping prior to MARAD acceptance for redelivery. event that vessel performance during specified dock and sea trials is unacceptable, the equipment in question is required to be opened for post-trial inspection and any defects for which the shipyard is responsible shall be corrected.

Information. At the beginning of the project performance period, the shipyard is required to submit a summary cost estimate and certain other cost data which are needed to establish acceptable system of progress payments to the shipyard. This system of progress payments is addressed in greater detail later in the paper.

During the project performance period, the shipyard is required to provide all plans, schedules, documents and other information as specified in the plan and correspondence procedure which is also addressed in greater detail later in the paper.

Growth Work. There are two types of growth work in a MARAD contract for vessel major conversion/reactivation. The first applies to changes in contract requirements which may include changes in specified conversion work to be accomplished. The second applies to delivery orders for supplementary repair work. Whether for a change order or a delivery order, contractual procedures provide for full MARAD involvement in the technical identification and authorization of growth work. The process requires the shipyard to submit an estimate including labor hours, material quantities and cost, and an estimate of delay, if any.

The contract provision applicable to changes also addresses constructive changes and acceleration. The shipyard is required to provide written notice to MARAD if it believes MARAD has ordered such events.

Progress Reviews. The shipyard is required to conduct quarterly progress reviews for MARAD at the shipyard during which the categories-- of engineering, production, material procurement, logistics and outstanding contractual matters are addressed.

Monthly meetings between MARAD and the shipyard are also held at the shipyard during the in-between months to review physical progress of vessel conversion/reactivation.

Specifications. The contract specifications provided to the shipyard by MARAD address the technical aspects of the conversion/reactivation project. These specifications include additional requirements for additional information to be furnished by the shipyard which are addressed in greater detail later in the paper.

Basis of Contract Award. Of primary importance in the pro forma contract, from a project monitoring standpoint, is the provision which states that the contract will be awarded to that responsive and responsible bidder with the lowest total responsive bid and whose redelivery date does not exceed the contract redelivery date. The term "responsible" is key in that it mandates a determination of contractor responsibility by MARAD's contracting officer in accordance with the Federal Acquisition Regulation (FAR). FAR 9.104-1, General Standards, includes several specific requirements which a prospective contractor must meet to satisfy a favorable determination of responsibility. A pre-award survey is generally conducted by MARAD in order to assess whether these requirements are or can be met. The shipyard's plan for accomplishing the conversion/activation project is reviewed during the survey.

#### PRE-AWARD SURVEY

After bids are opened, MARAD contacts the apparent low bidder and then follows up with a letter confirming arrangements for the onsite pre-award survey and requesting the information included in Table I.

Latest audited financial statements and management letter from Certified Public Accountant firm

Completed MARAD information form (SF 17): Facilities Available for the Construction or Repair of Ships

Time-phased production workforce allocation plan (separate plans for conversion and reactivation/repair)

Preliminary key event schedule

Summary cost estimate and detail cost backup sheets

Vendor quotations for material, equipment and services exceeding \$10,000

Input for following pre-award survey forms:

SF 1403 (General)

SF 1404 (Technical)  
 Resumes of key personnel  
 Evaluation of technical capabilities  
 Description of technical capabilities which yard lacks

SF 1405 (Production)  
 Shipyard organization  
 Production control system  
 Plant facilities  
 Production equipment  
 Long lead procurements for project  
 Major subcontracting  
 Personnel  
 Delivery performance record  
 Related previous production (government)  
 Current production orderbook

SF 1406 (Quality Assurance)  
 Organization  
 Instructions/procedures

SF 1407 (Financial Capability)

SF 1408 (Accounting System)

Table I Precontract Information from Apparent Low Bidder

The latest audited financial statements and management letter are needed to determine whether the bidder has or can obtain adequate financial resources to perform the contract.

The completed standard form SF-17 is needed to determine whether the bidder has or can obtain necessary production, construction, and technical equipment and facilities.

The time-phased production workforce allocation plan is needed to determine whether the bidder has, or can obtain, the necessary labor to perform the contract on a timely basis. Figure 1 is a typical workforce allocation plan which presents manhour loading by month and cumulative percent loading during the period when the vessel is in the yard. The fairly rapid buildup of manhours indicates that reactivation work commences at an early stage when engineering and material procurement for conversion work do not absorb a significant workforce. In Figure 1, the contract redelivery date is at the end of month 14.

The primary importance of Figure 1 from a project monitoring and progress evaluation standpoint is that it presents the shipyard's time-phased plan for allocating labor. Shipyard performance during the contract period is measured against this plan.

The preliminary key event schedule is needed to determine how the shipyard intends to approach the conversion/reactivation project. Will reactivation work be accomplished at the beginning, throughout or at the

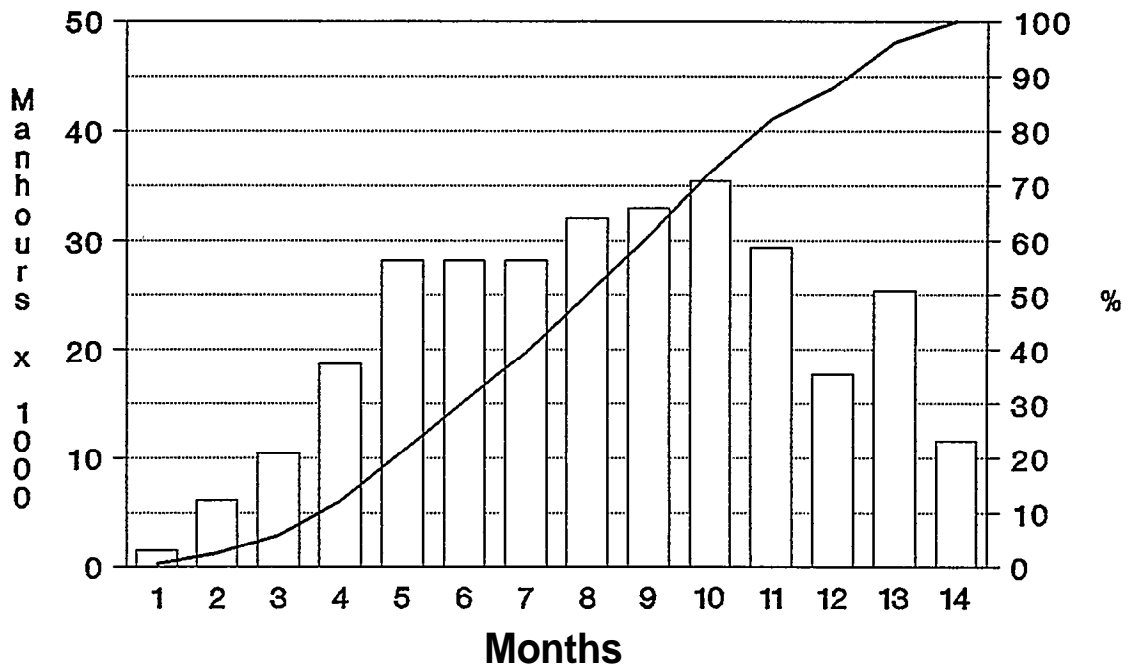

Figure 1 Time-Phased Production Workforce Allocation Plan for Base Contract Work

end? How long is conversion engineering expected to take? What are the target dates for receiving major equipments? Has the shipyard left anything off the schedule which MARAD considers important? Has enough time been allotted toward the end of the contract period for testing and trials? Answers to these types of questions provide MARAD with the secondary benefit of information pertinent to timely assignment of inspectors to its field construction office at the shipyard.

The summary cost estimate., detail cost backup sheets, and major vendor quotations are specific pro forma contract requirements. Although the shipyard is not obligated to furnish them prior to contract award, they do facilitate an effective pre-award survey and determination of responsibility.

The pre-award survey team must provide a complete survey report, inclusive of recommendations, to the contracting officer. This report is in the five sections indicated in Table I by the "standard form" (SF) identifiers. MARAD forwards blank forms to the shipyard prior to the survey and requests that appropriate information on the forms be completed to the maximum extent possible, and that the partially complete forms be returned to MARAD for review prior to the pre-award survey.

Thus far, this paper has addressed precontract considerations which impact on project monitoring. They provide a framework of requirements which the shipyard must comply with and a basic shipyard plan on how the work will be accomplished. The next section of the paper addresses post contract considerations which address information requirements provided for in the pro forma contract and contract specifications but which apply to the shipyard during the contract period.

#### POST CONTRACT CONSIDERATIONS

Table II is a list of information requirements in eleven specific areas

which, in aggregate, provide ongoing project monitoring information as work is being accomplished. All of these requirements are addressed in the plan and correspondence procedure which is an integral part of the pro forma contract.

#### Production schedules:

- Key event schedule
- Master production schedule (Including material ordering schedule and test schedule)
- Tank open and inspect schedule
- Working plan schedule and plans
- Purchase specifications
- Equipment technical manuals and engineer's operating manual
- Force reports
- Progress photographs
- Construction progress and payment report
- Receipts for contractor-furnished and government-furnished material
- Logistic support plan and schedule (including existing ship's inventory and condition report)
- Test memoranda
- Equipment and system technical reports as required by contract specifications

#### Table II Post Contract Information from shipyard

#### Plan and Correspondence Procedure (P&CP)

Under the plan and correspondence procedure, the shipyard is required to provide a master production schedule and key event schedule (Figure 2) to MARAD within 45 days after contract award, and to update and reissue these schedules on a monthly basis.

Item No.	<u>Planned</u>		<u>Revised</u>	<u>Actual</u>
	<u>I</u>	<u>t</u>	<u>Start</u>	<u>Finish</u>
			<u>Start</u>	<u>Finish</u>
			<u>m</u>	<u>h</u>

Figure 2 Key Event and Master Production Schedules

The master production schedule is required to identify all engineering and production activities which impact on project scheduling. It generally includes 100 to 200 line items and is in sufficient detail so that critical path(s) to project completion can be identified. The format for both the master production schedule and key events schedule includes baseline (originally planned), revised estimate (schedule slippage in excess of 15 days), and actual start and finish dates. The data in these two schedules provide the primary basis for ongoing monitoring of production schedule progress and for review of production activity and problems at the quarterly and monthly progress meetings.

Because most of the vessels in MARAD major conversion/reactivation projects are in excess of 20 years old, the condition of their tanks is often suspect. Accordingly, a separate "open and inspect" schedule for all deep tanks, double bottom tanks, peak tanks, cofferdams, cargo tanks and any other tanks subject to regulatory body inspection is required to be submitted within 45 days after contract award. The schedule must be developed to ensure that all tanks are opened and inspected in sufficient time for all repairs to be identified, priced and submitted to MARAD for action within eight months after ship availability.

A working plan schedule is required to be originally issued within 60 days after contract award and reissued thereafter with updates on a monthly basis. MARAD approves all shipyard working plans. Those that are approved at the headquarters level must be turned around with 20 days; those at the field construction office level within 8 days. This ongoing plan approval process affords a good opportunity to monitor engineering progress and its impact on production.

Purchase specifications are required to be included in a material control schedule and are subject to the same MARAD approval process as shipyard plans. This ongoing purchase specification approval process affords a good opportunity to monitor material procurement progress and its impact on production.

New equipment technical manuals, reworked portions of existing equipment technical manuals and updated portions of the engineer's operating manual are all subject to approval by MARAD.

Figure 3 is a typical force report required by the plan and correspondence procedure to be submitted on a monthly basis.

In this report, the shipyard is required to include shipyard hours expended during the month just ended for both base contract work and growth work. The cumulative hours expended since contract award and expected hours at project completion for both of these categories must also be included. The total number of shipyard employees is included to provide a means to approximate the percentage of shipyard labor resources being expended on the conversion/reactivation project. For project monitoring and progress evaluation purposes, the monthly force reports provide actual labor expenditure data for measurement against planned labor expenditure data.

To assist in project monitoring, a minimum of five photographs are required to be submitted on a monthly basis. The five photographs include two to indicate overall views of the entire weather decks and superstructure and at least three, as selected by the shipyard, to indicate significant progress or status for specific items during the reporting month.

	<u>Current Month</u>	<u>Cumulative</u>
<u>Manhours Expended</u>		
Base Contract Work	26,253	171,239
Change Orders/Delivery Orders	<u>4,791</u>	<u>35,688</u>
Totals	31,044	206,927
<u>Estimated Manhours at Completion</u>		
Base Contract Work		306,000
Change Orders/Delivery Orders		<u>50,000</u>
Total		356,000
<u>Total Number of Employees</u>		724

Figure 3 Force Report (End of Month 10)



Under MARAD contracts for major conversion/reactivation projects, progress payments are made to the shipyard in accordance with physical progress achieved based on a 10,000 point system representing material and labor value components for specified work. Figure 4 is a typical contract progress certification system in which aggregate material accounts for 40 percent (4,000 points) of the contract value for base contract work and labor accounts for 60 percent (6,000 points).

The system typically includes up to approximately 20 line items in the general category for cost accounts such regulatory bodies, towing, performance bond, tests, trials, general services, engineering, etc. From 50 to 100 lines items are usually included in conversion cost accounts and from 150-200 line items are usually included in reactivation/repair cost accounts. The up-to-ten line items in major material procurements/subcontracts cost accounts occur when material suppliers or subcontractors require progress payments. These are "material" costs to the shipyard and MARAD does not pay progress for material until it is received at the shipyard unless special arrangements are made on a line item basis. These special arrangements permit progress payments for offsite

In Figure 4, the aggregate material completion percentage is 70.0 and the aggregate labor completion percentage is 45.2 yielding a base contract work completion percentage of 55.12 for the project. Subtraction of

the previous time period completion percentage provides an incremental progress increase which when multiplied by the base contract price yields the progress payment value for the current partial payment period. For project monitoring and progress evaluation purposes, - the labor progress date is particularly important throughout the project for measuring against manhour expenditures, and toward the end of the project when monitoring efforts focus on work yet to be accomplished.

Progressing of growth work is separately handled on a line item basis. A change order or delivery order must be settled as to price before any MARAD payment for it is made. For a change order/delivery order settled for more than \$50,000, a MARAD payment can be made based on the percent of work complete. Figure 5 is a typical change order/delivery order status report maintained by MARAD's onsite construction representative to, in pa\*, assist in progressing growth work.

In Figure 5, the price for the lifeboats line item is settled so partial progressing can occur before the work is complete. Progressing at 100 percent for the radar line item can also occur because the work was completed on 11-3-89. For project monitoring purposes, the in Figure 5 are particularly useful for keeping track of growth work line items in the administrative process from identification to approval. For major conversion/reactivation projects, the number of growth work line items

Item No. Item Description	Material		Labor			Total	
	Point Value	% Comp.	Point Value	% Comp.	Point Value	% Comp.	
General			20				
Conversion			50-100				
Reactivation/Repair			150-200				
Major Material Procurements/ subcontracts			10				
Contract Totals	4,000	70.0	2,800	6,000	45.2	2,712	10,000 5,512

	Agreed Price	% Comp	Payable Amount
Change Orders/Delivery Orders (\$50,000 or Less)	\$ 34,500	100	\$34,500
Change Orders/Delivery Orders (Exceeding \$50,000)	\$134,000	40	\$53,600

Figure 4 Contract Progress Certification system

CO/DO No	Title	Estimated cost	CR Submittal Date	CO/DO Approval Date	Yard Item No.	Price Settlement Date	Settled Price	Work Completion Date
001	Lifeboats	\$57,250	2-1-89	2-17-89	416	3-14-89	\$53,198	
347	Main Circ. Pump	4,729	8-23-89	9-2-89				
491	Radar	8,118	9-22-89	9-23-89	506	9-23-89	7,793	11-3-89

Figure 5 change orders/Delivery Orders status Report

typically exceeds 700.

To assist MARAD's construction representative in progressing the material portion of line items in Figure 4 and in generally monitoring the receipt of material for production support purposes, the shipyard is required to provide MARAD with warehouse receipts for both contractor-furnished and government-furnished material.

Contract specifications for major conversion/reactivation projects require a significant shipyard effort in the area of logistics. Specific efforts include existing vessel inventory, spare parts procurement, loose item outfitting procurement, packaging/ labeling, onboard stowage, equipment validation, equipment technical manuals, etc. The shipyard is required to provide a logistic support schedule in the same format as Figure 2 (key event and master production schedules). For project monitoring purposes, the data in the logistic support schedule are particularly useful in assessing progress toward logistics completion at vessel redelivery.

Test schedules and test memoranda are required to be provided by the shipyard. MARAD approval of test memoranda is coordinated at the field construction office level. Since testing and trials essentially constitute the final segment of project inspection, the thorough and timely preparation of test memoranda is an important element of project monitoring.

The final item under the plan and correspondence procedure being addressed in this paper is the requirement for the shipyard to provide a variety of equipment and system technical reports addressed in contract specifications. These reports include equipment condition reports, tank

sounding reports, bearing clearance reports, cathodic protection reports, motor and generator megger reports, lube oil quality reports, etc. All of these reports assist MARAD's construction representative in monitoring the project from the standpoint of inspection and need for specific growth work.

#### INSPECTION AND EVALUATION

##### Onsite Inspection

MARAD contracts for vessel major conversion/reactivation invoke FAR clauses 52.246-4 and 52.246-6 which, in turn, are based on FAR Subpart 46.202-2, Standard Inspection Requirements, under FAR subpart 46.2, Contract quality Requirements. Subpart 46.202-2 states that the invoked clauses:

- "(1) Require the contractor to provide and maintain an inspection system that is acceptable to the Government;
- (2) Give the Government the right to make inspections and tests while work is in process; and,
- (3) Require the contractor to keep complete, and make available to the Government, records of its inspection work." (1)

Element (2) above and MARAD's contract progress certification system provide the cornerstones for MARAD's onsite inspection program regarding work in process. These cornerstones are supplemented by specific contract provisions and contract specification requirements. To assure compliance with contract/specification requirements, a MARAD field construction office is established at the shipyard and headed by a MARAD

construction representative. This construction representative has specified contract responsibilities and authorities and is supported by an inspection staff. The inspection staff includes an office manager and combinations of inspectors to perform hull, machinery, electrical and logistics inspection duties.

MARAD's construction representative and inspection staff constitute MARAD's primary means of project monitoring for work in process.

### Progress Evaluation

Whereas onsite inspection applies to work in process, progress evaluation applies to overall contractual performance which is essentially accomplished at MARAD's headquarters level.

Figure 6 is a set of curves applicable to the time-phased expenditure of production labor for base contract work. The data points in the curves are consistent with data presented in Figures 1, 3 and 4. The vessel availability curve is simply a straight line projection of the vessel's availability for accomplishment of base contract work from arrival at the shipyard through

the contract redelivery date. The planned *production* labor expenditure curve is taken directly from Figure 1 which was provided by the shipyard to MARAD in connection with the pre-award survey. A variation of these data would be splitting the curve into two curves; one for vessel conversion and one for vessel reactivation. The actual production labor expenditure curve is taken from Figure 3, the series of which provide manhour expenditure data on a monthly basis. Bid labor hours for base contract work is the 100 percent data point for manhours. Although generally not necessary for normal progress evaluation purposes, the percent actual production labor expenditure monthly data points may be adjusted to reflect the estimated manhours at completion for base contract work in Figure 3 rather than bid manhours. For example, if the shipyard decides to to "buy" a substantial amount of work it intended in its bid to accomplish with shipyard labor or if a serious overrun of labor hours is emerging, the 100 percent data point for manhours could significantly change and a recalculation of previous data point values may be needed for effective progress evaluation. The labor progress curve is taken from Figure 4, the series of which provide the required labor data.

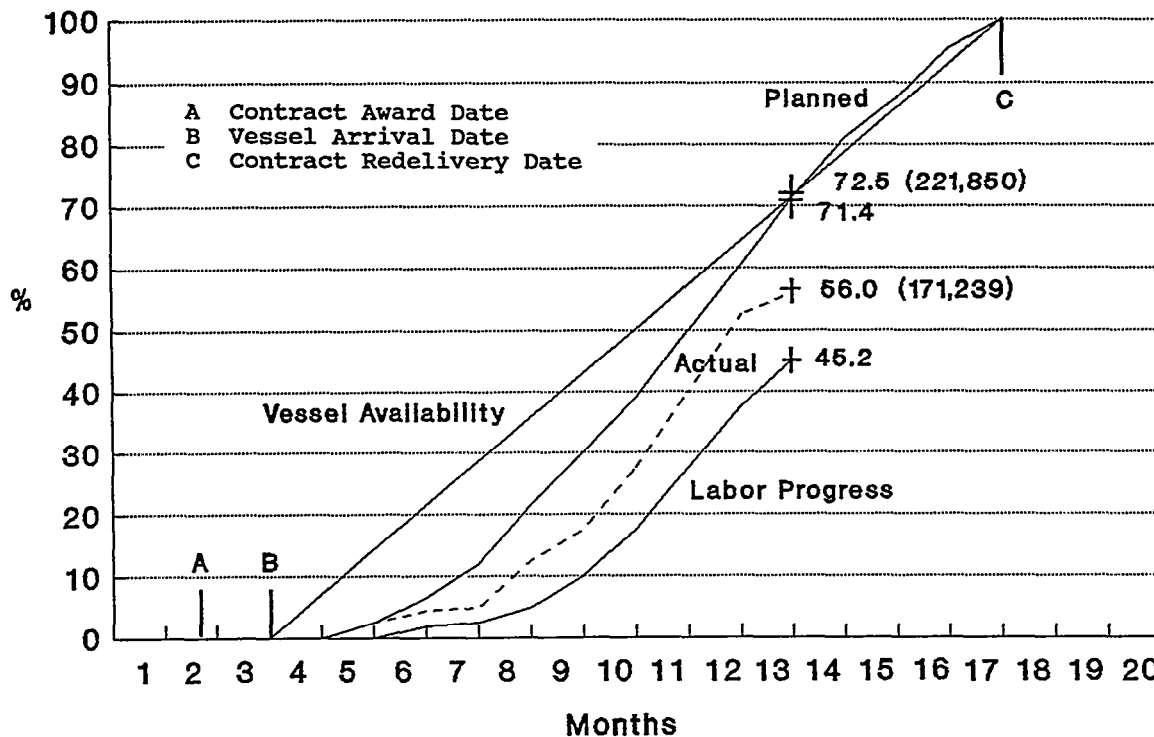

Figure 6 Time-Phased Production Labor Expenditures for Base Contract Work

The data in Figure 6 indicate that, as of month ten (13 minus 3), the following percentages apply:

Item	%	Manhours
Planned labor expenditure	72.5	221,850
Vessel availability	71.4	
Actual labor expenditure	56.0	171,239
Labor progress	45.2	

It is not possible to reach absolute conclusions from simplistic comparisons among the above data. It is possible, however, to identify trends and to suggest that specific possibilities should be examined in more detail. For example, actual labor expenditures lagged planned labor expenditures as of the end of month ten by 16.5 percent and divergence is evident. Is the project being undermanned? Has significant shipyard work been diverted to subcontract work? Should project manning be increased at this time? As another example, labor progress lagged actual labor expenditures as of the end of month ten by 10.8 percent. Is the shipyard

underprogressing from a labor standpoint? Is labor productivity less than it should be? Are hours being charged to this project that should not be? The worst case being suggested by the Figure 6 data is one of labor undermanning coupled with less than acceptable labor productivity. This may not be true but questions should be asked by both shipyard management and its customer, and answers should be found.

Figure 7 is the Figure 6 data extended to vessel redelivery with Case 1 reflecting a labor underrun and Case 2 a labor overrun. At this point in time, of course, we are no longer monitoring the project or evaluating progress but are assessing why the vessel was redelivered 80 days late and what happened to the manpower loading.

The data in Figure 7 indicate that, as of vessel actual redelivery, the following percentages applied:

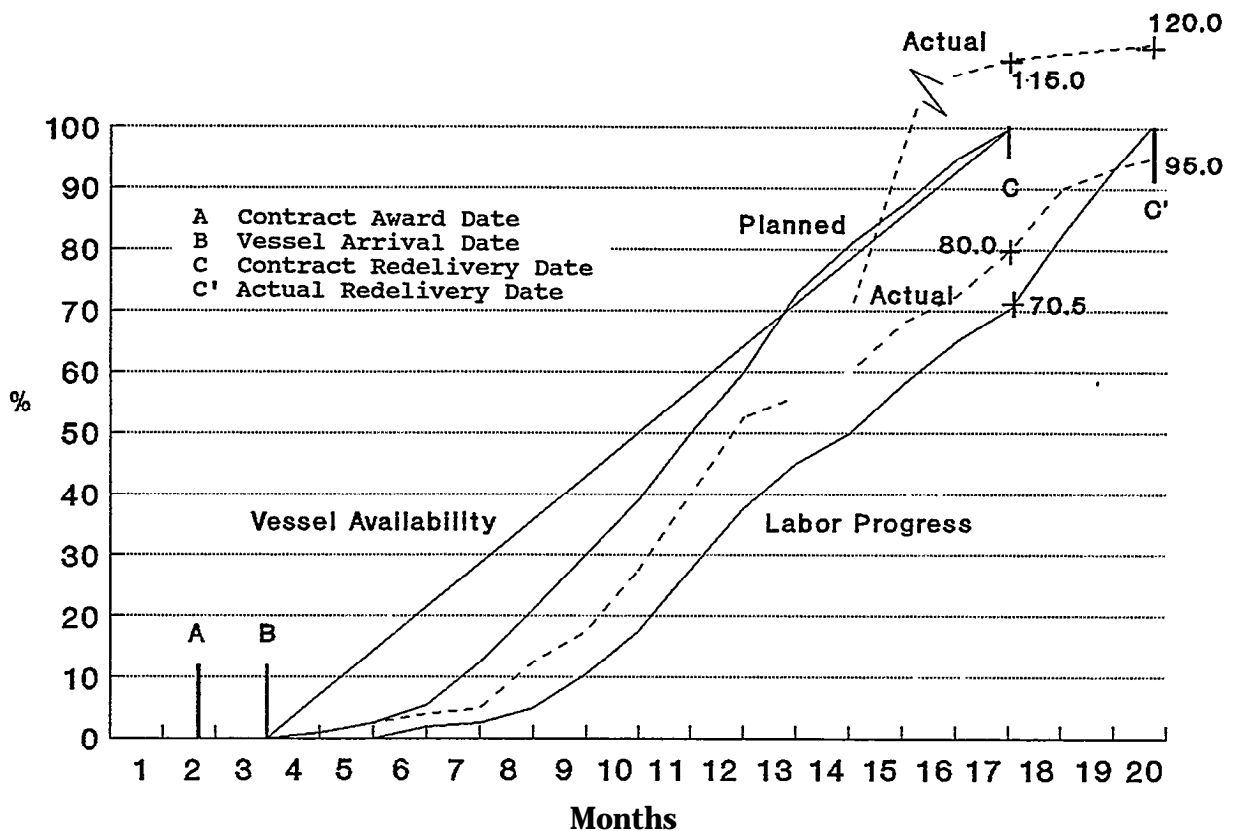

Figure 7 Time-Phased Production Labor Expenditures for Base Contract Work - Delay

Item	Case 1 %	Case 2 %
Planned labor expenditure	100.0	100.0
Vessel availability	--	--
Actual labor expenditure (as of contract redelivery date)	80.0	115.0
Actual labor expenditure (as of actual redelivery date)	95.0	120.0
Labor progress	100.0	100.0

contract specifications to assure an opportunity to effectively monitor the project and to evaluate progress during the period of performance. This paper has presented actions taken by the Maritime Administration to help assure that its project monitoring and progress evaluation processes are effective.

#### REFERENCE

1. Federal Acquisition Regulation (FAR) subpart 46.2, Contract Quality Requirements

Again, it is not possible to reach absolute conclusions from the above data or from comparisons among these data. It is possible, however, to suggest that specific possibilities should be examined in more detail. For example, in Case 1, the actual expenditure of labor as of vessel actual redelivery was only slightly less than the planned expenditure, but the actual expenditure was only 80.0 percent as of the contract redelivery date. Was the project undermanned causing delay? Was the delay caused by growth work in lieu of base contract work? Was the delay the responsibility of the customer? Were portions of the contract specifications defective? In Case 2, the actual expenditure of labor as of vessel actual redelivery was significantly greater than the planned expenditure. In fact, the actual expenditure was already 15 percent higher than 100 percent of the planned expenditure as of the contract redelivery date. In addition to the above questions, was there poor labor productivity particularly toward the end of the project? Was there substantial disruption and inefficiency due to growth work? Is there a basis for shipyard submission of a request for equitable adjustment to the customer? Should shipyard labor data bases be updated for future bidding purposes?

#### SUMMARY

As stated in the Abstract, the combination of fixed pricing and vessel conversion/reactivation creates a challenge to shipyards bidding for the contract in that price competition is intense while, at the same time, an unknown level of growth work can be expected in the vessel reactivation portion of the project. This challenge also extends to the customer whose primary objective is project completion within budget, on time and in compliance with specification and approved growth work requirements. To achieve this objective, the customer should include sufficient provisions and requirements in the contract and



# A Data Model for the Integration of the Pre-commissioning Life-cycle Stages of the Shipbuilding Product

**M. Welsh, Visitor**, Engineering Design Center, University of Newcastle, UK,  
**J. Lynch, Visitor**, COTEC Computing Services, Sunderland, UK, and **P. Brun, Visitor**,  
Institut des Recherches de la Construction Navale, Paris, France

## ABSTRACT

This paper reports some aspects of the work being carried out on the NEUTRARAS project under the ESPRIT II European research program. The aim of this project is to specify and implement a neutral product definition database for large marine-related artefacts, covering a large part of the complete product life-cycle. The results of this research program will facilitate the effective exchange of product-related data between disparate computer-based information systems, and hence promote a movement towards product life-cycle integration. The scope of the product model being developed as the basis for this integration is described in terms of its spatial and steel structural components, together with the implications for integration with other models of outfitting and engineering systems. The model is shown to encompass the wide range of product-related data which is associated with the various pre-commissioning stages of the product life-cycle. A suitable database architecture designed to support product data exchange and full life-cycle integration based on this product model, is described and discussed.

## NOMENCLATURE

AEC	Architecture, Engineering and Construction.
ASCII	American Standard Code for Information Interchange.
CAD	Computer Aided Design.
CADEX	CAD Geometry Data Exchange.
CAD*I	CAD Interfaces.
CALS	Computer Aided Acquisition and Logistics Support.
CEC	Commission of the European Communities.

EDI	Electronic Data Interchange.
ESPRIT	European Strategic Program for Research and Development in Information Technology.
IGES	Initial Graphical Exchange Specification.
ISO	International Standards Organisation.
NIDDESC	Navy Industry Digital Data Exchange Standards Committee.
SET	Standard d'Exchange et de Transfert.
VDAFS	Verband der Deutschen Automobilindustrie Flaechen Schnittstelle.

## INTRODUCTION

The pre-commissioning stages in the life-cycle of large, complex engineering artefacts, of which the shipbuilding product is an example, are normally associated with the generation and management of vast quantities of complex, inter-related product data. This data is concerned with all aspects of the product including its geometry, topology, functionality, the associated production processes, production planning and control, materials, quality control and so on.

The scope and complexity of the product-related data being created and manipulated throughout the various pre-commissioning stages of the complete product life-cycle, from requirements analysis, through the various design stages and finally into production, requires that equally comprehensive and coherent data models be specified and implemented to enable the effective management and exchange of such diverse product data between the associated application areas. The need for such data models is accentuated by the tendency to use increasingly complex heterogeneous computer-based information systems at the various pre-commissioning life-cycle stages. These life-cycle stages cover activities such as marketing, conceptual design,

## 2.0 PRODUCT-ORIENTED MATERIAL MANAGEMENT AND PERIPHERAL SYSTEMS

### 2.1 Features of Modern Shipbuilding

Modern society is often depicted as "high tech" or "information oriented". As compared to pre-World War II social environments, many different products having different specifications and configurations now impose significant manufacturing challenges. Impressive progress in management methods and facilities have made it possible to meet such demand.

Computer-aided design and manufacturing (CAD/CAM) and robots represent the trend in many modern industries. Even though shipbuilders are successfully introducing such methodologies for design and production, shipbuilding remains inherently labor intensive relative to other endeavors. Total application of such technologies requires huge investments, addressing an entire production system, that private shipyards cannot justify. Consequently, investments are generally limited to specific areas that can provide maximum returns with great dependence on vendors and subcontractors. Naturally, focus in-house is on areas which can maintain a high rates <sup>of operation</sup> ~~that investments will pay off~~ <sup>relatively</sup> short periods of time. Typical such work is hull part and pipe piece fabrication and assembly on-unit, on-block and on-board.

The best way to maintain high operation rates in-house is to increase work volume within a given period which, in ship production, means being very selective concerning in-house work and shortening construction periods by rationalizing production processes.

Shortening construction periods provides numerous advantages beyond savings in amortizing investments. There are also reductions in finance costs, costs for maintenance of ships' machinery, paint systems, etc., and in mooring costs at outfitting piers. Further, shortening construction periods requires relatively longer preparation time for design, material definition and material procurement and also contributes to reduction of the time required between contract award and delivery. The latter enhances sales opportunities and is already an essential factor for competition. [1]

The best and most economical solution for a shipyard to meet such demand is to break down an envisioned end product into interim products, i.e., parts and tiers of subassemblies, which are contrived to facilitate creation of larger assemblies and which are assigned for manufacture to the most specialized and cost-effective producers, in house or elsewhere. Such advanced shipbuilding is said to be product (interim product) oriented and is primarily an assembly process.

[1] "A consortium of Japanese shipyards looks the likely favorite to gain a lucrative \$350 million order for six containerships from U.S.-based Sea-Land **Services....** The three-yard line-up from Japan looks favorite for several reasons. One is the punishing delivery schedule called for by the major U.S. private operator." Lloyd's List, December 28, 1984.

## 2.2 Outline of Product-Oriented Material Management

### 2.2.1 Relationship Between Product Oriented Material Management and Product-Oriented Production System

Material management must necessarily be completely integrated wherever product-oriented production is being implemented. In other words, the objective of product-oriented material management is to procure materials for work packages each of which defines work to be accomplished to create a specific portion of an envisioned end product (zone), with a specific facility such as a process lane (problem area) during a specific division of the work process (stage). Thus, a product-oriented material management system is designed to just-in-time deliver materials required for work packages which reflect both design and production attributes and which impose a common build strategy on design, material procurement and production. [2]

Product-oriented production in shipbuilding is a methodology based upon a product work breakdown structure (PWBS) which conforms with the concept of Group Technology (GT). The purpose of GT, also called Family Manufacturing, is to produce different products required in varying quantities, such as parts and subassemblies needed to build ships, in a manner so organized to achieve production-line benefits. GT requires coordinated sales, design, material procurement and production far beyond that achieved by traditionalists. [3]

Unlike system orientation, product orientation requires:

- o contract design to be part of the shipbuilding process so that contract drawings and specifications address the building process as well as the end product, [4]
- o designers and those who perform material definition to regroup information conceived by system to facilitate design, into information organized by zone to facilitate production, [5] and
- o division of work per a PWBS.

PWBS first divides the shipbuilding process into three different types of work, hull construction, outfitting and painting, because they impose inherently different problems. Each is then subdivided into fabrication and assembly work. Also, PWBS classifies contemplated interim products in accordance with the resources they require, i.e., material, manpower, facilities and expenses. Finally, PWBS classifies interim products (parts and subassemblies) by characterizations of both a ship design and a manufacturing process which are called product aspects. The product aspects system and zone are means for dividing a ship design into manageable work parcels. Area (problem area) and stage are means for dividing the design, material procurement and production efforts.

The product aspect system, is retained because some work in a zone-oriented shipyard is more effectively performed by system, e.g., identifying all material requirements and procuring long-lead materials using system diagrams and in production, virtually all testing. Optimum progress of all work classified by zone/area/stage, requires integration of hull construction, outfitting and painting which, in turn, requires timely-purchasing and punctual delivery of different materials in varying-quantities. Such material management is essential to achieve smooth operation of the various process flows (production lines) that GT enables shipbuilders to exploit.

Effective material management requires full support from design so that all necessary technical information and requirements are prepared in time procurement processing. Time is most crucial in product-oriented manufacturing systems. Design, material management and production functionaries become highly interdependent and **must** constantly communicate with each **other** for productivity purposes.

[2] "Materials" includes all raw and/or fabricated items such as pipe and machinery respectively.

[3] See the National Shipbuilding Research Program (NSRP) publications "Product Work Breakdown Structure - Revised December 1982" and "Pipe Piece Family Manufacturing - March 1982 .

[4] See the NSRP publication "Pre-Contract Negotiation of Technical Matters - December 1984".

[5] See the NSRP publications "Integrated Hull Construction, Outfitting and Painting - May 1983" and "Design for Zone Outfitting - September 1983".



2.2.2 Functions of Product-Oriented Material Management

The major functions of material management are: material planning, procurement, and distribution.

In addition, material management includes a control function which constitutes one of the specialized sub-systems for a shipbuilding process. As for the product-oriented production concept, management and control are unique features of the product-oriented material management concept.

o Material planning is a function which:

- identifies required materials and associates them with contemplated work packages,
- prepares requisitions,
- performs value engineering, and
- participates in planning and control of overall material planning, budgets, schedules and **inventories**.

o Procurement is a function which:

- purchases from outside and inside sources,
- performs value engineering,
- makes payments, and
- participates in planning and control of budgets, schedules and inventories.

o Distribution is a function which:

- receives and stores material,
- does field expediting,
- palletizes and issues materials,
- transports materials to work sites, and
- participates in planning and control of schedules.

The principle and subordinate functions of product-oriented material management are shown in Figure 2-1.

FUNCTIONS	PLAN/SEE	DO
Material Planning	<ul style="list-style-type: none"> <li>o General material Planning</li> <li>o Budget control</li> <li>o Schedule control</li> <li>o Value Engineering</li> <li>o Inventory control</li> </ul>	<ul style="list-style-type: none"> <li>o Ship's material Planning</li> <li>o Requisition making for purchasing</li> </ul>
Procurement	<ul style="list-style-type: none"> <li>o Budget control</li> <li>o Schedule control</li> <li>o Value Engineering</li> <li>o Inventory control</li> </ul>	<ul style="list-style-type: none"> <li>o Purchasing</li> <li>o Outside manufacturing</li> <li>o Inside manufacturing</li> <li>o Payment</li> </ul>
Distribution	<ul style="list-style-type: none"> <li>o Schedule control</li> </ul>	<ul style="list-style-type: none"> <li>o Receipt and keeping</li> <li>o Field expediting!</li> <li>o Palletizing/issue</li> <li>o Transportation</li> </ul>

FIGURE 2-1: Functions of Product-Oriented Material Management.

### 2.3 Outline of Material Planning

**Material planning is actually the first stage of requisitioning, i.e., it is preparation for procurement. In general, material planning identifies material required (types, quality), quantities, delivery times, delivery sites, and establishes a standard material procurement plan for each ship (job) number. The design and production departments have major roles in such activity.**

Material planning is, broadly speaking, the backbone of a product-oriented material management system as it establishes basic policies for material selection, such as material grouping (classification), standardization, application, etc. These policies are most important in pursuing product-oriented concepts as any misdirection will seriously affect development of an effective material management system.

#### 2.3.1 Analysis of Material Classification

If interim products are relatively simple, material planning, which identifies a work breakdown and specific material lists per zone/area/stage, can be accomplished quite easily and early enough to allow ample time for procurement, palletizing and delivery to work sites per the production schedule. However, shipbuilding involves many complex interim products and relatively short durations between contract awards and ship deliveries. Following the same material planning procedures as for relatively simple end products is impractical.

The solution employs a material classification scheme, devised by analyzing the nature of items to be procured, which alleviates the initial design workload without negative affect on timely deliveries to production. Materials are classified so that designers involved in material planning (identification of function, quality and quantity) work in accordance with a priority sequence which first addresses imminent requirements and defers material planning for zone/area/stage work packages that are not required by production until later. In other words, material planning is sequenced to anticipate the build strategy which will be employed in production. Time allowed for design, particularly during crucial early design phases, is more wisely employed.

The scheme categorizes materials as: allocated, stock, and allocated stock. The material planning process is categorized to correspond.

The objective of such categorizations is to focus on the extent that quantity accuracy, specification comprehension and other technical information are required in order to place an order.

#### 2.3.2 Material Control Classifications

As described in the foregoing, materials are categorized as allocated, stock and allocated stock.

Allocated materials (A), sometimes called direct materials, are those which are ordered for a specific requirement in a specific ship (main engine, steering engine, etc.) and which require utmost attention from design, purchasing and production planning functionaries.

Stock materials (S), sometimes called running-stock or bin materials, are automatically replenished when stock levels reach predetermined quantities which trigger reorders. The triggering quantities and the amounts reordered are based upon past supply/demand records. S materials do not require material planning during design and production engineering. Examples are nuts, bolts, pipe flanges, etc.

Allocated stock materials (AS), are stock materials which are defined as a consequence of material planning during design engineering. The concepts for A and S materials are combined so that as specific needs are defined, AS materials are ordered periodically with both quantity and delivery-time margins determined by experience. This approach maintains a sufficient stock for known and contingent requirements pending reorders in response to further material definition. Stock for each AS item is controlled by periodically monitoring available supply, new requisitions, pending deliveries and pending issues for all building projects underway. The quantity margin is carefully adjusted during each periodic review so that no surplus remains after the last requirement is fulfilled. Examples of AS materials are large valves, expansion joints, etc., which are mostly standard materials and relatively expensive compared to S materials. [6]

---

[6] The concept for AS material is also referred to as the "Fixed Time Review System" or "Net Requirements" as described in Chapter 4 - Inventory and Management Control, H.B. Maynard's Industrial Engineering Handbook.

### 2.3.5 Role of Designers in Material Planning

Obviously, standardization of design, procurement and production are effective means to reduce costs, improve quality, shorten lead times for purchasing and enhance producibility. Standardization is a prerequisite for effective product-oriented material management. Also, the use of vendors' catalog items as shipyard standards, with preapproved functional performances and costs, saves critical design time, expedites purchasing and permits efficient use of stock material.

Standards require the selection of good quality materials to insure that they are acceptable to owners. Vendor catalog items that are declared to be shipyard standards must be constantly compared to new products. The use of available products as standards should be a basic-policy. In-house design and production of products is almost always significantly more expensive.

There should be two or three vendor's catalog items in a shipyard's standards file for each functional requirement. This insures competition for obtaining the best prices and delivery commitments. Note should be made that the two or three vendors' products declared as standards for the same requirement, must be functionally equivalent and do not have to be, nor can they be expected to be, physically identical.

Sometimes, there is only one vendor's product that can qualify as a shipyard standard for a specific function. For such cases, buyers should employ long-term contract agreements, perhaps even including escalation clauses, as means to avoid unfavorable terms when procurement is imminent.

#### 2.3.4 Determination of "Make" or "Buy"

The trend in modern, constantly self-developing shipbuilding systems is to only collect and assemble components which meet functional and quality requirements. In other words, the trend is to provide more value added in planning, including design, as means to enhance productivity by speeding up assembly work. Thus with few exceptions, e.g., parts for hull structure and pipe pieces required in vast quantities, subcontracting for the manufacturing of components from outside sources is almost always far more productive than manufacturing them in-house. Instead of spending significant capital resources to manufacture numerous components in-house, investing more in design, production engineering and procurement functions to efficiently purchase such components, is better business sense.

A major objective is to develop a design-featuring parts and subassemblies which facilitate assemble in accordance with a product-oriented build strategy devised by production engineers. Thus, any proposal for minimizing cost<sup>6</sup> after the design effort is likely to be very limited.

The role of designers in material procurement is especially significant as material costs, for the most part, are directly related to the material specifications they prepare. In preparing such specifications, designers analyze owners' requirements and establish needed functional performances, quality levels and quantities. Accordingly, designers must maintain awareness of their affect on material costs when they participate in material planning. Starting in basic design, i.e., as part of pre-contract negotiation of technical matters before contract award, value engineering should be routine in all design phases.

The tendency of some ship designers to pursue highly technical or sophisticated features only because they are a matter of personal interest has to be resisted. They must be focused on developing a design which is producible as well as compatible with state-of-the-art modern-technology.

### 2.4 Value Engineering

#### 2.4.1 Value Engineering in Design

Value engineering (VE), synonymous with value analysis or value improvement? was first applied mainly in purchasing to evaluate the qualitative value of existing products. Later, VE was expanded to design and elsewhere. for evaluating new products.

By examining a ship as a whole during basic design. it is possible to employ VE for devising the most cost effective, production-oriented methods without sacrificing any owner Specified functional requirements. Extending the same VE approach to functional and work-instruction design stages, makes possible considerable savings in both material and production costs.

Design is the only function in a shipyard organization that can evaluate the value of a product from both technological and economical aspects. Thus, design plays the most important part in reducing a ship's cost.

### 2.4.2 Value Engineering in Material Procurement

Almost always, material costs account for the major portion of a ship's cost. Therefore, particularly for shipyard6 which have perfected zone-oriented, integrated hull construction, outfitting and painting harmonized by statistical control methods, the greatest cost reduction opportunities which remain are associated with material management.

Simply demanding price cuts from vendors without some sort of compensation, is illogical. Instead, buyers should apply VE measures which would detect vendor proposals that are priced attractively, but which could be reduced further in cost by eliminating vendor work for features or levels of quality which exceed a POS.

Another way for buyers to achieve the same objective is to encourage vendors to propose their normally produced product6 insofar as they satisfy POS requirements. This gives vendors the opportunity to quote their most competitive prices.

### 2.4.3 Value Engineering in Other Areas

VE can be effectively applied in areas, other than design and material procurement, such as material distribution and production. For example, an analysis to determine whether to assemble a certain group of fittings on-unit, on-block or on-board, would have to take into account costs for transportation of completed assemblies versus transporting separate fittings. The former, usually more productive, may require temporary reinforcement while the latter does not.

Figure 2-2 shows typically, that initial or basic designers have most affect on a ship's cost, about 60%, while at the same time the cost of their efforts accounts for no more than 3% of incurred direct costs. The same figure shows that all design phases combined with material procurement activity affects 85% of a ship's cost while such efforts account for approximately 10% of incurred direct costs. Obviously, the efforts of design engineers are the most significant and decisive.

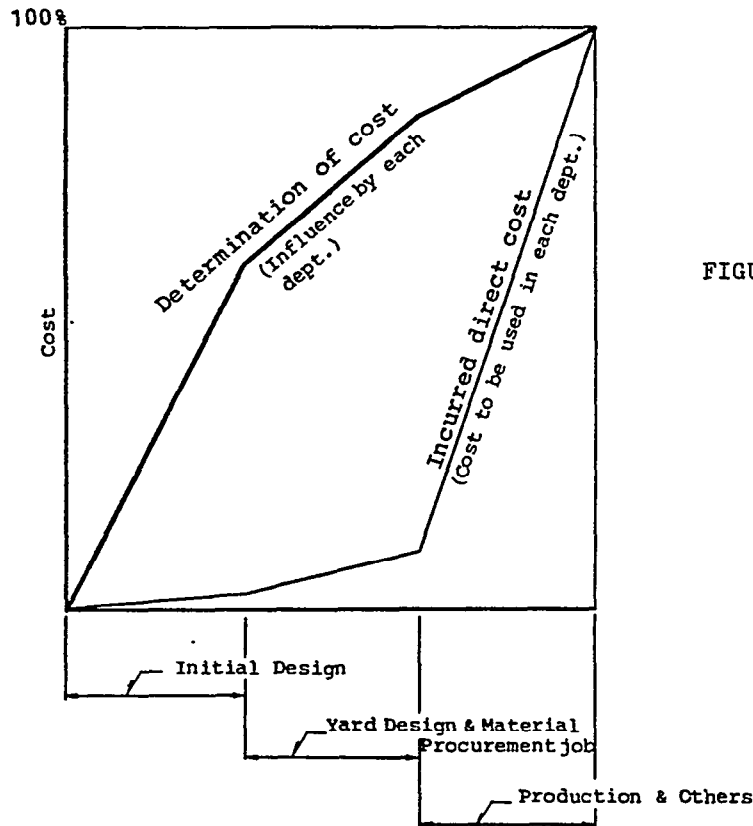

FIGURE 2-2: Responsibility for Determination of Cost vs. Incurred Cost.

2.5 Profit Control in Procurement

The objective of material procurement to acquire material in time and within an assigned budget is generally understood. Most buyers believe they have fulfilled their responsibilities when that objective has been achieved. However, from a modern manager's viewpoint each procurement activity is a cost center and an assigned budget is a yardstick to determine the amount of profit generated by each such activity. Profits so identified are controlled by management.

Another way to lower procurement cost is for management to assign target prices. However, this approach creates emotional problems between management and buying staffs when the targets are too severe and also among the buying staffs who try to outdo each other. Letting the buying staffs set their own price targets and relying more on VE is preferable as it provides more incentive. A suggested material budget/profit control sheet is shown in Figure 2-3.

Such budgets are established in order to attain two objectives, control of material quantities and control of material costs. The former is applied in design and production for the purpose of regulating actual expenditure as compared to preplanned quantities or weights. The latter is applied in material procurement for regulating actual prices as compared to budgeted prices.

The format used to control budgeted material amounts during basic design is called the Basic Material List (BML) from which a Material Budget Control List, complete with pricing, is developed. A typical such list is shown in Figure 2-4.

MATERIAL BUDGET/PROFIT CONTROL						
Job Order No.	Buyer in Charge		Cost Control Code	Budget \$	Target \$	Remarks
	Month	Result				
	This Month	Sum	Rest of Budget	Final Estimation for Target		

FIGURE 2-3: Material Budget/Profit Control Sheet per Buyer.

MATERIAL BUDGET CONTROL LIST

P. (12/30)

		Name	Particulars	Q'ty	Net Weight	Gross Weight	e	Price	Remarks
Accommodation	STD Material	2801 Steel							
		2807 Galv. Steel Plate							
		" Steel Wire							
		2808 Insulator							
		" "							
		2809 Miscellaneous							
		" "							
		Sum							
		2821 Window							
		" "							
		" "							
		" "							
		" "							
		2822 Side Scuttle							
		" "							
	" Outer Cover								
	Clear View Screen								

FIGURE 2-4: Example of a Material Budget Control List.

**NATIONAL SHIPBUILDING RESEARCH PROGRAM**

# **CASE STUDY 2**

**IMPLEMENTATION OF ZONE TECHNOLOGY IN REPAIR & OVERHAUL ENVIRONMENT**

## NATIONAL SHIPBUILDING RESEARCH PROGRAM

# CASE STUDY 2

## “USS GUSHING” QUESTIONS

1. What is the difference between CNSY and PHNSY that could account for the unsuccessful outcome?
2. What was the reason that the PHNSY Commander chose to attempt radical change on a major and critical project?
3. Why did the PHNSY Commander decide to enter a joint planning development agreement with CNSY?
4. Was the assignment given to the Project Superintendent clear?
5. What was the singular reason why the project goals were not achieved?
5. Why did the joint planning effort with CNSY fail?
7. What was the learning experience from previous successful NSY projects?
3. How did the PHNSY approach compare to the experience successful approach?
3. What did management at PHNSY do to try to reverse the deteriorating situation?
10. If you were the PHNSY Commander, when would you have intervened and what would you have done?



**NATIONAL SHIPBUILDING RESEARCH PROGRAM**

# **CASE STUDY 3**

**IMPLEMENTATION OF ZONE TECHNOLOGY IN REPAIR & OVERHAUL ENVIRONMENT**

## NATIONAL SHIPBUILDING RESEARCH PROGRAM

# CASE STUDY 3

## "BEAVERSTATE" CRANESHIP CONVERSION QUESTIONS

1. What was the difference between Naval shipyard and private shipyard cultures in repair and overhaul?
2. How did the Production trades view the Planning documentation?
3. Was the experience in nuclear overhaul work a positive or negative influence on planning and cost?
4. What was the first lesson learned by CNSY about commercial customers? Should they have been surprised?
5. What was the second lesson learned?
6. How could they avoid the problems knowing the situation at final accelerated bid time?
7. What is the lesson learned about changing to a different class of customer while performing traditional customers work?
8. What must be taken into consideration when a customer with an ongoing contract in a yard asked for significant changes?
9. How did CNSY turn the project around?
10. What is the final lesson learned by CNSY about "knowing your customer?"

**NATIONAL SHIPBUILDING RESEARCH PROGRAM**

# **ATTENDEE FORMS**

**DAILY LOG**

**COURSE EVALUATION**

**PERSONAL ACTION PLAN**

**IMPLEMENTATION OF ZONE TECHNOLOGY IN REPAIR & OVERHAUL ENVIRONMENT**

# DAILY LOG

The purpose of this daily log is for you to pick out and record the most personally significant experience of the day and what you learned from it.

This will involve reflecting on:

- what experience during the day was most significant to you personally
- why this was personally significant
- what you learned from it
- any actions you propose to take as a result

Of course, you need not restrict your record to only one experience.

You can also use the daily log to record your thoughts, ideas, insights and feelings. This may include reflections on what worked and what did not work (and why) and ideas for possible improvements. It may include reflections on the relevance of the course experiences to activities and experiences outside of the course.

# DAILY LOG

**DAY 1**

**WHAT WAS THE MOST PERSONALLY SIGNIFICANT EXPERIENCE?**

**WHY WAS THIS PERSONALLY SIGNIFICANT?**

**WHAT DID YOU LEARN?**

**WHAT ACTIONS WILL YOU TAKE OR PROPOSE AS A RESULT?**

**ALSO RECORD ANY OTHER THOUGHT, IDEAS, INSIGHT AND FEELING**

# DAILY LOG

DAY 2

WHAT WAS THE MOST PERSONALLY SIGNIFICANT EXPERIENCE?

WHY WAS THIS PERSONALLY SIGNIFICANT?

WHAT DID YOU LEARN?

WHAT ACTIONS WILL YOU TAKE OR PROPOSE AS A RESULT?

ALSO RECORD ANY OTHER THOUGHT, IDEAS, INSIGHT AND FEELING

# **DAILY LOG**

**DAY 3**

**WHAT WAS THE MOST PERSONALLY SIGNIFICANT EXPERIENCE?**

**WHY WAS THIS PERSONALLY SIGNIFICANT?**

**WHAT DID YOU LEARN?**

**WHAT ACTIONS WILL YOU TAKE OR PROPOSE AS A RESULT?**

**ALSO RECORD ANY OTHER THOUGHT, IDEAS, INSIGHT AND FEELING**

# COURSE EVALUATION

We would be very grateful for your feedback on the course. Please complete this evaluation form and return it at the end of the course. Two copies are provided so that you can keep a copy of your evaluation. Thank you!

THE MOST HELPFUL THINGS I LEARNED FROM THE COURSE ARE:

- 1.
- 2.
- 3.

WHAT I LIKED BEST ABOUT THE COURSE WAS:

WHAT I DISLIKED MOST ABOUT THE COURSE WAS:

RECOMMENDATIONS FOR FUTURE COURSES

ANY OTHER COMMENTS?

NAME (OPTIONAL)



# PERSONAL ACTION PLAN

In the light of your thinking and activities during this course, what are now your principal related targets or goals? Write the top three in order of priority:

1.

2.

3.

What actions will be necessary for you to achieve these targets or goals?

Your actions

Other people's action

1.

2.

3.

For each of your three targets or goals; write below something that would be visible evidence that you had achieved them:

1.

2.

3.

Enter the dates that you plan to complete each of your targets or goals:

1.

2.

3.

NAME:

DATE:

# COURSE EVALUATION

We would be very grateful for your feedback on the course. Please complete this evaluation form and return it at the end of the course. Two copies are provided so that you can keep a copy of your evaluation. Thank you!

THE MOST HELPFUL THINGS I LEARNED FROM THE COURSE ARE:

- 1.
- 2.
- 3.

WHAT I LIKED BEST ABOUT THE COURSE WAS:

WHAT I DISLIKED MOST ABOUT THE COURSE WAS:

RECOMMENDATIONS FOR FUTURE COURSES

ANY OTHER COMMENTS?

NAME (OPTIONAL)