

ENGINEERING FOR SHIP PRODUCTION

A TEXTBOOK

by

Thomas Lamb

Prepared for

The National Shipbuilding Research Program

by

**The Society of Naval Architects and Marine Engineers
Ship Production Committee
Education and Training Panel (SP-9)**

January 1986

**Contract No. DTMA-91-84-C-41045
The University of Michigan
Ann Arbor, *Michigan**

Report Documentation Page

Form Approved
OMB No. 0704-0188

Public reporting burden for the collection of information is estimated to average 1 hour per response, including the time for reviewing instructions, searching existing data sources, gathering and maintaining the data needed, and completing and reviewing the collection of information. Send comments regarding this burden estimate or any other aspect of this collection of information, including suggestions for reducing this burden, to Washington Headquarters Services, Directorate for Information Operations and Reports, 1215 Jefferson Davis Highway, Suite 1204, Arlington VA 22202-4302. Respondents should be aware that notwithstanding any other provision of law, no person shall be subject to a penalty for failing to comply with a collection of information if it does not display a currently valid OMB control number.

1. REPORT DATE JUN 1986	2. REPORT TYPE N/A	3. DATES COVERED -		
4. TITLE AND SUBTITLE Engineering For Ship Production A Textbook		5a. CONTRACT NUMBER		
		5b. GRANT NUMBER		
		5c. PROGRAM ELEMENT NUMBER		
6. AUTHOR(S)		5d. PROJECT NUMBER		
		5e. TASK NUMBER		
		5f. WORK UNIT NUMBER		
7. PERFORMING ORGANIZATION NAME(S) AND ADDRESS(ES) Naval Surface Warfare Center CD Code 2230 - Design Integration Tools Building 192 Room 128 9500 MacArthur Bldg Bethesda, MD 20817-5700		8. PERFORMING ORGANIZATION REPORT NUMBER		
9. SPONSORING/MONITORING AGENCY NAME(S) AND ADDRESS(ES)		10. SPONSOR/MONITOR'S ACRONYM(S)		
		11. SPONSOR/MONITOR'S REPORT NUMBER(S)		
12. DISTRIBUTION/AVAILABILITY STATEMENT Approved for public release, distribution unlimited				
13. SUPPLEMENTARY NOTES				
14. ABSTRACT				
15. SUBJECT TERMS				
16. SECURITY CLASSIFICATION OF:			17. LIMITATION OF ABSTRACT	
a. REPORT unclassified	b. ABSTRACT unclassified	c. THIS PAGE unclassified	SAR	18. NUMBER OF PAGES 487
				19a. NAME OF RESPONSIBLE PERSON

This book was prepared as an account of a government-sponsored program. Neither the United States, the Maritime Administration, nor The University of Michigan, as contractor to the government, nor any person acting on behalf of the Maritime Administration (a) makes any warranty or representation, express or implied, with respect to the accuracy, completeness, or usefulness of the information contained herein, or that the use of any information, apparatus, method or process disclosed herein may not infringe privately owned rights; or (b) assumes any liability with respect to the use of or for damages resulting from the use of any information, apparatus, method, or process disclosed herein.

As used in the above, "persons. acting on behalf of the Maritime Administration" includes any employee or contractor of the Maritime Administration to the extent that such employee or contractor prepares, handles, or distributes or provides access to any information pursuant to his employment or contract with the Maritime Administration.

This document is protected by copyright. All rights reserved. No part **of** this document may be photocopied, reproduced, or translated without prior written consent of The University of Michigan.

Technical Report Documentation Page

1. Report No.		2. Government Accession No.		3. Recipient's Catalog No.	
4. Title and subtitle ENGINEERING FOR SHIP PRODUCTION				5. Report Date January 1986	
				6. Performing Organisation code--	
7. Author(s) Thomas Lamb				8. Performing Organization Report No. JMTRI-86-11	
9. Performing organisation Name and Address Thomas Lamb (as a private consultant) 18303 84th Place West Edmonds, Washington 98020				10. Work Unit No. (TRAIS)	
				11. Contract or Grant No. DTMA-91-84-C-41045	
12 sponsoring Agency Name and Address Department of Transportation Maritime Administration Washington, D.C.				13. Type of Report and Period Covered Final	
				14. Sponsoring Agency code	
15. Supplementary Notes A project of the SNAME Ship Production Committee Education Panel (SF-9)					
16. Abstract This is the first book to be written on what appears to be a relatively new approach to the practice of engineering for the construction of current and future ships. The application of the recently introduced design-for-production technique is described and illustrated through examples. However, it is suggested that this technique is not really new and that it has come about only as an individual technique because ship designers have become isolated from the actual production of ships. The ship designers also appear to have forgotten that all design should be developed to be the best for production. Once the best production-oriented designs are developed, it is necessary to transmit the design information to the various departments in the shipyard that use the information. The methods currently used to do this are based on tradition and have not changed much over many years. They are not the most suitable for the efficient production of ships. Therefore, improvements to the existing shipyard engineering methods are presented, and as such are the basis for engineering for production. The book developed from the author's 1978 SNAME paper, "Engineering for Modern Shipyards," and U of W lectures on Ship Production Technology.					
17. Key Words Ship Design, Engineering and Engineering Management for Efficient Ship Production			10 Distribution Statement Available to the U. S. public through NTIS, Springfield, VA 22161		
19 SecurityClassif. (of this report) Unclassified		20-security classif (of this report) Unclassified		21 NO OF PAGES 466	22. PncO

CONTENTS

LIST OF FIGURES	vii
LIST OF TABLES	xvii
FOREWORD	xix
PREFACE	xxi
ACKNOWLEDGMENTS	xxii
INTRODUCTION	1
PART 1: DESIGN FOR SHIP PRODUCTION	9
1.1 General	9
1.2 What is Design for Ship Production..	16
1.3 Basic Design	33
1.4 Group Technology	89
1.5 structure	119
1.6 Hull OutFit	179
1.7 Machinery	199
1.8 Piping	211
1.9 HVAC	221
1.10 Electrical	225
1.11 Integration of Systems..	231
1.12 Advanced Outfitting	233
PART 2: ENGINEERING FOR SHIP PRODUCTION.	251
2.1 General	251
2.2 Traditional Engineering	253
2.3 Production-Compatible Engineering	256
2.4 Dimensioning	281
2.5 Reference Lines	292
2.6 Accuracy Control	293
2.7 Basic Design	308
2.8 Product Engineering	334
2.9 Material Requirements	374
2.10 Engineering Models	376
2.11 Computer-Aided Engineering	388
2.12 Technical Support	412
PART 3: ENGINEERING ORGANIZATION FOR SHIP PRODUCTION	415
3.1 General	415
3.2 Engineering Objectives	418
3.3 Organization	419
3.4 staffing	431
3.5 Training	435
3.6 Management	452
CLOSURE	461

LIST OF FIGURES

		Page
L.1	Traditional shipbuilding and isolated engineering	5
L.2	Advanced shipbuilding and integrated engineering	6
L.3	Overall productivity benefit of integrated engineering	7
1.1	Potential cost influence as construction phase progresses	11
1.2	The shipbuilding process	18
1.3	Makeup of total work time	20
1.4	Total work content	22
1.5	Methods and procedures to eliminate additional work content	23
1.6	Productivity space	24
1.7	Split-engine room with azimuthing propulsors, engines in skegs, and gas turbine electric with above-deck turbine room	36
1.8	Machinery space arrangement design for production	40
1.9	Hatch installation alternatives	42
1.10	Factors affecting double-bottom height	43
1.11	Factors affecting double-bottom height	44
1.12	Required space above ceiling for services	46
1.13	Alternative overhead deck space use	47
1.14	Select service zone for minimum deck heights	48
1.15	Module joining productivity considerations	50
1.16	Aesthetic and cost-effective deckhouses.	51
1.17	Access galleries and service trunks	53
1.18	Stem productivity considerations.	56
1.19	Types of shell plate curvature	60
1.20	Propeller aperture and rudder types	61
1.21	Rudder-type selection for producibility	62

1.22	Transom stem design for production	64
1.23	Stern profile shape for producibility	65
1.24	Productivity considerations for flat keels	66
1.25	Alternative maximum section shape for productivity improvement	67
1.26	Use of chines to simplify stern construction	69
1.27	Use of skeg to simplify stern construction	70
1.28	(a) Bulbous bow fabricated from regular shapes; (b) faired bulbous bow versus shine (elimination of stem casting)	71
1.29	Hard chine hull forms	74
1.30	Typical molded line definition	76
1.31	(a) Primary reference system; (b) comparison of traditional and suggested reference system	80
1.32	(a) Relation of secondary reference system to primary reference system; (b) relation of secondary reference system to primary reference system; (c) secondary reference system; (d) secondary reference system	82
1.33	Tertiary reference system	86
1.34	(a) Typical shipyard functional layout;(b)shipyard group layout.	90
1.35	Transition from craft to mass production	94
1.36	Types of processes	97
1.37	Departments affected by group technology	98
1.38	Structural component analysis summary	100
1.39	Shipbuilding classification and coding system (SCCS)	102
1.40	Optional zero digit for zone design and construction	112
1.41	Typical component information card using group technology	114
1.42	Group technology in design	115
1.43	Module connection definition	121
1.44	Module joining structural details	122
1.45	Longitudinal joining details	123
1.46	Use of cofferdams as a module joining aid	124

1.47	Arrangement of module joints to facilitate tank completion including alternate tank testing	125
1.48	Alternative arrangement of module joints to facilitate tank completion including alternate tank testing	125
1.49	Module joining structural detail	126
1.50	Plate straking/stiffener arrangements for productivity	129
1.51	Producibility considerations for module breaks	131
1.52	Cargo ship modules	132
1.53	Tanker "layer" system modules	133
1.54	"Layer" construction method	134
1.55	(a) Tanker structural detail for "layer" construction method; (b) tanker modules for layer" method	135
1.56	Standard and non-standard plates	137
1.57	Ways to reduce work content of insert plates	138
1.58	Curved module design for production	139
1.59	cut-out types	141
1.60	Longitudinal connections at bulkheads to eliminate collars	142
1.61	Cut-out alternatives for productivity	143
1.62	Oil/water step design for productivity	143
1.63	Floor/web frame stiffener designs	144
1.64	Typical brackets	145
1.65	Bracket detail for tee beam.s/longitudinals/frames/stiffeners	146
1.66	Web frame alternatives	147
1.67	Web frame design for productivity	149
1.68	Location of access holes in structure	150
1.69	(a) Built-in staging aids in D.B.; permanentPbuiltAn" aids for access	151
1.70	Tanker with "built-in" access galleries	153
1.71	Deck transverse/girder design to eliminate field cut penetrations and reinforcement	154

1.72	Bilge framing alternatives	155
1.73	Plate straking for productivity	157
1.74	Alternative panel stiffening systems	158
1.75	Corrugated panel details	159
1.76	Built-up corrugated panels	160
1.77	Fabricated stern frame	162
1.78	Rudder design for productivity	163
1.79	Foundation design for productivity	164
1.80	Foundation design for productivity	165
1.81	Standardizing manhole covers.	167
1.82	Standard exterior handrails	168
1.83	(a) Standard lifebuoy stowage; (b) details for standard lifebuoy stowage	169
1.84	Standard handrail detail	171
1.85	(a) Standard jack and ensign staffs; (b) details of fittings for standard jack and ensign staffs	172
1.86	Standard ladder rungs	174
1.87	Standard hand and toe holes	175
1.88	Standard eyebrows	176
1.89	Miscellaneous tank details for productivity	177
1.90	BLOHM+VOSS MI000 accommodation system	182
1.91	Typical modular accommodation unit	187
1.92	The Donn joiner bulkhead and lining system	188
1.93	The Hauserman “double-wall” system	189
1.94	DAMPA ceiling system	190
1.95	TNF joiner bulkhead and lining system	193
1.96	Alternate anchor stowage arrangements	194
1.97	Typical modular toilets	195

1.98	Common outfitted joiner bulkheads	196
1.99	Galley arrangement for productivity	197
1.100	“Designed-in” service space accessible by removing joiner lining . . .	198
1.101	Standard floor~plate system	200
1.102	Hinged floor plates adjacent to engine	201
1.103	Equipment-association network	203
1.104	Illogical arrangement system diagrammatic	204
1.105	Logical arrangement system diagrammatic	205
1.106	Integrated support concepts	207
1.107	Valve location designed for production and operation	208
1.108	Typical “on-unit” package	209
1.109	Distributive system corridors	210
1.110	Standard machinery space system corridors	212
1.111	Special pipe hanger and support system	214
1.112	Piping penetration design for productivity	215
1.113	Seachest design for production	216
1,114	Piping passing through tank tops	217
1.115	Sounding tube design for production	218
1.116	Pipe joints for module erection	219
1.117	HVAC design for production	222
1.118	Standard duct support	224
1.119	Typical hangers	226
1.120	Cable-retaining methods	226
1.121	Wireway racks	226
1.123	Small cable support design for production	227
1.123	Wireway hanger connection detail	228
1.124	Electrical foundation design for production	229

1.125 Electrical foundation detail	230
1.126 Integration of systems	232
1.127 Typical on-unit” advanced outfitting	234
1.128 Piping bundle “on unit” under construction	235
1.129 “On-block” advanced outfitting	236
1.130 “On-block” advanced outfitting	237
1.131 “On-board” advanced outfitting	238
1.132 “On-board” advanced outfitting	239
1.133 “Blue-sky” or open-air” advanced outfitting	240
1.134 Required change in contract performance time	241
1.135 Productivity improvement through advanced outfitting	243
1.136 Goals and benefits of advanced outfitting	244
1.137 Different product definition	246
1.138 Wartsila “macromodule” advanced outfitting	249
2.1 Large drawing handling problem	254
2.2 Phases of engineering for ship production	257
2.3 Flow of design and engineering information	258
2.4 Basic design flow integration with planning	262
2.5 Product engineering flow	263
2.6 Typical traditional performance schedule; required short-build cycle/performance schedule	265
2.7 Traditional shipbuilding and isolated engineering	266
2.8 Advanced shipbuilding and integrated engineering	267
2.9 Japanese shipbuilding quality standard (hull)	283
2.10 Phases of accuracy control	294
2.11 Space allocation	313
2.12 Structural module drawing	317
2.13 Distributive system routing diagrammatic	320

2.14	Electrical system distribution	322
2.15	Integration of production engineering and contract design	324
2.16	Product&age chart for structural module	325
2.17	Structural module breakdown	328
2.18	Hull zone breakdown; deckhouse zone breakdown; and machinery spaces zone breakdown	329
2.19	Ship breakdown stnxcture	332
2.20	Manually prepared zone design arrangement	335
2.2 1	CAD-prepared isometric zone design arrangement	336
2.22	Structure section process sheet	341
2.23	Structural plate process sheet	342
2.24	Structural subassembly work station information	343
2.25	Structural assembly work station information	344
2.26	Structural module work station information	345
2.27	Structural assemby working station parts list	346
2.28	Module-joining-welding work station information	347
2.29	Hull fitting work station information	348
2.30	Hull ventilation duct assembly work station information	348
2.31	Hull fitting work station information	349
2.31	Hull fitting installation work station information	350
2.33	Painting work station information	351
2.34	Unit foundation work station information	352
2.35	Pipe assembly work station information	353
2.36	Unit pipe installation work station information.	354
2.37	Unit eletricalI installation work station information	355
2.38	“On-block” advanced outfitting installation work station information for HVAC	356
2.39	“On-block” advanced outfitting installation work station information for pipe	35i

2.40	“On-block” advanced outfitting installation work station information for electrical	358
2.41	“On-board” advanced outfitting unit installation work station information	360
2.42	Normal “on-board” outfitting work station information for pipe	361
2.43	Pipe assembly installation work station information (parts list)	362
2.44	Zone information for electrical cable connecting	363
2.45	Zone information, electrical equipment location	364
2.46	Zone information, cable penetrations, starts, ends, and lengths	365
2.47	Zone information, wireway, and cable routing lengths	366
2.48	(a) Single-tier deckhouse construction; (b) unit deckhouse construction	367
2.49	Deckhouse zone information	369
2.50	Deckhouse zone information	370
2.51	Deckhouse zone information for joiner lining and bulkheads	371
2.52	Deckhouse zone information for joiner ceiling installation	372
2.53	Deckhouse zone information for furniture installation	373
2.54	Summary of the material-definition approach for <i>engineering for ship production</i>	375
2.55	Machinery space model showing three-dimensional advantage	377
2.56	Display model	378
2.57	Plating half-block model	379
2.58	Anchor handling model	380
2.59	Advanced outfitting model	381
2.60	Interference control/checking by model	382
2.61	Advanced outfitting unit models used to build up space model	384
2.62	Elomatic Oy Laser Scanner for Models	386
2.63	History of CAD/CAM in shipbuilding	389
2.64	Shipbuilding CAD/CAM system development	391

2.65	IACG schematic	393
2.66	BRITSHIP @ module organization	395
2.67	BRITSHIP 2/CADAM interface	395
2.68	AUTOKON 79 system	396
2.69	Traditional manual approach	398
2.70	Advanced integrated CAD/CAM approach	399
2.71	IACG data representation	400
2.72	Development of IACG data base	402
2.73	Expanding ship design data base	404
2.74	Integrated information system with common data base	407
2.75	Future IACG capabihty	409
3.1	The company gear	416
3.2	Functional organization	420
3.3	Product organization	420
3.4	Process organization	422
3.5	Customer organization	422
3.6	Matrix organization	423
3.7	MarAd/SNAME/IHI engineering organization	424
3.8	Typical U.S. engineering organization	424
3.9	Typical British engineering organization	424
3.10	IHOP organization	425
3.11	Suggested zone construction organization	425
3.12	Basis for engineering sections from expanding common data base	427
3.13	Product engineering function/zone matrix	428
3.14	Product engineering organization for zone construction	429
3.15	Basic design organization	430
3.16	Naval architects, employers, and occupations	434

3.17	Shipyard training for naval architects and engineers	436
3.18	Report form connecting engineering, purchasing, and production schedules	456
3.19	Schedule and work assignment bar chart	457
3.20	Performance report	458
3.21	Performance report for total project	459
c-1	U.S. required productivity improvement	462
c-2	Technology (productivity) requirements	463
c-3	Essential steps to successful goal achievement	464

LIST OF TABLES

	Page
I.1 Comparison of Isolated and Integrated Engineering	3
1.1 Typical Cost Estimate Summary Sheet	19
1.2 Structural Detail Cost Calculation	27
1.3 Application of Design for Production	31
1.4 Typical Dimensioning Methods Used by Isolated Engineering to Locate Items	78
1.5 Production Organizations	95
1.6 Modular Accommodation Systems	180
1.7 Typical Hull Outfit Standards List	181
1.8 Equipment-Association List	202
2.1 Production-Compatible Engineering	259
2.2 Work Station/Zone Information	261
2.3 Shipyard Specification	268
2.4 Building Plan	274
2.5 Product Definition	277
2.6 Typical Manhour Percentage Breakdown	280
2.7 Selection of Vital Points	295
2.8 Structural Processes to which Accuracy Control is Applicable	296
2.9 Planning Vital Points for a Bulk Carrier	298
2.10 Suggested List of Documents in a Contract Design Package	309
2.11 Proposed Contract Design for MarAd	312
2.12 Guidelines for Minimization of Piping Arrangement Plans.	315
2.13 Zone Design Arrangement	337
2.14 U.S. Shipyard IACG System Installations.	392
2.15 CAD/CAM Data Relationship	406

2.16	Engineering for Ship Production Task Breakdown	413
3.1	Graduate Engineers/1,000 Employees	431
3.2	Technologist and Technician Statistics for Shipbuilding Industry	433
3.3	British Shipbuilders' Training Courses	437

FOREWORD

Change is a common event of significant impact to everyone. Some people seek it and others dread it. Yet without change there would be no progress. Without progress an organization or industry will eventually die.

Some changes are pleasant for everyone, such as more money, a new house, etc. Yet in many other aspects the norm is "Don't rock the boat" and "Leave well enough alone." The problem is the boat is old and sinking, and all is not well in the U.S. shipbuilding industry. Thus change to improve the situation is justified.

- However, everyone proposing change is faced with the problem of resistance to change, which was well described by Machiavelli over 450 years ago in his book *The Prince*. His description is still appropriate today and therefore is worthy of quote.

It ought to be remembered that there is nothing more difficult to take in hand, more perilous to conduct, or more uncertain in its success, than to take the lead in the introduction of a new order of things. Because the innovator has for enemies all those who have done well under the old conditions and lukewarm defenders in those who may do well under the new.

Even with such a dire and unfortunately time-proven warning, this is a book about change, But not just change for change's sake. I believe that the proposed changes are necessary for U.S. shipbuilding to survive into the next decade. They may even assist in making the industry competitive with other developed countries if applied with the right attitude and in cooperation with the other necessary changes in shipbuilding management practice, computer application, production processes, and material control.

PREFACE

Shipbuilding in many traditional shipbuilding countries is at a cross-road, The rate of progress has been rather slow compared to the high-technology industries such as aerospace and electronics. In shipbuilding, progress is measured over decades instead of years or months, Everyone in shipbuilding knows what the historical progress has been, namely, wood to iron to steel, riveting to welding, sail to steam to diesel to nuclear to gas turbine propulsion power; and paddles to propellers to water and air jets,

In the last two decades there has been significant progress on the production side of shipbuilding in construction techniques and production control. The availability of computers has definitely been one of the major reasons for this. Another is that as the size of ships increased, so did the facilities to build them. Unfortunately, in some countries ship designers and engineers did not maintain their leading position in the shipbuilding process. Some engineering departments, by maintaining traditional engineering approaches, even hampered and slowed the progress by causing the need for reworking the engineering information into a form compatible with the actual shipbuilding approach,

To overcome this situation, practices such as *production engineering* and *design for production* developed. While it is a basic requirement of all good design that it be the best possible for production, it is obvious that *this was not happening*, *Design for production* has been around for over a decade, but its incorporation into normal ship design and engineering has been slow. Coupled with *design for production* and *production engineering* is the need for production-oriented engineering information, and some shipyards have been even slower in adapting to this necessary change. It is inconceivable to the author that design agents and shipyard engineering departments still prepare traditional total system working drawings for today's shipbuilders. It is not clear where the fault for this situation lies. Is it engineering's lack of production knowledge or tradition-bound stance, or is it some production departments' attitudes, such as "Just give us the plans on schedule for once, and we will build the ship in spite of its unproducibility," and "We' don't need simplified engineering information, we can read blueprints"? Whatever the reasons, they must be changed if a shipyard or a shipbuilding industry is to improve its competitive edge by full utilization of all the best tools and techniques available to it.

This book has been written to assist those engineers, designers, drafters, and engineering planners who want to regain their leadership position, to understand and apply some of the necessary techniques for successful *engineering for ship production*. The book is organized into three parts, namely:

- Part I: Design for Ship Production
- Part 2: Engineering for Ship Production
- Part 3: Engineering Organization for Ship Production

The last part is a necessary part of this book, as it is the framework which permits and promotes the successful working of the other two parts. Shipbuilding management is like that of any other industry. It consists of both general management principles and techniques, and specialized applications to suit the particular needs of the industry. The latter is covered in this book, and in particular, its requirements for *Engineering for Ship Production*.

Thomas Lamb
Edmonds, Washington
July 27, 1985

ACKNOWLEDGMENTS

The author acknowledges with thanks the training, teaching, encouragement, and support from many shipbuilders with whom he has interfaced throughout his career. In particular he must acknowledge with great appreciation the Marinette Marine Corporation management and production staff for their enthusiastic acceptance of “new and better ways.” This allowed theory to be turned into successful practice. He must also acknowledge the support and encouragement of his previous employer, Lockheed Shipbuilding company. Finally, the part played by Professor R Storch of the University of Washington must also be acknowledged. By inviting the author to be a guest lecturer for their Ship Production Technology Course, which has been offered on four occasions, he was able to “fine hone” his ideas into an integrated presentation.

However, these acknowledgments are not an attempt to shift any of the responsibility for the ideas, comments, or suggestions to any of them. The author accepts complete responsibility for the contents and in addition acknowledges that the ideas presented may not reflect the opinions of any person or company mentioned above. In fact, in almost all his career positions, he has worked with competent professional shipbuilders who have disagreed with some of them.

Where material was used that was not developed by the author, every attempt was made to obtain permission for its use. Where possible, complete reference has been made to the source of “borrowed” material. And, in the case of the following sources, approval was received, provided full recognition was given. This is willingly and gratefully done:

Royal Institution of Naval Architects
North East Coast Institution of Engineers & Shipbuilders
University of Strathclyde
A&P Appledore
University of Newcastle
Society of Naval Architects & Marine Engineers
British Shipbuilders
British Shipbuilding Training Board

The project was funded by the National Shipbuilding Research program and administered under a contract with The University of Michigan-Professor Howard Bunch, project Director.

INTRODUCTION

The term design for production is well known to present-day ship designers. It refers to a specific approach to the design of fabrication details. It takes into account production methods and techniques which reduce the production work content, simplify the complexity of the work, and fit it to the facilities and tools available, yet meet the specified requirements and quality. To some designers, this may appear to be the basis of any good design! However, it is obvious from the development of the design-for-production approach that this is not the general case today. Somewhere along the way designers have lost the purpose of their work, together with an understanding of production methods, and how their design decisions directly affect the construction cost.

Engineering for production determines the best techniques to transmit and communicate the design and engineering information to the various users in a shipyard.

The traditional approach to design and engineering was normally performed *without* any real input from the production department. Because of this, it is called the *isolated* engineering approach, and is defined as follows:

Isolated engineering is the approach where although design details are shown, they incorporate no production input or decisions such as block boundaries, piping flange or weld breaks, preferred details to suit production methods, etc.

It usually took a long time to develop the engineering and then for the production planning to reorganize the information into a production-compatible form.

The opposite extreme to isolated engineering is obviously *integrated engineering*, which has a deliverable end product that is completely compatible and directly usable by the production department. In *integrated engineering certain* drawings must still be prepared for the benefit of the owner, chartering agents, etc., for the operation and management of the ship after it is delivered, but these are small both in number and work content compared to the required production drawings. *Integrated engineering* does not permit the required engineering effort to be separated into “non-production” and “production.” It provides information required by the production process, compatible with the way the ship will be built, utilizing the facility to its best advantage. It thus prevents unnecessary engineering work from being performed, and therefore saves engineering and planning manhours through the elimination of duplication and wasted effort. Obviously, this also enables the engineering had time to be shortened, both due to reduced manhours and better sequencing of the engineering information issue.

Most U.S. shipyard engineering is somewhere between the two extremes, but nearer *to isolated than* it should be, considering today's objectives of reduced cost and shortened construction time. The most frequent situation in the U.S. is where an engineering department, or its design agent, prepares the engineering information on a complete ship single item (system) basis, but with considerable production decision information incorporated into it. Then another group, usually within the production department, takes engineering's information (drawings, sketches, material lists, etc.), and converts it into production-compatible information. This often requires further drawing effort, such as assembly sketches for structural blocks, piping detail sketches, lofting nested plate sketches and layout tapes, etc., for incorporation into work packages.

INTRODUCTION

Production-oriented engineering is being practiced by some U.S. shipyards through the efforts of various groups providing technology transfer from countries and individual shipyards that have clearly developed the *integrated engineering* approach. This has become quite an emotional issue to many engineering and production employees, and it is difficult in such cases to objectively discuss the issues. Opponents frequently raise the spectre of unacceptability by stating that:

- The customer will never accept block and advanced outfitting drawings!
- We tried something like it before and it will not work in our yard!
- Production will never accept engineering doing their work!
- Production managers and supervisors are insulted by simple work station or production drawings!

Once the objectives of *integrated engineering* are understood, all the above prove to be *incorrect*. Customers are enthusiastic about *the integrated engineering* approach when it is correctly explained to them, and some of the cost benefits returned to them. Production departments quickly appreciate the benefits when they receive the information they need in shorter time, and in an easier to understand form. It also alleviates the problem of the shortage of well trained and fully qualified craftsmen. The obvious reduction in production department manhours for planning and production engineering are additional reasons for their appreciation of the approach. *The customer (shipowner) also finds that integrated engineering* product drawings are better than the single system *isolated engineering* drawings for the maintenance and repair of the ship. Repair yards learn to prefer *integrated engineering* product drawings, as they can see all the structure and systems in a local area on one drawing rather than many, thus simplifying their planning, engineering, and estimating the repair *cost*.

Table I.1 summarizes the major differences between *isolated* and *integrated* engineering along with the benefits of the latter. Figure I.1 shows a typical design, engineering, and production schedule for the *isolated* engineering approach, and Figure I.2 shows *the same* for the *integrated engineering* approach. By comparing the two approaches it can be seen that the *integrated engineering* approach enables the production department to commence construction earlier and to complete the ship in a shorter time than the *isolated engineering* approach. This is because the engineering information for the first block is completed earlier than would be the many item drawings that the *isolated engineering* approach would need to complete before construction could commence. This in turn enables the lofting, processing, assembly, and outfitting of the block to occur earlier, resulting in the shortening of the construction time. Figure L3 shows that even though the *integrated engineering* approach increases the engineering effort, the total result is significant productivity improvement through manhour savings in planning, lofting, and production.

Both the *isolated* and *integrated engineering* approaches could use *the design for ship production* detail ideas presented herein, but unless it is with the involvement and agreement of both the engineering and production departments, *the isolated engineering* shipyard may not select the detail that would be the best for the shipyard. The *design-for-production* approach described in Part 1 should therefore be of use to most designers. However, this phase is only the tip of the iceberg. To achieve the complete goal of having the competitive edge over the competition through increased productivity, it is necessary to fully utilize *the integrated engineering* approach. To do this, it is necessary to *utilize engineering for ship production*. Part 2 describes this approach and its techniques. Part 3 discusses the engineering organization and management necessary to ensure the successful application of the first two parts.

TABLE I.1

COMPARISON OF ISOLATED AND INTEGRATED ENGINEERING

ISOLATED	INTEGRATED	BENEFIT
<p>Structural drawing prepared on Item basis from bow to stern, e.g.,</p> <ul style="list-style-type: none"> - Shell drawing - Dock drawing - Bulkhead drawing - Tank top drawing - Framing drawing 	<p>Structural drawing prepared on a construction sequence basis for sub-assemblies, assemblies and blocks, e.g.,</p> <ul style="list-style-type: none"> - Hob frame sub-assembly - Transverse bulkhead assembly - Double bottom block - Wing tank block 	<ol style="list-style-type: none"> 1. With Isolated approach construction cannot be started until a number of Item drawings are complete. For example, a typical block requires 13 drawings to show necessary data. With Integrated approach, construction can commence when the first block drawing is complete. 2. With Isolated approach, it is necessary for someone (Production Planning) to prepare block parts list and sequence assembly sketches. With Integrated approach, production can use engineering-prepared drawings directly, thus saving additional effort and time.
<p>Machinery arrangements laid out for individual equipment and piping installation</p>	<p>Machinery arrangements laid out for On Unit packages and Piping and greating package assemblies etc.</p>	<p>*On Unit* advanced outfitting has been demonstrated to be the greatest productivity improver. Also allows work to be performed on unit and the ship to be completed earlier.</p>
<p>System diagrammatics prepared for design use only in preparation of A & D drawings with not particular accuracy in equipment location or pipe routing.</p>	<p>System diagrammatics prepared accurately as possible including scheming for pipe routing with other systems and showing all information required for material procurement and planning.</p>	<ol style="list-style-type: none"> 1. By Integrating all system diagrammatics in a given space, the grouping for piping or various systems can be considered 2. Also, knowing that the diagrammatics are more accurate allows material to be ordered with greater confidence reduces the need for margins. 3. More complete diagrammatics are acceptable for owner and classification approval, it is not necessary to send A & D drawings for approval.
<p>A&O system drawing prepared for complete ship areas of ship without regard to block breakdown or "On unit" advance outfitting. Usually prepared as independent drawings for each system, thus making integration and grouping of piping and supports together for installation difficult, if not impossible.</p>	<p>System working drawing consist of final instructions to the production worker, such as pool shoots, installation sketches and material lists suitable for direct incorporation in work packages.</p>	<ol style="list-style-type: none"> 1. Elimination of traditional A&O system drawing. 2. Earlier availability of construction information for piping. 3. Prepared on a block basis. earlier installation of piping. <p>III. Eliminates additional stop which can introduce human error which can mushroom due to unexpected interferences and/or</p>

3

TABLE 1.1: Comparison of Isolated and Integrated Engineering (Continued)

I ISOLATED	INTEGRATED	BENEFIT
Engineering 'drawings' data that are unsuitable for direct issue to Production, must be further processed by Production Planning.	Engineering prepares all production-required drawings and data, such as structural sub-assembly, assembly and block sequencing sketches pipe spool sketches, advanced outfitting drawings and lists	<ol style="list-style-type: none"> 1. Elimination of some engineering effort resulting in time savings. 2. Cost savings due to eliminated effort. 3. Increase in mutual engineering/production knowledge and cooperation. 4. More problems solved on paper rather than on hardware.
No input for advanced outfitting.	Prepares advanced outfitting drawings and parts lists.	<ol style="list-style-type: none"> 1. Engineering designs ship to facilitate advanced outfitting. 2. Forces material definition to support advanced outfitting. 3. Results in a more integrated ship.
Detailed structural drawing is prepared from and therefore after is completed.	Lifting is an integrated part of structural development. Usual detailed drawings eliminated.	<ol style="list-style-type: none"> 1. Shortened time from contract award to cutting steel. 2. Increased productivity of combined engineering and lifting.
Independent planning and scheduling keyed to a master event schedule.	Integrated planning and scheduling for Engineering, material procurement, and Production for individual work packages.	<ol style="list-style-type: none"> 1. Compatibility of all detailed schedules. 2. Effect of change on one department automatically apparent to other departments. 3. Schedule items identifiable to simplest production package.

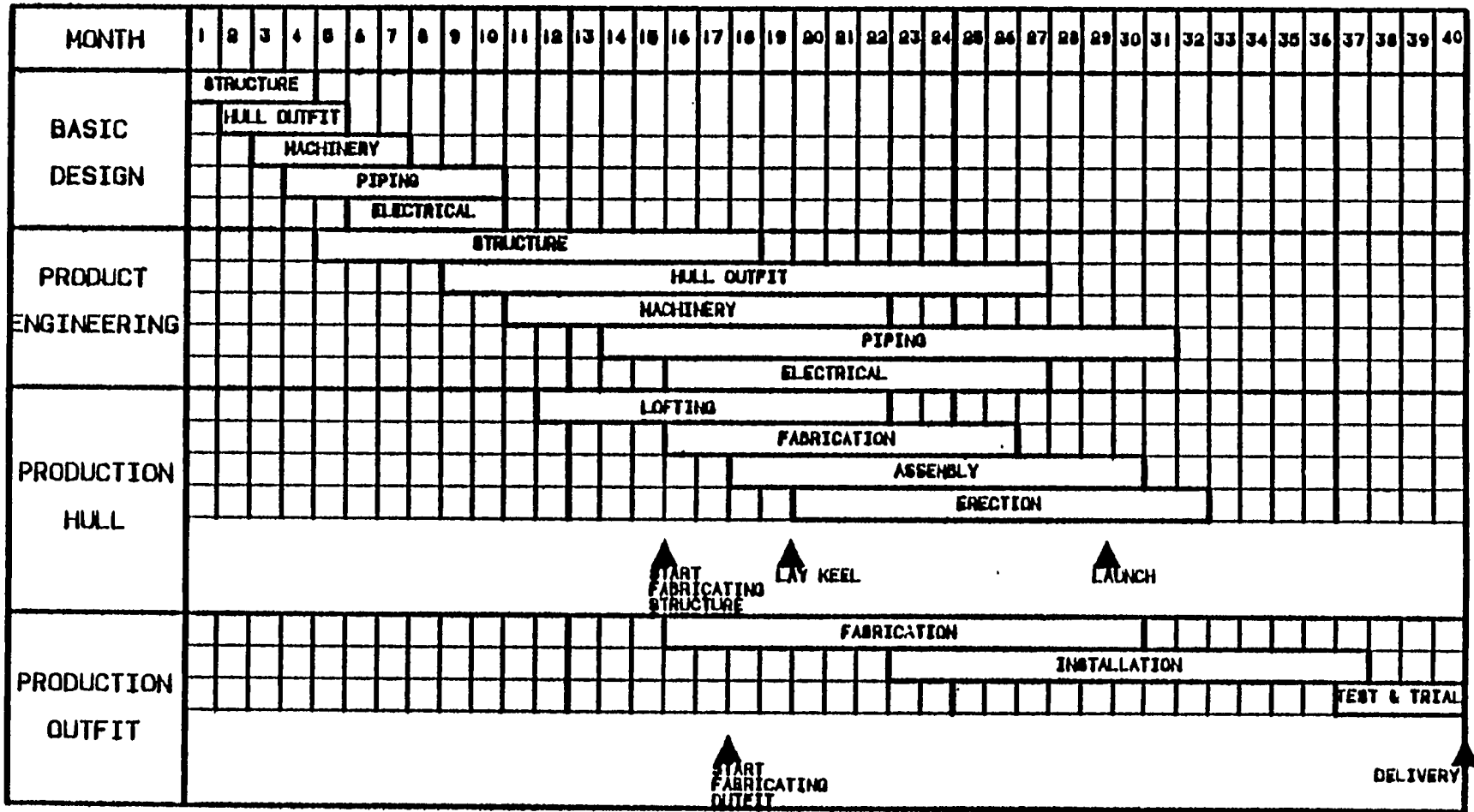

FIGURE I.1 Traditional shipbuilding and isolated engineering.

9

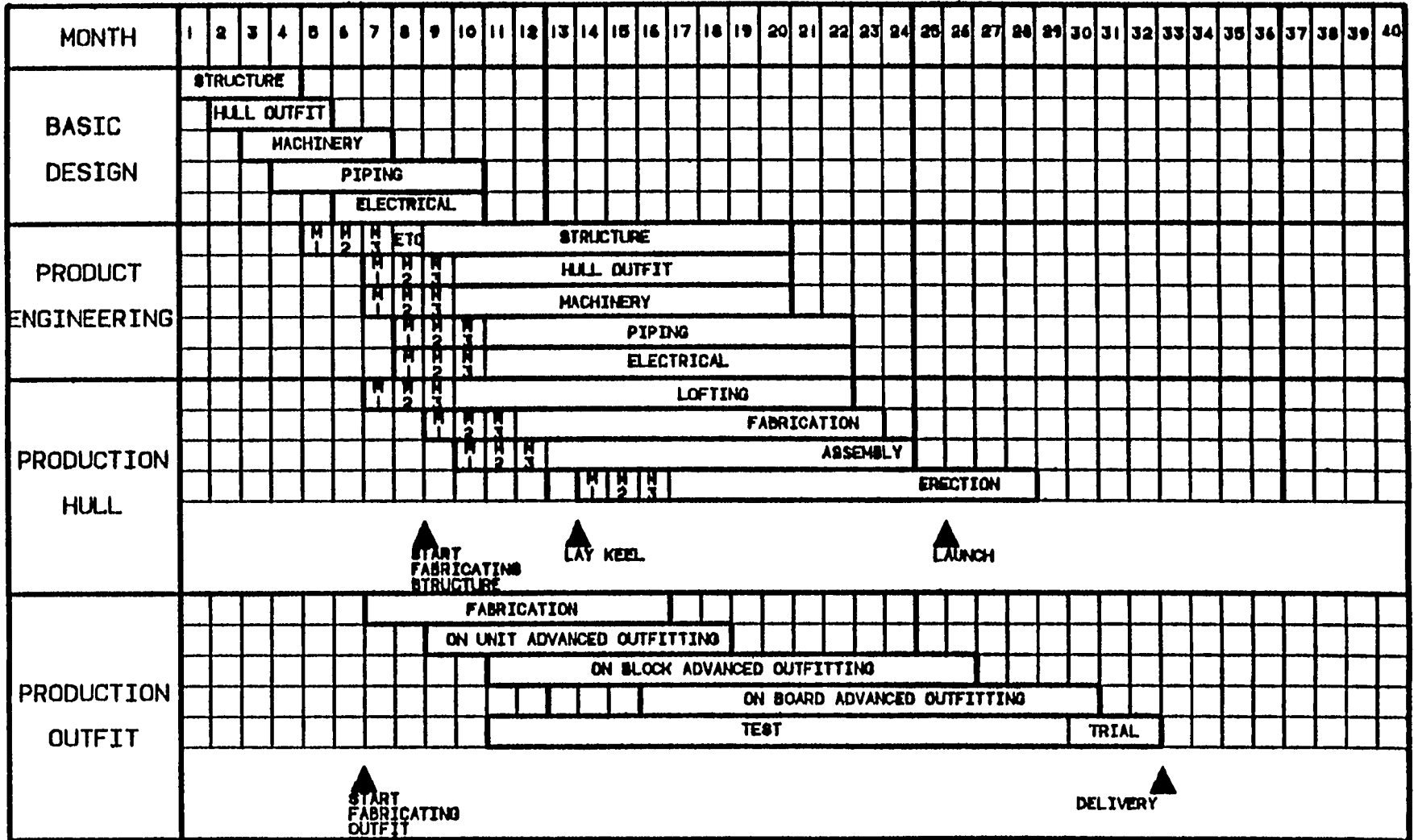

FIGURE I.2 Advanced shipbuilding and integrated engineering.

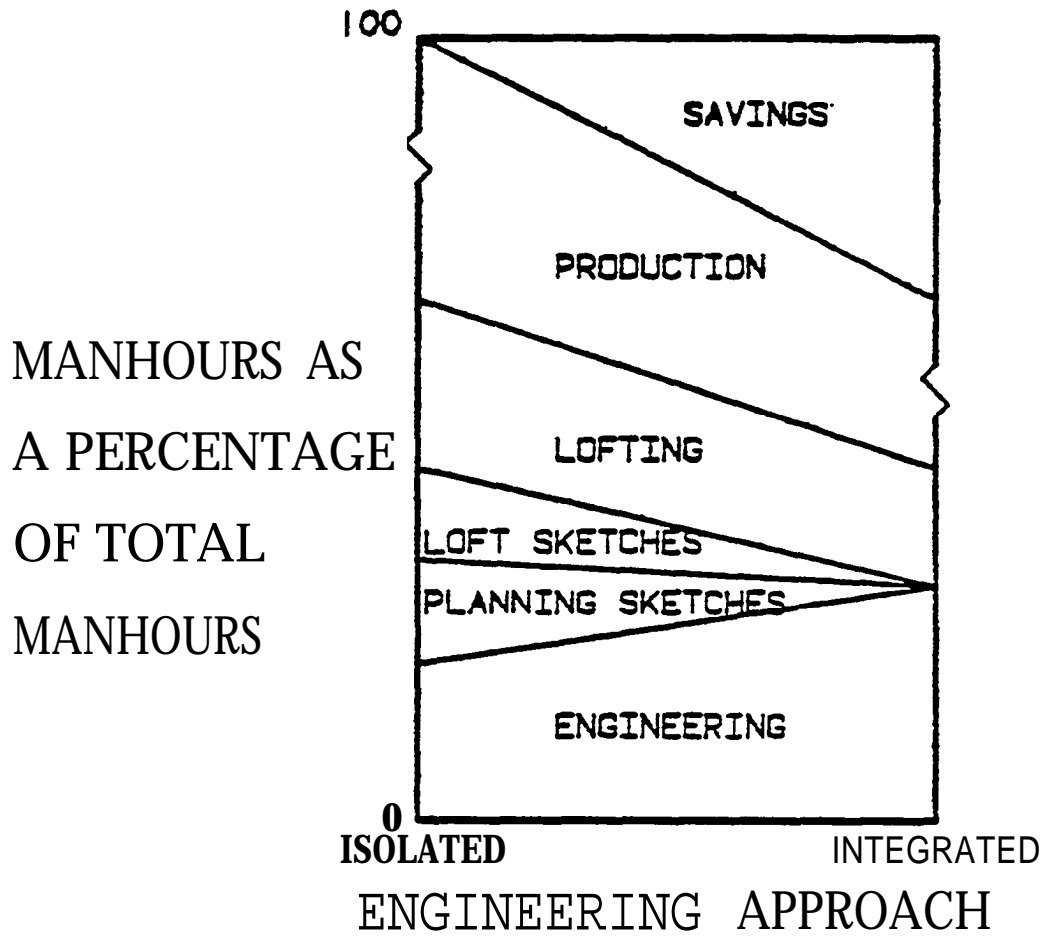

FIGURE L3 Overall productivity benefit of integrated engineering.

INTRODUCTION

PART 1

DESIGN FOR SHIP PRODUCTION

1.1 General

Notwithstanding the fact that all engineering design should be prepared to be the best possible for production, while meeting all the customer's requirements for quality, service, and maintainability, and thus be the most cost effective for the customer, it seems that ship designers have not kept this in mind as the industry changed from a craft to a process activity. Over thirty years ago, shipyards were craft organized, and the various engineering groups as well as production groups tended to work in isolation from each other. The amount of detail shown on the engineering drawings was quite small as the craftsmen were expected to and were able to use their training and experience to develop details on the job. As long as ships were assembled on the building berth in many small individual parts, this *system* worked quite well. Productivity depended almost entirely on the effort and ability of the production craftsmen. When welding replaced riveting, two important changes took place. First, it required better accuracy in cutting and fitting parts, which provided the impetus to develop better lofting and steel processing through optical projection and then computer-aided lofting and computer-aided manufacture. Second, it enabled structural prefabrication to take place in shops and platens away from the building berth.

Another significant event in ship production occurred during World War II when the U.S. was called upon to be the shipbuilder to the Allies. The techniques adopted at the multiple-ship shipyards were geared toward mass production, and to overcome the use of inexperienced labor. Extensive prefabrication was planned into the design to allow an assembly line approach to be used. Simplified engineering drawings were provided to the workers. Very detailed planning and scheduling of material receipt, processing, and installation were used along with a highly developed production control of the construction processes. This was possible due to the repetitive processes performed at each work station. Erection panels of up to fifty tons were handled in some of the shipyards. At the end of the war many shipbuilders closely examined the techniques developed in the U.S. shipyards and adapted them to their own facilities, and in some cases improved on them, as in the case of the National Bulk Carriers shipyard in Japan.

Ship production has continued to progress since then, going from simple prefabricated and pre-outfitted panels to 1,000-ton completely outfitted blocks. The construction of a new shipyard by Burmeister and Wain in 1960, which included a gantry crane of 600-ton lifting capacity, was the start of the development of high-output ship production facilities. The next significant development was the construction of the Gotaverken extrusion shipyard at Arendal in Sweden. After that a whole series of new shipyards was constructed throughout the world, but mainly in Japan. Many innovations were developed by the Japanese, and they became the leading shipbuilder in the world. The challenge facing existing shipyards was how to take the new technology and adapt it to their existing facilities with only the minimum investment necessary for them to stay competitive in their own market. New shipyards were generally constructed to build one or two types of ships, such as tankers and bulk carriers. As long as there was a sufficient market for those ship types, the specialized shipyards were the most efficient. With the downturn in demand for large bulk-type ships, and the general depressed market for all

shipbuilding over the last decade, these specialized shipyards have lost their attractiveness due to the need to produce diverse ship types. Fortunately, it was possible to obtain significant increases in productivity in existing shipyards without large investments in plant and construction equipment by redefining the ship design approach and planning the construction of the ship at the same time as the preparation of the drawings, thus being able to influence the design to suit the intended building plan.

Out of this era of noticeable change followed by the depressed shipbuilding market of the late 70s, the need for consolidation of facilities and ship production techniques developed. Along with this came the clear need for ship designers to become cost conscious as they applied their talents to the design of future ships. These are the conditions that have given birth to design for ship production, which is really design for minimum cost of ship production. This is accomplished by using the most efficient method of construction while still satisfying the many compromises resulting from conflicting requirements between the owner's desires, regulatory and classification rules, and the need to have a competitive edge over the other shipyards. The need is obvious and it should not have been necessary to develop a new science" to achieve it. However, it seems that ship designers have not, in general, changed with the changes in ship production and responded to the new needs. Many shipyard engineering departments continue to work in isolation, without taking into account the producibility of their designs.

It has been suggested by a number of sources that this occurred in the U.S. due to the fact that almost all the design and most of the detailed engineering has been and still is prepared by design agents and not by in-house shipyard engineering departments. When a design agent prepares a design for a shipowner, it is probable that no shipyard has been selected to build it at that time. It is therefore difficult for the design agent to include production aspects into the design for a given shipyard. This is most unfortunate, as it is at this stage in the total production process of a ship that the cost is being established and where there is the greatest opportunity to favorably, and vice versa, affect it. This is clearly shown in Figure 1.1, which shows that as the process moves from actual construction, the ability to influence cost, and therefore achieve cost savings, diminishes.

It would be normal to expect that design agents should be able to utilize all the cost influence to good purpose during detailed engineering development for a specific shipyard, but this is not known occurred havem There are many reasons for this, and in defense of the design agent, it is acknowledged that they can only do as good a job as the shipyard demands of them. They are in the service business and their goal is to please the customer. Why should they stick their necks out and try to change the shipyard's thinking? It is very difficult for a design agent to accomplish the goal to become an integrated extension of a shipyard's own engineering department. Theoretically, it should be possible, but only if the work is performed under a cost-plus contract. This is because a design agent's objective can only be to do as good a job as it can for the shipyard, and at the same time make as high a profit as it can in the competitive market it serves. Whereas, the shipyard's requirement of the engineering activity is to provide the production department with the information it needs, in the best form and quantity to enable them to construct the ship in a way that the total cost to the company is less than any of its competitors. This may require more than normal engineering to be provided, and if a design agent were to offer such an approach, it may be priced out of the running if competitors offer just the usual. Even when this is fully understood by all shipyard management, it is a brave and unusual engineering manager that will give a design agent a cost-plus contract to perform the engineering for a ship that his company was awarded on a fixed-price basis.

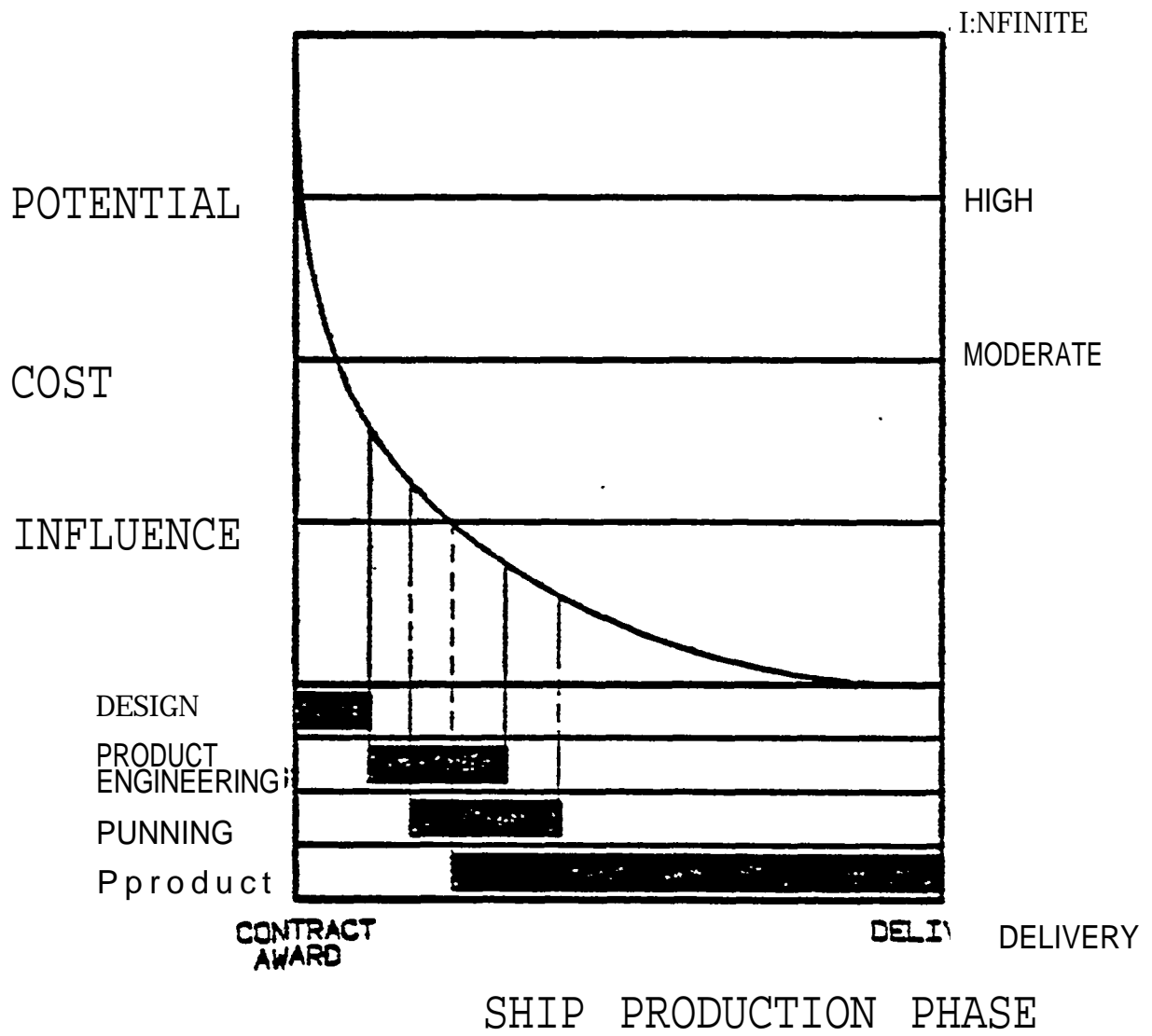

FIGURE 1.1 Potential influence as construction phase progresses.

Dr. Shinto, of IHI fame, in his lecture to The University of Michigan Shipbuilding Short Course in 1980, stated:

The basic design activity of the shipbuilding company is the core of the vitality of the company. It is the fundamental significance of the existence of the basic design department to pursue the question of what performance the vessel should have, and how, and at what cost the vessel should be built. Thus the basic design department should be at the core of the activity of the company. In this philosophy, and based on the experience of management in the Japanese shipbuilding industry, the marine consultant system so familiar in the U.S.A. is not very understandable. The existence of a shipbuilder with no such core for the development of basic technical progress is entirely beyond our comprehension. . . . Especially in cases when the issue of data is mistimed with respect to the production schedule, the data can be entirely without value. We have just had such bitter experiences when the design for an American owner was done by a consultant. It is our opinion that even when a consultant is employed, the consultant's activity should be confined to basic design which decides the performance and capability of the ship. All production design should be done in the yard.

How wonderful it would be if the solution was that simple! The reason for the marine consultant system in the U.S. goes back to the 1936 Merchant Marine Act, and the requirements that shipowners submit preliminary and contract designs to the Subsidy Board of the Maritime Administration before their application for construction differential subsidy could be approved and sent out to shipyards for competitive bids. Today, the main reason is the inability of the shipyards to maintain an in-house engineering staff large enough to handle the complete design and engineering for a new ship due to the lack of a long-term shipbuilding program to utilize them over a long period of time. The resulting prospect of hire and fire is unacceptable to most shipyard managements. The alternative to marine consultants that is available to shipyards is to follow the trend of the U.S. aircraft industry and to hire temporary help, but this approach certainly does not lend itself to better production-oriented designs for specific shipyards.

It is therefore essential that in the U.S., the design agent reverse the current lack of production consideration in designs and drawings by taking the lead in introducing design for ship production into all future contracts in which they are involved. At the start of any design for a specific shipyard, and especially when preparing the detailed engineering, it is imperative that the design agent spend the time with the shipyard planning and production staff necessary to develop an understanding of the shipyard's facilities, planning methods, preferred approaches to constructing the ship, and the design for ship production standards that the shipyard has decided is best for them. A big problem that the design agent must resolve is the lack of shipyard and, more specifically, ship production experience of their staff. Design agents will have to develop some innovative ways for their staff to obtain this experience, such as long-term agreements with shipyards to take the design agent's engineers and designers and put them through specially developed shipyard training courses.

As already stated, the use of design agents for both design and detailed engineering is not the only reason for this lack of production-oriented design and engineering. It is obvious that the shipyards have not demanded it. Unfortunately, it seems that the interfacing team in the shipyards was not ambitious enough to take the necessary steps to bring it about. This is probably the reason why in countries where design and engineering is prepared by in-house engineering departments, it has still been necessary to push the

design-for-production approach, and to teach it to both new and existing ship designers and production managers and workers as a new science.

While the correct application of industrial engineering techniques to shipbuilding will be of significant benefit, its application has in many cases only increased the isolation of the engineering department from the production activity and resulted in increased cost due to its being applied after the design is completed and the development of the detailed engineering well underway. This is equally true of the situation when production engineering groups are established within the production department. For this to be done, the shipyard management must first believe that it is beneficial to split and specialize engineering into two parts, namely, design and production. It is strongly suggested that this is fundamentally wrong and is where most of the interfacing problems originated. There is only one type of acceptable technical engineering, and that is when its producibility is fully and adequately considered from its conception. Of course, this approach requires that ship designers and engineers obtain knowledge of and experience in production processes and techniques and also be willing to accept the increased responsibility. They must stop being specialists and develop the ability to see the "big picture," even when considering a single detail. They must be able to develop engineering as a simulation of the actual construction of the ship. That is, it must be developed on a complete space basis involving all structure, machinery, piping, ventilation, electric equipment and cable, and outfit, rather than one item (system) at a time, such as the complete main deck structure or the fire main system for the complete ship, but still be fully aware of the need to integrate all systems on a complete ship basis.

The concepts of design for ship production are presented in the remainder of Part 1. It is usual to refer to only design for production. However, the insertion of ship into the title was deliberately done to make it clear that more than the techniques of design for production are being offered. The actual application of the concepts to shipbuilding is being presented, and the details proposed are directly usable in ship design.

SUGGESTED READING

The Shipbuilding Business in the United States of America Professor F.G. Fassett, Jr., editor. SNAME 1948.

"High productivity shipbuilding," *Welding and Metal Fabrication*. September 1957.

Symposium on the Reorganization of Some Tyneside Shipyards. NECIES, 18 November 1960.

"Some aspects of the development of modern hull construction." By J.M. Barfoed. NECIES, February 1963.

"Arendal shipyard," *Shipbuilding and Shipping Record*. June 6, 1963.

"Shipbuilding" throughout the world: New shipyards for superships." By D. Lesur. SOFRESID no. 15, 1969.

"The strategic development of ship production technology." By M.R Hargroves et al. NECIES, 28 April 1975.

"The constraints imposed on design and technical activities by shipbuilding production technology." By A.J. Marsh. International Conference on Structural Design and Fabrication in Shipbuilding, RINA 1976.

"Production methods Implications of production engineering." By I. McDougall. WEGEMT Managing Ship Production, University of Strathclyde, Glasgow, September 1980.

'Mitsubishi's major yards in the 1970s," *Shipbuilding International* April 1971.

"Shipbuilding in the United States." Webb Institute, July 10-12, 1972.

"A discussion of ship technology in the 1980s," *Philosophical Transactions of the Royal Society of London*. 5 September 1972.

"An objective look at shipbuilding in the United States." By EM. Hood et al. SNAME Diamond Jubilee International Meeting, 1968.

"Recent developments in management and production methods in Japanese shipyards." By H. Kihara et al SNAME Diamond Jubilee International Meeting, 1968.

"Some production research activities on steelwork and outfitting." By R. Hurst. SNAME Diamond Jubilee International Meeting, 1968.

"Present trends in the shipbuilding industry." By J. Lenaghan. *RINA Transactions* vol. 104, 1962.

"British shipbuilding in today's world." By N.A. Sloan. *RINA Transactions*, vol. 115, 1973.

“Creating a production facility for standard ships.” By D.B. Kimber et al RINA *Transactions*, vol. 119,1977.

Improved Design Process, Final Report. Ship Producibility Program, National Shipbuilding Research Program, April 1977.

“The progress of production techniques in Japanese shipbuilding.” By Dr. H. Shinto. University of Michigan, Shipbuilding Short Course, October 27-31,1980.

Report of the Commission on American Shipbuilding, 1973.

“Outfit planning.” National Shipbuilding Research Program, December 1979.

Producibility from Conceptual Design to Ship Construction. By L McDougall. IREAPS 1981.

“Toward responsible shipbuilding.” By J.W. Boylston and W.G. Leback. SNAME *Transactions*, vol 83, 1975.

“Characteristics and constraints of shipbuilding in the United States.” By H.L Freinberg et al. SNAME *Transactions*, vol. 87, 1979.

1.2 What is Design for Ship Production?

Design for production as a term has been in use in production engineering since the late 1950s, where it applied to the linked functions of production design and process design [1]. The production design covered the preparation of the engineering information that defined the production. The process design covered the development of the production plan. Therefore, as originally conceived, *design for production* covered not only the design of the production but also the design or selection of tools, methods, and production sequence for least cost. *Design for production* is the correlation of production design with the available or planned facilities and production methods. As such, a designer could not perform well at it without knowing or being advised as to how the design would be produced. Obviously, in the age of specialization, designers were not expected to know both production and process design, and separation of the function into design engineering and industrial engineering resulted. For this to work at all, good communication is essential. This is difficult most organizations, especially between specialties, and it is understandable that it has only been partially successful in some industries. To overcome this problem, it is being proposed that the ship designer accept more responsibility for the producibility of the design. To accomplish this, the ship designer must be better educated in production processes and relative costs.

More recently, *design for production* has been defined as the deliberate act of designing a product to meet its specified technical and operational requirements and quality so that the production costs will be minimal through low work content and ease of fabrication. It is simply addressing the fact that today's ship designers have a commitment to assess their ship designs for cost effectiveness. To do this, they must consider the relative efficiencies of available production processes and construction methods. This places additional responsibility on the designer. However, it must be willingly accepted, because if it is not, the effect on production costs can be fatal to his shipyard. Today's ship designer has both the opportunity and the obligation to design ships so that the minimum total cost is achieved. This opportunity cannot be seized by the ship designer in isolation. It is only possible through an awareness of the facilities and production techniques and methods used in the shipyard that will build the design. This necessitates continual interface and cooperation between the engineering and production departments.

Ship designers cannot effectively design for production without knowing how the ship will be constructed. Therefore, the principal problem for *design for ship production* is the development of this knowledge for engineering. This can be accomplished by the development of *shipyard production specification* for each shipyard and *building plans* for each ship to be constructed prior to commencing detailed engineering.

Ship designers are constantly referring to the ship's contract specifications for the performance requirements of the ship as well as the standard quality. It is suggested that every shipyard should have a *production or producibility specification*. This production specification would list facilities, equipment capacities, critical limits, standards, preferred design details, assembly and installation techniques and approaches. Then the engineering department would follow the production specification while developing the design and detailed engineering for the ship.

There is one other document necessary to complete the production information for the engineering department, and that is the *building plan*. Obviously the building plan

Numbers in brackets designate references at the end of each section.

follows the production specification, but details its application for a specific ship. It should define module boundaries, assembly and module construction sequence, module erection sequence, extent of advanced outfitting, and master construction schedule. From this the engineering department would develop its drawing list and preparation schedule. The building plan must be developed through input from both production and engineering personnel with adequate overall, as well as detailed, knowledge of ship design, detailed engineering, production processing, assembly, and erection

It is most important that quality be given prime importance throughout the application of *design for ship production*. This is because, just like cost, the greatest potential to ensure product quality occurs during the initial design phase and diminishes through detailed engineering and actual construction. If the quality of the design is good and easy to fabricate and utilizes the facilities to their best advantage, then the easier it is to obtain high product quality.

Before examining the concepts and application of *design for ship production*, it is worthwhile to review, in general terms, the major factors of the operation of a shipyard which influence its costs to construct ships. First, it is necessary to have some understanding of the shipbuilding process, and this is conceptually shown in Figure 1.2. It can be seen that it is divided into four phases, namely:

- | | |
|--------------------------|---|
| 1. Production Definition | Including engineering, planning, material procurement, and manufacturing data |
| 2. Component Process | Where either raw steel is processed into usable components or equipment is received |
| 3. Assembly Process | Where structural components are assembled and packaged machinery units constructed |
| 4. Ship Joining Process | Where structural modules are joined together and machinery, equipment, distributive systems, and outfit not previously installed in the modules are installed in the ship |

It can be seen that two control systems span all four phases, namely, quality control and production and material control. If engineering and planning output is considered as material necessary to build the ship, the horizontal line shown below engineering and planning would move above them.

Second, an overview of ship construction costs can be obtained by reviewing a typical shipyard "Ship Cost Estimate Summary Sheet." In the U.S., with its heavy dependence on naval ship construction, the estimate form usually follows the Navy Ship Work Breakdown groupings. Such an estimate summary sheet is shown in Table 1.1. The direct costs consist of work tasks which must be performed to accomplish the construction of the ship. However, the work task grouping is on the basis of ship systems rather than the way the ship will be built. It is feasible that with the availability of computers and simulation methods that a computer estimating system based on the simulation of the actual construction process could be developed. This would enable a superior cost-control method to be developed and give the ability to zero-in on the high cost processes, and target them for detailed cost analysis and productivity improvement.

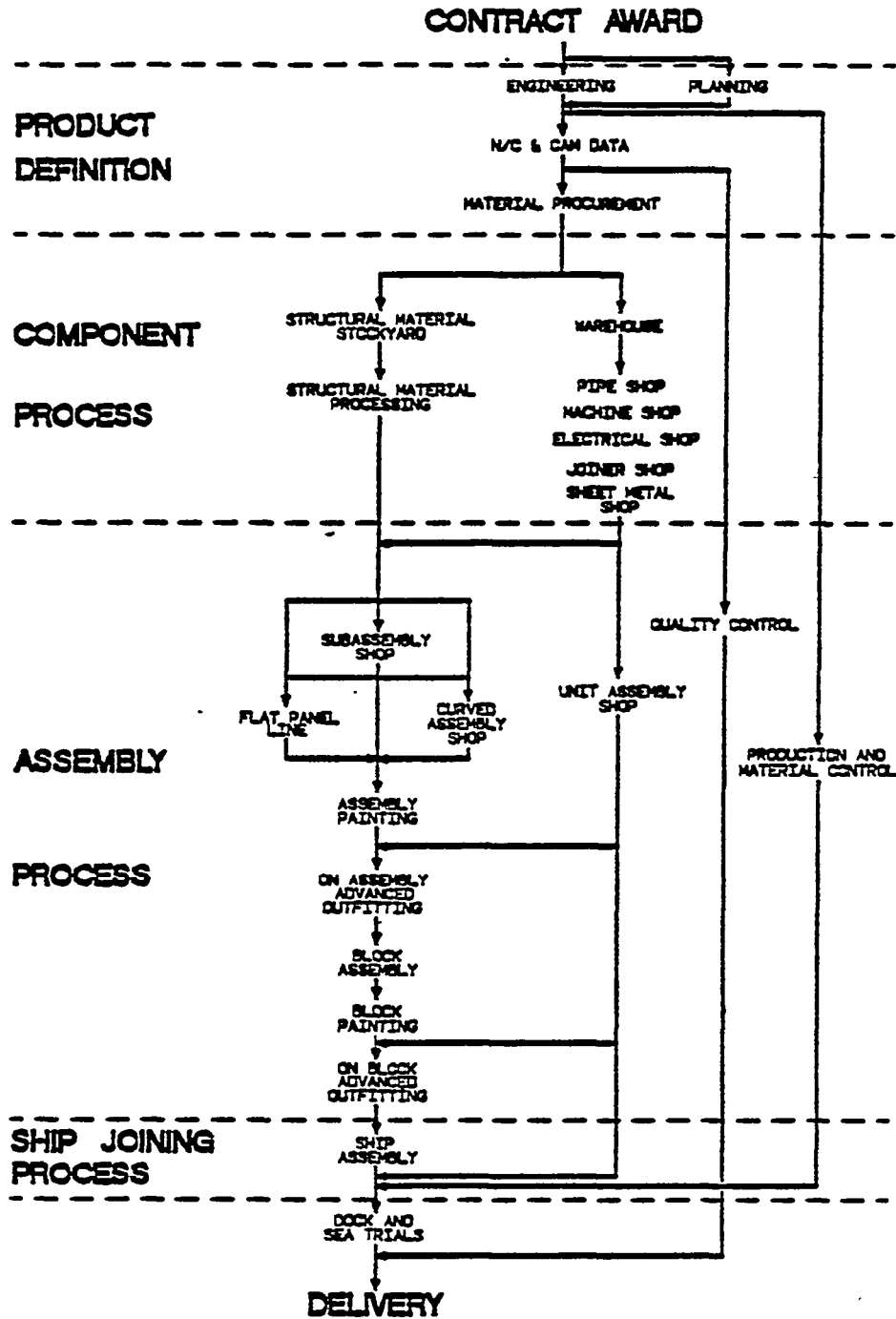

FIGURE 1.2 The shipbuilding process.

TABLE 1.1

TYPICAL COST ESTIMATE SUMMARY SHEET

DIRECT COSTS
Group 1: Hull Structure
Group 2: Propulsion Plant
Group 3: Electric Plant
Group 4: Command and Surveillance
Group 5: Auxiliary Systems
Group 6: Outfit and Furnishings
Group 7: Armament
Group 8: Integration/Engineering
Group 9: Ship Assembly and Support Services
TOTAL DIRECT COSTS
INDIRECT COSTS
O v e r h e a d
Escalation
Overtime
Bond
Insurance
Financing Interest
Owner Furnished Equipment Fee
Liquidated Damages
Delivery
TOTAL INDIRECT COSTS
TOTAL COST
PROFIT
MARGIN
Total Price

Whatever method is used, each work task has a minimum work content in manhours and duration which assumes that conditions are ideal, and that everything is done in the best possible way. How this ideal work content relates to actual manhours has been well described by Todd (2), and the following approach is based on his work. The total time to perform a given work task under existing conditions is made up of both effective/necessary time and ineffective/unnecessary time. The effective/necessary time consists of the minimum or ideal time plus additional time because of both design and production inefficiencies. The ineffective/unnecessary time consists of that due to management inefficiencies and that within the control of the individual worker.

Figure 1.3 graphically shows this division of total work time. This approach can be used, first, to examine just the engineering function, in which case all parts of it would be considered. This will be examined further in Part 2: Engineering for Ship Production. Second, *with regard to design for ship production, the* "Work Content Added By Defects in

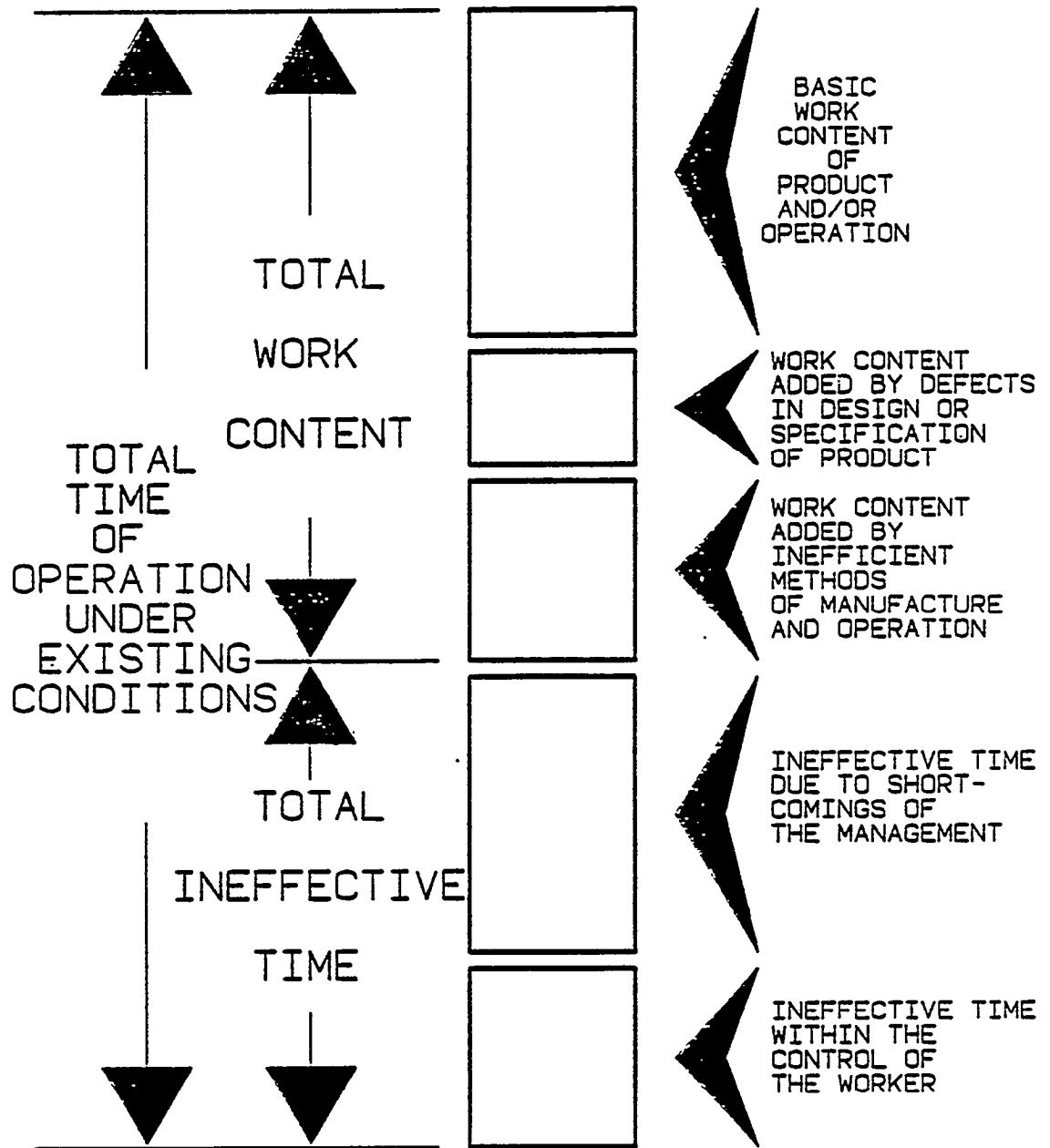

FIGURE 1.3 Makeup of total work time.

Design” is the only item necessary for further consideration at this time. All the other items are of importance, and must be solved to obtain improvements in total productivity, but are outside the control of the ship designer, and for that reason alone will not be examined any further. A good familiarization with them is, however, beneficial from the overall process awareness, and a complete knowledge of the “Work Content Added Due to Production Inefficiencies” is essential to the ship designer practicing design for *ship production*. For this reason, the “Work Content Added” for both design and production inefficiencies is shown in Figure 1.4 in more detail. Figure 1.5 shows methods and procedures that can eliminate the inefficiencies that add work content to the task. *Design for ship production* covers the first and last of the items identified under “Design Work Content Added.” The middle two items causing increased work content due to design relate to transmittal of engineering information, and as such will be examined in detail in Part 2: Engineering for Ship Production.

Todd [2] also proposed that productivity could be defined by three factors, namely, performance, method, and utilization, and suggested that by applying them as the three coordinates of productivity space, the benefits resulting from improvement in any one of them would increase the productivity in direct proportion, but that improvement in all of them at the same time would have a multiplying effect, resulting in greater productivity improvement than if they were simply added. This approach is shown graphically in Figure 1.6.

A&P Appledore have examined productivity factors in British, U.S., Scandinavian, and Asian shipyards. The productivity gap between the best British and U.S., and the Swedish and Japanese is significant. From analysis of the many inputs, they were able to conclude that modern facilities, advanced technology, or lack of union and demarcation problems were not solely responsible for high productivity. There are modern shipyards suitable for advanced technology that still have poor productivity. There are also shipyards with strong union influence which have high productivity. It is also well known that the Japanese shipyards achieved their high productivity without advanced computer-aided systems. Fortunately, they were able to recognize that all high-productivity shipyards had one capability in common, and that was the ability to organize work, such that facility utilization and labor utilization are optimized.

The productivity space concept can be used to explain this. Instead of method, utilization, and performance, consider facilities, management, and labor utilization. A low value in any one can offset improvements in either or both of the other two. For example, consider that the average value for the three factors for U.S. and British shipyards is 1.0. Then a possible combination for a Japanese shipyard could be:

Facilities	1.3
Management	1.3
Performance	1.2
Productivity =	2.03

Now if the British or U.S. shipyard decides to improve productivity by modernizing facilities without improvements in management or performance, then the productivity factors would be:

Facilities	1.4
Management	1.0
Performance	1.0
Productivity =	1.4

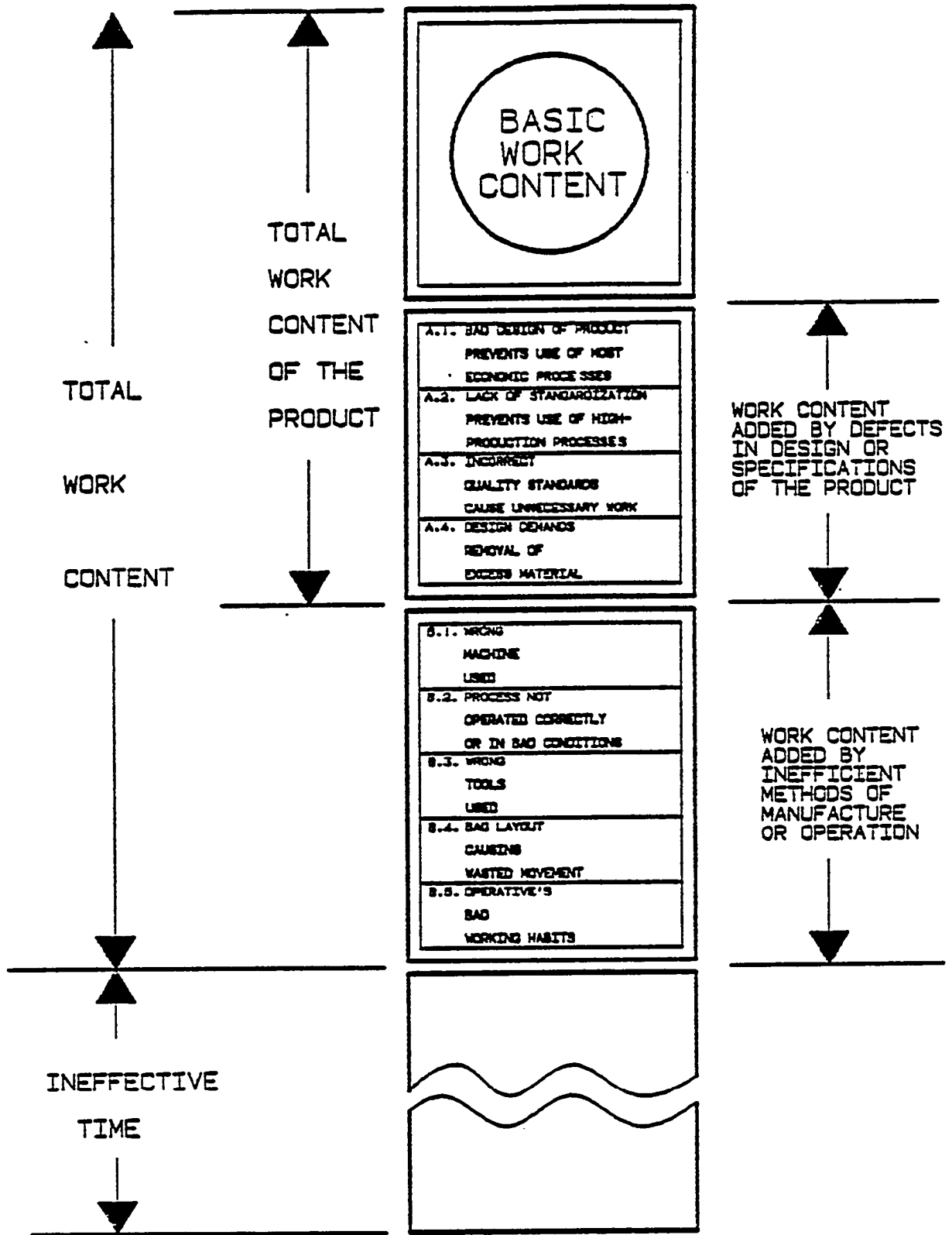

FIGURE 1.4 Total work content.

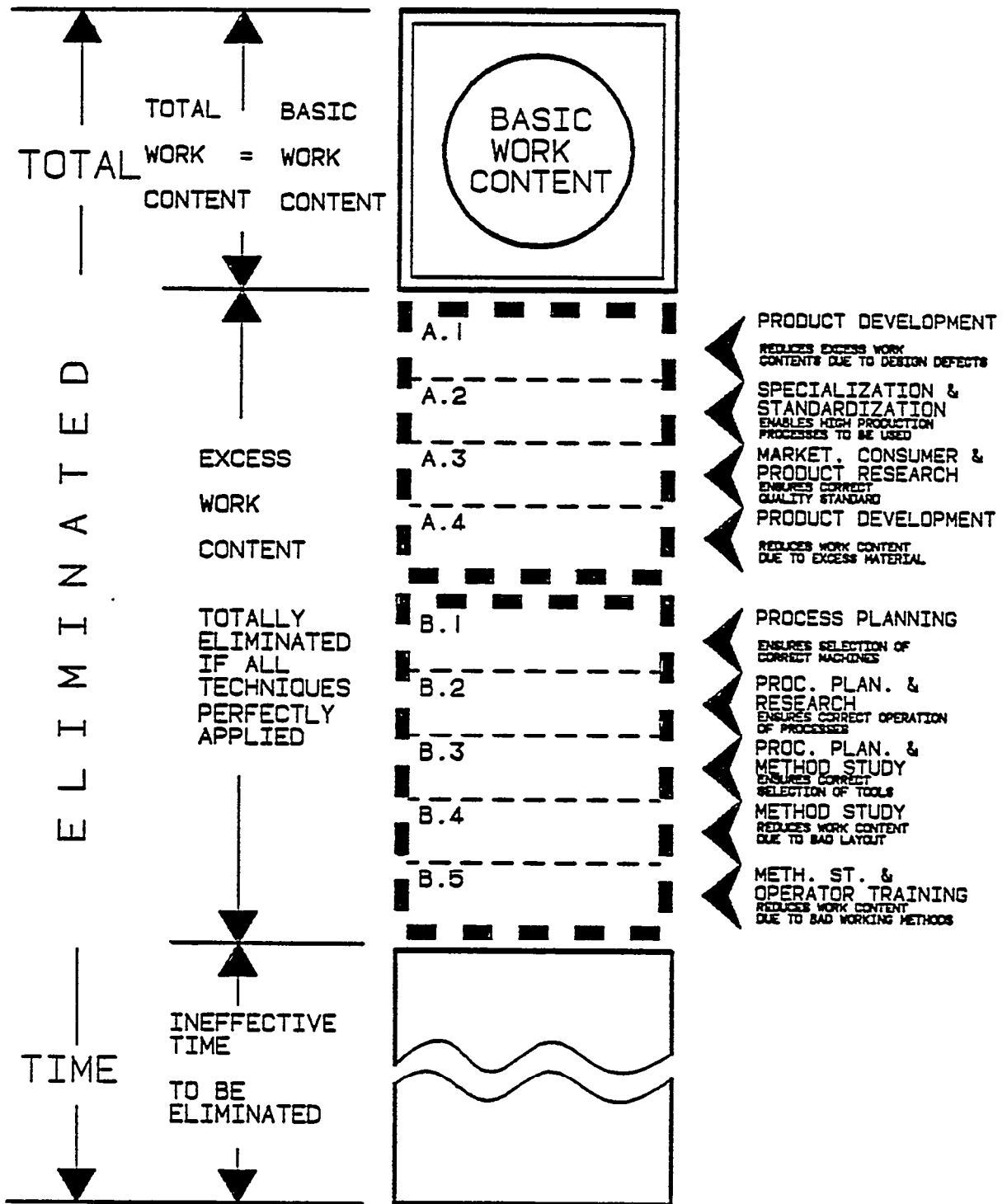

FIGURE 1.5 Methods and procedures to eliminate additional work content.

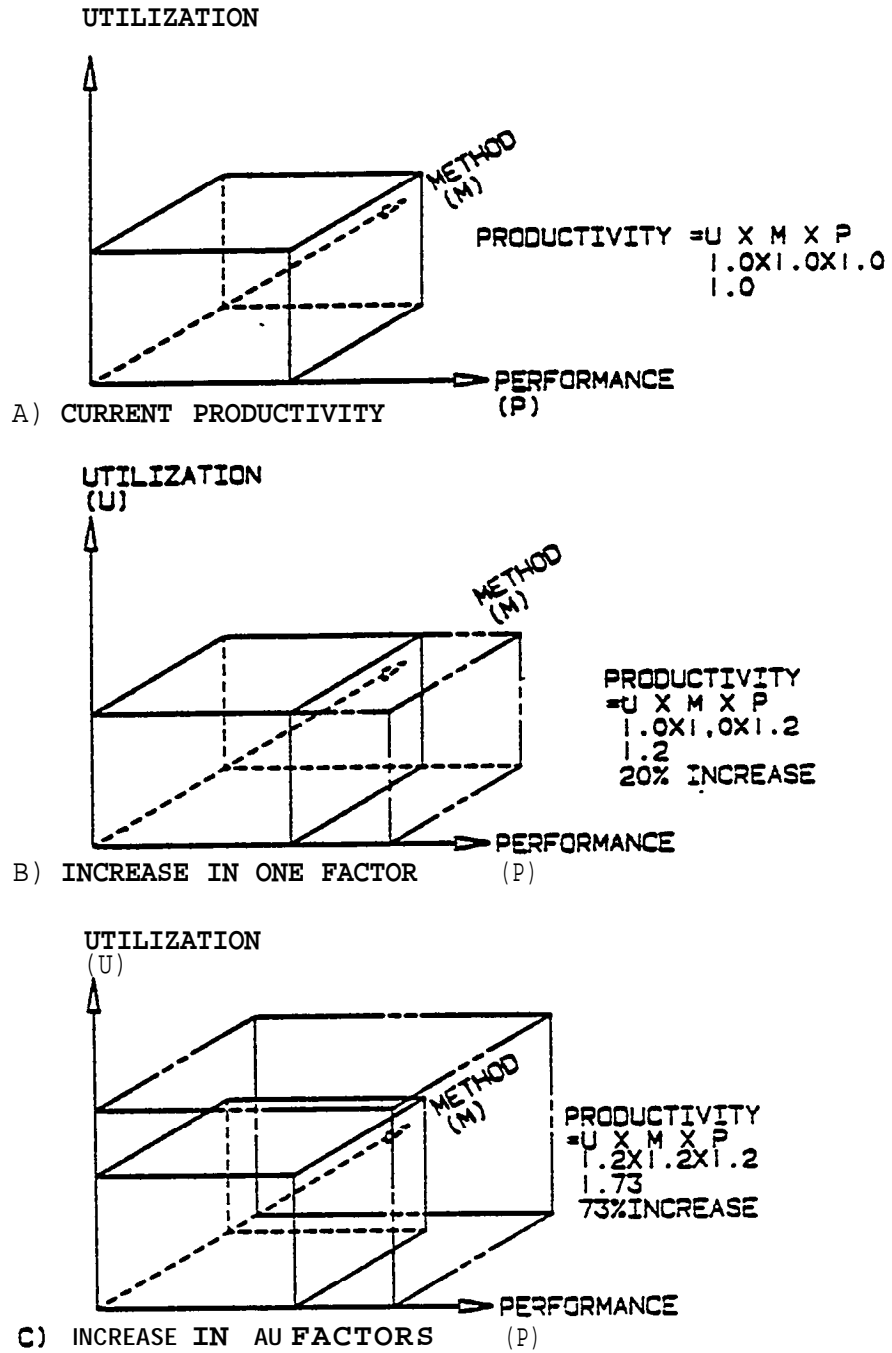

FIGURE 1.6 Productivity space.

This is still far below the Japanese productivity. Use of productivity space also shows how good management and worker performance can far out-perform a new shipyard with low management or performance. For example:

Facilities	0.8
Management	1.3
Performance	1.3
Productivity =	1.35

It is therefore clear that if a shipyard desires to improve productivity they should first determine the values of the three productivity factors and see where the lowest value is, and work to improve the lower two factors before changing the best. It is illogical to invest large sums of money to improve or build new shipyard facilities if existing utilization and performance are low. The exception to this is if improvements in all three are intended, thus allowing a quantum jump in productivity. For example, a new facility giving a 30% improvement coupled with 10% improvement in both utilization and performance would give almost a 60% improvement in productivity. Increases in both management and performance can be effected through design improvements. The problem is how can improvements in design be measured?

Two recent papers [3,4], by the same authors, on ship structural design for production, relate that its application is ineffective without a meaningful appraisal and that the appraisal must be based on a production-costing technique capable of taking into account various physical design differences as well as production processes. While much can be gained from the intuitive approach by knowledgeable and experienced designers, with and without input *from* planning and production, it is still subject to differences of opinion and the danger of errors of omission. That is, some aspect, process or work task is left out of the consideration. It would obviously be better to use an industry- or at least company-accepted merit factor on which to base the analysis. Unfortunately, there is no such merit factor currently available, and it is necessary only to discuss this matter with an experienced ship construction estimator to begin to appreciate the extent of this problem. Ship cost estimating systems do not consider the design or construction tasks in sufficient detail to be able *to be used as a design for ship production* merit factor. For example, for structure, the most detailed cost-estimating systems use combinations of total ship or module steel weight, module complexity factor, average weight per unit area, and joint weld length. These are not enough for a merit factor that will allow changes in details to be compared. What is required is a method that takes into account all the design and production process factors that can differ. At the present time such a method does not exist, nor is there an existing historical data library on which to develop such a system. It is therefore necessary to develop an approach, and then to collect the data required to use the system. This is where the application of work measurement and method study techniques can help. One effective way to develop a suitable merit factor is to collect a quantity of related data, and to obtain an equation fitting the data through the application of regression analysis. This is done by stating the equation in the form:

$$DFSPMF = a_0 + a_1\text{Factor} + a_2\text{Factor2} + \dots$$

The right-hand side of the equation may actually be a combination of factors. The data can be obtained from actual case studies, deliberately selected to cover all design and production factors, and in sufficient different combinations so that the equation can be solved and the regression coefficients obtained. Then a trial period is necessary where other case studies are chosen and the derived regression equation used to predict the work

contents. These are compared with the actual results of the case studies, and error analysis used to refine the coefficients.

From the above description, it should be obvious that what is proposed is not a simple exercise. Significant effort and thus cost would be involved as well as interruption of normal work in a shipyard. Nevertheless, it is necessary that the approach be completely developed *if full* benefits are *to be* obtained from the use of *design for ship production*.

This has been done by J. Wolfram [5] for welding manhours in a shipyard panel shop. The resulting regression equation developed in this case was:

$$\text{Welding Manhours} = 2.79 \cdot \text{NPS} + 0.0215 \cdot \text{JLFB} \cdot t_{\text{FB}} + 0.097 \cdot \text{JLCB} \cdot t_{\text{CB}} + 0.017 \cdot \text{JLF} \cdot \text{FCSA}$$

where: NPB = number of panel starts
 J L F B = *weld joint* length of flat panel butts
 t_{FB} = thickness of flat panels
 JLCB = weld joint length of curved panel butts
 t_{CB} = thickness of curved panels
 JLF = joint length for fillet welds
 FCSA = cross-sectional area for fillet welds

The prediction accuracy of the equation is still not high, but it is better than the shipyard's experience with the simple joint length/manhours approach. With continued use, it is expected that the accuracy will be improved.

The same approach could be used for all other shipbuilding processes with the final system becoming an effective labor-estimating system for both new construction cost estimating and tradeoff analysis.

Until the approach is fully developed for all processes, a less precise but similar approach could be used by applying known data and estimates for each design alternative. Table 1.2 is a suitable form to perform an appraisal manually for steel structure. Obviously, it could be performed by writing a computer program to perform the calculation, and it is even feasible to link the program with an interactive computer graphics system which would provide the merit factor program with the design and production factors required. Similar forms *or* programs could be developed for all *other* systems and production processes.

Design for ship production can therefore be applied in a number of ways, varying from a simple ease of fabrication "gut" decision to very detailed analysis through cost analysis using work measurement and method study techniques. The latter are considered the domain of industrial engineering (IE), but a good understanding of them will improve the ship designer's ability to prepare the best production-oriented designs for a given shipyard. In fact, it would be ideal if every ship designer could spend some time in the Industrial Engineering Department participating in work measurement cases. The study and review of actual work measurement shipyard case studies is the next best, and the minimum level of involvement for ship designers practicing design for ship production. Unfortunately, for both the shipbuilding industry and for the ship designer, such IE case studies of shipbuilding are few in number and not readily available. Although some

TABLE 1.2
STRUCTURAL DETAIL COST CALCULATION

PLATE PART			
PART DATA		WORK CONTENT COEF	M/G COST COEF
LENGTH	L	P1 - STRAIGHTEN	PST -
WIDTH	M	P2 - BLAST	PBL -
THICKNESS	T	P3 - PRIME	PPR -
AREA	A	P4 - BEAR	PBE -
PERIMETER LENGTH	P	P5 - FLAKE PLANE	PFP -
BEVEL LENGTH	BL	P6 - FLAKE PLANE BEVEL	PFB -
NUMBER OF SIDES	NS	P7 - CONTOUR BURIN	PCB -
NUMBER OF CUT OUTS	NO	P8 - CON. BURIN BEVEL	
CUT OUT PERIMETER LG CLIP	CLP	P9 - CON. BURIN. C O	
NUMBER OF HOLES	NH	P10 - CON. BURIN. HOLES	
HOLE PERIMETER LGH	HP	P11 - FLAKE	PFL -
FLAKE LENGTH	FL	P12 - ROLL	PRL -
NUMBER OF FLAKES	NF	P13 - PRESS	PLH -
ROLL RADIUS	RR	P14 - LINE HEAT	
ROLL LENGTH	RL		
RIDGE IN LENGTH	RI		
RIDGE IN WIDTH	RW		
CURVATURE COMPLEXITY	CC		
PLATE WEIGHT	PWT		
		COST COEFFICIENT	
		P10 - LABOR RATE	
		P10 - MATERIAL RATE	
WORK CONTENT			
PROCESS	UNIT	FUNCTION	WORK CONT
STRAIGHTENING	L X M P1		
BLAST	A X M P2		
PRIME	A X M P3		
BEAR	P X N X T X P4		
FLAKE PLANE	P X T X P5		
CONTOUR BURIN EDGES	BL X T X P6		
	P X T X P7		
	CLP X NO X T X P8		
	HP X NH X T X P9		
	BL X T X P10		
FLAKE	FL X NF X T X P11		
ROLL	RL X RR X T X P12		
RIDGE	RI X RW X T X P13		
LINE HEAT	BL X RW X T X P14		
TOTAL WORK CONTENT (TWC)			
COST			
LABOR	TWC X P10		
MATERIAL	P (MCC) X M/G COST COEFF		
MATERIAL	WT X P16		
TOTAL COST			

SECTION PART			
PART DATA		WORK CONTENT COEF	M/G COST COEF
LENGTH	L	S1 - STRAIGHTEN	SS -
WEB DEPTH	WD	S2 - BLAST	SB -
WEB THICKNESS	WT	S3 - PRIME	SP -
FLANGE WIDTH	FW	S4 - BEAR	SBH -
FLANGE THICKNESS	FT	S5 - SAW	SSW -
CROSS SECT. AREA	CSA	S6 - BURIN CUT OUTS	SS -
SURFACE AREA	SA	S7 - BURIN END CUT	
NUMBER OF CUT OUTS	NCO	S8 - BURIN SHIPED	
CUT OUT PERIMETER	CLP	S9 - HOLEDRILL	SH -
NUMBER OF CUTS	NC	S10 - ROLL	SR -
NUMBER OF END CUTS	NEC	S11 - PRESS	SP -
END CUT LENGTH	ECL	S12 - FLURFACE	SF -
NUMBER OF FLG SHIPED HYS	NFSH	S13 - LINE HEAT	SLH -
FLAKE RIBBLE LENGTH	FLR	S14 - TWIST	ST -
WEB SHIPED LENGTH	WSL		
AVER. BEND RADIUS	ABR		
BEND LENGTH	BL		
BEND DEPTH	BD		
Twist Angle	TA		
SECTION WEIGHT	SWT		
		COST COEFFICIENT	
		S10 - LABOR RATE	
		S10 - MATERIAL RATE	
WORK CONTENT			
PROCESS	UNIT	FUNCTION	WORK CONT
STRAIGHTENING	L X CSA X S1		
BLAST	L X SA X S2		
PRIME	L X SA X S3		
BEAR	A X NC X S4		
SAW	A X NC X S5		
BURIN CUT OUTS	NCO (FT X FW) + (NO X WT) S6		
BURIN END CUTS	NEC X ECL X WT X S7		
BURIN SHIPED	NFSH (FWL X FT) + (NWL X WT) S8		
HOLEDRILL	NCO X WT X CLP X S9		
ROLL	BL X ABR X S10		
PRESS	BL X BD X S11		
FLURFACE	L X SWT X S12		
LINE HEAT	BL X BD X S13		
Twist	L X TA X S14		
TOTAL WORK CONTENT (TWC)			
COST			
LABOR	TWC X S10		
MATERIAL	(MCC) X PROCESS WORK COEFF		
MATERIAL	SWT X S16		
TOTAL COST			

TABLE 1.2: (Continued)

SUB- ASSEMBLY			
PART DATA		WORK CONTENT COEF	W/O COST COEF
NUMBER OF PLATES	NP -	SA1 - FIT PLATE -	SAA-AUTO ASSEMB-
JAL. OF PLATES	PJM.-	SA2 - TACK PLATE -	SA1-B A HVLD.DIG-
MELD AREA	PMA -	SA3 - WELD PLATE -	SA1-0LB-AS TRMPT-
MELD FACTOR	PMF -	SA4 - TURN PLATE -	
NUMBER OF SECTIONS	NS -	SA5 - FIT SECTION -	
JAL. OF SECTIONS	SJM.-	SA6 - TACK SECTION -	
SECTION MELD AREA	SMA -	SA7 - WELD SECTION -	
NUMBER OF FITS	NF -	SA8 - SUB-ASSY HVLD -	
NUMBER OF TURNS	NT -	SA9 - SUB-ASSY TRMPT -	
PLATE WEIGHT	PWT -		
SECTION WEIGHT	SWT -		
		COST COEFFICIENT	
		SA10- LABOR RATE -	
WORK CONTENT			
PROCESS	QTY	FUNCTION	WORK CONT
FIT PLATES	NP	SA1	NP X PJM X SA1
TACK PLATES	PJM	SA2	PJM X SA2
MELD PLATES	PMA	SA3	PMA X PMA X SA3 X PMF
TURN SUB-ASSEMBLY	PWT	SA4	PWT X SA4
FIT SECTIONS	NS	SA5	NS X SJM X SA5 X SWF
TACK SECTIONS	SJM	SA6	SJM X SA6
WELD SECTIONS	SJM	SA7	SJM X SMA X SA7
WORLD ASSEMBLY	(PWT + SWT) X SA8		
TRANSPORT ASSEMBLY	(PWT + SWT) X SA9		
TOTAL WORK CONTENT (TWC)			
COST			
LABOR	TWC X SA10		
W/O COST	SA10(C) X PROCESS WORK CONTENT		
TOTAL COST			

ASSEMBLY			
PART DATA		WORK CONTENT COEF	W/O COST COEF
NUMBER OF PLATES	NP -	A1 - FIT PLATES -	AA-AUTO ASBY -
JAL. OF PLATES	PJM.-	A2 - TACK PLATES -	AA-ASBY HVLD -
PLATE MELD AREA	PMA -	A3 - WELD PLATES -	AA-ASBY HVLD-B-
PLATE MELD FACTOR	PMF -	A4 - TURN PLATES -	AA-ASBY TRMPT-
NUMBER OF SECTIONS	NS -	A5 - FIT SECTIONS -	
JAL. OF SECTIONS	SJM.-	A6 - TACK SECTIONS -	
SECTION MELD AREA	SMA -	A7 - WELD SECTIONS -	
NUMBER OF SUB-ASSY	NBA -	A8 - FIT SUB-ASSY -	
JAL. OF SUB-ASSY	JNBA-	A9 - TACK SUB-ASSY -	
MELD AREA OF S-A	MASA-	A10- WELD SUB-ASSY -	
NUMBER OF TURNS	NT -	A11- TURN ASSEMBLY -	
NUMBER OF MOVES	NM -	A12- MOVE ASSEMBLY -	
ASSEMBLY WEIGHT	AWT -	A13- WHEEL ASBY -	
		A14- TRANSPORT ASBY-	
		COST COEFFICIENT	
		A15- LABOR RATE -	
WORK CONTENT			
PROCESS	QTY	FUNCTION	WORK CONT
FIT PLATES	NP	A1	NP X PJM X A1
TACK PLATES	PJM	A2	PJM X A2
MELD PLATES	PMA	A3	PMA X PMA X A3 X PMF
TURN PLATES	PWT	A4	PWT X A4
FIT SECTIONS	NS	A5	NS X SJM X A5
TACK SECTIONS	SJM	A6	SJM X A6
MELD SECTIONS	SJM	A7	SJM X SMA X A7
FIT SUB-ASSEMBLIES	NBA	A8	NBA X JNBA X A8
TACK SUB ASSEMB	JNBA	A9	JNBA X A9
MELD SUB-ASSEMB	JNBA	A10	JNBA X MASA X A10
TURN ASSEMBLY	AWT	A11	AWT X A11
MOVE ASSEMBLY	AWT	A12	AWT X A12
ASSEMBLY WHEELING	AWT	A13	AWT X A13
ASSEMBLY TRANSPORT	AWT	A14	AWT X A14
TOTAL WORK CONTENT (TWC)			
COST			
LABOR	TWC X A15		
W/O COST	A15(C) X PROCESS WORK CONTENT		
TOTAL COST			

TABLE 1.2: (Continued)

MODULE			
PART DATA		WORK CONTENT COEF	M/O COST COEF
NUMBER OF ASSEMBLES NA -		A1 - FIT	NA * NA * ASSEMBLE -
JOINT WELD LENGTH AAL -		A2 - EXCESS FIT	NA * AAL * MOVE -
MODULE WELD AREA MA -		A3 - TACH	MA * MOVE * TURN -
MODULE WELD FACTOR MAF -		A4 - WELD	MA * MOVE * WELD -
NUMBER OF TURNS MN -		A5 - MOVE	MA * MN * TRANSPORT -
MODULE WEIGHT MW -		A6 - TURN	
MODULE OVERAL LENGTH MOL -		A7 - INWELD	
MODULE OVERAL WIDTH MOW -		A8 - TRANSPORT	
MODULE OVERAL HEIGHT MWH -			
NUMBER EXCESS SIDES ME -			
EXC MATERIAL LENGTH MEL -			
		COST COEFFICIENT	
		A9 - LABOR RATE	
WORK CONTENT			
PROCESS	QTY	FUNCTION	WORK CONT
FIT ASSEMBLES	NA	NA * AAL * A1	
REMOVE EXCESS	ME	ME * MEX * A2	
TACH ASSEMBLES	MA	MA * A3	
WELD ASSEMBLES	MA	MA * MAF * A4	
MOVE MODULES	MN	MN * A5	
TURN MODULES	MN	MN * A6	
INWELD MODULES	MN	MN * MOW * MWH * A7	
TRANSPORT MODULES	MN	MN * A8	
TOTAL WORK CONTENT (TWC)			
COST			
LABOR	TWC * A9		
MACHINES	(MCC) * PROCESS WORK CONTENT		
TOTAL COST			

SHIP			
PART DATA		WORK CONTENT COEF	M/O COST COEF
NUMBER OF MODULES MN -		B1 - ERUCT	MN * MOVE * HOLE -
JOINT WELD LENGTH AAL -		B2 - FIT	
MODULE WELD AREA MA -		B3 - EXCESS FIT	
MODULE WELD FACTOR MAF -		B4 - TACH	
MODULE WEIGHT MW -		B5 - WELD	
NUMBER EXCESS SIDES MEX -			
EXC EXCESS MAT LENGTH MEL -			
MODULE LENGTH ML -			
MODULE WIDTH MW -			
MODULE HEIGHT MH -			
		COST COEFFICIENT	
		B6 - LABOR RATE	
WORK CONTENT			
PROCESS	QTY	FUNCTION	WORK CONT
ERUCT MODULES	MN	MN * B1 * ML * MW * MH * MN	
FIT MODULES	MA	MA * AAL * B2	
EXCESS REMOVAL	ME	ME * MEX * MEL * B3	
TACH MODULES	MA	MA * A3 * B4	
WELD MODULES	MA	MA * MA * MAF * B5	
TOTAL WORK CONTENT (TWC)			
COST			
LABOR	TWC * B6		
MACHINES	(MCC) * PROCESS WORK CONTENT		
TOTAL COST			

shipyards have and still use work measurement techniques to assist them to define efficient production development, processing, facility layout and material handling, many consider it unsuitable for their operations, and look upon it as only useful when worker incentive schemes are to be implemented. This is partly because of the bad publicity and inaccurate reporting of some applications in the past, due to inexperienced users, and partly because early work measurement techniques required a level of detail and control that is not usually found in shipbuilding organizations. A number of simplified work measurement systems have been developed since the birth of the technique, and these are an effective tool for any shipyard desiring to improve its productivity. One of the best known is the MOST system [6]. Its name is an acronym for Maynard Operation Sequence Technique. The system uses an alphabetic code for certain human movements and equipment activities. Over many years of experience and computer analysis of the numerous case studies performed with the system, three sequences were identified that generally cover all manual work. Next, the activity identified by the alphabetic code was quantified by assigning a numerical suffix to the code letter which was based on extent and difficulty of the activity.

Most ship designers will not have either the experience or the time to use work measurement techniques, such as MOST, in their normal design decision process. However, if an industrial engineering capability exists in their shipyard, they should take every opportunity to use it, and to work with the industrial engineers to arrive at the best design for their shipyard. If such a capability does not exist in the shipyard or it is too busy with the many other areas they are involved in, and it is not reoriented by management, *design for ship production* can be performed. The ship designer with a team from planning and production can examine the different ways to design a detail, and rank them on the basis of a merit factor considering various producibility and cost aspects. When complete, the selected “best” design and the selection analysis can be sent to other departments that are involved in the process, for their review and concurrence. It is strongly recommended that a *design for ship production team* be established to review and maintain a shipyard’s existing standards, and at the early stage of all new ship design development to ensure that the design will be the most producible and cost-effective design for their shipyard. Table 1.3 is suggested as a minimum procedure for applying *design for ship production* based on experience and intuition of such a team.

The lack of a suitable analysis method and the shortcomings of the intuitive or “gut feeling” approach should not be allowed to dissuade ship designers from applying *design for ship production* in this way. With its constant application, questions will be asked which will result in a better understanding by engineering of production’s problems and vice versa

TABLE 1.3

APPLICATION OF DESIGN FOR PRODUCTION

-
1. Examine Existing Design
 - a. Count the number of unique parts
 - b. Count the total number of parts
 - c. Count number, type, and position of joints
 - d. Evaluate complexity of design
 - Simple measuring
 - Simple manual layout
 - Complicated manual layout
 - CAD/CAM applicability
 - Required manual processing
 - Required machine processing
 - e. Producibility aspects
 - Self-aligning and supporting
 - Need for jigs and fixtures
 - Work position
 - Number of physical turns/moves before completion
 - Aids in dimensional control
 - Space access and staging
 - Standardization
 - Number of compartments to be entered to complete work
 2. Examine Alternative Design(s) in Same Manner
 3. Select the Design that Meets the Objective of Design for Production, which is:

The reduction of production cost to the minimum possible through minimum work content and ease of fabrication, whilst still meeting the design performance and quality requirements.
-

REFERENCES

1. E.N. Baldwin and RD. Niebel, *Design for Production* (Homewood, Ill.: Irwin Inc., 1957).
2. F. Brian Todd, "The role of industrial engineering in shipyard production services," *Managing Ship Production* (Glasgow: University of Strathclyde, WEGEMT, 1980).
3. C. Kuo et al., "Design for production of ships and offshore structures." SNAME Spring Meeting, 1983.
4. C. Kuo et al., "An effective approach to structural design for production." RINA Spring Meeting, 1983.
5. J. Wolfram, "Application of regression methods to the analysis of production work measurements and the estimation of work content," *Welding Research International*: 9:1, 1979.
6. *Work measurements in the 1980s* (London: MOST Measurement Systems Ltd., Berkley Square House).

1.3 Basic Design

1.3.1 GENERAL. *Basic design covers all design from conceptual through contract.*

However, in some shipyards the only design that they become involved in is detail design, such as structural calculations and analysis, and system sizing based on an owner-prepared contract design and specification. The subject of ship design is well covered in many books [1,2,3,4,5,6] and in the transactions of the naval architecture and marine engineering professional institutions [7,8,9,10,11,12,13]. It will only be discussed to the extent necessary for the incorporation of design *for ship production*.

The extent of basic design varies from shipyard to shipyard and even in the same shipyard for different shipowners. One shipowner may be quite specific about what is required and present a very detailed contract design package. At the other extreme, the shipowner may simply state ship type, cargo deadweight, speed, and crew size. Considerable effort has been expended by researchers and designers in developing computer programs which optimize the design characteristics based on a particular merit factor [14,15,16,17,18,19]. The following items have been proposed as merit factors:

<u>Item</u>	<u>Proposer</u>
Construction Cost	shipyard
Propulsion Power	Designer
Steel Weight	shipyard
Deadweight Coefficient	Designer
Freight Rate	Owner
Capital Recovery Factor	owner
Return on Investment	owner

The proposers all had good arguments why their choice was correct, and perhaps it was in a given unique situation. However, the economic performance of the ship in its intended service is the only real merit factor. Some of the other items may be correct for tradeoff analysis and sensitivity studies. It is well known that the lowest-cost ship to build will not be the least-cost ship to operate. It is further known that the minimum steel weight ship will not be the least-cost ship to build [20]. Therefore, when computer optimizing programs are being used to design a ship for actual construction, it is essential that producibility aspects be integrated into the program.

For example, a particular shipyard may have building berth or dock limitation for length, breadth, and draft; depth due to crane lift height; and structural block size due to berth loading, transfer space, and crane capacity. A shipyard could decide ship breadth on the basis of multiples of maximum plate widths or ship lengths for transversely framed ships. It may be better, from the shipyard's point of view and still be operationally acceptable by the shipowner, to design a relatively long, narrow hull with extensive parallel body, than a shorter and beamier hull with no parallel body, because of the framing standardization and reduced shaping of shell plates, thus reducing total work content.

It may also be "better" to design with a larger-than-class standard frame spacing, and pay a weight penalty in thicker plating, as the reduction in work content would far outweigh the increased material cost. Fortunately, most optimization studies show that the proportions of an optimum design can be varied to suit building optimization with only slight detriment in the operating optimization merit factor. This can be seen from the

usual rather flat economic merit factor curves for a given ship size and speed. Therefore, a design based only on an operating optimization study should only be used to select major sensitive factors such as speed and size. Then the design details should be optimized for each shipyard, taking into account producibility factors while maintaining a speed/power performance close to the operating optimization relationship.

If for some reason the shipyard designers find the speed/power relationship is wrong, then the operating optimization study should be rerun using the correct relationship to see if the optimum size or speed changes. Once the design characteristics are selected, it is necessary to marry every design decision with producibility decisions.

1.3.2 ARRANGEMENTS. When developing the arrangement of a ship, decisions must be made regarding the location of cargo spaces, machinery space, tanks and their contents, number of decks in the hull, number of flats in the engine room, number of tiers and size of deckhouses, cargo handling gear type, capacity and location, accommodation layout, etc. It is therefore obvious that the development of the arrangement of a ship has a significant influence on its total construction work content. Yet it is usually performed with minimum production input. The construction work content is greatly affected by design decisions on:

- (a) Hold or tank lengths
- (b) Engine room location
- (c) Machinery arrangements
- (d) Cargo hatch sizes
- (e) Double-bottom height
- (f) Tween deck height
- (g) Use of corrugated and/or swedged stiffening
- (h) Location of tank boundaries
- (i) Deckhouse shape and extent of weather decks
- (j) Sheer and camber

In the current approach to ship production it is highly probable that the arrangement designer specializes in arrangement design and has never had any feedback from production departments on producibility aspects. The designation of the design general arrangement drawing as a contract drawing has more adverse effect on the cost of a ship due to unnecessary work content than any other contract drawing with the exception of the contact lines drawing, which can be equally detrimental if prepared without any regard to producibility.

(a) **Hold or Tank Lengths.** The frame spacing should be constant throughout the ship's length with the exception of the peaks, where the usual practice of incorporating smaller spacing can be followed if it has no adverse impact on the producibility of the bow and the stern. In the case of bulk carriers and general cargo ships, some designers deliberately varied the lengths of the different holds and tween decks to equalize the loading and unloading times [21]. This required that a vertical zone incorporating hold and tween-deck reefer lockers should be shorter than another zone without reefer lockers. Also the length of the holds towards the ends of the ship were longer to account for the shape forward and both the shape and shallower depth over shaft tunnels aft. Whether this approach is really worthwhile is uncertain.

There is no question that a basic cargo handling balance should be provided in a well designed ship. However, as the general cargo is hardly ever completely homogeneous, it is suggested that any imbalance resulting because of standardizing the lengths of the holds or tanks will be unnoticed in the operation of the ship. Container ships as well as bulk

carriers do handle homogeneous cargo as far as the ship designer is concerned. The hold or tank length should be a multiple of the frame spacing and be duplicated for each hold or tank as much as possible. This will allow the structural modules to be standardized.

For example, in a ship with five holds, of which three are in the parallel body and each hold has eight modules that are duplicates, then only eight different structural drawings must be prepared for three holds. Whereas, if the hold lengths are all different, then twenty-four structural module drawings are required.

When the standardization concept is carried over into lofting, process planning, and actual construction, the labor and time savings multiply. This approach is simply applying group technology on a macro level during basic design, thus ensuring it can be utilized at the micro level during product engineering, lofting, processing, and work station assembly. If it is necessary to vary the length of some holds or tanks, the length should be one or two web frame spaces more or less than the standard length, so that the standard drawings can be extended to the non-standard hold.

(b) Engine Room Location. In small ships the engine room can be located anywhere in the length that provides a workable loading/trim relationship for the intended operations. For large-ships the engine room is usually located aft of amidships. A popular location for the engine room in cargo liners is the two-thirds aft position [22]. In all other cases, the obvious producibility factors to consider are:

- Length of shafting.
- Engine room is not suitable for standardization of arrangement and structure. Therefore, the engine room should be located in the part of the ship least suitable for standardization. That is the ends.
- A shaft tunnel or alley is needed except for the all aft location.
- All aft deckhouse requires more tiers to provide adequate line of sight over bow.

Before the recent skyrocketing increase in fuel cost, a number of interesting novel machinery arrangements were developed, usually for novel ship types, but sometimes for traditional vessels such as tankers and bulk carriers. They were proposed for both reductions in material and operational costs as well as ease of production. Some of these which impact production are shown schematically in Figure 1.7.

(c) Machinery Arrangements. The development of the machinery arrangement consists of arranging the machinery and equipment necessary to propel and service a ship into an easily fabricated, installed, operated, and maintained plant. Often the machinery arrangement is developed during contract design as a contract drawing, which means it cannot be changed by the shipyard without the permission of the shipowner. To make matters worse, some machinery arrangements are still developed without any logical approach to the layout of the equipment or any consideration of piping and other system routing. Add to this the fact that very few contract machinery arrangement drawings prepared in the U.S. are developed with advanced outfitting or basic producibility in mind. The resulting dilemma facing a shipyard desiring to improve the producibility of the design is, what to do?

Once a contract drawing is prepared, the designer and even the shipowner resist any changes. To prevent this from occurring in the future, the ship designer preparing the

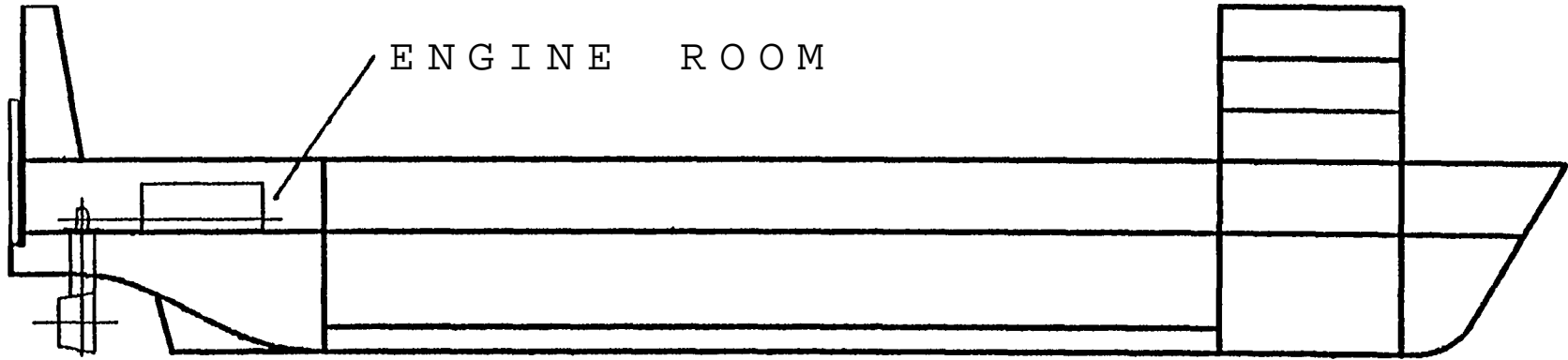

"Z" PROPELLOR
P & S

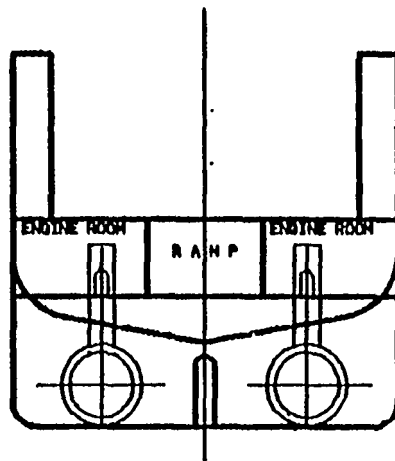

FIGURE 1.7. Split-engine room with azimuthing propulsors.

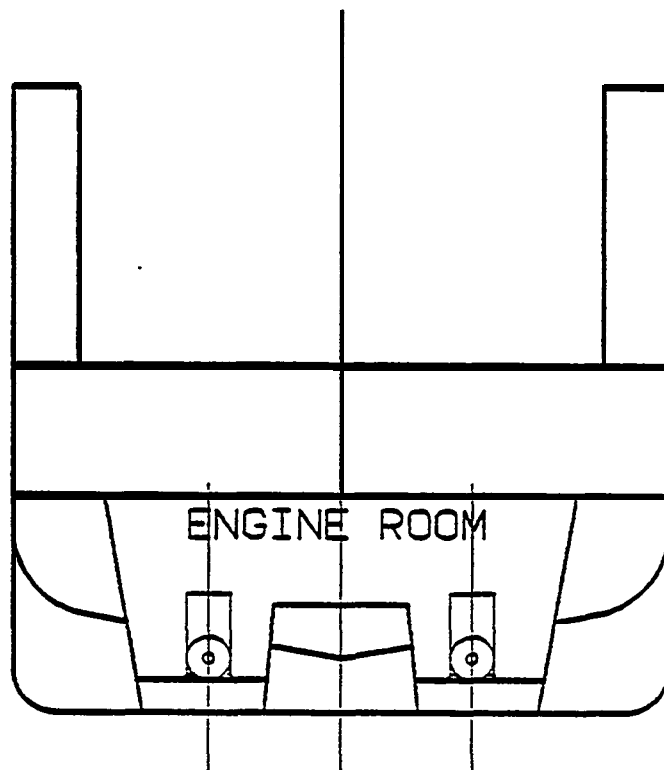
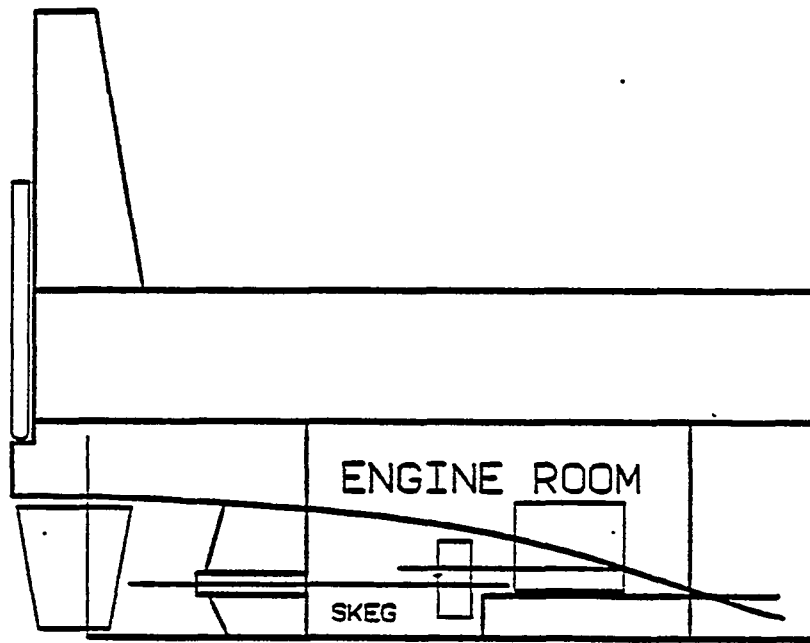

FIGURE 1.7 (Continued): Engines in skegs.

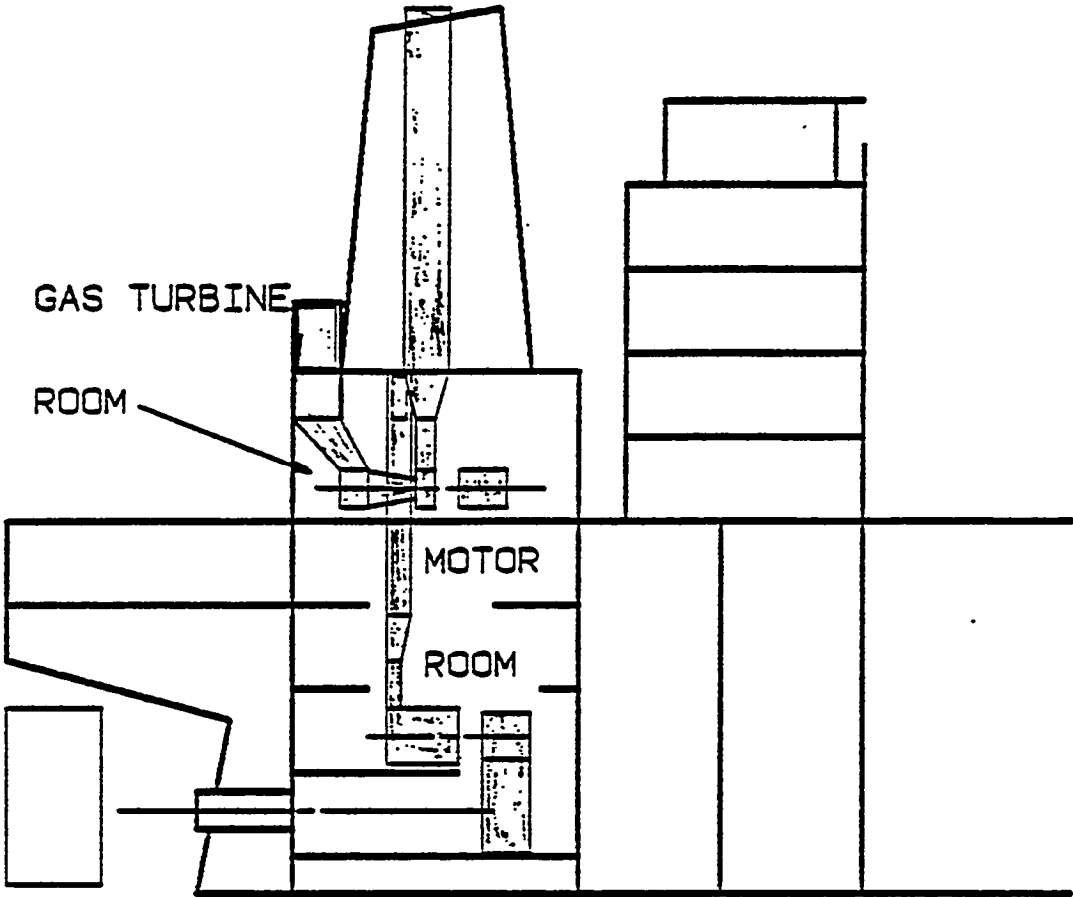

FIGURE 1.7 (Continued): Gas turbine/electric with above-deck turbine room.

contract design must find out the shipyard's approach to machinery space construction and make sure the machinery arrangement is compatible with the approach. It is essential that producibility be adequately considered during the development of the machinery arrangement, not only in the equipment layout but for the surrounding structure.

This important point can best be illustrated by an example. Figure 1.8 shows a typical large naval vessel machinery space arrangement consisting of two main machinery rooms (MM#1 and 2) and a central control room. The ideal from a producibility point of view, both MMRs should be identical arrangements, but that is obviously not possible in a twin-screw ship. The next best arrangement is to make the MMRs mirror images about the center line of the ship. This is possible if the shaft center lines are parallel to each other, and are horizontal. Unfortunately, this is often not possible, and the different plan angles and declivities of the shafts prevent exact mirror image spaces. However, even in this case the machinery spaces can be mirror images except for the propulsion machinery setting. The productivity benefits to be gained justify this approach. Obviously, only the aft space has two shafts in it. The forward space should simply be a mirror image of the aft space with the transiting shaft deleted. The mirror image requirements apply to the surrounding structure as well as the machinery arrangement. It can be seen from Figure 1.8(a) that duplicity of arrangements in the MMRs and surrounding structure was not attempted. The following differences are noted:

- The aft transverse bulkhead in MMR#2 is flush, whereas in MMR#1 it has stiffeners
- Vice versa for the forward bulkheads
- The casing is aft in MMR#1, and forward in MMR#2
- The control room is oriented differently with respect to each MMR

Figure 1.8(b) shows the same machinery arrangement developed to minimize necessary design, lofting, and installation work content by incorporating duplicity as much as possible. It should be noted that the control room is now in the same relative transverse location for each MMR, but obviously it is not longitudinally.

The layout of the auxiliary machinery has a major cost impact and therefore it is important to arrange it in the most cost-effective way. Today that means equipment package units, piping/grating units, and advanced outfitting. This is because advanced outfitting is driven by labor-saving goals such as straight lengths of pipe, right-angle pipe bends, combined distributive system & rating support units, all of which are performed in ideal shop conditions. However, the basic requirement in the design of engine rooms is the ease of machinery plant operation and maintenance. That must be met and not impaired regardless of the method of installation. Fortunately, the procedures used for developing advanced outfitting design are compatible with the basic requirement. If it is attempted to lay out auxiliary machinery during basic design, it must be determined if advanced outfitting of the machinery room is intended, as certain approaches must be followed if it is. Even if advanced outfitting utilizing equipment and piping units is not intended, it is still good design to approach the arrangement of machinery rooms into associated equipment groups and service passages or zones. It is suggested that only the unit boundary need be shown, and the equipment within each unit boundary listed.

If the ship designer does not take such matters into consideration and prepare production-oriented contract machinery arrangements, it is strongly suggested that the document they prepare be designated as a guidance drawing, and only be used to show required equipment.

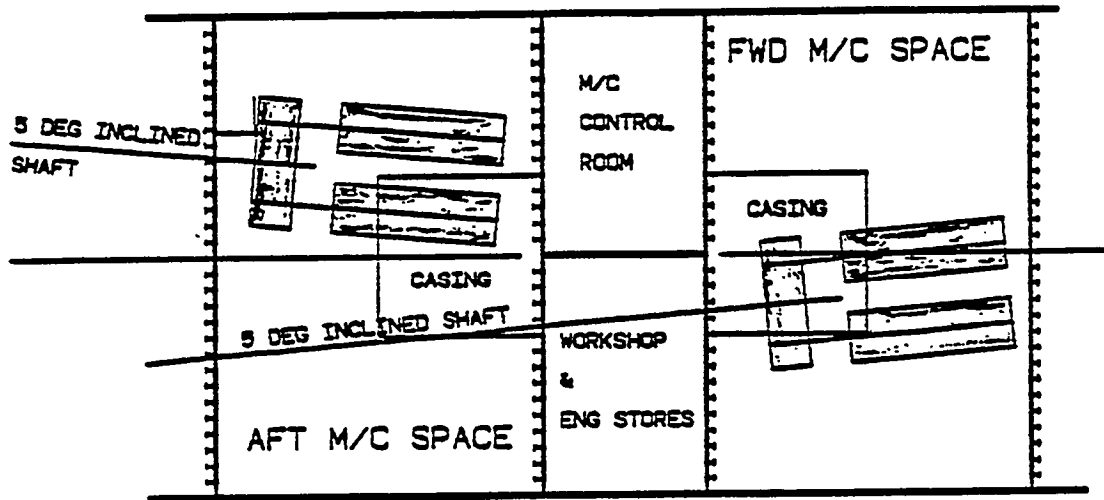

(a) Design without regard for production.

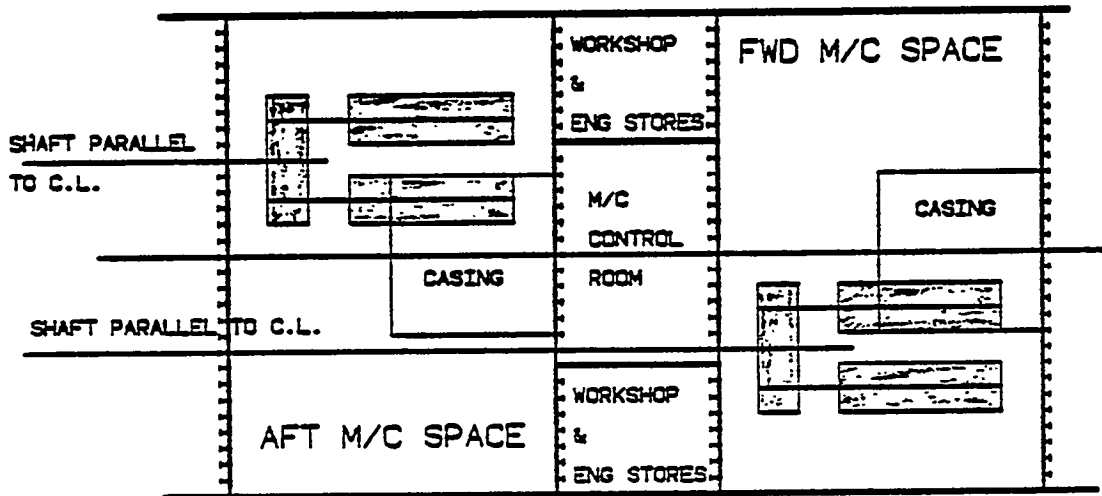

(b) Design for production

FIGURE 1.8 Machinery space arrangement design for production.

(d) Cargo Hatch Sixes. Standardization is the major producibility goal that applies to cargo hatchways and hatch covers. All cargo hatches should be identical on a given ship or size of ship for a given shipyard. This would allow hatch coamings and covers to be designed and lofted only once, and to be built on a process flow basis. In addition to size and detail, the location of the hatches relative to the hold transverse bulkheads should also be identical. The module erection sequence must also be decided at this stage as it will obviously affect the design, and in turn the work content for the hatch module and its installation. This can be seen from Figure 1.9, which details two possible design approaches that could be used.

Method A shows a hatch coaming that would be erected on top of the deck. It usually requires “stock or green” material to be left on the lower edge of the coaming for scribing to the deck. Also the fillet welds of the coaming to the deck are not suitable for machine welding due to the brackets on the outboard side, and no work surface for the machine on the inside. In fact, it is also necessary to provide staging inside the hatch coaming for the workers welding the inside fillet.

Method B incorporates part of the deck in the hatch module. Any “stock” material would be left on the outboard deck and the hatch module as a bum-in guide. It should be obvious that Method B allows machine welding of the deck seam and butt on top of the deck. Staging would still be required for the fitting and welding below the deck, but it would be simpler to erect and dismantle from the tween deck below.

(e) Double-Bottom Height. The height of the double bottom is usually derived from the appropriate classification rule depth for the center vertical keel. A designer may increase the depth over rule requirement but will seldom reduce it. Most double-bottom spaces are very small with difficult access for both workers and their tools. A problem often results from deciding the double-bottom height based on only the midship section. The bottom hull shape rises both forward and aft of the midship section. This obviously reduces the height in the double bottom outboard of the center line and below the minimum acceptable height for construction. Therefore, it is necessary to consider double-bottom height at the location where the hull shape reduces it to a minimum over the required length of double bottom.

The height for access between the shell and inner bottom frames or longitudinals should not be less than 15 inches, and if possible, 24 inches. It is possible to use a smaller double-bottom height with transversely framed ships than with longitudinally framed ships. This is because with longitudinal framing in the double bottom, the transverse plate floors need to be deeper to allow for a reasonable distance between the longitudinal cut-outs and access holes. This is shown in Figure 1.10 and 1.11. Normally, the access holes are restricted to 23-inch by 15-inch ovals due to the application of admeasurement regulations. However, for large ships (over 400 feet) U.S. admeasurers will allow larger holes if they are necessary for construction equipment access. If the shipowner desires the ship to be “measured” under the 1969 Tonnage Convention, there is no restriction on hole size, and therefore no need to keep the traditional access and lightening hole sixes. Sixes should be maximum allowable from a structural point of view.

(f) Tween-Deck Height The tween-deck heights may be decided by an operational requirement such as use of standard pallets, hanging refrigerated meat, maximum number of boxes that can be stowed on top of each other, carriage of containers, RO-RO cargo, etc. In such a case, the deck levels must be selected to allow cost-effective design of deck structure.

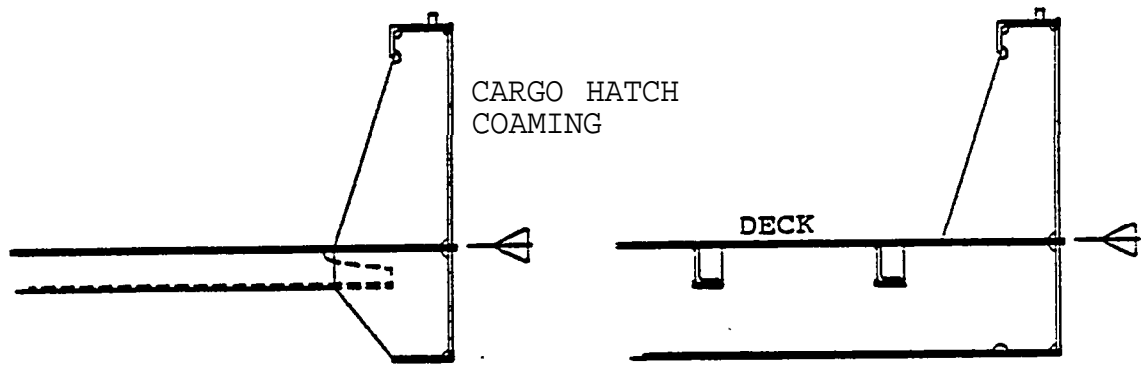

METHOD A

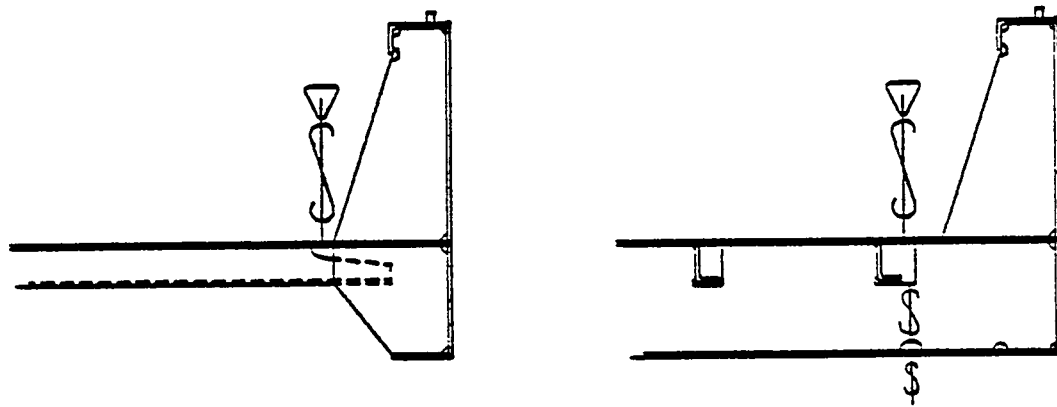

METHOD B

FIGURE 1.9 Hatch installation alternatives.

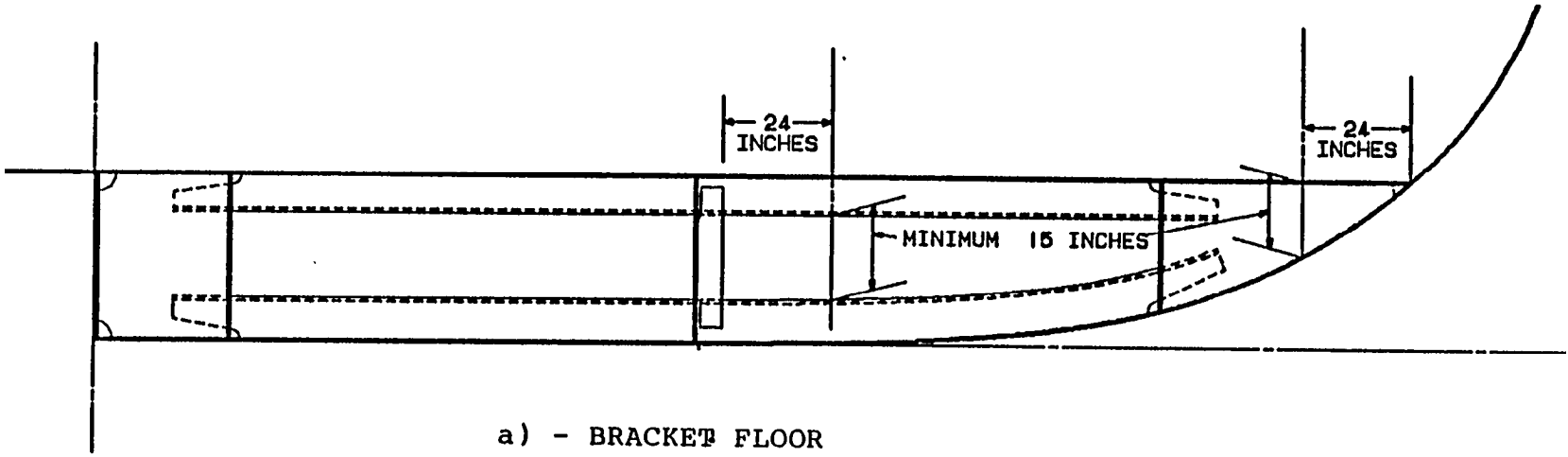

a) - BRACKET FLOOR

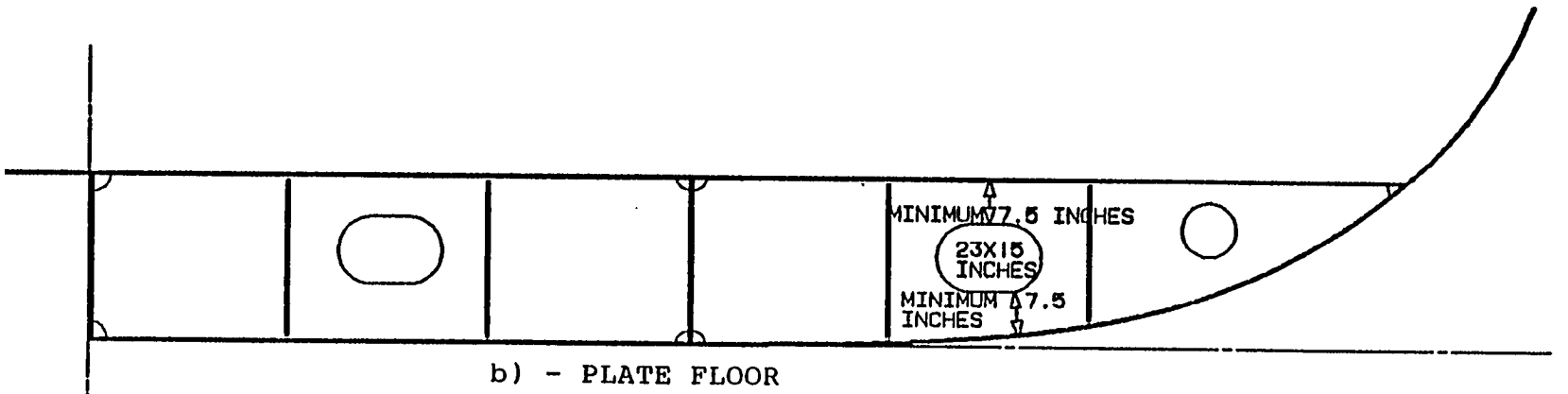

b) - PLATE FLOOR

A) TRANSVERSELY FRAMED

FIGURE 1.10 Factors affecting double-bottom height.

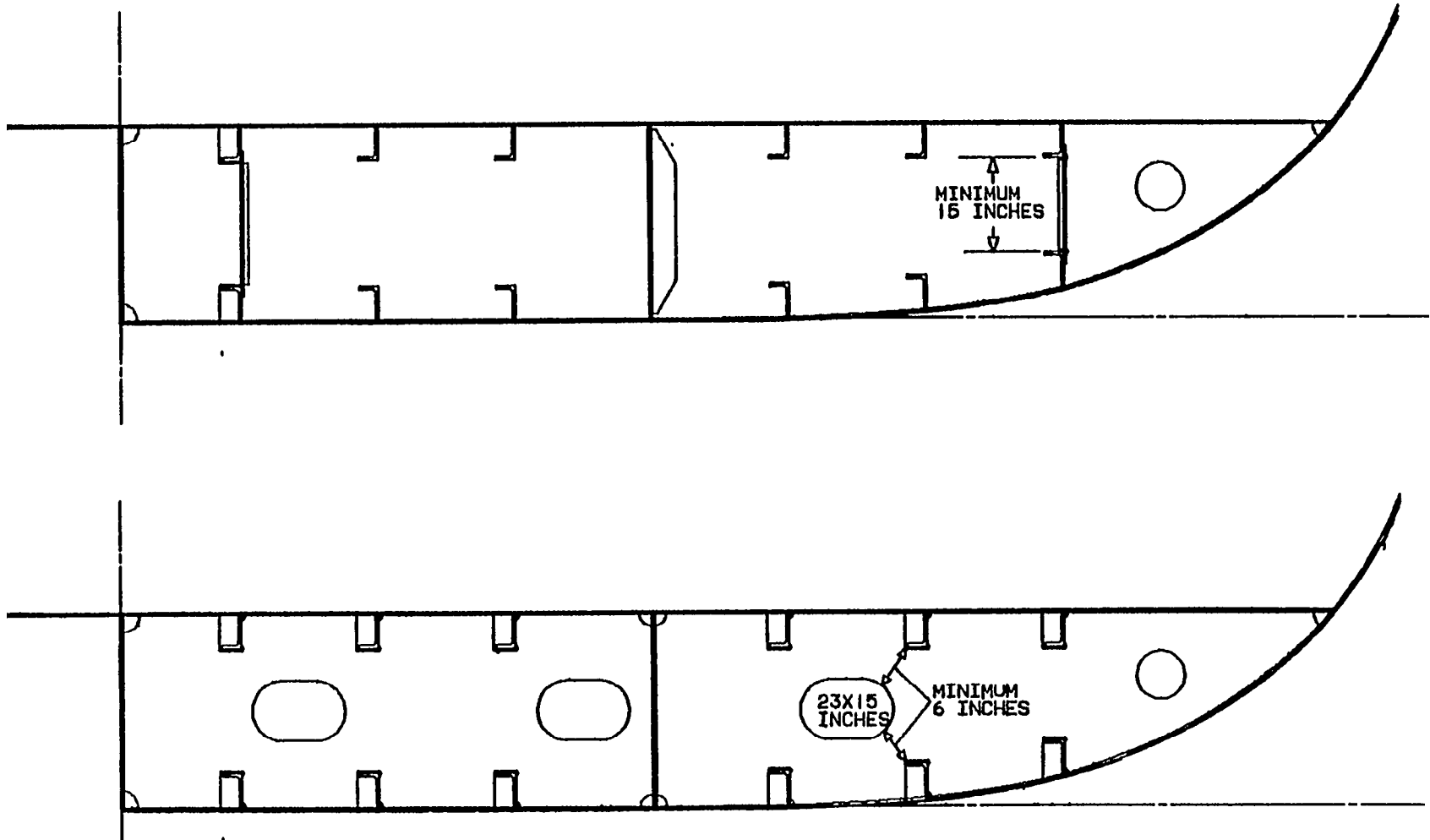

44

B) LONGITUDINALLY FRAMED

FIGURE 1.11 Factors affecting double-bottom height.

In way of accommodation, the tween-deck height should be selected to allow high productivity installation of the overhead ventilation ducting, piping, and wiring. If it is difficult for the designer to squeeze such systems into the allowable space, it will be many times more difficult and with high manhours for the production worker to install the systems. Beam/frame bracket size should also be considered when selecting tween-deck height in both cargo and accommodation spaces to ensure that the brackets do not encroach on cargo or accommodation space. It is usually possible to select a smaller tween-deck height in accommodation spaces with transverse beams rather than longitudinals. This is because longitudinally framed deck deep transverses add to the required height for fore and aft run services. Conversely, if the deck is longitudinally framed, additional tween-deck height should be provided. This requirement can be seen from Figure 1.12. When the tween-deck height must be kept to a minimum, it may be better to provide deeper deck transverse beams or non-structural steel bulkheads, and run systems through at constant height rather than work to minimum depth for the deck transverses, and drop the systems as shown in Figure 1.13. Another possible approach which is applicable to modern construction methods is to select zones over service areas, passageways and toilets, and provide only the allowable minimum clear deck height in way of the zones. The specified clear deck height is maintained in all other areas. This is shown conceptually in Figure 1.14.

(g) Use of Corrugated and Swedged Stiffening. One very effective way to reduce work content as well as the weight of steel for a design is to utilize corrugated and swedged stiffening for bulkheads, deckhouse decks, and sides. Figure 1.74 in Section 1.5.3(j) gives details of such corrugations and swedges. The work content is obviously reduced due to the number of parts to be processed and assembled, and joint weld length, but it is also due to the elimination of weld deformation with thinner plate. There is an increase in work content due to the forming effort, but the net result is a significant work content reduction.

Corrugated bulkheads can be effectively integrated with access ladders, pipe runs, space ventilation, and other items passing vertically through the space. Corrugated bulkheads can be used anywhere stiffened bulkheads are required. Corrugations for transverse bulkheads could be either vertical or horizontal, but for longitudinal bulkheads they must be horizontal. Vertical corrugations have less work content than horizontal, and are therefore preferred.

Swedged bulkheads can be used for tween-deck structural bulkheads, and for all miscellaneous non-structural steel or aluminum bulkheads. Swedges must be vertical. Swedge stiffening can also be used for deckhouse exterior bulkheads where again they would run vertically. Swedges could be used for decks inside deckhouses. For short deckhouses with no influence on the ship's longitudinal hull girder strength, the swedges could run transversely. For long deckhouses, the decks would be swedged in the longitudinal direction. The decks would be swedged downwards and the trough formed by the swedge filled with deck covering underlayment.

One disadvantage of corrugated and swedged construction is that it prevents machine welding of the edges perpendicular to the corrugations or swedges to connecting structure. This can be overcome by developing welding machines especially for this purpose, and in the case of swedges, modifying the ends so that the intersecting edge is straight.

(h) Location of Tank Bulkheads. From a production point of view, it would be ideal if the tanks in each erection module could be complete and tested before erection. This would enable any defects to be easily corrected on the module construction platens.

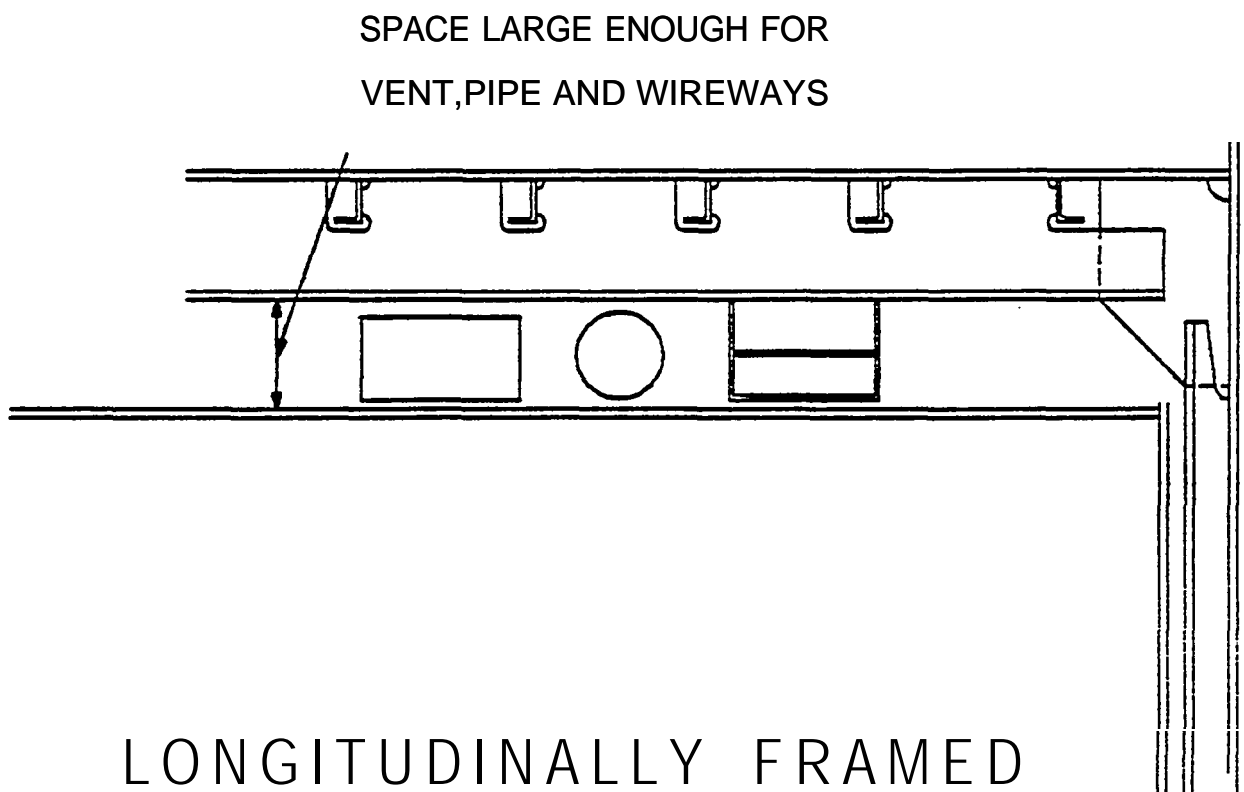
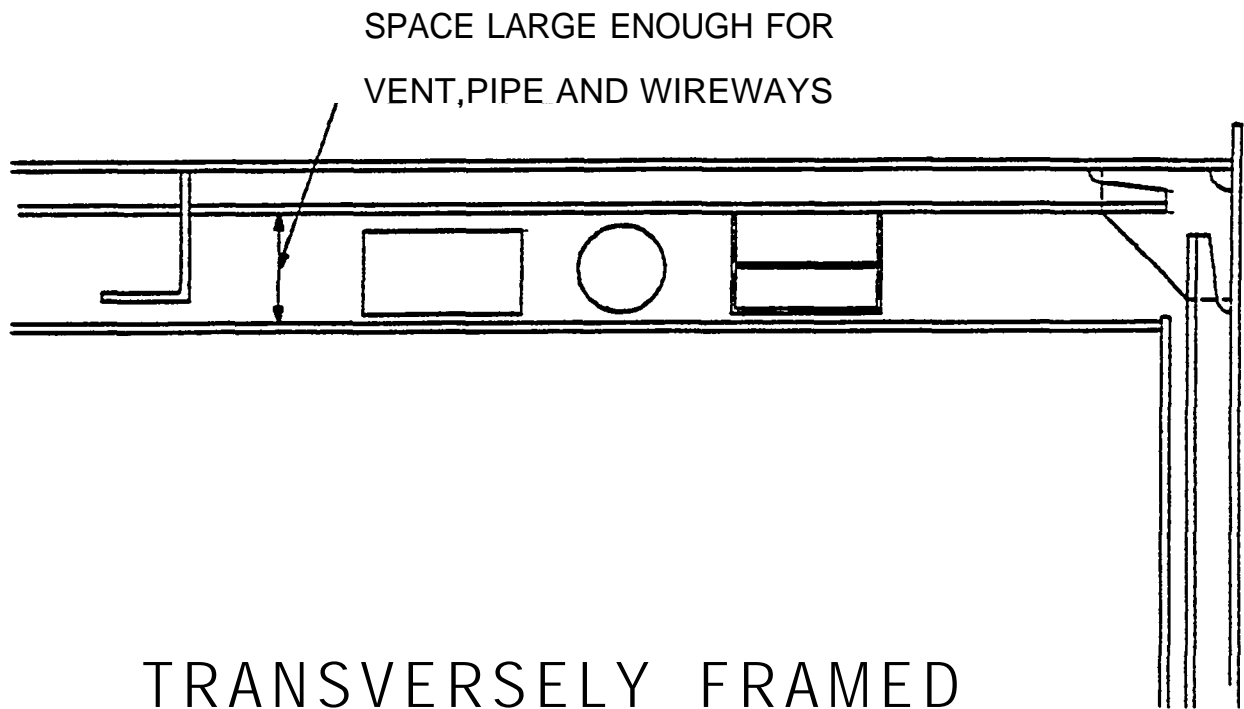

FIGURE 1.12 Required space above ceiling for services.

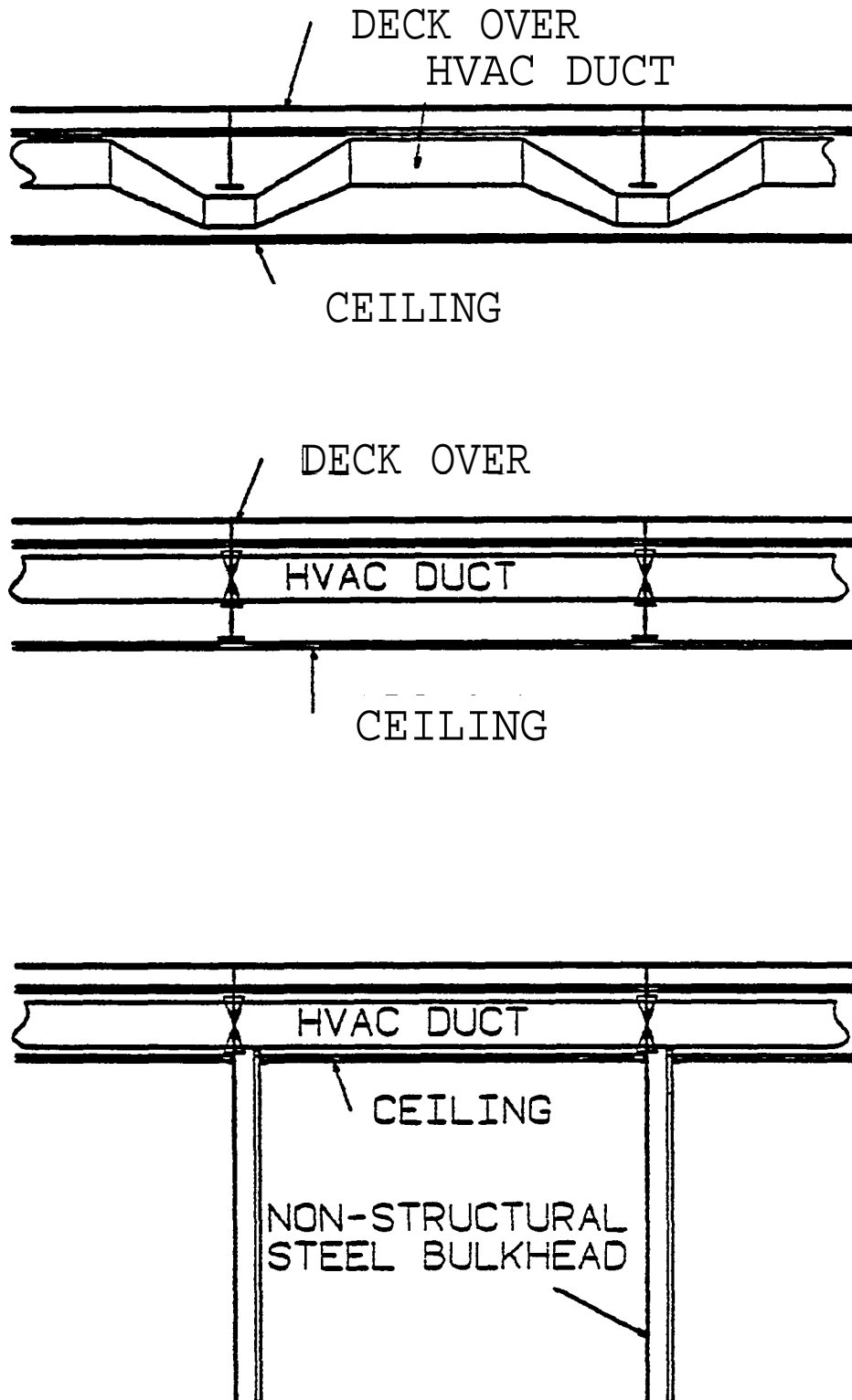
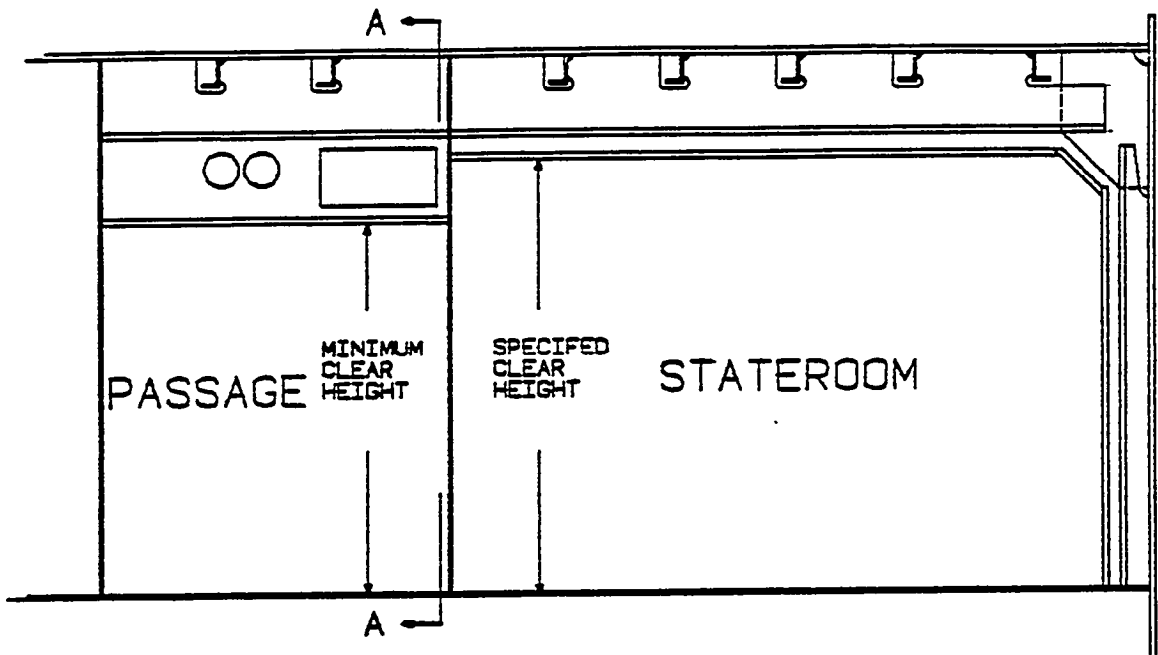
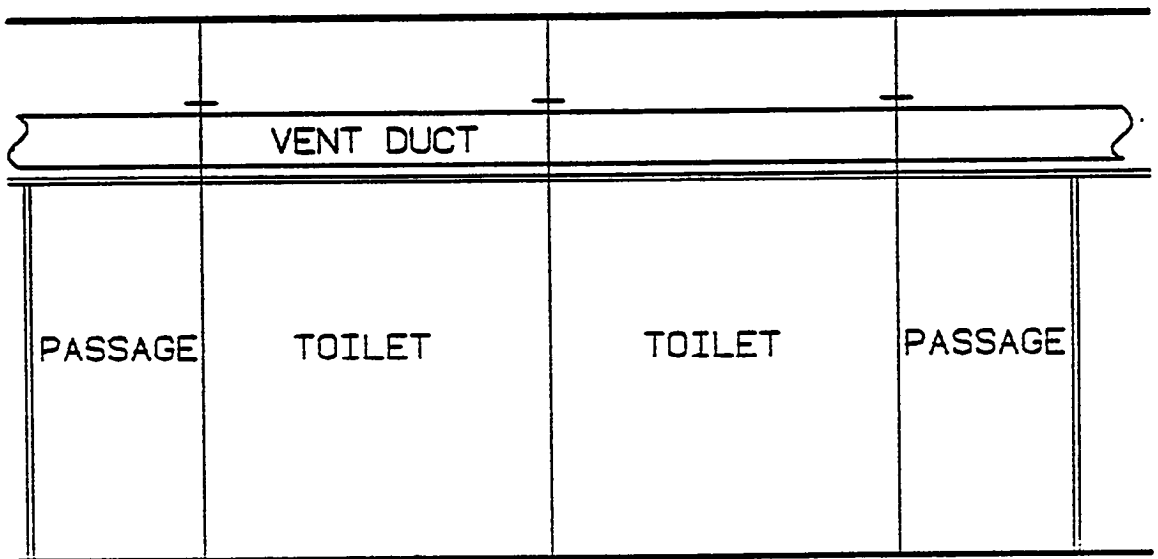

FIGURE 1.13 Alternative overhead deck space use.



TRANSVERSE SECTION THROUGH ACCOMMODATION



SECTION A-A

FIGURE 1.14 Select service zone for minimum deck heights.

This is not possible when common tank boundaries cross or are located at an erection joint. Usually only a portion of the tanks needs to be hydraulically tested. Then the erection joints can be located in the tanks which do not need to be tested. In addition, if the tanks are to be coated, it would be preferable to have no module connecting welding which would damage the coating, thus requiring rework.

One way to achieve this ideal would be to provide cofferdams in way of erection joints. This would reduce the amount of usable space in the hull for tanks, and would increase the steel weight. The work content would also increase due to additional manholes, sounding tubes, and air vents. However, it could still be a productivity net improvement, depending on design, extent of required testing, and tank coatings. Figure 1.15 shows this concept graphically. Obviously, there could still be some coating damage where the bulkheads are welded to the tank top, but this can be avoided by incorporating a strip of bulkhead onto the double-bottom module before it is coated. It could also be solved by increasing the cofferdam size to two frame spaces, but this may be unacceptable due to the cost.

(i) Deckhouse Shape and Extent of Weather Decks. Many ship designers allow aesthetics rather than producibility to influence them when designing deckhouses. Sloping house fronts, exterior decks along the sides and aft house bulkhead, and sweeping side screens add significant work content to the task of constructing a suitable deckhouse to accommodate the crew, and provide the necessary service spaces. While certain ships such as passenger and cruise ships can justify the cost of such aesthetic treatment, in general they are unnecessary additions for all other types of ships. They not only increase the construction cost, but they also cost more to maintain during the ship's operational life. The ship designer should develop simple deckhouse designs utilizing vertical and flat sides, and only provide exterior decks that are required for the safe access and working of the ship. Figure 1.16 shows the two extremes, and the additional cost aspects of the aesthetic streamlined design can be clearly seen.

(j) Sheer and Camber. About twenty-five years ago it was *unusual to see ships without sheer. Certain specialized ships such as train and car ferries were the only types for which it was acceptable to have flat decks. Next, tankers and bulk carriers dispensed with sheer, and today it is unusual to provide sheer for commercial ships. Sometimes so-called "straight line" sheer is provided, which consists of a straight horizontal deck line over the amidship portion of the ship, and straight line angled decks forward and sometimes aft. The advent of RO-RO ships and car transporters completed the disappearance of sheer. Even large warships are designed without sheer today. It is true that sheer impacts the survivability of a ship due to the greater depth to the margin line forward and aft, and this is why ships with no sheer pay a freeboard penalty. Sheer also influences deck wetness, but ships with no sheer can counteract this advantage by incorporating a forecastle and/or proper bow flare forward. Obviously the reason for eliminating sheer is that a flat deck has less work content than a deck with sheer. This is due to eliminating the need to shape the deck, angle the beams, and bend the longitudinal girders. This applies to decks in the hull as well as the deckhouse and superstructure.

Camber has had a similar development history, but has not so completely disappeared. It is quite common to provide "straight line" camber which is made up of either two lines peaking at the center or three lines with the middle line horizontal, and the outboard lines sloping down to the deck edge. If the deckhouse is designed with a minimum of weather deck area, then there is no need for camber on the decks in the deckhouse. Many designers are eliminating camber from their designs as a producibility improvement, as it obviously reduces work content. They logically argue that it is operationally acceptable because ships are seldom level when at sea, and even when in port they usually have trim and list.

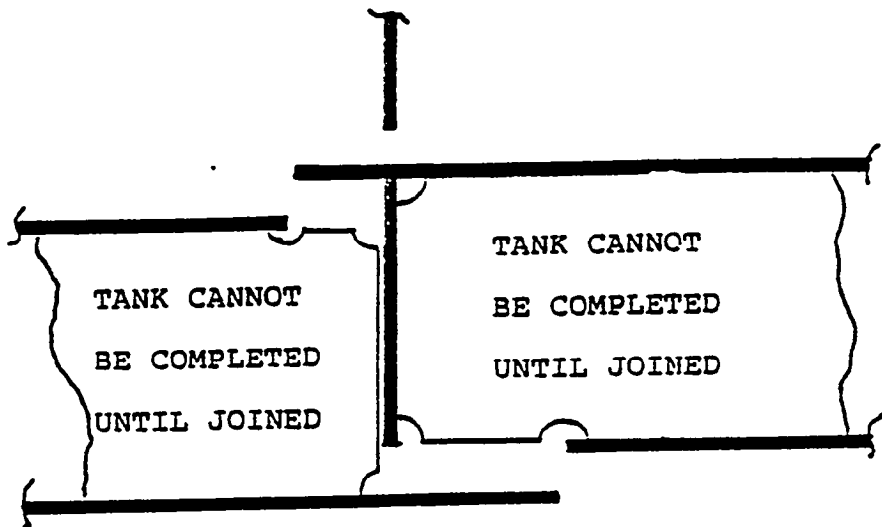

TRADITIONAL DESIGN - HIGH WORK CONTENT

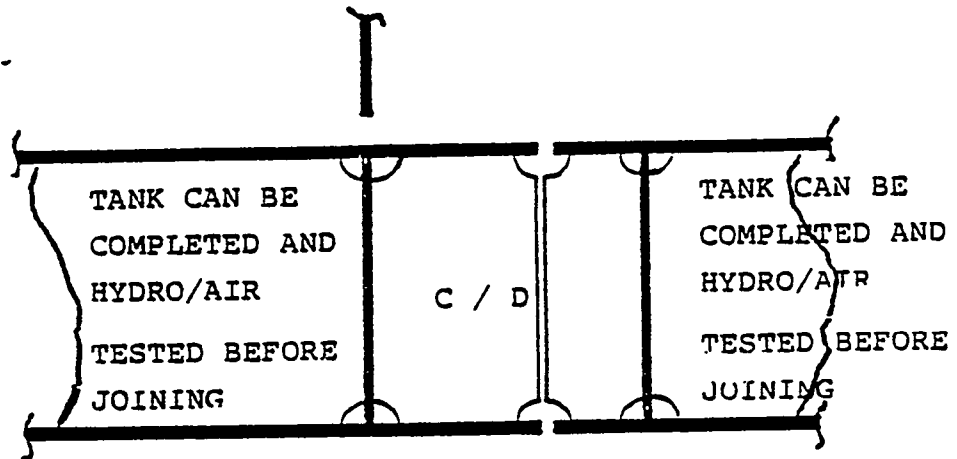

LOW WORK CONTENT NON-SELF-ALIGNING DESIGN

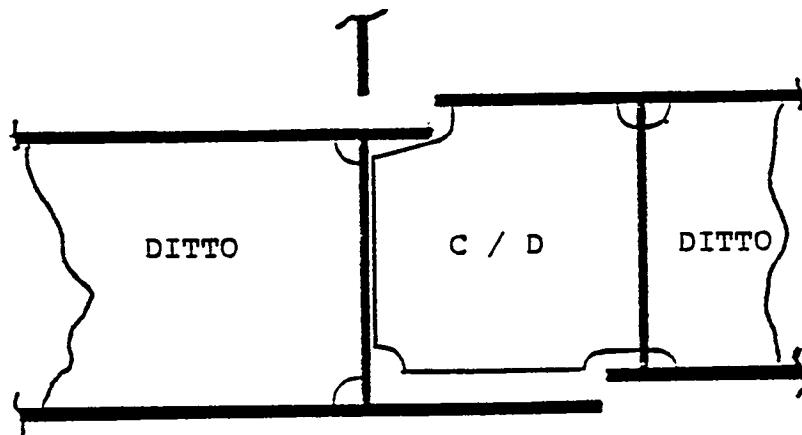

LOW WORK CONTENT SELF-ALIGNING DESIGN

FIGURE 1.15 Module joining productivity considerations.

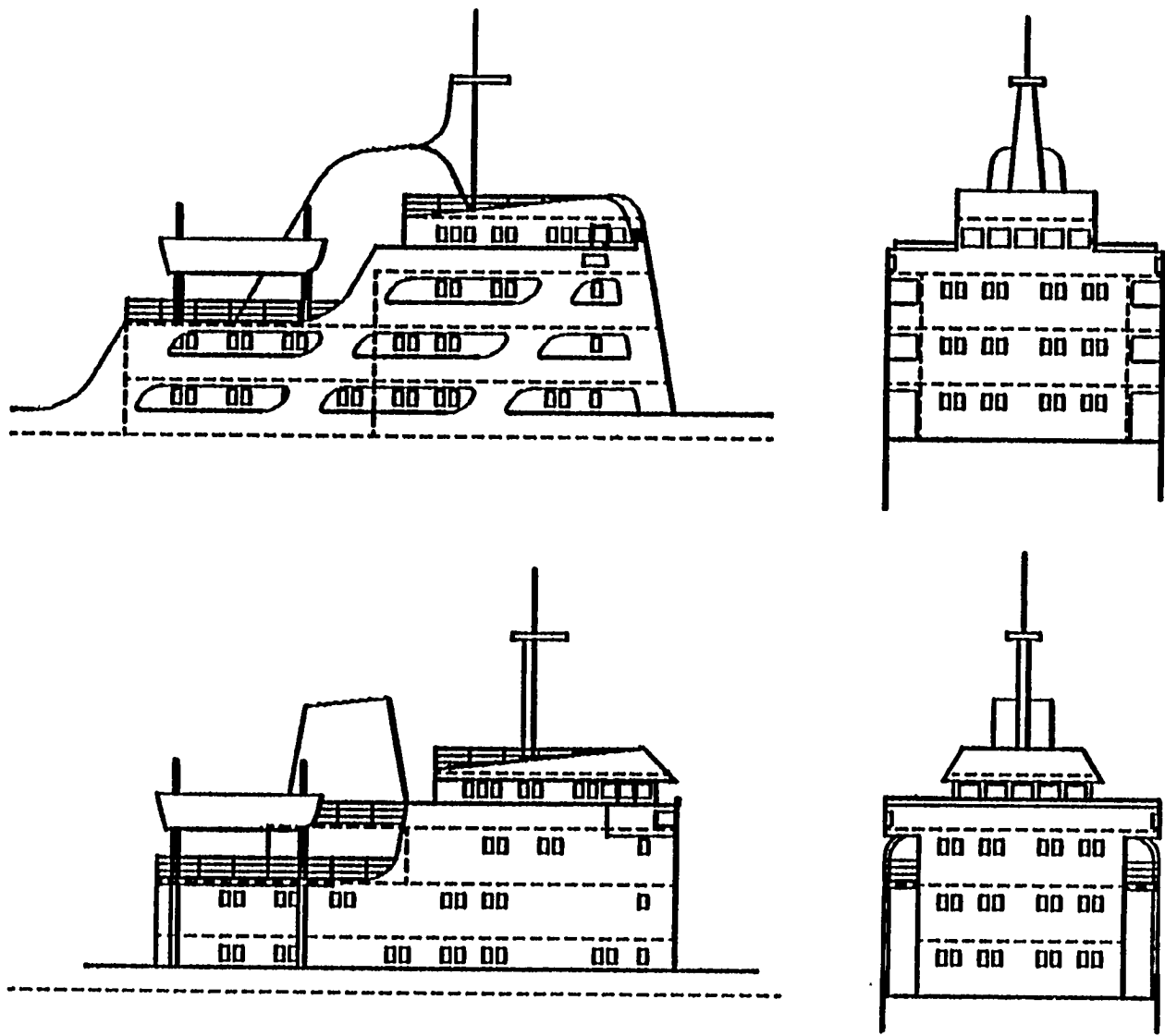

FIGURE 1.16 Aesthetic and cost-effective deckhouses.

(k) Access for Men and Equipment. The arrangement designer must consider how the ship will actually be constructed, and provide adequate access and work levels, including permanently built-in solutions, for men and equipment during the construction and later maintenance of the ship. Obvious ideas in this regard are:

- Galleries in tankers which eliminate need for staging.
- Service trunk passages or zones for deckhouses and above machinery spaces
- Cofferdam under deckhouses that will be constructed and outfitted completely before erection on the hull or between two blocks of a deckhouse erected in two tiers

These ideas are graphically illustrated in Figure 1.17.

(l) Effect of admeasurement rules. The application of the admeasurement rules has adversely affected structural design and therefore productivity for many years. Access holes in double-bottom floors and girders and tanks have been restricted in the U.S. to 23-by-15-inch ovals. Lightening holes have likewise been restricted to 18-inch diameter except in fuel oil tanks, where 30-inch-diameter holes are allowed, provided they are “strapped” by installing a 3/4-inch-wide flat bar horizontally across the middle of the hole. This is an obvious work content addition that has no real need. In the U.S., for small ships that benefited from being measured below 200, 300, 500, and 1600 gross registered tons, various admeasurement reduction devices such as full-depth plate floors on alternate frames, tonnage openings in cargo and accommodation spaces, and excess capacity of water ballast tanks all add significant work content to the ship. The 1969 IMCO Tonnage Convention will eventually eliminate the unproductive additional labor and material **cost** for the larger U.S.-built international voyage ships, as it eliminates all tonnage-reduction devices. However, the old practice will probably be continued indefinitely in the U.S. for small domestic voyage ships, thus perpetuating the unnecessary additional work content and material. By eliminating the tonnage reduction devices in the larger ships, the ship designer will be free to utilize access and lightening openings to suit the shipyard’s best approach to access for workers, equipment, and material

It is imperative that the arrangement designer be fully aware of the admeasurement method to be used for the ship, and if it is the “new” way to erase all “traditional” ~~tonnage-affected~~ design details from the ship arrangement, and utilize instead details that improve producibility.

1.3.3 LINES. As already stated, a lines drawing developed without attention to the impact on production of its various work content aspects can increase the work content significantly, and prevent high productivity and lowest construction cost. Slipper bows, cruiser stems, double and reverse-curture surfaces, keel, stem, and stern half sidings, and inappropriately located knuckles all add work content. Therefore, when preparing a lines drawing, the following items must be considered from a producibility point of view:

- (a) Stem
- (b) Stern
- (c) Stem Frame
- (d) Flat Keel
- (e) Maximum Section Shape
- (f) Single Screw Skeg
- (g) Bulbous Bow
- (h) Knuckles and Chines

These items are discussed further to illustrate the application of design *for ship production* to early design when the cost is most significant.

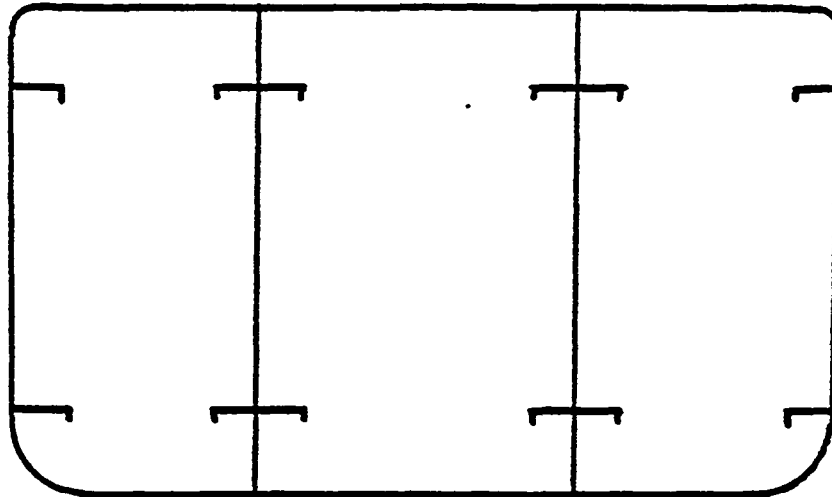

PERMANENT "BUILT IN" GALLERIES FOR CONSTRUCTION AND MAINTENANCE

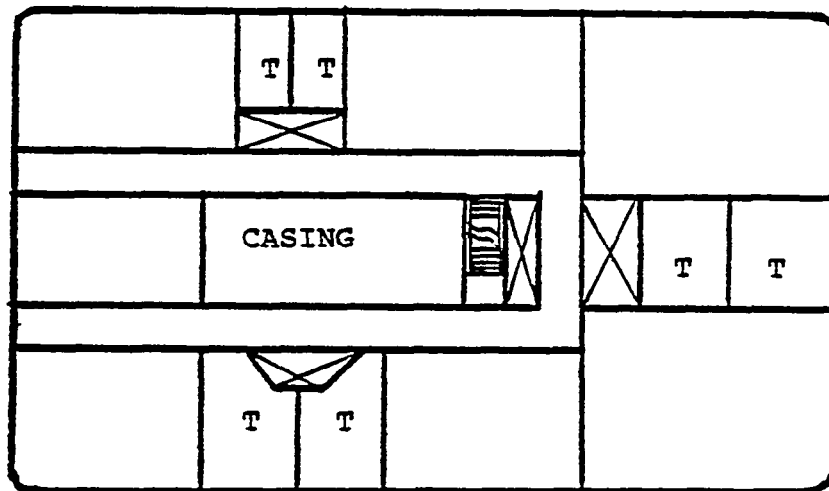

TYPICAL ARRANGEMENT OF SERVICE TRUNKS

FIGURE 1.17 Access galleries and service trunks.

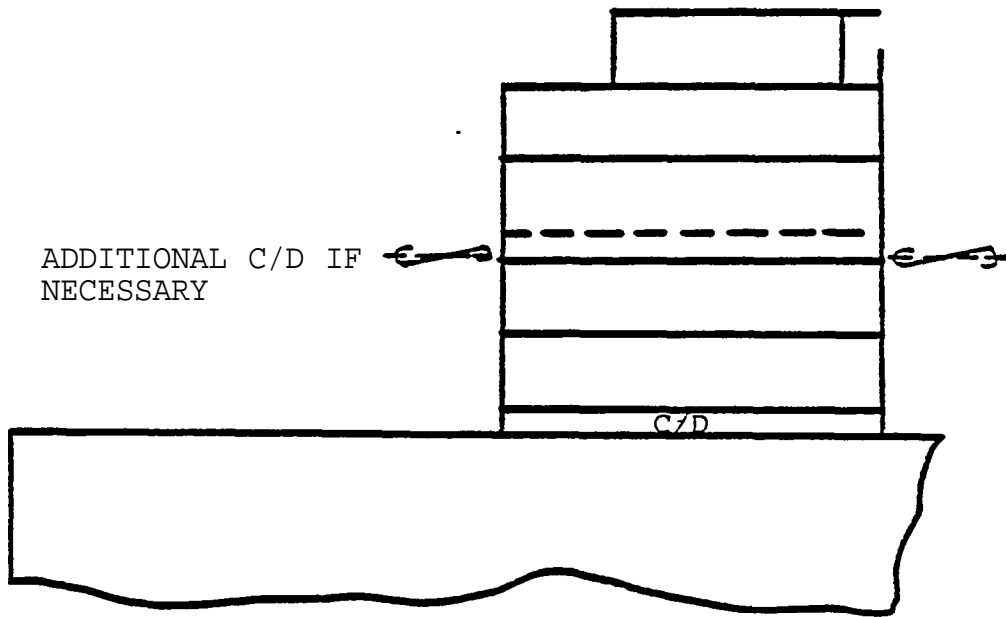
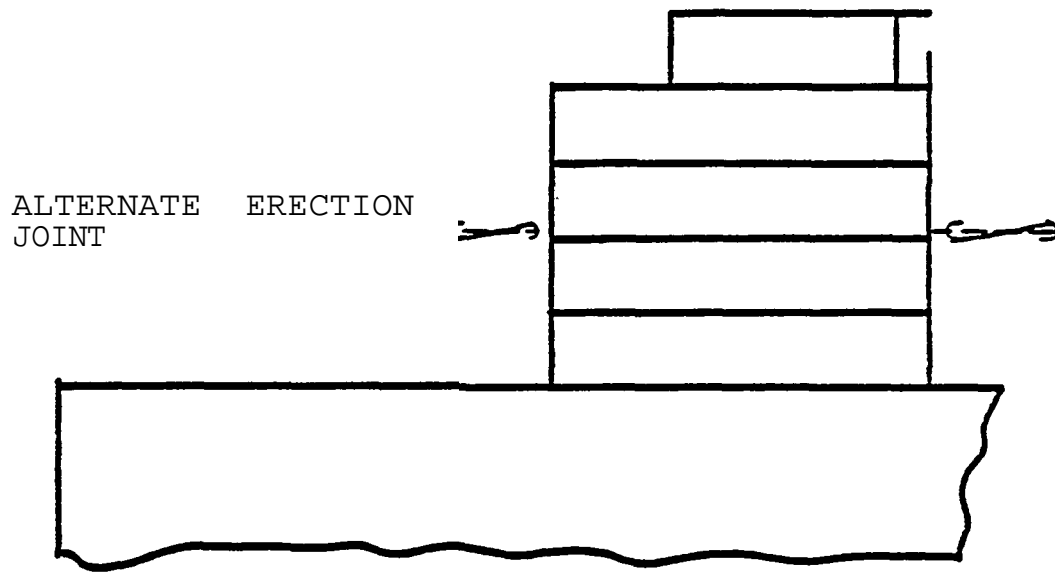

FIGURE 1.17 (Continued): Access and work levels for productivity improvement.

(a) Stem. The bow of a ship is one of the areas where designers regularly incorporate reverse curvature without any concern for its work content and *cost* impact. One only needs to look at a few ships to realize this unfortunate truth. Curved stems may look good but they are very costly. Even slight departures from a straight-line stem will add to the difficulty in fabricating it. The simplest stem is one formed from a cone. This will give elliptical waterline endings, not circular, as most designers use. As shown in Figure 1.18(b), the fore foot radius should be selected to assure fair shell plates at the fore foot shell stem connection. This is shown in Figure 1.18(c). Usually the lines designer is fairing on twenty-one stations and waterlines spaced 1, 2, and 4 feet, and local unfairness can be missed. To ensure that the fore foot shell plating will be fair, it is necessary to treat this part of the hull in more detail with closer water lines and additional frames. By proper attention to the production aspects of the stem shape, the need for a stem casting can be eliminated, as shown in Figure 1.18(d). The only reason stem castings are used today is because the complexity of the design necessitates it.

Most ships can be designed without the need for concave waterlines in the bow. For ease of production, straight and convex waterlines are preferable. In section the frames in the bow are usually concave to provide adequate deck area, but maintain vertical frames in way of the load waterline. This results in reverse-curvature shell plates. Reverse and double curvature are defined in Figure 1.19. Even though plate forming by line heating enables complex shapes to be processed without rolling and packing or pressing, it obviously is still additional work content compared to a single-curvature plate. The use of vertical sections in way of the load waterline is desired because it has been shown to be beneficial for resistance in smooth water. However, “V” sections are better for seakeeping, and as a ship is usually more in sea conditions, a ship can depart from minimum still water resistance lines in the bow, and still be an efficient seagoing ship. A certain amount of flare is necessary to maintain dry decks or rather minimize deck wetness. This can be effectively provided by straight sloped frames and knuckles as shown by Newton [23] and illustrated in Figure 1.18(e). The Mairerform bow was a good production design due to its parallel frames end eliminating of fore foot radius as shown in Figure 1.18(f).

(b) Stern. The term stern covers two important, independent, but obviously connected items, namely the propeller aperture and rudder arrangement, and the portion which is mostly above the design waterline aft of the rudder stock center line.

The single-screw propeller aperture has evolved from early counter stem combined rudder post types to the “open” or “mariner” style with spade or horn rudders as shown in Figure 1.20. The design approach tended to favor “closed” apertures to reduce the size of the rudder stock to the minimum. However, even though it results in the largest-diameter rudder stock, spade rudders have the least work content if properly integrated in the design of the stern structure, and modern bearings are utilized; This can be seen by comparing all the parts and the various work sequences involved in both approaches, as is done in Figure 1.21. It is most important to realize, however, that the design of the lower stem lines, and shape and style of propeller aperture, must be integrated with the design of the propeller to provide the best possible propeller/hull interaction.

The upper stem development proceeded from the counter stem to the cruiser and then transom stem. The cruiser stern reduced the total resistance and therefore required less propulsion power for a given ship and speed, and for this reason has been used for such a long time. The transom stem was utilized first on high-speed warships where at design speed the transom was “clear” of water and this resulted in an effective increase in waterline length, which proved beneficial from the resistance point of view. Merchant ship designers adopted the transom stem because of its obvious construction economy, but also

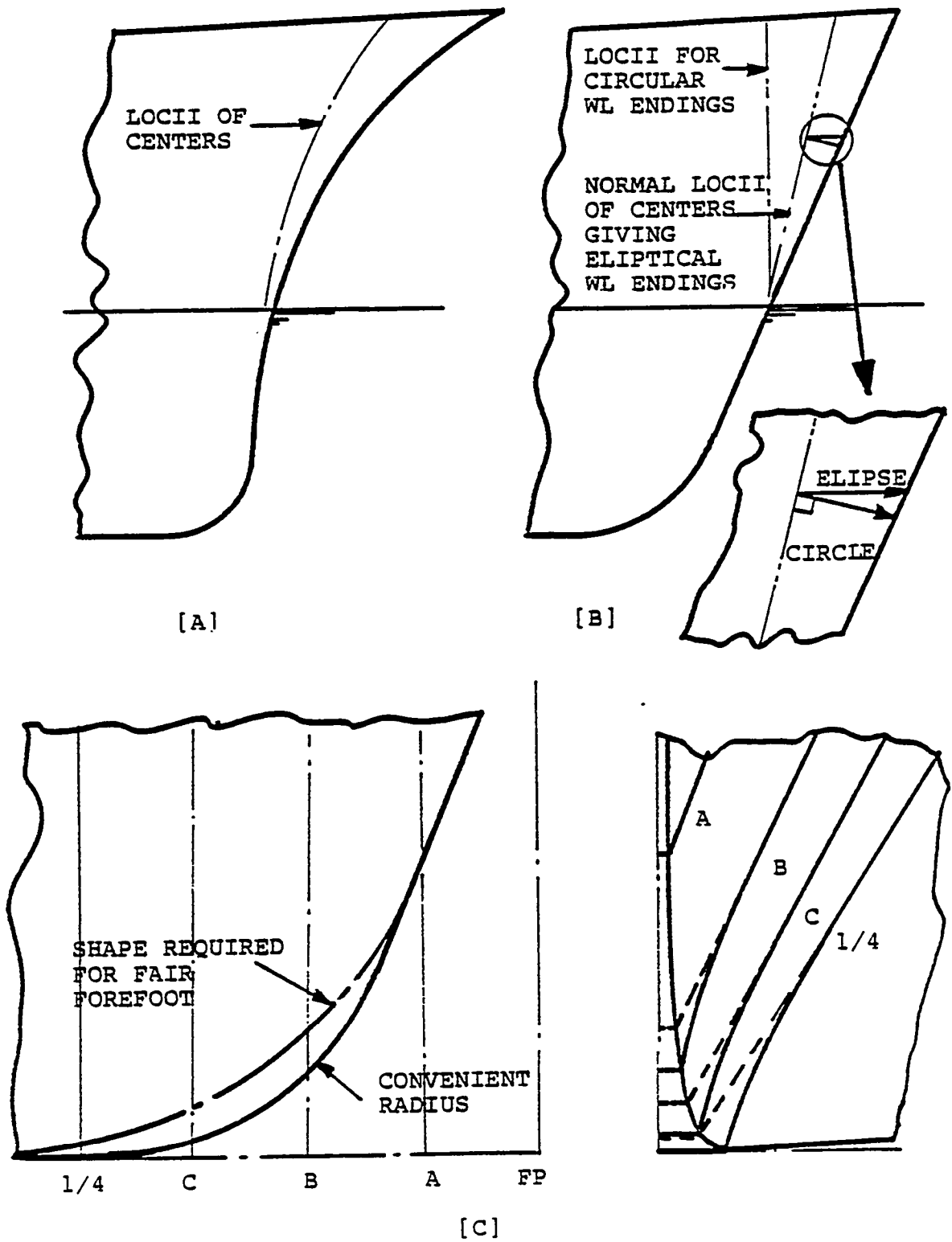
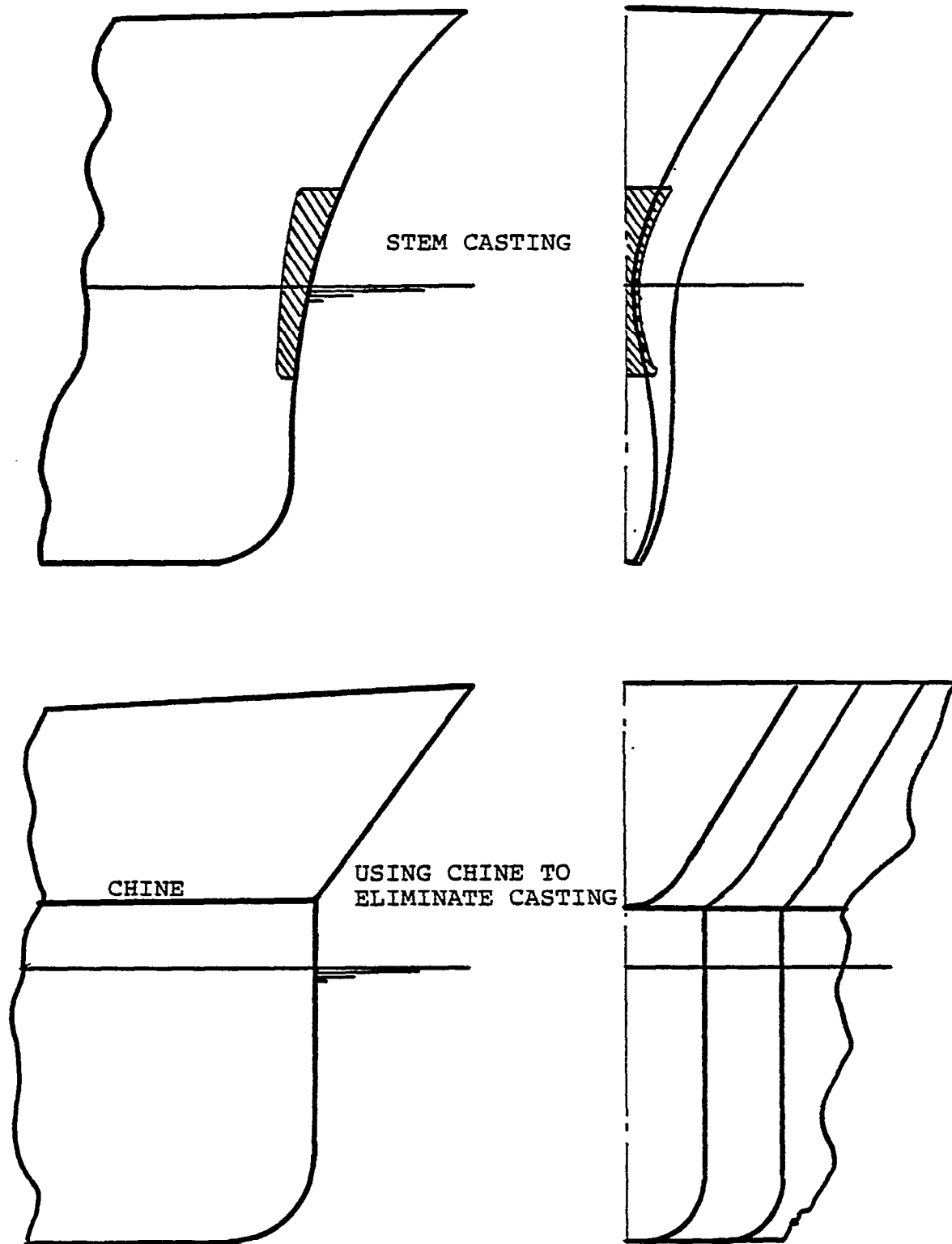
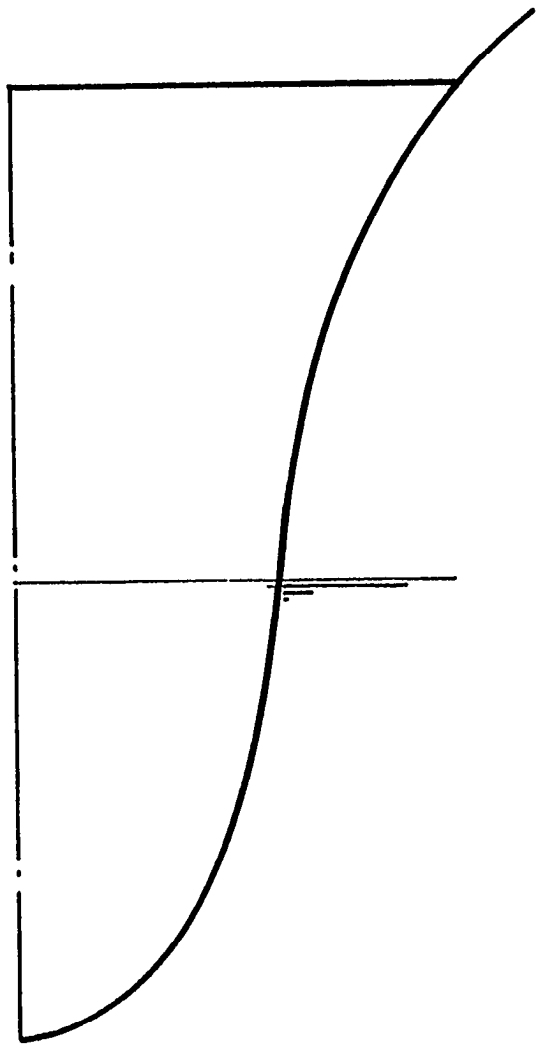

FIGURE 1.18 Stem productivity considerations.



[D]

FIGURE 1.18



NORMAL BOW FLARE

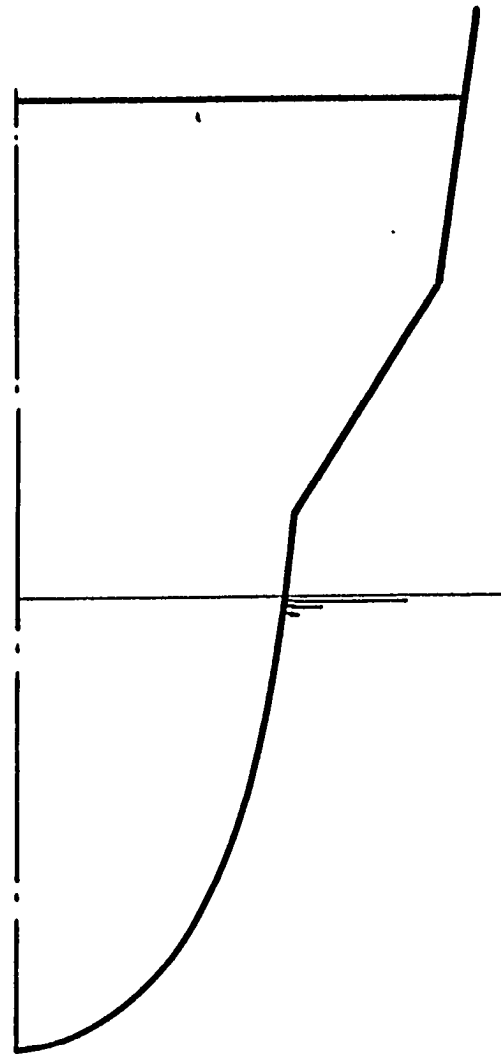

[E] FLARE FROM CHINES AND STRAIGHT FRAMES

FIGURE 1.18 (Continued)

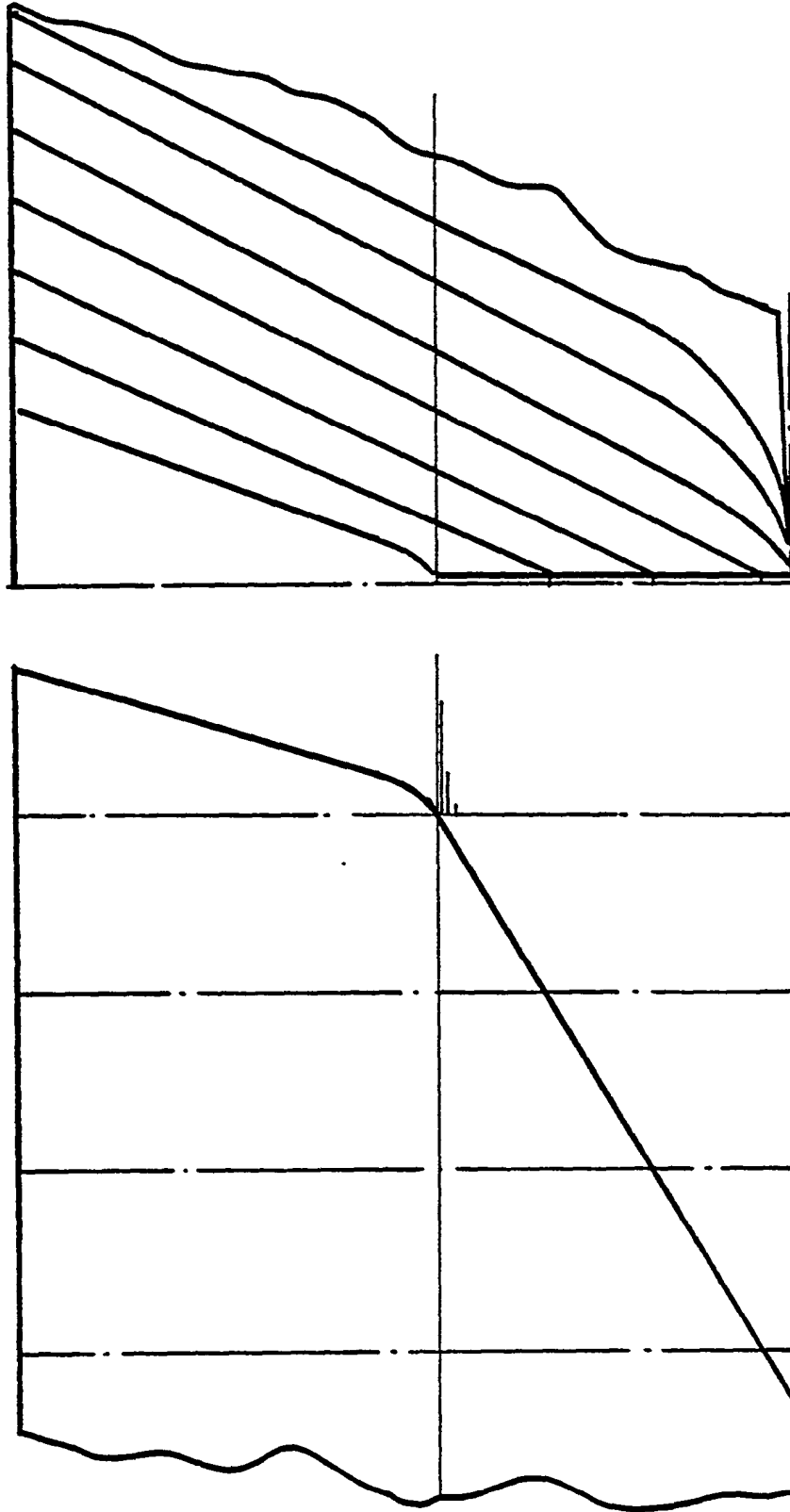

[F] MAIER FORM BOW

FIGURE 1.18 (Continued)

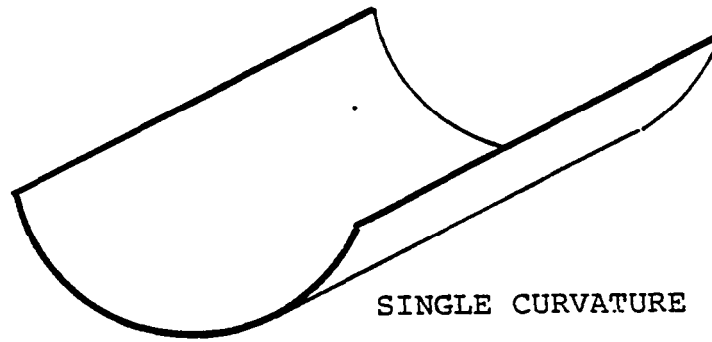

SINGLE CURVATURE

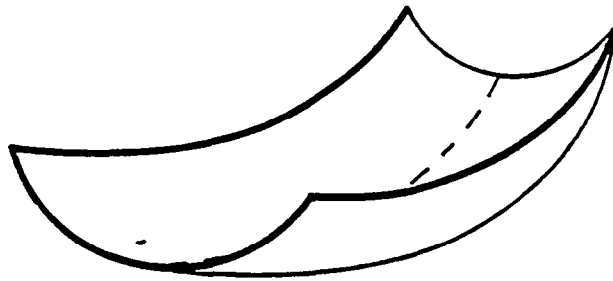

DOUBLE CURVATURE

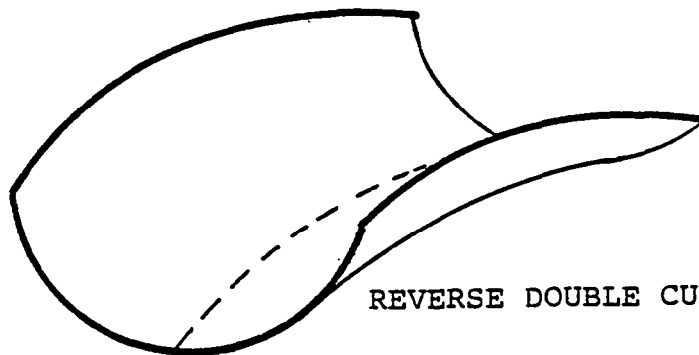

REVERSE DOUBLE CURVATURE

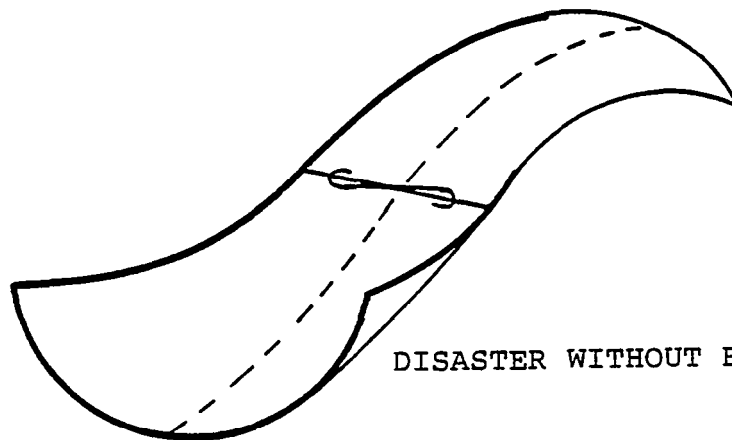

DISASTER WITHOUT BUTT

FIGURE 1.19 Types of shell plate curvature.

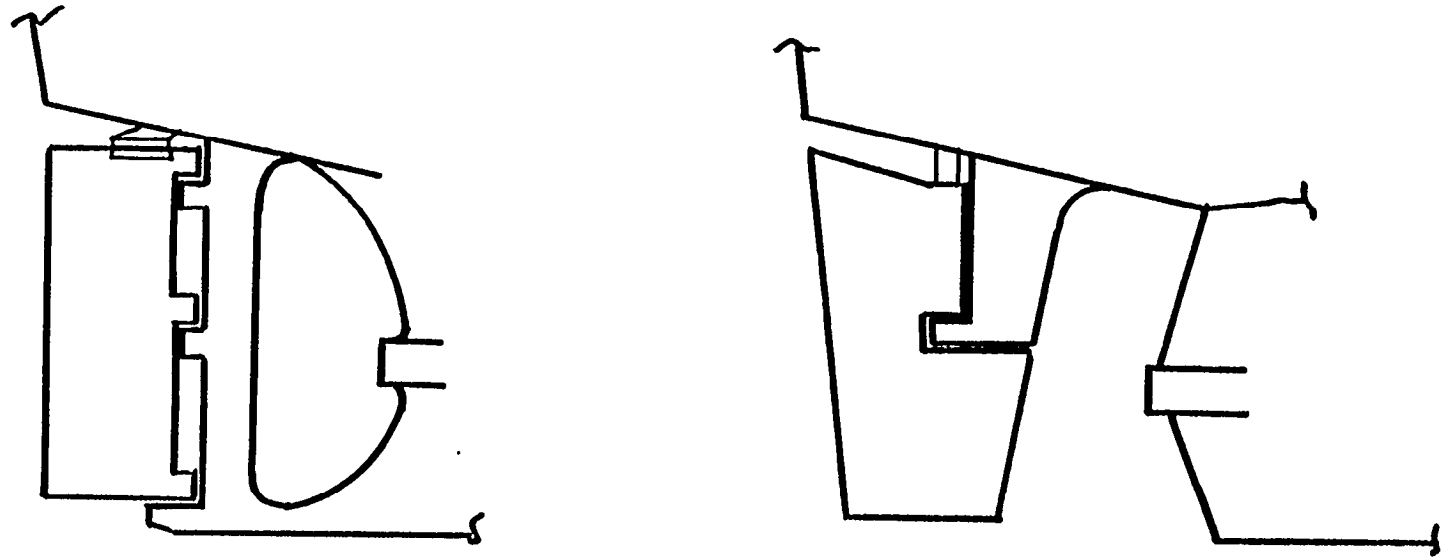

CLOSED APERTURE WITH STERN POST

OPEN STERN WITH RUDDER ON HORN

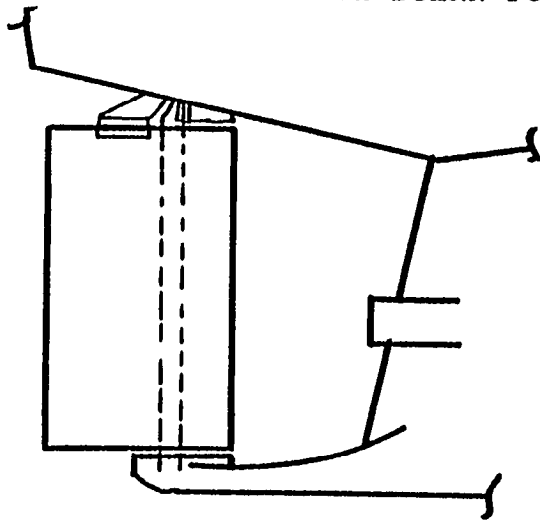

CLOSED APERTURE WITH SEMI-BALANCED RUDDER

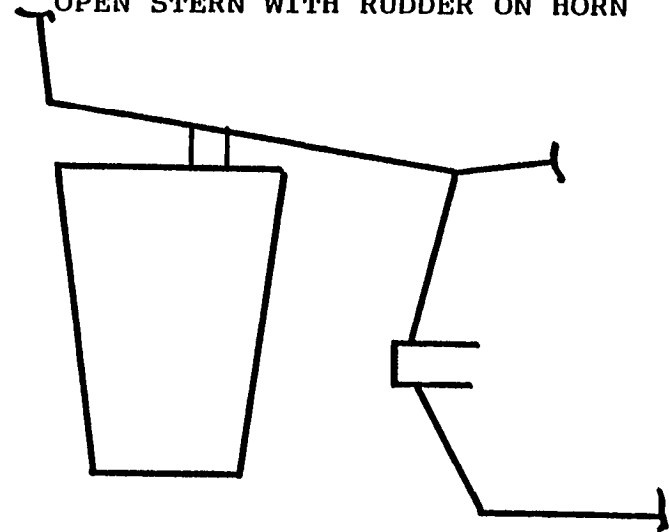

OPEN STERN WITH SPADE RUDDER

FIGURE 1.20 Propeller aperture and rudder types.

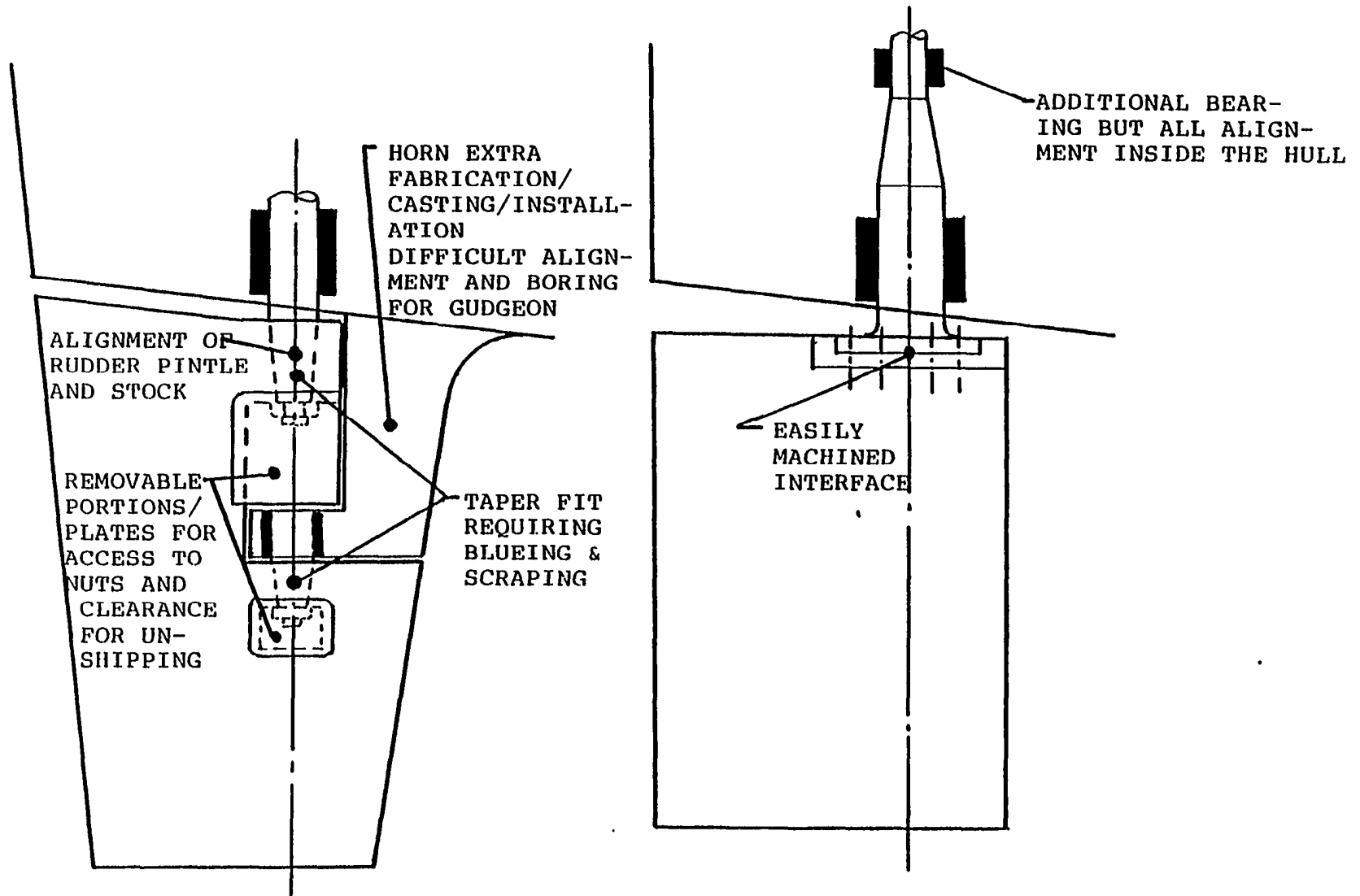

62

FIGURE 1.21 Rudder-type selection for producibility.

as it maintained deck width aft, which was important in deck cargo ships such as container ships and ships with all aft deckhouses. However, ship designers still introduced aspects which cause additional work content for transom sterns, by sloping it in profile and providing curvature in plan view as well as large radius corner connection between shell and transom. To be of minimum work content, the transom should be vertical and flat, with sharp corner connection between shell and transom. Figure 1.22 shows this approach.

(c) Stern Frame. At one time all stem frames were designed as castings. This enabled complex shape to be incorporated in the design, and also provided an early erected reference to build to when ships were constructed part by part on the building berth. In the early 1960s the widespread use of structural sub-assemblies (modules or blocks) necessitated the integration of the stern structural design. This resulted in the use of more fabricated stem frames. Stern castings are still used today, but this is only because the design of the hull around the stem 'aperture is too complex for the stem frame to be fabricated. Therefore, the ship designer must realize this fact, and select stem lines and propeller aperture shape to enable the stern frame to be easily fabricated as part of the stem module. Figure 1.23 illustrates this concept.

(d) Flat Keel. The width of the flat keel is a rule requirement for most classification societies. The developer of the lines may use this as the flat of keel dimension or simply use a standard. For designs with rise of floor, the selected width becomes the knuckle in the bottom. The width of the flat keel should be at least enough to extend over the keel blocks to allow welding of the erection seam for port and starboard modules. Where the bottom erection modules span the blocks, this is not important, although for ships where this occurs it is usually only for the midship modules, and it changes to port and starboard modules towards the ends. It is suggested that two other aspects must be considered to determine the width of the flat keel. The first is that the shipyard maximum plate width should be used as the flat keel width. The second is that if one of the flat keel seams is used as an erection module break, the flat keel width must suit the module-joining method including the internal structure. These concepts are shown in Figure 1.24.

(e) Maximum Section Shape. The design of the maximum section of the hull considers bilge radius, rise of floor, and slope of sides. There is considerable guidance on the maximum section coefficient based on resistance aspects. Obviously, the required coefficient can be satisfied by a combination of rise of floor, bilge radius, and even sloping sides. Rise of floor involves considerable additional work content compared to a flat bottom. Its only benefit is that it aids in tank drainage when the ship is in drydock completely upright. Any other time, the ship will be either trimmed or listed or both, and the usual small amount of rise of floor is of no benefit. For small vessels rise of floor will probably be necessary as the section shape without it would not be acceptable. Sloped sides can present docking and tug-handling problems. They have naval architectural design advantages of wider decks without resistance penalty for increased waterline beam required with vertical sides. They also provide better heeled stability. Sloped sides may appear strange, but they actually make more sense, from a design for ship production point of view, than rise of floor, and should be considered as an alternative to rise of floor as a means of achieving the required maximum section coefficient. Figure 1.25 gives some concepts of this approach. The bilge radius should be determined so that the side module erection joint is above the tangent of the bilge radius and the side, and above the double-bottom height or inboard of the tangent with the bottom in single-bottom ships. The use of conic sections for the hull bilge as it moves forward and aft from the maximum section would result in the bilge shape being an ellipse and not a radius. This fact must be appreciated by those designers that conveniently and assumingly cleverly try to maintain

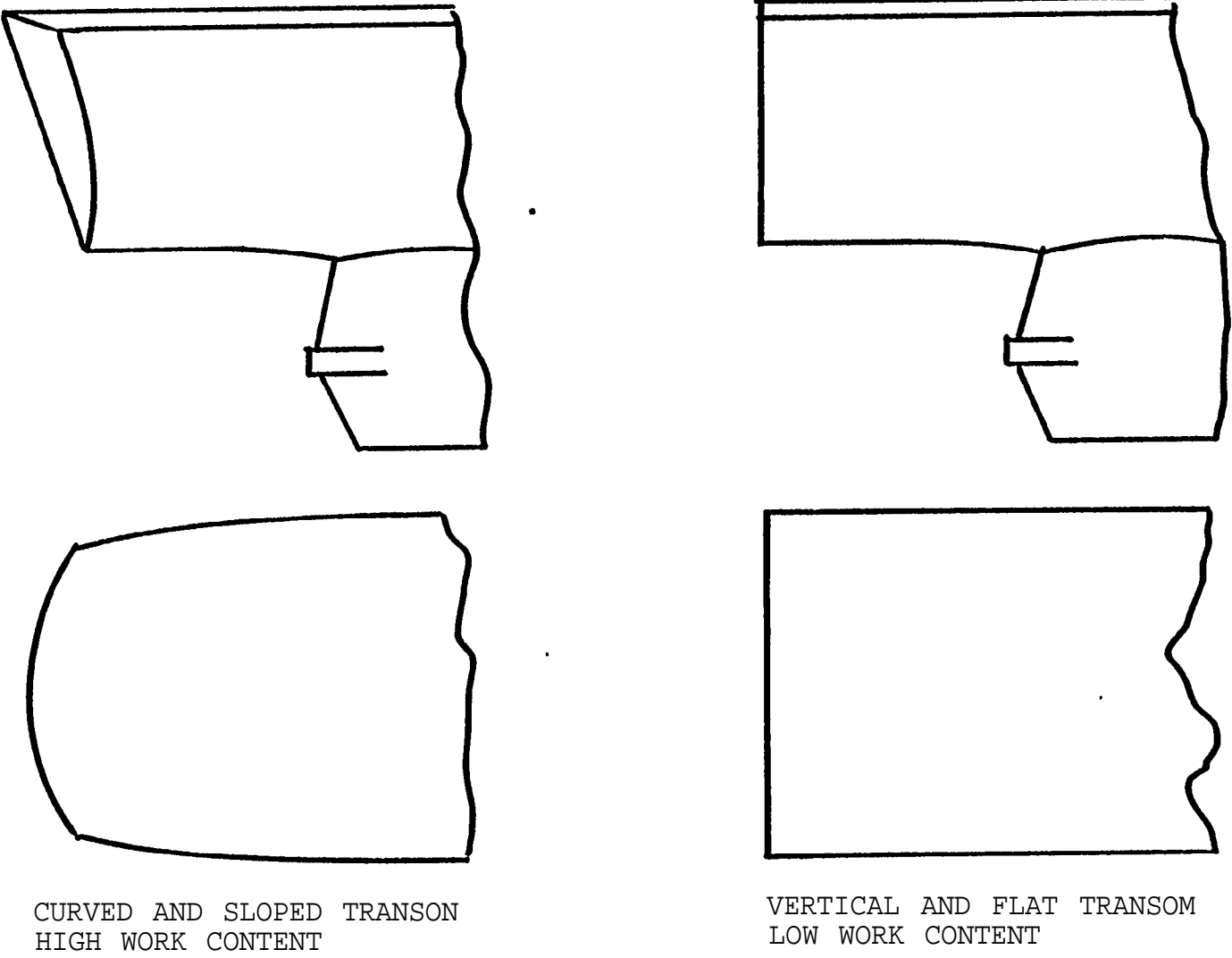
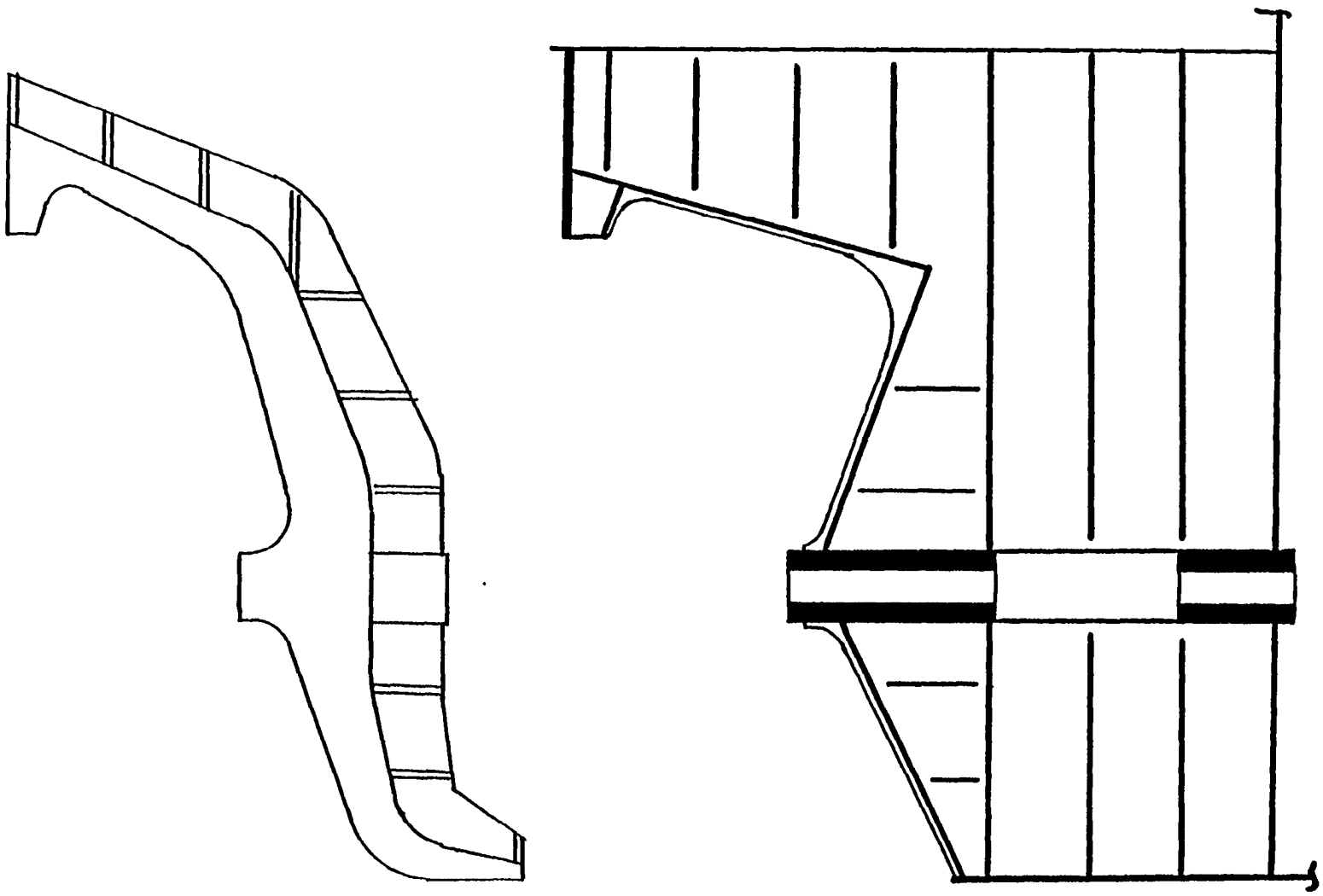

FIGURE 1.22 Transom stern design for production.



CAST STERN FRAME
COMPOUND CURVES NECESSITATED
CASTING

FABRICATED STERN FRAME
SIMPLE STRAIGHT LINES AND CHINES ENABLE
STERN FRAME TO BE FABRICATED AND INTEGRATED
INTO THE STERN MODULE

FIGURE 1.23 Stern profile shape for producibility.

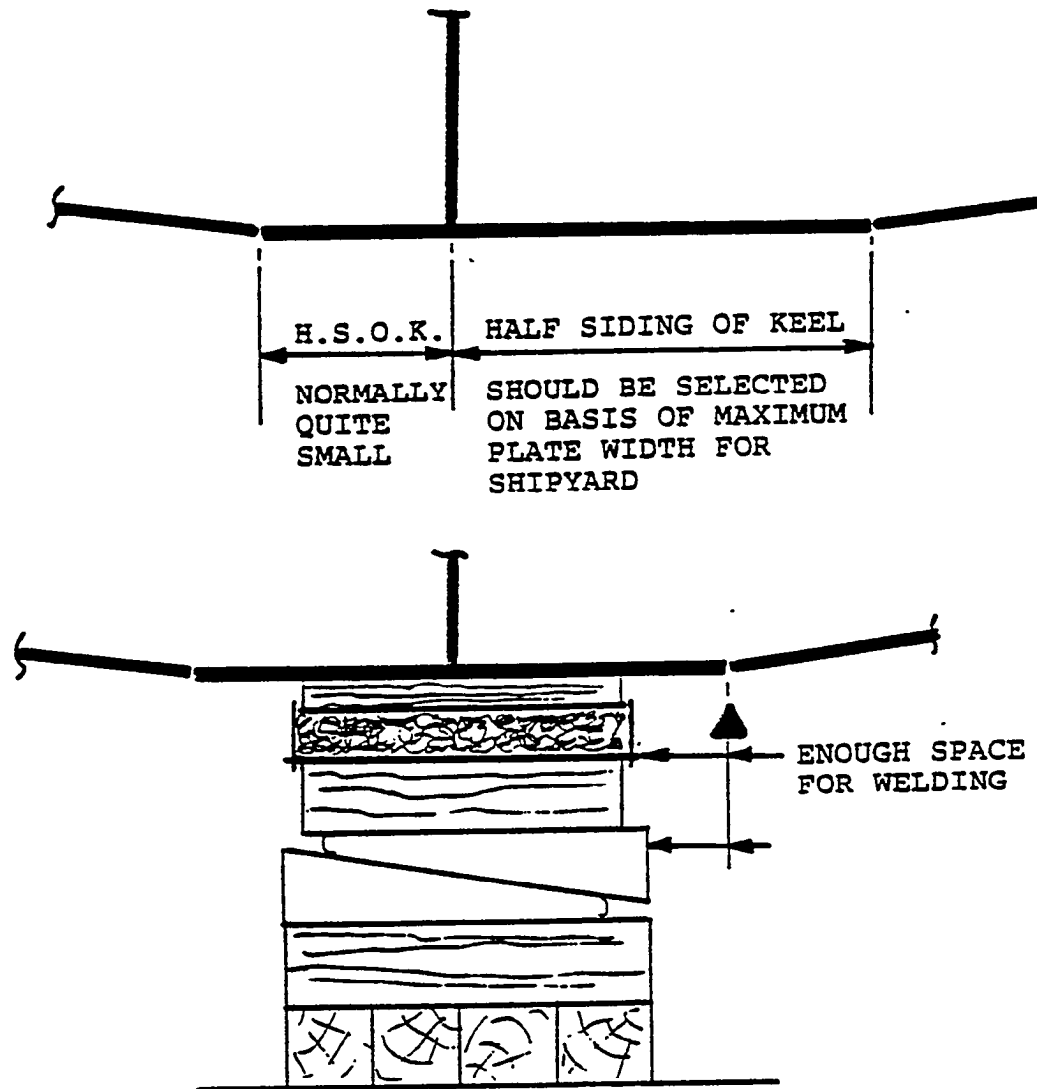

FIGURE 1.24 Productivity considerations for flat keels.

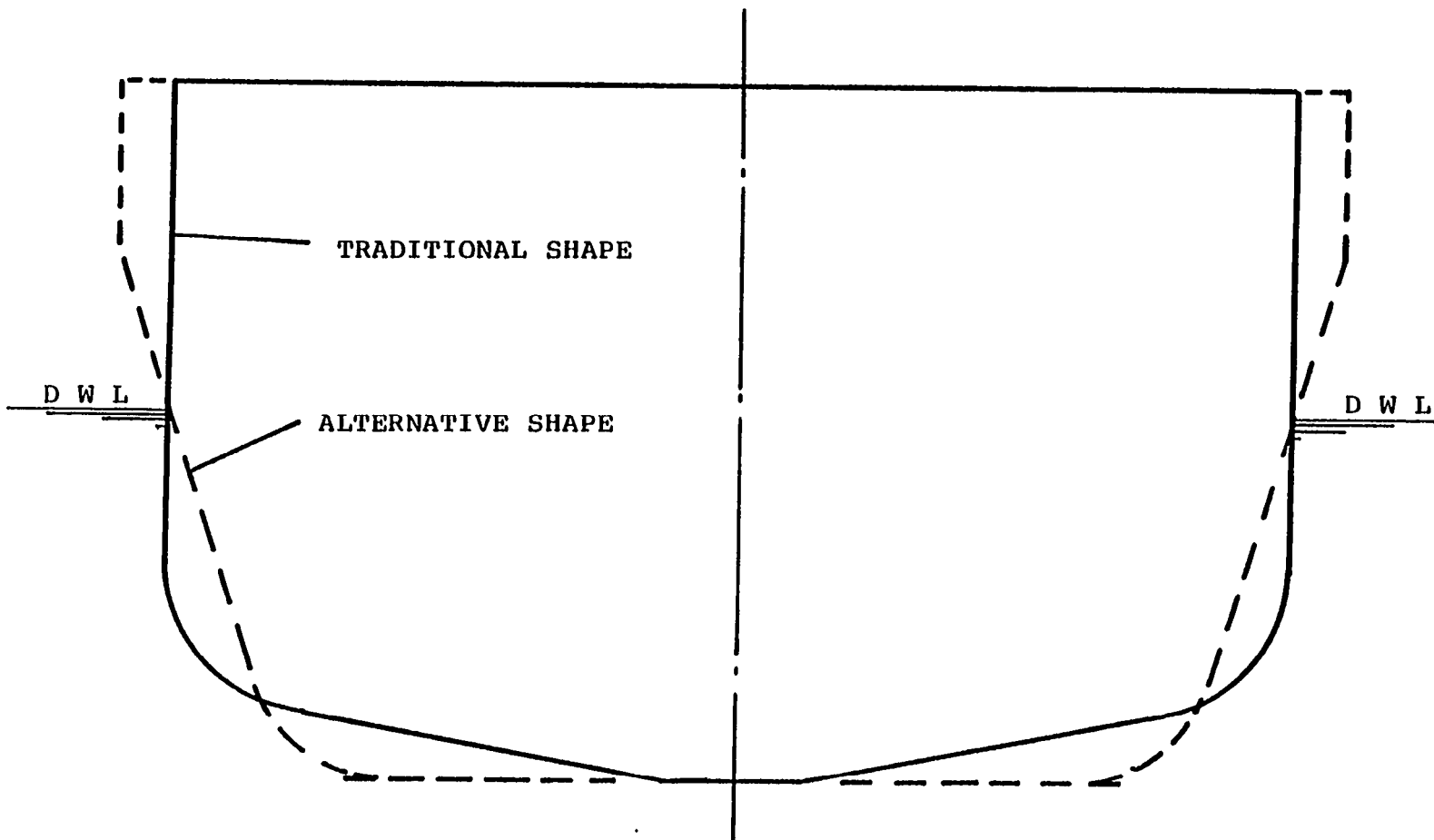

FIGURE 1.25 Alternative maximum section shape for productivity improvement.

radii as the bilge shape in the forward and aft bodies of the hull. This results in considerable increased work content as the shell plate former must form ellipse sections instead of circular.

(f) **Single-Screw Skeg.** The after-body lines of a single-screw ship are selected to provide low resistance and good flow to the propeller. Normal single-screw aft bodies are another part of the hull where reverse nature is found. This reverse curvature can be eliminated by carefully locating the transfer from convex double-curvature plates to concave plates at plate seams and erection butts. Even though double-curvature plates have less work content than reverse-curvature plates, it is still significant. One way to reduce the work content of the after-body even further is to separate the normal single-screw after-body into two parts, namely, the main hull and a skeg. This can be done in two ways. The first way is to attempt to follow the normal single-screw hull form as closely as possible by incorporating a chine or multi-chines joined in section by straight lines or simple curves, as shown in Figure 1.26. The chine(s) should lie in flow lines to prevent cross-flow turbulence. The second way is to design the after-body as a twin-screw warship type, and to add a skeg which can incorporate the shaft and its bearings, as shown in Figure 1.27. Both approaches can usually be used without any adverse impact on propulsion power. However, the latter approach has the least work content.

(g) **Bulbous Bow.** Bulbous bows are wave-resistance-reducing devices. They incorporate displacement at the bow forefoot, which sets up a surface wave pattern, ideally cancelling out the normal bow wave pattern, thus reducing the energy wasted in generating waves.

There are many bow arrangements which are classified as bulbous bows, but they achieve their benefits in different ways. The original concept of the bulbous bow was to ADD a wave generator that would be out of phase with the ship's bow wave, thus cancelling part or all of the bow wave. Early applications involved transferring displacement from the fore body in way of the load waterline entrance to the bow forefoot in the form of a faired-in bulb. More recently, the applications have been truer to the original concept by simply adding the bulb displacement. Another change is that the bulb is not faired into the shell, but knuckled at the intersection of bulb and shell. Obviously, the knuckled connection has less work content than the faired bulb. From the producibility point of view, the preferred shape of bulb in the transverse plane is a circle, but this can have some operating disadvantages such as bottom slamming in a seaway. Next preferred shape that does not have the slamming problem is an inverted teardrop, but it has a higher work content than the circle. A good compromise between design and production requirement is an inverted tear-drop constructed from parts of two cylinders, two spheres, a cone, and two flats, as shown in Figure 1.28. A similar approach to developing producible details should be applied to other types of bulbous bows for large slow-speed full-hull-form ships, such as tankers. Partial stem castings have been used for bulbous bows where they are faired into the shell. The casting can be omitted if the bulb connection to the shell is a knuckle.

(h) **Knuckles and Chines.** Many ship designers utilize chine hull form designs on the assumption that they are easier to build than round bilge forms. Although this is generally true for small ships, it is not always appreciated that chines can add work content to a design. Before discussing this further, it is necessary to understand the difference between chines and knuckles.

A formal definition of a chine is that it is the intersection of the bottom and side shell below the load waterline. However, it is usually used for any shell intersection curve, and

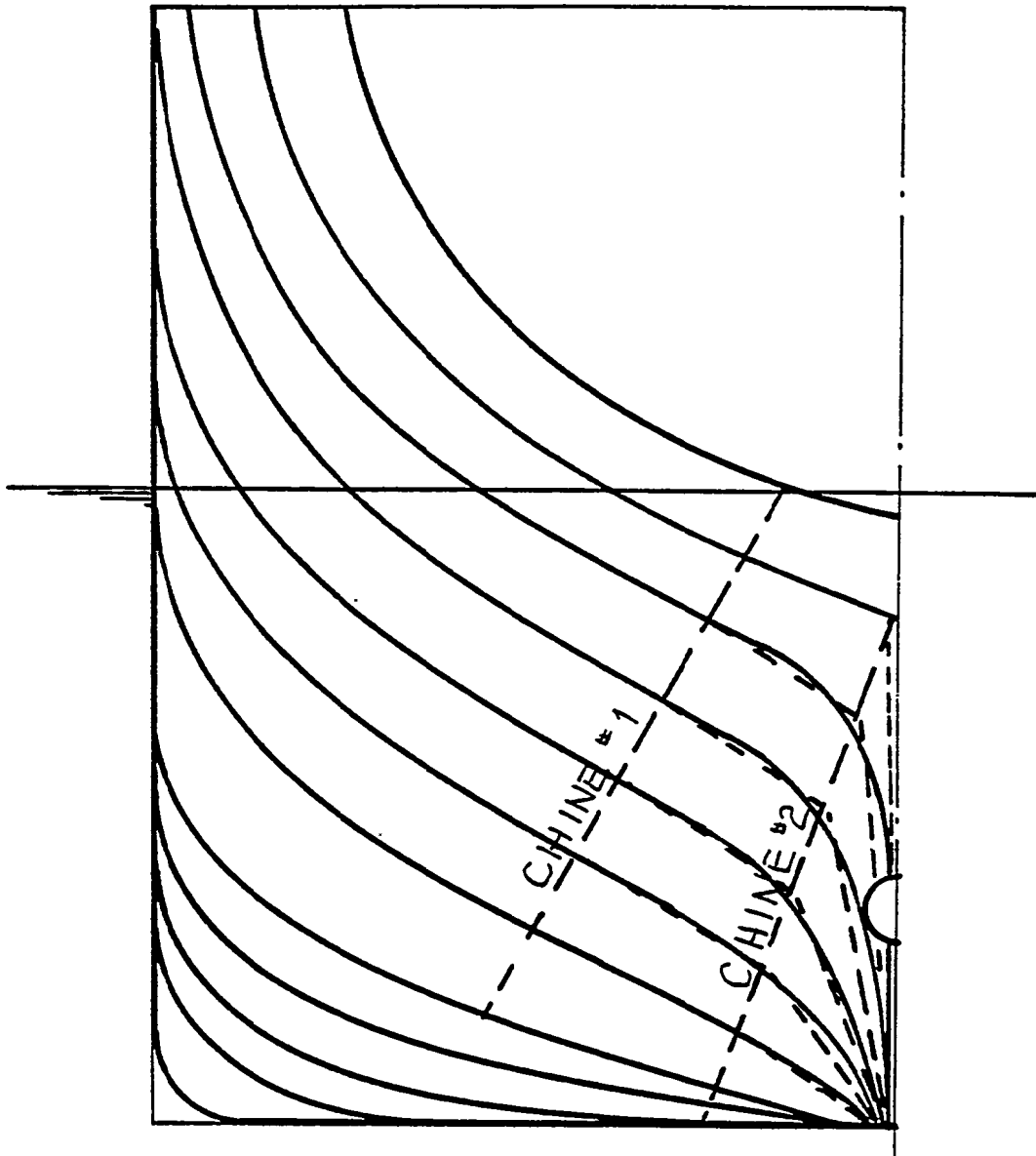

FIGURE 1.26 Use of chines to simplify stern construction.

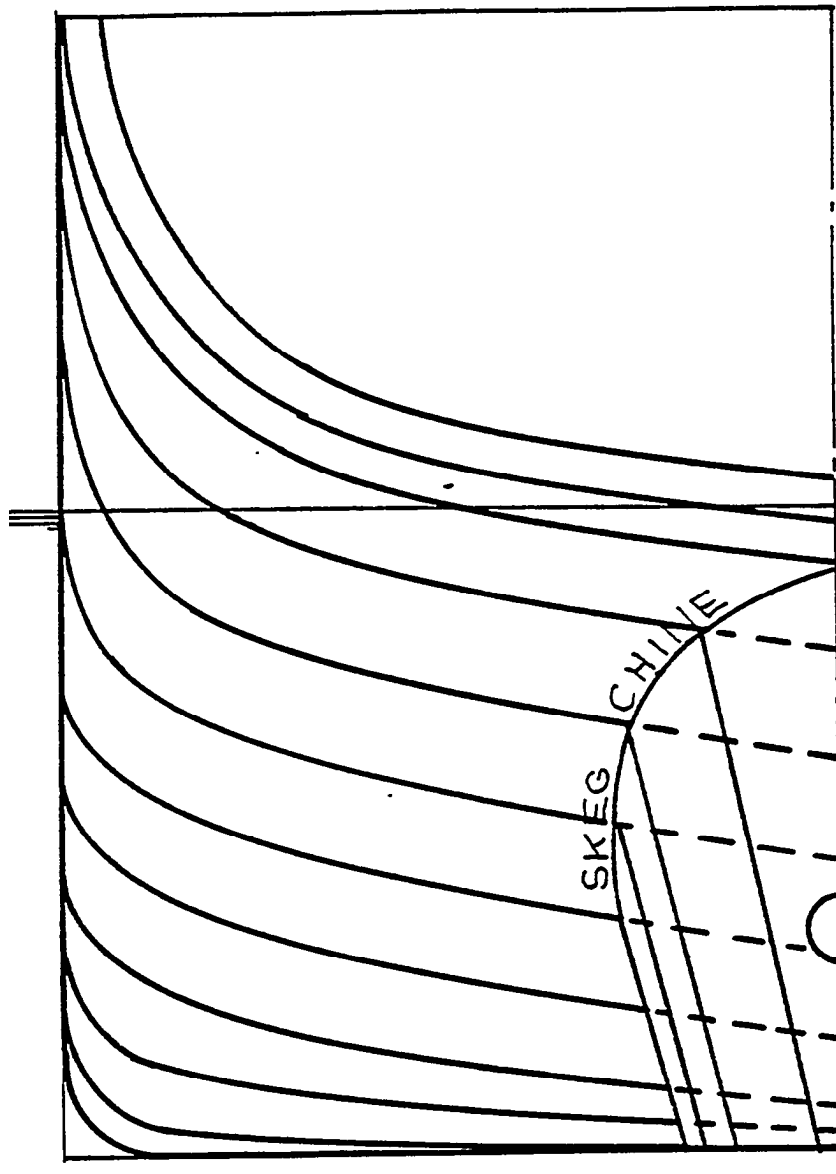

FIGURE 1.27 Use of keel to simplify stem construction.

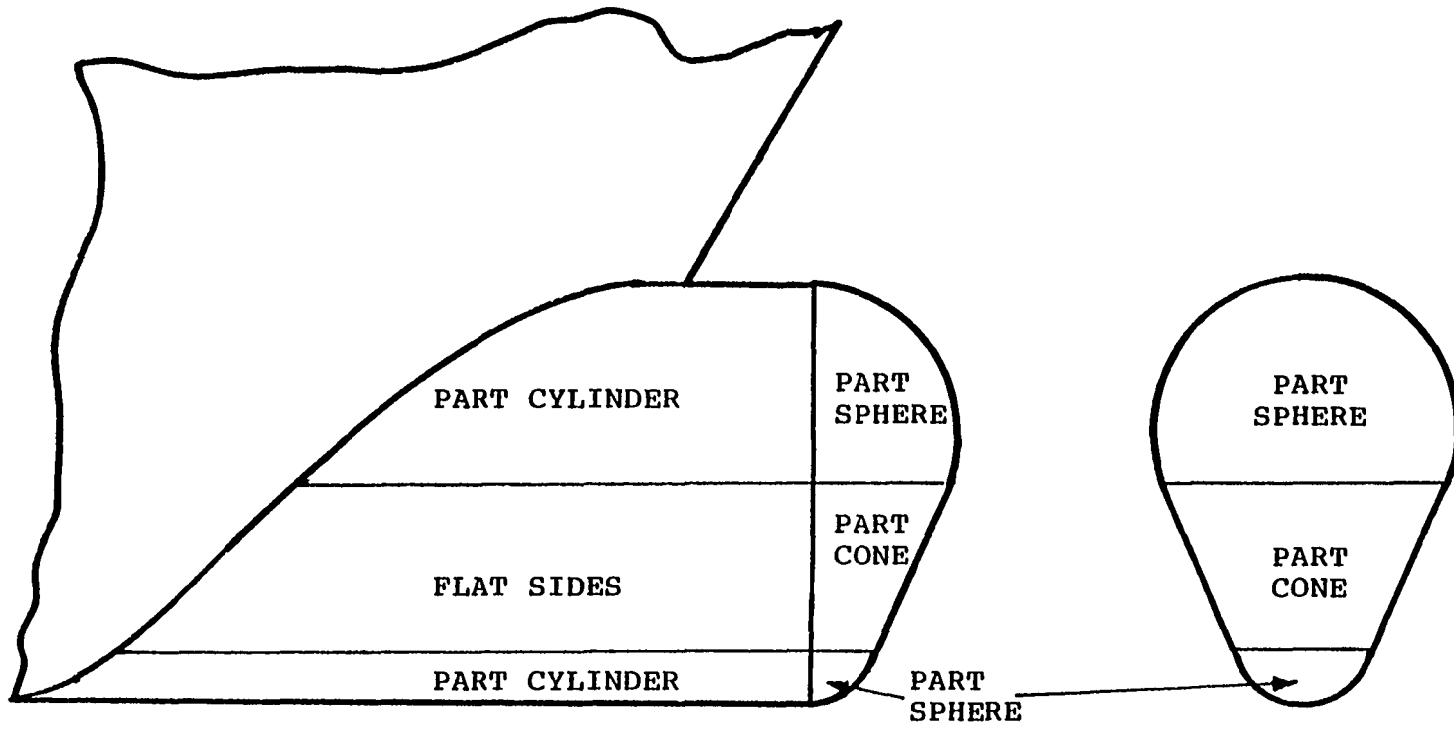

FIGURE 1.28(a) Bulbous bow fabricated from regular shapes.

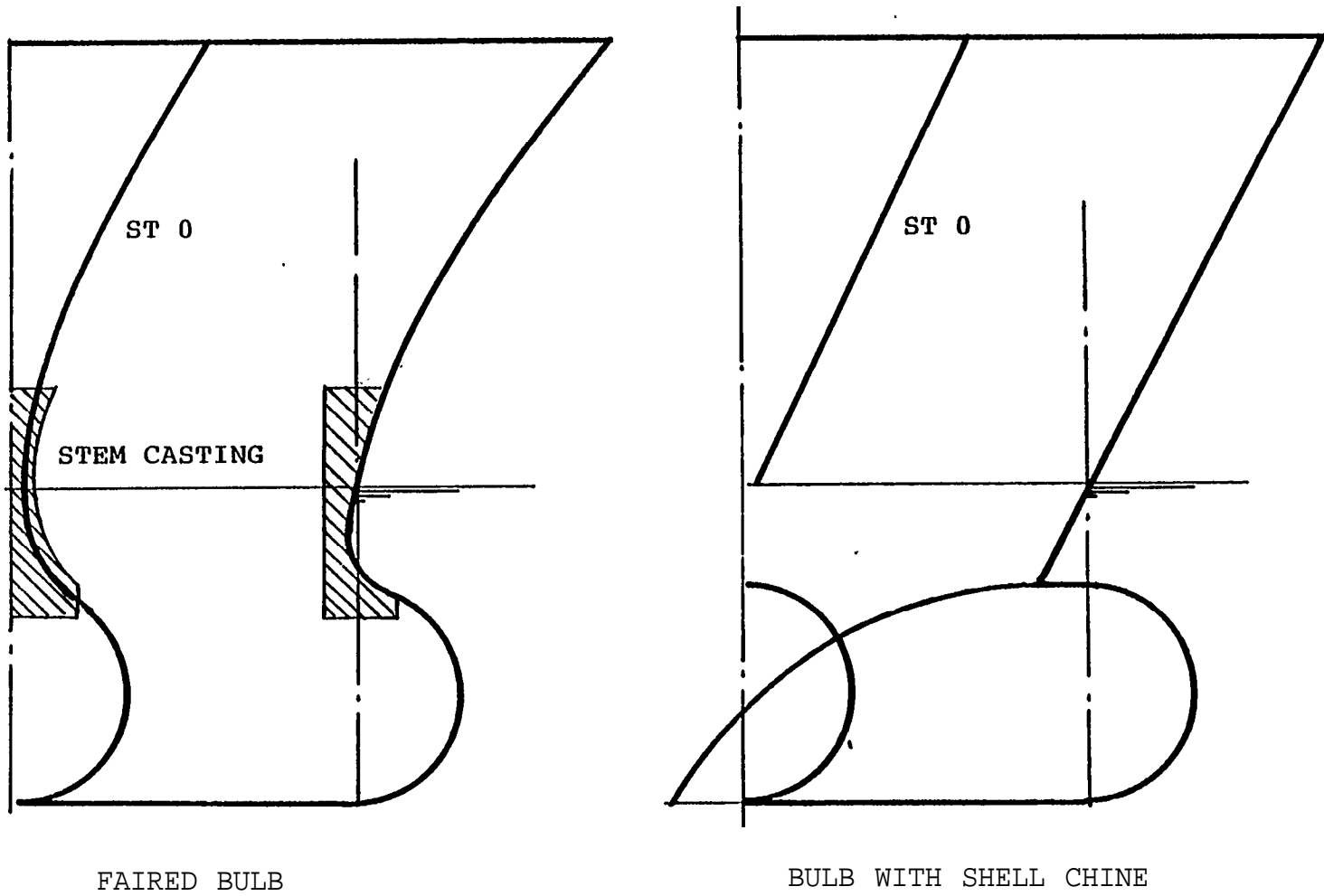

FIGURE 1.28(b) Faired bulbous bow versus chine (elimination of stem casting).

PART 1

in the case of double-chine hull forms, reference is made to upper and lower chines. A chine is always on the shell and nowhere else. A chine is usually a curve in at least one plane.

A knuckle can be 'anywhere on the ship. However, a knuckle is a straight line in two planes. Sometimes a chine located in the forebody above the load waterline is incorrectly identified as a knuckle because in profile it is a straight line. However, in the plan view it will be curved. Knuckles can be used anywhere in the ship, such as the shell in the parallel body, decks, bulkheads, deckhouse sides, etc.

When a chine is introduced into a design and it is curved in two views, it can present a problem if the ship is constructed in modules, as the chine is an obvious module break line. In addition, a chine that crosses a deck line introduces increased work content due to construction design details, including varying frame lengths and additional frame brackets. Chines are often located to follow flow lines as an attempt to prevent cross-flow over the chines, which will cause increased resistance. However, it is better, from a producibility point of view, to locate the chine parallel to the baseline, as this enables the chines to be logical module breaks used for alignment of modules, and permits standardization of design details for floors, frames, brackets, etc. These concepts are shown in Figure 1.29, which also shows the problems with current chine shapes.

The development of low resistance and efficient propulsion lines is a highly specialized field and often is performed by naval architects and hydrodynamicists with very little shipyard engineering and production experience. While it is not proposed that consideration of the producibility aspects be allowed to overrule the lines designer's decision where it could adversely affect the efficient operation of the ship after it is built, it is proposed that lines designers should obtain a better understanding of the impact their design decisions have on the cost of constructing a ship. Then they should incorporate producibility improvement aspects which have a high cost-reduction impact, and a small, if any, adverse impact on operational efficiency. In this context it should be remembered that a seagoing ship hardly ever operates in smooth water, and that the impact of any change should be considered in its seagoing environment, and not in merely a smooth-water towing tank test.

1.3.4 TAILORING DESIGN TO FACILITIES. While it is beneficial for a shipyard to be able to build any ship design, it is a well known fact that such general capability will increase the cost to build the shipowner's custom design, compared to a design that makes best use of a shipyard's facilities. Obvious shipyard-imposed requirements are:

- Ship dimensions and Limits
- Module maximum weight
- Module maximum size
- Panel maximum size
- Panel line turning and rotating capabilities

Obviously, a shipyard would be unwise to attempt to build a ship which was longer or wider than its building berths and/or docks, or higher than its cranes could reach. Of course this would not be so if part of its plan was to improve its facilities.

The module maximum weight can be dictated by berth crane capacity, shop crane capacity, and/or transporter capacity. Also, if advanced outfitting is to be incorporated into the module, the module steel weight must be reduced by the amount of advanced outfitting plus any temporary bracing and lifting gear used for the lift,

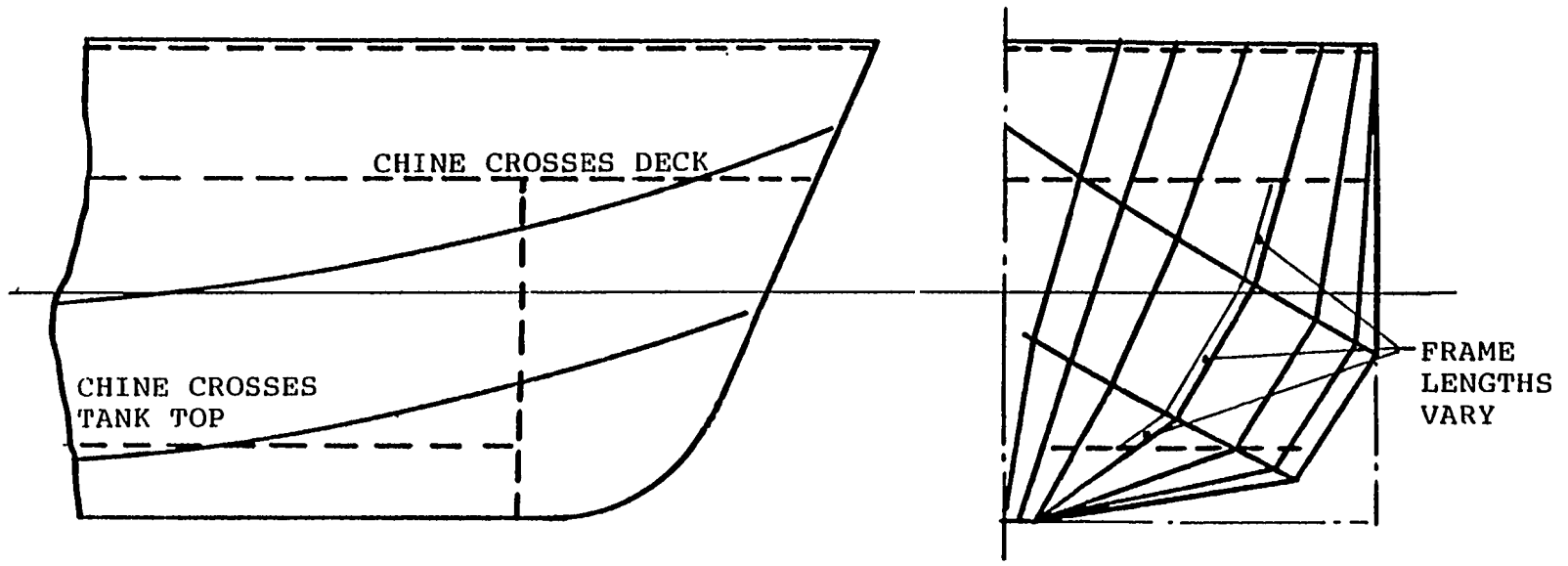

[A] TRADITIONAL CHINE FORM

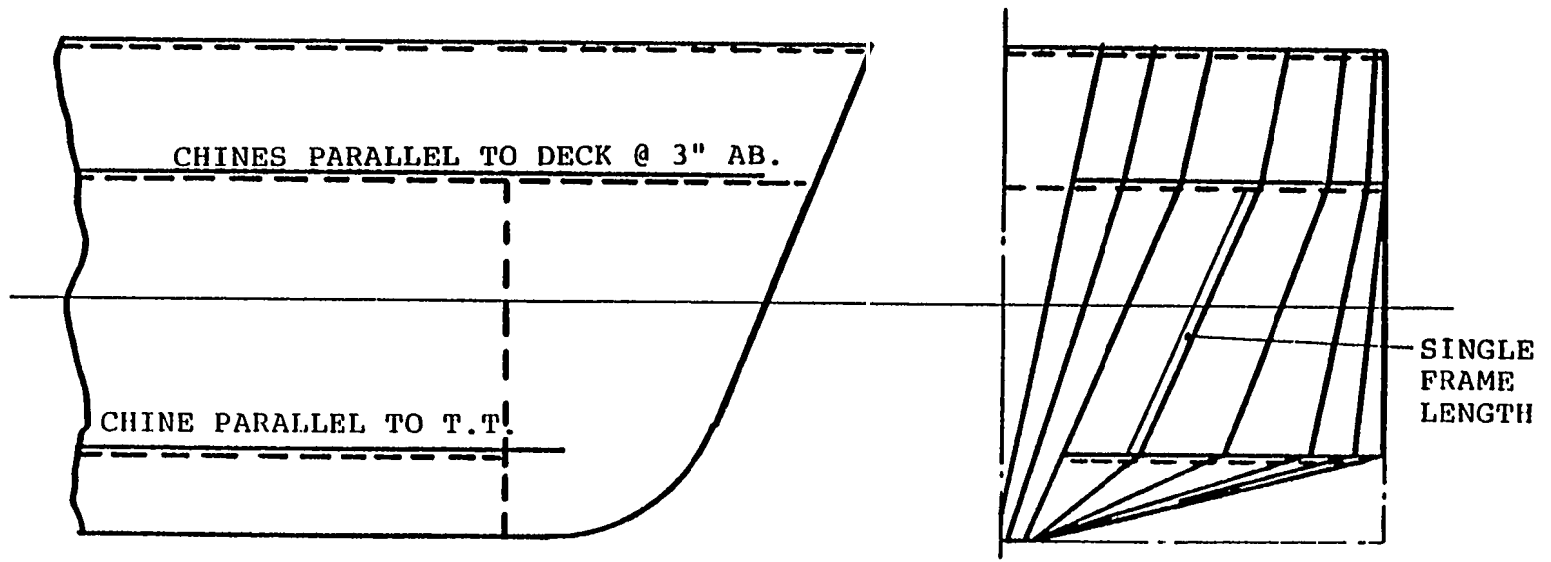

[B] PREFERRED PRODUCTION-ORIENTED FORM

FIGURE 1.29 Hard chine hull forms.

The module maximum size will depend on access throughout the shipyard for modules from assembly to erection, shop door sizes, and the shipyard's maximum plate size.

The panel maximum size will depend on the same factors as the module size, but may, in addition, be limited further by panel line size restrictions. It will also be decided by the panel line's ability to turn over the panel for welding both sides, unless one-sided welding is used, and to rotate the panel so that cross-seam stiffening can be used. A panel line with no rotation capability can achieve the same results by vertical straking of shell or bulkhead plating when the ship is transversely framed or the bulkheads vertically stiffened.

Not so obvious and often ignored requirements are:

- Maximum berth loading
 - spread of launchways
 - Maximum launch pressure on the ship's hull

The maximum berth loading could affect the extent of outfitting before launch and thus the productivity achieved in building the ship. Heavy concentrated weights such as propulsion engines and independent LNG tanks may not be able to be installed until the ship is afloat.

The spread of the launchways should be matched by basic ship's structure, such as longitudinal girders, in order to eliminate the need for any additional temporary strengthening, which only adds to the work content.

Likewise, the structure of the ship in way of the area subjected to maximum way end pressure and the fore poppet should be designed to withstand the launch loads without the need for additional temporary structure.

Whatever the facility requirements on the design, it is obvious that they must be fully industrial engineered, well documented, and communicated to the designers. The use of computer simulation techniques on interactive terminals [24] can serve as both an educational and informational tool to give ship designers a better understanding of the capabilities of a shipyard. The already-stated concept of a shipyard specification of parallel importance and applicability as the usual contract ship specification would also be an effective way to accomplish the transmission of the information to the ship designers. However, it would not in itself assure production-oriented designs. To assure this, it is essential that the ship designers be educated and trained in the field of design for ship production.

1.3.5 MOLDED AND REFERENCE LINES. The concept of the molded line is well rooted in ship design and construction. Design for ship production requires no changes to it. The thought process for design for ship production does enforce its consideration during the development of all structural design details. The usual practice of a shipyard having a standard molded line system is encouraged, and a very early document should be the description of the molded line system for every ship to be designed. A typical description is shown in Figure 1.30.

On the other hand, reference lines may or may not be used in different shipyards. Or in the same shipyard different reference lines may be used by different crafts. For example, the loftsmen may routinely locate water or buttock lines as reference lines on structural parts which may be used by structural fitters. Then the machinists and pipe

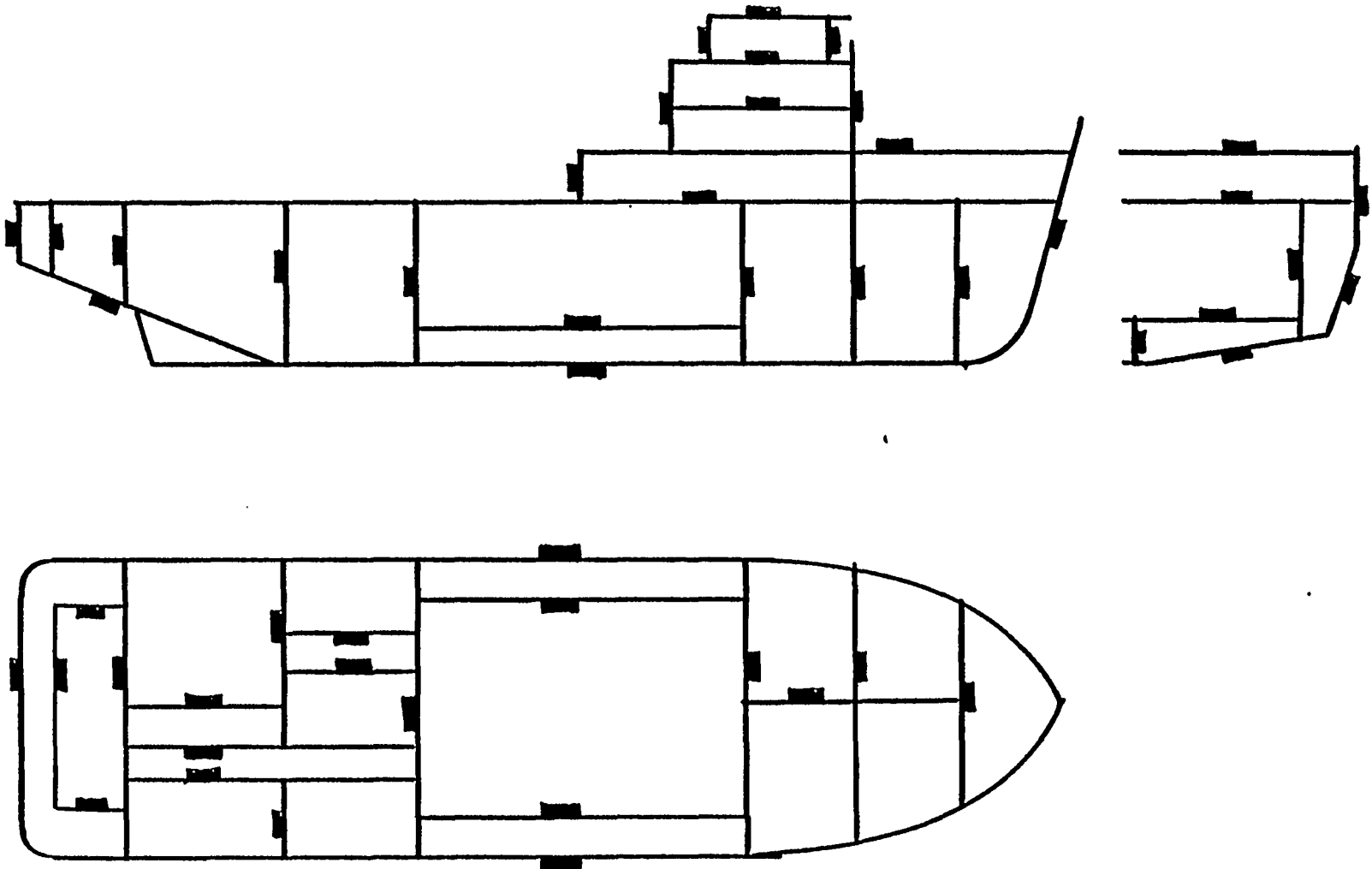

FIGURE 1.30. Typical molded line definition.

fitters may request that installation reference lines be provided in each space as they start to install equipment and outfit. In addition the outfitters may lay down their own reference lines from which they will locate joiner bulkheads. The final problem may be that none of the reference lines are measured from the same basis. To make matters even worse, the engineering department may not use any reference system in its drawings, and simply show dimensions all over the drawing, measuring from structure, other equipment, baseline, centerline, etc. Table 1.4 shows how disintegrated some engineering sources currently are. It is not surprising that the interference-control efforts in many engineering departments consume so large a part of the engineering budget and still are not effective, as proven by the large amount of field-discovered interferences. Much of the interference-control effort is spent in interpreting the different referencing and dimensioning methods used. Within each craft the problem necessitates planners, schemers, and layout preparers to duplicate the drafting effort to provide sketches the worker can understand.

If design, engineering, and all crafts used the same reference system, both the design and construction of the ship would be significantly less complicated. There are many reference system concepts, and some have been developed to accomplish specific goals. It is essential that the system meet the needs of each shipyard from design through engineering, lofting, processing, assembly, erection, outfitting, and machinery installation to completion. It is obvious that an integrated or universal system must be able to satisfy all user requirements. The use of an integrated reference system also enables an effective dimensional control system to be applied during the construction of the ship. It can also form the basis for measurements taken for accuracy control (AC) and eliminate the need for separate additional AC reference lines.

It is important to recognize and resolve the conflict between those who acknowledge that the structure will probably not be exactly where it should be, thus prohibiting the use of structure as a reference surface, and those who recognize the fact that at least two conditions exist. The first condition is where structure must be located as precisely as possible from another part of structure, such as the stern tube from the engine foundation. The second condition is where the contents of a space should be located to the boundaries of the space, even though the boundaries may not be located exactly on a total ship reference system basis. It is suggested that a reference system based on three-dimensional space for the total ship is not practical or advantageous to all crafts, and may in fact add work content to the job without any improvement in accuracy or quality. This suggestion is based on an examination of the needs of the various crafts to fabricate, assemble, and install their products. There is no disagreement that an integrated system should be used to erect structure, install advanced outfitting units and "on block" packages, and install nonstructural steel compartment boundary bulkheads. However, it appears overkill to use a three-plane reference system intersection in space in a compartment to locate furniture, fittings, lights, and switches. It is much easier to locate such equipment relative to the boundaries of the compartment. However, dimensions should be measured from only one of the boundary surfaces in each plane.

A possible reference system that meets the above concepts is described for illustrative purposes. It is made up of a three-level system, namely, the primary, secondary, and tertiary levels.

The primary level consists of three planes measured from the forward perpendicular, baseline, and centerline of the ship for each erection module. Two planes shall be continuous across adjacent modules to assist in alignment of modules during fit-up. Transverse planes shall be designated by an "L" and the distance in feet and inches from the origin, such as L360-6. Horizontal planes shall be designated by an "H"

TABLE 1.4

TYPICAL DIMENSIONING METHODS USED BY ISOLATED ENGINEERING TO LOCATE ITEMS

Engineering Section	System	Above Base Line	Off Center Line	Frame to Frame	From Near Side of Deck	From Structure Fore & Aft	From Structure Transversely
Hull	Structure Foundations outfit	X	X X	X X	X X	X	X
Machinery	Arrangements Piping HVAC	X	X X		X X	X X	X
Electrical	Arrangements Wireways	No	dimensions	given.	Only X	a pictorial X	layout. X

PART 1

and the distance above the baseline, such as H20-9, and similarly longitudinal planes by a "B" with S or P sign to designate to starboard or port, respectively, and the distance off the centerline, such as BS15-0. This level shall be used for structure, locating packaged equipment and piping units, foundations, major machinery, floor plates and grating, and will therefore be used on all drawings showing such items. This will standardize and reduce the amount of reference currently used for these drawings. This reference level will also be used by the loft. Figure 1.31 indicates the application of this level.

The secondary level would be used for all assembly work, excluding the ship's structure performed off the ship, such as advanced outfitting units, foundations, etc. The reference lines would be clearly identified on all drawings, and all dimensions would be measured from the secondary-level reference lines. The reference lines must be real; that is, there must be material (support structure) on which the lines can be permanently marked. The lines would be identified by their location within the primary level, such as L427-3.5. With each drawing a locating sketch would be included, showing the secondary reference level in relation to the primary level for the compartment in which the item was to be installed. Figure 1.32 illustrates how this could be done.

The tertiary or third reference level would be used for compartment arrangement and Foundation drawings for joiner work panels, door frames, ladders, "on-board" advanced outfitted electrical equipment, joiner bulkhead mounted equipment, furniture, etc. This level would use the intersection of the near side of the deck below or above (whichever is mutually agreed between engineering and production in a shipyard), the near side of the inboard longitudinal steel or joiner bulkhead, and the near side of the forward transverse steel or joiner bulkhead as its origin, and the planes in which each surface lies as the reference planes. Again the reference planes would be identified by their location within the primary level, as shown in Figure 1.33.

It should be obvious that such a system applied consistently to the engineering for a ship would simplify the interference-control problem, as all items would be measured to a common reference system for the total ship or for a specific compartment.

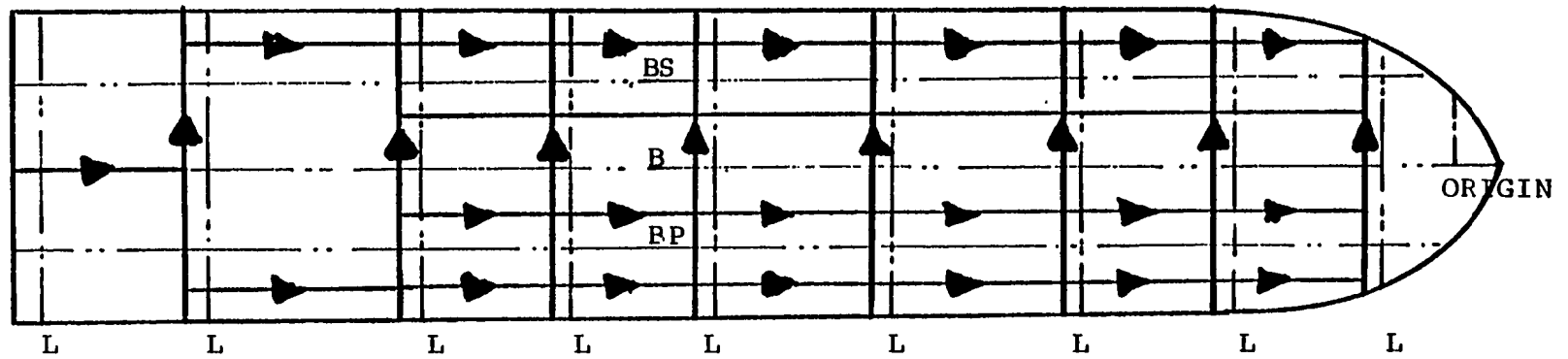
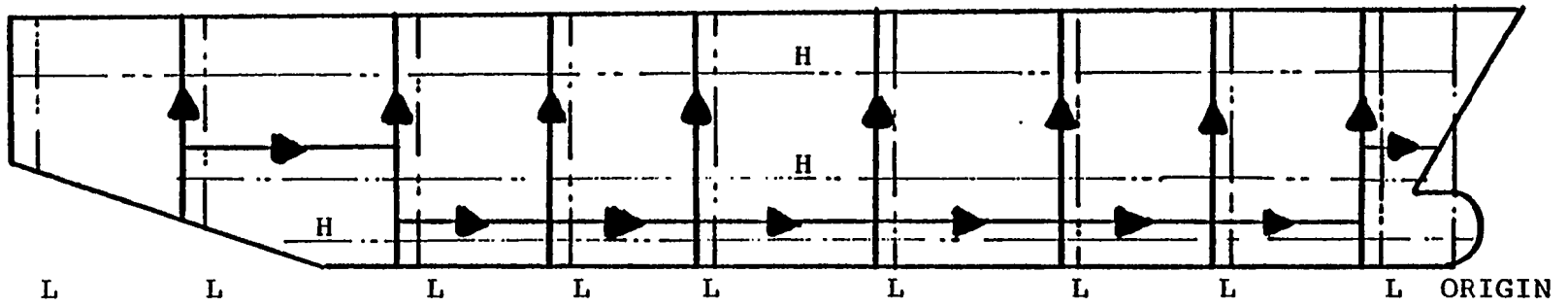
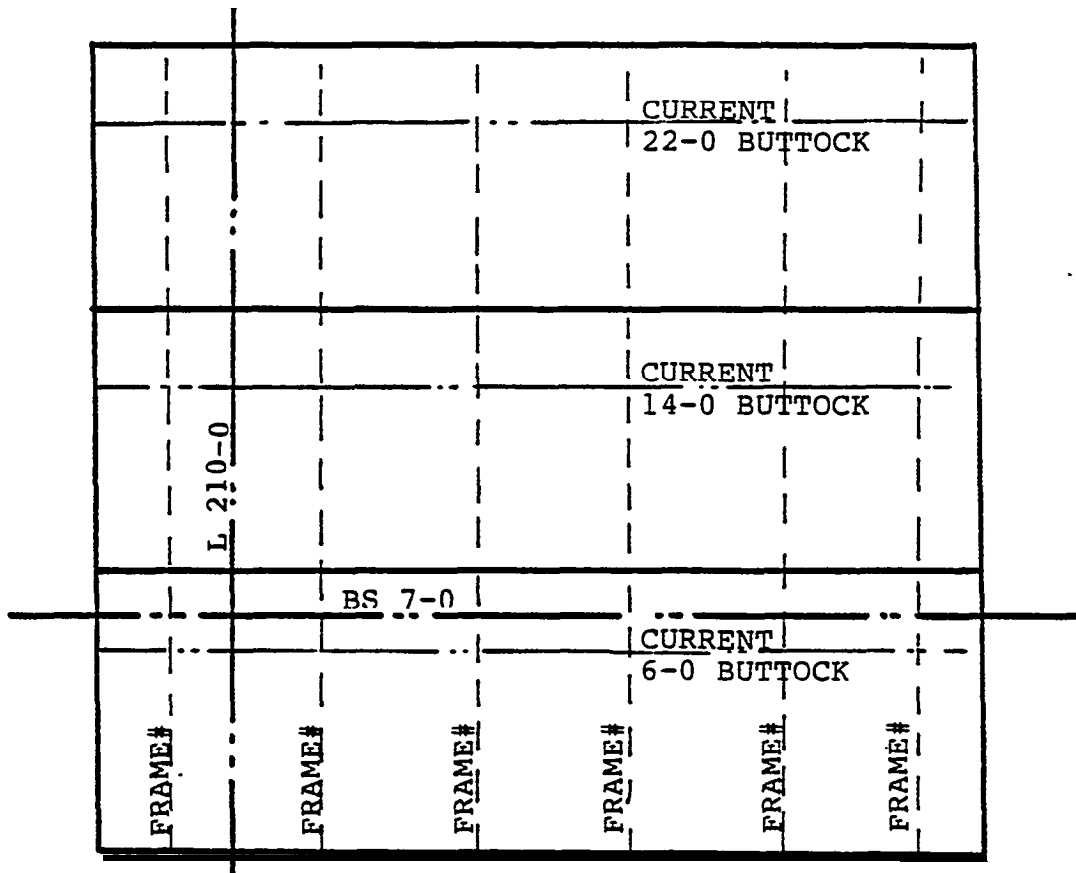
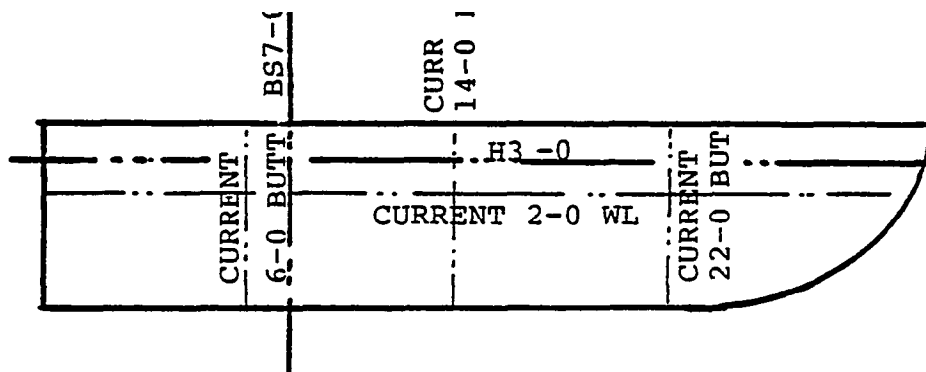

FIGURE 1.31(a) Primary reference system.



SHELL ASSEMBLY SHOWING CURRENT AND SUGGESTED MARKING
 (ONE LESS LINE BUT REFERENCE LINE L210 IS VISIBLE
 AFTER ASSEMBLY WHEREAS FRAME LINE DISAPPEARS UNDER FLOOR)



FLOOR ASSEMBLY SHOWING CURRENT AND SUGGESTED MARKING
 (TWO LESS LINES)

FIGURE 1.31(b) Comparison of traditional and suggested reference system.

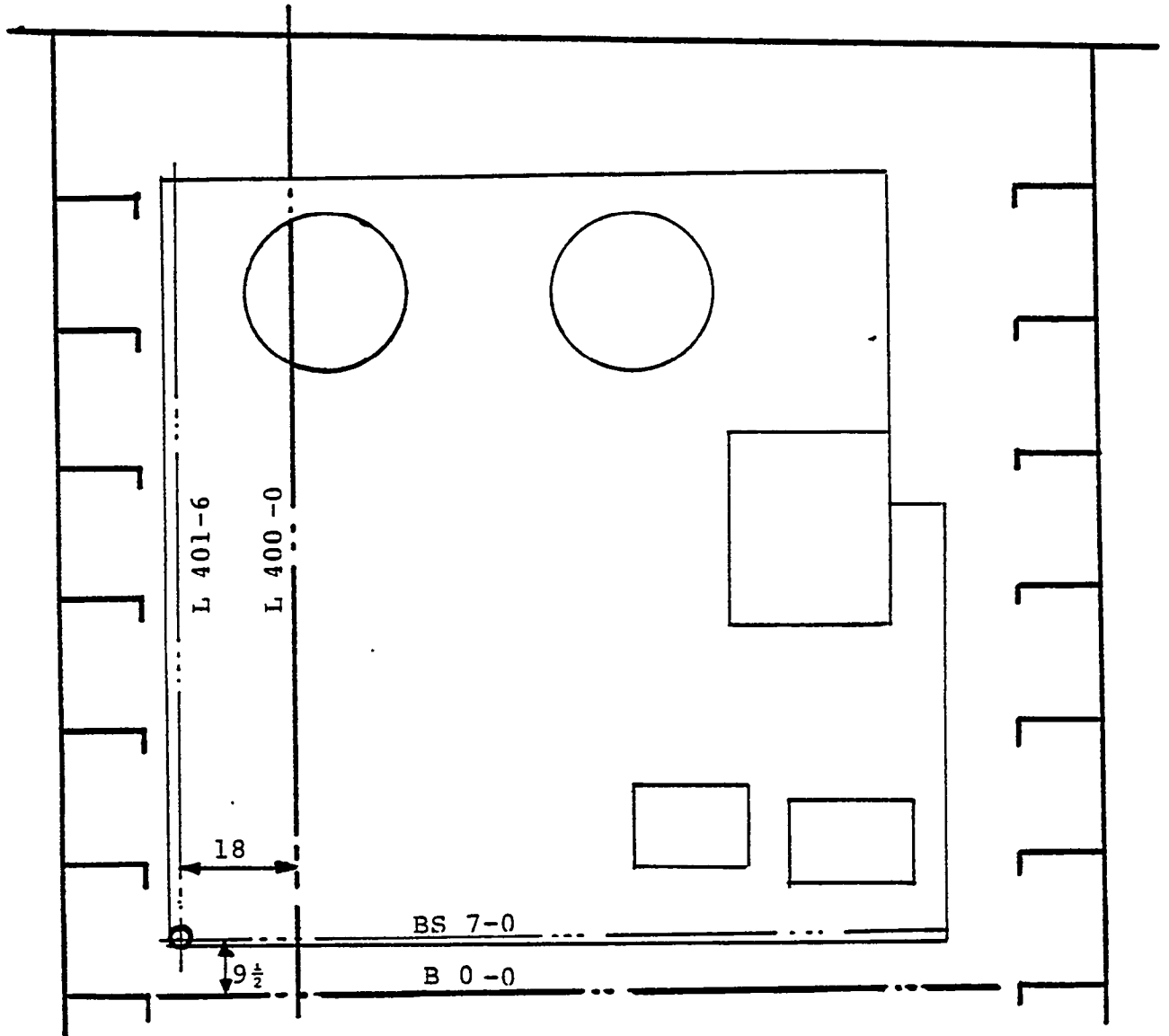

FIGURE 1.32(a) Relation of secondary reference system to primary reference system.

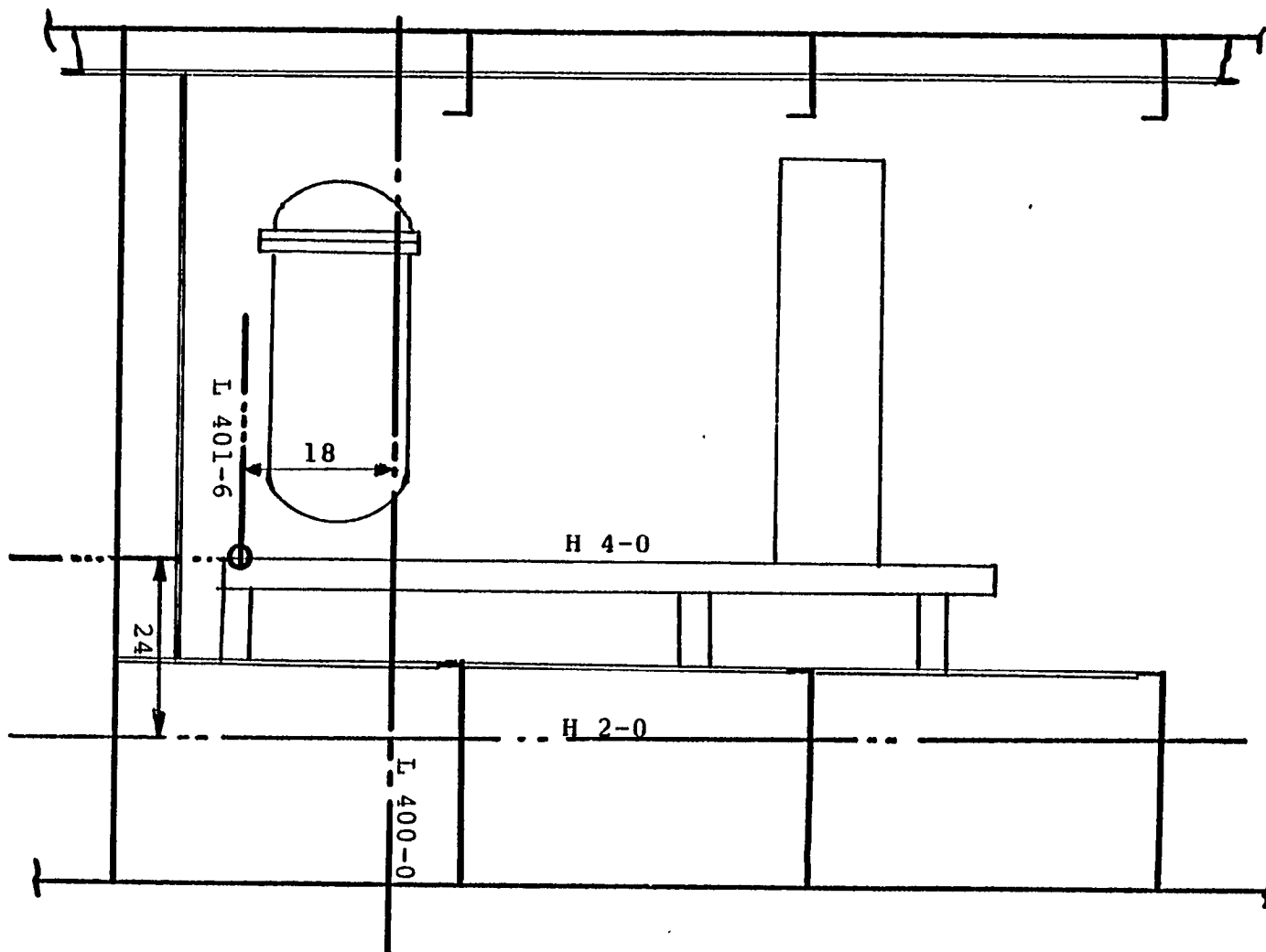

FIGURE 1.32(b) Relation of secondary reference system to primary reference system.

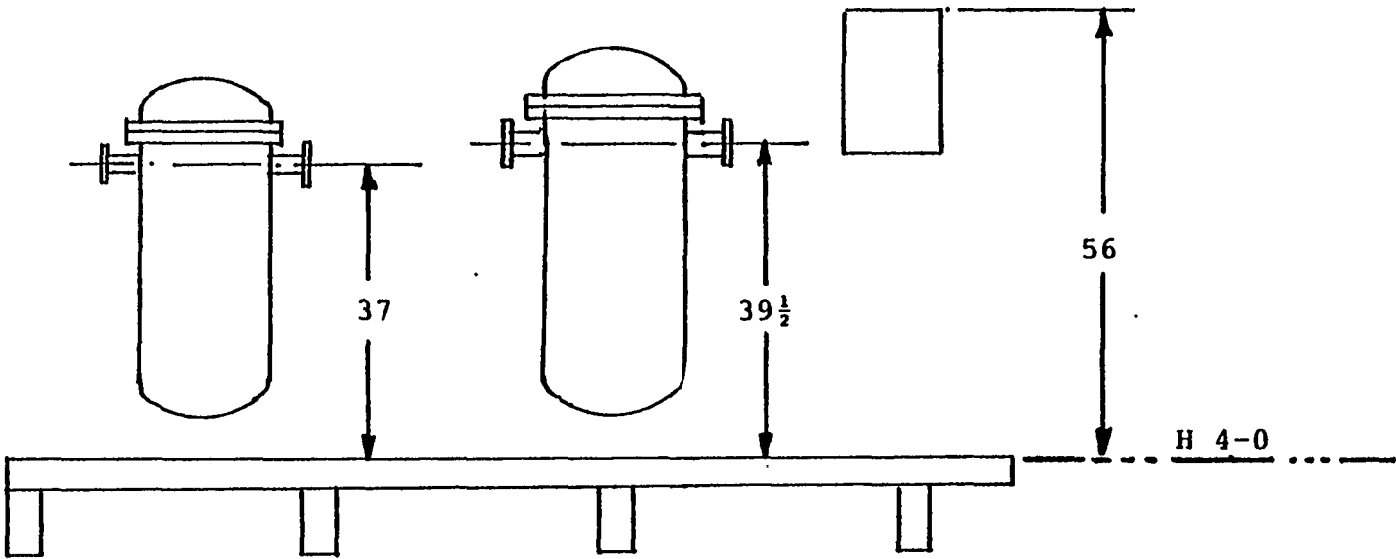

FIGURE 1.32(c) Secondary reference system.

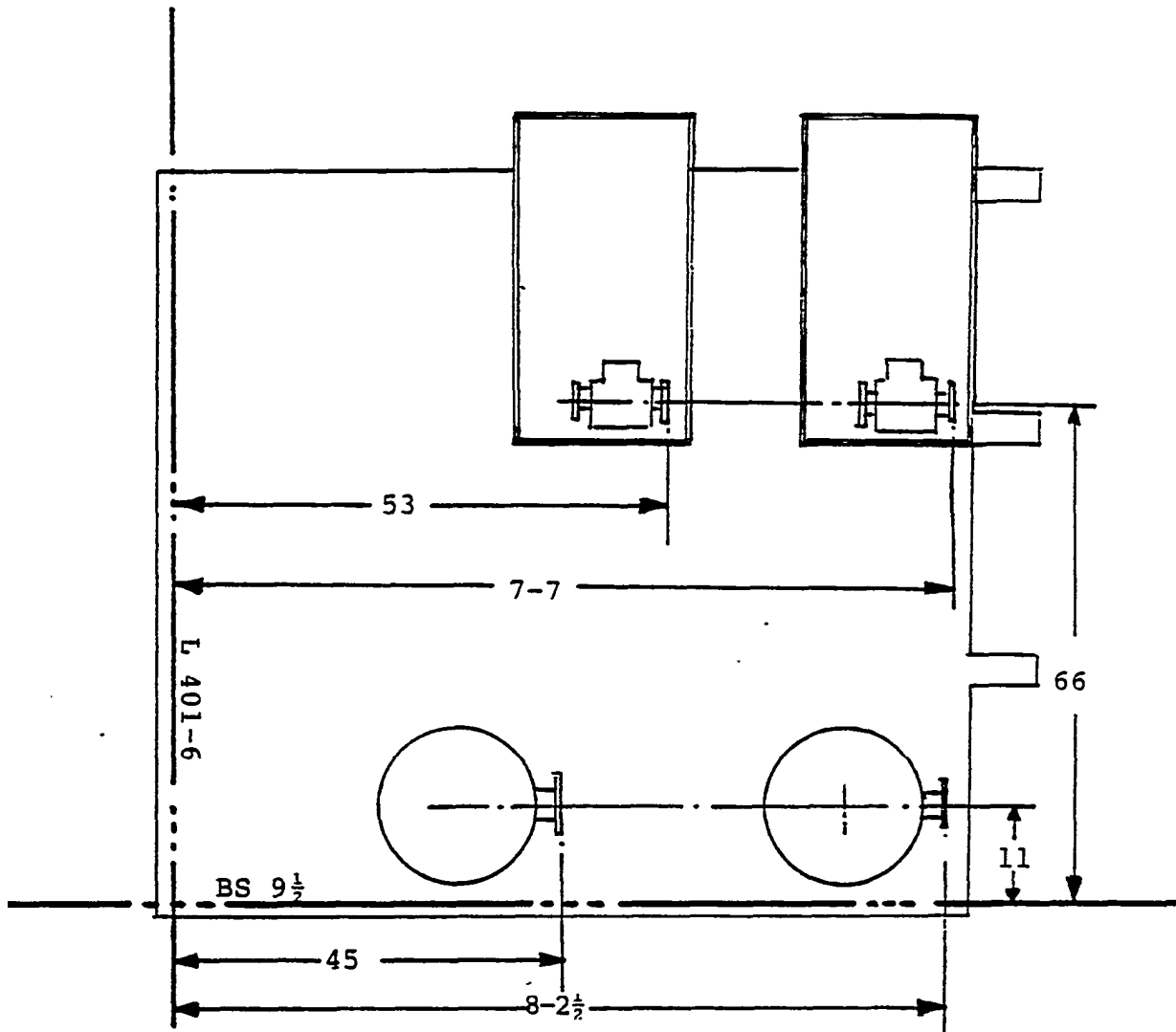

FIGURE 1.32(d) Secondary reference system.

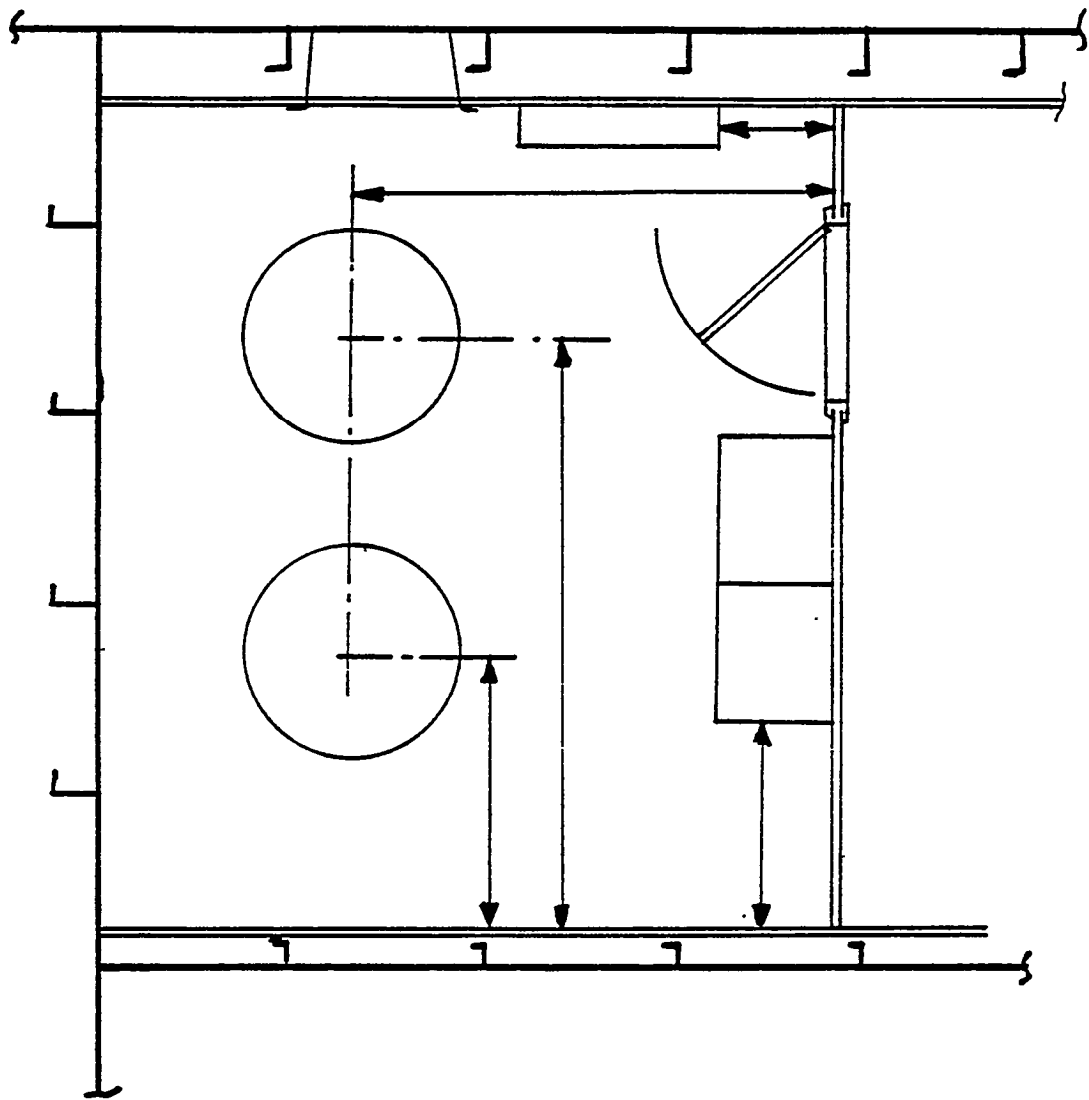

FIGURE 1.33 Tertiary reference system.

REFERENCES

1. R. Munro-Smith, Merchant ship design (London: Hutchinson and Company, 1964).
2. R. Munro-smith, Elements of ship design (London: Marine Media Management Ltd., 1975).
3. A. Kari, The design of merchant ships and cost estimating (London: Lockwood and Sons, 1948).
4. Design of merchant ships, Volume 4: Ships and Marine Engine Series (Haarlem, Holland: The Technical Publishing Company).
5. G.C. Manning, The theory and technique of ship design (New York Van Nostrand, 1956).
6. Ship design and construction SNAME 1980.
7. D.G.M. Watson, "Estimating preliminary dimensions in ship design, IESS Transactions, vol. 105, 1961-1962.
8. R.T. Miller, 'A ship design process," Marine Techology. SNAME, October 1965.
9. T. Lamb, "A ship design procedure," Marine Technology. SNAME, October 1969.
10. G.M. Watson et aL, "Some ship design methods," RINA Transactions, vol . 119, 1977.
11. D. Andrews, "Creative ship design," RINA Transactions, vol. 123, 1981.
12. D.C. Macmillan, Improvements in the ship design process. SNAME Los Angeles section, october 1977.
13. R Judge et al., "The RCN's application of method study to ship design, SNAME Marine Technology July 1967.
14. A.W. Gilfillan, "preliminary design by computer," IESS Transactions, vol. 110, 1966-1967.
15. K.W. Fisher, "Economic optimization procedures in preliminary ship design," RINA Transactions, vol. 114, 1972.
16. RD. Murphy et aL, "Least cost ship characteristics by computer techniques," SNAME Marine Technology, April 1965.
17. H. Benford, "Measures of merit for ship design," SNAME Marine Technology, october 1970.
18. H. Benford, "The practical application of economics to merchant ship design," SNAME Marine Technology, January 1967.

19. H. Benford, "Principles of engineering economy in ship design," SNAME Transaction, vol. 71,1963.
20. J.H. Evans, "Optimized design of midship section structure," SNAME Tarnsaction, vol. 71,1963.
21. A.G. Hopper, "Cargo handling and its effect on dry cargo ship design," RINA Transactions, vol. 106, 1964.
22. "K.R Chapman, "The optimum machinery position in dry cargo vessels, "NECIES Transaction,, 1963.
23. RN. Newton, "Wetness related to freeboard and flare, "RINA Transactions, vol. 102, 1960.
24. D.W. Camsey et al, "The application of computer simulation techniques to ship production," NECIES Transaction, 1983.

1.4 Group Technology

1.4.1 GENERAL. The basic concepts of group technology are not new. The first use of the principles of group technology was described by an American, RE. Flanders [1] in 1925. The next significant development was published by J.C. Kerr [2] in Britain in 1938 and then in France by a Swedish engineer, A. Karling [3] in 1949. However, the real development of group technology occurred in Russia in 1959 [4] and Germany in 1960 [5]. It was then utilized in factories in Eastern Europe and in the late 1960s its application began to increase in Britain and Western Europe. U.S. interest in group technology was slow to start, with initial flickerings in 1971 to 1973. Since 1976 the use of group technology in the U.S. has increased at an accelerated pace, as evidenced by 67 publications on group technology issued by the Society of Manufacturing Engineers over the last four years. This is partly due to its use with automated process planning.

As a science it has not had the worldwide success of other modern techniques developed about the same time, such as operations research. This is mainly because of misunderstandings over what group technology is! In its most general sense group technology is the integration of common problems, tasks, principles, and concepts to improve productivity. In a more restrictive sense it has been defined as a method to apply mass production techniques to products that vary widely in type and quantity. Reference [6] defines group technology as the organization of production facilities in self-contained and self-regulating groups or cells, each of which undertakes the complete manufacture of a family of components with similar manufacturing characteristics. The cell staff are often each capable of using several machines or processes, so that there are usually fewer men than machines. It further describes the following characteristics which distinguish group technology from conventional batch manufacturing systems:

1. Components are classified into groups or families according to the production processes by which they are produced.
2. Work loads are balanced between the production groups into which production facilities are organized rather than between separate manufacturing operations.
3. The production groups--the people, machinery, and components concerned--are clearly identifiable on the shop floor, though each group may vary considerably in size. In some situations the machinery is arranged to provide a flow of work to optimize the operation of key machine tools by providing them with a full range of secondary machine tools to ensure a balanced input and smooth outflow of work. In other situations the machinery is arranged so that there can be a continuous flow of work from one machine to the next, with the object of gaining some of the advantages of flow line production.
4. Each group works with a significant degree of autonomy.

Figure 1.34(a) shows a typical shipyard process flow which is a "functional layout" and Figure 1.34(b) shows a modified process flow arranged as a "group layout" with group or "product" cells. Note the duplication of the machines in each cell. This can result in low machine utilization, but this is usual in group layouts. It is the overall productivity of the cell that is important, not machine utilization. It clearly shows how both the material and production control is simpler with the group layout. Grouping machines and arranging of process flow is only one facet of group technology and usually is performed on the basis of the results of grouping all the products and processes involved.

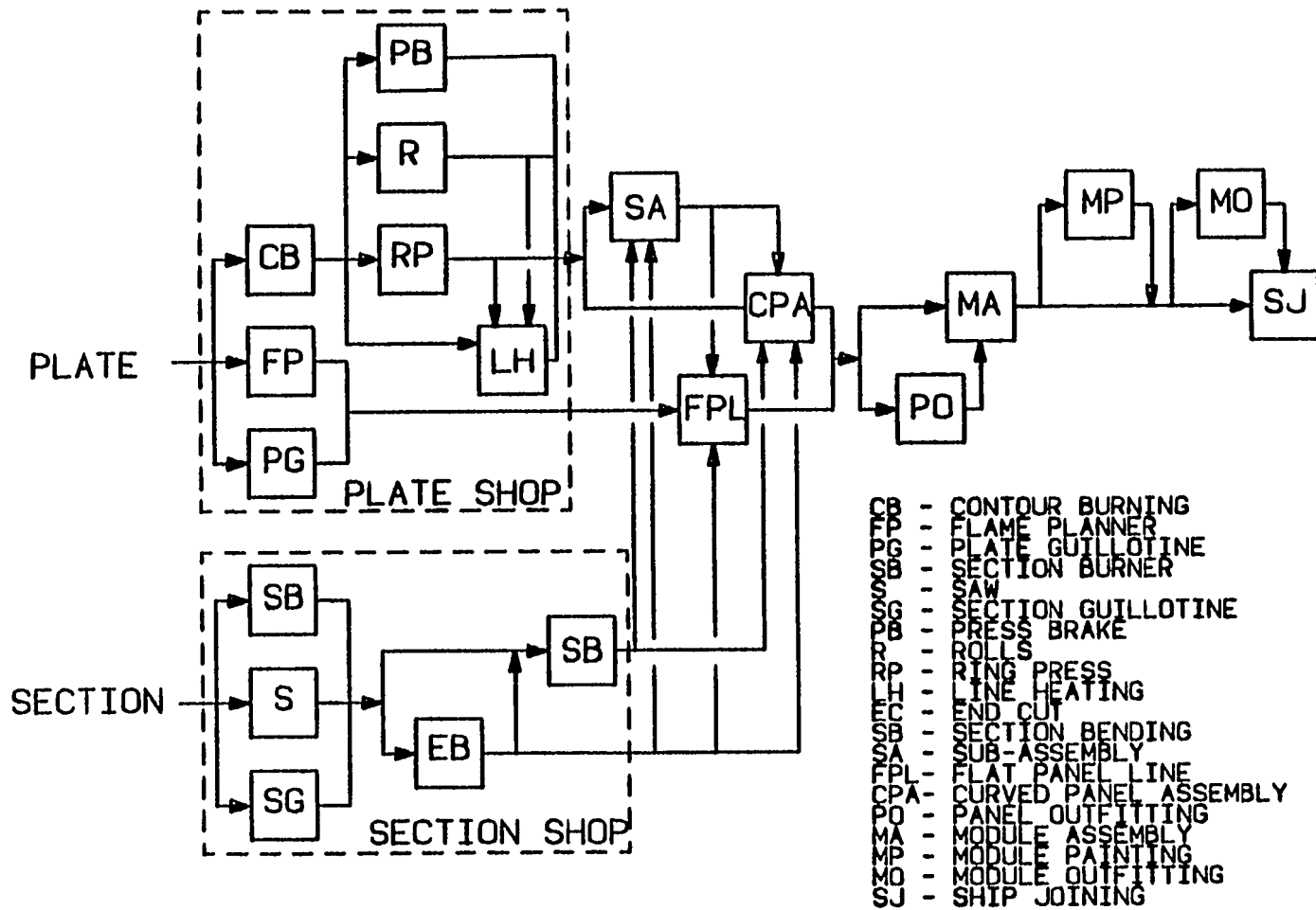

FIGURE 1.34(a) Typical shipyard functional layout.

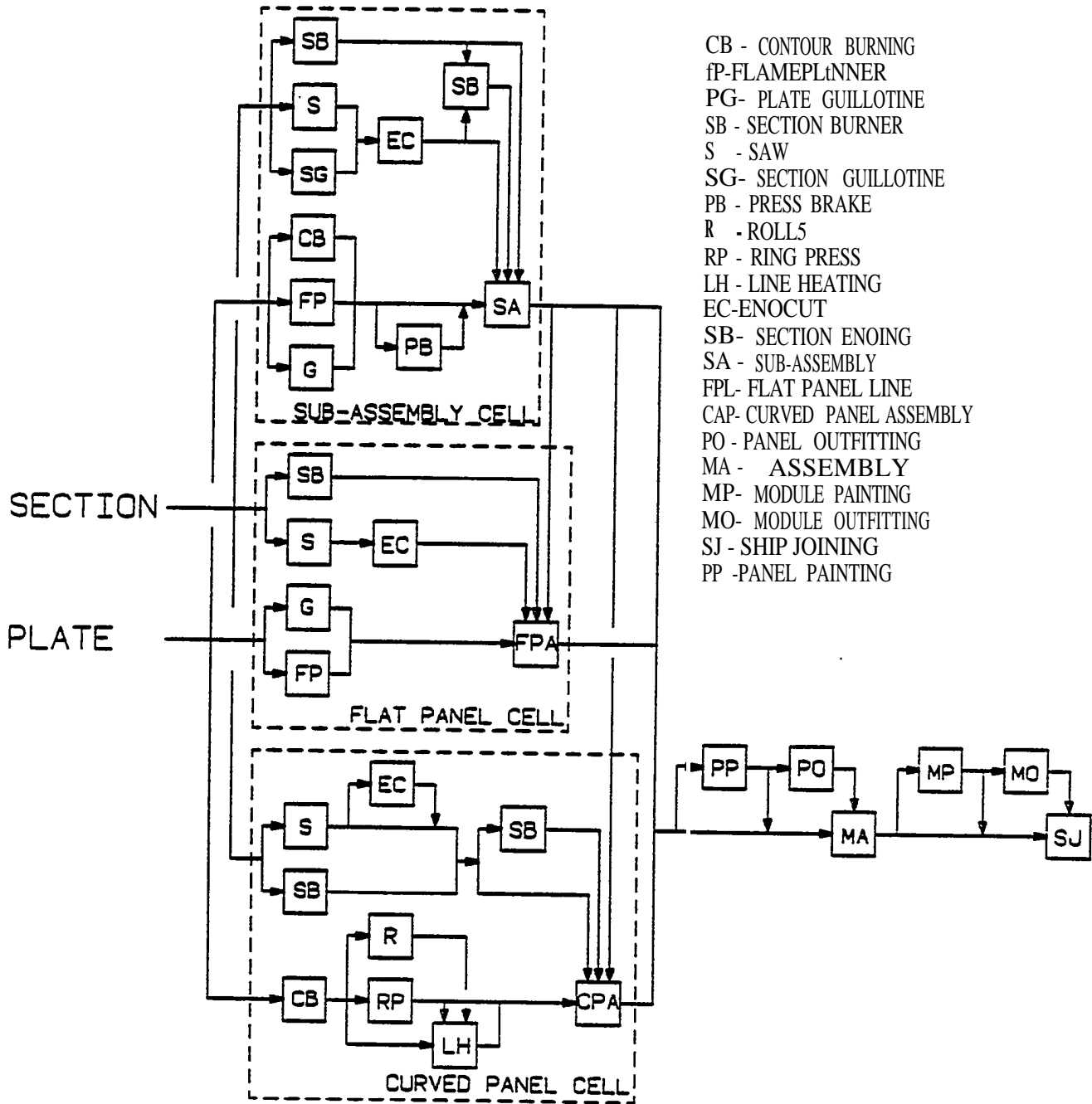

FIGURE 1.34(b) Shipyard group layout.

Experience from users of group technology shows that its benefits can cover reduction in construction time, reduction of inventories and work in progress, more effective and economical inspection, and simplified planning, scheduling, and control systems. It clearly supports the objectives, and is therefore an obvious part of design for skip production.

Its limited use to date in general industry is partly due to the fact that the foundation of group technology is classification and coding of like products and processes. Classification is a means of separating product data through similarities into groups or classes. Coding is the system which enables storing and retrieving the classified data so it can be organized, analyzed, and used for specific purposes. It should be remembered that group technology looks for the similarities and not differences. The similar products are grouped in families, and the families manufactured in groups of associated work stations. The necessary classification, coding, and analyzing involves significant effort. Because of the magnitude of the task, manual systems tended to deter the application. Nevertheless many systems have been developed by various specialists in this field. Some companies have used classification and coding systems to resolve manufacturing problems, only to forget them until another problem arose.

The development of group technology has, understandably, been closely tied to the development of classification and coding systems. Classification systems were developed for two basic group technology functions, namely, product variety reduction and grouping of parts for production. Product variety reduction utilizes identification and retrieval of similar designs, whereas grouping of parts for production requires the selection of parts with similar processes. Many classification and coding systems have been developed, and are described in the already-referenced textbooks on group technology. Most of the systems are for machined parts, but a few include sheet metal and piping fabrication. None of them are directly applicable to the shipbuilding industry, but some of them could be used as part of a shipyard system, and also much can be learned from them when developing a shipyard system.

1.4.2 APPLICATION OF GROUP TECHNOLOGY TO SHIPBUILDING. If group technology is not new, why has it not been applied to the shipbuilding industry before now? In addition to the above-mentioned general lack of use, a complete lack of knowledge of it and its benefits are the most obvious reason. Even in the case of some shipyard managers who have knowledge of group technology, the inability of shipbuilding management to establish and enforce the detailed work breakdown and engineering required for its application prevented its use. It required the Marad Technology Transfer program to introduce it to U.S. shipbuilders in the IHI Product Work Breakdown System Manual [7]. The manual describes how to classify shipbuilding products, and thus it is a partial application of group technology. Its usefulness is limited, as it did not present an associated coding system. Group technology has been applied to shipbuilding in Japan [7], Britain [8, 9, 10, 11, 12], and Russia [13]. These reports indicate that it has been applied successfully in the following shipbuilding areas.

- Design rationalization
- Development of effective production planning systems by analysis of product sizes, shapes, variety, and processes
- Structural material size variety reduction
- Improved presentation of engineering information to the shop floor through classification and coding of products
- Improved shop floor organization and layout based on statistical analysis of the product processes and flow

The reason for the current increase in interest in group technology is that it has been shown to be an effective way to assist industry to increase productivity. This must be the goal of every shipyard if they are to survive in the very competitive business area that is part of. Group technology is an essential prerequisite to computer-aided process planning (CAPP), which in turn is essential for automated factories.

The way that group technology achieves improvements in productivity can be better understood if the various production organization types are briefly described, and their application to shipbuilding considered. Production organizations are usually grouped into five categories. These were well defined by Marsh [14], and his titles are used as follows:

1. craft Organization (Job Shop)

Organization using well trained and experienced workers to perform many activities in one or a few locations. Most production decisions are left to the craftsman, who may approach each job in a different way. Required engineering data are minimum in scope and can be lacking in accuracy. Craft organizations are difficult to schedule and control.

2. Semi-Process Organization

Organization utilizing well trained and experienced workers, but attempting better planning and control by muting similar work processes to specific work areas. Requires more planning effort but scheduling and some control is attainable. Engineering has to be more detailed to enable planning to break down the work into task packages.

3. Process Organization (Batch)

This is the complete use of specific work areas to perform specialized activities. This enables workers to be trained only in the special activity they are selected to perform. Planning becomes more complex regarding scheduling and material control. Engineering is prepared for specialized process rather than total product.

4. Product or Group Organization

This type of organization focuses on a type of product, such as flat panels, and links all the processes together to complete the product. It then combines a number of products to make a new larger product, such as an erection module and ultimately the ship's hull. Planning is simpler as it follows a logical sequence of events. Again the extent of worker training is limited to those processes utilized in a given work station. Engineering is prepared to show the product to be processed at a given work station. Control can be precise due to the many available data points.

5. Mass Production Organization

This type of organization maximizes the use of mechanization, continuous flow lines, and specialization of activities at sequential work stations. Material handling is decided at the time of the facility design. Engineering is more involved in machine instructions, jig and tooling, and quality control data.

The differences and relative effort for each type of organization are summarized in Figure 1.35, which is based on a similar figure in reference [4]. The various organizations have also been categorized by Hargroves, Teasdale, and Vaughan [X], and Table 1.5 is based on their presentation. It shows the productivity gap existing between organizations currently producing one-off products and mass production organizations. It

TYPE	CRAFT	SEMI - PROCESS	PROCESS	PRODUCT	MASS PRODUCTION
ORGANIZATIONAL CHARACTERISTICS	PIECEMEAL PRODUCTION AND ERECTION	WORK AREAS DEFINED BUT FLEXIBLE	WORK STATIONS DEFINED AND FIXED GROUP TECHNOLOGY APPLIED	PRODUCTION FROM ALL WORK STATIONS SYNCHRONIZED WITHOUT BUFFERS	AUTOMATED CONTINUOUS FLOW
PLANNING	SIMPLE TOTAL SHIP BASIS	MORE COMPLEX SCHEDULING AND ROUTING OF UNITS AND ASSEMBLIES. FORWARD LOADING OF WORK AREAS	HIGHLY COMPLEX SCHEDULING AND ROUTING OF INDIVIDUAL COMPONENTS. FORWARD LOADING OF WORK STATIONS	SIMPLER THAN PROCESS. LESS NEED FOR ROUTING INSTRUCTIONS	SIMPLE SCHEDULING ROUTING FIXED BY PLANT
EXTENT OF MECHANIZATION			INCREASING →		
FLEXIBILITY			DECREASING →		
COMPLEXITY OF PLANNING	INCREASING →		DECREASING →		
EXTENT OF STANDARDIZATION			INCREASING →		
TYPICAL APPLICATION IN SHIPYARD		PANEL BAY GENERAL MACHINERY INTENSIVE AREAS	PANEL LINE ASSEMBLY WORK STATIONS	CONVEYORS IN FABRICATION EXTRUSION OF TUB	

FIGURE 1.36 Transition from craft to mass production.

TABLE 1.5
 PRODUCTION ORGANIZATIONS

	'One-Off'	Wide Variety of Products	A Variety of Products	A Few Kinds of Products	Mass Production
PRODUCTION STRUCTURE	Infinite Variety	LQw Quantity per Variety	Medium Quantity per Variety	Large Quantity per Variety	A Single Product Line
Production Type		Job Shop	Batch	Flow	
Production Layout		Fixed Positn.	Process	Product	
Production System		Craft Organized	Process Organized	Product Organized	
Pre-investment Planning		Low	Medium	High	
Operational Planning		High	Medium	Low	
Relative Productivity Opportunity		Low	Medium	High	



also shows the potential productivity improvement through group technology. Figure 1.36, also taken from their work, graphically illustrates the different processes. They state in their paper:

It is more than likely that the concept of group technology will prove to be the settling point of much of ship production activity in the future.

The traditional shipyard was craft organized, as are most shipyards today. In the past this worked quite well for a number of reasons, including:

- Workers had pride in being craftsmen and were prepared to take the time to be trained. Five-year apprenticeships were common.
- Employers were willing to invest time/money to train their employees.
- The demand for ships was great enough that it was not necessary to maximize productivity to survive.
- The trade unions in the shipbuilding industry resisted the changes that were necessary to improve through the application of modern production techniques, as they usually involved demarcation issues.
- Engineering departments were incapable of providing the type of engineering information required for modern shipbuilding techniques.

This last reason is discussed further in Part 3.

Group technology, applied from engineering through to ship delivery, can provide the basis on which improved shipbuilding production technology can be developed, and thus attain increased productivity. The availability of computers and the development of data base technology has enabled the full potential of group technology to be developed today. In fact the desire to use computers in manufacturing planning and control necessitates better classification and coding, and thus generates interest in group technology. Like any new technique, there is the danger that only part of group technology will be used, and thus its full potential will not be developed. When group technology is introduced into a shipyard, all departments are affected. This is indicated in Figure 1.37 and is well described in most textbooks on group technology [16,17].

So far most of the reported applications of group technology to shipbuilding have been in the area of ship structure. It has been used to group structural parts by both their geometry and processing characteristics for interim products such as subassemblies, assemblies, and modules. A ship's hull is constructed from steel plate and sections which are separately processed from the received material. The variety of parts is large, whereas the variety of subassemblies and assemblies is relatively small. The differences in size and work content of the interim products result in the work not being suitable for normal continuous flow processing. Group technology can partially overcome this problem by grouping the interim products into similar geometry and/or processing requirement groups, so that the effective individual group volume increases to the extent that some of the benefits of continuous flow processing can be obtained. If this can be done, improved productivity and shorter construction cycles are possible.

Group technology classification and coding systems should cover both product and process definition. The earlier separation of systems into product variety reduction and product families for production should be avoided. The already-mentioned work in Britain by the University of Glasgow and the British Ship Research Association (BSRA) has developed a system for ship structure. It has been used for a number of applications, including the statistical analysis of components and their work content. This in turn has been used in the development of new shipyards. Reference [10] reviewed eight

TREATMENT AND PREPARATION
FIXED Position LAYOUT

ASSEMBLING

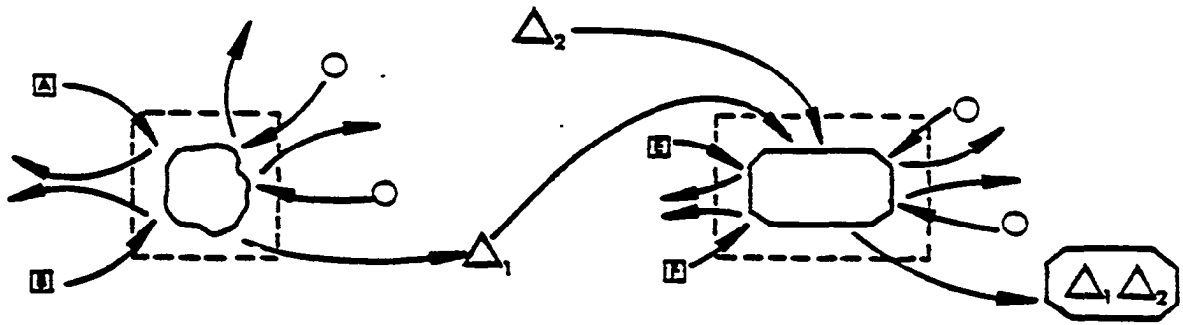

PROCESS LAYOUT

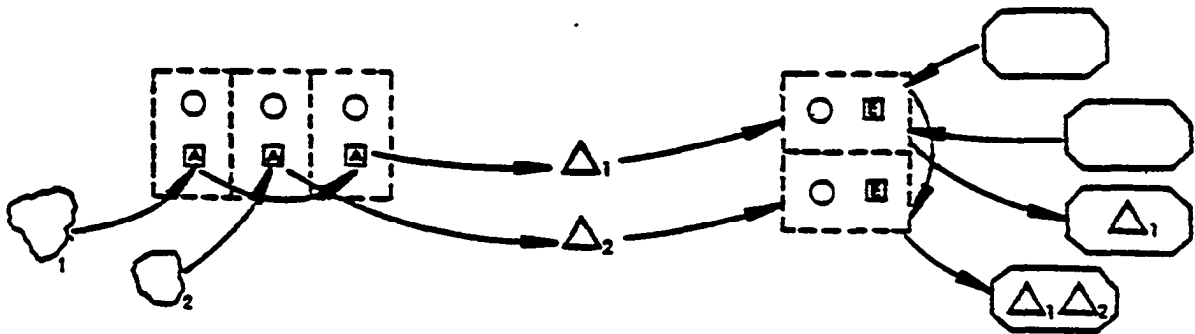

PRODUCT LAYOUT

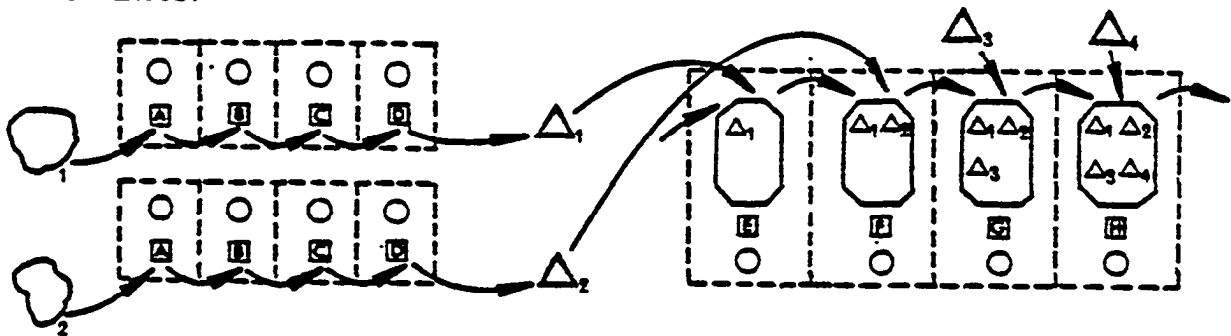

GROUP LAYOUT

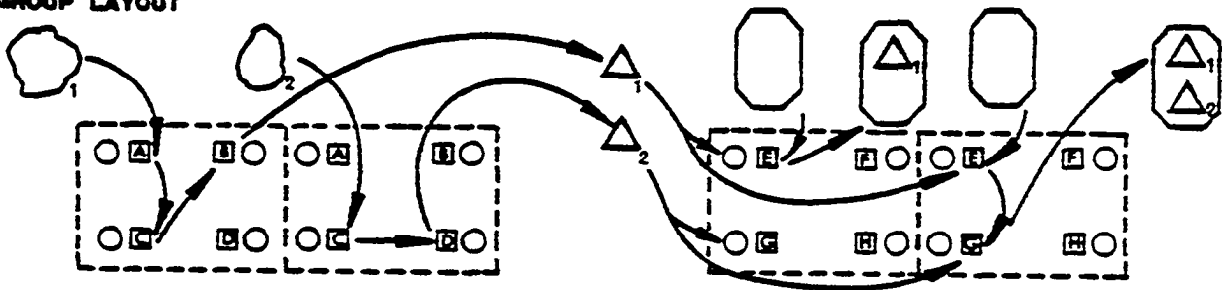

FIGURE 1.36 Types of processes.

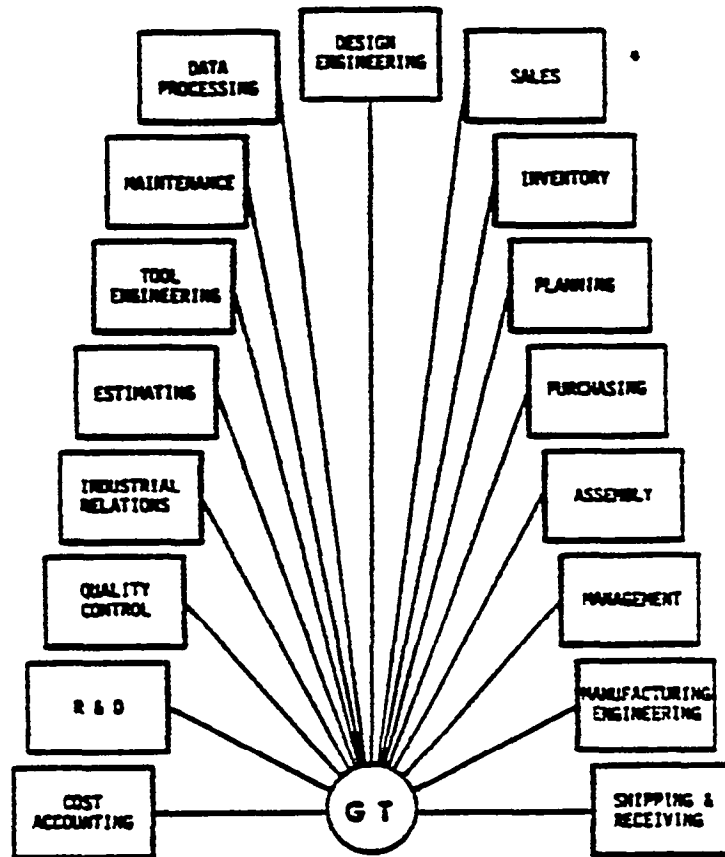

FIGURE 1.37 Departments affected by group technology.

classification and coding systems that were in use by British shipyards for ship structure, and was the basis for the final system adopted by BSRA. Reference [18] describes a proprietary classification and coding system developed in Holland. It is a general format system allowing users to input their own products and processes. The system is integrated with a computer-aided process planning capability. A typical summary of a structural component analysis is shown in Figure 1.38, token from reference [19]. Reference [20] gives details of three applications of group technology to shipbuilding. These show how the structural classification and coding system was used to develop a data base of design and production information for various ship types. This enabled similarity of components for different ships, structural process flow, work content, structural plate standardization, and new and existing facility analysis to be determined. The analysis of the structural process flow showed that no component required more than two welding processes, and 75% of all components had only one welding process before delivery to the module assembly.

It is not known if the BSRA structural classification and coding system has been expanded to cover all shipyard products and processes. However, it is essential that a complete system be developed to allow the full benefit of group technology to be achieved. With this in mind, the author developed a shipbuilding classification and coding system (SCCS). Figure 1.39 gives details of the system. It uses up to 17 digits, all numbers. The number of digits used varies depending on the product. However, the full 17-digit field is always used, 'For example, a structural plate product uses all 17 digits, whereas a subassembly uses only 11 of the digits for meaningful data. The first to the tenth digits are used for design classification, and the eleventh to seventeenth digits are used for processing classification. The use of the system can be seen from the examples given in the figure. For structure the following applies.

FIRST DIGIT**SHIP GROUP**

The subdivision of the ship into major systems. The U.S. Navy Ship Work -Breakdown Structure first digit groups are used because of the U.S. shipbuilding industry's familiarity with it.

SECOND DIGIT**BASE PRODUCT**

The subdivision into products as received by the shipyard. For example, plate, sections, etc.

THIRD DIGIT**TYPE**

The subdivision of base products into the various types that they can be. For example, sections could be flat bar, angle, channel, tee, etc.

FOURTH DIGIT**MATERIAL**

Defines the material in terms of specification and quality.

FIFTH DIGIT**SIZE CLASSIFICATION - LENGTH**

The sixth through tenth digits are used for different classification depending on the first two digits as follows:

SIXTH DIGIT

FOR PLATE - WIDTH
FOR SECTIONS - WEB DEPTH

SEVENTH DIGIT

FOR PLATE - THICKNESS
FOR SECTIONS - FLANGE WIDTH

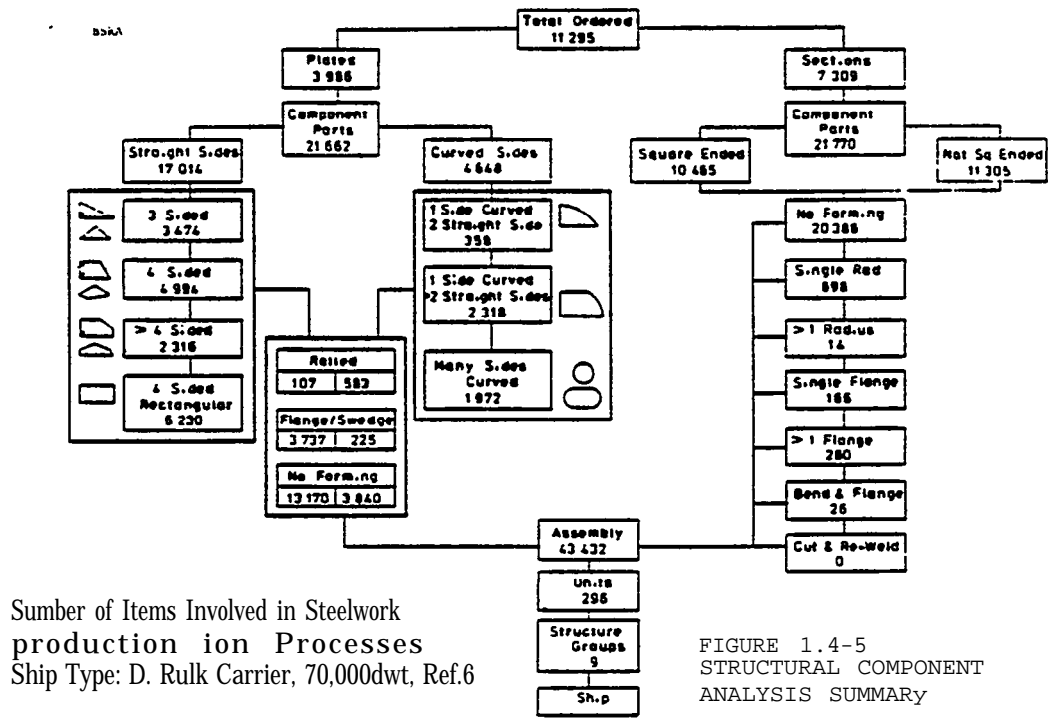
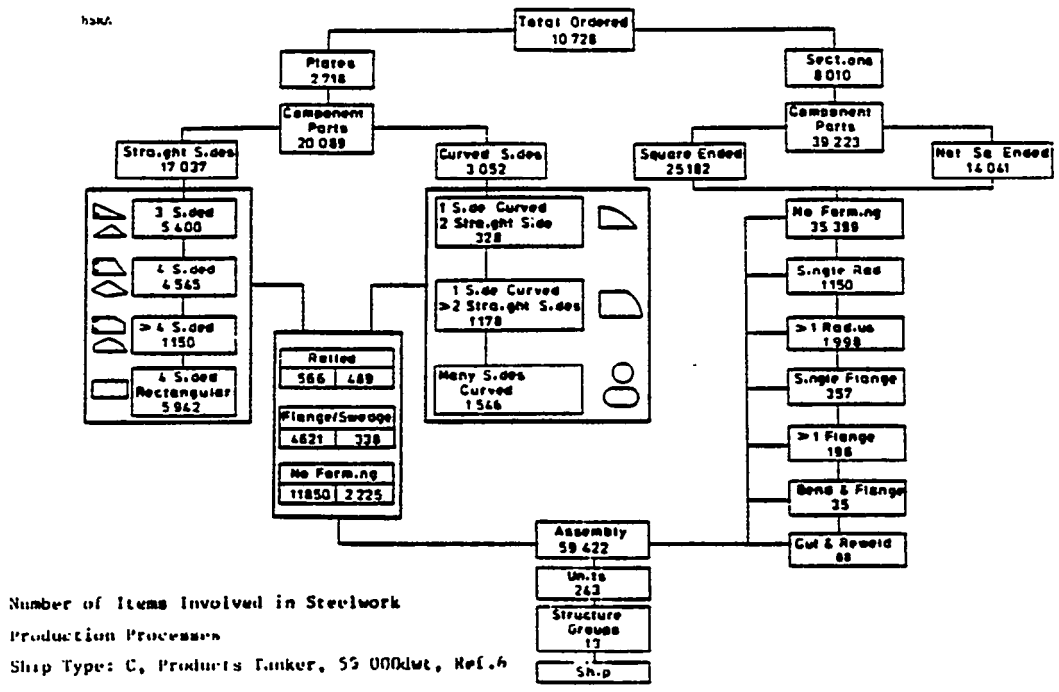

FIGURE 1.4-5
STRUCTURAL COMPONENT
ANALYSIS SUMMARY

FIGURE 1.38 Structural component analysis summary.

EIGHTH DIGIT	FOR PLATE - SHAPE FOR SECTIONS - WEB THICKNESS
NINTH DIGIT	FOR PLATE - HOLES AND SLOTS FOR SECTIONS - FLANGE THICKNESS
TENTH DIGIT	FOR PLATE - EDGE PREPARATION FOR SECTIONS - END CUT

The eleventh through seventeenth digits are used to classify the processes used to fabricate and install the products to build a ship as follows:

ELEVENTH DIGIT	PRE-PROCESSING TREATMENT Identifies the various preprocessing treatment for all products.
TWELFTH DIGIT	CUTTING Identifies cutting processes
THIRTEENTH DIGIT	FORMING Identifies forming processes
FOURTEENTH DIGIT	CONNECTION TYPE Identifies the connection type used to attach the classified product
FIFTEENTH DIGIT	WORK POSITION Identifies the work position for the connection of the product
SIXTEENTH DIGIT	WORK STATION Identifies the work station at which the product is installed
SEVENTEENTH DIGIT	EQUIPMENT USED Identifies the type of equipment used at the work station to make or install the product

The classification and coding system described was originally developed for the U.S. Navy first-digit breakdown, but it is obvious that this is not in strict accordance with the principles of group technology. For example, plate can be used in many of the systems, as can pipe. However, the intent was to develop an overall system that could be used for group technology. In keeping with the approach proposed for design and engineering for ship production, the first digit of the described system could be replaced by a classification that relates to hull, deckhouse, and machinery space, as shown in Figure 1.40.

Group technology and classification and coding systems are of no benefit unless they can be applied to existing shipbuilding practices so that they can be improved. The previously mentioned shipbuilding examples indicate some of the ways, but a shipyard must have a clear goal to achieve before applying any part of group technology. The goal should be clearly documented, and a review of possible methods to achieve it be made [21]. If group technology is selected as the best method, it is probable that better definition of the current status will be required, and that is where classification and coding is first applied. Once the classification and coding system is decided, it is necessary to collect data such as number of components routed through shop A. A data collection system is necessary, and the use of data processing equipment is probable. An essential part of the

FIRST DIGIT
BASED ON
US NAVY SWBS

0	
1	STRUCTURE
2	PROPULSION MACHINERY
3	ELECTRICAL
4	COMMAND & COMMUNICATION
5	AUXILIARY MACHINERY
6	OUTFIT
7	ARMAMENT
8	
9	SHIP ASSEMBLY & SUPPORT

SECOND DIGIT

FIRST DIGIT	1	2	3	4	5	6	7	9
	STRUCTURE	PROPULSION MACHINERY	ELECTRICAL	COMMAND & COMMUNICATION	AUXILIARY MACHINERY	OUTFIT	ARMAMENT	SHIP ASSEMBLY & SUPPORT
0	PLATE	CONTROLS	GENERATORS	SAFETY & SECURITY	VAC	PAINT MARKING		STAGING
1	SECTION	ENERGY GENERATOR	MOTORS	COMMAND & CONTROL	SALT WATER SYSTEMS	SHIP FITTINGS	DIRS & AMMUNITION	TEMPORARY SERVICES
2	SUB-ASSEMBLY	PROPULSION UNITS	TRANSFORMERS	NAVIGATION	FRESH WATER SYSTEMS	COMPARTMENTATION	MISSILES & ROCKETS	MATERIAL HANDLING & REMOVAL
3	ASSEMBLY	TRANSMISSION	SWITCHBOARDS	INTERIOR COMMUNICATION	FUEL SYSTEMS	PRESERVATION & COVERINGS	MINES	CLEANING SERVICES
4	FOUNDATION	PROPULSOR	CONTROLLERS	EXTERIOR COMMUNICATION	L O SYSTEMS	LIVING SPACES	DEPTH CHARGES	MOLDS & TEMPLATES
5	CASTINGS	PROPULSION SUPPORT	PANELS	SURFACE SURVEILLANCE	AIR, GAS & MISC. FLUID SYSTEMS	SERVICE SPACES	TORPEDOES	JIGS & FIXTURES
6	FLAT PANEL	FUEL & L O SUPPORT	CABLE	UNDERWATER SURVEILLANCE	SHIP CONTROL	WORKING SPACES	SHALL ARMS & PYROTECHNICS	LAUNCHING
7	CURVED PANEL	AUXILIARY PROPULSION	LIGHTING	COUNTER-MEASURES	RAS/FAS	STOWAGE SPACES	CARGO MUNITIONS	DRYDOCKING
8	NULL MODULE	OPERATING FLUIDS		WEAPON CONTROL	MECHANICAL HANDLING		AIRCRAFT RELATED WEAPONS	TESTS
9	DECKHOUSE MODULE	SPARE PARTS	SPARE PARTS	SPARE PARTS	SPARE PARTS	SPARE PARTS	SPARE PARTS	TRIALS

FIGURE 1.39 Shipbuilding classification and coding system (SCCS).

1ST DIGIT - I-STRUCTURE 2ND DIGIT - O-PLATE

	3RD	4TH	5TH	6TH	7TH	8TH	9TH	10TH	11TH	12TH	13TH	14TH	15TH	16TH	17TH
	TYPE	MATERIAL	LENGTH	WIDTH	THICKNESS	SHAPE	HOLE/BLOT	EDGE PREPARATION	PRE-PROCESSING TREATMENT	CUTTING	FORMING	CONNECTION TYPE	WORK POSITION	WORK STATION	EQUIPMENT USED
0	STANDARD	STEEL "A"	0 < 2	0 < 1	.125 < .20		NONE		NONE	NONE	NONE	NONE	DOWN HAND	SUB-ASSEMBLY	NONE
1	DIAMOND RATED PATTERN	STEEL "B"	2 < 4	1 < 2	.20 < .5				STRAIGHTENING ROLLS	WHEEL	FLANGE	FILLET WELD NON-CONT	VERTICAL	ASSEMBLY	OPTICAL MARKING MACHINE
2	GALVANIZED	STEEL "D"	4 < 8	2 < 4	.375 < .5				BLAST	RAM	PRESS	FILLET WELD CONTINUOUS	OVERHEAD	FOUNDATION	N/C PLANNING MACHINE
3	CLAD	STEEL "E"	8 < 12	4 < 6	.5 < 620				PRIME	MANUAL BURN	ROLL	BUTT WELD	ROTATE	FLAT PANEL LINE	ROLLO
4	EXPANDED	STEEL "D8"	12 < 20	6 < 8	.620 < .75			0 + 1	SPECIAL MARKING PRIME	FRAME PLANNED	RING PRESS	ONE SIDE BUTT WELD	TURN	CURVED PANEL LINE	PRESS
5	PERFORATED	STEEL "C8"	20 < 30	8 < 9	.75 < 1.			0 + 2	1+2+3	OPTICAL BURN	LINE HEAT	PLUG WELD	0 + 3	PANEL OUTFITTING	RING PRESS
6	DATA COUPLE	STEEL "H32"	30 < 40	9 < 10	1. < 1.20		1 + 2	1 + 2	2 + 3	N/C BURN	3 + 4	FAIR/FILL WELD	0 + 4	MODULE ASSEMBLY	STICK WELD ORAVITY FEED
7	0 + 1	STEEL "H36"	40 < 50	10 < 11	1.25 < 1.5		1+2+3	3 + 4	1+2+4	BITTING CUTTING	3 + 8	BOLT	1 + 3	MODULE OUTFITTING	NIG WELD
8	1 + 2	STEEL HY-80/100	50 < 60	11 < 12	1.5 < 2.		2 + 3	3 + 8	2 + 4	DRILL	4 + 8	RIVET	1 + 4	SHIP ASSEMBLY	TIG WELD
9	2 + 5	ALUMINUM	> 60	> 12	> 2.		4 + 8	3 + 6		ROUTER		OTHER	2 + 3	SHIP OUTFITTING	SHW-ARC WELD

FIGURE 1.39 (Continued)

1 ST DIGIT - I -STRUCTURE

2ND DIGIT-I-SECTION





	3RD	4TH	5TH	6TH	7TH	8TH	9TH	10TH	11TH	12TH	13TH	14TH	15TH	16TH	17TH	
	TYPE	MATERIAL	LENGTH	WEB DEPTH	FLANGE WIDTH	WEB THICKNESS	FLANGE THICKNESS	END CUT	PRE-PROCESSING TREATMENT	CUTTING	FORMING	CONNECTION TYPE	WORK POSITION	WORK STATION	EQUIPMENT USED	
0	FLAT BAR	STEEL "A"	0 < 2	0 < 1	0 < 1	< .125	< .125		NONE	NONE	NONE	NONE	DOWN HAND	SUB-ASSEMBLY	NONE	
1	ROUND BAR	STEEL "B"	2 < 4	1 < 2	1 < 2	.125 < .25	.125 < .25		STRAIGHT-ENDING ROLLS	SWEEP	ROLL BEND	FILLET WELD NON-CONT	VERTICAL	ASSEMBLY	SWEEP	
2	SEQUENTIAL BAR	STEEL "D"	4 < 8	2 < 4	2 < 4	.25 < .5	.25 < .5		BLAST	SAW	PRESS BEND	FILLET WELD CONTINUOUS	OVERHEAD	FOUNDATION	AUTO SWEEP	
3	ANGLE	STEEL "E"	8 < 12	4 < 6	4 < 6	.375 < .5	.375 < .5		PRIME	MANUAL BURN	LINE HEAT BEND	BUTT WELD	ROTATE	FLAT PANEL LINE	SAW	
4	CHANNEL	STEEL "DB"	12 < 20	6 < 8	6 < 8	.5 < .625	.5 < .625		SPECIAL MARKING PRIME		N/C BEND	2 + 4	TURN	CURVED PANEL LINE	AUTO SAW	
5	"I" OR WIDE FLANGE	STEEL "CB"	20 < 30	8 < 9	8 < 9	.625 < .75	.625 < .75	1 + 3	1+2+3		MANUAL TWIST	3 + 4	0 + 3	PANEL OUTFITTING	STICK WELD GRAVITY FEED	
6	TEE	STEEL "H30"	30 < 40	9 < 12	9 < 12	.75 < 1.	.75 < 1.		2 + 3		N/C TWIST		0 + 4	MODULE ASSEMBLY	MIG WELD	
7	TEE CUT FROM "I" OR WIDE FLANGE	STEEL "H36"	40 < 50	12 < 18	12 < 18	> 1.	1. < 1.25		1+2+4	FITTING CUTTING		4 + 5	BOLT	1 + 3	MODULE OUTFITTING	TIG WELD
8	TUBE	STEEL HY-80/100	50 < 60	18 < 24	18 < 24		1.25 < 1.5		2 + 4	DRILL		RIVET	1 + 4	SHIP ASSEMBLY	SUB-ARC WELD	
9	PIPE	ALUMINUM	> 60	> 24	> 24		> 1.5					OTHER	2 + 3	SHIP OUTFITTING	ROBOTIC WELDER	

FIGURE 1.39 (Continued)

1 ST DIGIT - 1 -STRUCTURE

2ND DIGIT -2-SUB-ASSEMBLY







	3RD	4TH	5TH	6TH	7TH	8TH	9TH	10TH	11TH	12TH	13TH	14TH	15TH	16TH	17TH
	TYPE	MATERIAL	LENGTH	WIDTH	DEPTH	SUB-ASSY SHAPE	WEIGHT	NUMBER OF PARTS PER SUB-ASSY	POST ASSEMBLY TREATMENT	CUTTING		CONNECT- ION TYPE	WORK POSITION	WORK STATION	EQUIPMENT USED
0	FLOOR	MILD STEEL	< 8	< 1	< .20		< 80	< 2	NONE	NONE		NONE	DOWN HAND		NONE
1	WEB FRAME	H. S. STEEL	2 < 4	1 < 2	.20 < .5		80 < 100	2 < 3	WIRE BRUSH	FITTING CUTTING		FILLET WELD NON-CONT	VERTICAL	ASSEMBLY	AUTO ASSEMBLY
2	BULKHEAD WEB	H. S. STEEL	4 < 8	2 < 3	.5 < .75		100 < 200	3 < 4	BLAST			FILLET WELD CONTIN- UOUS	OVERHEAD	FOUNDAT- ION	STICK WELD GRAVITY FEED
3	WELL STRINGER	ALUMINUM	8 < 8	3 < 5	.75 < 1		200 < 800	4 < 5	PRIME			BUTT WELD	ROTATE	FLAT PANEL LINE	MIG WELD
4	BULKHEAD STRINGER	OTHER	12 < 20	5 < 10	1 < 2		800 < 1000	5 < 7	FINISH COATING			ONE SIDE BUTT WELD	TURN	CURVED PANEL LINE	MIG WELD
5	BOTTOM GIRDER		20 < 30	10 < 15	2 < 3		1000 < 2000	7 < 8	1 + 3			FLUG WELD	0 + 3	PANEL OUTFIT- TING	SUB-ARC WELD
6	DECK GIRDER		30 < 40	15 < 20	3 < 5		2000 < 5000	10 < 15				FAIR/FILL WELD	0 + 4	MODULE ASSEMBLY	ROBOTIC WELD
7	DECK TRANSVERSE		40 < 50	20 < 30	5 < 8		8000 < 10000	15 < 20				BOLT	1 + 3	MODULE OUTFIT- TING	
8	BULKHEAD		50 < 60	30 < 40	> 10		10000 < 20000	20 < 30				RIVET	1 + 4	SHIP ASSEMBLY	
9			> 60	> 40			> 20000	> 30				OTHER	2 + 3	SHIP OUTFIT- TING	

FIGURE 1.39 (Continued)

1ST DIGIT - 1 - STRUCTURE

2ND DIGIT - 3 - ASSEMBLY







	3RD	4TH	5TH	6TH	7TH	8TH	9TH	10TH	11TH	12TH	13TH	14TH	15TH	16TH	17TH
	TYPE	MATERIAL	LENGTH	WIDTH	DEPTH	ASSEMBLY SHAPE	WEIGHT	NUMBER OF PARTS PER ASSEMBLY	POST ASSEMBLY TREATMENT	CUTTING		CONNECT-ION TYPE	WORK POSITION	WORK STATION	EQUIPMENT USED
0	WELL	MILD STEEL	< 8	< 1	< .25		< 500	< 2	NONE	NONE		NONE	DOWN HAUD		NONE
1	TRANSVERSE BULKHEAD	H. S. STEEL	2 < 4	1 < 2	.25 < .5		500 < 1000	2 < 3	WIRE BRUSH	FITTING CUTTING		FILLET WELD (NON-CONT)	VERTICAL		AUTO ASSEMBLY
2	LONGITUDINAL BULKHEAD	H. S. STEEL	4 < 8	2 < 3	.5 < .75		1000 < 2000	3 < 4	BLAST			FILLET WELD CONTINUOUS	OVERHEAD		STICK WELD GRAVITY FEED
3	TANKTOP	ALUMINUM	6 < 8	3 < 6	.7 < 1		2000 < 5000	4 < 6	PRIME			BUTT WELD	ROTATE	FLAT PANEL LINE	MIG WELD
4	FLAT	OTHER	18 < 20	5 < 10	1 < 2		5000 < 15000	5 < 7	FINISH COATING			ONE SIDE BUTT WELD	TURN	CURVED PANEL LINE	TIG WELD
5	HULL DECK		20 < 30	10 < 15	2 < 3		15000 < 20000	7 < 8	1 + 3			PLUG WELD	0 + 3	PANEL OUTFITTING	SUB-ARC WELD
6	HOUSE SIDE		30 < 40	15 < 20	3 < 5		20000 < 30000	10 < 15				FAIR/FILL WELD	0 + 4	MODULE ASSEMBLY	ROBOTIC WELD
7	HOUSE DECK		40 < 50	20 < 30	5 < 6		30000 < 50000	15 < 20				BOLT	1 + 3	MODULE OUTFITTING	
8	BULWARK		50 < 60	30 < 40	10 < 20		50000 < 100000	20 < 30				RIVET	1 + 4	SHIP ASSEMBLY	
9	TRUNK		> 60	> 40	> 20		> 100000	> 30				OTHER	2 + 3	SHIP OUTFITTING	

FIGURE 1.39 (Continued)

1 ST DIGIT -I- STRUCTURE

2ND DIGIT -4- FOUNDATIONS

	3RD	4TH	5TH	6TH	7TH	8TH	9TH	10TH	11TH	12TH	13TH	14TH	15TH	16TH	17TH
	SYSTEM	TYPE	MATERIAL	LENGTH	WIDTH	DEPTH	FOUNDATION SHAPE	WEIGHT	POST ASSEMBLY TREATMENT	CUTTING		CONNECT-ION TYPE	WORK POSITION	WORK STATION	EQUIPMENT USED
0		WELDED STEEL	MILD STEEL	< 1	< 1	< .06		< 50	NONE	NONE		NONE	DOWN HAND		NONE
1	WALL FITTINGS	FLUSH OR WITH INFLATABLE	H. S. STEEL	1 < 2	1 < 2	.06 < .8		50 < 100	WIRE BRUSH	FITTING CUTTING		FILLET WELD NON-CONT	VERTICAL		AUTO ASSEMBLY
2	PROPAGATION MACHINERY	PREDOMINANTLY PLATE	H. V. STEEL	2 < 3	2 < 3	.8 < .78		100 < 200	BLAST			FILLET WELD CONTINUOUS	OVERHEAD		STICK WELD GRAVITY FEED
3	ELECTRICAL	PREDOMINANTLY SECTION	ALUMINUM	3 < 4	3 < 4	.78 < 1		200 < 500	PRIME			BUTT WELD	ROTATE	FLAT PANEL LINE	MIG WELD
4	CONDUIT & CONDUIT ATTACH	PREDOMINANTLY PIPE OR TUBE		4 < 5	4 < 5	1 < 2		500 < 1000		FINISH COATING		ONE SIDE BUTT WELD	TURN	CURVED PANEL LINE	TIG WELD
5	AUXILIARY MACHINERY	REQUIRING BACK-UP		5 < 10	5 < 10	2 < 3		1000 < 2500		1 + 3		PLUG WELD	0 + 3	PANEL OUTFITTING	SUB-ARC WELD
6	OUTFIT	1 + 5		10 < 20	10 < 20	3 < 4		2500 < 5000				FAIR/FILL WELD	0 + 4	MODULE ASSEMBLY	ROBOTIC WELD
7	ARMAMENT	2 + 5		20 < 30	20 < 30	4 < 5		5000 < 10000				BOLT	1 + 3	MODULE OUTFITTING	
8		3 + 5		30 < 40	> 30	5 < 7		10000 < 25000				RIVET	1 + 4	SHIP ASSEMBLY	
9		4 + 5		> 40		> 7		> 25000				OTHER	2 + 3	SHIP OUTFITTING	

FIGURE .1.39 (Continued)

1 ST. DIGIT - 1-STRUCTURE

2ND DIGIT -7-HULL MODULE -8-DECKHOUSE MODULE

	3RD	4TH	5TH	6TH	7TH	8TH	9TH	10TH	11TH	12TH	13TH	14TH	15TH	16TH	17TH
	TYPE	MATERIAL	LENGTH	WIDTH	DEPTH	MODULE SHAPE	WEIGHT	NUMBER OF PARTS PER MODULE	POST ASSEMBLY TREATMENT	CUTTING		CONNECT-ION TYPE	WORK POSITION	WORK STATION	EQUIPMENT USED
0	BT HOLE BOTTOM	MILD STEEL	< 10	< 10	< 1	S.P. PANEL	< 800	< 2	NONE	NONE		NONE	DOWN HAND		NONE
1	DOUBLE BOTTOM	H. S. STEEL	10 < 20	10 < 20	1 < 8	RECTANG-ULAR BLOCK	2000-45000	2 < 3	WIRE BRUSH	FITTING CUTTING		FILLET WELD NON-CONT.	VERTICAL		AUTO ASSEMBLY
2	DEEP TANK	H. V. STEEL	20 < 30	10 < 10	2 < 3	BLOCK WITH ONE CURVED	8000 < 10000	3 < 5	BLAST			FILLET WELD CONTIN-UOUS	OVERHEAD		STICK WELD GRAVITY FEED
3	WIND TANK	ALUMINUM	30 < 40	10 < 20	3 < 5	CYLIND-RICAL BLOCK	10000 < 20000	5 < 10	PRIME			BUTT WELD	ROTATE		HIG WELD
4	DECK	OTHER	40 < 60	20 < 30	5 < 8		20000 < 30000	10 < 15	FINISH COATING			ONE SIDE BUTT WELD	TURN		TIG WELD
5	SIDE SHELL		50 < 60	30 < 40	10 < 20		30000 < 50000	15 < 20	1 + 3			PLUG WELD	0 + 3		SUB-ARC WELD
6	HATCHWAY		60 < 70	40 < 50	20 < 30		80000 < 100000	20 < 30				FAIR/FILL WELD	0 + 4		CONSUM-ABLE NOZZLE
7			70 < 80	50 < 60	30 < 40		100000 < 150000	30 < 40				BOLT	1 + 3	MODULE OUTFITT-ING	ROBOTIC WELD
8	BULKHARK		80 < 90	60 < 70	40 < 50		150000 < 250000	40 < 50				RIVET	1 + 4	SHIP ASSEMBLY	
9	TRUNK		> 10	> 70	> 50		> 200000	> 50				OTHER	2 + 3	SHIP OUTFITT-ING	

FIGURE 1.39 (Continued)

1ST DIGIT-2-PROPULSION MACHINERY 2ND DIGIT -2-PROPULSION UNITS

	3RD	4TH	5TH	6TH	7TH	8TH	9TH	10TH	11TH	12TH	13TH	14TH	15TH	16TH	17TH
	TYPE	CLASS	B H P	FUEL	LENGTH	WIDTH	HEIGHT	WEIGHT			CONNECTION TYPE			WORK STATION	EQUIPMENT USED
0	NONE	LOW SPEED	< 1000	MFO (HO)	< 3	< 1	< 2	< 1/2			HOLD DOWN BOLTS				
1	STEAM RECTIPRO- CATING	MEDIUM SPEED	1000 ≤ 5000	H2O	3 < 5	1 < 2	2 < 4	1/2 < 1			POURED CHOCKS & HOLD DOWN BOLTS				
2	STEAM TURBINE	HIGH SPEED	5000 ≤ 10000	GASOLINE	5 < 10	2 < 3	4 < 6	1 < 2			POURED CHOCKS HOLD DOWN BOLTS & SHEER BLOCKS			FOUNDATION	
3	Gas TURBINE	2 STROKE	10000 ≤ 25000	COAL	10 < 15	3 < 5	6 < 8	5 < 10			POURED CHOCKS HOLD DOWN BOLTS & FITTED DOWELS				
4	DIESEL	4 STROKE	25000 ≤ 50000	NUCLEAR	15 < 20	5 < 10	8 < 10	10 < 20			MACHINED CHOCKS HOLD DOWN BOLTS & SHEER BLOCKS				
5	GASOLINE	0 • 3	50000 ≤ 100000		20 < 30	10 < 15	10 < 15	20 < 50			MACHINED CHOCKS HOLD DOWN BOLTS & FITTED DOWELS				
6	ELECTRIC MOTOR	1 • 3	> 100000		30 < 40	15 < 20	15 < 20	50 < 100			MACHINED CHOCKS & FITTED BOLTS				
7		1 • 4			40 < 50	20 < 30	20 < 30	100 < 200						MOULF OUTFITTING	
8		2 • 3			50 < 75	> 30	> 30	200 < 500						SHIP OUTFITTING	
9		2 • 4			> 75			> 500							

FIGURE 1.39 (Continued)

1ST DIGIT -5-AUXILIARY SYSTEMS 2ND DIGIT -1-S. W. SYSTEMS

	3RD	4TH	5TH	6TH	7TH	8TH	9TH	10TH	11TH	12TH	13TH	14TH	15TH	16TH	17TH
	COMPONENT	TYPE	MATERIAL	DIAMETER	RATING	SCHEDULE	LENGTH	WEIGHT	PRE & POST PROCESSING TREATMENT	CUTTING	FORMING	CONNECTION TYPE	WORK POSITION	WORK STATION	EQUIPMENT USED
0	PUMPS	SINGLE PIPE	ASTM A106 OR. A	< 1/4	<125	5	< .25	< 50	NONE	NONE	NONE	BRAZE	DOWN HAND	CUTTING	HANDIAL CUT
1	VALVES	PIPE WITH BRANCHES	MIL-T 20187C	1/4 < 1/2	150	10	.25 < .5	50 < 100	BLAST	BAM	BEND	BUTT WELD, NO BACKING RING	VERTICAL	BENDING	AUTO CUT
2	PIPE	SINGLE BEND PIPE	CR60 ASTM A312-83 OR. 321	1/2 < 3/4	250	20	.5 < .75	100 < 200	WIRE BLANCH	BURN	BWADE	BUTT WELD, COUPLER BACKING RING	OVERHEAD	PULLING	HANDIAL BEND
3	FITTINGS	MULTI BEND PIPE	COPPER MIL-T 2107A	3/4 < 1	300	40	.75 < 1.	200 < 300	PICKLE	DISC	PULL *1*	BUTT WELD BACKING RING	ROTATE	BENDING	M/C BEND
4	HANDERS	0 * 2	COPPER ASTM B210-83	1 < 2	400	60	1 < 2	300 < 600	COAT	BEVELER		FLANGE	TURN	PIPE ASSEMBLY FABRICATION	BENDING MACHINE
5	BLEEVES	0 * 3	RED BRASS MIL-T 20168B	2 < 3	600	120	2 < 3	500 < 1000	GALVANIZE	1 * 4		BOCKET	0 * 3	UNIT FABRICATION	*1* PULL MACHINE
6	SIMULATIONS	1 * 2	CU-NI MIL-T 18420	3 < 6	900	160	3 < 5	1000 < 2000	1 * 4	3 * 4		SCREWED	0 * 4	PANEL OUTFITTING	AUTO FLANGE WELDER
7	HEAT EXCHANGERS	1 * 3	PVC	6 < 8	1500		5 < 10	2000 < 3000	3 * 4			VAN	1 * 3	MODULE OUTFITTING	HANDIAL WELDING
8	FILTERS	PIPE ASSEMBLY	DRP	12 < 18	2500		10 < 20	1000 < 8000	3 * 8			DRESSER COUPLING	1 * 4	SHIP OUTFITTING	ORBITAL WELDER
9	HANIFOLD			> 18	> 2500		> 20	> 8000					2 * 3		

FIGURE 1.39 (Continued)

1 ST DIGIT -5-AUXILIARY SYSTEMS 2ND DIGIT -I -S. W. SYSTEMS

	3RD	4TH	5TH	6TH	7TH	8TH	9TH	10TH	11 TH	12TH	13TH	14TH	15TH	16TH	17TH
	COMPONENT	TYPE	MATERIAL	DIAMETER	RATING	SCHEDULE	LENGTH	WEIGHT	PRE & POST PROCESSING TREATMENT			CONNECTION TYPE	WORK POSITION	WORK STATION	EQUIPMENT USED
0	PUMPS	L R 90 DEG ELBOW	ASTM A234 GR. B	< 1/4	<125	5	< .25	< 5	NONE			BRAZE	DOWN HAND		
1	VALVES	90 DEG ELBOW	ASTM A105 GR. 1	1/4 < 1/2	150	10	.25 < .5	5 < 10	BLAST			BUTT WELD NO BACKING RING	VERTICAL		
2	PIPE	L R 45 DEG ELBOW	ASTM A105 GR. 2	1/2 < 3/4	250	20	.5 < .75	10 < 20	WIRE BRUSH			BUTT WELD CONSUMABLE BACKING RING	OVERHEAD		
3	FITTINGS	90 DEG ELBOW	ASTM A181 GR. 1	3/4 < 1	300	40	.75 < 1.	20 < 30	PICKLE			BUTT WELD BACKING RING	ROTATE	SHAGING	
4	HANGERS	180 DEG RETURN	COPPER	1 < 2	400	80	1 < 2	30 < 80	COAT			FLANGE	TURN	PIPE ASSEMBLY FABRICAT-ION	
5	BLEEVED	TEE	BRONZE N1L-F 1183	2 < 3	600	120	2 < 3	80 < 100	GALVANIZE			SOCKET	0 + 3	UNIT INSTALAT-ION	
6	INSULATION	CROSBEE	CU-NI	3 < 4	900	160	3 < 4	100 < 200	1 + 4			SCREWED	0 + 4	PANEL OUTFITTING	AUTO FLANGE WELDER
7	HEAT EXCHANGERS	CLEAN OUT	P V C	4 < 12	1500		4 < 5	200 < 300	2 + 4			VAN STOFF	1 + 3	MODULE OUTFITTING	MANUAL WELDING
8	FILTERS	REDUCER	Q R P	12 < 18	2500		5 < 6	300 < 800	3 + 8			DRESSER COUPLING	1 + 4	SHIP OUTFITTING	ORBITAL WELDER
9	HANIFOLD	CAP		> 18	> 2500		> 6	> 800					2 + 3		

FIGURE 1.39 (Continued)

OPTIONAL ZERO DIGIT BASED ON ZONE DESIGN AND CONSTRUCTION

0	
1	HULL
2	DECK HOUSE
3	MACHINERY SPACE

FIGURE 1.40 Optional zero digit for zone design and construction.

data collection system is the data collection format. References [9,10,12] describe such formats and Figure 1.41 shows a typical format. Once the data is collection, it can be analyzed to provide the required information, such as number of weld connections per component prior to assembly into a module or the throughput of steel in a particular shop. The information provided by the analysis may be used to reduce component handling by relocating work stations, including processing machines and equipment.

Germane to design for ship production, a group technology analysis could be used to determine the number of similar component designs, allowing the selection of the best and reduction in variety. Once this is accomplished, every component design requirement can be checked at concept stage to see if an existing design will meet the requirement. This is conceptually shown in Figure 1.42.

As another example, assume that it is desired to determine the most producible design of double-bottom structure from the following options.

- Transverse All plate floors
- Transverse Combined plate and open floors
- **Longitudinal** **Maximum spacing with struts**
- **Longitudinal** Maximum spacing without struts

A typical hold length would be selected and the structural components coded for product design and processing. Then the following data could be extracted for each option and compared:

- (1) Number of parts
- (2) Number of unique parts
- (3) Number of each unique part
- (4) Number of plate parts
- (5) Number of parts cut from sections
- (6) Number of plates formed
- (7) Number of sections formed
- (8) Number of process steps for each part
- (9) Process flow quantities

By adding a few additional data items to the data collection forms it would be possible to extract

- (a) Joint weld length

A further example is the determination of the number of different section sizes to be used for a particular design. The various minimum scantling sizes as required to meet the Classification Society rules could be determined, coded, collected, and sorted. Suitable size ranges would then be obvious.

For a shipyard utilizing both contour and flame planing burning machines, the designer could code all plates and determine the machine type demand and make changes if they were not in balance. Use of cut plate with flanged or fabricated face plate instead of formed shapes is another necessary comparison where group technology can be used to advantage.

The concept of advanced outfitting can be analyzed by applying group technology techniques, as can emotional items such as welded pipe joints versus flanged pipe joints.

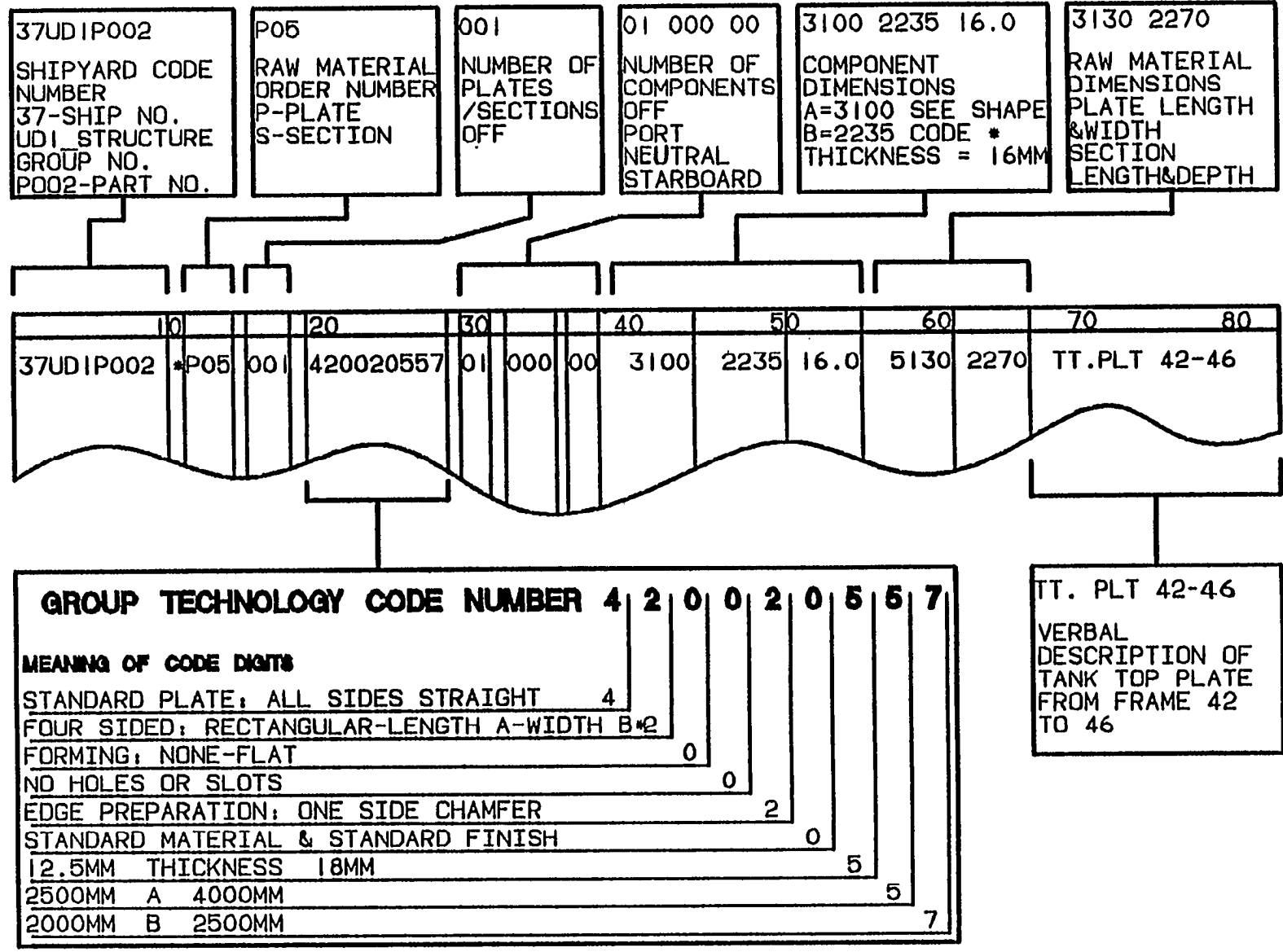

114

FIGURE 1.41 Typical component information card using group technology.

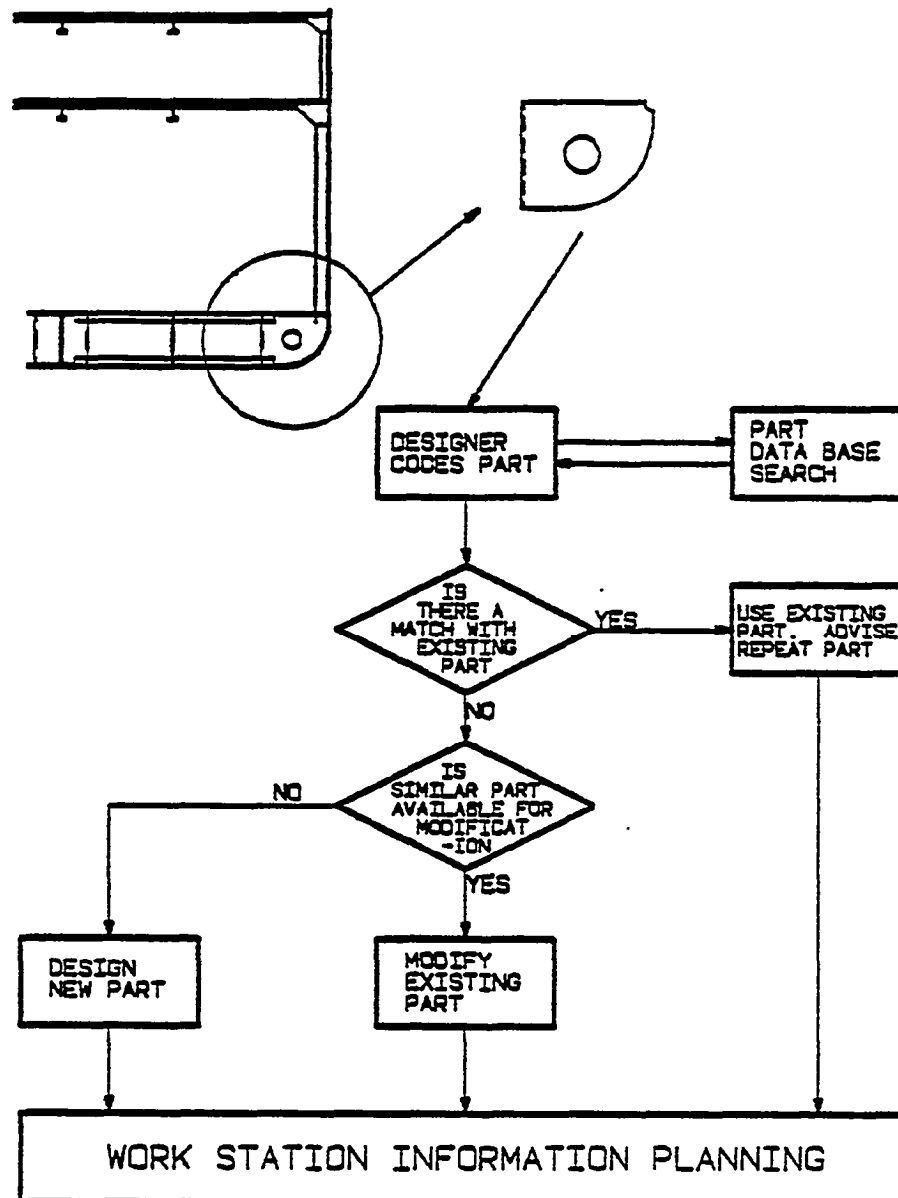

FIGURE 1.42 Group technology in design.

Existing design practice can be analyzed for required processing and thus work content, as can the impact of proposed improvements.

However, the ultimate benefit from the use of group technology in design for ship production is that if all interim products are coded it will be possible to utilize computer-aided process planing and thus eliminate the errors and inefficiency of manual process planning.

In summary, the application of group technology to shipbuilding provides an opportunity to develop better methods and techniques for the design and construction of ships. The notable benefits include:

- Reduction in number of enggineering drawings
- Reduction in new design
- Company standardization
- Reduction in design and engineering time and manhours
- Improved quality
- Better utilization of facilities
- Identification and elimination of high work content products and **processes**
- Simplified and automated planning
- Simplified scheduling and production control
- Simplified material flow system and control

REFERENCES

1. R.E. Flanders, 'Design manufacture and production control of a standard machine," ASME Transactions, vol. 46, 1925.
2. J.C. Kerr, "planning in a general engineering shop," Journal Inst Production Engineering, vol. 18, no. 1, January 1939.
3. A. Karling, Group production and its influences on productivity. Second International congress of Engineering Manufacture, Paris 1949.
4. S.P. Mitrofanov, The scientific principles of group technology. Leningrad 1959.
5. H. Opitz et al, statistical investigation on the utilization of machine tools in one-off and mass production. Aachen Technical University Research Report No. 831,1960.
6. Why group technology. National Economic Development Office, Crown Copyright, August 1975.
7. Product work breakdown system. U.S. Department of Commerce, Maritime Administration 1980.
8. G. Southern et al, Group technology in the shipbuilding industry. Annual Conference, Group Technology Division, Institute of Production Engineers, 1973.
9. S.K. Banarjee, "Shipyard production systems design: A statistical approach," International Journal of Production Research, vol. 17, no. 6, 1979.
10. S.K. Banerjee, Shipyard data systems. (One-day Working Party on Group Technology in Shipbuilding, Naval Architecture Department, Newcastle University 1976.)
11. S. Forbes, Unit and ship assembly. (One-day Working Party on Group Technology in Shipbuilding, Naval Architecture Department, Newcastle University 1976.)
12. G. Southern, Ship component production. (One-day Working Party on Group Technology in Shipbuilding, Naval Architecture Department, Newcastle University 1976.)
13. N.N. Varvarin et al, A group method of hull fabrication for one-off and short series ship construction. SUDOSTROENE, 8,36.
14. A.J. Marsh, The constraints imposed on design and technical activities by shipbuilding production technology. International Conference on Structural Design and Fabrication in Shipbuilding, RINA 1976.
15. M.R Hargroves et al, The strategic development of ship production technology, NECIES Transaction, vol. 91, 1974/1975.
16. G.M. Ransom, Group technology: A foundation for better total company operation (London: McGraw-Hill, 1972).
17. C.C. Gallagher and W.A. Knight, Group technology (London: Butterworths, 1973).

18. A. Houtzeel, "Classification and coding: A tool to organize information," IREAPS Symposium, 1982.
19. D.W. Camsey et al, "The application of computer simulation techniques to ship production," NECLES Transactions, vol. 99, 1982-1983.
20. C.C. Gallagher et al; Group technology in the shipbuilding industry: Progress report. Department of Management Studies, Glasgow University 1975.
21. G.H. Middle et al; "Organization problems and the relevant manufacturing system," International Journal of Production Research, vol 9, no. 2, 1971.

1.5 Structure

1.5.1 GENERAL. The design of ship structure is the process of applying rules and experience to integrate individual structural components into efficient and easily constructed assemblies, modules, and hull. The design of a ship's structure has a major influence on the construction cost of the ship through the work content and the quantity of material. Many ship structural designers use "standard structural details" which they may have "borrowed" from other designers in another shipyard. Or, for a naval ship, they may simply copy the old BUSHIP standards, which are over 20 years old. Chances are that the decision to use a particular detail will be made without any regard to producibility requirements for the shipyard involved. Obviously, the smaller the number of standard details considered, the easier it will be to use them. It should also be remembered that as there are a great number of connections between the structural components of a ship, the "best" design for one shipyard may not be the "best" for another. The "best" structural design detail depends on:

- l Module definition and erection methods
- l Manual versus computer-aided lofting
 - Manual versus N/C burning
 - Extent of automatic welding
 - Whether or not the shipyard has a panel line
- l Facility and equipment

However, the basic goal of design for ship production is to reduce work content, and the development of structural details should accomplish this goal. When deciding between alternative structural details, it is necessary to utilize the cost trade-off technique as stated in Section 1.2. The minimum considerations must include:

- l Number of parts
- l Joint weld length, type, and position
- l Completion of spaces/tanks within modules

A number of typical structural connections will be discussed, with alternatives showing better design for ship production details. However, before getting into the details, it is necessary to consider the selection of module boundaries.

1.5.2 MODULE DEFINITION. Although this aspect of planning and structural design appears to be reasonably handled by most U.S. shipyards, it is still possible to see module boundaries and structural details in way of the module breaks that are obviously not well thought out. When deciding module boundaries, a number of items must be considered, some obvious and some not so obvious. These are:

- Maximum- module size
- l Maximum module weight
 - Module turning limitations
- l Shell shape boundaries
- l Access for workers and machines for module joining
- l Extent of use of auto and semi-auto machines
 - Whether or not self-aligning
- l Internal connection detail
- l Framing method
 - Plate straking direction
- l In-line or staggered transverse breaks
- l Maximum or standard plate/shapes size

- Completion of adjacent spaces/tanks
- Blocking/support requirements
- Natural lifting points
- Use of excess material for fitting
- Large equipment arrangement and foundations to avoid overlapping module breaks
 - Design to eliminate plate or pin jigs

The importance of these items will become clear from the following discussions. Figure 1.43 shows the difference between “in-line” and “staggered” module transverse breaks. It applies to internal surfaces such as tank tops, girders, longitudinal bulkheads and decks as well as the obvious external shell. At one time it was a classification requirement to stagger the breaks. However, this is no longer the case. The use of staggered breaks is necessary if self-aligning modules are to be designed. Figure 1.44 shows various connection details in way of module transverse breaks, and Figure 1.45 the same for longitudinal breaks. As mentioned in Section 1.3, Basic Design, it can be beneficial to utilize cofferdams and duct keels as the location for the module breaks when the tanks are to be coated, as this allows adjacent tanks to be completed and tested before erection on the berth. This concept is shown in Figure 1.46.

Note that double cofferdams are only necessary for coated tanks. In fact, if it is necessary to hydra test only staggered tanks, there is no need for cofferdams if the tanks are uncoated. This is shown in Figure 1.47. However, it should be obvious that this approach increases the number of different modules required, and that a duct keel is still required. A combination of these approaches can be used even where the tanks are to be coated, and then half the tanks would need to be completed after joining. In this case the tank boundaries would be staggered one frame from the transverse bulkheads, and tank lengths would vary as shown in Figure 1.48. Figure 1.49 shows some other module break connection detail alternatives. The differences and benefits of some over others is obvious, but notes are included where appropriate. In reviewing the alternatives, it is necessary to look for the already-stated production-affecting factors of:

- Joint weld length of erection connection
 - Weld attitude
- Number of spaces to be entered to complete erection joining
- Self-aligning
- Number of parts involved in detail

The consideration of the framing method—that is, transverse or longitudinal—and plate straking direction should be performed together. This is because, in general, straking should be in the same direction as the framing. This is to eliminate the need for rat holes over plate butt welds or for grinding down plate butt welds in way of frames crossing the welds. Obviously, this cannot be adhered to in all cases, especially bulkheads where the plating thickness varies with depth and vertical stiffening is generally preferred. The age-old practice of keeping the molded side of the plating flush where plating strakes vary in thickness is a problem for panel lines due to requiring the upper surface of the panel to be flat for installation of stiffening. In such cases it may be better to locate the stiffeners on the uneven surface running parallel to the plate strakes. This would require horizontal stiffeners with varying scantlings, which is probably not a minimum work content approach. From a producibility point of view it is probably better to use vertical plate straking and vertical stiffeners, even though there will be an increase in weight due to the constant bulkhead plating thickness. These concepts are shown in Figure 1.50.

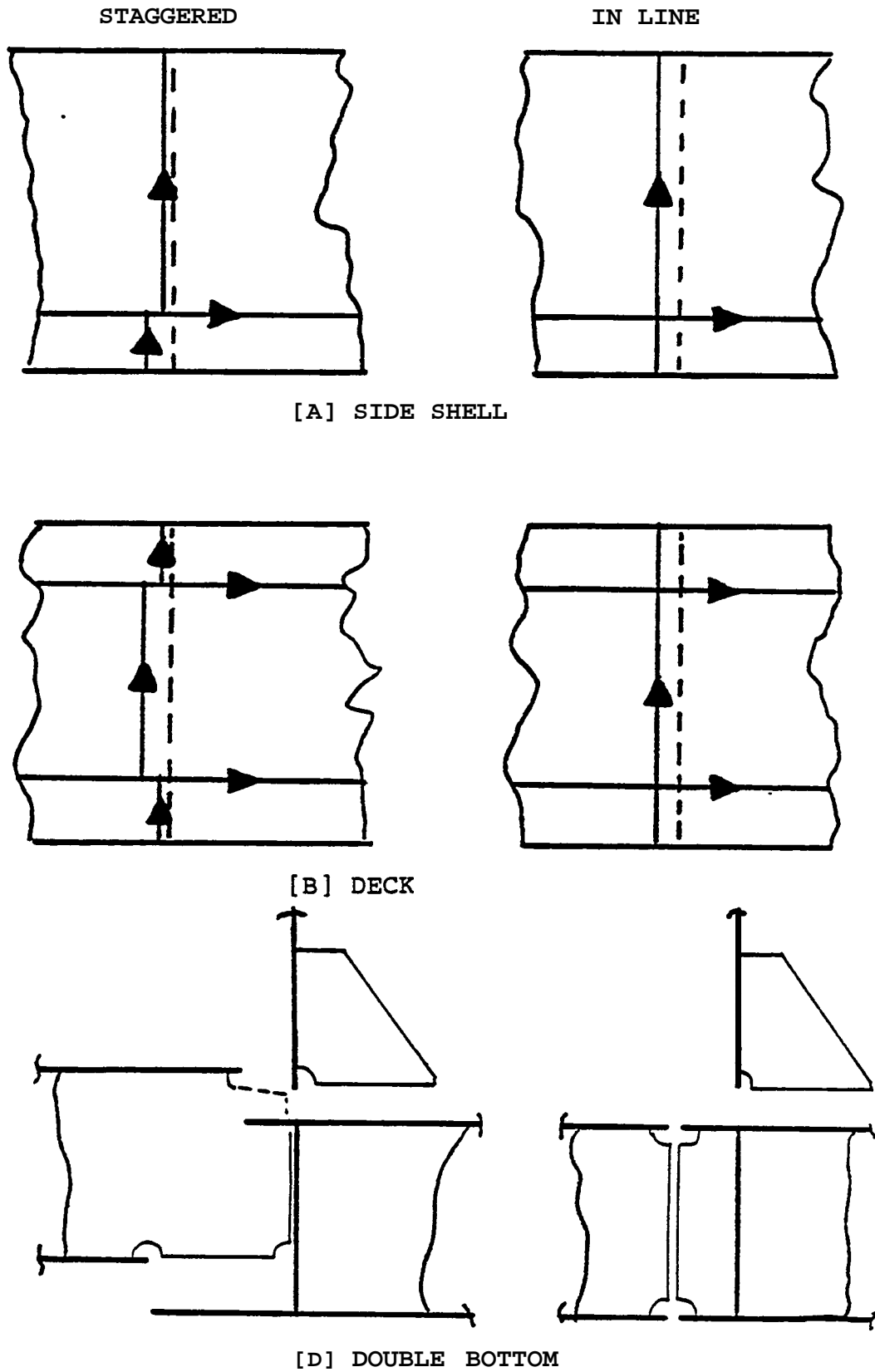

FIGURE 1.43 Module connection definition.

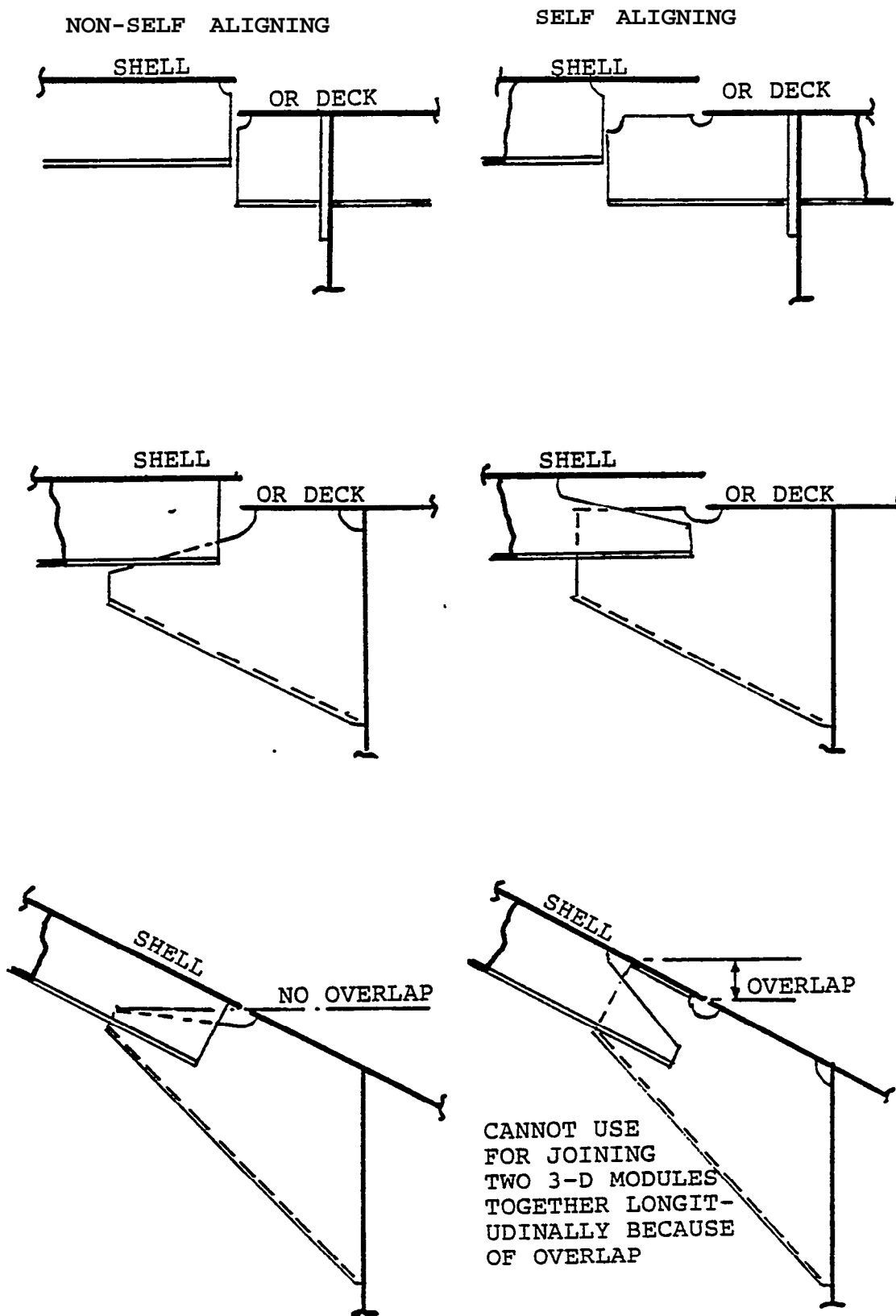

FIGURE 1.44 Module joining structural details.

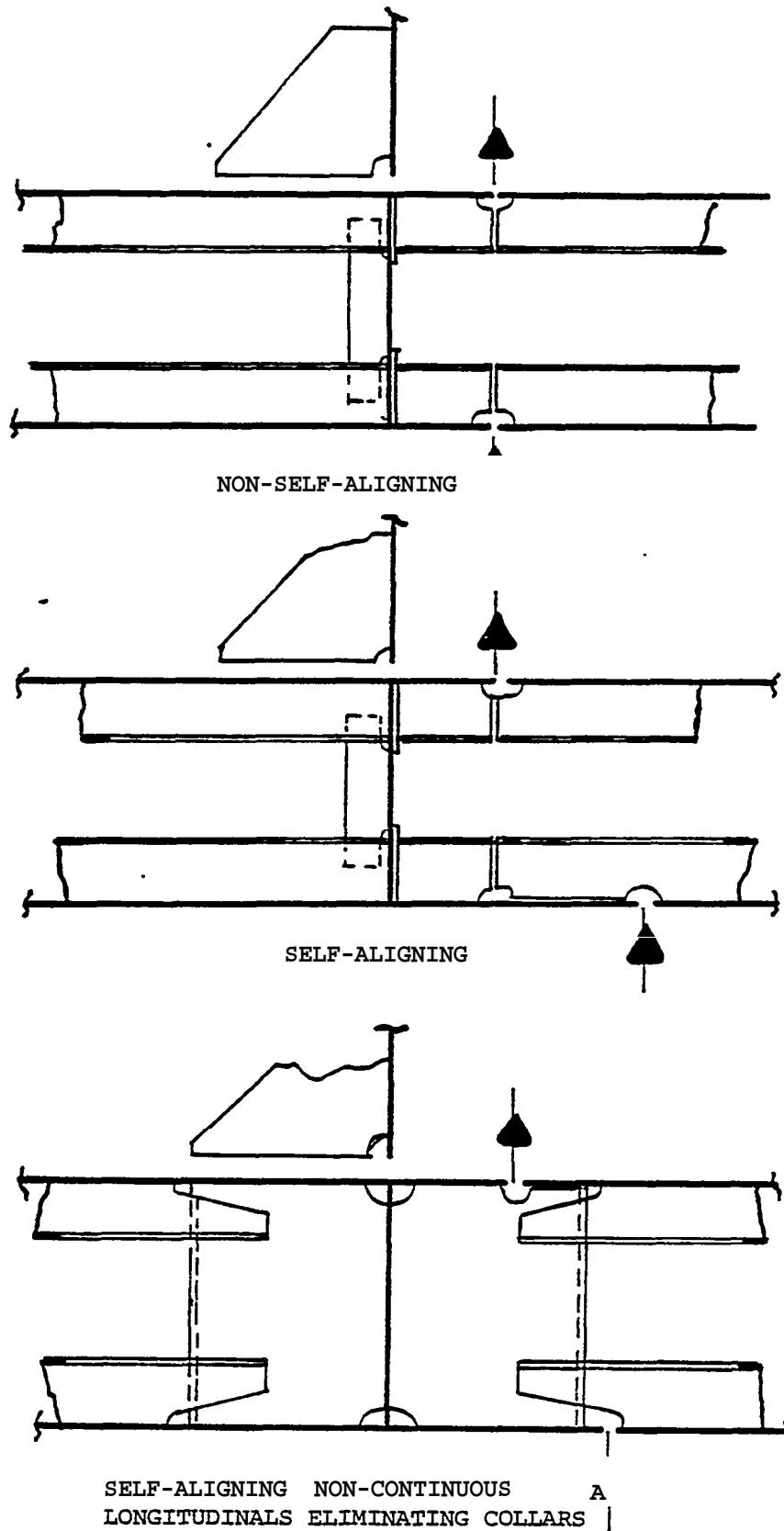
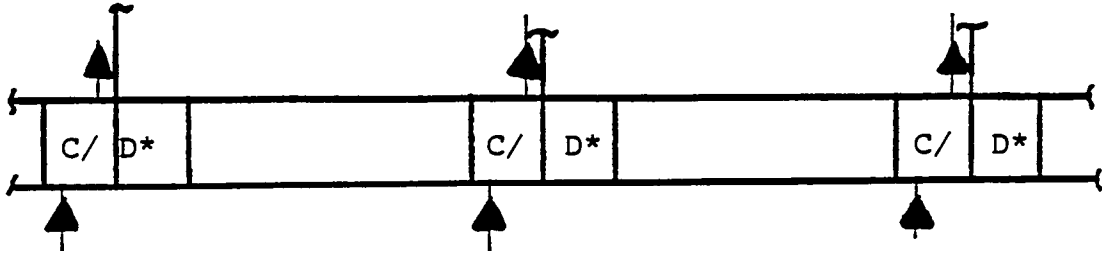
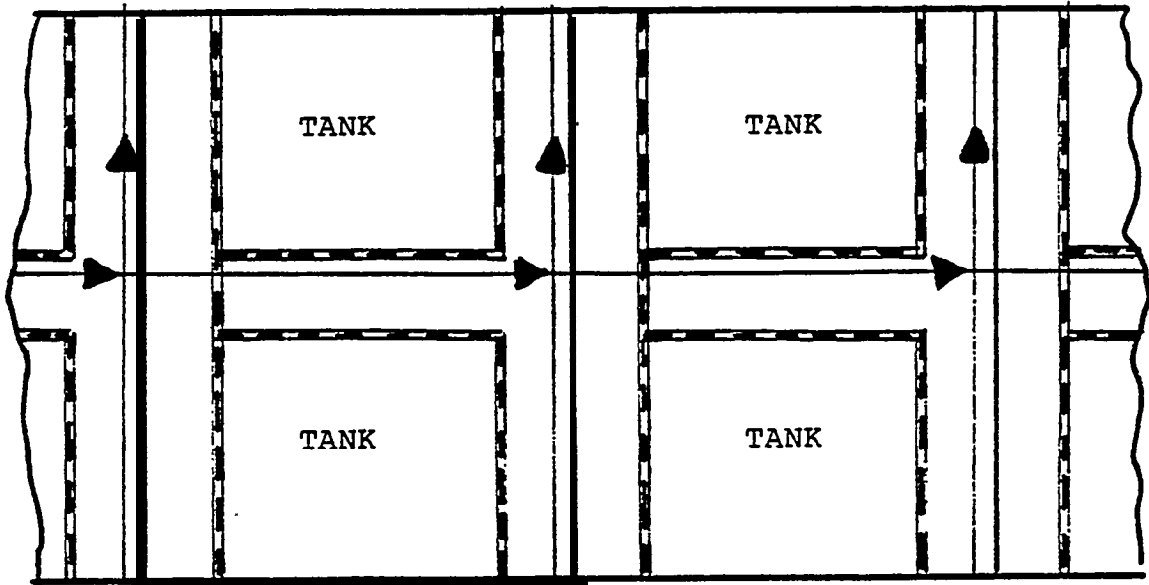

FIGURE 1.45 Longitudinal joining details.



ELEVATION OF DOUBLE BOTTOM



PLAN OF DOUBLE BOTTOM

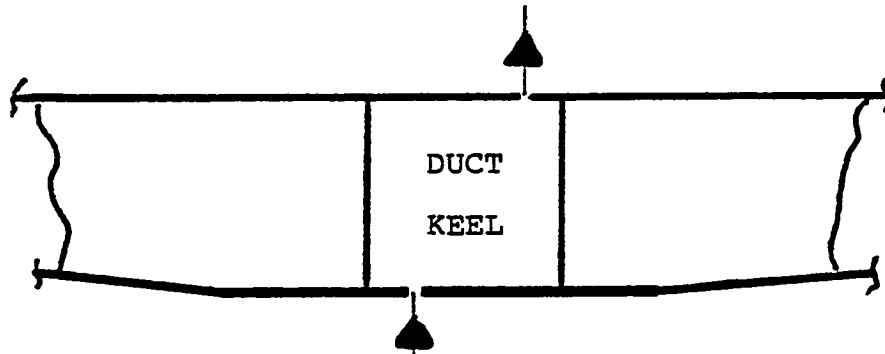

TRANSVERSE SECTION

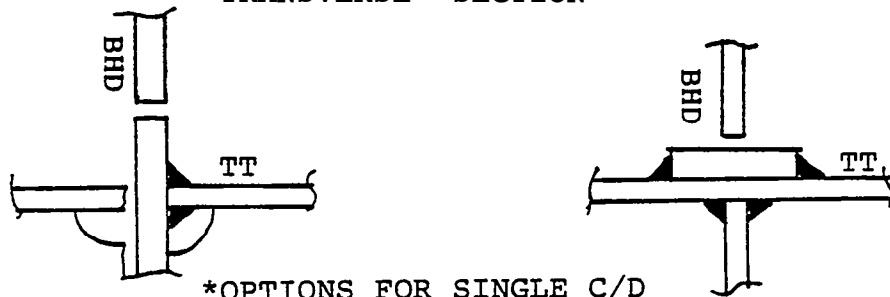

*OPTIONS FOR SINGLE C/D

FIGURE 1.46 Use of cofferdams as a module joining aid.

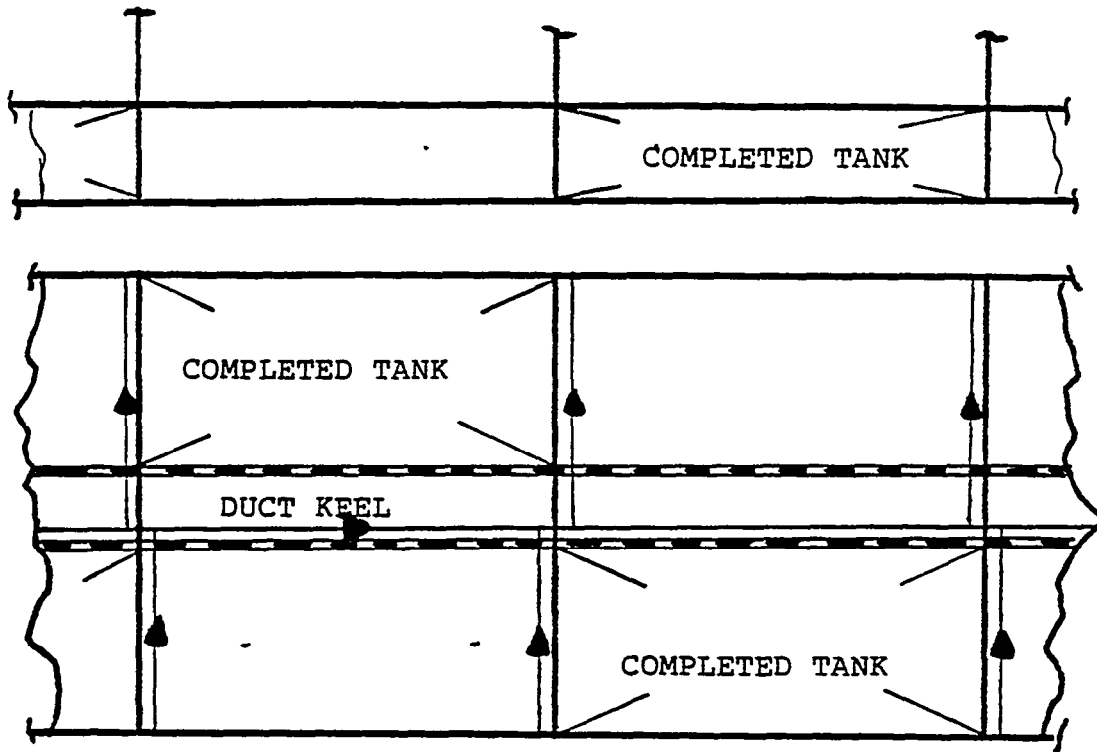

FIGURE 1.47 Arrangement of module joints to facilitate tank completion including alternate tank testing.

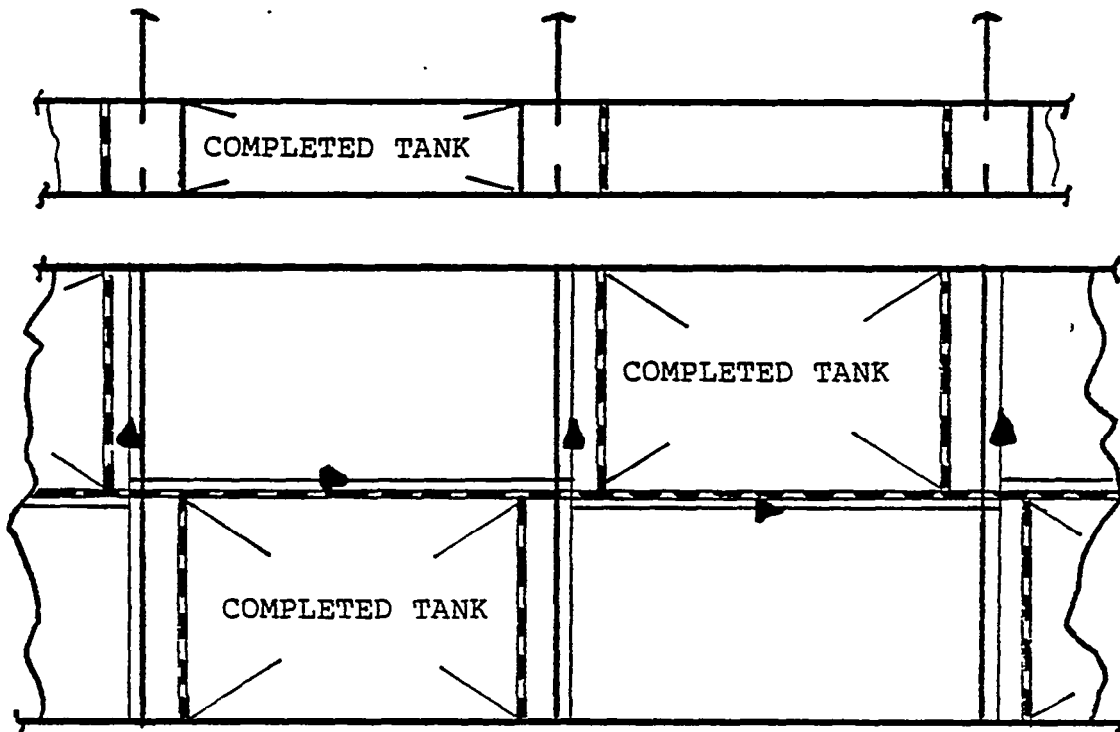
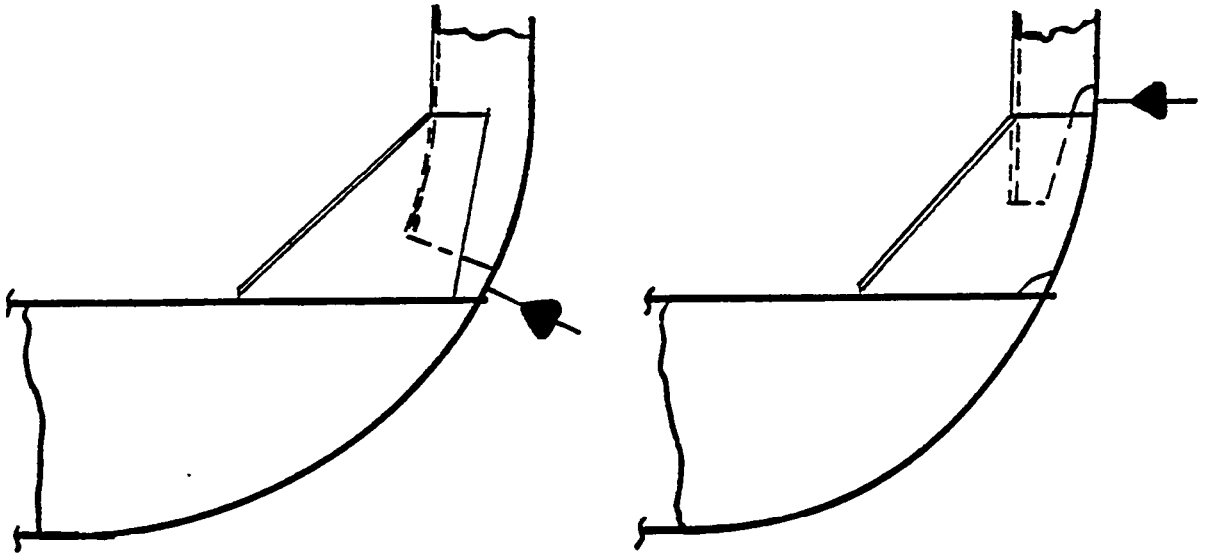

FIGURE 1.48 Alternative arrangement of module joints to facilitate tank completion including alternate tank testing.



DIFFICULT TO FIT AND
MAINTAIN CORRECT SHAPE

WITH MODULE ERECTION JOINT ABOVE
TANGENT POINT SIDE SHELL WILL HAVE
NO SHAPING IN PARALLEL MID-BODY
AND BRACKET WILL CONTROL BILGE SHAPE

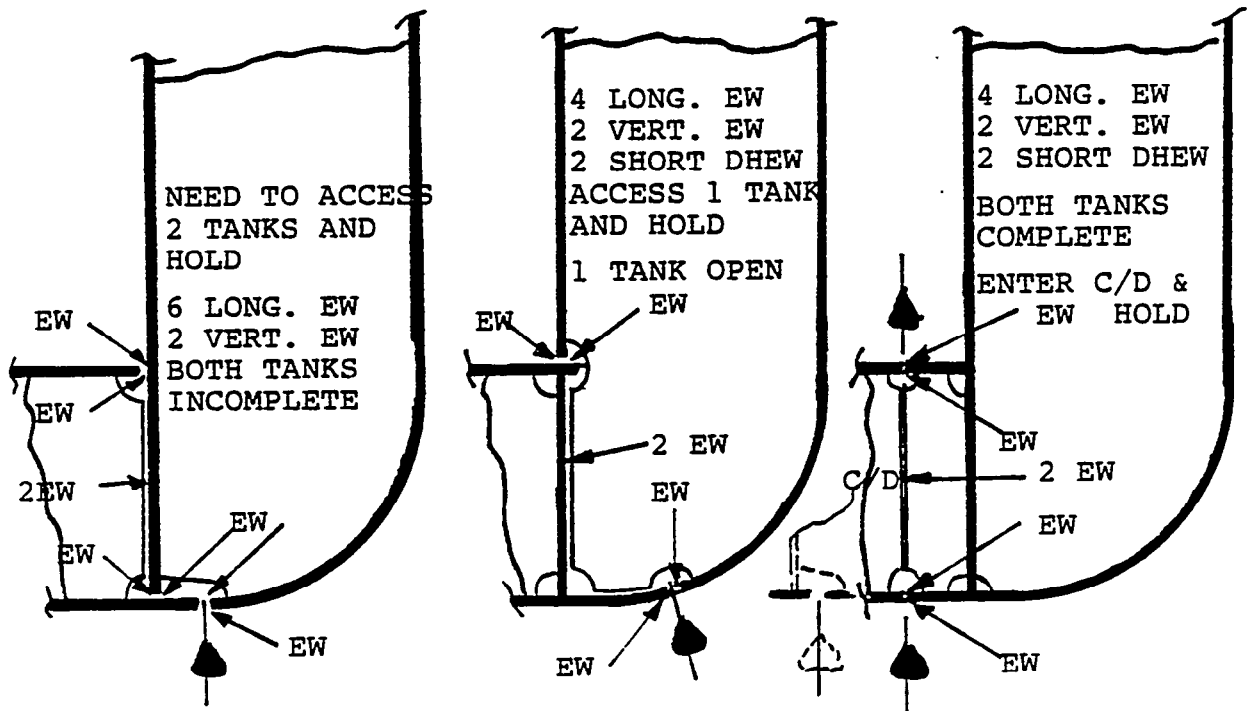

Figure 1.49 Module joining structural detail.

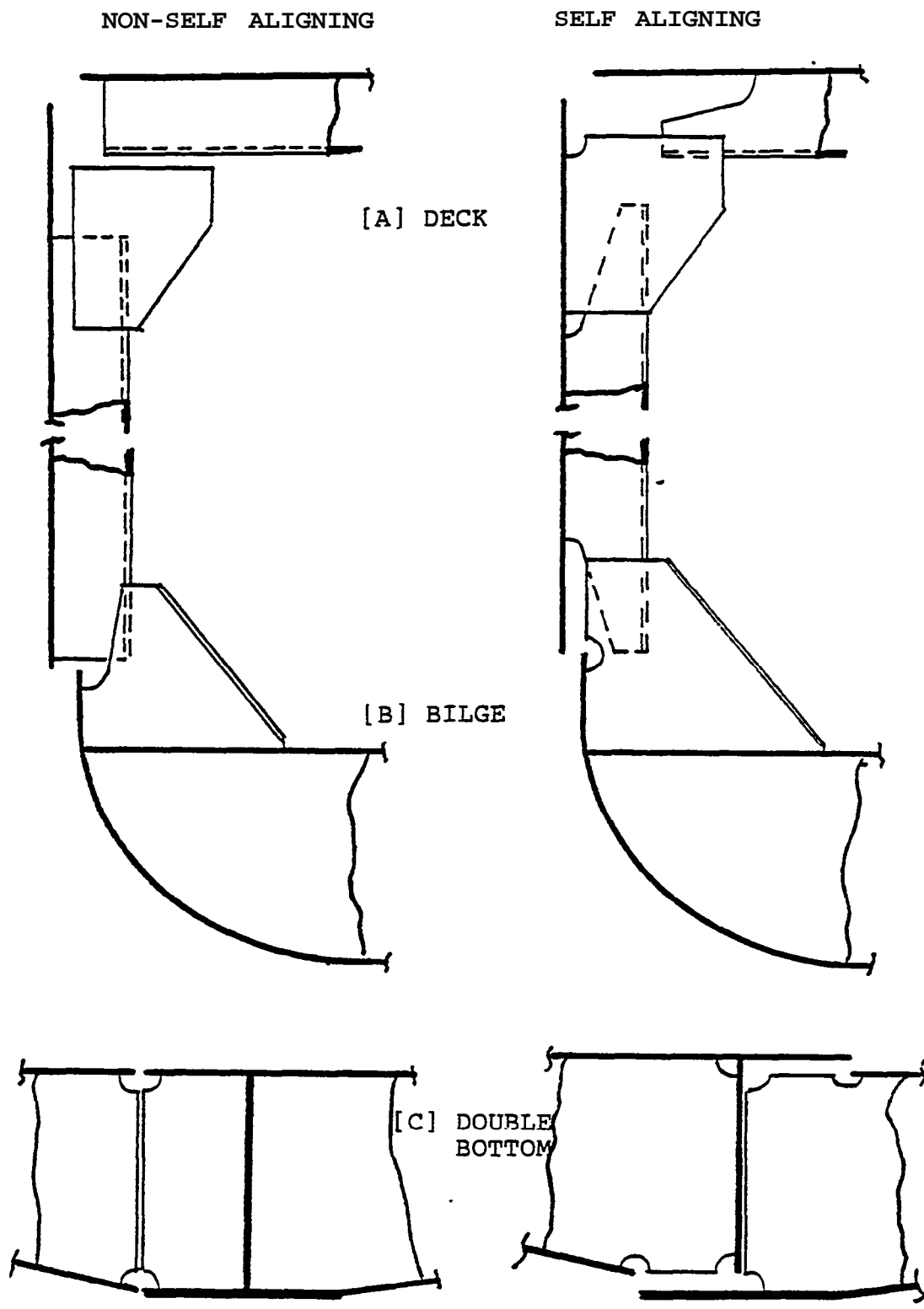
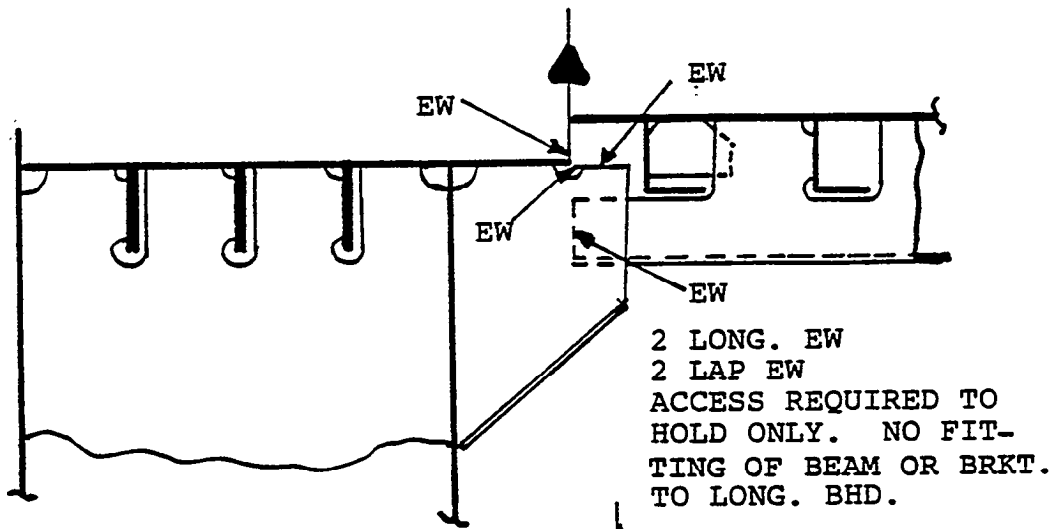
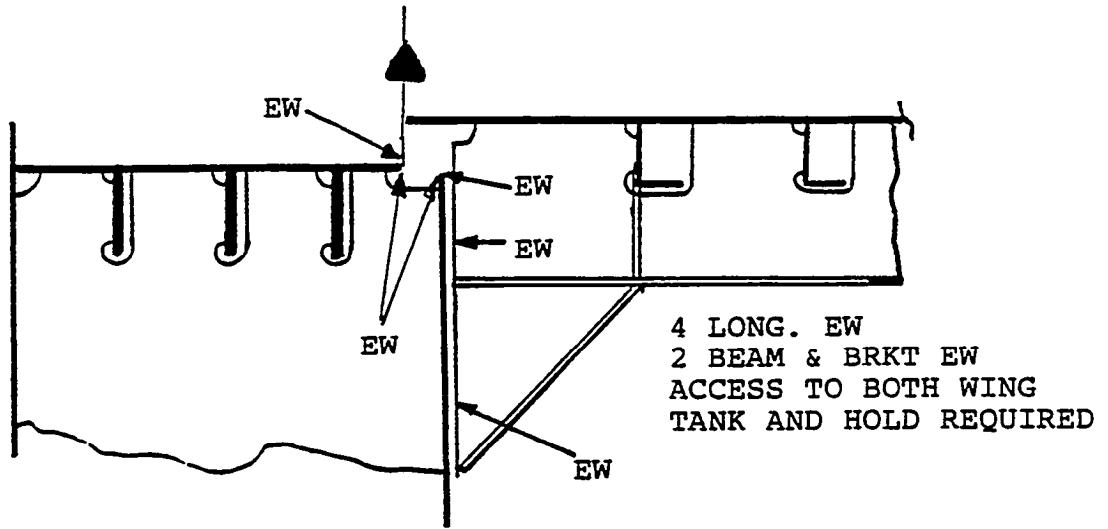

FIGURE 1.49 (Continued)



ALTERNATE FOR
TEE DEEP BEAM

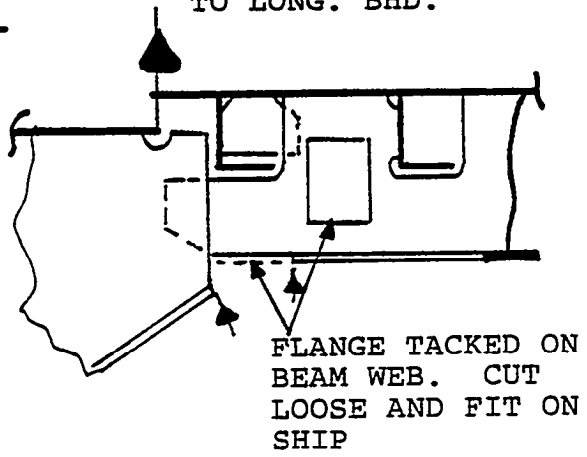

FIGURE 1.49 (Continued)

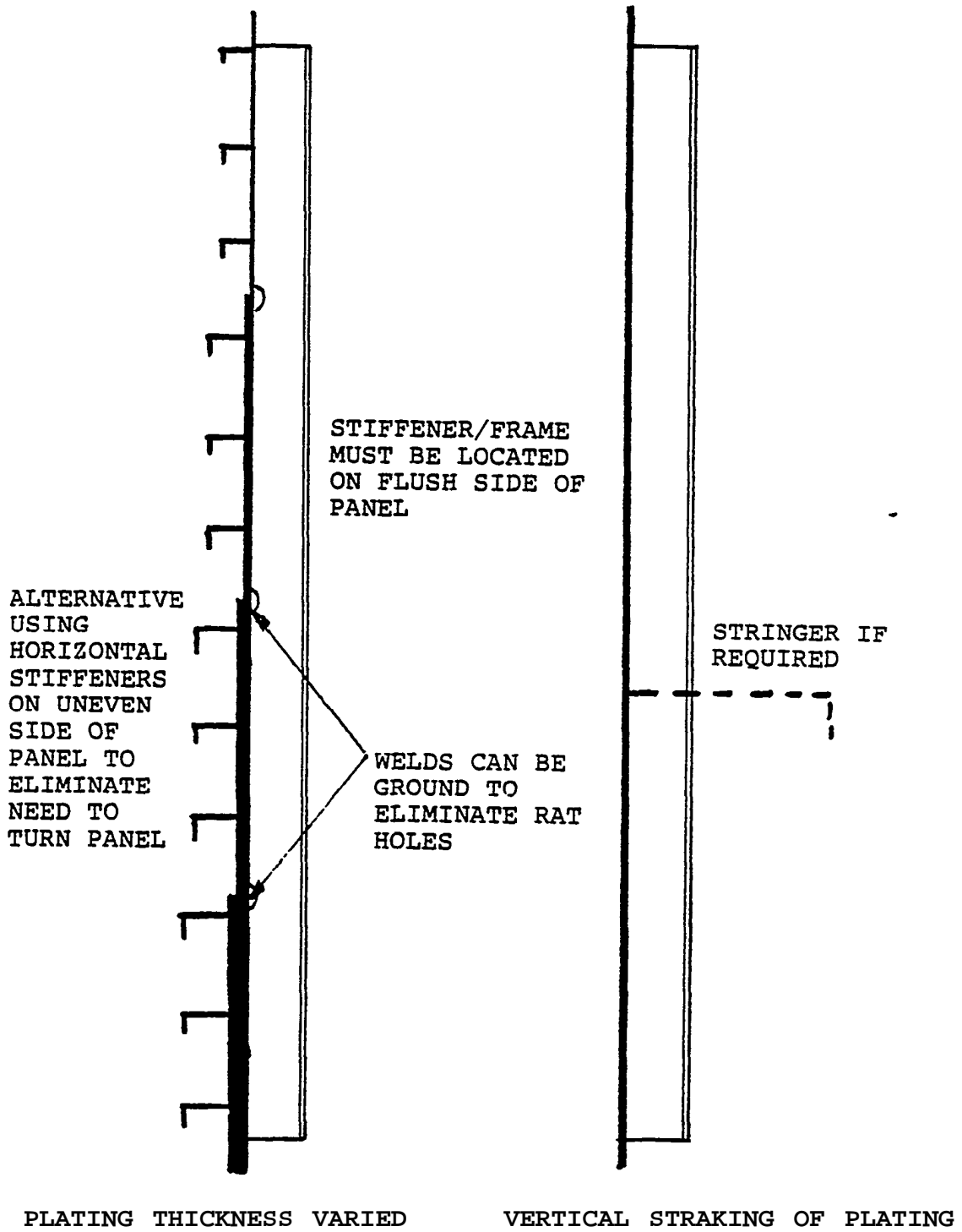

FIGURE 1.50 Plate straking/stiffener arrangements for productivity.

The module boundaries should be located at natural plate butts and seams. Module breaks should be located to minimum ship erection work content. For example, in a longitudinally framed ship it would be better to have long modules, whereas for a transversely framed ship, wide modules would be better. The reasons for this can be seen from Figure 1.51.

All these concepts are put together for two typical cases, namely a cargo ship and a tanker in Figure 1.52 and 1.53, respectively. The tanker case is based on the "layer" construction method. This method was developed in Scandinavia and improved in various stages by many shipbuilding countries. The principle involved is the maximizing of fillet welding in place of butt and down hand and vertical attitudes. The structural layers also become natural reference planes. This method is shown in Figure 1.54, and its application to tankers in Figure 1.55.

1.5.3 STRUCTURAL DETAILS. The labor manhours to construct the structure of a ship can be significantly reduced by proper attention to the design of structural details. A number of structural details are examined in this context.

(a) Shell Straking. The obvious goal for shell straking is to standardize the plates. A standard plate should not only be identical in size, but also in marking, bevelling, etc. This can only be accomplished by locating the stiffeners and webs in the same position on each plate as shown in Figure 1.56. To do this two options are possible. One is to consider stiffener and web spacing to suit the maximum width and length of plates to be used. The other is to select plate width and length to suit desired stiffener and web spacing. For example, if a shipyard desires to use a maximum plate size of 40 feet by 10 feet, the spacing of the stiffeners will be given by $10/n_s$ and of the webs by $40/n_w$, where both n_s and n_w must be whole numbers. If, on the other hand, the shipyard wishes to use a stiffener spacing of 3 feet, and a web spacing of 12 feet, the 40 by 10 plate would not allow standard marking. The correct standard plate size for the desired spacing would be 36 or 48 feet in length, and 9 or 12 feet in width. This shows that when considering structural design, all the factors that influence productivity and thus cost must be included. It is pointless to spend time and money to standardize design and facilities, and to lose much of the benefit by *not* understanding the impact of plate size. Correctly applied, the number of different shell plates in the parallel body of a tanker or bulkcarrier can be as few as five. When this approach is applied to decks, bulkheads, and tank tops, its impact can be a significant reduction of engineering, lofting, and production manhours. It also makes the use of special tooling practical as the small number involved can be cost-effective.

Another shell detail that involves extra work content is insert plates. This is because of the additional welding and chamfering of the insert plate. Figure 1.57 shows how this can be eliminated by making the insert plate the full strake width, thus significantly reducing the amount of additional welding. The chamfering can be eliminated by increasing the plating surrounding the insert plate to that necessary to gradually build up to the required insert plate thickness in steps allowed by the classification rules without chamfering.

Many shell assemblies and/or modules require plate jigs or pin jigs to be able to construct them. This is an additional work content, and by design can be eliminated. To do this, it is necessary to either have shell modules with decks, flats, and bulkheads that can be used as the reference planes on which to set the internal structure, and then attach the shell, or else the internal web frames must be deliberately designed with their inner surface in the same plane for each module, in the same way *that the* upper surface and bevel angle of roll sets are used. These concepts are shown in Figure 1.58.

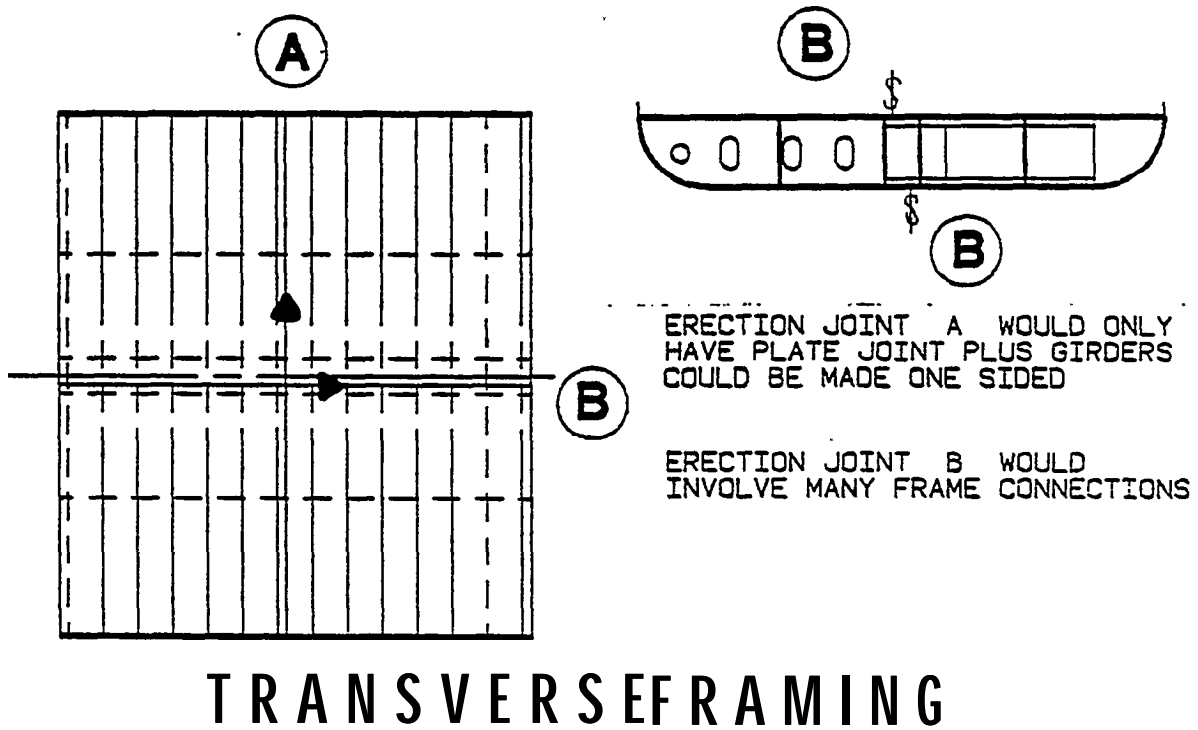
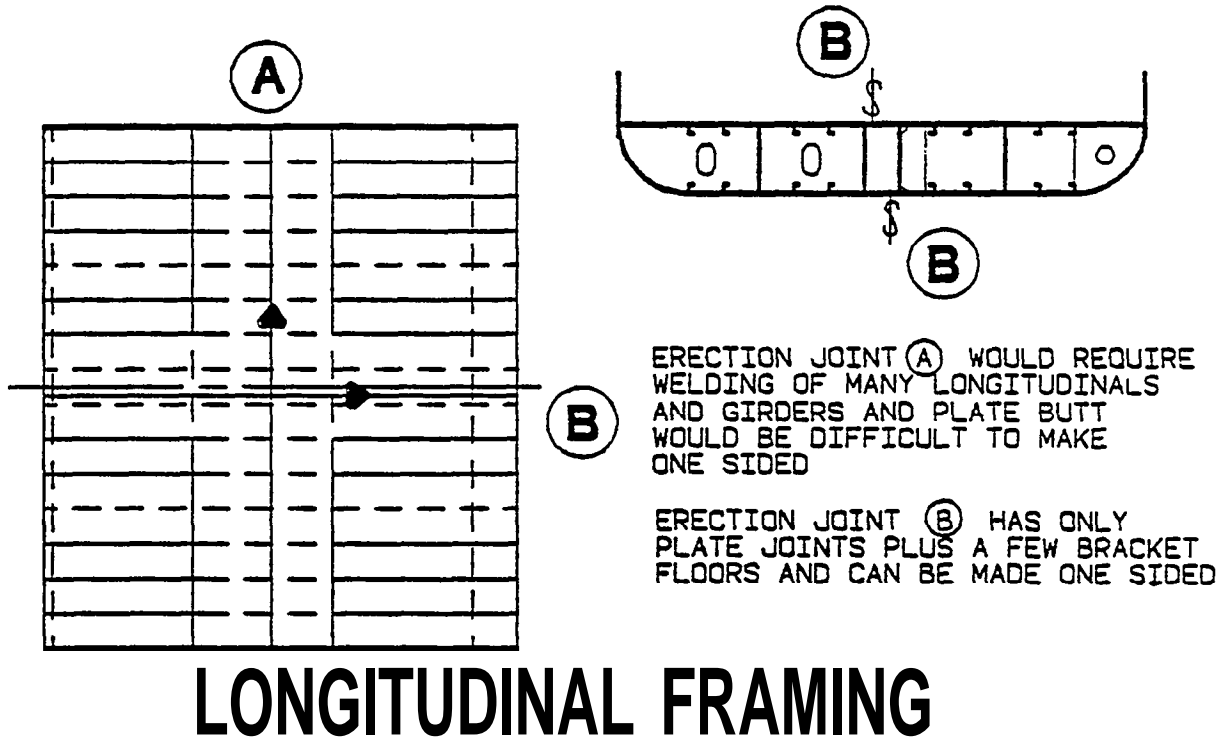

FIGURE 1.51 Producibility considerations for module breaks.

Structure

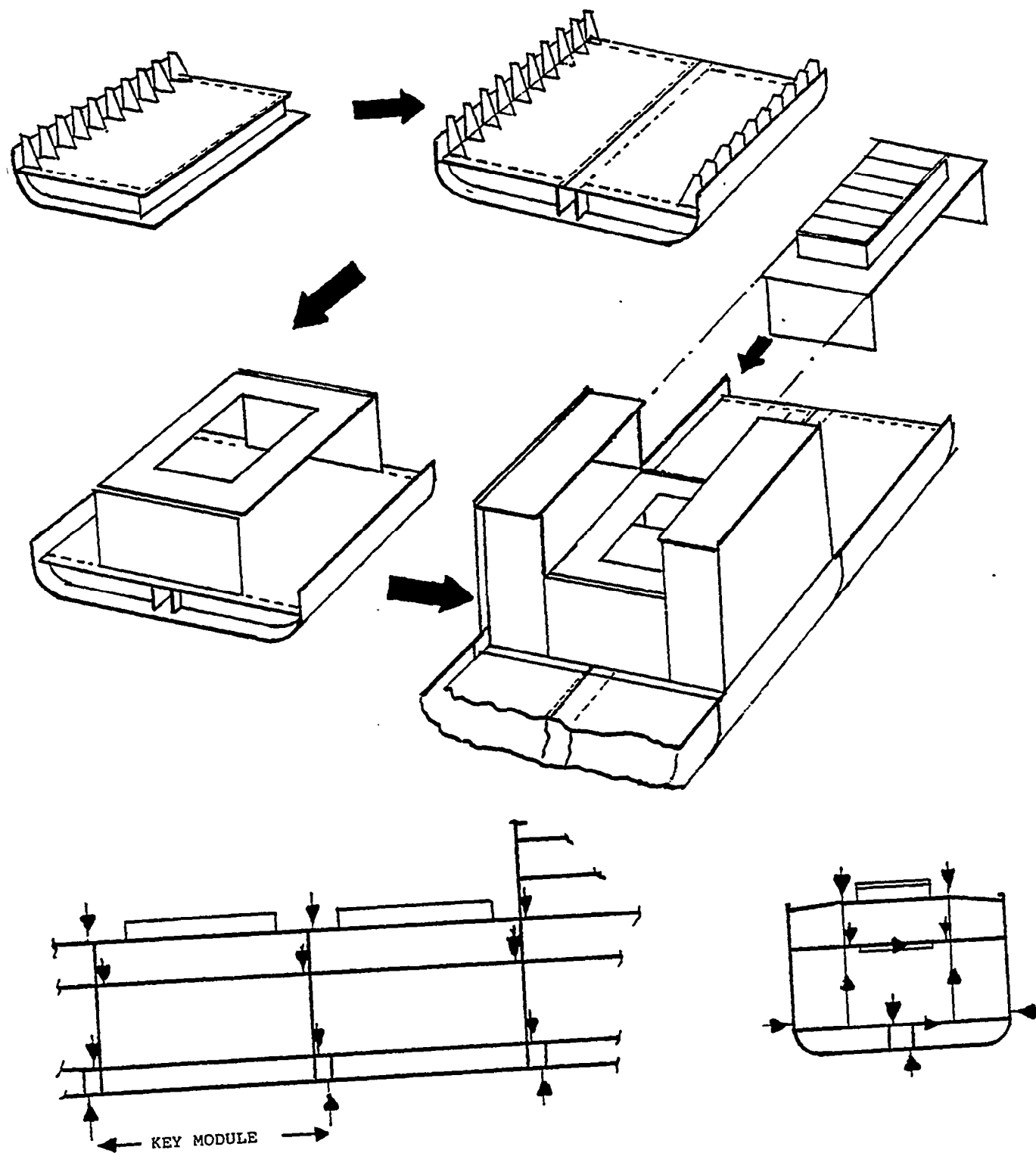

FIGURE 1.52 Cargo ship modules.

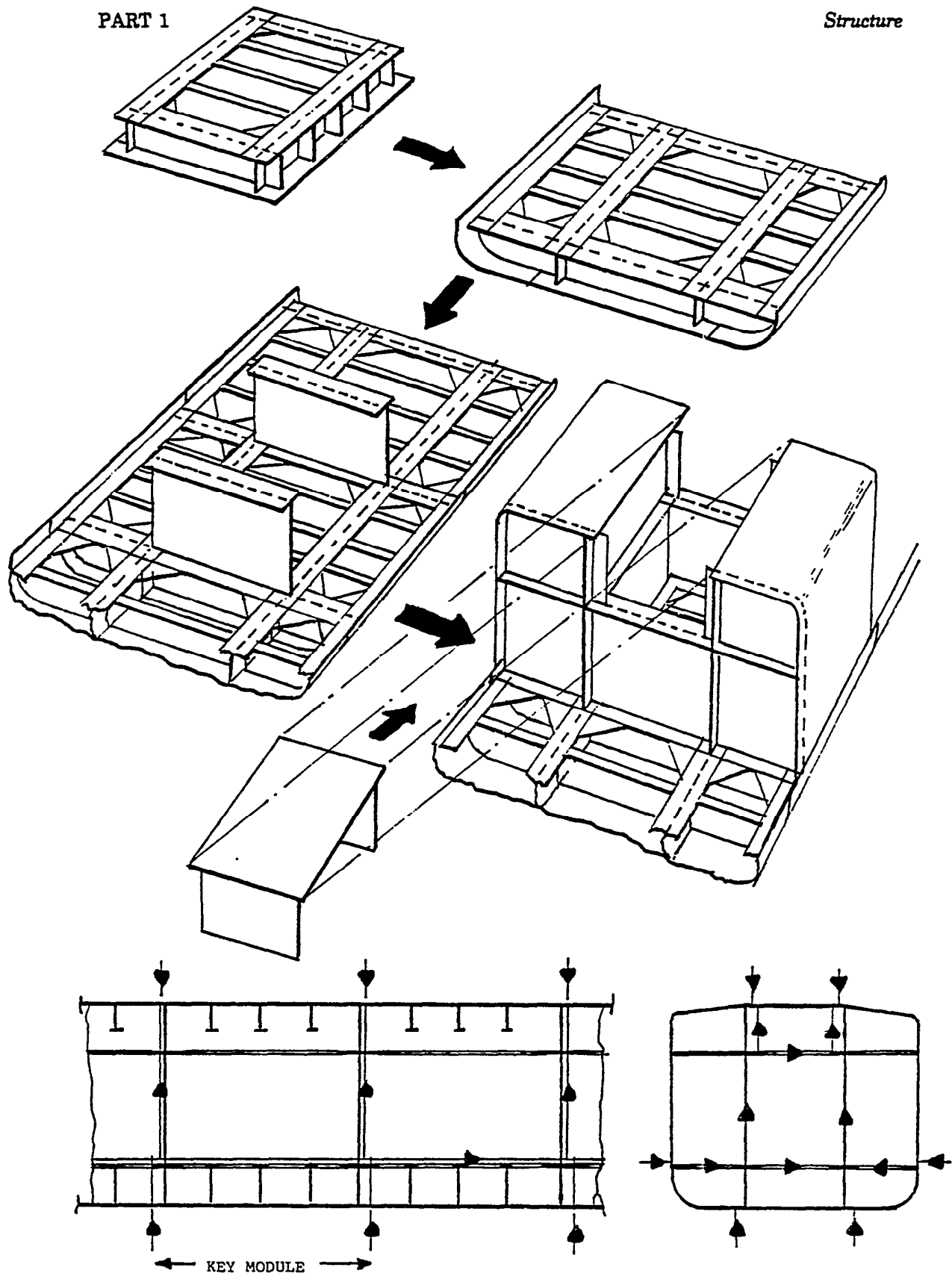
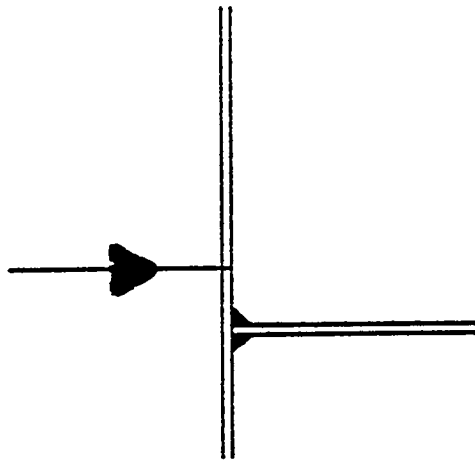
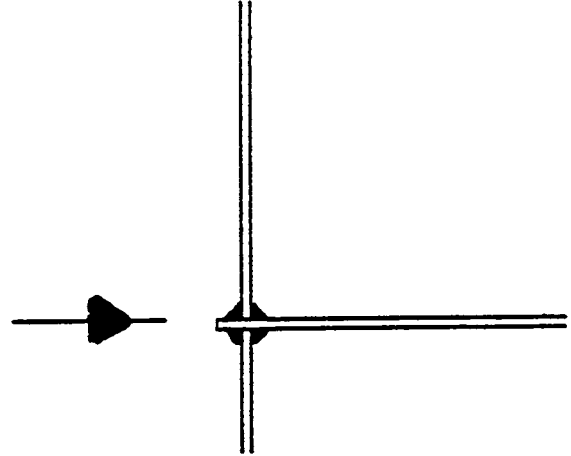

FIGURE 1.53 Tanker "layer" system modules.

TRADITIONAL



LAYER METHOD



TANK TOP, FLAT, OR INTERSECTING BULKHEADS

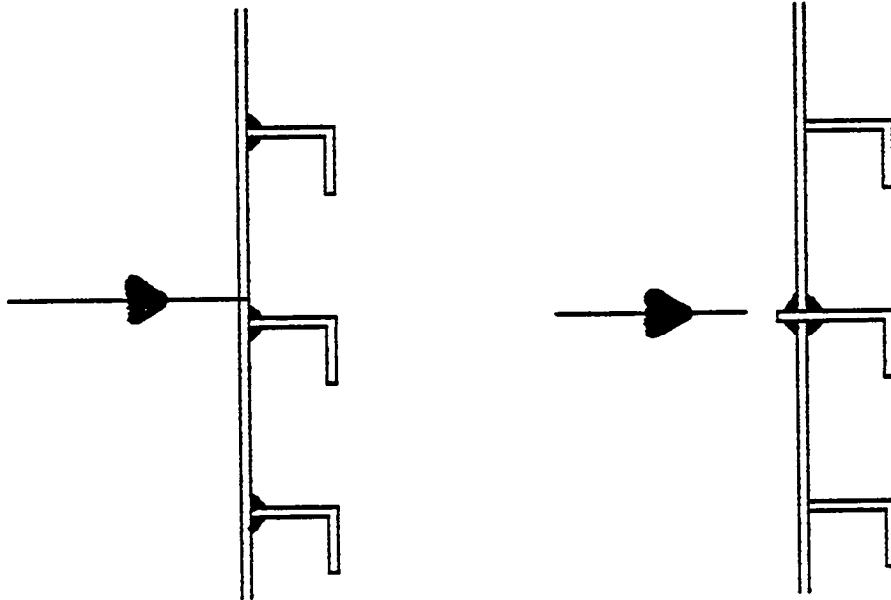

BULKHEADS WITH STIFFENERS

FIGURE 1.54 "Layer" construction method.

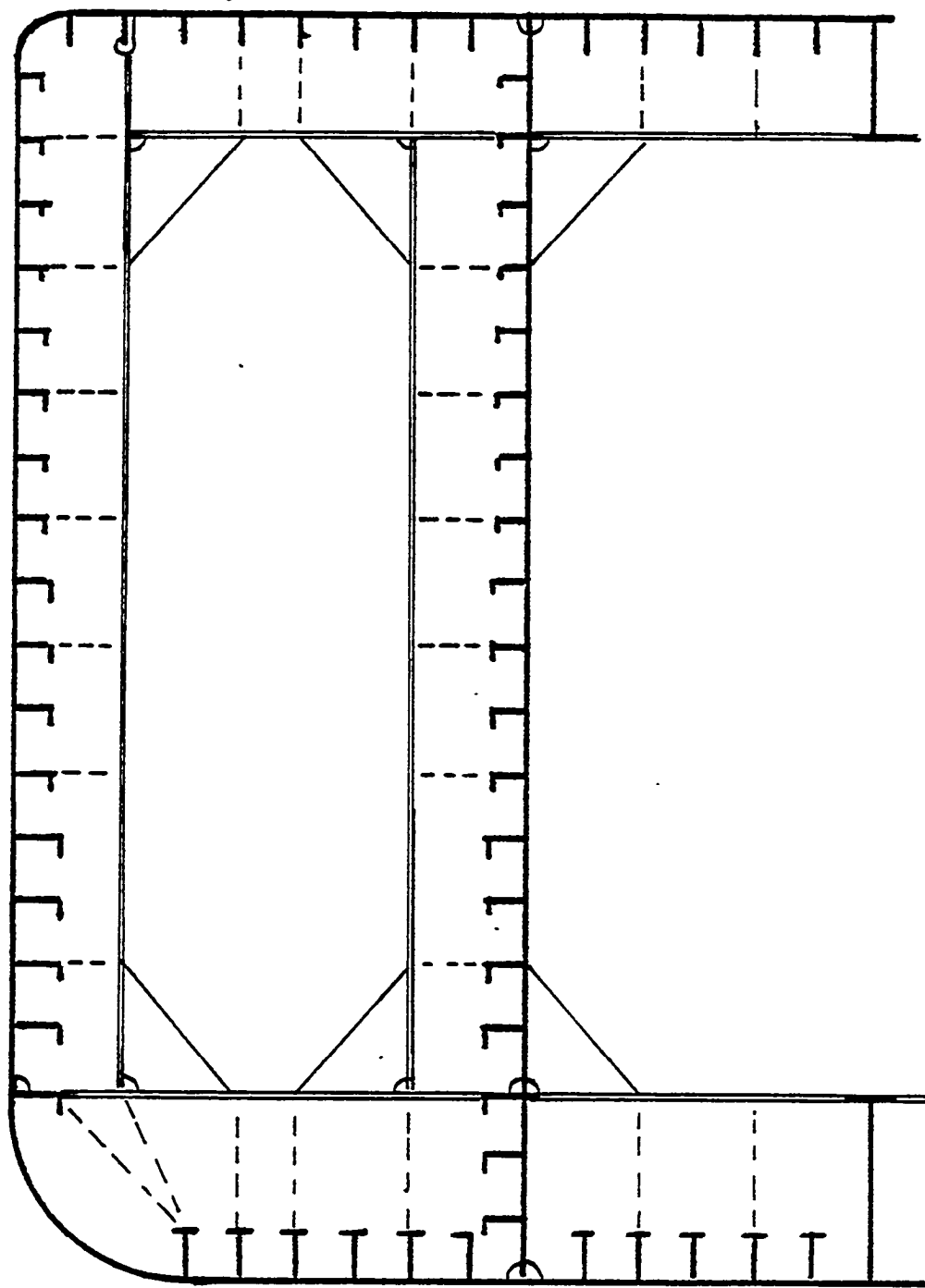

FIGURE 1.55(a) Tanker structural detail for "layer" construction method.

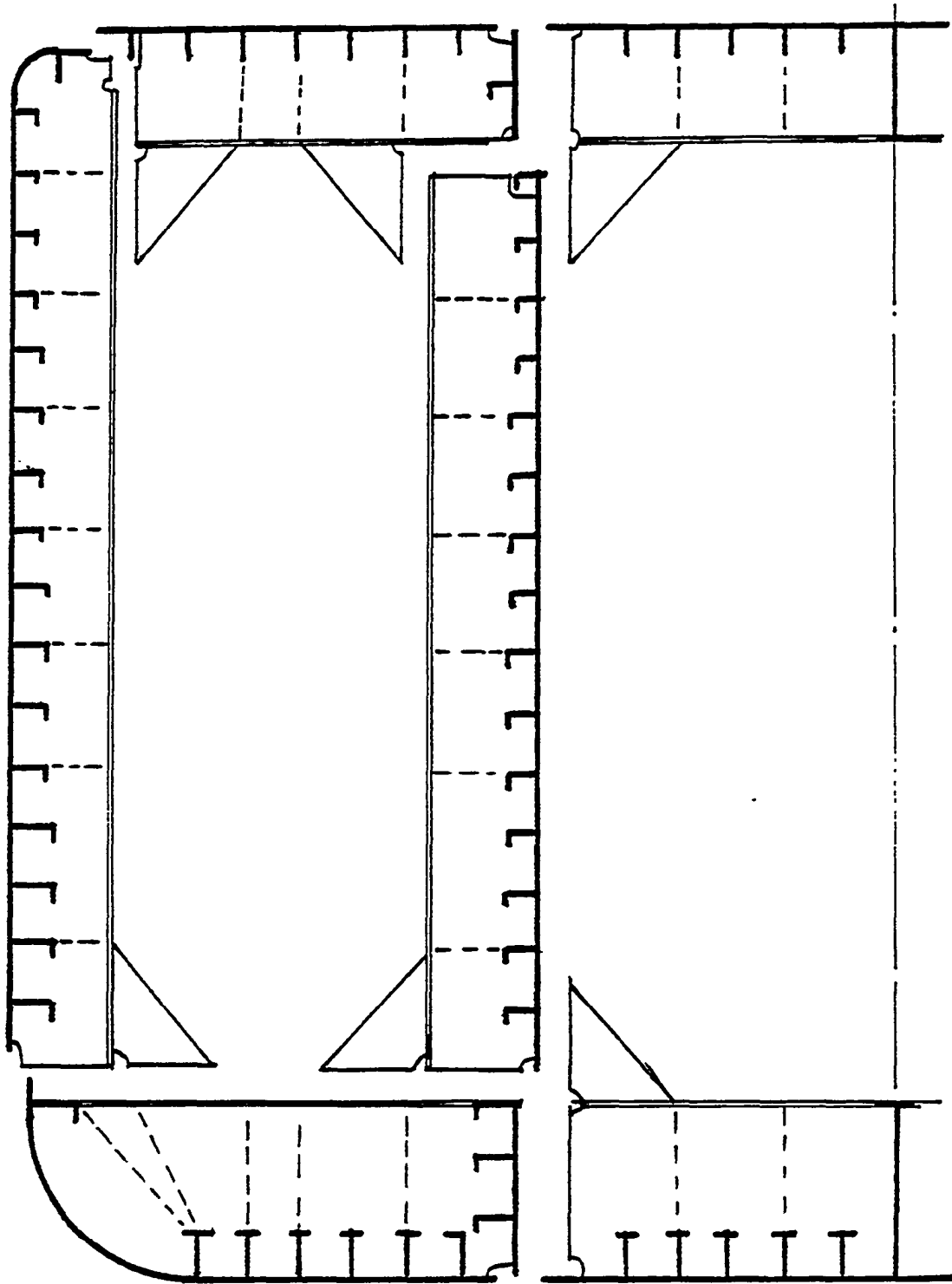
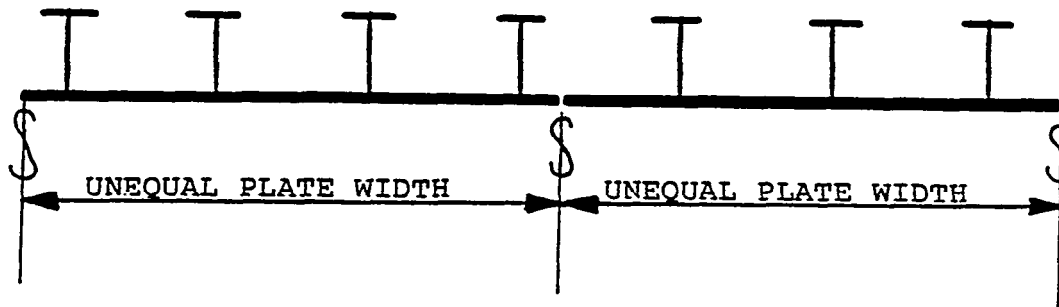
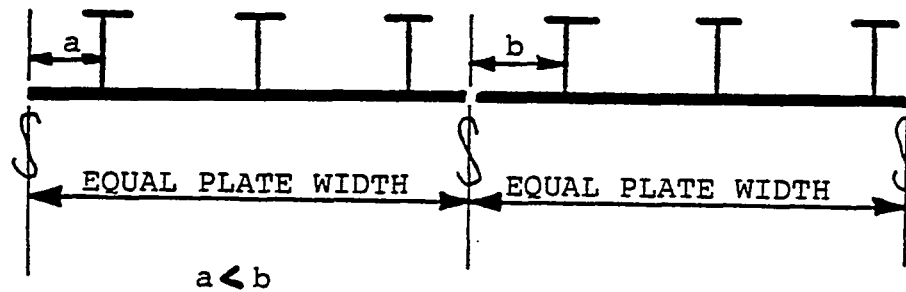

FIGURE 1.55(b) Tanker modules for "layer" method.



[A] NON-STANDARD PLATE WIDTH AND NUMBER OF STIFFENERS



[B] ALSO NON-STANDARD DUE TO DIFFERENT STIFFENER MARKING

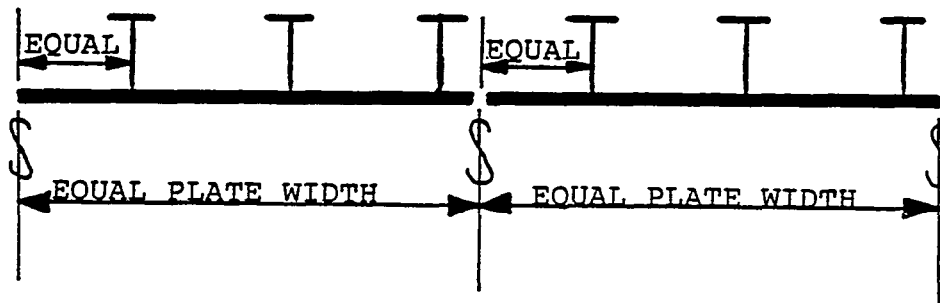

[C] STANDARD PLATES - PLATE WIDTH AND STIFFENER MARKING IDENTICAL

FIGURE 1.56 Standard and non-standard plates.

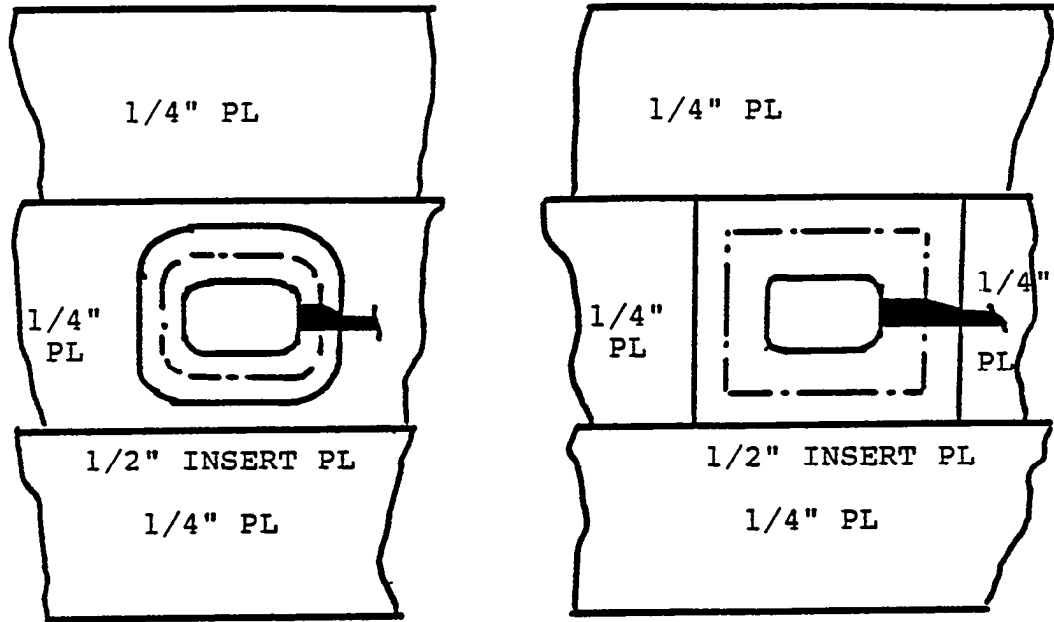

[A] TRADITIONAL INSERT PLATE

[B] IMPROVEMENT BUT STILL NEED CHAMFER

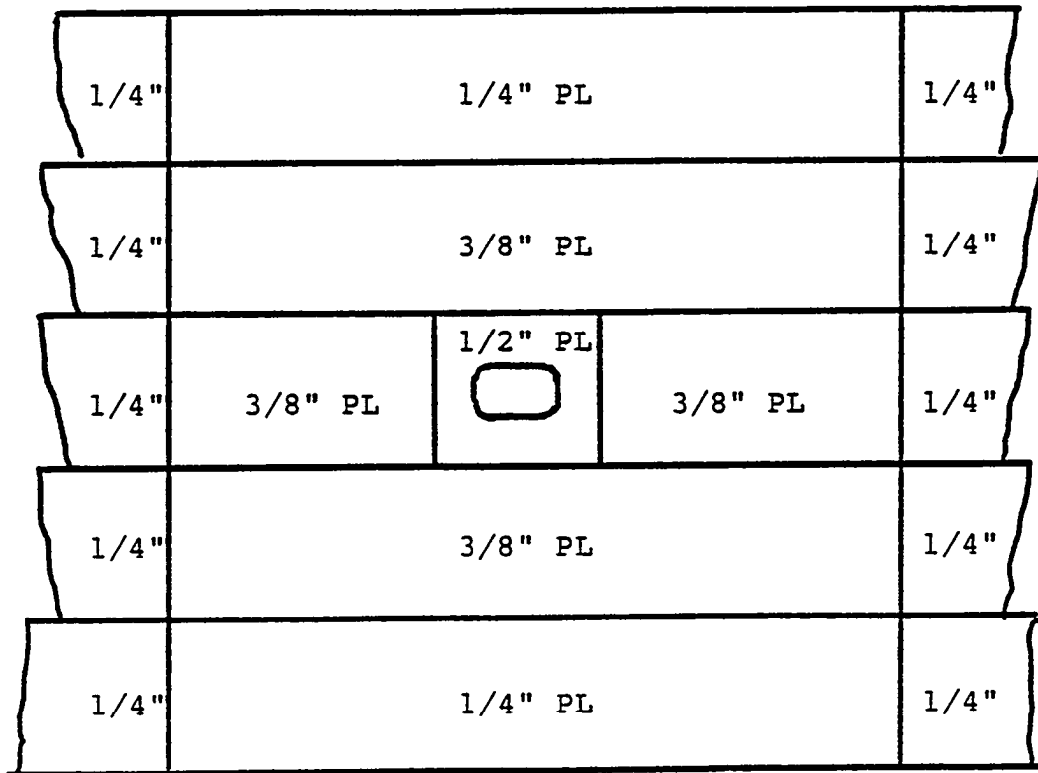

[C] IMPROVEMENT AND NO CHAMFERING REQUIRED

FIGURE 1.57 Ways to reduce work content of insert plates.

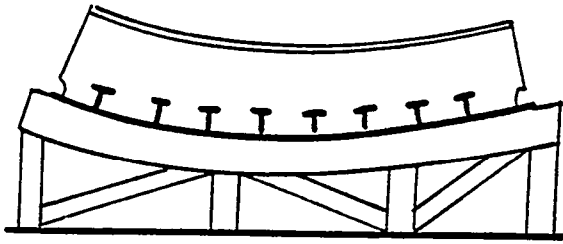
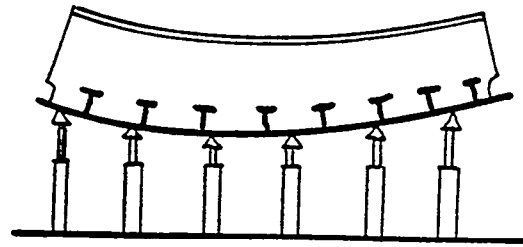
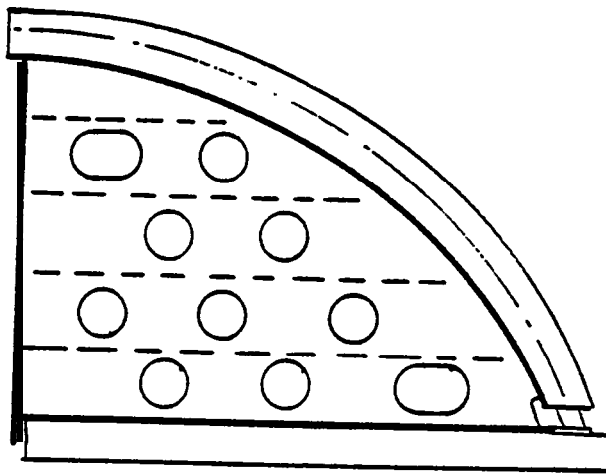

PLATE JIG



PIN JIG

BOTH HAVE EXTRA WORK CONTENT
TO REDUCE WORK CONTENT



USE BULKHEAD, DECK
OR FLAT TO BUILD
ON IF POSSIBLE

OR

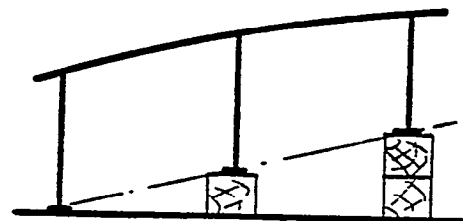
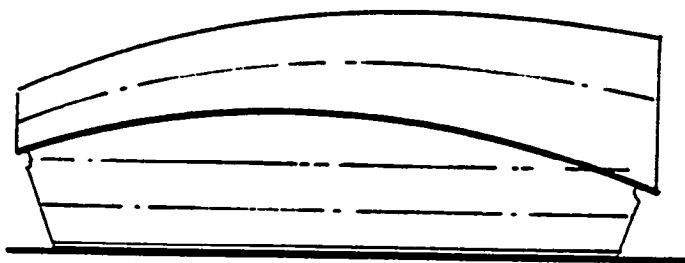

BUILD ON EGG CRATE OF WEB FRAMES AND LONGITUDINALS

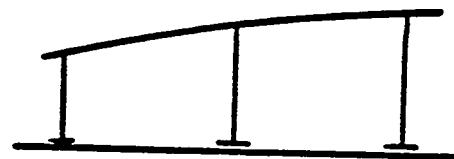
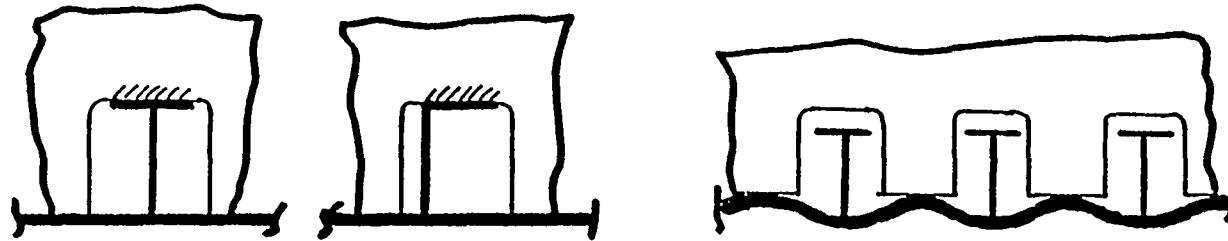

FIGURE 1.58 Curved module design for production.

(Ii) Cut-Outs. The design of cut-outs for frames, longitudinals, and stiffeners can also adversely influence work content, especially in naval work where most of them at the shell must be chocked or collared. Figure 1.59 shows some of the common types in use, and notes various comments on each type. It is possible to eliminate cut-outs by slotting the floor, web, or bulkhead, cutting away the flange of the frame, longitudinal or stiffener, and inserting a bracket to effectively maintain the sectional area as shown in Figure 1.60. Comer cut-outs, snipes, drainage, and air holes must take into account the construction methods, and equipment to be used. For example, if automatic or even gravity-feed welding is to be used, a detail allowing continuous fillet welding will be best, whereas for manual welding a complete edge cut detail may be better as shown in Figure 1.61. Also water and oil stops can be combined with some holes when manual welding details are used. Figure 1.62 illustrates this approach. The practice of making air holes smaller than drain holes in floors, girders, etc., is unnecessary, and they should be made the same size. An interesting detail developed for improved producibility associated with cut-outs and floor and web stiffeners is shown in Figure 1.63. It was developed by Burmeister and Wain in Denmark after considerable research into the stress distributions around various cut-out/stiffener detail. Usually the stiffener is connected to the longitudinal, requiring considerable work content to fit, align, and weld the connection. The improved detail moves the stiffener out of line with the longitudinal, thus eliminating the connection.

(c) Brackets. There are many approaches to the design of brackets for frames, beams, longitudinals, and stiffeners. Again they are usually based on borrowed industry standards, BUSHIPS standards, or a design agent's standard, instead of being thoroughly researched to determine the best design for a given shipyard. In the days of piece-by-piece erection on the building berth, brackets were very simple, and where shape was involved they were fitted at the ship frame by frame. Figure 1.64 shows the evolution of beam and frame brackets. Type A is a pre-computer-aided lofting and automatic burning bracket. It was often sheared or burned from plate scrap, and two standard sizes generally covered the complete ship. Standard II was used for shaped brackets, and the excess material was cut off when joining beam and frame. Type (B) shows a bracket which is practical only through the use of computer-aided lofting and optical or N/C burning. As Type (B) can be accurately produced, it can be used with advantage to correctly align frame to beam and shell to deck. Type C is a bracket which utilizes the same concept as Type (B) but attempts to eliminate the complex cutting of the ends of beams, frames, stiffeners, etc. Its advantage is that as the bracket is cut by automatic machines, ail shaping can be easily accomplished, and the end cut on the frame, etc., becomes a simple straight cut. Its disadvantage is that as it is still used for alignment, it usually requires a larger bracket, thus encroaching on internal space. Another way to reduce the work content of brackets is to use thicker material and eliminate flanging or welding on a face plate. This is allowed by classification rules. Figure 1.65 is a collection of brackets for "tee" beams and frames, including BUSHIPS standards which, it can be seen, are not "production kindly." Alternative bracket details are provided for comparison.

(d) Web Frames. Ships such as tankers and bulk carriers, and also some large naval ships, incorporate many web frames in their structural design. The usual approach utilizes ring web frames with their many face plates and web stiffeners. Figure 1.66 shows typical ring web frames, and an alternative approach utilizing non-tight bulkheads in place of the ring web frames. The non-tight bulkhead web frame can be constructed for less manhours than the usual ring web frame, as it eliminates many differing parts, including the thick face plates which are normally rolled. It can also be constructed on a panel line with automatic and semi-automatic assembly equipment. However, in the case of coated tanks, the cost increase for the coating for the additional surface area must be



TYPE A - WELD ON TOP - DIFFICULT TO FIT DUE TO PLATE DISTORTION FROM STIFFENER WELDING

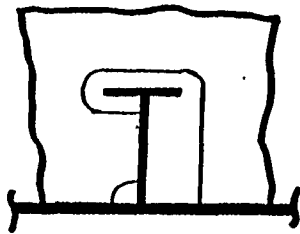

DIFFICULT TO INSTALL AS TEE BAR MUST BE THREADED THROUGH OPENING

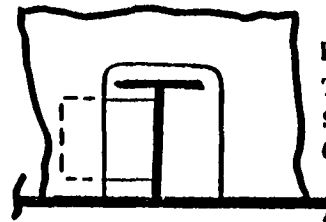

PREFERRED DESIGN FOR TEE BAR AS WEB/STRINGER CAN BE PLACED OVER STIFFENER ON PLATE

TYPE B - WELD ON SIDE FOR TEES

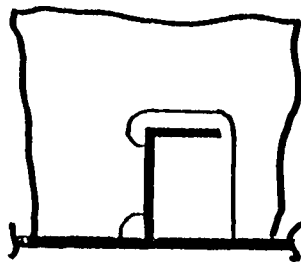

REQUIRES ACCURATE POSITIONING OF LONGITUDINALS, OTHERWISE FITTING OF EACH CONTACT EDGE WILL BE REQUIRED

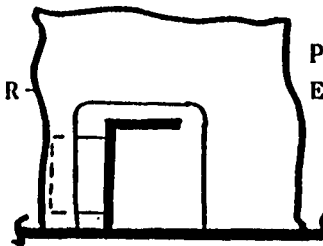

PREFERRED DESIGN TO ELIMINATE FITTING

TYPE C - WELD ON SIDE FOR ANGLES

FIGURE 1.59 Cutout types.

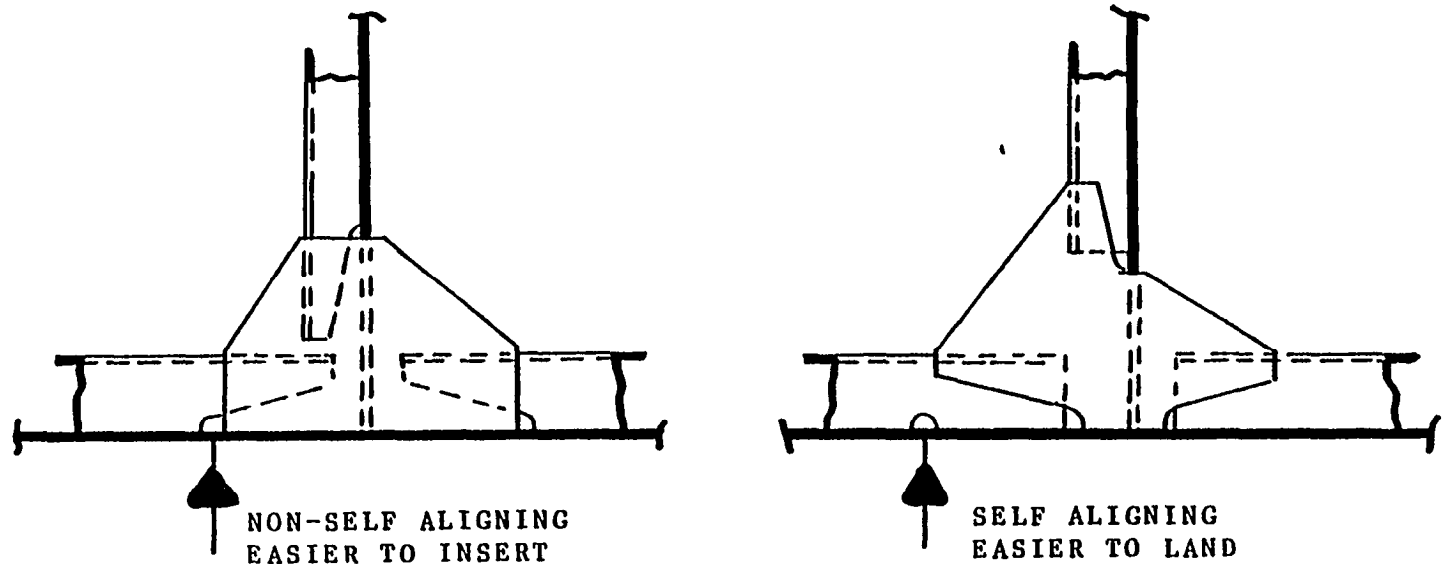

ALTERNATIVE WHEN LONGITUDINALS CAN BE CUT AT TRANSVERSE BULKHEADS

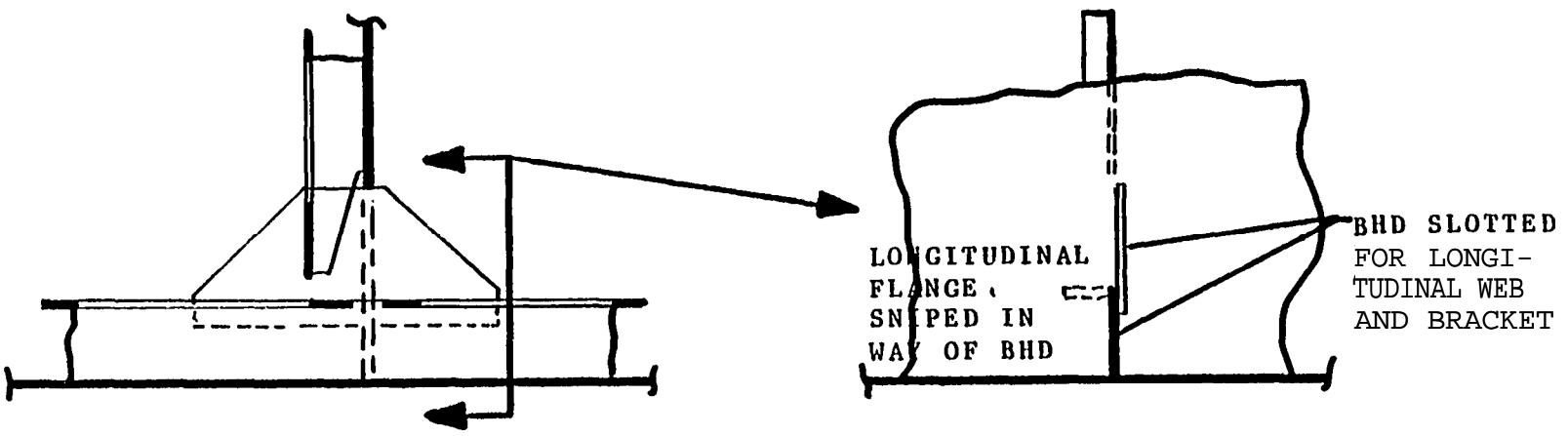

ALTERNATIVE WHEN LONGITUDINALS ARE TO BE CONTINUOUS

FIGURE 1.60 Longitudinal connections at bulkheads to eliminate collars.

142

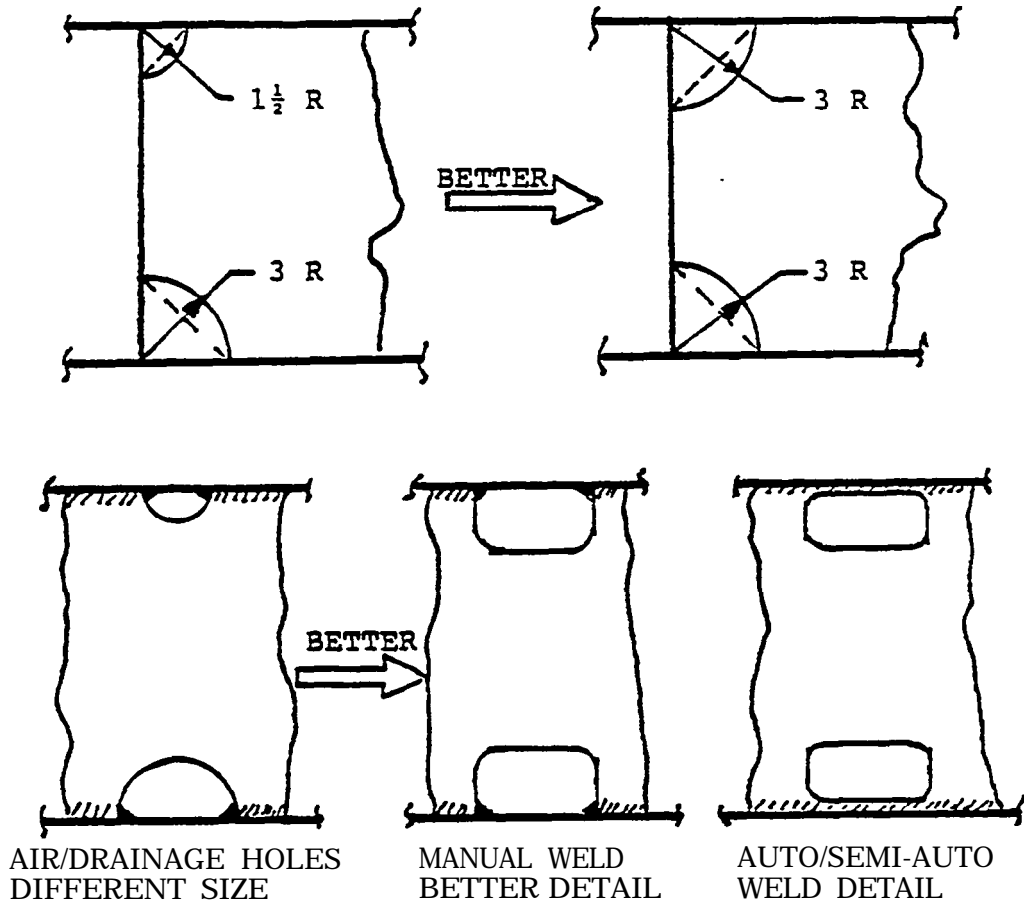

FIGURE X.61 Cut-out alternatives for productivity.

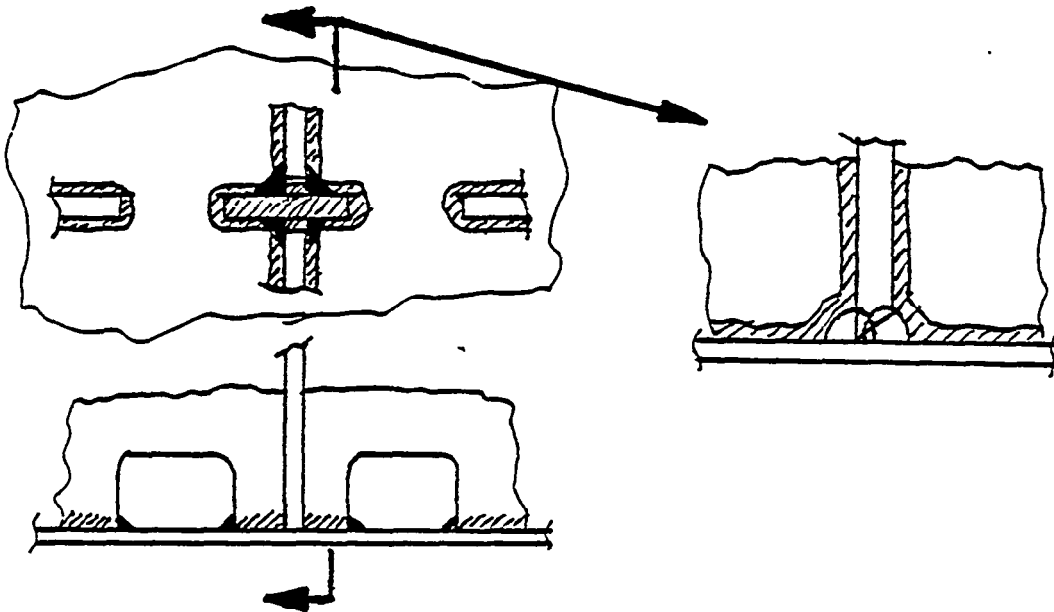
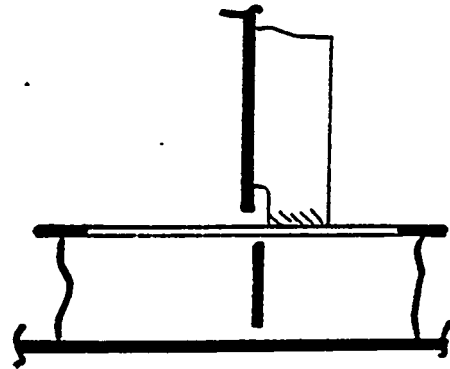
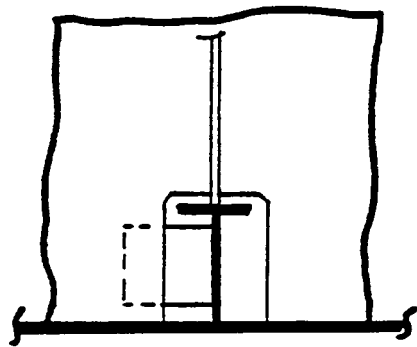
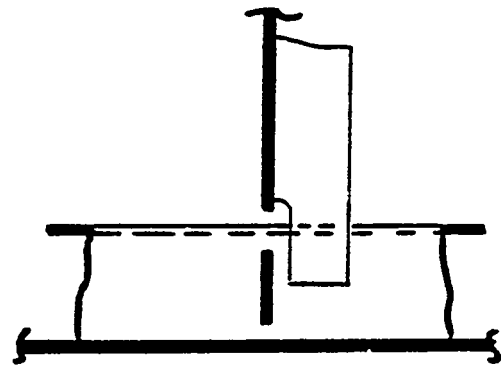
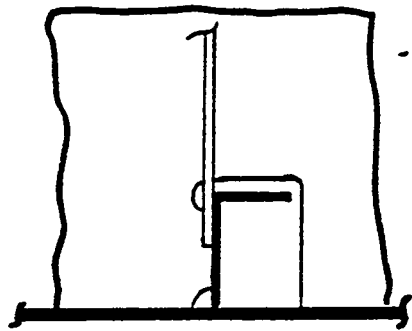

FIGURE 1.62 Oil/water stop design for productivity.



[A] TEE OPEN CUT-OUT WITH COLLAR AND ATTACHED STIFFENER



[B] ANGLE OPEN CUT-OUT WITH ATTACHED STIFFENER

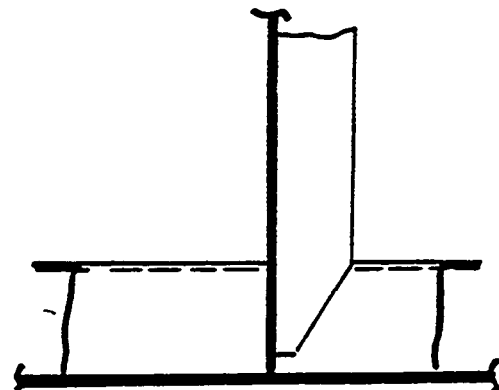
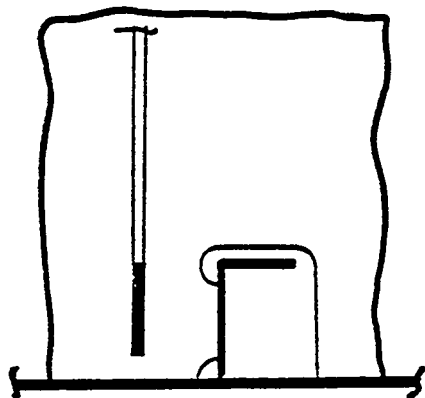

[C] ANGLE OPEN CUT-OUT WITH UNATTACHED STIFFENER

FIGURE 1.63 Floor/web frame stiffener designs.

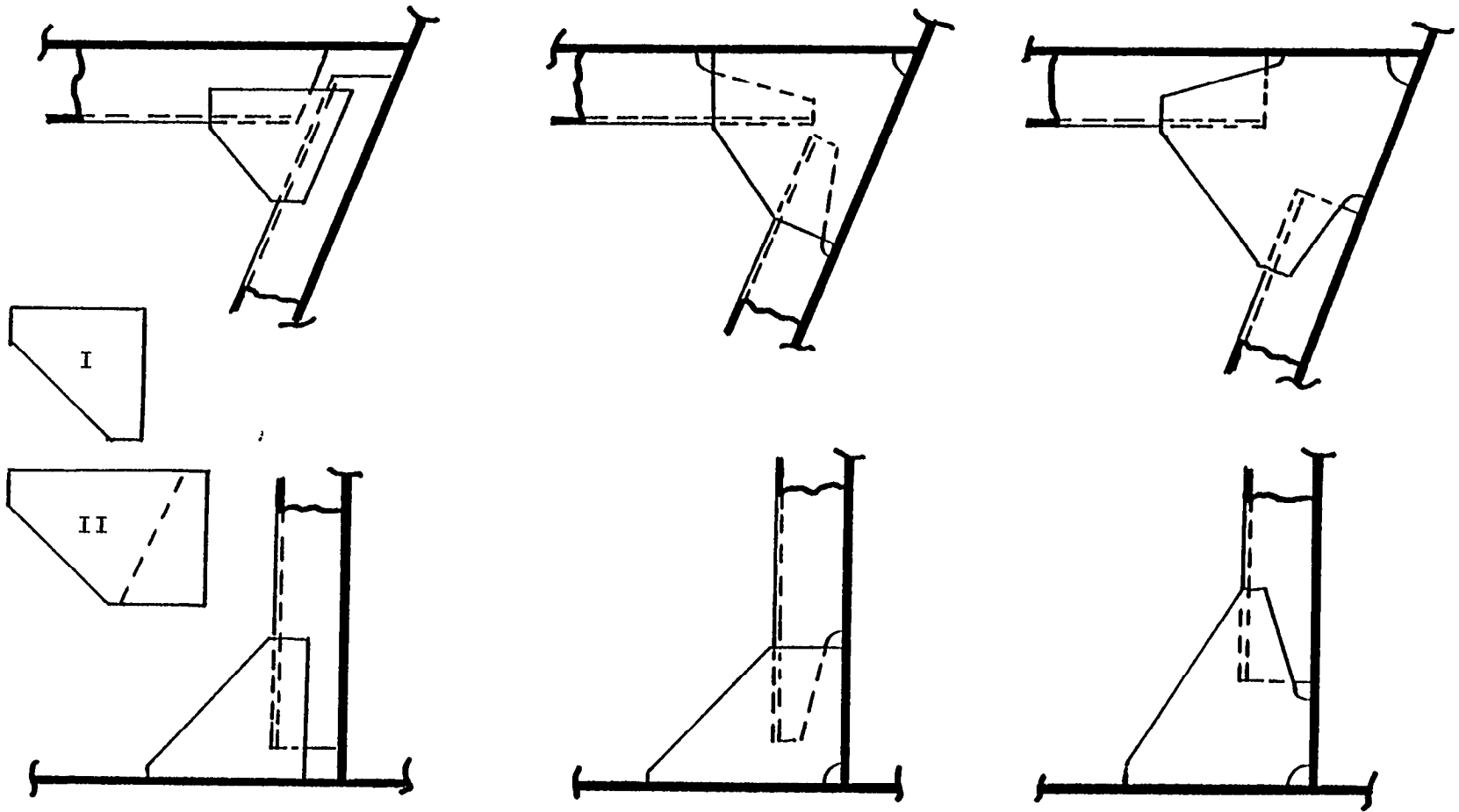

[A] SIMPLE PRE-COMPUTER

[B] COMPUTER AIDED DESIGN

[C] SQUARE SECTION
END CUT

FIGURE 1.64 Typical brackets.

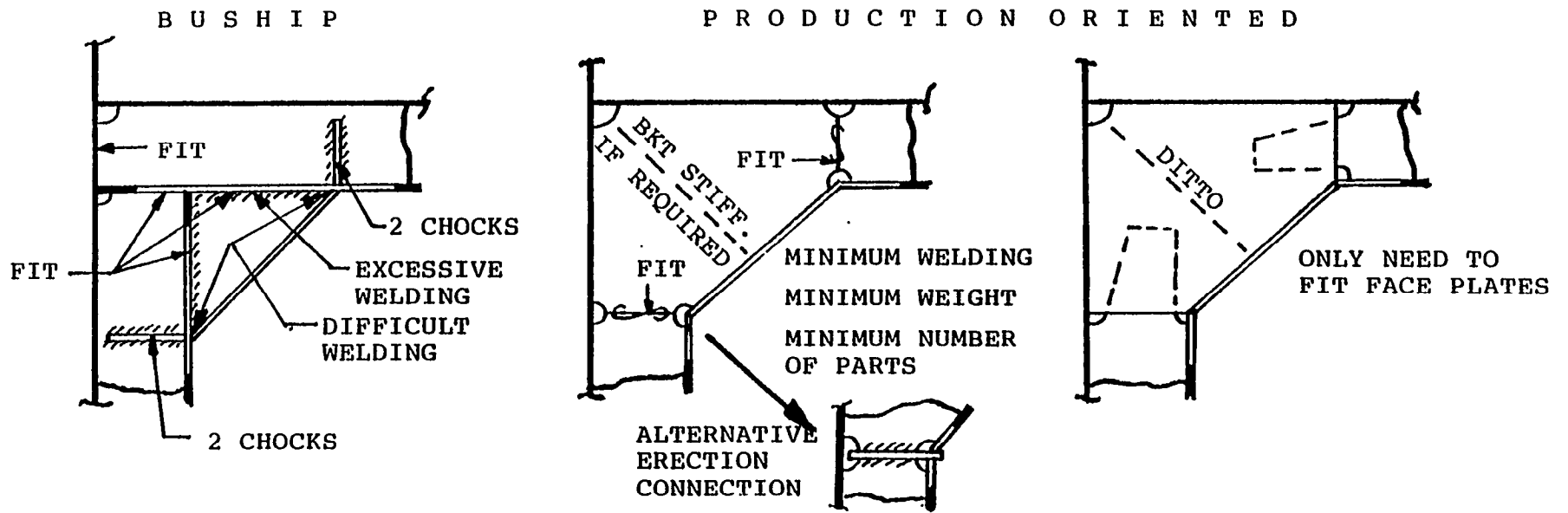

[A] - BEAM/FRAME DETAIL

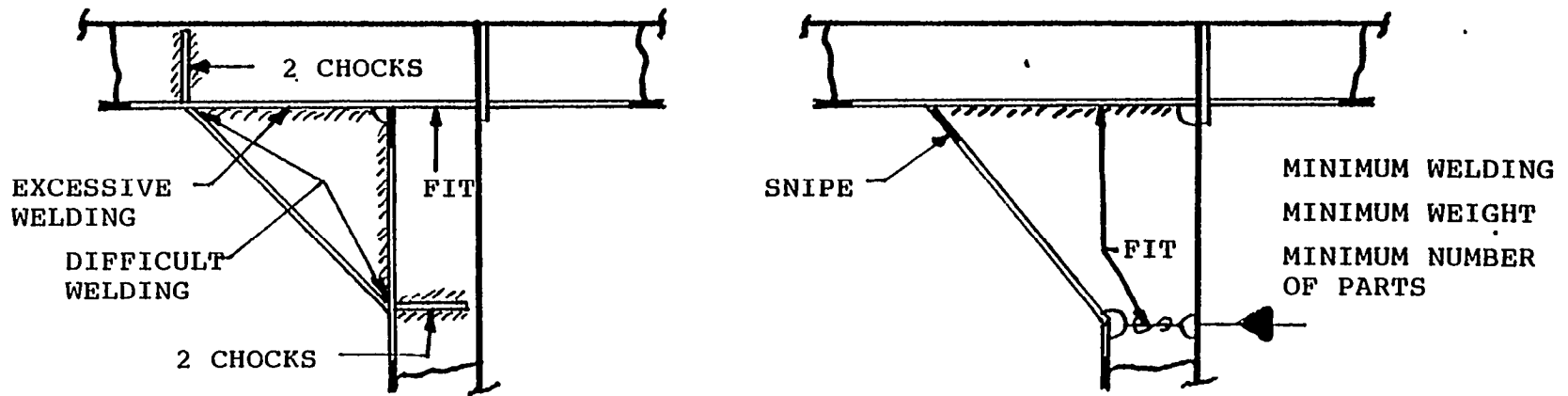

[B] - LONGITUDINAL/STIFFENER DETAIL

FIGURE 1.66 Bracket detail for tee beams/longitudinals/frames/stiffeners.

TRADITIONAL

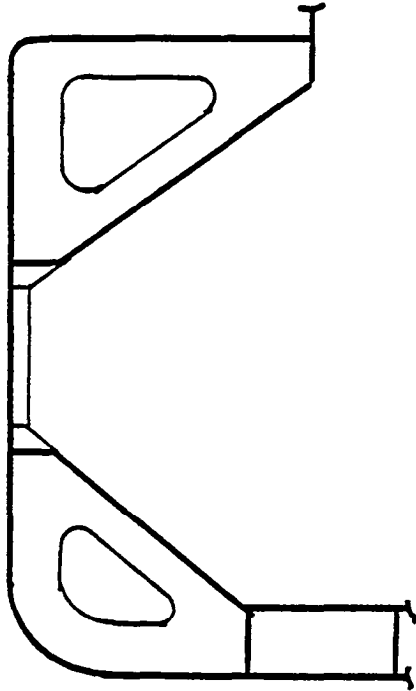

PRODUCTION ORIENTED

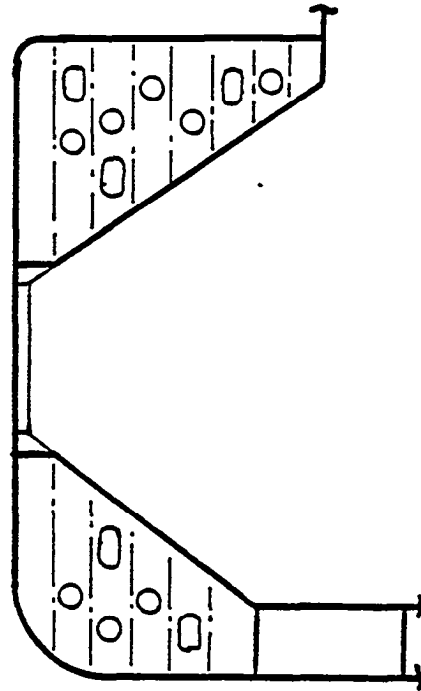

BULK CARRIER WEB FRAME

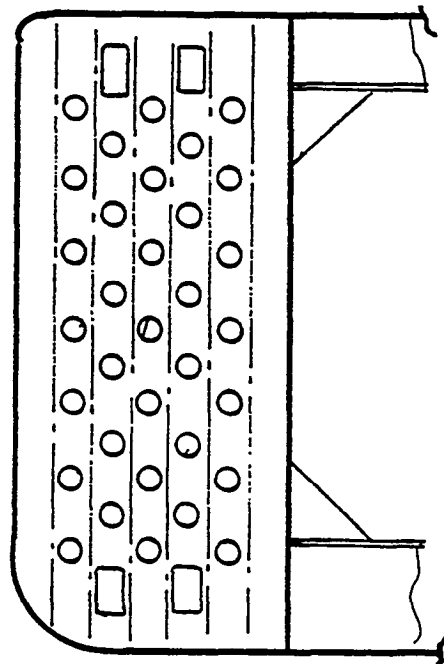
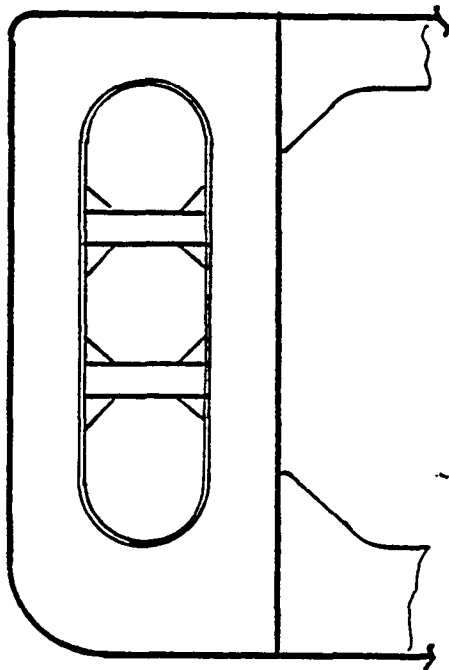

TANKER WEB FRAME

FIGURE 1.66 Web frame alternatives.

taken into account. Where ring web frames must be used, they should be simple in design, without any curved inner contours or shaped face plates. All the inner contours and face plates should be straight. Also the face plates should be located on one side of the web and not centered or even offset as a “tee.” These concepts are shown in Figure 1.67.

(e) Access. The location of access holes through the structure is important from the productivity point of view and must be considered for all positions of the assembly or module during construction, and not only for the final ship attitude as illustrated in Figure 1.68. It is a noticeable practice of many designers to center access holes in floor, girders, webs, etc., making them difficult to use. It is also puzzling why designers persist in using 23-inch by 15-inch-oval and 18-inch-diameter access holes. This is a carryover of U.S. admeasurement requirements that are only applied today to small ships that are pushing to get under the 200 or 300 gross registered tonnage. USCG admeasurement staff are not so concerned with access openings in large ships, and with the new international tonnage regulations now in force, there is no size limit for access holes.

During construction and for maintaining the ship in setice, staging is required in deep tanks and under flats and decks. This can be effectively provided by integrating the requirements into the design as permanent features. For example, for staging, 3-inch-diameter holes can be cut in floors, girders, web frames, deck transverses, etc., through which 2.5-inch-diameter staging pipe can be placed and staging planks laid across the pipes. This concept is shown in Figure 1.69, which also shows the cutting of hand and toe holes in the structure to assist access throughout the ship. These staging and access holes can be efficiently cut by the automatic burning machine when cutting the plate. Another approach to improve access is to design “built-in” construction and access galleries as shown in Figure 1.70.

(f) Penetrations. One area of significant work content faced by shipbuilders of naval and other sophisticated ships is the cutting of penetration holes for pipe, vent duct, and electric cable. This must obviously be done for systems when passing through bulkheads, decks, and external boundaries, but it is usual practice to see it also for deck transverses, girders, and web frames. The need to penetrate the latter items should either be eliminated or made easy to accomplish. It can be eliminated by the design of minimum depth members to allow running all systems below or inboard of the member. Conversely, if the tween-deck height is increased, the same goal can be achieved with normal depth members. Obviously, a combination of both may prove to be the best. It can also be accomplished by designing “open” structural members through which the systems can easily pass. That is, the depth of the member can be deliberately increased, and the web material cut away to allow access for system routing. Figure 1.71 illustrates this concept.

(g) Scantling Standardization/Number Reduction. In a recent contract design for a small 224-foot naval service ship, the design agent utilized 12 different thicknesses of plate and 51 different shapes. Although one of the worst examples ever seen, it is quite common for designs to be prepared without any regard to keeping size differences to a minimum. An example of what can be done in this area is the case of a shipowner’s contract design which had 30 different shapes. The shipyard reduced these to nine during detail design, with less than 1% increase in steel weight. However, the manhour savings resulting from the easier receiving, storing, handling, processing, and installing was 6% of the steel construction budget.

(h) Bilge Framing. In a longitudinally framed ship the longitudinals in way of the bilge radius are of high work content due to their shaping, twisting, closing angles, and cut-out chocking. The use of bilge brackets in place of the longitudinals is a productivity-improving alternative as shown in Figure 1.72. Obviously, with

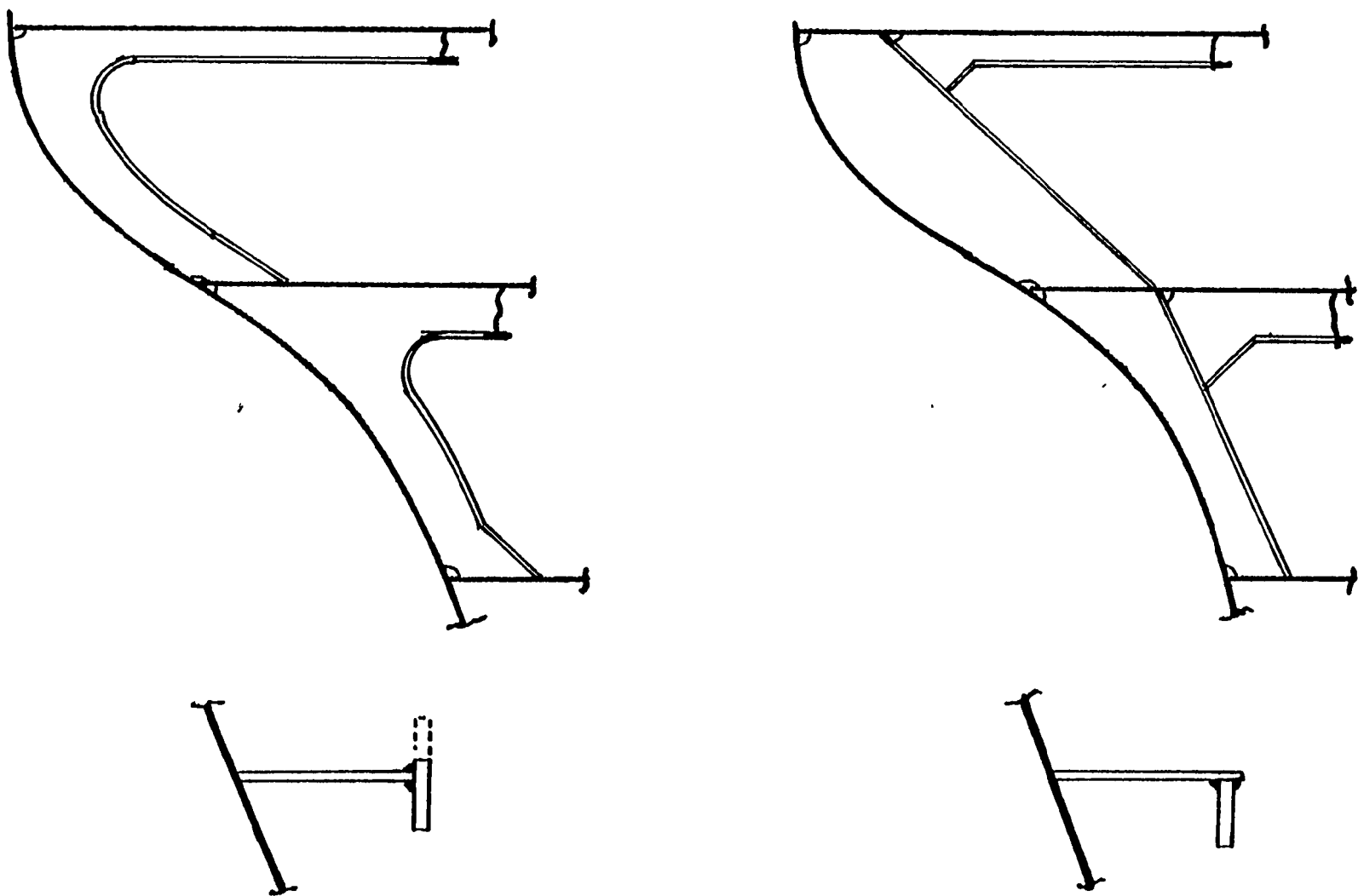
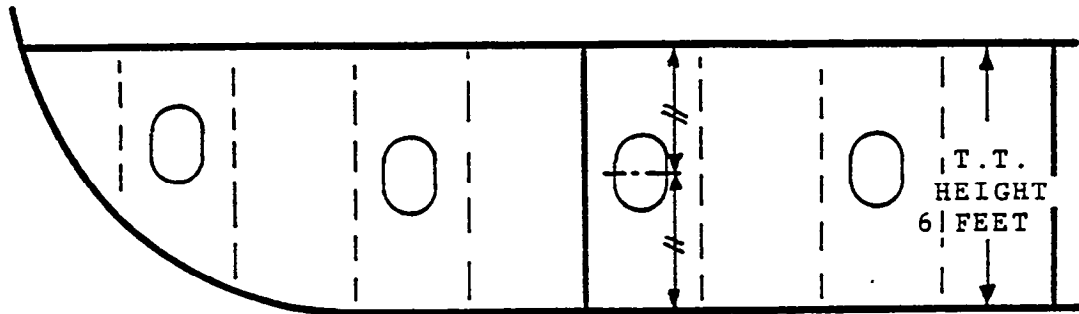
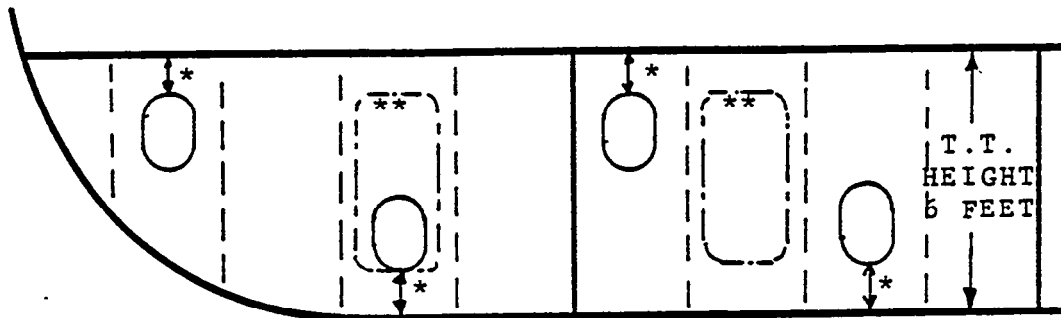

FIGURE 1.67 Web frame design for productivity.



CENTERED ACCESS HOLES - DIFFICULT ACCESS



ACCESS HOLES LOCATED FOR EASY ACCESS

- * HEIGHT FOR EASY ACCESS WHEN CONSTRUCTING MODULE BOTH UPSIDE DOWN AND FINAL ATTITUDE
- ** CONCEPT OF USING ACCESS HOLES AS LARGE AS STRUCTURALLY POSSIBLE INSTEAD OF TRADITIONAL 23 x 15 INCH TONNAGE DICTATED TYPE

FIGURE 1.68 Location of access holes in structure.

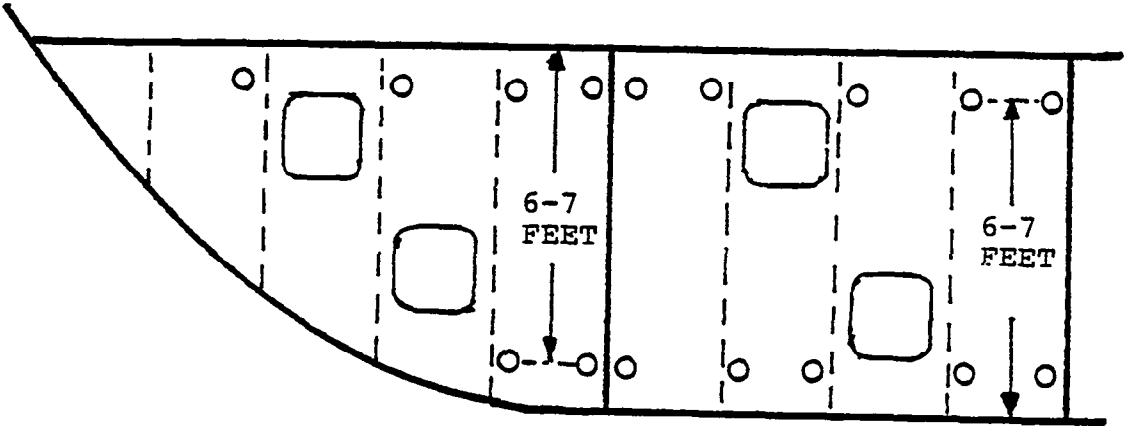

STAGING PIPE HOLES IN DOUBLE BOTTOM FLOORS

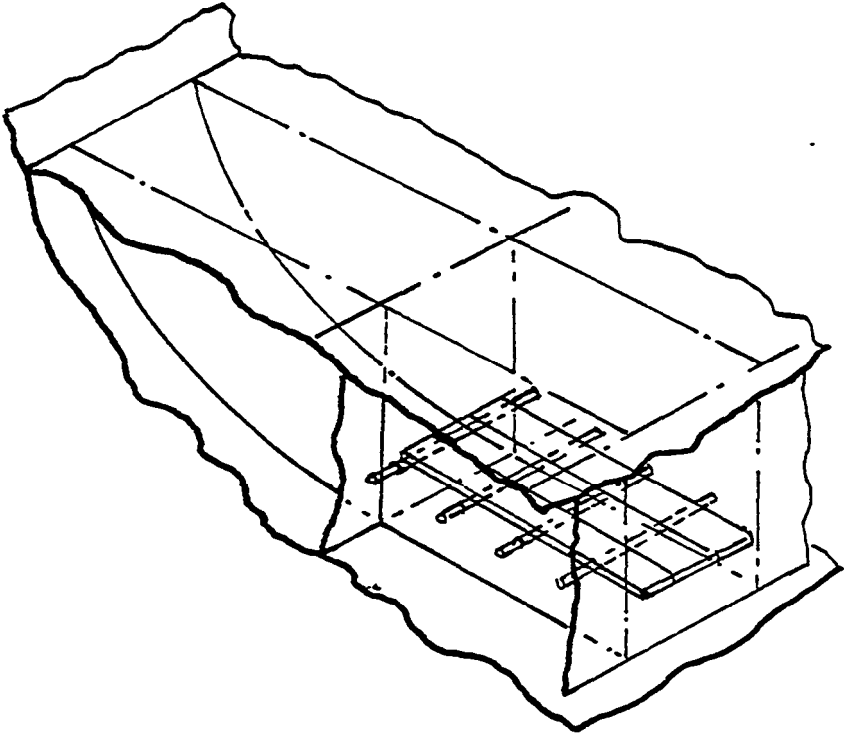

FIGURE 1.69(a) Built-in staging aids in D.B.

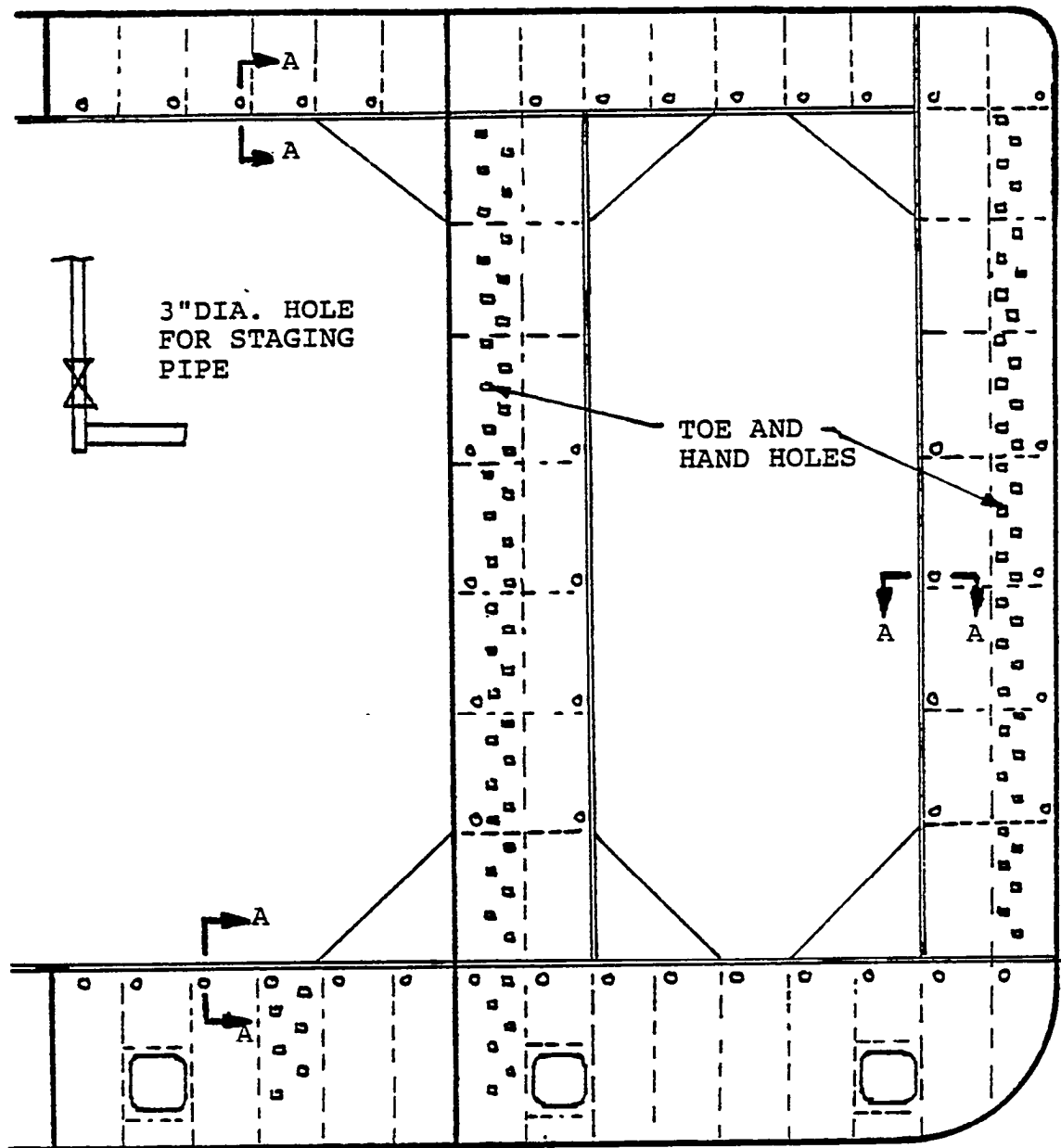

FIGURE I 1.69(b) Pennant "built-in" aids for access.

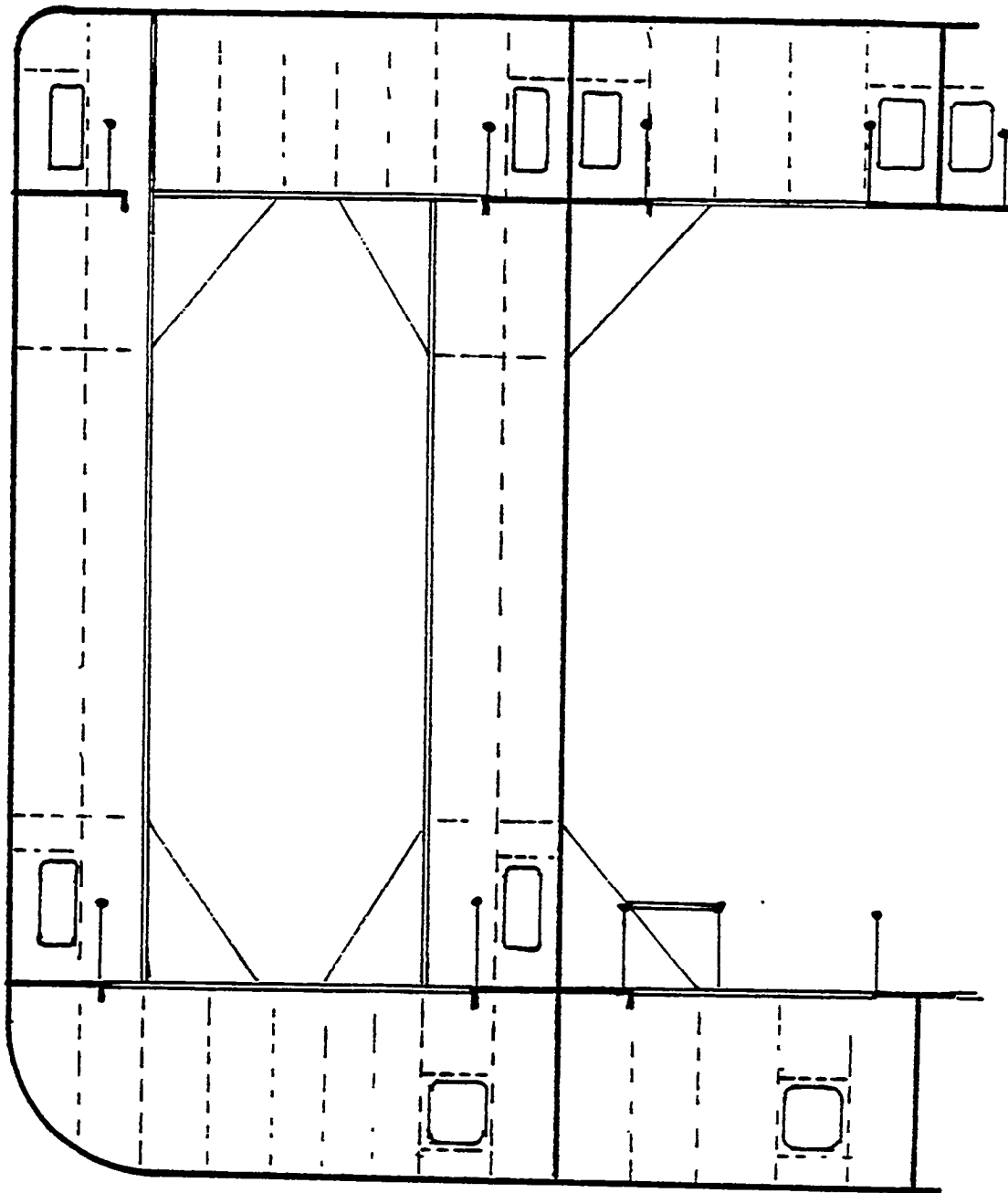
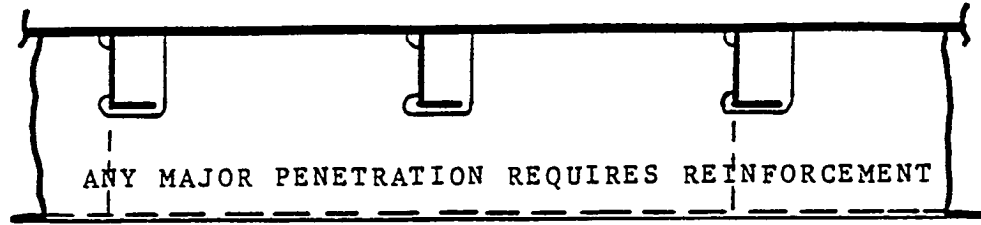
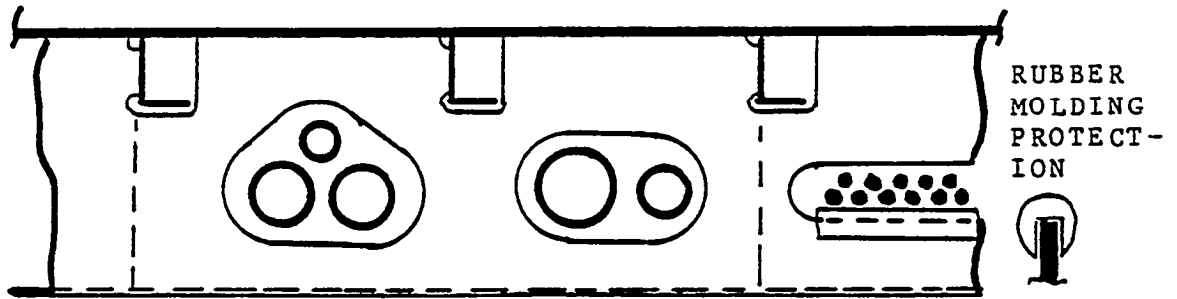

FIGURE 1.70 Tanker with "built-in" access galleries.



(A) TRADITIONAL DECK TRANSVERSE/GIRDER



(B) DEEPER DESIGN WITH TYPICAL STANDARD CUTS

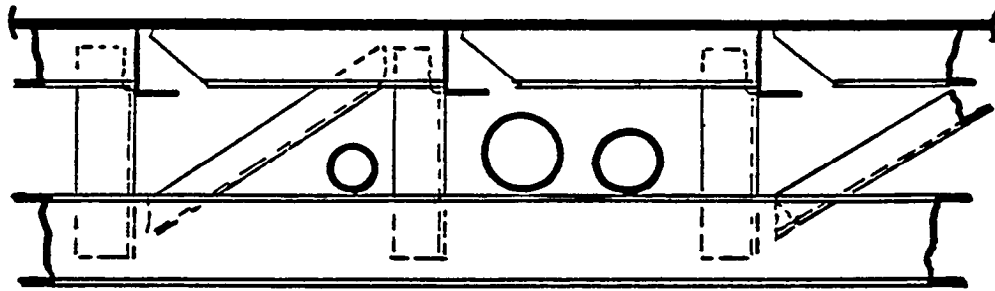

(C) BUILT UP ALTERNATIVE FROM SECTIONS

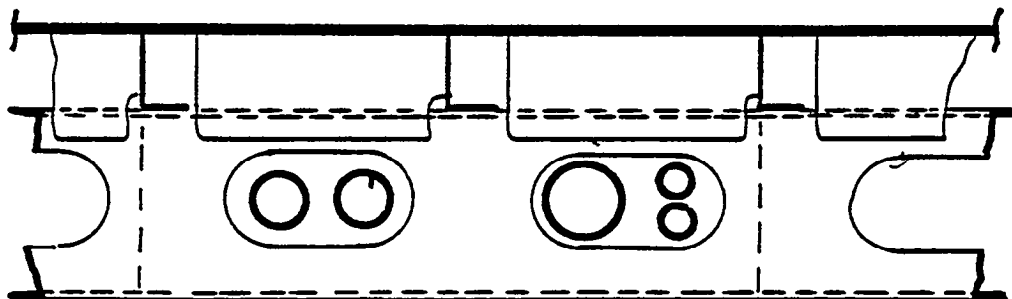

(D) BUILT UP ALTERNATIVE FROM PLATE

FIGURE 1.71 Deck transverse/girder design to eliminate field cut penetrations and reinforcement.

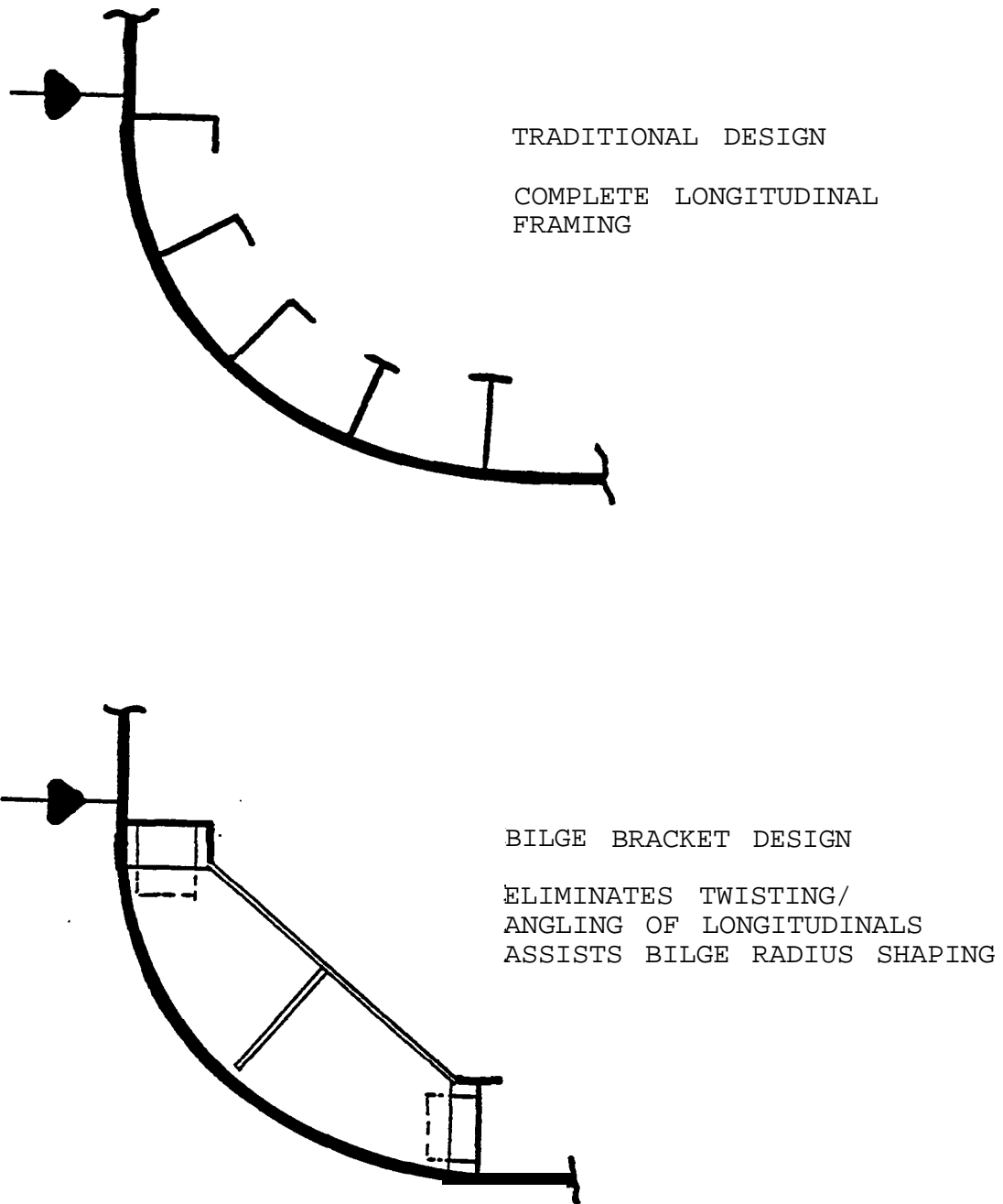

FIGURE 1.72 Bilge framing alternatives.

computer-aided lofting and N/C burning, the bilge brackets are easily produced. This approach also provides simpler and better control of the shape of the bilge shell plates.

(i) Plate Straking. In conjunction with transverse framing it is cost effective in some shipyards to adopt transverse straking of the bottom and side shell, tank tops, flats, and decks. This item was already discussed in conjunction with module boundaries where the advantage of the approach was stated to be its suitability for panel line fabrication. It has been shown to also reduce the joint weld length for the plating. This concept is illustrated in Figure 1.73.

(j) Corrugated, Swedged, and Custom-Stiffened Panels. The meaning of the various types of stiffening for structural panels can be seen in Figure 1.74. Corrugated bulkheads were extensively used in tankers and bulk carriers in the early 60s. They lost some of their attractiveness in tankers due to corrosion problems at the "work hardened" bends. With today's available tank coatings and segregated ballast tankers, this disadvantage has been eliminated, and the use of corrugated bulkheads in tankers is becoming popular once more. The obvious advantage of corrugated stiffened panels is the elimination of independent stiffeners and the accompanying welding. Where the length of corrugation is such that butts are necessary, the "layer" or "through plate" construction method as shown in Figure 1.75 is a way to reduce work content, especially if combined with a stringer. Many shipyards do not utilize corrugated bulkheads because they do not have the required forming capability. This can be overcome by subcontracting the forming work or by utilizing "built-up" corrugations as shown in Figure 1.76. Corrugated bulkheads provide many side cost reduction and operation benefits such as "natural" access trunks with built-in ladders and trunks for pipes, etc.

Swedges have been used to stiffen miscellaneous "non-structural" steel bulkheads for many years: Their initial use was for internal bulkheads around toilets, staterooms, storerooms, etc. They were first approved by Lloyds, and used on the vessel *Ocean Transport* for structural tween-deck bulkheads in 1959. A major benefit in the use of swedges is the elimination of plate distortion due to the welding of stiffeners to the plate. This is especially important for very light material. In addition to bulkheads, swedging has been used to stiffen deckhouse fronts, sides, and ends. There is no reason why swedged or small corrugated stiffened panels could not be used for decks. For long decks the swedges would run longitudinally. For short decks, such as those in deckhouses, the swedges could run transversely. The already-mentioned use of swedges for deckhouse exterior boundaries is also a good productivity improvement, and should be considered. The aesthetics of such a practice is quite acceptable to most shipowners.

The use of specially designed "custom" panels can also be a work content reduction approach. It is particularly worthwhile for very thin panels and special materials. In such a case the manufacturing tolerances must be tight, and the quality control consistently applied

Obviously, before utilizing any of the structural details discussed above, a complete producibility/cost benefit analysis should be performed by each shipyard to ensure that the selected detail is the best for their particular facility, equipment, and methods.

1.5.4 STRUCTURAL FITTINGS. It is usual to group certain items which are either integrated into the structure, such as stem and stem frames, or connected to it, such as bits, chocks, steel hatch covers, manholes, ladders and structural doors, into a category which is commonly known as structural Fittings. Foundations are sometimes included in this group. Many of the items in this group were castings in the past, and have been replaced by weldments such as bits, stems, and stem frames.

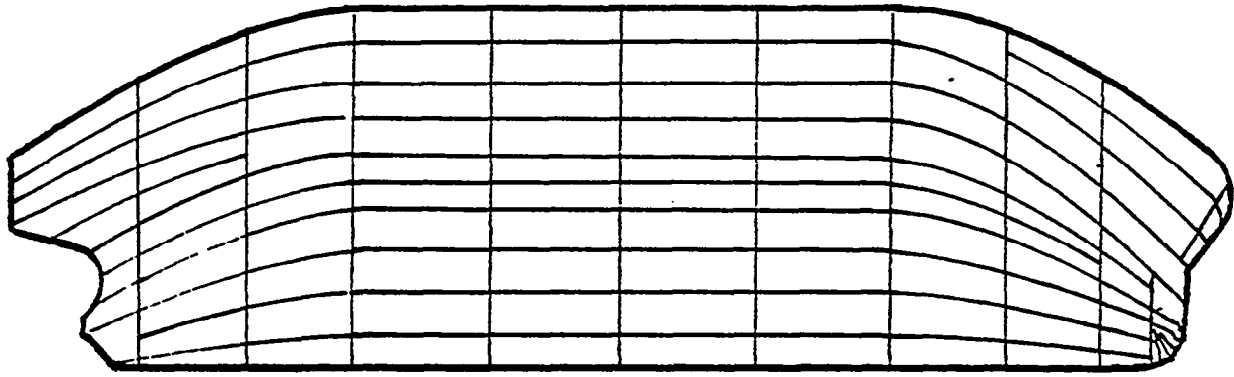

TRADITIONALLY STRAKED SHELL

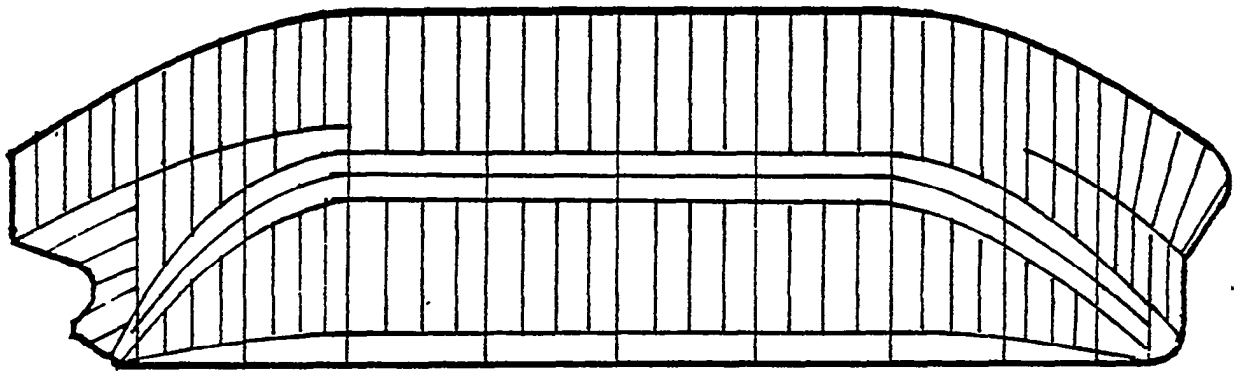

VERTICALLY STRAKED SHELL

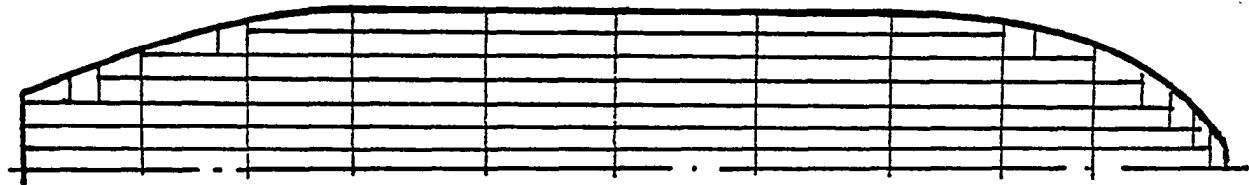

TRADITIONALLY STRAKED DECK

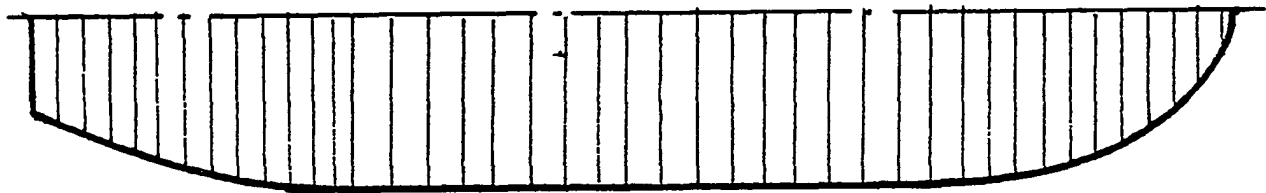

TRANSVERSELY STRAKED DECK

FIGURE 1.73 Plate straking for productivity.

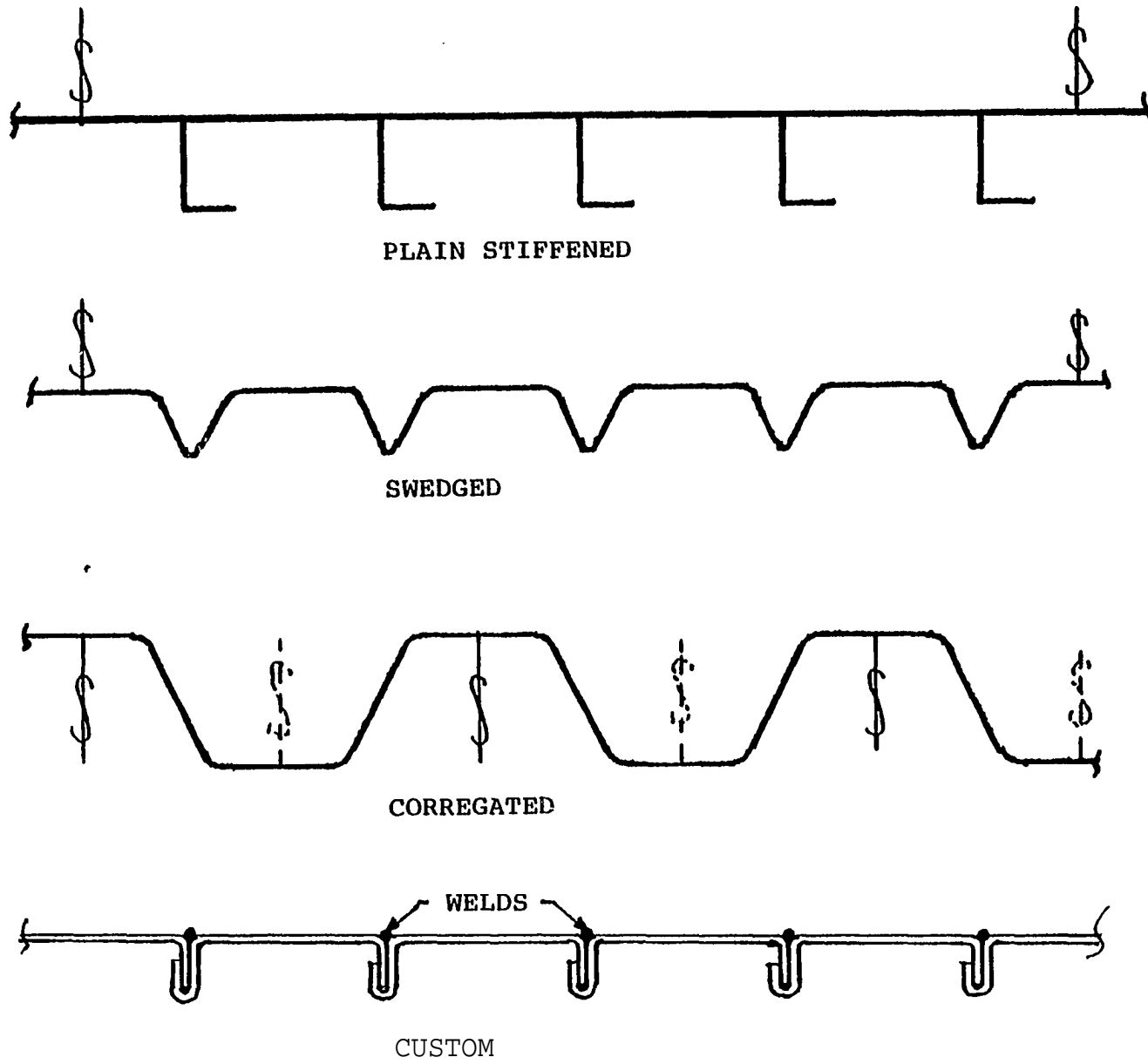

FIGURE 1.74 Alternative panel stiffening systems.

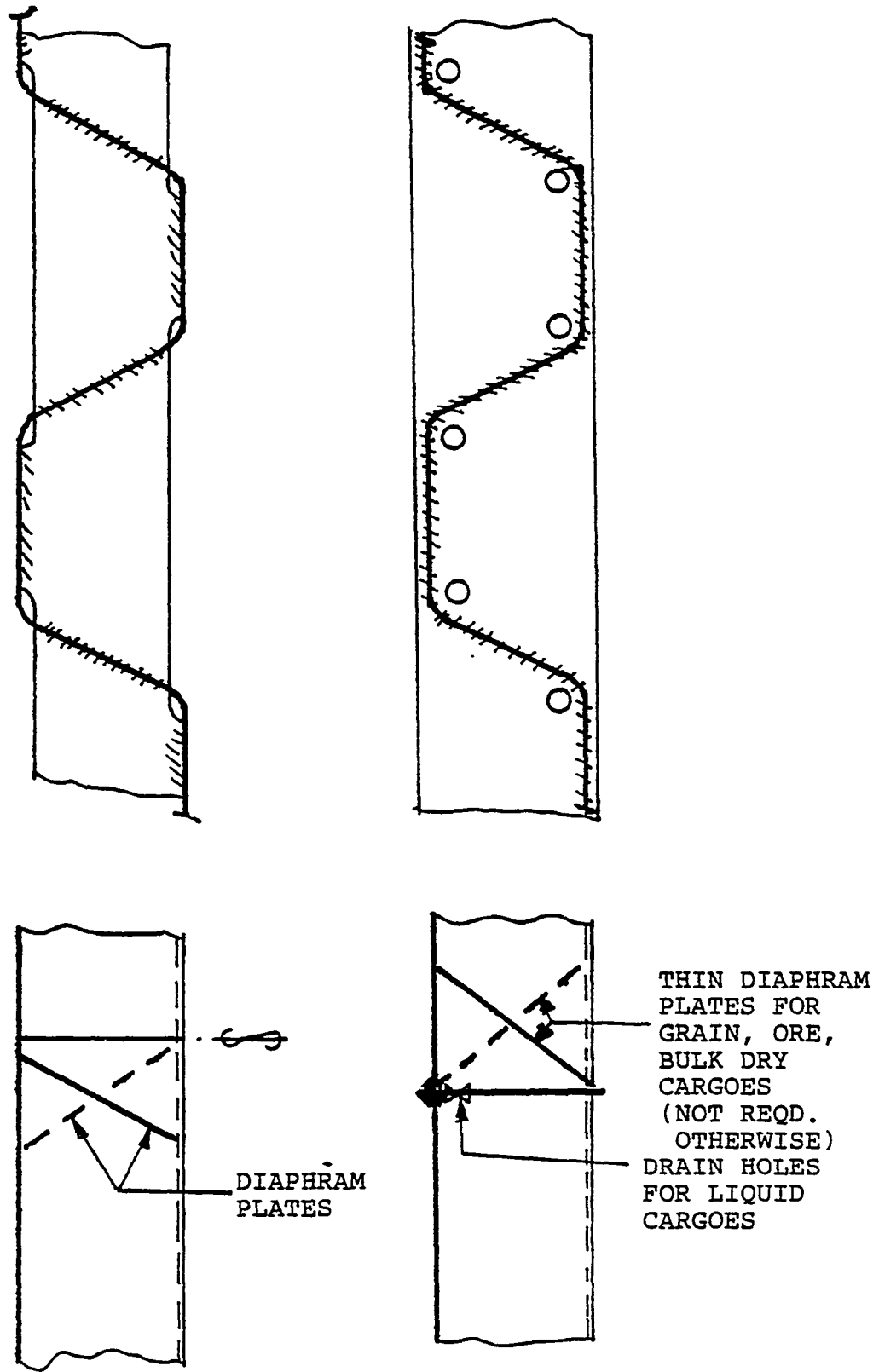

FIGURE 1.75 Corrugated panel details.

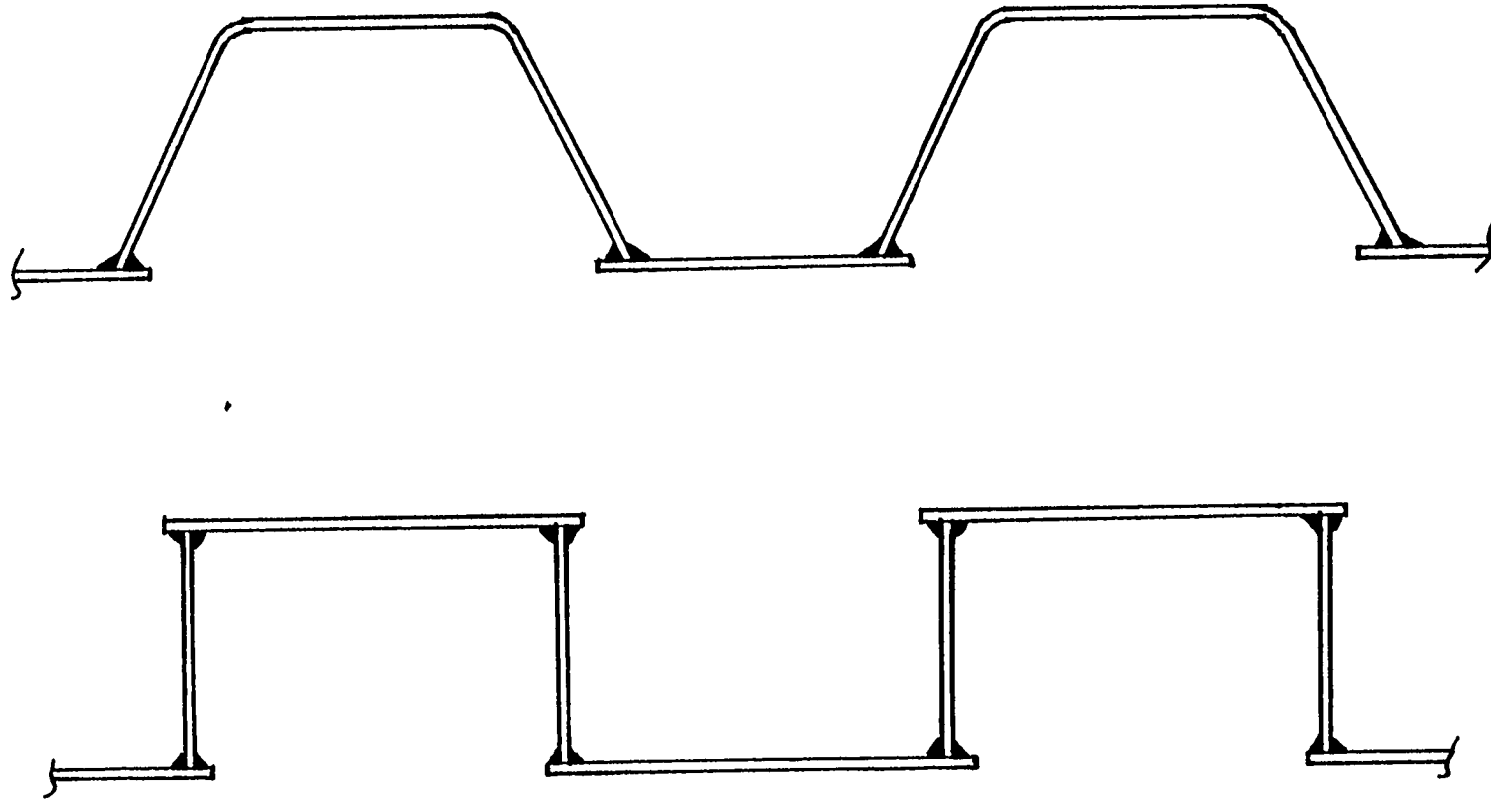

FIGURE 1.76 Built-up corrugated panels.

There is considerable opportunity to apply design-for-production techniques to structural fittings. For example, when stern frames were first designed to replace castings, they were still designed as an independent item from the rest of the stern structure, and this is still being done as can be seen in Figure 1.77. With modular construction there is no logic for this, and the stern frame should be integrated into the stem lower module. This was already discussed in Section 1.3.3(c). The work content would be significantly reduced, as the stem frame is effectively eliminated as a separate work item. The replacement of the stem casting by a weldment was already discussed in Section 1.3.3(g), but it obviously requires the cooperation of the developer of the lines to be able to do so. Typical approaches to simplifying stem details were given in Figure 1.18.

The traditional design of rudders results in high work content which can be reduced by simplifying the design through the following approaches:

- Constant section throughout the depth
- Vertical leading and trailing edges
- Spade rudder instead of rudder on horn or with sole piece
- **Horizontal bolting coupling instead of taper with nut**

These concepts are shown in Figure 1.78.

Foundations for marine equipment are traditionally pedestal type, made out of plate. They usually support only one piece of equipment. Even before advanced outfitting was developed, it was an obvious productivity advantage to integrate the foundations for multiple associated equipment, as shown in Figure 1.79. The unitization, as it was called, of steering gears, hydraulic power plants, inert gas systems, and purifier installations has been commonplace for decades. The grouping of small items into a mounting plate which was then installed on the ship was also commonplace. The use of standard foundations is obviously worthwhile, due to reducing engineering and lofting effort, and production manhours due to multiple runs and work familiarization. Foundation design for production depends on shipyard equipment and worker capability, but in general the following approaches have provided least work content design:

- (a) **Minimize number of parts.**
- (b) Minimize number of unique parts.
- (c) Do not mix plate and shapes. That is, make a specific foundation either all plate or all shapes.
- (d) Standardize on a few structural shapes such as angle, channel, or square tube.
- (e) Run support Vertical.
- (f) Provide required “structural back-up” on same side of structure as the foundation. That is, integrate it with the foundation.
- (g) Eliminate fitting joints. Maximize lapping design.
- (h) Use sheet metal independent drip pans in lieu of built in.
- (i) Foundation designer and equipment arranger should work together during design of foundation. Sometimes moving the equipment a few inches can significantly simplify the foundation design and construction with no adverse impact on arrangement.
- (j) Securing bolts must be easily accessible. Otherwise provide
Studs.

Some of these concepts are shown in Figure 1.80.

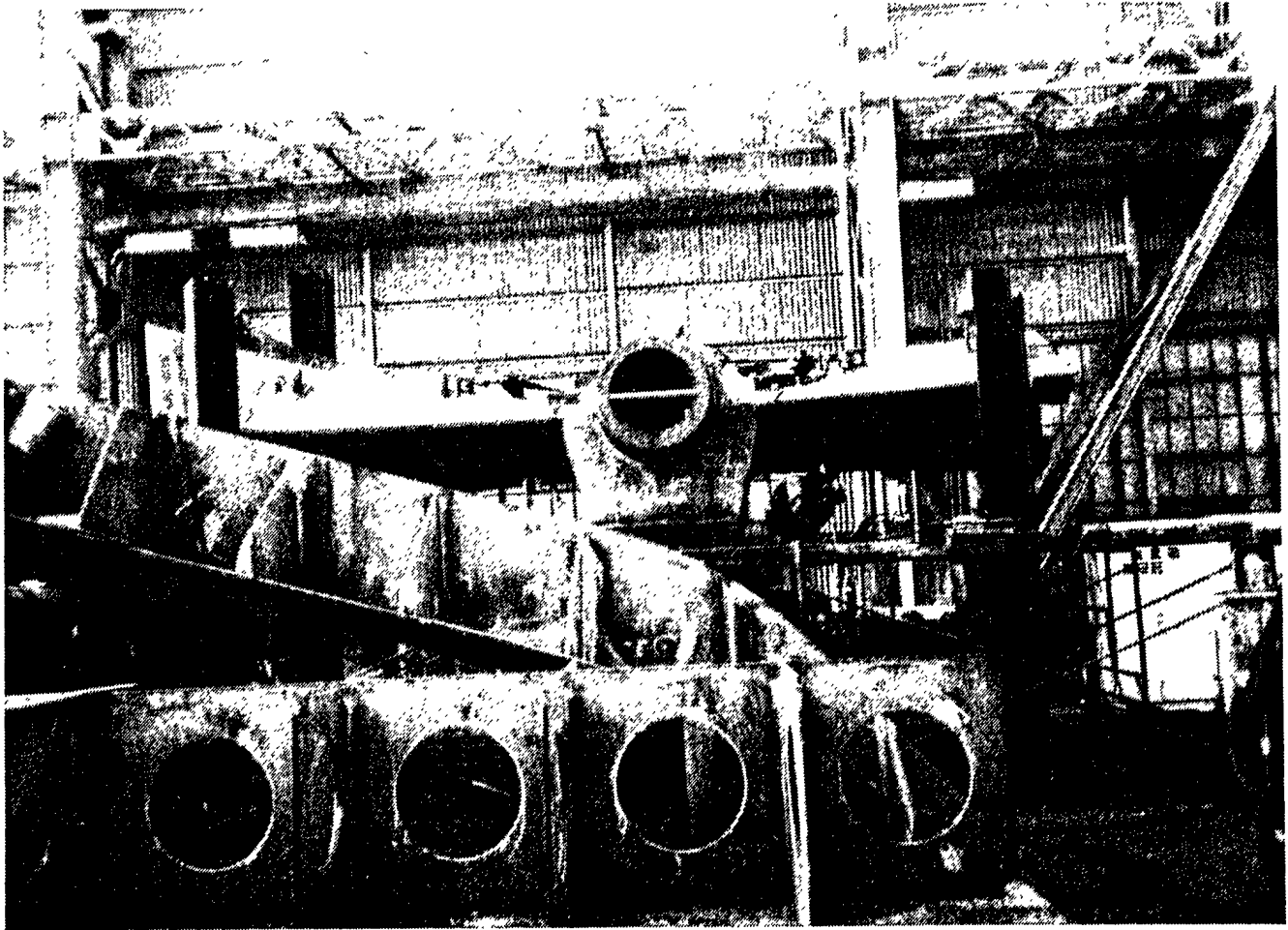
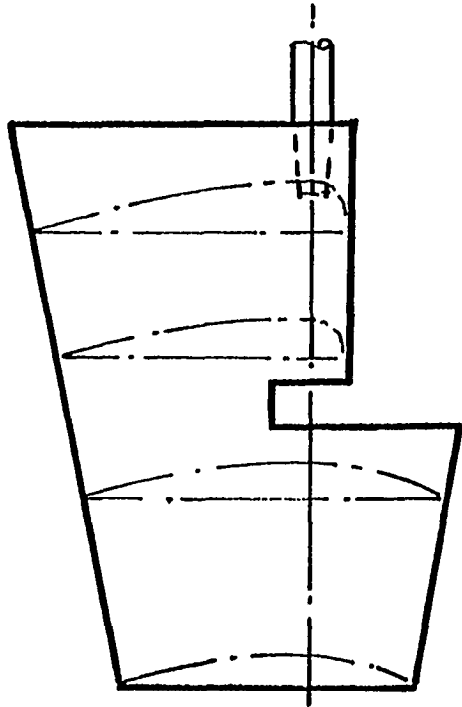
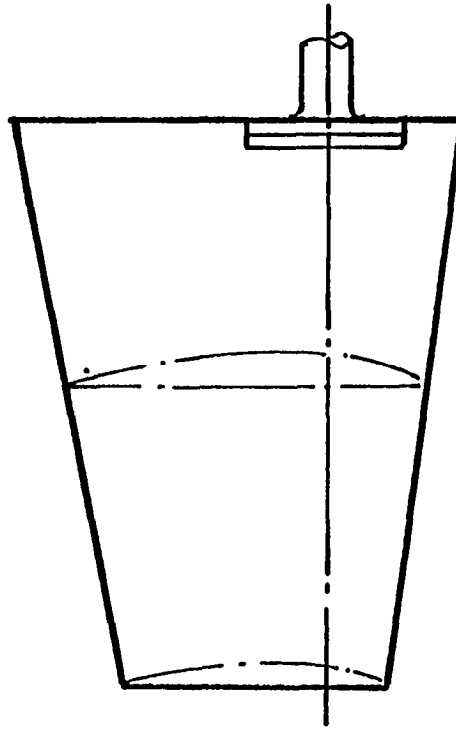

FIGURE 1.77 Fabricated stern frame.



TRADITIONAL, RUDDER
ON HORN



TRADITIONAL SPADE
RUDDER

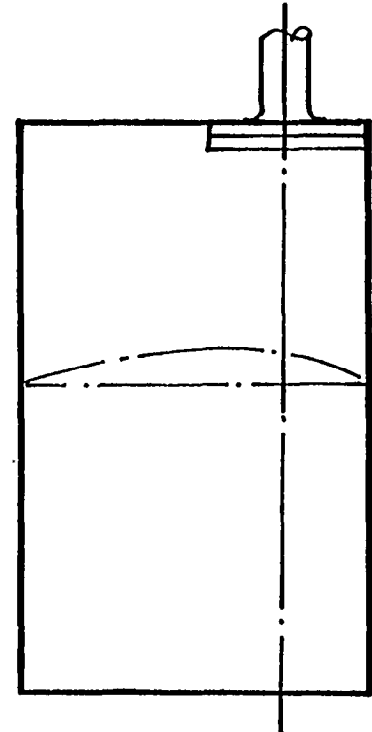

PRODUCTION-ORIENTED
RUDDER DESIGN

FIGURE 1.78 Rudder design for productivity.

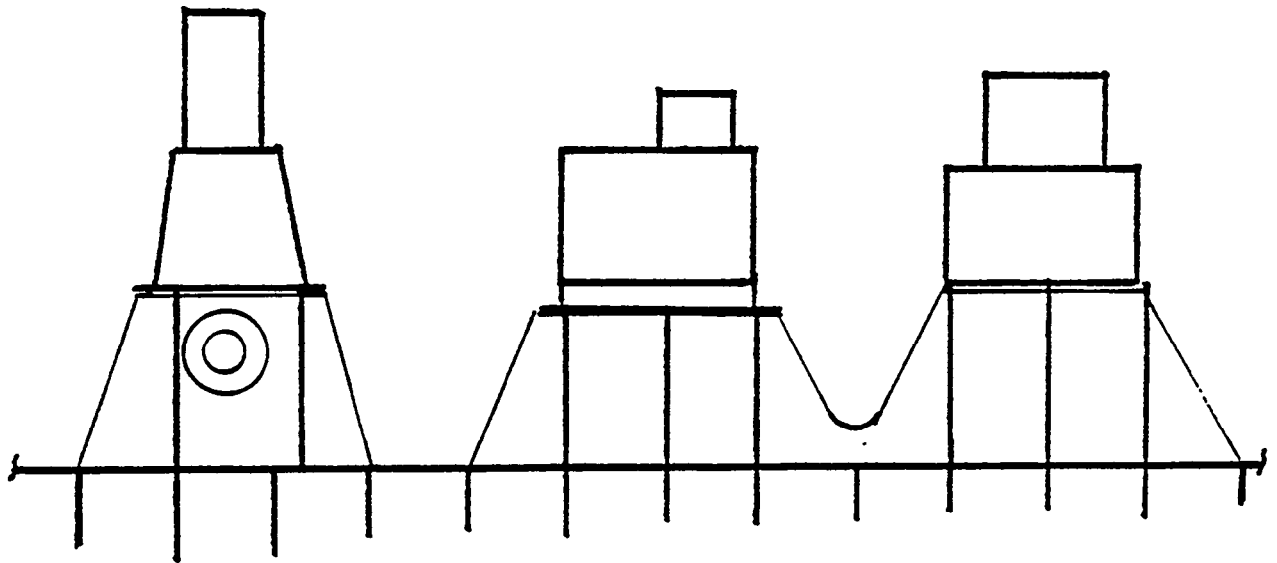

INDIVIDUAL FOUNDATIONS

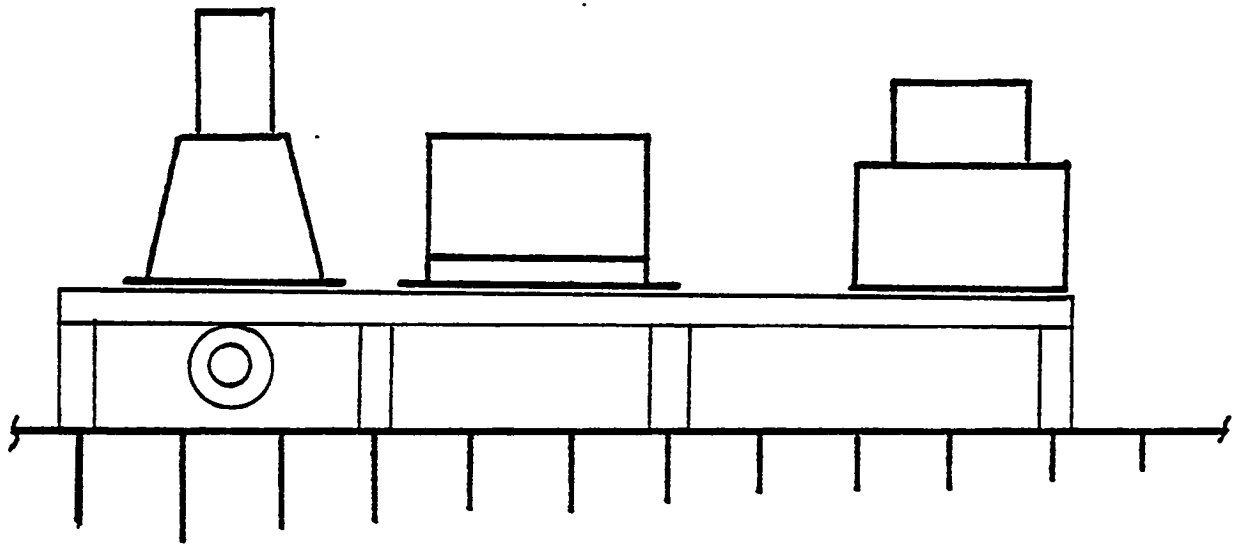

UNITIZED EQUIPMENT ON A COMMON BASE

FIGURE 1.79 Foundation design for productivity.

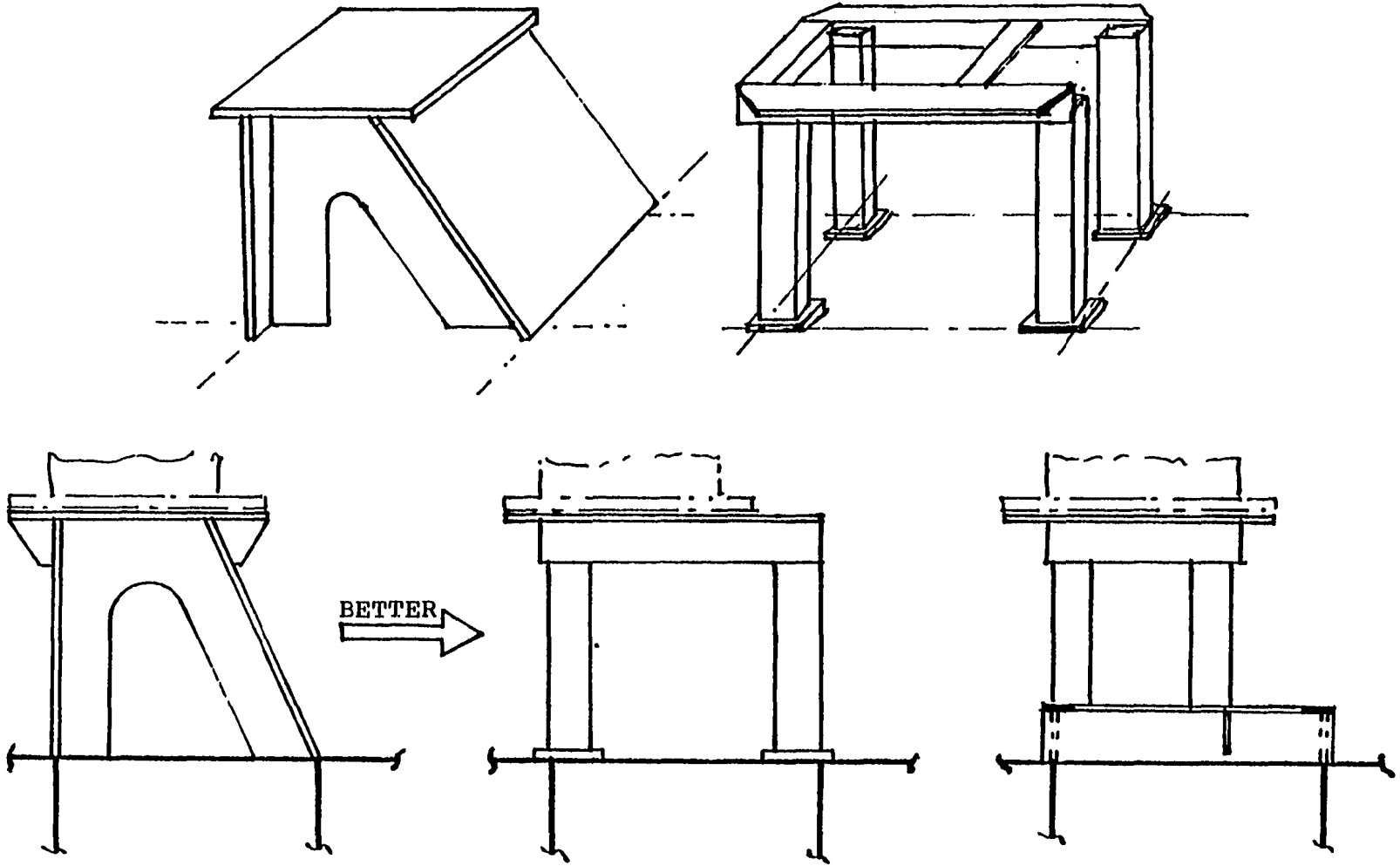

FIGURE 1.80 Foundation design for productivity.

For the remaining structural fittings, the use of standards is an essential design-for-production approach. It is illogical to redesign, and/or redraw items such as hatch covers, railings, structural doors, ladders, flat and ensign staffs, etc., for each new contract. Figures 1.81 through 1.88 show various possible standard structural fittings.

One item that is surprising in its lack of standardization in many shipyards is manholes and their covers. For some reason the cover and gasket for the coaming, raised, and flush types are made with different dimensions. There is no reason why the covers should not be the same, with only the different parts for each type being designed to suit. This is shown in Figure 1.81. Figure 1.82 shows an approach to standard railing. These can be constructed by small outside job shops, resulting in significant cost savings. It is possible to construct them out of Fiberglas instead of steel (or aluminum), again with resulting cost savings. The installation information would simply state how many standard railing units would be in&&d and their location; and required special sections such as return-end rails. Special attachments for equipment such as life rings would also be a standard, such as shown in Figure 1.83. External hand rails for house sides is another simple standard, as shown in Figure 1.84. Flagstaffs can be handled by one standard with alternate fittings for use as an ensign staff. They can be made from steel, aluminum, or fiberglass pipe. Figure 1.85 shows such an approach. Figures 1.86, 1.87, and 1.88 are possible standards for ladder rungs, toe and hand holes, and eyebrows. The design of independent tanks is an area with significant potential for design-for-production benefit. Figure 1.89 shows typical designs, and suggested improvements.

Obviously not 311 of the possible structural fittings have been covered, but the intent should be clear from those that are.

PART 1

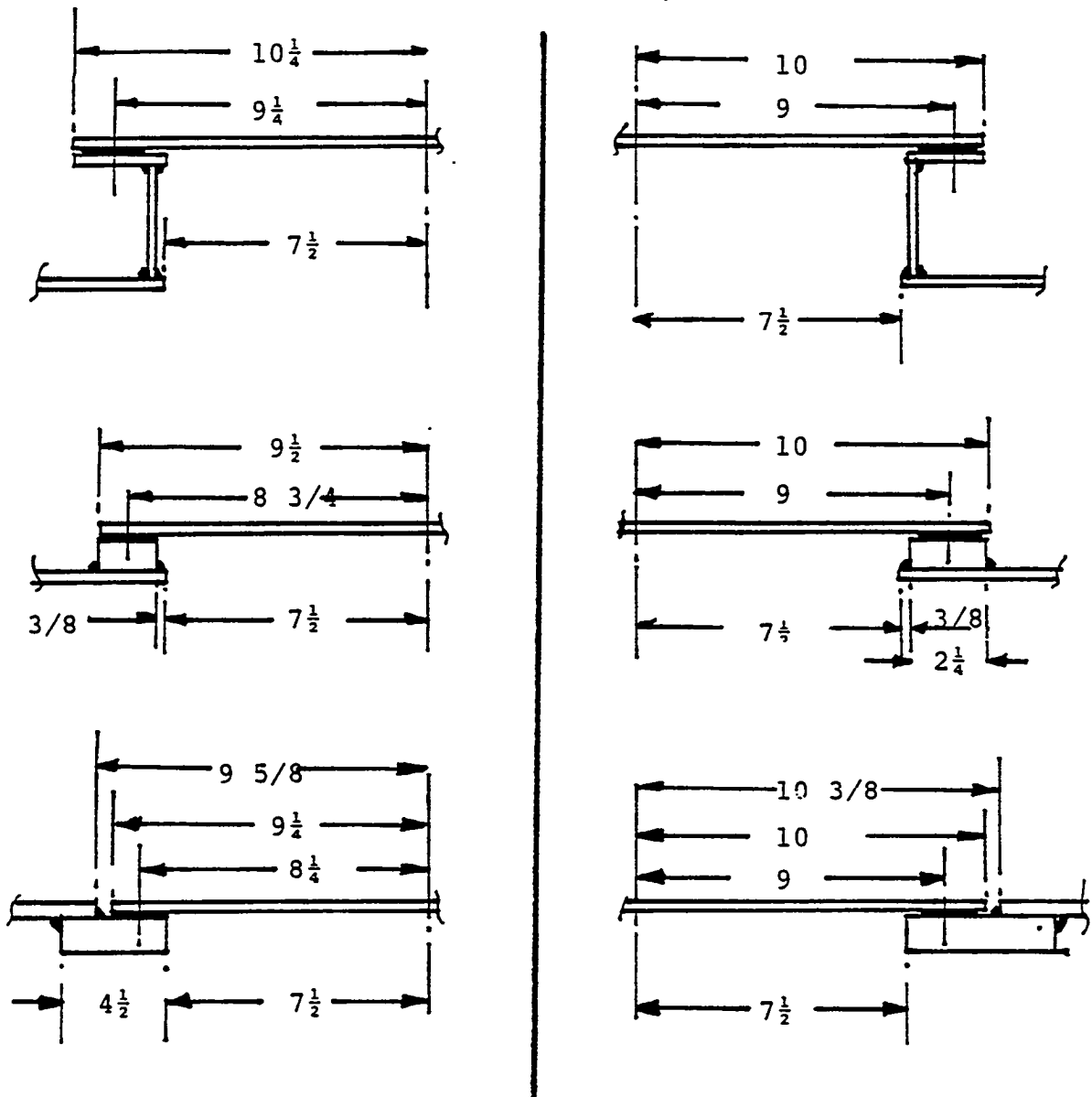

TRADITIONAL
COVERS DIFFERENT
GASKETS DIFFERENT

STANDARDIZED
COVERS SAME
GASKETS SAME

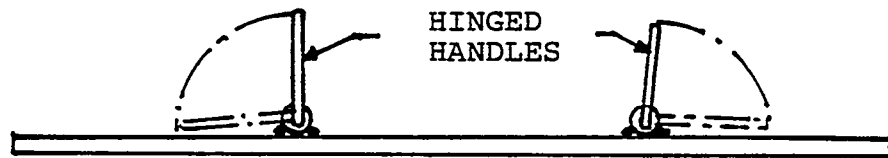

STANDARD MANHOLE COVERS

FIGURE 1.81 Standardizing manhole covers.

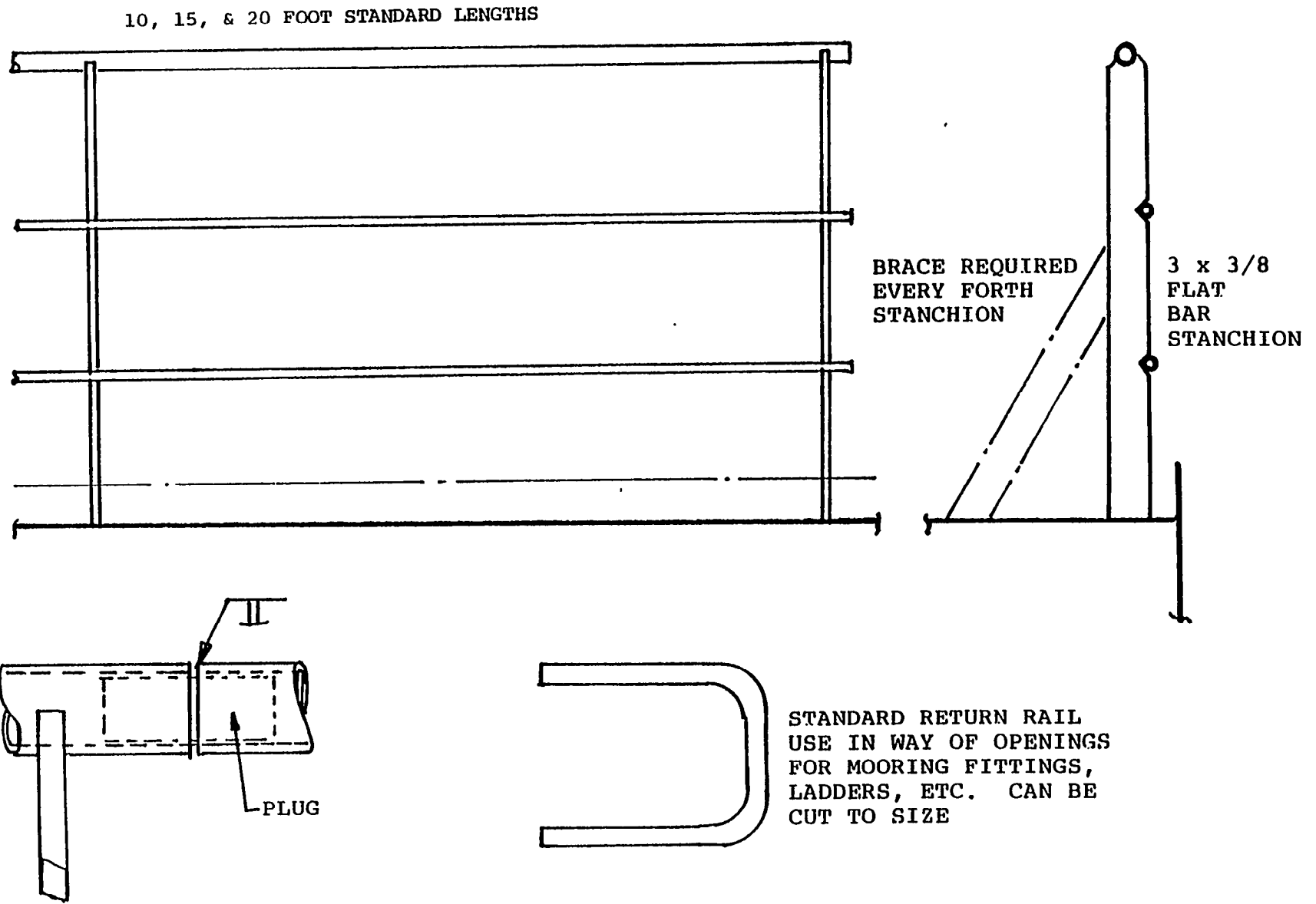
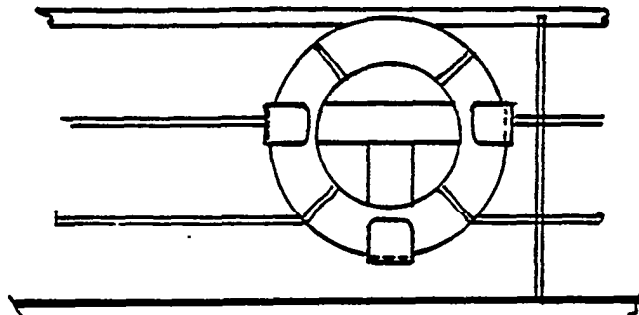
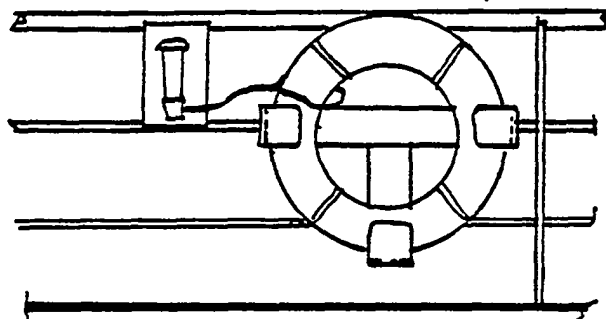

FIGURE 1.82 Standard exterior handrails.



STANDARD LIFEBOUY STOWAGE ON RAIL



STANDARD STOWAGE WITH LIGHT

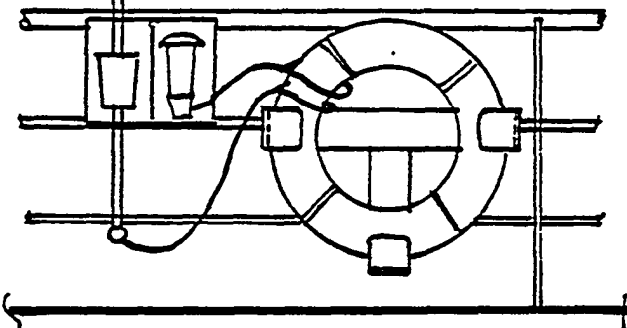

STANDARD STOWAGE WITH LIGHT AND FLAG BUOY

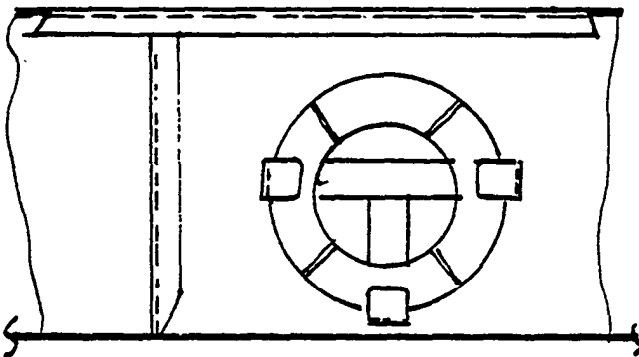

STANDARD LIFEBOUY STOWAGE ON BULWARK

FIGURE 1.83(a) Standard lifebuoy storage.

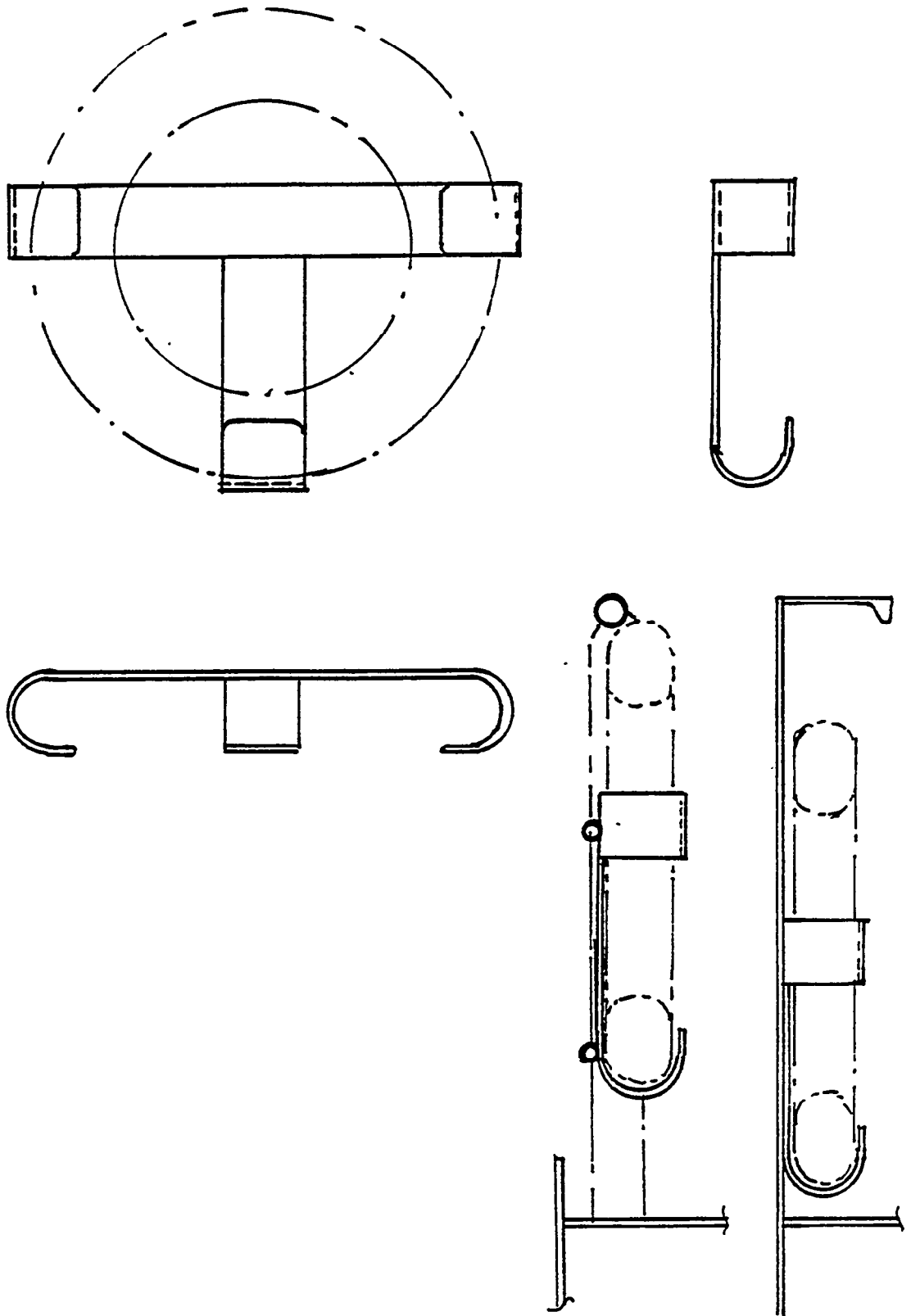

FIGURE 1.83(b) Details for standard lifebuoy stowage.

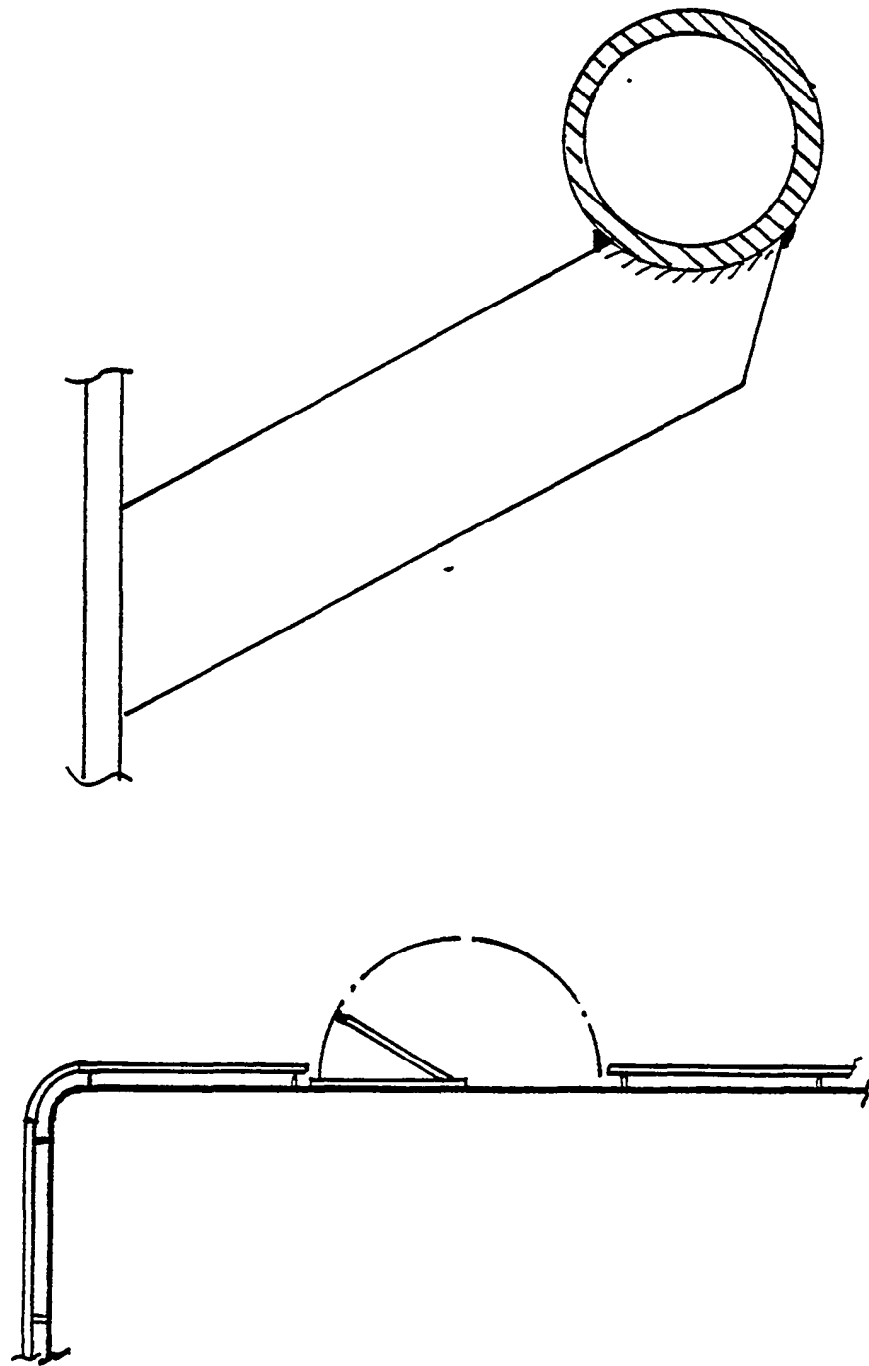

FIGURE 1.84 Standard handrail detail.

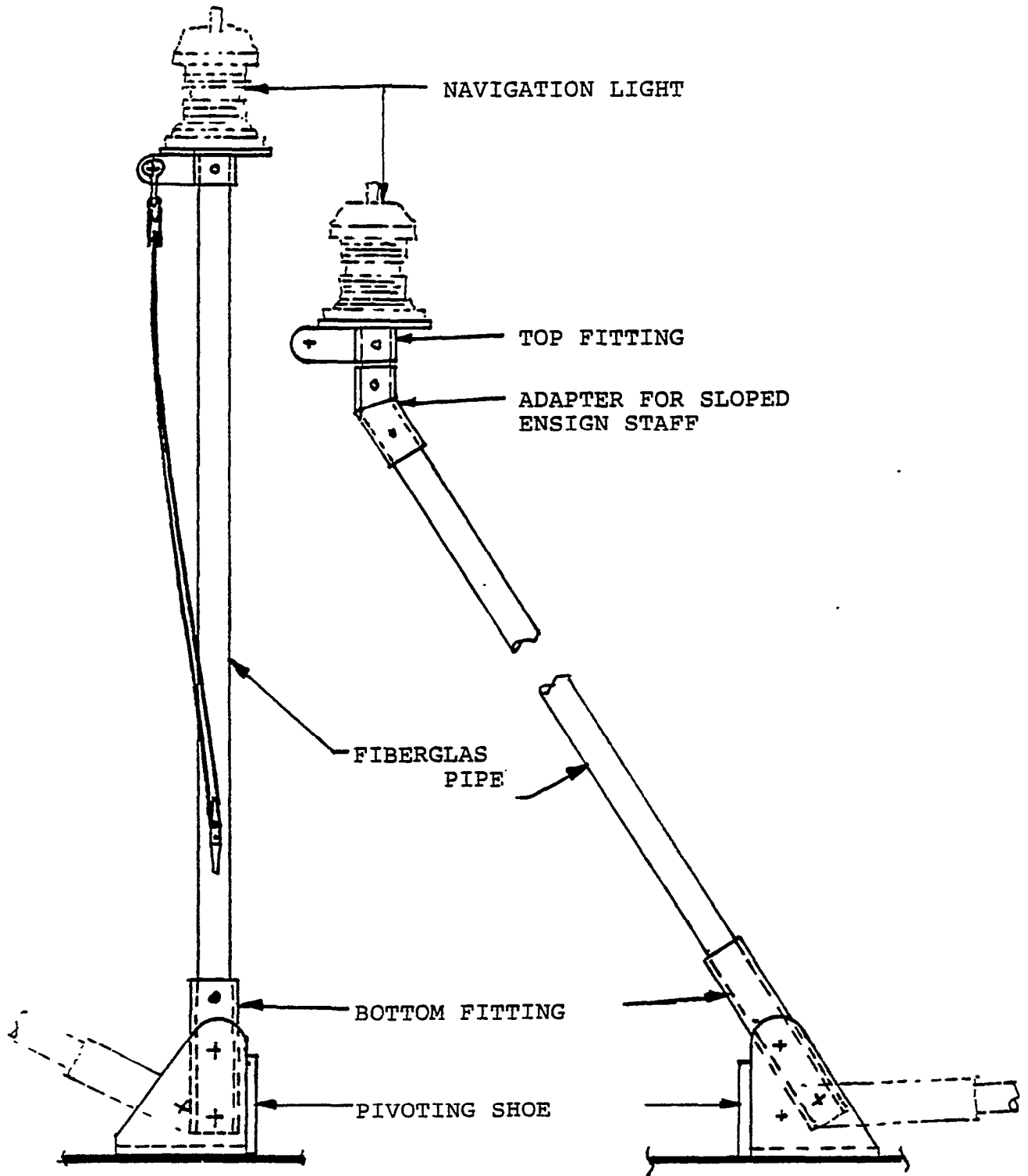
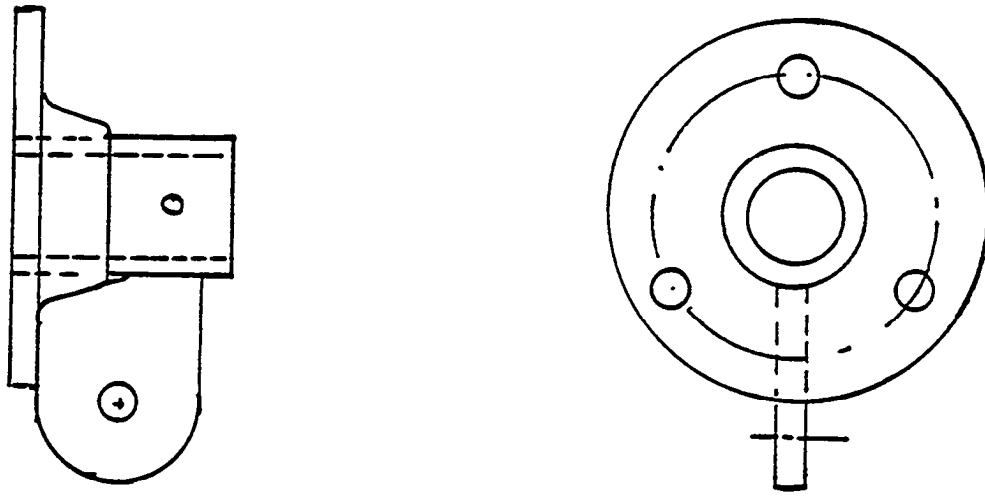
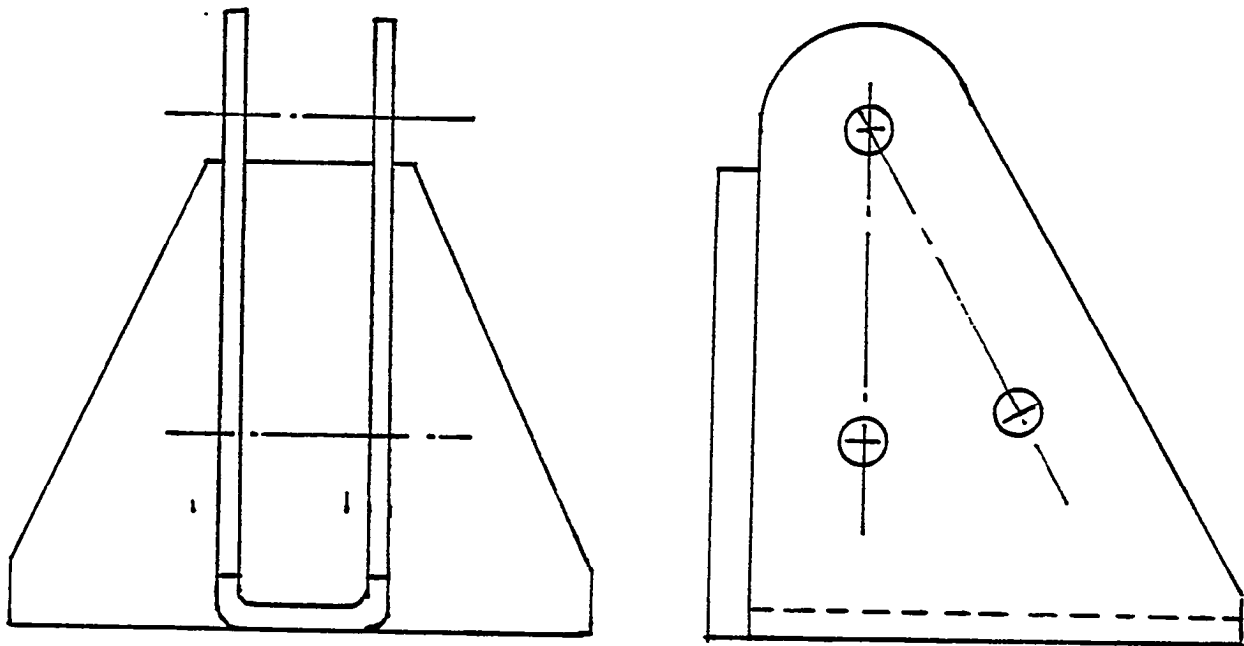

FIGURE 1.85(a) Standard jack and ensign staffs.



TOP FITTING



PIVOTING SHOE

FIGURE 1.85(b) Details of fittings for standard jack and ensign staffs.

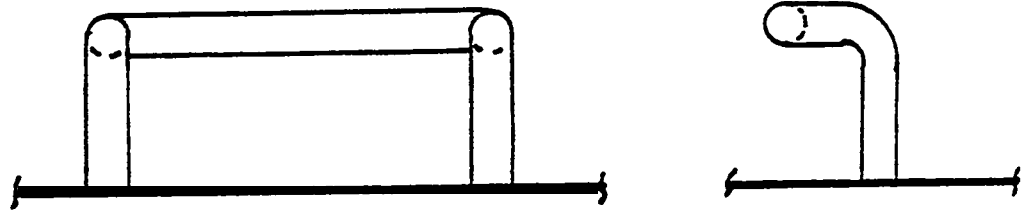

LADDER RUNG FOR WELDING TO STRUCTURE

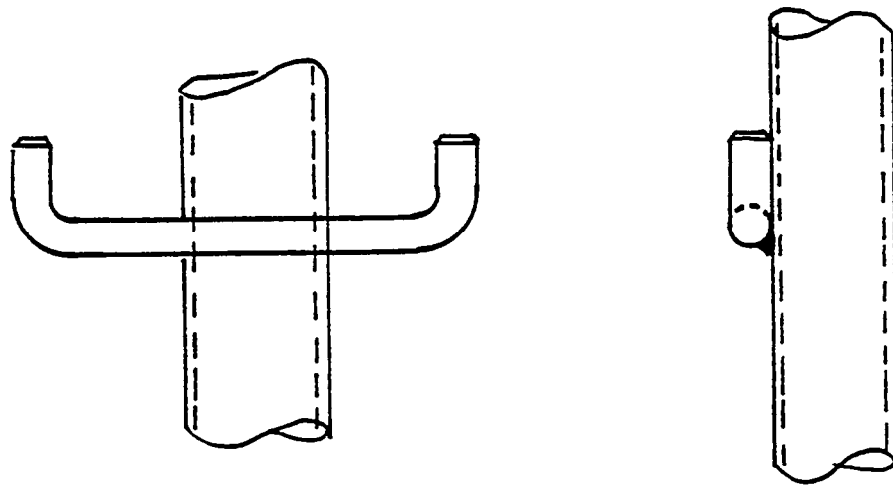

LADDER RUNG FOR WELDING TO MASTS, STAFFS, ETC.

FIGURE 1.86 Standard ladder rungs.

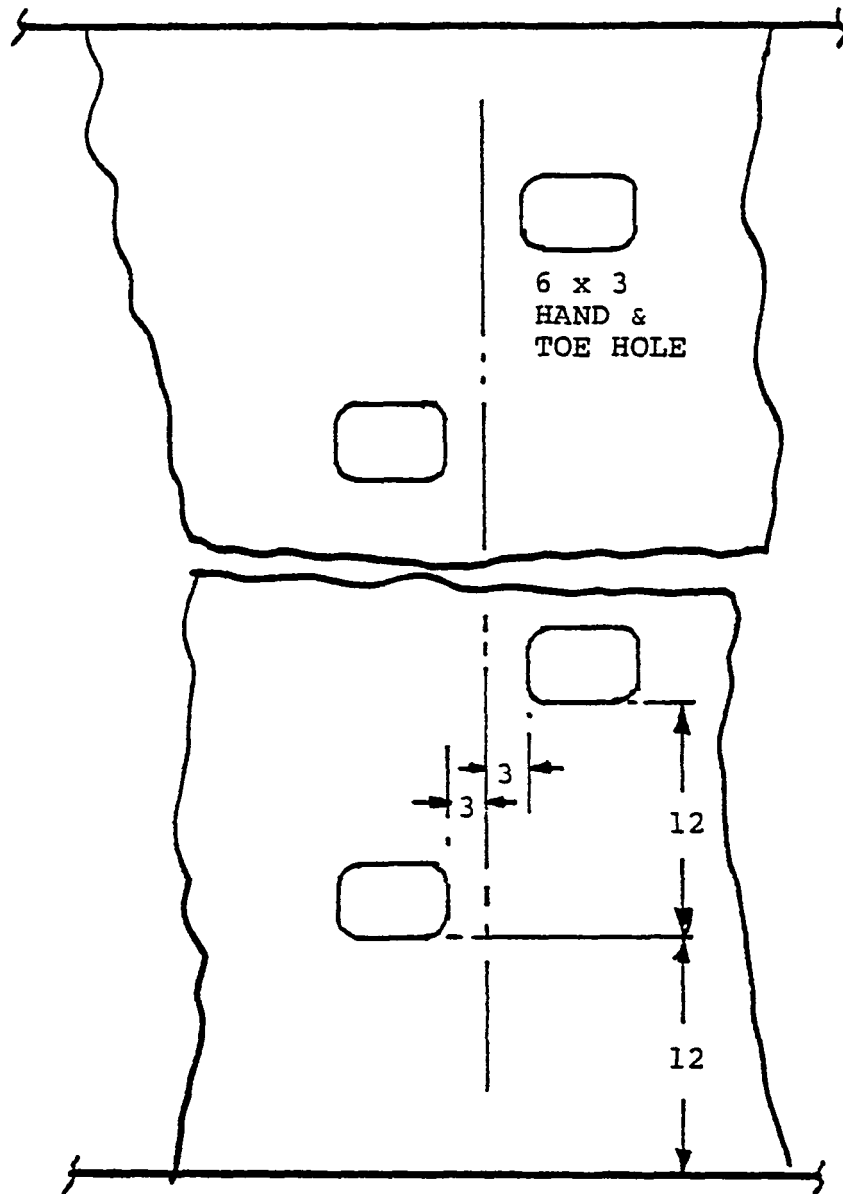
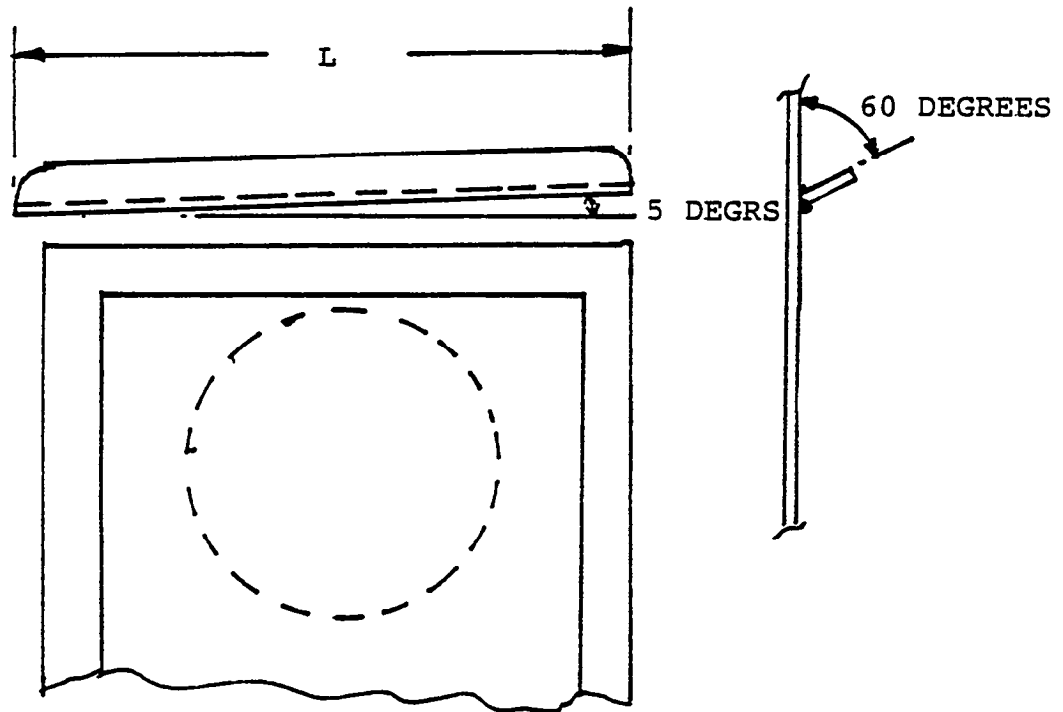

FIGURE 1.87 Standard hand and toe holes.



L - LENGTH

FOR DOORS L = 36

FOR WINDOWS L = 27

FOR AIRPORTS L = 27

FIGURE 1.88 Standardeyebrows.

TRADITIONAL

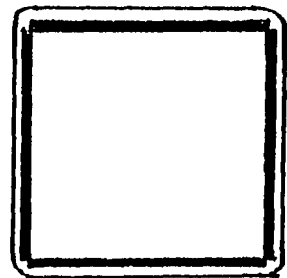
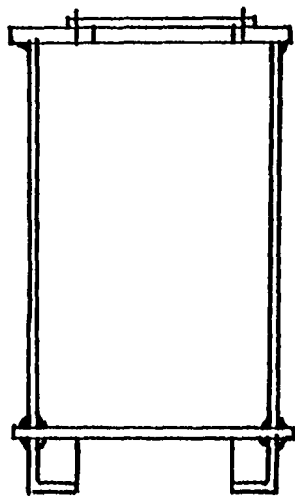

PRODUCTION ORIENTED

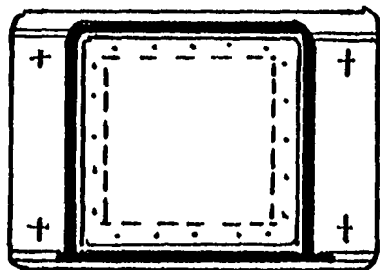
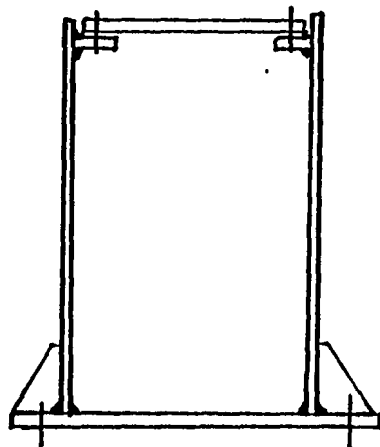

ALTERNATE
TANK SIDE
CONSTRUCTN

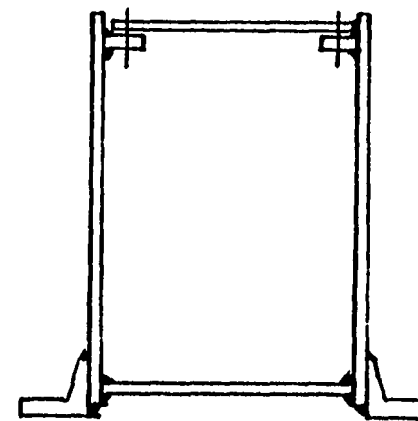

ROUND TANK MADE FROM
PIPE WITH FLANGE FOR
FOUNDATION CONNECTION

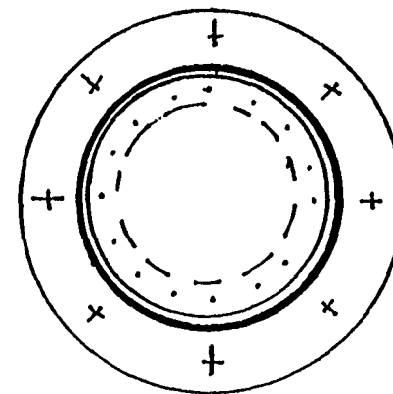

177

FIGURE 1.89 Miscellaneous tank details for productivity.

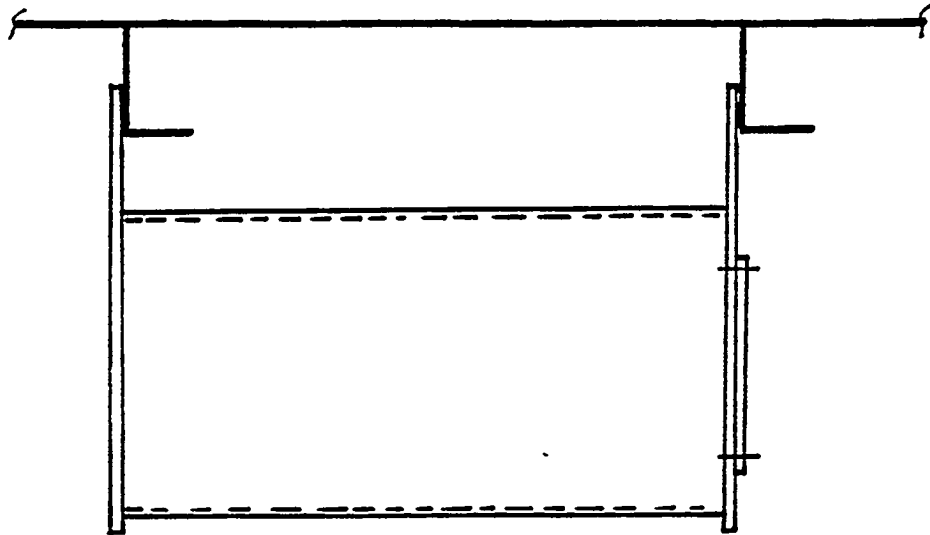

T R A D I T I O N A L

USING PIPE OR TUBES - NEEDS ACCURACY
IN LENGTH, SEPARATE HANDHOLE AND
INTERNAL WELDING IS NOT POSSIBLE

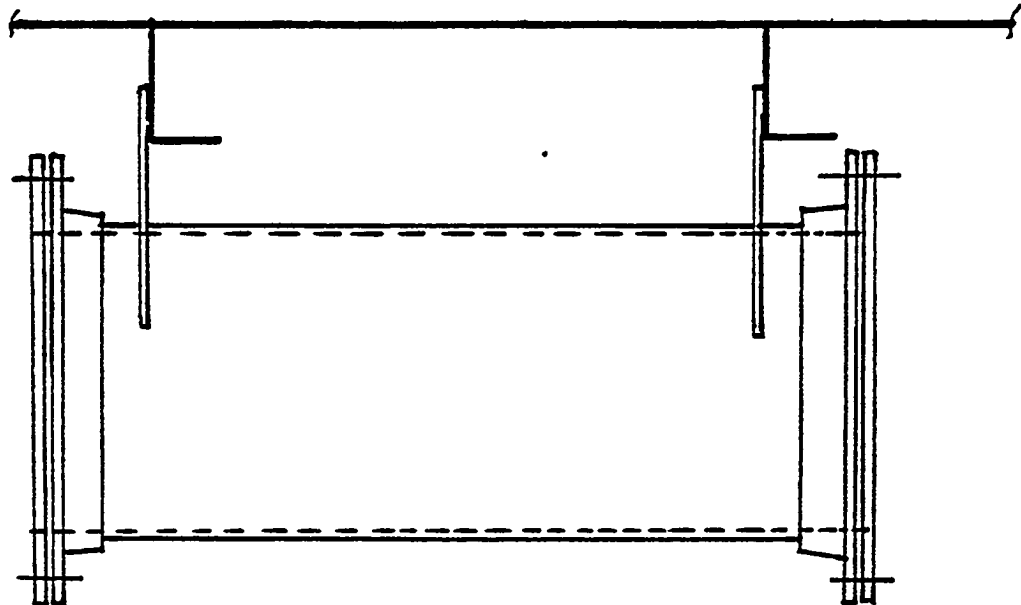

P R O D U C T I O N O R I E N T E D

TANK LENGTH NEED NOT BE ACCURATE.
ACCESS EASY, ALL WELDING OF INTERNAL
FAYING SURFACES IS COMPLETE

FIGURE1.89 (Continued)

1.6 Hull Outfit

Hull outfit covers all deck machinery, joiner-work, insulation, deck covering, and painting. In some shipyards it also covers hull piping and HVAC. The two latter items will be discussed separately in Section 1.8: Piping, and Section 1.9: HVAC. The major item of recent development in hull outfit that is a design-for-production concept is modular accommodation units. The advantages of modular accommodation units are, not surprisingly, similar to those for advanced Outfitting units, namely:

- Relocation of work from ship to shop, resulting in easier access, and cleaner and safer environment
- Possibility of assembly line techniques for multiple units
- Elimination of transporting many small parts to ship
- Simpler material control
- Reduction in material scrap
- Shorter installation time onboard the ship

Again, standardization is an essential design-for-production approach, not only for individual items, but for units such as modular toilets, modular furniture, complete cabins, galleys, and storerooms. Table 1.6 lists details of modular accommodation units. Table 1.7 shows a typical shipyard hull outfit standards list. Some of these concepts are shown in Figure 1.90 through 1.95. A number of design-for-production ideas for hull outfit are:

- Incorporate foundations for deck machinery into equipment design, and weld direct to ship structure.
- Use above deck slide or “A” frame anchor davit instead of hawse pipes (see Figure 1.96).
- Use modular accommodation units, if not complete cabin units at least modular toilets and common outfitted joiner bulkheads (see Figures 1.97 and 1.98).
- Keep furniture off the deck, supported by joiner bulkheads. This eliminates fitting of sub-bases. (see Figure 1.98).
- Use modular galley equipment/walls (see Figure 1.99).
- Use carpet over bare steel in cabins.
- Use troweled-in-place deck cove for passageways, storerooms, and work areas.
- Use non-grinding terrazzo in galley and toilets.

Another idea that results in significant reduction of production manhours is to apply hull insulation to joiner linings and ceiling instead of the inside surfaces of hull and deckhouse structure. This eliminates work effort for fitting insulation between and around frames and beams as well as cutting flaps for welded supports for ventilation ducts, pipe, and wireways. Many of the currently available modular accommodation systems use this approach, but it can be, and in fact was, used by a shipyard in Sunderland, England, in 1964 for traditional joiner lining and ceiling installations. As mentioned in Section 1.3.2(f), service spaces should be provided adjacent to toilet, laundry, and other service spaces which can be accessed by easy removal of joiner lining panels as shown in Figure 1.100.

TABLE 1.6
MODULAR ACCOMMODATION SYSTEMS

MODULAR TOILETS
<p>"MARINET" System manufactured by Ahlmann P.O. Box 725, D-2370, Rendsburg, West Germany</p> <p>Resine Armee s.a. 44590 Derval, France</p> <p>Frenkin Corporation 406 Railroad Street, Yehn, Washington 98598 USA</p>
COMPLETE MODULAR ACCOMMODATION
<p>Wartsila Cabin Modules Piikkio Works, SF-21500 Piikkio, Finland</p> <p>Hw50 system hW Metallbau, P.O. Box 1160, Syker Strabe 205-213, Thedinghausea, West Germany</p> <p>MODULUX, Cape Boards and Panels Ltd. Glasgow, Scotiand</p> <p>B+V MI000 System Blohm & Voss AG, P.O. Box 100720 D-200 Hamburg 1, West Germany</p>
JOINER BULKHEAD, LINER, AND C-G SYSTEMS
<p>DONN System, Dorm Corporation 1000 Cracker Road, West Lake, Ohio 44145 USA</p> <p>DAMPA Marine Ceilings Daempa A/S, DK 5690, Tamerup, Denmark</p> <p>TNF system Rockment A/S, DK-2640, Hedehusene, Denmark</p> <p>ISULAMIN Piannja AB, 2-95188 Lulea, Sweden</p> <p>Hauserman "Double Wall," Seiby, Battersby and Company Philadelphia, Pa., USA</p> <p>BPS CIS600, Brand and Personenschutz GmbH Elmenhorstrause 4, D-2000 Hamburg 50, West Germany</p>

TABLE 1.7

TYPICAL HULL OUTFIT STANDARDS LIST

[A] STANDARD ITEMS
Rails and Stanchions Watertight Doors Manholes Joiner Doors Exterior Ladders Interior Ladders Interior Stairs Window Casing Airport casing Jack and Ensign Staff Liferaft Stowage Lifebuoy Stowage Hull Markings Bat Proofing Furniture Watertight Hatches Oil Tight Hatches Escape Hatches and Scuttles Ullage Hatch Cleaning Hatch Docking Plug Spare Part Boxes Wood Grating Metal Grating Store Shelving Tank Sounding Board course Board Notice Boards Workshop Bench Shower Enclosure Toilet Enclosure
[B] STANDARD SYSTEMS
Joiner Lining, Bulkhead, and Ceiling Details Deck Covering Details Hull Insulation Details Paint Details Galley Dresser Details Storeroom Details Navigation Instrument Schedule Cathodic Protection Details Label Plate Details Curtain Plate Details Living Space Arrangements

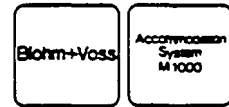

components of the accommodation system M 1000

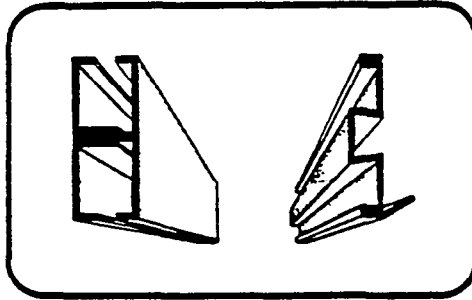

galvanized steel profiles
(two types)

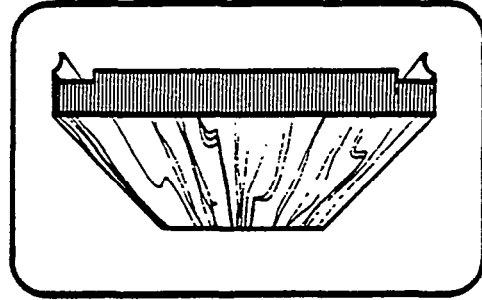

plastic faced steel sheets
(many colours and wood characters)

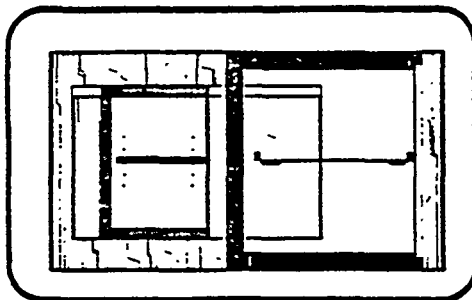

furniture in wood and steel

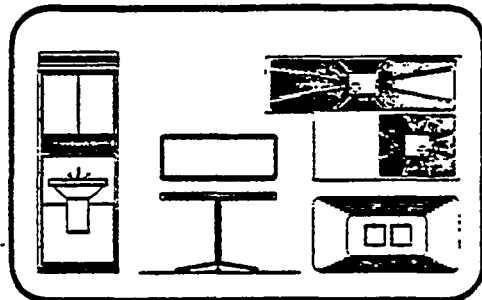

sanitary units, table tops, shower bath floor units, window boxes, all made of G R P

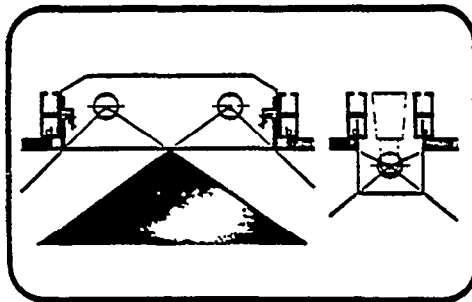

MI000 lighting units

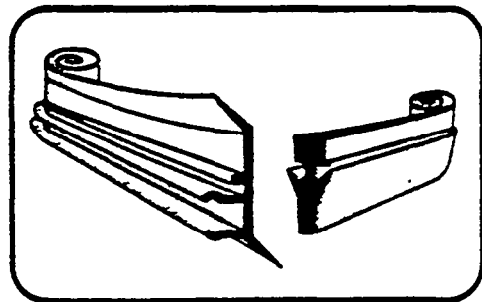

skirting board and filler, all made in PVC

FIGURE 1.90 BLOHM+VOSS MI000 accommodation system.

plan view of proposed
officer's cabin

Blohm+Voss	Apparaturen System M 1000
------------	---------------------------------

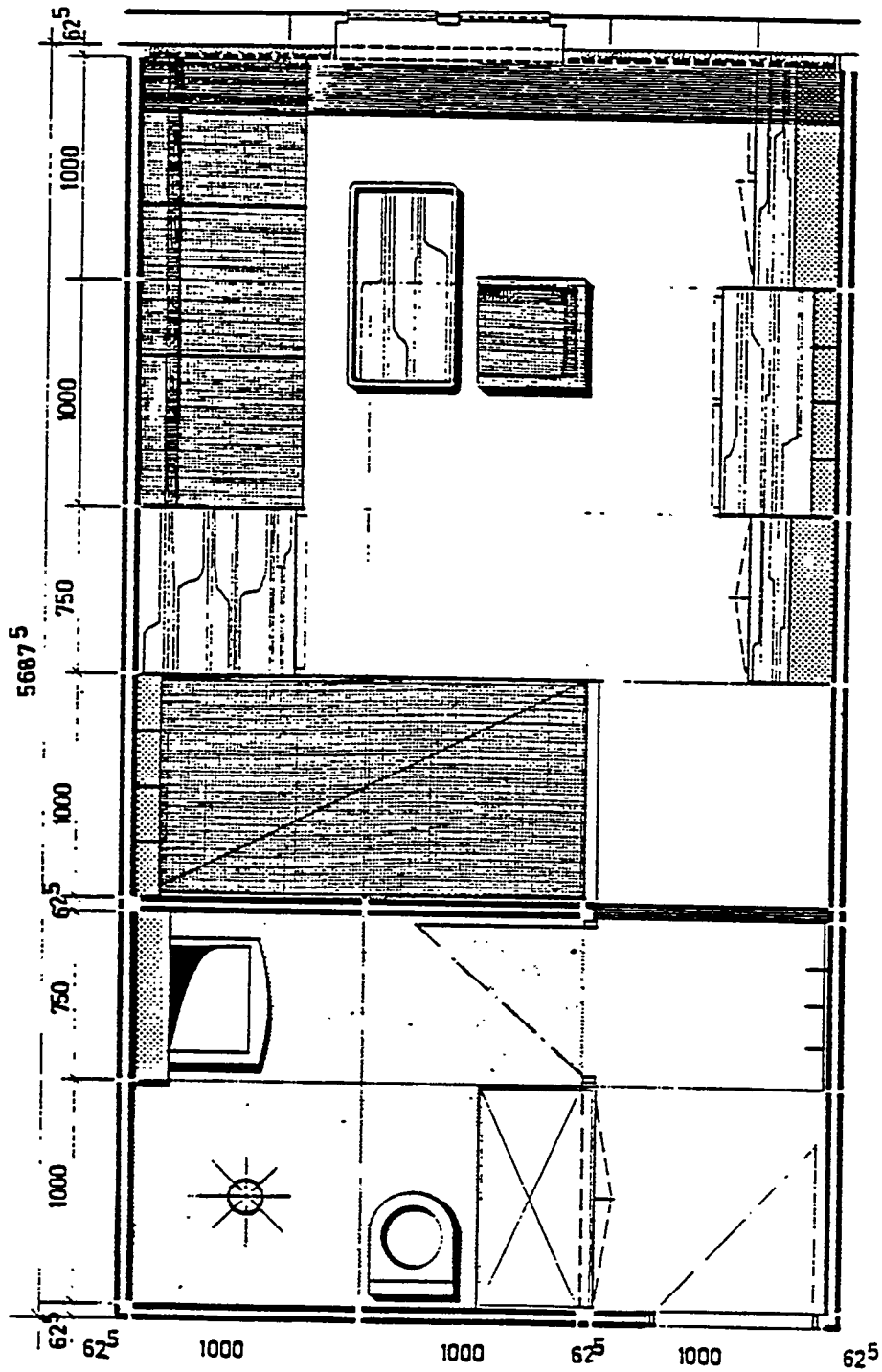
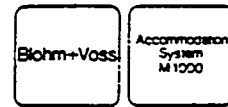

FIGURE 1.90 (Continued)



officer's cabin, wall views

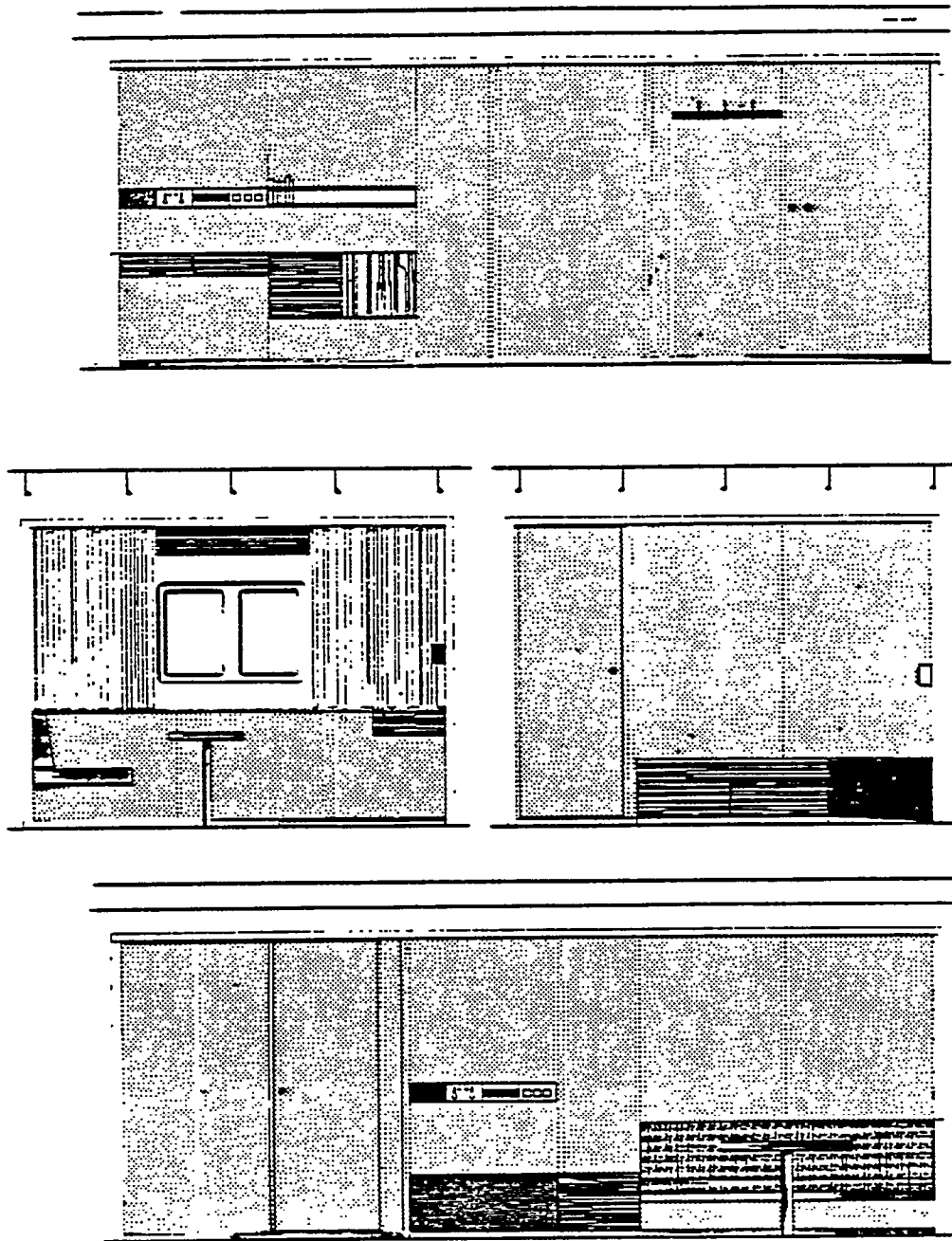
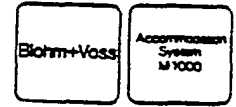

FIGURE 1.90 (Continued)



crew's cabin, plan view and wall views

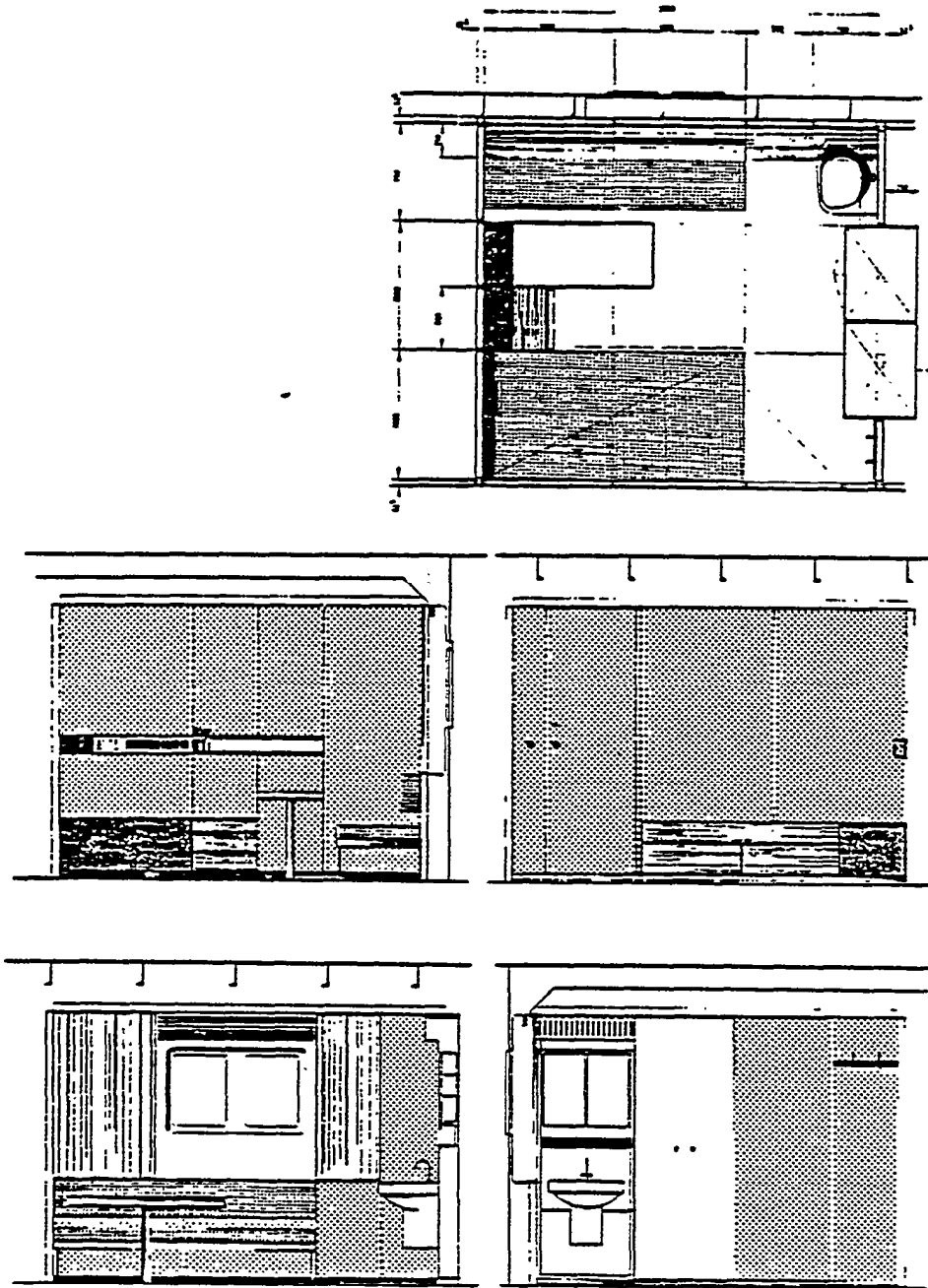

FIGURE 1.90 Eontimed)

vertical section through wall

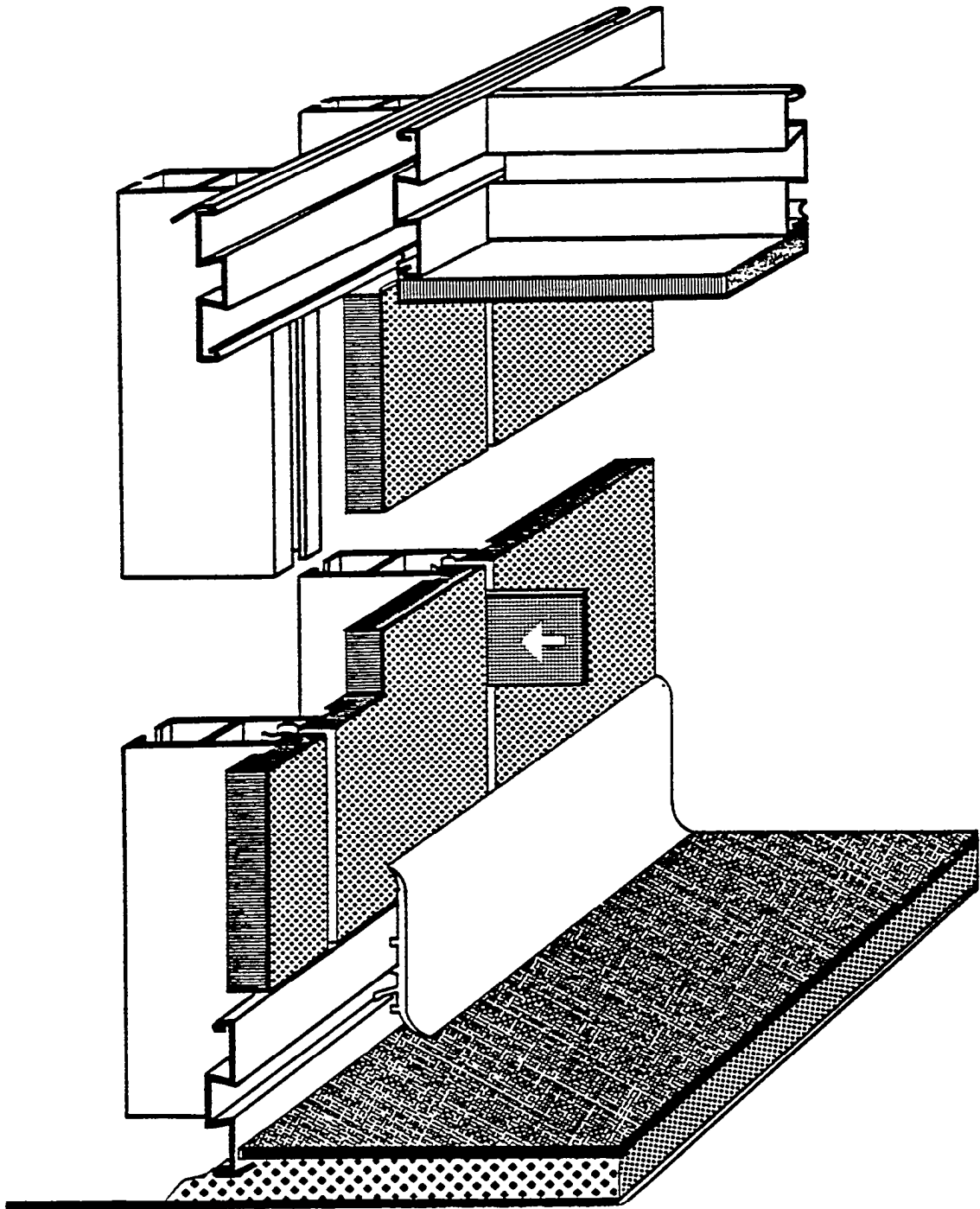
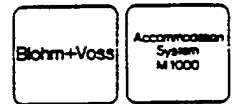

FIGURE 1.90 (Continued)

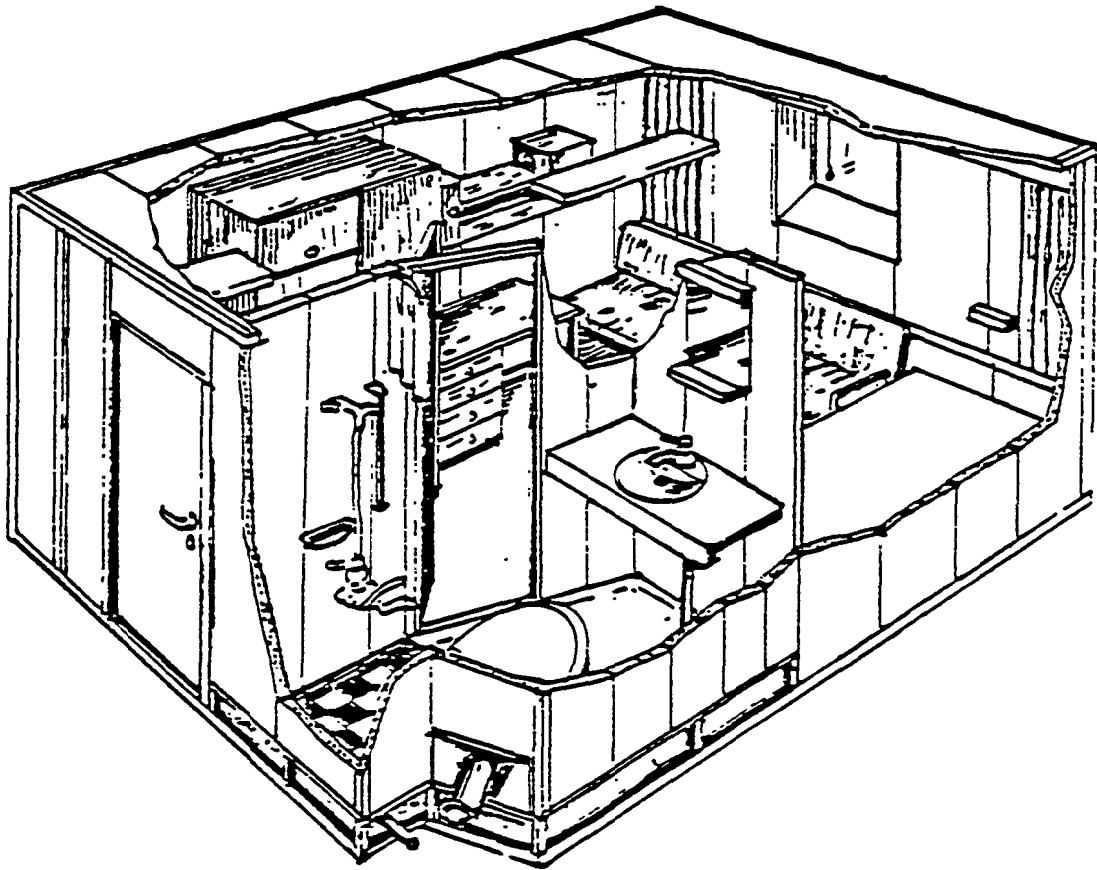

FIGURE 1.91 Typical modular accommodation unit.

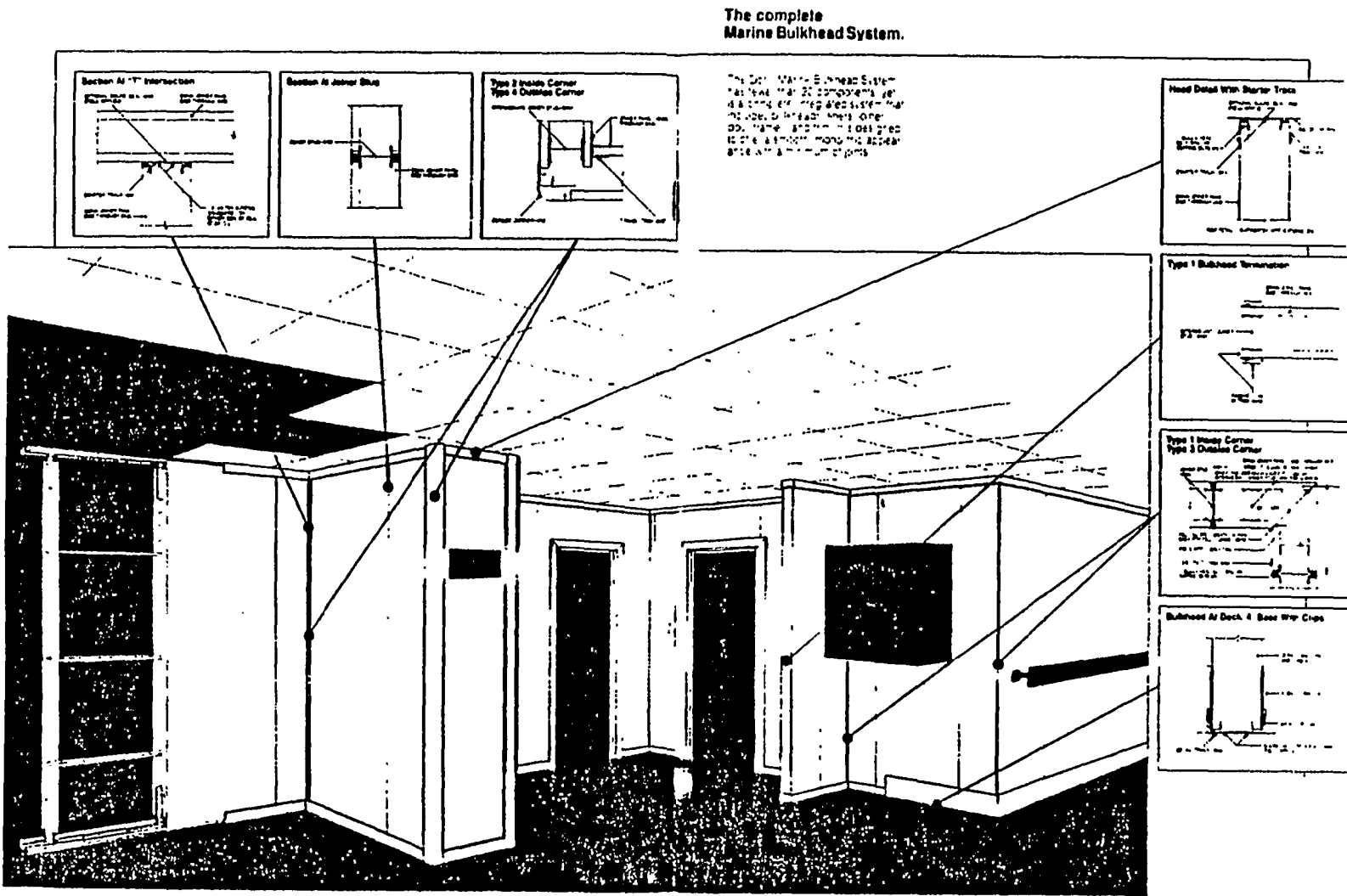

FIGURE 1.92 The Donn joiner bulkhead and lining system.

**DEMOUNTABLE
PARTITIONS
HAUSERMAN
"DOUBLE WALL"
(B-1C)**

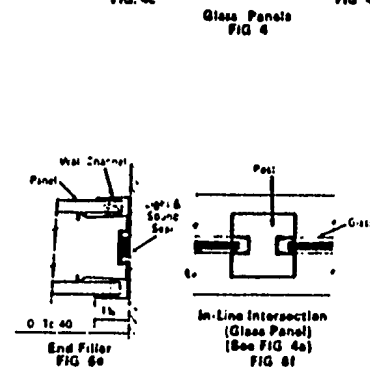
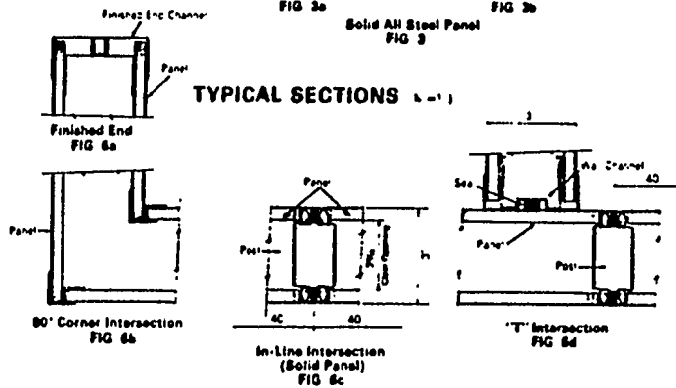
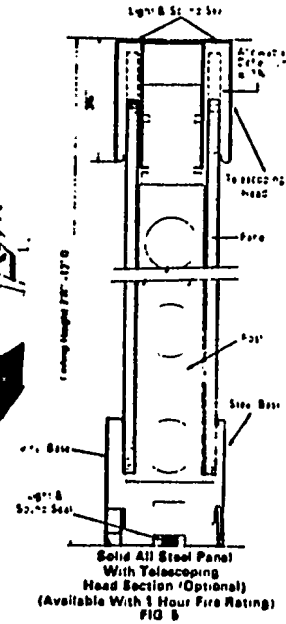
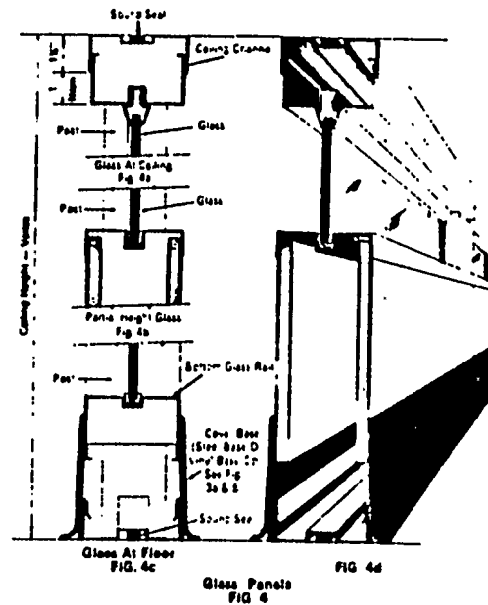
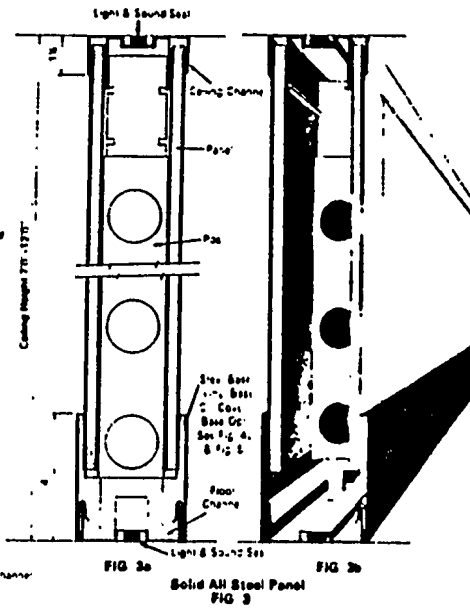

FIGURE 1.93 The Hauserman "double-wall" system.



DAMPA
Marine Products

DAMPA CONTINUOUS
CEILING SYSTEM

Technical Information
No. 02.02

April 1984

Ceiling units for DAMPA Continuous Ceiling System

a. Application
b. Dimension
c. Material
d. Surface treatment
e. Approximate consumption per sq.ft. ceiling
f. Weight
g. Packaging

**DAMPA Continuous Ceiling
Type 215/315**
a. Fire protection, sound insulation and absorption.
b. Profile height 25mm (1") covers 200/300 mm (8"/12" approx) installed, length 2'-18"
c. 0.5mm (0.02") steel, perforated with 1/16" diameter holes at 1/8" centers, 20.5% perforation. The inlay consists of black non combustible tissue and 25mm (1") mineral wool
d. Galvanized and baked enameled
e. 1.5/1 lin.ft.
f. 1.1/0.84 lb. per sq.ft.
g. Non-returnable cardboard boxes

**DAMPA Continuous Ceiling
Type 213/313**
a. Sound insulation and absorption and air injection.
b. Profile height 25mm (1") covers 200/300 mm (8"/12" approx) installed, length 2'-18"
c. See type 215/315. The wide flange of 213/313 is perforated with two rows of 1/8" x 1/4" slots at 1/8" staggered centers, corresponding to a free area of 1.32 in² per lin.ft. of panel, for air injection
d. Galvanized and baked enameled
e. 1.5/1 lin.ft.
f. 1.1/0.84 lb. per sq.ft.
g. Non-returnable cardboard boxes

We reserve the right to alter the materials described.

DAMPA (USA) INC. . P.O.Box79570 HOUSTON. TEXAS77279.USA. TELEPHONE: (713) 932-8666 . TELEX: 792336

FIGURE 1.94 DAMPA ceiling system.



DAMPA
Marine Products

DAMPA CONTINUOUS
CEILING SYSTEM

Technical Information
No. 03.01

April 1984

Installation Details for DAMPA Continuous Ceiling System

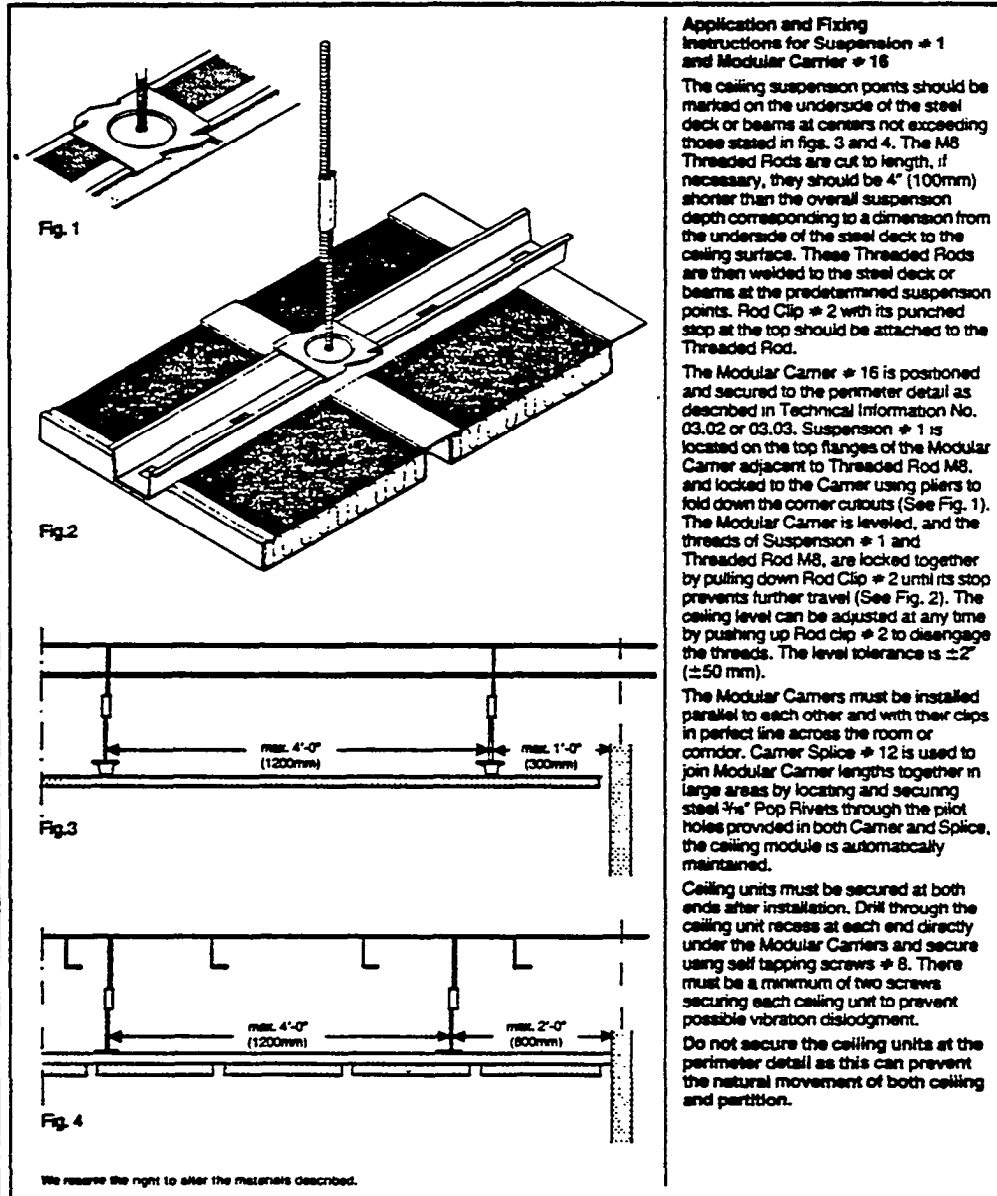

Application and Fixing Instructions for Suspension # 1 and Modular Carrier # 16

The ceiling suspension points should be marked on the underside of the steel deck or beams at centers not exceeding those stated in figs. 3 and 4. The M8 Threaded Rods are cut to length, if necessary, they should be 4" (100mm) shorter than the overall suspension depth corresponding to a dimension from the underside of the steel deck to the ceiling surface. These Threaded Rods are then welded to the steel deck or beams at the predetermined suspension points. Rod Clip # 2 with its punched stop at the top should be attached to the Threaded Rod.

The Modular Carrier # 16 is positioned and secured to the perimeter detail as described in Technical Information No. 03.02 or 03.03. Suspension # 1 is located on the top flanges of the Modular Carrier adjacent to Threaded Rod M8, and locked to the Carrier using pliers to fold down the corner cutouts (See Fig. 1). The Modular Carrier is leveled, and the threads of Suspension # 1 and Threaded Rod M8, are locked together by putting down Rod Clip # 2 until its stop prevents further travel (See Fig. 2). The ceiling level can be adjusted at any time by pushing up Rod clip # 2 to disengage the threads. The level tolerance is $\pm 2"$ (± 50 mm).

The Modular Carriers must be installed parallel to each other and with their clips in perfect line across the room or corridor. Carrier Splice # 12 is used to join Modular Carrier lengths together in large areas by locating and securing steel $\frac{3}{8}"$ Pop Rivets through the pilot holes provided in both Carrier and Splice, the ceiling module is automatically maintained.

Ceiling units must be secured at both ends after installation. Drill through the ceiling unit recess at each end directly under the Modular Carriers and secure using self tapping screws # 8. There must be a minimum of two screws securing each ceiling unit to prevent possible vibration dislodgment.

Do not secure the ceiling units at the perimeter detail as this can prevent the natural movement of both ceiling and partition.

DAMPA (USA) INC. · P. O. BOX 79570 · HOUSTON, TEXAS 77279, USA · TELEPHONE: (713) 932-8666 · TELEX: 792336

FIGURE 194 (Continued)

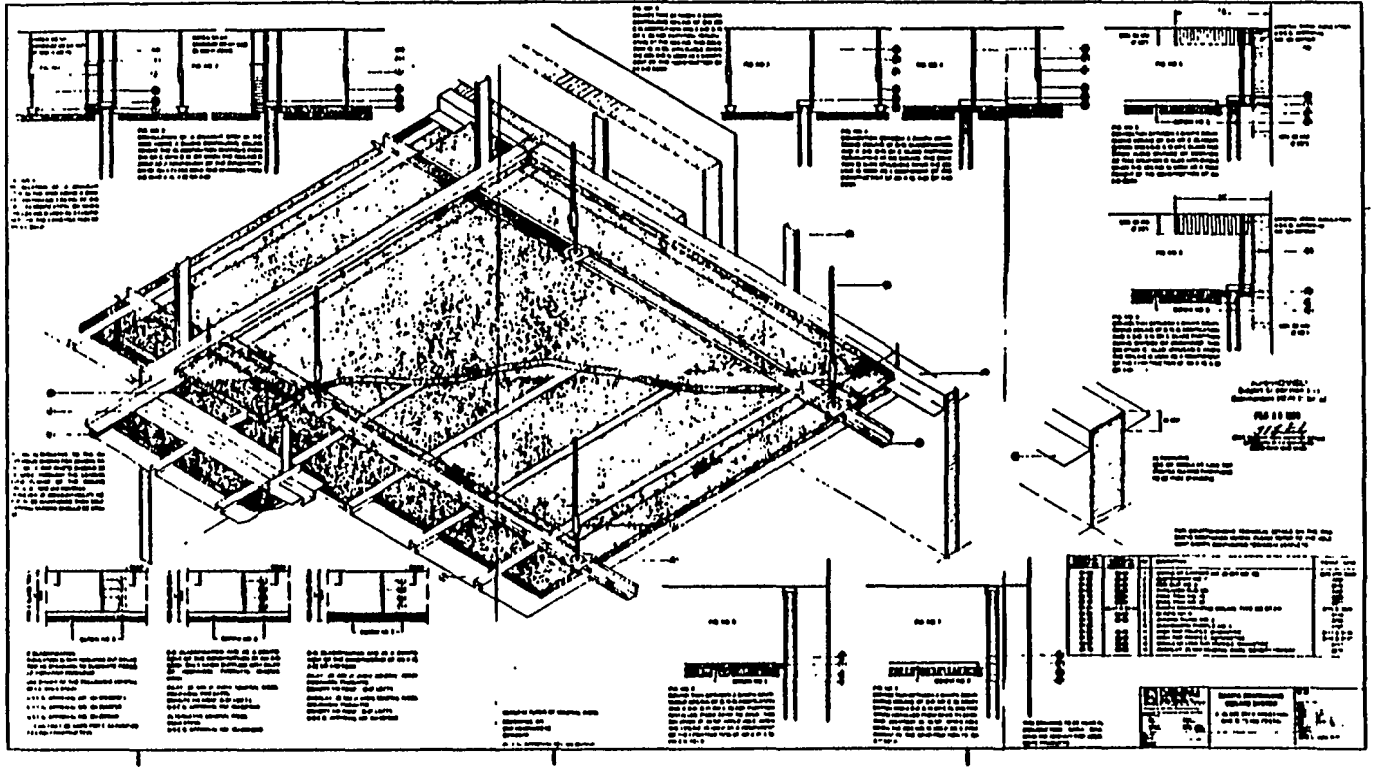

FIGURE 1.94 (Continued)

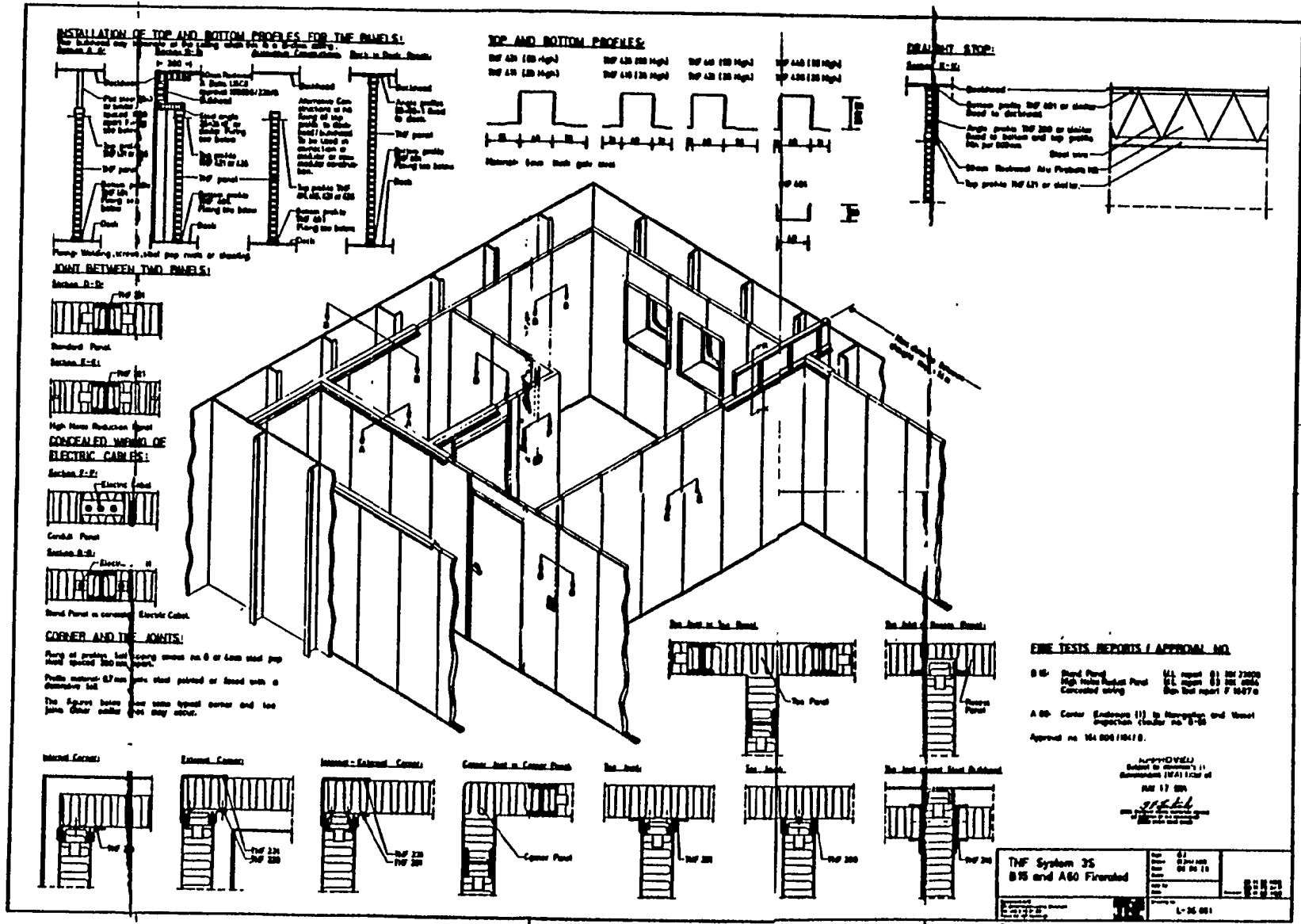
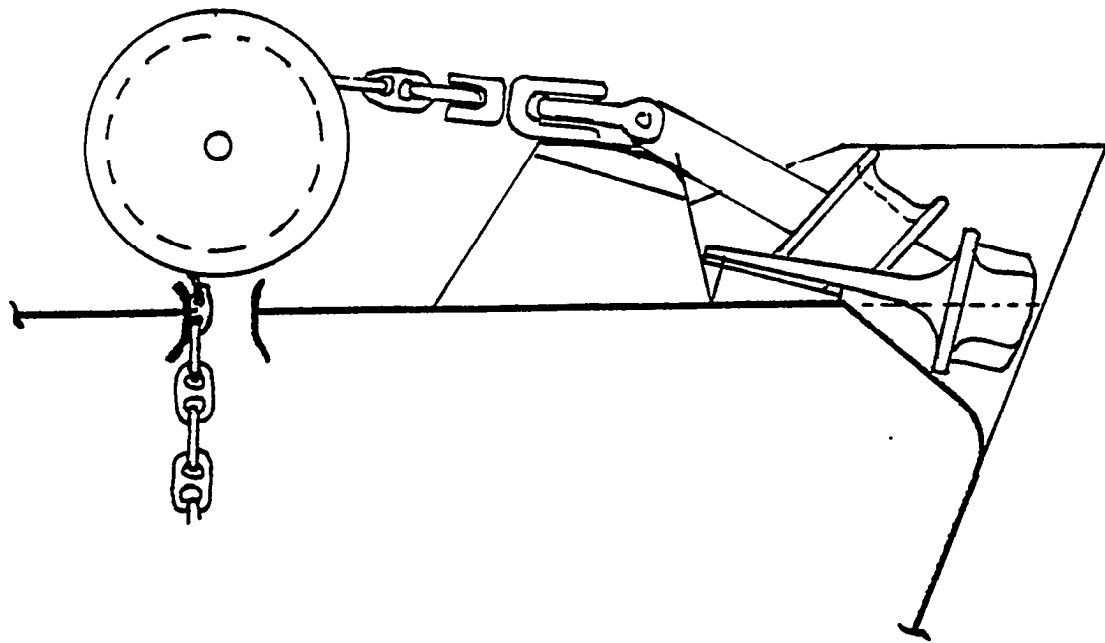
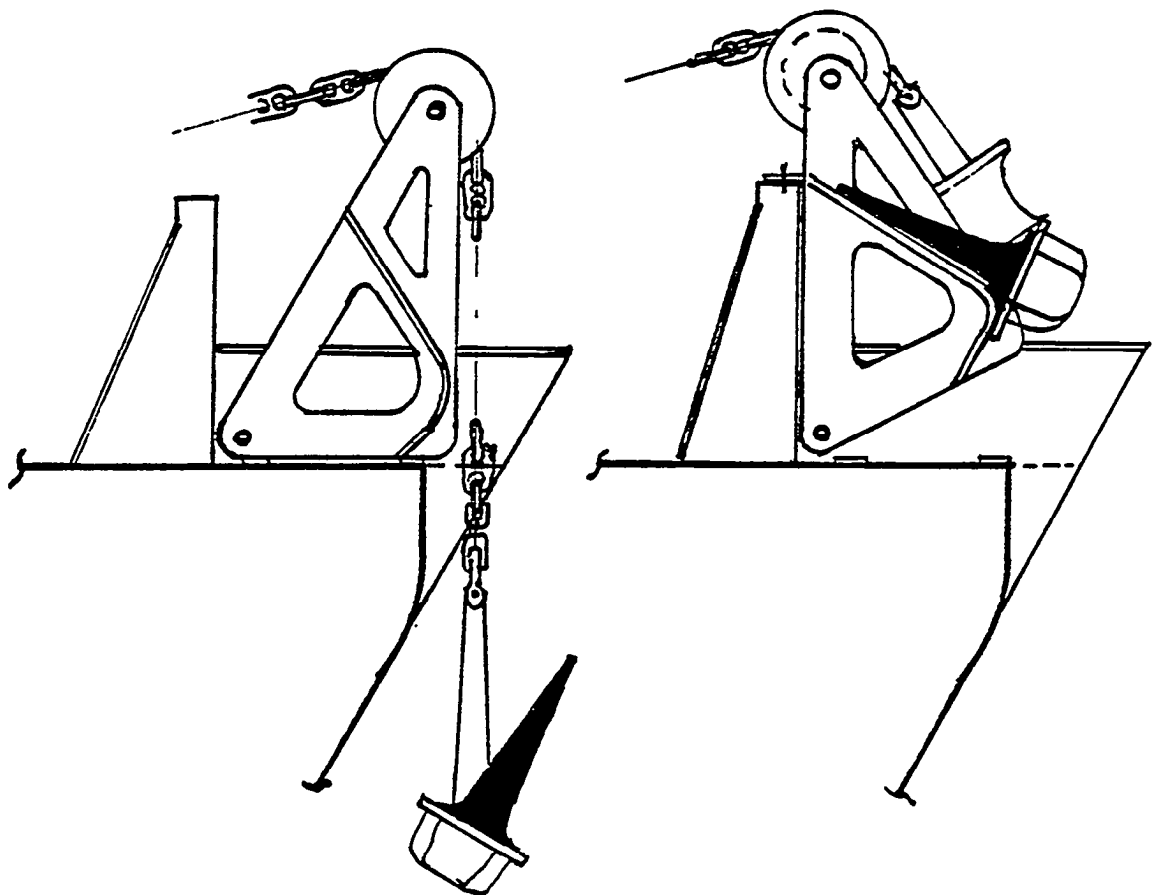

FIGURE 1.95 TNF joiner bulkhead and lining system.



[A] KOCKUM'S DECK ANCHOR STOWAGE ARRANGEMENT



[B] LAMB'S PIVOTING ANCHOR GALLOWS ARRANGEMENT

FIGURE 1.96 Alternat anchor stowage arrangements.

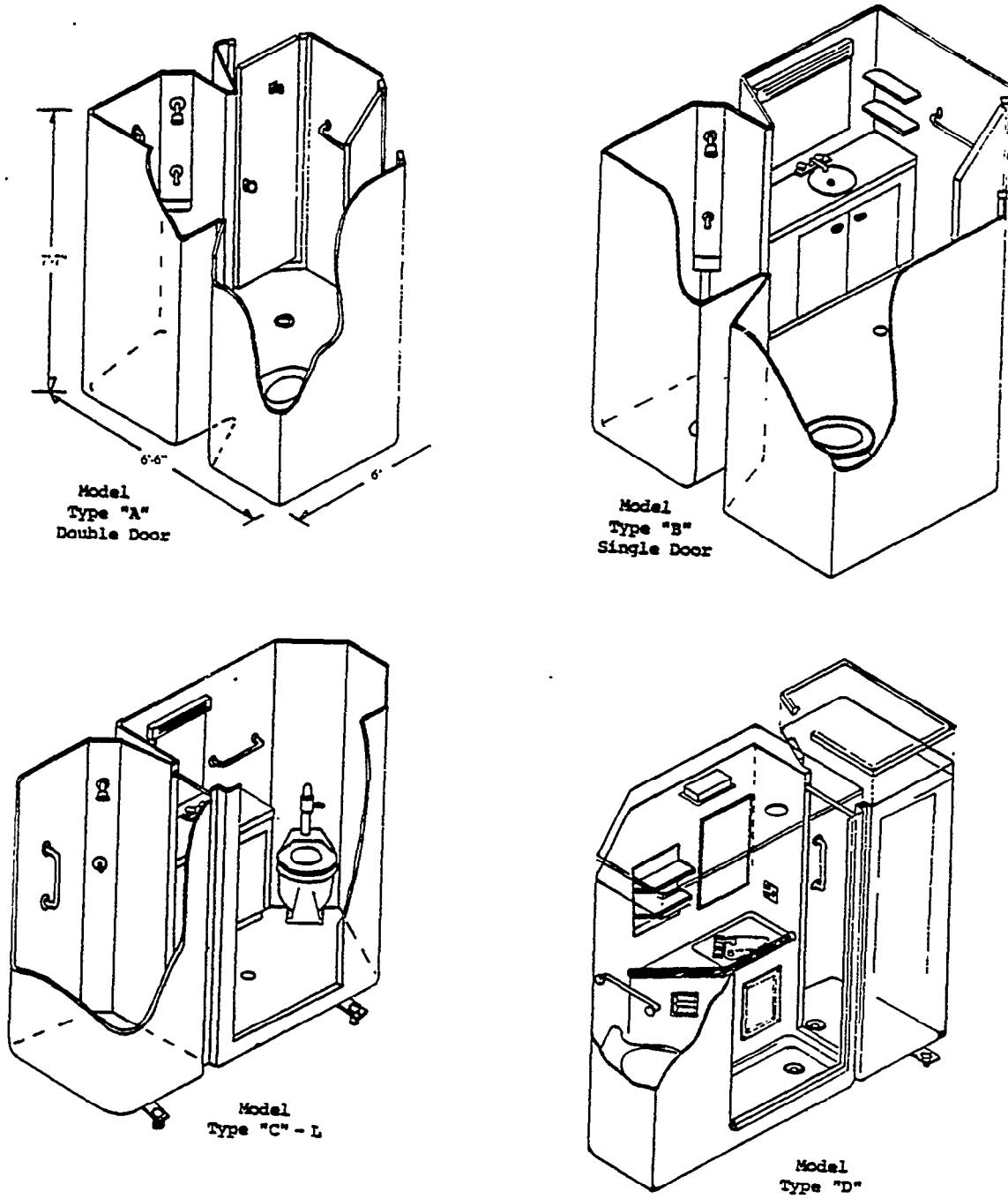

FIGURE 1.97 Typical modular toilets.

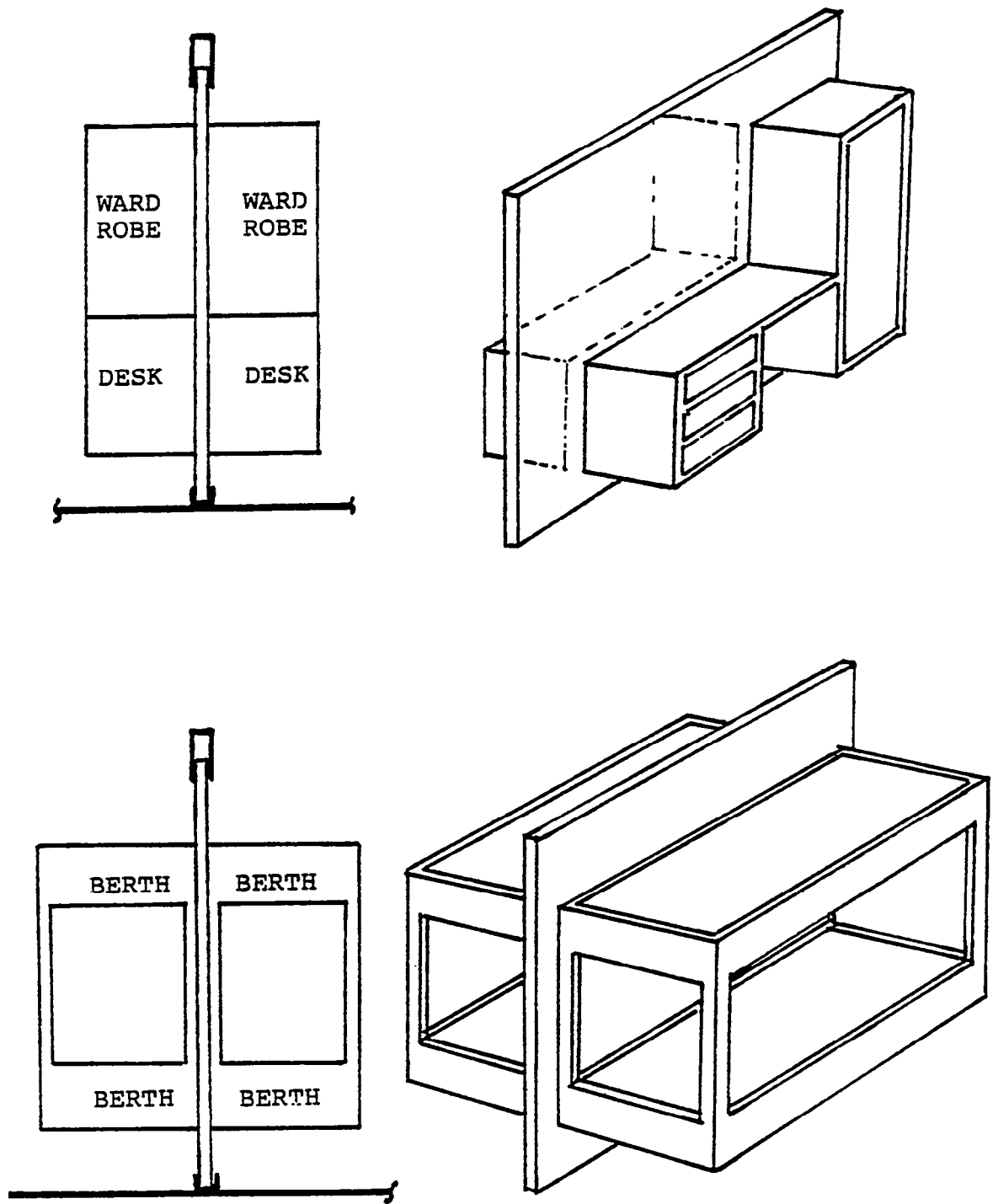

FIGURE 1.98 Common outfitted joiner bulkheads.

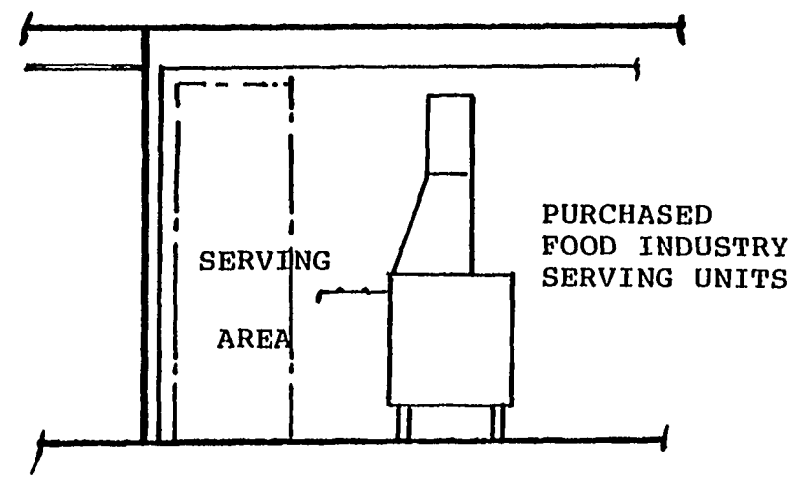
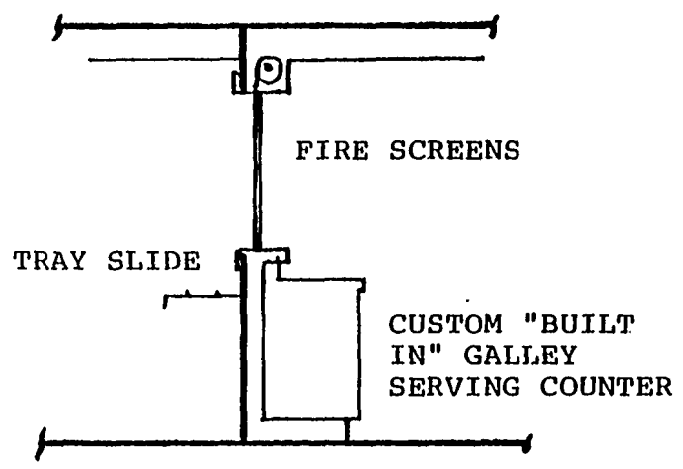
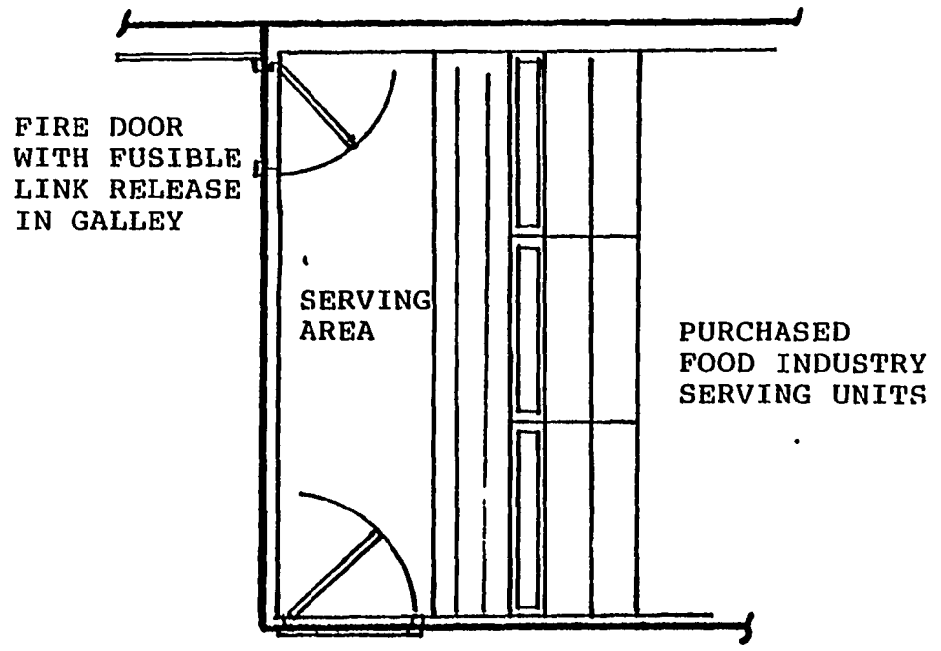
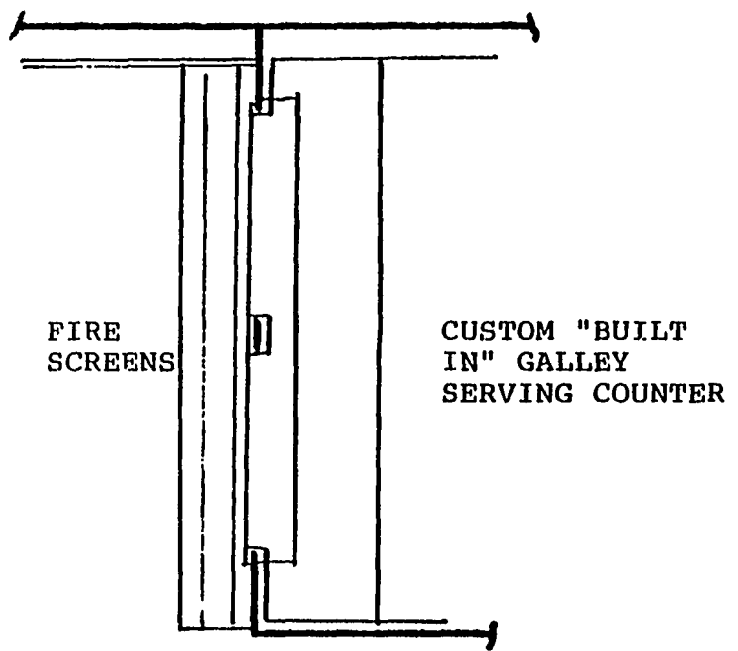

FIGURE 1.99 Galley arrangement for productivity.

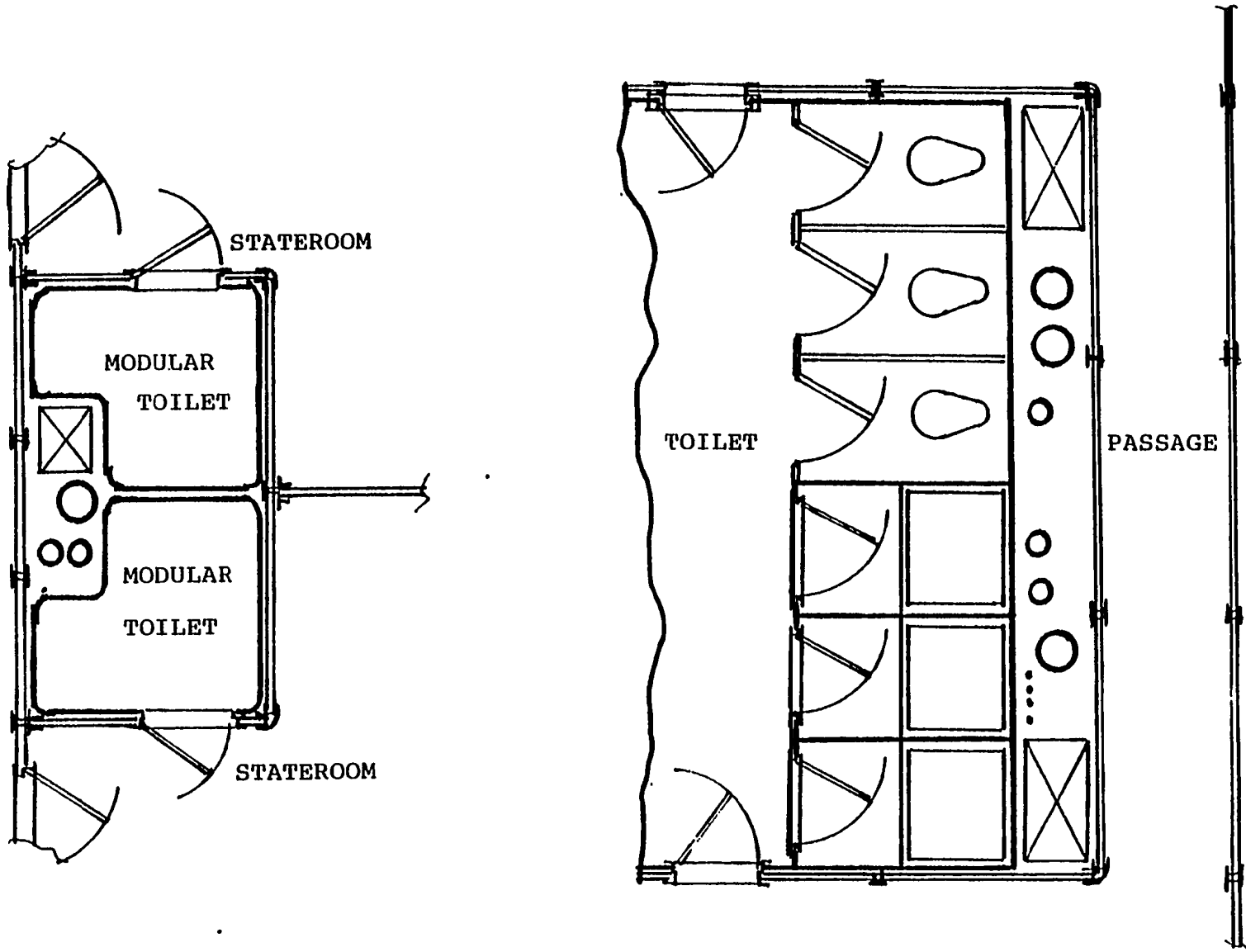

FIGURE 1.100 "Designed-in" service space accessible by removing joiner lining.

1.7 MACHINERY

1.7.1 GENERAL. Very few shipyards today design and manufacture the propulsion and auxiliary machinery which will be installed in the ships they construct. They will probably purchase the machinery from other companies specializing in the different items. Therefore, the machinery group is usually responsible for designing an integrated power plant from many "stock" or "standard" items of equipment available from many different suppliers. They may also be responsible for the design of machinery space ventilation, gratings, and ladders. The machinery arrangement and the major equipment should be decided during basic design, and if prepared as proposed in Section 1.3.2(c) it will be possible to continue the design-for-production approach in the development of the product engineering. The design of the machinery installation can significantly assist the ultimate goal of improved productivity by standardization. For example, foundations for propulsion and auxiliary machinery could be standardized for the equipment, and different ship structural arrangements designed to suit the standard foundations. Some years ago, Norske Veritas attempted to standardize the arrangement of machinery spaces. The idea was that all equipment associated with a given task or system should be grouped together, and that they should be located in the same area for similar ship types. The idea is still a good one as it allows machinery familiarization by both shipbuilders and crew of similar machinery plants for similar ship types. By utilizing such an approach, and assigning vertical and horizontal routing zones for different systems, such as piping, ventilation, and electrical wireways, the task of other engineering groups and production can be significantly reduced and simplified. Again, considerable engineering and production manhours can be saved by standardizing system-routing zones.

Assembly and module breaks should be carefully developed between hull and machinery design groups to ensure that no major equipment or their foundations extend over the breaks, as this will prevent installation of the equipment into the modules before erection and joining.

1.7.2 FLOOR PLATES. One area where many shipyards spend an inordinate amount of manhours is the installation of machinery space floor plates. This is usually because they are designed independently of other systems, which results in many interferences, and the floor plates end up being custom fitted onboard the ship. The application of the advanced outfitting "on-unit" approach will eliminate much of this problem, as can a proper design sequence when advanced outfitting is not used. Notwithstanding the many bad experiences with floor plates, it is possible to design and successfully use a standard floor plate system. Figure 1.101 shows such a system for floor plates. The pedestal supports can be used to support pipes and electric cable. It is beneficial to keep the area alongside the propulsion machinery clear of systems so as to eliminate foundation bracket/system interferences. This also provides a maintenance work area, and by incorporating hinged floor plates as shown in Figure 1.102, maintenance and access to the machinery space bilge is improved. The practice of designing machinery space railing stanchions out of pipe as well as rails should be stopped, and the simpler huh-type rails used. This concept is also shown in Figure 1.101. Where permissible, by regulatory and classification bodies, Fiberglas gratings should be considered in place of metal floor plates and gratings.

1.7.3 EQUIPMENT GROUPING. Even before the concept of advanced outfitting, it was good design practice to prepare an equipment-association list for any major piece of equipment to be arranged and installed in a ship. This association list was used for a number of purposes such as checking and equipment ordering, if the associated equipment was not provided with the major equipment. However, for the purpose in mind, it was and should be used to develop location in the system of all the items, and the connections

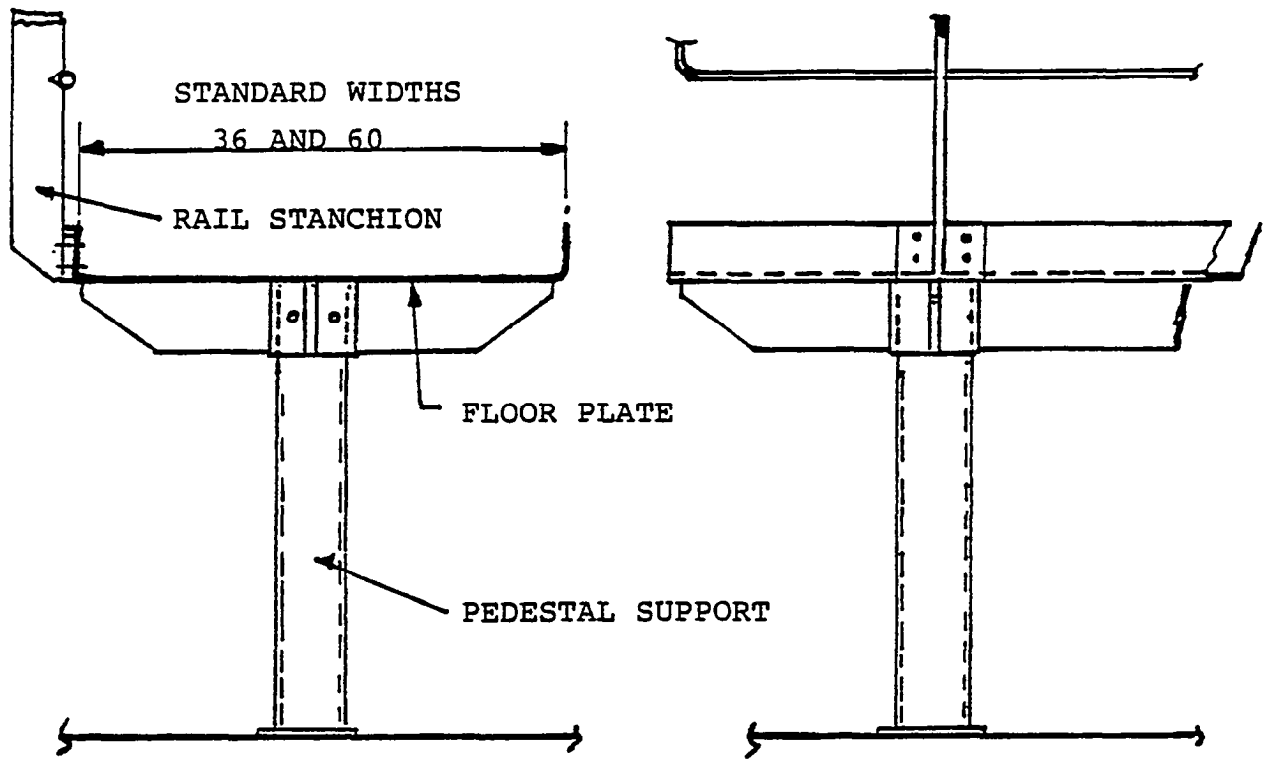

[A] BASIC COMPONENTS OF STANDARD FLOOR PLATE

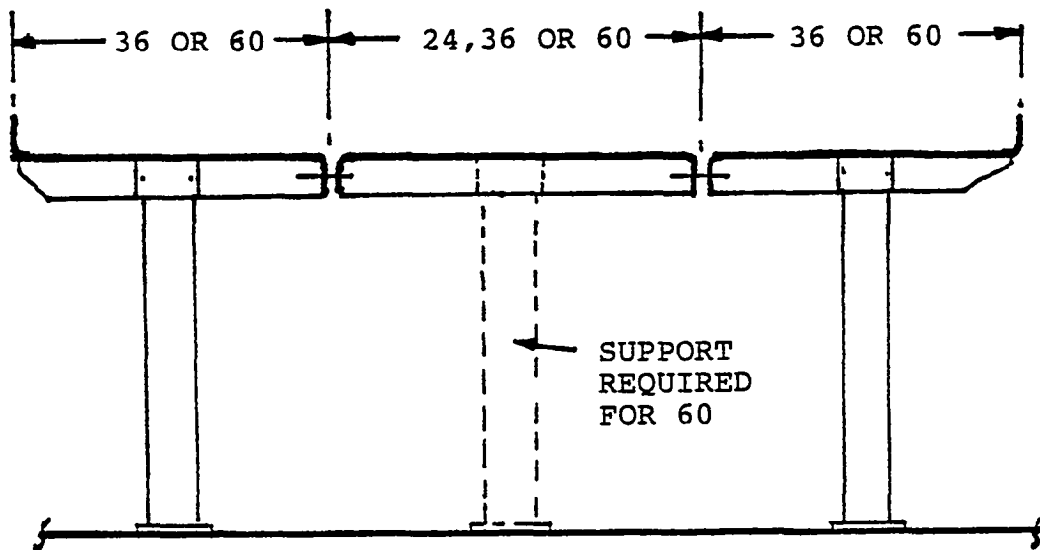

[B] COMBINING STANDARD COMPONENTS

FIGURE 1.101 Standard floor-plate system.

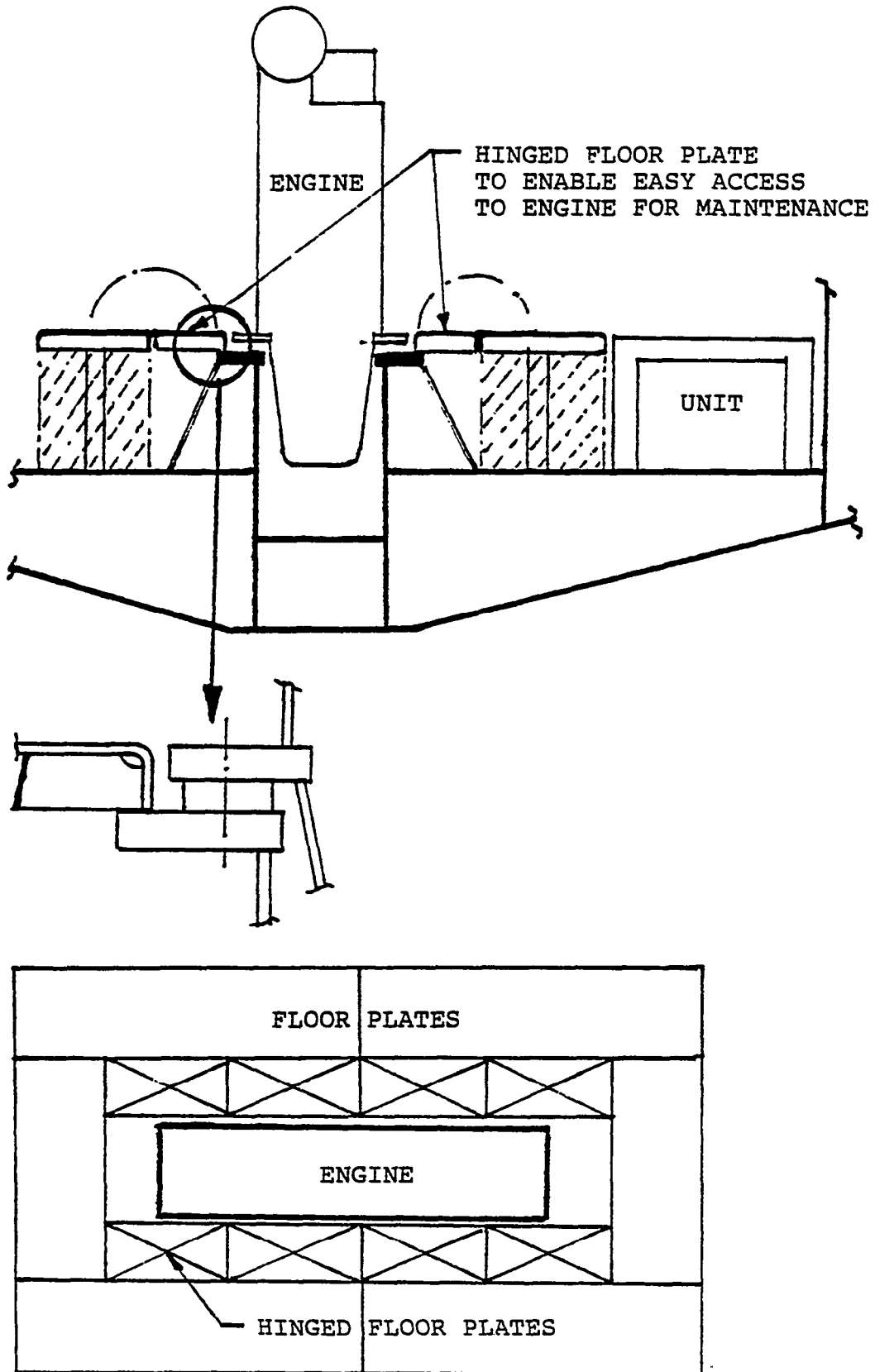

FIGURE 1.102 Hinged floor plates adjacent to engine.

between them. Only equipment which requires a foundation is listed. The addition of valves, gauges, switches, etc. is accomplished when preparing the diagrammatic. This equipment -association list was then developed into a “connection network” which became the basis of the system diagrammatic. For advanced outfitting “on-unit” construction, it is necessary to use the equipment-association list and network to select the grouping of the equipment in the unit. A typical equipment-association list is shown in Table 1.8, and Figure 1.103 is the resulting network.

TABLE 1.8
EQUIPMENT-ASSOCIATION LIST

System(s):	Propulsion Diesel Engine LO. semice
Major Equipment:	Propulsion Diesel Engine
Association Equipment:	LO. standby/Prelube Pump LO. Filter LO. Cooler L.O. Duplex strainer Rocker LO. System Tank Racker LO. standby Pump

Figure 1.104 shows a typical design diagrammatic prepared without any consideration of equipment-association grouping. It is easy to see the illogical location of items. Figure 1.105 shows a logically grouped diagrammatic developed from an equipment-association network

1.7.4 MACHINERY ARRANGEMENT. The machinery arrangement development obviously must take into account whether or not advanced outfitting is to be utilized. The equipment-association list, the network, and the final diagrammatic are the basis for the design of a machinery unit. The arrangement of the equipment, and the overall dimensions of the unit, will be affected by the space available in the machinery space, and the other equipment/units therein. It is therefore normal for the design of the unit and the arranging of the machinery space to be performed concurrently. Units should be arranged with the following points in mind:

- (a) Identical units for identical major equipment should be located identically with identical connections (true modularity).
- (b) Units should be located with both the major equipment and the system storage tanks in mind, so as to provide both the best operational and least-cost arrangement.
- (c) Completely forget the traditional concept of *mounting* equipment on the bulkheads, unless all the unit equipment will be installed as a unit on the bulkhead. The design of a unit must be developed from the concept of support from only one plane. Occasional braces can be allowed for high small plan area units.

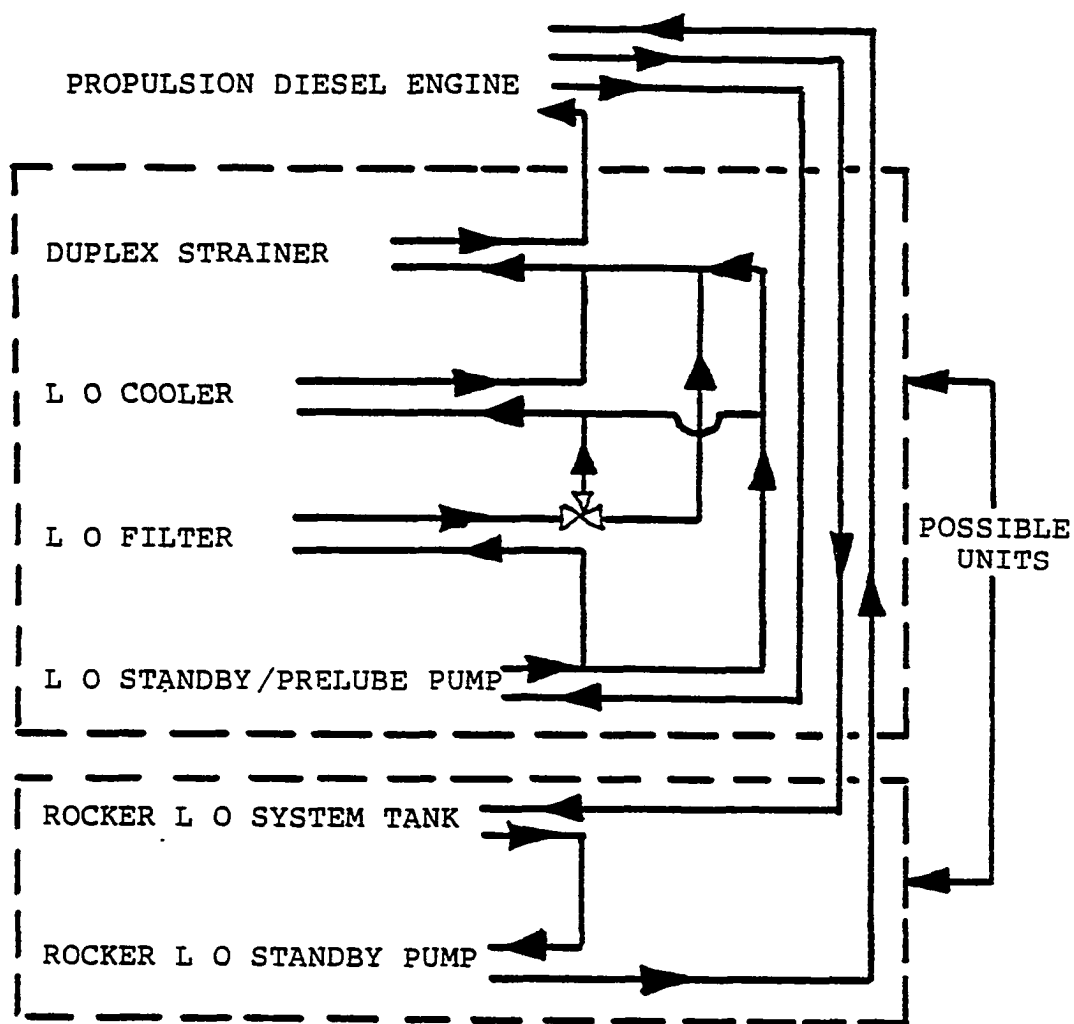

FIGURE 1.103 Equipment-association network.

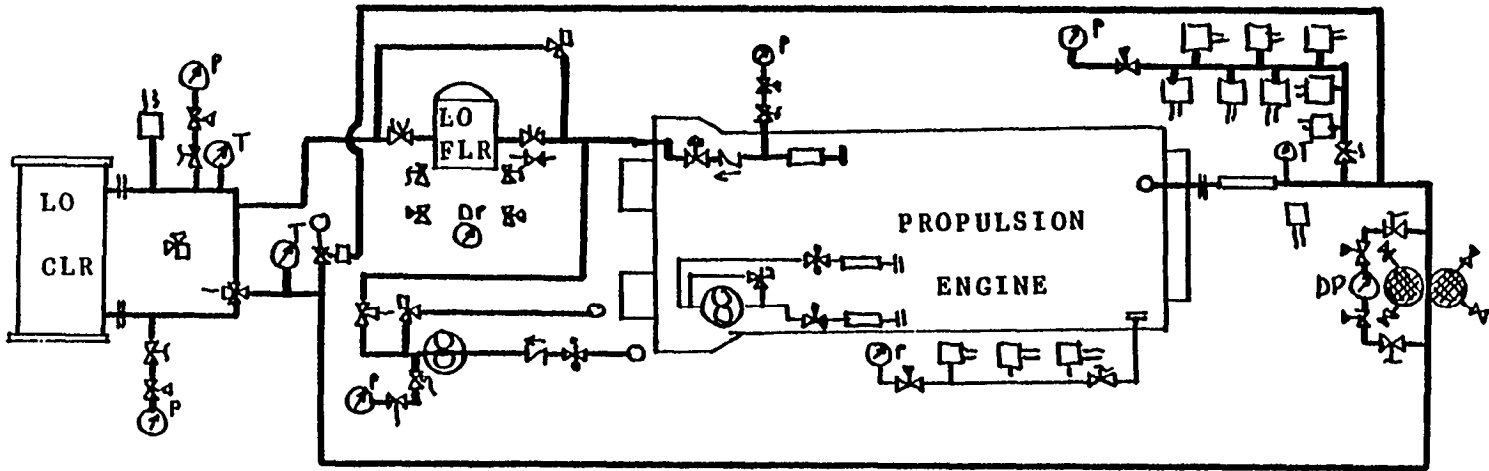

FIGURE 1.104 Illogical arrangement system diagrammatic.

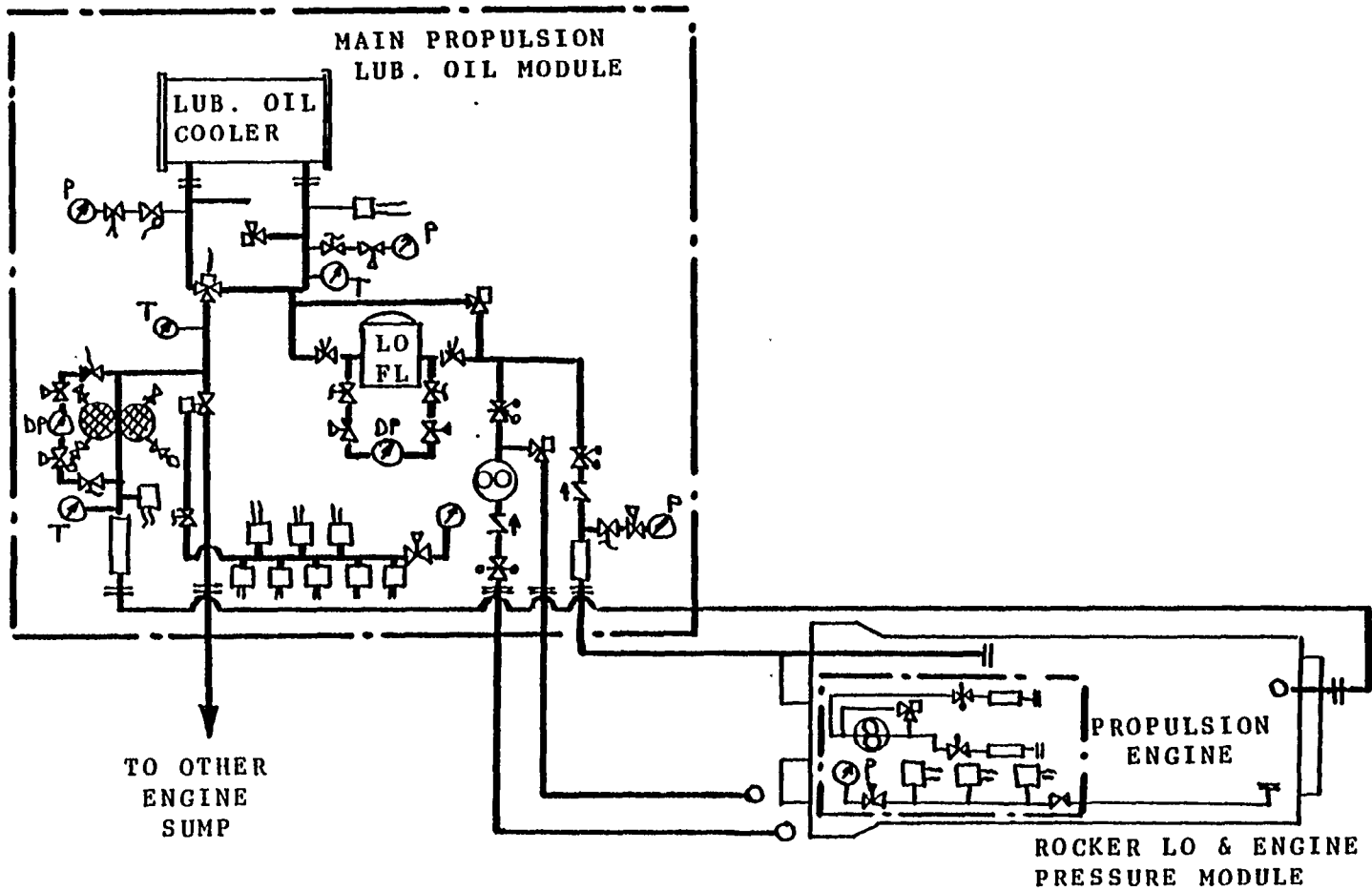
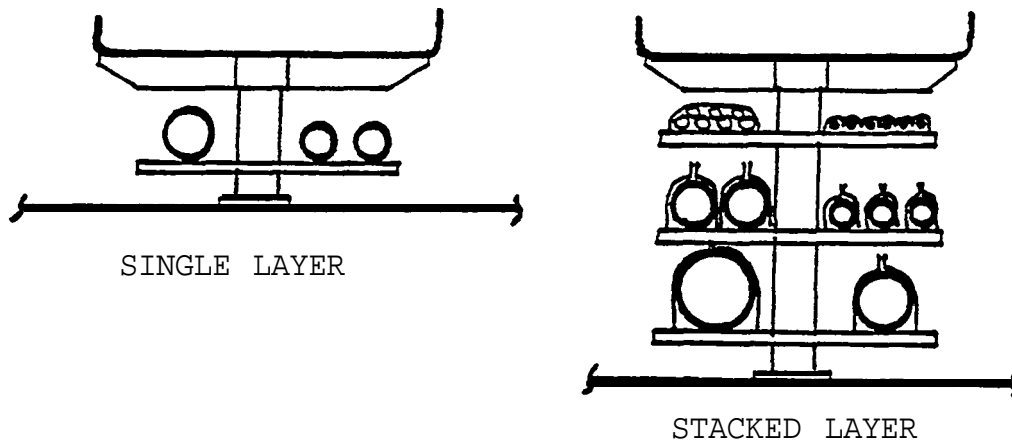

FIGURE 1.105 Logical arrangement system diagrammatic (easy application for "on-unit" advanced outfitting).

- (d) **Units should be arranged so that all piping runs are as short as possible, and only in the transverse and longitudinal directions. Diagonal runs should be avoided unless absolutely necessary to suit unit design. This will reduce the piping work content.**
- (e) In conjunction *with the arranging of units, distribution system routing zones* should be established. Where possible, major routing zones should be integrated with floor plates, gratings, walkways, and their supports.
- (f) Personnel access systems (grating, etc.) should not be more than that required to provide access to equipment requiring such access for intended functions such as normal and emergency operation, maintenance, and escape.
- (g) Maintenance lifting or pulling arrangement should be fully considered when designing the arrangement, and incorporated on the unit where practical.
- (h) Hand rails should be arranged for safe access during construction, and after installation of the unit.
- (i) Combine as many systems into a unit as possible and practicable with good design and productivity in mind. For example, if large ventilation ducts are in the vicinity, attempt to combine them with walkways, as shown in Figure 1.106.
- (j) Valves should be located so as to come up at the side of the grating and floor plates, as shown in Figure 1.107, and not below or through the middle of the floor plates.

Applying these concepts to unit design results in the unit shown in Figure 1.108, which is the L.O. system for the propulsion diesel engine.

1.7.5 SYSTEM ROUTING. The development of distributive systems is then simply a connecting together of the various equipment groupings to the service and storage tanks, and the major stand-alone equipment. To this must be added the desire to develop distributive systems into integrated, self-supporting piping, vent ducts, floor plates, handrails, wireways, etc. system packages. Figure 1.109 shows typical system-routing zones for a single-engine machinery space.



[A] COMBINED FLOOR PLATE/SYSTEMS SUPPORT

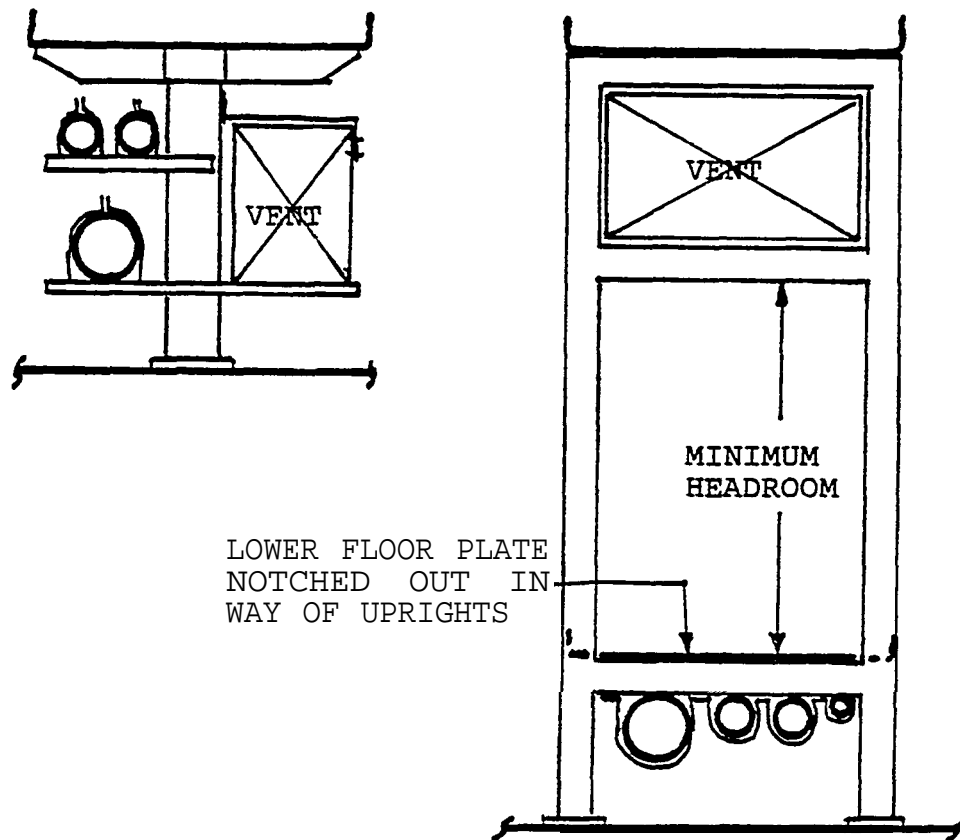

[B] COMBINED FLOOR PLATE/GRATING/SYSTEMS SUPPORT

FIGURE 1.106 Integrated support concepts.

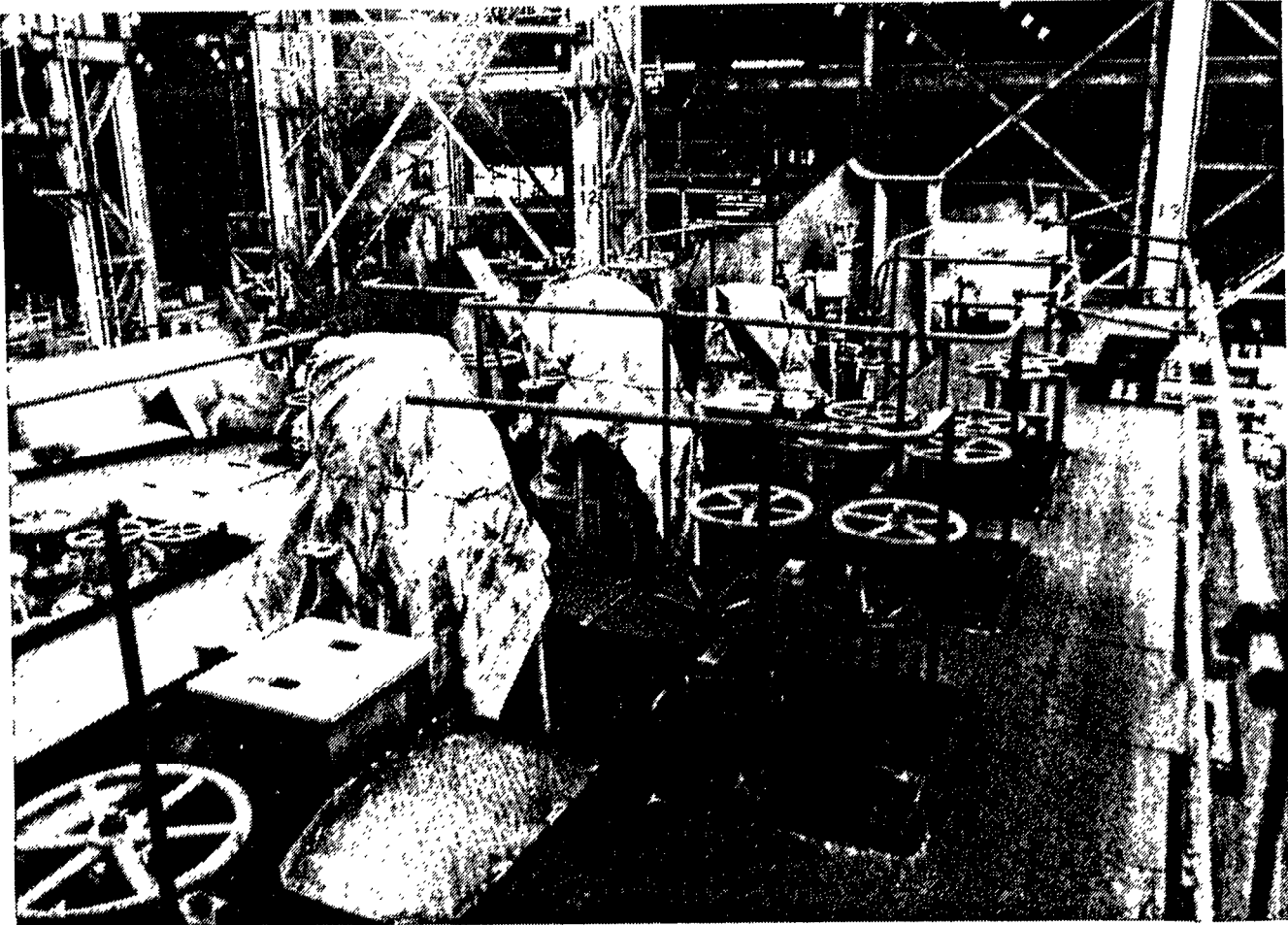

FIGURE 1.107 Valve location designed for production and operation.

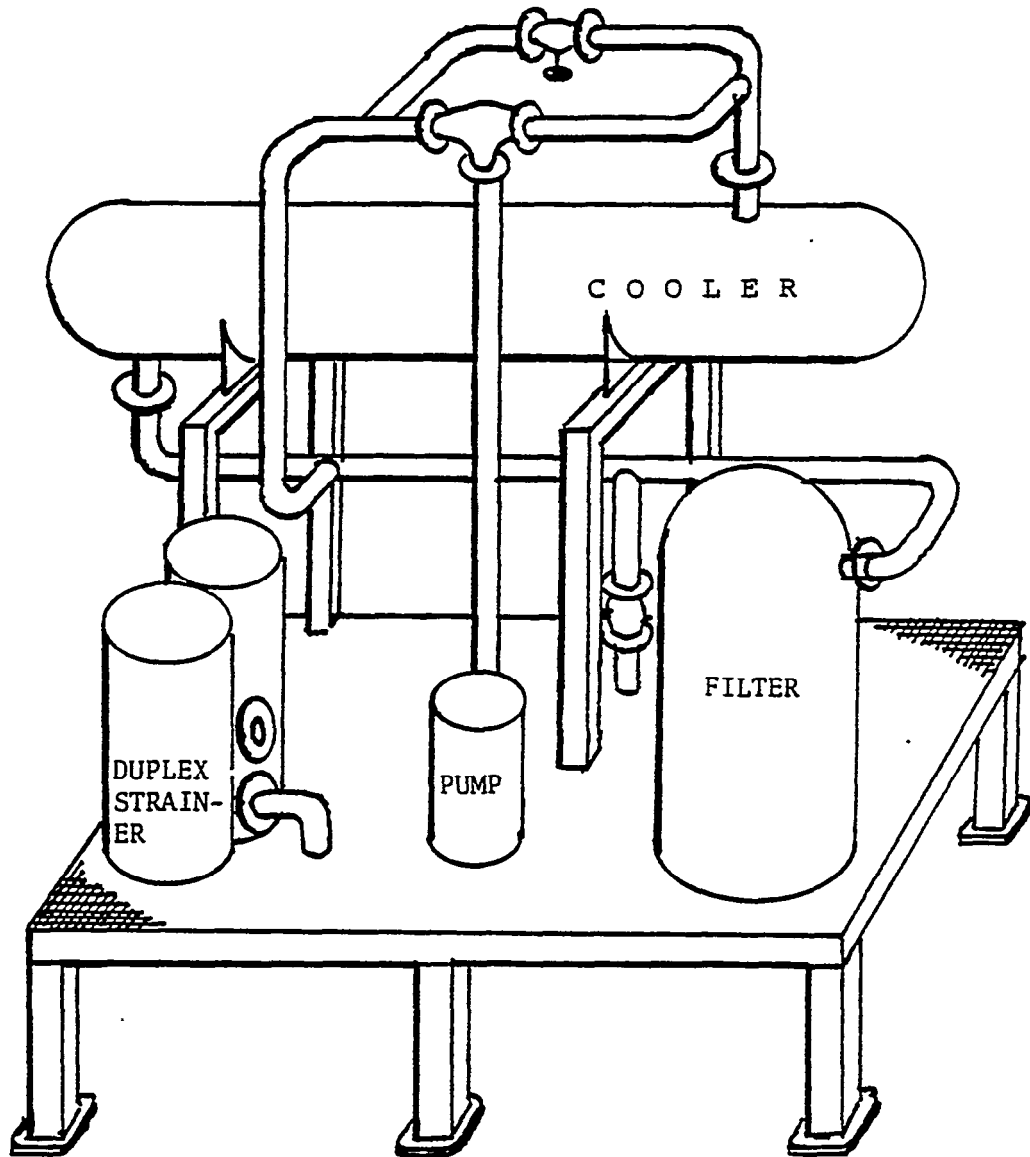

FIGURE 1.108 Typical "on-unit" package.

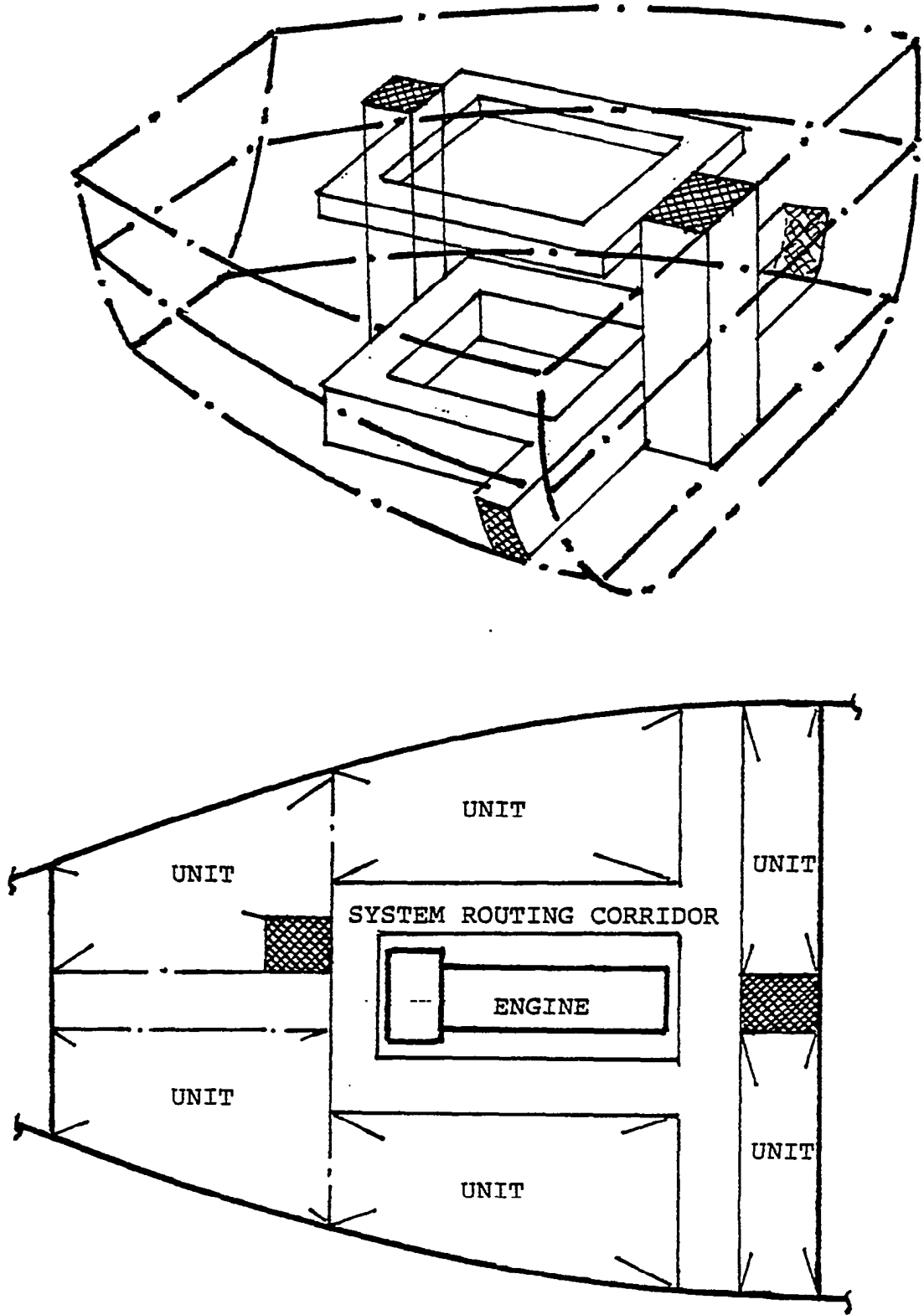

FIGURE 1.109 Distributive system corridors.

1.8 Piping

The design of piping systems in ships varies from simple in small ships to complicated in large naval ships. It is a major cost influence in U.S. shipbuilding because:

- Current dependency of industry on naval ships
- Generally higher class of commercial ships with more complicated distributive systems than foreign ships
- Reference for welded pipe connections instead of flanged or other mechanical connections

Unfortunately, very few U.S. shipbuilders have done much to improve the efficiency of their piping fabrication. Coupled to this is the fact that the design of piping systems has not been performed with production in mind, and the result is inefficient design and low productivity. That this is true can be proven by a visit to many recently constructed ships. It will be immediately obvious that each pipe system has been designed with individual hangers which may in turn be supported by primitive extensions to the ship's structure. Pipes will crisscross, be jogged around manholes, rise vertically through floor plates, and obstruct access to equipment. They may even penetrate structure that should never be penetrated. Yet it is clear that with some design planning, the design could have been simplified, and the above mistakes avoided with significant savings in material and construction manhours. The use of advanced outfitting has forced designers into locating pipe runs in pipe passageways (or zones). However, this was done by some designers long before advanced outfitting came into vogue. The efficient routing of all pipe in any part of the ship is a basic step in its design. The combining of hangers and supports is another. Yet as they are obviously not practiced by many piping designers, they are re-invented as essential techniques of design for ship production.

The first requirement for ship piping designers is a complete understanding of their shipyard's pipe fabrication facility and methods. This should be detailed in the shipyard production specifications. The actual application, and any unique requirements for a particular ship, should be detailed in the building plan. The piping designer must be aware of the assembly and module breaks so as to ensure that no equipment is located over breaks, and also to arrange natural connections at the breaks. Again, whether or not the advanced outfitting approach will be utilized, the steps outlined in Section 1.7 should be followed, namely:

- Prepare equipment-association lists
- Prepare equipment-association networks
- Prepare diagrammatic (use or modify a standard if possible)
- Select distributive systems zones
- Prepare routing diagrammatic
- Prepare zone design composites
- Prepare pipe assembly sketches and part list
- Prepare pipe installation instructions

Like all other systems, standardization will assist in accomplishing design for production . . . not only standard components but standard complete systems and standard routing zones. Figure 1.110 shows possible routing zone standards. The benefit of using these from ship to ship is that the shipyard designers and production workers will learn from repetition where the different zones and systems are located. If, in addition to standard systems routing zones, standard location for equipment is adopted, the resulting benefits would be very noticeable. The concern of many that the continual use of standards of this nature will restrict innovative development and progress in design must

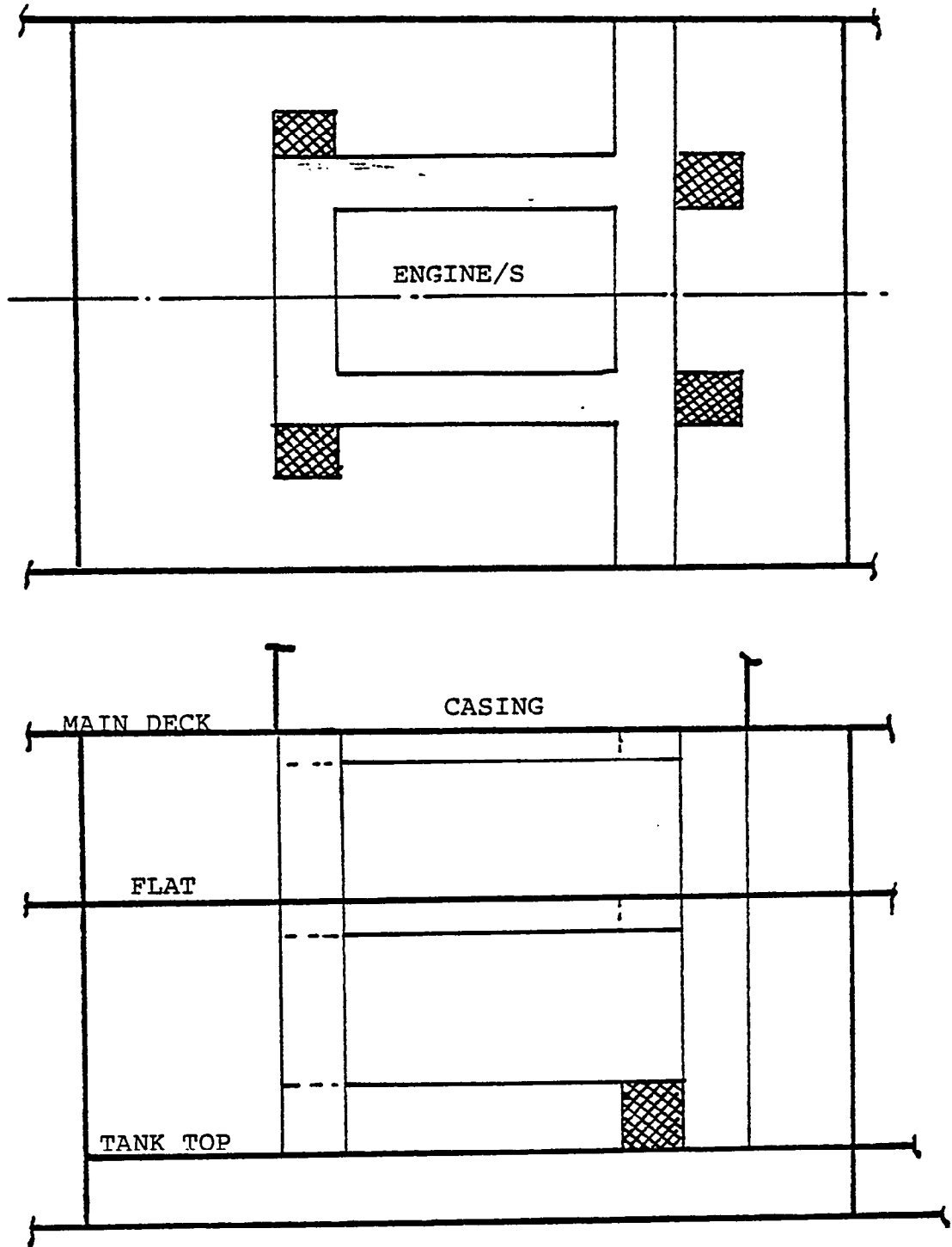

FIGURE 1.110 Standard machinery space system corridors.

be kept in mind. Where possible the system standards should be continually reviewed for improvement and when technology warrants it, the standard should be completely renewed.

Individual *design for ship-production* concepts for piping are worth development as there is significant opportunity for productivity improvements. The combining of a number of pipe runs into bundles or units has already been mentioned. The use of purchased pipe hangers should be fully evaluated compared to individual design and fabrication. Special hangers combined with unique support systems, such as those offered by UNISTRUT, shown in Figure 1.111, are worth considering. Another concept is the use of flanges as installation joints instead of welded joints. Flanges are used extensively in foreign shipbuilding, but have been resisted in the U.S. The use of DRESSER pipe couplings and VA-N-STONE flanges will reduce the installation manhours. One point of importance is that flanged pipes can be located closer together than welded pipes due to the need for space around welded pipes to 'get in' to weld. For bulkhead penetrations a flange connection at both sides of the bulkhead and installation of the "spool piece" during structural assembly can save significant piping installation manhours. Multiple penetration plates, and the use of bulkhead flanges instead of sleeves, is also a work content reducer. These concepts are illustrated in Figure 1.112.

The design of seachests should be developed to reduce work content. One obvious way is to reduce the number of parts. Figure 1.113 shows some ways this can be accomplished.

The use of PVC and Fiberglas pipe can reduce the fabrication and installation manhours, compared to traditional metal pipe. This results from the lighter weight and simpler joining method. There are certain ship systems for which PVC and Fiberglas pipe cannot be used, but where they can they should be fully considered.

Another detail that can incorporate work content reducing concepts is piping passing through a tank top. Flanges should be provided just above the tank top for filling, suction, and vent piping. This enables the piping to be easily blanked off for tank air testing, as shown in Figure 1.114. In some shipyards the navy inspectors have not allowed flanges in fill and suction piping. In this case, a flange should be provided just above the bellmouth in the tank. For the vent pipe the flange should be located just above the weather deck or other convenient place. It is common practice to install open-ended sounding tubes with striking plates welded to the tank bottom. Where the sounding tuba slopes at the end, it is common to close the end by a welded plate and slots in the tube, or to weld an angle clip over the end as shown in Figure 1.115. It is suggested that the slotted end with welded plate should be used in all cases, as it requires no work in the tank once the tube is installed. The second alternative is simpler, and if installed during the module assembly, will require minimum work content.

The structural definition and assembly methods must be studied before pipe breaks are selected. Pipe joints at bulkheads, flats, decks, etc., should be selected so that when made they are at an easy working height from an existing position on which the worker will stand. Many times such joints are located at an overhead position which needs staging to allow the worker to reach them. This is illustrated in Figure 1.116.

pipe clamps

Slotted hex head screw
and nut included

UNISTRUT All Purpose Metal Framing

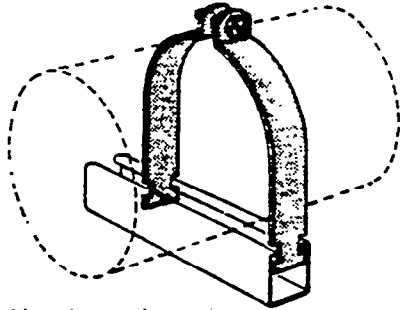

Finish — electro-galvanized

P 1425 thru P 1431

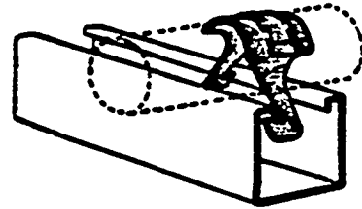

P 2426 thru P 2431

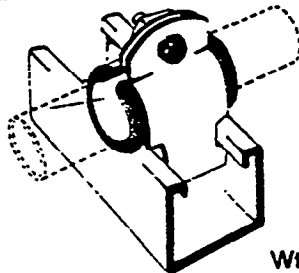

UNI-CUSHION

25 FEET PER BOX

Wt. Lbs./Box 2.5

P 2600

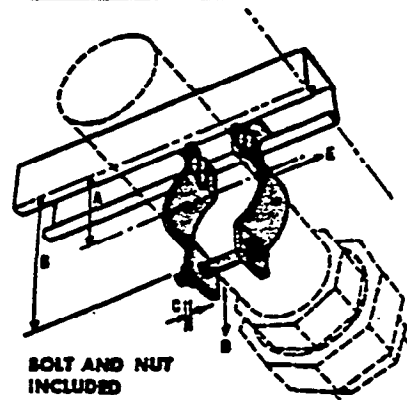

BOLT AND NUT
INCLUDED

P 3409 thru P 3417

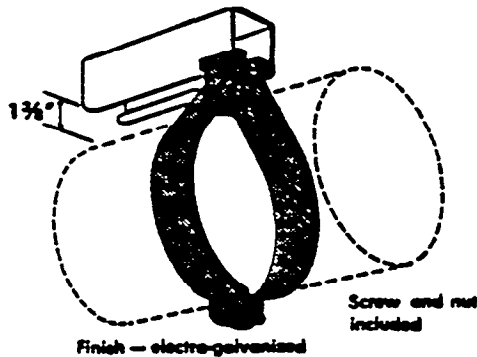

Finish — electro-galvanized

P 1563 thru P 1573

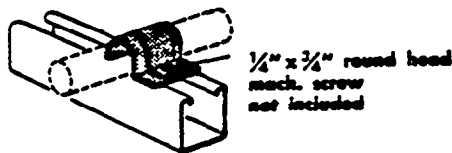

Finish — electro-galv

P 2008 thru P 2020

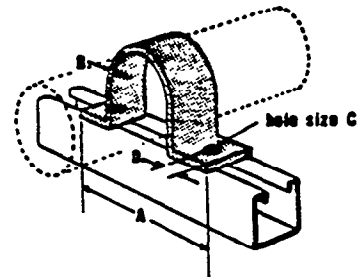

P 2558-5 thru P 2558-60

FIGURE 1.111 Special pipe hanger and support system.

215

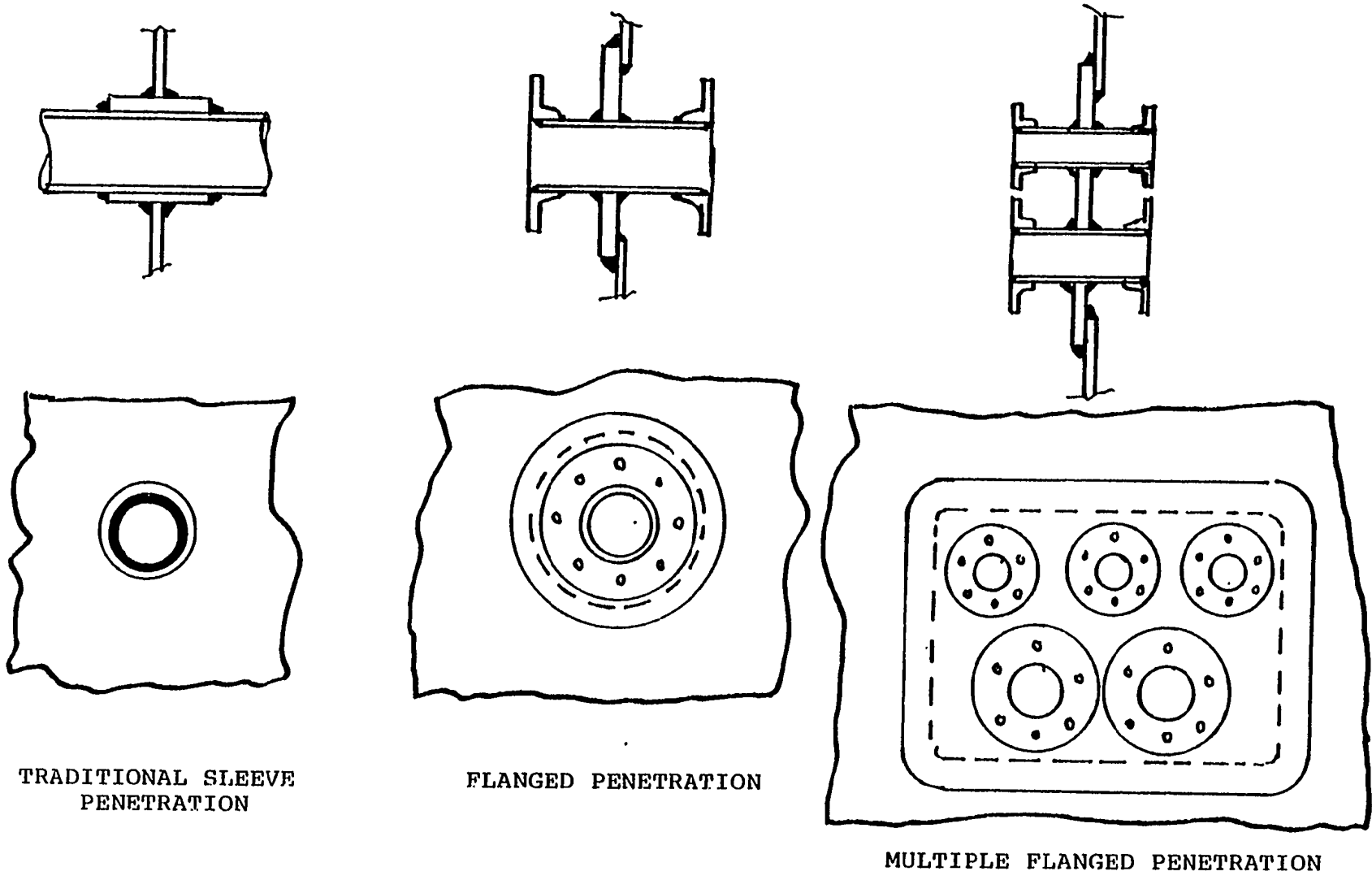

TRADITIONAL SLEEVE PENETRATION

FLANGED PENETRATION

MULTIPLE FLANGED PENETRATION

FIGURE 1.112 Piping penetration design for productivity.

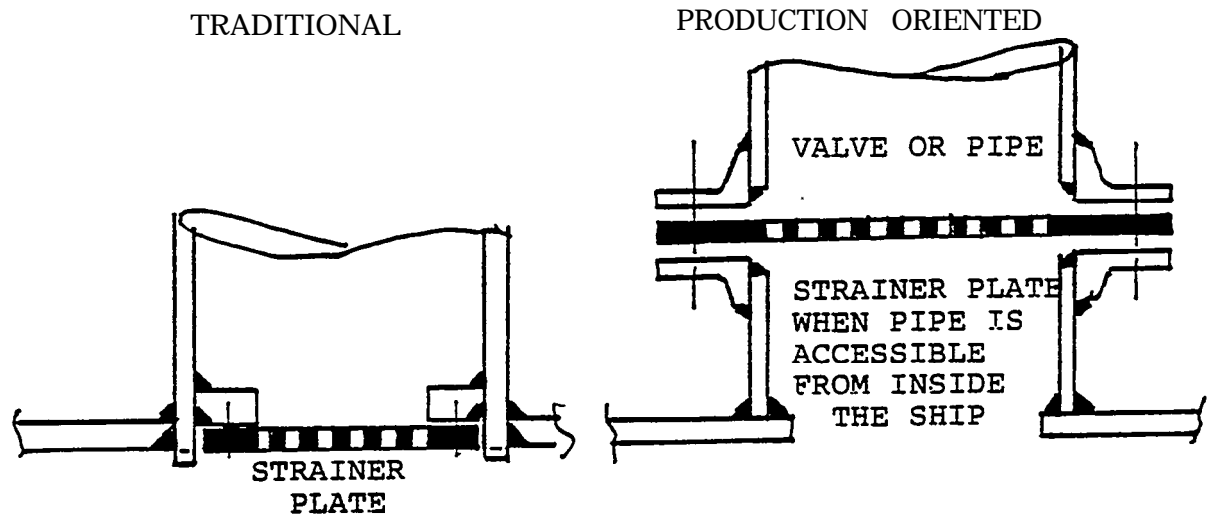

[A] PIPE/SHELL CONNECTION

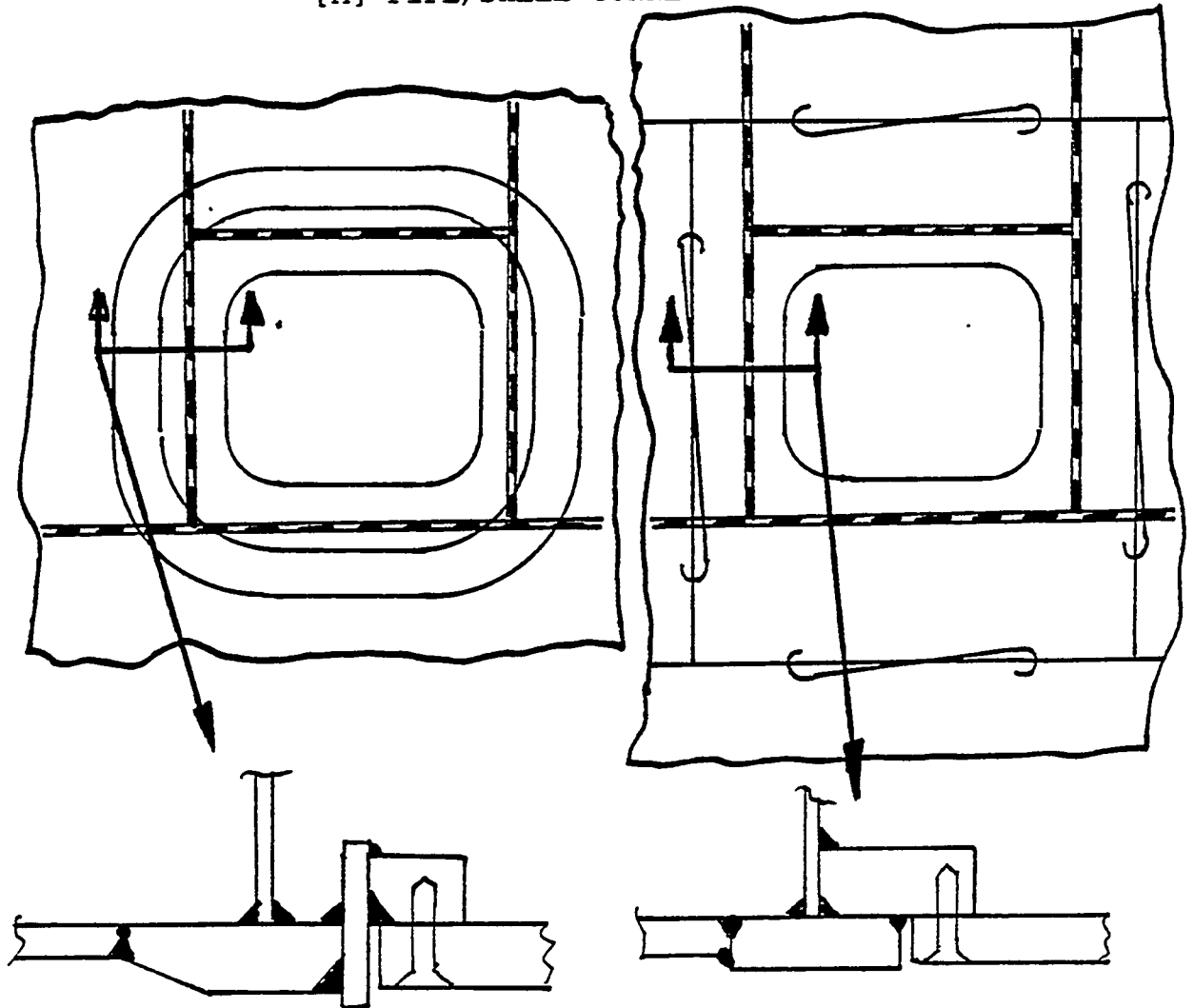

FIGURE 1.113 Seachest design for production.

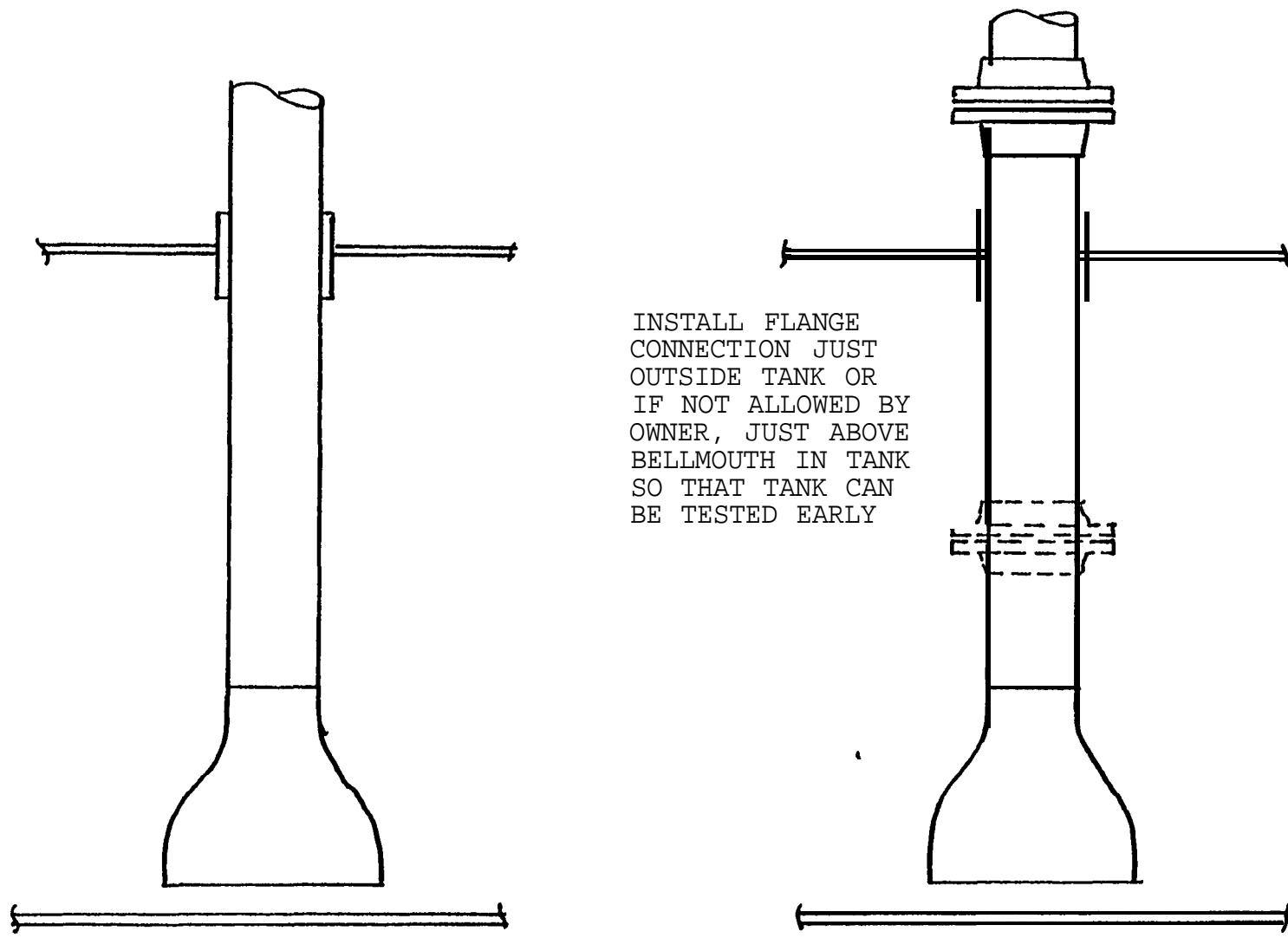

FIGURE 1.114 Piping passing through tank tops.

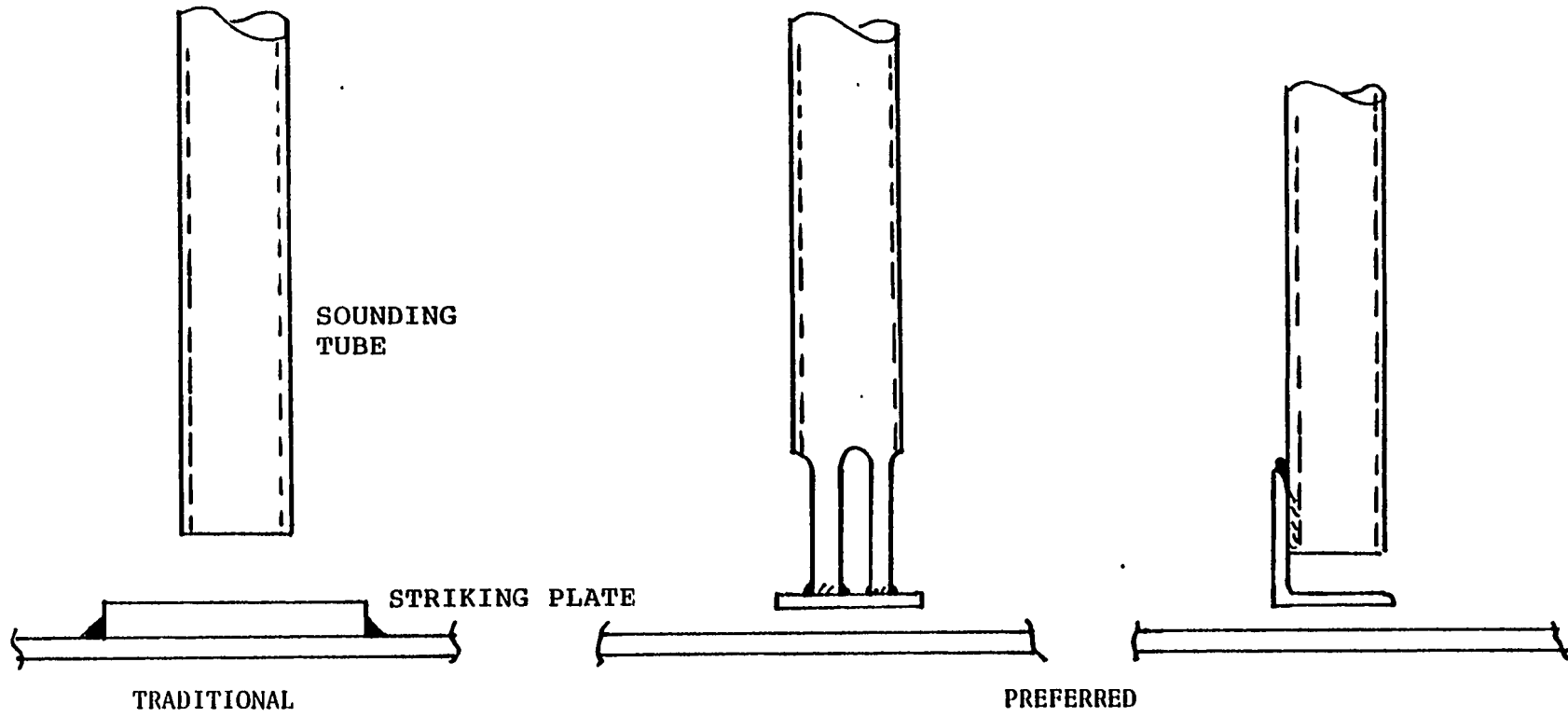

FIGURE 1.115 Sounding tube design for production.

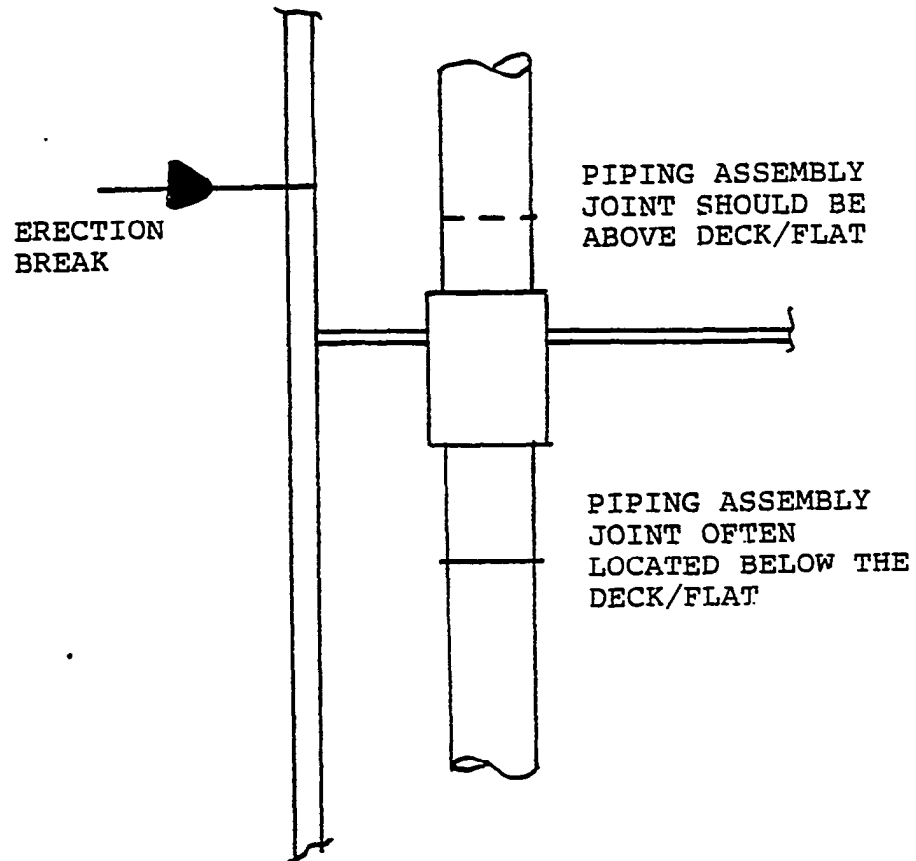

FIGURE 1.116 Pipe joints for module erection.

The quest for production-friendly pipe design can be greatly assisted by computer-aided design (CAD) piping systems. Some of those available today have pipe routing, interference avoidance, and alternate route selection capabilities. Even those without interference control usually end up with a better (more accurate, less interference) design than that prepared manually due to the logic, techniques, and greater accuracy of the system. Also, most of the CAD piping systems prepare the pipe assembly sketches and parts list. Some even give N/C instructions for numerically controlled pipe cutting, flange connecting, and bending machines. The CAD piping systems will be further discussed in Section 2.11.

A thorough investigation of the fabrication and installation benefits should be undertaken by a shipyard before adopting any of the above ideas.

1.9 HVAC

In traditional design and construction of ships, systems such as piping, HVAC, and electrical are always “fighting” each other for space. To overcome this problem some designers allocate space priorities to different systems such as HVAC first-large-diameter pipe next-electrical wireways-and so on. Unfortunately, from experience, this approach does not work well. This traditional conflict does not end with design and engineering, it continues out on the ship during construction. Added to this shipboard conflict is the “field run pipe” and “who gets there first” problems. However, this conflict can be changed into planned integration of systems by applying the approach described in Part 2: Engineering for Ship Production.

An essential step to ensure a production-friendly design of HVAC systems is to plan the distribution zones early in the design development at the same time as the development of the zones for piping and electrical systems. Again, the use of standards for HVAC components and diagrammatics is an effective design for production approach. Obviously, the standards should be minimum-work-content designs. Some concepts for ventilation duct are shown in Figure 1.117. The production-oriented designs are all easier to construct and have less work content. The design of duct hangers can simplify installation and reduce manhours, as shown in Figure 1.118. Also, where deep beams or closely spaced steel accommodation bulkheads are fitted, the duct can be installed through them during assembly, thus eliminating the hangers. By correctly planning the design of the HVAC systems during basic design, the need for high-work-content penetrations, duct jogging, and section changes can be eliminated. By considering louvers and plenum chambers as integral parts of the structure, instead of HVAC fittings, considerable design and installation manhours can be saved. The use of high-pressure ventilation systems will reduce the size of ducting, and can result in significant installation manhours savings. However, the cost of any special noise attenuation components will cancel out some of this saving.

The provision of insulation inside the duct as is used in naval construction is worth consideration as a work content reducer for commercial ships. However, it is not currently approved by USCG. Also, the use of individual room convector heater/cooler units should be examined as a potential productivity improver without any operational disadvantages.

The locating of HVAC equipment, and the selection of duct joints, must be compatible with the assembly and module breaks to facilitate advanced outfitting.

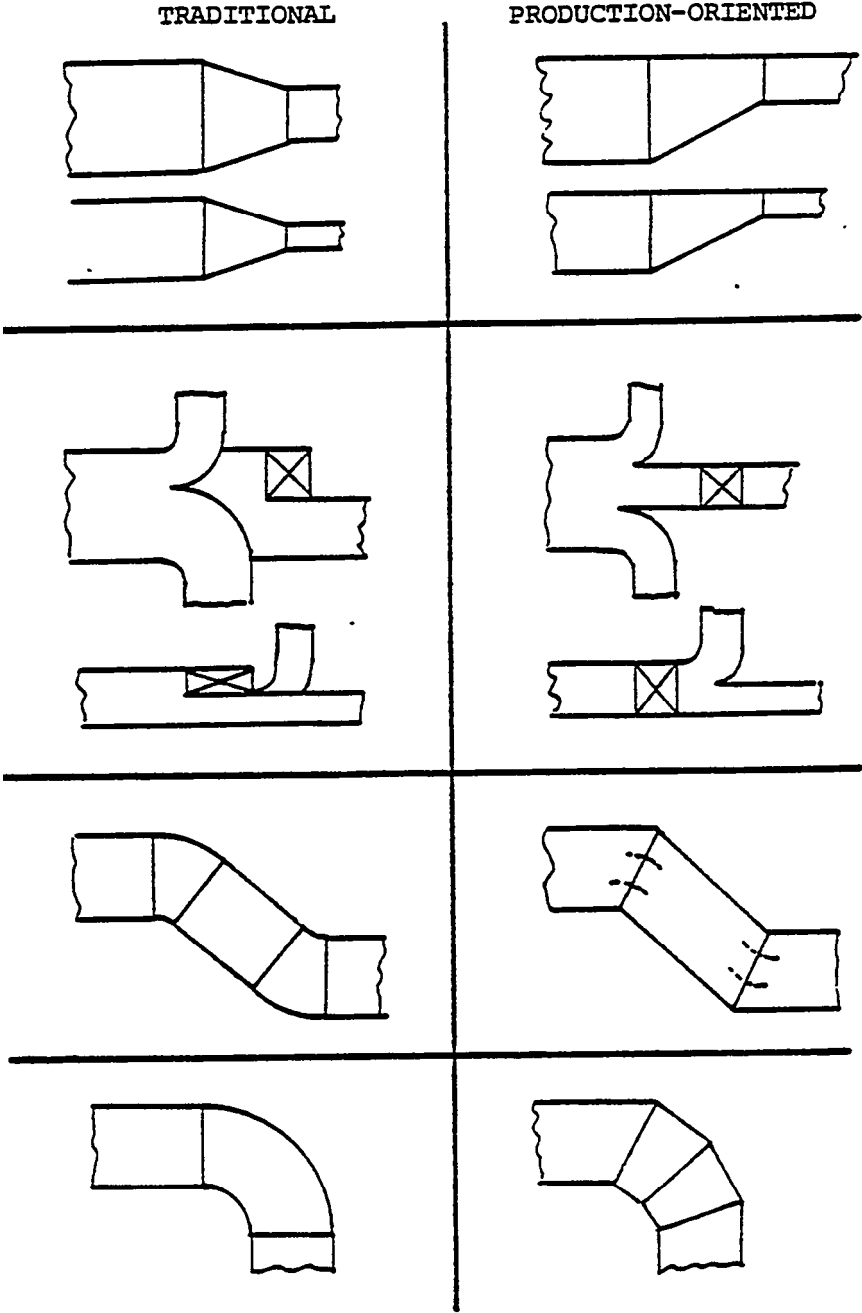

FIGURE 1.117 HVAC design for production.

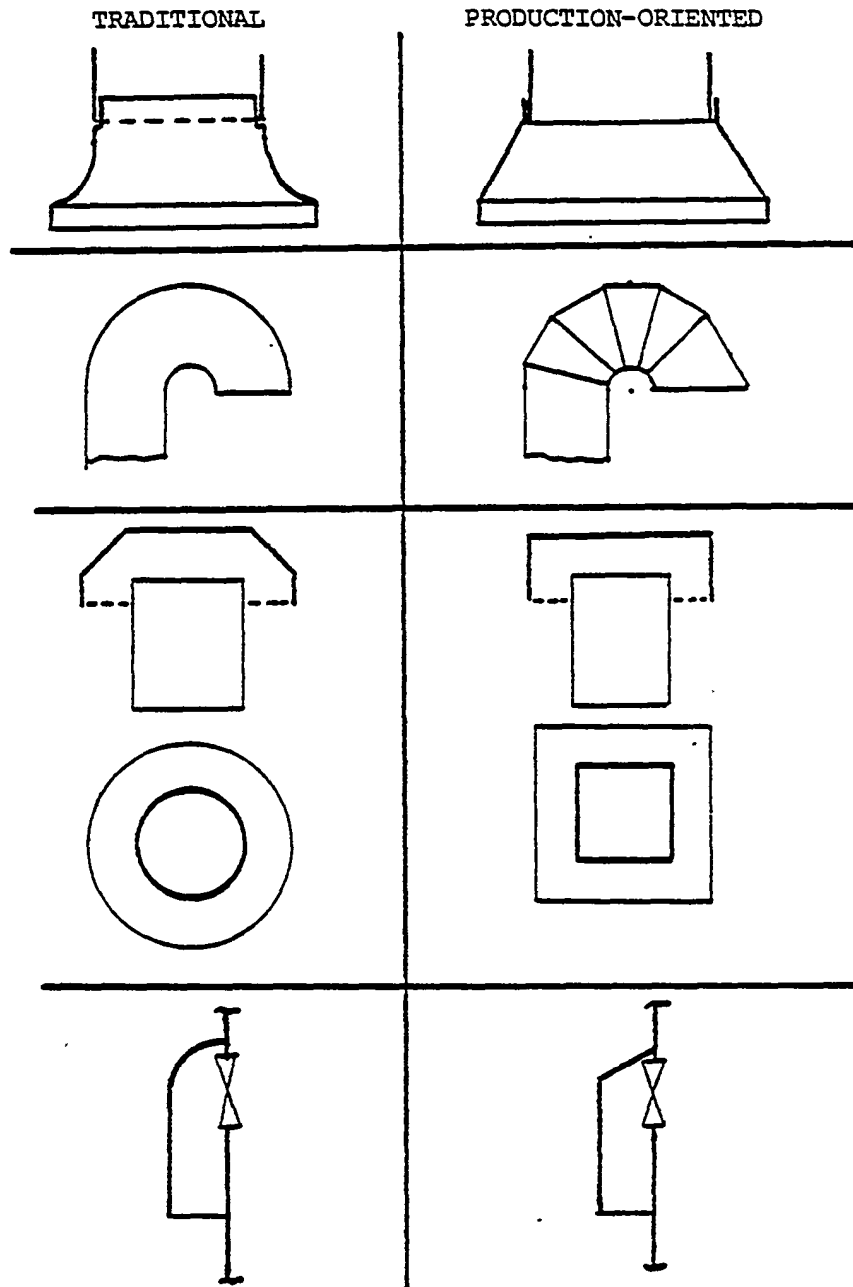

FIGURE 1.117 (Continued)

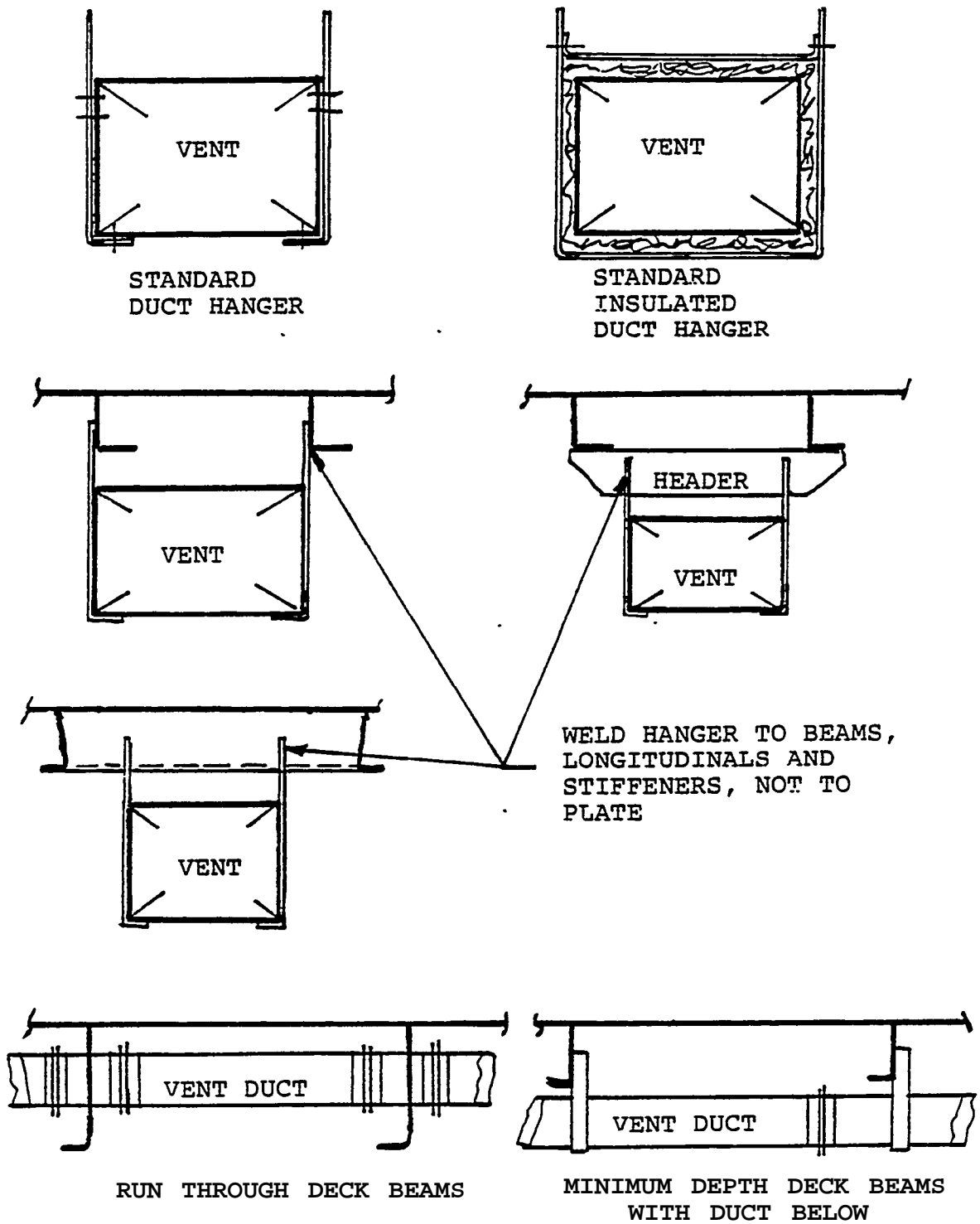

FIGURE 1.118 Standard duct support.

1.10 Electrical

As for the other traditional disciplines, the first design-for-ship-production-approach requirement for electrical systems is that they be considered along with and at the same time as the others. This integration of all systems is essential if an efficient and easily constructed ship is to be designed. Routing zones for wireways should be assigned during basic design and used for cable routing as the design is developed. The provision of “natural” cable breaks by equipment or panels in way of assembly and module breaks facilitates advanced outfitting.

In most shipyards, electrical design and engineer& is the minimum possible, leaving many decisions to the electrical craftsmen on the ship. For example, many electrical drawings are not drawn to any scale, and give “general” location of the equipment. This is a disaster when electrical equipment is installed early without regard to the installation of other systems, which in many cases leads to the electrical equipment being installed in a **position** assigned to another system, causing significant rework when the problem is discovered. Such an approach should never have been tolerated in the past, and today is absolutely not acceptable. All systems should be given equal and adequate treatment for the needs of today’s production approaches. In the case of advanced outfitting, it is mandatory that electrical design be developed in detail, and integrated with all other systems.

Marine electrical design and engineering is the ship discipline that has had the least effort to improve it. The **design-for~production potential is** therefore large, and it should be targeted for significant development. The impact of advanced outfitting and zone construction is substantial on traditional marine electrical design, but can be used to guide and **direct the required** electrical **design-for-ship-production** development. Aspects such as combined control panels for units, complete electrical installation on units, on-block and zone electrical installation, erection of complete deckhouses, etc., must be considered and allowed for in the design approach.

The type of wireway used has an obvious work content influence. Figure 1.119 shows two typical types. Type (A) requires cable to be “threaded and pulled” through each enclosed section formed by the supports on each side of the cross piece. Type (B) obviously eliminates this problem. However, the use of this type is disliked by some due to cable falling out when pulling. This can be prevented by providing lips, or by retaining clips, as shown in Figure 1.120. Both types are generally spaced close together (24 to 36 inches).

The “rack”-type wireway shown in Figure 1.121 has considerable installation manhour-saving potential due to the smaller amount of connections to the ship’s structure. The use of closely spaced clips for small cable runs as shown in Figure 1.122(a) is worth changing. A possible alternative is the use of lightweight channel with widely spaced connection to the structure as shown in Figure 1.122(b). Connections to structure should be to the web of the beam, frame, or stiffener, and not to the face of the members or to the plating, as shown in Figure 1.123. Obviously, on an unstiffened side of a bulkhead this cannot be done. In such cases, supports should still be in line with stiffening.

It is surprising how many shipyard standard electrical equipment foundations consist of as many parts as there are bolt connections. Design for production requires that they be in one piece, suitable for mounting the equipment before the foundation is installed on the assembly, module, or ship. This concept is shown in Figure 1.124. Also, the practice of providing custom foundations for equipment, and locating them out of alignment with stiffeners, thus requiring backup structure, should be eliminated. This concept is shown in Figure 1.125.

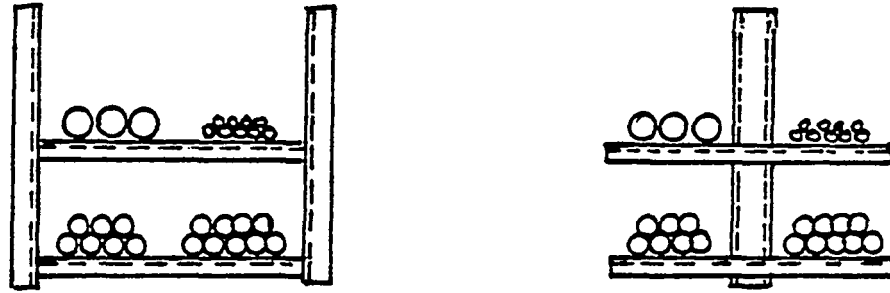

FIGURE 1.119 Typical hangers.

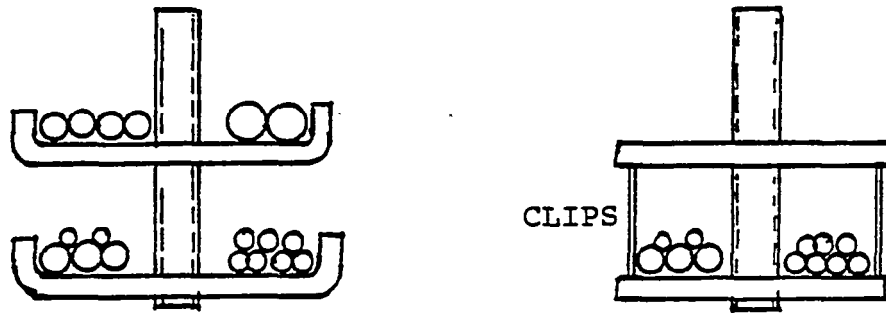

FIGURE 1.120 Cable-retaining methods.

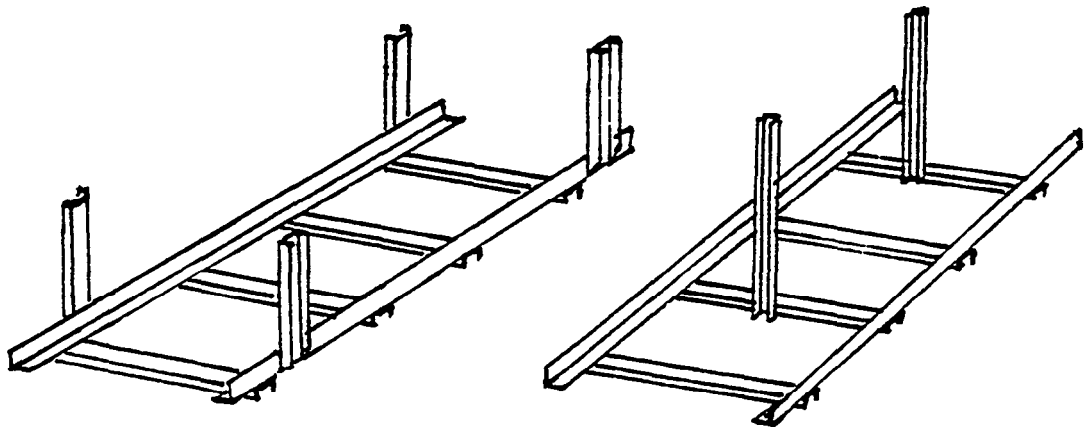
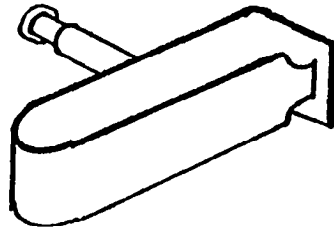
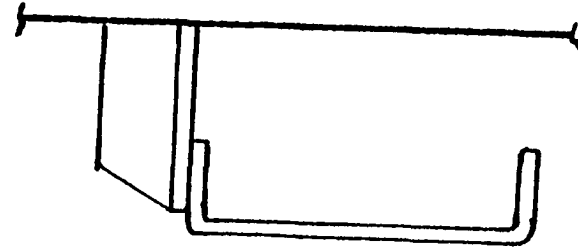

FIGURE 1.121 Wireway racks



[A] TRADITIONAL CLIP HANGER



[B] PREFERRED CHANNEL HANGER

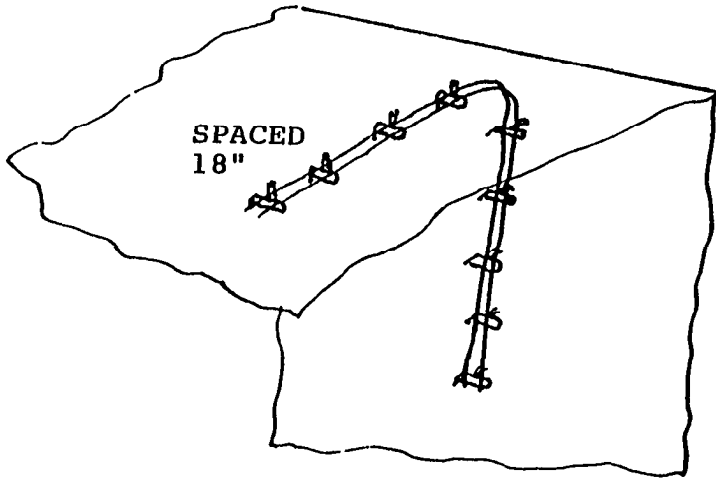

SPACED
18"

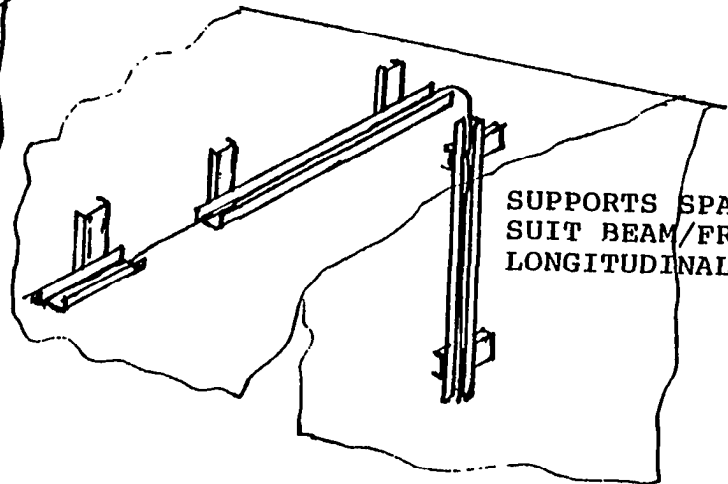

SUPPORTS SPACED TO
SUIT BEAM/FRAME/
LONGITUDINAL SPACING

FIGURE 1.122 Small cable support design for production.

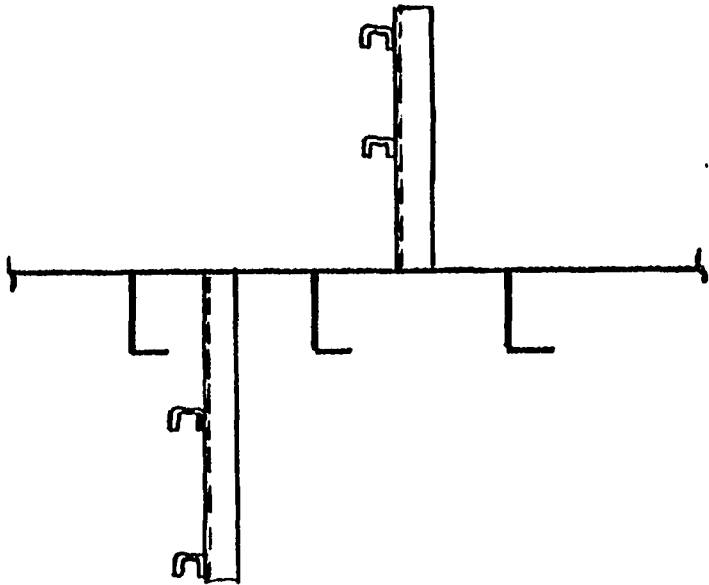

TYPICAL BAD PRACTICE - NOT PERMITTED
ON SHELL OR MAIN DECK PLATING

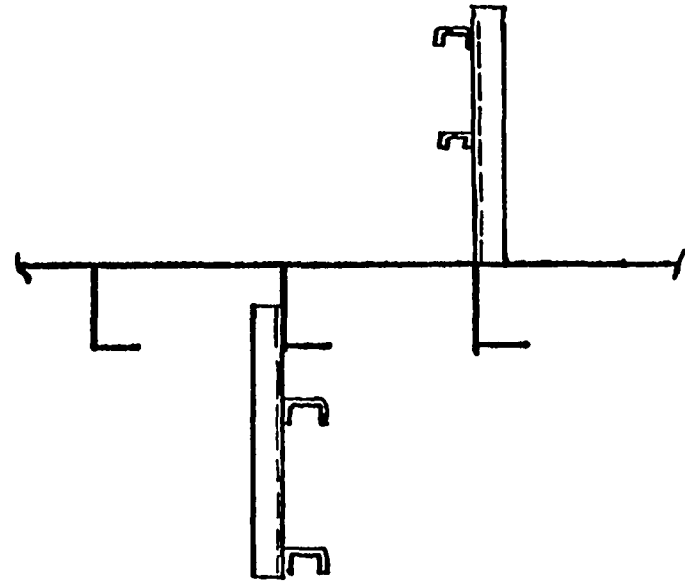

PREFERRED PRACTICE - ACCEPTABLE IN
ALL LOCATIONS

FIGURE 1.123 Wireway hanger connection detail.

TRADITIONAL

PRODUCTION ORIENTED

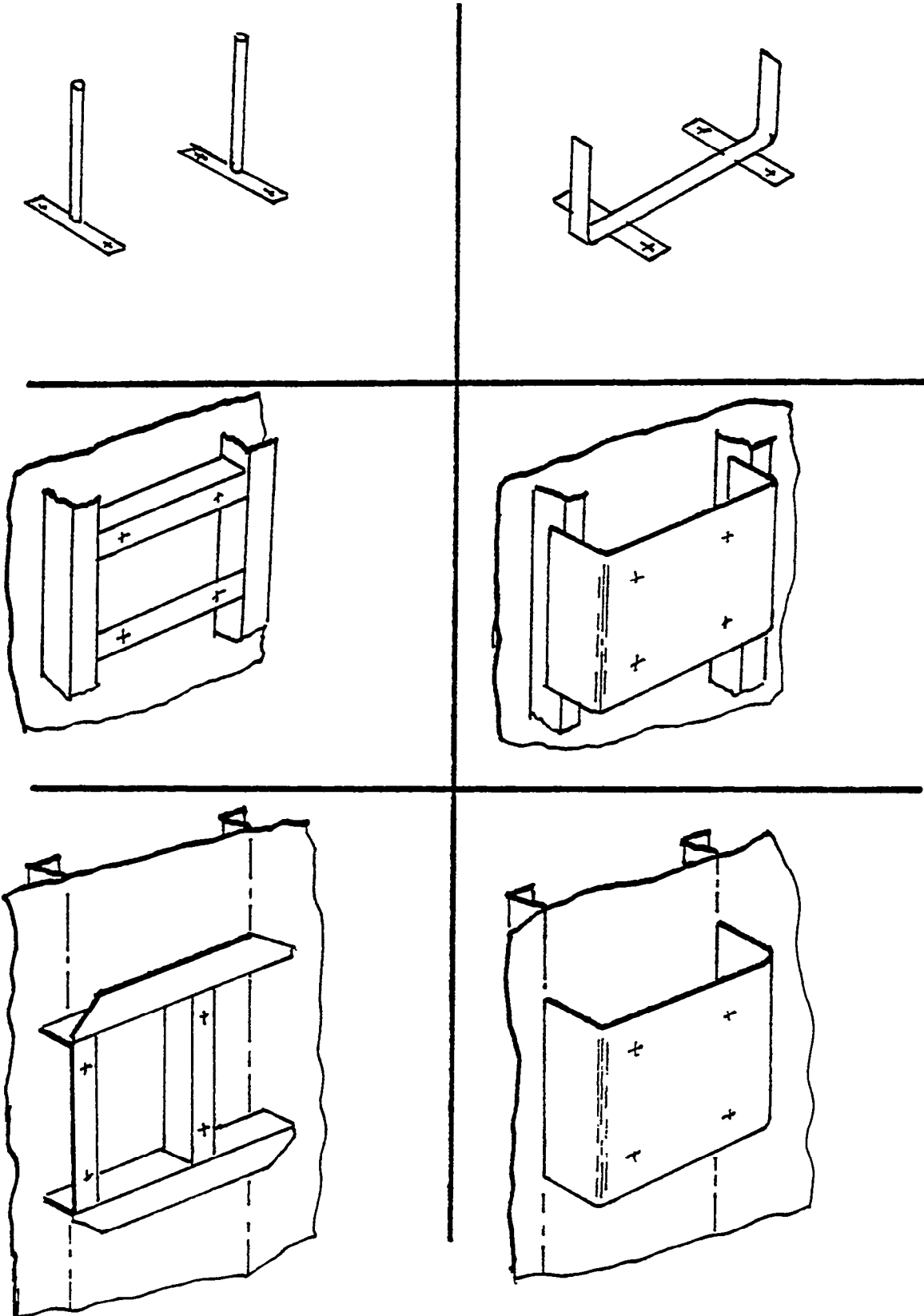
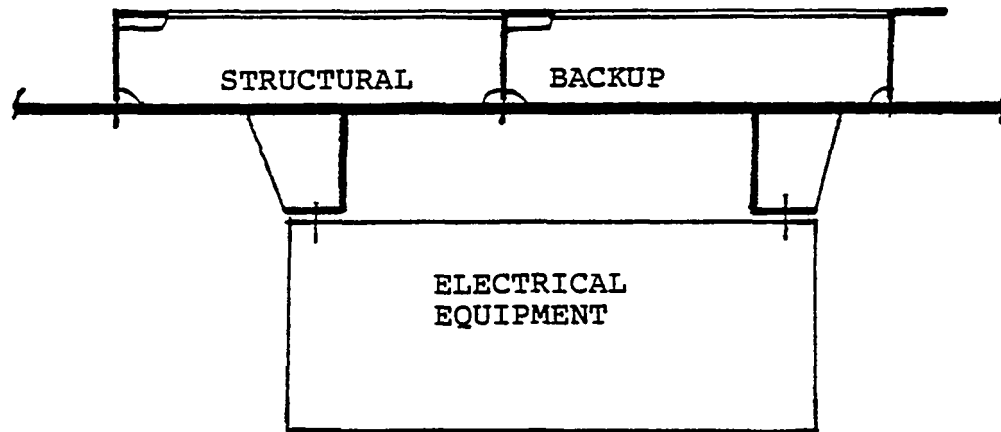
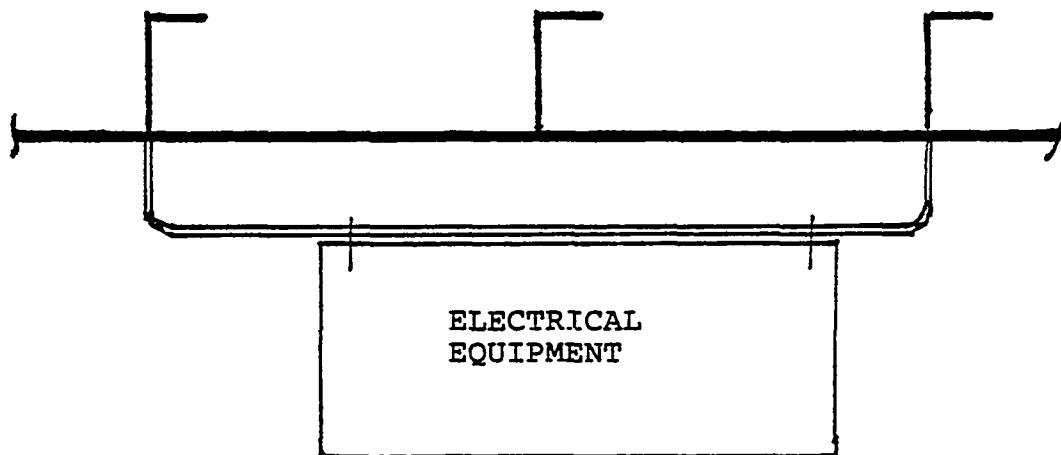

FIGURE 1.124 Electrical foundation design for production.



TYPICAL ELECTRICAL FOUNDATION WITH BACKUP



FLANGED PLATE FOUNDATION ELIMINATING NEED FOR BACKUP

FIGURE 1.125 Electrical foundation detail.

1.11 Integration of Systems

Everyone knows that the most cost-efficient ship has well-integrated components. Many others know that integration of the many systems also offers work content savings during construction. Therefore, deliberate efforts to integrate the ship systems during design **are an** essential part of **design for ship production**.

The approach is not new. It is just that the traditional **engineering** specialization/organization divides responsibility for individual systems in the same part of a ship to many groups. Also the preoccupation with independent systems design and current approach to working schedules apparently prevent many designers from attempting integrated design. The integration of systems for advanced outfitting units is simply a micro application of the approach, compared to the macro approach for the complete machinery space or the entire ship.

The specialization of skills in both engineering and production relies on the ability of managers to ensure that the design and construction of individual systems result in an integrated final product. This is accomplished in some industries by the use of systems engineering and specialized systems engineers. The systems engineers can be found in both staff and line management positions, and their interface with traditional design engineers can be either before or after the design of the individual systems is accomplished. Whatever the approach, it is obvious that there is a basic design need to ensure that all the parts of a product are efficiently integrated, and that the many compromises that are necessary during design are the best. In the past this function in the shipbuilding industry was performed by the managers and supervisors of design and engineering. In many cases this has worked, and still works well. It is obviously impacted by the engineering organization, and this should be arranged so that the work responsibilities naturally assist the system integration function by having groups responsible for all the engineering in specific parts (zones) of the ship.

It is still possible today to see machinery spaces where individual pipe runs have obviously been designed and installed independently of other pipe runs. Further, no attempt will have been made to integrate the pipe hangers, with each system being independently “hangered” to the ship primary structure. The foundations for the equipment will be individual, and floor plate and vent duct supports will also be independent. When surrounded by this inefficient application of material and production manhour effort, it is easy to see the additional cost and weight, and why it takes so long to complete.

Advanced outfitting necessitates integration of systems to obtain full benefits. Even when advanced outfitting is not being utilized, it is still beneficial, but not essential.

An innovative but practical attitude is required to successfully integrate the systems, and a major tool to assist this is the distributive system routing composite drawing incorporating the distributive system routing zones. It should be clear from the above that the composite should be used to integrate all possible systems within a zone. Figure 1.126 gives typical examples of system integration.

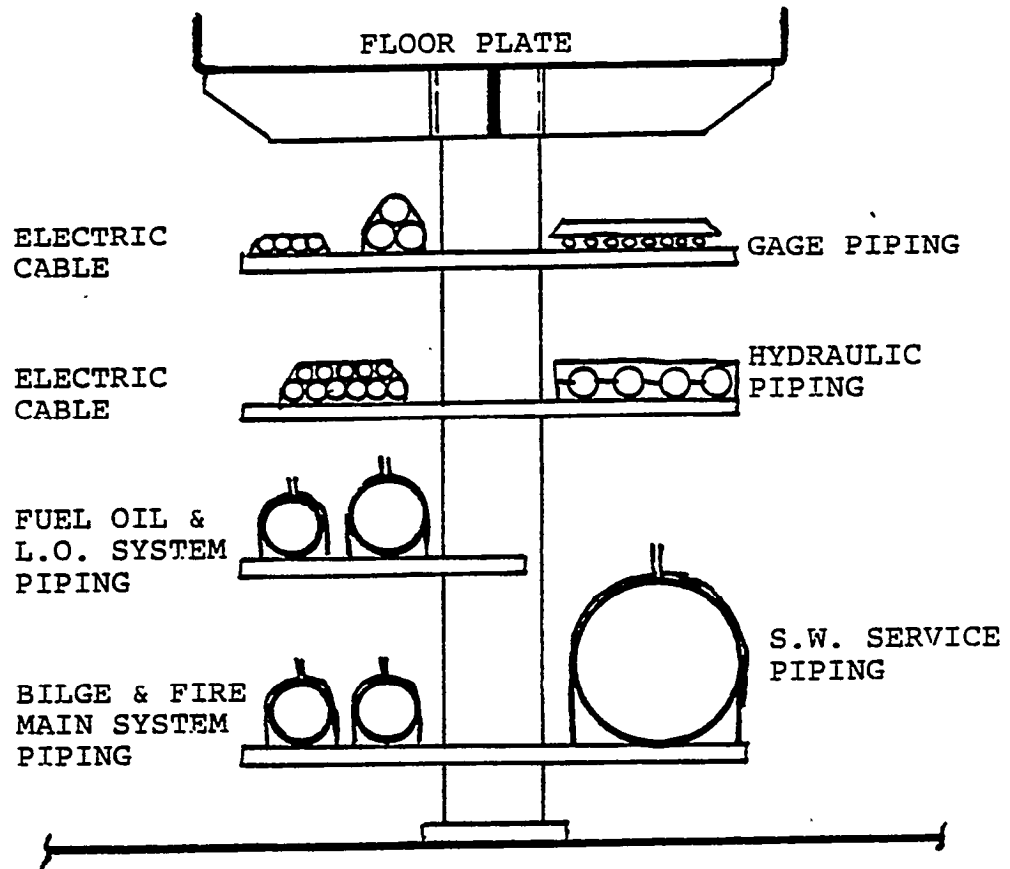

FIGURE 1.126 Integration of systems.

1.12 Advanced Outfitting

1.12.1 WHAT IS ADVANCED OUTFITTING. Advanced outfitting can be regarded simply as the fitting to ship structure, before and after it is erected on the building berth, of outfit items at a significantly earlier time in the building sequence than is traditional.

Advanced outfitting is normally subdivided into three types, namely:

- On Unit
- On Block
- OnBoard

“On-unit” advanced outfitting consists of constructing packages of equipment or bundles of pipe and other systems on a common foundation. The work is usually performed in a shop environment instead of onboard the ship. The packages incorporate unitized foundations and/or support bases, equipment, small tanks, pipe, fittings, controllers, electric cable, etc., and are completely painted except perhaps for a touchup coat. Where required and possible, the package is tested before installation “on block” or “on board.” Typical examples of “on-unit” advanced outfitting are shown in Figures 1.1.127 and 1.128.

“On-block” advanced outfitting consists of installing “units” (equipment modules), pipe bundles, foundations, etc., on a structural assembly or module before it is erected on the building berth. Structural assemblies may be erected as assemblies or joined to other assemblies or modules to form an “erection module.” Typical examples of “on-block” advanced outfitting are shown in Figures 1.129 and 1.130.

“On-board” advanced outfitting consists of installing “units” or individual pieces of equipment, pipe, etc., into the ship as it is on the building berth or once it is afloat. Typical examples of “on-board” advanced outfitting are shown in Figures 1.131 and 1.132. A special approach to “on-board” advanced outfitting is “open deck” or “blue sky” advanced outfitting. In this approach a complete compartment such as a machinery space is left open (deck off) until all the equipment is installed. It is normally used by shipyards which have covered building berths, especially for warship (frigate and destroyer) construction as shown in Figure 1.133.

1.12.2 WHY USE ADVANCED OUTFITTING. Traditionally, shipbuilding engineering attempts to complete all design and material procurement before commencing actual construction. In the past, shipbuilding companies in Japan and Europe had large order books, and were able to do this. This approach is illustrated in Figure 1.134(a). This has generally not been possible in most U.S. shipyards due to both commercial and naval ship procurement methods. It is quite usual for a U.S. shipyard to obtain a new ship construction order with no other *ongoing* work in the yard. The objective then is to get production started as soon as possible, and this causes an overlap of design, material procurement, and production activities, as shown in Figure 1.134(b). It is this overlap coupled with the traditional approach to both design and production which causes the extensive rework and equipment delay problems normally experienced in U.S. shipbuilding.

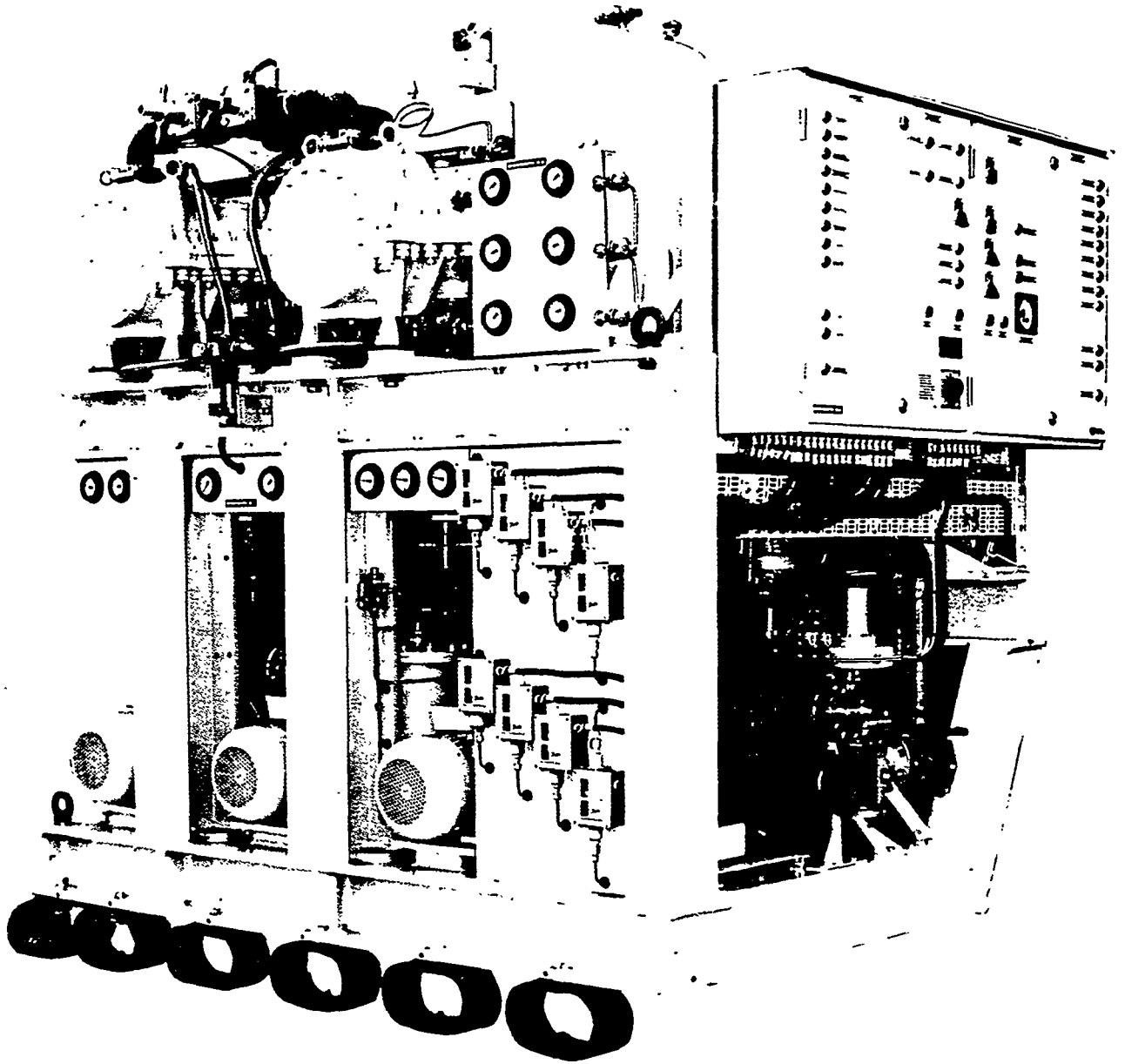

FIGURE 1.127 Typical "on-unit" advanced outfitting.

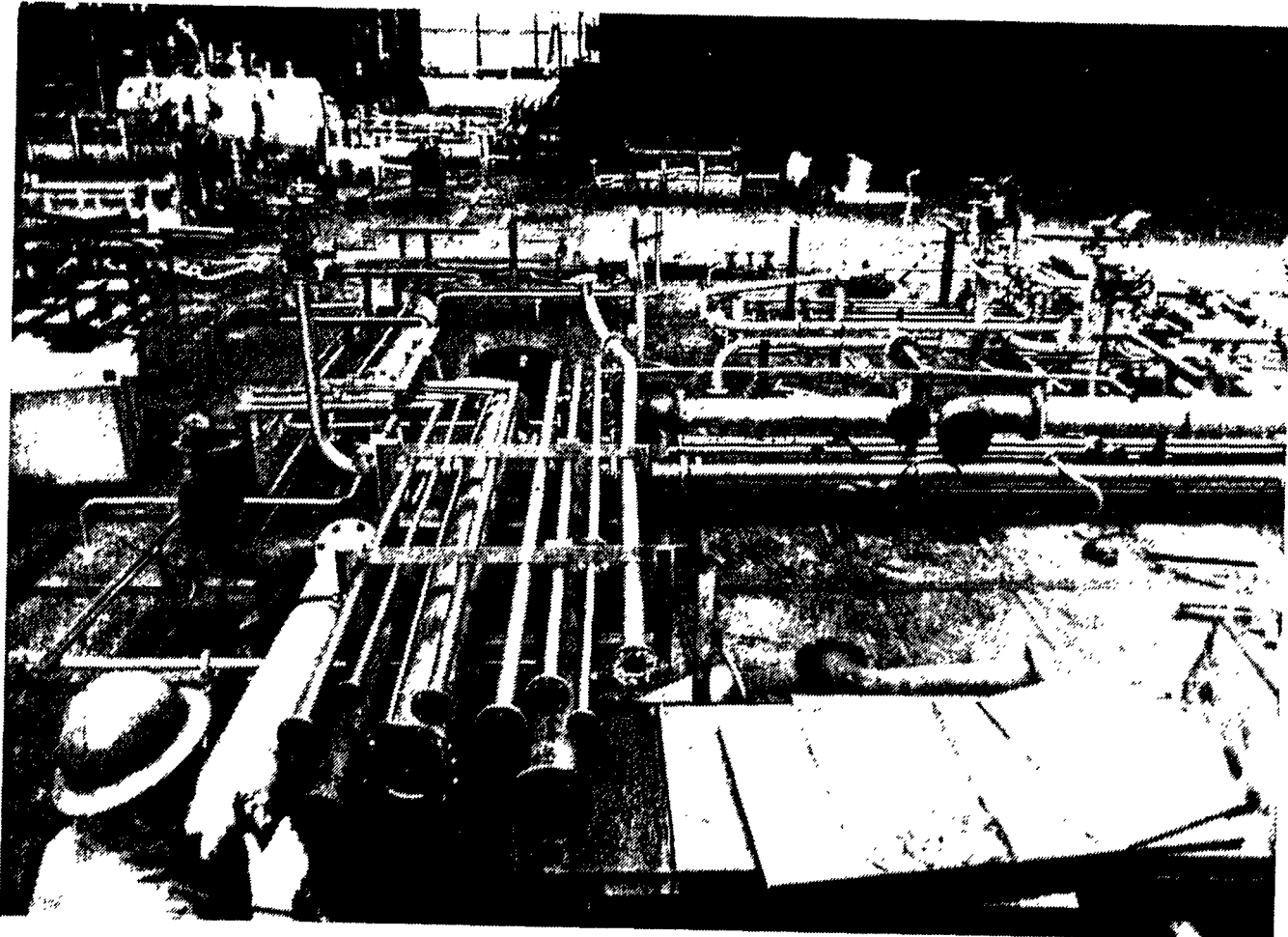

FIGURE 1.128 Piping bundle “on unit” under construction.

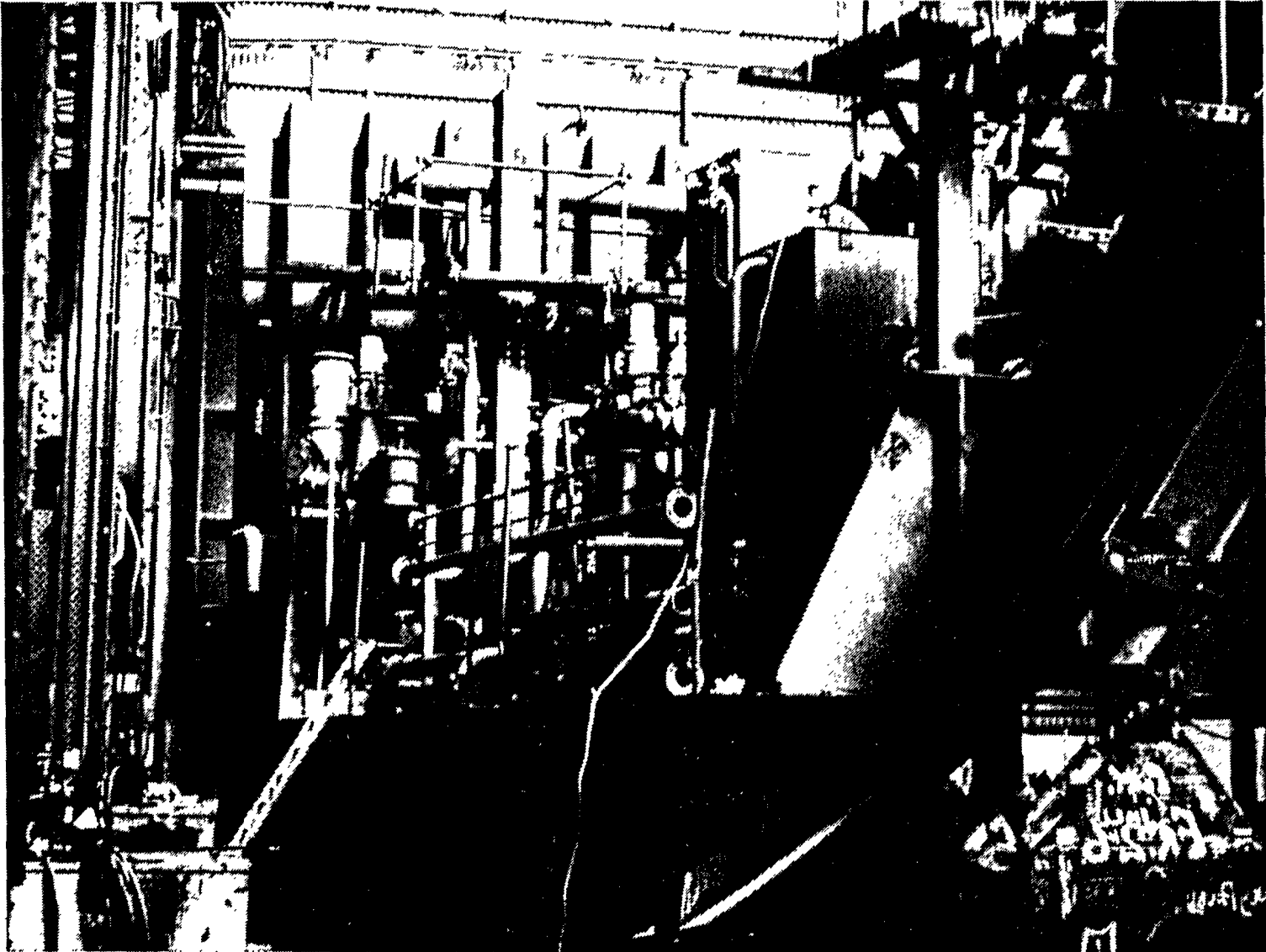

FIGURE 1.129 "On-block" advanced outfitting.

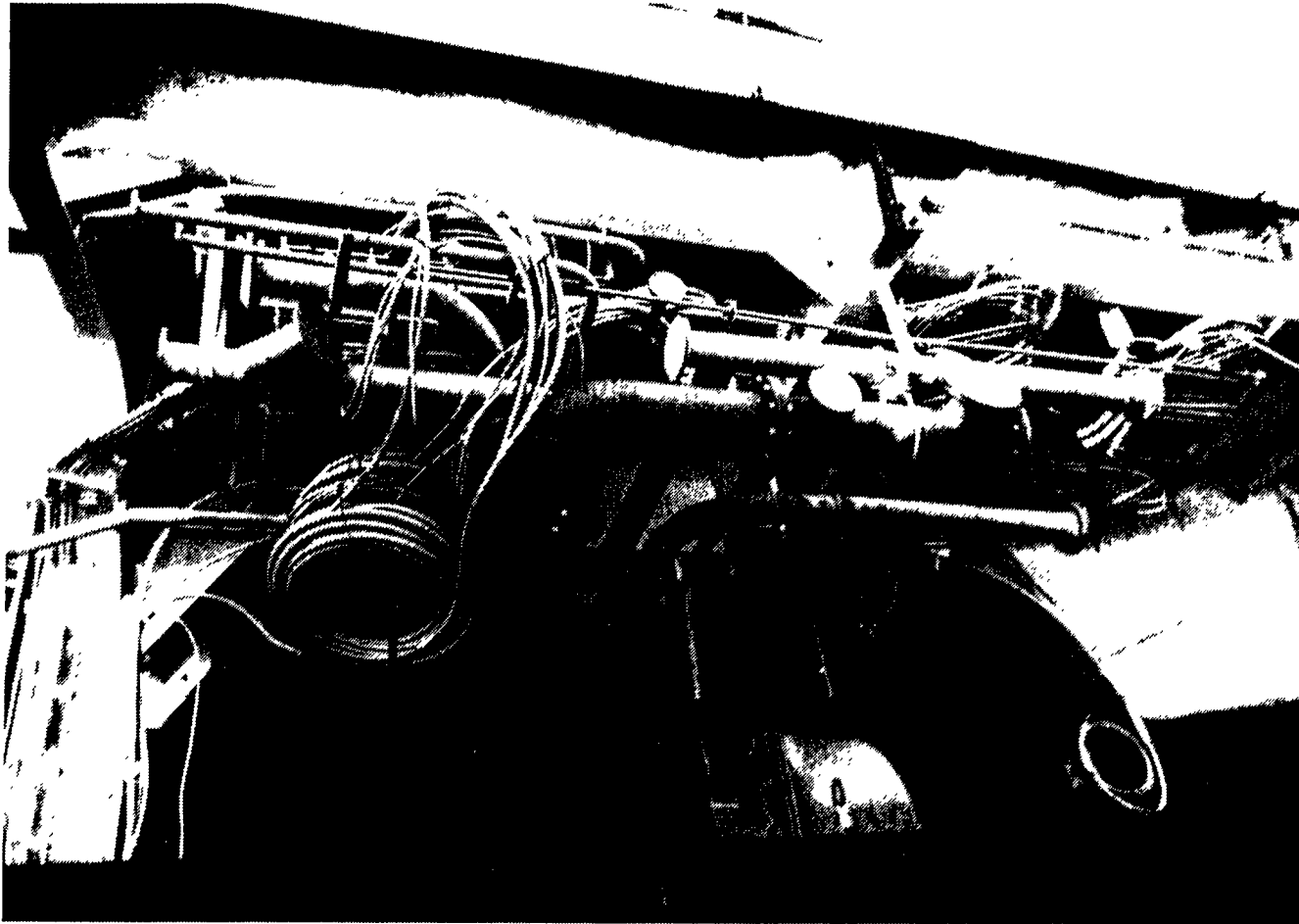
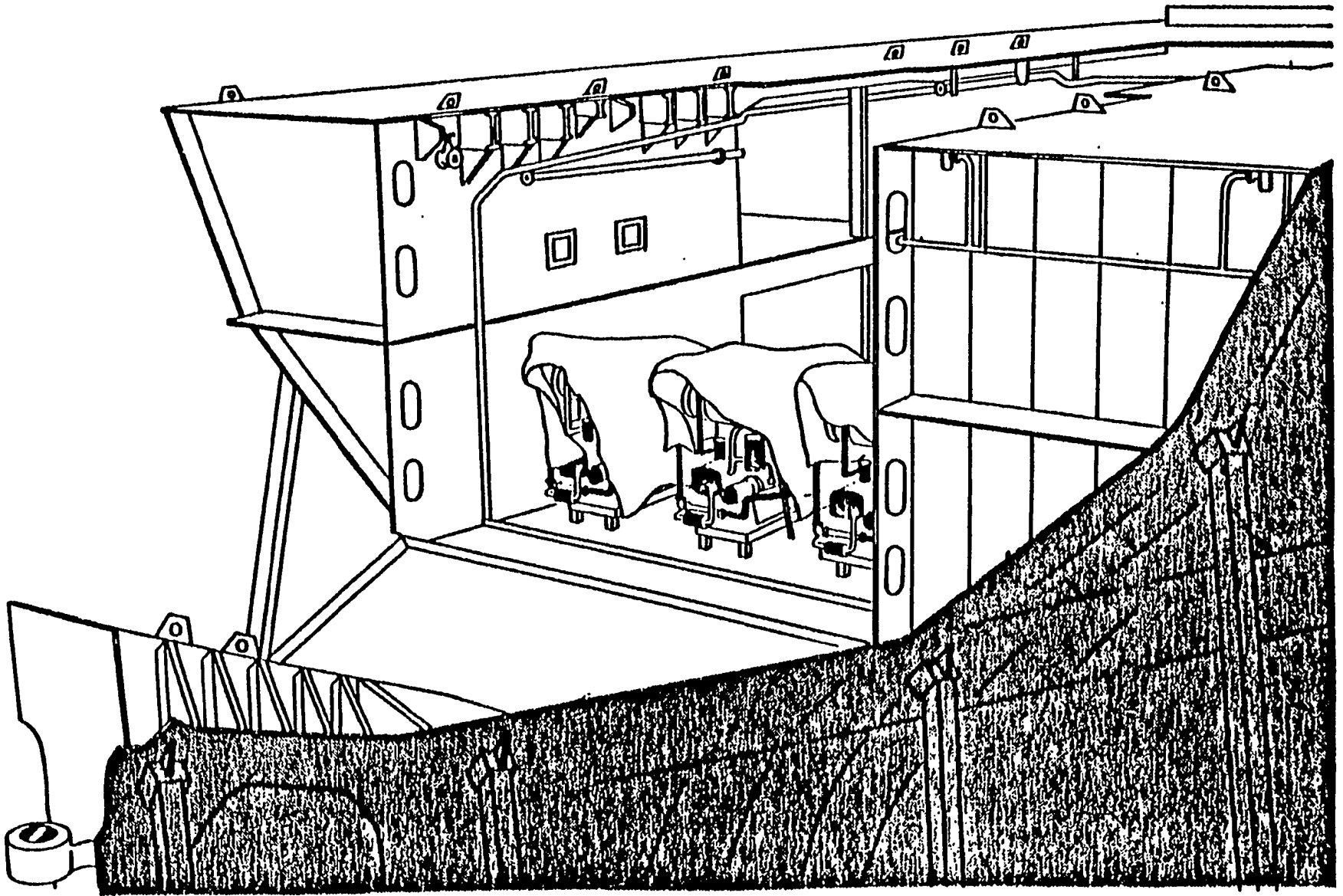

FIGURE 1.130 "On-block" advanced outfitting.



238

FIGURE 1.131 "On-board" advanced outfitting.

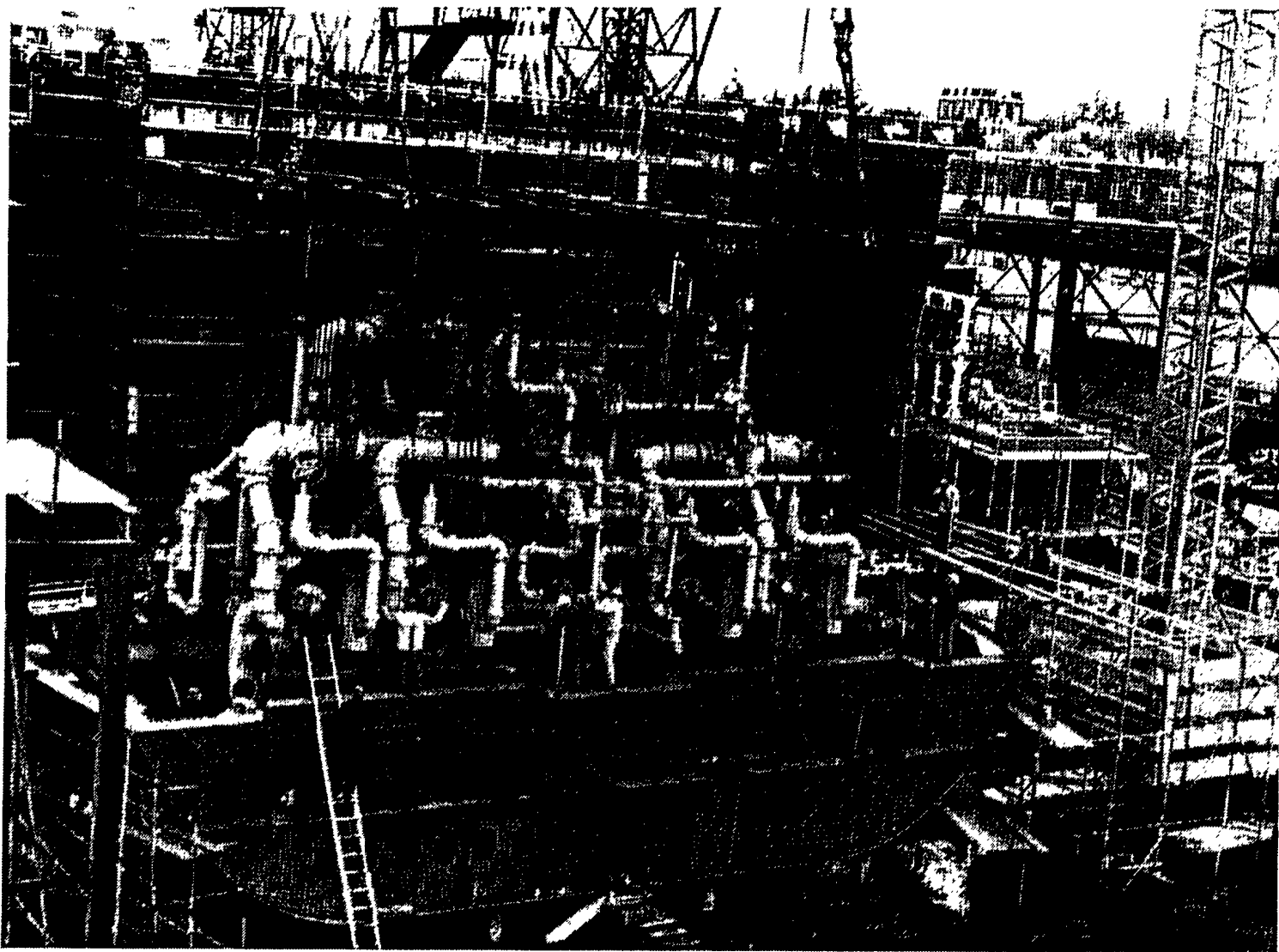

FIGURE 1.132 "On-board" advanced outfitting.

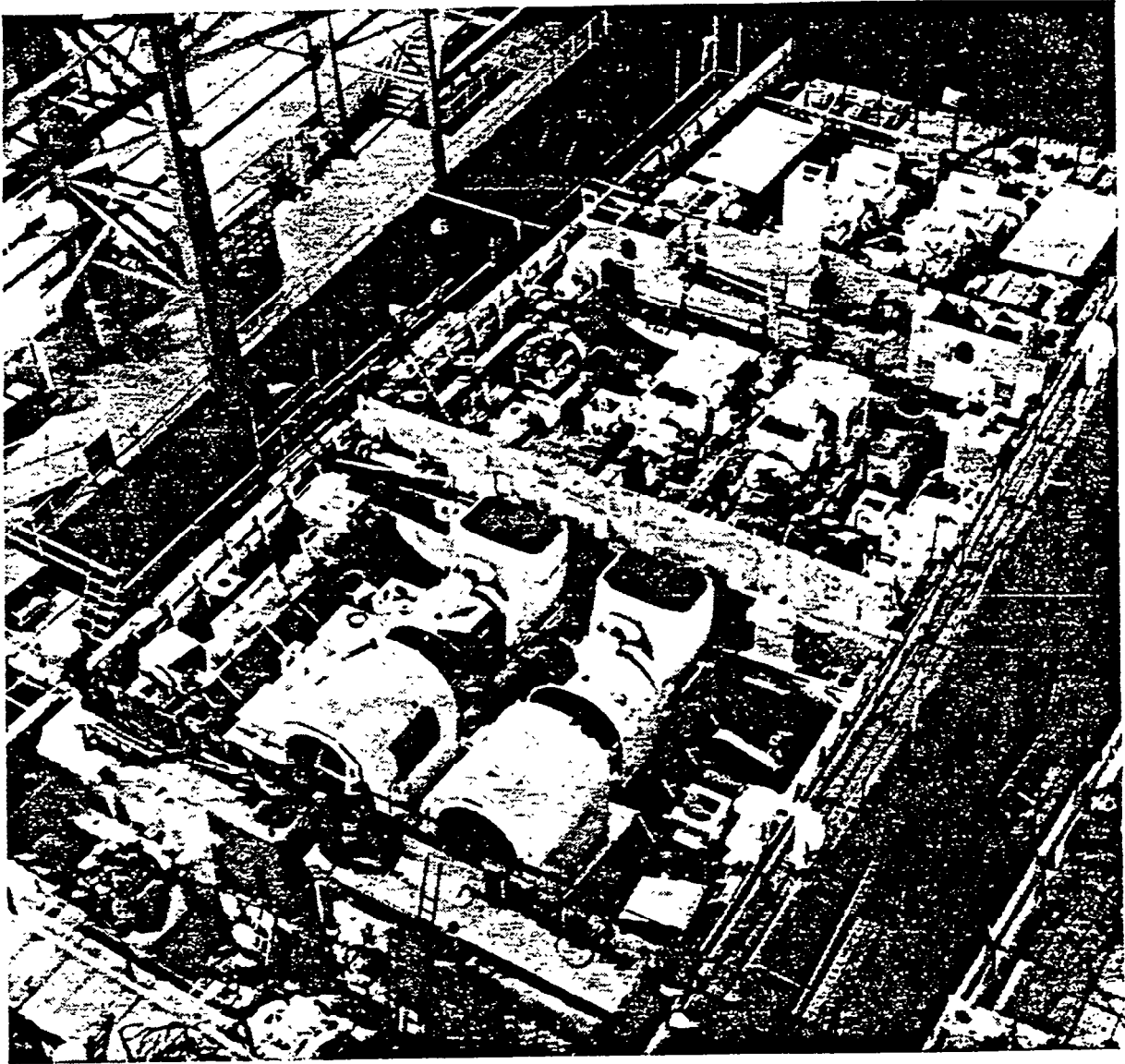
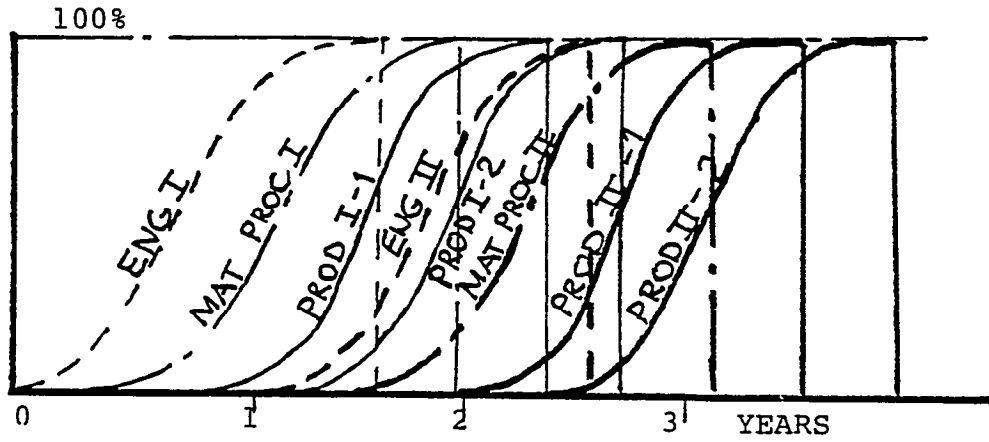
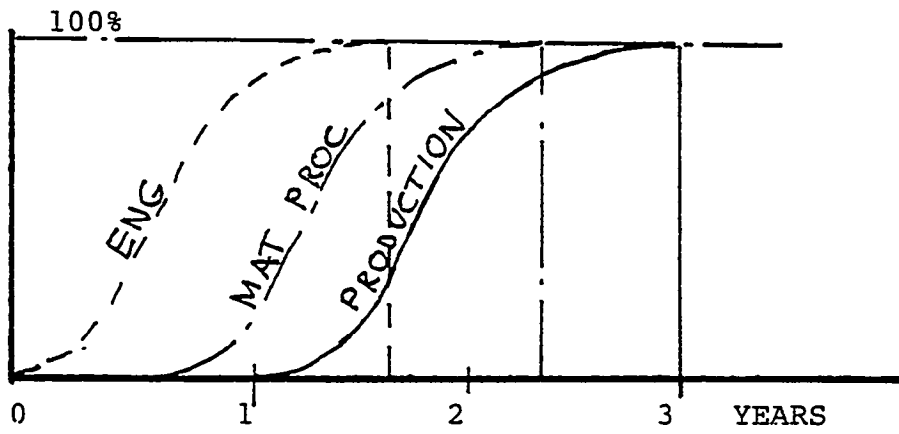

FIGURE 1.133 “Blue-sky” or “open-air” advanced outfitting.



[A] LARGE ORDER BOOK FOREIGN SITUATION



[B] TYPICAL U.S. SHIPYARD SITUATION

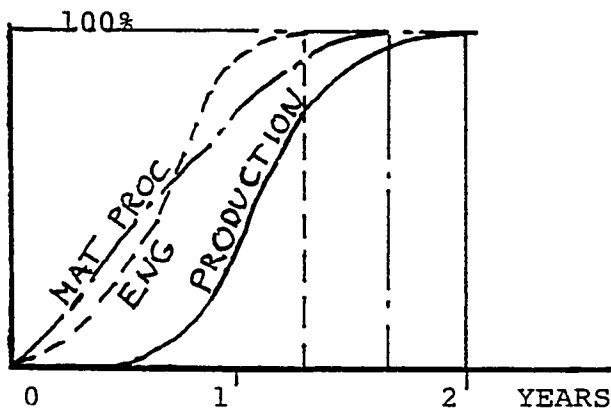

[C] FUTURE U.S. SHIPYARD REQUIREMENT

FIGURE 1.134 Required change in contract performance time.

In today's competitive shipbuilding situation, it is not enough to make the existing overlap work successfully. It is necessary to reduce the performance time, and at the same time increase productivity. Obviously, any reduction in performance time increases the overlapping of the activities as shown in Figure 1.134(c). This has been successfully done by a number of foreign shipyards, and they have presented the requirements based on their experience to accomplish both reduced contract performance time and increased productivity. The essential requirements are:

- A completely integrated planning function
- A planning, scheduling, and control system which is adequate for the task
- Maximum practical use of advanced outfitting
- Maximum use of industry standards for equipment
- Maximum use of company standards for system design and fabrication details
- An engineering approach that is compatible with production requirements, and the way the ship will actually be constructed
- A material procurement approach which is compatible with production schedule. This requires ordering and receiving material on a zone basis

The direct benefits of advanced outfitting are increased productivity and shorter building schedules. Increased productivity is possible as the workers' efficiency for "on-unit" versus "on-block" and "on-board" advanced outfitting is one half and one quarter, respectively. This can be seen from Figure 1.135 which is taken from NSRP publication, **Product Work Breakdown** Structure. This results from the following benefits:

- Earlier start to outfit fabrication and installation, thus better utilization of outfit crafts throughout the duration of construction rather than the heavy concentration near the end
- Logical sequencing of work
- Improved worker safety throughout easier access, better ventilation, better lighting, easier material delivery, etc.
- Simpler outfit planning and scheduling
- Installation of outfit in the best position and worker attitude
- Shop environment allowing cleaner work and better quality (less rework)

Figure 1.136 gives an overview of the goals and benefits of advanced outfitting as modified from a similar figure in the National Shipbuilding Research Program publication, **Outfit Planning**.

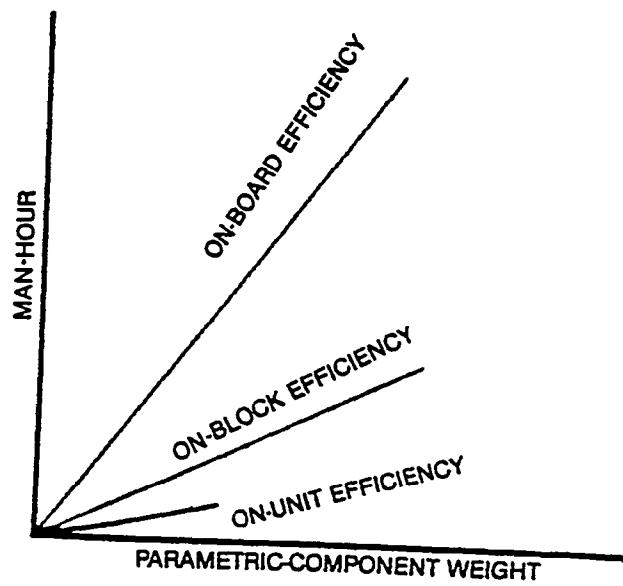

FIGURE 1.135 Productivity improvement through advanced outfitting.

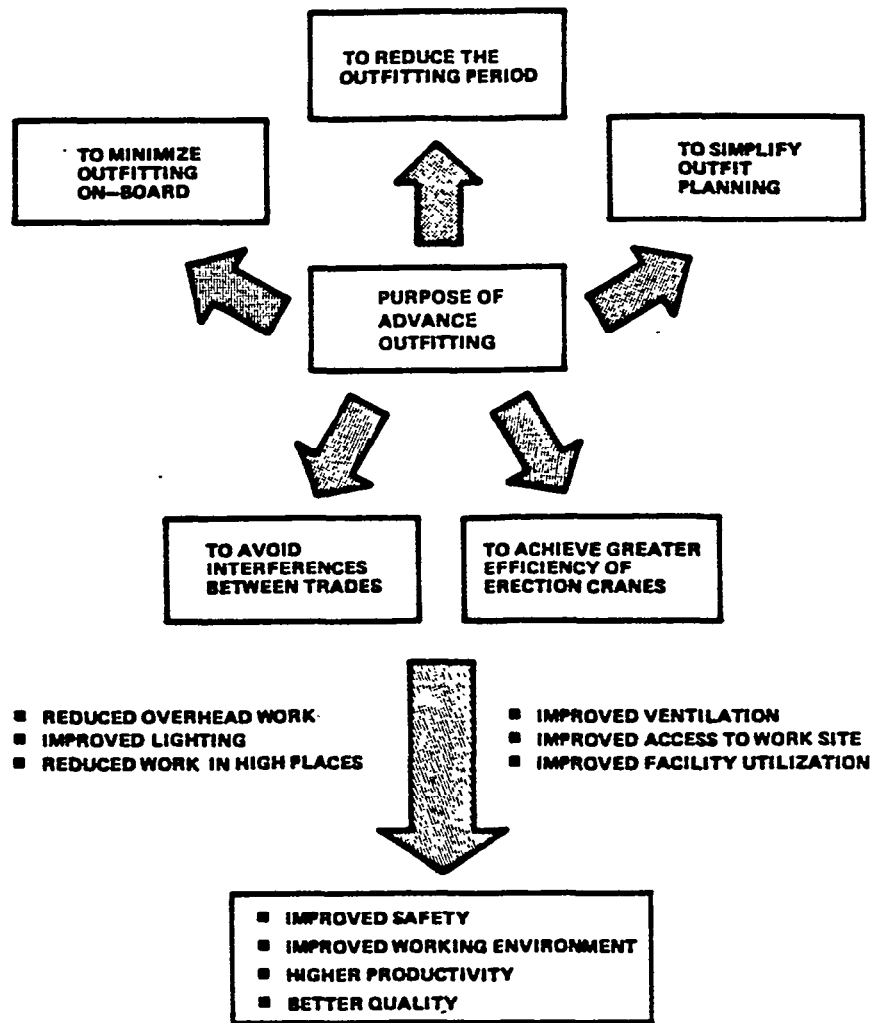

FIGURE 1.136 Goals end benefits of advanced outfitting.

1.121.3 DEFINITIONS. Because different countries, companies, and even people use different words to explain or describe the same item, it is necessary to give definitions for the use of specific words in this book. The confusion that can result from the lack of clear definition can be appreciated by reference to Figure 1.137. The following definitions which are applicable to advanced outfitting are used in this book.

MODULE	A structural item consisting of one or more subassemblies/assemblies which will be erected on the building berth and joined to other modules
ASSEMBLY	A structural item consisting of a single panel made up from individual plates, shapes, and subassemblies, such as deck, shell, bulkhead, etc.
SUBASSEMBLY	A structural item which is fabricated from processed plates and shapes, and which when completed will be incorporated with other subassemblies into an assembly or module
ADVANCED OUTFITTING	The installation of outfit items at an earlier stage of construction of the ship than is traditional as a means of shortening the construction time, and to increase productivity. It also enables the traditional outfitting crafts manning peak to be smoothed out
OUTFIT	A broad definition of all non-structural equipment and systems which are to be installed in or on a ship, including machinery
UNIT	A packaged group of outfit items installed on a common support system prior to installation in an assembly, module, or ship, and designed to be treated as a single component
ON UNIT	Term used to identify the activity of installing a group of outfit items into a package consisting of equipment, support, pipe, wiring, gratings, and controls
ON BOARD	Term used to identify the activity of installing units or individual outfit items in or on a ship on the building berth or afloat
ZONE	An assigned area or compartment in the shipyard and/or onboard the ship for the purpose of organizing information, planning, material, and resources to support the design and construction of the ship
MODULAR/ MODULARITY	The design of identical system details for identical equipment. For example, a ship with identical diesel generators, the detailed design of associated equipment units, connecting piping, etc., would be identical. The advantages of modularity are (a) savings in design and engineering manhours, and (b) savings to production manhours due to multiple unit construction.

ITEM SKETCH	U S A		J A P A N		BRITAIN
	1	2	1	2	
	SUB-ASSEMBLY	DITTO	DITTO	DITTO	DITTO
	ASSEMBLY		SUB-BLOCK	SECTION	SUB-UNIT
	MODULE	KEY ASSEMBLY	BLOCK	LARGE SECTION	UNIT
	UNIT	PACKAGE UNIT	MODULE	UNIT	MODULE

FIGURE 1.137 Different product definition.

1.12.4 UNIT DESIGN. The design of an actual unit will be dependent on the equipment to be incorporated, the space available for the unit, location of unit relative to supporting structure as well as production facilities, methods, and detail preferences. The unit should be designed to be self-supporting during construction, transportation, and installation into the module or ship. If the weight of such capability is unacceptable, a temporary means of supporting the unit must be provided. Some shipyards have developed and constructed special lifting frames to enable up to eight-point lifts for units, thus eliminating the need for additional support structure. The following general points should be considered when designing units:

- (a) Always develop the unit with as many purposes as possible integrated into it, such as various systems support, walkways and grating, ladders, miscellaneous tanks, ducting, etc.
- (b) Select the equipment grouping so that a minimum number of piping connections are required to a major stand-alone piece of equipment or to another unit.
- (c) Consider similar-size items of equipment so that a single large item will not require complete unit to be located in "open" space relative to deck height.
- (d) As much modularity as possible must be achieved. Identical equipment groupings should be the goal for duplicate systems and other similar systems.
- (e) The grouping of piping/grating units should be based on a grating/floor plate layout which adequately provides necessary access to all equipment, but it should **not** cover the entire open area. This is not necessary for efficient operation, and actually impedes observation and access to the area below the floor plate level. It is also not cost-effective shipbuilding practice, and defeats the purpose of advanced outfitting.
- (f) The design of the connection of the unit to the ship's structure must enable attachment by welding without damaging protective coatings in tanks, insulation under decks, etc.
- (g) Where practical, design unit piping to run below working-level floor plates rather than above for the obvious reason of efficient support integration.
- (h) Valves, controllers, gages, etc., should be grouped together for logical and efficient system operation.
- (i) When locating equipment, check that there is sufficient distance between items for the fittings, valves, gages, etc., that must be located between them so as to avoid pipe looping to achieve this as a later fix.
- (j) Always check and/or be aware of duplication and similarity of systems for the ship or other ships so as to benefit from it.

- (k) Incorporate in the unit design permanent access ladders/rungs that will be required on the ship for operation, and during unit construction and installation. This eliminates need for temporary ladders.
- (l) The design of unit foundations should follow the guidelines given in Section 1.5.4, and in addition the detail for on-block/on-board installation weld to supporting structure should take into account elimination of rework due to damage to paint, coatings, insulation, etc., on the other side of the structure.

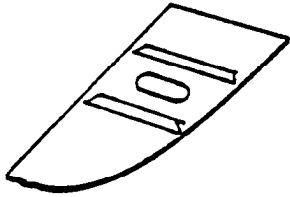
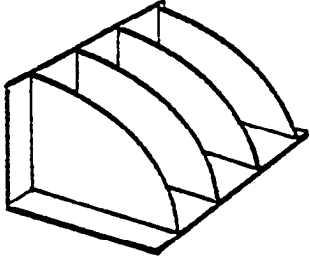
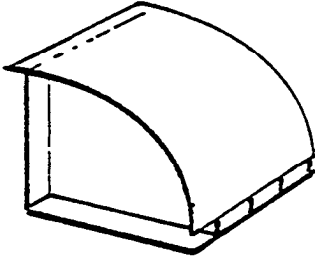
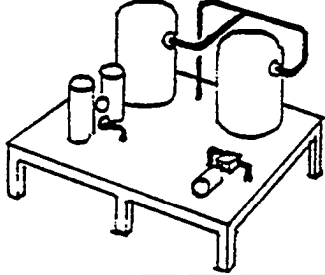
An interesting approach to advanced outfitting is the “macromodule” developed by Wartsila in Finland. Each unit is constructed on a framework of rectangular tubing. The lowest unit framework is suitably sized so that the units located above it can be supported solely by it. This concept is illustrated in Figure 1.138.

1.12.5 EFFECT ON DESIGN. Advanced outfitting is a natural derivative of modern or advanced shipbuilding technology. As such, its effect on design is insignificant if the design is already prepared to suit advanced shipbuilding techniques. However, its effect on a shipyard utilizing “traditional” design is enormous. This is because it is **necessary** to develop integrated zone design, which is difficult to achieve without extensive instruction and training of the designers as well as the production workers to accept the new design. It also requires presentation to and acceptance by the customer, who may or may not appreciate the advantages of the approach. It may be necessary to take the time to clearly show the cost and quicker delivery benefit to both the shipbuilder and the owner, and in addition the fact that the resulting integrated design is usually beneficial to the operation of the ship.

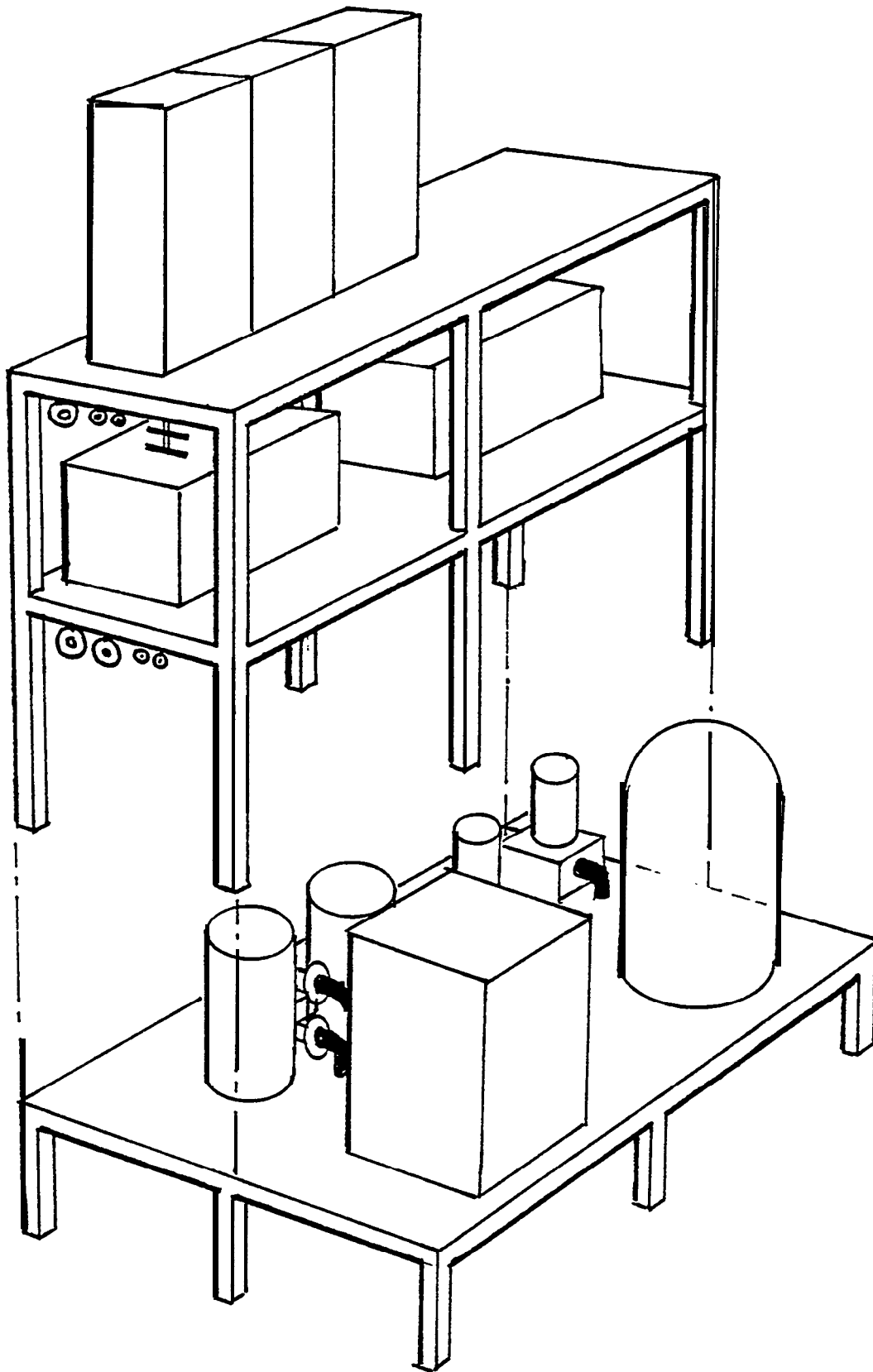

FIGURE 1.138 Wartsila "macromodule" advanced outfitting.

PART 2

ENGINEERING FOR SHIP PRODUCTION

2.1 General

Engineering for ship production is the use of production-oriented techniques to transmit and communicate the design and engineering data to the various users in a shipyard. There has been an increasing interest in this matter in the last few years, as witnessed by discussions on the format and content of engineering drawings. It is suggested that it is not the format and contents of engineering drawings that should be discussed, but rather what technical information is required to procure and construct the ship, and what is the best way to prepare and **transmit** this information. The format of engineering information including the content of drawings has developed over many years and changes and improvements have occurred very slowly, and in some shipyards and design offices, not at all.

The earliest shipbuilders used no drawing, relying on their eyes and the skills handed down from the master shipwright to the next generation through the apprenticeship system. The next phase used sheer draughts and rigging plans, which along with detailed “admiralty” models enabled the owners to understand the designer’s intent before the ship was built. Although later wooden shipbuilders eventually prepared a number of construction drawings, it was the development of iron ships that necessitated detailed construction drawings.

Traditionally, shipyards were craft organized and required only the minimum of drawings for which accuracy was not essential. The loft prepared the templates and made everyday decisions on structural details. The pipefitters worked from diagrammatics and developed their own pipe templates from the ship being built. This was also true for the other shipyard crafts.

The early industrial engineers quickly proved they could increase productivity by analyzing the work, breaking it down into small segments, creating specialization in work via type and skills, and planning the method to accomplish the work in detail. This approach proved popular to employers and some short-sighted workers as it eliminated the need for long general craft and skill training. As a result it became necessary to examine each task involved in constructing a total product, and subdivide it into small logical work packages, each containing detailed instructions on how to accomplish the task. This additional responsibility should have been shared between management and engineering. In many shipyards, production departments have responded quite well to this challenge, but often in the same shipyards, the engineering departments have not, even though they could have significantly assisted the shipyard in successfully meeting the challenge by altering their practices to suit the shipbuilding methods used by the shipyards.

The changeover from a traditional craft-organized shipyard to one of advanced technology has obviously had a tremendous effect on all shipyard departments. It should have had its second greatest impact on the engineering department. However, many engineering departments did not rise to this challenge and therefore lost what might have been their lead position for directing and controlling change. They simply ignored the needed changes and left them to be incorporated in the shipbuilding process after they

completed their work in the traditional manner. Such shipyards responded to this problem by getting the information in its necessary form for production from other sources, usually new groups which may have been called "Industrial" or "Production Engineering," or maybe from an existing planning group. Some shipyards have even accepted the fact that engineering information was inadequate for production, and left it to the production workers to make out as best they could, which has often resulted in the same work being done over many times before it is reluctantly accepted by the inspectors. It is not surprising that the attitude found in many shipyards throughout the world is that engineering is a necessary evil, and that ships are built in spite of engineering.

Production performance is largely dependent on the quality, quantity, and suitability of technical information supplied by engineering. By organizing for integrated engineering and preparing design and engineering for zone construction, engineering can step forward and take its proper place, and play an essential part in the renaissance of U.S. shipbuilding. This part discusses how this can be done, but first considers what is production-compatible engineering (integrated engineering) by comparing it with traditional engineering.

2.2 Traditional Engineering

The preparation of all the visual information used by the production department in a shipyard today is not usually performed solely by the engineering department. Most shipyards still have the various preparation phases divided in the way that was developed and used thirty to forty years ago. At that time, the division of labor into the following disciplines made sense due to the methods used:

- | | |
|-----------------------|--------------------------------------|
| • Engineering | Design and working drawings |
| • Loft | Full-size fairing of lines |
| | Layout of structural parts |
| | Template construction |
| • Pipefitters | Pipe templates and sketches |
| • Sheet-Metal Workers | Layouts, developments, and templates |
| • Shipwrights | Full-scale layout on ship |

However, U.S. shipyards have been improving their production processes for years, and their information needs have changed during this time. Some of them utilize structural module construction, pre-outfitting, advanced outfitting, and more recently, zone construction. To do these from traditional engineering is not impossible, but it requires additional planning and even design and engineering to be prepared after the traditional engineering is complete. This obviously does not lead to shorter performance time.

The preparation of structural drawings in many shipyards has really not developed much from the days of the iron ship. Only within the last two decades have a few U.S. shipyards prepared their structural drawings as “block” or “module” drawings showing each erection module of the ship on individual drawings, even though they had actually been constructing ships that way for twenty years. Yet most U.S. shipyards and the design agents that support them still prepare structural drawings as item drawings, such as:

Tank Top
 Shell Plating or Expansion
 Decks
 Bulkheads
 Frames
 etc.

The preparation of hull outfit, machinery, piping, HVAC, and electrical drawings have developed over time with the progress in the respective technologies. However, they are also currently prepared on a system basis and to differing levels of detail.

In many shipyard engineering departments, the installation of hull outfit systems and equipment is conveniently considered a craft akin to cabinetmaking, and with this in mind they give very little data to the production department in the belief it is better left to the master craftsmen. Other shipyards get around the need of having their engineering department involved by subcontracting joiner work to companies specializing in this field. In reality, there is no logical reason to give joiner work any less engineering effort than is given to hull structure or piping, especially as outfit can be just as large a consumer of both engineering and production manhours as structure or piping.

The machinery drawings are used by the shipbuilder as a definition of equipment arrangement so that the other engineering disciplines can prepare their detail design, such as foundations, piping, floor plates, grating, etc.

Piping drawings are for individual systems for the complete ship. They may or may not show pipe breaks, hangers, and some production-added information.

The same is true of HVAC and electrical, except that electrical drawings are sometimes little more than pictorial concepts with no locating dimensions for equipment.

Interference control in traditional engineering is provided usually by space composites, although engineering models are also extensively used for this purpose. A major problem is that the electrical crafts go ahead and complete their "hot work" before many of the other detailed systems and the composites are completed, in the easiest location, without checking it out or even feeding it back to engineering for their position in the composites. Apparent production work progress is being made early in the project, and everyone is happy until the interference problems start and extensive rework is required.

Traditional engineering usually includes the bills of material on the drawings or as a sheet of multisheet drawing. It also makes use of large drawings, often up to **12** feet in length. Figure 2.1 graphically portrays the problem this creates out on the ship compared to the proposed engineering *for ship production*.



FIGURE 2.1 Large drawing handling problem.

As each drawing is for the total ship, but is required each time part of it is being used in each module or zone, it must be printed and issued many times instead of once, resulting in wasted and duplicated effort. Also when being reissued because of a revision, planning and production must spend time to determine how many modules or zones are impacted by the revision.

Traditional engineering drawings contain little production-required information such as:

- Module weights
- Module breaks
- System breaks
- Lifting pad locations
- Bolting torque
- Piper hanger locations
- System testing
- Tolerances
- Quality requirements

Some shipyards attempt to provide some of this information on traditional engineering drawings by having prints of the drawings marked up with production data by the planning/production control groups for incorporation in the original of the drawings before formal issue. Others provide the required production information on unique additional documents to the traditional engineering drawings.

The practice of referencing ship specification, standard specifications, and other data used in design is a serious problem to production. To expect production workers or even their supervisors to have access and knowledge of the reference is impractical. Because of this they are often ignored and the work is not "done to spec." Engineering must provide production information in a clear and complete manner. This means that engineering must interpret the specifications and use applicable standards and give all the necessary information. In traditional design where it will still be necessary to list references for data control, this practice must be changed to using references as a way to record that the drawing has been prepared in accordance with the references, and not that production should do their work in accordance with the references.

From this discussion on traditional engineering, it is clear that it is not suitable for high-productivity, short-build cycle shipbuilding, and therefore has no place in today's struggle to maintain some semblance of competitive shipbuilding.

2.3 Production-Compatible Engineering

The first break from the traditional systems drawings occurred when some shipyards introduced structural module drawings. The **next stage** was the use of subassembly, assembly, and module-sequenced drawings, but these were initially prepared in addition to the structural module drawings. Next pipe sketches or drawings for pipe assemblies were prepared by engineering, initially manually and later by computer-aided design. Currently CAD/CAM is being used to provide production information for both pipe and sheet metal products. Today the goal for optimum data transmittal is to have an engineering information package for each work station (including zones on board the ship). This is not only for structure but for all other material and equipment. A work station drawing shows all the work that occurs at one location, either shop or ship zone. It can be one sheet showing the completed product at the end of all the work at a given work station with written sequence instructions, or it can be a booklet of drawings showing the sequenced buildup for the product from its received status to its completed status for the work station.

The MarAd/SNAME Ship Production Committee Japanese Technology Transfer efforts have resulted in a generally accepted work breakdown structure for design and engineering [1]. The proposed integrated engineering approach follows this generally accepted structure except that basic design also includes functional design, and the term **production engineering** covers transitional design and work instruction design. The proposed approach suggests that the design/engineering process can be conveniently divided into **basic design** and **product engineering**. The meaning of the different terms can be seen from Figure 2.2 and 2.3, which show the flow of the design and engineering information.

Both **basic design** and **product engineering** are further subdivided **into concept, preliminary, contract and functional design, transitional design, and work station/zone information**, respectively. **In basic design** all phases except **functional design** must be completed before the award of a contract. Functional design is the phase where the **contract design** is expanded to encompass all design calculations, drawings, and decisions. Table 2.1 lists typical functional design tasks.

Product engineering covers all tasks required to prepare the technical information to be transmitted to the production and other shipyard groups necessary to assist and direct the **construction of the ship**. It is divided **into** two phases. The first, **transitional design**, is the task of integrating all design information into complete zone design arrangements, and completing the ordering/assigning of **all** materials. **The second, work station/zone information preparation**, is the task of providing all drawings, sketches, parts lists, process instructions, production aids (such as N/C tape for plate burning/marketing and pipe fabrication) required by the production and other service departments to construct the ship. Table 2.2 lists typical work station/zone information preparation tasks.

Throughout basic design the tasks are accomplished on a system basis, whereas throughout product engineering the tasks are accomplished on a zone basis for transitional design, and a work station/zone basis for work station/zone information.

This process of design and engineering is integrated with the planning of the construction, and in constant participation and communication with the production department. This integration can be seen in Figure 2.4, which shows the process flow during contract and functional design. Figure 2.5 shows the process flow during transitional design and work station/zone information preparation. It should be noted that all planning is completed during contract and functional design.

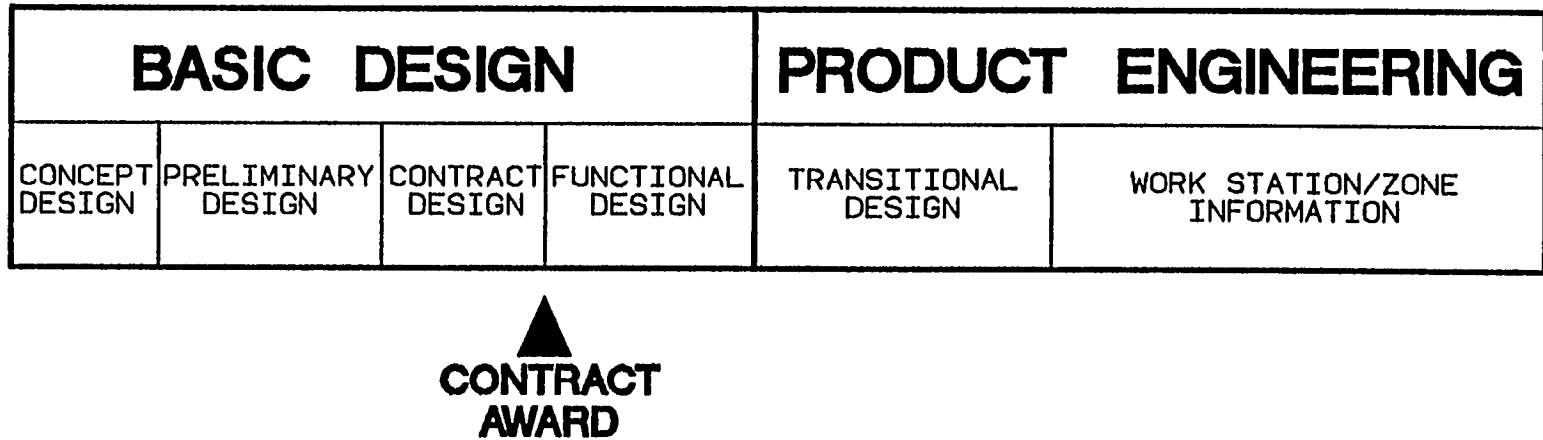

FIGURE 2.2 Phases of engineering for ship production.

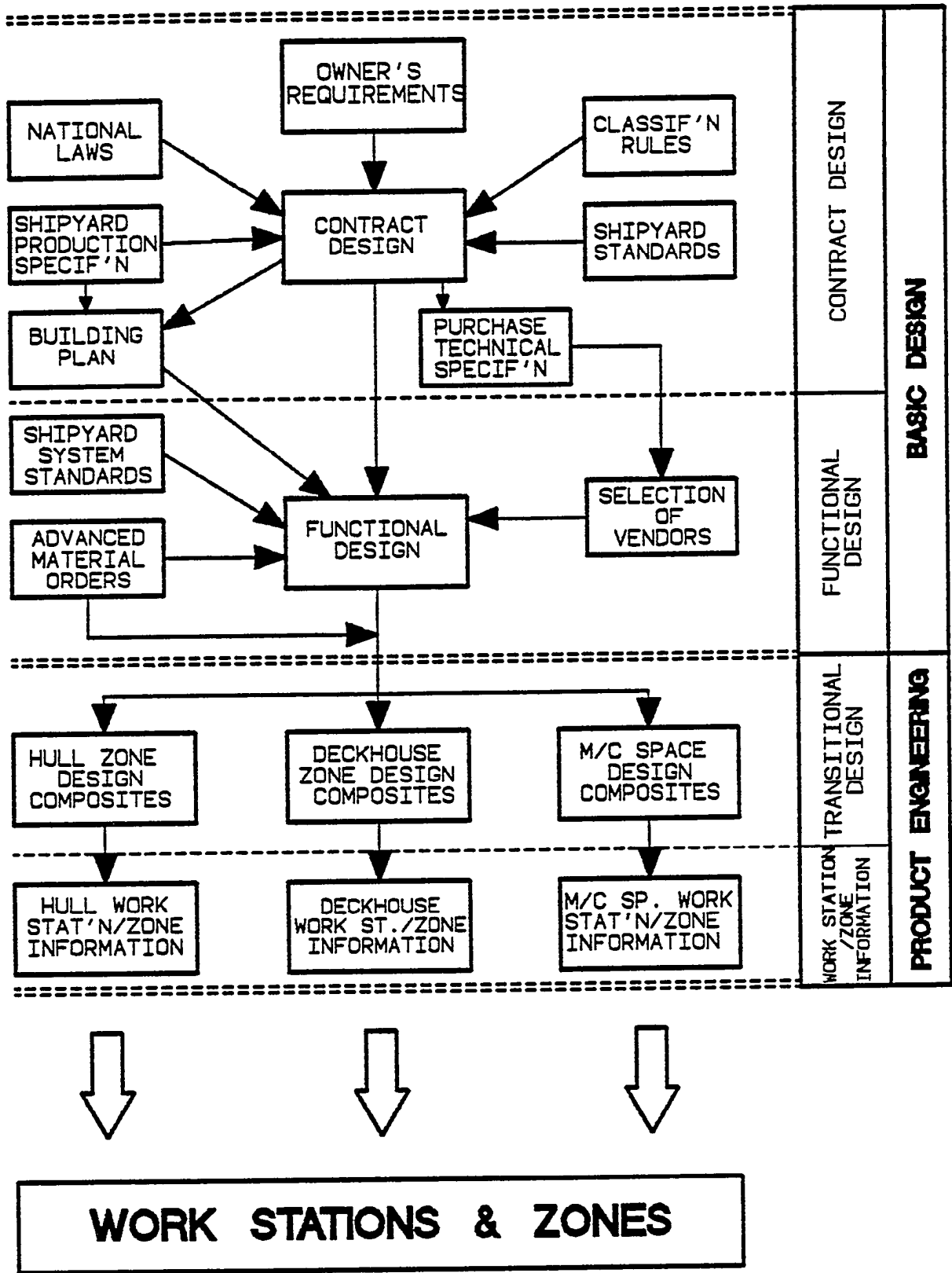

FIGURE 2.3 Flow of design and engineering information.

TABLE 2.1

PRODUCTION-COMPATIBLE ENGINEERING

HULL

General Arrangement
 Outboard Profile
 Lines
 N.A. Drawings
 Structural Module Drawings
 Major Foundations
 Weights, Centers, and Lifting Data
 Lists of Hull Outfit
 Lists of Hull Fittings
 Nameplates and Notices
 Summary Painting Schedule
 Summary Deck Covering
 Summary Hull Insulation Schedule
 Furniture List
 Plumbing and Fixture List
 Galley Arrangement
 Accommodation Arrangement
 Steering Gear Arrangement
 Rudder and Rudder Stock Arrangement
 Rudder and Propeller Lifting Gear Arrangement
 Anchor Handling Arrangement
 Mooring Arrangement
 Life-saving Equipment Arrangement
 Hull Piping System Diagrams
 Purchase Technical Specifications
 Advanced Material Ordering Lists
 Steel List per Module

MACHINERY AND PIPING

Machinery Arrangement Shafting Arrangement Stern Tube Arrangement M/C Space and Wheelhouse Control Console Arrangement Machinery Piping System Diagrams Diesel Exhaust Arrangement Lifting Gear in M/C Space M/C and Pipe Insulation Schedule Advanced Material Ordering Lists
--

TABLE 2.1 (Continued)

ELECTRICAL
Electrical Load Analysis One-Line Diagram Short Circuit Analysis List of Motors and Controllers List of Feeders and Mains Electrical E&I Diagrams List of Portable Electrical Equipment Advanced Material Ordering Lists
HVAC
Heating and Cooling Analysis HVAC Diagram and Equipment List HWAC Insulation Schedule Advanced Material Ordering Lists

TABLE 2.2

WORK STATION/ZONE INFORMATION

<p>A. STRUCTURE: Work station information consisting of:</p> <ul style="list-style-type: none"> • Sequenced isometric construction sketches and part lists for subassemblies. • Sequenced isometric construction sketches and part lists for assemblies. • Sequenced isometric construction sketches and part lists for modules. • Sequenced isometric construction sketches and part lists for module erection. <p>B. PIPING: Pipe assembly sketches and part lists. Sequenced pipe installation sketches and part lists for A/O units and zones.</p> <p>C. HVAC: Duct assembly sketches and parts lists. Sequenced installation sketches and part lists for equipment and ducting.</p> <p>D. MACHINERY: Sequenced installation of equipment (in conjunction with piping, electrical, HVAC) for A/O “on unit,” “on block,” “on board,” and zones.</p> <p>E. ELECTRICAL: Cableway installation for each module/zone including parts lists. Cable lengths and numbers per section for each module/zone. Equipment installation sketches and part lists for each module/zone.</p> <p>F. HULL OUTFIT: Sequence installation sketches and part lists for mooring fittings, doors, windows, ladders, handrails, paint, insulation, joiner work, deck coverings, deck machinery, furniture, galley equipment, provision storerooms, etc., for zones.</p> <p>G. ADVANCED OUTFITTING: Sequenced construction and installation sketches and part lists for foundations, grating, floor plates, equipment, pipe, electrical, and hull outfitting joiner work and furniture for units, modules, and zones.</p>

All the above work station/zone information will be designated by hull, deckhouse, or machinery-spacing grouping. There shall be no overlap of one group into another group's area to complete engineering work scope.

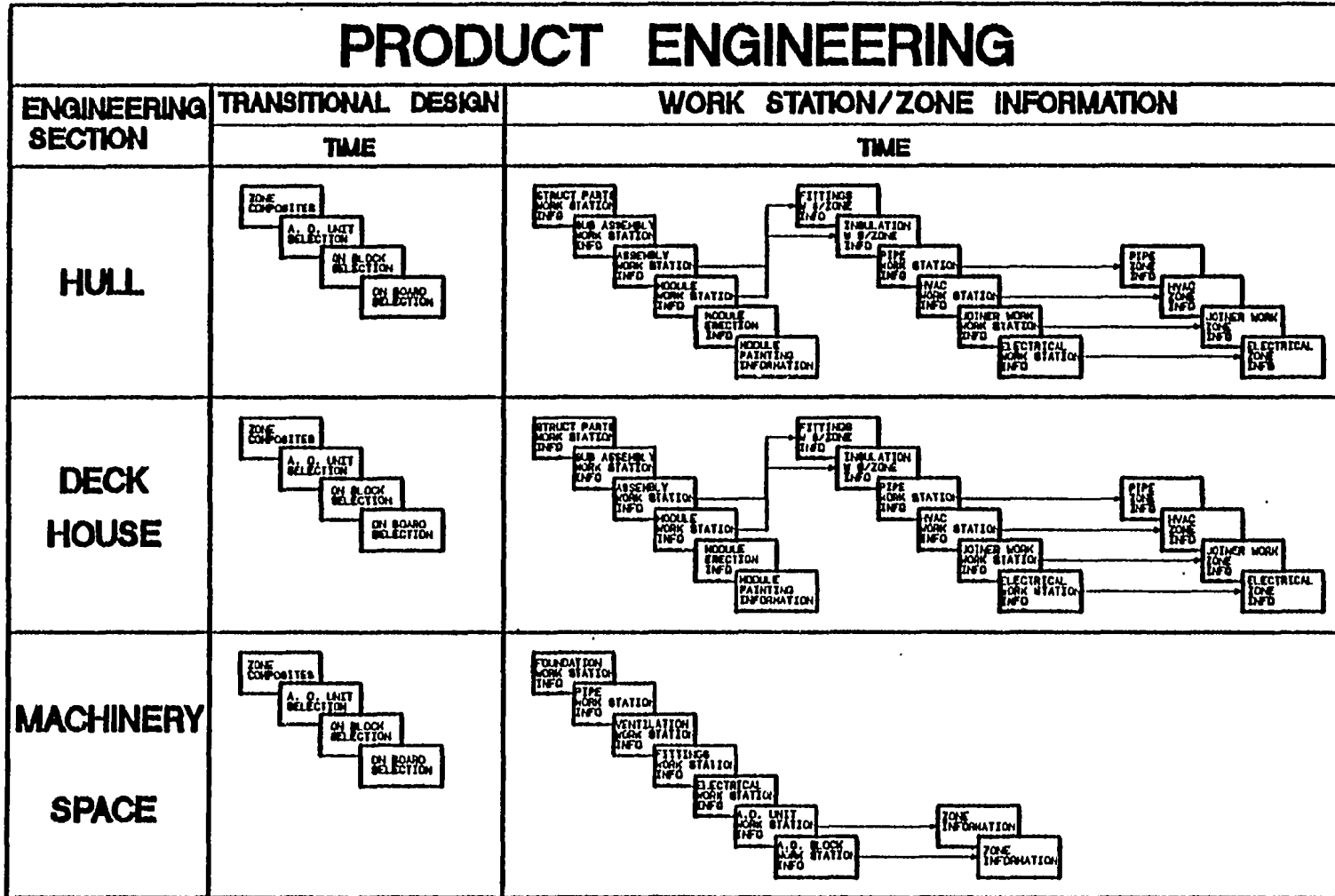

FIGURE 2.5 Product engineering flow.

The timing of the performance of the various design and engineering tasks is very important for the proposed approach. This is because all the design and engineering tasks must be performed in a shorter period of time, as shown in Figure 2.6, and all disciplines at the same time rather than staggered, as in traditional engineering, which was previously shown in Figures I.1 and I.2, and shown here in Figures 2.7 and 2.8 for convenience.

Figure 2.7 shows how the traditional approach to design, engineering, and construction has the cascading effect for each discipline. For example, the hull outfit is not started until many of the structural system type drawings are completed, and machinery, piping, HVAC, and electrical all have sequential staggered starts. This sequenced staggering of system starts is continued into production, where perhaps 50% of the structure is erected before any hull outfit, machinery, piping, HVAC, and electrical systems are installed.

In deliberate contrast, Figure 2.8 shows how the integration of engineering with planning and the use of zone construction can reduce both engineering and production performance time. It is accomplished by engineering preparing structural drawings for each module and outfit drawings for each zone. In this way it is not necessary to wait until up to thirteen structural system drawings are completed before the module work package can be completed. Also the piping information is developed for each module or zone instead of waiting until it is completed for the whole ship. This means that the time to start fabrication can be halved.

Zone construction including advanced outfitting installation requires engineering for the outfitting and machinery to be available at the same time as that for the structure. In fact, the installation of piping, ventilation ducting, ladders, mooring fittings, equipment foundations, and wireway supports should be accomplished on flat panels and/or three-dimensional modules along with items of equipment, such as auxiliary machinery and deck machinery.

Essential parts, and really foundations, to the proposed engineering approach are the previously discussed shipyard **production specification** and **building plan**. Reference [2] is a good description on the development of a building plan. Tables 2.3 and 2.4 give typical contents of each part, respectively. The approach also is based on the use of **zone construction**. It is further beneficial if all manufactured and purchased material to construct the ship is categorized within a standard classification system (product definition), and if the production methods to be used (product processes) are defined, work stations can be decided. All this information will be contained in the shipyard production specifications to be used by the engineers and planners when preparing the contract design and the building plan. The product definition can be based on a group technology classification and coding system such as the one described in Section 1.4.2, or it can be a simple listing of major products such as shown in Table 2.5. The product processes will be based on a process analysis for each product and the available work stations.

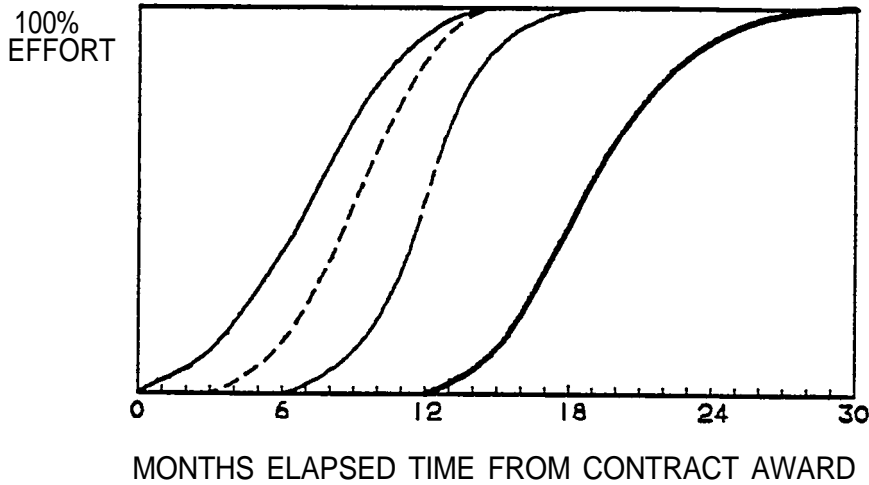

TYPICAL TRADITIONAL PERFORMANCE SCHEDULE

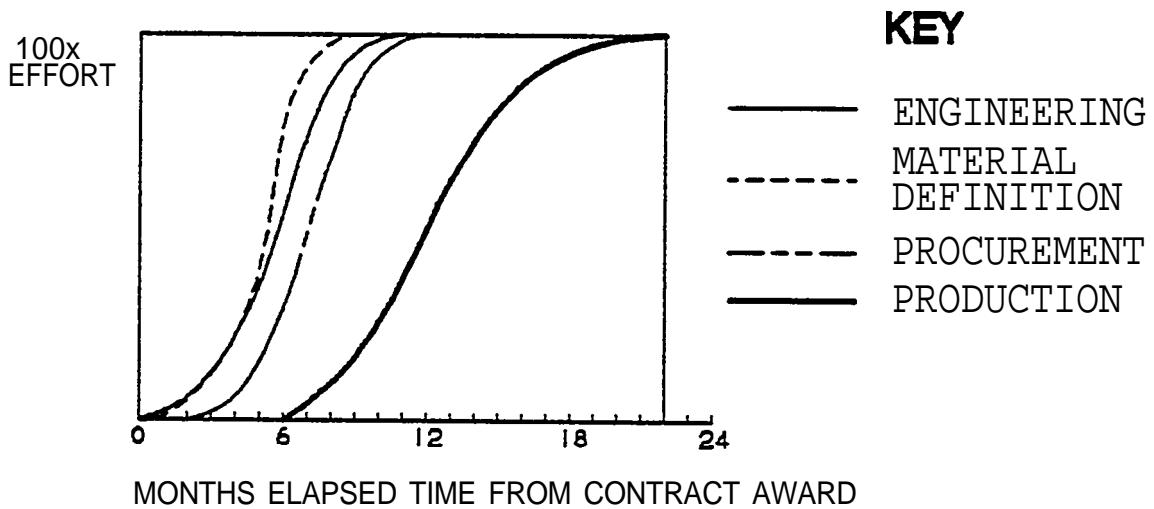

REQUIRED SHORT- BUILD CYCLE/ PERFORMANCE SCHEDULE

FIGURE 2.6 Traditional performance schedule; required short-build cycle/performance schedule.

266

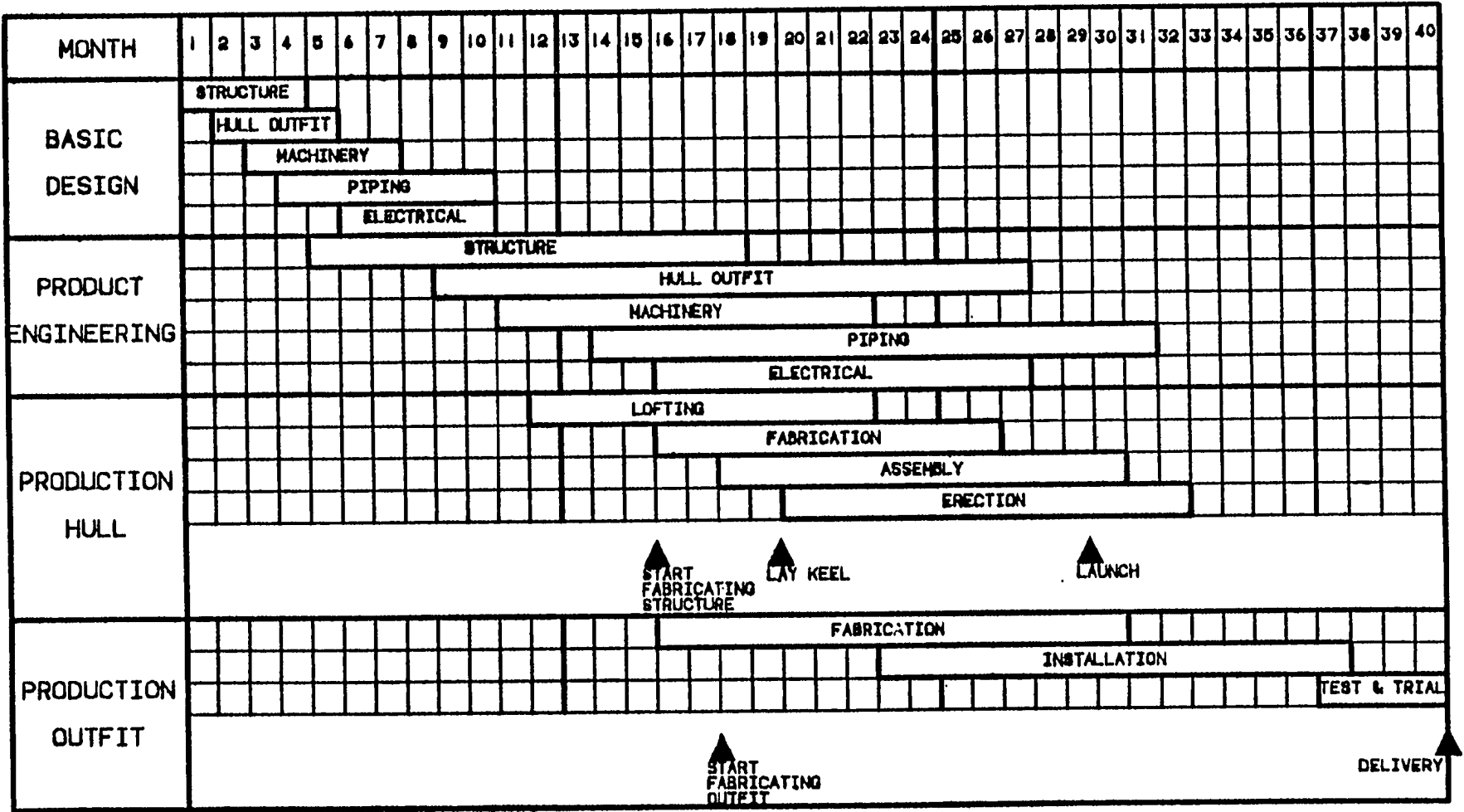
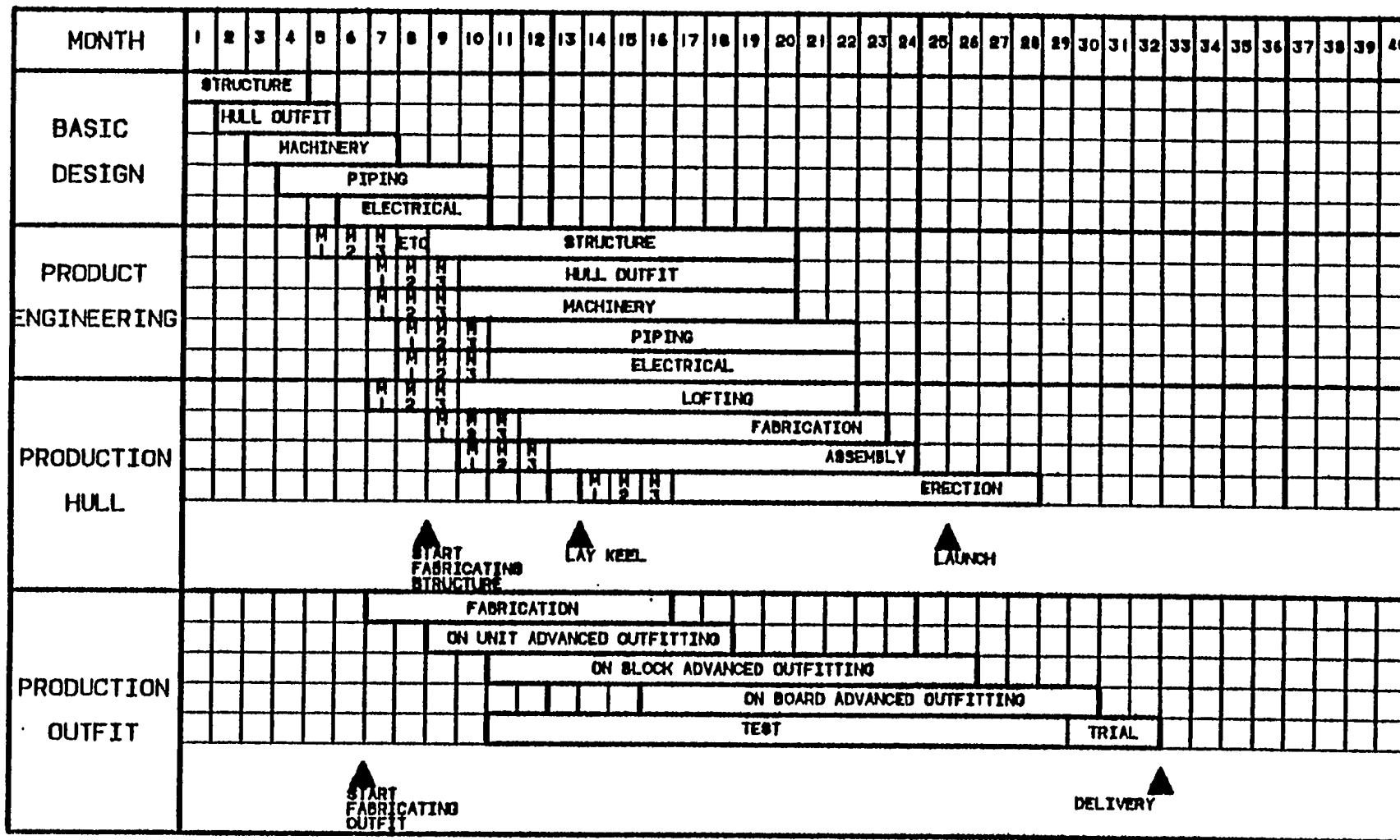

FIGURE 2.7 Traditional shipbuilding and isolated engineering.



267

FIGURE 2.8 Advanced shipbuilding and integrated engineering.

TABLE 2.3

SHIPYARD SPECIFICATION

SHIPYARD SPECIFICATION

I. 0 FACILITY DESCRIPTION

- 1.1 GENERAL
- 1.2 LOCATION
- 1.3 FACILITY ARRANGEMENT DRAWING

2. 0 FACILITY CAPACITY

- 2.1 TYPICAL PRODUCT HISTORY
- 2.2 MAXIMUM SIZE LIMITATIONS
- 2.3 BUILDING BERTHS
- 2.4 BERTH CRANAGE
- 2.5 BERTH SERVICES
- 2.6 STRUCTURAL PROCESSING WORK STATIONS/
CRANAGE/SERVICES
 - 2.6.1 PLATE STOCKYARD
 - 2.6.2 SHAPE STOCKYARD
 - 2.6.3 PLATE SURFACE PREPARATION
 - 2.6.4 PLATE BURNING
 - 2.6.5 PLATE FORMING
 - 2.6.6 SHAPE SURFACE PREPARATION
 - 2.6.7 SHAPE CUTTING
 - 2.6.8 SHAPE FORMING
 - 2.6.9 WELDING
 - 2.6.10 SUB-ASSEMBLIES
 - 2.6.11 PANEL LINE
 - 2.6.12 PIN JIG LINE
 - 2.6.13 ASSEMBLIES
 - 2.6.14 MODULES
- 2.7 PROPULSION MACHINERY WORK STATIONS
 - 2.7.1 ENGINES
 - 2.7.2 GEARS
 - 2.7.3 SHAFTING
 - 2.7.4 PROPELLERS
 - 2.7.5 THRUSTERS

TABLE 2.3 (Continued)

- 2.8 MACHINING WORK STATIONS/CRANAGE/
 - 2.8.1 SHOPS
 - 2.8.2 PORTABLE
- 2.9 PIPE PROCESSING WORK STATIONS/
CRANAGE/SERVICES
 - 2.9.1 PIPE SURFACE PREPARATION
 - 2.9.2 FITTING STORAGE
 - 2.9.8 PIPE PAINTING/COATING
 - 2.9.4 PIPE CUTTING
 - 2.9.5 PIPE WELDING
 - 2.9.6 PIPE SURFACE PREPARATION
 - 2.9.7 PIPE ASSEMBLIES
 - 2.9.8 PIPE PAINTING/COATING
 - 2.9.9 PIPE INSULATING
 - 2.9.10 PIPE KITTING
- 2.10 SHEET METAL WORK STATIONS/CRANAGE/
SERVICES
 - 2.10.1 SHEET METAL STORAGE
 - 2.10.2 SHEET METAL CUTTING
 - 2.10.3 SHEET METAL FORMING
 - 2.10.4 SHEET METAL JOINING
 - 2.10.5 SHEET METAL PAINTING
 - 2.10.6 SHEET METAL INSULATION
 - 2.10.7 SHEET METAL KITTING
- 2.11 ELECTRICAL WORK STATION/CRANAGE/
SERVICES
 - 2.11.1 WIRE WAY STORAGE
 - 2.11.2 CABLE STORAGE
 - 2.11.3 EQUIPMENT STORAGE
 - 2.11.4 PANEL CONSTRUCTION
 - 2.11.5 ELECTRICAL KITTING
- 2.12 PAINTING WORK STATION/SERVICES
 - 2.12.1 SURFACE PREPARATION FOR
PAINTING

TABLE 2.3 (Continued)

- 2.12 CONTINUED
 - 2.12.2 ASSEMBLY PAINTING
 - 2.12.3 MODULE PAINTING
 - 2.12.4 UNIT PAINTING
 - 2.12.5 ZONE PAINTING
- 2.13 ADVANCED OUTFITTING WORK STATIONS/
CRANAGE/SERVICES
 - 2.13.1 UNIT FOUNDATION/SUPPORTS
 - 2.13.2 UNIT PIPE INSTALLATION
 - 2.13.3 UNIT EQUIPMENT INSTALLATION
 - 2.13.4 UNIT ELECTRICAL INSTALLATION
 - 2.13.5 ON BLOCK INSTALLATION
 - 2.13.6 ON BOARD INSTALLATION
- 2.14 FITTING OUT
 - 2.14.1 FITTING OUT BERTHS
 - 2.14.2 CRANAGE
 - 2.14.3 DRY DOCKS
- 2.15 TEST AND TRIALS
 - 2.15.1 INSTRUMENTATION
 - 2.15.2 TANK TESTING-HYDRO & AIR
 - 2.15.3 DOCK TRIAL EQUIPMENT
 - 2.15.4 INCLINING EXPERIMENT
 - 2.15.5 TRIAL COURSE
- 2.16 SUPPORT SERVICES
 - 2.16.1 ACCESS EQUIPMENT
 - 2.16.2 STAGING
 - 2.16.3 MAN-LIFTS
 - 2.16.4 TEMPORARY LIGHTS
 - 2.16.5 TEMPORARY VENTILATION
 - 2.16.6 PORTABLE SANITATION UNITS
 - 2.16.7 FUELING
 - 2.16.8 PROVISIONING

TABLE 2.3 (Continued)

3. 0 ORGANIZATION AND RESPONSIBILITIES

- 3. 1 GENERAL
- 3. 2 ENGINEERING AND PLANNING
- 3. 3 PURCHASING
- 3. 4 MATERIAL HANDLING
- 3. 5 ADMINISTRATION
- 3. 6 SCHEDULING AND CONTROL
- 3. 7 DATA FLOW

4.0 WORK PRACTICES*

- 4. 1 BASIC DESIGN
- 4. 2 ESTIMATING
- 4. 3 PURCHASING
- 4. 4 PLANNING
- 4. 5 SCHEDULING
- 4. 6 CONTRACT ADMINISTRATION
- 4. 7 GROUP TECHNOLOGY
- 4. 8 WORK CLASSIFICATION
- 4. 9 PRODUCT WORK BREAKDOWN
- 4. 10 PROJECT CONTROL
- 4. 11 ACCURACY CONTROL
- 4. 12 MATERIAL HANDLING
- 4. 13 PRODUCT ENGINEERING
 - 4. 13. 1 DRAWING FORMS & CONTENTS
 - 4. 13. 2 MATERIAL DEFINITION
 - 4. 13. 3 MODULE HANDLING
 - 4. 13. 4 INTERFERENCE CONTROL
 - 4. 13. 5 LOFTING CAM
 - 4. 13. 6 PIPE CAM
 - 4. 13. 7 SHEET METAL CAM
 - 4. 13. 8 LIAISON/FIELD ENGINEERING
 - 4. 13. 9 ENGINEERING 0 A
- 4. 14 WELDING
- 4. 15 STRUCTURAL PROCESSING
- 4. 16 MACHINING
- 4. 17 MACHINERY INSTALLATION

TABLE 2.3 (Continued)

4. 0 CONTINUED

- 4. 18 PIPE PROCESSING
- 4. 19 HVAC PROCESSING
- 4. 20 ELECTRICAL INSTALLATION
- 4. 21 ADVANCED OUTFITTING UNITS
- 4. 22 ADVANCED OUTFITTING ON BLOCK
- 4. 23 ADVANCED OUTFITTING ON BOARD
- 4. 24 HULL INSULATION INSTALLATION
- 4. 25 JOINER WORK DIVISION INSTALLATION
- 4. 26 DECK COVERING INSTALLATION
- 4. 27 FURNITURE INSTALLATION
- 4. 28 JOINER WORK FITTING INSTALLATION
- 4. 29 PLUMBING FIXTURE INSTALLATION
- 4. 30 CONSTRUCTION SUPPORT SERVICES
- 4. 31 LAUNCHING
- 4. 32 INCLINING EXPERIMENT
- 4. 33 DOCK TRIALS
- 4. 34 SEA TRIALS
- 4. 35 DELIVERY
- 4. 36 GUARANTEE PERFORMANCE

5. 0 STANDARDS

- 5. 1 OWNER STANDARDS
- 5. 2 INDUSTRY STANDARDS
- 5. 3 SHIPYARD SYSTEM STANDARDS
- 5. 4 SHIPYARD PART STANDARDS
 - 5. 4. 1 EQUIPMENT
 - 5. 4. 2 ENGINEERING
 - 5. 4. 3 LOFTING
 - 5. 4. 4 STRUCTURAL
 - 5. 4. 5 WELDING
 - 5. 4. 6 PIPE
 - 5. 4. 7 FITTINGS
 - 5. 4. 8 OUTFIT
 - 5. 4. 9 HVAC
 - 5. 4 10 SURFACE PREPARATION
 - 5. 4 9 11 PAINTING

TABLE 2.3 (Continued)

*
AN ALTERNATE APPROACH TO WORK PRACTICES AND STANDARDS PRESENTED IN SPECIFICATION IS TO SIMPLY REFERENCE THEM INSTEAD AND TO PROVIDE SEPARATE INDIVIDUAL SHIPYARD HANDBOOKS OF PRACTICE AND STANDARDS.

TABLE 2.4
BUILDING PLAN

BUILDING PLAN

1.0 SHIP DESCRIPTION

- 1.1 GENERAL
- 1.2 PRINCIPAL CHARACTERISTICS
- 1.3 SPECIAL CHARACTERISTICS
- 1.4 WEIGHT BREAKDOWN

2.0 REGULATIONS & CLASSIFICATION

- 2.1 REGULATIONS
- 2.2 CLASSIFICATION
- 2.3 QUALITY

3.0 CONTRACT REQUIREMENTS

- 3.1 TYPE OF CONTRACT
- 3.2 DATE OF SIGNING
- 3.3 CONTRACTUAL DATES
- 3.4 PROGRESS PAYMENTS
- 3.5 PENALTIES/REWARDS

4.0 CONSTRUCTION DATA & QUANTITIES

- A.1 MAJOR EQUIPMENT LIST
- 4.2 NUMBER OF PLATES
- 4.3 NUMBER OF SHAPES
- 4.4 NUMBER OF SUB-ASSEMBLIES
- 4.5 NUMBER OF ASSEMBLIES
- 4.6 NUMBER OF MODULES
- 4.7 JOINT WELD LENGTHS
- A.8 PAINT AREAS
- A.9 DECK COVERING AREAS
- 4.10 FOOTAGE OF PIPE
- 4.11 NUMBER OF PIPE ASSEMBLIES
- 4.12 FOOTAGE OF ELECTRIC CABLE

TABLE 2.4 (Continued)

- 4.13 NUMBER OF UNITS
- A.14 NUMBER OF ZONES
- 4.15 NUMBER OF HULL COMPARTMENTS
- A.16 NUMBER OF MACHINERY COMPARTMENTS
- 4.17 NUMBER OF DECKHOUSE COMPARTMENTS
- 4.18 LAUNCH WEIGHT

5.0 BUILDING BUDGET

- 5.1 BUDGET LABOR HOURS
- 5.2 BUDGET MATERIAL COST

6.0 BUILDING SCHEDULE

- 6.1 KEY ACTIVITIES
- 6.2 BERTH CYCLE
- 6.3 MODULE SCHEDULE
- 6.4 HULL SCHEDULE
- 6.5 MACHINERY SPACE SCHEDULE
- 6.6 DECKHOUSE SCHEDULE
- 6.7 PRODUCT ENGINEERING SCHEDULE
- 6.8 MAJOR EQUIPMENT PROCUREMENT SCHEDULE
- 6.9 TEST & TRIAL SCHEDULE

7.0 BUILD STRATEGY

- 7.1 MODULE DEFINITION
- 7.2 ZONE DEFINITION
- 7.3 REFERENCE SYSTEM
- 7.4 ALIGNMENT
- 7.5 MOLDED LINES
- 7.6 ACCURACY CONTROL
- 7.7 TOLERANCES
- 7.8 HULL STRUCTURE
- 7.9 DECKHOUSE STRUCTURE
- 7.10 HULL OUTFITTING

TABLE 2.4 (Continued)

- 7.11 DECKHOUSE OUTFITTING
- 7.12 MACHINERY SPACE OUTFITTING
- 7.13 WORK STATIONS UTILIZED
- 7.14 PROCESSING LANES UTILIZED
- 7.15 MATERIAL STOWAGE AND FLOW

8.0 PRODUCT ENGINEERING

- 8.1 KEY DRAWING LIST
- 8.2 PURCHASE TECHNICAL SPECIFICATION

- 8.3 WORK STATION DRAWING LIST
- 8.4 MATERIAL LIST
- 8.5 CAM DATA LIST
- 8.6 WORK STATION PARTS LIST

TABLE 2.6
PRODUCT DEFINITION











PRODUCT DEFINITION		
CODE	NAME	EXAMPLES
PL 1	PLATE PART	 FLAT 1  SHAPED 2  FLAT NOTCHED 3
S 1	SECTION PART	 STRAIGHT 1  SHAPED 2
SA 1	SUB-ASSEMBLY	 FLAT 1  SHAPED 2  FLOOR 3  GIRDER 4
A 1	ASSEMBLY	 FLAT 1  SHAPED 2
M 1	MODULE	 DOUBLE BOTTOM 1  WING TANK 2  DECK WITH HATCH 5/3

TABLE 2.5 (Continued)

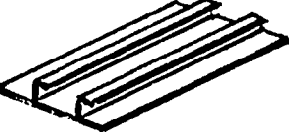
PRODUCT DEFINITION		
CODE	NAME	EXAMPLES
P 1	PIPE	  STRAIGHT P 11 BENT P 12
PT 1	PIPE TEE	
PV 1	PIPE VALVE	
PF 1	PIPE FLANGE	
PA 1	PIPE ASSEMBLY	

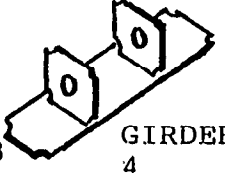
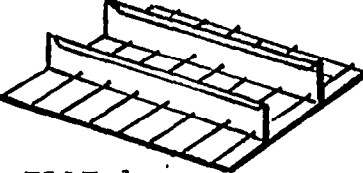
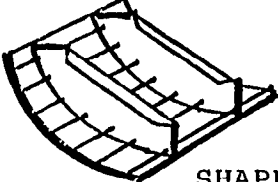
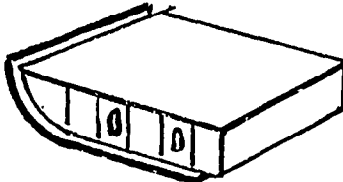
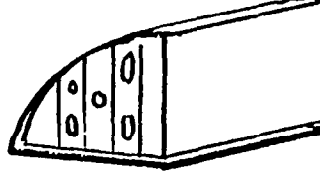
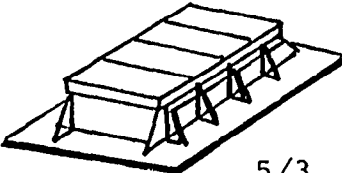
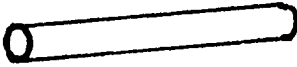
The proposed methods of preparing engineering data can actually reduce the hours for structural engineering, but will increase all the other areas by up to 30% except for piping engineering, which can increase up to 50% depending on the extent of the traditional engineering it replaces. The use of computer-aided design can reduce the structural and piping engineering. However, the overall increase in engineering manhours to accomplish the proposed work should be less than 20%. In return-for this additional effort by engineering, the production manhours should be reduced by 20% to 30%. It is easy to see that this is a worthwhile tradeoff. However, as an example, assuming a project that requires 250,000 manhours for traditional engineering, and a corresponding 1,000,000 production manhours for one ship, the proposed methods for engineering would require 50,000 additional manhours, but could result in up to 200,000 production manhours reduction per ship. Of course, if the shipyard using the traditional engineering approach had no effective planning, scheduling, and control system in operation, then it would be necessary to add the manhours necessary for this function, but they should not be more than 40,000, still resulting in a significant overall benefit to the shipyard. Another way of looking at it is, that on a one-ship basis, such an approach, including the new planning group, would be worthwhile with a 9% reduction in production manhours; a two-ship program requires only 4.5% reduction, and so on.

Table 2.6 shows typical percentage breakdowns for three ship types and both production and engineering. It can be seen that steel, outfit, and piping combined take 80% of production hours as well as about 80% of engineering for the commercial ships and about 70% for the naval ships.

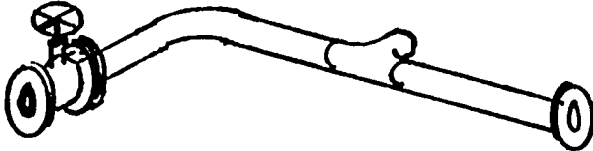
Many shipyards recognized this fact and examined the needs for these areas to see if their efficiency could be improved. As steel is the largest production percentage for most commercial vessels and large naval vessels, it is the area which has received the most attention. Piping and outfit lagged behind for some years, but have found compatibility with advanced shipbuilding in zone construction and advanced outfitting.

The suggestions on how the engineering can best be provided to the production department will be presented for each of the individual groups within the engineering department even though it is obvious that as much standardization as possible of data preparation is the ultimate goal. With this in mind, it is surprising how many different drawing scales are used by the different groups in the engineering department. There is really no need for more than two scales for each project. This is more significant when computer-aided drawings are utilized as the basis for, or start of, all other drawings. It also assists interference control if all drawings are to the same scale.

REFERENCES

1. **Integrated hull construction, outfit, and painting (IHOP)**. U.S. Department of Commerce, Maritime Administration, 1983.
2. J.D.F. Craggs, **Build strategy development. IREAPS** 1983.

TABLE 2.6

TYPICAL MANHOUR PERCENTAGE BREAKDOWN

	Offshore Supply Vessel	225 Kt DWT Tanker	Large Naval ship
PRODUCTION			
Steel	36	56	37
outfit	24	16	13
Machinery Installation	6	6	12
PiPing	22	14	21
Electrical	12	8	17
	100%	100%	100%
ENGINEERING			
Steel	23	35	20
outfit	27	10	20
Machinery Installation	8	15	15
Piping	28	32	30
Electrical	14	8	15
	100%	100%	100%
TRADITIONAL ENGINEERING AS A PERCENTAGE OF PRODUCTION ONE-SW BASIS	5%-25%	2%-10%	12%-30%

2.4 Dimensioning

There appear to be as many ways used to dimension drawings as there are dimensions on a drawing. Dimensions are provided in manual engineering so that continuing engineering development can use stated dimensions rather than scale-off prints of drawings, thus eliminating both human error and print accuracy problems. In computer-aided design (CAD) this is not necessary, and many superfluous and sometimes confusing dimensions are given on drawings. When computer-aided lofting (CAL) was introduced to shipbuilding, it changed the needs of structural drawings. It was no longer necessary to give many dimensions on the drawing, as these were developed and contained in the computer data base. Also as plates were marked and cut by N/C-controlled burning machines, the only dimensions that were still required to construct the structure of the ship were those for checking, dimensional control, and module erection.

The practice of presenting dimensions to an item on the opposite side of the molded line from the molded line is obviously useless to the production worker and forces the need to take time to find out the plating thickness or simply ignore it, possibly causing fit-up problems later on. The use of sequential dimensioning is not recommended for a number of reasons. One obvious one is that it perpetuates an initial error, whereas dimensioning to a common reference system is an automatic check on previous dimensions. It is a well-known fact that the structure of a ship is not a suitable reference from which to locate major machinery and equipment. This is because the structure may be inaccurately located relative to other structures and will almost always be inaccurate to a total ship reference system. The U.S. Navy specifications allow for ship structure to be out of tolerance one inch for each hundred feet in length. However, machined equipment like shafting is manufactured to a tighter tolerance, and merging it with the ship structure can be a problem.

Therefore, for *engineering for production*, dimensioning should be based on the following approach:

1. A total ship reference system should be used on drawings from which all dimensions are measured.
2. The total ship reference system should be shown on all functional design and transitional design drawings, and work station/zone drawings.
3. Dimensions locating equipment such as valves, pumps, engines, etc., should be measured to an actual physical surface such as a flange face, and not to an imaginary line such as the center line of a pump or an electric motor.
4. Dimensions should not be given from one piece of equipment, piping, or structure to another, but only as total dimensions from the appropriate reference plane.

One area that provokes considerable discussion but little action is tolerances. It is quite normal to find tolerances stated by engineering for any item involving machinery, but it is not normal for any other discipline. Total dimensional control requires that tolerances be stated for structure, pipe fabrication and installation, and outfit installation. This has been resisted by many shipyards as an unnecessary additional burden for the production department. However, it is necessary to reconsider the need for zone construction including structural module construction and advanced outfitting. In the NSFP publication *Process Analysis Via Accuracy Control*, issued in February 1982, Appendix D-1 gives a

sample of the “Japanese Shipbuilding Quality Standard (Hull Part)-1979” as well as other examples of accuracy standards reproduced in Figure 2.9. Such a standard, if developed for U.S. shipbuilding, would be a starting point in developing a total building tolerance procedure.

In applying tolerances to work station/zone drawings, it is essential to apply them correctly. The alignment of interfacing modules and outfit units is obviously critical, and the closest practical tolerances should apply. However, there are many other dimensions which can be given large tolerances. This aspect must be given full consideration in the early days of the design with the Planning department. To ensure this, it can be made a logical part of the building plan.

Division		Sub-assembly			UNIT : mm
Section	Sub-section	Item	Standard range	Tolerance limits	Remarks
Accuracy of Dimensions	Plate Block Sub-assembly	Twist of Sub-assembly	10	20	Measured as follows :  The point A, B and C are established in the same plane, then measured the deviation of the point D from that plane. May re-assemble partially when the deviation exceed the limits.
		Deviation of upper lower panel from Σ or B. L.	5	10	
		Deviation of upper lower panel from F R.L.	5	10	 ACCURACY OF THIS DIMENSION
	Curved plate Block Sub-assembly	Breadth of each panel	The same as for the flat plate Sub-assembly		
		Length of each panel			
		Distortion of each panel			
		Deviation of interior members from skin plating			
		Twist of Sub-assembly	15	25	The same as for the flat plate Sub-assembly
		Deviation of upper / lower panel from Σ or B.L.	7	15	Re-assemble partially when the deviation exceed the limits.
	Deviation of upper lower panel from F.R.L.	7	15		
	Block Sub-assembly including Stern frame	Distance between upper lower gudgeon (a)	5	10	

FIGURE 2.9 Japanese shipbuilding quality standard (hull).



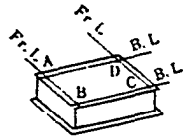
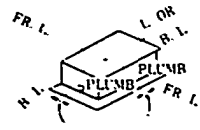
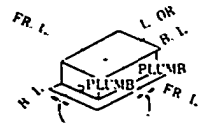

Gap between butt weld edge		
Item	Allowable limit mm	Remarks
<p>1. Butt weld plates</p> 	<p>$a \leq 5$</p> <p><u>In case</u></p> <p>1) $5 < a \leq 15$ When PL.thick ≥ 10 $\Delta 5 < a \leq 10$ When PL.thick < 10</p> <p>2) $25 \geq a > 15$ When PL.thick ≥ 10 $\Delta 15 \geq a > 10$ When PL.thick < 10</p> <p>3) $a > 25$ When PL.thick > 10 $\Delta a > 16$ When PL.thick < 10</p>	<p>When 'a' exceeds the allowable limit, the edges shall be treated as follows.</p> <p>1) The edge shall be built up by welding with a backing strip, and then back welding shall be done after removing the backing strip and after back chipping.</p>  <p>2-a) When the renewal of a longitudinal member is necessary, the scope of the renewal shall be decided case by case, with the agreement of the buyer and the classification society. For the other members, the plate of at least 300mm width shall be renewed.</p> <p>2-b) If 2-a is not applicable, the edge shall be built up by welding, and then the butt shall be welded.</p>  <p>3) The members shall be partially renewed in the same way as specified in above paragraph 2-a.</p>
<p>2. Butt weld of sections</p> 	<p>$a \leq 5$</p>	<p>When a exceeds the allowable limit, the gap shall be treated in the same way as the butt weld plates.</p>
<p>3. CES welding</p> 	<p>$17 \leq a \leq 40$</p> <p><u>In case</u></p> <p>1) $40 < a \leq 40 + t$</p> <p>2) $a > 40 + t$</p>	<p>When a exceeds 40mm, the gap shall be treated as follows.</p> <p>1) The edge shall be built up by welding.</p> <p>2) The plate shall be partially renewed.</p>
<p>4. Electro gas welding</p> 	<p>$10 \leq a \leq 30$</p> <p><u>In case</u></p> <p>1) $30 < a \leq 30 + t$</p> <p>2) $a > 30 + t$</p>	<p>1) The edge shall be built up by welding</p> <p>2) The plate shall be partially renewed</p>

FIGURE 2.9 (Continued)

<u>Deformation</u>		
		
Division	Item	Allowable limit mm
Shell plate	Parallel part side shell	6
	Parallel part bottom shell	6
	Fore and aft part	7
Double bottom tank top plate		6
Bulkhead	Longitudinal bulk-head	7 (t ≤ 13) 8 (t > 13)
	Transverse bulkhead (Swash bulkhead)	8
Strength deck	Parallel part (between 0.6 L B)	6
	Fore and aft part	8
	Covered part	9
Second deck	Bare part	8
	Covered part	9
Fore-castle deck Poop deck	Bare part	6
	Covered part	9
Super-structure deck	Bare part	6
	Covered part	9
House wall	Outside wall	6
	Inside wall	6
	Covered part	9
Δ Web of girder and trans		7
Δ Floor & girder in double bottom tank		7

FIGURE 2.9 (Continued)

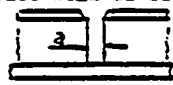

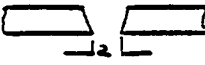
Distorsion & Straightness (Curvature)		
Item	Allowable Limit mm	Remarks
1. Distorsion of beams, frames or stiffeners (per 1 span)	1) $\delta \leq 7$ 2) $\delta \leq (5 + \frac{2l}{1000})$ 3) $\delta \leq 12$	1) When $l \leq 1000$ 2) When $1000 < l < 3500$ 3) When $l \geq 3500$
2. Distorsion of girder and long. (per 1 span)	1) $\delta \leq 5$ 2) $\delta \leq (3 + \frac{2l}{1000})$ 3) $\delta \leq 10$	1) When $l \leq 1000$ 2) When $1000 < l < 3500$ 3) When $l \geq 3500$
3. Straightness in the plan of flange and web	≤ 25 (per 10m length)	
4. Tr. BKM & stiff. with web (when free edges)	$\delta = l \times \frac{8}{1000}$ (max. 12)	
5. Filler (between deck)	1) $\delta = 6$ 2) $\delta = l \times \frac{1.2}{1000}$ (max. 12)	1) When $l \leq 5.000$ 2) When $l > 5.000$ 

FIGURE 2.9 (Continued)

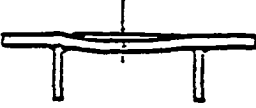
Division	Item	Remarks
HOLE	<p>(1) Circle Type</p> 	<p><u>Important number</u></p> <p>a) when, $t \leq 13$ min $\phi = 200mm$</p> <p>b) when, $t > 13$ $\phi = 15 \times t$ (standard) max = 450mm</p> <p><u>Other number</u></p> <p>a) when, $t \leq 16$ min $\phi = 200mm$</p> <p>b) when, $t > 16$ $\phi = 12 \times t$ (standard)</p>
	<p>(2) Oval Type</p> 	<p>- do. -</p>
	<p>(3) Square Type</p> 	<p>for temporary hole (min "R" = 150mm)</p>

FIGURE 2.9 (Continued)

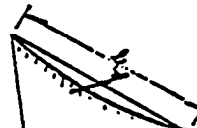

SHOP	ITEMS	ALLOWABLE TOLERANCE	FREQUENCY OF MEASURING	REMARKS
<u>Marking & Gas Cutting</u> (Section) (Fb)	*Check line for gas cutting of angles (after marking)	$a = \pm 1.5/64''$	8 pc/day (piece/day)	
	*Check line for gas cutting of angles (after cutting)	$e = \pm 1/32''$	5 pc/day	
	*Length of angles (after cutting)	$e = \pm 1.5/64''$	5 pc/day	
(Internal Member)	*Normality after gas cutting (Right Angle)	2/1500	5 pc/day	
	*Check line for gas cutting	$e = \pm 1/32''$	D ₀	
	*Length after gas cutting	$e = \pm 3/64''$	D ₀	
	*Width after gas cutting	$e = \pm 3/64''$	D ₀	
<u>Flame planar</u> (Flat shell plate flat plate)	*Length & Width after cutting	$a = \pm 1.5/64''$	5 pc/day	
	*Straightness	$e = \pm 1/64''$	2 pc/week	
	*Bevel Angle	$a = \pm 2.0 \text{ deg.}$	5 pc/day	
	*Normality (Right Angle)	$e = \pm 2/1500$	2 pc/week	
<u>Bending</u> (Section)	*Length of frames after bending	$e = \pm 1.5/32''$	5 pc/day	Girth length 
	*Straightness of inverted straight line of frames after bending	$e = \pm 3/32''$	5 pc/day	
(Plate)	*Round gunwale plate & Bilge plate	$e = \pm 1/8''$	ALL	
	*Setting degree of template	$e = \pm 1/4''/2''$	ALL	
	*Discrepancy between template and end of plate	$e = \pm 1/4''$		

FIGURE 6.9 (Continued)

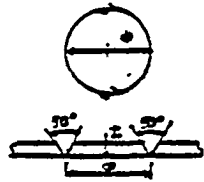
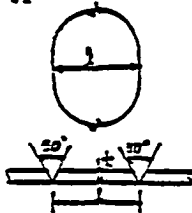
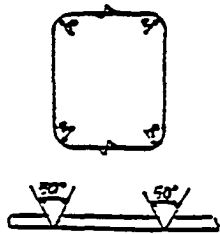



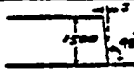
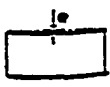





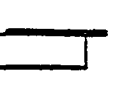

SHOP	ITEM	ALLOWABLE TOLERANCE	FREQUENCY OF MEASURING	REMARKS
<u>Bending</u>	*Height of sight seeing line	$e = \pm 1.5/16''$	5 pc/day	
	*Discrepancy of sight seeing line between templates and thread	$e = \pm 1/4''$	5 pc/day	
<u>Sub-Assembly</u>	*Positioning of stiffeners (FB. BKT) on a web plate	$e = \pm 1/32''$	8 pc/day	
	*Positioning of face plate to a web plate (keep shift dimension)	$e = \pm 1/32''$	8 pc/day	
	*Flatness of sub after sub-assembly	$e = \pm 1/8''$ (IG 31' 14'') $-e = \pm 1/4''$ (L 31' 14'')	8 pc/day	
	*Fitting angle of stiffeners to a web plate	$e = \pm 3 \text{ deg.}$		
	*Deformation of sub-unit	$e = \pm 1/4''$	8 pc/day	
<u>Assembly Fitting</u>	*Shift dimension between skin plates and frames/girders	$e = \pm 1.5/32''$	5 pc/day	
	*Shift dimension between skin plates and trans. web/floors	$e = \pm 1.5/32''$	5 pc/day	
	*Fitting angle between trans. web and skin plates	$e = \pm 5/1500$	5 pc/day	
	*Fitting angle between frames and skin plates (at the top)	$e = \pm 1/8''$	5 pc/day	
	*Level	$e = \pm 1/4''$	ALL	
	*Perpendicularity check by a plummet (at the end point)	$e = \pm 1/16''$	ALL	
	*Flatness of a unit	$e = \pm 1/4''/L$	20%	

FIGURE 2.9 (Continued)

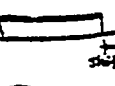
SHOP	ITEM	ALLOWABLE TOLERANCE	FREQUENCY OF MEASURING	REMARKS
<u>Assembly</u>				
<u>Marking</u>	*Length of plates	$e = \pm 1/8''$ (curved)	All	
	*Width of plates	$e = \pm 1.5/16''$ (plane)	All	
	*Diagonal length of plates (squaresness check)	$\Delta L = \pm 1/4''$ (curved) $\Delta L = \pm 1/8''$ (plane)	All	 $\Delta L = L_1 - L_2$
	*Marking lines by hand	$e = \pm 1/8''$ (curved)	4 units/ 2 days	
	*Straightness of plate edge	$e = 1/16''/L$	20%	
	*Width of corrugate	$e = 1.5/16''$	All	
	Height of corrugate	$e = 1/16''$	All	
	Normality of corrugate	$e = 1.5/16''$	All	
<u>Assembly</u>				
<u>Gas Cutting</u>	*Check line for gas cutting	$e = \pm 1/32''$	5 pc/day	
	*Depth of bevel	$e = \pm 1/32''$	5 pc/day	
	*Bevel Angle	$e = \pm 2.0 \text{ deg.}$	5 pc/day	
	*Straightness of plate edge	$e = \pm 1.5/32''$	20%	

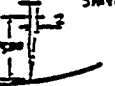
FIGURE 2.9 (Continued)

SHOP	ITEM	TOLERANCE	FREQUENCY OF MEASURING	REMARKS
<u>ERECTION</u> Bottom Shell	*Positioning: (Length wise) Measure on the check points on berth	$e = \pm 1/8''$	starting unit only	
	*Positioning: (Height) Measure at the most forward frame (2 points)	$e = \pm 1/4''$	All Units	By gauge
	*Level: (Between left side and right side) Measure on the points at forward edge	$e = \pm 1/4''$	All units	Pay attention to twist
	*Positioning: (Between left side and right side) Measure at the forward butt	$e = \pm 1/8''$	All units	Plumb down to the base line on berth
	*Connecting part between units: Check the bevels at seams and butts	$e = \pm 1/8''$	All units	
	*Discrepancy of ship's center	$e = \pm 1/8''$	All units	Measuring by transit

FIGURE 2.9 (Continued)

2.5 Reference Lines

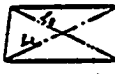
The need for and benefit of reference lines was discussed in detail in Section 1.3.5. It is proposed that **any engineering-for-ship-production** approach must utilize a reference system similar to the multi-level one described in Section 1.3.5. The reference system would be described in the building plan and utilized by engineering for both basic design and product engineering. It would be utilized by production to locate products and quality assurance (QA) to check configuration of the installation. It is therefore an important part of the total ship process and as such must be correctly used by engineering at the start, or it will only be partially successful throughout the remainder of the shipbuilding process. Appropriate reference planes must then be shown on every functional design drawing, in all transitional-design zone arrangement composites and work station/zone information packages. They should be marked on the structural parts as they are being burned and re-established after each process which obscures them, such as painting. It is only by actually performing the design and construction of a ship, with a total ship reference system, that the full benefits can be appreciated.

2.6 Accuracy Control

Accuracy control should not be confused with quality control. Accuracy control is the use of statistical methods and analysis by actual workers to monitor and control the accuracy of their processes so as to minimize product rejection or rework, thus helping to maximize productivity. The application of accuracy control to shipbuilding has been well described by Chirillo [1] and Starch [2,3,4]. What is of interest here is how it can be integrated into engineering and planning to become a routine day-to-day activity. Accuracy control consists of a number of phases as can be seen from File 2.10, which is reproduced from reference [1]. Accuracy control requires a close liaison between basic design, purchasing, product engineering, planning, and production control. It must be started in design and carried through testing and trials. It is recommended that accuracy control be an integral part of all shipyard groups rather than a separate group specializing in its application.

The successful implementation and use of accuracy control in a shipyard is dependent on the parallel use of some group technology techniques. The engineering, planning, procurement, and production systems should be based on a product-oriented breakdown system. Parts and processes should be standardized and classified to maximize repeatability of processes. It has been suggested [4] that without group technology any attempt to utilize accuracy control will be wasted effort.

Engineering must establish assembly and welding sequence documents as well as tolerances. Fabrication standards such as allowances for weld shrinkage and other excess allowances must be documented by engineering. Vital points and dimensions should be included in engineering drawings and work station/zone information rather than in independent accuracy control documents. This can be done by incorporating such information either directly into the body of the drawing or as a separate inset area for a key sketch for accuracy control purpose. A total ship reference system is an integral part of accuracy control for the obvious use in measurements. Suitable vital points for module and zone construction are given in Table 2.7 which is reproduced from reference [4]. Table 2.8 lists shipbuilding structural processes to which accuracy control can be advantageously applied. It is based on a similar table in reference [3]. Table 2.9, also taken from this reference, provides a concise example of the data required to be incorporated in the structural drawings.

REFERENCES

1. **Process analysis via accuracy control.** U.S. Department of Transportation, Maritime Administration, 1982.
2. RL. Starch, **Accuracy control of U.S. shipyards. IREAPS 1983.**
3. **Improving accuracy control while employing zone outfitting in U.S. shipyards.** U.S. Department of Transportation, Maritime Administration 1982.
4. **Accuracy control: A guide to its application in U.S. shipyards.** U.S. Department of Transportation, Maritime Administration 1983.

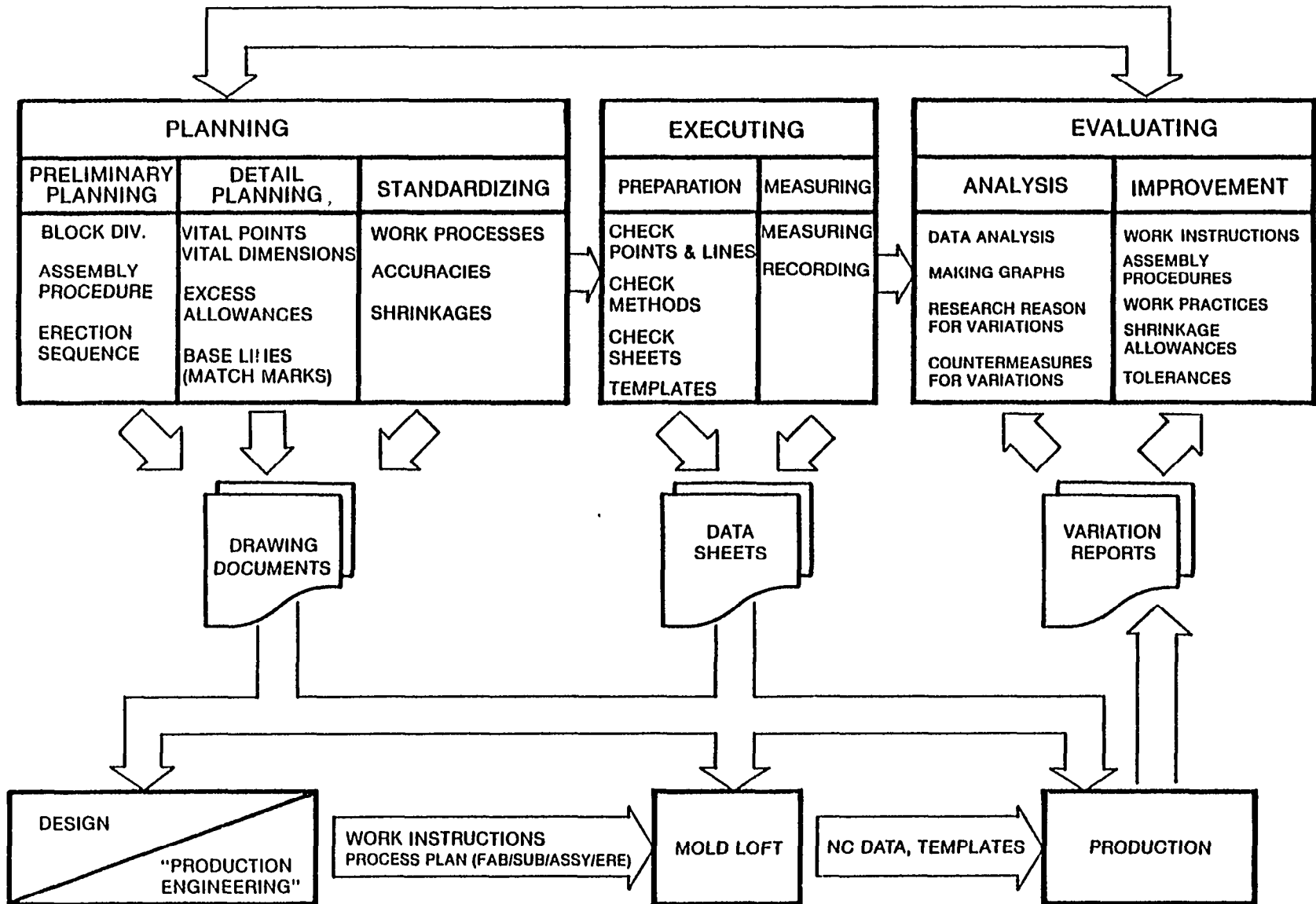

294

FIGURE 2.10 Phases of accuracy control.

TABLE 2.7
SELECTION OF VITAL POINTS

TYPE OF VITAL CHECK POINTS OR BASELINES	EXAMPLE	WHY THESE MEASUREMENTS ARE IMPORTANT
CHARACTERISTIC HULL DIMENSIONS	<ol style="list-style-type: none"> 1. straightness and level of hull baseline 2. length, draft, breadth of various points 3. hull volume-offsets at chine or bilges 4. tonnage/tankage measurements 	<ol style="list-style-type: none"> 1. Satisfy regulatory bodies 2. establish capacity/tonnage 3. quality assurance to customer 4. feedback to yard--A/C analysis 5. feedback to standards organizations-- modify standards 6. affect erection productivity
DIMENSIONS RELATED TO OPERATING REQUIREMENTS	<ol style="list-style-type: none"> 1. relative position of stem tube, shaft bearings, engine foundation and rudder post 2. location/alignment of special components--ro--ro ramps, gun 3. special customer requirements 	<ol style="list-style-type: none"> 1. affect performance. operation of vessel 2. feedback to yard--A/C analysis 3. feedback to standards agency 4. affect productivity of component installation 5. satisfy special customer requirements
MAJOR STRUCTURAL INTERSECTIONS AT BUTT JOINTS	<ol style="list-style-type: none"> 1. shell plate offsets at butt 2. chine offsets 3. locations of major bulkheads 4. large structural foundations-- location. flatness 	<ol style="list-style-type: none"> 1. affect strength, rework requirements. deformation during fabrication 2. feedback to yard--A/C analysis 3. feedback to standards agency 4. affect fabrication productivity
OUTFIT COMPONENT INTERSECTIONS AT BUTT JOINTS	<ol style="list-style-type: none"> 1. pipe ends which mate to another component on adjoining unit 2. machinery components mating to component on another unit 3. pipe penetration locations 	<ol style="list-style-type: none"> 1. affect proper operation of machinery 2. affect productivity of zone outfitting 3. feedback to yard--A/C analysis 4. feedback to standards agency
PROCESS RELATED MEASUREMENTS	<ol style="list-style-type: none"> 1. fitup gaps 2. welding shrinkage 3. welding distortion 4. bending accuracy 5. line heating 6. cutting, marking accuracy 7. curvature of components fabricated on pin jig 	<ol style="list-style-type: none"> 1. assist deterioration of process accuracy 2. affect productivity of subsequent processes 3. feedback to yard process evaluation 4. feedback to standards agency
MEASUREMENTS TO FACILITATE FABRICATION	<ol style="list-style-type: none"> 1. platen level 2. jig alignment/accuracy 3. building dock baseline alignment 4. baselines on parts, blocks to facilitate measurement. alignment assembly outfit. painting and erection 	<ol style="list-style-type: none"> 1. assist fabrication 2. affect productivity 3. feedback to yard--A/c analysis of alternative methods/processes

TABLE 2.8
STRUCTURAL PROCESSES TO WHICH ACCURACY CONTROL
IS APPLICABLE

PART
<ul style="list-style-type: none"> • Marking <ul style="list-style-type: none"> Marking method by template Ink marking Right-angle tool and method Thread length and diameter • cutting <ul style="list-style-type: none"> Tip nozzle and oxygen pressure Matching of rails and torch Machine error Height of torch above plate • Bending <ul style="list-style-type: none"> Shift of neutral axis Deformation of template Matching of templates Matching roundness of ends
SUBASSEMBLY
<ul style="list-style-type: none"> • Fitting <ul style="list-style-type: none"> Gap at fitting Matching method by jig • Welding <ul style="list-style-type: none"> Welding condition Sequence of welding Fitting gap Level of platen • Fairing <ul style="list-style-type: none"> Method of fairing (e.g., line heating)
ASSEMBLY
<ul style="list-style-type: none"> • Plate Joining and Fitting <ul style="list-style-type: none"> Degree of fitting gap Matching method by jig Level of platen • Automatic Welding <ul style="list-style-type: none"> Running direction Condition of welding Leveling Method of securing angle

TABLE 2.8 (Continued)

ASSEMBLY (continued)
<ul style="list-style-type: none"> • Marking <ul style="list-style-type: none"> Ink-marking method Tool and method for right angle Thread length and diameter • cutting <ul style="list-style-type: none"> Tip nozzle and oxygen pressure Matching of rails and torch Machine error Distance of torch from plate • Assembly and Fitting <ul style="list-style-type: none"> Fitting gap Matching method of base line Leveling • Welding <ul style="list-style-type: none"> Condition of welding Sequence of welding Binding method Positioning apparatus • Fitting of Reverse-Side Members and Welding <ul style="list-style-type: none"> Positioning method Angle-setting method Sequence of welding and condition
ERECTION
<ul style="list-style-type: none"> • Positioning <ul style="list-style-type: none"> Cribbing arrangement and leveling Method of leveling Method of deciding inclination Slope of building berth Bending and twisting of block Rectangularity of hull body • Welding <ul style="list-style-type: none"> Condition of welding Sequence of welding Joining gap and shape of edge preparation

TABLE 2.9

PLANNING VITAL POINTS FOR A BULK CARRIER

PLANNING VITAL POINTS FOR A BULK CARRIER

1. Identifying Vital Points

A. Basic

Vital points are necessary for achieving accuracy specified for an and product. Thus, identifying vital points Starts with the complete hull and proceeds. as any other planning activity, to address reverse production flow i.e.. erection. block assembly, sub-block assembly and part fabrication. Also. because they impose different problems. each major **division** of a ship body has its own vital-point explosion

Vital points can be classified and sub- classified as:

1. At Erection Stage

- a. Hold Zone
- b. Curved Zone
- c. stern zone

2. At Block Assembly

- a. Straight Block
- b. Curved Block
- c. Flat panel Base
- d. Curved panel base

3. At Part Fabrication**B. Detail Descriptions****1. Erection Stage****a. Hold Zone**

Usually accuracy of the hold zone impacts most on the overall form of the hull because it contains the **most** blocks For vital-point matters. the hold zone can be subdivided into:

- Tank Top Zone
- Top Side Tank zone

The tank top zone is the base of the hold and incorporates vital points for controlling:

- Center line of the ship.
- Relativity between each double bottom block.
- Level of tank top.

see Attachment 1.

The top side tank zone fixes the actual width and actual depth of the hull and contains vital points for controlling:

- Straightness of the base line.
- Width of the ship at main deck.
- Height of the ship at main deck.
- Level of main deck.

Details are shown in Attachment 2.

The vital points for setting each block on the ways is derived from the foregoing and noted for shipwright guidance as shown in Attachment 3.

TABLE 2.9 (Continued)

b. Curved Zone

Vital points in the curved zone are dependent on the hold zone because the block erection sequence usually starts in the curved zone.

In order to set a curved block, fixing suitable points is necessary. For example:

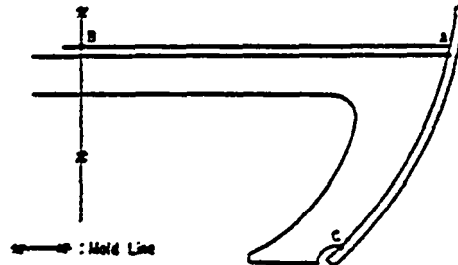

Point A: For setting the width.
 Point B: For keeping straightness.
 Point c: For setting the height, and checking the lower width.

Note 1: Loftsmen must prepare dimension L to locate A' on the shell:

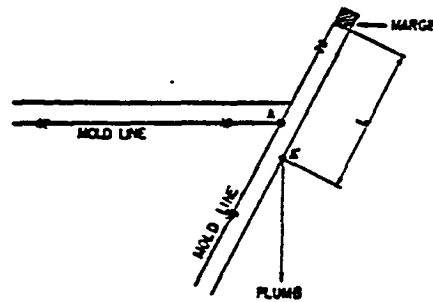

Note 2: TO locate point C, loftsmen must provide dimensions H and B.

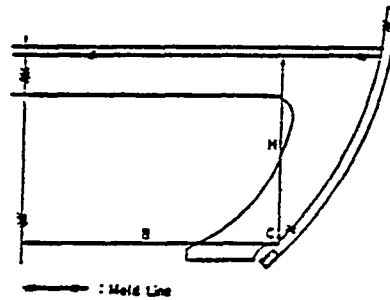
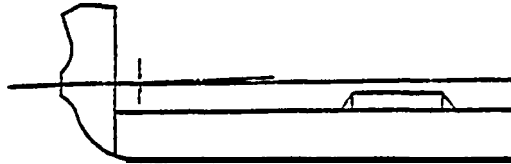

TABLE 2.9 (Continued)

c. stem zone

Accuracy of the stern zone influences a ship's performance significantly. Accuracy of the shaft line involves:

- Accuracy of center of stern tube,
 - Centering.
 - Height.
- Relationship between center of stern tube and the shaft line projected to the main engine seat:



Notice: Keeping this relationship precise is especially hard because of movement of the stern block during welding. Thus, fixing vital points and maintaining their positions requires the greatest possible care.

Usually the relationship between shaft and rudder centers are fixed in one block during block assembly. However, it is still difficult to align both of them with sufficient accuracy in a building berth. The sequence for welding the plate joints located forward of the after peak-tank bulkhead is critical.

2. Block Assembly Stage**a. Straight Block**

Straight blocks are located in the hold zone, there are several typical types defined by their locations. In order to define their vital points two questions should be asked:

- Which will be the most important points for hull erection?
- Which will be the most necessary points for block assembly?

A sample of a typical check is in Attachment 4.

TABLE 2.9 (Continued)

b. Curved Block

Flat-panel base, curved blocks are assembled on a platen in accordance with a sequence which is partly dependent upon internal structure

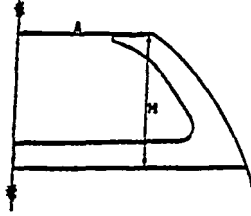

As shown the curved shell plates are set on block internals. Therefore, vital points are set to maintain vital dimensions such as A and H. The shell plate edge alignment with internal structure is also vital. See Attachment 5.

Curved-panel base, curved blocks are assembled on a pin jig. The procedure is to first join already formed plates to create a curved panel, layout the internal arrangement, and thereafter to fit and weld internals. Typical vital points and dimensions and an applicable checking procedure are described in Attachment 6.

3. Part Fabrication Stage

As establishing vital points in all of the many parts is impractical, parts which could cause consequential block inaccuracies are first identified. These typically are parts for:

- bottom girders
- bottom side floors
- hopper side tank floors
- hold frames

Vital point details and check sheets are provided in Attachment 7.

TABLE 2.9 (Continued)

VITAL POINTS FOR ACCURACY
AT ERECTION STAGE

In order to check and maintain accuracy of the tank top zone during the erection stage. three methods are necessary:

- Center Line Check of shift of each block in tank-top section.
- **Relativity** Check of center double bottom, center side double bottom, and budge blocks in every hold and over the full tank-top length.
- Level Check of each block both on the tank top and bottom.

Description**1. Center Line Check**

When Twice. once before fitting and once after welding.

who: worker and A/c engineer before fitting.
A/C engineer after welding.

Where At the front of each block on tank top.

How: By transit (allowance max. 1/8").

2. Relativity Check

When: Every block before fitting and and after welding an enter hold length.

who: **worker and A/cengineer before fitting and A/c engineer welding .**

Where: At the front edge of each block.

How: By transit (allowance max. 1/8" at each target).

Noticesif the relativity is larger allowed and thatamouts is less than 1/4",defer correction until welding is complete for a hold length.

3. Level check

When Every block before fitting and after welding .

who: Worker and A/C engineer before fitting and A/C engineer after welding.

Where At points A,B,c and D at forward frame of each bloc on top.

After welding, the level of the points at the bottom must be checked:

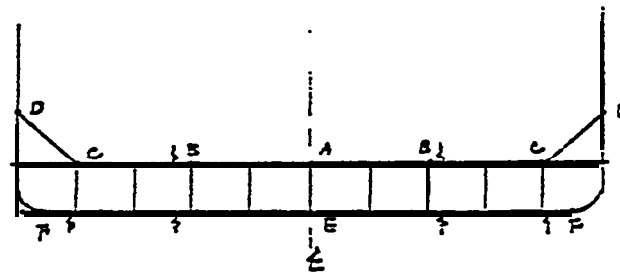

The data should be reconded and arranged in a simply style(picture,graph,chart,etc)Further each records should contain the date. time and temperature when the check was made. Recommended methods for recording these checks follow.

TABLE.33 2.9 (Continued)

THE VITAL POINTS FOR ACCURACY AT ERECTION
STAGE FOR TOP SIDE TANK ZONE

In order to check and maintain accuracy of the top side tank zone, four methods are necessary:

- Straightness of the base line
- Width of the ship at main deck
- Height of the ship at main deck
- Level of main deck

Descriptions

1. straightness of the Base Line

when: Twice once before welding and once after welding at each erection joint..

who: worker and A/C engineer before welding.

A/C engineer after welding.

where: At the line (see the figure at the end of this Attachment).

Notice: The base line must be marked on slabs before erection.

How: By transit

2. Width of the ship at main Deck

When: Twice, before and after welding.

Who: Worker and A/C engineer before welding.

A/C engineer after welding.

Where: At the base line of the front part of block (see the figure at the end of this Attachment).

How: By measuring.

3. Height of the Ship at Main Deck

When : Twice, before and after welding.

who: worker and A/C engineer before welding.

A/C engineer after welding.

Where: at the point supported by the pillar (see the figure at the end of this attachment).

How: By measuring

4. Level of Main Deck

When : Twice, before and after welding.

who : Worker and A/C engineer before welding .

A/C engineer after welding.

Where: at least 6 points as follow :

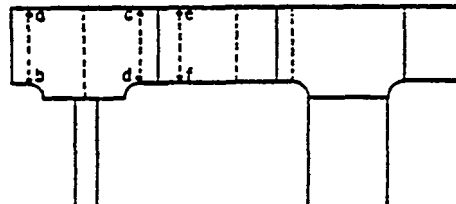
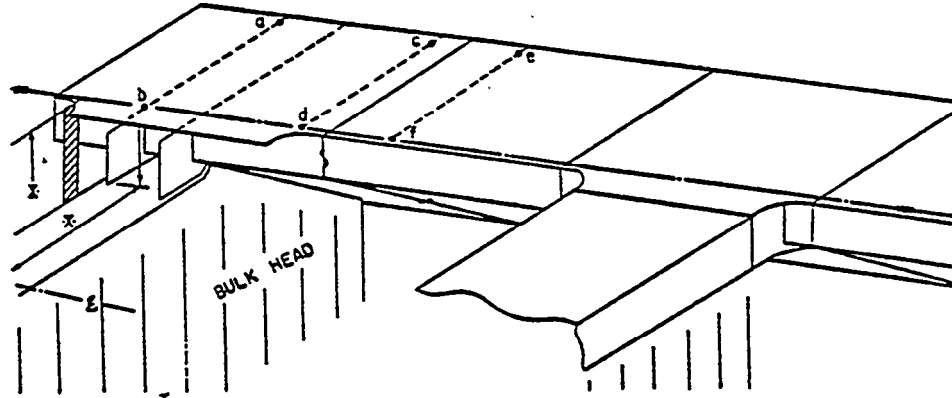

TABLE 2.9 (Continued)

Notice: Points a & b at forward end.
 Points c & d at aft end.
 Points e & f at forward part of f preceding block.
 How: By transit.



Appendix A, Attachment 3

BASE LINES FOR SHIPWRIGHT AT ERECTION
 (MARK *)

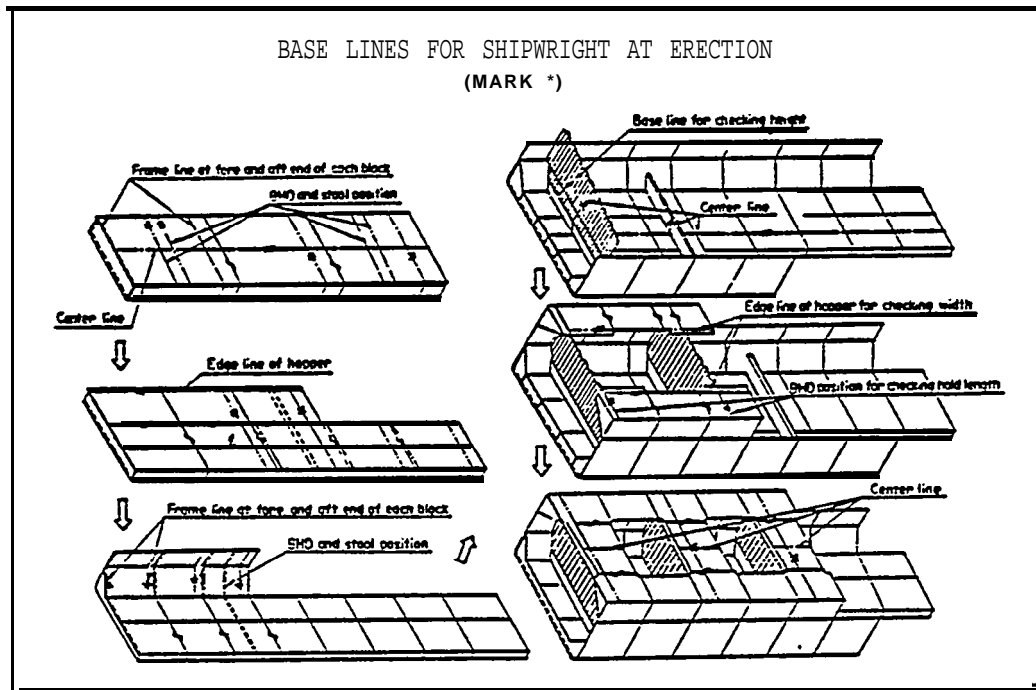
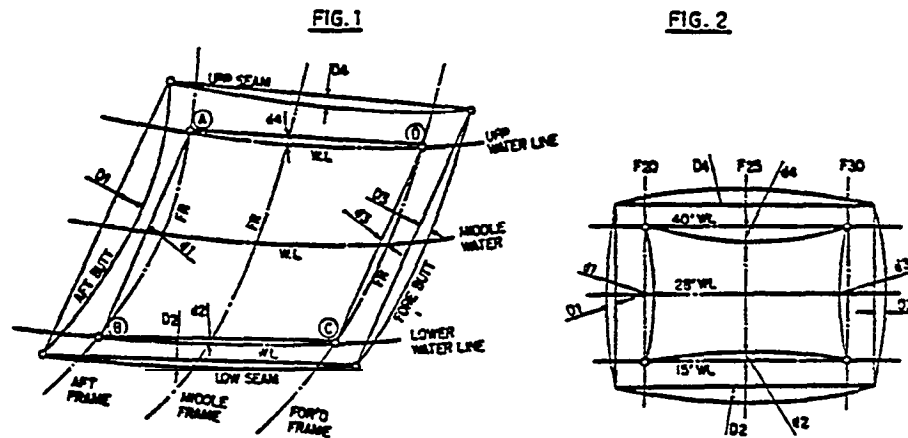

TABLE 2.9 Continued)

Curved Panel Base Blocks

1. A.C. Data Diagram



I. A.C. DATA DIAGRAM

It is generally difficult to check deformation of the curved unit shape. However, from the point of accuracy control it is necessary to check deformation of the curved shape during assembly work.

Then, the deformation checking data of the curved block should be prepared by the mold loft before they begin the assembly work.

Calculate the maximum curvature depths at the aft butt, for'd butt, upper erection seam, and the lower erection seam. Join AD, BC, AB and CD as shown in Fig. 1.

Calculate the upper waterline section's depth and the lower waterline section's depth at the middle frame. And also calculate the aft frame section depth and for'd frame section's depth at middle waterline.

Using the result of the above calculation, draw the checking data diagram as show in Fig.2.

TABLE 2.9 (Continued)

TABLE 2.6.III (Continued)

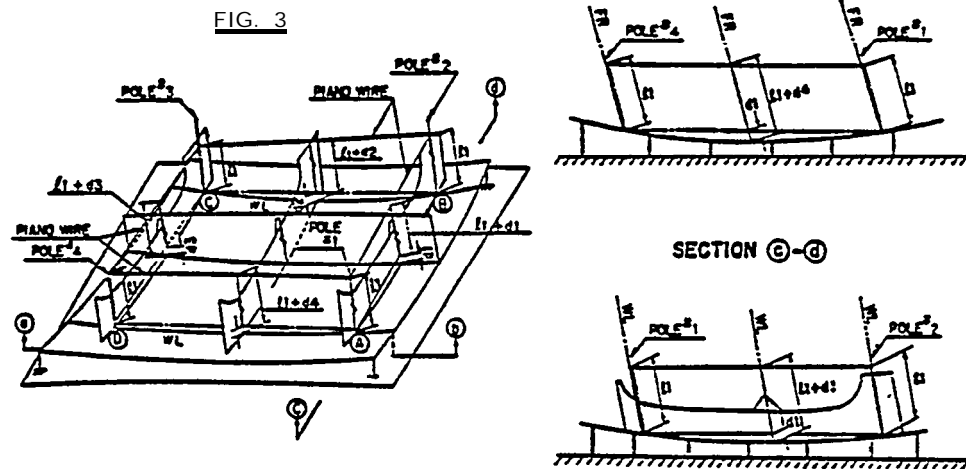
2. A.C. checking Procedure2. A.C. Checking Procedure

Using the checking data diagram, accuracy control activity is carried out as follows:

- (1) After plate joining, check the curvature depth at the aft butt, fore butt, upper seam and lower seam.
- (2) Before welding of the internal structures, set the poles at four (4) points (A, B, C and D) and strain piano wires as shown in the above Fig. 3. Measure the distance between the piano wire and the checking point on the shell plate. Mark down the level mark on each pole for deformation checking.
- (3) After the welding of internal structures, again set the poles at the same points, and check the distances in the same way as mentioned above.

Check the level mark on each pole for deformation of the block.

TABLE 2.9 (Continued)

HULL 751 (Zone-1) BASE LINE & CHECK LINE FOR VITAL POINTS		1
MEMBER & ITEM	MEANING & PURPOSE	NOTES
<p><u>Bottom Floor</u></p> <p><u>Tight Floor & Wall</u></p>	<p>D : Dimension to be checked The dimension is marked by NC operator and measured after cutting and sub-assembly.</p> <p>F : Guide lines for fitting stiffeners. *To be marked by NC burning machine . *To be used for fitting stiffeners at sub-assembly Two methods to be useful 1) to be marked at the end of stiffeners (Jig to be used) 2) to be marked at the fixed points.</p>	<p>Limited to the case of the neat cut before sub-assembly.</p>
	<p>*To be marked at the end of stiffeners.</p>	
	<p>*The dimension should be indicated in case that only one stiffener is different from others.</p>	

2.7 Basic Design

2.7.1 GENERAL. **Basic design covers all** design from conceptual to at least contract design. It is proposed that it should also cover functional design. In this way, after the award of a contract, all design to define all the systems and required material would be part of **basic design**. This would keep the responsibility of making the contract design work within the same group. The development of experience and skills would then be easily integrated into future contract designs. However, the main reason to include functional design in **basic design is the** concept that when functional design is completed, and the work tasks move on to product engineering, all design calculations, vendor selection, and system design including system sizing, routing, and grouping will be completed. Also, all planning should be developed parallel with **basic design**.

In **basic design the** division of the task should follow the traditional breakdown into naval architecture, marine engineering, and electrical engineering. Some shipyards may also desire to have designated system engineering and production engineering functions. Such a division is not being recommended, but is being discussed and also shown in Figure 2.4 in order to identify that such functions are necessary. It is suggested that they be integrated into the naval architecture, marine engineering, and electrical engineering responsibilities and handled as normal necessary tasks. Some of the tasks shown under Production Engineering may be handled by Planning rather than the Basic Design Group.

It is during **basic design** that **design for ship production** must be applied. As can be seen from Figure 2.4 the structural breakdown definition as well as zone and advanced outfitting "on-unit," "on-block," and "on-board" definitions must be decided during this phase. The building plan which will have been finalized for its initial issue at the end of the contract-design phase will be continuously developed parallel to the preparation of the functional design.

The concept and preliminary design process is well known and documented elsewhere [1, 2, 3, 4, 5]. Therefore, no further discussion of them will be given. However, it is emphasized that **design for ship production** should be incorporated in these phases of design.

Contract design and the various disciplines of function design, as well as the impact of regulatory and classification rules and owners' requirements, will be described in the context of the proposed **engineering for ship production**.

2.7.2 CONTRACT DESIGN. The 1930 Maritime Bill required that shipowners requesting government financial assistance in constructing new vessels had to submit preliminary data for the intended vessels and trade route. If MarAd approved the preliminary request, the shipowner then had to submit a contract-design package consisting of drawings and specifications to MarAd for review and approval. MarAd then sent out the package to interested shipbuilders who in turn submitted their bids to MarAd. Table 2.10 is the list of documents suggested by MarAd for a contract-design package.

Understandably, shipbuilders were unwilling to spend time preparing contract designs as they could not guarantee that they would be the lowest bidder when the design was sent out for bid. Thus, contract designs were mostly prepared by marine consultants. Although this system has produced many fine and successful ship types, it has a number of significant disadvantages. This can be understood by reviewing the list of documents in Table 2.10. Many of the drawings define basic construction and installation details which the shipbuilder must follow. When this is done, it is difficult to take full advantage of any particular shipyard's production facilities and methods as it is not known at the time which

TABLE 2.10

SUGGESTED LIST OF DOCUMENTS IN A CONTRACT DESIGN PACKAGE

The, specifications shall be prepared in framework similar to Maritime Administration Standard Specification for Cargo Ship Construction dated December 1972, and shall include, but not be limited to the following:

1. A list of regulatory bodies whose regulations shall apply.
2. A description of Maritime Administration participation.
3. A statement as to the standard of subdivision required.
4. A requirement for an estimate of light ship weight and center of gravity in accordance with Maritime Administration Classification of Weights, as well as an adequate system of weight and center-of-gravity control, and a stability and trim estimate for approval by the Administration prior to ordering material.
5. A requirement for a comprehensive vibration analysis of the hull and propulsion systems.
6. Detail requirements for all hull structures, equipment, outfit, and systems; main and auxiliary machinery components and systems and electrical and electronic items, systems, and installation.

The specifications shall also include a list of the following general characteristics:

Length overall
 Length between perpendiculars
 Beam, molded
 Depth, molded
 Draft, full load
 Displacement, full load
 Light ship weight
 Permanent ballast, if any
 Deadweight, excluding ballast
 Draft, scantling
 Draft, design full load
 Sustained sea speed at design full load draft
 Gross tonnage
 Net tonnage
 Number of containers
 Number of barges
 Dry cargo cubic
 Refrigerated cargo **cubic**
 Cargo oil cubic
 Fuel oil tankage, tons
 Fresh water tankage, tons
 Type of machinery
 Bated horsepower (ABS max.1
 Estimated fuel consumption at sea and in port
 Cruising radius
 Number of passengers
 Number of crew by departments

TABLE 2.10 (Continued)

 CONTRACT PLANS

- Lines Plan
- General arrangements, plans, and profiles
- Machinery arrangement plans, sections, and elevations
- Heat balance
- Midship section approved by regulatory bodies
- * Arrangements of accommodations
- * Arrangements of service spaces
- * Cargo handling (dry and liquid)
- * Piping system diagrams (bilge and ballast and fuel oil)
- * Electric load analysis
- * Electronics antenna system
- * Power and lighting one-line diagram-ship's service
- * Scantling plans, sections, and elevations
- * Shafting arrangement
- * Capacity plan
- * Curves of form

*These plans show arrangements, data, and equipment which are subject to alterations, developments, and refinements by the contractor pursuant to requirements of applicable sections of the specifications.

DESIGN STUDIES AND CALCULATIONS

- a. Estimate of lightship weight and center of gravity summarized by weight groups in accordance with Maritime Administration Weight Classification system and recorded on forms MA-36A to 36F inclusive. Also, furnish one copy of back-up sheets supporting this weight estimate.
 - b. Floodable length curves including bonjean curves and inboard profile of the vessel.
 - c. Intact trim and stability estimates for each operation condition, i.e., full cargo, half cargo, and no cargo, each cargo condition with full, half, and 10% consumables.
 - d. Damaged stability diagram and calculations prepared in accordance with the U.S. Coast Guard regulations for a one-compartment passenger ship and including the intact GM required to withstand heeling due to wind.
 - e. Longitudinal strength studies as required to establish adequacy of the ship's structure in both hogging and sagging conditions.
 - f. Model basin test predictions from the Naval Ship Research and Development Center or other U.S.-accredited facility for the full-load displacement, design displacement, and light draft displacement, giving shaft horsepower, effective horsepower with appendages, and effective horsepower for the bare hull.
 - g. Prior to signing of a contract any questions regarding scope, format, or detail required should be settled by conference between the applicant and Office of Ship Construction and the necessary modifications made to the contract documents.
-

shipyard will be the successful bidder. If the shipyard has developed standard details to suit its facilities, then it must either request, prior to bid, to use its own standards or else put in extra cost to deal with a non-standard vessel. Of course, it could bid based on its standard, and then hope that the shipowner will accept its standards if they are the successful lowest bidder. As an attempt to relieve this problem, consultants list certain plans as contract guidance **plans in the contract specifications**. It is suggested that if a drawing is for guidance only, then it is not really required, and it would be more economical to eliminate it. In most cases a special requirement can be adequately covered by description in the Contract Specifications and if anything more is required, by a simple sketch as a page in the contract specifications.

It is interesting that the U.S. shipyards with the best order book records (and therefore the most competitive) in recent years are those with their own design groups. This fact plus the knowledge that a design prepared without knowing who would build it would not be the most economical for a given shipyard, were some of the reasons why the 1970 Maritime Bill introduced the negotiated **contract**. **This allowed** shipowners and shipbuilders to get together directly to design and construct the most economical vessel the shipyard could build to meet the shipowner's requirements.

This approach had some early successes but mainly for bulk carriers and oil tankers; and a number of shipyards that did not have in-house design capabilities started to build up this capability. Unfortunately, the Arab oil embargo eliminated the U.S. tanker boom, and the general work recession has reduced the growth of world trade. Therefore, the demand for new vessel construction in the U.S. has fallen far short of the expectations of the early 1970s. The economic fact of no work, no need for in-house designers stopped the shipyard design group growth, and most new designs are again being prepared by consultants.

It is suggested that a better way to achieve a minimum-cost U.S. shipbuilding industry is to reduce the number and detail of the contract design plans prepared by a consultant. A **contract liens plan** should be provided if the model tank tests have been run as part of the contract design. If the model tank tests are to be run by the shipbuilder, or if the shipbuilder is contractually responsible for the trial speed, only a preliminary plan should be prepared showing body plan and bow and stern profiles [10]. Table 2.11 lists the documents which it is considered are adequate for the purpose of a contract-design package to enable a modern shipyard to bid. It should also satisfy MarAd if construction differential subsidy (CDS) is ever available again, especially as they have changed their role in the design approval area.

Many contract designs are submitted to the classification societies and regulatory bodies for approval before they are released to the shipyards for bidding. While it is appreciated that some shipyards may like the apparent insurance of knowing that contract documents are approved by such organizations, it is suggested that this is only necessary for novel design concepts, and not for normal modern ships. By eliminating this step, the contract design package could be in the hands of the shipbuilder at least two months earlier. If these two months were given to the shipbuilder as additional time to prepare his bid, it would enable a better bid to be prepared, thus ensuring the most competitive prices. It would also give the successful low-bid shipyard the responsibility of getting the design details approved as early as possible by his regional approval office. This is so important, as often when consultants get approval of contract plans, they are approved in New York or Washington, D.C., and the shipyard developing the plans proceeds as if everything is in order, until it is quickly brought back to reality when the regional office disapproves details based on the headquarters' approved contract design.

TABLE 2.11

PROPOSED CONTRACT DESIGN FOR MARAD

1. MarAd format specification
2. General arrangement
3. Capacity plan
4. Preliminary lines
5. Machinery arrangement
6. Piping-system diagrams (cargo if applicable, fuel, bilge and ballast)
7. Electrical one-diagram
8. Electric load analysis
9. Preliminary hydrostatics
10. Trim and stability booklet
11. Damaged stability booklet
12. Lightship weight estimate
13. Longitudinal strength calculations

If the contract design is prepared by the shipbuilder, the basic “planning” for the design of the machinery space should be performed. The locating of the propulsion machinery should take into account the space needed for units, pipe/system corridors, and working space such as shown in Figure 2.11. This is where the use of standards, such as standard machinery space arrangements, system units, system corridors, etc., pays off. This approach also enables a quick check on space requirements before the design has progressed too far. The module definition will also be prepared either for an in-house contract design, or as a bid preparation document for an owner-prepared contract design.

2.7.3 CLASSIFICATION AND REGULATORY ORGANIZATION REQUIREMENT. The drawings which must be sent to the classification society and regulatory body to obtain their approval and certificates for the vessel are listed in their rules and regulations. It is unusual to prepare drawings exactly matching the lists, but their intent is all that need be followed.

The normal practice of submitting the shipyard’s proposed drawing list to the various organizations which will be involved, to get their indication of the drawings they want to approve, achieves a useful end result, but often also results in organizations requesting drawings that they really do not need. In the past, many drawings were really shop detail and duplicated what was shown on other general drawings. Every attempt should be made to keep shop detail and instructions out of the drawing list and therefore the approval cycle. For example, many shipyards prepare work station drawings for each structural assembly in addition to the complete structural module drawings. The structural module drawings are approved but the shipyard still sends the assembly work station drawings for approval, which is completely unnecessary. ASS have indicated that they would rather not see the assembly drawings, but if a drawing is submitted to them they must review it and comment or approve same. The concept of approving a detail only once should be the guide on what is a drawing necessary for submittal to external organizations for approval or record and what is simply more detailed shop instructions of the same data and should be kept in-house. This is conveniently accomplished in the proposed approach by only submitting **functional design** data. It is an obvious requirement

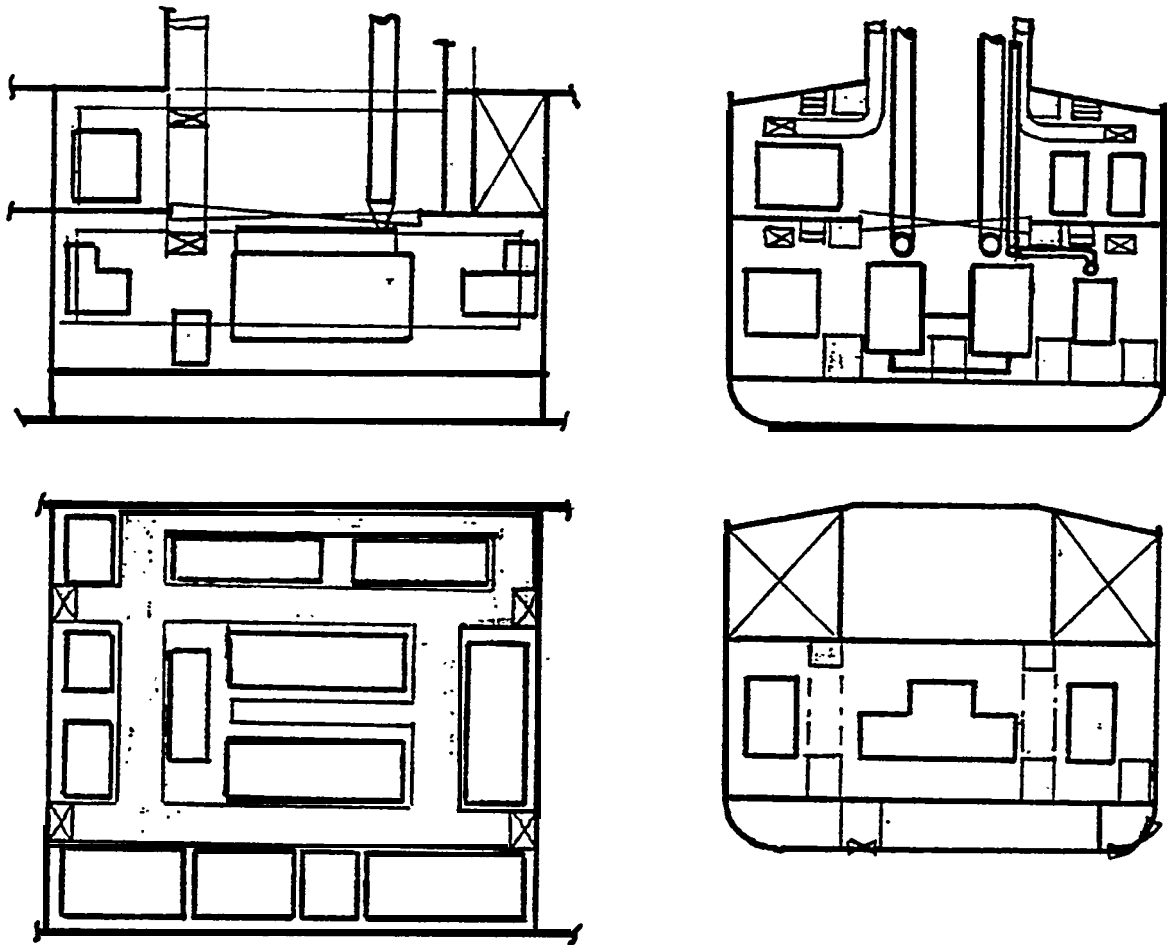

FIGURE 2.11 Space allocation.

that work station instructions should be given to resident owner and other inspectors to assist them in their work.

The procedure in this country where USCG approves hull drawings after they have been approved by ABS and also ABS approves machinery drawings for USCG is most beneficial to all concerned and complements the above suggestions.

It is recognized that many preparers of engineering data leave necessary information off their design drawings and diagrammatics, knowing that they will later submit detailed drawings. However, it is suggested that it is better to provide all the information required for approval on the drawings and diagrammatics even though it requires more detail and greater accuracy. Complete diagrammatics with piping shown in the correct location and all materials and equipment specified should be provided. Both the USCG and ABS have agreed to accept complete and accurate piping diagrammatics as full submittal for most piping systems, as can be seen from Table 2.12. It is not necessary to prepare a piping arrangement and detail plan for the classification and regulatory body approval. Again, this is the proposed approach, *in that **the functional design** completes all design and provides the information as desired by the classification and regulatory bodies.*

2.7.4 OWNER ENGINEERING'S REQUIREMENTS. The owner has the need for a number of types of engineering information as follows:

1. The same drawings as required by classification and regulatory organizations. The shipowner needs them for a record of the approvals from the various organizations and also as a means of checking to see that the vessel the shipbuilder plans to build is the one that was contracted for. This he accomplishes by approving drawings prior to construction and using them to inspect the work when under construction. They will also be a final record kept onboard as information that may be needed by the ship's crew.
2. Selected shipbuilder construction drawings which may be required by the owner to repair, convert and/or upgrade the ship throughout its life.
3. Special drawings and data not used by the shipbuilder but necessary for the ship operator, such as:

Capacity Plan
Fire Fighting Arrangements
Trim and Stability Booklet
Damage Stability Booklet
Safety Plan (Fire and Lifesaving)
Tank Sounding Tables
Ship Operating Manual

Although certain of the shipyard product-engineering data could be useful to a ship repairer in the event of damage to a ship's structure or systems, they are not essential, and therefore should not be provided as a normal part of the data package to the shipowner. However, the owner should be advised that he is encouraged to get from the shipyard any data such as structural material lists, N/C tapes or piping shop sketches, should he need them for future repairs or upgrading of the ship.

The shipowner also requires data lists, equipment manuals, and any other special instructional data necessary to enable safe and proper operation of the ship.

TABLE 2.12

GUIDELINES FOR MINIMIZATION OF PIPING ARRANGEMENT PLANS
CCGD3(mxn5)-11 Mar 1975

These guidelines are the result of:

- a. Proposals by two shipyards to eliminate most of the presently required piping arrangement plans.
- b. Previous favorable reactions by the OCMNs involved and by this office.
- c. Recent conceptual acceptance of the proposals by the Commandant (G-MMT).

Since the Commandant (GMMT) ruled that "arrangement drawings may be eliminated as is deemed acceptable by cognizant Technical and Inspection Offices provided enough data is available to verify that a system complies with the regulations," CCGD3 (MMT) has established the following policy guidelines:

- a. An arrangement plan of the main steam and other high-temperature systems may be required for the purpose of thermal stress analysis. An isometric and diagrams may be sufficient in some cases.
 - b. A detailed material list, including the information required by 46 CFR 565.01-10(d)(l) and in the case of valves and fittings, calling out either an approved standard (56.66-1 as cited in 56.29-1(a), or the manufacturer and model number of a valve or fitting which is not to an approved standard (to determine applicability of and compliance with 56.26-1(b) or(c)) shall be required for each system or group and for each ship or class.
 - c. Weld details and other pertinent typical shall be submitted either on the diagrammatic plan or separately.
 - d. The diagrammatic plans shall be of superior quality and shall include:
 - (1) indication of location, such as compartment name, level, frame, and P/S
 - (2) all valves, fittings, branches, etc., properly located
 - (3) sizes of piping
 - (4) all attachments to other systems, with appropriate identification and references
 - (5) clear and well-defined symbols (definitions may be submitted separately)
 - (6) indication of remote and/or powered controls
 - e. Incomplete and poor quality plans and bills of material, previously accepted for diagrams when arrangements were anticipated, will not be accepted in lieu of arrangements.
 - f. The following arrangement plans may be required and shall be submitted on request of the Officer in Charge, Marine Inspection or Technical Office.
 - (1) classes, I, I-L, II-L, and nuclear piping systems
 - (2) casualty-control systems such as firemain, foam, sprinkling, bilge, ballast, etc.
 - (3) high-hazard systems such as piping to burn LNG boiloff in boilers
 - (4) Other systems for which 46 CFR 56.01-10(c) presently requires arrangements.
-

TABLE 2.12 (Continued)

-
-
- g. The yard shall make all existing plans, diagrams, prints, fabrication and outfitting sketches and/or models, etc., available to the inspector upon his request.
 - h. Where diagrammatics do not provide sufficient information, but in the judgment of the Technical Office, plans of the entire system are not necessary, the Technical Office may utilize one or more of the following alternatives:
 - (1) request a sketch of a detail (such as manifolding, interlocks, etc.)
 - (2) require particular dimensions to be added to the diagrammatic (exact locations of foam monitors, etc.)
 - (3) direct the Inspector's attention to the questionable detail and comment on what would or would not be acceptable
-

2.7.5 STRUCTURAL FUNCTIONAL DESIGN. The **functional design structural drawings** should be prepared for each module. Steel ordering take-offs should also be prepared on a modular basis. This is very basic but very important. In most shipyards today, no production worker or even supervisor will be involved in all stages of the processing of hull structure from raw material to erection on the berth. Therefore, the practice to prepare a very detailed structural drawing indicating all the information that is necessary for lofting, cutting, processing, subassembly, module construction, and erection, is not an efficient method. Couple this with the old method of preparing the construction structural drawings as complete item drawings, such as deck plan, bulkhead plan, etc., and we have a system that can only lead to confusion when any structural subassembly or module construction is attempted. Instead, structural module drawings should be provided. A typical structural module drawing is shown in Figure 2.12. Such drawings show all the structure and details necessary to enable the product engineering for the module to be prepared. The standard structural detail and ship welding booklets should be used by product engineering to prepare the module work station information and loftsmen to loft the structural parts.

One obvious indicator of how this approach simplifies the understanding of the job to be done is the drawing references. A typical traditional structural drawing referenced thirteen other structural drawings, whereas the module structural drawing does not need to reference any. It also allows earlier start of work by production as previously discussed in Section 2.3.

An advantage of using module drawings compared to complete structural drawings is the simplification of the part numbering system. For example, consider a complete deck structural drawing. If the part numbering system consists of the drawing number and a sequential number, considerable effort must be used to group the parts in special subassembly, assembly, and module lists to help the computer-aided lofting programmer to nest parts needed for a given product, the material handlers to find the material and deliver it to the work station that will build the product. On the other hand, if structural drawings are prepared for each module, the part numbering can be unique to a given module, assemblies, and the subassemblies. That is, the part number will be the module/assembly/subassembly numbers, and a sequential number for each. The above-mentioned problems simply disappear with such an approach. Also, sequential numbers are smaller as they start with one for each module/assembly/subassembly. This obviously helps the marking of the individual parts, especially if they are small.

The engineering information preparation for the modular approach must be complete and accurate compared to the traditional practice. Whereas before, the designer could leave some details to be resolved by the loft, this is no longer acceptable.

The usual practice of preparing the lofting from and, therefore, after the preparation of the structural drawings should be changed. Most shipyards today utilize computer-aided lofting (CAL). The "initialization" of the CAL data base should be commenced as soon as possible. This includes the CAL fairing of the lines, interior and shell traces, butts and seams, etc. In the minimum, the CAL system can then be used to provide the basic structural module drawing backgrounds. Many shipyards are using computer-aided design (CAD) systems which are linked with the CAL system, in which case the drawing data base and the CAL data base are ideally one and the same or at least developed parallel and from each other. The lofting is then effectively developed along with the design, and is turned over to the product engineering group for the retrieval of the computer-aided manufacturing (CAM) details needed to process structural parts. Such an approach results in a significant reduction in engineering/lofting manhours due to the logical and hierarchical development of the detailed parts. This can be contrasted with the lofting after engineering approach, where even with module structural drawings, the CAL programmers are inclined to program each drawing separately. This, in turn, requires additional part programming and checking as well as the extra effort to check that interfacing parts shown on different drawings are compatible. Another advantage of utilizing a single-data-base CAD and CAL system is that the drawings will show details of the structure as they will be actually cut and processed. This obviously assists in interference avoidance and control, especially if all penetrations are programmed into the data base and cut by the N/C burning machine.

2.7.6 HULL OUTFIT FUNCTIONAL DESIGN. **Hull outfit functional design** consists of developing all the details for the outfit design and completing the definition of all outfit material. Again, the use of standards reduces the effort. Also ship standard details should be completed for issue to the product engineering section. A very large part of hull outfit functional design consists of preparing technical specifications for the purchase of required equipment and material. If the contract design for the ship is not prepared by the shipyard, considerable effort will be required to prepare accommodation layouts. The output from hull outfit functional design should include:

- List of Ladders
- List of Hatches
- List of Manholes
- List of Windows and Airports
- Summary Painting Schedule
- Summary Deck Covering Schedule
- Summary Hull Insulation Schedule
- Furniture List
- Plumbing Fixture List
- Galley Arrangement and Equipment List
- Anchor Handling Arrangement
- Mooring Arrangement
- Lifesaving Equipment Arrangement and List
- Hull Outfit Purchase Technical Specifications
- Advanced Material Orders for Hull Outfit Material
- Vendor Selection
- Vendor Plan Approval

2.7.7 MARINE ENGINEERING FUNCTIONAL DESIGN. **Engineering for ship production** places more responsibility and output demands on the marine engineering **function design than** does traditional engineering. This is because of the fact that all design calculations as well as system diagrammatics must be completed in this phase. The location of the machinery, units, system corridors, and working space will have been prepared for the contract design. In developing the functional design the Contract Design Marine Engineering is effectively checked. Any standards selected in the contract design phase are considered in greater detail and the design capacity confirmed. The system diagrammatic s must be prepared showing distribution in the assigned system corridors, and they must be sized and show required flow information.

To accomplish this a distributive system-routing diagrammatic for the machinery space should be developed, as shown in Figure 2.13. The systems for pipe, electrical, and HVAC must be located within their distribution corridors, and corridor sectional cuts are very helpful to control this. The master routing diagrammatic would become the basis for the transitional design phase distribution systems routing diagrammatics. All machinery Purchase Technical Specifications would be prepared during this phase, and as the system diagrammatics are complete, advance ordering of pipe, valves, fittings, and sheet metal will be performed. Vendor selection and vendor plan approval should also be completed.

Piping end-products should be:

- Piping Diagrammatics
- Pump List
- Pump Purchase Technical Specifications
- Valve List
- Advanced Material Ordering for pipe
- Advanced Material Ordering for pipe fittings
- Advanced Material Ordering for pipe insulation
- Advanced Material Ordering for pipe hangers

Where new units are to be designed the procedure outlined in Section 1.7.3 should be followed. This will result in unit arrangement and unit foundation drawings which along with their parts list are the end-product of the functional design **phase**.

HVAC end-products for this phase should be:

- Heating and Cooling Analysis
- Ventilation Diagrammatics
- Air Flow Calculations and Duct Sizing
- HVAC Equipment List
- HVAC Purchase Technical Specifications
- HVAC Heating and Cooling Diagrammatics
- Advanced Material Ordering for ducting, flanges, and hangers
- Advanced Material Ordering for ducting insulation

2.7.8 ELECTRICAL ENGINEERING FUNCTIONAL DESIGN. Again, all design calculations and distribution wiring diagrammatics (elementary and isometric or block drawings) should be completed during the functional design phase. The wiring diagrammatics should be routed in assigned wireway corridors and the cable size and type shown. If standard machinery units, accommodation units, etc., are used, the wiring diagrammatics would simply consist of distribution design to the standard units. The distribution design should take into account the modular breakdown, zone definition, and extent of advanced outfitting before erecting and joining modules. For example,

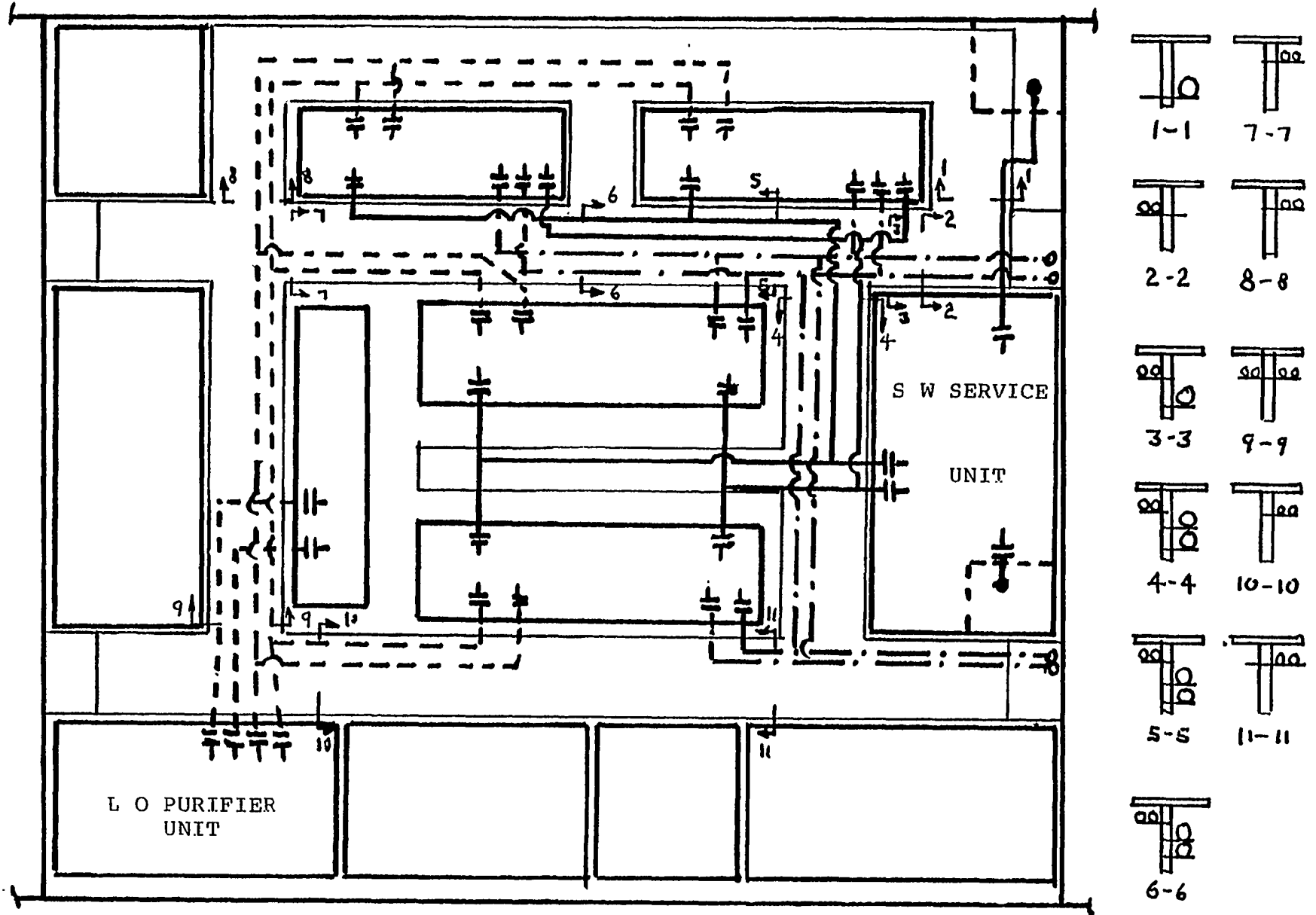

FIGURE 2.13 Distributive system routing diagrammatic.

Figure 2.14 shows two possible ways to arrange electrical system distribution. For passenger ships, warships, and multideck cargo ships, vertical distribution within each module will be best for production. It will also be best from the damage control aspect. For a bulk carrier or tanker, there is no choice and horizontal distribution is used. Again, all Purchase Technical Specifications and Advanced Material Ordering should be prepared. The end-products from this phase are:

- One-Line Diagram
- Electrical Load Analysis
- Short Circuit Analysis
- List of Feeders and Mains
- List of Motors and Controllers
- Electrical Purchase Technical Specifications
- Electrical Distribution Diagrams
- List of Portable Electrical Equipment
- Advanced Material Ordering for cable, cable hangers, etc.

2.7.9 SYSTEM AND PRODUCTION ENGINEERING. As already stated it is preferred to integrate both systems engineering and production engineering into the three **basic** design disciplines than to have separate specialist groups. However, for this to happen it is necessary to know what the functions of each group entail.

Systems engineering is an organized approach to the interactions between the parts of a system, such as a unit, a machinery space, a deck house, or a complete ship. It is based on two concepts, namely:

- The interconnections, the compatibility, the effect of one upon the other, the objectives of the whole system, the relationship of the system to the users, and the economic feasibility must receive even more attention than the parts, if the complete system is to be more successful.
- The ever-increasing degree of specialization necessitates a formal integration of the specialist parts to ensure that the overall objective solution is the best and most economical.

The tools of systems engineering consist of:

- systems Theory
- systems Analysis
- Computer Processing Aids
- Operations Research
- Decision Concepts
- Statistical Decision Theory

It is therefore necessary that design engineers become familiar with these tools so that the integration of systems engineering with the traditional shipbuilding engineering can be effectively accomplished. The role that systems engineering plays in **engineering for ship production is to ensure** that the various ship systems are well integrated and offer the best possible design and construction cost.

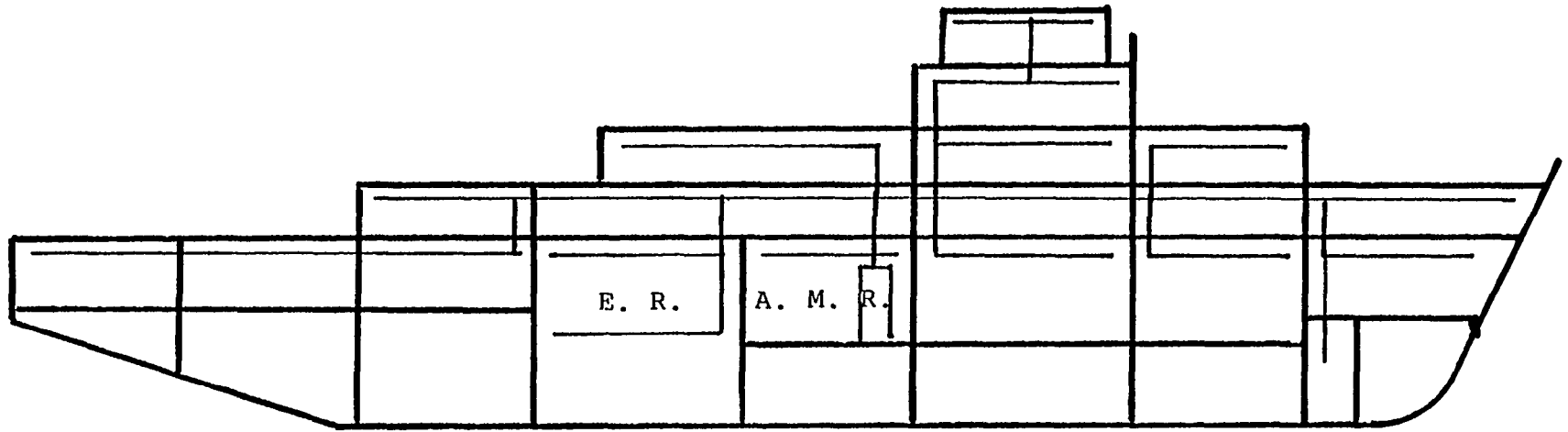

[A] VERTICAL DISTRIBUTION

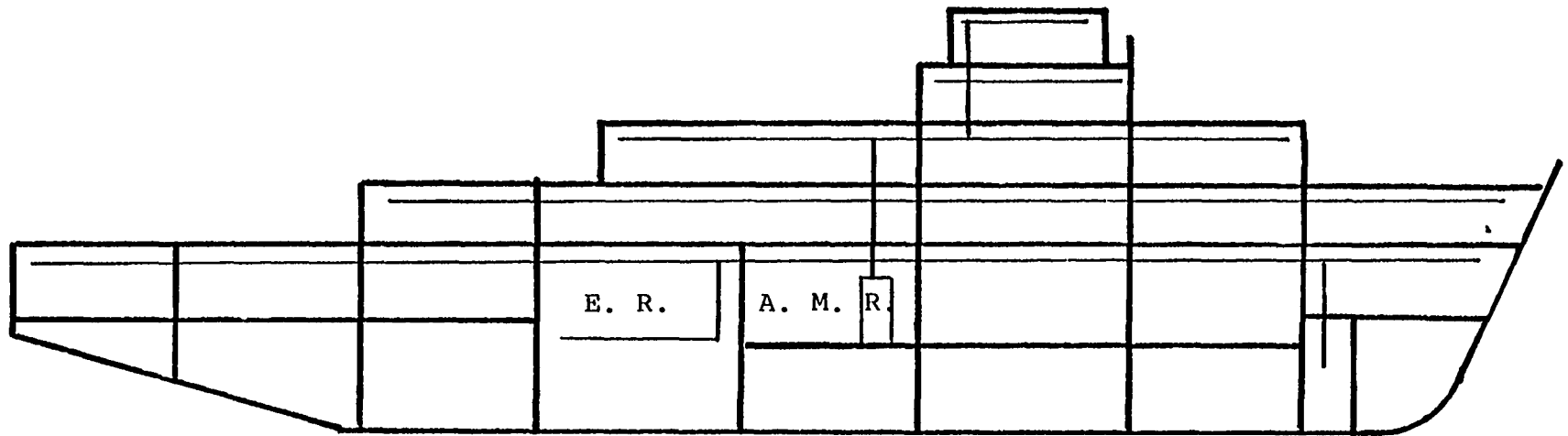

[B] HORIZONTAL DISTRIBUTION

FIGURE 2.14 Electrical system distribution.

Production engineering and industrial engineering are synonymous. They can be defined as the task of determining the best methods for performing the various manufacturing processes within a given facility, taking into account its limitations and operational goals. The functions of production engineering are:

- Product Definition
- Process Analysis
- Process Planning
- Value Engineering
- Work and Method Study
- Machine and Tool Requirements
- Process Information and Instruction Requirements
- Link between Engineering and Production Departments

For further discussion on the application of *production engineering to shipbuilding*, a number of technical papers are recommended [6,7,8,9]. The production engineering function can be shared in part between engineering and planning. However, the industrial engineering parts, such as work measurement and method study, require specialized training and experience.

In performing the production engineering function, decisions should be made on:

- Module Definition
- Zone Definition
- Assembly and Construction Approach
- Advanced Outfitting Approach

and this should be done *before the* functional design is commenced. This is very important because the application of production engineering during contract design makes possible the lowest cost design, whereas if it is applied after the completion of the contract design it will probably result in design changes in order to achieve low cost, but will have wasted time and design effort (cost). The production engineering decisions should become part of the building plan, as shown in Figure 2.15, which is based on a figure from reference [9]. An effective production engineering tool is the “Product/sage Chart” shown in Figure 2.16, which is based on a similar chart developed by A&P Appledore, Ltd. From such charts the sequencing of the products that go into a module, zone, or on to a unit can be better understood and planned.

The module definition should be based on a structural product breakdown listing such as shown in Figure 2.17. The zone definition can be similarly based on a zone breakdown listing as shown in Figure 2.18. Both breakdown listings are integrated as shown in Figure 2.19.

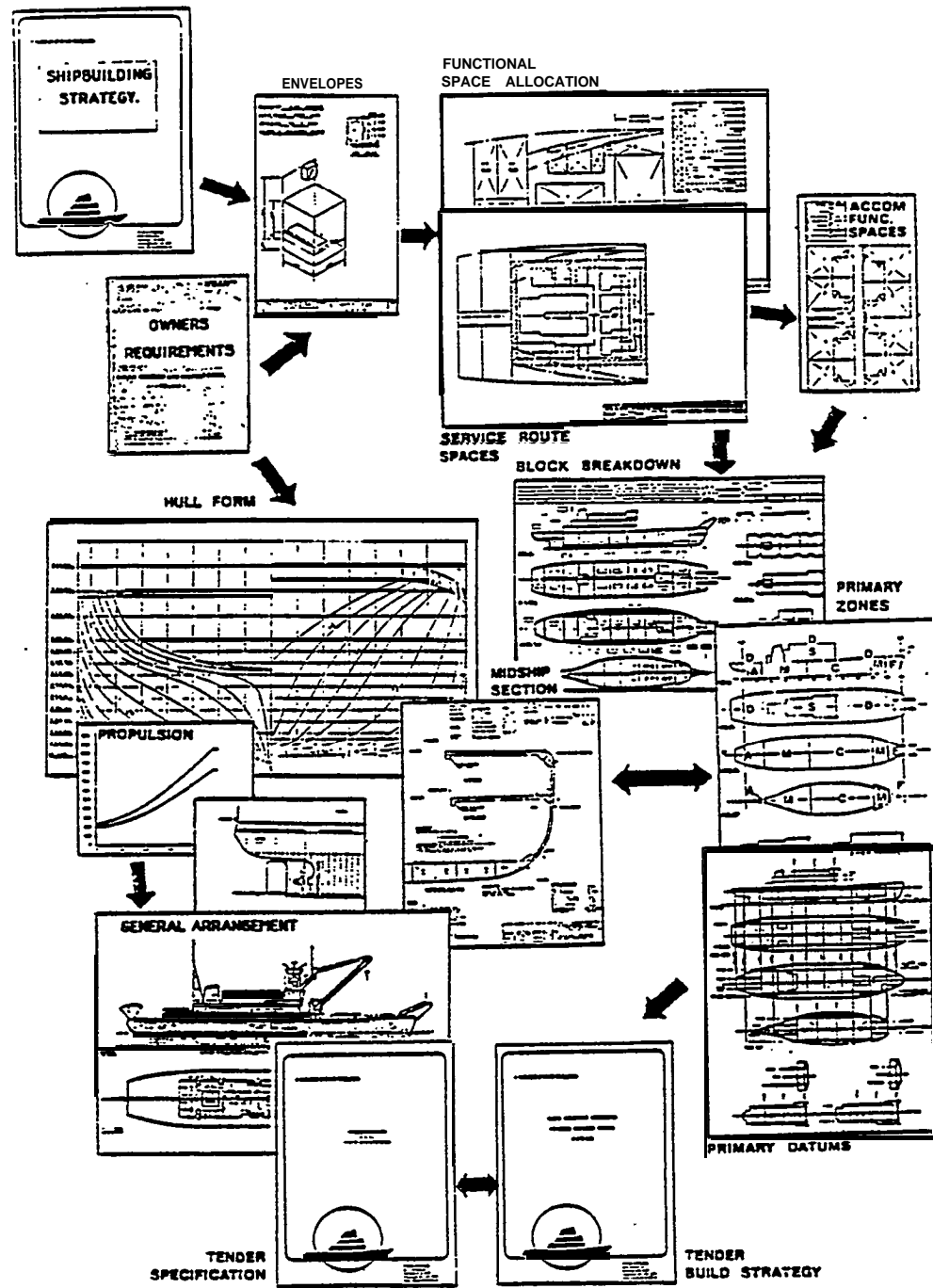

FIGURE 2.15 Integration of production engineering and contract design.

PRODUCT/STAGE CHART								
FINAL PRODUCT:	MODULE					CODE:	M1	
PRODUCT	S T A G E							
	1	2	3	4	5	6	7	
FLAT PLATE PART	M111-1 M111-2 M111-3	M112-1 M112-2	M11-1 M11-2	M12-1 M12-2 M12-3	M13-1	M1-1 M1-2 M1-3		
SHAPED PLATE PART					M13-2	M1-4 M1-5		
STRAIGHT SECTION	M111-4 M111-5	M112-3 M112-4 M112-5		M12-4 M12-5		M1-6 M1-7 M1-8		
SHAPED SECTION						M1-9 M1-10 M1-11		
SUB-ASSEMBLY		M111	M112					
ASSEMBLY				M11	M12	M13		
MODULE							M1	

325

FIGURE 2.16 Product/stage chart for structural module.

PRODUCT/STAGE CHART							
FINAL PRODUCT: UNIT					CODE: 311		
PRODUCT	S T A G E						
	1	2	3	4	5	6	7
UNIT FOUNDATIONS	311-185						
UNIT EQUIPMENT		311-527-1 311-527-2 311-532-1					
UNIT PIPE			311-527-1 311-527-2 311-527-3				
UNIT ELECTRIC				311-321-1 311-321-2 311-321-3			
UNIT PAINT		311-631-1 311-631-2				311-631-3 311-631-4 311-631-5	
UNIT							311

326

FIGURE 2.16 (Continued)

PRODUCT/STAGE CHART

FINAL PRODUCT: OUTFITTED ASSEMBLY					CODE: OM11		
PRODUCT	S T A G E						
	1	2	3	4	5	6	7
ASSEMBLY	M11						
UNIT			321 322 323				
WIREWAYS		M11-304-1 M11-304-2 M11-304-3					
HVAC			M11-512-1- M11-512-2- M11-512-3-				
PIPE				M11-521-1- M11-521-2- M11-521-3-	M11-526-1- M11-526-2-		
ELECTRIC CABLE						M11-311-1- M11-311-2- M11-321-1-	
OUTFITTED ASSEMBLY							OM11

327

PART 2

Basic Design

FIGURE 2.16 (Continued)

328

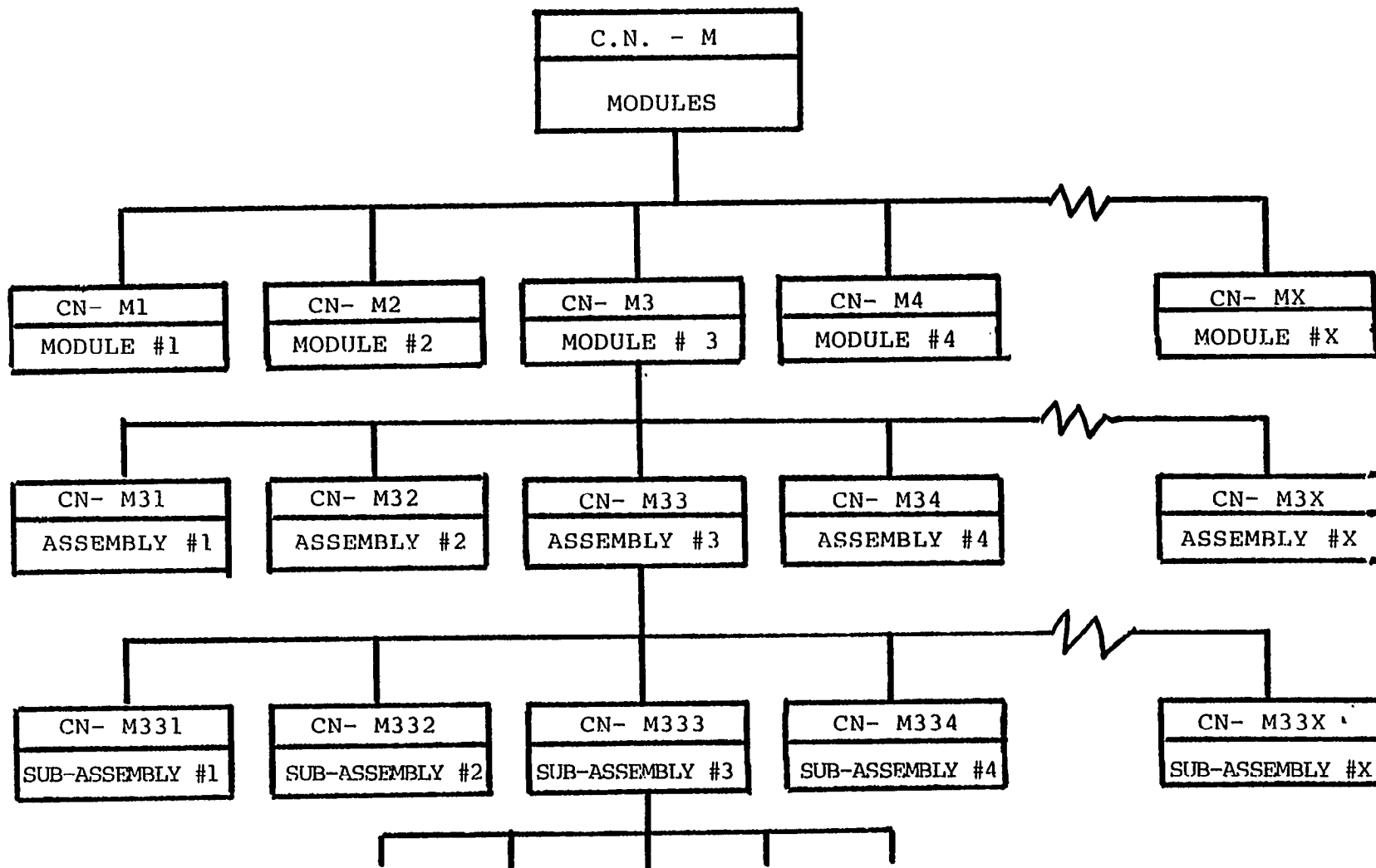

STRUCTURAL, PARTS NUMBERED ON WORK STATION DWGS.
CN-M333-11.0-1,2,3,ETC.

OTHER SYSTEM PARTS INSTALLED ON ASSEMBLIES
CN-M33-524-1,2,3,ETC.
CN-M33-183-1,2,3,ETC.

FIGURE 2.17 Structural module breakdown.

329

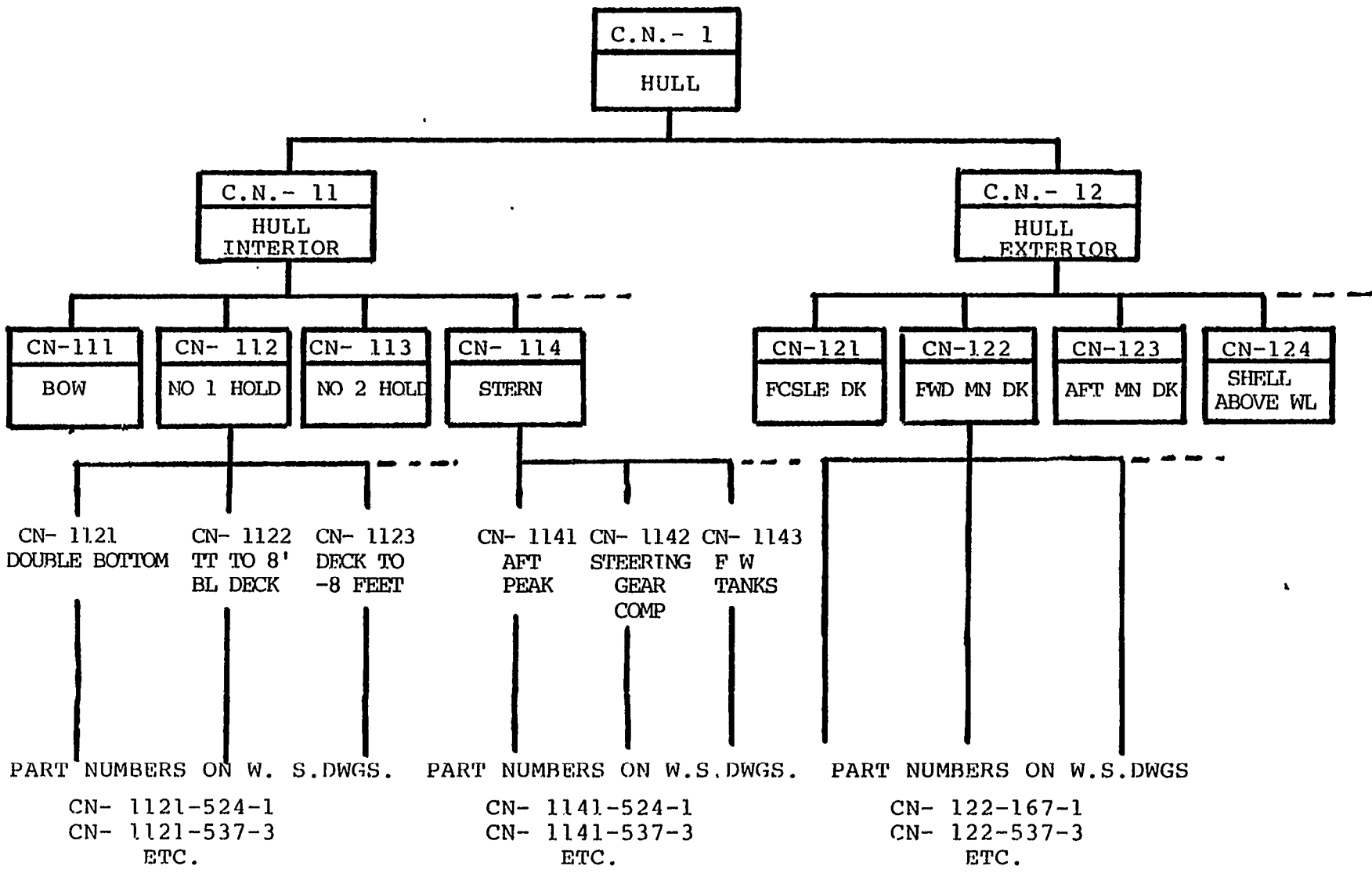

FIGURE 2.18 Hull zone breakdown.

330

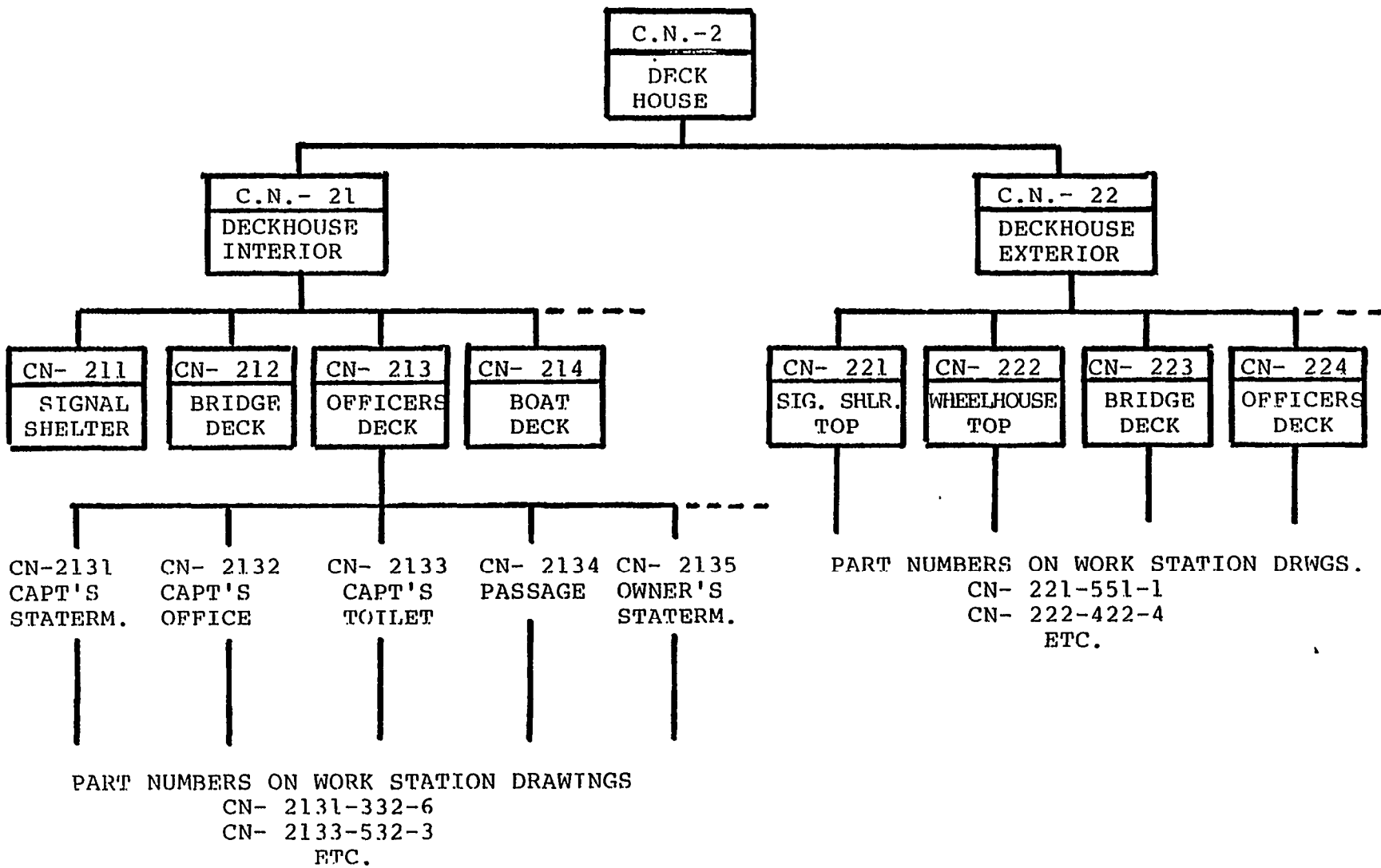
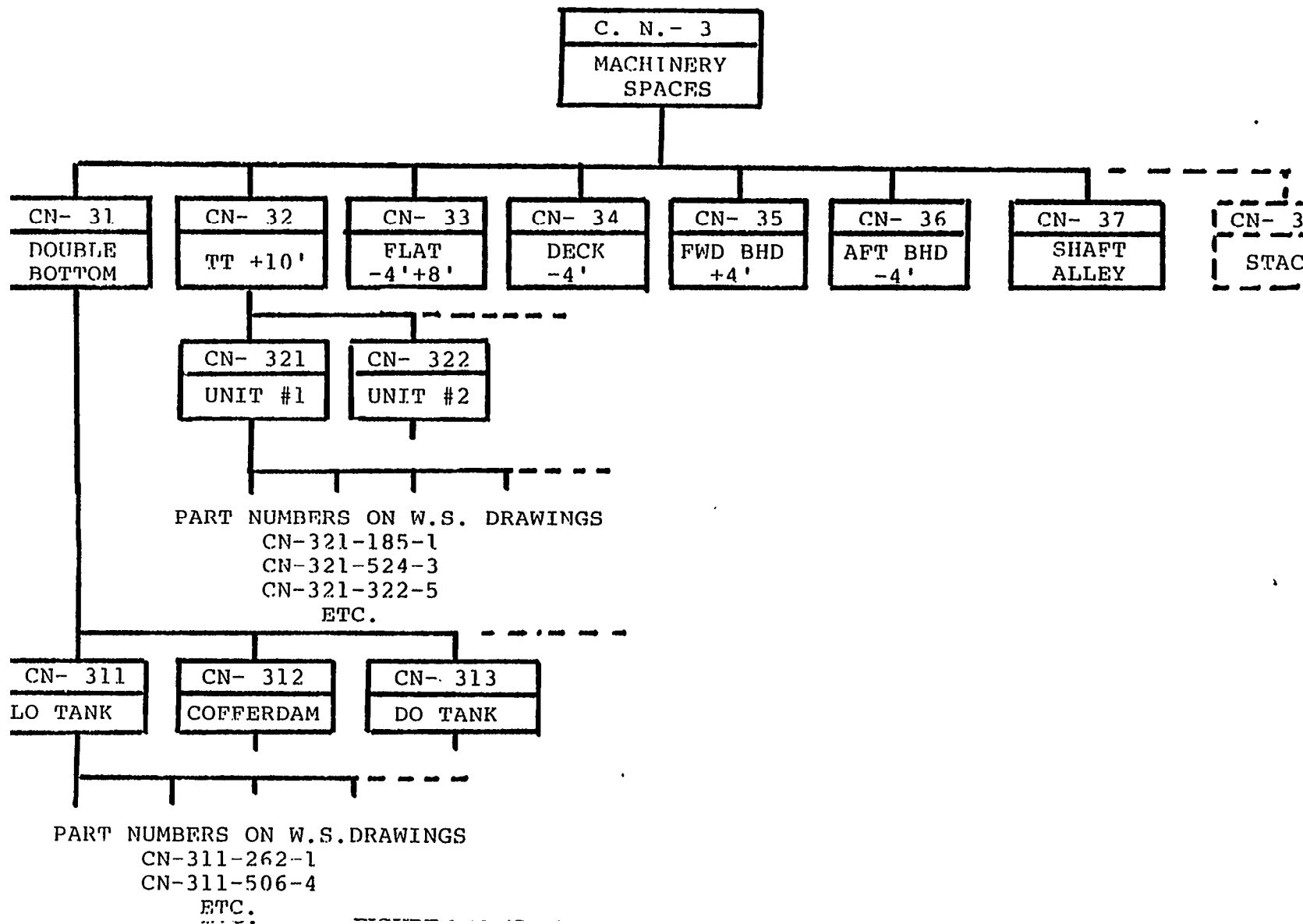

FIGURE 2.18 (Continued)-Deckhouse zone breakdown.



331

FIGURE 2.18 (Continued)-Machinery spaces zone breakdown.

332

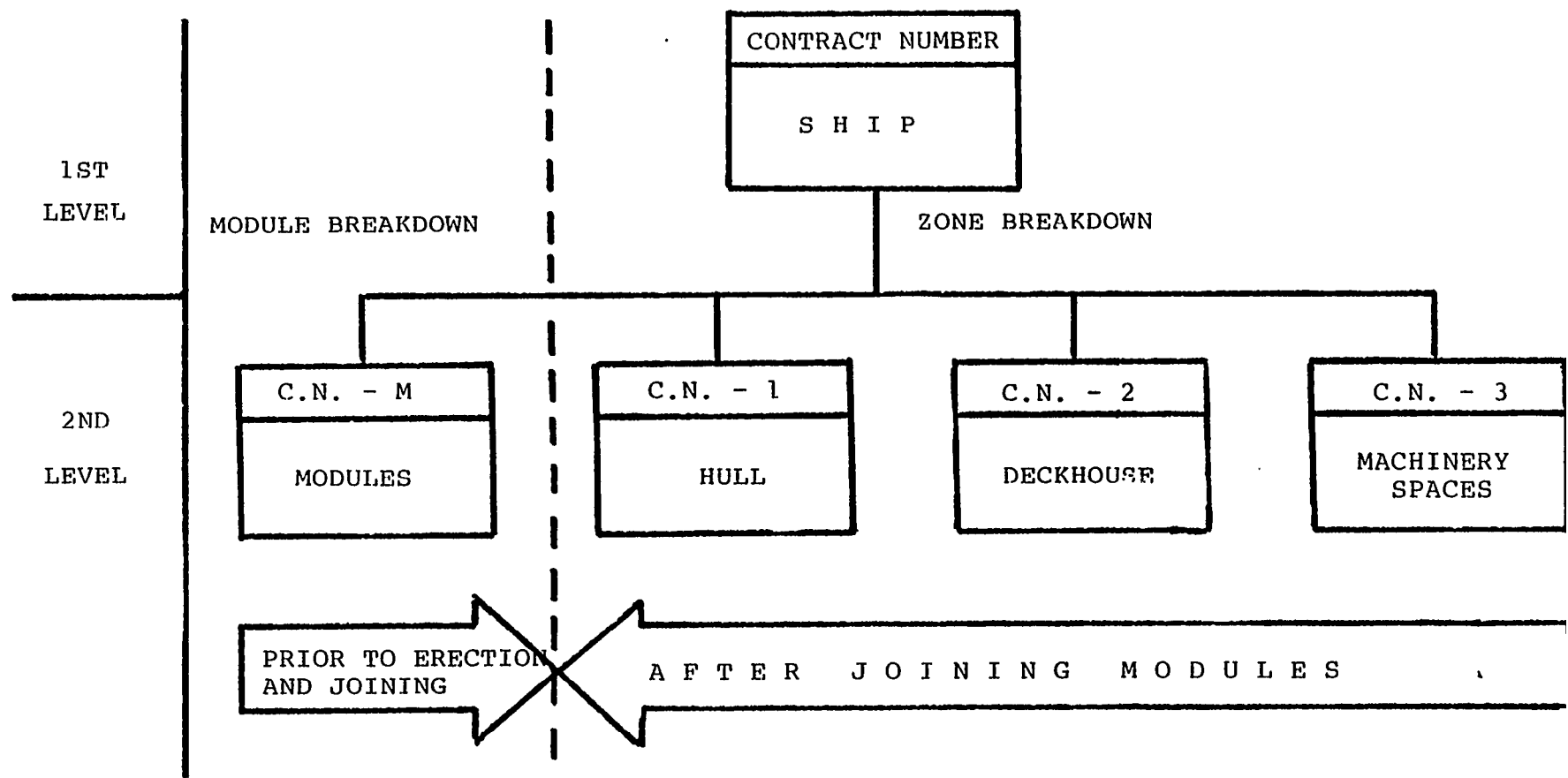

FIGURE 2.19 Ship breakdown structure.

REFERENCES

1. G.M. Watson, "Estimating preliminary dimensions in ship design," *IESS Transactions*, vol. 105, 1961-1962.
2. R.T. Miller, "A ship design process," *Marine Technology. SNAME*, October 1965.
3. T. Lamb, "A ship design procedure," *Marine Technology SNAME*, October 1969.
4. D.G.M. Watson et al, "Some ship design methods," *RINA Transactions*, vol. 119, 1977.
5. D. Andrew, "Creative ship designs," *RLNA Transactions*, vol. 123, 1981.
6. I. MacDougal, ***Production methods-Implications of production engineering.*** WEGEMT Managing Ship Production, University of Strathclyde, Glasgow 1980.
7. F. Brian Todd, ***The role of industrial engineering in shipyard production service.*** WEGEMT Managing Ship Production, University of Strathclyde, Glasgow 1980.
8. R. Bruce Woodruff, "Production engineering in a Naval shipyard," *ASNE Journal*, April 1978.
9. D.R. Martyr, "Guidelines for the preparation of a ship definition strategy," *British Shipbuilders Common Core Technology*, November 1984.
10. J.W. Boylston and W.G. Leback, "Towards responsible shipbuilding," *SNAME Transactions*, vol. 83, 1975.

2.8 Product Engineering

2.8.1 TRANSITIONAL DESIGN. The transitional *design can* be likened to building a prototype, except that it is being “constructed” on paper. If computer-aided design (CAD) is used, the prototype is effectively “modeled” in the computer. The most important task in *transitional design* is the selection of the zone/sub-zone breakdown for the design effort. As a guide, a sub-zone should be a compartment surrounded on all sides by major structural divisions such as deck/flat/tank top, transverse bulkheads, side shell, longitudinal bulkheads, etc.

Zone design arrangements are similar to the traditional composites. However, they are prepared from the distribution system routing diagrammatics developed from functional *design*, whereas the traditional composites are prepared from completed system arrangement and detail drawings. Traditional composites are drawn as an interference checking tool and for this purpose are “slices” through the compartment, showing only the item in the immediate layer below. Zone design arrangements show all the visible items seen from the viewing plane. All products should be included, no matter how small. The traditional composite practice of excluding pipe below 1.5-inch-diameter is no longer acceptable. When the zone design arrangements are prepared manually, the backgrounds can be provided by the computer-aided lofting (CAL) system. Manually prepared zone design arrangements should be drawn with single-line pipe representation. However, it is preferred to show double line, including insulation where appropriate. A typical manually prepared zone design arrangement is shown in Figure 2.20, and Figure 2.21 shows the same arrangement isometric prepared by CAD. Once the zone design arrangement is completed, the products are identified, such as

- unit
- Pipe Assembly
- Vent Assembly
- Wireway
- Foundation
- Floor Plate Group
- etc.

The required zone/unit material quantity is also developed at this time. Typical forms used for this purpose are shown in Table 2.13. By accumulating the material quantities as the zone design arrangements are prepared and deducting the material from the advanced material orders, effective material ordering control is possible. A listing of all the products in a zone/sub-zone provides an accurate compartment checkoff list.

Obviously, during the preparation of the zone design arrangements, all systems are developed for interference avoidance and checked for interferences as the work progresses.

It should be obvious that the use of CAD for this design phase has many advantages. Three-dimension solid modeling CAD systems enable a true prototype to be modeled and all working, maintenance, and access requirements to be checked prior to any construction.

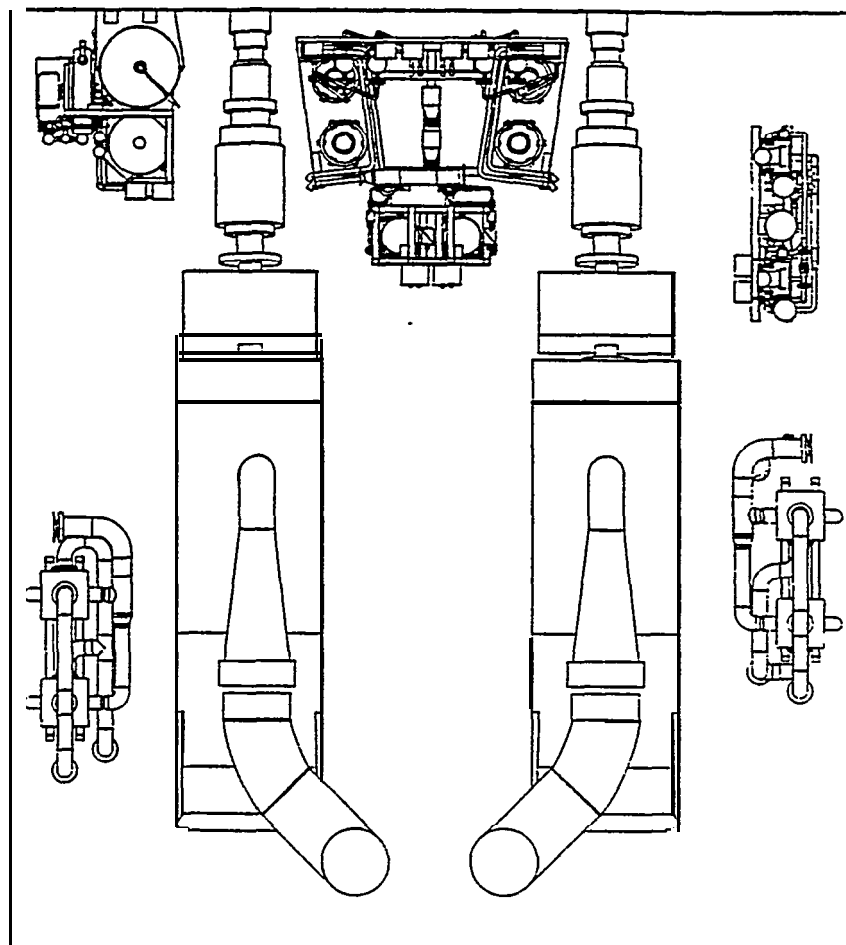
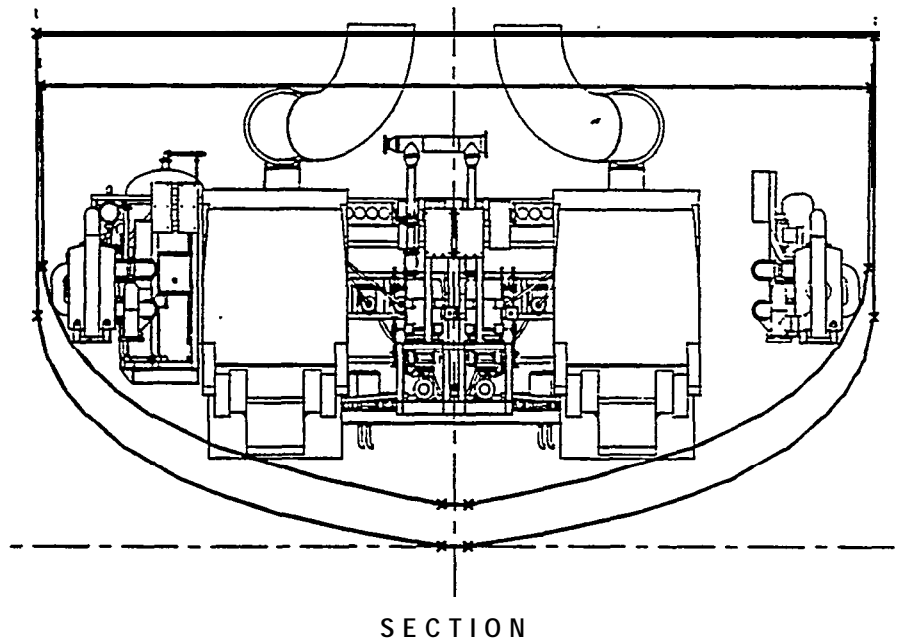
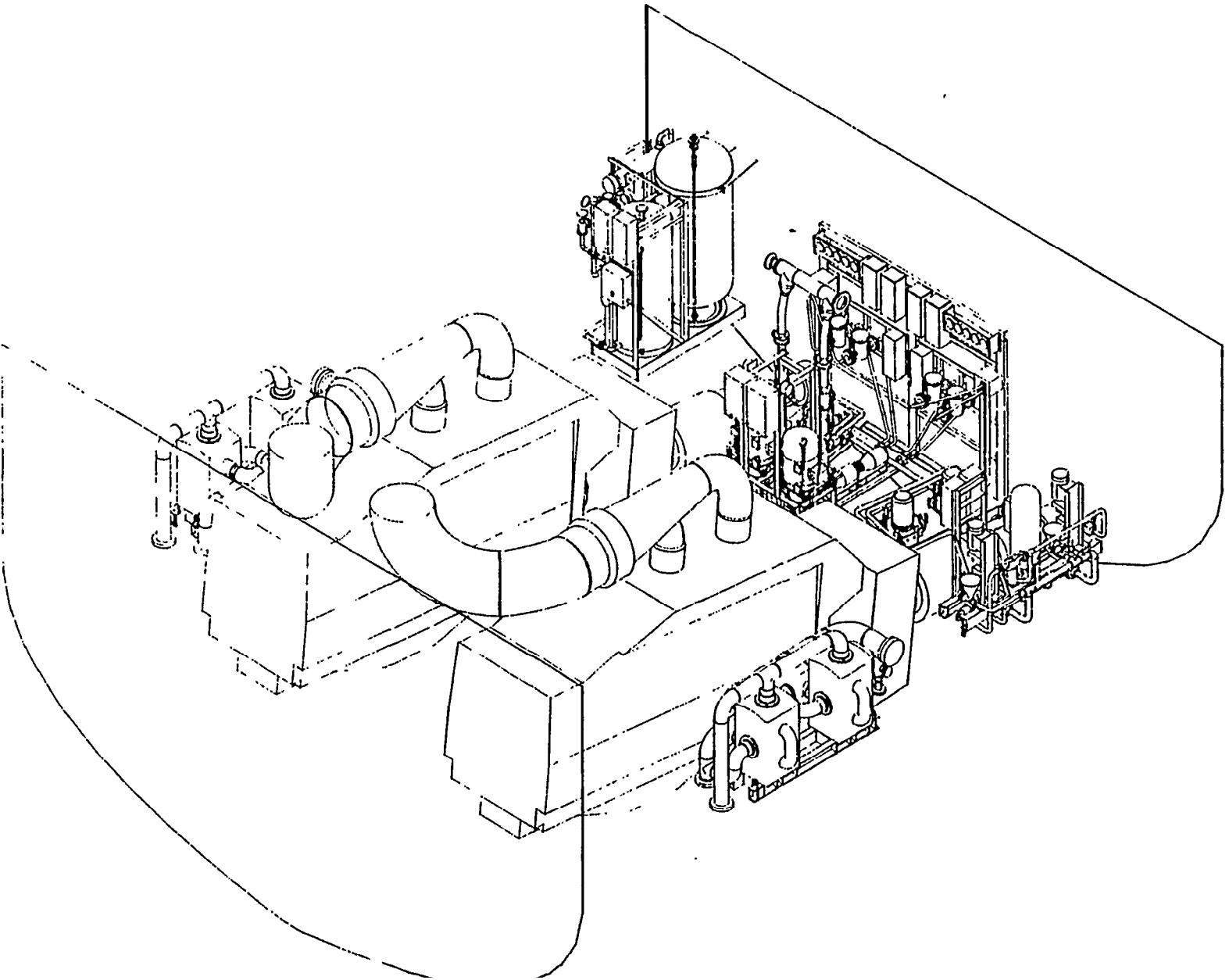

FIGURE 2.20 Manually prepared zone design arrangement.



336

FIGURE 2.21 CAD-prepared isometric zone design arrangement.

TABLE 2.13

ZONE DESIGN ARRANGEMENT

ZONE DESIGN ARRANGEMENT		ZONE NUMBER : 3 1	
PRODUCT: Fire Pump unit		PRODUCT NUMBER: 3 312	
CODE	DESCRIPTION	Q U A N T I T Y	
		NUMBER	MEASURE
1453066627	FOUNDATION	1	
	FLOOR	1	
	RAIL	1	
	LADDER	3	
5200661004	FIRE PUMP 1	1	
5200661004	FIRE PUMP 2	1	
5280661003	DUPLEX FILTER	2	
5228661.407	PIPE ASSEMBLY 1	1	
5228661407	PIPE ASSEMBLY 2	1	
5228661407	PIPE ASSEMBLY 3	1	
5228561407	PIPE ASSEMBLY 4	1	
5228641404	PIPE ASSEMBLY 5	1	

ZONE DESIGN ARRANGEMENT		ZONE NUMBER: 3 1	
PRODUCT: Pipe Assembly 1		PRODUCT NUMBER: 5 2 7 - 1	
CODE	DESCRIPTION	Q U A N T I T Y	
		NUMBER	MEASURE
5220461471	PIPE 6"	1	10 FEET
5220461482	PIPE 4"	1	20 FEET
5220441494	PIPE 11/2"	4	80 FEET
5230661463	90 ELBOW 6"	2	
5240000001	6" HANGER TYPE I	5	
5240000002	4" HANGER TYPE I	7	
5240000003	11/2" HANGER TYPE I	6	
5211100042	GATE VALVE 6"	2	
5221100032	GLOBE VALVE 4"	4	
5221100021	GLOBE VALVE 11/2"	3	

337

PART 2

Product Engineering

2.8.2 WORK STATION/ZONE INFORMATION. Many successful shipyards claim that their success is based on better work organization. They accomplish this through better planning, better instructions/information, and work packages. The work package concept is the division of a total task into many work packages for small tasks. Usual guidance is that a work package should be

- Two-week duration maximum
- 200 hours of work maximum
- For a maximum of three workers
- Includes only (but all) the information required by workers to complete the work package tasks
 - Drawings
 - Parts lists
 - Work instructions
- Production Aids
 - N/C Tapes
 - Templates
 - Marking tapes

The first three items are difficult to hold to for certain shipbuilding tasks on the berth but should be achievable for most shop work.

Engineering can effectively participate in preparing some of this information, and in doing so eliminate a lot of current duplication of effort. The selection of the tasks to meet the first three requirements will be decided by Planning. Engineering can prepare the information covered in the last two.

To do this, it is proposed that separate work station information be prepared for each work package. Work station information should be prepared on the following basis:

- Information should only show that necessary for a given work station.
- Information should consist of sketch(es) and parts list.
- Complete information for the tasks must be given. No referencing allowable.
- Separate work packages should be prepared for each craft (trade). Sketches and parts lists should not mix work that must be done by different crafts.
- Sketches should be prepared to show work exactly as workers will see it. That is, for equipment, piping or other products, which will be installed on an assembly when it is upside down, the sketch should be drawn that way rather than for the final attitude plan view.
- A reference system should be used, and all dimensions should be from the reference system planes.
- Information should be prepared so it can be issued on 11-inch by 8.5-inch sheets.

2.8.3 STRUCTURAL WORK STATION INFORMATION. Most shipyards today use computer-aided lofting (CAL) to prepare the lofting and develop the necessary production aids for the construction of the ship's structure. This eliminates the need for manual measuring and layout of plates. Therefore, the drawings used for subassembly,

A typical work station **information** package (process sheet) for structural shapes is shown in Figure 2.22. It shows the finished part for a floor stiffener. It gives material total quantity required to cut all the parts listed. It also handles the fact that the parts are of different lengths. Included on such a drawing can be delivery instructions regarding unused material and finished parts. Accuracy control data can also be included.

The CAL N/C plate cutting drawing with attached instruction sheet such as shown in Figure 2.23 is typical of a plate part work station information package.

Figures 2.24, 2.25, and 2.26 show the work station information packages for typical subassembly, assembly, and module, respectively. Note that for the assembly and module the parts lists are separate from the drawings. The parts list should be sequenced in the way that the product is to be constructed. Again, the "Product/Phase Chart" can be used to develop the sequencing. Figure 2.27 shows a typical parts list.

The work station information for the joining of the modules should include alignment, fitting, dimension control, accuracy control, and welding data. Figure 2.28 shows a typical welding work station information sheet.

2.8.4 HULL WORK STATION/ZONE INFORMATION. The hull work station/zone information will be provided for shops, assemblies, modules, and zones. The "Product/Stage Chart." is very helpful in deciding the work packages. Work station information for shops for both processing and assembly will be required for hull fittings, pipe, sheet metal, foundation structure, joiner, paint, and electrical work. Typical work station information packages are shown in Figures 2.29 and 2.30. It is suggested that assembly, module, or zone be used instead of the term "work station" for all installation work package information. The, assembly and module installation information will be prepared for hull. This would cover all "on-block" advanced outfitting work. Figures 2.31 through 2.33 show typical hull assembly and module information packages. Zone instruction information will also be prepared for the same type of products which would cover all "on-board" advanced **and remaining** normal **outfitting**. Work station and zone information for piping, electrical, and HVAC would be identical to that described in Sections 2.8.5 and 2.6.6, respectively. Work station and zone information for joiner work would be identical to that described in Section 2.8.6.

2.8.5 MACHINERY SPACE WORK STATION/ZONE INFORMATION. The work station/zone information prepared for the machinery spaces will be considerably simplified compared to the traditional engineering approach. This is mainly due to the logical breakdown of the total machinery space design and engineering and the preparation of work station/zone information packages in place of the traditional working drawings. The machinery arrangement becomes a series of major pieces of machinery, units, and connecting system corridor/floor plate units. However, the quantity of information provided to Production is vastly increased in scope compared to traditional engineering, plus all systems are given equal depth of consideration and shown to the same detail.

Work station information for shops for both processing and assembly will be required for foundation structure, pipe, sheet metal, paint, and electrical work. Work station information will also be required for machinery installation, unit assembly, pipe installation, etc., for units. A typical unit foundation work station information package is shown in Figure 2.34. Other typical unit work station information examples are shown in Figures 2.35 through 2.37.

Assembly and module information will be prepared for all machinery space "on-block" advanced outfitting work such as shown in Figures 2.38 through 2.40.

WORK STATION/ZONE INFORMATION SKETCH

WORK STATION NO.: 5	PRODUCT CODE: M4213-7 THRU 11	JOB: 000
PRODUCT NAME: FRAME - STRAIGHT		NUMBER OF PRODUCTS: 5

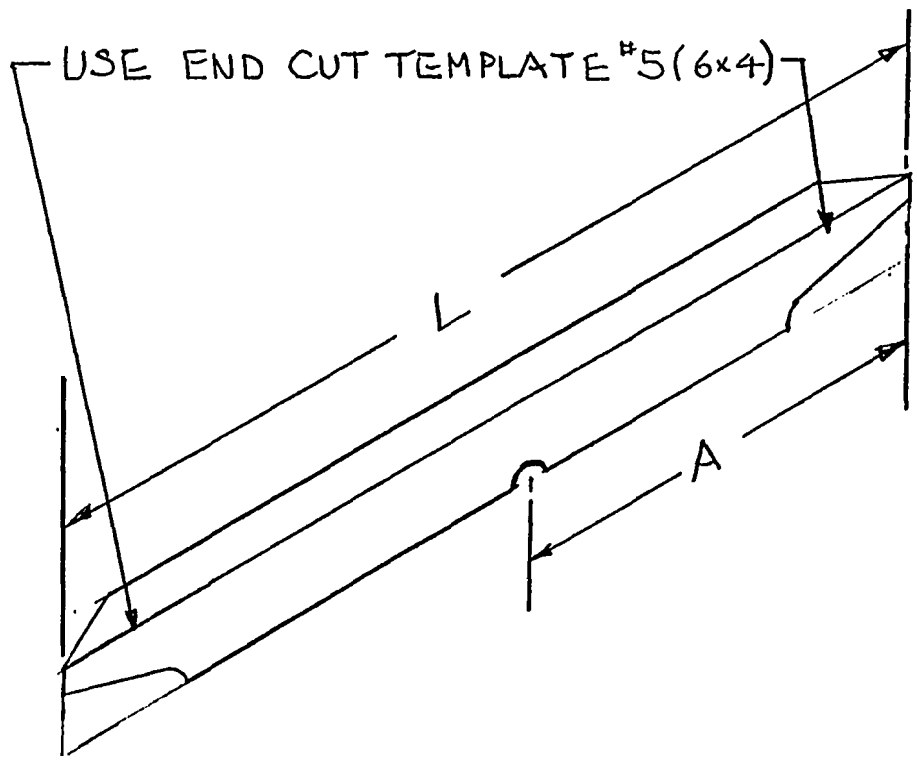

PART NUMBER	L	A
M4213-7	15-7	8-1
8	15-5	7-10
9	15-1	7-4
10	14-6	6-10
↓ 11	13-10	6-3

PREPARED BY: [Signature]	DATE: 5/21/85	PAGE OF
--------------------------	---------------	-----------

341

FIGURE 2.22 Structural section process sheet.

WORK STATION INFORMATION SHEET				
WORK STATION NO.: S5		PRODUCT CODE: M 417		JOB: 000
PRODUCT NAME: SUB-ASSEMBLY				NUMBER OF PRODUCTS: 1 (ONE)
PART CODE	PART NUMBER	DESCRIPTION	QUANTITY PER PRODUCT	QUANTITY ALL PROD.
1000421600	110-1	0.375" PLATE	1	1
1100440200	110-2	6" x 1/2" FLAT BAR	1	1
1100130101	110-3	4" x 1/4" FLAT BAR	1	1
1100130101	110-4	4" x 1/4" FLAT BAR	1	1
<div style="display: flex; justify-content: space-between;"> <div style="width: 60%;"> </div> <div style="width: 35%;"> <p>1. TACK WELD ALL PARTS FIRST</p> <p>2. COMPLETE WELDING - 110-2 START AT MIDDLE WORK IN BOTH DIRECTIONS</p> </div> </div> <div style="margin-top: 10px;"> <p>2 (CONT)</p> <p>110-3&4 START AT FIXED END WORK AWAY FROM FIXED END</p> </div>				
PREP. BY: T		DATE: 5-24-85		PAGE 4 OF 16

FIGURE 2.24 Structural subassembly work station information.

WORK STATION/ZONE INFORMATION SKETCH

WORK STATION NO.: S 14	PRODUCT CODE: M 41	JOB: 000
PRODUCT NAME: ASSEMBLY - LOWER BOW		NUMBER OF PRODUCTS: 1 (ONE)

SEQUENCE 1

1. JOIN SUB-ASSEMBLIES M412 AND M413 TO SUB-ASSEMBLY M411
2. INSTALL SUB-ASSEMBLIES IN ACCORDANCE WITH LAST DIGIT NUMERICAL ORDER
3. TACK WELD SUB-ASSEMBLIES M412 AND M413 TO M411 AND TO EACH OTHER
4. CHECK ALIGNMENT AND ACCURACY CONTROL MEASUREMENT
5. COMPLETE WELDING STARTING FROM INTERSECTION POINT OF ALL SUB-ASSEMBLIES \odot . WORK OUTBOARD P&S, FORWARD AND UP, STAGGERING SEQUENCE
6. WHEN WELDING IS COMPLETE TAKE ACCURACY CONTROL MEASUREMENTS

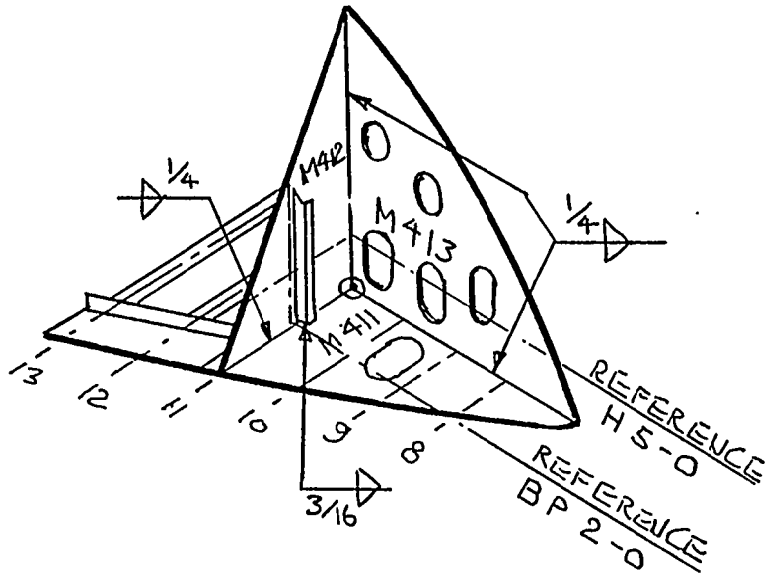

344

PREPARED BY: \perp	DATE: 5/23/85	PAGE OF
----------------------	---------------	---------

FIGURE 2.25 Structural assembly work station information.

WORK STATION/ZONE INFORMATION SKETCH

WORK STATION NO.: S 21	PRODUCT CODE: M 4	JOB: 000
PRODUCT NAME: MODULE - LOWER BOW		NUMBER OF PRODUCTS: 1

SEQUENCE 12

JOINING ASSEMBLY M41
TO ASSEMBLY M42

1. WELD TRANSVERSE BHD TO PEAK FLAT STARTING AT ϕ WORKING P&S
2. WELD ϕ BHD TO PEAK FLAT STARTING AT TVS BHD WORKING FWD
3. WELD FRAME ENDS TO PEAK FLAT
4. WELD STEM BAR

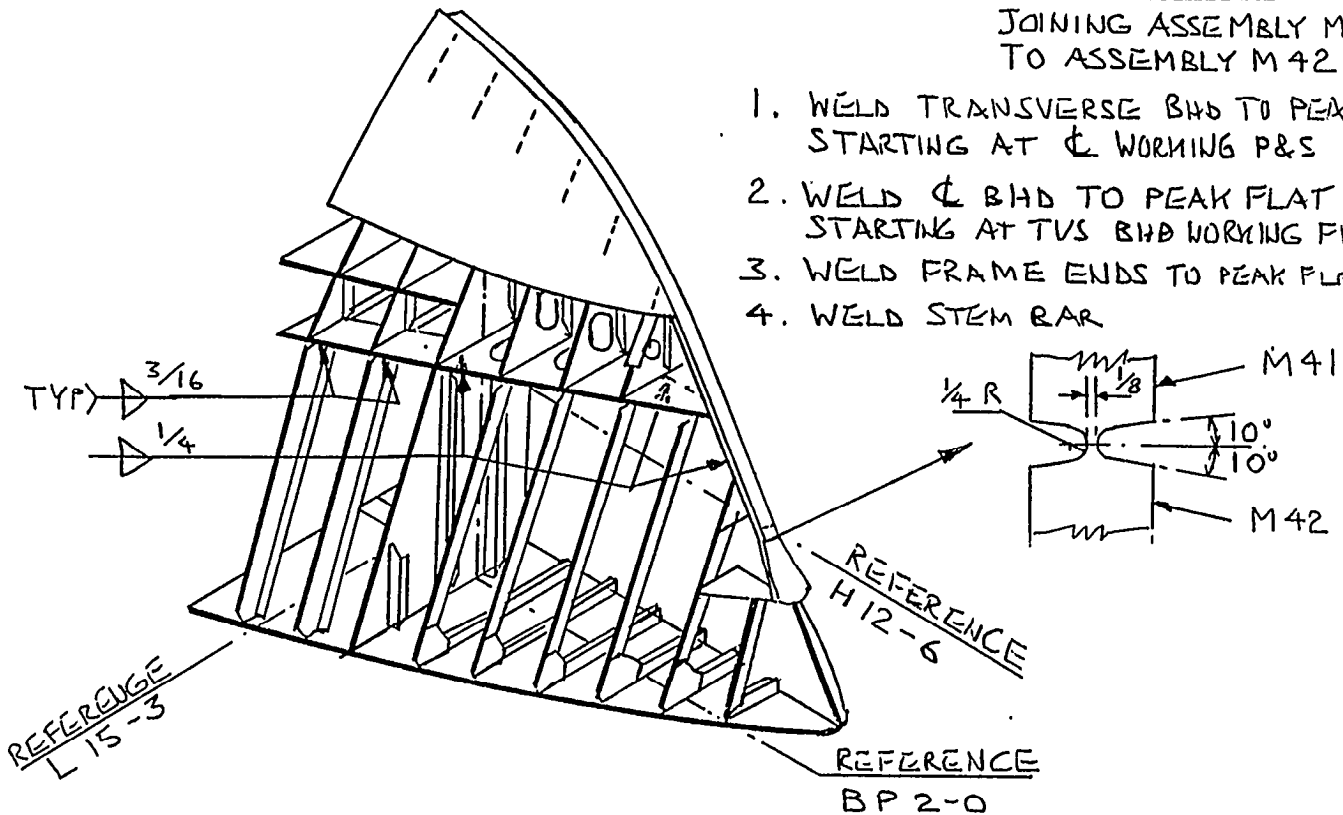

PREPARED BY: T	DATE: 5/24/85	PAGE 14 OF 17
----------------	---------------	---------------

FIGURE 2.26 Structural module work station information.

WORK STATION PARTS LIST				
WORK STATION NO. S 14		PRODUCT CODE: M41	JOB: 000	
PRODUCT NAME: ASSEMBLY - LOWER BOW			NUMBER OF PRODUCTS : 1 (ONE)	
PART CODE	PART NUMBER	DESCRIPTION	QUANTITY PER PROD.	QUANTITY ALL PROD.
SEQUENCE	1			
	M411	SUB-ASSEMBLY		
	M412	SUB-ASSEMBLY	1	1
	M413	SUB-ASSEMBLY	1	1
SEQUENCE	2			
	M414	SUB-ASSEMBLY	1	1
	M415	SUB-ASSEMBLY		1
	M416	SUB-ASSEMBLY	1	
	M417	SUB-ASSEMBLY		1
	M418	SUB-ASSEMBLY	1	
	M419	SUB-ASSEMBLY	1	1
SEQUENCE	3			
	x41-1	PART	1	
	H41-2	PART		1
	M41-3	PART	1	
	M41-4	PART	1	1
SEQUENCE	4			
	M41-A	ASSEMBLY (MINOR)	1	1
SEQUENCE	5			
	M41-5	PART		
	M41-6	PART	1	1
PREP. BY:		DATE:	PAGE	OF

FIGURE 2.27 Structural assembly working station parts list.

WORK STATION INFORMATION SHEET MODULE JOINING WELDING

SEQUEN.	I T E M	TYPE OF WELD	SIZE	WELDING PROCESS	R E M A R K S
MODULE M 4 TO M 3 JOB: 000					
1	CL 3RD TO TRYS 3RD	DOUBLE CONT FILLET	1/4	MANUAL	START AT MODULE WORK 20 1/2 WAVE
2	FLAT TO TRYS 3RD	DOUBLE CONT FILLET	1/4	MANUAL	START AT CL WORK 02 1/2 WAVE
3	FLAT KEEL TO PARTIAL	CONTINUOUS BUTT		MANUAL	START AT CL WORK P&S
4	STRINGER TO STRINGER	CONTINUOUS BUTT		MANUAL	START AT SKEL
5	MAIN DECK GIRDER TO GIRDER	CONTINUOUS BUTT		MANUAL	
6	MANDELA TO MANDELA	CONTINUOUS BUTT		MANUAL	UNDERSIDE SUSARE TOPSIDE
7	SKEL TO SKEL	CONTINUOUS BUTT		MANUAL	OUTS OF FIRST THEN INSIDE
PREP. BY: T		DATE: 5/26/85		PAGE 1 OF 1	

FIGURE 2.28 Module-joining-welding work station information.

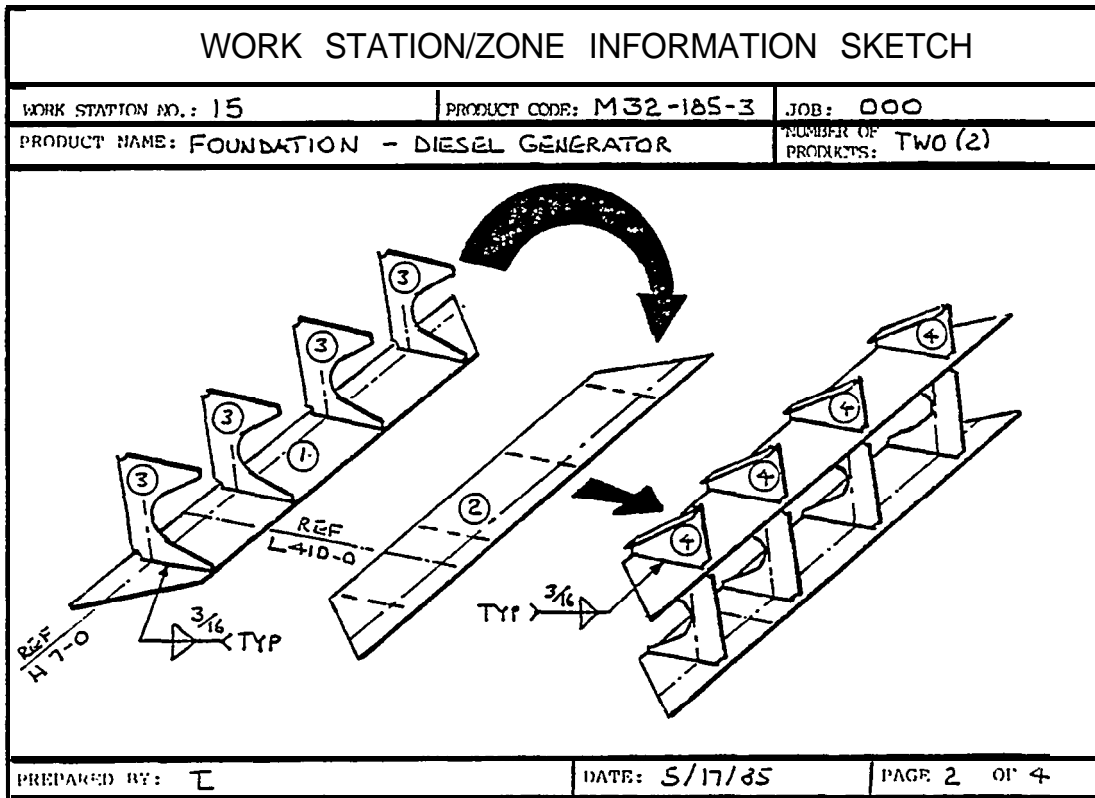

FIGURE 2.29 Hull fitting work station information.

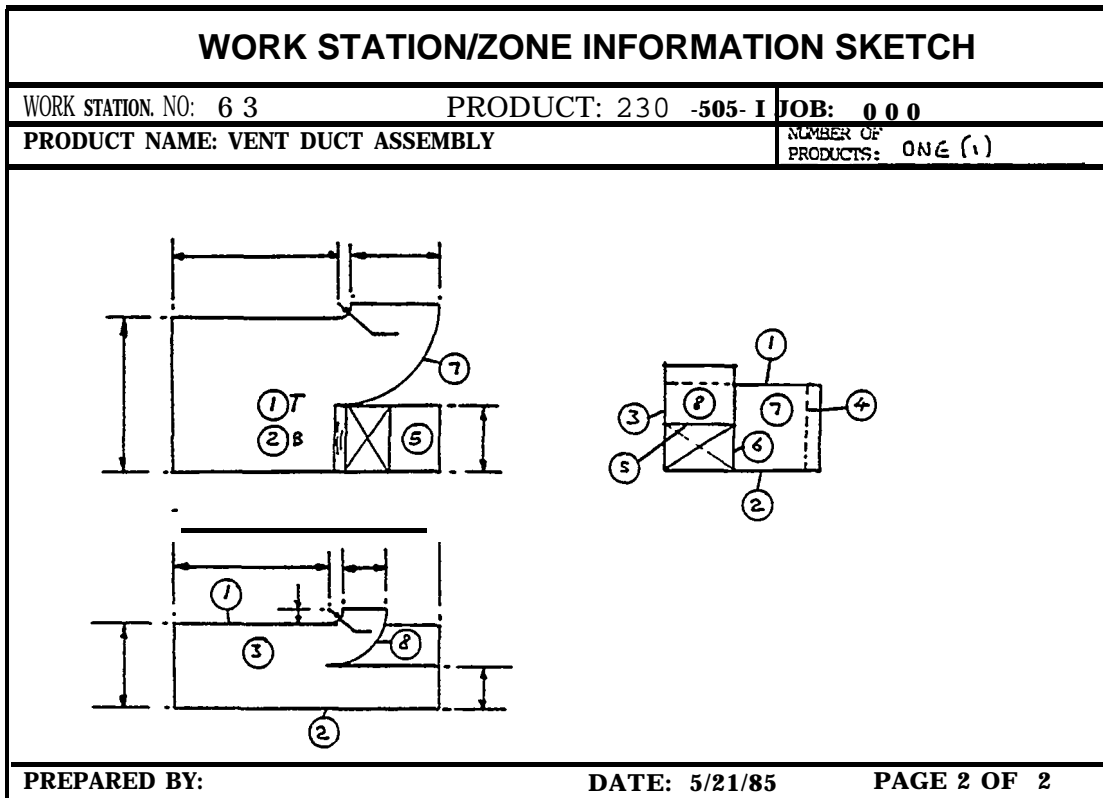
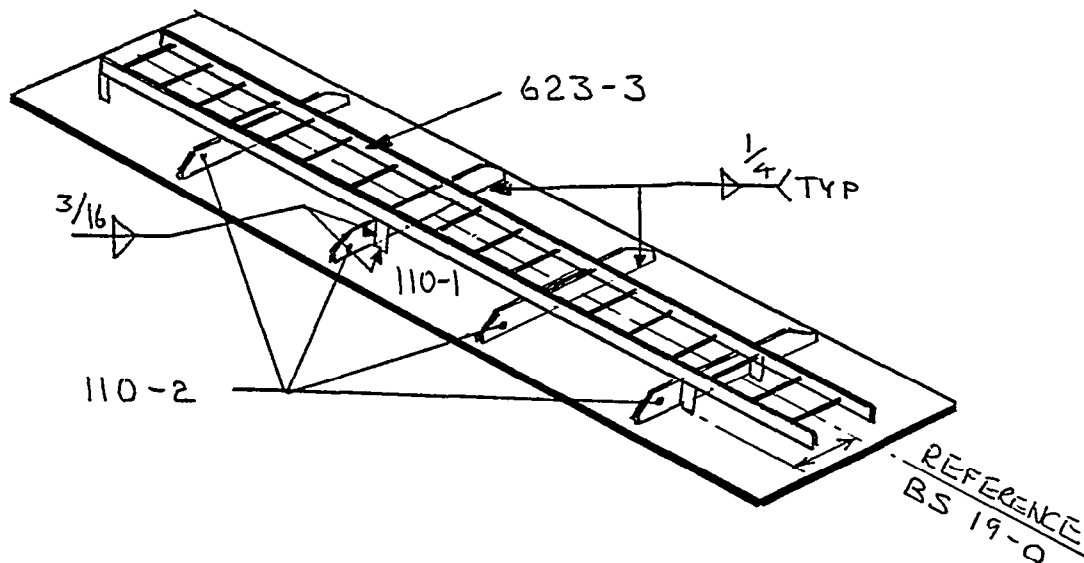

FIGURE 2.30 Hull ventilation duct assembly work *Station information.*

WORK STATION INFORMATION SHEET

WORK STATION NO.: S 5		PRODUCT CODE: OM 125	JOB: 000	
PRODUCT NAME: OUTFITTED SUB-ASSEMBLY			NUMBER OF PRODUCTS: 6 (SIX)	
PART CODE	PART NUMBER	DESCRIPTION	QUANTITY PER PRODUCT	QUANTITY ALL PROD.
1000421700	110-1	0.5 PLATE	1	6
1100130100	110-2	4 x .375 FLAT BAR	4	24
6143401	623-3	VERTICAL LADDER	1	6

1. TACK WELD 110-2 TO 110-1
2. COMPLETE WELDING
3. INSTALL LADDER



PREP. BY: 1

DATE: 5/26/85

PAGE 4 OF 12

FIGURE 2.31 Hull fitting work station information.

WORK STATION INFORMATION SHEET

WORK STATION NO.: S 7		PRODUCT CODE: OM 127-3	JOB: 000	
PRODUCT NAME: OUTFITTER PART			NUMBER OF 2	
PART CODE	PART NUMBER	DESCRIPTION	PER PRODUCT	ALL PROD.
000733710	M 127-3	SUB-ASSEMBLY	1	3
61414	621-1	MOORING CHOCK	1	3
61515	621-2	MOORING BITT	1	3
61613	167-1	RAISED MANHOLE COVER	1	3
61221	612-1	GUARD RAILS	1	3
1462031131	186-1	CHOCK FOUNDATION	1	3

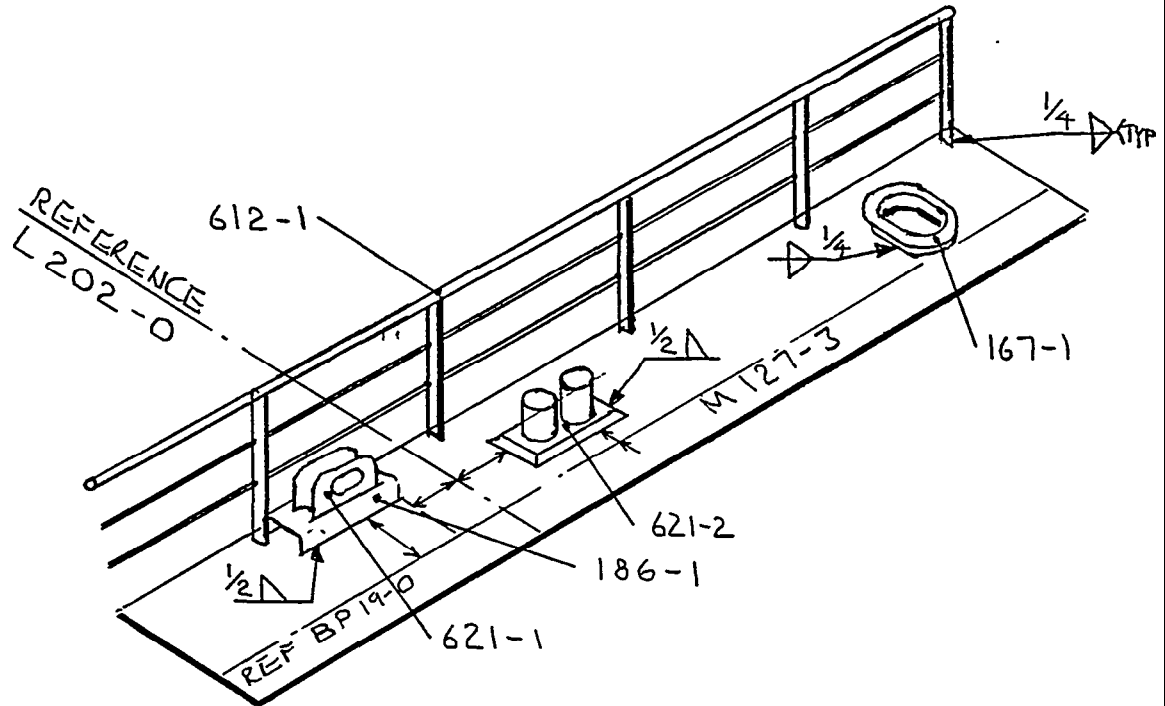

PREP. BY: T

DATE: 5/27/85

PAGE \ OF \

FIGURE 2.32 Hull fitting installation work station information.

WORK STATION/ZONE INFORMATION SKETCH

WORK STATION NO.: 54

PRODUCT CODE: OM \ 2

JOB: 0 0 0

PRODUCT NAME: OUT FITTED ASSEMBLY - PAINTED

NUMBER OF PRODUCTS: 1 (ONE)

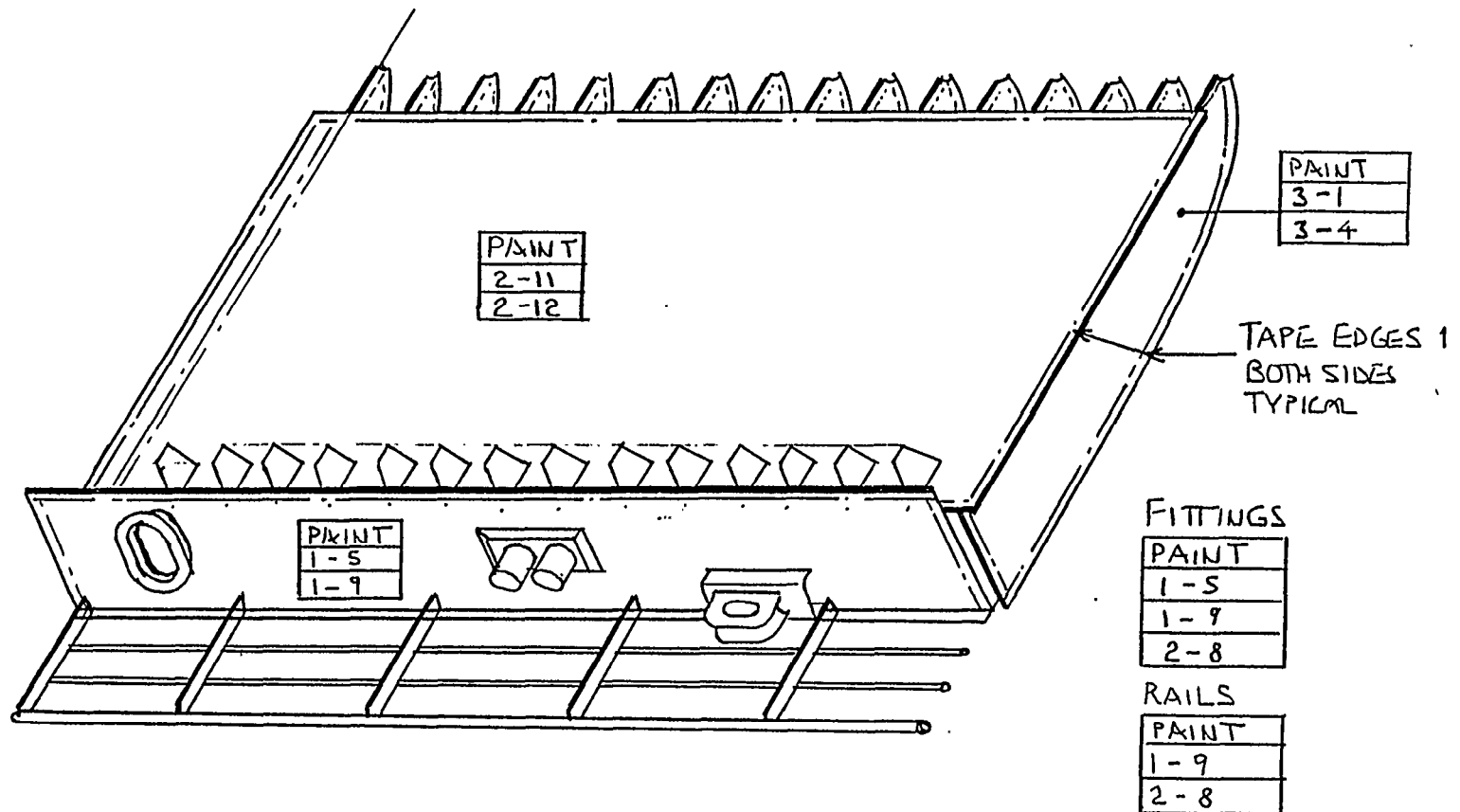

351

PREPARED BY:

L

DATE: 5/20/85

PAGE / OF /

FIGURE 2.33 Painting work station information.

WORK STATION INFORMATION SHEET				
WORK STATION NO.: 34		PRODUCT CODE: 321-185		JOB: 000
PRODUCT NAME: UNIT FOUNDATION				NUMBER OF PRODUCTS: 1
PART CODE	PART NUMBER	DESCRIPTION	QUANTITY PER PRODUCT	QUANTITY ALL PROD.
145307022	321-185-1	4x 1/4 SQUARE TUBE	2	2
145307022	321-185-2	4x 1/4 SQUARE TUBE	1	1
145305021	321-185-3	4x 1/4 SQUARE TUBE	2	2
145305010	321-185-4	4x 1/4 SQUARE TUBE	8	8
PREP. BY: -L		DATE: 5-19-85		PAGE 1 OF 1

FIGURE 2.34 Unit foundation work station information.

WORK STATION NO.: 62		PRODUCT CODE: 321-527-21	JOB: 000	
PIPE ASSEMBLY			NUMBER OF PRODUCTS: 1	
PART CODE	PART NUMBER	DESCRIPTION	QUANTITY PER PRODUCT	QUANTITY ALL PROD.
5120071473	321-527-21-1	8-PIPE SCH 80 ASTM A53	1	1
5135071431	321-527-21-2	8-TEE SCH 80 ANSI B16.1	1	1
5130071441	321-527-21-3	8-90° ELB SCH 80 ANSI B16.1	1	1
51520714	321-527-21-4	8-FLANGE 150# WELD NECK	2	2
5139071410	321-527-21-5	8-WELDING CAP SCH 80	1	1
51520614	321-527-21-6	4-FLANGE 150# WELD NECK	6	6

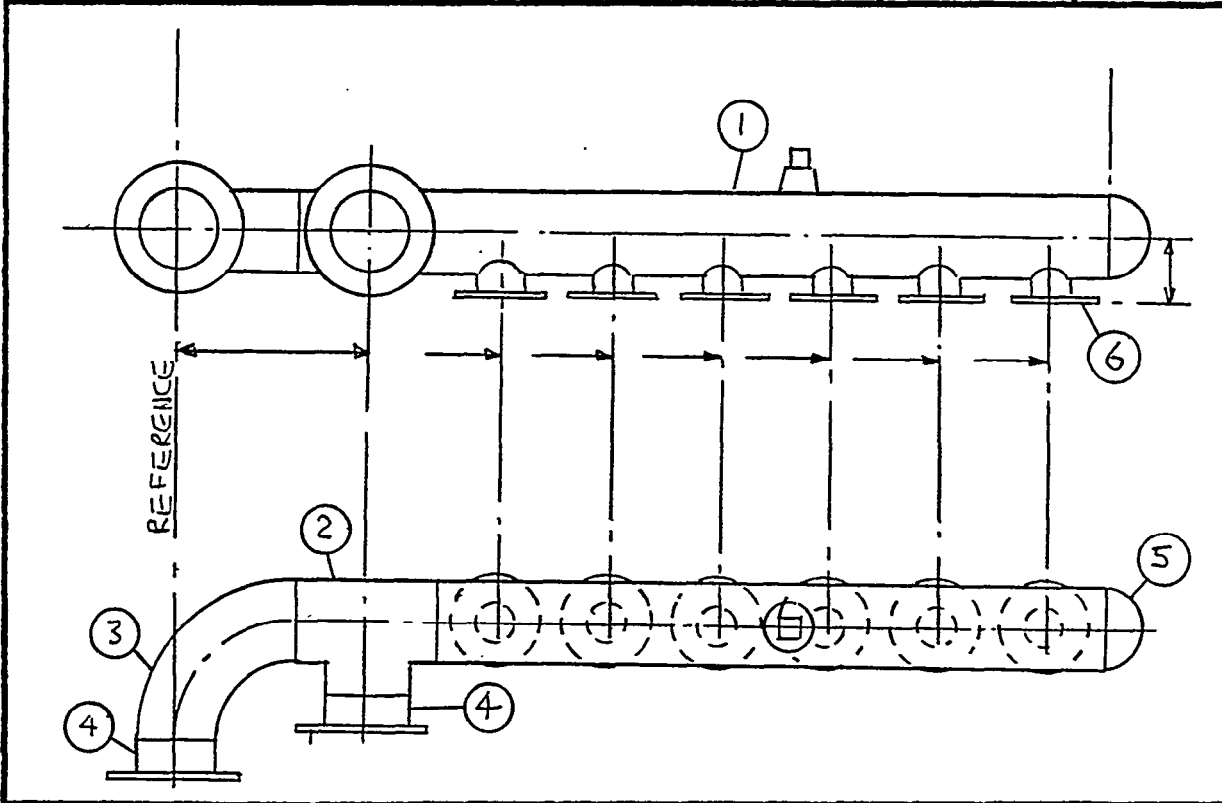

DATE: 5/20/85

WORK STATION INFORMATION SHEET				
WORK STATION NO.: 34		PRODUCT CODE: 321-527		JOB: 000
PRODUCT NAME: OUTFITTED: UNIT - PIPE				NUMBER OF PRODUCTS: 1 (ONE)
PART CODE	PART NUMBER	DESCRIPTION	QUANTITY PER PRODUCT	QUANTITY ALL PROD.
S128061484	321-527-1	PIPE ASSEMBLY	1	1
	321-527-2	PIPE ASSEMBLY	1	1
	321-527-3	PIPE ASSEMBLY	1	1
	321-527-4	PIPE ASSEMBLY	1	1
	321-527-5	PIPE ASSEMBLY	1	1
	321-527-6	PIPE ASSEMBLY	1	1
	321-527-7	PIPE ASSEMBLY	6	6
51850624	321-527-8	UNISTRUT HANGER SUPPORT	4	4

The diagram illustrates the installation of a unit pipe. The top portion is a side view of the pipe assembly, showing a horizontal pipe with several hangers. Callouts 1 through 8 identify various components: 1 and 2 are the main pipe sections; 3 and 4 are hanger rods; 5 and 6 are hanger supports; 7 is a vertical support post; and 8 is a hanger bracket. The bottom portion is a detail view of the hanger support assembly, showing a vertical hanger rod (9) passing through a support bracket (10) and a hanger support (11). Other components shown include a hanger rod (12), a hanger support (13), and a hanger bracket (14). Reference lines 'REF' are indicated at the ends of the assembly.

PREP. BY: L	DATE: 5/21/85	PAGE 1 OF 3
-------------	---------------	-------------

FIGURE 2.36 Unit pipe installation work station information.

WORK STATION/ZONE INFORMATION SKETCH

WORK STATION NO.: 34	PRODUCT CODE: 321-300	JOB: 000
PRODUCT NAME: OUTFITTED UNIT - ELECTRIC		NUMBER OF PRODUCTS: 1 (ONE)

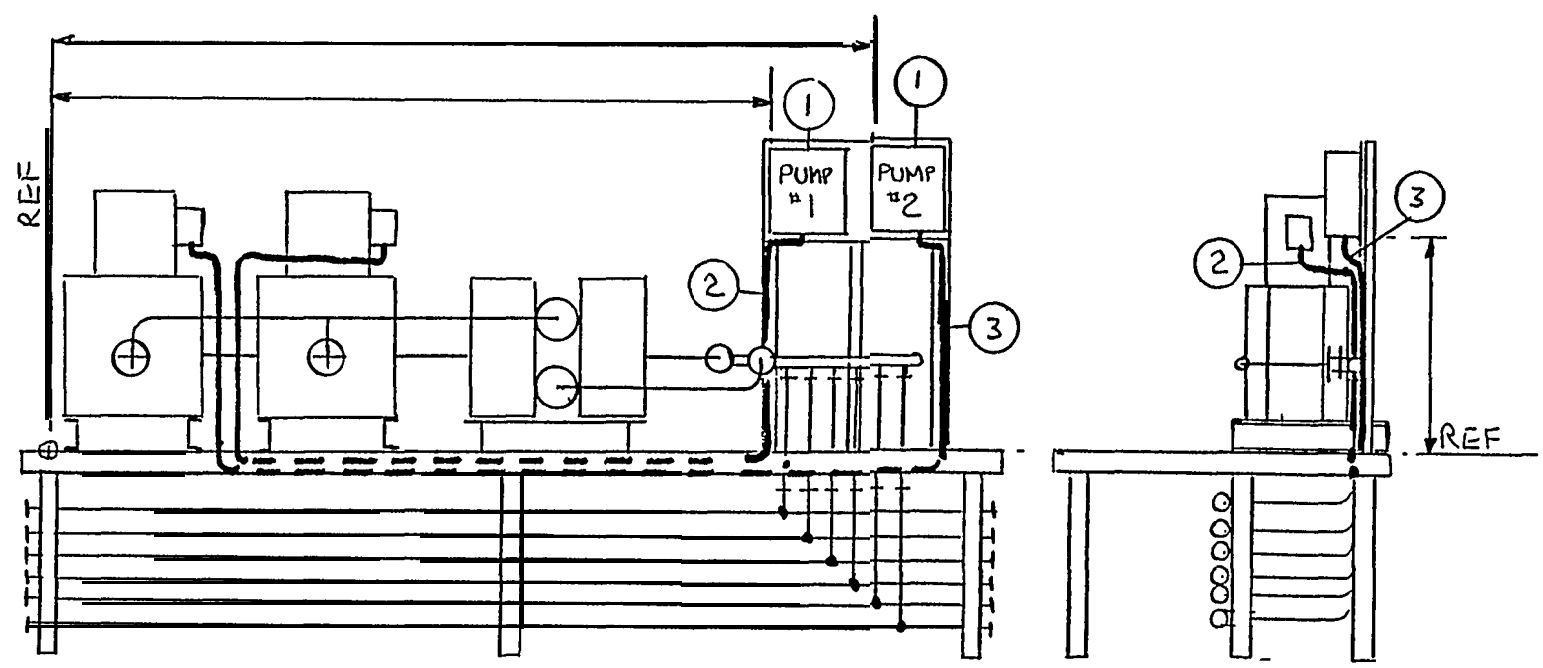

PREPARED BY: [Signature]

DATE: 5/23/85

PAGE 1 OF 2

355

FIGURE 2.37 Unit electrical installation work station information.

WORK STATION INFORMATION SHEET

WORK STATION NO.: 15		PRODUCT CODE: OM16	JOB: 000	
PRODUCT NAME: OUTFITTED ASSEMBLY-HVAC			NUMBER OF PRODUCTS: 1 (ONE)	
PART CODE	PART NUMBER	DESCRIPTION	QUANTITY PER PRODUCT	QUANTITY ALL PROD.
5034341	513-1	VENT DUCT	1 + MIRROR	1 + M
5031420	513-2	VENT DUCT	2	2
5031410	513-3	VENT DUCT	2	2
5031410	513-4	VENT DUCT	2	2
5034221	513-5	VENT DUCT	1	1
5034321	513-6	VENT DUCT	1	1
5034221	513-7	VENT DUCT	1	1
5031420	513-8	VENT DUCT	2	2

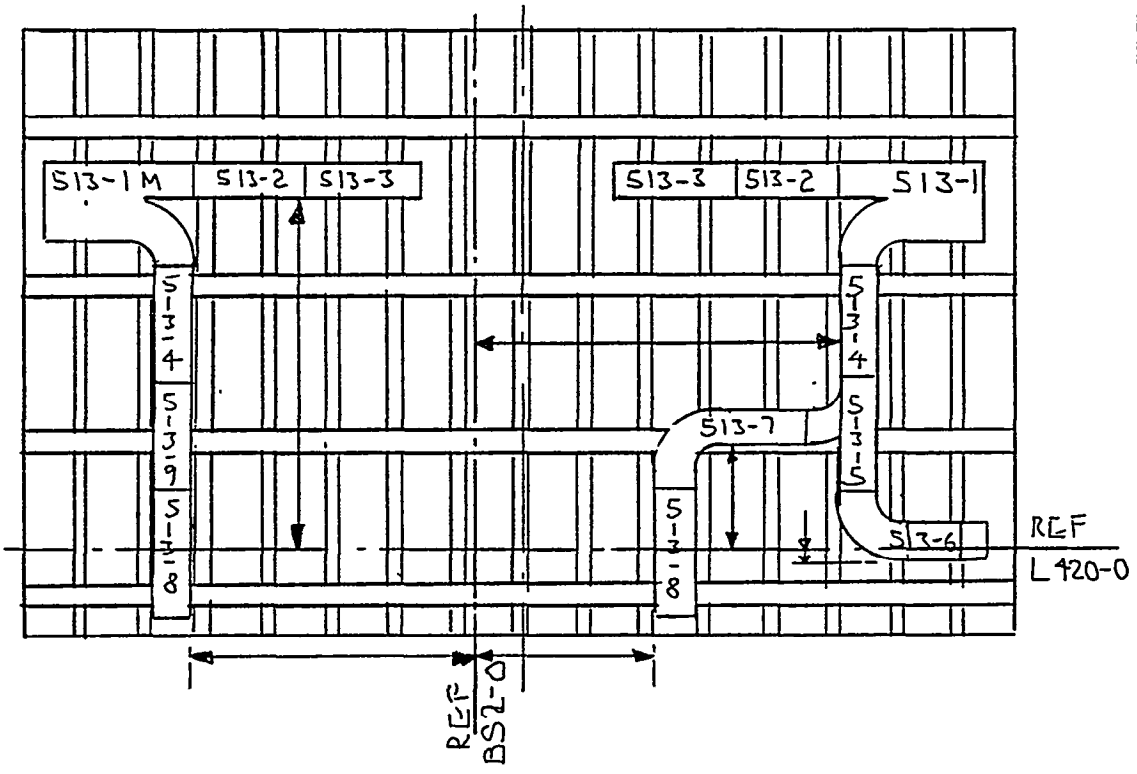

PREP. BY: L	DATE: 5/20/85	PAGE 1 OF 2
-------------	---------------	-------------

WORK STATION INFORMATION SHEET

WORK STATION NO.: 15		PRODUCT CODE: OM 16	JOB: 000	
PRODUCT NAME: OUTFITTED ASSEMBLY - PIPE			NUMBER OF PRODUCTS: 1(ONE)	
PART CODE	PART NUMBER	DESCRIPTION	QUANTITY PER PRODUCT	QUANTITY ALL PROD.
512863486	521-1	PIPE ASSEMBLY	1	1
512863485	521-2	PIPE ASSEMBLY	3	3
512863484	521-3	PIPE ASSEMBLY	2	2
512863484	521-4	PIPE ASSEMBLY	1	1
512863486	528-1	PIPE ASSEMBLY	1	1
512863484	528-2	PIPE ASSEMBLY	3	3
512863484	528-3	PIPE ASSEMBLY	1	1
512863486	529-1	PIPE ASSEMBLY	1	1

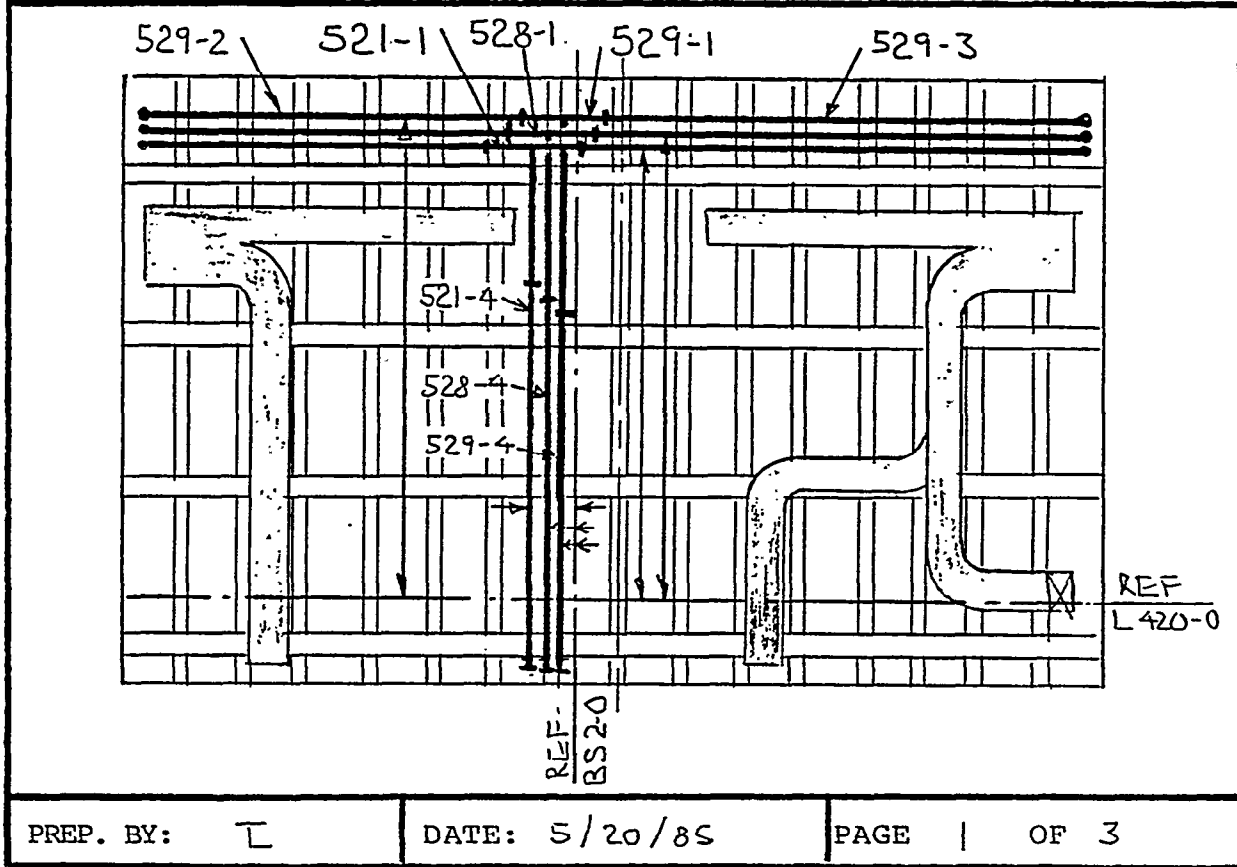

PREP. BY: └

DATE: 5/20/85

PAGE | OF 3

FIGURE 2.39 "On-block" advanced outfitting installation work station information for pipe.

WORK STATION INFORMATION SHEET

WORK STATION NO.: 15		PRODUCT CODE: OM16	JOB: 000	
PRODUCT NAME: OUTFITTED ASSEMBLY - ELECTRIC			NUMBER OF PRODUCTS: 1	
PART CODE	PART NUMBER	DESCRIPTION	QUANTITY PER PRODUCT	QUANTITY ALL PROD.
36104310	304-1	CABLE RACK	1	1
36104310	304-2	CABLE RACK	2	2
36104510	304-3	CABLE RACK	1	1
3714	332-1	LIGHT FIXTURE WITH FOUNDATION	12	12

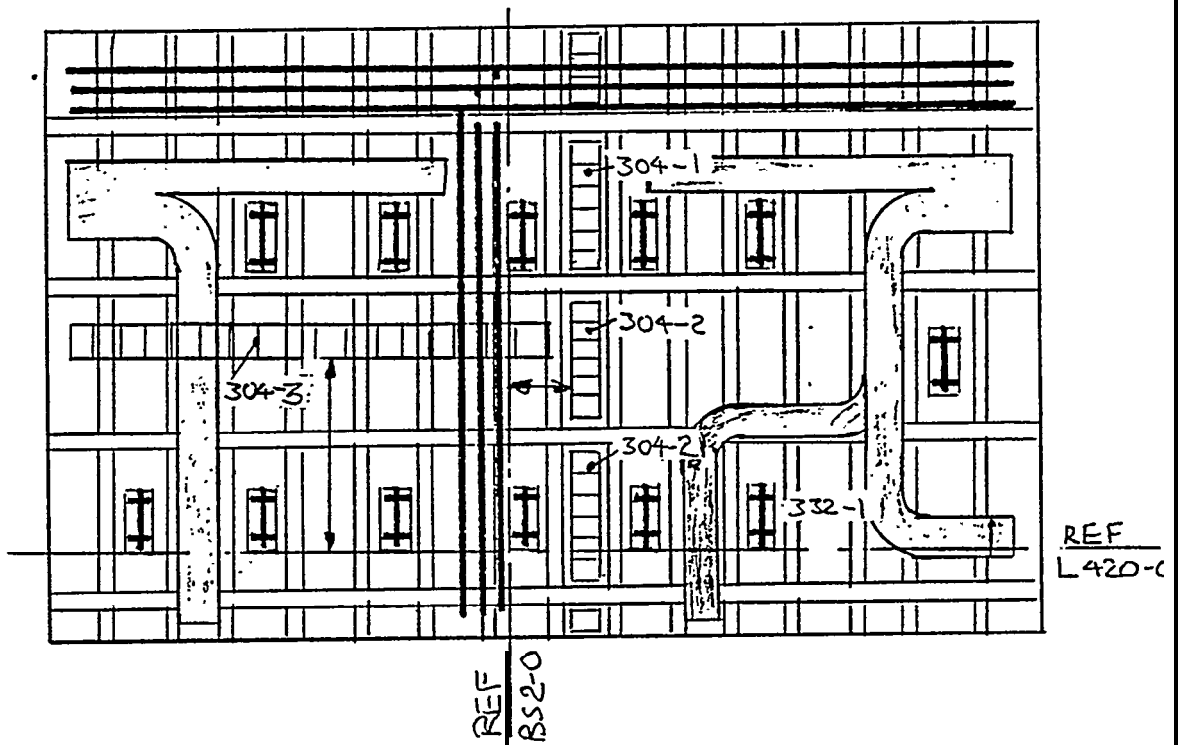

PREP. BY: -T	DATE: 5/21/85	PAGE 1 OF 2
--------------	---------------	-------------

FIGURE 2.40 "On-block" advanced outfitting installation work station information for electrical.

Zone information will be prepared for all products to be installed in zones which would cover all “on-board” advanced **and remaining normal** outfitting as shown in Figures 2.41 through 2.45. Figures 2.44 through 2.46, are for electrical work. Electrical Product Engineering should be prepared to show wireway installation on structural assemblies and modules in the attitude most suitable for the installation. It is not surprising that mistakes are made when installing wireways on a deck panel when it is lying in the shop upside down, and the wireway drawing is of the normal complete ship or space type, showing a plan view through the deck.

One area where electrical product engineering can save significant electrical production manhours is in identifying cables on each wireway, identifying cables starting and ending in each compartment, providing required length of cable for each run, and length of cable in each space where it starts or ends. Figures 2.45 and 2.46 show this type of approach.

Electrical fixtures in accommodation spaces should be located on the joiner work zone information sketches as shown in Figure 2.47. All distribution panels, controllers, junction boxes, and other electrical equipment must be shown and located on installation sketches, and the support connections to the structure included in the structural assembly and/or module work station sketches.

2.8.6 DECKHOUSE WORK STATION/ZONE INFORMATION. The deckhouse work station/zone information will be prepared in a similar manner to the hull and machinery space. However, the method and phasing of joining the deckhouse assemblies, whether the deckhouse will be erected on the hull in one or more parts, and the extent of advanced outfitting, all have a major impact on the work station/zone information approach. For example, a tiered approach could be used as shown in Figure 2.4S(a) where each deck level is assembled upside down, and all overhead systems installed. Then each tier would be erected on top of each other, right way up, and further outfitting installed before erection on the hull as one unit. Another option shown as (b) would be to build the complete deckhouse structure less wheelhouse upside down and install all overhead outfitting down hand. Then the deckhouse would be turned right way up, wheelhouse added, and outfitting completed before erection on the hull. Again, this is building strategy, and should be decided during contract design, and included in the building plan.

Figures 2.49 through 2.53 show typical work station/zone information for deckhouse-specific work. Work station/zone information for piping and electric would be identical to that described in Section 2.8.5.

WORK STATION/ZONE INFORMATION SKETCH

WORK STATION NO.: Z011E 32	PRODUCT CODE: 321	JOB: 000
PRODUCT NAME: INSTALLED UNIT - "ON BOARD"		NUMBER OF PRODUCTS: 1 (ONE)

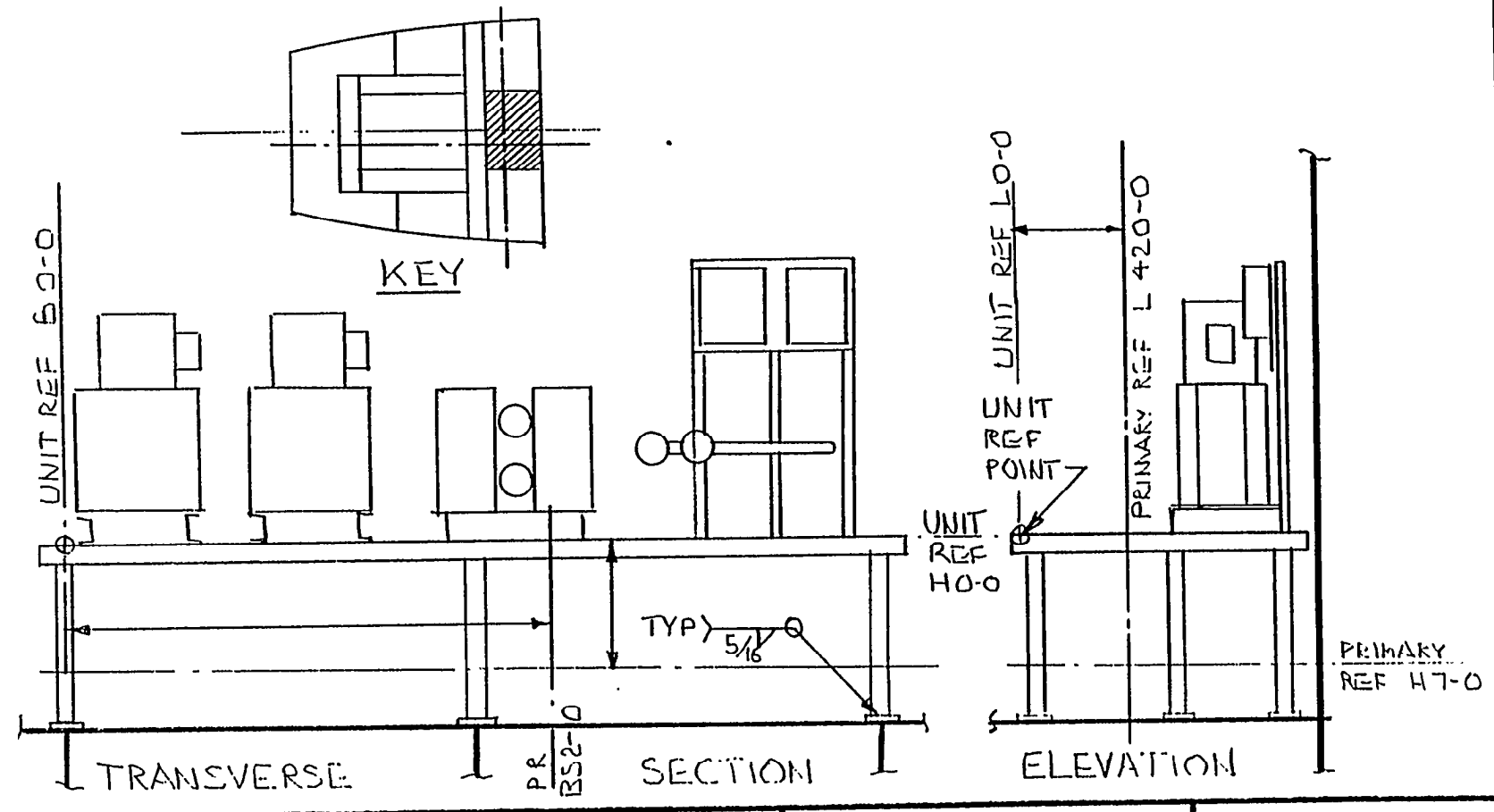

360

PREPARED BY: T	DATE: 5/24/85	PAGE 1 OF 2
----------------	---------------	-------------

FIGURE 2.41 "On-board" advanced outfitting unit installation work station information.

WORK STATION/ZONE INFORMATION SKETCH		
WORK STATION NO.: ZONE 34	PRODUCT CODE: 34-527	JOB: 000
PRODUCT NAME: ON BOARD OUTFITTING - PIPE		NUMBER OF PRODUCTS: 1 (ONE)
<p>NOTE: Y DIMENSION MEASURED FROM REF H 5-0</p> <p>MACHINERY SPACE ZONE 34</p>		
PREPARED BY: [Signature]	DATE: 5/26/82	PAGE 1 OF 2

361

FIGURE 2.42 Normal "on-board" outfitting work station information for pipe.

WORK STATION/ZONE INFORMATION SKETCH

WORK STATION NO.: ZONE 34					PRODUCT CODE: 34-527					JOB: 000					
PRODUCT NAME: ON BOARD OUTFITTING-PIPE										NUMBER OF PRODUCTS: 1 (ONE)					
PIPE ASSEMBLY		PARTS/P. A.		PIPE ASSEMBLY		PARTS/P. A.		PIPE ASSEMBLY		PARTS/P. A.		PIPE ASSEMBLY		PARTS/P. A.	
P. A. NUMBER	QTY	PART NUMBER	QTY	P. A. NUMBER	QTY	PART NUMBER	QTY	P. A. NUMBER	QTY	PART NUMBER	QTY	P. A. NUMBER	QTY	PART NUMBER	QTY
34-527-1	1	1	1	34-527-3	1	1	1	34-527-5	1	1	1				
		2	1			2	1			2	2				
		3	1			3	1			B4	16				
		4	2			4	1			W4	32				
		5	1			5	1			N4	16				
		6	6			6	6			34-527-6	1	1	1		
		B 12	64			B 4	48					2	1		
		W 12	128			W 4	96					3	2		
		N 12	64			N 4	48					B3	12		
34-527-2	1	1	1	34-527-4	1	1	1			W3	24				
		2	1			2	1	N3	12						
		3	1			3	1	34-527-7	1	1	1				
		4	3			4	2			2	2				
		5	2			B 4	24			B3	24				
		B4	12			W4	48			W3	48				
		W4	24			N4	24			N3	24				
		114	12												

PREPARED BY: T

DATE: 5/23/85

PAGE 2 OF 2

362

Product Engineering

PART 2

FIGURE 2.43 Pipe assembly installation work Station information (parts list).

WORK STATION/ZONE INFORMATION SKETCH

WORK STATION NO.: ZONE 23

PRODUCT CODE: 23-331

JOB: 000

PRODUCT NAME: ZONE OUTFITTING - ELECTRICAL

NUMBER OF PRODUCTS: 8 (EIGHT)

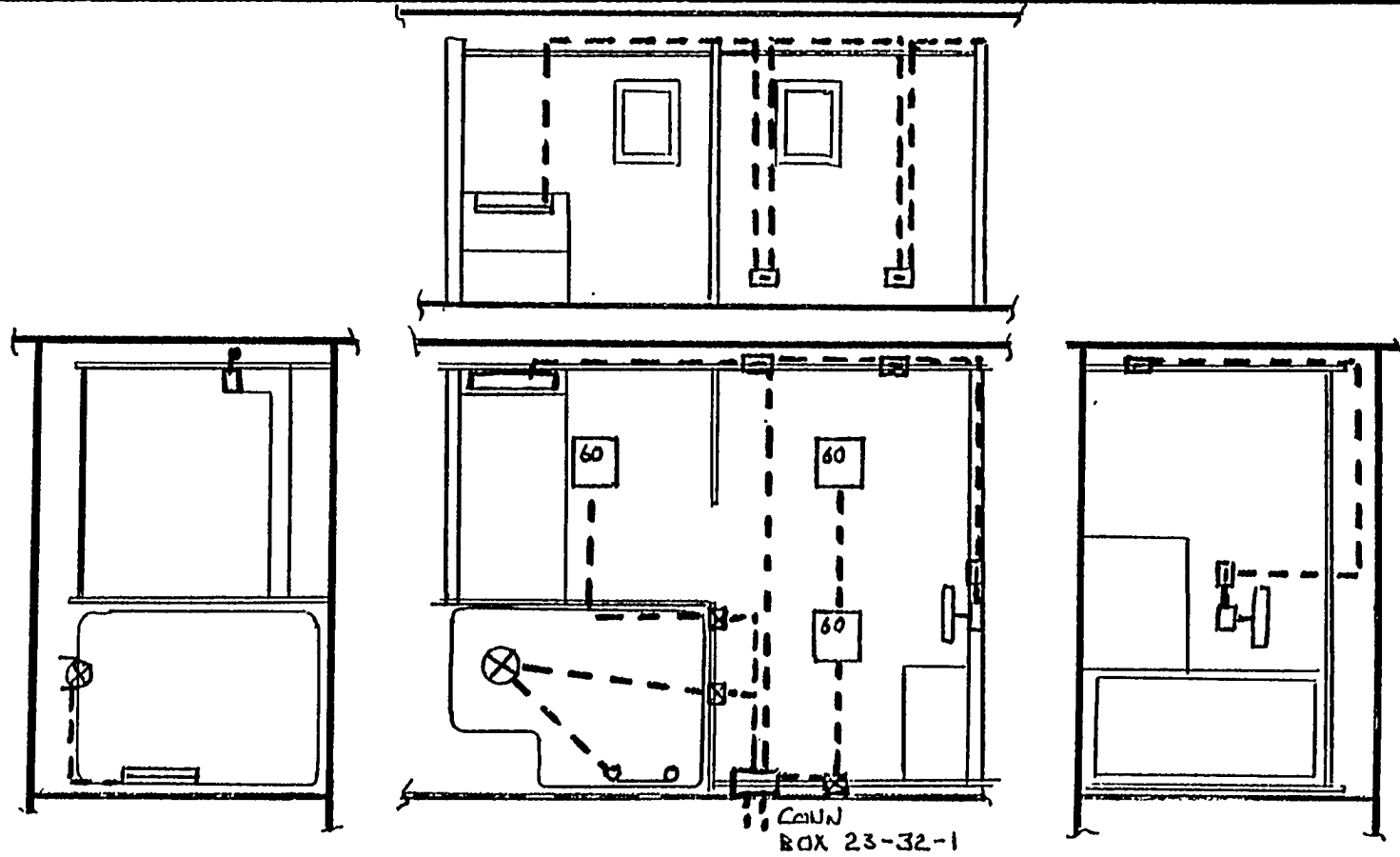

PREPARED BY: *TL*

DATE: 5/26/85

PAGE 2 OF 2

363

FIGURE 2.44 Zone information for electrical cable connecting.

WORK STATION/ZONE INFORMATION SKETCH

WORK STATION NO.: ZONE 322

PRODUCT CODE: 322-324

JOB: 000

PRODUCT NAME: ZONE OUTFITTING - ELECTRICAL

NUMBER OF PRODUCTS: 1 (ONE)

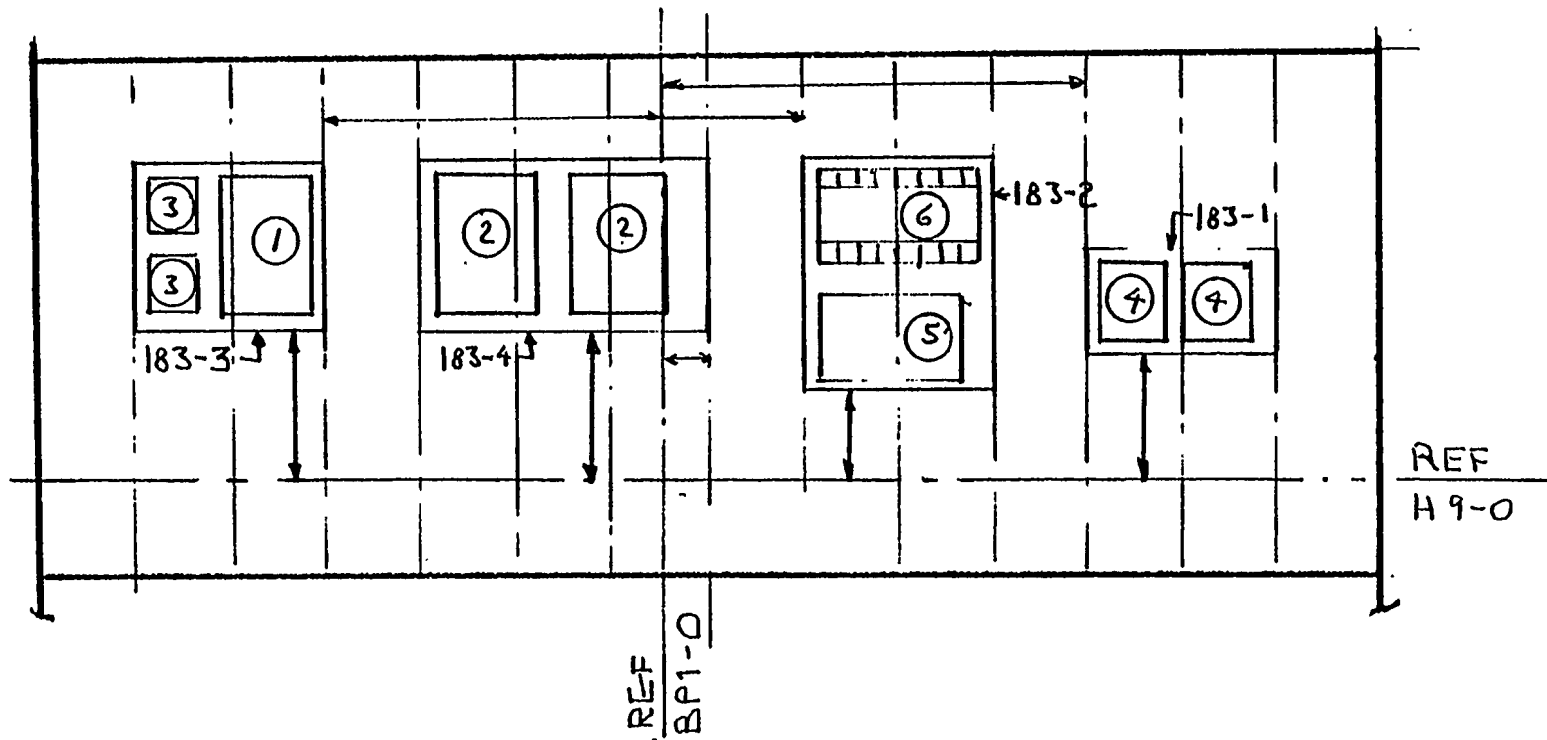

364

PREPARED BY: T

DATE: 5/27/85

PAGE 2 OF 2

FIGURE 2.45 Zone information, electrical equipment location.

WORK STATION/ZONE INFORMATION SKETCH

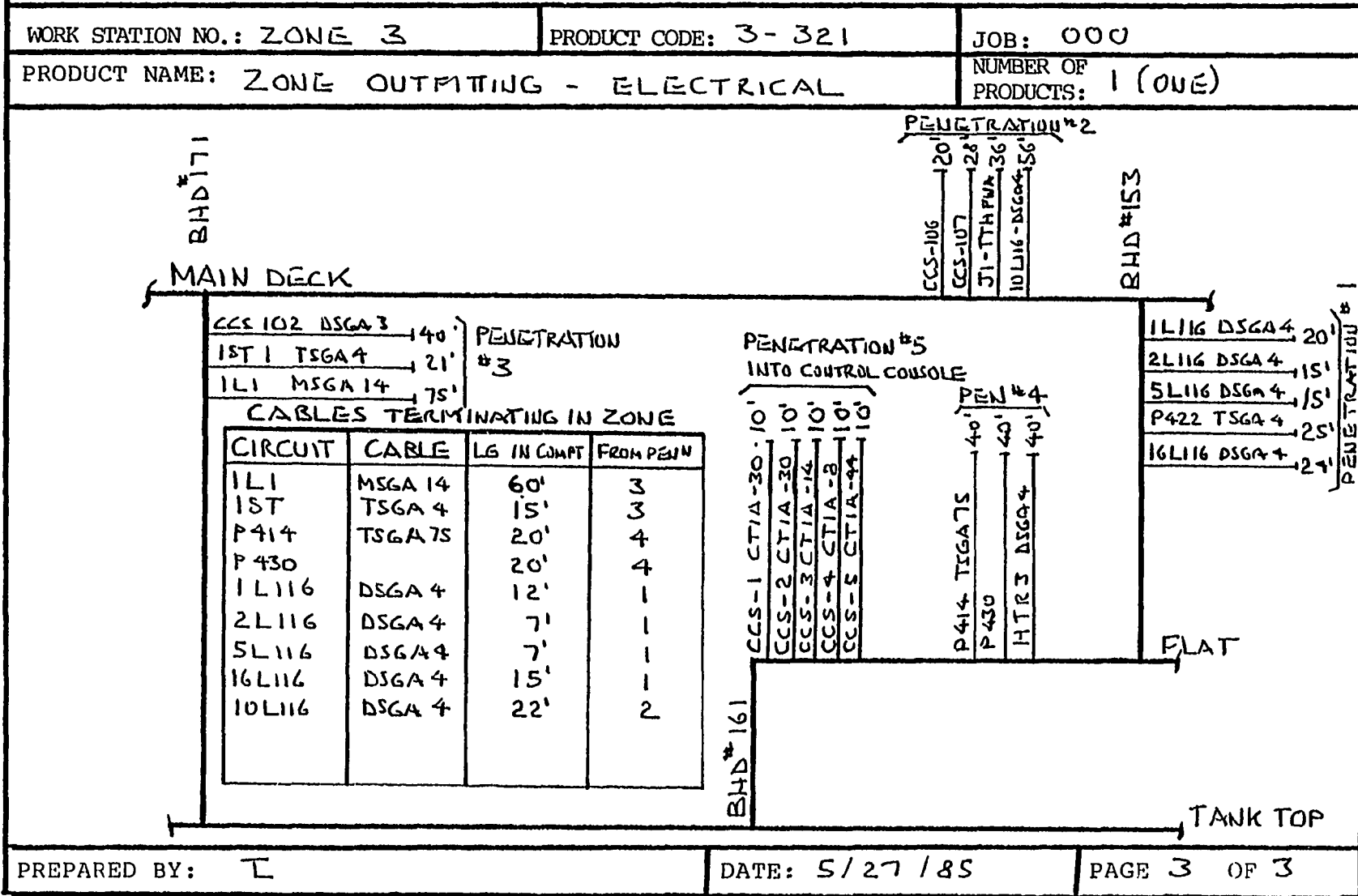

365

PART 2

Product Engineering

FIGURE 2.46 Zone information, cable penetrations, starts, ends, and lengths.

WORK STATION/ZONE INFORMATION SKETCH

WORK STATION NO.: ZONE 34	PRODUCT CODE: 34 - 321	JOB: 000
PRODUCT NAME: ZONE OUTFITTING - ELECTRICAL		NUMBER OF PRODUCTS: 1 (ONE)

CABLE	CIRCUIT	LENGTH	ROUTING
1-A			
MSCA-7	1LS	75'	1A, 1B, 2A, 2B, 3A, 3B
MSCA-7	2LS	75'	1A, 1B, 2A, 2B, 3A, 3B
TTRSA-2	1L4	48'	1A, 1B, 2A, 2B, 4A, 4B
DSGA-4	7P101	210'	1A, 1B, 2A, 2B, 4A, 4B
TSGA-4	1P412	78'	1A, 1B, 2A, 2B, 4A, 4B
1-B			
SAME AS 1-A			
PLUS			
DSGA-4	1P412	39'	1B, 2A, 2B, 3A,
FSGA-4	1SP412	65'	1B, 2A, 2B, 4A, 4B.
2-A			
MSCA-7	1LS		SEE 1A
MSCA-7	2LS		SEE 1A
TTRSA-2	1L4		SEE 1A
DSGA-4	7P101		SEE 1A
TSGA-4	1P412		SEE 1A
DSGA-4	1P412		SEE 1B
FSGA-4	1SP412		SEE 1B
2-B			
SAME AS 2A			
3-A			
MSCA-7	1LS		SEE 1A
MSCA-7	2LS		SEE 1A

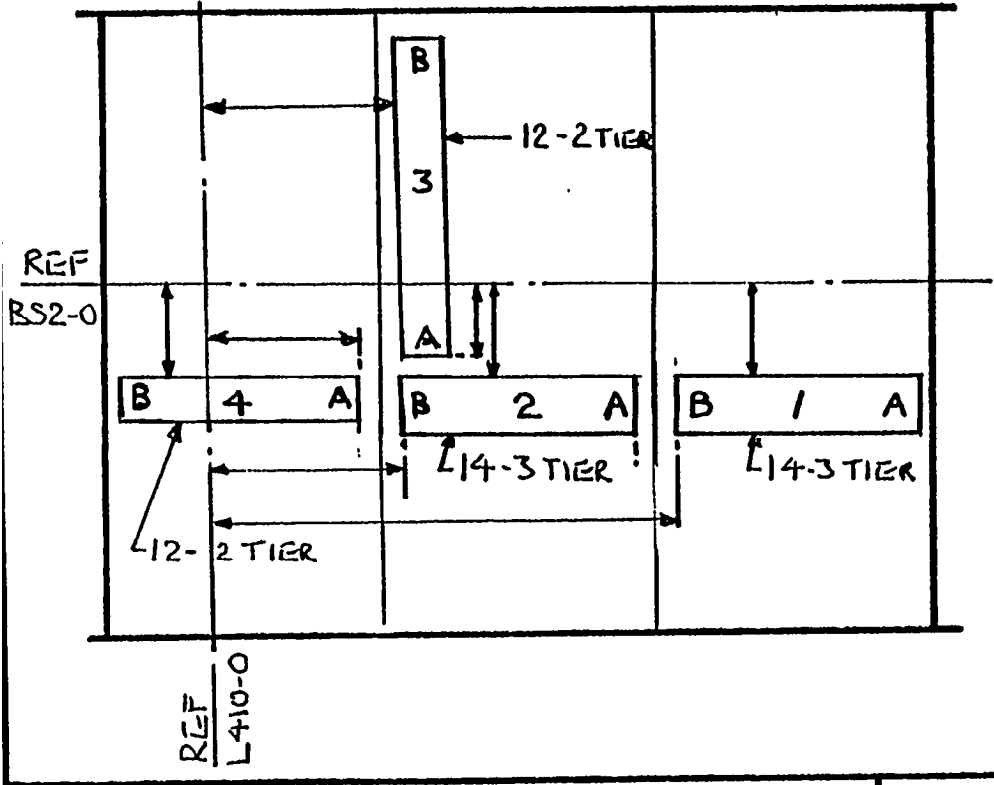

366

PREPARED BY: [Signature]	DATE: 5/28/85	PAGE 2 OF 3
--------------------------	---------------	-------------

FIGURE 2.47 Zone information, wireway, and cable routing lengths.

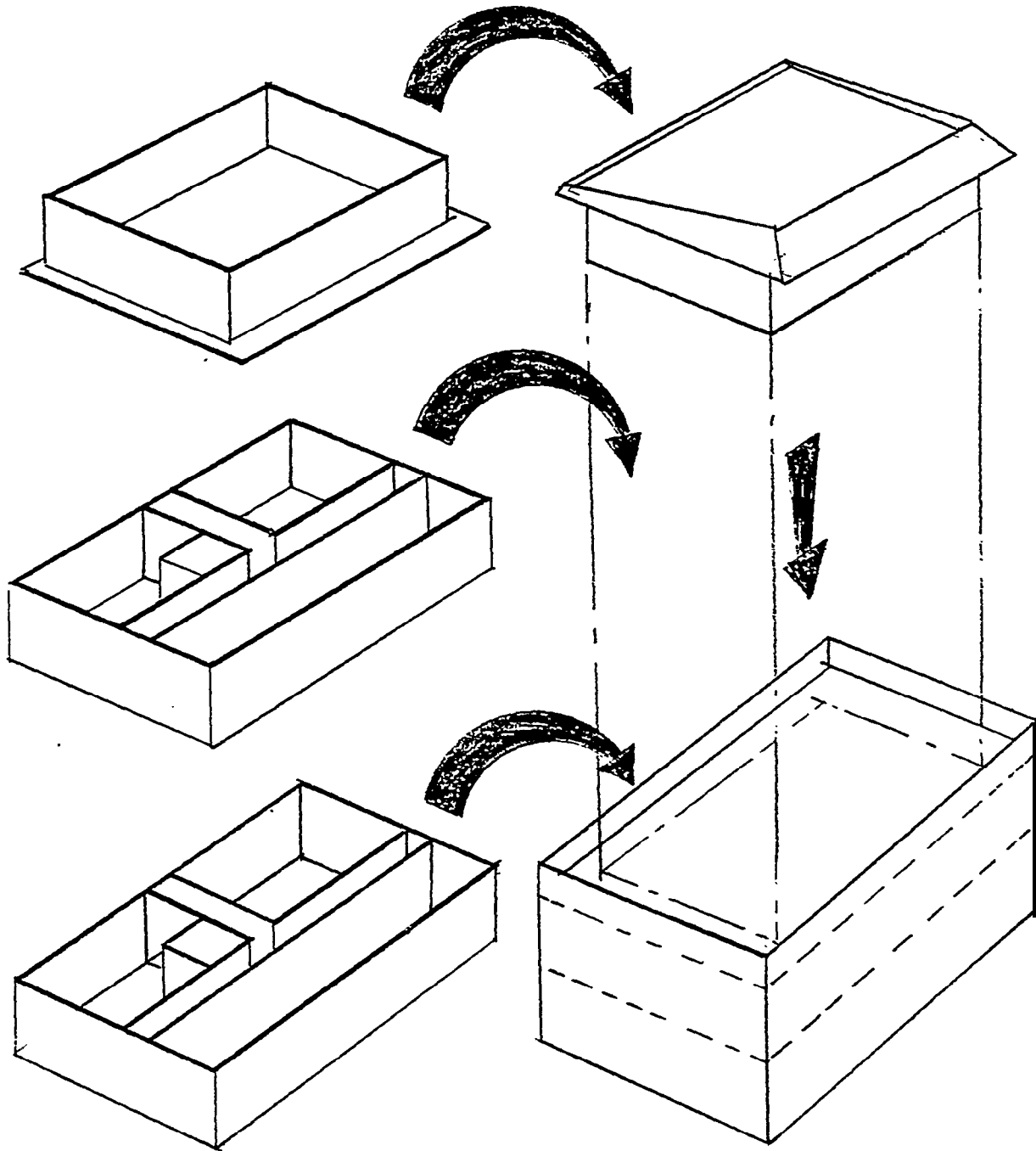

FIGURE 2.48(a) Single-tier deckhouse construction

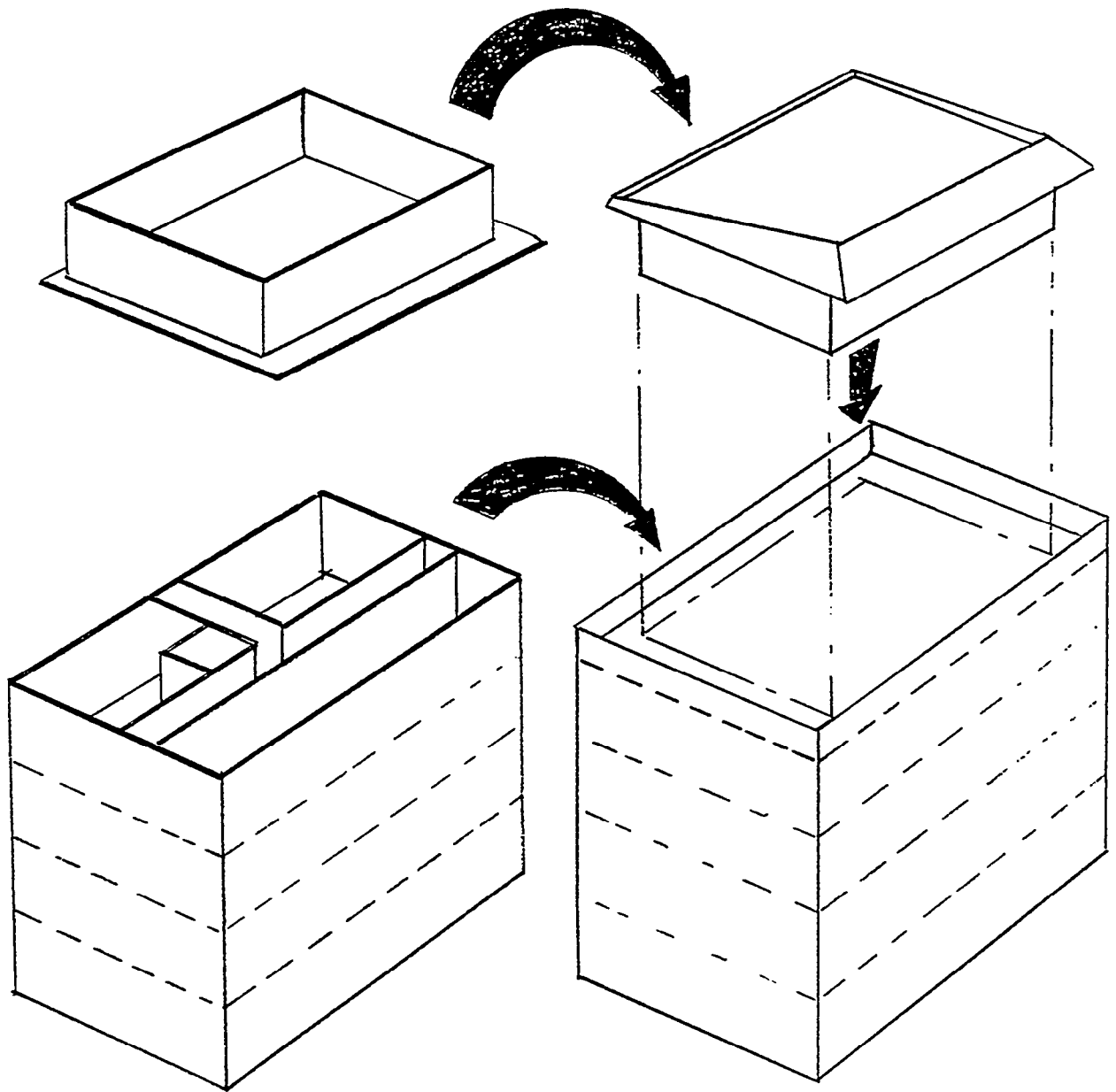

FIGURE 2.48(b) Unit deckhouse construction.

WORK STATION/ZONE INFORMATION SKETCH

WORK STATION NO.: ZONE 23

PRODUCT CODE: 23 - 620

JOB: 000

PRODUCT NAME: ZONE OUTFITTING - HULL FITTINGS

NUMBER OF PRODUCTS: 1 (ONE)

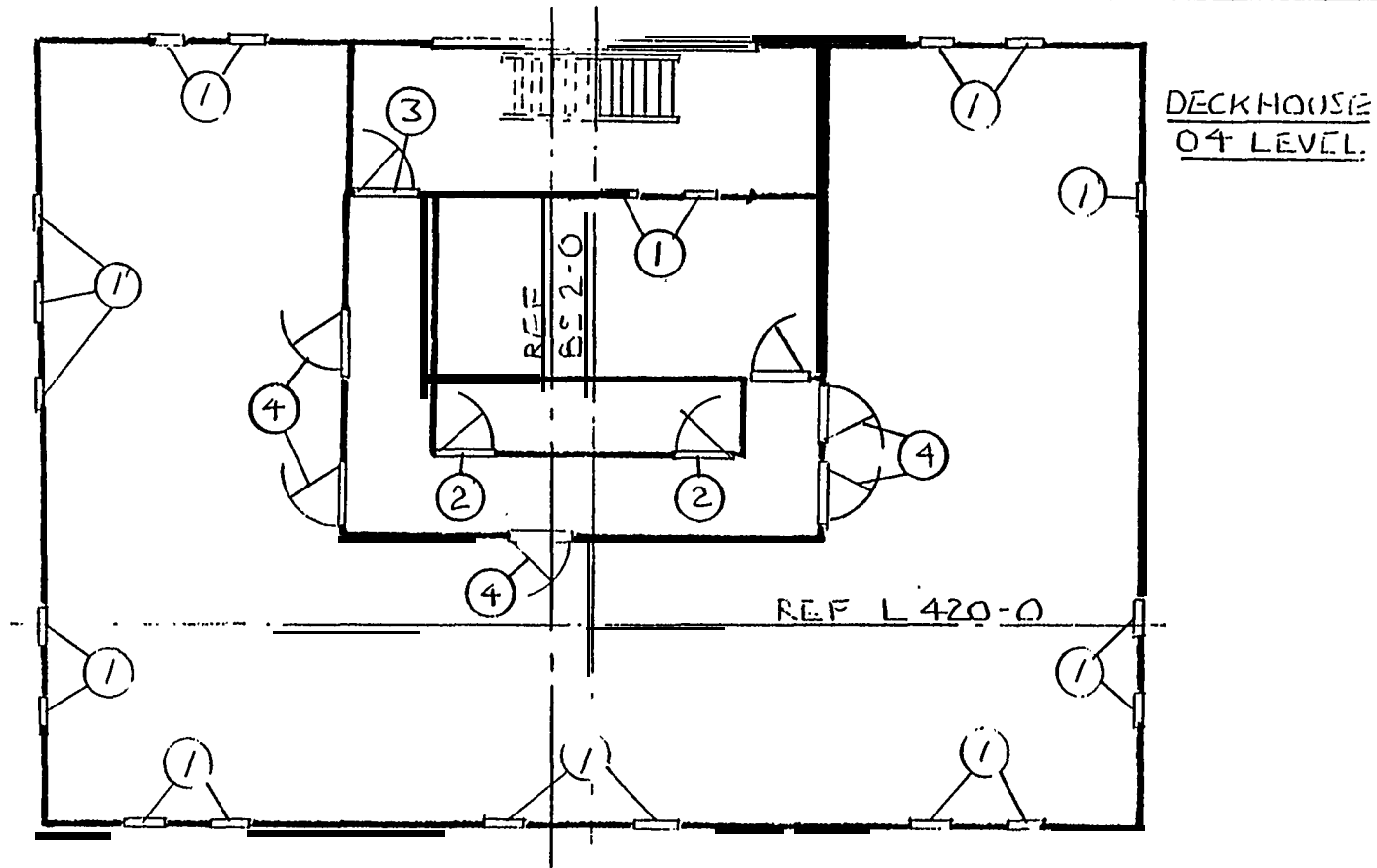

PREPARED BY: L

DATE: 5/4/85

PAGE 1 OF :

369

PART 2

Product Engineering

FIGURE 2.49 Deckhouse zone information.

WORK STATION/ZONE INFORMATION SKETCH

WORK STATION NO.: ZONE 23

PRODUCT CODE: 23 - 621-1

JOB: 000

PRODUCT NAME: ZONE OUTFITTING - JONKER END/LIVING SURF

NUMBER OF PRODUCTS: 1 (ONE)

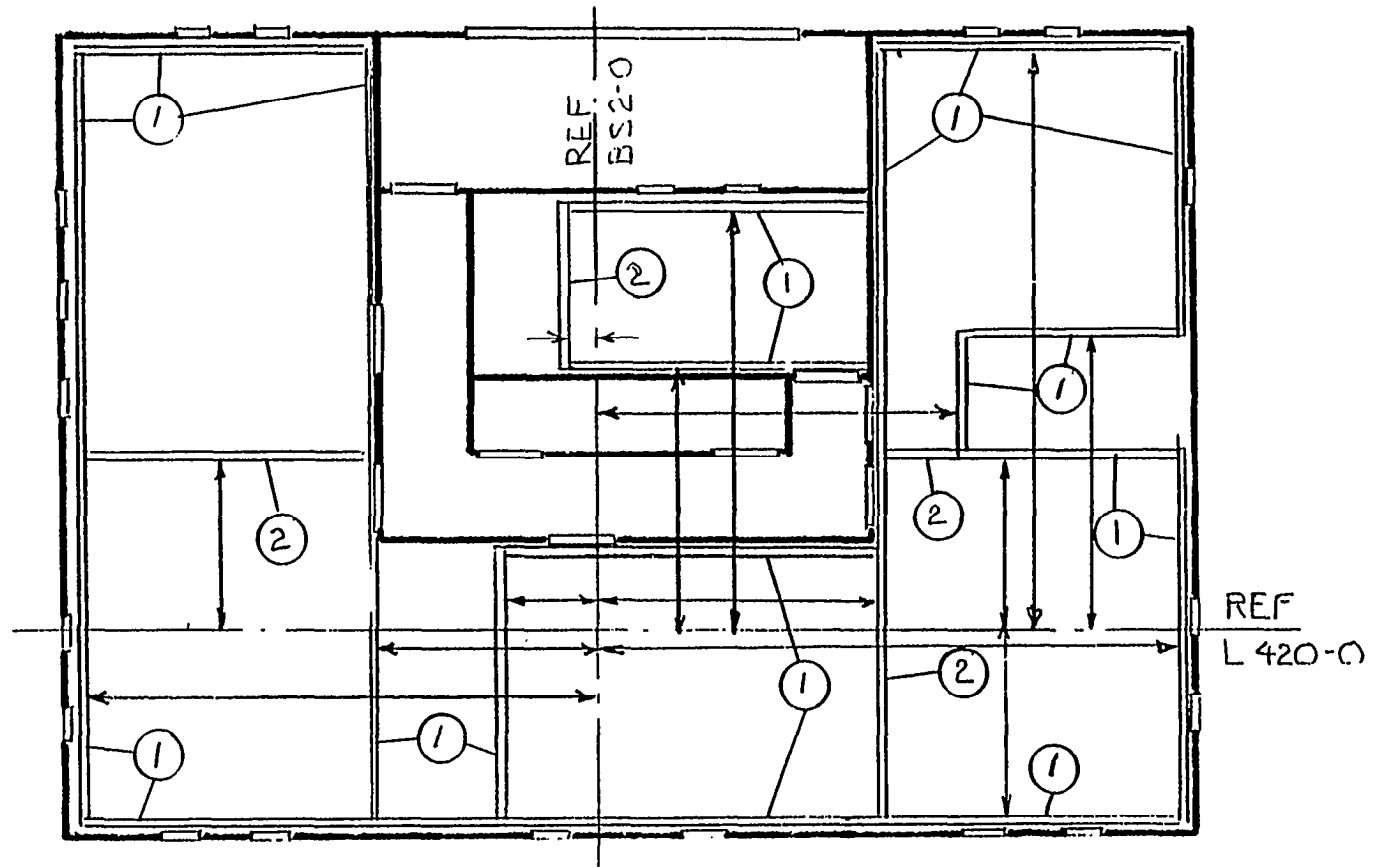

PREPARED BY: L

DATE: 5/4/85

PAGE 1 OF 2

370

Product Engineering

PART 2

FIGURE 2.50 Deckhouse zone information.

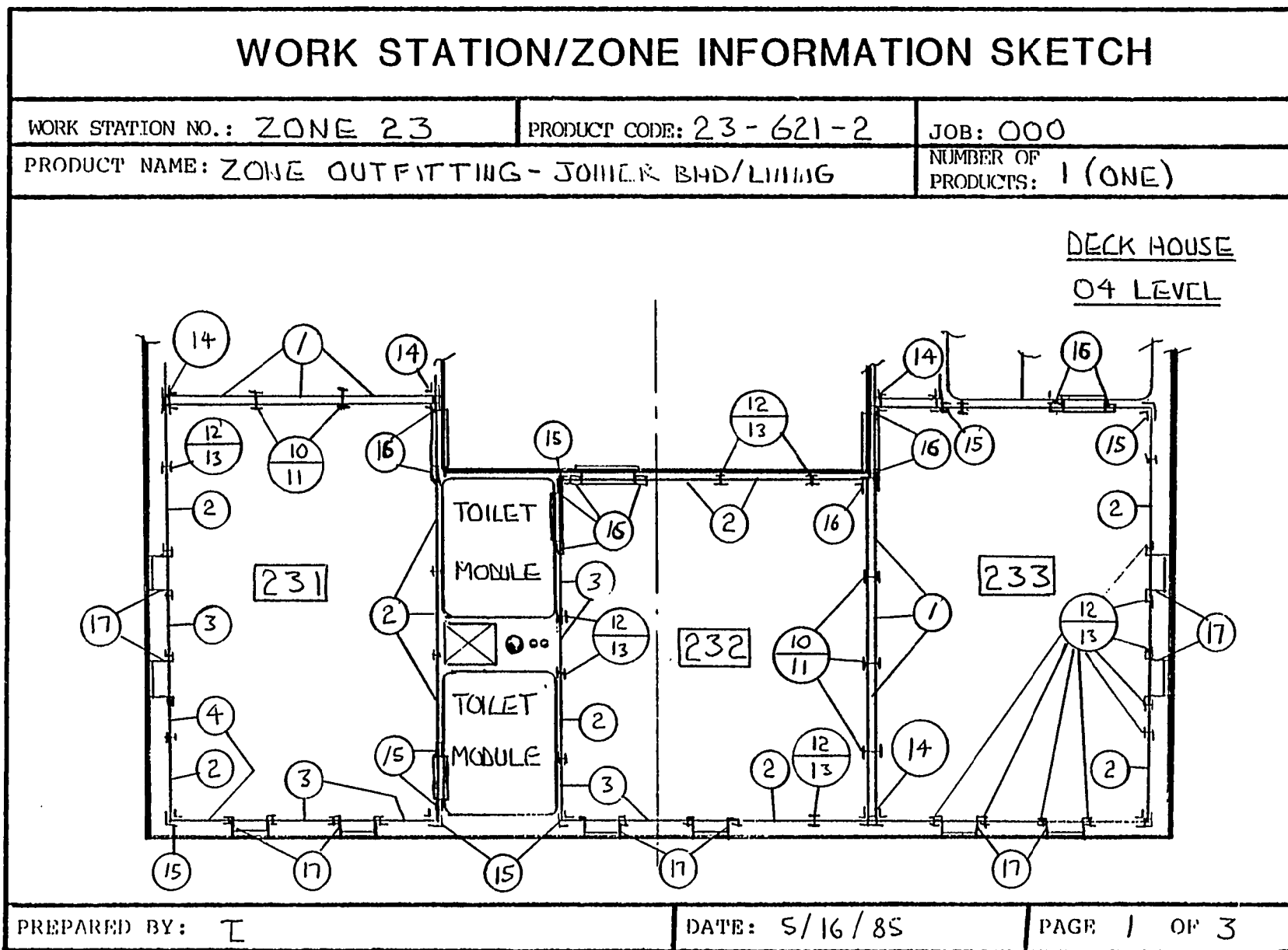

371

FIGURE 2.51 Deckhouse zone information for joiner lining and bulkheads.

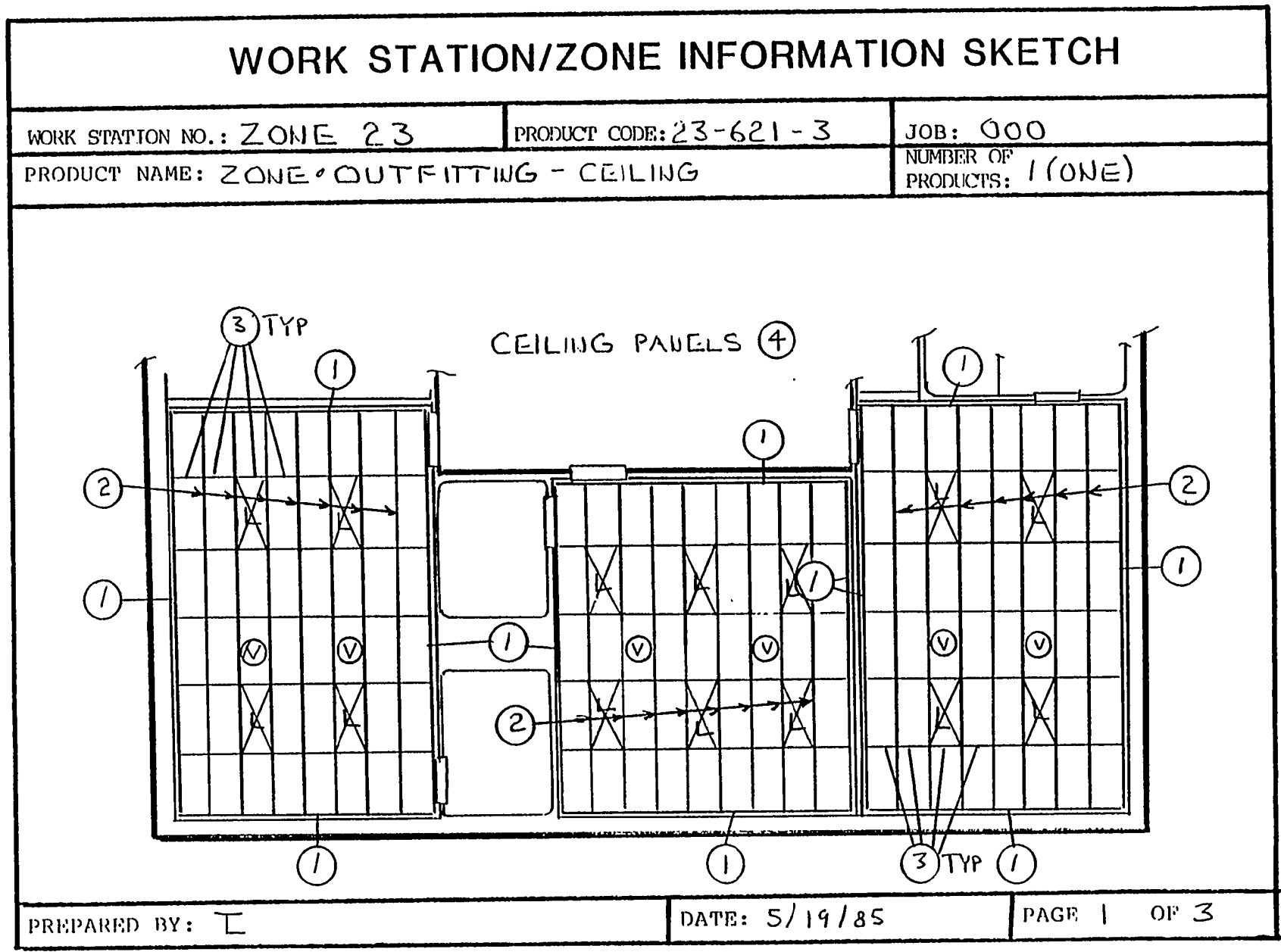

372

FIGURE 2.52 Deckhouse zone information for joiner ceiling installation.

WORK STATION INFORMATION SHEET				
WORK STATION NO.: ZONE 232		PRODUCT CODE: 232-641		JOB: 000
PRODUCT NAME: ZONE OUTFITTING - FURNITURE			NUMBER OF PRODUCTS: 1 (ONE)	
PART CODE	PART NUMBER	DESCRIPTION	QUANTITY PER PRODUCT	QUANTITY ALL PROD
6412405	232-641-1	HEADBOARD	1	1
6412101	2	L.H. BERTH	1	1
6412102	3	R.H. BERTH	1	1
6412501	4	WARDROBE	1	1
6412801	5	SETTEE	2	2
6412603	6	COFFEE TABLE	1	1
6412605	7	CORNER TABLE	1	1
6412704	8	BUREAU	1	1

PREP. BY: T	DATE: 5/16/85	PAGE 1 OF 2
-------------	---------------	-------------

FIGURE 2.53 Deckhouse zone information for furniture installation.

2.9 Material Requirements

The material requirements for zone **construction and engineering for ship production** have been briefly discussed already in Section 2.3, where it was shown that material needed to be defined, procured, and received earlier than is traditional. In Sections 2.7 and 2.8, material definition tasks were included in the description of the tasks to be accomplished in the different phases of engineering. Figure 2.54 summarizes the material definition approach for **engineering for ship production**. It shows how the major equipment is defined by purchase technical specification (PTS) during contract design, and the majority of raw material is defined by advanced material order per system during functional design. During transitional design, all material remaining to be defined is identified. Also, through the “Product/Stage Chart” approach, the preparation of the zone/unit lists is started. The sorting function, shown in Figure 2.54 under “Work Station/Zone Information,” corresponds to the “Product/Stage Chart” approach to work station parts list preparation.

A major requirement to ensure success of any material definition system is a detailed preparation and issue schedule which is compatible with the material ordering and material receipt requirements to construct the ship to plan. This integration of schedules must be a dynamic system changing as circumstances change, and not a once-prepared schedule that is attempted to be held to, even when it makes no sense.

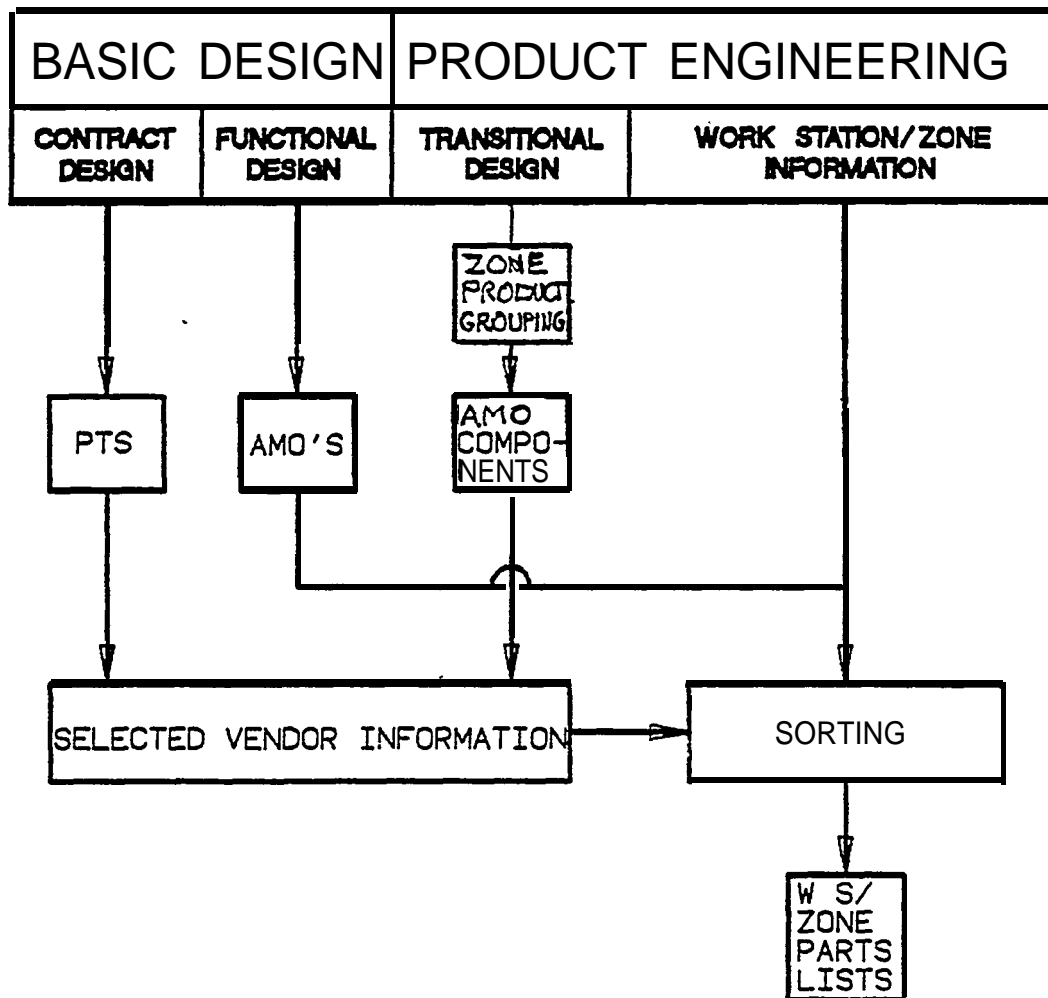

FIGURE 2.54 Summary of the material -definition approach for *engineering for ship production*.

2.10 Engineering Models

2.10.1 GENERAL. The use of models as design, display, and training aids has a long history. The early seventeenth century shipwrights constructed models (Admiralty Models) to obtain approval of their design, including the elaborate carvings, from the owner. Their use as an integrated part of the design and engineering process started about twenty-five years ago, and is well documented in a number of reports and articles [1,2,3,4]. This use was given added impetus by the developments in the plastics industry, and the production of accurate scale parts, structural shapes, pipe, and fittings, in plastic.

The obvious advantage of engineering models” (the name given to detailed accurate scale models used for design purposes) over any other design tool, other than full-scale mock-ups, is the true and easily viewed three-dimensional representation as shown in Figure 2.55.

Models have been used for the following ship design and construction purposes:

- Display (complete, partial, and breakdown), Figure 2.56
- Training
- Half-block plating model, Figure 2.57
- Anchor handling, Figure 2.58
- Advanced outfitting, Figure 2.59
- Launching
- Construction sequencing
- Structural module handling and erecting
- Interference control, Figure 2.60
- System design
- Material take-off
- Data base development
- Hydrodynamic testing
- structural testing
- Operation testing

Display and training models need not be accurate to scale, whereas for all the other uses accuracy is important. Engineering models have proved beneficial in design where there is a lack of good, experienced distributive system designers or ability of engineering managers to control the integration of design development in ships. A model can then act as a communications and conflict/problem-resolving tool.

One important requirement when utilizing engineering models is to construct them at the most beneficial stage of the design, engineering, and production cycle. Many times models to assist design and engineering are constructed too late to help them, and are not production-aid type, and end up being “show pieces” to impress the inexperienced visitors. It is also important that users be given some guidance in how to use engineering models. Many designers are so “impressed” with the overall impact of viewing a model that they do not see the detail problems that the models were to be used to eliminate. Another problem with engineering models is the carry-over of traditional design practices. For example, the age-old design practice not to prepare arrangement drawings for piping below 1.5-inch-diameter or to show small wireways is usually given as a requirement to the model builders. Also it is very seldom that pipe hangers will be modeled. This is unacceptable, and the “additional expense” of providing a “complete” model will be replaced many times by the elimination of production rework hours to change design to accommodate “field run” systems.

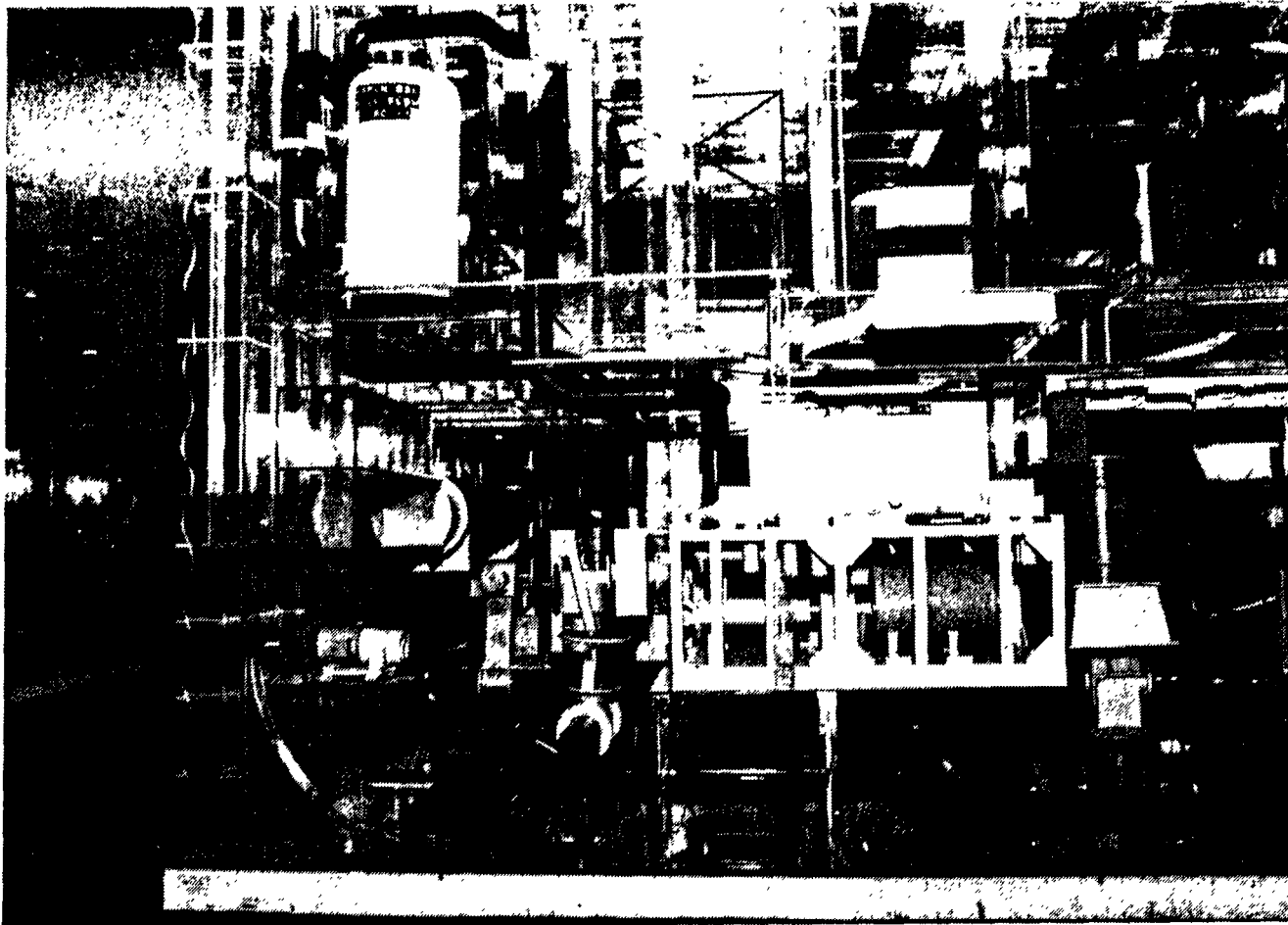

FIGURE 2.55 Machinery space model showing three-dimensional advantage.

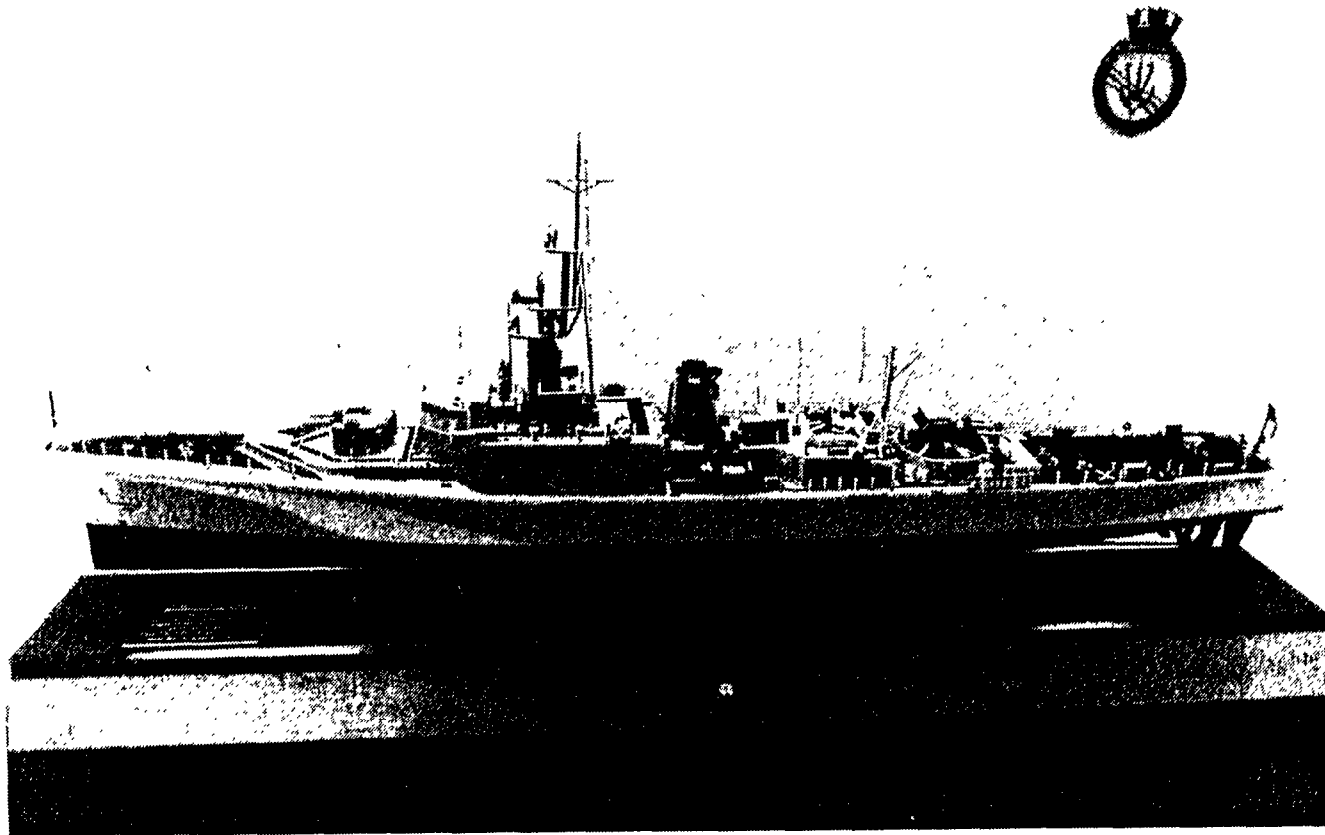

FIGURE 2.66 Display model.

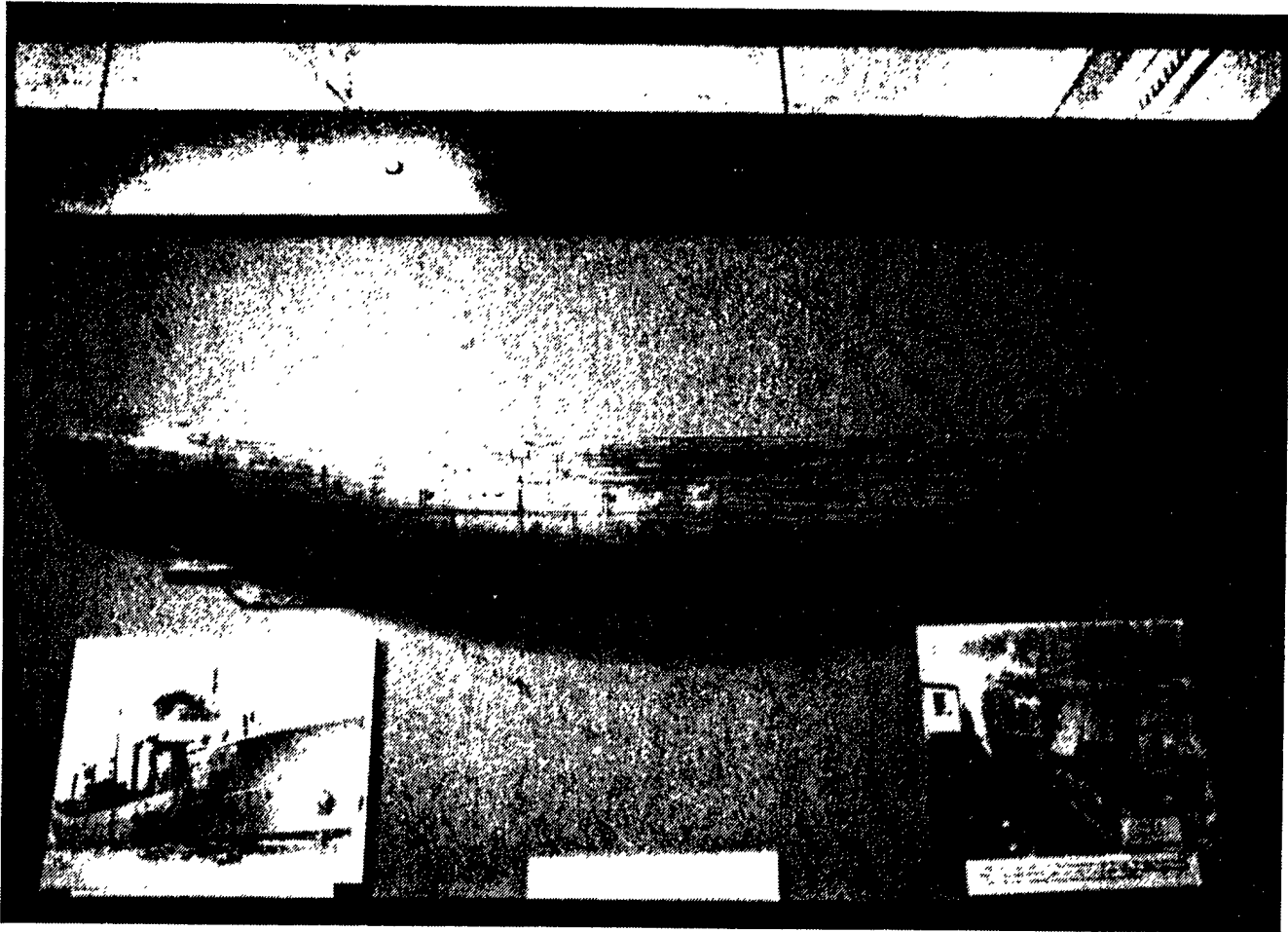

FIGURE 2.57 Plating half-block model.

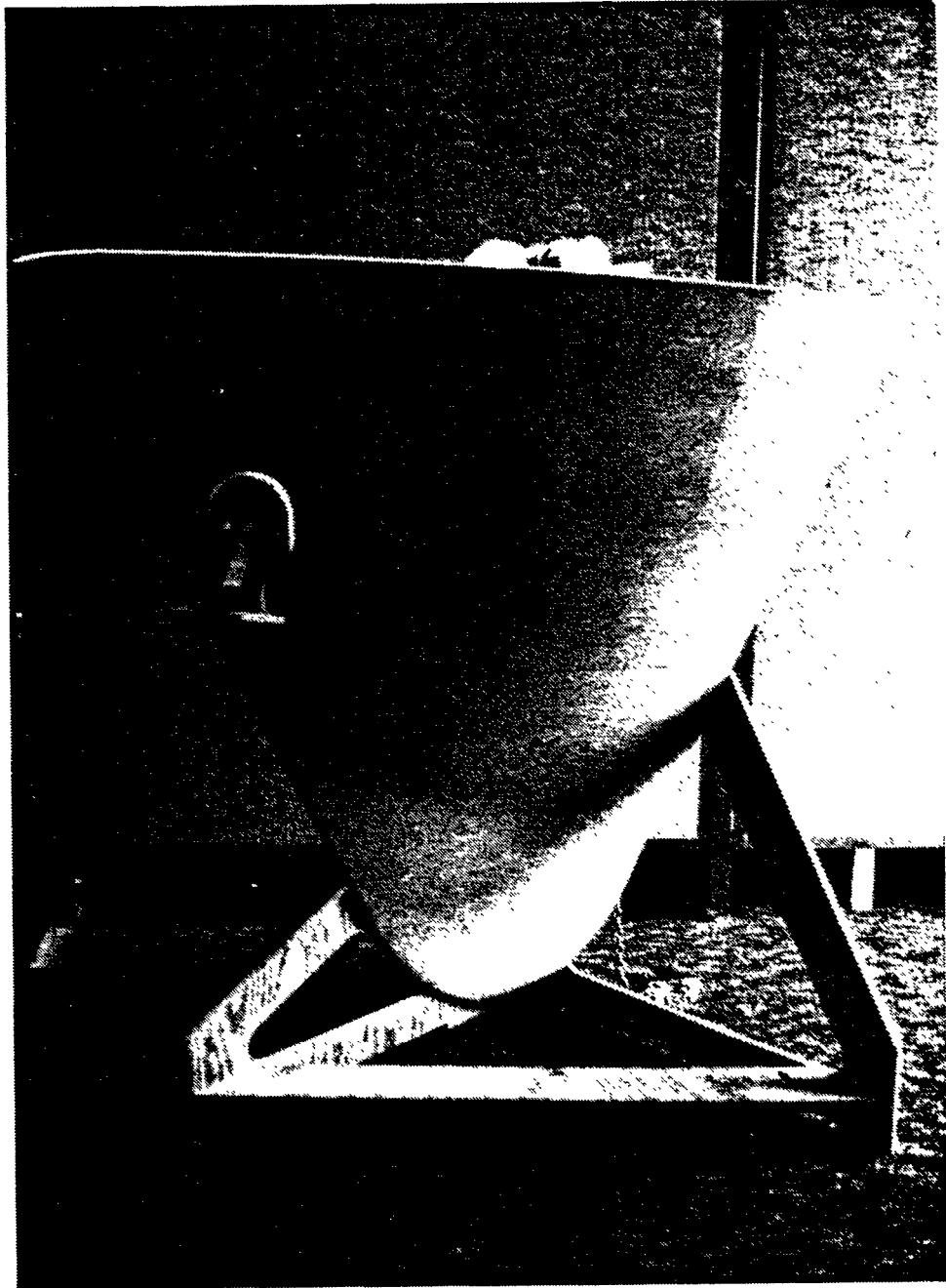

FIGURE 2.58 Anchor handling model.

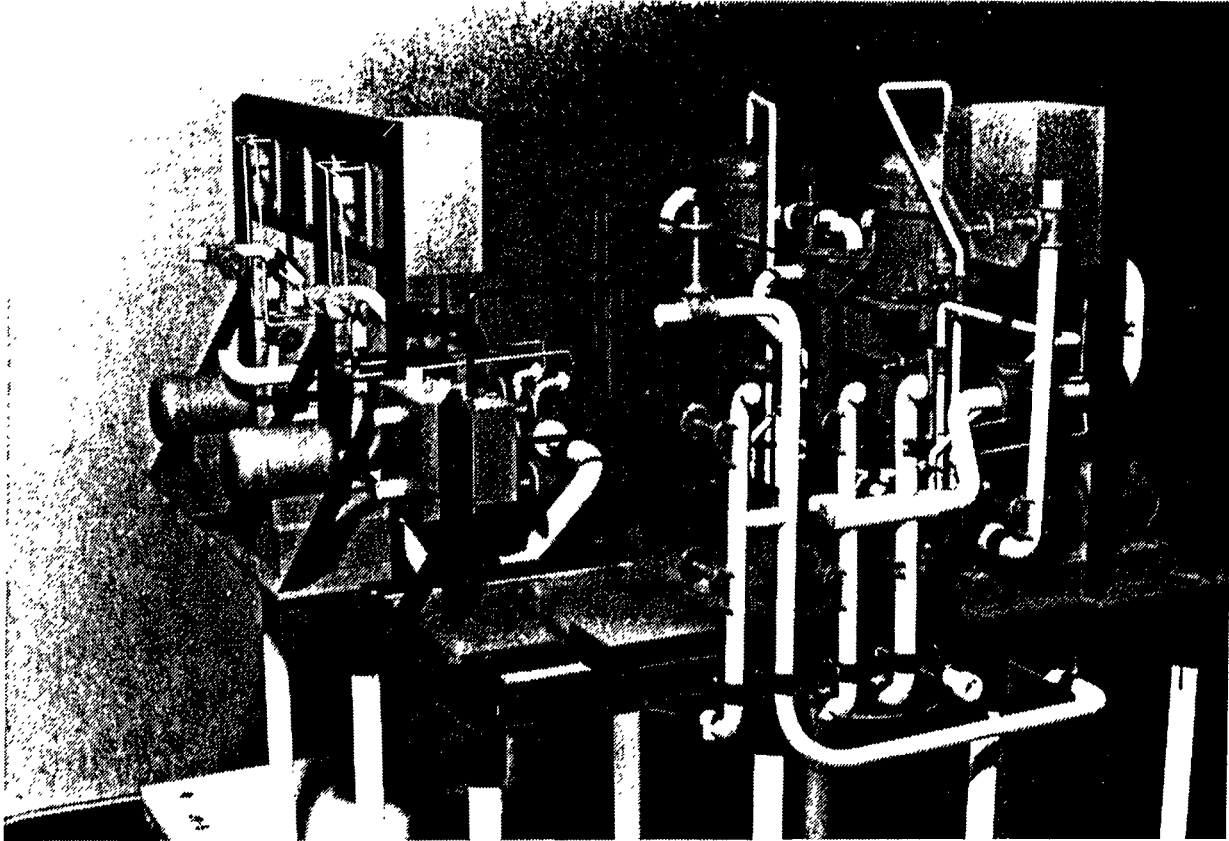

FIGURE 2.59 Advanced outfitting model.

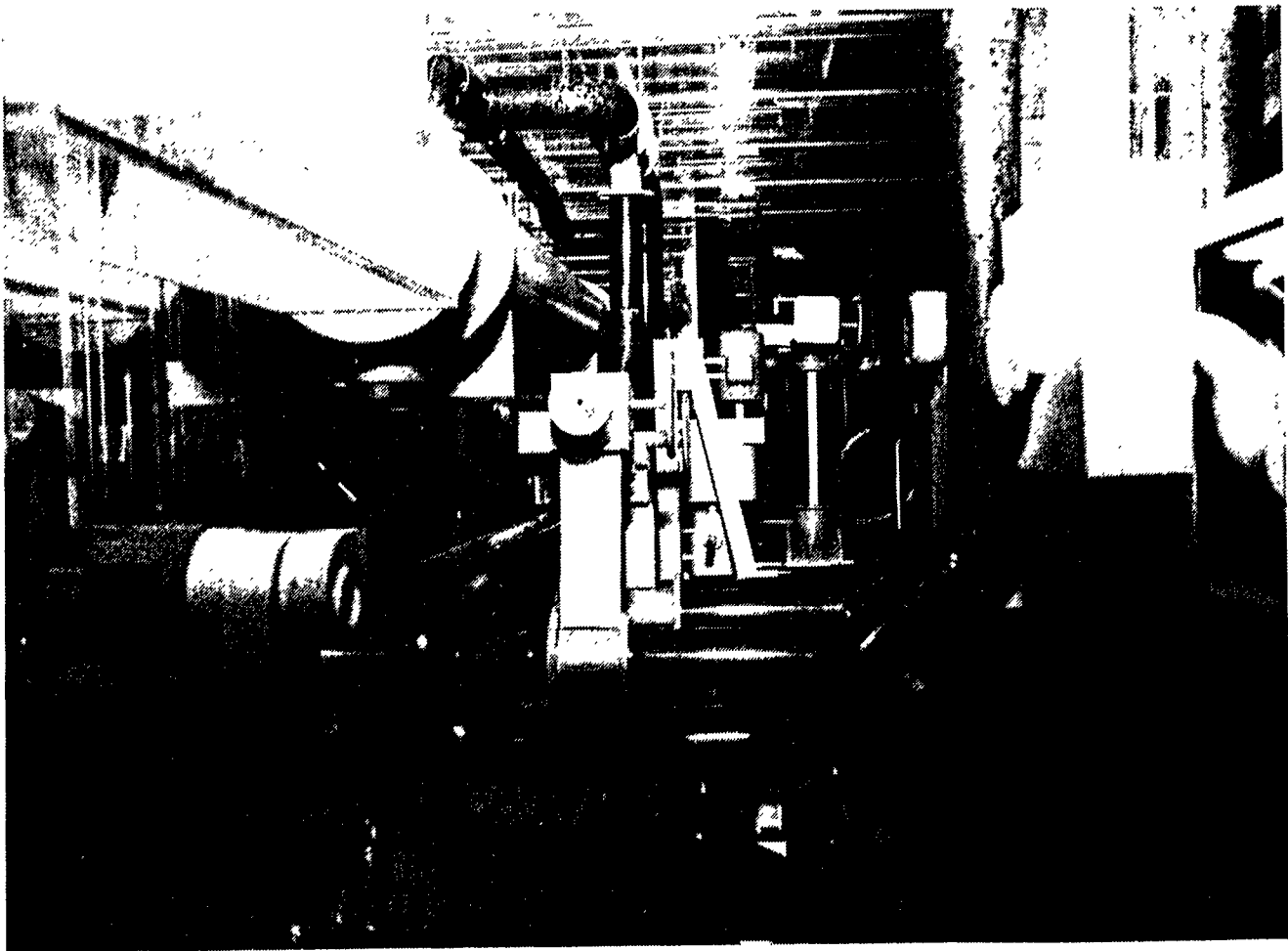

FIGURE 2.60 Interference control/checking by model.

If the **engineering-for-ship-production** approach is utilized, the benefit and need for engineering models diminishes, as both the system integration and engineering management problems are logically approached and reduced to workable size. If, in addition, computer-aided design (CAD) is used, the advantage of engineering models as design tools disappears. CAD solid modeling with 3D enables pictures of any design from any angle, and for any section to be readily available. However, many shipbuilders use engineering models often in a duplication role, and for that reason their application to the proposed **engineering-for-ship-production** approach will be discussed.

The areas concerned with herein are:

- System Design
- Material Take-Off
- Interference Control
- Data Base Development
- Advanced Outfitting Models

2.10.2 SYSTEM DESIGN MODELS. When a shipyard decides that models can be beneficially used to overcome the lack of arrangement by designers of distributive systems, they should be used completely. It is unsatisfactory to use them as a design tool for piping systems while preparing arrangement design on paper for electrical and HVAC. The model becomes the transitional design medium, and the product engineering should be prepared directly from it. This can be done by manually measuring and preparing the product engineering information, or photography [1], photogrammetry [2], and computer digitizing [3] can be used. The construction of the model must take into account the method to be used. For example, for photogrammetry, the model should be constructed in longitudinal vertical section—that is, sections between planes cut by buttock lines. It is probable that only certain “complicated” areas of the ship will be designed with the use of engineering models. Obvious areas are:

- Machinery Spaces
- Product Tanker Deck Piping
- Spaces such as Control Rooms, Communications Center, etc.
- Fan Rooms

It is also probable that the machinery-space section would make most use of engineering models. Hull and deckhouse sections would only use them in special cases. In the case of an engineering model for a machinery space which is to be advanced outfitted, the model should be constructed so that each unit is separate in order to control interference, and develop installation details and sequencing. When using engineering models for system design, the integration of the systems and their support structure must be given the proper consideration. Standard units should be used to build up the new arrangement design.

Depending on use of model, it may be beneficial to construct the structure of the intended assemblies and modules so that they can be used for advanced outfitting planning. If this is not done, module breaks and planned equipment access must be identified on the model structure so that the design is compatible with them.

When using a model for design, it is advantageous to indicate distributive system routing zones as blocked-out space, and to construct the detailed model of the zones separately from the main model as shown in Figure 2.61. When the detailed zone models are completed they are inserted into the main model. This gives a final check on interference with surrounding zone models. Obviously such a modeling approach offers the advantage of being used as a photographic sequencing tool to assist production in actually constructing the space that is modeled.

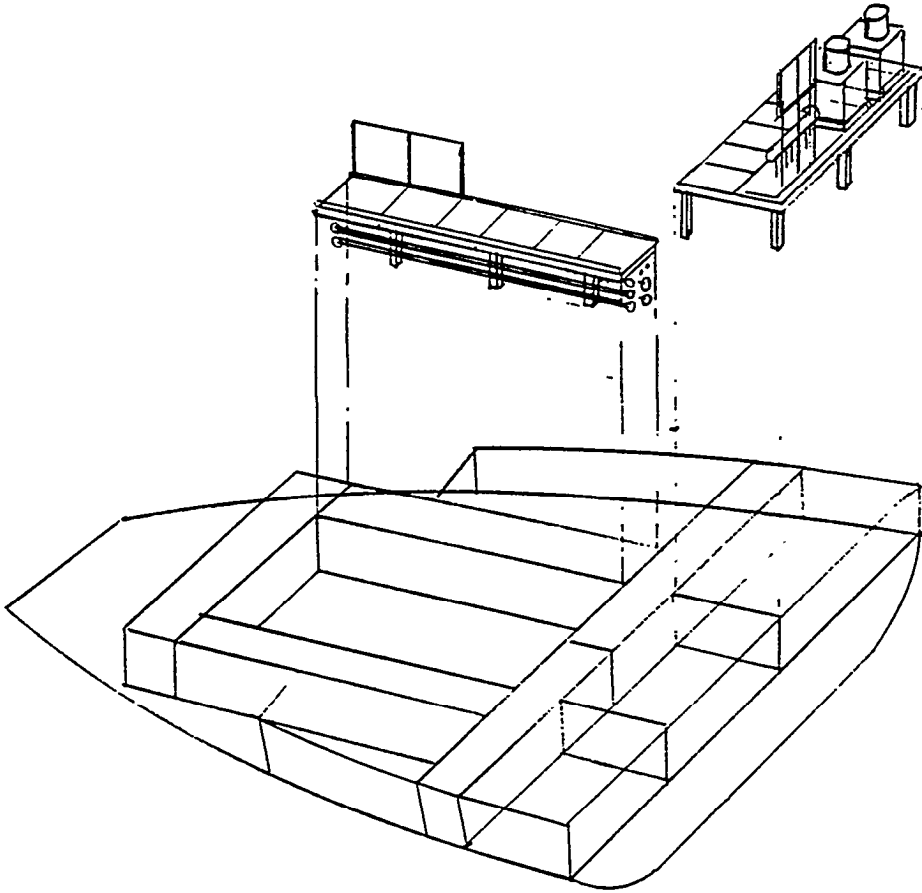

FIGURE 2.61 Advanced outfitting unit models used to build up space model.

2.10.3 MATERIAL TAKE-OFF MODELS. If an engineering model is constructed, the detailed material take-off can be made from it. Again, this can be achieved by manually measuring the model, and by analyzing dimensional photographs. When this is done, it is important to label material either on the model or in the photographs. An accurate listing of hangers and hanger support material is also possible if these are modeled. If computer digitizing is used for the distributive systems, then the material take-off will probably be provided by a computer software package along with the pipe assembly sketches, HVAC ducting sketches, and wire-way sketches.

Two other methods of obtaining detailed material lists are the Elomatic Oy Laser Scanner, which is shown in Figure 2.62, and the use of an electronic theodolite to measure angles from two known points, and a computer to prepare the data in the required format.

2.10.4 INTERFERENCE CONTROL MODELS. Models are useful for interference problems only if they are accurately constructed to a large scale, and include all systems no matter how small, as well as system support hangers. By using distributive system-routing zones, the problem of modeling the systems is substantially reduced. The design of system units, even if advanced outfitting is not used, also diminishes the interference problem. As the model would be used to design the systems rather than check them after they are designed on paper (traditional approach), the need for standard forms and procedures for reporting and resolving interference is eliminated. Again, the use of standard system units which are interference-free will diminish the overall interference problem for a new design.

2.10.5 DATA BASE DEVELOPMENT FROM MODELS. By using combined optical/computer measuring equipment, an engineering model can be the foundation for the technical information data base. The problem with this approach is deciding on the detail of the model, knowing it is going to be transferred for further development by computer-aided systems. The desire for a "cost-effective" approach may **result in** inadequate modeling and incomplete CAD. If a combined model/computer approach is to be used, it is suggested that the model be as complete as possible, and CAD only used to obtain manufacturing information such as pipe assembly sketches, sheet metal developments, NC information, etc.

2.10.6 ADVANCED OUTFITTING MODELS. Successful advanced outfitting depends on integrated planning, timely preparation of engineering data, and receipt of material and good installation sequence. Scale models for advanced outfitting planning are similar in look to design scale models, but are constructed differently and used differently. However, the modeling techniques and equipment are similar, and the same model builders can be utilized.

Advanced outfitting models are prepared for the structure in whatever stage of assembly that the advanced outfit items will be installed. For example, an erection block may consist of a double-bottom section, a transverse bulkhead, and the deck over. Advanced outfitting models of the double-bottom structure with and without the inner-bottom, and the bulkhead and deck on their own would be constructed. Advanced outfitting sequencing would then be developed for each assembly, as well as any installed after the outfitted assemblies are joined together to form the erection block. Models would only be constructed for assemblies and blocks with significant advanced outfitting requiring planned installation sequencing to develop optimum working position and access. Independent models would not be constructed to join together to form a complete or even partial ship model, although adjacent assembly and block models will be held together to ensure correct interfacing, and that there are no interferences of equipment and structure during the joining or erection of the assemblies.

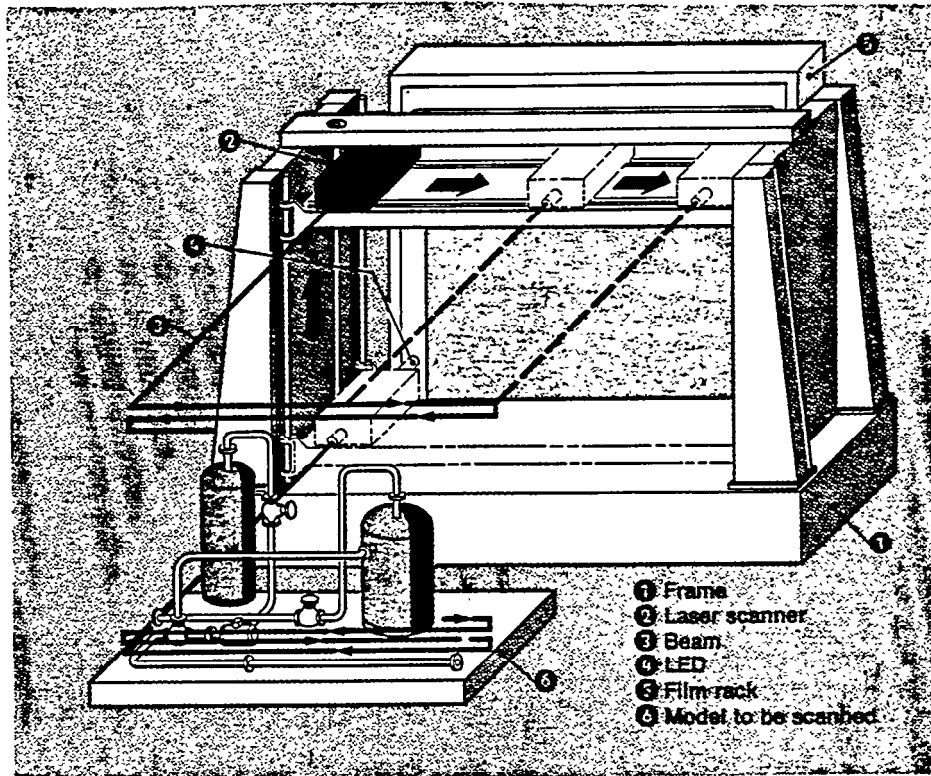

In the new laser measurement system, a model is placed in front of the "camera." A laser sends out a beam, 0.6 mm in diameter, and receives a reflected beam. The return signal is modulated to activate an LED situated just above the surface of a film. The laser moves horizontally back and forth along a support rail which drops approximately 0.3 mm after every horizontal scan. The result is an 850 by 500-mm picture.

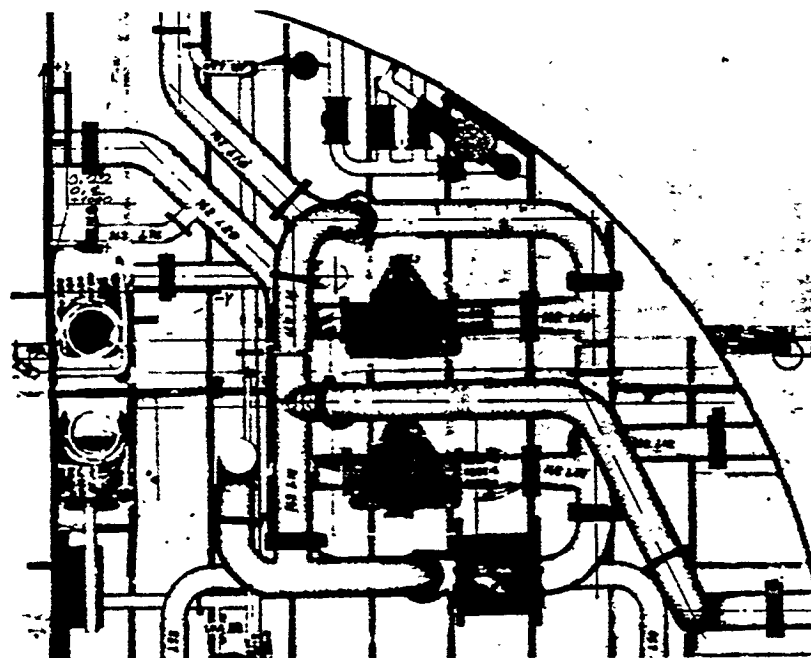

FIGURE 2.62 Elomatic Oy Laser Scanner for Models.

REFERENCES

1. *Use of scale models as a management tool.* National Shipbuilding Research Program, May 1974.
2. R.J. Bradford, *The T-ARC 7 machinery space scale model.* SNAME San Diego Section Meeting, 19 November 1980.
3. J. Ftohrer and G.L. Kraine, "A case study using models in the shipbuilding industry," *IREAPS Proceedings.*
4. *Design modeling.* National Shipbuilding Research Program, July 1984.

2.11 Computer-Aided Engineering

2.11.1 GENERAL. While the *engineering-for-shipproduction* approach could be performed without the use of computers, computer programs and systems, it is improbable that it would be so today. Most shipyards use computers for some design calculations, and for computer-aided lofting/preparation of numerical control tapes or for plate burning. To better understand the current use of computer application in ship design and construction, it is worthwhile to briefly review the history of computers in shipbuilding, and to examine their current applications.

2.11.2 HISTORY. Computers were introduced to many shipyards as accounting tools in the early 1950s. By the mid-50s many shipyards in a number of countries had adapted them to prepare the necessary but mundane calculations for hydrostatics, stability curves, and capacities. In 1959 a group of Scottish shipbuilders formed the Clyde Shipbuilders Computer Group. Each member shipyard agreed to commit one engineer each year to join a team to develop computer applications for shipbuilding. This group was taken over by the BSRA in 1964 as their Clyde area computer center. Another event about that time that is significant was the installation of a numerical-controlled (N/C) burning machine constructed by British Oxygen Company, utilizing a Ferranti Controller, in a U.K. shipyard. About that time a study was performed by Todd Shipbuilding Corporation, at their Seattle yard for the U.S. Navy, on the application of N/C for plate burning.

Meanwhile, a number of countries had developed suites of ship design programs, some of which are identified in Figure 2.63, which gives an overview of the history of CAD/CAM in shipbuilding. By the mid-60s, a number of shipyards had installed NC burning machines, but the preparation of the NC data was primitive, with every machine command having to be manually programmed using the basic machine control language.

A number of U.S. shipyards installed N/C-burning machines in the mid to late 60s, including Puget Sound Naval Shipyard, Bethlehem Steel Shipyard, General Dynamics, Quincy, and Avondale Shipyards. About this time a number of countries began to develop better ways to prepare the N/C data through computer-aided lofting (CAL). Again, these are included in Figure 2.63. All of these systems took the traditionally prepared structural drawings, and simply replaced normal manual lofting by CAL. In fact, the most successful of the early systems actually duplicated the loftsmen's existing craft rather than utilize computers in the best way to prepare the required data. In this way the loftsmen were able to make the transfer from loft floor or table to computer input forms and automatic drawing machines without too much trouble. Both Boeing and McDonnell Douglas aircraft companies had developed CAL systems for their own use, and when U.S. shipyards showed a need for this capability they both offered their services.

Two computer systems developed in this time frame stand out from the others because of their different approach. One is CASDOS [2], and the other is FOBAN. What made these systems different is that they were *not* computer-aided lofting systems, but computer-aided design systems. CASDOS, the U.S. Navy's Computer Aided Structural Detailing of Ships, was developed from 1965 to 1969. The second system [3] was developed in Spain by SENERMAR, who are marine consultants. Their intent from the start was to provide a computer-aided design, and provide the working drawings required to construct the ship. Later FOBAN was extended forward into CAL and CAM [4]. Most

YEAR	COMPUTER	I A C G	N / C	C A D	C A L	C A M
1801			Jacquard Automated Loom using punched cards			
1830	Babbage Analytical Engine					
1930	Bush builds first analog machine					
1943	COLOSSUS I - first digital computer built to prepare WWII navigation tables					
1946	U. of Pennsy. builds ENIAC					
1951	UNIVAC I 1st Generation					
1952			Parson & MIT develop 3 axis NC using punched cards			
1954			Introduction of NC machine tools in U.S.			Introduction of A/CIT
1959			BOC installs 1st NC flame burner in U.K. shipyard	Various shipyards & research groups develop design calculation programs		EWLE Planning system developed for BOC
1961	Development of 2nd Generation computers. Transistors replace vacuum tubes. Computing power increased by 10.					ESSI developed in Norway
1963		Sutherland develops SKETCHPAD				IBM completes MAPT System
1964		CDC introduce DIGIGRAPHIC CN announce their IACG developments				
1965	Development of 3rd Generation computers using miniature integrated circuits. Computing power increased by 100	IBM ALPINE System with 2250 scope for CN switch Lockheed Georgia develop NC parts programming IACG	NC flame burners installed in: Port Weller Puget Sound NS Bath, Steel		AUTOKON introduced. International shipyards	
1966		Lockheed decides to develop its own IACG System			STEREBEAR completed MIZAC completed	
1967			NC frame bender installed in UK shipyard		VIKING completed	
1968				CASDOS completed	ASTER completed BRITSHIP completed	
1969	Minicomputers developed	COMPUTERVISION offers IACG System	NC flame burner installed at Avondale	FORAN Completed	AUTOKON available in U.S.	
1972		Lockheed GA develops COGAP for NAVSEC			AUTOKON 71 available in U.S. Newport News license AUTOKON	
1973		CADAM marketed by IBM	LSCG installs NC Burning Mach.		MarAd purchase AUTOKON for U.S.	
1977			STW installs ENG Burning Mach.	LSCG license SPADES		
1978		CADAM installed at Avondale			AUTOKON 79 utilizing IACG for part generation and nesting offered to U.S. licensees	
1979	Microcomputers developed				CADAM and SPADES interface completed at Avondale	
1981		CADAM installed at MASSCO			BRITSHIP 2 implemented in UK shipyard using CADAM as IACG system	
1982		CADAM installed at Newport News LSCG, Peterson & J. J. Henry			MEDUSA and SPADES interface completed at Tacoma Ship FORAN 10 offered to world wide shipyards.	
1983		COMPUTERVISION selected by USN				

FIGURE 2.63 History of CAD/CAM in shipbuilding.

of the early CAL systems were gradually extended back into CAD so that structural drawings could be prepared through them as well as scientific design programs such as:

- Hydrostatics
- Stability Curves
- Subdivision
- Damage Stability
- Longitudinal Strength
- Launching
- Capacities
- New Hull Form Development

This is shown in Figure 2.64, which attempts to show the phased development of each system.

The changes in the application of CAD/CAM in shipbuilding were driven by the advances in computer technology and hardware, and not by declared need by the shipbuilders. The early application of CAD and CAL used batch input data sheets, and received the processed data back as batch-printed computer listings. The man/computer interaction was improved through the development of the cathode ray tube (CRT) and mini-computers. Most CAD systems use terminals with mini-computers, and CRTs for input and interactive control of the system. Many CAL systems in shipyards still use batch processing with cards or magnetic tape for input.

The CAM side of the systems has also improved with the same development of computer technology. Only a few U.S. shipyards with N/C-burning capability utilize DNC. Paper tape is still very much a part of the daily operating system.

The aircraft industry was an innovator and a proponent of Interactive Computer Graphic systems along with General Motors, who started working on a system in 1959, but kept its work secret until announced at a conference in 1964. Two aircraft companies developed their own systems through the late 1950s, namely McAUTO by McDonnell Douglas and CADAM by Lockheed. Other systems were developed by software groups such as CALMA, COMPUTERVISION, AUTOTROL, MEDUSA, and others. Reference [7] is an excellent introduction to IACG, and *its* early applications in the marine industry. Table 2.14 shows the current U.S. shipyard IACG system situation. It should be noted that these IACG systems are general purpose, and do not offer a complete shipbuilding system. There are only a few systems which come anywhere near that description, and some of these are: FORAN, BRITSHIP 2, AUTOKON, and STEERREAR.

The development of CAD in the area of outfit and distributive systems has been sporadic and stand-alone rather than a logical continuation of existing structural systems. There is no good system routing and interference control or avoidance package available, although most LACG CAD/CAM systems can be used to provide interference control.

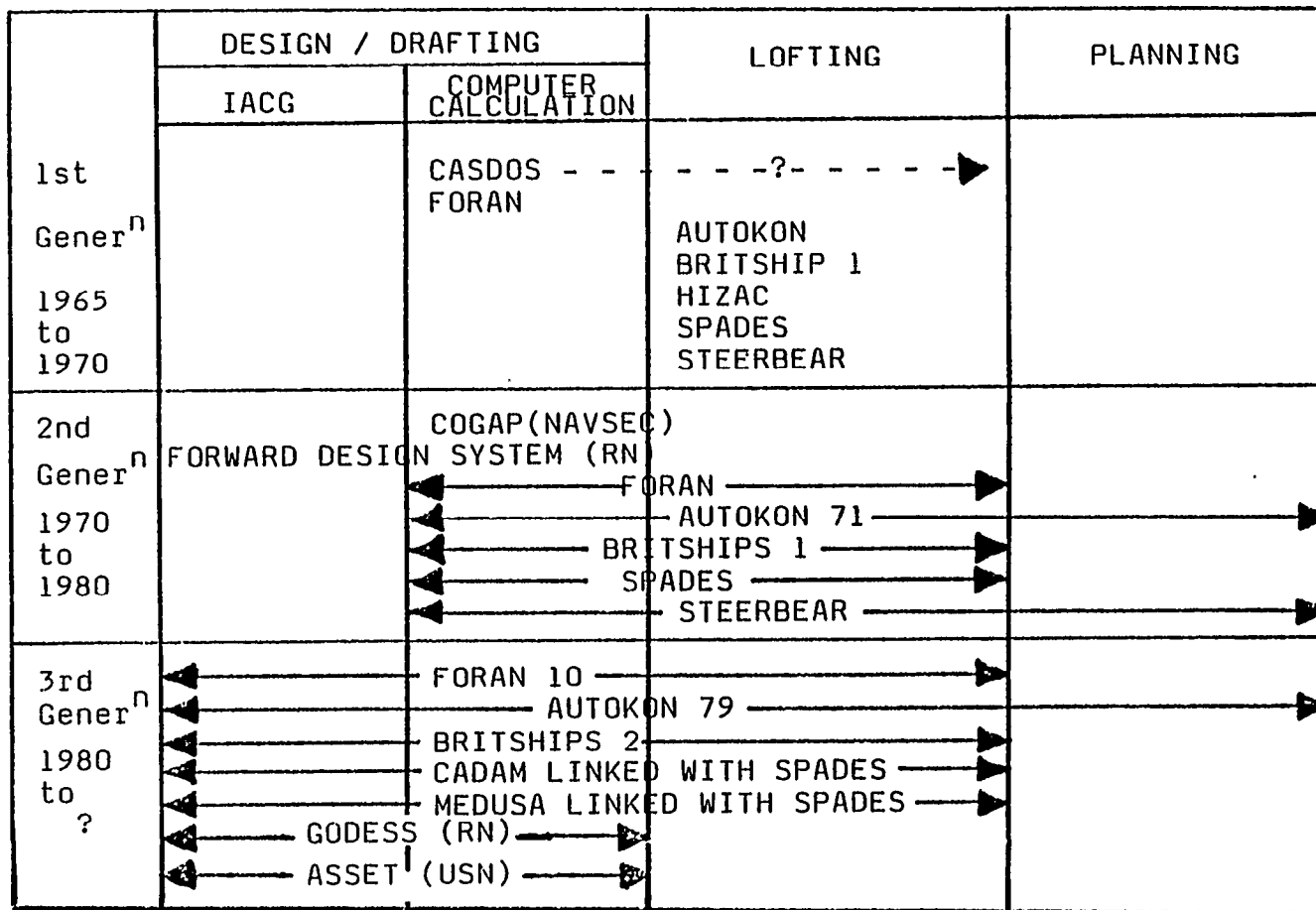

FIGURE 2.64 Shipbuilding CAD/CAM system development.

TABLE 2.14

U.S. SHIPYARD IACG SYSTEM INSTALLATIONS

System	Shipyards
COMPUTERVISION	NAVSEC Puget Sound Naval Shipyard J. J. McMullen (consultants)
CADAM	Avondale Shipyards, Inc. NASSCO Newport News Shipbuilding Lockheed Shipbuilding & Construction Co. Peterson Builders, Inc. J.J. Henry (consultants)
AUTO-TROL	Ingalls Shipbuilding Corporation
CALMA	Ingalls Shipbuilding Corporation
MEDUSA	Tacoma Boatbuilding Company
Self Developed	McDermott Shipyard, Inc.

2.11.3 CURRENT APPLICATIONS. CAD applications in shipyards include:

- Design calculations
- Drawing preparation
- Preparation of material lists
- Preparation of lofting data
- Preparation of pipe manufacturing data

CAM applications include:

- N/C burning
- N/C frame bending
- N/C pipe cutting and bending
- N/C sheet metal cutting

There are many shipyards in the U.S. now using N/C-burning machines, one with an N/C frame bender, and one with N/C sheet metal cutting. Most shipyards use computers for some design calculations, planning/control systems, and production data processing. Most of the original shipyard CAD/CAM systems have been modified to utilize IACG. This allows the engineer to interact with the computer to create, view, and analyze his design as it is displayed on the system selector box or panel, and a menu on the CRT. Figure 2.65 shows these items schematically. It is interesting that most of the developers of the original systems developed their own IACG software for their systems. However, BSRA did not [8,9]. Instead they selected an existing IACG system, and interfaced it with

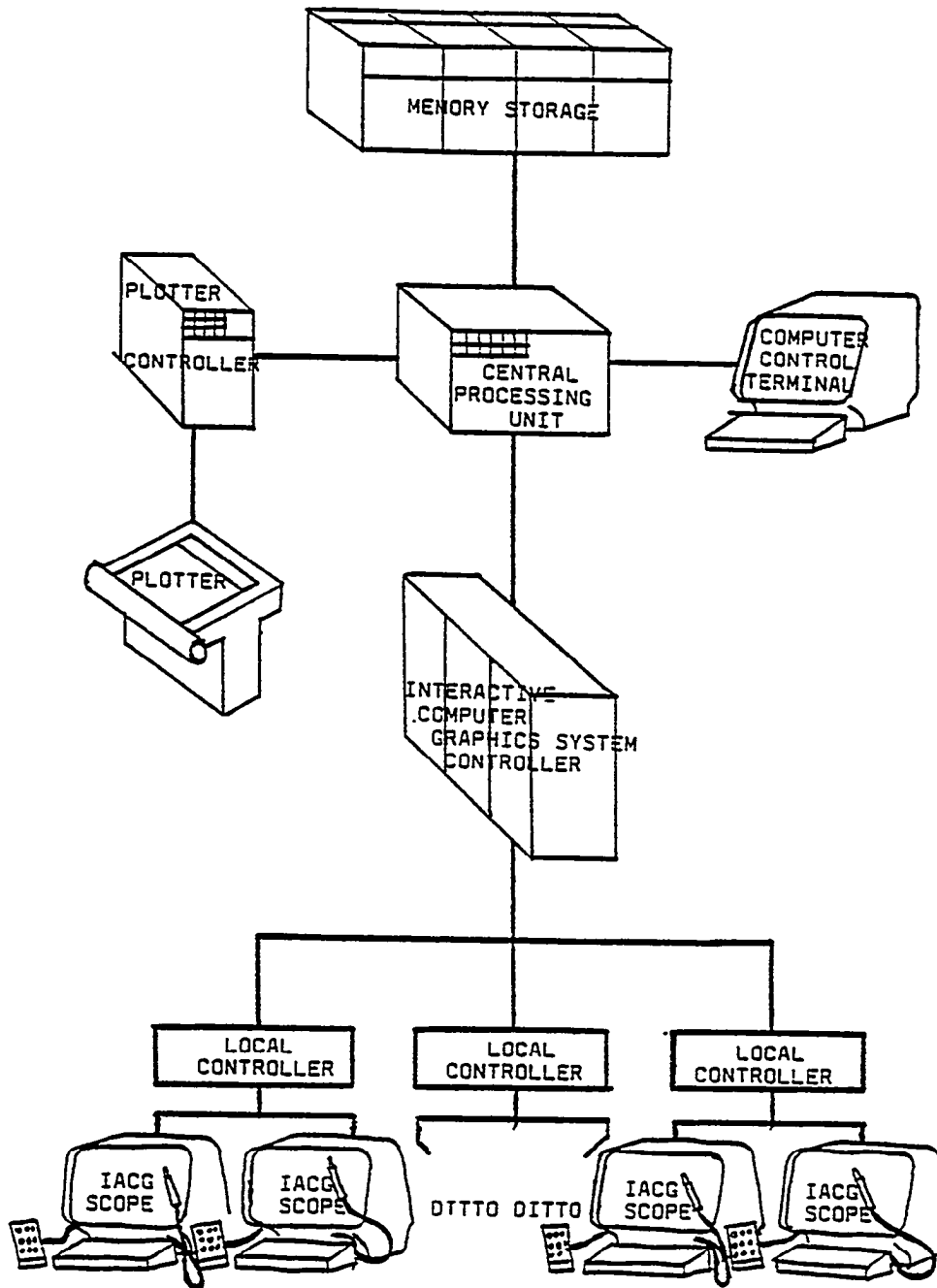

FIGURE 2.65 IACG schematic.

their unique shipbuilding system. They initially selected CADAM, and the currently available BRITSHIP 2 system uses CADAM. However, at the request of other British shipbuilders, they have adapted their system with COMPUTERVISION as the IACG module. Figures 2.66 and 2.67 show the BRITSHIP 2 system. Figure 2.68 shows similar data for AUTOKON 79.

Experience has shown that when any new system is available to an ongoing organization, the first phase of its use is simply to do the same thing they have been doing for some time, and with which everyone is comfortable. It usually still has benefits such as improved accuracy and shorter preparation time. Sometimes it is the only option to accomplish the work, as the availability of trained personnel for the old way is low. This has been true in many cases where shipyards lacking good loftsmen subcontracted the effort to CAL service companies. The danger of this approach is that the full potential of the new system is not utilized. The more enlightened approach is to step back away from existing details and to seek basic requirements, and to see how the new system can provide these. This approach makes it essential to have an implementation plan developed, detailing how the system will be used, before the system is made available. This should eliminate the danger of perpetuating traditional manual techniques and procedures.

This is especially true for CAD/CAM, and if it is used to design the product and prepare the detailed working drawings in the same way as before the introduction of CAD/CAM, then it is certain that the new system is *not* being fully utilized. When considering the application of CAB/CAM, the question must be asked whether the traditional drawings are needed. What is required to construct any product is:

- Manufacturing data in the most accurate and clearest form to enable the product to be produced.
- To deliver the information and the material in the shortest possible time for the minimum of input resources.

It is worthwhile to consider the purpose of traditional ship engineering drawings. They are used as part of the contract (*contract drawings*). They are used to develop the design (*design arrangements, scantling drawings, and system diagrammatics*). They are used to give details of construction (*structural, outfit, machinery arrangement, piping, HVAC*), and *electrical working drawings*, and finally, they are used to assist the owner and the crew in operating the ship (*ship's information booklet, machinery and equipment operating manuals, capacity plan, operating schematics, and guidance drawings for posting onboard the ship*), and to maintain, convert, and repair the ship when necessary (*copies of all design and working drawings filed onboard the ship and in the owner's main office*).

The owner also requires information to manage its use of, and to assist the crew in operating the ship, as well as to maintain, convert, and repair the ship. The designers must elaborate on the contract design, and pass on information to the developers on the details of construction, who in turn must pass on their information to the production workers. Again, the most efficient and effective way to accomplish this is by visual information, although written instructions are also necessary.

Traditionally, the production department uses the working drawings to lay off, lay out, process, assemble, and install material and equipment necessary to construct the ship. In most shipyards the information given in the traditional engineering drawings is insufficient, and additional manufacturing details and data have to be provided. This is usually done by the loft as they prepare the structural processing sheets, piping detailers

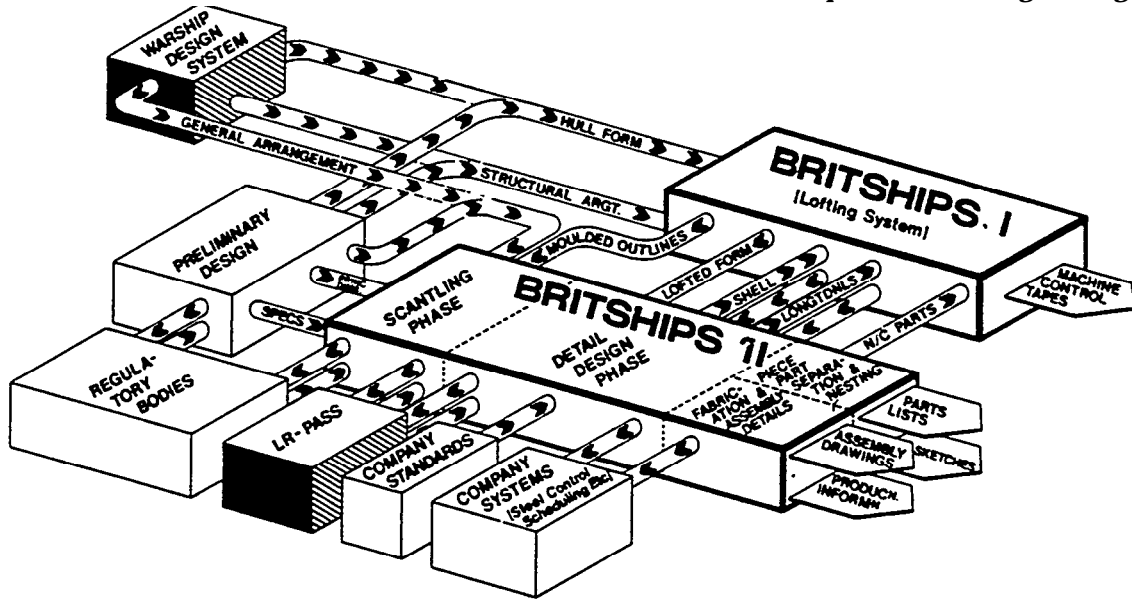

FIGURE 2.66 BRITSHIP @ module organization.

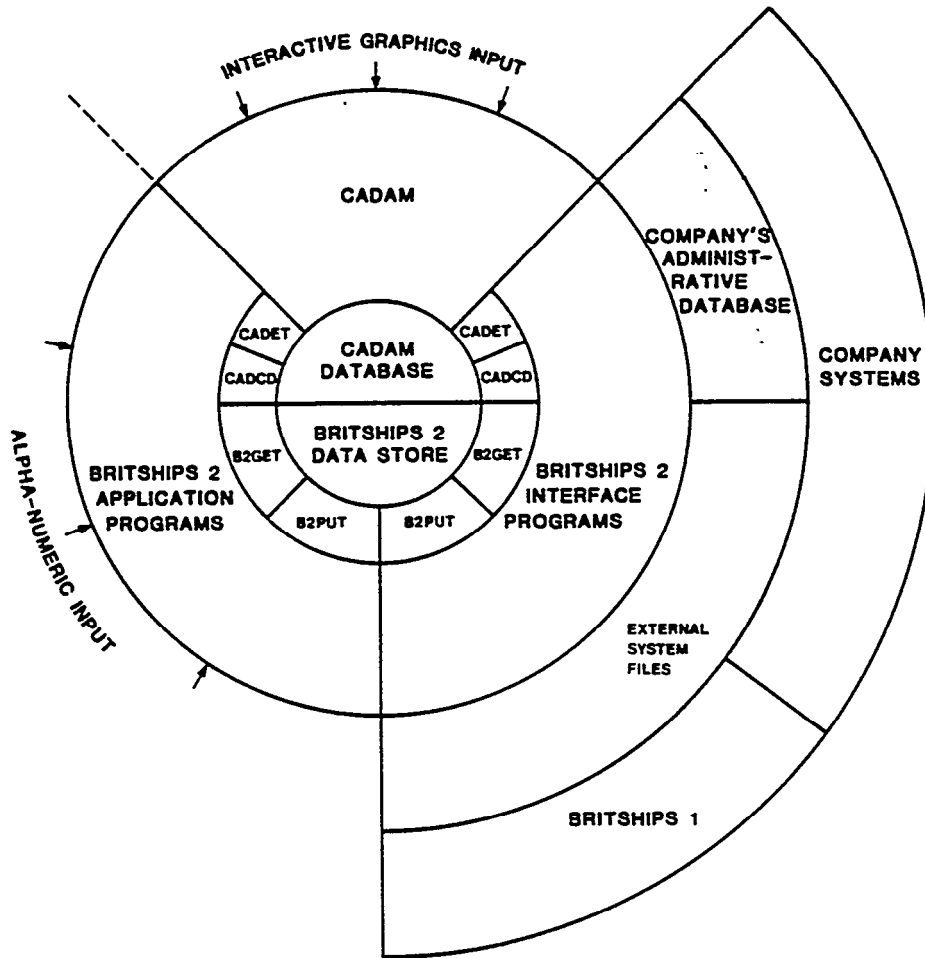

FIGURE 2.67 BRITSHIP 2/CADAM interface.

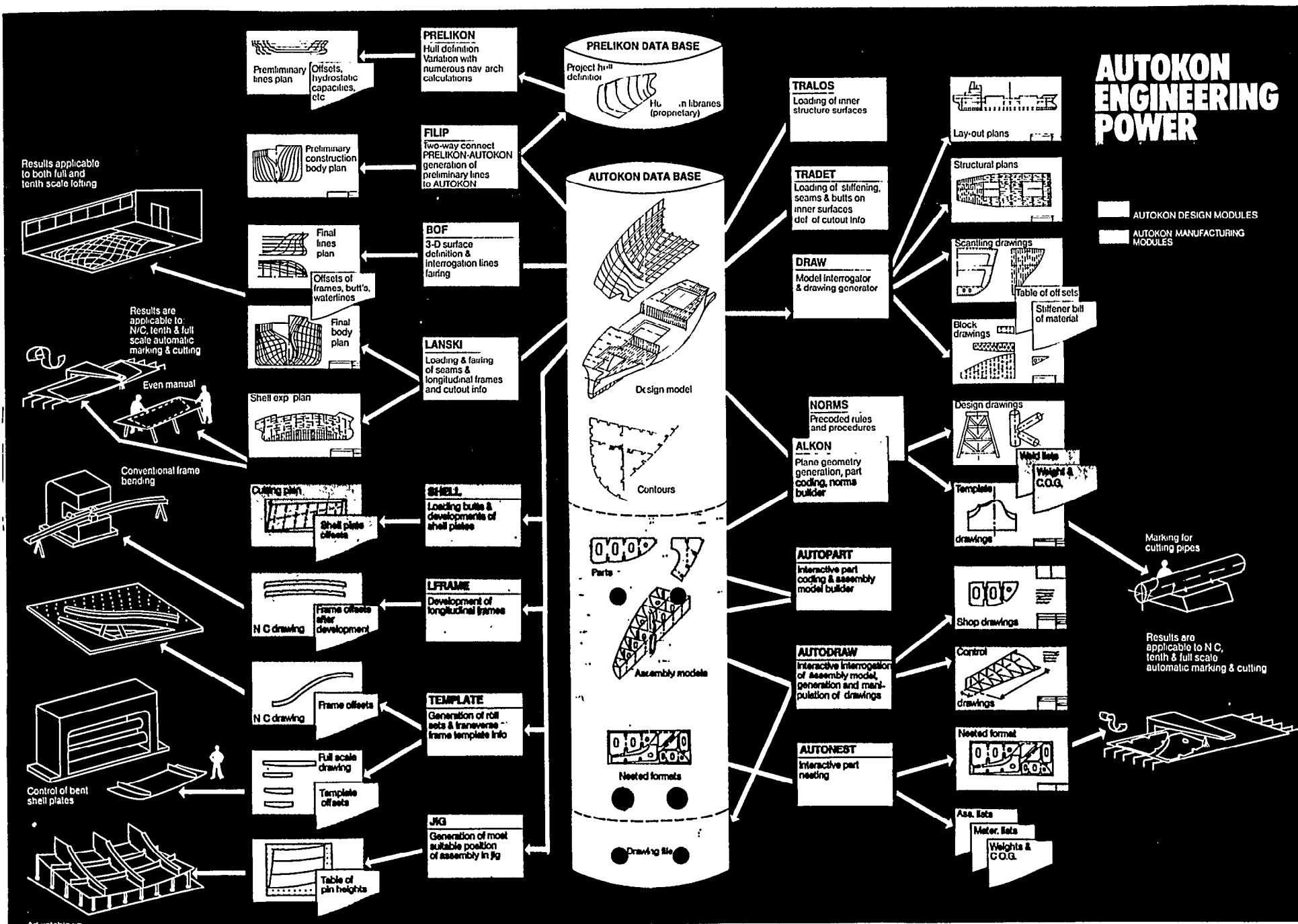

FIGURE 2.68 AUTOKON 79 system.

as they prepare pipe assembly sketches, layout and template makers as they develop sheet metal patterns, and planning as they prepare work packages including additional sketches, as well as written instructions to detail how the work will be sequenced and accomplished. This situation has developed over many decades, and it is difficult to change. However, change it must, if shipyards are to take full advantage of CAD/CAM to improve productivity, and thus their competitive position. The owner needs data that describe the ship in sufficient detail for contractual purposes. While certain characteristics can adequately be stated by words, the layout, arrangement, and overall aesthetics can most efficiently and effectively be stated by visual depiction.

With this knowledge plus an understanding of the capabilities of CAD/CAM systems, it is possible to set up today, with currently available systems, a procedure that would accomplish all the requirements which will be more efficient and effective than any other approach, for a given shipyard. To do this, it is necessary to develop a number of approaches which will accomplish the requirements, and to analyze each approach for its efficiency, effectivity, and lift-cycle cost. The extreme cases could be the existing basic traditional system as described above, and the other is one where no printed drawings are prepared. All the data are stored in a common data base that would contain all the information required at the various stages of contract, design, production, and operation of the ship. This extreme is possible today, but it is questionable if it would be accepted, as it is so far a departure from the existing situation. It is also uncertain if it would be cost effective at this time. It will therefore be discussed more in Section 2.11.5.

The future approach would necessitate a better integration of design, engineering, and production than is presently existing in most U.S. shipyards. A number of developers are calling this approach computer-aided engineering (CAE) to differentiate it from current CAD/CAM applications. A few others have named it integrated CAD/CAM. This is a better designation, as it clearly states what it covers. The future extreme could be called the paper-less approach, but it is preferred *to call* it the advanced *integrated CAD/CAM* approach. The first extreme will be named the traditional CAD/CAM approach. These extremes are pictorially presented in Figures 2.69 and 2.70.

Many U.S. shipyards without a CAD/CAM capability are preparing the information manually in an advanced format and eliminating unnecessary traditional detailed system drawings [10]. Unfortunately, some U.S. shipyards utilizing CAD/CAM are perpetuating the traditional approach by using the new *system* to prepare the usual traditional detailed system drawings. The other shipyards with CAD/CAM capability are operating somewhere in between the two extremes, but unfortunately closer to the traditional approach. This is because of the situation described at the beginning of this section, wherein the new system is used in the same way as before it was introduced.

Successful operation of CAD systems utilizing IACG demands that an entirely new approach be taken. *We are no longer preparing drawings, we are building the prototype in the computer.* Drawings may or may not be required, and if they are they can be an automatic fallout from the system. This is the most important fact to realize. If it is not accepted and followed in practice, the full benefit from today's best CAD/CAM systems will not be achieved. In using CAD/CAM systems we are no longer driven by a drawing schedule, but rather to build up a complete detailed data base which can provide the information necessary to develop and check the design, and to purchase and process material, and construct the ship within the desired time table. This approach necessitates a number of departures from existing CAD and CAL systems. For example, all data during design must be entered in a common three-dimensional coordinate system. Also, actual thickness of material must be entered. The traditional practice of using molded lines, and the thickness related to that, is no longer acceptable. Figure 2.71 shows how

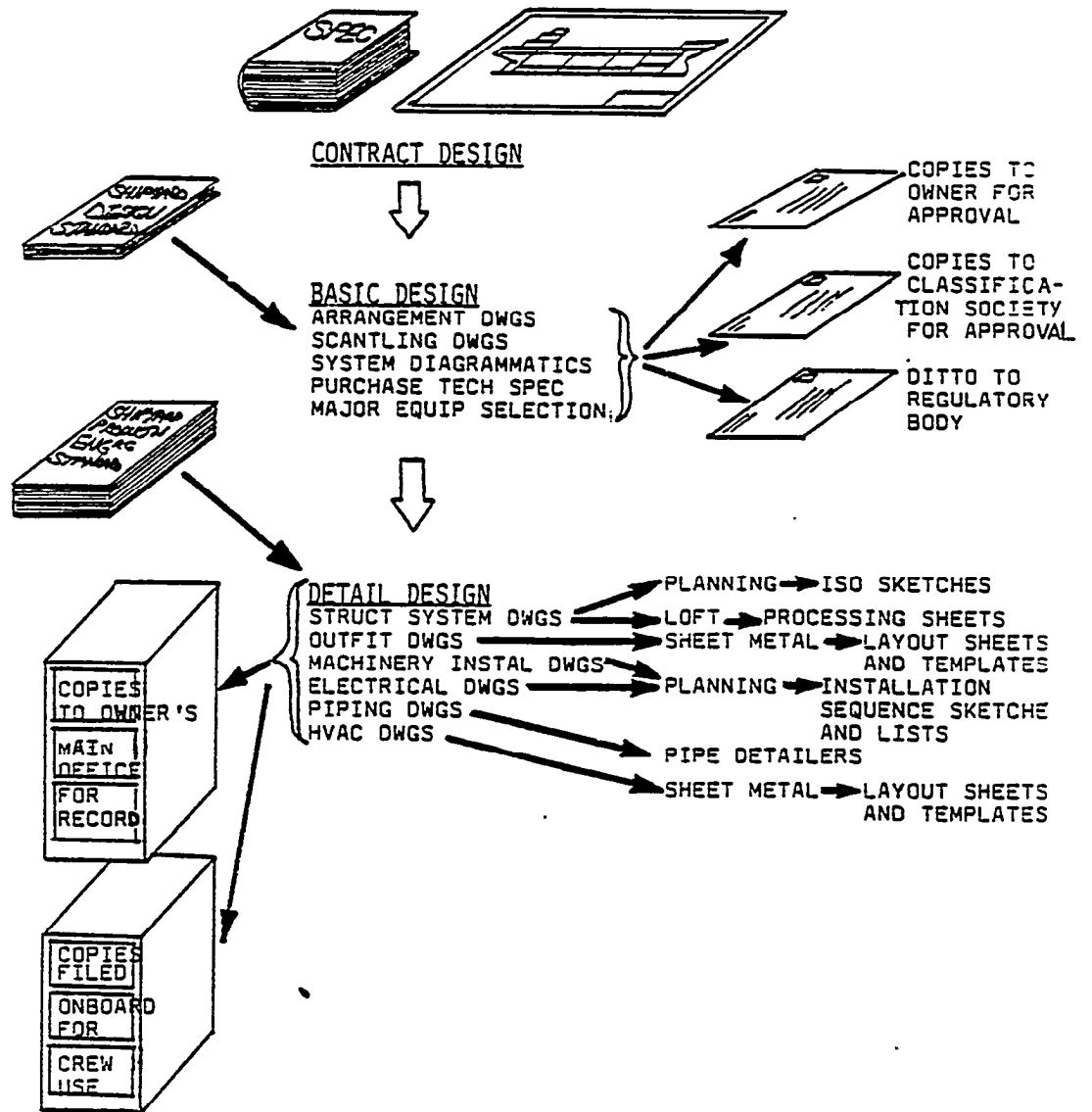

FIGURE 2.69 Traditional manual approach.

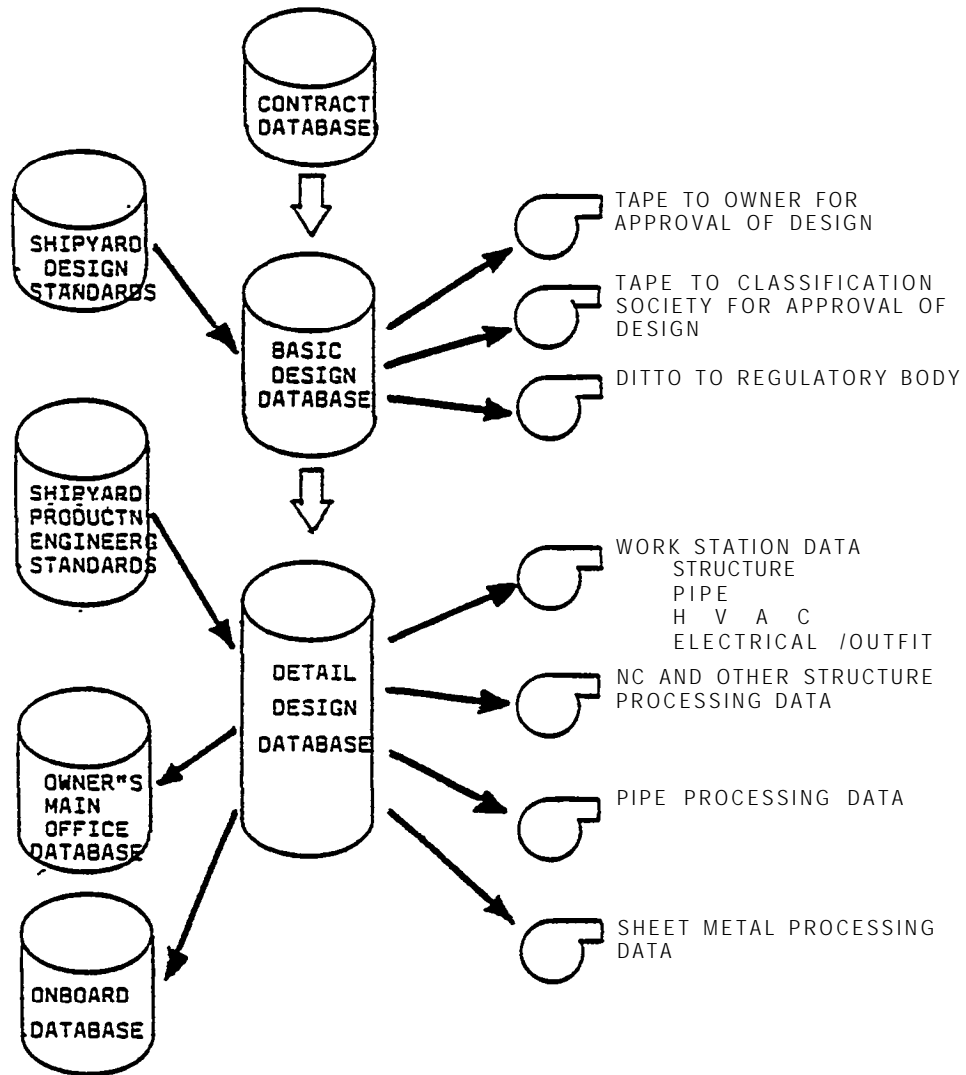
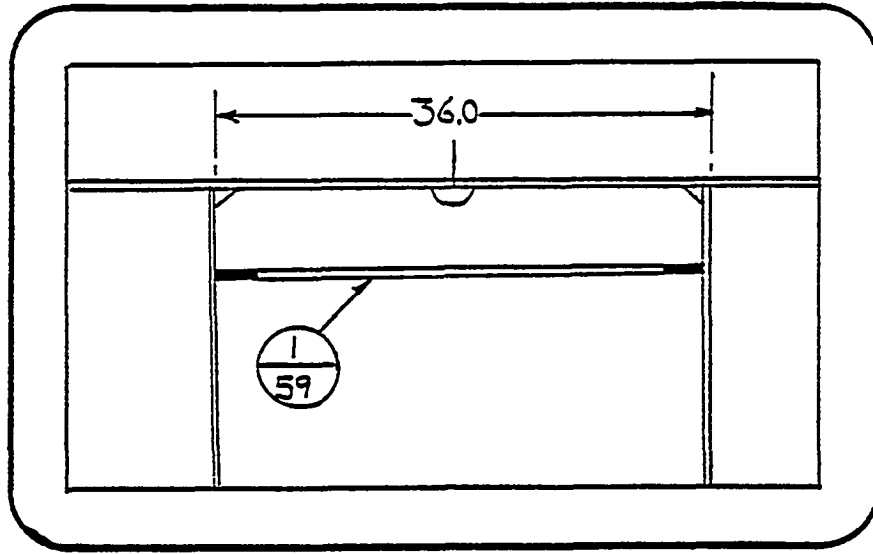
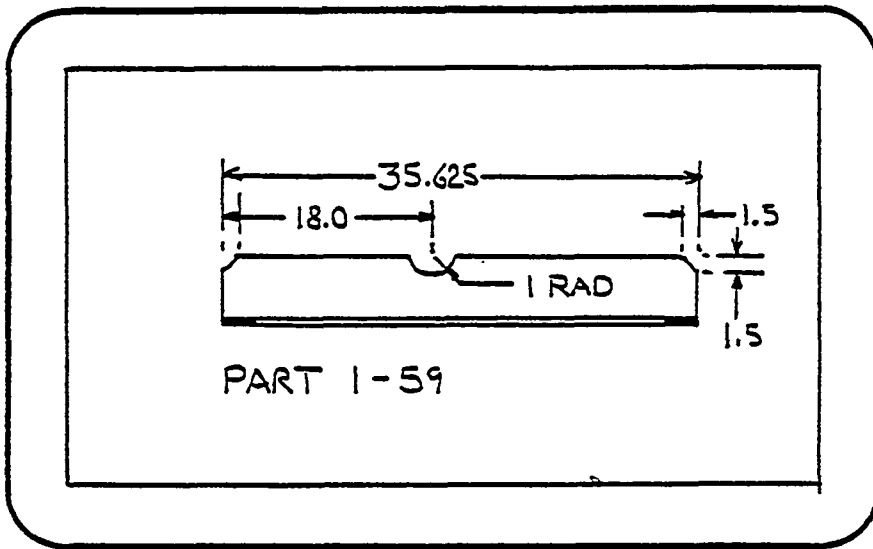

FIGURE 2.70 Advanced integrated CAD/CAM approach.



COMPLETE DATABASE MODEL



SELECTION OF PIECE FOR PROCESSING SHEET

This detail obtained by selecting eight elements. No need to use 36 spacing and subtract $3/8$ for plate thickness. Therefore, eliminates step where error could be introduced.

FIGURE 2.71 IACG data representation.

this has significant benefits compared to traditional drafting and lofting. At any time the stored data can be called to the terminal CRT and all or partial data selected for further development or printing as a hard-copy drawing.

Figure 2.72 is an attempt to pictorially show how the data base could be constructed. It shows that the traditional stages and disciplines overlap. An obvious advantage of this approach is that the data base is a dynamic composite at all times. If an item has to be changed or relocated, it is not done as a system isolated from all other systems, thus requiring a check of the independent composites, if they exist at all. It is an integrated action involving everything known to be in the vicinity of the item being changed.

There are many other advantages of IACG CAD/CAM, and most of them are well known. However, there are some which may not be appreciated for shipbuilding. Shipbuilding in this country cannot be considered a stable industry. The need for engineering staff fluctuates regularly, and for this reason there is a tremendous mobility of engineers. With this mobility a given shipyard loses its experience. Even with the best intention to develop standards and good records of past practices, it is never in a form that new engineers can easily find and use. CAD eliminates this problem by focusing on the objective to define an item only once, and then to duplicate it as required. It also provides an almost instantaneous memory of standards and past practice. As the engineer is interacting with a computer with a memory (data base) far more accessible than his own, or any other individual's, he is able to draw on that experience, and use directly or improve on that available. This enables operators to develop new designs far quicker than before CAD. Another benefit of increased and easier accessed documentation of previous designs is the avoidance of errors.

The single data base, and instantaneous access to it, also simplifies and improves change control.

The common data base would provide [17]:

1. Information independence: Making the information in the files independent of the various reports needed (this is because of the assumption that once the information is located, there is no effort required to generate the report).
2. Information non-redundancy: Minimizing the number of different files which contain the same information.
3. Information relatability: Having information in a form that all reports and forms can use or modify easily.
4. Information integrity: Improving information quality, consistency, and recoverability.
5. Information accessibility: Providing low-cost, easy access to information stored in various files.
6. Information shareability: Ensuring that many secretaries can access the same files without degrading performance.
7. Information security: Helping people mind their own business by keeping privileged information away from unprivileged people.

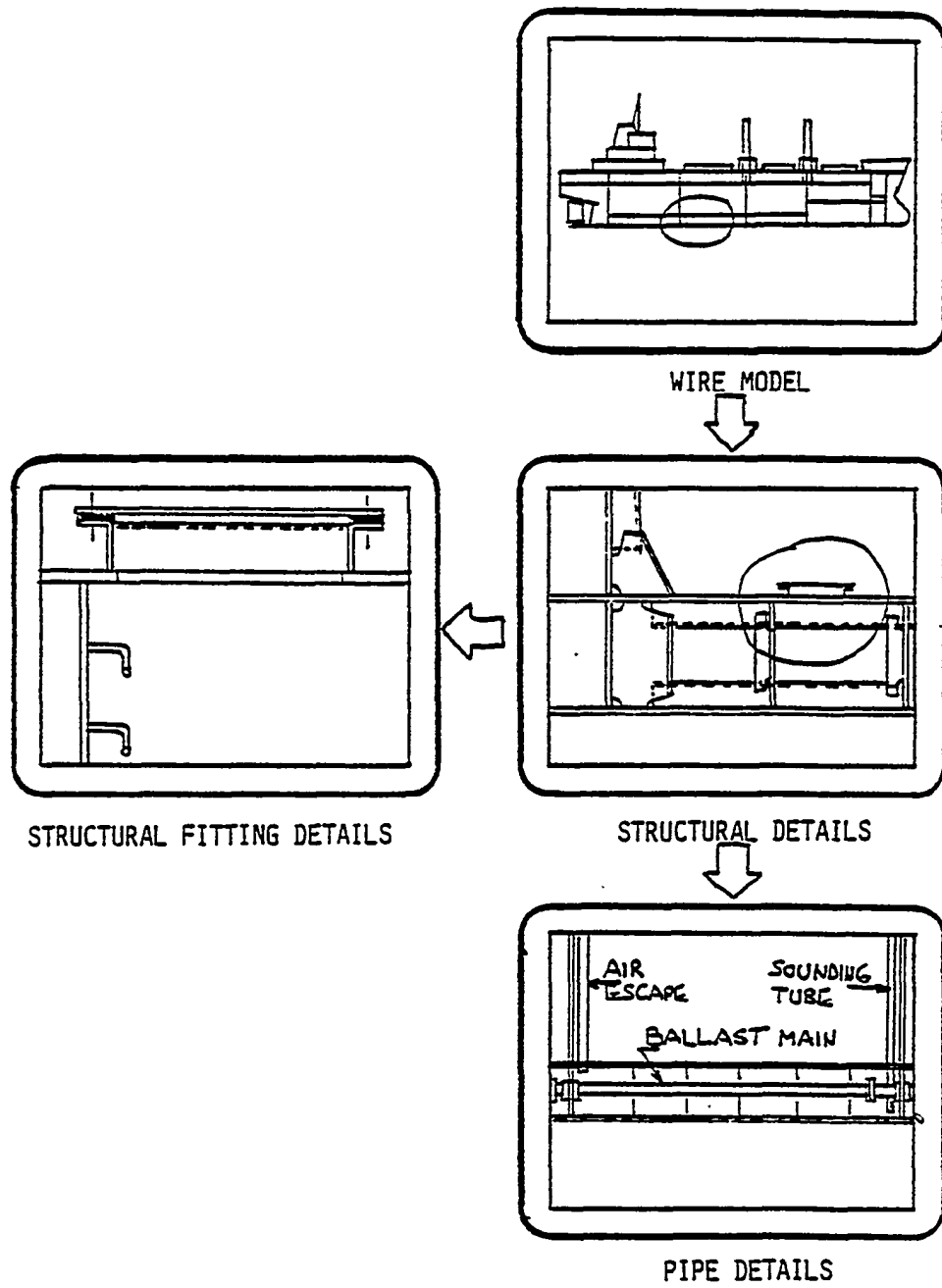

FIGURE 2.72 Development of IACG data base.

8. Information performance: Providing proper controls for changing the filing system as time and changing user needs cause the basic systems requirements to change.
9. Information administration: Supplying appropriate standards, procedures, and guidelines to ensure consistent evolution of the filing system as demands and technologies change.

2. 11. 4 CAD/CAM AND ENGINEERING FOR SHIP PRODUCTION. The major difference between manual and CAD design and engineering is that all manual approaches are based on producing drawings at the various stages in order to record and pass on design decisions, whereas the correct CAD approach is based on constructing a computer prototype from which data can be extracted at any stage in whatever format is desired.

With manual design, it does not matter if the drawings at the completion of one stage are usable in the next, although it is smart for this to be so. It is usual to redraw the parts of the previous stage drawings needed for the continuous development of the engineering. In CAD, this same approach could be, and sadly is, still used. However, using CAD correctly, and building a common data base from concept or at least contract design through work instruction information, requires that each stage be prepared so that it forms the logical foundation for the next stage. This leads to the concept of an expanding data base, as shown in Figure 2.73. This necessitates that each designer develop his work as a full-sized prototype in accordance with design to that stage, and in correct location to all other spaces, structure, outfit, etc., for the ship. A designer cannot develop the details in isolation, and then have someone else check to see if it fits, as is practiced in traditional manual engineering.

It is also necessary to develop the data in the best format from the start of preliminary design so as to be the foundation of a common data base suitable for development of the design and engineering through to work station/zone information.

Another major difference is that with manual design and engineering, the use of “Functional-drafting” and “systems-drafting” approaches makes economic good sense. With CAD, as it is the objective to model the complete ship, and as a duplication of details is so simple, “functional drafting” and/or “systems drafting” should not be used.

The final format of the work station/zone information is limited to drawings, sketches, and lists in manual engineering, whereas in CAD engineering the options are many.

Although the CAD/CAM systems that are specifically developed for shipbuilding are usable in a number of ways, it is probable that they were developed with a specific sequence of tasks in mind. It is therefore important that the shipyard techniques, planning, scheduling and material control desires, and engineering approach be at least conceptually developed when deciding which CAD/CAM system to use. The use of computers for ship design and engineering is a natural catalyst for *engineering for ship production*, in that they force the user to document his approach and to develop a logical sequence and formalization for the methods used. While CAD and CAD/CAM could be used to duplicate the traditional manual method, and produce data in exactly the same traditional format and content, it would not achieve all the possible benefits. On the other hand, if CAD/CAM is utilized to prepare the information for the proposed *engineering for ship production*, it would enhance the approach. The approach for *engineering for ship*

production and typical time frame is given in Table 2.15(a). It uses the normal shipbuilding language such as lofting, structure, machinery, outfit, etc. However, it is perhaps of more benefit to consider them all “interim products” of the “final product,” the ship, as is shown in Table 2.15(b). The *engineering for ship production* logic fits well with current computer system capability, but must be communicated to system developers for future development. Otherwise, it is possible the new developments will not perform the desired tasks in the best way for a shipyard. Computer application can provide the desired integration and control of all data for:

- Instantaneous access by all to latest design and status information
- One source of standards
- Work station visual information
- Work station parts list
- Material scheduling and procurement
- Work package schedule
- Product engineering schedule
- Progress control
- Configuration control

all based on a single source of information.

It can eliminate:

- Drawing prints
- Drawing vaults
- Engineers’ “private” drawing files and the problems associated with them
- Out-of-date drawings in hands of workers

The use of computers forces the users to logically think out what they want to do, and how they should do it *before they start*. Program flow diagrams, structured programming, etc., lead the user through the operation steps. In addition, as central processing unit (CPU) use time is usually expensive, programmers have developed a basic need to efficiently develop the required data, and to eliminate unnecessary steps and duplication of data

These goals are an exact matchup *with the goals of engineering for ship production*. As already stated, the biggest hurdle to overcome is the tendency to use computers to provide the same information as is currently provided, instead of using them to develop that which is required in the best way for the new tool, such as a full-size prototype of the design from which the necessary information to procure, fabricate, construct, and test the ship can be extracted and presented in the most effective way.

2. 11. 5 TEE FUTURE. The near future will probably see utilization of currently available CAD/CAM capabilities to their fullest and most efficient extent. The future extreme mentioned in a previous section based on a common integrated data base from contract negotiations through to the operation of the ship should occur in this time frame. This is conceptually shown in Figure 2.74. Users of the data would have IACG terminals by which they could call up any required data at any time after it was developed. Instead of contract drawings and typed specifications, a magnetic tape or disk would be delivered to prospective bidders. The bidders would expand the data base as required to furnish a bid. The successful bidder would use the data base to develop the contract data This

TABLE 2.15

CAD/CAM DATA RELATIONSHIP

Major Data Input	Time	Data Output
[A] NORMAL SHIPBUILDING TERMINOLOGY		
1. Construct hull definition	Month 1	
2. Develop structural details 3. Develop machinery layout 4. Develop distributive systems	Month 2 to Month 8	
5. Develop electrical details 6. Develop joiner work details	Month 4 to Month 9	1. NC data for structure processing 2. Work station Info for assemblies 3. Work station info for modules
	Month 6 to Month 12	4. Work station info for dist. system processing 5. Work station info for dist. system assembly 6. Work station Info for dist. system installation
	Month 12 to Month 18	7. Work station info for advanced outfitting 8. Work station Info for electrical installation 9. Work station info for outfit installation
	Month 9 to Month 24	10. Work station Info for module erection 11. Work station Info for module welding
[B] FOR INTERIM PRODUCTS		
1. Develop major characteristics of product	Month 1	
2. Define major purchased Interim products	Month 2 and Month 3	1. P.T.S for purchased Interim products
3. Divide product into zones	Month 2 to Month 4	
4. Develop detailed model of product zone by zone	Month 4 to Month 6	2. CAM information
5. Identify interim products	Month 6 to Month 12	3. Work station information for Interim products

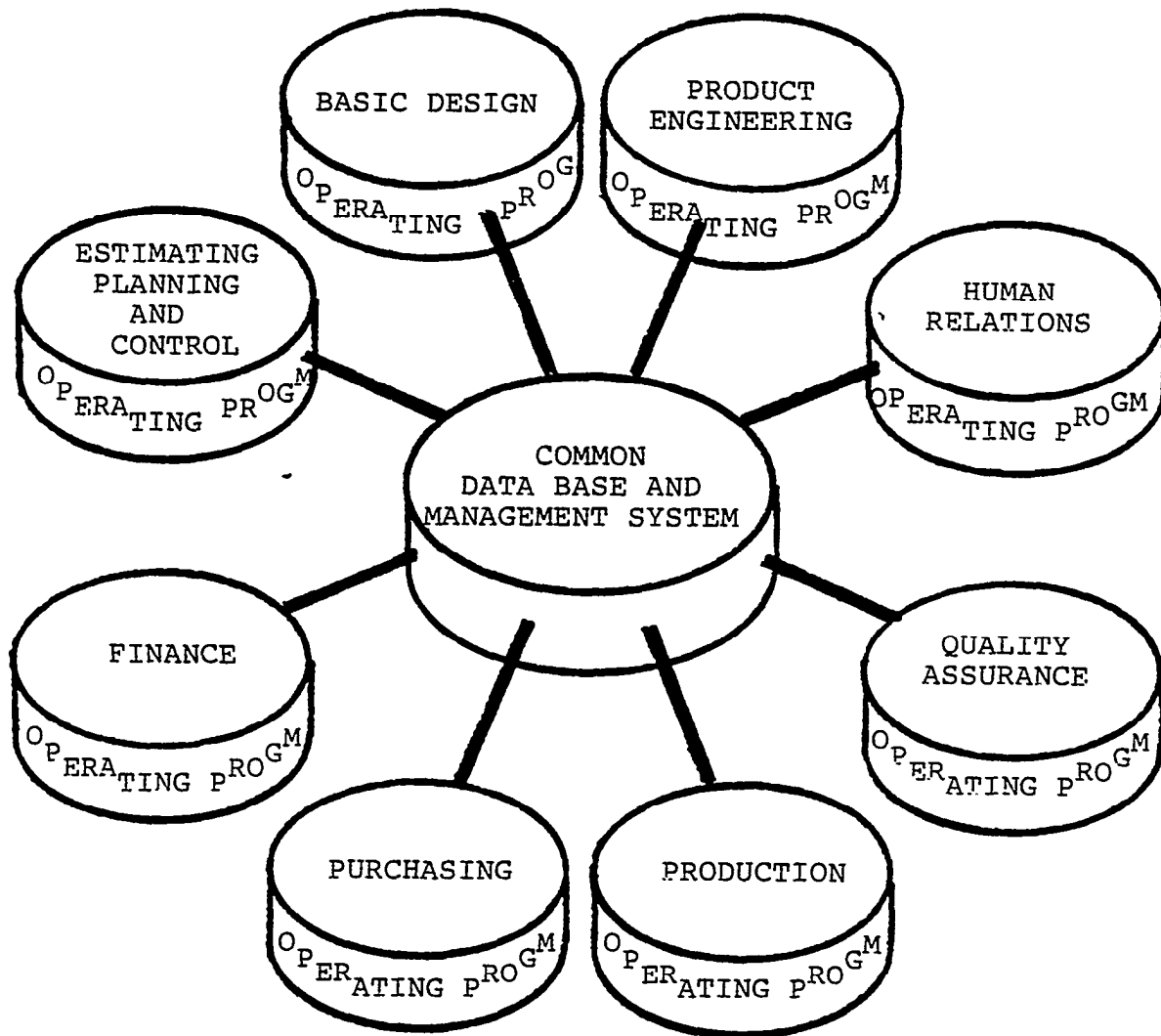

ALL FUNCTIONS ACCESS THE SAME DATA AND PROCESS IT TO THEIR NEEDS

FIGURE 2.74 Integrated information system with common data base.

contract data base would be used as the starting point for developing the detailed design of the ship. Magnetic tapes or disks would be provided to the owner, classification society, and regulatory bodies for their use in approving the design. The actual data would include math models, finite element models, system design calculations, structural analysis, and the visual information.

The final construction phase data base would be a full-scale computer mock-up of the ship. An automatic output from the construction phase data base would be bills of material, N/C instructions for structure and pipe processing, assembly and erection, and equipment installation. Again, actual printed drawings and text would not be produced but rather presented on IACG terminals at the various work stations. This could be accomplished by having all terminals connected to a central computer containing the data base or by transfer of selective parts of the data base to smaller "satellite" computers either directly by line connection to the host computer or by magnetic tape or disk.

Once the data base was completed, magnetic tapes or disks containing all the necessary information would be given to the owner and the operating crew. This approach is based on modeling the ship down to the minutest detail, and would be difficult to do with 2D CAD systems. A 3D system would be used, and this would require putting each item in the detail base only once. It would be possible to take a visual tour throughout the ship, and look at any item from any position within or without the ship. This possibility should excite anyone who has struggled and been frustrated over system routing, interference control, or compartment check-off lists. It would be like having a mobile video camera (or space probe for those who saw "The Empire Strikes Back") controlled by the operator. This is depicted in Figure 2.75. The application of this capability to human engineering, equipment removal routing, maintenance space, etc., is mind boggling.

The long-term future will see the development and use of complete design systems. What is meant by "design system" is one where upon logging onto the computer, the ship design system would be called up. A menu would then appear on the CRT from which the type of ship would be selected, such as bulk carrier, destroyer, landing ship dock, navy oiler, etc. The basic requirements such as speed, endurance, capacity, etc., would then be requested and entered. The computer system would then develop the design *automatically*, and show it on the CRT screen. Logically, the system would have built-in stops, at which time the operator could accept or change design details. It may even have the ability for the operator to interrupt the system at any time to change something.

Once the design was technically complete, production data, such as maximum size and/or weight of erection blocks, location of major module breaks, etc., as well as construction sequence and schedule would be entered, and the preparation of information such as material requisitions, bills of material, parts lists, and work instructions required for the procurement and production departments generated *automatically*. Obviously for such a system to operate, it is necessary to program the design algorithms and establish data bases containing acceptable marine design practice and decision tables. To do this for even one commercial ship type is quite an investment, and for a major combatant type would be three or four times as involved. The basic arrangement and structural detail are relatively straightforward, and some success in both these areas has been achieved [11,12,13,14]. It is the design of the distributive systems which requires the greatest effort. Standardization of both individual items as well as groups of items and complete systems would lessen the effort. To undertake the development of such a system will require significant resources of both talent and money. It may not be considered justifiable in this country due to the uncertainty associated with private shipbuilding. This would be

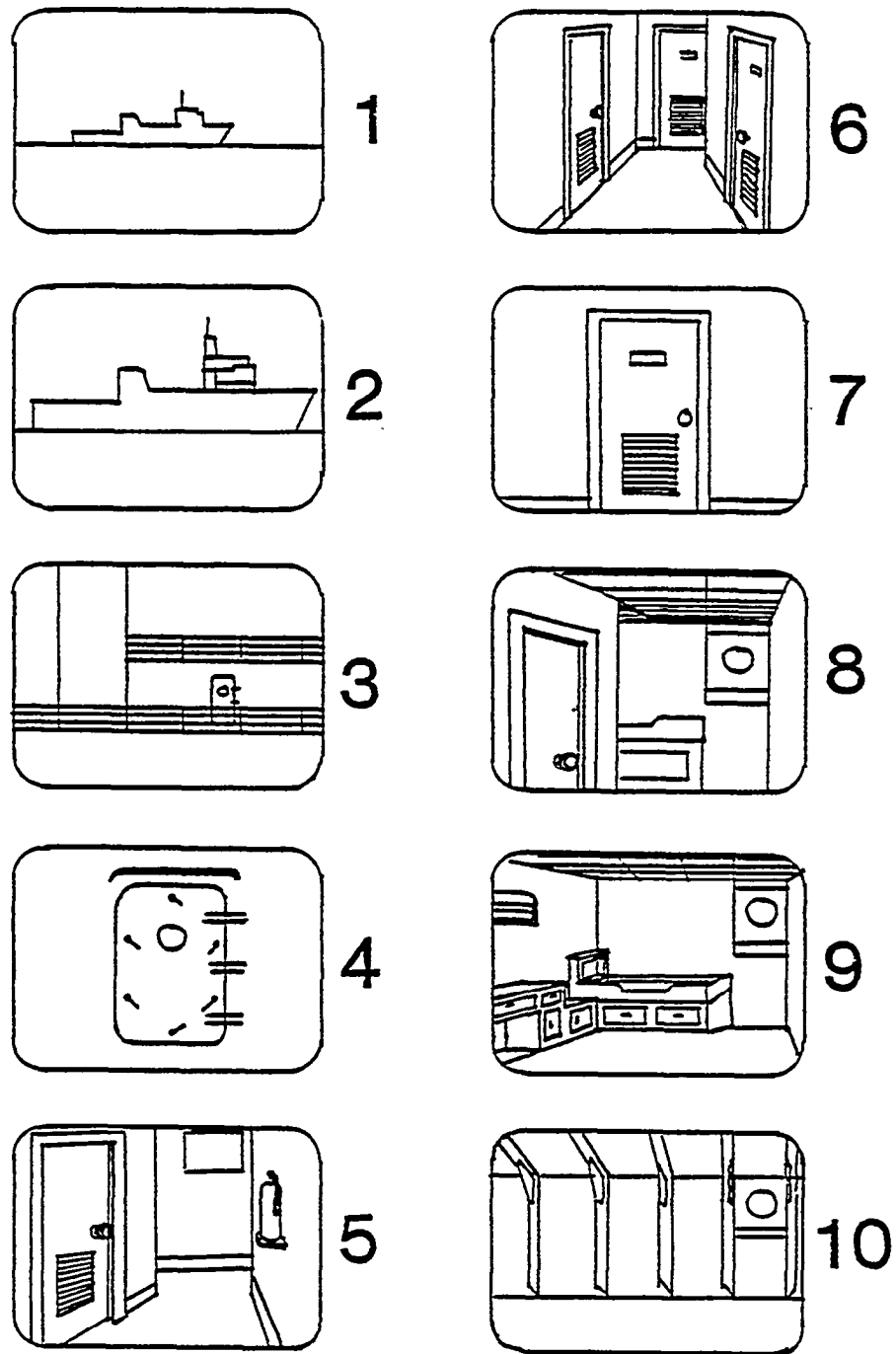

FIGURE 2.75 Future IACG capability.

most unfortunate, considering the lead the U.S. has in computers and interactive computer graphics. However, the development has already started in other countries [15&16], and U.S. shipbuilders may **have to wait on** others to develop the complete automatic ship design and production (AUTOSHIPDAP) system, and obtain it from them when and as they can.

REFERENCES

1. W. Height, *The geometry of the job*, *IESS*, vol. 101, 1957-1958.
2. J.J. Nachtsheim et al., *Computer aided structural detailing of ships (CASDOS)*. SNAME Spring Meeting, 1967.
3. J.A. Belda et al., "The FORAN system." *First International Conference on Computer Applications in Automation of Shipyard Operations and Ship Design (ICCAS)*, Tokyo, 28-30 August 1973.
4. P.C. McKinstry and C. Kuo, *Review of integrated systems for design and production*. WEGEMT, University of Strathclyde, September 1980.
5. T. Lamb, *The management of numerical control software and its impact on the operation of a shipyard*. SNAME Hampton Roads Section, February 7, 1974.
6. A.K. Greene, "Will turnkey CAD/CAM systems remain viable?" *Iron Age*, November 19, 1982.
7. A. Landsburg and F. Seibold, "Interactive computer graphics and the marine industry," *SNAME Marine Technology*, April 1973.
8. P.D. Forrest and M.N. Parker, "BRITSHIP 2: A shipbuilding steelwork design and production system." *Third International Conference on Computer Applications in the Automation of Shipyard Operations and Ship Design*, Annapolis, June 7-10, 1982.
9. P.D. Forrest and M.N. Parker, *Steelwork design using computer graphics*. RINA Spring Meeting, 1982.
10. T. Lamb, *Engineering for modern shipyards*. SNAME Great Lakes and Great Rivers Section, May 25, 1976.
11. I.M. Yuille, "The forward design system for computer-aided ship design using a mini-computer," *RINA*, vol. 120, 1978.
12. S.J. Holmes, "The application and development of computer systems for warship design." *RINA*, vol. 123, 1981.
13. T. Corm, "Computer-aided ship design and construction in the Navy." *REAPS*, June 21-22, 1977.
14. C.M. Carlson et al., "Computer aids for ship design integration and control." *ASNE Naval Engineers Journal*, April 1980.
15. J.A. Belda, "Ship design and production by CAD/CAM" *RINA Naval Architect*, July 1982.
16. "Computer-aided design is the only way to go." Editorial, *RINA Naval Architect*, July 1982.
17. "The role of computer-based information system in ICAM." *Sixth Annual ICAM Conference Proceedings*, January 17-20, 1982.

2.12 Technical Support

In addition to the functions and the tasks described, engineering must provide the usual technical support in the area of launching, inclining, tests and trials, ship configuration control, liaison, etc. Engineering for ship production requires further additional tasks, and the output from these should be incorporated into the work station/zone information, where possible. Such tasks include the following:

1. Use group technology to classify and code products for production control to:
 - Determine number of parts
 - Determine number of unique parts
 - Select appropriate processing plan
2. Determine joint weld length. This should be divided into weld type, size, and attitude.
3. Perform alternative design detail analysis.
4. Provide moving, turning, and lifting analysis and sketches for modules.
5. Provide access and staging sketches.
6. Provide blocking and temporary support sketches for assemblies, modules, and ship.
7. Include production, planning, scheduling, material handling, etc., data/instructions in the work station/zone information as it is prepared by engineering.

There are many other items which are performed by the craftsman or supervisor in the traditional shipyard which need to be performed prior to work package issue in the modern shipyard. These can in many cases be effectively and efficiently performed by the Engineering Department.

The total engineering effort can be broken down into a system compatible with the **engineering-for-ship-production** approach as shown in Table 2.16.

TABLE 2.16

ENGINEERING FOR SHIP PRODUCTION TASK BREAKDOWN

GROUP 1 - BASIC DESIGN - CONTRACT DESIGN		
811	-	Contract Design Calculations
812	-	Contract Design Drafting
813	-	Contract Specification Preparation
814	-	Contract Purchase Technical Specifications
815	-	Contract Estimating Support
816	-	Contract Material Take-Offs
817	-	
818	-	Contract Weight Calculation
819	-	
GROUP 2 - BASIC DESIGN - FUNCTIONAL DESIGN		
821	-	Functional Design Calculations
822	-	Functional Design Drafting
823	-	Change Orders
824	-	Purchase Technical Specifications
825	-	Vendor Technical Analysis
826	-	Material Take-Offs
827	-	Vendor Plan Approved
828	-	Weight Calculations
829	-	
GROUP 3 - PRODUCT ENGINEERING - TRANSITIONAL DESIGN		
831		Transitional Design Arrangements
832		Bills of Material
833		Computer-Aided Lofting
834	-	
835	-	
836	-	
837		
838	-	
839		
GROUP 4 - PRODUCT ENGINEERING - WORK STATION/ZONE INFORMATION		
841		Structural Sketches and Parts Lists
842		Pipe Assembly Sketches and Parts Lists
843		HVAC Assembly Sketches and Parts Lists
844		Installation Sketches and Parts Lists
845		Rework - Engineering
846		Rework - Vendor
847		Rework - Production Request
848		Rework - Production Error
849		

TABLE 2.16 (Continued)

GROUP 5 - INTEGRATED LOGISTICS SUPPORT (ILS)		
850	-	ILS Engineering
851	-	Maintenance
852	-	Support and Test Equipment
853	-	Supply support
854	-	Transportation
855	-	Engineering Drawing Specification
856	-	Technical Manuals and Other Data
857	-	Facilities
858	-	Personnel and Training
859	-	Training Equipment
GROUP 6 - ENGINEERING SERVICES		
861	-	Inclining Experiment
862	-	Launching
863	-	Test and Trials
864	-	Liaison
865	-	Technical Publications
866	-	Engineering Services to Production
867	-	Label Plates
868	-	Vessel Surveys
869	-	Reproduction
GROUP 7 - ADMINISTRATION		
871	-	Supervision
872	-	Engineering Planning
873	-	Scheduling and Progress Reporting
874	-	Conferences
875	-	Travel
876	-	Project Engineering
877	-	Drawing Checking
878	-	Engineering Q.A.
879	-	

PART 3

ENGINEERING ORGANIZATION FOR SHIP PRODUCTION

3.1 General

There have been, and notwithstanding the current world shipbuilding recession, still are many successful shipbuilding companies in the world. The engineering organization of these successful companies, although similar, probably has significant differences. These differences are due to the development of the companies, their products, and the skills and experience of their employees and their managers. The development of today's shipbuilding engineering organizations evolved as engineering work was split into hull and machinery, and then into structure, outfit, hull systems and machinery, machinery and electrical. Through time, design and technical calculations were separated from working drawing preparation. In most engineering organizations these divisions or, as they are often called, disciplines, still exist. However, the way ships are designed and built has significantly changed over the last 25 years. It is not surprising to many that engineering organizations did not change during this time to suit the design and building methods.

During the same time frame another significant change that directly affected engineering requirements occurred, namely, the demise of the craft apprenticeship system. This resulted in the workers being less skilled and experienced and required more and easier-to-understand data and instructions from the engineering organizations. As already stated in Part 1, the craft-organized shipyards work from the minimum of engineering, and the well-trained and experienced workers developed their own details. Because of this, engineering and production often were isolated from each other. Today's integrated shipbuilding necessitates a very close relationship between planning, engineering, and production employees. It also requires an intimate knowledge by the engineers of the methods used, and the difficulties involved in constructing a ship in the facility for which they work. Details can no longer be left to be solved by the loft, shipfitter, or pipe shop! Even though this approach appears to place more responsibility on the engineer, in general it is more enthusiastically accepted by the engineer. Unfortunately, it has been met with mixed emotions by other departments in shipyards. The reasons for this are many, ranging from incursion into "their area," to insulting their intelligence by the issue of simpler but better instructions.

Neither reason, or any in between, is justifiable. Everyone in the shipyard should be working as a team, ready to adapt to whatever approach helps it to achieve the goal of competitive ships in minimum construction time. An efficient, successfully operated company should be like a set of precision gears, each department like many input shafts with gears meshing with the production department, which of course is the output shaft. This concept is shown in Figure 3.1. Incidentally, communication is the necessary lubricant for the organization (gear) and the collection of the lubricating oil and its processing for return to the gear is the organization's feedback. For optimum performance, all service departments (input gears) must mesh with the production department (output gear) in exact accordance with the organization (gear) design. It must operate like a properly lubricated and maintained set of precision gears.

If any service department tries to do more or less than it is required to, or if the production department tries to drive a service department, then the total organizational

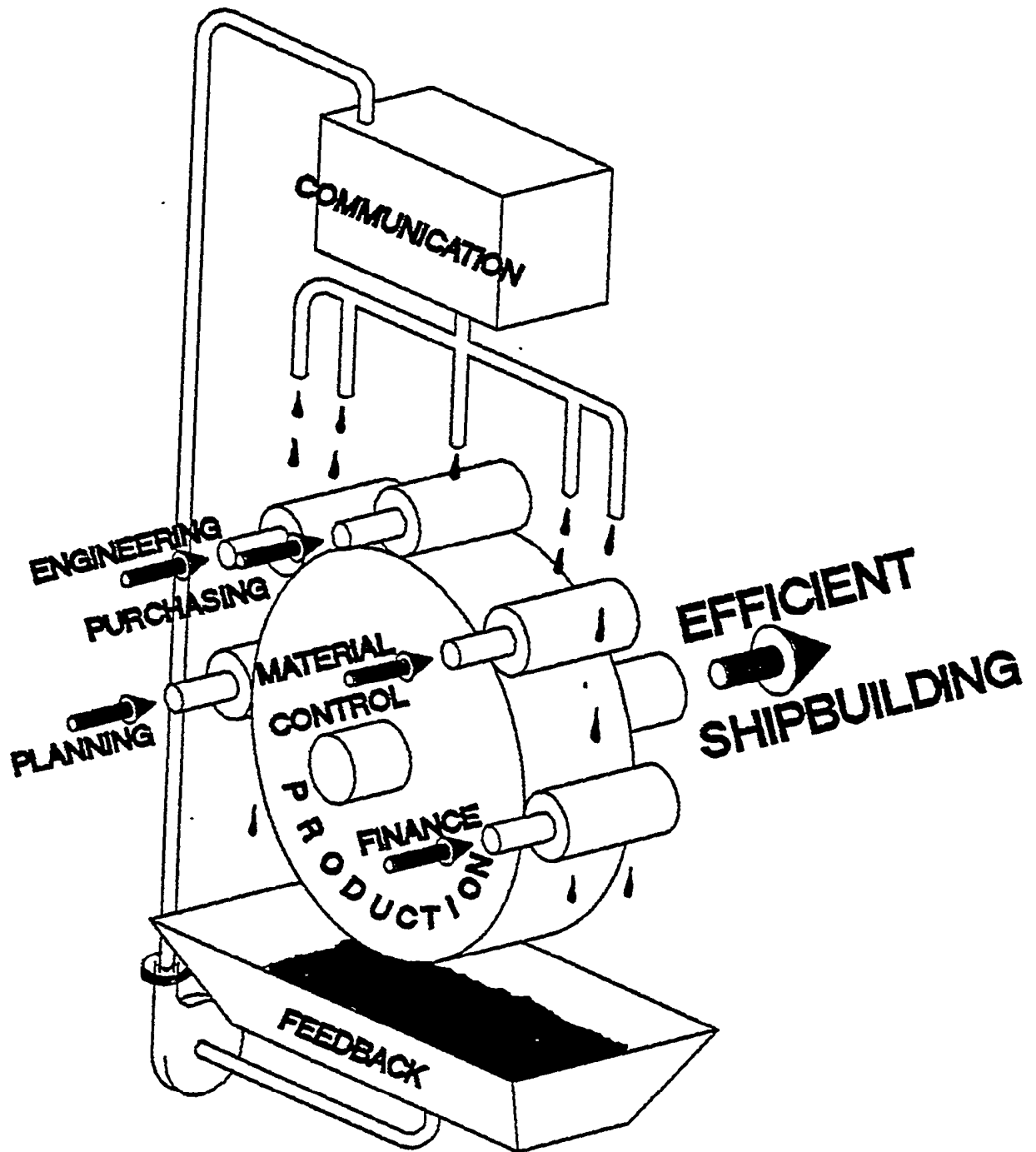

FIGURE 3.1 The company gear.

output diminishes, and the output gear will become overloaded and may self-destruct. Only by each part of the organization functioning as it is designed to will the efficiency approach its optimum. A set of precision gears can achieve 98% efficiency. It is doubtful if any organization can claim anywhere near this value.

Just as it is essential for the design of a gear, the detail requirements for each part of the organization must be fully understood to complete the design successfully. Therefore, it is essential that the objectives and results for every department be clearly defined, and the responsibility, authority, and accountability be correspondingly assigned to the departments.

Like most things in life, there is more than one way to approach the design of an organization, but in all cases the engineering goals must be clear and the resulting organization must be capable of achieving the goals. Even then it is only possible if all involved use the organization in the way it is designed. If the employees or, worse, the management do not enthusiastically adopt the integration of engineering and other departments, and the organization to allow this, full benefit from the approach will not be achieved.

3.2 Engineering Objectives

It is obvious that an organization cannot be designed if the functions of the parts are undecided. Therefore, the first step *in engineering organization* design is to establish the objectives of the engineering organization. This will depend on whether any part of the design and engineering will be performed by marine design consultants.

Based on the proposed *engineering-for-ship-production* approach, the objectives for a complete in-house engineering department include:

Design

- Perform concept, preliminary, and contract design
- Provide technical data for estimating and planning
- Provide all design support for new ship construction
- Provide *production engineering*
- Prepare all design drawings through key drawings and diagrammatic phase
- Prepare weight calculations
- Provide *systems engineering*
- MEET ALL ACCEPTED SCHEDULES

Engineering

- Organize *to best support integrated shipbuilding*
- Prepare drawings, material lists, lofting, layouts, pipe assembly drawings, and other production-required information
- Perform configuration control of all engineering information
- Provide engineering liaison to production department
- MEET ALL ACCEPTED SCHEDULES

For an engineering department using a marine design consultant to prepare both the design and the working drawings, objectives of the in-house engineering department include:

Design

- Provide overall design leadership and direction
- Provide production-oriented design requirements
- Provide continuous monitoring of project for unique production methods and facility involved
- MEET ALL ACCEPTED WORK SCHEDULES

Engineering

- Organize *to best support integrated shipbuilding*
- Provide overall engineering leadership and direction
- Ensure engineering is developed in the way desired for shipyard rather than what the consultant wants to do
- Prepare lofting, pipe assembly drawings, layouts, etc.
- Prepare the technical information to complete work package required by production department
- Provide engineering liaison to production department
- MEET ALL ACCEPTED WORK SCHEDULES

In both cases the objectives should be reviewed regularly to enable a self-improving capability to flourish.

3.3 Organization

Organizational theory has steadily developed along with the better understanding of human relations, motivation, and worklife sciences. That this is so is clear from a review of any bibliography on the subject of organization. It is not the intent to describe or recommend any of the theories, especially as the very foundations have been discredited in recent books about the most successfully operated U.S. companies [1] and future trends [2]. What will be discussed is the basic organizational requirements for a shipyard engineering department.

A number of papers and reports [3,4,5,6,7] touch on engineering organization, but only the later ones do so in any depth or cover the reasons for the differences. Books on general, technical, or engineering management [8,9,10] describe some organizational aspects which can be helpful when examining shipyard engineering organization. The more recent papers and reports on advanced shipbuilding technology all contain three basic principles for shipyard engineering organization:

1. Shipyard engineering should be divided *into basic design* and *product engineering*.
2. Engineering information should be presented in the simplest and most effective manner.
3. Engineering information should be developed to transmit only the information needed by one or more workers at a specific work station to perform the work at that work station.

To these three should be added a fourth, namely:

4. Engineering and planning are synonymous, and the product engineering section should prepare all planning material such as lofting, N/C processing data, pipe sketches, sheet metal layout, and work station process or instruction sheets.

The reason for this additional principle should be obvious to the readers of this book. It connects together the logical sequencing of the same data. With the increasing use of computers and software for CAD/CAM, it is possible to generate all the planning material as a natural fallout from the engineering data base.

Before proceeding, it is necessary to review some of the well-known organizational structures. These include:

- Function
- Product
- Process
- Customer
- Matrix

A functional *organization* is separated into major departments on the basis of function, such as production, engineering, marketing, finance, etc. This is the most common type of organization structure, as most people are educated and trained by function, and also organizations tend to copy other organizations. Such an organizational structure is shown in Figure 3.2

The *product organization* is divided into divisions on the basis of major products such as cars, trucks, and tractors. Figure 3.3 shows a typical product organization. Product

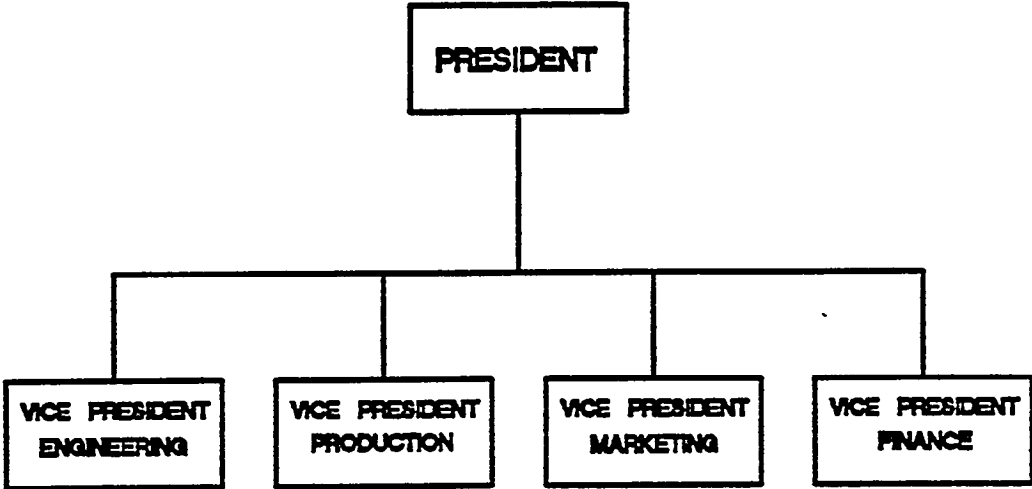

FIGURE 3.2 Functional organization.

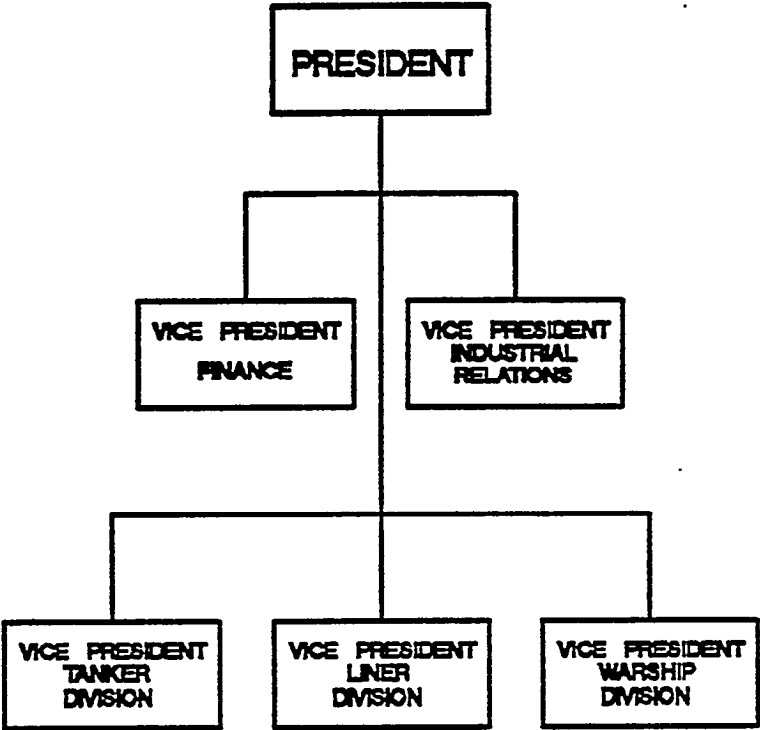

FIGURE 3.3 Product organization.

organization has been used for *the production* division of many large manufacturing companies.

Some manufacturing companies have found it beneficial to use an organization structure which fits in with the various processes through which their work moves, thus the name *process organization*, for which a typical structure is shown in Figure 3.4.

Service companies often utilize a customer organization structure. This type of structure is suited to sales-oriented divisions or departments such as marketing. A typical organization is shown in Figure 3.5. The usual reason for adopting this type of organization structure is to ensure that the needs of each customer are more than adequately met, and to give the appearance of special individual attention.

The matrix *organization* structure which is shown in Figure 3.6 developed from the attempt to combine the benefits of more than one of the above types. This type of organization was utilized extensively by defense contractors. In its most common form the matrix organization provides the manager with the benefits of both the function and product (project) organization types.

A number of these were *discussed in* Section 1.4 from the point of view of *production* systems. It was concluded therein that the modern shipyards were utilizing the product structure organization. Obviously, the most benefit will result if all departments are organized in the same way. Much of the current problems are due to the fact that departments within the same shipyard have different organization structures, and the resulting mismatch of personnel in them. For example, it is not uncommon to find that engineering is functionally organized, purchasing is product organized, and production is functionally organized. This has to be changed to achieve high-productivity shipbuilding. It is also necessary for all departments to be organized in the best way to support the production department.

The MarAd/SNAM-sponsored IHI Shipbuilding Technology books lead from outfit *planning to design for zone* outfitting. They develop a very specific approach to engineering organization which basically follows their overall production organization. This is shown in Figure 3.7. Figure 3.8 shows a typical U.S. shipyard engineering department organization, and Figure 3.9 the same for a British shipyard. The British organization is basically a two-zone type. The ship section handles and integrates everything outside of the machinery space, which is handled by the machinery section. This approach is also used by at least one of the successful large Japanese shipbuilders. However, in the British shipyard, even though engineering was somewhat product (zone) organized, the production department was still functionally (craft) organized. The U.S. shipyard engineering organization is functionally organized, with the different disciplines working in all areas. As such, it has little to recommend it for improved shipbuilding technology.

What, therefore, should be the organizational structure for the future in U.S. shipyards? It is suggested that it should not be the MarAd/SNAME IHI type. This is because the IHI approach is not "pure"; it mixes organization types such as functional, product, and process structure with zones. This can be seen from Figure 3.10, which shows that even though hull block construction, painting, and electrical are involved in all three zones, they are organized independently, and in a different way to the desired zone treatment of outfit. It can also be seen that electrical, which is a function, is treated at the same level as the zones, giving the D-A-M-E approach to outfitting. The inclusion of the "E" for electrical has no organizational basis for being linked in this way to the three zones. It is suggested that it is done simply because of tradition in some Japanese shipyards.

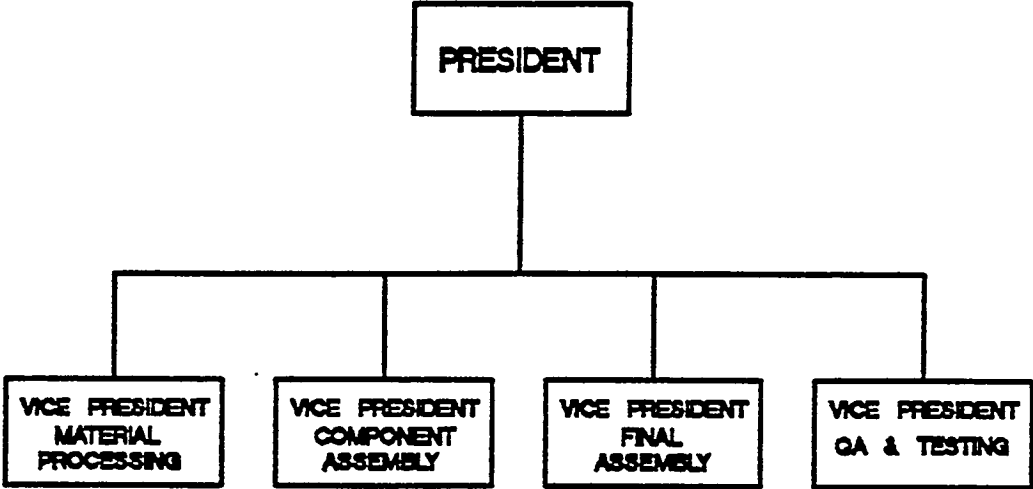

FIGURE 3.4 Process organization.

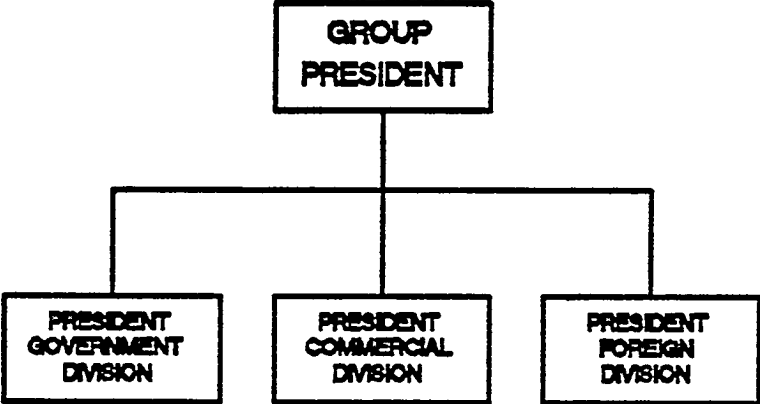

FIGURE 3.5 Customer organization.

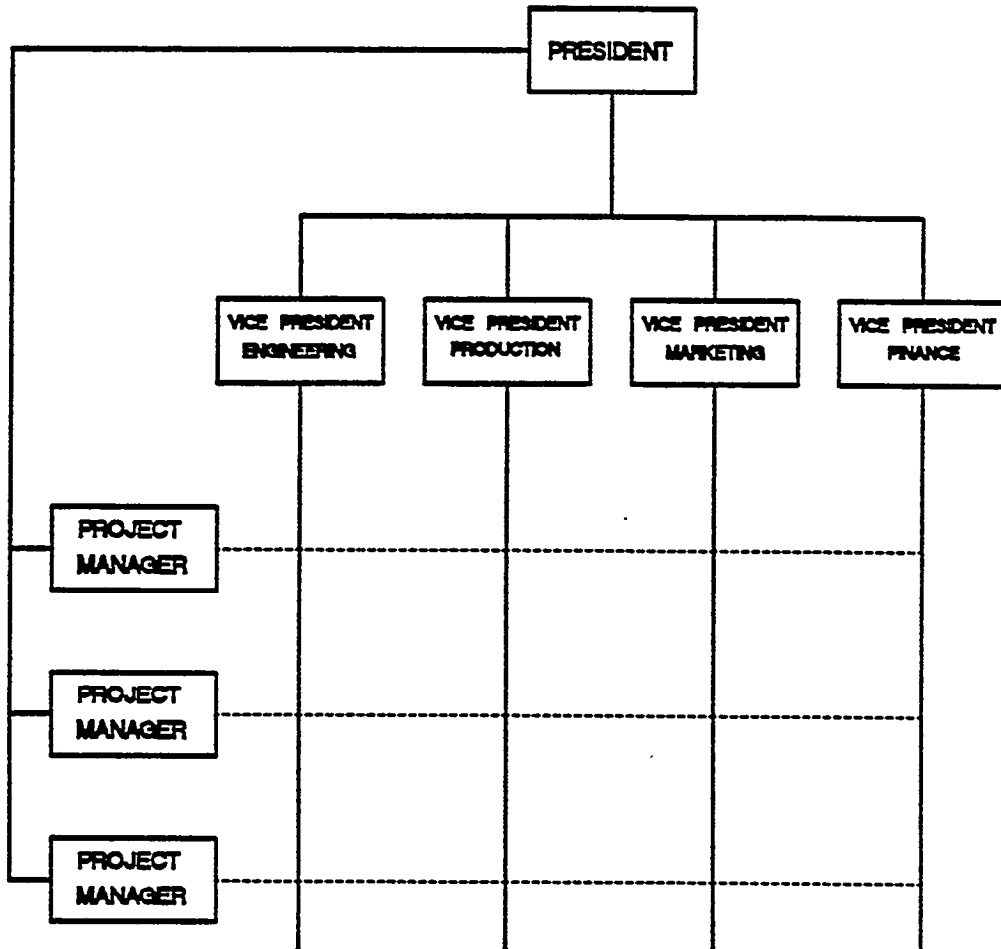

FIGURE 3.6 Matrix organization.

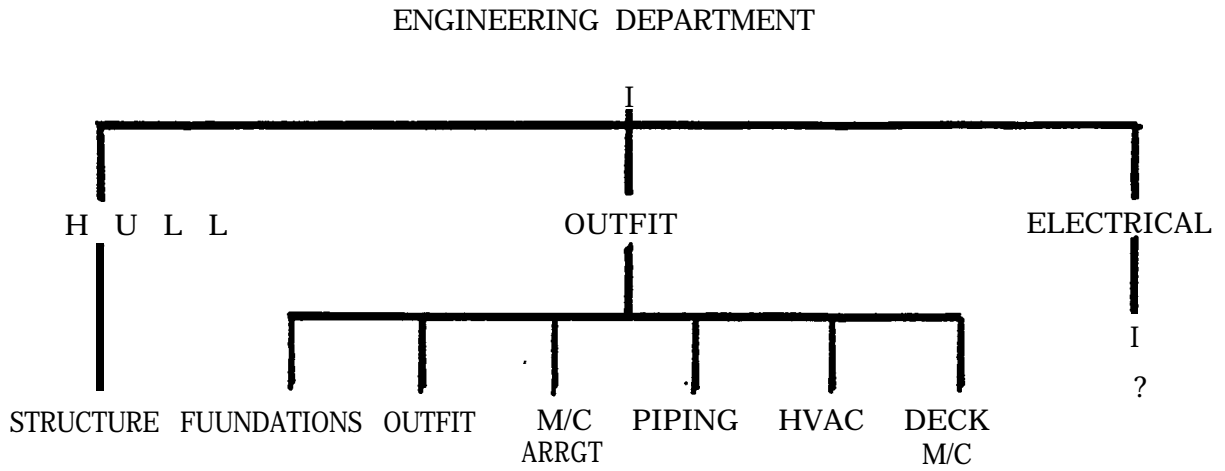

FIGURE 3.7 MarAd/SNAME/IHI engineering organization.

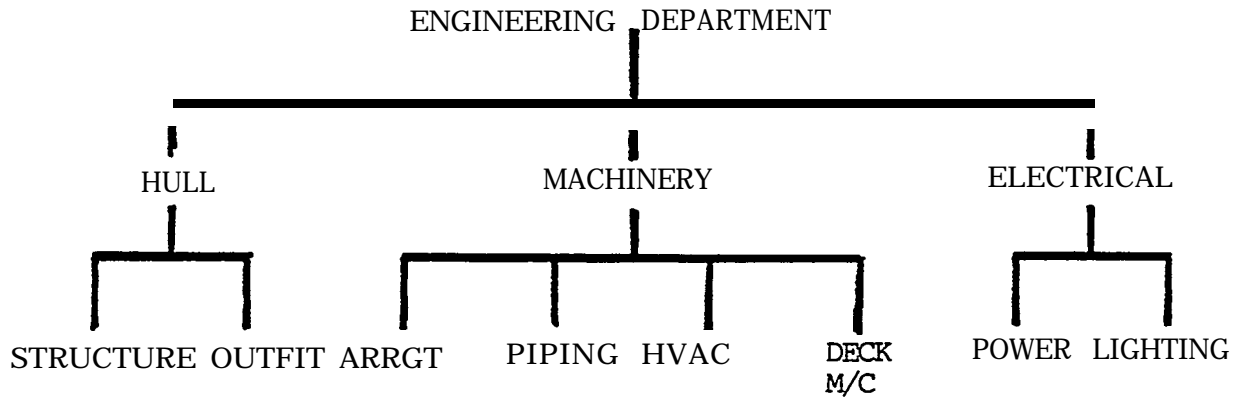

FIGURE 3.8 Typical U.S. engineering organization.

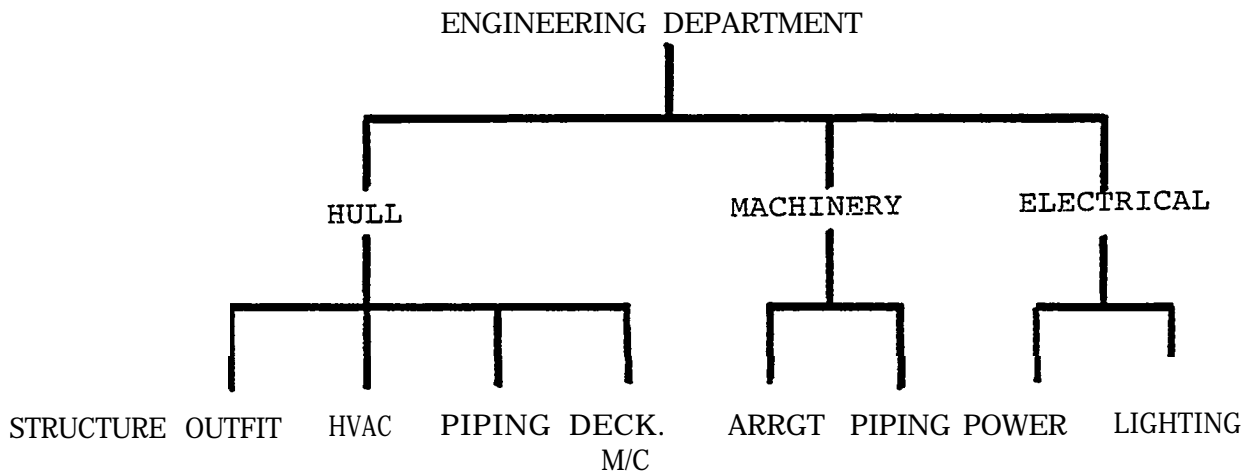

FIGURE 3.9 Typical British engineering organization.

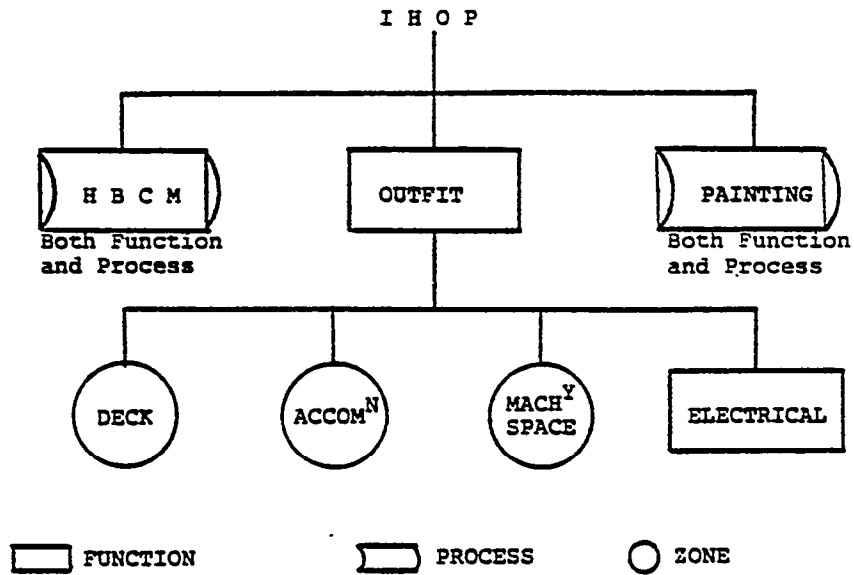

FIGURE 3.10 IHOP organization.

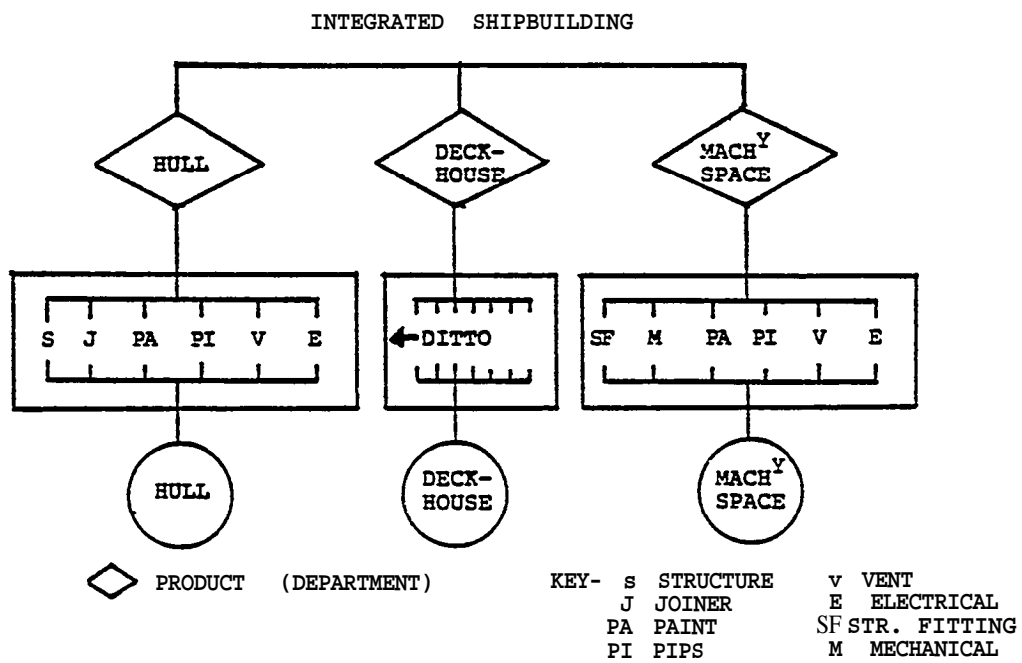

FIGURE 3.11 Suggested zone construction organization.

To develop an engineering organization, it is necessary to first develop the production organization with which it must blend. For this reason a hypothetical production organization is shown in Figure 3.11. It can be seen that there is no incompatible mixing of organization structures, and that it is based on a three-zone concept, namely hull, deckhouse, and machinery space. Each zone covers a basic product even though each product is constructed from similar interim products. There is duplication of crafts within the three departments, which is beneficial as long as there is a backlog of work to keep them all busy, and could lead to a restructuring of crafts in the future to improve their total performance in leaner and more competitive times.

It has already been stated that the engineering organization should be compatible with the production organization. Actually, this is only necessary for the *product engineering* section. The *basic design* section can be functionally organized if it best suits its purpose. The expanding data base concept described in Section 2.11.4 (Figure 2.73) logically leads to the organization of the *product engineering* section as three groups, namely: hull, deckhouse, and machinery space. This is shown conceptually in Figure 3.12. With such an organization structure no group is dependent on another group to complete their work, provide data, or have another group check their work for interferences.

As an aid for developing a suitable *product engineering* organization, it is worthwhile to construct an *engineering function zone* matrix such as Figure 3.13. From such a matrix the different product engineering needs for the three zones can be determined. It can be seen that the hull and deckhouse zones require the same functions, although the applications will be different. However, the functions and application for the machinery space are quite different, being for a power plant rather than a distribution or service system. For this reason, it is proposed that production engineering be organized as two groups, namely *ship* and *machinery*.

The *ship group* would have two supervisors, one for the hull zone and one for the deckhouse zone. These supervisors would control groups of designers and drafters which would expand and contract as the work required. Designers and drafters for both groups would be in the common Ship Section designer/drafter pool. Such an organization is shown in Figure 3.14. It is believed that U.S. shipyards would find it easier to change to this type of engineering organization than to the MarAd/SNAME IHI type.

All engineers, except those in management, liaison, or those being trained, will be in the *basic design section*. The positioning of engineers in the production departments at all levels from department to work station has been shown by the Japanese to lead to significant benefits, due to maintaining a high-technology level in production, and promote superior communication. In U.S. shipyards the duties and responsibilities of such engineers could be equivalent to those in Japanese shipyards, where they are involved in planning, scheduling, material flow, accuracy control, and manning requirements for their area of responsibility, or they may be restricted to the usual U.S. role of engineering liaison. In any case, such an approach would appear to be worthwhile for U.S. shipyards, as it would transfer the higher technical base out into the production department, and enable the engineers to gain production experience and better understanding of the production department's needs and problems.

A suitable organization structure for the *basic design section* in the hypothetical integrated shipyard is shown in Figure 3.15. It is a combined functional/matrix structure. The functions are the usual naval architecture, marine, and electrical engineering, whereas the matrix roles are for the production and system engineering input to the three functional roles. The production and system engineers are directly responsible to the basic design manager to direct, educate, train, and monitor the functional engineers in production-oriented design and systems integration, respectively.

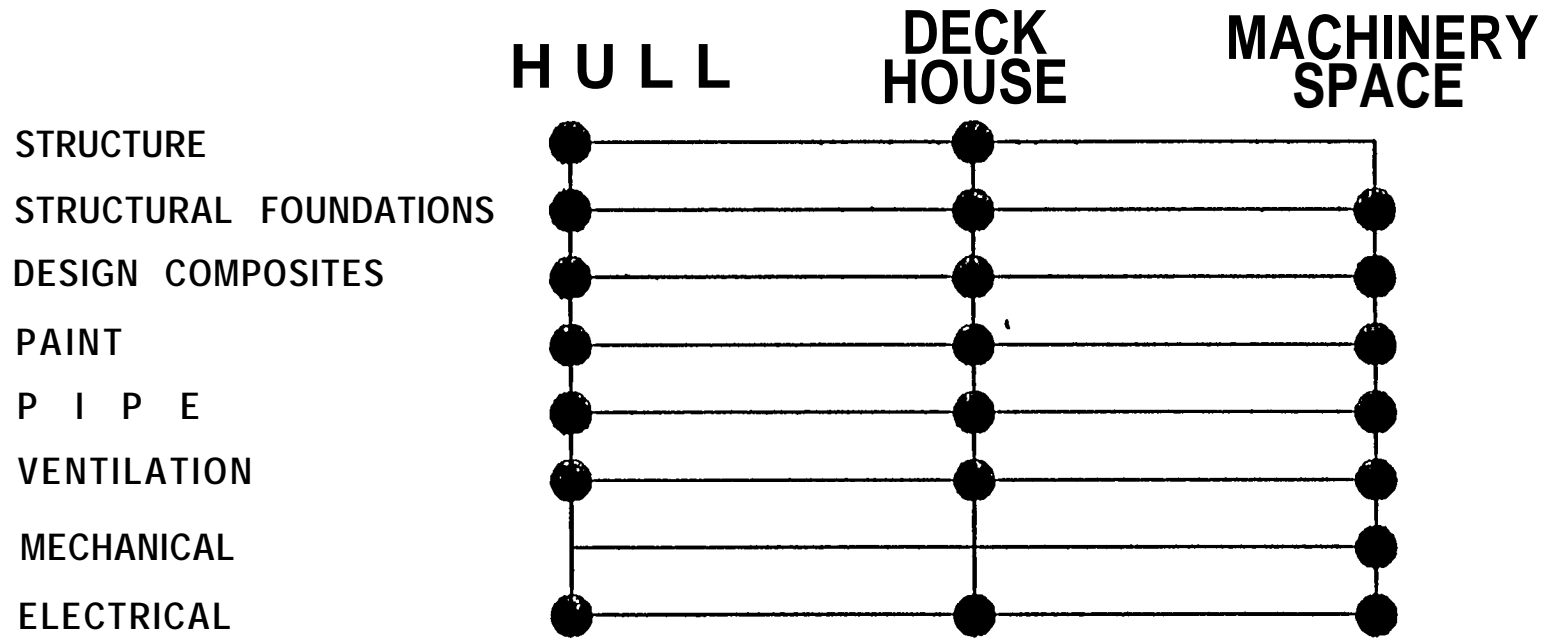

FIGURE 3.13 Product engineering function/zone matrix.

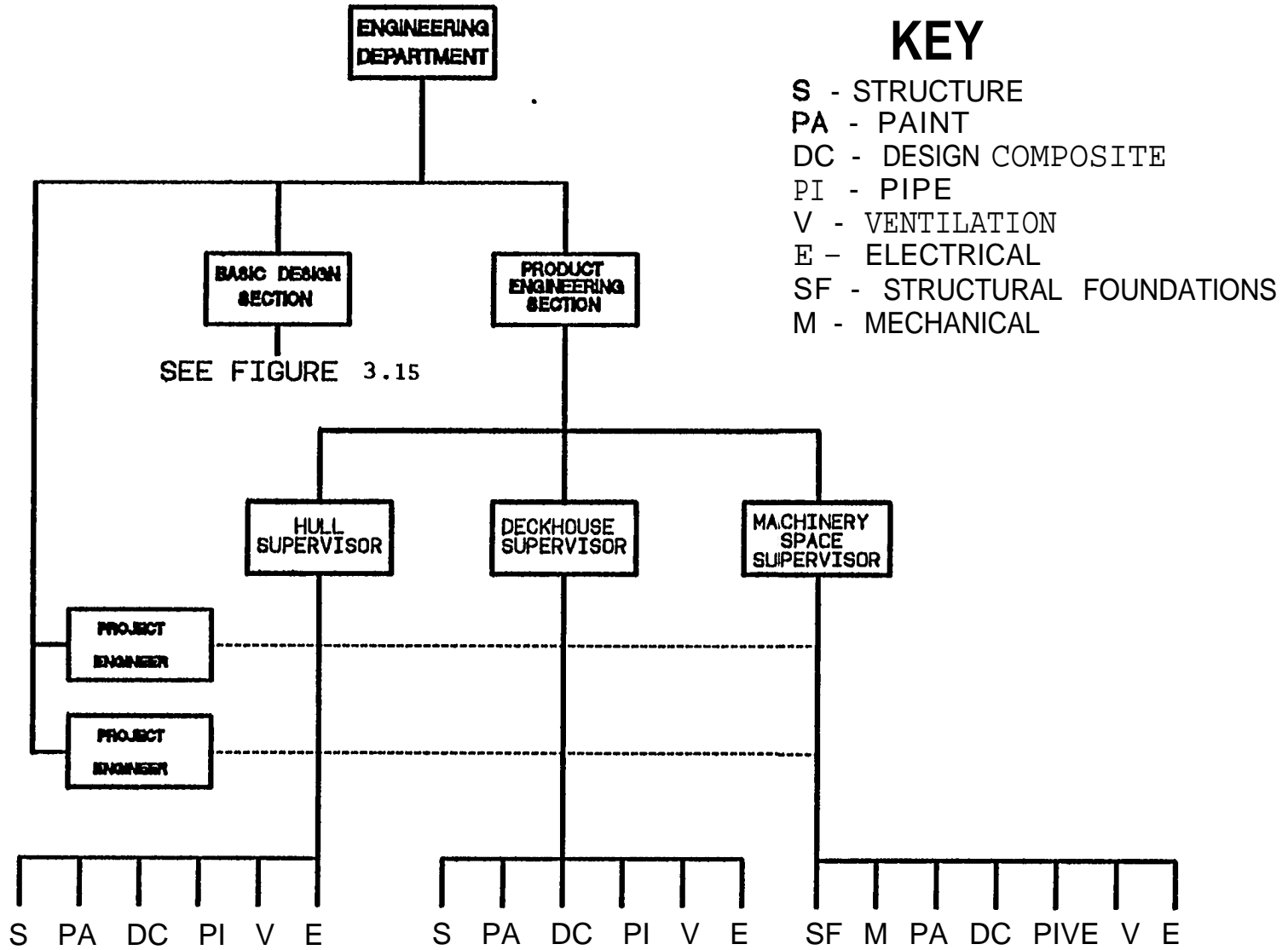

FIGURE 3.14 Product engineering organization for zone construction,

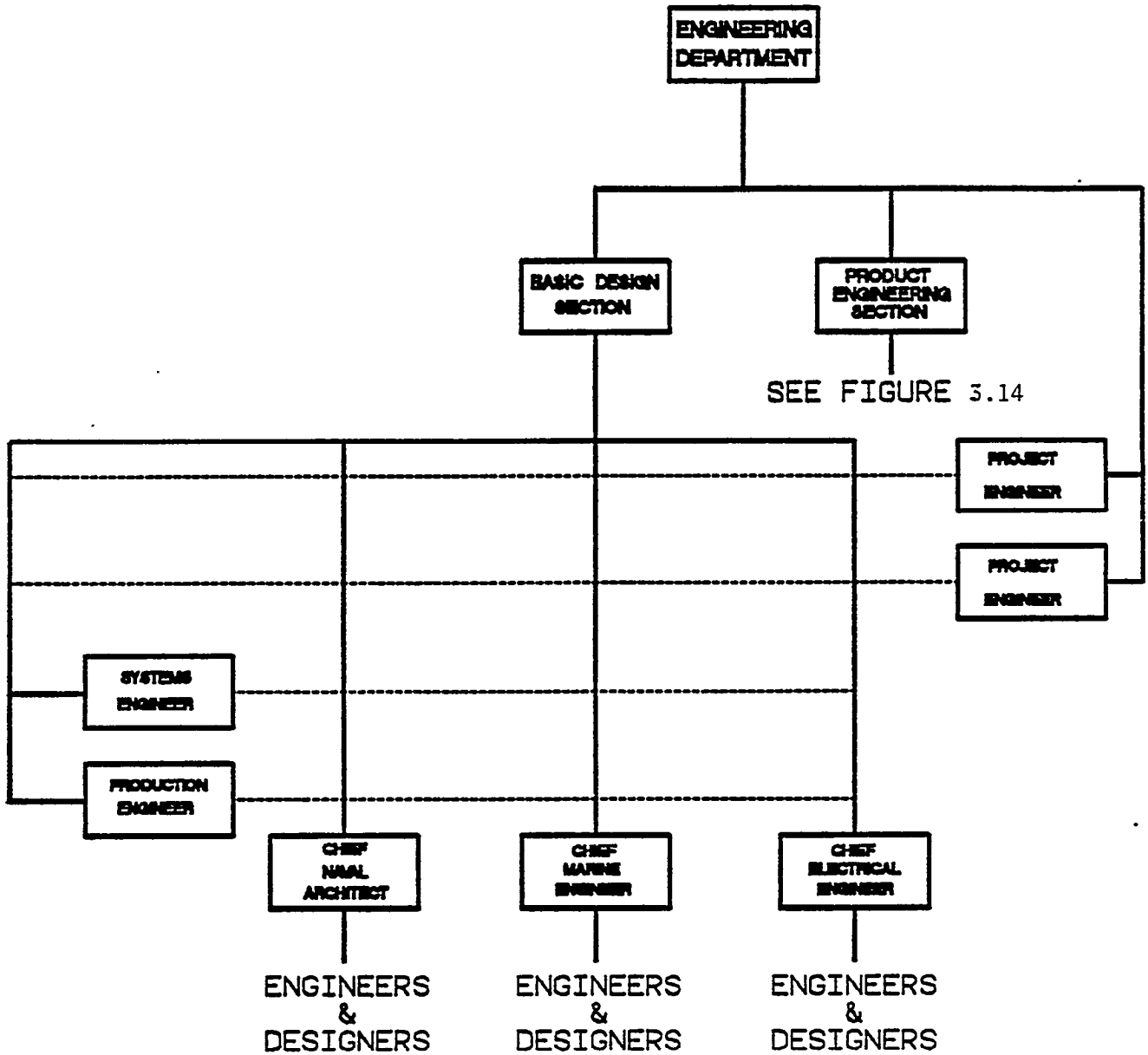

FIGURE 3.15 Basic design organization.

3.4 Staffing

The staffing of the organization is one of the most important factors affecting its success. Another is training. Even the best organization will not accomplish its goals effectively and efficiently if it is not staffed with the correct number of people with the correct balance of education, training, and experience. This is equally true of all departments in a shipyard, not only engineering. In order for the modern shipbuilding methods to be accepted and competently used, it is necessary to upgrade the technical and educational level of all shipyard managers and supervisors.

It is often stated [11,12] that the U.S. engineering problem is due to an inadequate number of engineers directly employed by the shipbuilding industry. While it is true that more engineers would give the engineering managers more resources to accomplish the work, it may simply mean more engineers preparing the work in the same outdated, inefficient way. It would obviously increase the cost of engineering, so there would need to be a resulting greater reduction in production manhours for it to make sense.

Table 3.1 gives the number of graduate engineers per 1,000 employees in the U.S. aircraft and shipbuilding industry as well as the same ratio for British and Japanese shipyards.

TABLE 3.1

GRADUATE ENGINEERS/1,000 EMPLOYEES

U.S. Aircraft Industry	10
U.S. Shipbuilding	5
British Shipbuilding	6
Japanese Shipbuilding	52

The SNAME SP-9 Panel on Education and Training issued a report, Curricular Needs of Shipyard Professionals, in June, 1984. This report shows that for ten U.S. shipyards, the ratio of graduate engineers per 1,000 employees was actually fourteen. Before it is concluded that this means that everything is therefore fine in the industry, it should be noted that the same report states that only 20% of the engineers were naval architects and marine engineers. The report states, "This means that the other 80% of the entry level technologists most likely have not been exposed to the shipbuilding industry prior to graduation."

Table 3.2 (from reference [13]) shows the ratio for both graduate engineers and designers for British shipbuilding. It can be seen that the number of graduate engineers has fallen from 13 to 6 per 1,000 employees from 1965 to 1974. The total number of technical staff has, however, remained constant at about 60 per 1,000 employees. The natural question is, does the shipbuilding industry really only require half the number of engineers that are necessary for the aircraft industry? Japanese experience shows a significantly higher ratio. However, it is necessary to look at the Japanese ratio closer to make sense of the comparison. Japanese graduates are of two types. The first is similar to U.S. and European engineering graduates. The second is similar to a technical college

student. The second type is not included in the U.S. or British ratios in Table 3.1. Nevertheless, it is probable that the Japanese ratio for the similar engineering graduates would be about 20 per 1,000 employees, still significantly higher than the U.S. and Britain. It is suggested that this higher number of technically educated people in the shipyards is a major reason for their success in shipbuilding and advanced shipbuilding technology.

Figure 3.16 shows the employers of and occupation of naval architects in the U.S., Britain, and Japan based on figures from reference [14]. Its message is clear! The U.S. needs more naval architects (and other engineers) in the shipyards. How can this be justified, let alone accomplished, in a contracting industry? It must be that training engineers in the advanced shipbuilding technology, and allowing them to practice the new way in both engineering and the other shipyard departments, must improve their performance to accomplish the goal of higher productivity and shorter building cycles for future ships. It is understandable that in the work-scarce and competitive situation U.S. shipbuilding is currently facing, it may be difficult for shipbuilding management to take such steps. However, those who survive the current crisis will probably be the ones who try innovative solutions to the current problems.

TABLE 3.2

**TECHNOLOGIST AND TECHNICIAN STATISTICS
FOR SHIPBUILDING INDUSTRY [3]**

Occupation	Numbers Employed						
	1965	1967	1968	1969	1970	1971	1974
Qualified Scientists & Engineers	1794	1599	957	771	545	445	508
Design & Other Draughtsmen	3863	3755	4084	3767	3796	3284	3473
Other Technicians	2283	2092	2336	2663	2214	1887	2071
Total Technicians	6140	5847	6420	6430	6010	5171	5544
Total of All Employees	136,059	128,649	121,454	120,196	122,250	115,892	100,886
QSE/Total Employees	1.32%	1.24%	0.79%	0.64%	0.45%	0.38%	0.50%
Total Tech./Total Employees	4.52%	4.64%	5.20%	5.35%	4.92%	5.00%	5.60%
(QSE + Total Tech)/Total Employees	5.84%	5.78%	6.09%	5.99%	5.37%	5.37%	6.09%
Total Tech/QSE	3.43/1	3.66/1	6.71/1	8.34/1	11.03/1	11.62/1	9.27/1
Draughtsmen/Total Tech	62.85%	64.22%	63.61%	58.58%	63.16%	63.51%	62.64%

Notes: Quantified Scientists and Engineers (QSS) include all employees who hold a university degree or equivalent, or are corporate member of appropriate professional institutions.
 Prior to 1968 the HNC was included in the definition of QSS but was subsequently excluded.
 Prior to 1969 tracers were included with draughtsmen.

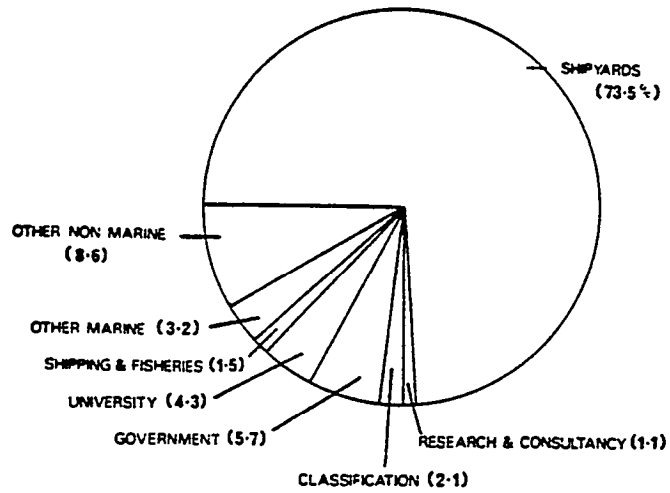
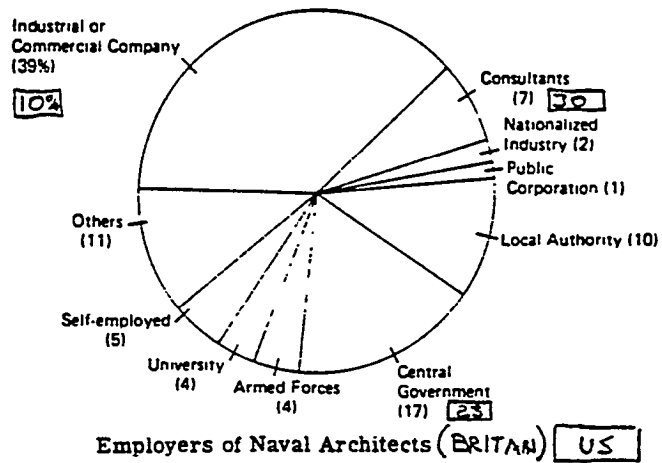

Employers of Naval Architects in Japan

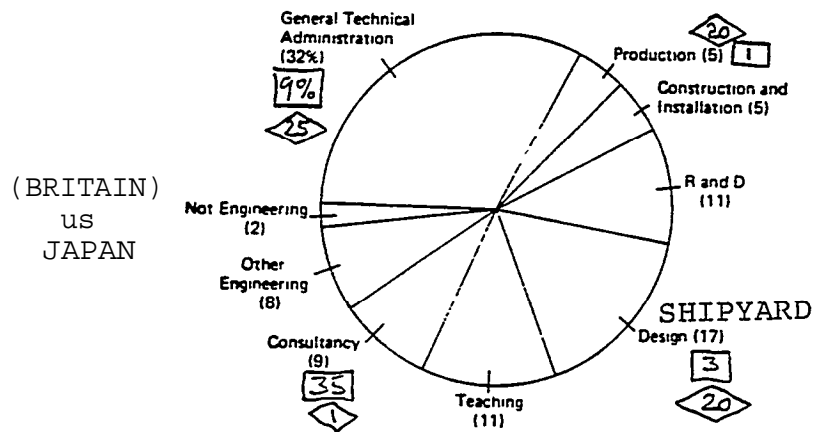

Occupation of Naval Architects by Type of Work

FIGURE 3.16 Naval architects, employers, and occupations.

3.5 Training

Training is another major factor affecting any organization. When it is realized that well planned and practical apprenticeships are almost nonexistent in the U.S. shipbuilding industry, and that most engineers and designers are left to “learn the hard way,” it is not surprising that it is close to the bottom of the shipbuilding technology ladder. It is essential for the U.S. shipbuilding industry to upgrade the knowledge level of shipyard employees. It will be futile to introduce advanced technology into shipyards if they are staffed by inadequately educated and trained personnel.

As it is obvious that there is not an abundance of engineering personnel already practicing the proposed **engineering for ship production**, it will be necessary to educate and train existing and new shipyard design and engineering department employees as well as those of marine design consultants in the methods and procedures to be used.

Another problem that must be recognized is that today's shipbuilding management, including engineering, has been trained in the traditional ways and is often too busy dealing with everyday problems to take time to learn and completely understand the new ways. In such an environment new graduates educated and others trained in advanced shipbuilding technology and engineering for ship production will be frustrated by the apparent lack of interest shown by these busy managers.

Therefore, it is suggested that shipyards, either individually or in association with other shipyards and/or universities and technical colleges, offer the education and training that is required to provide the level of advanced shipbuilding technology to increase the possibility of successful operation in the near and far future.

The subject of training for any industry is complex and large. It is not even suggested that it can be covered in an engineering approach book. It was necessary to briefly discuss it in order to draw attention to the need for a well planned effort by each shipyard and even by the industry. Until such a system is in use, it behooves each engineer and designer to plan his/her own training. With this in mind, a recommended reading reference on this matter is a recent paper by B.N. Baxter [15].

Figure 3.17, which is from a paper by G. Sivewright [16], indicates the thought and planning that must be expended to develop a successful program, as well as guide the self-trainer on areas to be developed to be a successful practitioner of *engineering for ship production*. Table 3.3 lists the training programs that were established by the British Shipbuilders Training Board for various professions in shipbuilding. Another reference worthy of reading is the RINA Symposium on the Training for Naval Architecture and Ocean Engineering [17].

It should be remembered that education and training are the food and exercise essential for the healthy and sustained life of any business. The shipbuilding industry in the U.S. will not become competitive if left undernourished and unfit.

- Notes:
 Bridging Training Programmes contain elements of general and objective training to meet individual needs.
 ARROW "A" - Trainee craftsmen selected as potential technicians to start general training.
 ARROW "B" - Trainee craftsmen during planned experience selected as potential technicians to start bridging training programme.
 ARROW "C" - New entry adults and craftsmen selected as potential technicians or draughtsmen to start bridging training programme.
 ARROW "D" - Trainee technicians complete technician training.
 ARROW "E" - Trainee draughtsmen recruited from craftsmen or new entry adults complete bridging training programme.
 ARROW "F" - Trainee draughtsmen start other technician job training programme.
 ARROW "G" - Trainee draughtsmen during planned experience selected for other technician jobs to start bridging training programme.
 ARROW "H" - Trainee draughtsmen on completion of first year training selected for other technician jobs start general training.

COLOUR KEY

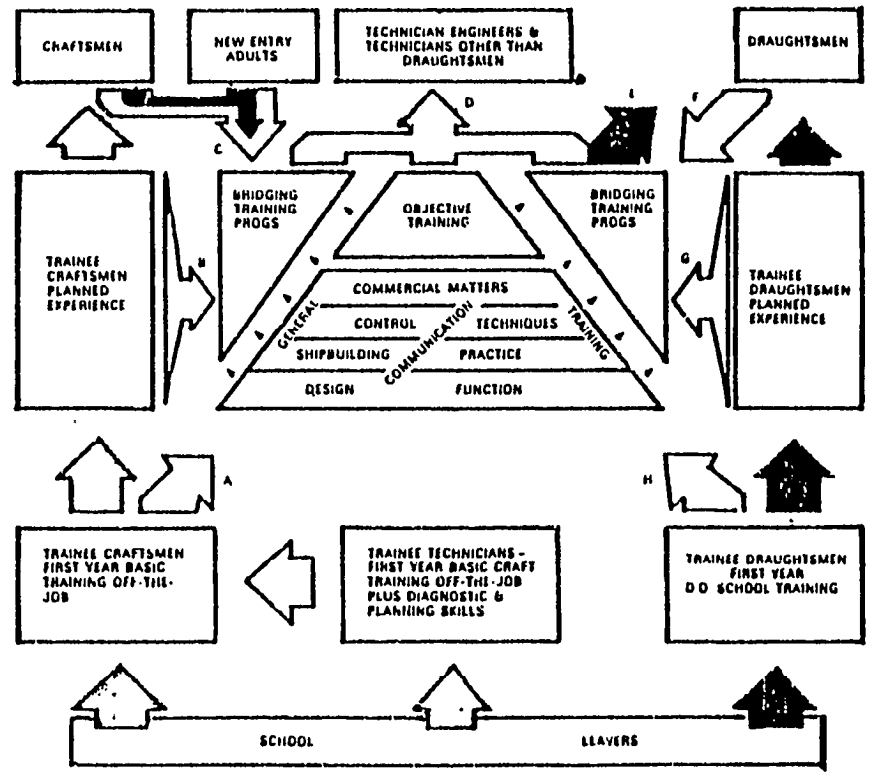
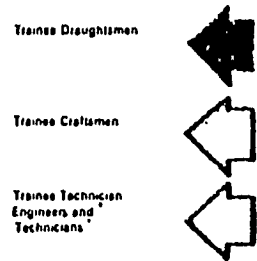

FIGURE 3.17 Shipyard training for naval architects and engineers.

BRITISH SHIPBUILDERS' TRAINING COURSES

COMMON BASIC TRAINING PROGRAMME

INDUCTION

The shipbuilding and shiprepairing industry or, where appropriate, the boatbuilding industry.

Short history of shipbuilding and shipping - the wooden, iron and steel ship era and progress in materials and propulsion machinery to date. The industry - size, distribution, products and customers.

Future prospects.

International competition.

The major associated industries, e.g. steel, engineering.

The Firm

History, organisation, layout.

Products, markets, main sub-contractors.

The skills used and the contribution of each trade to the end product.

Tour of the yard, shops and offices.

Trade Unions.

The trade union movement - its history and role.

Joint consultation - national, district, group and yard. The role of shop stewards and office representatives.

Conditions of Service

Hours, clocking, meal and tea breaks, lateness, absenteeism.

Payments: sickness payments, management of personal money.

Holidays, canteen, sports and social facilities.

Work rules, discipline.

Training and further education opportunities, career opportunities.

Safety and Health

The importance of safety, hygiene, safe working practices; accident prevention and good housekeeping.

The safety officer.

Fire precautions.

Factories and Offices Acts. Health and Safety at Work Act.

Shipbuilding and Shiprepairing Regulations. Woodworking Machines Regulations and Associated Codes.

SHIP CONSTRUCTION AND REPAIR

Visits to ships under construction and repair. Instruction to include:-

Layout of ship.

Ship terms.

Sequence of building a ship from inception to completion.

Overhaul, drydocking and damage repairs.

Types of ship and their functions.

HULL CONSTRUCTION

Practice in simple caulking, burning and metal-arc welding.

Visits to ships under construction and to fabrication and other shops.

Procedure for erecting the hull of a ship.

The principal tools, machines and equipment, hand and power, used for hull construction in the shops and yard.

The principal materials used - their characteristics and uses.

Contribution of the various metal-using trades.

Safety precautions.

LAUNCHING

Visit to ship being prepared for launching and being launched.

Procedure for launching a ship.

Contribution made by rigger and plater/shipwright.

Methods used at home and abroad.

OUTFITTING

Measuring, marking out, joining and fashioning wood and metal including practice in simple operations therein.

TABLE 3.3 (Continued)

Instruction to include:-

Procedure for fitting-out a ship.

The principal materials used, e.g. metals, wood laminates and plastics - their characteristics and uses.

The principal tools, machines and equipment, hand and power, used for outfitting in the shops and yards.

The contribution of the various outfitting trades.

Fittings and furnishings used.

Paint equipment and paints. Use and methods of application.

Health and safety precautions.

MACHINERY

Visits to engine works to see machinery under construction.

Visits to ships to see deck machinery, steering gear, etc.

Appreciation of engine room installations by use of plans, diagrams, or models. Instruction to include an introduction to:-

Various types of marine engines, turbines, reactor and nuclear propulsion.

Reasons for selection, e.g. cost, reliability, ease of maintenance, space, vibration.

Description of auxiliary machinery, function and layout.

Electric generators, compressors, pumps and lubrication methods.

TABLE 3.3 (Continued)

GENERAL TRAINING

PROGRAMME GUIDES AND EXAMPLES

A. DESIGN FUNCTION

Trainees should receive training in the drawing office appropriate to their specialisation, preferably in an area set aside for the purpose. The following is a general guide and must be related to the selected specialisation. The guide is more relevant to mechanical engineering and electrical engineering technician engineers and technicians: a programme for trainees in the hull construction and outfit group should be prepared by selecting suitable items from T.P.S. No. 7, Appendix C.

Training Programme Guide

Drawing Office Practice - BS308

- (a) Routine
- (b) Drawing and liaison
- (c) Standards
- (d) Development of drawing skills

Trainees should appreciate why particular systems and routines have been adopted and the support given by the Drawing Office to other departments.

Control of Size, Shape and Company Standards

- (a) Symbols, dimensions and tolerances
- (b) Interchangeability:

Trainees should understand the concept of tolerances and in addition to dimensional tolerances be made aware of geometrical tolerances in terms of squareness, flatness, parallelism, etc. They should know how tolerances are indicated and how they need to be interpreted. They should appreciate the need for standards and any special problems arising from metrication.

Selection of Materials and Components

- (a) Standard shapes and components
- (b) Properties

Trainees should understand the use of standard components and why standard shapes exist. They should appreciate the inter-relationship between such factors as weight, physical properties, cost and availability.

Production Processes

Trainees should be acquainted with methods of changing the shape and size of materials. They should understand the extent to which a method of construction may impose limitations on design. They should appreciate the safety hazards associated with different processes.

Fastenings

Trainees should appreciate the kinds of solution available to problems of locating components, enabling a correct choice to be made which takes account of the relevant factors of function, servicing, quantity, cost, time reliability.

Simple Power Transmitting and Control Systems

Trainees should be made aware of the choices which are available. Illustrations might be given, for example, of mechanical, electrical, hydraulic, pneumatic and electronic systems to demonstrate the range of options and the factors which influence their use.

Tribology

Trainees should appreciate the factors that need to be taken into account in the design of components having surfaces in contact.

Safety in Design

Trainees should be made aware of the steps that can be taken at the design stage to minimise hazards under operating conditions.

EXAMPLE 1

Trainee Technician Engineer Specialising in Mechanical Engineering

Drawing Office Practice

Work planning and allocation. Keeping up to date with technical knowledge. Liaison with suppliers, sub-contractors and customers.

Documents: parts lists, service schedules, inspection schedules, operating handbooks. Numbering and coding systems; duplicating (BS 4212). packaging, posting, issue of drawings.

Modification and design change procedures.

Drawing standards (BS30g).

Development of drawing skills using selected jobs.

Control of Size, Shape and Company Standards

Surface finish and machining symbols. Dimensions and tolerances. Limits and fits. Quality control. Testing.

Selection of Materials and Components

Typical shapes and sizes of raw materials, e.g. sheets, bar, plates, laminates. Relationship between material shape and size and component production method.

Manufacturing Processes

Methods of changing the shape and size of materials. Projects to be arranged to illustrate the extent to which the method of production may impose limitations on design.

Fastening

Nuts, bolts, studs, dowels, locking devices, spot welds, sheetmetal fasteners, rivets, catches, lock and tab washers, adhesives! self-tapping screws, circlips, other spring steel retainers. Types of thread, fixing devices and their uses. Illustration by seeing examples and by problem solving.

Simple Power Transmitting Devices

Appropriate emphasis on shafts, keys and keyways, gears, couplings shaft alignments.

Tribology

Appreciation of the design, manufacture and operation of bearing and bearing surfaces. Bearing materials and finishes, friction, wear, lubrication and lubricants.

Safety in Design

Refer to BS CP 3004:1964

Ergonomic and environment considerations.

EXAMPLE 2

Trainee Technician Engineer Specialising in Electrical Engineering

Drawing Office Practice

Work planning and allocation. Keeping up to date with technical knowledge. Liaison with suppliers, sub-contractors and customers.

Documents: parts lists, service schedule, inspection schedules, operating handbooks. Numbering and coding systems: methods of stockmg, issue of drawings, duplicating (BS 4212). packaging, posting.

Modification and design change procedures.

Drawing standards (BS 308, BS 9039)

Development of drawing skills using selected jobs.

Control of size, Shape and Company Standards

Dimensions and tolerances, symbolic representation of electronic components (BS 3939), colour codes, Quality testing and inspection requirements.

Understand circuit diagrams and corresponding wiring and component layouts. Typical circuit components values and the importance of positioning and screening of components and wires to avoid unnecessary stray capacity and unwanted coupling.

Selection of Materials and Components

Typical shapes and sizes in which materials are readily available. e.g. sheets, plates, rods, tubing, laminates. Understand use of different components, e.g. component rating and tolerances, the polarity of capacitors and diodes, the wattage of resistors: appreciate need for the differences in non-inductive resistors, wire-wound resistors, etc.

Awareness of properties of different insulating materials and their behaviour at high frequencies. Familiarity with manufacturers' data in relation to semi-conductor heat sinks: appreciation of problems associated with dissimilar metals in intimate contact: knowledge of safe range of working temperature and voltage for insulating materials and active components.

Ship Installations

Interpretation of drawings provided for electrical equipment installation and wiring. Assist in lining off at ship or mock-up equipment and cable runs.

Fastenings

Nuts, rivets, self-tapping screws, lock and tab washers, etc. Cable trays and mouting electrical equipment; patent fasteners and resilient mounts.

Simple Power Transmitting Devices

Appropriate emphasis on small gear trains, electro-mechanical devices, e.g. relays, selectors, electro-magnetic clutches.

Tribology

Appreciation of factors to be taken into account in design of related electro-mechanical components.

Safety in Design

Refer to basic safety requirements of Electricity (Factories Act) Special Regulations, 1908 and 1944.

B. SHIPBUILDING PRACTICE

Trainees should receive training in the appropriate specialisation i.e. hull construction and outfit. mechanical engineering or electrical engineering. A training programme should be produced using the following activities as a guide.

Training Programme Guide**(a) Construction and Manufacturing Processes - Machine Shops**

- (i) Forming machines
- (ii) Welding and cutting processes
- (iii) Shop layout
- (iv) Fabrication methods
- (v) Assembly methods
- (vi) Measurement and inspecting methods
- (vii) Safety precautions

(b) Construction and Fitting out - Berth

- (i) Berth arrangements
- (ii) Subassemblies - alignment
- (iii) Welding and burning
- (iv) Testing
- (v) Safety precautions

(c) Trials

Trainees should, wherever possible, attend trials and undertake, within their specialisation, tasks as a member of the trials team.

(d) Non-destructive Testing

A programme of training should be produced to include instruction and practice in all methods of non-destructive testing used by the company. Where appropriate a trainee should acquire knowledge of the relevant ionising Radiations (Scaled Sources) Regulations.

(e) Production Planning and Control

A programme of training should be produced with the objective that on completion a trainee will be able to interpret production planning and control data correctly.

(f) Investigation

A period of time should be allocated towards the end of this period of training to develop further a trainee's diagnostic ability. A project should be selected in line with production requirements which permits some analysis work. The following is a guide to the conduct of a suitable project:-,

- (i) Investigate failure of a component or sub-assembly, or piping system.
- (ii) Select method of investigation.
- (iii) Conduct investigation.
- (iv) Analyse results and identify causes.
- (v) Prepare report - oral and written.
- (vi) Submit proposals for remedial action.

Suggested Time: 6-9 months

EXAMPLE

Trainee Technician Specialising in Hull Construction

(a) Fabrication and Assembly

(i) Fabrication Shop

A training programme should be produced to include a period of time on each activity undertaken in the shop. Wherever possible a trainee should work on production items as a member of a team.

(ii) Building Berth

Selected areas of training should be identified and in line with the yard's production commitments a training programme produced to enable a trainee to obtain a working knowledge of the firm's method of assembly on the berth.

(b) Testing

Non-destructive Testing

A trainee should receive instruction and practice in the firm's methods of non-destructive testing in the shops and on the berth. On completion of this period of training a trainee should be able to interpret defects and recommend remedial action. Attention should be directed to the relevant ionising Radiations (Sealed Sources) Regulations.

Production Planning and Control

The trainee should assist in the production control office and undertake selected projects which could include the following:-

- (a) Attend production planning meetings.
- (b) Assist in producing charts for planning new contracts.
- (c) Assist in collecting and collating data from shops or berth, for comparison with the plan.
- (d) Assist with preparation of machine loading schedules.
- (e) Materials handling and layout.
- (f) Co-ordination of design changes.
- (g) Supply and stock holding of raw materials.
- (h) Control of production to ensure implementation of plan.

Investigation

- (a) As a project, undertake or assist in investigating a failure in fabrications or erecting a hull unit.
- (b) Carry out a "follow-up" exercise to determine whether an investigation report has resulted in effective action.
- (c) Assist the safety officer in a study to identify the cause of accidents and the remedial action required.

C. COMMERCIAL MATTERS

Training Programme Guide

(a) Ship Construction

(i) Sales-

Market research
Owner liaison
Estimates, proposals, specifications and contracts
Pricing
Public relations
Home and export

(ii) Repairs -

surveys
Estimates and contracts
Specifications
Work schedules

(b) Planning, Estimating and Costing

- (i) Financial accounting-cash receipts and procedures: data processing.
- (ii) Cost accounting - wages and salaries; material costs; overheads including administration and service costs; budgetary control.

(c) Purchasing

- (i) Participate with design and project teams-decision whether to buy, sub-contract or manufacture.
- (ii) Suppliers' location and reliability.
- (iii) Delivery dates and prices.
- (iv) Quantities and stock level: quality; preferred standards.
- (v) Production buying.
- (vi) Non-production buying.
- (vii) Sub-contracts.

Training Examples

1. Assist in estimating for a contract.
 2. Assist in a survey.
 3. Collect and collate information, e.g. sales promotion booklet, technical descriptive publication, instructor's handbook.
-
1. Assist in compiling a budget for a simple project.
 2. Under guidance, examine the expenditure relating to the budget of a selected project.
 3. Make recommendations for reducing overhead costs in a selected work area.
-
1. In respect of a specific item, assess whether it is cheapest to buy, sub-contract or manufacture.
 2. Investigate methods used in choosing a particular component, including consideration of cost, availability, policy, quality and replacement.
 3. Investigate range of information received by Purchasing Department and its use to place orders.

(d) Stores and Supplies

- (i) Stock levels; stock control; identification; storage systems; preservation: authority for issue/return/exchange; location inspection/analysis
- (ii) Raw materials
- (iii) Tools
- (iv) Goods inwards
- (v) Yard supply system and record

Training Examples

1. Carry out sample stock check of a short list of items, including reference to actual level compared with minimum, rate of consumption and value.
2. Check wastage rate of items having short shelf life: compared with stocks held and consumption.
3. Find out which procedures apply to disposal of surplus items.
4. Identify stock items with very low turnover rate; investigate reasons for this.
5. Examine quality control procedures relating to incoming goods, with special reference to their cost and justification.

Suggested Time: 6 months approximately

D. CONTROL TECHNIQUES**Training Programme Guide****(a) Instrumentation**

- (i) Fluid
- (ii) Electrical
- (iii) Physical
- (iv) Dimensions and shapes
- (v) Transduction
- (vi) Application
- (vii) Safety aspects

(b) Work Study

- (i) Definitions
- (ii) Organisation
- (iii) Industrial Relations Factors
- (iv) Elementary methods and applications
- (v) Examples

Training Examples

1. Participate in simple method study exercise, e.g. documentation of stock handling.
2. Subsequently carry out a similar exercise on operation in which the trainee is involved.
3. Whether opportunity arises, work study methods should be utilised when carrying out investigations or assignments.

(c) Computer Application

- (i) Computation
- (ii) Data processing and analysis
- (iii) Computer aided design
- (iv) Control (of procedures and machines)
- (v) Simulation

1. Write short report on use of computer employed by the company.
2. Assist systems analyst in collaring data for use in computer-based information service.
3. Demonstrate to trainee (on company machine or through a visit) computer operations and characteristics, e.g. speed, dependence upon detailed instructions (programme), Operating costs, storage, capability.
4. Record data required for calculating wages procedure for putting wages on the computer.

(d) Quality Control and Inspection

- (i) Functions, responsibilities and relationships.
- (ii) Equipment and procedures.
- (iii) Control and inspection techniques as applied to materials and equipment.

1. Find answers to such questions as: How does the company's quality control department carry out its responsibilities? How are standards of inspection set and communicated? What company benefits accrue through quality control? Prepare report for discussion with a senior quality control engineer.

Suggested Time: 8-10 weeks

TABLE 3.3 (Continued)

E. COMMUNICAITON	
Training Programme Guide	
<p>(a) Introduction of Terms</p> <ul style="list-style-type: none"> (i) Information (ii) Communication (iii) Transmission (iv) Reception (v) Feedback <p>(b) Originating a Communication (Written or oral)</p> <ul style="list-style-type: none"> (i) Objective (What) (ii) Reason (why) (iii) Recipient (Who) (iv) Place (Where) (v) Timing (When) (vi) Treatment (How much) (vii) Media, structure and cost (How) <p>(c) Reception and Subsequent Action</p> <ul style="list-style-type: none"> (i) Understanding and acceptance (ii) Handling (iii) Recording and retrieval (iv) Acknowledgement and action (Feedback) (v) Organisation arid Management <p>(d) Special Requirements</p> <ul style="list-style-type: none"> (i) Reports (ii) Specification (iii) Pro-formas (iv) Forms (v) Procedures 	<p style="text-align: center;"><i>Training Examples</i></p> <ol style="list-style-type: none"> 1. Use projects relevant to any stage of training as exercises in effective written or oral communication. 2. Write instruction relating to a familiar process. 3. Collect information and write technical abstract for works manager on such a subject as machine tools, test equipment. 4. Collect information and write technical abstract for a designer to cover specific range of bought-out parts. 5. Examine an order or instruction and provide answers to such questions as: <ul style="list-style-type: none"> (a) What does it mean and who should act on it? (b) Is it correctly written, so that it an achieve its objective? (c) It is not achieving its objective: <ul style="list-style-type: none"> (i) Why not? (ii) is there provision to ensure that originator knows? (iii) Are there factors other than communication involved? 6. Read and comment on company report concerning, for example, a development test or inspection procedure and identify contribution of good and bad communiati- tion. 7. Participate in format and informal discussions concerning, for example, the training programme or company work planning, taking turns as Chairman and Secretary. 8. Consider and comment on means of presenting various types of information, e.g. profit and loss, targets and achievement, time lost, production criteria. 9. Prepare and present selected items of induction training of junior trainees. 10. Conduct visitors around selected areas after preparing an itinerary and summary of information.

TABLE 3.3 (Continued)**OBJECTIVE TRAINING****EXAMPLE JOB DESCRIPTIONS AND TRAINING PROGRAMMES**

Example job descriptions and objective training programmes are included as follows:-

- (1) Example Job Description - Industrial Engineer.
- (2) Example Objective Training Programme - Industrial Engineer.
- (3) Example Job Description - Estimator.
- (4) Example Objective Training Programme - Estimator.
- (5) Example Job Description-Welding Technician.
- (6) Example Objective Training Programme - Welding Technician.
- (7) Example Job Description - Mechanical Engineering Draughtsman.
- (8) Example Objective Training Programme - Mechanical Engineering Draughtsman.

APPENDIX D (1)

EXAMPLE JOB DESCRIPTION - INDUSTRIAL ENGINEER

JOB TITLE:	Industrial Engineer
RESPONSIBLE TO:	Senior Industrial Engineer
DEPARTMENT:	Industrial Engineering
LIAISES WITH:	Staff in contracts, accounts, production and service departments. Production supervisors and shop stewards.
MAIN ACTIVITIES:	(a) Supplies management control information. (b) Monitors staff and direct labour manpower requirements. (c) Designs, implements and administers in-centre schemes and labour control procedures. (d) Leads team of assistant industrial engineers in method and project investigation. (e) Deputises for Senior Industrial Engineer in his absence. (f) Advises management on feasibility or suitability of capital equipment.

APPENDIX D (2)

EXAMPLE OBJECTIVE TRAINING PROGRAMME FOR INDUSTRIAL ENGINEER

The contribution made by general training to the skills and knowledge required for the job have been taken into account. The job calls for additional specific skills and knowledge and the objective training programme illustrates how these requirements may be met in a particular case.

PROGRAMME**A - SERVICE DEPARTMENTS****Training Specification**

To obtain:-

- (a) contact with persons with whom he will subsequently liaise.
- (b) understanding of the contribution made by other service departments.
- (c) knowledge of the relevance of his own function to the work of other service departments and of the need for co-ordination.

Time allowed - 4 weeks approximately.

Training Method: The trainee will spend about 2 days in each service department.

Training Examples: On completion of the attachment to each department the trainee should have an appreciation of the activities listed:-

1. **Soles**
 - type of market
 - sales contract estimating and pricing
 - escalation and relevance to contract price
 - product policy and range.
2. **Programme**
 - application of network analysis
 - manpower curves and requirements
 - use of computer.
3. **D.O. Design office**
 - preparation and distribution of drawings
 - material requisition.
4. **Purchasing**
 - inventory control
 - make or buy decisions
 - vendor appraisal and selection
 - re-order systems
 - economic batch quantities
 - bulk buying.
5. **Production Control**
 - shop loading/sequencing
 - store-keeping
 - materials movement
6. **Quality Control**
 - documentation
 - quality assurance
 - testing procedures.
7. **Accounts**
 - standard time, standard costs and cost controls
 - budgetary control
 - depreciation
 - overhead allocation
 - wage/salary structure
 - analyses of expenditure on materials, labour and capital equipment
 - computerisation.
8. **Personnel**
 - manpower analyses
 - trade unions
 - negotiating procedures
 - disputes procedures.

B - PRODUCTION DEPARTMENT

Training Specification

To obtain a knowledge of:-

- (a) manpower requirements.
- (b) plant capabilities and layout problems.
- (c) material handling.

Time allowed - 6 months approximately.

Training Method: The trainee will work in all principal production areas, undertaking projects. He will be responsible to the head in each area.

Training Examples: The following training examples should be undertaken in each area visited and short written reports vetted by the head foreman:-

- (a) Knowledge of total output of the area, with number employed.
- (b) Knowledge of machine and lifting appliance capabilities.
- (c) Knowledge and experience of material handling systems.
- (d) Knowledge of area layout.
- (e) Experience of production processes.
- (f) Gradually **assume** responsibility for part of the production process.

C-WORK STUDY DEPARTMENT

Training Specification

To obtain-

- (a) knowledge and experience of methods of analysing and recording work (e.g. process charts, networks).
- (b) experience of standard time derivation.
- (c) knowledge and experience of time study.
- (d) knowledge and experience of activity sampling.
- (e) knowledge and experience of learning curves.
- (f) experience of the maintenance and **issue** of work standards.

Time allowed - 9 months approx.

- Training Method:** The trainee will work in the Work Study Department under the guidance of a senior work study engineer. At appropriate intervals the following courses will be attended:-
- (i) Basic work study: method study techniques, work measurement, rating, activity sampling (2 weeks).
 - (ii) Skill training: timing and rating, selected techniques (1 week).
 - (iii) Industrial relations and negotiations (2 weeks).
 - (iv) Work study techniques: skills analysis, learning curves, report writing (1 week).
 - (v) Leadership styles and communication (1 week).
 - (vi) Cost/benefit analysis: costing studies, attitudes to change, case presentation at meetings (2 weeks).

Training Examples:

Method Study Section

- (a) Investigate selected operations and recommend new method standards. Monitor implementation and **feedback**.
- (b) From plant layout drawings develop optimum methods of performing selected operations.
- (c) Investigate existing operations to reduce costs.

Time Study Section

- (a) Use standard data to prepare synthetic times for methods developed.
- (b) Carry out time studies.
- (c) Assist in the investigation of complaints **on** time standards.

D-LAYOUTS AND METHODS

Training Specification

To obtain experience of:-

- (a) planning new or modified workshop layouts.
- (b) planning work flow.

Time allowed - 3 months approximately.

Training Method: The trainee will be given planned experience in the Planning Office under the guidance of selected planning engineers.

Training Examples:

- (a) Assist in the investigation of a proposal to re-site the pipeworkers.
- (b) Assist in the introduction of new equipment into a workshop.
- (c) Examine existing plate shop layout and suggest modifications.

E - SYSTEMS DESIGN AND ANALYSIS

Training Specification

To obtain experience of company management control systems.

Time allowed - 2 months approx.

Training Method: The trainee will work as a junior member of a project team, analysing, defining and developing management control information. He will be given experience of various charting and recording techniques.

APPENDIX D (3)

EXAMPLE JOB DESCRIPTION-ESTIMATOR

- JOB TITLE:** Estimator (in shiprepair firm)
- RESPONSIBLE TO:** Chief Estimator
- DEPARTMENT:** Estimating Office
- LIAISES WITH:** Shipowners, drawing office, purchasing office, cost office, works manager, ship managers, trade foremen, dock and classification authority officers.
- MAIN ACTIVITIES:**
- (a) Interprets drawings and specification; discusses with shipowners or their representatives.
 - (b) Establishes material costs, material availability and sub-contract item costs.
 - (c) Establishes labour costs by discussing craft hours breakdown with foremen: prepares manpower schedules.
 - (d) Establishes repair period and additional costs accounting for workshop loading, plan availability, docking charges.
 - (e) Produces estimates by collating information.
 - (f) Estimates work on site in consultation with shipowners or their representatives.
 - (g) Compares estimates with actual costs incurred and advises corrective action on accounts: maintains an up to date library on costs for estimating purposes.

TABLE 3.3 Continued)

EXAMPLE OBJECTIVE TRAINING PROGRAMME - ESTIMATOR

The contribution made by general training to the skills and knowledge required for the job have been taken into account. The job calls for additional specific skills and knowledge and the objective training programme illustrates how these requirements may be met in a particular case.

PROGRAMME**A-WORKSHOPS****Training Specification**

To obtain:-

- (a) knowledge of machine capabilities.
- (b) experience on production of standard and non-standard units.
- (c) experience of workshop problems relating to drawings and specifications.
- (d) **knowledge** of the economic choice of materials.
- (e) knowledge of manpower capabilities.

Time allowed -4 months approximately.

Training Method: The trainee will work in each workshop and will become conversant with the operation of each machine. The objective is not to instil a high degree of skill in machining but to provide an appreciation, through personal experience, of the capabilities and limitations of each workshop and a knowledge of the workshop problems.

Training Examples:

- (a) Use various simple machines on production items.
- (b) View manufacture of selected production items and establish and prepare a written report on capabilities of machines and lifting equipment.
- (c) Estimate quantity of material and manhours in selected production units.
- (d) Establish **material wastage and suggest cost savings.**

B - ON SITE**Training Specification**

To obtain:-

- (a) knowledge of dry dock and wet berth facilities.
- (b) knowledge of dock authority hire equipment.
- (c) experience of repair work on site.
- (d) experience of shipowner representatives and their requirements.
- (e) an appreciation of manpower allocation.
- (f) an understanding of difficulties involved in progressing work between workshops, sub-contractors and the repair site.

Time allowed - 3 months approximately.

Training Method: The trainee will work under the guidance of an outside foreman.

Training Examples:

- (a) Assist with dry docking, berthing.
- (b) Carry **out** routine work for the firm with the dock's authority.
- (c) Participate in a small repair contract and prepare reports on:-
 - (i) areas where costs could be improved.
 - (ii) the detailed manpower allocation (with assistance).
 - (iii) a comparison of ordered and delivery dates for sub-contract and workshop items.
- (d) Carry out routine work with shipowners representative.
- (e) Visit main sub-contractors to discuss delivery schedules.
- (f) Assist in allocating manpower **on** a repair job.
- (g) Assist in checking completed repair work and attend any classification authority tests.

C - OFFICE PROCEDURE**Training Specification**

To obtain:-

- (a) experience of the procedures used in the purchase and cost office.
- (b) skill in establishing the actual cost of jobs after completion.
- (c) knowledge of material costs and normal sub-contract unit costs.
- (d) knowledge of the company's tendering procedures.
- (e) knowledge of regular suppliers and the company's rating system.
- (f) experience in preparing purchase orders, dealing with enquiries and preparing draft letters.
- (g) experience in contacting representatives as a means of urging delivery.

Time allowed - 4 months approximately.

Training Method: The trainee will work in both the purchase office and the cost office under the guidance of the Purchasing Manager and Cost Controller respectively.

Training Examples:

- (a) Undertake routine material and equipment ordering.
- (b) From hourly records and material records produce the actual cost of a repair job.
- (c) Assist in the preparation of a tender and prepare a report itemising constraints in negotiations.
- (d) Prepare a programme of delivery dates for sub-contract items and follow a repair job. Report on areas for improvement.

D - ESTIMATING OFFICE

Training Specification

To obtain:-

- (a) knowledge of the build-up of estimates.
- (b) knowledge of the effect of price and wages increases on contract profitability.
- (c) experience in evaluating actual costs against estimate.
- (d) experience of all clerical procedures within the office.

Time allowed - 3 months approximately.

Training Method: The trainee will work in the Estimating Office under the Chief Estimator.

Training Examples:

- (a) Using simple drawings and specifications prepare under guidance an estimate for a tender.
- (b) Undertake all clerical duties and become familiar with the office procedures.
- (c) Assist in the interpretation of specifications and drawings and prepare under guidance an on-site estimate of a repair job.
- (d) Prepare written reports on current material and contractor's costs for office circulation.
- (e) Assist the Works Manager in finalising estimates.

APPENDIX D (5)

EXAMPLE JOB DESCRIPTION -WELDING TECHNICIAN

- JOB TITLE:** Welding Technician
- RESPONSIBLE TO:** Assistant Welding Engineer
- RESPONSIBLE FOR:** Functionally, 2 or 3 squads each consisting of a welder and a caulker.
- DEPARTMENT:** Welding Engineering.
- LIAISES WITH:** Drawing office, radiographer, works manager, ship managers, steel trades foremen, sub-contractors, welding manager.
- MAIN ACTIVITIES:**
- (a) Examines and reports on welds and welding procedures.
 - (b) Identifies faults of a non-welding nature, e.g. laminated plates and structural weaknesses and reports defects to the welding engineer.
 - (c) Organises non-destructive testing on ship structures and corrects the defects.
 - (d) Investigates and reports on welding problems and produces procedures.
 - (e) Undertakes welding defects at the request of subcontractors on **contracted** equipment.
 - (f) Tests and assesses performance of new welding rods.

APPENDIX D (6)

EXAMPLE OBJECTIVE TRAINING PROGRAMME FOR A WELDING TECHNICIAN

The contribution made by general training to the skills and knowledge required for the job have been taken into account. It is important that during this period the trainee achieves the company's standard of proficiency specified for craft trainees in all aspects of welding. The job calls for additional specific skills and knowledge and the objective training programme illustrates how these requirements may be met in a particular case.

TABLE 3.3 (Continued)

EXAMPLE JOB DESCRIPTION - MECHANICAL ENGINEERING DRAUGHTSMAN

- JOB TITLE:** Mechanical Engineering Draughtsman
- RESPONSIBLE TO:** Chief Mechanical Engineering Draughtsman
- DEPARTMENT:** Engineering Drawing Office.
- LIAISES WITH:** Design, construction and electrical drawing offices. production managers and foremen of engineering and pipework departments, sub-contractors.
- MAIN ACTIVITIES:**
- (a) Prepares machinery arrangement and floor plates, platforms and ladder drawings, from specifications and sub-contractors' drawings.
 - (b) Prepares piping system diagrams, geographical pipework arrangements, parts and materials lists from specifications and sub-contractors' requirements.
 - (c) Prepares stern gear drawings for shafting and stem tube from specification and in consultation with the design and construction drawing offices.
 - (d) Prepares drawings of components for manufacture.
 - (e) Prepares drawings for auxiliary equipment seatings and shell penetrations.
 - (f) Prepares control room layout, remote control systems and instrumentation drawings.
 - (g) Prepares arrangement drawings for (i) lifting, removal and maintenance of engine room equipment, (ii) engine room ventilation drawings and (iii) engine store rooms and workshops.
 - (h) Attends sea trial and produce "as fitted" drawings.

APPENDIX D (8)

EXAMPLE OBJECTIVE TRAINING - MECHANICAL ENGINEERING DRAUGHTSMAN

Account has been taken of the contribution made by General Training to the job skills and knowledge requirements. However, this job calls for additional specific skills and knowledge and the following Objective Training programme illustrates how these requirements may be made in a particular case.

PROGRAMME

A - QUALITY CONTROL DEPARTMENT

Training Specification

To obtain knowledge of:-

- (a) quality control and the required paperwork.
- (b) quality control checking systems.
- (c) test procedures.
- (d) sea trials procedures.

Time allowed - 3 months approximately.

Training Method: The trainee will work in the department and will be responsible to the departmental head. The trainee must be actively concerned in the selected department's activities; he should not be just an observer.

Training Examples:

- (a) Check quality of in-coming materials and report.
- (b) Assist departmental personnel with inspections on board ship when under construction.
- (c) Assist departmental personnel and Classification Society's surveyors with inspections and tests of systems on board ship when under construction.
- (d) Record data as instructed when ship is undergoing basin and sea trials.

B - PRODUCTION CONTROL DEPARTMENT

Training Specification

To obtain knowledge of:-

- (a) production control procedures.
- (b) procurement procedures.
- (c) P.E.R.T. systems and operation.

Time allowed - 3 months approximately.

TABLE 3.3 (Continued)

Training Method: The trainee will work in the department and will be responsible to the departmental head. The trainee must be actively concerned in the department's activities; he should not be just an observer.

Training Examples: Under supervision, plan and control the production of a pipe system; for example, fire-fighting system or bilge system.

C - SHIP DRAWING OFFICE

Training Specification

To obtain:-

- (a) contact with persons with whom he will subsequently liaise.
- (b) understanding of the contribution made by the Ship Drawing Office.
- (c) knowledge of the relevance of his own function to the work of the Ship Drawing Office and the need for co-ordination.

Time allowed - 8 weeks approximately.

Training Method: The trainee will work in sections with which he will liaise in the future.

Training Examples:

- (a) Ship steelwork - construction items
materials
building process.
- (b) Layout - space allocation for engine-room,
deck machinery.
- (c) System provision - pipe runs
auxiliary machinery
tanks
ventilation.
- (d) Ship specification - Classification Societies
owners requirements
British Standards
engine and machinery spares
refrigeration requirements.

D - MECHANICAL ENGINEERING DRAWING OFFICE

Training Specification

To obtain knowledge of:-

- (a) basic marine engines and ancillary equipment.
- (b) basic pipework systems for all ship's services.
- (c) types of valves and fittings for all ship's services.
- (d) location of equipment-special seatings.
- (e) types of piping used.
- (f) methods of connecting pipes, valves and fittings.
- (g) layout of ship's engine-room.
- (h) layout and siting of bridge and control instruments.
- (i) drawing office procedures.
- (j) supplier catalogues.

Time allowed - 6 months approximately.

Training Methods: The trainee will work on selected jobs arranged to develop his skill and knowledge in preparation for full participation in the work of the drawing office.

Training Examples:

- (a) Engine-room layout for a small ship or an auxiliary machinery space.
- (b) From a diagrammatic drawing or model of a piping system, prepare a schedule of valves, piping and coupling.

3.6 Management

Engineering for skip production must to be managed just like any other worthwhile activity. However, the approach to engineering can reduce the complexity of management in the same way it simplifies planning and scheduling. This is possible because of the following factors:

- Elimination of duplication of effort and data
- Organized to suit zones
- Integration of lofting and planning with engineering
- Material designed, selected, procured, and scheduled by zones
- All engineering disciplines working on each zone at the same time
- No issue of engineering information before it is completed for all disciplines for each zone

Management has been defined as the universal process of accomplishing work through others. This simple definition belies the complexity of managing people. It consists of handling and making decisions on many conflicting requirements at the same time. Because of this, management analysts try to eliminate the complexity by conveniently dividing it up into functions, and then discussing each function and the relationships between them. The four functions that are always listed are:

- Planning
- Organizing
- Directing
- Controlling

Other functions that are sometimes listed are:

- Leadership (a directing function)
- Assembling resources (part of organizing)
- Staffing (part of organizing)
- Training (part of organizing)
- Communication (part of directing)
- Decision making (involved in all functions)
- Budgeting (a planning function)

The additional functions can all be considered subsets of the first four, as shown by the relationships indicated in parenthesis.

Planning is the *who, what, where, and when* decision phase of management. It **utilizes tools** such as **work breakdown structures, task listings, sequencing, networking**, and critical *path method*, along with engineering and manufacturing skills to select an efficient approach to designing, procuring material, and constructing a product.

Organizing consists of both the design of the organization and its staffing and training. They have been discussed already.

Directing is the ordering by commands, instructing by example, or suggesting by consultation, of the necessary actions to obtain the desired result. It is here that the “art of management” is truly most applied. This art, as well as controlling people, is the melding of the planning and organizing, which in turn are tools or systems to determine if the “art” was successful in accomplishing the plan.

Controlling is the analysis of operating results in comparison with the plan. If the results do not conform, action must be taken to improve the future results so that the final outcome will achieve or better the plan. Controlling also involves feedback of the results, so they can be used by planning in the future. The control of any business endeavor requires the following basic knowledge:

- What has to be done?
- When should it be done?
- What resources does it require?

With this knowledge, managers can control the work if the following feedback is provided:

- Is the work being done on schedule?
- Is the performance better or worse than budgeted?
- How can problems be corrected?
- Are any adverse trends developing?

Any management control system must address all the above questions.

There is an obvious logical sequence of these functions for every project, namely, planning, organizing, directing, and controlling. Once initiated, the control function may require continuous replanning, reorganizing, and redirecting if results are not to plan.

As in any business, assuming an effective organization is in place, planning, scheduling, and control are the keys to success. Without them, the basic concepts of the modern integrated shipyard would be unworkable. It is therefore likely that in a modern shipyard an integrated management information system will be used for these functions. In such a case, it is necessary for engineering to prepare the information used by the system. Even with such an integrated system it is probable that engineering prepares two schedules which are unique to its function, and they are:

- **Drawing Schedule**

This schedule should list all product engineering drawings which are required to construct the ship. It should have an upper and lower row for each entry in which scheduled and actual dates are listed, respectively. Columns should be provided for dates for drawing start, completing, submittal to owner, classification and regulatory bodies, and issue. The drawing schedule is used for a number of purposes by the shipyard and others, such as an index of drawings, and as a record of approval action. It should *not* be used to control or progress the project. The drawing schedule could be an automatic fallout from the integrated planning, scheduling, and control system, as all the information is in the common data base.

- **Purchase Specification Schedule**

This schedule is required by the shipyard as a means of approval control of major purchased equipment and machinery, by the owner. It can also be used by the shipyard to record the status of activity on major equipment and machinery procurement. Again, it could be an automatic fallout from the integrated management system, as all the required information would be in the common data base.

There are still many shipyards where the different departments plan, schedule, and control independently! A major or key event schedule is used as the integrating document, but it is difficult to keep up-to-date for changes in any of the independent systems. The outcome is usually unreliable, confusing, and an open invitation to conflict between the

various departments. If an integrated system is not used, the engineering department must utilize a planning, scheduling, and control system of its own. In this case, it is important that the output from this department system can be utilized by purchasing and production as input to their systems. The system must provide as a minimum the three basic decisions, and the four feedbacks previously mentioned. The system should be simple to use. For example, it should accept employee time card data without any preprocessing manipulation and minimum additional data.

Such a system was developed some years ago by the author, and will now be discussed. It uses the initial planning, scheduling, and budgeting information as the basis and requires only progress estimates in addition to the employees' normal time cards. Even this step can be eliminated by using completion history of previously performed tasks as the performance efficiency. Figure 3.18 shows the report form that connects engineering, purchasing, and production schedules together. It does not include purchase technical specifications. It is prepared to tie together issue dates for drawings and other engineering information to production, and Bills of Material to purchasing. The report form is *not* used by engineering to progress or control the project. Figure 3.19 is the schedule and work assignment bar chart. The chart is produced from the initial schedule and budget information, and is continuously updated. It shows when each task is scheduled to be worked on, how many hours to be worked each day, and scheduled issue. As each report is issued, it also shows actual time worked on each task. This prevents the deliberately misleading practice of starting and recording the start for a task on the scheduled day, and then delaying any further work until later. It is also possible to show the various stages of work on a task, such as design calculations, drawing preparation, BOM preparation, checking, rework after checking, and rework after approval. Comparing the scheduled time against actual time for the last two items will give an actual indication of the technical excellence, or otherwise, of the engineering department. The program works back from the required issue date for engineering information, allowing for approval times, and determines days on which work must be done. If a start date is inputted, the number of hours required to be expended each day is also calculated and given. Otherwise the days are scheduled on the basis of an eight-hour day.

The program adds up the scheduled hours to be worked each day, and gives a total. Peaks and hollows in the daily work demand can be easily seen, and adjustments made to even out the maiming requirements. The program does not currently include an automatic resource allocation capability. Thus the "Schedule and Work Assignment Report" shows the three basic data requirements. By processing time charged to each task from the employees' normal time cards, each issue of the report is an excellent visual aid to quickly show how well the schedule is being adhered to. Thus the first feedback question can be answered. By incorporating estimated completion of each identified task, the program will develop data to answer the remaining three feedback questions, thus enabling analysis and resulting decision and action.

This information is shown in the performance report, such as Figure 3.20. It reports on the performance of the work compared to the budget, and determines individual variance as well as total project variance. It also projects time required for completion of each task and total project, and indicates where individual tasks can be done in time, with and without overtime. Therefore, the report clearly shows any task that is in trouble. This is again summarized for the total project, as shown in Figure 3.21. The system therefore is capable of indicating any problems such as delay and low performance, and what is necessary to get back on schedule and improve performance.

These reports have been found to be adequate tools to enable a number of engineering projects to be successfully managed, and the necessary schedule data communicated to purchasing and production departments. However, it is restated that to achieve the desired high-productivity, short-building-cycle shipbuilding, engineering planning, scheduling, and control should be part of an integrated management information system utilizing a common data base.

PROJECT NO 123		ENGINEERING EXTERNAL DOCUMENT SCHEDULE AND RECORDING REPORT						REPORT DATE 6-4-76		
IDENT NO	TITLE	SKETCH OR DRAWING	OR SKETCH OR DRAWING COMPLETION	DRAWING DWG ISSUG		SHOP SKETCH TO YARD	N/C TAPE ISSUE TO YARD	PROCESS SHFT TO YARD		
				APPROVL TO YARD	TO PURCH			TO YARD	TO YARD	
390-2100	LOWER FWD DEEP TK P	SCHD	1/ 5/76	1/30/76				3/26/76	4/23/76	4/23/76
	UNIT 3-90 SHOP SKETCH	ACTUAL	1/ 5/76	1/27/76				3/19/76	4/23/76	4/23/76
391-2100	LOWER FWD DEEP TK S	SCHD	12/20/75	1/30/76				3/26/76	4/23/76	4/23/76
	UNIT 3-91 SHOP SKETCH	ACTUAL	12/20/75	1/29/76				3/26/76	4/28/76	4/28/76
392-2100	UPPER FWD DEEP TK P	SCHD	1/ 5/76	1/30/76				3/26/76	4/23/76	4/23/76
	UNIT 3-92 SHOP SKETCH	ACTUAL	1/ 5/76	1/27/76				3/26/76	4/23/76	4/23/76
393-2100	UPPER FWD DEEP TK S	SCHD	1/19/76	2/ 6/76				4/ 2/76	4/30/76	4/30/76
	UNIT 3-93 SHOP SKETCH	ACTUAL	1/19/76	2/ 4/76				4/ 2/76	4/24/76	4/24/76
394-2100	LOWER BOW	SCHD	2/ 2/76	2/13/76				4/ 9/76	5/ 7/76	5/ 7/76
	UNIT 3-94 SHOP SKETCH	ACTUAL	2/ 2/76	2/13/76				4/ 2/76	5/ 7/76	5/ 7/76
395-2100	UPPER BOW	SCHD	2/ 2/76	2/13/76				4/ 9/76	5/ 7/76	5/ 7/76
	UNIT 3-95 SHOP SKETCH	ACTUAL	2/ 2/76	2/13/76				4/ 9/76	5/ 7/76	5/ 7/76
396-2100	FOCSLE	SCHD	1/26/76	2/20/76				4/16/76	5/14/76	5/14/76
	UNIT 3-96 SHOP SKETCH	ACTUAL	1/26/76	2/18/76				4/12/76	5/ 7/76	5/ 7/76
397-2100	DECKHOUSE	SCHD	1/19/76	2/20/76				4/16/76	5/14/76	5/14/76
	UNIT 3-97 SHOP SKETCH	ACTUAL	1/21/76	2/24/76				4/16/76	5/14/76	5/14/76
1-2401	RUDDER	SCHD	2/ 2/76	2/27/76	4/ 2/76	4/23/76	4/23/76		5/21/76	5/21/76
		ACTUAL	2/ 4/76	2/27/76	3/25/76	4/23/76	4/20/76		5/25/76	5/21/76
1-2402	RUDDER STOCK	SCHD	1/26/76	2/13/76	4/ 2/76	4/23/76	2/16/76			
		ACTUAL	1/26/76	2/13/76	3/25/76	4/16/76	2/16/76			
1-2403	RUDDER ARRANGEMENT	SCHD	1/12/76	1/30/76	4/ 2/76	4/23/76	2/16/76	6/25/76	6/25/76	
		ACTUAL	1/ 5/76	1/28/76	3/25/76	4/16/76	2/16/76			
1-2501	MAST ARR & DETAILS	SCHD	3/15/76	4/16/76	6/18/76	7/12/76	6/18/76	8/ 9/76	8/ 9/76	
		ACTUAL	3/15/76	4/16/76						
1-2503	YARDS & STAFFS ARR & DETAILS	SCHD	4/ 5/76	4/30/76	7/ 2/76	7/26/76	7/ 2/76			8/23/76
		ACTUAL	4/ 7/76	4/30/76						
1-2504	MISC DAVITS	SCHD	3/29/76	4/30/76	7/ 2/76	7/26/76	7/ 2/76			8/23/76
		ACTUAL	3/29/76	5/ 3/76						
1-3101	MOORING ARRANGEMENT	SCHD	3/22/76	4/23/76	6/25/76	7/19/76	6/25/76			8/16/76
		ACTUAL	3/18/76	4/21/76						

FIGURE 3.18 Report form connecting engineering, purchasing, and production schedules.

456

Management

PART 3

PROJECT NO 123

ENGINEERING WORK SCHEDULE AND RECORDING CHART

REPORT DATE 5- 6 -73

PAGE 5

ANNUAL CALENDER DAYS 63

DATA NO	CHG NO	EMPLOYEE NO	ISSUE DATE	70	77	84	91	98	105	112	119	126	133	140	147	154	161
				12MAR73	26MAR73	9APR73	23APR73	7MAY73	21MAY73	4JUN73	19MAR73	2APR73	16APR73	30APR73	14MAY73	28MAY73	11JUN73
				SMTWTFS	SMTWTFS	SMTWTFS	SMTWTFS	SMTWTFS	SMTWTFS	SMTWTFS	SMTWTFS	SMTWTFS	SMTWTFS	SMTWTFS	SMTWTFS	SMTWTFS	SMTWTFS
1-3601	111	5-21-73		11111	11111	11111	11111					D			I		
		201060		22222	22222	22222	22222					D					
		237723		46645	66442	88648	64438	48				D					
		291061		86448	48846	48848	68478	8				D					
	112					88888	88888	88888	88888			D					
		201060				2 24	2 445	4 42		24		D					
		237723				2 4	2 41	442		3 4		D					
		291061				44444	44444	44 44	64844	244		D					
	113									88888		D					
		157119								8888 8		D					
457	1-3602	111	5-28-73			88888	88888	88888	8883			D			I		
		237125				88484	8888 8	88888	4241			D					
		291061						44444	44444	4444		D					
	112							44444	44444	2424 . 4		D					
		157119									88888D	D					
		157119									8888D	D					
	1-3603	111	6-18-73						88888	88888	88888	D 888					I
		201060							88888	64888	888	D					
		291061									44444	D 44444	44				
	112										4466	D					
		157119										D					
	113											D			888		

FIGURE 3.19 Schedule and work assignment bar chart.

ENGINEERING PROJECT PERFORMANCE REPORT

GROUP REPORT

PROJECT NO	123	GROUP NO	410	REPORT DATE	JUNE 7, 1976	PAGE	7								
DWG OR ITEM NO	DESCRIPTION	CHG NO	COMP DATE	EST HOURS	PCT COMP	ALLOWED HOURS	ACTUAL HOURS	VAR HOURS	VAR PCT	PROJD HOURS	SCHD DAYS	DAYS REMN	DAYS REQD	DAYS LATE	REQD O/T HRS/DAY
1-3302	CARGO TANK	111	22MAR76	160	100	160	146	14	8.8	146	20	0	0	0	0
	HATCH COVERS	112	29MAR76	24	100	24	28	-4	-16.7	28	3	0	0	0	0
	ARRG & DFTAILS	113	12APR76	24	100	24	19	5	20.8	19	3	0	0	0	0
		116	26JUN76	16	0	0	0	0	0	0	2	2	0	0	0
1-3401	AIRPORT & WINDOW LIST	111	26APR76	240	100	240	264	-24	-10	266.7	30	0	0	0	0
		112	3MAY76	40	100	40	32	8	20	32	5	0	0	0	0
		113	17MAY76	40	100	40	44	-4	-10	44.4	5	0	0	0	0
		116	12JUL76	24	0	0	0	0	0	0	3	3	3	0	0
1-3601	HULL INSULATION	111	12MAY76	120	100	120	110	10	8.3	110.0	15	0	0	0	0
	ARRG & DETAILS	112	19MAY76	16	100	16	20	-4	-25	21.3	2	0	0	0	0
		113	31MAY76	16	0	0	0	0	0	0	2	2	0	0	0
		116	29JUL76	12	0	0	0	0	0	0	1.5	1.5	1.5	0	0
1-3602	JOINER WORK	111	24MAY76	320	100	320	290	30	9.4	353.2	40	0	0	0	0
	STANDARD DETAIL	112	7JUN76	64	60	38.4	42	-3.6	-9.4	66.4	8	0	3.5	3.5	XXX
		113	21JUN76	64	0	0	0	0	0	0	8	8	8	0	0
		116	16AUG76	40	0	0	0	0	0	0	5	5	5	0	0
2-3602	JOINER WORK	111	31MAY76	120	100	120	110	10			15	0	0	0	0
	ARRANGMFNT	112	7JUN76	16	80	12.8	8	4.8	37.5	10.0	2	0	1	1	XXX
	MAIN DECK	113	14JUN76	16	0	0	0	0	0	0	2	2	2	0	0
		116	2AUG76	12	0	0	0	0	0	0	1.5	1.5	1.5	0	0
3-3602	JOINER WORK	111	14JUN76	160	80	128	150	-22	-17.2	193.2	20	5	5.4	0.4	.64
	ARRANGMFNT	112	21JUN76	24	0	0	0	0	0	0	3	3	3	0	0
	01 DECK	113	28JUN76	24	0	0	0	0	0	0	3	3	3	0	0
		116	5JUL76	16	0	0	0	0	0	0	2	2	2	0	0
4-3602	JOINER WORK	111	5JUL76	400	60	240	255	-15	-6.3	426.9	50	20	21.5	1.5	.6
	ARRANGMFNT	112	19JUL76	80	0	0	0	0	0	0	10	10	10	0	0
	02 DECK	113	2AUG76	80	0	0	0	0	0	0	10	10	10	0	0
		116	9AUG76	40	0	0	0	0	0	0	5	5	5	0	0
5-3602	JOINER WORK	111	12JUL76	320	30	96	88	8	8.3	293.4	40	25	25.7	0.7	.23
	ARRANGMFNT	112	26JUL76	64	0	0	0	0	0	0	8	8	8	0	0
	03 DECK	113	9AUG76	64	0	0	0	0	0	0	8	8	8	0	0
		116	16AUG76	40	0	0	0	0	0	0	5	5	5	0	0

458

FIGURE 3.20 Performance report.

Management

PART 3

ENGINEERING PROJECT PERFORMANCE REPORT

SUMMARY REPORT

PROJECT NO 123		REPORT DATE JUNE 7, 1976							PAGE 1			
CHG NO	DESCRIPTION	EST HOURS	SCH PC: COMP	ACT PCT COMP	ALLOWED HOURS	ACTUAL HOURS	VAR HOURS	VAR PCT	PROJD HOURS	SCHD DAYS	DAYS REHN	REOQ MEN/DAY
111	DRAFTING	9016	52.3	50.3	4517	4727	- 210	- 4.7	9460	200	80	7.4
112	BILL OF MATERIAL	2350	46.1	45.3	1065	1040	25	2.4	2294	200	90	1.7
113	DWG CHECKING	1840	37.5	39.7	730	710	20	2.7	1790	200	105	1.3
116	APPROVAL CHANGES TO DWG	2240	21.3	22.3	500	470	30	6.0	2106	200	145	1.4
117	ENGINEERING SUPERVISION	3400	33.3	35	1330	1345	- 15	- 1.1	3042	400	190	1.6
119	ENG SERVICES TO YARD	1500	7.4	5	75	100	- 25	-33.3	2249	400	385	0.7
121	PURCHASE SPECIFICATION	400	100.0	100	400	393	7	1.8	393	20	0	0
122	MATERIAL ORDERING	600	100.0	81	486	470	16	3.3	580	25	0	XXX
123	VENDOR TECH ANALYSIS	400	95.3	97	388	395	- 7	- 1.8	407	150	75	0
125	VENDOR DWG APPROVAL	600	76.6	72	432	380	52	12.0	528	150	140	0.1
126	ALLOWANCE LIST	1000	0	0	0	0	0		1000	40	365	0.3
131	BOOKS AND MANUALS	450	25.3	30	135	138	- 3	- 2.2	460	150	365	0.1
132	DWG REPRODUCTION	800	44.2	45	360	351	9	2.5	780	200	365	0.2
134	SCHEDULES AND PROG REP	240	36.6	35	84	80	4	4.8	228	300	385	0
135	CONFERENCES	400	36.6	35	140	146	- 6	- 4.3	417	300	385	0.1
136	TEST AND TRIAL AGENDS	200	0	0	0	0	0		200	20	20	1.3
141	TAPE CONTROL	1200	57.6	59	708	699	9	1.3	1184	75	50	1.2
142	MATERIAL REQUISITION	200	50.1	52	104	100	4	3.9	192	20	60	0.2
143	PROCESS SHEETS	400	50.1	52	208	198	10	4.8	381	30	60	0.4
CONTRACT TOTAL		27636	42.9	42.2	11662	11742		- 3.1	28491			18.0

FIGURE 3.21 Performance report for total project.

REFERENCES

1. T.J. Peters and R. Waterman, *In search of excellence* (Harper and Row).
2. J. Naisbitt, *Megatrends* (Warner Books).
3. T. Lamb, *The impact of N/C on shipyard management*. SNAME Hampton Road Section, 1974.
4. *Improved design process*. The National Shipbuilding Research Program (NSRP), MarAd 1979.
5. T. Lamb, *Engineering for modern shipyards*. SNAME GL and GR Section, 1978.
6. *Integrated hull construction, outfitting, and painting*. (MOP), NSRP, MarAd 1983.
7. *Outfitting planning*. NSRP, MarAd 1979.
3. T-G. Hicks, *Successful engineering management* (McGraw-Hill Book Company) .
9. W.A. Cohen, *Principles of technical management*.
10. V.G. Hajek, *Management of engineering projects* (McGraw-Hill Book Company).
11. B. Baxter, "Qualifications for shipbuilding," *RLNA Transactions*, vol. 113, 1971.
12. L.D. ChiriUo et al., *Flexible manufacturing-What it means in shipbuilding*. SNAME PNW Section, February 1984.
13. D.B. Lynch, "Education of technician engineers and technicians for shipbuilding and ship repair industries." *RLNA Symposium on Education and Training for Naval Architects and Ocean Engineers*, April 1976.
14. J.B. Caldwell, "The Chapman Report-Ten years after." *RLNA Symposium on Education and Training fir Naval Architects and Ocean Engineers*, April 1976.
15. D. Baxter, "Training and development for shipbuilding," *IESS Tmnsactions*, vol. 125, 1981-1982.
16. G. Sivewright, "Industrial training for shipyard naval architects, technician engineers, and technicians.* *RINA Symposium on Education and Training for Naval Architects and Ocean Engineers*, April 1976.
17. *Symposium on education and tmining for nad architects and ocean engineers*. RINA, April 1976.

CLOSURE

Many shipbuilders state that the U.S. shipbuilding industry, to survive, must emulate the best Japanese technology. It is suggested that it is not good enough for the U.S. to try to catch up with the best competition by adopting their current technology. It should be obvious that while the U.S. was catching up, the competition would be improving. While it is often argued that it is possible to catch up at a faster rate than the best can improve, it rarely happens. Figure C.1 shows why. It is necessary for the U.S. shipbuilding industry to “leapfrog” over the competition to beyond where the competition expects to be five or ten years from now. Such a goal is attainable, and such achievements have been accomplished in the aerospace field. Hargrove [1] showed that such technological leaps have been made in the shipbuilding industry, and account for the technology gap between the best and the rest. Figure C.2, based on his findings, shows the quantum jump necessary for the U.S. shipbuilding industry to become competitive by the end of this decade. It can be done if the country decides to do it.

While it would be foolish to suggest that this can be accomplished through the efforts of engineering alone, engineering can play a significant role, along with innovative management, production utilizing the best shipbuilding technology, and motivated people, to achieve the desired goal. It will not be achieved by looking for improvements by modifying current methods. It will only be accomplished by concentrating on the overall objective, and then, without regard to the present ways, determining how to achieve it, and initiating the necessary action.

The challenge is clear! To become a viable industry the U.S. shipbuilding companies must:

**ACHIEVE COMPETITIVE,
PROFITABLE,
HIGH-PRODUCTIVITY,
SHORT-BUILDING-CYCLE,
SHIPBUILDING**

The only way to do this is to:

**USE INNOVATIVE AND CREATIVE
ENGINEERING AND MANAGEMENT
TO DEVELOP NEW
RATHER THAN IMPROVED
SHIPBUILDING
TECHNOLOGY**

Figure C.3 shows the essential steps, as a series of levels in the goal pyramid that must be reached to attain the goal. There are no shortcuts, and all the levels are necessary. Omit any one or more of them and it will be impossible to attain the goal. Education without a goal will only result in better educated people doing the same thing. Implementation without education and training is doomed to fail. Once the goal is determined, and the necessary education, achievement strategy, and training levels are reached, it is obviously essential to reach the implementation level. If the new technology is not actually used, all that will result is a better educated and trained shipbuilding staff still performing shipbuilding in the “old” traditional way.

PRODUCTIVITY

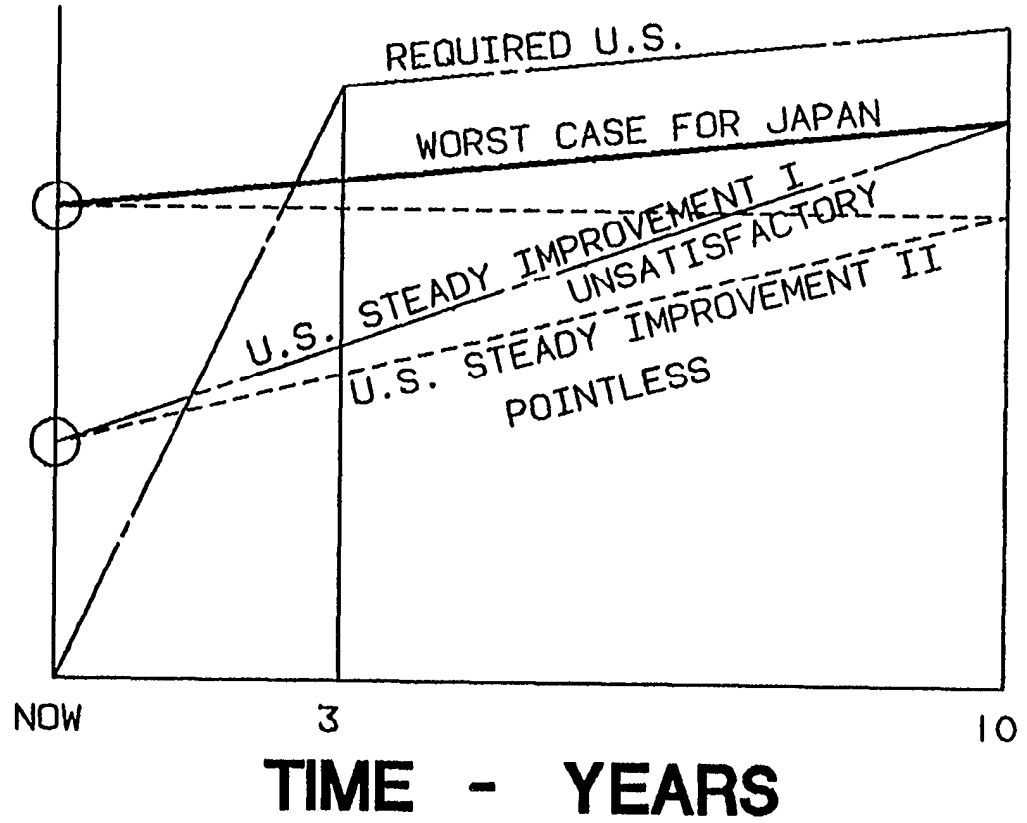

CLOSURE

FIGURE C.1 U.S. required productivity improvement.

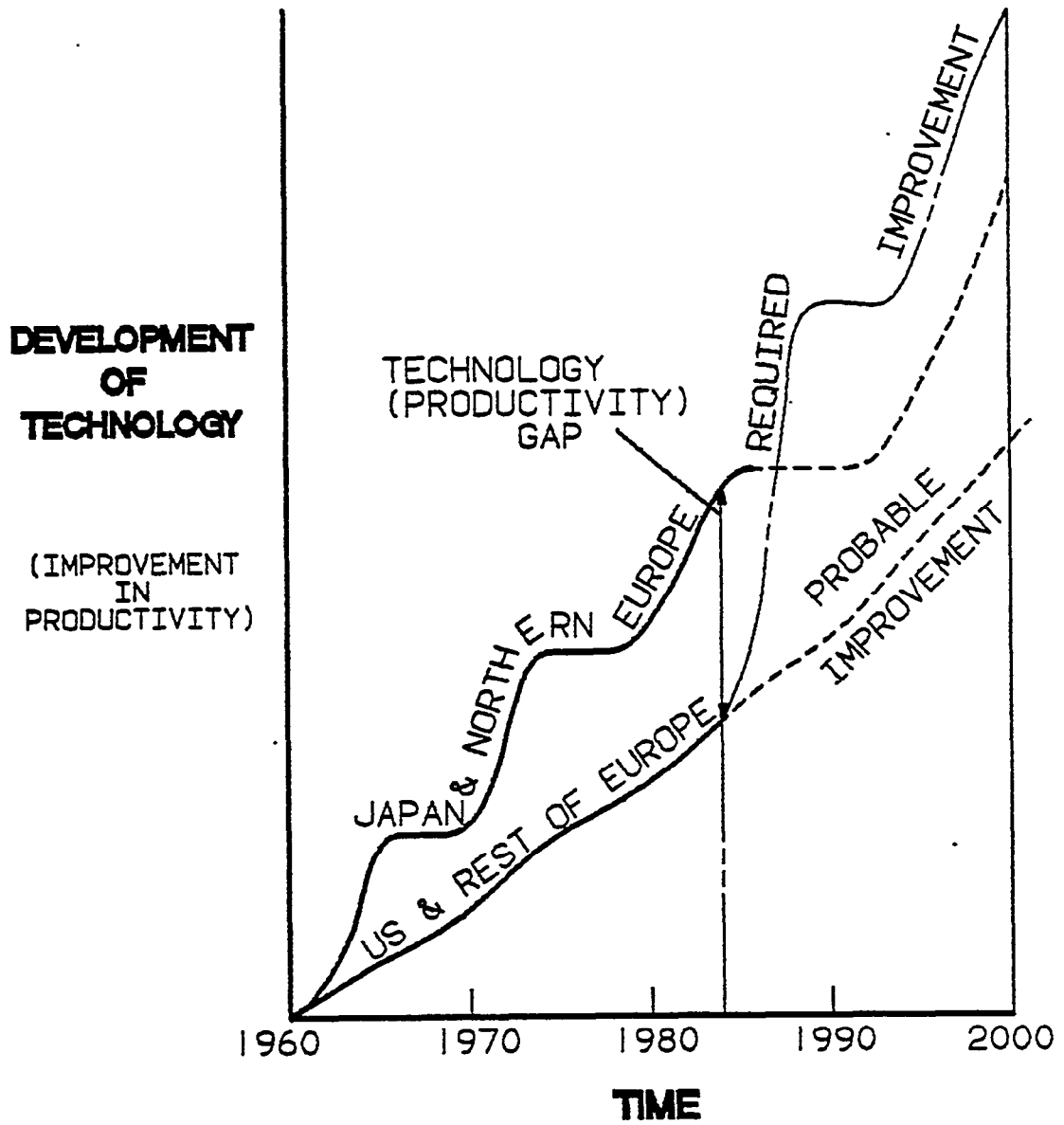

FIGURE C.2 Technology (productivity) requirements.

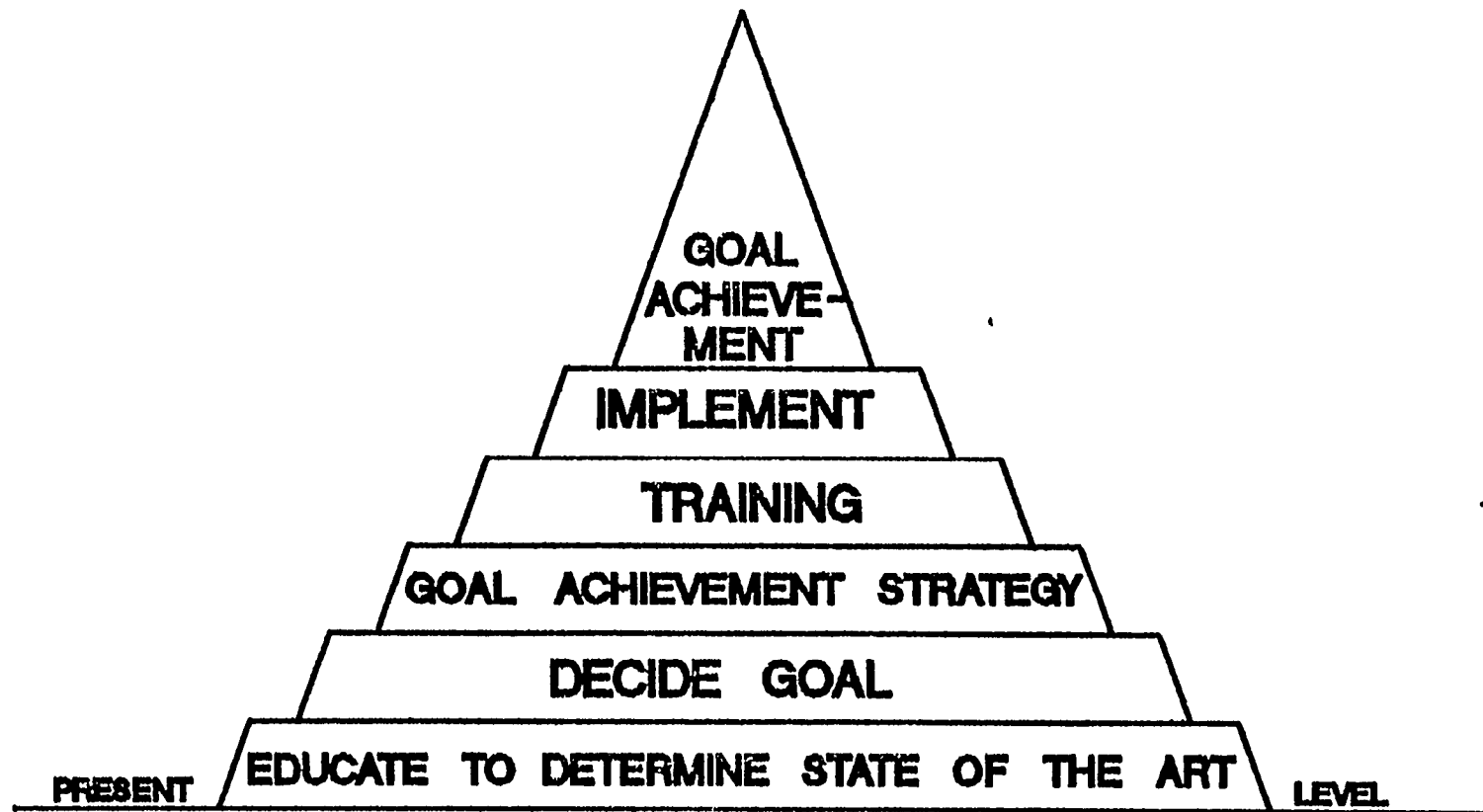

FIGURE (2.3 Essential steps to successful goal achievement.

REFERENCES

1. M.R. Hargroves et al., "The strategic development of ship production technology," *NECIES Transactions*, vol. 91, 1984/1985.