

Evaluation of Active Damping for Reduction of Noise, Vibration and Motion of Ground Vehicles by Multibody Simulation

Dr.-Ing. Wolf R. Krüger ⁽¹⁾, Ondřej Vaculín ⁽²⁾, PhD, Dr.-Ing. Martin Spieck ⁽¹⁾

DLR - German Aerospace Center

⁽¹⁾ Institute of Aeroelasticity

D - 37073 Göttingen

⁽²⁾ Institute of Robotics and Mechatronics

D – 82234 Wessling

Wolf.Krueger@DLR.de / Ondrej.Vaculin@DLR.de / Martin.Spieck@DLR.de

SUMMARY

Military (and also civil) off-road vehicles are subject to large vibrations which can have severe effects on drivers, crew and load. Ride quality is influenced by vehicle vibrations, which may be induced by a variety of sources including roadway roughness or off-road terrain, or they may be internally generated forces produced by vehicle subsystems, such as the engine, or the suspension mechanisms of weapons. Both short but high vibration peaks as well as long-duration, high frequency vibrations can pose either disorientation and safety problems or a health threat to passengers of a vehicle.

Most ground vehicles are equipped with passive spring and damping devices which have reached a high level of sophistication. However, they can usually only be tuned to a good performance in a relatively small operational range (weight, speed, excitation level) or they perform only moderately well over a wide operational range.

Semi-active suspension based on dampers, a concept also known as active damping, has reached production stage for luxury vehicles, trucks and trains, and has been proposed for military vehicles such as light armoured vehicles. It has proven to be an effective way to cope with a number of conflicting requirements, especially comfort, ride handling, ground contact of the tire, road friendliness, and it works well for a wide range of applications and over a large operational range. Multibody simulation is a widely accepted method from the evaluation of the potential of active suspension concepts by simulation to the set-up of virtual prototypes of vehicles.

The paper will give an overview over active damping techniques, present some state-of-the-art approaches for control and actuation, especially in coordination with other active chassis control approaches, and give examples of applications for ground vehicles.

1.0 ACTIVE DAMPING – AN OVERVIEW

1.1. Introduction

The suspension of a ground vehicle is made up of the elements that ensure a flexible link between the wheels and the car body or chassis. This flexibility shields the car body and thus the passengers from the shocks brought about by the irregularities in the road surface. Shock absorbers are a part of the suspension and control suspension oscillations. They absorb the excess energy accumulated by the springs and also by the tyres, and limit the rebound of each wheel. In doing so vibrations in the passenger compartment, as well as the loss of adhesion between the tyres and the road, are minimized.

Paper presented at the RTO AVT Symposium on “Habitability of Combat and Transport Vehicles: Noise, Vibration and Motion”, held in Prague, Czech Republic, 4-7 October 2004, and published in RTO-MP-AVT-110.

Report Documentation Page

Form Approved
OMB No. 0704-0188

Public reporting burden for the collection of information is estimated to average 1 hour per response, including the time for reviewing instructions, searching existing data sources, gathering and maintaining the data needed, and completing and reviewing the collection of information. Send comments regarding this burden estimate or any other aspect of this collection of information, including suggestions for reducing this burden, to Washington Headquarters Services, Directorate for Information Operations and Reports, 1215 Jefferson Davis Highway, Suite 1204, Arlington VA 22202-4302. Respondents should be aware that notwithstanding any other provision of law, no person shall be subject to a penalty for failing to comply with a collection of information if it does not display a currently valid OMB control number.

1. REPORT DATE 01 OCT 2004	2. REPORT TYPE N/A	3. DATES COVERED -			
4. TITLE AND SUBTITLE Evaluation of Active Damping for Reduction of Noise, Vibration and Motion of Ground Vehicles by Multibody Simulation		5a. CONTRACT NUMBER			
		5b. GRANT NUMBER			
		5c. PROGRAM ELEMENT NUMBER			
6. AUTHOR(S)		5d. PROJECT NUMBER			
		5e. TASK NUMBER			
		5f. WORK UNIT NUMBER			
7. PERFORMING ORGANIZATION NAME(S) AND ADDRESS(ES) DLR - German Aerospace Center Institute of Aeroelasticity D - 37073 Göttingen		8. PERFORMING ORGANIZATION REPORT NUMBER			
9. SPONSORING/MONITORING AGENCY NAME(S) AND ADDRESS(ES)		10. SPONSOR/MONITOR'S ACRONYM(S)			
		11. SPONSOR/MONITOR'S REPORT NUMBER(S)			
12. DISTRIBUTION/AVAILABILITY STATEMENT Approved for public release, distribution unlimited					
13. SUPPLEMENTARY NOTES See also ADM201923, Habitability of Combat and Transport Vehicles: Noise, Vibration and Motion (L'habitabilite des vehicules de combat et de transport: le bruit, les vibrations et le mouvement). , The original document contains color images.					
14. ABSTRACT					
15. SUBJECT TERMS					
16. SECURITY CLASSIFICATION OF:			17. LIMITATION OF ABSTRACT UU	18. NUMBER OF PAGES 24	19a. NAME OF RESPONSIBLE PERSON
a. REPORT unclassified	b. ABSTRACT unclassified	c. THIS PAGE unclassified			

The main goals of a suspension are thus to provide passenger comfort as well as good vehicle handling qualities. These goals are in part conflicting. While a comfortable suspension layout requires a rather soft setting of spring and damping, good road-holding is provided by a rather hard setting. This design conflict cannot be solved completely by passive suspensions, each suspension setting can only be a compromise. For heavy vehicles road friendliness plays a role in suspension design as well, as the dynamic loads a vehicle exerts on the road depend heavily on the weight of the vehicle and its suspension layout.

1.2. History

The idea of suspension control to solve the design conflict mentioned above has been brought forward already in the 1970ies. Early concepts for automotive applications have already been discussed by Karnopp [1], [2], for aircraft by Corsetti and Dillow [3], and for railway vehicles by Hedrick [4]. With the advent of microelectronics at the beginning of the eighties suspensions with computerized closed loop control have been subject of investigations [5]. Karnopp has published the so-called skyhook control concept for automotive applications [1]. This concept has found wide application in automotive and railway suspensions, both for research purposes as well as for production vehicles, and has been used for fully active and semi-active suspensions. A number of publication overviews are available, among them those co-authored by Dukkipati [6] and by Elbeheiry [7].

Studies by Karnopp [8] for automotive applications suggest that the efficiency of semi-active dampers is only marginally lower than of a fully active system, provided that a suitable control concept is used. Li and Goodall [9] investigate semi-active suspensions for the lateral damping of railway cars. A great number of publications are concerned with the design of control strategies for active and semi-active suspension; a research through relevant journals and conference proceedings is worthwhile and necessary, since a comprehensive literature overview of publications concerning control approaches for active suspensions is not known to the authors of this article.

There have also been practical applications of the technology in road vehicles. Active dampers based on several mechanical principles are available on the market. Currently, a number of luxury cars are equipped with this technology, see e.g. [10]. In the European COPERNICUS project, a truck has been equipped and tested with semi-active shock absorbers [12]. In that project the main aim has been to show that semi-active shock absorber control can be used to reduce dynamic tire forces which are a main cause of road damage.

In the aeronautical field, adaptive suspensions have been examined by Somm, Straub and Kilner in 1977 [13] who used a gas spring with an adaptive pressure which was used for military aircraft landing on unpaved runways. Catt, Cowling and Sheppard [14], Wentscher [15], Wang [16] and Krüger [17] have since performed simulation studies on active and semi-active aircraft suspensions. In the course of a European project, ELGAR (European Advanced Landing Gear Research, [17]), Liebherr Aerospace Lindenberg has built a test-rig demonstrator with a modified helicopter nose landing gear on a vertical shaker to prove the technical feasibility of the active damping concept for aircraft.

1.3. Suspensions of Variable Characteristics

Suspensions generally contain spring and damping devices. In conventional suspensions spring and damper characteristics are fixed. Those passive systems are restricted to generating forces in response to local relative motion, e.g. upper and lower strut of the shock absorber. In order to obtain an improved performance with respect to comfort and loads, the suspension characteristics can be made adaptable to vehicle parameters as well as to environmental conditions, e.g. the quality of the ground. Active systems may generate forces which are a function of many variables, some of which may be remotely measured, e.g. vertical acceleration, vehicle weight, and forward speed.

Basically, two different active suspension strategies exist. A first type is an a-priori setting of spring or damper characteristics according to the expected road quality and vehicle weight, and keeping those suspension characteristics constant. This variant is sometimes also called “adaptive suspension”. One variant of this suspension type are those suspensions of luxury cars or motorcycles which can be switched between sportive and comfortable operating modes.

A second type is the feedback of vehicle motion and, consequently, a dynamic suspension control. The basic sensor and control layout is similar for most systems and has already been described in the seventies and eighties: a sensor at the vehicle measures acceleration and velocity of the car body as well as the suspension deflection, and, via a control law, results in a change of suspension characteristics.

Several ways to classify suspension systems can be found in the literature, based on a number of classification categories: the degree, the bandwidth, the technology and the design approach of control, [19]. Prokop and Sharp [20], for example, distinguish between

- very slow active systems, the actuator cut-off frequencies of which are lower than the natural frequency of the body resonance (i.e. frequency range less than 1 Hz), e.g. load levelers and adaptive spring settings;
- slow-active systems, which show cut-off frequencies between the body and wheel natural frequencies of the system (i.e. frequency range between 1 Hz and 10 Hz), e.g. actuators for pitch and roll control; systems like these can be realized by pressure variations of a gas spring, e.g. Citroën Xantia [21], or adjustable mechanical devices [22]; active anti-roll bars or systems reducing pitch can be considered as slow-active systems as well. Another example is a semi-active system which adapts to the history of the Root Mean Square (RMS) value of suspension deflection. Such systems have are knows as Active Ride Control, Active Body Control or Dynamic Drive systems and are available from most car manufacturers;
- fast-active systems, with actuation bandwidth beyond the wheel-hop natural frequency, i.e. frequency range above 10 Hz, e.g variable dampers operating at high bandwidth. Semi-active dampers, as they are presented here, can be regarded as fast systems in the sense of this classification.

An improved performance can be achieved by the application of so-called preview sensors which scan the road for obstacles and rough patches and enter this additional information into the control loop [23]. Sensors using optical, ultrasound and radar technology may be applied, however, they pose problems concerning practical application (dirt, accuracy) and interpretation of data, e.g. how can a water-filled pothole be distinguished from the road, how a cardboard box from a stone... [24]. A good compromise for road vehicle suspensions is to use the motion of the front axle as preview for the rear axle [23].

Even optimal suspension control has its limits. First, a suspension realizing optimal frequency isolation between passenger and road or runway input would require an unlimited working space. Second, the wheel-hop natural frequency cannot be damped easily since in practice it is difficult to measure the tire deflection. Third, energy consumption limitations apply. Even though extreme opposite standpoints in respect of energy consumption are possible [23], conventional solutions with electro-hydraulic actuators require a substantial amount of energy since actuation occurs by virtue of high pressure oil flowing into the actuator and a corresponding volume of oil has to be exhausted to tank (atmospheric) pressure. It has been observed that the energy demands of the active suspension can be higher than those for steady state motion of the vehicle.

1.4. Semi-active Suspensions

In active shock absorbers oil is generally pumped from a pressurized reservoir into the shock absorber and out of it, responding to the commands of the controller. Semi-active systems do not require expensive active elements, such as hydraulic pumps, accumulators, pipe works, actuators etc. These systems cannot supply complete active forces. As pointed out above, in many cases semi-active systems are preferred to active systems, particularly because of the simplicity of their application for existing systems and their low energy demands. Semi-active suspensions are not considerably heavier than passive systems and less complex than their active counterparts. Furthermore, in many applications the current passive dampers can easily be replaced by semi-active dampers. Semi-active dampers are state-of-the-art in railway and automotive applications and have found an, albeit yet small, market.

Typical representatives of semi-active devices are (controllable) semi-active dampers (SAD), which are able to alternate damping ratio by means of a controllable orifice, according to an input signal. The input signal is usually of an electrical nature, Figure 1, [12]. Thus, the semi-active control is also known as “active damping” [14]. Among other semi-active principles are controllable friction devices and variable stiffness devices. The semi-active damper can be fail-safe in principle, because if the control signal is disconnected, the shock absorber behaves as a purely passive damper.

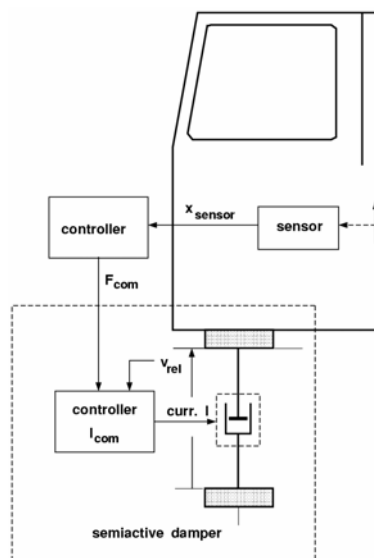

Figure 1: Layout of active damping suspension

As for a passive damper, the applicable force in a semi-active damper depends on the sign of the stroke velocity across the damper, see Figure 2. Since, contrary to the fully active actuator, the damper can only dissipate energy, not every control command can be applied and only forces can be produced which lie in the first and third quadrant of the force-stroke velocity plane, i.e. a positive force F_d in the sense of Figure 2 can only be supplied while the damper is compressing, a negative force can be supplied by an expanding damper. If the controller commands a negative force during damper compression, the best that can be done is to generate only a compression force as small as possible, in other words, to open the orifice completely. The requirement to be able to switch from force generation to near zero force generation in a very short time makes the semi-active damper an inherently highly nonlinear device.

A controller with a semi-active control scheme is often designed as if it was a fully active system. Control commands that lie in quadrant 2 and 4 of Figure 2 are then set to zero. This is known as a “clipped optimal” approach. It is evident, however, that a purely clipped optimal design strategy, i.e. operating the semi-active damper with the same parameters as found for the fully active controller, is only sub-optimal.

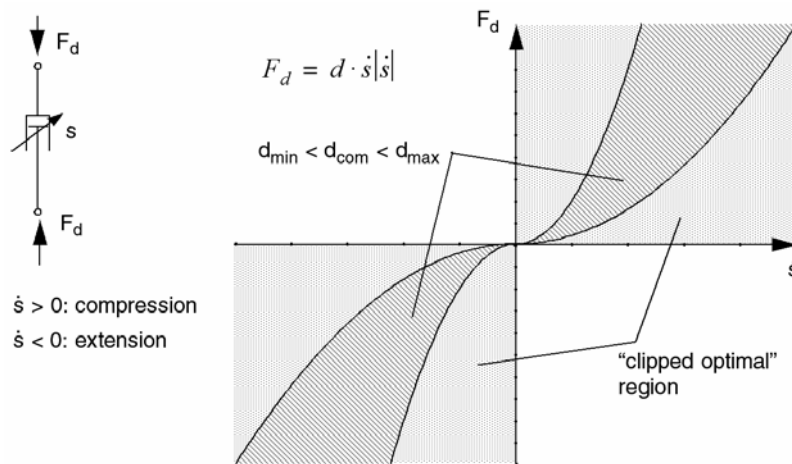

Figure 2: Principle of semi-active and clipped optimal control

Another restriction to the clipped optimal assumptions is the fact that a technical semi-active damper has a minimum and a maximum orifice size for the oil flow, resulting in a respective minimum and maximum controllable damping coefficient, and that it displays only certain available velocity/force characteristics (see Section 2.3). Therefore, a clipped optimal scheme has to be replaced by a realistic, limited system setting boundaries for the commands and operating with separately adapted gains.

2.0 ACTUATION HARDWARE

2.1 Semi-active actuators

Different types of semi-active suspensions have been tested or have been brought to the production stage. A complete active or semi-active suspension can consist of an arrangement of passive and active components. The active parts can be used in parallel with or as a substitute for passive elements. Most technical solutions put the actuator in parallel to conventional components. This is done for reasons of safety, i.e. to guarantee vehicle stability in case of actuator failure, and to reduce the load on the actuator. Furthermore, a certain amount of inherent damping, e.g. by friction, is present in most cases anyway. For control design purposes, however, it can also be of use to neglect the passive damping, or to see the actuator as a combination of all suspension parts. In several state-of-the-art systems available on the market, the functionalities of passive or active spring, passive or active damping and (parasitic) friction are combined in a single actuator.

The semi-active damper is a damper in which the functional relationship between damping forces and deflection velocity (i.e. damping coefficient) is adjustable by control input. The semi-active dampers can be manufactured based on controllable orifice, or controllable fluids technology. The dampers with controllable orifice are usually based on classical passive hydraulic dampers extended with electromagnetic valves. The variation of the orifice results in variation of a damping ratio. The second group contains dampers based on so-called "smart materials". The damping ratio is changed by variation of viscosity of special electro- or magneto-sensitive fluids. A third class of semi-active actuators is based on

controllable friction devices. Finally, a fourth approach suggests the use of linear electric motors for suspension control.

A complete semi-active damping system consists not only of the actuators, but also of sensors and controllers. The present availability, computing power, and reliability of a large variety of microelectronic controllers does not pose a limiting factor for the implementation. The choice of sensors is an important consideration, but a lot of suitable types are available. The key aspects are related to their cost and reliability. The primary demands on actuators are high reliability and sufficient performance for the desired frequency range.

The following sections try to give an overview over various principles of actuators for semi-active damping of suspensions. An example for hardware, either in prototype or in production stage, will be given for each technical principle. Please note, however, that the mention of commercially available products is by no means meant to be a comprehensive overview.

2.2. Passive shock absorbers

All hydraulic shock absorbers work by the principle of converting kinetic energy (movement) into thermal energy (heat). For that purpose, fluid in the shock absorber is forced to flow through restricted outlets and valve systems (orifice), thus generating hydraulic resistance. A telescopic shock absorber (damper) can be compressed and extended; the so-called bump stroke and rebound stroke. Telescopic shock absorbers can be subdivided into *twin-tube dampers*, available in hydraulic and gas-hydraulic configuration, and *mono-tube dampers*, also called high pressure gas shocks, Figure 3 [25].

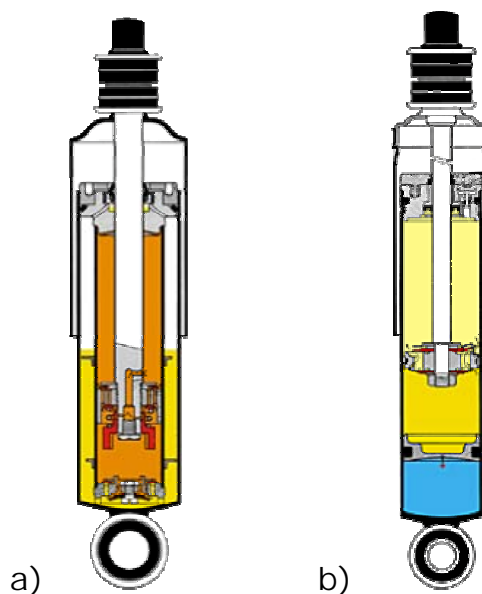

Figure 3: Passive shock absorbers: (a) twin tube, (b) mono tube [25]

During the bump stroke in the twin tube variant, a quantity of oil is forced to flow through a valve into the reservoir tube filled with air (1 bar) or nitrogen gas (4-8 bar). The resistance, encountered by the oil on passing through the foot valve, generates the bump damping. In the mono tube variant, no reservoir exists. The cylinder is not completely filled with oil; the lower part contains (nitrogen) gas under 20-30 bar. Gas and oil are separated by the floating piston. When the piston rod is pushed in, the floating piston is also forced down by the displacement of the piston rod, thus slightly increasing pressure in both gas and oil

section. Also, the oil below the piston is forced to flow through the piston. The resistance encountered in this manner generates the bump damping.

During the rebound stroke, the oil is forced to flow through the piston. The resistance, encountered by the oil on passing through the piston, generates the rebound damping. Simultaneously, some oil flows back, without resistance, from the reservoir tube through the foot valve to the lower part of the cylinder to compensate for the volume of the piston rod emerging from the cylinder. In the mono tube, part of the piston rod will emerge from the cylinder and the free (floating) piston will move upwards.

Incidentally, the oil-hydraulic aircraft shock absorber, the so-called oleo, is in the majority of cases a variant of the mono tube shock absorber, with an air spring in parallel to the damping which supports the complete aircraft weight [17].

2.3. Dampers with Controllable Orifice

The semi-active dampers with controllable orifice are usually modified passive hydraulic (or gas) dampers extended with a solenoid valve with a variable orifice. The proper parameter of the semi-active damper to be controlled is the pressure in the damper, which can be modified by opening and closing a proportional valve: the cross section can be tuned to each arbitrary size. This allows the continuously variable adaptation of the pressure and therefore of the damper characteristics from stiff to soft within a range defined by the completely closed and the opened valve cross section. Electrical current between zero amperes and a maximum value commands the adjustment of the valve. The damper force is then a function of the actual damper velocity and the valve cross section, i.e. the actual current.

Originally, discrete state (two or more) semi-active dampers were produced, which were equipped with one or more two-state (on-off) solenoid valves. Currently, continuously variable devices are available on the market. One of the significant advantages is that this concept does not require necessarily significant changes in vehicle design - just a replacement of shock absorbers.

The controllable shock absorbers used in the COPERNICUS/SADTS project [12] were specially manufactured by Mannesmann-Sachs. An electrical current between zero ampere and a maximal value commands the adjustment of the valve. The damper force is then a function of the actual damper velocity and the valve cross section, i.e. the actual current I_{act} . Figure 4 shows the force law of the semi-active damper, the force as a function of damper velocity and current. Changing the current, the reaction of the damper starts after a time delay of ca 5 ms in a phase of adaptation which is dependent on electrodynamics, valve dynamics and oil hydraulics. The time until the damper is fully adjusted to the new commanded steering current differs whether the valve is closed (total time ca 35 ms) or opened (ca 15 ms).

As an example for an available actuator, currently ZF Sachs offers a line of semi-active shock absorbers under the name of CDC (Continuous Damping Control) [26].

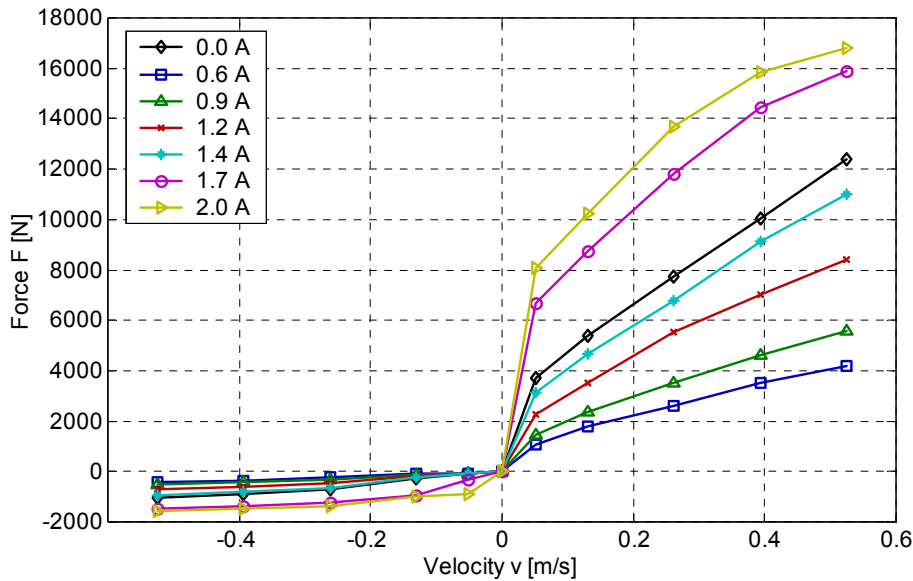

Figure 4: Characteristic of controllable hydraulic shock absorber

2.4. Dampers with Controllable Fluids

Electrorheological dampers

Electrorheological fluids (ERF) are a class of fluids which change their viscosity depending on an externally applied electrical field strength [27]. They have been known since the late 1940ies. The bandwidth of the resulting flow properties is large; the state varies between fluid and nearly solid material. The properties of these fluids are caused by polarizable particles within a nonconducting carrier fluid which disturb the flow when excited, see Figure 5. Hence flow, shear and squeeze processes can be controlled using electrical fields. ERF devices have several advantageous control properties. The response time between one and 15 ms is extremely fast. Furthermore, ERF devices are continuously controllable and operate subject to almost no wear. Problems with ERFs include relatively small rheological changes and extreme property changes with temperature.

ERF devices represent an class of interfaces between electronic control units and mechanical components which have gained increased scientific and economic interest in recent years. As a result, new generations of ERFs with optimized properties are now available. In particular, the difficulties like stability over long time periods and sedimentation of the polarizable particles have largely been resolved. The application areas for ERF devices are numerous. High frequencies and forces may be relatively easily controlled using flexible electronic units. Already many different applications have been reported, see [28], including a prototype of an adaptively controllable ERF-shock absorber by Schenck AG, Darmstadt [27].

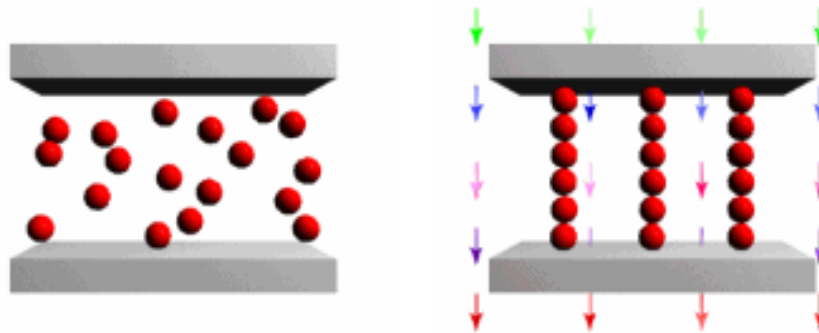

Figure 5: Work principle of electrorheological and magnetorheological dampers: Particles in an MR fluid without (left) and with (right) applied magnetic field [29]

Magnetorheological dampers

Magnetorheological (MR) fluids are materials which respond to an applied magnetic field with a change in rheological properties (elasticity, plasticity, or viscosity). Similar to electrorheological fluids they include polarizable particles of a micron size, but MR fluids are 20-50 times stronger than ER fluids. They can also be operated directly from low-voltage power supplies and are far less sensitive to contaminants and extremes in temperature, see [29], [30], [31]. Similar to ER fluids their discovery dates back to the late 1940ies.

The MR fluids are essentially suspensions of magnetizable particles having the size of a few microns in oil. Under normal conditions an MR Fluid is a free-flowing liquid with a consistency similar to that of motor oil, as indicated in Figure 5, left, [29]. Exposure to a magnetic field, however, can transform the fluid into a near-solid in milliseconds, Figure 5, right. Just as quickly, the fluid can be returned to its liquid state with the removal of the field. The degree of change in an MR fluid is proportional to the magnitude of the applied magnetic field. The MR effects are often greatest when the applied magnetic field is normal to the flow of the MR fluid.

Although power requirements are approximately the same as for ER fluids, MR fluids only require small voltages and currents, while ER fluids require very large voltages and very small currents. Besides the rheological changes that MR fluids experience while under the influence of a magnetic field, there are often other effects such as thermal, electrical, and acoustic property changes.

If the MR fluid is used in a damper, the damping ratio depends on an effective viscosity of the fluid which can be controlled by applied magnetic field, thus replacing mechanical valves commonly used in adjustable dampers. This offers the potential for a superior damper with little concern about reliability, since if the MR damper ceases to be controllable, it simply reverts to a passive damper.

A top-level functional representation of the MR damper is shown in Figure 6. The fluid that is transferred from above the piston to below (and vice-versa) must pass through the MR valve. The MR valve is a fixed-size orifice with the ability to apply a magnetic field, using an electromagnet, to the orifice volume. This results in an apparent change in viscosity of the MR fluid, causing a pressure differential for the flow of fluid which is directly proportional to the force required to move the damper rod. The small mono tube MR damper RD-1005-3 shown in Figure 6 is a typical commercially available representative manufactured by Lord Corp. The damper is originally designed to be applied in a semi-active seat suspension for heavy trucks.

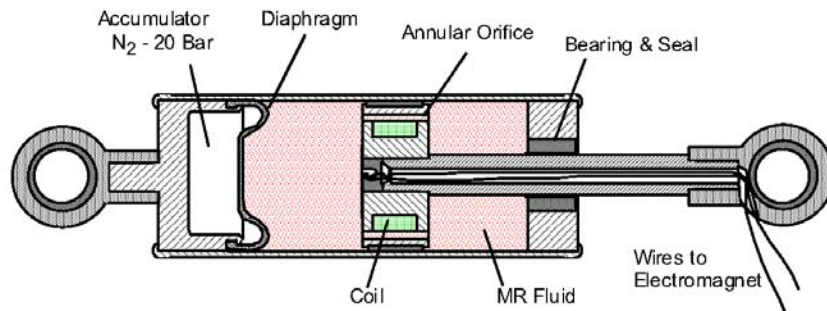

Figure 6: Sketch of a monotube MR damper for seat suspension from Lord [29]

2.5. Friction-based dampers

A frictional damper is a device which conceptually is composed of a plate fixed to a moving mass and a pad pressing against it. An external normal force is applied to a mass by the pad and consequently, in the presence of a relative motion between the pad and the plate, a frictional damping force is produced. The choice of using dry friction as a mean of achieving a damping effect is non-conventional, particularly in an automotive application. Pure dry (or lubricated) friction characteristics are of no practical use because of their harshness, but a controlled friction damper can be made to behave in a variety of ways emulating spring-like and pseudo-viscous characteristics [32], [33].

Because the actuator only needs to change the normal force exerted onto the vibrating element, it requires very little actuating displacement and mechanical power. The active element is not required to generate a displacement having the same order of motion as the mounts. Therefore, the amount of work done by the control actuator is significantly smaller than that required of a purely active control actuator. Also, since the friction actuator only dissipates energy from the system, (assuming the system was originally stable) it cannot cause instabilities to occur.

Several techniques to apply the external force to a pad are possible. Two realizations of the friction-based concepts are shown by Guglielmino [32] and Unsal [33]. While Guglielmino presents an actuator based on actuation of a small friction element by oil pressure, Figure 7a, Unsal uses actuation based on a novel, mechanically amplified piezo actuator, Figure 7b. Both concepts have been realized in a size comparable to a conventional car shock absorber and have been investigated on test rigs.

2.6. Linear Electromagnetic Motors

A relatively recent proposal has been the use of linear electromagnetic motors for suspension control. Inside a linear motor are magnets and coils. When electrical power is applied to the coils, the motor retracts and extends, creating motion between the wheel and car body. In principle those systems are not restricted to semi-active actuation but could also provide full support of the car body and spring properties. However, this static force would require a lot of energy, so in practical application linear motors can be placed in parallel to the springs and act as fast and powerful actuators. When used in semi-active mode, they can even generate electrical energy during the damping of vertical vehicle motion. This energy can in turn be used to apply additional fully active suspension control tasks like pitch and roll control. Bose has developed prototype versions of an active suspension based on linear electromagnetic motors and tested them on different vehicles [34]. Another proposal comes from Advanced Motion Technologies (AMT), a manufacturer of linear electromagnetic motors [35].

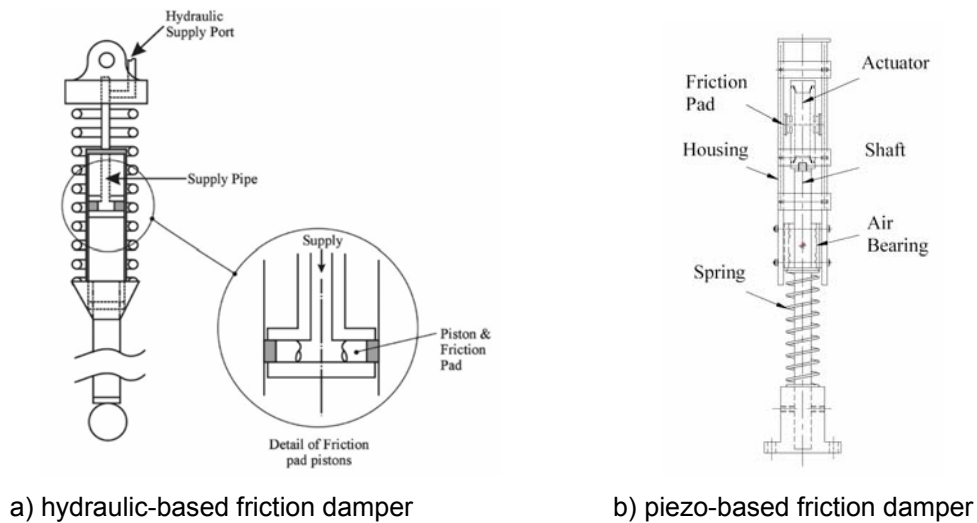

Figure 7: Two dry friction damper concepts, [32], [33]

3.0 CONTROL APPROACHES, SOFTWARE

3.1. Control Approaches for Active Damping

A conflict between comfort, road-tyre forces and suspension workspace is a significant problem in the suspension design. Many possible solutions of such a conflict exist, in which an improvement of one parameter leads to deterioration of the others; designer have to choose one of the solutions according to his or her experience. This problem is common for both passive and controllable suspensions.

Controller configuration and parameters are dependent on objectives to be satisfied as well as on quantities which can be measured. The controllers are usually designed in one configuration of the system parameters and often with a simplified model. Frequently, the system parameters can vary widely. Therefore the controller should be robust against their variations and design model simplifications. Of course, the control layout task requires a reliable model of the actuator and its dynamics.

A large variety of control design approaches is used for design of active and semi-active vehicle suspensions. A majority of authors designed controllable suspension in order to increase ride comfort, generally to isolate the passengers from the vibration caused by road unevenness. Another objective is the minimisation of road-tyre force fluctuation; although these goals are different from those for ride comfort, many control concepts could be similar for both ride comfort and a force fluctuation oriented suspension.

Two main approaches to controller design for the suppression of mechanical vibration can be distinguished. The first approach applies virtual force elements, which are incorporated between mass and inertial system or other mass. The force, which would be generated by the virtual elements, is generated by an actuator, [1], [12]. The second approach is based on concepts of the control theory. Since linearised systems are frequently used for the controller design, the controllers are very often also linear [38].

A frequently used example for the first approach mentioned is the well-known sky-hook controller. This concept is based on the consideration that for a quarter car both vertical wheel travel and the vertical vibrations of the car body will be minimized if the active suspension element tries to emulate a damper connecting the car body (the so-called sprung mass) to an imaginative point at the inertial reference system (thus the name sky-hook). This can be done by using the vertical velocity of the car body as feed back for the actuator control between sprung and unsprung mass, see Figure 8.

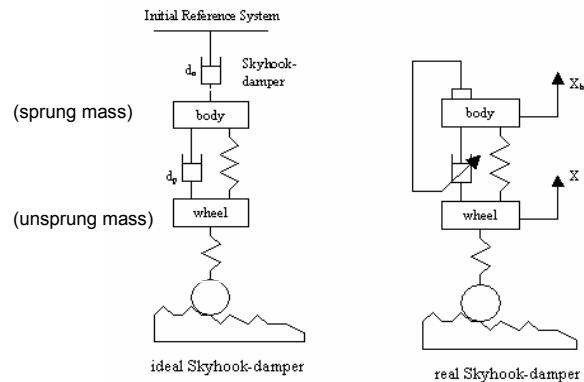

Figure 8: Principle of sky-hook damping [52]

Examples of linear suspension control are state-based controllers, e.g. designed by LQR, H_2 or H_{∞} methods, often accompanied by a state observer. Examples for non-linear control are a number of suggestions to use fuzzy control for the layout of semi-active suspensions [36], [37].

Control laws are often designed using 'clipped' approach. A controller and its parameters are designed as if the system was full-active. Such a control is applied to the semi-active system: the semi-active force is set equal to the force calculated by an active algorithm if the suspension power is dissipative, and it is set to minimum if power is positive. Another possibility is to fit controller parameters to the (nonlinear) semi-active system. There are two approaches, (i) design-by-simulation, in which the controller parameters are optimised for given scenario, [39], and (ii) nonlinear system control theory, [41].

It could be noted that although the design approach is of interest from a theoretical point of view, in practice the choice of a special control law often turns out to be less fundamental. Even with a relatively simple but robust control approach like sky-hook damping most of the potential of semi-active damping can be reached and good results concerning ride comfort or road friendliness are achieved [17].

3.2. Software for Simulation and Control

For the layout of active suspensions the simulation of the vehicle dynamics is of great importance. The most important tools for this purpose have traditionally been multibody programs like SIMPACK (by INTEC) [42], MSC.ADAMS [43], LMS Virtual.Lab Motion (formerly DADS) [44], or RecurDyn [45]. The method of multibody systems (MBS) is based on the simulation of mechanical basic elements such as mass, joints and springs and is complemented by numerous component models. For component-oriented models the manufacturers also like to use internal solutions, which were developed from the desire to frequently use existing, well-developed and efficient simulation components.

The special requirements for the models of mechatronic components can hardly be handled by common mono-disciplinary simulation tools, even if there are some extensions to other disciplines available. As model complexity and model reliability increases, couplings between disciplines and simulation tools become more and more important to model all relevant components of the vehicle with sufficient complexity. Some multidisciplinary tasks, like state-of-the-art control design, are performed in block-oriented computer aided control engineering (CACE) programs like MATLAB/Simulink [46] or object-oriented modeling approaches like those provided by Dymola/MODELICA [47]. For these tools component libraries, e.g. for hydraulics, mechanics, and control design are available.

To fully benefit from the main capability of the tools involved, interfaces between those tools are necessary. MBS and control engineering software can be coupled in a number of ways [48]. The most common interfaces are the export of linearized system matrices from the MBS model and its subsequent import in the CACE tool. The inverse way is also possible as most CACE tools have the ability for code export. Frequently used is furthermore the co-simulation of MBS and CACE tool via pre-defined IPC (inter process communication) interfaces where the models are solved in their respective environments while the tools exchange data at pre-defined and mostly constant time steps [49].

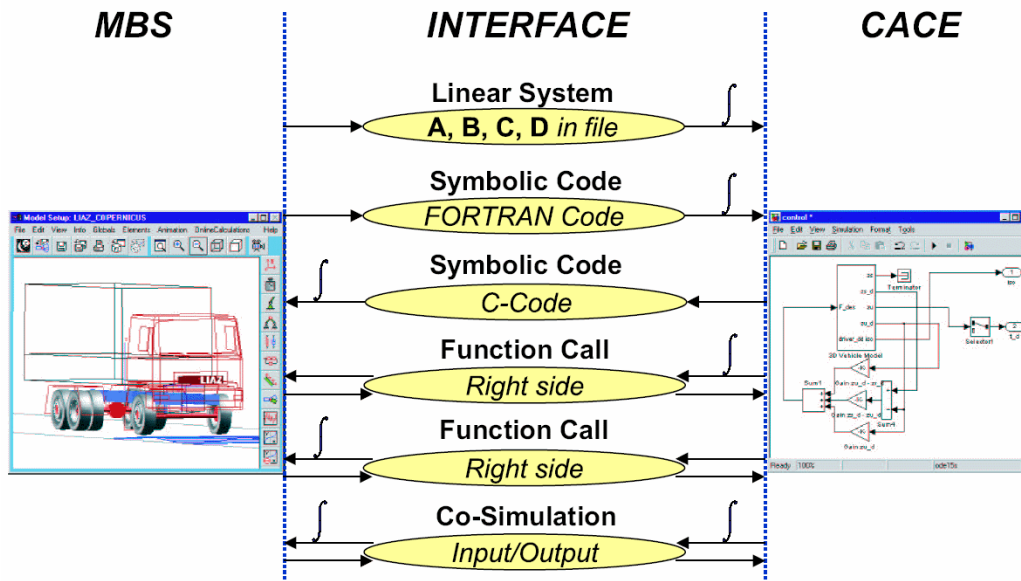

Figure 9: Coupling of multibody and control engineering software [48]

3.3. Combined Active Chassis control

A controllable suspension is not a single active system in a current passenger car or truck; the vehicle chassis are equipped with several more or less independent controllable systems such as brakes or steering. However the car manufacturers currently focus on connecting of the independent systems in order to get new functionalities, which are to increase ride comfort, active safety and last but not least driving pleasure. The integration and networking of individual chassis functions often called Global Chassis Control or Integrated Chassis Control is a new dimension, which brings the added value based on intelligent control programs [50].

The particular goals of Global Chassis Control are to achieve good handling independent of wind, vehicle loading and road surface, further extended dynamic driving limits of the vehicle, more driving pleasure, shorter braking distance, and lower level of roll, pitch and yaw motion as well as intelligent reaction on drivers' mistakes. Furthermore, the vehicle handling characteristics can partially be adjusted by software, the integration results in reduction of control units, etc.

One of examples of this approach is the optimisation of the vehicle for braking manoeuvres. The first systems already available on the market are based on the adaptive suspension. They switch the damping characteristic to the hard setting during the braking. However, such approach does not use the potential of integration synergy. In order to take advantage of the networking, it is necessary to apply dynamic control of the vehicle suspension, which is optimised for the braking. Particularly the emergency brake

manoeuvre, which is at present usually supported by brake assistant systems in order to apply maximum pressure in brake circuit, could be shortened with the aid of optimal controlled suspension, because the controllable suspension is able to decrease the fluctuation of the vertical tyre forces. Thus, active damping systems form part of a state-of-the-art electronic stability control system [51].

4.0 APPLICATION EXAMPLES

4.1. Military Vehicles

Active suspensions have long been a topic for military vehicles. Since military vehicles are by nature often operating at rough terrain, the question of vibration reduction is of great importance. The following example is a description of an investigations made with the help of dynamic driving simulations to improve the ride comfort of cross-country vehicles through controlled chassis; the example has been published by Hönlinger and Glauch [52].

The high mobility requirements for the investigated vehicle in heavy terrain resulted in a relatively rigid tuning of the spring/suspension system. When looking at the typical operational profile of these vehicles it becomes clear that more than 90% of the rides take place on roads, tracks and rough tracks. A controlled chassis would ensure the same mobility in heavy terrain and improve the ride comfort both on bad road stretches and in easy terrain. By this means the average speed can be increased while reducing the stress for the crew at the same time. A high ride comfort is especially necessary for fatigue-free driving over long distances and will essentially contribute to the operational security for the crew.



a) 8x8 off-road vehicle (33t)

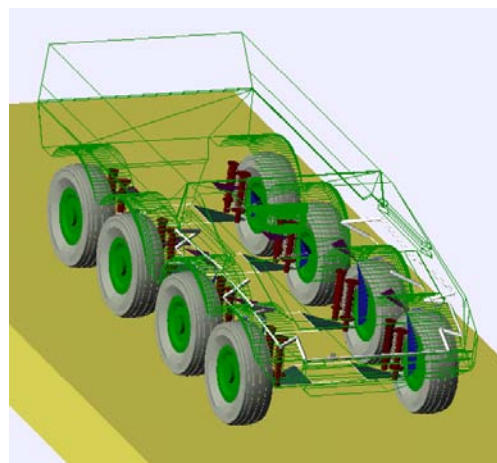

b) MBS model of 8x8 off-road vehicle

Figure 10: 8x8 military off-road vehicle [52]

The investigations were based on a four-axle, all-wheel driven cross-country vehicle of the 33 t weight class, designed for high average speed on roads and in terrain, Figure 10. The spring/suspension system is characterised by its high energy absorption to enable rapid crossing of high individual obstacles, ramps and long ground humps. The individually installed hydraulic limit-stop shock absorbers absorb a large amount of the shock energy and by this means enable influencing the vibration absorbers as regards improvement of ride comfort.

Taking the example of the elementary sky-hook control, the simulation results show that on corrugated tracks and sine-wave lanes both the vibrational behaviour, i.e. the maximum vertical accelerations, and the pitch movement can be noticeably reduced with the help of a controlled chassis, see Figure 11. No negative consequences as regards to an increase of maximum vertical acceleration in case of individual obstacles could be found; this is essentially influenced by the separate hydraulic limit-stop shock absorbers. Other simulations with regards to handling show that roll and pitch movements due to steering and braking can be considerably reduced with the help of the active control.

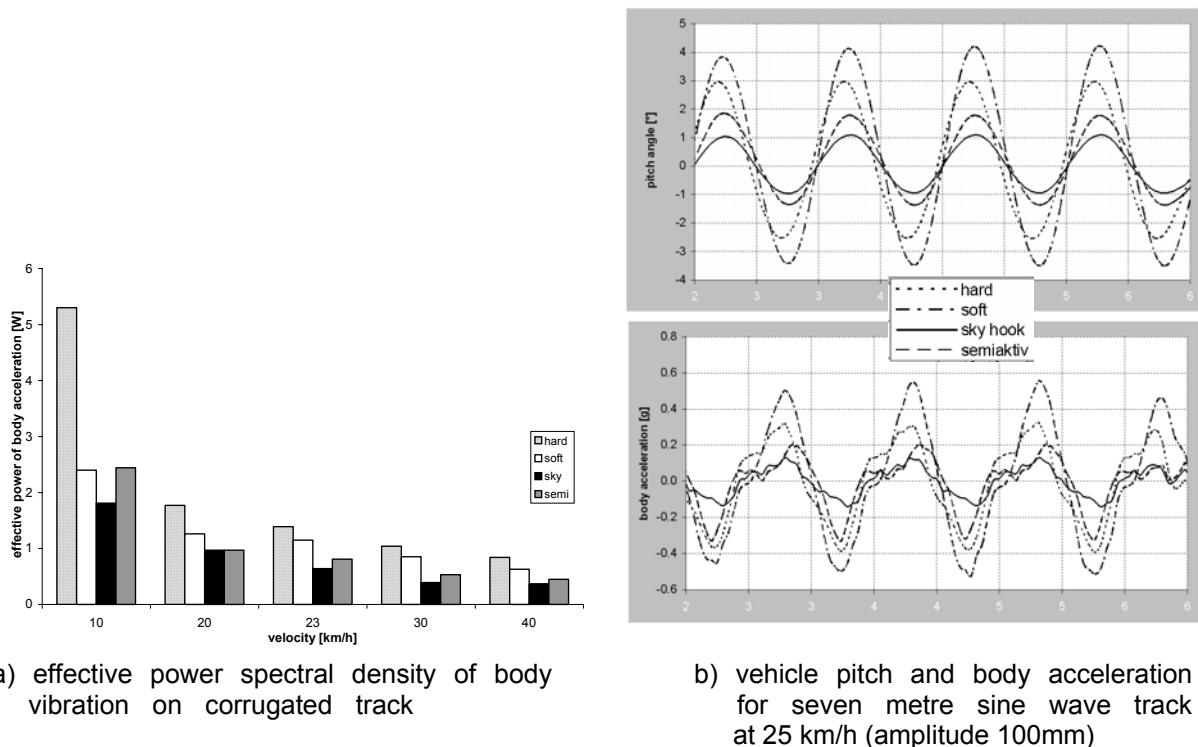

Figure 11: Simulation results for military off-road vehicle [52]

4.2. Civil Vehicles

The reduction of dynamic tyre forces is one of the approaches for the reduction of road damage caused by heavy trucks. Estimations indicate that a fully loaded truck deteriorates the road surface in the order of magnitude 10^4 times more compared to the passage of a passenger car.

A tractor trailer combination has been chosen to verify the contribution of semi-active damping for the road-friendliness, see Figure 12, [39], [53]. The continuously variable semi-active damper Mannesmann Sachs CDC N 50/55, which has been used in this research, requires input currents in the range from 0.6 A to 2 A. A current of 0.6 A represents the minimum damping curve and a current of 2 A the maximum damping curve, see Figure 4 in Section 2.3 above.



Figure 12: Tractor trailer with semi-active dampers

The semi-active dampers installed on the driven axle of the tractor are controlled with a control concept especially developed in the COPERNICUS project for road friendliness, the so called nonlinear extended groundhook, [41]. In order to optimize the controller, the vehicle has been modeled in the multibody software package SIMPACK, the controller has been implemented in MATLAB/Simulink and connected to the SIMPACK model. The controller has been optimized by simulation using multi-objective parameter optimization approach. The advantage of such a procedure is that the controller can be easily exported to a rapid prototyping environment, such as dSpace, which has been used in this project, Figure 13.

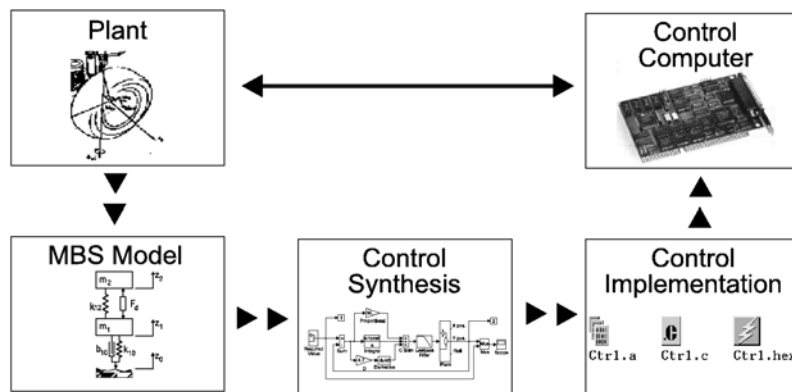

Figure 13: Control design process

The experimental results for a small bump are presented in Figure 14. The results indicate that the semi-active suspension has potential to decrease the road tyre forces by ca.10 to 20 %. Based on the evaluation criteria, i.e. the disproportionately large influence of dynamic forces on road deterioration, the proper semi-active suspension could contribute to a decrease of the road damage by up to 70%.

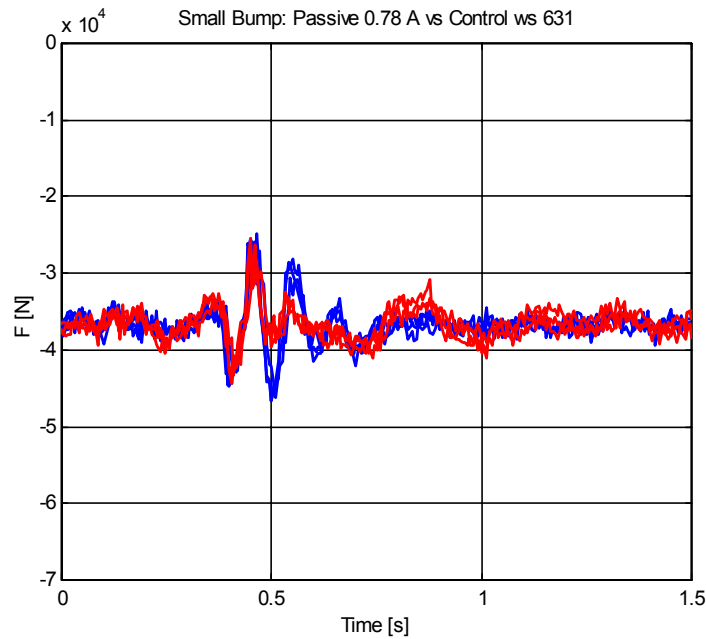

Figure 14: Experimental results

4.3. Railway Vehicles

An overview of practical implementations of active suspensions for railway vehicles is given in [19]. The semi-active damping is usually implemented to increase passenger ride comfort in the secondary suspension, i.e. the suspension between bogie and car body of a railway vehicle in both lateral (usually combined with yaw) and vertical (combined with pitch) directions. Very sophisticated suspension studies have been undertaken by Siemens SGP. In addition to several active components for lateral suspension and tilt systems, semi-active dampers are fitted across the secondary vertical suspension, see Figure 15, from a presentation by Stribersky, Müller and Rath, [54].

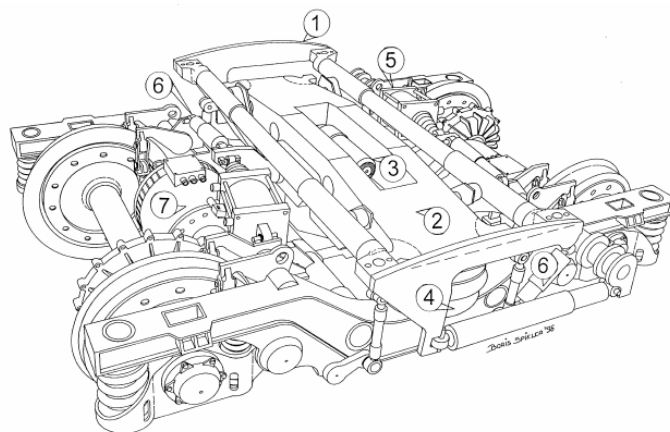

Figure 15: Railway bogie with semi-active dampers (6) in secondary suspension [54]

Limited state feedback control has been applied to derive the damping coefficient for a sky-hook damping approach. The simulation results are presented in Figure 16.

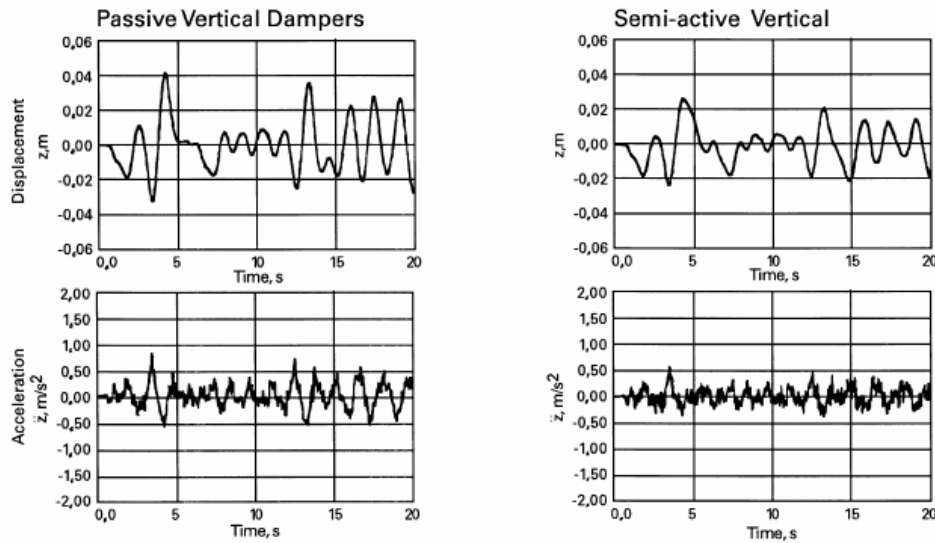

Figure 16: Simulation results of vehicles with passive and semi-active vertical dampers [54]

4.4. Aircraft

A landing gear of a large transport aircraft has to accomplish a variety of functions. Among others, it has to dissipate the energy of the vertical velocity at touchdown and suspend bumps from uneven runways/taxiways and provide a satisfying rolling comfort. A criterion which is regarded most determinative for the lay-out of the suspension components is the certification case of touch-down at high vertical velocity. In order to reduce the weight of the airframe the applied landing gear loads should be as low as possible. Because of the high stroke velocities occurring at a hard landing the shock absorber elements are designed to relatively low damping coefficients - only little damping action is applied at less violent movements. Vertical excitation of the fuselage caused by running over an uneven surface results in comparably low stroke velocities. The damping may therefore be too low if the excitation input meets a resonance frequency, leading to severe resonance oscillations of the structure.

Thus, the potential of semi-active shock absorbers especially in the nose landing gear has been investigated in [17]. Figure 17, left, shows the layout of the aircraft model. The aircraft configuration is that of a large civil transport aircraft with a maximum landing weight of 250 tons, a two-wheel nose landing gear, two main landing gears (four wheels, bogie) and a two-wheel center landing gear.

The airframe is described by a single elastic MBS body. Its properties have been derived from a NASTRAN finite element model which had been set up for loads and deformation analysis. Inside NASTRAN, a modal analysis was performed and the data transferred into SIMPACK via the pre-processor FEMBS in which the modes of interest for the simulation were selected. Natural frequencies up to 15 Hz were included in the model.

The landing gear was modeled as a “classical” rigid body MBS system. The elasticity of the landing gear has been introduced as spring elements in the joints. The effects that were taken into consideration were horizontal motion (“gear walk” induced by spin-up of the wheel or braking) and the attachment stiffness between landing gear and airframe.

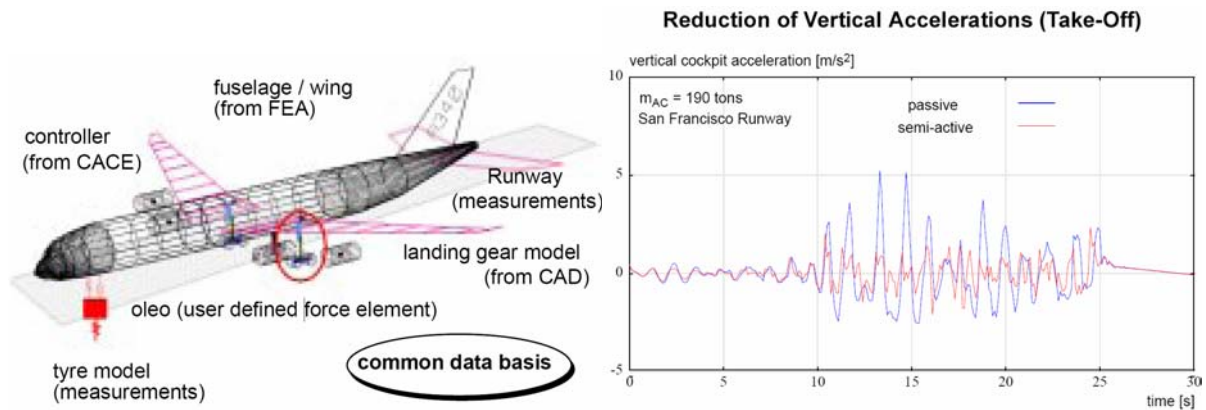

Figure 17: Aircraft multibody model set-up and simulation results for take-off [17]

The wheel has a rotational degree of freedom, the tire is modeled as a point follower with a vertical spring and horizontal slip.

The oleo consists of an air spring and a damping element in parallel. In Figure 17, right, results are shown for a sky-hook damping concept. The results show the vertical accelerations in the cockpit for a take-off on a rough runway. As long as the excitations are small the semi-active system does not lead to considerable improvements. However, during the roughest parts of the take-off run the semi-active system is able to reduce peak accelerations by a factor of three. The controller turns out to be rather robust in terms of changing operational parameters, most important aircraft weight and aircraft velocity. A full set of simulations can be found in [17].

5.0 SUMMARY AND OUTLOOK

Semi-active suspension, also known as active damping suspensions, are able to reduce vertical vibrations of a vehicle. The technology has reached maturity and finds its widest application in luxury cars. Furthermore, prototypes exist for use in military land vehicles, railway vehicles and aircraft landing gears, and the solutions have shown the potential of semi-active suspensions in these fields.

Semi-active actuators are based on viscous dampers with variable orifices, on electrorheological or magnetorheological fluids, on friction damping or on linear electric motors. Most commercially available cars with active dampers use viscous dampers, but magnetorheological fluid dampers are now also available for production vehicles. Friction dampers, electrorheological dampers and suspensions using linear electric motors all exist in various degrees of prototype stages, some already implemented in test vehicles

While most often improvement of ride comfort together with good road holding are the primary control criteria, other goals, like improvement of road-friendliness of a vehicle, are also possible. Active dampers are a highly non-linear system. Control of semi-active suspensions is often based on the simple, but effective sky-hook approach. However, a great number of investigations for optimized, more complex control schemes exist. The control layout is often performed using a combination of multibody dynamics tools and control engineering programs.

The future of active damping lies in the combination of semi-active actuators with other components of active body control and electronic stability programs. Both in control system layout and in active actuation technology the trend seems to be toward making active damping an integral part of combined suspension control.

6.0 REFERENCES

- [1] Karnopp, D., Crosby, M., Harwood, R.: Vibration control using semi-active force generators. *Journal of Engineering for Industry*, No 96, 1974, pp. 619-626.
- [2] Karnopp, D.: Are Active Suspensions Really Necessary. ASME Paper No. 78, WA/DE-12, 1978.
- [3] Corsetti, C.D., Dillow, J.D.: A Study of the Practicability of Active Vibration Isolation Applied to Aircraft During the Taxi Condition, Technical Report AFFDL-TR-71-159, Air Force Flight Dynamics Laboratory, Wright-Patterson Air Force Base, Ohio, 1972.
- [4] Hedrick, J.K.: Railway Vehicle Active Suspensions. *Vehicle System Dynamics*, 10, 1981, pp. 267-283.
- [5] R.M. Goodall, W. Kortüm: Active Controls in Ground Transportation - A Review of the State-of-the-Art and Future Potential. In: *Vehicle System Dynamics*, 12, 1983, pp. 225-257.
- [6] R.V. Dukkipati, S.S. Vallurupalli, M.O.M. Osman: Adaptive Control of Active Suspension - A State of the Art Review. *The Archives of Transport*, Vol. IV, 1992.
- [7] E.M. Elbeheiry, D.C. Karnopp, M.E. Elaraby, A.M. Abdelraaouf: Advanced Ground Vehicle Suspension Systems - A Classified Bibliography. In: *Vehicle System Dynamics*, 24, 1995, pp. 231-258.
- [8] D. Karnopp: Active Damping in Road Vehicle Suspension Systems. *Vehicle System Dynamics*, 12(6), 1983.
- [9] H. Li, R.M. Goodall: Linear and Non-linear Damping Control Laws for Active Railway Suspension. *Control Engineering Practice* 7, 1999, pp. 834-859.
- [10] M. Römer, H. Scheerer: Von Luft getragen - Das Federungs- und Dämpfungssystem. In: *Die neue S-Klasse*, ATZ Special Issue No 5, 1998.
- [11] GM's Magnetic Ride Control - The World's Fastest Reacting Suspension. General Motors Press Release, May 9, 2002.
- [12] O. Vaculín, M. Valášek: COPERNICUS Semi-Active Damping of Truck Suspensions and their Influence on Driver and Road Loads, Final Technical Report. SADTS, CIPA-CT-94-0130, DLR (Project Coordinator), Weßling, 1998.
- [13] P. T. Somm, H. H. Straub and J. R. Kilner: Adaptive Landing Gear for Improved Taxi Performance. Boeing Aerospace Company, 1977, AFFDL-TR-77-119.
- [14] T. Catt, D. Cowling and A. Shepherd: Active Landing Gear Control for Improved Ride Quality during Ground Roll. *Smart Structures for Aircraft and Spacecraft (AGARD CP 531)*, Stirling Dynamics Ltd, Bristol, 1993.
- [15] H. Wentscher: Design and Analysis of Semi-Active Landing Gears for Transport Aircraft. DLR Forschungsbericht 96-11, Deutsches Zentrum für Luft- und Raumfahrt, Köln, 1995.
- [16] X. Wang, U. Carl: Fuzzy Control of Aircraft Semi-Active Landing System. 37th AIAA Aerospace Sciences Meeting and Exhibit, Reno, NV, 1999.

- [17] W. Krüger: Integrated Design Process for the Development of Semi-Active Landing Gears for Transport Aircraft. DLR Forschungsbericht 2001-27, Deutsches Zentrum für Luft- und Raumfahrt, Köln, Germany.
- [18] EUROGEAR (eds.): ELGAR - European Landing Gear Advanced Research, Publishable Summary. BriteEuram, Report Number EG-ELGAR-P10, 2000.
- [19] Goodall, R. (1997), 'Active railway suspensions: Implementation status and technological trends', *Vehicle System Dynamics* 28(2/3), 87 - 117.
- [20] G. Prokop, R.S. Sharp: Performance Enhancement of Limited Bandwidth Active Automotive Suspensions by Road Preview. In: CONTROL '94 , University of Warwick, U.K., March 21-24, 1994 (IEE Publication No. 389), pp. 173-182.
- [21] J. Goroncy: Citroen Xantia Activa mit neuem Fahrwerk. In ATZ Automobiltechnische Zeitschrift 97, 1995, 7/8, pp. 416-417.
- [22] P.J.Th. Venhovens, A.C.M. van der Knaap: Delft Active Suspension (DAS). In: Pauwelussen, Pacejka (eds.): *Smart Vehicles*, Swets & Zeitlinger, Lisse, NL, 1995, pp. 139-165.
- [23] R.S. Sharp: Preview Control of Active Suspensions. In: Pauwelussen, Pacejka (eds.): *Smart Vehicles*, Swets & Zeitlinger, Lisse, NL, 1995, pp. 166-182.
- [24] R.G.M Huisman, F.E. Veldpaus, J.G.A.M. van Heck, J.J. Kok: Preview Estimation and Control for (Semi-) Active Suspensions. *Vehicle System Dynamics*, 22, 1993, pp. 335-346.
- [25] Koni online information. http://www.koni.com/_cars/_general_info/technology/construction/shockabs.html. Cars > General Information > Technology > Shock Absorbers. 26-Aug-2004.
- [26] CDC von ZF Sachs. ZF Sachs online information. <http://www.zfsachs.de>. Produkte > Pkw > Variable Dämpfung > CDC® – Continuous Damping Control > Referenzen > CDC Presse. 26-Aug-2004.
- [27] U. Rettig, O. v. Stryk: Numerical Optimal Control Strategies for Semi-Active Vehicle Suspension with Electrorheological Fluid Dampers. In: K.-H. Hoffmann, R.H.W. Hoppe, V. Schulz (eds.): *Fast Solution of Discretized Optimization Problems*. ISNM Vol. 138 (Birkhäuser Verlag, 2001) pp. 221-241.
- [28] T. Butz, O. v. Stryk: Modelling and Simulation of Electro- and Magnetorheological Fluid Dampers. *Z. Angew. Math. Mech.* (2002), Vol. 82, Issue 1, pp. 3-20.
- [29] Lord Corp. online information. <http://www.rheonetic.com>. 26-Aug-2004.
- [30] Jolly, M.R., Bender, J.W., and Carlson, J.D.: Properties and Applications of Commercial Magnetorheological Fluids, in SPIE 5th Annual Int Symposium on Smart Structures and Materials, San Diego, CA, 1998.
- [31] Reichert, B.A.: Application of Magnetorheological Dampers for Vehicle Seat Suspensions. Master's Thesis, Virginia Polytechnic Institute and State University, Blacksburg, Virginia, Dec., 1997.
- [32] Guglielmino, E., Edge, K.A. A controlled friction damper for vehicle applications. *Control Engineering Practice* 12 (2004) pp. 431-443.

- [33] Unsal, M., Niezrecki, C., Crane, C.D. A New Semi-active Piezoelectriv Based Friction Damper. Proc. Ninth International Conference on Sound and Vibration, Orlando, Jul 2002.
- [34] Bose Corp.: Bose Suspension System Whitepaper.
online: http://www.bose.com/pdf/technologies/bose_suspension_system.pdf
- [35] Advanced Motion Technologies (AMT) Corp.: Real time electronic control of wheel point vertical forces. online information: <http://www.q3000.com/applications-overview.asp> > *Vehicle Suspension*
- [36] Heinrich, A., Kreft, J., Dörrscheidt, F., Boll, M.: Fuzzy-Regelung eines semiaktiven PKW-Fahrwerks. atp - Automatisierungstechnische Praxis 36, 1994, pp. 23-30.
- [37] Heumann, H., Hall, B.B., Weston, W.: Fuzzy Logic Control of a Novel Suspension System. IMechE 1998 C553/032, 1998, pp. 323 ff.
- [38] Thompson, A.G.: An Active suspension with optimal linear state feedback, *Vehicle System Dynamics*, 17, 1976, pp.179-192
- [39] Valášek, M., Steinbauer, P. (1999), Nonlinear control of multibody systems, in 'EUROMECH Colloquium 404, Advances in Computational Multibody Dynamics', Lisbon.
- [40] Vaculín, O., Kortüm, W., Schwartz, W. (1996), Analysis and design of semi-active damping in truck suspension - design-by-simulation, in 'International Symposium on Advanced Vehicle Control, AVEC'96', Aachen, pp. 1087-1103.
- [41] Valášek, M., Novák, M., Šika, Z., Vaculín, O. (1997), 'Extended ground-hook -- new concept of semi-active control of truck's suspension', *Vehicle System Dynamics*, 27, pp. 289 -- 303.
- [42] SIMPACK User Manual, INTEC GmbH, <http://www.simpack.com>
- [43] Using ADAMS / CAR, Mechanical Dynamics, Inc., Ann Arbour, Michigan; 2001
- [44] LMS International, <http://www.lmsintl.com>
- [45] RecurDyn, FunctionBay, Inc., <http://www.functionbay.co.kr>
- [46] The MathWorks, <http://www.mathworks.com>
- [47] MODELICA: <http://www.modelica.org>; DYMOLA: <http://www.dynasim.se>
- [48] Vaculín, O., Krüger, W.R., Valášek, M. Overview of Coupling of Multibody and Control Engineering Tools. *Vehicle System Dynamics*, 2004, Vol. 41, No. 5, pp. 415-429.
- [49] W. Krüger, O. Vaculín, W. Kortüm. Multi-Disciplinary Simulation of Vehicle System Dynamics. RTA/AVT Symposium on Reduction of Military Vehicle Acquisition Time and Cost through Advanced Modeling and Virtual Product Simulation, Paris, 2002, RTO-MP-089, RTO 2003.
- [50] P. Rieth: Global Chassis Control – Sicherheit und Komfort durch Systemvernetzung, Tag des Fahrwerks 2002, Aachen.
- [51] Continental Automotive Systems: ESP II, Active Damping Control (ADC): <http://www.conti-online.com>

- [52] Hönlinger, M, Glauch, U. Mobility Analysis of a Heavy Off-Road Vehicle Using a Controlled Suspension. RTO/AVT Specialists' Meeting on "Structural Aspects of Flexible Aircraft Control", Ottawa, Canada, 18-20 October 1999, published in RTO MP-36.
- [53] Kortüm, W., Valášek, M., Šika, Z., Schwartz, W., Steinbauer, P., Vaculín, O. Semi-active Damping in Automotive Systems: Design-by-Simulation, *Int. J. Of Vehicle Design* 28 (1, 2, 3), pp. 103 – 120.
- [54] A Stribersky, H. Müller and B. Rath: The development of an integrated suspension control technology for passenger trains, *IMEchE* 1998, *Proc Instn Mech Engrs* Vol 212 Part F, pp. 33-42.

Detailed Analysis or Short Description of the AVT-110 contributions and Question/Reply

The Questions/Answers listed in the next paragraphs (table) are limited to the written discussion forms received by the Technical Evaluator. The answers were normally given by the first mentioned author-speaker.

P2 Author: W.R. Krueger, O. Vaculin, M. Spieck 'Evaluation of Active Damping for Reduction of Noise, Vibration and Motion of Ground Vehicles by Multibody Simulating' (DLR-DE)

The paper gives an overview over active damping techniques (according to the two strategies active suspension/active suspension): a description of passive hydraulic shock absorbers, semi-active hydraulic dampers with controllable orifices, electrorheological dampers, magnetorheological dampers, friction based dampers, controlled suspension with linear electromagnetic actuators follows, achieved by some state-of-the-art approaches for the control, in particular the global chassis control. Examples of applications for Ground vehicles, trucks, railway vehicles and even landing systems of aircrafts clearly show that the active suspension techniques are mature enough to be systematically implemented on the future Military Vehicles.

Discussor's name: J. Walentynowicz

Q. What is the power consumption of a semi-active suspension?

R. Estimations for semi-active actuators for trucks amount to a power consumption of 20-50 W per damper. For the linear electromagnetic motor the manufacturers claim that the combination of active damping and roll/pitch control requires less energy than needed for the air conditioning system. More exact information could not be found by the author as it is a proprietary information