

N-19903.26-2



# US Army Aviation

## Desert Operations

*Tactics, Techniques, and Procedures*

Southwest Asia Focus

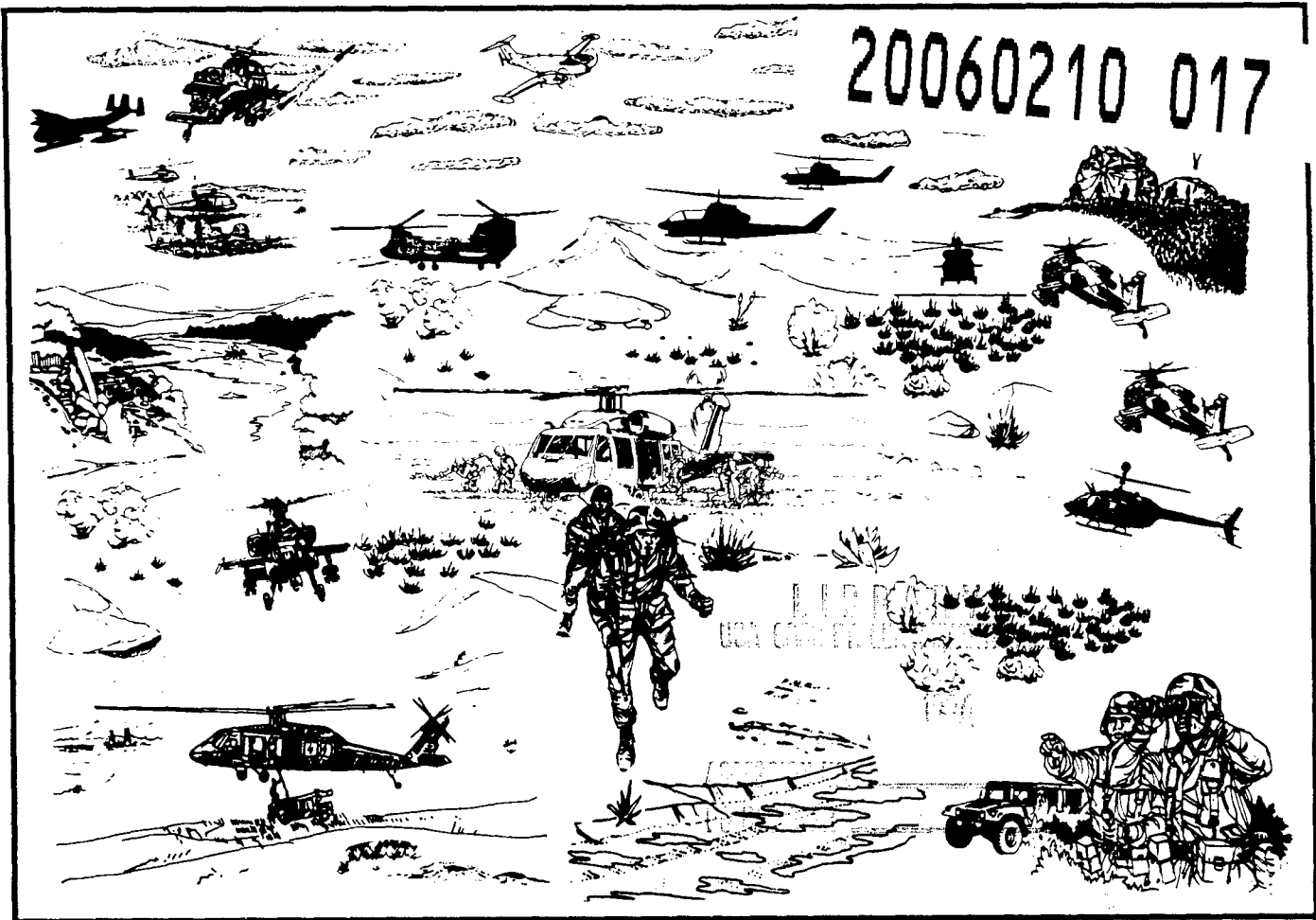

US Army Aviation Center, Fort Rucker, AL

November 1990



# Arabian Peninsula and Vicinity

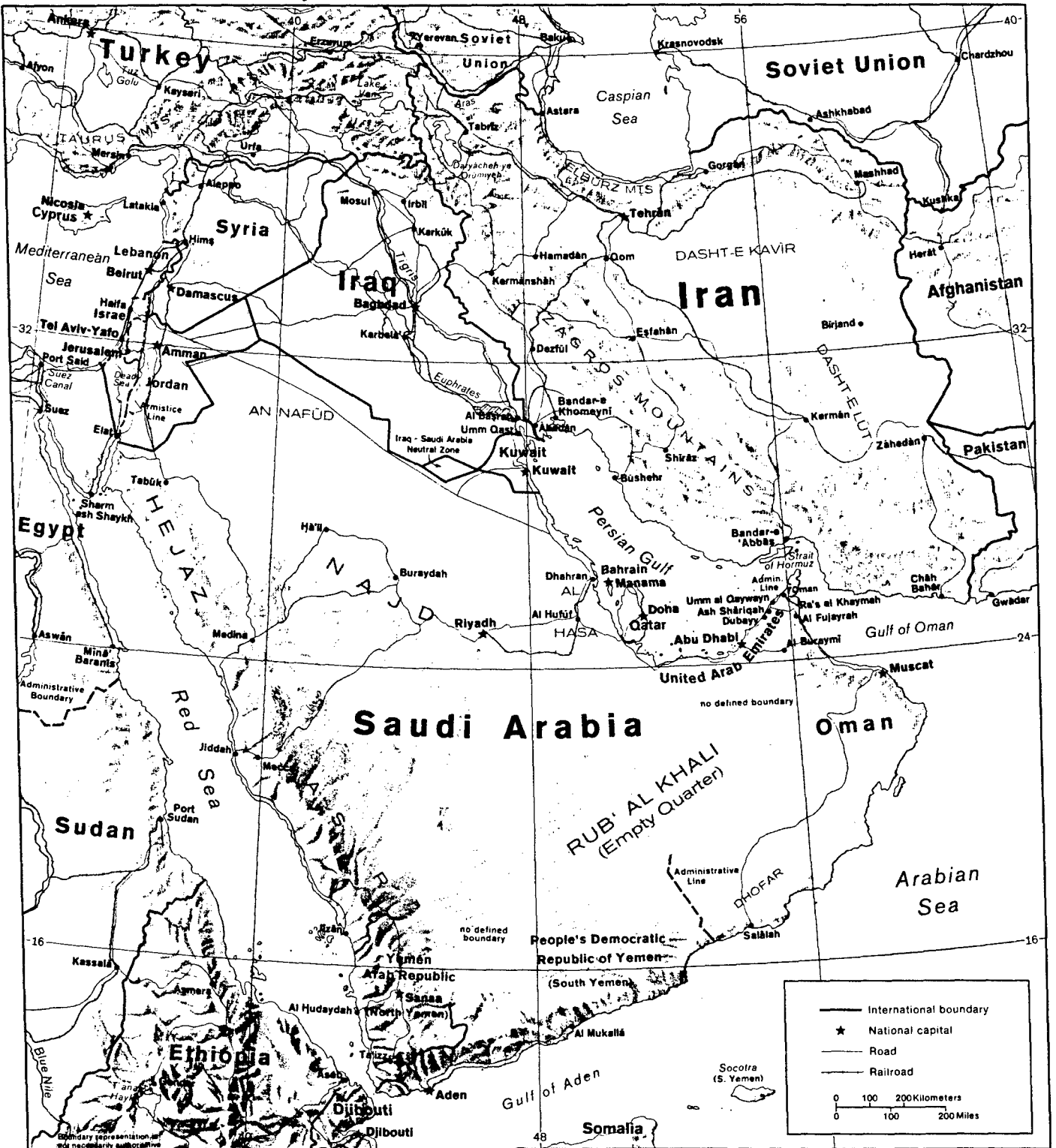

N 19903.26

## Preface

This document has been developed to provide desert-oriented tactics, techniques and procedures to aviation soldiers deployed on Operation Desert Shield. It contains information gathered from numerous sources: FMs, TCs, technical documents, studies, after action reports from Operation Bright Star, and lessons already learned from Operation Desert Shield. The document has been reviewed by seasoned aviators and maintainers with recent experience in Saudi Arabia, Kuwait, and Iraq. The intent of this document is not to be a sole-source document, but to provide necessary information to help you perform your mission. It is designed to be used in conjunction with established Army Doctrinal Manuals and unit SOPs.

Our effort to provide current information will not stop with the publication of this document. I strongly solicit your comments, good ideas, tactics, techniques, and procedures which will allow the safe and effective use of our most precious resource, the individual soldier.

I extend my sincere thanks to those activities and individuals that helped produce this document.

AVIATION, ABOVE THE BEST!

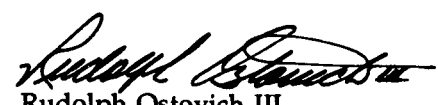

Rudolph Ostovich III  
Major General, Commander  
US Army Aviation Center and Fort Rucker

Table of Contents

<u>Chapter</u>		<u>Page</u>
<b>1</b>	<b>The Area .....</b>	<b>1-1</b>
	<b>GEOGRAPHY AND CLIMATE .....</b>	<b>1-1</b>
	GENERAL .....	1-1
	Terrain .....	1-1
	Winds.....	1-2
	Rainfall.....	1-2
	Lightning.....	1-2
	Light.....	1-2
	Vegetation.....	1-3
	Invertebrates.....	1-3
	Snakes and Reptiles.....	1-3
	SAUDI ARABIA.....	1-5
	KUWAIT.....	1-7
	IRAQ.....	1-9
	<b>AREA FORCES .....</b>	<b>1-10</b>
	KUWAIT.....	1-10
	Total Armed Forces .....	1-10
	SAUDI ARABIA.....	1-12
	Total Armed Forces .....	1-12
	Saudi Arabian Armed Forces Insignia .....	1-15
	IRAQ.....	1-16
	Tactics and Organization.....	1-16
	Historical Perspectives of the War Between Iraq and Iran.....	1-16
	Iraqi Offensive Operations.....	1-18
	Iraqi Defensive Operations .....	1-19
	Unit Structures.....	1-21
	Iraqi Armed Forces Insignia.....	1-24
	Total Armed Forces .....	1-25
	<b>CUSTOMS.....</b>	<b>1-28</b>
	ALCOHOL .....	1-28
	PORNOGRAPHY AND SEXUALLY EXPLICIT LITERATURE.....	1-28
	HANDSHAKING AND SITTING.....	1-28
	CONVERSATION.....	1-28
	FRIENDSHIP .....	1-28
	TOUCHING .....	1-28
	DISTANCE.....	1-29
	TIME .....	1-29
	CRITICISM.....	1-29
	PATRONIZING.....	1-29
	PHOTOGRAPHY.....	1-29
	WOMEN .....	1-29

<u>Chapter</u>		<u>Page</u>
<b>2</b>	<b>Environmental Effects on Personnel</b> .....	2-1
	<b>ACCLIMATIZATION</b> .....	2-1
	<b>WATER LOSS / CONSUMPTION AND SALT LOSS</b> .....	2-2
	<b>FATIGUE / SLEEP DEPRIVATION</b> .....	2-4
	FACTS ABOUT SLEEP DEPRIVATION.....	2-4
	GUIDELINES FOR SLEEP PLANS.....	2-5
	<b>SNAKES / INSECTS</b> .....	2-5
	FIRST AID FOR SNAKE BITE.....	2-6
	FIRST AID FOR SCORPION/INSECT BITES .....	2-7
	Scorpion Sting or Tarantula Bite First Aid .....	2-7
	Brown Recluse Spider or Black Widow Spider Bite First Aid.....	2-8
	<b>CLOTHING AND NECESSITIES</b> .....	2-9
	<b>HYDROGEN SULFIDE</b> .....	2-10
<b>3</b>	<b>Air Operations</b> .....	3-1
	<b>DESERT OPERATIONS</b> .....	3-1
	AIR CAVALRY.....	3-2
	ATTACK HELICOPTERS.....	3-2
	<b>FLIGHT</b> .....	3-3
	Takeoffs .....	3-3
	Airborne .....	3-3
	Navigation.....	3-4
	Landings.....	3-5
	Hovering.....	3-5
	<b>GENERAL LESSONS LEARNED</b> .....	3-6
	DESERT SHIELD AVIATION LESSONS LEARNED .....	3-6
	LESSONS LEARNED - EXERCISE IN EGYPT '83 (E'83).....	3-7
	Mobility / Loose Sand (E '83).....	3-7
	Sanitation (E '83).....	3-7
	Water (E '83) .....	3-8
	Jet Lag (E '83).....	3-8
	Aircraft Maintenance (E '83).....	3-8
	Aeromedical Factors (E '83).....	3-9
	Navigation (E '83) .....	3-9
	Communications (E '83).....	3-10
	Techniques of Movement (E '83).....	3-10
	Night Missions (E '83).....	3-10
	<b>THERMAL IMAGERY LESSONS LEARNED IN SAUDI ARABIA</b>	
	<b>DEMONSTRATION OF TANKS</b> .....	3-11
	Daytime Surface and Equipment Signatures .....	3-11
	Firing Signatures.....	3-12
	Vehicle Tracks.....	3-12
	Night Surface and Equipment Signatures .....	3-13
	Self-Illumination and Passive IR.....	3-13
	Antitank Fires .....	3-14
	Mobility and Maneuverability .....	3-14
	Thermal Imaging and Equipment .....	3-15

<u>Chapter</u>	<u>Page</u>
NATIONAL TRAINING CENTER AND RECENT DESERT EXERCISES LESSONS LEARNED .....	3-15
<b>NIGHT OPERATIONS .....</b>	<b>3-16</b>
NVG USAGE .....	3-17
CREW COORDINATION .....	3-18
SCANNING .....	3-18
EFFECTS OF SPEED .....	3-19
ALTITUDE .....	3-14
ALTITUDE .....	3-19
INADVERTENT INSTRUMENT METEOROLOGICAL CONDITIONS (IMC)...	3-19
DEPTH PERCEPTION.....	3-19
<b>PRIMARY CAUSES OF NIGHT OPERATIONS ACCIDENTS.....</b>	<b>3-20</b>
<b>LANDING ZONE SELECTION .....</b>	<b>3-21</b>
<b>LASER RANGING .....</b>	<b>3-21</b>
<b>WEAPON LETHALITY AND GUNNERY CONSIDERATIONS .....</b>	<b>3-22</b>
AMMUNITION.....	3-22
RANGE DETERMINATION .....	3-22
RUNNING FIRE TACTICS .....	3-23
Employment .....	3-23
Attack.....	3-26
Training Considerations .....	3-27
<b>DESERT SURVIVAL FOR AIRCREWS .....</b>	<b>3-28</b>
SURVIVAL ENVIRONMENT.....	3-28
Mirages and Illusions .....	3-28
Water.....	3-29
Travel.....	3-29
Signaling.....	3-30
<b>SEARCH AND RESCUE OPERATIONS.....</b>	<b>3-31</b>
MISSIONS.....	3-31
OPERATIONAL STAGES.....	3-31
PROCEDURES.....	3-32
AIR COVER.....	3-35
Rescue Escort Tactical Aircraft .....	3-35
Rescue Combat Air Patrol Tactical Aircraft .....	3-35
COMMUNICATIONS.....	3-35
Listening Overwatch.....	3-35
In-Flight Emergency Communications .....	3-36
Relay Transmissions.....	3-36
Distress Calls and Signals.....	3-36
Alternate Communications .....	3-39
Authentication Information.....	3-39
Authentication System.....	3-39
<b>DOWNED AIRCRAFT PROCEDURES.....</b>	<b>3-41</b>
COMMAND RESPONSIBILITIES.....	3-41
Low-Threat Area .....	3-41
High-Threat Area .....	3-41
Cross-FLOT Area .....	3-42

<u>Chapter</u>	<u>Page</u>
AIRCRAFT RECOVERY.....	3-42
AIRCRAFT DESTRUCTION .....	3-43
Destruction Methods .....	3-43
<b>ALSO (AIRCRAFT LIFE SUPPORT EQUIPMENT).....</b>	<b>3-45</b>
<b>INDIVIDUAL SURVIVAL KITS.....</b>	<b>3-45</b>
<b>STANDARD-ISSUE SIGNALING DEVICES.....</b>	<b>3-47</b>
AN/PRC-90 RADIO.....	3-47
AN/MK-13 FLARE .....	3-48
MK-3 SIGNAL MIRROR .....	3-49
<b>RISK ASSESSMENT .....</b>	<b>3-50</b>
RULES.....	3-50
BASIC METT-T HAZARDS.....	3-50
Mission.....	3-50
Enemy.....	3-50
Terrain .....	3-51
Troops.....	3-51
Time.....	3-52
RISK ASSESSMENT LESSONS LEARNED IN DESERT SHIELD.....	3-52
 <b>4 Ground Operations.....</b>	 <b>4-1</b>
<b>GENERAL ENVIRONMENTAL EFFECTS ON EQUIPMENT .....</b>	<b>4-1</b>
PRESSURE .....	4-1
AMMUNITION.....	4-1
COMMUNICATION EQUIPMENT .....	4-1
MEDICAL SUPPLIES.....	4-1
RADIANT LIGHT.....	4-2
DUST AND SAND .....	4-2
FILTRATION .....	4-2
ELECTRICAL INSULATION .....	4-3
WEAPONS.....	4-3
OPTICS .....	4-3
SAND ACCUMULATION .....	4-3
EXPANSION AND CONTRACTION OF FLUIDS.....	4-3
INSTRUMENTATION.....	4-4
STATIC ELECTRICITY.....	4-4
AIRCRAFT WINDOWS .....	4-4
<b>GROUND PASSIVE DEFENSE INITIATIVES.....</b>	<b>4-5</b>
TARGET ACQUISITION AND ATTACK.....	4-5
Means.....	4-5
Pickup Zones.....	4-5
Landing Zones.....	4-6
Forward Arming and Refueling Points (FARPs) .....	4-6
Command Posts .....	4-7
Downed Aircraft Positions.....	4-7
Company and Maintenance Areas .....	4-7
DESERT CONCEALMENT AND CAMOUFLAGE.....	4-7
Desert Camouflage Net.....	4-7

<u>Chapter</u>	<u>Page</u>
Burlap.....	4-7
Landing and Shut Down.....	4-7
POSITION SELECTION.....	4-8
DECEPTION.....	4-8
Devices.....	4-8
Use of Decoys.....	4-9
Operations.....	4-9
<b>AVIATION MAINTENANCE.....</b>	<b>4-10</b>
DEPLOYMENT PLANNING.....	4-10
GENERAL MAINTENANCE RULES FOR MAINTAINING AIRCRAFT IN THE DESERT.....	4-10
RULES FOR PERFORMING MAINTENANCE IN DAYTIME/HIGH TEMPERATURES.....	4-11
DESERT SHIELD AVIATION LESSONS LEARNED.....	4-12
<b>EQUIPMENT SPECIFIC SUGGESTIONS.....</b>	<b>4-16</b>
6TH CAV BDE, FORT HOOD AIRCRAFT MAINTENANCE LESSONS LEARNED.....	4-16
AH-64.....	4-16
CH-47.....	4-18
UH-60.....	4-18
GROUND-BASED EQUIPMENT.....	4-19
<b>DRIVING IN THE DESERT.....</b>	<b>4-21</b>
TECHNIQUES FOR SPECIFIC AREAS OF THE DESERT.....	4-21
Sand.....	4-21
Hillock Areas.....	4-22
Thorn Areas.....	4-22
Rocks and Boulders.....	4-22
LOST OR STRANDED.....	4-22
SURVIVAL NAVIGATION.....	4-23
LOST OR STRANDED TECHNIQUES.....	4-23
<b>5 IPB / Reconnaissance.....</b>	<b>5-1</b>
BATTLEFIELD AREA OF EVALUATION.....	5-1
OBSTACLES / KEY TERRAIN / AVENUES OF APPROACH.....	5-1
WEATHER ANALYSIS - NAIs - INTELLIGENCE SOURCES.....	5-2
RECONNAISSANCE AND SECURITY.....	5-2
EMPLOYMENT OF ARMY AIRCRAFT.....	5-3
<b>6 Chemical Warfare.....</b>	<b>6-1</b>
IRAQI CHEMICAL THREAT.....	6-1
IRAQI DELIVERY SYSTEMS - CHEMICALLY CAPABLE.....	6-1
IRAQI DECONTAMINATION CAPABILITIES.....	6-1
IRAQI INDIVIDUAL PROTECTION - PROTECTIVE SUITS.....	6-2
IRAQI INDIVIDUAL PROTECTION - PROTECTIVE MASKS.....	6-2



<u>Chapter</u>	<u>Page</u>
IRAQI CHEMICAL AGENTS .....	6-2
Sarin / Tabun .....	6-2
Persistent Nerve - VX (Possible).....	6-2
Blister / Mustard .....	6-3
<b>US AVIATION OPERATIONS TO COUNTER CHEMICAL</b>	
<b>ATTACK.....</b>	<b>6-4</b>
CHEMICAL WARNING AND REPORTING .....	6-4
CHEMICAL DETECTION .....	6-5
CONTAMINATION TRANSFER.....	6-7
PRINCIPLES OF CONTAMINATION AVOIDANCE.....	6-8
Detection Avoidance.....	6-8
Dispersion .....	6-8
Training.....	6-8
MISSION-ORIENTED PROTECTIVE POSTURE.....	6-9
In-Flight MOPP Status.....	6-9
On-the-Ground MOPP Status.....	6-9
INDIVIDUAL PROTECTIVE EQUIPMENT AND CLOTHING.....	6-10
MOPP Gear.....	6-10
Aviation Life Support Equipment (ALSE) .....	6-10
Night Vision Devices.....	6-10
M10A1 Canister .....	6-10
M24 Mask .....	6-10
M-43 Aircraft Protective Mask .....	6-11
Battle Dress Overgarment (BDO).....	6-12
Chemical Protective Footwear Covers .....	6-12
Chemical Protective Glove Set.....	6-12
AUIB.....	6-13
M-20 Simplified Chemical Protective Equipment (SCPE).....	6-13
DECONTAMINATION .....	6-13
Reasons for Decontamination.....	6-14
Decontamination Principles.....	6-14
Aircraft Spraydown.....	6-14
Deliberate Decontamination .....	6-14
Aircraft Decontaminants.....	6-15
Decontamination Sites and Layouts .....	6-16
Site Selection Requirements.....	6-16
Site Establishment.....	6-16
Decontamination Methods.....	6-17
FORWARD ARMING AND REFUELING POINTS.....	6-21
Aircrew Support.....	6-21
NBC Planning.....	6-22
 <b>7</b>	
<b>Laser Hazards on the Middle East Battlefield.....</b>	<b>7-1</b>
 GENERAL.....	 7-1
THE HAZARD .....	7-1
EFFECTS ON PERSONNEL .....	7-1

<u>Chapter</u>	<u>Page</u>
EFFECTS ON EQUIPMENT.....	7-4
Effects on Direct-View Optics.....	7-4
Effects on Indirect-View Optics .....	7-4
<b>PASSIVE COUNTERMEASURES .....</b>	<b>7-5</b>
LASER RANGEFINDERS / DESIGNATORS USED BY PERSONNEL .....	7-5
LASER RANGEFINDERS / DESIGNATORS USED ON VEHICLES.....	7-5
LASER FLASH .....	7-5
EMPLOYMENT.....	7-5
<b>PROTECTIVE MEASURES AND DEVICES.....</b>	<b>7-6</b>
LASER LIGHT .....	7-6
In-Band .....	7-6
Out-of-Band .....	7-6
MAGNIFYING OPTICS .....	7-6
LASER FILTERS .....	7-6
ELECTRO-OPTICAL WARNING SYSTEM.....	7-6
<b>ACTIVE COUNTERMEASURES .....</b>	<b>7-7</b>
DETECTION AVOIDANCE.....	7-7
OBSERVATION TECHNIQUES .....	7-7
SMOKE (OBSCURANTS).....	7-7
COUNTERFIRES.....	7-7
<b>SURVIVAL IN AN ACTIVE LASER ENVIRONMENT.....</b>	<b>7-8</b>
<b>POSITIVE UNIT TRAINING .....</b>	<b>7-8</b>
Leadership.....	7-8
Laser Misinformation.....	7-8
Basic Laser Risks .....	7-8
Protective Measures .....	7-9
Laser Hazard Reactions .....	7-9
<b>FIRST AID.....</b>	<b>7-9</b>
Flash Blindness .....	7-9
Minimal Retinal Burns.....	7-10
Serious Injury .....	7-10

Chapter 1  
**The Area**

**GEOGRAPHY AND CLIMATE**

**GENERAL**

The desert is essentially neutral, affecting both friendly and threat sides equally. You must prepare for it and take certain precautions to protect yourself and your equipment. While the climate and terrain is different to many of us, we should remember that the British maintained a field army and won a campaign in the Western Desert in World War II at the far end of a 12,000-mile sea line of communications with equipment considerably inferior to that of today. *Maximize the opportunities we have to learn and train in the desert now so you can deliver the military effectiveness you have been trained to provide.*

**Terrain**

There are three types of deserts:

- Mountain.
- Rocky plateau.
- Sandy or dune.

Mountain deserts have scattered ranges or areas of barren hills or mountains separated by dry, flat basins. High ground may rise gradually or abruptly from flat to a height of several thousand feet. Most of the infrequent rainfall occurs on high ground and runs off rapidly in the form of flash floods, eroding deep gullies and ravines, leaving sand and gravel around the edges of basins.

Rocky plateaus are relatively flat with places where solid or broken rock occurs at or near the surface. There may be cut or dry, steep-walled eroded valleys known as wadis in the Middle East.

Sandy or dune deserts are extensive, flat areas covered with sand or gravel, the product of ancient deposits or modern wind erosions. "Flat" is relative in this case, as some areas may contain sand dunes that are over 1,000 feet high and 10 to 15 miles long; trafficability in such areas will depend on windward/leeward gradients of the dunes and texture of the sand. Other areas may be totally flat for distances of 3,000 km or more.

Air temperatures in excess of 140°F have been observed in areas of Saudi Arabia during the last few months. Temperatures in this area have produced internal vehicle temperatures of nearly 160°F. One of the effects of such temperatures is that exposed equipment frequently becomes too hot to touch with bare hands. The cloudless sky of the desert, while permitting the earth to heat up during the day, can also allow it to cool to near freezing at night in certain areas.

### Winds

Desert winds can achieve almost hurricane force during certain times of the year, particularly during season changes. Dust and sand suspended within the wind can make life almost intolerable. Maintenance can become very difficult and visibility can be restricted to a few meters. Sometimes these winds can last for days at a time. Although there is no danger of you being buried alive by a sandstorm, visibility could become so restricted that you could become separated from your unit. In all deserts, rapid temperature changes invariably follow strong winds.

### Rainfall

The most common characteristic of all deserts is the lack of water. Rain, when it occurs, may consist of one single violent storm in a year. Such storms can cause high surface water runoff which, depending on soil consistency, will either reduce trafficability in wadis where the surface is covered with loam or somewhat improve it if the terrain is pure sand. Precipitation may occur in the form of hail even though ground temperature may be in the 90s. Rain occurring as much as several hundred miles away can cause flooding in another distant location. Otherwise dry stream beds can suddenly become hazardous as a channel of flooding. Therefore, *minimize the time you spend in these low-lying areas. Do not set up camp in dry stream beds; stories of walls of water 10 feet high roaring through them are true. Beware of rain clouds you see in the distance. Stay out of wadis!*

### Lightning

Lightning strikes frequently in the desert. *Keep exposure down to a minimum. Ensure all equipment is grounded when lightning is active in the vicinity.*

### Light

A powerful sun and low cloud density combine to produce unusually bright and glaring light conditions during the day. In certain circumstances, light allows such unlimited visibility that gross underestimation of distance is common. Look at the base of mountains when judging distances. Visibility conditions may, however, be degraded by mirages, blowing dust and sand, or heat shimmer, especially if you are looking toward the sun or through optics. Because mirages distort the shape of objects, particularly in the vertical dimension, positions you select for observation posts should be as high as possible. Vision with night observation devices and even with the naked eye is extremely good on moonlit nights. Blowing dust and sand can adversely affect lasing capabilities.

### Vegetation

The vegetation and wildlife of a desert have physiologically adapted to the conditions. Some plants have extensive lateral root systems to take advantage of the occasional rain, while others have deep roots to reach sub-surface water. For example, a palm tree indicates there is water within 2 to 3 feet of the surface; salt grass implies that water is about 6 feet deep; cottonwood and willow trees indicate water at a depth of 10 to 12 feet. The available vegetation is usually inadequate to provide much shade, shelter, or concealment.

### Invertebrates

Invertebrates, such as ground-dwelling spiders, scorpions, and centipedes, together with insects of almost every type, are found in quantity in the desert. Drawn to man as a source of moisture or food, lice, mites, and flies can be extremely unpleasant and carry diseases such as scrub typhus and dysentery. The stings of many scorpions and the bites of centipedes or spiders can be extremely painful, though seldom fatal. Some species of scorpions and spiders, however, can cause death. *When you camp, check your clothes and shoes before putting them on to see if any of these little creatures may have crawled into them.*

### Snakes and Reptiles

Snakes, lizards and other reptiles are perhaps the most characteristic group of desert animals with snakes being the most common threat. *Watch where you step. Wear your boots when walking, even to and from outdoor showers and facilities.* Snakes are especially active at night during hot weather, and may be seen coiled in shady spots during the day. **DON'T PLAY WITH SNAKES!**

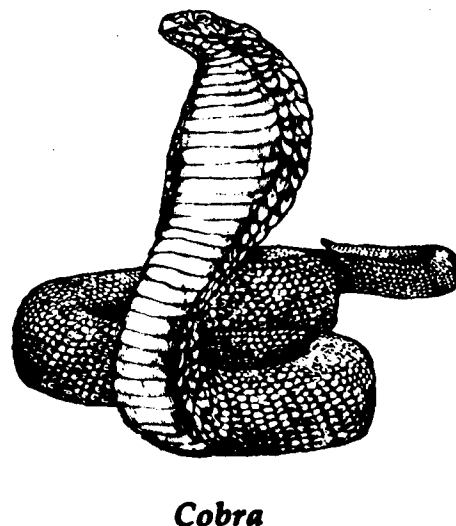
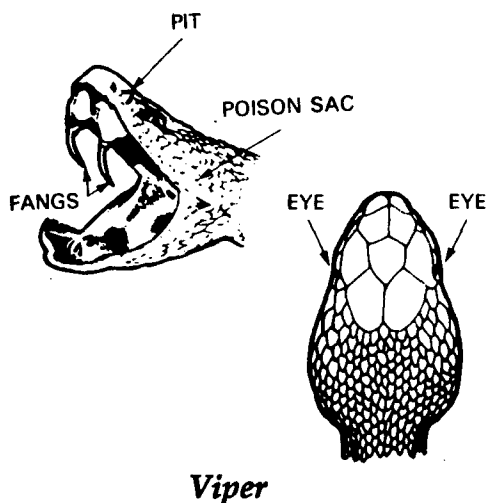

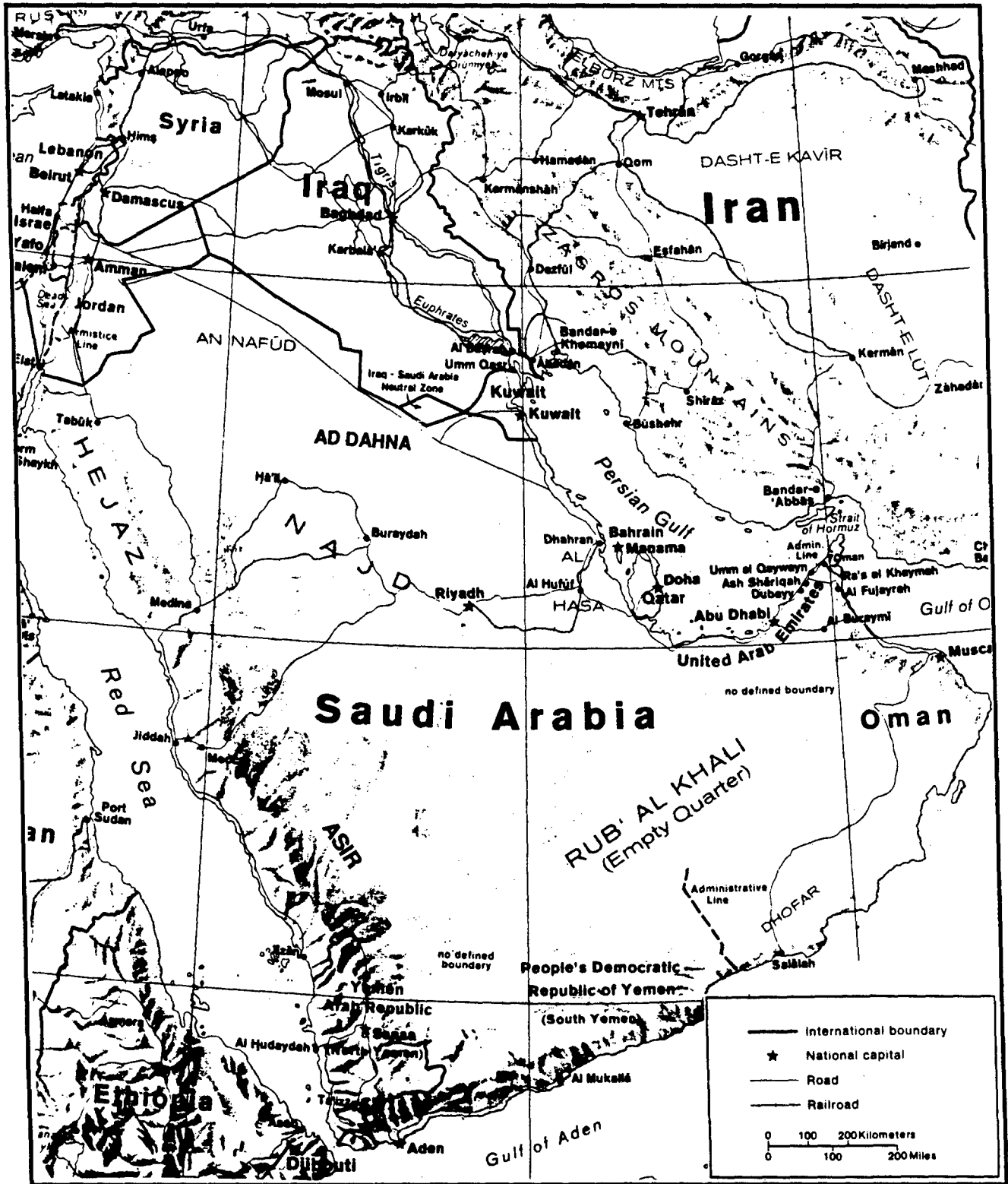

## SAUDI ARABIA

Saudi Arabia occupies most of the Arabian Peninsula, an area about the size of the United States east of the Mississippi River. Its exact size is uncertain because many of its boundaries are not firmly defined. It is about 2,218,000 square kilometers. The vast majority of its territory is desert.

Saudi Arabia has three great deserts:

- The Nafud in the north along the Saudi borders with Jordan and Iraq.
- The Ad Dahna runs from northern Saudi Arabia along the Saudi-Iraqi neutral zone south through the center of the country.
- The Rub Al Khali is the third and largest desert. It is over a half million square km in area and is located along the Saudi's southern border with Yemen and Oman.

Western Saudi Arabia, along the Red Sea, is made up of two low level mountain ranges:

- The Hijaz in the north which rises between 2,000 and 6,000 feet.
- The Asir in the south which rises up to 9,000 feet.

Both are rocky and steep, especially on the western sides. On the eastern sides, both slope gradually down to an extensive rocky plateau called the Najd. The Najd extends east to the center of the Arabian peninsula where it meets the Ad Dahna desert.

East of the Ad Dahna is another rock plateau, the Summan Plateau. Lower in elevation than the Najd, the Summan Plateau gradually drops in elevation to the flat coastal plains along the Persian Gulf.

Saudi Arabia has a desert climate characterized by extremely high temperatures during the day and sharp drops in temperatures at night. The temperature along the coastal regions near the Red Sea and the Persian Gulf is moderated by the presence of these bodies of water. In these areas, the temperature seldom rises above 100°F, but the relative humidity is unusually high. Inland, on the rocky plateaus of Najd and Summan, as well as in the deserts, the temperature can reach as high as 130°F. The heat gains intensity immediately after sunrise and dissipates at sunset, producing relatively cool nights. The almost nonexistent humidity of the central plateaus and deserts, combined with relatively low temperatures, can make nights on the Arabian Peninsula seem bitterly cold.

For most of the country, rainfall is slight and erratic. A region's entire annual rainfall may come in one torrential downpour. For this reason, most of the country's scarce water supply comes from springs and artesian wells. In the central portion of Saudi Arabia, Najd and the three deserts' natural wells and springs are few and scattered. Water must be hauled or pumped to the surface and its quality may be poor. In Eastern Arabia, and in the western mountains, wells and springs are relatively more common. Large numbers of these wells and springs in local areas constitute oases where the water is used for irrigation and agriculture.

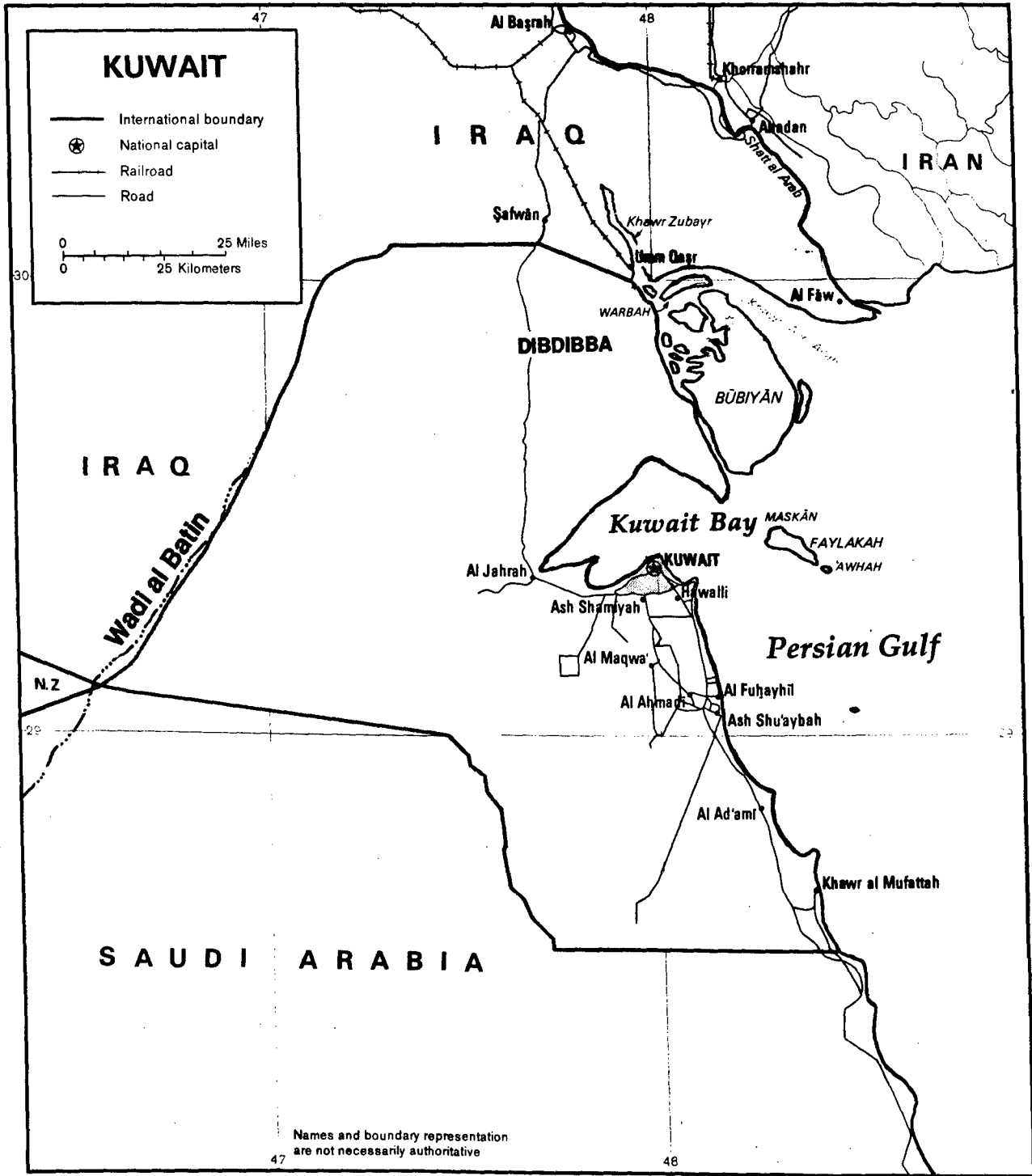



## KUWAIT

Kuwait is a country of approximately 20,150 square kilometers located between Saudi Arabia and Iraq, on the northeast corner of the Persian Gulf. Kuwait has an arid climate. Summers are extremely hot, dry, and almost cloudless with maximum temperatures ranging from 72° to 120°F. Winters are mild with only moderate cloudiness and meager precipitation. Temperatures range from 30 to 108 degrees. The relative humidity near the coast ranges between 50% and 90%. The annual precipitation is less than nine inches. Summer cloud cover generally averages below 10%. Cloud cover in winter ranges between 15% and 50%, with the majority occurring over the lowlands and foothills and isolated coastal areas. Visibility is generally best in winter and poorest in summer, with dust, blowing sand, haze, and fog causing the chief restrictions. Northerly surface winds predominate in winter and northwesterly winds in summer.

Except for the eastern coastal plain, Kuwait is a featureless desert rising 91 meters in the north to 274 meters in the south and falling gradually eastward to the Persian Gulf. The monotonous desert landscape is broken only by low rocky ridges or isolated hills. The Wadi al Batin, a well-marked and important depression, forms the boundary between Kuwait and Iraq. The northeastern portion of Kuwait's interior is an undulating gravel plain "dibdibba" with broad wadis, rocky ridges, small hills, and long, shallow depressions. The western portion of the dibdibba gradually rises from the northeast to the southwest with a sharp fall to Wadi al Batin in the west. Wadis and depressions trend southwest-northeast and are deeper than in the northeastern desert.

Sandstorms and dust storms are important climatic features of Kuwait. Visibility is greatly reduced at times, and the abrasive effects of sandstorms are not only discomforting to people, but detrimental to structures and exposed machinery. Wadis, streambeds that are normally dry, are numerous in Kuwait. With an exceptionally heavy rain, a wadi may be filled to overflowing in a very short time, producing a flash flood.

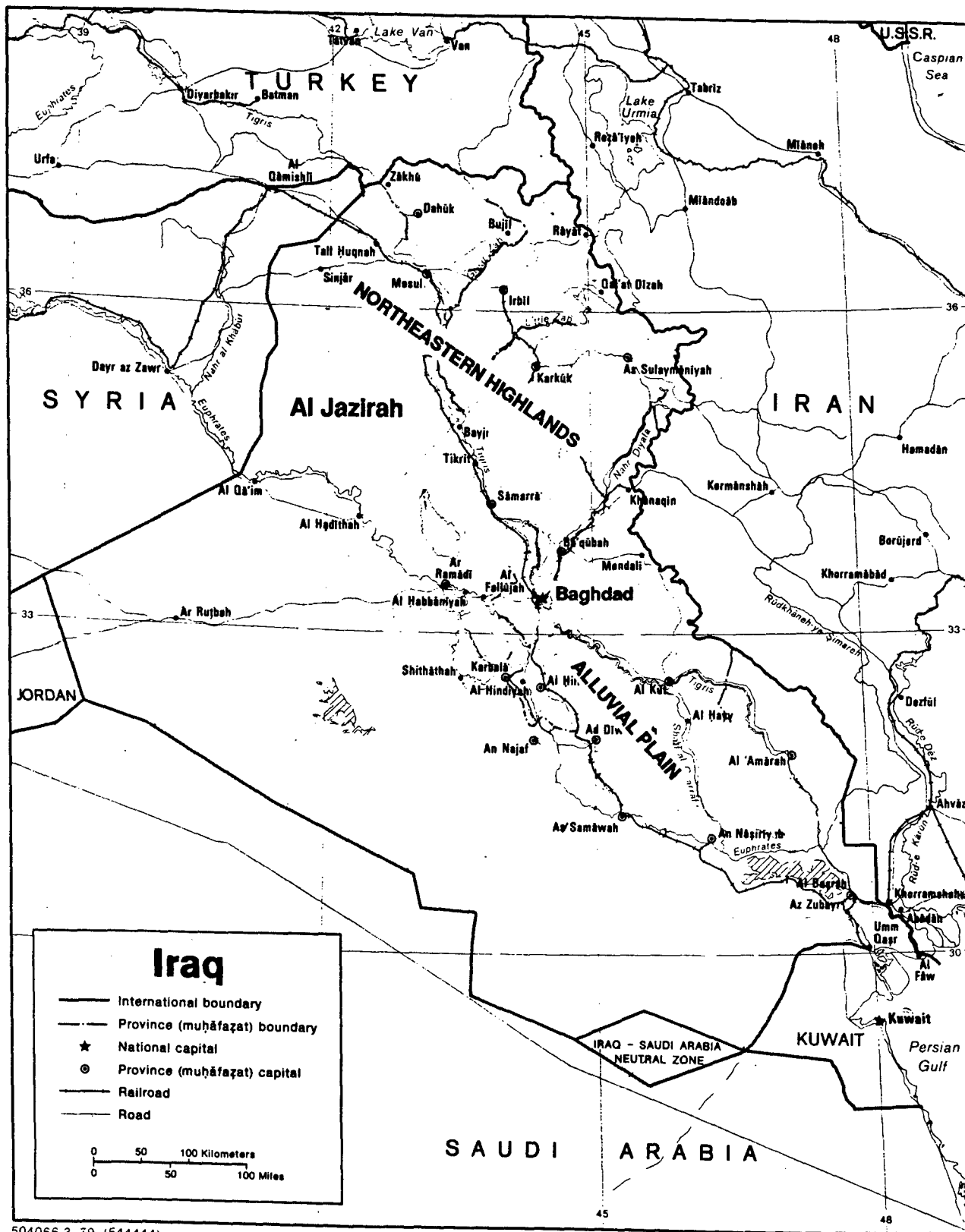

504066 3-79 (544444)

## IRAQ

Iraq's total land area is approximately 435,000 square kilometers and is comprised of four main regions:

- The desert in the west and southwest:
- The rolling upland between the Tigris and Euphrates rivers (in Arabic, the Dijhis and Furat, respectively).
- The highlands in the northeast.
- The central and southeastern alluvial plain through which the Tigris and Euphrates flow.

The desert zone, lying west and southwest of the Euphrates river, is a part of the Syrian Desert. The region is sparsely populated and consists of a wide stoney plain interspersed with rare sandy stretches. A widely branched pattern of wadis runs from the border to the Euphrates. Some wadis are more than 400 kms long, and carry brief, but torrential, floods during the winter rains.

The uplands region, between the Tigris north of Samarra and the Euphrates north of Hit, is known as Al Jazirah and is part of a larger area that extends westward into Syria, between the two rivers, and into Turkey. Water in the area flows in deeply cut valleys. Much of this zone may be considered desert.

The northeastern highlands begin just south of a line drawn from Mosul to Kirkuk, and they extend to the borders with Turkey and Iran. High grounds, separated by broad, undulating steppes, give way to mountains ranging from 1,000 to 4,000 meters near the borders. Except for a few valleys, the mountain area proper is suitable only for grazing in the foothills and steppes; adequate soil and rainfall make cultivation possible. Iraq's largest oil fields are located near Mosul and Kirkuk.

The alluvial plain begins north of Baghdad and extends to the Persian Gulf. The Tigris and Euphrates rivers lie above the level of the plain in many areas in this region. The whole area is a delta interlaced by the channels of the two rivers and by irrigation canals. Intermittent lakes, fed by the rivers in flood, also characterize southeastern Iraq. A fairly large area just above the merging of the two rivers at Al Qurnah and extending east of the Tigris beyond the Iranian Border is marshland, known as the Hawr al Hammerar. Much of it is permanent marsh, but some parts dry out in early winter, and other parts become marshland only in years of great flood.

Roughly 90% of the annual rainfall occurs between November and April, most of it in the winter months from December through March. The remaining 6 months, particularly the hottest ones of June, July, and August, at approximately 102°F, are dry. The summer months are marked by two types of wind. The southerly and southeasterly Sharqi, a dry, dusty wind with occasional gusts of 80 km an hour, occurs from April to early June and again from late September through November. From mid-June to mid-September, the prevailing wind, called the Shamal, is from the north and northwest. It is a steady wind which is fairly constant during this period. The very dry air brought by this Shamal permits intensive heating of the land surface by the sun, but the breeze has some cooling effect.

## AREA FORCES

This section lists many of the weapons systems anticipated in the Desert Shield theater. The myriad of equipment owned by the various countries in the region, particularly Iraq, indicates that a genuine complication may exist in this theater with respect to identification - friend or foe (IFF).

### KUWAIT

The following data are estimates as presented in The Military Balance, 1989-1990.

 These resources are presented for the purpose of indicating resources prior to the Iraqi invasion leading to Operation Desert Shield. No differentiation is made here as to what has happened to these resources, i.e. destroyed during invasion, captured, salvaged through flight to Saudi Arabia or other friendly country. We assume most of this equipment was captured.

#### Total Armed Forces

ACTIVE: 20,300

*Terms of service: conscription, 2 years (university students, 1 year).*

RESERVES: Obligation for 14 years following regular/conscript service. 1 month annual trg

ARMY: 16,000

2 armd bde (each with 2 armd regt, 1 arty bn: 1 with 1 mech inf, 1 with 2 mech inf regt)  
1 mech inf bde (with 1 armd, 3 mech inf/cdo regt, 1 arty bn)  
1 arty bde with 1 SP arty regt, 1 SSM bn

#### EQUIPMENT:

MBT: 275: 70 Vickers Mk 1, 40 Centurion, 165 Chieftain

RECCE: 100 Saladin, 90 Ferret

AIFV: 50 BMP-2

APC: 200 M-113, 130 Saracen, 100 Fahd

TOWED ARTY: 105mm: 36 M-109A2

MORTARS: 81mm; 120mm: 40

SSM: 12 FROG-7 launchers

ATGW: 20 HOT, TOW/Improved TOW (incl 56 M-901 SP), 200 Vigilant

RCL: 84mm: Carl Gustav; 106mm: 24

SAM: SA-7

---

NAVY: 2,100

BASES: El Adami (HQ), Shuwaikh

PATROL AND COASTAL COMBATANTS: 23:

Missile Craft: 8:

2 *Istiqlal* (FRG Lürssen FPB-57) PFM with 2 x MM-40 *Exocet* SSM

6 *Al Boom* (FRG Lürssen TNC-45) with 2 x MM-40 *Exocet*

Patrol: 15 inshore

AMPHIBIOUS: Craft only; 4 LCM

SUPPORT SHIPS: 3 Coastal transports

2 *Boraida* (mod Fr *Durance*) A"OR, 3 ocean tugs, 1 Royal Yacht

MARINES: 2 bn cdo

---

AIR FORCE: 2,200 (excl foreign personnel); 36 cbt ac, 18 armed hel

FGA: 24 A-4KU, 3 TA-4KU in store. Was replaced by F-18

FIGHTER: 2 sqn with 20 *Mirage* F-1CK, 4 F-1BK

12 *Lightning*, 4 *Hunter* in store

COIN/TRAINING: 1 sqn with 12 *Hawk* Mk 64

TRANSPORT: 2 DC-9, 4 L-100-30, 2 DHC-4; used also in civil role

HELICOPTERS: 3 sqn:

Attack: 12 SA-342K (with HOT), 6 AS-332 (Puma) (with *Exocet*; anti-ship)

Transport: 10 SA-330

TRAINING: 8 SA-342 hel

AD: KAFAD (Kuwait Air Forces and Air Defense): integrated AD control system plus; 1 SAM bn (6 bty each 2 x 12 *Improved HAWK*) SA-6 reported

AAM: R-550 *Magic*, Super R-530, AIM-9 *Sidewinder*

ASM: AS-11/-12, HOT, AM-39 *Exocet*

---

PARA-MILITARY:

NATIONAL GUARD: 1,500: Palace, Border Guard; 20 V-150, 62 V-300 *Commando* APC

CIVIL DEFENSE: forming

## SAUDI ARABIA

The following data are estimates as presented in The Military Balance, 1989-1990.

### Total Armed Forces

ACTIVE: 65,700

*Terms of service: voluntary; conscription, males aged 18-35, authorized.*

RESERVES: People's Army (Para-military): 850,000

ARMY: 38,000  
2 armd bde  
4 mech bde  
1 inf bde  
1 AB bde (2 AB bn, 2 SF coy)  
1 Royal Guard regt (3 bn)  
5 arty bn  
18 AD arty bty

### EQUIPMENT:

MBT: 550: 30 AMX-30, 50 M-60A1 (to be A3), 200 M-60A3

RECCE: 250 AML-60/-90

AIFV: 500+ AMX-10P

APC: 1,100 M-113 (incl TOW/comnd/spt variants), 30 EE-11 *Urutu*, 170 Panhard M-3

TOWED ARTY: 105mm: some 24 Model 56 pack, 40 M-101/-102 (in store); 155mm: 70 FH-70, 34 M-198

SP ARTY: 550: 275 155mm, 224 M-109, 51 GCT

MRL: 127mm: 6 *ASTROS II*

MORTARS: 107mm: 360 M-30 4.2-in

SSM: 9 Ch CSS-2

ATGW: BGM-71A *TOW* (incl 200 VCC-1 SP), M-47 *Dragon*, *HOT* (incl AMX-10P SP)

RCL: 75mm; 84mm: 450 *Carl Gustav*; 90mm; 106mm

AD GUNS: 40mm: M-42 SP; 90mm: 15 M-117

SAM: *Stinger*, 500 *Redeye*

---

NAVY: 7,200 (incl 1,200 marines)

BASES: Riyadh (HQ Naval Forces). Western Fleet: Jiddah (HQ), Al Wajh, Yanbu, Eastern Fleet: Jabayl (HQ), Al Qatif, Ras Tanura, Al Dammam, Ras al Mishab

FRIGATES: 8:

4 Madina (Fr F.2000) with 4 x 533mm, 2 x 406mm ASTT, 1 x AS-365N hel (AS 15 ASM) plus 8 Otomat-2 SSM, 1 x 100mm gun  
4 Badr (US Tacoma) (ASUW) with 2 x 4 Harpoon SSM, 2 x 3 ASTT (Mk 46 LWT)

PATROL AND COASTAL COMBATANTS: 13:

Missile Craft: 9 As Siddiq (US 58m) PFM with 2 x 2 Harpoon 4:  
2 Husa el Hussair (It Assad, hel version) 1 x AB-212 hel, 2 x Otomat SSM  
2 Husa el Hussair (It Assad) with 6 x Otomat, 2 x 3 ASTT

Torpedo Craft: 3 Dammam (FRG Jaguar) with 4 x 533mm TT

Patrol, Inshore: 1 US Pegasus PHI, 9 PCI in store

MINE WARFARE: 4 Addriyah (US MSC-322) MCC

AMPHIBIOUS: Craft only; 4 LCU, 12 LCM

SUPPORT AND MISCELLANEOUS: 6

2 Boraida (mod Fr Durance) A"OR, 3 ocean tugs, 1 Royal Yacht

NAVAL AVIATION:

Helicopters: 24 AS-365N, (4 SAR, 20 with AS-15TT ASM)

MARINES: (1,200): 1 inf regt, with 140 BMR-600P

---

AIR FORCE: 16,500; 179 cbt ac, no armed hel

FGA: 5 sqn:

3 with 63 F-5E;  
2 with 20 Tornado IDS

FIGHTER: 3 sqn with 42 F-15C. Tornado ADV being delivered

RECCE: 1 sqn with 10 RF-5E

AEW: 1 sqn with 5 E-3A

TANKER: 8 KE-3A, 8 KC-130H

OCU: 2 with 15 F-5B, 22 F-5F, 17 F-15D

TRANSPORT: 3 sqn:

35 C-130 (10-E, 25-H), 9 L-100-30HS (hospital ac), 35 C-212

HELICOPTERS: 2 sqn: 1 AB-204, 14 AB-205, 25 AB-206B, 29 AB-212, 17 KV-107 (SAR, tpt)

TRAINING: 30 *Hawk* Mk 60, 30 BAC-167 Mk 80, 30 PC-9, 2 *Jetstream* 31, 13 Cessna 172

ROYAL FLIGHT:

ac: 2 BAe 125-800, 2 C-140, 4 CN-235, 1 *Gulfstream* III, 2 *Learjet* 35, 2 VC-130H  
hel: 5 AS-61, AB-212

AAM: AIM-9J/L/P *Sidewinder*, AIM-7F *Sparrow*

ASM: AGM-65 *Maverick*

---

AIR DEFENSE FORCES: (4,000):

33 SAM bty:

16 with 128 *Improved HAWK*;  
17 with 68 *Shahine (Crotale)* fire units and AMX-30SA 30mm SP AA guns  
73 static *Shahine* fire units as static defense

EQUIPMENT:

AD GUNS: 20 mm: 100 M-163 *Vulcan*; 30mm: 53 AMX-30SA; 35mm: 180; 40mm: 120 L70 (in store)

SAM: 141 *Shahine*, 128 MIM-23B *Improved HAWK*

---

PARA-MILITARY:

NATIONAL GUARD: (Ministry of Interior) 56,000 (10,000 active, 20,000 reserve; 26,000 tribal levies):

2 mech inf bde each 4 all arms bn  
1 ceremonial cav sqn

EQUIPMENT:

APC: 700+ V-150 *Commando*

TOWED ARTY: 105mm: 50 M-102

RCL: 106mm

ATGW: TOW

AD GUNS: 20mm: 30 M-40 *Vulcan*

FRONTIER FORCE: 8,500

COAST GUARD: about 40 PCI, 24 hovercraft, about 400 boats

GENERAL CIVIL DEFENSE ADMINISTRATION UNITS: 10 KV-107 hel



Saudi Arabian Armed Forces Insignia

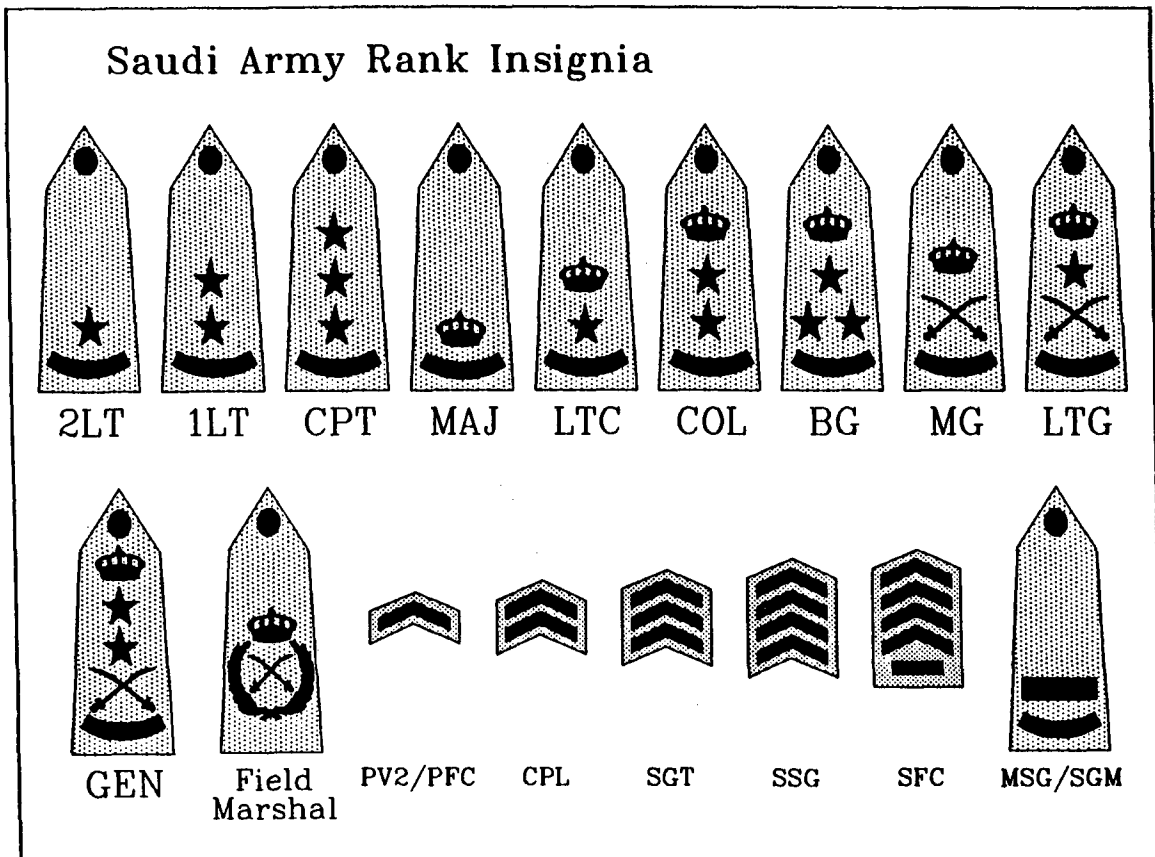

Figure 1-1. Saudi Arabian Armed Forces Insignia.

## IRAQ

### Tactics and Organization

The Iraqi Army was in combat against the Iranians for 8 years and developed into a battle-hardened force capable of conducting effective offensive and defensive operations. The Iraqi Army polished its offensive capability, achieving good results during final operations against the Iranians.

The maneuver brigades, (armor, mechanized infantry and infantry) are the lowest level units capable of independent operations. A combat brigade, reinforced with additional artillery, rocket, aviation and air defense support from division and higher commands, makes a powerful battlefield force.

An elite force, the Republican Guard Forces Command (RGFC), was initially organized to protect the Iraqi government. Later, this force was employed in highly successful offensive operations against the Iranians. Recently, brigades of the RGFC conducted the blitz-style attack into Kuwait.

### Historical Perspectives of the War Between Iraq and Iran

The following is based on a report entitled "Iraqi Power and US Security in the Middle East" developed this year at the US Army War College, Strategic Studies Institute, Carlisle Barracks, Pennsylvania.

During the static defense phase, the Iraqis built up elaborate defenses outside Basrah. In this undertaking, they employed the French Maginot concept. They established a series of defensive regions which were connected by earthen berms. Within the regions were numerous strong points. The Iraqis, however, outdid the French by making certain that this entire system was not only connected by an excellent road network and dispersed with ammunition dumps, but that it was backed up by a large, mobile counterattack force. The armored and mechanized units of the regular army corps and the Republican Guard performed the counterattack role with efficiency and crushing impact.

A major component of the Iraqi defensive doctrine which emerged during the static defense phase was the integration of chemical fires.

The Iraqis' military performance showed them to be expert problem solvers, and this is apparent in their handling of the static defense phase and the later move to the offense.

When dealing with Iraqi weaknesses, the conclusion must be speculative since, as noted earlier, very little is known of the decisionmaking process that directed the transformation from defense to successful offensive operations. The Iraqis can be formidable in defense, but one must also remember that their experience is against masses of fanatical light infantry which had limited artillery or armor support and almost no air support. This is not to discount their experience altogether, but it must be kept in mind. We have seen the Iraqis execute offensive operations, routinely supported by deep fires and integrated chemical fires. These have been executed as short jab counterattacks within a clear doctrinal framework.

Military commanders (Iranian, Syrian, Israeli or whomever) assaying to combat the Iraqis would find themselves facing an opponent who is:

- Armor heavy, fielding large numbers of T-72 tanks which they would use in massed formation supported by equivalent numbers of accompanying AFVs.
- Rich in long-range field artillery and apt to take the Soviet approach to fire support, throwing in everything, e.g, stand-off helicopter rockets, tanks in the indirect fire mode, and probably some not-too-close air support.
- Employing large numbers of a variety of types of attack helicopters as hunter-killer groups as well as in the aforementioned fire support role.
- In possession of a very large, mostly modern air force which has shown itself capable of conducting deep interdiction and battlefield interdiction missions.
- Capable of, and doctrinally attuned to, employment of chemical weapons by all available means to include mortars, helicopter fire, rockets, aerial delivered bombs, and rockets and artillery. These chemical fires would routinely be integrated in defensive fire plans and might occasionally be employed in offensive situations. If used offensively, they would normally be fired on artillery positions, logistic facilities in-range, suspected assembly areas, FARPS, and any detected command posts. We expect that these would be priority targets.
- Capable of firing large quantities of SCUD variants with conventional and possible chemical warheads with moderate accuracy. (You can expect that a SCUD might be accurate to within 500 meters (approx.) at two-thirds of US maximum range of about 300 km.) Whereas none of these weapons were used in tactical roles during the Iraq-Iran War, there is no reason to assume that they would not be employed against the rear areas of any hostile force. Such weapons pose significant risks to naval forces conducting off-loading operations at some port facility and would be likewise useful against almost any airfield within range.
- Viewed with ambivalence by its neighbors who see Iraq not only as the bulwark against Persian expansionism and Shi'a fundamentalism, but also as a potentially ruthless adversary.
- Equipped with some of the Arab Middle East's best educated troops. (Iraq boasts a literacy rate of over 55%, superior to Iran, Syria or Egypt.)
- Capable of considerable adaptation to changing circumstances as evidenced by the tremendous speed-up of the AI Faw operation and the successful execution of five major operations, apparently according to some timetable, at the rate of one a month until the end of the war.

Based on this assessment, it is believed Iraq's military would be vulnerable to a well-integrated combined arms force able to seize the initiative and conduct battle on its own terms, avoid the killing zones, subject the counterattack formations to interdiction, use high quality electronic warfare, and be

capable of bringing the air war directly to Iraqi cities. Wrestling the initiative from the Iraqi army is the key to neutralizing its operations.

#### **Iraqi Offensive Operations**

- Combined arms formations common
- Infantry and engineers lead through minefields
- In clear and open terrain...tanks lead
- Broken terrain or mines and obstacles...infantry leads
- Artillery prep
  - 45 - 60 minutes before assault
  - Then shifts to deep targets
  - Chemical weapons often mixed with prep
- Enemy reinforcements attacked by air and artillery
- Attacks attempt to bypass strong points
- Envelopment preferred
- Vertical envelopment may support attack
- Naval infantry may provide amphibious support
- Attack helicopter techniques...three (3) aircraft team
  - Battle captain in Hind directs
  - Gazelle armed with HOT missiles
  - BO-105 armed with rockets
  - Rely on attack helicopters for direct fire support
- Hinds deployed in groups of four or more to:
  - Loft rockets from low altitude
  - Pop-up and engage from multiple directions

**Iraqi Defensive Operations**

- Security zone forward of FLOT
- Reconnaissance units reinforced by infantry and artillery
- Strong forward defensive positions
- Defense in depth...obstacles in depth
- Maximum use of natural and manmade obstacles
- Minefields cover forward positions
  - Up to 350 meters deep
  - Mix normally three (3) APs and one (1) AT per cluster
  - Mixed with barbed wire
- Maximum use of tank ditches and berms
- Tank-heavy reserve used for counterattack
- ATGMs deployed forward
- Tanks are forward when needed in antitank role
- Iraqi antitank tactics include:
  - Channel enemy tanks to open areas
  - Employ antitank weapons in depth
  - Commandos in rear area ambush tanks

Sketches of an Iraqi brigade position defense and battalion-size triangular strongpoint are provided in Figures 1-2 and 1-3.

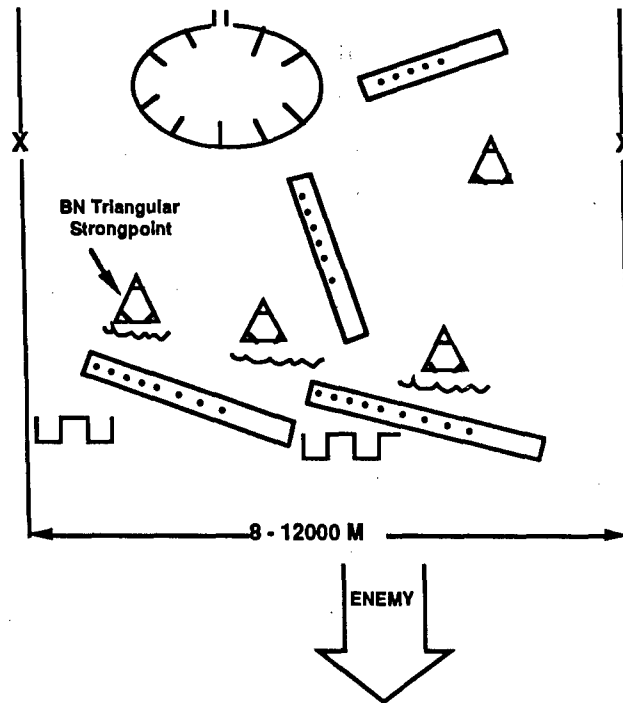

Figure 1-2. Iraqi Brigade Position Defense.

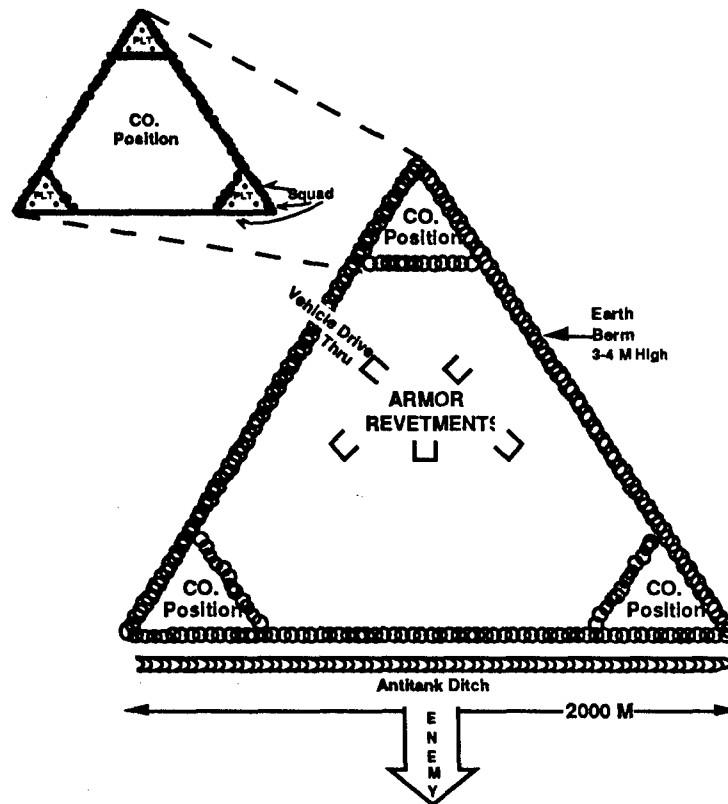

Figure 1-3. Iraqi Battalion-Size Triangular Strongpoint.

Unit Structures

The maneuver brigade organizations show the traditional Iraqi Army brigades, and the brigades of the RGFC. Although most Iraqi maneuver brigades are well balanced, the RGFC brigades are larger and equipped with better and more powerful weapons. Patches and unit markings may be removed, altered, or changed as part of deception operations.

Brigade structures are provided in the following Figures 1-4 through 1-9.

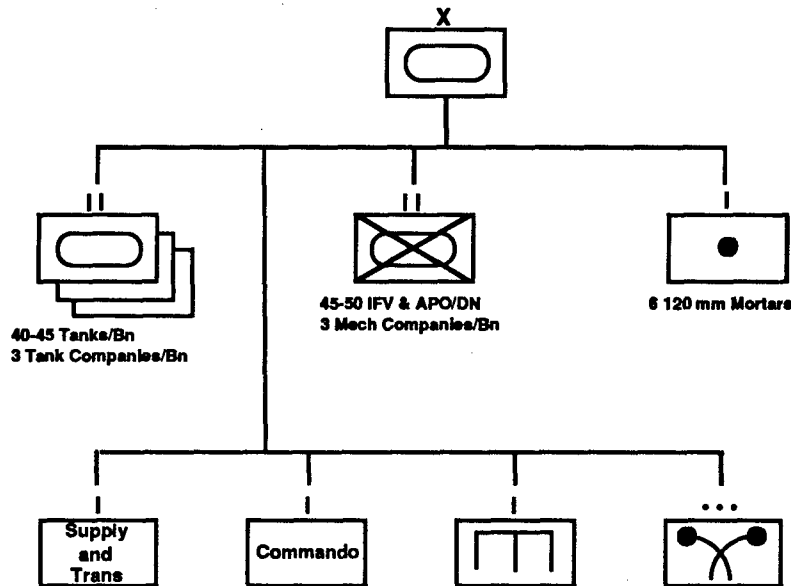

Figure 1-4. Iraqi Army Armored Brigade.

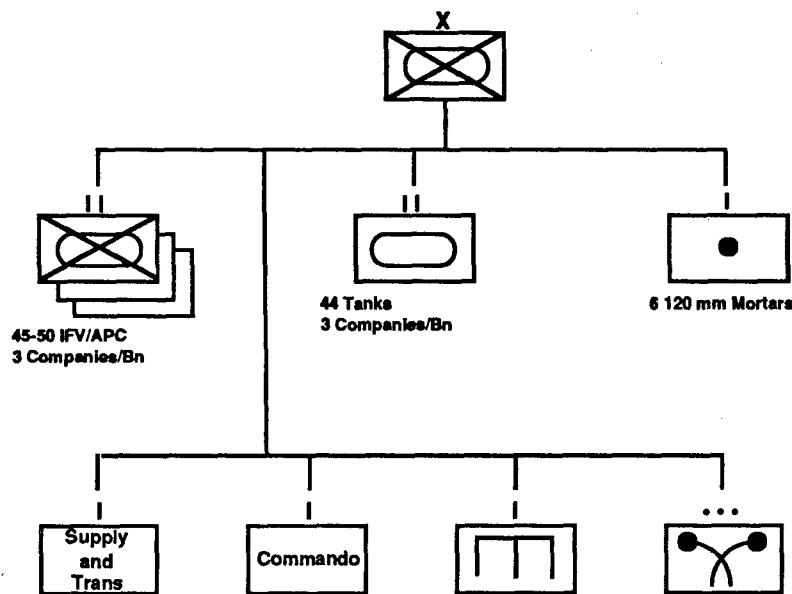

Figure 1-5. Iraqi Army Mechanized Infantry Brigade.

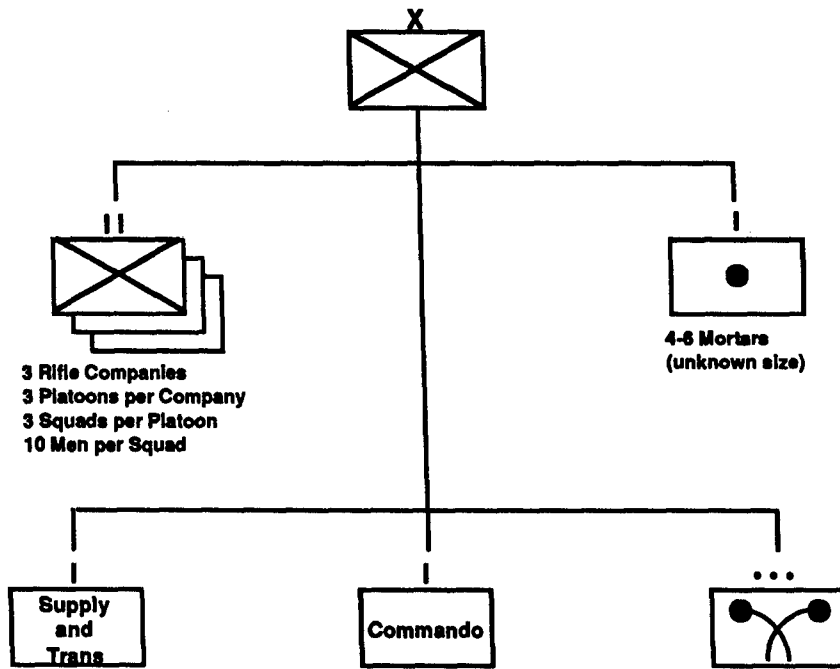

Figure 1-6. Iraqi Army Infantry Brigade.

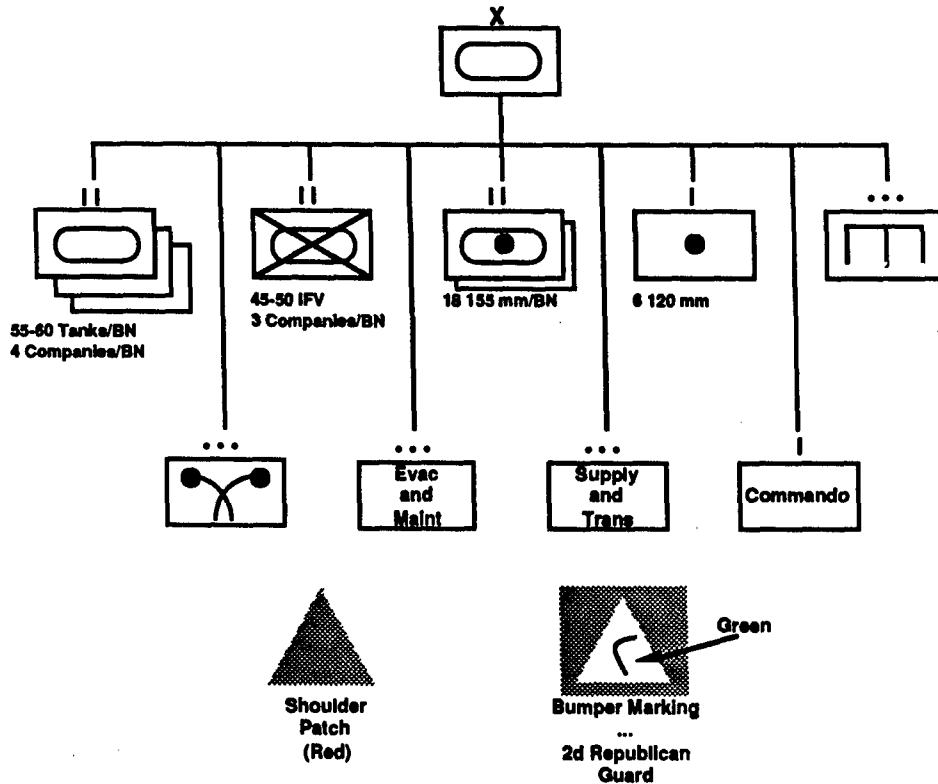

Figure 1-7. Iraqi Republican Guard Forces Command (RGFC) Armored Brigade.



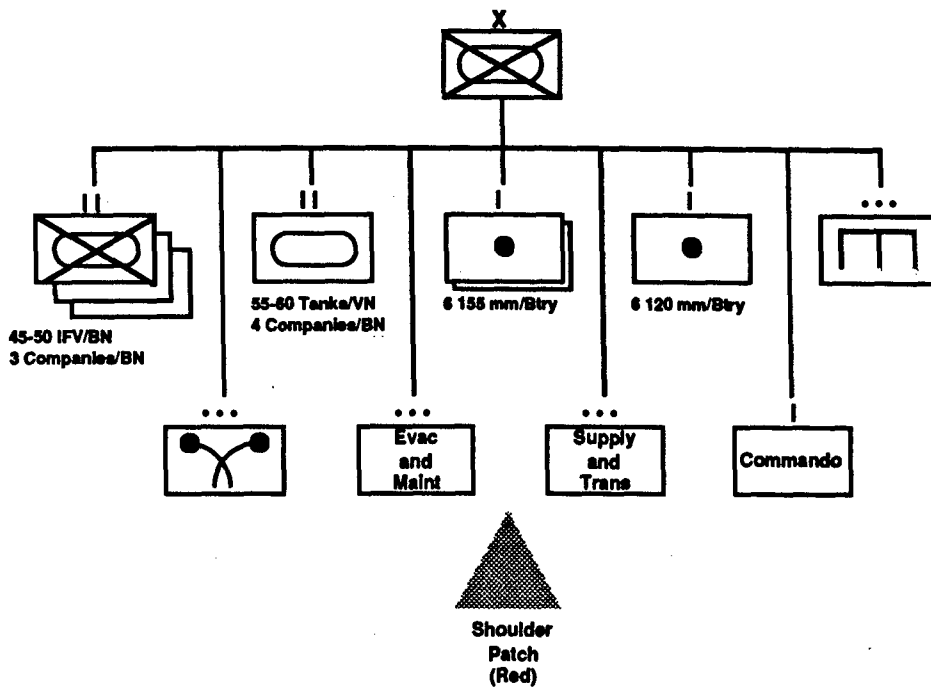

Figure 1-8. Iraqi Republican Guard Forces Command (RGFC) Mechanized Brigade.

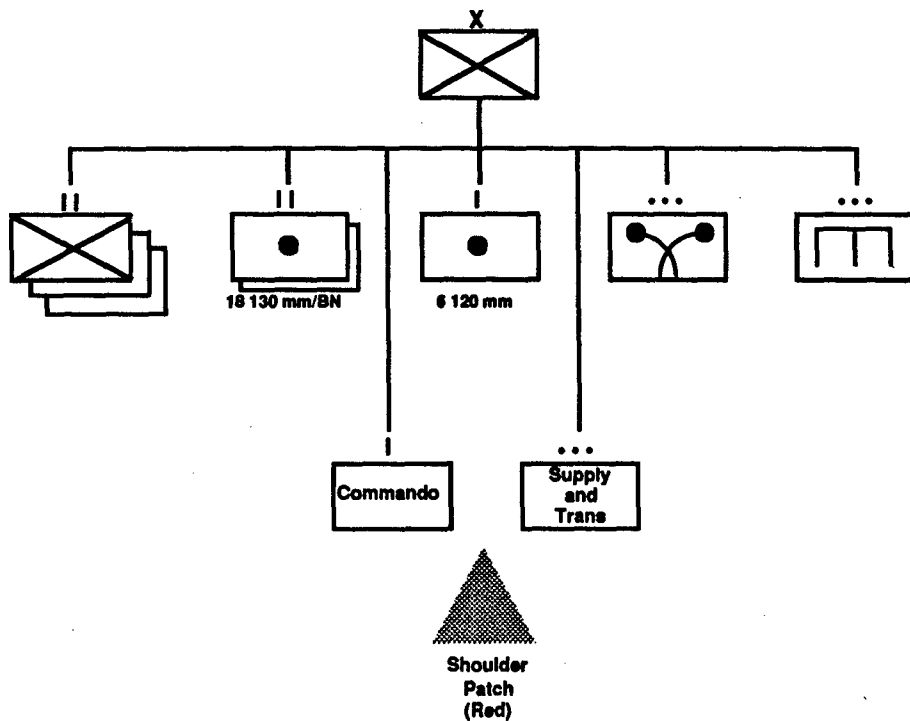

Figure 1-9. Iraqi Republican Guard Forces Command (RGFC) Infantry Brigade.

Iraqi Armed Forces Insignia

Sketches of Iraqi armed forces insignia are provided in Figure 1-10.

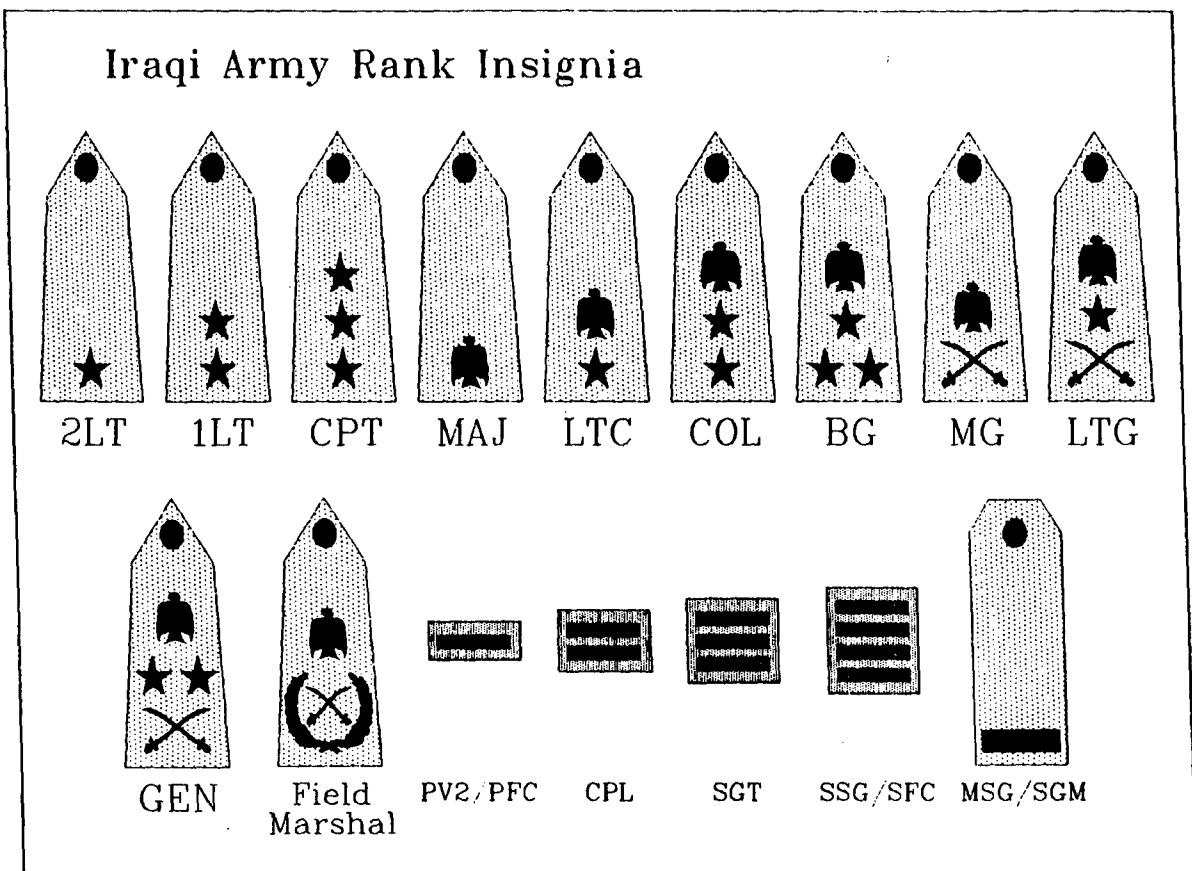

Figure 1-10. Iraqi Armed Forces Insignia.

**Total Armed Forces**

The following data are estimates as presented in The Military Balance, 1989-1990.

ACTIVE: 1,000,000

*Terms of service: 21-24 months.*

RESERVES: People's Army (Para-military): 850,000

ARMY: 955,000 (incl perhaps 480,000 recalled reserves)  
7 corps HQ  
7 armd/mech div  
42 inf div  
6 Presidential Guard Force div (3 armd, 1 inf, 1 cdo bde)  
20+ SF bde  
2 SSM bde

**EQUIPMENT:**

MBT: some 5,500: 2,500 T-54/-55/M-77, 1,500 Ch T-59/-69, 1,000 T-62, 500 T-72, 30 *Chieftain* Mk 3/5, M-60, M-47.

LIGHT TANKS: 100 PT-76

RECCE: incl BRDM-2, 300 AML-60/-90, FUG-70, ERC-90, MOWAG *Roland*, EE-9 *Cascavel*, 300 EE-3 *Jararaca*

AIFV: 1,000 BMP

APC: 7,100: BTR-50/-60/-152, OT-62/-64, M-113A1, Panhard M-3, EE-11 *Urutu*

TOWED ARTY: some 3,000: 105mm: M-56 pack; 122mm: D-74, D-30, M-1938; 130mm: M-46, Type 59-1; 152mm: M-1937, M-1943; 155mm: 100 G-5, 200 GHN-45, M-114

SP ARTY: 500:122mm: 2S1; 152mm: 2S3; 155mm: M-109, 85 AUF-1 (GCT)

MRL: 200: incl 122mm: BM-21; 127mm: 60 *ASTROS* II; 128mm: *Ababil*; 132mm: BM-13/-16; 180mm: *ASTROS* SS-40; 300mm: *ASTROS* SS-60

MORTARS: 81mm; 120mm; 160mm

SSM (launchers): 30 *FROG-7*; *Sigil*; 36 *Scud* B; *Abbas*; *Husayn*

ATGW: AT-3 *Sagger* (incl BRDM-2), AT-4 *Spigot* reported, SS-11, *Milan*, *HOT* (incl 100 VC-TH)

RCL: 73mm: SPG-9; 82mm: B-10; 107mm

ATK GUNS: 85mm; 100mm towed; 105mm: 100 JPz SK-105 SP

HELICOPTERS: some 160 armed helicopters

Attack: 40 Mi-24 with AT-2 *Swatter*; 20 SA-342; 13 SA-321, some with *Exocet* ASM; some 30 SA-316B with AS-12 ASM; some 56 Bo-105 with AS-11 ATGW

Transport: hy; 15 Mi-6; med: 100 Mi-8/-17, 6 AS-61, 10 SA-330, 20 Mi-4; lt: 3 A-109, 5 AB-212, 40 Bell 214 ST, Hughes 300C/500D/530F (30/30/26), 30 SA-342

AD GUNS: 4,000: 23mm: ZSU-23-4 SP; 37mm: M-1939 and twin; 57mm: incl ZSU-57-2 SP; 85mm; 100mm; 130mm

SAM: 120 SA-2, 150 SA-3, SA-6, SA-7, SA-9, SA-13, SA-14, 60 *Roland*

---

NAVY: 5,000

BASES: Basra, Umm Qasr

FRIGATES: 5:

4 *Hittin* (It *Lupo*) with 1 AB-212 hel (ASW), 2 x 3 ASTT; plus 8 x *Otomat* SSM, 1 x 127mm gun.  
1 *Khaldoum* (trg) with 2 x ASTT

PATROL AND COASTAL COMBATANTS: 38:

Corvettes: 4:

2 *Hussa el Hussair* (It *Assad*, hel version) 1 x AB-212 hel, 2 x *Otomat* SSM  
2 *Hussa el Hussair* (It *Assad*) with 6 x *Otomat*, 2 x 3 ASTT

Missile Craft: 8 *Nisan 7* (Sov *Osa*) with 4 x SS-N-2 *Styx* SSM

Torpedo Craft: 6 Sov P-6 with 2 x 533mm TT

Patrol, Inshore: 20:

3 SO-1, 4 *Nyryat II*, 13

MINE WARFARE: 8

MCM: 2 Sov T-43 MSC, 6 MSI

AMPHIBIOUS: 6:

3 *Al Zahraa* LST, capacity 250 tps, 20 tk, 1 hel  
3 Sov *Polnocny* LSN, capacity 180 tps, 6 tk

SUPPORT AND MISCELLANEOUS: 3

1 *Agnadeen* (It *Stromboli*) AOR, 2 Presidential yachts

---

AIR FORCE: 40,000 incl 10,000 AD personnel; some 513 cbt ac, no armed hel

BOMBERS: 2 sqn:

1 with 8 Tu-22; 1 with 8 Tu-16, 4 Ch H-6D

FGA: 17 sqn:

4 with 70 MiG-23BN;

4 with 64 *Mirage* F-1EQ5/EQ5-200 (EQ5 with *Exocet*; -200 with in-flight refueling);

2 with 30 Su-7;

3 with 50 Su-20;

2 with 30 Su-25;

2 with 40 Ch J-6

FIGHTER: 16 sqn with some 25 MiG-25, some 80 Ch J-7, 70 MiG-21, 30 *Mirage* F-1EQ, 18 MiG-29

RECCE: 1 sqn with 8 MiG-25

TRANSPORT: 2 sqn: 10 An-2; 6 An-12, 6 An-24; 2 An-26, 19 Il-76, 19 Il-14

TRAINING: incl MiG-15/-17/-21/-23U, Su-7U, 16 *Mirage* F-1BQ, 50 L-29, 40 L-39, 50 PC-7, 15 PC-9, 88  
EMB-312, 35 AS-202

AAM: R-530, R-550 *Magic*, AA-2/-6/-7/-8

ASM: AS-30 *Laser*, *Armat*, *Exocet* AM-39, C-601, AS-4, AS-5

---

## CUSTOMS

The Arab people are sensitive about the basing of foreign troops on their soil. *American forces are being advised to avoid any comments or actions that could lead anyone to believe that the U.S. deployment could be permanent.* Guidelines for soldiers deploying to the Middle East regarding Arab customs, courtesies and gestures are listed below:

### ALCOHOL

Moslem religion restricts the use of alcohol and it is prohibited by many host countries in the Middle East theater. Army officials say that in deference to the Arab hosts, *alcohol is prohibited.*

### PORNOGRAPHY AND SEXUALLY EXPLICIT LITERATURE

These subjects are very unacceptable in the Arab society, and *are also prohibited in the theater.*

### HANDSHAKING/SITTING

*Shake hands whenever meeting an Arab, and when leaving him. Never sit and expose the sole of one's shoes or bottoms of feet to an Arab.* It is regarded as an insult.

### CONVERSATION

Generally take the lead from what an Arab brings up in conversation, but *avoid asking personal questions. Do not ask questions about the women of an Arab family.*

### FRIENDSHIP

Arabs take friendship very seriously. The Arab concept of friendship is one of duration and intensity. Before an Arab enters into a friendship, he must find out all about a person to see how much influence one has and if the person might embarrass him. If someone misrepresents his background, not only will it affect credibility -- it can seriously harm the Arab's standing and that of his family. Remember, however, that the Arab system of friendship balances favors against obligations. *When favors are asked by an Arab, never give a flat "no."* That will signal a desire to end the friendship.

### TOUCHING

Touching and holding hands with members of the same sex in public are acceptable among Arabs and demonstrates friendship. *Touching or kissing members of the opposite sex in public is considered to be in extremely bad taste or obscene.*

### DISTANCE

Arabs stand very close to one another when talking. *Westerners may find this uncomfortable, but do not back away.*

### TIME

Do not be impatient with local people. If hurried, nothing will get done. However, *late arrival for an appointment is a public insult.*

### CRITICISM

Unlike Americans, Arabs *do not accept or give criticism directly. Even constructive criticism of an Arab's work or ideas in public is considered an insult. It is especially rude to contradict a person of status or a superior in rank or age. An Arab's ideas or suggestions should always be given recognition. If criticism is required, take the Arab aside privately and gradually lead up to the subject in an indirect and very tactful manner.* Arabs understand and appreciate tact because it protects public image and avoids insult.

### PATRONIZING

*Do not talk down to someone because he doesn't speak English well.*

### PHOTOGRAPHY

*Do not take pictures of military or civilian-installations or equipment, military or civilian police, or civilian airport or seaport facilities without permission of the host country. Do not photograph people at close range (particularly women) without permission.*

### WOMEN

*Do not stare at or strike up a conversation with Arab women in public.*





Chapter 2  
**Environmental Effects on Personnel**

**ACCLIMATIZATION**

As a rule of thumb, two weeks are required for a person to adjust to the fluctuating humidity and extreme heat. The following chart is a guideline for minimal acclimatization:

<u>Day</u>	<u>Less than 80°F WBGT*</u>	<u>More than 80°F WBGT*</u>
1	2 hours **	2 hours **
2	3 hours	3 hours
3	4 hours	4 hours
4	6 hours	5 hours
5	Regular duty	6 hours
6		Regular duty

\*Wet Bulb Globe Temperatures are less than dry bulb readings when relative humidity is less than 100%, as in the desert.

\*\* Total hours of work. Hours should be evenly divided between morning and afternoon.

**A key lesson learned is: use the "BUDDY SYSTEM", not only during acclimatization, but continuously during desert operations. Watch your buddy for signs of exposure to heat, dehydration, fatigue, and adherence to key principles of safe desert operation.**

Key environmental factors affecting personnel in the region include:

- **Radiant Light**
  - **Overexposure can cause severe sunburn, which can be fatal.**
  - **Acquire suntan in gradual stages at an increase of exposure of 5 minutes per day.**
  - **In all operational conditions you should be fully clothed in loose garments.** This will reduce sweat loss and permit moderated evaporation of sweat to cool your body.
  - **The sun is as dangerous on cloudy days as it is on sunny days.**
- **Wind**
  - **Combination of wind and sand can cause extreme irritation to mucous membranes and the lips.**
  - **Blown sand in the eyes causes conjunctivitis.**
  - **Use lip balms and eye ointments.**

## WATER LOSS / CONSUMPTION AND SALT LOSS

In extreme heat, the body is cooled by sweat. *Whenever possible, sweat should be retained on the skin to improve the cooling process and the only way to do this is to remain fully clothed - in loose clothing.*

Since sunburn inhibits sweating, every precaution must be taken to prevent sunburn. Common sense dictates maximum use of shade, sunscreen, and/or clothing that covers as much exposed skin as possible. During high desert temperatures, a resting man may lose as much as a pint of water per hour by sweating. In very high temperatures and low humidity, sweating may not be noticeable because it evaporates so fast that the skin will appear dry. *Whenever possible, leave sweat on the skin to improve the cooling process. The only way to do this is to avoid direct sunlight on the skin. This is the most important reason why you must remain fully clothed.*

When the body loses water, it also loses salt. Salt should be replaced by normal consumption of food...*do not use salt tablets.*

Drinkable water is the most basic need in the desert. *Don't drink untested water and don't use untested ice.*

An individual may lose more than 1 quart of water per hour through sweating. Water loss must be replaced by frequent intake of small amounts of water. *Water should be sipped, not gulped.* Gulping water causes the body to sweat more, thus increasing thirst. *Do not conserve water. Soldiers must drink when they are thirsty!* However, thirst is not an adequate indicator of dehydration. Dark urine is another indicator of dehydration.

The following chart is a guideline for water requirements:

<u>Activity</u>	<u>Typical Duties</u>	Quarts per person per day for drinking <u>WBGT*</u>	
		less than 80°	more than 80°
Light	Air crew duties, desk work, guard work, radio operating	6	9
Moderate	Moderate aircraft maintenance duties, FARP tasks	9	12
Heavy	Force march, route march heavy load/MOPP, digging-in	12	15

\* MOPP and/or aircrew clothing in combination with greenhouse effect of aircraft interiors can add 10°F to 20°F to the measured WBGT.

Following these requirements will not necessarily prevent dehydration. Dark urine is an indicator of dehydration.

Alcohol and soft drinks are not substitutes for water. Alcohol increases dehydration, and soft drinks are not absorbed as rapidly as water into body tissue.

Soldiers who are overweight, dieting, or past heat casualties are more prone to heat injuries. As such, their activities must be closely monitored.

Precautions to keep in mind and follow include:

- *DRINK water as advised.*
- *Adhere to work and rest schedules.*
- *Watch for signs of heat injury (know what they are).*
- *Know your individual physical condition and care for yourself accordingly.*
- *Use the buddy system.*

It is vital to ensure that there is no possibility of nonpotable (bad) water being mistaken for drinking water. Water that is not fit to drink, but not otherwise dangerous, may be used to aid cooling. It can be used to wet clothing so that the body does not use so much of its internal supply.

Issued water containers must be carried only for drinking water. *Sufficient water must be carried on a vehicle (including aircraft) to last you until the next planned resupply, plus a small reserve.* The best containers for small quantities of water (5 gallons) is plastic water cans.

Guidelines for water containers:

- Water in plastic cans will be good up to 72 hours, compared to metal which will only be good for 24 hours. *Change the water in canteens at least every 24 hours.*
- Water in water trailers, if kept in the shade, will last up to 5 days.
- *If the temperature outside exceeds 100°F, the temperature of water must be monitored, and when it exceeds 92°F, it should be changed, as bacteria will multiply and diarrhea may be experienced by personnel drinking from the contaminated water.*
- *If ice is put in water trailers, make sure it is tested first. Also, the ice must be removed before the trailer is moved as large chunks of floating ice will destroy the inner protection of the trailer.*
- It is a good idea to erect shade for water trailers to keep it cooler.
- *Train to not waste water.* Water that has been used for washing socks, for example, is perfectly good for a vehicle cooling system.

You cannot be trained to adjust permanently to a reduced water intake. An acclimated soldier will need as much, if not more, water because he sweats more readily. If the ration is not sufficient, there is no alternative but to reduce physical activity or to restrict it to the cooler parts of the day.

In very hot conditions:

- *It is better to take smaller amounts of water more often than to take large amounts occasionally.*
- *Drinking large amounts causes waste by excessive sweating and might cause heat cramps.*
- *As activity increases, you should drink more water.*
- *The best drinking water temperature is between 50° and 60°F.*
- *Wet cloths around containers helps to cool water.*
- *Alcohol and smoking cause dehydration and should be avoided.*

The temperature of your body is regulated within very narrow limits: too little salt may lead to heat cramps, too little salt and insufficient water may lead to heat exhaustion. A general collapse of the body's cooling mechanism will lead to heat stroke, which is potentially fatal. *To avoid these illnesses, you must be physically fit, thoroughly acclimated, and drink sufficient water with necessary salt.* If you expend more calories than you take in, you will lose the desire for food in hot climates, *you must remember to eat, with the heavier meal of the day scheduled for the cooler hours.*

## FATIGUE / SLEEP DEPRIVATION

Fatigue causes accidents. After 48 to 72 hours without sleep, soldiers become militarily ineffective. The best measure against fatigue is sleep. Water consumption, diet, physical conditioning, personal hygiene, and meaningful work all impact on fatigue. Ensure the impact is positive.

*Watch for the following symptoms of fatigue: (on yourself and your buddies)*

- |                                      |                                |
|--------------------------------------|--------------------------------|
| • Headaches                          | • Poor personal hygiene        |
| • Impatience/irritability            | • Loss of appetite             |
| • Inability to focus on task at hand | • Outright physical exhaustion |
| • Inability to make decisions.       |                                |

**These symptoms manifest themselves in:**

- |                      |  |
|----------------------|--|
| • Increased errors   | • Difficulty in following instructions |
| • Lack of motivation | • Carelessness                         |

All this may translate into unnecessary risk-taking or shortcuts to get the job done...an open invitation for an accident.

## FACTS ABOUT SLEEP DEPRIVATION

- You cannot train to overcome sleep loss.
- Tasks that are uninteresting and take a long time are extremely conducive to sleep.
- Performance of mental tasks requiring calculations, creativity, and ability to plan ahead declines by 25 percent for every 24-hour period of semi-continuous work without sleep.

- The abilities of leaders are degraded by sleep loss, impacting on quick and effective responses to changing battlefield conditions.
- Tasks that have been well-learned and repeatedly practiced are more resistant to sleep-loss effects (select the best trained to perform critical tasks).
- The ability to learn new information is compromised by sleep loss.
- Leadership ability cannot overcome sleep loss.
- Sleep loss over time (greater than 2 days) has a cumulative effect.

### GUIDELINES FOR SLEEP PLANS

- 6-8 hours sleep each night will maintain mental task performance indefinitely.
- 3-4 hours sleep each night will maintain mental task performance for 5-6 days.
- Less than 4 hours sleep each night (over a 3- to 6-day period) will impair military effectiveness.
- Best sleep periods, given limited choice, are 0300-0600 and 1600-1900.
- *Provide for a minimum of 4-5 hours quality sleep (uninterrupted); however, after 6-7 days, accumulated sleep loss will equate to performance of 48 hours without sleep.*
- *After 24-36 hours without sleep, decisions, calculations, etc., should be cross-checked by a second person. Use a mix of rested/unrested soldiers as check and balance.*
- *Allow for naps as often as possible.* Four 1-hour naps in a 24-hour period are as beneficial as 4 hours sleep; however, accumulative sleep loss is more severe with fragmented sleep.
- **Sleep plans should include provisions to recover from sleep loss.**
  - 12 hours of sleep/rest (at least 8-10 hours sleep) are required after 36-48 hours acute sleep loss.
  - 24 hours of sleep/rest (at least 15 hours sleep) are required after 36-48 hours sleep loss under conditions of high workload (12-16 hours per day). This is particularly important for commanders/staff with high mental task workloads.
  - 2-3 days sleep/rest are required after 72-96 hours sleep loss. The sleep/rest period means 8-10 hours sleep per day and light duty.

### SNAKES / INSECTS

***Bottom line--leave snakes alone.*** Snakes will burrow under the sand and seek shade during the day and heat at night. Chances of stepping on or otherwise disturbing a snake and it attempting a strike are remote if soldiers are alert and careful. There are poisonous snakes in the region (e.g., Cobra and Desert Horned Viper), but bites from nonpoisonous snakes can be just as harmful because of infection. Poisonous snakes do not always inject venom when they bite or strike a person. However, all snakes

may carry tetanus (lockjaw); anyone bitten by a snake, whether poisonous or not should immediately seek medical attention. *In the event you are bitten, attempt to identify and/or kill the snake. Take it to medical personnel for inspection / identification. TREAT ALL SNAKEBITES AS POISONOUS.* The treatment prescribed below is the currently recommended method. *Do not use the cut/suck method.* Additional information may be obtained in FM 21-11 First Aid for Soldiers.

### FIRST AID FOR SNAKE BITE

*These are the steps to be followed:*

1. *Remain calm, but act swiftly. Get the casualty to a medical treatment facility as soon as possible and with minimum movement. Have the casualty lie quietly and not move any more than necessary. If bite is on an extremity, DO NOT elevate the limb - keep it level with the body. If the casualty is alone when bitten, he should go immediately to a medical facility.*
2. *If the bite is on an arm or leg, place a constricting band (narrow cravat [swathe], or narrow gauze bandage) (1) one to (2) two finger widths above and below the bite as in Figure 2-1. If the bite is on the hand or foot, place a single band above the wrist or ankle. The band should be tight enough to halt blood flow of blood near the skin, but not tight enough to interfere with circulation. In other words it should NOT have a tourniquet-like effect.*

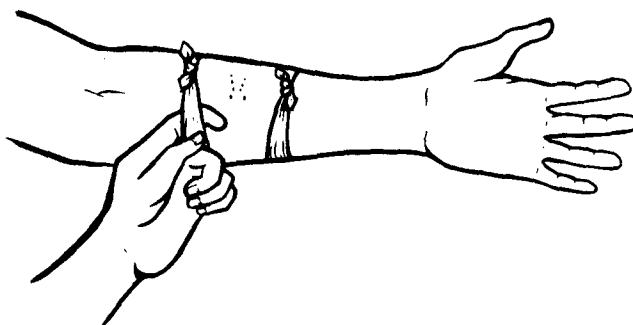

Figure 2-1. Constricting Band.

3. *If no swelling is seen, place the bands about (1) one inch from either side of the bite.*
4. *If swelling is present, put the bands on the unswollen part at the edge of the swelling.*
5. *If the swelling extends beyond the band, move the band to the new edge of the swelling. (If possible leave the old band on, place a new one at the new edge of the swelling, and then remove and save the old one in case the process has to be repeated.)*

6. *If possible, place an ice bag over the area of the bite. DO NOT wrap the limb in ice or put ice directly on the skin. Cool the bite area -- do not freeze it. DO NOT stop to look for ice if it will delay evacuation and medical treatment.*
7. *DO NOT attempt to cut open the bite or suck out the venom. If the venom should seep through any damaged or lacerated tissues in you mouth, you could immediately lose consciousness or even die.*
8. *If the bite is located on an arm or leg, immobilize it at a level below the heart. DO NOT elevate an arm or leg even with or above the level of the heart. (CAUTION: When a splint is used to immobilize the arm or leg, take extreme care to ensure the splinting is done properly and does not bind. Watch it closely and adjust it if any changes in swelling occur.*
9. *When possible, clean the area of the bite with soap and water. DO NOT use ointments of any kind.*
10. *NEVER give the casualty food, alcohol, stimulants (coffee or tea), drugs, or tobacco.*
11. *Remove rings, watches, or other jewelry from the affected limb.*
12. *It may be possible in some cases, for an aidman who is specially trained and is authorized to carry and use antivenin to administer it. The use of antivenin presents special risks, and only those with specialized training should attempt to use it!*

### FIRST AID FOR SCORPION / INSECT BITES

Scorpions, centipedes, assassin bugs, black widow spiders, flies, mosquitoes, and sand fleas can cause illness and infectious wounds. *Shake out clothing before dressing and check boots, etc., before putting them on. Where possible, boots should be placed off the ground or inside a waterproof bag or other container.*

#### Scorpion Sting or Tarantula Bite First Aid

1. *Wash the area.*
2. *Apply ice or freeze pack, if available.*
3. *Apply baking soda, calamine lotion, or meat tenderizer to sting / bite site to relieve pain and itching.*
4. *If site of sting / bite is on the face, neck (possible airway problems), or genital area, or if local reaction seems severe, or if sting is by the dangerous type of scorpion found in the Southwest desert, keep the casualty quiet as possible and seek immediate medical aid.*

*In more serious reactions (severe and rapid swelling, allergic symptoms, and so forth) treat the sting as you would a snakebite; that is, apply constricting bands above and below the sting. Be prepared to perform basic life supporting measures, such as rescue breathing and CPR.*

**CAUTION:** Insect bites / stings may cause anaphylactic shock (a shock caused by a severe allergic reaction). This is a life-threatening event and a **TRUE MEDICAL EMERGENCY!** Be prepared to perform the basic life support measures and to immediately transport the casualty to a medical facility.

**Brown Recluse Spider or Black Widow Spider bite first aid**

1. *Keep the casualty quiet*
2. *Wash the area*
3. *Apply ice or freeze pack, if available*
4. *Seek medical aid*

*Use insect repellent religiously. "Deet" repellent lotion is recommended (NSN 6840-01-284-3982). Also available is "Permetrin" repellent (NSN 6840-01-278-1336) for use on clothing.*

Figure 2-2 depicts some of the insects and a scorpion which may be found in the area.

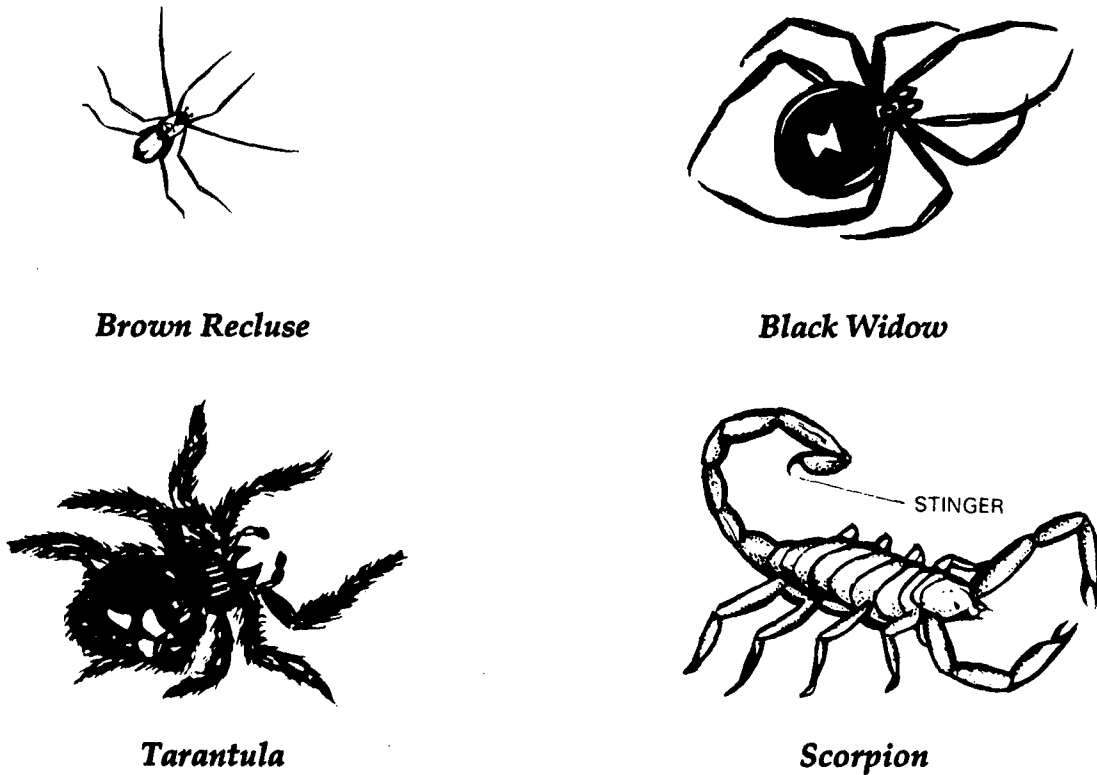

Figure 2-2. Insects and Scorpion Examples.



## CLOTHING AND NECESSITIES

Standard lightweight clothing is suitable for desert operations, but should be a desert camouflage compatible color, not fatigue green. Nonstarched, long sleeve shirts and full length trousers are worn, with pants tucked into combat boots. Special clothing may be required by repair and FARP personnel since they live in an environment of oils and greases with high risk of burns, thus clothing must have an ability to "breathe." *Aviators should wear the standard issue Nomex flight suit. Jungle boots should not be worn because sand will sift into them. A piece of cloth should be worn loosely around the neck as a sweat rag and to protect much of the face and neck against sun and sand (Figure 2-3). Recommend each soldier have the following equipment:*

- Sweater, field jacket, a woolen scarf for cold and night use, and a cotton one for day use.
- Sleeping bag.
- Chapstick (or vaseline), antsunburn ointment, salt tablets, foot powder, and insect repellent.
- Eye lotion or drops are also useful.
- Sunglasses and case (to prevent scratching when not in use).
- Bottled water.
- A lensatic compass, if available.
- Web belt with two quart canteens attached.
- Goggles.

Combat boots will wear out quickly in desert terrain, especially if it is rocky. The leather will dry out and crack, unless a nongreasy mixture, such as saddle soap, is used. Although difficult to do, *clothing must be kept relatively clean by washing in any surplus water that is available.* When water is not available, airing and sunning clothing will help to kill bacteria.



Figure 2-3. Protective Clothing.

## HYDROGEN SULFIDE

Hydrogen sulfide is a gas emitted from petroleum-based products. It has the characteristic "rotten egg" odor. It is a systemic poison that can be fatal. Expect to encounter the gas around oil well heads, drilling platforms, oil storage tanks, and pumping stations. Locally produced diesel fuel contains hydrogen sulfide. Handle diesel fuels in well-ventilated areas. The gas is heavier than air; therefore, it will concentrate in low areas (depressions) and confined areas such as cargo areas of ships. *If you smell the "rotten egg" odor, notify your chain of command.* Medical personnel should check the toxic level to determine if it is lethal.

*Caution: The odor may appear to go away. However, that does not mean the gas is not still present. Hydrogen sulfide gas may cause olfactory fatigue (i.e., your brain ceases to recognize the smell).*



## Chapter 3 Air Operations

### DESERT OPERATIONS

The desert is probably the most severe of all environments in which aviation units must operate. Employment standard operating procedures (SOPs) for desert operations are different from areas having an abundance of contrasting terrain and substantial vegetation. *Air combat operations which rely on heavy vegetation and varying contour terrain need to be flexible enough to incorporate different methods of camouflage and terrain flight techniques.* The varying types of sand alone have tremendous effects on operations: i.e. vast flat areas afford unlimited visibility; dunes are hard to distinguish at night; blowing sand impairs visibility and presents flight, attack, and maintenance problems; surface composition affects choice of landing zones, maintenance sites, FARPs and operating bases. Low hovering and taxiing generates blowing sand and dust which can cause aircrews to lose outside visual reference and, if performed near other aircraft or other equipment, present additional maintenance problems for that equipment. In dust storms, aircrews must resort to instrument flight. Sand also causes excessive wearing, pitting, and eroding of aircraft components.

In certain areas, the desert with its relatively level terrain and shallow compartments, contains few highly distinguishable terrain features to mask aviation forces. Formations of two or more aircraft can be seen 10 kilometers away because the dark airframes contrast against the desert sand. Aviation units normally deploy their aircraft along multiple routes and may need to consider widely dispersed formations. Aviation forces can make maximum use of deception techniques during periods of limited visibility.

Air operations is not the only area affected by the desert environment. Aviation ground operations may require flexibility and modification to work around the heat and the effects of the sand. *Work and sleep schedules may be modified to allow both air and ground operations to take place during cooler periods of the early morning, evening and night, while the hotter parts of the late morning and afternoon are reserved for rest.* Once again, *"flexibility," "appropriate," "as needed," and "based on the current environmental conditions" all become the key factors on which SOPs should be modified. SOPs for "like" battalions should be standardized in theater. Repair parts, lubricants, filters and high wear items such as bearings must be stocked in greater quantities. Cover and concealment of aircraft and ground operations equipment items in operating bases and FARPs may well follow the policy "if you can't hide it, make it look like something else."*

## AIR CAVALRY

Air Cavalry assets can conduct reconnaissance and security operations over great distances in the desert because of the lack of vegetation and relief. Even when they are sand-painted, armored vehicles stick out starkly against the sand. When combined with traditional target acquisition principles, such as dust signature and movement, these factors make it easier to acquire and engage armored and mechanized forces well out of range of their main guns. Cavalry troops:

- Should be employed as far forward in the battle area as possible within range of organic fire support.
- Use small groups of aircraft to perform reconnaissance and security missions.
- Provide timely and accurate information over vast expanses of the battlefield.
- Displace FARPs forward.
- Will require centralized planning, decentralized execution, and theater reliance on standardized SOPs during operations.

## ATTACK HELICOPTERS

Attack helicopter battalions (ATKHBs) are a potent force in desert warfare. If they are employed quickly and violently, maximum results can be obtained both in offensive and defensive operations. Attack helicopters may also perform air assault security. They are best used where a quick concentration of combat power is needed. A desert environment presents excellent target acquisition and engagement possibilities. However the desert environment requires flexibility in tactics, techniques and procedures. In addition, exact performance capabilities and weight and balance limits must be carefully determined.

 *Attack assets must remain dispersed to provide security. Mission planning which incorporates flexibility is a key ingredient in successfully employing the ATKHBs.*

*Running fires, as opposed to hovering fires, will provide the best attack method for minimizing blowing sand and dust signatures while still exploiting the antiarmor firepower of the attack helicopter.* Running fires are discussed later in this chapter under Weapon Lethality and Gunnery Considerations.

Evasive maneuvers are more easily accomplished with higher airspeeds. If helicopter-versus-helicopter or helicopter-versus-high performance engagements occur, higher airspeed will increase survivability during operations over open terrain. Airspeeds have to be adjusted for existing conditions, i.e. day/night, height above ground, terrain, visibility, etc.

*Performing the flight techniques required in desert operations at low altitudes is stressful. Training must be approached with a step-by-step method. Crew coordination is of paramount importance. Developing team integrity and flexibility is the most important consideration in training to conduct operations in the demanding environment of the desert.*

## FLIGHT

### TAKEOFFS

During preflight, pilots and crew chiefs must keep in mind that aircraft surfaces exposed to the sun will be very hot. *Crew and maintenance personnel should wear gloves.* Because running engines generate dust clouds, *ground operating time should be kept to an absolute minimum and as many preflight checks as possible should be performed prior to engine start.* Once engines are running, *pilots should minimize the use of power until actual takeoff to minimize blowing sand at other aircraft, personnel, or ground equipment.*

*Due to the severe effects of blowing sand on aircraft component life, HIT and power checks should, as much as possible, be performed in areas where blowing sand can be minimized. AVSCOM is coming up with an inflight HIT check.*

Takeoffs may best be achieved to minimize effects of blowing sand if they *employ a "get up and get out" approach, as warranted, based on local conditions.* This may involve near-maximum performance takeoff techniques.

In instances where aircraft internal temperatures have risen due to extreme effects of the sun and outside temperatures, *it may be necessary to operate specific electronic systems only after becoming airborne and internal aircraft temperatures have been reduced by cooling systems or other means.*

The crew chief and the pilot should *be aware of the location of each aircraft in order to avoid blowing sand on other aircraft, personnel, or ground equipment.* The effects of blowing sand on running aircraft are obvious. *Whenever possible, aircraft start, taxi, and takeoff should be staggered to minimize these problems.*

### AIRBORNE

Once airborne, the desert can present unique problems for the pilot. Visibility is one of those problems which can be two-sided. At times it can be very poor due to blowing dust and storms, while at other times it can be extremely good. When visibility is extremely good, the lack of identifiable terrain features couples with the excellent visibility and makes it difficult for pilots to judge distances. An inexperienced pilot may be more prone to underestimate range and may, on occasion, need to increase his range estimate by a factor of as much as (3) three to compensate.

The intense, glaring sunlight of the desert is another problem which makes enemy attacks harder to detect visually. *When on the offense, pilots should attack with the sun at or near their back whenever possible.* Attacking from the sun also eliminates most shadows that degrade optical weapon guidance and make visual target acquisition difficult for pilots. *Though attack from the sun is generally a good rule, it should not be followed to the point of making tactics predictable.*

The combination of desert and night presents additional problems for terrain flight techniques. *Both high and low ambient light combined with low contrasting terrain, which may rise gradually or rapidly in the areas of dunes, requires exacting crew coordination and scanning.* Depth perception and distance estimation are more difficult at night. Decreasing visual information, such as at night, increases the probability of spatial disorientation and also creates several illusions that can induce spatial disorientation. *Route reconnaissance during daylight hours (if possible) and detailed planning, including accurate mission risk assessment early in the planning process must be performed.*



As mentioned earlier, dust storms can cause visibility problems over the desert. They can rise as high as 8,000 feet above the surface and can reduce visibility to less than 100 meters. Dust storms can be a factor in tactics, since maneuvering and surprise attacks often occur under their cover. They can also provide concealment for withdrawing forces and evasive maneuvers. Intelligent use of moving dust can be a factor in tactics and may make a surprise attack or tactical withdrawal successful. Other visibility problems are caused by heat distortion. Heat distortion, the result of heat waves at the surface, causes images to shimmer making positive identification difficult and degrading depth perception during landing. The depth perception problem can be minimized by using objects and references in the pilots peripheral vision to help judge height and distance.

## NAVIGATION

Due to lack of terrain and poor reference points the aviator may rely on dead reckoning, self-contained navigation equipment and radio navigational aids. (FM 1-202, Par 2-2.)

Attack helicopters will move from assembly areas to battle positions (or holding areas if necessary) over attack routes which will provide whatever cover and concealment and prominent terrain features possible to assist in navigation and decrease the possibility of detection. Attack helicopters may have multiple routes for ingress and egress. Route reconnaissance, premission planning, and prebriefs will maximize the benefits to route planning in desert operations.

- Recon routes during the day to be flown at night, if possible.
- Speed is relative to aircraft altitude above the ground, desert conditions, and day/night -- during mission planning allow adequate maneuver time for slower airspeeds required for flying in constrained conditions and particularly in dunes.

Desert operations in this Middle East theater may provide increased problems for air traffic control. Air corridors, coordinating altitudes, restricted operations zones, minimum risk routes, air threat warnings, terminal control procedures, IFF codes, and available navigational aids should be disseminated to aviation units by airspace control units. Difficulty may be noticed in IFF. Iraq has a proliferation of different nationalities' weapons systems, to include a variety of aircraft. Because the

US is operating in a multinational environment alongside the British, French, and other aircraft / weapon producing countries, IFF will no doubt be a problem.

Due to the lack of identifiable terrain features, coupled with the lack of quality maps, identification of natural or man made features / navigational aids may be more difficult. Crew debriefs and review, along with documentation and dissemination of identified features, will aid in the distribution of navigational aiding terrain features to other units.

- Hand held LORAN is available and is being used by some units.
- Many 1/250,000 maps have serious inaccuracies.

### LANDINGS

Pilots require visual references to hover, or land. *When blowing dust from rotors is allowed to create a dust cloud in which visual references are lost, pilots must immediately transition to an instrument takeoff.*

- *Descents should be gradual at night.*
- *Avoid rapid flight altitude changes to initiate descents, climbs, or turns or to adjust airspeed. Rapid changes in altitude may degrade the aviator's viewing perspective outside the aircraft and may induce spatial disorientation.*
- *Use extreme care when descending into areas of limited contrast during periods of low illumination.*
- *To avoid drawing attention to units located near landing zone, pilots may use false landing techniques, landing at a variety of sites, only one of which is relevant.*
- *Aircrews must train for total crew coordination during landing / takeoff brown out conditions. Any crew member can call "go around" and pilot must react immediately. Crew chief / medic may see an obstacle or uneven terrain, co-pilot may observe wings not level, airspeed too fast etc. The key to the total aircrew coordination is the immediate reaction of the pilot at the controls.*
- *Plan takeoffs during the approach to landing*
- *Good mission planning and more attention to instruments inflight are essential.*

### HOVERING

Hover power checks conducted in sandy and dusty environments significantly reduce the life of aircraft components. The blowing sand or dust may also cause IMC at a hover. So that power requirements may be met, pre-mission performance planning is paramount. Aircraft fuel and ordnance loading must be considered during premission performance planning.

## GENERAL LESSONS LEARNED

Experience of the US and its allies indicates there are no problems, which cannot be overcome, that inhibit aircraft from operating in the desert. However, virtually all aircraft experience degraded performance when operated in the desert at high ambient temperature and high pressure altitude. The effects are well understood and are addressed in detail in each aircraft performance manual. There are, however, **unusual desert conditions involving sun, sand, wind, and visibility which call for pilot awareness and modification of techniques.**

### DESERT SHIELD AVIATION LESSONS LEARNED

- *Adopt a "crawl, walk, run" philosophy, if possible!*
- *Restrain honest enthusiasm - work and train smart - don't let enthusiasm take over.*
- *Don't let pride interfere with professional judgment.*
- *Don't be afraid to say no, or I'm too tired to be safe. Don't put yourself and others at risk.*
- *Know your limitations...avoid complacency...avoid over confidence.*
- *Don't throw away the rule book because you're in an imminent danger area.*
- *Develop an A2C2 plan.*
- *Reduce IP workload by eliminating base tasks not associated with desert environment.*
- *Individual and unit training should begin at the simplest level and progressively increase in difficulty. Until aircrews become proficient in individual skills, they should not attempt complex maneuvers and missions such as multihelicopter operations.*
- *Flight operations - units must plan their own flight following and flight ops programs. Do not expect an established program.*
-  • *The flying environment in Saudi Arabia is totally different than flying at NTC, Egypt, and Jordan. Aviators must not arrive thinking that prior training in those environments is adequate.*
- *Crew coordination is a MUST...drill, Drill, DRILL!*
- *Meticulous pre-mission planning is a MUST! It takes longer, so plan for it.*
- *Try to maintain crew integrity - habitual crews.*
- *Train to improve proficiency on blind cockpit drills so crew can spend more time scanning in / out, navigation, hazard avoidance, and recon.*
- *Conduct crew briefings and "brief-backs," emphasize terrain / hazards, disorientation procedures and navigation techniques.*



### LESSONS LEARNED - EXERCISE IN EGYPT '83 (E '83)

The following lessons learned are from an exercise in Egypt in 1983. Remember, these are lessons learned from years past...not doctrine.

#### Mobility / Loose Sand (E '83)

Trailers are no good off-road in loose sand. Mobility is dependent on trucks only. Best performers were the 5T, 2 1/2-ton Gamma Goat, 1/4-ton. With the auto transmission and V8 engine, the torque ratio causes CUCVs to get stuck easily. CUCVs should be used on hard surfaces only. Jeeps do okay only when they are breaking fresh ground. If 1/4-tons are sent over an area used by tracks and heavy wheels, they are easily stuck. Use of a line formation for resupply rather than a column works better in the desert.

1200 gallon tanker trucks get stuck fast with 1200 gallons, however with a reduced load of 600 gallons in the forward cell mobility was excellent. The 1200 gallon tankers could not move well when the 600 gallon load was placed in the rear cell.

600 gallon fuel pods mounted on a 5-ton truck work well when the load is reduced to a maximum of 500 gallons per pod or 1,000 gallons for both pods.

The sand crust, when broken, takes 2-3 weeks to reform a solid surface. The wind eliminates the soft sand and reduces the crust to a gravel/solid sand mix.

The darker colored sand, a blackish looking color, is a result of gravel/stone content. This surface is hard, allows the helicopters to land with minimum dust signature and tracks to move 2 1/2 times the normal rate.

Overall, tracks can move twice as fast (20-30 kmph) as they normally do for column and attack formations.

*Existing vehicle mobility estimates must be reduced by that portion of mobility attributed to trailers and CUCVs.*

#### Sanitation (E '83)

To preclude problems of disease, *it is absolutely essential to prohibit eating in tents or foxhole areas.* The mess hall must ensure all discarded food containers are placed in sealed plastic bags rather than the open cardboard boxes. Kool-aid draws flies as spills occur. Insecticide spray should be applied underneath the serving table before and after every meal. Trash receptacles must have plastic bag liners that are continuously sealed and replaced. Flies are a serious problem. They are drawn most to the latrine. An average of (1) one pound of lime per man per day is required to keep the fly and scorpion problem under control.

**Water (E '83)**

*Water and ice must be constantly tested for chlorine content by the medics. Water content/color needs to be inspected each time it is drawn. Ice must be tested before putting it in water supplies or before it is made available to individuals.* The water trailer needs to be inspected each day and cleaned every 24 hours. Chlorine bleach should not be used to clean out the trailer as it will asphyxiate anyone trying to clean out the inside. Soapy water and a scrub brush worked very well.

The availability of the 2 quart canteen helped eliminate dehydration and heat injury. Unit SOP required all personnel to carry a canteen at all times. No incidents of heat injury were experienced. Pre-deployment classes and emphasis on the NCOs to ensure all soldiers were drinking adequate water produced many good results.

**Jet Lag (E '83)**

Jet lag reduction training several days prior to departure works well. Performed as a command directive it will be followed. Following the destination time zone when boarding aircraft in the US bound for the Middle East results in travel and arrival proceeding well with a planned sleep period to occur as desired in Middle East time. The soldiers arrived in the Middle East ready for normal duty immediately. It is strongly recommended for this to be successful that Command emphasis on following jet lag reduction be made a part of the unit deployment plan.

**Aircraft Maintenance (E '83)**

Maintenance managers must anticipate requirements as best as possible using after action reports, shipment technical manuals, etc., along with personal experience and knowledge from within and other units. The following is a list of items which based on the past has not been available or were insufficient in quantity.

<u>ITEM</u>	<u>REMARKS</u>
Rubber gloves	
Black spray paint	
10/10 oil	
VIGV	
APUs	One was brought; however, two were required
Maint Stands	Two were brought to support the exercise. Four were needed to prep ACFT for deployment and redeployment in a timely manner.
Air compressor, 8CFM	One was brought which became inoperative; a second 8CFM was not available as an alternative
Fire truck or suitable equipment	Fire truck was requested for washing aircraft but was not made available

Recommendations: Any unit identified for overseas deployment be authorized IPD 02. At a minimum, 80% of all demands should be filled prior to deployment with an established finalized plan to "airloc" remaining demands as they are filled, and a 48 to 72 hour order shop time for additional requests generated in the field. Final 100% inventories should be conducted in detail and sufficient transportation resources be provided to carry the inventory. Lateral exchange of repair parts must augment the supply system and, in some cases, controlled exchange must be used to fill anticipated demands. Remember, there are 1.6 million NSNs listed on the AMDF.

- Aircraft blade erosion is a very serious problem.
- The Egyptians have most bearings protected by boots and caps that help minimize sand and dust damage.

#### **Aeromedical Factors (E '83)**

**Aeromedical factors, such as fatigue, were of greater impact during all modes of operation, due to visual illusions, such as relative motion and height perspective.** Aircraft equipped with radar altimeters allowed pilots to adjust more rapidly to the constantly changing perspectives (i.e., NVG, confidence in altitude judgement, visual illusions, judgement of height - day and night was very difficult). Low level banks in a Cobra are frightening.

- Higher airspeeds at lower altitudes made NOE flight even more fatiguing.
- Due to the bright sun, there was an increase in eye strain - even with sun visors.
- Heat generated turbulence and high desert winds were always present and many times greater than forecast, or, worse yet, not even forecast.
- Heat stress and dehydration were increased during flights of long duration.
- **The dehydration effect is very serious. Because the pilots do not feel they are sweating, they don't think they have a problem.**
- Eye strain due to the haze effect and sun glare is a problem. A set of sun glasses and the helmet sun visor are both necessary for day operation (0900-1800).

#### **Navigation (E '83)**

Every aircrew had 1:50, 1:250, and 1:500 thousandths maps at their disposal. Without exception, everyone felt that the 1:250 maps were much more accurate and easier to use than the 1:50 maps. The terrain features on the 1:50 maps were constantly changing and blended too well for accurate map reading. The 1:250 maps were used with dead reckoning navigation techniques. Only when there were large, distinct terrain features - such as a tall hill of more than 50 feet AGL difference in height or a deep wadi - was the 1:50 map very useful. Also, when traversing 3-4 kms per minute over a flat expanse

with not much terrain relief, a 1:50 map book becomes too large to be very practical. The 1:50 was used upon arrival at the predetermined battle area.

We found that by using the pressure altimeter and radar altimeter, we could interpolate them for a pretty fair estimate of terrain height to confirm our destination. This was a key aid for dead reckoning.

#### Communications (E '83)

Communication with the rear was usually very poor or non-existent. This was true even when directional FM antennas were used. Either a jump TOC or relay station is required to talk to rear elements over 25 km away.

#### Techniques of Movement (E '83)

There are advantages to higher flight speeds. (*Caution: Higher speeds may be used only as current, local conditions warrant.*)

- Better fuel economy is realized than having to use OGE power. About 15 to 20% more range.
- Larger payloads are possible due to no OGE hover requirement.
- Much more desirable tow standoff ranges.
- Less likelihood of LTE (Loss of Tail Rotor Effect).
- Less time to be acquired by ADA or fast movers.
- Due to high energy state, there is a better reaction to hostile helicopter attacks.
- There is a more predictable aircraft response in the hot weather environment.

#### Night Missions (E '83)

Several night missions were flown while in Egypt. Self-imposed parameters of 40% illumination and 40° of moon elevation were established. Some important points learned were:

- Careful crew selection was very important. Several inexperienced pilots suffered disorientation that would have been fatal if not checked.
- Radar altimeters became your best friend in the cockpit.
- Keep flights down to the smallest group of aircraft possible.
- Pink filters stand out like rotating beacons from 5 miles if anyone is observing with an NV device.
- Ground vehicles are easy to see due to the shadows cast and light on dark effect.
- Map reading is extremely difficult.
- Moon reflected off sand sometimes helped visibility and sometimes hindered it.

## THERMAL IMAGERY LESSONS LEARNED IN SAUDI ARABIA DEMONSTRATION OF TANKS '83

In August, 1983 a tank capabilities demonstration was performed in and around the Saudi military city of Sharorah. During the demonstration data was recorded on the performance of the vehicles, the environment, and the environmental implications for thermal imagery and signatures. Excerpts of this data are presented below to assist aviation personnel in gaining a better understanding of how thermal imagery may be affected in the Desert Shield Operation.

### Daytime Surface and Equipment Signatures

Daytime presented a particular challenge to the three types of thermal imaging systems (TIS); the M-1's TIS, the M-2's Integrated Sight Unit (ISU), and the upgraded AN/TAS-6 (TI).

The desert sand surface solar loaded rapidly after sunrise, resulting in:

- Very hot sand surface temperatures by noon.
- Hot sand surface presented a very hot background to the thermal imagers, causing "blooming" to occur on one system which hampered thermal sight usage during the middle of the day.
- Very low contrasts between the background and vehicles at rest both in the narrow and wide fields of view.
- Personnel presented negative thermal signatures against the hot sand background.
- Wheeled vehicles presented hot thermal signature "cues" from their engines, exhausts and particularly, their tires. This is estimated to be the result of the hot sand heating the air in the tires.

Surface temperature measurements on the rubber tires of various vehicles, as well as the rubber track pads of the AFV's, indicated that even while sitting still, these matte black finishes tended to solar load heavily, either by direct sunlight or reflection from the sand.

The M-1 presented a very distinct, detectable thermal cue from the exhaust plume emitted which appeared to rise 10 to 20 feet above and behind the vehicle. An attack pilot using thermal sights should be able to identify (sort of IFF) from this visual cue. The exhaust signature was immediately detectable when the vehicle's engine was revved while stationary, or at any time while the vehicle was moving. Its thermal signature after only a few moments of operation, was greater than any of the other vehicles present.

Its exhaust plume signature is easily contrasted from any dust kicked up by the vehicle as it moves. The thermal signature of the dust is negative (i.e., black in the "white hot" mode).

 The cold signature of the kicked up dust is due to the temperature of the sand one inch below the surface averages 3-5°F. less than the surface sand during the day. When moving it "bites" deep into the sand layer and kicks up these cooler underlayers of sand. This cooler sand not only creates a detectable negative thermal signature of its own, it also enhances the image of the exhaust plume.

Other systems also presented exhaust plumes that were detectable at close ranges but were not comparable in size, intensity or detectability. Yet, other systems presented no detectable exhaust signature.

Wheeled vehicles presented no detectable exhaust signature.

Movement by any of the AFVs caused their tracks, road and drive wheels, and other suspension elements to heat quickly, resulting in thermal signatures detectable against the hot sand background. Telling thermal signatures apart is extremely difficult. Crews must make positive identification.

#### **Firing Signatures**

The thermal firing signature of the blast of 105mm service APDS ammunition varies greatly from that of service HEP.

In fact, the service APDS round generates a thermal signature - flash and subsequent hot lingering gases - that appeared to be unique in this environment.

The thermal signature of a TOW ATGM firing is also detectable.

One tank which was not equipped with a thermal shroud on its gun tube, produced a very intense thermal "cue" from the gun after firing only 2 or 3 main gun rounds.

Tanks, equipped with a thermal shroud on its main gun barrel did not generate such a "cue" after firing.

The self-protection smoke grenades carried on some systems appeared to have no effect on obscuring the thermal signatures of the AFVs. In fact, it appears that due to the very hot air temperatures present, the effects of the smoke grenades were carried upward immediately after launch.

#### **Vehicle Tracks**

**The tracks made by vehicles moving in the sand during the day were detectable at some distances (500 meters +) by their thermal signatures.**

Orientation of a particular vehicle to the sun had a significant impact upon the vehicle's thermal signature. Due to the intensity of the sun's rays (and consequently, the solar loading effect), if one side of a vehicle was in the direct sun and the other simply illuminated (though not in the shade), observing the first side will show a positive thermal signature and the other a negative signature against the hot sand background. Thus tracking a vehicle as it maneuvered tested the skills of the thermal sight operator. The target's thermal signature could easily switch from positive to negative and back again depending upon the aspect seen.

### Night Surface and Equipment Signatures

Defensive positions kept under camouflage nets at all times are readily detectable at night (at very long ranges, 10km+), due to the fact that the sun still solar loads the equipment during the day through the netting. All vehicles observed at night, presented crisp and clear thermal signatures at ranges up to 250 meters. The variations in side skirting material (chobham vs. steel) could be easily detected at night because of the differential cooling of the two materials.

Personnel presented crisp, easily detectable thermal signatures at ranges to 400 meters (observed). The cooling sand surface provided an excellent high contrast background for the thermal signatures generated by personnel and equipment. This environment virtually free of natural vegetation, provided a "clutter-free" backdrop, accentuating and enhancing the capability of the thermal imager.

Movement of any kind was easily detectable at night at long ranges against the cooling desert background.



Disturbances in the sand surface caused by vehicle movement were detectable by FLIR. This was due to the fact that the sand mass just below the surface (>1") warmed more slowly during the day than did the surface layer, and correspondingly cooled more slowly at night. Thus when a vehicle drove over the sand at night, it churned the lower, warmer sand up to the surface. This warmer sand presented a detectable thermal signature, highlighting the path of movement of any vehicle for some time.



Personnel footsteps could be detected at close range at night for the same reasons noted.

Excavations made during the day were still observable against the remaining, undisturbed sand well into the night.



Main gun and ATGM hits on the rocky terrain generated visual and thermal flashes similar to the "steel-on-steel" flash characteristic of hits on hard targets. This prompted observers to call many shots "hits" when an assessment the following morning proved these to be near misses.

### Self Illumination and Passive IR

Tests were attempted to engage targets presented by self-illuminating them with an IR searchlight and detecting the targets with a passive IR system. They were totally unsuccessful. The desert at night provides ideal operating conditions for thermal imaging equipment, with the result that even "lesser" foreign systems using thermal sights may be more of a threat than expected. Well defined vehicle thermal signatures were rarely, if ever, observed during the day. The pronounced thermal signature of one system, including the portion of the signature contributed by the vehicle's exhaust plume made the vehicle relatively easy to detect against even the hot sand background.

### Antitank Fires

ATGMs, air and ground, provide the most accurate antitank fires.

### Mobility and Maneuverability

Movement was relatively easy over the packed sand, grasslands, and areas of rock mixed with sand. Movement was more difficult over areas of loose sand and through the rolling sand dunes, and was impossible across the steeper dunes and hills.

Movement from packed sand, grassland, or rock/sand combinations to areas of loose sand immediately caused all vehicles to slow down, and frequently caused wheeled vehicles to get bogged down.



Because of the glare, haze and frequently blowing sand, it was often difficult to see the horizon or detect changes in terrain.

The sand is virtually all one color over vast regions of the desert. This includes areas where dunes rose 30 feet or more off the floor of the desert. This made it difficult to see the edges of paths, dune sides, etc. to avoid navigation and driving errors.

Driving in the desert presented numerous hazards and required experienced guides. People experienced with the terrain and the way a variety of terrain features were frequently found together were able to "read" the differences by subtle changes in coloration and texture, and were able to change course, speed, and driving formations in advance of any problems.

Navigation in the desert requires the use of a compass, especially when driving among sand dunes. The sand dunes are constantly moved and reshaped by the prevailing winds. Markers and tracks left in the sand are, in most cases, obscured by blowing sand in less than 24 hours. The upward slope may end with a vertical drop of 30-60 feet or more.



Driving among the sand dunes presents a particular hazard, for what appears to be a long gentle dune slope may, in fact, be several dunes obscured due to loss of depth perception.

Wind gusts and steady currents constantly lifted this sand into the air creating conditions of low or no visibility while driving.

The sand penetrated all of the equipment used in the demonstration and had to be regularly cleaned from filters, engine areas, crew compartments, weapons, etc.

The first vehicle over a new patch of sand appeared to raise less of a dust/sand cloud than did subsequent vehicles traversing the same ground.

Saudi drivers have learned to minimize the sand/dust cloud raised by several vehicles traveling together by driving in echelon formations staggered to the wind. Following vehicles are careful not to drive in the tracks of preceding vehicles.



The dust and fine sand raised by main gun fire made it nearly impossible for a tank crew to correct its own fire.

 Target detection in the daytime is difficult due to the glare, the "mirage" effects of the shimmering heat, the lack of color contrast against the sand, and the blowing sand. Units not expecting these difficulties could be vulnerable to indigenous forces familiar with these factors.

 The need for "terrain-smart" forward scouts is paramount.

Troops should be taught to navigate in the desert. Getting lost among the sand dunes is easy to do, hard to recover from (because the sands are quickly shifting) and totally disorienting.

#### Thermal Imaging and Equipment

 The desert sands have a "memory" that allows a trained thermal sight operator to "read" prior movement, excavations (minefields?), and enemy emplacements.

The thermal sights appeared to be less affected by the glare and mirage effects of the day than were the visual sights.

The movement of AFVs was detectable at long range in the daytime due to the negative thermal signatures of the sand clouds raised.

The desert sand, when kicked up in large clouds, can obscure all thermal imagery. This can be used as a screen for potential enemy movement.

### NATIONAL TRAINING CENTER AND RECENT DESERT EXERCISES LESSONS LEARNED

- *Permission planning is critical. Communications must be highlighted due to the extensive geographical areas associated with deserts and the AH-64 limited communication capabilities.*
- *The old 3-5 km battle position has proven inadequate for desert operations for an Apache battalion. The AH-64 requires more room and additional BPs to maneuver when engaging moving targets, enhancing fire distribution, and conducting evasive maneuvers against threat ADA systems. A minimum of eight 5 km AH-64 BPs per company, should be used as a planning factor.*

## NIGHT OPERATIONS

The US Army Safety Center reports that over 80% of all night aviation accidents are caused by crew error and half of these result from improper scanning or poor crew coordination. Data suggest the number of night accidents could be significantly reduced by crew coordination training aimed at accomplishing crew duties in a prioritized and coordinated manner. *Aviation commanders must focus their training efforts in these areas to improve overall aviation safety. Habitual crew assignments are also strongly encouraged to increase crew efficiency and safety. Crew and collective NVG training must be strictly related to the METL and must be progressively done. Crews and units must learn to "walk before they run." Crew ability, not just individual crew member proficiency, must be a key element in risk assessment.*

Success in NVG operations requires detailed planning, including an accurate mission risk assessment early in the planning process. *Aviation commanders and individual commanders and individual aviators must work closely with ground commanders on missions with unacceptably high risks to reduce those risks so the mission can be accomplished safely. All commanders must know why training missions are classified high risk. Failure to do so makes them unable to take prudent risk reduction steps to protect their soldiers' lives. All commanders, both ground and aviation, are to be intimately involved in the risk assessment process for training with aviation units.*

Night Operations require:

- *Accurate risk assessments with commanders' personal involvement.*
- *Complete premission briefings, to include detailed assignment of responsibilities to every crewmember.*
- *Full participation by every crewmember, to include crew coordination and scanning for obstacle/altitude clearance.*
- *The pilot-in-command never - repeat never - to allow scanning of the flightpath to be interrupted. If the pilot on the controls must stop scanning, he must transfer the controls. If the pilot not on the controls decides to stop scanning, he must announce that decision so the rest of the crew can increase their scanning efforts.*

Many of the points presented throughout the remainder of this chapter are Desert Shield Army aviator lessons learned feedback.

- *Know all the illusions associated with night flying... you WILL see them all. (See TC 1-204 Par 1-12)*
- *If you don't have to work in sand dunes at night, don't.*

Conditions such as dust can restrict visibility and the amount of ambient light resulting in loss of visual acuity. Visibility restrictions normally occur gradually. Initially, the visual range is reduced followed by a loss of terrain definition. *As visibility decreases, night vision may become so impaired that terrain flight should be discontinued.* (TC 1-204, Par 4-2 e)

### NVG USAGE

Most NVG accidents occur when the aircraft is operating at low altitudes, i.e., hovering, taxiing, during approach and landing and during enroute at terrain flight altitudes. In these accidents, crews perceived altitudes were higher than actual. *The individual not on the flight controls must alert the aviator on the flight controls any time an unanticipated deviation from planned airspeeds or altitudes is experienced.* While the average altitude of NVG operations has been decreasing, airspeeds have not correspondingly decreased. *Airspeeds listed in ATMs are maximums and during low visibility, or when low contrast and smooth-textured surfaces are present, airspeed must be further reduced.*

Very low ambient light, i.e., less than 23%, 30° and very high ambient light levels over a highly reflective surface are circumstances that have been present in Desert Shield accidents. *When forecast ambient light is extraordinarily low, assume a higher risk factor for the mission during mission planning.* When light is extraordinarily high, the automatic brightness control feature of the NVG can degrade the goggle image and "hide" obstacles in the foreground of reflective surfaces. *Again, additional time must be allowed for detailed planning and actual mission execution. When performing missions under either of these circumstances, great care must be exercised to not overfly the capabilities of the goggles.*

Because of the sand haze layer, the stars appear to be higher than normal. This often gives pilots a feeling that the horizon is higher (or lower) than it actually is. Pilots often descend or climb in response to this incorrect sensory input.

- *Go back to the basics - get out the books.*

Using NVG systems, aviators can detect light sources that may not be visible to the unaided eye, such as lights from other aircraft, flashlights, burning cigarettes, and chemical light sticks. As the ambient light level decreases, aircrews can more easily detect these light sources but are less able to estimate distance correctly. Performance of NVG systems is directly related to ambient light. To light the flight path of a helicopter in low ambient light, an additional light source may be required.

Depth perception and distance estimation are difficult with NVG systems. The quality of an individual's depth perception in a given situation depends on: available light, type and quality of the NVG system, and degree of contrast in the field of view and the viewer's level of experience. The desert presents a poor contrast, if any at all. Viewers must rely on monocular cues. See TC 1-204 Par. 1-11.

Crews must consider specific items when conducting NVG operations with respect to scanning. Peripheral vision as compared with unaided flight is significantly reduced. Therefore, a continual scanning pattern to compensate for the loss must be employed. Moving the eyes will not change the viewing perspective; the head must be turned. However rapid head movement can induce spatial disorientation. Therefore the crew member must rotate his head and eyes slowly and continuously. With the newly modified NVG systems, a slight downward deflection of the eyes will provide all required visual information inside the cockpit.

**Warning:** The visual range of NVG devices may not allow aviators enough time to avoid obstacles. Therefore, aviators must exercise extreme care when using NVG during terrain flight modes. Reduce ground speed so that pilots can detect and avoid obstacles when ambient light levels are low or visibility is poor because of weather (or dust).

### CREW COORDINATION

Crew coordination has been cited as a frequent accident causal factor. Crew coordination is defined as "the interaction between crewmembers (communication) and actions (sequence or timing) necessary for flight tasks to be performed efficiently, effectively, and safely."

*When the aviator on the controls must stop scanning, he must transfer the controls or coordinate with other crewmembers to ensure obstacle clearance is maintained. When the aviator not on the controls must discontinue his scan to tune a radio, for example, he must announce that he is "INSIDE." The pilot on the flight controls and the nonrated crewmember in the aircraft, if applicable, acknowledge and then enlarge their scan to cover the area no longer being scanned by the pilot not on the control. When the aviator not on the flight controls resumes his scan, he must announce "OUTSIDE" so the other crewmembers can resume their standard scan responsibilities.*

Standardized crew coordination procedures may be the most effective tool for commanders to ensure safe NVG operations. *More detailed premission crew briefings covering specifically assigned scan areas, crew duties and crew coordination responsibilities are paramount for safe desert operations.*

Much can be gained by having "skull sessions" with all assigned crewmembers, rated and nonrated, as well as comprehensive, candid mission debriefings, where errors and "close calls" can be shared for mutual benefit.

Habituated crew and station assignments or battle rostered crews will further improve crew effectiveness.

### SCANNING

Scanning techniques adequate for desert operations are being reviewed. The following is the only data available at time of printing.

To scan effectively, a crew member must rotate his head and eyes slowly and continuously. A sector to be scanned must be understood by the other crew members. The pilot on the controls should use close cues to determine the altitude needed for obstacle clearance and to determine airspeed and closure rates.

The pilot not on the controls should use close cues, as well as mid-range and far cues, to evaluate route trends. He should then communicate these trends (i.e., turns, obstacles) to the pilot on the controls. When the pilot not on the controls stops scanning (for example to tune a radio), he must alert the crew that he is inside.

The pilot on the controls and the crew members in the rear of the aircraft (if applicable) acknowledge and then enlarge their scan to cover the area no longer being scanned by the pilot not on the controls.

### EFFECTS OF SPEED

- *Go slower when close to the ground*
- *Airspeeds published in ATMs are maximums, and under low ambient light or under lack of visual acuity reduced airspeeds may be required. (TC1-204 par. 6-1c)*

### ALTITUDE

- *Fly higher at night if possible*
- *Do not rely on radar altimeters for obstacle avoidance, they measure only obstacle clearance...they do not warn about clearance ahead of the aircraft and may contribute to a sense of false security for the aircrew. (TC1-204 pg 6-7)*
- *Radar altimeters are preferred for night terrain flight, especially during low light conditions and during flight over areas of limited contrast such as water and desert. (TC1-204 par 6-5b)*
- *Aviators must use care when descending into areas of limited contrast during periods of low illumination (TC1-204 pg 6-6)*
- *Aviators flying over the desert may not be able to judge distances and altitude because of a lack of depth perception and the scarcity of terrain features. (TC 1-204 Par 6-3F)*

### INADVERTENT INSTRUMENT METEOROLOGICAL CONDITIONS (IMC)

- *Practice inadvertent IMC...climb, don't descend to regain contrasts and definition with the ground.*

### DEPTH PERCEPTION

As the light level decreases, the ability to judge distances accurately is degraded and visual illusions become more common. See TC 1-204 Par. 1-11 for procedures.

## PRIMARY CAUSES FOR NIGHT OPERATIONS ACCIDENTS

The US Army Safety Center has studied crew error accidents occurring in night operations during the past 6 years and have found that **eight types of crew errors are repeatedly causing night accidents**. As simple and basic as they appear, these kinds of errors show up persistently in accident reports year after year. The eight types of crew error are listed below:

- **Improper scan** - improper direction of visual attention inside or outside the aircraft; i.e., too much or too little time on one object / area; scan pattern not thorough or systematic.
- **Improper distance estimation** - inaccurate estimation of distance between objects or rate of closure with objects.
- **Failure to detect hazards** - not identifying obstacles or recognizing other hazardous conditions (e.g., obstacles in landing area, unsecured equipment and improper control / switch position).
- **Improper coordination** - failure of crewmembers to properly interact and act (sequence and timing) with each other and / or others outside the aircraft performing flight tasks.
- **Failure to properly plan preflight** - failure to choose appropriate flight options for known conditions and contingencies and develop these into a course of action that will maximize the probability of mission accomplishment.
- **Failure to properly plan inflight** - improper inflight modification of flight plan or failure to properly modify flight plan in response to unanticipated events or conditions.
- **Failure to properly diagnose or respond to emergency** - improper identification of, or response to an actual, simulated or perceived emergency.
- **Failure to execute proper procedure for flight** - failure to properly execute procedures necessary to maintain or recover orientation in flight environments known to restrict visibility; e.g., snow , dust, IMC, black hole, and over black water.

## LANDING ZONE SELECTION

- *Select landing zones that have hard surfaces to avoid blowing sand and dust as much as possible.*
- In lieu of hard surface availability, landing sites should be chosen so as to minimize loose sand and grit.
- The UH-60 rotor disc produces a yellow halo when operating in a sandy environment which is visible to the unaided eye for several miles. Therefore, landing zones must be selected out of view of the opposition.
- Cross wind landings are best since dust blows away from other aircraft on the flight.
- Hard surface roads and gravel are the best landing zones.
- Landing in dust and soft, blowing sand is best performed with a running or roll-on landing.
- Landing areas should be treated with oil or chemicals, provided that concealment is not significantly degraded.
- Aircraft parking areas should not be too close to ground units which cannot move quickly as enemy attention may be drawn to these areas.
- Desert Shield feedback indicates the Inverted "Y" is inadequate for desert operations. Recommend a short landing area be established - about 20 meters by 60 meters of flat terrain. When aircrews brown out at 10 - 20 feet in this box and wings level, they will be assured of landing upright. There are not enough visual clues or terrain information from inverted "Y." These dimensions work well for UH-60s using roll-on landing technique.
- Units that need helicopter support should have soldiers that are trained in landing zone (in desert environment) selection, set-up, preparation and FM homing, to ensure satisfactory LZ selection and set-up.

## LASER RANGING

Erratic laser ranging in the presence of obscurants such as smoke, dust, sand, haze, etc. may be due to the laser energy being backscattered from the obscurants. *Try moving the TADS laser rangefinder / designator counter measures switch on the CPG fire Control Panel to the "LRF/D CCM" position. This may eliminate the problem.*

## WEAPON LETHALITY AND GUNNERY CONSIDERATIONS

### AMMUNITION

High explosive ammunition will lose some of its effect if it is allowed to explode under the surface of soft sand, absorbing much of the explosive force of the round. "HE quick" fuzing can be fired into rocky terrain with great effects. VT fuzing is best in desert terrain but not always available.

### RANGE DETERMINATION

Range determination is the biggest problem in accurate gunnery. Laser ranging is an appropriate solution, however, in dusty terrain lasers may not be effective or accurate. Alternate methods of determining range using maps and other measuring devices are often necessary.

- Nature of the target. A target that contrasts with its background appears closer. A target that either blends with its background or is partially hidden appears more distant.
- Nature of the terrain. Over smooth terrain, the pilot tends to underestimate range. Over rough terrain, the pilot tends to overestimate range.
- Visibility of the target. A target seen in full sunlight appears closer than one observed through haze or fog. When the sun is behind the target, the target appears more distant. When the sun is behind the observer, the target appears closer.
- Maps and photomaps. Before and during the mission, aircrews can use maps and photomaps to determine the ranges from prominent terrain features to the target. They can then compare actual ranges with ranges they have estimated visually. This procedure allows them to determine accurately the range to the target without unnecessarily exposing the aircraft. The use of maps and photomaps at night, however, is restricted because terrain features can be identified at limited ranges.
- Using Telescopic Sighting Unit (TSU) to determine range. When the sight is operating in the HI position, the gunner can see 4.6-degree FOV. The reticle image displayed in the TSU, as shown in Figure 3-1, consists of an outer circle with a vertical and a horizontal cross hair. Vertical marks that aid the gunner in estimating range to the target are positioned along the horizontal crosshair on high magnification only. The distance between the outer vertical marks is 10 mils; the inner marks, 2 mils. At the center of the sight reticle is an opening that is 0.4 mils wide, this area displaces a 54 inch square at the maximum range, 3750 meters, of the missile. This is the aiming point for the gunner when he is sighting on targets.

NOTE: As a rule, when gunners determine range to targets, for Soviet tanks, the mil values that they use are 6.5 meters long and 3 meters wide.



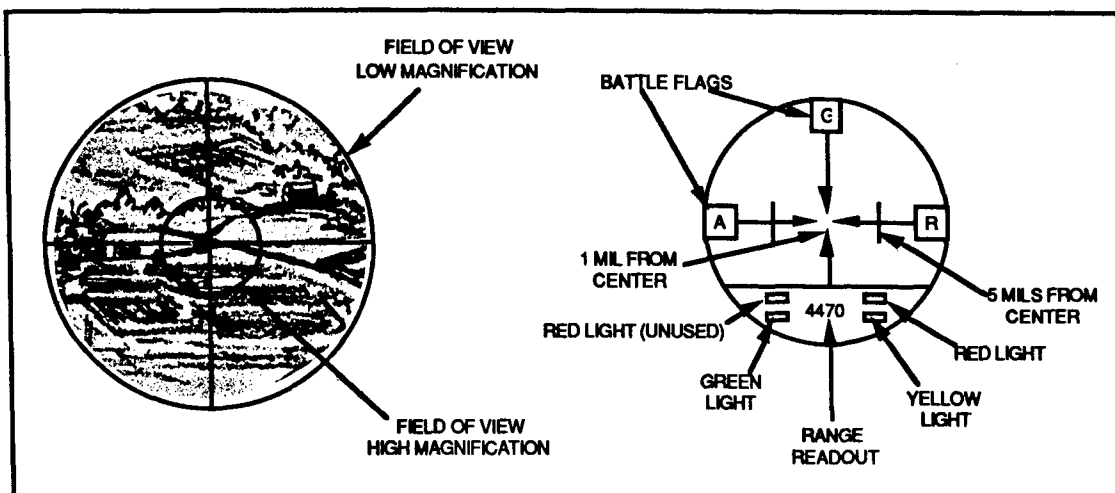

Figure 3-1. TSU Fields of View.

## RUNNING FIRE TACTICS

### Employment

The following techniques are being passed along to aviators who may not be familiar with running fires. The techniques have been proven by both the 6th Cavalry Brigade and the Israelis in the desert environment. These techniques are recommended as daytime-oriented tactics, although they can achieve the same desired objectives at night. Because, however they capitalize on coordination of firing while flying at relatively fast speeds, at relatively low altitudes above the earth, in a very controlled environment, they require greater skill and training. *If you were to use something similar to them at night you would obviously have to slow down and modify these techniques based on the terrain and situation you find yourself in.* These techniques are beneficial in this theater for several reasons:

- They don't involve hovering to fire, and therefore do not create the dust cloud associated with low hovers, and correspondingly don't subject the aircraft to the excessive wear and tear of hovering in the aircraft's own dust cloud of sand and dirt.
- They allow the pilot to engage a directly viewed target at greater than maximum missile range (assuming the target can be seen at such range), allow the pilot to fly along behind the missile after firing, and allow him to break off within range upon missile impact.
- They allow the pilot to break and run quicker since the pilot does not have pull out of a dust cloud from a hover.
- They allow a pilot to achieve greater accuracy in delivery of his missiles through a coordinated mix of climbs, dives, missile releases, and break aways because the aircraft is constantly moving.

It is emphasized that these techniques are not a requirement. They are offered for consideration in that they have been used before with excellent results.

They are particularly good for the Cobra (which must see his own target) and the Apache when the Apache is making autonomous shots, where the firing Apache can directly see the target from a long range and is doing his own designating and firing.

Running fires are an excellent attack method for exploiting the antiarmor firepower of the attack helicopter. Attack helicopters can engage enemy armor at maximum standoff and then rapidly move toward the target until within range where breakoff can be performed. This allows attack assets to remain dispersed and remote, to provide security, in that they may constantly be on the move as they approach and break away from the targets. Attack helicopters should enter the engagement area using multiple routes and small formations.

*Note: ATKHB personnel do not normally train or practice running fire attacks and will need specialized training and time to practice and rehearse these attacks.*

Running fire tactics are illustrated in Figure 3-2 through 3-4. Operational planning factors are provided in Figure 3-5 and Figure 3-6.

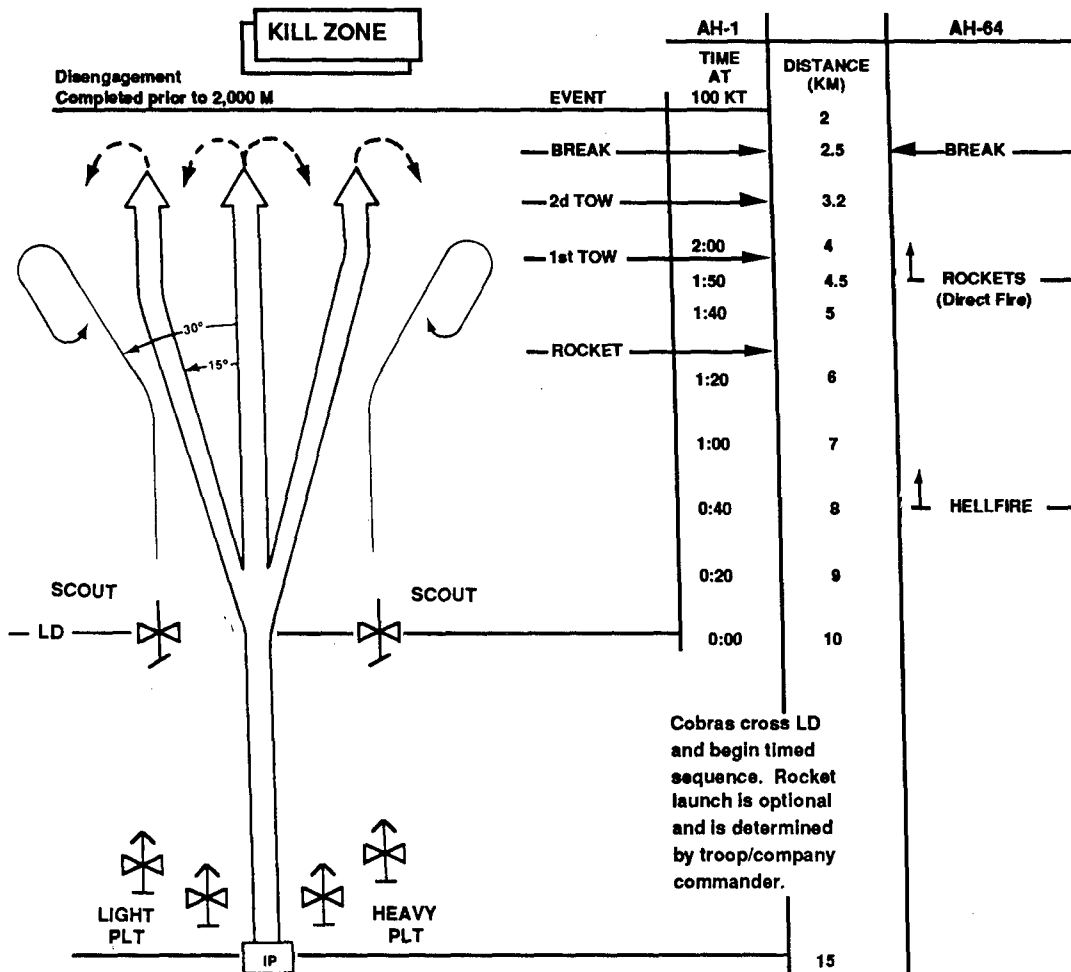

Figure 3-2. Running Fires Attack.

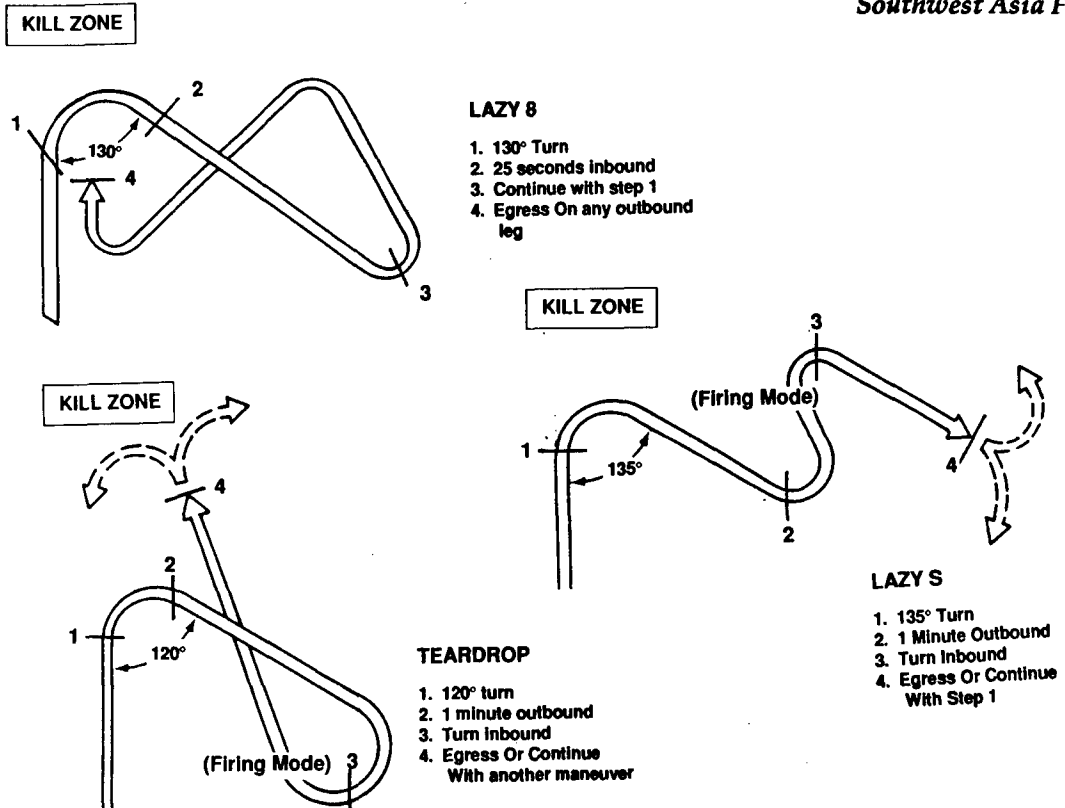

Figure 3-3. Reengagement Maneuvers.

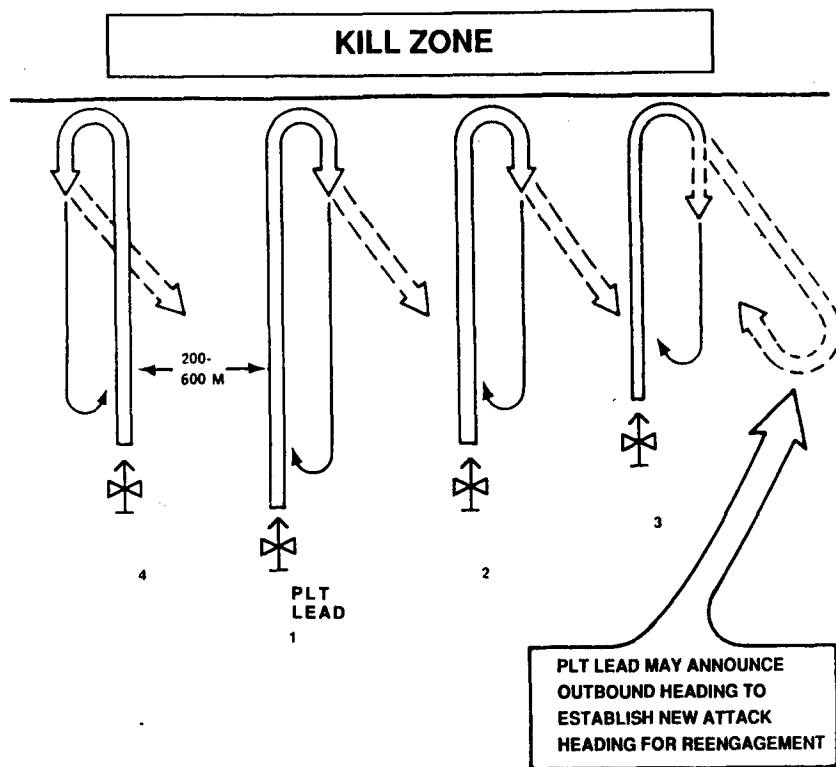

Figure 3-4. Attack Formation and Reengagement Maneuver.

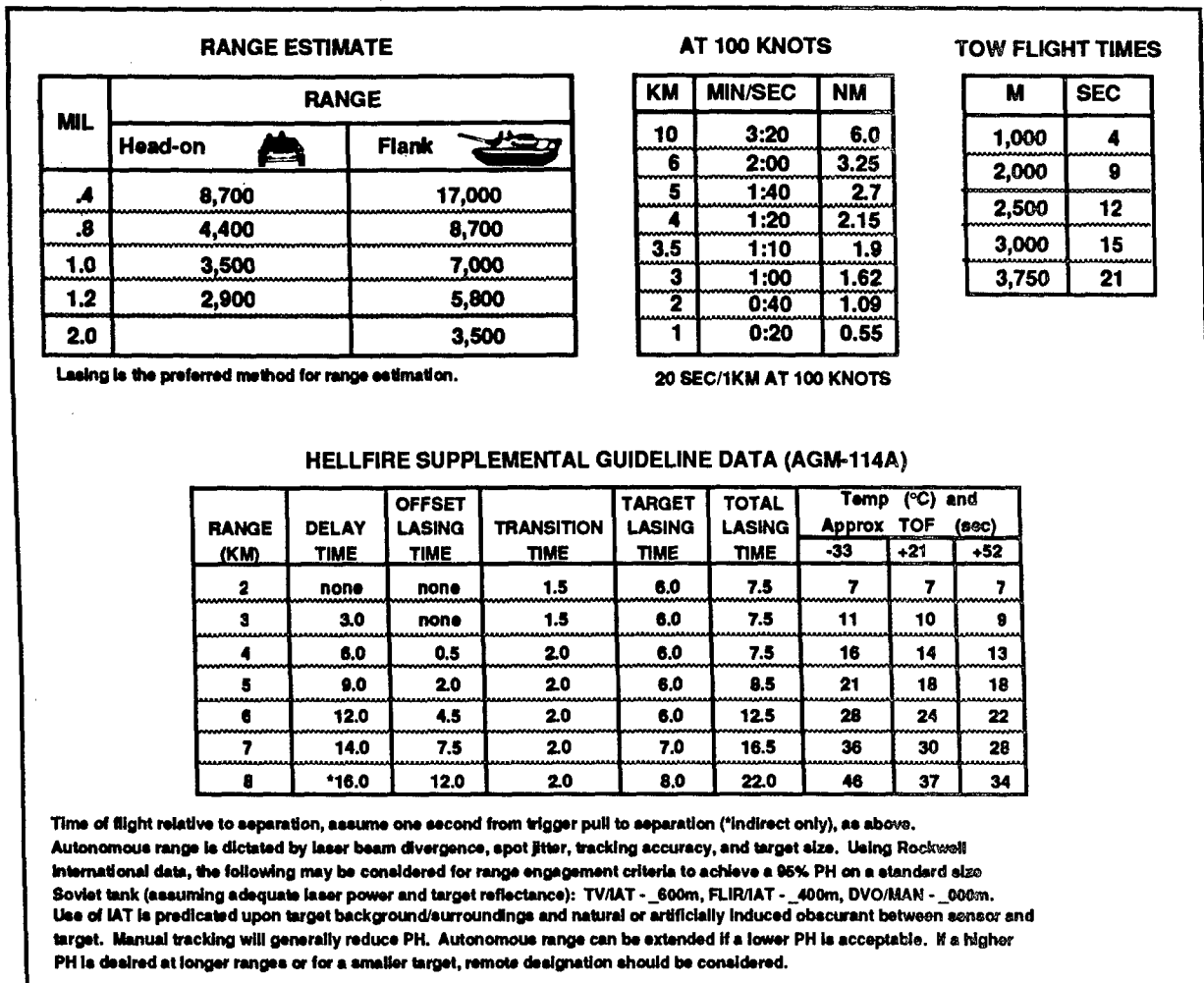
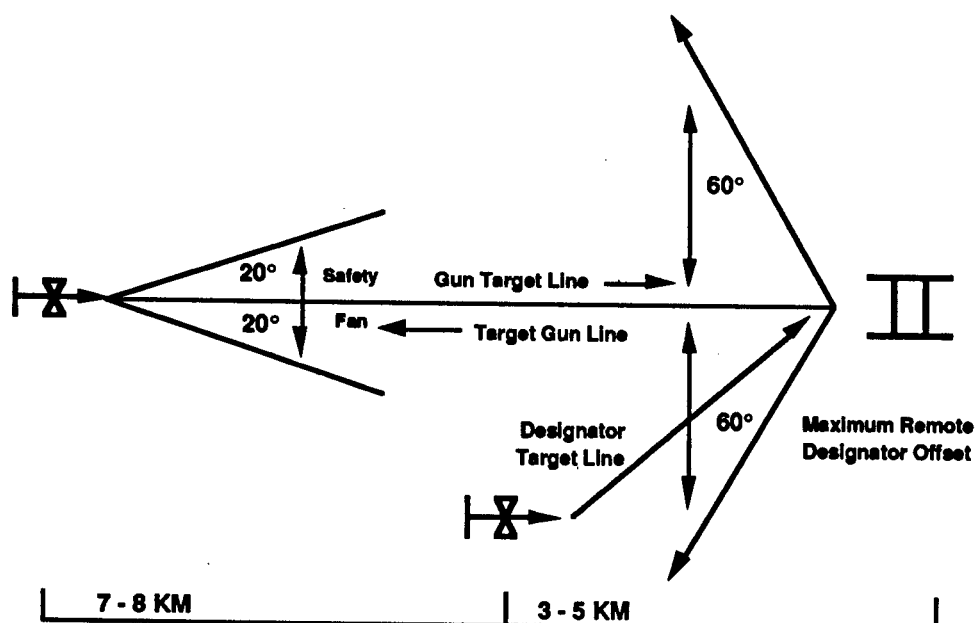

Figure 3-5. Attack Helicopter Operational Planning Factors.

### Attack

The attack battalions should depart the assembly areas and fly at an altitude that will avoid Threat radar or visual detection (25 to 50 feet AGL) and at an airspeed to avoid dust signature (30 - 120 KIAS). (These figures are for daytime.) After arrival at the holding areas (if used), the battalions should maintain an altitude which permits masking without creation of the hover-associated dust clouds. The formation flown during movement should be based on ADA and air-to-air threats.



Note: The more right angles and smaller the target, the less offset angle can be. Offset angle alone cannot be used to determine positioning for remote shots. Nature of target must also be evaluated.

Figure 3-6. Hellfire Remote Designator Distances and Offset.

#### Training Considerations

- Individual / crew / company / battle drills work well to train teams initially. Commands used by the team leader should be standardized within the unit.
- Training should begin with a maximum of two aircraft elements and progress to multiple aircraft formations.
- Performing the above flight techniques at low altitudes is stressful. *Training must be approached with a step-by-step method.* Crew coordination is of paramount importance.
- Running fire tactics are possible over varied types of desert terrain. A great deal of flexibility is possible when all factors are considered. Air cavalry elements should be integrated with the attack element to provide initial reconnaissance, flank security, and target suppression.
- Running fire tactics lead to increased capability when air-to-air threats are encountered. Evasive maneuvers are more easily accomplished with higher airspeeds. If helicopter-versus-helicopter or helicopter-versus-high performance engagements occur, higher airspeed will increase survivability during operations over open terrain.
- *Developing team integrity is the most important consideration in training to employ this tactic.*

After initial training, crews should practice performing in each team position.

Once again, ATKHB personnel do not normally train or practice running fire attacks and may need specialized training and time to practice and rehearse these attacks.

## DESERT SURVIVAL FOR AIRCREWS

- *Each unit must prepare to provide downed pilot / aircraft recovery.*
- *Desert survival training is a must; if not before arrival, immediately after.*

### SURVIVAL ENVIRONMENT

Desert surfaces vary greatly from eroded rock-strewn areas to dry lake beds. When faced with the decision to ditch, the pilot must carefully consider the terrain he is over. Although ditching is often possible because of the flat, barren, desert terrain, ditching should, if possible, be made prior to fuel starvation so that aircraft power is available when executing the forced landing. Desert terrain consisting of numerous large rocks and boulders presents the most severe threat to ditching.

The effects of sun and heat, combined with the lack of water, has proven to be the most dangerous environmental factor to confront downed aviators. The bright sun is hard on eyes, extremities, and skin. Sunburned hands can become particularly painful. The daily temperature extremes of the desert can be a problem. The daytime heat causes exhaustion and severely limits physical activity, whereas the sometimes bitter cold night limits sleep and causes exposure problems. Dust and blowing sand can frequently be problems. The medical reports from WW II on many rescued aviators indicate mild to serious sinusitis, probably due to irritation caused by the dust particles. Men also complained of continuous sore eyes caused by the sun's glare and abrasions of the eyelids and eyeballs caused by blowing sand and dust particles. These airborne particles also got into ears, nostrils, and mouths and sometimes caused severe irritation. Sunglasses intended for survival must be carried in a safe location, either in the aviator's personal equipment or the survival kit.

Most desert survivors reported the presence of flies and other insects, even in remote areas. Keeping flies away from wounds can be a problem. Sand flies are even more troublesome due to their small size, painful bite, and the fact that they can crawl through the finest nets. Sand flies often carry sand fly fever, however, their worst effect appears to be the constant scratching that results from their bites. Insect repellent is the best way to keep sand flies away. Mosquitoes are reported to be abundant near the coast and inland marshes. Desert survivors found little in the way of desert wildlife to bother them. Instead, the irritation and annoyance (limited primarily to the daylight hours) caused by flies, sand flies, ticks, mosquitoes, lice, and fleas proved to be the most significant problem.

### MIRAGES AND ILLUSIONS

Mirages are common in the desert and pose a potential problem for survivors. They are caused by the uneven density of the air near the surface and appear as a sheet of water on the desert. Mirages cause problems primarily in travel since they make it difficult to judge distance and obscure the intermediate

terrain that is hidden by the mirage. Mirages can be expected to hamper vision, navigation, and in some instances to magnify or conceal objects. Under these conditions visual acquisition of aircraft or vehicles is difficult as is trying to signal them. Though reports of mirages are very common, in most cases they were easily recognized as mirages and caused only minor difficulties.

Another desert optical illusion is caused by atmospheric refraction and results in distant objects appearing closer than they actually are. The conditions and effects are similar to those of electromagnetic ducting and when the conditions occur, distant objects appear closer and objects below the horizon are visible. Under slightly different conditions atmospheric refraction causes light waves to reach the observer by two or more different paths, causing distorted or multiple images of the object. Illusions also occur at dawn and dusk. The most interesting of these is the false-dawn illusion that occurs when the sun's spectral light appears on the western horizon. The fact that the sun initially appeared in what was thought to be the west has caused many anxious moments for desert survivors.

### WATER

Few aviators can expect to land in the desert with an adequate water supply. In nearly all desert survival reports, aviators attempted to obtain water by searching for wells, cisterns, or oases. Some sought relief from thirst by sucking on small pebbles, chewing grass or leaves, and sucking the juices from snails. Without water the lips usually become painful. The use of a chapstick, or some type of grease will help prevent drying of the lips. About five days without water, survivors reported the skin began to peel from their tongues and mucous membranes. *Aviators are specifically warned that alcohol, in any form, should be avoided in a survival situation.* Alcohol should be considered a food, not a source of water, since alcohol requires water for digestion and excretion from the body.

### TRAVEL

Experience from World War II indicates an uninjured man is capable of traveling 12 to 18 miles a day on average terrain at the beginning of the survival experience. As heat and the lack of water take effect, the daily distance decreases. Generally, this becomes noticeable about the fifth day, and by the fourteenth day many men were able to travel only 1 to 2 miles a day. The average time spent traveling by World War II survivors was 5 days, however, 20 days or more were not uncommon and one group traveled for 29 days. The greatest distance traveled by a group of survivors was 350 miles, while the average distance was 50 miles.

It appears night time travel and day time rest would be best in the desert, however, the survivor must consider that his chances of contacting passing vehicles or aircraft will be less at night than during the day time. In World War II, men who traveled at night sought day time shelter in caves, in the shade of trees or rock piles, and many found that burying themselves in a shallow depression

tended to reduce water loss, aid relaxation, and allow some sleep. Those who traveled during day light hours found the physical effects of the sun and heat severely handicapped their ability to travel. The most satisfactory time to travel is the early morning or late evening.

Standard issue flight suits proved quite satisfactory for desert travel. Whenever possible gloves and headgear should be retained for protection from the sun, however, substitutes can easily be made from parachute cloth if necessary. Government issue boots are also very satisfactory for desert use. Several survivors, however, experienced difficulty replacing their shoes due to the swelling of their feet that occurred when the shoes were removed during rest stops. One group of six survivors was forced to continue their travel barefoot because they could not get their swollen feet back into their shoes. Other men who walked barefooted across alkaline swamps or salt flats reported they suffered alkali burns on their feet.

### SIGNALING

Most signaling problems encountered in World War II have been resolved over the years. The creation of dedicated rescue forces and development of modern survival equipment will no doubt make desert rescues more rapid and successful. Optical problems in the desert, however, continue to affect signaling and rescue operations. The desert haze, coupled with the effects of mirages, complicate signaling. The haze often limits visibility to 400 yards, or less, and makes it impossible to see aircraft or survivors unless looking directly up or down through the haze. The haze also makes it very difficult to positively identify ground parties as friend or foe; consequently, survivors often hesitate to establish contact with ground parties or aircraft until they are relatively sure of identification or are desperate enough to surrender if necessary.

Though modern survival radios and signaling devices will usually lead to quick rescues in the future, aviators must be prepared to communicate with less sophisticated signaling and communications techniques in the event the modern equipment is lost or fails.



## SEARCH AND RESCUE OPERATIONS

### MISSIONS

Combat search and rescue (CSAR) missions are conducted to locate survivors and to return them to friendly control before the survivors can be captured. The first request for CSAR assistance may come from any source. CSAR missions are normally conducted in unfamiliar terrain to rescue personnel whose injuries are not known in advance.

### OPERATIONAL STAGES

CSAR operations are divided into five stages:

- Awareness. In the awareness stage, rescue personnel become aware that an emergency situation may exist.
- Initial action. During the initial action stage, preliminary action is taken to alert SAR facilities and to obtain information.
- Planning. An effective plan of operation is developed in the planning stage. It includes the search plan, the rescue plan, and the final delivery plan.
- Operation. SAR facilities are moved to the scene during the operation stage to conduct a search, rescue survivors, and deliver injured personnel to a suitable medical facility.
- Mission conclusion. In the mission conclusion stage, SAR facilities are moved from the safe delivery point to their regular location where they are prepared for another mission.

Commanders must place a high priority on the recovery of downed aircrews. Downed aircraft recovery teams, or DARTs, are comprised of maintenance, medical, and security personnel. These teams must be trained to react in any mission profile. Commanders must form the teams out of existing resources. This includes providing dedicated UH-1 or UH-60 aircraft with personnel locator system equipment to use in DART missions. MEDEVAC units are only responsible for the evacuation of injured personnel. Therefore, aviation units must plan for and accomplish internal search and rescue operations as well as mass casualty evacuation. DART is not a command option; it is a command responsibility.

Commanders are responsible for training, alerting rescue personnel, and ensuring that essential SAR equipment is carried aboard all aircraft that operate within a combat environment. If commanders request active SAR assistance, they must furnish rescue personnel--

- The type, number, tactical call sign, and radio frequency of aircraft, ships, or ground forces in distress.
- The last known course and speed, position, and intended track.
- The names and authenticators of distressed personnel.
- The type and amount of survival equipment aboard the aircraft.
- Any additional information that the SAR forces may need.

SAR forces should have the latest intelligence information about the area they will penetrate.

## PROCEDURES

Distressed persons may help effect their rescue by following specific procedures. The information distressed persons must provide to rescue personnel includes:

- The need for assistance.
- Their location and identify.
- Adjacent recovery vehicle sites

Combat search and rescue forces must be prepared to accomplish procedures listed in AR 525-90.

They must be thoroughly familiar with:

- Survival equipment and escape and evasion aids.
- Ditching, crash landing, and other emergency procedures.
- Survival techniques and procedures that apply to climate, terrain, and NBC contamination.
- Communication equipment, combat rescue signals, and other actions necessary for evacuation to friendly control.
- Rescue equipment, recovery subsystems, and operational techniques.
- The location of removal areas and aircraft on-station positions pertinent to their particular mission and procedures for using the areas or points.
- Authentication system procedures.

Aviation unit commanders must be prepared to conduct internal search and rescue operations. Unit aviators must be familiar with evacuation procedures contained in unit OPORDs and be ready to implement them. Figure 3-7 shows the suggested format of a CSAR annex to an OPORD.

In-flight procedures consist of notification, crash landing, and ditching. Upon reaching the ground, aircrews should initiate protective measures against enemy detection and hazardous NBC conditions. When the danger has passed, the crew moves toward removal areas. When the terrain or water necessitates a crash landing or ditching, aircrews should destroy or neutralize all classified equipment and documents on the aircraft and then destroy the aircraft.

UNCLASSIFIED SAMPLE

Copy \_\_\_ of \_\_\_ copies  
3-227th Avn Regt  
Fliegerhorst (MA 9757), AQ  
161000 Apr 90  
AF 01

ANNEX J (COMBAT SEARCH AND RESCUE) TO OPERATION ORDER NO 51-90

References: See OPORD 51-90.

Time Zone Used Throughout the Order: Alpha.

1. SITUATION

- a. Enemy Forces. See Annex B (INTELLIGENCE).
- b. Friendly Forces. See OPORD 51-90.
- c. Attachments and Detachments. See OPORD 51-90.

2. MISSION

As required, downed aircrews in hostile or contested territory avoid capture and effect recovery to friendly control. Organic aviation assets attempt to recover downed aircrews or locate their position for other CSAR forces.

3. EXECUTION

a. Concept of Operation.

(1) Maneuver.

(a) Once established on the ground, downed aircrews will attempt contact with and recovery by aircraft in the flight. If this is not possible or practical, the downed aircrews will escape and evade to the appropriate designated area recovery/extraction point. If recovery is not accomplished at the DARE point, aircrews should move to SAFE LBH01 and execute procedures as briefed for LBH01.

(b) UH-60 crews should plan missions to service DARE points IAW the DARE procedures listed in b below.

(2) Fires. Downed aircrews may call for suppressive fires from aircraft as required. When CSAR assets arrive on the scene, the recovery aircraft will assume responsibility for suppressive fires to avoid conflict with CSAR aircraft.

b. Coordinating Instructions.

(1) DARE assignments.

(a) Air Corridor Eagle: DARE 7 NB 159119.

(b) Air Corridor Hawk: DARE 9 NB 250159.

(2) DARE service windows.

(a) DARE 7 at 0300-0310, 17 Apr 90/18 Apr 90.

(b) DARE 9 at 0345-0355, 17 Apr 90/18 Apr 90.

UNCLASSIFIED SAMPLE

Figure 3-7. Suggested Format of a CSAR Annex to an OPORD.

UNCLASSIFIED SAMPLE

- (3) DARE procedures.
  - (a) Select a suitable recovery site at the DARE point and remain concealed.
  - (b) Note any enemy activity or emplacements that will affect recovery.
  - (c) Begin transmitting on 282.8 UHF for 15 seconds each minute, starting 5 minutes before the DARE window and continue through the window.
  - (d) Once communication is established with rescue, provide authentication and enemy situation and vector aircraft to the recovery site.
  - (e) Approach recovery aircraft with both arms up if possible.
  - (f) If no recovery is made by 17 Apr, wait 24 hours and try again.
  - (g) If recovery is unsuccessful on 18 Apr, begin movement to SAFE LBH01 and execute SAFE NFH01 procedures.
- 4. SERVICE SUPPORT
  - See OPOD 51-90.
- 5. COMMAND AND SIGNAL
  - a. Primary SAR frequency. 282.8.
  - b. Color of the day. Blue.
  - c. Number of the day. 8.

Acknowledge.

Signature

OFFICIAL:

S2

UNCLASSIFIED SAMPLE

Figure 3-7. Suggested Format of a CSAR Annex to an OPOD (continued).

## AIR COVER

Rescue escort tactical aircraft and the rescue combat air patrol provide air cover to SAR units participating in recovery operations. Rescue escort aircraft that can operate within the same altitude, speed, and endurance regimes of the SAR and ACR forces will escort these forces to and from the recovery area.

### Rescue Escort Tactical Aircraft

#### RESCORT Aircraft:

- Protect SAR vehicles en route to and from the recovery area from enemy ground fire.
- Conduct short-range visual and electronic search sweeps to assist the SAR force in locating survivors.
- Determine the level of enemy activity in the objective recovery area.
- Suppress the enemy's interdiction capability in the objective recovery area.
- Assume command and control functions for the SAR forces during area sanitation operations.
- Coordinate activities of all SARTF elements when acting as the on-scene commander.

### Rescue Combat Air Patrol Tactical Aircraft

RESCAP air-superiority tactical aircraft support the SARTF when the enemy attempts airborne interdiction of the SAR and ACR effort. RESCAP aircraft:

- Patrol the area and protect survivors until the SARTF arrives.
- Assist the SARTF in locating survivors.
- Assist RESCORT aircraft in suppressing ground fire.
- Protect against and suppress enemy air-to-air interdiction efforts.
- Function as the on-scene commander for the SAR forces until SARTF elements arrive.

## COMMUNICATIONS

Communications between distressed personnel and SAR personnel are essential to SAR operations. People in distress should use every means available to identify their locations and problems. In hostile territory, authentication is also required. If radio communication is lost, visual air-to-ground and ground-to-air signals can be used.

### Listening Overwatch

Unless the mission dictates otherwise, any aircraft operating in a hostile area will maintain a listening watch on emergency frequencies.

### **In-Flight Emergency Communications**

In-flight emergency communications are essential to SAR operations. The pilot calls on the frequency of the last contact, on an established common frequency, and on the international emergency frequencies. When the pilot has established communication or is "in the blind," he transmits the type of aircraft, tactical call sign, and position and course. He also transmits speed, altitude, nature of difficulties, and his intentions. The pilot continues to transmit a distress call on the appropriate emergency frequencies long enough to permit a direction finding plot of the aircraft's position, if possible. he then turns the transponder to the emergency position.

### **Relay Transmissions**

A friendly force receiving information concerning distressed aircraft or personnel forwards the information directly to the nearest friendly monitoring agency. If a crash is observed by another aircraft, that pilot relays the call sign of the downed aircraft and the exact location, bearing, and distance from a well-known landmark. The pilot reports whether the downed crew is alive and under surveillance and whether he has radio contact with the crew. He also reports any enemy air or ground activity. The pilot remains in the area as long as fuel permits or until he is relieved.

### **Distress Calls and Signals**

Personnel isolated in enemy territory will first concentrate on evading and surviving and then locating a suitable recovery site or area. Distressed personnel should not transmit distress calls "in the blind" or display international distress signals unless prebriefed to do so or friendly forces are known to be nearby.

#### **Distress Calls:**

- **Precontact transmission** - The initial distress call is a precontact transmission sequence followed by a listening period. First, the survivor turns on the locator beacon on the AN/PRC-90 for five to ten seconds and then turns it off. Next, he switches the radio to voice mode and makes emergency distress calls by repeating Mayday three times followed by his tactical call sign. Finally, the survivor listens for radio contact. Personnel isolated in hostile territory should not divulge their exact location, condition, or number of survivors unless they are certain of the authenticity of friendly forces. Even then, they should only divulge this information when requested to do so.
- **After precontact transmission** - Distressed personnel will remain alert for friendly aircraft, and CSAR aircraft will attempt to establish communication. SAR forces will require survivors to identify themselves, authenticate, and provide other information pertinent to the recovery. To

make initial contact with CSAR forces, distressed personnel will use the call sign RESCUE followed by their tactical call sign. (For example, "RESCUE, this is KILLER 24.") The CSAR aircraft will then respond with its tactical call sign.

**Distress Signals:**

- Body signals - Figure 3-8 shows the body signals that survivors can use during the day once they have attracted the attention of CSAR aircrews. Figure 3-9 shows aircraft acknowledgement signals.
- International visual signals - Figure 3-10 shows ground-to-air signals for use by survivors, and Figure 3-11 shows ground-to-air signals for use by search party personnel. The symbols may be constructed from any available material that contrasts with the background; for example, parachute canopy strips, torn clothing, rocks, and sticks. The symbols should be at least 10 feet high.

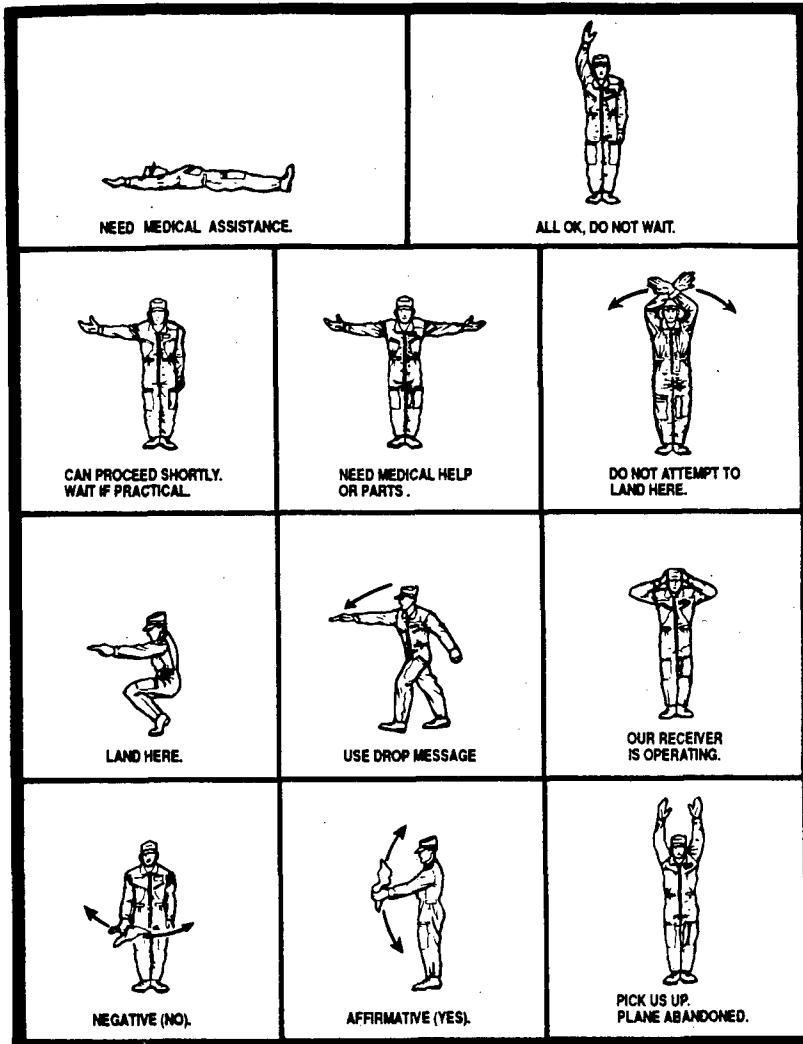

Figure 3-8. Body Distress Signals.

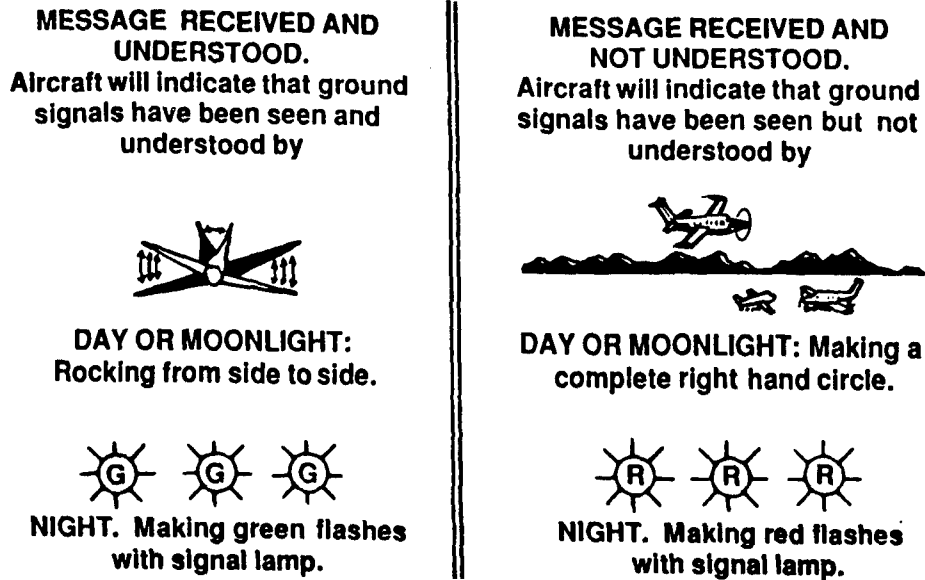
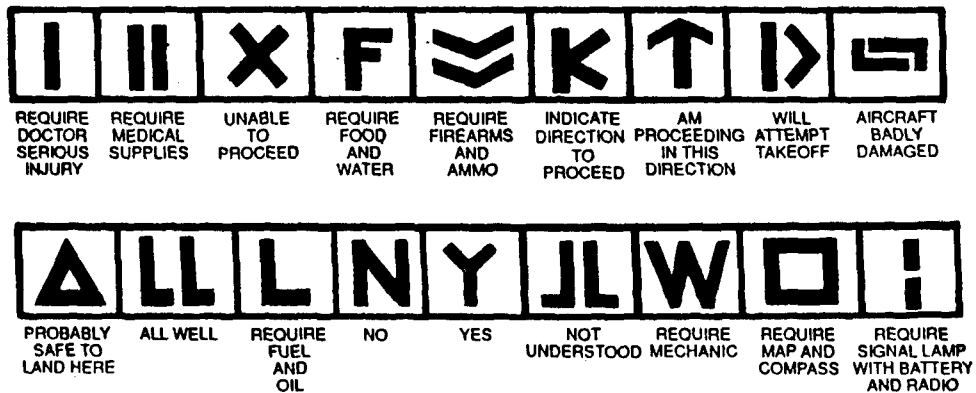

Figure 3-9. Aircraft Acknowledgment Signals.



IF IN DOUBT, USE INTERNATIONAL SYMBOL..... **SOS**

Figure 3-10. Survivor Ground-to-Air Signals.



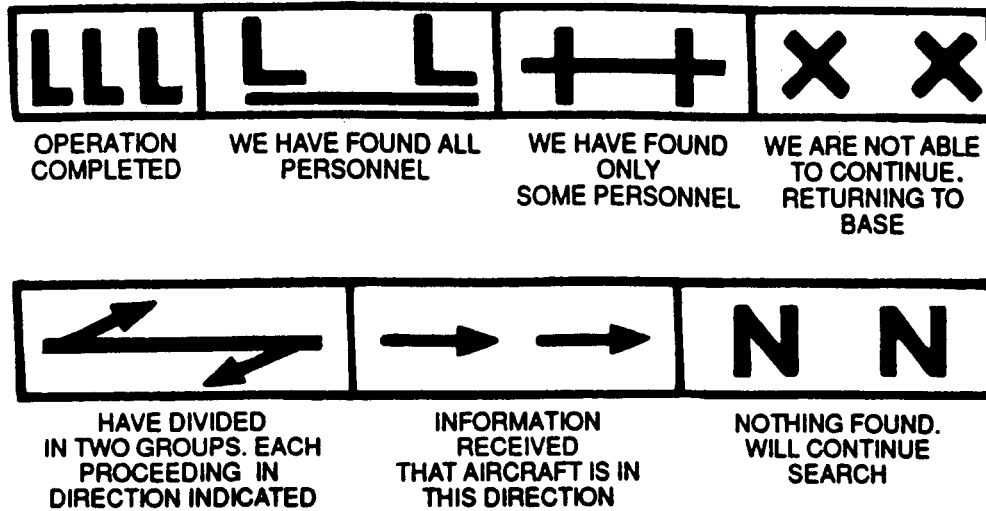

Figure 3-11. Search Party Ground-to-Air Signals.

**Alternate Communications**

The enemy may deny or hamper the use of radio communication. Therefore, distressed personnel may have to use other signaling devices such as mirrors, flares, colored panels, or lights to attract the attention of CSAR forces. Distressed personnel may also have to use alternate authentication methods that are theater approved.

**Authentication Information**

In wartime, the recovery of isolated personnel may depend on early authentication. Normally, isolated personnel will not receive assistance until their identify has been authenticated. Thus, authentication information must be used in a manner that maintains security and viability.

**Security.** Isolated personnel must not reveal authentication information to the enemy.

**Authentication System**

The principal method of authentication will probably be by radio using unit authentication numbers, data from the survivor's DD Form 1833, or locally developed authentication codes. Authentication can also be accomplished using visual signals or time-on-target requirements. For personnel controlled or

escorted in an escape and evasion net, authentication may also include fingerprints or a description of physical characteristics.

**Unit Authentication.** Tactical ground and aviation units are provided a unit authentication number consisting of four numbers.

**Personnel Authentication.** Aircrew authentication data consists of DD Form 1833. This form is completed by each person required to operate in or over hostile territory. It contains personal information for use by CSAR forces to positively identify survivors. After each crew member completes the card, it is classified CONFIDENTIAL and is maintained by appropriate unit intelligence or operations personnel. An easily remembered four-digit number is entered in item 14. This is the individual's personal authentication number and should not be in the individual's military records or be public information.

**Local Authentication Codes.** Units are encouraged to develop local SAR letters and colors for authentication codes. These additional authentication systems are published in the special instructions portion of the daily air tasking order and briefed to aircrews.



## DOWNED AIRCRAFT PROCEDURES COMMAND RESPONSIBILITIES

The procedures personnel follow in the event of a forced or crash landing will depend on the intensity of the threat and the organic capability of the aerial force. The proximity to the line of contact and the threat under which the recovery may be attempted will dictate the amount of time that is available to recover the aircraft and crew. Command responsibilities for executing downed aircraft procedures in low-threat, high-threat, and cross-FLOT areas are outlined below.

### Low-Threat Area

**The aviation unit commander:**

- Determines the extent of damage or injuries through communication or reconnaissance.
- Notifies the controlling headquarters of the situation and requests assistance as required.
- Coordinates the medical evacuation or evacuates injured personnel if medical assets are not available.
- Coordinates with AVUM and AVIM units for battle damage assessment or repair teams
- Continues the mission.

**If able, the aircraft commander:**

- Administers first aid.
- Removes, secures, or destroys critical items such as classified material, weapons, ammunition, and any other sensitive items.
- Contacts the aviation unit commander on the emergency radio.
- Assists in the recovery operation from the ground.

### High Threat Area

**The aviation unit commander:**

- Determines the extent of damage or injuries through direct communications or, if time and mission allow, directs the reconnaissance.
- Reports the situation to the appropriate authority and requests assistance.
- Requests evacuation of the injured or evacuates the injured if medical assets are not available.
- Evacuates all personnel if the mission allows.
- Continues the mission.

**If able, the aircraft commander:**

- Administers first aid.
- Removes, secures, or destroys critical items such as classified material, weapons, ammunition, and any other sensitive items.
- Contacts the aviation unit commander on the emergency radio.
- Assists in the recovery operation from the ground.
- Secures the immediate area around the aircraft.
- Prepares the aircraft for destruction on order or as directed by circumstances.
- Moves personnel, on order, to a rendezvous point or to the nearest friendly unit.

**Cross-FLOT Area**

**The aviation unit commander:**

- Determines the crew's condition.
- Records the aircraft's location.
- Notifies the controlling headquarters or nearest ground forces when such communication is permitted or feasible.
- Arranges for the dispatch of battle damage assessment or repair teams to recover the aircraft.
- Arranges for the destruction of the aircraft if the crew is unable to destroy it.
- Attempts evacuation of personnel if an air ambulance cannot be committed, if the mission will not be jeopardized, and if more aircraft will not be endangered unnecessarily.
- Continues the mission.

**If able, the aircraft commander:**

- Reports the situation to the aviation unit commander.
- Destroys the aircraft and all sensitive equipment unless otherwise ordered.
- Moves to a landing point indicated by rescue personnel.
- Proceeds to a planned pickup point or follows the escape and evasion plan if evacuation is not immediate.

**AIRCRAFT RECOVERY**

The organic capability of the aerial force dictates whether a recovery can be attempted. If the tactical situation permits, the controlling headquarters of the downed aircraft:

- Provides security for the downed aircraft and crew. (Ground forces may assist in providing security.)
- Dispatches personnel and equipment to recover the aircraft.

- Initiates rescue operations.
- Authorizes destruction of the aircraft if it cannot be recovered.

NOTE: As a rule, the brigade or higher commander decides to destroy aircraft and associated equipment in imminent danger of capture.

### AIRCRAFT DESTRUCTION

All units having aircraft and equipment that may be subject to capture must have a procedural plan. The plan outlines the extent of demolition to be performed; equipment destruction priorities; and, if applicable, explosives required. The plan addresses the time, equipment, and personnel required in any tactical situation.

To prevent the enemy from stripping equipment, unit personnel destroy essential aircraft equipment, including repair parts in stock, in priority sequence. Figure 3-12 shows the priority sequence for the destruction of the aircraft and equipment.

PRIORITY	PARTS
1	IFF equipment and classified electronic equipment with related publications and documents and other material as defined by the national government concerned
2	Installed armament
3	Engine assembly
4	Airframe, control surfaces, and undercarriage
5	Instruments, radios, and electronic equipment
6	Electrical, fuel, and hydraulic systems

Figure 3-12. Destruction Priorities for Aircraft and Equipment.

#### Destruction Methods

Aircrews follow established procedures for the destruction of aircraft by demolition, mechanical means, or fire.

**Demolition.** Self-destruction is an excellent way to destroy classified equipment. Built-in self-destruction devices should be given a chance to work before incendiaries or explosives are used to destroy the aircraft.

**WARNING:** *Explosives should be used in areas free of people to prevent injury caused by flying fragments.*

**Mechanical.** Aircrews can destroy auxiliary power unit engines by draining all oil from internal working parts and operating the engines until seizure occurs. They can also destroy an engine by firing a grenade launcher or small arms weapon into the front or rear case of the engine.

**WARNING:** *In propeller-driven aircraft, engine seizure can cause the crankshaft or propeller shaft to fail. Crews should evacuate the aircraft and stay clear of the propeller and turbine wheel areas.*

**Fire.** Aircrews should complete mechanical destruction before initiating destruction by fire. Aircrews can destroy metallic items by packing flammable materials, which have been soaked with a flammable petroleum product, under and around the items and igniting them.

**Before igniting a fire, aircrews should:**

- Remove and invert the battery.
- Remove the engine cowling and smash the fuel control and manifold.
- Smash instruments and avionics equipment and cut control cables, wire bundles, and hydraulic lines.
- Break off antenna masts and pitot tubes, open oil and fuel drain cocks, break oil lines, and puncture fuel cells outside the aircraft.
- Soak the interior of the aircraft with fuel.

**To ignite the fire, aircrews can:**

- Discharge a signal cartridge, a flare, or an incendiary grenade into the vapor field from a safe distance.
- Prepare a narrow fuel trail to a safe distance from the fuel vapor field and ignite the fuel with an ignited rag or paper attached to the end of a pole at least 6 feet long.
- Create a spark within the fuel vapor field by placing an aircraft battery away from the field and positioning the bare ends of two insulated wires .020 inch apart (within the field) and touching the opposite bare ends of the wires to the battery posts.

**WARNING:** *Use extreme care when using petroleum products to ignite fires.*

## ALSE (AIRCRAFT LIFE SUPPORT EQUIPMENT) AVIATION LIFE SUPPORT SYSTEM

The aviation life support system sustains aircrews in an emergency or survival situation. It is discussed in detail in Chapter 1 of FM 1-302.

### INDIVIDUAL SURVIVAL KITS

Two (2) survival kits are available to aircraft crewmembers for use when flying. The first is the Individual Hot Climate Survival Kit, which remains onboard each aircraft, one (1) each per crewmember. Figure 3-13 illustrates the components of the kit. The second kit is the Individual Survival Kit Vest-Type SRU-21/P (Figure 3-14). It is issued to individual crewmembers.

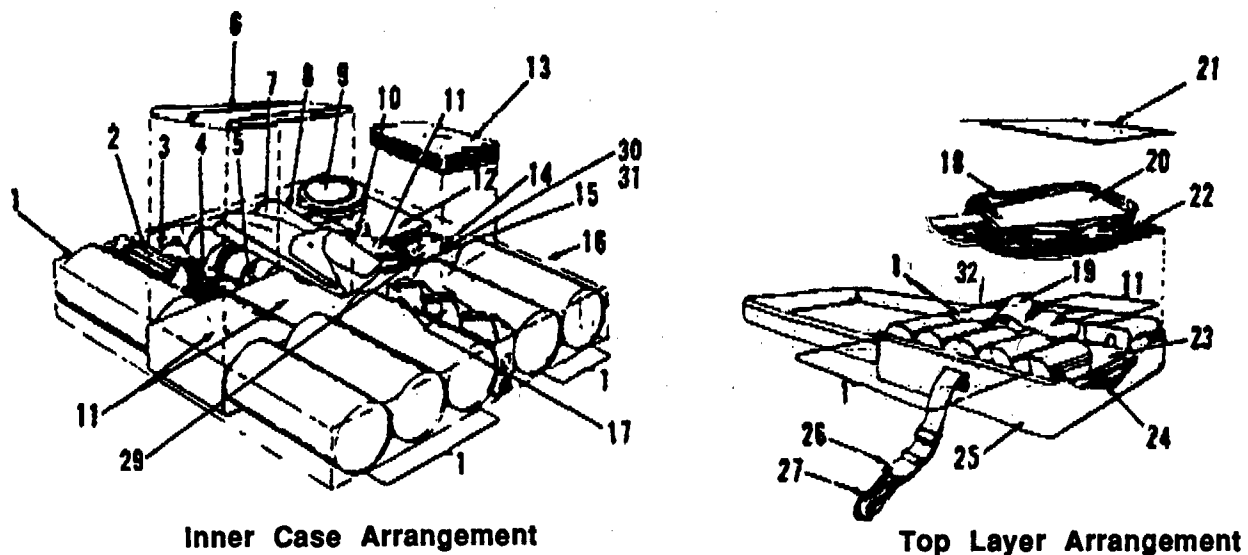

Figure 3-13. Individual Hot Climate Survival Kit.

- |                                   |                                     |   |
|-----------------------------------|-------------------------------------|---|
| 1. Canned drinking water-12 cans  | 11. Food packets-6 ea.              | 21. Kit packing list                        |
| 2. Knife sharpener                | 12. Compressed trioxane fuel-3 pks. | 22. Tarpaulin                               |
| 3. Plastic whistle                | 13. Fishing tackle kit              | 23. Survival manual (AFM64-5) (FM 21-76)    |
| 4. Smoke and illumination-2 ea.   | 14. MC-magnetic compass             | 24. Kit inner case                          |
| 5. Pocket knife                   | 15. Snare wire                      | 25. Kit outer case                          |
| 6. Signaling mirror               | 16. Frying pan                      | 26. Attaching strap                         |
| 7. Plastic water bag              | 17. Wood matches-1 container        | 27. Ejector snap                            |
| 8. First aid kit                  | 18. Insect headnet                  | 28. Blanket combat                          |
| 9. Sunburn-preventive preparation | 19. Reversible sun hat              | 29. Fire starter, magnesium                 |
| 10. Plastic spoon                 | 20. Tool kit                        | 30. Saw, finger grip                        |
|                                   |                                     | 31. Fire starter, spark lite                |
|                                   |                                     | **32. Net, multipurpose (net, gill fishing) |

\*\*Net, multipurpose can be placed anywhere in top layer.

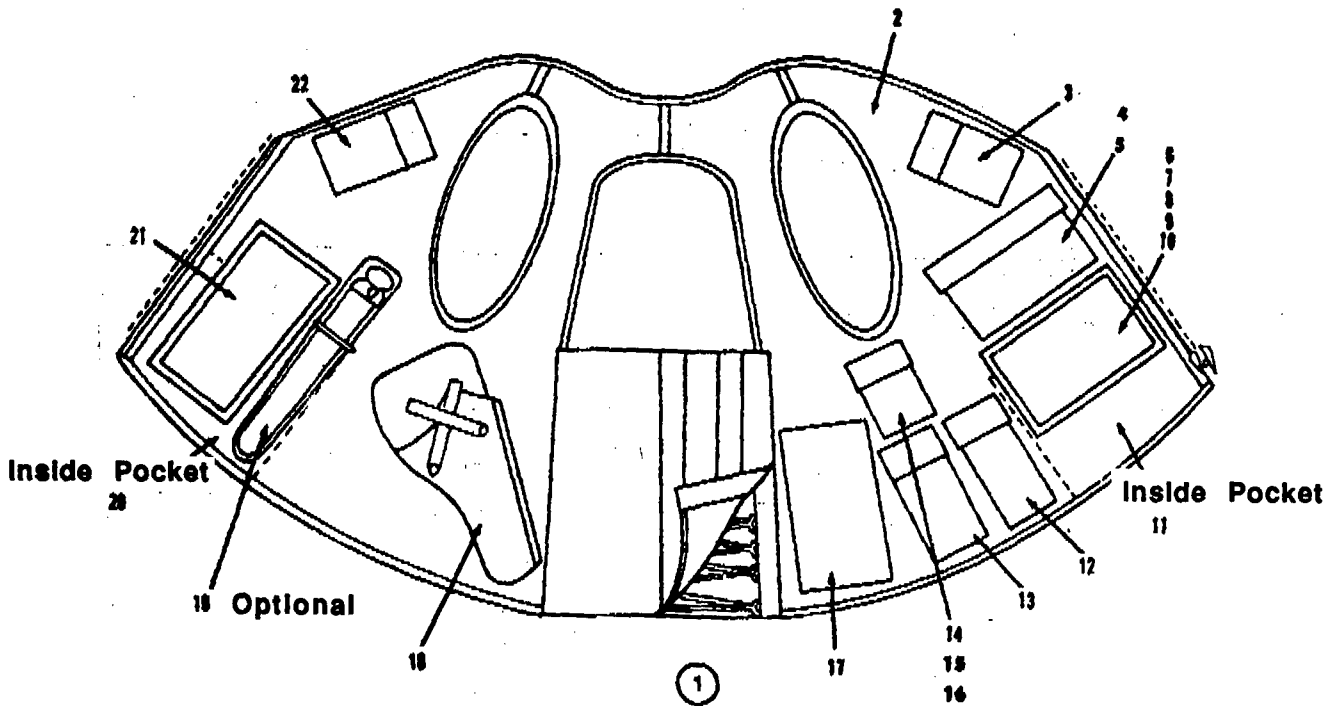

Figure 3-14. Individual Survival Kit Vest-Type SRU-21/P.

- |   |  |
|---|--|
| 1. Survival kit, individual vest type SRU-21/P                                  | 14. Cartridge, caliber .38 special ball M41  |
| 2. Vest, survival, individual   | 15. Cartridge, caliber .38 special tracer M41  |
| 3. Tourniquet, non-pneumatic, camouflage  | 16. Whistle, Ball: plastic O.D. with lanyard   |
| 4. Deleted  | 17. Signal kit; foliage penetrator   |
| 5. Light marker, distress SOU-5/E<br>Battery, BA-1574/U<br>Flashguard, AGR-FGIB | 18. Holster, revolver, nylon, .38 cal or 9mm   |
| 6. Survival kit, individual, trop. tact. aircrew                                | 19. Knife, hunting with sheath and sharpening stone (optional issue)                   |
| 7. Mirror, emergency signaling  | 20. Assembly instruction sheet and DD Form 1574 tag                                    |
| 8. Firestarter, aviation survival, magnesium                                    | 21. Radio set, AN/PRC-90, survival<br>Battery, BA-1568/U (for PRC-90 radio)            |
| 9. Blanket, combat casualty   | 22. Compass, magnetic unmounted, lensatic<br>Fastener, slide, interlocking: 15 in. lg. |
| 10. Insect repellent, 1 oz.   |  |
| 11. Bag, drinking water storage: 3 pt   |  |
| 12. Knife, pocket   |  |
| 13. Firestarter, aviation survival, spark lite                                  |  |

Each crewmember should examine their survival kit in accordance with TM 55-8465-213-10 and TM 55-1680-317-CL-1 before each flight for:

- Holes, cuts, frays, tears, or burrs.
- Loose or broken stitching.
- Defective or broken zippers.
- Missing or broken packet tie tape.
- Broken carrying handle and zipper.
- Lead seal and wire for indication of tampering or signs of pilfering.
- Operator's manual in pocket.
- Contaminants, petroleum products, or moisture.
- Indication of opening.
- Overall condition kit.
- Mildew or rot.
- Improper grommet seating.



## STANDARD-ISSUE SIGNALING DEVICES

The type of signals and the speed with which they are sent may determine the time it takes for rescue. Each crew member must know how to use the different types of signals. In friendly areas, any signaling methods may be used. In hostile area signaling methods may be limited because some devices alert enemy forces as well as friendly forces.

### AN/PRC-90 Radio

The AN/PRC radio is a dual-channel, battery-powered personal survival transceiver. It is used principally for two-way voice communication between downed aircrews and rescue aircrews. The AN/PRC-90 has a swept frequency beacon (243.0 megahertz) guide rescue personnel. Battery life in the beacon mode is 14 hours. The AN/PRC-90 is issued to all Army aircrews. In an emergency or a tactical situation, aircrews should follow the procedures described below for operating the AN/PRC-90 in hostile territory.

1. Select the highest exposed point (hill, rooftop, or uppermost portion of the aircraft). Set the radio in a secure upright position with the antenna oriented vertically and fully extended. Avoid placing the antenna near metal uprights or other antennas or rock formations that may contain conductive minerals. If the aircraft is in the water, keep the radio and the antenna as high as possible above the water.
2. Set the function switch to the BCN 243.0 position. Leave the radio in this mode until search aircraft, ships, or vehicles appear. (Failure to do so will interfere with direction finding equipment and could terminate the search.) Use this mode for at least 14 hours or until the search vehicles are contacted.
3. If there is reasonable doubt about beacon operation, make occasional brief voice or MCW Mayday/SOS transmissions. Limit transmissions to daylight hours for best dissemination. Follow a two-minute on, one-minute off; three-minute on, two-minute off; and ten-minute on procedure. Transmit the Mayday/SOS just after sunrise, at noon, and near sundown to take advantage of improved dissemination. Meteorological conditions will affect transmission range and quality.

**NOTE:** Direction finding in the MCW mode is difficult. The primary purpose is to ensure that the search operation continues. Battery life is reduced by voice or MCW operation.

4. To transmit VOICE or MCW, set the function switch counterclockwise to the VOICE/MCW 243.0 position. Either repeat Mayday at two- or three-second intervals by pressing the PUSH-TO-TALK button or send a coded SOS by pressing the MCW button. Set the VOL control to the MAX position.

NOTE: Attempt to make the SOS code side-tone well defined and rapid enough for experienced operators to easily recognize it. It will have a "di-di-dit, dah-dah-dah, di-di-dit" sound with spacing between the groups. The code explanation appears on the rear panel of the AN/PRC-90 radio.

5. When a rescue aircraft is within sight, call the rescue radio operator by turning the function switch clockwise to the VOICE/MCW 243.0 position and by using the calling procedure outlined in Figure 3-15. Press the PUSH-TO-TALK button, speak in a normal voice, and stand near the microphone during transmission. Adjust the VOL control to an adequate level for the speaker or earphone.

NOTE: Widely separated aircrews may transmit simultaneously. Rescue operators will assign the transmission frequency to avoid carrier interference on the same channel or advise changing the function switch to the alternate channel (VOICE 282.8). If contact is broken, personnel should return to the VOICE/MCW 243.0 position and repeat the above procedure.

6. Leave the controls set for voice operation until rescue personnel are within speaking distance or until otherwise directed.

ORIGINATING CALL (AN/PRC-90)	PROBABLE REPLY
<p>"CQ rescue craft, CQ, CQ, CQ, over."  (If no reply is received, continue to call CQ on VOICE or MCW at intervals until a reply is received.)</p>	<p>None or "Roger, roger, roger, read you loud and clear."</p>
<p>"Roger, roger. Crew status follows, over." (Report crew's physical status, missing crew members, and any emergency logistics or medical requirements.) "Roger, out."</p>	<p>"Roger. Your transmission understood. Stand by for reply, out."</p>

Figure 3-15. Recommended Voice Operating Procedures.

**CAUTION:** Do not open the AN/PRC-90 case chassis. Only higher category maintenance personnel may work on components. Opening the case will permit moisture and dust to enter the unit, resulting in a possible malfunction.

#### AN/MK-13 Flare

One version of the AN/MK-13 flare has plastic caps, and the other has cardboard caps. The plastic caps are color-coded to correspond with the day and night ends. The plastic caps are color-coded to

correspond with the day and night ends. The night end (red) has three protrusions for night recognition. The cardboard caps deteriorate and become detached through routine handling. A washer is attached to the night end lanyard for touch recognition if night operation is required and either of the caps is lost. The AN/MK-13 is identified as a Class C explosive. (TM 38-250 discusses the preparation of hazardous materials.) The flare or a similar pyrotechnic is carried aboard Army tactical aircraft.

### MK-3 Signal Mirror

The MK-3 signal mirror, shown in Figure 3-16, is an excellent signaling device. Crews should practice using it in advance. They should flash the mirror in the direction of the sound of the aircraft even though they cannot see the aircraft. Even on hazy days, rescue personnel can see the flash of a mirror before they can see the aircraft. If a signal mirror is not available, crews can signal with any object that is shiny on both sides. To use the MK-3, aircrews should:

- Reflect sunlight from the mirror onto a nearby surface.
- Bring the mirror up to eye level slowly and look through the sighting hole. (The bright light is the aim indicator.)
- Hold the mirror near the eye, turn it slowly, and then manipulate it so that the bright light is on the aiming point.
- Use the mirror freely in friendly areas and continue to sweep the horizon even though an aircraft or a ship is not in sight.
- Use the signal mirror only as an aimed signal in hostile areas.

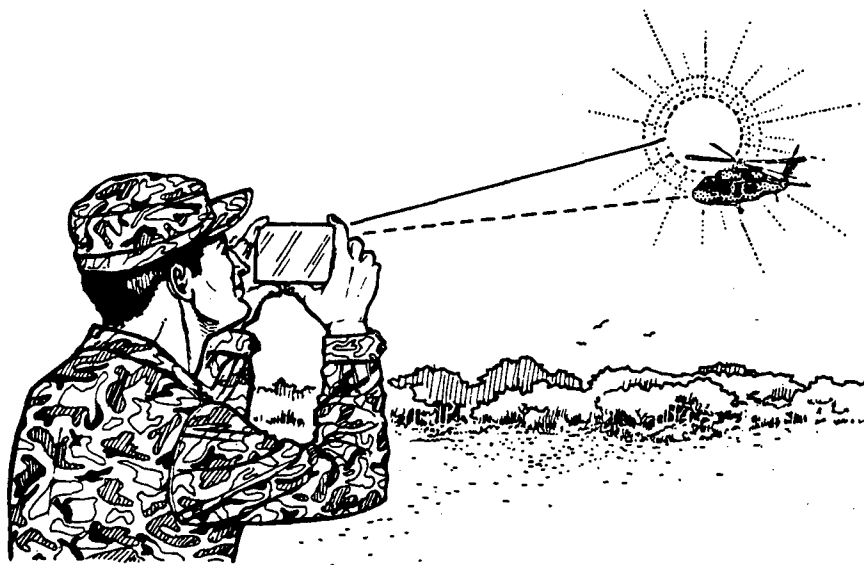

Figure 3-16. MK-3 Signal Mirror.

## RISK ASSESSMENT

Accident experience shows that mission-stopper accidents occur when victims are ignorant of hazards and countermeasures or when directed countermeasures are ignored. *The greatest effort should be in hazard identification and countermeasure enforcement.*

### RULES

Three rules guide the risk management process:

- **Accept no unnecessary risks.** The leader who has the authority to accept a risk has the responsibility to protect his soldiers from unnecessary risks. An unnecessary risk is one that, if eliminated, still allows mission accomplishment.
- **Make risk decisions at the proper level.** Make risk decisions at a level consistent with the commander's guidance. The leader responsible for the mission should make the risk decisions.
- **Accept risks if benefits outweigh the costs.** Leaders must take necessary risks to accomplish the mission. Leaders must understand that risk-taking requires a decision-making process that balances mission benefits with costs.

### BASIC METT-T HAZARDS

The following METT-T hazards are provided to provoke thought about issues to consider in your risk management actions. They are not all-inclusive.

#### Mission

- Middle East contingency in support of U.S. allies
- Accelerated mobilizations with short preparations
- Multinational, joint service, and combined force; language and standard operating procedure differences
- Command relationships
- Contingency mission assignments with mission orders
- Night operation emphasis
- Combined-arms missions; more complex
  - Boundaries/sectors
  - Communications
  - Coordination

#### Enemy

- Possible chemical agent use
- Aggressive, determined, war-proven enemy leadership
- Seasoned/battle experienced/well equipped enemy
- Enemy home ground advantage of area hazards and hazard utilization
- Probable terrorist threats



- Increased fratricide (friendly fire) threat due to--
  - Enemy and multinational force use of like equipment
  - Long-range engagements due to favorable terrain
  - Heat shimmer/dust interference with foe identification

#### Terrain

- Desert climate
  - Intense heat (+140°F.)
  - Extremely low humidity
  - Normally no rain, but thunderstorms/flash floods possible in mountains and wadis
  - Strong winds (30 mph in p.m.; 75 mph in windstorms)
  - Large fluctuations in day/night temperatures (up to 70°F.)
- Sandy deserts
  - Poor wheeled vehicle off-road mobility/stability
  - Limited water sources
  - Heat shimmer visibility degradation
  - Undefined trail boundaries
  - No natural shade
  - Snakes, lizards, scorpions
  - Sand storms
  - Congested oasis sites
- Rocky, mountain deserts
  - Poorly surfaced, boulder strewn, narrow, winding roads with steep shoulders and
  - Off-road vehicle travel poor to impossible
  - Limited water sources
  - Snakes, lizards, scorpions
  - Falling rocks
- Other areas
  - Lava beds and salt marshes hazards to vehicle and parked/landing aircraft mobility/stability
  - High-density urban market areas hazardous to mobility
  - Congested bivouac, port, and staging areas
  - Strong religion-influenced cultural taboos and lifestyle differences
  - Roads heavily used by pedestrians and beasts of burden
  - Little civilian compliance with established driving procedures, and no defensive driving awareness
  - High temperatures/humidity and intense light in coastal areas
  - Water hazards in gulf coastal areas
  - Thunderstorms with flash floods and extreme mud in mountains and coastal areas
  - Salt air and fog restrict visibility in coastal areas
  - Petroleum facilities contain fire and poisonous fumes hazards
  - Snakes, scorpions, centipedes, sea snakes, spiders, bugs
  - Strong vertical turbulence caused by high temperature and heating

#### Troops

- Assessment of training proficiency on complex tasks involving:
  - NBC training
  - Climate
  - Desert operations
  - Maintenance

- Desert survivability/operations training
- Heat-injury detection/prevention training
- Night operations training
- Physical fitness training
- Pilot/operator training on local conditions
- Leadership training
- Troop acclimitization
- Water availability
- Troop morale, stress, esprit, discipline
- Troop fatigue (quality and quantity of rest)
- Command climate and leadership quality
- Equipment status (increased maintenance requirements and long combat service support lines of communication)
- NBC equipment heat stress and visibility/mobility degradation
- Personal protective/safety equipment availability (goggles, work gloves, sunscreens, Chapstick, eye ointment, canteens, helmets, flack jackets, ear protection, dust respirators, specialized equipment, and plastic bags to store individual clothing in for protection from bugs, etc.)

#### Time

- Little time for preparations (activations and mobilizations)
- Jet-lag effects
- Intense pace

### RISK ASSESSMENT LESSONS LEARNED IN DESERT SHIELD

The following items are items for consideration which pertain to risk assessment and which have been identified by aviation personnel during the current crisis in the Middle East.

- Raise awareness levels of leaders and aviators on desert operations.
- Evaluate risk assessment for Saudi Arabia versus home station.
- Allow leaders to focus on real issues.
- Crew endurance is degraded exponentially due to the absence of quality rest and intense demands of desert flying.
- Information flow is essential - check, recheck, then check again.
- Don't assume anything.
- *Post hazard maps (dunes).*
- *Build a tailored reading file - and READ IT!*
- Put information in writing instead of voice.
- Close the loop with OPCON, attached GS or separate units.
- Don't piecemeal / fragment units in country. Deploy / redeploy maintaining unit integrity.
- Crew selection - experience is the key to success - the more demanding the mission, the more experienced the crew.



## Chapter 4 Ground Operations

### GENERAL ENVIRONMENTAL EFFECTS ON EQUIPMENT

#### PRESSURE

Severe heat increases pressure in closed, pressurized systems and increases the volume of liquids. *Care must be exercised to ensure that the working pressure of equipment is not allowed to rise above safety limits as a result of the sun and heat. Caution must be exercised when removing items such as filler caps.*

#### AMMUNITION

*Keep ammunition away from direct heat and sunlight. If it can be held by bare hands it is safe to fire. White phosphorus ammunition filler tends to liquefy at temperatures over 111°F, which will cause unstable flight unless projectiles are stored in an upright position.*

#### COMMUNICATION EQUIPMENT

 Dust affects communication equipment such as amplifiers, radio teletype sets, and computers. The latter, especially, is prone to damage due to its oil lubrication, so dust covers should be used whenever possible. Some receiver-transmitters have ventilating ports, and channels that can get clogged with dust. These must be checked regularly and kept clean to prevent overheating. *All radios, regardless of type, must be kept COOL and CLEAN. Place them in the shade and in a ventilated area whenever possible. If water is available, lay a damp towel on top of the radios, making sure that the air vents are not blocked. A small paint brush can be used to help keep radios clean.*

Desert tactics require dispersion, but the environment is likely to degrade transmission ranges. This degradation is most likely to occur in the hottest part of the day. If you start to lose contact, especially if noon is approaching, you must have alternate ways to communicate.

Some radios automatically switch on their second blower fan if their temperature rises too high, which normally only happens in temperate climates when they are transmitting. Amplifiers are liable to severely overheat and burn out. Some items of equipment are fitted with thermal cutouts, which open circuit breakers when equipment begins to overheat.

#### MEDICAL SUPPLIES

*During movement and at operation sites where extremely hot temperatures exist, continuous protection is necessary for medical items and supplies which deteriorate rapidly.*

## RADIANT LIGHT

Radiant light or its heat effects may be detrimental to plastics, lubricants, pressurized gases, certain chemicals, and infrared tracking and guidance systems. Items like CO2 fire extinguishers, M13 decontamination and reimpregnating kits, and missiles must be kept out of constant direct sunlight. Optics have occasionally been known to discolor under direct sunlight, so it is wise to minimize their exposure to the sun's rays.

## DUST AND SAND

Dust and sand are probably the greatest danger to the efficient functioning of equipment in the desert. It is almost impossible to avoid particles settling on moving parts and acting as an abrasive.

*Lubrication must be the correct viscosity for the temperature and kept to the absolute minimum in the case of exposed or semi-exposed moving parts.* Sand mixed with oil forms an abrasive paste. Lubrication fittings are critical items and should be checked frequently. Teflon bearings require constant inspection to ensure that the coating is not being removed. Dry lubricants such as graphite or WD-40 should be used on exterior parts.

Maintenance of engines is critical due to the strong possibility of sand or dust entering the cylinders or their moving parts when the equipment is stripped. *It is essential to have screens against flying sand (which will also provide shade for mechanics).* Tools must be kept clean and out of the direct sunlight or they will get too hot to handle.

Caution: the use of high pressure hoses may force sand and dust into seals and bearings - use low pressure.

## FILTRATION

It takes relatively little dirt to block a fuel line, and compression-ignition engines depend on clean air. The abrasive effect of sand in oil has already been mentioned.

*Air cleaners for every type of equipment must be examined and cleaned at frequent intervals. The exact interval depends on the operating conditions, but should be at least daily.*

*Filters must be used when refueling any type of vehicle, and the gap between the nozzle and the fuel tank filler must be kept covered.* Fuel filters will require frequent cleaning. Oil filters will need replacement more frequently than usual.

Engine oil analysis has shown increased amounts of silicon contents caused by sand and dust ingestion. Engine oil samples should be conducted frequently. Oil will require changing more often than in temperate climates.



## ELECTRICAL INSULATION

Wind-blown sand and grit will damage electrical wire insulation over a period of time. All cables that are likely to become worn should be protected with tape before insulation becomes worn. Sand will also find its way into parts of items such as "spaghetti cord" plugs, either preventing electrical contact or making it impossible to join the plugs together. *A brush, such as an old toothbrush, can often prove helpful to clean out such items before they are joined.* Additionally, a pencil eraser will work wonders on antenna connections.

## WEAPONS

Weapons may become clogged or missiles jammed on launching rails due to dust and sand accumulation. Sand or dust clogged barrels can lead to inbore detonation. *Muzzles must be kept covered by a thin cover so an explosive projectile can be fired through the cover without risk of explosion. Working parts of weapons must have minimum lubrication.* It may even be preferable to have them totally dry until going into combat.

## OPTICS

All optics are affected by blowing sand, which will gradually degrade their performance due to small pitting and scratches. *Guard against buildup of dust on optics, which may not be apparent until the low-light performance has substantially deteriorated. It may be advisable to keep optics covered with some type of plastic wrap until operations determine their use. Whenever possible, use the soft brush in the BII to clean optics. If possible, use a low air pressure system to blow all sand out before wiping or dusting to prevent scratching of the lens. NVG eyepiece lenses should be cleaned using wet lens paper. Do not wipe the lenses in a circular fashion; make one sweep across the lens and then use a different area of the lens cloth. Small particles on the periphery of the lenses are not detrimental to the night vision image.*

## SAND ACCUMULATION

Sand and dirt can easily accumulate in compartments and in the bottoms of aircraft and other vehicles. This accumulation, combined with condensation or oil, can cause jamming of control linkages as well as other problems which may result in damage. *Operator's checks and services become vital in this environment.*

## EXPANSION AND CONTRACTION OF FLUIDS

Air and all fluids expand and contract according to temperature. If you inflate tires to correct pressure during the cool night, they may burst during the heat of the day. If fuel tanks are filled to the brim at

night, they will overflow at midday. Servicing these items during the heat of the day can result in underpressures, overheating of tires, and a lack of endurance if the fuel tanks were not filled to their correct levels. *Find the midpoint of the temperature range during the day and check pressures and fuel levels at that time of the day. Locate the fill line on fuel tanks and do not overfill.*

## INSTRUMENTATION

Precision instruments, such as range finders, may require adjustment several times during the day depending on the temperature variation.

## STATIC ELECTRICITY

Static electricity is prevalent in the desert. It is caused by dry air coupled with an inability to ground electric charges due to dryness of the terrain. It is particularly likely with aircraft or vehicles having no conductor contact with the ground. The difference in electrical potential between separate materials may cause a spark between them, and if flammable gases are present, they may explode and cause a fire.

*A metal circuit must be made between fuel tankers and vehicles being refueled; contact must be maintained during refueling, and the equipment must be grounded.*

A further hazard of static electricity is with helicopter sling loads. *The hook should be allowed to touch the grounding wire before being loaded and a load grounded before being unhooked.* It is also necessary to turnoff all switches, uncouple electrical connectors, and ground all electrically operated weapons systems before rearming.

## AIRCRAFT WINDOWS

*Aircraft windows should be washed and rinsed without wiping. Wiping can cause excessive scratches on glass and plastic substances. Rain-X may help prevent erosion, but has not been tested. The best covers can be made from parachute cloth, and should be draped over the aircraft loosely and secured at the ground in such a manner to prevent blowing sand from hitting the aircraft, yet so as to not trap sand between the cover and the aircraft skin / windshield.*

## GROUND PASSIVE DEFENSE INITIATIVES

During combat operations, helicopters may be on the ground as much as two-thirds of the time. The enemy can use a variety of sensors to locate helicopters on the ground, and the enemy has a variety of weapons to attack targets that it detects. Helicopters will be used extensively on the battlefield. Therefore, they will be high-priority targets for air and artillery attacks. *Aviation units must seize every opportunity to confuse enemy efforts to detect, locate, and destroy aviation support area and aircraft on the ground. Unit personnel must use camouflage and concealment procedures that reduce the detectability of aviation assets.* The enemy can easily detect glint from aircraft canopies. *Therefore, unit personnel should install canopy (glare) covers as soon as possible after the engines and rotors stop.* Deception and camouflage techniques include dispersing aircraft on the ground, parking aircraft in nonsymmetrical patterns, and camouflaging aircraft and support equipment with terrain features. The use of terrain features will reduce the skylighting (silhouetting) of aircraft.

### TARGET ACQUISITION AND ATTACK

#### Means

Helicopters on the ground can be acquired and attacked in several ways. The simplest scenario is observation of a target by an armed aircraft, followed immediately by an attack. The helicopter would be a target of opportunity for an aircraft that is flying a specified route based on some form of intelligence. Helicopters on the ground can be acquired by any of these means:

- Radar
- Television
- Infrared detectors
- Infrared surveillance
- Visual (unaided and aided)
- Satellite and other photography
- Human intelligence (visual and acoustic)
- Air- and ground-based electronic surveillance

#### Pickup Zones

Detection of radio communication signals used in PZs will enable the enemy to determine the approximate location of the PZ. However, the enemy will need to employ a secondary means of detection before it attacks. Helicopter stay time in the PZ is usually about ten minutes. This should be less time than the enemy needs to obtain confirmation of the PZ's location. Electronic surveillance, therefore, does not pose a significant threat if PZs are used on a one-time basis. Electronic acquisition is also less likely if communications in the PZ are limited to the period when pickups are actually conducted. Any detection means accompanied by an attack pose a significant threat to helicopters at

PZs. Although radar is not a primary means for detecting helicopters on the ground at PZs, it is a threat to helicopters arriving and departing PZs.

#### Landing Zones

The same detection means to locate PZs also applies to LZs. However, LZs are more likely to be observed by armed aerial observers, artillery observers, and armed ground forces.

#### Forward Arming and Refueling Points (FARPs)

The FARP is vulnerable to detection by the means identified by PZs and LZs. The FARP will remain in place for an extended period, use communications, and produce thermal images from aircraft and fuel storage bladders. These may be sufficient to permit location by the enemy and result in an attack on the FARP. Helicopters at FARPs will be high-priority targets for armed reconnaissance aircraft and armed ground observers. Ground observers who do not attack a FARP will probably report its location for aerial attack. *FARP operations should be organized efficiently to reduce the time that aircraft will stay in the FARP. FARPs must be kept to the smallest size that can support the operational requirement and should be moved frequently. Communications must be kept to a minimum, and aircrews should be familiar with and use approved approach and departure procedures.* The use of infrared, thermal, and antiradar camouflage screens on equipment and helicopters at the FARP can help preclude detection of the FARP. When available, ballistic nets should be used to protect fuel storage bladders.

Figure 4-1 depicts an overview of a roll-on/roll-off FARP. This type of FARP layout utilizes a hard surface, such as a road, for aircraft to use in performing a roll-on landing. After landing, the aircraft immediately ground taxis off the road to a multistation refueling point. At completion of fueling, the aircraft again ground taxis to the hard surface and performs a running takeoff. This approach minimizes required space for landing, blowing dust, and aircraft downtime. It also maximizes refueling capability.

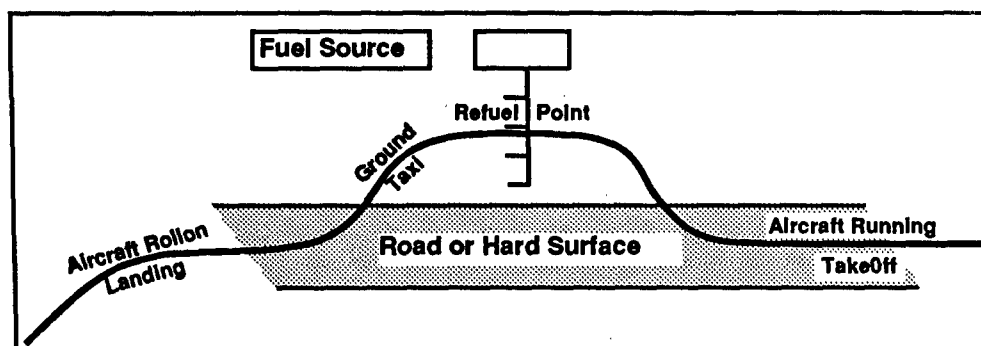

Figure 4-1. Roll-On/Roll-Off FARP.

#### Command Posts

The detection threat to CPs is similar to that for FARPs. Communications from CPs will increase the threat of electronic detection. Also, identification of a target as a CP will give it a high-attack priority. *The use of secure communications equipment with an electronic counter-countermeasures capability can degrade the enemy's electronic detection efforts.*

#### Downed Aircraft Positions

A downed helicopter is vulnerable to all of the identified target detection means. Other helicopters associated with rescue, removal, or repair may be detected by the same means.

#### Company and Maintenance Areas

Helicopters at company and maintenance areas are lucrative targets within a corps. They are vulnerable to all of the detection means identified for PZs and LZs.

### DESERT CONCEALMENT AND CAMOUFLAGE

The probability of detection and subsequent targeting of helicopters on the ground increases when helicopters are not camouflaged or when poor camouflage techniques are used. As the means of Threat detection change from visual to infrared, radar, and thermal detection systems, the more critical it becomes to conceal helicopters on the ground. Concealment is enhanced by the use of ultralight camouflage systems designed to degrade Threat detection capabilities.

#### Desert Camouflage Net

The standard net used in temperate climates is not suitable for desert operations. It is wide mesh, garnished with narrow multicolored strips running in different directions. It relies on the casting of irregular shadows to break up outline. The preferred net for desert operations is the light weight camouflage screening system (LWCSS), desert version, which provides concealment against visual, near IR, and radar target acquisition/surveillance sensor devices.

#### Burlap

Burlap, which is also spray-painted in a nondescript desert color, is used to cover all reflecting surfaces, excluding fire control optics, and shadow-producing areas under vehicle bodies. Aircraft equipped with windscreen covers will not require it.

#### Landing and Shut Down

Stationary aircraft take a relatively long time to conceal as they are fragile in comparison with other equipment, have a considerable heat signature, and must also be readily accessible for maintenance.

The more they are concealed the greater their response time is likely to be. *When approaching a landing site where aircraft will stay for some time the following actions should be taken in sequence:*

- *The aircraft must approach the site terrain-masked from enemy surveillance.*
- *It must shut down as soon as possible.*
- *All reflective surfaces are covered.*
- *It should be moved into shadow if it can be towed or pushed.*
- *Depending on type, the main rotor should be shifted until it is at an angle of 45 degrees with the fuselage and a net draped over rotor and fuselage. The rotor must be picketed to the ground.*

#### POSITION SELECTION

Position selection is critical, at every level. One of the fundamentals of camouflage, in any environment but particularly the desert, is to fit into the existing ground pattern with minimum alteration to terrain. A wadi bottom with vegetation or a pile of boulders that can be improved with grey burlap and chicken wire are good examples. *Sites chosen must not be so obvious that they are virtually automatic targets for enemy suppressive fires. Existing trails should be used and new trails should blend into old ones.*

Shadows, particularly in the morning and evening, identify objects, so equipment must be placed in total shadow (rarely found) or with its maximum vertical area towards the sun so that minimum shadow falls on the ground. The shadow can be broken-up, which is normally achieved by siting next to scrub or broken surface such as rocks.

#### DECEPTION

Deception delays and/or diverts Threat reconnaissance, intelligence, surveillance, and target acquisition efforts; denies fire and maneuver opportunities; and provides false targets. Decoys and other special effect devices can be used to portray real items of equipment, personnel, or ground positions such as FAAs, FARPs, and maintenance areas. Decoys aid survivability because they draw fire from real assets. Aviation units can gain the advantage by deceiving the enemy's target detection efforts. Providing false information about helicopter ground position may allow actual ground operations to continue unhindered by Threat targeting efforts.

#### Devices

Aviation passive defense initiatives, such as aircraft silhouettes and inflatable decoys, are being developed and evaluated as deception products. These products represent actual FARP equipment, personnel, and helicopters.

Decoys and other special effect devices are available from corps and division battlefield-deception elements. These elements may be contacted through the corps and division G3. Aviation units may also use unserviceable real assets for decoys or construct deception sites with the assistance of deception element personnel.

#### Use of Decoys

**Determine the purpose of the deception,** and ensure that it supports the commander's scheme of maneuver. If the purpose is to draw indirect and/or direct fire, the decoy site must be located to avoid collateral damage to real assets.

**Prepare the decoy location** to make the enemy believe something it wants to believe. For example, if an actual FAA is normally moved every 40 to 165 minutes, then the decoy FAA should be moved within that time. If camouflage is usually used on real aircraft and equipment, it should likewise be used on phony aircraft and equipment.

**Plan the site layout carefully.** Construct the phony site so it looks real. Use only decoys of assets that are normally found at the real site.

**Coordinate with adjacent friendly units.** Coordinate the location of phony sites with adjacent friendly units to avoid collateral damage from hostile fire. (A successful deception site will draw direct and/or indirect fire.)

#### Operations

Aviation units may perform missions to enhance the authenticity of a phony FARP. Aircraft can fly to and from real airheads and conduct communications with controllers to reinforce the idea that a real supporting attack is the main attack. **Deceptive uses of phony FARPs can influence the enemy's offensive and defensive operations.**

**Most commanders avoid attacking strongpoints. Real FARPs, located behind main defensive positions, are one of several indicators of strength. Thus, phony FARPs can show strength where strength is not and may cause the enemy to avoid attacking weaker points.**

A phony FARP can be used to replace a real FARP. This ploy reinforces intelligence gained and diverts attention from the new location of the real FARP. Also, phony FARPs that draw fire offer the opportunity to locate a real FARP at the same location after the strike.

Many units combine assets in one staging area, including FARPs, maintenance areas, and aviation operation centers. The sudden appearance or movement of a staging area is a signal of pending operations that most Threat commanders will not overlook.

## AVIATION MAINTENANCE

Aircraft maintenance in the desert is an endless struggle against sand and its effects. In 1944, US aircraft mechanics in North Africa were taught:

**Sand is the foremost foe of your equipment.** Not only the sand on the terrain, but the dust found in the air. Whenever the hard crust of the desert has been broken, there is dirty work afoot. There is the deadly scratching, gouging action of quartz-hard grains and pebbles, and the terrific abrasive qualities of dust with the fine consistency of talcum powder. The life of an aircraft's parts is unbelievably short once you let sand and dust get the upper hand....

The problems sand and dust cause aircraft are similar to those they cause vehicles. The particles cause abrasion, clogging of filters, contamination of fluids, and deterioration of seals. Each of these effects are potentially disastrous, not only for the obvious flight safety reasons, but also because they reduce the combat effectiveness of the force.

## DEPLOYMENT PLANNING

When planning for deployment, units should establish deployable libraries which contain all of the required manuals covering maintenance, operations, safety, standards, etc. This can be overlooked if not planned.

Do not expect support, (even though you will get support) take as much equipment / spare parts / tools as possible. Maintenance improvisations take extra work, and increase hazards to workers.

## GENERAL MAINTENANCE RULES FOR MAINTAINING AIRCRAFT IN THE DESERT

- *Locate maintenance sites on hard stands whenever possible, or on terrain where fine sand grains of high quartz content are at a minimum.*
- *If possible, locate maintenance sites to the windward of abrasive, loose sand areas. Consider carefully the direction of prevailing winds and avoid locating maintenance sites in the path of blowing sand that results from disturbances of the desert's surface.*
- *If possible, locate maintenance sites away from established flight corridors and flight paths.*
- *When conditions permit, improvise some sort of shelter which will minimize sand interference with servicing. A canvas lean-to, a half-tent, an improvised nose hanger, or a sand-break around the airplane, placed to windward are effective.*
- *Keep the maintenance site free of sand and dust as possible.*
- *During violent sand and dust storms, postpone repairs and service (if possible) until the storm abates. Do only such work as cannot be injured by dust and sand.*



- *These general rules cover conditions peculiar to desert maintenance. Rigidly follow the detailed aircraft technical manual for normal servicing.*
- *The most injurious action of sand and dust results from its adherence to oil-bearing surfaces. When mixed with oil, desert dust becomes an efficient grinding agent. Guard against it constantly, especially around close fitting parts or parts that work against friction. Clean, inspect, and lubricate regularly, frequently, continuously. This is a must.*
- *Surfaces that must be lubricated should be cleaned of sand and dust, inspected, and re-lubricated (lightly) much more often than during non-desert operations. Many surfaces (normally lubricated in non-desert areas) can be best operated dry in the desert. They must, however, be cleaned of sand and dust and inspected as frequently as possible.*
- *Lubricate sparingly and only where absolutely necessary. In certain instances, it may be better to sacrifice lubrication rather than risk the grinding, abrasive action of sand and dust.*
- *On landing, immediately seal all openings on the aircraft with dust-proof covers and after engine shut-down immediately install the intake and exhaust covers. Keep all covers on the aircraft while on the ground. After servicing; replace seals immediately.*
- *Do not lay tools on the desert ground. Every article, large or small, is either lost, stolen, or damaged when placed on the ground in the desert. If you must lay parts or tools on the ground, place them on a clean ground cloth or put them in a suitable clean receptacle.*
- *Metal parts removed from aircraft should be carefully cleaned, sealed in containers, and stored in lockers and bins away from sand and dust.*

### **RULES FOR PERFORMING MAINTENANCE IN DAYTIME / HIGH TEMPERATURES**

While the heat of the desert can seem unbearable, it poses no problems that, in reality, cannot be overcome if some basic "heat facts" are kept in mind.

- *Surface temperatures are determined by the heating effect of the sun minus whatever cooling effect may occur due to the wind.*
- *When there is no wind, or the velocity is low, aircraft skin temperature will run between 1.4 and 1.5 times higher than the free air temperature.*
- *In the daytime, metal surfaces of the aircraft will often be too hot to touch and maintenance personnel should be issued gloves or mitts that will permit them to handle metal tools or surfaces.*
- *During Red Flag 80-4 in Nevada, ramp temperatures frequently exceeded 125°F. It was so hot that several men wearing steel toed boots blistered their feet and had to replace their boots with tennis shoes.*

- *Whenever possible, aircraft should be parked under at least a partial cover to shade and cool the section of the aircraft under maintenance.*
- *Mats and pads should also be used to protect knees and elbows and it is also advisable to wrap tool handles with cord or tape to avoid burned hands.*
- *As a final precaution, whenever possible, maintenance on exposed aircraft should be scheduled for early morning, late afternoon, evening, or night, when the desert heat is less intense.*

### DESERT SHEILD AVIATION LESSONS LEARNED

- *Pull maintenance like you've never done before!*
- *Cover windscreens.*
- *Cover all moving components.*
- *Flush engines more frequently.*
- *Cover all inlets, openings, etc.*
- *Perform thorough post-flight.*
- *Parts wear out fast in the desert.*
- *Crew chiefs / mechanics need crew rest...don't go without it...remember the risk.*
- *Don't use recap tires.*
- **Mooring of all Army Aircraft in Sand Environment:**
  - **The ground anchor kit (NSN 8340-00-951-6423) requiring one (4 inch) ground anchor per aircraft mooring hard point is inadequate for loose sand.**
  - **The 8 inch ground anchor (NSN 4030-00-580-8287) is the preferred item. Use one anchor per aircraft mooring point.**
  - **If the preferred item is not available use one of the following alternates:**
    - **Four (4) anchors (each 4 inch) will provide improved holding power for each aircraft mooring point. The arrowheads should be driven in such a pattern that the attachment points on the ends of the wire rope should be as close as possible to form a single anchor point. Insure that the wire rope is driven down until only the thimble is on the surface. Polyester rope (1/2 inch diameter) or aircraft tiedown (webbing binder) can be used to attach the aircraft to the anchor assemblies.**
    - **Fence post (barbed wire) -- the post is approximately 3 inches wide with a "hat" shaped cross section. This item may be used if the ground anchors are unavailable. The post should be driven at a 30° vertical angle (away from the aircraft) into the sand until approximately 9 inches on the post remains above ground. Wrap polyester rope or one end of the webbing binder around the post several times and connect the other end to the aircraft. One post is required per aircraft mooring point.**

Supplies needed based on lessons learned and experience in previous desert operations and continuous maintenance of aircraft at Ft. Hood include:

- *A decent small portable vacuum sweeper - similar to a "Dust Buster" only stronger.*
- *A decent small air compressor capable of delivering 60 psi to be used in blowing out lines.*
- *Provide "lots" of pump-up bug / weed sprayers to be used in washing off sand in crevices around rotor head - high pressure not required.*
- *Purge-lubing will require much greater stockages of grease.*
- *Provide an "abundance" of "bubble towels" for use in wiping aircraft dry and removal of oil and grease.*
- *Provide standard issue nylon aviator gloves for mechanics - not heavy leather.*
- *Overstock 100 mph tape .*
- *The aft avionics bay of the AH-64 may be rapidly contaminated with sand. If absolutely necessary, the cooling fan which draws air through the louvers can be disconnected to slow contamination.*
- *Paint brushes work well for removing sand.*
- *Sensitive or delicate items should remain in the original package unopened until needed. If opened for inspection or other reasons and not used, they should be repacked in the original packaging if possible and sealed (airtight). If desiccant bags are available, they should be utilized to prevent moisture buildup from extreme temperature fluctuations. Repair parts should not be exposed to direct sunlight and should be stored in shaded, covered areas, if possible.*
- *If available, cardboard "Sun Visors" should be fabricated and placed inside cockpit enclosure windows to reduce direct heating and the "greenhouse" effect. This will prevent damage to electronic gear and radios, and extend the service life of those components. They should be fabricated out of a lighter shade of color to assist in reflecting direct sunlight.*
- *Aircraft having rotor seals which prevent fluid from leaking out (CH-47 mostly) will have considerable problems with deterioration of the seals if they are not kept clean. Aircraft developing leaks that require changing of the seals will have to undergo maintenance. It should be considered at that time by the commander or the maintenance office if during this time other seals of the same type or in the general area should be replaced. This consideration would be based on the current mission load and availability of aircraft. A general rule of thumb to follow is "If you have more than one seal leaking, you can expect the others to leak in a very short period of time." If they are replaced when others have to be replaced, you may in fact avoid future "downtime." Sacrifice a few extra hours down rather than pay a heavier price later.*

- **Blowing sand and dust are causing pitted canopies and windscreens, resulting in distortion and reduced visibility. Canopies with an abrasion resistant coating will be shipped to Southwest Asia to replace the unserviceable items.**
- **AVSCOM has procured eight climatic heat aircraft protective screens (CHAPS) and shipped them to Dhahran. They are made from ultra lightweight camouflage material. This covers the entire helicopter, weighs about 25 pounds, and acts as both a camouflage device, as well as a heat absorber (provides shade). AVSCOM will test the screens and, if satisfactory, will buy sufficient quantities for all aircraft in theater.**
- **Sand is causing accelerated wear in bearings and seals, resulting in replacement rates three to four times higher than in CONUS. AVSCOM is working to develop elastomeric bearings to replace teflon lined bearings.**
- **AVSCOM has contracted for 48 clamshell hangars for use in Saudi Arabia. The first two have been erected. Two additional units are in-country and two are enroute. Deliveries will continue at rate of four per week.**
- **TRANSCOM will implement an Air Force operated "Desert Express" to deliver high priority spares non-stop from CONUS to Saudi Arabia.**
- **AVSCOM has developed a two phase rotor blade erosion control program. Phase one is an interim fix it phase two being more permanent in nature. The interim fix consists of the application of a two part epoxy point. Even though the paint is 75% less effective than the more permanent procedure, it will provide some immediate protection until phase two of the program can be completed. Phase two consists of the application of abrasion resistant tape manufactured by 3M Corporation. Tape cannot be applied to blades while they are on the aircraft. A rotatable pool of rotor blades is being established from Aviation Intensive Management Item (AIMI) stocks as they arrive in theater. As shipsets of blades are taped, they will be exchanged with unprotected or lesser protected blades within operational aviation units.**
- **Cooling of all gas turbine engines prior to shutdown is absolutely essential. Any operator not performing a two minute cool down prior to shutdown is subjecting the engine(s) to excessive temperature change which may result in warping, twisting, and in extreme cases, cracking of engine components.**
- **Water containing excessive impurities may provide harmful to engine components. For this reason, only potable water should be used to wash engines.**
- **Engine and auxiliary power unit (APU) inlets and exhausts must be covered when aircraft is not in operation to prevent sand and dust infiltration. Deposits of sand and dust must be removed from intake and exhaust areas prior to each operation of engines and APUs.**

- Engine and auxiliary power unit (APU) inlets and exhausts must be covered when aircraft is not in operation to prevent sand and dust infiltration. Deposits of sand and dust must be removed from intake and exhaust areas prior to each operation of engines and APUs.
- Ballistic Armor Subsystem (BASS) Small Arms Protection for the UH-60 Blackhawk. There is a need for small arms protection. There were some tactical situations where the underside and lower third of the Blackhawk was penetrated by small arms fire, thereby inflicting injury to passengers and crew members. The BASS was developed and produced in very limited numbers for Special Operations units. Due to Operation Desert Shield, 200 sets of BASS have been procured for Blackhawks assigned to Assault Companies and an additional 75 sets are being developed and procured for Blackhawks assigned to MEDEVAC units.

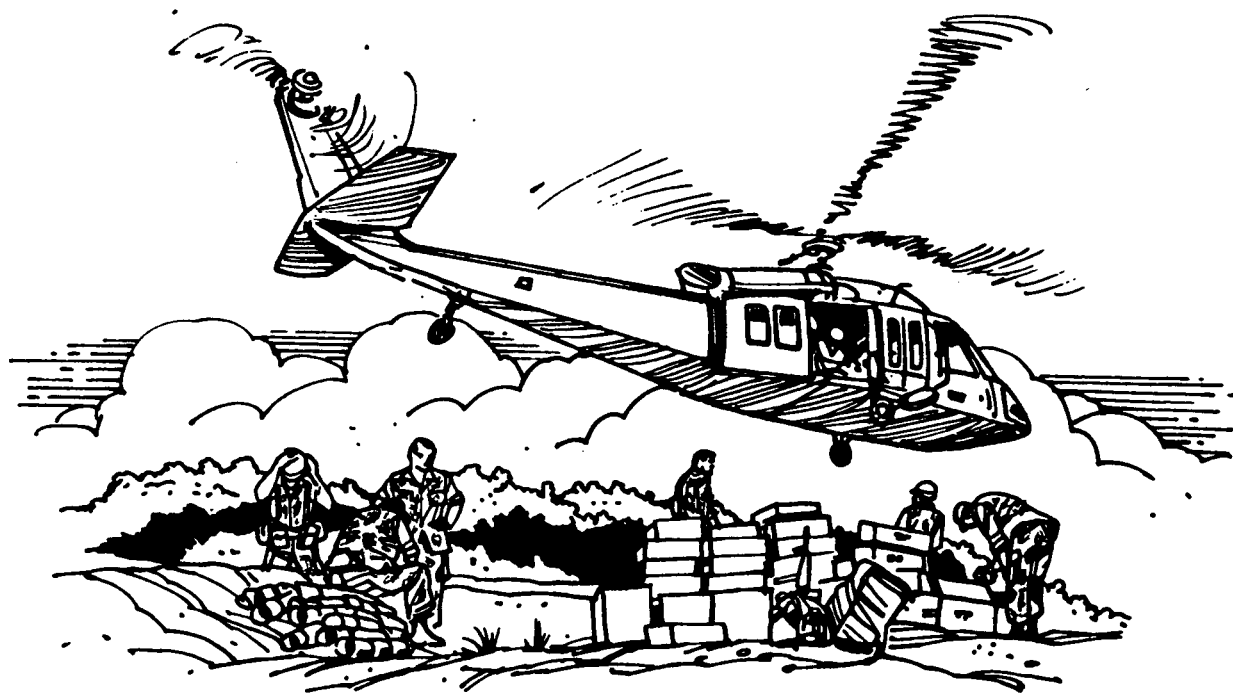

## EQUIPMENT SPECIFIC SUGGESTIONS

A word of caution - this section contains many suggestions to help you survive in the unusual conditions presented by the desert. These suggestions include several references to field expedient fixes. Maintenance improvisations can increase the hazards to workers and aviators. Use these suggestions wisely and if you have any doubt, check with your standards officer.

### 6th CAV BDE, FORT HOOD AIRCRAFT MAINTENANCE LESSONS LEARNED

#### AH-64

- *A field expedient installation of a Fram 3916 air filter (fits a fuel injected Chevrolet Camaro) taped (using 100 mph tape) over the inlet of the shaft driven compressor (SDC) particle separator will provide excellent filtering over the inlet. Remove and replace as warranted. Check tape frequently.*
- *Pieces of 1/4 inch gray foam filter material (as used in window air conditioners) might be used in the upper part of the intake throat of the ENCU. This same material may also be used in the aft avionics bay inlets.*
- *Wipe down the hydraulic cylinders on all servo cylinders immediately prior to every flight with a clean, dry rag - keep them dry.*
- *Keep the tires like new - inspect frequently for wear, nicks or gouges - they will go quicker in the heat with the slightest flaw.*
- *Cleanliness is essential.*
- *Purge-lube at night when cool so that as day comes and warming begins, grease will warm and swell causing an outward expansion preventing sand from being sucked into bearing during otherwise contraction of grease.*
- *Flush engines at least every 10 (ten) hours.*
- *Intensify the filters on any inlet screen.*
- *Remove and clean breech bolts on gun immediately before each mission.*
- *Lightly grease the ammo handling assembly with molybdenum sulfate after cleaning with "break-free."*
- *Cover the muzzle of the 30mm gun with plastic wrap and a rubber band to keep barrel free of sand - the plastic wrap can be fired thru and the heat will melt it with no problem.*
- *Periodically exercise the weapon system - in the air - (not on the ground) TADS/PNVIS too.*
- *Don't perform any moving equipment test on the ground due to blowing sand.*

- *Keep the dust caps on the Hellfires to protect the lenses from getting scratched.*
- *Check the door seals and any other soft rubber based sealant - use silicone sealer around doors.*
- *Anything that uses a 23699 oil base gear box seems to fail quicker.*
- *Continuously conduct FOD inspections using a borescope - pay particular attention to leading edge of inlet guide vanes / 1st stage compressor blades and check combustion liners for glass build up.*
- *GOB is better than WTR.*
- *Keep the TADS/PNVS retracted as much as possible to protect the germanium crystal lenses from sandblasting and scratching.*
- *Get a small air compressor and blow out aircraft with low air pressure prior to each flight.*
- *Use squeeze bottles (rather than pouring from a can or other container) to add oil to engine or transmission and cover the inlet with a rag to keep dust out while adding.*
- *Dry wipe around struts and seals.*
- *Check all nitrogen systems to be sure they are purged and no air has gotten in.*
- *Use 100 mph tape around fittings to prevent sand from getting in joints - replace frequently.*
- *Cannon plugs with loose connectors in back should have a clear silicone injected to make a permanent barrier to keep sand out of connection.*
- *ENCUC vents which draw air from outside should be blocked down and crew should be sure to have goggles on when first turning equipment on so ENCUC doesn't blow sand into crew's eyes.*
- *Inspect frequently and replace as needed "O rings" in ENCUC pass air manifold.*
- *Install a field expedient filter (gray window air conditioner foam) over generator inlet.*
- *When firing 30mm hold trigger until burst limiter stops the burst - this will stop shearing of pins in 30 mm drive motor.*
- *Clean the 30 mm immediately before flight using a low power air compressor before rearming - use "break-free" to lubricate gun carrier.*
- *To prevent the fuel boost pump and the solenoid valves from becoming defective: cover the boost pump exhaust duct whenever the aircraft is parked; lubricate the boost pump air motor by injecting light oil (aerosol or syringe) through the inlet tube; disassemble the boost pump solenoid valve and thoroughly clean the filter screen.*
- *The only known assist to preventing ICS boxes from sticking or burning out due to very fine dust ingestion is to limit canopy openings and cover when possible.*

## CH-47

- *Use caps and plugs everywhere possible whenever lines are removed.*
- *Better cleaning materials are needed to clean out sand - a small, yet sufficiently powerful handheld vacuum sweeper would be perfect.*
- *When wheeled aircraft are parked on asphalt - put short lengths of wooden 2 X 12s under the wheels to prevent tire melting.*
- *Watch for build up of sand in the under-floor cavities -- vacuum out frequently to reduce moisture holding at night and to keep aircraft clean.*
- *It might be a good idea to keep "belly plugs" in to minimize sand accumulation within aircraft cavities.*
- *Just prior to flight - clean sand out of crevices around rotor head, around back side of bearing housing and rotor head seals, and vertical and horizontal pins using a low pressure bath of water. A low pressure "pump-up bug / weed sprayer" might be good for this. This should be done as close to flight time as possible, yet provide sufficient time for the wash to dry.*
- *Perform "purge-lubes" on swash plates and hanger bearings. Purge lube until clean grease exudes and then remove excess grease.*
- *Inspect forward and aft spherical ball and slider assemblies to prevent coating of oil which will attract sand accumulation. Wash and rinse dry.*
- *When replacing seals cover area to reduce blowing sand.*
- *Put head covers on when not in use.*
- *Keep heads out of sun to prevent blowing oil seals due to increase in temperature/pressure.*
- *Minimize exposure of avionics black boxes to sun/heat - remove and store in cooler area as much as possible.*
- *"Increase in frequency" doesn't necessarily mean doubling or tripling the frequency - it must be sufficiently frequent to keep the aircraft clean and airworthy - some things need to be done just after flight, and some will need to be done immediately prior to flight - and some will need to be done both.*

## UH-60

- *Electrical wires laying against metal body will rub through if sand is not kept off - vacuum frequently - use tape as possible to provide extra protection.*
- *Coat tip caps with something like a polyurethane, fiberglass resin or "plasti-dip" to minimize erosion.*
- *Obtain engine covers like used at Ft. Hood which completely cover inlets, exposed portion of engine, and outlets of engine - made of a rubber coated nylon material similar to TADS cover.*



- *Install a field expedient filter over the main fuel tank vent port - use a fine cloth and resin it to airframe.*
- *Clean the transmission oil cooler fan and radiator daily or more frequently if needed.*

### GROUND-BASED EQUIPMENT

Tire consumption is very high, so *all vehicles must carry one spare tire or preferably two spare tires, and the unit PLL of tires must increase considerably.*

- *Do not exceed vehicle load limit. Reducing the vehicle load 10% below maximum could increase tire life by 25%.*
- *Check air pressure daily prior to operating vehicle; checking air pressure after vehicle has been driven will not provide a correct reading. An increase of 10 - 15 psi can occur after a vehicle has been driven.*
- *Speed accelerates heat buildup and tire wear. It is recommended that wheeled vehicles operating on improved highways in extreme temperatures not exceed 45 MPH.*
- *On rocky deserts, the M54 5-ton truck is prone to air hydraulic cylinder failure and power-steering leaks.*
- *CUCVs operate best in the sand when using the wide tires at 20 psi. Tires must be reinflated to recommended pressures before operating on paved or hard packed surfaces.*

Vehicle cooling systems and lubrication systems are interdependent, and malfunction by one will rapidly place the other under severe strain. All types of engines are apt to overheat to some degree, leading to excessive wear and, ultimately, leaking oil seals in the power packs. *Commanders should be aware which vehicle types are prone to excessive overheating, and ensure that extra care is applied to their maintenance.* Temperature gauges will read between 10° to 20°F hotter than normal. *Don't panic if your average operating temperature is 180°F and when operating your vehicle, the gauge shows 200 °F. Monitor the gauge. If the temperature keeps rising, shut the vehicle off and check for mechanical/cooling system problems. In instances where no problems are found, you might try increasing the vehicle RPM (while in neutral) to about 1200 RPM. This should increase the flow of coolant throughout the engine and radiator. Closely monitor the gauge. If this doesn't bring the temperature down, shut the engine off. There may be a problem which you haven't detected. Check oil levels to ensure that levels are within limits (too high may be as bad as too low), that seals are not leaking, and that oil consumption is not higher than normal. Keep radiators and air flow areas around engines clean and free of debris and other obstructions. Water-cooled engines should be fitted with condensers to avoid coolant waste, as steam, through the overflow pipe. Cooling systems' hoses must be kept tight (a drip a second is 7 gallons in 24 hours). Do not remove hood side panels from engine compartments while the engine is running as this will cause turbulence, leading to ineffective cooling.*

Batteries do not hold their charge efficiently in intense heat. *You will have to adjust the battery specific gravity (sg) to this environment.* The unit can either adjust its electrolyte to 1,200 to 1,225 sg or obtain sulfuric acid, electrolyte, with an sg of 1,2085 - 1,2185. *It may also be necessary to adjust the battery sg to compensate for cold nights.* TM 96140-100-12 contains information concerning these procedures. *Batteries must be checked daily, preferably twice daily. They must be kept full, but not overfilled, and a reserve of distilled water should be carried. Air vents must be kept clean or vapors may build up pressure and cause the battery to explode. Voltage regulators should be set at the lower end of their specifications.*

- *About one of every three vehicles should carry jumper cables to provide for servicing dead batteries.*

*Aviation Ground Power Unit (AGPU) - recommend limited operation in the "by-pass" mode since there is no filter over the bypass access door. Increase service schedule to ensure filter is clean to minimize by-pass operation. A field expedient filter might be rigged over by-pass access door.*

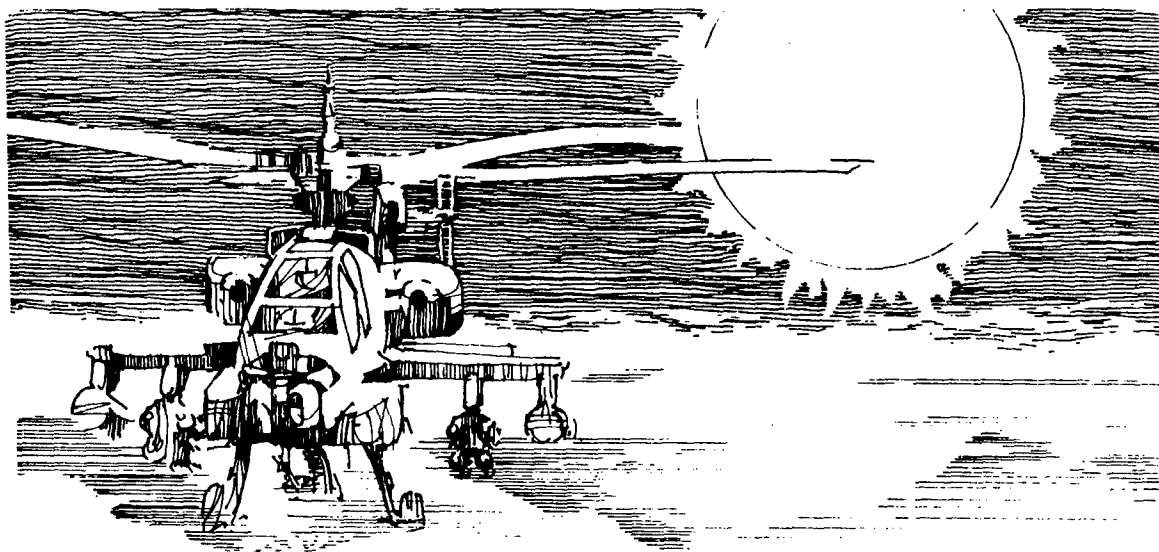

## DRIVING IN THE DESERT

Terrain varies from nearly flat, with high trafficability, to lava beds and salt marshes, with little or no trafficability. *Drivers should be well trained in judging terrain over which they will be driving so that they can select the best method of overcoming the varying conditions they will encounter.*

Track vehicles are best suited for desert operations. Wheel vehicles may be acceptable because they will go many places that track vehicles can't go; however, their much lower average speed in poor terrain may be unacceptable during some operations.

- HEMMTS, 5 ton and 2 1/2 ton trucks get bogged down easily in deep soft sand. Stay on the main roads whenever possible. If a vehicle does become stuck simply stop and have it towed out by a track vehicle - experience shows when operators try to power or rock out, damage occurs.
- HEMMTS have broken numerous drive shafts during operation Desert Shield. Drivers should stay in high trans range, not low trans.

Vehicles should be equipped with extra fan belts, tires and other items likely to malfunction, together with tow ropes (if not equipped with a winch), extra water cans, and desert camouflage nets. Air recognition panels, signal mirrors, and a tarpaulin for crew anti-sun protections are very useful.

The harsh environment requires a high standard of maintenance, which may have to be performed well away from specialized support personnel. *Operators should be fully trained in operating and maintaining their equipment.* Some types of terrain can have a severe effect on suspension and transmission systems, especially those of wheeled vehicles. *The unit PLL of tires should be considerably increased as sand temperatures of 165°F are extremely detrimental to rubber and weaken resistance to sharp rocks and plant spines. Items affected by mileage, such as wheels, steering, track wedge bolts, sprocket nuts, and transmission shafts, must be checked for undue wear when performing before, during, and after operation maintenance.*

## TECHNIQUES FOR SPECIFIC AREAS OF THE DESERT

### Sand

- The best time to drive on sand is at night or early morning when the sand is damp and traction is better.
- Vehicle loads must be evenly distributed. Use rear wheel drive where necessary to avoid digging in the front wheels.
- *Drivers should switch to all wheel drive or change gears before a vehicle bogs down.*
- *Select a gear before entering sand that will allow your vehicle to keep as much torque as possible without causing the wheels to spin and to minimize changing gears.*
- Some areas will be covered by a surface crust. This is caused by chemicals cementing sand particles together. In some cases it will be possible to drive on this crust and keep the dust

down. *If possible, stagger vehicles to windward in a line formation to avoid driving in preceding vehicles tracks and to minimize the dust trail.*

- *Crossing dunes requires careful reconnaissance. Normally, the upwind side of a dune will be covered by a crust and have a fairly gradual slope. The downwind side will be steeper and have no crust. Before crossing a dune, you should climb it on foot, checking the crust thickness, the degree of slope and softness of the downwind side, and the angle of the crest to ensure that the vehicle will not become "bellied up / high centered" at the top. If you are satisfied your vehicle can climb the dune, you should drive the vehicle straight up the dune at best speed, crest it and maintain a controlled descent on the other side. Watch for steep dropoffs on the downwind side of dunes. Dunes often have a sharp dropoff not visible from the driver's seat.*

#### Hillock Areas

- *The wind may have built up sand around small shrubs forming little hills. Do not drive wheeled vehicles through these areas without engineer assistance, unless the mission warrants.*

#### Thorn Areas

- *Cacti or thorn bushes will cause frequent tire punctures. When operating in areas with this type of vegetation, you will need to increase the number of tires carried in your unit's PLL.*

#### Rocks and Boulders

- *Rock and boulder-strewn areas, including lava beds, may extend for many miles. Desert rocks, eroded and sharp-edged, vary in size and are so numerous that it is almost impossible to avoid any but the largest. The harsh jolting will wear you out and severely wear wheels, springs, and shock absorbers. Vehicles can follow one another in this type of terrain, and it may be possible to reconnoiter and mark a route. Drivers, try to get a rolling effect as you cross large rocks by braking as your vehicle wheels ride over a rock so the axle settles relatively gently on the other side.*

### LOST OR STRANDED

*People survive in the desert because they know what to do if lost or stranded. It is a good idea to have at least two vehicles in your travelling party (use the buddy system). When driving, avoid going down steep slopes your vehicle may not be able to climb back up. Look for washouts, large rocks, and deep sand. If you get stuck, use extreme caution jacking the vehicle up, then place boards, brush, or blankets under the tires. Be certain the jack is stable; you may need to put something under the jack to stabilize*

*its base. Always let someone, friends or superiors, know where you are going, when you plan to return, and when to start searching if you don't return. Don't forget to check in when you return!*

### SURVIVAL NAVIGATION

*If lost, DONT PANIC, remember the sun rises in the east and sets in the west. When departing from your field site, know the direction in which you are departing.*

*If needed, make a field expedient compass.*

- *Put a stick in the ground.*
- *Lay a rock at the end of the shadow from the stick.*
- *Wait 15 minutes.*
- *Draw a line from the rock to the new end of the shadow.*

*The line represents the east-west line. In the morning, the rock will be the west end; in the afternoon, the rock will be the east end.*

### LOST OR STRANDED TECHNIQUES

*If your vehicle breaks down, stay near it. Your emergency supplies are there. Your vehicle has many other items useful in an emergency. A vehicle can be seen for miles, but a person on foot is very difficult to find. Tie a white or light-colored cloth to your antenna. Use mirrors and burn oil for signaling. When not moving, use available shade or erect shade from tarps, blankets, seat covers--anything to reduce the direct rays of the sun. Do not sit or lie directly on the ground; it may be 30°F or more hotter than the air. If you have water, DRINK IT. If water is limited, keep your mouth shut. Do not talk, eat, smoke, drink alcoholic beverages, or take salt. Keep your clothing on. It helps keep the body temperature down and reduces the dehydration rate. COVER YOUR HEAD. If a hat or cap isn't handy, improvise.*



## Chapter 5 IPB / Reconnaissance

### BATTLEFIELD AREA OF EVALUATION

In the desert more than in any other terrain, control of the initiative is critical. With the large space provided in the desert, maneuver becomes a fast-paced series of movements to identify and strike the enemy flanks. *Aviation units with swift long-range capabilities must rely on timely and accurate IPB and reconnaissance.*

The enhanced capabilities of airborne platforms to see farther will become even more important. In desert operations, areas of operation will be increased because of the increased visibility and spatial distances present. The mobility of aviation units makes them stronger and prime candidates for use. Because of the distances present, areas of operation may be drastically enlarged.

### OBSTACLES / KEY TERRAIN / AVENUES OF APPROACH

Inaccuracies on maps prevent a good analysis of reference points, dead space, mobility corridors, and slow-go terrain for ground troops. *Supplemental resources for the lay of the ground must be sought. Small discriminations in terrain should be identified during day operations, recorded, and disseminated.*

*As changes in dunes are noted, they should be publicized.*

Avenues of approach in the desert provide for rapid movement and ample maneuver space for the enemy. Because of the lack of restrictive terrain and key terrain it is difficult to guess where the enemy will go or what his intentions are. One of the ways to do this is identify where his objectives might be, then trace the most likely routes back to his current location.

In mountain deserts, rocks and relief may provide varied forms of obstacles. Wadis may form natural tank ditches.

In flat, sandy deserts, the shifting sand dunes provide the only significant obstacle, and they may not be obstacles. That depends on the slope of the dune and trafficability of the sand which makes up the dune.

The desert lacks the traditional terrain associated with key terrain. Natural resources such as oil, water, and food become key locations. Static locations of enemy and friendly troop concentrations are key terrain. This pertains primarily to less mobile forces such as support operations or light infantry. More traditional key terrain, such as histrionic astride a mountain pass or ground that overwatches a wadi, mobility corridor may be more likely found in a mountain plateau desert.

## WEATHER ANALYSIS - NAIs - INTELLIGENCE SOURCES

Deserts experience wide variations in temperature between day and night. Frequent and extreme changes in weather often occur such as dust storms, change in wind direction, and occasionally harsh rain storms with accompanying flash floods. Wind storms can reduce visibility, noise detection, and detection of dust signatures. Rain can also reduce dust signatures as well as severely limit trafficability. The moon's rise and set affect night visibility significantly for passive night vision devices and the naked eye.

In the desert, NAIs are used to focus reconnaissance and surveillance planning. It should be understood that these areas will not be exact as in other types of terrain. *Scouts and other assigned units must use these locations to orient, but they should also use initiative to adjust those areas on METT-T observed on the ground. Units must report what they see or don't see and any modifications that were made to the assigned area. They should be placed at maximum ranges of direct and indirect fires, lethal and nonlethal.*

## RECONNAISSANCE AND SECURITY

Along with the environmental aspects of desert operations, the lack of both natural and man-made CSS assets causes CSS assets to be more numerous and spread out. This makes excellent reconnaissance targets due to long range observation and fields of fire coupled with a lack of concealment.

*Security operations in a desert environment must emphasize all-around security provided by aggressive and continuous reconnaissance, establishing OPs on high ground, coupled with the effective use of camouflage. Obvious OP locations should be avoided as they are likely TRPs. Additionally, use radars, sensors, and observation devices to provide additional security, especially at night.*

Other considerations are dust from NOE flight, which can be seen as far as 20 km. This is especially true when the enemy is stationary. *Aviation units must use caution to avoid enemy AD weapons. Movement should be done at a tactical speed permitted by the terrain and dust conditions.*

In the desert, operations are very enemy oriented. This requires that exact information of the enemy deployment is critical to effective operations.

To take and retain the initiative, reconnaissance elements must provide the commander with timely information and any changes in enemy activity.

Destroying or deterring the enemy reconnaissance effort prevents the enemy from seeing the battlefield. This increases the survivability of our forces and allows us to employ the element of surprise.

The other effect of aggressive counterreconnaissance is to confuse the enemy and prevent him from identifying the true nature of our objectives. This prevents him from shifting forces in reaction to our movements.



Proper reconnaissance in the desert will identify weaknesses in enemy operations that can be exploited quickly. This keeps the enemy from developing momentum in the attack or from consolidating an effective defense.

Commanders should use air cavalry to check terrain which is inaccessible to armored vehicles. Air cavalry can also recon large, flat, open areas rapidly. Air cavalry is much more vulnerable to ADA fires in the desert. *Helicopters may have to operate higher than normal to avoid dust signature from rotor wash. Reconnoiter with the sun and escarpment as backgrounds when possible.*

Long range observation makes it difficult to infiltrate into and through main defensive belts. Wadis and ridges provide a concealed route for dismounted or mounted elements attempting to infiltrate. Moonlit nights often provide sufficient illumination that the naked eye and binoculars can be almost as effective as in the day. *If possible, reconnoiter with the sun at your back; this reduces the enemy's ability to acquire you. Use dust and sand storms like smoke. Increased range of observation allows reconnaissance elements to cover larger zones.*

## EMPLOYMENT OF ARMY AIRCRAFT

Attack aircraft flying low and slow may produce large dust clouds. These clouds of dust not only obscure aircraft acquisition systems but they are also easily detected.

These severe conditions require proper maintenance, engagement techniques, and positioning of Class III and V resources.

Extra maintenance will help offset the problems of heat, sand, and dust. Both air and ground crews must be aware that engines must be cleaned and filters changed more often during desert operations.

**Firing while flying above ETL diminishes the dust signature and aids in survivability.**

**The loss of load capabilities is overcome by placing FARP's closer to the engagement areas.**

When operating above ETL, attack aircraft can operate at higher gross weights than when hovering fire is used.

ATKHB personnel do not normally train or practice running fire attacks and need specialized training and time to practice and rehearse these attacks.



## Chapter 6

# Chemical Warfare

This Chapter addresses chemical warfare from two aspects. First, it presents an overview of possible threat chemical agents believed to be in Iraq's inventory and available for use. Second, it provides a review of procedures applicable to warning/reporting, detecting, and decontaminating of chemical agents for aviation personnel operating in the Middle East theater

## IRAQI CHEMICAL THREAT

### IRAQI DELIVERY SYSTEMS - CHEMICALLY CAPABLE

- 122mm Howitzer D-30                      Max Range - 15.3 km
- 122mm SP Howitzer - 2S1                Max Range - 15.3 km
- 130mm Field Gun - M46                  Max Range - 27.5 km
- 152mm SP Howitzer - 2S3                Max Range - 17.2 km
- 122mm Howitzer - M1938 (M-30)        Max Range - 11.8 km
- 152mm Howitzer M1943 - D1            Max Range - 12.4 km
- 122mm MRL - BM-21                    Max Range - 20.5 km
- 90 mm Air to Ground Missile            Max Range - 100 km
- Spray Devices - Usually sprayed from HIP Helicopters
- Also disseminated by Cluster Bombs and Mines

### IRAQI DECONTAMINATION CAPABILITIES

- One chemical company per division. Limited information on configurations, most probably various configurations of decontamination, reconnaissance, and smoke.
- The Iraqis most probably use older Soviet decontamination equipment; rather than the newer jet decontamination equipment. They probably have the older water decontamination equipment.
- ARS-14 - Equipped with 1 2,500 liter tank to decontaminate vehicles, large weapon systems, heavy equipment and terrain. Can decontaminate 50 tanks, 50 to 80 artillery pieces, or 500 meters of road 5 meters wide.
- DDP-2 - Trailer mounted decontamination unit. Has a steam chamber and boiler. Unit receives water from an external source.

### IRAQI INDIVIDUAL PROTECTION - PROTECTIVE SUITS

- OP-1 - Soviet made, impermeable protection. Large, 1 piece coverall-type suit, to include hood. Set includes leggings and gloves.
- LP-1 - Soviet made, impermeable protection. Worn primarily by reconnaissance troops. Two-piece construction, trousers include boots, jacket includes hood.

### IRAQI INDIVIDUAL PROTECTION - PROTECTIVE MASKS

- ShLEM - Iraqis most probably outfitted with old-style Soviet protective mask. Uncomfortable, difficulty breathing, no voice emitter, and no drinking tube.
- Model K - Communications mask, includes voice emitter. Low visual efficiency.

### IRAQI CHEMICAL AGENTS

#### Sarin / Tabun

- Symptoms - Difficulty breathing, drooling, nausea, vomiting, convulsions and dim vision (miosis).
- Effects - At low concentrations, incapacitates; kills if inhaled or absorbed through the skin.
- Rate of Action - Very rapid by inhalation, slower through the skin.
- How Disseminated - Aerosol or vapor.
- Protection Required - Protective overgarment and protective mask.
- Persistency in a hot climate - 2 hours to 12 hours.
- Decontamination - STB Slurry (not to be used on aircraft), household bleach, hot soapy water.  
DS-2 (not to be used on aircraft).

#### Persistent Nerve - VX (Possible)

- Symptoms - Difficulty in breathing, sweating, drooling, nausea, vomiting, convulsions, and dim vision (miosis).
- Effects - Incapacitates; kills if contaminated skin is not decontaminated rapidly.
- Rate of Action - Delayed through the skin, rapid through the eyes.
- How disseminated - Liquid or droplets.
- Protection required - Protective mask and protective overgarment.
- Persistency in a hot climate - 4 to 12 days.
- Decontamination - STB Slurry (not to be used on aircraft), household bleach, hot soapy water.  
DS-2 (not to be used on aircraft).



## US AVIATION OPERATIONS TO COUNTER CHEMICAL ATTACK

### CHEMICAL WARNING AND REPORTING

Due to undefined terrain features, identifying and plotting contaminated areas will be difficult and also require commanders to constantly update operation boards as contaminated areas clear rapidly. Information will be essential to elements required to leave and return to unit, i.e. mess, supply, and maintenance.

Recommendation: due to envisioned short contamination persistency, artillery smoke could be used to confirm grid locations and colored smoke used to mark contaminated areas until clear. If not, barrels filled with sand or sand bags to support markers may be required.

Keep warning and reporting methods "clear and distinct;" prepositioned gongs, makeshift sirens, or aerial flares can be used effectively (check unit SOP). Avoid commonplace warning horns. Units should avoid the employment of horns as a signal for a chemical attack. Doctrine states that metal on metal should be used. Commanders should enforce the employment of 155 mm / 105 mm canisters as a warning device for chemical attacks warning.

- Identifying contaminated areas (grid reference) will be extremely difficult
- Mark contaminated areas to six and eight digits whenever possible; areas marked with contaminated area overlays in a desert environment will need constant updating
- Agent vapors will travel rapidly over sparsely vegetated open areas
- Units spread over wide areas will have to use radio communications to warn elements
- Keep warning devices distinct, i.e., gongs, sirens, flares
- Keep reports simple; only send essential data required to speed warning dissemination. Follow up with additional information as required. Use JINTACCS message format whenever possible

All soldiers should have on their person a copy of CTA 3-6-3, NBC Warning and Reporting System, and be familiar with drafting messages. Commands must know communication capabilities of subordinate elements and vice versa in order to develop and expedite chemical warning traffic. Have available preprinted chemical message forms and header sheet to speed the process.

Do not hinder subordinate units not in the predicted hazard zone by sending "blanket messages." Example: Company A is under a chemical attack and gives the command "GAS" on the Squadron net, when based on wind direction only Alfa and Bravo Company were threatened. Develop and refine specific reporting procedures.

The inability of the M8A1 to detect other than nerve agents poses a tremendous threat to our forces. This problem is compounded by the slow response times associated with the M256 Kit (and the "point only" capabilities of the Chemical Agent Monitor (CAM)). Driven by the dictates of our equipment, recommend commanders implement an automatic masking policy when faced with unknown smoke or when observing artillery or bomblets. The key to overcoming these limited capabilities is flexibility.

Chemical operations in the desert are a two edged sword (heat casualties versus protection levels). Personnel must identify threats and assume increased MOPP postures rapidly. At the same time commanders must be sensitive to heat casualties caused by prolonged periods in MOPP. They must confirm the contamination in a timely fashion and adjust or eliminate MOPP levels appropriately.

Use the CAM for monitoring and point detection as well as affirming the presence or absence of chemical agents. The CAM will give the commander a much quicker assessment of vapor agent type and level. However, if time permits use the M256 as a back-up.

Wide fronts and greater dispersion of unit elements should be used to increase survivability. Rapidly shifting winds will require units to requisition greater numbers of Detectors and Alarm Units. Specific guidance can be found in FM 3-3.

### CHEMICAL DETECTION

The US system of classification of chemical agents is by physiological categories: nerve, blood, blister, and choking agents. Incapacitating and irritants may also be included. FM 8-9 has a detailed description of each agent's effect on personnel. Figure 6-1 provides a quick reference overview for the agents indicated.

Mustard/blister agent is a liquid agent and will be detected with the MB paper. (If fox NBC reconnaissance vehicle is available, use for stand-off detection and advanced party escort, or consider use of chemical observation posts (OPs) consisting of a two person team, upwind with M8 and M9 paper and M256 kits.)

- M8A1 chemical agent detector only detects nerve agents
- CAM can be used for point detection of blister/nerve agents
- M8 and M9 detection paper can be used for point detection of blister and liquid nerve agents
- M8 and M9 detection paper will NOT detect toxins or biological agents
- Observe wildlife or population centers for evidence of lethal chemical agent usage
- Terrain may dictate more detectors over wider fronts
- Plan for the requisition of larger numbers of batteries and filter elements for detectors and alarm units. Specific guidance can be obtained in TM 3-6665-312-12&P; pay special attention to the "Operation Under Unusual Conditions" section.
- Environment and lack of vehicle power for M8A1 will dictate higher use rates for detector batteries and filters
- Common battlefield interference will cause false alarms and the M8A1 cannot differentiate between munitions fumes and lethal agents. M256 Kit should be used if this happens.
- Chemical papers M8/M9 are fooled by petroleum products. Also, avoid abrading paper; this will cause false color change

TYPES OF AGENTS	SYMBOL	MEANS OF ID	SYMPTOMS IN MAN	EFFECTS ON MAN	RATE OF ACTION	HOW NORMALLY DISSEMINATED	PROTECTION REQUIRED	PERSISTENCY		DECONTAMINATION	
								Agent/Amt	Temp		Duration (days)
NERVE	GA GB GD	M256 M256A1 M19A2 M19 M8/M9 paper M8A1 alarm M272	Difficult breathing, sweating, drooling, nausea, vomiting, convulsions and dim vision.	At low concentrations, incapacitates; kills if inhaled or absorbed through the skin.  Incapacitates; kills if contaminated skin is not decontaminated rapidly.	Very rapid by inhalation. Slower through the skin.	Aerosol or vapor	Protective mask and protective clothing	GD	Hot Warm Mild Cold V Cold	.08 - 0.5 0.1 - 0.8 0.5 - 1.0 2.0 - 4.0 4.0 - 12	STB slurry, household bleach, 10% solution of lye or washing soda, DS2 steam and ammonia in confined area, hot soapy water, M258 series Kit.
								Moderate	V	Hot Warm Mild Cold V Cold	
BLOOD	AC CK	M256 M256A1 M19A2 M19 M272	Rapid breathing, convulsions, coma, and death.	Incapacitates; kills if high concentration is inhaled.	Rapid.	Aerosol or vapor	Protective clothing	Short Duration (5 to 10 minutes)		None needed in field.	
BLISTER	HD HN L HL CX	M256 M256A1 M272 M19A2 M19 M8/M9 paper	Mustard; nitrogen mustard-no early symptoms. Lewisite and mustard-searing of eyes and stinging of skin. Phosgene oxime-powerful irritation of eyes, nose and skin.	Blistered skin and respiratory tract; can cause temporary blindness, some agents sting and form welts on the skin.	Blister delayed hours to days; eye effects more rapid.	Liquid or droplets	Protective mask and protective clothing	HD	Hot Warm Mild Cold V Cold	1 - 3 2 - 6 6 - 24 12 - 36 48 - 140	STB, DS2, household bleach, M258 series kit, lye, wash with soap and water.
								Moderate	Hot Warm Mild Cold V Cold	4 - 8 12 - 24 24 - 48 72 - 168 168 - 4632	
INCAPACITANT	None known, a sleep inducer was reported in Afghanistan.	Unknown	Slowing of mental and physical activity; disorientation and sleep.	Temporarily incapacitates.	Unknown	Aerosol or vapor	Protective mask	Unknown		Unknown	
IRRITANT	DA DM CN CS PS	M19	Causes tears, irritates skin and respiratory tract.	Incapacitates, nonlethal	Very rapid	Aerosol	Protective mask	Relatively short		Aeration in open; Sodium carbonate solution. Alcoholic sodium hydroxide mixture. DKIE, HTH, or DS2.	

Figure 6-1. Threat Chemical Agents.



- The M256 detection kit is slow in response time (10 minutes plus)
- Placing chemical paper M8 and M9 on vehicles (including aircraft) so that it is visible is a good way of assessing the presence or absence of liquid chemical agents before exiting the vehicle.

**Caution:** Use of the red lens flashlight at night does not provide the capability to check chemical paper for red or brownish spots (signs of contamination). The spots are not visible with this mode of filtered light.

**Note:** M9 paper detects liquid agents only; for detection and identification the M8 paper should be used.

Additional key points to observe in general include the following:

- Never allow soldiers to leave their immediate work area without carrying individual chemical protective equipment.
- Carry all essential items (such as wrist watch, and grease pencils) in one plastic bag in case of chemical attack. Once in MOPP, it is dangerous to retrieve these items.
- Never consolidate chemical stocks; one complete set should be with the soldier's equipment, another set stored on his vehicle.
- Dispersed units will suffer fewer casualties from direct chemical attacks.
- Implement standard MOPP levels to enhance the unit survivability posture, see FM 3-4.
- Use "mask only" posture whenever there is no liquid agent threat and overhead cover is provided.
- Standard covering of supplies and equipment will greatly reduce contamination/spreading and subsequent reconnaissance activities.
- Check seals on water buffalos and five gallon cans; these often leak and are easily contaminated. Keep canteens full; once in a chemical environment there is no way to refill.

### CONTAMINATION TRANSFER

All soldiers should understand how they and their equipment become contaminated and how contamination spreads to other personnel and equipment. A unit may be the target of an NBC attack (on-target), or the downwind hazard from a contaminated unit may cause agents to drift into another unit's area (off-target). Aircrews may be required to fly into contaminated areas from which aircraft can transport contaminated equipment or personnel.

Rotary-wing aircraft can transfer contamination from the ground into the aircraft or vice versa. This transfer occurs when the rotor wash picks up dust, sand, leaves, or other contaminated debris. The debris or liquid droplets are then scattered throughout the aircraft. Some agents are like a fine spray

and, although suspended in the air, can settle on personnel or equipment like dew. Aircraft vibrations increase the settling of agents in remote areas of the airframe such as panel points or rivets. Alkyd-based paints on aircraft absorb the agents like sponges. Newer paints (such as agent-resistant coatings) are being developed that resist chemical agent absorption. Crews should check with the M8 paper for possible liquid contamination.

### **PRINCIPLES OF CONTAMINATION AVOIDANCE**

The principles of contamination avoidance are applying passive defensive measures; warning and reporting; locating, identifying, and marking NBC hazards; limiting the spread of contaminants; and avoiding contaminants.

Apply passive defensive measures. Passive defensive measures are not direct reactions to a specific attack but rather are measures taken to reduce vulnerability to being targeted. Aviation units must apply the principles of detection avoidance, dispersion, and training to protect personnel and materiel.

#### **Detection Avoidance**

Commanders must train their personnel in the principles of detection avoidance. Commanders should carefully choose unit positions and command post locations. They must ensure that their troops are protected as much as possible from detection by using natural concealment, cover, camouflage, and light discipline. Aviation units can also use air routes and firing positions that take advantage of natural vegetation and terrain features.

#### **Dispersion**

In cases where the terrain is not suitable for concealment, commanders can disperse their assets so that the unit presents a less lucrative target. Varying the pattern of unit deployment avoids stereotypic patterns that allow the Threat to identify the type of aviation unit being observed.

#### **Training**

Units must train to survive initial NBC attacks and to continue their missions without slowing down.

Desert Operations will present a number of challenges to unit leaders. Degradation can be kept to a minimum by utilizing collective protection capabilities as much as possible and by wisely implementing MOPP and work/rest cycles. Expect and plan for increased water consumption and high use rates of chemical overgarments. Do not degrade soldiers unnecessarily, i.e. soldiers with collective protection systems or in shelters do not require the same protection levels as ground troops.

## MISSION-ORIENTED PROTECTIVE POSTURE

Commanders select a level of protection based on the chemical or biological threat, temperature, work rate, and mission. The levels of protection are MOPP zero through MOPP4 plus a mask-only option. FM 3-4 describes the MOPP levels and option.

### In-Flight MOPP Status

Aircrews fly in MOPP4 gear when a high threat of CB agent use exists or when agents have been used on the battlefield. Aircrews also fly in MOPP4 gear when they conduct NBC reconnaissance operations. Some of the reasons for this are:

- Personnel cannot detect agents with their senses.
- Agent clouds travel vertically as well as horizontally.
- Aircrews exposed to CB agents may be grounded for an extended period.
- Aircraft are not equipped with advanced warning or detection devices.
- It is not practical to don CB equipment, including the mask, during flight.
- Aircrews exposed to sublethal dosages of CB agents (miosis) during flight may lose control of the aircraft and crash.
- Rotor wash may transfer droplets or contaminated dust inside the cockpit, creating a skin contact hazard.
- Aviation missions cover large areas, and agents may be present where troops are unavailable to report the attack.
- Even when agent hazard areas are marked on a map, winds and temperature gradients may change during the mission.

### On-the-Ground MOPP Status

When aircrews are on the ground, the MOPP status will depend on the ground situation. Preflight and postflight inspections may be conducted with a lower MOPP level if the ground situation does not require MOPP4. When aircrews fly in MOPP4 gear in uncontaminated aircraft, they may fly into known clean areas for rest and relief. If ground support areas (such as FARP and troop or maintenance area) are clean, aircrews may lower their MOPP status once they are on the ground.

The implementation of standard MOPP postures will provide a change in individual performance and survivability. **Recommend during day time operations, when chemicals will be least effective or employed, a level of MOPP 0 or 1. Increase this level to MOPP 2 in the evenings as it becomes cooler and the likelihood of attack/effects becomes greater.** A Standard MOPP level also allows for faster upgrading of posture.

## INDIVIDUAL PROTECTIVE EQUIPMENT AND CLOTHING

### MOPP Gear

MOPP gear consists of the CB protective mask, hood, overgarment, overboots, protective gloves, individual decontamination kit, detection equipment, and antidotes. FM 3-4 describes each item, to include service life and proper use.

Until a fire-retardant overgarment is fielded, aircrews will continue to wear the Nomex flight suit and gloves under the overgarment and protective gloves. When aircrews wear the Nomex gloves, they do not need to wear the white cotton inserts.

### Aviation Life Support Equipment (ALSE)

All soldiers must be issued a mask, an overgarment, and protective gloves in the correct sizes. Soldiers should ensure that they have the correct glove size so that their tactile sensitivity is not degraded. The size of the overgarment depends on the unit's policy for wearing ALSE. Usually, soldiers will wear the ALSE over the overgarment. During an emergency in a CB environment, aircrews need access to the contents of the survival vest. If the vest is worn under the overgarment, the soldier risks contamination to get to the vest. Commanders should carefully evaluate their policy and requisition overgarment sizes accordingly.

### Night Vision Devices

The AN/PVS-5 and AN/AVS-6 cannot be used with the present M24 aviator mask. Wearing the hood under the helmet with the M24 mask creates hot spots; individuals may need to be refitted with a larger size helmet.

### M10A1 Canister

Commanders should carefully evaluate whether individuals should change their own canisters. Changing the M10A1 canister is currently an organizational-level maintenance task. However, aviation personnel are widely dispersed on the battlefield, and maintenance or NBC personnel may not be available to change the canisters. Blood agents will degrade the canister, requiring the operator to change it after an attack. Therefore, aircrews should receive training in the procedure for changing the canister.

### M24 Mask

When wearing the M24 mask while operating the AH-1 telescopic sight unit, aviators should be careful not to scratch the mask lens. They should use a clear visor over the mask lens to prevent scratches. Some aviation units may receive M43 masks to replace the M24 masks.

**Note on vision when wearing M24 Mask:**

Use of the M24 protective mask reduces the peripheral vision of aircrews. To overcome this limitation, aircrews must continuously scan in all directions. The normal range of motion for the head is 90 degrees from either side of the centerline. The mask limits this 180-degree range to a 140-degree range. Therefore, aircrews must turn their heads to scan and compensate for the lost visual range. The mask also blurs or distorts the aircrew's vision in the cockpit, especially during night operations.

**M-43 Aircraft Protective Mask**

The M-43 is a new design aircrew protective mask developed specifically to overcome system integration problems with previously fielded aircrew masks. The M-43 provides exceptional protection from threat agents by using a filtered, forced-air system. The mask and hood are worn under the aircrew helmet. It features a drinking capability, an exceptional field of view, and a valsalva capability. The system includes a filter-blower unit that is powered by the aircraft systems when flying and a battery when outside the aircraft. Battery life is eight (8) hours. Mask characteristics are listed below:

- The facepiece protects the face, eyes, and respiratory system from field concentrations of all known chemical or biological (CB) and riot control agents.
- The facepiece, with integral hood, conforms closely to the user's face and head. This permits the use of the integrated helmet and display sighting system (IHADSS) equipment.
- The drinking system permits liquid intake while maintaining agent-proof integrity.
- The blower unit pushes air into the canisters. This maintains a positive pressure in the facepiece.
- The mask uses NATO standard filters that are easy to screw on or screw off.
- The mask will not protect the wearer from ammonia and carbon monoxide fumes or low oxygen content.
- Carrier. The mask carrier is used to store and carry the facepiece with canisters, blower motor, spare battery, and additional authorized items.
- Comfort cap. The comfort cap is designed to be worn under the flight helmet in a non-NBC environment. This is used in order to replace the bulk of the facepiece and hood and to provide a better fit for the aircrew member. It is important that each aircrew member be fitted with his flight helmet while wearing the comfort cap.
- Operation during an emergency.
- Emergency egress from on land.
  - Follow standard emergency egress procedures.

- Evaluate cockpit. The quick disconnect will separate from the blower, and the canisters will remain connected to the hose.
- Emergency egress on land and from water.
  - Follow standard emergency egress procedures.
  - Evacuate cockpit. The quick disconnect will separate from the blower, and the canister will remain connected to the hose.
  - Hold breath until canisters are out of the water and excessive water has been shaken out of them.
- Current limitations.
  - Weight and bulk. This problem should be fixed by the smaller, light auxiliary blower motor.
  - Corrective vision. Two fixes have been identified. First, extended wear contact lenses and second, corrective add-ons to the mask itself.

#### **Battle Dress Overgarment (BDO)**

This garment protects the wearer against contact with chemical agent vapors, aerosols, and liquid droplets; live biological agents; toxins; and radioactive particles. The BDO consists of a two-piece suit in a camouflaged pattern packed in a vapor-barrier bag. Once removed from the package and donned, its protective qualities last for fourteen (14) hours in a chemical contaminated environment and for twenty-two (22) to thirty (30) days in a non-chemical environment.]

The chemical protective overgarment (CPO) will last for six (6) hours in a chemical environment and fourteen (14) hours in a non-contaminated environment. The BDO is to be replaced with the Aircrew Uniform-Integrated Battlefield (AUIB).

#### **Chemical Protective Footwear Covers**

Over-boots are being replaced by the green vinyl overboot (rain boot).

#### **Chemical Protective Glove Set**

These gloves protect against liquid chemical agent and vapor hazards, biting insect vectors, and radiological dust particles. Each glove consists of an outer glove for protection and an inner glove for perspiration absorption. The outer gloves are made of impermeable, black, butyl rubber. The inner gloves are made of thin, white cotton. Aircrew members shall wear Nomex flight gloves in place of the white cotton inner gloves. A new glove made of thinner butyl rubber is currently being developed for aviators.

### AUIB

The AUIB is a single-layer NBC aircrew uniform that will replace the current flight suit and the NBC overgarment for aircrew use in an NBC environment. It combined Nomex and NBC protective carbon-filled foam in a sandwich material that reduced bulk and, to a degree, heat stress. The AUIB will be a two-piece uniform and will interface with the aircrew microclimate cooling system (AMCS).

The AMCS provides crew members aboard all Army aircraft the capability to function effectively for extended periods of time in hot, humid conditions, primarily when crew members are wearing full NBC protective clothing. The components of the system include a blower unit that provides cooled and filtered air or liquid, a torso cooling vest, and all plumbing and mounting equipment.

### M-20 Simplified Chemical Protective Equipment (SCPE)

The SCPE provides collective protection.

Additional information includes:

- Daytime weather conditions are not favorable to chemical attacks.
- Nightfall and early morning are advantageous to chemical attacks and must be considered in all planning of desert operations.
- Expect spot or on-target chemical attacks.
- Use collective protection capabilities as much as possible to relieve the effects of heat and MOPP.
- Expect an increase of three to five gallons of water per man in MOPP 3/4.
- Soldiers must wear BDU's under MOPP gear. Aircrews will wear Nomex flight suit and gloves under MOPP gear. Perspiration will degrade overgarment effectiveness.
- At night maintain high ground if possible. Agents will linger and settle in low areas. Conversely, agents will rise rapidly in the heat of daylight hours.
- Perform strenuous tasks at night and develop an effective work/rest schedule among crews.
- Plan operations with the weakest link in mind. Use degradation table in FM 3-4 for planning.

### DECONTAMINATION

NBC decontamination of aviation units is probably more difficult to perform than any other type of unit because both ground vehicles and aircraft must be decontaminated. Aircraft are especially difficult to decontaminate because of the sensitivity of aircraft to the standard decontaminants used by the Army.

#### Reasons for Decontamination

- Lethality.
- MOPP degradation.
- Equipment limitations.
- Limit the spread.

#### Decontamination Principles

- Decontamination as soon as possible.
- Decontamination of only what is necessary.
- Decontamination as far forward as possible.
- Decontamination by priority.

#### Aircraft Spraydown

Aircraft undergo hasty decontamination by simply being sprayed with clean water. If possible, soap and hot water can be applied to increase effectiveness. Again, this process only reduces the contamination hazard--it does not eliminate it. The M-17 Sanator works well for this operation. There are four M-17 Sanators per battalion.

#### Deliberate Decontamination

This category of decontamination is the responsibility of the contaminated unit and a chemical decontamination unit. Deliberate decontamination is usually conducted in conjunction with a unit restoration operation and involves completely relieving the contaminated unit of its combat, combat support, or combat service support mission. The main components of deliberate decontamination operations are detailed troop and detailed equipment decontamination.

**Detailed Troop Decontamination.** This step is performed by the contaminated unit. It is basically an improved MOPP gear exchange operation that is aided with hot water and supplies from the unit's parent battalion or brigade.

**Detailed Equipment Decontamination.** Decontaminating equipment is the primary mission of the chemical decontamination unit. The decontaminated site will be under the control of the chemical platoon leader. Prior coordination must be made by the contaminated unit in order to receive instructions on how the unit should proceed through the site. This process should allow the commander to decrease his MOPP level after completion.



Avoid contaminating the inside of vehicles as much as possible. Interior decontamination is difficult and corrosive properties associated with decontamination solutions are often damaging to wiring, optics, commo gear, etc. If vehicle is contaminated, follow NBC Entry and Exit Procedures and avoid exiting as much as possible. Your Chemical Agent Monitor (CAM) is great for a "quick sniff" to determine contamination inside and outside vehicles. If it is determined that the vehicle interior is contaminated, the Personal Decontamination Kit (M258A1) or the Decontamination Kit Individual Equipment M280(DKIE) is great for small interior contamination. For gross interior contamination, recommend spraying using the M11 or M13 Decon Apparatus. FM 3-5 provides a break down of available decontaminants and their uses.

*Note: STB and DS2 should not be used on aircraft.*

#### Aircraft Decontaminants

- **On the Ground**

- Only approved cleaning compounds can be used on aircraft. STB is corrosive to metals and DS-2 will soften rubber parts on the aircraft.
- Soap and water.
- Solvents. (PD 680)
- JP4 (for spot decontamination).

NOTE: Solvents and JP4 only remove the agent and do not neutralize their lethal characteristics. Care must be taken to avoid any remaining residue.

- Earth is a good decontaminant. Sand can be used to absorb and later remove the majority of liquid agent, thus saving valuable water supplies. Lack of overhead cover and terrain features will make units particularly vulnerable to attack during decontamination procedures; recommend decontamination operations be conducted in pockets (smallest elements possible) and dispersed over wide areas.

- **In Flight**

- Nonpersistent agents dissipate in 10 to 15 minutes.
- Persistent agents remain in the paint or in cubbyholes and remain a vapor hazard. Flying the aircraft for thirty (30) minutes at speeds of 90 knots dissipates 90 to 95 percent of the contamination. Five to ten percent of the contamination could remain a vapor hazard for long periods of time or until the aircraft is taken apart piece by piece and decontaminated during cannibalization or overhaul.

### Decontamination Sites and Layouts

Aircraft decontamination poses unique challenges to commanders. They must decide when to conduct the various levels of decontamination. Most aviation units will conduct hasty decontamination operations. They may also conduct deliberate decontamination operations if the situation requires it and time is available. Aviation battalions or squadrons are responsible for selecting and securing decontamination sites as well as augmenting chemical personnel. Units select decontamination sites before hostilities begin. The location of these sites will be classified. Chemical units are responsible for operating decontamination sites. Only partial decontamination of Army aircraft is accomplished at decontamination sites. The decontamination protects aircrews, FARP and unit personnel, and equipment and ensures the unrestricted movement of aircraft to FARP and unit locations.

### Site Selection Requirements

The decontamination area or site must accommodate the required aircraft, have a readily available water source, and allow for adequate drainage. The site should also be relatively secure but close enough to the FLOT or area of operations and FARP to facilitate a reasonably quick turn-around of aircraft. The site must have sufficient NOE routes no less than 2 to 3 kilometers from the station for entry and exit.

All aircraft must descend to NOE when approaching and departing the Army aviation decontamination station, or AADS, to prevent enemy radar from detecting the site. The site also must have slope angles not exceeding the landing capabilities of the using aircraft. If the area is sloped, the AADS should be set up across slope. The using aircraft must not be forced to land uphill or downhill. The AADS may be sited to allow the use of a natural fresh water supply rather than the use of a mobile water vehicle. If so, drainage should not be allowed to contaminate the fresh water supply. Tentative decontamination sites, like tentative command post and FARP sites, must be considered and integrated into the tactical plan. Final approval of the AADS should be made by the NBC officer or NCO or an aviator designated by the commander.

### Site Establishment

After the site is selected, reconnoitered, and secured, NBC defense personnel and the supporting chemical unit jointly establish the AADS. The unit commander may select a representative from the tactical command post or the S3 section to supervise the operation. As each company-level or troop-level unit is sequenced through the AADS, the remaining assets provide security.

Marking and burying at decontamination sites will be difficult if not impossible. Shifting sands would simply uproot markers or quickly uncover buried waste thus reintroducing a vapor threat. If wind

direction is favorable, recommend burning contaminated articles as an alternative. If not, saturation of garments with slurry prior to disposal would be a safe alternative.

### Decontamination Methods

Deliberate decontamination consists of detailed aircrew and aircraft decontamination. The aircrew or aviation unit maintenance personnel must be available to supervise the aircraft decontamination. FMs 1-111 and 1-117 contain the doctrine for aviation decontamination. Any of three methods may be used for the detailed aircraft decontamination. The three basic techniques or procedures are:

- The 4-station "hop through" (described in FM 1-102).
- The 4-station "pull through" (the optimum method).
- The 1-station method (described in FM 1-117).

The methods differ only in the setup of the decontamination site. The steps in decontaminating the aircraft are the same.

**Four-Station Pull Method.** In this method, aircraft are hooked to towing equipment and pulled through a decontamination line. Towing equipment and vehicles will become contaminated and must be decontaminated afterwards. This method is costly in terms of time and resources, but it is the most thorough way to remove contaminants. Figure 6-2 shows a four-station pull decontamination site.

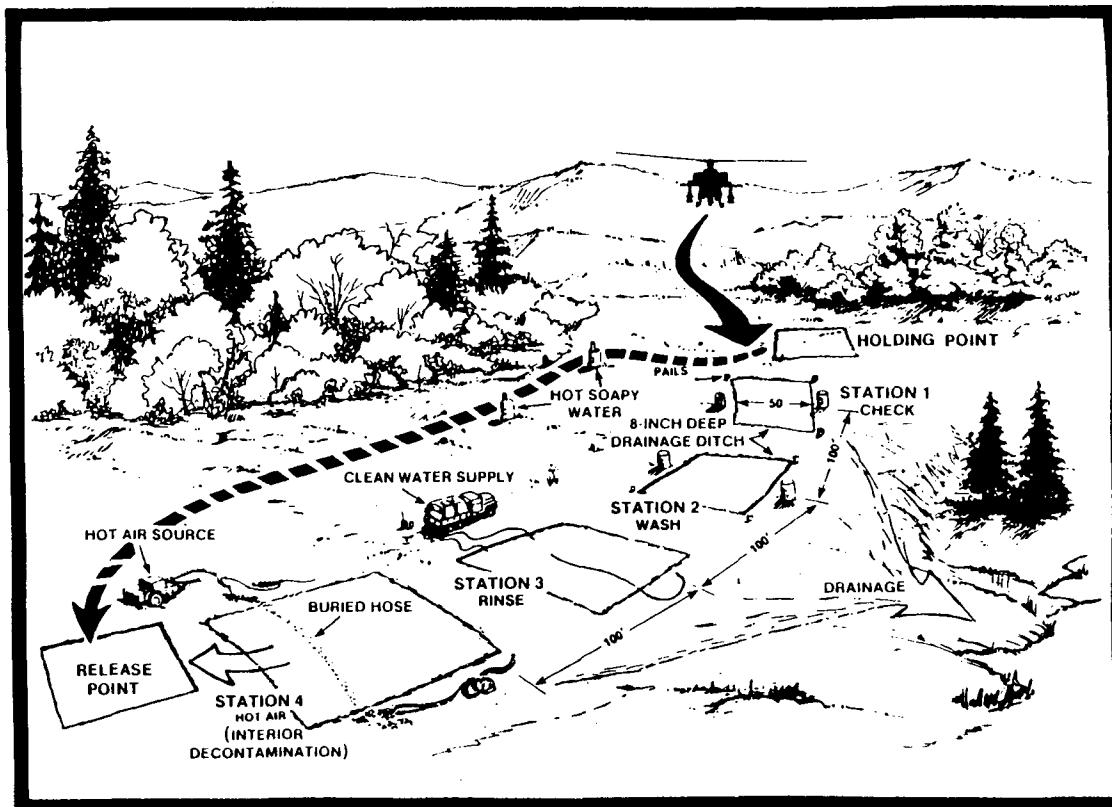

Figure 6-2. Four-Station Pull Decontamination Site.

- **Station 1**

Aircraft land and shut down at a designated area. The aircrew exits the aircraft and goes through the personnel decontamination site. Decontamination personnel check the aircraft for contaminants with the M256 kit, M8 or M9 paper, or chemical agent monitor (CAM).

Aircraft are pulled from the holding point through stations 2 through 4.

- **Station 2**

Decontamination personnel use the M17 Sanator to wash the entire aircraft with hot, soapy water.

- **Station 3**

The aircraft is rinsed with clean water using the M17 Sanator. (Warm water is preferred.)

- **Station 4**

The exterior of the aircraft is dried, and the interior is decontaminated. If a hot air source, such as a Herman-Nelson heater, is available, decontamination personnel can use it to blow warm air into the cockpit. Drying the cockpit in this manner will reduce the amount of contaminants. However, hot air should not be directed onto instruments or gauges. After completion the decontamination, personnel should check the aircraft for additional contaminants.

- **Release Point**

Aircraft are moved to a designated takeoff point. This will be the linkup point for the aircrew.

**Four-Station Hop Method.** This method is conducted the same as the four-station pull method except that Station 1 is set up 1 to 5 kilometers from the other stations. The aviator is required to fly the aircraft from Station to station. Standard ground-guiding (hand) signals will be used per FM 21-60 during aircraft movement. Aviators must ensure that decontamination personnel approach and depart the aircraft from the 45-degree forward position. Aviators must maintain engine RPM at flight idle at the decontamination stations. During movement between the stations, aircraft will take off from contaminated ground. However, the decontamination line can be spread out over a large area, increasing tactical survivability. Figure 6-3 shows a four-station hop decontamination site.

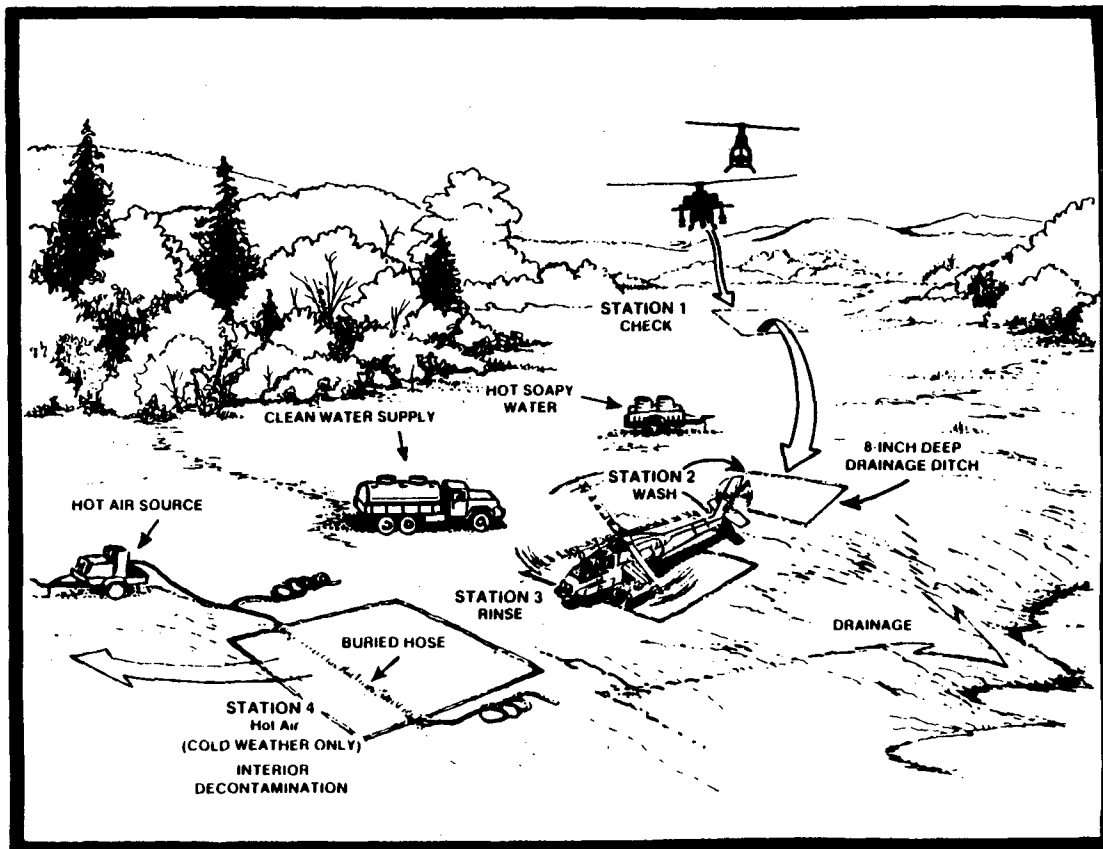

**Figure 6-3. Four-Station Hop Decontamination Site.**

- **Station 1**  
The station should be large enough to preclude other aircraft from having to land in the same spot. This will help avoid contaminating uncontaminated aircraft during the decontamination operation. Upon arrival at Station 1, the aviator will be ground-guided into position. After landing, the aviator should place the collective full down and maintain engine RPM at flight idle. Decontamination personnel check the aircraft for contaminants with the M256 kit, M8 or M9 paper, or chemical agent monitor (CAM). If the aircraft is contaminated, the aviator will reposition the aircraft to station 2 for the decontamination process.
- **Station 2**  
Decontamination personnel use the M17 Sanator to wash the entire aircraft with hot, soapy water. Visible contaminants must be washed from the windscreen before the aircraft is moved to the next station. Aviators must ensure that windscreens are clear of suds.
- **Station 3**  
The aircraft is rinsed with clean water with the M17 Sanator. (Warm water is preferred.) At no time will water be directed into the air intake system. Water will not be directed onto windscreens unless they required decontamination in Station 2.

- **Station 4**

Exterior areas that were washed and rinsed in stations 2 and 3 will be deiced and/or dried and checked for remaining contaminants. The aircraft's interior also will be decontaminated. If a hot air source, such as a Herman-Nelson heater, is available, decontamination personnel can use it to blow warm air into the cockpit. However, hot air must not be directed onto instruments and gauges because they are easily damaged. Aircraft will be checked for additional contaminants before they are released.

**One-Station Method.** This station is established the same as the four-station methods, but the station itself is mobile. Aircraft arrive in flights of four to eight, depending on the size of the site. All aircraft in the flight land and shut down in a single area, and aircrews exit the aircraft. Decontamination personnel move equipment to the aircraft and perform the decontamination steps. Aircrews are decontaminated at a nearby decontamination area. The one-station method is relatively quick, but runoff from the aircraft will contaminate the ground. When an aircraft takes off, rotor wash may recontaminate the aircraft as well as personnel and equipment at the site. Pressurized water sources include the M12A1 power-driven decontaminating apparatus, the M17 sanator system, and the M13 decontaminating apparatus portable. Figure 6-4 shows a one-station decontamination site.

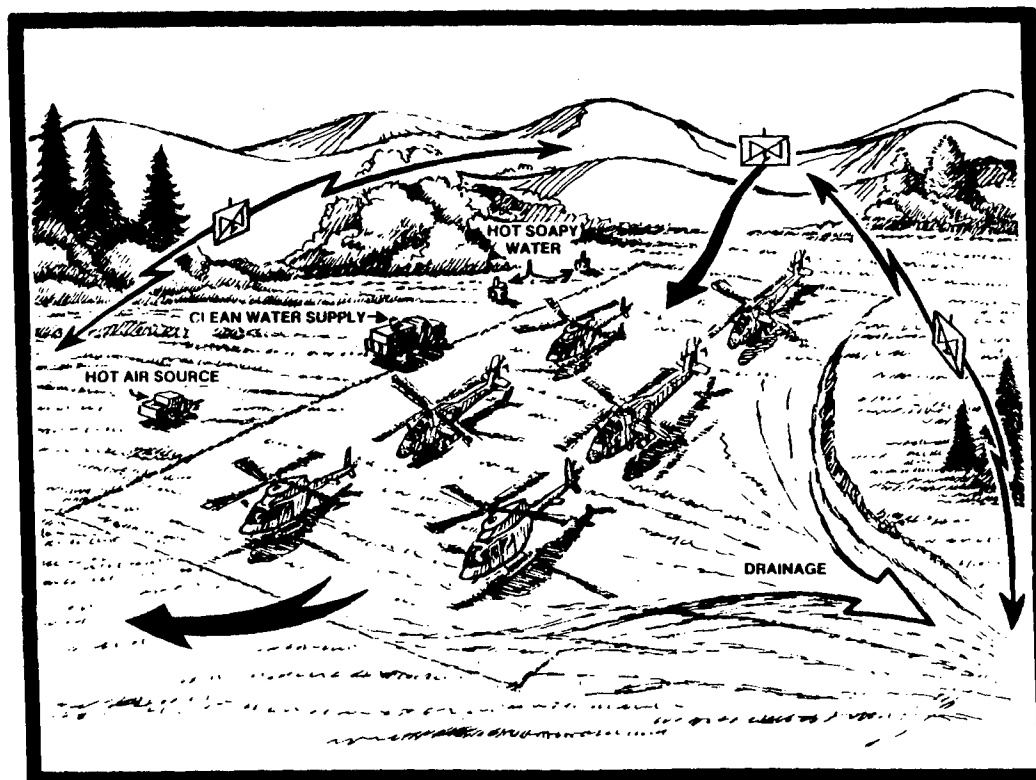

Figure 6-4. One-Station Decontamination Site.

**Safety Precautions.**

- At no time will station personnel cross in front of an aircraft that has a turret weapon system whether it is armed or not. If an aircraft has a weapon system of any type, the aircrew will ensure that the system is cleared and placed on SAFE before the aircraft enters the decontamination station. Station personnel also must not cross to the rear of a running aircraft unless a proper clearance distance from the turning tail rotor is maintained.
- The team leader will give all signals to aircrews. Before signaling the aircrews to move aircraft, the team leader will have visual contact with the other team member. Team leaders in each station will wear white arm bands in the manner prescribed by the unit SOP.
- Additional decontamination resources will be required by Aviation units to conduct Hasty/Deliberate decontamination. This problem exists primarily due to space constraints and safety problems associated. Aviation units, at a minimum, should add an additional M13 decontamination apparatus to each resupply/rearm vehicle. Additionally vehicles initially planned for resupply/rearm may have to become carriers for water and decontamination assets. (The M13 decontamination apparatus for ground vehicles has DS-2 which can NOT be used on helicopters.)

Some final thoughts on decontamination in general:

- Requisition early (pre-stock) and requisition as soon after attacks as possible. Decontamination operations are labor and resource intensive.
- Well-trained leaders and knowledgeable soldiers will speed and ease decontamination operations.
- Know your people and know their sizes; requisition wisely; pay special attention to smaller items sometimes overlooked, i.e. inlet valve assemblies, head harnesses, eye lens outserts, drinking hose assemblies, canister hoses, vehicle and NBC filters, etc.
- Follow guidance in FM 3-5 to determine quantities of decontaminants required. If personnel do not have another set of MOPP gear, they should not remove gear (contaminated). If other gear is available and the situation permits, the crew should change into the uncontaminated gear.

## **FORWARD ARMING AND REFUELING POINTS**

### **Aircrew Support**

Forward arming and refueling points enable aviation units to apply continuous pressure on the Threat by decreasing turnaround times and by increasing loiter times. If FARPs are near or collocated with other units that have NBC support, NBC support for the aviation elements may be arranged with those units. In a CB environment, the commander will have difficulty keeping attack aircraft in operation. However, teams of aviation assets can rotate in and out of the MOPP gear exchange or rest and relief

site after several turnarounds. Clean and contaminated FARPs may be established to facilitate rapid relief-on-station operations and prevent repetitive contamination. The mission and temperature will determine how often the crews visit a rest and relief station.

#### NBC Planning

Detailed preplanning is the key to successful FARP operations in an NBC environment. Because FARPs are vital to the aviation mission, the issues below are included to assist commanders in planning FARP operations. General, nuclear damage, and CB contamination considerations are covered in the issues listed below.

The manner by which friendly STRIKWARNs or CHEMWARNs will be passed to FARPs and to aircraft being serviced at the FARPs.

- The use of smoke to lessen FARP vulnerability during site preparation and closure.
- The training of at least one member of the FARP in the two previous considerations.
- Dosage estimates when the FARP is operating in a radiologically contaminated area; how this dosage estimate will affect operational planning.
- Awareness of FARP personnel concerning nuclear damage to aircraft. (They must be able to identify nuclear damage to armament systems.)
- Knowledge of FARP personnel on how to minimize nuclear blast effects and thermal damage to fuel blivets and other FARP equipment.
- Assistance of the supported or parent unit in hasty decontamination.
- Guidance to FARP ground personnel concerning the best routes through or around contaminated areas.
- Visual or radio communications FARP personnel may use to warn the aircrew on an incoming aircraft that a FARP site is contaminated. Also, the method by which an aircrew warns FARP personnel that the aircraft is contaminated.
- In a chemically contaminated area, the individuals designated to dismount at the FARP.
- If aircrews dismount, the provisions made for spot decontamination to lessen the transfer of contamination.
- The provisions made to keep contamination out of the cockpit (especially that carried in on boots) when aircrews enter the aircraft.
- During high-sortie missions, how FARP personnel wearing MOPP4 gear can keep up with the workload; plans made for rest and relief or assistance.
- When JP4 or JP8 is used as a spot decontaminant, the need for personnel to be trained in its hazards.
- The training of FARP personnel to use covers in a manner that does not create foreign object damage hazards.
- The preparation of FARP personnel to accept contaminated supplies.
- The coordination and provision of personal need for aircrews at the FARP.
- The commander must forward hazard information to FARPs. FARP elements use hazard information for selecting routes, setting up sites, and selecting clean areas for rest and relief. The FARP will probably become contaminated while support aircraft may become clean. However, the opposite may also occur. Aircrews and FARP personnel should establish a standard method of communicating NBC hazard warnings between them. Hand and arm signals, panels, flags, or any other type of standard signal should be included in unit SOPs.



**Chapter 7**

**Laser Hazards on the Middle East Battlefield**

**GENERAL**

Aviation personnel must prepare for encounters with directed energy in combat in the Middle East. All parties to the conflict, both friendly and advisory, have access to directed energy weaponry. Laser rangefinders/designators used by both threat and friendly forces are sources of laser hazards within the combat environment. Laser emitters may be encountered almost anywhere on the battlefield, and they pose a serious threat to aircrews and acquisition, targeting and visionic equipment onboard the aircraft. Laser hazards can occur not only from a direct hit from a laser beam, but also from a reflected hit from a beam directed elsewhere. The laser light may be reflected from water, aircraft canopies or windshields, or other reflective surfaces. Injury can also result from reflection from nonpolished objects like a wall or a sand dune. In-band laser light can penetrate aircraft canopies and reflect from lightly painted surfaces and glass instrument covers.

**THE HAZARD**

The hazards to personnel and equipment from lasers depend largely on the radiation wavelength, the beam intensity, and the exposure time. The danger to personnel results from either direct or reflected exposure to radiation, which could ignite clothing or damage unprotected skin or eyes. Lasers can also adversely affect optical systems. Both direct-view (binoculars and weapon sights) and indirect (image conversion devices) optical systems can be damaged by the effects of far-, near-, and visible-infrared lasers.

**EFFECTS ON PERSONNEL**

If an individual's eyes are struck by a visible light laser, the individual may experience flash blindness or other injury or both. The victim will feel nothing if the injury is minor. A common symptom is pain similar to that caused by a grain of dust in the eye. The victim may have difficulty seeing fine details and may experience disorientation or pain or see dots and streamers floating in his vision.

Only the visible- and near-infrared light entering the eye will harm the retina, as shown in Figure 7-1. The eye is more vulnerable to damage at night since the iris is normally open wider than during the day (Figure 7-2). Laser effects on the eyes include flash blindness, minor and major retinal burns, and impaired night vision. The effect of flash-blinding on vision is similar to the temporary effect of a flash-bulb. The effects last from seconds to minutes and may leave colored spots in the eyes. Minor retinal burns can cause discomfort and interfere with vision and may not be immediately noticeable. Major retinal burns result in major damage to or loss of vision. The injuries involve bleeding inside the eye, immediate pain, and possible permanent loss of or impaired vision. Night vision acuity may be lost because of undetected damage. A laser attack that damaged the fovea, where most of the cones are located, might go unnoticed because rod cells are used for night vision. Foveal damage may affect vision sharpness and color interpretation. Normal cockpit tasks, obstacle avoidance, and the use of acquisition or targeting devices could become difficult or impossible.

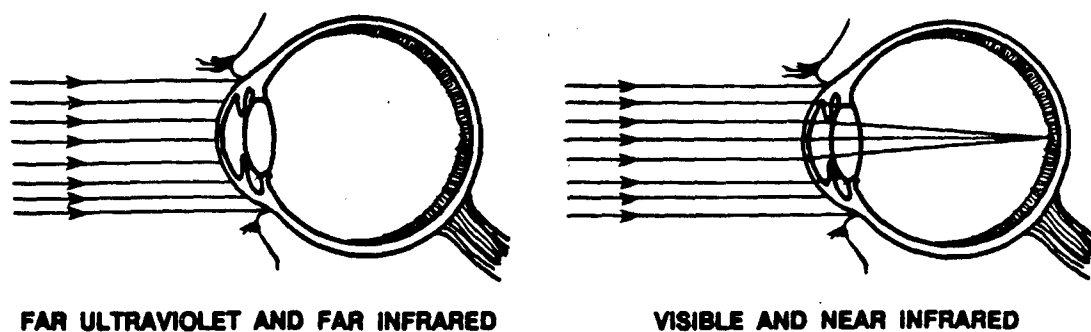

Figure 7-1. Laser Entering the Eye.

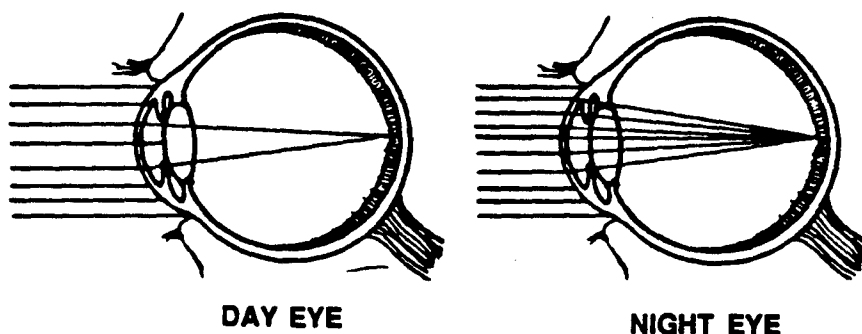
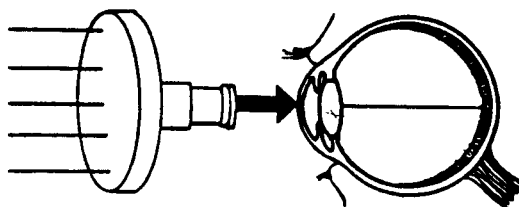

Figure 7-2. Increased Night Hazard.

The use of magnifying optics in a laser environment can be extremely dangerous. The optics focus the beam to a much smaller area and concentrate the power of the beam. Binoculars, TSUs, TADS (direct-view optics), and handheld stabilized sights send more light into the eye. Figure 7-3 illustrates how magnifying devices increase the vulnerability of the eyes to laser damage. At tactical distances of 1 to 2 kilometers, exposure to lasers through unprotected optics (without filters) makes injury likely. However, the narrow field of view of optical systems and the small spot size reduce the likelihood that a laser beam will actually enter the system and damage the eye.



**MAGNIFYING OPTICS**

Figure 7-3. Magnification Hazard.

Burns may result from reflected laser light focused on the retina of the eye. Figure 7-4 shows an example of hazardous laser reflection.

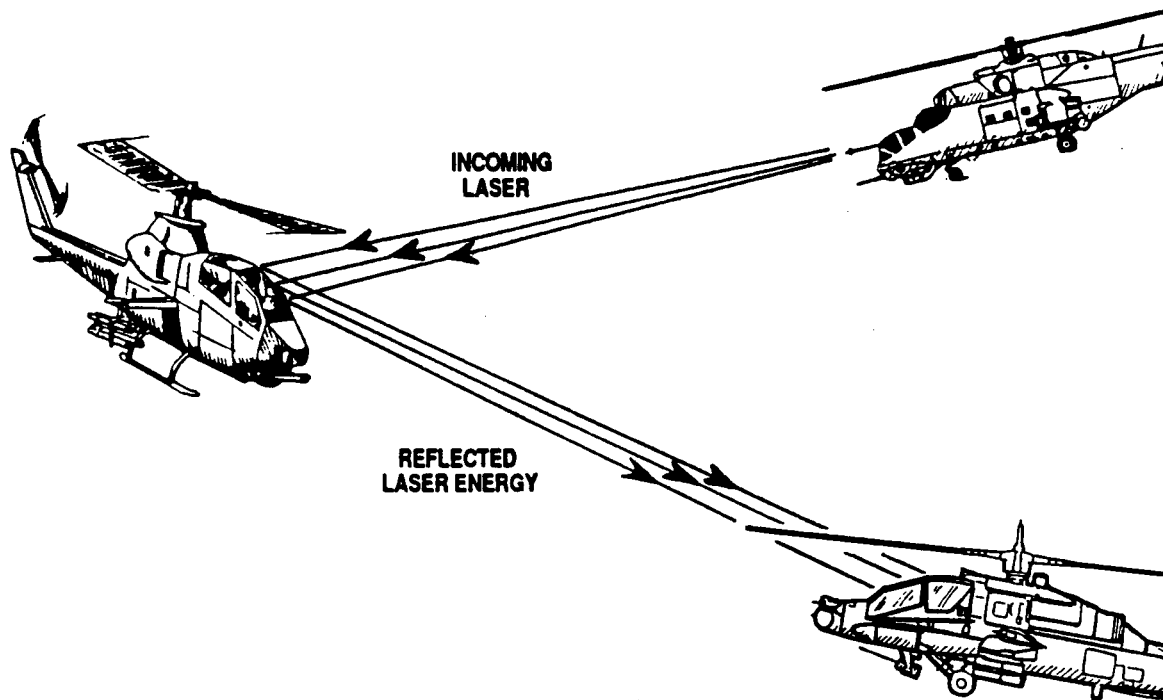

Figure 7-4. Hazardous Laser Reflection.

## **EFFECTS ON EQUIPMENT**

### **Effects on Direct-View Optics**

Direct-view optics are hard to damage with visible- and near-infrared lasers. These optics are designed to pass as much light as possible. If a laser is powerful enough or close enough, it may pit reticles, destroy protective filters, and crack lenses.

**Nonfiltered Optics.** The optical device may not have the right filter in place when lased. In this case, the viewer may suffer severe eye damage long before the optical sight is damaged.

**Ordinary Optics.** Far-infrared lasers do not penetrate ordinary optics. The energy is deposited on or in the lenses and windows. A far-infrared laser that is powerful or close enough can craze, crack, or shatter outside lenses or windows. Crazing results in a frosted or sand-blasted appearance. A crack with no impact scar (like the scar from a rock on a windshield) may indicate laser damage.

### **Effects on Indirect-View Optics**

Image conversion devices, such as night vision devices and tracking systems on current weapon systems, are subject to damage from near-infrared and visible lasers. If the image converter is sensitive to light from the laser, the viewer will see a bright flash of light. Overloaded circuits may cause the system to lose power and then restart. If the damage to the tube is not severe, the display will reappear with dark spots or lines. If the tube is destroyed, the display will remain dark. The flash from the display may dazzle the operator briefly. However, the operator is completely protected from eye injury by such systems.

## **PASSIVE COUNTERMEASURES**

The most likely known laser threat is the Laser Rangefinder/Designator (LRF/D). Aircrews must be able to recognize the presence of LRF/D on the battlefield. Unfortunately, each device can come in many possible sizes and shapes. However, some reliable clues can help determine whether a device is a laser range finder/designator.

### **LASER RANGEFINDERS/DESIGNATORS USED BY PERSONNEL**

The size of an LRF/D can vary from the size of binoculars (handheld) to the size of an orange crate (mounted on a vehicle). Laser range finders/designators used by personnel are easily recognized.

### **LASER RANGEFINDERS/DESIGNATORS USED ON VEHICLES**

The LRF/D system mounted on a vehicle can be an integral part of the platform with very few, if any, discernible physical characteristics. This is true of an LRF/D mounted on a tank. The best way to determine whether an armored vehicle has an LRF/D is to know which vehicles are equipped with these devices and to be able to recognize them.

### **LASER FLASH**

A smokeless, red flash from a device is a clue that it is an LRF using a ruby laser. However, some lasers use invisible infrared light. Therefore, lack of a visible flash from a device does not mean that it is not an LRF. If a crew member detects an LRF flash, he should not look at it without laser-filtering protection.

### **EMPLOYMENT**

Sometimes an LRF can be identified by the way it is being employed, especially if it is used with a missile system. The way the LRF is handled and other specific things that occur while it is being used can help identify it.

## **PROTECTIVE MEASURES AND DEVICES**

Whether laser use is deliberate (enemy) or accidental (friendly), the results will be the same. If a crew member uses an optical sight (direct-view) or scans without a laser filtering device and laser light enters his eyes, injury will probably occur. Protective measures and devices can prevent or reduce the severity of laser injuries on the battlefield. Night vision devices, such as the AN/PVS-5 and the AN/AVS-6, and thermal-imaging systems offer complete eye protection from low-energy lasers.

### **LASER LIGHT**

#### **In-Band**

Laser light, which is in-band to direct-view (400 to 700 nanometers) optical devices, will pass directly through the system unaffected by the optical glass. Therefore, eyeglasses or sunglasses will not prevent eye injury from in-band lasers. Aircrews must wear specially designed protective visors on their helmets to obtain laser protection.

#### **Out-of-Band**

Out-of-band laser light is absorbed by the first optical source in the optical train. Thus, aircrews wearing eyeglasses or sunglasses or looking through any optical device will be somewhat protected from eye injury. Some damage to a crew member's cornea may occur unless he places an optical lens in front of his eye or uses a protective visor.

### **MAGNIFYING OPTICS**

Since direct-view magnifying devices increase the severity of eye injury from lasers, aircrews should use magnifying optical devices only when necessary for critical tasks such as Threat identification. In a known or suspected laser environment, indirect-view magnifying devices, such as the FLIR or the TADS operated in the day television mode, will protect the observer from eye injury.

### **LASER FILTERS**

Laser light can be stopped by filters. A good laser filter will absorb or reflect more than 99 percent of the laser light for which it is designed. A laser filter must allow all other colors to pass through except those that it protects against. Therefore, a laser filter is useful only against those lasers for which it is designed. The filters may be built into the equipment or come as clip-on additions to the eyepiece.

### **ELECTRO-OPTICAL WARNING SYSTEM**

The AN/AVR-2 laser warning receiver will warn aircrews against laser-equipped Threat weapon systems. The AN/APR-39(V)1 will identify the quadrant from which the Threat laser range finder is lasing the aircraft.

## ACTIVE COUNTERMEASURES

Some tactical expedient protective measures will be effective against laser exposure. However, they may give aircrews a false sense of security in the wrong circumstances. They may also increase vulnerability to lethal weapon fire. Some expedients that reduce vulnerability and probability of injury are detection avoidance, observation techniques, and smoke (obscurants). Counterfires can cause defeat of laser threat both before and after detection.

### DETECTION AVOIDANCE

Detection avoidance measures follow the rule of "what can be seen can be hit." Detection avoidance techniques maximize the benefits of terrain features for available cover and concealment. The masking provided by terrain and vegetation can prevent detection by Threat laser devices. The cardinal rules for detection avoidance are given in TC 1-201.

### OBSERVATION TECHNIQUES

If aircrews detect the use of lasers, they should not observe the area unless all crew members use protective devices. These devices include laser protective visors or indirect-view observation devices.

### SMOKE (OBSCURANTS)

Smoke or thick, naturally occurring obscurants can block visible and near-infrared lasers. Some weather conditions can reduce the effectiveness of laser weapons or prevent their use altogether. Weather conditions, such as clouds, fog, rain, and snow, affect the electro-optical characteristics of the target. Vehicle- and artillery-deployed smoke can help absorb or block out laser energy. Even with an intense amount of smoke protection, some lasers are powerful enough to penetrate through the smoke and cause eye damage.

### COUNTERFIRES

The sensitive and fragile sophisticated subsystems of laser weapons make them highly susceptible to damage from both hostile fires and movement. A "hard kill" from indirect fire is not necessarily required to defeat a laser weapon. Vibration from explosions may possibly cause an optical system to become misaligned and thus useless. Vibration associated with high speed crossing of rough terrain could damage the optical train and cause breakdown.

Thus, diversionary tactics to keep Threat lasers moving from place to place on the battlefield may be effective. Artillery fire is an effective countermeasure to lasers. It creates a dust cloud around the laser vehicle and contaminates or shatters mirrors, limiting the effectiveness of the laser beam.

Another weakness of a laser weapon is the fragile exit window or mirror for the laser. Breaking this window with small-arms fire, Flechette or fragmentation artillery munitions, could render the laser ineffective. The window or mirror must be kept clean to transmit the laser beam outward. Any dirt or film attached to the window or mirror would absorb the energy instead of transmitting it.

## **SURVIVAL IN AN ACTIVE LASER ENVIRONMENT**

### **POSITIVE UNIT TRAINING**

#### **Leadership**

Good leadership can prevent panic. Positive training before battle, setting an example during laser encounters, and knowing what to do are critical. Stress in eye-injured soldiers can best be treated by leader example. Fear of blindness will be a natural response. Increased knowledge of lasers will help build the soldiers' confidence and offset their fear about lasers. Commanders should include laser avoidance and reaction methods in unit SOPs.

#### **Laser Misinformation**

The most serious obstacle to training and operating effectively on the directed energy weapon battlefield is the false impression many people have about lasers. Science fiction and sensational press are prime sources of misleading information about lasers. Unit training efforts should focus on common misimpressions and replace them with truths about lasers.

#### **Basic Laser Risks**

Aviation personnel must be made aware of basic laser risks. Aircrews and aviation support personnel must be informed about the risks associated with the operation of aircraft laser equipment. Aircrews should be cautioned about the type and extent of injuries that can occur in and around areas where laser range finders/designators are operated. They must also be informed about the dangers associated with the deliberate ranging of friendly aircraft, vehicles, and personnel. A laser beam focused near or on the aircrew's faces or optics or even on the side of a vehicle may allow laser energy to penetrate the unfiltered magnifying optics. Crew members not using filter protection devices may sustain serious eye injury.



### **Protective Measures**

Aviation unit training must emphasize aircrew use of the aviator's helmet laser visor when aircrews perform missions in an anticipated or a known laser environment. To reduce the chances of laser injury, aviation support personnel must be trained to wear laser protective spectacles when performing aviation ground support functions.

### **Laser Hazard Reactions**

Aviation units SOPs must include the tactical reactions expected of unit personnel if laser hazards are encountered. Some guidelines to consider when developing a laser SOP are discussed below.

- If the laser spot is nearby but not on you, the laser may look like a single bright, pure-colored flash or a series of flashes.
- If you detect a laser beam while at the flight controls, close your eyes momentarily if it will not jeopardize the immediate safety of your aircraft and crew. Turn your head away or maneuver the aircraft to avoid viewing the laser directly. As soon as possible, use the protective visor or spectacles, submit the appropriate report, and continue the mission.
- If you detect a laser beam while not at the flight controls, momentarily close your eyes or look away from the laser. Use the protective visor or spectacles and take the flight controls if required. Assist the pilot in command as necessary in submitting the appropriate report and accomplishing the mission.
- If you experience a sudden blurring of vision or a feeling like sand in your eye, you may have been hit with an infrared laser. In extreme cases, sudden pain and loss of vision may occur. (You will not be forewarned because humans cannot see infrared laser light.) Pain or the inability to see may require the immediate transfer of the flight controls. The injury may be so severe that medical aid is required before continuation of the mission.

### **FIRST AID**

Unit training should include first aid training for laser casualties. Aviation missions are frequently conducted in remote areas where medical assistance is not readily available. Therefore, crew members should be trained in the treatment of laser injuries. FM 8-50 discusses first aid for laser casualties in detail.

### **Flash Blindness**

Flash-blinded crew members will recover in a matter of seconds to minutes if no other injury is present.

**Minimal Retinal Burns**

Some disorientation and loss of fine vision may result from minimal burns. A crew member suffering from these injuries should not be assigned tasks that require fine visual acuity until his vision clears.

**Serious Injury**

If a crew member is seriously injured, the crew may proceed to a medical treatment facility if the mission allows. If the crew member can function (single eye injury and no shock or panic) and another crew member can assume aircraft control, then the crew should continue the mission. Uninjured crew members should watch injured crew members for signs of shock.