



# High-Pressure Combustion Chamber Dynamics

Vigor Yang  
The Pennsylvania State University  
University Park, Pennsylvania 16802, U.S.A.  
*\*Email: [vigor@psu.edu](mailto:vigor@psu.edu)*

Presented at  
International Symposium on Energy Conversion Fundamentals  
Istanbul, Turkey, June 21-25, 2004

---

# Report Documentation Page

Form Approved  
OMB No. 0704-0188

Public reporting burden for the collection of information is estimated to average 1 hour per response, including the time for reviewing instructions, searching existing data sources, gathering and maintaining the data needed, and completing and reviewing the collection of information. Send comments regarding this burden estimate or any other aspect of this collection of information, including suggestions for reducing this burden, to Washington Headquarters Services, Directorate for Information Operations and Reports, 1215 Jefferson Davis Highway, Suite 1204, Arlington VA 22202-4302. Respondents should be aware that notwithstanding any other provision of law, no person shall be subject to a penalty for failing to comply with a collection of information if it does not display a currently valid OMB control number.

1. REPORT DATE <b>22 JUN 2004</b>		2. REPORT TYPE <b>N/A</b>		3. DATES COVERED <b>-</b>	
4. TITLE AND SUBTITLE <b>High-Pressure Combustion Chamber Dynamics</b>				5a. CONTRACT NUMBER	
				5b. GRANT NUMBER	
				5c. PROGRAM ELEMENT NUMBER	
6. AUTHOR(S)				5d. PROJECT NUMBER	
				5e. TASK NUMBER	
				5f. WORK UNIT NUMBER	
7. PERFORMING ORGANIZATION NAME(S) AND ADDRESS(ES) <b>The Pennsylvania State University University Park, Pennsylvania 16802, U.S.A.</b>				8. PERFORMING ORGANIZATION REPORT NUMBER	
9. SPONSORING/MONITORING AGENCY NAME(S) AND ADDRESS(ES)				10. SPONSOR/MONITOR'S ACRONYM(S)	
				11. SPONSOR/MONITOR'S REPORT NUMBER(S)	
12. DISTRIBUTION/AVAILABILITY STATEMENT <b>Approved for public release, distribution unlimited</b>					
13. SUPPLEMENTARY NOTES <b>See also ADM001793, International Symposium on Energy Conversion Fundamentals Held in Istanbul, Turkey on 21-25 June 2005., The original document contains color images.</b>					
14. ABSTRACT					
15. SUBJECT TERMS					
16. SECURITY CLASSIFICATION OF:			17. LIMITATION OF ABSTRACT	18. NUMBER OF PAGES	19a. NAME OF RESPONSIBLE PERSON
a. REPORT <b>unclassified</b>	b. ABSTRACT <b>unclassified</b>	c. THIS PAGE <b>unclassified</b>			



# Why Supercritical Combustion Research?

- most booster engines operate at supercritical conditions
- current understanding not sufficient to support design optimization

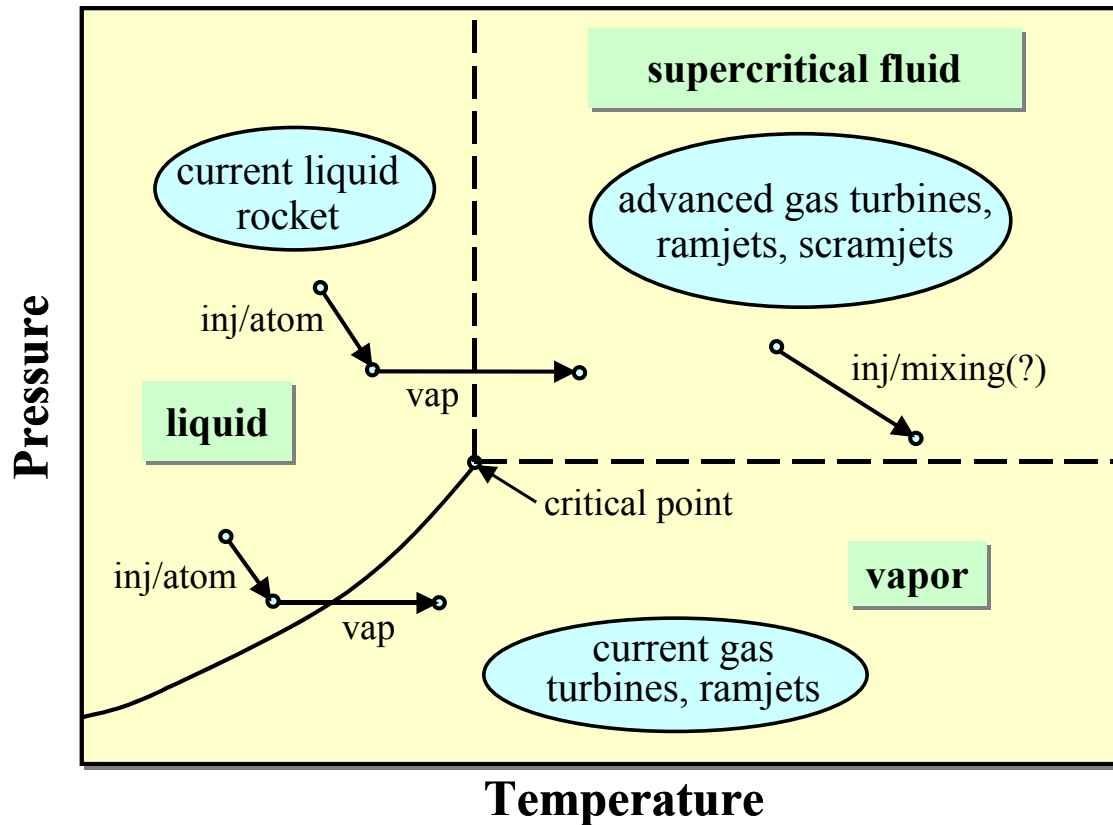



# Liquid Rocket Chamber Conditions

## Critical Properties of Propellants

	Pcr (MPa)	Tcr (K)
H <sub>2</sub>	1.3	33.3
Oxygen	5.04	154.4
RP-1	2.344	685.95

## F-1 Engine (Saturn V)

	Fuel Inj.	Oxy Inj.	Cham.
T (K)	294.3	89.5	3546
P (MPa)	7.9	8.8	7.8

## Space Shuttle Main Engine

	Fuel Inj.	Oxy Inj.	Cham.
T (K)	879.0	126.0	3700
P (MPa)	24.8	33.0	22.58

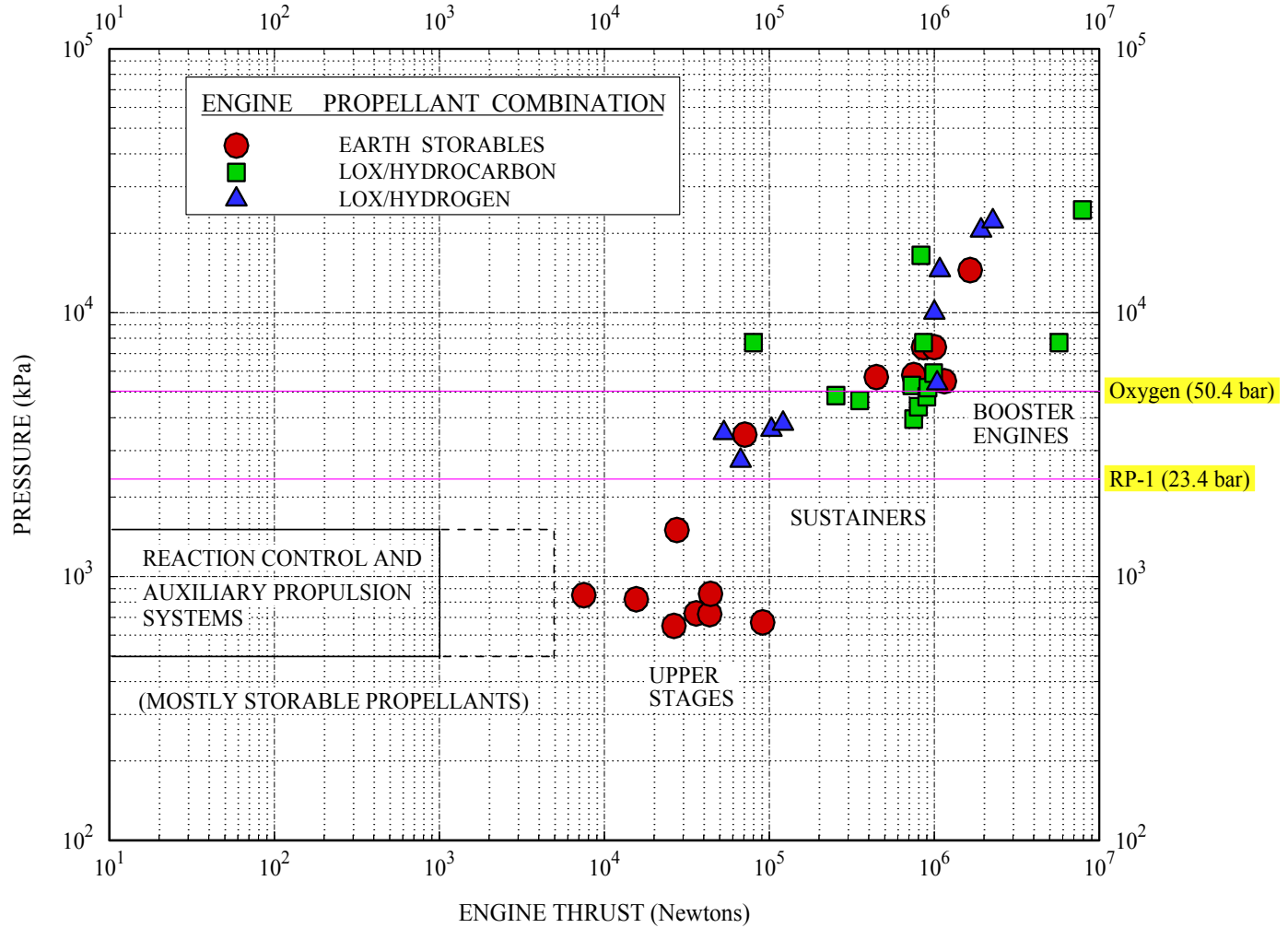



# Flow Diagram of RD-170 Engine

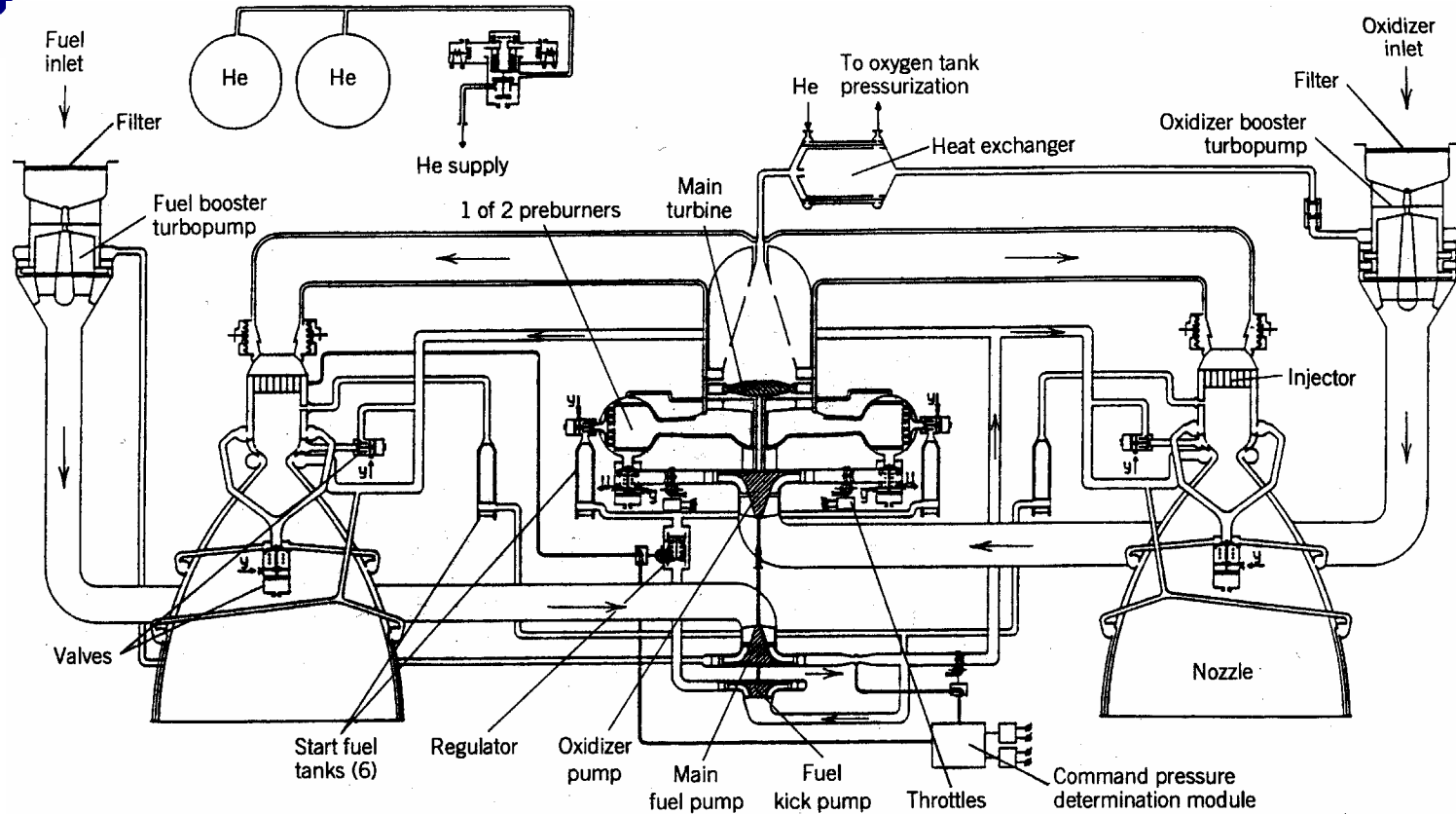

- Energia booster and Zenit first stage, up to 10 flights.
- LOX/kerosene, one main two boost turbopumps
- 806 ton thrust (vacuum), 337 seconds of  $I_{sp}$ , O/F ratio of 2.63
- Chamber pressure 250 bar, turbine inlet pressure 519 bar and temperature 772 K



- Tamura et al. / NAL (Japan)
- Mayer, Oschwald, Haidn, etc. / DLR (Germany)
- Habiballah, Vingert, Grisch, etc. / ONERA (France)  
Candel et al. / Ecole Central Paris (France)
- Woodward, Pal, Santoro, etc. / Penn State (USA)  
Talley, Chehroudi, etc. / AFRL (USA)  
Blevins, Morris, etc. / NASA Marshall (USA)

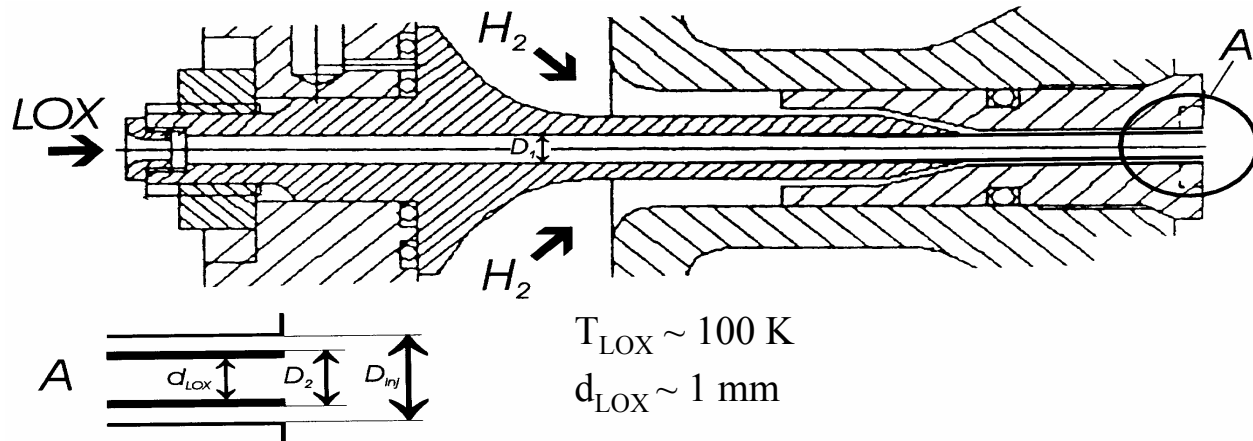

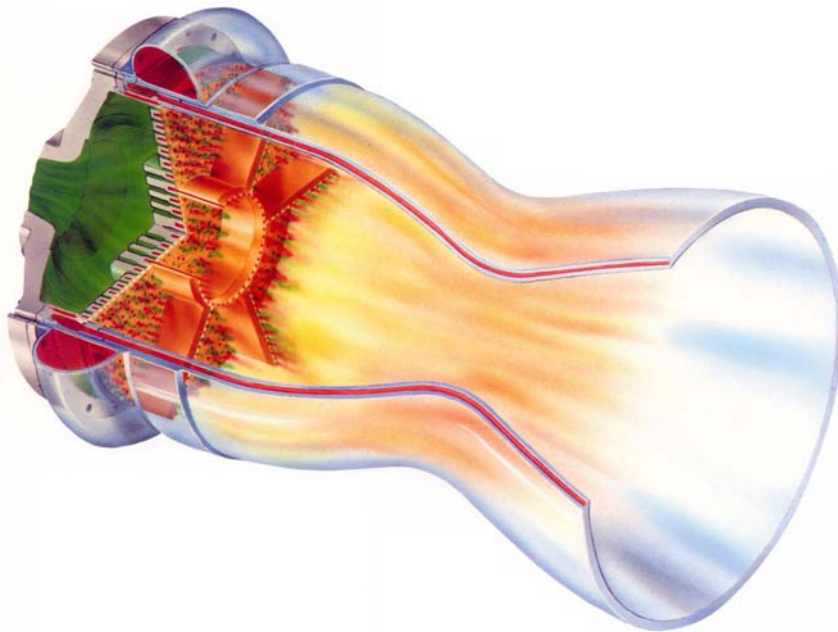
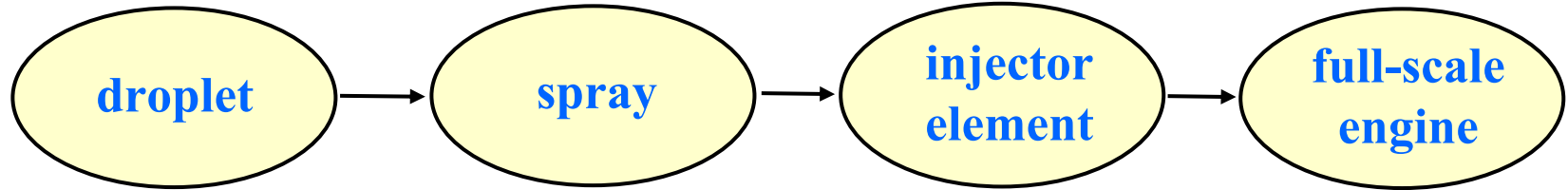

- Oefelein / DoE Sandia Lab. (USA)
- Bellan / NASA JPL (USA)
- Farmer / U. of Nevada (USA)
- Habiballah, et al. / ONERA (France)
- Yang / Penn State (USA)



$p_{cr} = 3.39 \text{ MPa}$ ,  $T_{cr} = 126 \text{ K}$ ,  $T_{\infty} = 300 \text{ K}$ ,  $T_{in} = 99 \sim 120 \text{ K}$   
 $u_{in} = 10 \sim 15 \text{ m/s}$ ,  $D_{in} = 0.254 \text{ mm}$ ,  $Re = 25,000 \sim 75,000$

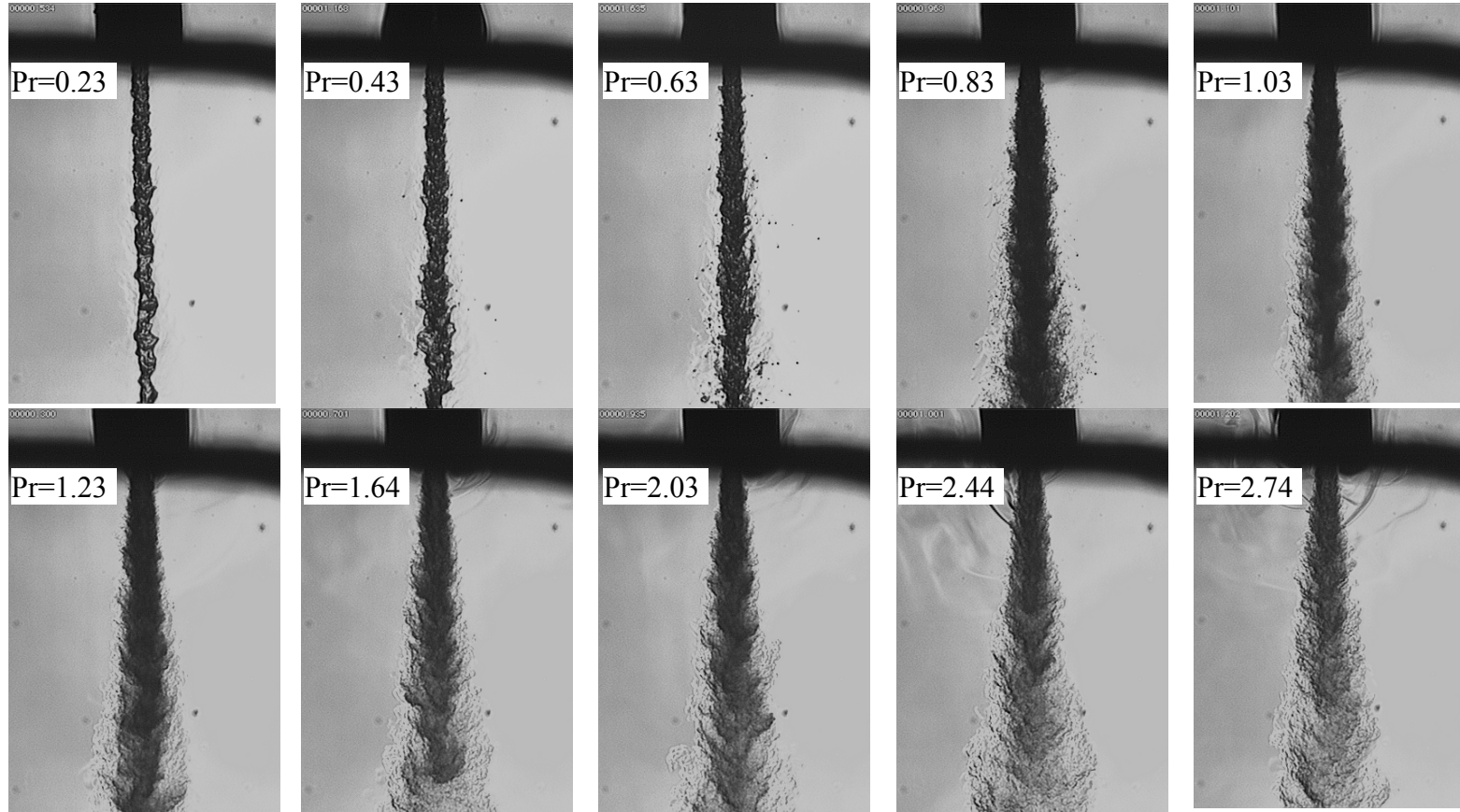





# Characteristics of Supercritical Fluid Jet

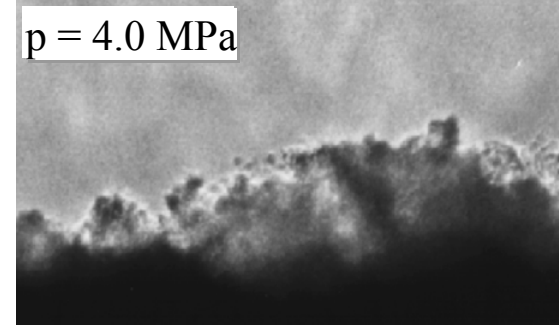
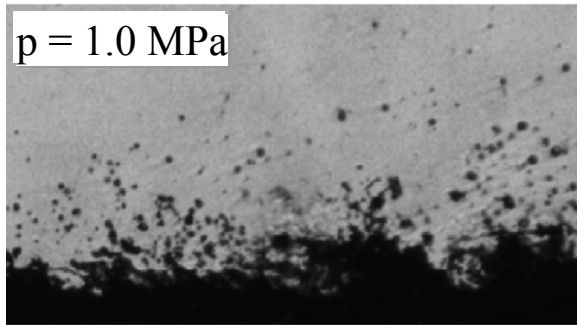
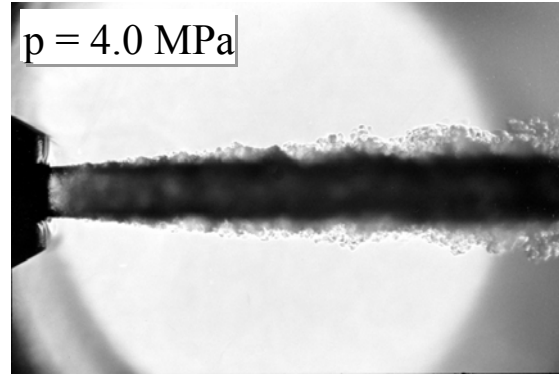
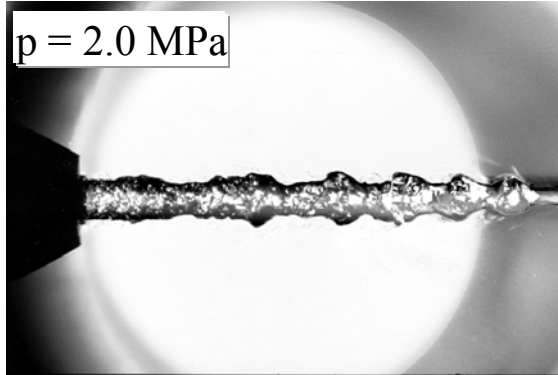

Mayer et al.  
*AIAA 1996-2620*  
 $T_{\text{LN}_2} = 105 \text{ K}$   
 $T_{\text{GN}_2} = 300 \text{ K}$   
 $u_{\text{LN}_2} = 10 \text{ m/s}$   
 $D_{\text{in}} = 1.9 \text{ mm}$

- **Thermodynamic non-idealities and transport anomalies in transcritical regime**
  - rapid property variations
  - large density gradient
- **Diminishment of surface tension and enthalpy of vaporization**
- **Pressure-dependent solubility**
- **High Reynolds number**



# Effect of Pressure on Turbulence Scales

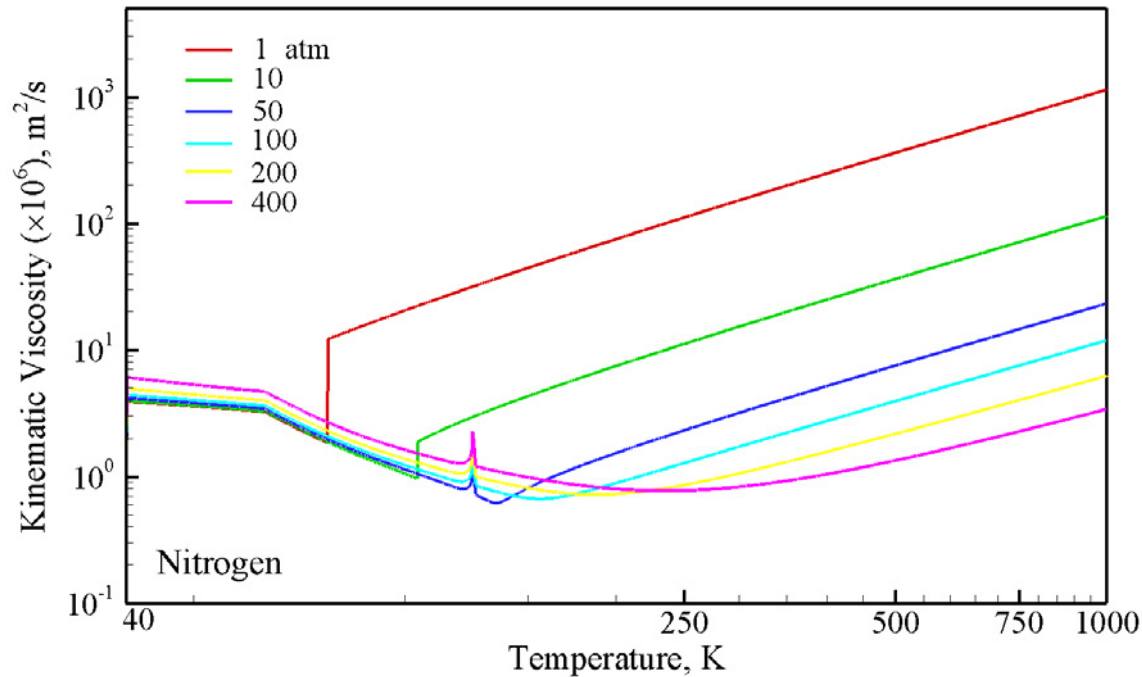

- Pressure increases from 1 to  $10^2$  atm,  $Re_t$  increases by  $10^2$
- Kolmogorov microscale  $\eta_t/l_t \sim Re_t^{-3/4}$  (decrease by 1.5 order)
- Taylor microscale  $\lambda_t/l_t \sim Re_t^{-1/2}$  (decrease by 1.0 order)



• Favre-filtered conservation equations

$$\frac{\partial \bar{\rho}}{\partial t} + \frac{\partial (\bar{\rho} \tilde{u}_j)}{\partial x_j} = 0$$

$$\frac{\partial (\bar{\rho} \tilde{u}_j)}{\partial t} + \frac{\partial (\bar{\rho} \tilde{u}_i \tilde{u}_j + \bar{p} \delta_{ij} - \bar{\tau}_{ij})}{\partial x_j} = - \frac{\partial (R_{ij} + L_{ij} + C_{ij})}{\partial x_j}$$

$$\frac{\partial (\bar{\rho} \tilde{E} + q)}{\partial t} + \frac{\partial [(\bar{\rho} \tilde{E} + \bar{P}) \tilde{u}_j - \overline{u_i \tau_{ij}}]}{\partial x_j} = - \frac{\partial (K_j + Q_j + q_j)}{\partial x_j}$$

• Closure requirements

- Thermodynamic and transport properties  $Z, C_p, \mu, \lambda, D_{im}$
- Subgrid-scale turbulence interaction  $R, L, C$
- Chemical kinetics  $\bar{\dot{\omega}}_i$



# Equations of State

- Soave-Redlich-Kwong (SRK)

$$p = \frac{RT}{v-b} - \frac{a}{v(v+b)}$$

- Peng-Rubinson (PR)

$$p = \frac{RT}{v-b} - \frac{a}{v(v+b)+b(v-b)}$$

- Benedict-Webb-Rubin (BWR)

$$p = \sum_{n=1}^9 a_n \rho^n + \sum_{n=10}^{15} a_n \rho^{2n-17} e^{-\gamma \rho^2}$$

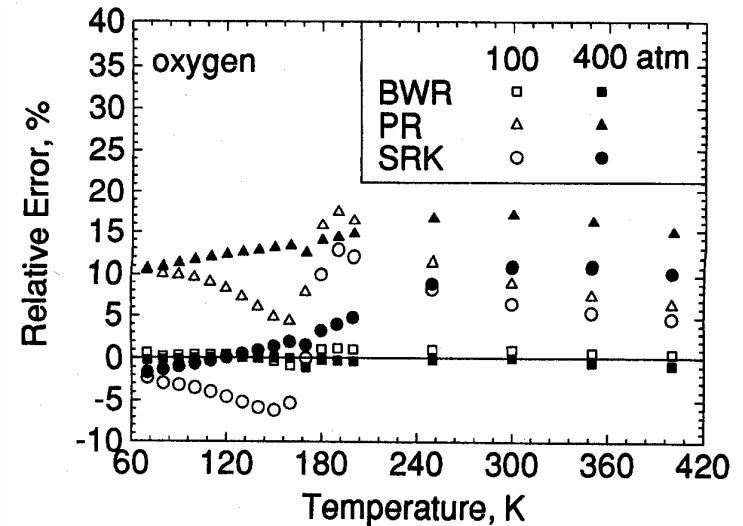
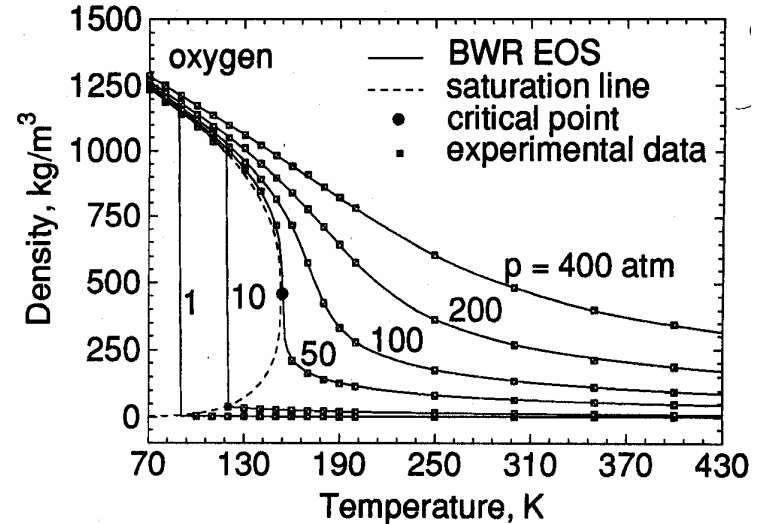



- Sensible enthalpy:  $h(\rho, T) = h^0(T) + \Delta h_{exc}(\rho, T)$
  - Internal energy:  $u(\rho, T) = u^0(T) + \Delta u_{exc}(\rho, T)$
  - Specific heat  $C_p(\rho, T) = C_p^0(T) + \Delta C_{p,exc}(\rho, T)$
- $\Delta h_{exc}, \Delta u_{exc}, \Delta C_{p,exc} =$  dense fluid corrections  
 $h^0(T), u^0(T), C_p^0(T), =$  values in dilute-gas limit

Pressure-explicit type of EOS:

$$\Delta h_{exc} = \int_0^\rho \left[ \frac{p}{\rho^2} - \frac{T}{\rho^2} \left( \frac{\partial p}{\partial T} \right)_\rho \right] d\rho + RT(Z - 1)$$

$$\Delta u_{exc} = \int_0^\rho \left[ \frac{p}{\rho^2} - \frac{T}{\rho^2} \left( \frac{\partial p}{\partial T} \right)_\rho \right] d\rho$$

$$\Delta C_{p,exc} = -T \int_0^\rho \left[ \frac{1}{\rho^2} \left( \frac{\partial^2 p}{\partial T^2} \right) d\rho + \frac{T(\partial p / \partial T)_\rho^2}{\rho^2 (\partial p / \partial \rho)_T} \right] - R$$



# Thermophysical Properties of Nitrogen

• compressibility factor

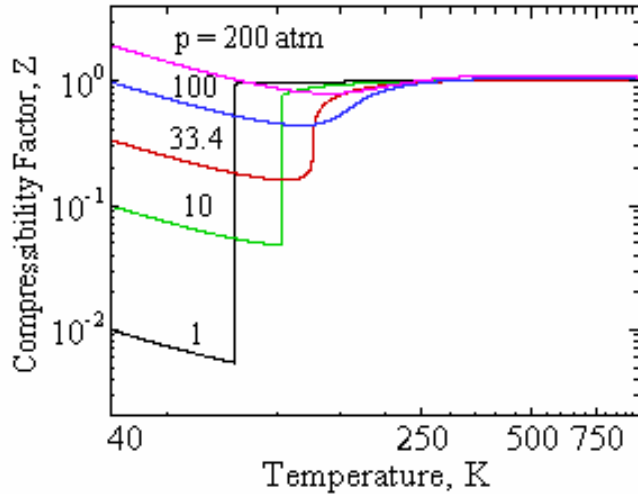

• specific heat

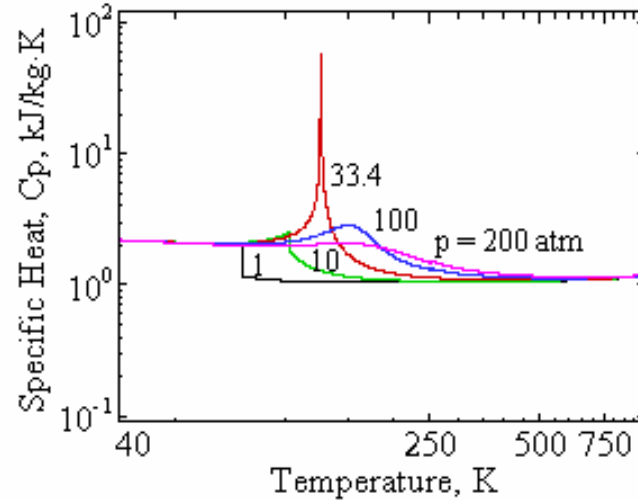

• dynamic viscosity

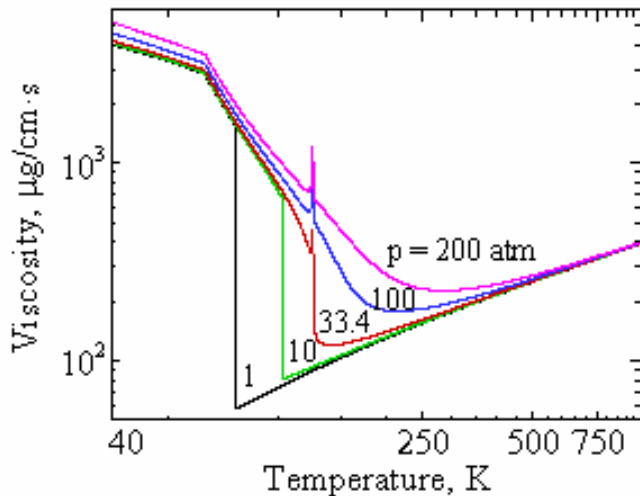

• thermal conductivity

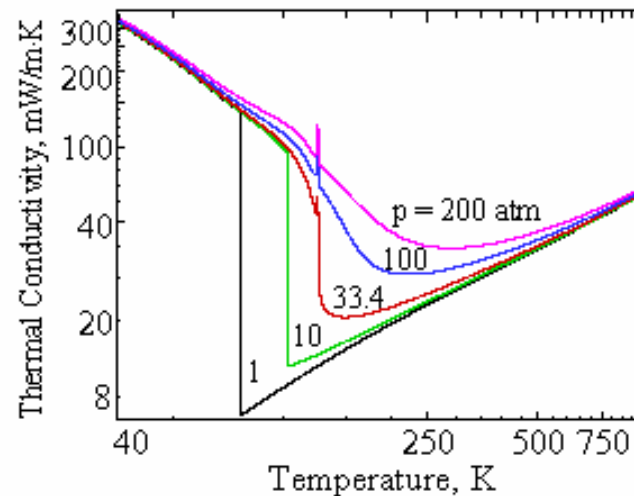



# Droplet Vaporization and Combustion in Quiescent and Convective Environments

Department of Mechanical & Nuclear Engineering

- **Liquid oxygen (LOX) droplet vaporization & combustion in hydrogen and water**  
 $5 < p_{\infty} < 300 \text{ atm}$   
 $500 < T_{\infty} < 2500 \text{ K}$   
 $50 < D_0 < 300 \mu\text{m}$
- **Hydrocarbon droplet vaporization & combustion in air and oxygen**  
 $5 < p_{\infty} < 200 \text{ atm}$   
 $300 < T_{\infty} < 2500 \text{ K}$   
 $100 < D_0 < 1000 \mu\text{m}$
- **Unsymmetrical dimethylhydrazine (UDMH) droplet vaporization and decomposition combustion**  
 $1 < p_{\infty} < 180 \text{ atm}$



# Spherical Mode (100 atm, 0.2 m/s; $t=610 \mu\text{s}$ )

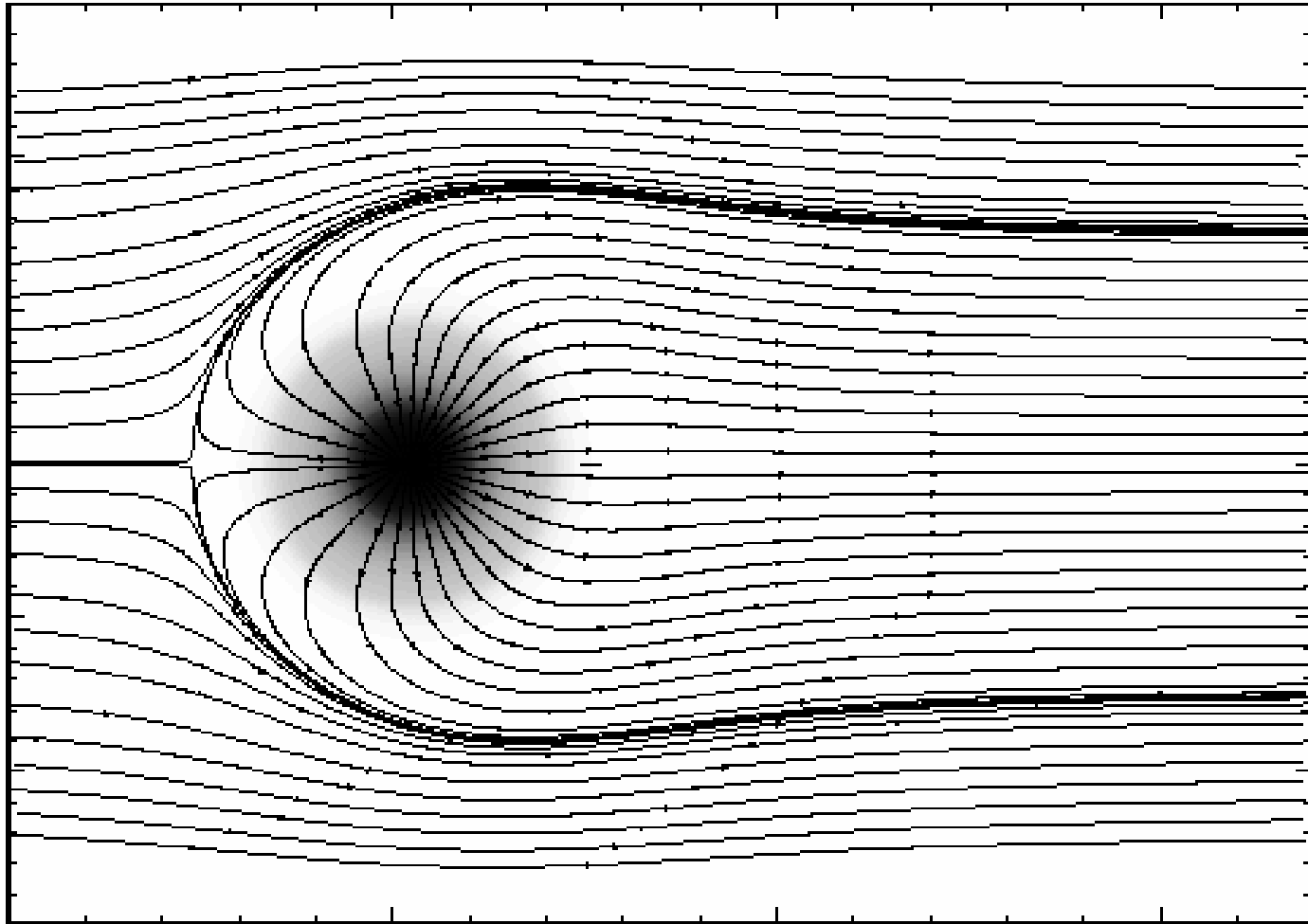



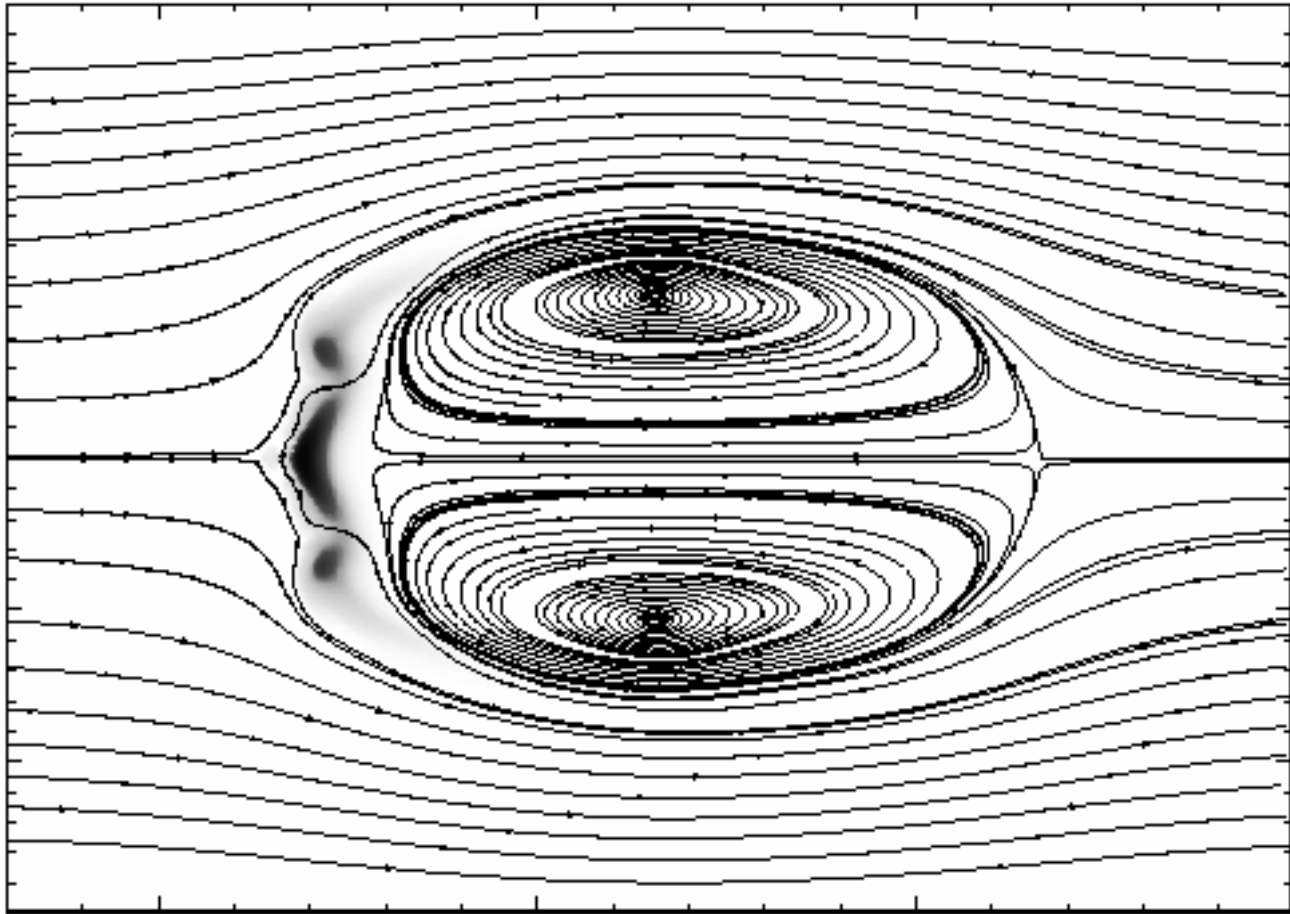



# Flow and Temperature Fields

Department of Mechanical & Nuclear Engineering

$P_\infty = 100 \text{ atm}$ ,  $T_\infty = 1000 \text{ K}$ ,  $u_\infty = 20 \text{ m/s}$ ,  $T_0 = 100 \text{ K}$ ,  $d_0 = 50 \text{ }\mu\text{m}$ ,  $H/R = 8$

$t = 8 \text{ }\mu\text{s}$

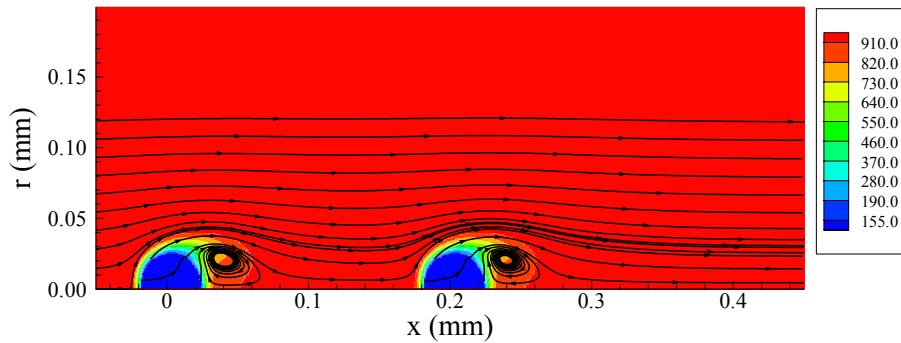

$t = 90 \text{ }\mu\text{s}$

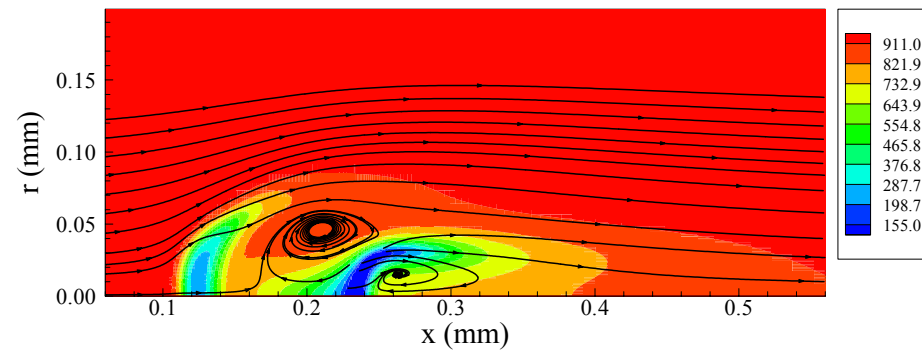

$t = 40 \text{ }\mu\text{s}$

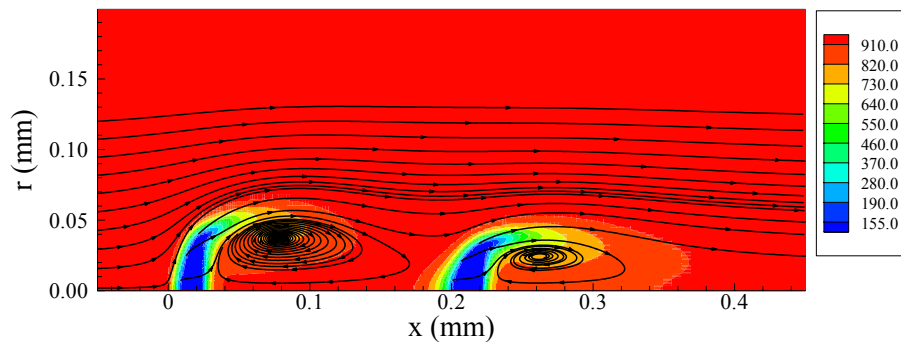

$t = 110 \text{ }\mu\text{s}$

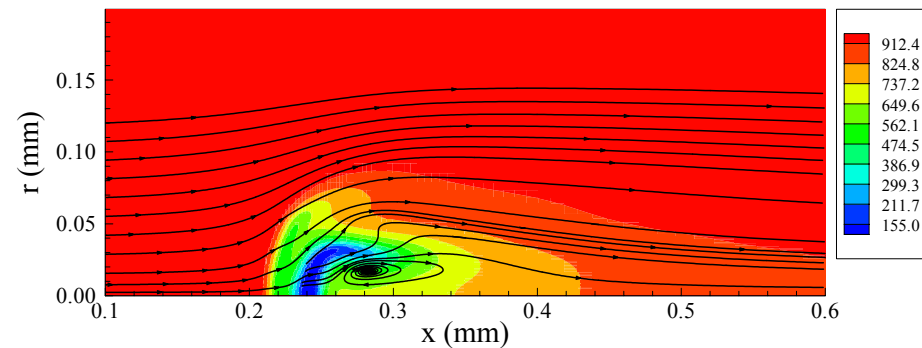

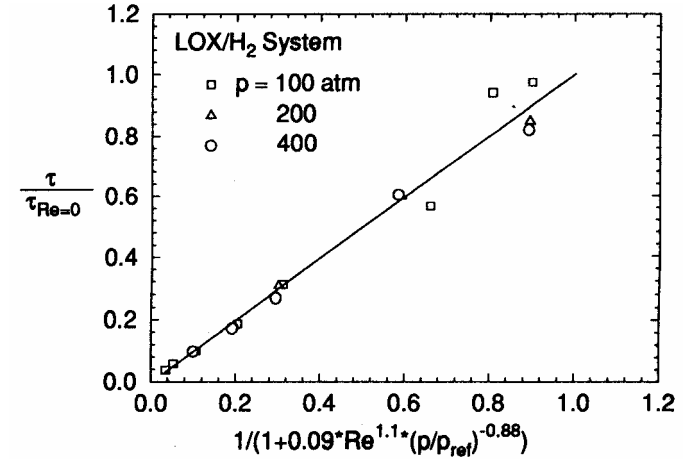
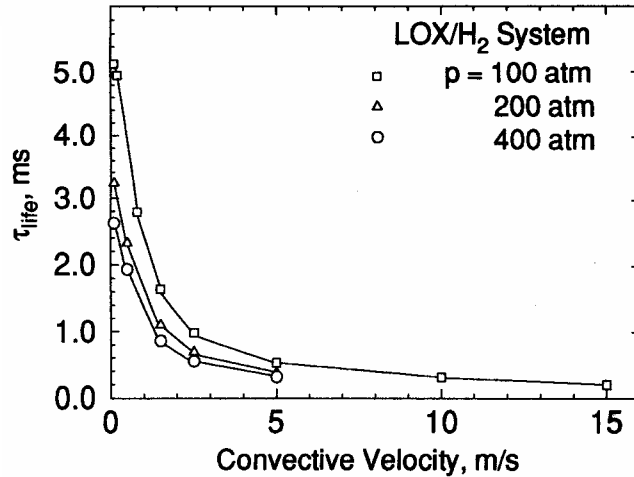

- **effect of ambient pressure on**
  - thermophysical properties
  - critical mixing state
  - convective heat transfer
- **effect of ambient velocity on**
  - convective heat transfer

- **atmospherical condition**

- Ranz and Marshall's correlation

$$\frac{\tau_f}{\tau_{f,Re=0}} \propto \frac{h_{Re=0}}{h} = \frac{1}{1 + 0.3 Re^{1/2} Pr^{1/3}}$$

- **supercritical condition**

- LOX/hydrogen system

$$\frac{\tau_f}{\tau_{f,Re=0}} \propto \frac{h_{Re=0}}{h} = \frac{1}{1 + 0.15634 Re^{1.1} Pr_{O_2}^{-0.88}}$$



# Supercritical Fluid Injection

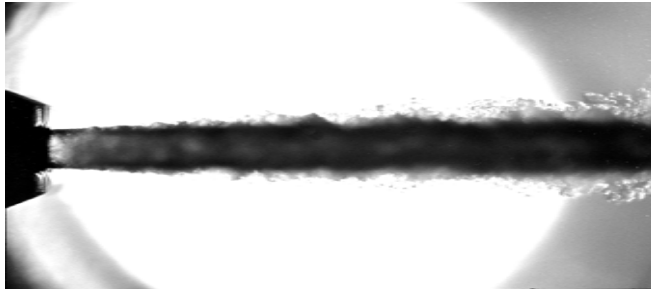

$p_{ch} = 4.0 \text{ MPa}$   
 $T_{LN2} = 105 \text{ K}$   
 $T_{GN2} = 300 \text{ K}$   
 $u_{LN2} = 10 \text{ m/s}$   
 $D_{in} = 1.9 \text{ mm}$

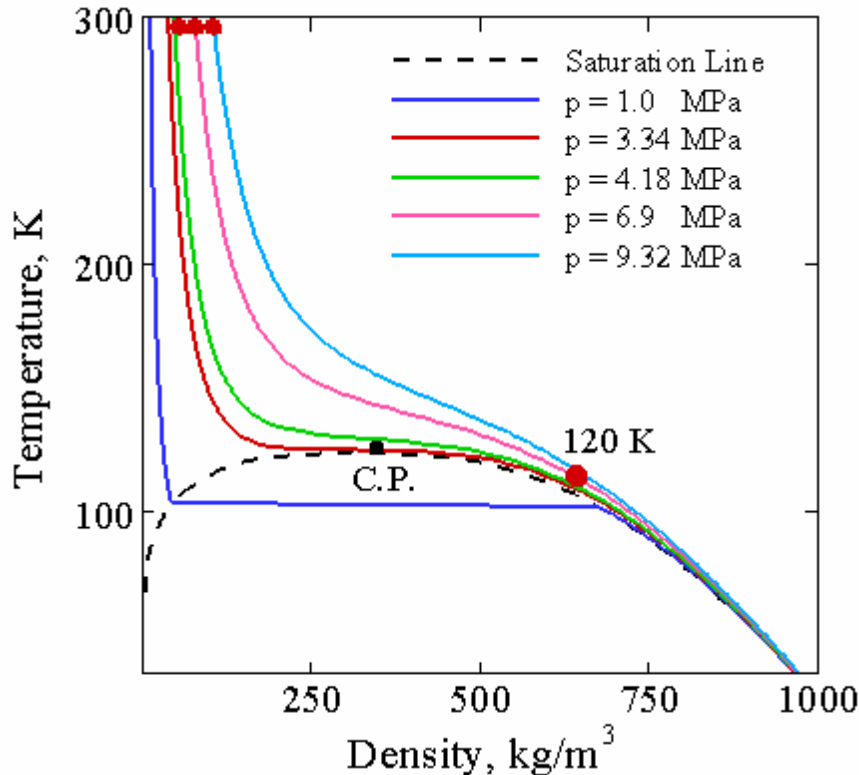
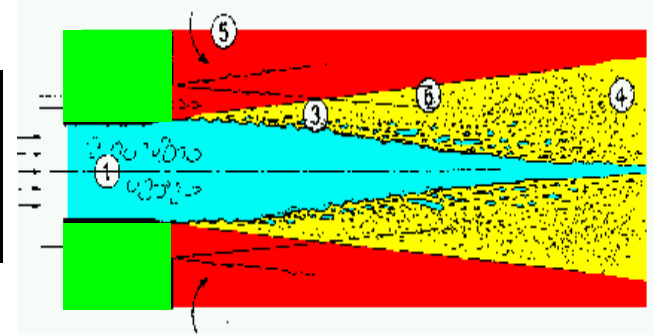

$p_{\infty} = 3.4 - 10.0 \text{ MPa}$ ,  $T_{\infty} = 300 \text{ K}$ ,  
 $T_{inj} = 120 \text{ K}$ ,  $D_{inj} = 0.254 \text{ mm}$ ,  
 $u_{inj} = 15 \text{ m/s}$ ,  $Re = 20000 - 40000$

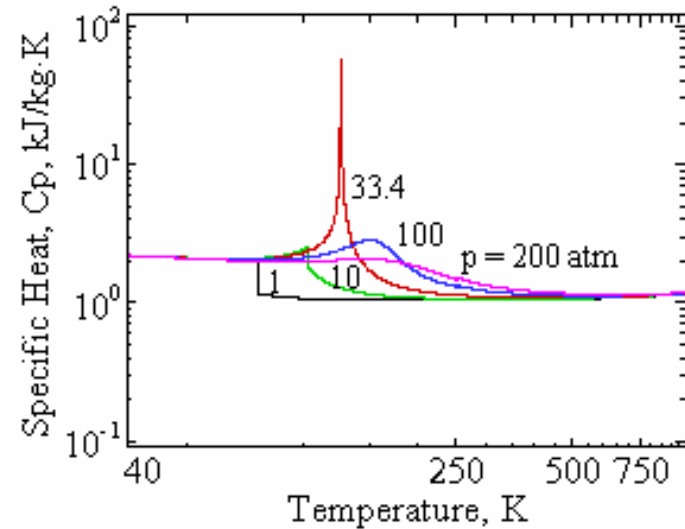



( $p_\infty = 6.0$  MPa,  $T_\infty = 300$  K,  $u_{in} = 4.9$  m/s,  $T_{in} = 132$  K,  $D_{in} = 2.2$  mm)

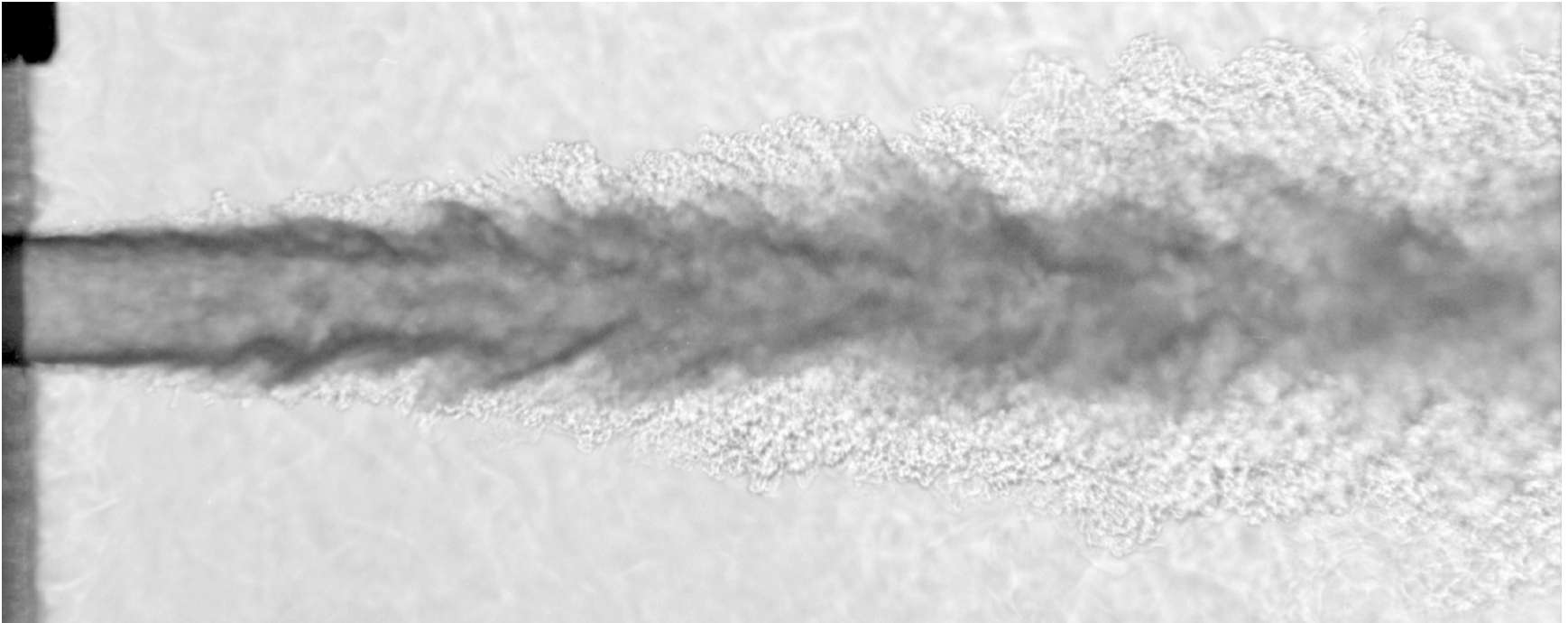



# Computational Domain and Grids

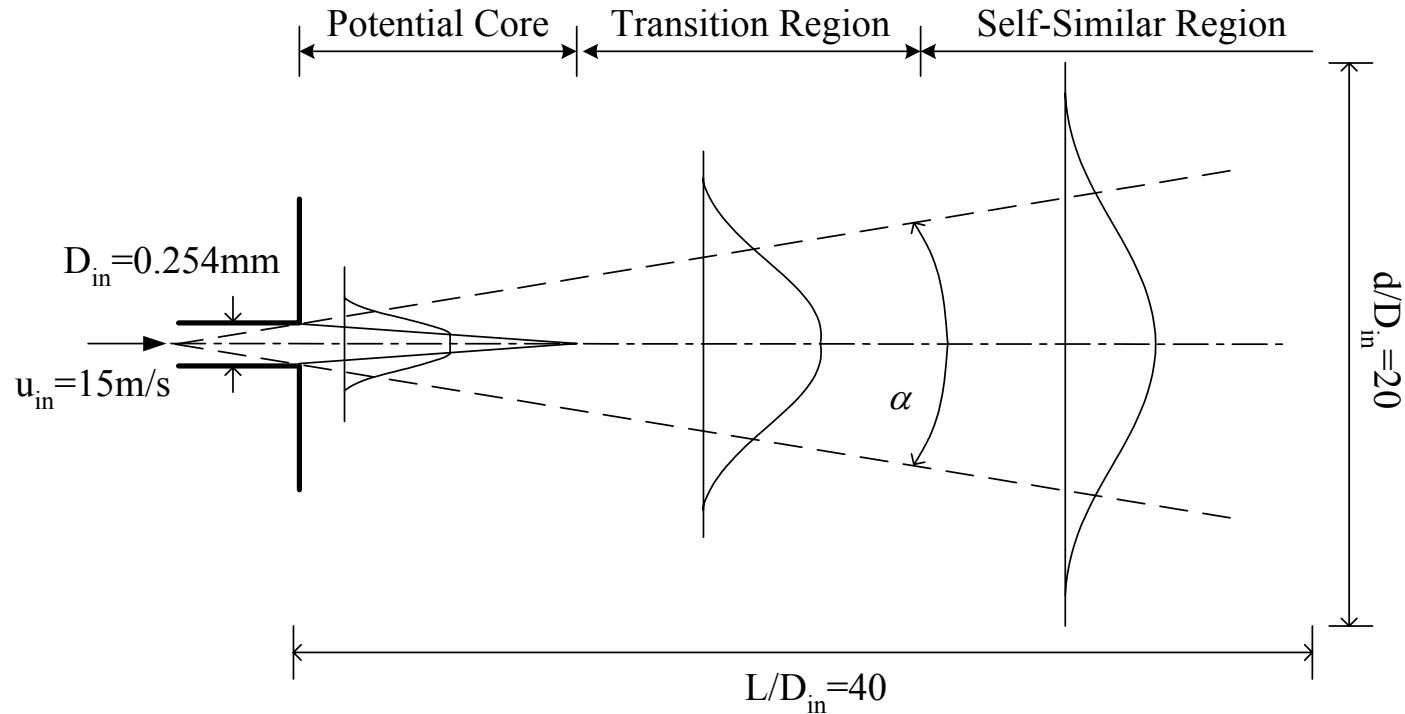

- Kolmogorov microscale  $\eta_t/l_t \sim Re_t^{-3/4}$
- Taylor microscale  $\lambda_t/l_t \sim Re_t^{-1/2}$
- $3.4 \leq p_{ch} \leq 10.0 \text{ MPa}$  and  $D_{in} = 0.254 \text{ mm}$
- $3 < \lambda_t < 5 \text{ } \mu\text{m}$



total grids

$$225 \times 75 \times 72 = 1,215,000$$

mean grid spacing in  
near injector region

$$\Delta = 5 \text{ } \mu\text{m}$$



# Density Gradient Field

Department of Mechanical & Nuclear Engineering

$(p_\infty = 9.3 \text{ MPa}, T_\infty = 300 \text{ K}, u_{in} = 15 \text{ m/s}, T_{in} = 120 \text{ K}, D_{in} = 254 \text{ }\mu\text{m})$

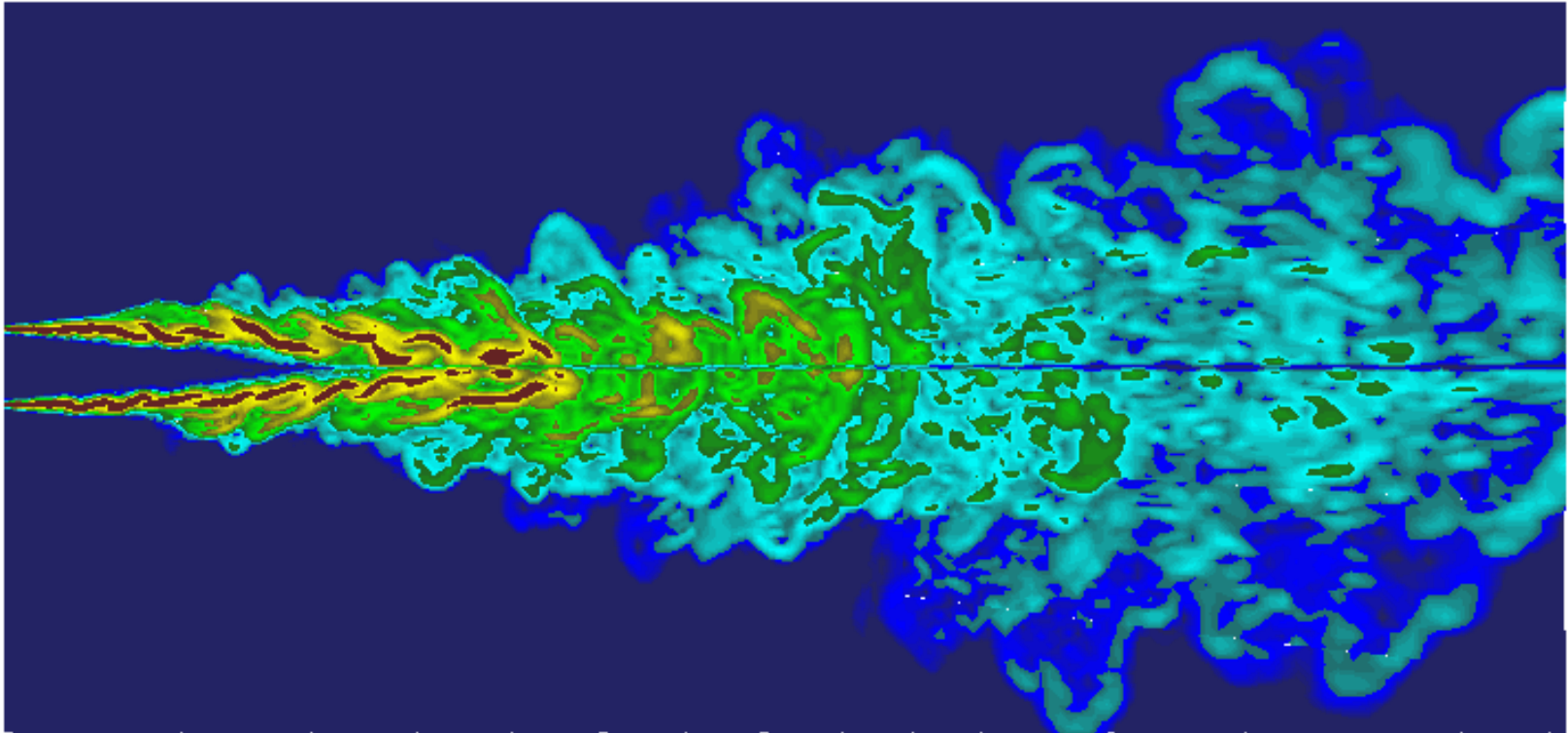

$|\nabla\rho| \text{ (kg/m}^4\text{)}$



1.0000E+04   3.9401E+04   1.5524E+05   6.1167E+05   2.4100E+06





# Time Evolution of Density Gradient Field

$(p_\infty = 6.9 \text{ MPa}, T_\infty = 300 \text{ K}, u_{\text{in}} = 15 \text{ m/s}, T_{\text{in}} = 120 \text{ K}, D_{\text{in}} = 254 \mu\text{m})$

$t = 0.000 \text{ ms}$

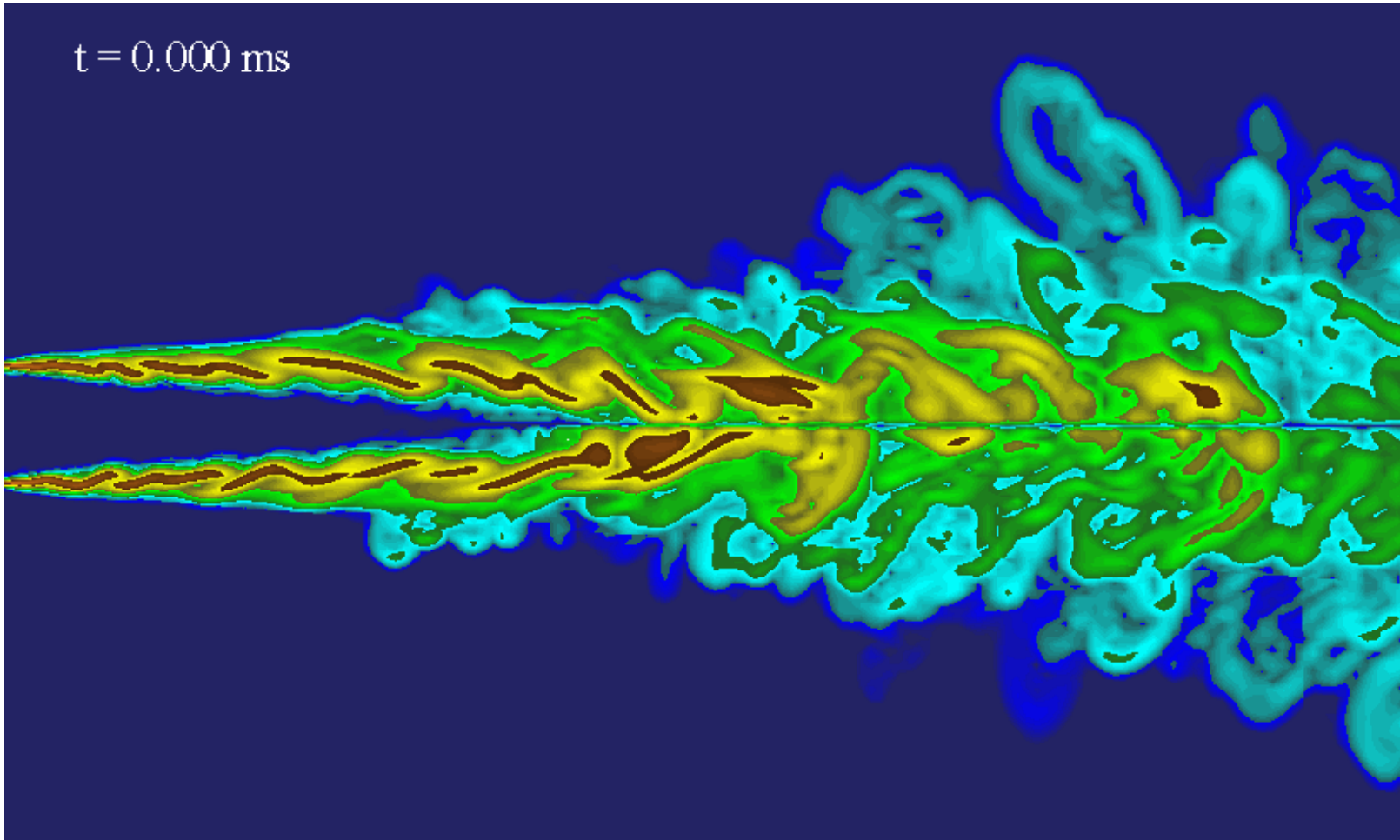



# Snapshots of Density and Temperature Gradient Fields

Department of Mechanical & Nuclear Engineering

$(p_\infty = 9.3\text{MPa}, T_\infty = 300\text{K}, u_{in} = 15\text{m/s}, T_{in} = 120\text{K}, t = 1.550\text{ms}, D_{in} = 254\mu\text{m})$

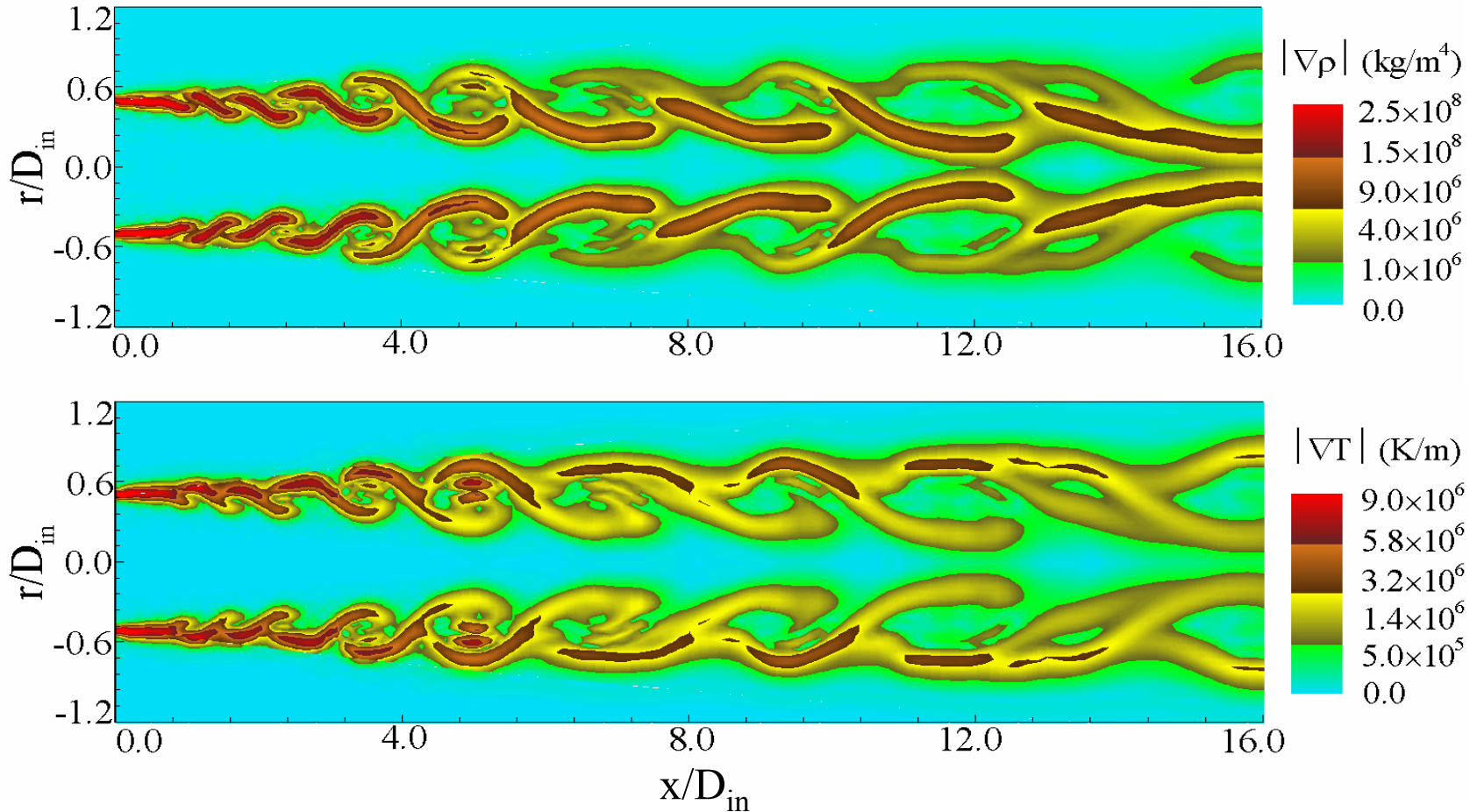



# Most Energy Containing POD Modes of Axial Velocity

1 8 5 5 Department of Mechanical & Nuclear Engineering

$(p_\infty = 9.3 \text{ MPa}, T_\infty = 300 \text{ K}, u_{in} = 15 \text{ m/s}, T_{in} = 120 \text{ K}, D_{in} = 254 \mu\text{m})$

pre-burst region  
(density-stratified jet)

burst region

post-burst region  
(gaseous jet)

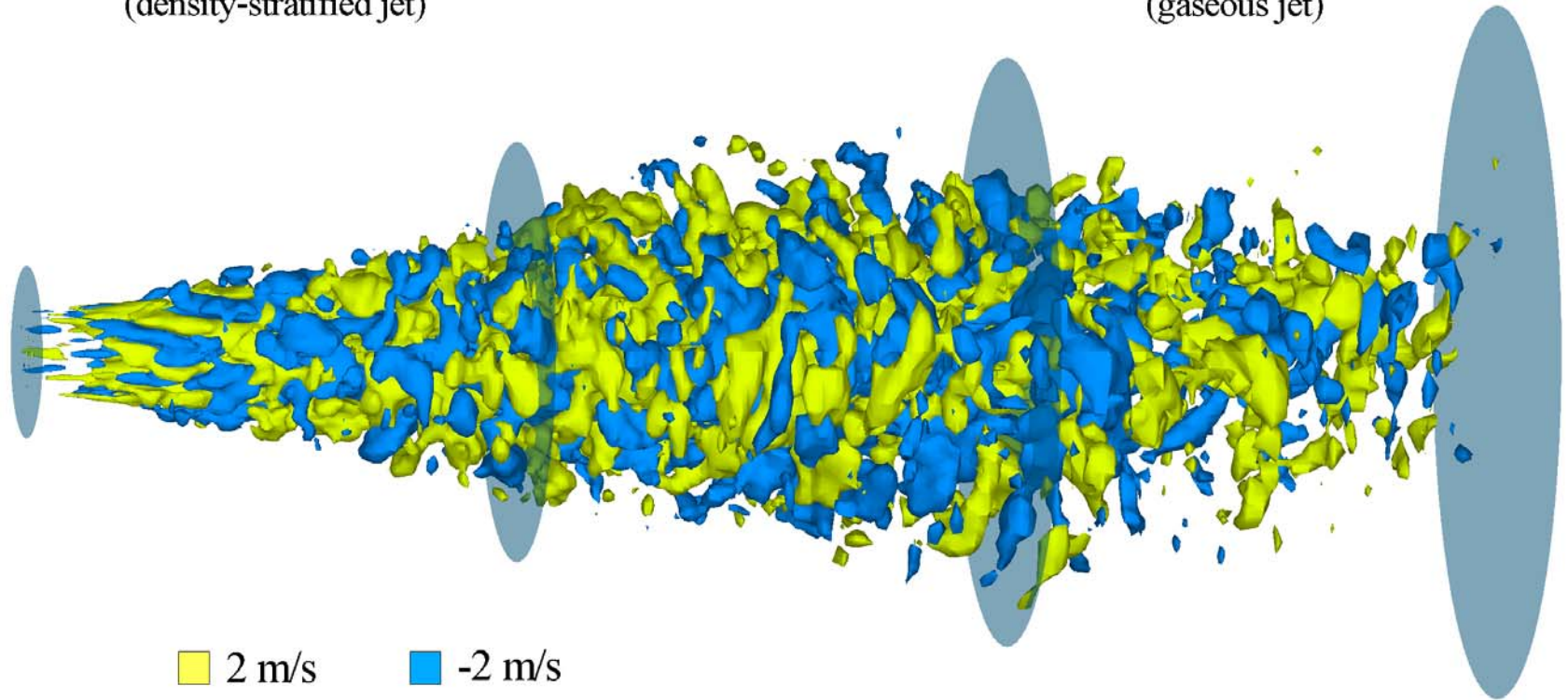



# Iso-Surfaces of Pressure and Density Gradients

Department of Mechanical & Nuclear Engineering

$(p_\infty = 9.3 \text{ MPa}, T_\infty = 300 \text{ K}, u_{in} = 15 \text{ m/s}, T_{in} = 120 \text{ K}, D_{in} = 254 \mu\text{m})$

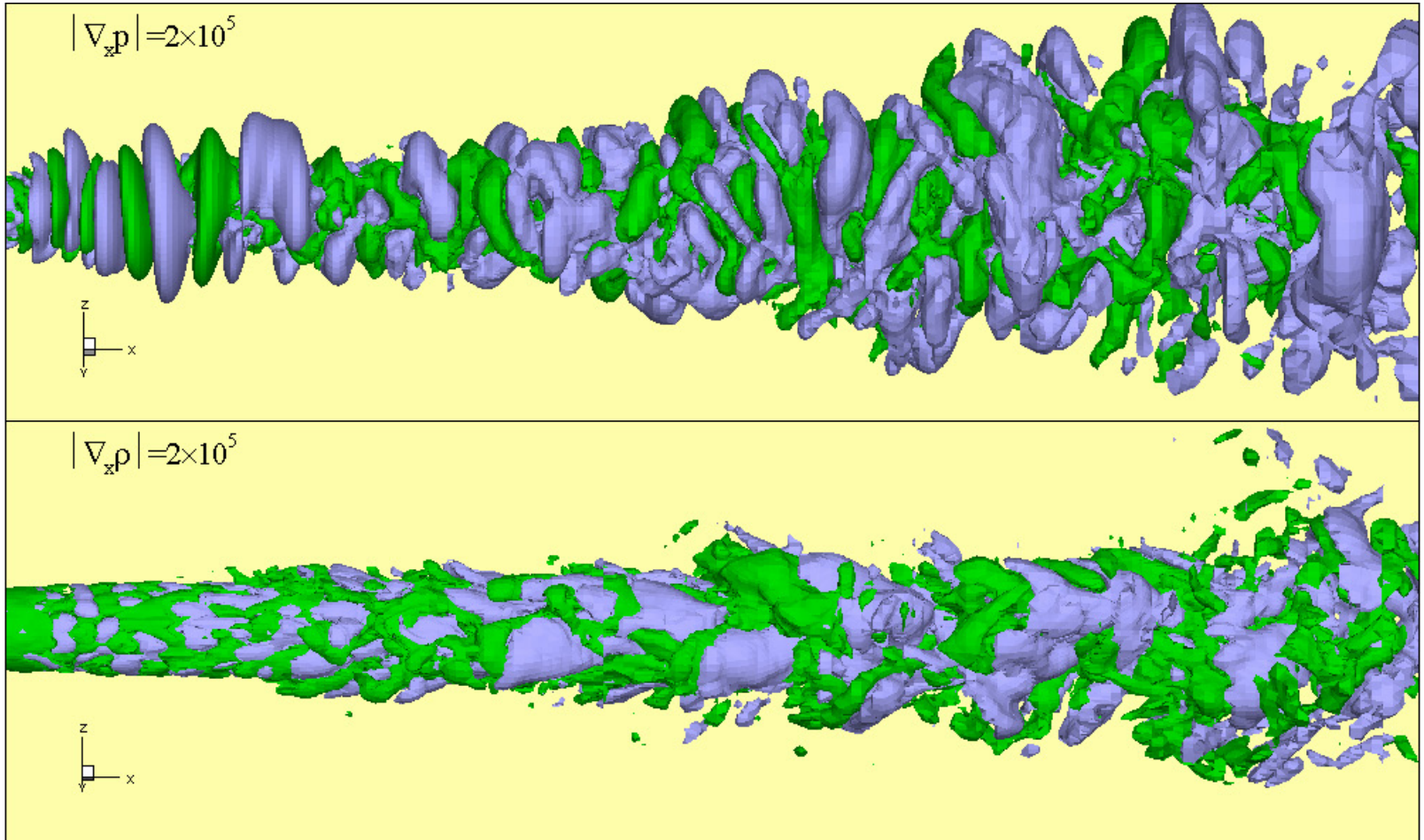



# Effect of Pressure on Density and Temperature Fields

Department of Mechanical & Nuclear Engineering

$$T_\infty = 300\text{K}, u_{in} = 15\text{m/s}, T_{in} = 120\text{K}, D_{in} = 254\mu\text{m}$$

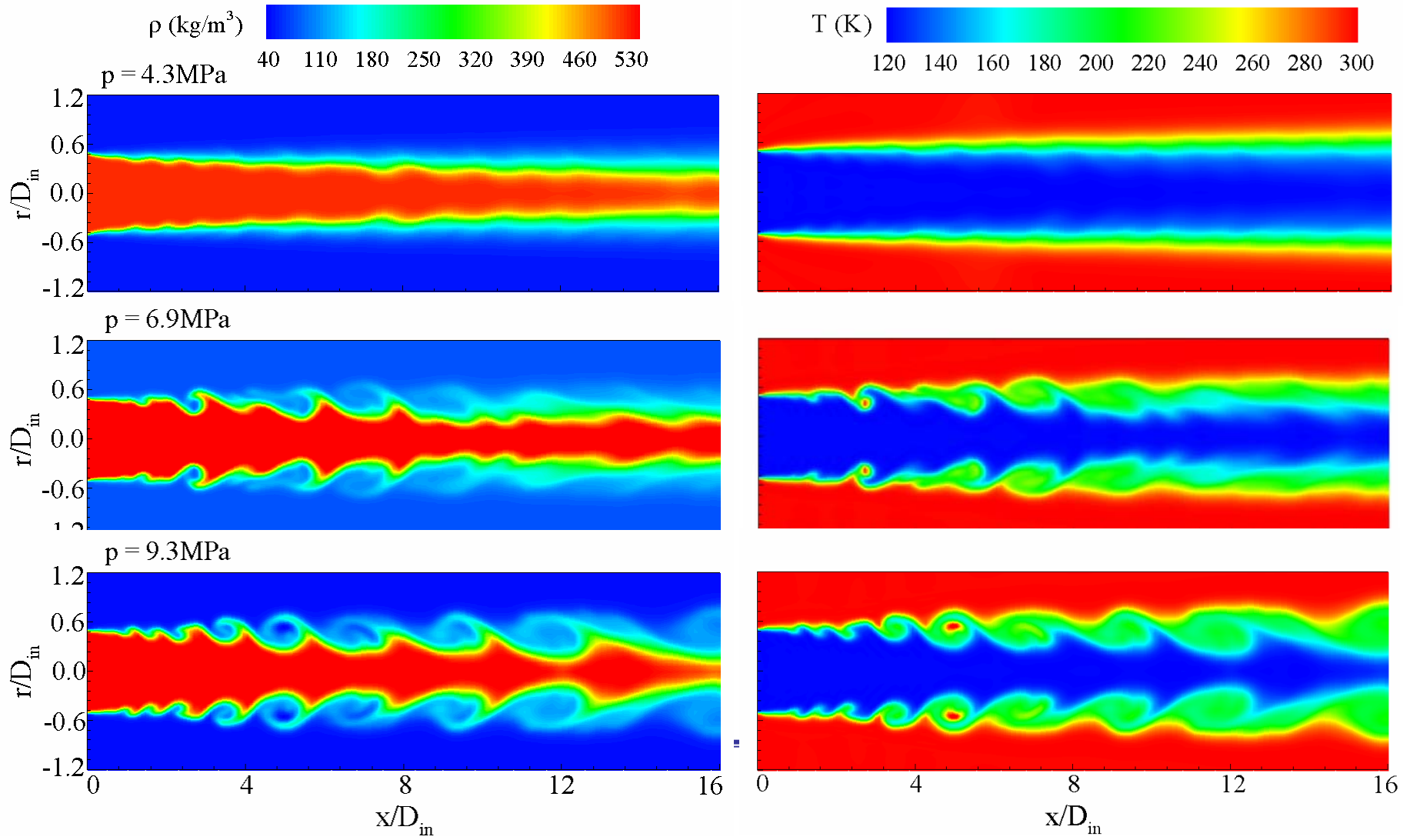





# Power Spectral Densities of Velocity Fluctuations

Department of Mechanical & Nuclear Engineering

$(p_\infty = 9.3\text{MPa}, T_\infty = 300\text{K}, u_{in} = 15\text{m/s}, T_{in} = 120\text{K}, D_{in} = 254\mu\text{m})$

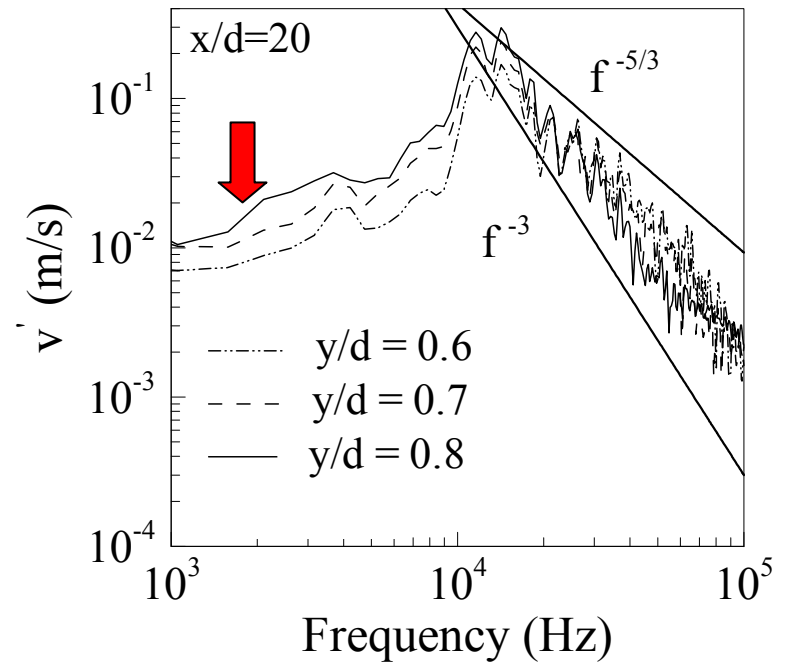
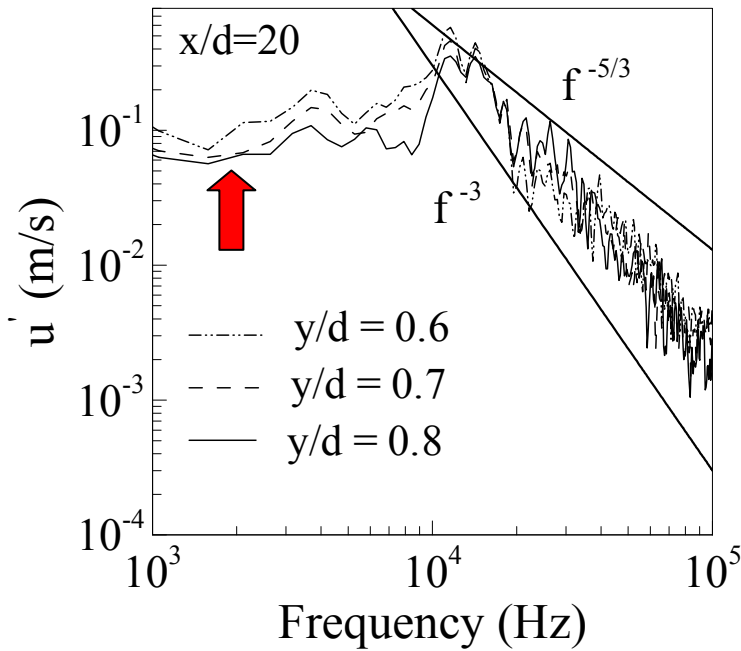

Large density-gradient regions act like a solid wall that amplifies the axial turbulent fluctuation but damps the radial one.



# Vortex Shedding Frequency

$(p_\infty = 9.3\text{MPa}, T_\infty = 300\text{K}, u_{in} = 15\text{m/s}, T_{in} = 120\text{K}, D_{in} = 254\mu\text{m})$

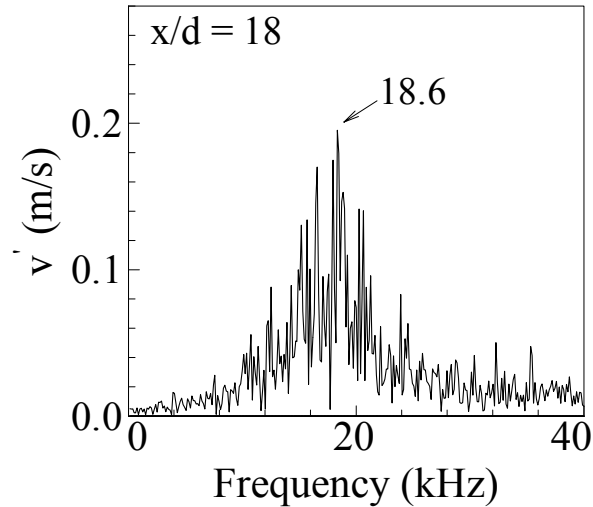
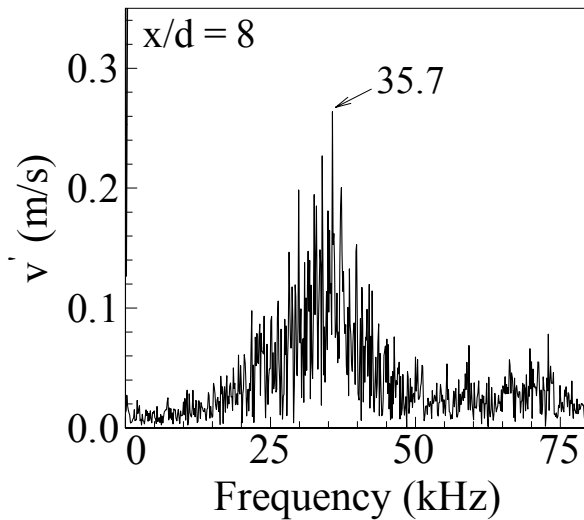
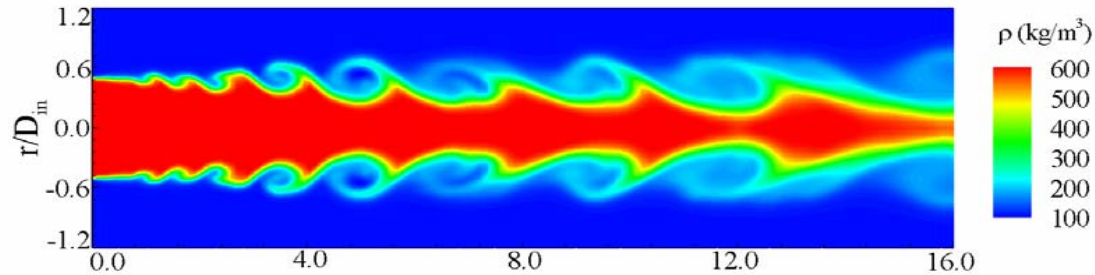

## Jet flow instability analysis

$$St_j = f_j \theta_0 / \bar{U}$$

where  $0.044 \leq St_j \leq 0.048$

$$\bar{U} = 15 \text{ m/s}$$

## Momentum thickness

$$\theta_0 = 0.02 \text{ mm}$$

$$\theta_0 = \int_0^\infty \frac{u}{U_{\max}} \left(1 - \frac{u}{U_{\max}}\right) dy$$

choose

$$St_j = 0.046$$

then

$$f_1 = 34500$$

$$f_2 = 17250$$



# Linear Stability Analysis of Real Fluid Jet

## Approach

- Two-dimensional fluid jet instability at supercritical conditions.
- Unified treatment of real-fluid thermodynamics and transport phenomena.
- Disperse equation solved by Newton-Ralpson method.

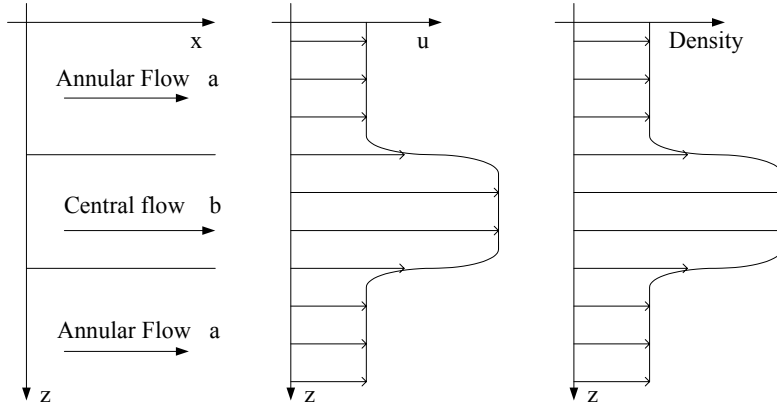

## Conclusions

- As the density ratio increases, the spatial growth rate of the interfacial instability wave decreases. ➡ Density stratification tends to stabilize the mixing layer.
- Density stratification has little effect on the frequency of the most unstable mode.

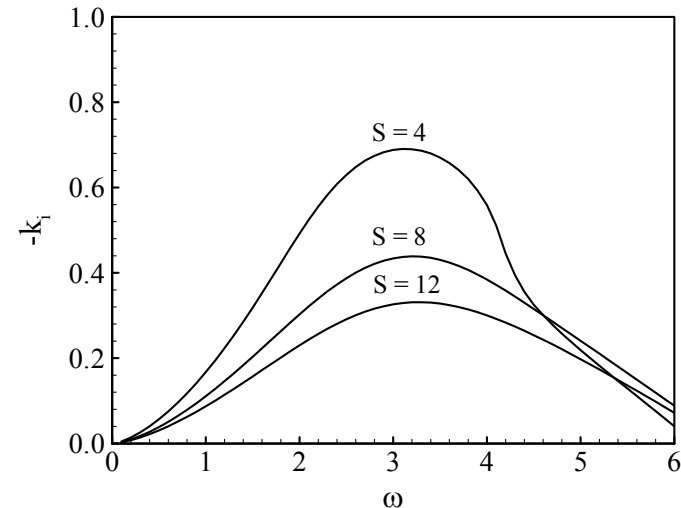



# Bi-Propellant Swirl Co-Axial Injector

Component	Geometrical characteristic	Spray-cone angle	Pressure drop	flow rate
oxidizer	2	80	0,426	172,9
fuel	24,5	135	0,696	64,8
oxidizer	-	-	0,426	172,3
fuel	-	-	0,696	64,8

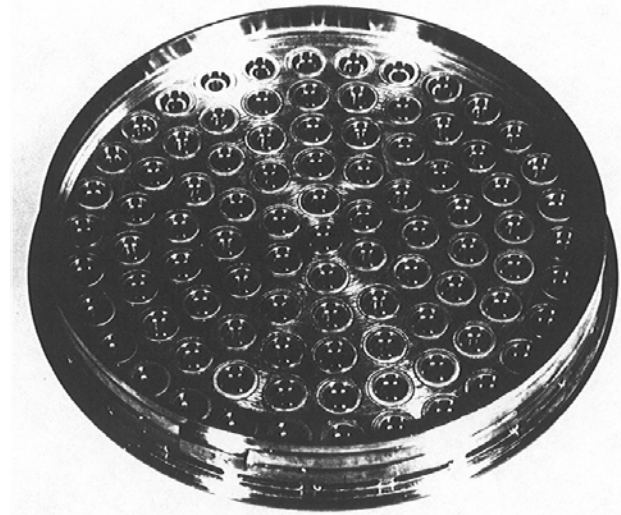
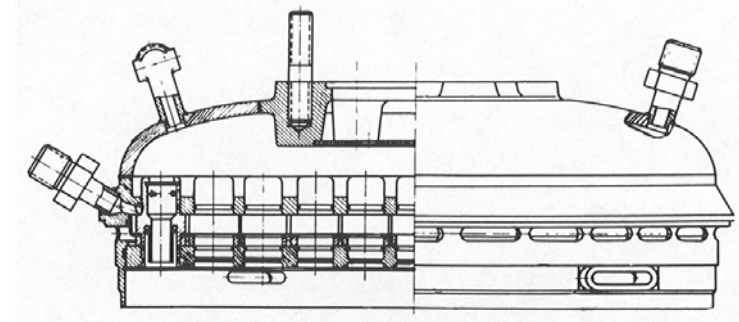





## Issues

- Swirling jet dynamics at supercritical conditions.
- Flame stabilization mechanisms of swirl co-axial injector.
- Liquid rocket thrust chamber dynamics.

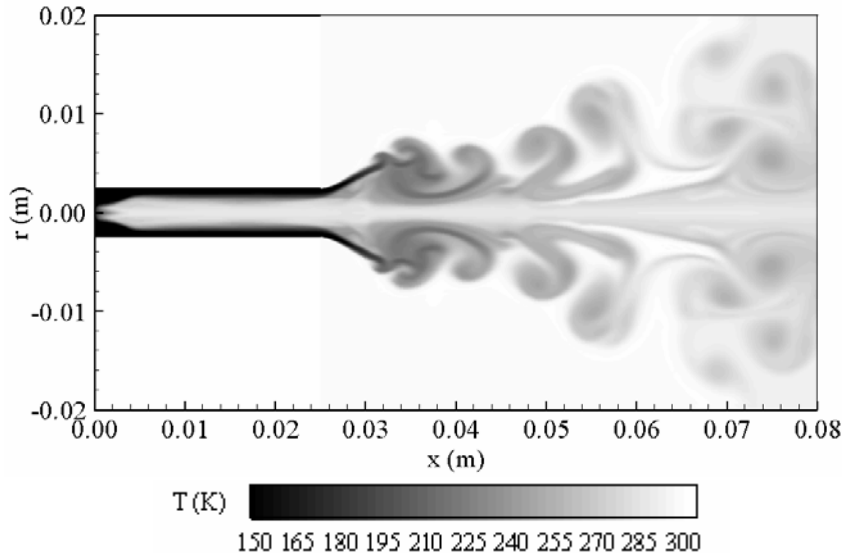
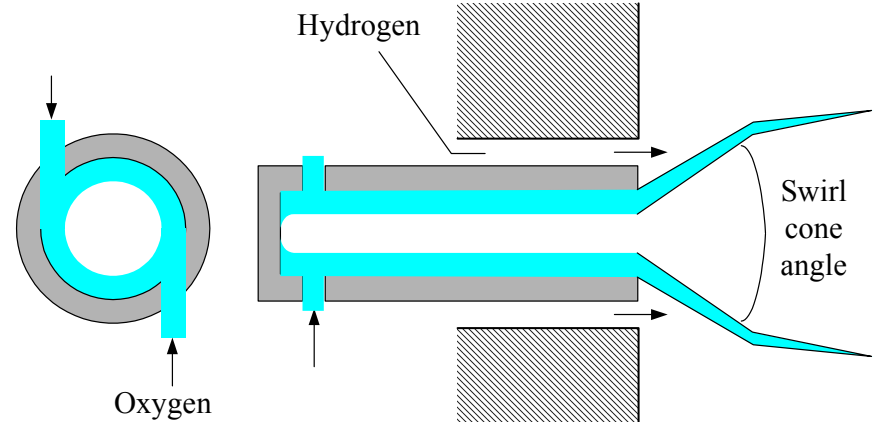

## Major Results

- Liquid film thickness and swirl cone angle.
- Detailed flow structures, including central recirculation zone, surface instability, etc.
- Response of injector dynamics to external forcing.

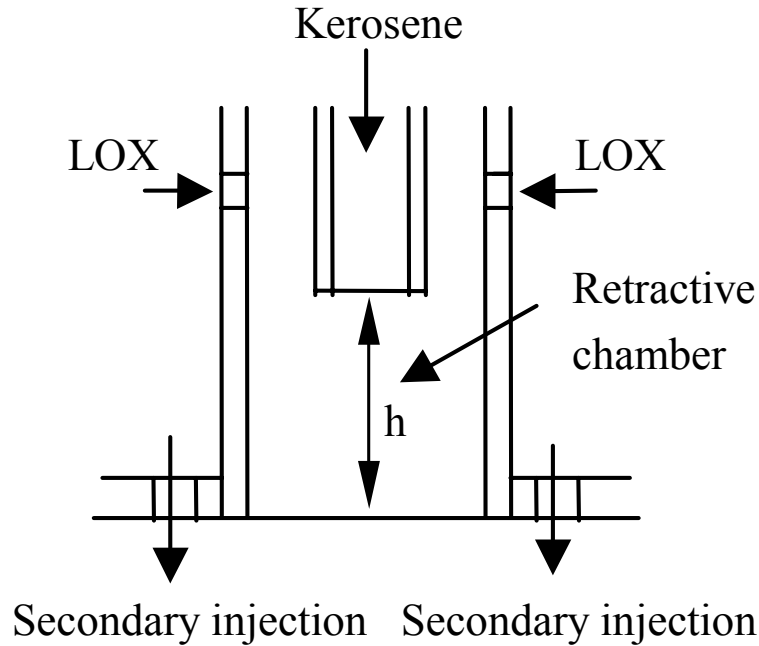

oxidizer-rich preburner injector

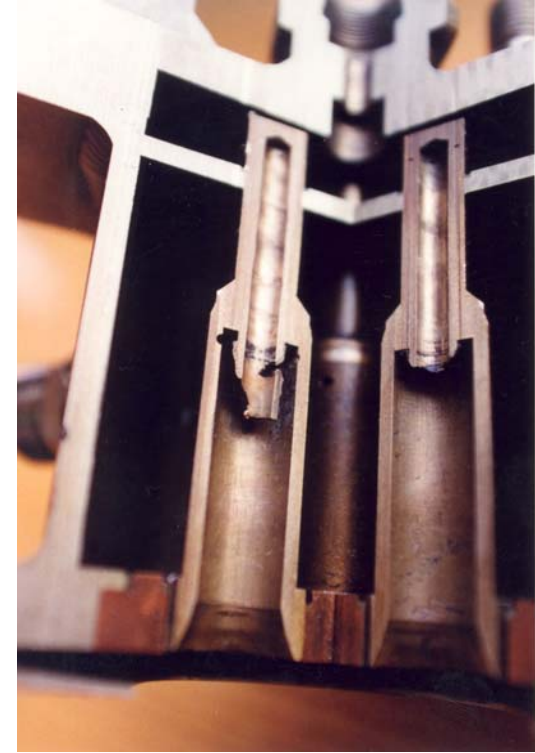

damaged inner centrifugal injector



# Time Evolution of Swirling Jet

1 8 5 5 Department of Mechanical & Nuclear Engineering

( $p_\infty=10.0$  MPa,  $T_\infty=300$  K,  $u_{inj}=30$  m/s,  $T_{inj}=120$  K,  $\theta=30^\circ$ , nitrogen )

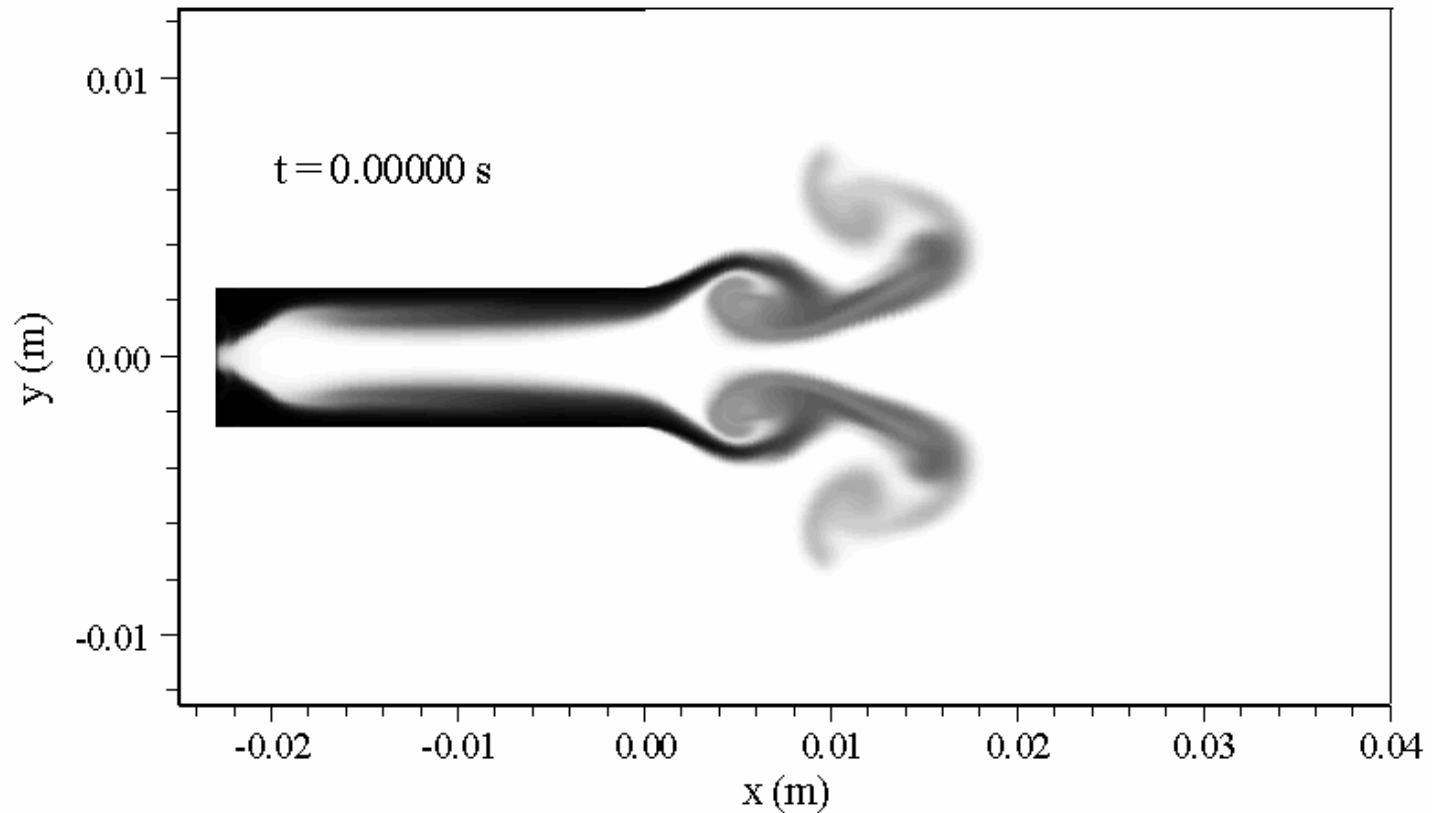



# Time Evolution of Swirling Jet

Department of Mechanical & Nuclear Engineering

( $p_\infty = 10.0$  MPa,  $T_\infty = 300$  K,  $u_{inj} = 30$  m/s,  $T_{inj} = 120$  K,  $\theta = 30^\circ$ , nitrogen)

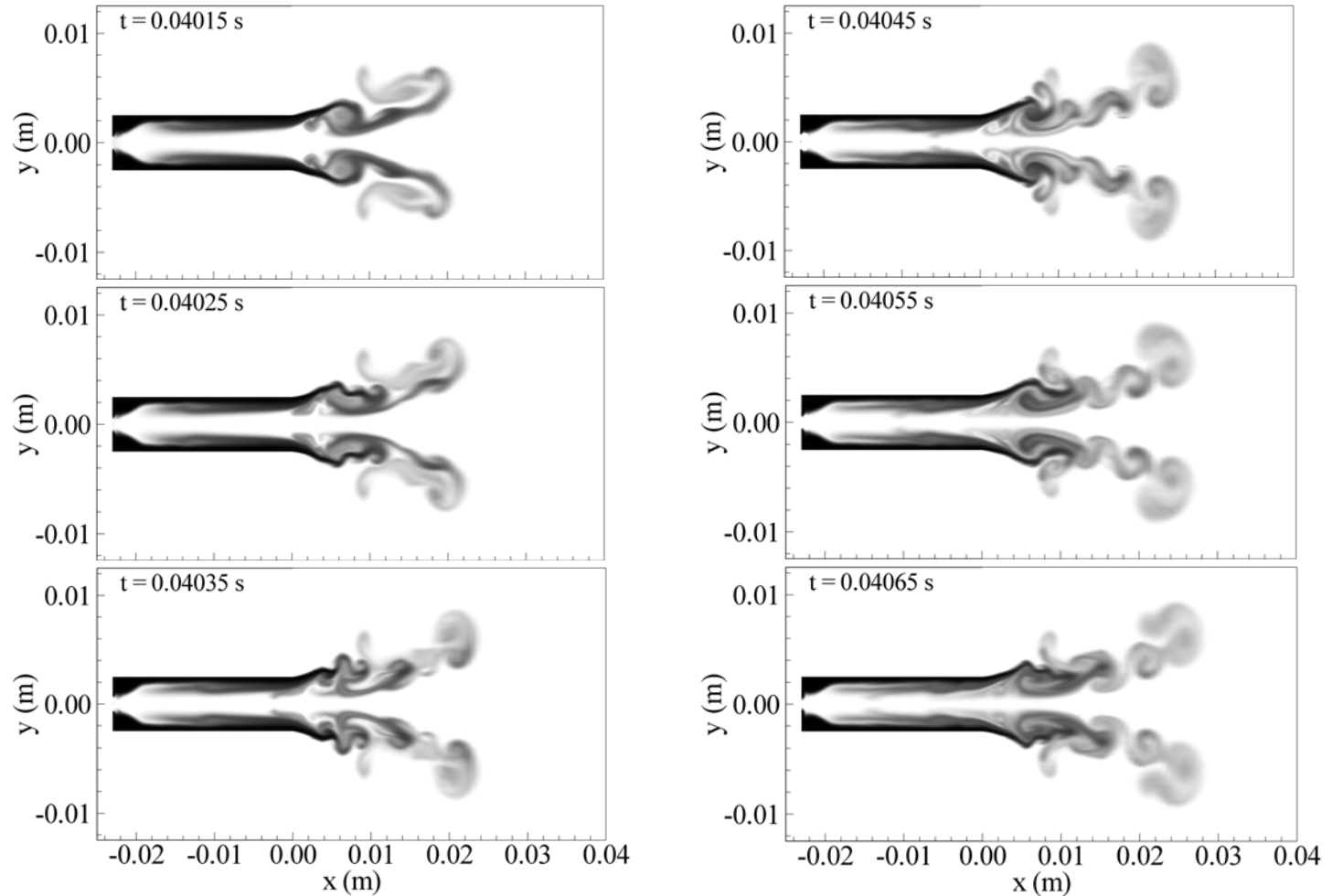

Temperature (K)

120 140 160 180 200 220 240 260 280 300



# Disintegration of Swirling Water Jet

(Inamura, Tamura and Sakamoto, JPP, 2003)

1 8 5 5 Department of Mechanical & Nuclear Engineering

Water Injection,  $L/D=11.67$ ,  $K=1.0$

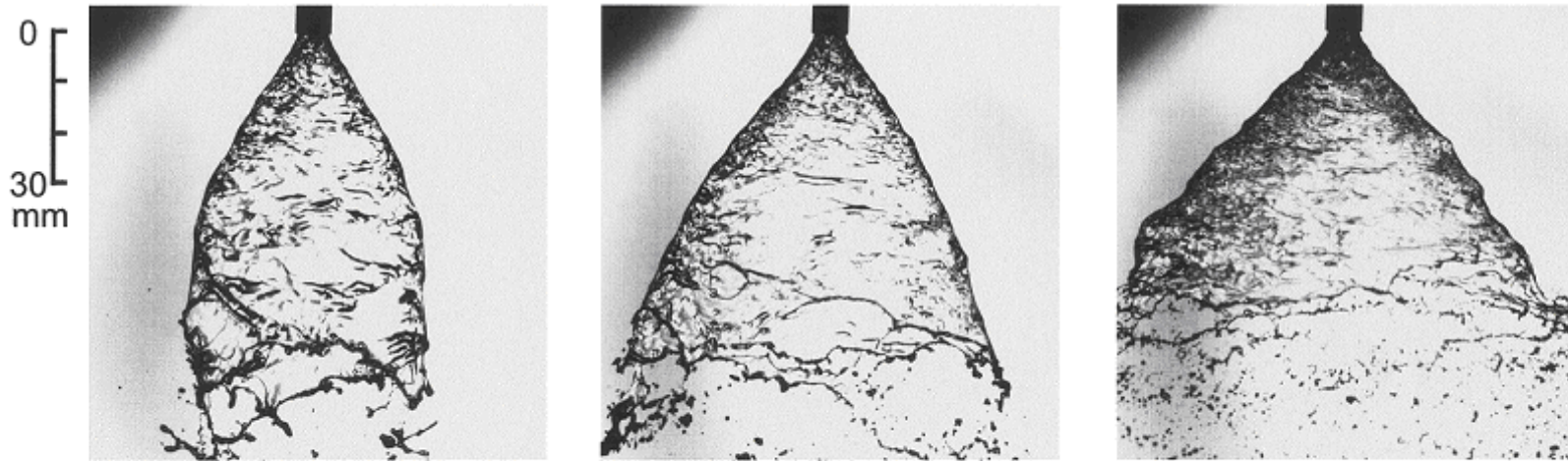

(1)  $M_l = 26.1$  g/s

(2)  $M_l = 32.5$  g/s

(3)  $M_l = 48.6$  g/s

- A hollow cone sheet forms around the injector exit.
- The conical sheet fluctuates vigorously and disintegrates into ligaments and droplets at the sheet tip.
- The sheet breakup point approaches the injector as the liquid flow rate increases.



# Theoretical Analysis of Swirl Injector (1/2)

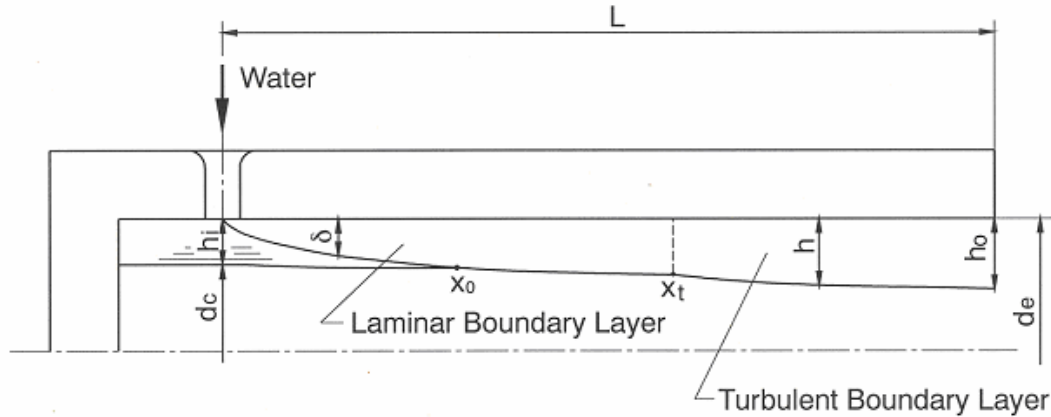

( Inamura et al. *JPP*, 2003 )

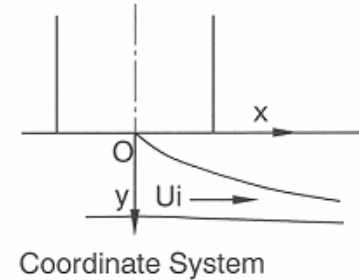

$$x < x_0$$

$$\frac{d}{dx} \int_0^\delta (U_i u - u^2) dy = \frac{\tau_w}{\rho_l}$$

where

$$\tau_w = \rho_l \nu_l \left( \frac{\partial u}{\partial y} \right)_{y=0}$$

and

$$\delta^* = 5.84 \sqrt{x^* / \text{Re}}$$

$$Q = U_i h_i = \int_0^\delta u dy + U_i (h - \delta)$$

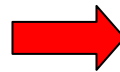

$$h^* = 1 + (3/10) \delta^*$$



# Theoretical Analysis of Swirl Injector (2/2)

$$x_0 < x < x_t$$

$$h^* = 1.429 / \{1 + A(x^* - x_0^*)\} \quad A = 1.682(v_l / Q)$$

$$x_t < x$$

$$h^* = 0.02798(x^* / \text{Re}^{1/4}) + C_1 \quad x_0^* = 0.0598 \text{Re}$$

$$C_1 = 1.429\{1 + A(x_t^* - x_0^*)\} - 0.0279(x_t^* / \text{Re}^{1/4})$$

$$x_t < x < x_0$$

$$h^* = 0.02798(x^* / \text{Re}^{1/4}) + C_3$$

$$C_3 = 1.143 - 0.02798(x_0^* / \text{Re}^{1/4})$$

$$x_0^* = \{(1.182 - C_2) / 0.2893\} \text{Re}^{1/4}$$

## Film Thickness at Post Exit

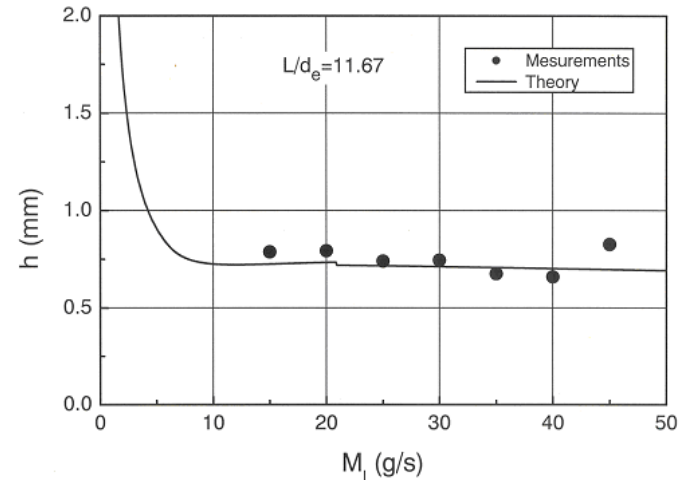
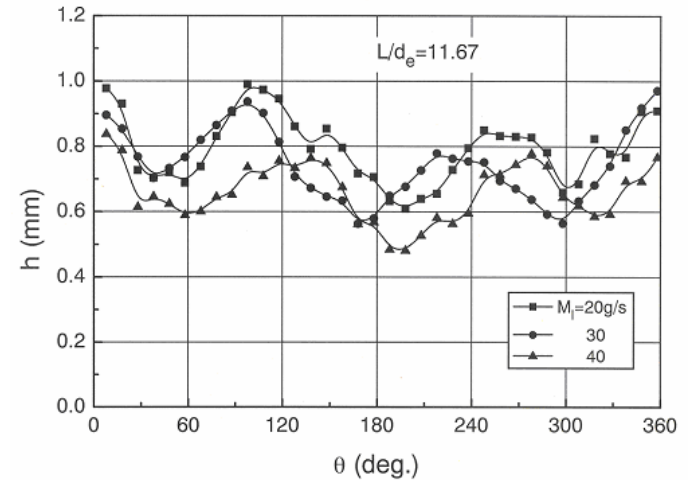



# Limiting Extremes: 2) Diffusion Processes Dominate

- "High" Heating Rates

- diminished intermolecular forces promote diffusion processes prior to atomization
- injected jet vaporizes forming continuous fluid in presence of exceedingly large interfacial gradients
- diffusion flame resides within annular post wake separating oxygen jet from outer hydrogen flow

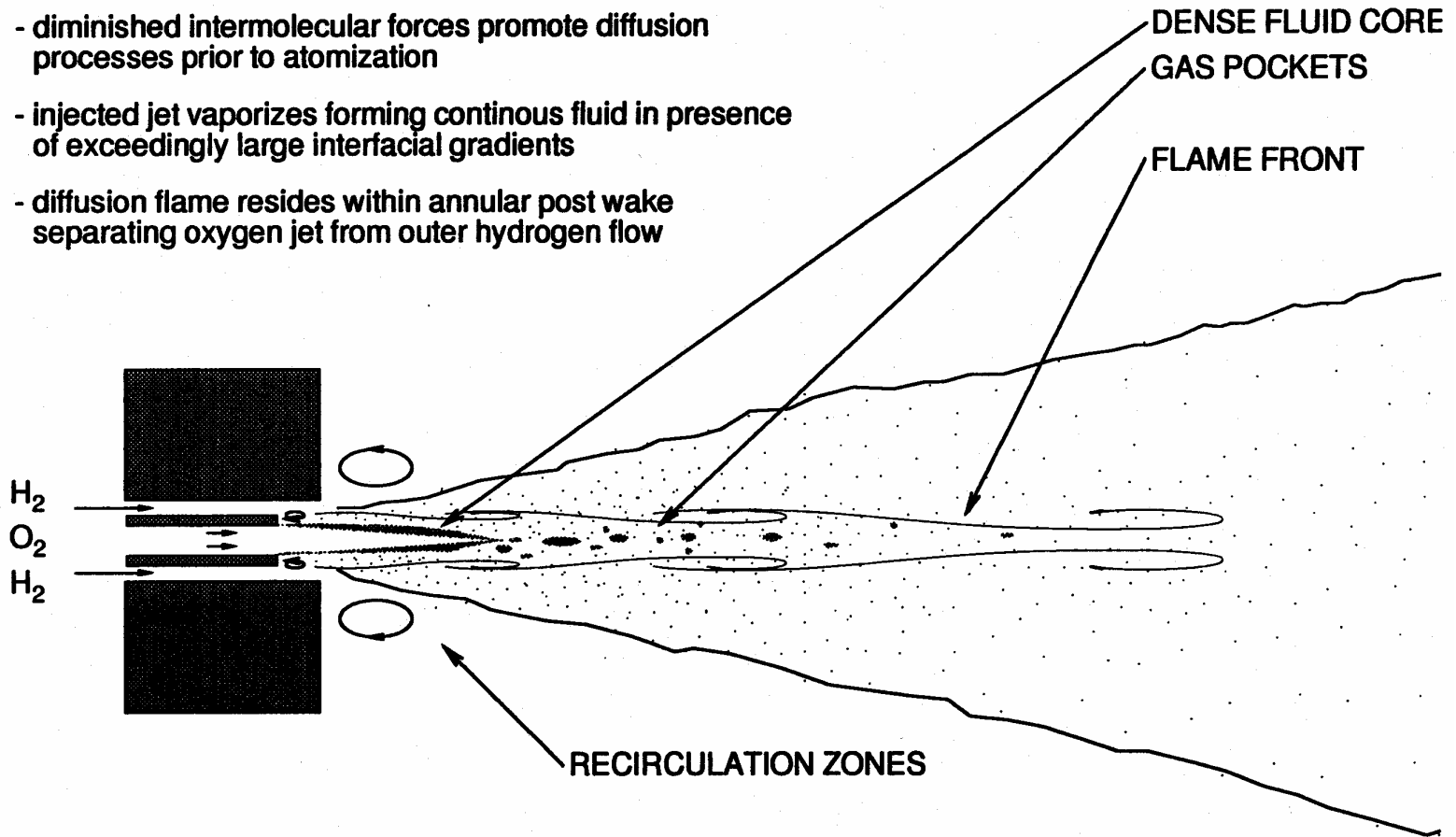





# Burning LOX Jet at Supercritical Pressure

*(Mayer, DLR, Germany; Tamura, NAL, Japan)*

1 8 5 5 Department of Mechanical & Nuclear Engineering

$(u_{\text{LOX}} = 30 \text{ m/s}, u_{\text{H}_2} = 300 \text{ m/s}, T_{\text{LOX}} = 100 \text{ K}, T_{\text{H}_2} = 300 \text{ K}, p = 6 \text{ MPa})$

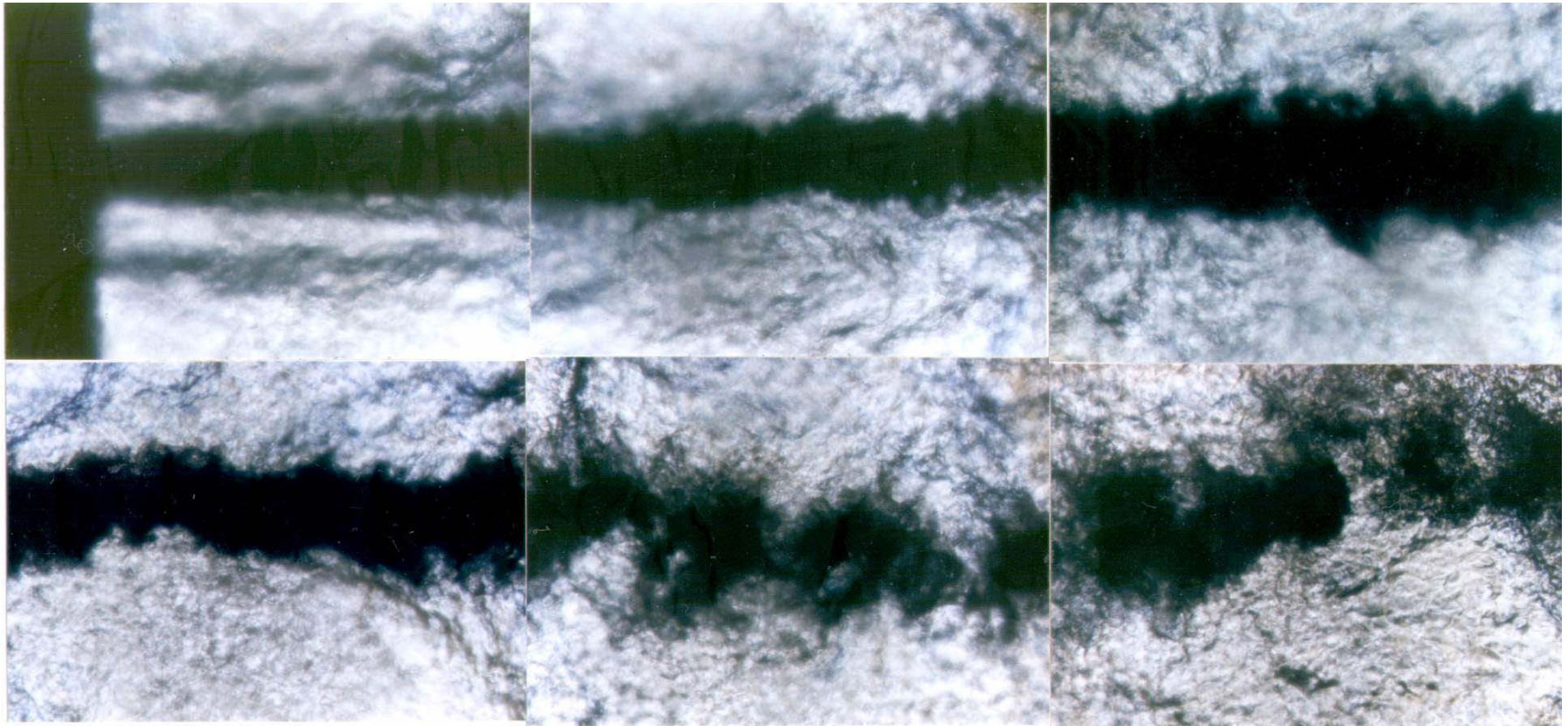

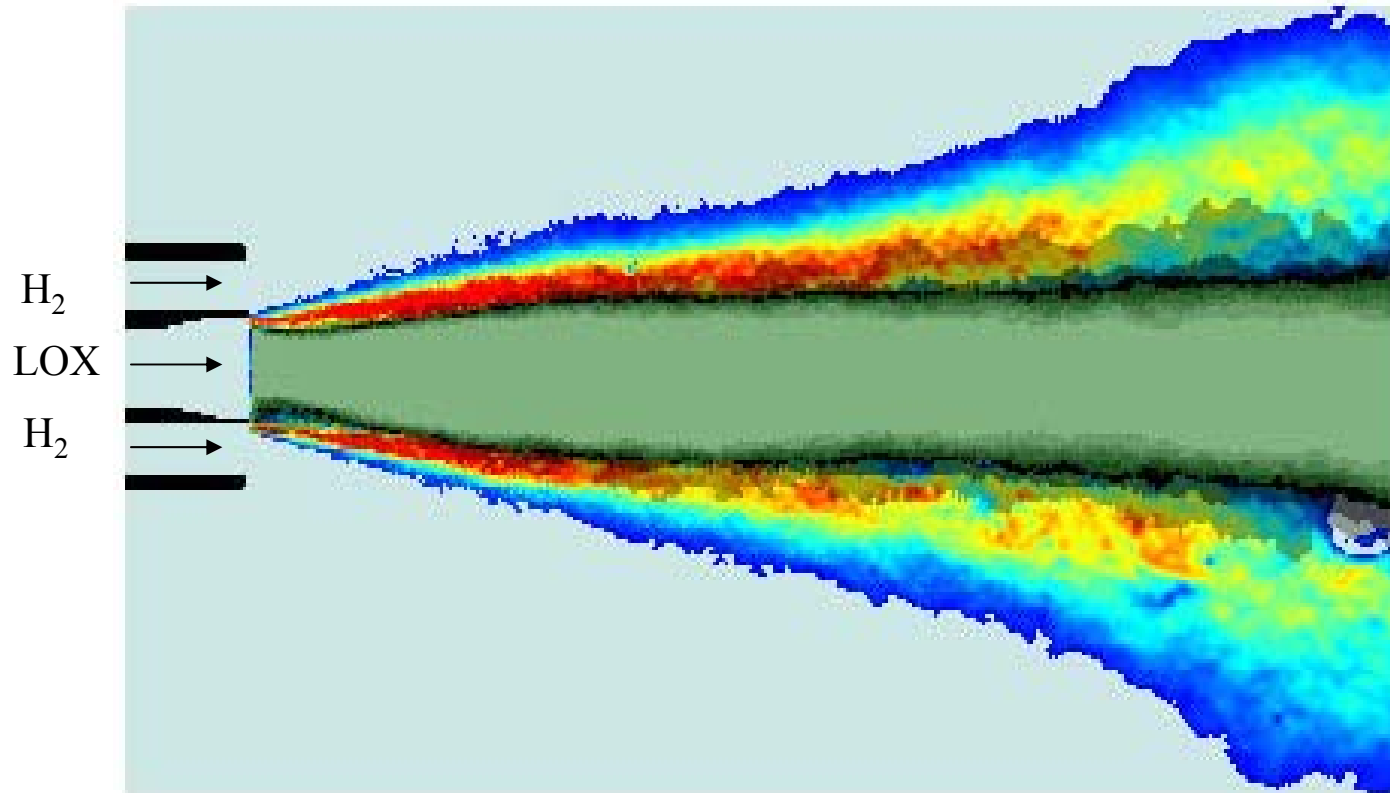

Combined OH emission and backlighting images (Ph.D thesis of Matthew Juniper)



# LOX/Hydrogen Shear-Coaxial Injector Dynamics

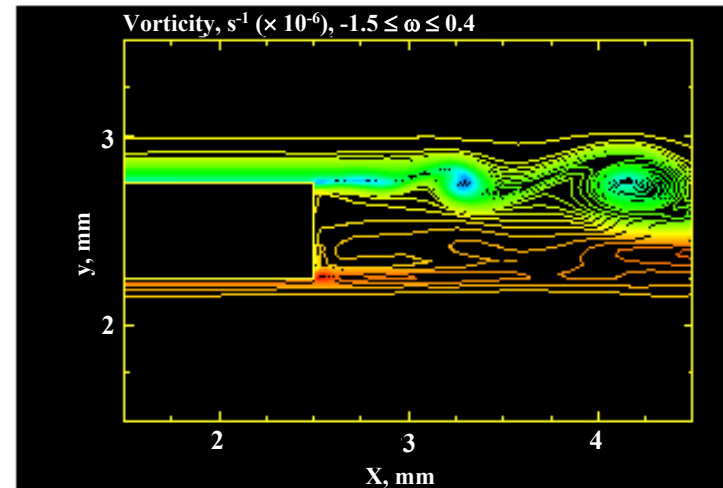
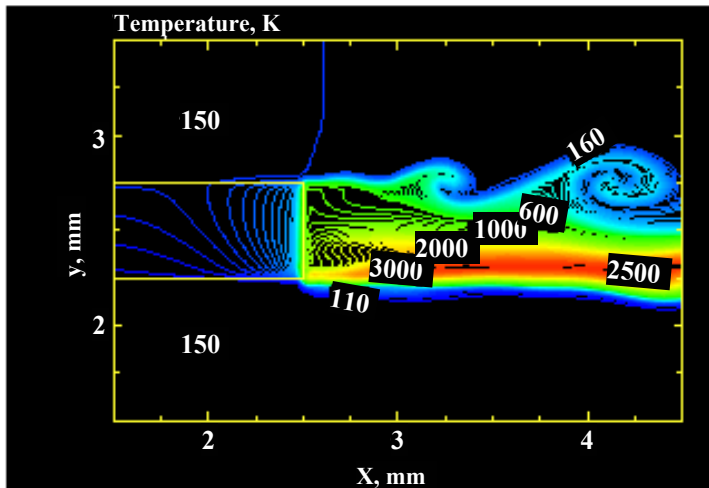
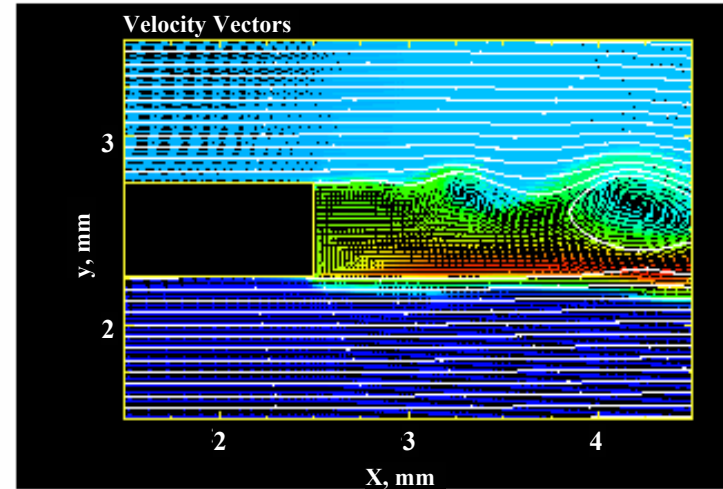
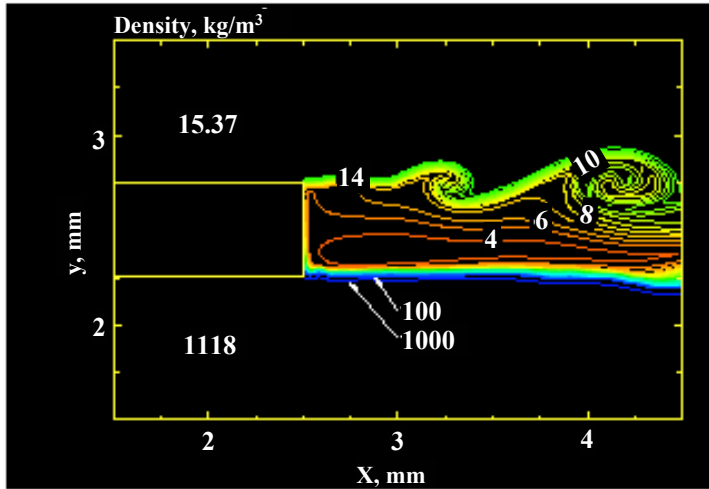



# Modeling and Simulation of Supercritical Combustion

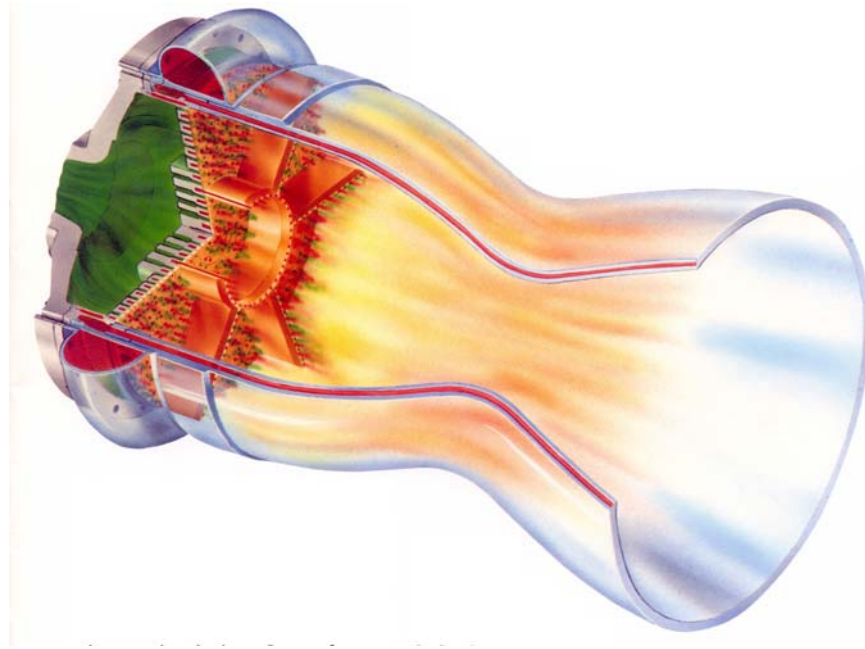
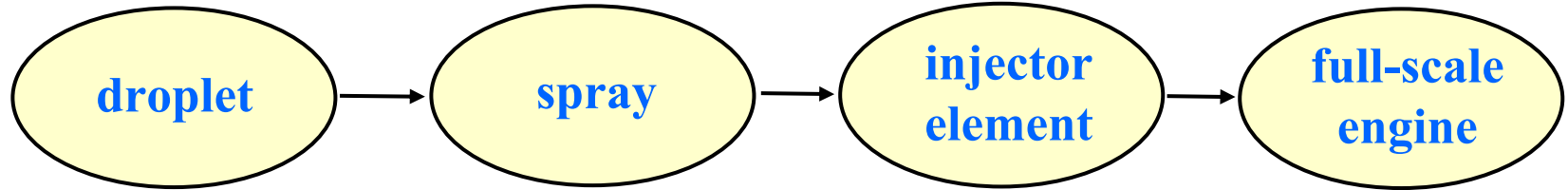

PENNSTATE



1 8 5 5 *Department of Mechanical & Nuclear Engineering*

---

---

**Thank You!**

---

---





# Effect of Pressure on Mean Temperature Distributions

$(T_\infty = 300 \text{ K}, u_{in} = 15 \text{ m/s}, T_{in} = 120 \text{ K}, D_{in} = 254 \mu\text{m})$

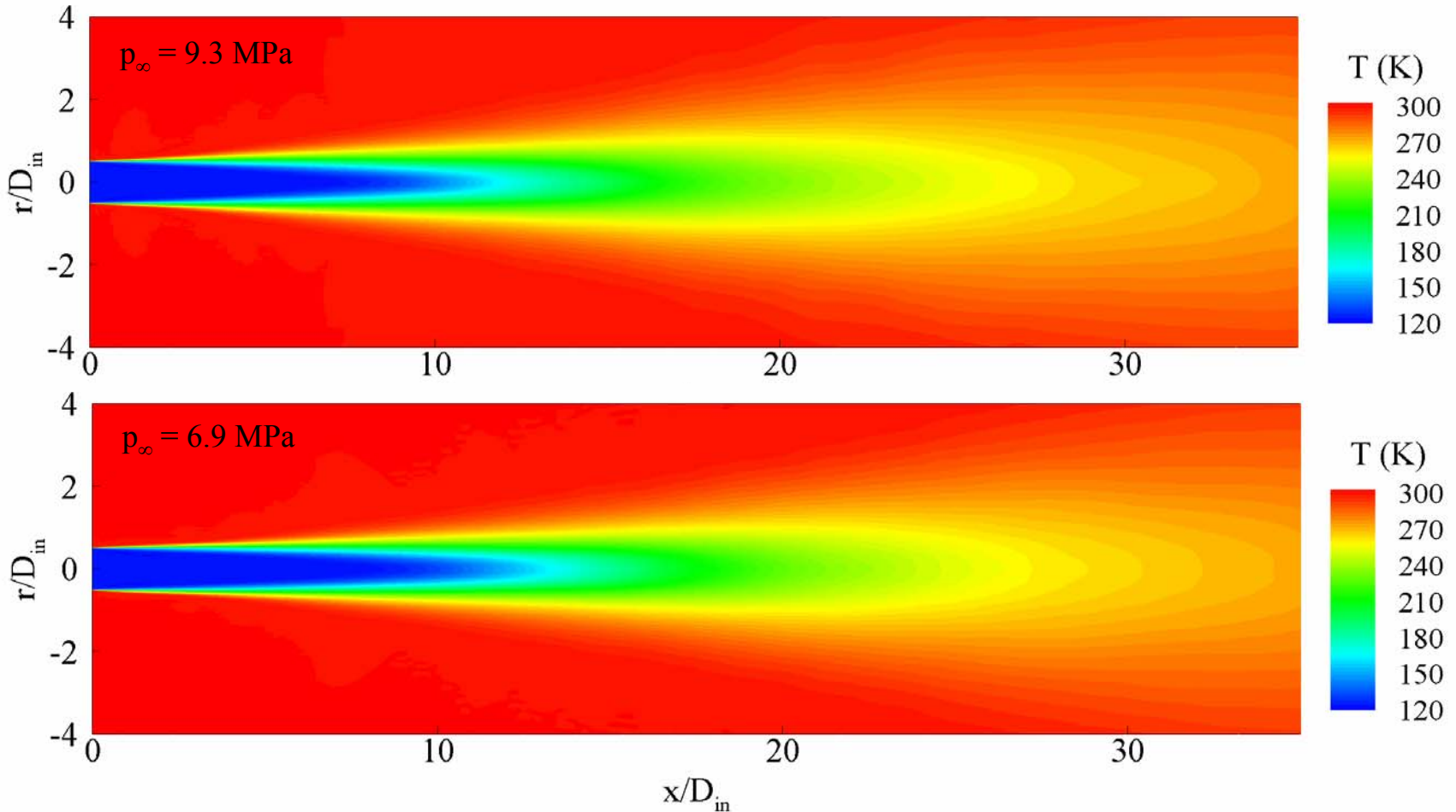



# Effect of Pressure on Mean Velocity Distributions

$(T_\infty = 300 \text{ K}, u_{in} = 15 \text{ m/s}, T_{in} = 120 \text{ K}, D_{in} = 254 \text{ }\mu\text{m})$

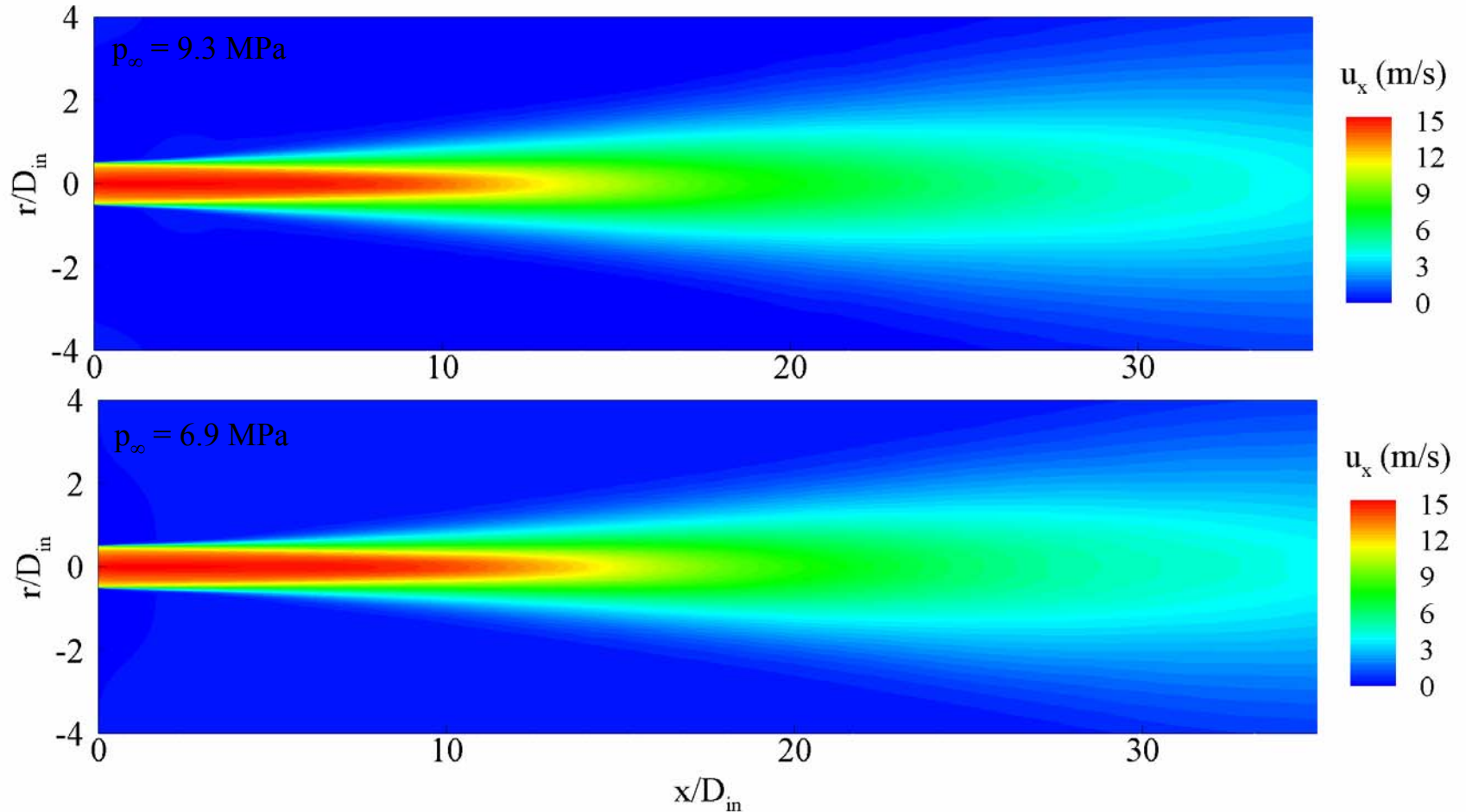





# Frequency Spectral of Radial Velocity Oscillations

$p = 4.2 \text{ MPa}$

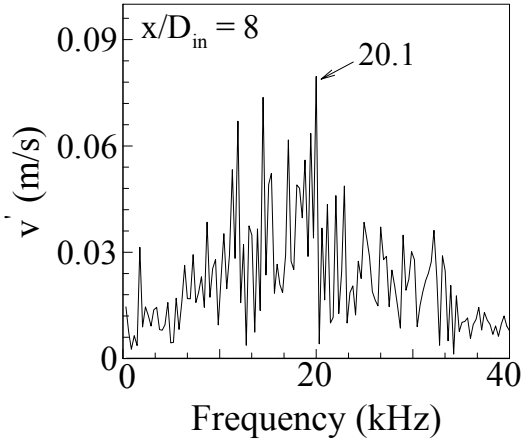

$p = 6.9 \text{ MPa}$

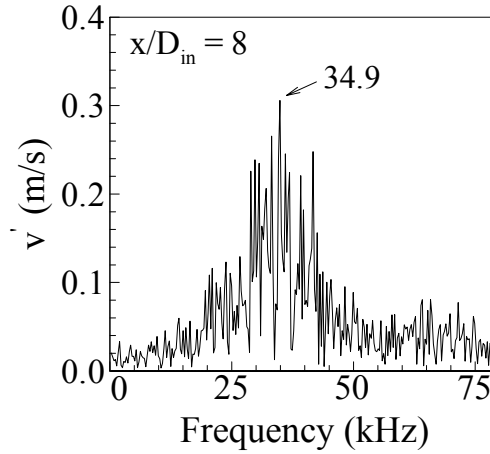

$p = 9.3 \text{ MPa}$

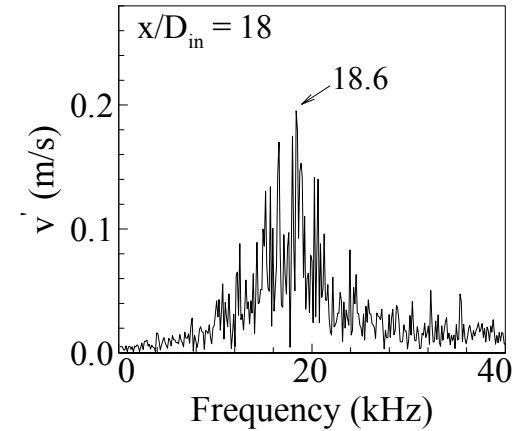
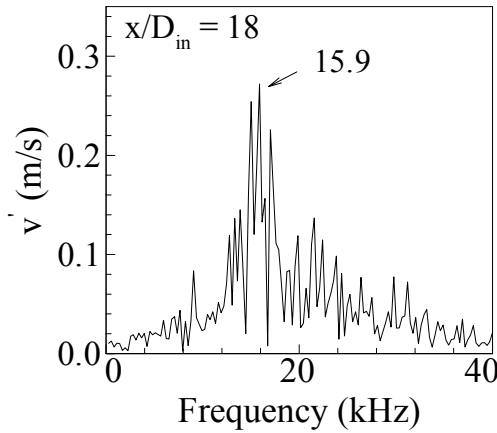
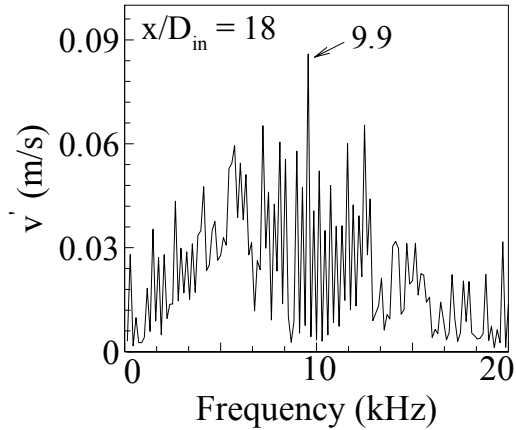
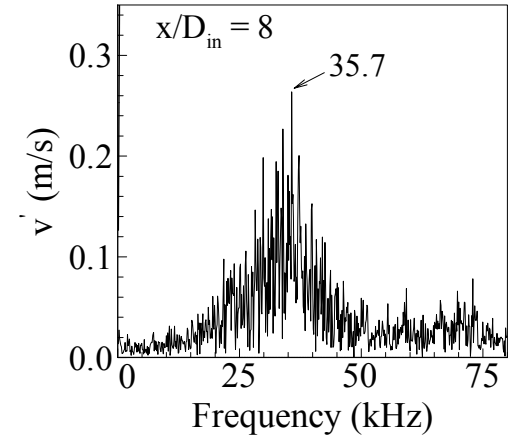



# Normalized Density and Temperature Distributions along Radial Direction

Department of Mechanical & Nuclear Engineering

$$T_{\infty} = 300\text{K}, u_{in} = 15\text{m/s}, T_{in} = 120\text{K}, D_{in} = 254\mu\text{m}$$

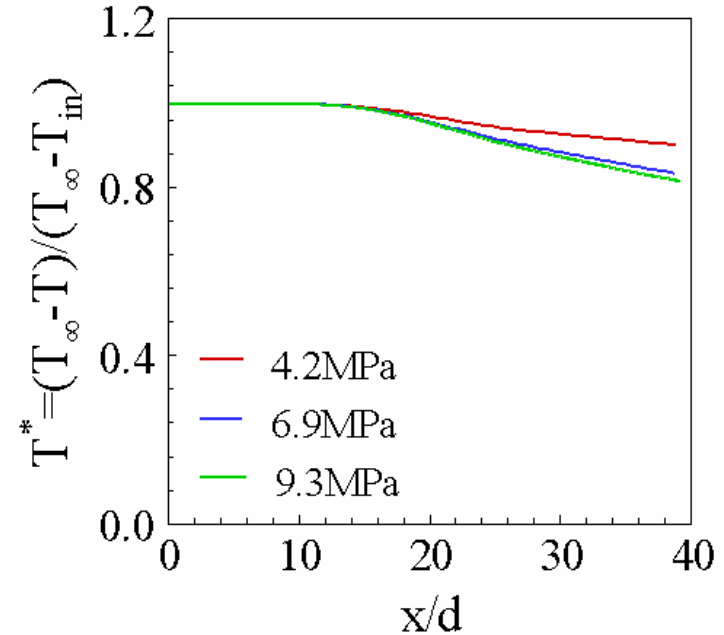
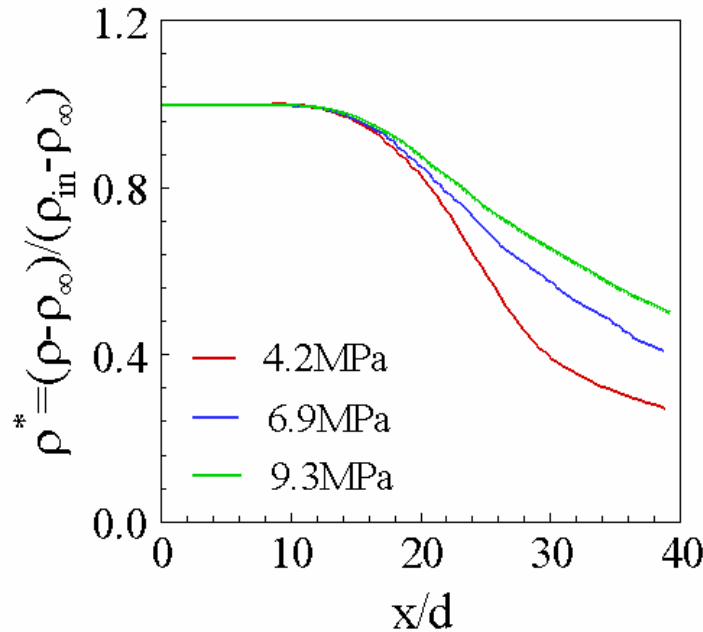

- Thermal diffusivity of nitrogen is relatively lower in the region where the temperature is near the critical temperature.
- Most thermal energy transferred from the hot ambient gaseous nitrogen to the cold jet is used to facilitate volume expansion.



# Numerical Challenges

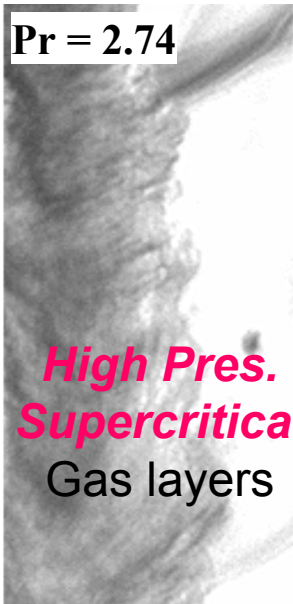
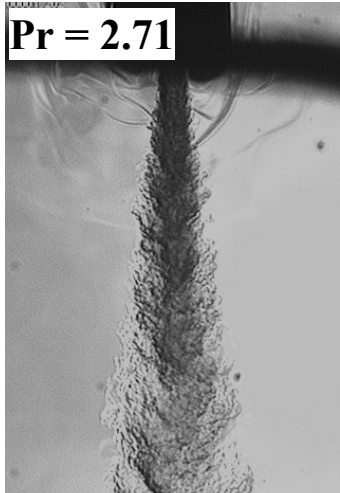

## Challenges

- machine round-off errors at low speeds
- eigenvalue disparity
- time accuracy
- real-fluid behavior
- robust and efficient numerical treatment

## Solutions

- pressure decomposition
- preconditioning method
- dual time-stepping integration technique
- partial mass/molar properties
- derivation of numerical Jacobians and thermodynamic properties based on fundamental thermodynamic theories



$(p_\infty = 9.3\text{MPa}, T_\infty = 300\text{K}, u_{\text{in}} = 15\text{m/s}, T_{\text{in}} = 120\text{K}, D_{\text{in}} = 254\mu\text{m})$

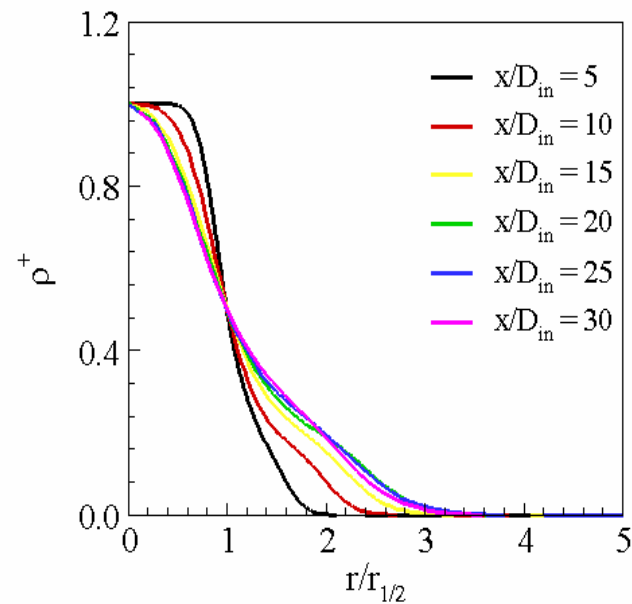
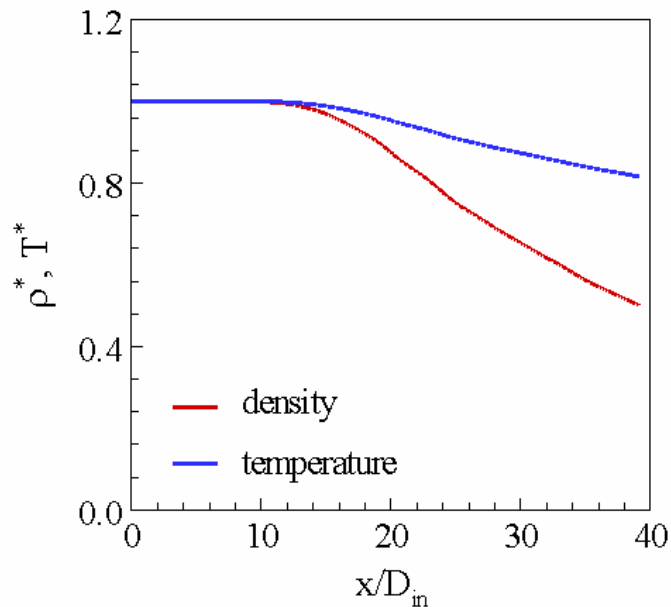

- Due to the “near critical slow down”, the temperature of nitrogen fluid increases slowly along the jet centerline.
- A self-similar density profile exist when  $x/d > 15$ .

PENNSTATE



1 8 5 5

*Department of Mechanical & Nuclear Engineering*

---

---

