



MODELING STUDY TO QUANTIFY THE BENEFITS OF
GROUNDWATER CONTAMINANT SOURCE
REMEDICATION

THESIS

David E. Wagner, Captain, USAF

AFIT/GES/ENV/06M-07

DEPARTMENT OF THE AIR FORCE
AIR UNIVERSITY

AIR FORCE INSTITUTE OF TECHNOLOGY

Wright-Patterson Air Force Base, Ohio

APPROVED FOR PUBLIC RELEASE; DISTRIBUTION UNLIMITED

The views expressed in this thesis are those of the author and do not reflect the official policy or position of the United States Air Force, Department of Defense, or the United States government.

AFIT/GES/ENV/06M-07

MODELING STUDY TO QUANTIFY THE BENEFITS OF GROUNDWATER
CONTAMINANT SOURCE REMEDIATION

THESIS

Presented to the Faculty

Department of Systems and Engineering Management

Graduate School of Engineering and Management

Air Force Institute of Technology

Air University

Air Education and Training Command

In Partial Fulfillment of the Requirements for the
Degree of Master of Science in Environmental Engineering and Science

David E. Wagner, B.S.

Captain, USAF

March 2006

APPROVED FOR PUBLIC RELEASE; DISTRIBUTION UNLIMITED.

MODELING STUDY TO QUANTIFY THE BENEFITS OF GROUNDWATER
CONTAMINANT SOURCE REMEDIATION

David E. Wagner, B.S.
Captain, USAF

Approved:

 /signed/
Dr. Mark N. Goltz
Chairman, Advisory Committee

14 March 2006
date

 /signed/
Dr. Charles A. Bleckmann
Member, Advisory Committee

14 March 2006
date

 /signed/
Dr. Junqi Huang
Member, Advisory Committee

14 March 2006
date

 /signed/
Dr. (Major) Jeffrey L. Heiderscheidt
Member, Advisory Committee

14 March 2006
date

Abstract

The purpose of this research was to quantify the benefits of groundwater contaminant source remediation by using a model to simulate how reduction of source mass was related to reduction of contaminant concentration at a receptor. Specifically, this thesis sought to answer three research questions: (1) how are contaminant source mass reduction and reduction of mass flux leaving the source-zone related; (2) how can we quantify the effect of the important natural attenuation processes that act upon the dissolved contaminant as it travels from the source zone to downgradient receptors, and (3) under specified site conditions, what is the maximum contaminant flux leaving a source-zone that natural attenuation can effectively degrade to achieve a concentration goal at a receptor. The research questions were answered through a comprehensive literature review and the use of Groundwater Modeling Software (GMS 5.1) to model an actual tetrachloroethene (PCE) contaminated site at Dover AFB, Delaware. Using actual hydrogeologic and contaminant conditions at the site, a power function was applied to determine the relationship between source mass reduction and contaminant flux reduction, while the advection-dispersion equation, with biodegradation source/sink terms to model PCE decay coupled to daughter product production, was utilized to model the effects of natural attenuation on dissolved chlorinated ethene fate and transport. The culmination of this study was the development of a model which coupled the power function with a dissolved contaminant fate and transport model to provide a tool which

estimates the amount of source mass removal necessary to achieve a concentration goal at a receptor.

Acknowledgements

I would like to thank my thesis advisor, Dr. Mark Goltz, for his tireless support and guidance on this project. His enthusiasm for the subject and patience were greatly appreciated as I worked to understand the intricacies of this study. I would also like to thank my sponsor, Lt Col Mark Smith at the Air Force Center for Environmental Excellence for supporting this study.

I would also like to thank my thesis committee Dr. Jeff Heiderscheidt, Dr. Charles Bleckmann, and Dr. Junqi Huang. Dr. Heiderscheidt, thank you for your help with the modeling aspects of the study. Dr. Bleckmann, thank you for helping me to better understand the relevant microbiology. Dr. Huang, thank you for your patience and for helping me to understand and utilize the modeling software.

This study was partially supported by the Strategic Environmental Research and Development Program through Project CU-1295, Impact of DNAPL Source Zone Treatment: Experimental and Modeling Assessment of Benefits of Partial Source Removal.

David E. Wagner

Table of Contents

	Page
Abstract.....	iv
Acknowledgements.....	vi
Table of Contents.....	vii
List of Figures.....	ix
List of Tables.....	xi
I. Introduction.....	1
1.1 Motivation.....	1
1.2 Research Questions.....	10
1.3 Methodology.....	10
1.4 Scope and Limitations.....	11
II. Literature Review.....	12
2.1 Overview.....	12
2.2 Treatment Alternatives.....	14
2.3 Natural Attenuation.....	16
2.3.1 Advection.....	18
2.3.2 Dispersion.....	20
2.3.3 Sorption.....	21
2.3.4 Biotic Transformations.....	23
2.3.4.1 Direct Aerobic Oxidation.....	25
2.3.4.2 Cometabolic Aerobic Oxidation.....	26
2.3.4.3 Anaerobic Reductive Dechlorination (Direct)	27
2.3.4.4 Anaerobic Reductive Dechlorination (Cometabolic)	28
2.3.4.5 Anaerobic Oxidation (Direct)	28
2.3.5 Abiotic Transformations.....	28
2.4 Modeling.....	29
2.4.1 Contaminant Fate and Transport Modeling.....	29
2.4.2 Source/Sink Term.....	31
2.4.2.1 First-Order Decay.....	31
2.4.2.2 Monod Model.....	33
2.4.2.3 Dual-Monod Model.....	35
2.4.2.4 Lee et al. (2004) Model.....	36
2.4.3 Modeling Source Mass Reduction and Flux Reduction.....	42
2.4.3.1 Mass Flux.....	43
2.4.3.2 Mass Transfer Correlations.....	44
2.4.3.2.1 Miller et al. (1990)	46

	Page
2.4.3.2.2 Imhoff et al. (1994)	48
2.4.3.2.3 Nambi and Powers (2003)	49
2.4.3.3 Power Functions.....	49
2.4.3.3.1 Zhu and Sykes (2004)	51
2.4.3.3.2 Parker and Park (2004)	54
2.4.3.3.3 Falta et al. (2005a)	54
 III. Methodology.....	 56
3.1 Overview.....	56
3.2 Area 6 at Dover AFB.....	56
3.2.1 Physical Characteristics at Area 6.....	56
3.2.2 Groundwater Hydrology at Area 6.....	58
3.2.3 Geology at Area 6.....	59
3.2.4 Chemistry at Area 6.....	60
3.2.5 Contamination at Area 6.....	62
3.3 Model Selection and Implementation.....	64
3.3.1 The Model.....	64
3.3.1.1 Source Remediation Model.....	64
3.3.1.2 Contaminant Fate and Transport Model.....	69
3.3.1.2.1 Flow Model.....	70
3.3.1.2.2 Source/Sink Term.....	71
3.3.2 Model Testing.....	73
3.4 Model Sensitivity Analysis.....	77
 IV. Results and Analysis.....	 79
4.1 Introduction.....	79
4.2 Source Remediation.....	79
4.3 Natural Attenuation.....	82
4.4 Impact of Source Remediation on Concentration Downgradient.....	86
4.5 Sensitivity Analysis.....	90
 V. Conclusions.....	 92
5.1 Summary.....	92
5.2 Conclusions.....	92
5.3 Recommendations for Further Research.....	94
 Bibliography.....	 96
 Vita.....	 102

List of Figures

	Page
Figure 1. Environmental Fate of TCE.....	2
Figure 2. DNAPL Behavior in the Subsurface.....	4
Figure 3. DNAPL at Residual Saturation.....	5
Figure 4. Mass Flux Reduction to Source Mass Reduction.....	7
Figure 5. Natural Attenuation.....	17
Figure 6. NA Processes Active in Contaminant Plumes at DOE Sites.....	18
Figure 7. Effects of Advection, Dispersion and Sorption.....	21
Figure 8. Sorption Isotherms.....	22
Figure 9. Aerobic Oxidation (Direct).....	25
Figure 10. Aerobic Oxidation (Cometabolic)	26
Figure 11. Anaerobic Reductive Dechlorination of PCE.....	28
Figure 12. Hydrogen Utilization.....	38
Figure 13. Mass Flux Reduction to Source Mass Reduction.....	43
Figure 14. Mass Transfer Correlations Versus Power Functions.....	50
Figure 15. Concentration Versus Mass Reduction for Various Γ Values.....	52
Figure 16. Area-6 Site at Dover AFB, Delaware.....	58
Figure 17. Groundwater Contours at Area 6.....	59
Figure 18. Area-6 Geology.....	60
Figure 19. Reaction Zones at Area 6.....	61
Figure 20. PCE Plume Contours.....	62
Figure 21. Mass Transfer Correlations Versus Power Functions.....	65

	Page
Figure 22. Mass Removed Versus Source Concentration (C/Cs) Reduction for Various Γ Values.....	67
Figure 23. Source Concentration (C/Cs) Reduction Versus Mass Removed for Various β Values	68
Figure 24. Groundwater Contours for This Study	74
Figure 25. Clement et al. (2000) Groundwater Contours.....	75
Figure 26. PCE Contamination Contours ($\mu\text{g/L}$) After 40 Years Predicted by Clement et al. (2000).....	76
Figure 27. PCE Contamination Contours ($\mu\text{g/L}$) After 40 Years Predicted by This Study	77
Figure 28. Contaminant Flux Versus Mass Reduction	81
Figure 29. Arrival of Contamination at Receptor 200 Meters Downgradient	83
Figure 30. PCE Plume	84
Figure 31. CAH Concentrations Versus Time at a Receptor 800 m Downgradient of a 48 mg/L PCE Source	85
Figure 32. Steady-State PCE Concentration at Varying Source Mass Reductions for a Monitoring Well 800 Meters Downgradient of the Source	86
Figure 33. Steady-State TCE Concentration at Varying Source Mass Reductions for a Monitoring Well 800 Meters Downgradient of the Source	87
Figure 34. Steady-State VC Concentration at Varying Source Mass Reductions for a Monitoring Well 800 Meters Downgradient of the Source	87

List of Tables

	Page
Table 1. Biodegradation Mechanisms	25
Table 2. Reported First-Order Decay Rate Constants (d^{-1})	32
Table 3. Typical Monod Parameter Values for Chlorinated Solvents.....	34
Table 4. Reaction Zone Degradation Rates	61
Table 5. Estimated Contaminant Mass Release Rates in kg/yr.....	63
Table 6. Model Parameters.....	64
Table 7. Steady-State PCE Concentrations (ppb) at Varying Source Mass Reductions for a Monitoring Well 800 Meters Downgradient of the Source.....	88
Table 8. Percent Mass Reduction Necessary to Achieve Remediation Goals.....	90
Table 9. Sensitivity Analysis Results.....	90

MODELING STUDY TO QUANTIFY THE BENEFITS OF GROUNDWATER CONTAMINANT SOURCE REMEDIATION

I. Introduction

1.1 Motivation

Approximately one-third of the nation's drinking water comes from groundwater (Masters, 1998). It has been estimated that there are between 300,000 and 400,000 sites where this important resource has been contaminated and the United States will spend approximately \$1 trillion cleaning up these sites over the next 30 years (NRC, 1994).

Of the 25 most frequently detected groundwater contaminants, the chlorinated aliphatic hydrocarbons (CAHs) trichloroethylene (TCE) and tetrachloroethylene (PCE) are ranked first and third respectively (NRC, 1994). In the past, TCE, PCE, and other chlorinated solvents have been used extensively as cleaners and degreasers. The prolific use of chlorinated solvents, coupled with improper cleanup and disposal of the waste products, has led to widespread contamination at industrial and Department of Defense (DoD) sites throughout the U.S. (Stiber et al., 1999).

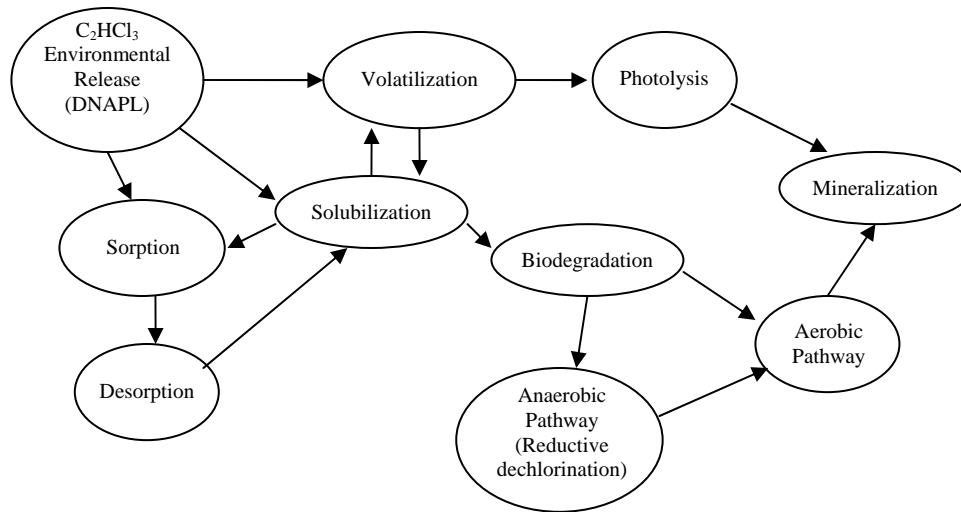

Figure 1. Environmental Fate of TCE (from Bleckman, 2005)

Figure 1 depicts the processes that affect a CAH like TCE when it is released into the environment. As Figure 1 shows, TCE released into the environment as a separate phase liquid may undergo volatilization, solubilization, or sorption. Of course, it may also remain in the liquid form, and since CAHs have densities greater than water, separate phase CAHs are referred to as dense non-aqueous phase liquids or DNAPLs. In general, CAHs at contaminated sites are found in the subsurface in the gaseous, dissolved, sorbed, or DNAPL phases (Henry et al., 2002).

CAHs released on or below the ground may travel as a separate phase DNAPL to the groundwater. Once reaching the groundwater, the CAH may solubilize and be transported in the dissolved phase to downstream receptors, thereby posing a risk to nearby drinking water sources. The U.S. Environmental Protection Agency (EPA) has specified maximum contaminant levels (MCLs) for both PCE and TCE in drinking water as 0.005 milligrams per liter (mg/L) or 5 parts per billion (ppb) (U.S. EPA, 2002b)—that is, water that contains dissolved concentrations of these CAHs above 5 ppb is deemed to

have an adverse effect on health (U.S. EPA, 2002b). The problem of PCE and TCE contamination was initially brought to public attention in 1978-1979 when PCE and TCE were found in municipal wells in Long Island (NY), Boston, and California (Jackson, 2002).

Dissolved CAHs in the groundwater may biodegrade through the anaerobic process of reductive dechlorination (Figure 1). In anaerobic reductive dechlorination, chlorine atoms are replaced with hydrogen atoms. PCE, which has four chlorine atoms (C_2Cl_4), is degraded to TCE, C_2HCl_3 , then to dichloroethene (DCE), $C_2H_2Cl_2$, and then vinyl chloride (VC), C_2H_3Cl , before finally the last chlorine atom is replaced by a hydrogen atom to form ethene, C_2H_4 (Aiken and LaPat-Polasko, 2002). While ethene does not have a drinking water MCL, DCE and VC have MCLs of 70 ppb and 2 ppb respectively. In fact, VC is a confirmed human carcinogen (ACGIH, 2003).

The CAHs may also degrade due to aerobic oxidation in an oxygenated environment. In aerobic oxidation, some of the less chlorinated CAHs, such as DCE and VC, are directly oxidized into carbon dioxide, water, chlorine, and electrons (U.S. EPA, 2000). An alternative form of aerobic oxidation is cometabolism, where a co-contaminant serves as an electron donor and carbon source, rather than the CAH itself (U.S. EPA, 2000).

As stated earlier, TCE and PCE may be found in the subsurface as DNAPLs. DNAPLs have a higher density than water and a low solubility. When DNAPLs are released onto the surface of soil, they are driven downwards and laterally by gravitational and capillary forces (Bradford et al, 2003). The DNAPLs initially move downwards through the vadose zone above the water table. When they reach the water table, because

they are denser than water, they continue their downward movement through the saturated zone until they are impeded by a layer of sufficiently low permeability.

When a DNAPL comes into contact with a low permeability layer in the saturated zone, there are two ways for the DNAPL to continue its downward movement. The DNAPL may spread horizontally and flow around the layer, as shown in Figure 2 where the clay layer represents a low permeability layer. Or, the DNAPL may pool on top of the low permeability surface until it develops enough pressure to displace the water and flow through the low permeability media (Domenico and Schwartz, 1998). The DNAPL will continue to flow downward until it reaches a layer of sufficient impermeability and size, such as the bedrock shown in Figure 2, to contain the DNAPL.

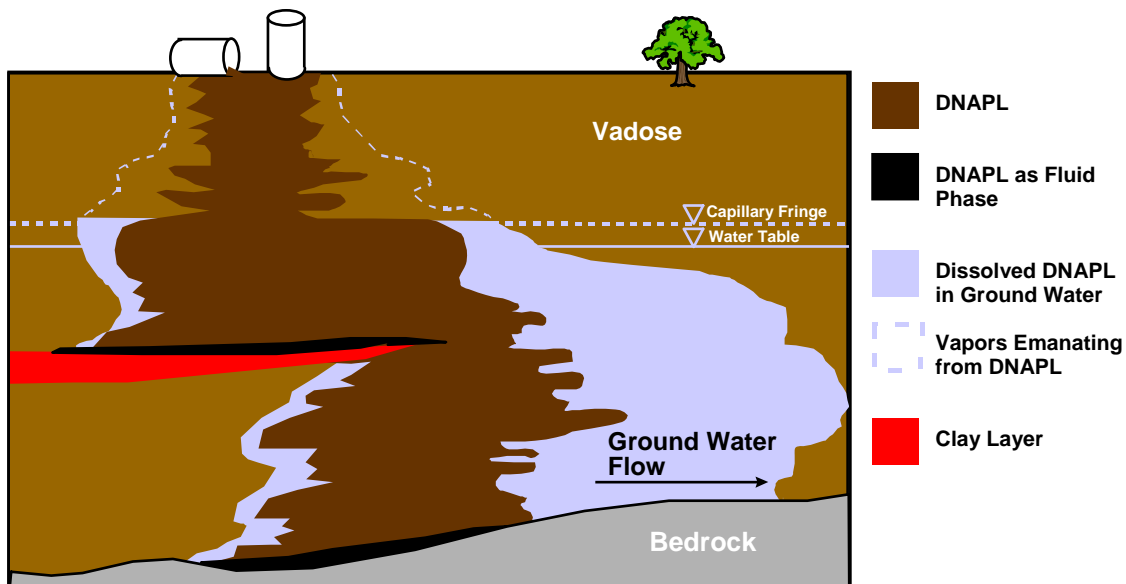

Figure 2. DNAPL Behavior in the Subsurface (from NRC, 1994)

As the DNAPL migrates through the subsurface, a trail of residual contamination is left behind. Figure 1.2 shows how residual DNAPL, which may be referred to as a DNAPL

globule or ganglion, is contained within the pore spaces of the solids in the saturated zone.

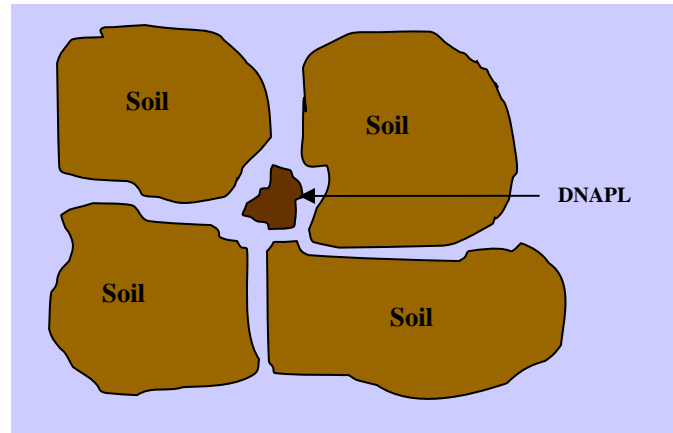

Figure 3. DNAPL at Residual Saturation (after Domenico and Schwartz, 1998)

The residual DNAPL, which is the non-wetting phase, is surrounded and held in place by water, the wetting phase, which is more strongly attracted to the soil. The DNAPL residual will remain in place until it slowly dissolves into the passing groundwater (NRC, 1994). Similarly, DNAPL pools that form on low permeability layers will also slowly release dissolved contaminant into the groundwater. As the DNAPL dissolves into the flowing groundwater, a plume of contamination will be created which may stretch for miles downgradient. Due to the relatively low solubility of DNAPLs and the rate of DNAPL dissolution, which has been shown to be mass transfer-limited (Sorenson, 2002; Zhu and Sykes, 2004), DNAPLs often become sources of contamination that can persist for decades or even centuries (NRC, 1994; Zhu and Sykes, 2000).

The difficulties of locating and quantifying DNAPL in the subsurface, as well as the mass transfer-limited dissolution of CAHs, makes remediation of DNAPL contamination very challenging. Some experts have hypothesized that DNAPL

contaminated sites can never be completely remediated (Henry et al, 2002). These difficulties, coupled with the costs of DNAPL cleanup, have motivated the development of remediation technologies and strategies that minimize (cleanup) costs while maximizing benefits to the environment and human health.

Since it is nearly impossible to precisely locate DNAPL in the subsurface, much less quantify the mass of contaminant that is in the DNAPL phase, the extent of DNAPL contamination has typically been estimated by measuring the concentration of dissolved contaminant. However, to quantify the environmental and human health benefits of DNAPL cleanup, recent work has shown that rather than measuring the reduction of DNAPL source mass or the reduction of contaminant concentrations in the source zone, it is more appropriate to quantify the reduction of contaminant mass flux leaving the source zone (Soga et al., 2004; Jawitz et al., 2005) where flux is defined as contaminant mass passing through a cross-sectional area of the subsurface aquifer per unit time and has the units of $\text{mass-length}^{-2}\text{-time}^{-1}$ (Clark, 1996). Mass flux measurements are proposed as a more appropriate measure of the risk posed by a contaminant source than source zone contaminant concentrations (Einarson and Mackay, 2001). Remediation technologies used to reduce the source mass may also reduce the mass flux. Figure 1.3 shows how reduction in source mass can lead to a reduction in mass flux exiting the source zone, while still leaving pockets of high contaminant concentrations in the source zone unaffected.

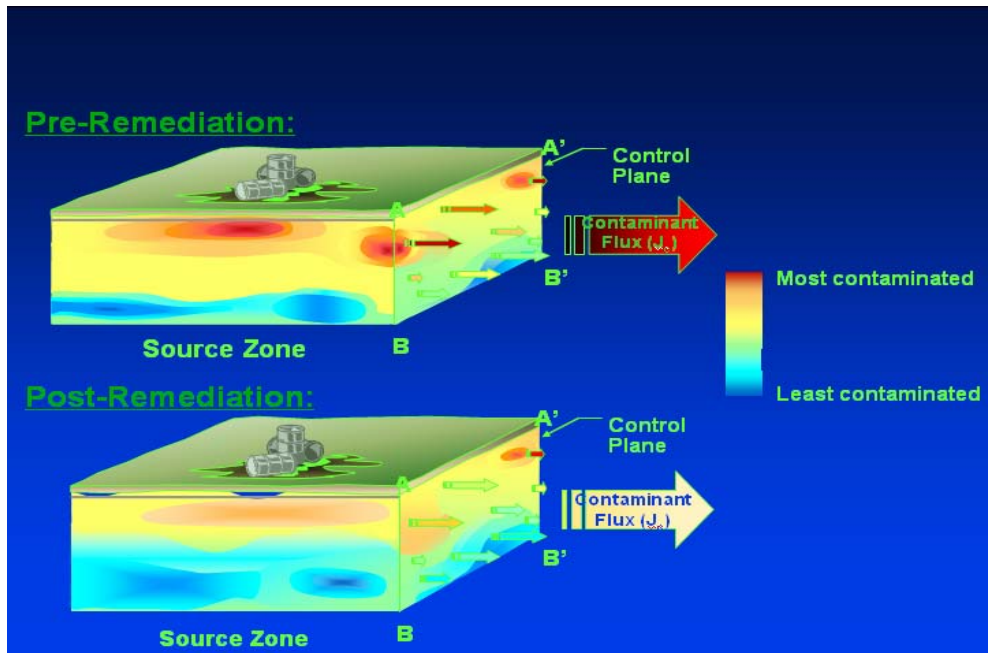

Figure 4. Mass Flux Reduction to Source Mass Reduction (Annable et al., 2005)

In Figure 4, the pre-remediation source zone has three areas depicted as being “most contaminated.” This large (as compared to post-remediation) degree of contamination leads to a contaminant flux that is also in the “most contaminated” range. Looking at the figure, we see that the remediation removed contaminant from the areas of high permeability while leaving contamination in areas of low permeability. While there still may be high contaminant concentrations in the source zone after remediation, and the mass of contaminant removed may not necessarily be a large percentage of the initial mass present, the contaminant mass flux leaving the source zone has been decreased, resulting in a reduction in the hazard at downgradient receptors. This is an important idea which shows that flux reduction does not depend solely on the amount of mass removed, but instead depends on the site characteristics.

Ex situ (above ground) or *in situ* (in ground) remediation technologies may be used to accomplish source mass reduction. *Ex Situ*, or pump-and-treat, remediation

technologies involve pumping the contaminated groundwater out of the ground and then treating it through processes such as incineration or solidification/stabilization (U.S. EPA, 2001). *In situ* technologies used to remediate DNAPLs include thermal desorption, chemical oxidation, and surfactant flushing (Lehr et al., 2002). Containment techniques may be utilized when these techniques are unable to achieve the necessary contamination reduction. Containment techniques include slurry walls or sheet pile (Domenico and Schwartz, 1998).

All of these remediation technologies have proven to be expensive in the past and are often unable to reduce the contaminant to below maximum concentration levels (Jackson, 2002), leading researchers to pursue alternate methods. This is not to say that source mass removal should not continue to be accomplished. Source mass removal is important, but the ultimate goal should be to reduce the amount of contaminant mass flux leaving the source zone, as that is directly related to risk downgradient.

Recent studies (Zhu and Sykes, 2004; Parker and Park, 2004; Falta et al., 2005) attempt to quantify how source mass removal results in reduction of dissolved contaminant flux leaving the source zone. After leaving the source zone, this dissolved contaminant flux is further reduced through natural processes collectively referred to as natural attenuation (NA). NA refers to the physical, biological, and chemical processes which work to reduce the toxicity, mass, and/or mobility of a contaminant naturally (Scow and Hicks, 2005). Some of the processes involved in natural attenuation include dispersion, dilution, sorption, and volatilization, as well as, biodegradation (NRC, 1999).

The idea of applying NA as a remediation technique was not accepted until 1994, but the U.S. EPA now recognizes NA as both a stand-alone and complementary

remediation process (Mulligan and Yong, 2004). As of 1995, NA was being used at 48% of underground storage tank, UST, sites, while pump-and-treat was only being utilized at 29% of the sites (Kremer, 1997). Unfortunately, the public does not always support the use of this technique and has referred to it as the “do nothing” approach (NRC, 2000). Further research into the utilization of NA as a remediation technology shows that this is clearly not the case.

NA as a remediation technique requires monitoring and an excellent understanding of the inherent processes that are reducing the contaminant flux (Schirmer and Butler, 2004). One of the major components of NA is the biological processes. Modeling these processes has been the subject of a large amount of research in the past. There have been numerous models proposed and used to describe these processes; these models are described in more detail in Chapter 2 of this thesis.

Based on the above discussion, it is apparent that a key question that needs to be answered is: what are the risk reduction benefits of removing DNAPL mass from the source zone? It is to be hoped that at a remediation site, sufficient source mass removal can be accomplished so that contaminant flux leaving the source is reduced to an extent such that NA processes may be adequate to diminish dissolved contaminant concentrations in the plume sufficiently to protect human health and the environment at downgradient receptors. There has not been much published that relates the impact of source mass reduction, due to application of source remediation technologies, on concentration (*i.e.* risk) reduction at receptors. The ability to quantify the benefits of source mass reduction in terms of concentration reduction at receptors would allow decision-makers and regulators to make informed assessments of whether the

contamination source has been adequately remediated (*i.e.* will NA be sufficiently protective of human health and the environment?) or is additional engineered remediation necessary?

1.2 Research Questions

1. How are source mass reduction and reduction of mass flux leaving the source-zone related?
2. How can we quantify the effect of the important natural attenuation processes that act upon dissolved chlorinated solvent contaminants?
3. Under specified site conditions, what is the maximum contaminant flux leaving a source-zone that NA can effectively degrade to achieve a concentration goal at a receptor?

1.3 Methodology

A literature review will be conducted to determine how mass flux from a DNAPL source is related to DNAPL source mass reduction and to determine what models are available to quantify the extent to which NA processes reduce dissolved chlorinated solvent concentrations in groundwater plumes. The mass flux/mass reduction literature review will focus on theoretical and modeling studies, as well as the results of laboratory and, if available, field experiments. The literature review for modeling methods will focus on determining what models are available to quantify the extent to which NA processes reduce dissolved chlorinated solvent concentrations in groundwater plumes. More specifically, the focus of this part of the literature review will be upon application of NA models to simulate field data. The literature review will also include a search for a well-characterized site at which NA is occurring and NA processes have been modeled.

Our approach will be to use this site model as a component of our overall model. The overall model will couple a source model, which simulates how reduction in source mass results in reduction of mass flux leaving the source, with the site model. The overall model will be applied to demonstrate how source mass reduction leads to flux reduction and how flux reduction leads to concentration reduction at receptors. The model will further be used to conduct sensitivity analyses to assess the impact of varying degrees of source mass removal on contaminant concentrations at downgradient receptors under various conditions.

1.4 Scope and Limitations

Limitations:

1. Only CAH contamination, specifically PCE and TCE, are being considered explicitly in this research.
2. When determining the mass flux downgradient of the contamination zone, the source mass reduction due to application of a generic source remediation technology was modeled. This study is not concerned with, and does not attempt to model, the effectiveness of any specific technology in reducing source mass.
3. Modeling results are based on the hydrogeologic conditions at a specific site. Results will vary depending on site-specific characteristics.

II. Literature Review

2.1 Overview

Chlorinated aliphatic hydrocarbons (CAHs) such as trichloroethylene (TCE) and tetrachlorethylene (PCE) are the first and third most prevalent groundwater contaminants, respectively (NRC, 1994). When spilled in sufficient quantity, these organic compounds, in the form of dense non-aqueous phase liquids (DNAPLs), are able to move through the vadose zone, eventually reaching the water table and penetrating into the saturated zone. The density of these CAHs allows them to continue through the saturated zone until they encounter sufficiently impermeable layers that cause the DNAPL to pool. While the DNAPL flows downward through the vadose and saturated zones, residual contamination is entrapped by capillary forces in the pore spaces of both zones. As groundwater flows past the residual and pooled DNAPL in the saturated zone, the contaminants, perhaps over decades or even centuries, slowly dissolve, resulting in a plume of dissolved contamination that can extend for miles downstream. The dissolved contaminants in the plume can affect receptors far from the DNAPL source zone, where we define the source zone as the area containing the residual and pooled contaminant (NRC, 1994; Zhu and Sykes, 2000).

Remediation strategies employed to protect human health and the environment from CAH contamination may be categorized as either plume or source zone remediation strategies. The remediation methods used in the source zone are directed toward either removing the source of contamination or containing the contamination (Wiedemeier, 1999). Unfortunately, it is conceded that with current technologies, we are unable to totally remove DNAPL source zone contaminants and in many cases containment may

also be very difficult (Jawitz et al., 2005). Plume remediation is focused more on reducing the contamination that arrives at downgradient receptors to levels that are not harmful. Plume remediation techniques may include pump-and-treat and monitored natural attenuation (Domenico and Schwartz, 1998). Monitored natural attenuation (MNA) is a strategy by which natural processes reduce the contaminant concentrations to “acceptable” (i.e. protective of health and the environment) levels, while the processes are monitored to assure remediation goals are being achieved (U.S. EPA, 1999). In addition to monitoring, models are often used to predict whether natural attenuation, or engineered processes, will be sufficient to reduce the contamination to acceptable levels. Models have been developed to simulate the fate and transport of contaminants (Petrunic et al., 2005; Lee et al., 2004; Domenico and Schwartz, 1998; Droste, 1997). There have also been models developed that predict the relationship between source zone mass and source zone strength or the concentration of contamination in the source zone (Falta et al., 2005; Parker and Park, 2004; Zhu and Sykes, 2004; Nambi and Powers, 2003; Imhoff et al., 1994; Miller et al., 1990).

The remainder of this chapter will discuss some treatment alternatives and the processes involved in natural attenuation. The models used to describe the fate and transport of dissolved CAHs and models used to determine the relationship between contaminant source mass and contaminant concentration in the source zone will also be discussed.

2.2 Treatment Alternatives

As discussed earlier, there are traditionally two ways to employ remediation at a site: source zone treatment, or plume management.

Source zone treatment refers to remediation accomplished in the source zone and may be accomplished in one of two ways: *ex situ* or *in situ*. *Ex situ* remediation strategies remove the contaminated groundwater from the subsurface and then treat it. *In situ* technologies treat the contamination without removing it from the subsurface (Domenico and Schwartz, 1998). Complete removal of DNAPL mass from the source zone, whether through *ex situ* or *in situ* processes, has proven to be unattainable, although source mass reductions of 60-70% have been shown to be possible (Soga et al., 2004).

Ex situ remediation technologies employed in the source zone focus on removing the contaminant mass from the subsurface (Jawitz et al., 2005). One *ex situ* technology used to remediate DNAPLs is surfactant flushing (Lehr et al., 2002). In surfactant flushing, a chemical is pumped through the subsurface to solubilize and mobilize the DNAPLs so that they can be removed from the subsurface (Sellers, 1999). *Ex situ* technologies are somewhat less desirable than *in situ* remediation technologies because the contaminant must be removed from the subsurface, typically resulting in increased costs due to the generation of an additional hazardous waste stream that must be managed. *In situ* technologies employed in the source zone include *in situ* chemical oxidation (ISCO) and thermal treatment (AFCEE, 2006). These strategies are able to destroy the contaminant while in the subsurface.

Containment techniques may be used when other techniques are unable to achieve the necessary contamination reduction. Containment techniques include slurry walls or

sheet pile, both of which are simple barriers to prevent downgradient transport of the contaminant (Domenico and Schwartz, 1998). While these methods prevent the contaminant from migrating downgradient, they do not remove the contamination from the groundwater and may lead to problems in the future. There have also been cases where this method has been employed and the entire contaminant mass was not contained. However, if properly constructed containment is able to provide a temporary solution to complex contaminant sites, while a more detailed, thorough plan is developed.

Plume treatment also uses *in situ* and *ex situ* remediation strategies. *In situ* technologies include permeable reactive barriers and enhanced bioremediation. Enhanced bioremediation is a process where the natural soil conditions are enhanced in order to provide an optimal environment for microorganisms which naturally degrade the contamination (Lehr, 2002). This strategy has been receiving an increased level of attention due to the reduced costs (it may require less energy and there is no waste stream generated) associated with employment (U.S. EPA, 2000).

Ex situ, or pump-and-treat, remediation technologies involve pumping the contaminated groundwater out of the ground and then treating it through processes such as incineration or solidification/stabilization (U.S. EPA, 2001). As with the source zone *ex situ* remediation strategies, these technologies are somewhat less desirable than *in situ* remediation technologies. However, once removed, decontaminated groundwater may be returned to the soil (AFCEE, 2006). Although these technologies were initially thought to be very useful, they have begun to lose favor because of the low solubility and mass transfer-limited dissolution of the contaminants (NRC, 1994).

While each of these methods may work to some degree, in general, remediation of CAHs is a very costly and lengthy process (Jackson, 2002.). The downward migration of DNAPLs through a heterogeneous subsurface causes a complex distribution of residual contamination in the source zone making it difficult to find and remediate the contamination (Christ et al., 2005a). Source zone remediation of CAHs is further complicated by their low solubility and mass transfer-limited dissolution (Christ et al., 2005a; Bradford et al., 2003; NRC, 1994). Current literature concedes that complete removal of contamination from the source zone is impossible and in many cases it may be difficult to reduce the concentration levels to below regulatory limits (Christ et al., 2005a; U.S. EPA, 2003). This difficulty makes the idea of flux reduction goals rather than concentration reduction goals more appealing. That is, it is proposed that the goal of a source zone remediation effort should be reduction of contaminant mass flux leaving the source to a sufficient extent so that natural (or engineered) processes acting upon the dissolved contaminants in the plume are protective of the health of downgradient receptors (Jawitz et al., 2005). The focus of this research is on the processes that may contribute to natural attenuation of the aqueous phase CAH (i.e. the natural processes that lead to a reduction in contaminant concentration) and how those processes, coupled with source zone remediation, can be utilized to insure that regulatory health standards are achieved at downgradient receptors.

2.3 Natural Attenuation

Natural attenuation (NA) is the reduction of contaminant concentrations at downgradient receptors due to fate and transport processes such as dispersion, sorption,

biotic, and abiotic transformations (Wiedemeier et al., 1999). In order to determine that NA is occurring at a site, there are three site characteristics that should be present

(Wiedemeier, 1999):

1. There should be evidence that the contaminant plume has stabilized and/or the mass of contamination is decreasing; and
2. Chemical and analytical data should indicate that the site conditions favor biodegradation and biodegradation is occurring; and
3. There are microbiological data that show biodegradation is occurring at the site.

Figure 5 visually depicts how NA may lead to a reduction of contaminant concentration at a downgradient receptor.

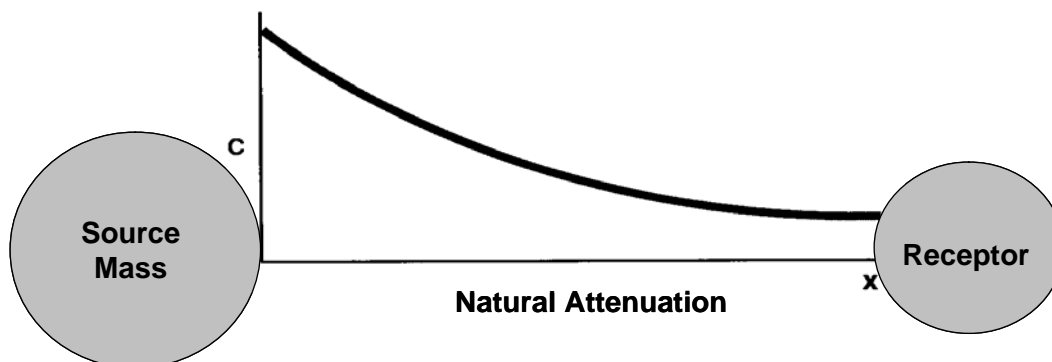

Figure 5. Natural Attenuation (from Wiedemeier et al., 1999)

In Figure 5, NA of the contaminant is occurring between the source mass (where the environmental release occurred and the residual contamination resides) and a downgradient receptor. The extent of the contaminant concentration reduction will depend on which processes are occurring and the rate at which the processes act upon the contaminant.

Some of the important NA processes and their prevalence at a sample of 178 Department of Energy (DOE) chlorinated solvent sites are shown in Figure 6.

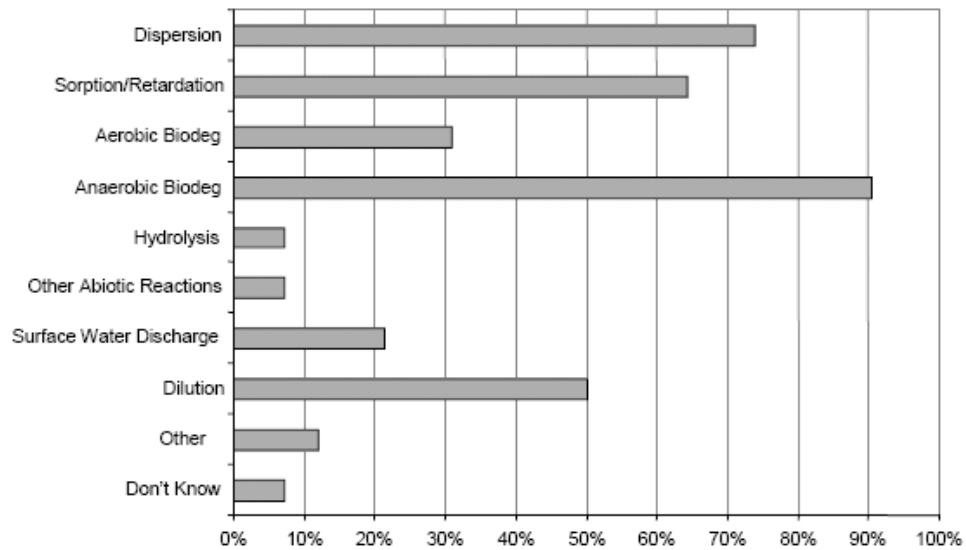

Figure 6. NA Processes Active in Contaminant Plumes at DOE Sites (DOE, 2004)

Figure 6 shows that anaerobic biodegradation, which falls under the broader category of biotic transformation, is the most prevalent NA process at these sites, with an occurrence of over 90%. The next most prevalent mechanisms are the physico-chemical processes of dispersion and sorption/retardation, which both occur at well over half of the sites. No other processes have been shown to occur at more than half of the sites. Some of these processes are discussed in more detail below.

2.3.1 Advection.

The transport of contaminants downgradient due solely to the movement of groundwater is referred to as advection (Domenico and Schwartz, 1998). If advection is the only process occurring, it is generally assumed that the contaminant will move at the same velocity as the groundwater (Domenico and Schwartz, 1998). Due to advection, a contaminant is expected to arrive at a downgradient receptor at a time, t , which may be found by Equation 1:

$$t = \frac{x}{v} \quad (1)$$

Where:

x = distance to downgradient receptor [L]

v = groundwater velocity in the x-direction [LT^{-1}]

After time t , the concentration arriving at the downgradient receptor, and at all points less than x , will be equal to the concentration in the source zone, assuming the source zone concentration remains constant and advection is the only process affecting contaminant transport. Groundwater velocity may be determined using Darcy's Law (from Domenico and Schwartz, 1998):

$$v = -\frac{K}{n_e} \frac{\partial h}{\partial l} \quad (2)$$

Where:

K = the hydraulic conductivity [LT^{-1}]

n_e = the effective porosity [-]

$\frac{\partial h}{\partial l}$ = the hydraulic gradient [LL^{-1}]

In reality, contaminant is never transported by advection alone. In a porous medium, dispersion is another important physical transport process.

2.3.2 Dispersion.

Dispersion is the process by which a contaminant plume will spread three-dimensionally (Domenico and Schwartz, 1998). There are two important processes that cause dispersion: diffusion and mechanical dispersion. Diffusion is the process by which a concentration gradient induces the spreading of contamination from high concentration areas to areas of lower concentration (Domenico and Schwartz, 1998). Mechanical dispersion mixes the contaminant with the groundwater. Heterogeneities cause the groundwater to flow through tortuous pathways and encounter regions of varying hydraulic conductivities in the subsurface, leading to velocity variations. As the groundwater flows around solid particles and through regions of varying hydraulic conductivity the dissolved contaminant mass, which is carried by the flowing water, disperses (Domenico and Schwartz, 1998). Diffusion is typically negligible in relation to the mechanical dispersion, unless the groundwater velocity is very small (Wood, 2005). The equation for the mechanical dispersion coefficient, D , is based on experimental data which have shown that mechanical dispersion is directly proportional to groundwater velocity. The constant of proportionality is designated as the dispersivity (Domenico and Schwartz, 1998). Equation 3 relates dispersion coefficient, dispersivity, and groundwater velocity (Clark, 1996).

$$D_i = \alpha_i * v \quad (3)$$

Where:

D_i = the dispersion coefficient in the i^{th} -direction [L^2T^{-1}]

α_i = the dispersivity in the i^{th} -direction [L]

The values for dispersivity are dependent upon the medium (Domenico and Schwartz, 1998). Typically, longitudinal spreading, in the groundwater flow direction, is 3-10 times greater than spreading transverse to flow (Clark, 1996).

2.3.3 Sorption.

Sorption is the process by which chemicals partition to aquifer solids. The sorption process will cause the contaminant mass to move through the subsurface more slowly than the groundwater itself (NRC, 2000). Sorption will cause the contaminant to reach a downgradient receptor later than it would if sorption was not significant. Also, during cleanup, sorbed contaminant may slowly desorb, resulting in “tailing” (low contaminant concentrations that persist for a long-time). The impact of sorption on contaminant transport is illustrated in Figure 7.

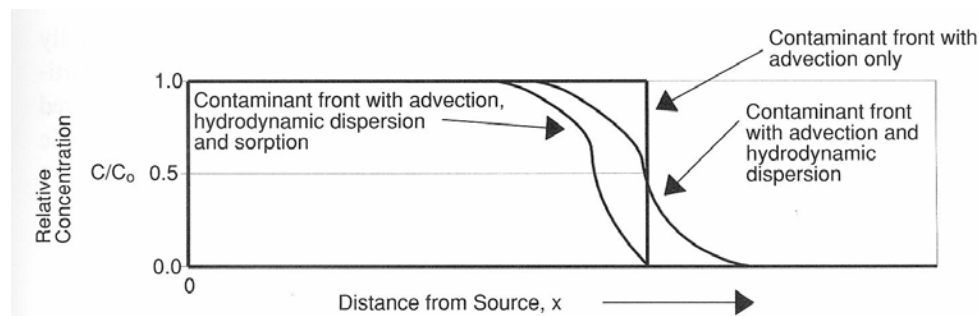

Figure 7. Effects of Advection, Dispersion and Sorption (Wiedemeier et al., 1999)

The effect of the sorption process on contaminant transport, can be modeled using the retardation factor, R_f . Sorption causes the velocity of the contaminant to be less than the velocity of the groundwater, as contaminant molecules that are sorbed to the aquifer

solids are immobile (Wiedemeier, 1999). If we assume that sorption is an equilibrium process, we typically model the concentration of sorbed contaminant as a function of dissolved contaminant concentration using one of the following three isotherms:

Langmuir, Freundlich, or linear isotherm (Figure 8).

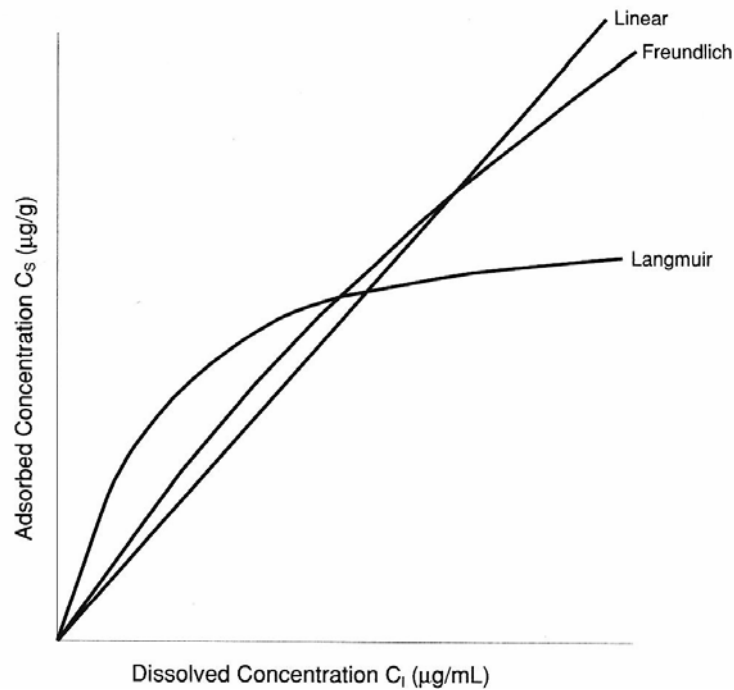

Figure 8. Sorption Isotherms (Wiedemeier, 1999)

The Langmuir model is based on the hypothesis that there are only a finite number of sorption sites on the aquifer solids to which the contaminant can sorb (Wiedemeier, 1999). So, initially at low dissolved concentrations, the relationship between the sorbed and dissolved concentrations will be linear, as the number of sorption sites is virtually unlimited. Eventually, as the dissolved concentration increases, sorption sites become limiting and the isotherm flattens out. Ultimately, at high dissolved concentrations, all sorption sites are filled and the sorbed contaminant concentration reaches its maximum

value. The Freundlich isotherm is empirical, and assumes that the sorbed concentration is proportional to the dissolved concentration raised to a power (Wiedemeier, 1999). The linear sorption isotherm is a variation of the Freundlich model, and is the model most often used for NA studies. It is typically valid when the contaminant concentration is low (less than half of the contaminant's solubility) (Wiedemeier, 1999). In this model, there is a linear relationship between the sorbed concentration and dissolved concentration, with the proportionality constant referred to as the distribution coefficient, K_d . That is, the distribution coefficient is the ratio of the sorbed contaminant concentration to the dissolved contaminant concentration. The retardation factor is a function of the distribution coefficient, as shown below (Domenico and Schwartz, 1998).

$$R_f = \left[1 + \frac{(1-n)}{n} \rho_s K_d \right] \quad (4)$$

Where:

n = Porosity [-]

ρ_s = Solids density [ML^{-3}]

K_d = Distribution coefficient [L^3M^{-1}]

2.3.4 Biotic Transformations.

As shown in Figure 6, biotic transformation, or biodegradation, is the dominant natural attenuation mechanism affecting CAH fate in many groundwater systems (Wiedemeier et al., 1999). Biodegradation of groundwater contaminants occurs as a result of the microorganisms present in (or sometimes added to) the subsurface (NRC, 2000). These microorganisms may transform the contaminants directly, by metabolizing

the contaminant, or indirectly, through co-metabolic processes, where the contaminants are fortuitously degraded by microorganisms that are metabolizing other compounds for energy and growth (NRC, 2000). These biotransformations may be oxidative or reductive (U.S. EPA, 2000; Wiedemeier et al., 1999). Oxidation and reduction processes occur when electrons are transferred from one compound to another, where the compound losing the electron (the electron donor) is said to be oxidized, while the compound gaining the electron (the electron acceptor) is said to be reduced. Collectively these are referred to as “redox” reactions (NRC, 2000). Additionally, these processes may occur in aerobic (in the presence of oxygen) or anaerobic (without oxygen) environments. As shown in Figure 6, aerobic biodegradation was found at over 30% of the DOE sites, while anaerobic biodegradation was found at over 90% of the sites.

There are five common biotic transformations for CAHs: direct or cometabolic aerobic oxidation, direct or cometabolic anaerobic reductive dechlorination, and direct anaerobic oxidation (U.S. EPA, 2000; Wiedemeier et al., 1999). In each of these processes there are three necessary components: a carbon source (primary growth substrate), an electron donor (reductant), and an electron acceptor (oxidant). Of course, the presence of the appropriate microorganisms is also critical. Table 1 summarizes these five biodegradation processes:

Table 1. Biodegradation Mechanisms (from U.S. EPA, 2000; Wiedemeier et al., 1999)

Biodegradation Mechanism	Carbon Source	Electron Donor (Reductant)	Electron Acceptor (Oxidant)	Comments
Aerobic oxidation (direct)	CAH	CAH	Oxygen	Only less chlorinated CAHs can be degraded
Aerobic oxidation (Cometabolic)	Organic carbon	Cometabolic (e.g. toluene, methane, propane)	Oxygen	CAH oxidized by cometabolic mechanism
Anaerobic reductive dechlorination (direct)	Organic carbon or CO ₂	Hydrogen	CAH	Greater chlorinated CAHs are more readily available
Anaerobic reductive dechlorination (cometabolic)	Other organic carbon or CO ₂	Hydrogen	Cometabolic electron acceptor	CAH reductively dechlorinated by cometabolic mechanism
Anaerobic oxidation (direct)	CAH	CAH	Available electron acceptor (ex. Fe(III))	Shown to be significant process for DCE and VC

These processes are described in more detail, below.

2.3.4.1 Direct Aerobic Oxidation.

Aerobic oxidation requires the presence of oxygen as well as the appropriate microorganisms in the subsurface. The oxygen serves as the electron acceptor, while the CAH serves as the electron donor and the carbon source for the microorganisms (U.S. EPA, 2000). A visual depiction of this process can be seen in Figure 9.

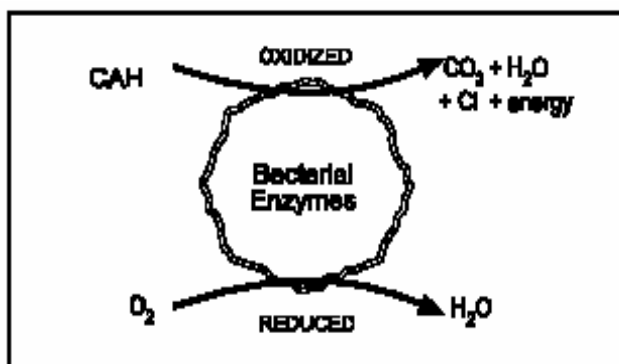

Figure 9. Aerobic Oxidation (Direct) (U.S. EPA, 2000)

Figure 9 shows how direct aerobic oxidation is able to convert the less chlorinated compounds, such as DCE and VC, into carbon dioxide, water, chlorine, and electrons (U.S. EPA, 2000).

2.3.4.2 Cometabolic Aerobic Oxidation.

Cometabolic aerobic oxidation also requires oxygen to be present, but the contaminant is not utilized as the electron donor or carbon source. An additional electron donor, such as methane, toluene or ammonia must be present to act as a carbon source for the microorganisms. This co-contaminant is metabolized by the microorganisms and enzymes or cofactors produced by the process will fortuitously breakdown the chlorinated solvent. This process, utilizing toluene as the electron donor can be seen in Figure 10.

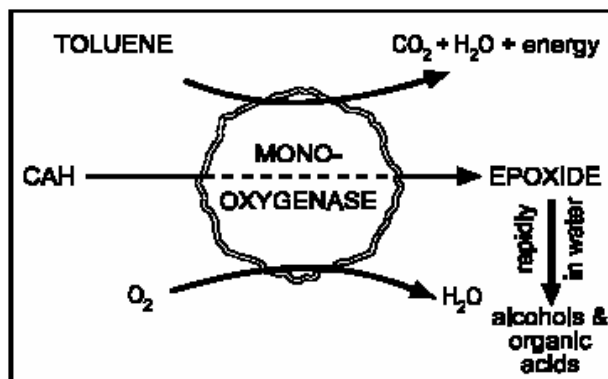

Figure 10. Aerobic Oxidation (Cometabolic) (U.S. EPA, 2000)

As Figure 10 shows, cometabolic aerobic oxidation of CAHs will also produce carbon dioxide and water, but instead of the CAH being directly mineralized, alcohols and

organic acids are produced. These are subsequently oxidized by other microorganisms. This process has been shown to be applicable for TCE, DCE, and VC degradation (U.S. EPA, 2000) (see Table 1).

2.3.4.3 Anaerobic Reductive Dechlorination (Direct).

When oxygen is not present in the subsurface, the chlorinated solvents may undergo anaerobic reductive dechlorination or halorespiration. In direct anaerobic reductive dechlorination, hydrogen is used as the electron donor and the chlorinated solvent is the electron acceptor, while organic carbon or carbon dioxide is used as the carbon source (U.S. EPA, 2000). The presence of hydrogen in the groundwater is vital to this process (U.S. EPA, 2000). As shown in Figure 11, the hydrogen used in halorespiration replaces chlorine on the chlorinated contaminants.

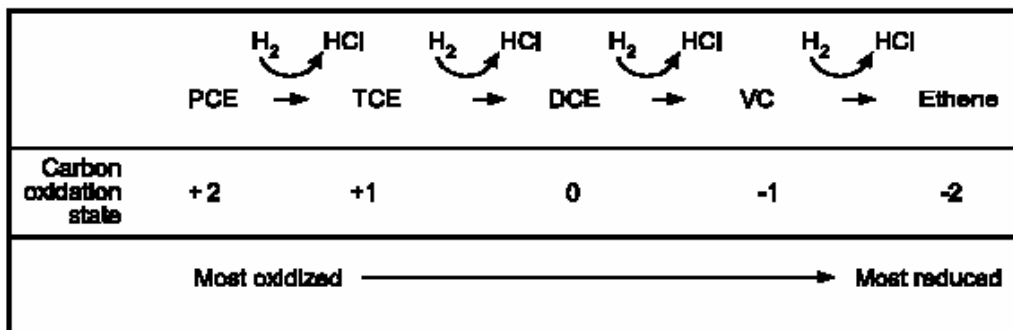

Figure 11. Anaerobic Reductive Dechlorination of PCE (U.S. EPA, 2000)

With each step the chlorinated compound becomes less chlorinated until finally it is reduced to ethene. This process has been shown to occur more readily with highly chlorinated compounds such as PCE and TCE (U.S. EPA, 2000). Unfortunately, this dechlorination may stall and lead to the accumulation of VC, a known human carcinogen, in the environment.

2.3.4.4 Anaerobic Reductive Dechlorination (Cometabolic).

As with all cometabolic processes, cometabolic anaerobic reductive dechlorination requires the presence of a primary electron donor and acceptor. This process requires the presence of hydrogen which is utilized as the electron donor (U.S. EPA, 2000). Studies have shown that this hydrogen may be present as a result of fermentation of organic matter in the subsurface (Chapelle et al., 1997). Ferric iron, nitrate, carbon dioxide and sulfate have all been found to be possible electron acceptors for this process (U.S. EPA, 2000). When the primary donor is metabolized by the microbes in an anaerobic, reducing environment, byproducts of the process will degrade the chlorinated solvent (U.S. EPA, 2000). The microorganisms receive no benefits from this auxiliary process. PCE, TCE, DCE, and VC are all thought to be susceptible to degradation through this process (U.S. EPA, 2000).

2.3.4.5 Anaerobic Oxidation (Direct).

In direct anaerobic oxidation, the microorganisms are able to degrade the chlorinated solvents while in an oxidizing environment with no oxygen. The chlorinated solvent is used as the electron donor, while another compound, such as ferric iron, is used as the electron acceptor (Wiedemeier et al., 1999). This process seems to be most applicable for the lesser chlorinated solvents, such as DCE and VC (see Table 1).

2.3.5 Abiotic Transformations.

Abiotic transformations degrade the chlorinated solvents without the intervention of microorganisms. There are three notable abiotic processes: hydrolysis, elimination, and abiotic reductive dechlorination (U.S. EPA, 2000). As shown in Figure 6, abiotic processes are relatively minor at most sites compared to biotic transformations.

2.4 Modeling

Mathematical models have been developed to simulate groundwater flow and contaminant fate in the subsurface. These models incorporate the processes detailed in Section 2.3, as well as other physical, chemical, and biological processes that may be important to represent how contaminants move, accumulate, and degrade in the subsurface. These models, by allowing us to simulate the predicted time-history of contaminant concentrations at downgradient receptors, enable us to evaluate the hazard posed by contamination at a site, as well as assist us in choosing an appropriate remediation strategy to minimize the risk to the environment and human health.

This research will focus on models that simulate the processes affecting dissolved CAH fate and transport, in order to determine how reduction in DNAPL mass in a source zone due to application of a remediation technology may result in reduction in contaminant concentrations at downgradient receptors.

2.4.1 Contaminant Fate and Transport Modeling.

The equation typically used to simulate the fate and transport of dissolved contaminants in groundwater is the Advection-Dispersion Equation (ADE) (Clement, 1997):

$$\frac{\partial C_k}{\partial t} = \frac{\partial}{\partial x_i} \left(D_i \frac{\partial C_k}{\partial x_j} \right) - \frac{\partial}{\partial x_i} (v_i C_k) + \frac{q_s}{n} C_{S_k} + r_c \quad (5)$$

$$\frac{d\tilde{C}_{im}}{dt} = \tilde{r}_c \quad (6)$$

Where:

C_k = Aqueous-phase concentration of k^{th} species [ML^{-3}]

k = Species (i.e. TCE, PCE, etc.)

D_j = Dispersion coefficient in the i^{th} direction [L^2T^{-1}]

v_i = Pore velocity [LT^{-1}]

q_S = Volumetric flux of water per unit volume of aquifer
representing sources and sinks [T^{-1}]

n = Porosity [L^3L^{-3}]

C_S = Concentration of source/sink [ML^{-3}]

r_c = Rate of all reactions in the aqueous phase [ML^3T^{-1}]

\tilde{C}_{im} = solid-phase concentration of the im^{th} species [MM^{-1}]

\tilde{r}_c = rate of all reactions that occur in soil-phase [ML^3T^{-1}]

Equation 5 includes the different processes that affect the change in contaminant concentration per unit time. The major physical processes are advection, as represented by the second term on the right-hand-side of Equation 5 and dispersion in the i^{th} -direction, as represented by the first term on the right-hand-side of the equation. Note from the discussion in Section 2.3.2 that dispersion is assumed proportional to groundwater velocity. Equation 6 models the fate of the sorbed contaminant.

In order for the fate and transport model to be utilized efficiently, computer modeling codes have been developed. According to Barry et al. (2002), one of models which is often used is the Reactive Transport in 3-Dimensions (RT3D) model. RT3D uses operator splitting to sequentially solve the advection equation, dispersion equation,

source-sink mixing equation, and single-species reaction equation, which are the second, first, third, and fourth terms respectively in Equation 5 (Clement, 1997). Advection is determined through the use of the method of characteristics, a modified method of characteristics, a hybrid method of characteristics, or by the upstream finite-difference solution scheme, while the dispersion and source-sink mixing packages are solved by explicit finite-difference approximations (Clement, 1997). There are 10 different reaction modules, including a user-defined module, which may be applied to simulate biochemical reactions that affect contaminant fate and transport (Clement, 1997). The equations for the contaminant accumulation or removal rate are detailed in Section 2.4.2.

2.4.2 Source/sink Term.

When dealing with chlorinated solvents, the degradation of one species, PCE for instance, may lead to the accumulation of another; TCE in the case of reductive dechlorination. Similarly, TCE may subsequently degrade to DCE, which may degrade to VC, which may degrade to ethene. This process may stall at any point depending upon the subsurface conditions. In this section, we look at four models that have been used to simulate the degradation kinetics of chlorinated solvents: first-order decay model, the Monod model, the dual-Monod model, and a variation of the dual-Monod model (Lee et al., 2004).

2.4.2.1 First-Order Decay.

The first-order decay model is based on the assumption that the rate at which a compound degrades is proportional to its concentration, as shown in Equation 7 (Domenico and Schwartz, 1998).

$$r_c = \lambda C \quad (7)$$

Where:

r_c = Contaminant decay rate [$\text{ML}^{-3}\text{T}^{-1}$]

λ = First-order decay rate constant [T^{-1}]

C = Contaminant concentration [ML^{-3}]

In order to use this equation to model the removal of a contaminant from the subsurface, it would be necessary to conduct enough research to quantify the first-order decay rate at a particular site, for a particular contaminant. So, while the model would be fairly easy to use, application at a site may require extensive research and money. Typical decay rates (in units of day^{-1}) for chlorinated solvents are shown in Table 2.

Table 2. Reported First-Order Decay Rate Constants (d^{-1}) (from Suarez and Rifai, 1999)

	All Studies	Aerobic Oxidation	Aerobic Cometabolism	Reductive Dechlorination
PCE				
Number of rates	47	11	5	31
Range reported rates	0-0.410	0-0.004	0-0.054	0-0.410
Mean	0.051	0.001	0.025	0.068
TCE				
Number of rates	86	12	17	56
Range reported rates	0-3.130	0-0.028	0.024-1.650	0-3.130
Mean	0.173	0.005	0.586	0.086
<i>cis</i>-1,2-DCE				
Number of rates	34	0	5	25
Range reported rates	0-1.960	N/A	0.081-1.960	0-0.200
Mean	0.004	N/A	0.476	0.004
VC				
Number of rates	26	4	4	8
Range reported rates	0-1.960	0.043-0.125	0.055-1.960	0-0.520
Mean	0.229	0.087	1.023	0.153

2.4.2.2 Monod Model.

The equation for the Monod model is shown below (Droste, 1997).

$$r_c = \frac{kXC}{K + C} \quad (8)$$

Where:

r_c = Contaminant decay rate [$\text{ML}^{-3}\text{T}^{-1}$]

k = Maximum specific rate of substrate (contaminant) utilization [$\text{MM}^{-1}\text{T}^{-1}$]

X = Active cell density [ML^{-3}]

C = Contaminant concentration [ML^{-3}]

K = Monod half-maximum rate concentration [ML^{-3}]

The maximum specific rate of substrate utilization is the mass of contaminant removed per mass of microorganisms per time. The active cell density is the concentration of microorganisms that are degrading the contaminant. The Monod half-maximum rate concentration is the contaminant concentration at which the rate of contaminant utilization is half the maximum rate (Droste, 1997). All of these values, except the active cell density, would need to be determined based on a literature review or experimentation. Determining the values for each parameter in this equation is likely to require more extensive research and money than the first-order model, but the results may be a better representation of the actual biodegradation process. Table 3 shows some typical values for these parameters.

Table 3. Typical Monod parameter values for chlorinated solvents (from Suarez and Rifai, 1999)

Compound	Type of Study	Redox Environment	Culture	K (mg/L)	k (mg/mg-day)	Initial Concentration (mg/L)	Reference
PCE	Methanogenic fluidized bed reactor	Anaerobic		12.00			Ballapragada et al., 1997
	Biofilm reactor				0.00	0.99	Fathepure and Tiedje, 1994
	Fed-batch reactor	Anaerobic	Methanogenic Consortium				Gao et al., 1995
TCE	Growth reactor	Aerobic		0.37	0.53	14.70	Alvarez-Cohen and McCarty, 1991
	Growth reactor	Aerobic-cometabolism (formate)		8.20	7.60	10.10	Alvarez-Cohen and McCarty, 1991
	Growth reactor	Aerobic-cometabolism (methane)	Mixed methanotrophic	0.13	0.00-1.13	1.00	Anderson and McCarty, 1996
	Methanogenic fluidized bed reactor	Anaerobic		19.00			Ballapragada et al., 1997
	Growth reactor	Aerobic-cometabolism (phenol)	Filamentous phenol-oxidizers		0.10-0.25		Bielefeldt et al., 1994
	Microrocosm	Aerobic-cometabolism (toluene)			1.50	0.66	Jenal-Wanner and McCarty, 1997
	Microrocosm	Aerobic-cometabolism (phenol)			3.00	0.66	Jenal-Wanner and McCarty, 1997
	Growth reactor	Aerobic-cometabolism (propane)	Propane-oxidizing culture		0.04	3.00	Keenan et al., 1994
	Batch	Aerobic	<i>Methylomonas methanica</i> 68-1	0.60	438.59		Koh et al., 1994
	Batch	Aerobic	<i>Methylosinus trichosporium</i> OB3b	29.48	187.70		Koh et al., 1994
	Continuous Reactor	Aerobic	<i>Methylosinus trichosporium</i> OB3b	16.51	54.71	9.17-13.10	Oldenhuis et al., 1991
Continuous Reactor	Aerobic-cometabolism (methane)	Mixed methanotrophic	19.00			Strand et al., 1994	
cis-1,2-DCE	Growth reactor	Aerobic-cometabolic (phenol)	Filamentous phenol-oxidizers		0.27-1.50		Bielefeldt et al., 1994
	Continuous Reactor	Aerobic	<i>Methylosinus trichosporium</i> OB3b	2.91	25.40	12.60-25.20	Oldenhuis et al., 1991
	Methanogenic fluidized bed reactor	Anaerobic		28.00			Ballapragada et al., 1997
VC	Methanogenic fluidized bed reactor	Anaerobic		23.00			Ballapragada et al., 1997
	Small-Column Microcosm	Aerobic-cometabolism (methane)				1.00-17.00	Dolan and McCarty, 1995

The active cell density is typically modeled by another Monod expression (Fennell and Gossett, 1998).

$$r_x = \frac{dX}{dt} = Y \left(-\frac{dS}{dt} \right) - b_d X \quad (9)$$

Where:

Y = Microorganisms growth yield [MM⁻¹]

$\frac{dS}{dt}$ = Change in substrate concentration per time [ML⁻³T⁻¹]

b_d = First-order decay coefficient [T⁻¹]

2.4.2.3 Dual-Monod Model.

The dual-Monod model is based on the assumption that the rate of contaminant decay is a function of both the contaminant concentration and the concentration of a second substrate (Petrunic et al., 2005). In the case of degradation of a chlorinated solvent, this additional substrate may be a co-contaminant necessary for cometabolic degradation, or an electron donor (where the chlorinated compound is the electron acceptor), as occurs in direct anaerobic reductive dechlorination (as discussed in Section 2.3.4.3). The equation for the dual-Monod model is shown below (Petrunic et al., 2005).

$$r_c = kX \left(\frac{C_1}{K_1 + C_1} \right) \left(\frac{C_2}{K_2 + C_2} \right) \quad (10)$$

Where:

r_c = Contaminant decay rate [ML⁻³T⁻¹]

k = Maximum specific rate of substrate utilization [$\text{MM}^{-1}\text{T}^{-1}$]

X = Active cell density [ML^{-3}]

C_1 = Concentration of first substrate [ML^{-3}]

C_2 = Concentration of second substrate [ML^{-3}]

K_1 = Monod half-maximum rate concentration for first substrate
[ML^{-3}]

K_2 = Monod half-maximum rate concentration for second substrate
[ML^{-3}]

Again, this model would require more extensive research and money than the previous two models, but the results would be a better representation of the actual biodegradation mechanisms.

2.4.2.4 Lee et al. (2004) Model.

The Lee et al. Model is a modified dual-Monod model. This model was developed specifically to simulate the reductive dechlorination of PCE to ethene (Lee et al., 2004). The model assumes that biodegradation is limited by the concentration of the electron donor (molecular hydrogen), and the electron acceptor (the chlorinated solvent), concentrations. Further, Lee et al. (2004) hypothesize that there are three different microbial species competing for the hydrogen electron donor: two species of dechlorinators, those that reduce PCE to TCE to DCE and those that reduce DCE to VC to ethene, and one species of methanogens. The equation developed to model this process can be seen in Equation 11 (Lee et al., 2004).

$$r_c = kX \left(\frac{C_a}{K_a \left(1 + \frac{C_2}{K_2} \right) + C_a} \right) \times \left(\frac{C_d - C_{d,th}}{K_d + (C_d - C_{d,th})} \right) \quad (11)$$

Where:

r_c = Contaminant decay rate [$\text{ML}^{-3}\text{T}^{-1}$]

k = Maximum specific rate of substrate utilization* [$\text{MM}^{-1}\text{T}^{-1}$]

X = Active cell density* [ML^{-3}]

C_a, C_d = Concentration of electron acceptor/donor [ML^{-3}]

C_2 = Concentration of dechlorination product [ML^{-3}] (e.g. TCE when C_a is PCE)

K_a, K_2, K_d = Monod half-maximum rate concentration of electron acceptor/dechlorination product/donor, respectively* [ML^{-3}]

$C_{d,th}$ = Threshold donor concentration [ML^{-3}]

All of the variables that have an asterisk (*) will change depending upon which dechlorinators are being utilized. For instance, if the equation is being used to determine the rate of degradation for PCE, the values will be different from what they would be for the degradation of VC. This is due to the different species of dechlorinating microorganisms that are active. In Equation 11, note the $1 + C_2/K_2$ term in the denominator. This term serves to reduce the rate of decay of a parent contaminant due to the presence of its degradation product (TCE if PCE is the parent compound, and VC if DCE is the parent compound). Decay rate of the parent compound is reduced because the

degradation product competes with the parent compound for electrons from the hydrogen electron donor. Figure 12 visually depicts the competition for hydrogen:

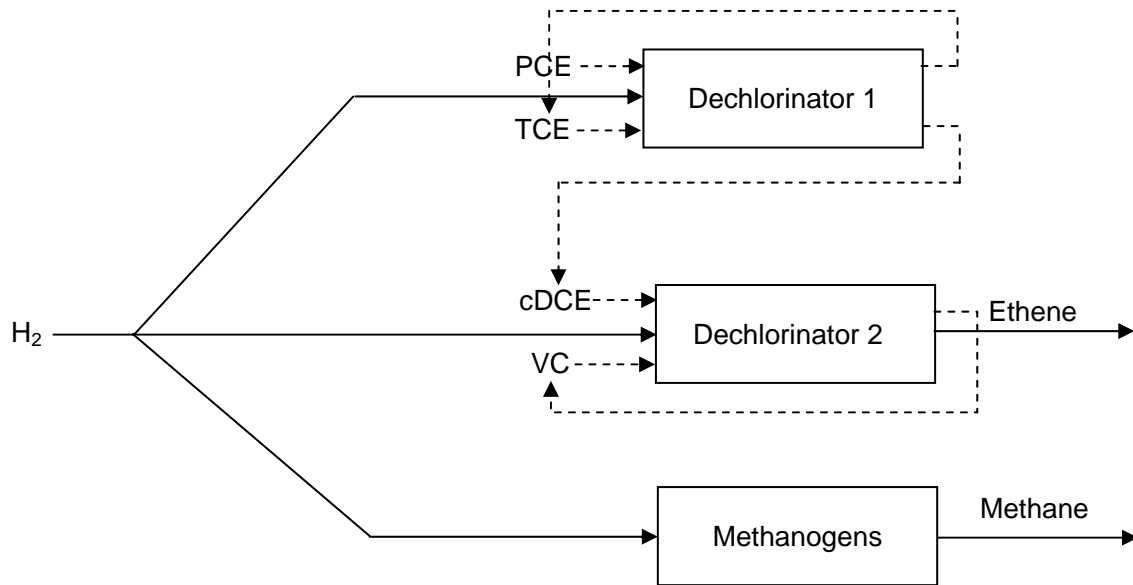

Figure 12. Hydrogen utilization (from Christ, 2005)

Figure 12 shows how hydrogen is used by the first species of dechlorinators, dechlorinator 1, which degrades PCE to TCE and TCE to DCE. Hydrogen is also used by the second species of dechlorinators, dechlorinator 2, to degrade DCE to VC and VC to ethene. Finally, the hydrogen is used by the methanogens to produce methane. It should be noted that these three species are in competition for the hydrogen, and the hydrogen is not necessarily divided equally between the species (Christ, 2005).

Clapp et al. (2004) described the rate of hydrogen utilization ($r_{H_2, dech}$) by dechlorinators as follows (Clapp, et al., 2004):

$$r_{H_2,dech} = F_{H_2/PCE,dech}r_{PCE} + F_{H_2/TCE,dech}r_{TCE} + F_{H_2/DCE,dech}r_{DCE} + F_{H_2/VC,dech}r_{VC} \quad (12)$$

Where:

$F_{H_2/PCE,dech}$, $F_{H_2/TCE,dech}$, $F_{H_2/DCE,dech}$, $F_{H_2/VC,dech}$ = Stoichiometric coefficient relating hydrogen reduction to PCE, TCE, DCE, and VC reduction [-]

$r_{PCE,TCE,DCE,VC}$ = rate of PCE, TCE, DCE, and VC reduction
[ML⁻³T⁻¹]

Clapp et al. (2004) described the rate of hydrogen utilization ($r_{H_2, meth}$) by methanogens as follows:

$$r_{H_2, meth} = \left(\frac{k_{meth} X_{meth}}{1 + \frac{\sum C_{PCE,TCE,DCE,VC,ETH}}{K_{I,CE,meth}}} \right) \times \left(\frac{C_{H_2} - C_{H_2,th,meth}}{K_{s,H_2,meth} + (C_{H_2} - C_{H_2,th,meth})} \right) \quad (13)$$

Where:

k_{meth} = Maximum H₂ utilization rate constant for methanogens [MM⁻¹T⁻¹]

X_{meth} = Methanogen biomass concentration [ML⁻³]

$K_{I,CE,meth}$ = Chloroethene noncompetitive inhibition constant for methanogens (same for PCE, TCE, DCE, VC, and ETH) [ML⁻³]

$C_{H_2, th, meth}$ = Threshold H₂ concentration for methanogens [ML⁻³]

$K_{s, H_2, meth}$ = Monod half-maximum rate concentration for H₂ [ML⁻³]

Clapp et al. (2004) modeled the growth of the three cultures of microorganisms ($r_{X,dech1}$, $r_{X,dech2}$, and $r_{X,meth}$) through Equations 14-16:

$$r_{X,dech1} = -Y_{dech} (r_{PCE} + r_{TCE}) - b_{dech1} X_{dech1} \quad (14)$$

$$r_{X,dech2} = -Y_{dech} (r_{DCE} + r_{VC}) - b_{dech2} X_{dech2} \quad (15)$$

$$r_{X,meth} = -Y_{meth} r_{H_2} - b_{dech1} X_{dech1} \quad (16)$$

Where:

$Y_{dech, meth}$ = Dechlorinators (assumed to be the same for PCE, TCE, DCE, and VC) or methanogens growth yield [MM^{-1}]

$b_{dech1, dech2}$ = first-order endogenous decay rate constant for the dechlorinator populations [T^{-1}]

The amount of hydrogen needed will depend on the process. Yang and McCarty (1998) found that at higher rates of reduction, less total hydrogen was needed. Thus, reduction of PCE to TCE and DCE, which occurs at a faster rate than reduction of DCE to VC and ethene, requires less hydrogen. There is also evidence that there is a specific range of hydrogen concentrations within which the dechlorinators compete best with methanogens (Yang and McCarty, 1998). The hydrogen levels would have to stay within this range in order for the microorganisms to accomplish the dehalogenation of the CAHs. Therefore, to support reductive dechlorination, hydrogen must not only be present, but must be continuously produced.

Hydrogen production in the subsurface may result from fermentation of organic compounds. The hydrogen concentration has been modeled in two ways: by assuming a

constant concentration of hydrogen is present (Chu *et al.*, 2004; Chu *et al.*, 2005) or using Monod kinetics to describe the production of hydrogen by fermentation (Fennell and Gossett, 1998).

Fennel and Gossett (1998) utilized the Monod model modified to include a reduction in rate as the electron donor approaches its equilibrium concentration. This model is shown below (Fennell and Gossett, 1998).

$$r_{donor} = \frac{-k_{donor} X_{donor} (S - S^*)}{K_{S(donor)} + S} \quad (17)$$

Where:

r_{donor} = Net rate of donor fermentation [$\text{ML}^{-3}\text{T}^{-1}$]

k_{donor} = Maximum specific rate of donor fermentation [$\text{MM}^{-1}\text{T}^{-1}$]

X_{donor} = Donor-fermenting biomass [ML^{-3}]

S = Donor concentration [ML^{-3}]

S^* = Equilibrium concentration of donor [ML^{-3}]

$K_{S(donor)}$ = Monod half-maximum rate concentration [ML^{-3}]

Equation 17 describes how the donor, particulate organic matter, is fermented. This fermentation will produce hydrogen, which may be utilized as an electron donor to support dechlorination and methane production, as described above (Fennell and Gossett, 1998). A donor which has a high maximum specific rate constant will ferment quickly and produce a relatively high concentration of hydrogen. However, this hydrogen may be utilized too quickly and then complete dechlorination may not occur. A donor that ferments slowly and maintains an optimal hydrogen concentration for a long period of

time would be ideal to support reductive dehalogenation of CAHs (Fennell and Gossett, 1998). Although this model incorporates the important mechanisms that control reductive dechlorination, it requires knowledge of numerous parameter values, which would typically be unavailable at a contaminated site. In addition, concentrations of donors to drive the fermentation process would have to be quantified. While this model may provide a very accurate representation of the actual biodegradation mechanisms, the required knowledge necessary to employ such a model is very extensive.

2.4.3 Modeling Source Mass Reduction and Flux Reduction.

Now that we have discussed how a variety of models may be used to simulate the fate and transport of dissolved CAH contaminants in a plume, let us now turn our attention to simulating the source term for these models. The source term is the driver for the fate and transport model; quantifying the contaminant concentration and mass flux at a model boundary. Ultimately, by modeling the source concentration and flux, and simulating the downgradient contaminant concentrations that result from the source term, we have the ability to quantify the benefits of source zone remediation. That is, we have the ability to predict how source mass reduction may lead to reductions in source concentrations which in turn leads to reductions in contaminant mass flux leaving the source, which finally results in concentration (and risk) reductions at downgradient receptors.

In the past, mass transfer correlations have been used to predict dissolution rates of NAPL into groundwater (Nambi and Powers, 2003; Imhoff et al., 1994; Miller et al., 1990). New research has used a power function model to simulate how reduction of source zone NAPL mass results in reduction of the contaminant concentration in the

source zone (Falta et al., 2005a; Falta et al., 2005b; Zhu and Sykes, 2004; Parker and Park, 2004). Before we discuss these models, however, let us begin with a discussion of mass flux.

2.4.3.1 Mass Flux.

As discussed in Chapter 1, mass flux is defined as contaminant mass passing through an area normal to the direction of flow per unit time (units of mass-length⁻²-time⁻¹) (Clark, 1996). Recently, investigators have proposed that mass flux reduction may be the best measure of the efficiency of a source remediation technology application (Soga et al., 2004; Jawitz et al., 2005). Although it is clear how source zone remediation in a homogeneous aquifer would lead to flux reduction, remediation in heterogeneous aquifers are not likely to lead to a one-to-one reduction in mass flux. Figure 13 illustrates how source mass reduction may lead to a reduction in flux, while not appreciably decreasing the maximum dissolved concentration in a contaminated source.

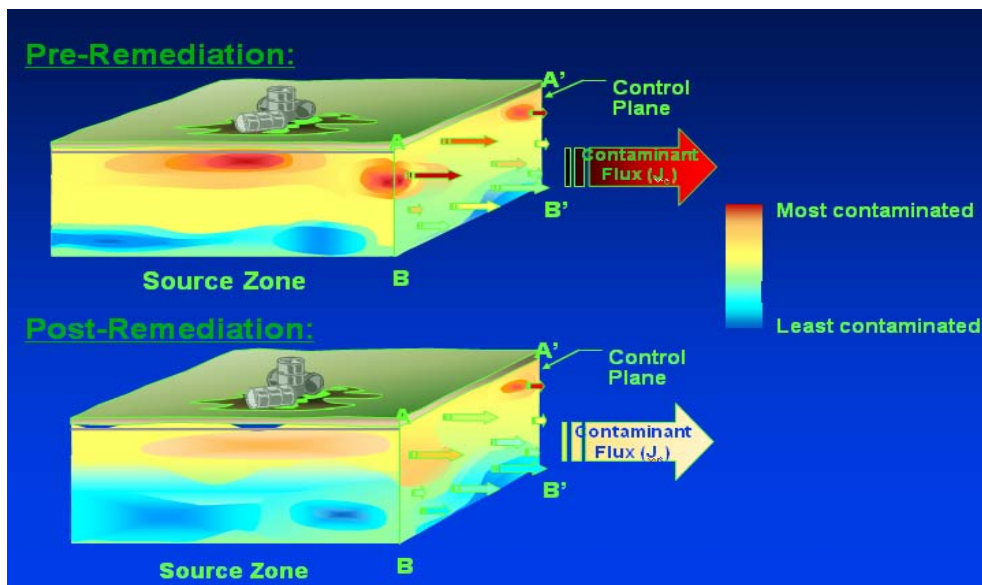

Figure 13. Mass Flux Reduction to Source Mass Reduction (Annable et al., 2005)

In Figure 13, we see that remediation has reduced the overall flux leaving the source zone. However, it is also clear that there are regions in the source zone at which the contaminant concentrations remain high. It is generally accepted that complete removal of the source mass and reduction of source concentrations to regulatory limits (typically defined by Safe Drinking Water Act maximum contaminant levels) are not achievable (Jawitz et al., 2005). Thus, a more realistic cleanup goal is one that targets reduction of mass flux leaving the source zone to an extent such that downgradient natural or engineered processes are protective of health and the environment (Soga et al., 2004). Therefore, we desire to investigate models that simulate how NAPL mass is related to dissolved NAPL concentration and mass flux. As noted earlier, we will look at two methods of modeling the relationship between NAPL mass and dissolved NAPL concentration: mass transfer correlations and a power function model.

2.4.3.2 Mass Transfer Correlations.

Mass transfer correlations use field or experimental data and correlations between dimensionless parameters, such as the Sherwood number and Reynolds number, to model the relationship between NAPL mass reduction and concentration reduction (Nambi and Powers, 2003). A general equation for a mass transfer correlation would look like

Equation 18:

$$Sh = a Re^b \theta_n^c \quad (18)$$

Where:

Sh = Sherwood number [-]

Re = Reynolds number [-]

θ_n = volumetric fraction of NAPL in the system [L^3L^{-3}]

a, b, c = empirical parameters [-]

The field or experimental data would be used to determine the empirical parameters a , b , and c . The Sherwood number (Sh) is a dimensionless parameter which compares mass transfer between the NAPL and aqueous phases with diffusive mass transfer. Mass transfer between the two phases is a complex function dependent on system hydrodynamics (Weber and DiGiano, 1996). The Sherwood number is defined below (from Clark, 1996).

$$Sh = \frac{J_A L}{D_{AB} c_A^*} \quad (19)$$

Where:

J_A = interfacial mass flux of contaminant between the NAPL and aqueous phases [$ML^{-2}T^{-1}$]

L = NAPL characteristic length scale [L]

D_{AB} = diffusion coefficient for contaminant in water [L^2T^{-1}]

c_A^* = equilibrium concentration of contaminant [ML^{-3}]

The Reynolds number (Re) is a dimensionless parameter measuring the ratio of the inertial and viscous forces of the water flowing past the NAPL (Clark, 1996). The equation for the Reynolds number (Re) is (from Clark, 1996).

$$\text{Re} = \frac{\rho qL}{\mu} \quad (20)$$

Where:

ρ = density of the fluid [ML⁻³]

μ = dynamic viscosity [ML⁻¹T⁻¹]

By substituting Equations 19 and 20 into Equation 18 the correlation between “remediation” (reduction of NAPL volume) and flux reduction can be seen:

$$J_A = \left(\frac{D_{AB} C_A^*}{L} \right) (a) \left(\frac{\rho qL}{\mu} \right)^b \left(\frac{V_{NAPL}}{V_{Total}} \right)^c \quad (21)$$

Where:

V_{NAPL} = volume of NAPL in source zone [L³]

V_{Total} = total volume of source zone [L³]

Since, in most if not all cases, the parameters a , b , and c will have non-negative values (Nambi and Powers, 2003) and most of the parameters will remain constant, it is clear to see how remediation at a site (a reduction in V_{NAPL}) would lead to a reduction in flux, J_A .

Correlations that predict the flux of NAPL under various conditions have been developed in a number of studies. Below, we discuss three of these mass transfer correlations.

2.4.3.2.1 Miller et al. (1990).

The Miller mass transfer correlation (Miller et al., 1990) assumes steady state dissolution (Nambi and Powers, 2003). This correlation is valid when the volumetric

fraction of NAPL is between 0.016 and 0.07, and the Reynolds number is between 0.0015 and 0.1 (Miller et al., 1990). Equation 22 shows the Miller mass transfer correlation (from Nambi and Powers, 2003):

$$Sh' = 425 Re^{0.75} \theta_n^{0.60} \quad (22)$$

Where:

$$Sh' = \text{modified Sherwood number [-]}$$

The modified Sherwood number (Sh'), as used in Equation 22, differs from the traditional Sherwood number (Sh) seen in Equation 19, in that it incorporates a mass transfer rate coefficient that lumps the mass transfer coefficient [LT^{-1}] with specific surface area [L^2L^{-3}] (Nambi and Powers, 2003). The equation for the modified Sherwood number can be seen in Equation 23 (from Nambi and Powers, 2003):

$$Sh' = \frac{\hat{k}L^2}{D_{AB}} \quad (23)$$

Where:

$$\hat{k} = \text{lumped mass transfer rate coefficient [T}^{-1}\text{]}$$

The mass transfer rate coefficient is found using the Darcy velocity and a characteristic length scale (from Nambi and Powers, 2003):

$$\hat{k} = -\frac{q}{L} \ln\left(\frac{C^* - C}{C^*}\right) \quad (24)$$

Where:

q = Darcy velocity [LT^{-1}]

C^* = equilibrium contaminant concentration [ML^{-3}]

C = contaminant concentration [ML^{-3}]

The characteristic length scale (L) used in Equations 23 and 24 is the length of the NAPL source zone (Nambi and Powers, 2003).

Substituting for the modified Sherwood number and Reynolds number, it can be shown that Equation 22 becomes Equation 25:

$$\left(\frac{-qL \ln\left(\frac{C^* - C}{C^*}\right)}{D_{AB}} \right) = 425 \left(\frac{\rho q L}{\mu} \right)^{0.75} \left(\frac{V_{NAPL}}{V_{Total}} \right)^{0.60} \quad (25)$$

This equation shows that remediation at a contaminated site, which would lead to a decrease in NAPL volume (V_{NAPL}), would lead to a decrease in NAPL concentration (C).

2.4.3.2.2 Imhoff et al. (1994).

The Imhoff mass transfer correlation (Imhoff et al., 1994) is valid when the volumetric fraction of NAPL in the system is between 0 and 0.04, and the Reynolds number is between 0.0012 and 0.021 (Imhoff et al., 1994). Equation 26 shows the Imhoff mass transfer correlation (Nambi and Powers, 2003):

$$Sh' = 150 Re^{0.87} \theta_n^{0.79} \quad (26)$$

Equation 26 is very similar to Equation 22. The major differences between these two equations are the conditions under which they're applicable.

2.4.3.2.3 Nambi and Powers (2003).

The Nambi and Powers mass transfer correlation is valid when the NAPL saturation is between 0.01 and 0.35, and the modified Reynolds number is between 0.018 and 0.134 (Nambi and Powers, 2003). Equation 27 shows the Nambi and Powers mass transfer correlation (Nambi and Powers, 2003):

$$Sh' = 37.5 Re'^{0.61} S_n^{1.24} \quad (27)$$

Where:

Re' = modified Reynolds number [-]

This modified Reynolds number utilizes the interstitial or seepage velocity as the characteristic velocity instead of the Darcy velocity (Nambi and Powers, 2003).

2.4.3.3 Power Functions.

Power functions are based on the assumption that reducing the mass of NAPL in the source zone leads to a decrease in the contaminant concentration (Zhu and Sykes, 2004). Knowing the groundwater Darcy velocity and the relationship between mass

reduction and concentration reduction, one may predict how the flux of contaminant leaving the source zone is reduced as a result of source mass reduction.

Research (Zhu and Sykes, 2004) has shown that power functions are able to fit data equally as well as mass transfer correlations. Figure 14 shows how this is possible with regard to modeling a breakthrough curve:

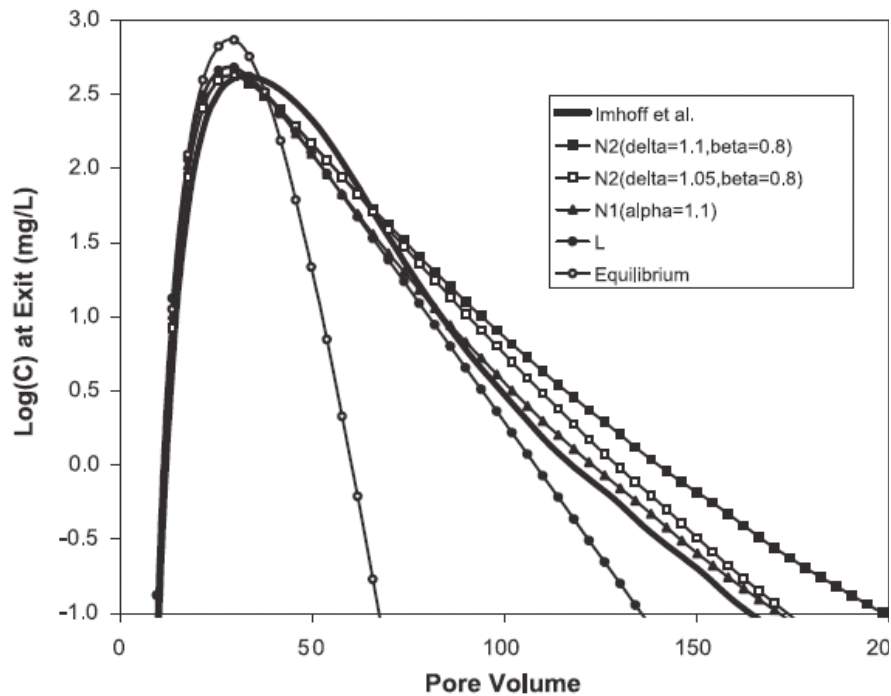

Figure 14. Mass Transfer Correlations Versus Power Functions (Zhu and Sykes, 2004)

In Figure 14, the Imhoff et al. (1994) model refers to Equation 26; the N2 model is discussed below in Section 2.4.3.3.1 (Equation 30); the N1 and L models may also be found in Section 2.4.3.3.1 (Equation 29 and 28 respectively).

2.4.3.3.1 Zhu and Sykes (2004).

Zhu and Sykes proposed three different powers function models of increasing complexity (Zhu and Sykes, 2004). The first model to be discussed assumes a linear

relationship between mass reduction and concentration reduction. This model is referred to as the L model in Figure 14 and can be seen in Equation 28 (from Zhu and Sykes, 2004):

$$C_0(t) = C_s \frac{M(t)}{M_0} \quad (28)$$

Where:

$C_0(t)$ = source zone concentration at time t [ML⁻³]

C_s = equilibrium concentration or solubility [ML⁻³]

$M(t)$ = residual mass remaining at time t [M]

M_0 = initial residual mass [M]

From Equation 28, it is obvious that a decrease of the residual mass in the source zone would lead to a corresponding decrease in concentration. For instance, if the mass is reduced to 10% of the initial value, the concentration would be equal to 10% of the equilibrium concentration. While this linear relationship may be appropriate at some homogeneous sites, in general the relationship is not likely to be linear. Equation 29 depicts a model, referred to as the N1 model in Figure 14, that allows for more flexibility in the relationship between mass reduction and concentration reduction (from Zhu and Sykes, 2004):

$$C_0(t) = C_s \left(\frac{M(t)}{M_0} \right)^\Gamma \quad (29)$$

Where:

$$\Gamma = \text{power-law index [-]}$$

In Equation 29, Γ is an empirical parameter which describes concentration reduction as a nonlinear function of mass reduction (Zhu and Sykes, 2004). Figure 15 shows how mass removal would affect concentration for various Γ -values:

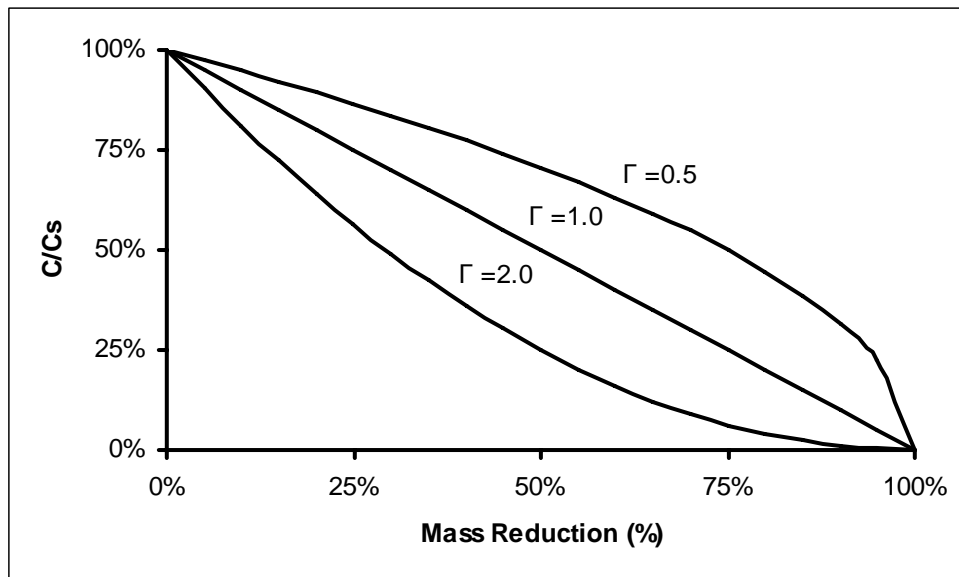

Figure 15. Concentration versus mass reduction for various Γ values

Figure 15 shows that with a value of Γ of 2.0, removal of 50% of the source mass results in a concentration reduction of 75%, while for the same mass removal, concentration is reduced only approximately 30% if Γ equals 0.5. This shows the importance of the Γ parameter. At a site where there is a large proportion of contaminant mass sorbed to the soils or entrapped in low permeability zones, the concentration versus mass reduction curve would be expected to look similar to the $\Gamma=2.0$ curve. Initially, small amounts of

remediation would lead to relatively large reductions in concentration, however, the contamination at this site may be present for a very long time as it slowly desorbs from the soils or migrates out of the low permeability zones. Conversely, if a larger proportion is located in areas of high permeability, it would take larger amounts of mass reduction to achieve similar concentration reductions initially, as shown by the $\Gamma=0.5$ curve. In general, research has found that the relationship between flow field heterogeneities and the DNAPL architecture has a significant effect on the Γ value (Falta et al., 2005b). Lower Γ values would be expected for source zones in which there is a positive correlation between hydraulic conductivity and the DNAPL saturation. Typically, Γ values used have ranged from 0.5 to 2.0 (Zhu and Sykes, 2004; Falta et al., 2005a).

In addition to the power-law index, Γ , a multiplier, β , may be used to show that the contaminant concentration is not at equilibrium at time zero (Zhu and Sykes, 2004):

$$C_0(t) = \beta C_s \left(\frac{M(t)}{M_0} \right)^\Gamma \quad (30)$$

Where:

$$\beta = \text{parameter [-]}$$

Equations 28 and 29 assume equilibration between the NAPL and aqueous phases, so that the contaminant concentration is initially at solubility. β in Equation 30 allows for non-equilibrium. Values for β will range from 0 to 1.0, depending on the initial conditions at the site. This equation is referred to as the N2 model in Figure 14.

2.4.3.3.2 Parker and Park (2004)

The Parker and Park (2004) model is similar in form to Zhu and Sykes (2004)

Equation 30. The Parker and Park (2004) model is:

$$\frac{C_o(t)}{C_s} = \frac{\kappa_o L}{\bar{q}} \left(\frac{\bar{q}}{\bar{K}_s} \right)^{\beta_1} \left(\frac{M(t)}{M_o} \right)^{\beta_2} \quad (31)$$

Where:

κ_o = empirical parameter [T⁻¹]

L = source length in flow direction [L]

\bar{q} = average Darcy velocity [LT⁻¹]

\bar{K}_s = average saturated hydraulic conductivity of
model domain [LT⁻¹]

β_1, β_2 = empirical parameters [-]

Equation 31 is essentially the same as Equation 30, but β is replaced with parameters to show how physical quantities such as the source length, water Darcy velocity, and hydraulic conductivity affect the relationship between mass reduction and concentration reduction.

2.4.3.3.3 Falta et al. (2005a)

The Falta et al. (2005a) model is similar to the Zhu and Sykes model (Equation 30) and the Parker and Park (2004) model (Equation 31):

$$\frac{C_o(t)}{C_o} = \left(\frac{M(t)}{M_o} \right)^\Gamma \quad (32)$$

Falta et al. (2005a) define C_o as the “flow-averaged contaminant concentration at the source zone control plane corresponding to an initial source zone mass of M_o .” In essence, C_o is equal to βC_s as defined by Zhu and Sykes (2004).

III. Methodology

3.1 Overview

This chapter details the important characteristics of Area 6 at Dover Air Force Base (AFB), Delaware, which is the site that is modeled, in order to demonstrate the relationship between remediation in a contaminated source zone and reduction in contaminant concentration at a downgradient receptor. The models selected to quantify the benefits of groundwater contaminant source remediation are also discussed. There are two models utilized: 1. a source zone remediation model which shows the relationship between source mass reduction and source strength reduction; and 2. a model which includes the important physical, chemical, and biological processes that impact dissolved contaminant fate and transport. The source model provides the boundary condition for the fate and transport model. The fate and transport model consists of two separate model codes within the GMS software package: MODFLOW to simulate the groundwater flow field, and RT3D to simulate the physical, chemical, and biological processes affecting the dissolved contaminant's fate and transport (Clement, 1997). These two codes were utilized to investigate the effects of source zone remediation on contaminant concentration at downgradient receptors at the Dover site.

3.2 Area 6 at Dover AFB

Area 6 at Dover Air Force Base, Delaware is the site of both fuel-hydrocarbon and chlorinated solvent groundwater contamination that is thought to have occurred over approximately 40 years (Clement, 2000). In 1994, this site became the research topic for

a group of industrial and government agencies (the Remediation Technology Development Forum, RTDF) working to determine the feasibility of utilizing a monitored natural attenuation remediation strategy for the chlorinated solvents at the site (Clement, 2000). Because of the data collected for this research and other studies the site has been very well-characterized (Clement et al., 2000; Davis, et al., 2002; Witt, et al., 2002). These studies have examined the groundwater biogeochemistry (Witt et al., 2002), characterized the microbial community structure (Davis, et al., 2002), and developed a model for field-scale application (Clement et al., 2000) at the site. Evidence from these studies has shown that the three “lines of evidence” (see Section 2.3) have all been satisfied indicating that natural attenuation is occurring at the site (Davis, et al., 2002; Witt et al., 2002). The comprehensive characterization of this site and apparent natural attenuation makes this site an ideal location to study the effects of source zone remediation. The remainder of this section will discuss the physical, hydrologic, geologic, chemical, and contaminant characteristics of the site.

3.2.1 Physical Characteristics at Area 6.

Area 6 covers approximately 2 square miles, including portions of the St. Jones River. Military operations in the past have contaminated the groundwater at multiple sites within Area 6 with both fuel-hydrocarbons and chlorinated solvents (Clement et al., 2000). Although the exact source zone locations are not known, Figure 16 shows the locations of 13 potential contaminant source zones.

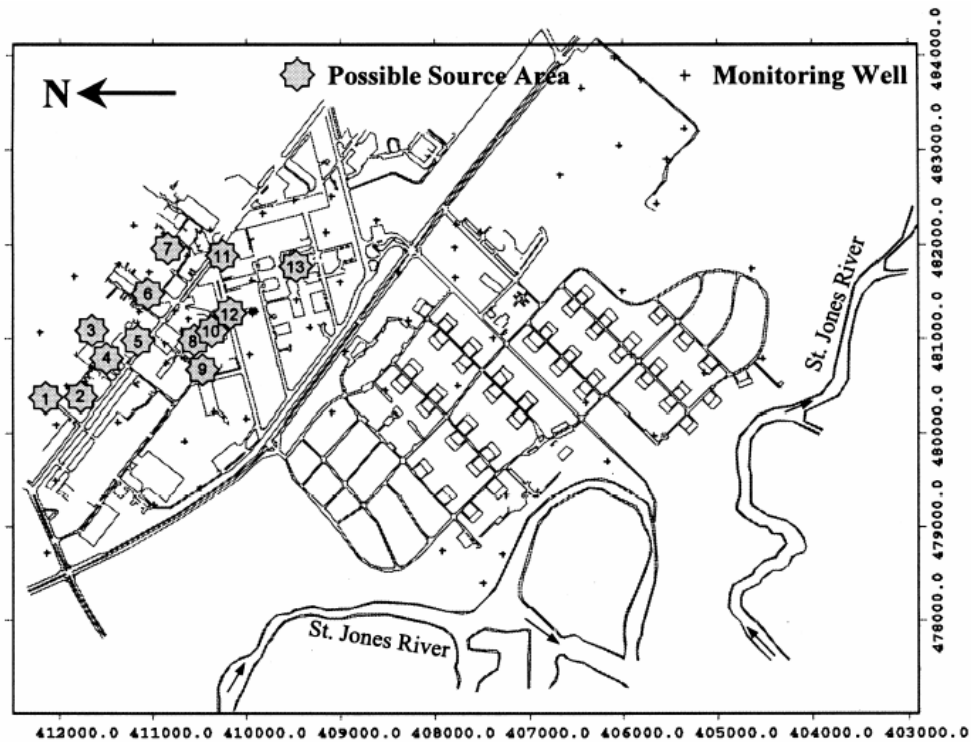

Figure 16. Area-6 Site at Dover AFB, Delaware (Clement et al., 2000)

The coordinate system used in Figure 16 is the State Plane coordinates (NAD-83) measured in feet (Clement et al., 2000). The entire site covers more than 9,000 feet in the north-south direction and 6,000 feet in the east-west direction (Clement et al., 2000).

3.2.2 Groundwater Hydrology at Area 6.

The general flow of groundwater at Area 6 is from the north (where the contaminant source zones are) toward the St. Jones River (Clement et al., 2000). Data collected in a March to April 1997 study showed that the groundwater levels range from 14 to 3 feet above mean sea level (Clement et al., 2000). Figure 17 shows the groundwater contours at Area 6.

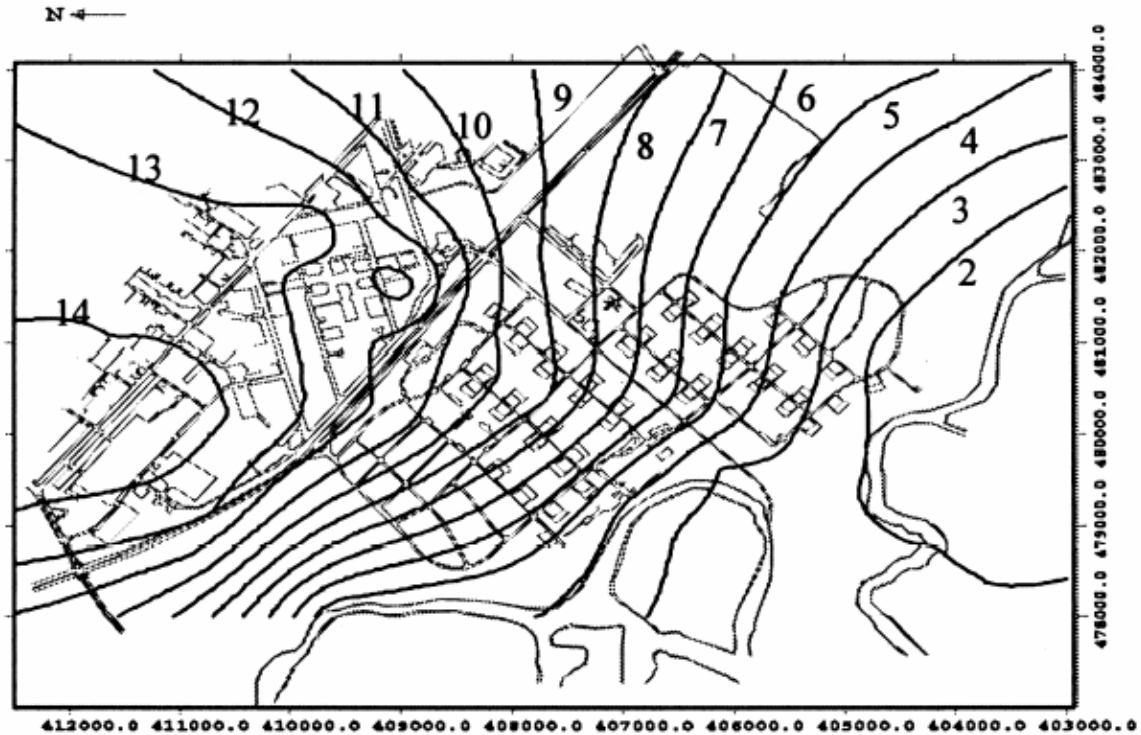

Figure 17. Groundwater Contours at Area 6 (Clement et al., 2000)

The groundwater contours depicted in Figure 17 were used to calibrate the groundwater flow model (MODFLOW) utilized in this study.

3.2.3 Geology at Area 6.

The geology of Area 6 shows that the aquifer is split into two separate zones, a shallow zone and a deep zone, with an effective average recharge to the deep zone of 0.0006 feet per day (Clement et al., 2000). The shallow zone is approximately 5 to 10 feet deep and consists primarily of silty sands. The deep zone is 10 to 15 feet thick, consisting primarily of silty and gravelly sands. Studies have found that the hydraulic conductivity of the shallow zone is approximately 35 feet per day, while the deep zone hydraulic conductivity is approximately 85 feet per day (Clement et al., 2000). Figure 18 shows a cross-section representing the geology at Area 6:

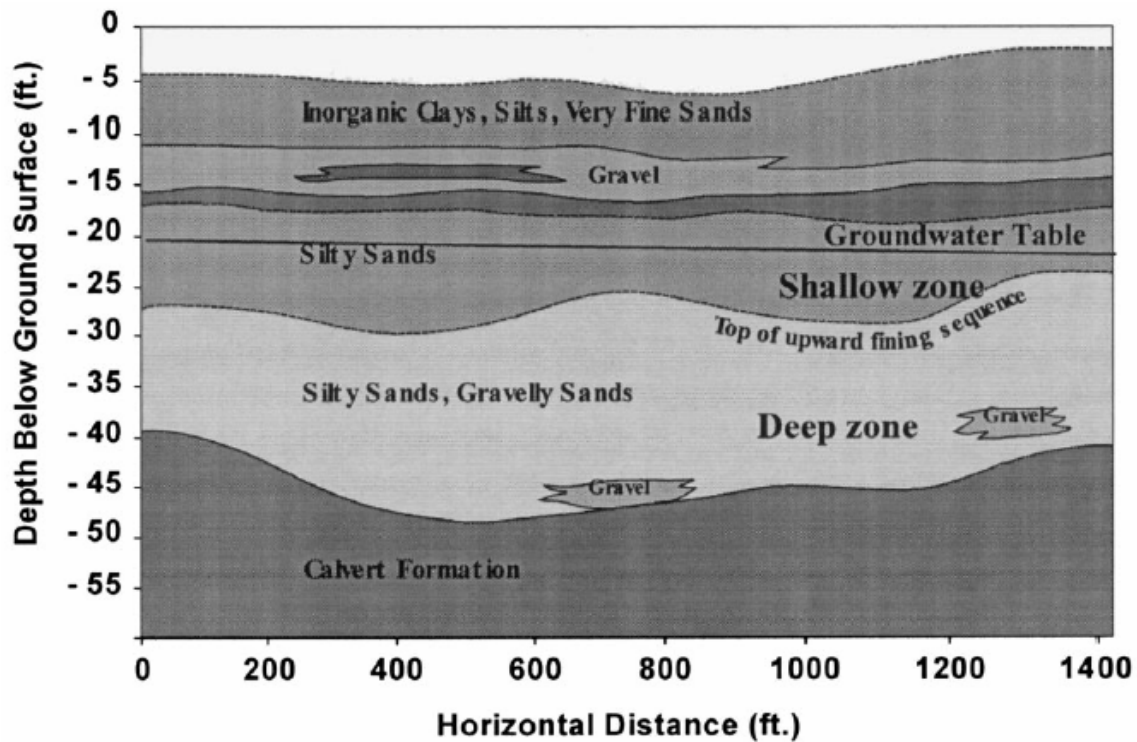

Figure 18. Area-6 Geology (Clement et al., 2000)

As Figure 18 shows, the Calvert formation, a low-permeability clay layer, lines the bottom of the aquifer impeding downward migration (Clement et al., 2000). The average porosity at the site was found to be 0.38 (Clement et al., 2000).

3.2.4 Chemistry at Area 6.

Clement et al. (2000) found that the contaminant degradation at Area 6 could be accurately represented by first-order decay. Further, research found that there were four distinct reaction zones: anaerobic zone-1, anaerobic zone-2, transition zone, and aerobic zone (Clement et al., 2000). Figure 19 presents a visual depiction of the four reaction zones.

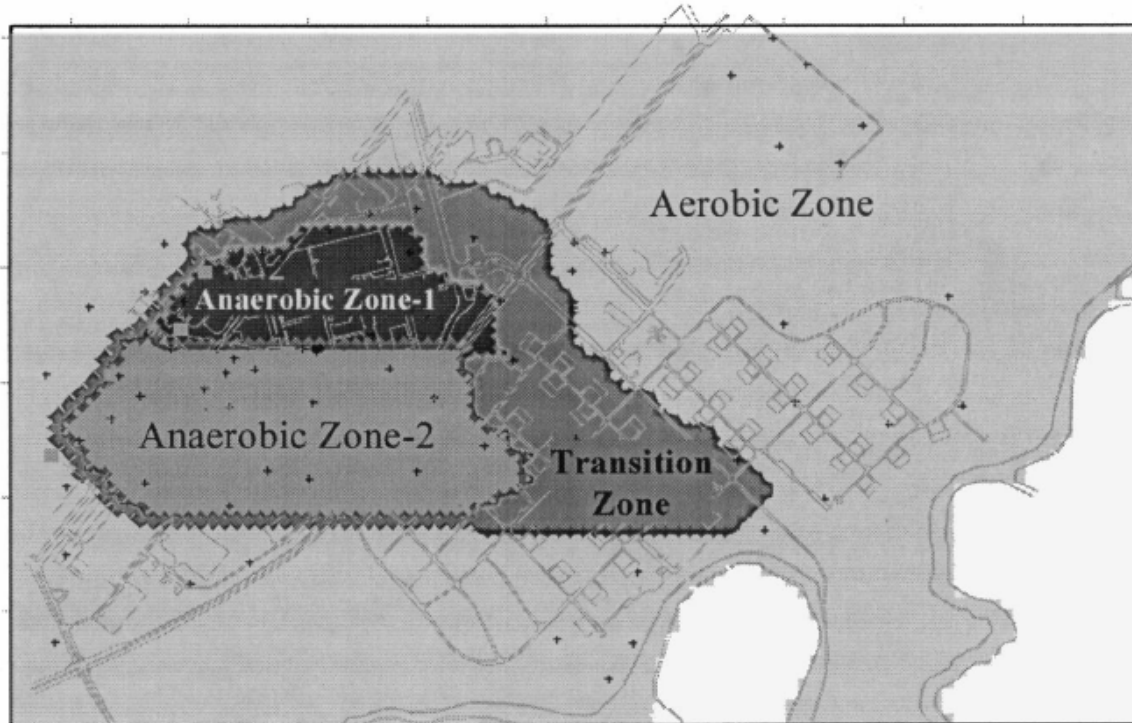

Figure 19. Reaction Zones at Area 6 (Clement et al., 2000)

Table 4 shows the degradation rate constants for each of the reaction zones shown in Figure 19.

Table 4. Reaction Zone Degradation Rates (Clement et al., 2000)

Calibrated degradation rate constants (day^{-1})

First-order rate constant	Associated contaminant	Anaerobic zone-1	Anaerobic zone-2	Transition zone	Aerobic zone
K_p (anaerobic)	PCE	3.2×10^{-4}	4.0×10^{-4}	1.0×10^{-4}	0.0
K_{T1} (anaerobic)	TCE	9.0×10^{-4}	4.5×10^{-4}	1.125×10^{-4}	0.0
K_{T2} (aerobic)	TCE	0.0	0.0	0.4×10^{-5}	1.0×10^{-5}
K_{D1} (anaerobic)	DCE	8.45×10^{-4}	6.5×10^{-4}	1.625×10^{-4}	0.0
K_{D2} (aerobic)	DCE	0.0	0.0	1.6×10^{-3}	4.0×10^{-3}
K_{V1} (anaerobic)	VC	8.0×10^{-3}	4.0×10^{-3}	1.0×10^{-3}	0.0
K_{V2} (aerobic)	VC	0.0	0.0	0.8×10^{-3}	2.0×10^{-3}
K_{E1} (anaerobic)	ETH	2.4×10^{-2}	1.2×10^{-2}	0.3×10^{-2}	0.0
K_{E2} (aerobic)	ETH	0.0	0.0	0.4×10^{-2}	1.0×10^{-2}

As Table 4 shows, PCE was not found to degrade under aerobic conditions. This is in

agreement with the discussion in Section 2.3.4, PCE is not likely to degrade under aerobic conditions. Also, both anaerobic and aerobic degradation occur in the transition zone, but they occur at less than half of their rates for the anaerobic and aerobic zones (13-25% of anaerobic zone degradation rate; 40% of aerobic zone degradation rate). The geometry of the aerobic and anaerobic reaction zones (see Figure 19) and the reaction rate constants associated with each zone (see Table 4) were assumed to remain constant.

3.2.5 Contamination at Area 6.

It is hypothesized that contaminant was released into the aquifer at Area 6 from various source locations (see Figure 16) and at various times over the 40-year history of the site (Clement et al., 2000). Figure 20 shows the PCE plume contours found at Area 6 based on the spring 1997 study.

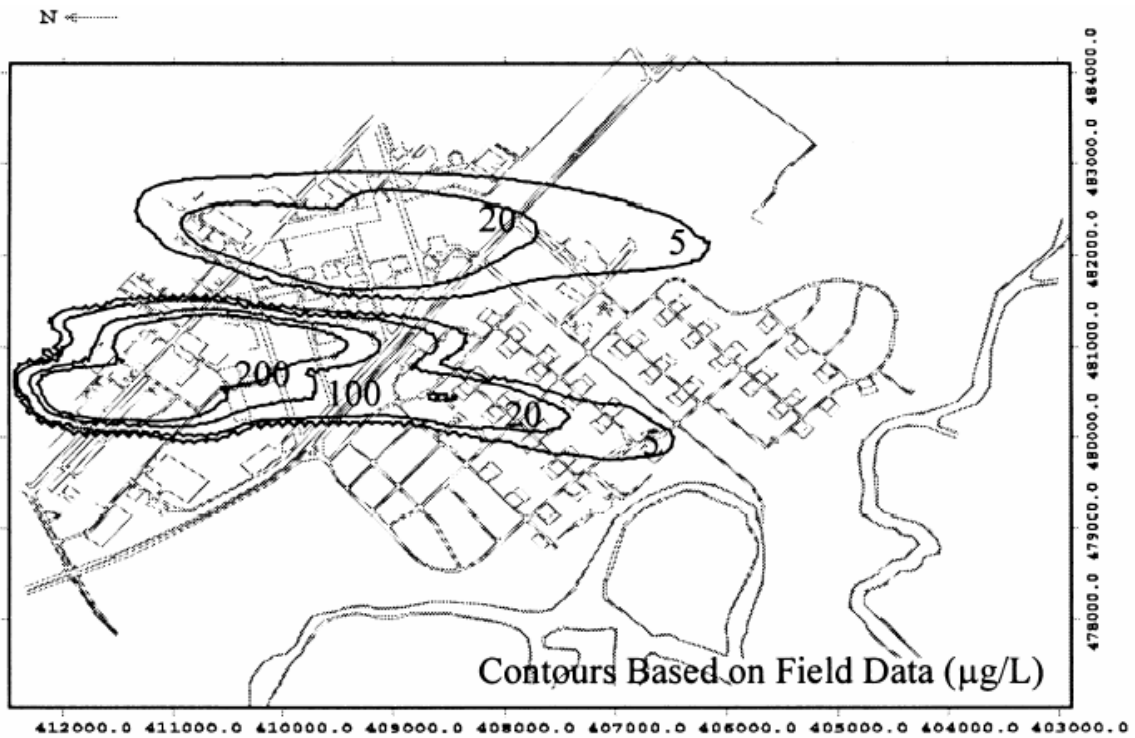

Figure 20. PCE Plume Contours (Clement et al., 2000)

Clement et al. (2000) calibrated their model to observed plume concentration data shown in Figure 20 and total plume contaminant mass estimates, to estimate the rate of mass flux from DNAPL to the aqueous phase at each of the 13 suspected source zones. These estimated source zone mass flux rates are shown in Table 5:

Table 5. Estimated Contaminant Mass Release Rates in kg/yr (Clement et al., 2000)

Source number	Stress period #1		Stress period #2		Stress period #3		Stress period #4	
	PCE	TCE	PCE	TCE	PCE	TCE	PCE	TCE
1	1	10	2	10	1	8	1	1
2	1	2	1	2	1	1	1	0
3	1	52	1	1	0	1	0	1
4	1	19	2	19	2	8	2	2
5	25	413	25	165	17	74	0	17
6	1	9	0	1	0	1	0	1
7	1	1	1	1	1	1	0	0
8	0	5	0	5	0	5	0	5
9	10	1	31	517	10	1	1	1
10	0	41	0	41	0	4	0	2
11	2	0	0	413	0	0	0	0
12	0	21	0	21	0	17	0	2
13	0	0	0	0	0	0	0	0

The stress periods referred to in Table 5 are each 10 years in length, the source number refers back to Figure 16, and the units of the mass release rate is kilograms per year.

Although the contaminant would have been released in the form of a DNAPL, it appears that continuous free-phase DNAPL is no longer present (Clement et al., 2000). Instead, it is hypothesized that the contaminant source is present as ganglia entrapped in the pore spaces and sorbed or diffused contamination in the low-permeability clay lenses (Clement et al., 2000).

Table 6 shows the additional parameters used to set up the model used in this study.

Table 6. Model Parameters

<u>Parameter</u>	<u>Value</u>	<u>Source</u>
Porosity (n)	0.38	Clement et al., 2000
Horizontal Hydraulic Conductivity (K): upper aquifer	10.7 m/d	Clement et al., 2001
lower aquifer	25.9 m/d	Clement et al., 2002
Recharge to deep zone	0.00018288 m/d	Clement et al., 2003
Longitudinal Dispersivity	12.192 m	Clement et al., 2004
Ratio of Vertical Dispersivity to Longitudinal Dispersivity	0.2	Clement et al., 2005

3.3 Model Selection and Implementation

3.3.1 The Model

The purpose of this study is to answer three research questions, as posed in

Section 1.2:

1. How are source mass reduction and reduction of mass flux leaving the source-zone related?
2. How can we quantify the effect of the important natural attenuation processes that act upon dissolved chlorinated solvent contaminants?
3. Under specified site conditions, what is the maximum contaminant flux leaving a source-zone that NA can effectively degrade to achieve a concentration goal at a receptor?

The model(s) selected will be used to answer all of these questions, so model selection is vital to the outcome of this research. The remainder of this section will discuss the source remediation and fate and transport models selected for use in this study.

3.3.1.1 Source Remediation Model

For the purposes of this study, a model must be selected to simulate the effect of source remediation. This model must be selected to answer the first research question: how are source mass reduction and reduction of mass flux leaving the source zone related? From the current literature, we see that either mass transfer correlations or

power functions may be used to answer this question.

Research (Zhu and Sykes, 2004) has shown that power functions and mass transfer correlations are able attain similar results. The important step in the modeling process is selecting the applicable mass transfer correlation for the site conditions or determining the appropriate parameter values for the power function. Figure 21 shows how a breakthrough curve can be modeled using either a mass transfer correlation (referred to as Imhoff et al. in the figure) or power function (referred to as, N2, N1, and L):

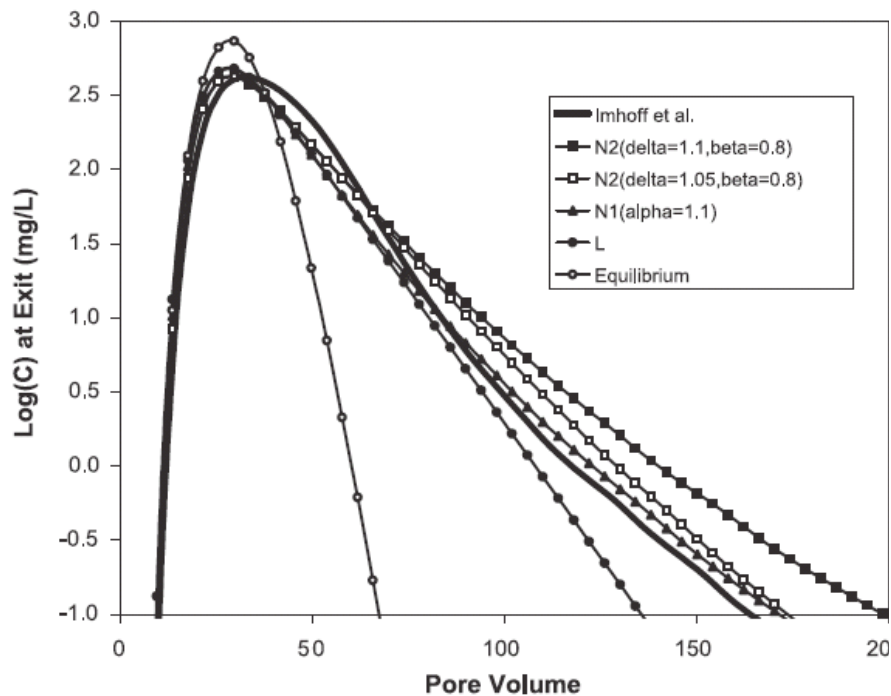

Figure 21. Mass Transfer Correlations Versus Power Functions (Zhu and Sykes, 2004)

In Figure 21, the Imhoff et al. model referenced is the same model discussed in Chapter 2 (Section 2.4.3.2.2, Equation 26); the N2 model was presented by Zhu and Sykes (2004) and discussed in Chapter 2 (Section 2.4.3.3.1, Equation 30); and the N1 and L models

may be found in the same section (Section 2.4.3.3.1, Equations 29 and 28 respectively). As the figure shows, there is very little difference between the results of the mass transfer correlation and power function models.

Either mass transfer correlations or power functions may be used to model the relationship between source zone remediation and source zone strength. Because this research is interested in the effect of source zone mass depletion on natural attenuation in the plume, not specific effects within the source zone, and in the interest of computational efficiency, the Zhu and Sykes (2004) power function model (Section 2.4.3.3.1, Equation 30) will be used for this study. This equation is shown again below (from Zhu and Sykes, 2004):

$$C_0(t) = \beta C_s \left(\frac{M(t)}{M_0} \right)^\Gamma \quad (33)$$

Where:

$C_0(t)$ = source zone concentration at time t [ML⁻³]

β = non-equilibrium parameter [-]

C_s = equilibrium concentration or solubility [ML⁻³]

$M(t)$ = residual mass remaining at time t [M]

M_0 = initial mass [M]

Γ = power-law index [-]

This equation is used because it clearly shows how source zone remediation will result in source zone strength reduction, while still providing the freedom to tailor the equation to data found at the site by varying Γ and β . Figure 22 shows how the value for Γ affects

the relationship between source mass reduction and source strength reduction:

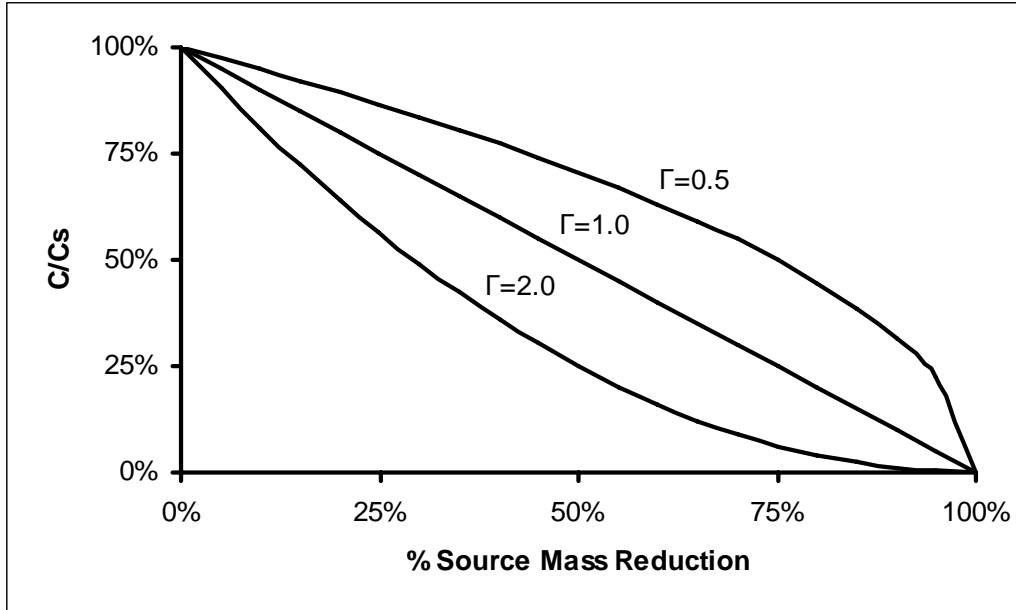

Figure 22. Source Concentration Reduction (C/Cs) Versus Mass Removed for Various Γ Values

Source mass reduction is found using Equation 34:

$$\% \text{ Source Mass Reduction} = \frac{M_0 - M(t)}{M_0} * 100\% \quad (34)$$

Figure 22 demonstrates that varying the Γ value for the power function will lead to increased or diminished reductions in source concentration per unit mass reduction. This relationship is further examined during this study by modeling the reduction of contamination concentration at a downgradient receptor for various Γ values and mass removals in the source zone.

Figure 23 shows how the value β affects the relationship between source zone

remediation and source zone concentration reduction:

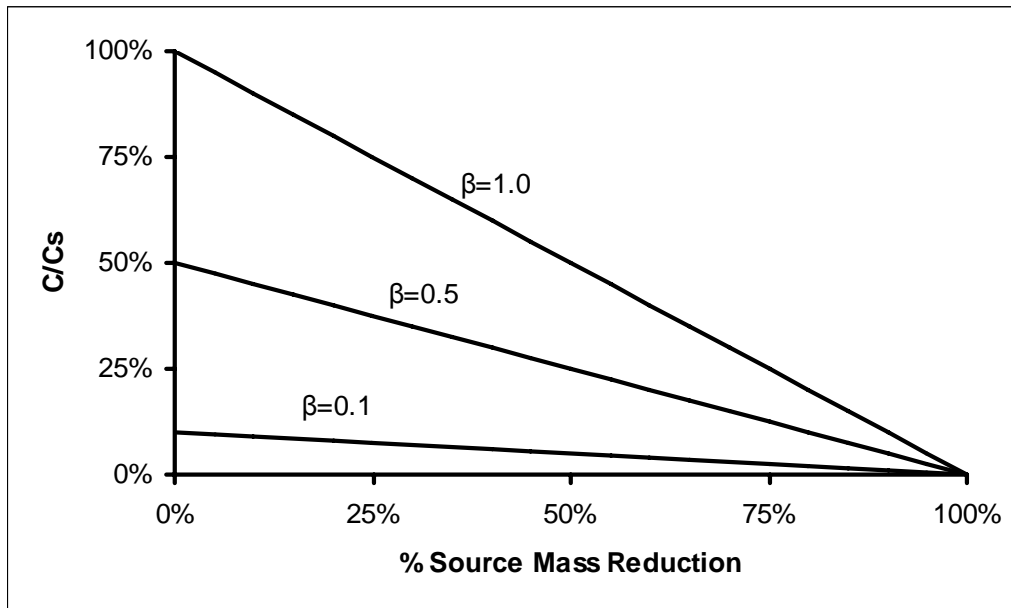

Figure 23. Source Concentration Reduction (C/C_s) Versus Mass Removed for Various β Values

Figure 23 illustrates how varying the β value will lead to different source zone concentrations prior to mass removal. For instance, if a β -value of 0.5 is selected, the initial source zone concentration will be $0.5C_s$ as opposed to $0.1C_s$ for β equals 0.1 or $1.0C_s$ for β equals 1.0. The equilibrium concentration for PCE used in this study is 150 milligrams per liter (Sellers, 1999). β accounts for the fact that, due to mass transfer limitations, the source concentration will not usually be at equilibrium (*i.e.* solubility)

The Zhu and Sykes (2004) power function model is used to determine the value for the source zone concentration used in this study. The flux leaving the source zone is then calculated by multiplying this source concentration by the Darcy velocity (see Section 2.3.1, Equation 2).

When using Zhu and Sykes (2004) power function for this study, the source zone concentration was assumed to remain constant for the entire run of the model (generally 60 years). This assumption was necessary to investigate how changing the source zone concentration (through source zone remediation, as modeled by the power function) would affect the concentration arriving at the downgradient receptor.

3.3.1.2 Contaminant Fate and Transport Model.

The contaminant fate and transport model will be used to answer the second research question from Section 1.2: how can we quantify the effect of the important natural attenuation processes that act upon dissolved chlorinated solvent contaminants?

As discussed in Section 2.4.1, the Advection-Dispersion Equation (ADE) will be used to model the fate and transport of the contaminant. This equation as used is shown below (from Clement, 1997):

$$\frac{\partial C_k}{\partial t} = \frac{\partial}{\partial x_i} \left(D_i \frac{\partial C_k}{\partial x_j} \right) - \frac{\partial}{\partial x_i} (v_i C_k) + r_c \quad (35)$$

$$\frac{d\tilde{C}_{im}}{dt} = \tilde{r}_c \quad (36)$$

Where:

C_k = Aqueous-phase concentration of k^{th} species [ML^{-3}]

k = Species (i.e. TCE, PCE, etc.)

D_i = Dispersion coefficient in the i^{th} direction [L^2T^{-1}]

v_i = Pore velocity [LT^{-1}]

r_c = Rate of all reactions in the aqueous phase [ML^3T^{-1}]

\tilde{C}_{im} = solid-phase concentration of the im^{th} species [MM^{-1}]

$$\tilde{r}_c = \text{rate of all reactions that occur in soil-phase [ML}^3\text{T}^{-1}\text{]}$$

Equations 35 and 36 are utilized within the framework of the Department of Defense Groundwater Modeling Software (GMS) version 5.1. GMS is employed to run the MODFLOW2000 and Reactive Transport in 3-Dimensions (RT3D) computer codes which employ the fate and transport model.

3.3.1.2.1 Flow Model.

GMS uses the MODFLOW2000 computer code to model the three-dimensional steady state and transient movement of groundwater (USGS, 2000a). This is accomplished using a model based on the following partial differential equation (from USGS, 2000a):

$$\frac{\partial}{\partial x} \left(K_{xx} \frac{\partial h}{\partial x} \right) + \frac{\partial}{\partial y} \left(K_{yy} \frac{\partial h}{\partial y} \right) + \frac{\partial}{\partial z} \left(K_{zz} \frac{\partial h}{\partial z} \right) - W = S_s \frac{\partial h}{\partial t} \quad (37)$$

Where:

K_{xx} , K_{yy} , and K_{zz} = Hydraulic conductivity along the x, y, and z-axis respectively [LT^{-1}]

h = Potentiometric head [L]

W = Volumetric flux per unit volume [T^{-1}]

S_s = Specific storage of the porous material [L^{-1}]

t = Time [T]

In this study, the flow model was used assuming the groundwater flow was at steady-state, so the potentiometric head did not change with time and the specific storage was

not used. In order to use this model to determine the steady-state conditions, the physical boundaries of the site were set as constant head boundaries. Once the boundary conditions were set, the model was run. The model uses the finite-difference method to solve Equation 20 and determine the head for each cell (USGS, 2000a). The new heads calculated in MODFLOW are then used in the Darcy equation (see Section 2.3.1, Equation 2) to determine the groundwater velocity which is used in the fate and transport model (see Equation 35).

3.3.1.2.2 Source/Sink Term.

The source/sink term, as represented in the ADE as r_c and discussed in Section 2.4.2, is used in this study to represent the biodegradation of the chlorinated solvents. In Chapter 2, we considered four different models for chlorinated solvent biodegradation: first-order decay, the Monod model, the dual-Monod model, and a variation of the dual-Monod model (Lee et al., 2004). All of these models may be used in RT3D as built-in modules or developed as user-defined modules (Clement, 1997). For the Dover AFB site, Clement et al. (2000) used a first-order model and developed estimates for the first-order decay rates. Thus, that is the model we will use in this study. While the first-order model is simpler than the other models, due to its simplicity, it ignores some of the actual processes. However, since we do not have the detailed understanding of the site necessary to model these processes, nor do we know the parameter values to use for these other models, we follow Clement et al. (2000) and use the first-order model, incorporating both aerobic and anaerobic processes, as implemented in RT3D Module 7, to simulate dissolved chlorinated solvent transport at the Dover site. Parameters used in the model are the ones used by Clement et al. (2000) and presented in Table 3.0.

This model uses the following versions of Equation 35 to describe the fate and transport of the dissolved chlorinated compounds (from Clement, 1997):

$$\frac{\delta[PCE]}{\delta t} = \frac{\delta}{\delta x_i} \left(D_{ij} \frac{\delta[PCE]}{\delta x_j} \right) - \frac{\delta}{\delta x_i} (v_i[PCE]) - K_p[PCE] \quad (38)$$

$$\frac{\delta[TCE]}{\delta t} = \frac{\delta}{\delta x_i} \left(D_{ij} \frac{\delta[TCE]}{\delta x_j} \right) - \frac{\delta}{\delta x_i} (v_i[TCE]) + Y_{T/P} K_p[PCE] - K_{T1}[TCE] - K_{T2}[TCE] \quad (39)$$

$$\frac{\delta[DCE]}{\delta t} = \frac{\delta}{\delta x_i} \left(D_{ij} \frac{\delta[DCE]}{\delta x_j} \right) - \frac{\delta}{\delta x_i} (v_i[DCE]) + Y_{D/T} K_T[TCE] - K_{D1}[DCE] - K_{D2}[DCE] \quad (40)$$

$$\frac{\delta[VC]}{\delta t} = \frac{\delta}{\delta x_i} \left(D_{ij} \frac{\delta[VC]}{\delta x_j} \right) - \frac{\delta}{\delta x_i} (v_i[VC]) + Y_{V/D} K_{D1}[DCE] - K_{V1}[VC] - K_{V2}[VC] \quad (41)$$

$$\frac{\delta[ETH]}{\delta t} = \frac{\delta}{\delta x_i} \left(D_{ij} \frac{\delta[ETH]}{\delta x_j} \right) - \frac{\delta}{\delta x_i} (v_i[ETH]) + Y_{E/V} K_{V1}[VC] - K_{E1}[ETH] - K_{E2}[ETH] \quad (42)$$

Where:

$[PCE], [TCE], [DCE], [VC], [Eth]$ = Concentration of PCE, TCE, DCE, VC, and ethene, respectively $[ML^{-3}]$

$K_p, K_{T1}, K_{D1}, K_{V1}, K_{E1}$ = First-order anaerobic degradation rates for PCE, TCE, DCE, VC, and ethene, respectively $[T^{-1}]$

$K_{T2}, K_{D2}, K_{V2}, K_{E2}$ = First-order aerobic degradation rates for TCE, DCE, VC, and ethene, respectively $[T^{-1}]$

$Y_{T/P}, Y_{D/T}, Y_{V/D}, Y_{E/V}$ = Chlorinated compound yield under anaerobic reductive dechlorination conditions (0.79, 0.74, 0.64, and 0.45, respectively) $[MM^{-1}]$

The chlorinated compound yield coefficients ($Y_{B/A}$) are used to track mass. For example, $Y_{T/P} = 0.79$ indicates that the anaerobic reduction of 1 gram of chlorinated compound A (PCE in this instance) leads to the production of 0.79 gram of chlorinated compound B (TCE in this case).

In Equations 38-42, the left-hand side of the equation is an accumulation term for chlorinated solvents in both the dissolved and sorbed phases. Typically, the accumulation term would be multiplied by the retardation factor for each contaminant. However, in this study, retardation was assumed to be negligible (i.e. the retardation factor is 1.0 for all contaminants). On the right-hand side, the first term describes the change in contaminant concentration due to dispersion. The second term describes the change in contaminant concentration due to advection. The third term in Equation 38 represents the contaminant lost to anaerobic degradation, while the third term in Equations 39-42 represents contaminant production. The fourth and fifth terms in Equations 39-42 are the concentration reductions due to anaerobic and aerobic degradation, respectively.

The concentration of PCE in the source zone was used as a boundary condition. The PCE concentration was determined by the Zhu and Sykes (2004) power function, while the concentrations of TCE, DCE, VC, and ethene at the boundary were set to zero. All CAH initial concentrations throughout the aquifer were set to zero.

3.3.2 Model Testing.

The model was tested to verify that results similar to those obtained by Clement et al. (2000) could be produced. This was accomplished by specifying the hydraulic

conductivity at the site (see Table 6) and setting the heads at the site borders as the boundary conditions. MODFLOW was then run to calculate the steady-state groundwater contours. Figures 24 and 25 compare the results of this study to the results of the Clement et al. (2000) study.

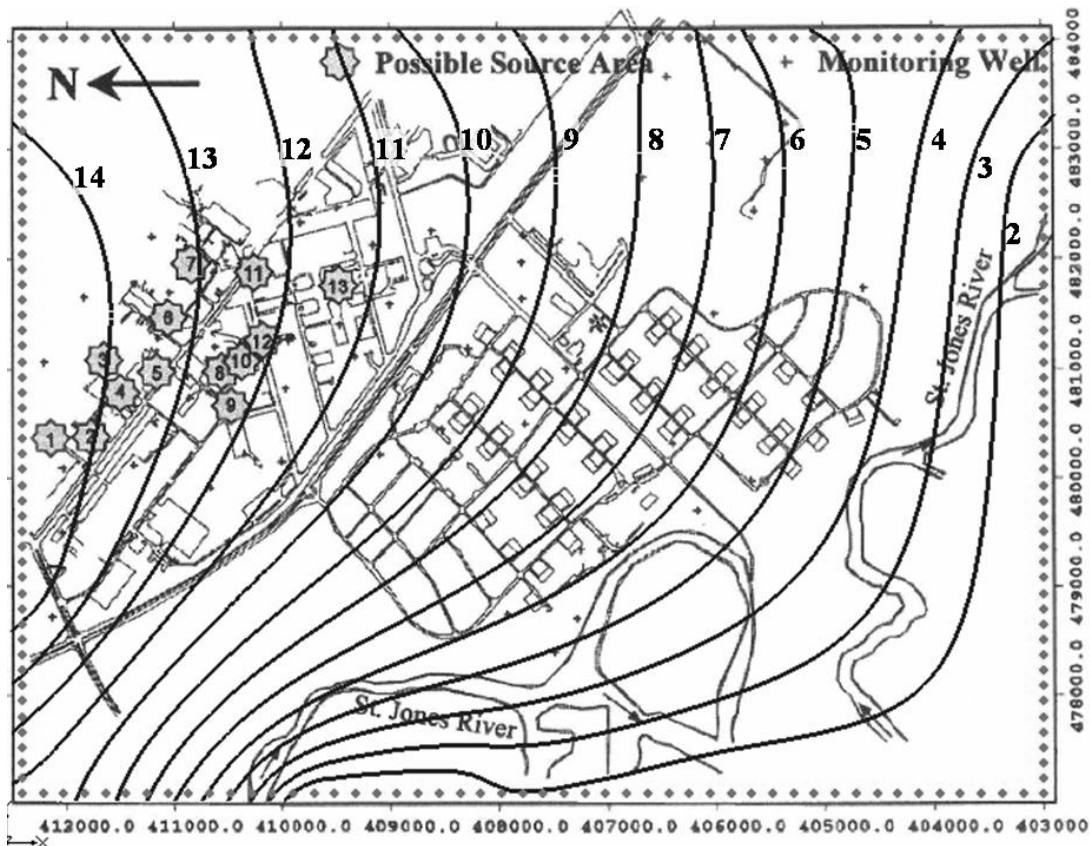

Figure 24. Groundwater Contours for This Study

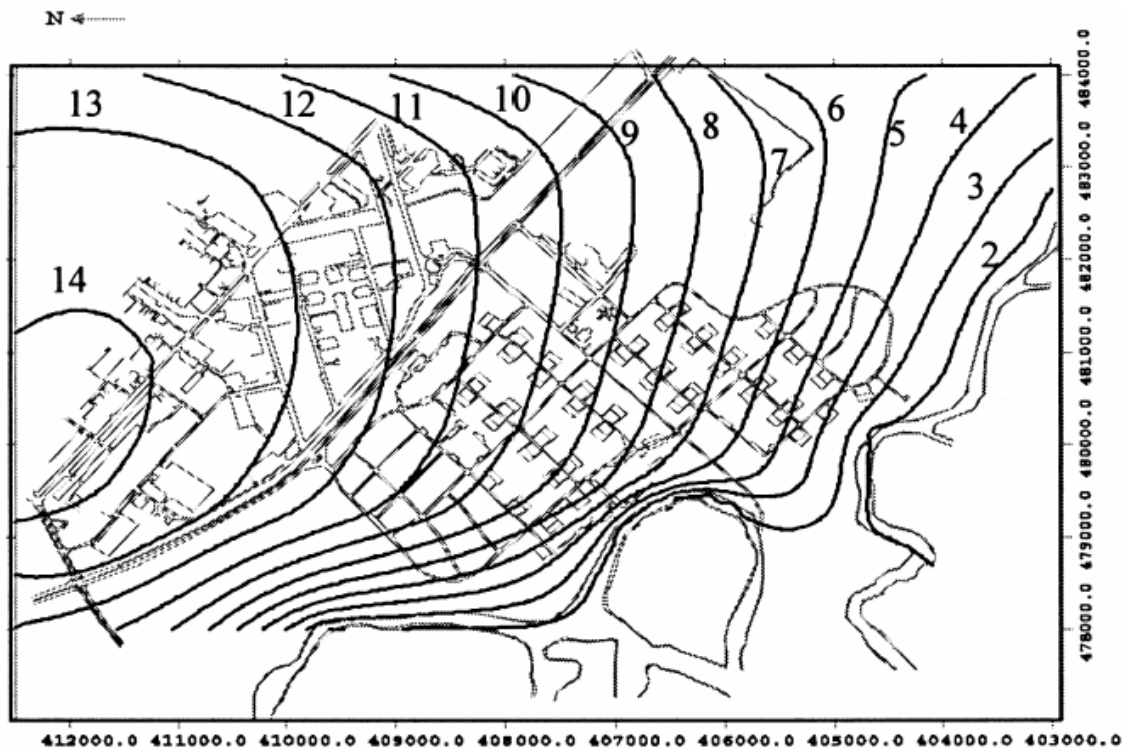

Figure 25. Clement et al. (2000) Groundwater Contours

Figure 24 and 25 both show the groundwater flowing toward the south and west of the site, but the contours found in this study are not identical to those found by Clement et al (2000). A significant discrepancy between the two figures is the inclusion or exclusion of the St. Jones River. This study did not include the river as a boundary condition while it was set as a boundary in the Clement et al. (2000) study. However, both studies do show a similar trend for the groundwater flow, so the model developed for this study is considered acceptable.

Following verification of the flow model, the reaction zones (see Figure 36) along with the reaction rate constants (see Table 4) were input into RT3D. Also, the estimated contaminant mass release rates used in Clement et al. (2000) (see Table 5) were input into RT3D at the appropriate source zone locations (see Figure 16). This was accomplished

by using injection wells with a very low flow rate ($0.000001 \text{ m}^3/\text{d}$) and calculating the concentration of contaminant necessary, at that flow rate, to achieve the annual mass loading rates shown in Table 5.

With all the parameters input, RT3D was run. The results showing the PCE plume concentration contours after simulating 40 years of transport are shown for Clement et al. (2000) and for this study in Figures 26 and 27, respectively:

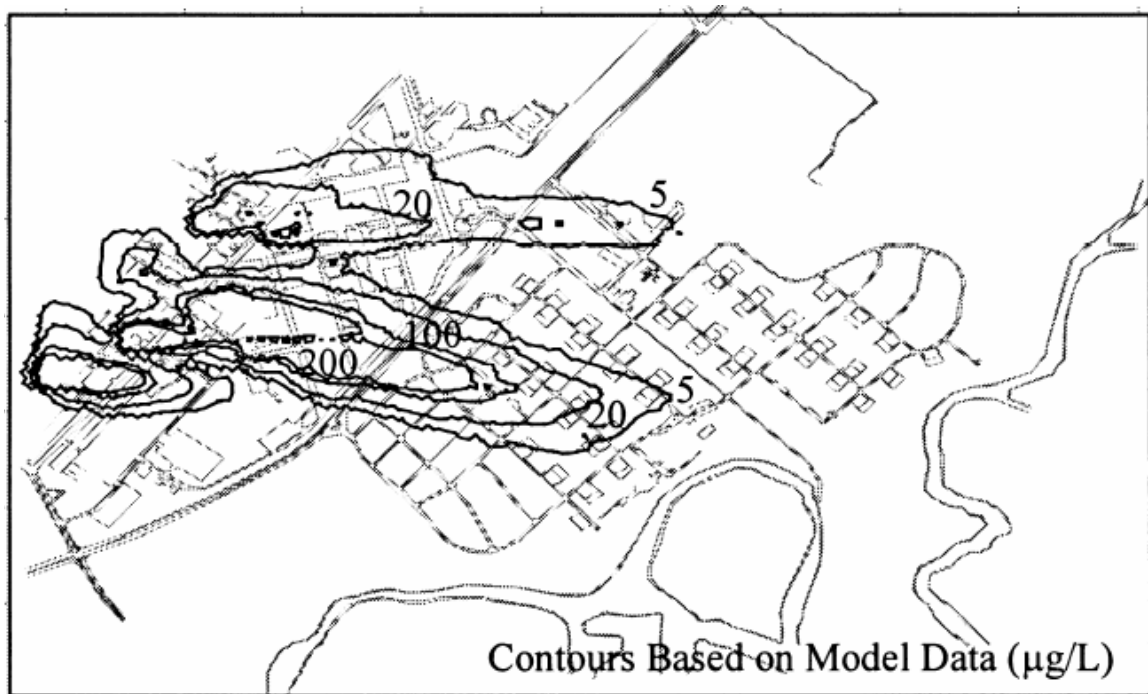

Figure 26. PCE Contamination Contours ($\mu\text{g/L}$) After 40 Years Predicted by Clement et al. (2000)

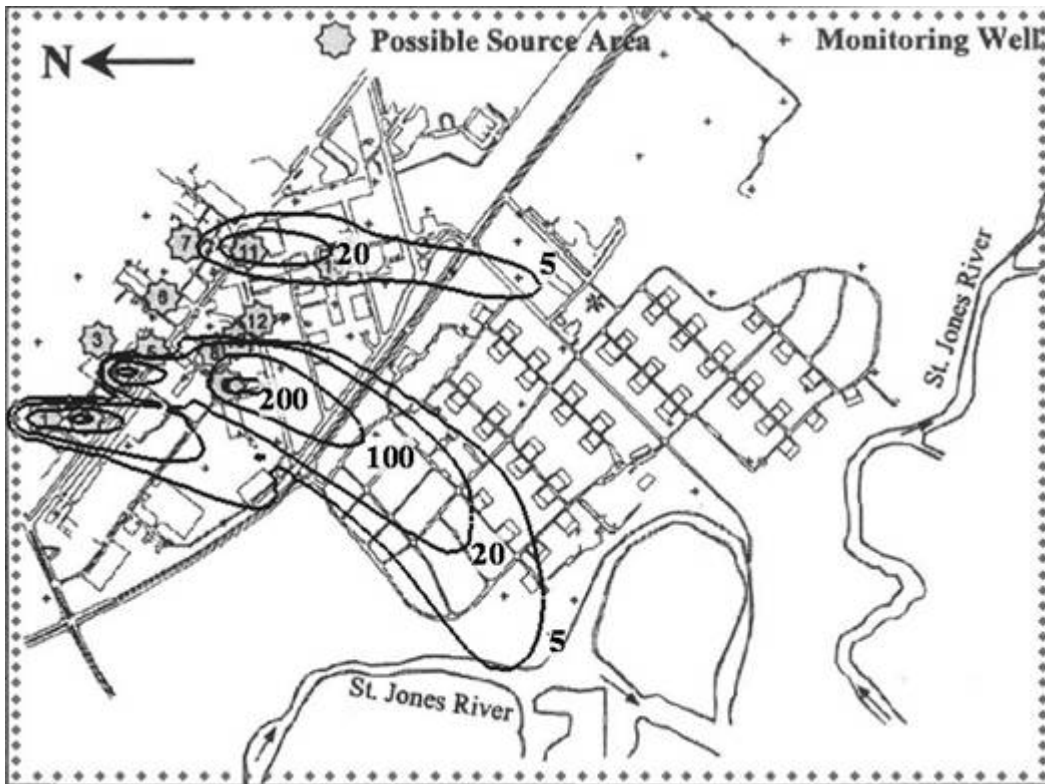

Figure 27. PCE Contamination Contours ($\mu\text{g/L}$) After 40 Years Predicted by This Study

While the model simulations are not duplicates, the general size, magnitude, and direction of the PCE plume is similar in both models. Similar results were found for TCE, DCE, VC, and ethene. These results give us confidence that the model in this study is comparable to the model used by Clement et al. (2000) to simulate chlorinated compound fate and transport at the Dover site.

3.4 Model Sensitivity Analysis.

The third research question was answered through the use of a sensitivity analysis. This sensitivity analysis was performed in order to show how the value of Γ in the source remediation model and the extent of source mass removal (i.e. M/M_0) influence model-predicted concentrations downgradient. The receptor location selected

for the sensitivity analysis was a point 800 meters downgradient of the source zone, along the estimated centerline of the contaminant plume. This point was selected because it was the furthest point along the plume centerline that exhibited steady state conditions for contaminant concentrations within the 60-year timeframe of the simulation. The value of Γ was varied from 0.1 to 10.0. Although these limits may be somewhat unrealistic, they are used for illustrative purposes, in order to clearly show the effect of very low and very high values of the parameter. The extent of source zone remediation was varied from no mass removal (0%) to nearly complete removal (99%).

The first step in running the sensitivity analysis was to establish a baseline. The baseline model assumed source mass removal of 60% and a Γ value of 1.1. The model was then run to determine the PCE concentration at a receptor 800 meters downgradient of the source zone. Once this baseline was established, the model was run for source zone remediation levels of 0% and 99% and Γ values of 0.1 and 10.0. Sensitivity was then measured using Equation 43 (from Wood, 2005):

$$S = \left| \left(\frac{df}{f} \right) \left(\frac{x}{dx} \right) \right| \quad (43)$$

Where:

S = relative sensitivity [-]

df = model output range

f = model output

x = baseline input

dx = input range

IV. Results and Analysis

4.1 Introduction

Chapter 1 (see Section 1.2) introduced three research questions:

1. How are source mass reduction and reduction of mass flux leaving the source-zone related?
2. How can we quantify the effect of the important natural attenuation processes that act upon dissolved chlorinated solvent contaminants?
3. Under specified site conditions, what is the maximum contaminant flux leaving a source-zone that NA can effectively degrade to achieve a concentration goal at a receptor?

Chapters 2 and 3 presented and discussed the models we will use to answer these questions, using site conditions at an actual contaminated site at Dover AFB as an example. This chapter presents and analyzes the results of this study. First, the results of the power function selected (see Section 2.4.3.3.1, Equation 30) are analyzed to determine how source mass reduction and reduction of mass flux leaving the source zone are related. Following this discussion, the second research question is analyzed. The natural attenuation processes are modeled through the use of the fate and transport model along with the source/sink model used in RT3D (discussed in Section 3.3.1.2 and 3.3.1.3). The final research question is discussed using the combined model which incorporates all of the models discussed in Section 3.3.1. Finally, the results of the sensitivity analysis described in Section 3.4 are presented.

4.2 Source Remediation

The Zhu and Sykes (2004) power function model (see Section 2.4.3.3.1, Equation

30) shows how source mass reduction and reduction of concentration in the source zone are related. The power function can be rearranged to show this relationship more clearly (from Zhu and Sykes, 2004):

$$\frac{C_0(t)}{\beta C_s} = \left(\frac{M(t)}{M_0} \right)^\Gamma \quad (44)$$

Where:

$C_0(t)$ = source zone concentration at time t [ML⁻³]

β = parameter [-]

C_s = equilibrium concentration or solubility [ML⁻³]

$M(t)$ = residual mass remaining at time t [M]

M_0 = initial residual mass [M]

Γ = power-law index [-]

Equation 44 shows how remediation or reduction of mass in the source zone leads to a reduction of concentration in the source zone. This concentration reduction can in turn be related to flux reduction by multiplying the concentration by the groundwater velocity (see Section 2.3.1, Equation 2). Since this study assumes the groundwater contours are at steady-state, and that source remediation has no impact on the flow field, the concentration reduction is directly proportional to the flux reduction. The percentage of source mass reduction can be determined by using Equation 45.

$$\% \text{ Source Mass Reduction} = \frac{M_0 - M(t)}{M_0} * 100\% \quad (45)$$

It should be noted that, although this study looked at source mass reductions of up to 99%, complete remediation is highly unlikely. Attaining a source mass reduction of 60-70% is a more reasonable estimate for a maximum remediation value (Soga et al., 2004).

Figure 28 helps to illustrate how changes in the power-law index affect the relationship between source mass reduction and flux reduction. As discussed in Section 2.4.3.3.1, the power-law index, Γ , is dependent upon site characteristics.

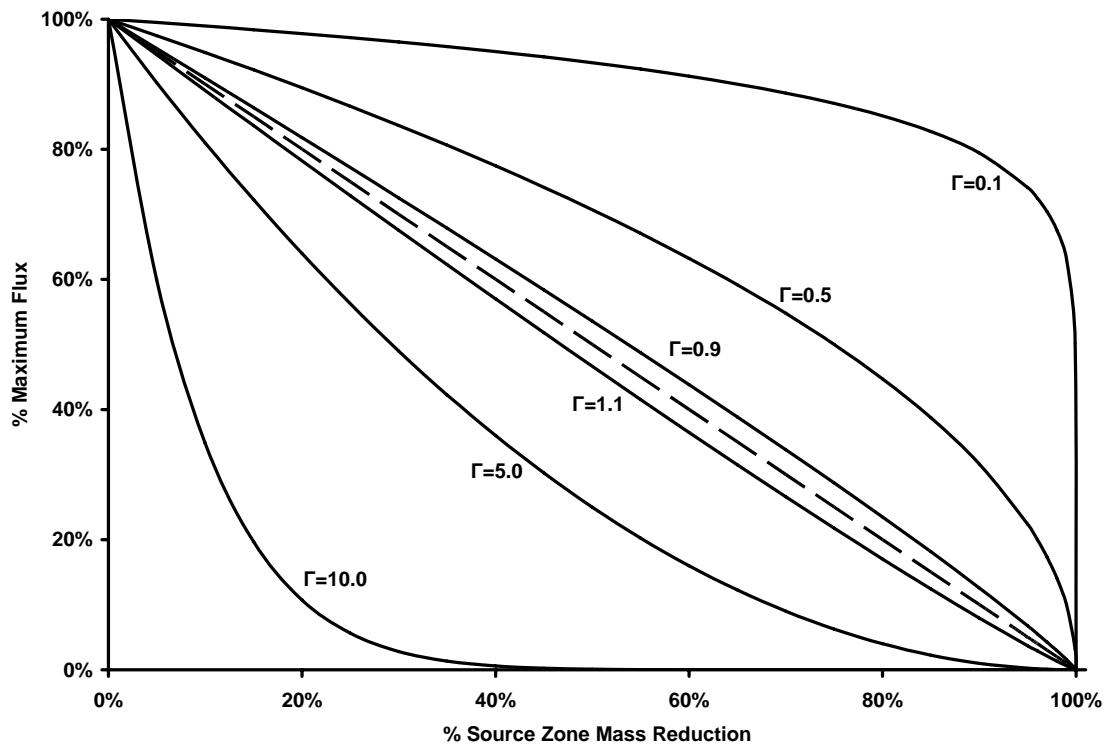

Figure 28. Contaminant Flux Versus Mass Reduction (dashed line represents the results for $\Gamma=1.0$)

This figure shows how the percentage of flux reduction due to mass reduction is dependent upon the power-law index, Γ . For instance, at 60% mass reduction the

corresponding fluxes emanating from the source zone are approximately 0%, 20%, 40%, 60%, and 100% of the initial or maximum flux, βC_S , for $\Gamma=10.0, 2.0, 1.0, 0.5,$ and 0.1 respectively. These differences are significant when attempting to minimize the flux leaving the source zone. In general, this figure shows that mass reduction in the source zone results in reduction of flux leaving the source zone.

4.3 Natural Attenuation

RT3D was used to quantify the natural attenuation processes that act upon dissolved chlorinated solvent contaminants. The fate and transport model along with the source/sink model within RT3D were utilized as discussed in Section 3.3.1.2. This model was used to predict the contaminant plume concentrations resulting from given source zone contamination concentrations. When running the model in GMS, the source zone concentration selected remained constant for the duration of the simulation, typically 60 years. As discussed (see Section 2.3), natural attenuation processes will change both the arrival time of the contaminant at a downgradient receptor and the concentration of contaminant. Figure 29 shows the arrival of contamination at a downgradient receptor when the source zone provides a continuous PCE concentration of 48 mg/L:

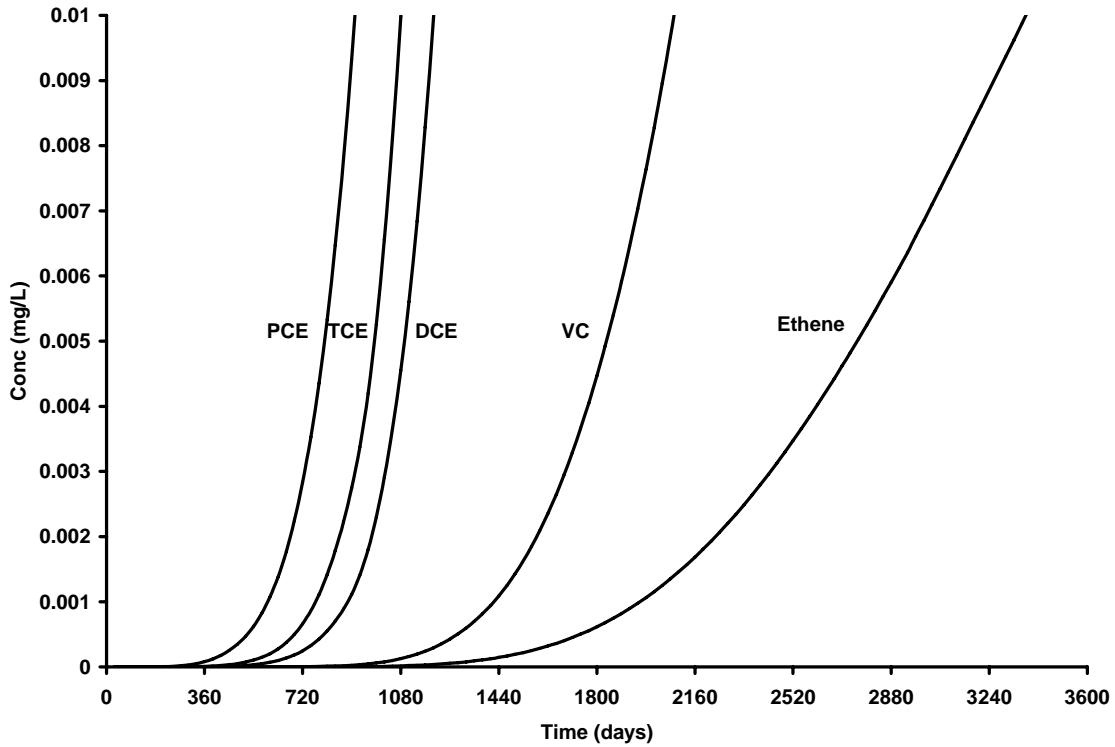

Figure 29. Arrival of Contamination at Receptor 200 Meters Downgradient

Figure 29 indicates that PCE contamination arrives at the downgradient receptor at very low levels approximately one year after the source zone is contaminated. Using Darcy's Law (see Section 2.3.1, Equation 1 and 2), if advection were the only process controlling PCE transport, we'd expect the contamination wouldn't reach the receptor until approximately 3700 days after contaminant was introduced into the aquifer at time 0. However, due to longitudinal dispersion, low concentrations of PCE reach the receptor at a much earlier time. Figure 29 also shows that biodegradation is occurring, as PCE (which was the only contaminant initially in the aquifer) is degraded to TCE, DCE, VC, and ethene, all of which arrive at the receptor.

The effect of dispersion on PCE plume characteristics is illustrated in Figure 30. The figure shows the model predicted PCE concentration contours after 60 years of

transport, assuming a constant PCE source zone concentration of 48 mg/L PCE (the same source concentration used for Figure 29).

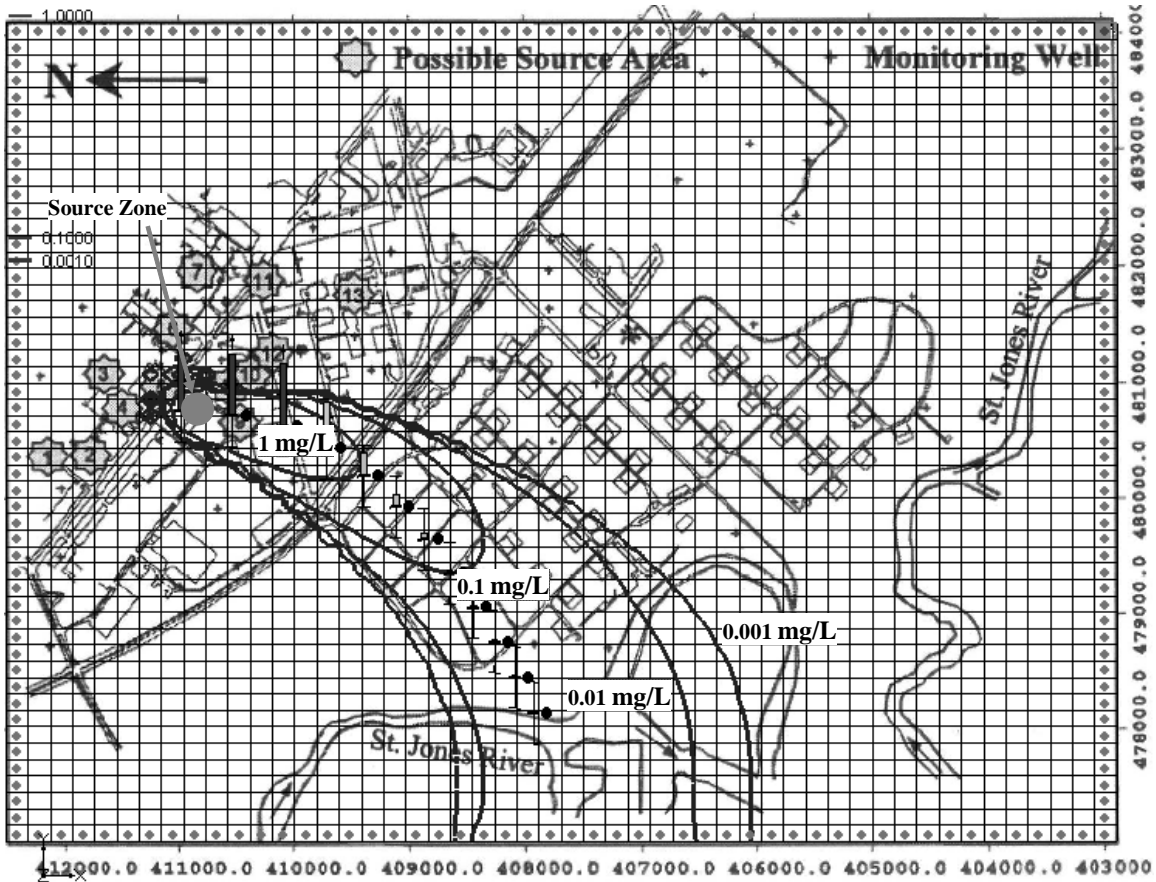

Figure 30. PCE Plume

This figure illustrates how the contamination spreads transversely as it travels downgradient. Due to this transverse dispersion, the plume width is considerably larger than the source width. This transverse spreading serves to reduce concentrations along the plume centerline.

To illustrate the combined effects of dispersion and degradation, let us look at the concentration versus time breakthrough curve at a receptor 800 m downgradient of a

constant concentration source of PCE (source concentration equals 48 mg/L). Since the source zone concentration remains constant, the contaminant concentrations at a downgradient receptor eventually reach steady-state, as shown in Figure 31.

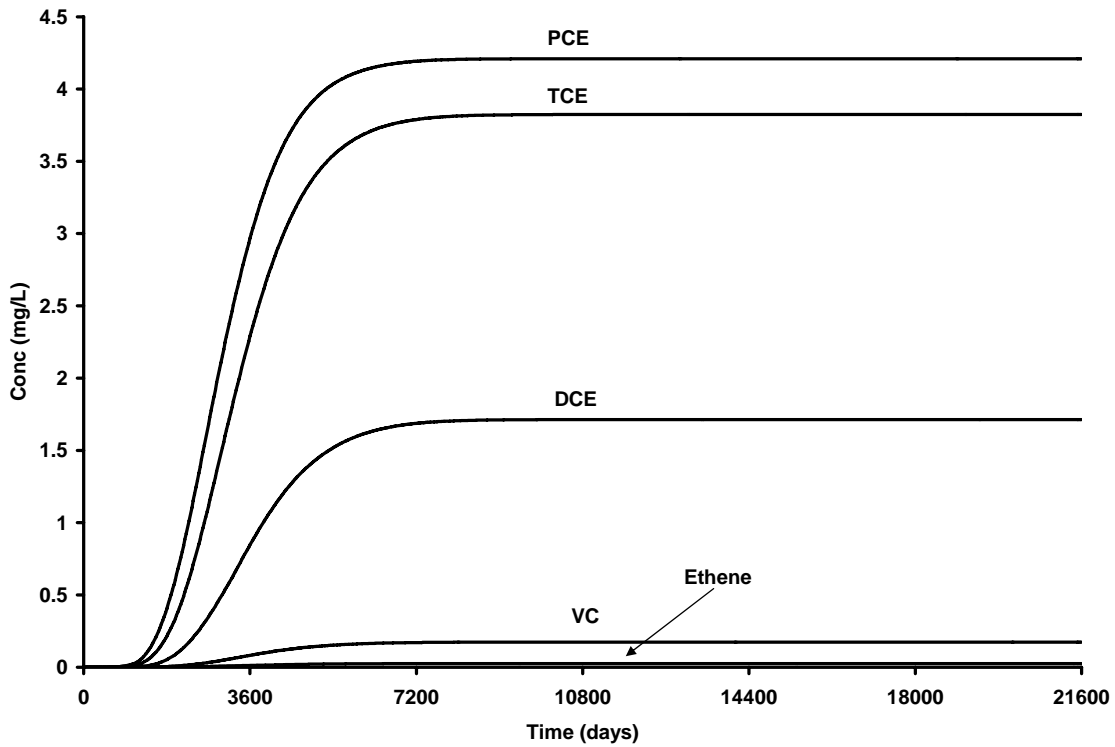

Figure 31. CAH Concentrations Versus Time at a Receptor 800 m Downgradient of a 48 mg/L PCE Source

This figure shows that the combined effects of degradation and transverse dispersion have reduced the PCE concentration, which was 48 mg/L at the source, to less than 4.5 mg/L. Degradation has also resulted in the production of daughter products. In this particular example, we note that steady-state CAH concentrations are on the order of mgs/L. Since the MCLs for CAHs are on the order of $\mu\text{gs/L}$, we see that for a source concentration of 48 mg/L, NA processes are inadequate to protect human health at a receptor x m downgradient. Thus, source zone mass reduction, which will result in

source concentration and flux reduction, may be required to achieve MCLs downgradient.

4.4 Impact of Source Remediation on Concentrations Downgradient

By combining the Zhu and Sykes (2004) power function model and the fate and transport model in RT3D, we can estimate how source remediation is related to concentration reductions at downgradient receptors. Figures 32 through 34 use the model developed in this study and the Dover site conditions to show the concentration reduction achieved at a receptor 800 meters downgradient of the source zone versus the mass reduction in the source zone:

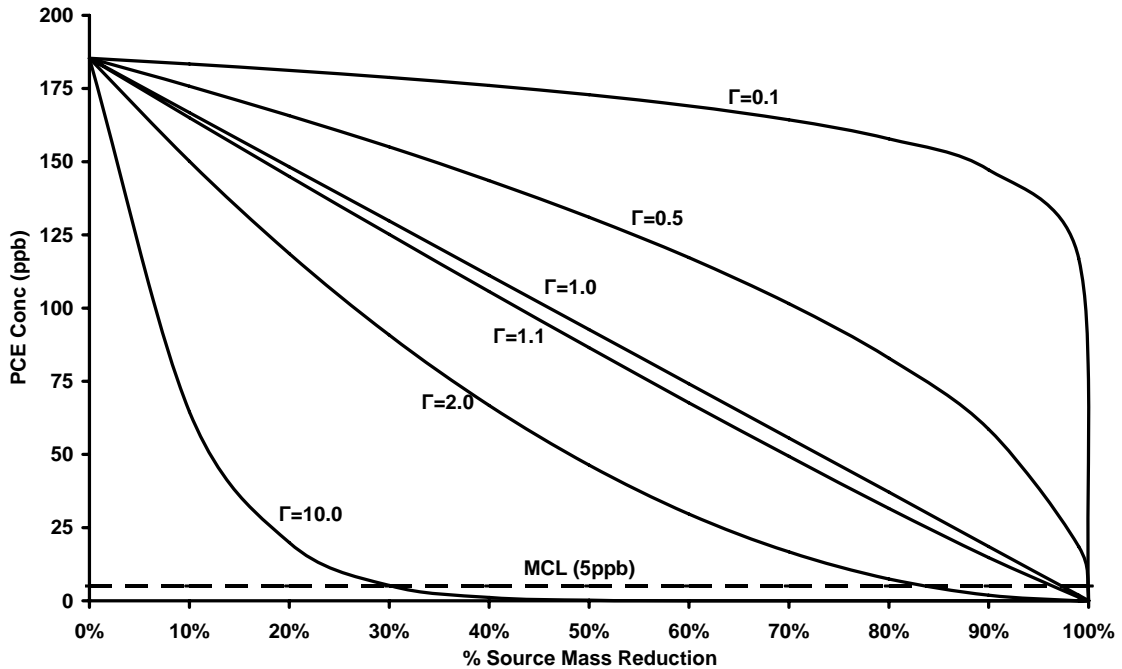

Figure 32. Steady-State PCE Concentration at Varying Source Mass Reductions for a Monitoring Well 800 Meters Downgradient of the Source

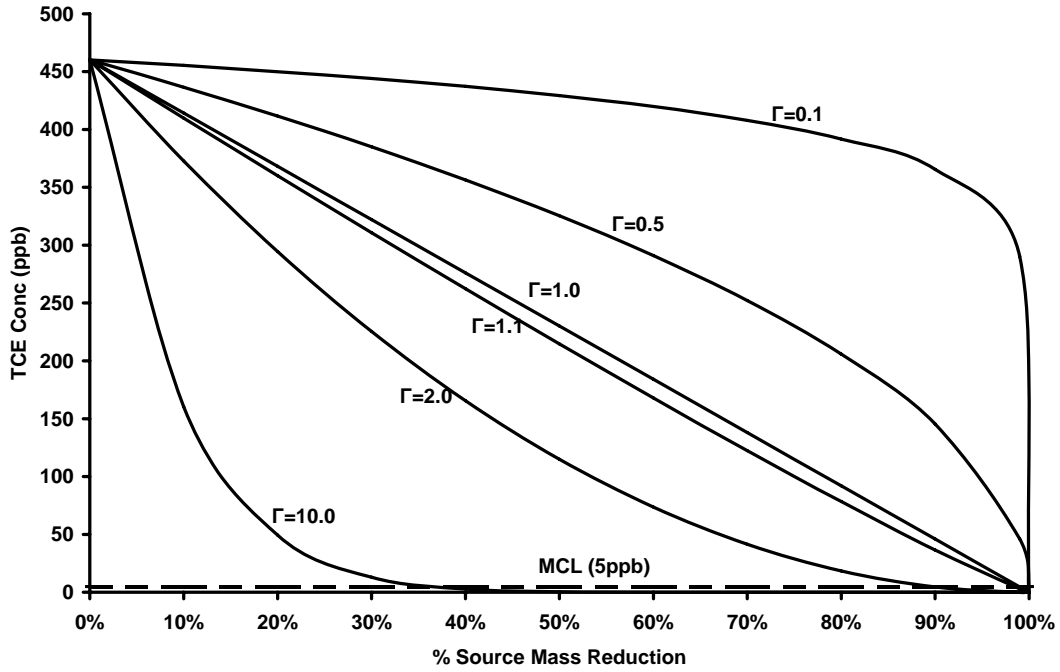

Figure 33. Steady-State TCE Concentration at Varying Source Mass Reductions for a Monitoring Well 800 Meters Downgradient of the Source

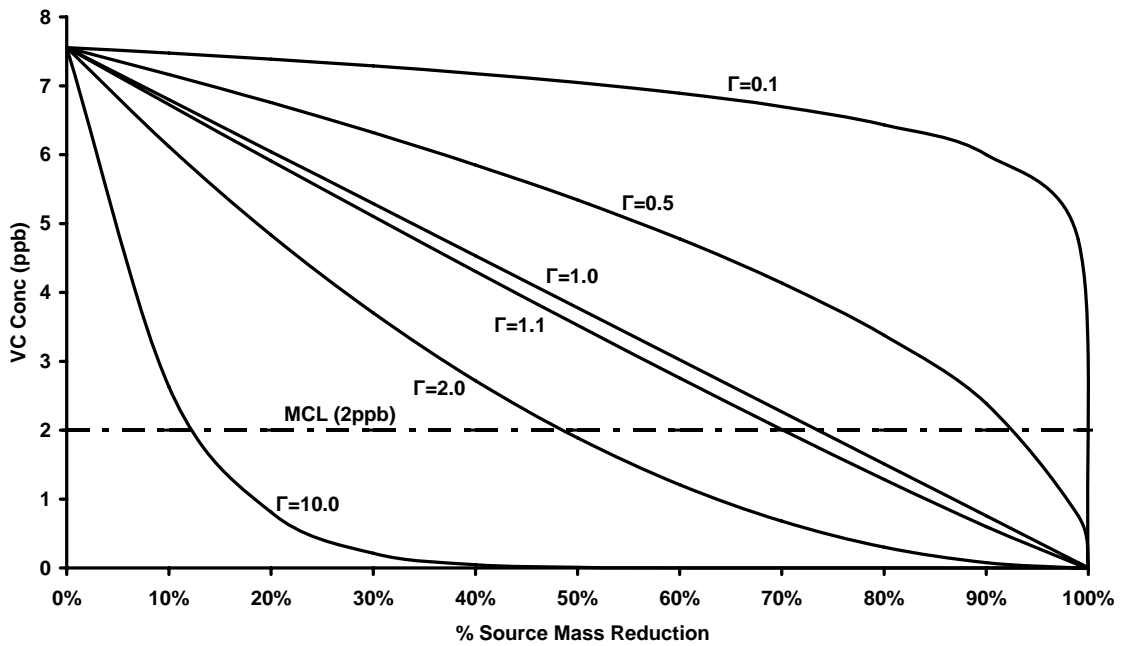

Figure 34. Steady-State VC Concentration at Varying Source Mass Reductions for a Monitoring Well 800 Meters Downgradient of the Source

Figures 32, 33, and 34 show how the reductions in source mass leads to PCE, TCE, and VC concentration reductions, respectively, at a receptor 800 meters downgradient along the centerline of the contaminant plume. These figures also show the respective maximum contaminant levels (MCLs), often used as the remediation goal, of the contaminants. When utilizing the Zhu and Sykes (2004) power function in this model, the β -value used was 0.8, indicating that the initial or maximum concentration for the PCE concentration in the source zone is 80% of the equilibrium concentration of PCE. The equilibrium concentration, C_s , of PCE used in this model is 150 mg/L. Also, the percentage of source mass reduction is equal to the portion of mass removed from the source zone, as shown previously by Equation 45.

Table 7 shows the PCE concentrations used to create Figure 32.

Table 7. Steady-State PCE Concentrations (ppb) at Varying Source Mass Reductions for a Monitoring Well 800 Meters Downgradient of the Source

	$\Gamma=0.1$		$\Gamma=0.5$		$\Gamma=1.0$		$\Gamma=1.1$		$\Gamma=2.0$		$\Gamma=10.0$	
0%	185	-	185	-	185	-	185	-	185.3	-	185.3	-
10%	183	1%	176	5%	167	10%	165	11%	150.1	19%	64.5	65%
20%	181	1%	166	6%	148	11%	145	12%	118.6	21%	19.9	69%
30%	179	1%	155	6%	130	12%	125	14%	90.8	23%	5.2	74%
40%	176	2%	144	7%	111	14%	106	16%	66.7	27%	1.1	78%
50%	173	2%	131	9%	93	17%	86	18%	46.3	31%	0.2	84%
60%	169	2%	117	11%	74	20%	68	22%	29.6	36%	0.02	92%
70%	164	3%	101	13%	56	25%	49	27%	16.7	44%	0	100%
80%	158	4%	83	18%	37	33%	32	36%	7.4	56%	0	-
90%	147	7%	59	29%	19	50%	15	53%	1.9	75%	0	-
99%	117	21%	19	68%	2	90%	1	92%	0.02	99%	0	-

The values in Table 7 show the steady-state PCE concentration in parts-per-billion (ppb) and the percentage of concentration reduction for each Γ value and source mass reduction value. This table illustrates how at low source mass reductions, higher Γ values lead to

increased concentration reduction per unit of source mass reduction. However, at higher source mass reduction, the lower the Γ value, the higher the concentration reduction per unit of source mass reduction. It is important to note, though, even small amounts of remediation lead to concentration reductions at downgradient receptors.

By using Figures 32-34 and Table 7 we can estimate how much source mass removal is required to achieve contaminant concentrations at a downgradient receptor that do not exceed MCLs. For instance, if the site conditions at the source dictate that $\Gamma=2.0$, approximately 85% of the mass in the source zone would need to be removed to reduce PCE concentrations downgradient to below the MCL. However, if this were accomplished, the corresponding TCE concentration would still be well above the MCL, while the VC concentration would be well below the MCL. In order to get all contaminant concentrations below their respective MCLs, approximately 90% mass removal at the source would need to be accomplished in this scenario. Depending on the feasibility of removing 90% of the source mass, this may lead to the decision that another strategy (e.g. containment, engineered plume remediation, etc.) is necessary for this site. Of course, this is all highly dependent on the Γ -value. Table 8 shows the approximate source mass reductions needed to attain the MCLs for the different contaminants based on Figures 32-34:

Table 8. Percent Mass Reduction Necessary to Achieve Remediation Goals

	$\Gamma=0.1$	$\Gamma=0.5$	$\Gamma=1.0$	$\Gamma=1.1$	$\Gamma=2.0$	$\Gamma=10.0$
PCE	100%	100%	98%	98%	85%	30%
TCE	100%	100%	100%	99%	90%	35%
VC	100%	93%	74%	71%	49%	12%

As Table 8 shows, for the parameters at the Dover AFB site, the source mass reduction necessary to accomplish the remediation goals for VC is typically much less than what is needed to achieve PCE goals and PCE goals are more easily attained than TCE goals.

4.5 Sensitivity Analysis

The results of the sensitivity analysis described in Section 3.4 are presented in

Table 9:

Table 9. Sensitivity Analysis Results

Γ -value		<u>Model Output</u>			<u>Percentage of Baseline</u>			<u>Relative Sensitivity</u>		
		PCE Conc (mg/L)	TCE Conc (mg/L)	VC Conc (mg/L)	PCE Conc (mg/L)	TCE Conc (mg/L)	VC Conc (mg/L)	PCE Conc (mg/L)	TCE Conc (mg/L)	VC Conc (mg/L)
1.1	baseline	6.76E-02	1.68E-01	2.76E-03	-	-	-			
0.1		1.69E-01	4.20E-01	6.89E-03	250%	250%	250%	0.278	0.278	0.278
10		1.54E-05	3.83E-05	6.27E-07	0%	0%	0%			
% Reduction										
60%	baseline	6.76E-02	1.68E-01	2.76E-03	-	-	-			
0%		1.85E-01	4.60E-01	7.55E-03	274%	274%	274%	1.650	1.650	1.650
99%		1.17E-03	2.91E-03	4.78E-05	2%	2%	2%			

As indicated in Section 3.4, these results are based on the concentrations attained at a point 800 meters downgradient of the source zone along the estimated plume centerline. All concentrations are the steady-state values. The time duration for the model is 60 years. Table 9 indicates that the percentage of mass reduction in the source zone (% Reduction) has a more significant influence on the model output, contaminant

concentration, than the Γ -value used. It should be noted that the range of input values used does not significantly affect the relative sensitivity of the parameters, so even if using a range of Γ values of 0.5-2.0, which may be more reasonable, the overall results are the same. These results offer some consolation since the Γ -value at a site is a characteristic of the site and therefore cannot be varied, but the percentage of source mass reduction can be changed based on the source remediation technology selected for the site.

V. Conclusions

5.1 Summary

In this thesis, research was accomplished to better elucidate how a reduction in the mass of a groundwater contamination source zone results in reduction in contaminant concentration at the source, which subsequently results in reduction in contaminant flux leaving the source, and ultimately, leads to a reduction in concentration at downgradient receptors. A power function (Zhu and Sykes, 2004) was used to describe the relationship between source mass reduction and reduction of contaminant concentration in the source zone. The Advection-Dispersion Equation (ADE), with first-order decay, was used to quantify the effect of the important natural attenuation processes that act upon dissolved chlorinated solvent contaminants. Finally, the power function and ADE were coupled within the computer program RT3D to simulate the effect of source zone mass removals upon receptor concentrations. The model was calibrated using the Dover AFB site conditions (Clement et al., 2000) and then used to quantify how source mass removals and downgradient concentrations were related at a real site. A sensitivity analysis was also accomplished to determine which parameters most significantly influence model results.

5.2 Conclusions

1. Based upon a review of the literature, we found that a power function (Zhu and Sykes, 2004) can be used to describe the relationship between source mass reduction and reduction of contaminant concentration in the source zone. This relationship is

dependent on the initial mass (M_0), initial concentration (βC_s), and the power function parameter (Γ). When multiplied by the Darcy velocity, this power function can be used to show the relationship between mass reduction and contaminant flux reduction. At low mass removal percentages, higher Γ values have larger relative benefits for source mass reduction (i.e. a higher Γ -value results in more flux reduction per source mass reduction). At high mass removal percentages, this reverses and sites with lower Γ values will have larger relative benefits per source unit of source mass reduction. The power function demonstrates that the benefits of source remediation are dependent upon both the site conditions and mass removal.

2. This study has shown how the ADE, with first-order decay, can be used to quantify the effect of the important natural attenuation processes that act upon dissolved chlorinated solvent contaminants. The ADE, with first-order decay, model was used to show how NA affects the contaminant concentration as it travels downgradient. This model was used to show that NA alone can significantly reduce contaminant concentrations. In one example (see Section 4.4) the contamination was reduced by 90% by the time it reached a receptor 800 meters downgradient. This same example, however, also found that the concentration at this downgradient receptor was still nearly 1000 times the maximum contaminant level (MCL) for the contaminant. These results show that, while NA may be helpful in reducing contaminant concentrations, source zone remediation may also be necessary to protect human health at downgradient receptors.

3. We have shown how a model combining the power function model to simulate source remediation and the ADE to simulate dissolved CAH fate and transport can be used to quantify the effect of source mass removal on concentrations at downgradient receptors. The model provided insights into the potential benefits of source remediation at a real site. In particular, we saw that for high values of Γ , relatively small reductions in source mass could lead to concentration reductions at receptors that met remediation goals.

4. In the sensitivity analysis, we have quantified the impact of source remedial technology (the extent of source zone mass removal) and site conditions (the Γ -value) on the contaminant concentration reaching a downgradient receptor. The sensitivity analysis for this model indicated that the extent of source mass removal has a greater impact on simulated concentrations than the Γ -value. This is encouraging, as the extent of source mass removal can be engineered, while the value of Γ is a function of site conditions.

5.3 Recommendations for Further Research

1. Develop a method for using the characteristics at a source zone to determine the Γ -value.
2. Consider the benefits of replacing the first-order model for dissolved CAH transport with a model that incorporates more of the actual biochemical processes. The first-order model is a simple and useful model, but utilizing a more complex model that accounts for degradation process details (such as the dependence of rate on both donor and acceptor concentrations) may lead to a better representation of degradation

processes in the plume, which may ultimately give us a better quantification of the benefits of source zone remediation.

3. Accomplish a lab or meso-scale study to validate the model with experimental data. Such a study would lend additional credibility to the model developed in this study.

Bibliography

- Aiken, B.S., Lapat-Polasko, L. "Estimating Chlorinated Ethene Bioattenuation Rates From a Single Well," *Chlorinated Solvent and DNAPL Remediation*. 109-118. Washington, D.C.: Oxford University Press, 2002.
- Air Force Center for Environmental Excellence (AFCEE). "Technologies: Source Zones," 5 Mar 2006 <http://www.afcee.brooks.af.mil/products/techtrans/NAPLSourceZoneTreatment/NAPLOverview.asp>.
- American Conference of Government Industrial Hygienists (ACGIH). 2003 TLVs and BEIs. ACGIH Worldwide, Ohio, 2003.
- Annable, M.D., C.G. Enfield, R.W. Falta, M.N. Goltz, J.W. Jawitz, P.S.C. Rao, and A.L. Wood, Impacts of DNAPL source treatment on contaminant mass flux, Partners in Environmental Technology Technical Symposium and Workshop, Washington DC, 29 November – 1 December 2005.
- Anderson, M. P., Woessner, W. W. Applied Groundwater Modeling. Academic Press: San Diego. 1992.
- Barry, D.A., Prommer, H., Miller, C.T., Engesgaard, P., Brun, A., Zheng, C. Modelling the fate of oxidisable organic contaminants in groundwater, *Advances in Water Resources*, Vol. 25, 945-983, 2002.
- Benjamin, M.M. Water Chemistry. McGraw Hill: Boston. 2002.
- Bleckman, C.A., Class handout, ENVR 772, Remediation Design and Management. Graduate School of Engineering and Management, Air Force Institute of Technology, Wright-Patterson AFB OH, October 2005.
- Bradford, S.A., Rathfelder, K.M., Lang, J., Abriola, L.M. Entrapment and dissolution of DNAPLs in heterogeneous porous media. *Journal of Contaminant Hydrology*, Vol. 67, 133-157, 2003.
- Chappelle, F.H., Wrobley, D.A., Woodward, J.C., Lovley, D.R. Practical Considerations for Measuring Hydrogen Concentrations in Groundwater. *Environmental Science and Technology*, Vol 31, No. 10. 2873-2877, 1997.
- Christ, J.A., Ramsburg, C.A., Abriola, L.M., Pennell, K.D., Loffler, F.E. Coupling aggressive mass removal with microbial reductive dechlorination for remediation of DNAPL source zones: A review and assessment. *Environmental Health Perspectives*, Vol. 113(4), 465-477, 2005a.

- Christ, J.A. A Numerical Investigation of Metabolic Reductive Dechlorination in DNAPL Source Zones. Ph.D. Dissertation. The University of Michigan, 2005b.
- Chu, M., Kitanidis, P.K., McCarty, P.L., Possible factors controlling the effectiveness of bioenhanced dissolution of non-aqueous phase tetrachloroethene, *Advances in Water Resources*, Vol. 27, 601-615, 2004.
- Chu, M., Kitanidis, P.K., McCarty, P.L., Modeling microbial reactions in the plume fringe subject to transverse mixing in porous media: When can the rates of microbial reaction be assumed to be instantaneous?, *Water Resources Research*, Vol. 41, W06002, 1-15, 2005.
- Clapp, L. W., Semment, M. J., Novak, P. J., and Hozalski, R. M. Model for In Situ Perchloroethene Dechlorination via Membrane-Delivered Hydrogen. *Journal of Environmental Engineering*, Vol. 130, No. 11. 1367-1381, 2004.
- Clark, M. M. Transport Modeling for Environmental Engineers and Scientists. John Wiley & Sons, Inc, New York, 1996.
- Clement, T. P., Johnson, C. D., Sun, Y., Klecka, G. M., Bartlett, C. Natural attenuation of chlorinated ethene compounds: model development and field-scale application at the Dover site. *Journal of Contaminant Hydrology*, Vol. 42, 113-140, 2000.
- Clement, T. P. RT3D - A Modular Computer Code for Simulating Reactive Multi-species Transport in 3-Dimensional Groundwater Systems. PNNL-SA-11720. Richland, Washington: Pacific Northwest National Laboratory, 1997.
- Cohen, R.M., Mercer, J.W. DNAPL Site Evaluation. CRC Press, Inc., Florida, 1993.
- Davis, J.W., Odom, J.M., DeWeerd, K.A., Stahl, D.A., Fishbain, S.S., West, R.J., Klecka, G.M., Decarolis, G.M. Natural attenuation of chlorinated solvents at Area 6, Dover Air Force Base: characterization of microbial community structure. *Journal of Contaminant Hydrology* Vol. 57, 41-59, 2002.
- Domenico, P. A., Schwartz, F. W. Physical and Chemical Hydrogeology. Wiley and Sons, New York, 1998.
- Droste, R.L. Theory and Practice of Water and Wastewater Treatment. Wiley and Sons, Hoboken, NJ, 1997.
- Einarson, M.D., Mackay, D.M. Predicting impacts of groundwater contamination. *Environmental Science and Technology*, Vol. 35, No. 3, 66A – 77A, 2001.
- Falta, R. W., Rao, P. S., Basu, N. Assessing the impacts of partial mass depletion in DNAPL sources zones I. Analytical modeling of source strength functions and plume response. *Journal of Contaminant Hydrology*, Vol. 78, 259-280, 2005a.

- Falta, R. W., Basu, N., Rao, P. S. Assessing the impacts of partial mass depletion in DNAPL sources zones II. Coupling source strength functions to plume evolution. *Journal of Contaminant Hydrology*, Vol. 79, 45-66, 2005b.
- Fennell, D. E., Gossett, J. M. Modeling the Production of and Competition for Hydrogen in a Dechlorinating Culture. *Environmental Science and Technology*, Vol 32, No. 16. 2450-2460, 1998.
- Henry, S.M., Hardcastle, C.M., Warner, S.D. "Chlorinated Solvent and DNAPL Remediation: An Overview of Physical, Chemical, and Biological Processes," *Chlorinated Solvent and DNAPL Remediation*. 1-20. Washington, D.C.: Oxford University Press, 2002.
- Imhoff, P.T., Arthur, M.H., Miller, C.T. An experimental study of complete dissolution of a nonaqueous phase liquid in saturated porous media. *Water Resources Research*, Vol. 30(2), 307-320, 1994.
- Jackson, R.E. "The Evolution of DNAPL Remediation Practice," *Chlorinated Solvent and DNAPL Remediation*. 21-35. Washington, D.C.: Oxford University Press, 2002.
- Jawitz, J.W., Fure, A.D., Demmy, G.G., Berglund, S., Rao, P.S.C. Groundwater contaminant flux reduction resulting from nonaqueous phase liquid mass reduction. *Water Resources Research*, Vol. 41, W10408, 1-15, 2005.
- Kremer, Fran. "Appropriate Opportunities for Application of Natural Attenuation in the Civilian Sector," 120-123. *Proceedings of the Symposium on Natural Attenuation of Chlorinated Organics in Ground Water*. Washington, DC: Office of Research and Development, 1997.
- Lee, I., Bae, J., Yang, Y., McCarty, P. Simulated and experimental evaluation of factors affecting the rate and extent of reductive dehalogenation of chloroethenes with glucose, *Journal of Contaminant Hydrology*, Vol. 74, 313-331, 2004.
- Lehr, J., Hyman, M., Gass, T.E., SeEVERS, W.J., Handbook of Complex Environmental Remediation Problems. McGraw-Hill, New York, 2002.
- Lovley, D.R., Chapelle, F.H., Woodward, J.C. Use of Dissolved H₂ Concentrations To Determine Distribution of Microbially Catalyzed Redox Reactions in Anoxic Groundwater, *Environmental Science and Technology*, Vol. 28(7), 1205-1210, 1994.
- Masters, G.M. Introduction to Environmental Engineering and Science. Prentice Hall, New Jersey, 1998.

- Miller, C.T., Poirer-McNeill, M.M., Mayer, A.S. Dissolution of trapped nonaqueous phase liquids: Mass transfer characteristics. *Water Resources Research*, Vol. 26(11), 2783-2796, 1990.
- Mulligan, C.N., Yong, R.N. Natural attenuation of contaminated soils. *Environment International*, Vol. 30, 587-601, 2004.
- Nambi, I.M., Powers, S.E. Mass transfer correlations for nonaqueous phase liquid dissolution from regions with high initial saturations. *Water Resources Research*, Vol. 39(2), SBH 4-1 – SBH 4-11, 2003.
- National Research Council, (NRC). Natural Attenuation for Groundwater Remediation. National Academy Press, Washington, D.C., 2000.
- NRC. Ground Water & Soil Cleanup. National Academy Press, Washington, D.C., 1999.
- NRC. Alternatives for Ground Water Cleanup. National Academy Press, Washington, D.C., 1994.
- Parker, J. C., Park, E. Modeling field-scale dense nonaqueous phase liquid dissolution kinetics in heterogeneous aquifers. *Water Resources Research*, Vol. 40, W05109, 1-12, 2004.
- Petrunic, B.M., MacQuarrie, K.T.B., Al, T.A. Reductive dissolution of Mn oxides in river-recharged aquifers: a laboratory column study. *Journal of Hydrology*, Vol. 301, 163-181, 2005.
- Schirmer, M., Butler, B.J. Transport behaviour and natural attenuation of organic contaminants at spill sites. *Toxicology*, Vol. 205, 173-179, 2004.
- Scow, K.M., Hicks, K.A. Natural attenuation and enhanced bioremediation of organic contaminants in ground water. *Current Opinion in Biotechnology*, Vol. 16, 1-8, 2005.
- Sellers, K. Fundamentals of Hazardous Waste Site Remediation. CRC Press LLC, Boca Raton, Florida, 1999.
- Soga, K., Page, J.W.E., Illangasekare, T.H. A review of NAPL source zone remediation efficiency and the mass flux approach. *Journal of Hazardous Materials*, Vol. 110, 13-27, 2004.
- Sorenson, Jr., K.S. "Enhanced Bioremediation for Treatment of Chlorinated Solvent Residual Source Areas," *Chlorinated Solvent and DNAPL Remediation*. 119-131. Washington, D.C.: Oxford University Press, 2002.

- Stiber, N.A., Pantazidou, M., Small, M. J. Expert System Methodology for Evaluating Reductive Dechlorination at TCE Sites. *Environmental Science and Technology*, Vol. 33(17). 3012-3020, 1999.
- Suarez, M.P., Rifai, H.S. Biodegradation Rates for Fuel Hydrocarbons and Chlorinated Solvents in Groundwater. *Bioremediation Journal*, Vol. 3(4), 337-362, 1999.
- Suthersan, S.S. Natural and Enhanced Remediation Systems. CRC Press LLC, Boca Raton, FL, 2002.
- United States Department of Energy (DOE). "Natural and Passive Remediation of Chlorinated Solvents: Critical Evaluation of Science and Technology Targets," WSRC-TR-2003-00328, 2004.
- United States Environmental Protection Agency (U.S. EPA). "The DNAPL Remediation Challenge: Is There a Case for Source Depletion," EPA/600/R-03/143, 2003.
- U.S. EPA. "Calculation and Use of First-Order Rate Constants for Monitored Natural Attenuation Studies," EPA/540/S-02/500, 2002a.
- U.S. EPA. "List of Contaminants & Their MCLs." EPA 816-F-02-013, 2002b.
- U.S. EPA. "Use of Bioremediation at Superfund Sites," Office of Solid Waste and Emergency Response Directive 542-R-01-019, 2001.
- U.S. EPA. "Engineered Approaches to *In Situ* Bioremediation of Chlorinated Solvents: Fundamentals and Field Applications." EPA 542-R-00-008, July, 2000.
- U.S. EPA. "Use of Monitored Natural Attenuation at Superfund, RCRA Corrective Action, and Underground Storage Tank Sites." Directive 9200.4-17P, April, 1999.
- U.S. EPA. "Technical Protocol for Evaluating Natural Attenuation of Chlorinated Solvents in Ground Water." EPA/600/R-98/128, September, 1998.
- U.S. EPA. "A Manual of Instructional Problems for the U.S.G.S. MODFLOW Model." EPA/600/R-93/010, February, 1993.
- United States Geological Survey (USGS). "MODFLOW-2000, The U.S. Geological Survey Modular Ground-Water Model - User Guide To Modularization Concepts and the Ground-Water Flow Process." Open-File Report 00-92, 2000a.
- USGS. "Hydrogeology and Simulation of Ground-Water Flow at Dover Air Force Base, Delaware." Water-Resources Investigations Report 99-4224, 2000b.

- Weber, W.J., DiGiano, F.A., Process Dynamics in Environmental Systems. Wiley Interscience, New York 1996.
- Wiedemeier, T.H., Rifai, H.S., Newell, C.J., Wilson, J.T. Natural Attenuation of Fuels and Chlorinated Solvents in the Subsurface. John Wiley & Sons, Inc., New York, 1999.
- Witt, M.E., Klecka, G.M., Lutz, E.J., Ei, T.A., Grosso, N.R., Chapelle, F.H. Natural attenuation of chlorinated solvents at Area 6, Dover Air Force Base: groundwater biogeochemistry. *Journal of Contaminant Hydrology* Vol. 57, 61-80, 2002.
- Wood, R.C. Modeling Application of Hydrogen Release Compound to Effect *In Situ* Bioremediation of Chlorinated Solvent-Contaminated Groundwater. United States Air Force, Wright-Patterson Air Force Base, Ohio, 2005.
- Yang, Y., McCarty, P.L. Competition for hydrogen within a chlorinated solvent dehalogenating anaerobic mixed culture. *Environmental Science and Technology*, Vol. 32 (22), 3591 – 3597, 1998.
- Zhu, J., Sykes, J.F. Simple screening models of NAPL dissolution in the subsurface. *Journal of Contaminant Hydrology*, Vol. 72, 245-258, 2004.
- Zhu, J., Sykes, J.F. The influence of NAPL dissolution characteristics on field-scale contaminant transport in subsurface. *Journal of Contaminant Hydrology*, Vol. 41, 133-154, 2000.

Vita

Captain David E. Wagner graduated from Liberty High School in Bethlehem, Pennsylvania. He entered undergraduate studies at Bucknell University in Lewisburg, Pennsylvania where he graduated with a Bachelor of Science degree in Civil Engineering in May 2000. He was commissioned to be a bioenvironmental engineer in the Air Force through direct accession in November 2000.

His first assignment was at Edwards AFB as a bioenvironmental engineer in March 2001. In August 2004, he entered the Graduate School of Engineering and Management, Air Force Institute of Technology. Upon graduation, he will be assigned to the Air Force Institute of Operational Health at Brook City-Base, Texas.

REPORT DOCUMENTATION PAGE

Form Approved
OMB No. 074-0188

The public reporting burden for this collection of information is estimated to average 1 hour per response, including the time for reviewing instructions, searching existing data sources, gathering and maintaining the data needed, and completing and reviewing the collection of information. Send comments regarding this burden estimate or any other aspect of the collection of information, including suggestions for reducing this burden to Department of Defense, Washington Headquarters Services, Directorate for Information Operations and Reports (0704-0188), 1215 Jefferson Davis Highway, Suite 1204, Arlington, VA 22202-4302. Respondents should be aware that notwithstanding any other provision of law, no person shall be subject to a penalty for failing to comply with a collection of information if it does not display a currently valid OMB control number.

PLEASE DO NOT RETURN YOUR FORM TO THE ABOVE ADDRESS.

1. REPORT DATE (DD-MM-YYYY) 23-03-2006		2. REPORT TYPE Master's Thesis		3. DATES COVERED (From - To) Apr 2005-Mar 2006		
4. TITLE AND SUBTITLE Modeling Study to Quantify the Benefits of Groundwater Contaminant Source Remediation				5a. CONTRACT NUMBER		
				5b. GRANT NUMBER		
				5c. PROGRAM ELEMENT NUMBER		
6. AUTHOR(S) Wagner, David E., Captain				5d. PROJECT NUMBER		
				5e. TASK NUMBER		
				5f. WORK UNIT NUMBER		
7. PERFORMING ORGANIZATION NAMES(S) AND ADDRESS(S) AFIT/ENV 2950 Hobson Way WPAFB OH 45433-7765				8. PERFORMING ORGANIZATION REPORT NUMBER AFIT/GES/ENV/06M-07		
9. SPONSORING/MONITORING AGENCY NAME(S) AND ADDRESS(ES) Smith, Mark L. Lt Col AFCEE Air Force Center for Environmental Excellence 3300 Sidney Brooks Brooks City-Base TX, 78235 Phone: (210)536-5626				10. SPONSOR/MONITOR'S ACRONYM(S)		
12. DISTRIBUTION/AVAILABILITY STATEMENT APPROVED FOR PUBLIC RELEASE; DISTRIBUTION UNLIMITED.				11. SPONSOR/MONITOR'S REPORT NUMBER(S)		
13. SUPPLEMENTARY NOTES						
14. ABSTRACT The purpose of this research was to quantify the benefits of groundwater contaminant source remediation by using a model to simulate how reduction of source mass was related to reduction of contaminant concentration at a receptor. This thesis sought to answer three research questions: (1) how are contaminant source mass reduction and reduction of mass flux leaving the source-zone related; (2) how can we quantify the effect of the important natural attenuation processes that act upon the dissolved contaminant as it travels from the source zone to downgradient receptors, and (3) under specified site conditions, what is the maximum contaminant flux leaving a source-zone that natural attenuation can effectively degrade to achieve a concentration goal at a receptor. These questions were answered through a comprehensive literature review and the use of Groundwater Modeling Software (GMS 5.1) to model an actual tetrachloroethene (PCE) contaminated site at Dover AFB, Delaware. Using actual conditions at the site, a power function was applied to determine the relationship between source mass reduction and contaminant flux reduction, while the advection-dispersion equation, with biodegradation source/sink terms to model PCE decay coupled to daughter product production, was utilized to model the effects of natural attenuation on dissolved chlorinated ethene fate and transport. The culmination of this study was the development of a model which coupled the power function with a dissolved contaminant fate and transport model to provide a tool which estimates the amount of source mass removal necessary to achieve a concentration goal at a receptor.						
15. SUBJECT TERMS Groundwater, DNAPL, CAH, Source Zone Remediation, Natural Attenuation						
16. SECURITY CLASSIFICATION OF:			17. LIMITATION OF ABSTRACT UU	18. NUMBER OF PAGES 114	19a. NAME OF RESPONSIBLE PERSON Mark N. Goltz, AFIT/GES	
REPORT U	ABSTRACT U	c. THIS PAGE U			19b. TELEPHONE NUMBER (Include area code) (937) 785-3636 x4638; e-mail: mark.goltz@afit.edu	