

REPORT DOCUMENTATION PAGE

Public reporting burden for this collection of information is estimated to average 1 hour per response, including the time for reviewing instructions, data needed, and completing and reviewing this collection of information. Send comments regarding this burden estimate or any other aspect of this burden to Department of Defense, Washington Headquarters Services, Directorate for Information Operations and Reports (0704-0188), 1215 Jefferson Davis Highway, Suite 1204, Arlington, VA 22202-4302. Respondents should be aware that notwithstanding any other provision of law, no person shall be subject to any penalty for failing to comply with a collection of information if it does not display a currently valid OMB control number. **PLEASE DO NOT RETURN YOUR FORM TO THE ABOVE ADDRESS.**

1. REPORT DATE (DD-MM-YYYY) 12-31-2005		2. REPORT TYPE Annual		3. DATES COVERED (From - To) 05-01-2004 - 09-30-2005	
4. TITLE AND SUBTITLE DURIP: Integrated Sensing and Computation for Passive Covert Radar, Signals Intelligence, and Other Applications Driven by Moore's Law				5a. CONTRACT NUMBER	
				5b. GRANT NUMBER FA9950-04-1-0318	
				5c. PROGRAM ELEMENT NUMBER	
6. AUTHOR(S) Aaron Lanterman				5d. PROJECT NUMBER	
				5e. TASK NUMBER	
				5f. WORK UNIT NUMBER	
7. PERFORMING ORGANIZATION NAME(S) AND ADDRESS(ES) Georgia Tech Research Corp. Georgia Institute of Technology 505 Tenth Street, NW Atlanta, GA 30332-0420				8. PERFORMING ORGANIZATION REPORT NUMBER 1	
9. SPONSORING / MONITORING AGENCY NAME(S) AND ADDRESS(ES) Air Force Office of Scientific Research Dr. Jon Sjogren AFOSR/NM Room 713 801 North Randolph Street Arlington, VA 22203-1977				10. SPONSOR/MONITOR'S ACRONYM(S) AFOSR	
				11. SPONSOR/MONITOR'S REPORT NUMBER(S) 1	
12. DISTRIBUTION / AVAILABILITY STATEMENT N/A <i>Approved for public release, distribution unlimited</i>					
13. SUPPLEMENTARY NOTES N/A					
14. ABSTRACT Passive radar systems employing "illuminators of opportunity" such as commercial television and FM radio signals instead of dedicated radar transmitters have been the subject of increasing interest over the past decade. Under the subject contract funds, components for a flexible passive radar testbed were purchased that allow the exploration of many different passive radar architectures over a wide range of frequencies, from the lower VHF TV band (around 50 MHz) to the lower cell phone band (almost to 1 GHz). Particular emphasis is placed on multiple-antenna passive radar systems employing beamforming, i.e. not just two-antenna interferometry, since beamforming passive radar systems have not been previously explored in academic settings. Extensive technical detail on the components is given, so that this report may also serve as a "user's manual" for the system.					
15. SUBJECT TERMS					
16. SECURITY CLASSIFICATION OF:			17. LIMITATION OF ABSTRACT None	18. NUMBER OF PAGES 18	19a. NAME OF RESPONSIBLE PERSON Aaron Lanterman
a. REPORT Unclassified	b. ABSTRACT Unclassified	c. THIS PAGE Unclassified			19b. TELEPHONE NUMBER (include area code) 404-385-2548

DURIP: Integrated Sensing and Computation for Passive Covert Radar, Signals Intelligence, and Other Applications Driven by Moore's Law
AFOSR grant FA9550-04-1-0318

Final Report

Principal Investigator: Aaron D. Lanterman; Co-PI: David V. Anderson

School of Electrical and Computer Engineering
Georgia Institute of Technology

MC 0250

Atlanta, GA 30332

(404)-385-2548; lanterma@ece.gatech.edu

Abstract

Passive radar systems employing "illuminators of opportunity" such as commercial television and FM radio signals instead of dedicated radar transmitters have been the subject of increasing interest over the past decade. Under the subject contract funds, components for a flexible passive radar testbed were purchased that allow the exploration of many different passive radar architectures over a wide range of frequencies, from the lower VHF TV band (around 50 MHz) to the lower cell phone band (almost to 1 GHz). Particular emphasis is placed on multiple-antenna passive radar systems employing beamforming, i.e. not just two-antenna interferometry, since beamforming passive radar systems have not been previously explored in academic settings. Extensive technical detail on the components is given, so that this report may also serve as a "user's manual" for the system.

1. Background

Radar systems that "hitchhike" off of existing communication signals offer clandestine operation. The cost dynamics of such systems are also attractive since the cost of the transmitter is replaced by the cost of the computational power needed to make sense of the reflected signals. Due to this vastly lower cost, many countries that formerly could not afford an extensive air defense system are now finding radar within their reach. Here at home, such inexpensive radars offer the possibility of filling surprisingly large gaps in radar coverage. Passive radar was recently the subject of a special issue of the IEE Proc. on Radar, Sonar, and Navigation (June 2005, Vol. 152, Issue 3), guest edited by Dr. Paul Howland of NATO NC3A; this special issue may be consulted for further background information.

Passive radar a quintessential example of an application that is primarily driven by Moore's law. In the past, advances in radar capability rested mostly on the development of better hardware, whereas now, great strides are more readily made with smarter signal processing. Another example is real-time Signals Intelligence (SIGINT) with spatial and frequency diversity, where beamforming arrays are used to extract communications or instrumentation signals of interest from an increasingly cluttered background, and there is a need to exploit signals over a wide spectrum.

20060405003

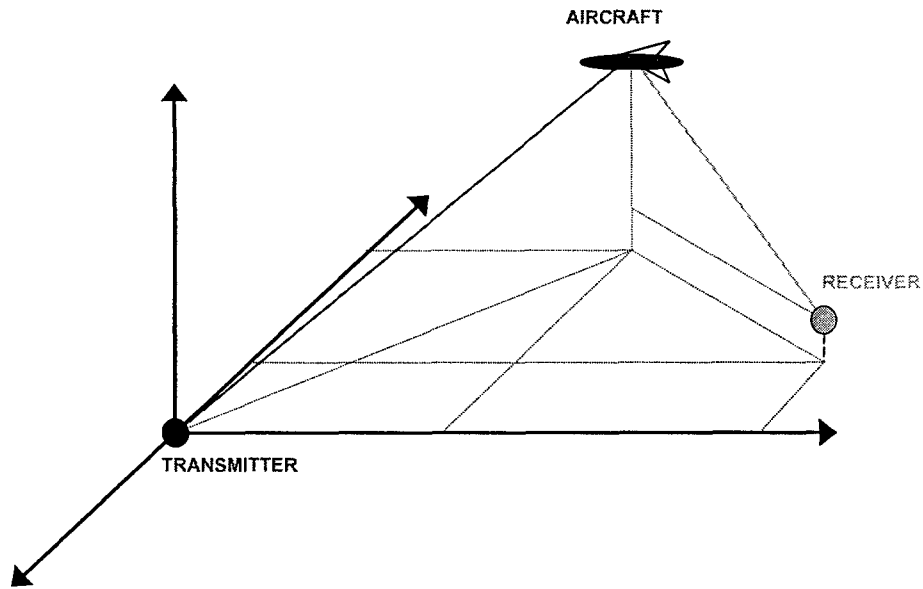

Passive radars are fundamentally bistatic (or multistatic), in nature, as illustrated above. The low frequencies used in passive radar make it difficult to accurately locate targets in angle, although reasonable time delay (range) and excellent Doppler (range rate) information is available. To easily locate targets, multiple transmitters must be exploited, as illustrated below. Each transmitter/receiver pair locates the target along an ellipse (in 2-D tracking) or ellipsoid (in 3-D tracking, although problems with geometrical dilution of precision usually prevent passive radar systems from extracting good altitude information unless the target is at a particularly high altitude, such as in some ballistic missile tracking applications.) We see that if multiple targets are present, there may be difficulties with "ghost" targets.

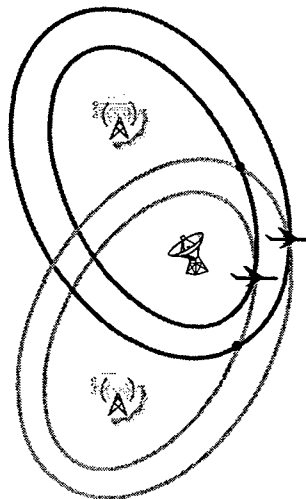

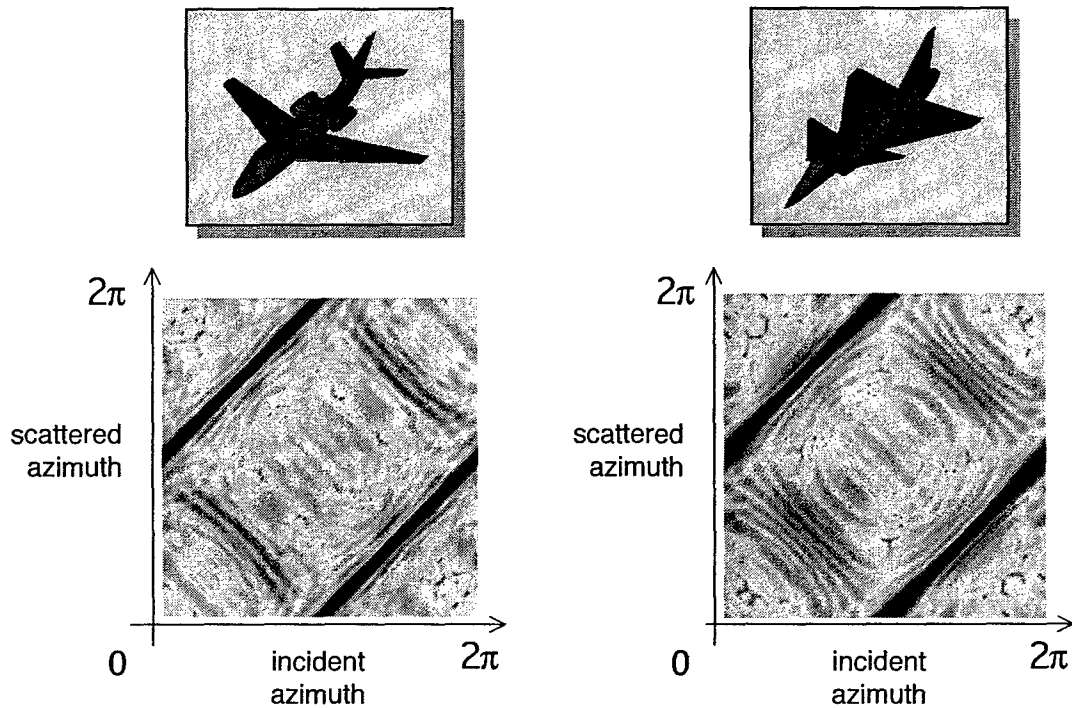

The low frequencies used in passive radar may prove useful in automatic target recognition. To ensure robust classification in the presence of noise and errors in estimates of position and orientation, it is helpful if the Radar Cross Section (RCS) of the targets vary “slowly” with small changes in these components of the state vector. The variation in RCS, as characterized by the number of nulls encountered as a target’s aspect changes, is proportional to the electrical length of the target. At FM-band frequencies (100 MHz), a fighter-sized aircraft is approximately five wavelengths long. In contrast, at the X-band frequencies used by many active radars (10 GHz), the same aircraft would be 500 wavelengths long.

One approach to target identification that we have been exploring for many years is to compare the collected data to target libraries synthesized using electromagnetic codes. For example, the above figure shows an example of the RCS (Radar Cross Section) seen by a hypothetical transmitter-receiver pair at 100 MHz for a particular flight path, for three different targets. The RCS was computed using the method of moments code FISC (Fast Illinois Solver Code). The CAD models input to FISC were purchased from Viewpoint Digital.

2. Testbed Overview

2.1. Design Philosophy

The goal in choosing equipment under this DURIP project was not to eventually create a prototype of any one particular system, but to have a flexible set of building blocks that may be rearranged to explore many different kinds of systems. The tools must be able to keep graduate students busy for many years to come.

Funds from the Demetrius T. Paris Junior Professorship were used to supplement the funding provided by the DURIP.

2.2. Testbed Location

Atlanta, and Georgia Tech in particular, is an ideal location for performing passive radar studies. Many powerful transmitters are located just east of Georgia Test. America's busiest airport, Hartsfield, lies to the south; Dobbins Air Force Base lies to the northwest; and Peachtree-DeKalb Airport, which hosts small private aircraft, lies to the north.

The equipment has been placed on the 5th floor of the Van Leer building on the main Georgia Tech campus. The Van Leer building is the headquarters of the School of Electrical and Computer Engineering. The 5th floor is particularly convenient since one can walk out a door right onto the roof without having to deal with ladders and hatches. All sorts of equipment is already on the roof (antennas, satellite dishes, solar panels, etc.), so there is no problem with putting up more antennas. (Unfortunately, the owners of the Centergy building in Tech Square, which now houses the Center for Signal and Image Processing that the principle investigator has his main office, will not let us put any research equipment on their roof.) The 5th floor of Van Leer is also the home of Profs. Greg Durgin and Paul Steffes and their graduate students; they are a useful resource.

In making equipment and system design choices, a significant amount of advice was provided by Prof. John Sahr of the Univ. of Washington, and his former student Dr. Frank Lind, who is now with the MIT Haystack Observatory. Some of the equipment was chosen to be analogous with that purchased by Dr. Lind under another DURIP, funded by ONR. Prof. Paul Steffes and Greg Durgin of the School of Electrical Computer Engineering at Georgia Tech, and Prof. Steffes' student (now Dr.) Allen Petrin, also deserve thanks for their advice.

2.3. Data Collection Techniques

For signals below 300 MHz, we use a “direct digital” downconversion technique in which aliasing effects are deliberately exploited to facilitate the downconversion process withing an explicit analog mixing stage. As an illustration, consider the Fourier spectrum of the FM radio band, with a typical spectrum indicated via triangles:

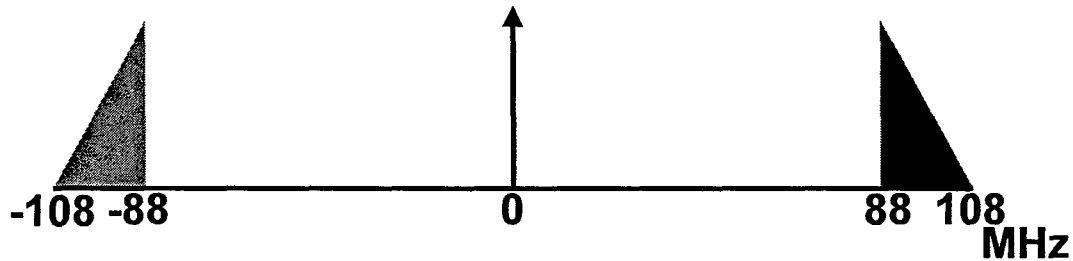

If we sample this signal at 72 Msamples/second, aliases of the shown triangles will appear at integer multiples of 72 MHz:

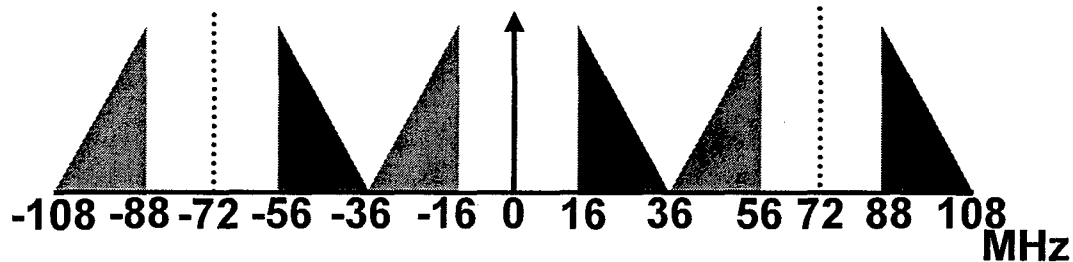

Notice that the copies of the signal are uncorrupted, i.e., there are no overlapping triangles. (However, we had to pick the sample rate carefully. Notice that if we tried to sample the lower VHF TV band, 54-88 MHz at 72 Msamples/second, there would be some overlap between the aliases and hence the signal would not be recoverable.)

We are then free to focus on just the region between the Fourier frequencies of -36 MHz to 36 MHz (i.e., half the sample rate). Once digitized, we can consider the signal in terms of normalized “digital” frequencies common in the Digital Signal Processing Literature, where the analog frequencies are divided by the sample rate:

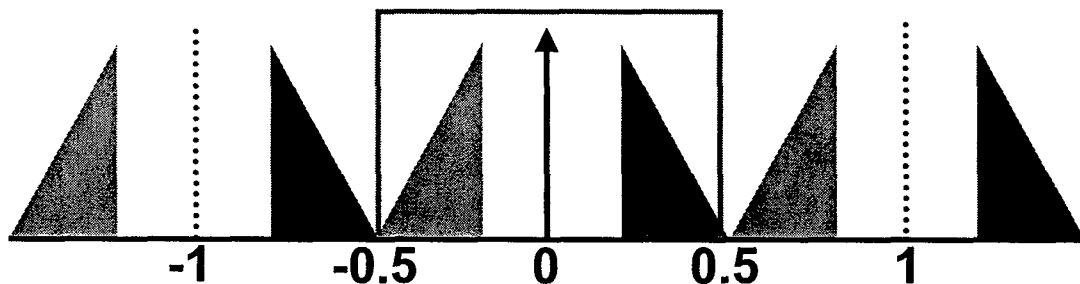

The final conversion to a complex baseband may be done in the digital domain:

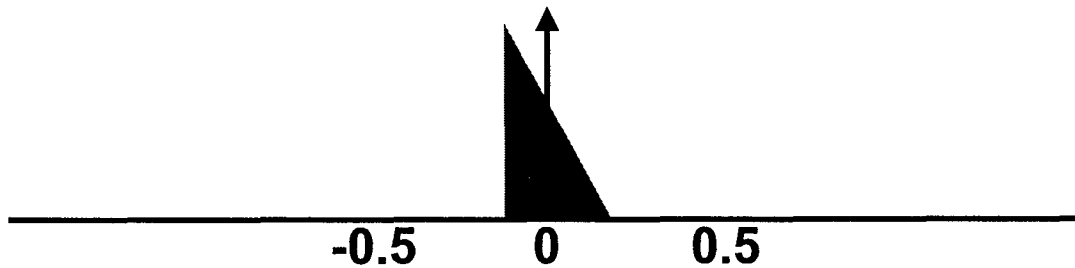

This direct digital conversion technique allows us to avoid the artifacts associated with an analog mixing stage. Unfortunately, we can not push the direct digital conversion technique too far; at signal frequencies above 300 MHz, jitter in the sample clock becomes exacerbated when aliased and becomes a dominant effect. Hence, we need to resort to an analog mixing stage for signal frequencies above 300 MHz. We take a two-stage approach, in which an analog mixer and image rejection filter is used to bring the signal down to an intermediate frequency below 300 MHz, and then the remaining downconversion is done using the aliasing-based direct digital conversion technique.

2.4. Exploitable Transmitters

In this subsection, EIRP stands for Effective Isotropic Radiated Power; it is in the horizontal plane and given in kilowatts. RCAGL stands for Radiation Center Above Ground Level, and is given in meters.

Some significant Analog TV transmitters in the Atlanta are listed in the table below.

Call	Ch.	EIRP	RCAGL	Latitude (N)	Longitude (W)
WSB	2	100	311	33° 45' 51"	84° 21' 42"
WAGA	5	100	335	33° 47' 51"	84° 20' 2"
WXIA	11	316	305	33° 45' 24"	84° 19' 55"
WPBA	30	1380	315	33° 45' 35"	84° 20' 7"
WATL	36	2690	352	33° 48' 27"	84° 20' 26"
WGCL	46	2340	349	33° 45' 27"	84° 20' 26"
WUPA	69	2630	291	33° 45' 34"	84° 23' 19"
WTBS	17	2240	326	33° 46' 57"	84° 23' 20"

Some significant FM radio transmitters in the Atlanta area are listed in the table below.

Call	Freq.	EIRP	RCAGL	Latitude (N)	Longitude (W)
WRAS	88.5	100	168	33° 41' 4"	84° 17' 23"
WRFG	89.3	100	46	33° 44' 56"	84° 24' 26"
WREK	91.1	40	78	33° 46' 41"	84° 24' 22"
WZGC	92.9	99	233	33° 45' 34"	84° 23' 19"
WSTR	94.1	100	292	33° 45' 35"	84° 20' 7"
WPCH	94.9	99	314	33° 48' 27"	84° 20' 27"
WKLS	96.1	99	315	33° 48' 27"	84° 20' 26"
WSB	98.5	100	292	33° 45' 33"	84° 20' 5"
WVEE	103.3	100	292	33° 45' 33"	84° 20' 5"

The final table in this section lists some digital TV stations in the Atlanta area.

Call	Ch.	EIRP	RCAGL	Latitude (N)	Longitude (W)
WXIA	10	16.5	288	33° 45' 24"	84° 19' 55"
WGCL	19	49	348	33° 48' 27"	84° 20' 26"
WSB	39	490	286	33° 45' 51"	84° 21' 42"

3. Equipment

3.1. Acknowledgments

In making equipment and system design choices, a significant amount of advice was provided by Prof. John Sahr of the Univ. of Washington, and his former student Dr. Frank Lind, who is now with the MIT Haystack Observatory. Some of the equipment was chosen to be analogous with that purchased by Dr. Lind under another DURIP, funded by ONR. Prof. Paul Steffes and Greg Durgin of the School of Electrical Computer Engineering at Georgia Tech, and Prof. Steffes' student (now Dr.) Allen Petrin, also deserve thanks for their advice.

3.2. Front End

Nine Diamond Antenna D130J discone antennas (purchased from RF parts), which are essentially omnidirectional in azimuth with a unity gain of approximately¹ 2 dbi, allow the exploration of beamforming techniques such as those used by Lockheed Martin's Silent Sentry 3 system, in which the same antenna array is used to receive both direct-path and reflected-path signals. They are 1.7 meters in length, with a maximum diameter of 0.41 meters, and weigh only 2.2 pounds. They are equipped with N connectors. Only six are needed for the six A/D inputs on the digital receiver cards; via the spectrum analyzer, the remainder allow for future expansion as well as taking general impressions of the entire RF region of interest without having to apply splitters (and hence associated

¹ Per e-mail from Wayne Bayman of Diamond Antenna dated 8/25/2004.

signal losses) to the six antennas feeding the digital receiver inputs. (Nine D130J discones \times \$82.95 each = \$746.55; \$746.55 + \$44.90 = \$791.45)

We will explore linear, circular, and cross array arrangements:

Linear 

Circular 

Cross 

For a linear array, the optimum antenna spacing is one-half of the exploited wavelength. The following table shows optimum spacings for several bands of interest, although smaller spacings can still be if needed due to space constraints.

Bands (MHz)	Center (MHz)	$\lambda/2$ (m)	Linear Array Width (m)
54-78	66	2.27	16.6
88-108	98	1.53	9.2
192-204	198	0.75	4.6
480-580	530	0.28	1.7
600-700	650	0.23	1.4
824-956	890	0.17	1

Two KMA4113 log periodic antennas allow exploration of systems such as Paul Howland's FM radio demonstration system at NATO and John Sahr's Manastash Ridge Radar, in which one directional antenna picks up the reflected path signal from the airplanes and a second antenna copies the direct path from the exploited transmitter(s). The 30-element aluminum and stainless steel antennas have a frequency coverage of 40.6 MHz to 1.3 GHz, with a free space antenna gain of 8 dBi, a front/back ratio of 26 dB, and a SWR of 1.8:1.0 or less. They have a boom length of 12', their longest element is 12' long, and they weigh 12 pounds. (Cost: 2 KMA4113 antennas \times \$350 each = \$700; 2

vertical mounting plates \times \$30 each = \$60; 2 ferrite baluns with N-connectors \times \$35 each = \$70; \$700+\$60+\$70+\$23 shipping = \$853.)

Nine Narda Microwave N53BK50100 lightning arrestors and nine Narda Microwave 562 DC blocks provide protection from wanted natural phenomena. Typically, only six of each will be needed, but additional spares are handy in case such natural phenomena decide to strike. The lightning arrestors operate up to 2 GHz with a maximum insertion loss of 0.2 dB, and a maximum VSWR of 1.06 in the 0-1 GHz band and 1.35 in the 1-2 GHz band. The 562 model DC blocks boast a frequency range of 0.01 to 12.4 GHz, with a maximum VSWR of 1.5 in the 10-20 MHz band and 1.3 in the 0.2-12.4 GHz band, and a maximum insertion loss of 0.5 db in the 0.01-11 GHz band and 1.0 dB in the 11-12.4 GHz band. Both the DC blocks and the lightning arrestors have N connectors. (Nine N53BK50100 arrestors \times \$67.38 = \$606.42; Nine N53ZB01090 gas capsules for the arrestors \times \$9 = \$81; Nine 562 DC blocks \times \$364 = \$3,276; \$606.42 + \$81 + \$3276 + \$5.12 shipping = \$3,968.65.)

Filters from Lorch Microwave and Microwave Filter Company with N connectors provide filtering at the antenna for six different bands of interest; these bands correspond to refinements of the bands associated with the number models of Angle Linear preamps described below. Since we have a six channels, this involves 36 different filters that may be swapped in and out of the system to explore different configurations.

The Lorch filters, with part numbers 8BP3-XX/YY-N, each have eight sections, with specifications given in the table below. (Six Lorch filters for each band \times \$380 each = \$2,280; Three bands \times \$2,280 = \$6,840; \$6,840 + \$10.80 shipping = \$6,850.80.)

	8BP3-530/100-N	8BP3-650/100-N	8BP3-890/132-N
3 db passband (spec.)	480-580 MHz	600-700 MHz	824-956 MHz
Ins. Loss (max spec.)	2.0 dB @ 530 MHz	2.0 dB @ 98 MHz	----
Min. rej. at low end	40 dB @ 430 MHz	40 dB @ 450 MHz	----
Min. rej. at high end	40 dB @ 630 MHz	40 dB @ 750 MHz	----

The specifications of the filters from Microwave Filter Company are given in the following table. (Six 15528 \times \$245 each = \$1,470; Six 15529 \times \$245 each = \$1,470; Six 15530 \times \$210 each = \$1,260. \$1260 + \$21 shipping = \$1,281.)

	MFC Model 15528	MFC Model 15530	MFC Model 15529
3 db passband (spec.)	54-88 MHz	88-108 MHz	174-216 MHz
Meas. max loss in pb	1.2 dB	1.0 dB	1.5 dB
Ins. Loss (measured)	0.95 dB @ 66 MHz	1.0 dB @ 98 MHz	2.5 dB @ 198 MHz
Min. rej. at low end	40 dB @ 42 MHz	40 dB @ 76 MHz	40 dB @ 158 MHz
Meas. rej. at low end	50 dB @ 42 MHz	41 dB @ 120 MHz	42 dB @ 158 MHz
Min. rej. at high end	40 dB @ 100 MHz	40 dB @ 120 MHz	40 dB @ 238 MHz
Meas. rej at high end	45 dB @ 100 MHz	45 dB @ 120 MHz	45 dB @ 238MHz

Angle Linear preamps are placed after the bandpass filters at the antenna. Angle Linear is a small company and has extremely long lead times, but its price/performance ratio was the best that we could find. In lower frequencies, the amplifiers are optimized to work best in a 100 MHz frequency band specified by the customer; in higher frequencies, they are specified to work best within a chosen 50 MHz frequency band.

		Purpose	Unit cost	Cost of 6
HY0510BNE	50-100	VHF TV ch. 2-6	\$178.60	\$1,071.60
HY0914BNE	90-140	FM radio	\$178.60	\$1,071.60
HY1722BNE	170-220	VHF TV ch. 7-13	\$178.60	\$1,071.60
HY4858GNE	480-580	UHF TV	\$223.25	\$1,339.50
HY6070GNE	600-700	UHF TV	\$223.25	\$1,339.50
HY8595GNE	850-950	cell phone	\$223.25	\$1,339.50
HY0520BSE	50-200	before A/D converters	\$186.20	\$1,117.20
Shipping				\$54.40 (total)
Total				\$8,404.90

Only analog TV stations are present in the VHF TV bands. The particular UHF bands were chosen to contain several interesting digital TV transmitters in the Atlanta area, in addition to several high-power analog TV transmitters.

The BNE and BSE preamps are hybrid bipolar designs, and the GNE preamps are hybrid PHEMT designs. The BNE/GNE preamps, which are intended to go near the antenna after the filter, have N connectors. The BSE preamps, which is intended to form part of a variable gain amplifier just before the digital receiver cards, have S connectors.

The last amplifier in the above table, the HW0520BSE, is a particular custom design kindly formulated for us by Chip Angle, the proprietor of Angle Linear. It covers a 150 MHz bandwidth, which is wider than his standard designs. Instead of being placed at the antenna like the other preamps, it is combined with digitally controlled attenuators to form a variable gain section before the digital receiver A/D converter inputs.

An **Acopian 15PT10 power supply** provides the power for the Angle Linear preamps throughout the system. (15PT10: \$520 + \$20 shipping = \$540.)

3.3. Analog Mixing Stage

Nine Minicircuits ZX05-25MH-S double-balanced mixers, with SMA connectors, provide necessary analog multiplications when operating above 300 MHz. They have an LO/RF range of 5-2500 MHz and an IF range of 5-1500 MHz, with an LO level of +13 dBm and a typical RF 1 dB compression point of +9 dBm. The IP3 at the center band is typically 18 dBm. The reported conversion loss has a mean of 6.9 dB, with a standard deviation of 0.1 dB and a maximum of 8.8 dB. Although we only have six channels, having a few extra mixers allows us to select for specific measured characteristics. Isolation characteristics are listed in the table below. Note that for the purposes of this project, the "Medium Range" is the range of interest. (Nine ZX05-25MH-S mixers \times \$37.95 = \$341.55; \$341.55 + \$4.54 shipping = \$346.09.)

	Low range	Medium Range	High Range
Freq. range	5-50	50-1250	1250-2500
LO-RF Iso. (dB) Typ/Min	47/28	34/23	34/23
LO-IF Iso. (dB) Typ/Min	34/23	32/18	23/17

A Rohde & Schwarz SML01 Signal Generator (9 kHz to 1.1 GHz) provides the local oscillator needed for exploitation of transmitter frequencies above 300 MHz. It also facilitates characterization of system components (e.g., measuring frequency responses of specific filters, preamplifiers, etc.) as well as general testing and debugging. (SML01: \$4,928; ZZA-221 19" rack adaptor: \$108; \$4,928 + \$108 + \$73 shipping = \$5,109.)

3.4. Power Dividers

Splitters from IF Engineering include two 3-way power dividers (PD-3003-S) with SMA connectors (to distribute clock signals to different cards), three 3-way power divider (PD-3004-N) with N connectors (for use at the antennas), and one 9-way power divider (PD-9004-S) with SMA connectors (to split a local oscillator signal to different mixers). The splitters are designed to have low phase shifts between different outputs, and are designed to work best in the frequency regions of interest. The specifications are given in the table below (Two PD-3003-S \times \$105 each = \$210; three PD-3004-N \times \$165 each = \$495; PD-9004-S: \$440; \$210 + \$495 + \$440 + \$5.80 shipping = \$1,150.80.)

	PD-3003-S	PD-3004-N	PD-9004-S
Freq. Range (MHz)	10-500	20-1000	20-1000
Isolation (dB) Min.	25	22	25
Ins. Loss (dB) Max.	0.75	1.25	2.0
Amp. Bal. (dB) Max	+/- 0.2	+/- 0.2	+/- 0.3
Phase Bal. Max.	+/- 3 deg	+/- 5.0	+/- 3 deg
VSWR Max.	1.3:1 (in and out)	1.4:1 (in) 1.3:1 (out)	1.5:1 (in and out)
Impedance Nom.	50	50	50

3.5. Signal Conditioning Before A/D Conversion

A second set of Lorch Microwave filters, with part numbers 8BP3-XX/AYY-S, may be used to reject unwanted images after hardware mixing stages and also to remove small spurious frequency content that may arise in the preamplifiers. The filters have eight sections and SMA connectors. Our SMA-connector filter for the lower VHF TV band does not include the 78-88 MHz since there are no transmitters of sufficient power in that band; the upper VHF TV band SMA-connector filter only covers 192-204 (instead of the full 174-216 MHz band) for the same reason. Specifications are given in the following table. (Six filters for each band × \$365 each = \$2,190; Three bands × \$2,190 = \$6,570; \$6,570 + \$29.34 shipping = \$6,599.34.)

	8BP3-66/A24-S	8BP3-98/A20-S	8BP3-198/A12-S
1 db passband (spec.)	54-78 MHz	88-108 MHz	192-204 MHz
1 db passband (meas.)	52-80 MHz	84-111 MHz	188-206 MHz
Ins. Loss (max spec.)	1.45 dB @ 66 MHz	2.2 dB @ 98 MHz	4.4 dB @ 198 MHz
Ins. Loss (measured)	0.95 dB @ 66 MHz	1.0 dB @ 98 MHz	2.5 dB @ 198 MHz
Min. rej. at low end	-----	-----	60 dB @ 175 MHz
Meas. rej. at low end	-----	-----	57 dB @ 175 MHz
Min. rej. at high end	45 dB @ 95 MHz	45 dB @ 125 MHz	60 db @ 225 MHz
Meas. rej at high end	57 dB @ 95 MHz	54 db @ 125 MHz	63 dB @ 225 MHz

The measured quantities in the above table are estimated averages over the measurements for the six units provided by the manufacturer.

To maximize the number of bits used in the A/D conversion process, we wanted to provide a gain control stage before the digital receiver inputs. When asking for advice on variable gain amplifiers, many sources suggested that one is typically better of using a fixed gain amplifier followed by a variable attenuator. Our gain stage consists of **Kay Elemetrics 1/4550-SMA 8-bit digital controlled attenuators** with **Kay Elemetrics 4000 logic adapters**, which allow the attenuators to be controlled by TTL signals, followed by HW0520BSE preamps. The 1/4550 attenuators operate up to 500 MHz, with an attenuation range of 0-16.5 dB (with attenuation pad values of 0.1, 0.2, 0.4, 0.8, 1, 2, 4, and 8 dB), an insertion loss of 1.0 dB in the DC-250 MHz band and 2.5 dB in the 250-500 MHz band, a a VSWR of 1.2:1 in the DC-250 MHz band and 1.3:1 in the 250-500 MHz band. In the DC-250 MHz band, it boasts an attenuation accuracy of 0.1 dB; in the 250-500 MHz band, it has an accuracy of 0.2 dB for the 0.1-0.8 dB steps and 0.3 dB for the 1-8 dB steps. (Six 1/4550-SMA attenuators × \$341 each = \$2,046; six 4000 logic adapters × \$30 each = \$180.)

The TTL signals are provided by a **Measurement Computing PCI-DIO48H 48-bit high drive 64 mA digital I/O board**. (PCI-DIO48H: \$179.10; CIO-MINI50 50 pin universal screw terminal accessory: \$62.10; two C50FE-2 2' 50 conductor ribbon cables × \$22.50 each = \$45.)

3.8. Cables and Miscellaneous RF Parts

Miscellaneous cable, connector, and termination equipment (all with male connectors) from **Pasternack** is listed below. Cable length, in inches, is given by the YY number after the dash in the PEXXXX-YY item number. The terminators must be placed on the unused outputs of the IF Engineering power dividers.

Item	Type	Connector	Q	Unit Cost	Total Cost
PE3385-18	RG142	SMA	8	\$37.51	\$300.08
PE3385-24	RG142	SMA	9	\$38.72	\$348.48
PE3696-24	RG142	BNC-SMA	2	\$31.46	\$62.92
PE3062-144	RG214	N	9	\$71.39	\$642.51
PE3062-6	RG214	N	9	\$36.41	\$327.69
PE3422-60	RG214	SMA	9	\$91.85	\$826.65
PE3385-12	RG142	SMA	45	\$33.76	\$1,519.00
PE3696-12	RG142	BNC-SMA	1	\$29.04	\$29.04
PE6149	Terminator	SMA	10	\$17.55	\$175.50
PE6153	Terminator	N	3	\$19.75	\$59.25
PE9069	Barrel	SMA	36	\$13.25	\$477.00
PE9007	Barrel	N	18	\$8.75	\$157.50
Total					\$4,925.82

For the longest run of RG214 cable, 12', the cable loss calculator at www.timesmicrowave.com computes a loss of 0.2 dB at 100 MHz (FM radio band) and 0.8 dB at 900 MHz (cell phone band). For the longest run of RG142 cable, 2', the cable loss calculator gives a loss of 0.2 dB at 900 MHz. At 900 MHz, RGA142 has a reported loss of 12.12 db per 100 feet, and RG214 has a reported loss of 6.834 dB per 100 feet at 900 MHz. The trend of RG214 seeming to have about the half the loss (in db) than RG142 seems consistent throughout the frequency bands of interest.

Eight 80' lengths of Andrews CINTA-600 cable from RF Davis, with N connectors, provide the connection from the external antennas to the rest of the equipment. The 80' length will allow us to conveniently place the antennas on the western part of the roof; this arrangement may allow some mild shielding from the direct-path signal if desire. The eight lengths allows us to create permanent connections to both log-periodic antennas and six discones, or put out additional discones (for instance, for directly hooking to a spectrum analyzer). CINTA-600 is 1/2" wide, with a foam dielectric. Andrew's CINTA line is intended to match the characteristics of Times Microwave's well-known LMR line. Using the attenuation calculator provided at www.timesmicrowave.com, approximate losses indicated for the 80' run are 0.6 db at 100 MHz (FM radio band) and 2 db at 900 MHz (cell phone band). (Eight lengths of Andrews CINTA-600 80" cable = 640 feet × \$0.92/foot = \$588.80; 16 N male connectors × \$17.95 each = \$287.20; 16 install charges × \$11 each = \$176; \$588.80 + \$287.20 + \$176 = \$1,052; \$1052 + \$123.59 = \$1,175.59.)

3.9. Tools

Miscellaneous tools from Digikey round out the available resources. (WTCPT-ND controlled-output soldering station: \$140.09, six replacement tips of varying sizes and temperatures, namely PTA-7ND, PTA8-ND, PTF7-ND, PTF8-ND, PTS7-ND, PTF-8ND, covering 0.062", 0.031", and 0.015", and 700 and 800 degrees \times \$5.43 each = \$32.58; K414-ND ESD safe pump desolderer with tip: \$26; K415-ND desolderer tip replacement: \$6.08; 431-1041-ND cutter: \$40.98; 431-1042-ND long needle nose pliers: \$40.98; 431-1034-ND short flat nose pliers: \$35.98; \$140.09 + \$32.58 + \$26 + \$6.08 + \$40.98 + \$40.98 + \$35.98 + \$7.65 shipping = \$330.34.)

3.10. Computation

The passive radar paradigm shifts costs from traditional radar hardware to the digital signal processing (DSP) know-how and horsepower required to make sense of the received signals. The price of radar hardware remains relatively fixed, while the cost of computational power continues to plummet. Passive radar can thus boast something active radar cannot: its further development is primarily driven by Moore's law.

Three Dell Poweredge 2850s, with dual 3.2 GHz Xeon processors with 1 MB caches and 800 MHz front side busses, form the user interface of the system. Each computer has 2GB of 400 MHz RAM, a 36 GB hard drive, a 1.44 MB floppy drive, and a 24X IDE CD-ROM. Two of the Poweredge 2850s each contain an EchoTek digital receiver card, and the remaining third allows additional computation and visualization. One of the computers contains the Mountain Computing GPIB and TTL digital output (for driving the Kay Elemetrics attenuators) control boards. (Three Ultrasharp 2100FP 20" Flat Panel Displays \times \$809.10 each = \$2,427; Three Cordless Comfort Duo Keyboard and Mouse \times \$79.16 each = \$237.48; Three 3.2 GHz Poweredge 2850s \times \$5,186.48 each = \$15,559.44; 24 unit short rack for Dell Poweredge Base: \$983.75.)

Eight PowerEdge 1850s, with dual 3.0 GHz Xeon processors, configured in a Beowulf architecture, provide computational horsepower. The features (cache, main RAM, bus speed, and floppy and CD-ROM drives) are similar to those of the PowerEdge 2850s described above. (Eight Poweredge 1850s \times \$2,726.21 = \$21,809.68)

A PowerEdge 2850, with dual 2.8 GHz Xeon processors acts as a file server for one terabyte of data available from a RAID array. Its features are similar to those of the PowerEdge 2850s described above. (One 2.8 GHz PowerEdge 2850: \$4,607.85; EMC AX100 Array Dual Processor Enclosure with 4 \times 250 GB 7200 rpm serial-ATA drives: \$11,894.80; Two QLogic 2340 2 Gigabit optical (fibre channel) PCI Host Bus Adapters (HBA) \$755.54 \times 2 each = \$1,511.0; \$4,607.85 + \$11,894.80 + \$1,511.00 = \$18,013.65.)

Cisco switches ordered from Dimension Data provide high-speed connectivity between the computers. (Cisco Catalyst 3750 24-way 10/100/100T + 4 SFP Standard Multilayer Switch (WS-C3750G-24TS-S): \$3,848; Two Cisco GE SFP, LC Connector XC Transceivers (GLC-SX-MM) \times \$275 each = \$550; $\$3,848 + \$550 = \$4,398$.)

The Beowulf computing nodes and the RAID storage and server are housed in a **NetShelter** rack and powered by a **Power Distribution Unit (PDU)**. (NetShelter VX 42U enclosure (containing 1850s and storage equipment): \$863.06; Rack Power Distribution Unit (PDU), Metered, Zero U ("consumes no front panel rack mounting space"), 7.2 kW: \$321.26; $\$863.06 + \$321.26 = \$1,184.32$.)

4. Example Scenario

The example shown in the block diagram on the following page illustrates the flexibility of the available "building blocks." Suppose one wanted to explore fusing data from three quite different sources: 1) narrowband lower-VHF analog TV (as in Paul Howland's PHD thesis), 2) "wideband" FM radio (as in Paul Howland's newer demonstration system at NATO or John Sahr's Manastash Ridge Radar), and wideband digital TV (as in some experimental SAIC work funded by DARPA). We could build such a system as shown below. The two KMA4113 logperiodic antennas are used, one to pick up the direct-path signals and one to pick up the aircraft reflected signals. (Note that we are assuming that the three exploited transmitters are within the main beam of the direct-path antenna.) The IF Engineering PD-3004-N is needed to feed the reflected-path signal to three different filter/amplifier combinations; similarly, another PD-3004-N is needed to feed the direct-path signal to two different filter/amplifier combinations. (In typical narrowband processing, the reflected path signal is treated as a Doppler-shifted sinusoidal carrier, so there is no need to collect the direct-path VHF analog TV signal as we know the structure of the signal already.) These splitters introduce losses that must be taken into account in system performance modeling.

We must use both the 105 MHz and the 72 MHz clocks. The 72 MHz clock allows aliased-based direct digital detection of the direct-path and reflected-path FM signals. For the TV channel 2-6 band, 105 MHz allows aliased-based direct digital detection of the reflected-path signal; if we tried to use the 72 MHz for channels 2-6, the aliases would overlap and corrupt the data. For the wideband digital transmitter in the UHF band, we cannot use aliasing to do the downconversion by itself; an analog mixdown stage is needed. The multiply signs in the diagram represent the Minicircuits mixers. A splitter, such as an IF Engineering PD-3003-S or a PD-9004-S is needed to feed the local oscillator signal from the Rohde & Schwarz SML01 to the two mixers. Bandpass filters are placed after the mixers to reject unwanted images.

One of the gain control stages, labeled "GC," represents one of the 50-200 MHz optimized Angle Linear preamps followed by one of the Kay Elemetrics attenuators.

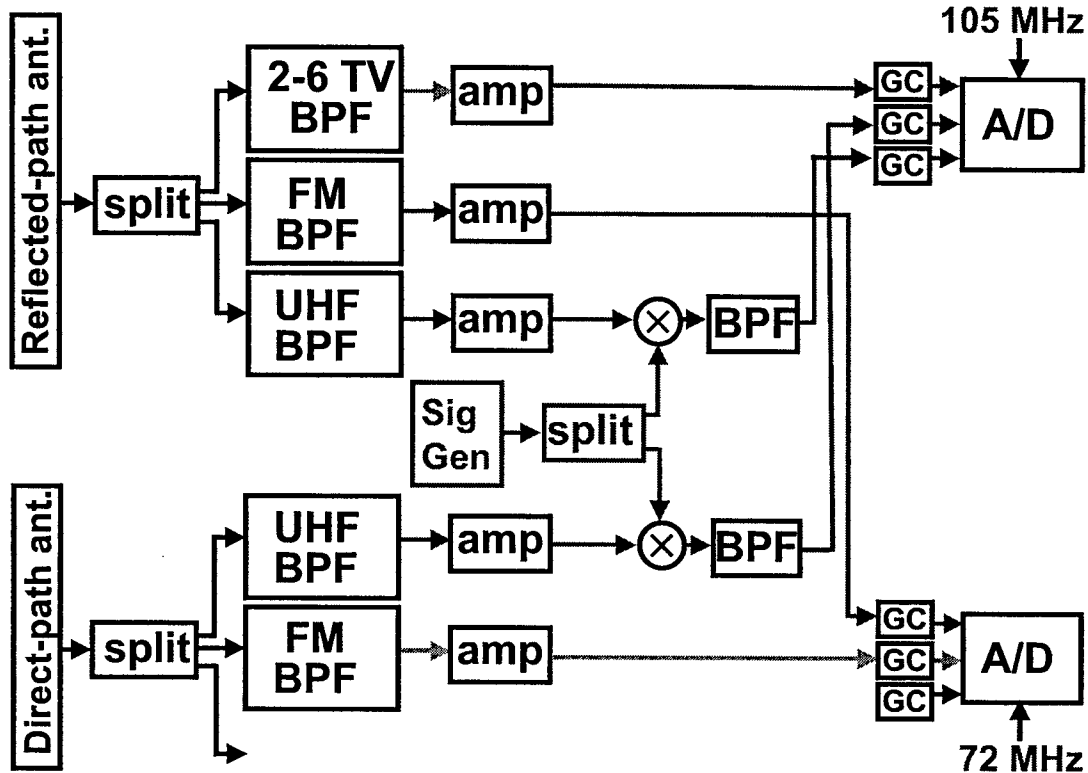

5. Related Journal Publications by the PI and Colleagues

- L.M. Ehrman and A.D. Lanterman, "An EKF for Estimating Aircraft Orientation from Velocity Measurements," *IEE Proc. Radar Sonar and Navigation*, letter of acceptance subject to minor revision received Jan. 9, 2006; revised version submitted Feb. 2006.
- L.M. Ehrman and A.D. Lanterman, "Chernoff-Based Prediction of ATR Performance from Rician Radar Data, with Application to Passive Radar," *Optical Engineering*, letter of acceptance subject to minor revision received Feb. 2, 2006; undergoing revision in preparation for submission.
- L.M. Ehrman and A.D. Lanterman, "Automatic Target Recognition via Passive Radar, Using Precomputed Radar Cross Sections and a Coordinated Flight Model," *IEEE Trans. on Aerospace and Electronic Systems*, submitted June 2005; letter requesting moderate revisions received March 2006; undergoing revision.
- M. Tobias and A.D. Lanterman, "Probability Hypothesis Density-Based Multitarget Tracking with Bistatic Range and Doppler Observations," *IEE Proc. - Radar, Sonar, and Navigation*, Vol. 152, No. 3, June 2005, pp. 195-205.

6. Related Conference and Workshop Presentations by the PI and Colleagues

- A.D. Lanterman, "Passive Radar Imaging and Target Recognition using Illuminators of Opportunity," *NATO Symposium on Target Identification and Recognition Using RF Systems*, Oslo, Norway, Oct. 11-13, 2004.
- A.D. Lanterman (with L.M. Ehrman), "Assessing the Performance of a Covert Automatic Target Recognition Algorithm," *SPIE Defense & Security Symposium*, Orlando, FL, March 28-April 1, 2005. (See paper reference above).
- A.D. Lanterman, "A Passive Radar Testbed at Georgia Tech," *4th Multinational Passive Covert Radar Conference*, Syracuse Univ. Hotel and Conference Center, Syracuse, NY, Oct. 5-7, 2005.
- M. Tobias (with A.D. Lanterman), "Using the Probability Hypothesis Density for Multitarget Tracking with Passive Radar," *4th Multinational Passive Covert Radar Conference*, Syracuse Univ. Hotel and Conference Center, Syracuse, NY, Oct. 5-7, 2005.