

*Defense Science Board
Summer Study*

on

**Transformation:
A Progress Assessment
Volume I**



DISTRIBUTION STATEMENT A
Approved for Public Release
Distribution Unlimited

20060309 069

February 2006

*Office of the Under Secretary of Defense
For Acquisition, Technology, and Logistics
Washington, D.C. 20301-3140*

This report is a product of the Defense Science Board (DSB). The DSB is a Federal Advisory Committee established to provide independent advice to the Secretary of Defense. Statements, opinions, conclusions, and recommendations in this report do not necessarily represent the official position of the Department of Defense.

This report is Unclassified.



DEFENSE SCIENCE
BOARD

OFFICE OF THE SECRETARY OF DEFENSE
3140 DEFENSE PENTAGON
WASHINGTON, DC 20301-3140

MEMORANDUM FOR UNDERSECRETARY OF DEFENSE (ACQUISITION,
TECHNOLOGY, & LOGISTICS)

SUBJECT: Final Report of the Defense Science Board (DSB) 2005 Summer Study on
Transformation: A Progress Assessment (Volume 1)

I am pleased to forward Volume 1 of the Final Report of the DSB 2005 Summer Study on "Transformation: A Progress Assessment," chaired by General Larry Welch (USAF, Ret.) and Dr. Robert Hermann. The study assessed the Department of Defense's progress towards transformation, concentrating on identifying objectives and recommending actions to meet emerging challenges. Volume 2 will be the study's sub-panel reports and is in final draft.

The Department of Defense (DoD) has succeeded in producing revolutionary changes in its ability to perform major combat operations through evolutionary improvements, as demonstrated in recent conflicts. DoD has improved its adaptation in other operational capabilities by leveraging valuable combat experienced personnel. Of concern, however, DoD has produced little change or improvement in the business practices of the enterprise, namely a requirement to align the major DoD entities, develop a multi-year business plan and reform the acquisition process. The report also addresses other areas of concern that could potentially impact a successful DoD transformation: Joint Concept Development, human resources, our deficiency of multi-agency campaign planning and future challenges for the defense industry.

The Task Force provided recommendations to improve the topics of concern. The Task Force's observations and recommendations have been consistent with the previous DSB studies and, if implemented, will improve the Department's transition to an organization adapted to meet the challenges of the 21st Century.

I endorse all of the Task Force's recommendations and encourage you to forward to the Secretary of Defense.

Dr. William Schneider, Jr.
DSB Chairman



DEFENSE SCIENCE
BOARD

OFFICE OF THE SECRETARY OF DEFENSE
3140 DEFENSE PENTAGON
WASHINGTON, DC 20301-3140

MEMORANDUM FOR THE CHAIRMAN, DEFENSE SCIENCE BOARD

SUBJECT: Final Report of the Defense Science Board (DSB) 2005 Summer Study on Transformation: A Progress Assessment

The 2005 DSB Summer Study Task Force on Transformation: A Progress Assessment has completed its work and a final report is attached. The Task Force assessed the Department's progress towards transformation, concentrating on identifying objectives and recommending actions to meet emerging challenges.

The Task Force's assessment included analysis of the Department's current transformation efforts and objectives, with recommendations of ways and means to meet emerging and persistent challenges.

The Task Force noted that continuous transformation had produced revolutionary improvements in the capability of U.S. armed forces to conduct effective major combat operations. With the ongoing experience in Iraq, the Department has also become an adaptive, learning organization in dealing with the demands of missions other than major combat operations.

In contrast to the continuing transformation in the capabilities of the operating forces, there was little progress in the business practices of the enterprise. The report identifies and makes recommendations on aligning roles, responsibilities, and accountability among the four entities that make up the Department; the Office of the Secretary of Defense, The Chairman of the Joint Chiefs of Staff and the joint staff, the Combatant Commands, and the force providers (Services and Defense Agencies). The Department needs a multi-year business plan linking mission resources to mission purposes. Major changes are needed to make the acquisition process effective and efficient. The Combatant Commands should be accorded far more influence in identifying the capabilities needed to perform their assigned operational missions.

The report also addresses issues in Joint Concept Development and in addressing the joint capabilities needed to bring capabilities provided by the Services and defense agencies together in an effective joint operating force across a wide range of needs. It also addresses human resource issues, the need for multi-agency campaign planning, and issues for defense industry in the current and likely future national security environment.

As special subjects, the report also addresses disruptive challenges. The Task Force also stressed the importance of the special potential for transformation available from officers of all levels who have met the complex challenges in Iraq of dealing nearly simultaneously with the demands of major combat, providing protection, providing basic services to the population, adjudicating disputes, acting as de facto mayors, all in a complex and dangerous environment.

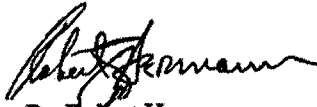

Dr. Robert Hermann
Task Force Co-Chair



GEN Larry Welch
Task Force Co-Chair

TABLE OF CONTENTS

Executive Summary 1

Introduction..... 5

DoD Business Practices 9

Joint Capabilities Integration and Development System (JCIDS)..... 19

Joint Concepts 21

Disruptive Challenges..... 23

 An Emerging Transformation Driver..... 23

Multi-Agency Integration 25

Joint Forces Development..... 29

 Logistics..... 29

 Network-Enabled Operations..... 31

Defense Industry 33

 Industrial Base 33

Human Resources (HR)..... 35

Summary of Recommendations..... 39

Appendices

Appendix A. Terms of Reference A-1

Appendix B. Task Force Membership..... B-1

Appendix C. Briefings Received C-1

Appendix D. Acronym List..... D-1

LIST OF FIGURES

Figure 1. Mechanism for the Priority Decision Process	9
Figure 2. Business Plan Activity Flow	10
Figure 3. Matrix of Accounting for Resources by Mission	11
Figure 4. The Acquisition Chain of Authority.....	16
Figure 5. Revised Acquisition Chain of Authority	17
Figure 6. "How-to-fight" concepts	21
Figure 7. DoD Human Resources Allocation (1000s).....	35

EXECUTIVE SUMMARY

Transformation is a continuous process with no foreseeable end point. To meet 21st century challenges, the Department of Defense (DoD) will need capabilities that are constantly evolving and improving. Transformation demands changes in the DoD culture, process, and capabilities; changing the way the Department conducts combat operations, conducts business, and interacts with other agencies and nations.

The Department, through the Undersecretary of Defense for Acquisition, Technology, and Logistics (USD(AT&L)), directed the Defense Science Board (DSB) to convene the 2005 Summer Study Task Force on Transformation to assess the DoD's transformation progress. The Task Force's assessment includes a description of the current status of the Department's transformation efforts, identifies transformation objectives, and recommends ways to better meet emerging and persistent challenges. The Task Force specifically examined the following areas of the Department's enterprise:

- Business Processes,
- Concepts and Experimentation,
- Net-enabled Operations,
- Defense Industry and Acquisition,
- Human Resources and Enterprise Culture,
- Multi-agency Integration, and
- Adaptable Force Capabilities.

Task Force members and advisors are listed in Appendix A. During the course of work, the Task Force met with representatives from various fields of expertise, all with regard to transformation efforts. Based on the information received from the broad range of knowledgeable individuals in government, commercial, and academic environments, as well as through a series of interactive debates, the Task Force arrived at the findings and recommendations in this report. Volume II of this report, published separately, contains further detail on the Task Force findings and support for those findings.

The Task Force started with an effort to understand and articulate the most basic purposes of the Department. Those purposes are to:

- Project the potential of globally applied military force to defend the homeland and its interests as a means to:
 - Hold at risk of destruction any serious threat to the U.S. anywhere in the world alone or with allies;
 - Be capable of effective stability and reconstruction operations; and
 - Be capable of extensive support for homeland security and disaster response.
- Apply this potential to:
 - Influence allies, and other potential partners;

- Shape the intentions and actions of potential adversaries; and
- Defeat adversaries with military power when necessary.
- Provide the management competence to:
 - Provide confidence in the body politic that it is being well served;
 - Gain the resources to provide the needed standing capabilities and to deploy and employ the capability as needed; and
 - Attract the needed quality people into the service of the Department from government and industry.

The overall assessment is that the Department has produced revolutionary progress in capabilities to conduct major combat operations and is on a path of continuing transformation in these capabilities. The Department has embraced the need for transformation of other operational capabilities and is using the experiences in Afghanistan, Iraq, and global counter-terrorism campaigns for this purpose; but still has much to do to transform the way the enterprise does business. Transformation should be measured in outputs, not inputs. Accordingly, the following are some key outputs in the attributes of transformed Force combat capabilities with a comment on progress on each attribute. These are discussed more fully in the report.

- Joint integration – The level of joint integration in the most recent major combat operation, Operation Iraqi Freedom (OIF) – is unprecedented in U.S. military history and the pace and success of the major combat operations phase reflects the power of that integration.
- Global presence, access, and reach – The demands on U.S. Forces around the globe have continued to be varied and demanding and the Forces have met the need, although with significant challenges.
- Responsive and sustaining logistics – While there has been progress, this remains a major limiting factor in global operations.
- Network-enabled operations infrastructure, services, and combatant command employment capabilities – While network-enabled capabilities are immature, in some cases rudimentary, it is clear that the concepts are increasingly well understood and the initial benefits convincing.
- Persistent surveillance – This remains an inadequately defined demand with the consequent inadequately addressed need.
- Global precision strike – The existing Force has the capability to strike virtually any target, anywhere in the world, at any time with precision. There are significant shortfalls in responsiveness and ISR support.
- Non-kinetic operations – Immature at best.
- Joint C2 structure, processes, readiness – Developing, but in need of significant further development and more exploitation of the network-enabled environment potential.

- Training & education for intermixed combat and stability and reconstruction operations – Developing rapidly in an adaptive, learning organization with experience in Afghanistan and Iraq.
- Multi-agency integration – Needs much attention, development, and commitment, with direction from the President, leadership from the Secretary of Defense, and cooperation from multiple agencies.

Related to multi-agency integration, National Security Strategy extends beyond combat objectives—and beyond stability and reconstruction before, during, and following combat—to establishing functioning free enterprise economies and democracies. It is important to understand that the National Security Strategy is about much more than combat objectives or even stability and reconstruction operations. In fact, the set of broader goals are far more demanding, complex, costly, and wide reaching in scope than achieving victory on the battlefield. Meeting the National Security Strategy objectives requires a robust and integrated civilian-DoD, multi-agency capacity as part of a broader strategic focus to enable the full array of available U.S. capabilities to achieve strategic objectives.

To address the challenges associated with continuing transformation in areas in need of increased emphasis, the following is a summary of key actions needed in the Department. Again, these are addressed in more detail in the report:

- Enforce accountable responsibility for roles in force capability building with the needed balance in influence among providers and users.
- Establish a Business Plan to discipline resource allocation to mission purposes.
- Restructure concept development and JCIDS to focus priorities on warfighters capability needs.
- Modify the acquisition system to deliver capabilities on time and on cost.
- Form a Joint Logistics Command to create an end-to-end supply chain.
- Lead a multi-agency concept development and national-level campaign planning process.
- Create a process to identify and deal with disruptive challenges.
- Direct the human resource strategy to meet the demand for increased performance – military and civilian.



INTRODUCTION

In January 2005, the DSB was tasked by the USD(AT&L) to form a Summer Study Task Force to provide an assessment of the DoD's continuing transformation process. As directed in the Summer Study Terms of Reference (TOR), the assessment describes the current status of the DoD's transformation, identifies appropriate transformation objectives, and makes recommendations to meet emerging and persistent challenges. Specifically, the Summer Study examined the DoD's scope and strategy for transformation in the following areas of the DoD enterprise:

- Joint Concepts and Experimentation,
- Disruptive Challenges,
- Adaptable Force Capabilities,
- Net-enabled Operations,¹
- Business Processes,
- Defense Industry and Acquisition,
- Human Resources and Enterprise Culture, and
- Multi-agency Integration².

Transformation is supported by a three-part strategy to continuously transform the DoD's culture, process, and capabilities; transforming how DoD conducts combat operations, how DoD conducts its business, and how DoD works with other agencies and nations, all in a continuously changing environment. As Secretary of Defense Donald Rumsfeld noted in the 2005 National Defense Strategy, transformation is "about changing the way we think about challenges and opportunities [and] adapting the defense establishment to that new perspective."

The overall goal of transformation is to create a climate of continuous improvement across the enterprise. Transformation is central to the daily business of the enterprise in producing outputs from continuous adjustment to changing demands of the operating environment. Moreover, transformation is the key to a continuing capability to deal with the uncertainty that the Secretary of Defense describes as a "defining characteristic of today's strategic environment."³

To be effective, transformation must be embedded in the daily business of the enterprise. It can not be effective if treated as an overlay or appliqué on the daily business of the enterprise. Accordingly, guidance on transformation must be embedded in the Strategic Planning Guidance, rather than treated in separate guidance or in separate organizations.

¹ The Summer Study Task Force prefers net-enabled to net-centric to describe the concept for providing the best available information to decision makers.

² The Summer Study Task Force prefers multi-agency to interagency since multi-agency is a more accurate way to articulate an integrated approach to bringing the capabilities of a set of agencies together to address whatever challenge needs attention.

³ National Defense Strategy (March 2005).

Within the transformation environment, the rate of change is driven by leadership climate, an ever-changing world environment, changes in mission, adjusting to adaptive adversaries, and opportunities to alter a predetermined course of action. Change in military capabilities is seldom revolutionary, though continuous evolution can and has produced revolutionary capabilities. The bottom line is that to be successful in an ever-changing and uncertain world environment, transformation must be integrated into the daily fabric of the enterprise.

Understanding the fundamental purpose of the enterprise is an essential prerequisite to assessing progress in transforming the enterprise and its capabilities. The fundamental purposes of the Department are:

- Projecting military power to defend the homeland and the nation's interests anywhere, anytime with the capability to hold at risk any threat to the U.S.;
- To conduct stability and reconstruction operations before, during, and after any destructive use of military power; and
- To be ready to support and augment domestic capabilities.

These capabilities need to be structured and articulated to serve the multiple purposes of assuring friends and allies, deterring potential adversaries and defeating adversaries when needed.

Attributes of a transformed Force capability include:

- Joint integration;
- Global presence, access, reach;
- Responsive and sustaining logistics;
- Network-enabled operations infrastructure, services, and combatant command employment capabilities;
- Persistent surveillance;
- Global precision strike;
- Non-kinetic operations;
- Joint command and control (C2) structure, processes, readiness;
- Training and education for intermixed combat and stability and reconstruction operations; and
- Multi-agency integration.

An assessment of the Department's progress at producing this set of attributes will be presented at the end of this report.

In addition to transforming the capabilities of the force, the Department must conduct and manage its business in such a way as to persuade the body politic to provide the resources required to attract individuals with talent and experience into the service of the Department. Given the unpredictable nature of violent challenges to the nation's interest, the DoD must attract and maintain a standing force of well-qualified people from both government and industry capable of meeting a wide variety of challenges. This need is relatively independent of current

threat assessments. Given the inability to predict threats of high consequence in the 21st century, the necessary approach is capability-based – a challenge beyond the threat-based approach. Capability-based forces can deal with predicted and unpredicted threats across a wide range of changing environments.

Several key actions are essential to enable transformation within the DoD enterprise. Each of the following recommended actions will be discussed within this report:

- Enforce responsibility for roles in Force capability building with appropriate balance in influence among providers and users.
- Establish a Business Plan to discipline resource allocation to mission purposes.
- Restructure concept development and Joint Capability Integration and Development System (JCIDS) to focus priorities on warfighters' priority capability needs.
- Modify the acquisition system to deliver capabilities on time and on cost.
- Form a Joint Logistics Command to create an end-to-end supply chain with global reach.
- Lead a multi-agency concept development and national-level campaign planning process.
- Create a process to identify and deal with disruptive challenges.
- Establish a human resource strategy to meet the demand for increased performance—military and civilian.

As an overall assessment of transformation progress, the Department has:

- Produced revolutionary progress in capabilities to conduct major combat operations and is on a path of continuing transformation in these capability areas;
- Embraced the need for transformation of other operational capabilities and is leveraging the experiences of Afghanistan, Iraq, and global counter-terrorism campaigns to further advance the transformation of an adaptive, learning enterprise; and
- Much to do to transform the enterprise business practices to include acquisition management, human resource management, and multi-agency planning and execution.

An important set of change drivers at work in transforming major combat operations is widely applicable to the broader enterprise and there is a robust lessons learned process to capture and understand these change drivers. However, at the top of the list are commitment to the mission and accountability for outcomes. For major combat operations, the commitment is long standing and widely shared and accountability for outcomes is clear and compelling, where outcomes are regularly tested in the crucible of combat operations.

Transforming the enterprise's front-end processes is critical to meeting the demands of daily operations. Those processes include the Department's business practices to include acquiring approved capabilities⁴, the JCIDS process, and the JCD&E process. These three important elements of a capability-based planning approach have an overarching impact on the

⁴ As a part of the Planning, Programming, Budgeting, and Execution (PPB&E) process.

enterprise as they are used to allocate resources to capability needs, guide priority choices, and provide an operational basis for determining needs.

The Department's business practices, with respect to Planning, Programming, Budgeting, and Execution (PPB&E), are to allocate resources to support mission purposes; the JCIDS process is to identify and prioritize capability gaps and proposals; and the JCD&E is to provide actionable visions of future ways to fight and is to reduce the uncertainty of future options. After assessing the overall effectiveness of each process as currently implemented, it is evident that DoD's front-end processes lack the structure, method, and focus to support key transformation objectives:

- The current PPB&E process does not produce a Business Plan that allocates resources to mission needs and disciplines the process of acquiring approved capabilities with specified resources in a specified time period;
- The current approach to concepts development is too cumbersome, takes too long, and requires too much consensus building to be useful in driving the needed change;
- JCIDS, rather than strengthening the influence of joint needs, submerges them in a sea of force provider interests. Capability based planning is not widely understood and is sometimes used to justify the progress in programs that are not meeting even known needs;
- JCD&E is not informing force development;
- Capability based planning is not widely understood; and
- Resource allocation continues to be dominated by the Force Providers and the Joint Staff.

DOD BUSINESS PRACTICES

DoD needs, but does not have, a multi-year Business Plan capable of relating resources to mission purposes. An effective Business Plan would give decision makers a clear understanding of the need for—and impact of—resource decisions. While the Department has a number of complex mechanisms and processes for resource allocation, the need is for a fully interoperable system that would succeed as an executable business plan. In addition, confusion remains over roles in identifying needs, proposing and choosing solutions, executing programs, and overseeing performance.

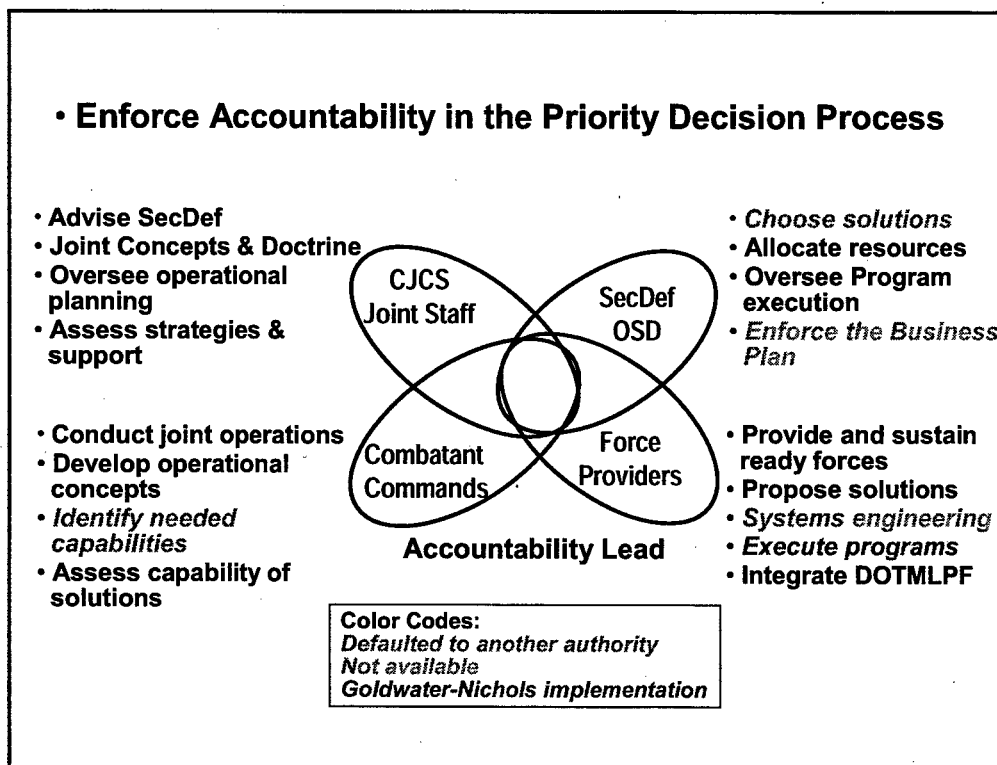

Figure 1. Mechanism for the Priority Decision Process

Figure 1 illustrates an effective and efficient allocation of roles within the context of existing laws and directives. There are four groups within the DoD: the Secretary of Defense and his staff; the Chairman, Joint Chiefs of Staff (CJCS) and his staff; the Combatant Commander (COCOM) responsible for conducting operations; and the Force Providers, comprised of the Services and Defense Agencies. The figure is intended to convey that while all the groups participate in most of the activities required to provide and operate effective forces, there should be accountable leaders for each role. Much of the following description reiterates current practice. However, the items in italics are areas where roles need to be clarified and enforced. The discussion following the figure addresses those areas.

- The COCOMs integrate force capabilities to conduct the DoD's operational missions. They should lead the process of identifying the capability needs that require higher priority, since they have the operational responsibility to employ all the Armed Forces as a joint team.

These commands should also lead the process of assessing the capability needs of the approved solution. At present, the lead in these roles defaults to the Force Providers and Joint Staff.

- The Force Providers are responsible for providing and sustaining ready forces with the needed capabilities. They have the expertise and institutional capabilities to propose solutions to identified capability needs (including the systems engineering capability to ensure that solutions are viable) and to execute approved programs. The acquisition authority chain excludes the most knowledgeable Force Provider leadership from the role of acquiring capabilities.

The Force Providers must also take the lead role in ensuring that materiel solutions support, and are supported by, the full range of Doctrine, Organization, Training Materiel, Leadership, Personnel, Facilities (DOTMLPF).

- The Secretary and his staff supported by the CJCS and his staff choose the solutions to capability needs, allocates resources to execute the decisions and oversee program execution. At present, the Force Providers and Joint Staff lead much of this effort. The Secretary also enforces the Business Plan. At present there is no plan that qualifies as a Business Plan.
- The CJCS, supported by the Joint Staff, advises the Secretary of Defense and the President on a range of defense strategy, mission assignment, Force capability, and operational matters.

Figure 2 illustrates the flow of activity in creating and executing the Business Plan:

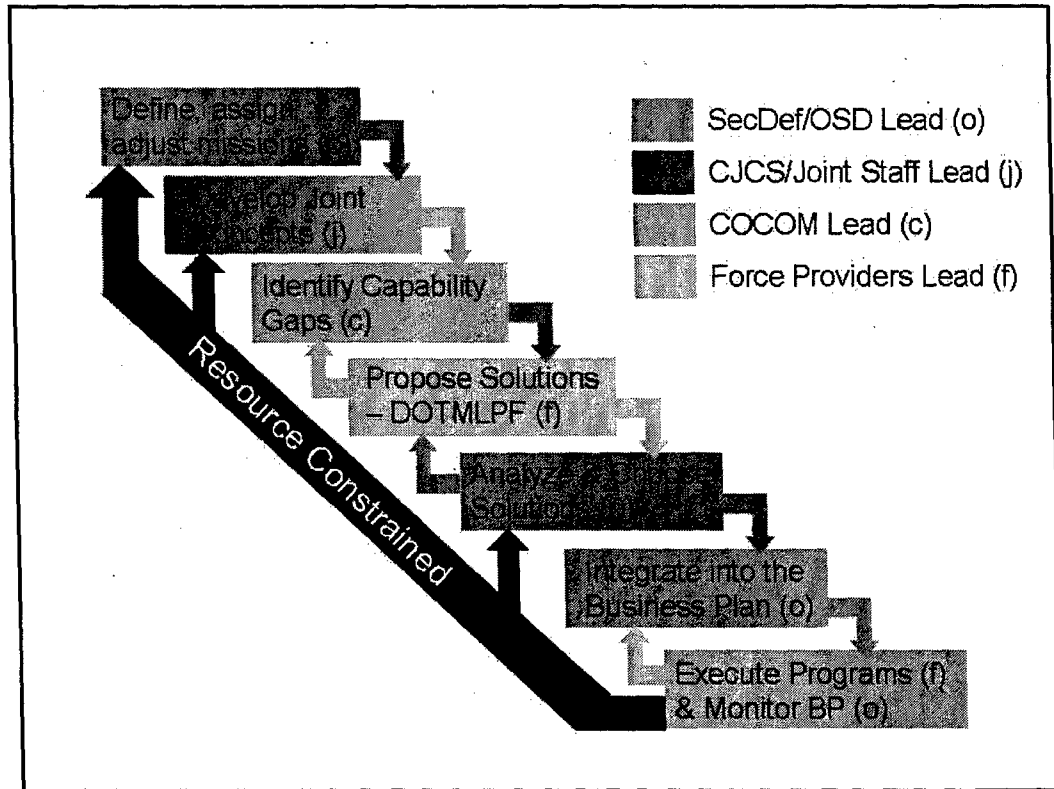

Figure 2. Business Plan Activity Flow

- The Secretary of Defense, supported by the CJCS, will define, assign, and adjust missions.
- The CJCS leads the Joint Concepts process with heavy COCOM participation.
- The COCOMs identify needed capabilities supported by the Joint Staff, and with strong support from the Force Providers.
- The Force Providers lead the process of proposing solutions.
- The Secretary of Defense, supported by the CJCS and Joint Staff, chooses solutions; the Secretary and his staff also integrate the solutions into the business plan—specifying what is to be done, in what time period, with what resources, and with what output.
- The Force Providers are then fully accountable for delivering the capability on time and within allocated resources, while the Secretary of Defense’s staff monitors the overall process.

Various steps in this process create feedback into earlier steps of a continuous cycle of change within resource constraints. However, the discipline for the system comes from the Business Plan.

Focusing the mechanisms and processes on mission needs dictates that resources are accounted for by mission as well as by Force Provider. In this case, the mission purposes are described as the missions of the combatant commanders. There are at least two compelling reasons for adding accounting by mission purpose. The first is that for combatant commanders’ inputs on priority need to be credible, they must pass through the crucible of the hard trade-offs within the mission resources of the combatant commander. The second is that if the purpose of allocating the Department’s resources is to support missions then they must be accountable by mission purpose.

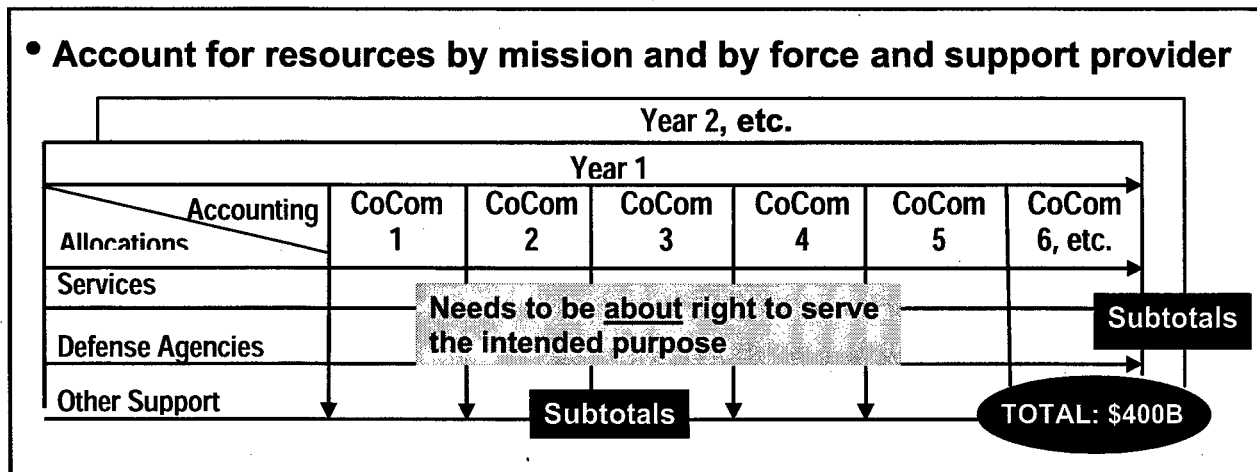

Figure 3. Matrix of Accounting for Resources by Mission

Figure 3 illustrates the needed matrix of accounting for resources by mission (identified as the output) and by Force Provider (who uses the resources as inputs to create the needed capabilities). Note that the resources are not allocated to the combatant commands. They are still allocated to the Force Providers, responsible for delivering the needed capabilities.

There is concern that accounting for resources by mission will be difficult and imperfect, since the concept will be new to the DoD. The Task Force agrees that while the DoD may experience some initial difficulty, this process can be accomplished without excessive effort or the need for perfection. The approach only needs to maintain the basic principles while transitioning from the current approach by Force Provider.

The governing product needs to be a metric-based, multi-year, resource constrained, output-oriented Business Plan that allocates resources to mission purposes, constrained by expected resources, and executed by the Force Providers with progress measured against the plan objectives.

The Secretary of Defense should:

- Assemble a small direct-reporting cell to create and maintain a metric-based, multi-year plan that specifies what is to be done, when, with what resources, and with what capability output – to discipline:
 - Allocating resources to mission purpose;
 - Constraining plans to intended resources;
 - Plan execution by Force Providers with OSD oversight; and
 - Measuring progress against plan objectives.
- Enforce the roles assignment in the force building process; and
- Require that Combatant Commanders make inputs on priorities in a resource constrained context with tradeoffs within their mission account.

To provide for effective, integrated management of business practices within the Department, USD(AT&L) needs clear authority and accountability to ensure that the information systems are network-enabled, providing the needed access for shared information and collaboration across the enterprise.

There are effective commercial systems available that are designed for integration to support managing the business functions of the Department. These systems should be used as is with only the minimum interfaces needed to apply them to peculiar DoD needs – which should be few and far between.

USD(AT&L) will need authority over architectures, resources, and personnel.

The Secretary of Defense should address the need for an integrated DoD business management information system by:

- Designating USD(AT&L) as the lead organization to manage acquisition of all new business process support systems;
- Ensuring that these systems are network-enabled to provide the shared information and collaborative planning essential to a complex, adaptable enterprise;
- Maintaining the integrity of commercial-off-the-shelf (COTS) systems, adjust the business processes accordingly, and adapt appropriate interfaces;
- Ensuring adequate authority over architecture, applications, resources, and personnel to achieve implementation; and

- Hiring experienced key people to lead the Department effort and outsource the balance.

Acquisition

An important output of the Business Plan is acquisition of approved capabilities. While there is significant and continuing transformation in a number of critical areas, acquisition reform efforts to date have not transformed acquisition by any credible measure. The system is still not delivering systems on-time and on-cost. The process remains inflexible and risk averse. The acquisition system is the weak link in the transformation chain.

The guidance is too broad and the process does not produce realistic cost and schedule estimates, hence program buy-in is common with predictable results in cost and schedule performance. The process continues to be dominated by the Force Providers with minimum influence from those who must employ the acquisition output to conduct mission operations.

Given that programs tend to be binary – there is either 1 or 0 for any needed capability – the system accepts excessive risk in seeking capabilities in a single bite that need spiral development. Risk can be managed through incremental development and fielding of improved capabilities over time. Using this spiral approach, cost, schedule, and technical risk assessments must be treated as a troika. Credible cost and schedule assessments are not possible without credible technical risk assessments. Conversely, technical risk is driven by cost limitations and schedule goals.

Joint force commanders' requests for opportune advances in capabilities are too often met with the need to get in line for the POM process. In addition, the COCOMs need access to appropriate engineering and analyses support to make credible inputs. There are also barriers to commercial industry participation created by different accounting and reporting rules and different business processes. These deny the Department access to some of the most advanced technologies in key areas such as biotechnology. Barriers to the global market created by export control and other constraints also deny the Department access to important advances in technology and increase the cost to the Department.

The acquisition system is also in need of approaches to improve recruiting, training, and retention of the human resources needed to manage a complex enterprise seeking to provide the best systems on time and on cost.

USD(AT&L) has lost much of the technical talent needed – some due to a large decline in numbers of major programs, some due to ethics and conflict of interest practices that deny access to industry experience, and some due to an aging workforce. The Services face similar challenges. This state of affairs places demands on the acquisition training and education establishment that are well beyond current capabilities.

The Secretary of Defense should work with the Administration and Congress to establish an omnibus legislative initiative that would:

- Establish as an aim of public policy recruiting the best qualified technical leaders and specialists from the private sector at the mid-career and senior levels;
- Create uniform standards for financial disclosure, ethics treatment, and related processes; and
- Mitigate the financial impact by substituting transparency, recusal, and other measures to address the “appearance” of conflicts-of-interest.

To address the problems of extensive cost and schedule overruns currently impacting a major set of acquisition activities, the USD(AT&L) and Force Providers need to make more realistic assessments of technical feasibility to include more use of Red Teams and better adherence to the Technology Readiness Level process in concert with incremental development and fielding of new and improved capabilities.

With the increasingly complex systems and systems of systems needed for effective, adaptable forces, integration and manufacturing have become major program risks and need to be included in the readiness assessment.

USD(AT&L) and Force Providers should limit technical reach in seeking capabilities:

- Require that Force Providers build small experienced Technical Red Teams to independently assess technical feasibility,
- Rigorously enforce the Technology Readiness Level process, and
- Include integration risk and manufacturing readiness in the technical assessment.

USD(AT&L) needs to return the acquisition culture to a credible spiral development process. This means limiting the initial spiral to be fielded to a useful increment of added military capability, where there is no worse than moderate risk in achieving cost, schedule, and performance goal with growth potential for future useful increments of needed capability. As each increment is acquired, operational experience and experimentation will provide invaluable insights into what is needed in the next increment. At the same time technology development will provide opportunities that are best exploited with the next increment.

Spiral development is a key to delivering complex capabilities on cost and on schedule. For example, in the cases of the F-15, F-16, and F-18, the first increment was the A model with expectations managed within the limits of well understood risks. These initial deliveries to the combat forces provided capabilities clearly superior to existing fighter aircraft and enabled retirement of systems that were increasingly expensive to maintain and that would probably not be used in combat again. These A models were fielded close to on time and on cost. There were some performance compromises that were made within the bounds of what the user found acceptable as technical difficulties emerged. In contrast to the A model, the F-16, Block 60 and F-15E have combat capabilities not envisioned at the time the A models were designed. Spiral development provided a steady stream of increased military capability delivered, for the most part, on time and on cost. In contrast the tendency today is toward giant single steps with high cost, schedule, and performance risk.

As in the past, technical surprise will be a fact of life and programs cannot meet cost and schedule goals in the face of unforeseen technical challenges if locked into performance requirements that cannot be relaxed without the concurrence of multiple committees who have no accountability for delivering the capability. These decisions must be responsive to the judgments of the Force Providers and those who need the capability to meet mission requirements – the combatant commands.

As needs and opportunities emerge during operations, the Force Providers' response to pop-up warfighter needs tends to be to start working the needs into the next POM. What is needed is a mechanism to respond quickly to operational needs with funding that does not depend on the POM process.

USD(AT&L) should recast the development/production process to:

- Limit the first stage of spiral development to designs providing:
 - A useful increment of added military capability where there is no more than moderate risk in achieving cost, schedule, and performance goals, and
 - Grow capabilities in subsequent spirals as operational experience, experimentation, technology maturation, and program experience dictate.
- Move from requirements-based execution to judgment-based execution
 - Force capability trade-offs to maintain cost and schedule as development challenges emerge and as new capability needs and opportunities are identified.
- Provide a mechanism for the rapid insertion of new capabilities into forces engaged in operations
 - To include systems engineering, funding, and acquisition support; and
- Intensify efforts to maintain stable funding.

In even the most carefully conceived, well structured, and best managed programs, there will be unexpected technical challenges. In the rapidly changing world, there will always be significant changes in the priority of needs between program approval and product delivery. For example, for the F-15A and B-1B programs which were delivered on-schedule and on-cost, the technical challenges with defensive avionics precluded meeting the specified capability. The early models of both were fielded without that capability, on schedule and on cost. Later models incorporated the needed capabilities, with the need further refined with operational experience. All the models provided a large increase in military capability and proved to be highly effective in major combat. The point is that it is almost a certainty that to field any major system on schedule and on cost, there will have to be compromises as technical challenges emerge, and there needs to be mature and credible operational judgment to ensure that those compromises do not undermine the initial military utility.

Furthermore, even in the Cold War Era of only incremental year-to-year change, the relative importance of the military characteristics agreed to at the outset of the program change dramatically by product delivery. For example, an oft-quoted slogan for the F-15, designed as an air superiority fighter, was: “not one pound for air to ground” and the F-15A and C were faithful to that credo. Long before the completion of the planned buy, an all-weather, air-to-ground capability became a high priority for the combatant commander in Europe. The specifications for the E model were vastly different from those envisioned for the F-15 when the program was approved. This capability has proved itself repeatedly in combat. Again, senior people steeped in operational understanding were able to shape the program to meet emerging needs. There are similar examples in past procurements in the Department of the Army and the Navy Department.

The DoD implementation of the acquisition aspects of the Goldwater-Nichols Act provided an acquisition chain of authority outside the Force Provider chain of authority as illustrated in Figure 4.

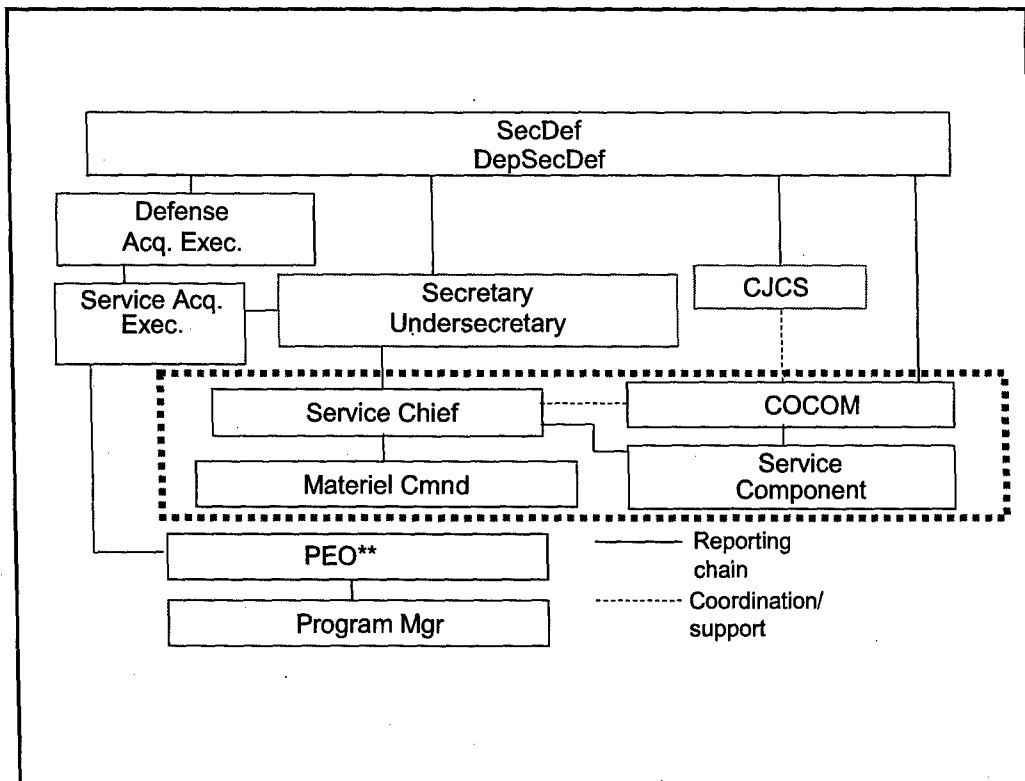

Figure 4. The Acquisition Chain of Authority

The issue – and an inevitable contribution to poor performance in acquisition – is that the most senior operational judgment – the Service chief, material command commander, Service component commander to the combatant command, and thus the combatant commander – is excluded from the acquisition decision chain. In the absence of this accountable operational judgment, the minimum risk approach for the acquisition chain is slavish dedication to often outdated specifications that were approved years before by the Joint Requirements Oversight Council (JROC), numerous Defense Acquisition Board actions, and contract arrangements. This inevitably leads to large cost and schedule overruns. To restore accountability to the Force Provider and to leverage experienced operational judgment and inherent authority, the acquisition chain of authority should be modified to include the senior leadership of the Force Providers as shown in Figure 5.

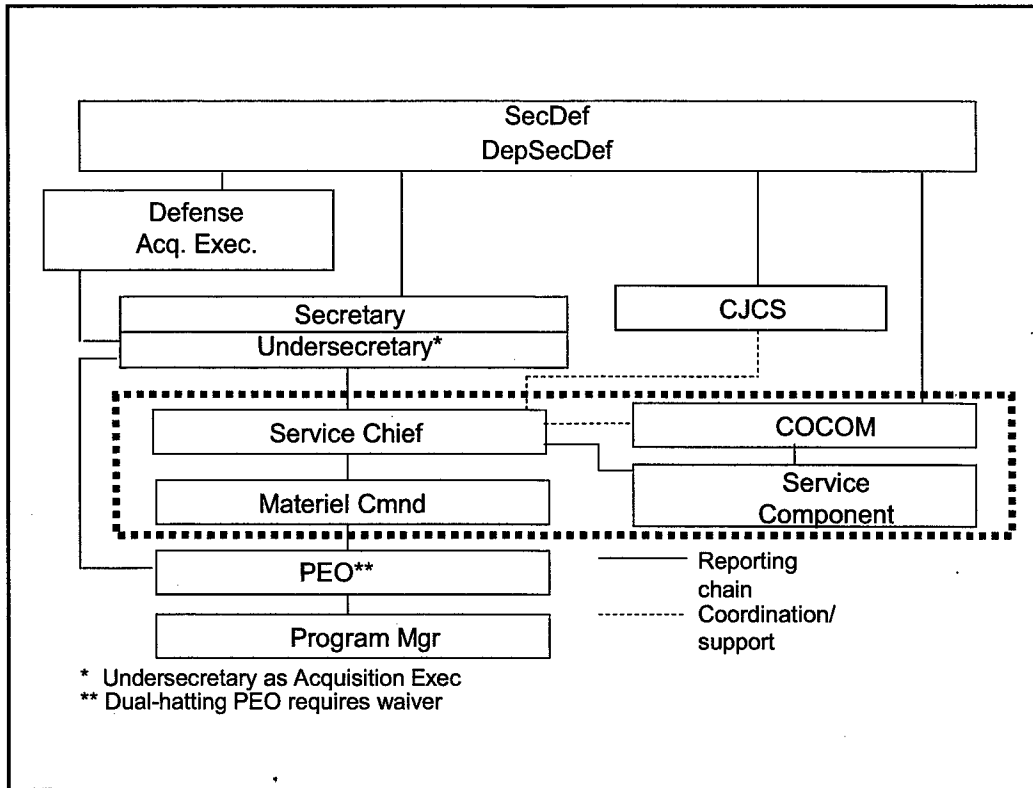
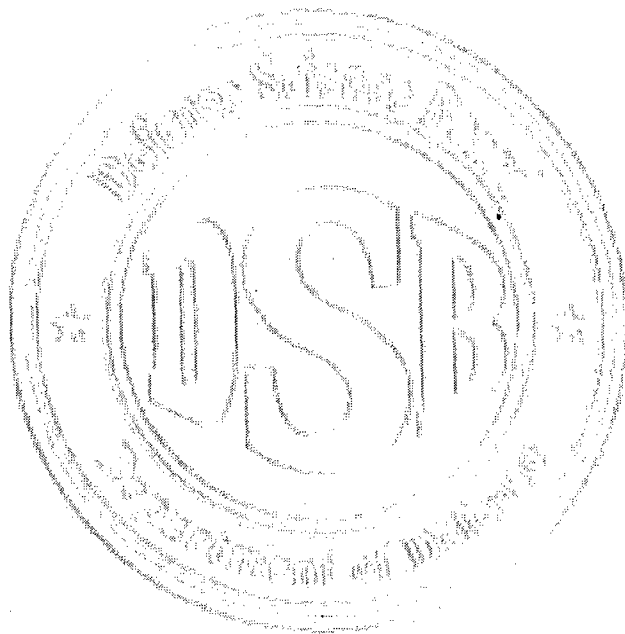

Figure 5. Revised Acquisition Chain of Authority

This change in the chain of authority requires no change to the law. It does require a waiver to DoD directive to dual-hat the PEO. The organization shown in Figure 5 would assign the Service Undersecretary as the Service Acquisition Executive. This would provide the cleanest line of authority but this is not essential to the concept of direct access to the Defense Acquisition Authority and accountability by the Force Provider senior leadership.

The Secretary of Defense should restructure the acquisition process to give Force Providers civilian and military leadership clear responsibility and accountability through the Service chain of authority for delivering approved capabilities.



JOINT CAPABILITIES INTEGRATION AND DEVELOPMENT SYSTEM (JCIDS)

The purpose of the JCIDS is to ensure high priority for the challenges of bringing together Force capabilities for the Force Providers into an effective Joint Force. Important to this purpose is ensuring a strong voice for warfighters tasked with identifying priority needs. In practice, the system has not been found to provide for increased warfighter influence, as it continues to be dominated by the Force Providers and the Joint Staff.

Additionally, the current process has attempted to encompass a wide range of programs to ensure that the entire investment portfolio makes the best investments in needed capabilities. While this is a noble purpose, there are already processes in the DoD to do that, however imperfectly, and attempts to add a JCIDS contribution to that worthy purpose has only rendered the JCIDS so unwieldy as to make it ineffective in its intended purpose of focusing intensely on key challenges faced by the warfighters in integrating and employing Joint Forces.

The CJCS should:

- Restructure the JCIDS to focus the JCIDS and the JROC on key needs to bring force capabilities together to provide integrated joint capabilities across the spectrum of Doctrine, Organization, Training, Materiel, Leadership, Personnel, and Facilities (DOTMLPF). This would empower the J-8 to simplify the JCIDS ponderous processes and apply metrics and best practices. Detailed program assessments should be left to improved versions of other existing processes under the purview of the Secretary, the Deputy Secretary, the USD(AT&L), and the leadership of the Force Providers,
- Leave the detailed assessment of programs to other existing processes, and
- Provide for direct support to the COCOMs to analyze and assess solutions to needs offered by the Force Providers.

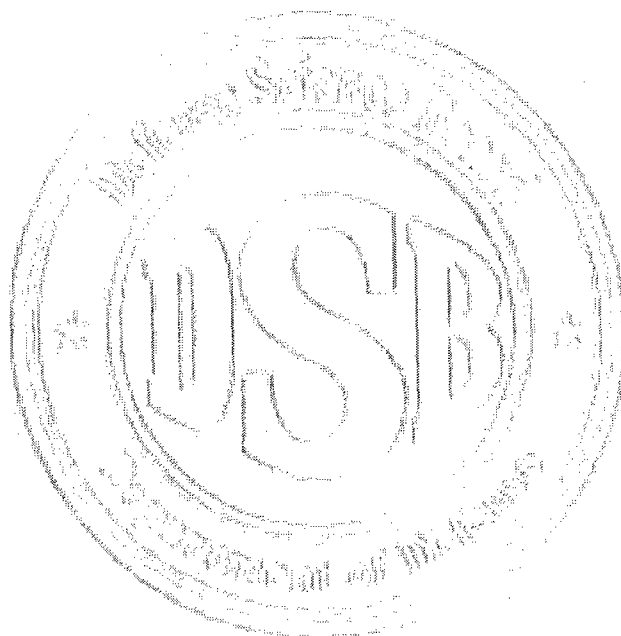

JOINT CONCEPTS

A useful assessment of Joint Concepts development must begin with agreement on what is expected. As currently structured, the pursuit of a complex family of Joint Concepts consumes much energy for little return. Still, there are two useful Joint Concepts purposes. The first is to provide the basis for future “how-to-fight” concepts. The second is to serve as guidance for Force development. Both have to be responsive and dynamic to keep concepts relevant.

Figure 6 provides some examples of “how-to-fight” concepts that evolved from a wide range of intellectual effort. The figure portrays rapid evolution from the first Gulf War in 1991 to Operation Iraqi Freedom (OIF) in 2003. This is particularly noteworthy in that this transformation built on a military success with continuous improvement.

<u>Desert Storm</u>	<u>Iraqi Freedom</u>
• Threat based	Capability based
• Force based	Effects (output) based
• Mass forces	Mass effects
• Contiguous operations	Distributed operations
• Sequential operations	Parallel operations
• De-conflicted Service ops	Integrated Joint operations
• Interoperable	Interdependent
• Organic heavy firepower	Joint fires
• Vertical Information flow	Networked information flow
• Hierarchical C2	Self-synchronizing C2
• Control executes intent	Control informs intent
• Rich forward support	Minimum footprint — rich reachback

A rich set of emerging operating concepts from studies, wargames, experiments, and operational experience

Figure 6. “How-to-fight” concepts

This set of “how-to-fight” concepts virtually revolutionized the way U.S. forces wage major combat operations. For example, the concept in Desert Storm was to deploy multiple divisions—mass forces—to sweep the territory and drive the Iraqis from Kuwait. In OIF, much smaller forces operated in a distributed fashion to use the battlespace as needed to occupy Baghdad and take control of the government.

In Desert Storm, a 100-day air campaign was followed by a 100-hour ground campaign with multi-Service operations deconflicted. In OIF, there was one campaign—the Joint campaign—with simultaneous, interdependent air and ground operations. That is, the ground forces depended on Air Force, Navy, and Marine air support for their heavy firepower, and the

air forces depended on ground forces to increase the exposure of enemy ground forces to air attack.

As for concepts to guide force development, there is clear guidance on the principles for concept development and experimentation suggesting that:

- Concept development and experimentation are linked,
- Red teaming is essential for success,
- Concepts need to be the result of both competitive and collaborative thinking; they are not useful as merely lowest-common-denominator consensus outputs, and
- Warfighters and Force providers need to be continuously engaged to “ensure competition of ideas.”

However, as suggested earlier, the current family of joint concepts requires a broad consensus arrived at with great difficulty. The current work program is overly ambitious and has consumed the efforts of large numbers of valuable personnel with limited return on the investment. The level of effort expended and the consensus necessary to produce a concept can lead to stagnation rather than dynamic change.

The Secretary of Defense and CJCS should:

- Ensure that the concepts are relevant and dynamic guiding capability needs that connect to resource allocation;
- Use COCOM inputs to choose a small critical set of problems for concept development. Select 2 or 3 important areas where we do not have the conceptual basis for the needed capability, then evolve the concept development effort;
- Demand competition of ideas to include continuous participation by concept cells at the regional combatant commands;
- Direct that USJFCOM orchestrate the process; and
- Direct that concepts be more clearly validated by experiments and/or operational experience.

Another recurring theme is the need for the Department to lead significantly more effective multi-agency integration, which should start at the concept level.

DISRUPTIVE CHALLENGES

A special category of capability concern is the potential of disruptive challenges—that is the emergence of increased capabilities for adversaries to negate critical U.S. capabilities such as precision attack, dominant battlespace awareness, decision superiority, or a set of the “how-to-fight” concepts described earlier. Potential disruptive challenges could also be defined as those that marginalize U.S. influence in areas critical to U.S. interests, to include denying access or use of international airspace, freedom of the seas, operations in space, or use of cyberspace. Presently, a number of attack modes exist that, if executed, could have disruptive effects on the U.S. homeland. Finally, there are new technologies where our own understanding of their potential power is immature at best.

While the Task Force found extensive activity in the area of disruptive challenges, it did not find a comprehensive, coherent effort to identify and address these challenges. Instead, Task Force findings indicate that much of the current effort addresses excursions to traditional challenges or approaches that the US can use to disrupt adversary operations rather than the reverse—adversary as disruptor. Technology is only one enabler of new capabilities and adversaries are demonstrating considerable skill in fielding new capabilities using readily available technology.

The process of searching and dealing with disruptive challenges needs to be embedded in the regular business of the DoD so that its products can inform intelligence collection and analysis, concept development and experimentation, operational planning and DOTMLPF investments.

The Secretary of Defense should:

- Set the “disruptive” threshold well above excursions from traditional challenges;
- Establish an integrated effort that includes:
 - Red-teaming to ensure that the scope of the effort is wide and in-depth,
 - Net Assessment to help decision makers understand the possible consequences and prioritize responses; and
- Assign the overall responsibility to USD/Policy.

AN EMERGING TRANSFORMATION DRIVER

The demands of continuing operations in Afghanistan and Iraq have produced a cadre of military personnel at multiple levels from Sergeant to General Officer who have, in effect, served in a broad set of roles, often simultaneously (e.g., warriors, mayors, security providers, service providers, trainers, infrastructure builders, non-kinetic operations practitioners, public relations, etc.). They did so with little guidance but with empowerment from above. This cadre provides a capability that is unique and that was created at great cost. The Department can take advantage of this cadre as a major force for change particularly since these individuals are highly oriented towards change and can deal effectively with ambiguity and uncertainty—key characteristics of the environment demanding transformation.

The Department needs to ensure that future assignments leverage this experience, because of the inherent value to the DoD and because the demand outside of the Department for personnel with these experiences and proven capabilities is high. Because the current structure may not have existing positions calling for these special qualifications, the Secretary of Defense should task the Service Chiefs to track, assign, empower, and reward this special cadre. Special attention is warranted to create opportunities for utmost utilization of their capabilities. It is important that the Department move quickly to leverage their capabilities. It is important that the Department moves quickly to leverage the unique experiences of these people so as not to lose them to the private sector.

The SecDef should task the Service Chiefs to:

- Identify and track (via a specialty qualification) these differentially experienced individuals;
- Manage and assign these personnel to positions enabling them to be change agents for transformation; and
- Empower them and set conditions for their success.

The SecDef and CJCS should:

- Identify positions and projects where these individuals can be effective change agents, and
- Create new positions and projects to do the same.

MULTI-AGENCY INTEGRATION

The National Security Strategy extends beyond combat objectives—and beyond stability and reconstruction before, during, and following combat—to establish functioning free enterprise economies and democracies. It is important to understand that the National Security Strategy is about more than combat objectives or even stability and reconstruction operations. In fact, the set of broader goals is far more demanding, complex, costly, and wide reaching in scope than achieving victory on the battlefield. Meeting the National Security Strategy objectives requires a robust and integrated civilian-DoD, multi-agency capacity as part of a broader strategic focus to enable the full array of available U.S. capabilities to achieve strategic objectives.

The Task Force determined that the enterprise does not have a multi-agency integrated planning capability that is able to produce executable multi-level campaign plans, such as campaign plans to serve major strategic objectives (e.g., WMD proliferation, militant Islam, China, Struggle Against Violent Extremists, etc.), and campaign plans for a range of places and issues to achieve specific strategic objectives, (e.g., N. Korea, Iran, maritime interdiction, covert action, pop-up contingencies, etc.). These integrated, multi-agency campaign plans are needed to mobilize, commit and employ the needed set of national capabilities to serve major strategic objectives, and to direct the needed capabilities to achieve strategic objectives in more narrowly define places and issues. The process also needs to include dynamic planning to deal with pop-up contingencies and needs to be able to support strategic operations ranging from long-term shaping and strengthening the capacity of institutions, to stabilization and reconstruction activities before, during, and after combat. It is important to note that the need for this process cannot be adequately addressed after the onset of a crisis. These multi-agency efforts must be integrated, synchronized, and resourced from the onset of strategic operation planning.

The U.S. government-civilian agencies and the DoD do not have sufficient experience in multi-agency activities and lack training and educational programs to provide competence in multi-agency campaign planning and execution. It is essential that multiple agencies employ shared collaboration, decision-making aids, and execution tools to assess, plan, and execute integrated operations.

While the Department cannot control or assume responsibility for multi-agency integration, it seems clear that success will require the leadership of the agency with the greatest stake in most operations—the DoD. Accordingly, the Secretary of Defense should lead the National Security Council (NSC) in creating the mechanisms and processes required to deliver a multi-year National Security Strategic Plan for the President's consideration every other year. The plan needs to contain enough detail to be executable by identifying likely places and issues (and assigning strategic objectives for each), by describing the plan's desired outcomes, and by assigning specific responsibilities with metrics to agencies.

The NSC also needs to establish standing oversight groups and task forces to produce the needed multi-agency campaign plans focusing on proactive shaping, but also providing for the full range of possible responses if shaping proves inadequate. The Task Force believes that none of this will be effective unless there is a standard process to ensure resource allocation to meet objectives. The NSC should require an Office of Management and Budget (OMB) review during the annual budget cycle for that purpose.

As suggested earlier in this section, there will be unique training, education, and experience requirements to provide competency for multi-agency planning and execution. This

means there must be the needed headroom to allow people to gain the competency, rewards for that competency, and active work to persuade the right people to engage in multi-agency activities. There also needs to be a standardized set of tools across appropriate agencies to facilitate planning collaboration and integrated execution.

In addition to the leadership role with the NSC, the Secretary of Defense needs to strengthen DoD capabilities for multi-agency operations by developing doctrine for military support of civilian agencies, creating mechanisms for DoD support to the multi-agency planning process, and adapting proven DoD Joint planning processes to multi-agency compatibility. Additionally, the Department's training and education system can and should include multi-agency planning and education.

The Secretary of Defense should:

- Lead the NSC effort to create a mechanism to provide the President with a five-year National Security Strategic Plan (NSSP) to:
 - Identify the places and issues requiring multi-agency campaign plans;
 - Establish the strategic objective of each place and issue;
 - Detail the end-state and metrics; and
 - Assign specific taskings with key performance parameters.
- Establish standing multi-agency oversight groups and task forces for the NSC for each selected place or issue. Each task force is to:
 - Produce a multi-agency campaign plan for each selected place of issue;
 - Focus on proactively shaping the environment in selected nations and regions; and
 - Provide for a range of responses if shaping is inadequate.
- With OMB, conduct a review during the annual budget cycle to ensure that resource allocations and expenditures match the selected priorities and plans.

The NSC should cause U.S. Government agencies to provide training, education, and experience for competency in planning and executing integrated multi-agency operations to include:

- Creating headroom and billets for cross-agency personnel exchanges;
- Establishing career paths and incentives that reward multi-agency experience similar to the DoD Joint practice for Joint service;
- Recruiting personnel who seek overseas deployments, and reward those who accept such assignments; and
- Developing standardized tools to assess, plan, and execute missions.

The Secretary of Defense should strengthen DoD capacities for effective integrated multi-agency operations by:

- Developing doctrine that guides military support of civilian agency diplomatic and economic solutions to strengthen nation-states;
- Creating mechanisms for responsive DoD support of the multi-agency planning processes;
- Adapting Joint planning processes for multi-agency inputs and to inform multi-agency integrated (MAI) planning;
- Structuring DoD's training and education system to include the Services professional education to reflect these new requirements; and
- Establishing criteria so that the officer promotion system rewards MAI education and experience in a manner similar to Joint education and experience.

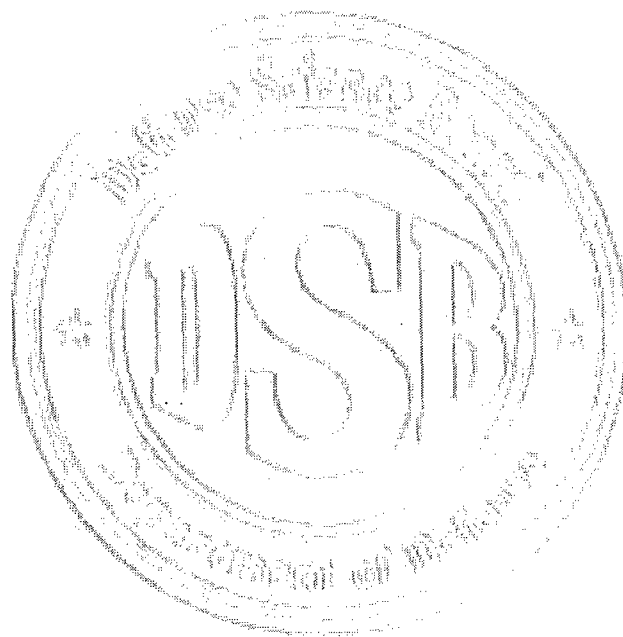

JOINT FORCES DEVELOPMENT

Continuous evolution has produced a revolutionary transformation of major combat capabilities with the process strongly accelerated by the major contingencies in Afghanistan and Iraq and by current counter-terrorism activities.

As expected, the greatest advances have come from increased attention to integrating force capabilities provided by the Services into effective Joint forces. To this end, there are new levels of Army/Marine collaboration in doctrine, equipment, C2, and other key aspects. The Task Force also sees new relationships between conventional forces and special operations components. The Department has transitioned from deconflicted, interoperable concepts to integrated, interdependent operations, to include ground forces dependence on air-delivered firepower closely integrated into the ground maneuver plan. The Department now needs to extend these experiences to the broader set of missions and to the multi-agency arena. The Department also needs to continue the transformation of major Force capabilities to address continuing weaknesses, e.g:

- The need for mechanisms and processes to quickly leverage current combat experiences;
- A more coherent understanding of the national objectives by the operating forces and a better understanding of strategic objectives at the tactical level;
- Improved intelligence preparation of the battlespace;
- More mature C2 and information integration, and
- Capacity and systemic problems in strategic deployment to include deployment planning information and support systems.

The demands of deployment and employment are increasingly complex and have substantial technical systems content. Also, since U.S. forces are likely to remain involved in operations continuously there is a critical need to be able to insert capabilities rapidly into ongoing operations. Consequently, the DoD, especially the COCOMs requires readily available competent systems engineering support.

LOGISTICS

Logistics is, by any measure, big business in the Department, employing over 1 million people and carrying an inventory of roughly \$67 billion, with a significant part of that inventory no longer relevant to activities and systems being supported. One measure of responsiveness is distribution of in-stock items in response to user orders. Since 1996, the logistics system has improved its delivery time from 26 to 21 days in comparison to large commercial operations that routinely deliver in 1-3 days.

Transformation of logistics capabilities will be heavily dependent on integrated business systems and educated and motivated people who understand what is expected. In current practice, there is an internal transaction for each segment in the supply chain (e.g., from depot packaging to depot shipping; from depot shipping to package consolidation into truck-size loads; from truck movement to strategic shipping mode; and from strategic transportation to theater receiving, repackaging, movement, etc.). Furthermore, the system optimizes each segment (e.g., filling the trucks or rail cars for efficient use, optimizing the efficiency of the strategic

transportation, repackaging for efficient use of theater transport). Optimizing each segment inevitably sub-optimizes the major objective of end-to-end movement from source to user. Integrated business processes supported by integrated business systems are essential in place of the currently fractionated process using some 600 different information systems and system architectures that apply technology to legacy practices rather than best practices.

Over the past several decades, there have been large numbers of studies, recommendations, new processes, very large information systems projects, and new organizations created in search of an effective end-to-end logistics supply chain. In one of the many prior efforts to forge an end-to-end supply change, U.S. Transportation Command (USTRANSCOM) was assigned the additional mission of Distribution Process Owner (DPO). While this was an important step, it did not go far enough to meet the objective of an effective supply chain. The necessary step is to assign a joint command the authority and accountability for providing this essential support to global operations.

This Joint Logistics Command would subsume the current USTRANSCOM mission, would absorb the Defense Logistics Agency (DLA), and would be supported by the Service logistics commands in a component command role. The Service logistics commands would continue to perform their Service functions, as is the case with other component commands.

Theater commanders would continue to be responsible for harmonizing the logistics flow demand with operations in the theater. System program managers would retain responsibility for the life cycle support plan and for configuration control of the supported system. An integrated logistics information system is also necessary for an effective end-to-end supply chain.

Numerous commercial enterprises exist that regularly practice and employ these means. The command should form an external board of advisors comprised of personnel from the commercial sector with the appropriate industry expertise and experience.

The Secretary of Defense should create a Joint Logistics Command:

- Responsible for global end-to-end supply chain,
- That includes the TransCom mission, DLA, Service logistics and transportation commands as components to JLC with:
 - Regional Combatant Commanders retaining operational control of the flow of in-theater logistics; and
 - Program Managers retaining responsibility for lifecycle logistics support plan and configuration control.

An integrated logistics information system will be essential to eliminate the need for multiple systems with multiple transactions across multiple seams.

The USD/AT&L should:

- Lead the work to create an integrated logistics information system, and
- Appoint an external advisory board of relevant industry experts to assist in guiding this effort.

NETWORK-ENABLED OPERATIONS

The output of a functioning network-enabled system is to provide the best available information to decision makers at all levels in a wide range of environments and circumstances. Support for this concept includes robust infrastructure, policies, and support to provide for the competency necessary by its users.

To realize the potential of networked-enabled system, the Joint Forces culture will have to value horizontal integration and information sharing, which necessitates a movement from need-to-know to right-to-know. This approach will mean that information does not belong to the originator or the holder; it will belong to anyone who needs it and has a right to it. The decision maker will determine their need for the information, based on the bounds of classification.

In their assessment of this concept, the Task Force recognizes that the Department's understanding of the net-enabled (net-centric) concept is maturing. The demands of distributed operations and the mercurial nature of operational demands in Afghanistan and Iraq have led to a near-explosive growth in horizontal integration with practitioners embracing a wide variety of enablers—inside and outside normal channels. Despite this increased awareness of the net-enabled concept, progress in providing the necessary infrastructure, services, and policies is lagging.

Communities of interest (COI), comprised of entities with shared purposes and needs, are forming and registering. Their purpose is to address the issues of sharing data and applications and provide the necessary interfaces for connecting global network services. As such, the network-centric operational environment (NCOE) is essential for providing horizontal integration across the COIs. Failure or the inability to do so can lead the COI effort into a new set of stovepipes.

The challenges of providing Joint C2 capabilities and the supporting NCOE warrant special attention. The DoD Chief Information Officer (CIO) should have responsibility and accountability for providing capabilities to the NCOE. The U.S. Joint Forces Command (USJFCOM) is currently assigned the mission of supporting theater C2 needs, and U.S. Strategic Command (USSTRATCOM) the global C2 services mission. However, the assignment needs clarification to ensure understanding across the combatant commands, the Joint Staff, and the Force Providers.

The Secretary of Defense should:

- Assign clear responsibilities for joint C2 capabilities and NCOE development:
 - DoD CIO for NCOE infrastructure, policies, and services,
 - USJFCOM for theater-level joint C2 systems support, and
 - USSTRATCOM for global C2 services.

The current processes for selecting and deploying capabilities wastes a significant share of reservists' active duty time, creates transportation bottlenecks, and does not provide timely response to COCOM mission needs.

The need for persistent surveillance is widely accepted, yet the details of persistent surveillance in operational terms are not well understood. The increasing complexity of information systems, including those supporting C2, make demands on operators that require continuous systems engineering support. Therefore, USJFCOM is the logical choice as the entity

responsible for providing that capability, as USJFCOM has numerous regional COCOM support missions.

The Secretary of Defense should assign JFCOM the task of developing an end-to-end joint force management (selection and deployment system). CJCS and USD (I) should describe the concept of persistent surveillance in operational terms.

USD(AT&L) should establish the systems engineering capability at USJFCOM to support the regional COCOM need for support in applying net-enabled infrastructure and services.

The Department's lessons-learned mechanisms could focus special attention on capturing the unique experiences of Army and USMC officers in Operation Iraqi Freedom (OIF) and Operation Enduring Freedom (OEF). Throughout OIF/OEF, Army and USMC officers have conducted combat as well as stability-and-reconstruction operations, virtually simultaneously. To meet those mission demands, forces operating in the theater have worked freely to create networking solutions at multiple levels. Examples include <http://www.companycommander.com>, <http://www.platoonleader.com>, and CAVNET (the 1st Cavalry Division internet). The Department should take action to ensure that these innovative experiences are captured and leveraged.

DEFENSE INDUSTRY

INDUSTRIAL BASE

With the rapidly evolving demands on the Forces, the Defense Industrial Base must deal with a new and changing acquisition landscape requiring that platforms be more and more effective (e.g., electronics, software, information technology, and services). The handful of defense contractors who produce these platforms must also shift their focus. Furthermore, as support and system operations become more complex, the defense industry will be called on to provide a wider range of services to the forces.

While there are fewer major platform programs, there is greatly increased emphasis on system-of-systems engineering, ranging from complex system-of-systems configurations within platform programs (e.g., F-22, JSF, Next Generation Submarine) to complex multi-system programs (e.g., Future Combat System and Missile Defense). Unfortunately, industry has experienced difficulty meeting program management and system engineering challenges due to declining numbers in program management personnel and experienced engineers.

The Defense Industrial Base is increasingly isolated from the broader domestic and the global economy. It is less agile and innovative than it once was. The industrial base operates under a unique set of rules and regulations that deters industry providers. Also, there are an increasing number of barriers that prevent access to non-U.S. sources of technology. As the DoD undergoes transformation, access to non-U.S. sources of technology will be vital to maintaining state-of-the-art capabilities within the enterprise.

Anyone doing business with the Department of Defense must adhere to the myriad rules, regulations, and practices that are peculiar to serving the DoD. These obstacles limit the use of Other Transactions Authority (OTA), Federal Acquisition Regulation (FAR) Part 12, and other programs to reach beyond traditional defense companies. In order to attract commercial sources, the DoD will have to embrace commercial business practices.

USD(AT&L) should renew efforts to remove barriers that prevent the entry of non-traditional companies to the Defense business and Defense access to commercial technology, attacking the myriad rules, regulations, and practices that limit the use of OTA, Part 12, and other programs to reach beyond traditional defense companies.

To assure U.S. access to the best technologies and the full range of needed capabilities, USD(AT&L) needs to focus more intensely on integrating the DoD's access to the global and commercial supply chains. Export controls that limit relationships and access must be addressed and the munitions list reduced. Delays within the export license process can be avoided by shortening the process, increasing discipline, and controlling actions—set an achievable response standard and enforce it.

USD(AT&L) should take steps to achieve greater integration of DoD, global defense, and commercial supply chains:

- Undertake a renewed effort to reform/simplify export controls and dramatically shorten the munitions list, and

- Dramatically shorten the export license process – set an achievable response standard and enforce it.

HUMAN RESOURCES (HR)

It is clear that the Department is making greater demands on its people across a broad spectrum of complex environments. HR issues driven by transformation include language and culture education, training and ranges, the military and government civilian manpower and personnel systems, the Reserve Forces, and the use of Service contractors. To enable transformation of the enterprise requires a more adaptive, experienced, broadly educated total Force to meet the increasing spectrum of demands in Joint, multi-agency, and international environments. Additionally, the DoD must employ effective and adaptive training regimens to integrate and balance forces comprised of active and reserve military, government civilian, and Service contractors. The Task Force found that while the DoD has done well in moving to an all-volunteer Force, there are new challenges in sustaining a professional Force that can meet rapidly changing needs.

Occupation*	# Civ		# Mil		Total	
	1996	2005	1996	2005	1996	2005
Maintenance/ Engineering	233	198	445	402	678	600
Administration	262	270	119	207	382	476
Combat	12	8	324	296	336	304
Service, Supply, and Procurement (Logistics)	132	92	152	127	283	218
Health/Medical	28	28	131	112	159	140
Technical	114	76	91	50	205	128
Comm/Intelligence	6	7	137	118	143	125
Other/Unknown	50	8	180	60	229	69
Total	874	687	1,599	1,370	2,472	2,057

* PA&E categories

Figure 7. DoD Human Resources Allocation (1000s)

Figure 7 illustrates the Department's current allocation of human resources in thousands. The chart categorizes people by occupation using specified PA&E categories, but does not reveal what people are actually doing. Nevertheless, it provides compelling evidence of the need for more attention to how human resource is used. For example, there are about one-third more military people maintaining systems than are assigned to operate them in combat. There are also about two-thirds as many military people in administration as in combat specialties. Only about

one-fifth of the people in uniform are in combat specialties. There has been no significant change in this ratio during the past ten years despite numerous tooth-to-tail efforts. To address human resource allocation shortfalls within the enterprise, the DoD should use military personnel for military functions only and use civilian government personnel for other inherently governmental functions.

Competitive sourcing should be utilized for all other functions under A-76. Furthermore, this Task Force strongly urges USD(P&R) to conduct an audit of military, civilian, and contractor personnel (including their full cost), give first priority to warfighting needs, and develop and monitor a time-phased plan with milestones to realign human resources.

The Secretary of Defense should direct (consistent with the President's Management Plan #5):

- Use military people for military functions,
- Use civilian government personnel for other inherently governmental functions, and
- Use competitive sourcing for all other functions under A-76.

USD(P&R) should:

- Conduct an audit of military, civilian, and contractor personnel - including their full cost,
- Give first priority to warfighting needs, and
- Develop and monitor a time-phased plan with milestones to realign human resources.

The military's HR system has produced outstanding leaders and warfighters. Moreover, the DoD has successfully built an all-volunteer force that is the most powerful and effective combat force in the world by a wide margin. Despite these advances, it is not postured to meet future needs.

The Task Force found that current career rules are inefficient and inflexible based on a "one size fits all" model of arbitrary career profiles governed by Defense Officer Personnel Management Act (DOPMA). Rules governing 20-, 30- and 35-year retirements (with vesting at 20 years) demonstrate an overly simplistic approach to HR management that retains some personnel beyond their most effective contribution to the enterprise, and contributes to the early departure of other personnel when their contribution is still much needed. It is clear to this Task Force that the 20-year retirement rule creates incentives contrary to the needs of the Department.

By the extent of the Department's favoring of youth over experience, the current value system has driven valuable individuals into mandatory separation from the enterprise. For example, highly productive military personnel with seven to eight years of experience in some specialties such as aircrew, engineering, and information technology (IT), are at the beginning of their period of greatest value to the DoD. They must then decide to remain for 20 years or leave the military to begin building a new career that includes vesting in a retirement plan.

Additionally, the military's HR system has not manned much-needed specialty occupations, such as acquisition executives, foreign area officers, and IT specialists. The system currently invests inefficiently in education and training, and needs to be better synchronized with career paths. Moreover, today's operations demand increased responsibility at lower levels. Fortunately, junior leaders are demonstrating extraordinary aptitude for learning on the fly.

Technology has also multiplied the effects controlled by individuals, as evidenced by company-grade officers controlling divisions' worth of firepower and brigades' worth of territory.

To address the training needs of the Force, USD(P&R) should leverage the experience of the Service-based training revolution for Joint training and education. There has long been a need for a multi-dimensional⁵ training environment and it must accommodate multi-Service participation in Joint training. It also needs to leverage the potential of live, virtual (simulators), and constructive (simulations) support for training. The Joint National Training Capability initiative, managed by USJFCOM with USD(P&R) and Joint Staff J-7 oversight, provides the framework for the needed set of programs. The Department has identified important new demands on training for individuals and units in ongoing operations and these lessons need to be expeditiously folded into education and training programs. While the full set of live, virtual, and simulation approaches contribute to both training and testing, USD(P&R) and the Force Providers need a robust plan to sustain the essential range structure in the face of the various pressures on air, sea, and land space.

The Task Force's assessment of the civilian HR system reveals a longstanding need to implement the National Security Personnel System for civilian HR management that will give the Secretary of Defense control over the civilian workforce. Continued delays in implementation of the system endanger hard-fought legislative accomplishments, including Congress's support of the initiative. The Task Force strongly recommends that the Secretary of Defense accelerate and implement the redesign of the military HR management system.

The Task Force has found unprecedented demand for contractors to provide a wide range of services in the combat zone. Given the distributed nature of combat, there is no way to separate areas as previously done in past conflicts. Contractors are often directly involved in areas where combat actions are occurring. This raises a range of unresolved legal issues regarding the contractors' relationship to the military commander, status of Force issues, legal authorities of the military commander and the host nation, etc. These issues need to be resolved quickly for the short term and carefully assessed for the long term.

Furthermore, as military operations in the field increasingly depend on contractors who must operate in harm's way to provide the needed services, DoD needs to find approaches that will boost confidence in the readiness and willingness of the contractor community to provide these services in high-risk combat environments.

Finally, there is a lack of language and cultural understanding within the DoD. The Task Force realizes that this is not a new issue and that it has been a problem for U.S. military operations since the Indian Wars of the 19th century through the Philippine Insurrection in the early 20th century, in Vietnam, and again in current operations. The Task Force urges the DoD to develop a focused approach that addresses the inadequate quantity and quality of language and cultural understanding skills and expertise required for long-term success.

The Secretary of Defense should:

- Accelerate and implement the ongoing redesign of the military career system to leverage experience and emphasize performance, and
- Demand aggressive implementation of the National Security Personnel System to give DoD management control of the civilian HR.

⁵ Multi-dimensional is at least two ways.

The USD(P&R) should:

- Develop a Reserve forces model that improves predictability for Reserve Forces' active duty commitments;
- Provide an effective mechanism and process to keep employers of Reserve members serving on active duty informed of changes in commitments; and
- Create a strategic focus on meeting the needs for language skills and cultural understanding.

The USD(P&R) and Force Providers should:

- Extend Service-based training transformation advancements to Joint activities;
- Build a multi-dimensional training environment (including live training, simulations, and simulators) through the Joint National Training Capability (JNTC);
- Ensure that operational "lessons" are integrated into education and training; and
- Develop a robust range plan to ensure that the mix of real and simulated capabilities support the need for future realistic testing and training.

SUMMARY OF RECOMMENDATIONS

DOD BUSINESS PRACTICES

The Secretary of Defense should:

- Assemble a small direct-reporting cell to create and maintain a metric-based, multi-year plan that specifies what is to be done, when, with what resources, and with what capability output – to discipline:
 - Allocating resources to mission purpose,
 - Constraining plans to intended resources,
 - Plan execution by Force Providers with OSD oversight, and
 - Measuring progress against plan objectives.
- Enforce the roles assignment in the force building process, and
- Require that Combatant Commanders make inputs on priorities in a resource constrained context with tradeoffs within their mission account.

The Secretary of Defense should address the need for an integrated DoD business management information system by:

- Designating USD(AT&L) as the lead organization to manage acquisition of all new business process support systems;
- Ensuring that these systems are network-enabled to provide the shared information and collaborative planning essential to a complex, adaptable enterprise;
- Maintaining the integrity of COTS systems, adjust the business processes accordingly, and adapt appropriate interfaces;
- Ensuring adequate authority over architecture, applications, resources, and personnel to achieve implementation; and
- Hiring experienced key people to lead the Department effort and outsource the balance.

The Secretary of Defense should work with the Administration and Congress to establish an omnibus legislation initiative that would:

- Establish as an aim of public policy recruiting the best qualified technical leaders and specialists from the private sector at the mid-career and senior levels;
- Create uniform standards for financial disclosure, ethics treatment, and related processes; and
- Mitigate the financial impact by substituting transparency, recusal, and other measures to address the “appearance” of conflicts-of-interest.

USD(AT&L) and Force Providers should limit technical reach in seeking capabilities:

- Require that Force Providers build small experienced Technical Red Teams to independently assess technical feasibility;
- Rigorously enforce the Technology Readiness Level process; and
- Include integration risk and manufacturing readiness in the technical assessment.

USD(AT&L) should recast the development/production process to:

- Limit initial spiral development to designs providing:
 - A useful increment of added military capability where there is no more than moderate risk in achieving cost, schedule, and performance goals,
 - Grow capabilities in subsequent spirals as operational experience, technology maturation, and program experience dictate.
- Move from requirements-based execution to judgment -based execution,
 - Force capability trade-offs to maintain cost and schedule as development challenges emerge and as new capability needs and opportunities are identified.
- Provide a mechanism for the rapid insertion of new capabilities into forces engaged in operations to include systems engineering, funding, and acquisition support, and
- Intensify efforts to maintain stable funding.

The Secretary of Defense should restructure the acquisition process to give Force Providers civilian and military leadership clear responsibility and accountability through the Service chain of authority for delivering approved capabilities.

JOINT CAPABILITIES INTEGRATION AND DEVELOPMENT SYSTEM (JCIDS)

The CJCS should:

- Restructure the JCIDS to focus the JCIDS and focus the JROC on key needs to bring force capabilities together into integrated joint capabilities across the spectrum of Doctrine, Organization, Training, Materiel, Leadership, Personnel, and Facilities (DOTMLPF),
- Leave the detailed assessment of programs to other existing processes, and
- Provide for direct support to the COCOMs to analyze and assess solutions to needs offered by the Force Providers.

JOINT CONCEPTS

The Secretary of Defense and CJCS should:

- Ensure that the concepts are relevant and dynamic guiding capability needs that connect to resource allocation,
- Focus the concept development and experimentation work on a manageable set of challenges and insist on competition of ideas to include continuous participation by concept cells at the regional combatant commands,
- Direct that USJFCOM orchestrate the process, and
- Direct that concepts be validated by experiments and/or operational experience.

DISRUPTIVE CHALLENGES

The Secretary of Defense should:

- Set the “disruptive” threshold well above excursions from traditional challenges,
- Establish an integrated structure and process that includes:
 - Red-teaming to ensure that the scope of the effort is wide and in-depth,
 - Net Assessment to help decision makers understand the possible consequences and prioritize responses, and
- Assign the overall responsibility to USD/Policy.

AN EMERGING TRANSFORMATION DRIVER

The SecDef should task the Service Chiefs to:

- Identify and track (via a specialty qualification) these differentially experienced individuals,
- Manage and assign these personnel to positions enabling them to be change agents for transformation, and
- Empower them and set conditions for their success.

The SecDef and CJCS should:

- Identify positions and projects where these individuals can be effective change agents, and
- Create new positions and projects to do the same.

MULTI-AGENCY INTEGRATION

The Secretary of Defense should:

- Lead the NSC effort to create a mechanism to provide the President with a five-year National Security Strategic Plan (NSSP) to:
 - Identify the places and issues requiring multi-agency campaign plans;
 - Establish the strategic objective of each place and issue;
 - Detail the end-state and metrics; and
 - Assign specific taskings with key performance parameters.
- Establish standing multi-agency oversight groups and task forces for the NSC for each selected place or issue. Each task force is to:
 - Produce a multi-agency campaign plan for each selected place or issue;
 - Focus on proactively shaping the environment in selected nations and regions; and
 - Provide for a range of responses if shaping is inadequate.
- With OMB, conduct a review during the annual budget cycle to ensure that resource allocations and expenditures match the selected priorities and plans.

The NSC should cause U.S. Government agencies to provide training, education, and experience for competency in planning and executing integrated multi-agency operations, to include:

- Creating training headroom and billets for cross-agency personnel exchanges;
- Establishing career paths and incentives that reward multi-agency experience similar to the DoD practice for Joint service;
- Recruiting personnel who seek overseas deployments, and reward those who accept such assignments; and
- Developing standardized tools to assess, plan, and execute missions.

The Secretary of Defense should strengthen DoD capacities for effective integrated multi-agency operations by:

- Developing doctrine that guides military support of civilian agency diplomatic and economic solutions to strengthen non-states;
- Creating mechanisms for responsive DoD support of the multi-agency planning processes;
- Adapting Joint planning processes for multi-agency inputs and to inform multi-agency integrated (MAI) planning;

- Structuring DoD's training and education system to include the Services professional education to reflect these new requirements; and
- Establishing criteria so that the officer promotion system rewards MAI education and experience in a manner similar to Joint education and experience.

JOINT FORCES DEVELOPMENT

The Secretary of Defense should create a Joint Logistics Command:

- Responsible for global end-to-end supply chain,
- That Includes the TransCom mission, DLA, Service logistics and transportation commands as components to JLC with;
 - Regional Combatant Commanders retaining operational control of the flow of in-theater logistics, and
 - Program Managers retaining responsibility for lifecycle logistics support plan and configuration control.

The USD(AT&L) should:

- Lead the work to create an integrated logistics information system, and
- Appoint an external advisory board of relevant industry experts to assist in guiding this effort.

The Secretary of Defense should:

- Assign clear responsibilities for joint C2 capabilities and NCOE development:
 - DoD CIO for NCOE infrastructure, policies, and services,
 - USJFCOM for theater-level joint C2 systems support, and
 - USSTRATCOM for global C2 services.

The Secretary of Defense should assign JFCOM the task of developing an end-to-end joint force management (selection and deployment system).

CJCS and USD (I) should describe the concept of persistent surveillance in operational terms.

USD(AT&L) should establish the systems engineering capability at USJFCOM to support the regional COCOM need for support in applying net-enabled infrastructure and services.

DEFENSE INDUSTRY

USD(AT&L) should renew efforts to remove barriers that prevent the entry of non-traditional companies to the Defense business and Defense access to commercial technology, attacking

the myriad rules, regulations, and practices that limit the use of OTA, Part 12, and other programs to reach beyond traditional defense companies.

USD(AT&L) should undertake work that is focused towards greater integration of DoD, global defense, and commercial supply chains, to include:

- Undertake a renewed effort to reform/simplify export controls and dramatically shorten the munitions list, and
- Dramatically shorten the export license process – set an achievable response standard and enforce it.

HUMAN RESOURCES

The Secretary of Defense should direct (consistent with the President's Management Plan #5):

- Use military people for military functions,
- Use civilian government personnel for other inherently governmental functions, and
- Use competitive sourcing for all other functions under A-76.

USD(P&R) should:

- Conduct an audit of military, civilian, and contractor personnel - including their full cost,
- Give first priority to warfighting needs, and
- Develop and monitor a time-phased plan with milestones to realign human resources.

The Secretary of Defense should:

- Accelerate and implement the ongoing redesign of the military career system to leverage experience and emphasize performance; and
- Aggressively pursue implementation of the National Security Personnel System to give DoD management control of the civilian HR.

The USD(P&R) should:

- Develop a Reserve forces model that improves predictability for Reserve Forces' active duty commitments,
- Provide an effective mechanism and process to keep employers of Reserve members serving on active duty informed of changes in commitments, and
- Create a strategic focus on meeting the needs for language skills and cultural understanding.

The USD(P&R) and Force Providers should:

- Extend Service-based training transformation advancements to Joint activities,
- Build a multi-dimensional training environment (including live training, simulations, and simulators) through the Joint National Training Capability (JNTC),

- Ensure that operational “lessons” are integrated into education and training, and
- Develop a robust range plan to ensure that the mix of real and simulated capabilities support the need for future realistic testing and training.



APPENDICES

A. TERMS OF REFERENCE



ACQUISITION,
TECHNOLOGY
AND LOGISTICS

THE UNDER SECRETARY OF DEFENSE

3010 DEFENSE PENTAGON
WASHINGTON, DC 20301-3010

JAN 19 2005

MEMORANDUM FOR CHAIRMAN, DEFENSE SCIENCE BOARD

SUBJECT: Terms of Reference—Defense Science Board 2005 Summer Study on Transformation: A Progress Assessment

Since the end of the Cold War, the Department of Defense has engaged in a wide range of military and humanitarian operations. As President G.W. Bush stated in the 2002 National Security Strategy, “The major institutions of American national security were designed in a different era to meet different requirements. All of them must be transformed.” In response to this call to arms, the Department of Defense initiated wide-ranging plans, policies, and programs to transform itself. As described in the Secretary of Defense’s 2003 Transformation Planning Guidance (TPG), the scope of the Department’s transformation efforts encompassed how we fight, how we do business, and how we work with others. While the TPG states, “there will be no moment at which the Department is transformed,” the Department must evaluate both the effectiveness and the direction of its transformation efforts.

You are requested to form a Defense Science Board Summer Study to provide an assessment of the Department’s continuing transformation process. The assessment should describe the current status of the Department’s transformation efforts, identify the appropriate transformation objectives, and recommend ways and means to meet the emerging and persistent challenges as identified in the 2004 National Defense Strategy.

The TPG outlined the Department’s three-part strategy for transformation: Transformed culture, Transformed processes, and Transformed capabilities. Within the Department’s transformation scope and strategy, the Study should consider are the following:

1) Concepts and Experimentation. Post Cold War operational concepts are continuously evolving. In response to the Secretary’s request for joint concepts of operations, the concept community developed a family of joint concepts organized in a hierarchy including the overarching Joint Operations Concepts (JOpsC), subordinate Joint Operating Concepts (JOC), supporting Joint Functional Concepts (JFC), and detailed Joint Integrating Concepts (JIC). In addition, the Services developed supporting service concepts. The Air Force is developing the



Air Force Concepts of Operations (CONOPS); the Navy and Marine Corps are developing the Naval Operating Concept for Joint Operations (NOC); and the Army is pursuing the Future Force concept. These concepts address the development of future joint forces' transformational capabilities and characteristics, but an assessment is needed of the state of the joint concept development and experimentation process that integrates Service provided capabilities into effective joint operational capabilities. Further, the assessment should examine how well the Department integrates the rest of the U.S. government (USG) capabilities to provide the capabilities to deal with 21st Century adversaries. The Study should address alternative operational constructs and concept development processes, which would enable the Department of Defense to better meet the challenges of the 21st century by applying the entire array of power available to the USG. The Study must focus on important functional concepts and capabilities, such as logistics and battlespace awareness, which provide essential elements to implementing joint concepts. Finally, experimentation provides an important feedback mechanism into the iterative development of joint concepts. Consequently, the study must assess the state of experimentation, the interrelationships between a series of experiments within an experimental campaign, and, especially, the relationship and involvement of service and combatant command experimentation efforts.

2) International competitors seek to develop and possess breakthrough technical capabilities intended to supplant U.S. advantages in particular operational domains. Because of this aspect of the security environment, the study should address disruptive challenges from a variety of sources such as technology, demographics, and legal. In addition, the Study should define the scope of the problem and capabilities DoD requires to address these challenges.

3) As an element of net-centric operations, the Department is developing a broad range of networked systems to generate new capabilities and multiply existing force structure effectiveness. The Study should assess the adequacy and effectiveness of the approaches to realize the potential advantages of net-centric operations.

4) The Department's force structure still is burdened with Cold War legacy components. A significant transformation effort seeks to transform the joint force into smaller, rapid, more agile forces with greater deployability and lethality than much of the current force. However, strategic guidance and operational experience confirm that some joint force operations will continue to require sustained presence and an ability to confront heavy, concentrated firepower to achieve desired effects and mission accomplishment. Since the Department's transformation efforts must reconcile expeditionary agility and responsiveness with persistence and durability, the study should focus on the Department's need

for evolving joint forces to cover the spectrum of military engagement and accomplish the full range of missions assigned to DoD.

5) The Study should provide insights into two approaches to adaptability. The first examines how DoD might provide for high adaptability of the force by increasing the tempo of inserting promising science and technology initiatives into the acquisition process. The second approach should compare materiel, technological, conceptual, and organizational efforts to provide adaptability to surprise.

6) Industry partners are key to providing transformational capabilities. Consolidation since the Cold War peak has reduced the number of market participants (~ 32 to 8) at prime and subsystem levels. The Study should assess the suitability of the structure of the defense industry to the needs of Transformation.

7) Culture is a decisive characteristic of innovative military organizations. Future joint operations envision increasingly complex and heavy cognitive demands on personnel at all levels. The Department must examine how to adapt its culture to producing personnel able to meet the high knowledge demands of interdependent joint, interagency, and multinational operations. In addition, the Study should focus specifically on the human resources needed to develop and acquire new materiel, adapt existing systems to leverage past investment, exploit technologies, design organizations, and devise knowledge management procedures.

8) The Department's business processes, including its logistics and acquisition practices, must support and facilitate transformation. The assessment should evaluate progress made towards streamlining and reforming these processes and recommend a strategy for going forward especially in the area of acquisition of joint interoperable systems.

The Task Force will provide an interim report by May 2005.

The study will be sponsored by me as the Acting Under Secretary of Defense (Acquisition, Technology and Logistics), Under Secretary of Defense (Policy), Under Secretary of Defense (Personnel and Readiness), Director, Force Transformation, and Director, Defense Research and Engineering. Gen Larry Welch, USAF (retired), and Dr. Robert Hermann will serve as the Task Force Chairmen. Dr. Jerry McGinn, OUSD(P), will serve as the Executive Secretary, and Lt Col Dave Robertson will serve as the Defense Science Board Secretariat representative.

The Task Force will operate in accordance with the provisions of P.L. 92-463, the "Federal Advisory Committee Act," and DOD Directive 5105.4, the "DoD Federal Advisory Committee Management Program." It is not anticipated that this Task Force will need to go into any "particular matters" within the meaning of Section 208 of Title 18, U.S. Code, nor will it cause any member to be placed in the position of acting as a procurement official.

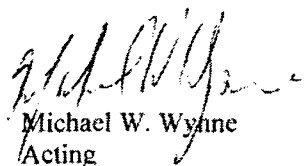

Michael W. Wynne
Acting

B. TASK FORCE MEMBERSHIP**CO-CHAIRMEN**

Gen Larry Welch, USAF (Ret.)

Institute for Defense Analysis

Dr. Robert Hermann

Global Technology Partners

MEMBERS

Dr. Craig Fields

Defense Science Board

Mr. Rich Haver

Northrop Grumman

Dr. George Heilmeier

Telcordia Technologies

Dr. Joseph Markowitz

Private Consultant

Mr. Arthur Money

ALM Consulting

Mr. Walter Morrow

MIT Lincoln Laboratory

Dr. James Wade

Defense Group Inc.

DEFENSE INDUSTRY AND ACQUISITION

Dr. Paul Kaminski, Co-Chairman	Private Consultant
Mr. Phil Odeen, Co-Chairman	Private Consultant
Mr. Pierre Chao	CSIS
Ms. Natalie Crawford	RAND
Mr. Gil Decker	Private Consultant
Ms. Christine Fisher	Private Consultant
Mr. Jack Welch	Private Consultant

GOVERNMENT ADVISORS

LTC Bob Jones

DEPARTMENT OF DEFENSE BUSINESS PRACTICES

Dr. Jacques Gansler, Co-Chairman	University of Maryland
Dr. Ronald Kerber, Co-Chairman	Private Consultant
Mr. Denis Bovin	Bear Stearns
Mr. Robert Luby	IBM
Dr. Robert Lucky	Telcordia Technologies
Mr. William Lynn	Raytheon
Mr. David Oliver	EADS North America

GOVERNMENT ADVISORS

CAPT Marion Eggenberger	United States Navy
-------------------------	--------------------

FORCE CAPABILITY EVOLUTION

Gen James McCarthy, USAF (Ret.), Co-Chairman	United States Air Force Academy
Gen Michael Williams, USMC (Ret.), Co-Chairman	LMI
Mr. Robert Fitton	Resource Consultants, Inc.
Dr. Richard Ivanetich	Institute for Defense Analyses
Dr. Williamson Murray	Institute for Defense Analyses
Mr. Ronald Mutzelburg	Boeing
Mr. John Quilty	Private Consultant
Admiral William Studeman	Private Consultant
Mr. Mike Swetnam	Potomac Institute for Policy Studies
Mr. Larry Wright	Booze, Allen and Hamilton

GOVERNMENT ADVISORS

LTC Robert Larsen	United States Army
LtCol. Mark Murphy	United States Air Force
Captain Melanie Winters	United States Navy

HUMAN RESOURCES

Dr. John Foster, Jr., Co-Chairman	Northrop Grumman
Dr. William Howard, Jr., Co-Chairman	Private Consultant
Mr. Reggie Brown	United States Army
Mr. Charles Cragin	Private Consultant
Ms. Ginger Groeber	Private Consultant
CSM Lawrence Holland	United States Army Reserve Affairs
Mr. Christopher Jehn	Cray, Inc.
Mr. Michael Parmentier	Booz Allen Hamilton
Mr. Bernard Rostker	RAND
Mr. Robert Silberman	Strayer University
Dr. Michael Vlahos	John Hopkins University
Mr. Kim Wincup	SAIC

GOVERNMENT ADVISORS

Ms. Jeanie Fites	OUSD P&R
Dr. Janice Laurence	OUSD P&R
Ms. Ann Lee	OUSD P&R

JOINT OPERATIONS CONCEPTS AND DOCTRINES

Dr. Ted Gold, Co-Chairman	Private Consultant
Mr. John Stenbit, Co-Chairman	TRW
Dr. Joseph Braddock	The Potomac Foundation
Dr. William Graham	National Security Research
Mr. James Kurtz	Institute for Defense Analysis
Gen William Hartzog, USA (Ret.)	Burdeshaw Associates Ltd.

GOVERNMENT ADVISORS

Mr. Bruce Brown	OASD NII/CIO
BGen David Fastabend	USA TRADOC
LtCol Robert Jones	United States Army
Mr. Patrick McCarthy	JFCOM/J-5
BGen Robert Schmidle	United States Marine Corps
Col J.P. Sosa	United States Air Force
Mr. Michael Starry	TRADOC
Mr. Steve Weir	JFCOM/J-9
Col Edward Yarnell	USMC JCS/J7

MULTI-AGENCY INTEGRATION

Mr. Michael Bayer, Co-Chairman	Private Consultant
Ms. Michelle Flournoy	CSIS
Mr. Alan Schwartz	Private Consultant

GOVERNMENT ADVISORS

Col Christopher Conlin	United States Marine Corps
Dr. Mark Mandeles	The J. deBloch Group
Dr. Jerry McGinn	Northrop Grumman

EXECUTIVE SECRETARY

Dr. Jerry McGinn

Northrop Grumman

SUPPORT STAFF

Ms. Michelle Ashley

SAIC

Mr. Albert Berlo

SAIC

Ms. Diana Conty

SAIC

Mr. Robert Genkinger

SAIC

Mr. Jon Hamblin

SAIC

Ms. Cassandra Jastrow

SAIC

Ms. Kimberlee Moore

SAIC

C. BRIEFINGS RECEIVED

PLENARY BRIEFINGS

Gen James Cartwright	United States Strategic Command	The New Triad
VADM Arthur Cebrowski, USN (Ret.)	Director, Force Transformation	Defense Transformation Overview
CAPT Ralph Janikowsky	OPNAV N708T	Naval Transformation Roadmap
Maj Timothy Keeports	United States Air Force	USAF Transformation Flight Plan
Mr. Kenneth Krieg	USD (AT&L)	Program Analysis and Evaluation
Mr. Patrick McCarthy	Program Manager, Joint Transformation Roadmap and Strategic Planning Analyst, JFCOM/J-5	Joint and Allied Transformation
Mr. Allan Shaffer	DDR&E	Disruptive Technologies Study
Mr. Stephan Smith	Director, Army Transformation Office	Army Transformation Roadmap
Lt Col Steve Waller	AF/XI	Joint Net-Centric Operations
Gen Larry Welch, USAF (Ret.)	IDA	Summer Study on Transformation: A Progress Assessment
COL Ric Witt	United States Air Force	Strategic Transformation Appraisal
Col Edward Yarnell	United States Marine Corps JCS/J7	Joint Transformation

DEFENSE INDUSTRY AND ACQUISITION

Mr. John Ablard	LMI	DoD Transactions
Mr. Mark Arena	RAND	Selected Acquisition Report (SAR)
Ms. Tina Ballard	Deputy Assistant Secretary of the Army (Policy and Procurement)	US Army Brief on Transformation
Mr. John Birkler	RAND	Defense Industrial Base Issues
Mr. Bill Cooper	JCS J-8	JCIDS Overview
Ms. Natalie Crawford	RAND	Industry Concerns Regarding Acquisition
Mr. Jeff Drezner	RAND	Defense Industrial Base Issues
Mr. Thomas Essig	Director of Program Analysis and Business Transformation for the Navy (Acquisition)	US Navy Brief on Transformation
LtGen Larry Farrell, USAF (Ret.)	President and CEO, National Defense Industrial Association (NDIA)	Industry Concerns Regarding Acquisition
Mr. Bob Hale	LMI	Industry Concerns Regarding Acquisition
Mr. Rick Jackson	LMI	Industry Concerns Regarding Acquisition
Mr. Joe Kampf	President and CEO, Anteon	Acquisition Policies, Regulations, and Procedures
MGen Tim Malishenko, USAF (Ret.)	Vice President of Contracts and Pricing for Boeing	Commercial Acquisition Processes
Ms. Susan Marquis	LMI	Industry Concerns Regarding Acquisition
Dr. Sumner Matsunaga	The Aerospace Corporation	National Security Space Industrial Base
Mr. Jeffrey Poindexter	The Aerospace Corporation	National Security Space Industrial Base
Mr. Stan Soloway	President of the Professional Services Council (PSC)	Services Industry in the Acquisition Process
Mr. Jack Spencer	The Heritage Foundation	The Defense Industrial Base

Gen Larry Welch, USAF (Ret.)	IDA	Past Defense Science Board (DSB) Studies
Mr. Charlie Williams	Deputy Assistant Secretary of Contracting for the Air Force (Acquisition)	Air Force Acquisition and Contracting
Mr. John Young	Vice President of Corporate Contracts and Pricing, Northrop Grumman	Major Acquisition Programs
Mr. Obaid Younossi	RAND	Selected Acquisition Report

DEPARTMENT OF DEFENSE BUSINESS PRACTICES

Mr. Paul Brinkley	Deputy Under Secretary for Business Transformation	DoD Business Management Modernization Program (BMMP): Program Realignment and Changes
Ms. Ellen Embrey	Deputy Assistant Secretary of Defense, Force Health Protection	Medical Readiness Review
Mr. David Fisher	Special Assistant to Deputy Under Secretary of Defense (Financial Management), OSD FMTT	Financial Management Transformation Team (FMTT): Priorities, Capabilities, and Initiatives
Ms. Marilee Fitzgerald	Civilian Personnel Management Service	Civilian Human Resources
Mr. Tim Freihofer	SES, Joint Deployment Employment Sustainment Organization	Integrated Logistics Initiative
Dr. Jacques Gansler	University of Maryland	Competitive Sourcing
Mr. Tom Hall	Deputy PM for Sigma Ops & Support, NAVAIR	NAVAIR Activity Based Costing
Mr. Louis Kratz	ADUSD (LPP), OUSD (AT&L)/DUSD (L&MR)	Transforming DoD Business Practices: Logistics
Mr. Mark Krzysko	Deputy Director, Defense Procurement & Acquisition Policy, E-Business	Business Transformation within the Department of Defense
GEN David Maddox, USA (Ret.)	Army Science Board	Army Science Board 2004 Ad Hoc Study: Intra-Theater Logistics Distribution in the CENTCOM AOR
Dr. Dan McNicholl	General Motors	Business Systems: Legacy Systems and Outsourcing
Mr. Tom Modly	Deputy Under Secretary of Defense (Financial Management), OSD (AT&L)	DoD Business Management Modernization Program (BMMP): Program Realignment and Changes
Dr. Clark Murdock	Senior Advisor, CSIS	Beyond Goldwater-Nichols: DoD and USG Reform for a New Strategic Era

Ms. Norma St. Claire

Defense Integrated Military
Human Resources System
(DIMHRS) for Personnel and
Pay (Pers/Pay)

LtGen George Taylor

Air Force Surgeon General

Medical Readiness Review

Dr. Linton Wells

Acting ASD(NII), DoD CIO,
OSD(AT&L)

Enterprise Services and
Operations

FORCE CAPABILITY EVOLUTION

Col Leonard Blaisol	United States Marine Corps	USMC Brief on Transformation
CDR Bryan Clark	United States Navy	USN Brief on Transformation
Mr. Mark Greer	Defense Intelligence Agency	DIA IT Transformation
Col Bruce Hollywood	United States Air Force	Analytic Agenda
LtCol Bob Larsen	United States Army	
Mr. Patrick McCarthy	JFCOM – J538	Joint Transformation Roadmap
Mr. Stephen Moore	USJFCOM	Joint Training/Training Transformation
Dr. Williamson Murray	IDA	Historical Perspective on Transformation
CAPT Al Nadolski	USJFCOM	JFCOM’s Support to Intelligence Transformation
MG Robert Scales	United States Army, (Ret.)	Historical Perspective on Transformation
COL Rick Smith	United States Army	US Army Brief on Transformation
COL Al Sweetzer	United States Army	Operational Assessment 2005
Col Gail Wojtowicz	United States Air Force	USAF Brief on Transformation
Col Peter Zielinski	United States CENTCOM	CENTCOM Brief on Transformation

HUMAN RESOURCES

Mr. Charlie Abell	Principal Deputy Under Secretary of Defense P & R	Overview of OSD 5 HR Transformation Goals – OSD P&R
Mr. Roger Blanchard	Assistant Deputy Chief of Staff, Personnel	AF/DP Human Resources
Mr. Reggie Brown	United States Army	QDR Update
Mr. William Carr	Acting Deputy Under Secretary of Defense, Military Personnel Policy	Transforming Military Personnel Management
Adm Arthur Cebrowski (Ret.)	OSD	Round Table Discussion: HR & Readiness Transformation through the Lens of Transformation
Dr. David Chu	USD (P&R)	Transformation Goals of Personnel and Readiness
Dr. Curt Gilroy	Director, Accession Policy: OUSD (P&R)	Active Duty Recruiting Update
VADM Gerry Hoewing	United States Navy, DNCO (M&P)	Overview of the Navy HR Transformation
Maj. Gen. Thomas Jones	United States Marine Corps	USMC Training and Education Transformation
Dr. Paul Mayberry	Deputy Under Secretary of Defense, Personnel & Readiness	Range Sustainment – OUSD (P&R)
Ms. Gail McGinn	Deputy Under Secretary of Defense	Language Transformation – OSD (Plans)/P&R
Mr. Michael Rhodes	Assistant Deputy Commandant	USMC Manpower and Reserve Affairs
Mr. Harry Thie	RAND	Changes to the Management of Officers
Ms. Ellen Tunstall	Acting Deputy Under Secretary, Civilian Personnel Policy	Transforming Civilian Personnel NSPS – ODUSD (P&R)
Dr. Michael Vlahos	John Hopkins University	Alternative (and unexpected) Transformation
Mr. Roy Wallace	HQDA G-1	Army Personnel
Mr. Kim Wincup	SAIC	Language and Regional Experience

Dr. John Winkler

Deputy Assistant Secretary of
Defense

Reserve Component
Transformation – Reserve
Affairs, Manpower, and
Personnel

JOINT OPERATIONS CONCEPTS AND DOCTRINES

Mr. Bruce Brown	IDA	Combatant Commands
Gen James Cartwright	USSTRATCOM	The New Triad
COL Fred Guendel	J-7/JFCOM	Concepts to Doctrine, Integrating the Good Ideas
Mr. Dick Gullickson	DTRA	DTRA Programs in Transformational Technologies
Mr. Andrew Hall	IDA	IDA Briefing
LtCol Bruce Hollywood	J-8/ASMD	Analytic Agenda
Mr. Kenneth Krieg	USD (AT&L)	Program Analysis and Evaluation
GEN John Landry	CIA	Intelligence Community Inputs
LtCol Bob Larsen	J-8/OFT	JROC Warfighting Capability Based Analysis and Assessment
Col Richard Marchant	OFT	Office of Force Transformation (OFT) Review of COCOM Experimentation
Mr. David Markov	IDA	IDA Briefing
Mr. Andy Marshall	Director	Net Assessment
Mr. Patrick McCarthy	JFCOM	Joint Transformation Roadmap and Lessons Learned
Dr. Pat McDaniel	DARPA	Advanced Technologies
Mr. Steve Moore	JFCOM	Joint National Training Capability
CAPT Al Nadolski	J-2/JFCOM	US JFCOM's Support of Intelligence Transformation
Dr. Charlie Rhodes	DARPA	Advanced Technologies
Round Table Discussion	JWFC	Joint Warfighting Center Demonstration
Mr. Alan Shaffer	DDR&E	Disruptive Technologies Study
Dr. Martin Stickley	DARPA	Advanced Technologies
COL Al Sweetzer	United States Army	Operational Assessment '05
Dr. George Ullrich	DTRA	DTRA Programs in Transformational Technologies
LtCol Steve Waller	AF/XI	Joint Net-Centric Operations

APPENDICES

Col Ric Witt	United States Air Force	Strategic Transformation Appraisal
Col Edward Yarnell	USMC JCS/J-7	Joint Intelligence Coordination Staff (JICS), Interagency Processes, and Joint Operations Centers (JOC)
COL Peter Zielinski	CENTCOM	Central Command

MULTI-AGENCY INTEGRATION

MG Herbert Altshuler	Commander, USACAPOC (A)	US Army Civil Affairs and Psychological Operations Command Perspective
COL Joe Anderson	United States Army	US Army Warfighter Perspective: Stability and Support Operations
ADM Dennis Blair	IDA	Overview of 2004 DSB Summer Study
Mr. Chris Burnham	Acting Under Secretary for Resource Management	Interagency Planning: Proposals to Increase Foreign Affairs Collaboration
Mr. William Cave	SAIC	Phase Four Planning for Operation Iraqi Freedom (OIF)
Col Christopher Conlin	JFCOM	A Warfighter's Perspective on OIF
Mr. Lawrence Cooley	Management Systems International	Foreign Aid, Assistance, and Economic Development
Ambassador Jim Dobbins	RAND	Interagency Lessons Learned from Stability and Reconstruction Operations in Kosovo, Bosnia, Haiti, Afghanistan, and Somalia
Dr. Craig Fields	Senior Fellow, DSB	Overview of 2004 Summer Study: Transition To and From Hostilities
Mr. John Hamre	CSIS	Interagency Experience and Lessons Learned from Diplomatic Security
Mr. John Hartford	National Counterintelligence Executive (NCIX)	National Counterintelligence Perspective
Mr. Len Hawley	Consultant to USJFCOM	Interagency Decisionmaking and Policy Planning for Crisis Response
Mr. Andy Hoehn	RAND	DoD Security Assistance and Interagency Integration
Secretary Marty Hoffman	DoD Reconstruction Support Office	Interagency Experience in Afghanistan

Mr. Tim Hoffman	OSD Policy	Policy and Guidance for Combatant Commanders' Warplans
BGen John F. Kelly	United States Marine Corps	Interagency Concerns within Military Operations
Prof Erik Kjonnerod	National Defense University	Interagency Transformation, Education and After-Action Review (ITEA) Program
Adm Joe Lopez	Halliburton	Perspective from Experiences as a Contractor on Battlefield
Hon. Paul McHale	Assistant SecDef Homeland Defense	Final Strategy for Homeland Defense Civil Support
Mr. Frank Miller	The Cohen Group	National Security Council Perspectives
Dr. Jeffrey Nadaner	Deputy Assistant SecDef, Stability Ops	Initiatives on Stability and Reconstruction from
Mr. Andrew Natsios	United States Agency for International Development	Interagency Integration and the US Agency for International Development
Mr. David Oliver	EADS North America	CPA Experience in Iraq
Ambassador Carlos Pascual	Office of the Coordinator for Reconstruction and Stabilization	Interagency Lessons Learned
COL John Peabody	United States Army	Warfighter Perspective: Army Congressional Liason
Mr. Daniel Serwer	United States Institute for Peace	Interagency Lessons Learned from Stability and Reconstruction Operations in Kosovo, Bosnia, and Iraq
Mr. Vincent Vitto	DSB/C.S. Draper Lab, Inc.	Strategic Communication: highlights from the 2004 DSB Summer Study
Mr. Mike Walker		Lessons Learned from Special Events
Dr. Linton Wells	Acting ASD(NII), DoD CIO, OSD(AT&L)	Interagency Communications during Complex Contingencies
MG Robert Wood	JE/JFCOM Joint Futures Lab	Interagency Joint Concept Development and Experimentation

D. ACRONYMS

C2	command and control
CIO	Chief Information Officer
CJCS	Chairman of the Joint Chiefs of Staff
COCOM	Combatant Command
COI	communities of interest
COTS	commercial-off-the-shelf
DAE	Defense Acquisition Executive
DLA	Defense Logistics Agency
DoD	Department of Defense
DOPMA	Defense Officer Personnel Management Act
DOTMLPF	doctrine, organization, training materiel, leadership, personnel, and facilities
DSB	Defense Science Board
FAR	Federal Acquisition Regulation
HR	human resources
IT	information technology
JCD&E	Joint Concept Development and Experimentation
JCIDS	Joint Capabilities Integration and Development System
JNTC	Joint National Training Capability
JROC	Joint Requirements Oversight Committee
MAI	multi-agency integration
NCOE	network-centric operational environment
NSC	National Security Council
NSSP	National Security Strategic Plan

OEF	Operation Enduring Freedom
OIF	Operation Iraqi Freedom
OMB	Office of Management and Budget
OTA	Operational Test Agency
OSD	Office of the Secretary of Defense
PA&E	Program Assessment and Evaluation
PEO	Program Executive Officer
POM	Program Objective Memorandum
PPB&E	planning, programming, budgeting, and executing
SAE	Service Acquisition Executive
SAVE	struggle against violent extremists
SecDef	Secretary of Defense
U.S.	United States
USD(AT&L)	Under Secretary of Defense for Acquisition, Technology, and Logistics
USD(P&R)	Under Secretary of Defense for Personnel and Readiness
USJFCOM	United States Joint Forces Command
USMC	United States Marine Corps
USSTRATCOM	United States Strategic Command
USTRANSCOM	United States Transportation Command
WMD	weapons of mass destruction