

ERDC/CERL SR-04-33

Construction Engineering
Research Laboratory



US Army Corps
of Engineers®
Engineer Research and
Development Center

Proceedings of the Facility Area Network (FAN) Workshop

Francois Grobler, Jeffrey G. Kirby, and
E. William East – Editors

October 2004



Proceedings of the Facility Area Network (FAN) Workshop

Francois Grobler, Jeffrey G. Kirby, and E. William East – Editors

*Engineer Research and Development Center
Construction Engineering Research Laboratory
PO Box 9005
Champaign, IL 61826-9005*

Final Report

Approved for public release; distribution is unlimited.

Prepared for U.S. Army Corps of Engineers
Washington, DC 20314-1000

Under Consolidated Facility Object Model (Project HD630H)

ABSTRACT: The Facilities Area Network (FAN) Workshop was hosted in February 2004 by the U.S. Army Engineer Research and Development Center (ERDC) as part of Consolidated Facility Object Model” (CFOM) project. The purpose of that work is to develop prototype projects in design, construction, and operations that demonstrate the benefits of secure web service confederations. The FAN Workshop was convened as part of the goal-setting phase of the CFOM project to assess the state of the art of required enabling technologies; review standards-development activities for relevant data exchange technologies; define technology gaps that must be filled; and identify opportunities to collaborate with other agencies and leverage related research and technology transfer activities. This report documents the proceedings of the FAN Workshop, and includes copies of all papers and multimedia presentations offered at the workshop.

DISCLAIMER: The contents of this report are not to be used for advertising, publication, or promotional purposes. Citation of trade names does not constitute an official endorsement or approval of the use of such commercial products. All product names and trademarks cited are the property of their respective owners. The findings of this report are not to be construed as an official Department of the Army position unless so designated by other authorized documents.

DESTROY THIS REPORT WHEN IT IS NO LONGER NEEDED. DO NOT RETURN IT TO THE ORIGINATOR.

Contents

Index of Multimedia Presentations.....	iv
Preface.....	v
1 Introduction	1
Background.....	1
Workshop Objectives.....	2
Organization of This Document	3
2 Workshop Agenda and Overview	4
3 Workshop Papers and Presentations	9
Keynote Presentation	9
<i>Facility Area Networks — Workshop Purpose</i>	<i>9</i>
Current Practice.....	11
<i>Facility Operations and Maintenance Management Issues at GSA.....</i>	<i>11</i>
<i>Operation and Maintenance Support Information (OMSI)</i>	<i>12</i>
<i>Seeing the Big Picture: An Application of Hand-Held Technologies in Managing Environmental Data</i>	<i>16</i>
Data Collection and Integration	26
<i>The Role of Ubiquitous Computing in Facility Life-Cycle Information Integration</i>	<i>26</i>
<i>Using Sensor Systems and Standard Project Models to Capture and Model Project History for Building Commissioning and Facility Management.....</i>	<i>43</i>
<i>RFID Technology for Pervasive, Ubiquitous Computing in the Life-Cycle of Construction Projects</i>	<i>57</i>
<i>FAN-Related Research at CMAG</i>	<i>73</i>
<i>IFC Model Server Technology</i>	<i>78</i>
Concluding Presentation (27 February 2004).....	94
4 Discussion Sessions.....	95
General Issues in Facility Area Networking (26 February 2004).....	95
Development and Implementation Issues (27 February 2004)	95
<i>Data Source Considerations.....</i>	<i>96</i>
<i>Data Access.....</i>	<i>97</i>
<i>User Support</i>	<i>98</i>
<i>Central Versus Local Storage.....</i>	<i>98</i>
<i>Instrumentation of Facilities</i>	<i>98</i>
5 Workshop Conclusion: Summary and Recommendations.....	100
Report Documentation Page.....	102

Index of Multimedia Presentations

Presentation 1: Facility Area Networks — Workshop Purpose (East).....	9
Presentation 2: Operation and Maintenance Support Information (OMSI) (Dunn).	12
Presentation 3: Seeing the Big Picture (Britt).....	23
Presentation 4: Role of Ubiquitous Computing in Facility Life-Cycle Information Integration (Liu).....	38
Presentation 5: Using Sensor Systems and Standard Project Models (Akinci).	52
Presentation 6: RFID Technology (Jaselskis).....	66
Presentation 7: FAN-Related Research at CMAG (Lytle).....	73
Presentation 8: IFC Model Servers (Grobler).....	87
Presentation 9: Concluding Presentation (East).....	94

Preface

The workshop documented in this report was conducted for Headquarters, U. S. Army Corps of Engineers (HQUSACE), under Program 21 2040 622784T4100, “Military Facilities Engineering Technologies”; Project HD630H, “Consolidated Facility Object Model.” The technical monitor was Dr. Paul A. Howdyshell, CEERD-CV-ZT.

The work was performed by the Facilities Management Branch (CF-F) of the Facilities Division (CF), Construction Engineering Research Laboratory (CERL). The Project Manager was E. William East. Vickey J. McDonald and Jeff Moll, contractor with Resource Center Enterprises, are acknowledged for their contributions and support. Technical editing support was provided by Gordon L. Cohen and Vicki A. Reinhart, Information Technology Laboratory – Champaign. Mark W. Slaughter is Chief, CEERD-CF-F, and L. Michael Golish is Chief, CEERD-CF. The Technical Director of the Facility Acquisition and Revitalization research domain is Dr. Paul A. Howdyshell, CEERD-CV-ZT. The Director of CERL is Dr. Alan W. Moore.

CERL is an element of the Engineer Research and Development Center (ERDC), U.S. Army Corps of Engineers. The Commander and Executive Director of the ERDC is COL James R. Rowan, EN, and the Director is Dr. James R. Houston.

1 Introduction

Background

The Facilities Area Network (FAN) workshop was organized as part of a U.S. Army Research, Development, Test, and Evaluation (RDTE) project entitled “Consolidated Facility Object Model” (CFOM). The purpose of that work is to develop prototype projects in design, construction, and operations that demonstrate the benefits of secure web service confederations. The initial CFOM proof-of-concept-demonstration will address facility operations and maintenance.

The objectives of the CFOM project are to:

1. Demonstrate the benefits of integrating life-cycle information management through selected high-impact applications.
2. Create a secure information infrastructure that allows the exchange of information among authorized business partners and systems.
3. Identify how the Federal government can adapt ongoing public, private, and international progress in the field to develop government-wide project information standards.

Although inventory and management information is generated and revised by individual stakeholders throughout a facility life cycle, there is currently no straightforward channel or mechanism for sharing the information among all concerned stakeholders, especially those with responsibilities upstream or downstream in the life cycle. Overall, the problem involves technology, corporate culture, and organizational inertia. The current CFOM work focuses on technology development and transfer.

In general terms, CFOM is intended to address the problem of maintenance activities that require a high level of effort in terms of information-seeking and data-reporting. The excessive amount of time required to process relevant facility O&M information decreases ‘wrench time’ and work quality compared with the optimal situation in which all required information is available and conveniently accessible.

The tools and systems currently available to help address facility stakeholder requirements were developed as needed and where resources were available. Despite efforts to standardize future tools, stand-alone legacy systems will continue as part of the management environment for the foreseeable future. Emerging generic web service standards identify communication protocols but do not adequately address the issue of creating reliable and secure system confederations. The CFOM project will define and build a confederated web service architecture specifically to serve the needs of stakeholders in the area of facilities operations and maintenance.

It is hypothesized that providing real-time access to as-built facility information, repair histories, schematics, and repair manuals will dramatically decrease unproductive data-seeking time while ensuring higher reliability of the stored information. Easy access to the right data at the right time is expected to improve productivity and work quality. Furthermore, by incorporating robust wireless communications capabilities, personnel will be able to enter data directly at the point of activity and eliminate duplicative, untimely, and often error-prone data reporting processes. In order to achieve these improvements, however, Facility Area Networks must bring together the power of distributed data services and context-aware computing devices in a reliable, cost-effective manner.

There are technology-driven opportunities to exploit and leverage. The concept of location-based “augmented reality” could enable personnel who need facility information to obtain it in real time through a web service confederation. Hand-held and wearable computers could provide means to deliver such information to individual users.

Workshop Objectives

The FAN Workshop was convened as part of the goal-setting phase of the CFOM project to:

- Assess the state of the art of the various enabling technologies required for Facility Area Networks.
- Review and assess standards-development activities for data exchange technology relevant to Facility Area Networks.
- Define the technology gaps that must be overcome in order to achieve the vision of real-time access to life-cycle information by government facility owners, managers, and tenants.

- Identify opportunities for leveraging and collaboration, and to plan a course of action within the CFOM and FAN contexts to capitalize on those opportunities.

Organization of This Document

The remainder of this report covers the proceedings of the workshop. Chapter 2 provides the agenda, an overview of workshop content, and a list of attendees. Chapter 3 reproduces copies of the papers and multimedia PowerPoint® presentations in the order presented. Chapter 4 offers a summary of the workshop discussion sessions that followed the presentation sessions. Chapter 5 provides a summary of the major points and recommendations developed by workshop attendees.

2 Workshop Agenda and Overview

A facsimile of the workshop agenda is presented below through page 6.

Facility Area Network (FAN) February 26-27, 2004 Construction Engineering Research Laboratory 2902 Newmark Drive Champaign, IL 61820 GDSS Room, Collaboratory, Training Conference Room		
AGENDA		
Feb 26:		
0800-0810	Welcome	CERL Director, Dr. Alan Moore
0810-0815	Administrative Announcements	CERL/Bill East
0815-0830	Purpose of Meeting	CERL/Bill East
Current Practice		
0830-0845	GSA Future Direction on Maintenance Management	GSA/Dean McCauley
0845-0930	OMSI: Operation, Maintenance, and Support Information -- Capturing Facility Data During Design and Construction	Navy/Bill Dunn
0930-0945	Break	
0945-1030	Automated Resource Management System (ARMS) A real-time, wireless capable, integrated client/server, computer application designed to capture, process, and share environmental baseline survey data	CERL/Tad Britt
Data Collection & Integration		
1030-1115	The Role of Ubiquitous Computing in Facility Life-Cycle Information Integration	UofI/Liang Liu
1115-1200	Assessment of the usage of different sensor systems and standard product models in creating, accessing and transferring data for building commissioning and facility management	CMU/Burcu Akine
1200-1245	Lunch (No Host Catered)	
1245-1330	RFID Technology for Pervasive, Ubiquitous Computing in the Life-Cycle of Construction Projects	Iowa State/ Edward Jaselskis
Prepared 11 February 2004		

Facility Area Network (FAN)

February 26-27, 2004

Construction Engineering Research Laboratory
2902 Newmark Drive
Champaign, IL 61820
GDSS Room, Collaboratory, Training Conference Room

1330-1415	Position Tracking Using Ad-Hoc Wireless and Laser Measurement Technology: Experiences at the Construction Metrology and Automation Group	NIST/Alan Lytle
1415-1430	Break	
1430-1515	IFC Data Service	CERL/ Francois Grobler
1515-1615	Lab Tour	CERL/ Public Affairs Office
1615	Close	
Feb 27:		
0800-0810	Administrative Announcements	CERL/Bill East
Summary, Results, & Findings		
0810-1130	Summary of State of Practice/Future Directions	ALL
1130-1230	Lunch (No Host Catered)	
1230-1430	Conclusions, Actions, Recommendations	ALL
1430	Closure	

Prepared 11 February 2004

Facility Area Network (FAN)

February 26-27, 2004

Construction Engineering Research Laboratory
2902 Newmark Drive
Champaign, IL 61820
GDSS Room, Collaboratory, Training Conference Room

Attendees:

Burcu Akinci, CMU
Muhsine Tanyel Turkaslan-Bulbul, CMU
Esin Ergen, CMU
Chris Gordon, CMU
Alan Lytle, NIST
Edward Jaselskis, IA State
Bill Dunn, Navy
Reginald Gavett, GSA
Dean McCauley, GSA
Liang Y. Liu PhD, UofI
Lucio Soibelman PhD, UofI
Jeff Moll, RCE
Bill East, CERL
Jeff Kirby, CERL
Tad Britt, CERL
Francois Grobler, CERL

Prepared 11 February 2004

Dr. Alan W. Moore, Director of ERDC-CERL, opened the workshop in a welcome address. Dr. Moore emphasized the central role of facilities in the execution of the Army mission. He spoke about the importance of managing and maintaining the facilities in a sustainable manner, in the context of good stewardship of military lands and being good neighbors to nearby communities. He welcomed the participating experts and expressed delight to have a group of such distinguished scholars to address these issues in the workshop. Dr. Moore sketched an image of very intelligent buildings that can monitor themselves, adjust appro-

priately to detected user and environmental stimuli, and even initiate service calls or repair themselves. He challenged workshop participants to aspire to setting a roadmap for the achievement of facilities of such sophistication while being practical and affordable.

The presentation sessions were initiated by Bill East, who gave the keynote presentation and explained the goals of the workshop. His introduction was followed by a three-speaker session on Current Practice.

Dean McCauley, General Services Administration (GSA), spoke on the nature of the GSA real estate mission, its current practices. Mr. McCauley explained how GSA views issues related to property management and how those relate to the goals of the FAN workshop.

Bill Dunn, Naval Facilities Engineering Command (NAVFAC), provided the background on the Operations and Maintenance Support Information (OMSI) Program and the original motivation for the project. Referring to a publication of the National Research Council entitled *Stewardship of Facilities*, he pointed out that O&M constitutes 60 – 85% of the total life-cycle ownership cost of facilities. OMSI has been an ongoing program that originally started with the goal of better organization of paper information. Recently OMSI has been converted to an Extensible Markup Language (XML) standard and was offered to the International Alliance for Interoperability (IAI), which incorporated OMSI elements into the International Foundation Classes (IFC) models (see www.iai-international.org).

Dr. Tad Britt of CERL and Thomas Lilly of Coonewah Consulting concluded the Current Practice session with a presentation on a relatively low-cost, ruggedized handheld computer equipment and database package designed for the convenient recording of observations (i.e., data, including digital photographs) for baseline cultural resources inventory surveys. The system, which automatically logs the location of the observation, is a real-time, wireless-capable, integrated client/server computer application that has obvious potential for O&M applications.

The next session, Data Collection and Integration, began with Dr. Liang Liu, University of Illinois at Urbana-Champaign, with a presentation on data collection in construction to serve the needs of O&M activities. Dr. Liu noted gaps in facility life-cycle information and identified construction as the weakest link in the information stream. He stated that ubiquitous computing technologies hold ample promise while recognizing challenges posed by worker resistance to technology change. Dr. Liu reviewed his work in the area of wearable and wireless

computing and provided some updates on the latest available technology, and he offered insights into the value of centralized, web-based data storage.

Dr. Burcu Akinci, Carnegie Mellon University, is with her colleagues and students engaged in research into several relevant areas. Dr. Akinci gave an overview of their work on sensor systems (including laser scanning, embedded sensors, etc) and standard project models to capture project histories, the use of Radio Frequency Identification (RFID) chips for storing building component histories, and testing the capabilities of the IFC model to store data required for building commissioning.

Dr. Ed Jaselskis, Iowa State University, presented the results of his research, including several case studies, into the usefulness of RFID technology to enhance construction operations from a life-cycle perspective.

Alan Lytle, National Institute of Science and Technology (NIST), Construction Metrology and Automation Group, provided an overview of NIST's construction integration and automation technology research. Mr. Lytle talked about position tracking using ad hoc wireless and laser measurement technology, and he provided insight into ongoing experience at NIST with its automated steel construction test bed and ad-hoc wireless localization.

In the final technical presentation, Dr. Francois Grobler, ERDC-CERL, provided an overview of the IAI's IFCs, an open international standard for modeling facility life-cycle information and IFC-based Building Information Models (BIMs). Dr. Grobler discussed the status of IFC object model servers for serving as a life-cycle repository of relevant, shared facility information. He also reported on the Simple Access to Building Life-cycle Exchange (SABLE) project, which is working to develop open standards for industrial-strength distributed web-based object servers.

The workshop concluded with two discussion sessions.

3 Workshop Papers and Presentations

Keynote Presentation

Facility Area Networks — Workshop Purpose

Bill East, ERDC-CERL

Presentation 1: Facility Area Networks — Workshop Purpose (East).

● ● ● facility area networks

workshop purpose

26 February 2004
Champaign, IL

● ● ● cfom project

consolidated facility object model

- life-cycle facility information model
- web-service confederation(s)
- demonstration of potential
- proof-of-concept demonstration in O&M arena

2 17-Sep-04

● ● ● problem

- maintenance tasks have high proportion "information seeking" and "data reporting" operations.
- non-work time decreases "wrench-time" and decreases work quality

3 17-Sep-04

● ● ● hypothesis

- providing reliable, real-time access to as-built facility information, repair histories, schematics, and repair manuals will decrease "data seeking" operations.
- providing robust wireless networks will eliminate duplicative "data reporting" operations.
- having "right-data" at "right-time" will improve quality of work accomplished.

4 17-Sep-04

East presentation concluded

approach

Facility Area Networks, or FANs, bring together the power of distributed data services and context-aware computing devices to dramatically decrease the cost and improve the quality of facility operations.

5 17-Sep-04

approach

- o web service federations
- o ubiquitous wireless networks
- o appropriate device forms
- o position locating technology
- o contextual information retrieval

6 17-Sep-04

results expected

7 17-Sep-04

direct results...

- o decrease in cost
 - right work done first time by right person
 - reduce return time for parts/tools
 - reduce time to document work orders in field
- o quality standardization
 - manufacturers instructions available
 - operators shared best-practice available
 - access to remote experts available
 - Installation specific best-practices

8 17-Sep-04

indirect result...

- o reduce inventory control cost
 - operators produce real-time inventory
 - walk-through/drive-by inventory
 - locate moved equipment without hunting

9 17-Sep-04

measurable results...

- o decrease o&m cost
 - increase in "wrench-time" per day
 - decrease in late work order reporting
 - decrease in return repair visits
 - decrease travel cost, double-up on jobs/site
- o reduce inventory cost
 - decrease cost of finding lost/moved items
 - reduction in cost of record keeping
 - improved quality of inventory data
 - small tool tracking

10 17-Sep-04

technology gaps

- o advanced computer representations of as-built facility data/knowledge
- o context-sensitive, user-aware, intelligent information retrieval/collaboration/archiving
- o infrastructure for secure transmission over distributed computing networks
- o pervasive networks of automated and semi-automated agents
- o location-aware user interfaces
- o accessing existing facility data
- o defining standards

11 17-Sep-04

objective of workshop

- o identify technology gaps
- o calibrate fan against industry/research efforts
- o Identify existing o&m information infrastructure needs

12 17-Sep-04

Current Practice

Facility Operations and Maintenance Management Issues at GSA

Dean McCauley, General Services Administration

(Mr. McCauley did not present a paper, but a short summary of his remarks is offered. — B. East, proceedings editor)

Mr. McCauley explained that the General Services Administration (GSA) is one of the world's largest building and facility owners and is increasingly challenged to act like a commercial real estate company in responding to market pressures and "keeping their tenant happy." He stated that approximately 66% of property management and ownership budget is devoted to operations and maintenance (O&M), and that during the life time a building the building services systems are typically replaced 2-3 times. This realization have prompted GSA to strive for an approach to design better in terms of the life-cycle demands of building systems, and take better care of the transfer of information from the design and contracting phases to ownership and O&M.

He welcomed this opportunity to collaborate on FAN and considered such collaboration very timely from the GSA perspective because they have a new initiative to adopt a nation-wide maintenance management system (MMS) in the GSA. Some of the drivers of this initiative are ownership of information, better asset tracking, part usage, warrantee tracking and more efficient work processing. Those issues coincide with the goals of the FAN workshop and GSA is interested to learn how the new technologies can support their goals.

Operation and Maintenance Support Information (OMSI)

Bill Dunn, Naval Facilities Engineering Command (NAVFAC)

Presentation 2: Operation and Maintenance Support Information (OMSI) (Dunn).

Operation & Maintenance Support Information (OMSI)

FAN Workshop
26 February 2004

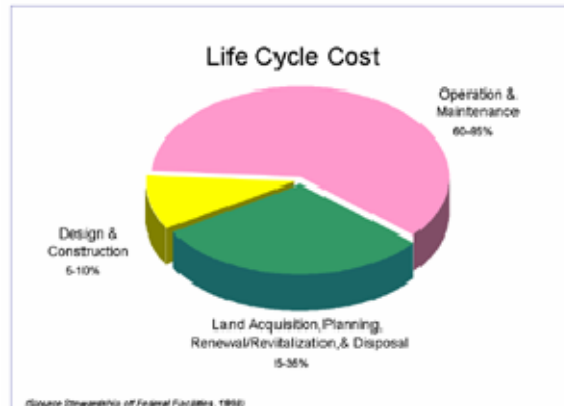

Life Cycle of Buildings

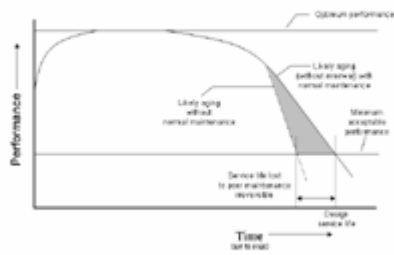

Service Life and Performance

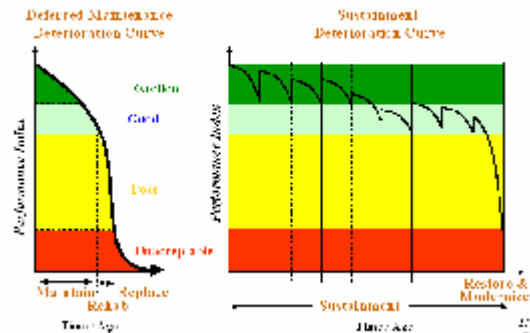

Past Practices

- + O&M submittals in unusable format - boxes, piles
- + Data quickly lost
- + Poor or no PW
- + Repairs difficult and costly
- + Warranties not maintained or lost
- + Mission impact
- + Result?....



Facility User Perception

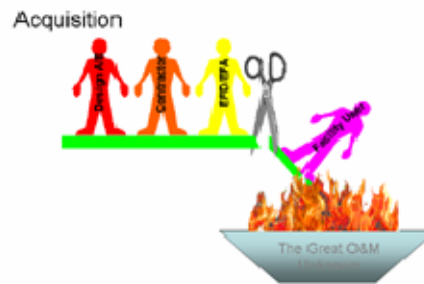

Dunn presentation continued

What is OMSI?

- Information** that helps the Facility User and PW Staff effectively Operate, Maintain and Repair a Facility.



Benefits

- Provides Data for OMS (Archibus, Maximo, etc.)
- Planning Tool for O&M Workload, Space Planning
- Safer, More Efficient System Start-up & Operation
- Orderly Compilation of all As-Built Product Data
- Faster Repairs & Reduced Downtime
- Future Alterations that Fit Original Concept
- Lower O&M Costs

Program

- 84 OMSI delivered in last five years (\$773-Mil Constr Costs, \$6 Mil OMSI Costs)
- 29 OMSI currently working (\$385 Mil Constr Costs, \$3 Mil OMSI Costs)
- 72 OMSI Planned (\$942 Mil Constr Costs)

Principal OMSI Elements

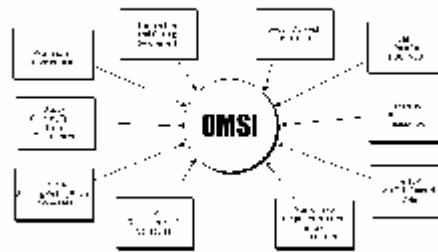

Principal OMSI Elements

Part II Facility Info

- Facility and System Description
- Design Concept, Basis of Design
- Basic Data for P&ID
- Site and Floor Plans/Utility Cuts
- Equipment Inventory
- Supply Inventory Requirements
- Extended Warranty Information
- Training Requirements & SNR Matrix

Principal OMSI Elements

Part II Primary Systems Information

- Operation
 - System Descriptions
 - System Flow Diagrams
 - Start-Up & Shut Down
 - Operating Instructions
- Maintenance
 - Lubrication Schedules
 - P&ID Plans, Schedules and Procedures
- Repair
 - Troubleshooting Guides & Diagnostic Techniques
 - Repair Procedures

Principal OMSI Elements

Part III Product Data

- Organized record of Material and Equipment
- Arranged by Utilimat classification
 - Catalog Cuts
 - Key Shop Drawings
 - Test Reports
 - Manufacturer's Data Sheets
- O&M Data (Equipment not included Part II)
- Warranties
- Referenced by Parts I & II

Data Packages

Current Guide Spec Section 01 26 00

Line Package Location	1	2	3	4	5	Data Package Guideline
1. General and Specific Requirements for O&M	X	X	X	X	X	General O&M
2. Specific Requirements for O&M	X	X	X	X	X	Specific O&M
3. O&M Data	X	X	X	X	X	O&M Data
4. Warranties	X	X	X	X	X	Warranties
5. Training Requirements	X	X	X	X	X	Training Requirements

NFGS 01781 O&M Data

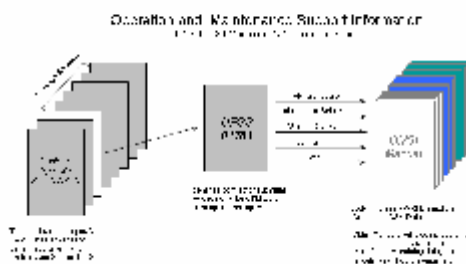

OMSI Budget Costs

Funding plus Apportionable Supporting Facilities Costs	OMSI Cost	
	Complex	Non-Complex
Below \$5,000,000	1.00 - 2.00%	0.75 - 1.00%
\$5,000,000 to \$20,000,000	1.20 - 2.00%	0.75 - 1.25%
\$20,000,000 to \$50,000,000	0.95 - 1.65%	0.50 - 1.00%
Above \$50,000,000	0.50 - 1.00%	0.25 - 0.75%

Dunn presentation continued

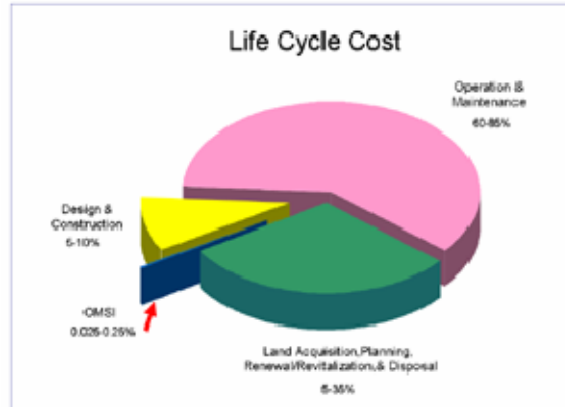
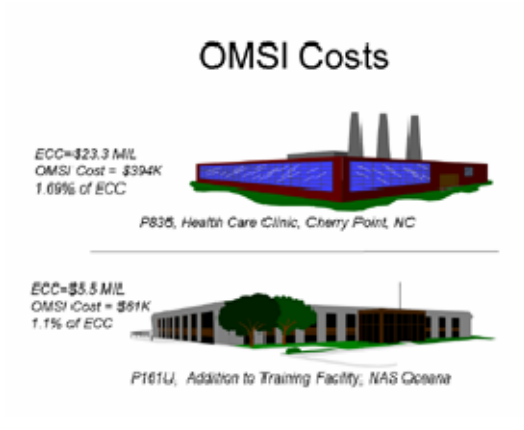

Anecdotal Evidence of Value

- A new employee of the Combat Swimmer Trainer Facility, NAB Little Creek had recently read the OMSI for the Chemical Feed System, when a chlorine tank head blew off. He followed the life safety instructions in the OMSI, "...evacuate immediately - do not take a single breath" and escaped unharmed...though the soys in his pocket had turned black from the chlorine gas.

Anecdotal Evidence of Value

- Chill water pump disintegrated during military exercise at FCTC Dam Neck. John Schaech, the MCD, was able to quickly identify and replace the pump by using the detailed OMSI information. Mr. Schaech also uses OMSI as the prime reference for contract maintenance of his HVAC systems.



OMSI Benefits

- Provides Data for CMMS (Archibus, Maximo, etc.)
- Planning Tool for O&M Workload, Space Planning
- Safer, More Efficient System Startup & Operation
- Orderly Compilation of all As-Built Product Data
- Faster Repairs & Reduced Downtime
- Future Alterations that Fit Original Concept
- Lower O&M Costs



What's Next?

- Increased Electronic Delivery of O&M Information
 - CMMS Applications (i.e., Archibus, Maximo, etc)
 - Develop Standard for Facilities Information (FMOC XML Prototype)
 - Dynamically Assembled Documents
 - Self Generated & Installed
 - Smart Facilities / Systems (IAI)
 - Automated Commissioning
 - Self Diagnostic Systems



'Three generations of OMSI'



Dunn presentation concluded

Sample HTML Deliverable



The HTML is rendered after a client-side XSL transformation (using IE6 itself). The XSL T can be customized for the end-user's specific purpose.

Subtotals and totals can be calculated by the XSL T, rather than trying to forecast the needs of the user when creating the data.

XML

Intelligent Document

Processing Application

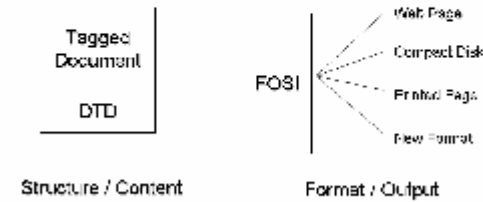

XML Advantages

- Data intelligent: application and system independent.
- Portability across various systems and applications.
- Flexibility beyond traditional publishing.
- Data longevity- data does not need to be converted when applications or systems become obsolete.
- Reusability- documents can be assembled & outputted to various mediums without reentry or reformatting.

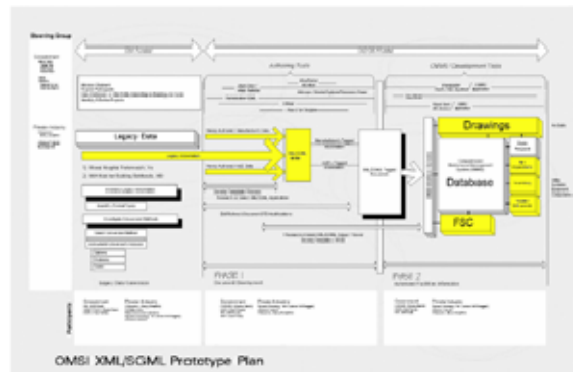

Questions & Comments



Bill Dunn, P.E. 757-322-4613
 FAX 757-322-4714
 William.H.Dunn@navy.mil



Commander
 LANTNAVFACENCOM
 Attn: Code BE14BD
 6506 Hampton Blvd
 Norfolk, VA 23508-12789

Seeing the Big Picture: An Application of Hand-Held Technologies in Managing Environmental Data

Tad Britt, ERDC-CERL

Seeing the Big Picture: An Application of Hand-held Technologies in Managing Environmental Data

Tad Britt, RPA
Senior Research Archeologist
Land and Heritage Conservation Branch
ERDC-CERL-CN-C
John.T.Britt@erdc.usace.army.mil

Thomas G. Lilly, Jr., RPA
Principal Investigator
Coonewah Consulting, Inc.
coonewah@jam.rr.com

ABSTRACT

The Automated Resource Management System (ARMS™) automates collection, synchronization, analysis, reporting, and archiving of georeferenced data in a variety of applications not attainable conventionally. ARMS™ technology enables an innovative life-cycle management process that significantly improves data collection, reliability, and integration capabilities as well as facilitates stewardship, compliance, and sustainability requirements. It provides an innovative, cost-effective and time-efficient, programmatic approach to understanding and solving environmental management issues. Applications may include: environmental, safety, security, military, educational, emergency management, land use, fish and wildlife management, construction and maintenance of highways and waterways, mining, exploration, manufacturing, recreational management, urban restoration, and cultural resource management.

At first glance the inclusion of an environmental paper in these proceedings may seem out of place. However, if you look at the big picture, the fundamental issue is the same—life-cycle resource management. Whether you are dealing with the built environment and infrastructure, or the natural environment and cultural landscape, the initial basic concerns are the same—knowing the physical location of each resource, as well as its geospatial relationship to others on the landscape/facility. Once this baseline order is established, then the problem solving and management issues can then be addressed. Life-cycle management requires planning, data collection, and analysis in order to anticipate, identify, and solve problems. The objective is to develop an intuitive, business management practice, integrating logic-based technologies that will provide the decisionmaker the pertinent information to improve efficacy. Given that, a programmatic management model, that identifies the problems and ranks their priority and tracks their resolution, can then be implemented for the duration of the project/facility, in a proactive, efficient process.

This paper demonstrates a life-cycle approach to automating and improving cultural resource management. The ideas and practices presented here can be used as a model to develop similar approaches to improve other environmental programs, and conceptually, to facility management and other arenas.

DoD installations and Federal land-holding Agencies are tasked with complying with a variety of environmental legislations (e.g., NEPA, NHPA, ESA, CWA, etc.). These laws are designed to inventory, manage, and conserve natural and cultural resources. Environmental sustainability and land-use requirements at installations are often difficult to achieve due to competing needs and restrictions. Complex integrated programs are essential to meet these mission objectives. Central to this issue is the need for accurate and consistent data. Current methods and techniques used to collect data are labor intensive, time consuming and costly. Given the common, less-than-ideal field circumstances, important information can be missed or recorded improperly. Factors such as the competence of the technician,

inconsistent data collection practices between contractors, and the redundancy and errors associated with manual recordation/transcription techniques, all affect the quality and reliability of the data.

While existing commercial off-the-shelf tools are available for natural and cultural resources data collection needs, they are typically single, stand-alone technologies that have limited functionality and integration capabilities. With increased emphasis to implement and maintain sustainable environmental practices, innovative technologies and applications must be developed to meet mission requirements. The solution is a new specialized technology that addresses environmental issues programmatically—an Automated Resource Management System (ARMS™).

ARMS™ is an innovative management process that can be used to study and resolve a wide variety of environmental issues. It consists of integrated digital technologies and specialized software applications that will significantly improve the methods used to collect, store, and analyze environmental data throughout the life-cycle process.

ARMS™ can be used for all types of routine and complex, natural and cultural resources investigations (e.g., inventory, evaluation, mitigation), including development, sustainability, and rehabilitation efforts. It can serve as a powerful decision-making tool to facilitate both short- and long-term management requirements (e.g., monitoring/change detection of historic properties, invasive species encroachment, etc.). And, it inherently has the ability to track and measure field data collection practices, which can then be analyzed to implement methodological improvements.

The basic components of ARMS™ are:

- An in-field application consisting of:
 - Two or more small, ruggedized, sun-shielded, portable computers as the field units for manually recording and integrating data from instruments and other sources (e.g., specialized data entry forms, aerial photography, digital map coverages)
 - A robust tablet PC to consolidate data from two or more field units and to run other applications.
- High-resolution, digital instruments (i.e., camera, global positioning system, compass, clock, and bar code labeler) to collect data.
- The ability to collect, store, and synthesize different types of data to a common shared database:
 - Geographical Information System (GIS) data (compliant with FGDC and SDSFIE standards)
 - Global Positioning System (GPS) data
 - Manually entered data
 - Other associated media (e.g., video and audio).
- Data fusion software to interface and synchronize existing hardware functions and software applications.
- Wired, infrared and/or digital wireless communications devices that will:
 - Transmit and store data for remote uploading and downloading from the field units to the office unit
 - Print bar coded labels to track field specimens
- Additional peripherals may include: laser range finder, audio and video capabilities, inclinometer, altimeter, thermometer, barometer, geophysical instruments, etc.

Illustrations depicting the business processes, hardware configuration, and costs as well as portability of the ARMST[™] in a field setting are included in Figures 1-3.

Embedded in the system is a fully functional GIS. The benefit of having geospatially referenced attribute data is that it expedites the resolution of critical environmental management issues. For critical land-use decisions, real-time wireless transmission of data and images are available—enabling the ARMST[™] to serve as a virtual-desktop in the field.

The ARMST[™] components are ergonomically designed for ease of setup and use. The flexibility of the system is that it allows the user to select and pre-load software applications and configure hardware tailored for the specific type and level of investigation (e.g., wetlands delineation, cultural resources inventory, habitat assessment). Project data and GIS coverages can also be pre-loaded prior to fieldwork (e.g., survey transects and sample plot coordinates). This will ensure accuracy and efficiency and cut down on unanticipated delays. The handheld PCs contain interactive electronic databases that can either be populated automatically, via integrated elements and/or from hardware attached to expansion ports. All databases are relational and denormalized.

For each specific environmental application the ARMST[™] program contains a series of digital forms that are organized in a logical, progressive manner. The application guides the user through the various required or recommended steps, or displays alternative choices for the user. Menus consist of a series of drop-down lists with options and/or radio buttons. For each program, links are provided for off-line access to pre-loaded, digital reference guides to aid the user while in the field (e.g., soil descriptions, artifact typologies, plant references, architectural elements, etc.). Each form is versatile and can be customized for unique situations. Included on every form is a space to manually enter data for circumstances not anticipated. To ensure accuracy and efficiency, each form must be filled out completely before the program advances to the next form.

A key feature of this field unit is a single pushbutton that activates a number of automated and time-saving measurements at once—a “snapshot” with a time stamp that is simultaneously applied to the entire data set. The operator aims the unit at the target and presses the record button, which captures a digital image, obtains GPS positioning, azimuth, elevation, and other metric attributes, and then stores the data in a database with a time stamp and unique I.D. attached. Because the data is collected digitally it allows for immediate verification of the quality and usefulness of the data. Finally, the collected data (i.e., forms, GPS, GIS shape files, video and audio images) are downloaded from the field unit to the tablet PC. This is done in a one-step process using either an infrared, wired, or radio frequency connection, or a serial or USB connection, between the field units and the tablet PC. This in-field computer, which has more powerful software tools, is then used for additional processing and analysis. An efficient feature of ARMST[™] is an automated, pre-programmed function on the tablet PC that is structured to query the database in order to generate customized reports at the end of the project (e.g., archeological site forms, plant and/or animal inventories, etc.), thereby reducing transcription redundancy.

All field specimens (e.g., artifacts, soils, minerals, plants, etc.) are collected, bagged, and affixed with a unique bar code label in the field. The labels are printed to include text descriptions (e.g., project I.D. and provenience data). The benefit of bar coding is that it facilitates automated inventory, tracking, and retrieval of the specimen throughout the life cycle of the project, and to improve curation and future research requirements.

ARMST[™] technology significantly improves data collection, reliability, and integration. ARMST[™] technology, coupled with an enterprise level, SDSFIE compliant data structure such as a relational database (i.e., Oracle or SQL server), and/or a GIS database (i.e., ArcGIS, MapObjects) is flexible and

can be used for a variety of different environmental studies. These other fields may include, but certainly are not limited to: safety, security, military, educational, emergency management, land use, fish and wildlife management, construction and maintenance of highways and waterways, mining, exploration, manufacturing, recreational management, and urban restoration.

Finally, the ability to share accurate, georeferenced data across multiple platforms while addressing different environmental and management requirements will significantly improve real-time decision-making capabilities. The ARMS™ technology demonstrates an innovative, programmatic approach to understanding, anticipating, and solving environmental management and sustainability issues throughout the life-cycle of the project.

ARMS™ was conceived and developed by the U. S. Army Corps of Engineers, Engineer Research Development Center, Construction Engineering Research Laboratory, Champaign, IL. The prototype and computer code were produced by Coonewah Consulting, Inc., Jackson, MS, under contract to Geo-Marine Inc., Plano TX (DACA42-02-D-0012-0001). The total cost for development was \$93,103.00. Of that figure, \$13,228.04 was used to purchase the hardware (\$5,084.02 x 2) and software (\$3,060). The ARMS™ patent application was filed with the US Patent Office on 8 December 2003 (COE-564, serial number 10/729,269).

For additional information, please contact:

Mr. Tad Britt, RPA
Senior Research Archeologist
Land and Heritage Conservation Branch
ERDC-CERL
P.O. Box 9005
Champaign, IL 61826-9005
Voice (800) 872-2375
FAX (217) 373-7266
John.T.Britt@erdc.usace.army.mil

Figure 1. ARMS™ Business Management Process Overview

The diagram below proposes data flow with the hardware and software recommended.

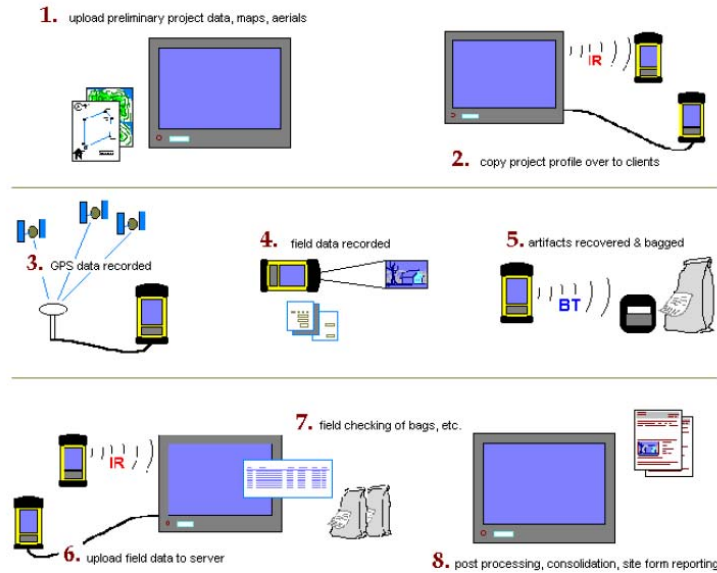

- Step 1: Maps, aerial photographs, and other geo-referenced data are uploaded into a new project using SoloOffice.
- Step 2: Base maps and project information is compiled and copied over as a whole to the field devices running SoloField.
- Steps 3 - 5: Field devices log GPS coordinates, elevation, and prompt the field user to enter data regarding the field survey that is being conducted at that station. This includes recordation of form data as well as any notations, photographs, video, or dictation that needs to be recorded. If material is recovered, a bag number with relevant station data is generated and transmitted to print a label for the collection bag.
- Step 6: Data are uploaded to the tablet PC where they are consolidated and check lists are generated.
- Step 7: After data from multiple field units have been consolidated, a series of checks ensure that all bags/specimens recorded have been collected. In addition, the consolidated GIS data facilitates in-field spot-checking for anomalies prior to leaving the field.
- Step 8: The in-field tablet PC is not the final resting place for these data, so the consolidated files may either be uploaded to a centralized server or backed up on tape or CD.

Figure 2. ARMS™ Prototype Hardware Specifications:

The recommended equipment to be employed for one field unit includes:



- 1) TDS Recon Handheld PC
 - Ruggedized: Yes
 - Processor: 400 MHz Intel Xscale
 - Memory: 64 SDRAM + 128 MB Flash storage
 - Battery Life: 15 hours
 - Dimensions: 6.5 x 3.8 x 1.8 inches
 - Weight: 490 grams
 - IP Rating: 6.7
 - Price: \$3,100.00
- 2) Garmin N17 GPS Receiver
 - Ruggedized: Yes
 - Communication: Serial cable
 - Accuracy: 3 meter
 - Battery: 12v NiMH, 8 hours
 - Weight: 373 grams
 - Price: \$900.00
- 3) FlyCAM 1.3 Megapixel CompactFlash Camera
 - Ruggedized: No
 - Communication: CF Type II
 - Resolution: still 1280 x 1024, video 240 x 3320 @30 fps
 - Price: \$104.53
- 4) SimpleTech 1 Gig CompactFlash Card
 - Ruggedized: No
 - Communication: CF Type II
 - Price: \$288.49
- 5) Cognitive Code Ranger RD23 Direct Thermal Portable Printer
 - Ruggedized: Yes
 - Communication: RJ45 Serial, Bluetooth/WiFi optional
 - Resolution: 203 dots per inch
 - Battery Life: 8 hours
 - Weight: 680 grams
 - Price: \$691.00

Software Recommended

Solo Office	\$1,000.00
Solo Field (licensed per field unit)	\$1,000.00
WinCESoft CF Camera Driver (per field unit)	\$30.00



Figure 3. ARMS™ Prototype in Survey Mode.

Presentation 3: Seeing the Big Picture (Britt).

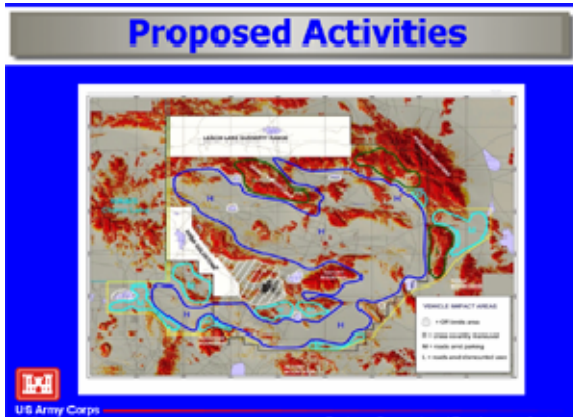
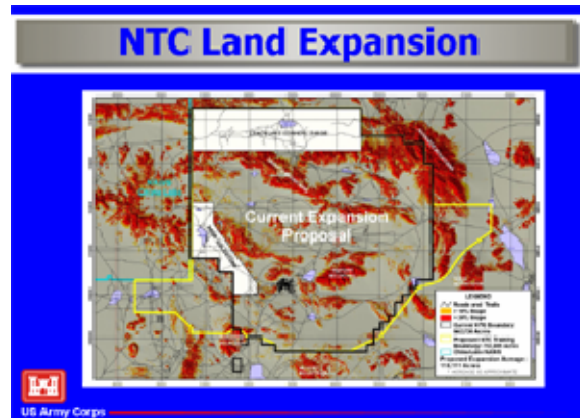
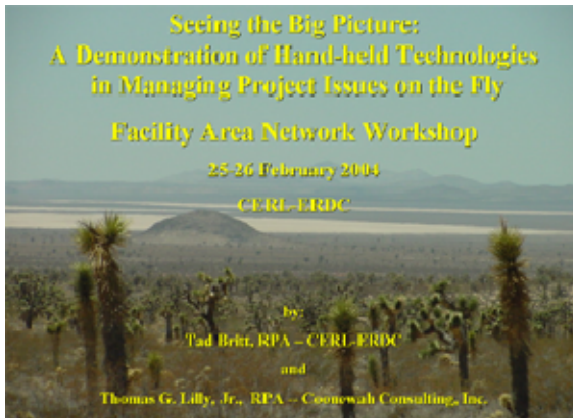

Goal: To demonstrate an integrated approach to understanding, anticipating, and solving cultural resource management issues programmatically

Approach:

- 1) A ruggedized hand-held computer for collecting data with high-resolution digital instrumentation
- 2) A normalized relational database for storing and sharing the data, and
- 3) A GIS based archeological predictive model and management (APMM) tool for analyzing and interpreting the data

US Army Corps

Automated Resource Management System (ARMS™)

OBJECTIVE: To research, design, develop, and validate a fully integrated client-server data collection and analysis application to enhance environmental compliance and stewardship programs

- ARMS™ may be used for all types of routine and complex natural and cultural resources investigations as well as development, sustainability, and rehabilitation efforts
- ARMS™ is a real-time tool, fulfilling both short- and long-term management requirements
- (e.g. monitor site change detection, invasive species encroachment, etc.)
- ARMS™ will facilitate data collection efforts associated with the GIS and BA process in a much more time-efficient and cost-effective manner

US Army Corps

WHY?

- Environmental management and land use practices are often competing for the same resources
- Need for georeferenced data to reconcile issues
- Conventional methods are costly and inefficient
 - Reliance on manual recordation
 - Training and experience of the technicians
 - Inconsistent data collection practices
 - Transcription errors

US Army Corps

WHY?

- ARMS™ integrates diverse and complex geospatial and attribute data in a user friendly environment
- Virtual desktop in the field for decision making
- Cost effective
- Time efficient
- Planning tool for future studies
 - Captures and analyzes metrics for methodological improvements

US Army Corps

WHERE

- Environmental
- Safety
- Security
- Military
- Educational
- Emergency Management
- Land Use
- Urban Restoration
- Cultural Resource Management
- Fish and Wildlife
- Forestry
- Construction
- Highways
- Waterways
- Mining
- Exploration
- Manufacturing
- Recreational Management

US Army Corps

Britt presentation continued

The basic components of the ARMS™ unit:

- A portable tablet computer as the Server and at least two ruggedized handheld PCs as the Clients
 - High-resolution, digital instruments (i.e., camera, global positioning system, compass, clock, and bar code labeler) to collect data
- ARMS™ has the ability to collect, store, and synthesize different types of data to a relational database:
 - GIS data
 - GPS data
 - Spreadsheet data
 - Form-entered user data
 - Other associated media (video and audio)



US Army Corps

ARMS™ Continued:

- Data fusion software to interface and synchronize existing software applications
- Cabled, infrared, and/or digital wireless communications devices that shall:
 - Print bar coded labels for artifact/specimen bags
 - Transmit and store data for remote uploading and downloading from the client to the server
- Capability to interface with other modules (e.g., various remote sensing platforms, photogrammetry, soil testing instruments, etc.)



US Army Corps

ARMS™ Field Data Collector



- 1) TDS Recon Handheld PC
- 2) Garmin H17 GPS Receiver
- 3) FlyCAM 1.3 Megapixel CompactFlash Camera
- 4) IBM 1 Gg Micro-drive for CompactFlash
- 5) Intersec PB20 Direct Thermal Portable Printer

Software Recommended:
Solo Office and Solo Field (licensed per client)



US Army Corps

User Flexibility

- The flexibility of the ARMS™ hardware/software configuration is that it allows the user to select the appropriate tool, or suite of tools, commensurate with the level of investigation (i.e., inventory, evaluation, mitigation) and suitable for the environmental conditions



US Army Corps

ARMS™ Data Processing Steps

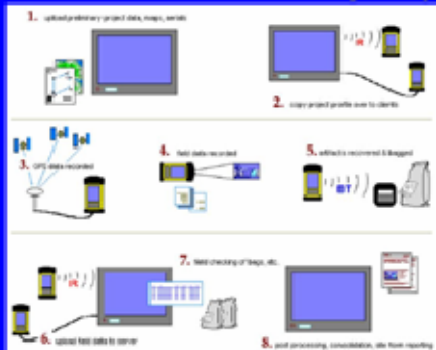

US Army Corps

Field Data Collection



US Army Corps

ARMS™ in Action

(Yes! You can really see the screen)



US Army Corps

Features

- A key feature of this field unit is a single pushbutton that activates a number of automated and time-saving measurements at once—a "snapshot" with a time stamp that is simultaneously applied to the entire data set
- Field observations and other types of data can be manually entered onto project specific, customized forms, which are pre-loaded on ARMS™, as required



US Army Corps

Britt presentation concluded

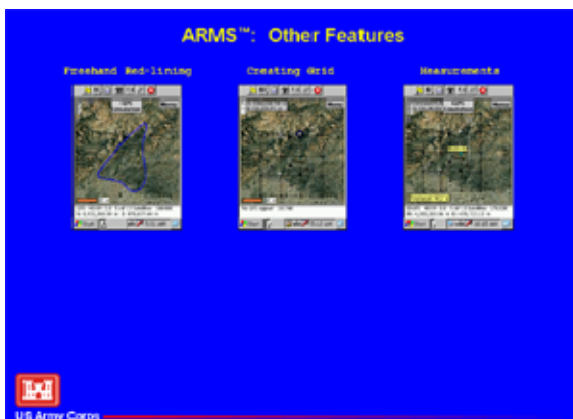
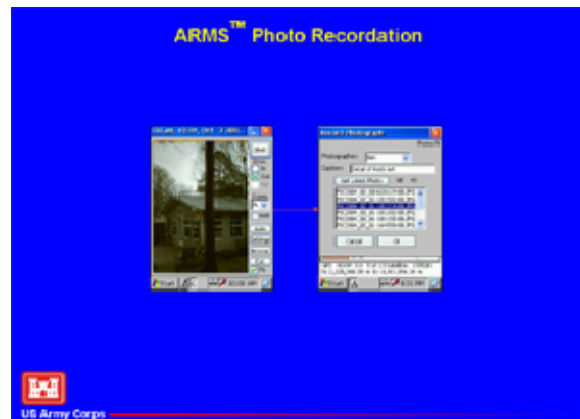
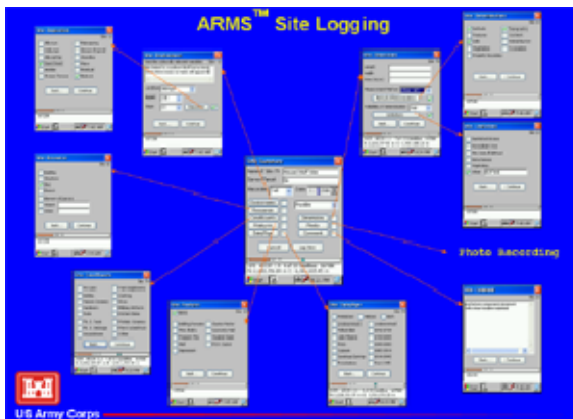
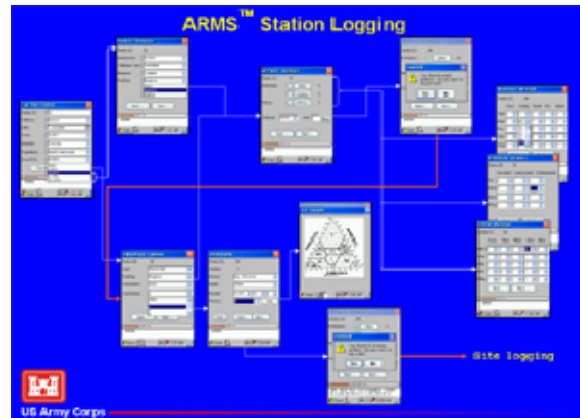
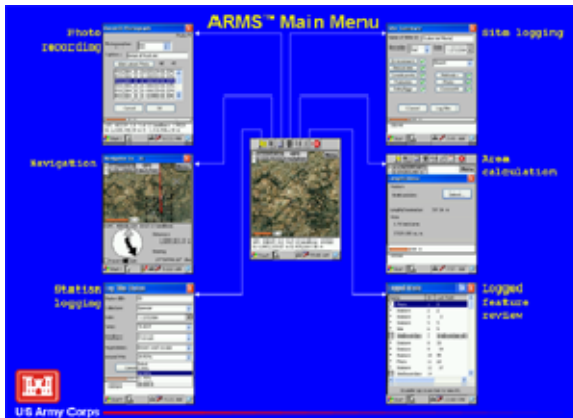

- ### Reliability
- Task checklist and a series of menus are generated by the software, which are displayed on the ruggedized field unit to ensure completeness, accuracy, and efficiency of the survey
 - ARMS™ field unit has a 1Gb Flashdrive for constant data security
 - Customized digital data forms are provided from the menus to allow the operator to easily enter standard data sets in a logical, systematic manner
 - Finally, the raw data, reports, and photos are downloaded (in a one-step process using a wire or radio frequency connection) to the Server for reporting and further analysis using more powerful software tools

- ### Specific Benefits of ARMS™ as a Business Management Process
- Technical merit: a "fail safe" approach
 - Leveraging ability that builds on previous CERL/VIUC efforts
 - Technology transfer to address a variety of land use and environmental management issues
 - Cost effectiveness as demonstrated in its ability to track, monitor, and measure field data collection practices to increase efficiency
 - Improved business process to support Installation and DoD MERTs

- ### Conclusion
- ARMS™ technology as a business process is Patent Pending — COE 564
 - Will be demonstrated in March 2004 at Fort Irwin, NTC.
 - Development cost \$93K
 - ARMS™ prototype cost \$7K

Data Collection and Integration

The Role of Ubiquitous Computing in Facility Life-Cycle Information Integration

Liang Liu, UIUC, Department of Civil and Environmental Engineering

The Role of Ubiquitous Computing in Facility Life-cycle Information Integration

Liang Y. Liu, Associate Professor
Department of Civil & Environmental Engineering
University of Illinois at Urbana-Champaign
205 N. Mathews Ave.
Urbana, IL 61801; (217)333-6951; e-mail: LLIU1@uiuc.edu

ABSTRACT

Mobile computing devices, wireless communications, and sensors have enabled a new era of ubiquitous computing for the facility life cycle of design, construction, operation/maintenance, and disposal/recycle. Compared to other phases, the operation and maintenance phase carries the longest duration and often incurs the highest costs. During this phase, many design and construction problems may surface, causing operational or maintenance problems. These problems can reduce the quality of service and even pose safety hazards to the residents of a facility or the general public. Facility engineers in the past often acted passively; many voiced their dissatisfactions only in undocumented conversations. There is an excellent opportunity to integrate knowledge gained during the facility operation/maintenance phase into other phases of the facility life cycle. Many sophisticated owners are seeing the benefits of a better integration by facility engineers actively participating in design and construction decisions. This integration not only promotes constructability during the design phase, but also facilitates transfer from the construction phase to the operation/maintenance phase. During the operation and maintenance phase, two main challenges exist to all facility operators today —record tracking and resource management. Several advances in information technology are gradually changing the tasks of facility operators and maintainers, especially in mobile computing, wireless communications, and sensors. This paper introduces these new technologies and presents the lessons learned from case studies of research projects conducted at the University of Illinois at Urbana-Champaign.

INTRODUCTION

Facility managers, public and private, face the challenges of managing facilities with limited resources. The performance of these public and private facilities, such as bridges, factories, water treatment plants, warehouses, locks and dams, barracks, classrooms, offices, campuses, hospitals, power plants, ports, harbors, and leased properties, affects the safety and quality of life of millions of people daily. A common response from almost all facility managers is that they are being asked to do more with less and less resources. Many facility managers are using facility management software to track their inventories, maintenance records, conditions, and operating costs. Others are implementing enterprise-to-field level information integration using various hardware devices and software, including the use of the Internet. Several technologies are gradually shaping how facility managers conduct their management tasks. These technological advances are changing the tasks of facility management in the future, a move toward ubiquitous computing. This paper introduces these promising technological advances and presents several case studies from field tests conducted by researchers at the University of Illinois and their collaborators. The paper is organized into four main sections. The first section reviews the needs and tasks of facility operation and maintenance. Next is a description

of existing and emerging hardware and software, which may become indispensable tools for facility managers. The third section describes four case studies of technology field tests. Lastly, lessons learned will be drawn from these cases followed by conclusions.

GAPS IN FACILITY LIFE CYCLE INFORMATION MANAGEMENT

All facilities go through the life cycle of design, construction, operation/maintenance, and recycle/disposal. During this life cycle many individuals and organizations are involved and knowledge generated. Unfortunately, however, there exist many gaps when a facility goes through the life cycle. In a typical design-bid-build project, contractors will only see the design of a facility when it is completed. This lack of input and constructability causes the architecture/engineering/construction industry a great deal of cost overruns, schedule delay, construction claims, and contract disputes. At the completion of the construction phase, many facility managers face the daunting task of establishing accurate as-built information, because many changes usually happen during the construction phase. Significant losses of information and knowledge occur at each exchange of the responsibility between the four phases of the facility life cycle. These losses seem to stem from different viewpoints and responsibilities of parties involved. For example, designers are concerned about functions and forms, while construction managers are focusing on managing construction processes, progress, budget, and safety. Facility managers on the other hand concentrate on facility condition, inventory, and maintainability. Each party involved needs to establish its own information framework to conduct their chartered tasks. Many opportunities for cost saving, constructability, and maintainability are lost because of the lack of integration of information and knowledge during the various phases of the facility life cycle.

PROBLEM STATEMENT

The gaps in information losses during the facility life cycle not only create problems for facility operators and maintainers, but also prevent learning and improvement in design and construction. Can new technological advances help? Which are promising ones? Are there good strategies to implement these new technologies more cost effectively?

RESEARCH APPROACH

To answer the problem statement outlined previously, researchers at the University of Illinois, (1) explored the tasks and challenges of facility management through literature and from the author's personal research, teaching, and consulting experience, (2) identified promising technologies that may play a role to improve the facility life-cycle information integration, (3) conducted field tests of these technological advances, and (4) summarized lessons learned and recommendations from the field tests. The following sections describe each of the tasks.

(1) Review of Facility Management Tasks

From encounters with facility managers, researchers often hear complaints from facility managers on a facility. These complaints in general can be traced to design mistakes or poor construction quality. Many facility managers said they are stuck and have to live with these

mistakes that could be avoided. For example, one frustrated hospital administrator stated that he received approximately 3,000 sheets of design (no as-built update) drawings and one truckload of warranty information on his newly built hospital. It took his staff more than three months, plus \$85,000 of survey contract, to establish accurate facility information so that they can begin to operate effectively. The following highlights the tasks and challenges faced by most facility operators, owners, and administrators:

- Lack of accurate as-built information on drawings and warranty information
- Difficulty in tracing design and construction problems
- Limited record storage space
- Non-computerized data or records-- no search, retrieve, or cross-reference capabilities.
- Errors and inconsistencies in records and facility data
- Tracking of maintenance records and resources (manpower, equipment, and materials)
- Turn-over of personnel and loss of key maintenance knowledge
- Difficulty in prioritizing limited budget for facility maintenance decisions
- Organizational mandates on enterprise integration and decision making
- Labor and resources needed to conduct condition checking or inspections
- More responsibilities with less resources
- Top management needs information within unreasonable timeframe

(2) Identification of Promising Technological Advances

Based on the tasks and challenges identified earlier, an investigation was conducted to identify promising areas in information technology that may improve the tasks of facility operators and maintainers. Three areas were identified to impact the future of facility operation and maintenance: (1) mobile computing, (2) wireless communications, and (3) sensors. These three technologies enable a ubiquitous computing environment, a facility area network, which may well support facility management tasks in the future. The mobile computing devices are becoming cheaper and more rugged with increasing capabilities and speed. Wireless communication network coverage has increased from buildings to campuses to townships, cities, and to metropolitan areas. Sensors are making building components “smart” to automatically report problems or conduct diagnostics. The following sections describe these three technological advances.

Mobile Computing Research and New Advances

Many researchers have contributed to field data collection by developing various hardware and software programs. Among them, Garrett [1998] designed Mobile Inspection Assistant (MIA), a wearable computer, for bridge inspection applications. Liu [1997] developed digital hard-hat systems for construction documentation and collaboration. De La Garza [1998] explored wireless communications and hand-held devices for tracking construction schedule. Pena-Mora [2001] extended collaboration using hand-held computers. Jaselskis [2000] utilized Radio Frequency Identification (RFID) to track and collect data for construction materials. These endeavors have led to new developments as a result of IT advances, especially in the areas of computer hardware, software, and communications. Various industries are exploring new use of these computing devices. Handheld and wearable computers are gaining more popularity in the utility and construction industries. They are used not only to access information in the field but

also to collect data, such as tracking conditions and resources. Many of these handheld computer manufacturers offer attachments such as digital cameras and digital recording of sound, making these handheld computers useful tools for collecting multimedia data. There are three general categories of mobile computing devices available: PDA's, wearable computers, and PC tablets. PDA's are handheld computers, such as Palm or Pocket PC's, capable of collecting field data into databases. They are small and relatively inexpensive, at \$300-\$800 range, running operating systems such as PalmOS and PocketPC. These hand-held computers are considered companion devices that can dock and synchronize with a PC computer to upload or download data. Wearable computers are customized industrialized PC's with a heads-up display which allows hands-free operations. Some include voice recognition and command operations. PC tablets have the size of a laptop computer with a touch-sensitive screen and handwriting capabilities. Weighted at 2-4 lbs, these PC tablets allow field personnel to enter data on electronic forms as if they were writing on a paper form. Another emerging and popular device is the hybrid PDA-phone, which combines cellphone and PDA into one single device. Figure 1 shows some examples of these mobile computing devices.



Figure 1. Wearable and Hand-held Computers

Wireless Communications

Wireless networking has improved dramatically in the last 10 years. The performance of local wireless networks is narrowing the gap with the wired ones. Furthermore, the wide spread of cellular phones, PDA's (personal data assistant), and hand-held computers are creating the need for wide area wireless networking. The increased popularity and usage of wireless data access using hand-held devices have pushed the Internet into cellular phones, PDA's, and hand-held PCs. These wireless Internet access devices are made possible by wireless infrastructure and standards such as CDPD (Cellular Digital Packet Data) in the U.S, GSM in Europe and Asia, and WAP (Wireless Application Protocol) for Web access. Although the bandwidth is still limited, the concept of anytime anywhere e-mail and Web access has gained serious attention from potential users. Many facility operators, such as leasing companies in the Bay area, are

distributing wireless PDAs to their maintenance workers to record conditions and to track costs of maintenance.

Several wireless communication standards are available today. They include IEEE802.11a, IEEE802.11b, IEEE802.11g, Bluetooth, high bandwidth digital cellular network, and satellite communications. IEEE (Institute of Electrical and Electronics Engineers) members and researchers have developed standard protocols for wireless communication networks, which have made it possible for computing devices to communicate with one another. Many mobile and data logging devices are now designed to use these standard protocols so that they can exchange data easily. IEEE802.11a and IEEE802.11b are two of the most widely used standards for wireless communication networks. Bluetooth is another wireless standard that uses different frequencies and bandwidth. Typically used for short ranges of 10 to 100 meters, Bluetooth has the ability to connect sensor clusters and interface with data loggers for field collection of inspection data. The popularity of cellular phones has pushed the demand for high-speed data in addition to voice. Many metropolitan areas now have providers of wireless Internet access from cellular phones and PDAs at 100 to 400 kbps. This will be a technology to watch because many utility companies are considering developing field applications using this infrastructure. For larger area coverage, satellite communications, such as Hughes Satellite Networks, which utilize VSAT low-orbit satellites for telecommunications, allow data to be transmitted from the field to remote locations.

Sensors for Facility & Infrastructure Condition Monitoring

Sensor technologies have dramatically changed the way we collect data from the field. These embedded sensors transmit data related to specific characteristics. Some sensors detect the existence of certain substances; others detect deformations, corrosions, cracks, and loss of cable tensions. Figure 2 shows some of the common sensors used by civil engineers to monitor the health and condition of a facility. They include the accelerometers, strain gauges, tension/pressure meters and tile sensors among others. Although mostly used on research projects at this time, these sensors will eventually become an integrated part of the facility design to collect long-term conditions more efficiently and effectively.

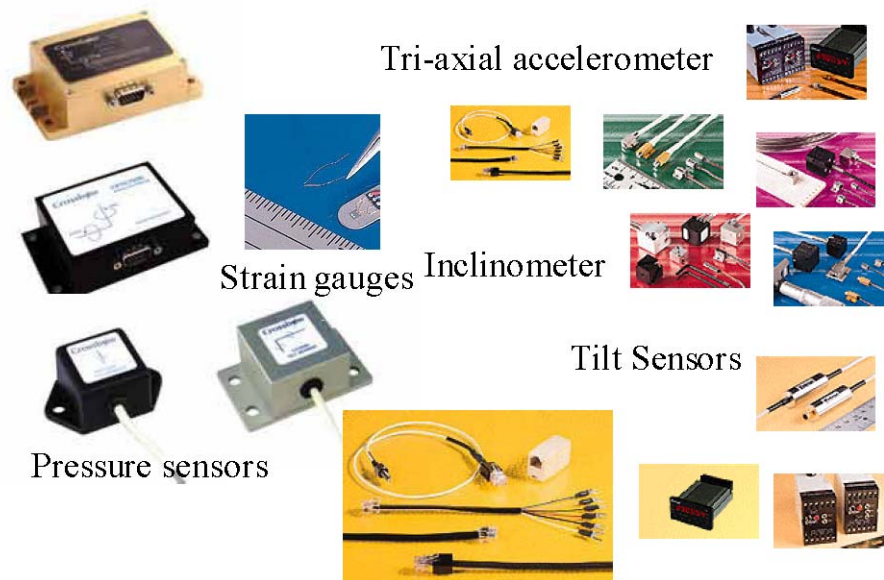

Figure 2. Sensors for Infrastructure Condition Monitoring

(3) Field Test Case Studies and Application Examples

Since 1992, researchers at the University of Illinois have been exploiting promising technologies for use in the facility life cycle. With a mixture of public and private industry funding, several research projects were conducted to field test new information technologies. The following four case studies highlight the scope and the lessons learned from these field tests.

The Digital Hardhat Project System

The Digital Hard Hat system field-tested the pen-based computer, multimedia capture and retrieval, and wireless communications. Various field tests had been conducted to better understand how these technologies may help facility manager (Stumpf 1998). The results indicated both promises and limitations of wireless communications and pen-based mobile computing. This project clearly demonstrated the potential of pen-based computing and wireless communications for facility operators and maintainers.

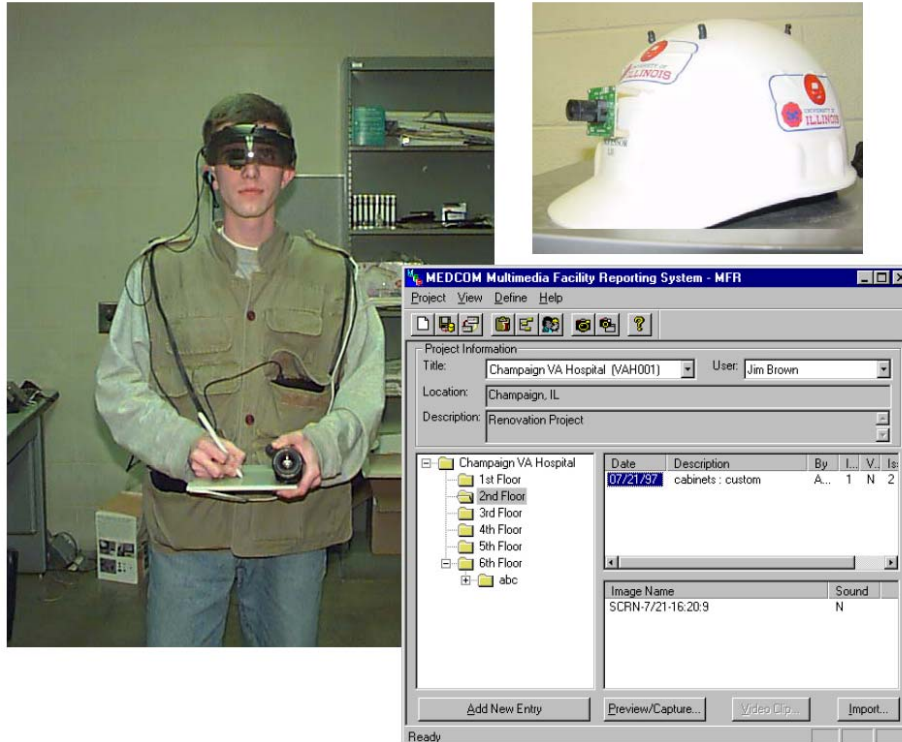

Figure 3. The Digital Hardhat System

The Tunnel Log System

A second project used to field test mobile computing was the construction of a tunnel in LA. The researchers utilized hand-held PDAs to document a subway construction project near Hollywood station (Liu 2000). Workers in general were receptive to the technologies at the foreman level; however, more training is needed to bring the foremen up-to-date on computer technology. Most foremen seemed to have techno-phobia at first, but after tutorials everyone was able to use the mobile device well, despite the complaints on small screen display and handwriting recognition. In this field test, foremen experimented data entry of daily project information, such as manpower and progress of tunnel grouting.

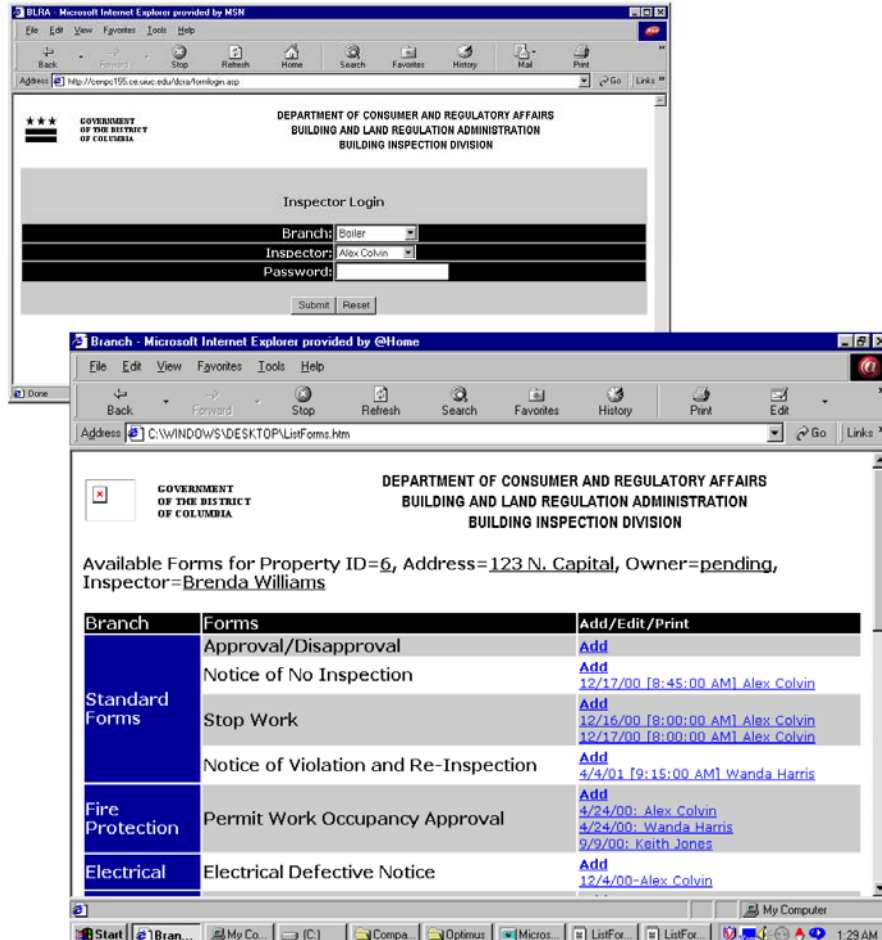

Figure 5. BLRA Inspection System

Sensors for Infrastructure Monitoring

Sensor technologies have dramatically changed the way we collect field data. These embedded sensors transmit data related to specific characteristics. Some sensors detect the existence of certain substances; others detect deformations, corruptions, cracks, and loss of cable tensions. These embedded sensors provide data streams to offsite experts so that inspections can be conducted remotely. Taking advantage of sensor technologies and wireless technologies, researchers at the University of Illinois at Urbana-Champaign field

tested sensors on a model bridge to simulate data communications and management in a sensor-rich environment in the future. Figure 6 shows the model bridge and data obtained on cable strains and bridge accelerations from an induced vibration. Data from remote locations are transmitted via the Internet, so that inspectors can assess the conditions remotely [Ballado, Trupp, and Liu 2003].

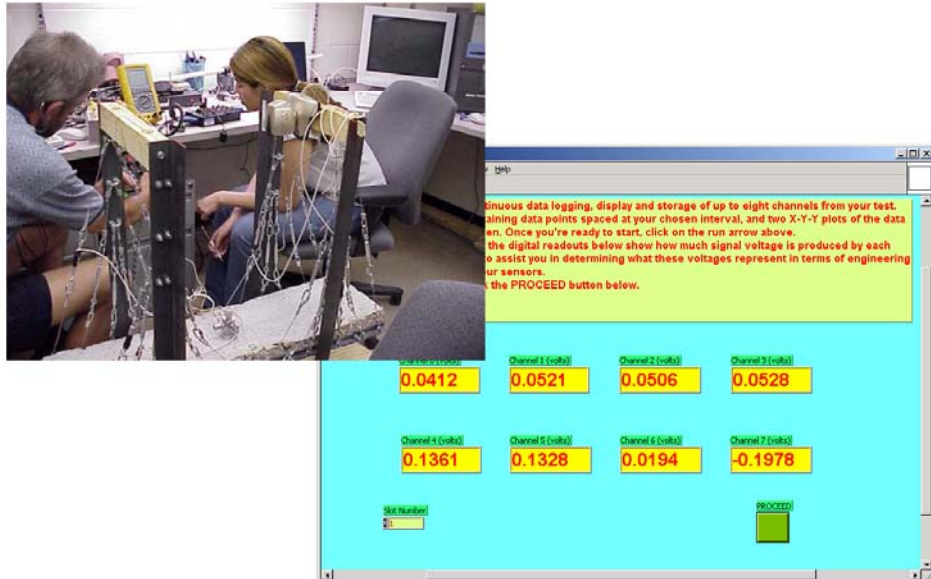

Figure 6. Sensors for Infrastructure Monitoring

LESSONS LEARNED

(1) A Vision for Facility Life Cycle Information Integration

As described in the previous sections, the ubiquitous computing environment will play a key role in facility management in the future. Sensors, wireless communications, and mobile computing will provide a computing environment without boundary to all phases of facility life cycle. This ubiquitous environment will provide better information integration throughout the life cycle. Although there are more issues to be resolved, the technology advances are well positioned to improve how we manage facilities in the future. In addition to the management life cycle of design, construction, operation/maintenance, recycle/disposal, there is likely a life cycle of design of sensor and mobile computing to facilitate the life cycle integration of facility information and knowledge as described in Figure 7.

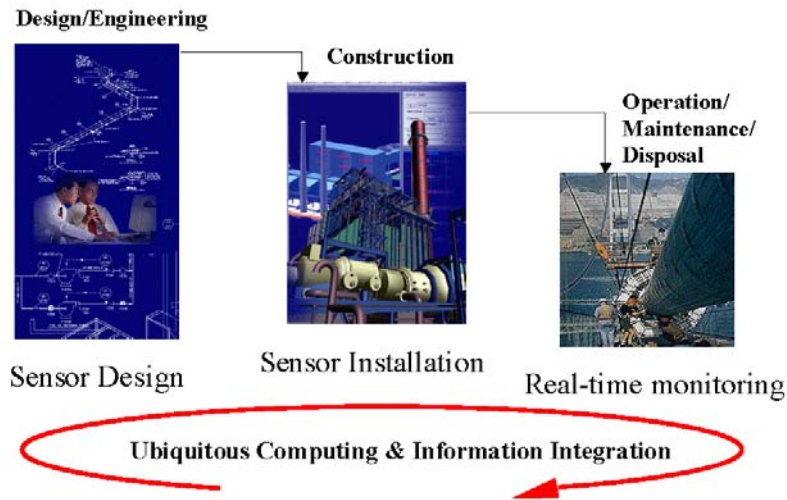

Figure 7. Ubiquitous Computing for Facility Life Cycle Information Integration

(2) Practical Strategies for Implementing New Technologies

As expected, new technologies come with high costs, risks, and implementation problems. Many people asked why they are not seeing a wide spread applications of these technologies. IT managers wonder where the expected payoffs for the investments are. Top management wonders how to choose proper technologies. Workers are puzzled by new systems they have to get used to. These are among the common questions people ask about new technologies. By nature, new technologies are risky. Technologies are developed based on certain assumptions of use and conditions. Many companies take either a positive attitude or a passive attitude toward technologies. The positive ones seek new and innovative ways of doing business, whereas the passive ones catch up because their competitors are using new technologies. Positive or passive, companies or organizations benefit most by understanding the technologies and their work processes. Most successful companies using technologies to their advantages are those that integrate technologies into their processes or invent new processes enabled by new technologies. It is critical for management to realize that technologies are tools, and tools do not produce results if they are not utilized properly. Many new technologies do fail, adding misery to people and organizations that believe in them. Common reasons for these failures include technology assumptions, standards, implementation, and training. Facing all these uncertainties, facility operators and maintainers may consider the following strategies:

- Form an IT committee within the firm to constantly evaluate new IT developments.

- Evaluate new technologies and weigh the benefits/costs, focusing on process reengineering.
- Pilot-test promising technologies on small-scale projects or divisions.
- Compare competing technologies.
- Invest in, not only hardware, but also training.
- Integrate data into information and knowledge throughout the whole life cycle of a facility.

CONCLUSIONS

Information technology tools can and will become indispensable tools for facility operators and maintainers. These tools, especially in mobile computing, wireless communications, and sensors, can help facility managers better track records and manage resources. These technological advances can also improve the integration of information/knowledge, narrowing the information losses and gaps throughout the facility life cycle. Undeniably, new technologies come with uncertainties, risks, costs, problems, and resistance. Facility managers interested in implementing these technologies must recognize the nature of new technologies, their lifecycle, and most importantly how to integrate their work process with technologies. Adopting technologies for technology's sake often leads to failures. A winning strategy for adopting new technologies hinges upon a common vision among management, users, and industry standards. It is important for facility managers to articulate their needs to the hardware and software industry so that more products will be developed toward the needs of facility operation/maintenance-- the longest duration of facility life cycle. Sensors, mobile devices, and communication tools will continue to shape and change how we manage a facility throughout the life cycle. Good returns on technology investment can only be ensured if a prudent implementation strategy is developed and implemented. Among various responsibilities of facility operators and maintainers, the record tracking and resource management are the most challenging ones. These two tasks can be very well served by using sensors, mobile computing, and wireless technologies. In the current climate of tight budget and lean resources, using technologies might be the only means to achieve more with less.

References

- K. Ballado, T. Trupp, and L.Y. Liu, "Mobile and Sensor-based Infrastructure Inspections," *Proceedings of ASCE Construction Congress V*, American Society of Civil Engineers, Honolulu, Hawaii, March 2003.
- De la Garza, J.M., and Howitt, I., "Wireless Communication and Computing at the Construction Jobsite," Elsevier Science, *Automation in Construction, an International Journal for Construction Professionals*, Vol. 7, No. 4, May, 1998, pp.327-347.
- Garrett, Jr., J. H., D. P. Sieworiek and A. Smailagic, "Wearable Computer for Bridge Inspection," *Proceedings of the International Symposium on Wearable Computers (ISWC)*, pp. 160-161, Pittsburgh, PA, October, 1998

Jaselskis E. and T. El-Misalami, "Radio Frequency Identification Application for Cosntructors," *Proceedings of 17th International Symposium on Automation and Robtics in Construction*, pp. 393-396, Teipei, Taiwan, September 2000.

L. Y. Liu, "Hand-held Multimedia Documentation for Tunnel Inspections," *Proceedings of Computing in Civil Engineering*, American Society of Civil Engineers, pp. 1125-1131, Stanford, California, August 2000.

A. Stumpf, L. Y. Liu, C. S. Kim, and S. Y. Chin, *Delivery and Test of the Digital Hardhat System at the U.S. Army Corps of Engineers Fort Worth District Office*, USA CERL Technical Report, December 1998.

Presentation 4: Role of Ubiquitous Computing in Facility Life-Cycle Information Integration (Liu).

The Role of Ubiquitous Computing in Facility Life Cycle Information Integration

January 26-27, 2004
 AUTACERL
 by
 Jimmy Y. Liu, Associate Professor
 Construction Engineering & Management Program
 Department of Civil & Environmental Engineering
 University of Illinois at Urbana-Champaign

Gaps in Facility Life-cycle Information Management

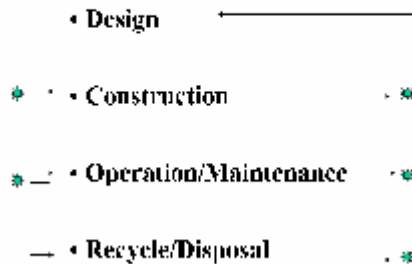

Challenges of Facility Operators/Maintainers



- Lack of accurate as-built
- Condition checking
- Record keeping
- Resource management
- Field data collection
- Data/information/knowledge integration

Promising IT Advances

- Mobile Computing
- Wireless Communications
- Sensors



Ubiquitous Computing

Case Studies & Field Tests

1. Digital Hardhat System
2. Tunnel Log System
3. BLRA Inspection System
4. Sensor Monitoring

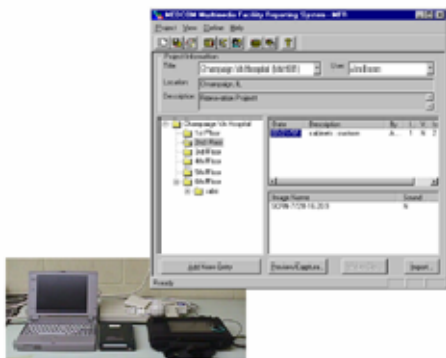

Pocket PC, Palm Pilot, Tablet PC, and Wearable Computers



Liu presentation continued

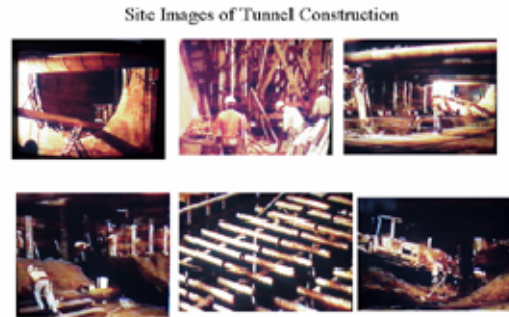
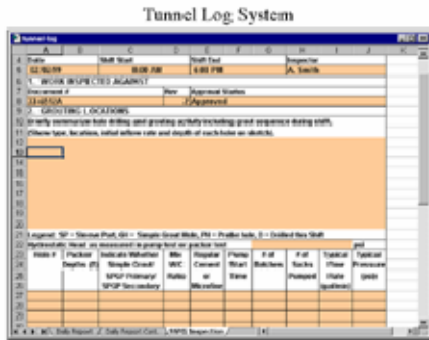

Multimedia Documentation & Internet-based Access/Storage



Web-based Inspection & Administration System

Case Study:

DC Government Building & Land Regulatory Administration

1. End User Study
2. Process Analysis
3. Technological Analysis
4. Implementation Example

**DCRA-BLRA Head Quarter
(Inspectors arrive for work +7:30am)**



Inspection Planning and Scheduling



Inspector/Coordinator Consultation



**Inspectors locate permit information
(On-line computerized system is being deployed)**



Liu presentation continued

Inspector's Notepad

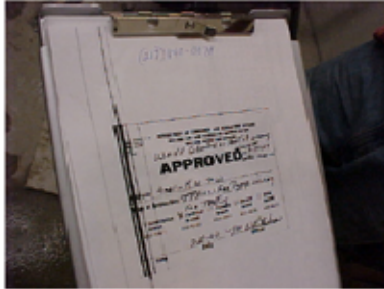

Typical site condition for inspection: Indoor, outdoor, construction equipment, materials, personnel, & temporary facilities



Inspectors communicate/coordinate with other inspectors & BLRA office from the site



On-site Test Results Recording

10004 100 100 11/2/03 3557 22 89.8

MANUAL STATES - JHT

AUTOMATIC STATES -

TEST #	BORE #1	BORE #2	BORE #3	BORE #4	BORE #5
1	100	100	100	100	100
2	100	100	100	100	100
3	100	100	100	100	100
4	100	100	100	100	100
5	100	100	100	100	100
6	100	100	100	100	100

Inspector Tasks Analysis

- ▼ Inspectors at home
 - ▼ Inspectors at BLRA office
 - ▼ Find parking
 - ▼ Arrive at office
 - Inspectors with pending notices/paperwork
 - Call a contractor with an inspection/notice of violation
 - ▼ Leave BLRA office
 - ▼ Travel to inspection site
 - ▼ Inspectors at
 - Inspectors at site
 - All site reports
 - ▼ Complete inspections for the day
 - ▼ Travel back to BLRA office
 - ▼ Find parking
 - ▼ Arrive at BLRA office
 - Complete and file inspection reports
 - ▼ Inspectors leave for home
- Legend:
- ▼ Leave office
 - Leave
 - Delay
 - Task

Where Information Technology Could Be Useful!

Information Technology (IT):

Computer hardware, software, & telecommunications resources that allow a system to perform tasks on the Internet, Intranet, or other networks.

Promising areas for ERDC & BLRA inspections:

- Inspection scheduling (by inspectors or by administrators)
- Reporting writing and filing
- Permit information on-line and on sites
- Computerized database access to BOCA codes & others
- Multimedia information on laptops (text, images, and sound)
- Wireless data synchronization/communications
- IT-based reports

Proposed Inspector Tasks Using Information Technology

- ▼ Inspectors at home
 - ▼ Inspectors from home using online flight scheduler web site
 - Leave inspection schedule to BLRA computer
 - ▼ Travel to inspection site
 - ▼ Find parking
 - Inspectors at site
 - All site reports ready on available computer, internet, & information with BLRA computer
 - ▼ Complete inspections for the day
 - ▼ Inspectors leave for home
- Legend:
- ▼ Leave office
 - Leave
 - Delay
 - Task

Technology Assessment

Four Possible Platforms:

1. Lightweight notebook computer
2. Wearable Computer
3. Palm/Pocket PC's
4. Web/Internet Enabled Cellular Phones

Liu presentation continued

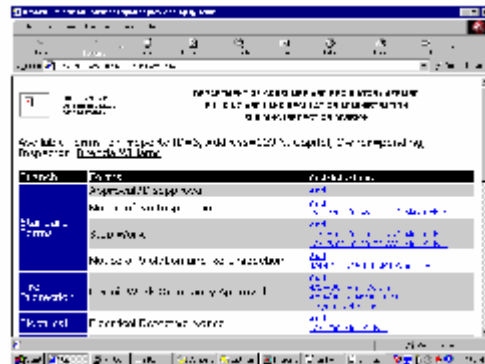

New Generation of Sensors and Wireless Technologies

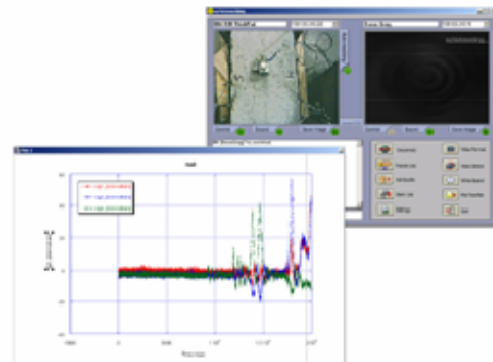
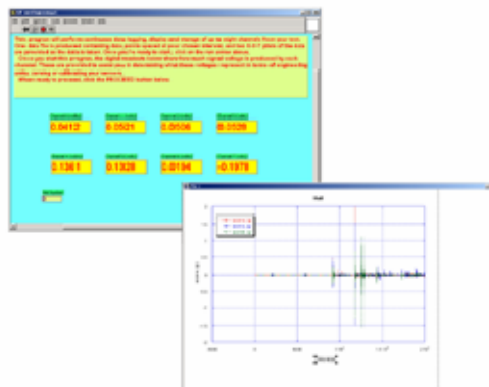
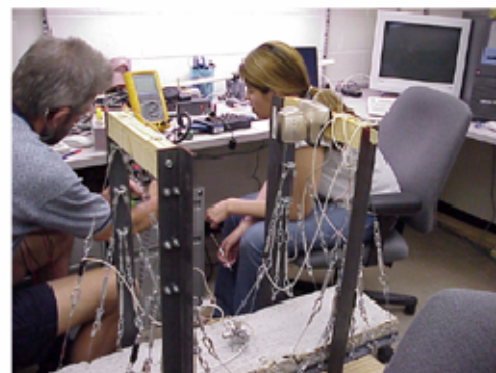

Liu presentation concluded

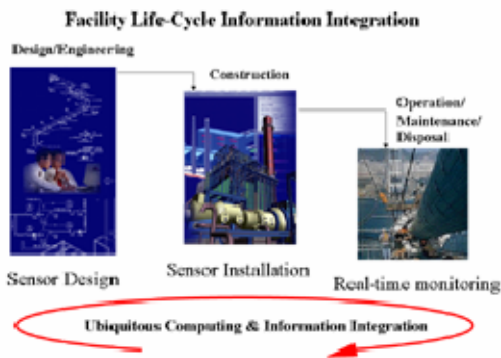

Conclusions

- Main Challenges of Facility Operation & Maintenance
Conditions & Record Tracking
Resource Management
- New Information Technology Advances
Mobile Computing, Wireless Communications, Sensors
- Life-cycle Information Integration

Using Sensor Systems and Standard Project Models to Capture and Model Project History for Building Commissioning and Facility Management

Burcu Akinci, CMU, Department of Civil and Environmental Engineering

Using sensor systems and standard project models to capture and model project history for building commissioning and facility management

Burcu Akinci

Assist. Prof., Civil and Environmental Engineering, Carnegie Mellon University
bakinci@cmu.edu

1. Background

Advances in sensor and tagging systems provide a way to capture the as-built history of a construction project to be utilized during facilities management. Recent developments in generating 3D environments using laser scanning technologies, and in acquiring quality information about built environments using embedded and other advanced sensors create an opportunity to explore the feasibility of frequently gathering complete and accurate three-dimensional and quality-related as-built data frequently throughout the construction and facility management phases of a facility [Akinci et al 2002a; Gordon et al 2003].

Similarly, advances in Radio Frequency Identification (RFID) technology minimize earlier technological problems, such as metal interference, and economical limitations and can be applied to provide an environment to capture, store and communicate data in addition to the ID information on the component [FIATECH 2003; Akinci et al 2002b]. As a result, it is now possible to deploy this technology to capture the history of various facility components throughout the facility lifecycle and hence enable components to achieve Level 1 intelligence, which is defined as having a unique identification, being capable of communicating its status (form, composition, location, key features) effectively with its environment, and being capable of storing data about itself (current and historical data) [EPCGlobal 2003].

The current trends in the A/E/C industry for the use of integrated project models have also shown that a semantically rich integrated project database, combining multiple views for project participants, can support various project management and facility management functions [e.g. Froese et al 1999; Yu et al 1998]. These standard models provide an opportunity to support data exchange during building commissioning, which is an activity that occurs at the interfaces between different phases of a facility delivery life cycle.

This paper discusses three on-going research projects at Carnegie Mellon, focusing on utilizing different sensor systems and RFID technologies to capture the history of a facility and assessing the capabilities of Industry Foundation Classes for enabling the data transfer during building commissioning.

2. Problem Statement

Not having a complete project history of as-built conditions of facility components results in a waste of time and money during operation and maintenance of a facility. Not capturing and storing a complete project history minimizes the learning that can occur within an owner organization.

In addition, when a problem occurs with a component during facility management, one might need to access the history of a component to correctly diagnose and resolve the problem effectively [Akinici et al 2002b]. For example, when a crack occurs on a precast component, to be able to correctly diagnose the problem, one needs to access information about material, casting and curing processes during the manufacturing phase, the transportation and installation conditions from the construction phase, and any special conditions that the component might have faced during its service life [Akinici et al 2002b; Ergen et al 2003]. Currently, most of these information items are stored in various documents and memos, while some are stored digitally in distributed databases located in several companies. As a result, it becomes very difficult to collect all the historical information needed to correctly diagnose and resolve the problem, and a significant amount of time and money can be wasted to resolve the problem. This issue is further pronounced on components such as pipe spools and HVAC ducts that need to be continuously maintained throughout facility operations and maintenance.

Finally, data collected during building commissioning, which occurs multiple times from the design until decommissioning of a facility, is currently stored in reports. Building commissioning provides important information that can be utilized during facilities management. It is beneficial to leverage current standardization efforts, such as Industry Foundation Classes, to transfer the data captured and stored in building commissioning systems to different facility management systems. The latest version of the Industry Foundation classes provide some specifications that can be utilized for capturing and transferring building commissioning data. However, further specifications need to be developed to be able to fully support that process.

3. Approaches, Examples and Results

This section describes three on-going research projects at Carnegie Mellon that leverage the technologies described in Section 1 and focuses on addressing the problems stated in Section 2.

3.1. Capturing the history of a construction project using laser scanners, embedded sensor systems and integrated project models

In this research project, we target not only capturing the history of a construction project, but also analyzing the data captured and identifying possible non-conformances at the time that data is collected. A large percentage of non-conformances in construction occur

during the construction process, resulting in costly rework and adversely affecting the overall performance of the built environment [e.g., Burati and Farrington 1987]. Researchers from the Architecture, Robotics, and Civil and Environmental Engineering departments at Carnegie Mellon University are exploring the utilization of reality capture technologies, and data modelling approaches for identifying non-conformances early in the construction process and for capturing and storing the history of a construction project [Akinci et al 2002a; Gordon et al 2003].

In our approach, we use a core "living" (continuously updated and maintained) project model composed of a three-dimensional design model with explicit design specifications and multiple views, a construction process model, and an as-built model of a facility to store the history of a facility. The product model and the construction process models are obtained from design and scheduling software systems. Using this information, we create inspection plans for scanning and embedded sensing to be utilized during construction. During construction, laser scanners and embedded systems are utilized to capture the as-built conditions and to provide frequent and accurate 3D geometric and quality-related (e.g., component identity, thermal, etc.) as-built information to the integrated project model. This project model provides the necessary project history for the project managers and owners of the facility. In addition, the defect detection and management modules in the proposed approach utilize this project model to identify critical spatio-temporal and quality-related deviations of the work-in-place and construction activities and products that are impacted from these critical deviations. It is expected that this defect management process will in turn trigger a change in the design and or in the construction schedule.

As part of this effort, we conducted several case studies on construction projects in Pennsylvania to identify challenges and opportunities in applying specific reality capture technologies and in coordinating suites of these tools on construction sites. During these case studies, we embedded sensing in concrete and frequently obtained laser scans. Below include some of the initial results obtained from these case studies [Gordon et al 2003].

3.1.1 Creating Inspection Plans and Determining Measurement Goals

It is inefficient to fully saturate a built-environment with embedded sensors and laser scanning activities. It is important to identify ahead of time what types of sensors should be utilized when. In the case studies, we reviewed available design documentation for requirements to be verified using laser scanners and embedded sensing at specific points in the construction schedule [Gordon et al 2003].

3.1.2 Embedded Sensing and Sensor Planning

Embedding sensors into a facility requires commitment to a certain location and time period for sensing, without the option to revisit the sensors for maintenance or replacement. Many issues, such as modality, location, time and duration of sensing, and data communication and storage, should be considered in an embedded sensor plan.

Sensor planning becomes much more difficult for larger deployments under the dynamic and complex conditions experienced on construction sites over time.

Given a construction schedule, design model, and defined inspection goals, the output of the embedded sensor planning process is a series of decisions of when and where to sense what properties of a component for how long and with what sensor. To simplify this process for the case studies, we used a single type of sensor and fixed a receiver and data logger in a secure construction trailer. In these studies, we discovered that the data logger needed additional memory to make sufficient temperature readings in the field, where the timing of concrete placement is more variable than under controlled conditions.

3.1.3 Laser scanner planning

The goal of laser scanner planning is to optimize the use of scanners to achieve a given set of measurement goals in the built environment. Total saturation of the construction environment with laser scans is an inefficient option and at the same time, sparse scanning risks missing areas of interest that may be occluded or otherwise hard to access for necessary measurements. To minimize the cost of scanning, researchers from the Robotics Institute are constructing an algorithm that determines optimal scanner configurations based on current site conditions, measurement goals, and the goal of minimizing costs. The algorithm developed so far performed well on the case study site with few overlapping goal spaces, but had difficulty when multiple goals existed in close proximity.

3.1.4 Laser scanning

Given laser scan plans, we experimented with two laser scanners : (1) a commercially-available Zoller + Fröhlich LARA 25200 (Z+F scanner), (2) a research test-bed, composed of two actuated SICK lasers (CTA scanner). The Z+F scanner is able to scan 360° horizontally and 70° vertically, and capture range and reflectance data for each point. It has a maximum range of 25 meters. It takes approximately 90 seconds to complete a scan. We averaged 6 minutes per scan with spin-up time and interface navigation included. Figure 1 shows an example of that scan. The CTA scanner is made of two SICK lasers: one mounted horizontally and one vertically, with each able to scan a 180° line. The CTA scanner has a maximum range of 80 meters. A scan takes approximately 45 seconds to complete; total scan time, including spin-up time and interface navigation, averages 2 minutes.

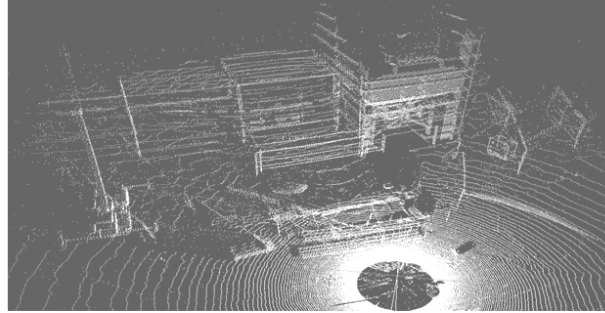

Figure 1. Z+F scanner output (from Gordon et al 2003)

The scale and detail required for each measurement goal determines the choice of scanner. Data generated from the Z+F was of very high density and quality, with one problem: range data that exceeds 25 meters wraps around to 2 meters. We found that the ability to scan up to 80 meters, as in the case of CTA scanner, can make construction applications of laser scanning time-effective, especially for a large number of measurement goals [Gordon et al 2003].

3.1.5 Object Recognition

Using the 3D point cloud output of the laser scanning process, the team was able to visualize the geometric as-built site conditions. However, a point cloud does not provide an optimal representation to allow high-level reasoning about defects and their early detection. In addition, the goal of capturing the history of a project can be achieved by recognizing and representing objects in a scene. Object recognition provides the bridge between the raw data and a CAD model of the site, abstracting the point cloud data into a higher-level, more portable representation. The algorithm developed by the team can detect objects with arbitrary and unknown pose. The existing site model provides an initial estimate of the location of the model objects within the 3D point cloud. This a priori knowledge allowed us to focus the recognition algorithm on the relevant region of the data and to process the data at a higher resolution than would be possible if the entire point cloud was used.

3.1.6 Representation of as-built information in standard project models

To automate the assessment of as-built conditions and to be able to represent and store the history of a construction project, both as-built and as-designed models need to be represented in a semantically rich way and the necessary relationships between these two models need to be created and maintained throughout construction. IFC Rel 2x specifications have limitations in modeling as-designed and as-built information into one project model to support the automation of as-built conditions. It is necessary to extend the current IFC representation without increasing the complexity unnecessarily from both an understandability and a processability point of view. For the purpose of allowing IFCs to represent both design and as-built information in one project model simultaneously, we

propose a solution that allows for fast processing of the IFC model without increasing the complexity of the IFCs. This was accomplished through the utilization of the *IfcRepresentationContext* concept in IFCs and adding a new attribute called Context to the *IfcRelationship* class.

3.2. Utilizing RFID tags to capture the history of a component

RFID is an automatic identification technology used to identify, track, and detect various objects. RFID systems are composed of two components: a tag, and a reader. An RFID tag is an electronic label that stores data and is attached to objects. Readers, which send RF (Radio Frequency) signals for communication, are used to read data from these tags. A reader is composed of an antenna, a transmitter/receiver and decoder. Current RFID technologies use three frequency ranges: low (100-500 kHz), intermediate (10-15 Mhz), and high (850-950 Mhz / 2.4-5.8 Ghz). RFID tags can be classified as either active or passive based on the power source. An active tag has an internal battery for power. A passive tag utilizes the energy generated by a reader/antenna. Active tags have a greater read/write range (up to 30 m). However, they are larger in size, more expensive, and have a limited life span (5-10 years). Passive tags are cheaper, smaller, lighter, and have unlimited life span. However, they require a more powerful reader and have shorter read ranges. Tags also can be read only (RO), read / write (R/W) or write once / read many (WORM). After the data is read from any type of transponder, it can be sent to a host computer, or stored on a reader to be later uploaded to a computer [Akinci et al 2002].

In this research, we leverage these features of the RFID technology and assess the capability of this technology to store some critical historical information about a component so that various related parties can access and write relevant information as the component moves through its supply-chain.

We are currently performing several pilot case studies in a precast manufacturing and a pipe spool manufacturing plants. The initial results of a field test done at a pipe spool manufacturing plant showed that active tags operating at 433.92 MHz frequency at a read/write distance of 60-150 feet work well for storing some information on the tag and reading id and other information from multiple tags in a short period of time [FIATECH 2004].

3.3. Evaluation of IFC specifications to support building commissioning

ASHRAE defines commissioning as the process of ensuring that systems are designed, installed, functionally tested and capable of being operated and maintained to perform in conformity with the design intent (Guideline 1-1996). The role of commissioning, as we call it embedded commissioning, is to complement each of the lifecycle phases and their interactions through timely building system evaluation. To be able to support this, current standardization efforts, such as Industry Foundation Classes, need to represent the building commissioning data to be exchanged at different phases.

Our approach includes developing a prototype system to collect building commissioning information and a test rig to assess the capabilities of various releases of Industry Foundation Classes in exchanging the necessary building commissioning data (Figure 2). We approach this from two angles. First, we are exploring the representational needs of building commissioning process and the management of building commissioning data. The second facet of our approach is testing the adequacy of Industry Foundation Classes for support of commissioning process and exploring the possibilities of data exchange.

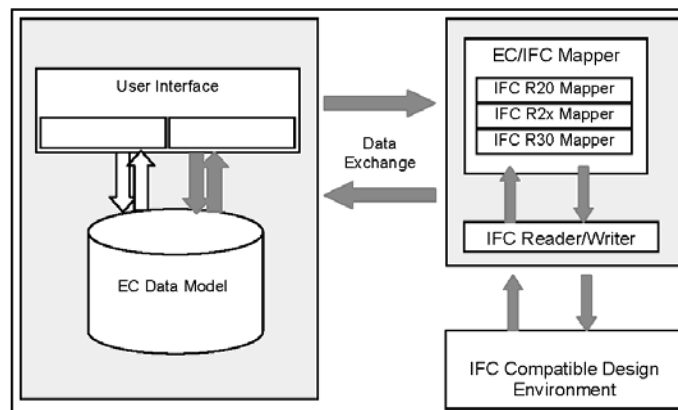

Figure 2. Building Commissioning based IFC Test Rig

Initially, we have focused our effort developing a representation schema that shows the data that need to be represented for building commissioning activity performed for HVAC components during post-construction. We specifically focused on developing data models for fans and air filter units. We have tried mapping our building commissioning fan and air filter model to IFC release 2. In that case, we were able to represent about 60% of the building commissioning data items using IFCs. In the recent release of IFCs, the data representation within the HVAC domain got significantly augmented with the use of predefined property sets. Using that release, we were able to map 90 % of our information to the specifications. We are currently performing further tests and developing and testing additional data models within the HVAC domain.

4. Conclusions and Recommendations

Reality-capture technologies, such as laser scanners and embedded sensing systems, available to the Architecture/Engineering/Construction industry provide a way to capture the history of a project to be used during facility management. Similarly, advances in RFID technologies enable the capture and storage of a product's history on the product itself and enable Level 1 intelligence for facility components. To be able to get full benefits from these technologies, it is necessary to plan for how these technologies can be utilized on construction sites. In addition, data modeled in current standard project

models, such as Industry Foundation Classes, should be enhanced to enable the representation of the data captured in these devices. Finally, additional specifications also need to be developed to enable embedded commissioning, which complements each of the lifecycle phases and their interactions through timely building system evaluation.

5. Acknowledgements

The research projects described in this paper is being funded by NSF, NIST and PITA. These institutions' supports are gratefully acknowledged. Any opinions, findings, conclusions or recommendations presented in this paper are those of author's and do not necessarily reflect the views of these institutions.

Several people are involved in the research projects described above: Omer Akin, Jim Garrett, Martial Hebert, Daniel Huber, Ramesh Krishnamurti, Kuhn Park, Tanyel Turkaslan-Bulbul, Esin Ergen, Chris Gordon, Frank Boukamp, Scott Thayer, Ed Latimer, and Hongjun Wang. The author acknowledges their contributions to the research projects described.

6. References

- Akinci, B. and Boukamp, F. 2002. " Representation and Integration of As-Built Information to IFC Based Product and Process Models for Automated Assessment of As-Built Conditions." the *Nineteenth International Symposium on Automation and Robotics in Construction (ISARC 2002)* September 23-25, 2002, Washington, DC USA, 543-549.
- Akinci, B., Garrett, J., Patton, M. 2002a "A Vision for Active Project Control using Advanced Sensors and Integrated Project Models." *Specialty Conference on Fully Integrated and Automated Project Processes*, Virginia Tech, January 23-25, 2002, ASCE, 386-397.
- Akinci, B., Patton, M., and Ergen, E. 2002b. "Utilizing Radio Frequency Identification on Precast Concrete Components - Supplier's Perspective." the *Nineteenth International Symposium on Automation and Robotics in Construction (ISARC 2002)* September 23-25, 2002, Washington, DC USA, 381-386.
- Burati, J.L.J. and J.J. Farrington, Cost of Quality Deviations in Design and Construction. 1987, The Construction Industry Institute, The university of Texas at Austin: Austin, Texas.
- EPCGlobal 2004. <http://archive.epcglobalinc.org/>.
- Ergen, E., Akinci, B., Sacks, R. 2003 "Formalization and Automation of Effective Tracking and Locating of Precast Components in a Storage Yard." *EIA9: E-Activities and Intelligent Support in Design and the Built Environment, 9th EurolA International Conference*, pg. 31-37, Istanbul, Turkey.

- FIATECH 2004. Draft Report on Field Trials of RFID Technology for Tracking Fabricated Pipe.
- Fischer, M. 1999, Personal Communications.
- Froese, T., et al. 1999, Industry Foundation Classes for Project Management - First Light. *Electronic Journal of Information Technology in Construction*. 4: p. 17-36.
- Gordon, C., Boukamp, F., Huber, D., Latimer, E., Park, K., Akinci, B. 2003 "Combining Reality Capture Technologies for Construction Defect Detection: A Case Study." *EIA9: E-Activities and Intelligent Support in Design and the Built Environment, 9th EuroPLA International Conference*, pg. 99-108, Istanbul, Turkey.
- Latimer IV, D., Thayer, S., Latimer, E., Michaux-Smith, L. 2002. Sensor Space Planning System. *ICVS*.
- Yu, K., T. Froese, and F. Grobler. 1998. International Alliance for Interoperability: Industry Foundation Classes. in *Computing in Civil Engineering, Proceedings of the International Computing Congress*. 1998. Boston, MA: ASCE.

Presentation 5: Using Sensor Systems and Standard Project Models (Akinci).

Using sensor systems and standard project models to capture and model project history for building commissioning and facility management

Burcu Akinci, Assist. Prof.



Problem Statement

- Not having a complete *project history of as-built conditions* of facility components can result in a waste of time and money during operation and maintenance.
 - The San Francisco Airport Authority estimates that 10% of the work hours of its 300 engineers (~\$1.5 million/year) are spent searching for facility information [Fischer 1999]
- Accessing the *history of a component* is necessary for efficient and effective diagnostics during facility management.
- **Building commissioning** data can be utilized throughout the life cycle of a facility.

02/26/2004

3

Research Projects

- ASDMCon: Utilizing laser scanners, embedded sensor systems and Industry Foundation Classes for capturing and modeling a project's history.
- RFID for capturing a product's history
- Evaluation of IFCs for Building Commissioning

02/26/2004

5

ASDMCon Participants

Faculty:

CEE: Burcu Akinci, Jim Garrett, Mark Patton

Robotics: Martial Hebert, Scott Thayer

Architecture: Ramesh Krishnamurti

Postdocs:

Robotics: Daniel Huber, Nicolas VanDapel (P)

Graduate Students:

CEE: Frank Boukamp, Chris Gordon, Sameer Khadkatkar (P)

Robotics: Ed Latimer, Rajiv Saxena, DeWitt Latimer (P), Bob Wang (P)

Architecture: Kuhn Park

Undergraduates:

CEE: Sarah Schrass, Martha Alunkal(P)

ECE: Peter Allen

Robotics: Lisa Michaux-Smith, Jennifer Lin

Architecture: Don Havey, John Oduroe (P)

02/26/2004

7

Outline

- Problem Statement
- Motivating Technologies
- Research Projects
 - ASDMCon
 - Product History and RFID
 - IFCs and Building Commissioning
- Conclusion

02/26/2004

2

Motivating technologies and efforts

- For capturing and analyzing a project's history
 - Laser scanners
 - Embedded sensor systems
- For capturing and accessing a product's history
 - Radio Frequency Identification Tags
- For transferring data from building commissioning
 - Industry Foundation Classes

02/26/2004

4

ASDMCon

Advanced Sensor Based Deviation Detection and Management at Construction Sites

<http://www.ce.cmu.edu/~itr/>



Carnegie Mellon

02/26/2004

Motivating Technologies

- Laser scanners for quickly creating 3D models of the built environment.
- Embedded sensors to monitor performance of components and materials.
- Integrated project models (e.g., IFC, CIMSteel, etc.) to transfer data and to create an integrated as-designed and as-built models.

02/26/2004

8

Akinci presentation continued

Laser scanners enable building 3D as-built models

- Example from a warehouse project



02/26/2004

9

Embedded sensors enable collecting quality info

- Capabilities of certain embedded sensing systems
 - Strain gauges
 - Nucleation and growth of cracks
 - Estimate of shrinkage
 - Estimate of set time and curing rate
 - Temperature gauges
 - Maturity - accurately predict strength
 - Maturity - compliance of mix with specifications
 - Information about curing environment
 - RFID tags
 - ID information, and any programmable information
- Wireless technologies to collect the information

02/26/2004

10

Embedded sensors enable collecting quality info

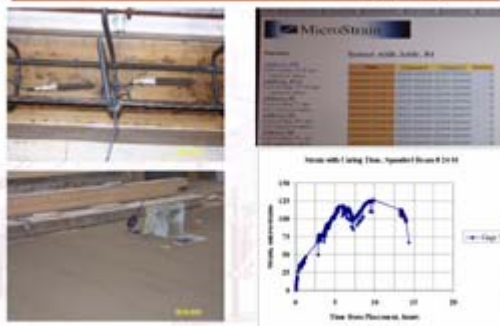

02/26/2004

11

ASDMCon Approach



02/26/2004

Research Areas/Objectives

- Scan planning
 - Developing general "next-best-view" algorithms
- Sensor and inspection planning
 - Developing formalisms to strategies for allocating sensors to gather the relevant quality related information.
- Object recognition
 - Developing mechanisms for recognition of facility components
- Integrated "living" project models
 - Developing a representation schema and mechanisms for storing multiple views in a project model (creating true 3D design models).
 - Developing a construction specifications model within the integrated project models.
- Automating the analysis of as-built conditions
 - Developing a formalism to identify and categorize significant deviations.

02/26/2004

13

A warehouse project

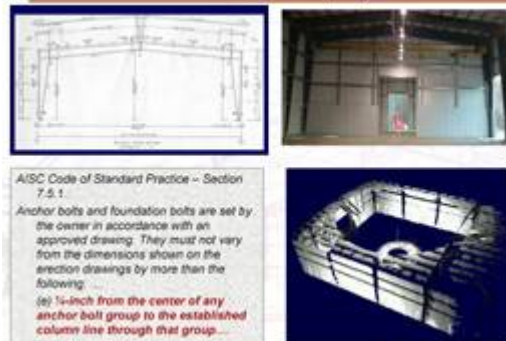

Laser Scanning Process

- Used two different laser scanners:
 - Zoller + Fröhlich LARA 25200
 - Scans 360° horizontally and 70° vertically
 - captures range and reflectance data for each point
 - maximum range: 25 meters
 - ~90 seconds to complete a scan
 - ~6 minutes per scan (spin-up time + interface navigation + scan)
 - CTA research scanner
 - A research test-bed, composed of two actuated SICK lasers, each able to scan a 180° line
 - maximum range: 80 meters
 - ~45 seconds to complete a scan
 - ~2 minutes per scan (spin-up time + interface navigation + scan)

02/26/2004

15

Laser Scanning Process

- Which scanner to use?
 - Determined by scale and detail required for each measurement goal
- Z+F scanner:
 - + High data density and quality
 - Range data that exceeds 25 meters wraps around to 2 meters, causing overlap of far data with near
- CTA test-bed:
 - + Range of 80 meters can make construction applications of laser scanning time-effective
 - lower data density and quality

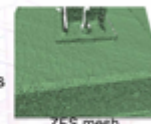

02/26/2004

16

Akinci presentation continued

A laser scan of a portion of a current site

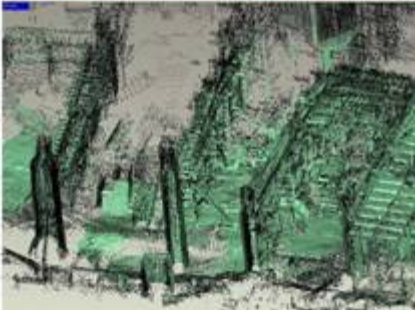

02/26/2004 17

Laser Scanning Conclusions

- Total saturation of the construction environment with laser scans is inefficient and can be ineffective.
- Sparse scanning risks missing areas of interest that may be occluded or otherwise hard to access for necessary measurements.
- Quality of scans generated is highly dependent on the scan plan.
- Goal:
 - Optimizing the use of scanners to achieve a given set of measurement goals in the built environment
 - Minimize cost of scanning
- Input: Information goals, determined based on
 - Design info
 - Schedule info
 - Construction specification info
 - Previous as-built info

02/26/2004

18

Object Recognition Process

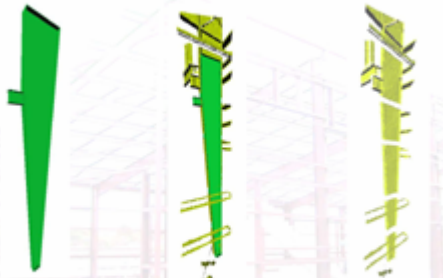

•Easiest objects for the system to recognize are often the hardest objects to model with a CAD system.

Embedded Sensing



02/26/2004

20

Identification of discrepancies

- Short-term approach – Visual inspection:
 - Overlay 3D design model and 3D as-built model to look for discrepancies
- Long-term Vision – Automation:
 - Automating the process of comparing as-built and design models

02/26/2004

21

Situation assessment: Assessment of as-built conditions

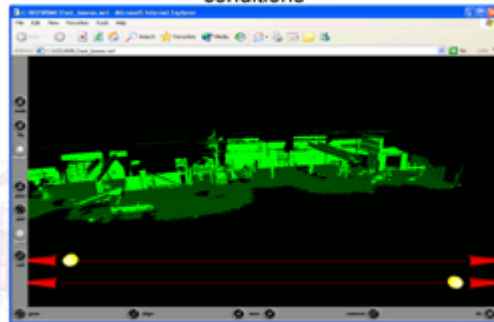

02/26/2004

22

Situation assessment: Integration of design and as-built

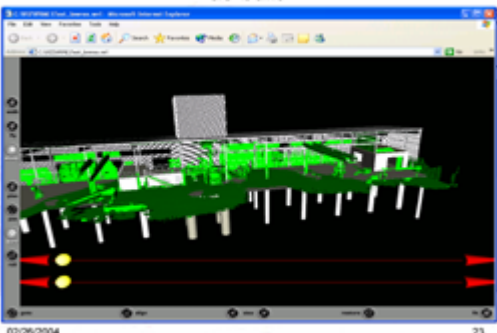

02/26/2004

23

Integration of design and as-built is valuable

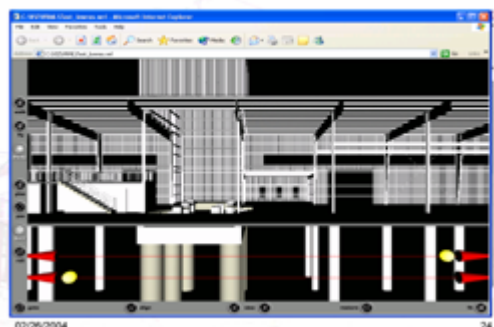

02/26/2004

24

Akinci presentation continued

Integration of design and as-built is valuable

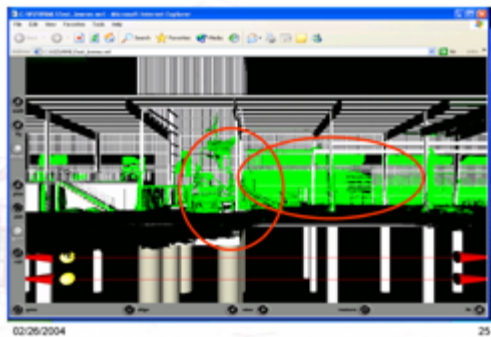

Project history visualization environment

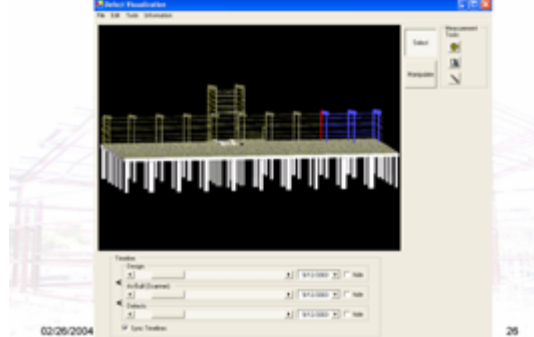

Modified IfcRelationship-Class



ASDMCon Conclusions

- Laser scanners and embedded sensors can be deployed to collect as-built construction information with project-team cooperation.
 - The usage of these devices should be carefully planned.
 - The data collected from these devices should be processed and analyzed.
 - Current project models need to be enhanced to be able to represent the history of a project.
- 02/26/2004 28

Utilizing Radio Frequency Identification for Capturing the History of Building Components

Burcu Akinci, Esin Ergen, Rafael Sacks



Historical information is needed to understand why a crack exists

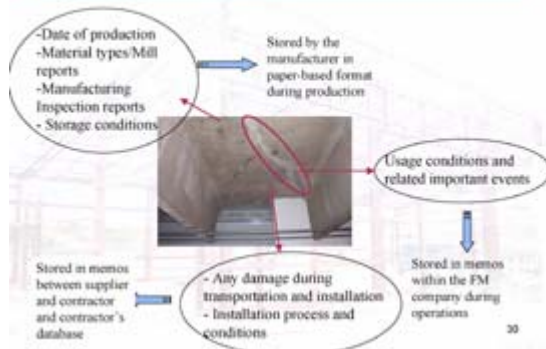

Need for a data collection and storage system

- An automatic data collection and storage system:
- to capture the status information at various milestones.
 - to integrate this data in a database automatically to minimize errors and to enable real-time reporting.
 - to transfer relevant information about a component with the component.
- Leverage RFID, DGPS and load sensor technologies.
- Goal: Achieve Level 1 intelligence on building elements:
- Has a unique identification,
 - Is capable of communicating its status (form, composition, location, key features) effectively with its environment
 - Is capable of storing data about itself (current and historical data)
- 02/26/2004 31

Approach for capturing and storing a component's history on a component

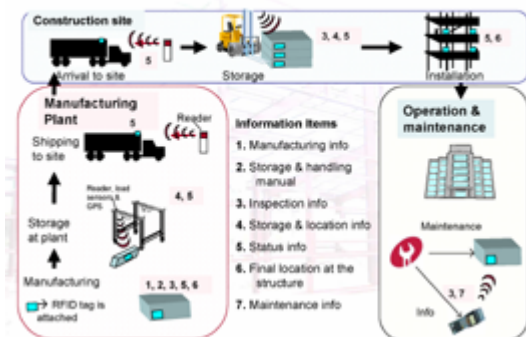

Akinci presentation concluded

Results and Conclusions

- Performing several pilot case studies in a precast manufacturing and a pipe spool manufacturing plants.
- The initial results of a field test done at a pipe spool manufacturing plant showed that
 - active tags operating at 433.92 MHz frequency at a read/write distance of 60-150 feet and having a memory up to 0.5 MB work well for storing some information on the tag and reading id and other information from multiple tags in a short period of time is viable [FIATECH 2004].
 - some technical limitations, such as metal interference, that were experienced in the trials appeared to be resolved with relatively minor adjustment to the work procedure [FIATECH 2004].
- Further work is being done to identify the information items that should be stored on these components.

02/26/2004

33

Embedded Commissioning

- ASHRAE defines commissioning as the process of ensuring that systems are designed, installed, functionally tested and capable of being operated and maintained to perform in conformity with the design intent (Guideline 1-1996).
- The role of embedded commissioning is to complement each of the lifecycle phases and their interactions through timely building system evaluation.
- To be able to support this, current standardization efforts, such as Industry Foundation Classes, need to represent the building commissioning data to be exchanged at different phases.

02/26/2004

35

Results and conclusion

- Performed a small test case consisting of fan and air filter.
- Tested the data exchange between our BC model and IFC Rel 2 and Rel 2x2.
- Using IFC Rel 2, we were able to exchange about 60% of the data.
- Using IFC Rel 2x2 class specifications and the property sets, we were able to exchange 90% of the data.
- Further testing will be done with additional classes.

02/26/2004

37

Testing the capabilities of IFCs for transferring building commissioning data

Omer Akin, Jim Garrett, Burcu Akinci
Tanyel Turkaslan-Bulbul, Hongjun Wang, Ipek Gursesl



Carnegie Mellon

02/26/2004

Approach

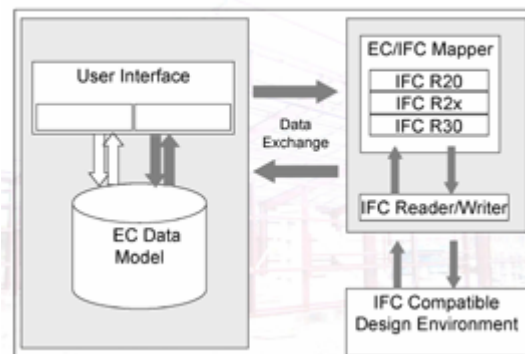

Overall Conclusions

- The capabilities of data capture technologies is significantly getting better.
- Need for developing formalisms for planning the usage of these technologies and analysis of the data captured by these technologies.
- Standard data models are getting better in representing building commissioning and project history related data.

02/26/2004

38

RFID Technology for Pervasive, Ubiquitous Computing in the Life-Cycle of Construction Projects

Ed Jaselkis, Iowa State University, Department of Civil and Construction Engineering

RFID Technology for Pervasive, Ubiquitous Computing in the Life-Cycle of Construction Projects

Edward J. Jaselkis¹

Abstract: This paper provides construction industry owners and contractors with current information about enhancing their operations using radio frequency identification (RFID) technology. Radio frequency identification involves the use of tags, or transponders, that collect data and manage it in a portable, changeable database; communicate routing instructions and other control requirements to equipment; and withstand harsh environments. This paper describes a pilot test using RFID tags to enhance the material management process on an actual construction project. It also investigates ways to integrate RFID technology throughout the project life cycle, improving productivity, cost, schedule, quality, and safety.

Background

Radio frequency identification technology can play an important role in developing a pervasive, ubiquitous computing environment. This will reduce overall project cost, schedule, improve quality, and safety during construction as well as facility operations and maintenance. Radio frequency identification involves the use of tags, or transponders, that collect data and manage it in a portable, changeable database; communicate routing instructions and other control requirements to equipment; and withstand harsh environments. It can be viewed as a sister technology to bar code labels which use light waves instead of radio waves to read a tag. An RFID system comprises tags, or transponders, and a reader that, depending on configuration, includes an antenna and scanner. The tag contains a small integrated circuit chip and an antenna that is encapsulated in a protective shell. The reader contains, at a minimum, an antenna and scanner and is used to communicate with the tag. Tags can be categorized as read only or have both read and write capabilities. Moreover, they are classified as active, which means they include a battery, or passive, which means they are powered by the reader's energy field. The memory capacity of the tags varies from 64 to 32,768 bytes (one byte equals eight bits of binary code). The technology, in existence for several years, is currently being used in several application areas such as vehicle access, personnel identification, asset tracking, livestock identification, and tolls and fees. Application development is currently underway in areas related to groceries, postage stamps, and baggage identification in airports.

The primary benefits of using RFID technology are its ability to store data and retrieve it at a later time. In addition, unlike bar code labels, it is more robust because RFID tags are not damaged as easily, can be read in direct sunlight, and survive harsh conditions. Limitations include higher tag costs compared to bar code labels; lack of standardization, which prohibits one manufacturer's reader from reading another manufacturer's tag; and potential interference from steel objects and other radio frequency signals.

¹ Associate Professor, Department of Civil and Construction Engineering, Iowa State University, 450 Town Engineering Building, Ames, IA 50011 Phone: (515) 294-0250 Email: ejaselk@iastate.edu

Problem Statement

This paper addresses how RFID technology can improve several construction and owner-related processes. Several construction-related processes can be potentially enhanced using this technology such personnel accountability, safety, and material control. For the owner, the greatest enhancements relate to improving their asset management process. Discussions with both owner and contractors indicate that material and asset management are two key areas where interest in using such a device is the highest.

Approach

This paper considers the use of radio frequency tags to assist both the contractor during construction and owner during the operation phase. A pilot test was conducted to explore the usefulness of this technology from the contractor's perspective as it relates to material management. This is followed by a more general discussion of other applications. Overall, this research explores how to best integrate RFID technology throughout the project life cycle to improve productivity, cost, schedule, quality, and safety.

Example

A pilot test was conducted which involved receiving pipe supports and hangers on a Bechtel Power Plant project in Ackerman, Mississippi. The current procedure involves unloading and shaking out pallets of supports and hangers, manually "kicking and counting" items, checking them against a packing list, and manually entering data into Bechtel's material tracking system that calls it PTS, or Procurement Tracking System. This process is time consuming and prone to mistakes.

Using the RFID approach, an RFID tag is placed on the pipe support at the supplier's fabrication plant. Like the manual approach, pallets are still unloaded and shaken out. Using RFID, only one worker is required to kick and count the pipe supports instead of two using the traditional manual approach. The worker scans the tag, populating the screen with information related to the pipe hanger's purchase order number, release number, and requisition number. Three questions were answered related to each hanger's quantity, condition, and storage location. This information was then written back to the tag for later use. Once all tags had been scanned, the last step involved downloading the data to the PTS.

The pilot test involved a total of 28 hangers with RFID tags. To compare the manual and RFID approaches, time measurements were taken for both methods. The research team initially timed the manual approach used to receive these hangers. Earlier, Bechtel field procurement workers timed the manual approach, using three other shipments of pipe hangers and supports, and provided the research team with these data. Workers were trained for approximately fifteen minutes on the use of the Telxon reader. Figure 1 shows a worker receiving a pipe support using the RFID approach.



Figure 1: Worker Receiving Pipe Support using RFID Approach

The research team used several methods to record observations for this pilot test. A video camera was used to record the entire process, including shaking out the pallets, manually receiving the pipe supports, and receiving pipe supports using RFID. Also, a digital camera was used to provide still photographs of the process. Finally, conversations with the field workers, warehouse supervisor, and other research team members were audio taped for future reference.

Results

Table 1 summarizes the time requirements for performing the receipt process using the manual and RFID approaches. The table shows the three steps of the pipe hanger receiving process for the project (i.e, unloading, receiving, and data transfer). This process begins by unloading the trucks and storing the material in the laydown area regardless of approach (manual versus RFID), making the timing of this step the same for both approaches. It is included in this analysis, however, to show the complete cycle. The next step involves unpacking the pallets and receiving the items. For the manual approach, this step means checking off each item from the packing list. A Telxon reader is used to scan the tag and write information back to the tag using the RFID approach. Step 3 involves recording this information into the PTS.

As mentioned earlier, Bechtel had made three time studies using the manual approach (refer to the first three columns in the Table 1). Note that the average time to unload one hanger varied from approximately 0.54 minutes to 1.89 minutes. Since the research team was unable to time the unloading process for this pilot test, a simple average, 1.07 minutes, is used, based on the unload times from the previous shipments.

The time to manually receive the pipe hangers and supports (includes shaking out pallets and providing verification with packing list) varied from 2.84 minutes to 6.31 minutes. The wide variability in the time it took to complete the receiving process can be explained by some reported unavoidable problems in each trial. For example, in the third manual test (on February 1, 2000), one of the packing lists had item numbers but no tag numbers. Thus, the receivers had to go back and cross reference the items, which

required considerable time. In the second manual test (on January 24, 2000), some hangers had no item numbers, and others were not even on the packing list. The time required to receive the pipe supports and hangers using the RFID approach was approximately 2.42 minutes. Much of the time savings using RFID results from using only one person for the verification process.

Table 1: Pilot Test Time Measurements

Method	Manual			Manual	RFID
Date	1-18-00	1-24-00	2-1-00	2-10-00	
Observer	Bechtel			Researcher Team	
Number of hangers received	166	95	76	28	
Step 1: Unloading					
Number of workers involved in unloading hangers	3	3	2	Not Available	
Unload hangers from truck using forklift (minutes)	30	60	30	Not Available	
Average time to unload one hanger (minutes)	$3*30/166 = 0.54$	$3*60/95 = 1.89$	$2*30/76 = 0.79$	Average = 1.07	
Step 2: Receiving					
Number of workers involved in receiving hangers	2	1	2	2	1 (use of RFID reader only)
Time to shake out pallets (minutes)	Included in next item			19 (2 persons)	
Time to verify received hangers, including unpacking time (minutes)	240	270	240	17 (2 persons)	30 (1 person)
Average time to receive one hanger (minutes)	$240*2/166 = 2.89$	$270*1/95 = 2.84$	$240*2/76 = 6.31$	$2*(19+17)/28 = 2.57$	$[(2*19)+(1*30)]/28 = 2.42$
Step 3: Data Transfer					
Time to enter all hanger data into PTS (minutes)	60	75	40	Not Performed	Not Performed (assume 20 minutes for all hangers)
Average time to enter one hanger into PTS (minutes)	$60/166 = 0.36$	$75/95 = 0.79$	$40/76 = 0.53$	Not performed Average=0.56	$(20/28) = 0.71$

Average Time for the Three Steps

Average total time to complete the receiving process for one hanger (minutes)	(0.54+2.89+0.36) =3.79	(1.89+2.84+.79) =5.52	(0.79+6.31+.053) =7.63	(1.07+2.57+0.56) =4.20	(1.07+2.42+0.71) =4.20
-------------------------------------------------------------------------------	---------------------------	--------------------------	---------------------------	---------------------------	---------------------------

The last step in the receiving process involved entering the data into the Bechtel PTS, which is accomplished by a clerk in the warehouse. The average time to enter one hanger into PTS is 0.56 minutes but varied from a low of 0.36 minutes to a high of 0.79 minutes. It was not possible to directly download the data from the Telxon reader into PTS since the software interface was not developed, so an assumption was made that it would take at most 20 minutes to perform this operation for any number of hangers. As can be seen from Table 1, it took approximately 4.2 minutes per hanger to complete the receipt process using RFID compared to an average of 5.29 minutes [(3.79+5.52+7.63+4.2)/4] using the manual approach.

Overall, the Bechtel field and warehouse personnel liked various aspects of the technology. In particular, they appreciated the ability to read tags in direct sunlight unlike bar code labels that can be difficult to read in the same situation. Additionally, the RFID tags were well protected and less susceptible to damage than the bar code labels. However, to read the tag properly, the RFID antenna had to be within a few inches of it. In addition, tags that had the metal tie wire running across the top of the enclosure were difficult to read because the wire, in some way, interfered with the radio signals. In these cases, the reader antenna had to be positioned underneath the tag to properly scan it. Workers also liked knowing when a tag had already been scanned because the answers to their questions would appear on the screen of a previously scanned pipe hanger or support.

The software application worked well for the first construction site pilot, but feedback from the field material receiving team reflected the need to make some improvements before conducting the next pilot. The main issue involved writing back to the tag fewer times. In this test, the workers needed to write back to the tag after answering each of the three questions, requiring considerable bending and causing sore knees after a while. By enabling workers to answer the questions and write back to the tag only once, the receiving process will be less strenuous and will also lead to greater time savings.

RFID's Role in a Pervasive, Ubiquitous Computing Environment

Radio frequency identification can be used to support the pervasive, ubiquitous computing environment in several areas. There are numerous other construction-related applications such as personnel accountability, safety, rigging and testing equipment, fleet management, measuring and testing equipment, and quality. For the owner, the greatest benefit is related to improved asset management. In the following sections, each of these areas is discussed in greater detail.

Construction

Personnel Accountability

Radio frequency identification tags can be beneficial in the area of personnel accountability as it relates to timekeeping, certification, and tool management. In terms of timekeeping, each craft worker on the construction site could wear an RFID badge for checking in into and out of the job site, providing a more automated approach than the old “brassing” system, which is still used today. Workers could simply walk through a portal and be automatically entered into the time-keeping system.

This same badge could be used to record certification and medical records as well. A worker’s latest certification data could be recorded on the tag, identifying the worker’s level of proficiency in the areas of welding and specialized safety training (e.g., fall protection, man-lift training, and confined space training). Relevant medical information could also be written to the tag, indicating possible limitations that would assist foremen and superintendents in providing the most suitable work assignments.

The worker RFID badges could also be used for enhanced tool management. Worker’s badges could be scanned at the tool shed along with the tools that they check out. This system would facilitate faster tool checkout and better tool and small equipment accountability. The tool shed supervisor would have access to current data regarding which workers have tools checked out. If someone else needed that particular tool or piece of equipment, it could be easily determined who had the item.

Safety

Construction site safety can also be enhanced using RFID tags. The tags could be attached to equipment such as ropes, electrical extension cords, and safety harnesses and contain pertinent information such as date of last inspection, date of next inspection, and any possible use restrictions. Such RFID tags would make it easier for the safety coordinator to keep track of all safety equipment and ensure that they are in safe operating condition before each use. Additionally, certain types of construction equipment (e.g., backhoes, cranes, and man lifts) could include an interlock that would prevent the machine from starting unless the proper code is read from a worker’s RFID badge, showing that the appropriate level of proficiency had been achieved.

Rigging Equipment

Similar to the tagging of safety equipment, RFID tags can also be placed on all rigging equipment such as chokers, chains, and hooks. Appropriate information such as date of last inspection, date of next inspection, and possible restrictions (e.g., load limits and attaching procedures) could be provided on each tag. Prior to using the rigging equipment, workers would be able to verify the equipment’s integrity. If an item is damaged during a lift, this could be recorded on the RFID tag, warning potential future users. This field can be changed once the piece of rigging gear has been fixed and recertified.

Fleet Management

Radio frequency identification technology can also be used to enhance the fleet management program for both construction and facility operation organizations. Several types of equipment used for building and maintaining a facility (e.g., cranes, trucks, forklifts, dozers, and front-end loaders) have their own unique maintenance requirements. Cranes and dozers, for example, require frequent lubrication of moving parts so that these

components perform at their peak capability. Radio frequency identification tags could be attached to each vehicle to track its maintenance history (e.g., oil changes, lubrication schedule, and tire rotations). As the equipment is moved from job to job, the vehicle's complete maintenance history will be available. These tags can provide equipment mechanics with specialized maintenance instructions, helping them perform their jobs better.

Furthermore, RFID can be linked to on-board sensors to monitor equipment performance and location anywhere in the world. On-board instruments, such as engine temperature sensors, oil gauges, coolant gauges, and geopositioning sensors (e.g., global positioning systems), could provide data input to an active transponder located in the vehicle. If certain set point values are exceeded (e.g., engine temperature is above normal), a signal could be sent out to the fleet management software program indicating a potential concern with a particular piece of equipment and including its location. This signal would prompt the notification of a mechanic to investigate the problem.

Measuring and Testing Equipment

Radio frequency identification tags can also be used to enhance the quality system associated with the calibration and control of measurement and test equipment (M&TE) such as pressure and vacuum gauges, dial indicators, thermometers, torque indicators, and ultrasonic measuring equipment. Each piece of M&TE can include an RFID tag programmed with data to meet project contract requirements, specifications, and relevant codes and standards. For example, tags can contain information related to the property number, calibration date, calibration agency, standard reading, as-received reading, after adjustment reading (if required), storage requirements, and due date for next calibration. The convenient features of this approach are that the information follows the piece of equipment and workers do not need to have access to the database.

Quality

Radio frequency identification can also be used to improve the quality control of various processes that involve numerous steps such as installation of pipe spools. In this application, the following steps are included: receipt, inventory, installation (i.e., fit-up, tack welding, full welding, quality control acceptance, hydro testing, heating tracing, insulation, and turnover). The general foreman or piping superintendent could scan the tag on a pipe spool to see if the quality control inspector has provided acceptance of a certain step. If a particular quality issue arises, identified by a combination of writing to and placing a visual marking on the tag, hold points could be placed on the pipe spool during any step of the process, providing workers with necessary information before they continue the installation process. For example, the workers could be instructed not to heat trace a particular pipe spool until all of the welds have been certified. Or, the instruction may be not to insulate the pipe until it has been hydro tested. Quality control specialists can then perform their test and scan the test information back to the tag, indicating that this pipe spool is ready for the next step. Quality control might want to frequently perform some audits using a checklist, scanning an RFID tag, and scanning a template to verify if it is set or unset. On small projects, this quality control procedure may be easy to track, but on large projects, it could be more difficult.

Facility Management

Owners can also benefit from the use of RFID technology during the maintenance and operations phase. The owner's primary interest would probably be the protection of the asset and its warranty. After the construction and start-up phases are completed, the contractor is required to provide the owner with a turnover package, including as-built drawings, specifications, warranties, operation manuals, and preventive maintenance requirements. Radio frequency identification tags attached to each asset could contain some of this information as well as a history of its installation process (e.g., preventive maintenance performed during the construction phase and start-up date). During the operating life of the plant facility, the owner would continue using the tag for maintenance.

As an example, consider an electric motor being tracked from the construction to operations phase (Figure 2). An RFID tag could be used to facilitate the installation process, including such information as the serial number, manufacture data, unit cost, number of windings, rate revolutions per minute, rated voltage, preventive maintenance issues, and important installation instructions. When this motor is turned over to the owner, the information could become part of the owner's capital asset management program and enhance its performance. The owner would likely continue using the RFID tag during operations by recording maintenance procedures performed on the asset and referring to other information stored on the tag as the need arises, such as installation information for maintenance during a scheduled outage.

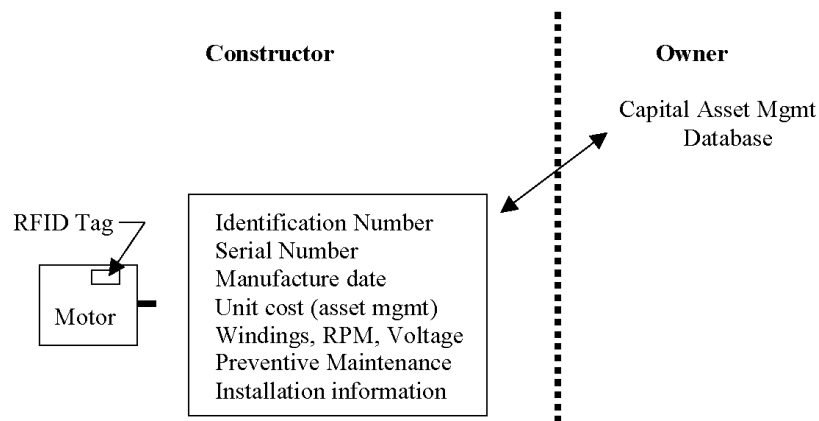

Figure 2: Project Life Cycle Asset-Tracking Model

Conclusions

Radio frequency identification is becoming more popular as a tagging and identification technology. In addition to its relatively large storage capacity, it is very reliable and extremely robust in harsh environments. This technology can play an important role in developing a pervasive, ubiquitous computing environment as described in this paper. Overall, this technology has significant potential for enhancing several processes in the construction and facility operations environment.

Recommendations

In order for this technology to become more widely accepted in a construction and operations environment several issues will need to be addressed. Interoperability standards will need to be developed (as was done for bar codes) that would allow generic tag readability. This is occurring, but very slowly, as manufacturers are reluctant to share proprietary information about their particular RFID system. Metal still hampers the ability to read and write to tags which can increase the inconvenience in using such devices. Perhaps other frequencies can be explored that would be less sensitive to metallic objects. Cost may still be an issue for using these tags on all items; it may make more sense to use RFID tags on the more expensive engineered items that require life-cycle monitoring and establish a different monitoring approach for bulk items.

Acknowledgments

The authors greatly appreciate the support of the Construction Industry Institute (CII). They are particularly thankful for the guidance and inspiration of the research team. This paper is similar in concept to "RFID's role in a Fully Integrated, Automated Project Process," presented at the ASCE Construcion Congress in 2003.

References

Jacobs, Bill. (1999) "At last, IT departments can directly track assets to reduce their costs" *Automatic ID News*.

Presentation 6: RFID Technology (Jaselskis).

RFID Technology for Pervasive, Ubiquitous Computing in the Life- Cycle of Construction Projects

Dr. Edward J. Jaselskis
Iowa State University

Outline

- Introduction
- Technology Description
- Suitable Construction Applications
- Pilot Tests
- RFID's role in Life-Cycle Management
- Conclusions

Introduction: Project Goals

- Investigate RFID potential to enhance construction operations
 - reduce cost
 - reduce cycle time
- Provide RFID suppliers with information regarding construction industry needs

Introduction: Approach

- Determine capabilities, current applications, benefits, limitations, and costs
- Identify potential construction applications
- Pilot RFID applications in a construction and maintenance and operations environment

What is RFID?

- RFID technology involves the use of tags or transponders that can collect data and manage it in a portable, changeable database
- “High tech” bar code label

What are its Components?

- Tags or transponders
- Reader (usually includes antenna and scanner)

RFID Tags

- Integrated circuit chip and antenna
- Encapsulated to protect against shock, fluids, dust, dirt, or other contaminants
- Different shapes and sizes

Sample RFID Tags



Jaselskis presentation continued

RFID Tag Characteristics

	Active	Passive
• Power Source	Battery	Magnetic Field
• Read Range	5 to 100 ft	Inches up to ~ 3 feet
• Lifetime	3 to 10 years	Unlimited lifetime

RFID Tag Read-Write Capabilities

	Read-Write	Read-Only
• Memory capacity	64 to 32,768 bits	8 to 128 bits
• Information content	Can be altered	Cannot be altered
• Data transfer speed	~ 3,000 bits/second	~ 8,000 bits/second

Reader

- Transmits electromagnetic field that activates tag
- Receives information transmitted by tag
- Monitors incoming transponder signals to assure valid tag data

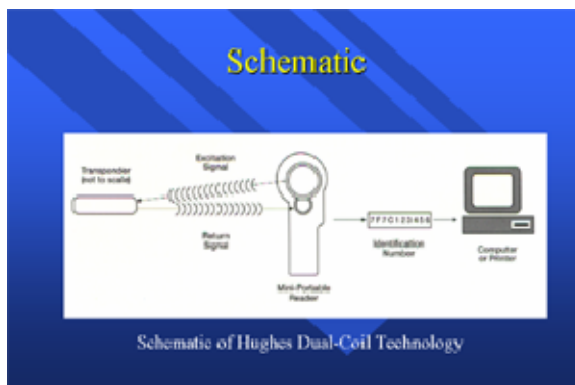

Benefits

- Operates in dirty, oily, wet, or harsh environments
- Functions in non line-of-sight operations without requiring contact or an unobstructed view
- Fast and highly accurate
- Difficult to copy code

Costs

Item	Price Range
• Tags	
Active (each)	up to \$ 250
Passive (each)	\$ 1.00 – 150
• Readers (includes Scanner and antenna)	\$200 – 10,000
• Software development	\$ 100 - \$10,000

Limitations

- Closed systems
 - one manufacturer's reader cannot read a tag made by another manufacturer
- Metal hampers RF tag operation by blocking and canceling the signal
- Potential interference from other RF systems
- Batteries wear out on active systems

Jaselskis presentation continued

Sample Applications

- Tolls and Fees (Ez-Pass)
- Vehicle Access (parking structures, gate control)
- Personnel identification (badges)
- Asset tracking (maintenance, gas cylinders, fleet management)
- Livestock/animal control (animal identification)

Fleet Management (Amtech)



Applications (Indala)



Potential Construction Applications

- Conducted Workshop
 - 31 people attended including construction, owner, and RFID supplier companies
 - information exchange (RF tagging technology capabilities and limitations)
 - Discussed concerns and potential applications

Key Points from Workshop

- Technology has its strengths and limitations for Construction
 - Strengths: data storage, non line-of-sight reading, operates in harsh environments, high reliability (low error rate), rapid data transfer rate
 - Limitations: lack of standardization, passive tags require close read range, metal interferes with signal, higher costs compared to bar codes

Key Points from Workshop

- Few OEMs specialize in applying RFID to construction industry processes
- Both bar code labels and RFID tags should be considered complimentary technologies

Pilot Tests

- Contractor Perspective
 - Material receipt of pipe hangers/supports
- Owner Perspective
 - Installation of "smart instruments"
 - Maintenance of pressure relief valves
 - Operator rounds
 - Steel component tracking

Contractor Pilot

- Pipe Supports/hangers received using RFID on two Bechtel projects (Red Hills and Exxon Baytown)
- Comparison made between manual "kick and count" and RFID approach

Jaselskis presentation continued

Equipment Overview



- Telxon(R) Handheld Computer
- RFID Reader by SAT
- RFID Tags

Radio Frequency ID

Technology Overview

- RFID tag/chip emits radio frequency
 - no line of sight required (not a "visual" technology like barcoding)
 - readable and writable - store data back to the chip



RFID Tag



Field Name	Value	Unit	Comment
rfPurchaseOrder	228310117195	No	
rfPurchaseOrder	1074942099	No	
rfPurchaseOrder	1189024215	No	
rfPurchaseOrder	54124	No	
rfPurchaseOrder	2	No	
rfPurchaseOrder	1	No	
rfPurchaseOrder	3	No	
rfPurchaseOrder	4	No	
rfPurchaseOrder	5	No	
rfPurchaseOrder	6	No	
rfPurchaseOrder	7	No	
rfPurchaseOrder	8	No	
rfPurchaseOrder	9	No	
rfPurchaseOrder	10	No	

RFID Pilot Test Summary

Pipe Supports/Hangers Receipt

- Step 1: Encode and Affix RFID Tags (Piping Technology & Products)
- Step 2: Receipt into Laydown Yard
- Step 3: Detailed Receipt using RFID+Handheld Reader
- Step 4: Import Receiving File into Material Tracking System

Step 1: Encode and Affix

(at Piping Technology)

- Several fields are encoded on RFID tags
- Fields are chosen to uniquely identify the pipe support
 - a) in Piping Technology's system (job number and item number) and
 - b) in customer's system (PO#, mark #)

Step 1: Encode and Affix

(at Piping Technology)



Read Only Fields

Read/Write Fields (not by the field)

List of fields encoded

Step 1: Encode and Affix

(at Piping Technology)



Material at PT&P's plant layed out for shipping

Step 1: Encode and Affix

(at Piping Technology)



RFID Tag is affixed prior to shipment

Jaselskis presentation continued

Step 2: Receipt into laydown yard

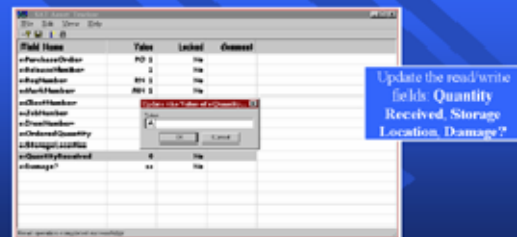

Step 2: Receipt into laydown yard

Step 3: Detailed Receiving
Using RFID + HandheldStep 3: Detailed Receiving
Using RFID + HandheldStep 3: Detailed Receiving
Using RFID + HandheldStep 3: Detailed Receiving
Using RFID + HandheldStep 4: Import Receiving File into
Material Tracking System

Simple CSV File
w/ all receiving data

Material Tracking System:

- Bechtel's PTS (Procurement Tracking System)
- Stone and Webster's Atlas System

Red Hills Pilot Results:
Engineered Items

- RFID Strengths
 - Time savings
 - Workers liked technology
 - "Flag" written to tag indicated received item
 - No double entry
- RFID Limitations
 - Metal interferes with reader
 - A lot of bending down to read and write to tag
 - Sun glare made it difficult to see reader screen

Jaselskis presentation continued

Red Hills Pilot: Time Study

Method	Manual	RFID
Time required to unload 100 hangers (minutes)	107	107
Time required to verify 100 hangers (minutes)	356 (2 people)	242 (1 person)
Time required to enter 100 hangers into PTS (minutes)	52	20 (estimated)
Total time required (minutes)	515	369

Baytown Pilot

- Differed from Red Hills Pilot





- ### Baytown Pilot Results: Bulk Items
- RFID Strengths
 - Time savings from downloading data
 - Tags can be reused for bulks as they are not tracked throughout the project life-cycle
 - Workers liked technology
 - "Flag" written to tag indicated received item
 - RFID Limitations
 - Current test design was not ideal for bulk items
 - Metal interferes with reader

- ### Pilot Summary
- RFID worthwhile pursuing
 - Enhancements required
 - Increase read range (at least 12 inches)
 - Need an open system

RFID'S Role in Life-Cycle Management

- ### OBJECTIVE
- Investigate ways to integrate RFID technology throughout the project life cycle to improve:
- Productivity
 - Cost
 - Schedule
 - Quality
 - Safety Performance



Jaselskis presentation concluded

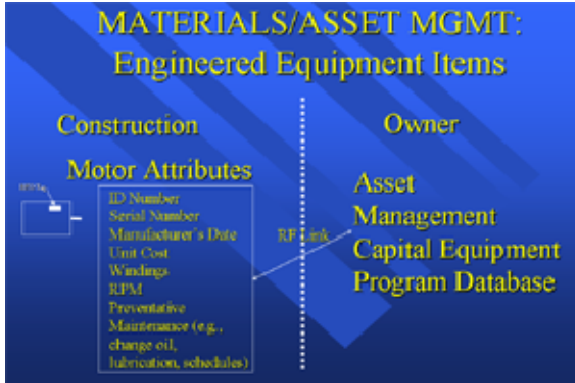

Conclusions

- RFID is a proven technology
- Significant potential for both owners and contractors



FAN-Related Research at CMAG

Alan Lytle, NIST

Presentation 7: FAN-Related Research at CMAG (Lytle).



FAN-RELATED RESEARCH AT CMAG

Alan Lytle

Construction Metrology and Automation Group

William Stone, Kam Saidi, Gerry Cheok, Nick Scott

Intelligent Systems Division

Adam Jacoff, Rick Norcross, Brian Weiss



National Institute of Standards and Technology

FAN 2004



OVERVIEW

- CMAG Introduction
- Automated Steel Construction Testbed
 - RFID / Laser Tracking / LADAR Imaging
- Ad-Hoc Wireless IP Tracking
- UWB Tracking



National Institute of Standards and Technology

FAN 2004



CONSIAT

Construction Integration and Automation Technologies

OBJECTIVE

To provide measurement systems, and protocols, and standards to integrate and automate the construction and design process as part of integrated and automated capital project delivery, enabling industry to achieve design and construction and design cycle-time and cost reductions.



National Institute of Standards and Technology

FAN 2004



CONSIAT

Construction Integration and Automation Technologies

- 861-4106 Performance of Innovative Technologies for Automated Steel Construction
- 861-4103 Measurement Processes and Metrics for Construction Component Tracking
- 861-4104 Field Sensor Data and Construction Process Integration Interface Protocols
- 861-4101 System Integration and Performance Analysis for Next Generation LADAR
- 861-4102 Construction Object Recognition
- 861-4100 Metrics for LADAR Range Imaging and Registration
- 861-4109 Design and Construction of a LADAR Calibration Facility
- 863-5016 Product Data Standards for Steel Construction
- 863-5292 Interoperability Standards for Capital Facilities – Improving Equipment Design, Specification, Purchase, Fabrication, and Installation
- 868-1018 Economic Analysis of Construction Industry Institute Benchmarking Data
- 868-1208 Interoperability Cost Analysis of the U.S. Construction Industry



National Institute of Standards and Technology

FAN 2004



CONSIAT

Construction Integration and Automation Technologies

Performance of Innovative Technologies for Automated Steel Construction
 Measurement Processes and Metrics for Construction Component Tracking
 Field Sensor Data and Construction Process Integration Interface Protocols
 System Integration and Performance Analysis for Next Generation LADAR
 Construction Object Recognition
 Metrics for LADAR Range Imaging and Registration
 Design and Construction of a LADAR Calibration Facility
 Product Data Standards
 Interoperability Standards
 Economic Analysis of Construction Industry Institute Benchmarking Data
 Interoperability Cost Analysis



National Institute of Standards and Technology

FAN 2004



CAPITAL PROJECTS TECHNOLOGY ROADMAP

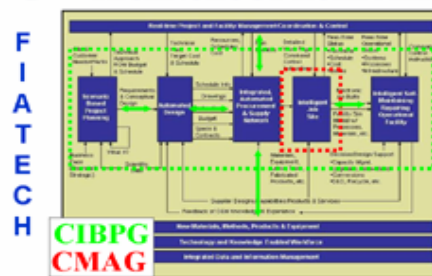

National Institute of Standards and Technology

FAN 2004

Lytle presentation continued

AUTOMATED STEEL CONSTRUCTION TESTBED

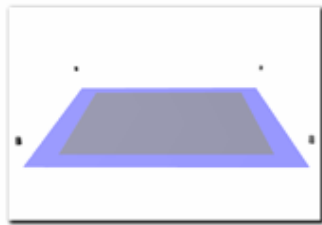

ASC TESTBED

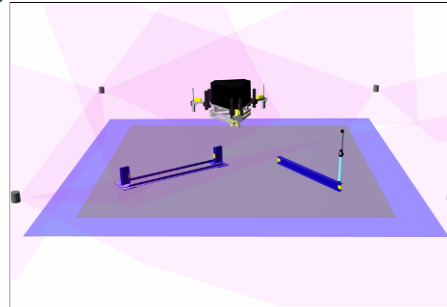

ASC TESTBED

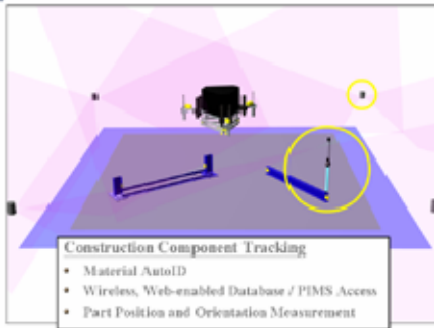

- Construction Component Tracking**
- Material AutoID
 - Wireless, Web-enabled Database / PIMS Access
 - Part Position and Orientation Measurement

NIST Comp-TRAK



SITE MEASUREMENT SYSTEM



Laser Transmitter

Computer Board

SITE MEASUREMENT SYSTEM

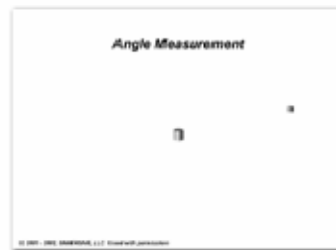

ASC TESTBED

Automated Steel Construction

- Innovative Robotic Systems
- New Connection Technologies

Field Sensor Data / Interface Protocols

- Material / Trades Tracking
- Site Instrument Data Communication

Construction Component Tracking

- Material AutoID
- Wireless, Web-enabled Database / PIMS Access
- Part Position and Orientation Measurement

**ASC TESTBED
FY03 Accomplishments**

- Combined
 - RoboCrane 6 DOF Manipulator
 - Real-Time Laser Positioning for robot tracking in 6DOF
 - Comp-TRAK part pose measurement
 - Automated beam gripper mechanism
 - Assembly scripts from commercial 4D CAD package
- Demonstrated
 - Multiple component pick and place with 4D CAD generated assembly sequence



Lytle presentation continued



ASC TESTBED



Video accelerated SX



ADVANCED CRANE CONTROL Learn from Autonomous Mobility



ADVANCED CRANE CONTROL Learn from Autonomous Mobility



Army Research Laboratory Demo III Tactical Readiness Level 6 Testing

Evaluation Autonomous Mobility performance in a "representative environment"

- THREE SITES
 - Arid (Tooele, UT)
 - Rolling Hills / Vegetative Cover (FTIG, PA)
 - Urban (FTIG, PA)

GENERAL DYNAMICS, NIST

TRL-6 TESTING



TERRAIN "AS-BUILT"

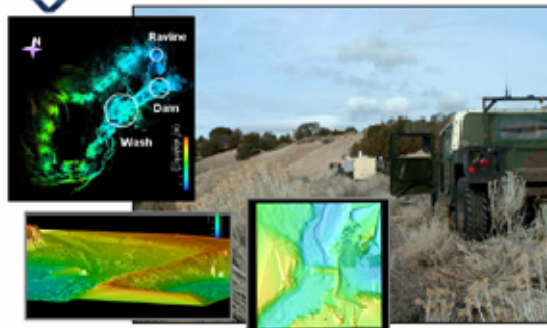

APPLICATION TO ASCT

- "Truth Model" for path planning
- Combine with RFID to trim component search field

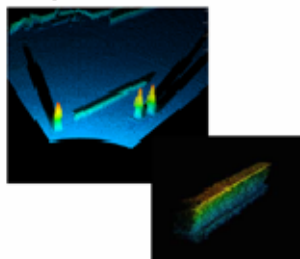

- Create "work surfaces"
- Pinpoint target locations in structure and then track crane/payload to those positions.



CSEM FLASH LADAR

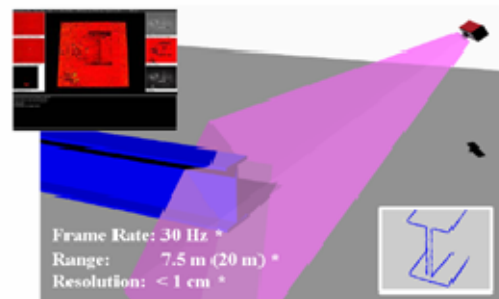

* Manufacturers Specification

Lytle presentation continued



ASC TESTBED

Future Efforts – FY04



- Improve real-time tracking and control
- High frame-rate (fast) LADAR for obstacle avoidance and payload delivery
- High resolution (slow) LADAR for as-built information



Next Generation LADAR

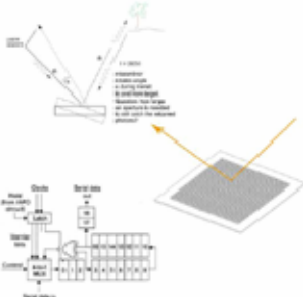

Fast LADAR at NIST:

FANDANGO:
Fast ANgular Deflection Experiment At NIST.GOV

MEMS-based beam deflection

PHASER: Pico-second High-reliability Sensor Readout



Next Generation LADAR

FANDANGO



650 kHz 0-D LADAR

MEMS beam deflection

1X(10)⁶ Degrees/s Demonstrated 8/2003

Accuracy: 3 mm

FOV: 24 deg.



LADAR Calibration Facility

- Purpose
 - Calibration / performance evaluation
 - Test bed for developing evaluation metrics and test protocols
 - Prototype instrument design
- Indoor facility (2)
 - Climate controlled
 - Artifact based
- Outdoor facility
 - Evaluate varying terrain and environments in field conditions
 - Long range calibrations

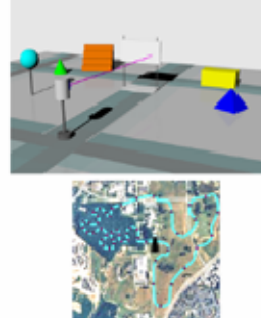

Wireless Ad-Hoc Localization



- The concept behind a grid-based localization service



Wireless Ad-Hoc Localization



- Localization Service
 - Implemented Familiar Linux on handheld computer (client being tracked)
 - Implemented Familiar Linux on single board computers (wireless sensor "cubes")
 - Developed software for grid-based localization
 - Demonstrated localization within a 40 m x 40 m area
- Publications
 - Smith, P. and Dyer, W., "Wireless Ad-Hoc Networks for Mobile Tracking", National Institute of Standards and Technology Technical Report 030, July 2003



UWB ROBOT TRACKING

Urban Search and Rescue Test Arenas



FCC Certified*
4.8 – 6.4 GHz*
Accuracy – 3 m*
Stand Dev – 0.5 m*

* Man. Spec. – Multiplexed Solutions, Inc.



EM Penetration Research



Proposed Technical Approach:

- Conduct frequency-dependent dielectric constants for construction materials
- Use existing NIST digital archive of laboratory tests (1000 conducted or NIST 1995 for 27 materials)
- Develop Fourier algorithms to operate on existing data
- Develop and test a 3D graphics based tool to automatically generate a CAD model out of the propagation characteristics for the materials likely to be present in certain class of construction for a given "typical" situation
- Validate models through field tests
- Make EM propagation models available as input to commercial sector for location systems

Operational Capability:
Create a comprehensive digital library of experimentally-derived building material dielectric (EM) penetration properties that will enable the development of accurate 3D tracking systems for law enforcement and firefighting personnel operating within buildings.

Deliverables:
Digital library of EM penetration through construction materials
Quarterly and technical reports
Full-scaled rapid infrastructure (3D modeling) software

Lytle presentation concluded



FAN-RELATED RESEARCH AT CMAG

Alan Lytle

Construction Metrology and Automation Group

William Stone, Kam Saidi, Gerry Cheok, Nick Scott

Intelligent Systems Division

Adam Jacoff, Rick Norcross, Brian Weiss

IFC Model Server Technology

Francois Grobler, ERDC-CERL, Engineering Processes Branch

IFC Model Server Technology

Francois Grobler,
ERDC-Champaign

Introduction

This paper examines open, model-based, web servers to serve Facility Management and Facility Area Networks. The IFC (Industry Foundation Classes) specification of the International Alliance for Interoperability (IAI) is briefly introduced and arguments are presented for using a common object model in the evolving Building Information Model (BIM) and FAN (Facility Area Networks). The status of IFC model servers is reviewed and conclusions are presented on existing and developing capabilities.

Background

The International Alliance for Interoperability (IAI) has been actively pursuing interoperability in the Architecture, Engineering, Construction and Facility Management industries for 8 years. The IAI is a non-profit global alliance of the building, research and information technology industries working to enable and promote interoperability (sharing information via integrated technological solutions) across disciplines, technical applications and the facility life cycle.

The IAI is dedicated to improving processes, enabling integrated information exchange and encouraging collaborative working within the industry. Organizations within the alliance include architecture, engineering, construction (AEC), building owners and maintainers, facility managers (FM), product manufacturers, software vendors, information providers, government agencies, trade and professional associations, research laboratories, and universities.

A major part of the IAI's mission is to define, promote and publish the IFC (Industry Foundation Classes) Model specification, which enables IT companies to integrate interoperable functionalities into their software applications, tools and systems. The IFCs are based on non-proprietary, freely available, international open standards, have regular releases, and provide a global software certification process. The IAI continues to work on additional and improved functionalities to be included in upcoming IFC releases. The IAI also develops XML schema (e.g., ifcXML or aecXML) to complement the IFC Model, enhance Internet communication and e-commerce transactions.

What does interoperability mean?

Interoperability is the sharing and exchanging of information via integrated technological solutions, no matter what project phase, discipline or participant role in the building life cycle. It involves innovative and integrated concepts of real time, on-line 3D/4D virtual projects, comprehensive project data, value adding capabilities, project partner collaboration (clients, service providers, product suppliers, end users) and stretches across technical applications, tools and systems. The object oriented, intelligent data allows attributes such as geometry, relationships, code compliance, materials, cost and time factors to be added and maintained within the virtual model. It integrates with web-

based technologies and allows each participant to use technologies and software specific to their needs without losing, compromising or corrupting project data.

The benefits of interoperability in the building community include improved productivity, competitive advantage, increased profitability, integrated processes, seamless information flow, whole-of-project approach and enhanced capabilities. It also incorporates improved, collaborative processes that result in reduced time, cost and rework by all project participants throughout all phases of the life of the facility.

Data exchange in IFC

Interoperability is enabled by the IFC standard that defines the common semantics for a shared data model used by project participants. In order to exchange information freely the messages (data packets) must be based on this shared data model. However, in IFC several syntaxes are acceptable. In file-based exchanges between IFC compatible software the data is exchanged as in "STEP Physical File" (SPF) format as defined by ISO1030-Part 21). The IFC model is also expressed in XML, i.e. ifcXML is automatically generated from the IFC model (documented in the EXPRESS language per ISO 10303-Part 11) using a methodology and software developed by the IAI, based on an ISO translation methodology for generating XML from EXPRESS product models (ISO 10303-Part 28). ifcXML is extensively used by the model servers described below for Internet based communication of data. aecXML is an effort of the North American IAI to develop schemas for North American needs based on ifcXML, while incorporating elements of XML already in use for commerce purposes (i.e. XML that does not overlap in scope with ifcXML).

Building Information Model

Recently the concept of Building Information Model (BIM) was popularized in the trade press, but the concept has a much longer lineage. The notion to store all project relevant data over its lifecycle can be traced to at least the NSF sponsored Woods Hole Workshops in the 1970's and perhaps earlier. The IAI community has been pursuing the same concept since the beginning.

Many of the benefits mentioned above can only be realized in the context of a shared data storage capability that covers the facility life-cycle and allow access to relevant data to participants in the process as needed, while offering the owner of the facility the control needed to:

- 1) Safeguard this valuable information.
- 2) Archive this information in a vendor independent format (a big issue with government owner who routinely own facilities for decades, or even centuries)
- 3) Exchange software conveniently when newer, more powerful software becomes available.

Figure 1 depicts the concepts of a BIM in the center of the facility life cycle, providing data access to the many business processes of interest along the way.

While a firm definition for BIM has not emerged yet, this paper proposes the following definition:

A computable representation of the physical and functional characteristics of a facility, and its related project/life-cycle information. It integrates all the relevant aspects into a coherent organization of data that computer applications can access, modify and/or add to it, if authorized to do so, using open industry standards.

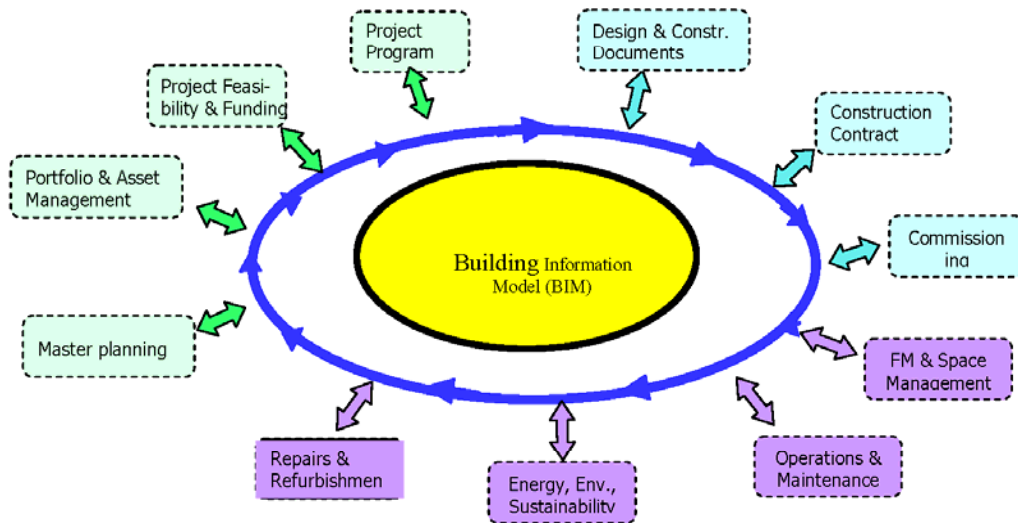

Figure 1: Building Information Model

Why a model server?

A large number of software products have implemented support for file-based exchanges of IFC model project data, i.e. IFC read and write functionality. These exchanges have clearly demonstrated the benefits of using common semantics and syntax in exchanging common information about projects, and pilot projects have shown that the file exchange does serve certain situations well. However, when file based exchange is used in real projects the limitations of file exchange become evident very quickly. If there are a large number of participants, such as real project invariably have, the management required to make sure each participant is using the right version of the files becomes impractical. Additionally, managing access rights, versioning and the right to make and save changes become a significant burden, is cumbersome and prone to human mistakes.

Additionally, direct communication over the Web, from application to application is not feasible.

What is a model server?

The Web-based model server approach solves these problems. The model server provides a central repository of the shared information in the IFC model and all authorized users have instant access to the most up-to-date information that is relevant to their discipline from anywhere where Web services are available, using any device. (IFC model server access has been demonstrated via mobile phone in Japan to a server in Finland). Additionally data management features such as partial model exchange, merge, append and changes tracking become possible. It is these additional features that make model servers much more than a document management system.

Advantages of using a model server

The advantages of using a model server in conjunction with FAN are important and pervasive. While it is possible to provide significant enhancements to various operations and transactions without using the common semantics of an underlying object model, the real power of interoperability is only realized when that is the case. It is estimated that every piece of information used in the life cycle of a construction project is entered more than seven times, with the commensurate share of errors and distortions. Using different data models for different parts of the process only perpetuates the problem. Object server technology based on IFC models make available the most accurate, up-to-date-information throughout the building life cycle, as the information evolves. Using standard Web services any device that can connect to the Internet, including devices of interest to FAN, can access this information.

One strong benefit of using a BIM on a model server is difficult to quantify – that is the expectation that once all the BIM data is readily available, correct and up-to-date, ingenuity will lead to many new methods of management, analysis and prediction that the industry have not dreamed of yet, and some of the intelligent agent capabilities that we have dreamed about.

Software developers can readily use IFC model services in their software products by creating clients that communicate with the server using standard Web technologies (XML, Web services/SOAP). End users who are mostly interested in “pushing the ‘save as’ button, don’t interact with, and can be unaware of, the server function; for them it simply appears as the ability of the software they are using to share IFC models over the internet.

As a result the proposed FAN element software could be built upon the shared BIM, accessible in an open standards and being developed and populated as the facility moves along its life cycle. The FAN modules could access this information using standard web services with context aware hardware, enabled by the extensive geometry, space, product and other information that is served by the IFC servers.

Model server development in IFC community

The IAI started its efforts towards interoperability with the development of the IFC model, because that type of international consensus standard making can be time

consuming. However, it was anticipated from the beginning that model servers will be used in “real world” application and deployment.

A number of middle-ware projects were launched quite early and as a result several product have been developed. For example, the Finnish company Olof Granlund developed “BS Pro” (BS for building services) around 1998 to serve as object server between IFC model based building information and energy simulation software. This product served its intended function rather well and today the DOE and Lawrence Berkeley National Laboratory are still using it for their premier energy simulation engine “EnergyPlus”. BS pro is more aptly described as middleware, not a full-fledged model server.

The second generation of IFC servers was started by the Secom IFC server, developed by the Japanese firm with that name. The purpose of this server was to serve IFC data in a legacy format for use by domestic Japanese software. Later the developer, Yoshinobu Adachi, joined forces with VTT in Finland during a sabbatical and developed IMSvr during 2001 and 2002 [1]. Work on IMSvr was completed in September 2002.

Some of the technology challenges addressed in this project were:

- Storing IFC model data in a database system. (SQL Server, Oracle, etc)
- Automatic schema conversion from EXPRESS to database schema by utilizing XML technology
- XML based SOAP communication between model server and client software

The IMSvr is in the public domain and available for use. Since it is freeware extensive support is not available, but Mr. Adachi has been willing to provide help as needed. A brief review of IMSvr by the Technical Coordinator for the BLIS software development group) is available [2]

Several other commercial efforts started around the same time and resulted in commercial and fully supported products. The most notable products are the EuroStep Model Server for IFC (EMS) [3] and EPM EXPRESS Data Manager (EDM) [4].

EMS is a pure Java application and supports MySQL, SQL Serve and ORACLE databases. The native data access format for EMS is XML per ISO 10303-Part 28. The data interface can be used with http-request, XML-exchanges or with SOAP wrapped messages. It provides a strong set of model server capabilities such as version and change management, document management and linking, model browsing and more.

EDM is a suite of software offering a native object database with interface building and application building utilities. It also offers a basic set of model server type capabilities and access control.

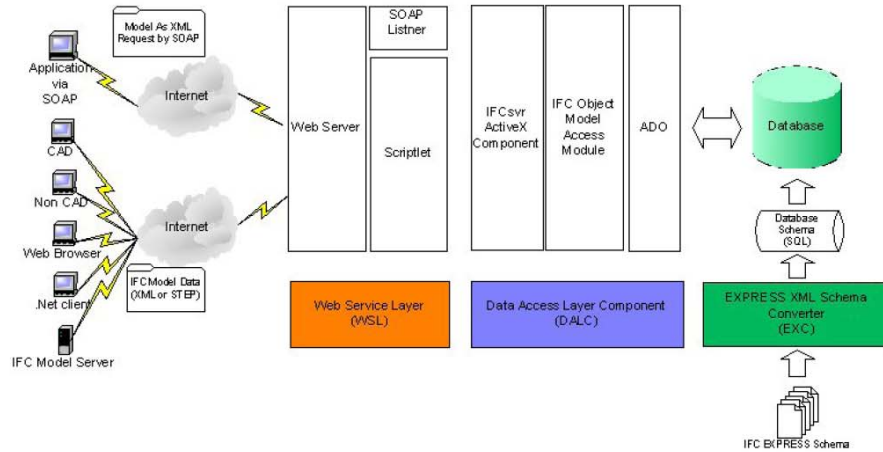

Figure 2: The IMSvr Framework

SABLE project

The SABLE acronym stands for “Simple Access to the Building Lifecycle Exchange”. The Sable project is a collaborative, open effort to develop model server specifications. Close to 20 companies are participating in the project that started in mid-2003 and is scheduled to complete by mid 2005. According to the SABLE website [5] the objective is:

In short SABLE is about harmonizing the access to IFC model servers and the access to the data that persists on these servers by defining a common low level API to IFC Model Servers and a set of high-level domain specifics API to the IFC data model.

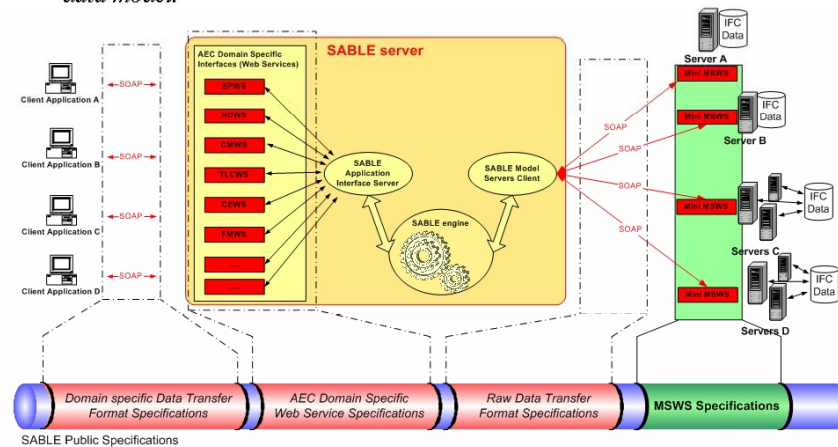

Figure 3: The SABLE Server Concept

SABLE will have the following model server capabilities:

- 1) Administration – Create and manage projects/facilities; create and manage roles; create and manage participants/users; manage roles in projects and assignment of participant to roles.
- 2) Data fetch – Get containment tree; object by ID; object by type.
- 3) Data modification – Create and manage objects and BIM; ownership and access to objects.
- 4) Documentation – Create, link and get documentation to relevant elements of model and objects.
- 5) Import/Export – Import and export model data in STEP Physical File (10303, part 21) and XML (10303, part 28 – which is still in Committee Draft status) [6].
- 6) Information – Set and get project and model information; set and get project and model metadata; get model statistics.
- 7) Create store and execute partial model queries.
- 8) Session management – login; select project; model; logout.
- 9) Versioning – Set and get model versions; manage versions; merge.

In addition to strengthening the expected model server capabilities such as versioning, access control, tracking ownership of objects and change rights, SABLE extends the notion of IFC model server in mainly two ways:

- 1) SABLE enables a BIM across multiple distributed model servers
- 2) SABLE facilitates easier IFC compatible software implementation by defining a series of Domain Specific Web Services. The current goals are:
 - Architecture Design Web Service (ADWS)
 - Space Planning Web Service (SPWS)
 - HVAC Design Web Service (HDWS)
 - Construction Management Web Service (CMWS)
 - Thermal Load Calculation Web Service (TLCWS)
 - Quantity take-off Web Service (QTOWS)
 - Cost Estimation Web Service (CEWS)
 - Facility Management Web Service (FMWS)

For the purpose of developing FAN services and BIM use by Government facility owners, it would be important to participate in the business case development and requirements definition of Facility Management Web Services in the SABLE project.

Status of IFC models servers

In summary, currently there are several 2nd generation IFC model servers available from commercial vendors, such as EDM and EMS, as well as IMSvr available in the public domain. These servers store a BIM on a single database server using commercial DBMS such as MySQL, SQL Serve and ORACLE.

The SABLE project is a combined effort of all the players in the category above as well as many other software vendors and user organization, to create a robust, industrial-strength, distributed environment for storing BIM with all the services necessary to

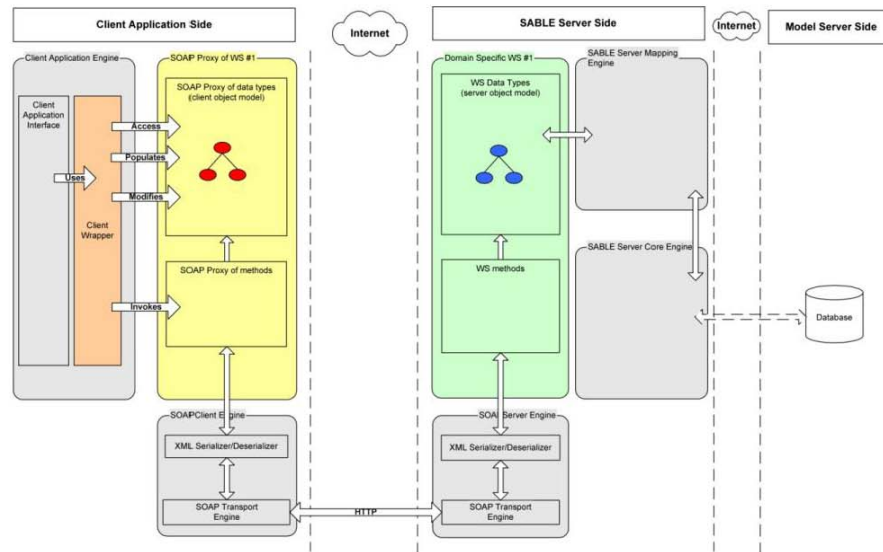

Figure 4: Overview of the SABLE Architecture

facilitate rapid and robust application development. Progress on the ABE project is according to schedule and expected to conclude by mid-2005. Many of the vendors involved in the project are implementing the SABLE capabilities as the specification are being proposed and proofed, so it is expected that commercial offerings based on the SABLE specifications will become commercially available by late 2005.

Some of the accomplishments of the SABLE project to date are:

- Model Server Web Services (MSWS) Specification published – December 2003
- SABLE II high level Resources API "Geometry", "Architecture", "Thermal Analysis" all started in June-July 2003.
- SABLE High level Domain API "Quantity Information for Cost Estimation" started in January 2004.

Conclusions

In order to elevate the AEC+FM industries to the next plateau of efficiency (in fact, to turn around a alarming decline in productivity) the fragmentation of the industry has to be addressed. The most promising approach to this achievement is data sharing, or interoperability, among project participants along the life cycle of facilities.

Facility Area Networks offer new levels of work productivity and quality in the Facilities Ownership, Operation and Maintenance area. However, to maximize these benefits it is important that FANs do not develop new "islands" of interoperability, outside the

industry effort by the IAI. It is crucial that FANs utilize the existing and evolving IFC model as the basis for modeling its own data, so that merging it into the larger stream of BIM life cycle information can be accomplished efficiently and accurately.

The IFC model servers that are currently available provide the initial capabilities necessary for developing FAN demonstrations within the context of IFC-based BIM. Emerging capabilities through the SABLE project are likely to fully satisfy the requirements of "real world", deployed FANs, if the requirements are considered in the SABLE project.

The Collaboration with the SABLE project from the FAN development community is recommended to ensure any specific requirements are considered in the specification. The development of the Facility Management Web Service (FMWS) module has not yet started (at this writing in Feb 2005) and this forum would offer the ideal opportunity to elevate any FAN specific requirements for inclusion in the FMWS specification.

References

- [1] IMSvr webpage: <http://cic.vtt.fi/projects/ifcsvr/>
- [2] BLIS Review: IMSvr, Jiri Hietanan, <http://www.blis-project.org/~sable/> (see Resources and Reviews)
- [3] <http://www.eurostep.com/>
- [4] <http://www.epmtech.jotne.com>
- [5] <http://www.blis-project.org/~sable/>
- [6] ISO/CD 10303-28: "Product data representation and exchange: Implementation methods: XML Schema governed representation of EXPRESS schema governed data", June 2003

Presentation 8: IFC Model Servers (Grobler).

IFC Model Servers

26 Feb, 2004

Francois Grobler,
with material from Jim Mitchell
and Patrick Houbaux

IFC Model Servers - 26 Feb 2004

Presentation Overview

- IFC basics
 - ◆ IFC is ready!
- Why Building Information Model (BIM)?
 - ◆ O&M FAN should be BIM-based
- Project use of IFC Model Server
 - ◆ IFC can be used for real projects
- IFC model servers - introduction
 - ◆ IFC model servers available for prototype FAN
- The SABLE project
 - ◆ Recommend FAN participation in SABLE FM work
- Conclusions

IFC Model Servers - 26 Feb 2004

Industry Foundation Classes (IFC) - "Virtual Building Pieces"

IFC Model Servers - 26 Feb 2004

Object-oriented Modeling

International Open Standard = IFC model

IFC Model Servers - 26 Feb 2004

IFC model – completeness (May 2003)

(relative to capabilities used in current software)

IFC Model Servers - 26 Feb 2004

IFC 2x2: Facility Management

- Improved asset definition
Improved utilization of time, cost and work order data
- Simplified order provision
Improved utilization of spare part stock
- Extended cost model
Improved costing of any object with any type of cost, at any point in the lifecycle. Cost through cost capture, budget, estimating, work set up
- Condition Monitoring
Captures condition data including both measured by instrumentation and assessed by visual inspection
- Request Capture
Captures and links data used for planning and maintenance work and allocation of resources to work orders
- Service Life Data
Relates all information to service life cost use and management including reference and location service life data (SLD) based on service life factors
- Environmental impact
Capture of environmental impact data for objects allowing impact assessment to be carried out in support of sustainable building
- Permits
Provision of permits for access, security, work
- Operating and Maintenance information
Provision of requests to define operating and maintenance information based on the IFC 2x2x2 of requests developed under SLD domains

IFCs are "open".
You can extend it!

IFC Model Servers - 26 Feb 2004

Implementation of IFC model

- Database of IFC software
- Available at: www.iai-international.org
(follow the link to implementation)

IFC Model Servers - 26 Feb 2004

Why Building Information Models (BIM)?

- Background
 - ◆ Point-to-point data exchange vs. interoperability
 - ◆ BIM
- Advantages of BIM
- Implications for FAN

IFC Model Servers - 26 Feb 2004

Grobler presentation continued

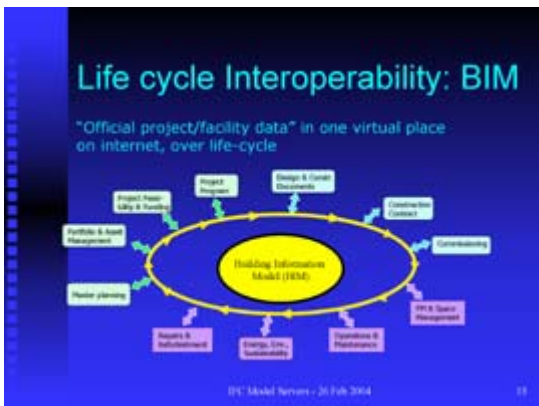
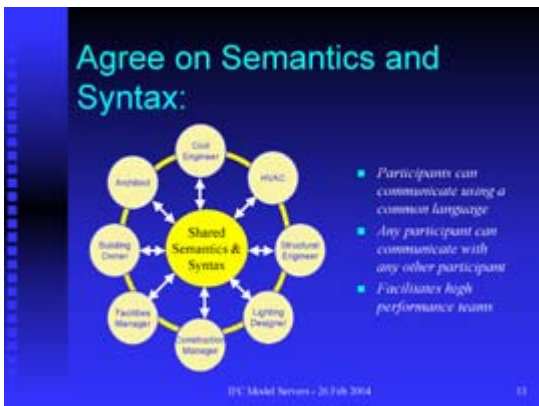
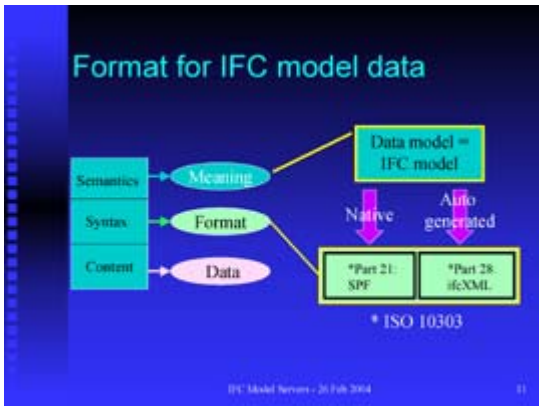
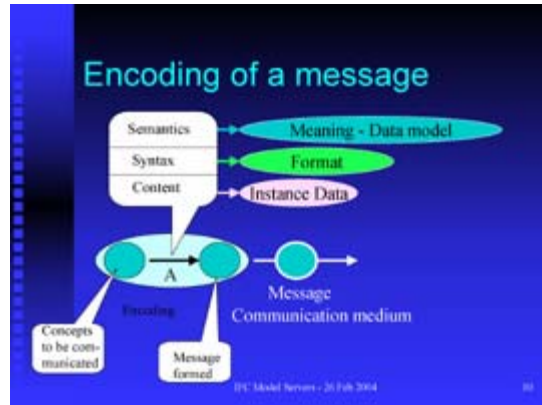
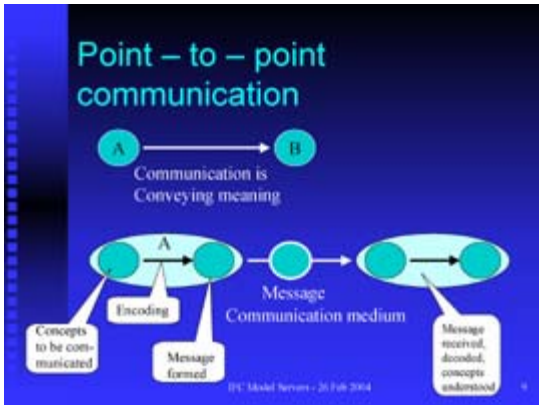

Grobler presentation continued

What is BIM?

"A computable representation of the physical and functional characteristics of a facility, and its related project/life-cycle information. It integrates all the relevant aspects into a coherent organization of data that computer applications can access, modify and/or add to it, if authorized to do so, using open industry standards."

- Francois Grobler, 2004

Should be based on open standard!

IFC Model Servers - 26 Feb 2004

Role of IFC Model Servers

IFC Model Servers - 26 Feb 2004

IFC alignment with other models: Partner-aeXML

IFC Model Servers - 26 Feb 2004

Advantages of BIM

- Facility owner owns and controls their valuable data; up-to-date, accurate, accessible
- Software is interchangeable; users in charge!
- Opportunities for process improvement
- Evolving building brain -> "smart", self-aware

BIM standard needed

- Implications for FAN
 - Opportunity to integrate sensing and control with condition, operational information
 - Could derive data from BIM as needed
 - Contribute to BIM for use by others

IFC Model Servers - 26 Feb 2004

Must deal with Facility Portfolio

IFC Model Servers - 26 Feb 2004

IFC Object Servers

IFC Model Servers - 26 Feb 2004

Why is a new classification system necessary?

IFC Model Servers - 26 Feb 2004

OmniClass Tables

11 - Construction Entities - by Function	32 - Services
12 - Spaces - by Function	33 - Disciplines
13 - Construction Entities - by Form	34 - Organizational Roles
14 - Spaces - by Form	35 - Process Aids
21 - Elements (UniFormat [®])	41 - Information
22 - Work Results (MasterFormat [™])	42 - Materials
23 - Products	49 - Properties
31 - Phases	

See www.occsnet.org

IFC Model Servers - 26 Feb 2004

Grobler presentation continued

Demonstration of Effective Information Flow in the Building Industry enabled by IFC Model Servers

AEC Systems
Orlando, 19 February 2004

DDS NO, EPM NO, Graphisoft R&D HU, Olof Granlund FI, Tekla Corp. FI, Solibri FI

IFC Model Servers - 26 Feb 2004 25

Munkerud Project

- Collaboration between OBOS og Selvaagbygg through joint venture SELBOS AS
- 36 apartments in Phase I
- Søndre Nordstrand, Oslo
- Finished in 2003

IFC Model Servers - 26 Feb 2004 26

Strategy for Collaboration

Strategy for collaboration

IFC Model Servers - 26 Feb 2004 27

IFC Implementations

IFC Model Servers - 26 Feb 2004 28

Design Phases – Finland ARK95

Project Stages	Models
1 Facility study	1 Requirements Model
2 Project planning	2 Spatial Model
3 Overall design	3 Element Model
4 Detailed design	4 Documentation Model
5 Construction	5 Construction Model
6 Commissioning	6 Operations Model

IFC Model Servers - 26 Feb 2004 29

IFC Model Server provides Versioning capability

IFC Model Servers - 26 Feb 2004 30

2021 Munkerud project

IFC Model Servers - 26 Feb 2004 31

DDS Ark Partner - Drawings

IFC Model Servers - 26 Feb 2004 32

Grobler presentation continued

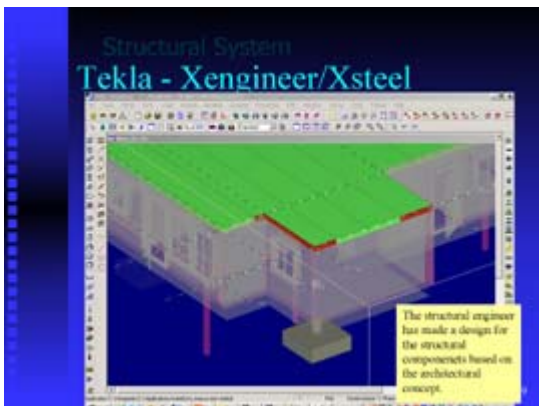
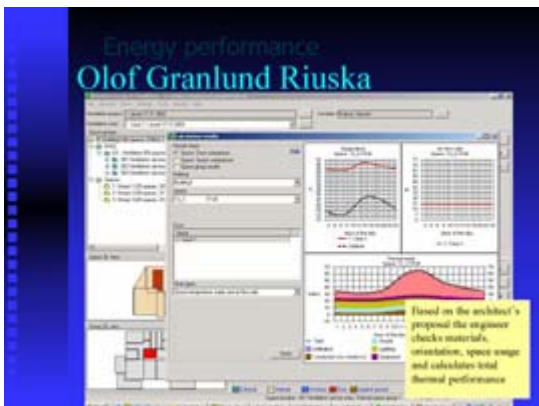
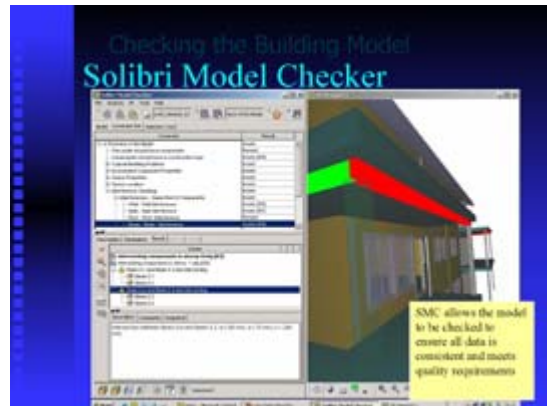
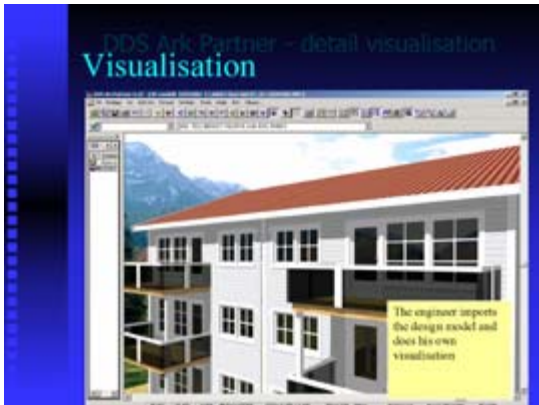

Grobler presentation continued

Building services - full integration Complete building services

Coordination, the most complex of current tasks now done upon all the multi-disciplinary data available from the model server

What is the impact of IFC? What is the impact of IFC?

- Building owner may take ownership of decisions and all information in building life cycle.
- Neutral standard provides low friction information logistics.
 - ◆ Higher information quality
 - ◆ Increase of reuse of information
 - ◆ Increase in competitive edge - locally & internationally
- Better decisions through changes

IFC Model Servers

- Definition of a Model server
- A bit of history
- IMSvr
- SABLE specification

Definition of an IFC Model Server

- A persistent object repository and associated object management capabilities to provide and control access to IFC model data.
- It typically also includes methods to serve IFC objects across the Internet
- May depend on relational databases for persistent, secure storage of data.

IFC Model Servers: a Short History

- Servers were anticipated from the beginning
- Example of first generation –
 - ◆ BS Pro – Olof Granlund, Finnish Contractor
- IFC model server – Secom, Japan
- 2nd generation
 - ◆ IMSvr – collaboration between VTT & Secom
 - ◆ EuroStep – EMS
 - ◆ EPM Jotne – EXPRESS data manager (EDM)

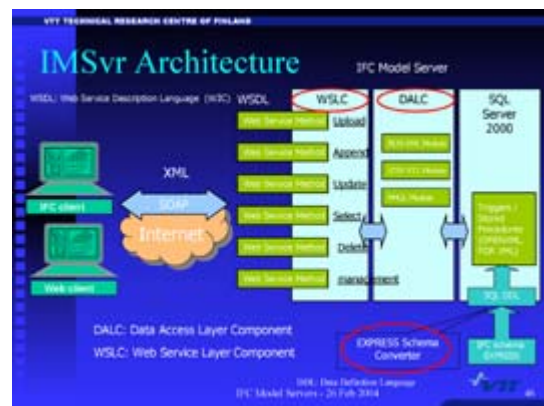

Brief Introduction of IMSvr Web Service Methods

- GetProjectList
 - ◆ Returns list of IFC projects stored in the model server
- GetObject
- FindObjects
 - ◆ Returns IFC objects that are specified by entity type as XML format.
- SetAttribute
- BatchExportModel
 - ◆ Returns IFC model that is specified by project name as BLIS-XML format.
- RunPMQL
 - ◆ Returns the result of partial model query as XML or STEP P21 format.

Example of SOAP Communication between IFC Model Server and Client software

Request: Get an IFC object

```
<?xml version='1.0' encoding='UTF-8' standalone='no'?>
<SOAP-ENV:Envelope xmlns:SOAP-ENV='http://schemas.xmlsoap.org/soap/envelope/' xmlns:xsi='http://www.w3.org/2001/XMLSchema-instance' xmlns:xsd='http://www.w3.org/2001/XMLSchema'>
  <SOAP-ENV:Header/>
  <SOAP-ENV:Body>
    <GetIFCObjectRequest xmlns='http://schemas.xmlsoap.org/soap/envelope/'>
      <EntityName>IFC_PROJECT
    </EntityName>
    </GetIFCObjectRequest>
  </SOAP-ENV:Body>
</SOAP-ENV:Envelope>
```

Response from Server

```
<?xml version='1.0' encoding='UTF-8' standalone='no'?>
<SOAP-ENV:Envelope xmlns:SOAP-ENV='http://schemas.xmlsoap.org/soap/envelope/' xmlns:xsi='http://www.w3.org/2001/XMLSchema-instance' xmlns:xsd='http://www.w3.org/2001/XMLSchema'>
  <SOAP-ENV:Header/>
  <SOAP-ENV:Body>
    <GetIFCObjectResponse xmlns='http://schemas.xmlsoap.org/soap/envelope/'>
      <IFCObjectData xmlns='http://schemas.xmlsoap.org/soap/envelope/'>
        <EntityName>IFC_PROJECT
        <EntityID>1
        <EntityDescription>Project description
        </EntityData>
      </IFCObjectData>
    </GetIFCObjectResponse>
  </SOAP-ENV:Body>
</SOAP-ENV:Envelope>
```

Grobler presentation concluded

VTT TECHNICAL RESEARCH CENTRE OF FINLAND

Client Example: Java Servlet implementation (Apache-SOAP)



Developed by VTT Building and Transport

<Selecting building element on VRML interface
<Getting selected element's properties from IFC model Server

IFC Model Server - 26 Feb 2004

IMSvr Info

- <http://cic.vtt.fi/projects/ifesvr/>
- In public domain
- Can be used now
 - ◆ Not a commercial product – support depend on original developers
- Next – SABLE project

IFC Model Server - 26 Feb 2004

Conclusions

- IFC is ready for pilot and real projects
- FAN should be BIM interoperable
- Examples of IFC Model Server Operation have been successfully demonstrated
- IFC models server are available for prototype FAN
- Recommend FAN to participate in SABLE FM view definition

IFC Model Server - 26 Feb 2004

Concluding Presentation (27 February 2004)

Bill East, ERDC-CERL, Facilities Maintenance Branch

Presentation 9: Concluding Presentation (East).

● ● ● facility area networks

workshop purpose

26 February 2004
Champaign, IL

● ● ● what does it look like?

2 17-Sep-04

● ● ● results to be measured

- decrease o&m cost
 - increase in "wrench-time" per day
 - decrease in late work order reporting
 - decrease in return repair visits
 - decrease travel cost, double-up on jobs/site
- reduce inventory cost
 - decrease cost of finding lost/moved items
 - reduction in cost of record keeping
 - improved quality of inventory data
 - small tool tracking

3 17-Sep-04

● ● ● technologies

- web service federations
- ubiquitous wireless networks
- appropriate device forms
- position locating technology
- contextual information retrieval

4 17-Sep-04

● ● ● objectives

- identify technology gaps
- calibrate fan against industry/research efforts
- Identify existing o&m information infrastructure needs

5 17-Sep-04

● ● ● the way forward...

6 17-Sep-04

4 Discussion Sessions

General Issues in Facility Area Networking (26 February 2004)

At the conclusion of Dr. Grobler's presentation (see page 78), a general discussion touched on issues related to the Building Information Model (BIM), legacy data, classification, and other topics. The main discussion explored the benefits of establishing a secure, web-based, virtually centralized but physically distributed repository for facility life-cycle information. It was generally agreed that the BIM concept is desirable from the perspective of the facility owner, who can control their own facility information as valuable resource. If the BIM is based on an open standard that supports interoperability, such as IFC, owners will not be held captive by software vendors' proprietary file formats and can select the most appropriate programs in the suite of software to operate on the BIM.

Development and Implementation Issues (27 February 2004)

The main discussion session took place on Friday, 27 February 2004. Mr. East presented an illustration (Figure 1) to organize the discussion for FAN purposes, and this approach was accepted by the workshop group.

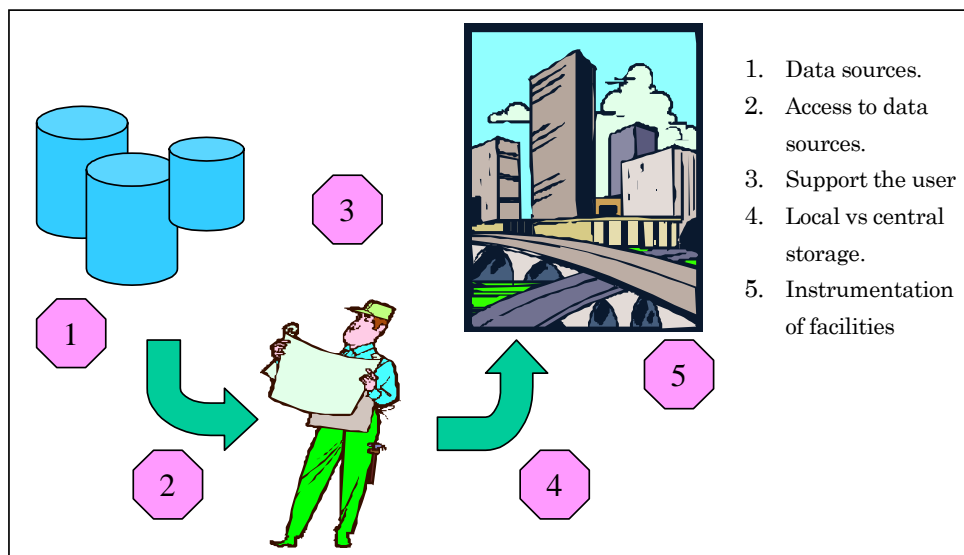

Figure 1. Organizing the FAN approach to facility life-cycle support.

Data Source Considerations

Data sources (item 1 in Figure) was the first topic considered. It was generally agreed that the life-cycle BIM approach must be promoted and that such a central data repository is a prerequisite and must initiate the process. Maintenance Management Systems (MMS) were discussed in this context, but it was agreed that the required BIM would contain much more than MMS and that it would serve a broader spectrum of users. It also was agreed that the IFC model and open standards such as IFC are much preferred to proprietary options.

The IFC model was explored next to check its capabilities compared to perceived requirements in the FAN area. It was noted that mixed information can be stored in the IFC model and text information can be externally referenced. Since object-based information in the IFC model can be programmatically accessed by software, inventories such as furniture asset lists can be easily constructed. Using an IFC-based BIM could significantly reduce the current difficulty of the reliable, affordable transfer of useful information between the design/construction phase and the O&M phases. However, it was noted that such as-built usage would require strict discipline in terms of continually updating the BIM information as the project evolves. It was expected that such discipline would be readily attainable because all members of the project team would be motivated to keep the BIM information current since they would be using the shared information for their own operational purposes.

Omniclass (see www.occsnet.org) was discussed as providing the needed classification system to properly populate an IFC-based BIM. Responding to a question about the potential cost of using Omniclass, Dr. Grobler explained that the copyright for Omniclass is held by a non-profit development group and that he expects that no royalties would be required to use it.

The issue of legacy data and the difficulty of converting it to BIM format was discussed. Dr. Grobler mentioned that the U.S. Coast Guard (USCG) has developed IFC-based BIMs of the Charleston Base Facilities. Their experience showed that basic IFC models of existing facilities can be developed for about \$20,000 per building, i.e., about \$0.17 per square foot. The USCG BIMs were primarily developed for facility management and planning purposes and lacked details necessary for other purposes, but these were still intelligent models that could be used for a variety of purposes.

Mr. Dunn noted that it would be more cost-effective to start new facilities as BIM and said the Navy hoped to derive the OMSI data for O&M purposes from

the IFC model. Mr. McCauley made reference to the GSA equipment numbering scheme and the need to track equipment conveniently (possibly with RFID tags) in a database or BIM. The GSA was considering a mapping from existing systems to IFC-based BIMs using an open classification system (Omniclass), where possible, rather than a proprietary one.

The discussion turned to implementation issues, and it was noted that the IFC model will evolve over time, thus a flexible underlying technology is needed. Such technology would rely on keywords and classification systems (or lexicons), and it should be speedy, simple, and universal (preferably international, because that provides incentive for large software vendors to adopt it). Implementation of the SABLE (Simple Access to the Building Life-cycle Exchange) specification for IFC object models server was extensively discussed. The SABLE project is an effort by members of the Building Lifecycle Interoperable Software (BLIS) group (see <http://www.blis-project.org/~sable/>) and is an open standard for “middleware” object servers to interface via the Web between user software and actual databases. The SABLE-based servers will be full-featured, distributed, web-based servers that can be connected to relational or object-oriented database back-ends to physically store the BIM information. Questions related to relational versus object-oriented databases to store IFC information were not an issue because both have been successfully used. SABLE servers will also provide security, users controls, versioning of the BIM, and other features required for full-scale industrial use.

Dr. Grobler explained that the SABLE workgroup approaches specification development by business case and that the data/transaction view definition for facility management has not been started yet. He stated that this situation represents an opportunity to the FAN group to become involved and ensure that its requirements are considered in the process.

At this point the group realized that most of the discussion time had elapsed and it agreed to move to new topics.

Data Access

Access to data sources (item 2 in Figure 1) was addressed in a discussion of object tagging. It was noted that both active and passive RFID tags are necessary for economical real-world solutions since passive tags are very inexpensive compared with active tags. The ability to read a tag from a distance is needed only when the tagged object is moving, such as a loaded truck or moving pieces of equipment. A stationary object could be well serviced by a passive tag, and the

manufacturer could even install such tags more affordably than attachment by the owner. Addressing the data access issue requires tradeoff analysis to determine how much information should be available from the tag versus how much should reside on a hand-held device. Also, if the information is to be available in the BIM, questions of worker access will involve a trade-off between network availability and access versus the amount of wireless bandwidth available.

User Support

User support (item 3 in Figure 1) was briefly discussed in the context of discussing what capabilities and information should be made available on hand-held devices to support the worker. It was noted that position location (either by global positioning system [GPS] or triangulation) of worker and RFID tags would be a requirement, and that three-dimensional BIMs are an enabling technology for sophisticated position location. Another issue discussed was repair and service manual information, which must be conveniently and instantly available through a combination of tags, hand-held devices, and network access.

Central Versus Local Storage

A question related to data access that prompted significant discussion was, "If a building is wired, why do I need RFID tags at all?" The group explored the question from various angles, including the issue of local versus central storage (item 4 in Figure 1). It was concluded that a certain amount of planned redundancy would be beneficial. As a general rule, the group thought it best to store supply chain information on the tag (Manufacturer -> supplier-> yard; quantity; who is responsible for the warranty, etc.) and to store operational information in the BIM. Because workers must maintain a high degree of mobility, the consensus was that BIM-based network information will not be sufficient, and that select service information also must be on the RFID tag. Dedicated research would be needed, with due consideration of the amount of wireless bandwidth available, to develop optimal solutions that define what information to store on tags locally, or on hand-held devices, or on the network connected to the BIM.

Instrumentation of Facilities

Item 5 in Figure 1 produced significant discussion that invoked a comparison of very intelligent buildings with the mammalian central nervous system. A smart building was envisioned to have a brain, memory, a nervous system, and 'sense organs.' The building's brain would encompass the process and control capability of the building software; the central memory would incorporate all BIM data

content; and the nervous system would consist of the networking capability (whether hard-wired or wireless), with data supplied to the system by RFID tags and other sensors analogous to sense organs.

In a building with a 'central nervous system,' key building components could take the initiative and 'announce' their need for service. For example, a mechanical room could detect water on the floor and report it as an anomaly and symptom of a potential problem. It was envisioned that a sensor detecting an anomaly could invoke a Bluetooth® (wireless networking protocol) call for help while reporting suspect conditions such as the unwanted presence of water, off-specification water temperature, or elevated CO₂ level. RFID tags could serve as nerve and distributed memory cells for a 'self-aware' building: they and other distributed micro devices could "talk" to the building network. RFID tags could also evolve into 'agent' capabilities if they contain rules to self-process and were able to communicate bi-directionally to invoke appropriate action in actuator devices.

At this point in the discussion the available time was up, and the workshop concluded with Mr. East thanking the participants for their contributions.

5 Workshop Conclusion: Summary and Recommendations

The attendees of the workshop developed a considerable amount of agreement and consensus over the course of the workshop. Workshop participants left in general agreement on the following points:

1. The group endorsed the hypothesis that “having the right data at the right time” is expected to improve productivity and quality of work accomplished.
2. BIM modeling is considered an important facilitating technology for making available the right data at the right time.
3. BIM based on open standards, such as IFC, is strongly preferred over closed, proprietary standards.
4. Based on the reported status of industry developments, the group supported further exploration of how IFC-based BIM may be used in FAN and O&M in general. It is believed that sufficient capabilities now exist to vigorously start planning, testing, and piloting efforts to deploy this technology.
5. In order to make a BIM management approach practical for large-scale implementation, government and industry need distributed, web-based, object server technology such as that promised by SABLE servers.
6. Science and technology to help create BIM for existing facilities are needed, and the co-existence of BIM and legacy systems presents rich opportunities for research.
7. RFID tag technology can support many aspects of FAN and O&M in general.
8. Wireless networking is an important technology for providing access to information by workers and creating virtual networks linking sensors, RFID tags, controllers, and BIM.
9. Secure confederations of such networks will be required.
10. Laser scanning technology holds promise to aid in the modeling of existing facilities as BIMs, at least at the ‘building carcass’ level.
11. The design, organization of information, and knowledge structures of intelligent buildings is an open field of technical pursuit, and much further exploration is warranted.
12. Certain industry standards and practices must be worked out and adopted. For example, deployment of a BIM approach in the design / construction / fa-

cility management interface will require the review and updating of contractual and other legal arrangements. Industry standards will have to be established to address new or updated legal requirements — for example, specifying when a BIM is to be transferred from construction contractor to owner/operator during the commissioning phase.

Several recommendations were developed for further work based on the FAN concept illustrated in Figure 1:

1. Support BIM by creating a consortium to implement a U.S Government-owned implementation of the SABLE object server specification. Mr. East proposed that a consortium of potential users (government agencies) could fund ERDC-CERL to develop the software implementation. The consortium would ensure that diverse government requirements were fully represented during development, and it would own the resulting software. Once fully-developed, the government model server could be supported through Cooperative Research and Development Agreements.
2. Demonstrate the impact and benefits of BIM using existing web services and, if necessary, proprietary databases. Without a clear demonstration of benefits, it is unlikely that key decision makers will be convinced to endorse the long-term effort required.
3. Develop a matrix of the technology required for ubiquitous computing in FAN applications. Because the manufacturers of existing related technologies are focused largely on logistics, special devices and sensors need to be identified and specified for processing information required for effective management of facility construction, operations, and maintenance.

REPORT DOCUMENTATION PAGE

Form Approved
OMB No. 0704-0188

Public reporting burden for this collection of information is estimated to average 1 hour per response, including the time for reviewing instructions, searching existing data sources, gathering and maintaining the data needed, and completing and reviewing this collection of information. Send comments regarding this burden estimate or any other aspect of this collection of information, including suggestions for reducing this burden to Department of Defense, Washington Headquarters Services, Directorate for Information Operations and Reports (0704-0188), 1215 Jefferson Davis Highway, Suite 1204, Arlington, VA 22202-4302. Respondents should be aware that notwithstanding any other provision of law, no person shall be subject to any penalty for failing to comply with a collection of information if it does not display a currently valid OMB control number. PLEASE DO NOT RETURN YOUR FORM TO THE ABOVE ADDRESS.

1. REPORT DATE (DD-MM-YYYY) 10-2004		2. REPORT TYPE Final		3. DATES COVERED (From - To)	
4. TITLE AND SUBTITLE Proceedings of the Facility Area Network (FAN) Workshop				5a. CONTRACT NUMBER	
				5b. GRANT NUMBER	
				5c. PROGRAM ELEMENT NUMBER 21 2040 622784T4100	
6. AUTHOR(S) Francois Grobler, Jeffrey G. Kirby, and E. William East				5d. PROJECT NUMBER HD630H	
				5e. TASK NUMBER	
				5f. WORK UNIT NUMBER	
7. PERFORMING ORGANIZATION NAME(S) AND ADDRESS(ES) U.S. Army Engineer Research and Development Center (ERDC) Construction Engineering Research Laboratory (CERL) PO Box 9005 Champaign, IL 61826-9005				8. PERFORMING ORGANIZATION REPORT NUMBER ERDC/CERL SR-04-33	
9. SPONSORING / MONITORING AGENCY NAME(S) AND ADDRESS(ES) U.S. Army Corps of Engineers (HQUSACE) 441 "G" Street NW Washington, DC 20314-1000				10. SPONSOR/MONITOR'S ACRONYM(S) CEERD-CV-ZT	
				11. SPONSOR/MONITOR'S REPORT NUMBER(S)	
12. DISTRIBUTION / AVAILABILITY STATEMENT Approved for public release; distribution is unlimited.					
13. SUPPLEMENTARY NOTES Copies are available from the National Technical Information Service, 5285 Port Royal Road, Springfield, VA 22161.					
14. ABSTRACT The Facilities Area Network (FAN) Workshop was hosted in February 2004 by the U.S. Army Engineer Research and Development Center (ERDC) as part of Consolidated Facility Object Model" (CFOM) project. The purpose of that work is to develop prototype projects in design, construction, and operations that demonstrate the benefits of secure web service confederations. The FAN Workshop was convened as part of the goal-setting phase of the CFOM project to assess the state of the art of required enabling technologies; review standards-development activities for relevant data exchange technologies; define technology gaps that must be filled; and identify opportunities to collaborate with other agencies and leverage related research and technology transfer activities. This report documents the proceedings of the FAN Workshop, and includes copies of all papers and multimedia presentations offered at the workshop.					
15. SUBJECT TERMS Information management, workshop, facility management, operational maintenance, maintenance					
16. SECURITY CLASSIFICATION OF:			17. LIMITATION OF ABSTRACT SAR	18. NUMBER OF PAGES 102	19a. NAME OF RESPONSIBLE PERSON E. William East
a. REPORT Unclassified	b. ABSTRACT Unclassified	c. THIS PAGE Unclassified			19b. TELEPHONE NUMBER (include area code) 217/373-6710