



**NAVAL
POSTGRADUATE
SCHOOL**

MONTEREY, CALIFORNIA

THESIS

**SUICIDE TERRORISM: HOW PSYCHOLOGICAL
OPERATIONS
CAN MAKE A DIFFERENCE**

by

Eric Schoennauer

September 2005

Thesis Advisor:

Anna Simons

Second Reader:

Glenn Robinson

Approved for public release; distribution unlimited

THIS PAGE INTENTIONALLY LEFT BLANK

REPORT DOCUMENTATION PAGE			Form Approved OMB No. 0704-0188
Public reporting burden for this collection of information is estimated to average 1 hour per response, including the time for reviewing instruction, searching existing data sources, gathering and maintaining the data needed, and completing and reviewing the collection of information. Send comments regarding this burden estimate or any other aspect of this collection of information, including suggestions for reducing this burden, to Washington headquarters Services, Directorate for Information Operations and Reports, 1215 Jefferson Davis Highway, Suite 1204, Arlington, VA 22202-4302, and to the Office of Management and Budget, Paperwork Reduction Project (0704-0188) Washington DC 20503.			
1. AGENCY USE ONLY (Leave blank)	2. REPORT DATE September 2005	3. REPORT TYPE AND DATES COVERED Master's Thesis	
4. TITLE AND SUBTITLE: Suicide Terrorism: How Psychological Operations Can Make a Difference			5. FUNDING NUMBERS
6. AUTHOR(S) : Eric Schoennauer			
7. PERFORMING ORGANIZATION NAME(S) AND ADDRESS(ES) Naval Postgraduate School Monterey, CA 93943-5000			8. PERFORMING ORGANIZATION REPORT NUMBER
9. SPONSORING /MONITORING AGENCY NAME(S) AND ADDRESS(ES) N/A			10. SPONSORING/MONITORING AGENCY REPORT NUMBER
11. SUPPLEMENTARY NOTES The views expressed in this thesis are those of the author and do not reflect the official policy or position of the Department of Defense or the U.S. Government.			
12a. DISTRIBUTION / AVAILABILITY STATEMENT Approved for public release; distribution is unlimited			12b. DISTRIBUTION CODE
13. ABSTRACT (maximum 200 words) <p>Military Psychological Operations (PSYOP) is based on a Cold War construct that has not been significantly overhauled since the end of that era. Today's most pressing challenge, the Global War on Terrorism (GWOT) requires a different solution set. The Quadrennial Defense Review, the Information Operations Roadmap, the National Strategy for Combating Terrorism and the Report of the 9/11 Commission all recognize this fact. How the military PSYOP community can best adjust to this new environment and effectively address one of its major threats, that of suicide terrorism, is the subject of this paper.</p> <p>I will argue that examining what can, and arguably should, be done to counter the threat of suicide terrorism will also help us to see ways in which PSYOP could better be configured and employed in this new era. The first chapter of my thesis will examine the evolution of suicide terrorism in some detail but will quickly focus on what have emerged as the consensus opinions as to the motivations and vulnerabilities of this tactic. Chapter two looks at the identified motivations and vulnerabilities from a PSYOP perspective and tries to apply logical PSYOP measures against them. In chapter three I review the assets and organizational structure of the PSYOP community and suggest ways the current structure could be best applied to meet the threat. Chapter four then looks for a way ahead and focuses on how and why making three critical changes to military Psychological Operations could improve the organizations ability to accomplish its mission; not only in terms of seeking to mitigate suicide attacks but also with respect a whole host of new and expanded missions the PSYOP community will increasingly be called upon to address in the contemporary operating environment.</p>			
14. SUBJECT TERMS Suicide Terrorism, Terrorism, PSYOP, Psychological Operations, Restructuring, Deterrence Theory, Terrorist Motivations			15. NUMBER OF PAGES 73
			16. PRICE CODE
17. SECURITY CLASSIFICATION OF REPORT Unclassified	18. SECURITY CLASSIFICATION OF THIS PAGE Unclassified	19. SECURITY CLASSIFICATION OF ABSTRACT Unclassified	20. LIMITATION OF ABSTRACT UL

THIS PAGE INTENTIONALLY LEFT BLANK

Approved for public release; distribution is unlimited

**SUICIDE TERRORISM: HOW PSYCHOLOGICAL OPERATIONS CAN MAKE
A DIFFERENCE**

Eric M. Schoennauer
Major, United States Army
B.S., United States Military Academy, 1993

Submitted in partial fulfillment of the
requirements for the degree of

MASTER OF SCIENCE IN DEFENSE ANALYSIS

from the

**NAVAL POSTGRADUATE SCHOOL
September 2005**

Author: Eric M. Schoennauer

Approved by: Dr. Anna Simons
Thesis Advisor

Dr. Glenn Robinson
Second Reader/Co-Advisor

Dr. Gordon McCormick
Chairman, Department of Defense Analysis

THIS PAGE INTENTIONALLY LEFT BLANK

ABSTRACT

Military Psychological Operations (PSYOP) is based on a Cold War construct that has not been significantly overhauled since the end of that era. Today's most pressing challenge, the Global War on Terrorism (GWOT) requires a different solution set. The Quadrennial Defense Review, the Information Operations Roadmap, the National Strategy for Combating Terrorism and the Report of the 9/11 Commission all recognize this fact. How the military PSYOP community can best adjust to this new environment and effectively address one of its major threats, that of suicide terrorism, is the subject of this paper.

I will argue that examining what can, and arguably should, be done to counter the threat of suicide terrorism will also help us to see ways in which PSYOP could better be configured and employed in this new era. The first chapter of my thesis will examine the evolution of suicide terrorism in some detail but will quickly focus on what have emerged as the consensus opinions as to the motivations and vulnerabilities of this tactic. Chapter two looks at the identified motivations and vulnerabilities from a PSYOP perspective and tries to apply logical PSYOP measures against them. In chapter three I review the assets and organizational structure of the PSYOP community and suggest ways the current structure could be best applied to meet the threat. Chapter four then looks for a way ahead and focuses on how and why making three critical changes to military Psychological Operations could improve the organizations ability to accomplish its mission; not only in terms of seeking to mitigate suicide attacks but also with respect a whole host of new and expanded missions the PSYOP community will increasingly be called upon to address in the contemporary operating environment.

THIS PAGE INTENTIONALLY LEFT BLANK

TABLE OF CONTENTS

I.	INTRODUCTION.....	1
A.	UNDER CLOUDY SKYS.....	1
B.	DEFINING THE BATTLESPACE: TERMS AND TERMINOLOGY	2
II.	MOTIVATIONS	5
A.	THE HISTORICAL PERSPECTIVE.....	5
B.	CURRENT TRENDS IN SUICIDE ATTACKS	7
1.	Growth of Suicide Attacks	8
2.	Targeting Democracies for Nationalist Purposes.....	9
3.	The Diversification of Suicide Attackers	9
C.	MOTIVATIONS BEHIND SUICIDE ATTACKS	12
1.	What Makes a Suicide Bomber?	13
2.	Why do Organizations Choose the Suicide Option?.....	18
III.	VULNERABILITIES AND ABILITY OF THE CURRENT PSYOP MODEL TO EXPLOIT THEM.....	25
A.	MAKING IT ALL USEFUL: EXPLOITING VULNERABILITIES.....	25
1.	Motivation to Vulnerability Linkage	25
2.	Deterrence Theory and Terrorism	27
B.	MILITARY PSYCHOLOGICAL OPERATIONS DEFINED.....	29
1.	PSYOP: Its Background and Purpose	29
2.	The Current PSYOP Template	31
C.	PSYOP’S PROBLEMS AND HOW THEY HURT THE FIGHT AGAINST SUICIDE TERRORIST	35
1.	PSYOP: An Outdated Structure	35
a.	<i>Cold War Era Structure</i>.....	36
b.	<i>Tactical Focus</i>	36
c.	<i>Conventional Adversaries</i>	38
2.	The Source – Message – Receiver Breakdown in PSYOP.....	40
3.	Source – Message – Receiver and Suicide Terrorism.....	43
IV.	THE WAY AHEAD.....	47
A.	ESTABLISH A POOL OF HIGHLY TRAINED EXPERTS.....	48
B.	INCREASED PSYOP INTEGRATION ON MID AND HIGH LEVEL STAFFS.....	50
C.	INCREASED PSYOP TRAINING FOR ALL LEADERS.....	51
D.	IN CONCLUSION	53
	LIST OF REFERENCES	57
	INITIAL DISTRIBUTION LIST	59

THIS PAGE INTENTIONALLY LEFT BLANK

LIST OF FIGURES

Figure 1.	Hamas leaflet honoring the sacrifices of its members.	21
Figure 2.	Schematic view of Huth's model of deterrence	28
Figure 3.	Organizational and Command structure of PSYOP forces in a garrison (i.e. non-deployed or Peacetime) environment.	32
Figure 4.	Organization of a Tactical POB as configured to support a Corps structure...	33
Figure 5.	Current Organization of PSYOP units in both the active duty and Army Reserve components.	37
Figure 6.	Hierarchy of Needs	40

THIS PAGE INTENTIONALLY LEFT BLANK

LIST OF TABLES

Table 1.	Socio-economic profile of Egyptian Islamist Militants (Ibn Khaldun Center as cited by Richards and Waterbury, 1996)	11
Table 2.	Matrix of vulnerabilities for selected motivations of behind suicide terrorism.....	26
Table 3.	Matrix of the major PSYOP deficits that impede the optimal exploitation of the vulnerabilities of the selected motivations behind suicide terrorism.....	44

THIS PAGE INTENTIONALLY LEFT BLANK

I. INTRODUCTION

A. UNDER CLOUDY SKYS

In April of 1983 an Iranian sponsored Islamic agent drove a truck loaded with more than 400 pounds of explosives into the US embassy in Beirut and detonated it killing himself and 63 others. This spectacular attack not only very publicly struck at the American presence in the region but also wiped out the CIA's Middle East bureau and killed 17 Americans. Six months later Ismalal Ascari, building upon the success of the previous attack, drove a 19-ton water delivery truck loaded with more than 15,000 pounds of TNT up to the four story US Marine barracks and set off what has been described as the largest non-nuclear blast in human history. Ascari's suicide attack claimed the lives of 241 US Marines, sailors and soldiers. Just two minutes later a similar, but less explosive, suicide attack destroyed the French Embassy in Beirut and took 63 more lives. Within four months US forces withdrew from Lebanon. The French would shortly follow.

Twenty years later, under cloudy skies, diplomats, politicians, friends and family members of those early victims to suicide terrorism gathered at Arlington National Cemetery to plant a Lebanese cedar and remember. Who could have imagined back in 1983 that at the twenty year anniversary the dignitaries would be speaking about not breaking faith with those fallen soldiers in "the tasks we have ahead" ("Terrorist Bombing...", 2003)? Who could have imagined that after two decades the events in Lebanon in 1983 would be remembered not as some ghastly aberration but rather as a seminal event in the emergence of modern asymmetric warfare? Speaker after speaker, both French and American, spoke at that memorial service and drew parallels between the 1983 attacks in Beirut and the attacks of September 11th 2001.

Indeed, most researchers into suicide terrorism today refer back to Beirut as the starting point for contemporary studies into the phenomenon. In the intervening twenty plus years, terrorism's most sensational variant, the suicide attack, has spawned thousands of articles, studies, essays, and books in English alone. But not one of those learned works produced the nugget of information or lead to a plan of action that would

prevent the 1998 taking of 257 lives in dual suicide attacks on the US Embassies in Kenya and Tanzania, or the 2000 suicide attack on the US Cole that killed 17 or, most frighteningly, the September 11th coordinated suicide attacks that killed nearly 3,000. Even in the aftermath of these and, literally, hundreds of other horrific suicide attacks, the willingness to conduct suicide missions against US interests has grown dramatically over the last year – most especially in Iraq, where such attacks are now an almost daily occurrence.

This thesis examines the contemporary phenomenon of suicide terrorism, its brief history and rapid growth, and its key actors and their motivations. The problem with research into suicide terrorism thus far has not been the lack of scholarly thought but the failure to identify those factors that it might take to put together an effective strategy capable of addressing the threat. The aim of this thesis is to examine the work that has been done in order to distill a few key facts that could then be exploited as part of a concerted effort to slow, if not reverse, the trend towards increasingly horrific, suicide attacks. A second aim is to isolate those key motivational factors that the US Psychological Operations (PSYOP) forces have the greatest potential of impacting. With these factors as the basis for conducting PSYOP this thesis will then analyze Army's current PSYOP structure and consider how it might need to adapt in order to most effectively address suicide terrorism.

The reason for focusing the analysis of the current PSYOP structure on suicide terrorism is not just because of its rapid growth or its critical role in contemporary operations. Rather I chose suicide terrorism as a my basis of analysis of the PSYOP structure because it is arguably emerging as one of the most difficult challenges to PSYOP forces. Not only is suicide terrorism widely viewed as the most difficult type of operation to prevent but the potential for massive destruction if it is combined with the use of Weapons of Mass Destruction (WMD) is enormous. Therefore, if PSYOP forces are capable of effectively addressing this threat they are also likely to be best arrayed to address other important challenges.

B. DEFINING THE BATTLESPACE: TERMS AND TERMINOLOGY

Words matter. The words we use create subjective as well as objective feelings that impact the way we and our target audience regard a given event. The oft repeated

cliché that “one man’s terrorist is another’s freedom fighter,” while seemingly trite, is in fact part of the very problem the US faces in attempting to combat terrorism: namely, that all too often we either can’t or won’t accurately define terrorism itself. Our inability to effectively articulate an objective difference between those “military” actions we support or take part in and those we oppose leaves us open to charges of hypocrisy and imperialism. Indeed, the term “terrorism” has become so negatively charged within the West that our leaders often apply it liberally to just about any violent action which the American and/or Western public can easily be led to condemn. The problem with doing this, of course, is that it dilutes the value of our words for the very audiences we should most be trying to affect. When we describe the use of roadside bombs and mortar attacks on US troops in Iraq as terrorist acts it plays well to a supportive, domestic audience, but to many non-Americans it smacks of self-righteousness and a lack of self-awareness. After all, if the US gained its independence with the support of Minute-Men sharpshooting at Red Coats, if the US won the Second World War fire bombing Dresden, if the US defeated Saddam not once but twice with the help of 500 pound bombs dropped from out of sight on nearly defenseless Iraqi soldiers, then how can we label mortar teams or roadside bombers terrorists?

It is not enough that we Americans or Europeans be satisfied with our definition of terrorism. Our challenge is to persuade the rest of the world that “terrorism” is evil and that it can be defined and separated from other, ‘just’ forms of warfare. One definition useful to that end defines terrorism as the use of violence by non-state actors against noncombatants or civilian targets for political ends (Cronin, 2002, p2). This definition does not describe all the acts we oppose. It does, however, provide us with a legitimate starting point in the effort to draw a distinction between what some might otherwise call “freedom fighters” and those we hope to stigmatize as true “terrorists.” While such a distinction is critical to any effort to influence attitudes about suicide operations, at points this thesis will address both suicide terrorism (i.e. those events directed largely against civilians) and suicide attacks, the more general category that can include terrorism against civilians as well as attacks directed against military targets or

soldiers. Although we can – and should – condemn both we should use care to apply the label terrorism only to those incidents directed against (or that have a substantial effect on) civilian targets.

A suicide terrorist, then, is a non-state actor who intentionally targets civilians for political effect and with the full knowledge that the mission's success requires his or her death. As Scott Atran points out in his work "Genesis of Suicide Terrorism," the significant characteristic of such an attack is that it is primarily one of psychological warfare whose primary target is not its victims but its witnesses – both its direct and indirect witnesses – via media reporting (2003, March, p154). If we accept these definitions then it follows that the ultimate success or failure of a suicide attack rests largely on how it is perceived *after the fact*. Any effort to reduce suicide attacks will thus depend on our ability to help shape the perception of the attack itself. Understanding the actor's motivations and those who both sent him and orchestrated his actions will help us shape those perceptions.

II. MOTIVATIONS

A. THE HISTORICAL PERSPECTIVE

Suicide attacks, in one form or another, have been carried out as a part of warfare for centuries. Their use by the Jewish sect of Zealots against their Roman occupiers gives us the modern English word *zealot*, meaning a fanatical adherent to a cause. Within the Arab Muslim tradition there are the Assassins, who would publicly murder corrupt leaders with a complete willingness to meet immediate death at the hands of bodyguards. In fact, they each welcomed this death so as to draw maximum attention to the act. During World War II the Japanese codified suicide attacks by creating a mythology around the Kamikaze. Viewed objectively, what we could say is that, historically, suicide attacks have been a kind of last gasp response by a weakened opponent when no other option seemed available. To some degree the same holds true today. The sponsors of suicide attacks are uniformly outgunned and over matched by vastly superior state opponents. However, the changing political and social realities, such as the end of the cold war, the spread of democracy, and the proliferation of instantaneous, omnipresent global information/news networks have created a fertile environment for the proliferation of suicide terrorism. As a result, the degree to which suicide tactics have been employed since the mid-eighties and their ability to create strategic effects threaten to seriously affect the nature of modern warfare. The events of 9/11 as well as the proliferation of weapons of mass destruction (WMDs) are ominous warnings (or tempting examples) as to just how much impact a few dedicated individuals bent on a suicide mission can have if they are backed by a well funded organization and a solid plan.

If 1983 Beirut is ground zero for contemporary suicide attacks then what was it about events that year that spawned the growth of this new tactic in warfare? While there is likely no single simple answer there are several key points upon which most respected analyses agree. One, the tactical success of the operations proved the potential utility of asymmetric operations against a vastly superior force. Two, the dramatic nature of the attack emboldened a more widespread opposition to the US and French presence in Lebanon. Three, the combined effect of the tactical success and an emboldened

opposition was enough to achieve a strategic success against two vastly superior forces in a matter of months. The dramatic success of such a relatively low cost act (in terms of dollars, personnel and risk to the organization) was too spectacular for any out-gunned military organization to overlook. Thus, according to Hoffman & McCormick, in their recently released article “Terrorism, Signaling, and Suicide Attack,” some would be emulators describe the success of those suicide attacks in Beirut as “one of the factors that led to their own decision to resort to suicide terrorism” (2004, p244).

Among the first two organizations to attempt to capitalize on the apparent success of the suicide attack were the Lebanese Hezbollah and the Sri Lankan Liberation Army of Tamil Eelam (LTTE). In many obvious ways these two organizations were (and are) quite different. Hezbollah (meaning Party of God) is a religiously fundamentalist organization dominated by the Shiite Muslims of Lebanon engaged in an on-again, off-again civil war and committed to removing outside (read Israeli and/or Western) influence from the country, and ultimately from the region. By contrast, the LTTE began as a Marxist-leaning social and ethnic revolutionary movement that sought the creation of a new independent Tamil state separate from Sri Lanka. What both organizations had in common, then, wasn't religious fanaticism. What they did share, instead, was declining popular support brought about by years of attrition warfare waged against qualitatively superior forces and with no prospects for reversing their steady decline. Suddenly the carnage inflicted upon the Americans and French in Lebanon demonstrated that there was a way to strike back asymmetrically and with much greater effect than conventional tactics had previously afforded.

Equally as important to both Hezbollah and the LTTE was the effect such spectacular events had on re-energizing support for each organization. While much of the support stemmed from the success of the operations themselves, the importance of the suicide component of the attack cannot be overlooked. From the perspective of potential supporters the willingness of one of their own to sacrifice his or her own life for the sake of the cause is a powerful symbol. Robert Cialdini has dubbed this phenomenon – whereby people will follow the lead of others who they feel are similar to them – the social proof, and his studies indicate its application predictably appeals to deeply rooted human needs (2001). Thus, by including the suicide element in the mission not only is

the mission rendered tactically simpler, but it appeals to hardwired emotions within the community, increasing the motivation to somehow join in.

Finally, it can't be overlooked that, the 1983 Beirut attacks were successful. And not just successful on a tactical or operational sense, but arguably completely successful in a strategic sense in that they achieved the stated objective of forcing US and French military forces out of Lebanon. In some ways this maybe the least important of the three factors because the track record of all subsequent suicide attacks in achieving strategic success has been mediocre at best. Hezbollah's 1983-85 suicide campaign to force Israel out of Lebanon involved six suicide attacks, claiming 96 lives and yielding a partial Israeli withdrawal to a South Lebanese Security zone. Sixteen suicide attacks over the next twelve months took 179 more lives, but resulted in no immediate change in the Israeli position. For its part, LTTE's initial wave of 14 suicide attacks claimed 164 lives and resulted only in four months of unsuccessful negotiations. What followed was a bloody five-year LTTE campaign involving 54 additional suicide attacks and 629 fatalities, but no change in the Sri Lankan government's position (Pape, 2003, p6).

B. CURRENT TRENDS IN SUICIDE ATTACKS

Before trying to identify current trends in suicide attacks let me offer a cautionary note: To think of suicide terrorism, or any terrorist attacks, as having a singular cause, or even to speak in terms of a direct cause and effect relationship is to over-simplify a very complex and multifaceted issue. Smelser and Mitchell, editors of *Terrorism: Perspectives from the Behavioral and Social Sciences*, put it well when they write that "the search for a single or even a few causes is misqualified, the factors influencing contemporary terrorism are a blend" (2002, p.18). Still the caution against attaching too much meaning to identified (or perceived) trends should not blind us to observing and trying to make sense of what trends there may be. More important for this thesis is not to identify all trends in suicide attacks, but to select those trends that bear upon what we, as an Army, can and must do to reduce the proliferation of suicide attacks. The three trends most relevant to that objective are: the recent growth in suicide attacks and organizations willing to sponsor such attacks; the targeting of democratic societies by nationalist organizations; and the increasing diversification of the pool of willing participants for suicide operations.

1. Growth of Suicide Attacks

Despite the mediocre results suicide terrorism has had in achieving its sponsors' *stated* goals, the increase in such attacks has been dramatic. According to statistics compiled by Robert Pape based on a query of the Lexis Nexis on-line database, the rate of suicide attacks rose from 31 in the eighties, to 104 in the nineties, to 53 in just the first two years of this decade. And, according to Pape, all this occurred at a time when the overall rate of terrorist attacks actually declined by nearly half, from a peak of 666 in 1987 to 348 in 2001 (2003, p1). The current trend of near daily suicide attacks in Iraq and the surge of Chechen suicide attacks in Russia are clear indicators that suicide terrorism shows no signs of declining.

Not only have the number of actual suicide attacks been on the rise, so too have been the number of organizations sponsoring such attacks. While Hezbollah and the LTTE alone were responsible for the vast majority of suicide attacks throughout the eighties and early nineties, the mid- to late-nineties saw more and more organizations, such as Hamas, the Kurdish Workers Party (PKK), Al Qaeda, Islamic Jihad and the Turkish Revolutionary People's Liberation Front join the ranks of suicide sponsors. In the first four years of this century two more Palestinian organizations, two Egyptian organizations, multiple militant Islamic organizations in Kashmir, the Chechens and multiple anti-American organizations in Iraq all sponsored suicide attacks (Merari, 2003). Increasingly it seems rebel or terrorist organizations are finding it harder to motivate and attract supporters in a media and popular environment dominated by high profile suicide attacks without engaging in such acts themselves. This is particularly true of conflicts or regions where there are multiple rebellious/terrorist organizations operating (and thus competing). In Israel, organizations such as the PLO's Fatah and the Popular Front for the Liberation of Palestine (PFLP), which had not previously utilized suicide attacks, saw their support eroded when Hamas and the al-Aqsa Martyrs Brigade began launching high profile suicide attacks. By the start of the second intifada in September of 2000 both Fatah and the PFLP were engaging in suicide attacks against Israel. Similarly, as Iraq has emerged as a laboratory for growing violent anti-establishment organizations, the number of separate organizations claiming responsibility for suicide attacks has become hard to accurately count.

2. Targeting Democracies for Nationalist Purposes

Thus far, suicide attacks can be said to arise out of some kind of nationalist/independence movement directed at removing forces perceived as those of occupation and/or oppression. The targeted forces (or state) are almost always democratic and, thus, vulnerable to shifts in the popular mood. The first modern suicide attacks in Lebanon were designed to force the withdrawal of first American and French, then later Israeli, forces from the country. From 1983 to 1986 there were at least 28 separate suicide attacks (resulting in more than 600 fatalities) directed against the US, France and Israel (Pape, 2003). During this same time frame, despite the raging civil war and social divisions within Lebanon and rising Syrian influence I could find no definitive record of significant suicide attacks directed either inwardly or against Syria. Subsequent major terrorist campaigns involving the use of suicide tactics (the LTTE against Sri Lanka, the Palestinians against Israel, the PKK against Turkey, the Chechens against Russia, and various Iraqi groups against coalition forces) all have democracies as their primary targets.

Additionally, each organization sponsoring suicide attacks espouses, at least overtly, a nationalist cause or agenda with a specific immediate goal of removing ‘foreign’ forces or influence. Even Usama bin Laden, in his 1996 Declaration of War, attributes the motivation for Al-Qaeda attacks against the US as “the inability of the regime [the Saudi Government] to protect the country, and allowing the enemy of the Ummah – the American crusader forces – to occupy the land” (Al-Mass’ari [trans.], 1996). In his declaration of war bin Laden goes to great lengths to criticize the Saudi government as both corrupt and beholden to Western/American interests. Yet, it is America (and to some extent the greater Western World) rather than the more insular, decidedly undemocratic Saudi government, against which Al-Qaeda has directed the bulk of its effort and virtually all of its suicide campaigns.

3. The Diversification of Suicide Attackers

Early on in the study of suicide attacks it was widely assumed that the suicide terrorist himself (and they were all believed to be men) was predominately unsuccessful, socially isolated, and had low self-esteem (Israeli, 1997). Such assumptions, it seems, reflected more of a populist ‘gut feeling’ than a scientifically verified reality. More

recent research led the Congressional Research Council to conclude that “stereotypes about who is likely to carry out terrorist suicide attacks are evaporating” (Cronin, 2003, p8). This finding has been supported by the conclusions of the largest known analytical study of suicide and potential suicide attackers, that conducted by Dr. Ariel Merari in Israel, which contradicts the notion of the suicide terrorist as a social misfit. True, most (but not all) have been single, young (in their twenties), and male, but their education level has tended to be significantly higher than that of the base population as a whole, and they seemed to come from economic backgrounds evenly distributed when compared to their base population. Also, with the exception – for the most part – of attacks sponsored by overtly religious organizations, women have been employed in suicide attacks with great effectiveness in non-trivial numbers (2003). All these findings indicate that potential suicide attackers, and militants in general, are drawn from a much broader base than we would like to believe. Such a trend is supported by statistics gathered in Palestine and Egypt as well as anecdotal evidence that similar trends exist throughout the Middle East. A study by the Islamic Activism Research Project over the last three decades of the twentieth century shows just how pronounced diversification has become in Egypt and seems to prove that militancy at least is no longer bound by identifiable socio-economic strata (see Table 1).

Background of Egyptian Islamist Militants

	<u>1970's</u>	<u>1980's</u>	<u>1990's</u>
Age Categories			
< 20 Years	6%	11%	23%
20-25 Years	28%	31%	48%
25-30 Years	61%	53%	24%
> 30 Years	6%	5%	5%
Education			
< Secondary	2%	5%	9%
Secondary	8%	12%	29%
Junior College	11%	24%	42%
University and up	79%	59%	20%
Community of Resience			
Villages	0%	7%	18%
Shanty towns	8%	16%	36%
Towns	37%	43%	31%
Large Cities	55%	34%	15%

Table 1. Socio-economic profile of Egyptian Islamist Militants (Ibn Khaldun Center as cited by Richards and Waterbury, 1996)

Furthermore, suicide terrorism is not merely a tool of religious zealots and fanatics. Nor is there any indication that the role of religion in suicide terror attacks has grown substantially. As mentioned earlier, the largest perpetrator of suicide terror attacks is the Marxist inspired LTTE. Even within the Muslim community, a large and growing percentage of suicide attacks are attributable to predominately secular organizations. One of Israel's leading researchers into the phenomenon, Dr. Merari, asserts that nearly two-thirds of the early suicide attacks in Lebanon during the eighties were carried out by secular groups. And while the first suicide attacks carried out by Palestinians in Israel were almost exclusively the work of militant religious organizations, nearly a third of the suicide attacks conducted against Israel since 2000 have come from two secular organizations – Fatah and the Popular Front for the Liberation of Palestine (2003, p.6). According to many who have studied the backgrounds of suicide attackers, including Dr. Ehud Spinzak, the late Dean of the Lauder School of Government and Diplomacy in Israel, suicide terrorism is not merely the product of religious fervor. Spinzak's analysis of more than fifty Muslim suicide bombers led him to conclude that no single profile

(religious or otherwise) linked the potential attackers, but rather that intense struggles produce several different types of people with a potential willingness to sacrifice themselves for a cause (2000). Strength of religious belief is but *one* of these factors.

These broad trends alone, however, are of little practical use in attempting to devise a strategy to combat suicide attacks. Although they offer us a start, what is needed is more thorough exploration of the motivations and conditions under which suicide attacks have flourished. Such an examination should distinguish between the two key components of a suicide attack: the individual participants and the supporting organization. It is critical to analyze the suicide attack at both these levels because, especially from the psychological and behavioral points of view, they are separate and distinct. The motivations, objectives and vulnerabilities may also be distinct. This is not to say that either aspect should be examined in isolation. As a behavioral scientist from the National Research Council has put it, given that there is no single cause nor one key factor that drives terrorism, “the most appropriate way to organize these factors is in a nesting or combinatorial way, each adds its value at a different level and significance to work towards more complete accounts and explanations” (Smelser & Mitchell, 2002). Fortunately much work has been done in this field and both the individual suicide attacker and the sponsoring organization have been examined in depth. From these studies I have selected four motivating factors that the US has the best potential to affect.

C. MOTIVATIONS BEHIND SUICIDE ATTACKS

As mentioned previously, the academic work addressing suicide attacks is both large and impressive. My challenge has been to wade through this body of work and identify the points of commonality upon which researchers agree and, in some cases, to evaluate and decide between competing opinions and/or reconcile discrepancies. This task was made somewhat easier by bearing in mind that my primary purpose is to find motivations that might lead to vulnerabilities that can be exploited from a *Psychological Operations* point of view. From this perspective motivations are not all equal. More to the point, some motivations which, in many senses might seem to be among the most

influential, were in fact quickly excluded from my list.¹ In other instances, motivations which some may view as less significant have come to the fore in my examination. In such cases, we must again bear in mind that there is no one single motivation or condition that results in suicide attacks; all elements function together to form a general condition out of which, in some cases, suicide terrorists can and do emerge.

Consider what it takes to create a pearl in nature: the right mix of current, water temperature, and salinity combined with the right oyster and that critical speck of sand. While you could argue that the speck of sand or the oyster are the most important components for growing a gem pearl it is just as true that by affecting current, temperature or salinity (minor attributes?) you can either diminish the quality of the pearl or prevent it from growing at all. Similarly, becoming a terrorist, let alone one willing to participate in a suicide attack, is not the result of any single motivational factor. While each factor is important in its own right, the critical element is how the factors all work together when placed in a *situational context* (Smelser and Mitchell, 2002).

The astute observer might note that while pearls, like terrorists, occur naturally, they are much more likely to form when care has been taken to grow them under carefully controlled conditions. Under such circumstances, the nature of the terrorist organization – or the oyster farm – becomes extremely relevant to the production of the final product. The organization and the individual (the farm and the oyster) are connected, but they are also two very different things. For this reason I have broken up the examination of motivations into two short sections, the first devoted to the individual, and second to the organization.

1. What Makes a Suicide Bomber?

What else could I say? If I were a young Palestinian immersed from birth in the Palestinian ethos, I'd have become a third-grade teacher?

-- Ehud Barak, Former Israeli Prime Minister, when asked if he would have joined a Palestinian guerrilla group had he been born a Palestinian (Hroub, 2000).

¹ Most religion-based motivations fall into this category, for example. Although I must admit that I have never had a predisposition to viewing the issue of terrorism or suicide attacks as hallmarks of a “religious” war, my decision to exclude most aspects of the religious debate from further analysis stems almost entirely from the difficulty posed for a predominately Christian country to try to understand, let alone preach and espouse, the “proper” definition of Islam.

One popular perception of suicide terrorists is that they must have some sort of mental pathology. While such a view may be understandable given some of the ghastly acts such individuals have carried out, there is no research to indicate this is the case. In fact, the overwhelming conclusion reached by psychologists and behavioral scientists who have studied both failed suicide attacks and the history of actual suicide attacks, is that in almost every case the evidence indicates that participants in suicide missions appeared to be psychologically normal and acting with a complete understanding of their actions (Cronin, 2003). Suicide attackers may be under strong social and organizational influences, but they are almost never “crazy.”

I concur with the National Research Council’s preface to its study of individual motivations of terrorists, which states 1) there is no single “typical” terrorist psychology, 2) many terrorists are psychologically inaccessible and 3) Western psychological concepts and assessments may not be directly transferable to radically divergent cultures from which many terrorists spring (Smelser & Mitchell, 2002, p30). With this being said, though, if we are committed to trying to mitigate the growth of suicide terrorism we must not only acknowledge these limitations but drive beyond them in order to reach the best assessment we can *in spite of* our limitations. Within that context, many authors have identified recurring aspects that may serve as motivators for individuals who choose to participate in a suicide attack. I have narrowed that list down to four key motivations that may be particularly susceptible to potential US influence. They are: 1) unfulfilled expectations and resentment; 2) pent up energies with a lack of outlets; 3) group indoctrination; and 4) the feeling of empowerment from being able to strike back.

Study after study has found that, contrary to popular misconception, neither poverty nor lack of education are distinguishing factors in the background of suicide attackers. The most comprehensive analyses of such individuals have concluded that they come from all socio-economic levels of their communities in proportion to the population as a whole. Suicide attackers actually seem to be better educated than the general population with nearly twice as many having attended university (Merari, 2003). While perhaps not behind their peers economically or educationally, these individuals do seem, instead, saddled with a profound *sense of unfulfilled expectations and resentment*.

This may be of particular note in the Middle East where perceptions of personal honor hold a high place in both society and the family. In many cases even to marry requires a decent job and the ability to support a family. However, the failure of economic development to keep pace with rising populations, urbanization and higher educational levels has left most Middle Eastern populations with masses of young men gathered together in urban centers and with little opportunity to advance their social or economic status. In such cases, regardless of a person's actual economic or educational level, the sense that there is no hope of achieving his individual potential can be hugely traumatic. As a result, the leadership of most militant organizations and a large portion of suicide attackers have come from the pool of those aspiring to become the elite and the "best and brightest." These are members of the younger generation who have worked to achieve some education only to be confronted with a reality that seems to offer only unemployment or underemployment in jobs well below their expectations (Richards and Waterbury, 1996). For some, martyrdom may offer an opportunity to impress an audience or be remembered in a way that doesn't seem possible given the hand they have been dealt. In these cases, attackers are often "driven by a sense of humiliation or injustice" (Cronin, 2003, p6).

This personal disappointment is super-imposed upon a more general, region-wide feeling of collective repression. For decades, the Middle East has been submersed in a "collective sense of historical injustice, political subservience, and social humiliation vis-à-vis the global powers" (Atran, 2003, p.1536). As a result, young people grow up with deep-seated feelings of resentment and frustration. These feelings may be compounded by increased exposure to the wealth, plenty and temptation of the West, whether through travel, tourism, radio or television. Such feelings of resentment are easily predictable and common throughout world history: "those who are dominated – or who believe themselves to be dominated – by stronger outside powers come to resent and oppose their oppressors" (Smelser and Mitchell, 2002).

This feeling of unfulfilled expectations and the resulting resentment is magnified by a sense of helplessness. The political climate within the Middle East is among the least representative or responsive to popular will in the world. Only two countries (Israel and Turkey) in the entire Middle East can be said to be functional, representative

democracies. In all other countries political dissent is highly regulated at best, and more often savagely repressed. As a result of state sponsored repression there are few venues for venting resentments which gradually grow within affected individuals. It is said that the mosque and Islam offer the only real forum for meaningful political dissent.

The pressure of political repression is made all the more intense by the lack of alternative social releases available in the region. The conservative nature of Islamic society keeps men and women largely separated: social interaction between the sexes is confined to courtship with the intent to marry. Thus, without the prospect of a decent job or housing, men are unlikely to be able to invest their energies in pursuing a mate (Richards and Waterbury, 1996). Imagine the levels of *pent up energy* that would exist in any society where rapid urbanization has left large pools of un- or under-employed males stagnating together, unable to climb the economic ladder, greatly restricted in their opportunities to interact with the opposite sex, and unable to voice their dissatisfaction through any sort of functional political process.

The world, however, is a free market system and in any marketplace filled with resentment and pent up energies someone will find a use for that energy. Not surprisingly, this is exactly what organized oppositions seek to tap. In many cases, opposition provides a valuable outlet by which to vent pent up energy. However, the authoritarian nature of most Middle Eastern states seldom provides such opposition with accepted avenues for dialogue. Some minor opposition may be overlooked so long as it presents no real threat to the status quo, but those who seek real change are quickly eliminated or driven underground. As a result, the middle or moderate forces are gradually eroded; individuals who oppose the status quo must either surrender their convictions or harden themselves to forces of the state. Human beings are social creatures; under difficult circumstances we become even more so, often seeking out the support of like minded individuals. A population teeming with unfulfilled expectations, resentment and pent up energy provides all the necessary ingredients to begin the process of *group indoctrination*.

Like the other factors, group indoctrination is helped along by many social factors common throughout the Middle East. Virtually all Arab societies are characterized by

high birth rates and relatively high proportions of young people compared to those of working age or the elderly. When combined with rapid urbanization the net effect is less familial influence, “younger siblings in particular are likely to suffer from a lack of parental investment of resources and emotional care” (Smelser and Mitchell, 2002, p.22). In such situations, it is common for social organizations (or gangs) to play an increasingly influential role in the social and political development of youth. Absent any moderating alternatives (since most of these have either been co-opted by the state or proven themselves ineffectual) the most militant and committed organizations have little competition when it comes to attracting new supporters.

However, it is a misconception to regard such organizations as merely violent, cold-blooded terrorist organizations. For instance, though Hamas, one of the most prolific sponsors of suicide attacks, is commonly noted in the West only for its bombings and attacks on passenger buses, Palestinians see it as a “multidimensional political movement that is involved in wide scale social, cultural and charitable activities as an organization with ties to parties, organizations and states” (Hroub, 2000, p4). The organization is able to attract large pools of supporters primarily through its routine and innocent actions. The organization gradually applies basic principles of persuasion to this base. These principles involve the creation of bonds with new peers and the identification and development of common interests; the establishment of authority – the religious, educational, and charismatic reputation of the leadership; to address scarcity, providing services to the community that authorities are not providing; to instill/encourage reciprocity, asking new members to repay the group through action (Cialdini, 2001).

Throughout this process, individuals self-select for more and more “important” or dangerous positions within the organization. Those who have demonstrated the most willingness receive progressively more training and indoctrination. Eventually “self contained suicide cells canalize disparate religious or political sentiments of individuals into an emotionally bonded group of fictive kin who willfully commit to die spectacularly for one another and for what is perceived as the common good of alleviating the community’s onerous political and social realities” (Atran, 2003, p1534). According to experts, these individuals, while not crazy, are “manipulated by the pressures and belief

structures of the group” (Cronin, 2003, p8). This group indoctrination is one of the most important components in providing the individual with the motivation to forfeit his or her own life in a suicide operation for his or her chosen cause.

For those individuals who ultimately find themselves on the path towards conducting a suicide attack the prospect of *empowerment* offered by being able to strike back against the forces that have been repressing not only the individual, but his whole society must be overwhelming. After years of being marginalized, and hearing repeatedly how his or her entire society has been held back by forces which are so obviously powerful and omni-present (can anyone anywhere escape the influence of Western media, values, capitalism or the images of US or Israeli military might?) the individual who willingly submits himself to a “higher” purpose must naturally feel a weight lifted and a sense of personal empowerment. Before committing to the organization the individual had nothing. Then, after joining, he belongs, he has friends, supporters and a purpose – “he is engaged in a life and death struggle with the establishment, his picture is on the ‘most wanted’ posters...he is lionized as a hero” (Smelser and Mitchell, 2002, p36). For those of us in the West who have never felt so powerless the empowerment gained through the willingness to sacrifice one’s life for a cause may be too hard to sufficiently appreciate.

Taken together, these four factors significantly contribute to the individual motivation to participate in a suicide attack. What individuals, in turn, need is an organization with the motivation to organize and launch such attacks.

2. Why do Organizations Choose the Suicide Option?

Our enemy possesses the most sophisticated weapons in the world and its army is trained to a very high standard. . . . We have nothing with which to repel killing and thuggery against us except the weapon of martyrdom. It is easy and costs us only our lives.

--Dr. Ramadan Shalah, Secretary General of the Palestinian Islamic Jihad
(Sprinzk, 2000)

Organizational motivations behind suicide operations, like individual motivations, have been studied at length. Here, too, I find four factors worth focusing on: publicity, fundraising and recruitment, achieving political objectives and the lack of effective alternatives.

Terrorist organizations face an interesting paradox: to survive against oppressive regimes, superior technological resources, and/or military might they must remain secretive. But in order to achieve their goals, grow their support base, and raise resources they must act publicly. **Publicity** is essential to the terrorist organization. Most terrorist organizations are now operating their own web sites where they have the potential to reach millions, but only if public interest can be generated (Jenkins, 2004). While the internet is open to all, the truly *mass* media outlets are still controlled by either governments or multinational corporations. However, in an era of global news coverage, terrorists have found that free access to the mass media can be generated in an instant through dramatic actions. If terrorist action is understood to be about drawing attention to a cause or issue, then the violence of a suicide attack is an almost impossible temptation to ignore. The bottom line is that suicide attacks are more likely to be noticed and attract more publicity than other actions (Cronin, 2003; Hoffman and McCormick, 2004).

This publicity is important to the sponsoring organization for a number of reasons, including drawing attention to its grievances/issues, intimidation of its opponents/target population, mobilization of its constituent population and enhancing its own credibility. However, contrary to popular belief the last two factors, rather than the first two, are likely the most important. Achieving its stated goals and hurting its enemies may help an organization achieve its long term objectives, but first it must establish its base in order to survive. We must constantly remind ourselves that these organizations face tremendous obstacles in opposing strong established governments, including the paradox that to survive they must remain secretive enough to avoid reprisals but public enough to harness outside support. Suicide attacks allow them to minimize both costs and risks. With a few hundred dollars and a motivated recruit an organization can gain instantaneous media exposure, with little risk of having members captured and interrogated. Targets are chosen for theatrical value and acts are played out

on a public stage to achieve maximum attention (Hoffman and McCormick, 2004). Further, the “martyrdom” nature of the operation draws in the constituent population by highlighting the self-sacrifice of one of their own for the cause. Thus, the act draws publicity to the organization while minimizing the risk to its other members.

As I have hinted at, the publicity factor goes hand in hand with supporting the organization’s *fundraising and recruitment* ability. The National Research Council observes that the ability of a “terrorist” organization to recruit new members is largely related to its perceived success “or at least publicity” (Smelser and Mitchell, 2002). The case of Hamas is one good example of how suicide attacks can be exploited. Prior to its adoption of suicide attacks against Israelis in the mid-nineties Hamas was just one of many rival organizations. And while many factors have contributed to Hamas’ growth over the last ten years, its dramatic and effective exploitation of suicide attacks is among the most critical. Hamas’ suicide attacks brought it attention and allowed it to portray itself as the only organization that was able to effectively fight for Palestinian rights against the Israelis. Just as importantly, though, Hamas publicized and exploited the sacrifice of the attackers. After each suicide attack thousands of leaflets honoring the sacrifice would be posted and distributed throughout the Occupied Territories (see image 1), and large funerals organized so that the sacrifice and Hamas’ efforts would not go unnoticed. So effective was Hamas’ suicide campaign at generating supporters and expanding the deeply religious organization’s base that today it is arguably the largest, most influential Palestinian organization in the Occupied Territories and its membership includes large numbers of non-practicing Muslims (Hroub, 2000). By the late nineties the Palestinian Islamic Jihad had likewise adopted suicide tactics and dramatically boosted its popular support. Today, faced with declining support even secular Palestinian organizations now conduct suicide attacks.



Figure 1. Hamas leaflet honoring the sacrifices of its members.
 (downloaded 1 August 2004 from Hamas' own web site, www.hamasonline.com)

The fact is that the image of a young person proclaiming commitment to a cause and organization, and then willfully sacrificing his or her life for that cause, has become a powerful recruitment tool. Most experts agree that suicide attacks build both group cohesion and enhance the political base within the organization's constituent community. From a psychological point of view, honoring the memory of the attacker predisposes the community to honor the sponsoring organization (Hoffman and McCormick, 2004; Cronin, 2003). Scott Atran quotes a 2002 Pew Research Center study which seems to show a sharp increase in support of militant causes after suicide attacks, and decreasing support for the American Global War on Terrorism. From a financial perspective these attacks may be even more effective according to Atran, who notes the more than \$100 million raised by a Saudi telethon for the Al-Quds Intifada after a suicide bombing of a supermarket by an 18 year old Palestinian girl (2003).

These first two factors behind an organization's decision to sponsor suicide attacks provide the practical reasons behind a decision to launch an attack. The third provides the ideological reason: the sponsors feel that *suicide attacks advance their*

political objectives. According to Khaled Mishall, political bureau chief of Hamas, the intifada and the adoption of relentless suicide attacks have accomplished more in months than was achieved in a decade by the “so-called” peace process (Mishall, 2003). Robert Pape, in his examination of 186 suicide attacks from 1980 to 2001, concluded that the evidence clearly demonstrates that the number of such attacks has been steadily rising because “terrorists have learned that it pays” (2003, p2). While Pape later questions the degree to which attacks have *actually* achieved their political ends, especially in cases where those ends have been ambitious, he finds that attack sponsors *believe* they are effective – or at least more effective than any alternative tactic. Many observers have noted the success of Hezbollah in forcing the Israeli withdrawal from southern Lebanon thanks to Israel’s inability to deal specifically with the threat of suicide attacks. According to Palestinian Islamic Jihad leader Ramadan Shalah, Israel’s retreat from Lebanon was brought about “on the battlefield and through jihad and martyrdom,” not through negotiations (Hoffman and McCormick, 2004).

While the *actual* record of suicide attacks in achieving political objectives may be questionable, the effectiveness of suicide attacks in achieving their tactical objectives are apparent for everyone to see. Suicide attacks are simply more likely to be successfully executed and generate more casualties than other means available to most organizations. Palestinian suicide attacks from 2000 to 2002 accounted for less than 1% of all attacks but caused 44% of the casualties (Cronin, 2003, p9). Pape’s study of suicide attacks from 1983-2001 attributed 48% of all fatalities to the 3% of terrorist attacks that were suicide missions (2003). And according to Hoffman and McCormick, suicide attacks worldwide are four times more deadly than conventional terrorist attacks (2004). Whatever the exact numbers, the fact is that suicide attacks attract publicity and kill or maim their targets with much more effect than anything else yet devised. Taken together with some arguable successes in achieving US, French and eventually Israeli withdrawal from Lebanon, it’s easy to see how organizations can view suicide attacks as the potentially most successful actions they can take.

The final motivating factor behind launching a suicide attack is the excuse: essentially, *there are no effective alternatives*. According to Rashad al-Shawwa, a former mayor of Gaza, the root cause of the Palestinian intifada, suicide attacks and,

indeed, all acts of violence against the Israelis has been the absolute absence of any effective alternative by which people can express their rage. When asked what led to the militancy and violence, Al-Shawwa told an Israeli radio interviewer the following:

One must expect these things after twenty years of debilitating occupation. People have lost hope. They are frustrated and don't know what to do. They have turned to religious fundamentalism as their last hope. They have given up hoping Israel will give them anything (Hroub, 2000).

The terrorist organizations use this widespread belief that there are no peaceful means of achieving results in order to fuel support for militancy. Shawwa isn't alone. Organization after organization that has adopted suicide tactics has claimed to have done so as a last resort. Against superior Israeli forces Palestinians have often claimed that suicide attacks amount to fighting with "the only tools they possess" (Hoffman and McCormick, 2004).

THIS PAGE INTENTIONALLY LEFT BLANK

III. VULNERABILITIES AND ABILITY OF THE CURRENT PSYOP MODEL TO EXPLOIT THEM

A. MAKING IT ALL USEFUL: EXPLOITING VULNERABILITIES

So as we have seen from the previous chapter, the tactic of suicide terrorism is driven in large part by real and tangible motivations. These motivations are the most likely explanations for the growth of suicide terrorism as a tactic and, left unchecked, these motivations are precisely why it will only be a matter of time before suicide terrorism is combined with the use of Weapons of Mass Destruction (WMD) to achieve catastrophic effect – *unless* something is done to interrupt these motivations. But suicide terrorism is not impossible to counter. It is a tactic extraordinarily dependent upon a complex (and potentially fragile) set of inter-related motivations.

1. Motivation to Vulnerability Linkage

Thus far, most of the research and analysis that has gone into suicide terrorism has focused entirely on motivations, root causes and the psychology behind the behavior. The research has produced a better understanding of motivations. However, for an understanding of motivations to be useful in combating suicide attacks the motivations must be dissected by those responsible for Public Diplomacy, Information Operations and PSYOP. Especially if one accepts that motivation is a critical ingredient – or Center of Gravity¹, in military parlance – of a suicide attack. The key to attacking this center of gravity is to identify motivational vulnerabilities that US forces have the potential to *exploit*. If the vulnerabilities are chosen correctly and successfully exploited such a process has the potential to undermine, erode or otherwise dilute motivations below the level required to trigger suicide attacks.

Like the motivations themselves, their vulnerabilities fall into two distinct groupings: individual and organizational. Each of the motivations I have identified has at least one major vulnerability that could potentially be exploited by US forces. While I

¹ Joint Publication 3-0 defines the Center of Gravity (CoG) as “the foundation of capability” and quotes from Clausewitz calling the CoG “the hub of all power and movement, on which everything depends...the point at which all our energies should be directed.” (1995, p. III-20).

have outlined these motivations and their associated vulnerabilities in the matrix below my primary interest is to answer the question of *how can we exploit these vulnerabilities to achieve our desired effect?*

MATRIX OF VULNERABILITIES

<u>Motivation</u>	<u>Vulnerability</u>
<i>Individual</i>	
Unfulfilled expectations/wounded Pride	Desire to live, prosper, achieve
Pent up energy	Tasks, work, hope
Group indoctrination	Family ties and/or the creation of new groups
Empowerment – ability to strike back	The inherently non-violent nature of Islam
<i>Organizational</i>	
Publicity	Negative publicity
Fund raising/recruitment	Negative publicity contributing to loss of support
Achieves political objectives	Creation of a political backlash
Lack of alternatives	Creation of real alternatives

Table 2. Matrix of vulnerabilities for selected motivations of behind suicide terrorism.

Individual and organizational motivations are related and, indeed, synergistic factors in leading to suicide terror attacks. The turbulence and hopelessness that gives rise to the individual motivations behind suicide attacks is the foundation upon which terror organizations are building. Terror organizations have an incentive to perpetuate the turbulence that fosters hopelessness because it grows the pool of potential supporters. The process spirals into ever more destructive cycles as rival organizations compete for attention. Breaking the cycle will mean dealing with both the individual and organizational motivations behind suicide attacks. Long term solutions will demand addressing the underlying conditions that provide the motivation for the individual suicide terrorist. While this is likely to be very difficult work in the best of circumstances we can expect the challenge to be magnified many times by the ongoing chaos and instability common throughout the Middle East. However without solving, or at least mitigating, this immediate security and stability problem we may never be able to stem the rising tide of attraction to radical terrorist organizations. A shorter term solution might be achievable by addressing those organizational vulnerabilities that seem most penetrable to us. If we can undermine the organizational motivations to conduct suicide attacks we could then use the resulting lull in violence to publicize on going efforts to

improve the underlying conditions. In order to gain the time we need to begin addressing individual motivations we should begin by dealing with organizational motivations.

2. Deterrence Theory and Terrorism

Deterrence theory suggests it is possible to deter suicide terrorism by concentrating on the organizations that sponsor it. Any action a rational actor takes in furtherance of a goal can potentially be deterred if the actor can only be made to *believe* that the given action will not support the goal. The case of deterring terrorism requires that we engage the larger universe in which the *terrorist* operates. Just as we do not focus on deterring individual soldiers from launching an attack against a neighboring state, so too we cannot effectively focus on deterring individual terrorist from committing acts of terrorism. While acknowledging that we may never be able to deter the actions of every individual terrorist, or even every sponsoring organization, the traditional concepts of deterrence provide a basis upon which a program for deterring organized, systematic suicide terror attacks can be built.

Detractors might argue that people like bin Laden cannot be deterred, only killed. They might be right, but it is important to remember that organizations like al-Qaeda are, in reality, networks of disparate cells and loosely allied organizations, each with its own decision making cycle subject to outside influences. Deterrence theorists Davis and Jenkins provide a solid explanation of the terrorist's system and argue effectively for the merits of adopting a "broad-front strategy aimed at influencing the many different parts of the al-Qaeda system" (2002, p. xiii). The terrorist system they describe is made up of many components, ranging from the leadership, lieutenants, and foot soldiers to the financiers, supporting population segments and state sponsors. While some of these elements may be all but undeterable the vulnerabilities of other segments provide an opportunity to apply very traditional deterrence methodology. Indeed one of the most vulnerable components of the terrorist system may well be its state *and organizational* sponsors. While the concept of statelessness offers some protection to the terrorist organization, the reality is that there is some state control in virtually every part of the globe has some state control. Sophisticated terrorist actions require a level of support that can most readily be found by operating in an at least marginally developed state and

with the support of a fairly well developed organization. To the degree that this is true, the terrorist system becomes venerable to actions taken against the state and/or sponsoring organization.

Paul Huth's 1988 work, *Extended Deterrence and the Prevention of War*, is a study and analysis of classic deterrence techniques. In it Huth argues that deterrence is built upon credibility and stability. He describes a stable deterrent posture as one that maintains a "fine balance between demonstrating firmness and readiness to use force on the one hand and provoking the attacker and creating a spiral of escalating hostility on the other" (1988, p.11). According to the theory, for the US to employ deterrence successfully its opponent must believe it to possess both the capability and intention to act, thus making US threats or inducements seem credible (see Figure 1).

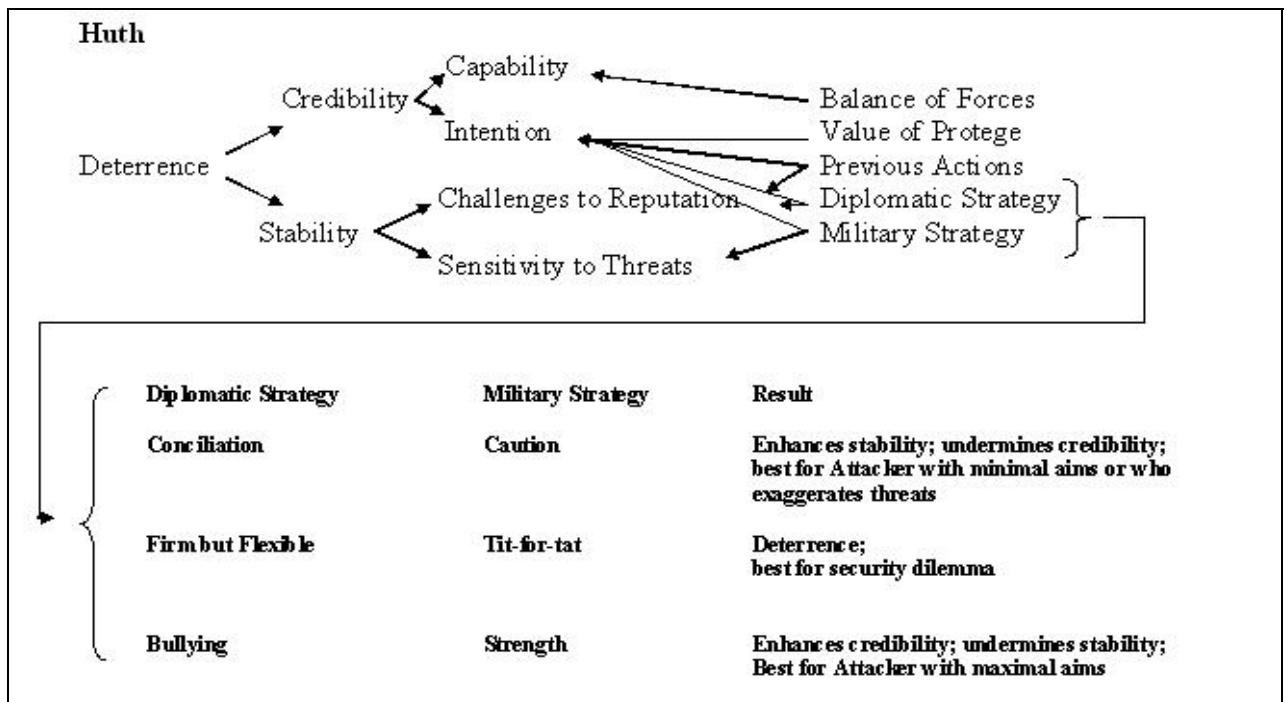

Figure 2. Schematic view of Huth's model of deterrence

Psychological Operations are predicated on the belief that individual and group actions can be influenced. Deterrence theory provides a theoretical construct which reinforces and supports this belief. If one hopes to optimally employ PSYOP forces it must be done in a manner that takes into account the basic principles and requirements suggested by deterrence theory. The challenge for the military is to adapt deterrence

theory for use by PSYOP forces to achieve a tangible effect in influencing target audiences. Perhaps the most effective way to influence them and wage this battle is by concentrating on winning the small day to day battles. Deterrence is not a task that is simply accomplished and then left behind as we move on. If an event is deterred even one day then there has been an effect. The challenge is to perpetuate the process. In terms of suicide terrorism this means each day without an attack or even a reduction in the levels of attacks is a small victory upon which we can continue to build.

B. MILITARY PSYCHOLOGICAL OPERATIONS DEFINED

Even if exploiting vulnerabilities to reduce the threat from suicide terrorism seems like a viable course of action, in practice actually executing such a mission requires an organization with the mission, resources and structure capable of not only developing and executing a major strategic influence program but also coordinating and integrating key elements of that program across various DoD, DoS and interagency levels. As of the writing of this paper *no such organization exists*.

The absence of such an organization has been noted at various levels of government over the years. Although numerous solutions have been suggested or partially implemented none has effectively taken hold. For decades, however, the US Army's PSYOP branch has been actively involved in tackling many of these issues. And, in the absence of any other organization, many people seem eager to see the Army's PSYOP community assume greater responsibility for achieving such strategic missions.

So, what is the current PSYOP force structure, how did it evolve and has it been successful? This section reviews PSYOP's mission, history and current structure as a precondition for the further examination of PSYOP's role in combating suicide terrorism and into the future.

1. PSYOP: Its Background and Purpose

The 4th Psychological Operations Group (Airborne) (4th POG) traces its history as a unit back to 7 November 1967 when the Group Headquarters was officially constituted in Vietnam (Special Operations Command, ND). The establishment of the 4th POG was a natural reaction to what the army at the time, and its political leadership, recognized as a need to win the "hearts and minds" of the Vietnamese people. However, psychological operations themselves were neither a new military concept nor a new tool for US forces.

The ancient Chinese military philosopher Sun Tzu repeatedly referenced the importance of psychological warfare, acknowledging “one need not destroy one’s enemy, one need only destroy his willingness to engage” (Cleary, 1991, p.57). For America, psychological operations received new levels of attention during World War II as the allies discovered the effectiveness of axis propaganda. As the post-war world settled into a semi-permanent state of aggression the army itself came to recognize the need for a structured, coherent, non-violent means of engagement. Thus in April of 1952 the Army established the Psychological Warfare Center at Fort Bragg, NC (Special Operations Command, ND).

From its conceptual beginnings as a warfare school house in 1952 and its organizational inception in the jungles Vietnam, the US Army’s Psychological Operations (PSYOP) community has grown into the world’s largest force dedicated to the study and employment of Psychological Warfare. With most of the Army’s PSYOP units and capabilities found in the reserve component, the 4th POG represents the sole active duty PSYOP unit in the American armed forces (Global Security, ND). With fewer than 1200 active duty soldiers (or 26% of all PSYOP forces) the 4th POG is further subdivided six subordinate battalions. Four of these battalions function as divisional subordinate units, directly responsible for all PSYOP activities within distinct geographical regions. The remaining two battalions are functional subordinate units, responsible for providing unique PSYOP functions and skills in support of the regional PSYOP battalions. Even prior to the invasion of Iraq these 1200 soldiers are among the army’s most heavily deployed forces, conducting exercises, training foreign forces, and executing their wartime mission in every theater of the world 365 days a year.

While PSYOP has remained a part of the Special Operations community its use and organization has increasingly tended towards the conventional. More than three quarters of all PSYOP units are tactical, built primarily around the use of the loud speaker. Nevertheless, PSYOP, as defined by both army and joint publications, has a broader mission than the tactical weighting of the organization would suggest. According to Army Field Manual (FM) 3-13 “Psychological operations are planned operations that convey selected information and indicators to foreign audiences to influence their emotions, motives, objective reasoning *and ultimately to influence the*

behavior of foreign governments, organizations, groups and individuals” [emphasis added] (2003, p. 2-3). Nothing in this definition seems to suggest that PSYOP forces should be focused, let alone disproportionately focused, towards either tactical or conventional operations. To the contrary, both Army FMs and Joint Publications (JP) go on to say “PSYOP is a mainstay of US government efforts to influence foreign audiences at the strategic, operational and tactical levels” (FM 3-13, FM 33-1-1, JP 3-13 and JP3-53).

However, an expansive vision of PSYOP as described in Army, Joint and even national plans does not seem to collate with what is, in reality, an organization that has seen little structural or organizational change since the end of the cold war. Before we can proceed further, then, it is appropriate to examine the current PSYOP force structure.

2. The Current PSYOP Template

Psychological Operations in the DoD today is Joint Mission dominated by a relatively small number of US Army PSYOP forces.³ These specially trained PSYOP forces are consolidated under the control of the US Army Civil Affairs and Psychological Operations Command (USACAPOC). USACAPOC and all PSYOP forces, in turn, fall under the command of the US Army Special Operations Command (USASOC) and ultimately under the Joint Services Headquarters of the US Special Operations Command (USSOCOM).

³ Total Army PSYOP forces today number around 1,500 active duty personnel largely concentrated in the 4th PSYOP Group (POG) out of Fort Bragg, NC. The Army Reserve contains an additional two PSYOP Groups (the 2nd POG , Cleveland, OH, and the 7th POG, Mountain View, CA). Additionally, the US Army Civil Affairs and Psychological Operations Command (USACAPOC), also located at Fort Bragg, but commanded by a Reserve General Officer

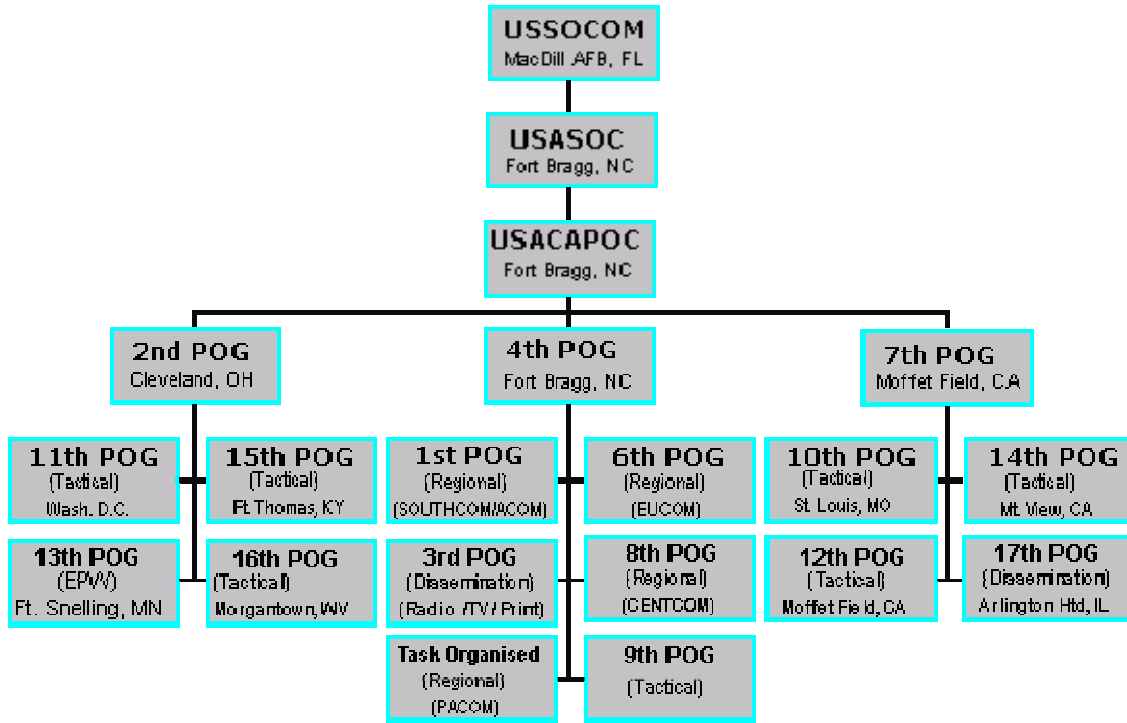

Figure 3. Organizational and Command structure of PSYOP forces in a garrison (i.e. non-deployed or Peacetime) environment.

Although both the Navy and Air Force have PSYOP, elements their numbers are in the hundreds and tend to either focus on specialized tasks⁴ or the positions are filled as ‘additional duties’ (requirements being filled by personnel primarily trained in another field or specialty). Of the approximately 4,500 PSYOP troops assigned to USACAPOC more than sixty percent are in the reserve forces and nearly all of those are battlefield PSYOP soldiers assigned to Tactical PSYOP Battalions (POBs). These tactical POBs are designed to provide battlefield PSYOP support to corps level units or the SOF community. The Tactical POB HQs can serve as a Corps PSYOP Support Element (CPSE) while their subordinate PSYOP Companies are allocated down to the Division level. Each Tactical PSYOP Company consists of three platoons with three squads each. While the Tactical PSYOP Company and Battalion may have a limited product design

⁴ Naval PSYOP capabilities are dominated by the audiovisual production capability of various Fleets, the Naval Imaging Command and Naval Reserve PSYOP AV unit that supports the Atlantic Fleet. Although the Fleet Tactical Readiness Group (FTRG) has the capability to conduct civil radio broadcasts it lacks personnel trained in PSYOP and must be augmented with PSYOP specialists when necessary. The Air Force PSYOP capabilities are mostly confined to providing the EC-130 Commando Solo aerial broadcast platform. All six Commando Solo platforms are assigned to the 193rd SOG (US Air National Guard) based in Harrisburg, PA.

section, their primary use has been to provide the soldiers and equipment to disseminate PSYOP messages to the battlefield or tactical environment – most commonly via loudspeakers.

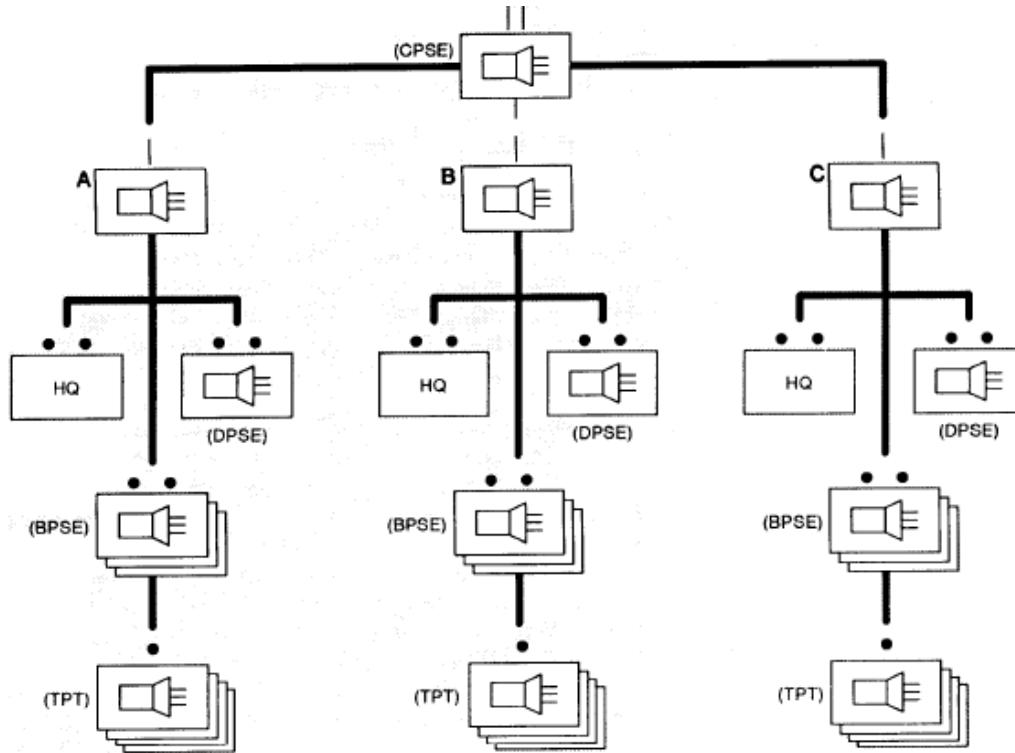

Figure 4. Organization of a Tactical POB as configured to support a Corps structure.
 The POB HQ remains at the Corps HQ and functions as a Corps PSYOP Support Element (CPSE). Individual Tactical PSYOP Companies are sliced out to subordinate Divisions where their HQs act as the Division PSYOP Support Element (DPSE) and Sections are sliced to Brigades.

Unlike the tactical POBs which number between 500 and 900 soldiers each, Regional POBs range from 120 to 180 soldiers. These Regional POBs support unique geographical areas (Europe, Asia, etc.) and their corresponding US military commands (EUCOM, PACOM, etc.). The Headquarters of these regional battalions are designed be deployable elements that can form the nucleus of a Joint PSYOP Task Force (JPOTF), while their companies function as Product Development Centers responsible for PSYOP product development, testing and evaluation of culturally and regionally specific material. The JPOTF itself is responsible for developing and coordinating the overall

regional PSYOP message as approved by the Joint Task Force Commander. Because the tasks of the Regional POB require extensive regional knowledge these soldiers receive basic language training as well as familiarization training in their assigned region. The Regional POBs are further augmented by a six to ten person Strategic Studies Detachment (SSD) staffed by highly educated civilian analysts with extensive regional, linguistic, and cultural expertise.

Until recently that was the extent of military PSYOP: one active duty Group, no PSYOP General Officer, no coordinating staff element outside of USACAPOC, no inter-agency coordination element and only token representation in minor positions on Corps or higher staffs. This structure was built to support a cold war, conventional model of warfare. As such, the PSYOP component was generally thought of (if it was thought of at all) as a combat multiplier best utilized in a direct support capacity to encourage surrenders/desertions and/or to keep civilians off the streets. However though the purpose and structure of PSYOP has not changed significantly since the end of the cold war the nature of conflict itself (with an increasing trend towards stability support operations and countering asymmetric threats) and the sociopolitical environment have changed dramatically. That such a structure is simply insufficient for responding to the increasing challenges in the information warfare environment was widely recognized even in the pre-9/11 environment (Defense Science Board Task Force, 2000, p9).

The recent creation of a Joint PSYOP Support Element (JPSE) within USSOCOM represents a huge step forward, although as of the writing of this paper the JPSE is still at less than fifty percent of its authorized end strength and its only claim to actual “jointness” is one Air Force Behavioral Psychologist and a handful of positions slotted for “Air Force” civilians.⁵ Additionally the restructuring of all army units from division based to brigade/“unit of action” (UA) based-forces has been accompanied by the inclusion of positions for PSYOP-trained officers on staffs down to the brigade/UA level.

These recent efforts represent another significant step forward for military PSYOP, but even taken as a whole they are still only the first steps towards beginning to

⁵ The inclusion of a trained behavioral psychologist, a position which surprisingly does not exist at all with the Army’s entire PSYOP community, is in fact a major benefit to the PSYOP community and perhaps one small indicator of the potential benefits of further leveraging a more truly Joint Services approach.

address the shortcomings that are preventing the force from reaching its potential. The contemporary operating environment for military operations has changed much more rapidly than the military as a whole, and PSYOP forces in particular. At a time when new doctrine and national policy statements are radically changing the demands being placed on PSYOP forces too little has so far been done to rebuild the organization to meet these challenges. Unfortunately, the ambitions and intent for PSYOP do not match up very well with the reality of how PSYOP today is organized.

C. PSYOP'S PROBLEMS AND HOW THEY HURT THE FIGHT AGAINST SUICIDE TERRORIST

So can PSYOP adequately exploit these vulnerabilities as it is currently organized? Unfortunately the short answer is probably not, at least not nearly as effective as it has the potential to do. The current record shows that on the whole PSYOP efforts against our current adversaries in Iraq have not gained much traction and have demonstrated marginal results at best. Creditable polls taken in Iraq as recently as June of 2004 indicated that intensive PSYOP promotional efforts the vast majority of Iraqi's (81%) said they had no confidence in Coalition Forces and a full 92% of Iraqi's said they viewed Coalition Forces more as Occupiers than as Liberators (2%) or Peacekeepers (3%). Efforts to build support for the Coalition Provisional Authority fared no better, with 78% expressing no confidence, making even the United Nations dismal 67% no confidence rating look good by comparison (IIACSS, 2004). Even in terms of some of the least subjective information tasks polls show that only about 11% of Iraqis believe coalition forces are trying hard to restore basic services such as electricity and water (Soriano and Komarow, 2004).

Why hasn't PSYOP been more successful? There are at least two major reasons: 1) an outdated organizational structure and mindset; and 2) a breakdown in basic source-message-receiver linkages.

1. PSYOP: An Outdated Structure

The problem with the current PSYOP structure is that it was simply not designed to engage in the kind of long term, highly complex missions – such as nation building, and unconventional warfare – that it is increasingly called upon to assist with. The

PSYOP structure is still based on cold war era threats, focused on achieving tactical objectives and designed to counter conventional/military adversaries.

a. Cold War Era Structure

As observed by the Defense Science Board Task Force (DSBTF) in May of 2000, “while neither the definition nor the purpose of PSYOP has significantly changed since the end of the Cold War, the nature of conflict, the available technologies, the sociopolitical environment, and the character of operations involving military forces have all changed dramatically” (DSBTF, 2000, p9). Unfortunately, more than four years later, and after the shock of the 9/11 attacks, so little had changed that a September 2004 DSBTF report on strategic communications again found that “while the strategic situation is wholly unlike the Cold War, our response nonetheless has tended to imitate...that era” (DSBTF, 2004, p36). The report goes on to cite specific examples of how this Cold War mindset has inhibited efforts to effectively communicate with a completely different target audience that must be reached to adequately support of the war on terrorism.⁶ This is not a unique observation; indeed, it has been made repeatedly by both outside scholars and DoD insiders alike since the early days of the emerging New World Order.

b. Tactical Focus

Of the nearly 5,000 PSYOP trained soldiers in the US Army almost between 80 and 90 percent serve in tactical a tactical capacity, as previously mentioned. In terms of the unit break down, the current Army vision is for all eight Reserve POBs and both Reserve Group HQs to be almost exclusively tactical and for no Reserve forces to be dedicated to either operational or strategic PSYOP missions. While the active duty PSYOP forces have four regionally focused battalions (each providing support to one of the major regional commands) these regional POBs actually comprise between 120-180 soldiers each, in comparison with a tactical POB that has more than 500 soldiers. Despite efforts to rotate soldiers between tactical and regional assignments numbers and training disparities mean that most PSYOP soldiers have their experiences weighted towards

⁶ The 2004 DSBTF report notes that: 1) Muslims are too often incorrectly thought of as “masses yearning to be free” and consequently liberated by the West; 2) we continue to think and act as if the communications environment were stable and routine rather than dynamic and fast paced; 3) our support for authoritarian allies was never successfully challenged by the authoritarian Soviet regime, but it *is* being used to “strongly undercut our message” *by our current adversaries*. (DSBTF, 2004, p36).

occasional senior Lieutenant Colonel. With a lack of strategic or operational job opportunities the natural tendency within the PSYOP community will continue to be to focus primarily on tactical roles and missions and the tactics, techniques and procedures (TTPs) that are necessary to achieve such objectives.

c. Conventional Adversaries

In line with the long-time PSYOP focus on both the Cold War model and the tactical mission has been a tendency to focus on both conventional adversaries and conventional objectives. In cases where this predilection matched the situation, PSYOP has enjoyed great success. For example, in Operation Desert Shield/Storm more than a hundred thousand Iraqi soldiers surrendered and scores of other units were rendered ineffective largely as a result of well coordinated kinetic (bombs, artillery, missiles) and non-kinetic (PSYOP, force demonstrations, public diplomacy) campaigns. Against the conventionally arrayed Iraqi forces PSYOP programs are widely regarded to have had a significant impact. To a lesser extent similar successes were noted in support of the invasion of Panama, the invasion of Afghanistan and the initial invasion of Iraq. In all cases, civilians were largely directed away from and kept off the battlefield, morale of conventional opposition forces was dramatically reduced, and the opponents' will to resist in a conventional sense was destroyed. So focused on the conventional opponent (or enemy state) has been the official PSYOP community that, prior to rewriting the Psychological Operations Field Manual in September of 2003, not one of the 26 separate "opportunities of PSYOP success" identified at the Operational level and beyond directly applied to unconventional opponents or guerrilla warfare (FM 33-1-1, 5 MAY 94, p. 2-3 thru 2-5). In fact, in an odd irony, at least 11 of those "PSYOP opportunities" (which are generally focused on the conventional state's vulnerabilities) could best be applied not by US forces but rather by our adversaries in either Iraq or Afghanistan.⁷

⁷ Specifically FM 33-1-1 (5 MAY 94) cited the following 11 conventionally focused areas in which it appears that Iraqi insurgents would be much more likely to have any opportunity than the coalition forces: Manpower shortages in the opponent's military (Iraqi Army/Police), Political disunity and lack of confidence in opponent leaders, Inability of the opponent's government to provide for the needs of the people (security), Failure of draftees or reservists to report for duty (Iraqi Police), Defections and/or desertions (Iraqi Army/Police), Failure of transportation systems (oil pipeline disruptions and highway bombings), Failure of opponent governments' allies to come to their assistance (lack of NATO or Arab forces), Numerous defeats and high casualties (at least high Iraqi civilian casualties), Excessive periods of combat (multiple rotations for some US forces?), Overaged, inexperienced or untrained troops (Iraqi Army), Poorly indoctrinated soldiers (Iraqi Army).

These three structural shortcomings – a Cold War structure, a tactical focus, and a focus on conventional adversaries – have inhibited the nation’s ability to utilize Psychological Operations as effectively as possible in the current conflicts in Iraq and Afghanistan or more generally in support of the larger ongoing War on Terror. This mindset perpetuates an outdated force structure and organization that have been very successful in support of conventional missions or when exploiting basic needs to achieve simple quick actions. Here again we need to refer back to the First Gulf War and the invasion of Panama when US PSYOP forces exploited hunger, lack of shelter and fear of immediate death to achieve simple and direct actions that answered the underlying Physiological and Safety needs. In those cases enemy soldiers – the target audience – of such attacks abandoned their positions, put down their weapons and left the battlefield in large numbers. During the early phases of combat operations in support of Operations *Iraqi Freedom* and *Enduring Freedom* PSYOPers were able to exploit basic needs and were generally successful: civilians were kept off the battlefield and large troop formations generally disbanded or failed to fight.

But our wars are becoming less conventional. On the unconventional battlefield our set of desired actions are much more complex and the Cold War structure strains to adjust to these new complexities. On the unconventional battlefield tactical engagements may have very different objectives from those our current tactical forces (both PSYOP and otherwise) were designed to achieve. Since the President declared an end to “major combat operations,” PSYOP forces have increasingly been focused on building support for coalition forces, enhancing a belief in democratic principles, and encouraging faith in the rule of law. Programs to achieve those ends, like all PSYOP programs, demand certain actions be taken – such as obeying coalition rules, voting, and reporting insurgents. The trouble is that such actions are much more complex and demand exploiting much higher level needs – esteem, belonging and self-actualization – than the more basic immediate actions (surrender, stay off the roads, runaway) that PSYOP forces were designed to achieve in a more purely conventional environment (see diagram 4 below to conceptualize the hierarchy of needs).

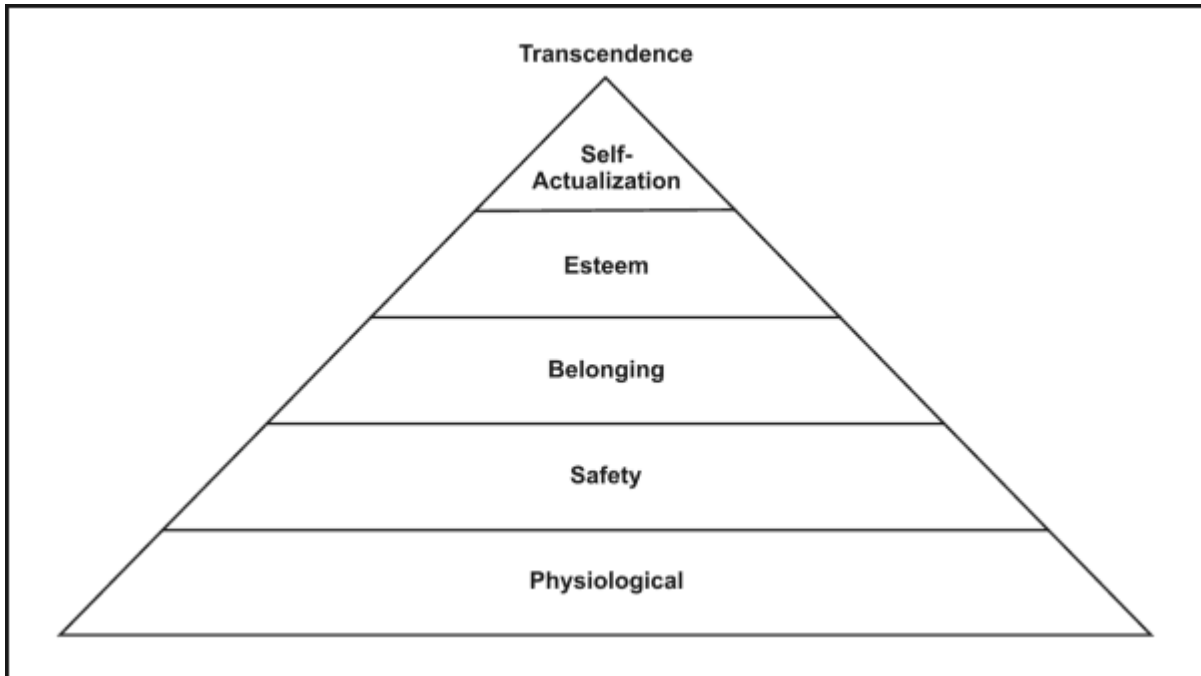

Figure 6. Hierarchy of Needs

More basic actions exploit more basic needs (as seen towards the bottom of the transcendence chart in Figure 6 above) require less expertise and less suffocated messages from the party seeking to influence immediate action. While exploiting basic needs may be accomplished by applying a basic level of Psychological influences; a much more comprehensive and deliberate approach will be necessary to effect actions that are more dependant on the higher level needs.

To some degree the failure of Psychological Operations to achieve a greater level of success in combating suicide attacks has resulted from an inability to effectively apply the basic PSYOP principles due to this outdated organizational structure. These organizational problems have not only led to ongoing problems conducting basic Source – Message – Receiver linkages but also created an environment in which resolving this disconnect is all but impossible given the current organization.

2. The Source – Message – Receiver Breakdown in PSYOP

During initial training, PSYOP soldiers and officers are taught that there are three basic components of the persuasive communication process: source, message and receiver. Each of these components is equally important in its own right. Like a three-legged stool, no PSYOP program can support weight if any one of its three components

fails; however strong one or two of the components may appear to be a single weak leg can (and will) undermine an entire program.

We can define *source* as where a message is thought to come from, both in a physical sense (whether from radio, print, TV, loudspeakers) and conceptually (is the message coming from a credible leader). This is critical because we understand the basic requirement of a successful message is that it be accepted. Acceptance is largely determined by how the target audience feels about the message source. In many cases the interplay between the strength of the physical and conceptual sources can either strengthen or weaken the message as a whole. For example, in a society where there is little confidence in written accounts, statements from otherwise respected and credible sources disseminated in print would likely be discounted. On the other hand, sometimes seeing televised images that support a message, even if they come from a lesser (but still credible) source might enhance the overall strength of the message. Still, for most target audiences the conceptual source of the message will usually carry more weight. The logically flawless argument or perfect video evidence will seldom prove effective unless the conceptual source which presents/endorsees the message has some level of credibility with the target audience.

The *message* is what we are trying to “sell” to the Target Audience (TA). Each message must use appropriately selected themes and symbols believed to be best suited to exploit identified vulnerabilities. Traditionally, PSYOP has focused on getting the TA to take a specific action (stay indoors, obey curfews, surrender, retreat, run away). Such direct, simple and specific desired actions allow for equally direct, simple and specific messages. This is what US PSYOP has practiced for decades, what it was organized to do and what it does best. Increasingly, however, the actions PSYOP forces have been asked to support are much more complex and require multiple steps. Even a seemingly straightforward message, such as telling the TA to report suspected terrorists, may require an entire series of intermediate/supporting messages that reinforce a number of critical

themes as part of an overall PSYOP campaign. Each step in the process might be necessary to create an atmosphere that allows for the final message “report suspected terrorist” to be effectively received.⁸

PSYOPers hope their target audience will be the *receiver*. I write ‘hope’ because, though it is critical to ensure the TA and the receiver are one and the same, this doesn’t always work out; making sure the two are the same usually requires a lot of regional knowledge and some hard work. Knowing (understanding) the receiver/target audience is critical for two reasons. First, since our desired outcome is generally some kind of action, we need to be targeting receivers who are actually capable of conducting the action required. However basic this principle is, it has far reaching implications. In terms of the medium employed this suggests that print or internet products should not be critical to a campaign to publicize a curfew in a rural or largely illiterate area or that radio and television messages seeking to influence the population of a totalitarian regime may not be effective if that population has very limited access to other than state controlled radio and TV. In terms of target audience selection it means we must know, for example, whether a protest we don’t want people engaging in is being driven by a mass movement, a narrow interest or a few influential individuals so that our PSYOP effort can be appropriately tailored to target that audience which is capable of taking the action we desire. Further, actually knowing who to target, who is capable of taking the action we desire, is different from country to country, group to group, situation to situation and it depends thoroughly on an in depth understanding of the specific decision making dynamics of the particular culture or cultures involved. Within each society differing target audiences are uniquely influenced by the role of mother, father, religious leader or history, pride, shame and so on. To induce a desired action the more precisely we know who our actual target audience is the more likely we are to develop effective products and ultimately achieve the desired action.⁹ Second, we need to know who the receiver is intended to be so that we are able to effectively assess and target their vulnerabilities.

⁸ The number and content of such intermediate messages and supporting themes is totally dependent on the specific situation but might include such themes as “Terrorists are bad,” “Police and/or Coalition forces are trustworthy and good,” “Your future will be better without Terrorists” and so on.

⁹ In US marketing terms: if we know the decision to buy “healthy” breakfast foods is made by mothers we design our message to reach the mother. In contrast, the decision to buy high sugar cereals is driven by the children so those cereals are marketed in programs aimed at winning over the child.

Neither the source nor the message can be chosen accurately unless we have a well developed understanding of our desired receivers. The better we understand the receivers the more likely the right source and message can be designed to elicit the desired action.

Finally, there must also be a mechanism in place to effectively link all three and disseminate the product in a timely manner since all too often the first message out is the one which resonates the loudest and the longest. Ultimately we could say that the success of any PSYOP product or program depends upon harmonizing these three components so that each is optimized not just individually but, just as importantly, in terms of how all three components work together and doing it all in a very timely manner.

3. Source – Message – Receiver and Suicide Terrorism

Because the source-message-receiver concept is so critical to PSYOP product and program development I have chosen to examine whether the current PSYOP force is adequately configured to exploit the previously identified motivational vulnerabilities of suicide terrorists. What I have concluded is that in every case the ability of PSYOP forces to optimally exploit the potential vulnerabilities meet with serious shortcomings in at least one of the three basic components of persuasive communications.

Source: In four cases the ability of PSYOP forces to exploit vulnerabilities is directly inhibited by our inability to present a credible source. This is true of any hopes PSYOP forces may have of exploiting family ties to undermine group indoctrination, using the non-violent nature of Islam to undermine the empowerment of striking back, using bad publicity to undermine fund raising and recruiting, or of creating a political backlash that would visibly endanger the political objectives of the sponsors of suicide terrorism.

Message: In another three cases the current configuration of PSYOP forces and staff relationships diminish the ability of any potential product or program to consistently deliver an effective message. To be effective the message must consistently be in line with observed actions and other messages. The inability of the current structure to provide a mechanism that can dependably link the actions of maneuver forces on the ground, with PSYOP programs and on-going public and private diplomacy is non-

existent. The lack of such a mechanism inhibits the effectiveness of efforts to erode pent-up energies by creating a PSYOP program that promotes tasks, work and hope; or to change publicity for the enemies cause into bad publicity; or to end the perception of a lack of alternatives by publicizing real alternatives.

Receiver: Finally two more vulnerabilities are not fully exploitable because today’s PSYOP force structure isn’t adequately supported so as to allow a sufficient level of cultural expertise. To be sure, the PSYOP community includes in its numbers a great many talented and astute individuals who do possess what is, undeniably, a cultural expertise. Many of these individuals have worked quietly for years within the Strategic Studies Detachments of the four regional POBs. Others are soldiers who have studiously applied themselves to extensive regional studies and have years of foreign exchanges and experiences under their belts. Nevertheless, with an entire world to cover and with a preponderance of the effort within PSYOP being focused on battlefield tactical skills rather than cultural and regional ones, these individuals are stretched far too thin. As a result, the PSYOP community often lacks the understanding of the target audience necessary to fashion a response sophisticated enough to address unfulfilled expectations in the TA, let alone to counteract the phenomena of suicide attacks spurring terrorist fundraising and recruiting efforts.

<u>Motivation</u>	<u>Vulnerability</u>	<u>PSYOP Deficit</u>
<i>Individual</i>		
1) Unfulfilled expectations and wounded Pride	Desire to live, prosper, achieve	Don’t understand the TA
2) Pent up energies	Tasks, work, hope	Uncoordinated actions
3) Group indoctrination	Family ties and/or creation of new groups	Lack of credible sources
4) Empowerment – ability to strike back	Inherently non-violent nature of Islam	Lack of credible sources
<i>Organizational</i>		
5) Publicity	Bad Publicity	Uncoordinated actions
6) Fund raising/recruitment	Bad Publicity and loss of support	Lack of credible sources Don’t understand the TA
7) Achieves political objectives	Creates political backlash	Lack of credible sources
8) Lack of alternatives	Creation of real alternatives	Uncoordinated actions

Table 3. Matrix of the major PSYOP deficits that impede the optimal exploitation of the vulnerabilities of the selected motivations behind suicide terrorism

Effectively exploiting the motivational vulnerabilities of suicide terrorists requires a PSYOP structure that is capable of meeting these vulnerabilities and adapting to future challenges as they emerge. In order to achieve the greater level of sophistication needed to overcome these deficits demands some structural changes within the PSYOP and Information Operations communities.

THIS PAGE INTENTIONALLY LEFT BLANK

IV. THE WAY AHEAD

Do not try to do too much with your own hands. Better the Arabs do it tolerably than that you do it perfectly. It is their war, and you are to help them, not to win it for them.

– T. E. Lawrence, Twenty-Seven Article', Arab Bulletin, 20 August 1917

Despite the challenges identified in this thesis, I advocate neither the total abandonment of the current PSYOP structure nor even especially radical changes to it. The current PSYOP force structure has after all contributed to victories on the battlefield in Desert Storm and Operation Iraqi Freedom as well as helping to alleviate ethnic hatreds and providing support to emerging democracies in Bosnia and Kosovo. Too dramatic a change to the force structure would threaten to shatter the PSYOP capabilities of the current system during a time of war while setting any new system up for failure by overloading it with responsibilities before it has time to be fully established. A radical restructuring would threaten many of PSYOP's real strengths: unconventional thinking, sound basic principles, solid leadership (at both the NCO and officer level) and unit ties to combatant commands, to name just a few. Such an approach would be too much like "throwing the baby out with the bath water." Too much that is good and not easily replaced could easily be lost. Furthermore such sweeping changes would be exceedingly difficult to achieve in the cost-constrained environment in which the military operates.¹⁰

However, to plod along trying to make the current organization function in ways, and for missions, for which it was not designed invites failure or at least greatly delays success. For all the reasons discussed earlier, some targeted changes must be implemented if the PSYOP community hopes to effectively exploit the existing vulnerabilities of suicide terrorists and the larger asymmetric threat in general. There must be a level of measured change, both organizationally and conceptually. Leaders throughout the military (and political) establishment must accept the premise that PSYOP is at least as much about *their* decisions, attitudes, and actions as it is about product or

¹⁰ I use "cost" here in the broad sense to include limited personnel and the bureaucratic effort necessary to make such changes more so than the actual dollar "cost."

message a PSYOP soldier that can try to disseminate. PSYOP leaders must think beyond the tactical level and emerge as much as program coordinators rather than as just program implementations. Finally, specific changes must be made to the PSYOP organization that will better enable PSYOPers to effectively conduct an integrated Source-Message-Receiver analysis that allows for an optimized product and program development. Three changes most easily implemental and likely help achieve these effects are: 1) the establishment of a pool of highly trained regional and behavioral experts from which to draw as situations emerge; 2) integration of senior civilian and military PSYOP personnel on staffs responsible for operational and strategic planning; and 3) increased Psychological Operations training for all leaders so that they better appreciate the uses and limitations of PSYOP forces and products.

A. ESTABLISH A POOL OF HIGHLY TRAINED EXPERTS

A pool of highly trained regional and behavioral experts upon which to draw at the outset of an emerging situation is absolutely critical to the ability of PSYOP forces to effectively conduct their missions. As elementary as this may sound no such pool exists, at least not to the degree that is necessary to oversee such major undertakings as we now find ourselves in Iraq and Afghanistan. Currently each PSYOP Battalion has a section of from six to ten academic and regional experts formed into a Strategic Studies Detachment (SSD) and responsible for keeping abreast of developments in there part of the world, with particular focus on how such developments affect our ability to conduct Psychological Operations in a given area. Given my personal experiences I would say that the four regional SSDs are staffed by well qualified professionals who are quite effective in maintaining the baseline level of knowledge necessary to support ongoing *peacetime* operations. However, there is no way that such an element can provide the level of regional and cultural expertise necessary to support the PSYOP requirements of a major conflict let alone the multiple, protracted conflicts in which we currently find ourselves.

Yes, the SSD of the one CENTCOM focused PSYOP Battalion has been augmented, but to say this is too little too late would be an understatement. Even today, three years into involvement in Afghanistan and two years into Iraq, the sum total of true Afghanistan and Iraq experts on the PSYOP staff is little more than a handful of

overworked personnel to support continuous operations in two extremely complex and dynamic environments. Furthermore, there exists only one (1) trained behavioral scientist on the PSYOP staff and he works in the newly formed and still emerging Joint PSYOP Support Element (JSPE) located at MacDill Air Force Base in Florida, almost a 1,000 miles away from the PSYOP planners at Fort Bragg and half a world away from the forward PSYOP elements in the Middle East.

While it would be impossible for PSYOP to maintain a staff of experts capable of supporting wartime efforts against all foreseeable threats there is no reason that DoD together with the PSYOP community cannot establish a system and protocol for quickly establishing an ad hoc pool of contracted expertise. DoD currently maintains research contracts with countless universities, research centers and private think tanks. DoD, together with PSYOP, ought to establish protocols for bringing together experts from such bodies, and others as appropriate, in order to facilitate the rapid formation of groups that can analyze the psychological dimensions of a conflict from its very first stages . As a crisis develops, experts in various fields could be called upon to address specific issues, while the pool as a whole would remain focused on identifying PSYOP vulnerabilities and key target audiences. Today most of these tasks fall to mid-level Army officers (who have generally had only a basic orientation to the region) or more often to non-commissioned officers or even young 18 to 21-year-old specialists. This military cadre with its basic PSYOP training did prove effective for decades in creating PSYOP products that demanded basic actions based on basic needs (e.g. abandon your positions or you will be bombed, stay off the roads or you may be mistaken for the enemy combatants).

In the contemporary operating environment however PSYOP is being called upon to influence much more complex levels of thought. To undermine the motivations that lead to suicide attacks is potentially one of the most complex tasks we are being called upon to address – involving the TA’s thoughts, feelings and emotions. Yet even those motivations can be influenced but to do so will require a much greater level of expertise than we can achieve by even the very best efforts of the military PSYOP cadre alone. The task of influencing actions that are driven by higher order needs is one best addressed by those with decades of study and experience behind them. This includes not

only regional and cultural experts but experts in the fields of marketing and behavioral psychology. Fortunately in the US such people exist in our universities and think tanks in our corporations and diplomatic corps. They are an invaluable resource which we desperately need to develop a system for exploiting.

Experts alone, however, will address only a part of the problem. While they can help us to better understand our target audience and they can help us in developing the correct themes and messages a good understanding of the target audience is only one of the three major deficits PSYOP faces in struggling to mitigate suicide attacks.

B. INCREASED PSYOP INTEGRATION ON MID AND HIGH LEVEL STAFFS

We also need to better integrate PSYOP personnel into mid and high level staffs. As stated in FM 3-05.301, PSYOP should be “planned, coordinated and executed before, during and after conflicts, and *must* be integrated at all echelons to achieve its full force-multiplier potential” [emphasis added] (YEAR, p. I-1). Until recently, the small number of PSYOP trained personnel meant that few were available for service on staffs outside of the Special Operations Community. Even regional combatant commanders seldom had more than one field grade PSYOP officer and perhaps an NCO or two on his entire staff. Changes to current unit manning documents are now for the first time pushing PSYOP officers down to the division level. This is an important first step, but a small one. The impact that one lone mid-grade officer – even the brightest and most capable officer – can have on such a large and senior staff is questionable. In such a case the placement of the officer becomes critical. Unfortunately, current plans show little sign of reversing the trend in higher level headquarters of burying PSYOP officers deep within the bowels of the staff – most frequently, as a member of an Information Operations cell that provides its input through the non-kinetic effects portion of the fires and effects section within the Operations section. Such is the nature of staff work, however, if PSYOP or any other function assumes a truly pivotal role in operations then it must have a direct relationship with the key decision makers with the organization.

The placement of PSYOP officers within mid and higher level staffs (i.e. at division level and up) is compounded both by the lack of sufficient numbers of senior PSYOP officers and, quite frankly, a lack of sufficient expertise within the PSYOP

officer corps. As has been mentioned repeatedly, the PSYOP military cadre simply does not possess adequate training to be able to develop and implement extremely complex PSYOP programs on its own without support from outside experts.¹¹ One possible solution would be to augment the placement of a uniformed PSYOP officer on operational and strategic staffs with the addition of a civilian PSYOP liaison. Much like a political liaison, this civilian PSYOP liaison would be part of the Commanding General's special staff and would need to possess both a basic technical understanding of military PSYOP and an in-depth background in cross cultural communications and influence. While such a PSYOP liaison would ideally be a permanent part of the staff another option would be to dispatch liaisons out from PSYOP headquarters or some other central pool to staffs, as necessary, to support their upcoming operations.

This integration of PSYOP expertise on staffs at the division level and up is critical because the more complex the desired reaction to a PSYOP product, the more it depends on an integrated effort across the full spectrum of military operations. Complex actions cannot be achieved by use of PSYOP products alone. Products must be paired with action on the ground to reinforce a common message that is being directed at the target audience. It is “the *combination* of PSYOP products and actions” that leads the target audience to take the desired action (FM 3-05.301, YEAR, p. I-1). To interrupt the complex chain of events and motivations that leads to a suicide attack absolutely demands complete integration of PSYOP messages with the actions of US forces and allied forces on the ground. We cannot say one thing with our PSYOP messages when our actions are interpreted by the target audience to mean something else. Unless actions are better coordinated with PSYOP messages we will not be able to fully exploit the vulnerabilities that could begin to reduce the level of suicide attacks.

C. INCREASED PSYOP TRAINING FOR ALL LEADERS

No matter how important it is to establish a pool of highly trained experts and to increase PSYOP integration on mid and high level staffs, the success of PSYOP missions really comes down to the degree to which military commanders on the ground believe in

¹¹ It is worth mentioning quite clearly that the civilian experts would likely be even less effective if they were to try to implement PSYOP programs on their own without coordination through the uniformed PSYOP element. Uniformed PSYOP personnel have a unique understanding of both military culture, operational requirements and their place within the entirety of the commanders plan.

and put emphasis on the psychological aspect of warfare. Despite numerous policy proclamations and lots of very hard work by theorists the fundamental changes necessary to meet the current challenges have not been made. While an IO doctrine of sorts has been established the leadership necessary to effectively implement it is missing. Key military leaders either aren't grasping the importance or the imperative of coordinating their actions within the context of a larger IO/PSYOP campaigns or they are lacking an adequate level of properly trained and articulate PSYOP planners/staff officers. I would argue that it's a combination of both.

Combat leaders tend to feel most comfortable with the principles and tactics they grew up with (especially when those tactics contributed to building the most effect combat force in the history of warfare). The military's leaders today grew up in an environment that rewarded their ability to "put steel on target" or close with and engage the enemy. Quite simply today's leaders have made their rank by their ability to effectively employ what are known as kinetic options. Given this it seems small wonder that they might doubt the effectiveness of non-kinetic options that are easy to construe as too "touchy feely." Yet, General Officers are also by and large exceptionally intelligent individuals and what it required to convince them of the value of PSYOP may be nothing more than showing them exactly how and what PSYOP can contribute to them on the battlefield.

To overcome this initial skepticism about PSYOP we need to begin an immediate and comprehensive education program that systematically explains why PSYOP is a necessary component to winning wars in the contemporary environment, how actions on the ground must be integrated into the overall PSYOP plan and what the benefits of a successful implemented PSYOP plan can be. While this training is important for our senior leaders, it is just as important that it be integrated at both the War College and Command and General Staff College levels. The better senior staff and subordinate leaders understand the importance of integrating all actions with the PSYOP plan the more likely that all plans will be effectively coordinated with strategic PSYOP objectives. Clausewitz's of course described war as a continuation of politics by a different means. What is essential for today's military commanders and leaders at all levels is that, as Maurice Tugwell puts it in "Terrorism as a Psychological Strategy,"

“*persuasion* is the ultimate purpose of every action” (1990, p. 1). Such a unity of effort not only leads to better coordinated actions, a necessity for reducing suicide attacks, but it also paves the way for the increased use of more credible local sources to provide PSYOP messages to the TA. If the commanders and senior leaders understand the importance of PSYOP messages coming from credible sources then they will design their operational plans to support the recruitment of such sources and help to enhance the prestige of friendly local sources. It should be noted that nothing may be more important for generating actionable intelligence. And actionable intelligence, as many have noted, is critical in the war on terrorism.

According to FM 3-13 “PSYOP personnel can also assist commanders by advising them of whom to influence and how” (2003, p. 2-3) but seemingly few commanders are fully aware of the role they themselves must play in psychological operations. More and better training about PSYOP – what it is, its capabilities and its limitations – is needed for military leaders at every level to make them fully aware that every leader is himself a key component in any psychological operation and that without his active participation few PSYOP programs can be fully successful.

D. IN CONCLUSION

Neither in Iraq nor elsewhere in the Arab world have we been able to effectively influence the notion that the US is working hand in hand with the Israelis to control Arab oil and undermine both Islam and Arab independence. Our inability to make an effective counter-argument undermines the flow of the critical intelligence that we require to be able to effectively erode the insurgency in Iraq and disable terrorist organizations such as Al-Qaeda, but it also impedes our ability to present *potential* suicide terrorist from becoming actual suicide terrorist.

We know we can win military engagements but our inability to win the Information War indicates that putting steel on targets alone will likely not be enough to secure the end results we desire. The clear implication for US strategic planners is that the military campaign plan must be carefully crafted to function hand in hand with a corresponding PSYOP plan. That is, we simply must consider how our military actions

will likely affect our ability to influence the opinions of key target audiences. All our troops, our actions and the conduct of our leaders lay a foundation upon which all “PSYOP” programs must be built.

Our inability to maintain popular support for our actions in Iraq has been a key ingredient in providing a safe operating environment for insurgent forces to grow and network. While John Keegan cites a figure of better than 80% of Iraqis supporting Saddam’s overthrow (2004, p207) post invasion polls in Iraq as early as April of 2004 indicate that not only do a solid majority of Iraqis now favor an immediate American withdrawal but an amazing 71% view the Americans more as occupiers than liberators (Soriano, C. and Komarow, S., 28 April 2004). Around the Arab world polls find similar results, there is little trust for US motives in Iraq. In fact, even greater majorities throughout the Arab (better than three quarters on average) world felt that the US decision to invade Iraq was motivated by support for Israel and oil (Telhami, S., March 2003). The fact of the matter is that many people and many in the Arab/Muslim world in particular, are “disturbed by the extent to which their traditional cultures are being invaded by Western – that is largely US – popular culture” (Libicki, 1995, ch6 p4). This trend was described by Libicki in 1995 as Kulturkampf: a form, or at least a perceived form, of cultural warfare that many consider little different from an actual shooting war. It seems that the US finds itself in precisely the type of information environment envisioned by Libicki when he wrote that someday the element of trust may be so eroded that “part of the target population is predisposed to believing anything, part believing nothing, part predisposed to believe the opposite of whatever the media put out, and the rest floating in worlds of their own” (1995, ch6 p2).

The problem with such an information environment is that once trust is eroded it becomes increasingly difficult to get people to do anything. In the case of Iraq the result is that not enough ordinary Iraqis have enough faith in either the US or the Iraqi government for them to turn in suspected insurgents and thus deny them the safe heavens they need to operate, train and grow. Without such popular support insurgents are free to learn by trial and error, and to expand and refine their own networks – which will inevitably lead to more effective and violent attacks, potentially even including the use of so call weapons of mass destruction (WMDs).

Given the complexity of addressing suicide terrorism and its potential for even greater dangers if employed in conjunction with the use of WMDs it is imperative that every tool with any potential for mitigating the threat be effectively employed. For this reason PSYOP forces have no choice but to seek out ways to better address the threat from suicide terrorism. I sometimes wonder, given the effort being devoted to trying to figure out how to technologically defeat Improvised Explosive Devices, whether a comparable effort is being made to figure out how to defeat the existing suicide bomber threat. The changes to the way we look at and organize PSYOP were derived from my research into suicide terrorism however they also have a wider application as part of a larger effort to modernize military PSYOP for a Cold War force to one flexible and powerful enough to meet a broad range of challenges that are emerging in the contemporary operating environment.

If we hope to engage our enemies effectively in an information war then our PSYOP plan must be well conceived by experts who understand the target audience, the region and the issues. We must coordinate our messages with our actions, not just in the strategic sense but in the tactical sense as well. The PSYOP messages the people hear must agree with the actions they perceive around them. Of course none of this will happen just because the PSYOP community wants it too, the success of PSYOP depends as much on our ability to educate military leaders as to the importance of PSYOP as it does on the PSYOP communities ability to step up to meet the challenges ahead.

THIS PAGE INTENTIONALLY LEFT BLANK

LIST OF REFERENCES

- Arquilla, J. and Ronfeldt, D. (2000). *Swarming and the Future of Conflict*. Santa Monica, CA: Rand.
- Atran, S. (2003, March 7). "Genesis of Suicide Terrorism." *Science*, 299, 1534-1540.
- Cialdini, R. (2001, October). "Harnessing the Science of Persuasion." *Harvard Business Review OnPoint*, Product Number 7915.
- Cronin, A. (2003). *Terrorists and Suicide Attacks*. Washington, DC: Congressional Research Service.
- Hoffman, B. (1998). *Inside Terrorism*. New York, NY: Columbia University Press.
- Hoffman, B and McCormick, G. (2004). "Terrorism, Signaling, and Suicide Attack." *Studies in Conflict & Terrorism*, 27, 243-281.
- Hroub, K. (2000). *Hamas*. Washington, DC: Institute for Palestine Studies.
- IIACSS Polling. "Public Opinion in Iraq." In *Newsweek Online*. Retrieved 13 December 2004 from <http://www.msnbc.msn.com/id/5217741/site/newsweek>
- Israeli, R. (1997). "Islamikaze and Their Significance." *Terrorism and Political Violence*, 9, 96-121.
- Jenkins, B. (2004, August 23). "World Becomes the Hostage of Media-Savvy Terrorist." *USA Today*, p.11A.
- Keegan, J. (2004). *The Iraq War*; New York, NY: Alfred A. Knoph Press.
- Laqueur, W. (1999). *The New Terrorism: Fanaticism and the Arms of Mass Destruction*. New York, NY: Oxford University Press.
- McCauley, C. (2003). "Psychological Issues in Understanding Terrorism and the Response to Terrorism." In *The Psychology of Terrorism: Volume III: Theoretical Understandings and Perspectives* (pp. 3-18). Westport, CT: Praeger Press.
- Merari, A. (2003). *Suicide Terrorism*. Unpublished Article by Prof. Ariel Merari, Department of Psychology, Tel Avid University.
- Merari, A. (1990). "The Readiness to Kill and Die: Suicidal Terrorism in the Middle East." In *Origins of Terrorism: Psychologies, Ideologies, Theologies, States of Mind* (pp.192-207). Cambridge: Cambridge University Press.

- Mishall, K. (2003). "Our Programme is Ejection of the Occupier." Retrieved 3 August 2004, from www.hamasonline.com
- Pape, R. (2003, August). "The Strategic Logic of Suicide Terrorism." *American Political Science Review*, 97, 1-19.
- Richards, A. and Waterbury, J. (1996). *Political Economy of the Middle East*. Boulder, CO: West View Press.
- Smelser, N. and Mitchell, F. (Eds.). (2002). *Terrorism: Perspectives from the Behavioral and Social Sciences*. Washington, DC: The National Academies Press.
- Soriano, C. and Komarow, S. "Poll: Iraqis out of Patience." In *USA Today Online*. Retrieved 13 December 2004 from www.usatoday.com/news/world/iraq/2004-04-28-poll-cover_x.htm
- Sprinzak, E. (2000). "Rational Fanatics." *Foreign Policy*, September/October 2000. Retrieved 1 September 2004, from <http://www.foreignpolicy.com/resources>.
- Tugwell, M. (1990). "Terrorism as a Psychological Strategy." In *Psychological Operations and Political Warfare in Long-term Strategic Planning* (pp. 69-81). Westport, CT: Praeger Publishers.

INITIAL DISTRIBUTION LIST

1. Defense Technical Information Center
Ft. Belvoir, Virginia
2. Dudley Knox Library
Naval Postgraduate School
Monterey, California
3. Eric Schoennauer
Headquarters, 25th Infantry Division
Scholfield Barracks, Hawaii
4. Dr. Anna Simons
Naval Postgraduate School
Monterey, California
5. COL James Treadwell
Joint PSYOP Support Element
MacDill Air Force Base, Florida
6. COL Michael Seidl
2nd PSYOP Group
Parma, Ohio