

THE  
HISTORY OF  
FORT LEAVENWORTH  
1952-63

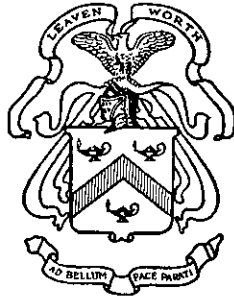

compiled by  
TALBOTT BARNARD  
Major, Artillery, US Army

With Foreword by  
MAJOR GENERAL HARRY J. LEMLEY, JR.  
US Army

U. S. ARMY  
COMMAND AND GENERAL STAFF COLLEGE  
Fort Leavenworth, Kansas  
1964

# Report Documentation Page

*Form Approved*  
*OMB No. 0704-0188*

Public reporting burden for the collection of information is estimated to average 1 hour per response, including the time for reviewing instructions, searching existing data sources, gathering and maintaining the data needed, and completing and reviewing the collection of information. Send comments regarding this burden estimate or any other aspect of this collection of information, including suggestions for reducing this burden, to Washington Headquarters Services, Directorate for Information Operations and Reports, 1215 Jefferson Davis Highway, Suite 1204, Arlington VA 22202-4302. Respondents should be aware that notwithstanding any other provision of law, no person shall be subject to a penalty for failing to comply with a collection of information if it does not display a currently valid OMB control number.

1. REPORT DATE <b>1964</b>	2. REPORT TYPE	3. DATES COVERED -			
4. TITLE AND SUBTITLE <b>The History of Fort Leavenworth 1952- 63.</b>		5a. CONTRACT NUMBER			
		5b. GRANT NUMBER			
		5c. PROGRAM ELEMENT NUMBER			
6. AUTHOR(S)		5d. PROJECT NUMBER			
		5e. TASK NUMBER			
		5f. WORK UNIT NUMBER			
7. PERFORMING ORGANIZATION NAME(S) AND ADDRESS(ES) <b>Army Command &amp; General Staff College, Combined Arms Research Library ,250 Gibbon Avenue, Fort Leavenworth, KS, 66027-2314</b>		8. PERFORMING ORGANIZATION REPORT NUMBER			
9. SPONSORING/MONITORING AGENCY NAME(S) AND ADDRESS(ES)		10. SPONSOR/MONITOR'S ACRONYM(S)			
		11. SPONSOR/MONITOR'S REPORT NUMBER(S)			
12. DISTRIBUTION/AVAILABILITY STATEMENT <b>Approved for public release; distribution unlimited</b>					
13. SUPPLEMENTARY NOTES					
14. ABSTRACT <b>Since the founding of Fort Leavenworth in 1827, the years have brought about a transition in atmosphere at the post from that of a frontier garrison to one of advanced military education. During these changing times in the development of our Nation, Fort Leavenworth has continuously fulfilled mission of increasing importance to the Armed Forces of the United States. The activities, events, and accomplishments that have taken place here deserve to be a source of pride for all personnel, past and present, who served at Fort Leavenworth. This History of Fort Leavenworth, 1952-63 brings up to date the original history written in 1927 by Col Elvid Hunt, revised by Capt Walter E. Lorence in 1937, and published for the period 1937-51 by Col Orville Z. Tyler.</b>					
15. SUBJECT TERMS					
16. SECURITY CLASSIFICATION OF:			17. LIMITATION OF ABSTRACT	18. NUMBER OF PAGES <b>53</b>	19a. NAME OF RESPONSIBLE PERSON
a. REPORT <b>unclassified</b>	b. ABSTRACT <b>unclassified</b>	c. THIS PAGE <b>unclassified</b>			



## FOREWORD

Since the founding of Fort Leavenworth in 1827, the years have brought about a transition in atmosphere at the post from that of a frontier garrison to one of advanced military education. During these changing times in the development of our Nation, Fort Leavenworth has continuously fulfilled missions of increasing importance to the Armed Forces of the United States.

The activities, events, and accomplishments that have taken place here deserve to be a source of pride for all personnel, past and present, who served at Fort Leavenworth. This *History of Fort Leavenworth, 1952-63* brings up to date the original history written in 1927 by Col Elvid Hunt, revised by Capt Walter E. Lorence in 1937, and published for the period 1937-51 by Col Orville Z. Tyler.

  
HARRY J. LEMLEY, JR.  
Major General, US Army  
Commandant



# CONTENTS

---

	Page
FOREWORD .....	2
CHAPTER I. INTRODUCTION .....	5
CHAPTER II. SIGNIFICANT EVENTS AND ACTIVITIES .....	8
The years 1952-55 .....	9
The years 1956-59 .....	12
The years 1960-63 .....	17
CHAPTER III. POST UNITS AND ORGANIZATIONS .....	24
The Combined Arms Group .....	24
The US Disciplinary Barracks .....	25
Munson Army Hospital .....	27
Midwest Relay Station .....	28
The Air Defense Battery .....	30
Sherman Army Airfield .....	32
The Museum .....	32
CHAPTER IV. THE COLLEGE, 1952-63 .....	35
The Korean War Period .....	36
The Doctrinal Mission .....	37
Staff Reorganization .....	37
Student Activities .....	38
Educational Survey Commission .....	38
Diamond Jubilee Celebration .....	39
Major Revisions .....	40
Bell Hall .....	41
Nuclear Weapons Instruction .....	42
Educational Advisor .....	42
Academic Awards .....	42
Effects of the Army Reorganization .....	43
Conclusion .....	43
CHAPTER V. THE COLLEGE TODAY .....	44
The Staff and Faculty .....	45
Resident Courses .....	46
Nonresident Instruction .....	47
The Allied Personnel Program .....	48
The Military Review .....	49
The Printing Plant .....	51
Library Division .....	51
Guest Speakers .....	52
The Honors Program .....	52
Conclusion .....	52

	Page
CHAPTER VI. COMMUNITY LIFE .....	53
Community Activities .....	53
Civic Relations .....	57
Special Services .....	58
Social and Professional Organizations .....	59
APPENDIX	
I. CHRONOLOGY OF EVENTS .....	62
II. MAP OF FORT LEAVENWORTH .....	63
III. COMMANDANTS, 1952-63 .....	65
IV. ASSISTANT COMMANDANTS, 1952-63 .....	66
V. DEPUTY POST COMMANDERS AND CHIEFS OF STAFF, 1952-63 .....	66
VI. COLLEGE SECRETARIES, 1952-63 .....	66
VII. HEADS OF KEY ACTIVITIES .....	67
VIII. POST CONSTRUCTION PROJECTS .....	68
IX. BUILDING AND PLACE NAMES .....	72
X. ORGANIZATION CHARTS .....	73, 75, 77, 79, 81, 83, 85
BIBLIOGRAPHY .....	87
INDEX .....	88

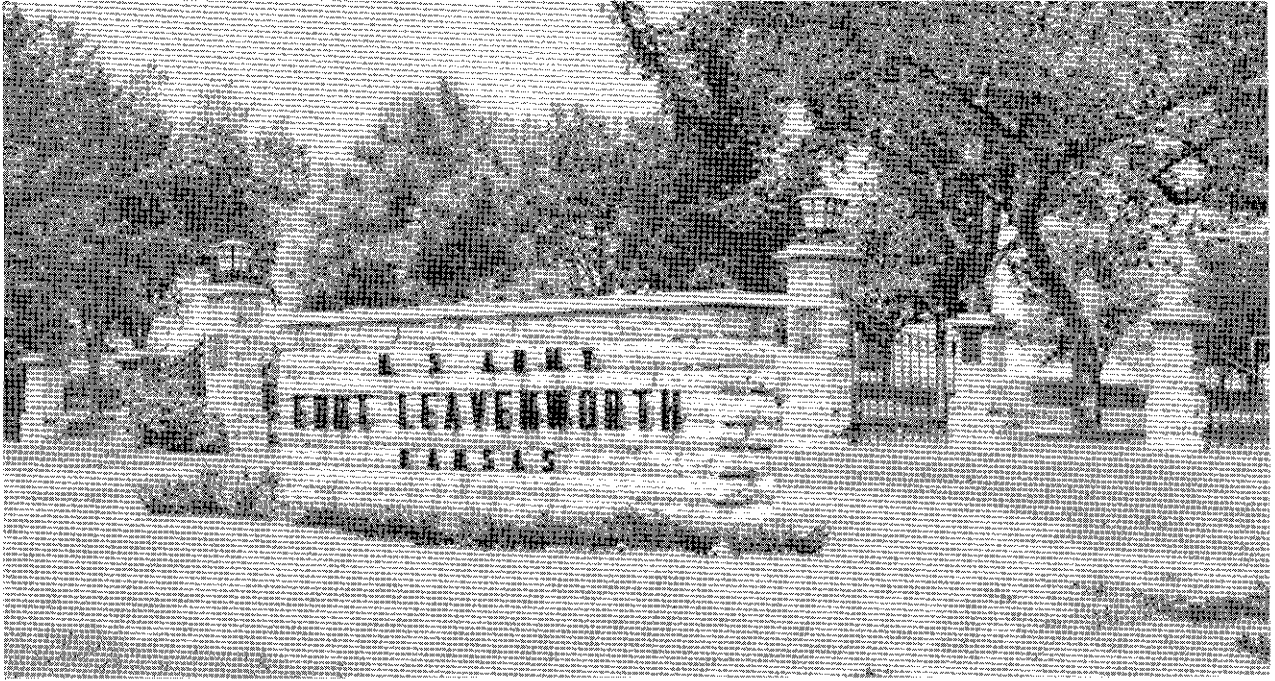

*US Army Photo*

Main entrance to Fort Leavenworth

---

## CHAPTER I

### INTRODUCTION

---

Fort Leavenworth today is a picturesque, tree-shaded military reservation of some 6,000 acres abounding with historical markers, monuments, and structures that graphically aid the observer in bridging the gap from the present to the rich heritage of the past. In addition to the U. S. Army Command and General Staff College and a multitude of fine Post facilities, Fort Leavenworth is the site of a National Cemetery, the US Disciplinary Barracks, the Midwest Relay Station, and an air defense missile battery.

Centrally located in the heart of the United States on the western bluffs of the Missouri River, Fort Leavenworth was founded in 1827. In May of that year, an expedition of four infantry companies under the command of Col Henry Leavenworth landed in keel boats at the present site of the Post to establish a permanent military garrison for the protection of overland trade along the Santa Fe Trail. The location selected by Colonel Leavenworth was approved by the War Department and the new outpost

was designated "Cantonment Leavenworth." The following years were busy ones for the garrison which was charged with the mission of keeping peace between Indians and traders while protecting the interests of the Government. Later, as the westward movement of immigrants opened the Oregon Trail in 1845, protection of caravans and the exploration of territory along this route were added to the missions of Post troops. By mid-nineteenth century the Post, now designated "Fort Leavenworth," had become a main depot from which the military outposts of the West were supplied, and an important station of cavalry troops engaged in the protection of settlers and Government agencies from the marauding Plains Indians.

The signing of the Kansas-Nebraska Act in May 1854 triggered a rush of claim-staking "Free Staters" and "Slave Staters" into these new territories west of the Missouri River. The ensuing border troubles between the two factions frequently required the intervention of military forces from Fort Leavenworth. During



this same period, military operations were directed to suppress the ever more hostile Indians, as the tribes in the area were forced from land and livelihood by the settlers. The city of Leavenworth, then situated 3 miles south of the Post, became the first incorporated town in the Kansas Territory in June 1854, and the first territorial governor established his office and quarters at the Fort in October of that year.

With the outbreak of the Civil War, Fort Leavenworth served as a base of operations for Federal troops in Kansas and Missouri. Camp Lincoln was established on the reservation as a center for mustering in, equipping and training regional volunteers, and mustering them out of the Union forces as their terms of enlistment expired. This camp was in operation from 1861 until 1865 when the end of the war presaged a new role for Fort Leavenworth.

The incredible hardships suffered by prisoners of the Civil War resulted in far-reaching reforms of the existing military prison system. In 1874 provisions were made for a military prison to be located at Fort Leavenworth to serve as a facility for long-term prisoners then confined in guardhouses at each of the various military installations throughout the country. Conversion of quartermaster buildings to a military prison was completed in the spring of 1875 and the transfer of prisoners to Fort Leavenworth was begun.

The Civil War also brought about the realization that the officer corps of the Army required a progressive system of military education in addition to the essential qualities of leadership recognized in the past. Fort Leavenworth was destined to play a major and continuing part in this educational system. While President of the United States, Gen Ulysses S. Grant ordered a reorganization of the Army which provided for formal officer schooling. As a result, Gen Philip H. Sheridan was directed to establish the first school for advanced officer education within the Military Division of the Missouri.<sup>1</sup> For some time, Maj Gen John Pope, commanding the Department of Missouri, had urged the consolidation of the numerous small outposts in his area of responsibility by the establish-

<sup>1</sup> The Military Division of the Missouri consisted of the following Departments: Texas, Dakota, the Platte, and the Missouri.

ment of a sizable garrison and military school at Fort Leavenworth. General Pope's recommendations were, to a large extent, responsible for the issuance of General Orders Number 42 by Headquarters of the Army on 7 May 1881 which directed that a School of Application for Infantry and Cavalry be organized at Fort Leavenworth.

Col Elwell S. Otis was appointed commandant of the school, an academic staff was assembled, and a course of instruction prepared for the first class of 42 student officers which commenced in March 1882. The title of the school was changed in 1886 to the United States Infantry and Cavalry School and continuous improvements were made in the course of instruction and the academic facilities. In 1898, the Spanish-American War, and the Philippine Insurrection which followed, caused a suspension of systematic Army education for 4 years.

Fort Leavenworth was designated a permanent post in 1902 and was garrisoned with a regiment of infantry, a squadron of cavalry, an artillery battery, an engineer battalion, a signal company, and medical detachments. These troop units were placed in support of the school which reopened in August of that year as the General Service and Staff College. In this same year, the remains of General Leavenworth, who had died of illness and injuries in 1834 while on campaign along the Santa Fe Trail, were reinterred in the Fort Leavenworth National Cemetery. The elaborate ceremonies, which took place on Decoration Day, were attended by thousands of people.

The school was again closed in 1916 for the duration of World War I. Graduates served with distinction during the war in key positions, some commanding divisions and brigades while many others were assigned high level staff duties. During these war years, Fort Leavenworth became a training camp for inductees, and the school facilities were used to train officer candidates.

The school system was reinstated at the Post in 1919 with the opening of the School of the Line and the more advanced General Staff School. In the years between World Wars I and II, approximately 4,500 officers were graduated from the academic institution at Fort Leavenworth.

When the United States was drawn into World War II, for the first time during a national emergency the school continued operations. An expansion of the educational program and school facilities began on an unprecedented scale. Instruction was intensified as courses were shortened and the size of the classes increased tremendously. From the 27 wartime classes which were conducted, approximately 19,000 graduates were provided the Armed Forces. In addition to the school, the garrison of Fort Leavenworth again supported the needs of the emergency by processing hundreds of thousands of personnel through induction, reception, and separation centers organized at the Post.

The school was given its present designation, the Command and General Staff College, in 1946 in recognition of its status as a higher institution for professional military education. An Associate Course was added the following year. This shorter course of instruction pro-

vided the means to train additional officers, including those from the National Guard and Reserve components. In 1950, Fort Leavenworth supported the Army War College which was relocated at the Post to resume operations that had been interrupted by the war. This college was moved to Carlisle Barracks, Pennsylvania, after the graduation of the first class in 1951.

The Korean War made increased demands on Fort Leavenworth and the College for officers to fill command and staff positions of an Army expanding through partial mobilization.

The cold war has emphasized further the requirements for mature, skilled leadership in the diversified Army of today. The chapters that follow deal with the activities, accomplishments, and missions fulfilled by Fort Leavenworth and the U. S. Army Command and General Staff College in keeping pace with these requirements.



*US Army Photo*

The Post in 1957 (view to the north)

---

## CHAPTER II

### SIGNIFICANT EVENTS AND ACTIVITIES

---

The tempo of routine was quickened at Fort Leavenworth in 1952 as the Post and the U. S. Army Command and General Staff College met the mobilization requirements of the Korean War. Many more students were in residence at the College than in previous years. The number enrolled in the Regular Course rose to over 500, and the Associate Courses, scheduled on a semi-annual basis, provided an increased supply of officers trained for command and staff duties. Although it was termed a "conflict" and fought in a far-away country, the war remained prominent in the thoughts of most Army personnel even as it began to fade from the headlines. The fierce winter battles had been fought at Bloody and Heartbreak Ridges, and the Korean front was in a condition of uneasy stalemate as peace talks were resumed at Panmunjom.

In 1952, a distinguished soldier, the honor graduate of the class of 1926 at Fort Leavenworth, Gen Dwight D. Eisenhower, was elected to the highest office of our Nation. The hopes for an early end to the fighting in Korea were aroused by General Eisenhower's pledge to visit that wartorn country if elected and by the United Nations truce talks. However, the bitter, costly struggles for White Horse Mountain, Old Baldy, and Pork Chop Hill were still to come.

During this same period, activity taking place in Nevada was to require an entirely new appraisal of the concepts for tactical warfare. This activity culminated the following year in an intense bright flash and the rise of an ominous, ugly, mushroom-like cloud over Frenchman's Flat. With this successful detona-

tion of a surface-delivered, relatively small-yield nuclear weapon, military texts and tactical doctrine would never be the same.

Against this somber, potentially explosive background, the events and activities at Fort Leavenworth began in 1952, the year that marked the 125th anniversary of service by the Post to the Army and the United States.

#### THE YEARS 1952-55

Maj Gen Horace L. McBride, Commanding General at Fort Leavenworth and Commandant of the College, welcomed the 1952 General Staff Course class shortly before his departure from the Post to command the Army forces in the Caribbean. His duties were assumed in April by a recent veteran of the Korean War, Maj Gen Henry I. Hodes, who had commanded the 24th Infantry Division, served as Deputy Commanding General of the Eighth Army, and been a member of the United Nations truce delegation.

General Hodes "got his feet wet"—literally—at Fort Leavenworth almost immediately as the melting of unusually heavy snows swelled the Missouri River to flood stage. Hand to hand combat was waged against the surging, muddy waters by an improvised task force of person-

nel calling themselves the "Fort Leavenworth River Rats." Organized from the Post garrison, including the Army Band, inmates of the Disciplinary Barracks, civilian employees, staff and faculty members, and student officers, the task force labored for a week reinforcing and raising the dikes protecting Sherman Air Force Base. The river waters eventually rose more than ten feet above the runways of the airfield located in the northeastern part of the military reservation. Troop units from Fort Riley, Kansas, and Fort Leonard Wood, Missouri, arrived to assist the personnel from the Post and work continued until, just as the battle appeared to have been won, a section of dike collapsed and forced an evacuation of the area. All of the flood-fighters were evacuated safely under the personal direction of General Hodes, including those stranded on the dikes who were picked up by a hard-working engineer barge, the "Chico." The river which quickly covered the airfield, receded within a few weeks. The Post resumed normal operations and preparation for a combined celebration of Armed Forces Day and Fort Leavenworth's 125th anniversary.

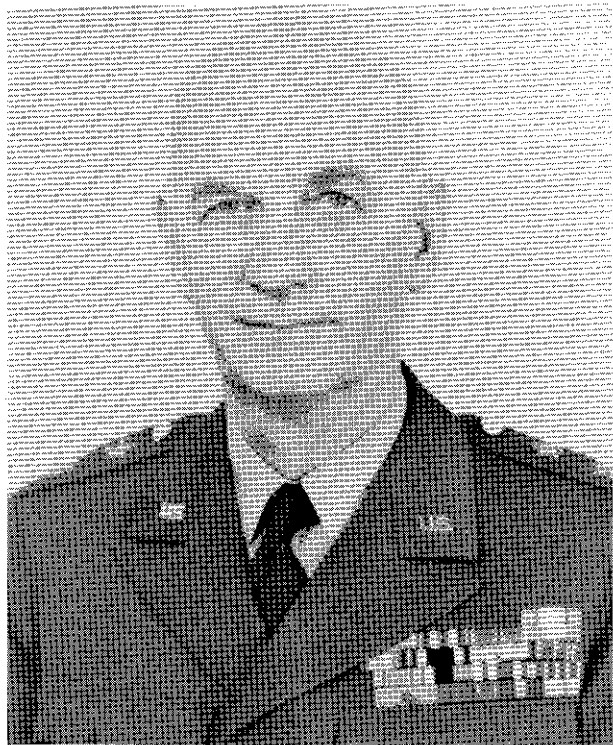

US Army Photo  
*Maj Gen Horace L. McBride*



US Army Photo  
*Maj Gen Henry I. Hodes*

The two-day celebration opened with a Pioneer Parade through the city of Leavenworth on 9 May 1952. Horse-drawn vehicles from the Post Museum, with drivers and passengers attired in frontier dress and authentic military uniforms of the past, were a colorful sight to the many spectators along the route of march. An open house at Fort Leavenworth was held following the parade with an impressive array of weapons and equipment on display. Troops of the 31st Infantry Division from Camp Atterbury, Indiana, demonstrated the firepower of a rifle company with a "mad minute" of sustained fire from every available weapon. Following a program by the Air Force Drum and Bugle Corps and the Army Field Band, the curtain was raised on an historical pageant—Frontier Fort to Command College—depicting the story of the Post from early western exploration to the present time. Presented on two successive evenings in a natural amphitheater south of Cody Road, the professionally directed performance, climaxed by a fireworks display, was the highlight of the scheduled festivities. The program for the second day included an Armed Forces Day parade in Leavenworth, fly-overs by Air Force and Navy aircraft, demonstrations of aerial resupply and heavy equipment parachute drops, a horse show, and the second presentation of the pageant. The entire celebration, the largest of its kind ever presented in the Fort Leavenworth area, commemorated this anniversary in the growth and development of the Post in a never-to-be-forgotten manner.

Graduation exercises for over 600 members of the Regular Course were held the following June, according to custom, on the tree-shaded Main Parade—the site of the original Cantonment Leavenworth. Secretary of the Army Frank Pace, Jr. delivered the graduation address, and diplomas were presented by Col Max S. Johnson, the Assistant Commandant. This class, the largest thus far in the post-World War II period, quickly dispersed to all points of the compass, with many of its former members in possession of orders for the Far East Command (FECOM) and Eighth Army units in Korea.

Projects for the improvement and expansion of Post facilities to meet the needs of an increasing student population continued. The commissary was moved from an overcrowded

location in the Post Exchange building to its present site along the southern part of Grant Avenue in a former consolidated mess hall. Ground was broken for 74 sets of new student quarters in the area east of Pershing Park.

General Johnson, promoted to brigadier general the preceding November, left the position of Assistant Commandant in February 1953 for the Far East. His replacement, Col Charles E. Beauchamp, who had commanded the 32d Regiment in the early Korean fighting, arrived from Washington, D. C., to assume the responsibilities for the operations of the Command and General Staff College. Within a few months Col Thomas B. Hediken turned over his responsibilities as Chief of Staff at Fort Leavenworth, which involved the supervision of all non-College elements at the Post, to Col Charles G. Meehan.

The Fort Leavenworth Museum, possessing one of the largest collections of old horse-drawn wagons, carriages, and sleighs in existence, was reopened on Armistice Day 1953. It had been closed in 1950 pending approval by Department of the Army for use of a building large enough to house the entire collection. Through the efforts of General Hodes, the museum was established in the Bluntville area of the Post in a former stable. Its valuable and interesting collection of historically significant properties again was placed on public display.

The Post Chapel at Fort Leavenworth, a picturesque stone structure with an interior lined with plaques perpetuating the memory of deceased soldiers, held commemoration services on 3 May 1953. Occasioned by the 75th anniversary of the laying of the cornerstone, the services also dedicated a new electric organ in memory of the officers and men of the 7th Cavalry Regiment who had given their lives in the Korean War. Maj Melborne C. Chandler organized the fund that made the purchase of the organ possible, and Miss Margaret C. Berry was on hand, as she had been so often in the past, to play the organ prelude for the service.

Saint Ignatius Chapel, a Gothic style structure located on the Post but the property of the Kansas City Archdiocese, was in the process of complete redecoration under the direction of Chaplain (Maj) Joseph M. Mollner. The chapel, already containing many historical testimonials and memorials, was enhanced by bronze tablets honoring the priests and military chaplains

who had served at the Post since 1869. New statuary and murals were also added.

As the year 1954 opened, the Post was revisited by a former Assistant Commandant of the Command and General Staff College who had gone on to win fame and the Medal of Honor in Korea. Maj Gen William F. Dean spent several days at Fort Leavenworth en route to his new assignment with Sixth Army. The Korean truce had become effective the preceding July when a 12-minute ceremony terminated more than 3 years of bitter fighting. The early days of that war were vividly recalled by General Dean in an address to the students of the College as he described the circumstances leading up to his capture, and his long months of confinement by the North Koreans.

In March 1954, Maj Gen Garrison H. Davidson, a former assistant commander of General Dean's 24th Infantry Division, was designated to assume command of Fort Leavenworth upon the departure of General Hodes for Europe. Requirements of General Davidson's assignment as senior Army member of the Weapons System Evaluation Group in Washington delayed his arrival at the post until July, and General Beauchamp, who had by then been



*US Army Photo*  
Maj Gen Garrison H. Davidson

promoted to one-star rank, acted as commanding general and commandant during the interim period.

The same summer the residents of the Post and the city of Leavenworth were startled by the arrival of a seemingly inexhaustible supply of aircraft to Sherman Army Airfield.<sup>1</sup> Seventy-one liaison aircraft from Fort Sill, Oklahoma, were flown to the airfield for reconnaissance use by the students at the College. This, the largest group of aircraft ever assembled at the Post, conducted as many as 300 individual flights a day as students closely scrutinized the terrain adjacent to the Missouri River, the setting for a tactical problem "Attack of a River Line."

June 1954 was an active month at Fort Leavenworth. Traditionally busy just prior to graduation ceremonies, which were held for some 600 students that year, the Post prepared to take part in the Centennial Celebration with the city of Leavenworth. The week-long celebration, marking the 100th anniversary of the city's founding and the opening of the Kansas Territory for settlement in 1854, included daily parades, historical exhibits, athletic events, picnics, horse shows, street dances, and numerous other festive activities. A stage spectacle—Jubilee—including 16 separate scenes portraying the history of the area, was presented nightly. Wednesday, 9 June, was proclaimed "Military Day" and the Band and an Honor Guard from Fort Leavenworth led troops from Fort Riley, the Centennial Queen and her court, high school bands, and other marching units from various civic organizations in a massive street parade.

Troops from Fort Riley participated two weeks later in a regimental retreat parade to honor the arrival of Secretary of the Army Robert T. Stevens for a conference with his civilian aides. Aides representing 37 states, the District of Columbia, and the six continental armies were present for the conference—the first of its kind ever held. General officers present included the Chief of Staff of the Army and principal Department of the Army staff members, and the Commanding Generals of the Army Field Forces, the six army areas, and the Military District of Washington. For many of

<sup>1</sup> Name changed from Sherman Air Force Base with the transfer from Air Force to Army control in 1953.

the officers, among them Gen Matthew B. Ridgway, Lt Gen Williston B. Palmer, and Major Generals Arthur G. Trudeau, James M. Gavin, Robert N. Young, and Gilman C. Mudgett, the conference was a homecoming to the scene of their student days at the College.

A retirement ceremony was held in front of Sherman Hall, the Post and College Headquarters, on 31 July 1954 to honor Colonel Meehan who was succeeded as Chief of Staff by Col Chandler P. Robbins, Jr. General Davidson had arrived to assume command at Fort Leavenworth and was present with other members of the Post and the College staff and faculty to bid Colonel Meehan farewell upon his completion of 30 years of Army service.

Otis Hall, originally constructed as quarters for bachelor officers in 1902, was the site of an interesting event in June 1955. A plaque was dedicated by Maj John S. D. Eisenhower, immediately after his graduation from the College, to commemorate the residence in the building by President (then Major) and Mrs. Eisenhower in 1925-26. The president was then a student in the Command and Staff School where his son John claimed to remember his father "sweating over his books in a study at the top of the house."

The housing situation at Fort Leavenworth was becoming increasingly critical as the size of the College staff and faculty increased along with the numbers of students at the Post. Over 100 student family housing units were reconstructed from four-family quarters to their original two-family design—a project which, although necessary, further complicated the problem. Appeals for rental housing were made by the Post to all nearby communities from Kansas City to Atchison, Kansas. Approval for the construction of 50 Capehart duplex houses was secured, and occupancy of the 237 sets of "inadequate" quarters in the West Normandy area was permitted on a voluntary basis. Continuing student occupancy of these converted World War II barracks buildings has been permitted up to the present time, although plans call for them to be dismantled during 1964. With the passing of these structures from the Fort Leavenworth scene, a prime topic of conversation will have been eliminated among

---

\* Kenneth S. Davis, *Soldier of Democracy, a Biography of Dwight Eisenhower*. New York, 1945.

those officers and wives claiming to have spent most of the winter months adjusting thermostats and window openings in the old buildings that apparently remained frigid on the first floor and stifling on the second, despite all attempts to regulate the inside temperature.

The Fort Leavenworth Historical Committee was organized by General Davidson to enhance the prestige and history of the Post and the Command and General Staff College. Originally headed in 1955 by Col Louis Büttner, Director of Administration at the Post, the committee completed plans and initiated a program resulting in the identification and marking of historic landmarks, places, and buildings at Fort Leavenworth as well as improvements and additions to the Post Museum.

Brig Gen William F. Train had the stars of that rank pinned on his shoulders by General Davidson upon his arrival to assume the duties of Assistant Commandant.

General and Mrs. Davidson contributed significantly to the increase in Post population in September 1955 when twin daughters, Bonny Elaine and Gail Marie, were born to them at the Post hospital.

The old brick YMCA building, erected in 1907 on the corner of Pope and McClellan Avenues by Miss Helen Miller Gould in memory of her financier father, Jay Gould, was purchased by the Post. It was then completely renovated at a cost of over \$100,000, most of the money coming from nonappropriated special services funds, as a facility for the use of all Post personnel for reading, study, and recreation. Named the Patch Community Center after the late Gen Alexander M. Patch, Jr., a graduate of the Command and General Staff School who later commanded the Seventh Army during the 1944 invasion of southern France, the building was officially reopened by General Davidson in December.

#### THE YEARS 1956-59

General Davidson departed early in July 1956 for his new assignment at the United States Military Academy. Fittingly, one of his last official acts was to participate in a rededication of the General Henry Leavenworth monument in a ceremony held at the Fort Leavenworth National Cemetery on the Fourth of July. The incoming Commandant, Maj Gen Lionel C. McGarr, and his family met officers and ladies

from the Post and members of the civilian community at an official reception at the Officers' Club. This social event marked the beginning of a 4-year tour for General McGarr<sup>3</sup>—a tour that would result in numerous improvements in the Post and major changes in the College.

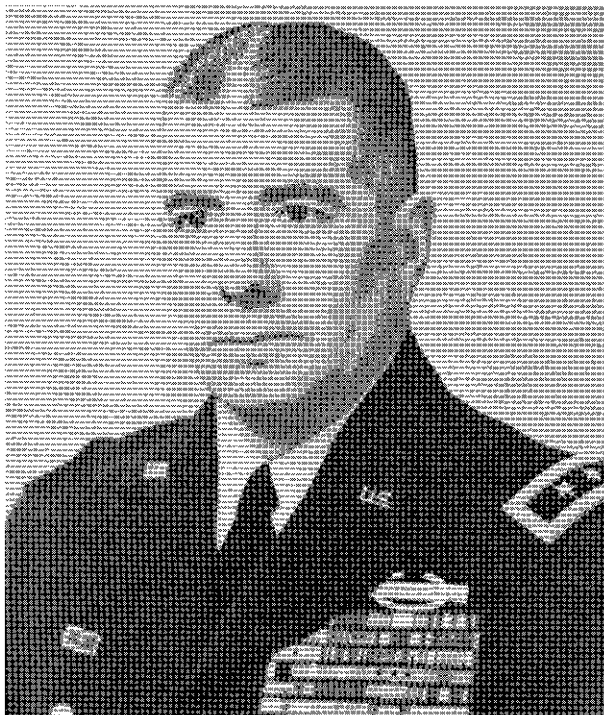

*US Army Photo*

*Maj Gen Lionel C. McGarr*

On 6 November 1956, General McGarr turned a shovelful of earth on Arsenal Hill which symbolically started construction of a new academic building at the Post for the Command and General Staff College. Long required and continually recommended, this construction project would create the splendid facilities of J. Franklin Bell Hall and provide an environmental setting in keeping with the importance of the instructional mission of the College.

Ceremonies were held later that same month in connection with academic facilities for children of dependents. The Commandant delivered the principal address at dedications for two elementary schools on the Post. The recently completed structure on Biddle Boulevard was named "The General Douglas MacArthur School," and the other school in the Pershing

<sup>3</sup> Maj Gen Stuart Heintzleman has been the only previous commandant to serve a longer tour of duty (July 1929-February 1935) in the twentieth century.

Park area, which had been in use since 1953, was named "The General Dwight D. Eisenhower School." Messages of appreciation and congratulations were received from both individuals for whom the schools were named.

Colonel Robbins, Deputy Post Commander, left Fort Leavenworth in January 1957. Originally assigned as chief of staff, his position title had been changed to deputy post commander, although his responsibilities remained unchanged. His successor, Col William W. Culp, was no stranger to the Post, having just served with the College for over 3 years on his fourth tour of duty at Fort Leavenworth.

Another major change in personnel occurred the following July. General Train, the Assistant Commandant, departed for the 8th Infantry Division in Germany. More than 400 officers and their ladies filled the main ballroom of the Officers' Mess to wish the General and his lady Godspeed. The gala evening featured a skit concerning the general's early life and Army career. A satire of the well-known television program, "This Is Your Life," the skit was based on documentation and pictorial material provided by Mrs. Train. The office of the Assistant Commandant was then occupied by Brig Gen Frederick R. Zierath who had arrived from an assignment with the 3d Infantry Division at Fort Benning, Georgia. General and Mrs. Zierath were introduced to the officers and ladies of the Post, as well as many prominent civic leaders from the local area, at the farewell reception for General Train.

As indicated earlier in this chapter, the College was at this time to undergo a significant reorganization and reorientation, as an entirely new curriculum was planned and written for the academic year 1957-58. "Keeping pace with the future" became the watchword among the hard-pressed members of the College staff and faculty as this major undertaking was accomplished successfully.

Events were rapidly taking place in many areas at Fort Leavenworth. A new five-digit telephone dial system was installed, creating only temporary confusion among the many subscribers to the Post Telephone Exchange. An attractive information booth was constructed of stone on Grant Avenue just inside the main entrance as a service to the many visitors to Fort Leavenworth. Plans were announced for



the construction of an additional 200 sets of Capehart family quarters to begin in November 1957, as the initial construction project to house 100 families neared completion. Fort Leavenworth received the National Safety Council's "Award of Honor for Distinguished Service to Safety" for superior achievements in accident prevention for 1956. The award was presented to General McGarr by the Commanding General of the Fifth US Army, Lt Gen William H. Arnold, who noted that the Post had received similar recognition in a Department of the Army award for the preceding year.

The Henry Leavenworth Chapter of the Association of the United States Army, which had been founded in October 1956, as one of the first local chapters of that organization, announced the results of its first election in April 1957. The chapter, which has since grown to one of the largest in the country and won numerous awards for its support of the US Army and its national defense mission, installed Harold E. Purdy of Kansas City, Missouri, as its first president, and a board of governors composed of local civilian members and officers of the Post. Mr. Charles S. Stevenson, who had served as temporary chairman of the chapter from its inception and had guided the initial organization, presided over the meeting and the installation of new officers. Scheduled in conjunction with a chapter meeting in the Post Theater were displays and demonstrations of the latest Army equipment, an open-air lunch for the attending members, a band concert, and tours of the Post. Gen Charles L. Bolte, US Army, Ret., delivered the principal speech of the day.

Pope Hall, which was built prior to the turn of the century as a recreation and dance hall for the Post garrison, was gutted by fire in May 1957. The medieval-appearing structure, with thick walls of locally quarried stone, was used at the time to present instruction in the tactical employment of nuclear weapons. The fire was presumed to have been started by faulty electrical wiring. Over \$200,000 damage was caused before the flames were brought under control by Post and Leavenworth firemen, assisted by prisoners from the Disciplinary Barracks. The cost to repair the old, familiar building was considered prohibitive, and it was eventually torn down. Today, a metal marker denotes the location of Pope Hall and

the former Kansas territorial capitol building which earlier stood on the same site. The area is now a parking lot.

Operation BLUBBER was brought to a close in June as final results were announced by Col Norman W. Anderson, the Post Surgeon. The operation was an outcome of the Army-wide emphasis on physical fitness, and was designed to assist overweight personnel in trimming down to a satisfactory level. Consisting of diets, exercise, and periodic weighing and measuring, the program was conducted throughout the 1956-57 academic year. Results indicated that will power was probably the most important requirement for success.

The Post took on a "new look" effective with the changeover to winter uniforms in October 1957. "Pinks and greens" and olive drab—shade 33, the long-familiar semidress and duty attire for Army officers, were placed in storage as the Army Green uniform was prescribed for all Army personnel. Many of the out-dated uniforms later were collected and donated to Allied armies and ROTC organizations.

The Fort Leavenworth Dramatics Club opened the Post theatrical season with a 3-day run of a comedy, "The Tender Trap." Although records indicate that dramatic productions have been staged at Fort Leavenworth since the days when General Custer is alleged to have appeared before the footlights, it is doubtful that any had been better received than this overwhelming success. It was unanimously agreed that everyone connected with the production turned in an outstanding performance. Lt Col Jean P. Meslet, the French Liaison Officer to the College, who was later to deservedly gain a reputation as the "Chevalier of Fort Leavenworth," starred in his first Dramatic Club role.

Fort Leavenworth was mentioned with increasing frequency in the press media of the Nation during the first half of 1958. The period and the publicity will be remembered by many because of the presence at the College of Lt Gen Rafael L. Trujillo, Jr., son of the Dominican Republic dictator. Because of his extracurricular activities, the 28-year old general became ineligible for the award of a graduation diploma.

In January 1958, a group of enthusiasts ob-

tained official permission to form an off-duty flying club at the Post. The Fort Leavenworth Flying Club was chartered for purposes of recreation and to stimulate interest in aviation. Its constitution and by-laws provided that it would be self-supporting. The regulations of the Civil Aeronautics Association still govern the operations and maintenance of the aircraft used by the club. Lt Col Frederick St. John, Post Transportation Officer at the time, was elected the first club president. Two light aircraft, an L-17 and an L-21 which were surplus to the needs of the Army, were loaned to the club until the club treasury would permit their purchase. The club has increased in popularity, membership, and scope of activities to the present time through its operations based at Sherman Army Airfield.

The Post construction program was in evi-

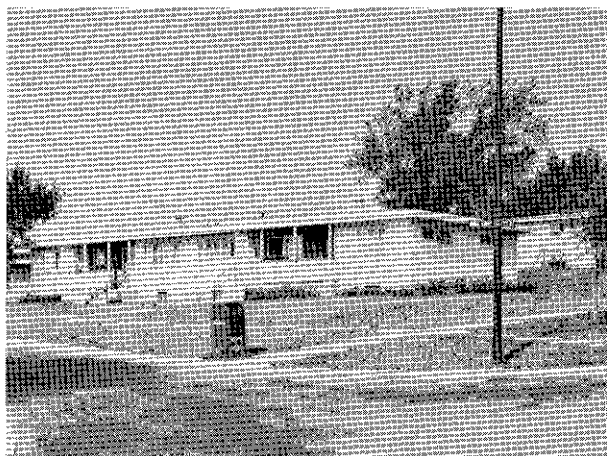

US Army Photo

*Oregon Village dependent housing area*

dence in many parts of the military reservation, with most attention directed toward the completion of Bell Hall. Work began in March 1958 on a permanent building to contain bachelor officers' quarters and a student field ration mess. The building was designed to improve living conditions for the many officers without families at the Post. These consist of a bonafide bachelor variety as well as the geographical bachelors attending the shorter Associate Courses of the College for whom dependent travel is not authorized. Additional meal and snack service was provided in April when a new cafeteria opened adjacent to the Post Exchange. The first Capehart housing project, located south of the National Cemetery near the junction of Cody Road and Biddle

Boulevard, was opened at the first of the year. The housing area occupies ground astride a branch of the famed Oregon Trail and, upon the recommendation of the Fort Leavenworth Historical Society, it was duly named "The Oregon Village."

Ceremonies to start the construction of a Nike Hercules missile air defense system for the greater Kansas City area were held in July 1958 at what is now the headquarters area for Battery D, 5th Missile Battalion, 55th Artillery.

Students of the 7th, 8th, and 9th grades at Fort Leavenworth began classes in a newly completed school building on the east side of Grant Avenue near the main entrance to the Post. The school was dedicated in December 1958 by General McGarr and named in honor of Gen George S. Patton, Jr. General Patton's son, a graduate of the Command and General Staff College, expressed appreciation of the dedication to his deceased father's memory in a message read during the ceremony.

Numerous sporting events were held at the Post in 1958. The Annual Spring Horse Show, sponsored by the Fort Leavenworth Hunt, was held under ideal conditions on a May weekend. The traditionally colorful events included equitation and jumping, hunter, and parade competition which drew contestants and spectators from miles around. Members of the Hunt revived an old custom in September by staging an organized hunt ride over the rolling terrain of the Post. Old coaches, which had been used to follow the hunt in earlier days, were again made available for transportation by the Post Museum. The Sunday morning ride ended at the Hunt Lodge where a bountiful breakfast was served to the riders and their guests.

The Fifth US Army Tennis Tournament was held on the Post courts during the summer, and was followed by the 1958 Inter-Service Golf Tournament in August. The highlight of this annual golf classic was the open division play of 5-man teams from each of the services in competition for the coveted James V. Forrestal Trophy. Top honors in this event of 72-hole medal play were carried off by the Army team for the second straight year despite strong competition.

Two other unrelated events—one historically curious, the other historically nostalgic—took place just prior to the coming of winter. Nearly

100 members of the Kansas City Horseless Carriage Club, determinedly driving 30 automobiles of the period 1925 and earlier, made a stop-over at the Post Museum during their annual cross-country trip. The Fort Leavenworth Hunt graciously offered equine assistance if required. Fortunately for the pride of the intrepid motorists, the offer proved unnecessary.

More than a dozen "stalwarts" of the 32d US Volunteer Infantry Association paid a visit to Fort Leavenworth during their 25th annual reunion in late September. The association was formed in 1934, with membership including veterans of the 32d Volunteer Infantry Regiment and widows of deceased veterans. The regiment was mobilized and trained at Fort Leavenworth in the summer of 1899, and departed some 1,300 strong that fall for service in the Philippines during the Spanish-American War. The small group of members were welcomed to the Post by General Zierath and visited the area south of Merritt Lake where a stone marker and bronze tablet mark the location of their old encampment. A brief memorial service for the veterans who had died during the year was held by Chaplain (Lt Col) William B. Sharp at the Post Chapel. A luncheon in the Consolidated Troop Mess concluded the visit, at which time C. H. Rhoades of Leavenworth, Kansas, was nominated president of the association for the coming year.

One of the major events of the year—at least, in the minds of the smaller members of the Post community—is the annual Halloween program. The arrangements for 1958 included a Saturday morning parade for all the lively little spooks, with marching music provided by the Army Band and a detachment of ROTC cadets from Leavenworth High School. The parade, as always, was a sight to behold. Members of the Fort Leavenworth Hunt led their mounts over the route while wagons from the Post Museum collection bulged at the seams with costumed children. That night a mammoth carnival was staged at the Sherman Army Airfield hangars with displays, games of skill and chance, and refreshment stands attracting nearly every child on the Post. Parents armed with purchased scrip handled the financial arrangements for a night of merriment. All the profits were given to the Post Activities Fund.

Col Francis A. Liwski arrived on Post in

October to fill the position of Deputy Post Commander which had been vacated by the departure of Colonel Culp for the Army Command Management School the previous August. Colonel Liwski occupied this position until his retirement at the Post nearly 4 years later.

As the 1958 holiday season approached, Fort Leavenworth took on a festive appearance. The public was invited to tour the Post and observe the striking results of this effort. Many outdoor trees were brilliantly lighted, as were numerous buildings along the main thoroughfares. A huge replica of Santa perched atop a "moon rocket" was in place over the Army Field Printing Plant to capture the spirit of Christmas in a manner which also recognized the interest of the time in our national space program. The feature attraction was the exterior of Bell Hall where the age-old "Merry Christmas and Happy New Year" greeting was spelled out in a blacklite display, and where six beautifully decorated trees were illuminated by changing lighting effects.

The new \$5 million academic building of the Command and General Staff College, considered to be the most modern educational plant west of the Mississippi River, was officially dedicated as J. Franklin Bell Hall on 14 January 1959. Approximately 1,400 guests assembled in the building's main auditorium as the Honorable Wilbur M. Brucker, Secretary of the Army, delivered the principal address of the day following an introductory speech by General McGarr. Virtually all of the College facilities were under one roof for the first time since 1881. Students and instructors were moved into the fully equipped classrooms from previous locations in Gruber, Muir, and Andrews Halls which originally had been constructed as a riding hall, stable, and gymnasium, respectively.

The Post lost the services of a well-known figure when Bob Baker retired in March 1959. The 78-year old barber began the practice of his profession at the forerunner of the Command and General Staff College in 1910, and his shop had long been a favorite gathering place for faculty members and student officers. Many of his patrons will recall Mr. Baker holding forth in his Grant Hall establishment, with diplomas on the wall attesting to his "graduation" from various courses of the College, as he recounted

tales of his associations with famous Army leaders in the past. He was an avid skeet shooter and had donated the Bob Baker Trophy to the Post Skeet Club in 1957. This trophy is competed for annually, with the stipulation that it will always remain at Fort Leavenworth.

The collection of the Fort Leavenworth Museum was moved from a remote area of the Post to its present location in Andrews Hall shortly after that building was vacated by the College. Under the able direction of Miss Mildred Cox then, as now, the Museum Curator, the relocation of this popular tourist attraction was quickly accomplished. The newly occupied building permitted the expansion of historical exhibits planned by Miss Cox, the Post Historical Committee, and the museum Board of Counselors. The museum was formally opened in May, and a tremendous increase in "business" ensued as over 12,000 visitors viewed the displays within the first 3 months.

Numerous visitors, three separate class graduations in one day, Armed Forces and Frontier Day celebrations, and a Combined Arms and Services Conference resulted in a very busy month for Fort Leavenworth in May 1959. As on many similar occasions in the past, the Post was equal to the task. The Frontier Day celebration deserves further mention since it was conducted simultaneously with the yearly Armed Forces Day events and set a precedent for the next several years. Plans for this combined celebration on 16 May were a joint City-Post venture. An open house was held at the Post that Saturday morning which, along with the many permanent items of historical interest and the newly reopened Museum, permitted the general public to visit Bell Hall and view the academic facilities of the College for the first time. That evening Frontier Day events were staged at Sherman Army Airfield. The field and hangars were decorated with relics of the past as thousands of people, young and old, relived the early days when the Post had been a staging area for the long treks West over the Santa Fe and Oregon Trails. A chuck-wagon dinner, a pioneer costume contest, games for the children, and an old-time family-style dance climaxed the memorable day.

The Post housing picture was considerably brightened in the late summer of 1959 when over 100 Regular Course student families were

able to occupy quarters in the second of the Capehart construction projects. All the quarters had not been completed when the class reported to Fort Leavenworth, however, and an emergency project labeled "Operation Welcome Hand" was initiated to ease the situation. A temporary housing office manned by Post personnel at the Leavenworth Chamber of Commerce received more than 40 offers from Leavenworth families willing to share their homes with an incoming Army family. These initial difficulties were overcome with the rapid completion of the remaining quarters in the area named "Kansa Village" for an early Indian tribe of the Missouri Territory. Truesdell Hall, with quarters for 90 bachelor officers and a modern 350-man student officers field ration mess, also was completed in August. Located at the intersection of Grant and Stimson Avenues, the building was named after the late Maj Gen Karl Truesdell, Commandant of the Command and General Staff School, during World War II.



US Army Photo

Kansa Village dependent housing area

### THE YEARS 1960-63

The International Group of the Fort Leavenworth Officers' Wives Club sponsored an event in January 1960 that proved so successful it became another Post tradition. The event, an International Exposition, which depicted the cultures and customs of the 43 countries represented by Allied student officers then attending the Command and General Staff College, was held for 2 days at the Officers' Open Mess. The Allied students and their families prepared national exhibits with materials from their native lands. They were assisted by their respective embassies in the United States. The exhibits included products of culture, in-

dustry, and history arranged in an attractive display for each country. Uniformed Allied officers and members of their families attired in native dress presented a colorful sight as they greeted the general public and explained the various exhibits. Mrs. Leo J. Nawn supervised the arrangements for the exposition which was acclaimed as one of the most educationally enjoyable activities ever conducted at Fort Leavenworth.

General Zierath was honored at a farewell reception upon his departure in January from the position of Assistant Commandant for a new assignment as Chief of Staff of the Alaskan Command. Not long after, invitations were extended to the permanently assigned officers of the Post and their wives for a reception marking the arrival of the new Assistant Commandant, Brig Gen William A. Cunningham, III, and Mrs. Cunningham.

General McGarr's appointment calendar for July 1960 was marked with the dates of many farewell formations scheduled prior to his departure after 4 years of what had been originally intended as a 2-year tour of duty. His next assignment was Chief of the Military Assistance Advisory Group on the far side of the world in a country with which many other personnel of the US Army would soon become intimately familiar—the Republic of Vietnam. A reception honoring General and Mrs. McGarr given by the Leavenworth Chamber of Commerce was followed by another at the Post. On July 29, General McGarr formally relinquished command at Fort Leavenworth at retreat ceremonies in front of Bell Hall. General and Mrs. McGarr departed the Commandant's quarters at Number 1 Scott Avenue on 4 August. The strains of "Auld Lang Syne" were provided in the background by a military band as the couple drove off through a gathering of military personnel of the Post and their dependents wishing them bon voyage.

General Cunningham served as Acting Commandant until the arrival of Maj Gen Harold K. Johnson in mid-August from Germany where the general was Chief of Staff of the NATO Central Army Group. General Johnson had first been assigned to Fort Leavenworth after his release as a war prisoner of the Japanese. He graduated from the College in 1947 after

which he served as a faculty member for several years.

November 1960 will be remembered as the month in which John F. Kennedy was elected



US Army Photo

Maj Gen Harold K. Johnson

the 35th President of the United States. The exciting presidential campaign which featured the televised Kennedy-Nixon debates was a constant topic of discussion throughout the Post as it absorbed the attention of the Nation. Another topic of conversation at the time among military personnel was the announced curtailment of dependent travel to overseas areas.

The first housing area specifically designated for Post enlisted personnel since 1908 was completed as 1960 drew to a close. This, the third Post Capehart housing project, and the last such project to be completed to date, contains 100 duplex, two-story buildings in an area to both sides of Biddle Boulevard near the southern boundary of the military reservation. The first 20 families completed their move into the project, named Santa Fe Village, in time to greet the New Year in new quarters.

An early visitor to the Post in 1961 was former President Harry S Truman who addressed the students and faculty of the Com-

mand and General Staff College in January. Mr. Truman has since become a frequent speaker at Fort Leavenworth, with his presentations especially noted for candid, forthright, and humorous responses to queries from the audience during the concluding question and answer periods.

May is usually a busy month at the Post, and May 1961 was no exception. Armed Forces Week was celebrated by another Frontier Day for which a replica of a pioneer fort, complete with simulated log blockhouses and a palisade, was constructed at Sherman Army Airfield. Named "Old Fort Sunflower," it was gaily decorated with blossoms of the Kansas state flower to provide a setting for the day's entertainment. The activities of the week, which included the fifth annual spring meeting of the Henry Leavenworth Chapter of the Association of the United States Army (AUSA), featured sky-diving exhibitions by a team of parachutists from the 7th Special Forces from Fort Bragg, North Carolina. This crowd pleasing program of "spot" jumping, mid-air baton passing, and free-fall aerobatics was followed by a tactical jump by two special forces detachments from US Air Force C-123 aircraft.

An impressively large number of general officers converged on Fort Leavenworth on 23 May for a special 1-day conference devoted to National Guard affairs. The 46 senior officers attending this meeting, plus those enrolled in various courses of the College, created a total temporary population of 112 US Army generals—a formidable concentration of "stars" by any standards.

The largest horse show in the history of the Fort Leavenworth Hunt up to that time took place 27-28 May 1961 with Lt Col Floyd W. Townsley, President of the Hunt, carrying off top honors in the final open jumping event. General Johnson was on hand to present ribbons and trophies to the winners among the 468 entrants and 105 horses that were shown.

A different type of presentation was made by General Johnson in July when he pinned the second stars on the shoulders of the Assistant Commandant, General Cunningham. The promotion to major general resulted in a shortened tour of duty at Fort Leavenworth, as General Cunningham departed for a new assignment in Germany.

Moving on a permanent change of station

was merely routine for Brig Gen Harry J. Lemley, the new Assistant Commandant, who arrived with his wife, two daughters, and son in August 1961. The Lemleys, who had moved their household five times in connection with their recently completed tour in Germany, were to find an unaccustomed degree of stabilization at Fort Leavenworth where General Lemley is presently the Commanding General and Commandant of the Command and General Staff College.

The creeping spread of international communism in 1961 prompted the Henry Leavenworth Chapter of the AUSA to conduct a guest speaker program to further the security of the Nation and to accent the vital role of the US Army as an instrument of national security. Because of this very effective program, the chapter received the AUSA award for the best single promotional project among the association's chapters throughout the world. The award-winning program employed seven authoritative speakers, all members of the staff and faculty or students of the College, to alert citizens of northwestern Missouri, northeastern Kansas, and the communities in the Kansas City area to communism's methods and dangers. Some 75 presentations were given to meetings of adult civic, business, and professional groups, with an estimated total attendance of 6,300 persons.

On 26 September 1961, Fort Leavenworth received a certificate, signed by Secretary of the Interior Stewart L. Udall, which officially designated the Post a "Registered National Landmark." The application for this designation was submitted by the Secretary of the Army in recognition of the historical significance attained by Fort Leavenworth since its establishment. A bronze plaque commemorating this designation was prepared and dedicated the following Armed Forces Day, when it was emplaced in front of the Post Museum.

An eagerly awaited event, held every 2 years at the Post, is the Mardi Gras Ball. The highly popular event is sponsored by the Daughters of the US Army for the benefit of the hospital emergency fund. Proceeds from the March 1962 Mardi Gras also provided for a newly established scholarship fund for high school seniors at Fort Leavenworth. Co-chairmen for the costume ball were Mesdames Albert L. Kotzebue and Dandridge F. Hering. The main ballroom

of the Officers' Open Mess was transformed into a resemblance of the French Quarter in New Orleans, with facsimiles of the French Market, the Old Absinthe House, and the Gem Bar realistically portrayed and stocked to satisfy the inner needs of the more than 1,200 attending revelers. Mrs. Lewis A. Pick, wife of a student at the College, reigned as Queen of the Ball while the elected King, habitually selected by the students from among the College instructors, was Lt Col Guy G. McConnell.

Currency was converted to party money for wagering at the many games of chance that were organized and supervised by Dr. Ivan J. Birrer, the College Educational Advisor. Party money was also exchanged at a brisk rate at the numerous concessions doing a land-office business in costumed dolls, candies, balloons, flowers, and comical souvenir photos. Circulating shrimp and oyster bars, as well as attractive roving flower girls with large baskets of pink and red carnation corsages, sped the flow of dollars for the cause. Maj Albert L. Kotzebue was master of ceremonies during the Queen's coronation and the following program of entertainment. First prize for the most humorous costume was awarded to a student portraying a doomsday prophet and carrying a sign "Are you ready for the end?" making unmistakable reference to the close of the College course. Two can-can chorus lines headlined the program. The first, composed of well-rehearsed ladies of the Post, performed in a manner worthy of the Follies Bergere. The other, made up of male members, ran through a routine with a lesser degree of professional competence but considerably more hilarity. The fun-filled evening successfully provided a noteworthy social event for the year and a source of revenue for a deserving cause.

General Lemley, in the spring of 1962, visited Vietnam to view at first hand the counterinsurgency operations in that country by the South Vietnamese forces and their American advisors. Shortly after his return, he presented a resumé of his observations at the annual meeting of the Henry Leavenworth Chapter of the AUSA. In his closing remarks following a concise description of the situation, General Lemley reiterated his belief that the struggle in South Vietnam is waged against a strong and determined enemy by capable and dedicated people whose freedom must be preserved.

Two weeks of top-level discussions on ways to improve the combat effectiveness of the US Army took place at the Post in June 1962 under the sponsorship of the US Continental Army Command. Over 75 general officers attended this, the second, Worldwide Combat Arms Conference, with Under Secretary of the Army Stephen Ailes heading the list of approximately 300 distinguished visitors. General Johnson served as overall coordinator for the conferences which were conducted in Bell Hall.

On 1 July 1962 a new combat developments agency came into being at Fort Leavenworth. Designated the Combined Arms Group (CAG), it is an integral part of the US Army Combat Developments Command established in the major reorganization of the Department of the Army. General Johnson, in addition to his duties as Commanding General of Fort Leavenworth, and Commandant of the Command and General Staff College, assumed a third position as Commanding General of CAG. Along with combat developments elements located with several of the Army service schools, CAG directs the activities of a Combined Arms Agency (CARMSA) formed at the same time from the doctrinal elements of the College instructional departments. Col Robert C. Works was named Deputy Commander of the Combined Arms Group, and Col Robert H. Deason was appointed Commanding Officer of the Combined Arms Agency.

Each summer the Post has been a temporary home for groups of high school ROTC students. Two groups of 100 cadets each were trained in a typical encampment in July 1962 in the charge of the Kansas City ROTC detachment. The boys, coming from Leavenworth, Kansas City, Independence, and St. Joseph, follow a strict training schedule beginning each morning with a reveille formation at 0500. Squad tactics and similar field problems take up much of the training week which is concluded after the young prospective officers take to the rifle range to fire the weapons they have carried in drill during the past school year. By the time the last camp formation is dismissed, the boys have gained a new confidence in themselves, have perhaps lost a few excess pounds and developed a few unfamiliar muscles, have gained an appreciation of Army field duty, and have a respect for Fort Leavenworth's mosquito, chigger, and tick inhabitants as well.

Colonel Liwski closed a 30-year military career and a 4-year tour of duty as Chief of Staff at a retirement ceremony in Bell Hall at the end of July 1962. He was succeeded by Col Robert C. Erlenbusch who previously had been the Post G4. Colonel Erlenbusch was still serving in this position at the end of 1963.

Several of the more adventurous military personnel at the Post obtained official Army sanction for a Fort Leavenworth Sport Parachute Club in October 1962. The 27 charter members elected Col Joseph B. Seay, at that time the Post G4, as the first club president. Colonel Seay put his previous parachuting experience, which began with a jump over New Guinea in 1943, to good use in quickly establishing the selection and training criteria for the free-falling membership of the new club. All joining members are required to complete a stringent course of prejump training, make five closely supervised static-line jumps, and at least three more static-line jumps employing the use of a dummy ripcord before they are permitted to make their first actual free-fall jump.

Several statistics compiled for the year 1962 serve to provide an insight into the size and scope of the Post operation. Over 3,500 students were graduated from courses of the Command and General Staff College while some 26,000 officers were enrolled in nonresident extension courses. The sum of \$36 million was spent during the year for salaries, supplies, and services. The monetary value of the physical facilities at Fort Leavenworth was appraised at \$73 million. The local AUSA chapter, selected that year as the best overall chapter in the world, announced a membership of 2,015. The Post oversubscribed its established United Fund drive goal by 133 percent when a total of over \$37,000 was pledged. Not least significant by any means, 310 babies were born in 1962 at the Munson Army Hospital.

New Year's Day, 1963, was the promotion date for General Lemley to the two-star rank of major general. The next month saw General Johnson leaving the Post for duty in Office of the Deputy Chief of Staff for Military Operations. General Lemley became the second Commandant in history to move up from the Assistant Commandant's position to the command of Fort Leavenworth.

In assuming the threefold responsibilities of

his new position, General Lemley is in the unique position of reporting to three superior officers. They are the Commanding Generals of the US Continental Army Command, the Fifth US Army, and the US Army Combat Developments Command. As Post Commander, he



*US Army Photo*

*Maj Gen Harry J. Lemley, Jr.*

serves as chief administrator for a complex multimillion dollar operation, and attends a wide variety of boards and committees. As the head of Fort Leavenworth's first family, he and his wife are expected to attend countless social functions in the furtherance of military and civic relations. These functions are not permitted to interfere with official duties, but they demandingly restrict the time that the general may devote to normal family life.

General Lemley travels extensively, for the most part to supervise the activities of the Combined Arms Group with its 10 subordinate agencies spread from Virginia to Arizona. He greets nearly every official visitor to the Post, and hosts a great number of them in his quarters at No. 1 Scott Avenue. In 1962, over 3,300 visitors were entertained in the Commandant's home. During an average work week in excess of 50 office hours, the general reads and signs hundreds of papers requiring his attention each day, and somehow finds time



to personally conduct a multitude of promotion and awards ceremonies for the thousands of personnel under his command.

An atmosphere of tense expectation built up in the first weeks of March 1963 as the day approached for the arrival of a team of officers from the Pentagon. The team, from the Officer Personnel Directorate, arrives at this time each year to announce the future assignments of the student officers attending the



*US Army Photo*

*Commandant's quarters at No. 1 Scott Avenue*

Command and General Staff Officer Course. The Post was the scene of hectic activity immediately after the announcements were made as officers and their wives spread the news and compared locations for their next duty stations. The chief operator at the Post switchboard has learned from long experience that extra help is required that evening to handle the hundreds of long-distance calls placed by the student families to relatives and friends.

Many officers of the College staff and faculty and the Post garrison, in addition to the students, were making movement plans about this same time. The average tour of duty for permanently assigned officers at Fort Leavenworth is 3 years, with about one-third of them departing and arriving during the summer months. The new Assistant Commandant, Col Elias C. Townsend, arrived for duty in April from an assignment as Assistant Chief of Staff, G3, with the Second US Army. Colonel Townsend, an instructor at the College in 1946-48, was promoted to brigadier general in August.

Physical fitness was a current topic in the spring of 1963 when the Army Physical Combat

Proficiency Test was scheduled for the first time for all male soldiers under 40 years of age. Those who wisely prepared for the test by practice at the course set up in the Bluntville Bowl area found significant differences between the new requirements and the old Physical Fitness Test. When the final results were posted after more than 1,000 men had been tested, top honors went to the assistant Protestant chaplain of the Post, Chaplain (Capt) Wayne G. Shelton. In an almost perfect performance in the five-event test, the 34-year old chaplain scored 498 out of a possible 500 points, leaving a mark for combat arms officers to strive for in the future.

The Post detachment of the Women's Army Corps, commanded by Capt Margaret Clifford, celebrated the 21st anniversary of their corps in May 1963. Arrangements for their birthday party were made by those detachment members soon to be retired after 20 or more years of service. One of the first WAC detachments to be authorized; it arrived at Fort Leavenworth in 1943 and was expanded to nearly 300 members during World War II. There are presently 71 enlisted women and 6 WAC officers serving at the Post in assignments to the Munson Army Hospital, Midwest Relay Station, the dental clinic, library, and other Post and College activities.

Another unit of the garrison deserving mention is the 371st Army Band which has provided a variety of music at the Post since 1947. The band has averaged over 50 performances a month, playing receptions, sports events, numerous other military and religious activities, in addition to filling a schedule of outdoor morning concerts on summer weekends. The Band has also performed in Leavenworth, traveled to many surrounding communities to play for civic functions, and provided stage music for the Post Dramatics Club.

Work began in November 1963 for the removal of a familiar Post landmark. The old Fort bridge, which was constructed in 1872 and subsequently carried the traffic of Highway 92 across the Missouri River, had been closed since the Leavenworth Centennial Bridge was completed in 1955. Now considered a menace to navigation on the river, it was scheduled for demolition. During the process, the wooden flooring of the bridge accidentally caught fire in a rather spectacular fashion as flames en-

gulfed the complete length of the span. Firemen stood by in frustration without practical means to extinguish the blaze until a barge with fire-fighting equipment aboard was brought upstream. After several days the last embers ceased smoldering, the onlookers in Bell Hall turned away from their windows and redirected their attention to office chores, and workmen again began to dismantle the metal structure.

The awful news of the assassination of President John F. Kennedy on the 22d day of November was received with shocked incredulity at Fort Leavenworth, as it was all over the world. While confirmatory reports were announced, and the aftermath of events was televised from Dallas, realization of the actual loss suffered by the Nation took effect. Instructions were issued, as the Post flag was lowered to half-staff, for

all assigned officers to assemble in the auditorium of Bell Hall the following morning where General Lemley performed the sad duty of reading the official notification of the President's death from the Secretary of Defense.

The usually gay Post holiday season passed against a subdued, somber background as scheduled celebrations were cancelled, and a sense of deep personal loss remained the predominant emotion in the hearts of all Americans. The year 1963 came to an end not long after the flag was once more flying at full-staff to mark the end of the period of national mourning. Personnel at the Post prepared to enter the coming year experiencing, with their fellow countrymen everywhere, a spirit of re-dedication to the ideals so often clearly expressed by the late 35th President of the United States.

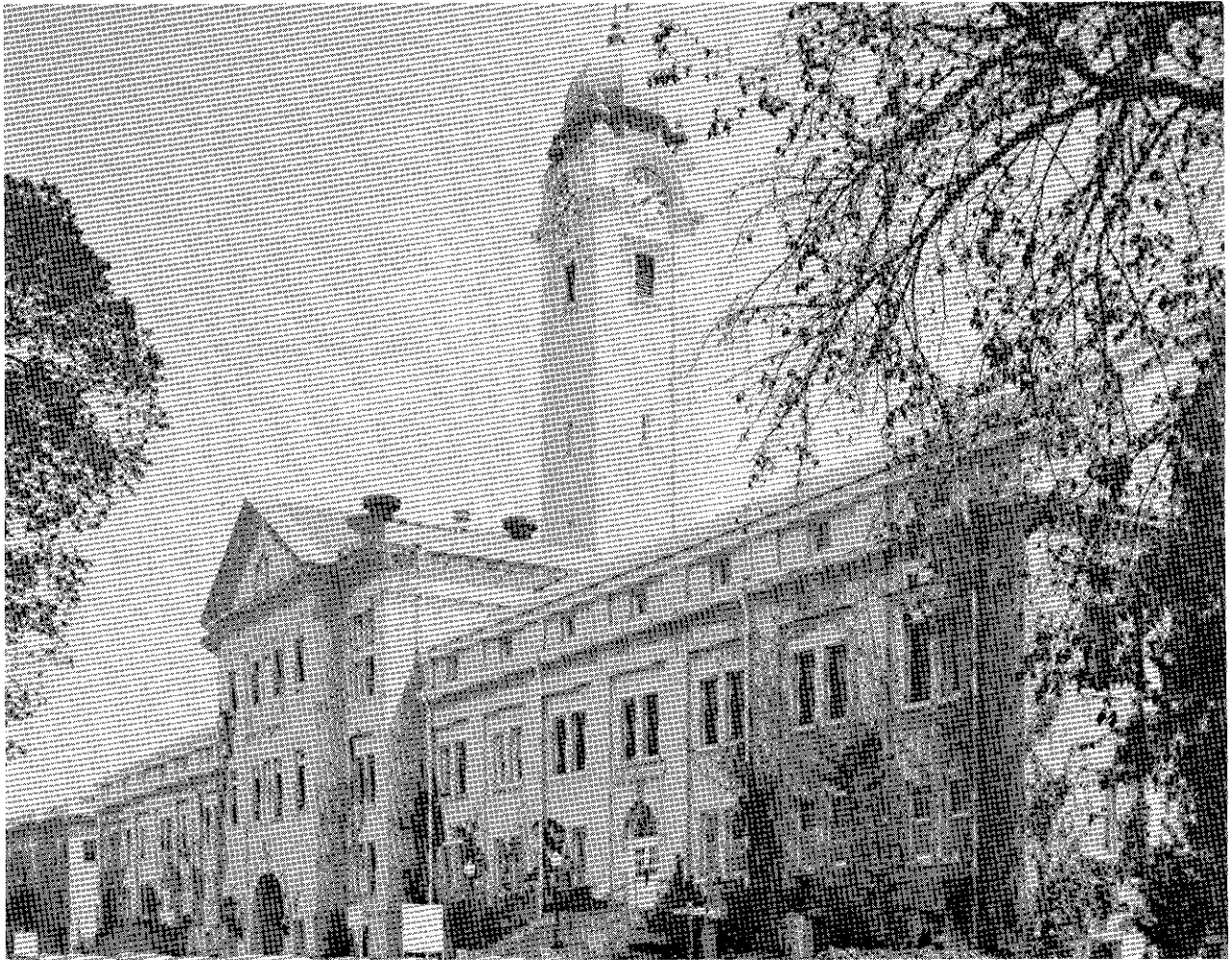

*Post Headquarters, Fort Leavenworth*

*US Army Photo*

---

### CHAPTER III

#### POST UNITS AND ORGANIZATIONS

---

It is widely known that Fort Leavenworth is the home of the U. S. Army Command and General Staff College, and it is true that the College is the major military activity located at Fort Leavenworth. It is less generally known that Fort Leavenworth is the home of several other diversified operations of a unique and important nature. This chapter discusses the more prominent of these operations.

##### **THE COMBINED ARMS GROUP**

The newest among the agencies at Fort Leavenworth came into existence as a result of a study directed by the Honorable Robert S.

McNamara, Secretary of Defense, in February 1961. A study was made of the Department of the Army functions, organizations, and procedures in the light of current and projected trends, and resulted in the reorganization of the Army in 1962. In January 1962, the Command and General Staff College began studies to determine how this Army reorganization would affect the College and the other service schools of the combat arms. These studies concluded that the Departments of Doctrine and Combat Developments of the College should be deactivated. Further, it was decided that the

personnel from these departments should form the nucleus of two new organizations to be located at the Post; the US Army Combined Arms Group and the US Army Combined Arms Combat Developments Agency. These study conclusions were approved and implemented.

Orders from the US Army Combat Developments Command at Fort Belvoir, Virginia, established the Combined Arms Group (CAG) at Fort Leavenworth as a subordinate element effective 1 July 1962.<sup>1</sup> Maj Gen Harold K. Johnson assumed command on that date. Subsequent orders organized and assigned the following combat developments agencies to the CAG from existing activities at the military installations indicated: Air Defense at Fort Bliss, Texas; Armor at Fort Knox, Kentucky; Artillery at Fort Sill, Oklahoma; Aviation at Fort Rucker, Alabama; CBR at Fort McClellan, Alabama; Engineer at Fort Belvoir; Infantry at Fort Benning, Georgia; Intelligence at Fort Holabird, Maryland; Communications-Electronics at Fort Huachuca, Arizona; and Combined Arms located at Fort Leavenworth, Kansas, with the headquarters element.<sup>2</sup> These far-flung agencies, composed of nearly 1,100 personnel, immediately began operations under the central direction of the CAG.

The mission of the CAG, as set forth in the Activation Plan, is to formulate and document current doctrine for the Army; to anticipate the nature of land warfare in the future; to determine the types of forces and material needed in the future; and to determine how these forces and material should be employed. This formal mission statement was in agreement with the thoughts of Lt Gen John F. Daley, the first Commanding General of the Combat Developments Command, who felt that his command should supply answers to the questions: "HOW SOULD THE ARMY BE ORGANIZED? HOW SHOULD THE ARMY FIGHT?"

A formal ceremony was held on the concourse in front of Grant Hall on 2 July 1962 to dedicate the two new organizations at the

<sup>1</sup> General Orders No. 5, Headquarters, US Army Combat Developments Command, Fort Belvoir, Virginia, 21 June 1962.

<sup>2</sup> General Orders No. 9, Headquarters, US Army Combat Developments Command, Fort Belvoir, Virginia, 30 June 1962.

Post. The CAG occupied office and work space in the Grant-Sherman Hall facilities. The Combined Arms Agency (CARMSA) moved into areas on the third floor of Bell Hall which afforded its members ready access to the reference material of the College Library.

The Headquarters of the CAG, in addition to an administrative element, is organized in three divisions. A Plans and Programs Division monitors the 5-year programs for combat development, and the worldwide programs of troop testing new doctrine and organizations. An Organization and Doctrine Division supervises the preparation of studies dealing with operational and organizational concepts and materiel objectives. This supervision includes the preparation of doctrinal field manuals and tables of organization and equipment. The evaluation of materiel requirements for combat and combat support elements, and the monitoring of various materiel test and evaluation programs are accomplished by the Materiel Division. Accomplishments of the CAG in the first year and a half of its existence have been the monitoring and supervision of subordinate agencies which resulted in the preparation of over 160 doctrinal studies and publications, some 40 tables of organization and equipment and more than 150 materiel or development requirements and objectives.

Col Wilson M. Hawkins assumed the position of CAG Deputy Commander on 15 June 1963 from the first officer appointed to direct the affairs of that organization within the Commanding General's policy guidance, Col Robert C. Works. The Combined Arms Group and the Command and General Staff College today enjoy a mutually beneficial relationship enhanced by their physical proximity and their operation under the command of a single individual, the Commanding General of Fort Leavenworth. Close cooperation between the two has increased the fund of tactical knowledge available to the CAG for developing doctrine, and the ability of the College to assimilate approved doctrine into its tactical teachings.

#### THE US DISCIPLINARY BARRACKS

For nearly 90 years, the facilities of the US Disciplinary Barracks have housed men who have failed in some respect to adjust to society or their military environment. The history of the USDB goes back to 21 May 1874 when an

amendment to a previous act of Congress changed the location of a military prison from Rock Island Arsenal, Illinois, to Fort Leavenworth. From that time, the programs of the USDB have evolved slowly in keeping with the changes now apparent in modern penology. New theories and practices have been tried and tested; some discarded and others adopted. Today the USDB, which serves both the Army and the Air Force, is a community unique within the larger community of Fort Leavenworth. Activities conducted at the USDB reflect the progressive approach of both Services toward the reeducation of the inmates. The atmosphere is corrective rather than punitive. Although their freedom is restricted, the prisoners carry on many of the activities of normal society.

From the day a prisoner arrives until the day he leaves, he is involved in a program aimed at determining the basic cause of punishable behavior, and preparing him to assume a responsible role in society upon his release from confinement. Should a prisoner need psychiatric counseling, additional educational opportunities, vocational training, the experience of supervised group living, recreational opportunities, or religious training, these requirements can be met within the overall program. To fulfill these requirements, almost half of the assigned staff of the USDB consists of psychiatrists, psychologists, social workers, teachers, counselors, work supervisors, athletic supervisors, library workers, classification experts, and lawyers. Col Weldon W. Cox, Commandant of the USDB from 1959-63, often remarked, "What a prisoner accomplishes while inside the walls is partly his responsibility—the institution helps him to help himself."

Motion pictures are shown on weekends and holidays, and a hobby shop provides a means for constructive relaxation. The USDB also has a well-equipped gymnasium. During the summer, baseball and softball leagues are organized; while in the winter months, football and basketball are the major athletic events. Volley ball, wrestling, boxing, weight-lifting, and trampoline exercises round out the extensive sports program.

Since the first classes were begun in 1888, education has been a main feature of the USDB program. During the 1963 fiscal year, 256 prisoners successfully completed high school gen-

eral educational development tests, and 44 completed the same tests on a college level. In addition, 156 men completed formal classroom study for high school, 48 completed group study classes or correspondence courses at the high school level, and 492 completed similar work at the college level.

Since 1960, an Associate in Arts degree in the junior college program has been avail-

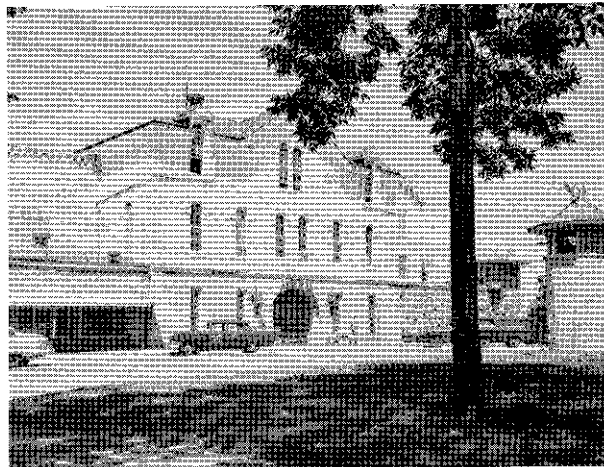

*US Army Photo*  
*Entrance to the US Disciplinary Barracks*

able through a joint effort by the USDB and the Junior College of Highland, Kansas.

Closely related to the educational program is a vocational training program. A major improvement to this program has been the recent completion, by prisoner labor, of a modern vocational industries building within the walls of the USDB Main Unit. The first major building project for the USDB since 1930, this structure provides training facilities for the development of skills in tailoring, electrical work, photography, sheet metal work, printing, and upholstery. On-the-job training is offered in such fields as dry cleaning, laundry operation, plumbing, cooking, carpentry, barbering, and automobile repair. Vocational skills acquired by the prisoners in many of the fields are put to use to reduce the operational costs of the USDB, as well as to provide a source of prison revenue by offering commercial-type services to the personnel of Fort Leavenworth.

A major subsidiary of the USDB is the Farm Colony and Greenhouse. Prisoners assigned to agricultural work raise hogs, beef cattle, and poultry and cultivate several hundred acres of land with crops of corn, milo, alfalfa, and oats.

The Farm Colony consists of more than 600 acres in an area northwest of the prison's Main Unit. Located between the Farm Colony and the USDB is the prison greenhouse, reportedly the largest in the State of Kansas. The sale of plants and flowers, as well as farm produce to residents of Fort Leavenworth and other authorized personnel, also provides a considerable amount of revenue to the USDB Vocational Training Fund.

Minimum custody prisoners are quartered at the Farm Colony and at the Local Parolee Unit. These men move from their quarters to their jobs without direct supervision, and many of their duties are accomplished away from the prison in various areas of the Post.

For those prisoners due to return to civilian life, a prerelease counseling program provides instruction concerning job applications, civilian legal problems, parole supervision, travel pay, family adjustment problems, and many other related matters. Men selected to return to military duty undergo an additional training program. Those who return to the Army are retrained in basic soldiering duties by the Military Training Branch of the First Guard Company, and Air Force personnel are sent to an Air Force unit that has been organized for a similar purpose.

Both Army and Air Force officers are assigned to the USDB. Their training and experience include special penological schooling at the baccalaureate, master, and doctorate levels. More than 450 enlisted men perform duties at the USDB. These assigned personnel, with a representation of combat veterans as well as college graduates and technicians and a broad range of training and background, are assigned to the First Guard Company currently commanded by Maj Lawrence E. Person. They are trained cooks and guards, specialists in psychological testing and social case work, administrative specialists, and engineering supervisors.

A third group of specialists are the civilians employed at the USDB by the Department of the Army. They include men and women with special skills and training in correctional work. Such trades as shoe repair, upholstering, and barbering are taught to prisoners under the direction of both civilian and military personnel.

Rehabilitating men who have failed in the

military service is a specialized mission and far from an easy assignment. For the recently assigned Commandant, Col E. L. Slobe, and his staff, the search for better ways to help men at the US Disciplinary Barracks will remain their first objective.

#### MUNSON ARMY HOSPITAL

A major step forward in the continuing program of health and welfare at Fort Leavenworth was taken in April 1958 when ground was broken for a new military hospital. Construction of the \$3 million building was based upon plans made available by the US Air Force. While this construction was taking place, medical service was provided from the building complex on Thomas Avenue where it had been located since 1902. Col Joseph T. Caples, Commander of the Hospital and Post Surgeon, was busy at the time as he directed the many routine hospital activities while taking an active supervisory interest in the new building.

Colonel Caples was known as the unofficial historian of Fort Leavenworth because of his interest in the local area and his extraordinary familiarity with Fort Leavenworth in the past. The Colonel had lived at the Post four times previous to his current assignment; first with his father who was stationed here in 1909, a second time while his father took part in the Mexican Campaign in 1916-17, a third time when his father was a student in the General Staff School in 1921, and yet again when he himself was a student in 1942. Colonel Caples' family history in this location goes back much farther than that, however. His great-great-grandfather was the president of the association that founded the City of Leavenworth in 1854.

With the completion of construction, the movement of hospital equipment into the new facility began in January 1961. One month later, patients were moved from the old hospital buildings, and the new health center was in full operation in its new location by 27 February 1961. The buildings from which the hospital was moved serve today to house the Dental Clinic, offices of the American Red Cross, and provide billet space for enlisted personnel.

Colonel Caples presided over a program of formal dedication ceremonies on 29 March 1961 during which the hospital was named in honor of Brig Gen Edward L. Munson, who had

served with distinction in the Army from 1893 to 1932. General Munson had been an instructor in the Army Service Schools, which later developed into the United States Army Command and General Staff College, and founded the Medical Field Services and Correspondence School at Fort Leavenworth. The scheduled program, to which the public was invited, included a welcome by Maj Gen Harold K. Johnson, Commanding General of the Post, a dedication address by Maj Gen Thomas J. Hartford, the Deputy Surgeon General of the Army, and a tour through the facilities of the new hospital.

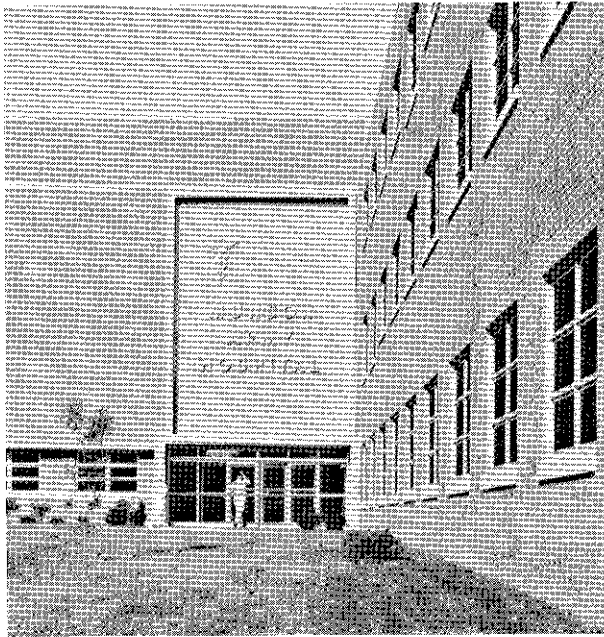

*US Army Photo*  
*Main entrance to Munson Army Hospital*

The fully air-conditioned, three-story hospital is equipped with the most modern medical equipment. Presently providing beds for a maximum of 90 patients, provisions were incorporated into the basic design for an expansion to a 190-bed unit if required. Two floors of the building contain rooms for patients. These rooms vary in size from single-bed rooms to those with six beds. There are three surgical operating rooms, two delivery rooms, a pharmacy, modern kitchen and dining areas, and two food service units for wards.

Rooms for patients are colorfully decorated and most have all the comforts of a home bedroom. Each bed has a two-way communication system to a nursing station, and a pillow

speaker for listening to radio or recorded programs. Remote controlled television sets are mounted from the ceilings and connected to the pillow speaker system. Telephone jacks installed in each room are provided for the patients' convenience. An interesting innovation is a communications system whereby key hospital personnel can be contacted without disturbing the patients through the use of transistorized pocket receivers. A Special Services library, a branch Post Exchange and snack bar, and a barber shop are also available in the hospital.

A health center of this type requires a sizable and diversified staff, including medical, surgical, nursing, administrative, and coordinating services. Over 200 personnel are assigned under the command of Col John H. Taber, who assumed the duties of Commanding Officer and Post Surgeon from Colonel Caples in August 1963, to staff and operate the facilities of Munson Army Hospital. Among these is Colonel Oliver Buesing, Chief of Surgery, one of the outstanding surgeon's in the Army. Many of the services rendered by the hospital however, especially in the area of dependent medical care and preventive medicine, could not be provided without the wholehearted and enthusiastic support of the Red Cross Volunteer Program by the distaff population of Fort Leavenworth. These women, working as Gray Ladies, Staff Aides, Nurses' Aides, and Registered Nurses, contribute thousands of hours of volunteer service to the hospital each year. Nearly 300 of these women participate annually in the program during peak workload months.

#### **MIDWEST RELAY STATION**

On 12 December 1957, Headquarters, Fifth US Army, published General Orders Number 145 establishing the US Army Midwest Relay Center at Fort Leavenworth, Kansas, effective 2 January 1958. Subsequent authority delegated operational control and the responsibility for the accomplishment of the Midwest Relay Center mission to the Commanding General, Fort Leavenworth.

The history of the Midwest Relay Station began in December 1952 when a prototype teletypewriter system was placed into operation at Chicago, Illinois. This system was manufactured specifically to test the automatic concept

and to determine its possibilities for military application. This early test conclusively demonstrated that this equipment could provide a much higher and more reliable grade of service with a considerable saving to the Government in the cost of personnel salaries alone. In very basic terms, this system converts a message prepared by the originator into a perforated paper tape. The tape is then fed through a transmitter that transforms the printed words to electrical impulses traveling at the speed of light to a destination where the impulses are reconverted to a paper or, in some instances, to a final copy of the message in page form. The automatic switching components of the system are set into operation upon receipt of the electrical impulses from an incoming teletypewriter line. From these impulses, the destination and relative importance of the message are determined, and the message is automatically routed to the destination in accordance with its importance without human assistance or intervention. Messages addressed to more than one agency or headquarters are reproduced in the appropriate number of copies by the equipment and automatically routed to the proper addressees.

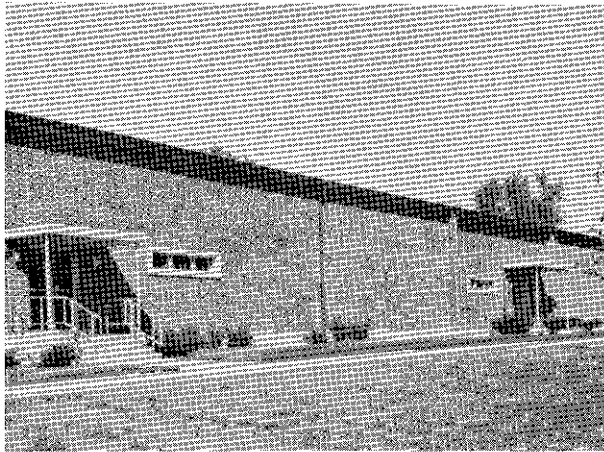

*US Army Photo*  
*Exterior of the Midwest Relay Station*

With the proven feasibility of fully automatic switching, the Chief Signal Officer of the Army determined that it would be far more economical to operate a few large relay stations, each serving large geographical areas, than many smaller stations to serve specific commands. This concept represented a major departure from previous doctrine which normally placed a commander's communication facilities di-

rectly under his control. Accordingly, plans were made for a West Coast Relay Station at Davis, California; an East Coast Relay Station at Fort Detrick, Maryland; and a Midwest Relay Station to be established in the Kansas—Missouri area. Under this concept, the Midwest Relay Station currently is serving Government and military activities located throughout 21 states and 4 army areas.

The Fort Leavenworth location was approved by the Department of the Army and the exact locations for the main station, receiver station, and transmitter station were determined prior to 1956 when the contract was signed for the construction of the main station building on Biddle Boulevard. The radio transmitter station was located adjacent to Sherman Army Airfield and its construction began in June 1958. Later that year, construction was begun on the radio receiver station which was located at the Sunflower Ordnance Works in Desoto, Kansas. Additional construction and improvement of the station's facilities have taken place.

Equipment began arriving from the manufacturers in September of 1958 and installation was completed by October of the following year. The installation was accomplished by teams from the Army Signal Engineering Agency with assistance provided by the personnel assigned to the station under the command of Lt Col John A. Anderson. In this manner, station personnel gained valuable experience in a phase of the overall training program designed to familiarize them with the equipment they would later operate and maintain.

It was realized from the beginning that the training of personnel was the key to successful operation of the Midwest Relay Station. This initially presented a serious problem due to the limited number of personnel having previous experience with automatic switching equipment. These personnel were to be found primarily among those who had been associated with the prototype test in Chicago, and those at the relatively new West Coast Relay Station. A limited number of the more experienced individuals were recruited from these installations. The required remainder, both military and civilian, were selected on the basis of long experience in the communications field and familiarity with network operations as they existed prior to the advent of automatic switch-



ing. This system of selection proved to be highly successful and although many of the skilled military personnel have been transferred from the station, most of the key civilians originally recruited are still present. Advantage was taken of every available training resource. Classes for switchmen were conducted by the Automatic Electric Company at their Chicago factory. Representatives of the Kleinschmidt Corporation assisted in the training of repairmen at classes conducted by the Midwest Relay Station. Personnel were sent both to Chicago and the West Coast Relay Station to observe and become familiar with the operations there. Between September 1959 and January 1960, 69 individuals were trained in automatic operations at classes conducted at Fort Leavenworth in the building now occupied by the Army National Bank. It is historically significant to note that this building had first been used almost eight decades earlier for the instruction of student officers in the school that was to develop into the U. S. Army Command and General Staff College.

The cut-over to live traffic began on 2 January 1960, the second anniversary of the organization of the Midwest Relay Station. With the cut-over, the station began its automatic switching service on an around the clock basis which has continued without interruption until the present. Credit must be given to the outstanding performance and devotion to duty of the personnel responsible for the initial organization and training which resulted in what the commander of the Army Communications Agency described as the most successful cut-over in network history.

The formal dedication of the Midwest Relay Station, then commanded by Lt Col Hanford T. Colwell, took place on 18 February 1960 with ceremonies held at the Fort Leavenworth Officers' Open Mess and at the main station. Dedication ribbons at the entrance to the station were cut by Maj Gen Ralph T. Nelson, Chief Signal Officer of the Army, and Maj Gen Lionel C. McGarr, Commanding General of Fort Leavenworth. Guests and visitors present, more than a hundred in number, included State and local government officials from the surrounding area, Post staff personnel, representatives of the companies that had manufactured equipment for the station, and prominent Signal Corps representatives from Fifth US Army and the

Washington, D. C. area. The ceremonies were recorded on film by photographers from the Army Pictorial Center, and later edited into a newsreel type pictorial report which is still available through the Army film library system.

The Midwest Relay Station, currently commanded by Lt Col Gerald C. Von Bargen, has been designated a class II activity of the Army Strategic Communications Command. Its mission is to relay electrical communications and data for government installation in the central portion of the United States. As a part of the World Wide Strategic Army Communications Network, the station is capable of relaying messages to and from any installation in any part of the world in which United States or Allied forces may be located. It also functions as an important element of the Defense Communications System and serves as a transfer point for Army and Air Force traffic. In return for the administrative support it is provided by Fort Leavenworth, the Midwest Relay Station also operates and maintains the Post Communications Center. The station has processed approximately 27 million messages in its first 4 years of operation, with over 600,000 messages handled in one month during 1963.

It is anticipated that the station will become a part of the Global Satellite Communications System and will continue to expand its services within its area of operations. In the event of emergency, the Midwest Relay Station will provide the Nation with the most modern and efficient communications service available in the world.

#### **THE AIR DEFENSE BATTERY**

The construction of a Nike Hercules defense for the Kansas City area was approved by the Department of the Army in late 1957. With Senate approval in May 1958, negotiations began for the purchase of land and the award of contracts for the design and construction of the defense project. The contract for construction was awarded in June 1958 and the notification to proceed was issued the following month. Ground-breaking ceremonies were conducted at Fort Leavenworth on the future site of the Delta Battery Headquarters at Pope Avenue and Bidle Boulevard on 23 July 1958.

Battery D, or Delta Battery, is one of the four firing units of the 5th Missile Battalion

(Nike Hercules), 55th Artillery. The battalion headquarters is located at the Naval Air Station, Olathe, Kansas.

The ceremonies were sponsored by the Henry Leavenworth Chapter of the Association of the United States Army. A powerful Hercules missile formed a backdrop for the speakers platform, and the sounds of heavy earthmoving machinery could be heard as the chaplain offered a prayer for peace. Civilian dignitaries present for the occasion were headed by Kansas Governor George Docking. Brig Gen Frederick Zierath, the Assistant Commandant of the Command and General Staff College, represented Fort Leavenworth and delivered the official welcome to the numerous participants and guests.

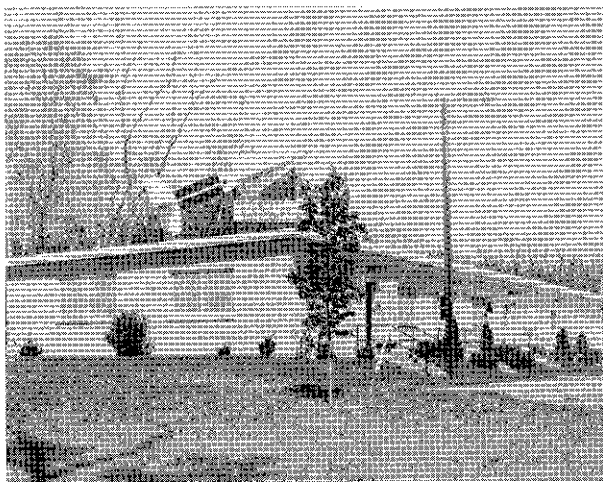

*US Army Photo*  
*Headquarters of the Air Defense Battery*

In August 1959, filler personnel began reporting to Fort Leavenworth for assignment to Delta Battery. At the same time, the officers, key noncommissioned officers, and specialists of the battery, then commanded by Capt Guy J. Marzari, reported for "package" training at the Army Air Defense Center, Fort Bliss, Texas. This training, which developed individual and unit proficiency so necessary for the successful operation and maintenance of the Hercules system, was completed in October and the trained personnel departed for Fort Leavenworth to join the remainder of Delta Battery.

By November 1959 sufficient personnel and equipment had arrived at the battery site to permit the emplacement of the equipment and the start of an intensive unit training program.

The battery was declared operational in April 1960. It is interesting to note that the battery launching area, from which Hercules missiles would be launched, is located on the same hill where the earthworks of Fort Sully were constructed during the Civil War for a similar mission, but against an entirely different type of threat.

Delta Battery draws on Fort Leavenworth for logistical support. Battery officers and many of the enlisted personnel reside on the Post and participate actively in Post functions. Conducted tours through the battery facilities in cooperation with Post activities, and demonstrations with the sentry dogs that guard the perimeters of sensitive battery installations have been a source of interest to many Post visitors. The battery sponsors annual Christmas and Easter parties for the children of Saint John's Orphanage, Kansas City. In addition to donations from battery personnel toward the purchase of clothing for the orphans, the days preceding Christmas each year find the men of Delta Battery busily engaged during their off-duty time collecting and repairing toys to be distributed as gifts to these children. Through organized efforts such as these, and the promotion of good will by its individual members, Delta Battery has greatly assisted Fort Leavenworth in maintaining a record of outstanding civic relations.

The battery is tested on the effectiveness of its training programs by an annual service practice conducted at the McGregor Firing Range in New Mexico. This service practice consists of the actual firing of Nike Hercules missiles at simulated hostile targets and provides the basis for a thorough evaluation of the battery's firing operations. The battery has fired 17 missiles under these conditions thus far with a perfect score of seventeen target "kills." The battery has consistently been rated "Superior" on its annual general inspection. It has never failed successfully to demonstrate its ability to store, handle, and prepare for firing the powerful nuclear warheads with which its missiles can be armed. Because of these and other similar achievements, this unit has been designated the "Outstanding Battery of the Year" by the 4th Region, Army Air Defense Command, to which it is assigned for the 2 years this award has been in existence.

The history of Delta Battery, although relatively brief, is a source of pride to the present battery commander, Capt Milton Welsh, and the members of his unit. Delta Battery remains in constant readiness to fulfill its assigned mission to actively defend the Kansas City area against aerial attack should the national policy of deterrence fail.

#### **SHERMAN ARMY AIRFIELD**

The center of air activity for Fort Leavenworth and the Command and General Staff College is Sherman Army Airfield located east of the US Disciplinary Barracks on the Missouri River flats. The field was established under the jurisdiction of the Disciplinary Barracks in 1923 by the Army Air Corps. At this time it was merely a strip 1,800 feet long in a field of alfalfa and was intended only for emergency landings. Named in 1936 for Maj William Sherman, US Air Corps, who had supervised major improvements of the field, it was then under the control of the Army Air Corps, later the US Air Force. The expanding role of Army aviation resulted in the transfer of the field to the Army and Fort Leavenworth in 1953.

An important and busy activity was incorporated with the operation of the field in 1954 when a Transportation Corps aircraft maintenance and supply detachment was moved from Fort Riley, Kansas, to Fort Leavenworth. This relatively small detachment, presently commanded by Maj Edward F. O'Donnell, supports Army aircraft, including those of the Army Reserve and National Guard throughout 11 states in the Fifth US Army area. The detachment operates a U-1A utility aircraft to fly maintenance personnel and supply parts wherever needed to accomplish its mission.

Effective 1 January 1959, a 5-year lease was granted to the City of Leavenworth permitting use of the field by privately owned aircraft listed with the Civil Aeronautics Agency and equipped with two-way radios. The Post Aviation Officer has since been responsible for the flight pattern and safety of all aircraft within the control zone of the field.

In 1960, the field was designated a class A airport—one which averages more than 100 take-offs and landings a day—and began operations on a 24-hour basis. That same year a significant improvement of landing surfaces

was completed. The main runway was topped with asphalt in a strip 5,900 feet long and 100 feet wide. The field drainage system was improved as well as the secondary 5,400 foot cinder runway.

The Post Army Aviation Detachment, currently commanded by Maj John P. Westphal, is now assigned 17 fixed-wing aircraft and 3 light helicopters. The operations at Sherman Army Airfield, in addition to providing aviation support to the Post and College, provide facilities for the maintenance of flying proficiency by permanently assigned and student officers. The number of aviators assigned as students at the College has increased yearly. Not only are aircraft made available to these pilots, but their flight records are maintained by personnel at the field. The Aviation Division also operates a Link trainer which simulates instrument flight for aviators sharpening their blind flying skills.

#### **THE MUSEUM**

There are indications that an attempt was made as early as 1924 to establish a museum at Fort Leavenworth to preserve the many historical military relics which were located throughout the Post. A formal request from Fort Leavenworth to establish a museum was approved by the War Department in 1938 and the Post Museum was established that year. Originally, the museum was situated in Building No. 74 which now houses the Army Education Center. From the very start, the museum has maintained a collection of period animal-drawn vehicles that is probably unsurpassed anywhere in the country. Among these authentic means of transportation of the early West are stagecoaches, prairie schooners, numerous horse-drawn buggies and sleighs, and old Army vehicles of all descriptions. For years these vehicles were rented for a small fee, and provided to military and civilian organizations engaged in activities with an historical theme. The holdings of the museum were placed in storage in the fall of 1950 when the museum was placed in a standby condition.

Shortly before his departure in 1952, General McBride directed that plans be made to reactivate the Post Museum. It was reestablished in Building No. 391 and opened with appropriate ceremonies in 1953. The collection of a small local quartermaster museum was

consolidated with the existing holdings, and the museum activity was placed under the office of the Headquarters Commandant for administrative purposes.

In 1955, General Davidson formed an historical committee to study and report upon a program at the Post which would encourage public and private support of the museum, and thus encourage increased understanding and support of the US Army. The committee recommended the organization of a Post historical society and a permanent historical committee; the initiation of plans to restore and preserve the numerous available historical sites and objects; the acquisition of a civilian museum curator; and the appointment of a Post historian. The committee's recommendations were approved and implemented. A very active historical program was conducted with local and state historical societies which served to further civic relations.

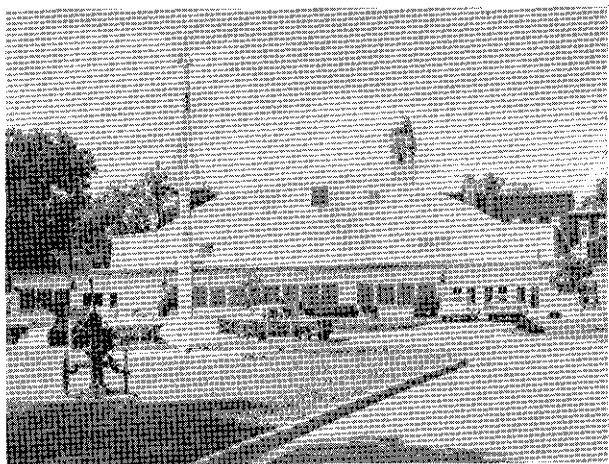

*The Post Museum*

*US Army Photo*

A civilian curator for the museum was approved during the tenure of General McGarr as Commandant, and Miss Mildred C. Cox was employed in September 1958. The following year the museum was relocated in Andrews Hall with the primary considerations being a more advantageous site and an increased building capacity. Well over half of the available floor space is now taken up by exhibits and displays, with the remainder used for an auditorium, administrative and shop areas, and storage.

The mission of the museum was established in 1960:

The mission of the Fort Leavenworth Mu-

seum is to collect, preserve, and present a fully adequate graphic artifactual display of the history of Fort Leavenworth and all military facilities located at Fort Leavenworth (including the United States Army Command and General Staff College, the United States Army Hospital, the United States Army Midwest Relay Station, and the United States Army Disciplinary Barracks) and to develop and preserve historical sites and monuments throughout the military reservation. The Museum serves as a medium for fostering knowledge and understanding of the history, traditions and development of Fort Leavenworth and its related facilities, stimulating esprit de corps and improving public relations.<sup>3</sup>

A Board of Governors was established for the museum in 1960 to guide and support the museum program. The board also administers a non-government fund created by donations from Post activities and organizations, and those received from the general public. Relics and other historical objects are purchased from this fund. An unofficial group of counselors was also formed in 1960 to provide liaison with regional museum activity and gain support for the Fort Leavenworth Museum. In addition, the counselors furnish professional advice and assistance to the museum Curator and Board of Governors. The counselors represent the Department of the Interior, the Kansas State Historical Society, the Harry S Truman Library, and the museum in St. Joseph, Missouri.

Since the relocation of the museum in Andrews Hall, an active plan for expansion of the collections and exhibits has been in effect. Until sufficient properties are acquired to meet the requirements of this long-range plan, depicting the entire span of history for the Fort Leavenworth area, relics added to the collection are cased in exhibits of isolated but related themes. A wide variety of attractive and historically interesting exhibits are displayed for the many visitors to the museum. Although the major collection grouping consists of the old vehicles, the museum's holdings include artillery pieces, uniforms and related military equipment, Indian artifacts and western pioneer relics, and objects from foreign lands donated by Allied officers. A section of Andrews

<sup>3</sup> General Order No. 130, Headquarters, Fort Leavenworth, Kansas, 11 July 1960.

Hall is set aside for a display of period rooms such as could be found in the homes of the early settlers of the Kansas Territory. The reconstruction, furnishing, and maintenance of these rooms has been accomplished by the Leavenworth County Historical Society. An appealing exhibit, and a source of envy for the younger male visitor, is a collection of miniature soldiers that has been loaned to the museum by Lt Col S. von Schrittz. These thousands of miniatures, authentically uniformed and equipped in the most minute details, are arranged in formations depicting military regiments of the world.

Stimulated by a progressive museum program, visits to the museum have increased from about 500 persons each month in 1958 to a total of over 54,000 persons in 1963. Miss Cox and her museum staff conduct group tours for Post personnel, visiting dignitaries, and groups from schools and civic and professional organizations. The museum personnel participate in numerous local, state, and regional historical affairs. The Fort Leavenworth Museum, by reflecting what the community is and what it once was, creates a consciousness of the heritage and affairs of the Post unattainable by any other means.

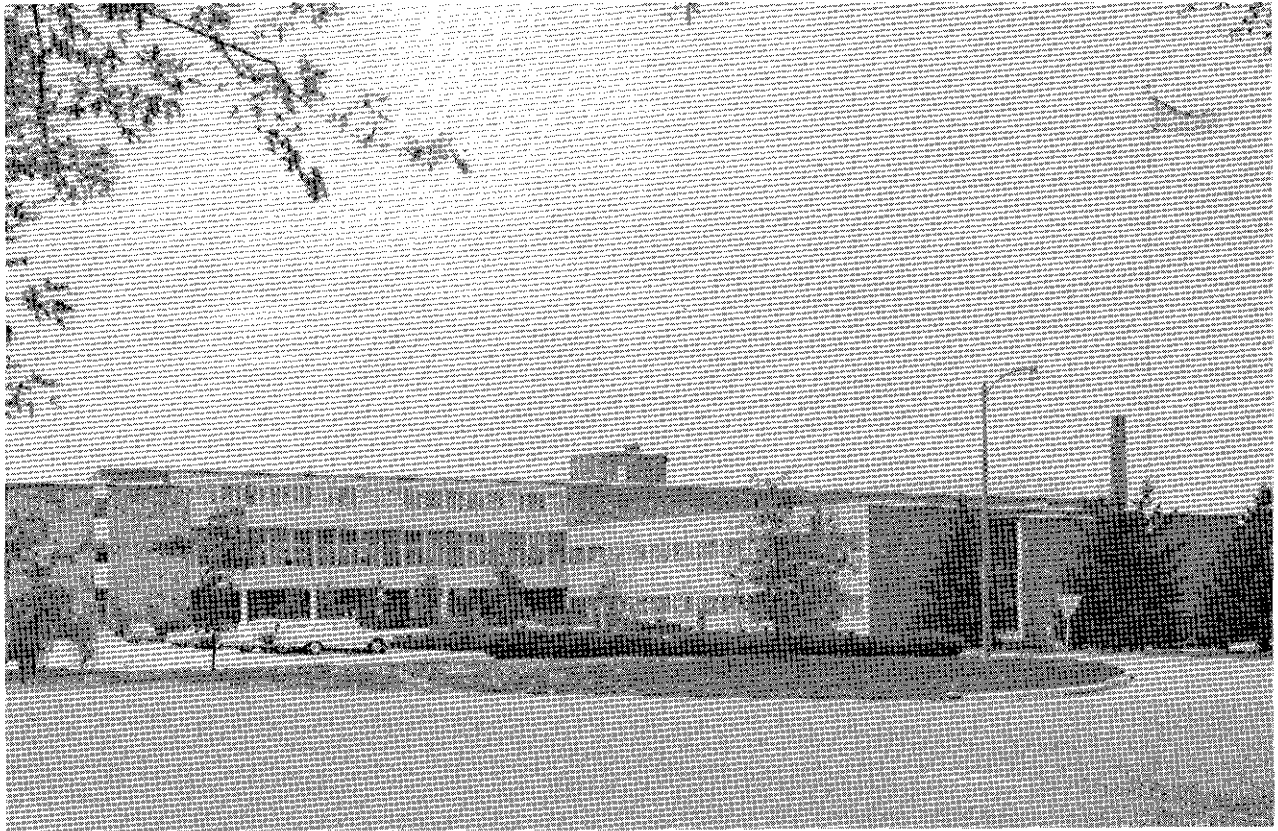

*J. Franklin Bell Hall (front view)*

*US Army Photo*

---

## CHAPTER IV

### THE COLLEGE, 1952-63

---

In the years following World War II, the mission and operational procedures of the U. S. Army Command and General Staff College became more firmly established than in any previous period in the history of the academic institution at Fort Leavenworth. The primary course of instruction, the 10-month Regular Course, was conducted once each year from September until June. A shorter, 13-week Associate Course was also scheduled each year as a means for increasing the professional ability of the officer corps within all three components of the Army: the Regular Army, the National Guard, and the Army Reserve. The stated purpose of the two courses was identical: "To prepare officers for duty as commanders and staff officers at the division and higher levels."<sup>1</sup>

<sup>1</sup> Circular No. 202, War Department, 9 July 1946.

The College staff and faculty maintained offices and supporting facilities in the Grant—Sherman—Sheridan Hall complex under the clock tower which had become a symbol of recognition for officers of many nationalities throughout the world. Student classroom activities were concentrated, for the most part, in Gruber and Andrews Halls. Gruber Hall, originally a massive brick riding hall, housed the classes of the Regular Course students. The smaller classes for the Associate Course were conducted in the wood-constructed Andrews Hall.

The academic pace and pressure which had long been associated with student life at the Army's senior school of tactical knowledge were not diminished after completion of the accelerated wartime program. Selection for attend-

ance at the College continued to be made on a highly competitive basis. Competition during the demanding courses of instruction is a very tangible aspect of a student's assignment as class members vied for positions at the top of the final academic standings. Graduation from the Command and General Staff College is a signal achievement in an officer's career, an achievement to which a great deal of importance is attached in determining his future assignment to positions of increasing responsibility.

### THE KOREAN WAR PERIOD

The initiation of the "police action" following the Communist invasion of South Korea had less immediate impact upon the planned and programed activities of the Command and General Staff College than any previous conflict involving US Army forces. To some degree, this may be explained by the fact that the extent of military effort that was eventually required for enforcement of the United Nations' principles in that country was not initially indicated. Then, too, the curriculum of the College, which had been expanded to include the many diverse military aspects of World War II, required little actual modification to incorporate lessons learned from the combat operations in Korea. While the Korean War necessitated no major changes in College organization or instruction, the Chinese Communist intervention and the resulting mobilization of US Army components created a greater demand for trained officers. Fort Leavenworth and the Command and General Staff College were called upon to satisfy this demand.

The size of the Regular Classes was increased, beginning with the course starting in 1951 which contained approximately 550 members. Starting in 1952, and continuing until the present time, the Associate Course was scheduled twice a year from January until May and from August to December. Initially, about 280 students were enrolled in each class. The Associate Course was lengthened from 13 to 16 weeks in 1953 and, beginning that year, the class was divided into two groups for the final month of the course. One group of student officers received specialized instruction in the combat arms during that period, and the other group devoted their time to the study of the logistical fields.

The College organization in 1952, as it had evolved at the direction of Commandants Maj Gen Horace L. McBride and his successor, Maj Gen Henry I. Hodes, included five instructional departments. Supervised by an Executive for Instruction, Col James W. Coutts, these departments presented all of the classes to the resident courses. Department I, headed by Col Frederick H. Loomis, presented instruction relating to intelligence matters. Col Marshall W. Frame was in charge of Department II which was concerned with armored operations and logistics. Department III, supervised by Col Keith H. Ewbank, taught ground operations and air support, while Col Charles R. Murray and Department IV were charged with airborne and amphibious operations. Department V dealt with personnel matters and was under the direction of Col William S. Bodner. Non-resident instruction by extension course for student officers was administered by Department VI under Col James B. Evans. Another instructional group, Department VII, was established that year to prepare and present instruction in the tactical employment of nuclear weapons. These instructors, under Col Karl F. Eklund, occupied Pope Hall where they presented their first course of instruction in the fall of 1952.

The curriculum of the College was planned and administered as directed by the Assistant Commandant. Emphasis was placed on command responsibilities, the functions of the general staff as it contributes to command, and the coordination of the general staff operating as a team.<sup>2</sup> Instruction was, as it is now, based upon a process of learning by application. The student became familiar with the subject matter by individual reading and study outside scheduled class hours. The subject matter was then clarified by classroom application through the use of practical exercises, map exercises, and conferences. Most of the instruction was presented to groups of from 50 to 80 students each.

The Program of Instruction for the Regular course totaled 1,253 hours of classroom work and related activities. Students began their studies with a thorough grounding in the principles of war and fundamentals of combat, and

<sup>2</sup> Instructional Circular No. 1, Command and General Staff College, Fort Leavenworth, Kansas, 1 September 1953.

continued through field army operations. An exercise designed around a joint Army, Navy, and Air Force operation, including an amphibious landing and an airborne assault, put the students through their paces in a realistic manner. Fifteen examinations took up 58 hours of the course as a means for student evaluation.

### THE DOCTRINAL MISSION

An object of continuous study within the area of operations of the Command and General Staff College had been the relationship of the staff and faculty to the formulation of tactical doctrine<sup>3</sup> for the Army. When Maj Gen Garrison H. Davidson arrived at the College as Commandant in July 1964, he reviewed the doctrinal mission as stated in SR 350-5-5: "to initiate action as necessary to formulate or revise (tactical and logistical) doctrine (of the combined arms and services)." This mission was especially significant at the time because of the tactical adaptations for the conduct of land warfare resulting from the existence of nuclear weapons. At that time a relatively small section of 12 officers was charged with the development of future doctrine, while the responsibility for current doctrine was split between the Executive for Instruction and the Executive for Research and Evaluation. Realizing that current doctrine was the basis for the curriculum at the College, the Commandant assigned this area of responsibility to the Executive for Instruction, Col John A. Gavin. For the development of future doctrine, an organization based on a weapon system approach was established. This new organization was placed under the direct supervision of Col Seth L. Weld, Jr., the Executive for Research and Analysis. It was composed of three agencies: Current Analysis Section (CAS), Combat Developments Department (CDD), and Advanced Operations Research Department (AORD). AORD was concerned with developing doctrine within a long-range time frame of 10 or more years in the future. CDD was assigned a similar function, but limited to a midrange time frame of 5 years. The CAS function was to handle

<sup>3</sup> "Principles, policies, and concepts, applicable to a subject, which are derived from experience or theory, compiled and taught for guidance. It represents the best available thought that can be defended by reason." —*Dictionary of US Army Terms*, Department of the Army, January 1961.

doctrinal studies and other similar projects assigned to the College by outside agencies, thus freeing AORD and CDD from the interruptions of planned operations that these activities had caused in the past.

A total of 42 officer positions were included in the faculty organization for doctrinal matters and, eventually, 35 of these spaces were filled. To insure that the best qualified officers were made available to fill the authorized spaces, General Davidson wrote and talked with the chief of each technical service, and personally visited in Washington, D.C., with a representative of each arm and service. All were keenly interested and enthusiastic in their support of the College effort in this field.

### STAFF REORGANIZATION

Another major action undertaken by General Davidson in 1954 was the reorganization of the College staff along directorate rather than executive lines. A feature of the existing organization that appeared to warrant correction was the span of control that was required by the Assistant Commandant, who had 21 officers reporting to him directly. The Commandant directed an ad hoc committee to take the matter under study, and the committee's recommendations were placed in effect about 1 year later.

A significant aspect of the resulting reorganization was the assignment of all instructional responsibilities to a Director of Instruction. Col William W. Culp, the first officer to occupy this position, was placed in charge of the resident and nonresident instruction departments—seven in number. An academic staff, the special representatives of the technical and administrative services, and sections representing the other US Armed Forces, as well as liaison officers from Great Britain and France, were under his supervision. In short order, the Director of Instruction became the focal point around which the execution of the College instructional mission revolved. The two other directorate agencies constituting the new organization were the Director of Research and Analysis, previously mentioned, and the office of College Secretary, then directed by Col John F. Franklin, Jr., which carried out the administrative and supply functions for the College, supervised the Printing Plant, the



Bookstore, the Library, and many other activities.

Simultaneously with this reorganization, a curriculum plan was devised to start with the 1956-57 Regular Course, which featured four phases of instruction. Phase I familiarized the student with certain basic principles and techniques, phase II was devoted to the application of these principles and techniques to the solution of relatively simple military problems, while phase III was concerned with increasingly broader and more complex problems and situations. Phase IV consisted of subject matter which would provide the student a general understanding of military affairs to widen his knowledge and background. The first three of these phases were presented in numerical sequence, with a certain desirable degree of overlap. The phase IV subjects were interspersed throughout the entire course.

#### STUDENT ACTIVITIES

The Regular Class of 1954-55 engaged in a publishing venture that produced a class yearbook to preserve the memory of their tour at Fort Leavenworth. This was the first project of this type to be accomplished by student officers as far as can be determined. The resulting volume, titled *The Bell*, established a precedent that has been followed by the publication of a similar yearbook by each succeeding Regular Class. Lt Col Jack N. Hemingway served as Editor-in-Chief for the first yearbook staff of 52 officers and 6 wives. The book, which was prepared for the presses in an amazingly short period of time, presented an attractively balanced reflection of the serious and humorous side of student life, and also included separate group photographs of each student officer and his family. Cartoon work by student artists gave recognition to a common academic affliction known as the "green sheet shakes." This phrase described a state of trepidation experienced prior to committing one's memory and knowledge to written solutions on the familiar green-colored examination answer sheets.

The class will be sure to remember the hours spent on staff studies examining the practicality of combining the G2 and G3 operations; the times when the 201st Armored Cavalry was called upon to save the day in a theoretical problem situation; and the classroom time ex-

ended in fruitless efforts to enable the 20th Division to capture the French town of Lambaille. Recollections of the days spent in Gruber Hall include the evasive action required to elude the persistent wasps attending classes with the students, and the flexibility of classroom arrangements made possible by a rather complicated system of movable walls. These adaptable partitions had already been "immortalized" by a student's poem that concluded:

. . . and when I make my last long hike,  
If the heavenly host are workmanlike,  
Those Pearly Gates will open like—  
The folding walls of Gruber.<sup>4</sup>

#### EDUCATIONAL SURVEY COMMISSION

In 1955, General Davidson, as Commandant of the College, requested an objective evaluation of the academic operation at Fort Leavenworth from an "outsider's" point of view. The last such appraisal, made in 1946 by a group of prominent civilian educators, resulted in the adoption of numerous changes and modifications in the College curriculum and instructional methods. Because of the many developments in the College that had occurred since 1946, the Commandant decided that it was time for another survey. Whereas the original survey group had been composed entirely of civilian members, General Davidson felt that it was desirable to have the survey performed by a combination of military personnel and civilians.

The Educational Survey Commission was made up of three corps commanders of World War II; retired Lieutenant Generals Troy H. Middleton, Geoffrey Keyes, and Manton S. Eddy. The remainder of the commission consisted of three civilian educators, with equally distinguished backgrounds in their fields; Doctors Harl Douglass, H. F. Harding, and Jacob S. Orleans.<sup>5</sup> The commission was in session at the Post in January and March of 1956, and submitted a final report that June.

In general terms, the Survey Commission endorsed the operations of the College and approved recent efforts by the staff and faculty to increase the educational stature of the insti-

<sup>4</sup> Lt Col R. M. Walker—Class of 1952.

<sup>5</sup> Dr. Douglass at the time was Director, College of Education, University of Colorado; Dr. Harding was Professor of Speech, Ohio State University; and Dr. Orleans was Director of Research and Education, City College of New York.

tution. The final report included numerous specific recommendations for possible improvement and areas that appeared to warrant study. The commission's report was completed within weeks of General Davidson's departure and the incoming Commandant, General McGarr, understandably deferred action on the recommendations until he could complete a personal and directed study of the academic situation of the time. It should be noted that General McGarr did concur later in over two-thirds of the commission's recommendations and incorporated them in the next major revisions within the College.

### DIAMOND JUBILEE CELEBRATION

The 7th of May 1956 marked the 75th anniversary of the founding of the military school system at Fort Leavenworth which had developed into the Command and General Staff College, and a Diamond Jubilee Program was held at the Post to commemorate the occasion. The scheduled ceremonies included an address by the Secretary of the Army, Wilbur M. Brucker, a reception and luncheon for some 500 invited military and civilian guests, and a parade by the 16th Infantry Regiment of the 1st Infantry Division from Fort Riley, Kansas. This parade also marked the first time that a unit of the 16th Infantry had set foot on the Fort Leavenworth Reservation since 1899 when elements of the regiment had departed the Post for service in the Spanish-American War. Another feature of the program was the presentation to the College of the original "Leavenworth Lamp" by the Kansas City Chapter, Military Order of the World Wars. This lamp was the outcome of a desire of the Commandant in 1955 for a traditional symbol of learning suitable for an award to indicate past membership on the College staff and faculty. The following description of the lamp is based on the design finally approved as a composite of ideas submitted in a Post-wide suggestion contest held in October 1955:

The base is the traditional lamp of learning symbolizing the knowledge acquired at the College—from which is emerging a mailed fist symbolizing the military nature of the knowledge taught at the College.

Clenched in the fist are a rifle and sword connoting the origin of the College in 1881 as the School for Application of Infantry and

Cavalry in the past with a guided missile symbolizing the future.

The entire symbol thus represents the idea that from the College emerge the leaders, who with their knowledge and control of the past, present, and future weapons of war protect our liberty.<sup>6</sup>

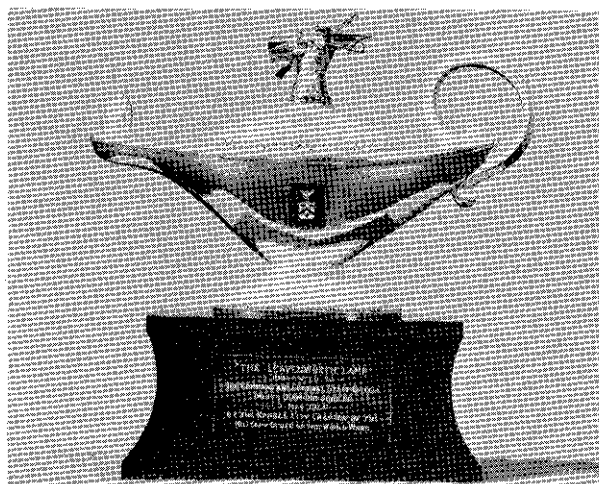

US Army Photo

*The Leavenworth Lamp*

The lamp was unveiled before Secretary Brucker and the large audience which had gathered in Andrews Hall to hear the Honorable Mr. Brucker's address. The first of many miniature replicas of the original Leavenworth Lamp was presented to General Davidson in July of 1956 immediately prior to his departure from the Post.

Other visible evidence of General Davidson's tour as Commanding General of Fort Leavenworth is the distinctive shoulder patch now worn by all military personnel assigned to the College and the Post garrison. The request for such a patch was submitted in 1954 and was approved and authorized for wear in June 1956. The official description of this now-familiar patch reads:

On a white shield 2½ inches in width and 2½ inches in height overall, with a ¼ inch red border, a blue chevron between three blue lamps, two at the top above the chevron and one below.

The design is based on the shield of the device approved for the school.<sup>7</sup>

<sup>6</sup> Afteraction Report 3 July 1954 to 9 July 1956, Commandant, The Command and General Staff College, Fort Leavenworth, Kansas.

<sup>7</sup> *Ibid.*

## MAJOR REVISIONS

In July of 1956 a new Commandant, Maj Gen Lionel C. McGarr arrived at the Command and General Staff College. Several factors indicated to General McGarr the necessity for further revisions of the College organization and curriculum. Most apparent among these factors were the report of the Educational Survey Commission, a USCONARC requirement directing increased emphasis on nuclear weapons instruction and nuclear warfare, and the pending conversion of the Army's divisions to the pentomic battle group structure.

Because of the magnitude of the changes envisioned by the Commandant, and the necessity for maintaining continuity of student instruction and College operation, a transitional organization of instructional committees was planned and established to commence academic preparations for the Regular Course of 1957-58. The personnel required to staff these committees were drawn from the officers assigned to the existing instructional departments. The departments continued with the instruction of the classes in residence, but gradually transferred increasing numbers of personnel to the instructional planning committees as they were made available by the completion of courses. The result was an orderly transfer of all necessary personnel to the new committees which was completed during the academic break between Regular Courses in the summer of 1957. The planning committees then became the instructional departments for the next scheduled courses. A large share of the credit for this reorganization and complete revision of the College curriculum is due to Col Ward S. Ryan, who was appointed as the coordinator for the entire project.

The revised organization was a departure from the centrally controlled director staff concept in that the principal College staff was now composed of assistants to the assistant commandant (a title later changed to chief). These positions initially included an Assistant for Resident Instruction, first filled by Col Harold C. Davall; an Assistant for Non-resident Instruction, to which Col Edward C. Dunn was appointed; and an Assistant for Research and Analysis with Col William M. Connor first assuming those duties. Later in the

same year, the office of the Assistant for Research and Analysis was eliminated and the missions it had served were expanded and assigned to the newly created positions of the Assistant for Doctrine and the Assistant for Combat Developments. Colonels Dunn and Victor W. Hobson, respectively, were the initial heads of these activities.

The instructional departments that grew out of the planning committee system were established along more functional, self-contained lines. The Departments of Nonresident Instruction and Special Weapons, which had previously been functionally organized departments, were retained intact within the new structure of the College staff and faculty. The remaining instructional responsibilities were assumed by the Departments of the Armored Division, the Infantry Division, Airborne Operations and Army Aviation (later this department was also to include Unconventional Warfare), Staff and Education, Larger Units and Administrative Support, and Combat Developments. Separate doctrinal elements, consisting of a nucleus of officers assigned this function on a full-time basis, were formed within each of the departments. These elements assisted the College in keeping abreast of the expanding doctrinal mission by conducting the actual review, revision, and development of doctrine. Departmental coordination in doctrinal matters was accomplished by the Assistant for Doctrine.

Another feature of this reorganization was the elimination of the academic staff. Under the new concept of decentralization, which had been recommended by the Educational Survey Commission, the instructional departments were granted increased authority for the development of curriculum content which had formerly been controlled by the academic staff. A decentralization of subject matter review was effected, with this responsibility delegated to the departments, as opposed to the previous control of these matters by a College review board.

The curriculum for the 1957-58 academic year was completely rewritten. When placed into effect, the Regular Course program devoted approximately 67 percent of the instruction to intelligence and operations subjects, with the remainder taken up by logistics, personnel, and civil affairs subjects. With the outbreak of small-scale aggression in several areas through-

out the world, recognition was given to the necessity for increased emphasis on limited war. Applicatory instruction with geographical problem settings was almost equally divided between general war and limited war situations, with about 7 percent of the instruction oriented on conditions short of actual war. In the past, nearly 90 percent of the locales for this applicatory instruction had been in western Europe. The new program of instruction placed over 30 percent of these problem settings in eastern Europe (to include the USSR), and another 40 percent in the Middle East, Africa, and Asia.

A standard 6-hour academic day was established with instruction equally divided between the morning and afternoon periods. This method of operation lent itself to the development of classroom instruction around 3-hour instructional blocks, and greatly facilitated scheduling of the program.

#### BELL HALL

Of tremendous importance to the growth and development of the Command and General Staff College was the completion of this new academic building. General Davidson had traveled to Washington, D. C., in mid-1955 to appear before the Senate Appropriations Committee and was successful in obtaining the reinstatement of the project in the Military Construction Program. The House Military Affairs Committee had previously approved the expenditure of funds for such a project, but the bill was eliminated by the House of Representatives. Plans for the building were developed and approved, Congressional approval was granted in the summer of 1956, and construction began the following November.

This \$5 million structure was dedicated on 14 January 1959 to the memory of Maj Gen James Franklin Bell, a holder of the Medal of Honor. General Bell had been instrumental in assisting the Secretary of War in the development of an overall plan for the Army educational system following the conclusion of the Spanish-American War. In recognition of the ability he had displayed in this connection, General Bell was designated Commandant of the Schools and Staff College at Fort Leavenworth during the years 1903-06. While in that capacity he established a reputation as the founder of modern methods of instruction in the Army.

Secretary of the Army Wilbur M. Brucker,

on his second trip to the Post within a year, delivered the dedication address at ceremonies held in the spacious auditorium of Bell Hall. The ceremonies included a symbolic completion of the laying of the cornerstone, and the uncovering of a memorial plaque in General Bell's honor. The activities of this day culminated the efforts of past commandants and faculty members, originating as early as 1935, to obtain an academic facility which would support adequately the contributions by the College to the Army and the Nation.

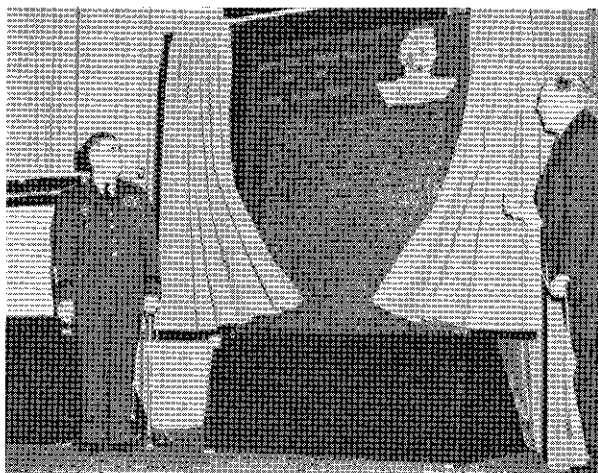

*US Army Photo*  
Unveiling of the memorial plaque in honor of General Bell by Secretary of the Army Brucker and General McGarr

J. Franklin Bell Hall is a figure 4 shaped building situated on Arsenal Hill overlooking the Missouri River. It contains over 300,000 square feet of floor space. Its unique design provides a two-story classroom and auditorium unit, a basement unit, and a three-story office unit containing a faculty briefing room, library, and offices. The classroom wing contains 24 large, fully equipped classrooms which will each accommodate 55 students with ease. The main auditorium has a capacity of 1,425 persons and the faculty briefing room has over 300 seats. Bell Hall's completion made possible the consolidation of academic facilities which had been housed either in antiquated buildings or converted structures dispersed over a considerable area of the Post. Two individuals most intimately concerned with the interior arrangements and appointments of the ultramodern building were Dr. Ivan J. Birrer, the College Educational Advisor, and Maj Wilfred C. Washcoe, the head of the College Editing and

Publishing Unit. With the increase in classroom space and other facilities provided by Bell Hall, an increased student enrollment was authorized by the Department of the Army commencing with the 1959-60 academic year. The Regular Course was planned for a student body of 750 officers, and 400 officers were to attend the Associate Courses.

The College in 1959 prepared to sponsor a course to be conducted under the auspices of the Chief of Information. First known as the Special Information Course for Reserve Components Officers, it was designed to provide personnel in the civilian community from the fields of information, education, public relations, and politics with an understanding of Army requirements, developments, missions, and goals. The first class was held for 2 weeks in August of the same year for 50 selected officers. Guest speakers and instructors from various Department of the Army agencies were provided to augment the instruction prepared and presented by the College staff and faculty.<sup>9</sup>

#### **NUCLEAR WEAPONS INSTRUCTION**

Slide rules, P(f) nomographs, scaling laws, and nuclear damage templates became tools of the military trade as instruction to provide the requisite knowledge for the tactical employment of nuclear weapons was added to the College curriculum. First presented by the College in a 6-week course in the fall of 1952, nuclear weapons instruction had developed into two courses by 1956. A 5-week course was presented to students selected Army-wide, and a 3½-week course was presented to selected graduates of the Regular and Associate Courses to train specialists in this field. These Nuclear Weapons Employment Courses (NWECC) continued in this manner until the shorter course was determined at the direction of USCONARC in 1958. Responsibility for the 5-week course was transferred to the Artillery and Missile School in July 1962 when the training requirement had diminished because of the incorporation of this instruction in the programs of the branch service schools. A 1-week refresher course for officers previously awarded the MOS prefix of a nuclear weapons employment officer is conducted at the College on a recurring basis.

<sup>9</sup> The last course of this type was conducted in June 1963. No further such courses are scheduled.

A 2-week Senior Officer Nuclear Weapons Employment Course (SONWEEC) was initiated in March of 1957 with the purpose to train major unit commanders and their senior staff officers in the tactical, logistical, and administrative doctrine, techniques, and procedures applicable in employing nuclear weapons to support Army operations, including training in the technical considerations and operations involved. In 1961, the course title was changed to the Senior Officers Advanced Operations Course, a title deemed better suited to indicate that the course was no longer solely restricted to nuclear weapons employment, but now provided a working knowledge of considerations applicable to current and future warfare. Six courses of 1 week's duration were conducted during fiscal year 1962. The course was discontinued in May 1962 because of its close similarity to a course then commencing at the Air Defense School.

#### **EDUCATIONAL ADVISOR**

A unique position at the College is that of the civilian Educational Advisor. His duties involve advising and providing consultation to the staff and faculty on matters of educational policy, methods, and procedures. Dr. Ivan J. Birrer has ably filled this position since 1948, and has become a familiar personality to thousands of officers serving tours of duty at the Post. He has provided invaluable continuity in College operations and developments over the years, as the military membership of the College has changed time and again, and its educational philosophy has been progressively developed. In recognition of Dr. Birrer's outstanding contribution to the College, he received the Meritorious Civilian Service Award in July 1960. General McGarr, in making the presentation, paid tribute to the ability, loyalty, and sincerity Dr. Birrer has devoted to the College and the many community activities in which he is engaged. In a turnabout presentation, the Educational Advisor then presented the Commandant a token from the staff and faculty—a miniature Leavenworth Lamp—commemorating the close of General McGarr's eventful tour at the Post.

#### **ACADEMIC AWARDS**

Two awards for student academic achievement have been instituted at the College in recent years. The General George C. Marshall

award to the top student of a graduating class was presented by Gen George H. Decker, the Army Chief of Staff, during graduation ceremonies of the Associate Course on 16 December 1960. This distinction for scholastic accomplishment was accorded for the first time to Lt Col John A. Ely. The initial presentation of the Gen John J. Pershing award was made to Lt Col Asa Barnard in June 1962. This engraved medallion recognizes the first-ranking student in the 5-year USAR school program of extension and resident instruction. Appropriately, the award was established 40 years from the time that General Pershing, then War Department Chief of Staff, had ordered the initiation of an Army extension course program.

### EFFECTS OF THE ARMY REORGANIZATION

The organization and routine of the College had remained relatively stable since 1957 until a change was required by the major reorganization of the Department of the Army in mid-1962. A part of this reorganization provided for the forming of the Army Combat Developments Command which would consolidate under one agency the combat developments missions then assigned to USCONARC, the technical and administrative services, and other agencies. The mission of this command included the development of "doctrine and the preparation of tables of organization and equipment and field manuals to disseminate new or revised doctrinal concepts." This mission assignment reduced the doctrinal and combat developments functions previously performed by the College. The Chief of Resident Instruction, Col Jasper J. Wilson, was then given the responsibility for insuring that the instruction presented at the College conformed with current doctrine and Army policy.

Concurrently with the relief from the doctrinal mission, the teaching departments underwent a reorganization which provided for an even more functional assignment of responsibility. Five departments were established, including the Department of Nonresident Instruction which remained essentially the same as before. The new faculty structure consisted of the following departments and assigned objectives. The Department of Command, headed by Col Wilson M. Hawkins, was to give resident

instruction in the art of command; the functions, techniques, procedures, and relationships of the staff; the command, staff, and technical aspects of the employment of special weapons; political-military theory; and the basis of national strategic planning. The Department of Division Operations formed under Col Lawrence M. Wilson was to give resident instruction in division operations, less joint and combined aspects. Col William H. Blakefield, assigned as the Secretary of the College in 1963, was placed in charge of the Department of Joint, Combined, and Special Operations which was to present instruction in joint and combined operations; joint operations to include airborne, amphibious, air-ground, and air defense operations; counterinsurgency and unconventional warfare; psychological warfare; electronic warfare; and war gaming. Col Augustus T. Terry, Jr., was placed in charge of the Department of Larger Unit Operations which dealt with resident instruction in corps (less the airborne corps) and field army operations; and combat service support of larger units (above division level) including the employment of logistical commands.<sup>10</sup>

Another change placed in effect at the same time was the elimination of the final specialized phases of instruction in either the combat or logistical fields for the students of the Associate Courses. The course duration was increased to 18 weeks and one common program of instruction became effective for all Associate class members.

### CONCLUSION

The years in the history of the U. S. Army Command and General Staff College treated in this chapter have brought about the growth and development of the College to an undisputed position as the senior Army school of tactical knowledge—a status that has been justly accorded worldwide recognition. The College programs have matured and crystallized to the extent that major changes appear neither justified nor required in the foreseeable future. This has been made possible only by the evolution of an academic institution with sufficient inherent flexibility in operation and philosophy to maintain its leading position in the Army's role of national defense.

<sup>9</sup> *Report on the Reorganization of the Army*, Department of the Army, December 1961.

<sup>10</sup> *Organization and Functions Manual*, Headquarters, Fort Leavenworth, Kansas, December 1962.

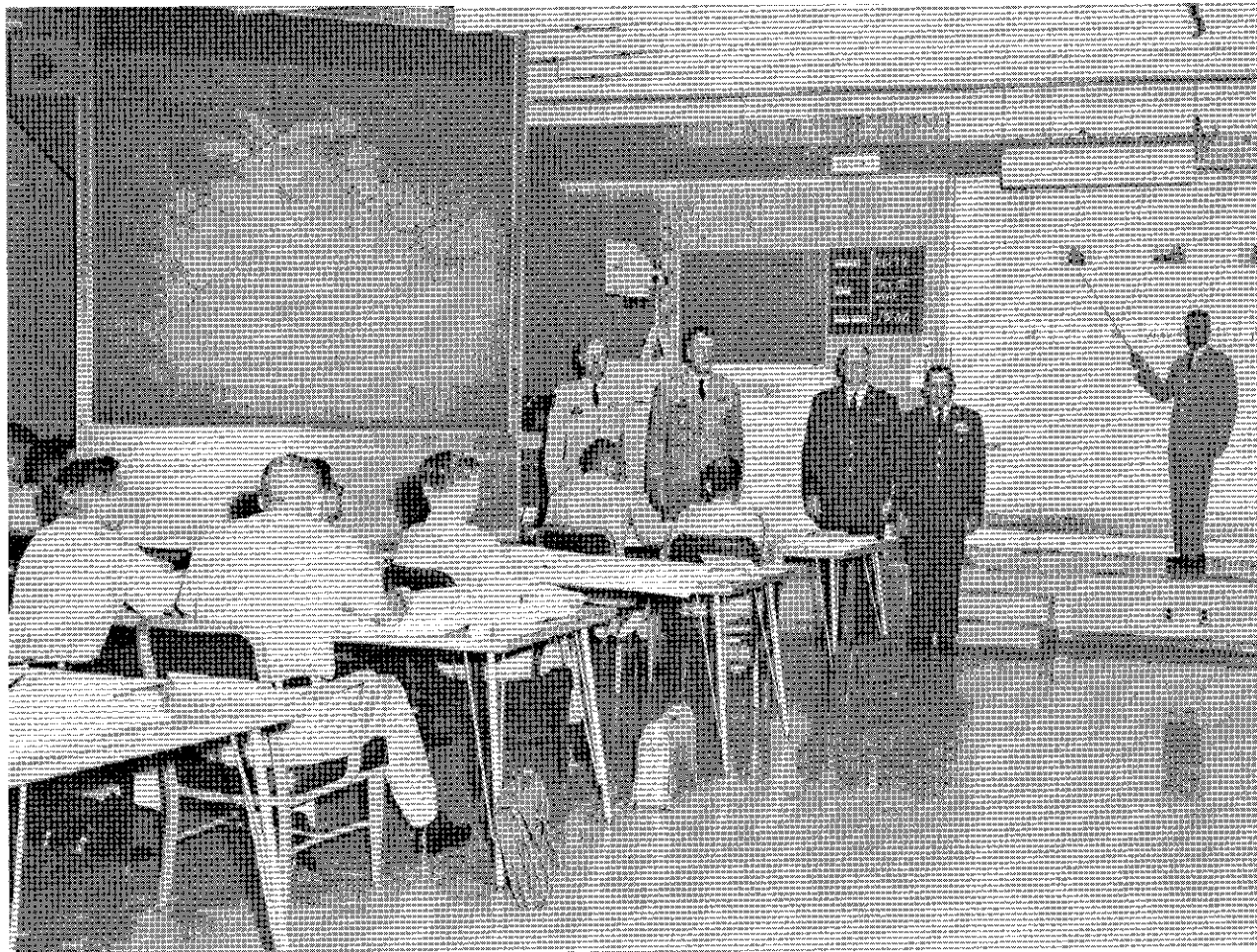

*Student officers receiving instruction*

*US Army Photo*

---

## CHAPTER V

### THE COLLEGE TODAY

---

The year 1963 passed without interruption or disturbance of planned operations as the academic mission of the U. S. Army Command and General Staff College was accomplished. Students arriving for the first course of the calendar year—the spring Associate Course—reported to Bell Hall for registration and processing and were greeted with the efficiency which has become an accustomed feature of the Post and College functioning. Procedures for this purpose have been effectively established to take care of the multitude of details that an officer must attend to upon arrival at a new post. For this one centralized operation, the processing line includes representation from

all Post activities, official and extracurricular. Students are able to accomplish every requirement from the completion of travel vouchers to registering their automobiles. The same friendly assistance was experienced in the late summer by the more than 700 members of the 1963-64 Regular Class when they found that quarters had been assigned and household goods moved in; or cots, bedding, and other furnishings set up until their personal effects would arrive. With the Regular Class in residence, and either the spring or fall Associate Courses underway, the student population at Fort Leavenworth approaches 1,200 officers.

A perpetual student problem arises in the search for automobile parking spaces in the vicinity of Bell Hall. Some students effectively solve this problem with bicycle transportation, while many others walk to and from classes and thereby obtain the benefits of exercise to compensate for an otherwise fairly sedentary academic day. Student athletic programs are organized for each class to furnish physical exertion to alleviate the mental exertion that occurs during the schoolday. Students work off excess energy, maintain physical fitness, and occasionally break bones in intramural volleyball, bowling, basketball, softball, and tennis tournaments as well as in many other Post sports facilities.

Friday evening is generally a period of relaxation for the students after the conclusion of the week's classes. Much of informal entertaining takes place in student family quarters, and the activity in the large student apartment building known as the Beehive leaves no doubt concerning the reason for its name. Many student officers gather at the Officers' Club during "happy hour" for animated discussions during which the classroom battles are refought and the college solution is a much discussed topic. The average student, however, spends much of his weekend time studying in preparation for the coming week. The College sets a traditionally demanding pace for its students, emphasizing military education rather than training.

#### THE STAFF AND FACULTY

The College at present is organized to operate within the guidelines and general policies prescribed by the Commandant, Maj Gen Harry J. Lemley, Jr., and under the supervision of the Assistant Commandant, Brig Gen Elias C. Townsend. The College Secretary, Col William H. Blakefield, is the principal subordinate to the Assistant Commandant in the planning, preparation, and conduct of College affairs. The bulk of College staff functions are delegated to three coordinating agencies: the offices of the Chief of Resident Instruction, the Chief of Nonresident Instruction, and the Secretariat.

Col Francis W. O'Brien, as Chief of Resident Instruction, is responsible for the staff supervision of the instruction presented to students

at the College and for the recommendation of policy concerning the curriculum. The Chief of Nonresident Instruction, Col Richard M. Leonard, exercises similar authority over the College programs of nonresident instruction.

On two occasions in 1963, the College structure underwent revision. With the first revision, the Office of the Secretary assumed several responsibilities which had been delegated previously to the Chiefs of Resident and Nonresident Instruction and the Class Supervisor. These included the classroom support for the resident courses, the assembly and distribution of resident and nonresident instructional materials, and the administration, direction, and supervision of the resident US students. Also assigned to this office was the supervisory responsibility for the Army Field Printing and Instructional Aids Plant and the College Book Store. These functions were placed under the staff supervision of Col I. L. Luthi with the title of Deputy Secretary/Class Director, and the entire agency was titled the College Secretariat.

The second revision resulted in the discontinuance of the Department of Nonresident Instruction. Responsibility for the preparation of nonresident courses and instructional material was given to the appropriate resident departments, thus consolidating all instructional activities.

Organization of the instructional departments and the responsibilities discharged by each remain as discussed in the preceding chapter. The services of a variety of other special staff sections and agencies also contribute to the depth of experience within the broad scope of the College staff and faculty activities. Liaison officers from the British, French, and Canadian Armies present resident instruction and advise on matters concerning their respective armed forces. In May 1963 arrangements were completed for a liaison officer from the Federal Republic of Germany to be assigned to the College, the officer to be named at a later date. Representatives of the US Navy, Marine Corps, and Air Force accomplish identical duties for their Services. A group of US Army special representatives from the technical and administrative services are assigned within the instructional departments to furnish advice and



assistance in areas related to their branches and agencies.

### RESIDENT COURSES

The Regular Course program for the 1963-64 academic year was designed:

To provide officers with a working knowledge for wartime and peacetime duty, to include the joint aspects thereof, as commanders and general staff officers at division, corps, field army, and army group (operations only) to include their combat support systems. To provide a basis for satisfactory performance in a wide variety of command and staff positions at nontactical headquarters. To provide the basis for future development for progression to higher command and staff responsibilities.<sup>1</sup>

Over 1,150 hours of academic instruction were included in the Regular Course, of which over 40 percent were scheduled for practical work and about 30 percent for conferences. The course included 670 US officers who average 35 years of age and 12 years of commissioned service. Over 80 percent of the students were in the grade of major. Prerequisites for attendance included a maximum age of 40 years, a minimum of 8 but not more than 15 years of promotion list service for Regular Army officers, a minimum of 8 but not more than 15 years commissioned service for Reserve officers on extended active duty, and a minimum of 8 years commissioned service for Reserve Component officers in an active status but not on active duty.<sup>2</sup> In addition to the US members, the class included 75 Allied officers in the grades of captain through brigadier general representing the armed forces of 46 foreign countries.

Two Associate Courses were scheduled for the 1963-64 academic year. Each of these 18-week courses was programed for 448 students of the Regular Army, Reserve Components on active duty or active duty for training only, and our Allied armed forces. Nearly 45 percent of the first class was made up of Regular Army officers. The stated purpose of this course is:

To provide officers with a working knowledge for wartime and peacetime duty as com-

<sup>1</sup> Program of Instruction for Command and General Staff Officer Course, Fort Leavenworth, Kansas, April 1963.

<sup>2</sup> *Ibid.*

manders and general staff officers of divisions and logistical commands and a general knowledge of the duties of commander and general staff officers at corps and field army to include their combat support systems. To provide the basis for future development for progression to higher command and staff responsibilities.<sup>3</sup>

Qualifications for attendance at the Associate Course are the same as those established for the Regular Course except that a student may be 44 years of age, Regular Army officers must have between 15 and 19 years of promotion list

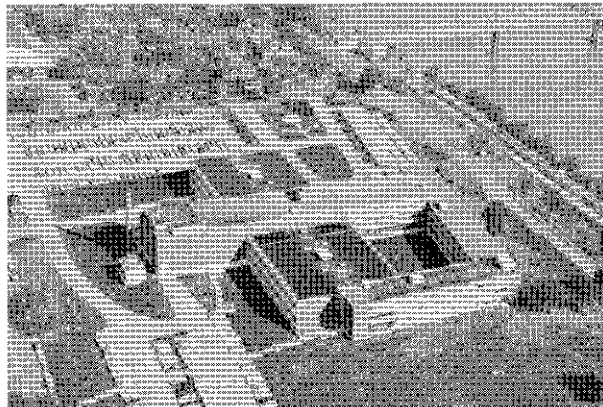

*J. Franklin Bell Hall* US Army Photo

service, and Reserve Component officers on active duty must not have over 19 years of commissioned service.<sup>4</sup>

A preparatory course is conducted prior to the beginning of each Regular Course at the College. This course is provided for the Allied students, US officers of the Navy, Marine Corps, and Air Force, and selected US Army officers. It is a resident course of 8 weeks to prepare students for the Regular Course and to orient the Allied officers on the customs and traditions of the United States. The course is presented in two phases, with the US officers joining the Allied students for phase II, the final 3 weeks of the instruction.

Allied officers scheduled for an Associate Course attend a similar precourse orientation for 1 week. Future plans provide that all Allied students who attend the Associate Course will go to the first (or fall) course of each academic year. Under this plan, these Allied stu-

<sup>3</sup> Program of Instruction for Associate Command and General Staff Officer Course, Fort Leavenworth, Kansas, April 1963.

<sup>4</sup> *Ibid.*

dents will also attend the 8-week preparatory course along with the Regular Course Allied officers, and the 1-week orientation program will be discontinued.

In both the Regular and Associate Courses, Allied students receive an 18-hour instructor orientation program to prepare them for instructor duties if they are so assigned upon return to their countries. This program is scheduled during the time the US students of the class are receiving classified instruction.

Two types of Command and General Staff Officer Refresher Courses are also conducted at the College. Of these, a 1-week combat division course is presented to two classes, each of approximately 230 students, during the early summer months. One class is composed of National Guard division commanders, general staff officers, and their principal assistants. The other class consists of officers assigned to similar positions in Army Reserve divisions and maneuver area commands. The purpose of both courses is identical—"to provide refresher training as a unit to commanders and staffs of National Guard and Army Reserve, armored, mechanized, infantry, and training divisions, and maneuver area commands; to develop staff teamwork; and to instruct in the application of current doctrine."<sup>5</sup>

The second type of refresher course, also 1 week long, is scheduled once a year for about 60 officers assigned as commanders, operational staff section directors, and their principal assistants of Army Reserve logistical commands. This course provides "military training and education as a unit to commanders and staffs of Army Reserve logistical commands, including the principles and techniques of combat service support provided by a communications zone for one or more field armies."<sup>6</sup>

The College prepares newly assigned members of the staff and faculty for instructor duties by an Instructor Training Course which is scheduled prior to the start of each academic year and at other times as required. These courses, a little over 1 week in duration, orient the prospective instructors on the College or-

<sup>5</sup> Program of Instruction for Command and General Staff Officer Refresher—Combat Division, Fort Leavenworth, Kansas, December 1963.

<sup>6</sup> Program of Instruction for Command and General Staff Officer Refresher—Logistical Command, Fort Leavenworth, November 1962.

ganization and operation, instructional philosophy, and methodology, and provide them with practical work in the preparation and presentation of instruction. Additional training for author/instructors is provided by an annual Instructor Workshop. The lecture and conference periods of this course afford a staff and faculty understanding of the College guidance and curriculum changes directed for the coming academic year, and include discussions of problems and various means to overcome them.

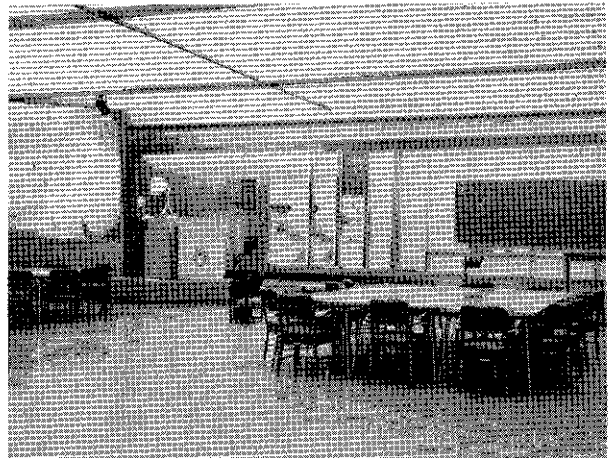

*US Army Photo*  
*Typical classroom arrangement in Bell Hall*

#### **NONRESIDENT INSTRUCTION**

Nonresident programs of instruction have been developed concurrently with the resident programs of the College to provide professional military education for present and potential commanders and general staff officers of all three Army components. The courses presented are in two categories—career courses and special courses. Career courses are the USAR School Associate Command and General Staff Course and the USACGSC Extension Course. The special courses are the Special Extension Course—Preparatory and the Special Extension Course—Graduate Refresher.

The USAR School Associate Command and General Staff Course is a 5-year program of classroom instruction for Reserve Component officers conducted for approximately 120 hours a year. The instruction each year is divided into two periods. The reserve duty training period consists of 24 classroom assemblies, each lasting 2 hours, conducted from September through May at a USAR school in the student's community. The second period is a 2-week active duty encampment during

June, July, or August at an Active Army site in the student's army area. The active duty training period in the fifth and final year is conducted at Fort Leavenworth for all students. The entire program of instruction closely parallels the resident Associate Course, and students who successfully complete the course are awarded a diploma from the College. The USAR schools are staffed by Reserve officers not on active duty, and are supervised by the appropriate corps commanders and school commanders.

The USACGSC Extension Course also parallels the resident Associate Course and is presented by correspondence to members of all Army components. It consists of 28 subcourses, each of which contains from three to nine lessons. Students who satisfactorily complete all subcourses are awarded a certificate of completion by the College. They may obtain a diploma by attending the 2-week fifth year active duty training period of resident instruction at Fort Leavenworth. The programs of this course and the USAR schools course have been designed to permit students to transfer from one to the other to alleviate conflicts with their civilian occupations and duties with their reserve units.

The Special Extension Course—Preparatory was initiated in 1958 and is now sent to all officers selected to attend the Regular and Associate Courses. It is a course of self-instruction containing material designed to introduce the selected officers to the basic terms, procedures, concepts, and organizations used in resident instruction at the College.

A Graduate Refresher Extension Course is available to graduates of either resident or nonresident courses of the College as a means of keeping up with the latest College instruction on Army doctrine, organization, techniques, and procedures. The course was first offered in 1960 and consists of eight lessons in two parts to permit incorporation of the latest information. The first part is issued in January and the second part in June.

Additionally, the office of the Chief of Non-resident Instruction distributes staff training material to Reserve Component units which supplements the instruction presented in the resident refresher courses. All available material is listed in a catalog published annually, and provides up to 120 hours of instructional

subjects applicable to the various Reserve Component units.

In May 1961 a 1-week instructor training conference was instituted for the officers who instruct in the USAR School Associate Command and General Staff Courses. The primary purpose of this conference is to familiarize these selected instructors with the educational philosophy and policies of the College, and thus promote high standards of instruction in the USAR schools. The principal objective of this training is to provide at least one instructor graduate for each USAR school. As of May 1963, 207 instructors from 97 schools had attended this conference.

#### THE ALLIED PERSONNEL PROGRAM

Each year, officers from Allied nations all over the world converge on Fort Leavenworth to attend the Regular and Associate Courses of the College. This interesting aspect of the College operation is one of the most unique, and most potentially rewarding, of the activities at the Post.

The program for the officers of countries allied with the United States had its modest beginning in 1894 with the enrollment of a lieutenant of the Swiss army for 6 months of instruction. In 1908, two officers from the Mexican Army attended the Staff College course, and the pattern was established for the continuing inclusion of Allied officers in the resident courses of instruction. By the end of the 1963-64 academic year approximately 2,600 Allied officers will have been graduated from the College. This program is a vitally important feature of our Nation's efforts to strengthen the alliances with free nations of the world by increasing the professional competence of their military leaders.

Allied student officers are administered by the Office of the Director Allied Personnel. This office, presently in the charge of Col David M. Ramsey, Jr., is responsible for all matters concerning the Allies except the instruction presented in the courses. The organization consists of an Instructional Section and an Administrative and Personnel Affairs Section. The functions of the latter section are for the most part explained by its title, and include the resolution of all the problems incidental to the stay of a visitor in a foreign land. The Instructional Section plans and conducts preparatory

courses for the Allies and monitors their academic progress, paying particular attention to any language difficulties they may encounter. In addition, the section arranges an orientation program to acquaint these students with the American way of life. The official phases of this program include a wide variety of educational films and visits to points of interest in the Middle West. A major feature of the program are trips to industrial centers and the Washington, D. C. area.



US Army Photo

*Allied wives at a tea sponsored by the International Group of the Fort Leavenworth Officers Wives Club*

The Allied officers' lives at Fort Leavenworth are not devoted entirely to an official or academic existence. It is essential that they feel at home, and this is capably handled by US officers and their families as well as families and civic groups in the surrounding civilian community. Unofficially, the Allied officers and their families are given an insight into American social customs and activities both on and off the Post. An officer of the Fort Leavenworth garrison is assigned to each Allied officer on a voluntary basis to sponsor his stay at the Post—a program which results in many mutually enjoyable and rewarding friendships. The International Group of the Fort Leavenworth Women's Club plays a major role in making the Allied officers and their families welcome by providing assistance and social activities. Under the auspices of the local chapter of the Junior Chamber of Commerce, US families in Leavenworth are assigned, again on a voluntary basis, as civilian sponsors for each Allied family. The Rotary Clubs of Leavenworth and Kansas City, the Kansas City chapters of the American Red

Cross and Military Order of World Wars, and other civilian groups host a variety of social functions for the Allied students each year.

In return for information acquired about the United States, the Allied officers take advantage of an opportunity to increase the general knowledge and appreciation of their countries among the US personnel at Fort Leavenworth by participating in the College "Know Your World" program. This program is a series of travelogs presented by the Allied officers after normal class hours. The periods are well attended and of great interest to military and civilian personnel.

Through this program of academic and social activities, the Allied students take back to their countries a well-grounded understanding of who we are, how we live, and what makes up our basic philosophies. They also become acquainted with other Allied students and, by their classroom and off-duty associations, further their understanding of the people and customs of many different nations.

#### THE MILITARY REVIEW

The *Military Review* is an official Army publication, published by specific authorization of the Department of the Army. Publication is financed with appropriated funds and the magazine is subject to Government printing regulations. The mission of the *Military Review* is to provide a forum for the expression of military thought, with emphasis on the doctrine pertaining to division and higher levels of command. The views expressed in the magazine are those of the authors and are not necessarily those of the Army or the Command and General Staff College.

The *Military Review* accomplishes its mission through the publication of original articles of current interest by authoritative US and foreign authors, digests of selected articles from foreign and domestic sources, reviews of books on professional military subjects, and a military notes section of short, illustrated feature items. Printed monthly and distributed to approximately 21,000 readers, the magazine's influence extends over a wide area. It is a valuable source of material for the Command and General Staff College, the Army War College, Army Reserve schools, and other Army educational and training facilities. It is also stocked in the libraries of numerous civilian

universities, and principal US and foreign military installations.

In the furtherance of inter-American military knowledge and cooperation, the magazine is also published in Spanish for Latin and South American countries, and in Portuguese for distribution in Brazil. Publication of the Spanish-American edition is supervised by US Army officers; the Brazilian edition, because of the extensive use of the publication by the military forces of that country, is edited by an officer assigned by the Brazilian Ministry of Defense. Recently, at the recommendation of the current Brazilian Editor, Lt Col Joao A. Faco, the Chief of the Brazilian Military Commission in Washington, D. C., assumed a degree of responsibility for the Brazilian edition.

Significant changes in concept and format of the *Military Review* have been implemented since 1960 by the Editor in Chief, Col Kenneth E. Lay. Emphasis on purely doctrinal matters has been deemphasized under the premise that official field manuals are the appropriate publications for the dissemination of doctrine. In 1961 it was decided that each issue would present a balanced coverage of various subject areas, rather than the special issue practice of the past. Currently, for example, an issue may contain a historical article, one on counter-insurgency, perhaps one on world strategy, another on division organization, and others.

A beneficial liaison relationship was established in 1961 when Lt Col Daniel E. Halpin, a member of the Army War College Faculty, was announced as an Associate Editor of the *Military Review*. In a mutual agreement between the Commandants of the two colleges, this Associate Editor reviews possible source material at the War College for *Military Review* articles, and makes recommendations concerning publication to the editor in chief. He also furnishes advice and assistance concerning source material under consideration by the *Military Review* about which the War College may have particular knowledge.

Prior to 1961, editions of the *Military Review* reflected an austerity policy. Major consideration was given to economy of space, and white unprinted areas were regarded as wasteful. Understandably, this policy did not lend itself to the production of an attractive

magazine. The January 1961 edition of the *Military Review* introduced the new look which was based, in part, upon a survey of the magazine's readers. Page size was increased as was the type face. A simple, attractive cover design was incorporated and more liberal and judicious use of illustrations and artwork was employed. The guideline was that each article would be treated as a separate case, illustrated and laid out in a manner best suited to make it attractive and readable. A military digests section of condensed reprints of previously published material was discontinued, with these digests treated similarly to original articles and interspersed throughout the magazine.

The 40th year of publication was celebrated by the staff of the *Military Review* in February 1962. An open house, held in the editorial offices, and an official reception were attended by members of the College staff and faculty, and civilian guests prominent in the fields of educational and commercial journalism. Gen Barksdale Hamlett, the Army Deputy Chief of Staff for Military Operations, was the guest of honor and speaker at the reception held at the Officers' Open Mess. A program for continued improvement in the publication of the *Military Review* was announced by the Commandant, General Johnson, and published in a special 40th Anniversary supplement to the magazine.

Effective with the November 1963 issue, an awards program to recognize outstanding authorship was established that differed from previous programs of this nature. As announced by the Commandant, General Lemley, the program provides that authors of award articles will receive a \$25 bonus and an engraved certificate in addition to a standard honorarium. Award articles will be selected, without regard to number, and announced in subsequent issues of the *Military Review*. In a revised selection process, each of the College departments and staff agencies submits monthly nominations for evaluation by the *Military Review* staff which will, in turn, submit recommendations to the Commandant for final approval.

Other recent innovations designed to increase the popularity and circulation, while improving the content of the magazine, include the distribution of informative news letters, a facts and features handout for general use, a trial

subscription plan at reduced rates for graduates of the College, and an effort to sell the the *Military Review* in service school book stores.

The above measures, and numerous others, have been taken at the offices of the *Military Review* by a staff determined that the publication will continue to warrant the tribute paid in 1962 on the occasion of its 40th year of existence:

Throughout this age of remarkable development, the *Military Review* has kept pace with the needs of the Army it serves. Through its close association with the Command and General Staff College, it has provided an important medium for the presentation and dissemination of Army doctrine. As a forum for the expression of informed opinions and advanced thinking, the *Military Review* has afforded our military leaders that opportunity for critical analysis and frank evaluation which is so essential to progress.<sup>7</sup>

#### THE PRINTING PLANT

After many years of operation with sections physically separated in several locations, the Army Field Printing and Instructional Aids Plant moved into its present location on Grant Avenue in 1950. The primary mission of the Plant is to provide printing and training aids to support resident and nonresident instruction at the College. Within the capabilities of the Plant, support is also rendered to Post activities and other authorized agencies. In addition, the Plant prints the *Military Review* and operates an Audio-Visual Communications Center (formerly known as a Film and Equipment Exchange) and a Photographic Laboratory.

As one of the more modern facilities of its type in the Army, the Plant has undergone numerous changes in recent years to effect greater economy and more efficient use of manpower and material. These changes have included a phasing out of letterpress equipment, which has been replaced by cold-type composition and an augmented lithographic capability. Modernized processes and the mechanization of hand operations have been incorporated as new equipment has become available to satisfy requirements of the Plant. The College makes

extensive use of overhead transparencies as instructional aids because of the ease with which information can be imparted by this technique. The capability for production of these instructional aids was significantly increased in 1952 when a complete silk screen processing facility was added to the Plant, and again in 1956 when color film processing equipment was installed in the Photographic Laboratory.

Today the Army Field Printing and Instructional Aids Plant is equipped and staffed to provide limited letterpress printing; complete lithographic printing of multi-colored maps, map overprints, and overlays; instructional texts and administrative publications; a wide variety of instructional aids; and photographic development and printing facilities in support of the College and the Post.

#### LIBRARY DIVISION

An important facility of the College today is its Library Division under the supervision of Mr. Anthony F. McGraw. The Library Division is administered by the College Secretariat to provide materials and assistance to the students, the staff and faculty, and the military personnel and their dependents at Fort Leavenworth. The Library has been a recognized necessity for academic operations from the founding of the first school at the Post. From a rather inauspicious start in those early years, almost entirely caused by a lack of funds, the Library has grown to present holdings of over 85,000 volumes and periodicals, more than a score of newspaper subscriptions, and a impressive number of pamphlets, documents, and tape recordings.

A College Archives was first established in 1943 as a repository for numerous classified documents received during World War II. In 1963, the holdings of this document library number over 230,000 items, including extensive files of microfilm, and provide an invaluable source of military reference and background material in nearly every imaginable field. The Library, which was located in Wagner Hall until 1959, now occupies most of the second and third floors in the center wing of Bell Hall. In 1963, the Archives was consolidated with the Library and is now operated as an integral part of the Library Division. The Library is used extensively at the present time in connec-

<sup>7</sup> Message from the Secretary of the Army, Washington, D. C., January 1962.

tion with administrative, educational, and research activities at the College.

### **GUEST SPEAKERS**

The Guest Speaker Program of the College has proved a most effective means to provide a general knowledge in support of the curriculum through the services of a vast array of authoritative lecturers, both military and civilian. As an indication of the importance currently attached to this facet of the College operation, about 40 eminently qualified speakers present provocative and vital topics to each Regular Course. More than 100 hours are allotted for this purpose.

Topics cover a broad spectrum ranging from the goals of US diplomacy and military strategy, current developments in critical geographical areas of the world, communistic policies and long-range plans, to the military possibilities enabled by technological advances in space. The last 30 to 40 minutes of a guest speaker presentation are usually devoted to a question and answer period. Often, following the formal presentation, seminars are scheduled, with the speaker and selected students examining aspects of the subject matter in more detail.

The Chief of Resident Instruction is responsible for the implementation of the Guest Speaker Program, which is developed by his office and the instructional departments. The program consists of two parts: College speakers and departmental speakers. The College speakers present subject matter on broad topics with general application to the curriculum as a whole, while the departmental speakers discuss topics in support of a specific department.

During the 1958-59 academic year, the first British lecturer to the United States under the exchange program sponsored by the Kermit Roosevelt Foundation spoke at the College. This lecture series has continued since that time.

The Guest Speaker Program is recognized as an important supplement to classroom instruction at the College. During recent years, the College has been most successful in obtaining

as guest speakers high level military officers and civilians well qualified in their fields.

### **THE HONORS PROGRAM**

Members of the 1963-64 class of the Command and General Staff Officer Course were the first student officers to be offered an opportunity to participate in a voluntary program officially known as the Honors Program. On 21 March 1963, this program was accredited by the North Central Association of Colleges and Secondary Schools for the award of the degree Master of Military Art and Science. Actual award of this degree cannot be accomplished until approval is granted by the Congress of the United States. The Honors Program, which was designed to complement the Regular Course, consists of the course itself, a thesis describing a research experience on a significant problem within the scope of the College curriculum, and comprehensive written and oral examinations.

Lt Col Bruce C. Koch was appointed the special assistant to the College Secretary to plan and organize the program, and he worked closely with Dr. Birrer in its development. Students electing to take advantage of the program are assigned faculty advisors to provide assistance in their research efforts.

Although the first Honors Program is scheduled for completion subsequent to the time of this writing, this challenging addition to the curriculum gives every indication of providing qualified students an opportunity to demonstrate their capacities for advanced scholarship. As such, it marks yet another milestone in the progress of the College.

### **CONCLUSION**

This chapter has covered briefly the present organization, operation, and activities of the U. S. Army Command and General Staff College. Despite the certainty of predictable and unforeseen future developments, the College can be expected to insure, as it has so capably in the past, that continuing service to the Army and the Nation is rendered by an academic institution "Prepared in Peace for War."

## CHAPTER VI

### COMMUNITY LIFE

The greater portion of the Fort Leavenworth community is made up of student officers and their families. This population, although predictably transitory, is accorded treatment at the Post in keeping with the justifiable importance attached to the end product of the U. S. Army Command and General Staff College

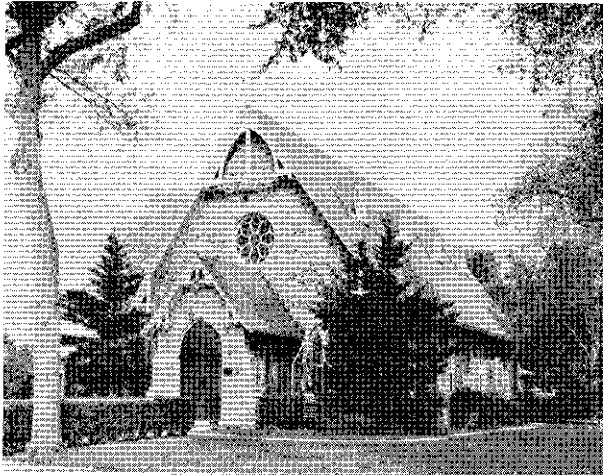

*The Post Chapel*

*US Army Photo*

—the officer graduate. Many of the organizations and activities of the Post have been oriented on a mission to simplify, while at the same time enrich, the life of the students and their dependents in a manner unique within the Army establishment. Exclusive absorption in an academic routine can be detrimental to any well-adjusted person. This fact has long been recognized at Fort Leavenworth which probably offers more spiritual, professional, social and recreational opportunities than any other military installation or civilian community of comparable size.

#### COMMUNITY ACTIVITIES

Religious services and activities, a community focal point at every Army post, are available to all at Fort Leavenworth. Three Army chaplains plan and present spiritual programs centered around chapel exercises and religious education. The present Post Chaplain, Chaplain (Lt Col) Henry L. Durand, also guides the Catholic religious activities. Chaplains (Lt Col) Theodore V. Koepke and (Capt)

Wayne G. Shelton serve the Protestant members of the military community.

Protestant religious programs provide general Sunday services at the Post Chapel and the Normandy Chapel as well as services for the Episcopal, Lutheran, and Latter Day Saints denominations. The choirs at both chapels are notably outstanding. Several Protestant groups complement the services of worship. Col James E. Simmons heads the Protestant Men of the Chapel which assists by providing ushers, setting up Christmas, Easter, and outdoor services, and supporting chapel organizations. The Protestant Women of the Chapel are directed by Mrs. James N. Love and attend to many chapel activities. In addition to an Altar Guild, this women's group holds sessions of religious study, repairs and maintains choir and acolyte vestments, and promotes charitable functions. The Protestant Youth of the Chapel are organized in a senior group by Lt Col and Mrs.

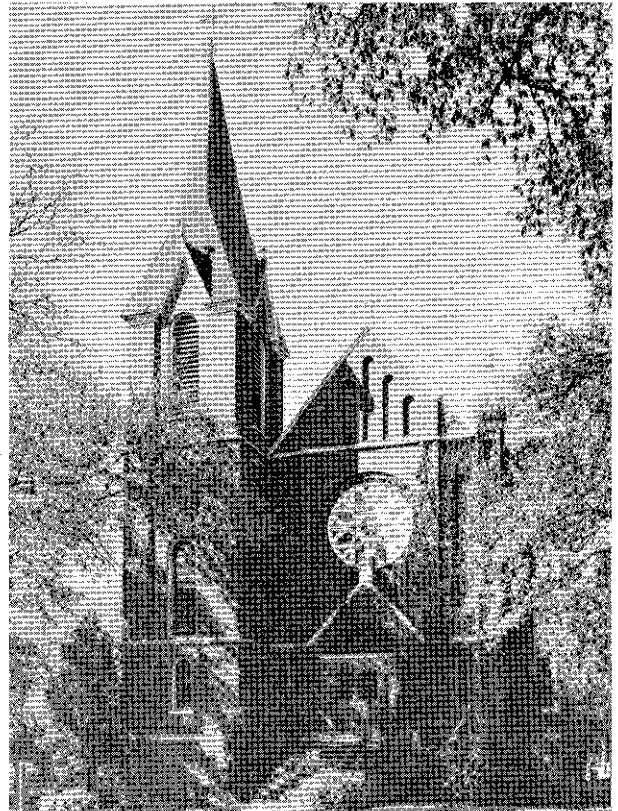

*St. Ignatius Chapel.*

*US Army Photo*



Charles B. Ablett and Chaplain (Maj) and Mrs. Thomas J. McMinn, and a junior group by Col and Mrs. Albert D. Shutz. The groups meet at the Post Chapel Center on alternate Sundays. Protestant acolytes serve at both chapels and meet at the call of the Acolyte Fathers for practice and refreshments.

The Sunday School enrollment averages 1,400 children in classes scheduled at the Post Chapel Center and Annex as well as the Normandy Chapel Annex. The current Board of Superintendents is composed of Lt Cols Wayne F. Pickell, John D. Ford, Raleigh O. Taylor, and Harvey D. Piper. Classes are conducted for children from 2 years of age through senior high school age.

An adult Bible study group meets regularly at the Post Chapel Center Annex and additional Bible studies are scheduled for a women's class, an enlisted class, and Sunday School classes. Opportunities are provided during the year for all Protestants desiring membership with a specific denomination to attend preliminary instruction and become members of their selected church.

The Catholic religious program at the Post provides Catholic families with a schedule of services to meet their religious needs. A total of seven Sunday Masses are held at the St. Ignatius and Normandy Chapels besides weekday morning and afternoon Masses. An adult choir and two youth choirs enhance liturgical life and observances of the parish. All members of parish families are invited to join the several active parish societies.

The Holy Name Society, with Col Richard M. Leonard as president, is the organization for all Catholic men of the Post. Corporate reception of Holy Communion by the society is a monthly affair. The society, among its other activities, assists in supervising the St. Ignatius parochial school system. The Altar Rosary Society conducts monthly meetings at which Mrs. Melvin E. Hoekstra presides. A principal project of these Catholic women is the adornment of the chapel altar and sanctuary. All Catholic high school students, in the grades 9 through 12, are eligible for membership in the Catholic Youth Organization Teen-age Club of St. Ignatius Parish. The club's objective is to provide an opportunity for discussion of the religious and moral issues facing our youth. Lt Col Theodore W. Peterson is the supervisor of

this group which also conducts a variety of social events at its weekly meetings. An Altar Boys Guild is directed by Maj Eugene J. Ringel to encourage young boys to assist at the altar during Mass and devotions.

Scouting is a major character building activity for the younger members of the Fort Leavenworth community. Four troops of Girl Scouts represent the Brownie, Junior, Cadette, and Senior levels of scouting. A program for the older boys is provided by five Boy Scout Troops and an Explorer Scout Post. The Post's Cub Scouts lay claim to belonging to the largest Cub pack in the world.

The Girl Scout program in 1963 was opened to girls from 7 to 17 years of age, regardless of previous scouting experience. The current neighborhood chairman is Mrs. Dayton F. Caple. Spring campouts and day camps are planned for all age groups, and the girls' camping area on the Post, Camp Conestoga, is the scene for campfires and songfests in the fall.

The theme for 1963's Boy Scout activities was "Scouting and Advancement" as every Scout was encouraged to progress in rank and merit badge achievement along with the healthy fun and companionship that Scouting has always provided. A traditional fall kick-off dinner launches each year's schedule of events which include frequent camping and hiking trips in areas around the Post. A permanent campsite, Camp Miles, was completed during the summer of 1963 in the northwestern part of the military reservation through a mutual effort by Scouts and parents. Monthly Courts of Honor are arranged by the chairman of the Troop Committee—now Col John O. Austin—to present a Scout of the Month Award, ranks of advancement, and merit badges.

Cubmaster for the "largest pack in the world" is Maj Gerd S. Grombacher. The pack has an annual membership of more than 300 boys which, because of its size, is divided into four pack groups. In February the pack organizes its annual Blue and Gold banquet for the young Scouts and their parents, and in May they gather for a Cub Scout picnic.

The teen-age population at Fort Leavenworth is one of the largest at any Army post in the country. Fulfilling the needs of this group for wholesome recreation and entertainment is the Army Brats Club. The club provides music, dancing facilities, ping-pong and billiard tables.

Other assets include an outdoor patio, a snack bar, and modern clubroom furniture. Supervision is provided by a full-time manager and an advisory council, but the most important feature of the club is that the sole responsibility for its planning and maintenance is in the hands of the teen-agers themselves.

A Youth Activities Association (formerly known as the Dad's Club) coordinates all Post youth activities, making certain they operate smoothly. The association's general membership, with Col Abb Chrietzberg as president, includes the fathers of all children at the Post. It handles the organizational affairs and budgets of the Scout groups, the youth baseball leagues, a junior golf program, and the Army Brats Club. In addition, the association allocates funds to the Special Services youth projects for playgrounds, basketball leagues, bowling, swimming, sports instruction, and the Patch Community Center. Money to support all these popular facilities and organizations, so important to the younger set, comes from a number of sources, but primarily from the Leavenworth United Fund and proceeds from the Post Thrift Shop.

The Post Rod and Gun Club is open to all military personnel and dependents interested in outdoor life—whether it be hunting, fishing, training field dogs, or fish and game conservation. A clubroom located in McNair Hall is used for biweekly meetings, which usually include a speaker and films on some aspect of hunting and fishing, and the several parties sponsored by the club during the year. The club holds a fishing derby each year for young anglers, with prizes for the boy or girl catching the biggest, smallest, and most fish. A spring fishing trip to the Lake of the Ozarks is also arranged for club members. Cabins, boats, and motors are reserved in advance of the motor caravan departing the Post for a weekend of sport. One of the chief aims of the club, however, is to promote fish and game conservation. In a recent operation supervised by club president, Col Frank H. Barnhart, Jr., Merritt Lake was cleaned and restocked with fish, and the club plans to repeat the project in adjoining Smith Lake. Game bird cover and food crops have been distributed over the reservation game area, and the local supply of quail has been increased by stocking and controlled hunting to complement the doves, pheasants, rabbits, and squirrels

found in the Post's hunting areas. A yearly drawing for prizes of outdoor equipment is arranged to provide funds for these conservation projects.

An extremely spirited and colorful organization at Fort Leavenworth is the hunt. First organized in 1926, the hunt was officially recognized as a member of the National Steeple Chase and Hunt Association in 1931, and subsequently became one of the most famous organizations of its type in the country. At the outset of World War II, the hunt was disbanded and its colors retired. In 1951, a group of military personnel obtained the use of two stables on the Post and organized a self-supporting, private riding club which, for the sake of tradition, assumed the name "The Fort Leavenworth Hunt."

During the 12-year period of this history, the hunt operated facilities for the stabling of private mounts, and conducted a variety of informal riding activities—schooling, trail riding, field days or gymkhanas—as well as social events. Major annual activities were the spring and fall horse shows featuring equitation, hunter, jumper, and novelty classes. The excitingly interesting shows have attracted large numbers of entries by horsemen from neighboring areas of Kansas, Missouri, and Nebraska. A formal Hunt Ball has usually been conducted at the time of the spring show.

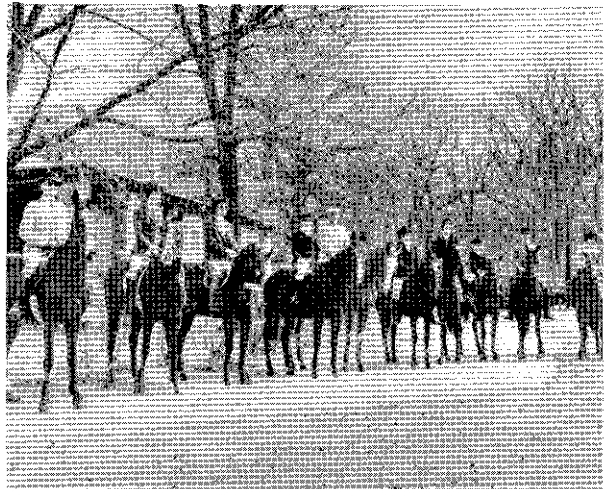

*Photo by Lt Col Richard W. Swenson  
A group of members of the Fort Leavenworth Hunt  
assembled at the Hunt Lodge.*

Until recently, the management of the hunt has been handled by an elected board of governors, and the regular membership varied

from 35 to 50 officers and enlisted personnel. The number of mounts stabled by the hunt has been between 35 and 65 creating an average annual requirement for some 10,000 bales of hay and straw, and about 5,000 bushels of oats. Three employees were maintained by the hunt membership, with the members themselves pitching in for special projects. In recent years, the nature of the hunt membership has somewhat shifted. With a diminishing number of "old cavalymen" on the active roles of the Army, adult membership has decreased, with a compensating increase in active junior riders. A Junior Hunt Council has been organized as part of the regular riding association.

Also, in recent years, two events have been established as traditional hunt activities. Each year, on an evening just before Christmas, mounted hunt members turn out in force, accompanied by other members riding in the old hunt bandwagon and hay cart, for "carolling on horseback." The other popular event is a semiannual "Day at the Races" held at the Officers' Mess for all mess members. The Mess building is decorated in a racetrack motif, and the feature attraction of the evening is a race of wooden horses "ridden" by ladies of the Post over a backgammon-like track according to the fall of dice.

In April 1962 the hunt broadened its activities by contracting for stable management and the operation of a rental riding and instruction program. This service has been enthusiastically received and has resulted in an increase of several hundred associate members. The profits from this operation are devoted to needed improvements to hunt property and facilities.

The official name of the riding association was changed to "The Hunt, Fort Leavenworth" on April 7, 1963. In July of that year, under the supervision of The Hunt President, Col Edward R. Lewitz, The Hunt began truly living up to its name by reviving fox hunting as one of its activities. Kennels were built for a pack of 14 foxhounds, and live and drag hunts have been scheduled during the season under the capable control of Masters of Foxhounds Maj H. A. Kellner (US Army-retired) and Lt Col Charles C. Ross.

An outstanding service to the community is contributed by the Red Cross Volunteers who donated well over 30,000 hours of their time to

the Munson Army Hospital during 1962-63. These dedicated women are a familiar and welcome sight to the patients and hospital staff as they perform duties as gray ladies, nurses aides, staff aides and in other capacities in the less glamorous side of hospital routine. Mrs. Robert H. Deason is chairman of these volunteer services that assist the hospital medical staff in the clinics and wards, the library, and during annual physical examinations and special inoculations for Post personnel.

The military education system at Fort Leavenworth discussed in the two preceding chapters is supplemented by an adult civilian education system for assisting active duty military personnel in raising their levels of formal schooling. The Post Education Center arranges for educational programs such as correspondence courses, preparatory group study classes, proficiency testing, and instruction from accredited colleges and universities. In one recent year, 169 enlisted men completed high school through the center, and over 60 gained the equivalent of a year of college study. Increasing numbers of officers, both permanent party and students, attain the academic requirements for the Army's degree completion program while at Fort Leavenworth. Evening courses from the University of Kansas and nearby Park and St. Mary's Colleges are offered by the center for this purpose. Many of these Army "bootstrappers" go on to earn baccalaureate degrees.

The Post community engages in so many varied activities that a comprehensive description of them all would be most difficult. It is even more difficult to determine an interest outside normal family life and military duties that cannot be pursued through membership in one of Fort Leavenworth's community organizations. For the more active sportsmen, flying, parachuting, skeet, judo, and even cricket clubs are available. The one recreational activity attracting the greatest participation continues to be the game of golf, as devotees flock to the Post's fine 27-hole course on days of fair weather (and other days not so fair) throughout the entire year.

An extensive, long-range program for improvement and maintenance of the golf course was initiated in June 1963 under the guidance of the Assistant Commandant, General Townsend. The golf director at the time was Col

James B. Kemp who got the program underway. On Colonel Kemp's retirement in August, he was succeeded by Col Robert W. McCartney. The greenskeeper serving under both directors was Mr. Cecil Miller. A tremendous improvement in the playability and appearance of the course has been brought about through the preparation of a detailed, written plan for the course, improved management techniques, and a more effective use of materials for maintenance. Installation of a permanent sprinkling system on the greens was begun, holes were renumbered to facilitate better control of play from the first and tenth tees, numerous trees were planted along the fairways, and the "back 9" was beautified by the draining and dredging of Merritt Lake. These and other measures, including the employment of a consultant on golf courses from Kansas State, have resulted in returning this course to its former position as one of the finest in this area.

The traditional hub of Post social activity, the Fort Leavenworth Officers' Open Mess, is scheduled for a major renovation. A general repair and refurbishing of the swimming pool were completed in July 1963 and a bath house and poolside snack bar will be ready for the 1964 season. The complete renovation, planned under the supervision of Col William H. Blakefield, President of the Board of Governors, includes remodeling and construction modifications to practically every interior facility of the Mess building. The present dining room will include an informal dining area and beverage lounge to be known as the Sutler's Room. In addition to all new furnishings, the formal dining area will contain a charcoal broiler where diners can see their steaks and lobster prepared. A new private dining room, complete with bar and pantry service, will be installed in the space now occupied by the business offices. A considerable amount of new equipment will be added to the kitchen which will then be rearranged to provide more efficient food service. The main ballroom will be remodeled to provide for division into four smaller areas by means of portable wall sections. The entire ballroom will then be redecorated and an enclosed service bar constructed in one corner. These, the first modifications other than minor structural improvements to be made to the Mess building which was originally designed as a dairy barn, are scheduled for completion

in late 1964. At that time, the membership of the Mess will be afforded facilities unprecedented in the long history of the Post, and a caliber of service in keeping with the long-established Fort Leavenworth community traditions.

#### CIVIC RELATIONS

The cordial relationship enjoyed by the Post with the city of Leavenworth has continued over these years. The degree of cooperation between military and civilian officials is evidenced by numerous joint projects.

The city of Leavenworth, in May 1957, received a Certificate of Achievement from the Secretary of the Army as official recognition of the exceptional contributions made by the city in the interests of the Post. The award was presented by General McGarr at the annual dinner of the Leavenworth Chamber of Commerce in the Cody Hotel. The citation noted the outstanding patriotic service performed by the city since 1952, and the city's continuing demonstration of its devoted interest in problems of immediate concern to Fort Leavenworth. In 1959, Leavenworth adopted the slogan: "The Best Army Town in the USA." Thousands of military personnel and their dependents who have been treated with warmth and hospitality by the citizens of Leavenworth wholeheartedly agree to the validity of that slogan.

In 1958, the Post established "A Day at Fort Leavenworth"—a visit to the military establishment by select groups from the surrounding communities. This recurring event brings together business, professional, and civic leaders for an orientation on the College, the Post and its activities, and the modern Army. It is intended to promote understanding and stimulate interest in military affairs, and has been most successful in attaining these objectives. Special invitations are also extended from time to time to groups of industrialists to view College operations. This project provides a means of acquainting these business executives with the aims and results of the College programs. It also encourages them to permit those among their employees who are members of the Army National Guard and Reserve to attend resident courses of the College for which they may qualify.

In cooperation with the Mayor of Leaven-

worth, a Civilian-Military Council of 10 members was formed in 1959. Five prominent civic figures were appointed to council membership by the mayor as counterparts to five officers from Fort Leavenworth. The council meets periodically to discuss and resolve any area of friction which would tend to disturb harmonious relations between the City and the Post.

An opportunity to further the Army's information goals is provided through the participation of members of the College staff and faculty, students at the College, and personnel assigned to the Post in a program of public speaking. The program is coordinated by a Speakers Bureau, supervised by the Post Information Office, which fulfills requests from civic, fraternal, industrial, veterans, and Reserve organizations for guest speakers. Allied officers also take part in the program which has arranged speaking engagements in the four-state area of Kansas, Missouri, Nebraska, and Iowa. The Information Office itself, managed by Lt Col John J. Killian and his principal assistant Mrs. Henrietta Elving, plays a key role in keeping the civilian community abreast of developments at the Post and within the Army by a continuous flow of information releases to local news media.

Other cooperative efforts effectively strengthening civic relations are the enthusiastic support of the Henry Leavenworth Chapter of the Association of the United States Army, annual United Fund drives, and joint sponsorship of many commemorative and festive activities. Typical of the cooperation in the last category was the staging of the Leavenworth County Fair in August 1963, where Fort Leavenworth went all out to provide unusual sports demonstrations, musical and vocal talent, and administrative and publicity support to insure the success of the 4-day event.

### **SPECIAL SERVICES**

The Post agency responsible for maintaining morale and welfare through planned recreational activities is the Special Services Office headed by Lt Col Robert A. Domos. With offices located in the Patch Community Center, Special Services is concerned with six recreational areas: sports, handicrafts, youth activities, the Post Library, a Service Club for enlisted personnel, and musical and theatrical entertainment.

Outdoor sports facilities managed by Special Services provide opportunities for participation in a diversity of athletics. Two swimming pools, 10 tennis courts, lighted softball diamonds and a football field, and two ice skating rinks are scenes of healthy, enjoyable recreation in the appropriate season. A 14-lane bowling alley, two gymnasiums, squash and handball courts, and a swimming pool are provided for indoor athletics. Softball and basketball draw large crowds to the scheduled contests of the Post teams—the Leavenworth Knights—with teams from the surrounding area. Nearly all these facilities are made available to the Post children through year-round scheduling of junior leagues and tournaments. Children can spend many active hours in playground areas, some 27 in all, conveniently located throughout the Post.

A well-stocked Post Library is operated by Special Services in the Patch Community Center, and branch libraries are maintained at the US Disciplinary Barracks and its local parolee unit, as well as at Munson Army Hospital. The Post Service Club is a favorite gathering place for enlisted personnel, and offers television, games, and reading material in addition to evening programs of bingo, music, and dancing. The Post Theater provides showings of current motion pictures during the evening for adult and family entertainment, and Saturday matinees which attract, as intended, a vociferous small-fry audience. The Special Services entertainment section also sponsors soldiers shows, maintains a library of music and recordings, and furnishes advice and assistance to the Fort Leavenworth Dramatics Club.

Hobbyists and "do-it-yourselfers" are well provided for at the Special Services Craft Shop. Tools and materials for jewelry making, enamelling, ceramics, leathercraft, woodworking, photography, and oil painting may be obtained for use on a self-directed basis. Classes in ceramics and painting are scheduled, and instruction can be provided on request in other handicrafts. An automotive craftshop, complete with servicing and shop facilities, was recently opened as a most welcome convenience for the increasing number of amateur mechanics.

Special Services makes provisions for the children at Fort Leavenworth in fields other than sports. Classes in puppetry, acrobatics, drama, and dancing are all held at the Patch

Community Center. Special children's parties at Christmas, Easter, and Halloween have become traditional; and now puppet plays, dramatic presentations, and dance recitals have become special events for the youngsters demonstrating newly acquired talents before admiring parents.

One of the most popular attractions, based on attendance, in which Special Services has a hand, is the Independence Day fireworks display. This evening display is co-sponsored by Fort Leavenworth and the Leavenworth Chamber of Commerce, and has drawn thousands of persons in each of the 16 years it has been staged. The spectators gather on the north shore of Merritt Lake for this spectacular program of pyrotechnics and military band music.

Cultural entertainment for the general public, such as performances by the Kansas City Philharmonic, the University of Missouri String Orchestra, and other local band concerts are arranged by Special Services.

Periodically a consolidated Post activities registration period is conducted by the Special Services to acquaint newcomers and students arriving at Fort Leavenworth with all the many recreational opportunities available to the Post community. The Special Services office fulfills an important responsibility by contributing to the atmosphere of pleasantly rewarding activity on the Post.

#### **SOCIAL AND PROFESSIONAL ORGANIZATIONS**

The most widespread social organization at the Post, the Fort Leavenworth Officers Wives Club, began its 1963-64 season with a welcoming tea in September at the Officers' Open Mess. All student, staff and faculty, and garrison wives were invited to this annual gathering of old and new members which featured a talk by Maj Gen Harry J. Lemley, Jr., the Commanding General.

Monthly luncheons are held for the club's membership, and each of these affairs is followed by a special program of entertainment or an educational subject. While these get-togethers enable the members to make new acquaintances and strengthen old friendships, it is the unusual variety of special interest groups, coordinated by Mrs. Anthony B. Cristo, the Club President, and a capable staff of assistants, that makes the club such an interesting and unique organization.

An Art Group offers lessons in oil painting by an instructor from the Kansas City Art Institute and arranges a spring exhibit of the members' work. Members of the Great Books Group select and review a number of literary classics each season. Other clubwomen meet frequently to develop and maintain fluency in French and German through conversation in those languages.

A Sewing and Tailoring Group meets each week at the McClellan Officers' Club Annex for instruction in beginner, intermediate, and experienced seamstress classes. Felt, patterned, and cocktail hats are the fall projects for the ladies of the Millinery Group. Other domestic skills are developed by a House and Gardens Group which plans a series of programs dealing with homemaking.

The International Group always comprises a large membership as it continues its service to the community by providing American-style hospitality to the families of the Allied student officers. The friendships established, the background knowledge gained, and the awareness of actual contribution by the ladies active in this group have long proved to be more than adequate compensation for their time and energy.

The game of bridge, consistently a popular pastime among the women, is prominent on the club's calendar of events. Duplicate sessions are scheduled two evenings a week, and one weekday afternoon is set aside for social bridge. More active recreation is the objective of golf and tennis groups, and women's bowling leagues are quickly established each year.

A Senior Set arranges social gatherings for dependent and visiting mothers, aunts, and grandmothers. Just to make sure that no field of endeavor is overlooked, the club recently added programs devoted to interior decorating and public speaking.

The Daughters of the US Army is an organization accepting as members the daughters of officers of the Armed Forces. The daughters of Allied student officers are also cordially invited to join the Fort Leavenworth chapter which was reactivated on the Post following World War II.

The Daughters were originally formed 36 years ago at Fort Benning, Georgia, to provide its members a means to keep in touch with one another as military assignments moved them

to stations all over the world. The chapters at many Army installations, however, work not only to maintain contact among the membership but also to support charitable and social activities. The Fort Leavenworth chapter sponsors a hospital emergency fund, providing nursing care for women and children. With its funds it purchases various items for the comfort of the patients in Munson Army Hospital. Scholarships for deserving high school students and donations to the Post museum fund are among the worthy projects of the organization.

Funds for these projects are derived in part from sales of a Post activities calendar prepared each year by the members. The principal source of money, however, is the proceeds from the gala Mardi Gras celebration staged by the Daughters every 2 years at the Post. Mrs. Albert D. Shutz served as chapter president to supervise the planning of these charitable projects, as well as evening social affairs, at business meetings following each monthly luncheon.

The Boughton Memorial, completed in 1922 on Kearney Avenue south of Sumner Place, serves two distinct purposes. Constructed as a meeting place for Hancock Lodge, No. 311, A. F. & A. M. of the Masonic Order, provisions were made in the building appropriation bill for a portion of the first floor to be set aside for the Fort Leavenworth Post Office. Hancock Lodge, which was instituted in 1889, is one of the most well known among military personnel. It was named after Gen Winfield S. Hancock, a former commander of the Department of Missouri and a Democratic presidential candidate in the elections of 1880. The building was dedicated to the memory of Col Daniel H. Boughton, who served as Assistant Commandant of the schools at Fort Leavenworth and as Master of Hancock Lodge. This old and honored lodge organizes a full schedule of activities for Masons and their associated organizations with regularly stated communication for degree work.

The Association of the US Army (AUSA) is an organization with headquarters in the Nation's capital and chapters throughout the United States and overseas. As the one organization representing the entire Army, it is devoted to the premise that a strong, modern, mobile Army is vital to our national security. General membership in the AUSA is open to

any individual subscribing to the association's aims and objectives.

The Henry Leavenworth Chapter of the AUSA, organized in 1956, has expanded to approximately 2,000 members. The geographical area of the chapter includes eastern Kansas and western Missouri. Chapter activities within this area are administered from the office of the chapter secretary at Fort Leavenworth. The chapter was cited by the AUSA in 1959, 1960, and 1961 for outstanding service to its community and the Army. In 1962 it was declared the best chapter, overall, in the AUSA and became the only chapter to receive the annual award for the second time for best telling the Army's story. The chapter, in 1963, again earned this national award.

The objectives of the Henry Leavenworth Chapter for 1963-64 are (1) to support the cause of national defense and to improve this support by wider member participation, improved public relations, and liaison activities; (2) to strengthen the ties with leaders of industry, commerce, and the professions by an aggressive campaign to enroll these leaders in chapter membership, and by providing speaker programs to service and civic groups; and (3) to insure more effective chapter cooperation and liaison with educational institutions and to encourage the prestige and student participation in the ROTC program.

To achieve these objectives, the chapter has established community liaison chairmen in the more populous urban centers within its area. It has sponsored several of the "Days at Fort Leavenworth" for industrial, civic, and professional groups which included orientations on the Command and General Staff College, the AUSA, and recent Army developments and functions. The chapter's theme for 1962-63 in telling the Army's story was "the Army's role in today's world." Col J. W. Morgan arranged the speaker program around this theme with presentations covering a wide range of informative topics. During the year, 41 speakers, consisting of students and faculty of the Command and General Staff College, appeared before nearly 100 civic, service, church, school, and college groups. Chapter awards during the same year were made to 125 outstanding ROTC cadets, students, educators, and others for excellence and service in a variety of fields.

The chapter traditionally has an annual dinner dance at the Fort Leavenworth Officers' Mess in June each year. Approximately 200 members, including Maj Gen Harry J. Lemley, attended the 1963 meeting. Figuring prominently in the affairs of the chapter, in addition to the president Col Ted C. Bland, are Mr. Vic Shalkoski—vice president, Mr. Wendell Lehman—treasurer, and Lt Col Wayne F. Pickell—secretary. By past performance, and present efforts, the Henry Leavenworth Chapter of the AUSA insures future support of its parent association in accomplishing the AUSA's stated purpose of "fostering, supporting, and advocat-

ing the legitimate and proper role of the Army of the United States."

Community life at Fort Leavenworth is as diversified and rewarding as the backgrounds, experiences, and interests of the inhabitants of the Post. The innumerable facets of this complex society both supplement and complement the vital military missions accomplished by the military members of the community. The compatible, beneficial synthesis of the official and unofficial aspects of Army life has given rise to the exceptional reputation enjoyed and maintained by Fort Leavenworth as an outstanding asset among the Nation's military resources.



**APPENDIX I**  
**CHRONOLOGY OF EVENTS**

---

- 1952—Associate Command and General Staff Officer Course scheduled on a semiannual basis.  
—Maj Gen H. L. McBride departed command in March.  
—Maj Gen H. I. Hodes assumed command in April.  
—125th Anniversary Celebration of the founding of Fort Leavenworth, 9-10 May.
- 1953—Associate Command and General Staff Officer Course increased from 13 to 16 weeks.
- 1954—Maj Gen G. H. Davidson assumes command in March.  
—City of Leavenworth Centennial, 6-12 June.
- 1956—Diamond Jubilee celebration of the 75th anniversary of the U. S. Army Command and General Staff College, 7 May.  
—Maj Gen L. C. McGarr assumed command in July.  
—General Henry Leavenworth Monument rededicated, 4 July.  
—Henry Leavenworth Chapter of the Association of the US Army organized in December.
- 1957—Major changes in the College curriculum and organization.
- 1958—Inter-Service Golf Tournament held on Post, 19-22 August.
- 1959—Dedication of Bell Hall, 19 January.  
—Armed Forces and Frontier Day celebration, 16 May.  
—Combined Arms and Services Conference, 18-22 May.  
—Increase in student input to both the Regular and Associate Command and General Staff Officer Courses.
- 1960—Dedication of the Midwest Relay Station, 18 February.  
—The Air Defense Battery became operational in April.  
—Maj Gen H. K. Johnson assumed command in August.
- 1962—The Military Review celebrated its 40th anniversary, 13 February.  
—Fort Leavenworth designated a National Historic Landmark, 12 May.  
—Combat Arms Conference II, 19-29 June.  
—Activation of the Combined Arms Group, 1 July.
- 1963—Maj Gen H. J. Lemley, Jr. assumed command in January.  
—Initiation of the student Honors Program.  
—Post observed period of mourning for the death of President John F. Kennedy, 22 November.

APPENDIX II  
MAP OF FORT LEAVENWORTH

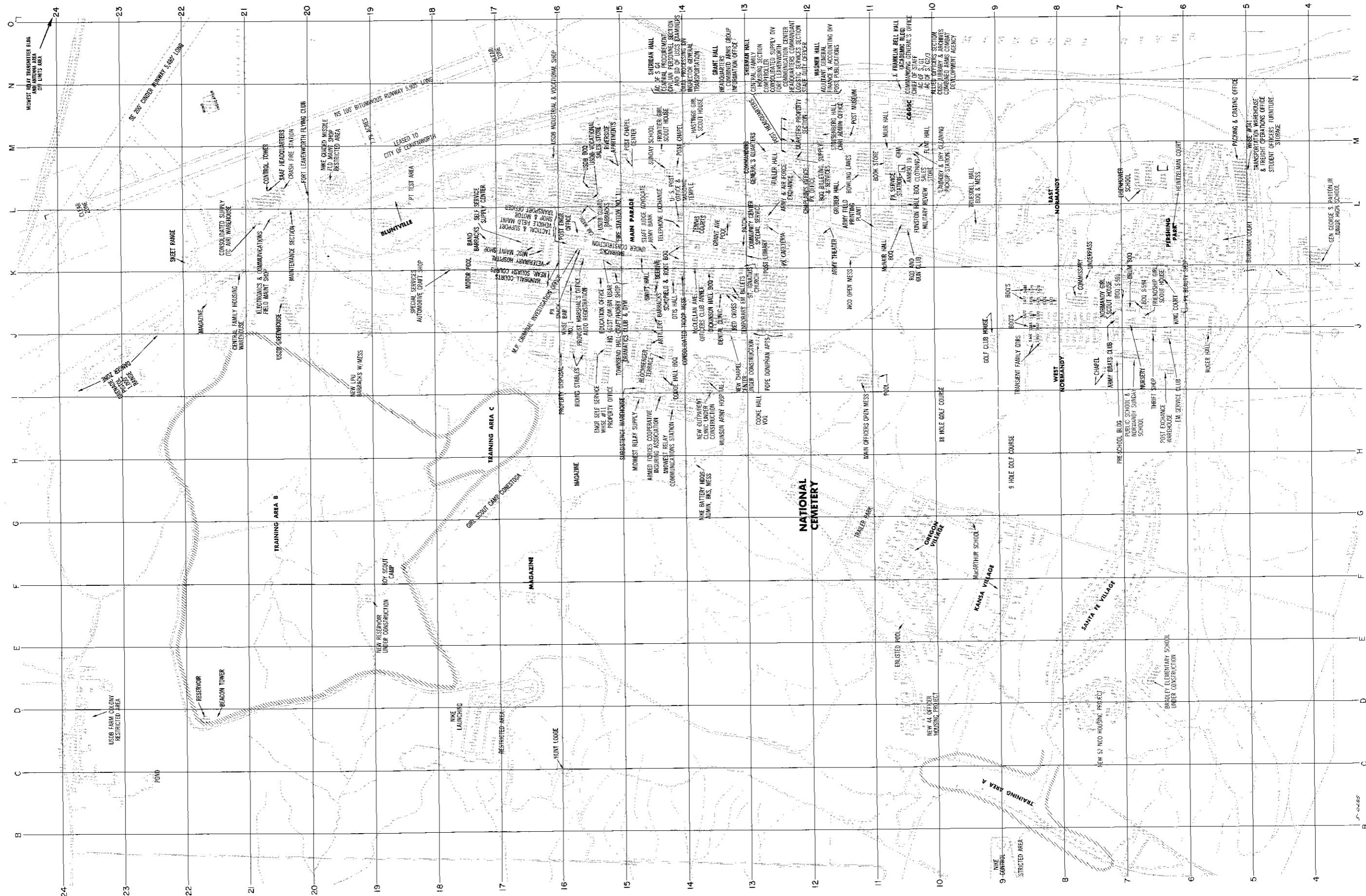



**APPENDIX III**  
**COMMANDANTS, 1952-63**

---

McBride, Horace L., Maj Gen	October 1950	— March 1952
Hodes, Henry I., Maj Gen	March 1952	— March 1954
Beauchamp, Charles E., Brig Gen	March 1954	— July 1954
Davidson, Garrison H., Maj Gen	July 1954	— July 1956
McGarr, Lionel C., Maj Gen	July 1956	— August 1960
Johnson, Harold K., Maj Gen	August 1960	— February 1963
Lemley, Harry J., Maj Gen	February 1963	—

**APPENDIX IV**  
**ASSISTANT COMMANDANTS, 1952-63**

---

Johnson, Max S., Brig Gen	April 1951	— February 1953
Beauchamp, Charles E., Col	February 1953	— April 1955
Train, William F., Brig Gen	April 1955	— July 1957
Zierath, Frederick R., Brig Gen	July 1957	— January 1960
Cunningham, William A., Brig Gen	January 1960	— July 1961
Lemley, Harry J., Jr., Brig Gen	August 1961	— January 1963
Townsend, Elias C., Brig Gen	April 1963	—

---

**APPENDIX V**  
**DEPUTY POST COMMANDERS AND CHIEFS OF STAFF, 1952-63**

---

Hedekin, Thomas B., Col	July 1950	— June 1953
Meehan, Charles G., Col	June 1953	— July 1954
Robbins, Chandler P., Col	August 1954	— January 1957
Culp, William W., Col	January 1957	— August 1958
Courser, Malcolm W., Col	August 1958	— October 1958
Liwski, Francis W., Col	October 1958	— July 1962
Erlenbusch, Robert C., Col	July 1962	—

---

**APPENDIX VI**  
**COLLEGE SECRETARIES, 1952-63**

---

Lamont, James M., Col	1952	— 1954
Franklin, John F., Jr., Col	1954	— August 1957
Buynoski, Adam S., Col	August 1957	— July 1959
McKee, Edgar S., Col	August 1959	— June 1960
Broberg, Richard A., Col	June 1960	— July 1962
Edwards, Edward G., Col	July 1962	— July 1963
Blakefield, William H., Col	July 1963	—

**APPENDIX VII**  
**HEADS OF KEY ACTIVITIES**

---

**DEPUTY COMMANDERS, THE COMBINED ARMS GROUP**

Works, Robert C., Col	July 1962	— June 1963
Hawkins, Wilson M., Col	June 1963	—

**COMMANDING OFFICERS, STATION HOSPITAL**

Alexander, Frank O., Col	July 1951	— May 1953
Anderson, Norman W., Col	May 1953	— July 1957
Russell, Joseph P., Col	July 1957	— June 1959
Caples, Joseph T., Col	June 1959	— July 1963
Taber, John H., Col	August 1963	—

**COMMANDANTS, US DISCIPLINARY BARRACKS**

Davis, James W., Col	June 1952	— September 1959
Cox, Weldon C., Col	September 1959	— November 1963
Slobe, Elmer L., Col	November 1963	—

**COMMANDING OFFICERS, MIDWEST RELAY STATION**

Hancock, Hampton S., Capt	January 1958	— March 1958
Cunningham, Thomas P., Maj	March 1958	— April 1958
Anderson, John A., Lt Col	April 1958	— September 1959
Colwell, Hanford T., Lt Col	September 1959	— May 1961
Collins, John M., Maj	May 1961	— July 1961
Von Bargaen, Gerald C., Lt Col	July 1961	—

**COMMANDING OFFICERS, THE AIR DEFENSE BATTERY**

Marzari, Guy J., Capt	August 1959	— April 1961
Main, Robert G., Capt	April 1961	— November 1962
Gibson, Leland D., Jr., 1st Lt	November 1962	— January 1963
Sanderson, John O., 1st Lt	January 1963	— March 1963
Welsh, Milton, Capt	March 1963	—

## APPENDIX VIII

### POST CONSTRUCTION PROJECTS

---

From June 1950 through 1956, military construction at Fort Leavenworth was limited to minor construction projects and maintenance. However, non-Government owned building construction at the Post was expanded during that period, beginning with the leasing of a tract of Fort Leavenworth land, approximately 0.5 acre located at the southwest intersection of Biddle Boulevard and Kearney Avenue, to the Army Cooperative Fire Association for construction of a two-story office building, No. 325, which that association completed in 1953. Later, in 1959, a second structure, Utility Building No. 322, was constructed on this same acreage by this firm.

In August 1952, a portion of the reservation, 18.36 acres, was leased to the Fort Leavenworth School District for a school site and, by 1955, the Eisenhower (Elementary) School, Building No. 327, located on the east side of the Pershing Park housing area was completed. It was in July 1955 that 15.02 acres of Post land were leased to the Fort Leavenworth School District for construction of another elementary school—the MacArthur School, Building No. 326, located on the west side of Biddle Boulevard in the Oregon Village housing area. With the leasing of a third tract, 13.03 acres, in November 1957, the Fort Leavenworth School District constructed the General George S. Patton, Jr., Junior High School, Building No. 392, located on the east side of Grant Avenue, just to the south of the Pershing Park housing area. A combination Maintenance Shop-Storage Building No. 351 was completed by the school district in 1963. This structure was located just north of the school.

Major military construction resumed at Fort Leavenworth in 1957 when the US Army Signal Midwest Relay Station Mission was assigned this command. The Midwest Relay Station Communications Building, No. 136, located on the west side of Biddle Boulevard south of Kearney Avenue, was completed that year. The original one-story main building was of concrete foundation, concrete floors, concrete block and brick walls, with tar and gravel roof. In 1959, an addition to this main building was necessary to house equipment for an expanded op-

eration; and, finally in 1961, the unfinished basement for this addition was completed. During 1963, construction of a second addition, with basement, was added to the main building. The Midwest Relay Station Transmitter Building, No. 138, and antenna area, located in a restricted area beyond the northeast dike area of Sherman Army Airfield, were completed in 1961; and in the same year, two emergency generator buildings were constructed—Building No. 139, located in the above restricted area; and Building No. 121, located near the Communications Building, No. 136. In March 1960, a tract of 13.47 acres of US Department of Justice land, located within the southwest boundaries of the US Federal Penitentiary lands, was purchased; and the Midwest Relay Station's Micro Wave Repeater Building, No. 2002, with supporting facilities, was completed in 1961. In 1960, two buildings with supporting facilities for housing Midwest Relay Station's Radio Receiver Station equipment (Building No. 2000) and a Standby Generator Building (Building No. 2001) were constructed on land of the Sunflower Ordnance Works near Lawrence, Kansas.

In 1957, three identical concrete block ammunition storehouses, Buildings No. 112, 113, and 179, were completed. These storehouses are located in the magazine area—extending northward from McPherson Avenue and east of Sheridan Drive.

Located just inside the Grant Avenue entrance to Fort Leavenworth, on the east side of the avenue, is the Post Entrance Building, No. 51 (Information Office). This unique stone structure was completed in April 1958. Construction was performed by USDB prisoners, using native stone that, until the year 1957, inclosed a portion of the east wall of the Fort Leavenworth National Cemetery. This native stone was quarried during the latter part of the nineteenth century from one of the several quarries located on the reservation at that time.

Construction on the new academic building housing the United States Army Command and General Staff College—James Franklin Bell Hall, Building No. 111, began after a ground-breaking ceremony on 5 November 1956

and was completed 24 November 1958. This building is located on historic Arsenal Hill overlooking the Missouri River. Its design is the shape of the figure four and contains three floors with basement. It is constructed on drilled piers to rock footing with concrete foundation walls, concrete floors, steel frame window wall with insulated porcelain panels—brick faced masonry exterior walls, and concrete with 5-ply built-up roofing. This building contains the following facilities:

Twenty-four 50 student capacity classrooms

Auditorium with balcony and stage—1,425 seats

Briefing Room with stage—323 seats

Library and office space

Cafeteria with 316 serving capacity

Barber Shop

Storage areas

Boiler Room located in sublevel basement.

Prior to construction of Bell Hall Academic Building, No. 111, the Command and General Staff College occupied space in 15 buildings on the Post. With completion of this new structure, numerous changes resulted throughout the Post by the relocation of activities in those buildings previously occupied by the College. During 1960, extensive modification and alteration to the west half of Gruber Hall, Building No. 302, was made to accommodate a 14-lane bowling center for Special Services. In 1959, the Post Museum moved to Andrews Hall, Building No. S-801, a former College classroom building.

During 1951, 1952, and 1953, 227 sets of student officer family quarters were constructed under the Wherry Family Housing Act. This housing was located on the former site of World War I barracks and is presently known as Pershing Park. Ownership and title for these quarters were transferred to Fort Leavenworth by the US District Engineer through condemnation action in 1958, at which time the Post Engineer accepted real property accountability, to include maintenance and repair responsibility, for these buildings. These one-family quarters were constructed on a three-bedroom plan, prefabricated wood frame, without basement; however, since 1958, many dwellings have been modified to include a fourth bedroom with half-bath and a clothes closet.

In 1957, just south of the Fort Leavenworth

National Cemetery and Post Trailer Park, construction of 50 two-officer-family dwellings, under the provisions of the Capehart Housing Act, was completed. These one-story duplexes, some with basements and others without basement, were of reinforced concrete foundation, oak and vinyl asphalt tile floors, with hardboard siding and brick veneer trim walls. This area, originally known as Capehart I, is now known as Oregon Village.

In 1959, just south and west of Oregon Village, 40 four- and six-officer-family dwellings (20 each four-plex and 20 each six-plex—200 sets of quarters), constructed under the Capehart Housing Act, were completed. These two story, four- and six-plex dwellings with basement were of reinforced concrete foundation, oak and vinyl asphalt tile floors, with concrete block and brick walls. This Capehart II area is now known as Kansa Village.

During 1960, 100 each two-noncommissioned-officer family dwellings (100 duplexes—200 sets of quarters), constructed under the Capehart Housing Act, were completed. This housing was constructed just south and west of Kansa Village. These two-story, with basement, duplexes were of reinforced concrete foundation, oak and vinyl tile floors, and hardboard siding walls. This Capehart III area is presently known as Santa Fe Village.

With completion of the foregoing new housing areas, 28 buildings comprising the Bluntville (USDB noncommissioned officer) housing, which had been constructed in the late 1870's were demolished. Five other noncommissioned quarters located on west Kearney Avenue, which were built in 1884, were demolished, as were many of the semipermanent barrack-type structures of World War II vintage, which had been converted to family quarters, located in the West Normandy area.

Construction of a new bachelor officers' quarters with mess (Building No. 225—Truesdell Hall), located northeast of the intersection of Grant and Stimson Avenues overlooking Smith and Fuller Lakes, was completed in 1959. This 90-bedroom bachelor officers' quarters, with mess serving capacity for 340 persons, is a two-story structure (irregular design) of reinforced concrete foundation, concrete slab and asphalt tile floor, and concrete and brick walls. This building contains an in-



dividual heating plant boiler room, kitchen, an entrance lobby, and a lounge.

Upon completion of Truesdell Hall in 1959, the Enlisted Men's Consolidated Troop Mess, which had been located in Building No. 48, was moved to Building No. 244, the former Consolidated Officers' Mess—just north of the old Station Hospital Building, No. 198.

Since its designation as a class A airfield, improvements at Sherman Army Airfield to provide increased capabilities of operation began in 1958 with construction of the control tower atop Hangar Building No. 132 and the installation of a radio room, during 1960, at the base of the control tower. Also, during 1960, the north/south runway was completely resurfaced and reduced in width to 100 feet, using a bituminous surface over a rock base, with rock surface and base stabilized shoulders (50 feet wide) on both the east and west sides of this runway. At the same time, the north, south, and northeast taxiways were increased in surfaced areas.

In 1959, Fort Leavenworth, through lease action, granted exclusive use of 7.79 acres of Sherman Army Airfield land to the city of Leavenworth (Kansas) for use as the city's municipal airport. This area is located due south of the Guided Missile Field Maintenance Shop, Building No. 75, and is to be used for hangar and maintenance building space as well as taxiway to the runways. Included in this lease was the concurrent use, with the US Army, of an additional tract of 233.50 acres of Sherman Army Airfield which comprises the runways and taxiways of the main field.

During 1960, construction was completed on the four widely dispersed United States Army Air Defense Command (USARDCOM) Nike-Hercules Missile Bases (two sites in Missouri and two sites in Kansas) and the Missile Battalion Headquarters site established for the air defense of the Metropolitan Kansas City area. One of these bases, Nike Site KC-80, was located at Fort Leavenworth. Twenty-seven buildings and structures, with supporting facilities, dispersed in three distinct and separate areas make up the Fort Leavenworth site. These areas are as follows: Nike Battery Headquarters area—located north of the National Cemetery; Nike Control (restricted), Nike Launch (restricted) areas—located along

the western boundary of the Fort Leavenworth Reservation.

The logistical support mission for all four bases, battalion headquarters, and the ARAD-COM troop units operating them in this air defense was assigned Fort Leavenworth. To provide the necessary guided missile field maintenance support for these units, a new Guided Missile Field Maintenance Shop, Building No. 75, was constructed in 1961. This building is located at Sherman Army Airfield—just south of Hangar Building No. 132.

In 1961, construction was completed on the Munson Army Hospital, Building No. 343. This three-story, with basement and penthouse, 90/190-bed hospital structure has a reinforced concrete foundation, concrete slab and asphalt tile floors, concrete block and brick walls, and a built-up tar and gravel roof. The Munson Army Hospital Powerplant, Building No. 344, was completed that same year and has a reinforced concrete foundation, concrete floors, concrete block and brick walls, and built-up tar and gravel roof. This powerplant contains three boilers fired by fuel oil fed from two 10,000-gallon capacity tanks. The Munson Army Hospital area is located northeast of the intersection of Pope Avenue and Biddle Boulevard.

As of December 1963, the old Station Hospital Building, No. 198, located on Thomas Avenue, still contained the Dental Clinic on the first floor of the north wing; however, since 1962, the remainder of the building has been the home of Headquarters Company and Headquarters Detachment troops.

During February 1963, construction was completed on two-story with basement Army Nurses and WAC Officers' quarters. These two structures, Building No. 338 and Building No. 339, located on the west side of Kearney Avenue just east of Dodge Hall (Building No. 268), are identical in exterior design with concrete foundations, concrete floors, brick masonry walls, and asphalt shingle roofs. Although identical in exterior design, because of construction differences within the interiors, Building No. 338 has a designed capacity for 16 persons, whereas Building No. 339 has a designed capacity for 19 persons. At an appropriate dedication ceremony, this building area was officially dedicated as Blochberger Terrace.

In February 1954, a license dated 27 October 1905, which granted the Young Men's Christian Association, Inc., the right to construct and maintain a building (YMCA) on the Fort Leavenworth Military Reservation, Kansas, was terminated and a contract consummated the purchase of the YMCA Building by the United States Army. This building, No. 345, located at the northeast intersection of Pope and McClellan Avenues, was dedicated and designated as Patch Community Center to be used by Special Services for community activities.

The second disposal action by sale of Fort Leavenworth Military Reservation land since the Reservation was established in 1827 occurred during 1958 when 9.44 acres of land was quit-claim deeded to Leavenworth for the city's Municipal Waterworks Treatment Plant. This acreage is located in the extreme southeast corner of the Reservation and had been leased to Leavenworth for the plant during the time that the city supplied water for Fort Leavenworth.

During the period 1952 through 1963, there was no new construction for religious education facilities. The requirements for space were met by using existing structures vacated by previous activities. Upon completion of the

new schools, Building No. 53 and Building No. 333 located on Scott Avenue north of the Post Chapel, which formerly housed the Post schools, were (in 1956) diverted to use as Sunday Schools. In the West Normandy area, Building No. S-682 and Building No. S-683, which formerly had been used for Post schools (in 1959), were converted for religious educational functions.

The support of Fort Leavenworth in its progressive construction program over the past 12 years has required an orderly and timely increase in utilities, roads, sidewalks, and parking areas. Some statistics that indicate the magnitude of maintenance required of the Post Engineer as of December 1963 are as follows:

- Electrical distribution lines, approximately 115 miles
- Gas pipeline, 138,376 lineal feet
- Steam distribution lines, 27,286 lineal feet
- Sanitary sewer, 211,542 lineal feet
- Ground drainage, storm sewers, etc., 190,219 lineal feet
- Water pipelines, 292,321 lineal feet
- Roads, approximately 60 miles
- Sidewalks, 119,903 square yards
- Vehicle parking areas, 206,022 square yards

**APPENDIX IX**  
**BUILDING AND PLACE NAMES**

---

Swift Hall—in April 1952 for Brig Gen Eben Swift, Commandant of the US Army Service Schools at Fort Leavenworth in 1916.

Townsend Hall—in April 1952 for Col E. F. Townsend, Commandant of the US Army Infantry and Cavalry School at Fort Leavenworth from 1890 to 1894.

Dodge Hall—in February 1953 for Col Henry Dodge, Commanding Officer of Fort Leavenworth from 1834 to 1836.

Ruger Hall—in February 1953 for Maj Gen Thomas H. Ruger, Commandant of the US Army Infantry and Cavalry School at Fort Leavenworth from 1885 to 1886.

Drum Hall—in February 1953 for Lt Gen Hugh A. Drum, Commandant of the US Army General Service Schools at Fort Leavenworth from 1920 to 1921.

Patch Community Center—in December 1955 for Gen Alexander M. Patch, Jr., Commanding General of Seventh Army during the 1944 invasion of southern France.

Oregon Village—in June 1958 for the close proximity of the housing area to the head of the Oregon Trail.

J. Franklin Bell Hall—in January 1959 for Maj Gen J. Franklin Bell, Commandant of the US Army General Service and Staff College from 1903 to 1906.

Kansa Village—in July 1959 for the Kansa Indian tribe believed to have had a village at this location.

Truesdell Hall—in August 1959 for Maj Gen Karl Truesdell, Commandant of the U. S. Army Command and General Staff School from 1942 to 1945.

Santa Fe Village—in December 1960 for the close proximity of the housing area to a branch of the Santa Fe Trail.

Munson Army Hospital—in May 1960 for Brig Gen Edward L. Munson, founder of the Medical Field Services School at Fort Leavenworth in 1910.

Camp Miles Boy Scout Camp—in June 1963 for Maj Gen Nelson A. Miles, Commanding Officer of Fort Leavenworth from 1871 to 1876.

# APPENDIX X ORGANIZATION CHARTS

## FORT LEAVENWORTH, KANSAS (CLASS I INSTALLATION AND ACTIVITIES) STAFF DIRECTORY

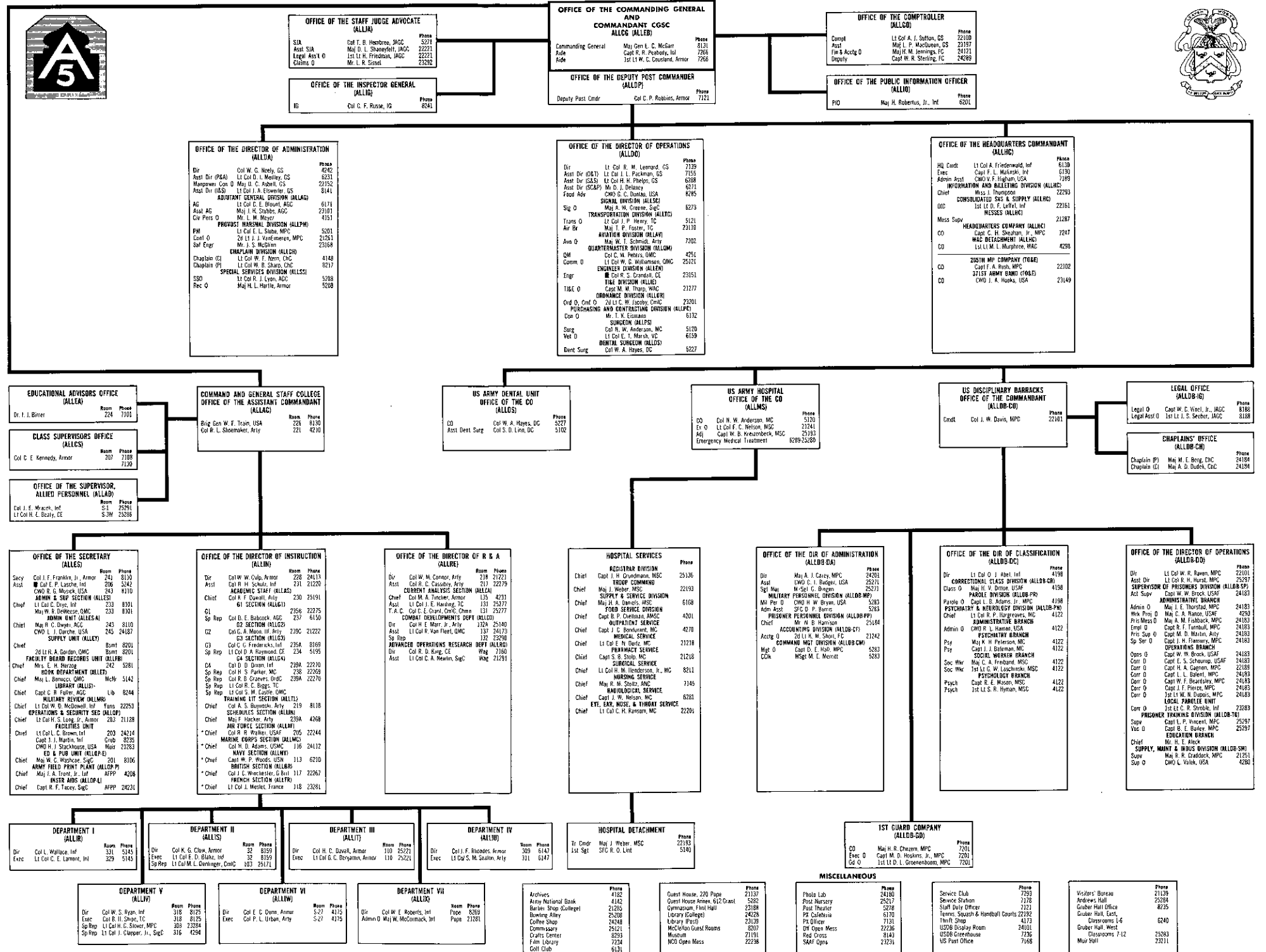

\* Service and liaison representatives

Prepared by: Lt. Col. G. S. Comptroller

Approved by: Maj. Gen. US Army Commanding

Date: 15 July 1956



**FORT LEAVENWORTH, KANSAS  
(CLASS I INSTALLATION)  
ORGANIZATIONAL DIRECTORY**

MUtual 2-7000



Butterfield 6-5800

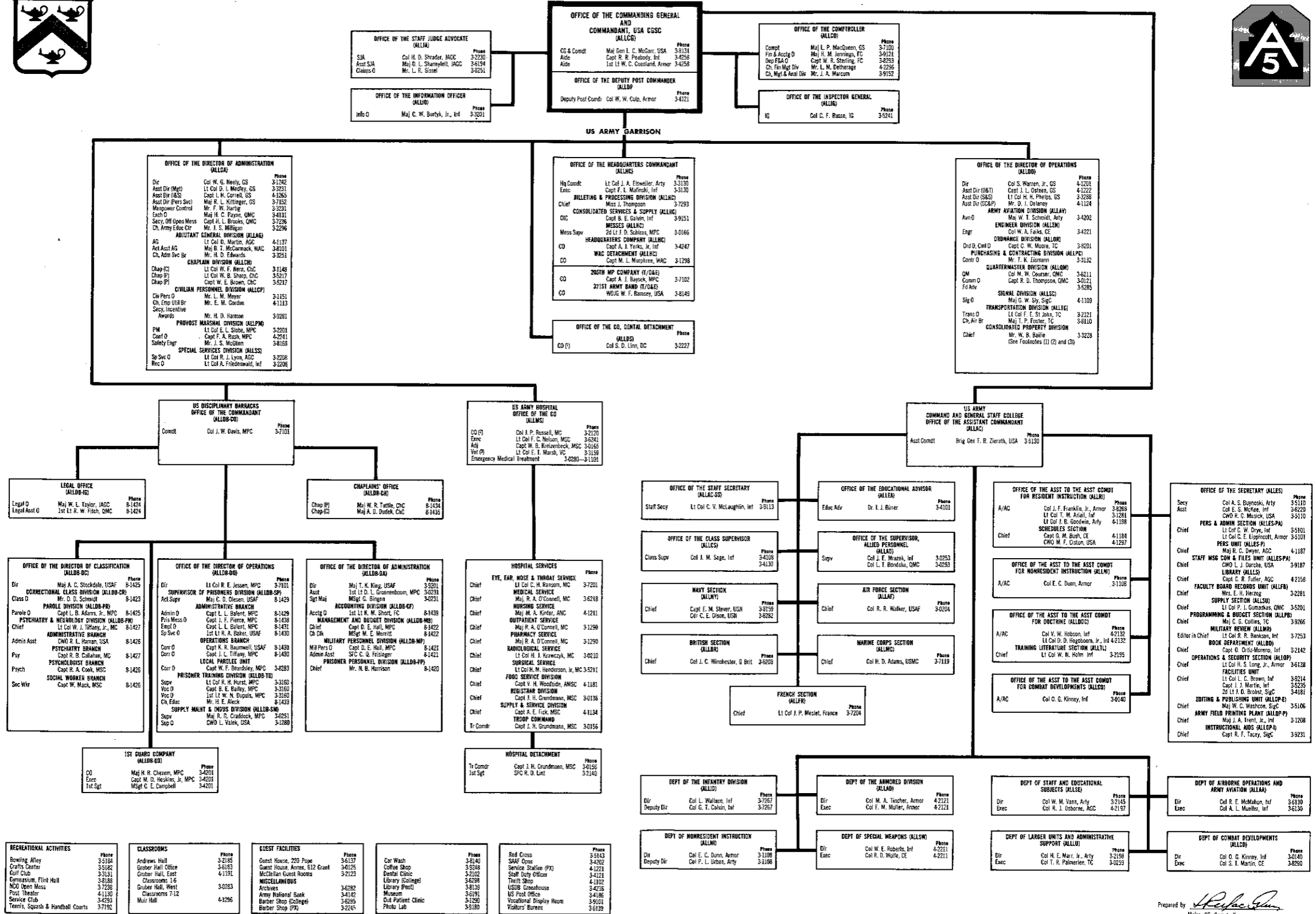

FOOTNOTE: (1) CG, Dental Detachment, also serves as Dental Surgeon under the supervision of the Director of Operations, US Army Garrison.  
 (2) CG, US Army Hospital, also serves as Surgeon under the supervision of the Director of Operations (US Army Garrison).  
 (3) The Veterinarian is under the supervision of the Surgeon.

Prepared by: *[Signature]*  
 Major, GS, Comptroller

Approved by: *[Signature]*  
 Major Gen. US Army, Commanding

Date: 5 Aug 1957



**FORT LEAVENWORTH, KANSAS  
(CLASS I INSTALLATION)  
ORGANIZATIONAL DIRECTORY**

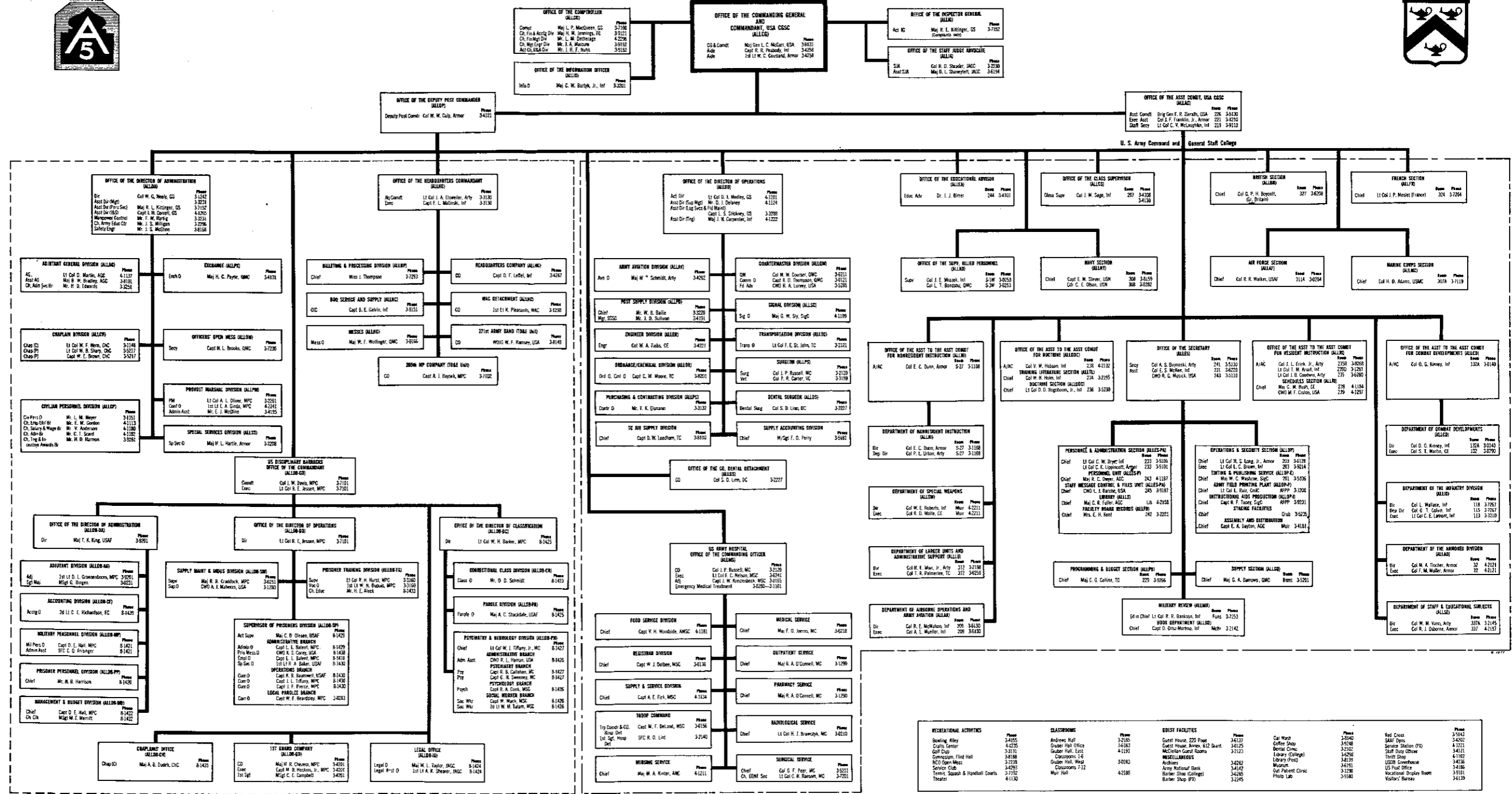

Program Supervision exercised by Director of Administration.  
 Program Supervision exercised by Director of Operations.

Prepared by *[Signature]*  
 Major, US Army, Comptroller

Approved by *[Signature]*  
 Major, US Army, Commanding

Date: 1 January 1958







FORT LEAVENWORTH, KANSAS  
(CLASS I INSTALLATION)  
ORGANIZATIONAL DIRECTORY

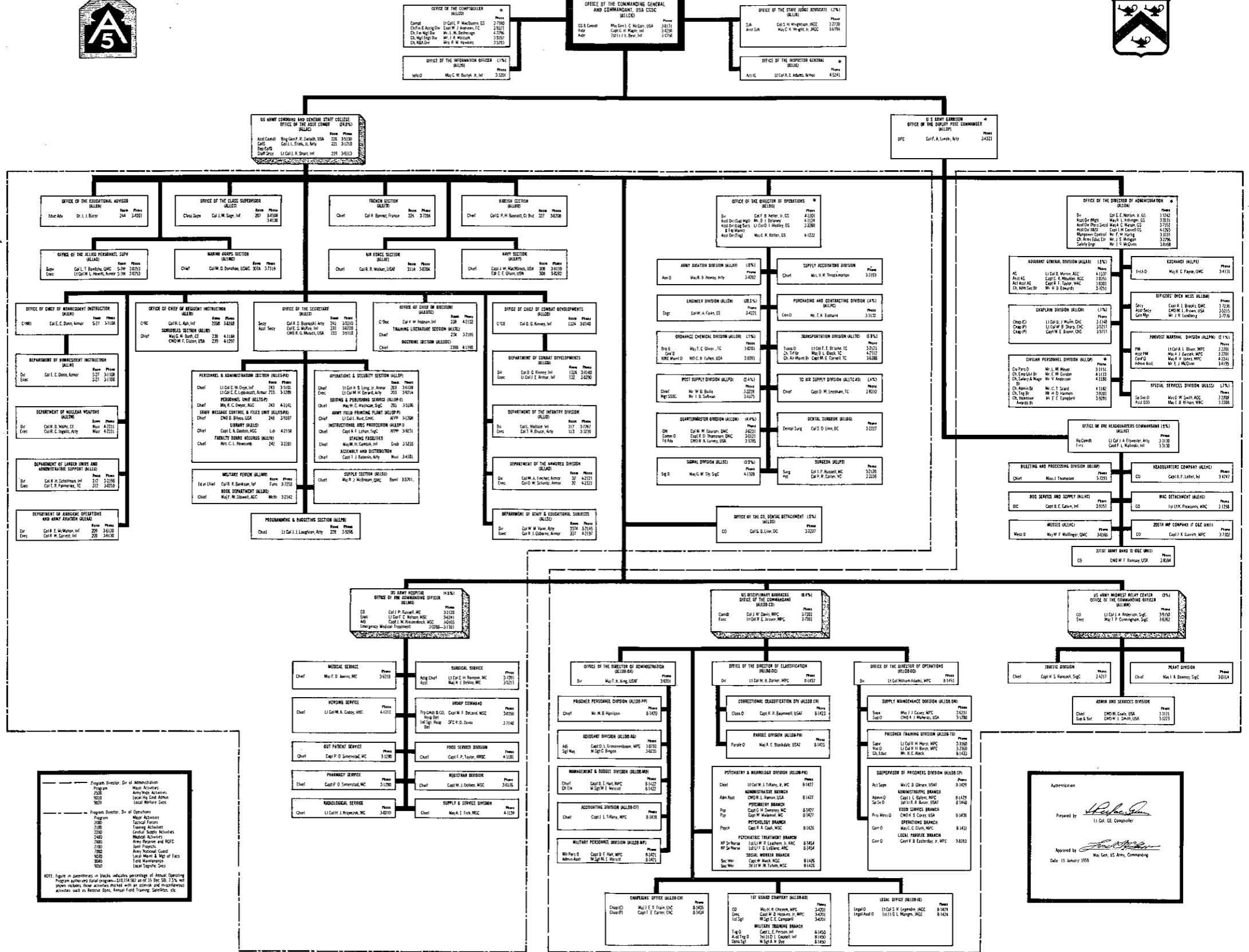

NOTE: Figure in parentheses in boxes indicates percentage of Annual Operating Program authorized total program—100% of total. 75% will show activities those activities marked with an asterisk and miscellaneous activities such as Reserve Date, Annual Field Training, Seminars, etc.

Authorizations  
Prepared by: [Signature]  
Approved by: [Signature]  
Date: 15 January 1959





# FORT LEAVENWORTH, KANSAS ORGANIZATIONAL DIRECTORY

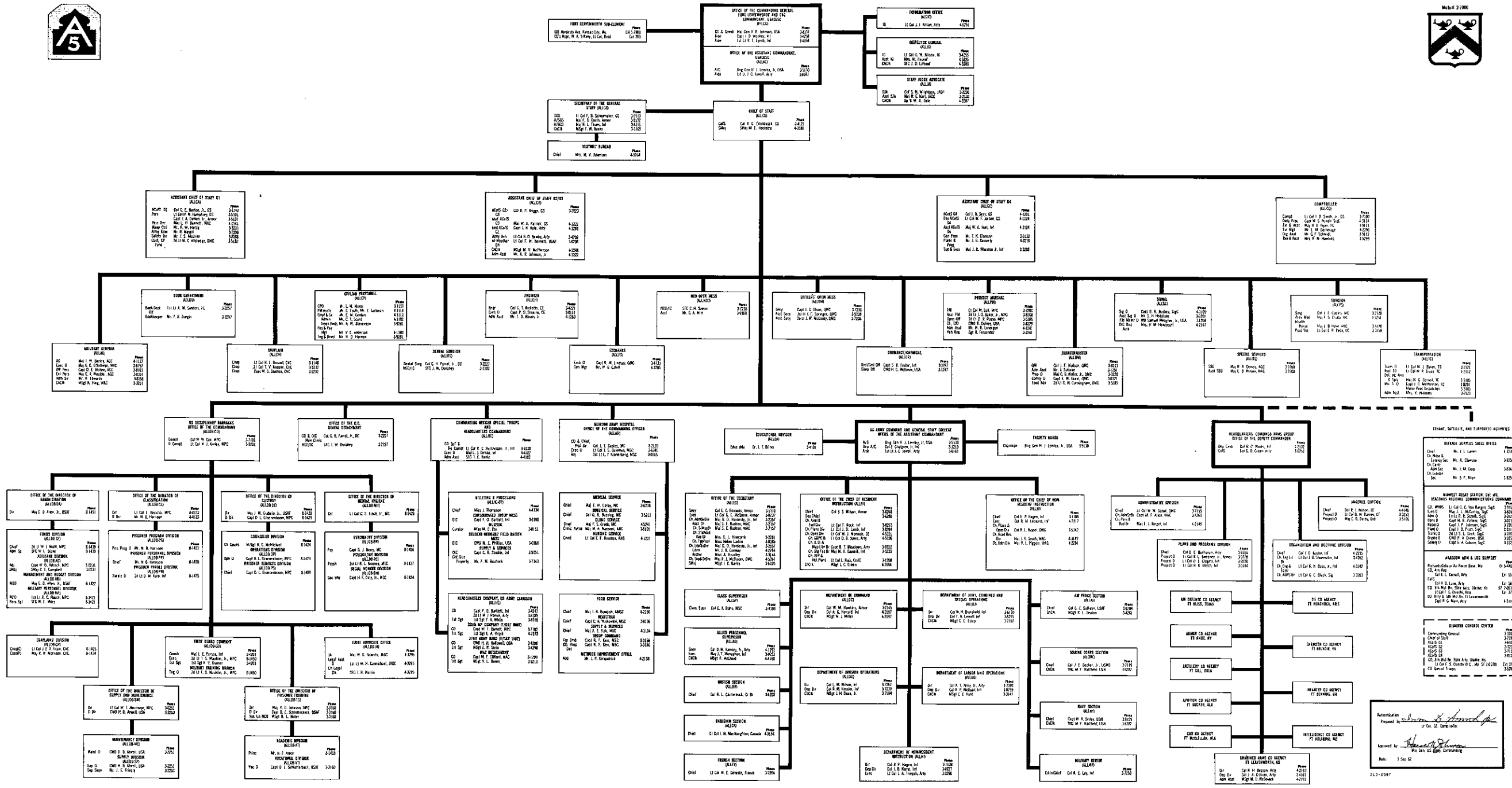



**FORT LEAVENWORTH, KANSAS  
(CLASS I INSTALLATION)  
ORGANIZATIONAL DIRECTORY**

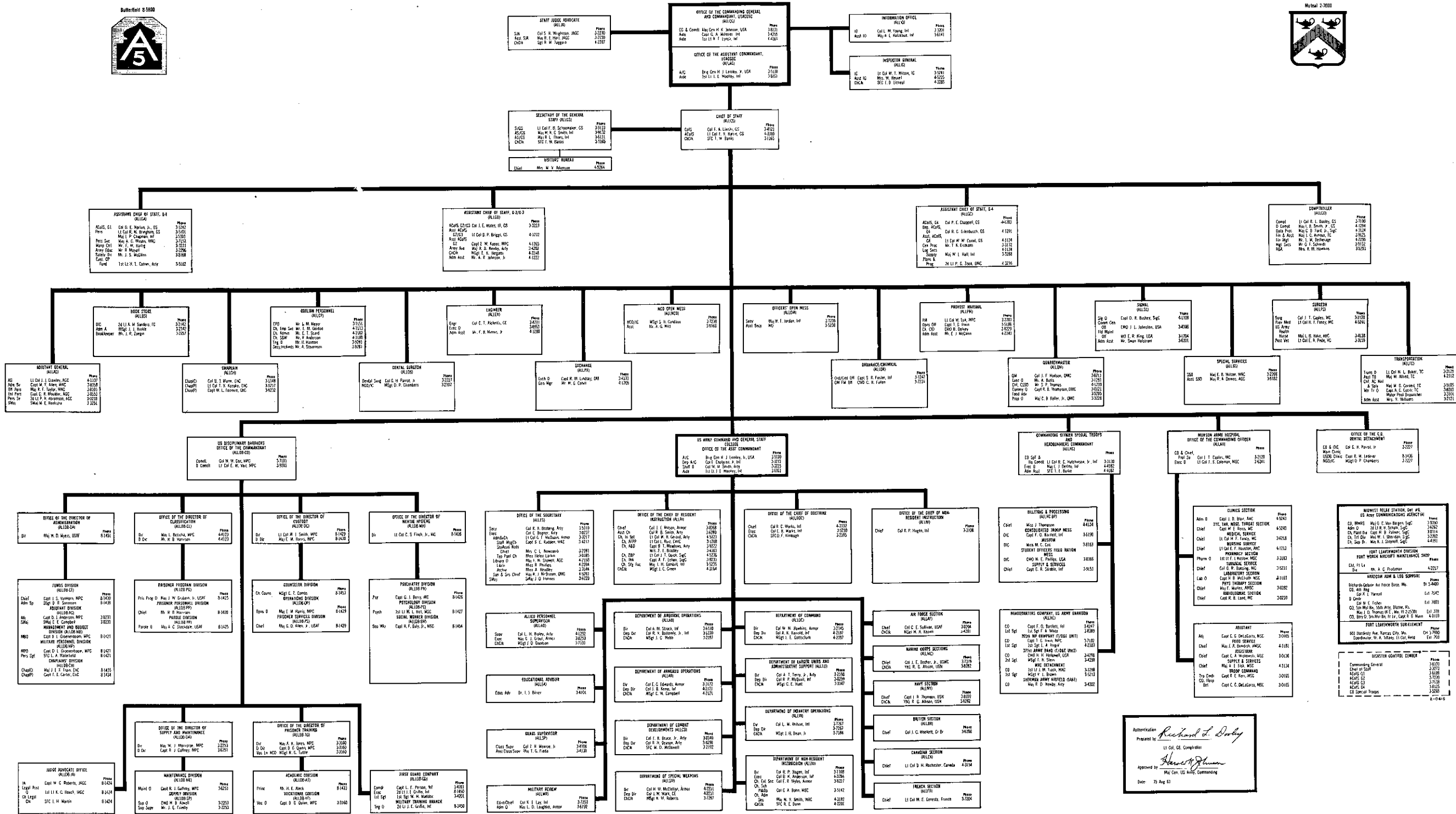

Authenticating  
Richard L. Dohy  
Lt Col, GS, Comdrant  
Approved by  
[Signature]  
Maj Gen, US Army, Commanding  
Date: 25 Aug 83





FORT LEAVENWORTH, KANSAS ORGANIZATIONAL DIRECTORY

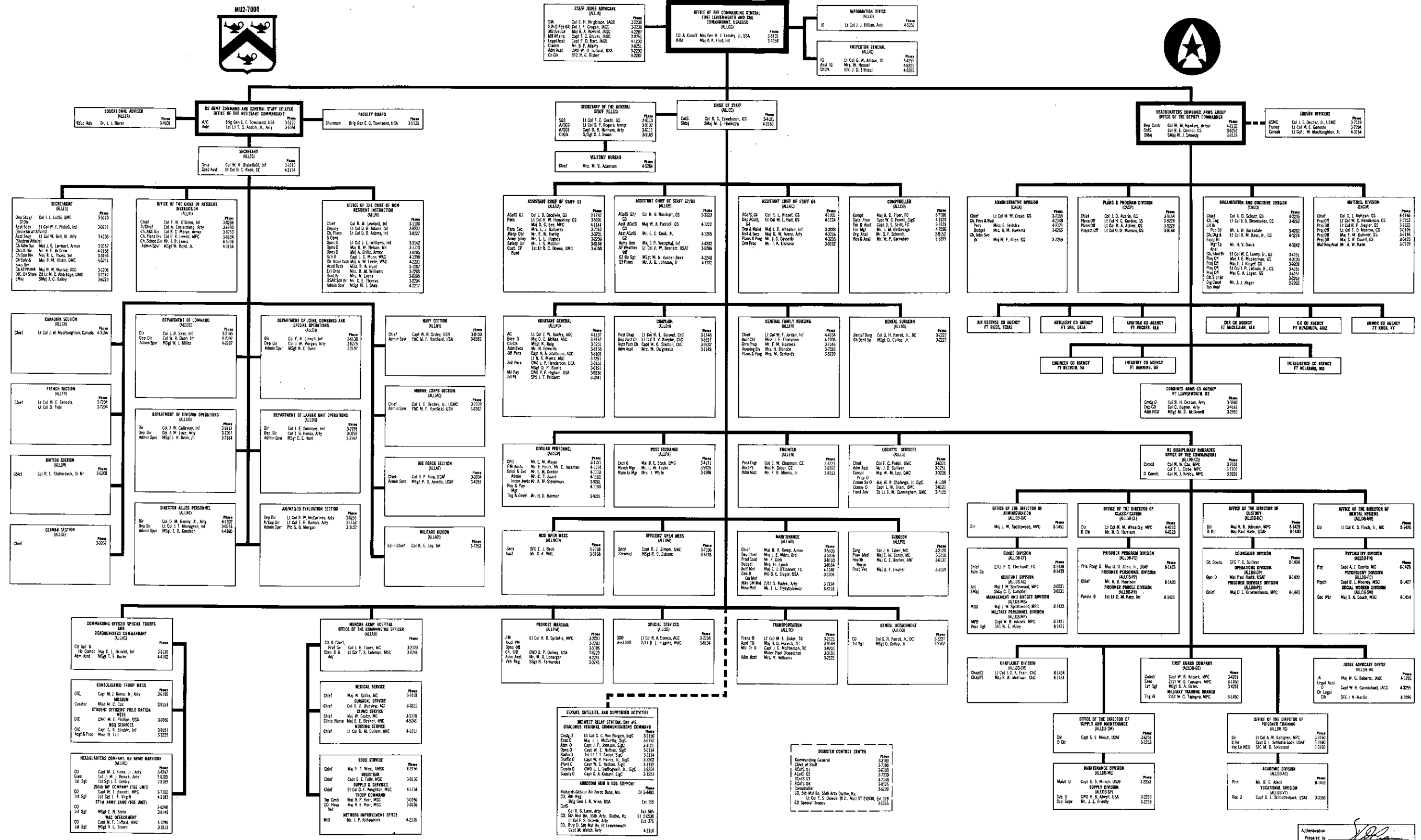

STAFF JUDGE ADVOCATE (ALLO) Col C. H. Wright, JAG 2228

OFFICE OF THE COMMANDING GENERAL (ALLO) Lt Col J. J. Kiffin, Army 4521

INFORMATION OFFICE (ALLO) Lt Col J. J. Kiffin, Army 4521

EDUCATIONAL ADVISOR (ALLO) Lt Col J. J. Kiffin, Army 4521

US ARMY COMMAND AND GENERAL STAFF COLLEGE (ALLO) Brig Gen E. C. Townsend, USA 3418

FACULTY BOARD (ALLO) Brig Gen E. C. Townsend, USA 3418

SECRETARY OF THE GENERAL STAFF (ALLO) Lt Col F. E. Smith, GS 3411

CHIEF OF STAFF (ALLO) Col R. G. Ewald, GS 3421

HEADQUARTERS COMBINED ARMS GROUP (ALLO) Lt Col W. M. Rankin, Army 4212

UNION OFFICERS (ALLO) Lt Col J. E. Decker, Jr., USMC 3219

SECRETARY (ALLO) Lt Col W. M. Rankin, Army 4212

OFFICE OF THE CHIEF OF RESIDENT INSPECTION (ALLO) Lt Col J. E. Decker, Jr., USMC 3219

OFFICE OF THE CHIEF OF NON-RESIDENT INSPECTION (ALLO) Lt Col J. E. Decker, Jr., USMC 3219

SECRETARY OF THE GENERAL STAFF (ALLO) Lt Col F. E. Smith, GS 3411

CHIEF OF STAFF (ALLO) Col R. G. Ewald, GS 3421

INFORMATION OFFICE (ALLO) Lt Col J. J. Kiffin, Army 4521

ADMINISTRATIVE DIVISION (ALLO) Lt Col W. M. Rankin, Army 4212

PLANS & PROGRAM DIVISION (ALLO) Lt Col W. M. Rankin, Army 4212

ORGANIZATION AND DOCTRINE DIVISION (ALLO) Lt Col W. M. Rankin, Army 4212

MATERIAL DIVISION (ALLO) Lt Col W. M. Rankin, Army 4212

CANADIAN SECTION (ALLO) Lt Col J. W. MacLaughlin, Canada 4314

DEPARTMENT OF COMMAND (ALLO) Col J. E. Decker, Jr., USMC 3219

DEPARTMENT OF JOINT, COMBINED AND SPECIAL OPERATIONS (ALLO) Col J. E. Decker, Jr., USMC 3219

NAVY SECTION (ALLO) Lt Col J. W. MacLaughlin, Canada 4314

ASSISTANT CHIEF OF STAFF G1 (ALLO) Lt Col J. E. Decker, Jr., USMC 3219

ASSISTANT CHIEF OF STAFF G2/GS (ALLO) Lt Col J. E. Decker, Jr., USMC 3219

ASSISTANT CHIEF OF STAFF G4 (ALLO) Lt Col J. E. Decker, Jr., USMC 3219

COMPTROLLER (ALLO) Lt Col J. E. Decker, Jr., USMC 3219

AIR DEFENSE CO AGENCY (ALLO) Ft Bliss, Texas

ARTILLERY CO AGENCY (ALLO) Ft Sill, Okla

AVIATION CO AGENCY (ALLO) Ft Rucker, Ala

COR AGENCY (ALLO) Ft McClellan, Ala

FRENCH SECTION (ALLO) Lt Col M. E. Geneste 3726

DEPARTMENT OF DIVISION OPERATIONS (ALLO) Col J. E. Decker, Jr., USMC 3219

DEPARTMENT OF LARGER UNIT OPERATIONS (ALLO) Col J. E. Decker, Jr., USMC 3219

NAVY CORPS SECTION (ALLO) Lt Col J. W. MacLaughlin, Canada 4314

ASSISTANT GENERAL (ALLO) Lt Col J. E. Decker, Jr., USMC 3219

CHAPLAIN (ALLO) Lt Col J. E. Decker, Jr., USMC 3219

CENTRAL FAMILY HOUSING (ALLO) Lt Col J. E. Decker, Jr., USMC 3219

GENERAL SURGEON (ALLO) Lt Col J. E. Decker, Jr., USMC 3219

ENGINEER CO AGENCY (ALLO) Ft Belvoir, Va

INFANTRY CO AGENCY (ALLO) Ft Benning, Ga

INTELLIGENCE CO AGENCY (ALLO) Ft Meade, Md

ARMOR CO AGENCY (ALLO) Ft Knox, Ky

BRITISH SECTION (ALLO) Lt Col R. L. Clutterbuck, Gt Br 3628

DEPARTMENT OF DIVISION OPERATIONS (ALLO) Col J. E. Decker, Jr., USMC 3219

DEPARTMENT OF LARGER UNIT OPERATIONS (ALLO) Col J. E. Decker, Jr., USMC 3219

AIR FORCE SECTION (ALLO) Lt Col J. W. MacLaughlin, Canada 4314

ASSISTANT GENERAL (ALLO) Lt Col J. E. Decker, Jr., USMC 3219

CHAPLAIN (ALLO) Lt Col J. E. Decker, Jr., USMC 3219

CENTRAL FAMILY HOUSING (ALLO) Lt Col J. E. Decker, Jr., USMC 3219

GENERAL SURGEON (ALLO) Lt Col J. E. Decker, Jr., USMC 3219

ENGINEER CO AGENCY (ALLO) Ft Belvoir, Va

INFANTRY CO AGENCY (ALLO) Ft Benning, Ga

INTELLIGENCE CO AGENCY (ALLO) Ft Meade, Md

ARMOR CO AGENCY (ALLO) Ft Knox, Ky

GERMAN SECTION (ALLO) Lt Col M. E. Geneste 3726

DEPARTMENT OF DIVISION OPERATIONS (ALLO) Col J. E. Decker, Jr., USMC 3219

DEPARTMENT OF LARGER UNIT OPERATIONS (ALLO) Col J. E. Decker, Jr., USMC 3219

AIR FORCE SECTION (ALLO) Lt Col J. W. MacLaughlin, Canada 4314

ASSISTANT GENERAL (ALLO) Lt Col J. E. Decker, Jr., USMC 3219

CHAPLAIN (ALLO) Lt Col J. E. Decker, Jr., USMC 3219

CENTRAL FAMILY HOUSING (ALLO) Lt Col J. E. Decker, Jr., USMC 3219

GENERAL SURGEON (ALLO) Lt Col J. E. Decker, Jr., USMC 3219

ENGINEER CO AGENCY (ALLO) Ft Belvoir, Va

INFANTRY CO AGENCY (ALLO) Ft Benning, Ga

INTELLIGENCE CO AGENCY (ALLO) Ft Meade, Md

ARMOR CO AGENCY (ALLO) Ft Knox, Ky

COMMANDED OFFICER SPECIAL TROOPS (ALLO) Lt Col J. W. MacLaughlin, Canada 4314

DEPARTMENT OF DIVISION OPERATIONS (ALLO) Col J. E. Decker, Jr., USMC 3219

DEPARTMENT OF LARGER UNIT OPERATIONS (ALLO) Col J. E. Decker, Jr., USMC 3219

AIR FORCE SECTION (ALLO) Lt Col J. W. MacLaughlin, Canada 4314

ASSISTANT GENERAL (ALLO) Lt Col J. E. Decker, Jr., USMC 3219

CHAPLAIN (ALLO) Lt Col J. E. Decker, Jr., USMC 3219

CENTRAL FAMILY HOUSING (ALLO) Lt Col J. E. Decker, Jr., USMC 3219

GENERAL SURGEON (ALLO) Lt Col J. E. Decker, Jr., USMC 3219

ENGINEER CO AGENCY (ALLO) Ft Belvoir, Va

INFANTRY CO AGENCY (ALLO) Ft Benning, Ga

INTELLIGENCE CO AGENCY (ALLO) Ft Meade, Md

ARMOR CO AGENCY (ALLO) Ft Knox, Ky

COMMANDED OFFICER SPECIAL TROOPS (ALLO) Lt Col J. W. MacLaughlin, Canada 4314

DEPARTMENT OF DIVISION OPERATIONS (ALLO) Col J. E. Decker, Jr., USMC 3219

DEPARTMENT OF LARGER UNIT OPERATIONS (ALLO) Col J. E. Decker, Jr., USMC 3219

AIR FORCE SECTION (ALLO) Lt Col J. W. MacLaughlin, Canada 4314

ASSISTANT GENERAL (ALLO) Lt Col J. E. Decker, Jr., USMC 3219

CHAPLAIN (ALLO) Lt Col J. E. Decker, Jr., USMC 3219

CENTRAL FAMILY HOUSING (ALLO) Lt Col J. E. Decker, Jr., USMC 3219

GENERAL SURGEON (ALLO) Lt Col J. E. Decker, Jr., USMC 3219

ENGINEER CO AGENCY (ALLO) Ft Belvoir, Va

INFANTRY CO AGENCY (ALLO) Ft Benning, Ga

INTELLIGENCE CO AGENCY (ALLO) Ft Meade, Md

ARMOR CO AGENCY (ALLO) Ft Knox, Ky

COMMANDED OFFICER SPECIAL TROOPS (ALLO) Lt Col J. W. MacLaughlin, Canada 4314

DEPARTMENT OF DIVISION OPERATIONS (ALLO) Col J. E. Decker, Jr., USMC 3219

DEPARTMENT OF LARGER UNIT OPERATIONS (ALLO) Col J. E. Decker, Jr., USMC 3219

AIR FORCE SECTION (ALLO) Lt Col J. W. MacLaughlin, Canada 4314

ASSISTANT GENERAL (ALLO) Lt Col J. E. Decker, Jr., USMC 3219

CHAPLAIN (ALLO) Lt Col J. E. Decker, Jr., USMC 3219

CENTRAL FAMILY HOUSING (ALLO) Lt Col J. E. Decker, Jr., USMC 3219

GENERAL SURGEON (ALLO) Lt Col J. E. Decker, Jr., USMC 3219

ENGINEER CO AGENCY (ALLO) Ft Belvoir, Va

INFANTRY CO AGENCY (ALLO) Ft Benning, Ga

INTELLIGENCE CO AGENCY (ALLO) Ft Meade, Md

ARMOR CO AGENCY (ALLO) Ft Knox, Ky

COMMANDED OFFICER SPECIAL TROOPS (ALLO) Lt Col J. W. MacLaughlin, Canada 4314

DEPARTMENT OF DIVISION OPERATIONS (ALLO) Col J. E. Decker, Jr., USMC 3219

DEPARTMENT OF LARGER UNIT OPERATIONS (ALLO) Col J. E. Decker, Jr., USMC 3219

AIR FORCE SECTION (ALLO) Lt Col J. W. MacLaughlin, Canada 4314

ASSISTANT GENERAL (ALLO) Lt Col J. E. Decker, Jr., USMC 3219

CHAPLAIN (ALLO) Lt Col J. E. Decker, Jr., USMC 3219

CENTRAL FAMILY HOUSING (ALLO) Lt Col J. E. Decker, Jr., USMC 3219

GENERAL SURGEON (ALLO) Lt Col J. E. Decker, Jr., USMC 3219

ENGINEER CO AGENCY (ALLO) Ft Belvoir, Va

INFANTRY CO AGENCY (ALLO) Ft Benning, Ga

INTELLIGENCE CO AGENCY (ALLO) Ft Meade, Md

ARMOR CO AGENCY (ALLO) Ft Knox, Ky

COMMANDED OFFICER SPECIAL TROOPS (ALLO) Lt Col J. W. MacLaughlin, Canada 4314

DEPARTMENT OF DIVISION OPERATIONS (ALLO) Col J. E. Decker, Jr., USMC 3219

DEPARTMENT OF LARGER UNIT OPERATIONS (ALLO) Col J. E. Decker, Jr., USMC 3219

AIR FORCE SECTION (ALLO) Lt Col J. W. MacLaughlin, Canada 4314

ASSISTANT GENERAL (ALLO) Lt Col J. E. Decker, Jr., USMC 3219

CHAPLAIN (ALLO) Lt Col J. E. Decker, Jr., USMC 3219

CENTRAL FAMILY HOUSING (ALLO) Lt Col J. E. Decker, Jr., USMC 3219

GENERAL SURGEON (ALLO) Lt Col J. E. Decker, Jr., USMC 3219

ENGINEER CO AGENCY (ALLO) Ft Belvoir, Va

INFANTRY CO AGENCY (ALLO) Ft Benning, Ga

INTELLIGENCE CO AGENCY (ALLO) Ft Meade, Md

ARMOR CO AGENCY (ALLO) Ft Knox, Ky

COMMANDED OFFICER SPECIAL TROOPS (ALLO) Lt Col J. W. MacLaughlin, Canada 4314

DEPARTMENT OF DIVISION OPERATIONS (ALLO) Col J. E. Decker, Jr., USMC 3219

DEPARTMENT OF LARGER UNIT OPERATIONS (ALLO) Col J. E. Decker, Jr., USMC 3219

AIR FORCE SECTION (ALLO) Lt Col J. W. MacLaughlin, Canada 4314

ASSISTANT GENERAL (ALLO) Lt Col J. E. Decker, Jr., USMC 3219

CHAPLAIN (ALLO) Lt Col J. E. Decker, Jr., USMC 3219

CENTRAL FAMILY HOUSING (ALLO) Lt Col J. E. Decker, Jr., USMC 3219

GENERAL SURGEON (ALLO) Lt Col J. E. Decker, Jr., USMC 3219

ENGINEER CO AGENCY (ALLO) Ft Belvoir, Va

INFANTRY CO AGENCY (ALLO) Ft Benning, Ga

INTELLIGENCE CO AGENCY (ALLO) Ft Meade, Md

ARMOR CO AGENCY (ALLO) Ft Knox, Ky

COMMANDED OFFICER SPECIAL TROOPS (ALLO) Lt Col J. W. MacLaughlin, Canada 4314

DEPARTMENT OF DIVISION OPERATIONS (ALLO) Col J. E. Decker, Jr., USMC 3219

DEPARTMENT OF LARGER UNIT OPERATIONS (ALLO) Col J. E. Decker, Jr., USMC 3219

AIR FORCE SECTION (ALLO) Lt Col J. W. MacLaughlin, Canada 4314

ASSISTANT GENERAL (ALLO) Lt Col J. E. Decker, Jr., USMC 3219

CHAPLAIN (ALLO) Lt Col J. E. Decker, Jr., USMC 3219

CENTRAL FAMILY HOUSING (ALLO) Lt Col J. E. Decker, Jr., USMC 3219

GENERAL SURGEON (ALLO) Lt Col J. E. Decker, Jr., USMC 3219

ENGINEER CO AGENCY (ALLO) Ft Belvoir, Va

INFANTRY CO AGENCY (ALLO) Ft Benning, Ga

INTELLIGENCE CO AGENCY (ALLO) Ft Meade, Md

ARMOR CO AGENCY (ALLO) Ft Knox, Ky





## BIBLIOGRAPHY

---

- Brucker, Wilbur M. "The U. S. Army Command and General Staff College Dedicates Bell Hall," *Military Review*, Vol XXXVIII (March 1959), p. 3.
- Cantrell, James L. "On the Life of Riley," *Military Review*, Vol XXXVI (May 1956), p. 35.
- Command and General Staff College, *The Story of Fort Leavenworth and the Command and General Staff College*. Pamphlets (1955 and 1959). *The Leavenworth Lamp*. Pamphlet (1956). *Formal Dedication Ceremony—Bell Hall*. Pamphlet (1959).
- Culp, W. W. "Resident Courses of Instruction," *Military Review*, Vol XXXVI (May 1956), p. 15.
- Davidson, Garrison H. *After Action Report*. Ft Leavenworth, Kansas, 1956.
- Davis, Kenneth S. *Soldier of Democracy*. New York, 1945.
- Dugas, Meade J. "The Allied Officer at the College," *Military Review*, Vol XXXVI (May 1956), p. 42.
- Fort Leavenworth. *From Frontier Post to Home of the United States Army Command and General Staff College*. Pamphlet (1959).
- General Orders Files, 1952-63. Office of the Assistant Chief of Staff, G1, Ft Leavenworth, Kansas.
- Hunt, Elvid, and Walter E. Lorence. *History of Fort Leavenworth 1827-1937*. Rev. ed. Ft Leavenworth Kansas, 1937.
- Leavenworth Chamber of Commerce. *Centennial Historical Program*. Leavenworth, Kansas. Pamphlet (1954).
- Leavenworth Times*. Special August Issues, 1955-63. Leavenworth, Kansas.
- Management Guide*, Ft Leavenworth, Kansas, 1956.
- McDonald, Marie, and Dorothy Hyle. *The Illustrated Guide to Fort Leavenworth, Leavenworth and Vicinity*. Ft Leavenworth, Kansas, 1955.
- McGarr, Lionel C. "USA Command and General Staff College Keeps Pace With the Future," *Military Review*, Vol XXXVII (April 1957), p. 3. *Special Report of the Commandant*. Ft Leavenworth, Kansas, 1959. *End of Tour Report*. Ft Leavenworth, Kansas, 1960.
- McGregor, Edward W. "The Leavenworth Story," *Military Review*, Vol XXXVI (May 1956), p. 62.
- News Release Files, 1952-63. Information Office. Ft Leavenworth, Kansas.
- Nonresident Instruction Programs. Command and General Staff College, Ft Leavenworth, Kansas. Pamphlet (1963).
- Organizational and Functional Manual*, Ft Leavenworth, Kansas, 1954.
- Organization and Functions Manual*, Ft Leavenworth, Kansas, 1962.
- Programs of Instruction—Resident Courses, Command and General Staff College 1952-63. College Library Files.
- Tyler, Orville Z., Jr. *The History of Fort Leavenworth 1937-1951*. Ft Leavenworth, Kansas, 1951.

# INDEX

	<i>Page</i>		<i>Page</i>
Ablett, Lt Col Charles B. ....	54	Clifford, Capt Margaret .....	22
Ailes, Under Secretary of Army Stephen .....	20	Colleges—	
Air Defense Battery .....	30-32	Army War .....	7
Allied Officers .....	17, 18, 48-49	Command and General Staff .....	7, 8, 13, 16, 17, 19, 21, 22, 24, 30, 32, 35-52, 53, 68-69
Anderson, Lt Col John A. ....	29	General Service and Staff .....	6
Anderson, Col Norman W. ....	14	Highland Junior .....	26
Andrews Hall .....	16, 17, 33, 35, 39	Colwell, Lt Col Hanford T. ....	30
Archives .....	51	Combat Developments Command .....	25, 43
Armed Forces Day .....	9-10	Combined Arms Agency .....	20, 25
Army Air Corps .....	32	Combined Arms Group .....	20, 21, 24-25
Army Brats .....	54-55	Connor, Col William M. ....	40
Army Strategic Communications Command .....	30	Construction .....	68
Arnold, Lt Gen William H. ....	14	Coutts, Col James W. ....	36
Arsenal Hill .....	13, 41, 69	Cox, Mildred .....	17, 33, 34
Associate Course .....	1, 8, 15, 33, 46	Cox, Col Weldon W. ....	26
Association of the		Crafts .....	58
United States Army .....	14, 19, 20, 21, 31, 60	Crietzberg, Col Abb .....	55
Audio-Visual Communications Center .....	51	Cristo, Mrs. Anthony B. ....	59
Austin, Col John O. ....	54	Culp, Col William W. ....	13, 16, 37
Automatic Electric Company .....	30	Cunningham, Brig Gen William A. ....	18, 19
Baker, Bob .....	16	Daley, L. Gen John F. ....	25
Band, 371st Army .....	9, 22	Daughters of the US Army .....	59
Barnard, Lt Col Asa .....	43	Davall, Col Harold C. ....	40
Barnhart, Col Frank H., Jr. ....	55	Davidson, Bonny Elaine .....	12
Beauchamp, Col Charles E. ....	10	Davidson, Gail Marie .....	12
Beauchamp, Gen Charles E. ....	11	Davidson, Maj Gen Garrison H. ....	11, 12, 33, 37, 38, 39, 41
Beehive .....	45	Dean, Maj Gen William F. ....	11
Bell, Maj Gen James Franklin .....	41	Deason, Col Robert H. ....	20
Bell Hall .....	12, 13, 15, 16, 18, 23, 25, 41-42, 51, 68-69	Deason, Mrs. Robert H. ....	56
Bell Yearbook .....	38	Decker, Gen George H. ....	43
Berry, Margaret C. ....	10	Delta Battery .....	31-32
Birrer, Dr. Ivan J. ....	20, 41, 42, 52	Department of Command .....	43
Blakefield, Col William H. ....	43, 45, 57	Department of Division Operations .....	43
Bland, Col Ted C. ....	61	Department of Joint, Combined, and	
Bodner, Col William S. ....	36	Special Operations .....	43
Bolte, Gen Charles L. ....	14	Department of Larger Unit Operations .....	43
Boughton, Col Daniel H. ....	60	Department of Nonresident Instruction .....	43
Boughton Memorial .....	60	Diamond Jubilee .....	39
Boy Scouts of America .....	54	Docking, Governor George .....	31
Brucker, Secretary of the Army Wilbur M. ....	16, 39, 41	Domos, Lt Col Robert A. ....	58
Buesing, Col Oliver .....	23	Douglass, Dr. Harl .....	38
Buildings .....	72	Dunn, Col Edward C. ....	40
Büttner, Col Louis .....	12	Durand, Chaplain (Lt Col) Henry L. ....	53
Camp Lincoln .....	6	Eddy, Lt Gen Manton S. ....	38
Camp Miles .....	54	Education Center .....	56
Caple, Mrs. Dayton F. ....	54	Educational Advisor .....	20, 41, 42, 52
Caples, Col Joseph T. ....	27	Educational Survey Commission .....	38, 40
Career courses .....	47	Eisenhower, Gen Dwight D. ....	8, 12
Catholic Youth Organization .....	54	Eisenhower, Maj John S. ....	12
Centennial, Leavenworth .....	11	Eklund, Col Karl F. ....	36
Chandler, Maj Milborne C. ....	10	Elving, Mrs. Henrietta .....	58
Chapels—		Ely, Lt Col John A. ....	43
Normandy .....	53, 54	Erlenbusch, Col Robert C. ....	21
Post .....	10, 53, 54	Evans, Col James B. ....	36
St. Ignatius .....	10, 54	Ewbank, Col Keith H. ....	36
Civilian-Military Council .....	58		

	<i>Page</i>	<i>Page</i>	
Facó, Lt Col João H. -----	50	Kansa Village -----	17
Farm Colony -----	26, 27	Kellner, Maj H. A. -----	56
Flying Club, Fort Leavenworth -----	15	Kemp, Col James B. -----	57
Ford, Lt Col John D. -----	54	Kennedy, President John F. -----	18, 23
Fort bridge -----	22	Keyes, Lt Gen Geoffrey -----	38
Forts—		Killian, Lt Col John J. -----	58
Belvoir -----	25	Kleinschmidt Corporation -----	30
Benning -----	13	Know Your World -----	49
Bliss -----	25	Koch, Lt Col Bruce C. -----	52
Bragg -----	19	Koepke, Chaplain (Lt Col) Theodore V. -----	53
Detrick -----	29	Kotzebue, Maj Albert L. -----	20
Holabird -----	25	Kotzebue, Mrs. Albert L. -----	19
Huachuca -----	25		
Knox -----	25	Lay, Col Kenneth E. -----	50
Leonard Wood -----	9	Leavenworth, Col Henry -----	5
McClellan -----	25	Leavenworth, Gen Henry -----	6, 12
Riley -----	9, 11, 32, 39	Leavenworth, Cantonment -----	5, 10
Rucker -----	25	Leavenworth Centennial Bridge -----	22
Sill -----	25	Leavenworth, City ---	6, 10, 11, 17, 27, 32, 49, 57, 70, 71
Frame, Col Marshall W. -----	36	Leavenworth Lamp -----	39, 42
Franklin, Col John F., Jr. -----	37	Lehman, Wendell -----	61
Frontier Day -----	17, 19	Lemley, Brig Gen Harry J. ---	19, 20, 21, 23, 45, 50, 59, 61
		Leonard, Col Richard M. -----	45, 54
Gavin, Maj Gen James M. -----	12	Lewitz, Col Edward R. -----	56
Gavin, Col John A. -----	37	Liaison officers -----	45
Girl Scouts of America -----	54	Library, Command and General Staff College ---	25, 51
Global Satellite Communications System -----	30	Library, Post -----	58
Gould, Helen Miller -----	12	Liwski, Col Francis A. -----	16, 21
Gould, Jay -----	12	Loomis, Col Frederick H. -----	36
Grant, President Ulysses S. -----	6	Love, Mrs. James N. -----	53
Grant Hall -----	16, 25, 35	Luthi, Col I. L. -----	45
Greenhouse -----	26, 27		
Grombacher, Maj Gerd S. -----	54	McBride, Gen Horace L. -----	9, 32, 35
Gruber Hall -----	16, 35, 38	McCartney, Col Robert W. -----	57
Guest Speakers -----	52	McConnell, Lt Col Guy G. -----	20
		McGarr, Maj Gen Lionel C. ---	12, 13, 14, 15, 16, 18, 30, 33, 39, 40, 41, 42, 57
Halpin, Lt Col Daniel E. -----	50	McGraw, Anthony F. -----	51
Hamlett, Gen Barksdale -----	50	McGregor Firing Range -----	31
Hancock, Gen Winfield S. -----	60	McMinn, Chaplain (Maj) Thomas J. -----	54
Harding, H. F. -----	38	McNair Hall -----	55
Hartford, Maj Gen Thomas J. -----	28	Marshall, Gen George C. -----	42
Hawkins, Col Wilson M. -----	25, 43	Marzari, Capt Guy J. -----	31
Hediken, Col Thomas B. -----	10	Masonic Order -----	60
Heintzleman, Maj Gen Stuart -----	13	Master of Military Arts and Science -----	52
Hemingway, Lt Col Jack N. -----	38	Medal of Honor -----	11
Hercules missile -----	31	Meehan, Col Charles G. -----	10, 12
Hering, Mrs. Dandridge F. -----	19	Merritt Lake -----	16, 55, 57, 59
Historical Committee, Fort Leavenworth ---	12, 17, 33	Meslet, Lt Col Jean P. -----	14
Hobson, Col Victor W. -----	40	Middleton, Lt Gen Troy H. -----	38
Hodes, Maj Gen Henry I. -----	9, 10, 11, 35	Midwest Relay Station -----	28-30
Hoekstra, Mrs. Melvin E. -----	54	Military Division of the Missouri -----	6
Honors Program -----	52	Military Order of World Wars -----	39, 49
Horseless Carriage Club -----	16	<i>Military Review</i> -----	49-51
Hunt, Fort Leavenworth -----	15, 19, 55-60	Miller, Cecil -----	57
		Missouri River -----	9, 11, 41
Instructional Aids Plant -----	51	Mollner, Chaplain (Maj) Joseph M. -----	10
International Group -----	17, 49, 59	Morgan, Col J. W. -----	60
		Mudgett, Maj Gen Gilman C. -----	12
Johnson, Maj Gen Harold K. -----	18, 19, 20, 21, 28, 50	Muir Hall -----	16
Johnson, Col Max S. -----	10	Munson, Brig Gen Edward L. -----	27
		Munson Army Hospital -----	21, 27-28, 56, 70

	<i>Page</i>		<i>Page</i>
Murray, Col Charles R. -----	36	St. John, Lt Col Frederick -----	15
Museum, Fort Leavenworth -----	10, 12, 15, 16, 17, 19, 32-34	St. John's Orphanage -----	31
Names, buildings and places -----	72	Santa Fe Trail, -----	5, 6, 17
National Cemetery, Fort Leavenworth, -----	5, 6, 12, 68	Santa Fe Village -----	18
National Guard -----	19	Schools (civilian)—	
Naval Air Station, Olathe -----	31	Gen Dwight D. Eisenhower -----	13
Nawn, Mrs. Leo J. -----	18	Gen Douglas MacArthur -----	13
Nelson, Maj Gen Ralph T. -----	30	Gen George S. Patton -----	15
Nike Hercules -----	15, 30-32	Schools (military)—	
Nonresident instruction -----	47-48	Application for Infantry and Cavalry -----	6
Nuclear weapons employment -----	42	General Staff -----	6
O'Brien, Col Francis W. -----	45	Line -----	6
O'Donnell, Maj Edward F. -----	32	US Infantry and Cavalry -----	6
Officers' Open Mess -----	57	Schriltz, Lt Col S. von -----	34
Officers' Wives Club -----	59	Seay, Col Joseph B. -----	21
Oregon Trail -----	15, 17	Secretariat -----	45
Oregon Village -----	15	Shalkoski, Vic -----	61
Orleans, Jacob S. -----	38	Sharp, Chaplain (Lt Col) William B. -----	16
Otis, Col Elwell S. -----	6	Shelton, Chaplain (Capt) Wayne G. -----	22, 53
Otis Hall -----	12	Sheridan, Gen Philip H. -----	6
Pace, Secretary of the Army Frank, Jr. -----	10	Sheridan Hall -----	35
Palmer, Lt Gen Williston B. -----	12	Sherman, Maj William -----	32
Patch, Gen Alexander M., Jr. -----	12	Sherman Air Force Base -----	9, 11
Patch Community Center -----	12, 55	Sherman Army Airfield -----	11, 15, 16, 17, 19, 29, 32
Pershing, Gen John J. -----	43	Sherman Hall -----	12, 35
Person, Maj Lawrence E. -----	27	Shoulder patch -----	39
Peterson, Lt Col Theodore W. -----	54	Shutz, Col Albert D. -----	54
Pick, Mrs. Lewis A. -----	20	Shutz, Mrs. Albert D. -----	60
Pickell, Lt Col Wayne F. -----	54, 61	Simmons, Col James E. -----	53
Piper, Lt Col Harvey D. -----	54	Slobe, Col E. L. -----	27
Places -----	72	Smith Lake -----	55
Pope, Maj Gen John -----	6	Special courses -----	47
Pope Hall -----	14, 36	Special Information Course -----	42
Printing Plant, Army Field -----	51	Special Services -----	58-59
Protestant Men of the Chapel -----	53	Sport Parachute Club -----	21
Protestant Women of the Chapel -----	53	Stevens, Secretary of the Army Robert T. -----	11
Protestant Youth of the Chapel -----	53	Stevenson, Charles S. -----	14
Purdy, Harold E. -----	14	Sunflower Ordnance Works -----	29
Ramsey, Col David M. -----	48	Taber, Col John H. -----	28
Red Cross volunteers -----	56	Taylor, Lt Col Raleigh O. -----	54
Refresher courses -----	47	Terry, Col Augustus T., Jr. -----	43
Registered National Landmark -----	19	Thrift Shop -----	55
Regular Course -----	8, 10, 17, 35, 46	Tour of duty -----	22
Religious services -----	53-54	Townsend, Brig Gen Elias C. -----	22, 45, 56
Resident courses -----	46-47, 52	Townsend, Col Elias C. -----	22
Rhoades, C. H. -----	16	Townsley, Lt Col Floyd W. -----	19
Ridgway, Gen Matthew B. -----	12	Train, Brig Gen William F. -----	12, 13
River Rats, Fort Leavenworth -----	9	Trudeau, Maj Gen Arthur G. -----	12
Robbins, Col Chandler P., Jr. -----	12, 13	Truesdell, Maj Gen Karl -----	17
Rock Island Arsenal -----	26	Truesdell Hall -----	17, 69
Rod and Gun Club -----	55	Trujillo, Lt Gen Rafael L., Jr. -----	14
Ross, Lt Col Charles C. -----	56	Truman, President Harry S -----	18
Ryan, Col Ward S. -----	40	Udall, Secretary of the Interior Stewart L. -----	19
		US Disciplinary Barracks -----	25-27
		US Volunteer Infantry Association -----	16
		Von Bargaen, Lt Col Gerald C. -----	30

	<i>Page</i>		<i>Page</i>
Wagner Hall .....	51	Women's Army Corps .....	22
Walker, Lt Col R. M. ....	38	Works, Col Robert C. ....	20, 25
Washcoe, Maj Wilfred C. ....	41	Worldwide Combat Arms Conference .....	20
Weld, Col Seth L., Jr. ....	36	Young, Maj Gen Robert N. ....	12
Welsh, Capt Milton .....	32	Young Men's Christian Association .....	12, 71
West Coast Relay Station .....	30	Youth Activities Association .....	55
Westphal, Maj John P. ....	32	Zierath, Brig Gen Frederick R. ....	13, 16, 18, 31
Wilson, Col Jasper J. ....	43		
Wilson, Col Lawrence M. ....	43		

