

The author hereby certifies that the use of any copyrighted material in the thesis manuscript entitled:

“Toward Development of an Oral, Plant-based Vaccine Against *Escherichia coli* O157:H7.”

beyond brief excerpts is with the permission of the copyright owner, and will save and hold harmless the Uniformed Services University of the Health Sciences from any damage which may arise from such copyright violations.

Nicole A. Judge
Department of Microbiology and Immunology
Uniformed Services University of the Health Sciences

Report Documentation Page

Form Approved
OMB No. 0704-0188

Public reporting burden for the collection of information is estimated to average 1 hour per response, including the time for reviewing instructions, searching existing data sources, gathering and maintaining the data needed, and completing and reviewing the collection of information. Send comments regarding this burden estimate or any other aspect of this collection of information, including suggestions for reducing this burden, to Washington Headquarters Services, Directorate for Information Operations and Reports, 1215 Jefferson Davis Highway, Suite 1204, Arlington VA 22202-4302. Respondents should be aware that notwithstanding any other provision of law, no person shall be subject to a penalty for failing to comply with a collection of information if it does not display a currently valid OMB control number.

1. REPORT DATE

2004

2. REPORT TYPE

3. DATES COVERED

-

4. TITLE AND SUBTITLE

Toward Development of an Oral, Plant-based Vaccine Against Escherichia coli O157:H7

5a. CONTRACT NUMBER

5b. GRANT NUMBER

5c. PROGRAM ELEMENT NUMBER

6. AUTHOR(S)

5d. PROJECT NUMBER

5e. TASK NUMBER

5f. WORK UNIT NUMBER

7. PERFORMING ORGANIZATION NAME(S) AND ADDRESS(ES)

Uniformed Services University of the Health Sciences, F. Edward Herbert School of Medicine, 4301 Jones Bridge Road, Bethesda, MD, 20814-4799

8. PERFORMING ORGANIZATION REPORT NUMBER

9. SPONSORING/MONITORING AGENCY NAME(S) AND ADDRESS(ES)

10. SPONSOR/MONITOR'S ACRONYM(S)

11. SPONSOR/MONITOR'S REPORT NUMBER(S)

12. DISTRIBUTION/AVAILABILITY STATEMENT

Approved for public release; distribution unlimited

13. SUPPLEMENTARY NOTES

The original document contains color images.

14. ABSTRACT

Enterohemorrhagic Escherichia coli (EHEC) O157:H7 is the most common infectious cause of bloody diarrhea in the United States, and a sequela of this infection, the hemolytic uremic syndrome (HUS), is the primary cause of acute renal failure in children in the U.S. The majority of U.S. cases of EHEC O157:H7 have occurred as a consequence of ingestion of undercooked, contaminated hamburger or produce and/or water contaminated with bovine manure. Intimin is the primary adhesin of EHEC O157:H7, and is required for colonization of neonatal calves. I hypothesized that an intimin-based vaccination strategy in calves might reduce colonization of cattle with EHEC O157:H7. To test this concept in a small animal model, I developed transgenic tobacco plant cells that expressed the full length or carboxy-terminal portion (Int261) of EHEC O157:H7 intimin and then immunized mice parenterally with intimin expressed from the plant cells, or fed mice the transgenic plant cells, or both. I was able to show that these mice not only generated an intimin-specific mucosal immune response when primed parenterally and boosted orally but also exhibited a reduced duration of EHEC O157:H7 fecal shedding after challenge. These results suggest that transgenic plants are attractive and feasible production and delivery systems for an intimin-based vaccine for cattle, and such a vaccine can reduce the duration of EHEC O157:H7 shedding in a small animal model. In addition, Shiga toxin type 2 (Stx2) is another important EHEC O157:H7 virulence factor that plays a critical role in the development of potentially fatal HUS in humans. I developed a toxoid of Stx2 by making site-directed changes to the nucleotide sequence of the Stx2 A subunit gene that abrogated cytotoxicity in vitro and in vivo. The Stx2 toxoid elicited toxin-neutralizing antibody when parenterally injected in mice. I also optimized both the Stx2 A toxoid subunit and the B subunit for expression in plants and, thus laid the groundwork for future expression of this Stx2 toxoid molecule in plants.

15. SUBJECT TERMS					
16. SECURITY CLASSIFICATION OF:			17. LIMITATION OF ABSTRACT	18. NUMBER OF PAGES 177	19a. NAME OF RESPONSIBLE PERSON
a. REPORT unclassified	b. ABSTRACT unclassified	c. THIS PAGE unclassified			

Standard Form 298 (Rev. 8-98)
 Prescribed by ANSI Std Z39-18

Abstract

Title of Dissertation:

Toward Development of an Oral, Plant-based Vaccine Against *Escherichia coli*
O157:H7

Nicole A. Judge, Doctor of Philosophy, 2004

Thesis directed by:

Alison D. O'Brien, Ph.D.

Professor, Department of Microbiology and Immunology

Enterohemorrhagic *Escherichia coli* (EHEC) O157:H7 is the most common infectious cause of bloody diarrhea in the United States, and a sequela of this infection, the hemolytic uremic syndrome (HUS), is the primary cause of acute renal failure in children in the U.S. The majority of U.S. cases of EHEC O157:H7 have occurred as a consequence of ingestion of undercooked, contaminated hamburger or produce and/or water contaminated with bovine manure. Intimin is the primary adhesin of EHEC O157:H7, and is required for colonization of neonatal calves. I hypothesized that an intimin-based vaccination strategy in calves might reduce colonization of cattle with

EHEC O157:H7. To test this concept in a small animal model, I developed transgenic tobacco plant cells that expressed the full length or carboxy-terminal portion (Int₂₆₁) of EHEC O157:H7 intimin and then immunized mice parenterally with intimin expressed from the plant cells, or fed mice the transgenic plant cells, or both. I was able to show that these mice not only generated an intimin-specific mucosal immune response when primed parenterally and boosted orally but also exhibited a reduced duration of EHEC O157:H7 fecal shedding after challenge. These results suggest that transgenic plants are attractive and feasible production and delivery systems for an intimin-based vaccine for cattle, and such a vaccine can reduce the duration of EHEC O157:H7 shedding in a small animal model. In addition, Shiga toxin type 2 (Stx2) is another important EHEC O157:H7 virulence factor that plays a critical role in the development of potentially fatal HUS in humans. I developed a toxoid of Stx2 by making site-directed changes to the nucleotide sequence of the Stx2 A subunit gene that abrogated cytotoxicity *in vitro* and *in vivo*. The Stx2 toxoid elicited toxin-neutralizing antibody when parenterally injected in mice. I also optimized both the Stx2 A toxoid subunit and the B subunit for expression in plants and, thus laid the groundwork for future expression of this Stx2 toxoid molecule in plants.

Toward Development of an Oral, Plant-based Vaccine Against
Escherichia coli O157:H7

By

Nicole Ann Judge

Dissertation submitted to the Faculty of the
Department of Microbiology and Immunology Graduate Program of the
Uniformed Services University of the Health Sciences
F. Edward Hèbert School of Medicine
in partial fulfillment of the
requirements for the degree of
Doctor of Philosophy 2004

To my parents:

For giving me a love of and faith in growing things

Acknowledgements

To my family: I am very grateful to my parents who always supported me and gave me the love and strength to be or do anything I wanted. I am thankful to my husband, Tim, who is my guiding light, safe harbor, and the love of a lifetime.

To Alison: Your passion allowed me to pursue a dream and your wisdom helped that dream come true.

To the members of my committee: Drs. Jerse, Ji, Mason, Metcalf, and Sei, thank you for your guidance and encouragement along this journey.

To my friends and mentors: Thanks to Karen and Louise who were always willing to share their knowledge, advice, friendship, and the occasional beer or two.

To all of my fellow students and lab mates throughout my time at USUHS: Your friendship, conversation, and fellowship made this trip lighter and will never be forgotten.

To Joyce Van Eck, Joan Lenz, Zhong Huang, Bryan Maloney, and Yong-Sun Moon at The Boyce Thompson Institute for Plant Research: Thank you for the Arabidopsis plant transformation and characterization, and for training in NT-1 cell transformation and culture growth.

Table of Contents

Introduction

I.	Enterohemorrhagic <i>E. coli</i> O157:H7.....	1
	Diseases caused by EHEC O157:H7.....	2
	Diagnosis.....	2
	Epidemiology.....	3
	Cattle and EHEC O157:H7.....	4
	Virulence Determinants of EHEC O157:H7.....	6
	EHEC O157:H7 plasmid.....	6
II.	Intimin and Adherence to the Intestinal Mucosa.....	7
	History.....	7
	LEE.....	8
	Intimin Affects Colonization of EPEC in Humans and EHEC O157:H7 in Cattle.....	12
III.	Shiga Toxins in <i>E. coli</i>	16
	History.....	16
	Stx Structure and Function.....	16
	Stx and HUS.....	17
IV.	Transgenic Plant-based Vaccines.....	20

V. Specific Aims of this Dissertation.....	22
--	----

Materials and Methods

Intimin.....	24
Bacterial strains, plasmids, and media.....	24
Plant optimization – <i>eae</i> (2165-3010).....	28
Plant-expression plasmid construction.....	30
Adherence assay.....	33
Plant materials, growth, and transformation.....	34
Detection of intimin _{O157} expressed in plant cells.....	36
Immunoblotting.....	36
Mouse feeding assay.....	39
NT-1 cell feeding assay.....	39
ELISA.....	40
Nickel affinity chromatography of His-tagged intimin _{O157} from plant cells.....	41
Mouse model of intimin _{O157} -dependent colonization.....	41
Statistics.....	42
Stx2 Toxoid.....	43
Vero cell cytotoxicity assay.....	43
Stx2 toxoid construction and purification.....	43
Stx2 toxoid immunizations in mice.....	45

Toxin neutralization assay.....	46
Stx2 toxoid plant optimization.....	46
Stx2 B: Plant optimization and synthesis.....	47

Results

I.	Expression and antibody response to transgenic plant-expressed intimin _{O157}	52
	NT-1 plant cells that express full-length and his-tagged intimin _{O157}	52
	Antibody response to full-length intimin _{O157}	57
	Optimizing NT-1 cell expression of the carboxy-terminal portion of intimin _{O157}	62
	Glycosylation of Int ₂₆₁ in CSP20.....	75
	Colonization of mice by EHEC O157:H7 is dependent on intimin _{O157}	86
	Generation of intimin _{O157} -specific serum and fecal antibodies.....	89
	Challenge of vaccinated mice with EHEC O157:H7.....	92
	Expression of Int ₂₆₁ in a whole plant model: <i>Arabidopsis</i> <i>thaliana</i>	97
II.	Construction of a Shiga toxin type 2 toxoid for expression in plants.....	101
	Rationale for initiating experiments on Stx2 toxoids rather	

than Stx1 toxoids.....	101
Evaluation of an A ₂ B subunit antigen as an Stx2 toxoid.....	101
Rationale and strategy for construction of a site-directed Stx2 toxoid.....	109
Modification of Stx2 to create a toxoid.....	110
Analysis of Stx2 toxoid capacity to elicit Stx2-neutralizing antibodies.....	110
Optimization of the Stx2 toxoid subunit genes for expression in plants.....	110

Discussion

I. Expression of intimin _{O157} or a portion thereof in plant cells and a whole plant model.....	120
II. Immune response to intimin _{O157} expressed in plant cells.....	123
III. Glycosylation of Int ₂₆₁ in plant cells when expressed with the addition of a plant specific signal peptide.....	125
IV. The mouse model of intimin _{O157} -dependent bacterial colonization and immune response to Int ₂₆₁ expressed in plant cells blocks bacterial adherence.....	127
V. Stx2 toxoid can elicit a Stx2 toxin neutralizing immune response in mice.....	128
VI. Future Directions.....	129

References.....132

List of Tables

Table 1. Intimin types and associated bacterial strains.....	15
Table 2. Bacterial strains used in this study.....	25
Table 3. Plasmids used in this study.....	26
Table 4. Oligonucleotide sets for <i>eae</i> (1959-2804) plant expression optimization by QuikChange™ site-directed mutagenesis.....	29
Table 5. Stx2 B subunit ligase chain reaction oligonucleotides.....	51
Table 6. Immune response of BALB/c mice fed NT-1 cells that express intimin _{O157}	64
Table 7. Immune response of mice fed NT-1 cells expressing Int ₂₆₁	70
Table 8. Serum IgG from mice fed CSP20 does not recognize Int ₂₆₁ from pMW103 on ELISA.....	76
Table 9. Immune response of BALB/c mice fed or boosted with NT-1 cells that express Int ₂₆₁	91

List of Figures

Figure 1. Homology of the intimin proteins from EHEC O157:H7 strain EDL933 (γ -intimin) and EPEC O127:H6 strain 2348/69 (α -intimin).....	10
Figure 2. The crystal structure of Shiga toxin from <i>Shigella dysenteriae</i>	19
Figure 3. Examples of NT-1 cells transformants.....	38
Figure 4. The nucleotide sequence of the plant-optimized Stx2 B subunit gene.....	50
Figure 5. Full-length and his-tagged intimin _{O157} plant-expression constructs.....	54
Figure 6. Western blot analysis of NT-1 cells that expressed his-tagged (H) and full-length (F) in intimin _{O157}	56
Figure 7. An isotypic monoclonal antibody to Stx2B did not recognize plant-expressed intimin _{O157} from NT-1 cells.....	59
Figure 8. Western blot analysis of soluble intimin _{O157} expressed in NT-1 cells.....	61
Figure 9. Carboxy-terminal third intimin _{O157} (Int ₂₆₁) plant cell expression constructs.....	67
Figure 10. Serum from mice fed Int ₂₆₁ -expressing NT-1 cells block bacterial adherence to HEp-2 cells.....	72
Figure 11. Western blot analysis of CSP5 extracts.....	74

Figure 12. Western blot analysis of higher molecular weight bands expressed by older cultures of CSP20.....	78
Figure 13. Western blot analysis of Int ₂₆₁ from CSP20 before and after treatment with trifluoromethanesulfonic acid (TFMS) to deglycosylate the protein.....	81
Figure 14. Theoretical location of potential sites of N-linked glycosylation in Int ₂₆₁	83
Figure 15. Far Western blot analysis of Int ₂₆₁ from CSP20 to assess whether it bound to nucleolin.....	85
Figure 16. Western blot analysis of Int ₂₆₁ expressed by C34.....	88
Figure 17. Serum from mice immunized with Int ₂₆₁ from C34 blocked bacterial adherence to HEp-2 cells.....	94
Figure 18. Duration of EHEC O157:H7 colonization in mice immunized with Int ₂₆₁	96
Figure 19. Western blot analysis of Int ₂₆₁ expression in <i>Arabidopsis</i> leaf material.....	100
Figure 20. Expected Stx2 B subunit multimerization pattern upon crosslinking of the EHEC O157:H7 <i>stx2</i> $\Delta A_1kan::A_2B$ sonic lysate with dimethyl suberimidate (DMS).....	104
Figure 21. Stx2 B subunit multimers expressed from EHEC O157:H7 <i>stx2</i> $\Delta A_1kan::A_2B$	106

Figure 22. Toxin neutralization assay using serum from a mouse immunized with a lysate of a sonically disrupted culture of EHEC O157:H7 <i>stx2</i> ΔA_1 kan:: <i>A_2B</i>	108
Figure 23. Vero cell cytotoxicity assay of Stx2 toxoid purified from pNR100.....	112
Figure 24. Stx2 toxin neutralization assay with serum from a mouse immunized with Stx2 toxoid purified from pNR100.....	114
Figure 25. Agarose gel of Stx2 B synthetic gene.....	117
Figure 26. Agarose gel of amplified Stx2 B ligase chain reaction (LCR) product.....	119

Introduction

I. Enterohemorrhagic *E. coli* O157:H7

Before 1982, *Escherichia coli* O157:H7 was a rare serotype isolated from only sporadic cases of bloody diarrhea. However, in February of 1982, two outbreaks of severe bloody diarrhea in Oregon and Michigan thrust this virtually unknown serotype into the national spotlight (Riley *et al.*, 1983). Riley *et al.* described the clinically distinct gastrointestinal illness caused by *E. coli* O157:H7 as one that is characterized by severe abdominal cramps, grossly bloody diarrhea, and the absence of polymorphonucleocytes in the stool. In addition, epidemiological evidence suggested that consumption of undercooked hamburgers from a fast food chain was the primary risk factor for developing diarrhea. *E. coli* O157:H7 was isolated from the stools of infected patients, as well as from a hamburger patty from the lot of meat used at the restaurants. These initial findings led to the classification *E. coli* O157:H7 as a new subset of pathogenic *E. coli*, called enterohemorrhagic *E. coli* (EHEC), and established an epidemiological link between the bacterium and cattle. Subsequent studies on EHEC O157:H7 identified critical factors that are required for the full virulence of this organism in animal and tissue culture models (reviewed in Paton and Paton, 1998; Frankel *et al.*, 1998). Currently, a major thrust of EHEC O157:H7 research is the development of methods to reduce the incidence or prevent EHEC O157:H7 disease in humans. One approach to reduce the likelihood that humans will come in contact with this low-infectious-dose (Tilden, Jr. *et al.*, 1996; Griffin, 1998) bacterium is to decrease the prevalence of EHEC O157:H7 carriage in cattle. Currently, the general estimate of the proportion of cattle that

harbor the microbe in their intestines (when manure and multiple sites on the animals are sampled by sensitive means) approaches 30 % (Elder *et al.*, 2000). Consequently, the major goal of this project is to provide proof of the principle that a transgenic plant vaccine can be constructed that will lead to a protective immune response in a surrogate animal model for cattle and reduce the level and/or length of shedding of the agent in animal feces.

Diseases caused by EHEC O157:H7. EHEC O157:H7 causes diarrheal disease that can range from mild, non-bloody diarrhea to hemorrhagic colitis. Indeed, this organism is the leading cause of infectious bloody diarrhea in the United States (Centers for Disease Control and Prevention, 1994). A potentially fatal sequela of infection with EHEC O157:H7 is the hemolytic uremic syndrome (HUS), a disease that is characterized by thrombocytopenia, microangiopathic hemolytic anemia, and acute renal failure. In fact, EHEC O157:H7-mediated HUS is the primary cause of acute renal failure in children in the United States and Canada (Centers for Disease Control and Prevention, 1994). In 1999, the Centers of Disease Control and Prevention estimated that over 73,000 cases of human disease and 60 deaths per year in the United States were caused by EHEC O157:H7 (Mead *et al.*, 1999).

Diagnosis. When patients present with symptoms indicative of EHEC O157:H7 disease, positive diagnosis of this serotype is fairly straightforward. EHEC O157:H7 is distinguished from other *E. coli* in culture by the inability to ferment sorbitol (Wells *et al.*, 1983). In the clinical laboratory, stool samples are plated on sorbitol-MacConkey

agar (SMAC) to identify sorbitol-negative colonies (white) that are confirmed as EHEC O157:H7 by additional serological or biochemical tests. Antisera raised against the O157 and H7 antigens are used in slide agglutination assays. DNA probe and PCR assays, commonly based on *stx* (Shiga toxin) genes and EHEC O157:H7-specific *eae* (intimin) DNA sequences, are other procedures used to identify EHEC O157:H7. In addition, culture enrichment, immunomagnetic separation, and multiplex and real-time PCR are newly developed, highly sensitive methods for detection, and in some cases, quantification of EHEC O157:H7 from fecal and environmental samples, raw meat, and other tissues (Naylor *et al.*, 2003; Lekowska-Kochaniak *et al.*, 2002; Sharma and Dean-Nystrom, 2003). Indeed, incorporation of enrichment steps and immunomagnetic beads coated with anti-O157 sera into the newer O157:H7 isolation methods has lead us to understand that the incidence of infection in cattle is much higher than estimated 5 years ago (Elder *et al.*, 2000; Keen and Elder, 2002; Laegreid *et al.*, 1999).

Epidemiology. Since widespread testing started for EHEC O157:H7 in the early 1980's, this serotype has been found to be ubiquitous in both dairy and beef cattle. Cattle are considered the primary reservoir for this bacterium, and although they generally remain asymptomatic, they shed the bacteria into the environment in their feces.

Epidemiological evidence has implicated a variety of foods of bovine origin, such as ground beef (Griffin and Tauxe, 1991), roast beef (Abdul-Raouf *et al.*, 1993a), and raw milk (Keene *et al.*, 1997a) with human disease. In addition, human disease is associated with numerous other foods, such as salad vegetables (Abdul-Raouf *et al.*, 1993b), unpasteurized apple cider (Centers for Disease Control, 1997) and juice (Centers for

Disease Control, 1996b), and alfalfa sprouts (Breuer *et al.*, 2001), as well as contaminated drinking and recreational water (Swerdlow *et al.*, 1992; Keene *et al.*, 1994; Centers for Disease Control, 1996a; Centers for Disease Control, 1999). Person-to-person spread has also resulted in outbreaks reported from nursing homes and day care centers (Samadpour *et al.*, 1993; Belongia *et al.*, 1993). Contact with farm animals, their environment and livestock density are also major risk factors for EHEC O157:H7 infection (Centers for Disease Control, 2001; O'Brien *et al.*, 2001; Valcour *et al.*, 2002).

Cattle and EHEC O157:H7. The ecology of EHEC O157:H7 in cattle and on the farm is complex and has thus far frustrated production-level intervention strategies focused on precluding the entry of the organism into the human food chain. Although beef and dairy cattle are considered the primary reservoir for this *E. coli* serotype, EHEC O157:H7 is widespread in nature and can colonize a number of different species, including birds, sheep, deer, dogs, and humans, as well as survive and multiply in certain environmental niches (Wallace *et al.*, 1997; Kudva *et al.*, 1996; Keene *et al.*, 1997b; Armstrong *et al.*, 1996; LeJeune *et al.*, 2001). EHEC O157:H7 within the cattle population is endemic, and although the serotype can be found on most farms, its prevalence can fluctuate from less than 0.5% to approximately 28% (Hancock *et al.*, 1998; Elder *et al.*, 2000). EHEC O157:H7 is more frequently isolated from cattle during the warmer months of spring and summer, and this pattern correlates with the increased incidence of human disease during these months (Hancock *et al.*, 1998; Griffin, 1995). Recent studies by Naylor *et al.* show that EHEC O157:H7 colonizes the terminal 3 to 5 cm of the rectum in the bovine host (Naylor *et al.*, 2003). In addition, they observed that the majority (13 out of 15) cows in

their study persistently shed EHEC O157:H7 for more than 3 weeks, a finding that suggests that the duration of colonization may be greater than previously suspected. This prolonged colonization in cattle could provide a greater opportunity for EHEC O157:H7 contamination of beef products, the environment, and other cattle in the herd that are not yet colonized. In addition to colonizing the gastrointestinal tract, EHEC O157:H7 can persist and proliferate on cattle hide surfaces, oral cavities, and environmental water sources, such as water troughs and contaminated lakes and drinking wells (Elder *et al.*, 2000; Keen and Elder, 2002; Conradi, 1903; Samadpour *et al.*, 2002; Centers for Disease Control, 1999). These extra-gastrointestinal sites of EHEC O157:H7 persistence are not only potential sources of human infection but also increase the possibility of re-colonization of the cattle and spread of the bacterium in the cattle population. Several studies showed that irrigation can spread EHEC O157:H7 onto crops and that the proximity of vegetable fields or processing facilities to cattle farms can provide a significant potential for contamination (Solomon *et al.*, 2002; Hilborn *et al.*, 1999). Based on such reports, a number of investigators have concluded that a decrease in the amount of EHEC O157:H7 shed and in the number of cattle that excrete the serotype could lead to a significant reduction in the prevalence of the bacteria in cattle and the farm environment and a decline in the incidence of human EHEC O157:H7-related disease (Jordan *et al.*, 1999; Hancock *et al.*, 1998). In particular, the stochastic simulation study performed by Jordan *et al.* suggested that vaccination of cattle with an agent that would result in the reduction of colonization and shedding of the serotype held the greatest potential impact for reducing EHEC O157:H7 contamination of cattle carcasses (Jordan *et al.*, 1999). Not only would this approach reduce carcass

contamination, it would also diminish the amount of EHEC O157:H7 entering the environment and decrease potential pollution of wells, and of recreation and irrigation water. A decrease in contamination of irrigation water would likely reduce secondary contamination of non-bovine foodstuffs, such as fruits and vegetables.

Virulence Determinants of EHEC O157:H7. *E. coli* first emerged as potential pathogens in the 1940's when two researchers hypothesized that "summer diarrhea" that plagued infants and young children in England and North America was due to pathogenic *E. coli* (Bray, 1945; Bray and Beavan, 1948). In these experiments, Bray and Beavan isolated and raised anti-sera against homogenous strains of *Bacterium coli neapolitanum* (*E. coli*) obtained from stools of infants with diarrhea. The anti-sera agglutinated 87.5% of *E. coli* strains isolated from 90 children with diarrhea and only 4% of strains from 180 control patients. Since then, research involving pathogenic *E. coli*, especially EHEC O157:H7, has grown and converged with numerous fields of laboratory-based and epidemiology-based investigations. All pathogenic *E. coli* have underlying commonalities with respect to virulence characteristics and pathogenesis, of which EHEC O157:H7 is no exception. Three of these common factors are that: 1) critical virulence components are plasmid encoded; 2) pathogenic *E. coli* have specific and characteristic interactions with the intestinal mucosa; and, 3) enterotoxins and cytotoxins are often produced.

EHEC O157:H7 Plasmid. Almost all EHEC O157:H7 strains have a large, 90 Kb plasmid (pO157), but experimental findings about the contribution of pO157 to EHEC

O157:H7 virulence are contradictory (Karch *et al.*, 1987; Toth *et al.*, 1990; Tzipori *et al.*, 1987; Wadolowski *et al.*, 1990a). These disparate conclusions about the importance of pO157 genes may reflect the absence of any animal model or culture system that completely mimics human infection. That pO157 is likely to play some role in EHEC O157:H7-evoked disease is suggested by the numerous plasmid genes that encode potential virulence factors, e.g., hemolysin (Schmidt *et al.*, 1994), catalase (Brunner *et al.*, 1996), and serine protease (Brunner *et al.*, 1997).

II. Intimin and Adherence to the Intestinal Mucosa.

History. EHEC O157:H7 has the capacity to produce attaching and effacing (A/E) lesions in the colonic epithelium of cultured human intestinal tissue and animals (Phillips *et al.*, 2000; Dean-Nystrom *et al.*, 1997; Donnenberg *et al.*, 1993). A/E lesions are characterized by the adherence of the bacteria to the apical surface of the intestinal epithelium and the subsequent destruction of the microvilli. While investigating A/E lesion formation by EHEC O157:H7 in gnotobiotic piglets, Tzipori *et al.* (Tzipori *et al.*, 1986) observed that the lesions were very similar to those produced by enteropathogenic *E. coli* (EPEC), though at different intestinal sites. In addition to extensive damage to the brush border of the intestine, intimate adherence of EPEC and EHEC O157:H7 was also characterized by the accumulation of actin under the adherent bacteria (Knutton *et al.*, 1989). Through the use of fluorescein-labeled phalloidin to bind the accumulated actin, a fluorescent actin staining (FAS) test was developed by Knutton and colleagues

(Knutton *et al.*, 1989) and proved to be a powerful tool in further investigations of the factors influencing the adherence of EHEC O157:H7. FAS was used to screen EPEC for genes required to facilitate the adherence of the bacteria to HEP-2 cells, a human laryngeal cell line (Jerse *et al.*, 1990). Jerse *et al.* discovered a chromosomally-encoded gene in EPEC, *eae* (for *E. coli* attaching and effacing, and originally referred to as *eaeA*), that is necessary for the formation of A/E lesions, and that the *eae* gene produces a 94 kDa outer membrane protein, later appropriately termed intimin due to its capacity to facilitate intimate attachment of the bacteria to host cells. The *eae* gene is also present in EHEC O157:H7 (Yu and Kaper, 1992; Beebakhee *et al.*, 1992) and plays a role in inducing A/E lesions *in vitro* and *in vivo* (Donnenberg *et al.*, 1993; McKee *et al.*, 1995). The amino-terminal region of intimin mediates outer membrane localization of the protein and facilitates the functional surface expression of the host cell binding domain of the molecule: the carboxy-terminus (Fig. 1) (Liu *et al.*, 1999). While EPEC and many EHEC strains share intimin as a common virulence factor, EHEC strains produce Shiga toxins, very potent enterotoxins, and lack bundle forming pili (BFP) which are important for the initial adherence of EPEC to the intestinal epithelium. In addition, EPEC, but not EHEC, regulates the expression of intimin using the plasmid-encoded regulatory (*per*) region present on the 60 MDa plasmid, which also encodes BFP (Gomez-Duarte and Kaper, 1995).

LEE. The EPEC and EHEC O157:H7 *eae* genes are located in a ~35 kb chromosomal pathogenicity island named LEE (locus for enterocyte effacement) that also includes additional genes that comprise a type III secretion system and mediate adherence in

Figure 1. Homology of the intimin proteins from EHEC O157:H7 strain EDL933 (γ -intimin) and EPEC O127:H6 strain 2348/69 (α -intimin). The EHEC EDL933 *eae* gene is 2802 bp and is predicted to encode a protein of 934 amino acid residues. The EHEC *eae* gene is slightly smaller than the EPEC O127:H6 *eae* gene, which is 2817 bp and is predicted to encode a 939 amino acid residue protein. The overall homology of the structural genes is 83% at the amino acid level. The first 2/3 of the proteins (amino acids 1-704) share 94% identity and the remaining 25% of the proteins share 49% amino acid identity (Yu and Kaper, 1992).

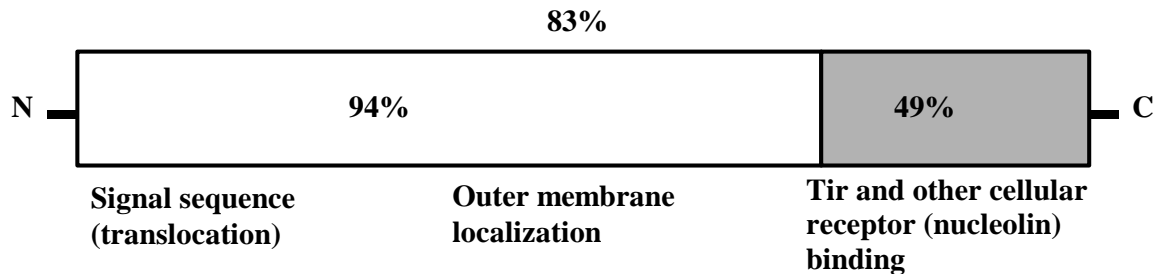
EHEC O157:H7 Intimin

conjunction with *eae* (McDaniel *et al.*, 1995). The LEE can be divided into 3 regions. The middle region contains the genes for intimin and Tir, the translocated intimin receptor. Tir is a bacterial protein that acts as an intimin receptor after it is translocated to the host cell via the type III secretion system. The genes that comprise the type III secretion system are present in the second region, upstream of *eae* and *tir* in the LEE (Kenny *et al.*, 1997). This *E. coli* type III secretion system shares similarities to systems found in other enteric pathogens such as *Yersinia*, *Shigella*, and *Salmonella*. The third region of the LEE encodes several proteins that are secreted through the type III secretion system. One such protein, Esp A (for *E. coli* secreted protein A) forms a tube-like structure that is critical for the secretion of other LEE encoded proteins such as Tir (Kenny *et al.*, 1997). The complete sequence for EHEC O157:H7 strain 933 shows that EPEC LEE and EHEC O157:H7 LEE share 41 genes with an average nucleotide identity of 93.9% across the shared genes (Perna *et al.*, 2001). The degree of identity is not consistent over the 41 common genes. Some EPEC and EHEC O157:H7 LEE genes, like the *esc* genes that make the type III secretion apparatus show 98-100% identity and other genes, such as *eae* and *tir*, display 87% and 33% identity, respectively. These LEE-encoded effector proteins interact directly with host cells and their variability suggests different host cell tropisms for EPEC versus EHEC. Indeed, when *eae* from EPEC O127:H6 is cloned into an *eae* mutant of EHEC, the resulting EHEC clone is able to colonize piglet intestine, though in a manner more characteristic of EPEC (small intestine) than EHEC (large intestine) (Tzipori *et al.*, 1995).

Intimin Affects Colonization of EPEC in Humans and EHEC O157:H7 in Cattle.

Intimin is required for EHEC O157:H7 to colonize host mammalian cells *in vitro* and *in vivo* (Donnenberg *et al.*, 1993; McKee *et al.*, 1995). Moreover, antibodies specific to intimin can block adherence of the bacteria to cultured cells and intestinal mucosa (Gansheroff *et al.*, 1999; Dean-Nystrom *et al.*, 2002). Experimental infection of human volunteers with EPEC by Levine *et al.* showed that the patients made an antibody response to a 94 kDa outer membrane protein that was later identified as intimin (Levine *et al.*, 1985; Jerse and Kaper, 1991). In addition, one volunteer who had preexisting antibody to intimin did not develop diarrhea when challenge with the EPEC strain, a finding that suggests that antibody to intimin may protect from EPEC-mediated disease. Other studies confirmed the induction of intimin-specific antibody, along with other antibodies to additional *E. coli* virulence factors such as the Esps or Tir, upon natural infection with EPEC or EHEC strains (Martinez *et al.*, 1999; Li *et al.*, 2000; Karpman *et al.*, 2002).

Intimin interacts with mammalian cells through two receptors. When EHEC O157:H7 comes in contact with target host cells, Tir is injected into the cells by the bacterium through the type III secretion system. Tir incorporates into the host cell outer membrane and acts as an intimin receptor (DeVinney *et al.*, 1999) that mediates the close adherence of the bacteria to the eukaryotic cell surface leading to A/E lesion formation. The most severe symptoms of EHEC O157:H7 infection are associated with the production of Shiga toxins, however the ability to form A/E lesions is an essential virulence factor for EHEC and EPEC as well. The absence of Tir, or the inability to deliver Tir to host cells abrogate pedestal formation in host cells by both EHEC and

EPEC strains (Kenny *et al.*, 1997; DeVinney *et al.*, 1999). Both EHEC O157:H7 and EPEC share the ability to form A/E lesions within the host cell, though the mechanisms by which they initiate host cell cytoskeletal changes are very different. One major difference is that EPEC Tir is tyrosine phosphorylated within the host cell whereas EHEC O157:H7 initiates pedestal formation by an as yet unknown tyrosine phosphorylation-independent mechanism. EPEC Tir can complement a Tir deficient EHEC strain, but EHEC Tir can not complement an EPEC Tir mutant (Kenny, 2001; DeVinney *et al.*, 2001) because EHEC O157:H7 Tir lacks a critical tyrosine residues at position 474 and is not phosphorylated in host cells. EPEC strains that deliver EPEC Tir lacking this tyrosine residue are unable to form pedestals (DeVinney *et al.*, 2001). These results suggest that while EPEC Tir is dependent on tyrosine phosphorylation to induce cytoskeletal changes, EHEC Tir does not have the same requirements. It is still unknown how EHEC initiates A/E lesion formation in the absence of tyrosine phosphorylation, though it is interesting to speculate that EHEC O157:H7 has evolved into a more self-sufficient pathogen compared to EPEC. EHEC O157:H7 requires other bacterial encoded factors, delivered by the type III secretion system, for intimate adherence and pedestal formation via the Tir-intimin_{O157} interaction (DeVinney *et al.*, 2001). Thus EHEC O157:H7 is not limited to relying on the host cell tyrosine kinases at least at this early stage of attachment. In addition, intimin can interact with a host-cell surface-expressed protein called nucleolin (Sinclair and O'Brien, 2002). Both Tir and nucleolin bind intimin on the carboxy-terminal portion of the molecule (Frankel *et al.*, 1994; Frankel *et al.*, 1995; Sinclair and O'Brien, 2002). This observation suggests that although this portion of intimin is the most divergent among the different intimin types (Yu and Kaper,

1992) (Fig. 1; Table 1), the carboxy-terminus is very important for intimin host-cell interactions and may influence binding affinity to cells in different anatomical sites of the intestine (Tzipori *et al.*, 1995).

In addition, antibodies to intimin_{O157}, specifically antibodies directed to the carboxy-terminal third of intimin_{O157}, can block adherence of wild type EHEC O157:H7 to HEp-2 cells (McKee and O'Brien, 1996; Gansheroff *et al.*, 1999). Furthermore, colostrum from sows immunized intramuscularly with intimin from EHEC O157:H7 contains anti-intimin_{O157} antibodies that can protect suckling piglets from colonization with wild type EHEC O157:H7 (Dean-Nystrom *et al.*, 2002). These studies suggest that antibodies specific to the carboxy-terminal third of intimin_{O157} play an important role in blocking adherence of the bacterium to host cells and can protect a host from EHEC O157:H7-mediated disease. EHEC O157:H7 can colonize calves and adult cattle, sheep, and a variety of other domestic and wild animals (Cray, Jr. and Moon, 1995; Kudva *et al.*, 1996; Keene *et al.*, 1997b; Wallace *et al.*, 1997), and intimin_{O157} is required for EHEC O157:H7 to colonize neonatal calves and adult sheep and cattle (Dean-Nystrom *et al.*, 1998; Cornick *et al.*, 2002). These data, along with the finding that antibodies specific to intimin_{O157}, especially the carboxy-terminal third of intimin_{O157}, can block bacterial adherence to HEp-2 cells and prevent infection of suckling piglets, strongly suggest that intimin_{O157} is an attractive candidate for an EHEC O157:H7 anti-transmission vaccine for cattle.

Table 1: Intimin Types and Associated Bacterial Serotypes

Intimin Type	Bacterial strain	Reference or Accession number
Alpha	EPEC O127:H6	(Adu-Bobie <i>et al.</i> , 1998)
Alpha 2	EPEC O125:H6	(Acheson <i>et al.</i> , 1995)
Beta	EHEC O26:H11	(Adu-Bobie <i>et al.</i> , 1998)
	RDEC-1	(Adu-Bobie <i>et al.</i> , 1998)
	<i>Citrobacter rodentium</i>	(Adu-Bobie <i>et al.</i> , 1998)
Gamma	EHEC O157:H7	(Adu-Bobie <i>et al.</i> , 1998)
	EHEC O55:H7	(Adu-Bobie <i>et al.</i> , 1998)
Gamma 2	EHEC O111:H-	(Acheson <i>et al.</i> , 1995)
Delta	EPEC O86:H34	(Adu-Bobie <i>et al.</i> , 1998)
Epsilon	EHEC O121:H19	(Acheson <i>et al.</i> , 1995)
Iota	EHEC O145:H4	(Ramotar <i>et al.</i> , 1990)
Kappa	EHEC O118:H5	(Ramotar <i>et al.</i> , 1990)
Lambda	NT strain 97-3 (China)	AAL32028
Eta	EPEC O125:H-	(Ramotar <i>et al.</i> , 1990)
Zeta	EHEC O84:NM, EHEC	(Tarr and Whittam, 2002; Ramotar <i>et al.</i> ,
	O84:H4	1990)
Theta	EHEC O111:H8	(Tarr and Whittam, 2002)

III. Shiga Toxins in *E. coli*

History. Shiga toxin (Stx), produced by *Shigella dysenteriae* serotype 1, is the prototype toxin of a large family of structurally and functionally-related toxins that was first discovered in 1903 by two independent groups (Conradi, 1903; Neisser and Shiga, 1903). O'Brien *et al.* in 1977 and 1982 reported that certain *E. coli* strains produce a cytotoxin that cross-reacts with anti-sera raised against Shiga toxin (O'Brien *et al.*, 1977; O'Brien *et al.*, 1982). EHEC O157:H7 isolates from the 1982 hamburger outbreak were also found to produce a cytotoxin that was neutralized by anti-Shiga toxin antibodies (O'Brien *et al.*, 1983). Shiga toxins of Shiga-toxin producing *E. coli* (STEC) were called Shiga-like toxins and, alternatively, Vero toxins due to their similarity to Stx from *Shigella* and their Vero cell cytotoxicity (Calderwood *et al.*, 1996; Karmali *et al.*, 1996). Since then, *E. coli* strains have been shown to produce two main forms of Stx: Stx1 and Stx2 (Strockbine *et al.*, 1986). Stx and Stx1 are antigenically identical and only differ in one amino acid (Strockbine *et al.*, 1988). Stx2 is sufficiently antigenically distinct from Stx and Stx1 such that polyclonal antisera to Stx or Stx1 does not neutralize Stx2 or any of its numerous variants that include Stx2c, Stx2d [Stx2d1, Stx2d2], Stx2e, and Stx2f (Ito *et al.*, 1990; Melton-Celsa *et al.*, 1996; Marques *et al.*, 1987; Schmidt *et al.*, 2000; Schmitt *et al.*, 1991; Teel *et al.*, 2002).

Stx Structure and Function. All members of the Stx family share genetic, antigenic, and structural features. All have an A1:B5 noncovalently associated subunit structure. The Stx A subunit (~35 kDa) is cleaved to produce A₁ (~28 kDa) and A₂ (~4 kDa)

portions. The A₂ subunit remains associated with the A₁ subunit via a disulfide bond and serves to link the A₁ to the B pentamer (Fig. 2). All of the toxins have the same enzymatic function of inhibition of protein synthesis by depurination of an adenine residue from 28S ribosomal RNA of the 60S ribosome. The A₁ subunit contains the N-glycosidase activity (Endo *et al.*, 1988; Saxena *et al.*, 1989). The glutamic acid at position 167 of the A subunit is the active site and is critical for enzymatic activity (Hovde *et al.*, 1988), though other amino acid residues in the A subunit (such as the tyrosine at position 77) are also important for toxicity (Deresiewicz *et al.*, 1992). The B subunit of Stx (~7 kDa per monomer) forms a pentameric structure that typically binds to globotriaosylceramide (Gb₃), except in the case of Stx2e that binds to Gb₄ (Jacewicz *et al.*, 1986; Lindberg *et al.*, 1987; De Grandis *et al.*, 1989).

Stx and HUS. In 1983, Karmali *et al.* established a link between infection with Vero toxin (Stx)-producing *E. coli* and hemolytic uremic syndrome (HUS) (Karmali *et al.*, 1983), and he later confirmed that Stxs play a major role in the development of HUS (Karmali *et al.*, 1985; Griffin, 1995). Virtually all isolates of *E. coli* and *Shigella* incriminated in cases of HUS produce one or more forms of Stx. In fact, EHEC O157:H7 strains produce Stx1 and Stx2, or Stx2 alone, or, less commonly, Stx1 only (Obrig, 1998). Although Stx1 and Stx2 are equally toxic for Vero cells, Stx2, either injected in a pure form or when expressed from STEC in the gastrointestinal tract of mice, appears to be more toxic than Stx1 (Melton-Celsa and O'Brien, 1998). Louise and Obrig demonstrated that endothelial cells are 1000 times more sensitive to Stx2 than to Stx1 (Louise and Obrig, 1995). In addition, epidemiological data suggests that Stx2 may

Figure 2. The crystal structure of Shiga toxin from *Shigella dysenteriae* (Fraser *et al.*, 1994). The Stx A and B subunit structures are shown in this figure. The Shiga toxin family has an A₁:B₅ noncovalently associated subunit structure. The A₂ subunit remains associated with the A₁ subunit via a disulfide bond and serves to link the A₁ to the B pentamer.

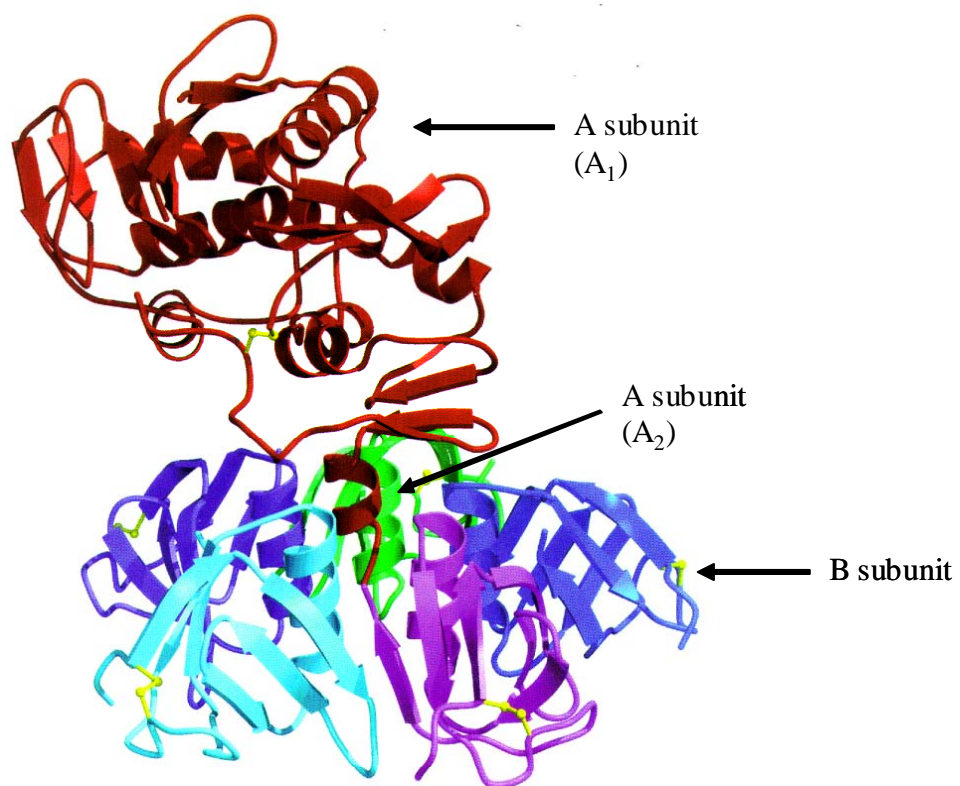

play a more critical role in the development and severity of HUS, although Stx1-only producing strains have also been associated with cases of HUS (Scotland *et al.*, 1987; Ostroff *et al.*, 1989).

IV. Transgenic Plant-based Vaccines

In 1990, a consortium of philanthropic, health, and government organizations led by the World Health Organization developed the Children's Vaccine Initiative (CVI). The CVI's lofty goals included developing safe, orally administered, multicomponent, heat stable vaccines that could be widely accessible to the children of underdeveloped countries (Douglas, Jr., 1993). The CVI focused attention on technologies that would make vaccines less expensive and more reliable, especially for the developing world. It also drew attention to multi-component vaccines that could be delivered orally, thus simplifying administration and eliminating the cost and risks associated with needles and syringes. Each of the CVI's requirements for the ultimate vaccine could potentially be met in plant-based vaccine technology.

Since the early 1990's, numerous vaccine antigens and other pharmaceuticals (such as secretory antibodies) have been successfully expressed in plants. The vaccine antigens include hepatitis B surface antigen (HBsAg) (Mason *et al.*, 1992; Thanavala *et al.*, 1995; Kong *et al.*, 2001), enterotoxigenic *E. coli* heat-labile toxin B subunit (LT-B) (Haq *et al.*, 1995; Mason *et al.*, 1998; Tacket *et al.*, 1998; Lauterslager *et al.*, 2001), Norwalk virus capsid protein (NVCP) (Mason *et al.*, 1996; Tacket *et al.*, 2000), cholera toxin B subunit (Arakawa *et al.*, 1997; Arakawa *et al.*, 1998), and many others. In

addition, other medically important pharmaceuticals have been successfully expressed in plants, such as secretory antibodies (Ma *et al.*, 1995; Ma *et al.*, 1998) and other human proteins, such as cytokines (Ganz *et al.*, 1996).

LT-B and NVCP expressed in transgenic potato were tested in mice and in human clinical trials. In mice, potatoes that expressed LT-B induced LT-B-specific immune responses that protected the animals from a subsequent toxin challenge (Mason *et al.*, 1998). Humans fed such potatoes developed LT-B-specific serum IgG, fecal IgA, and anti-LT IgA antibody-secreting cells (Mason *et al.*, 1998; Tacket *et al.*, 1998). Mice immunized orally generated an antibody response to NVCP expressed in transgenic tobacco or potato (Mason *et al.*, 1996). Additionally, 95% of human volunteers fed transgenic potatoes that expressed NVCP virus-like particles developed significant increases in the number of NVCP-specific IgA antibody-secreting cells and 30% and 20% developed NVCP-specific serum IgG and fecal IgA, respectively (Tacket *et al.*, 2000). These results show that plants can express bacterial and viral vaccine antigens that are immunogenically similar to native proteins and that these plant-expressed antigens can induce specific immune responses upon oral immunization.

Many pathogens infect or invade via mucosal surfaces, so the capacity of plant-based vaccines to induce mucosal immunity is a great advantage. The plant cells act as a natural microencapsulation system to protect the vaccine antigens from being degraded in the upper digestive tract before they can reach the gut-associated lymphoid tissue (GALT). Recent studies on HBsAg expressed in transgenic potatoes suggests that oral delivery of this antigen can act as an immunological “prime” and can lead to the development of a strong, long-lasting secondary serum antibody response upon a

parenteral boost with a sub-immunogenic dose of yeast-derived HBsAg (Kong *et al.*, 2001). Other research suggests that plant-based oral vaccines can significantly boost mucosal immune responses primed by parenteral injection (Van der Heijden *et al.*, 1989; Lauterslager *et al.*, 2001). Parenteral priming of the immune system may allow the GALT to react successfully to the small amounts of antigen delivered during oral immunization and thus decrease the possibility of inducing oral immunotolerance to plant-based and other orally delivered vaccine antigens.

V. Specific Aims of this Dissertation

The underlying hypothesis of this project is as follows. When intimin_{O157} or a portion of that molecule is expressed by plant cells and delivered to an animal alone or as a boost for parenterally injected intimin_{O157}, the intimin_{O157}-specific immune response that is elicited leads to a reduction in the degree and/or duration of colonization of that animal with wild-type EHEC O157:H7. Three specific aims were designed to test this multi-tiered hypothesis. The first aim was to successfully express intimin_{O157}, or a plant-optimized carboxy-terminal portion of the protein (Int₂₆₁), in NT-1 cells, a tobacco plant cell system. The second aim was to determine whether the plant-expressed intimin_{O157} proteins were immunogenic in mice when partially purified and parenterally injected or when fed directly to mice in plant cell material. The final aim of this project was to determine if the intimin_{O157}-specific immune response in mice could: i.) block adherence of wild type EHEC O157:H7 strain 86-24 in a HEp-2 cell adherence assay and ii.) block

or reduce the duration of colonization with the same strain in an intimin_{O157}-dependent mouse model of colonization.

The final section of the dissertation describes my efforts to create a site-directed mutant Stx2 holotoxoid that retains the native structure of the toxin, is totally non-toxic, and is capable of eliciting toxin-neutralizing antibody. For this purpose, both the Stx2 A and B subunits were plant-optimized and cloned into plant expression vectors. The ultimate goal of the Stx2 toxoid studies initiated here is to express the toxoid in plants and to use these transgenic cells as an oral vaccine against Stx2-mediated disease.

Materials and Methods

Intimin

Bacterial Strains, Plasmids, and Media. The bacterial strains used in this study are summarized in Table 2. The plasmids used in this study are summarized in Table 3. EHEC O157:H7 strain 86-24 (Griffin *et al.*, 1988) was isolated in 1986 from a patient in Seattle, WA and was kindly provided by Dr. Phil Tarr. The full-length (pEB310) and histidine-tagged intimin_{O157} expression plasmids, pEB313 (encodes all but the first 34 amino acids of the *eae* gene) and pMW103 (encodes the carboxy-terminal third of intimin_{O157}) have been described previously (McKee *et al.*, 1995; McKee and O'Brien, 1996; Gansheroff *et al.*, 1999). EHEC O157:H7 strain 86-24 expressing the GFP (green fluorescent protein) arabinose-inducible plasmid p166 was used to visualize bacteria in the adherence assay (see “adherence assay” below for details) (Sinclair and O'Brien, 2002). Streptomycin-resistant derivatives of strain 86-24 [called 86-24 Str^r (Melton-Celsa *et al.*, 1998)] and its isogenic, intimin_{O157}-negative mutant strain 86-24 *eae*Δ10 [called 86-24 Str^r *eae*Δ10 (McKee *et al.*, 1995)] were used to distinguish EHEC O157:H7 from other fecal bacteria during the colonization assay by plating on sorbitol MacConkey agar with 100 μg/ml streptomycin. The *Agrobacterium tumefaciens* strain EHA105, plasmids with plant-specific expression components (pBTI210.3, pBTI210.4, pIBT210), and the binary vector pGPTV-Kan were generously provided by Dr. Hugh Mason (Arizona State University, Tempe AZ) from the Boyce Thompson Institute for Plant Research (Ithaca, NY). All *E. coli* strains and clones were grown in Luria Bertani (LB) broth or on LB agar.

Table 2. Bacterial strains used in this study

Strain	Relevant characteristics	Reference
86-24	<i>E. coli</i> O157:H7, intimin positive	(Griffin <i>et al.</i> , 1988)
86-24-GFP	<i>E. coli</i> O157:H7 with p166	(Sinclair and O'Brien, 2002)
86-24 Str ^R	<i>E. coli</i> O157:H7, Str ^R	(Melton-Celsa <i>et al.</i> , 1998)
86-24 Str ^f <i>eae</i> Δ10	<i>E. coli</i> O157:H7, intimin negative, Str ^R	(McKee <i>et al.</i> , 1995)
DH5α	<i>E. coli</i> cloning host, <i>recA</i>	(Hanahan, 1983)
XL-1 Blue	<i>E. coli</i> cloning host, <i>recA</i> , <i>lacI^q</i>	(Bullock <i>et al.</i> , 1987) from Stratagene (La Jolla, CA)
<i>Agrobacterium tumefaciens</i> EHA105	Plant transformation strain	(Hood <i>et al.</i> , 1993)

Table 3. Plasmids used in this study

Plasmid	Relevant characteristics	Reference or source
Intimin:		
pEB310	Wild-type <i>eae</i> ORF, from 86-24, in pBRKS-	(McKee <i>et al.</i> , 1995)
pEB313	Truncated <i>eae</i> (bp 109-2804), in pQE32 (Qiagen)	(McKee and O'Brien, 1996)
pMW103	Truncated <i>eae</i> , (bp 1959-2804), in pQE31 (Qiagen)	(Gansheroff <i>et al.</i> , 1999)
pNR37	<i>eae</i> from pMW103, plant optimized	This study
Plant Expression Vectors:		
pIBT210	CaMV 35S promoter, TEV 5' UTR, Vsp 3' UTR	(Haq <i>et al.</i> , 1995)
pBTI210.3	CaMV 35S promoter, TMV Ω 5' UTR, Vsp 3' UTR	Dr. Hugh Mason
pBTI210.4	With plant-specific signal peptide sequence	Dr. Hugh Mason
pGPTV-Kan	Binary vector; Kan ^R	(Becker <i>et al.</i> , 1992)

 Plant-specific Intimin

Expression Vectors:

pNR12	Full-length <i>eae</i> from pEB310	This study
pNR14	Truncated <i>eae</i> from pEB313	This study
pNR49	<i>eae</i> from pNR37 with signal peptide sequence from pBTI210.4	This study
pNR50	<i>eae</i> from pNR37	This study

Stx2:

pMJ100	<i>stx2</i> from <i>E. coli</i> O157:H7 86-24 in pBluescript; Amp ^R	(Weinstein <i>et al.</i> , 1989)
pNR100	<i>stx2</i> Y77S, E167Q (toxoid)	This study
pNAJ58	<i>stx2</i> Y77S, E167Q; plant optimized	This study
pNAJ65	<i>stx2</i> Y77S, E167Q A subunit only from pNAJ58 in pIBT210	This study
pNAJ73	<i>stx2</i> B subunit; plant optimized (synthetic) in pBTI210.3	This study

Prior to plant cell transformation, *Agrobacterium* strains were grown in YM broth (0.4 g yeast extract, 10 g mannitol, 0.1 g NaCl, 0.2 g Mg SO₄-7H₂O, 0.5 g K₂HPO₄ per liter). Antibiotics were added at the following concentrations as needed for selection: ampicillin 100 µg/ml, kanamycin 50 µg/ml, carbenicillin 100 µg/ml. Plasmid DNA was isolated by the Miniprep procedure (Qiagen, Valencia, CA). Restriction enzymes were purchased from New England Biolabs (Beverly, MA) and restriction enzyme digested DNA fragments were purified by agarose gel electrophoresis and eluted from the gel using the GENECLEAN SPIN columns and reagents (Bio 101, Carlsbad, CA). T4 DNA ligase was purchased from U.S. Biochemicals (Cleveland, OH) and Pfu ligase was obtained from Stratagene (La Jolla, CA). The polymerase chain reaction (PCR) was done with AmpliTaq (Roche, Branchburg, NJ) and Pfu Turbo (Stratagene) polymerases in a MJ Research Minicycler (Watertown, MA). Sequencing was performed with the ABI Big Dye Sequencing kit (Applied Biosystems, Inc., Foster City, CA). Products were separated and analyzed by the Biomedical Instrumentation Center at Uniformed Services University with the Applied Biosystems model 377 or 3100. Sequence results were compared to published sequences using the Wisconsin Sequence Analysis package from the Genetics Computer Group, Inc. (Madison, WI).

Plant Optimization – *eae* (2165-3010). Thirteen independent changes were made to the nucleotide sequence of the intimin gene from pMW103 with the QuikChange™ Site-directed Mutagenesis Kit (Stratagene). The seven sets of oligonucleotides listed in Table 4 were designed according to the protocol listed in the QuikChange™ manual. The initial mutagenesis reaction was done with 50 ng of

Table 4: Oligonucleotides sets for *eae* (1959-2804) plant expression optimization by QuikChange™ site-directed mutagenesis

Oligo set	Oligo
1-forward	GGGTCAGCCAGTTAA <u>C</u> AA <u>C</u> CAATCCGTTACATTCTCAACAAACTTTGG
1-reverse	CCAAAGTTTGTGAGAATGTAACGGATTG <u>G</u> TT <u>G</u> TTAAGTGGCTGACCC
2-forward	GGCTGCAATATGGTCA <u>A</u> TTTAAACTGAAAGCAAGCGG
2-reverse	CCGCTTGCTTTCAGTTTAA <u>A</u> TTGACCATATTGCAGCC
3-forward	GGGAAAGTCACTTTGAATGGTAAAGG <u>C</u> TCTGTCGTAATTAAAGCC
3-reverse	GGCTTTAATTACGACAG <u>A</u> GCCTTTACCATTCAAAGTGACTTTCCC
4-forward	GGTGATAAGCAAACAGTAAGTTACACTAT <u>C</u> AAGGCACCGTCG
4-reverse	CGACGGTGC <u>C</u> TT <u>G</u> ATAGTGTAAGTTACTGTTTGCTTATCACC
5-forward	GCTATGTCCATTTGCAAAAA <u>C</u> TT <u>G</u> TTACCATCCACACAGACGG
5-reverse	CCGTCTGTGTGGATGGTAA <u>C</u> AA <u>G</u> TTTTTTGCAAATGGACATAGC
6-forward	GGTATTGTCAGATAT <u>C</u> TATGACTCATGGGGGGCTGCAAA <u>C</u> AA <u>G</u> TATAGCC
6-reverse	GGCTATA <u>C</u> TT <u>G</u> TTTGCAGCCCCCATGAGTCATAG <u>A</u> TATCTGACAATACC
7-forward	GGATTAACAGACATCTAGTGAGCA <u>A</u> CGTTCTGGAGTATCAAGC
7-reverse	GCTTGATACTCCAGAACG <u>T</u> TGCTCACTAGATGTCTGTTTAATCC

pMW103 and 125 ng of each primer from primer set #1 in a total volume of 50 μ l. In addition, 1 μ l of Pfu Turbo polymerase was added to each reaction tube immediately prior to placing the sample tubes into the Minicycler. The samples were subjected to a 30 second hot start at 95°C, then 12 cycles of 95°C for 30 seconds, 55°C for 60 seconds, and 68°C for 12 minutes. After the cycles were completed, each reaction mixture was digested with *DpnI*, and 1-5 μ l of the digested reaction were transformed into the supercompetent cells provided with the kit as outlined in the QuikChange™ manual. The transformed cells were plated on LB agar with ampicillin. Several ampicillin-resistant colonies were selected, and 3 ml overnight LB broth cultures prepared from each colony. Bacteria were then harvested by centrifugation, and plasmid DNA purified from the pelleted organisms. The *eae* sequences were amplified by PCR from the plasmids, and the PCR products were then eluted from an agarose gel and sequenced. Clones in which the sequence of the mutated, PCR-amplified *eae* gene had been confirmed were used in the next round of mutagenesis with the next set of mutagenesis primers. The final plant-optimized intimin_{O157} clone from pMW103 (Gansheroff *et al.*, 1999) that contained all 13 nucleotide changes was called pNR37. The intimin_{O157} protein encoded by this gene on this plasmid has an amino-terminal histidine tag and consists of the carboxy-terminal 261 amino acids of intimin_{O157} from EHEC O157:H7 (Int₂₆₁).

Plant-expression Plasmid Construction. The nucleotide sequence for the VspA signal peptide was amplified by PCR from pHB306 (Richter *et al.*, 2000). A fragment that contained the nucleotide sequences for tobacco etch virus (TEV) 5'-UTR and the VspA signal peptide (encodes M A M K V L V F F V A T I L V A W G A) was ligated

into the *XhoI-SacI* sites of pIBT210.1 (Haq *et al.*, 1995) to make pBTI210.4. Plasmid pBTI210.4 codes for a plant-specific signal peptide 5' to a *SacI* site, a cauliflower mosaic virus (CaMV) 35S promoter, TEV 5'-UTR, and a VspB 3' flank. Plasmid pBTI210.3 was created by digestion of pHB211.1 (Richter *et al.*, 2000) with *NcoI*. This restriction enzyme digested DNA was 3' end-filled with Klenow polymerase and then further digested with *XhoI* and mung bean nuclease. The resultant blunt-ended vector fragment was ligated to generate pHB211. The *HindIII-NcoI* fragment of pHB211 that contained the sequences for the CaMV 35S promoter fused to the tobacco mosaic virus (TMV) 5'-UTR was ligated into pIBT210.1 to create pBTI210.3.

Plasmids that encoded full-length or histidine-tagged fragments of intimin_{O157} for expression in plants were constructed by standard procedures. PCR was used to amplify full-length intimin_{O157} from pEB310 (McKee *et al.*, 1995). The primers used, TGGTGGATCCATAACATGATTAC (forward) and CTAGGAGCTCTTATTCTACACAAACCGCATAG (reverse), contained *BamHI* and *SacI* sites respectively. The amplified product was cut with *BamHI* and *SacI* and ligated into pBTI210.3 to make pNR9. Plasmid pNR9 was cut with *NcoI*, subjected to mung bean digestion, and the resultant blunt-ended vector was religated to create pNR23. The *EcoRI-HindIII* fragment of pNR23 was cloned into pGPTV-Kan to create pNR12, a plant-expression construct that was designed to express full-length intimin_{O157}. Plasmid pNR12 was then transformed by electroporation into *A. tumefaciens* EHA105.

PCR was used to amplify the DNA that contained the gene for histidine-tagged intimin_{O157} from pEB313 (McKee and O'Brien, 1996). The primers used, TTAACCATGGGAGGATCTCAC (forward) and

CAGATTTTACCCGGGGTGGTTATGG (reverse), contain *NcoI* and *SmaI/XmaI* sites respectively. The amplified product was cloned into a T-tailed bluescript vector from the TA cloning® kit (Invitrogen, Carlsbad, CA). The resulting plasmid was cut with *NcoI* and *SmaI* and ligated into pBTI210.3 to generate pNR27. The *EcoRI-HindIII* fragment of pNR27 was cloned into pGPTV-Kan to make pNR14, a plant-expression construct that was designed to express histidine-tagged, slightly truncated (minus 35 amino acids from the amino-terminus) intimin_{O157}. Plasmid pNR14 was then transformed by electroporation into *A. tumefaciens* EHA105.

The DNA that contained the gene for the histidine-tagged carboxy-terminal third of intimin_{O157} (the carboxy terminal 261 amino acids; Int₂₆₁) was amplified by PCR from pNR37. The primers used, GAGAGGAGCTCCACCATCACC (forward) and ACTGGAGCTCGACCCGGGGTACC (reverse), each contain a *SacI* restriction site. The amplified product was cut with *SacI* and cloned into pBTI210.4 to make pNR45. The *EcoRI-HindIII* fragment of pNR45 was cloned into pGPTV-Kan to create pNR49, a plant-expression construct that was designed to express the histidine-tagged carboxy terminal third of intimin_{O157} with a plant-specific signal peptide on the amino-terminus of the protein. Plasmid pNR49 was transformed by electroporation into *A. tumefaciens* EHA105.

The DNA that contained the gene for the histidine-tagged carboxy-terminal third of intimin_{O157} was amplified from pNR37 by PCR. The QuikChange™ Site-directed Mutagenesis Kit (Stratagene) was used to introduce an *NcoI* site just 5' of the histidine-tagged gene. The primers used to create the *NcoI* site were, CAGAATTCATTAAGAGGAGAAATTAACCATGGGAGGATCTCACC (forward)

and GGTGAGATCCTCCCATGGTTAATTTCTCCTCTTTAATGAATTCTG (reverse). The plasmid was cut with *NcoI* and *KpnI*, and a fragment that contained the *Int₂₆₁* gene was cloned into pBTI210.3 to make pNR44. The *EcoRI-HindIII* fragment of pNR44 was cloned into pGPTV-Kan to make pNR50, a plant-expression construct that was designed to express the carboxy-terminal third of intimin_{O157} without a signal peptide. Plasmid pNR50 was transformed by electroporation into *A. tumefaciens* EHA105.

Adherence Assay. HEp-2, human laryngeal epithelial cells (ATCC# CCL23) were maintained by serial passage in complete MEM (Eagles minimal essential medium [BioWhittaker, Walkersville, MD], 10% fetal bovine serum, 20 mM L-glutamine, 100 µg/ml gentamicin and 100 U penicillin G). Assays to assess adherence of EHEC to HEp-2 cells were done as previously described (Gansheroff *et al.*, 1999) with slight modifications. HEp-2 cells were seeded into eight well plastic Lab-Tek® chamber slides (Nunc, Inc., Naperville, IL) at 2×10^5 cells per well and grown for 24 hours to form subconfluent monolayers. Freshly grown bacterial cultures were inoculated into 0.5 ml Luria broth and grown overnight statically. Preimmune sera and sera from immunized animals were diluted directly into 300 µl of adherence medium (Eagles minimal essential medium, 1% mannose, 0.4% sodium bicarbonate). After preliminary testing, sera dilutions of 1:60 and 1:100 were chosen to assess serum antibody adherence-blocking activity. Similar dilutions of PBS (phosphate buffered saline pH 7.2) also served as additional controls. Bacteria and diluted sera were preincubated at 37°C for 35 minutes. The tubes were gently mixed 3 times during this period. The HEp-2 cell monolayers were washed 2 times with Hank's balanced salt solution (with Mg^{2+} and Ca^{2+}), the

preincubated solutions of sera and bacteria were added to the cells, and the HEp-2 cells and bacteria were then incubated for 2 1/2 hours at 37°C. The cell layers were washed once with Dulbecco's PBS (with Mg²⁺ and Ca²⁺), and fresh arabinose adherence medium (Eagles minimal essential medium, 2% arabinose, 0.4% sodium bicarbonate) that contained sera (or PBS) was added for a second 2 1/2 hours incubation period. The monolayers were washed 6 times with PBS and fixed with 300 µl 3% formaldehyde for 20 minutes at room temperature. The fix was removed and the cell layers washed an additional 2 times with PBS. The slides were then mounted by means of the SlowFade™ Antifade kit (Molecular Probes, Eugene, OR). The cell layers were examined with an Olympus BX60 system microscope with a BX-FLA reflected light fluorescence attachment. All images were obtained with a SPOT RT CCD digital camera (Diagnostic Instruments, Inc., Sterling Heights, MI). Reduced adherence in the HEp-2 cells adherence assay was determined by visual, qualitative analysis of the digital images.

In addition to the bacterial adherence assay, the serum samples were also tested for the capacity to kill EHEC O157:H7 strain 86-24 in a bactericidal assay. Bacteria and sera, or PBS control, were added to 300 µl adherence medium as described above. After 3 hours at 37°C, the samples were diluted in PBS and plated on MacConkey agar with sorbitol to determine the CFU per ml.

Plant Materials, Growth, and Transformation. Untransformed *Nicotiana tabacum* cv Bright Yellow 2 (NT-1) cells (An, 1985) were obtained from The Boyce Thompson Institute for Plant Research (Ithaca, NY). The NT-1 cells were grown at 25°C on a rotary shaker (150 rpm) in 40 ml NT medium (Murashige minimal organics medium

[LifeTechnologies, Gaithersburg, MD], 30 g/L sucrose, 3 μ M thiamine, 0.58 mM myoinositol, 1.3 mM KH_2PO_4 , 1 μ M 2,4-Dichlorophenoxyacetic acid (2,4-D), 2.5 mM 2[N-morpholino]ethanesulfonic acid, pH 5.7). These cells were subcultured (1 part cells:19 parts NT medium) every 7 days. To facilitate transformation, binary vectors of interest were introduced into *A. tumefaciens* EHA105 by electroporation (200 Ω , 2.5 kV, 25 μ F). *Agrobacterium* strains that contained the construct of interest were used to transform NT-1 cells as previously described (An, 1985) with minor modifications. Three days after subculture, acetosyringone was added to the NT-1 cells to a final concentration of 20 μ M, and the cells were abraded by repeated pipeting (~20 times with a 10 ml pipet). Four milliliters of cells were cocultivated with 10-15 μ l of *Agrobacterium* [*Agrobacterium* strains were grown at 30°C overnight in YM medium (0.4g/L yeast extract, 10g/L mannitol, 0.1g/L NaCl, 0.2 g/L $\text{MgSO}_4\cdot 7\text{H}_2\text{O}$, and 0.5 g/L K_2HPO_4) to an OD_{600} of approximately 0.5] for 3 days. The cells were washed 3 times with 50 ml NTC (NT-1 medium that contained 500 μ g/ml carbenicillin) followed by sedimentation at 1000 rpm for 4 minutes to remove the *Agrobacterium*. The cells were then suspended in 4 ml NTC and plated on 2 NTCK plates [NT-1 medium that contained 500 μ g/ml carbenicillin and 200 μ g/ml kanamycin with 0.7% Agar type A (Sigma, St. Louis, MO)]. After 3-4 weeks, individual transformed calli were transferred to fresh NTCK plates and grown at 25 °C (Figure 3).

Arabidopsis thaliana transformation by *Agrobacterium tumefaciens* was done at Boyce Thompson Institute for Plant Research in Ithaca, NY by means of the floral-dip transformation protocol outlined by Clough and Bent (Clough and Bent, 1998).

Arabidopsis plants were transformed with *Agrobacterium* strains that contained pNR12,

pNR14, pNR49, or pNR50. Seeds from transformed plants were grown and leaf material was sent to Uniformed Services University. The leaf material was processed in either NT-1 cell extraction buffer or directly into sodium dodecyl sulfate-polyacrylamide gel electrophoresis (SDS-PAGE) loading buffer before being subject to SDS-Page and subsequent Western blot analysis.

Detection of Intimin Expressed in Plant Cells. A small amount of plant cell material (~0.03 g), resuspended in an extraction buffer (25 mM sodium phosphate, pH 6.6, 100 mM NaCl, 10 mM EDTA, 0.1% Triton X-100, 10 µg/ml leupeptin, and 50 mM sodium ascorbate), was disrupted by sonication (25 second pulse; 5 sec. on, 10 sec. off). The lysed material was clarified by centrifugation (12,000 x g, 3 minutes, 4°C), and proteins in the extract were subjected to SDS-PAGE (4% stacking gel, 10% separating gel) using a Mini Protean II slab cell apparatus according to the manufacturer's instructions (BioRad, Hercules, CA). The separated proteins on the Tris Glycine SDS-PAGE gels were transferred onto nitrocellulose and probed with anti-intimin monoclonal or polyclonal antibodies (Levine, 1987; Gansheroff *et al.*, 1999).

Immunoblotting. The proteins separated by SDS-PAGE were electroblotted onto nitrocellulose. The membranes were blocked with 5% nonfat dried milk in Tris-buffered saline pH 8, with 0.1% (vol/vol) Tween 20 (TBS+T) overnight and incubated 1 hour with primary antibodies diluted 1:5000 in TBS+T plus 5% milk. Membranes were washed in TBS+T and incubated for 1 hour in TBS+T plus 5% milk with the appropriate horseradish peroxidase-conjugated secondary antibody (BioRad). The signal was

Figure 3. Examples of NT-1 cells transformants. NT-1 cells newly transformed with *A. tumefaciens* strains that carried plant expression constructs were plated as a lawn on NT agar plates supplemented with carbenicillin and kanamycin (NTCK). After approximately three weeks, kanamycin resistant NT-1 cell clones were distinguished as actively growing cell clusters on a lawn of susceptible, not actively growing cells (panel A). At 6 weeks, the kanamycin resistant cell clusters were sufficiently large to be subcultured onto to fresh NTCK plates (panel B). After an additional month of growth on the fresh NTCK plate, the transformed NT-1 cell clone clusters were of the appropriate size to start NTCK broth cultures or to harvest samples of the cluster for testing of antigen protein expression (panel C).

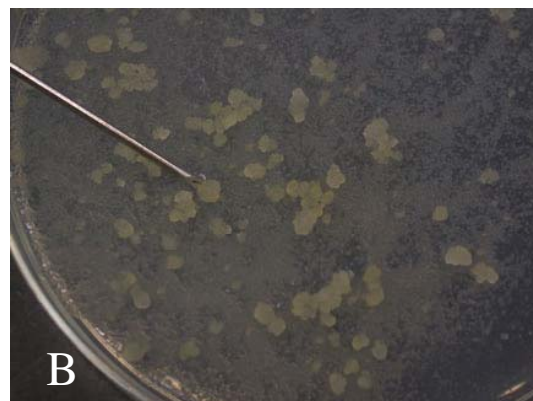

visualized by chemiluminescence with the ECL™ (Enhanced Chemiluminescence)-Plus detection kit from Amersham (Piscataway, NJ). Antigen amounts were quantified by comparing the Western band intensity to that of a control of known concentration with NIH Image 1.61 (Sinclair and O'Brien, 2002).

Mouse Feeding Assay

NT-1 cell feeding assay. NT-1 cells or transgenic NT-1 cell clones that expressed full length or his-tagged intimin_{O157}, or Int₂₆₁ were grown in 40 ml suspension culture to confluency (about 7 days). The cells were pelleted by gentle centrifugation, and culture medium was removed. Five grams of NT-1 cell material were aliquoted into individual small, plastic weigh dishes, and 0.5 grams of sucrose was added to each sample. The amount of intimin protein delivered in the 5 g dose was determined semi-quantitatively as described above. A 7.5 µg dose of purified cholera toxin (Sigma) was also added to appropriate samples to serve as an oral adjuvant. The addition of this dose of CT did not have any detrimental effects on the mice (i.e., loose stool or diarrhea). Female BALB/c mice, 16-18g, (Charles River Laboratories, Inc.) were fasted overnight before they were allowed to eat the plant material *ad libitum*. The 5 g dose of the plant material was usually consumed within 8 hours. The mice were bled by tail vein cut, and fecal pellets were collected both prior to and after feeding. Blood samples were allowed to clot at room temperature for 15 minutes and centrifuged at 10,000 x g for 10 minutes at 4°C to pellet red blood cells. A second, 2 minute centrifugation step was used to further clarify each serum sample. These clarified serum samples were stored at -20°C until assayed. Fecal samples were frozen, lyophilized overnight, and then homogenized in

PBS, pH 7.2 (for every 15 fecal pellets, 0.8 ml PBS was used). The resuspended fecal material was centrifuged for 5 minutes, and each clarified supernatant was transferred to a clean tube and stored at -20°C until assayed. Mice immunized intraperitoneally (i.p.) with purified his-tagged intimin_{O157} [from pEB313 (McKee and O'Brien, 1996)], or Int₂₆₁ [from pMW103 (Gansheroff *et al.*, 1999)] + TiterMax®, 20 µg on day 0 and 10 µg on days 7 and 14, served as the positive control.

ELISA. To measure anti-intimin_{O157} antibodies, an ELISA was developed. For that purpose, U-bottomed 96-well microtiter plates were coated with 50 ng/well purified histidine-tagged Int₂₆₁ from pMW10 (Gansheroff *et al.*, 1999). Serum samples were serially diluted from a titer of 1:50 to 1:781250 and fecal pellet extracts were diluted from 1:50 to 1:3200 and incubated overnight at 4°C. The plates were washed, and goat anti-mouse IgG (1:3000) or goat anti-mouse IgA (1:3000) conjugated to alkaline phosphatase was added to the appropriate plates. The plates were then incubated at room temperature for 1 hour. The antigen-antibody reactions were detected colorimetrically by incubation with tetramethylbenzidine (TMB) peroxidase substrate (BioRad) for 15 minutes followed immediately by measurement of the absorbance at 600 nm with an ELx800 microtiter plate reader (Bio-Tek Instruments Inc., Winooski, VT). The titer was defined as the reciprocal of the highest dilution of serum or fecal extract that gave an absorbance reading above both background and pre-immune levels. Mice were considered responders if they had detectable serum or fecal titers at the last collection point. Mice with no titer or that lost titer by the last collection point were called non-

responders. The geometric mean of the responders' titers was used to determine the mean response per group.

Nickel Affinity Chromatography of His-tagged Intimin from Plant Cells.

Approximately 20 ml of packed NT-1 cells from a 7 day shaking culture was resuspended in 25 ml modified extraction buffer (25 mM sodium phosphate, pH 6.6, 100 mM NaCl, 0.1% Triton X-100, 10 µg/ml leupeptin, and 50 mM sodium ascorbate) and subjected to sonic disruption (5 minutes; 30 sec. on/off). The sonic lysate was centrifuged to remove any cellular debris and was mixed with 4 ml of equilibrated Ni-NTA slurry (Qiagen Inc.) at 4°C for 1 hour. Intimin was purified by a non-denaturing protocol as outlined in the Qiagen manual. The protein was eluted with 10 ml of 250 mM imidazole, pH 7.8 and collected in 5, 2 ml fractions. Samples from the clarified sonic lysate, wash, and each elution fraction were subject to SDS-PAGE, electroblotted to nitrocellulose, and were visualized with an anti-intimin_{O157} polyclonal antibody (Gansheroff *et al.*, 1999). Elution fractions that contained the intimin_{O157} protein of interest were pooled and dialyzed against 1 liter of PBS pH 7.2 overnight at 4°C. The pool of samples was concentrated, and the amount of protein was determined by BioRad protein assay. The purity of the sample pool was estimated by Coomassie stain (Bio Rad) of the material after separation on SDS-PAGE gels. Western blot analysis was done to ascertain that the bands seen were indeed intimin_{O157}.

Mouse Model of Intimin_{O157} -dependent Colonization. Female BALB/c mice, 16-18 g, (Charles River Laboratories, Inc.) were fasted over night and water was removed

from cages at least 4 hours prior to the inoculation. The bacterial inoculum was prepared by seeding a 25 ml LB culture that contained 100 µg/ml streptomycin with 2-3 colonies of streptomycin-resistant EHEC O157:H7 strain 86-24 Str^R or 86-24 Str^R *eae*Δ10 each from a fresh overnight plate culture. The broth culture was shaken at 37°C for 3 hours. The entire culture was centrifuged and resuspended in 2.5 ml freshly-prepared, filter-sterilized 20% sucrose. The mice were scruffed and allowed to drink 50 µl of the inocula from a micropipet. Animals received a total inoculum of 10⁸-10⁹ colony forming units (CFU) in each of two doses administered 4 hours apart. Fecal pellets were collected from individual mice daily, weighed, serial dilutions were made in PBS, and plated on sorbitol-MacConkey agar (Wells *et al.*, 1983) with 100 µg/ml streptomycin to determine CFU/g feces and duration of colonization. In addition, several sorbitol-negative colonies, from different mice at each collection time point were tested by slide agglutination with O157 antiserum (Difco Laboratories, Sparks, MD) to further confirm they were colonized with the challenge strain. All mice were free of Str^R, O157 agglutination-positive colonies prior to challenge.

Statistics. The SPSS 11.0 statistical package was used to calculate the mean duration of colonization and the duration of colonization among mouse groups. The Log-rank test was used to determine the statistical significance of the difference in duration of colonization among the mouse groups. The two-sided t-test for independent samples was used to determine the statistical significance between the groups' serum and fecal antibody titers. The Fisher exact test was used to compare the significance of the

difference in the number of mice per group making an intimin_{O157}-specific immune response.

Stx2 Toxoid

Vero Cell Cytotoxicity Assays. Ninety-six well microtiter plates were seeded with 1×10^4 Vero cells (Green monkey kidney cells) per well, 24 hours before the start of the assay. Bacterial cell lysates were prepared by sonically disrupting cells from broth cultures. The lysates were then centrifuged to remove cellular debris. The clarified supernatants were serially diluted in tissue culture media and added to the wells of the Vero cell microtiter plates (Gentry and Dalrymple, 1980). The plates were incubated for 48 hours then the adherent cells in each well were fixed with 10% formalin and stained with crystal violet. The absorbance at 600 nm was measured in each well with the ELx800 microtiter plate reader (Bio-Tek Instruments, Inc.). The cytotoxic titer per milliliter of culture lysate was expressed as the reciprocal of the highest dilution required to kill 50% of the cells in a well (CD_{50}/ml).

Stx2 Toxoid Construction and Purification. Two changes were made to the nucleotide sequence of the Stx2 A subunit gene from pMJ100 (Weinstein *et al.*, 1989) with the Stratagene QuikChangeTM Site-directed Mutagenesis Kit (Stratagene). The first change was the substitution of a serine for a tyrosine at amino acid position 77 (Y77S) by means of the primers,

GATTATTGAGCAAATAATTTATCTGTGGCCGGGTTTCGTTAATACGG (forward)

and CCGTATTAACGAACCCGGCCACAGATAAAATTATTTTGCTCAATAATC (reverse). The second change was the substitution of a glutamine for a glutamate at amino acid position 167 (E167Q) by means of the primers, GTTTTGTCACTGTCACAGCACAAAGCCTTACGCTTCAGGCAG (forward) and CTGCCTGAAGCGTAAGGCTTGTGCTGTGACAGTGACAAAAC (reverse). The resulting plasmid that contained both changes was called pNR100. Bacterial cell lysates from this clone were tested for cytotoxicity by the Vero cell cytotoxicity assay (as described above), and the toxoid protein was visualized by Western blot analysis with rabbit anti- Stx2 antibodies (prepared by Ms. Edda Twiddy).

Stx2 toxoid protein was expressed by growing 500 ml pNR100 cultures ($OD_{600} \sim 0.5$) with 1mM IPTG for 5 hours shaking at 37°C. The bacterial cultures were harvested and centrifuged to remove the culture supernatants, and the bacterial pellets were frozen overnight. The pellets were thawed and then resuspended in 20 ml TEAN (50mM Tris pH 7.5, 1mM EDTA, 0.2M NaCl, 0.02% sodium azide) for every 500 ml of starting culture. The resuspended cells were sonically disrupted (10 min; 30 sec on/off) and then pelleted by centrifugation to remove cellular debris. The clarified sonic lysates were stored at -20°C until used.

A 3 ml antibody affinity column with 3 mg/ml of the anti-Stx2 A subunit monoclonal antibody (MAb) 11E10 was kindly prepared by Ms. Edda Twiddy. (Perera *et al.*, 1988). The 11E10 MAb was linked to AminoLink plus resin (Pierce, Rockford, IL) by the pH 10 coupling method according to the Pierce manual. The column was stored in TEAN at 4°C.

The pNR100 Stx2 toxoid clarified sonic lysate was thawed, and the 11E10 antibody affinity column was brought to room temperature for 15 minutes prior to addition of the lysate. A 5 ml sample of sonic lysate was added to the column and allowed to bind at 4°C overnight. The column was washed with 10 bed volumes (~30 ml) TEAN until the OD₂₈₀ was ~0.05, then the toxoid was eluted from the column with 0.1M glycine, pH 3 in 1 ml fractions. The OD₂₈₀ values of these fractions were recorded, and the 3-4 fractions that showed a spike in OD₂₈₀ (~0.06 or greater) were pooled, dialyzed against 1 liter PBS pH 7.2 overnight at 4°C, and concentrated. Small samples (~10 µl) of sonic lysate, column wash, pre-dialysis pooled elution fractions, and post-dialysis concentrated toxoid were subject to SDS-PAGE. The gels were Coomassie (Bio Rad) stained or transferred to nitrocellulose and visualized by immunoblot with Stx2 polyclonal antibody to ascertain the purity and approximate concentration of the toxoid (Stx2 polyclonal antibody prepared in rabbits by Ms Edda Twiddy). The isolated toxoid was then tested in a Vero cell cytotoxicity assay before evaluation as an immunogen in mice.

Stx2 Toxoid Immunizations in Mice. Female BALB/c mice, 16-18g, (Charles River Laboratories, Inc.) were injected i.p. with ~10 µg Stx2 toxoid + TiterMax® on day 0 and ~5 µg toxoid on days 10 and 25. One week after the final immunization, the mice were bled by tail vein cut, and the serum was assayed for the capacity to neutralize Stx2 toxin as described below.

Toxin Neutralization Assay. Vero cells were prepared as in the cytotoxicity assay. Both pre and post-immune sera from mice immunized with the Stx2 toxoid were serially diluted and added to the Vero cell plates. Purified Stx2 toxin lysate was diluted to ~ 2.0 CD₅₀ and ~20 CD₅₀. Two-fold dilutions of the serum samples were tested in duplicate for capacity to neutralize both the low and high cytotoxic dose by incubating the serum samples with the toxin for 3 hours at 37°C. Samples of the mixtures (100 µl) were added to the Vero cells, and the plates were incubated for 48 hours at 37°C then fixed, stained, and read at 600 nm with a microtiter plate reader.

Stx2 Toxoid Plant Optimization. Three additional changes were made to the nucleotide sequence of the Stx2 toxoid A subunit with the QuikChange™ Site-directed Mutagenesis Kit to optimize the gene for expression in plants. The first and second changes disrupted RNA destabilization motifs located from base 253 to 257 and 528 to 532. The primers used to alter base 253 were, GTGTATATTGTTTAAATGGGTACTGTGCCTGTTACTGGG (forward) and CCCAGTAACAGGCACAGTACCCATTTAAACAATATACAC (reverse). The primers used to alter base 532 were, CTGATTATTGAGCAAATAATTTGCTGTGGCCGGGTTTCG (forward) and CGAACCCGGCCACAGACAAATTATTTGCTCAATAATCAG (reverse). The third change disrupted a polyadenylation motif from base 1115 to 1120. The primers used to alter base 1119 were, GGCGACAGGCCTGTTATAAAAATAAGCAATACATTATGGG (forward) and CCCATAATGTATTGCTTATTTTTATAACAGGCCTGTCGCC (reverse). All changes

were confirmed by sequencing. The optimized Stx2 toxoid A subunit was amplified by PCR with primers designed to introduce 5' *XbaI* (GGAACACCTCTAGATGAAGTG) and 3' *SacI* (GCTGAGCTCCTTTATTTACCCG) sites flanking the Stx2 A subunit. The *XbaI-SacI* fragment was cloned into pIBT210 (Haq *et al.*, 1995) to create pNAJ65.

Stx2 B: Plant Optimization and Synthesis. To optimize the Stx2 B subunit for expression in plants, extensive changes to the nucleotide sequence of the gene were required. It was not feasible to make the 37 nucleotide changes by site-directed mutagenesis, so the entire Stx2 B subunit gene was re-synthesized by a ligase chain reaction (LCR) protocol. The nucleotide sequence of the plant optimized Stx2B subunit is listed in Figure 4. The primers used in the Stx2 B subunit synthesis are summarized in Table 5. The LCR method of Chalmers and Curnow, with minor modifications, was used for the LCR (Chalmers and Curnow, 2001). Briefly, all of the oligonucleotides were resuspended in water to 250 μM , and 15 μl of each was premixed and phosphorylated with T4 polynucleotide kinase for 2 hours at 37°C. The reaction was stopped by heating the samples to 80°C for 10 minutes. A 40 μl sample of the heat-inactivated phosphorylation reaction was aliquoted to a fresh tube, and 4 μl 10X Pfu ligase buffer and 2 μl Pfu ligase were added. The LCR reaction consisted of a 1 minute hot-start at 95°C, then 40 cycles of 1 min 30 s at 55°C, 1 min 30 s at 70°C, and 30 s at 95°C, and final incubations at 55°C for 2 min and 70°C for 2 min. The resulting LCR product (~360 base pairs) was amplified three times using the oligos 2B1 and 2B10 (Table 5) at 10 μM each. The LCR product was gel purified, digested with *BspHI* and *SmaI*, and ligated into the *NcoI-SmaI* site of pBTI210.3 to create pNAJ73. The sequence

of the synthetic B subunit gene in pNAJ73 that was made by LCR was confirmed and contained no additional PCR-induced mutations despite amplification of the LCR product 3 times to produce sufficient product to cut and clone.

Figure 4. The nucleotide sequence of the plant-optimized Stx2 B subunit gene. Thirty seven individual nucleotide base changes (in bold) were made to the original Stx2B subunit gene to optimize the gene for expression in plants. Flanking sequence that incorporated specific restriction enzyme sites (*BspHI* and *SmaI*, underlined) was added for cloning purposes. The ATG start and TAA stop codons are designated in italics.

5' - GCAT GCAT CGAT CGAT GCTA GCTA TAGC TAGC ATCG ATCG TCAG
AATC ATG AAG AAG ATG TTC ATG GCT GTG CTC TTT GCA TTG GCT TCT
GTG AAT GCA TTG GCA GCT GAT TGT GCT AAG GGT AAG ATT GAG TTC
TCC AAG TAC AAT GAG GAT GAT ACA TTC ACA GTG AAG GTG GAT GGG
AAG GAG TAC TGG ACC AGT AGG TGG AAC CTC CAA CCA CTC CTC CAA
AGT GCT CAA TTG ACA GGA ATG ACT GTC ACA ATC AAG TCC AGT ACC
TGT GAG TCA GGC TCT GGA TTT GCT GAG GTG CAA TTC AAC AAT GAC
TAA CCCGGG ATGC GCAT AGTA TCAG GATC CGAT CATG ACTG CGTA – 3'

Table 5. Stx2 B Subunit Ligase Chain Reaction Oligonucleotides

2B1	GCAT GCAT CGAT CGAT GCTA GCTA TAGC TAGC ATCG ATCG
2B2	TCAG AATC ATG AAG AAG ATG TTC ATG GCT GTG CTC TTT GC
2B3	A TTG GCT TCT GTG AAT GCA TTG GCA GCT GAT TGT GCT AAG
2B4	GGT AAG ATT GAG TTC TCC AAG TACAAT GAG GAT GAT ACA T
2B5	TC ACA GTG AAG GTG GAT GGG AAG GAG TAC TGG ACC AGT AG
2B6	G TGG AAC CTC CAA CCA CTC CTC CAA AGT GCT CAA TTG ACA
2B7	GGA ATG ACT GTC ACA ATC AAG TCC AGT ACC TGT GAG TCA G
2B8	GC TCT GGA TTT GCT GAG GTG CAA TTC AAC AAT GAC TAA CC
2B9	CGGG ATGC GCAT AGTA TCAG GATC CGAT CATG ACTG CGTA
2B10	TACG CAGT CATG ATCG GATC
2B11	CTGA TACT ATGC GCAT CCCGGG TTA GTC ATT GTT GAA TTG
2B12	CAC CTC AGC AAA TCC AGA GCC TGA CTC ACA GGT ACT GGA C
2B13	TT GAT TGT GAC AGT CAT TCC TGT CAA TTG AGC ACT TTG GA
2B14	G GAG TGG TTG GAG GTT CCA CCT ACT GGT CCA GTA CTC CTT
2B15	CCC ATC CAC CTT CAC TGT GAA TGT ATC ATC CTC ATT GTA C
2B16	TT GGA GAA CTC AAT CTT ACC CTT AGC ACA ATC AGC TGC CA
2B17	A TGC ATT CAC AGA AGC CAA TGC AAA GAG CAC AGC CAT GAA
2B18	CAT CTT CTT CAT GATT CTGA CGAT CGAT GCTA GCTA TAGC
2B19	TAGC ATCG ATCG ATGC ATGC

Results

I. Expression and antibody response to transgenic plant-expressed intimin_{O157}.

NT-1 plant cells that express full-length and his-tagged intimin_{O157}. We began our studies by constructing two expression vectors, pNR12, that contained the full-length intimin_{O157} gene from pEB310 (McKee *et al.*, 1995) and pNR14, that contained the gene for histidine-tagged intimin_{O157} from pEB313 lacking the signal peptide (McKee and O'Brien, 1996) (Fig. 5). The expression of both proteins was driven by a cauliflower mosaic virus 35S promoter (CaMV 35S). The expression constructs also included a tobacco mosaic virus Ω 5' untranslated region (TMV Ω 5'-UTR) and a 3' soybean vegetative storage protein polyadenylation sequence (3' VSP) to facilitate translational initiation and 3' end processing, respectively. A neomycin phosphotransferase gene (*ntp2*) that conferred kanamycin resistance was included in the constructs to facilitate detection of successfully transformed plant cell clones. When these plant expression constructs were transformed into NT-1 cells by *Agrobacterium*-mediated transfer, 6 clones (3 full-length intimin_{O157}, 3 his-tagged intimin_{O157}) were obtained out of approximately 100 tested (~50 clones from each transformation) that expressed appreciable levels of intimin_{O157} protein. Furthermore, the expressed protein appeared to be the same size (~94 kD) as purified intimin_{O157} expressed from pEB313 (McKee and O'Brien, 1996) (Fig. 6).

Figure 5. Full-length and his-tagged intimin_{O157} plant-expression constructs. The full-length intimin_{O157} plant-expression construct that contained the intimin_{O157} gene from pEB310 (McKee *et al.*, 1995) was called pNR12. The his-tagged intimin plant-expression construct that contained the intimin_{O157} gene from pEB313 (McKee and O'Brien, 1996) was named pNR14. The his-tagged intimin_{O157} gene was missing 35 amino acids (signal peptide) from the amino-terminus and was his-tagged on the N-terminus as well. These expression vectors shared common plant expression elements such as a cauliflower mosaic virus 35S promoter (CaMV 35S), and a tobacco mosaic virus Ω 5' untranslated region (TMV Ω 5'-UTR) and a 3' soybean vegetative storage protein polyadenylation sequence (3' VSP) to facilitate translational initiation and 3' end processing, respectively. A neomycin phosphotransferase gene (*ntp2*) was incorporated into the constructs to confer kanamycin resistance to successfully transformed plant cell clones.

Full-length Intimin Expression**His-tagged Intimin Expression**

Figure 6. Western blot analysis of NT-1 cells that expressed his-tagged (H) and full-length (F) intimin_{O157}. Intimin_{O157} (100 ng) purified from pEB313 (McKee and O'Brien, 1996) was used as a positive control. Extracts (~ 100 µg total protein) of NT-1 cells only (NT-1 only) and NT-1 cells transformed with the pGPTV-Kan vector only (NT-1 + vector) served as negative controls. Extracts of NT-1 cells transformed with pNR14 that expressed his-tagged intimin_{O157} (~94 kD) were named H11, H17, and H42. Extracts of NT-1 cells transformed with pNR12 that expressed full-length intimin_{O157} (~94 kD) were named FL7, FL11, and FL25. The intimin_{O157}-specific proteins on this blot were detected with an intimin_{O157} monoclonal antibody (Gansheroff *et al.*, 1999).



These intimin_{O157}-expressing transgenic NT-1 cell clones produced 8-10 µg of intimin_{O157} per gram of total plant material. Intimin_{O157} amounts were determined semi-quantitatively as described in the Materials and Methods (p. 39) The intimin_{O157} expressed from plant cells reacted on Western blot analysis with an intimin_{O157} polyclonal antibody, as well as an intimin_{O157} monoclonal antibody (Levine, 1987; Gansheroff *et al.*, 1999), but not with an isotypic monoclonal antibody BC5 against another antigen, Stx 2B (Downes *et al.*, 1988) (Fig. 7). These latter Western blot findings demonstrate the specificity of the binding of the anti-intimin_{O157} monoclonal antibody to the intimin_{O157} produced in the plant cells. The majority of the intimin_{O157} protein produced in the transgenic plant cells was soluble and present in the clarified sonic lysate; only a small amount of intimin_{O157} was detected in the pellet of cellular debris after sonication and processing of the transgenic plant cells (Fig. 8).

Antibody response to full-length intimin_{O157}. Once we had established that intimin_{O157} could be expressed in transgenic NT-1 cells at levels comparable to other proteins produced by plant cells {Dr. Hugh Mason, personal communication}, we chose one of our highest intimin_{O157}- expressing clones (FL25) to proceed with mouse i.p. and oral immunization assays. The first group of 5 mice was immunized i.p., three times over a period of six weeks, with FL25 plant cell extract that had been dialyzed overnight against PBS pH 7.4 and emulsified one to one with TiterMax®. The mice received about 300 ng intimin_{O157} protein per injection of FL25 material containing approximately 500 µg total protein. The mice immunized with the FL25 material made a modest serum IgG

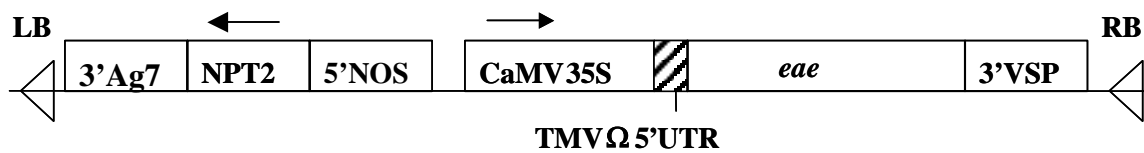
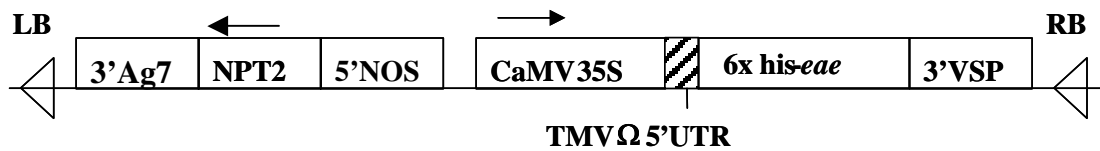
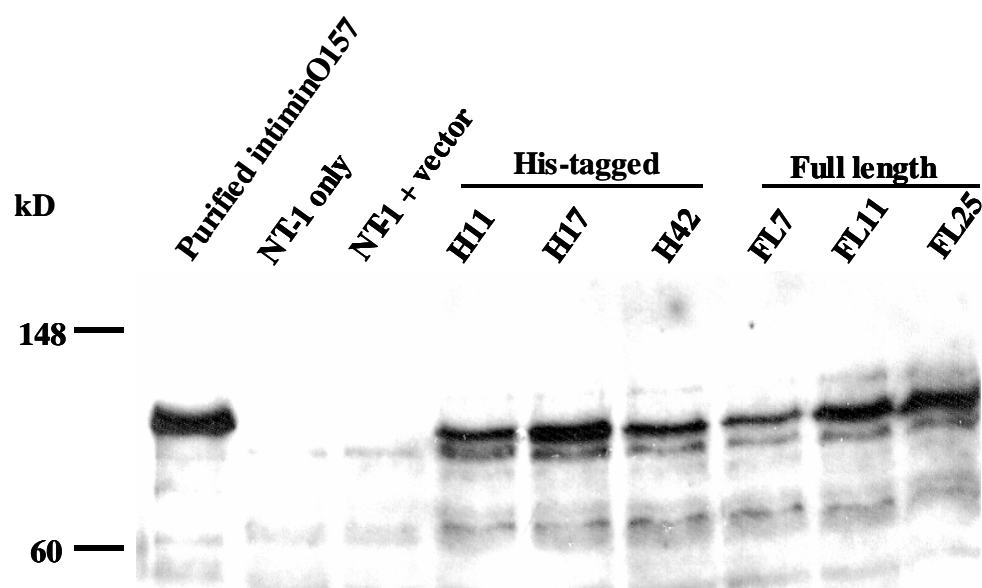
Figure 7. An isotypic monoclonal antibody to Stx2B did not recognize plant-expressed intimin_{O157} from NT-1 cells. BC5 recognized Stx2 B subunit (~7 kD) in the Stx2 toxin lane, but did not react with any proteins from the plant cell extracts nor the purified intimin_{O157} control (100 ng).

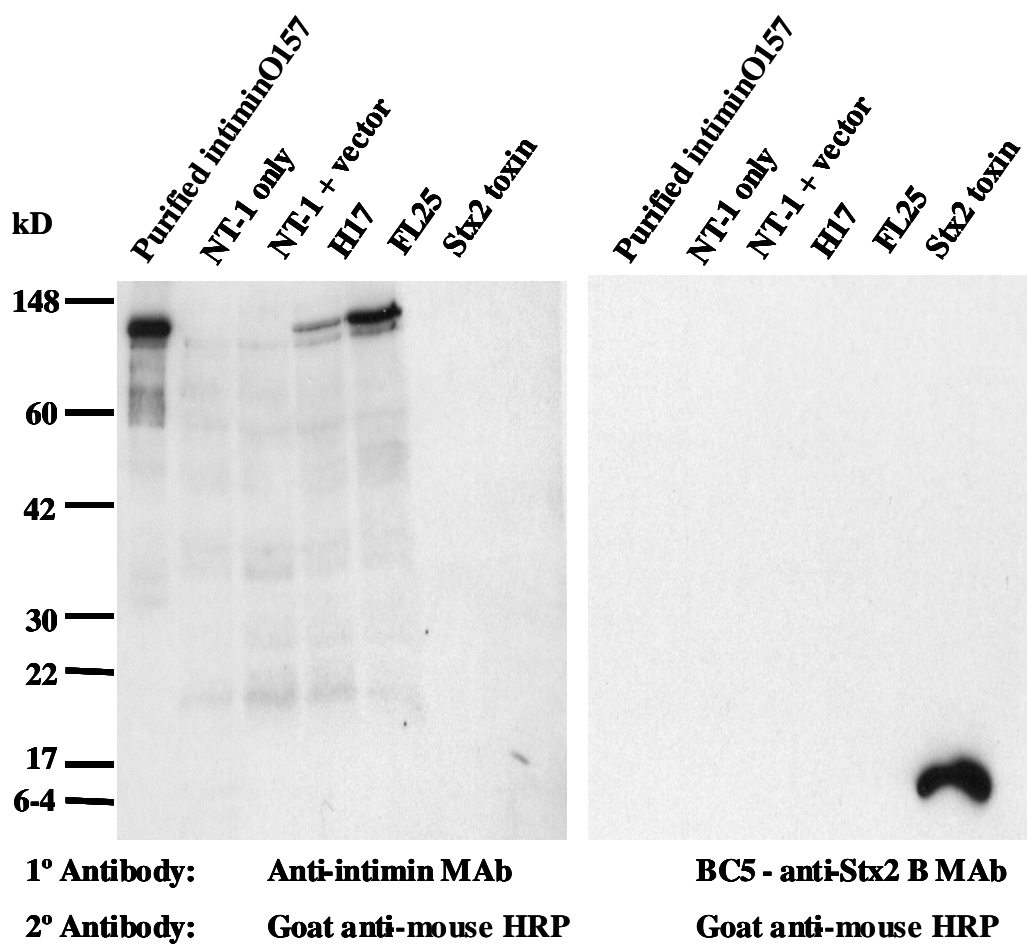
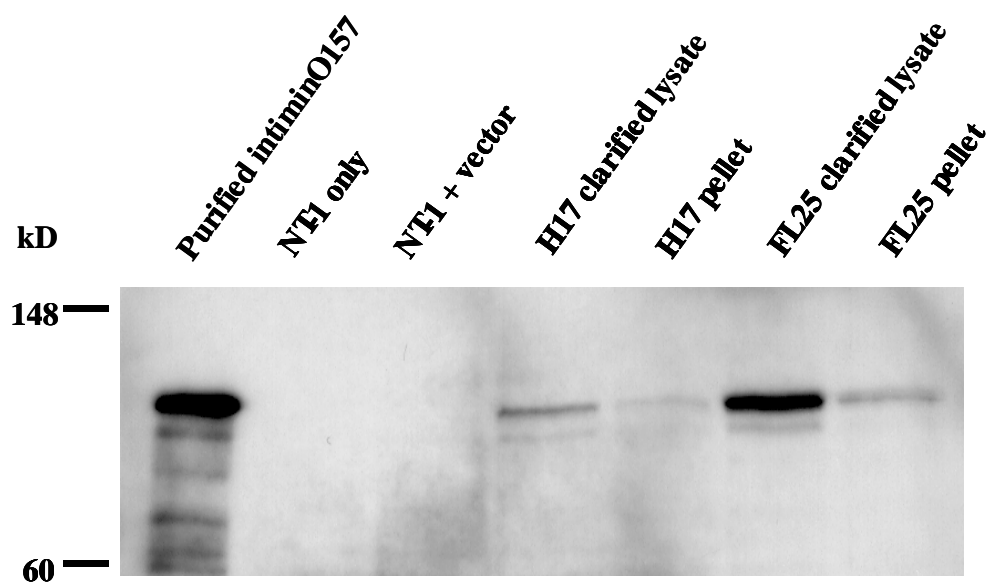

Figure 8. Western blot analysis of soluble intimin_{O157} expressed in NT-1 cells. The majority of the intimin_{O157} protein produced in the transgenic plant cells was soluble and present in the clarified sonic lysate (H17 and FL25 clarified lysate). Only a small amount of intimin_{O157} was detected in the pellet of cellular debris after sonication and processing of the transgenic plant cells (H17 and FL25 pellet). 100 ng of purified intimin_{O157} was used as the control.



response to intimin_{O157} (based on Western blot analysis), even though they received a much smaller dose of intimin_{O157} than the positive control mice (group n=5) that received 25 µg intimin_{O157} per injection (Table 6). These results indicate that mice can make an antibody response to the plant-expressed, full-length intimin_{O157} when delivered i.p and that these antibodies recognize intimin_{O157} expressed from bacterial cells. Another 2 groups of mice (group n=5) were fed FL25 plant material that contained approximately 40 µg total of intimin_{O157} in 4 grams of plant material, either with or without cholera toxin (CT) as an oral adjuvant. The CT-B subunit has been shown to have strong adjuvant properties for stimulating both serum IgG and mucosal IgA responses to unrelated, non-coupled antigens after intranasal as well as oral co-administration (Tochikubo *et al.*, 1998). Mice that were fed FL25 plant material with CT as an oral adjuvant made both a serum and fecal intimin_{O157}-specific IgG response based on Western blot analysis results shown in Table 6. Even mice that were fed FL25 material without cholera toxin made a recognizable intimin_{O157}-specific fecal IgG response. These promising initial results suggested that plants could express intimin_{O157} and that mice injected with or fed transgenic plant material were able to mount an intimin_{O157}-specific immune response.

Optimization of NT-1 cell expression of the carboxy-terminal portion of intimin_{O157}.

Based on our results with the transgenic plant clone FL25, we decided to make changes in the nucleotide sequence of a small portion of intimin_{O157} in an attempt to optimize its expression in NT-1 cells. We speculated that should such an increase in antigen

Footnotes for Table 6.

^a Serum IgG results based on reactivity of immunized mouse sera on Western blot to purified intimin_{O157} from pEB313 (McKee and O'Brien, 1996) and detection with a goat anti-mouse-horseradishperoxidase secondary antibody.

^b Fecal IgG results based on Western blot reactivity of fecal extracts on to purified intimin_{O157} from pEB313 (McKee and O'Brien, 1996).

^c Qualitative immune response references as determined by Western blot analysis: ++++ = strong intimin_{O157}-specific positive response, ++ = modest positive response, + = weak positive response, - = no or undetectable intimin_{O157}-specific response

^d ND – not determined

^e Cholera toxin, 7.5 µg (Sigma)

Table 6. Immune response of BALB/c mice fed NT-1 cell that express intimin_{O157}

Group/Immunization	Vaccination Method	Serum	Fecal
		IgG ^a	IgG ^b
1: Intimin _{O157} from pEB313 (McKee and O'Brien, 1996) given i.p.	25 µg intimin _{O157} +TiterMax [®] i.p. days 0,14,21	++++ ^c	++++
2: NT-1 cell lysate given i.p.	100 µl NT-1 cell lysate+ TiterMax [®] i.p. days 0,14,21	-	-
3: Intimin _{O157} from FL25 given i.p.	300 ng intimin _{O157} i.p. on days 0,14,21	+	ND ^d
4: Intimin _{O157} from FL25 given i.p.	300 ng intimin _{O157} + TiterMax [®] i.p. on days 0,14,21	++	ND
5: Fed NT-1 cells	4 g NT-1 cells fed on days 0,7,14	-	-
6: Fed FL25 cells	4 g FL25 (40 µg intimin _{O157}) cells fed on days 0,7,14	-	+
7: Fed FL25 cells + CT ^e	4 g FL25 (40 µg intimin _{O157}) cells + 10 µg CT fed on days 0,7,14	+	++

concentration result, we would likely elicit a more vigorous immune response in our mouse model and possibly eliminate the need for an adjuvant. We elected to work with the carboxy-terminal third of the intimin_{O157} protein that is comprised of the C-terminal 261 amino acids (Int₂₆₁). The carboxy-terminus of intimin is the cell-binding domain of intimin_{O157} (Frankel *et al.*, 1994; Frankel *et al.*, 1995), and we previously found that antibodies to the carboxy-terminal third of the molecule block adherence of wild type EHEC O157:H7 to HEp-2 cells (McKee and O'Brien, 1996; Gansheroff *et al.*, 1999). The gene for Int₂₆₁ (*eae* 1959-2804) was obtained from pMW103 (Gansheroff *et al.*, 1999) and thirteen independent changes were made to the nucleotide sequence of this gene with the QuikChange™ Site-directed Mutagenesis Kit (Stratagene) to create pNR73 (described in detail in the Materials and Methods). The Int₂₆₁ gene from pNR73 was cloned into two different plant cell expression vectors: pNR49 and pNR50 (Fig. 9). One of these clones (pNR49) was constructed so as to contain the sequence for a plant-specific signal peptide 5' to the start of the Int₂₆₁ gene. This signal peptide was added to increase expression of Int₂₆₁ in the plant cells by directing the translation of the optimized Int₂₆₁ into the endoplasmic reticulum of the plant cell where it would also be protected from cytosolic proteases and where it would be more accessible to any chaperones required for proper protein folding. In fact, 4 out of 5 of the first Int₂₆₁-expressing NT-1 cells clones with the signal peptide (CSP) produced appreciable levels of Int₂₆₁. One of these clones, CSP5, produced about 10 µg Int₂₆₁ (~35 kD) per gram of total NT-1 cell material as determined by Western blot analysis (as described in Materials and Methods, p.39). Mice fed this clone (total of 50 µg Int₂₆₁ each on days 0,7,and 14) with (n=5) or without (n=3) CT had Int₂₆₁-specific serum IgG and fecal IgA responses as determined

Figure 9. Carboxy-terminal third intimin_{O157} (Int₂₆₁) plant cell expression constructs. Plasmids pNR50 and pNR49 were constructed to contain the plant-optimized gene for Int₂₆₁ from pNR73. In addition to the shared plant-expression elements (nptII, CaMV 35S, and vsp 3'), pNR49 was also designed to contain a plant-specific signal peptide. The signal peptide sequence gene in pNR49 was located so that when expressed it would be at the N-terminus of Int₂₆₁ and target expression of that protein directly into the plant cell endoplasmic reticulum. Plasmid pNR49 was also designed to include a tobacco etch virus 5' untranslated region (TEV 5'), which has the same function as TMV 5', to facilitate translational initiation.

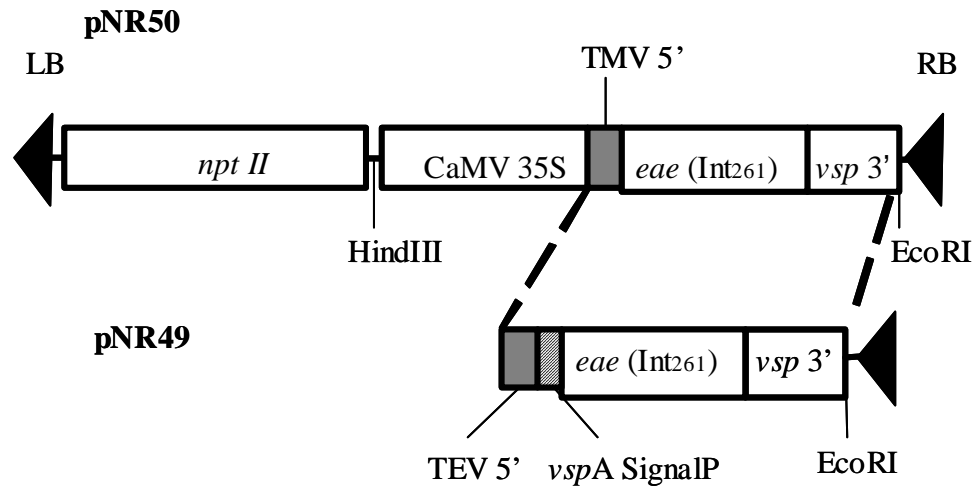

by an ELISA with purified Int₂₆₁ from pMW103 (Gansheroff *et al.*, 1999) (Table 7) as the antigen in the assay. The serum from mice that had an Int₂₆₁-specific IgG response also blocked adherence of EHEC O157:H7 strain 86-24-GFP in a qualitative HEp-2 cell bacterial adherence assay (Fig. 10). A bactericidal assay (described in Materials and Methods, p. 34) done concurrently with the adherence assay showed that samples of EHEC O157:H7 strain 86-24-GFP grown in adherence medium with immune sera grew to the same density (avg., 1.81×10^9 CFU/ml) as bacteria grown in adherence medium with PBS (1.66×10^9 CFU/ml). These results indicated that the reduced number of bacteria observed on the adherence assays with immune serum was not due to bacterial cell death. From these data with the sera from mice immunized with transgenic plant cell material, we concluded that mice not only make Int₂₆₁-specific immune responses when they are fed Int₂₆₁-expressing plant cells, but that this immune response is also functional in blocking bacterial adherence of EHEC O157:H7 strain 86-24 in an *in vitro* assay. Unfortunately, before additional mouse feeding assays could be done with CSP5, the stock of this culture became contaminated with mold, Int₂₆₁ expression was lost, and the clone was unsalvageable (Fig. 11). Please note that untransformed and transgenic plant cell stocks and clones must be kept in continuous culture because the plant cells do not remain viable when frozen in glycerol stocks as do bacterial cells. Thus, these continuous NT-1 cell cultures are at risk for contamination and can exhibit alterations in protein expression (such as reduction or loss of protein expression) as the culture ages.

Further testing of NT-1 cell clones transformed with pNR49 revealed another clone, CSP20, that expressed Int₂₆₁ protein (~10-13 μ g Int₂₆₁ per gram of NT-1 cell material), and this clone was used for further testing (Fig. 11). The initial mouse feeding

Footnotes for Table 7.

^aSerum IgG and fecal IgA titers defined as the geometric mean of the reciprocal of the highest dilution of serum or fecal extract that gave an absorbance reading (A_{600}) above both background and pre-immune levels. Mice were considered responders if they had detectable serum or fecal titers at the last collection point. Mice with no titer or that lost titer by the last collection point were called non-responders. The titers reflect the geometric mean of responders only.

^bInt₂₆₁ affinity purified from pMW103 (Gansheroff *et al.*, 1999)

*Serum of responders [in parenthesis (number of responders/total group number)] that blocked adherence of EHEC O157:H7 to HEp-2 cells *in vitro*. Serum from mice fed CSP20 was also tested but did not block adherence.

^cSignificantly higher serum IgG titer compared to other groups ($P < 0.0001$; two-sided t-test). Number of serum IgG responders not significantly higher compared to other groups ($P > 0.143$; Fisher's exact test).

^dFecal IgA titer not significantly higher compared to other groups ($P > 0.1$; two-sided t-test). Number of fecal IgA responders not significantly higher compared to other groups ($P > 0.487$; Fisher's exact test).

^eOnly three mice in group for sample collection after death of one mouse during blood draw.

^fCholera toxin, 7.5 μ g (Sigma)

Table 7. Immune response of mice fed NT-1 cells expressing Int₂₆₁

NT-1 clone	Immunization Method	Serum IgG ^a	Fecal IgA ^a
CSP5	Control, i.p. 25 µg Int ₂₆₁ ^b + TiterMax™, on day 0,14,21	56250 (4/4)* ^c	270 (3/4) ^d
	Fed 5g CSP5 (~50 µg Int ₂₆₁) on days 0,7,14	50 (1/3)* ^e	156 (2/3)
	Fed 5g CSP5 (~50 µg Int ₂₆₁) + CT ^f on days 0,7,14	112 (4/5)*	156 (2/5)
CSP20	Control, i.p. 25 µg Int ₂₆₁ ^b + TiterMax™, on day 0, 10 µg on days 14,21	781250 (5/5)* ^c	217 (5/5) ^d
	Fed 5g CSP20 (~65 µg Int ₂₆₁) on days 0,7,14	137 (8/8)	75 (6/8)
	Fed 5g CSP20 (~65 µg Int ₂₆₁) + CT ^f on days 0,7,14	85.5 (6/8)	108 (6/8)

Figure 10. Serum from mice fed Int₂₆₁-expressing NT-1 cells block bacterial adherence to HEp-2 cells. Adherence of EHEC O157:H7 strain 86-24-GFP (Sinclair and O'Brien, 2002) to a HEp-2 cell monolayer was seen in the absence of serum (panel A). Panel B shows a similar pattern of adherence of EHEC O157:H7 strain 86-24-GFP in the presence of non-immune serum (1:60 dilution) from a mouse fed NT-1 cells only. Panel C shows reduced EHEC O157:H7 strain 86-24-GFP adherence in the presence of serum (1:60 dilution) from a mouse immunized orally with NT-1 cells expressing Int₂₆₁ (CSP5). Reduced adherence determined by visual, qualitative analysis of the digital images.

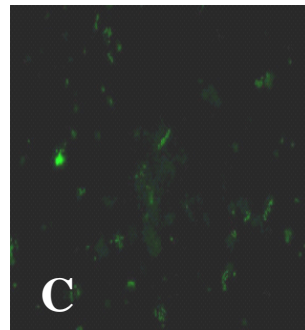
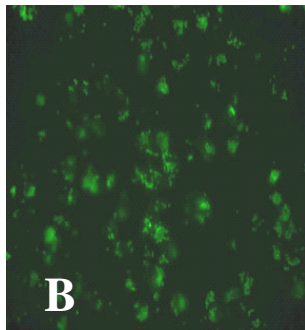
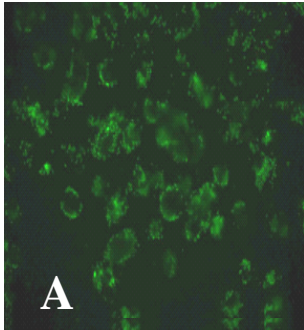
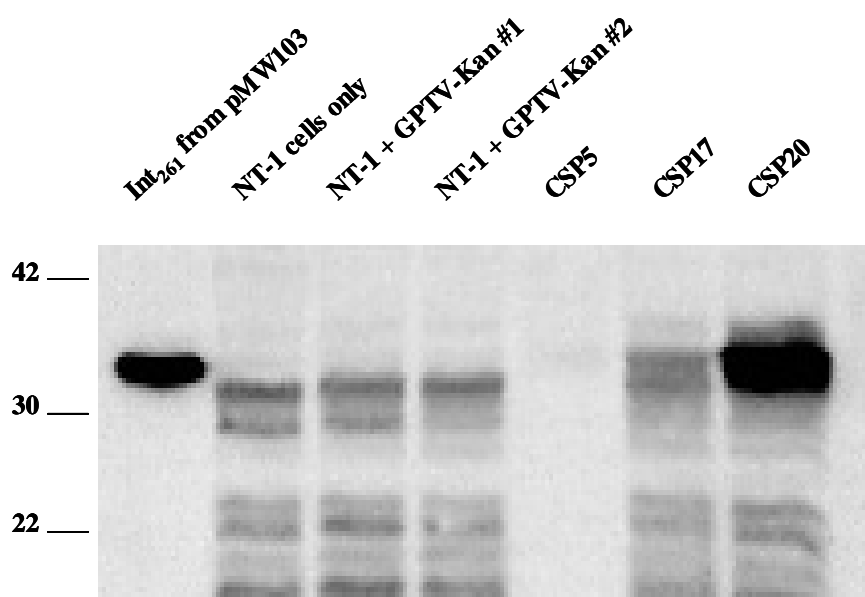

Figure 11. Western blot analysis of CSP5 extracts. CSP5 lost expression of Int₂₆₁ and showed dramatically reduced overall protein expression levels after mold contamination. Two new NT-1 cell clones expressing Int₂₆₁, CSP17 and CSP20 are also shown. Int₂₆₁ from pMW103 (75 ng) was used as a positive control (Gansheroff *et al.*, 1999).



assays with CSP20 showed that mice fed CSP20 with or without CT made Int₂₆₁-specific serum and fecal antibody responses (Table 7, p. 70). However, mice immunized orally with CSP20 in a subsequent experiment did not elicit a detectable (titer detection limit >50) Int₂₆₁-specific immune response by ELISA (Table 8), and serum of immunized mice from the initial and subsequent experiments did not block adherence of EHEC O157:H7 strain 86-24 from HEp-2 cells *in vitro*. We hypothesized that the Int₂₆₁ protein expressed from CSP20 was becoming altered over time in culture. CSP20 was in continuous culture for many months whereas CSP5 was cultured for less than a month before being used in initial feeding experiments (Table 7, p. 70). I decided to proceed by determining if and how Int₂₆₁ in CSP20 was being modified.

Glycosylation of Int₂₆₁ in CSP20. Prompted by the unexpected negative results detailed directly above, the Int₂₆₁ expression from CSP20 was re-assessed. On Western blot analysis, Int₂₆₁ appeared to express one or two slightly higher molecular weight Int₂₆₁-specific bands (Fig. 12). I then re-evaluated the Int₂₆₁ deduced amino acid and noted that it contains two potential asparagine-linked glycosylation sites (NQS and NTS) that could have been modified by glycosylation in this endoplasmic reticulum-targeted form. The two higher molecular weight bands observed in Int₂₆₁ from CSP20 (Fig. 12) could result from glycosylation of either one or both of these N-linked sites. We also noticed that sera from mice immunized with CSP20 that did not recognize Int₂₆₁ from pMW103 (Gansheroff *et al.*, 1999) did recognize nickel affinity chromatography purified Int₂₆₁ from CSP20 (Table 8). These results suggested that Int₂₆₁ from CSP20 had been altered, potentially by glycosylation, and that this change in the protein had adversely affecting the immune response to the antigen. We hypothesized that the higher molecular weight

Table 8. Serum IgG titers from mice fed CSP20 does not recognize Int ₂₆₁ from pMW103 on ELISA				
	ELISA Plate Bound Antigen	Int ₂₆₁ from pMW103 (Gansheroff <i>et al.</i> , 1999)	Int ₂₆₁ from CSP20 (plate culture)	Int ₂₆₁ from CSP20 (broth culture)
Immunization Method and Antigen				
Injected i.p., Int ₂₆₁ from pMW103 (Gansheroff <i>et al.</i> , 1999)		871250	6250	31250
Fed CSP20		<50 ^a	250	250
Fed CSP20 with CT ^b		50	250	250

^a 50 -titer limit of detection

^b CT – purified cholera toxin, 7.5 µg (Sigma)

Figure 12. Western blot analysis of higher molecular weight bands expressed by older cultures of CSP20. After 6 months of continuous culture on NT media plates and broth, CSP20 expressed one or two higher molecular weight intimin-specific species (CSP20) not present in the purified intimin control (purified Int₂₆₁ from pMW103, 75 ng). These higher molecular weight intimin bands became more evident as the culture aged, i.e. they were not as prominent in earlier cultures (Fig. 11).

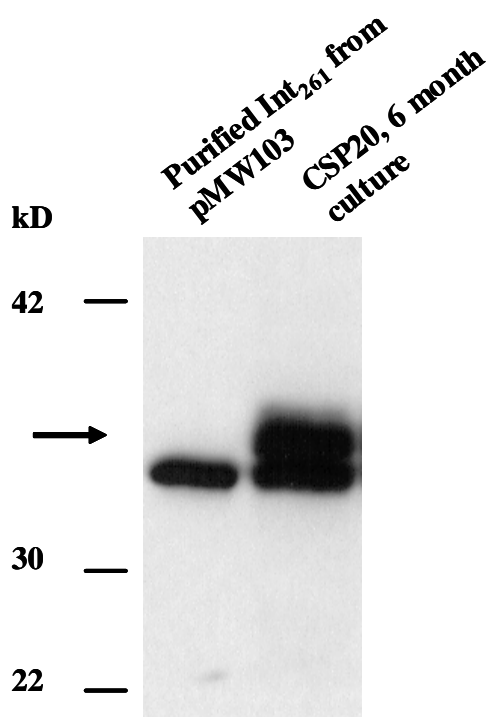

bands represent a glycosylated form of Int₂₆₁ that was recognized by the murine host differently than the protein made by bacteria.

To determine whether Int₂₆₁ from CSP20 was in fact glycosylated, Int₂₆₁ from CSP20 was purified by nickel affinity chromatography and then subjected to a deglycosylation protocol with a Glyko[®] GlycoFree[™] Chemical Deglycosylation Kit from Prozyme (San Leandro, CA). This kit contains trifluoromethanesulfonic acid (TFMS) as a reagent to non-selectively remove both N- and O-linked glycans from glycoproteins without altering the primary protein structure. The appearance of a band after treatment of Int₂₆₁ from CSP20 with TFMS that was consistent with the size of control Int₂₆₁ [~35 kDa when purified from pMW103 (Gansheroff *et al.*, 1999) by nickel affinity chromatography], strongly suggested that Int₂₆₁ from CSP20 was glycosylated (Fig. 13).

The location of the two potential N-linked glycosylation sites in Int₂₆₁, as illustrated on the EPEC carboxy-terminal intimin ribbon structure (Fig. 14), do not appear to be situated in either the Tir or nucleolin binding domains (Luo *et al.*, 2000; Sinclair and O'Brien, 2002). To test this prediction, we asked whether glycosylated Int₂₆₁ could bind to nucleolin and Tir. Based on qualitative analysis by Far Western blot analysis (Fig. 15), we concluded that Int₂₆₁ from CSP20 does bind nucleolin, and, therefore, glycosylation of Int₂₆₁ does not appear to block interaction with this host-cell receptor for intimin (Sinclair and O'Brien, 2002). Unfortunately, for technical reasons, the results of the Far Western analysis of Tir binding to Int₂₆₁ were inconclusive (data not shown).

Because the glycosylation of the Int₂₆₁ molecule in CSP20 adversely affected the immune response to this antigen, even though the antigen appeared to maintain the

Figure 13. Western blot analysis of Int₂₆₁ from CSP20 before and after treatment with trifluoromethanesulfonic acid (TFMS) to deglycosylate the protein. Int₂₆₁ purified by nickel affinity chromatography (from CSP20) migrated as two visible intimin-specific bands that were of higher molecular weight than Int₂₆₁ from pMW103 (Gansheroff *et al.*, 1999). After treatment of Int₂₆₁ purified from CSP20 with TFMS, which non-selectively removes N and O-linked glycans from proteins, the higher molecular weight intimin-specific bands disappeared and a band consistent with the size of control Int₂₆₁ (~35 kD, 75 ng protein loaded in well) appeared.

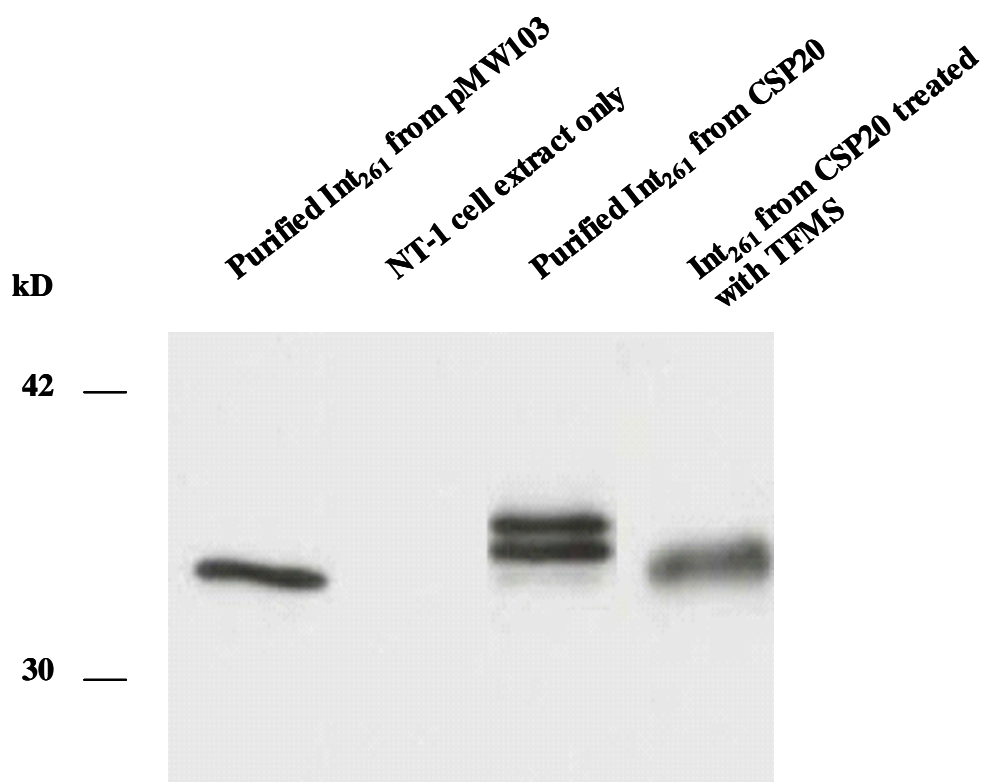
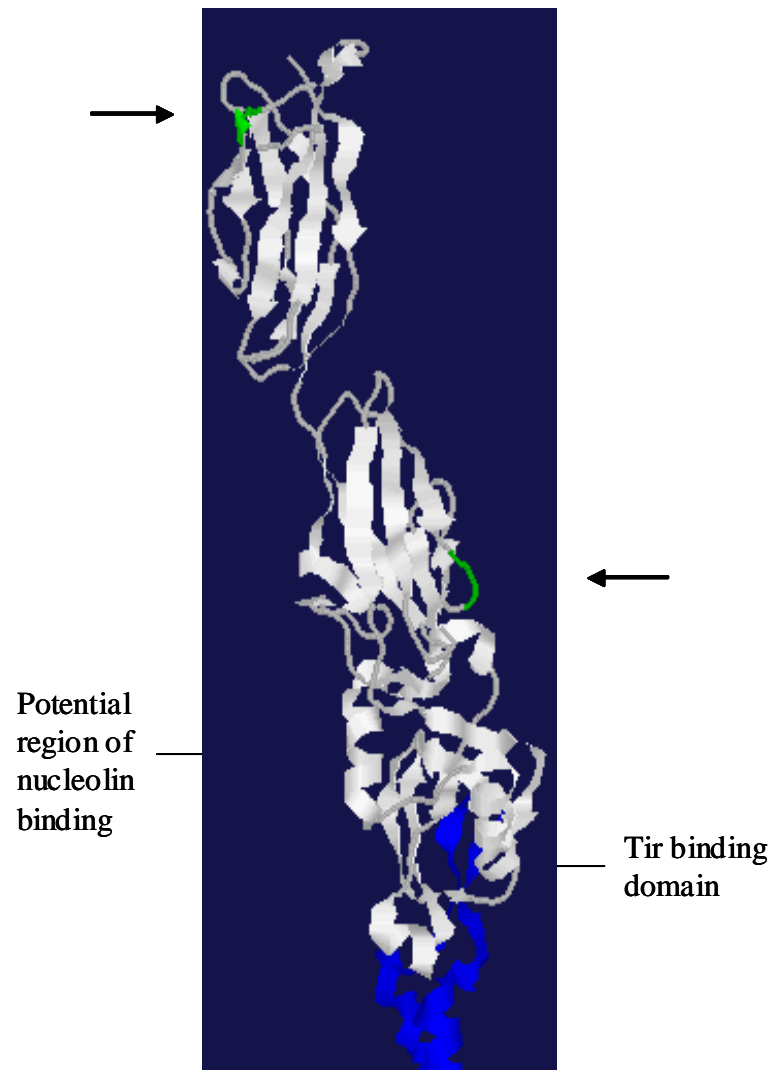
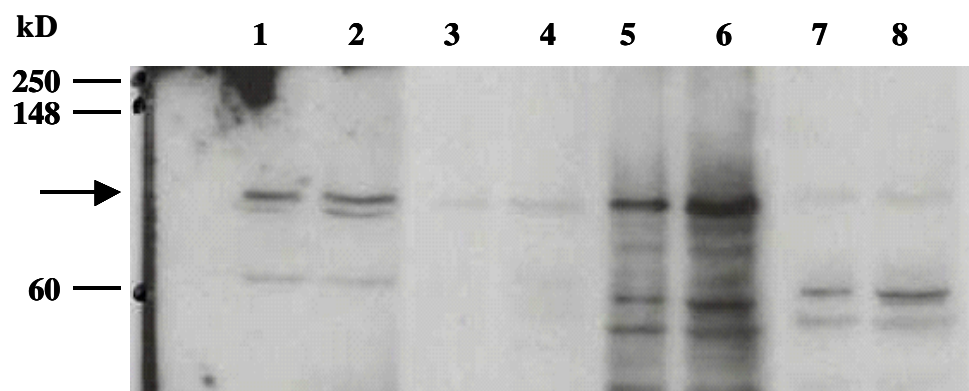

Figure 14. Theoretical location of potential sites of N-linked glycosylation in Int₂₆₁ based on a ribbon crystal structure of the EPEC intimin- (in white) bound to the translocated intimin receptor (Tir, in bright blue) (Luo *et al.*, 2000). The carboxy-terminal domain of EPEC intimin shown consists of amino acid residues 858-939. The Tir binding domain is located at residues 904-909. Based on the amino acid sequence of EHEC intimin_{O157}, there are two potential sites for N-linked glycosylation with the C-terminus of intimin_{O157}, shown on the EPEC ribbon structure in green and highlighted with arrows. Glycosylation at either or both of these sites would not appear, based on this structure, to interfere with Tir or nucleolin binding (Luo *et al.*, 2000; Sinclair and O'Brien, 2002).



Ribbon drawing adapted from (Luo *et al.*, 2000).

Figure 15. Far Western blot analysis of Int₂₆₁ from CSP20 to assess whether it bound to nucleolin. HEP-2 cell protein extracts electroblotted to nitrocellulose were cut into strips and incubated with various intimin_{O157} proteins. Lanes 1 and 2 were incubated with PBS and no intimin_{O157}. Lanes 3 and 4 were incubated with 6 µg intimin_{O157} from pEB313 (McKee and O'Brien, 1996). Lanes 5 and 6 were incubated with 6 µg Int₂₆₁ from pMW103 (Gansheroff *et al.*, 1999). And Lanes 7 and 8 were incubated with 6 µg Int₂₆₁ from CSP20. The blot of lanes 1 and 2 was then probed with a nucleolin monoclonal antibody and the bands that resulted were each ~110 kD protein, sizes consistent with that of nucleolin. The other blots were probed with intimin_{O157} polyclonal antibodies to detect the sizes of the bands to which the intimin proteins were bound. All of the intimin proteins appeared bound to a protein(s) in the HEP-2 cell lysates of ~110 kD, sizes consistent with that of nucleolin (arrow).



function of binding to nucleolin, we elected to discontinue experiments with CSP20. Instead, we used an NT-1 cell clone transformed with pNR50, C34, that expressed Int₂₆₁ without the addition of a signal peptide and in an apparently unglycosylated state (Fig. 16). C34 expressed ~3 µg Int₂₆₁ per gram of total plant material.

Colonization of mice by EHEC O157:H7 is dependent on intimin_{O157}. In anticipation of testing the *in vivo* efficacy of the transgenic plant vaccine in blocking bacterial colonization with EHEC O157:H7, we sought to develop a small animal, intimin_{O157}-dependent model of bacterial colonization. Previously our laboratory had reported that mice that are treated with streptomycin and then fed a-Str^R version of EHEC O157:H7 can be successfully colonized with the organism at high levels (Wadolkowski *et al.*, 1990a). However, Dr. Marian McKee, while a graduate student in this laboratory, found no evidence of intimin_{O157}-dependent colonization of mice treated with streptomycin in their drinking water (unpublished finding), perhaps because the oral antibiotic enhanced bacterial colonization with EHEC O157:H7 strain 86-24 *eae*Δ10 Str^R to such a high level as to abrogate differences between this mutant and wild-type. Note that even an *E. coli* K-12 strain colonizes streptomycin-treated mice well (Wadolkowski *et al.*, 1990a; Wadolkowski *et al.*, 1990b). In this study, I confirmed Dr. McKee's observation.

Several other groups have reported that untreated mice or mice given cimetidine are transiently colonized with clinical strains of EHEC O157:H7 (Wadolkowski *et al.*, 1990a; Nagano *et al.*, 2003; Conlan and Perry, 1998). However, none of these explored the intimin_{O157}-dependent nature of the bacterial colonization. Therefore, I evaluated the impact of intimin on the colonization of untreated mice with EHEC O157:H7. I found

Figure 16. Western blot analysis of Int₂₆₁ expressed by C34. NT-1 cell clone C34 transformed with pNR50 expressed Int₂₆₁ (C34-plate culture and C34-suspension culture) that did not appear to be glycosylated like CSP20. 75 ng of Int₂₆₁ from pMW103 used as a positive control (Gansheroff *et al.*, 1999).

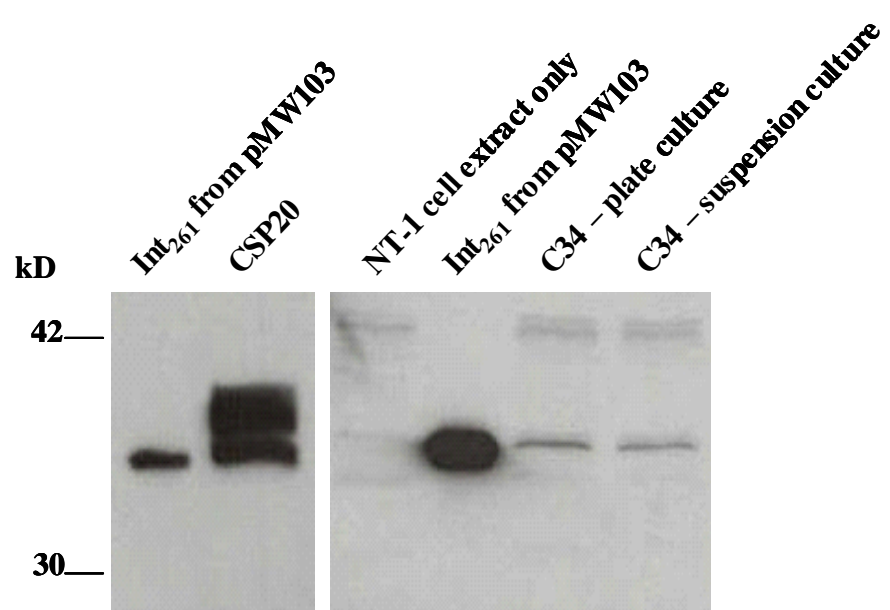

that untreated mice could be colonized with the strain at modest levels (approximately 1×10^3 CFU/g feces) for a mean of 10 days (range 6.4 to 13.4 days for unimmunized mice), an observation consistent with our finding in ferrets (Melton-Celsa *et al.*, 1998). With this untreated mouse model of EHEC O157:H7 colonization, in an experiment limited to 7 days, EHEC O157:H7 86-24 Str^R colonized BALB/c mice a mean of 6.4 days, whereas the intimin_{O157}-negative mutant EHEC O157:H7 86-24 Str^R *eae*Δ10 showed a statistically significant reduction in the duration of colonization (mean, 3.2 days; $P < 0.005$; Log-rank test). Thus, in this model of EHEC O157:H7 infection, as in the ferret, colonization was augmented by the presence of intimin_{O157}. In addition, two different infectious doses of EHEC O157:H7 86-24 Str^R, 1×10^6 CFU or 1×10^9 CFU, were tested to see if a lower infectious dose could also lead to bacterial colonization and might therefore be a better model to ascertain the functionality of an anti-intimin_{O157}-specific immune response. Mice (n=5) challenged with 1×10^9 CFU EHEC O157:H7 86-24 Str^R were colonized a mean of 6.4 days in an experiment limited to 7 days, whereas mice fed 1×10^6 CFU were colonized a mean of 3 days ($P = 0.027$, Log-rank test). The lower infectious dose of 1×10^6 EHEC O157:H7 86-24 Str^R colonized mice (mean 3 days) to the same degree as EHEC O157:H7 86-24 Str^R *eae*Δ10 (mean 3.2 days) thus did not function as an intimin_{O157}-dependent model of bacterial colonization.

Generation of intimin_{O157}-specific serum and fecal antibodies. We tested several different vaccination strategies with C34 in BALB/c mice. The vaccine protocols and the serum IgG and fecal IgA and IgG ELISA results are summarized in Table 9. To maximize the immune response to orally administered Int₂₆₁, we tried a prime-boost protocol (Groups E and F) similar to that used to elicit an enhanced immune response to

Footnotes for Table 9.

^aSerum and fecal pellet extracts were collected throughout the experiment and were evaluated by ELISA for the presence of antibodies to Int₂₆₁. The titer was defined as the geometric mean of the reciprocal of the highest dilution that gave an absorbance (A_{600}) above both pre-immune and background levels. Responders, in parenthesis, were defined as mice that had a detectible titer at the final sample collection point (7 days after the final feeding or injection). Mice with no titer or that lost titer by the last collection point were called non-responders. The titers reflect the geometric mean of responders only.

^bSignificantly higher serum IgG titer and responders compared to other groups ($P < 0.0001$; two-sided t-test and $P < 0.003$; Fisher's exact test)

^cFecal IgA titer compared to group E and F, $P = 0.019$ and $P = 0.013$, respectively (two-sided t-test). Number of fecal IgA responders compared to group E and F, $P = 0.175$ and $P = 1.000$, respectively (Fisher's exact test).

^dCT – purified cholera toxin, 7.5 μg (Sigma)

Table 9. Immunogenicity in BALB/c mice of NT-1 cells that express Int₂₆₁

Group/Immunization	Vaccination Method	Serum ^a IgG titer (responders)	Fecal ^a titer (responders)
A: Int ₂₆₁ from pMW103 given i.p.	20 µg Int ₂₆₁ +TiterMax [®] i.p. day 0; 10 µg Int ₂₆₁ +TiterMax [®] i.p. days 10 and 20	300000 (10/10) ^b	560 (8/10) ^c [IgA only]
B: Fed NT-1 cells only	5g NT-1 cells fed on days 0, 7, 14	<50 (0/10)	<50 (0/10)
C: Fed C34 cells only	5 g C34 (~15 µg Int ₂₆₁) fed on days 0, 7, 14	<50 (0/10)	340 (4/10) [IgG and IgA]
D: Fed C34 cells with CT ^d	5 g C34 (~15 µg Int ₂₆₁)with CT fed on days 0, 7, 14	<50 (0/10)	280 (6/10) [IgG and IgA]
E: Int ₂₆₁ (Ni-affinity purified) from C34 given i.p.; Fed NT-1 cells only	~15 µg Int ₂₆₁ from C34+TiterMax [®] i.p. on day 0; 5 g NT-1 cells fed on day 7 and 14.	50 (1/10)	150 (5/10) [IgA only]
F: Int ₂₆₁ (Ni-affinity purified) from C34 given i.p.; Fed C34 cells with CT ^d	~15 µg Int ₂₆₁ from C34+TiterMax [®] i.p. on day 0; 5 g C34 (~15 µg Int ₂₆₁) with CT fed on day 7 and 14.	80 (3/10)	180 (7/10) [IgA only]

the B subunit pentamers of heat-labile enterotoxin of *E. coli* (LT-B) (Lauterslager *et al.*, 2001). Five of 10 mice primed by injection of purified Int₂₆₁ from C34 and then fed non-transgenic plant material developed an intimin-specific fecal antibody response. These results suggested that even a single inoculation with Int₂₆₁ from C34 can prime for a subsequent mucosal antibody response to intimin. Seven of 10 mice primed by injection of Int₂₆₁ from C34, then boosted by feeding C34 (with CT as an oral adjuvant) produced an intimin-specific fecal IgA response. In addition, 3 out of 10 mice developed a serum IgG response, and serum samples from these mice blocked adherence of wild type EHEC O157:H7 to HEp-2 cells compared to pre-immune serum controls (Fig. 17). Although the fecal IgA titer for group A was significantly higher than both groups E and F ($P=0.019$ and 0.013 , respectively; two-sided t-test), the number of mice making an Int₂₆₁-specific fecal IgA response in both groups E and F did not differ significantly from the number responding from group A ($P= 0.175$ and 1.000 , respectively; Fisher's exact test).

Challenge of vaccinated mice with EHEC O157:H7. With this intimin-dependent mouse model of EHEC O157:H7 colonization, we orally infected the same groups of immunized mice described in Table 9 with EHEC O157:H7 strain 86-24 Str^R. We found that mice primed with an intraperitoneal (i.p.) injection of Int₂₆₁ from C34, then fed homologous C34 plant material showed a statistically significant ($P<0.002$; Log-rank test) reduction in the duration of colonization (as measured by fecal shedding) compared to the negative control mice fed non-transgenic NT-1 cells only (Fig. 18). These mice primed and boosted with Int₂₆₁ from transgenic plant material also exhibited a statistically

Figure 17. Serum from mice immunized with Int₂₆₁ from C34 blocked bacterial adherence to HEp-2 cells. Panel A shows adherence of EHEC O157:H7 strain 86-24-GFP to HEp-2 cell monolayers in the presence of non-immune serum. Panel B shows reduced adherence of EHEC O157:H7 strain 86-24-GFP to HEp-2 cell monolayers in the presence of serum from a mouse that was primed i.p. with Int₂₆₁ from C34, then boosted with oral feedings of C34 plant material with cholera toxin as an oral adjuvant. Reduced adherence determined by visual, qualitative analysis of the digital images.

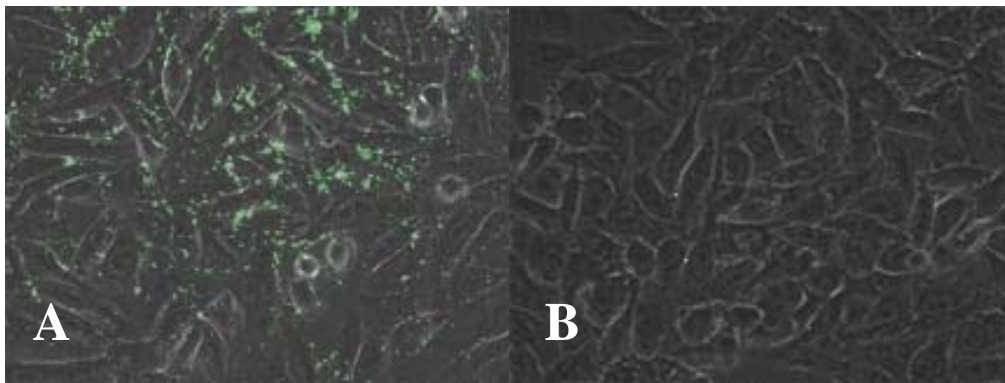
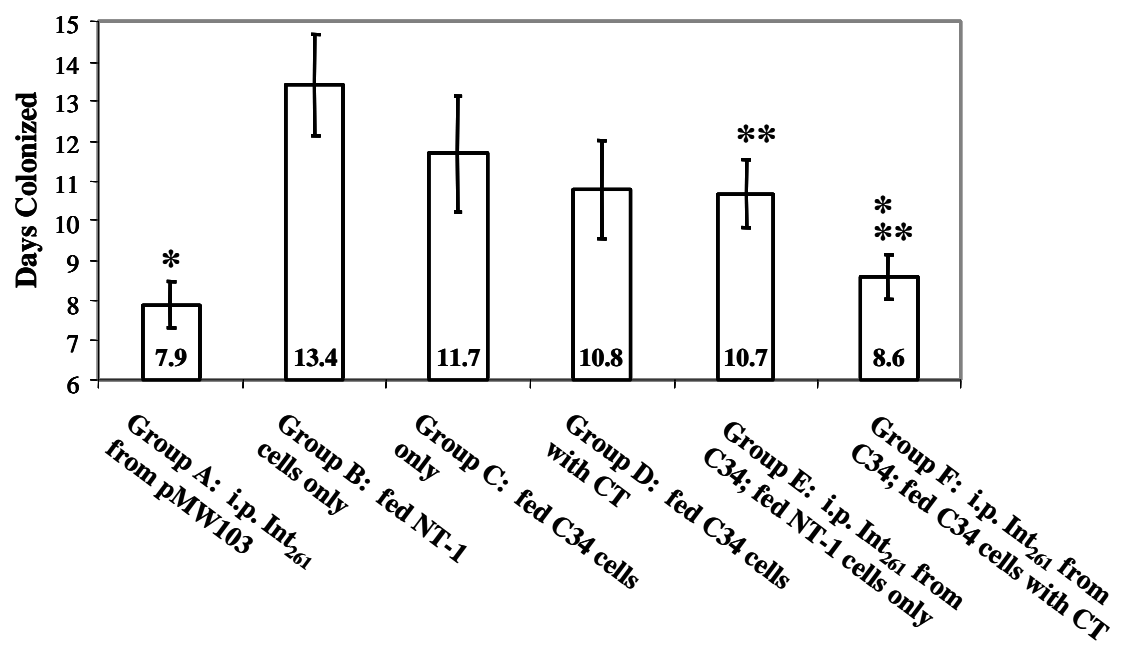

Figure 18. Duration of EHEC O157:H7 colonization in mice immunized with Int₂₆₁. All mice from the same groups as shown in Table 9 (p. 91) were challenged with wild type EHEC O157:H7. Mice in both groups A and F (*) showed a statistically significant ($P < 0.002$, Log rank test) reduction in the duration of colonization compared to group B. No other groups demonstrated a statistically significant reduction compared to group B. Mice from group F (**) also showed a statistically significant decrease in the duration of bacterial colonization compared to mice from group E ($P = 0.033$; Log-rank test). The Int₂₆₁ material used to immunize mice in group A was nickel-affinity purified from pMW103 (Gansheroff *et al.*, 1999). Purified cholera toxin (7.5 μg ; Sigma) was used as an oral adjuvant in groups D and F.



significant decrease in the duration of bacterial colonization compared to mice only immunized i.p. with Int₂₆₁ from C34, then boosted with non-transgenic plant material ($P=0.033$; Log-rank test). These results suggest that the feeding of transgenic, Int₂₆₁-expressing plant material plays a significant role in boosting the immune response to Int₂₆₁ and in reducing the duration of bacterial colonization. The positive control mice, injected i.p., 3 times with highly purified Int₂₆₁ from pMW103 (Gansheroff *et al.*, 1999), also displayed a statistically significant reduction in the duration of colonization versus the negative control ($P<0.002$; Log-rank test). There was no difference in the duration of shedding between the positive control immunizations and the prime-boost protocol with oral delivery of transgenic plant material that expressed Int₂₆₁ as a boost. This latter observation suggests that immunization with a plant-based oral vaccine can induce an immune booster response sufficient to provide protection from a challenge with wild-type EHEC O157:H7.

Expression of Int₂₆₁ in a whole plant model: *Arabidopsis thaliana*. As a consequence of our success in the expressing Int₂₆₁ in NT-1 cells and in collaboration with Boyce Thompson Institute for Plant Research in Ithaca, NY, we proceeded to transform a whole plant model, *Arabidopsis thaliana*, with *Agrobacterium* strains that carried the intimin_{O157} and Int₂₆₁ expression constructs. We used the floral dip method (as described in Materials and Methods, p. 35). *Arabidopsis* leaf material grown from transformed seeds was sent to Uniformed Services University for Western blot analysis. Leaf material proteins extracted directly into SDS-Page loading buffer proved to be the optimal

preparation method for visualizing Int₂₆₁ expression. *Arabidopsis* plants transformed with intimin_{O157} expression constructs (pNR12 or pNR14) did not produce any intimin_{O157}-specific proteins. However, 3 out of 6 plant clones transformed with pNR49 (Int₂₆₁ gene with a plant-specific signal peptide sequence) expressed Int₂₆₁-specific protein. In addition, 1 out of 4 plant clones transformed with pNR50 (Int₂₆₁ gene without signal peptide sequence) produced Int₂₆₁-specific protein (Fig.19). These results show that Int₂₆₁ can be expressed in a more complex, whole plant model. Furthermore, these results suggest that the plant-optimization of the Int₂₆₁ gene may improve the efficiency of the antigen's expression in plants.

Figure 19. Western blot analysis of Int₂₆₁ expression in *Arabidopsis* leaf material. The *Arabidopsis* leaf proteins were extracted directly into SDS-Page loading buffer prior to SDS-Page and subsequent Western blot analysis. *Arabidopsis* clones 7, 8 and 10, transformed with pNR49, expressed Int₂₆₁ specific protein (~35 kD). Clone 21, *Arabidopsis* transformed with pNR50, expressed Int₂₆₁-specific protein (~35 kD).

II. Construction of a Shiga toxin type 2 toxoid for expression in plants.

Rationale for initiating experiments on Stx2 toxoids rather than Stx1 toxoids. The majority of isolates of EHEC O157:H7 produce both Stx1 and Stx2 (Obrig, 1998). We elected to first focus on the construction of a Stx2 toxoid, rather than a Stx1 toxoid, for eventual expression in plant cells. Our reasons for this choice were based on several published observations. First, Stx2 is more toxic than Stx1 when injected into mice or when expressed by STEC and fed to these animals (Melton-Celsa and O'Brien, 1998; Melton-Celsa *et al.*, 1998). Second, expression of Stx2 by O157:H7 appears to be more likely to lead to development of HUS in an infected patient, although Stx1-only producing strains have also been associated with cases of HUS (Ostroff *et al.*, 1989; Scotland *et al.*, 1987). Third, Stx2 is more toxic for human renal and intestinal capillary endothelial cells than is Stx1 (Louise and Obrig, 1995) even though Stx 1 is more toxic per antigen unit to Vero cells than is Stx2 (unpublished data, O'Brien laboratory).

Evaluation of an A₂B subunit antigen as a Stx2 toxoid. Our first approach for construction of this Stx2 toxoid was to try to express the A₂ subunit with the Stx2 B pentamer. Recall that Stx2, like Shiga toxin from *Shigella dysenteriae* and Stx1, has an A₁:B₅ noncovalently associated subunit structure (Fig. 2, p. 19). The Stx2 A subunit (~35 kDa) is cleaved to produce A₁ (~28 kDa) and A₂ (~4 kDa) portions. The A₂ subunit

remains associated with the A₁ subunit via a disulfide bond and serves to link the A₁ portion of the subunit to the B pentamer. Shiga toxin type 1 (Stx1) B subunits, when expressed from a recombinant plasmid, can form functional pentamers that elicit toxin neutralizing antibodies (Ramotar *et al.*, 1990; Acheson *et al.*, 1993; Acheson *et al.*, 1995). Stx2 B subunits do not form functional pentamers or elicit Stx2 neutralizing antibodies when expressed in a recombinant form, unless the subunits are expressed with the Stx1 B leader sequence (Acheson *et al.*, 1995; Marcato *et al.*, 2001). Since the A₂ portion of Stx1 is required to noncovalently bind the A₁ subunit to the B pentamer and is very important for full toxicity of the molecule (Austin *et al.*, 1994), we hypothesized that the A₂ portion of Stx2 may be critical for B subunit pentamerization. Therefore, we decided to express the Stx2 B subunit in conjunction with its A₂ portion with the hopes that this construct would produce functional Stx2 B subunit pentamers.

The construct used was EHEC O157:H7 *stx2* Δ A₁kan::*A*₂B, where the A₁ subunit of the toxin was replaced by a kanamycin resistant cassette (made by Dr. Clare Schmidt; unpublished). This construct was not cytotoxic and appeared to produce B subunit pentamers when the material was cross-linked with dimethyl suberimidate (DMS), as seen in Figures 20 and 21. Unfortunately, when this material was injected i.p. into female BALB/c mice, they (n=5) did not make Stx2-neutralizing antibodies (Fig 22). One possible explanation for these results is that Stx2 B pentamers expressed from this recombinant construct is not stable and readily dissociates when not crosslinked. We speculate that the multimeric Stx2 B subunit structures express the Stx2 toxin neutralizing epitopes whereas the immunodominant epitopes recognized on the Stx2 B subunit monomers do not elicit such antibodies. Indirect evidence in support of this

Figure 20. Expected Stx2 B subunit multimerization pattern upon crosslinking of the EHEC O157:H7 *stx2* $\Delta A_1kan::A_2B$ sonic lysate with dimethyl suberimidate (DMS). Recombinant Stx2 B subunits are predicted to form into multimers of differing sizes when crosslinked with increasing concentrations of DMS.

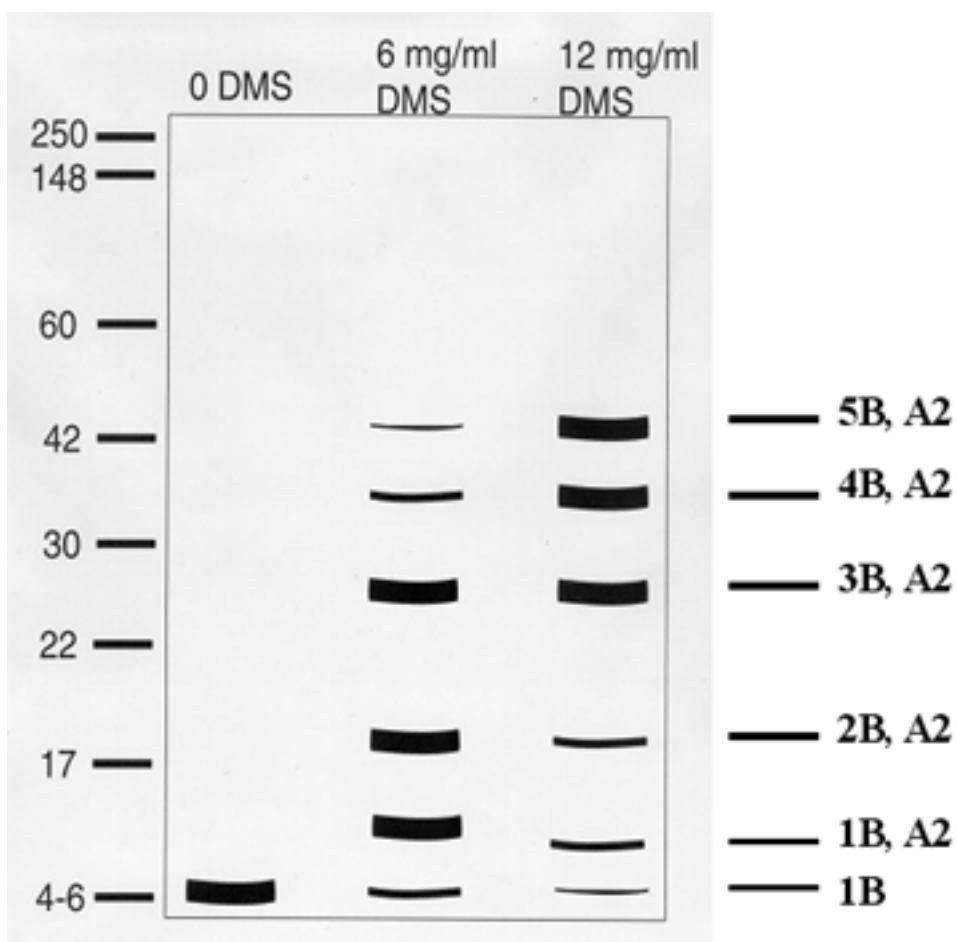

Figure 21. Stx2 B subunit multimers expressed from EHEC O157:H7 *stx2*

$\Delta A_1kan::A_2B$. Stx2 toxin or Stx2 B subunits from EHEC O157:H7 *stx2* $\Delta A_1kan::A_2B$ were crosslinked with 0, 12, 24, or 48 mg/ml DMS, separated by SDS-Page, transferred to nitrocellulose, and probed with BC5, a Stx2 B subunit-specific MAb (Zieg et al., 1978). Without DMS, both wild-type and recombinant B subunits existed as monomers (~7 kD). With increasing concentrations of DMS both wild-type and recombinant B subunits exhibited similar patterns of multimerization. The higher molecular weight bands present in the wild type Stx2 toxin lanes are most likely due to the presence of the complete A_1 subunit.

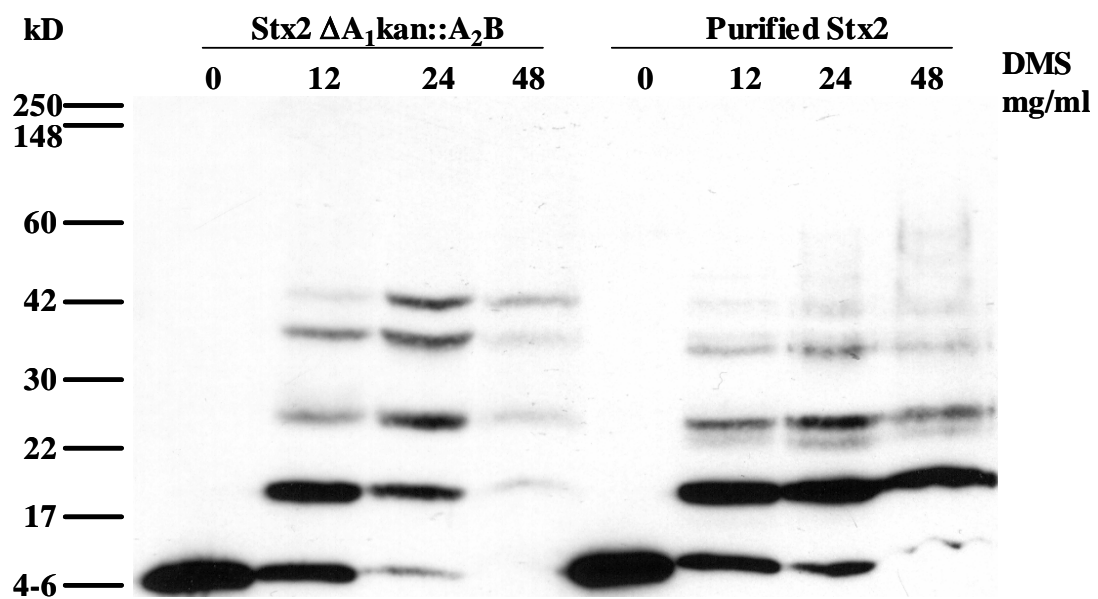
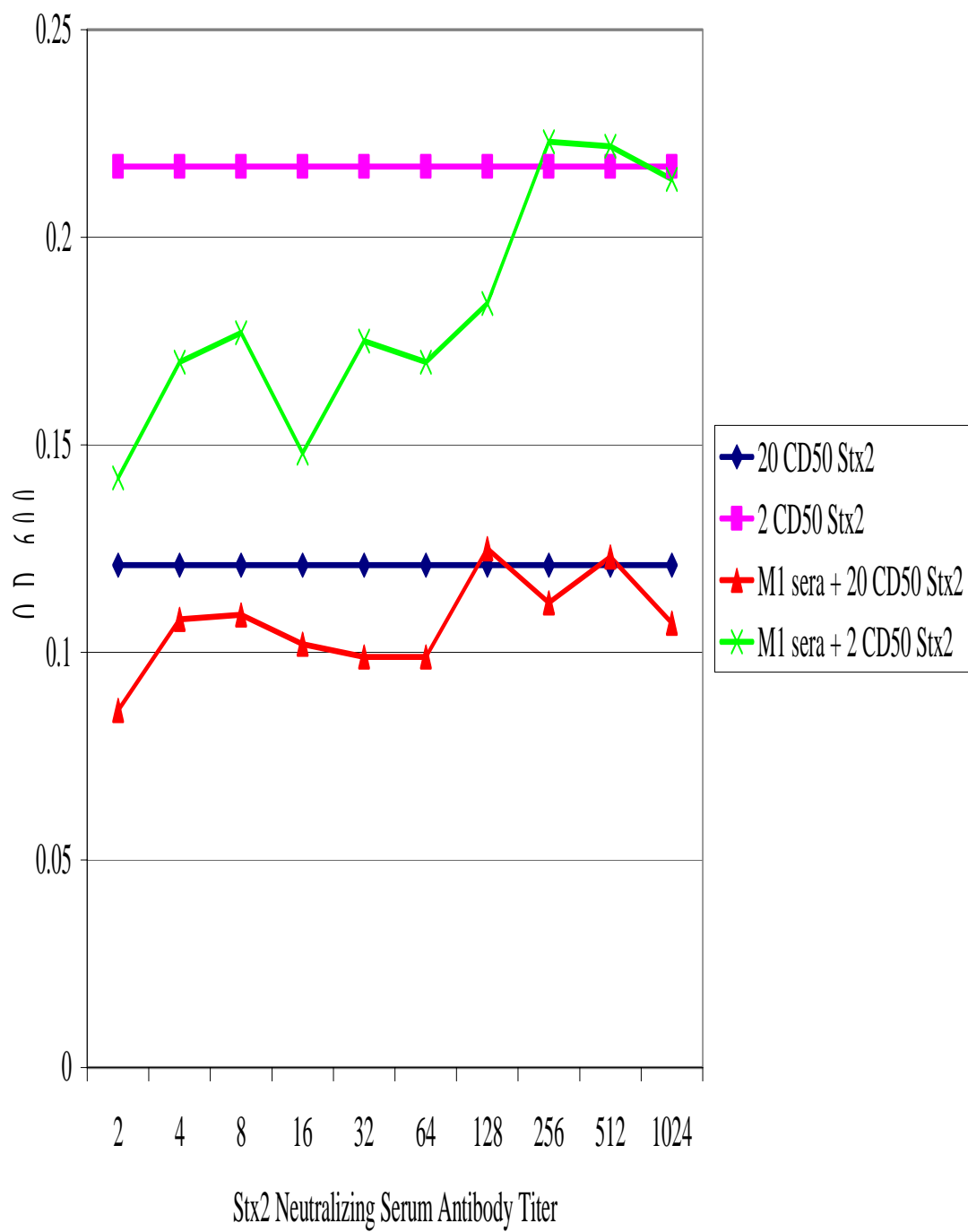

Figure 22. Toxin neutralization assay using serum from a mouse immunized with a lysate of a sonically disrupted culture of EHEC O157:H7 *stx2* $\Delta A_1kan::A_2B$. The OD values were obtained by measuring the absorbance at 600 nm in each well with the ELx800 microtiter plate reader (Bio-Tek Instruments, Inc.). The cytotoxic titer (CD50 – the dose of toxin where 50% of the cells die) of culture lysate was expressed as the reciprocal of the highest dilution required to kill 50% of the cells in a well. Therefore, the lower the OD₆₀₀ reading, the higher the cytotoxic dose. Neutralizing serum antibodies prevent Vero cell death, and, thus one expects an increase in the OD₆₀₀ reading for wells with immune sera plus toxin compared to wells that contain toxin alone or toxin plus prebleed sera. Ten serial two-fold dilutions were prepared in Vero cell tissue culture medium starting at a dilution of 1:2. These serum dilutions were tested with both 2x CD50 and 20x CD50. Serum from mouse #1 (M1) could not neutralize either 2xCD50 or 20xCD50 of purified Stx2, as the presence of this serum did not result in higher OD₆₀₀ readings from the 2xCD50 or 20xCD50 controls. The data shown here are from mouse #1 and are representative of all mice that were immunized with EHEC O157:H7 *stx2* $\Delta A_1kan::A_2B$.

Toxin Neutralization Assay: Mouse immunized with recombinant Stx2 B



premise is the fact that Donohue-Rolfe *et al.* were able to generate a Stx2 B monoclonal antibody (4D1) that was raised against holotoxin that did not recognize Stx2 B monomers on Western blot (Donohue-Rolfe *et al.*, 1989; Acheson *et al.*, 1995). Another explanation for the findings of these investigators is that the epitope is present on the Stx2B monomer but is conformationally dependent and not detected on Western blot analysis.

Rationale and strategy for construction of a site-directed Stx2 toxoid. Our next approach for creation of a Stx2 toxoid was to attempt to alter, by site-directed mutagenesis, certain codons for amino acids that are required for enzymatic activity of Stx2. We reasoned that mice immunized with such a toxoid would generate antibodies to both the Stx2 A and B subunits. We also hypothesized that the Stx2 B subunit would be more likely to pentamerize in a holotoxoid molecule than when expressed alone on a recombinant plasmid, and, therefore, that Stx2 toxin neutralizing epitopes would be conserved. Finally, we rationalized that expression and assembly of multiple subunits in a plant system was not an unreasonable expectation based on previous research that showed that functional antibodies can be expressed in plant systems (Ma *et al.*, 1995; Ma *et al.*, 1998).

The first step in Stx2 toxoid construction was to identify amino acid residues in the Stx2 A subunit that abrogate cytotoxic activity. The enzymatic function of Stx2 is the inhibition of protein synthesis by depurinating an adenine residue from 28S ribosomal RNA of the 60S ribosome. The A₁ subunit contains the N-glycosidase activity (Endo *et al.*, 1988; Saxena *et al.*, 1989). The glutamic acid at position 167 of the A subunit is the

active site and is critical for enzymatic activity (Hovde *et al.*, 1988), though other amino acid residues in the A subunit (such as the tyrosine at position 77) are also important for toxicity (Deresiewicz *et al.*, 1992).

The modification of Stx2 to create a toxoid. We used the QuikChange™ Site-directed Mutagenesis Kit (Stratagene) to change the glutamic acid at position 167 to glutamine and the tyrosine at position 77 to a serine. We decided to change both residues, even though each individual residue successfully abrogated Vero cell cytotoxicity (Fig. 23), to prevent spontaneous reversion to a toxic molecule.

Analysis of toxoid capacity to elicit Stx2-neutralizing antibodies. The resulting recombinant plasmid was named pNR100. That plasmid was transformed into XL-1 Blue (Stratagene), and the Stx2 toxoid was expressed and purified by affinity chromatography over a column to which the Stx2A MAb, 11E10, had been coupled (Perera *et al.*, 1988). This purified material was emulsified one to one with TiterMax® and used to immunize mice as detailed in the Materials and Methods section (p. 45). These immunized mice remained healthy, made Stx2 toxin neutralizing antibody, and were able to survive purified Stx2 toxin injections of up to 1 µg toxin (Fig. 24).

Optimization of the Stx2 toxoid A and B subunit genes for expression in plants. We further applied the strategy of site-directed mutagenesis to make three additional changes to the A subunit of the catalytically-inactivated Stx2 toxoid so as to optimize expression

Figure 23. Vero cell cytotoxicity assay of Stx2 toxoid purified from pNR100. The OD values were obtained by measuring the absorbance at 600 nm in each well. The CD50 of culture lysate was expressed as the reciprocal of the highest dilution required to kill 50% of the cells in a well, as represented by the straight line (blue diamonds). Therefore, the higher the OD₆₀₀ reading, the lower the cytotoxic dose. The CD50 of the Stx2 toxin control was approximately 5×10^3 CD50/ml (purple squares). Purified Stx2 toxoid, from three different preparations, purified on the dates shown, had no evidence of cytotoxicity.

Stx2 Toxoid Vero Cell Cytotoxicity

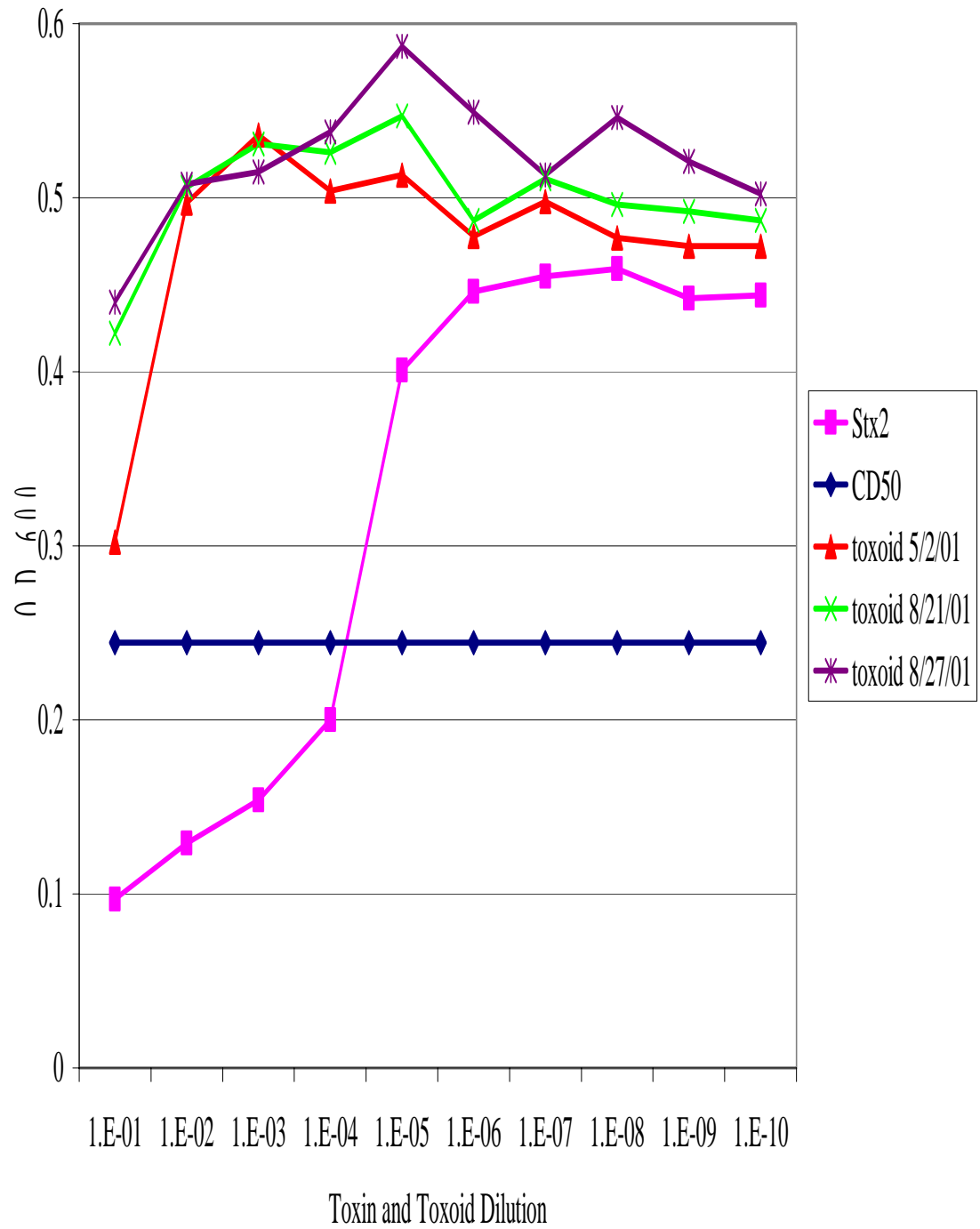
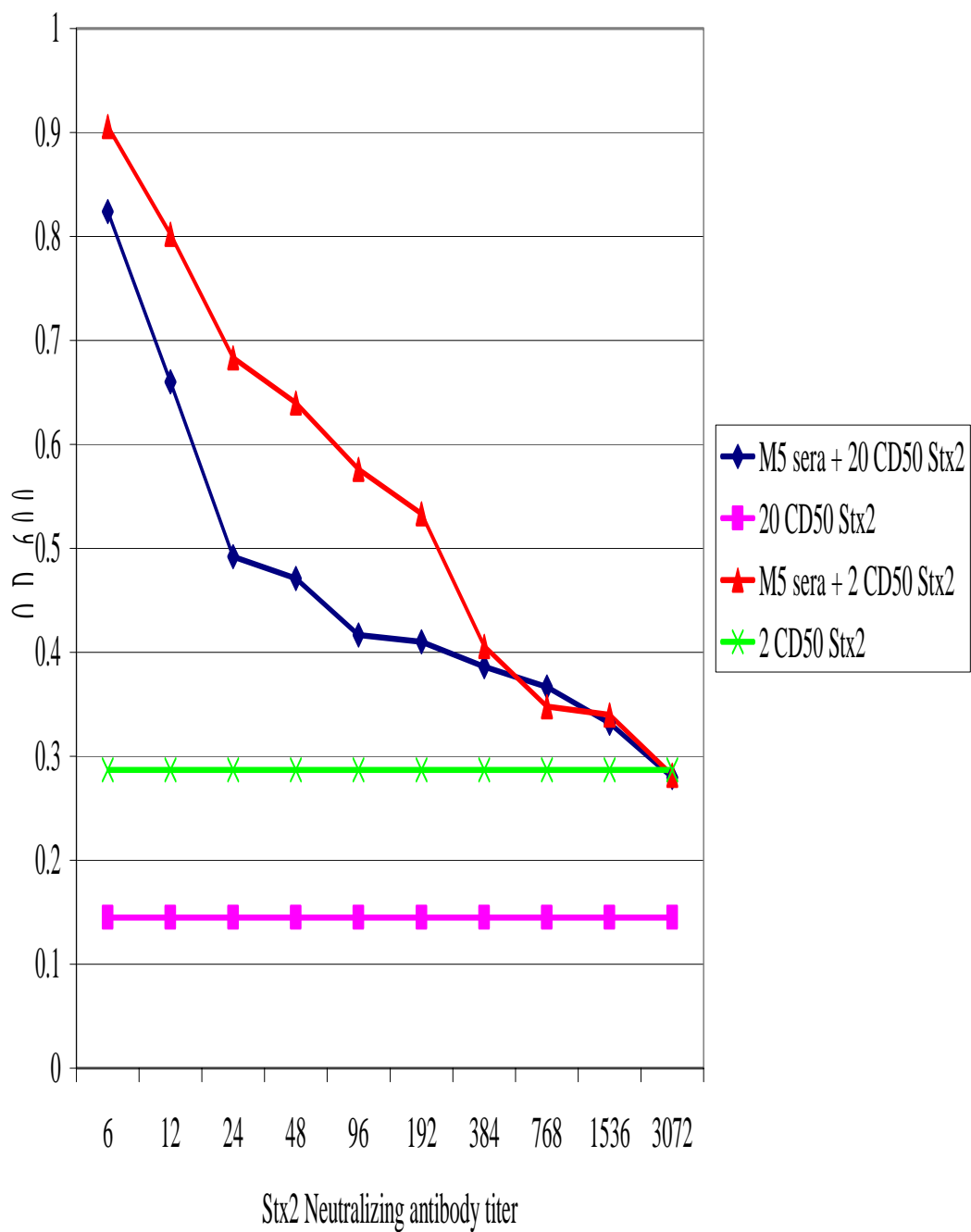

Figure 24. Stx2 toxin neutralization assay with serum from a mouse immunized with Stx2 toxoid purified from pNR100. The OD values were obtained by measuring the absorbance at 600 nm in each well. The CD50 of culture lysate was expressed as the reciprocal of the highest dilution required to kill 50% of the cells in a well, therefore the higher the OD₆₀₀ reading, the lower the cytotoxic dose. Neutralizing serum antibodies prevent Vero cell death, and, thus one expects an increase in the OD₆₀₀ reading for wells with immune sera plus toxin compared to wells that contain toxin alone or toxin plus prebleed sera.. Ten serial two-fold dilutions were prepared in Vero cell tissue culture medium starting at a dilution of 1:6. These serum dilutions were tested with both 2xCD50 and 20xCD50. Serum from mouse #5 (M5) had a Stx2 toxin neutralizing titer for both 2xCD50 and 20xCD50. The data shown here are from one mouse and are representative of all mice that were immunized with Stx2 toxoid purified from pNR100.

Toxin Neutralization Assay: Mouse immunized with Stx2 toxoid



of the molecule in plants. The first and second changes were designed to disrupt RNA destabilization motifs located from base 253 to 257 and 528 to 532. The third change disrupted a polyadenylation motif from base 1115 to 1120. The Stx2 A subunit that contained the two toxoid changes and the additional three plant-expression optimization changes was cloned into pIBT210 to create pNR65.

To optimize the Stx2 B subunit for expression in plants, extensive changes to the nucleotide sequence of the gene were required. It was not feasible to make the 37 nucleotide changes necessary to codon-optimize the gene for plant-expression by site-directed mutagenesis, so the entire Stx2 B subunit gene was re-synthesized. We initially tried to synthesize the Stx2 B subunit by an assembly PCR method as described by Stemmer *et al.* (Stemmer *et al.*, 1995). However, we could not successfully re-synthesize the Stx2 B plant-optimized gene by this technique. Therefore, we chose to try the ligase chain reaction (LCR) as an alternate approach (Chalmers and Curnow, 2001). The oligonucleotides used for LCR are outlined in Table 5 and the sequence of the plant-optimized Stx2 B subunit gene is provided in Figure 3. The resulting LCR product (~360 bp) (Fig. 25) was amplified three times using primers 2B1 and 2B10 (Table 5). The final amplified LCR fragment (Fig. 26) was digested with appropriate restriction enzymes and cloned into pBTI210.3 to create pNAJ73.

Figure 25. Agarose gel of Stx2 B synthetic gene. PCR amplification of neat (assembly #1) and a 1:10 dilution (assembly #2) of the Stx2 B subunit assembly PCR product should be approximately 360 base pairs (bp); however, no such product was visible in the assembly PCR lanes. PCR amplification of neat (LCR #1) and a 1:10 dilution (LCR #2) of the Stx2 B subunit ligase chain reaction (LCR) show LCR products of approximately 360 bp are faintly visible in the LCR #1 lane. The LCR fragment was purified from the LCR #1 lane and subjected to three additional rounds of PCR amplification with primers 2B1 and 2B10 (Table 5).

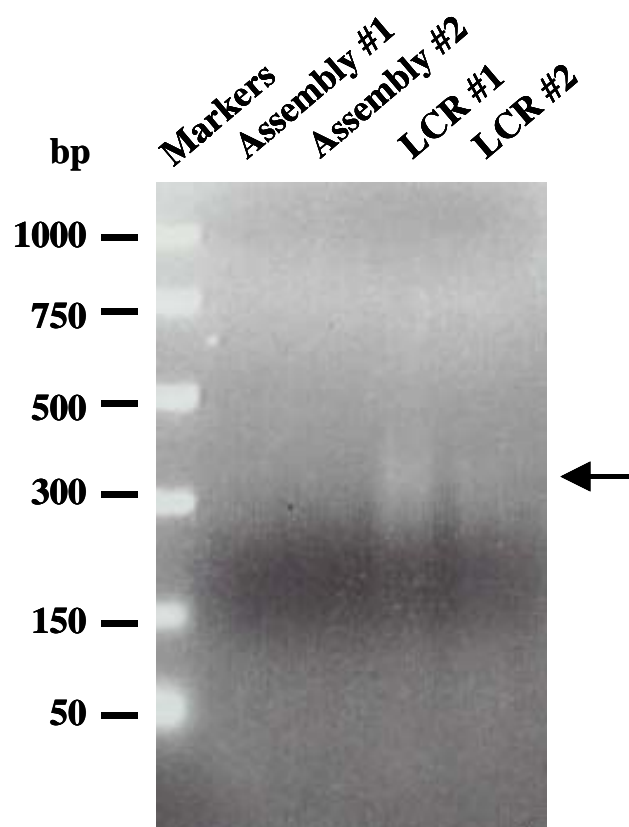
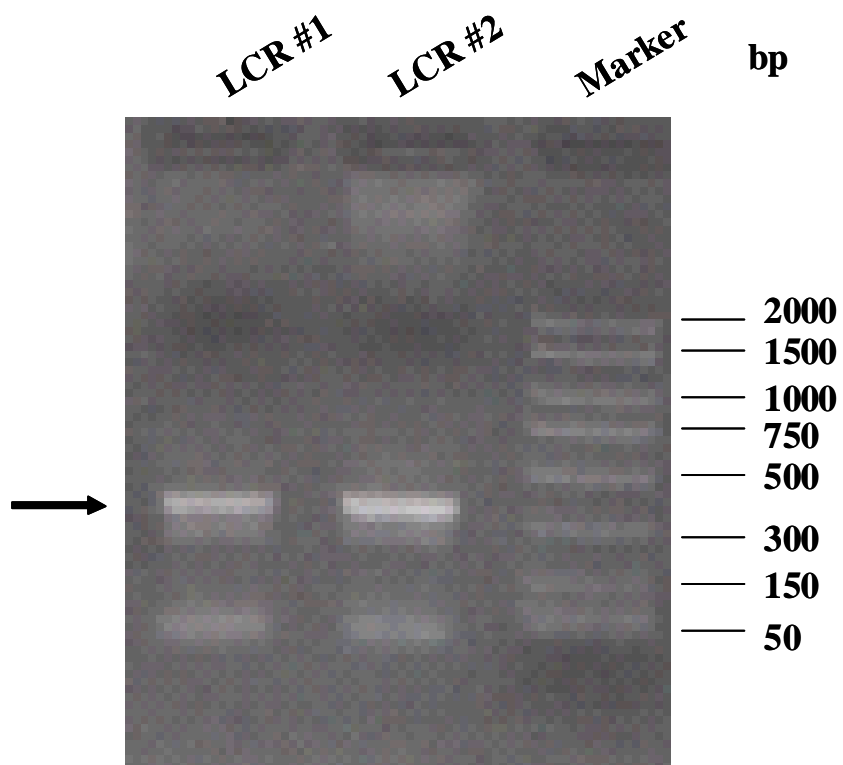

Figure 26. Agarose gel of amplified Stx2 B ligase chain reaction (LCR) product. LCR #1 and LCR #2 show LCR bands (~360 bp) amplified from the LCR product first synthesized in figure 25.



Discussion

The major results of this dissertation research fulfilled the specific aims of the project as defined in the introduction. These findings were as follows. First, we constructed NT-1 transgenic plant cell clones and showed that these cells could express full-length, histidine-tagged or the carboxy terminal portion of intimin_{O157} (Int₂₆₁). As a corollary, we demonstrated in a collaborative study with the Boyce Thompson Institute that plant-optimized Int₂₆₁ can also be produced in a whole plant model (*Arabidopsis thaliana*). Second, we found that mice fed plant cells that expressed full-length or Int₂₆₁ made intimin_{O157}-specific serum and fecal immune responses. Furthermore, we demonstrated that oral delivery of Int₂₆₁ in plant cells, as a boost for parenterally injected homologous antigen, enhanced the intimin_{O157}-specific immune response. Third, and perhaps most importantly, we discovered that this prime-boost strategy led to induction of a serum response that could inhibit EHEC O157:H7 adherence *in vitro* and that this immunization protocol also reduced the duration of colonization of mice with wild type EHEC O157:H7. Fourth, a Stx2 site-directed toxoid that we constructed could elicit Stx2 toxin neutralizing antibodies when injected i.p. into mice and that these mice could survive a likely fatal Stx2 toxin challenge.

I. Expression of intimin_{O157} or a portion thereof in plant cells and a whole plant model.

Numerous bacterial toxin vaccine antigens have been successfully expressed in

and delivered using transgenic plants, for example, enterotoxigenic *E. coli* heat labile toxin B subunit and *Vibrio cholerae* toxin B subunit (Haq *et al.*, 1995; Mason *et al.*, 1998; Tacket *et al.*, 1998; Lauterslager *et al.*, 2001; Arakawa *et al.*, 1997; Arakawa *et al.*, 1998). Surface-expressed proteins from viral pathogens, such as Hepatitis B and Norwalk virus, have also been effectively expressed in transgenic plant systems (Kong *et al.*, 2001; Mason *et al.*, 1992; Mason *et al.*, 1996; Richter *et al.*, 2000; Tacket *et al.*, 2000; Thanavala *et al.*, 1995). The expression of intimin_{O157} or Int₂₆₁ in a transgenic plant system is the first reported production of a bacterial surface protein as a transgenic protein in a genetically transformed plant cell and whole plant system.

Several obstacles had to be overcome to successfully express Int₂₆₁ in plant cells and plants. First, we had to optimize the gene for Int₂₆₁ for better expression in plant systems because plants favor specific codons for certain amino acids during protein translation that differ from those codons preferred by viral, bacterial, or mammalian systems. For example, Gram negative bacteria use the codon GCG 34.3% of the time to encode alanine whereas dicotyledonous plants (such as tobacco) use GCG only 6.6% of the time to encode the same amino acid and prefer GCU (44.6% usage) to code for alanine (Ausubel *et al.*, 1989). In addition, there are sequence motifs present in bacterial genes that when transcribed by plant systems can lead to RNA destabilization and gene splicing that can result in a reduction or abrogation of expression of the transformed gene. We found that the modified gene for Int₂₆₁ expressed with greater frequency (4 out of 5 clones expressed Int₂₆₁) than the genes for the non-optimized full length and his-tagged intimin_{O157} proteins (6 total out of ~100 clones expressed intimin_{O157}).

Another challenge faced during the course of this project was contamination of the NT-1 cell culture with mold, yeast, and/or bacteria. Untransformed and transgenic plant cell stocks and clones must be kept in continuous culture because the plant cells can not be frozen in glycerol stocks like bacterial cells. In addition, the NT-1 cells in broth were cultured for 7-10 days and NT-1 cells on agar plates were cultured for 21-30 days. These extended culture times put the NT-1 cell cultures at risk for contamination and can increase alterations in protein expression (such as reduction, loss, or modification of protein expression) as the culture ages. A product from Phytotechnology Laboratories Inc. (Shawnee Mission, KS), Plant Preventative Mixture (PPM), is a broad-spectrum anti-microbial that can be used in plant tissue culture to prevent contamination, or, when used in higher concentrations, can be used to decontaminate plant cell cultures. Unfortunately, use of this product with the intimin_{O157} and Int₂₆₁-expressing NT-1 cell clones, slowed plant cell growth and thus decreased overall production of intimin_{O157} and Int₂₆₁ in PPM-treated cultures.

In addition to expressing Int₂₆₁ in NT-1 plant cells in culture, in conjunction with The Boyce Thompson Institute for Plant Research in Ithaca, NY, we were able to successfully express Int₂₆₁ in a whole plant model, *Arabidopsis thaliana*. Three out of 6 *Arabidopsis* plants transformed with pNR49 (includes plant-specific signal peptide sequence) and 1 out of 4 plants transformed with pNR50 expressed Int₂₆₁. These results suggest that Int₂₆₁ can be expressed in a whole plant system. Whole plant systems tend to be more problematic expression systems due to increased complexity and the difficulty of transforming some whole plant species.

II. Immune response to Intimin_{O157} expressed in plant cells.

Many pathogens infect or invade via mucosal surfaces, so the capacity of plant-based vaccines to induce mucosal immunity is a great advantage. Plant cells act as a natural microencapsulation system to protect the vaccine antigens from being degraded in the upper digestive tract before they can reach the gut-associated lymphoid tissue (GALT). Recent studies suggest that plant-based oral vaccines can significantly boost mucosal immune responses primed by parenteral injection (Van der Heijden *et al.*, 1989; Lauterslager *et al.*, 2001). Parenteral priming of the immune system may allow the GALT to react successfully to the small amounts of antigen delivered during oral immunization and thus decrease the possibility of inducing oral immunotolerance to plant-based and other orally-delivered vaccine antigens. Our studies support these recent findings by demonstrating that parenteral priming of mice with intimin purified from transgenic plant cells can assist in the development of an intimin-specific fecal immune response when these mice are subsequently boosted with oral feeding of the same intimin-expressing transgenic plant material. Furthermore, in this study mice parenterally primed, then orally boosted, showed a statistically significant decrease in the duration of colonization with wild type EHEC O157:H7 upon challenge ($P < 0.002$; Log-rank test). Mice immunized entirely by oral feeding did exhibit a reduction in the duration of colonization versus unimmunized mice, though the reduction was not statistically significant. These results suggest that a combination of vaccination strategies with a vaccine antigen produced in and delivered by transgenic plants can function in inducing beneficial, specific immune responses. In addition, further testing is needed to determine

if higher antigen levels in the plant material or additional doses of plant material, when delivered orally, could elicit sufficient, specific immune responses that would result in a reduction in the duration of bacterial colonization without the need for a prime by parenteral injection.

This study also explored the use of cholera toxin (CT) as an oral adjuvant to enhance the systemic and mucosal immune responses of mice co-administered intimin_{O157}-expressing NT-1 cell material. CT is considered a potent mucosal adjuvant (reviewed in Freytag and Clements, 1999; Corthesy and Kraehenbuhl, 1999). In fact, CT successfully augmented serum immune responses to Hepatitis B surface antigen expressed in transgenic potato plants (Kong *et al.*, 2001). In addition, CT can facilitate B cell switching to an IgA isotype (Lycke and Strober, 1989) and can promote long-term immunological memory to co-administered antigens (Vajdy and Lycke, 1992). Although the mice given CT in this study did not exhibit any side effects of CT administration (loose stool or diarrhea), the enterotoxicity of CT limits its utility as an adjuvant for the induction of mucosal immunity. One way to eliminate the enterotoxic activity is to construct non-toxic derivatives of the molecule. However, the basis for the adjuvanticity of CT is in some dispute. Investigators have linked this activity with the ADP-ribosylating activity catalyzed by the CT-A subunit (Lycke *et al.*, 1992) that is responsible for the enterotoxicity of the molecule. By contrast, other investigators have demonstrated successful adjuvant activity upon the administration of CT-B subunit, either co-administered with or coupled to the antigen of choice (Isaka *et al.*, 1998; Czerkinsky *et al.*, 1989). Therefore, we remain hopeful that non-enterotoxic derivatives of CT or the closely related enterotoxigenic *E. coli* heat-labile toxin (LT) (Freytag and

Clements, 1999) can be used as mucosal adjuvants to enhance overall systemic and local immune responses to a variety of whole-cell killed bacteria or viruses or recombinant vaccine antigens such as transgenic plants.

III. Glycosylation of Int261 in plant cells when expressed with the addition of a plant-specific signal peptide.

Intimin_{O157} is required for EHEC O157:H7 to colonize neonatal calves and adult sheep and cattle (Dean-Nystrom *et al.*, 1998; Cornick *et al.*, 2002) and antibodies to intimin_{O157}, especially to the carboxy-terminal third of the molecule, can block bacterial adherence to HEp-2 cells and prevent infection of suckling piglets. These findings suggest that intimin_{O157} is an attractive candidate for an EHEC O157:H7 anti-colonization and anti-transmission vaccine for cattle, especially if the antigen was produced in and delivered by transgenic plants. Transgenic plant vaccine technology can offer several advantages for the production and delivery of vaccine antigens for humans and especially livestock. Transgenic plants offer the flexibility to function as low cost, efficient, and practical vaccine antigen oral delivery systems to stimulate mucosal immunity or to boost and shift initial immunity to a mucosal antibody response (Lauterslager *et al.*, 2001; Van der Heijden *et al.*, 1989). One of the challenges associated with transgenic plant vaccine technology can be relatively low antigen expression in plant tissues. In an effort to increase Int₂₆₁ expression in NT-1 cells, a plant-specific signal peptide was used. The signal peptide gene, from the soybean *vspA*, was cloned 5' to the start of the Int₂₆₁ gene. In theory, the addition of the signal peptide directs the translation of Int₂₆₁ into the plant

cell endoplasmic reticulum (ER) and thus removes the antigen from the presence of potentially damaging cytosolic proteases. The translation of Int₂₆₁ in the plant cell ER also makes the protein available to chaperones within the ER to assist in proper folding of the molecule. While the addition of the signal peptide increased Int₂₆₁ expression in NT-1 cells, the antigen appeared to be modified as visualized on Western blot. We demonstrated that this modification was due to glycosylation by chemically deglycosylating the plant expressed protein with TFMS.

Our discovery that non-glycosylated bacterial proteins can be glycosylated in transgenic plant systems highlights an issue not previously reported in other studies of vaccine antigen expression in transgenic plants. In fact, recently published studies found that the fusion of the same plant-specific signal peptide to the Hepatitis B surface antigen increases expression of the antigen and enhances the immunogenicity of the molecule (Sojikul *et al.*, 2003). We found that the addition of the signal peptide and the subsequent glycosylation of Int₂₆₁ expressed in NT-1 cells resulted in an aberrant immune response that was unable to block adherence of EHEC O157:H7. Although the addition of a plant-specific signal peptide increased the vaccine antigen expression levels in the plant cells, the signal peptide may have caused the protein to be glycosylated in the plant expression system by trafficking the newly expressed protein directly into the ER, where glycosylation occurs co-translationally. The removal of the plant-specific signal peptide from the Int₂₆₁ plant expression constructs resulted in decreased protein expression but appeared to produce an unglycosylated protein. Our experience emphasizes one of the problems involved in the successful production of bacterial vaccine antigens in transgenic plant systems.

IV. The mouse model of intimin_{O157}-dependent bacterial colonization and immune response to Int₂₆₁ expressed in plants blocks bacterial adherence.

A mouse model of intimin_{O157}-dependent colonization was developed to test the efficacy of the Int₂₆₁ NT-1 cell oral vaccine. In our study, we used the same method to inoculate mice that we reported in a ferret model of EHEC O157:H7 infection (Woods *et al.*, 2002). We showed in an experiment limited to 7 days that EHEC O157:H7 86-24 Str^R colonized untreated BALB/c mice with a mean colonization time of 6.4 days, whereas the intimin-negative mutant 86-24 Str^R *eae*Δ10 displayed a statistically significant reduction in the duration of colonization (mean, 3.2 days; $P < 0.005$; Log-rank test). Treatment of the mice with 5 g/L streptomycin in their drinking water raised the overall bacterial colonization level so high as to obscure any evidence of an intimin_{O157}-dependence of the colonization. With this untreated mouse model, we showed that mice immunized with an i.p. injection of Int₂₆₁ from NT-1 cells, then boosted by feeding the same plant material made an Int₂₆₁-specific immune response and demonstrated significantly lower levels of bacterial colonization upon challenge with EHEC O157:H7. These results suggest that intimin_{O157} is an important bacterial colonization factor in the mouse model and that this model can serve as a tool to ascertain the effectiveness of an intimin_{O157}-based vaccine.

V. **Stx2 toxoid can elicit a Stx2 toxin neutralizing immune response in mice.**

Epidemiological data suggest that Stx2 may play a more critical role in the development and severity of HUS than Stx1, although Stx1-only producing strains have also been associated with cases of HUS (Scotland *et al.*, 1987; Ostroff *et al.*, 1989). Because of these findings, we chose to focus initially on the production of a plant-based vaccine using a recombinant Stx2 B subunit antigen or a Stx2 holotoxoid to be delivered orally and that would provide protection from Stx2-mediated disease.

We found that a recombinant Stx2 B subunit antigen expressed without the Stx2 A subunit did not elicit Stx2 toxin neutralizing antibodies. This result supports the observation of Acheson *et al.* that Stx2 B subunits must pentamerize to elicit Stx2 toxin-neutralizing antibodies (Acheson *et al.*, 1995). Expression of the Stx2 B subunits out of context of the complete Stx2 A subunit may destabilize the pentamers and cause them to form Stx2 B monomers. By contrast, an Stx2 holotoxoid molecule that we created by site-directed mutagenesis appeared similar to the wild-type Stx2 toxin when visualized by Western blot analysis, but did not evoke a cytotoxic response when tested on Vero cells. When this material was injected into mice, the material was not toxic to the mice, and the mice made Stx2 toxin-neutralizing antibodies. The Stx2 toxin-neutralizing antibody response was sufficiently robust to protect the mice from a subsequent toxin challenge of up to 1 μg purified Stx2 toxin. The lethal dose of purified Stx2 toxin for mice is approximately 1 ng (Tesh *et al.*, 1993; Lindgren *et al.*, 1994). These results suggest that the Stx2 toxoid was indeed structurally similar to the Stx2 toxin and most likely was

comprised of stable Stx2 B multimers and/or pentamers capable of eliciting Stx2 toxin-neutralizing antibodies.

To facilitate the optimal expression of the Stx2 toxoid molecule in plants, we speculated that several changes to the nucleotide sequence of the Stx2 A and B subunits would be needed. Indeed, the changes to the Stx2 B subunit were extensive and several methods were tried to resynthesize the Stx2 B subunit gene. The first approach employed a variation of a gene assembly protocol originally described by Stemmer *et al.* (Stemmer *et al.*, 1995; Mason *et al.*, 1998). After several months of limited success with this method, this approach was abandoned. However, we were successful in synthesizing a plant-optimized Stx2 B subunit gene when we used the ligase chain reaction (LCR) (Chalmers and Curnow, 2001). LCR uses ligase to assemble the oligonucleotides that span the synthetic gene, rather than using the oligonucleotides as overlapping primers in a complicated PCR procedure (Chalmers and Curnow, 2001; Stemmer *et al.*, 1995).

VII. Future Directions

The ultimate goal of the intimin_{O157} portion of this project was to create a transgenic plant that would function as an anti-transmission vaccine against EHEC O157:H7 for cattle. The antigen used in this vaccine is specific for EHEC O157:H7. We believe that this vaccine could also protect against colonization with other strains expressing gamma-type intimin, such as EHEC O55:H7 (Fig. 1; Table 1, p. 15-16) (Gansheroff *et al.*, 1999). However an intimin_{O157}-specific vaccine may have limited utility against other EHEC strains, such as O26:H11 (beta-type intimin), because

adherence of these organisms to HEp-2 cells are not blocked by intimin_{O157} antibodies (Gansheroff *et al.*, 1999). Our finding that these transgenic cells synthesize the carboxy terminal portion of EHEC intimin_{O157} (Int₂₆₁) in a conformation immunologically equivalent to the native protein underscores the feasibility of transgenic plant-based systems for expression and delivery of oral vaccines. Plant expression systems are flexible and have the potential to express and deliver numerous different vaccine antigens, such as many different intimin types, within the same vaccine dose. Ongoing research in the lab is investigating EPEC alpha-type intimin as a potential plant-based vaccine candidate. For further intimin_{O157} vaccine development, we plan to express a signal sequence-free Int₂₆₁ construct in a whole plant amenable to large-scale production, perhaps by recently developed models of chloroplast transformation and expression (Heifetz and Tuttle, 2001) that maximize protein expression and minimize protein modification (such as glycosylation). The selected plant system will likely be alfalfa because this plant is compatible with oral feeding to cattle and is amenable to both nuclear and chloroplast transformation methods. In conjunction with Dr. Wayne Curtis of Penn State University (State College, PA) and Dr. Evelyn Dean-Nystrom of the USDA (Ames, Iowa), we scaled-up production of the NT-1 cell clone C34. Dr. Dean-Nystrom is feeding this Int₂₆₁-expressing plant material to calves and testing the cattle for intimin_{O157}-specific immune responses. Debate still exists as to whether feedlot food type, holding pen cleanliness, or water quality management would offer the benefit of reducing EHEC O157:H7 colonization levels in cattle (Diez-Gonzalez *et al.*, 1998; LeJeune *et al.*, 2001; Smith *et al.*, 2001). One might hypothesize that removing or reducing environmental sources of EHEC O157:H7 infection, such as soiled bedding or

contaminated water sources, would reduce the prevalence of EHEC O157:H7 in cattle. Unfortunately, these hypotheses have not been adequately tested. However, the notion that reduction of sources of EHEC O157:H7 infection and contamination has strong intuitive appeal, that these measures would reduce not only prevalence of EHEC O157:H7 in cattle, but also reduce the risk of human infection through other environmental sources such as drinking or recreational water and fruits and vegetables. We believe the use of transgenic plants for the production and delivery of a EHEC O157:H7 vaccine for cattle, alone or in conjunction with other potential control methods (Brashears *et al.*, 2003), could lead to a significant decrease in the level of colonization or percent of cattle infected with pathogenic *E. coli* O157:H7. Such a reduction will likely translate into a decline in beef carcass and environmental contamination by EHEC O157:H7 and a decrease in transmission of the bacterium to humans.

Our laboratory is currently working on the assembly of a plant expression vector that will produce plant-optimized Stx2 B subunit and non-catalytically active A subunit (contains the Y77S and Q167E toxoid changes). The ultimate goal of this research will be to create a transgenic plant-based oral vaccine for humans comprised of Int₂₆₁ and Stx2 toxoid. We propose that such a vaccine would reduce or eliminate EHEC O157:H7 infection in humans and concomitantly minimize the effects of Stx2-related pathology.

Reference List

Abdul-Raouf, U. M., Beuchat, L. R., and Ammar, M. S. (1993a). Survival and growth of *Escherichia coli* O157:H7 in ground, roasted beef as affected by pH, acidulants, and temperature. *Appl.Environ.Microbiol.* *59*, 2364-2368.

Abdul-Raouf, U. M., Beuchat, L. R., and Ammar, M. S. (1993b). Survival and growth of *Escherichia coli* O157:H7 on salad vegetables. *Appl.Environ.Microbiol.* *59*, 1999-2006.

Acheson, D. W., Calderwood, S. B., Boyko, S. A., Lincicome, L. L., Kane, A. V., Donohue-Rolfe, A., and Keusch, G. T. (1993). Comparison of Shiga-like toxin I B-subunit expression and localization in *Escherichia coli* and *Vibrio cholerae* by using *trc* or iron-regulated promoter systems. *Infect.Immun.* *61*, 1098-1104.

Acheson, D. W., De Breucker, S. A., Jacewicz, M., Lincicome, L. L., Donohue-Rolfe, A., Kane, A. V., and Keusch, G. T. (1995). Expression and purification of Shiga-like toxin II B subunits. *Infect.Immun.* *63*, 301-308.

Adu-Bobie, J., Frankel, G., Bain, C., Goncalves, A. G., Trabulsi, L. R., Douce, G., Knutton, S., and Dougan, G. (1998). Detection of intimins α , β , γ , and δ , four intimin derivatives expressed by attaching and effacing microbial pathogens. *J Clin.Microbiol.* *36*, 662-668.

An, G. (1985). High-efficiency transformation of cultured tobacco cells. *Plant Physiol* 79, 568-570.

Arakawa, T., Chong, D. K., and Langridge, W. H. (1998). Efficacy of a food plant-based oral cholera toxin B subunit vaccine. *Nat.Biotechnol.* 16, 292-297.

Arakawa, T., Chong, D. K., Merritt, J. L., and Langridge, W. H. (1997). Expression of cholera toxin B subunit oligomers in transgenic potato plants. *Transgenic Res.* 6, 403-413.

Armstrong, G. L., Hollingsworth, J., and Morris, J. G., Jr. (1996). Emerging foodborne pathogens: *Escherichia coli* O157:H7 as a model of entry of a new pathogen into the food supply of the developed world. *Epidemiol.Rev.* 18, 29-51.

Austin, P. R., Jablonski, P. E., Bohach, G. A., Dunker, A. K., and Hovde, C. J. (1994). Evidence that the A2 fragment of Shiga-like toxin type I is required for holotoxin integrity. *Infect.Immun.* 62, 1768-1775.

Ausubel, F. M., Brent, R., Kingston, R. E., Moore, D. D., Seidman, J. G., Smith, J. A., and Struhl, K. (1989). "Current protocols in molecular biology." Greene Publishing Associates and Wiley Interscience, New York.

Becker, D., Kemper, E., Schell, J., and Masterson, R. (1992). New plant binary vectors with selectable markers located proximal to the left T-DNA border. *Plant Mol.Biol.* 20, 1195-1197.

Beebakhee, G., Louie, M., De Azavedo, J., and Brunton, J. (1992). Cloning and nucleotide sequence of the *eae* gene homologue from enterohemorrhagic *Escherichia coli* serotype O157:H7. *FEMS Microbiol.Lett.* 70, 63-68.

Belongia, E. A., Osterholm, M. T., Soler, J. T., Ammend, D. A., Braun, J. E., and MacDonald, K. L. (1993). Transmission of *Escherichia coli* O157:H7 infection in Minnesota child day-care facilities. *JAMA* 269, 883-888.

Brashears, M. M., Galyean, M. L., Loneragan, G. H., Mann, J. E., and Killinger-Mann, K. (2003). Prevalence of *Escherichia coli* O157:H7 and performance by beef feedlot cattle given *Lactobacillus* direct-fed microbials. *J.Food Prot.* 66, 748-754.

Bray, J. (1945). Isolation of antigenically homogenous strains of *Bact. coli neapolitanum* from summer diarrhoea of infants. *J.Pathol.Bacteriol.* 57, 239-247.

Bray, J. and Beavan, T. E. D. (1948). Slide agglutination of *Bacterium coli* var. *neapolitanum* in summer diarrhoea. *Journal of Pathology and Bacteriology* 60, 395-401.

Breuer, T., Benkel, D. H., Shapiro, R. L., Hall, W. N., Winnett, M. M., Linn, M. J., Neimann, J., Barrett, T. J., Dietrich, S., Downes, F. P., Toney, D. M., Pearson, J. L., Rolka, H., Slutsker, L., and Griffin, P. M. (2001). A multistate outbreak of *Escherichia coli* O157:H7 infections linked to alfalfa sprouts grown from contaminated seeds. *Emerg.Infect.Dis.* 7, 977-982.

Brunder, W., Schmidt, H., and Karch, H. (1996). KatP, a novel catalase-peroxidase encoded by the large plasmid of enterohaemorrhagic *Escherichia coli* O157:H7. *Microbiology* 142 (Pt 11), 3305-3315.

Brunder, W., Schmidt, H., and Karch, H. (1997). EspP, a novel extracellular serine protease of enterohaemorrhagic *Escherichia coli* O157:H7 cleaves human coagulation factor V. *Mol.Microbiol.* 24, 767-778.

Bullock, W. O., Fernandez, J. M., and Short, J. M. (1987). XL1-Blue: a high efficiency plasmid transforming recA *Escherichia coli* strain with beta-galactosidase selection. *BioTechniques* 5, 376-378.

Calderwood, S. B., Acheson, D. W. K., Keusch, G. T., Barrett, T. J., Griffin, P. M., Strockbine, N. A., Swaminathan, B., Kaper, J. B., Levine, M. M., Kaplan, B. S., Karch, H., O'Brien, A. D., Obrig, T. G., Takeda, Y., Tarr, P. I., and Wachsmuth, I. K. (1996). Proposed new nomenclature for SLT (VT) family. Letter. *Amer.Soc.for.Microbiol.NEWS* 62, 118-119.

Centers for Disease Control (1996a). Lake-associated outbreak of *Escherichia coli* O157:H7--Illinois, 1995. MMWR Morb.Mortal.Wkly.Rep. 45, 437-439.

Centers for Disease Control (1996b). Outbreak of *Escherichia coli* O157:H7 infections associated with drinking unpasteurized commercial apple juice--British Columbia, California, Colorado, and Washington, October 1996. MMWR Morb.Mortal.Wkly.Rep. 45, 975.

Centers for Disease Control (1997). Outbreaks of *Escherichia coli* O157:H7 infection and cryptosporidiosis associated with drinking unpasteurized apple cider--Connecticut and New York, October 1996. MMWR Morb.Mortal.Wkly.Rep. 46, 4-8.

Centers for Disease Control (1999). Public health dispatch: Outbreak of *Escherichia coli* O157:H7 and *Campylobacter* among attendees of the Washington County Fair -- New York, 1999. MMWR 48, 803.

Centers for Disease Control (2001). Outbreaks of *Escherichia coli* O157:H7 infections among children associated with farm visits--Pennsylvania and Washington, 2000. MMWR Morb.Mortal.Wkly.Rep. 50, 293-297.

Centers for Disease Control and Prevention (1994). Addressing emerging infectious disease threats: a prevention strategy for the United States (Executive summary). MMWR 43 (No.RR-5), 1-18.

Chalmers, F. M. and Curnow, K. M. (2001). Scaling up the ligase chain reaction-based approach to gene synthesis. *BioTechniques* 30, 249-252.

Clough, S. J. and Bent, A. F. (1998). Floral dip: a simplified method for *Agrobacterium*-mediated transformation of *Arabidopsis thaliana*. *Plant J.* 16, 735-743.

Conlan, J. W. and Perry, M. B. (1998). Susceptibility of three strains of conventional adult mice to intestinal colonization by an isolate of *Escherichia coli* O157:H7. *Can.J.Microbiol.* 44, 800-805.

Conradi, H. (1903). Über Iosliche, durch asptische Autolyse erhaltene Giftstoffe von Ruhr- und Typhus-Bazillen. *Dtsch Med Wochenschr* 29, 26-28.

Cornick, N. A., Booher, S. L., and Moon, H. W. (2002). Intimin facilitates colonization by *Escherichia coli* O157:H7 in adult ruminants. *Infect.Immun.* 70, 2704-2707.

Corthesy, B. and Kraehenbuhl, J. P. (1999). Antibody-mediated protection of mucosal surfaces. *Curr.Top.Microbiol.Immunol.* 236, 93-111.

Cray, W. C., Jr. and Moon, H. W. (1995). Experimental infection of calves and adult cattle with *Escherichia coli* O157:H7. *Appl.Environ.Microbiol.* 61, 1586-1590.

Czerkinsky, C., Russell, M. W., Lycke, N., Lindblad, M., and Holmgren, J. (1989).

Oral administration of a streptococcal antigen coupled to cholera toxin B subunit evokes strong antibody responses in salivary glands and extramucosal tissues. *Infect.Immun.* 57, 1072-1077.

De Grandis, S., Law, H., Brunton, J., Gyles, C., and Lingwood, C. A. (1989).

Globotetraosylceramide is recognized by the pig edema disease toxin. *J Biol.Chem.* 264, 12520-12525.

Dean-Nystrom, E. A., Bosworth, B. T., Cray, W. C., Jr., and Moon, H. W. (1997).

Pathogenicity of *Escherichia coli* O157:H7 in the intestines of neonatal calves. *Infect.Immun.* 65, 1842-1848.

Dean-Nystrom, E. A., Bosworth, B. T., Moon, H. W., and O'Brien, A. D. (1998).

Escherichia coli O157:H7 requires intimin for enteropathogenicity in calves. *Infect.Immun.* 66, 4560-4563.

Dean-Nystrom, E. A., Gansheroff, L. J., Mills, M., Moon, H. W., and O'Brien, A. D.

(2002). Vaccination of pregnant dams with intimin(O157) protects suckling piglets from *Escherichia coli* O157:H7 infection. *Infect.Immun.* 70, 2414-2418.

Deresiewicz, R. L., Calderwood, S. B., Robertus, J. D., and Collier, R. J. (1992).

Mutations affecting the activity of the Shiga-like toxin I A-chain. *Biochemistry* 31, 3272-3280.

DeVinney, R., Puente, J. L., Gauthier, A., Goosney, D., and Finlay, B. B. (2001).

Enterohaemorrhagic and enteropathogenic *Escherichia coli* use a different Tir-based mechanism for pedestal formation. *Mol.Microbiol.* 41, 1445-1458.

DeVinney, R., Stein, M., Reinscheid, D., Abe, A., Ruschkowski, S., and Finlay, B. B.

(1999). Enterohemorrhagic *Escherichia coli* O157:H7 produces Tir, which is translocated to the host cell membrane but is not tyrosine phosphorylated. *Infect.Immun.* 67, 2389-2398.

Diez-Gonzalez, F., Callaway, T. R., Kizoulis, M. G., and Russell, J. B. (1998). Grain

feeding and the dissemination of acid-resistant *Escherichia coli* from cattle. *Science* 281, 1666-1668.

Donnenberg, M. S., Tzipori, S., McKee, M. L., O'Brien, A. D., Alroy, J., and Kaper,

J. B. (1993). The role of the *eae* gene of enterohemorrhagic *Escherichia coli* in intimate attachment in vitro and in a porcine model. *J Clin.Invest* 92, 1418-1424.

Donohue-Rolfe, A., Acheson, D. W., Kane, A. V., and Keusch, G. T. (1989).

Purification of Shiga toxin and Shiga-like toxins I and II by receptor analog affinity chromatography with immobilized P1 glycoprotein and production of cross-reactive monoclonal antibodies. *Infect.Immun.* 57, 3888-3893.

Douglas, R. G., Jr. (1993). The Children's Vaccine Initiative--will it work? *J.Infect.Dis.*

168, 269-274.

Downes, F. P., Barrett, T. J., Green, J. H., Aloisio, C. H., Spika, J. S., Strockbine, N. A., and Wachsmuth, I. K. (1988). Affinity purification and characterization of Shiga-like toxin II and production of toxin-specific monoclonal antibodies. *Infect.Immun.* *56*, 1926-1933.

Elder, R. O., Keen, J. E., Siragusa, G. R., Barkocy-Gallagher, G. A., Koohmaraie, M., and Laegreid, W. W. (2000). Correlation of enterohemorrhagic *Escherichia coli* O157 prevalence in feces, hides, and carcasses of beef cattle during processing. *Proc.Natl.Acad.Sci.U.S.A* *97*, 2999-3003.

Endo, Y., Tsurugi, K., Yutsudo, T., Takeda, Y., Ogasawara, T., and Igarashi, K. (1988). Site of action of a Vero toxin (VT2) from *Escherichia coli* O157:H7 and of Shiga toxin on eukaryotic ribosomes. RNA N-glycosidase activity of the toxins. *Eur.J Biochem.* *171*, 45-50.

Frankel, G., Candy, D. C., Everest, P., and Dougan, G. (1994). Characterization of the C-terminal domains of intimin-like proteins of enteropathogenic and enterohemorrhagic *Escherichia coli*, *Citrobacter freundii*, and *Hafnia alvei*. *Infect.Immun.* *62*, 1835-1842.

Frankel, G., Candy, D. C., Fabiani, E., Adu-Bobie, J., Gil, S., Novakova, M., Phillips, A. D., and Dougan, G. (1995). Molecular characterization of a carboxy-terminal eukaryotic-cell- binding domain of intimin from enteropathogenic *Escherichia coli*. *Infect.Immun.* *63*, 4323-4328.

Frankel, G., Phillips, A. D., Rosenshine, I., Dougan, G., Kaper, J. B., and Knutton, S. (1998). Enteropathogenic and enterohaemorrhagic *Escherichia coli*: more subversive elements. *Mol.Microbiol.* 30, 911-921.

Fraser, M. E., Chernaia, M. M., Kozlov, Y. V., and James, M. N. (1994). Crystal structure of the holotoxin from *Shigella dysenteriae* at 2.5 Å resolution. *Nat.Struct.Biol.* 1, 59-64.

Freytag, L. C. and Clements, J. D. (1999). Bacterial toxins as mucosal adjuvants. *Curr.Top.Microbiol.Immunol.* 236, 215-236.

Gansheroff, L. J., Wachtel, M. R., and O'Brien, A. D. (1999). Decreased adherence of enterohemorrhagic *Escherichia coli* to HEp-2 cells in the presence of antibodies that recognize the C-terminal region of intimin. *Infect.Immun.* 67, 6409-6417.

Ganz, P. R., Dudani, A. K, Tackaberry, E. S., Sardana, R., Sauder, C., Cheng, X., and Altosaar, I. Expression of human blood proteins in transgenic plants: the cytokine GM-CSF as a model protein. Owen, M. R. L. and Pen, J. 281-297. 1996. Wiley.
Transgenic plants: a production system for industrial and pharmaceutical proteins.

Gentry, M. K. and Dalrymple, J. M. (1980). Quantitative microtiter cytotoxicity assay for *Shigella* toxin. *J Clin.Microbiol.* 12, 361-366.

Gomez-Duarte, O. G. and Kaper, J. B. (1995). A plasmid-encoded regulatory region activates chromosomal *eaeA* expression in enteropathogenic *Escherichia coli*.

Infect.Immun. 63, 1767-1776.

Griffin, P. M. (1995). *Escherichia coli* O157:H7 and other enterohemorrhagic *Escherichia coli*. In Infections of the gastrointestinal tract. M. J. Blaser, P. D. Smith, J. I. Ravdin, H. B. Greenberg, and R. L. Guerrant, Eds. (New York:Raven Press, Ltd.). pp. 739-761.

Griffin, P. M. (1998). Epidemiology of Shiga toxin-producing *Escherichia coli* infections in humans in the United States. In *Escherichia coli* O157:H7 and other Shiga toxin-producing *E. coli* strains. J. B. Kaper and A. D. O'Brien, Eds. (Washington, D.C.:ASM Press). pp. 15-22.

Griffin, P. M., Ostroff, S. M., Tauxe, R. V., Greene, K. D., Wells, J. G., Lewis, J. H., and Blake, P. A. (1988). Illnesses associated with *Escherichia coli* O157:H7 infections. A broad clinical spectrum. *Annals of Internal Medicine* 109, 705-712.

Griffin, P. M. and Tauxe, R. V. (1991). The epidemiology of infections caused by *Escherichia coli* O157:H7, other enterohemorrhagic *E. coli*, and the associated hemolytic uremic syndrome. *Epidemiol.Rev.* 13, 60-98.

Hanahan, D. (1983). Studies on transformation of *Escherichia coli* with plasmids. *J Mol.Biol.* 166, 557-580.

Hancock, D. D., Besser, T. E., Rice, D. H., and Tarr, P. I. (1998). Ecology of *Escherichia coli* O157:H7 in cattle and impact of management practices. In *Escherichia coli* O157:H7 and other Shiga toxin-producing *E. coli* strains. J. B. Kaper and A. D. O'Brien, Eds. (Washington, D.C.:American Society for Microbiology). pp. 85-91.

Haq, T. A., Mason, H. S., Clements, J. D., and Arntzen, C. J. (1995). Oral immunization with a recombinant bacterial antigen produced in transgenic plants. *Science* 268, 714-716.

Heifetz, P. B. and Tuttle, A. M. (2001). Protein expression in plastids. *Curr.Opin.Plant Biol.* 4, 157-161.

Hilborn, E. D., Mermin, J. H., Mshar, P. A., Hadler, J. L., Voetsch, A., Wojtkunski, C., Swartz, M., Mshar, R., Lambert-Fair, M. A., Farrar, J. A., Glynn, M. K., and Slutsker, L. (1999). A multistate outbreak of *Escherichia coli* O157:H7 infections associated with consumption of mesclun lettuce. *Arch.Intern.Med.* 159, 1758-1764.

Hood, E. E., Gelvin, S. B., Melchers, L. S., and Hoekma, A. (1993). New *Agrobacterium* helper plasmids for gene transfer to plants. *Transgenic Res* 2, 208-218.

Hovde, C. J., Calderwood, S. B., Mekalanos, J. J., and Collier, R. J. (1988). Evidence that glutamic acid 167 is an active-site residue of Shiga-like toxin I. *Proc.Natl.Acad.Sci.U.S.A* 85, 2568-2572.

Isaka, M., Yasuda, Y., Kozuka, S., Miura, Y., Taniguchi, T., Matano, K., Goto, N., and Tochikubo, K. (1998). Systemic and mucosal immune responses of mice to aluminium-adsorbed or aluminium-non-adsorbed tetanus toxoid administered intranasally with recombinant cholera toxin B subunit. *Vaccine* 16, 1620-1626.

Ito, H., Terai, A., Kurazono, H., Takeda, Y., and Nishibuchi, M. (1990). Cloning and nucleotide sequencing of Vero toxin 2 variant genes from *Escherichia coli* O91:H21 isolated from a patient with the hemolytic uremic syndrome. *Microb.Pathog.* 8, 47-60.

Jacewicz, M., Clausen, H., Nudelman, E., Donohue-Rolfe, A., and Keusch, G. T. (1986). Pathogenesis of *Shigella* diarrhea. XI. Isolation of a *Shigella* toxin-binding glycolipid from rabbit jejunum and HeLa cells and its identification as globotriaosylceramide. *J Exp.Med.* 163, 1391-1404.

Jerse, A. E. and Kaper, J. B. (1991). The *eae* gene of enteropathogenic *Escherichia coli* encodes a 94- kilodalton membrane protein, the expression of which is influenced by the EAF plasmid. *Infect.Immun.* 59, 4302-4309.

Jerse, A. E., Yu, J., Tall, B. D., and Kaper, J. B. (1990). A genetic locus of enteropathogenic *Escherichia coli* necessary for the production of attaching and effacing lesions on tissue culture cells. *Proc.Natl.Acad.Sci.U.S.A* 87, 7839-7843.

Jordan, D., McEwen, S. A., Lammerding, A. M., McNab, W. B., and Wilson, J. B. (1999). Pre-slaughter control of *Escherichia coli* O157 in beef cattle: a simulation study. *Prev.Vet.Med.* 41, 55-74.

Karch, H., Heesemann, J., Laufs, R., O'Brien, A. D., Tacket, C. O., and Levine, M. M. (1987). A plasmid of enterohemorrhagic *Escherichia coli* O157:H7 is required for expression of a new fimbrial antigen and for adhesion to epithelial cells. *Infect.Immun.* 55, 455-461.

Karmali, M., Lingwood, C. A., Petric, M., Brunton, J., and Gyles, C. (1996). Maintaining the existing phenotype nomenclatures for *E. coli* cytotoxins. *Amer.Soc.for.Microbiol.NEWS* 62, 167-169.

Karmali, M. A., Petric, M., Lim, C., Fleming, P. C., Arbus, G. S., and Lior, H. (1985). The association between idiopathic hemolytic uremic syndrome and infection by verotoxin-producing *Escherichia coli*. *J Infect.Dis.* 151, 775-782.

Karmali, M. A., Steele, B. T., Petric, M., and Lim, C. (1983). Sporadic cases of haemolytic-uraemic syndrome associated with faecal cytotoxin and cytotoxin-producing *Escherichia coli* in stools. *Lancet* 1, 619-620.

Karpman, D., Bekassy, Z. D., Sjogren, A. C., Dubois, M. S., Karmali, M. A., Mascarenhas, M., Jarvis, K. G., Gansheroff, L. J., O'Brien, A. D., Arbus, G. S., and Kaper, J. B. (2002). Antibodies to intimin and *Escherichia coli* secreted proteins A and B in patients with enterohemorrhagic *Escherichia coli* infections. *Pediatr.Nephrol.* *17*, 201-211.

Keen, J. E. and Elder, R. O. (2002). Isolation of shiga-toxigenic *Escherichia coli* O157 from hide surfaces and the oral cavity of finished beef feedlot cattle. *J.Am.Vet.Med.Assoc.* *220*, 756-763.

Keene, W. E., Hedberg, K., Herriott, D. E., Hancock, D. D., McKay, R. W., Barrett, T. J., and Fleming, D. W. (1997a). A prolonged outbreak of *Escherichia coli* O157:H7 infections caused by commercially distributed raw milk. *J Infect.Dis.* *176*, 815-818.

Keene, W. E., McAnulty, J. M., Hoesly, F. C., Williams, L. P., Jr., Hedberg, K., Oxman, G. L., Barrett, T. J., Pfaller, M. A., and Fleming, D. W. (1994). A swimming-associated outbreak of hemorrhagic colitis caused by *Escherichia coli* O157:H7 and *Shigella sonnei*. *N.Engl.J.Med.* *331*, 579-584.

Keene, W. E., Sazie, E., Kok, J., Rice, D. H., Hancock, D. D., Balan, V. K., Zhao, T., and Doyle, M. P. (1997b). An outbreak of *Escherichia coli* O157:H7 infections traced to jerky made from deer meat. *JAMA* *277*, 1229-1231.

Kenny, B. (2001). The enterohaemorrhagic *Escherichia coli* (serotype O157:H7) Tir molecule is not functionally interchangeable for its enteropathogenic *E. coli* (serotype O127:H6) homologue. *Cell Microbiol.* 3, 499-510.

Kenny, B., DeVinney, R., Stein, M., Reinscheid, D. J., Frey, E. A., and Finlay, B. B. (1997). Enteropathogenic *E. coli* (EPEC) transfers its receptor for intimate adherence into mammalian cells. *Cell* 91, 511-520.

Knutton, S., Baldwin, T., Williams, P. H., and McNeish, A. S. (1989). Actin accumulation at sites of bacterial adhesion to tissue culture cells: basis of a new diagnostic test for enteropathogenic and enterohemorrhagic *Escherichia coli*. *Infect.Immun.* 57, 1290-1298.

Kong, Q., Richter, L., Yang, Y. F., Arntzen, C. J., Mason, H. S., and Thanavala, Y. (2001). Oral immunization with hepatitis B surface antigen expressed in transgenic plants. *Proc.Natl.Acad.Sci.U.S.A* 98, 11539-11544.

Kudva, I. T., Hatfield, P. G., and Hovde, C. J. (1996). *Escherichia coli* O157:H7 in microbial flora of sheep. *J Clin.Microbiol.* 34, 431-433.

Laegreid, W. W., Elder, R. O., and Keen, J. E. (1999). Prevalence of *Escherichia coli* O157:H7 in range beef calves at weaning. *Epidemiol.Infect.* 123, 291-298.

Lauterslager, T. G., Florack, D. E., van der Wal, T. J., Molthoff, J. W., Langeveld, J. P., Bosch, D., Boersma, W. J., and Hilgers, L. A. (2001). Oral immunisation of naive and primed animals with transgenic potato tubers expressing LT-B. *Vaccine* 19, 2749-2755.

LeJeune, J. T., Besser, T. E., and Hancock, D. D. (2001). Cattle water troughs as reservoirs of *Escherichia coli* O157. *Appl. Environ. Microbiol.* 67, 3053-3057.

Lekowska-Kochaniak, A., Czajkowska, D., and Popowski, J. (2002). Detection of *Escherichia coli* O157:H7 in raw meat by immunomagnetic separation and multiplex PCR. *Acta Microbiol. Pol.* 51, 327-337.

Levine, M. M. (1987). *Escherichia coli* that cause diarrhea: enterotoxigenic, enteropathogenic, enteroinvasive, enterohemorrhagic, and enteroadherent. *J Infect. Dis.* 155, 377-389.

Levine, M. M., Nataro, J. P., Karch, H., Baldini, M. M., Kaper, J. B., Black, R. E., Clements, M. L., and O'Brien, A. D. (1985). The diarrheal response of humans to some classic serotypes of enteropathogenic *Escherichia coli* is dependent on a plasmid encoding an enteroadhesiveness factor. *J Infect. Dis.* 152, 550-559.

Li, Y., Frey, E., Mackenzie, A. M., and Finlay, B. B. (2000). Human response to *Escherichia coli* O157:H7 infection: antibodies to secreted virulence factors. *Infect. Immun.* 68, 5090-5095.

Lindberg, A. A., Brown, J. E., Stromberg, N., Westling-Ryd, M., Schultz, J. E., and Karlsson, K. A. (1987). Identification of the carbohydrate receptor for Shiga toxin produced by *Shigella dysenteriae* type 1. *J Biol.Chem.* 262, 1779-1785.

Lindgren, S. W., Samuel, J. E., Schmitt, C. K., and O'Brien, A. D. (1994). The specific activities of Shiga-like toxin type II (SLT-II) and SLT-II- related toxins of enterohemorrhagic *Escherichia coli* differ when measured by Vero cell cytotoxicity but not by mouse lethality. *Infect.Immun.* 62, 623-631.

Liu, H., Magoun, L., Luperchio, S., Schauer, D. B., and Leong, J. M. (1999). The Tir-binding region of enterohaemorrhagic *Escherichia coli* intimin is sufficient to trigger actin condensation after bacterial-induced host cell signalling. *Mol.Microbiol.* 34, 67-81.

Louise, C. B. and Obrig, T. G. (1995). Specific interaction of *Escherichia coli* O157:H7-derived Shiga-like toxin II with human renal endothelial cells. *J Infect.Dis.* 172, 1397-1401.

Luo, Y., Frey, E. A., Pfuetzner, R. A., Creagh, A. L., Knoechel, D. G., Haynes, C. A., Finlay, B. B., and Strynadka, N. C. (2000). Crystal structure of enteropathogenic *Escherichia coli* intimin-receptor complex. *Nature* 405, 1073-1077.

Lycke, N. and Strober, W. (1989). Cholera toxin promotes B cell isotype differentiation. *J.Immunol.* 142, 3781-3787.

Lycke, N., Tsuji, T., and Holmgren, J. (1992). The adjuvant effect of *Vibrio cholerae* and *Escherichia coli* heat-labile enterotoxins is linked to their ADP-ribosyltransferase activity. *Eur.J.Immunol.* 22, 2277-2281.

Ma, J. K., Hiatt, A., Hein, M., Vine, N. D., Wang, F., Stabila, P., van Dolleweerd, C., Mostov, K., and Lehner, T. (1995). Generation and assembly of secretory antibodies in plants. *Science* 268, 716-719.

Ma, J. K., Hikmat, B. Y., Wycoff, K., Vine, N. D., Chargelegue, D., Yu, L., Hein, M. B., and Lehner, T. (1998). Characterization of a recombinant plant monoclonal secretory antibody and preventive immunotherapy in humans. *Nat.Med.* 4, 601-606.

Marcato, P., Mulvey, G., Read, R. J., Vander, H. K., Nation, P. N., and Armstrong, G. D. (2001). Immunoprophylactic potential of cloned Shiga toxin 2 B subunit. *J Infect.Dis.* 183, 435-443.

Marques, L. R. M., Peiris, J. S. M., Cryz, S. J., and O'Brien, A. D. (1987). *Escherichia coli* strains isolated from pigs with edema disease produce a variant of Shiga-like toxin II. *FEMS Microbiol.Lett.* 44, 33-38.

Martinez, M. B., Taddei, C. R., Ruiz-Tagle, A., Trabulsi, L. R., and Giron, J. A. (1999). Antibody response of children with enteropathogenic *Escherichia coli* infection to the bundle-forming pilus and locus of enterocyte effacement-encoded virulence determinants. *J Infect.Dis.* 179, 269-274.

Mason, H. S., Ball, J. M., Shi, J. J., Jiang, X., Estes, M. K., and Arntzen, C. J.

(1996). Expression of Norwalk virus capsid protein in transgenic tobacco and potato and its oral immunogenicity in mice. *Proc.Natl.Acad.Sci.U.S.A* 93, 5335-5340.

Mason, H. S., Haq, T. A., Clements, J. D., and Arntzen, C. J. (1998). Edible vaccine protects mice against *Escherichia coli* heat-labile enterotoxin (LT): potatoes expressing a synthetic LT-B gene. *Vaccine* 16, 1336-1343.

Mason, H. S., Lam, D. M., and Arntzen, C. J. (1992). Expression of hepatitis B surface antigen in transgenic plants. *Proc.Natl.Acad.Sci.U.S.A* 89, 11745-11749.

McDaniel, T. K., Jarvis, K. G., Donnenberg, M. S., and Kaper, J. B. (1995). A genetic locus of enterocyte effacement conserved among diverse enterobacterial pathogens. *Proc.Natl.Acad.Sci.U.S.A* 92, 1664-1668.

McKee, M. L., Melton-Celsa, A. R., Moxley, R. A., Francis, D. H., and O'Brien, A. D. (1995). Enterohemorrhagic *Escherichia coli* O157:H7 requires intimin to colonize the gnotobiotic pig intestine and to adhere to HEp-2 cells. *Infect.Immun.* 63, 3739-3744.

McKee, M. L. and O'Brien, A. D. (1996). Truncated enterohemorrhagic *Escherichia coli* (EHEC) O157:H7 intimin (EaeA) fusion proteins promote adherence of EHEC strains to HEp-2 cells. *Infect.Immun.* 64, 2225-2233.

Mead, P. S., Slutsker, L., Dietz, V., McCaig, L. F., Bresee, J. S., Shapiro, C., Griffin, P. M., and Tauxe, R. V. (1999). Food-related illness and death in the United States.

Emerg.Infect.Dis. 5, 607-625.

Melton-Celsa, A. R., Darnell, S. C., and O'Brien, A. D. (1996). Activation of Shiga-like toxins by mouse and human intestinal mucus correlates with virulence of enterohemorrhagic *Escherichia coli* O91:H21 isolates in orally infected, streptomycin-treated mice. *Infect.Immun.* 64, 1569-1576.

Melton-Celsa, A. R. and O'Brien, A. D. (1998). Structure, biology, and relative toxicity of Shiga toxin family members for cells and animals. *In Escherichia coli* O157:H7 and other Shiga toxin-producing *E. coli* strains. J. B. Kaper and A. D. O'Brien, Eds. (Washington DC:ASM Press). pp. 121-128.

Melton-Celsa, A. R., Rogers, J. E., Schmitt, C. K., Darnell, S. C., and O'Brien, A. D. (1998). Virulence of Shiga toxin-producing *Escherichia coli* (STEC) in orally- infected mice correlates with the type of toxin produced by the infecting strain. *Jpn.J Med.Sci.Biol.* 51 *Suppl.*, S108-S114.

Nagano, K., Taguchi, K., Hara, T., Yokoyama, S., Kawada, K., and Mori, H. (2003). Adhesion and colonization of enterohemorrhagic *Escherichia coli* O157:H7 in cecum of mice. *Microbiol.Immunol.* 47, 125-132.

Naylor, S. W., Low, J. C., Besser, T. E., Mahajan, A., Gunn, G. J., Pearce, M. C., McKendrick, I. J., Smith, D. G., and Gally, D. L. (2003). Lymphoid follicle-dense mucosa at the terminal rectum is the principal site of colonization of enterohemorrhagic *Escherichia coli* O157:H7 in the bovine host. *Infect.Immun.* 71, 1505-1512.

Neisser, M. and Shiga, K. (1903). Ueber freie Recptoren von Typhus- und Dysenterue-Bazillen und ueber das Dysenterie Toxin. *Dtsch Med Wochenschr* 29, 61-62.

O'Brien, A. D., LaVeck, G. D., Thompson, M. R., and Formal, S. B. (1982). Production of *Shigella dysenteriae* type 1-like cytotoxin by *Escherichia coli*. *J Infect.Dis.* 146, 763-769.

O'Brien, A. D., Lively, T. A., Chen, M. E., Rothman, S. W., and Formal, S. B. (1983). *Escherichia coli* O157:H7 strains associated with haemorrhagic colitis in the United States produce a *Shigella dysenteriae* 1 (Shiga) like cytotoxin. *Lancet* 1, 702.

O'Brien, A. D., Thompson, M. R., Cantey, J. R., and Formal, S. B. Production of a *Shigella dysenteriae*-like toxin by pathogenic *Escherichia coli*, abstr.B-103. Abstr.77th Annu.Meet.Am.Soc.Microbiol. 1977.

O'Brien, S. J., Adak, G. K., and Gilham, C. (2001). Contact with farming environment as a major risk factor for Shiga toxin (Vero cytotoxin)-producing *Escherichia coli* O157 infection in humans. *Emerg.Infect.Dis.* 7, 1049-1051.

Obrig, T. G. (1998). Interaction of Shiga toxins with endothelial cells. *In Escherichia coli* O157:H7 and Other Shiga Toxin-Producing *E. coli* Strains. J. B. Kaper and A. D. O'Brien, Eds. (Washington, DC:ASM Press). pp. 303-311.

Ostroff, S. M., Tarr, P. I., Neill, M. A., Lewis, J. H., Hargrett-Bean, N., and Kobayashi, J. M. (1989). Toxin genotypes and plasmid profiles as determinants of systemic sequelae in *Escherichia coli* O157:H7 infections. *J Infect.Dis.* *160*, 994-998.

Paton, J. C. and Paton, A. W. (1998). Pathogenesis and diagnosis of Shiga toxin-producing *Escherichia coli* infections. *Clin.Microbiol.Rev.* *11*, 450-479.

Perera, L. P., Marques, L. R., and O'Brien, A. D. (1988). Isolation and characterization of monoclonal antibodies to Shiga-like toxin II of enterohemorrhagic *Escherichia coli* and use of the monoclonal antibodies in a colony enzyme-linked immunosorbent assay. *J Clin.Microbiol.* *26*, 2127-2131.

Perna, N. T., Plunkett, G., III, Burland, V., Mau, B., Glasner, J. D., Rose, D. J., Mayhew, G. F., Evans, P. S., Gregor, J., Kirkpatrick, H. A., Pósfai, G., Hackett, J., Klink, S., Boutin, A., Shao, Y., Miller, L., Grotbeck, E. J., Davis, N. W., Lim, A., Dimalanta, E. T., Potamouisis, K. D., Apodaca, J., Anantharaman, T. S., Lin, J., Yen, G., Schwartz, D. C., Welch, R. A., and Blattner, F. R. (2001). Genome sequence of enterohaemorrhagic *Escherichia coli* O157:H7. *Nature* *409*, 529-533.

Phillips, A. D., Navabpour, S., Hicks, S., Dougan, G., Wallis, T., and Frankel, G.

(2000). Enterohaemorrhagic *Escherichia coli* O157:H7 target Peyer's patches in humans and cause attaching/effacing lesions in both human and bovine intestine. *Gut* 47, 377-381.

Ramotar, K., Boyd, B., Tyrrell, G., Gariepy, J., Lingwood, C., and Brunton, J.

(1990). Characterization of Shiga-like toxin I B subunit purified from overproducing clones of the SLT-I B cistron. *Biochem.J.* 272, 805-811.

Richter, L. J., Thanavala, Y., Arntzen, C. J., and Mason, H. S. (2000). Production of

hepatitis B surface antigen in transgenic plants for oral immunization. *Nat.Biotechnol.* 18, 1167-1171.

Riley, L. W., Remis, R. S., Helgerson, S. D., McGee, H. B., Wells, J. G., Davis, B. R.,

Hebert, R. J., Olcott, E. S., Johnson, L. M., Hargrett, N. T., Blake, P. A., and Cohen,

M. L. (1983). Hemorrhagic colitis associated with a rare *Escherichia coli* serotype. *N.Engl.J Med.* 308, 681-685.

Samadpour, M., Grimm, L. M., Desai, B., Alfi, D., Ongerth, J. E., and Tarr, P. I.

(1993). Molecular epidemiology of *Escherichia coli* O157:H7 strains by bacteriophage lambda restriction fragment length polymorphism analysis: application to a multistate foodborne outbreak and a day-care center cluster. *J Clin.Microbiol.* 31, 3179-3183.

Samadpour, M., Stewart, J., Steingart, K., Addy, C., Louderback, J., McGinn, M., Ellington, J., and Newman, T. (2002). Laboratory investigation of an *E. coli* O157:H7 outbreak associated with swimming in Battle Ground Lake, Vancouver, Washington. *J. Environ. Health* 64, 16-20, 26, 25.

Saxena, S. K., O'Brien, A. D., and Ackerman, E. J. (1989). Shiga toxin, Shiga-like toxin II variant, and ricin are all single-site RNA N-glycosidases of 28 S RNA when microinjected into *Xenopus* oocytes. *J Biol.Chem.* 264, 596-601.

Schmidt, H., Karch, H., and Beutin, L. (1994). The large-sized plasmids of enterohemorrhagic *Escherichia coli* O157 strains encode hemolysins which are presumably members of the *E. coli* α -hemolysin family. *FEMS Microbiol.Lett.* 117, 189-196.

Schmidt, H., Scheef, J., Morabito, S., Caprioli, A., Wieler, L. H., and Karch, H. (2000). A new Shiga toxin 2 variant (Stx2f) from *Escherichia coli* isolated from pigeons. *Appl. Environ. Microbiol.* 66, 1205-1208.

Schmitt, C. K., McKee, M. L., and O'Brien, A. D. (1991). Two copies of Shiga-like toxin II-related genes common in enterohemorrhagic *Escherichia coli* strains are responsible for the antigenic heterogeneity of the O157:H- strain E32511. *Infect. Immun.* 59, 1065-1073.

Scotland, S. M., Willshaw, G. A., Smith, H. R., and Rowe, B. (1987). Properties of strains of *Escherichia coli* belonging to serogroup O157 with special reference to production of Vero cytotoxins VT1 and VT2. *Epidemiol.Infect.* 99, 613-624.

Sharma, V. K. and Dean-Nystrom, E. A. (2003). Detection of enterohemorrhagic *Escherichia coli* O157:H7 by using a multiplex real-time PCR assay for genes encoding intimin and Shiga toxins. *Vet.Microbiol.* 93, 247-260.

Sinclair, J. F. and O'Brien, A. D. (2002). Cell surface-localized nucleolin is a eukaryotic receptor for the adhesin intimin-gamma of enterohemorrhagic *Escherichia coli* O157:H7. *J Biol.Chem.* 277, 2876-2885.

Smith, D., Blackford, M., Younts, S., Moxley, R., Gray, J., Hungerford, L., Milton, T., and Klopfenstein, T. (2001). Ecological relationships between the prevalence of cattle shedding *Escherichia coli* O157:H7 and characteristics of the cattle or conditions of the feedlot pen. *J.Food Prot.* 64, 1899-1903.

Sojikul, P., Buehner, N., and Mason, H. S. (2003). A plant signal peptide-hepatitis B surface antigen fusion protein with enhanced stability and immunogenicity expressed in plant cells. *Proc.Natl.Acad.Sci.U.S.A* 100, 2209-2214.

Solomon, E. B., Potenski, C. J., and Matthews, K. R. (2002). Effect of irrigation method on transmission to and persistence of *Escherichia coli* O157:H7 on lettuce. *J.Food Prot.* 65, 673-676.

Stemmer, W. P. C., Cramer, A., Ha, K. D., Brennan, T. M., and Heyneker, H. L.

(1995). Single-step assembly of a gene and entire plasmid from large numbers of oligodeoxyribonucleotides. *Gene* 49-53.

Strockbine, N. A., Jackson, M. P., Sung, L. M., Holmes, R. K., and O'Brien, A. D.

(1988). Cloning and sequencing of the genes for Shiga toxin from *Shigella dysenteriae* type 1. *J Bacteriol* 170, 1116-1122.

Strockbine, N. A., Marques, L. R., Newland, J. W., Smith, H. W., Holmes, R. K.,

and O'Brien, A. D. (1986). Two toxin-converting phages from *Escherichia coli* O157:H7 strain 933 encode antigenically distinct toxins with similar biologic activities. *Infect.Immun.* 53, 135-140.

Swerdlow, D. L., Woodruff, B. A., Brady, R. C., Griffin, P. M., Tippen, S., Donnell,

H. D., Jr., Geldreich, E., Payne, B. J., Meyer, A., Jr., Wells, J. G., and . (1992). A waterborne outbreak in Missouri of *Escherichia coli* O157:H7 associated with bloody diarrhea and death. *Annals of Internal Medicine* 117, 812-819.

Tacket, C. O., Mason, H. S., Losonsky, G., Clements, J. D., Levine, M. M., and

Arntzen, C. J. (1998). Immunogenicity in humans of a recombinant bacterial antigen delivered in a transgenic potato. *Nat.Med.* 4, 607-609.

Tacket, C. O., Mason, H. S., Losonsky, G., Estes, M. K., Levine, M. M., and Arntzen, C. J. (2000). Human immune responses to a novel norwalk virus vaccine delivered in transgenic potatoes. *J.Infect.Dis.* *182*, 302-305.

Tarr, C. L. and Whittam, T. S. (2002). Molecular evolution of the intimin gene in O111 clones of pathogenic *Escherichia coli*. *J Bacteriol* *184*, 479-487.

Teel, L. D., Melton-Celsa, A. R., Schmitt, C. K., and O'Brien, A. D. (2002). One of two copies of the gene for the activatable shiga toxin type 2d in *Escherichia coli* O91:H21 strain B2F1 is associated with an inducible bacteriophage. *Infect.Immun.* *70*, 4282-4291.

Tesh, V. L., Burris, J. A., Owens, J. W., Gordon, V. M., Wadolkowski, E. A., O'Brien, A. D., and Samuel, J. E. (1993). Comparison of the relative toxicities of Shiga-like toxins type I and type II for mice. *Infect.Immun.* *61*, 3392-3402.

Thanavala, Y., Yang, Y. F., Lyons, P., Mason, H. S., and Arntzen, C. (1995). Immunogenicity of transgenic plant-derived hepatitis B surface antigen. *Proc.Natl.Acad.Sci.U.S.A* *92*, 3358-3361.

Tilden, J., Jr., Young, W., McNamara, A. M., Custer, C., Boesel, B., Lambert-Fair, M. A., Majkowski, J., Vugia, D., Werner, S. B., Hollingsworth, J., and Morris, J. G., Jr. (1996). A new route of transmission for *Escherichia coli*: infection from dry fermented salami. *Am.J Public Health* *86*, 1142-1145.

Tochikubo, K., Isaka, M., Yasuda, Y., Kozuka, S., Matano, K., Miura, Y., and Taniguchi, T. (1998). Recombinant cholera toxin B subunit acts as an adjuvant for the mucosal and systemic responses of mice to mucosally co-administered bovine serum albumin. *Vaccine* 16, 150-155.

Toth, I., Cohen, M. L., Rumschlag, H. S., Riley, L. W., White, E. H., Carr, J. H., Bond, W. W., and Wachsmuth, I. K. (1990). Influence of the 60-megadalton plasmid on adherence of *Escherichia coli* O157:H7 and genetic derivatives. *Infect.Immun.* 58, 1223-1231.

Tzipori, S., Gunzer, F., Donnenberg, M. S., de Montigny, L., Kaper, J. B., and Donohue-Rolfe, A. (1995). The role of the *eaeA* gene in diarrhea and neurological complications in a gnotobiotic piglet model of enterohemorrhagic *Escherichia coli* infection. *Infect.Immun.* 63, 3621-3627.

Tzipori, S., Karch, H., Wachsmuth, K. I., Robins-Browne, R. M., O'Brien, A. D., Lior, H., Cohen, M. L., Smithers, J., and Levine, M. M. (1987). Role of a 60-megadalton plasmid and Shiga-like toxins in the pathogenesis of infection caused by enterohemorrhagic *Escherichia coli* O157:H7 in gnotobiotic piglets. *Infect.Immun.* 55, 3117-3125.

Tzipori, S., Wachsmuth, I. K., Chapman, C., Birden, R., Brittingham, J., Jackson, C., and Hogg, J. (1986). The pathogenesis of hemorrhagic colitis caused by *Escherichia coli* O157:H7 in gnotobiotic piglets. *J Infect.Dis.* 154, 712-716.

- Vajdy, M. and Lycke, N. Y.** (1992). Cholera toxin adjuvant promotes long-term immunological memory in the gut mucosa to unrelated immunogens after oral immunization. *Immunology* 75, 488-492.
- Valcour, J. E., Michel, P., McEwen, S. A., and Wilson, J. B.** (2002). Associations between indicators of livestock farming intensity and incidence of human Shiga toxin-producing *Escherichia coli* infection. *Emerg.Infect.Dis.* 8, 252-257.
- Van der Heijden, P. J., Bianchi, A. T., Bokhout, B. A., Dol, M., Scholten, J. W., and Stok, W.** (1989). Quantification of antigen-specific antibody-secreting cells in the small intestine and other lymphoid organs of mice after oral booster immunization. *Immunology* 66, 404-409.
- Wadolkowski, E. A., Burris, J. A., and O'Brien, A. D.** (1990a). Mouse model for colonization and disease caused by enterohemorrhagic *Escherichia coli* O157:H7. *Infect.Immun.* 58, 2438-2445.
- Wadolkowski, E. A., Sung, L. M., Burris, J. A., Samuel, J. E., and O'Brien, A. D.** (1990b). Acute renal tubular necrosis and death of mice orally infected with *Escherichia coli* strains that produce Shiga-like toxin type II. *Infect.Immun.* 58, 3959-3965.
- Wallace, J. S., Cheasty, T., and Jones, K.** (1997). Isolation of vero cytotoxin-producing *Escherichia coli* O157 from wild birds. *J Appl.Microbiol.* 82, 399-404.

Weinstein, D. L., Jackson, M. P., Perera, L. P., Holmes, R. K., and O'Brien, A. D.

(1989). *In vivo* formation of hybrid toxins comprising Shiga toxin and the Shiga-like toxins and role of the B subunit in localization and cytotoxic activity. *Infect.Immun.* 57, 3743-3750.

Wells, J. G., Davis, B. R., Wachsmuth, I. K., Riley, L. W., Remis, R. S., Sokolow, R.,

and Morris, G. K. (1983). Laboratory investigation of hemorrhagic colitis outbreaks associated with a rare *Escherichia coli* serotype. *J Clin.Microbiol.* 18, 512-520.

Woods, J. B., Schmitt, C. K., Darnell, S. C., Meysick, K. C., and O'Brien, A. D.

(2002). Ferrets as a model system for renal disease secondary to intestinal infection with *Escherichia coli* O157:H7 and other Shiga toxin-producing *E. coli*. *J Infect.Dis.* 185, 550-554.

Yu, J. and Kaper, J. B. (1992). Cloning and characterization of the *eae* gene of

enterohaemorrhagic *Escherichia coli* O157:H7. *Mol.Microbiol.* 6, 411-417.

Zieg, J., Hilmen, M., and Simon, M. (1978). Regulation of gene expression by site-

specific inversion. *Cell* 15, 237-244.