

REPORT DOCUMENTATION PAGE

AFRL-SR-AR-TR-04-
0497

1e
9
ity

data needed, and completing and reviewing this collection of information. Send comments regarding this burden estimate or any other aspect of this burden to Department of Defense, Washington Headquarters Services, Directorate for Information Operations and Reports (0704-01 4302). Respondents should be aware that notwithstanding any other provision of law, no person shall be subject to any penalty for failing to provide information required by this collection of information if it does not display a valid OMB control number. PLEASE DO NOT RETURN YOUR FORM TO THE ABOVE ADDRESS.

1. REPORT DATE (DD-MM-YYYY) 09-18-04		2. REPORT TYPE Final		3. DATES COVERED (From - To) 4/1/03-5/31/04	
4. TITLE AND SUBTITLE "Developing Signal Processing Algorithms for Weak GPS Signal Acquisition in Urban Environment"				5a. CONTRACT NUMBER F49620-03-1-0225	
				5b. GRANT NUMBER	
				5c. PROGRAM ELEMENT NUMBER	
6. AUTHOR(S) Yu T. Jade Morton				5d. PROJECT NUMBER	
				5e. TASK NUMBER	
				5f. WORK UNIT NUMBER	
7. PERFORMING ORGANIZATION NAME(S) AND ADDRESS(ES) Miami University 7 Roudebush Hall Oxford, OH 45056-3563				8. PERFORMING ORGANIZATION REPORT NUMBER	
9. SPONSORING / MONITORING AGENCY NAME(S) AND ADDRESS(ES) USAF, AFRL AFOSR 4015 Wilson Blvd Room 713 Arlington, VA 22203-1954				10. SPONSOR/MONITOR'S ACRONYM(S) AFOSR	
				11. SPONSOR/MONITOR'S REPORT NUMBER(S)	

12. DISTRIBUTION / AVAILABILITY STATEMENT N/A		DISTRIBUTION STATEMENT A Approved for Public Release Distribution Unlimited		20041008 222
--	--	--	--	--------------

13. SUPPLEMENTARY NOTES N/A	
--------------------------------	--

14. ABSTRACT This report describes project progress on developing signal processing algorithms for weak GPS signal acquisition in typical urban environment where no more than three satellites are in direct view of a receiver. To successfully determine a user position, signals that are weakened due to presence of man-made and/or natural structures needs to be acquired. This can be a challenge task since the nominal level satellite signals act as interference during the weak signal acquisition. This report documents the progress we have made in accessing and mitigate the interference among satellite signals. The receiver platform with which we tested our algorithms is a software GPS receiver developed at AFRL/SNRP at WPAFB. As part of the proposed project, we worked on interfacing a portable GPS RF front end with a laptop PC via existing high speed USB2. This report also documents the successful implementation of software driver functions for the USB interface and other related projects.	
--	--

15. SUBJECT TERMS	
-------------------	--

16. SECURITY CLASSIFICATION OF: Unclassified			17. LIMITATION OF ABSTRACT	18. NUMBER OF PAGES	19a. NAME OF RESPONSIBLE PERSON Y. T. Jade Morton	
a. REPORT	b. ABSTRACT	c. THIS PAGE			19b. TELEPHONE NUMBER (include area code) 513-529-6070	

Developing Signal Processing Algorithm for Weak GPS Signal Acquisition in Urban Environment

AFOSR grant F49620-03-1-0225

Final Report

Principal Investigator: Y. T. Jade Morton

Department of Electrical and Computer Engineering

Miami University

Oxford, OH 45056

1. Objectives

The objective of this research project is to develop signal processing algorithms to acquire weak GPS signals that are mixed with strong signals. Current GPS receivers are capable of acquiring and tracking satellite signals with C/N_0 as low as 24 dB-Hz without aid and without extensive computing time. To achieve this level of sensitivity, there cannot be substantial interference from other satellites with strong signal levels. In practice, however, the weak signals may coexist with much stronger signals from other satellites. This may happen when only a limited area of the sky is exposed to a receiver, such as in the case of navigating in city canyons or under a forest canopy. The presence of the strong signals may produce high cross-correlations between the strong signals and a weak signal during the weak signal acquisition, resulting in complete loss or false acquisition of weak signals which may be necessary in determining the user position. Effective algorithms are needed to mitigate the cross-correlation interference between the strong and the weak satellite signals so that sufficient number of satellites can be acquired and used for user position determination.

An additional objective was to establishing a simulation model for evaluation of Ultra-wide band signal interference on GPS receiver as desired by AFRL. UWB devices are the latest research topics in communication systems. They have the potential to revolutionize techniques in wireless personal area network (WPAN). Academic and industry leaders are predicting a mass market of many varieties of UWB devices in the foreseeable future because of their low cost, low power, high spatial capacity, high data rate, and low communication range. Such a mass market is also a dangerous one in that UWB's wide spectrum ranges may create interference over several restricted radio spectrum bands, including the GPS bands. In the past three years, several groups have researched to access the impact of UWB devices on GPS receiver performances using hardware approach. Such approaches have some major drawbacks. Many UWB signals are new theoretical signals that cannot yet be generated using hardware. Setting up an experiment with a collection of UWB devices for testing purpose is forbidden due to its potential interference with existing communication systems. Furthermore, it is difficult to distinguish what is the major factor that contributes to the degradation of receiver performance under UWB interference using a hardware-based GPS receiver because of the differences in various GPS hardware architecture. A more flexible and feasible way is needed to provide aggregated UWB interference on GPS receivers.

2. Status of Effort

CA Code Self-Interference Mitigation:

- A thorough investigation of existing literature on various interference mitigation technologies was performed. The problem we intend to solve is similar to the near-far problem in CDMA technology. The main challenge here is that the signal we are interested in acquiring can be extremely weak. Our goal was to be able to acquire signals at the sensitivity limit of a stand-alone GPS receiver. To do so, we need to remove the interference in a very thorough manner.
- We performed a quantitative assessment on the amount of interference between a strong and a weak signal using both analytic analysis and simulations. Our findings indicate that the interference is a function of the strong signal power and the weak signal power. Based on our assessment, we established the upper and lower boundaries for the strong signal level and the weak signal level at which interference removal may be effective.
- We investigated two approaches in interference removal: direct reconstruction and subspace project method. In both methods, the strong signals are acquired and tracked first. In the direct reconstruction method, the strong signal parameters obtained via acquisition and tracking are used to directly reconstruct the strong signals. In the subspace projection method, the strong signals are treated as an interference subspace of the total input signal. Projection of the input onto this subspace contains the total strong signals. In both approaches, the reconstructed total strong signals are subtracted from the input, resulting in a net signal consisting of weak signals, noise, and residue errors. By controlling the level of residue errors through appropriate signal processing procedures, we were able to acquire weak signals at the sensitivity level.
- We tested our algorithms using simulation data and we also performed evaluation of the software using hardware-based simulator data. The projection method outperforms the direct reconstruction method under all conditions. This is the method we presented in our conference paper. The final work has been submitted to the journal *Navigation* for publication.
- We implemented a set of custom USB2 driver functions to work with the Cypress FX2 transceiver to establish a low cost high speed (up to 400 Mbs/s) data acquisition interface between the GPS RF front end and a lap top PC. This implementation made it possible for us to create a portable software receiver for flexible data acquisition under difficult environment. A detailed technical report on this project has been submitted to AFRL. The physical implementation has been turned over to AFRL and has been used in data collection experiment.

UWB-GPS Interference Study

- We thoroughly researched UWB-GPS interference studies as well as current development in UWB technology. Based on the research, we developed a framework for an software-based approach to evaluate UWB-GPS interference.

- We successfully created a simulated GPS front end to assess aggravated Ultra-wide-band (UWB) devices interference on GPS receiver performance. This approach is valuable because it made it possible to evaluate the impact of new UWB signals and modulations scheme on GPS receivers in a timely manner. Moreover, it made it possible to evaluate the effect of aggregated UWB sources on a GPS receiver performance. It also allows the use of dual use of real and simulated data for the interference studies. The preliminary results are presented and published at the IEEE-PLANS conference in April 2004. The work has also been invited to be published at IEEE Aerospace and Electronics Magazine.

Other Support Projects:

- Implementation of a low-cost high-speed USB2.0 interface between a radio frequency front end and software GPS receiver processing unit. This implementation made it possible to perform data collection under difficult experimental environment. The project has been completed and the complete system has been turned over to AFRL at WPAFB. The system has been used successfully in data collection experiment.
- Creation of a neural network model to predict ionosphere delay error for single frequency GPS receiver. The creation of this model will allow a software receiver to dynamically incorporate the error correction using real measurements. The model has been completed and initial training and testing results have been analyzed and published.
- Design and implementation of a DPGS-aided autonomous lawn mower. This on-going interdisciplinary project integrates several sensors with GPS receiver to intelligently navigate a vehicle over a given field. It has to overcome many typical navigation problems such as signal obstruction by buildings and trees, precision path control, object identification and avoidance, etc. The project will provide an excellent test bed for future sensors and navigation research. The first version of the design entered the autonomous lawn mower competition sponsored by the Institute of Navigation in June 2004. The project won second place in performance and best production plan award. A second senior capstone team is working on improving the navigation precision and handling of more difficult environment.

Research Team Status:

- We were able to recruit and actively involve two graduate students in the projects. Both students worked at the AFRL/WPAFB during summer 2003 and 2004 under this contract and have gained valuable experience and knowledge in signal processing, GPS systems, and software development. These two students will continue pursuing their master's degree under the PI's supervision.
- We were also able to recruit and involve several undergraduate students to work on navigation related projects. One undergraduate student worked on developing neural networks models for ionosphere error corrections for GPS receivers. Several undergraduate students joined my senior capstone team to

design and implement an autonomous lawn mower aided by a custom differential GPS receiver system and other navigation sensors.

3. Accomplishments

1. The GPS strong-weak signal interference problem was successfully solved for common operating conditions. A conference paper was presented and published. A journal paper has been submitted for publication.
2. A low cost, flexible USB2 interface was established between GPS RF front end and portal PC. Traditionally, dedicated data acquisition boards are used to interface the front ends and PCs. They can be bulky, expensive, and requires custom driver functions. The new interface opened a completely different approach to acquire high speed digital samples. Both Stanford University and Ohio University have expressed interests in learning more about this project. The hardware and software have been turned over to AFRL and has been used in data taking experiments.
3. A simulation model was created to evaluate UWB-GPS interference. Preliminary results were presented and published at the 2004 IEEE PLANS conference proceeding. The work has also been invited and submitted to IEEE Aerospace and Electronics Magazine for publication.
4. A neural network model of ionosphere delay correction for signal frequency GPS receiver has been created and trained using over two solar cycles of incoherent scatter radar data. The model output was validated against the one generated by the International Reference Ionosphere Model (IRI) using real measurements. Our model outperforms the IRI model. The work was presented and published at the 2004 IEEE PLANS conference.
5. A GPS-aided autonomous lawn mower was created and entered the 1st Autonomous Lawn Mower competition sponsored by the Institute of Navigation. The lawn mower team won best Production Plan and second place demonstration award.

4. Personnel Supported

Y. T. Jade Morton, PI

Qihou Zhou, Faculty, Miami University

Marcus P. French, Graduate student, Miami University

Jason E. Smith, Graduate student, Miami University

Christopher Mantz, Undergraduate student, Miami University

Brett McNally, Undergraduate student, Miami University

Micah Stutzman, Undergraduate student, Miami University

Collin Korando, Undergraduate student, Miami University

Jeffrey Macasek, Undergraduate student, Miami University

5. Technical Publications

Morton, Y.T. J., M. P. French, Q. Zhou, J. B.Y. Tsui, D. M. Lin, M. M. Miller, "A Software Approach to Access Ultra-Wide Band Interference on GPS

- Receivers," Invited and submitted to *IEEE Aerospace and Electronic Magazine*, July, 2004.
- Miller, M., J. Raquet, J. Morton, F. Van Grass, B. Pervan, and L. O'Rear, "Just keep rolling a lawn, ION's autonomous mowers," *GPS World*, pp16-26, Sept., 2004.
- Martin, J. D., Y. T. Morton, Q. Zhou, "Neural Network Development for the Forecasting of Upper Atmosphere Parameter Distributions," to appear in *Advances in Space Research*, 2004.
- Morton, Y. T. J., J. B. Y., Tsui, D. M., Lin, M. M., Miller, J., Schamus, Q., Zhou, and M. P., French, "Assessment and handling of CA code self-interference during weak GPS signal acquisition", *Submitted to Navigation*, Nov. 2003.
- McNally, B., Stutzman, M., Korando, C., Macasek, J., Mantz, C., Miller, S., Morton, J., Campbell, S., Leonard, J., "The Miami Red Blade: An Autonomous Lawn Mower," *2004 Institute of Navigation Annual Conference Proceedings*, June 2004, Dayton, Ohio.
- Morton, Y.T. J., Q. Zhou, M. P. French, J. B.Y. Tsui, D. M. Lin, M. M. Miller, "A Software Approach to Access Ultra-Wide Band Interference on GPS Receivers," *2004 IEEE PLANS Conference Proceedings*, Monterey, CA, April 26-29, 2004.
- Mantz, C., Q. Zhou, and Y. T. Morton, "Application of a neural network model to the GPS ionosphere error correction," *2004 IEEE PLANS Conference Proceedings*, Monterey, CA, April 26-29, 2004.
- Morton, Y. T. J., J. B. Y., Tsui, D. M., Lin, M. M., Miller, J., Schamus, Q., Zhou, and M. P., French, "Assessment and handling of CA code self-interference during weak GPS signal acquisition", *Proceedings of the 2003 Institute of Navigation GPS Conference*, Portland, OR, Sept. 2003.
- Liou, L.L, J. B. Tsui, D. M. Lin and J. Schamus, F. van Graas, and Y. T. J. Morton, "Passive Altimeter Study Using GPS Flight Data," *Proceedings of the 2003 Institute of Navigation GPS Conference*, Portland, OR, Sept. 2003.
- Smith, J. E., Y. T. J. Morton, and J. Caschera, "Implementation of a custom USB device for a GPS software receiver," Technical Report, Air Force Research Laboratory, WPAFB, August, 2003.

6. Interactions/Transitions

6.1 Presentations

- Y. T. J. Morton, "Software GPS receiver and applications," *2004 AFOSR Program Review*, University of Delaware, Delaware, June 2004.
- McNally, B., Stutzman, M., Korando, C., Macasek, J., Mantz, C., Miller, S., Morton, J., Campbell, S., Leonard, J., "The Miami Red Blade: An Autonomous Lawn Mower," *2004 Institute of Navigation Annual Conference*, Dayton, Ohio, June 2004.

- Morton, Y.T. J., Q. Zhou, M. P. French, J. B.Y. Tsui, D. M. Lin, M. M. Miller, "A Software Approach to Access Ultra-Wide Band Interference on GPS Receivers," *2004 IEEE PLANS Conference*, Monterey, CA, April 26-29, 2004.
- Mantz, C., Q. Zhou, and Y. T. Morton, "Application of a neural network model to the GPS ionosphere error correction," *2004 IEEE PLANS Conference*, Monterey, CA, April 26-29, 2004.
- Morton, Y. T. J., Tsui, J. B. Y., Lin, D. M., Miller, M. M., Schamus, J., Zhou, Q., and French, M. P., "Assessment and handling of CA code self-interference during weak GPS signal acquisition", *2003 Institute of Navigation GPS Conference*, Portland, OR, Sept. 2003.
- Morton, Y. T. J., "Developing A Simulation Model for Accessing UWB Interference on Software GPS Receivers," Sensors Directorate, Air Force Research Laboratory, Wright Patterson Air Force Base, August, 2003.
- Smith, J. E., Y. T. Morton, J. Cashera, J. Schamus, "Implementation of a custom USB device for a GPS software receiver," Sensors Directorate, Air Force Research Laboratory, Wright Patterson Air Force Base, August, 2003.
- Liou, L.L, J. B. Tsui, D. M. Lin and J. Schamus, F. van Graas, and Y. T. J. Morton, "Passive Altimeter Study Using GPS Flight Data," *2003 Institute of Navigation Conference*, Portland, OR, Sept. 2003.
- Mantz, C., Q. Zhou, Y. T. Morton, M. Sulzer, "Neural network and its application to space weather forecasting," CEDAR, Longmont, CO, June, 2003.
- Rodgers, M., J. E. Smith, J. E., G. A. Pizza, J. D. Martin, Y. T. J. Morton, "Interfacing a radio frequency front end with a software GPS receiver," Miami University Undergraduate Research Symposium, Oxford, Ohio, April, 2003.
- Mantz, C., Q. Zhou, Y. T. Morton, "Neural network and its application to space weather forecasting," Miami University Undergraduate Research Symposium, Oxford, Ohio, Nov, 2003.

6.2 Transitions

- A documented interference removal software has been turned over to AFRL/SNRP at WPAFB.
- A documented software simulation model for UWB-GPS interference evaluation has been turned over to AFRL/SNRP at WPAFB.
- An entire library of custom USB2.0 driver functions that provides interfacing between the GPS RF front end and a lap top PC has been turned over to AFRL/SNRP at WPAFB.
- All testing circuitry and hardware development kit for the USB2.0 interface has been turned over to AFRL/SNRP at WPAFB.
- A complete set of documents on the USB2.0 hardware and software has been turned over to AFRL/SNRP at WPAFB. This set of documents have also been requested and given to Stanford University (with approval from AFRL/SNRP).

The following list of people has been provided with the software algorithm, documentations, or hardware developed under this contract:

Dr. James Tsui
Air Force Research Laboratory
Reference Sensors and Receiver Application Branch (SNRP)
Wright Patterson Air Force Base, OH 45433-7318
Phone: 937-255-6127 ext 4320
Email: James.Tsui@wpafb.af.mil

Mr. David Lin
Air Force Research Laboratory
Reference Sensors and Receiver Application Branch (SNRP)
Wright Patterson Air Force Base, OH 45433-7318
Phone: 937-255-6127 ext 4243
Email: David.Lin@wpafb.af.mil

Mr. Liyeh Liou
Air Force Research Laboratory
SNDI
Wright Patterson Air Force Base, OH 45433-7318
Phone: 937-255-6127 ext 3386
Email: Lihyeh.Liou@wpafb.af.mil

7. Patent Disclosures
None.
8. Honors
Jade Morton, NRC/AFOSR summer faculty fellowship, May-August 2003.

APPENDIX

Published Works

given pulse amplitude, as the repetition rate increases the acquisition rate declines. The decline is accelerated when the pulse repetition rate approaches the high end of the projected data rate for UWB applications.

VI. CONCLUSIONS AND FUTURE PLANS

This paper presented a simulation model for the GPS RF front end. This simulation model consists of a GPS antenna, RF to IF conversion, CA code bandpass filter, and analog to digital converter. This simulation model incorporated a variety of elements such as the use of experimental data (GPS antenna frequency response), mathematical modeling (down conversion), and signal processing tool boxes (bandpass filter). Several other necessary components were also created in conjunction with the RF front end model. These include the generation of UWB pulses and the algorithm used to handle long sequence of input data.

The simulation model established through this study will provide a framework for studying the impact of any combination of future UWB signals on GPS receivers at various stages. It has the advantage of having the flexibility to work with a variety of GPS receiver architectures and allows a closer look into the fundamental aspects of interference and performance degradation. It can be a valuable tool for the GPS and UWB community to study a signal of interest before deploying it into the mass market.

There are several follow up projects:

1. GPS RF front end simulation model validation using real UWB signals.
2. UWB source simulation. As new UWB sources are being proposed, approved, and implemented, we can simulate these signals and use them in the interference evaluations.
3. More acquisition stage impact analysis. The preliminary results only examined the interference of the Gaussian monopulse using random dithering as the modulation scheme. More realistic signals and modulation scheme should be used in future research.
4. Interference study at the tracking and post processing stages.

ACKNOWLEDGEMENTS

This project was supported by an AFOSR summer faculty fellowship award and AFOSR/AFRL under contract #F49620-03-1-0225. The authors would like to thank the following organizations and individuals for their help and support for this project:

- Mr. Kenneth Walker of the Sensors Directorate, AFRL/SNRW, for providing access to Multispectral Solutions TFP 1001 UWB signal generator.
- Dr. Steven Hary of the Sensors Directorate, AFRL/SNRP, for editing the manuscript and for providing valuable suggestions and comments to the work.
- Mr. Boyd Holsapple, Pete Howe, and Liyeh Liou of the Sensors Directorate, AFRL/SNRP, for their help and support during this project.

REFERENCES

- [1] Federal Communications Commission, First Report and Order, ET Docket 98-153, "Revision of Part 15 of the Commission's Rules Regarding Ultra-Wideband Transmission Systems", adopted Feb. 14, 2002.
- [2] Leeper, D. G., "Ultrawideband - The Next Step in Short-Range Wireless", IEEE 2003 IMS/RFIC Symposium, P357-360, June, 2003.
- [3] Aiello, G. R., "Challenges for Ultra-wideband (UWB) CMOS Integration", IEEE 2003 IMS/RFIC Symposium, P361-364, June, 2003.
- [4] Anderson, D. S., Drocella, E. F., Jones, S. K., and Settle, M. A., "Assessment of compatibility between Ultrawideband systems and Global Positioning System (GPS) Receivers", NTIA Special Publication 01-45, Washington D.C., February, 2001. Internet URL: http://www.ntia.doc.gov/osmhome/reports/UwbGps/NTIASP_01_45.pdf.
- [5] Titus, B. M., Dafesh, P. A., Wong, R., Maine, K. P., and Stansell, T. A. Jr., "Assessing Ultra Wide Band (UWB) interference to GPS receivers", Proceedings of 2002 Institute of Navigation GPS Conference, Portland, Oregon, September 11-14, 2002, P1251-1259.
- [6] Erlandson, R. J., and Van Dierendonck, A. J., "GPS receiver susceptibility to ultra-wideband RFI: test results and RFI link analysis", Proceedings of 2001 Institute of Navigation GPS Conference, Salt lake City, UT, September 11-14, 2001, P14-25.
- [7] Luo, M., Akos, D., Koenig, M., Opshaug, G., Pullen, S., and Enge P., "Testing and research on interference to GPS from UWB transmitters", Proceedings of 2001 Institute of Navigation GPS Conference, Salt lake City, UT, September 11-14, 2001, P1-13.
- [8] Win, M. Z., and Scholtz, R. A., "Impulse radio: HOW IT WORKS", IEEE Communications letters, Vol.2, NO. 1, P10-12, January 1998.
- [9] Aiello, G. R. et al., <http://www.multibandofdm.org/papers/15-04-0010-02-003a-multi-band-ofdm-jan04-presentation.pdf>.
- [10] Melbpm, M. et al., <ftp://ftp.802wirelessworld.com/15/03/15-03-0334-03-003a-xtremespectrum-cfp-presentation.pdf>.
- [11] Van Dierendonck, A. J., "Chapter 8. GPS Receivers", in Global Positioning System: Theory and Applications, Volume 1, edited by B. W. Parkinson and J. J. Spilker Jr., published by AIAA, 1996.
- [12] Tsui, J. B., Fundamentals of Global Positioning System Receivers, A Software Approach, John Wiley & Sons, 1st edition, 2000.
- [13] Akos, D. M., and Tsui, J. B. Y., "Design and implementation of a direct digitization GPS receiver front end", IEEE Tran. On Microwave theory and Techniques, Vol. 44, No. 12, P2334-2339, 1996.
- [14] Akos, D., J. Thor, "A direct RF sampling multifrequency GPS receiver," IEEE Position Location and Navigation Symposium, Palm Springs, CA, April, 2002.
- [15] Lin, D. M., Tsui, J. B. Y., "Comparison of Acquisition Methods for Software GPS Receivers", Proceedings of Institute Of Navigations GPS Conferences, P2385-2390, Salt Lake City, Utah, 2000.

Application of a Neural Network Model to GPS Ionosphere Error Correction

Christopher P. Mantz, Qihou Zhou, and Yu T. Morton
Department of Manufacturing & Mechanical Engineering
Miami University
Oxford, OH 45056 USA

Abstract- This paper presents the use of neural network modeling to predict electron concentration in the altitudes from 140 to 660 km as well as total electron content (TEC) to reduce GPS signal propagation errors. In training the neural network we have used incoherent scatter radar (ISR) data from the Arecibo Observatory, solar flux data from National Oceanic and Atmospheric Administration (NOAA), and simulated data from the International Reference Ionosphere (IRI). The ISR data covers almost two solar cycles, which allows the network to make accurate predictions based on local time, seasonal, and solar cycle variations above Arecibo, Puerto Rico (18.21N, 66.45W). We demonstrate that neural network models are not only accurate predictors of dynamic systems, but also perform better than the commonly referenced IRI model.

typically used in training, which resulted in potentially large errors.

To make the long term forecast of an empirical model accurate, it is essential to use a training data covering at least one full solar cycle. In this study, data collected by the incoherent scatter radar (ISR) at Arecibo, Puerto Rico during the period of 1986 to 2000 were used for this purpose. In the following sections, we will describe the neural network model developed and the data preparation for training the neural work. A comparison between the neural network predictions with the actual data and the International Reference Ionosphere (IRI) model will be presented, followed by discussions and conclusions.

I. INTRODUCTION

Ionosphere propagation delay is the largest error source for single frequency GPS. At L1 frequency, the range error caused by one total electron content (TEC) unit ($1 \times 10^6/\text{cm}^2$) is about 0.163 m [1]. With tens of TEC units along GPS signal path through the ionosphere, ionosphere delays can account for position errors in the order of tens of meters. A common approach to reduce ionosphere propagation delay is to use ionosphere models to estimate the TEC. Although both empirical and first-principle models are now available to estimate the TEC, large errors often exist in these models because of the ionosphere variability. In order to reduce the positioning error of single frequency GPS receivers, it is imperative to have better ionosphere models.

The main objective of this paper is to report an empirical ionosphere model obtained using neural networks. The most common use of neural network modeling is in short-term ionospheric prediction, as in [2][3][4] [5]. Typical forecasting was accurate up to 24 hours in advance using a feed forward, multilayer neural network. These previous studies showed that neural network models are capable of making short-term predictions under normal atmospheric conditions. Ionosphere prediction under disturbed conditions still presents a challenge. The main focus of this paper is to report a model that is capable of long-term predictions under geomagnetic quiet conditions. Although modeling for long term prediction has been attempted [6], less than a solar cycle data were

II. THE MODEL

A number of neural network architectures can be found in the literature [7]. A feed forward neural network with back propagation was selected for this study based on previous modeling work experience and on careful examinations of parameters associated with the training data and expected outputs.

A four layer neural network is used in the model. The first layer contained four network inputs: local time t , solar irradiance flux $\Phi_{10.7}$, and two inputs $\sin(2\pi d_n/365)$, $\cos(2\pi d_n/365)$ which are related to day number d_n . The last two inputs are used to enforce the periodic nature of seasonal variation.

Although we initially trained for the geomagnetic index, K_p , as well, this index was taken out in the final model, which is further discussed in Section V. The second and third layers, or hidden layers, are the most important layers of the network. These layers determine how precisely the network will train and how much it is capable of learning.

The degree of complexity and consistency of the training data are critical factors in selecting network architecture design. In general, more complex data sets require more complicated networks for accurate simulation. Overly complicated network architectures will have adverse effects on model performance. For example, too many neurons in the hidden layers will result in extended training time and lead to overtraining which could introduce too much simulation variability and inconsistent results.

We chose to use thirteen hidden neurons in each of the hidden layers and fifteen neurons in the final layer as an optimum compromise between network complexity and performance. The fifteen neurons in the final layer correspond with the ISR measurements taken at fifteen different altitudes, ranging from 144km to 664km with 37km altitude increments. Tables 1 and 2 contain more details of the network architecture and training parameters.

Table 1
NETWORK TRAINING PARAMETERS

Network Architecture	feed forward
Performance Function	mean square error
Training Function	Levenberg-Marquardt backpropagation
Epochs	200
Momentum Rate	0.001
Goal	0.1

Table 2
NETWORK ARCHITECTURE SPECIFICS

Layers	Number of Neurons	Transfer Function
1	4	hyperbolic tangent
2	13	hyperbolic tangent
3	13	hyperbolic tangent
4	15	linear

III. DATA PREPARATION

The electron density data were taken using the incoherent scatter radar (ISR) located near Arecibo, Puerto Rico. The ISR data set used in the study contains about 210 days of electron concentration distributions from years 1986 to 2000. The altitude covers the majority of the ionosphere F-region from 144 km to 660 km with a height resolution of about 37 km. Readers are referred to [8] and [9] for a description of the incoherent scatter radar principles and the nature of the data taken by ISRs.

In training our neural network, we also used the 10.7 cm solar irradiance index $\Phi_{10.7}$ and the geomagnetic index K_p . Both indices were obtained from the NOAA website: <http://www.ngdc.noaa.gov>. The outputs of our neural network are compared against data from the International Reference Ionosphere (IRI). The IRI data was obtained from the NASA Goddard Space Flight Center website: <http://nssdc.gsfc.nasa.gov/space/model/models/iri.html>. A description of the IRI model can be found at the website and in reference [10].

Prior to training, the ISR data required a minimal amount of filtering and signal processing. Outliers and bad data points were eliminated and replaced by artificial data points based on linear interpolation. In order to evaluate the validity of the neural network, we selected four days in 1993 from the ISR

data as our control days. The selected dates, March 18th, June 16th, October 19th, and December 8th, all in 1993 were close to the summer and winter solstice as well as the spring and fall equinox to represent a variety of solar conditions. Data from these four days were excluded from the training data for the neural network model.

IV. RESULTS

Our validation results proved that the network model performed adequately for all of the control days. Fig. 1 includes three plots that demonstrate the basic validity of the network output by comparing the simulation with actual measurements and IRI model results. Fig. 1(a) shows the neural network simulation results. Fig. 1(b) is the actual data measured by Arecibo ISR. And Fig. 1(c) is the IRI model results.

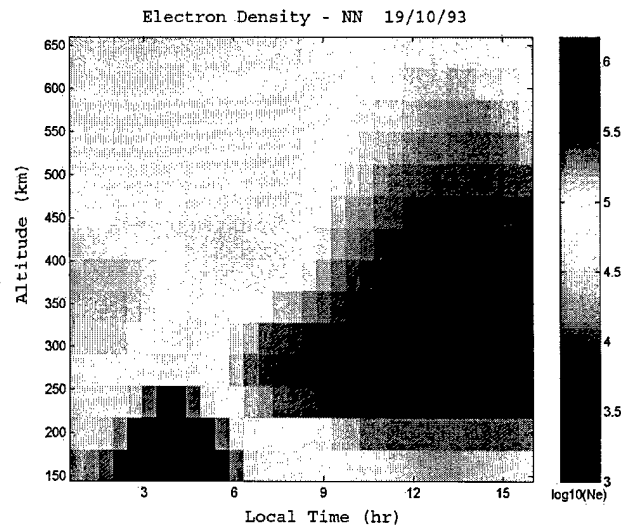

Figure 1(a)

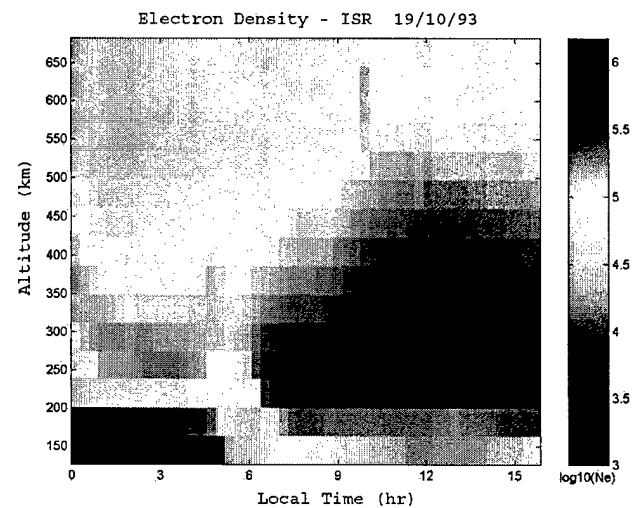

Figure 1(b)

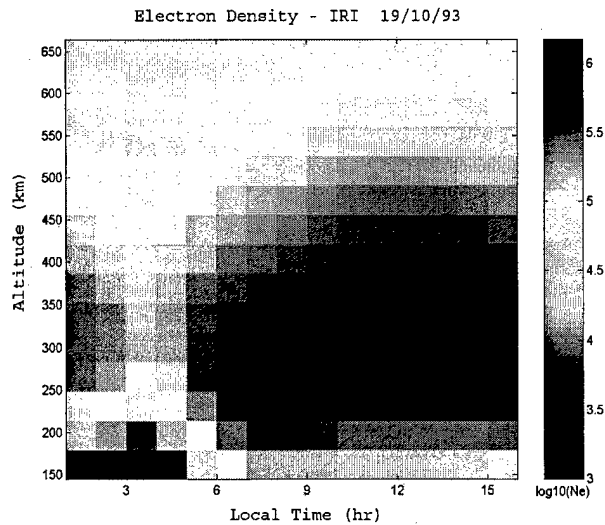

Figure 1(c)

Fig. 1. Electron concentration profiles above Arecibo, Puerto Rico, Oct.19th, 1993

- (a) Generated by neural network
- (b) Arecibo incoherent scatter radar measurement
- (c) IRI model output.

The color scheme in the figures is used to represent electron concentration values and it is in logarithm scale. The neural network simulated results captured most of the critical features of the ionosphere. For example, the peak ionization height and the peak density magnitude of the simulated results closely match those of the actual data. The neural network simulation has a well defined minimum around 500 local time (LT). This phenomenon has often been observed at Arecibo and is generally known as post-midnight collapse. The sharp reduction in the ionization is generally thought to be due to the reverse of neutral wind from the equator-ward direction before midnight to pole-ward direction afterwards. The post-midnight collapse in the actual data was not as pronounced as in the simulated data. This could be due to the variability of the neutral wind in the F-region or disturbances in the electric field.

The IRI model also contains the main features of the actual ionosphere. The three plots in Fig. 1 differ mostly on the onset time of rising ionization during the day above the F-region peak. This can be seen by comparing the contour represented at an electron density of $10^5/\text{cm}^3$. Slightly below 500 km, the neural network simulation shows that the ionosphere reaches a concentration of $10^5/\text{cm}^3$ at about 900 LT while the IRI model reaches the same level as early as 500 LT. The actual data shows that the 10^5 contour at 475 km occurs at a local time of about 800 LT. The neural network model does not have any knowledge of real physical processes. Its outputs are based solely on what were used in the training. The difference between neural network simulated results and the actual data should be within the natural variability of the data. The IRI model, meanwhile, is also an empirical model that uses Arecibo ISR data as part of

its input as well. It is not clear to us why the enhancement of ionization typically associated with solar ionization in the IRI model appears to occur much earlier than in the actual data.

Of particular interest is the comparison of total electron content (TEC) for the three types of data used in the above comparison. Since the ISR data we used only covers the altitude range from 144 km to 660 km, we will only use this altitude range to calculate the TEC. To distinguish this coverage from the true total electron content, we will use FTEC to represent the column abundance from 144 km to 660 km in TEC units (i.e., 10^{16} electrons/ m^2). Fig. 2 shows the FTEC comparison for the four control days, including Oct.19th, 1993.

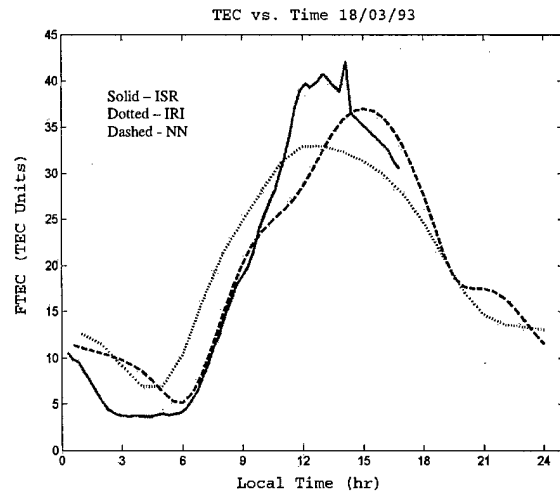

Fig. 2(a)

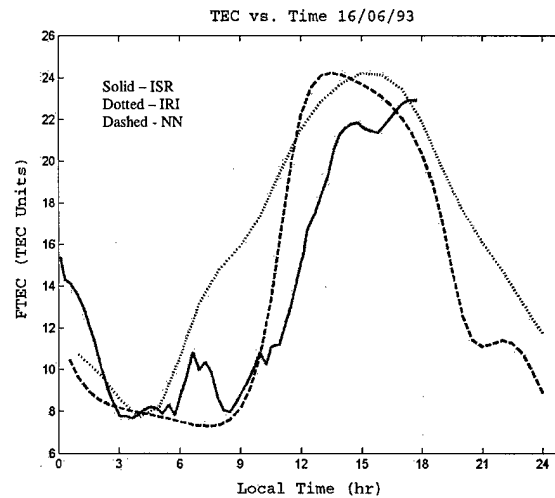

Fig. 2(b)

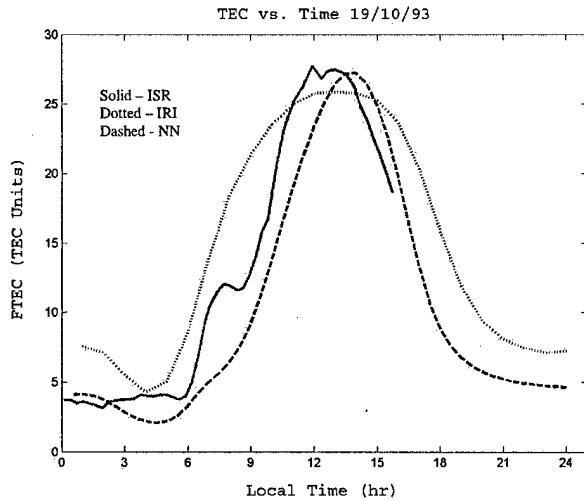

Figure 2(c)

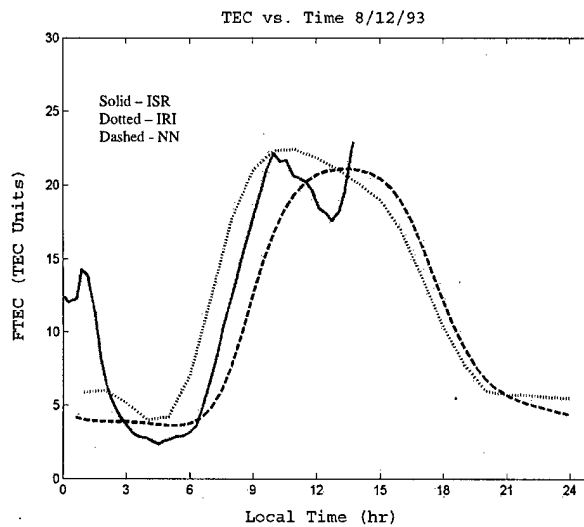

Figure 2(d)

Fig. 2 (a-d). A comparison of the F-region electron column abundance for March 18th, June 16th, Oct. 10th, and Dec. 8th, 1993. The solid line, dashed line, and dotted lines are for ISR, neural network model, and IRI model, respectively.

In general, the neural network simulation is closer to the actual data than the IRI model. In particular, the neural network model does a much better job than the IRI during the sun rising hours. For all the four control days, the IRI rising slope in the morning hours is ahead of the actual data. On the average, the rising slope of the IRI model is about 3 hours ahead of the actual slope. Although the rising slope of the neural network model does not always coincide with the actual data, the statistical average is about zero. We thus conclude that neural network model is more accurate in forecasting the TEC.

Our study shows that a neural network approach can be an effective tool to model the ionosphere. The advantages of such an approach are simplicity and flexibility. When training a neural network, we only need to specify the sequence of input parameters and target parameters. A neural network approach also allows updating the model without invoking previous data used, and models can be updated progressively.

We have modeled the electron concentration of the ionosphere using incoherent scatter radar data. If we are only interested in modeling TEC, dual frequency GPS receivers may potentially provide a much larger source of TEC data. Because satellites and receivers can be anywhere, it would be a formidable task to obtain a global TEC model using dual frequency data with a traditional modeling approach. Neural network modeling is particularly appealing in assimilating this type of data. In the neural network approach, we would simply use the satellite and receiver positions (in addition to date, time, solar cycle variation) as our input parameters and the measured TEC as our targets. As long as there is a sufficient amount of training data available, a reasonable TEC model, suitable for obtaining the TEC in any direction, can be fairly easily developed. We hope to be able to demonstrate this in the future.

As pointed out in Section II, this neural network model was not trained to account for geomagnetic index. It is well known that Kp has important ramifications on ionospheric modeling, and we did attempt to incorporate this parameter into our model. We realized early on that disturbances of this nature are very difficult to simulate due to the opposing effects that the same Kp may produce. Periods of high geomagnetic disturbance may result in abnormally high as well as abnormally low electron densities. Training a neural network to simulate for a target that does not have a consistent corollary will do little for accurate simulation. Although we did not train for Kp, we found that the neural network model did a reasonably good job of predicting under disturbed conditions. Fig. 2(d) had a Kp value of 6.2, which was higher than ninety percent of the model data. This day does not provide enough evidence to claim accurate prediction so we hope to include the effect of geomagnetic disturbance in future models. Such models will include an additional input parameter to differentiate uncharacteristic electron content caused by geomagnetic storms.

It should be pointed out that despite all of its advantages, a neural network typically does not shed any light on the physical process involved. When using base functions for modeling, it is easier to relate the output to specific input parameters, making physical interpretation somewhat easier. For this reason, a neural network approach is appropriate for applications where the objective is focused on the outcomes rather than the underlying processes. Since GPS users are mainly concerned with accurate position determination, a neural network model will provide the appropriate tool for ionosphere delay correction.

In conclusion, we have developed a neural network model to forecast the electron concentration in the ionosphere. The Arecibo incoherent scatter radar data from 1986 to 2000 were used to train our neural network, which contains 4 layers and 45 neurons. After experimenting with several types of neural networks, we found that the feed forward multilayer neural network performed the best. This neural network model is found to predict the ionosphere above Arecibo more accurately than the commonly used International Reference Ionosphere. Although our current neural network model is only applicable to a single location, we intend to expand it using existing data available at various data centers or TEC data collected by dual frequency GPS receivers. Such a model should be able to improve the positioning accuracy of single frequency GPS systems.

ACKNOWLEDGEMENT

The Arecibo Observatory is the major facility of the National Astronomy and Ionosphere Center, which is operated by Cornell University under a cooperative agreement with the National Science Foundation. CPM is supported by the Miami University through the Undergraduate Student Scholarship program, the Office for the Advancement of Research and Scholarship, and a research grant from the School of Engineering and Applied Sciences.

REFERENCES

- [1] Klobuchar, J.A. "Ionospheric Effects on GPS," Chapter 12 in Global Positioning System: Theory and Applications, Vol. 1, edited by Parkinson, B. W. and Spilker, J. J. Jr.s., AIAA Inc., 1996.
- [2] Boberg F., P. Wintoft, and H. Lundstedt, "Real time Kp predictions from solar wind data using neural networks," *Phys. Chem. Earth*, **25**, 275-280, 2000.
- [3] Wintoft P., Lj, R. Cander, "Ionospheric foF2 Storm Forecasting using Neural Networks," *Phys. Chem. Earth*, **25**, 267-273, 2000.
- [4] Martin, J. D., Y. T. Morton, Q. Zhou, "Neural network development for the forecasting of upper atmosphere parameter distributions," to appear in *Adv. in Space Research*, 2004.
- [5] Tulunay E., C. Ozkaptan, and Y. Tulunay, "Temporal and spatial forecasting of the foF2 values up to twenty four hours in advance," *Phys. Chem. Earth*, **25**, 281-285, 2000.
- [6] McKinnell L.A., A. W. V. Poole, "Ionospheric variability and electron density profile studies with neural networks," *Adv. Space Res.* **27**, 83-90, 2001.
- [7] Hagan, M. T., H. B. Demuth, and M. Beale, Neural Network Design, PWS Pub. Co., Boston, 1996.
- [8] Zhou, Q., "Two day oscillations of electron concentration in the lower ionosphere," *J. Atmo. Solar-Terr. Phys.*, **60**, 1669-1677, 1998.
- [9] Zhou, Q., and Sulzer, M.P., "Incoherent Scatter Radar Observation of the F-Region Ionosphere at Arecibo During January 1993," *J. Atmos. Solar-Terr. Phys.*, **59**, 2213-2229, 1997.
- [10] D. Bilitza, "International Reference Ionosphere 2000," *Radio Science*, **36**, No.2, 261-275, 2001.

The Miami Red Blade: An Autonomous Lawn Mower

Students: Brett McNally, Micah Stutzman, Collin Korando, Jeffrey Macasek, Christopher Mantz, Scott Miller
Advisors: Jade Morton, Scott Campbell, James Leonard
School of Engineering and Applied Science, Miami University, Oxford, OH

BIOGRAPHY

Brett McNally is a senior undergraduate student double majoring in Engineering Management and Manufacturing Engineering at Miami University.

Micah Stutzman is a senior undergraduate student double majoring in Engineering Management and Manufacturing Engineering at Miami University.

Collin Korando is a senior undergraduate student double majoring in Engineering Management and Manufacturing Engineering at Miami University.

Jeffrey Macasek is a senior undergraduate student double majoring in Engineering Management and Manufacturing Engineering at Miami University.

Christopher Mantz is a senior undergraduate student majoring in Engineering Management at Miami University.

Scott Miller completed his undergraduate study in Engineering Management and Manufacturing Engineering at Miami University in May 2004.

Dr. Jade Morton holds a BS in Physics from Nanjing University, China, a MS in Electrical Engineering from Case Western Reserve University, a MS in Systems Analysis from Miami University, and a PhD in Electrical Engineering from the Pennsylvania State University. She was a post doctor research fellow at the University of Michigan and is currently an Assistant Professor in the Department of Electrical and Computer Engineering at Miami University. Her research interests are digital signal processing, software GPS receivers, and modeling of the ionosphere.

Dr. Scott Campbell obtained his BSEE from Ohio Northern University, MSEE from Case Western Reserve University, and Ph.D. from Wright State University. He has over 15 years of industrial experience working for NCR and Lexis-Nexis. His teaching and research interests are security, mobile computing, distributed

computer, operating systems, networks, Internet and multimedia. He is currently an Assistant Professor of Computer Science and Systems Analysis at Miami University.

Mr. James Leonard holds a BSEE and a MSEE from The Ohio State University. Mr. Leonard was the Technical Director of the Reference Systems Branch of the Automatic Target Recognition Division of the Sensors Directorate, and the Air Force lead of the Computer Assisted Minimally Invasive Surgery dual use project with the Cleveland Clinic Foundation, Picker International, Ohio Aerospace Institute, and the Wright Patterson Medical Center. Jim Leonard currently directs the Automatic Target Recognition (ATR) Performance Assessment team of the AFRL Sensors Directorate and is an adjunct professor at Miami University.

ABSTRACT

This paper presents the design and implementation of an autonomous lawn mower, the Miami Red Blade. The lawn mower was created to enter the First Autonomous Lawn Mower Competition sponsored by the Institute of Navigation in June 2004.

1. INTRODUCTION

As an excellent successful example of technological innovation and ingenuity, the Global Positioning System (GPS) has widely been called a "utility", providing safe navigation and other functions freely to all without direct cost [1]. GPS has found applications in almost every aspect of civil lives. Yet, new innovative uses of this powerful technology continuously emerge. In September 2003, the Institute of Navigation (ION) announces the call for the First Autonomous Lawn Mower Competition to be held in Dayton, Ohio, on June 4~5, 2004 [2]. The competition will be judged by the time it takes for an autonomous lawn mower to mow a field with given field corner coordinates. The GPS receiver is a critical element in the autonomous mower design.

The subsequent document describes the general design of Miami University's GPS-aided autonomous lawnmower, the Miami RED BLADE, for the competition. Topics of discussion include a general overview of the lawnmower design, a description of the major sensing, control, mechanical, and safety components of the lawn mower. Performance of the current lawn mower and future modifications will also be presented.

2. MOWER SYSTEMS OVERVIEW

The autonomous mower can be broken down into a few basic building blocks: the sensing system, the control/PC system, the servo system, and the base lawnmower. The integration and functionality of each of these elements is imperative to the success of the robot. The following figure helps describe how these critical components interact and form the building blocks of the Miami RED BLADE.

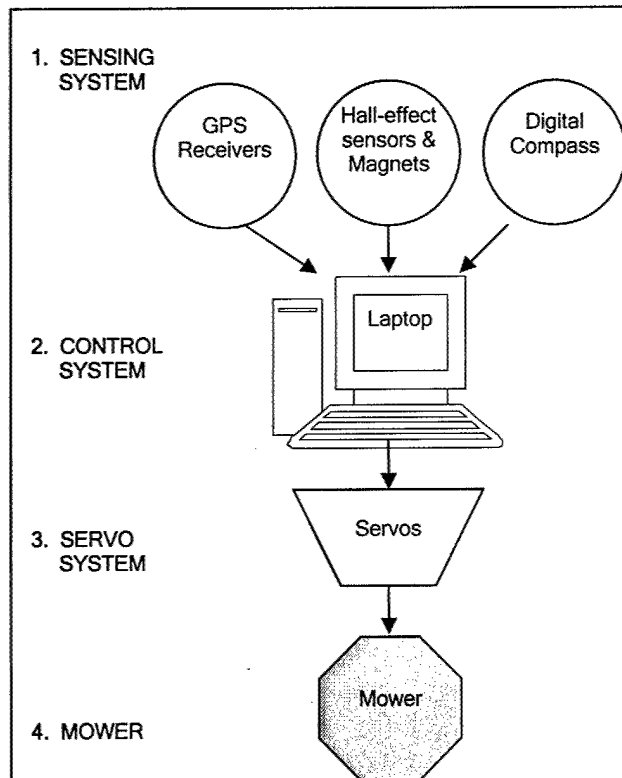

Figure 1: Mower System Overview

2.1. SENSING SYSTEM

The sensing system is comprised of three major inputs: a differential GPS (DGPS) receiver system, the hall-effect/magnetic speedometer, and the digital compass. The DGPS system consists of two low-cost Garmin GPS 16 receivers and custom carrier phase positioning calculation software. Conventional double differencing approaches were used in the carrier phase

computation algorithm [3]. This custom DGPS system generate precise user location measurements and determine, within 2cm accuracy, the relative location of the lawnmower referenced to the base station as it is running in the field. The drawback of the GPS system is the 1 second interval between position updates. If the lawnmower is moving at a maximum speed of 10km/h, the mower will travel 2.7m between location updates. This range is not acceptable to provide accurate navigation. For this reason, two more sensors are incorporated onto the RED BLADE to help track locations between GPS updates.

The Hall-effect/magnet sensor system is comprised of a series of twenty-four magnets affixed to each lawnmower drive wheel, and a Hall-effect sensor attached to the mower frame near the wheel. As the wheel rotates the magnets pass the Hall-effect sensor whose outputs are monitored by a microcontroller. The controller sends the magnet count of each wheel to the controlling computer, where travel distance and wheel speed can be calculated. The orientation of the mower is determined using a digital compass which updates every tenth of a second. This provides heading direction and information as to the mower's orientation in space. Combining these inputs allows for the mower's position to be monitored. The data from these two instruments and from the GPS receivers is sent to the control system where it is used to help make decision to navigate the mower.

2.2. CONTROL SYSTEM

The control system consists of an on-board laptop computer and a collection of computer programs integrated into one guidance algorithm. The control software consists of three major parts: (1). High level path planning, coordinate transformations, and field layout interpretations; (2). A PID control loop that constantly compares sensor inputs with the ideal path prediction provided by the path planning algorithm, computes necessary corrections to the mower speed, acceleration, position, and heading; (3). Low level interface programs between the control loop and the sensors and actuators. Additional utility types of software were also created to forecast satellite availability, testing field setups, mower state monitoring and tracking, etc.

Part (1) and (2) of the control software are written in Matlab. The low level interface programs are written in C and Java. Path planning will be performed prior to operation of the lawnmower. The control loop will be executed sequentially while the low level interface programs are multi-threaded event-driven processes. Several alternative mowing paths are being investigated.

2.3. SERVO SYSTEM

The above control algorithm is able to generate information as to the speed each wheel should be traveling; however, this information does nothing to physically interact with the mower controls. To achieve this correspondence, team Miami needed to incorporate a servo control system into the mower. The servos are attached to the control shaft of the hydrostatic pump on each wheel. The position of the control shaft determines how fast each wheel will move. By rotating the control shaft, the wheel will either move in forward or reverse. The servos are then attached to the control shaft through a gear system; where they convert voltage inputs into physical movement. By controlling the position of each servo, the speed and location of the mower can be controlled and/or predicted. Two sets of Compute Motor's OEM 770X servo motors and controllers donated by Parker Hannifin were used on the lawn mower.

2.4. BASE MOWER

A commercial grade 42-inch hydrostatic lawnmower was chosen as the base unit of RED BLADE. The major reason to choose the hydrostatic mower was the capability of controlling each drive wheel independently. Meaning, the speed and direction of the left wheel could be controlled independently of the right. This feature allows for turns and straight line cuts to be made using computer control. Many other mechanical features were added to the mower to make it self sufficient and user friendly. These modifications include several key features that will be described in the latter portion of this document. Major mower modifications include the following: the electrical system, kickstand, sensor placement (GPS, magnets, compass), servo connections, carrying case, and safety features. All modifications were made to comply with competition rules.

3. SENSORS

3.1. GPS

The GPS system is the key navigation component of RED BLADE. The selected GPS product and design for RED BLADE is a custom differential GPS system developed for this project. This system consists of two Garmin GPS16 receivers communicating through a set Freewave radio modems, and custom carrier phase processing software. Test shows that this system is capable of generating relative position accuracies within 2 cm.

Several GPS receiver systems were studied for use on RED BLADE. These receiver systems were tested for accuracy and cost efficiency. Ultimately, high position accuracy was the most desirable feature to be obtained for

the team's lawnmower. For this reason, a dual unit custom differential system was selected.

The dual receiver differential system was initially tested for both stationary as well as dynamic motion. The unique system was developed using two low cost Garmin GPS16 receivers. One unit acts a stationary base station and the other is a moving rover unit located on the mower. Communication between the two units is achieved through a set of Freewave spread spectrum radio transceivers. The figure below shows the setup of the differential system.

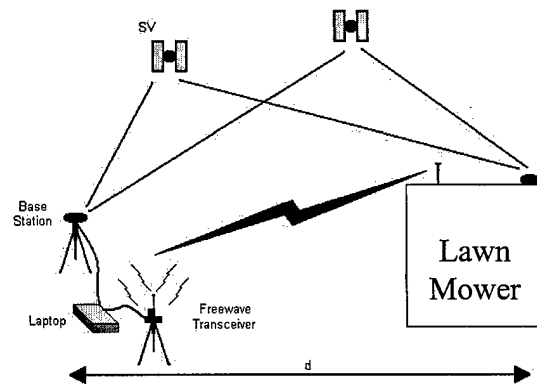

Figure 2: Garmin GPS16 Differential System Setup

The differential processing software has two major components: (1) GPS receiver data acquisition, and (2) Relative rover to base station position calculations using carrier phase measurements. The figure below provides a conceptual explanation of the principles behind the carrier phase differential technique. For two GPS receivers A and B, separated by a short distance d , the signal from the satellite to each receiver can be considered parallel (d is short compared to receiver to satellite distance). A given reference point in the carrier signal from the same satellite arrives at the two receivers at different times. This time difference is characterized by ϕ , the carrier phase difference, derived from the two receiver measurements. The phase difference consists of N (full) + Δ (partial) cycles of the carrier. This phase difference is the so-called single differencing which contains errors associated with receiver clock offset, multipath, etc. Further differentiating the phase difference between two satellites leads to the so-called double differencing which eliminates the user receiver clock error contribution.

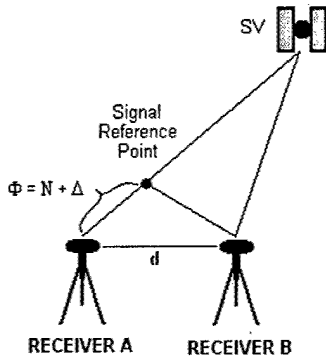

Figure 3: Carrier Phase Diagram

Using carrier-phase measurements to obtain relative position readings between two receivers has been an ongoing research topic for many years. In the RTK algorithm developed for the lawn mower project, we took into consideration of the short baseline length between the base station and rover. An additional consideration is the given to the fact that we can accurately measure the initial baseline length so that a small the integer ambiguity search space is required, thereby allowing the processing software to resolve the integer ambiguity quickly and accurately. Single point as well as dynamic motion testing of the Garmin GPS16 differential system has led to very accurate results. Measurements and data collected from several tests provided relative position accuracies of less than 2cm.

The accuracy level allows for precise positioning and control of the lawn mower to take place. The GPS unit provides position updates every 1s. Combining these position updates with continuous magnetic counters and the digital compass creates a very reliable and accurate position sensor system.

The GPS receiver was placed on a 1m tall platform located above the intersection of the center of the mower and the wheel axel. The platform was constructed of PVC plastic as shown in the picture. The platform itself is supported using steel unistruts and t-joints. These struts were bolted to the steel frame of the mower. The purpose of the 1m platform is to provide the receiver with a clear view of the sky and satellites.

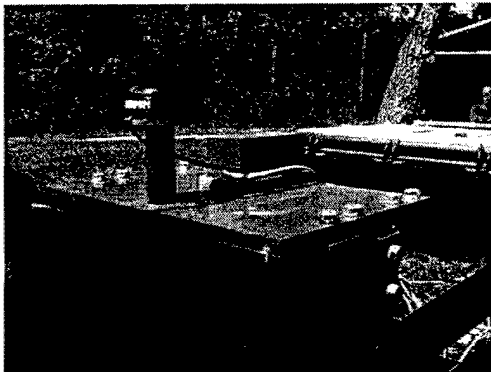

Figure 4: Garmin GPS16 Receiver and Stand

3.2. HALL-EFFECT/MAGNETIC SPEEDOMETER

The purpose of the magnetic sensing system is to predict the mower's location in between GPS updates with the assistance of the digital compass. The GPS system produces position updates approximately every second. For control purposes, it is crucial to determine the mower's location more frequently than this 1 second time interval.

The custom sensing system developed consists of 24 magnets and one Hall-effect sensor for each wheel. The sensors are monitored using a Parallax BS2e microcontroller [4].

The magnetic system required some mechanical modification to the mower and wheel hubs. The inner hub of each wheel was inlaid with a series of 24 small magnets. These magnets were spaced precisely at every 15 degrees around the inner hub at a specified radius. Each magnet location was milled, inlaid with the magnet (North facing out), and set with polyurethane glue. A small bracket was machined and bolted to each side of the mower to secure the Hall Effect sensors at the correct locations. Extension wires connected the sensors directly to the BS2e microcontroller lying within the protective electronics case.

As the tires rotate, the sensor detects the magnetic fields, and software counts the number of magnets that pass by the sensor. The spaces between the magnets represent 2.125 inches of the outer diameter of the tire. For example, if the sensor detected 8 magnets, it may be derived that the contact point between the tire and the ground has moved 17 inches (8×2.125). In other words, the wheel traveled 17 inches. Using a magnetic system on each tire allows the main control program to calculate relative mower positions with the assistance of the digital compass. Throughout any given elapsed time, the magnetic system can be used to determine how far each wheel has traveled. Taking readings from these two sensors allows for precise positions to be predicted in between GPS updates. The BS2e microcontroller monitors the magnetic systems continuously. This system is reliable in the short run, but position errors may accumulate in the long run. For this reason, this system works in conjunction with GPS which provides guaranteed positioning independent from the movements of the wheels.

The white hub of each wheel is inlaid with 24 magnets set at every 15 degrees. The Hall Effect sensor located at the end of the blue wires detects the magnetic field as each magnet passes. This input is monitored using BS2e microcontroller, hardware, and software.

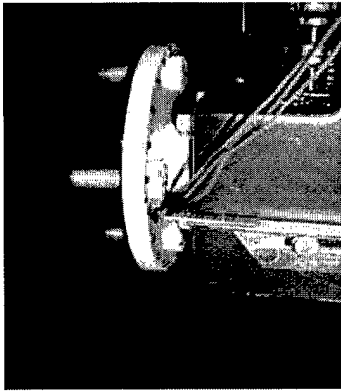

Figure 5: Magnets and Hall Effect Sensor

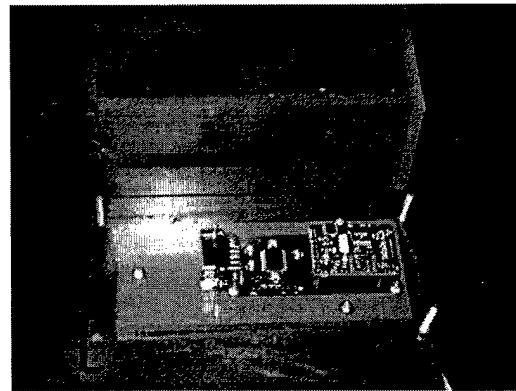

Figure 6: Digital Compass

3.3. DIGITAL COMPASS

The purpose of the digital compass is to provide the control program with an orientation reading of the mower. The mower's orientation with respect to the designated field is a critical element to the lawnmower control. At all times, it is imperative to know which direction the mower is facing. The compass is a major component of position determination working in conjunction with the Hall-effect/magnet system.

The digital compass is a two axis HRM 3200 compass donated by Honeywell. A two-axis compass is limited to one plane of reference and would be unable to detect the pitch and roll of the mower. The digital compass communicates through a serial port connection with the central control computer. It outputs a reading between 0 and 360 degrees, with a resolution of one tenth of a degree. 0 degrees corresponds to a heading of due north. The compass then sweeps through every 90 degrees with 90 being east, 180 being south, and 270 being west.

The compass is in operation at all times. At any point the control program may check the compass serial port and gather a reading. Programs to read from the serial ports have been written in both C and MatLab. The compass readings are utilized to predict and plot the location of the mower in combination with the magnet sensors and GPS receivers.

The compass was initially calibrated post its installation onto the mower. The RED BLADE is made of several different types of metals and combines a series of electronic components. These materials and components alter the magnetic environment of the compass. The compass was calibrated using Honeywell procedures to help adapt it to the lawnmower.

The digital compass was mounted on a PVC platform located over the center of the mower. A key feature of the installation of the compass was to align it on center and perpendicular to the wheel axis. This ensures the compass orientation readings are correlated to the forward travel direction of the mower.

4. CONTROL

4.1. PURPOSE

The control system is the brain of the lawnmower. It makes logical decisions to be implemented by the lawnmower while operating in the field. The control system utilizes 3 sensor inputs during operation and several user inputs before operation. Inputs provided by the user include the type of mowing pattern to be performed and the four corners of the field. Sensor inputs include mower orientation from the compass, GPS position and velocity inputs, and magnetic wheel readings. Based on these inputs and the field of operation, the mower makes decisions and sends outputs to the servo drive system to navigate the mower. Programming languages used for the control system include MatLab, C, and Java. The high level operating control system and GPS positioning are carried out by MatLab. C is used to implement the low level hardware driver functions. Java applications were written to provide communication between the C codes and the control algorithm. Java is also used in implementing the user interface of the control as well as data log and system monitoring.

4.2. OVERVIEW

The following figure provides an overview of the control software. The control program consists of three major steps in conjunction with sensor inputs.

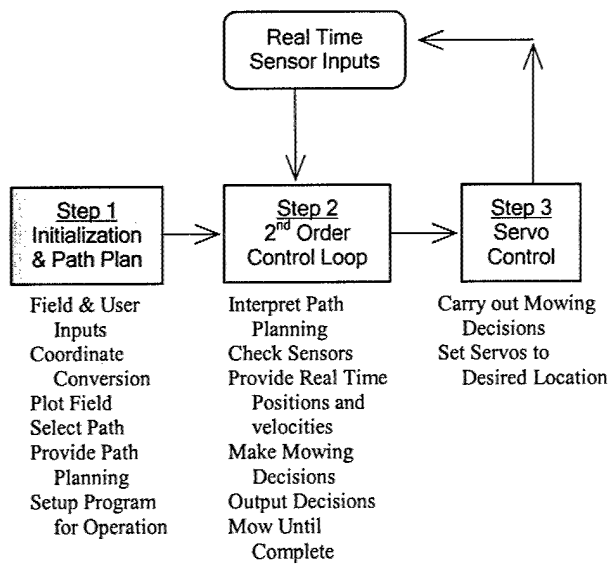

Figure 7: Control System Overview

4.2.1. PATH PLANNING

Initializing the control program requires several actions to take place. The major actions to address include setting up the field to be mowed, setting a designated mowing path within that field, and inputting other user requests.

The field is created based on the coordinates of the 4 corners provided by the competition committee and input by the user. These corner points are designated as latitude/longitude positions. Following, the field is transposed into the field xy-absolute measurements. The absolute field may then be plotted. To account for the orientation of the field with respect to the earth, the direction north is also determined relative to the field. All latitude and longitude positions are transposed to relative absolute coordinates with respect to the field from this point forward. Using absolute positions allows for other sensors that only detect the surrounding environment (such as the magnetic system) to be used along with GPS.

Following the creation of the field, a predetermined path or route of the lawnmower can be created within that field. These mowing routes are designated with path IDs and can be referenced at any time through the control loop. Designating a path for the mower to follow is used to keep the mower on track at all times by comparing the path to the positions determined using the sensor inputs. A multiple number of path options can be used or created. The types of paths that have been created for RED BLADE include: mowing an up and down pattern, including a perimeter mow, and mowing a spiral type pattern similar to a Zamboni.

Other user inputs for the control program include setting a maximum speed, acceleration parameters, and geometric parameters such as the blade size and the amount of mowing overlap. Further inputs are also

incorporated into the program. One example is a sky monitor which represents satellite paths at any time and day. This monitor is used to help inform the GPS program which satellites should be tracked.

4.2.2. CONTROL LOOP

The main control loop provides the basic structure to run and operate the lawnmower autonomously. The system consistently checks and monitors the lawnmower's position and compares this position to a desired location determined by path planning. The following diagram shows the basic control loop.

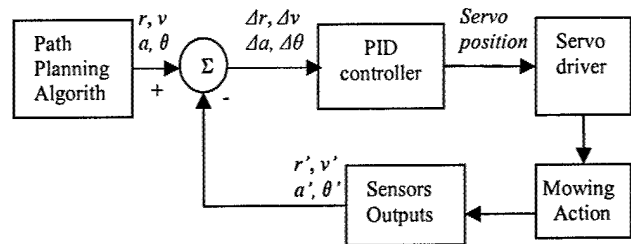

Figure 8: Control Algorithm Block Diagram

The path planning algorithms generates ideal mower states for a given instant of time during the mowing operation. The state variables include the position, velocity, acceleration, and mower orientation. This ideal set of state variable values is compared with the actual state generated by sensors on the lawn mower. The difference between the ideal state and the actual state are feed to a simple PID control loop in which the desired servo positions for both the left wheel and right wheel are determined to bring the mower to the idea state. The servo position is sent to the servo driver which in turn drives the mower to the desirable mowing path.

A major challenge for this control system is the rate of sensor inputs. Ideally, the mower needs to be monitored nearly continuously to ensure that its operation remain stable throughout its operation. To increase system stability, several tests have been conducted to measure changes in the control gain versus input sampling rate. The sampling rate is how often the sensors provide signal updates. Time intervals between updates may not be exact for each sensor and cannot be controlled. Rather, when a sensor update is provided, the control program needs to immediately take it and use the information for its decision making. During operation, the sampling rate cannot be controlled; the gain in the control system however can. By continuously tracking the sampling rate throughout operation, the control system can alter the control gain accordingly. Results of this system have provided the mower with stable operation control.

Another important issue in the control software is to ensure all the sensors are correlated in real time. The reason for this is because of potential time delays in processing software and signal transmission. For

example, if a GPS input is used 1 second after it arrived (real time), the control program would think its current position was the GPS input. In reality, the mower, operating at top speed, may have moved up to 3 meters in that time interval. These timing errors could be detrimental to the mowing operation. To ensure measurements from all sensors are correlated properly, it is imperative to time tag sensor inputs using the computer internal clock.

4.2.3. SERVO CONTROL

The servo control program encapsulates the control commands from the laptop to the servo microcontroller. These commands follow the specific language for the microcontrollers set by Parker Hannifin. Basic commands include initializing the servos, calibrating the servos, and sending the servos to a specified location. Programs written in Matlab, C, and Java are used to communicate these commands to the servo controller.

Initialization of the servos involves tuning the servos to the proper acceleration, torque, velocity, and location. An init program was created to run these procedures. Where ever the servos are located at the time of the init is set to be the zero point of the servo. Calibration procedures are written to ensure the zero point of the servo can be set to the same location for every mowing operation.

Once the servos have been initialized and calibrated, they are ready for operation. Commands used during operation involve specifying and sending the servo to an exact location. Each location on the servo corresponds to wheel speed. By controlling these servo locations, wheel speeds can be adjusted, and the mower can navigate accordingly. Programs in C have been developed to send commands as well as provide wheel speed feedback.

5. SERVO SYSTEM

The purpose of servos (actuators) is to provide a mechanical means of controlling the lawnmower. The actuators are the link between control software and mower movement. In the case of the RED BLADE hydrostatic lawnmower, the servos are used to replace the actions of the handlebars.

It is important to first understand what type of mechanical action is required by the servo. Initially, the handlebars were connected to a lever for each wheel. This lever, when moved, caused a valve to open and close on the hydrostat motors. Opening the valve causes fluid to circulate throughout the motor. This circulation drove the wheel's rotation. The higher amount of fluid flow allowed for a quicker rotation of the wheel. Reversing the direction of the fluid by moving the valve in the opposite direction would cause the wheel to rotate in reverse. Rather than using handlebars to control the opening and

closing of the hydrostat motor valves, servos were used instead.

Two Neometric series rotary servos from Parker Hannifin provide the actuator control of the Hydrostatic motors. A microcontroller accompanies each servo. The size of the servo is 70mm x 92mm. They can provide a maximum of 6-61 lb-in. of torque.

The servo drives are used to control the location of the hydrostatic valves corresponding to each wheel. Precise locations of these valves are imperative to controlling the lawnmower's speed and position. A great deal of time and efforts was spent calibrating the servos to ensure they provided the correct amount of torque and power to control the hydrostats properly.

The servo drives work hand-in-hand with the control software. The control software sends an output to the servo controllers to designate a position each servo should be located at. These positions translate into a corresponding wheel speed. It is imperative that the zero location of the servo is the same for every mowing operation. If this is not the case, during one operation a servo location of 100 increments may be .5 m/s and at another time it may be .2 m/s. This discrepancy could cause serious operation problems. The following table is an example of possible servo positions and their corresponding speed.

Left Servo Position	Left Wheel Speed	Right Servo Position	Right Wheel Speed
100	1.000 m/s	100	0.950 m/s
120	1.025 m/s	120	0.980 m/s
200	1.300 m/s	200	1.100 m/s
500	2.600 m/s	500	2.300 m/s

Table 1: An Example of Servo Positions versus Wheel Speeds

This type of table can be created for each wheel and span over many servo position increments. This table can then be used to set wheel speeds properly and alter relative speeds up and down in order to control the path of the lawnmower. A feedback system has also been developed to monitor if the location chosen matches the correct speed. If necessary, alterations can be made.

A custom 3:1 gear ratio was developed and used on the servo drives. The larger gear is attached to the hydrostatic valves, the smaller gear is attached to the servo, and a rubber drive belt interconnects the two. This gear system improves the location accuracy of each servo and minimizes the torque required to keep the servo in place. An aluminum stand and bracket system has been manufactured on the back of the mower to support the servos and align them properly with the hydrostat motors.

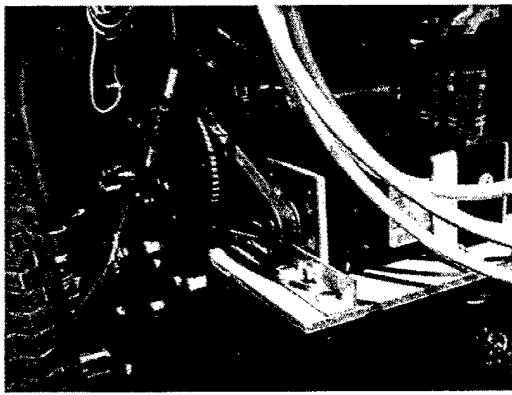

Figure 9: Servo Gear and Support System



Figure 11b: After Picture Front View

6. MOWER MODIFICATIONS

6.1. OVERVIEW

Many mechanical modifications were implemented onto the mower. These modifications were necessary to provide RED BLADE with the proper structure, support, and protection for all of its components. Other modifications were necessary to provide safety and ease of use when operating. Several specific mower modifications include the servo support system, the protective Pelican electronics case and stand, the dash board, the kick stand, the GPS and compass stand, the magnet sensing system, and the wiring. The following is a before and after photo of the RED BLADE.

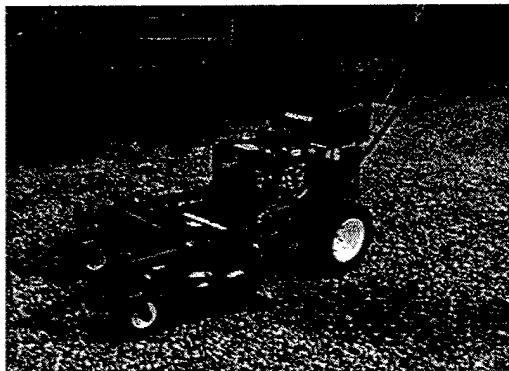

Figure 10: Before Picture

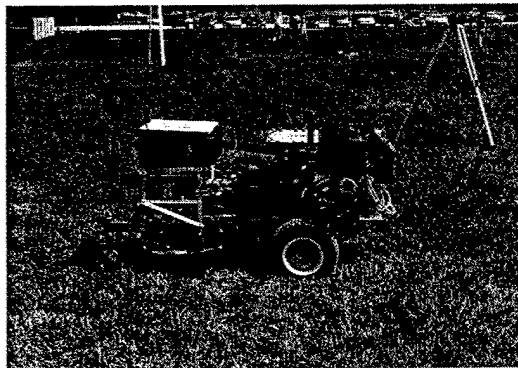

Figure 11a: After Picture Side View

6.2. SERVO SUPPORT

The servo support system was briefly described under the actuators subsection. The support system was manufactured out of 0.25" aluminum stock. Aluminum brackets were aligned on the support pad to jive with the orientation of the hydrostat valves. Each gear in the servo system was keyed to prevent slippage during operation. The gears were then attached to their proper locations using set screws and set pins. The rubber belt provides the mechanical translation of motion from the servo drives to the hydrostat pumps.

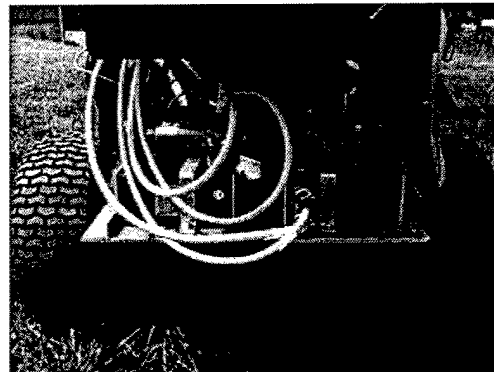

Figure 12: Servo Support

6.3. PROTECTIVE CASE

The pelican case harbors and protects the control system of the autonomous lawnmower. Components located within the case include the laptop computer, the servo microcontrollers, the Basic Stamp, and the Freewave modem. It is essential for this protective waterproof case to protect the sensitive equipment by dampening lawnmower operating vibrations. The pelican case is supported and lifted off the deck of the lawnmower to allow ample clearance for the servo batteries. A custom stand was manufactured using 0.125" thick angle iron.

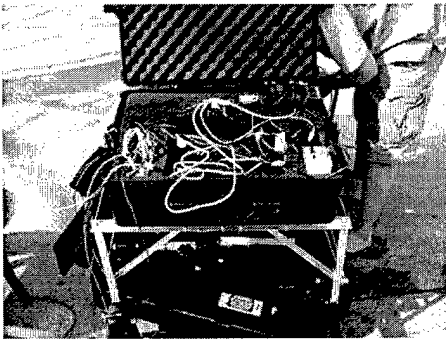

Figure 13: Protective Pelican Case

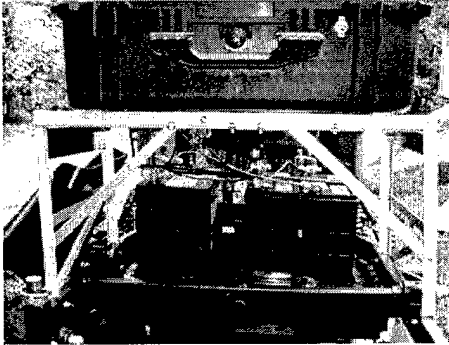

Figure 14: Support Stand and Batteries

6.4. DASHBOARD & SAFETY

A custom dashboard was created to contain the appropriate user operating devices that were previously located on the handlebars. Initially, the handlebars did not meet ION specifications for mower height. They also inhibited autonomous control and were therefore removed. Key features such as the throttle, ignition, and blade control were moved from the handlebars to the dashboard. For safety, an emergency stop switch was placed on top of the dashboard. This stop was hard wired into the kill switch of the ignition. An R/C E-stop was also mounted on the back side of the dash. The R/C stop allows on operator to remotely kill the engine from a safe distance.



Figure 15: The Dashboard

6.5. KICKSTAND

A user friendly modification made to the lawnmower was a kick stand shown in the following figure. The kick stand, modeled after a typical dirt bike kick stand, decreases the amount of effort and time to raise and lower the lawnmower. Utilizing the kickstand allows for ease in testing and calibration procedures. The kickstand is manufactured out of aluminum stock and connected with nuts and bolts. An iron rod provides a lever arm to lift the mower up and down.

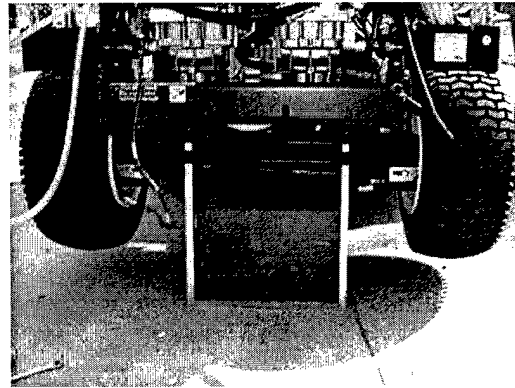

Figure 16: The Kick Stand

6.6. GPS STAND

The GPS and compass stand can be seen in the figure below. The basic function of the PVC stand is to provide the compass and GPS receiver with a safe and supported location for operation. The stand is made out of .5" PVC and is supported using 2 unistrut beams and t-joints. The GPS receiver is raised above the stand to help eliminate potential multi-path errors as well as provide the GPS antenna with a clear unobstructed view of the sky. Further, the compass was positioned directly over the central axis of the lawnmower to provide accurate orientation readings.

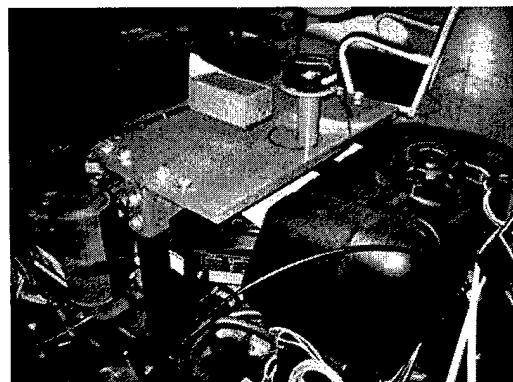

Figure 17: GPS and Compass Stand

6.7. WIRING

The last modifications made to the lawnmower included wiring the components and providing on/off switches for power. Generally, all wires needed to run from the pelican case at the front of the lawnmower to the equipment located at the back of the lawnmower. Prior to doing so, two facts were considered: the hot exhaust system located on the left side of the mower and the necessity to keep the pelican case waterproof. To accommodate these facts, a waterproof 4" diameter PVC pipe was ran along the right side of the mower. The pipe avoided the hot exhaust and provided a channel for all wires to run through. After running these wires 2 power switches were also added. The car batteries were wired in series with an on/off switch located on the opposite side of the pelican case. The 36 volts from these batteries provides ample power to the servo drive systems. The GPS receiver, compass, radio modem, and BS2e were wired to another switch and were supplied with 12volts of DC power. These switches and wiring techniques minimizes potential hazards and problems.

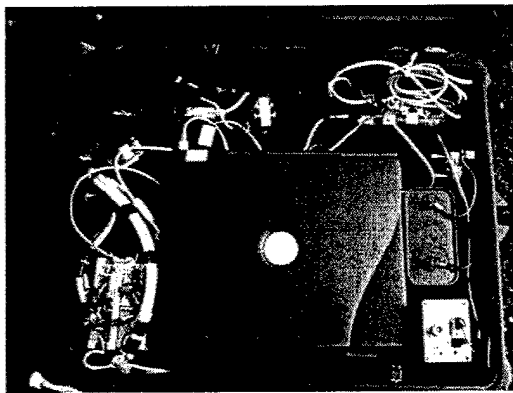

Figure 18: Electronics Case

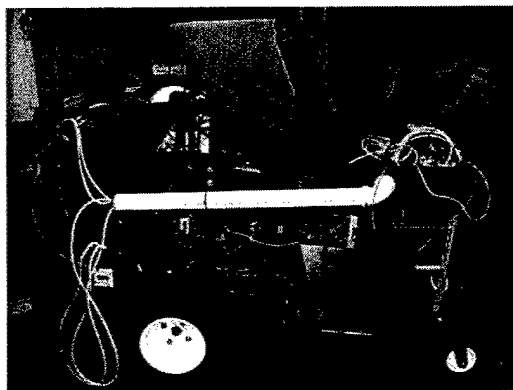

Figure 19: The Wiring

7. CONCLUSIONS AND FUTURE THOUGHTS

The Miami RED BLADE combines many mechanical, sensing, navigation, and control features to

create the ultimate lawn mowing machine. The machine is an intelligent robot responding to its environment through a series of several sensors. The autonomous lawnmower is able to make operating decisions based on its determined environmental location and user defined information. These decisions are carried out through a servo controlled drive system. Together these systems provide autonomous operation to any owner whom may kick back and relax in the shade.



Figure 20: The field mowed by Miami Red Blade during the First Autonomous Lawn Mower Competition. The blue line marks the field boundary.

It is the hope of this team for this project to continue in Miami University's future. This is only the beginning of autonomous lawnmower design. The RED BLADE prototype provides the basic structure for advanced lawn cutting robots. Future considerations of the mower will involve integrating several other sensing systems and safety features. These systems would allow for obstacles such as trees, gardens, houses, pets, and children to be avoided throughout the mowing process. Other features will allow users to track the perimeter of their lawn one time to teach the mower the field layout. Following, the mower could save this information and mow accordingly. Control software can be continuously improved and new sensors and components can always be added to make the mower more efficient, accurate, and less costly.

8. ACKNOWLEDGMENTS

The following individuals and organizations have provided valuable support in various forms such as financial assistance, technical support, inspirations, and equipment donations/discounts towards the creation of the Miami RED BLADE. This work is not possible without their contributions.

- ❖ Institute of Navigation (ION)
- ❖ Miami University School of Engineering & Applied Science
- ❖ Miami University Office for Advancement of Research and Scholarship

- ❖ Miami University Page Center for Entrepreneurship
- ❖ Snapper
- ❖ John Deere
- ❖ Outback Guidance
- ❖ Freewave Technologies
- ❖ Parker Hannifin
- ❖ Pelican
- ❖ Honeywell
- ❖ AutoZone
- ❖ Mr. Frank Boynton (Navtech GPS Supplies)
- ❖ Dr. Anthony Choi (Miami University)
- ❖ Mr. Don Dunkleburger and Joe Macke (Snapper)
- ❖ Dr. Marek Dollar (Miami University)
- ❖ Mr. John Furrey (Parker Hannifin)
- ❖ Mr. Ted Hemmelgarn (Richard Equipment)
- ❖ Mr. Mike Hinegardner (Parker Hannifin)
- ❖ Dr. Jay Kayne (Miami University)
- ❖ Mr. Rodney Kolb (Miami University)
- ❖ Dr. Mikel Miller (AFRL)
- ❖ Mr. Ryan Moore (RECO)
- ❖ Dr. Gilbert Pacey (Miami University)
- ❖ Dr. John Raquet (AFIT)
- ❖ Mr. Jeffrey Peterson (Miami University)
- ❖ Mr. Jeffrey Riggs (ASIC Corporation)
- ❖ Mr. Don Reed (Pelican)
- ❖ Mr. James Roberts (Keyence)
- ❖ Mr. Jay Schamus (General Dynamics)
- ❖ Nick Schubert (Novatel)
- ❖ Mr. William Silva (Novatel)
- ❖ Dr. Amit Shukla (Miami University)
- ❖ Mr. Stu Merkamp (John Deere)
- ❖ Dr. Frank van Grass (Ohio University)
- ❖ Mr. Ken Weis (Honeywell)
- ❖ Dr. Qihou Zhou (Miami University)

References

- [1] Mcneff, J. G., "The Global Positioning System," IEEE Trans. On Microwave Theory and Techniques, Vol. 50, No. 3, pp645-652, March 2002.
- [2] <http://www.ion.org/satdiv/lawnmower.cfm>
- [3] Raquet, J. "A Short Course on Carrier Phase DGPS," Given to AFRL/WPAFB in fall 2003, at AFRL/SNRP, Wright patterson Air Force Base.
- [4] <http://www.parallax.com/>

Just Keep Rolling a Lawn

ION's Autonomous Mowers



You might not know it from your own backyard performance, but mowing a lawn accurately and precisely constitutes a difficult systems problem, requiring centimeter-level accuracy and precision control for straight lines and smooth turns. Three student teams answered the Institute of Navigation's call to produce a smarter-than-the-average lawnmower.

Mikel Miller, John Raquet, Jade Morton, Frank Van Graas, Boris Pervan, and Laura O'Rear

As industry and society continue to make GPS navigation systems part of daily life, some frontiers remain unexplored. Take lawn mowing, for example. Who has not, while sweating behind a lumbering mower on a hot day, wished that a robot would do the job, while we sat in the shade sipping lemonade? The Institute of Navigation's (ION) Dayton Section, located in southern Ohio — well known for large lawns and hot, humid summer days — did something about this by hosting the First Annual Autonomous Lawnmower Competition. Sponsored by ION's Satellite Division, the event sought to inspire college students to pursue navigation-related research projects and a career in this field.

The competition took place June 4–5, 2004, at Rotary Park in Beavercreek, Ohio, prior to ION's 60th Annual Meeting in Dayton. The top three teams received cash awards for mowing the most lawn in the shortest time. Teams also submitted detailed reports

on mower and navigation system designs, prototype cost, and projected production cost. Judges evaluated mower production costs for reasonableness, and added penalty seconds to the total time score for high-cost designs.

The teams displayed their labor-saving devices during the Annual Meeting and made 20-minute presentations, and ION publications and announcements provided international recognition. Organizers plan to feature all three mowers at ION GNSS 2004 in Long Beach, California, in September.

The Illinois Institute of Technology (IIT), Miami University — Ohio, and Ohio University participated in the inaugural competition. Student teams worked closely with faculty advisors to design and build "smart" lawnmowers that could self-navigate and cut rectangular areas of approximately 150 square meters.

The teams received world coordinates for their respective fields' corners. The lawnmowers were to mow assigned areas without going outside a three-

BEST AVAILABLE COPY

meter safety zone. The team that cut the most grass in the shortest time, after taking into account time penalties, was crowned the winner. Any time spent outside the mowing field but within the safety zone was converted to a time penalty.

Each team had a unique design (see following sections), and all mowers cut some portion of the playing field. Ohio University's mower was the fastest and cut approximately 13 square meters of grass in less than a minute before the mower stopped near the center of the field. After observing the mower in this position for more than a minute, the Ohio University team remotely stopped its mower and informed the judges that the team's final attempt was over.

Miami University's mower actually mowed more grass than Ohio University — approximately 18 square meters — before it left the designated safety buffer area and had to be remotely stopped. Since approximately 5 square meters of the cut grass lay outside the designated mowing area, time penalties were assessed, negatively affecting its final score.

The entrant from Illinois was attributed a symbolic 0.5-square meter for passing the qualifying tests and showing the robust functioning of its system; last-minute difficulties, explained later, prevented the team from demonstrating full vehicle performance.

Based on these scores, Ohio University took first place and a check for \$2,500, Miami University received \$1,500 for its efforts, and Illinois Institute of Technology won \$1,000.

In addition to the mowing competition, each team's technical reports and production plans were judged for technical content, clarity, and format. BearingPoint, a business consulting and systems integration firm and event sponsor, awarded Miami University's team a \$1,500 check for first place in the Best Report portion of the competition.

Design Rules

Lawnmowers must be autonomous and unmanned and cannot be remotely controlled during the competition. All navigation equipment (except a GPS differential base station), controls, and power must be carried by the lawnmower.

For safety, the maximum lawnmower speed is limited to 10 kilometers/hour.

Each lawnmower must be equipped with both a manual and a wireless remote emergency stop capability.

Lawnmower dimensions cannot exceed 2.0 meters length, 1.5 meters width, and 1.0

meter height. Cutting width cannot exceed 0.5 meter and weight cannot exceed 250 kilograms.

Lawnmower movement must be accomplished through direct contact with the ground, and power must come from combustible fuel, batteries, or both.

Safety. Judges conduct a safety check to test the functionality of each lawnmower's manual and wireless emergency stops, and to verify top speed. Qualifying tests verify each mower's ability to function inside the field of operation.

Navigation. The lawnmower can only use any or all of the existing radio-naviga-

tion systems, as well as lawnmower-based sensors (for example, inertial sensors, vision, and so on). Systems requiring local installations — besides a local differential GPS base station — are not allowed (for example, buried wires, poles).

Teams. Teams consist of undergraduate and graduate students with at least one faculty advisor. Interdisciplinary teams are encouraged (electrical engineering, mechanical engineering, computer science), and business/non-engineering students are invited to participate in marketing, sponsorships, and other program management functions.

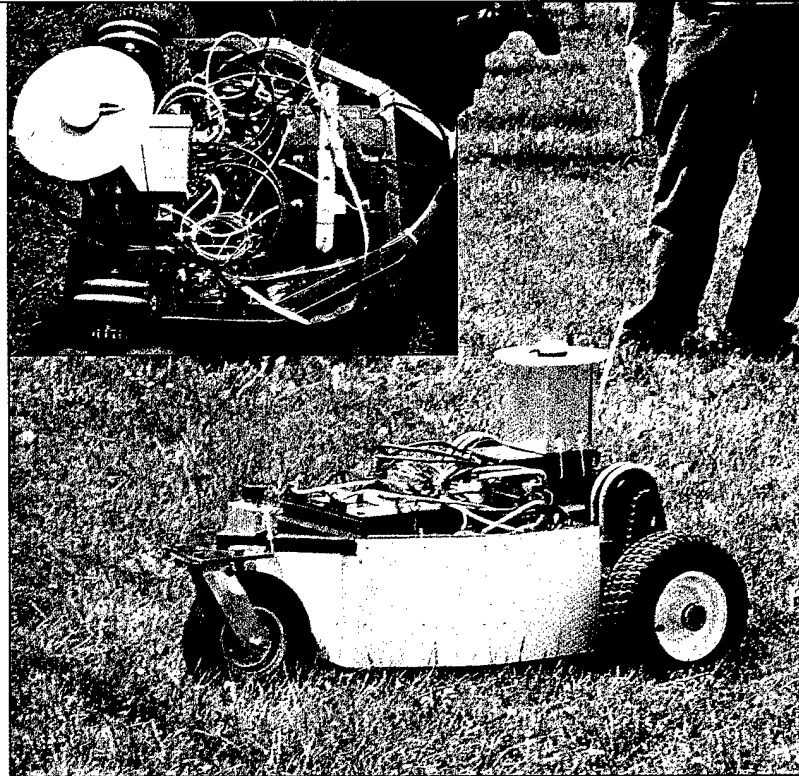

▲ **THE OHIO UNIVERSITY** entrant took first place, mowing 13 square meters in less than a minute. Inset, a view showing the GPS antenna on top of the motor controller (left), processor and datalink cards (middle) and batteries (right).

With increasing interest from the navigation community, we expect this event to grow rapidly. The next competition will take place in June 2005, prior to ION's 61st Annual Meeting in Cambridge, Massachusetts, over a slightly more difficult course, with obstacles added to the playing field. Each subsequent year will bring further challenges to the competition with the goal of developing mowers that can navigate any lawn autonomously and safely.

Besides the benefit to all of us in Ohio with lawns, the Dayton Section and the Satellite Division hope that this competition will inspire college students to

pursue navigation-related research projects and careers in this field. We look forward to next year's competition, and invite anyone interested to participate or come and watch the festivities.

The lemonade is on us!

The following accounts were drawn from the student reports from each competing team.

Ohio University

Ohio University's team designed a custom chassis utilizing a 3D computer drafting program. The chassis, constructed of aluminum tubing and plating, optimizes flexibility, space utilization, weight distribution, and the ability to turn at any desired radius. The battery-powered drive system controls both rear wheels independently and can provide up to 1.5 horsepower to each drive motor, more than enough to reach and maintain the 10 kilometer/hour speed limit. A third 0.4 horsepower electric motor turns a 19-inch cutting blade. Two 24VDC batteries keep the mower going for up to 2 hours after charging.

As accuracy is the most-weighted requirement in the competition, the team implemented a relative GPS solution to provide centimeter-level mower navigation with respect to a fixed reference station, installed on a tripod close to a field corner. The reference station consists of a GPS receiver that broadcasts GPS code and carrier phase measurements through a datalink to the mower. The reference station is battery-powered for up to 10 hours of unattended operation on a single charge. Designed as a turnkey system, it broadcasts measurements automatically after power is applied to the reference station. All GPS processing functions are implemented on the mower platform (see **Figure 1**).

In the mower, GPS measurements from the reference station combine with code- and carrier-phase

measurements from the mower's own GPS receiver. Custom software written for the 586 single-board processor tracks the relative position of the mower's GPS antenna with respect to the field coordinates at a 1-second update rate. The relative solution is initialized using pseudorange measurements from both the reference and mower GPS receivers. Following initialization, triple-difference carrier phases maintain the relative position to within a few centimeters.

High-rate path corrections are obtained from the onboard heading gyroscope connected to a low-level microcontroller. Prior to mowing the field, GPS coordinates are input to the 586 processor, which in turn provides an optimal path generation, represented by desired waypoints, headings, velocity values, and positional thresholds for turn executions. While waiting for the assigned start-time, the gyroscope drift is calibrated. As soon as the mower starts moving, occasional gyro drift calibrations are performed using the GPS ground track.

Cutting Edge. Upon entering the field, the low-level controller turns on the mower blade, which continues running as long as the mower remains within the field boundaries and the emergency stop command is not activated. The 586 processor performs high-level positioning and heading generation, producing new desired headings every second to adjust and maintain the path of the mower. The low-level microcontroller updates the two independent drive wheels through a motor controller unit approximately 67 times per second. Using differential velocity steering, the mower can precisely follow a commanded heading received from the 586 processor. The low-level controller also gets its position from the known, commanded velocity, its heading history, and its most-recent GPS position.

A looping sequential-state machine forms the structure of the low-level controls. This state machine consists of ten states in which the mower may exist: initial state, wait and idle, wait and mow, accelerate and track heading, constant velocity and track heading, decelerate and stop, turn, shut down, turn and adjust, and decelerate and track heading. The mower will step through the corresponding state sequence depending on the situation and command given.

Team members. Jidong Huang (graduate student); Ryan Knapp, Doug Hall, Dustin Bates, Brian Becker (undergraduates); Frank Van Graas (faculty advisor).

Miami University

The Miami Red Blade has five major sys-

▼ **FIGURE 1** Ohio University reference station (below) and mower diagrams (right)

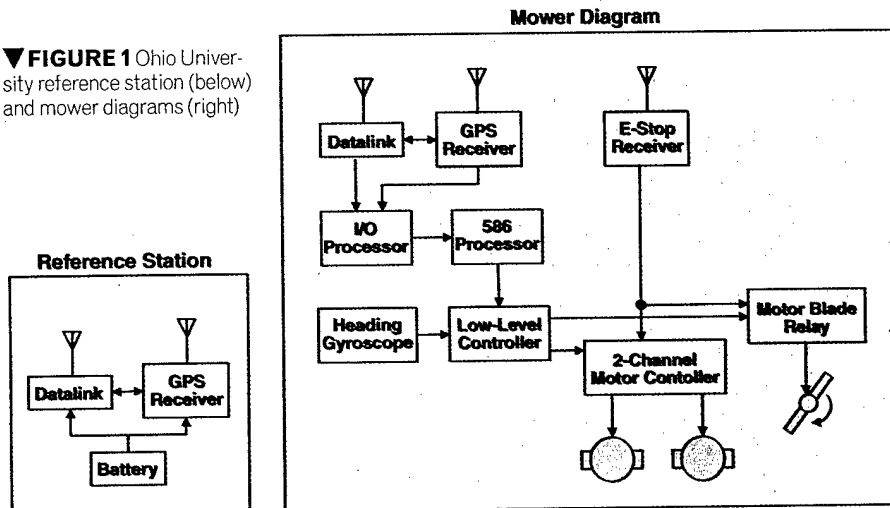

>>>APPLICATION CHALLENGE



▲ **FIRING UP** Miami University's Red Blade

tem components: the mower position and orientation sensors, servo actuation systems, control system, base lawnmower, and safety system (see **Figure 2**).

Sensing System. The sensing system uses three major inputs: a differential GPS (DGPS) receiver system, a Hall-effect/magnetic speedometer, and a digital compass. The DGPS system consists of two low-cost consumer-grade GPS receivers and custom carrier-phase positioning calculation software. A set of radio modems transmit receiver data to the controller on the lawn mower. Conventional double-differencing approaches drive the carrier-phase computation algorithm. This custom DGPS system generates precise user location measurements and determines, within 2-centimeter accuracy, the relative location of the lawnmower referenced to the base station as it runs in the field.

The drawback of the GPS system is the 1-second interval between position updates. If the lawnmower moves at a maximum speed of 10 kilometers/hour, the mower will travel 2.7 meters between location updates. This range is not ac-

ceptable to provide accurate navigation. For this reason, Red Blade incorporates two more sensors, the Hall-effect/magnet sensors and a digital compass, to help track locations between GPS updates.

The Hall-effect/magnet sensor system consists of a series of 24 magnets affixed to each lawnmower drive wheel, and a Hall-effect sensor attached to the mower frame near the wheel. As the wheel rotates, the magnets pass the Hall-effect sensor whose outputs are monitored by a microcontroller. The microcontroller sends the magnet count of each wheel to the controlling computer, which calculates travel distance and wheel speed. A digital compass determines mower orientation, updated every tenth of a second. Combining these inputs provides mower position monitoring. The data from these two instruments and from the GPS receivers goes to the control system mower navigation decisions.

Control System. The control system consists of an onboard laptop computer and a collection of computer programs integrated into one guidance algorithm. The control software consists of three major parts:

- high-level path planning, coordinate transformations, and field layout interpretations;
- a PID control loop that constantly compares sensor inputs with the ideal path prediction provided by the path planning algorithm, and also computes necessary corrections to the mower speed, acceleration, position, and heading; and
- low-level interface programs between the con-

► **FIGURE 2** Miami Red Blade system overview (below) and control algorithm overview (right)

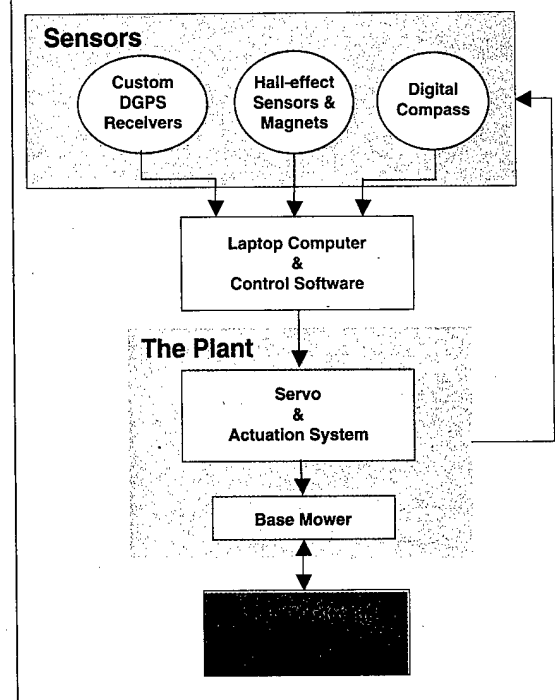
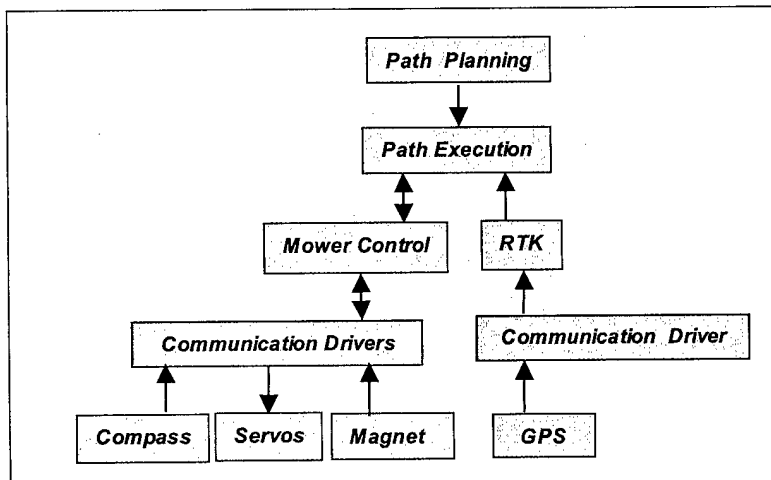

control loop, and the sensors and actuators.

Additional utility software accomplishes fundamental tasks such as forecasting satellite availability and mower state monitoring.

The first two parts of the control software are written in Matlab. The low-level interface programs are written in C and Java. Path planning is performed prior to mower operation. The control loop executes sequentially while the low level interface programs are multithreaded event-driven processes.

Servo System. Two servo motors and controllers are used on the lawn mower. The servos are attached to the control shaft of the hydrostatic pump on each wheel. The position of the control shaft determines how fast each wheel moves and in which direction (forward or reverse). The servos are linked to the control shaft through a gear system, where they convert voltage inputs into physical movement. Controlling the position of each servo controls and/or predicts the speed and location of the mower.

Base Mower. A 42-inch hydrostatic lawnmower served as the base unit for the Red Blade. The major reason to choose the hydrostatic mower was the capability of controlling each drive wheel independently. Many other mechanical features added to the mower make it self-sufficient and user-friendly. These modifications provide Red Blade with the proper structure, support, and protection for all of its components. Other modifications added safety and ease of use when operating. Specific modifications include the servo support system, the protective Pelican electronics case and stand, the dash board, a kick stand, the GPS and compass stand, the magnet sensing system, and the wiring.

▼ **MEET LEONARD,**
a modular control device
from the Illinois Institute of
Technology, shown here with
companion mower

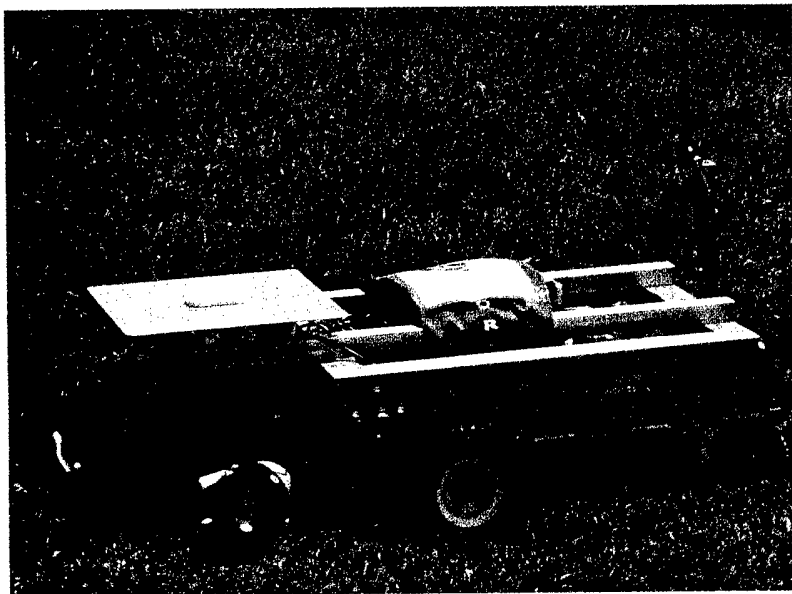

Control Panel. A custom dashboard contained the appropriate user operating devices such as the throttle, ignition, and blade control, previously located on the handlebars. Initially, the handlebars did not meet ION specifications for mower height. They also inhibited autonomous control and were therefore removed. An emergency stop switch, hard-wired into the kill switch of the ignition, was placed on top of the dashboard. A remote control E-stop was also mounted on the back side of the dash.

The GPS and compass stand (made of PVC, unistrut beams, and t-joints) provide the compass and GPS receiver with a safe and sturdy location for operation. The GPS receiver/antenna was raised above the stand to help eliminate potential multipath errors as well as provide the antenna with an unobstructed view of the sky. Further, the compass was positioned directly over the central axis of the lawnmower to provide accurate orientation readings.

Team Members. Brett McNally (team leader), Micah Stutzman, Collin Koranda, Chris Mantz, Jeff Macasek, Scott Miller, Andrew Walker (undergraduates); Jade Morton, Scott Campbell, and James Leonard (faculty advisors).

Illinois Institute of Technology

The IIT lawnmower prototype consists of two units: the vehicle ("Leonard"), containing the navigation sensors, computer, and power supply, and providing motion and steering; and the grass-cutting device, a standard off-the-shelf electric lawnmower.

The mobile platform was not specifically built for mowing missions, but was designed with flexibility to accommodate various tools and sensors. This modular structure provides the advantage of use not only for lawnmowing, but also spreading fertilizer and seeds, sweeping concrete surfaces, or removing snow. From a marketing perspective, this versatility becomes a decisive asset (**Figure 3**).

Leonard, an automated ground vehicle (AGV), performs trajectory-tracking operations. Carrier-phase differential GPS (CDGPS) measurements are fed back to the controller, which sends optimal correction commands to the motors.

IIT opted for a differential-drive vehicle concept for its simplicity and robustness. Steering is performed by differencing angular velocity measurements from two opposing driving wheels. The actuators consist of two DC motors with gear-and-belt type reducers. The power is delivered by two 12V DC batteries that provide up to four hours of autonomous operation. All components except the antennae and wheels are enclosed in a waterproof and dustproof rugged aluminum frame. Two floating

APPLICATION CHALLENGE

AUTONOMOUS NAVIGATION

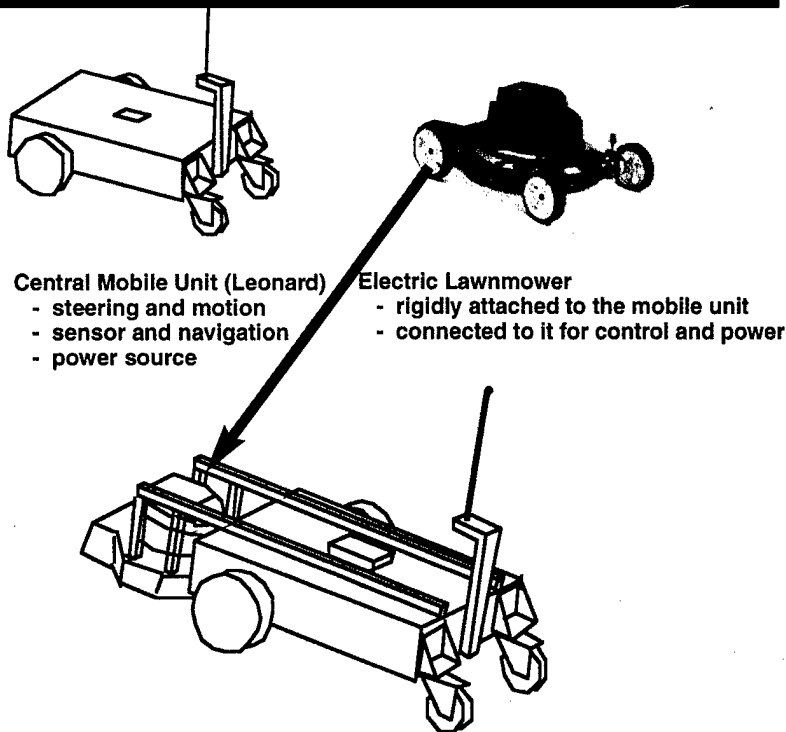

Snow Removal



Seeder

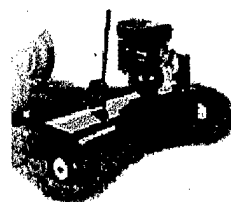

Lawn combing

FIGURE 3 Illinois Institute of Technology modular design

casters ensure vehicle balance and stability. The lawnmower is a separate module rigidly mounted on the mobile platform. It carries its own 12V DC battery that powers a motor directly linked to a 15-inch cutting blade. The mower can operate for up to 45 minutes.

Sensors and Computer. The DGPS sensor is composed of a GPS receiver and a spread spectrum data link in communication with the reference station. The GPS patch antenna is fixed at the center of an aluminum plate to minimize the effects of multipath reflections. Also, low cost optical encoders are integrated to the motor driving shafts.

FIGURE 4 IIT conceptual design

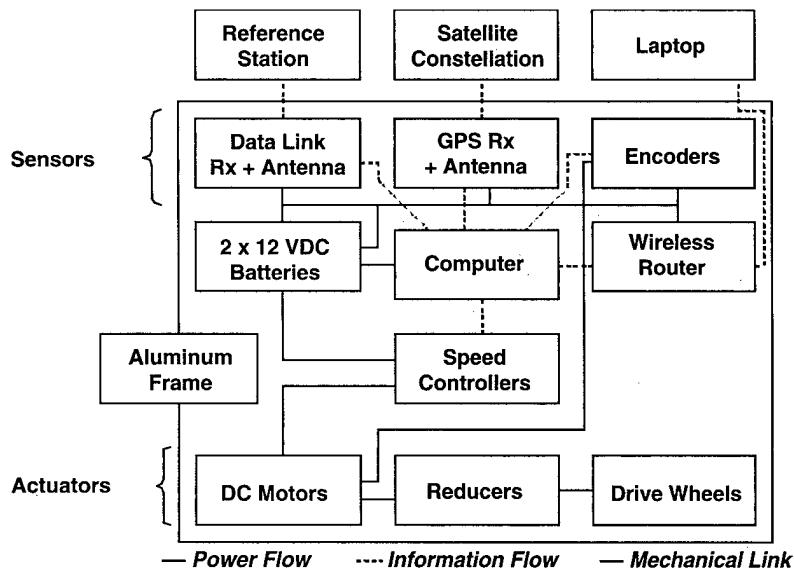

An embedded computer equipped with a data acquisition card processes the sensor data and sends commands to the motors via speed-controller interfaces. The speed controllers, or motor drives, provide the necessary amperage to the motors at the computer's request. A wireless system enables remote control, and can provide real-time monitoring.

Control System. The navigation and guidance control system is based on a detailed dynamic model. Linearized along the desired trajectory, at a constant velocity of 2 kilometers/hour, the equations of motion for the vehicle result in a fifth-order state space representation.

The control system, a discrete closed-loop feedback algorithm, uses a linear quadratic regulator (LQR) whose controller performance index weights are distributed to minimize cross-track error and avoid drive-motor saturation regions.

A seventh-order Kalman filter using CDGPS sensor inputs provides the basis for state estimation. Optimal performance of the estimator requires that process and sensor noise be accurately modeled. The team derived and implemented detailed random process models in terms of vehicle design parameters to account for disturbances such as ground slope and rugged terrain. The correlation of the GPS measurements due to multipath reflections is modeled with a first-order Markov process.

The controller's time constant (here 0.5 seconds) is limited by both the actuator's bandwidth and the DGPS update rate, and determines the frequency per unit distance of the cross-track-error corrections, for a given vehicle velocity.

The control strategy for mowing a rectangular field takes advantage of the forward/backward motion capability of the vehicle. It aims to simply to go back and forth straight along the field, each trip offset by the width of the cutting blade. More elaborate tactics are considered for future work. In particular, Leonard has the capability to operate at various speeds (that could change depending on the proximity of the mower to the field's edges), and can perform zero-radius turns.

Subject to Murphy's Law. Leonard successfully passed tests in Chicago and demonstrated cross-track control accuracy of less than 10 centimeters (standard deviation) at a nominal velocity of 2 kilometers/hour. IIT expected similar performance for the competition in Ohio — that is, until the main board of the small customized computer failed 36 hours before the start of the competition!

In a couple of sleepless days, the team redesigned the computer system (including power supply and interfaces) using off-the-shelf equipment. They also reinstalled and reconfigured the operating system, and rewrote part of the navigation program that they could not recover from the former hard drive. The last lines of codes were written at 5 a.m. in the parking lot of the Holiday Inn in Beaver Creek, Ohio.

In a final twist of fate, after setting everything up on the competition field, IIT realized that in its haste to reach Beaver Creek in time, the team had forgotten the rack hard drive for the DGPS reference station's computer back in Chicago. Obviously they were disappointed because this prevented them from demon-

strating the results of their hard work. Nevertheless, IIT maintains a very positive impression of the whole experience, having successfully completed the qualifying safety tests and demonstrated the robust mechanical functioning of the system.

Team Members. Scott Bachmann; Mathieu Joerger (team leader), Moon Heo, Fang Chan, Livio Gratton, and Samer Khanafseh (graduate students); Boris Pervan (faculty advisor). ☉

Manufacturers

Ohio University employed two **NovAtel** (Calgary, Alberta, Canada) *Allstar* GPS receivers, a set of **FreeWave Technologies** (Boulder, Colorado) OEM radio modems, a *3DM Gyro-Enhanced Orientation Sensor* from **MicroStrain** (Williston, Vermont), and a two-channel *AX2850* DC motor controller from **RoboteQ** (Scottsdale, Arizona).

Miami University used two **Garmin** (Olathe, Kansas) *GPS 16* receivers, custom carrier-phase positioning calculation software, a set of **Freewave Technologies** radio modems, a **Honeywell** (Plymouth, Minnesota) *HRM 3200* digital compass, **Parker Hannifin** *Compumotor OEM 770X* servo motors and controllers, and a **Snapper Pro Hydro** mower.

The Illinois Institute of Technology used a **NovAtel ProPakII** containing *L1/L2 OEM 3* GPS receivers.

Marketing Analysis

(Excerpts from the University of Miami's report)

Target Market. We intend to appeal to the young and middle-aged homeowner. We feel this lawnmower could be targeted to men and women alike. We foresee a particular niche with families on the go and parents with tight schedules.

Advantages. Most current models work similar to a pool cleaner. They run random patterns and avoid objects as they work. This often results in areas of uncut grass and drastically increased cutting time (days). Today's products require a wire to be run around the perimeter of the lawn, similar to an invisible fence for dogs. This limits the travel of the mower but also creates excess cost for the homeowner. It will also cause inconvenience when a homeowner decides to change landscaping or home additions.

Tactics. We will concentrate our marketing on

the promise of more free time and ease of operation. No longer will people need to slave under the hot sun during their time off, just to do it again in a week. Family life and the joys of good weather will be used to induce guilt and eventually create even more distaste for lawn care.

"Would you change your mind if we told you that every year you spend 24.4 hours of your life guiding a lawnmower. An entire day each year! This may not move you, but when you think that most of your time spent with a lawnmower is on your weekend under a cloudless sky, that day looks much more valuable. Shall we begin to mention the time spent cleaning grass clippings out of your hair or sweat off your back? If mowing a lawn provided a health benefit, sweat and sore arms would be a welcome sacrifice, but for most people the process of mowing a lawn is dull, time-consuming, non-beneficial, and boring.

Are we far off in our assumption that you share this sentiment?"