

**NOT MEASUREMENT
SENSITIVE**

MIL-HDBK-17-1F
Volume 1 of 5
17 JUNE 2002

Superseding
MIL-HDBK-17-1E
23 JANUARY 1997

**DEPARTMENT OF DEFENSE
HANDBOOK**

COMPOSITE MATERIALS HANDBOOK

**VOLUME 1. POLYMER MATRIX COMPOSITES
GUIDELINES FOR CHARACTERIZATION
OF STRUCTURAL MATERIALS**



This handbook is for guidance only. Do not cite this document as a requirement.

AMSC N/A

AREA CMPS

DISTRIBUTION STATEMENT A. Approved for public release; distribution unlimited.

Report Documentation Page

Form Approved
OMB No. 0704-0188

Public reporting burden for the collection of information is estimated to average 1 hour per response, including the time for reviewing instructions, searching existing data sources, gathering and maintaining the data needed, and completing and reviewing the collection of information. Send comments regarding this burden estimate or any other aspect of this collection of information, including suggestions for reducing this burden, to Washington Headquarters Services, Directorate for Information Operations and Reports, 1215 Jefferson Davis Highway, Suite 1204, Arlington VA 22202-4302. Respondents should be aware that notwithstanding any other provision of law, no person shall be subject to a penalty for failing to comply with a collection of information if it does not display a currently valid OMB control number.

1. REPORT DATE 17 JUN 2002	2. REPORT TYPE N/A	3. DATES COVERED -		
4. TITLE AND SUBTITLE Composite Materials Handbook, Vols 1-5		5a. CONTRACT NUMBER		
		5b. GRANT NUMBER		
		5c. PROGRAM ELEMENT NUMBER		
6. AUTHOR(S)		5d. PROJECT NUMBER		
		5e. TASK NUMBER		
		5f. WORK UNIT NUMBER		
7. PERFORMING ORGANIZATION NAME(S) AND ADDRESS(ES) Army Research Laboratory, Weapons and Materials Research Directorate		8. PERFORMING ORGANIZATION REPORT NUMBER		
9. SPONSORING/MONITORING AGENCY NAME(S) AND ADDRESS(ES)		10. SPONSOR/MONITOR'S ACRONYM(S)		
		11. SPONSOR/MONITOR'S REPORT NUMBER(S)		
12. DISTRIBUTION/AVAILABILITY STATEMENT Approved for public release, distribution unlimited				
13. SUPPLEMENTARY NOTES MIL-HDBK-17/1F, Revision C, D, E, and F. Revision D, Change Notice 1				
14. ABSTRACT				
15. SUBJECT TERMS				
16. SECURITY CLASSIFICATION OF:			17. LIMITATION OF ABSTRACT UU	
a. REPORT unclassified	b. ABSTRACT unclassified	c. THIS PAGE unclassified		18. NUMBER OF PAGES 586
				19a. NAME OF RESPONSIBLE PERSON

FOREWORD

1. This Composite Materials Handbook Series, MIL-HDBK-17, are approved for use by all Departments and Agencies of the Department of Defense.
2. This handbook is for guidance only. This handbook cannot be cited as a requirement. If it is, the contractor does not have to comply. This mandate is a DoD requirement only; it is not applicable to the Federal Aviation Administration (FAA) or other government agencies.
3. Every effort has been made to reflect the latest information on polymer (organic), metal, and ceramic composites. The handbook is continually reviewed and revised to ensure its completeness and currentness. Documentation for the secretariat should be directed to: Materials Sciences Corporation, MIL-HDBK-17 Secretariat, 500 Office Center Drive, Suite 250, Fort Washington, PA 19034.
4. MIL-HDBK-17 provides guidelines and material properties for polymer (organic), metal, and ceramic matrix composite materials. The first three volumes of this handbook currently focus on, but are not limited to, polymeric composites intended for aircraft and aerospace vehicles. Metal matrix composites (MMC) and ceramic matrix composites (CMC), including carbon-carbon composites (C-C) are covered in Volume 4 and Volume 5 , respectively.
5. This standardization handbook has been developed and is being maintained as a joint effort of the Department of Defense and the Federal Aviation Administration.
6. The information contained in this handbook was obtained from materials producers, industry, reports on Government sponsored research, the open literature, and by contact with research laboratories and those who participate in the MIL-HDBK-17 coordination activity.
7. All information and data contained in this handbook have been coordinated with industry and the U.S. Army, Navy, Air Force, NASA, and Federal Aviation Administration prior to publication.
8. Copies of this document and revisions thereto may be obtained from the Document Automation and Production Service (DAPS), Bldg. 4D, (DODSSP/ASSIST), 700 Robbins Avenue, Philadelphia, PA 19111-5094.
9. Beneficial comments (recommendations, additions, deletions) and any pertinent data which may be of use in improving this document should be addressed to: U.S. Army Research Laboratory, Weapons and Materials Research Directorate, Attn: AMSRL-WM-MA, Aberdeen Proving Ground, MD 21005-5069, by using the Standardization Document Improvement Proposal (DD Form 1426) appearing at the end of this document or by letter.

CONTENTS

	Page
Foreword.....	ii
Summary of Changes	xvii
CHAPTER 1 OBJECTIVES	1
1.1 INTRODUCTION.....	1
1.2 PURPOSE.....	1
1.3 SCOPE.....	2
1.3.1 Strength properties and allowables data	3
1.3.2 Volume 1: Guidelines for Characterization of Structural Materials	3
1.3.3 Volume 2: Material Properties	3
1.3.4 Volume 3: Materials Usage, Design, and Analysis Guidelines	4
1.4 USE OF THE DOCUMENT AND LIMITATIONS	4
1.4.1 Roadmaps for use of Volumes 1 - 3	4
1.4.2 Source of information.....	16
1.4.3 Use of data and guidelines in applications	16
1.4.4 Strength properties and allowables terminology.....	16
1.4.5 Use of references	16
1.4.6 Use of tradenames and product names	17
1.4.7 Toxicity, health hazards, and safety.....	17
1.4.8 Ozone depleting chemicals.....	17
1.5 APPROVAL PROCEDURES.....	17
1.6 SYMBOLS, ABBREVIATIONS, AND SYSTEMS OF UNITS.....	18
1.6.1 Symbols and abbreviations.....	18
1.6.1.1 Constituent properties.....	23
1.6.1.2 Laminae and laminates	23
1.6.1.3 Subscripts	24
1.6.1.4 Superscripts.....	25
1.6.1.5 Acronyms.....	26
1.6.2 System of units	27
1.7 DEFINITIONS.....	29
REFERENCES	50
CHAPTER 2 GUIDELINES FOR PROPERTY TESTING OF COMPOSITES	1
2.1 INTRODUCTION.....	1
2.1.1 Building-block approach to substantiation of composite structures.....	1
2.1.2 Test levels and data uses	2
2.1.2.1 Structural complexity levels	2
2.1.2.2 Data application categories	3
2.1.2.3 Test program definition	4
2.2 TEST PROGRAM PLANNING	5
2.2.1 Overview	5
2.2.2 Baseline and alternate approaches for statistically-based properties	6
2.2.3 Issues of data equivalence	6
2.2.4 Test method selection	7
2.2.5 Population sampling and sizing	11
2.2.5.1 Sample size selection.....	11
2.2.5.2 Batch quantity effects on ANOVA	12

Volume 1, Foreword / Table of Contents

2.2.6	Material and processing variation, specimen preparation and NDE	13
2.2.6.1	Materials and material processing.....	13
2.2.6.2	Specimen preparation and NDE	16
2.2.7	Moisture absorption and conditioning factors.....	16
2.2.7.1	Moisture diffusivity	18
2.2.7.2	Moisture equilibrium content.....	18
2.2.7.3	Conditioning and test environment.....	20
2.2.8	Material operational limit (MOL).....	20
2.2.8.1	Steam pressure delamination	24
2.2.8.2	MOL considerations for high temperature composite systems	24
2.2.8.3	Hot Wet Testing - Report Moisture Content at Failure.....	27
2.2.9	Nonambient testing.....	29
2.2.10	Unidirectional lamina properties from laminates.....	29
2.2.11	Data normalization.....	29
2.2.12	Data documentation.....	29
2.2.13	Application specific testing needs.....	31
2.3	RECOMMENDED TEST MATRICES.....	31
2.3.1	Material screening test matrices.....	31
2.3.1.1	Mechanical property screening.....	31
2.3.1.2	Mechanical property screening for high-temperature material systems.....	32
2.3.1.3	Fluid sensitivity screening.....	33
2.3.2	Material qualification test matrices	38
2.3.2.1	Constituent test matrix.....	38
2.3.2.2	Prepreg test matrix	38
2.3.2.3	Lamina test matrices.....	39
2.3.2.4	Filament-wound materials test matrix.....	41
2.3.3	Material acceptance test matrices	42
2.3.4	Alternate material equivalence test matrices.....	42
2.3.4.1	Qualification of alternate source composite materials.....	42
2.3.4.1.1	Introduction.....	42
2.3.4.1.2	Goal and approach.....	42
2.3.4.1.3	Material compatibility.....	43
2.3.4.1.4	Key material or structural performance parameters.....	43
2.3.4.1.5	Success criteria	43
2.3.4.1.6	Lamina-level test matrices for alternate material assessment.....	45
2.3.4.1.7	Laminate-level test matrices for alternate material assessment.....	48
2.3.4.1.8	Alternate material evaluation summary.....	48
2.3.4.2	Evaluation of changes made to previously qualified materials.....	48
2.3.4.2.1	Modification categories.....	50
2.3.4.2.2	Actions required for each modification category	51
2.3.4.2.3	Implementation	51
2.3.4.2.4	Validation test matrices	56
2.3.5	Generic laminate/structural element test matrices	56
2.3.5.1	Introduction	56
2.3.5.2	Overview.....	58
2.3.5.2.1	Lamina strength test matrix.....	58
2.3.5.2.2	Bolt bearing and bearing/bypass strength test matrix.....	60
2.3.6	Alternate approaches to basis values.....	64
2.3.6.1	Lamina mechanical property test matrix for regression analysis	64
2.3.7	Data substantiation for use of basis values from MIL-HDBK-17 or other large databases	66
2.4	DATA REDUCTION AND DOCUMENTATION	67
2.4.1	Introduction	67
2.4.2	Lamina properties from laminates	67
2.4.2.1	Methodology	68
2.4.2.2	Tension strength tests.....	69

2.4.2.3	Compression strength tests	70
2.4.2.4	Other properties	70
2.4.3	Data normalization	70
2.4.3.1	Normalization theory	71
2.4.3.2	Normalization methodology	71
2.4.3.3	Practical application of normalization	74
2.4.4	Dispositioning of Outlier Data	75
2.4.5	Data documentation	78
2.5	MATERIAL TESTING FOR SUBMISSION OF DATA TO MIL-HDBK-17	78
2.5.1	Introduction	78
2.5.2	Material and process specification requirements	80
2.5.3	Sampling requirements	80
2.5.3.1	Additional requirements for B and A data classes	81
2.5.3.2	Data pooling	81
2.5.4	Conditioning requirements	82
2.5.5	Test method requirements	82
2.5.6	Data documentation requirements	82
2.5.7	Data normalization	87
2.5.8	Statistical analysis	87
2.5.9	Mechanical properties of laminae and laminates	87
2.5.9.1	Unidirectional properties from laminates	87
2.5.9.2	Strength and strain-to-failure	87
2.5.9.3	Elastic moduli, Poisson's ratios, and stress/strain curves	88
2.5.10	Chemical properties	88
2.5.11	Physical properties of laminae and laminates	88
2.5.11.1	Density	88
2.5.11.2	Composition	88
2.5.11.3	Equilibrium moisture content	88
2.5.11.4	Moisture diffusivity	88
2.5.11.5	Coefficient of moisture expansion	88
2.5.11.6	Glass transition temperature	88
2.5.12	Thermal properties	89
2.5.12.1	Coefficient of thermal expansion	89
2.5.12.2	Specific heat	89
2.5.12.3	Thermal conductivity	89
2.5.12.4	Thermal diffusivity	89
2.5.13	Electrical properties	90
2.5.14	Fatigue	90
	REFERENCES	92
CHAPTER 3 EVALUATION OF REINFORCEMENT FIBERS		1
3.1	INTRODUCTION	1
3.2	CHEMICAL TECHNIQUES	1
3.2.1	Elemental analysis	1
3.2.2	Titration	2
3.2.3	Fiber structure	2
3.2.4	Fiber surface chemistry	2
3.2.5	Sizing content and composition	5
3.2.6	Moisture content	5
3.2.7	Thermal stability and oxidative resistance	5
3.2.8	Chemical resistance	5
3.3	PHYSICAL TECHNIQUES (INTRINSIC)	6
3.3.1	Filament diameter	6
3.3.2	Density of fibers	6

3.3.2.1	Overview.....	6
3.3.2.2	ASTM D 3800, Standard Test Method for Density of High-Modulus Fibers.....	7
3.3.2.3	Recommended procedure changes to Section 6.6.4.4.1 (helium pycnometry) for use in measuring fiber density.....	8
3.3.2.4	Density test methods for MIL-HDBK-17 data submittal.....	8
3.3.3	Electrical resistivity.....	8
3.3.4	Coefficient of thermal expansion.....	9
3.3.5	Thermal conductivity.....	9
3.3.6	Specific heat.....	9
3.3.7	Thermal transition temperatures.....	9
3.4	PHYSICAL TECHNIQUES (EXTRINSIC).....	9
3.4.1	Yield of yarn, strand, or roving.....	9
3.4.2	Cross-sectional area of yarn or tow.....	10
3.4.3	Twist of yarn.....	10
3.4.4	Fabric construction.....	10
3.4.5	Fabric areal density.....	10
3.5	MECHANICAL TESTING OF FIBERS.....	10
3.5.1	Tensile properties.....	10
3.5.1.1	Filament tensile testing.....	11
3.5.1.2	Tow tensile testing.....	11
3.5.1.3	Fiber properties from unidirectional laminate tests.....	14
3.5.2	Filament compression testing.....	14
3.6	TEST METHODS.....	14
3.6.1	Determination of pH.....	14
3.6.1.1	Scope.....	14
3.6.1.2	Apparatus.....	14
3.6.1.3	Procedure.....	15
3.6.2	Determination of amount of sizing on carbon fibers.....	15
3.6.2.1	Scope.....	15
3.6.2.2	Apparatus.....	15
3.6.2.3	Materials.....	16
3.6.2.4	Procedure.....	16
3.6.2.5	Calculation.....	16
3.6.2.6	Preparation of crucibles for reuse.....	17
3.6.3	Determination of moisture content or moisture regain.....	17
3.6.3.1	Scope.....	17
3.6.3.2	Apparatus.....	17
3.6.3.3	Sample preparation.....	17
3.6.3.4	Procedure.....	17
3.6.3.5	Calculations.....	18
3.6.4	Determination of fiber diameter.....	18
3.6.4.1	Description and application.....	18
3.6.4.2	Apparatus.....	18
3.6.4.3	Calibration.....	20
3.6.4.4	Prepare slide.....	20
3.6.4.5	Measuring procedure.....	20
3.6.4.6	Calculation.....	21
3.6.5	Determination of electrical resistivity.....	21
3.6.5.1	Scope.....	21
3.6.5.2	Apparatus.....	21
3.6.5.3	Sample preparation.....	21
3.6.5.4	Procedure.....	21
3.6.5.5	Calculation.....	21
3.6.5.6	Calibration and maintenance.....	22
3.6.5.7	Definition of units of measurement.....	22

REFERENCES	23
CHAPTER 4 MATRIX CHARACTERIZATION	1
4.1 INTRODUCTION.....	1
4.2 MATRIX SPECIMEN PREPARATION.....	1
4.2.1 Introduction	1
4.2.2 Thermoset polymers	2
4.2.3 Thermoplastic polymers.....	3
4.2.4 Specimen machining.....	3
4.3 CONDITIONING AND ENVIRONMENTAL EXPOSURE	4
4.4 CHEMICAL ANALYSIS TECHNIQUES	4
4.4.1 Elemental analysis.....	4
4.4.2 Functional group and wet chemical analysis	4
4.4.3 Spectroscopic analysis	4
4.4.4 Chromatographic analysis	6
4.4.5 Molecular weight and molecular weight distribution analysis	6
4.4.6 General scheme for resin material characterization	7
4.5 THERMAL/PHYSICAL ANALYSIS AND PROPERTY TESTS	14
4.5.1 Introduction	15
4.5.2 Thermal analysis.....	15
4.5.3 Rheological analysis	16
4.5.4 Morphology	17
4.5.5 Density/specific gravity	17
4.5.5.1 Overview	17
4.5.5.2 Recommended procedure changes to Sections 6.6.4.2, 6.6.4.3 and 6.6.4.4 (D 792, D 1505 and helium pycnometry) for use in measuring cured resin density.....	18
4.5.5.3 Density test methods for MIL-HDBK-17 data submittal	18
4.5.6 Volatiles content.....	19
4.5.7 Moisture content	19
4.6 STATIC MECHANICAL PROPERTY TESTS	20
4.6.1 Introduction	20
4.6.2 Tension.....	20
4.6.2.1 Introduction	20
4.6.2.2 Specimen preparation.....	20
4.6.2.3 Test apparatus and instrumentation	21
4.6.2.4 Tensile test methods for MIL-HDBK-17 data submittal.....	22
4.6.3 Compression.....	22
4.6.3.1 Introduction	23
4.6.3.2 Specimen preparation.....	23
4.6.3.3 Test apparatus and instrumentation	23
4.6.3.4 Limitations.....	24
4.6.3.5 Compressive test methods for MIL-HDBK-17 data submittal.....	24
4.6.4 Shear	24
4.6.4.1 Test methods available	24
4.6.4.2 Torsion specimen preparation	25
4.6.4.3 Iosipescu shear specimen preparation.....	25
4.6.4.4 Test apparatus and instrumentation	25
4.6.4.5 Limitations.....	25
4.6.4.6 Shear testing methods for MIL-HDBK-17 data submittal	25
4.6.5 Flexure.....	26
4.6.5.1 Introduction	26
4.6.5.2 Specimen preparation.....	26
4.6.5.3 Test apparatus and instrumentation	26

4.6.5.4	Flexural test methods for MIL-HDBK-17 data submittal	27
4.6.6	Impact	27
4.6.7	Hardness.....	27
4.7	FATIGUE TESTING.....	27
4.8	TESTING OF VISCOELASTIC PROPERTIES	28
	REFERENCES	29
CHAPTER 5	PREPREG MATERIALS CHARACTERIZATION	1
5.1	INTRODUCTION.....	1
5.2	CHARACTERIZATION TECHNIQUES - OVERVIEW.....	1
5.3	SAMPLING.....	2
5.4	PHYSICAL CHARACTERISTICS AND PROPERTY TESTS.....	2
5.4.1	Physical description of reinforcement.....	2
5.4.1.1	Alignment.....	2
5.4.1.2	Gaps	2
5.4.1.3	Width.....	3
5.4.1.4	Length.....	3
5.4.1.5	Edges.....	3
5.4.1.6	Splices	3
5.4.2	Resin content.....	3
5.4.3	Fiber content.....	3
5.4.4	Volatiles content.....	3
5.4.5	Moisture content	4
5.4.6	Inorganic fillers and additives content	4
5.4.7	Areal weight	4
5.4.8	Tack and drape	4
5.4.9	Resin flow	4
5.4.10	Gel time 4	
5.5	TEST METHODS	4
5.5.1	Resin extraction procedure for epoxy resin prepregs.....	4
5.5.2	Procedure for HPLC/HPSEC analysis of glass, aramid, and graphite fiber prepregs.....	6
5.5.2.1	Reverse phase HPLC analysis	6
5.5.2.2	Size Exclusion Chromatography (SEC) analysis	7
5.5.3	Procedure for Fourier transform infrared spectroscopy (FTIR)	7
5.5.4	Procedure for differential scanning calorimetry (DSC)	7
5.5.5	Procedure for dynamic mechanical analysis (DMA).....	8
5.5.6	Procedure for rheological characterization	8
	REFERENCES	9
CHAPTER 6	LAMINA, LAMINATE, AND SPECIAL FORM CHARACTERIZATION	1
6.1	INTRODUCTION.....	1
6.2	SPECIMEN PREPARATION	1
6.2.1	Introduction	1
6.2.2	Traceability.....	2
6.2.3	Test article fabrication	2
6.2.4	Specimen fabrication	3
6.3	CONDITIONING AND ENVIRONMENTAL EXPOSURE	4
6.3.1	Introduction	4
6.3.2	Fixed-time conditioning.....	5
6.3.3	Equilibrium conditioning.....	6
6.3.3.1	Accelerating conditioning times	7

6.3.3.2	Procedural hints	8
6.4	INSTRUMENTATION AND CALIBRATION	10
6.4.1	Introduction	10
6.4.2	Test specimen dimensional measurement	10
6.4.2.1	Introduction	10
6.4.2.2	Calibrated microscopes	10
6.4.2.3	Micrometers	10
6.4.2.4	Scaled calipers	11
6.4.2.5	Precision scales	11
6.4.2.6	Rulers and tape measures	12
6.4.2.7	Special hole diameter measuring devices	12
6.4.2.8	Calibration of dimensional measurement devices	12
6.4.3	Load measurement devices	12
6.4.3.1	Introduction	12
6.4.3.2	Load cells	13
6.4.3.2.1	Design and specification considerations	13
6.4.3.3	Other load measuring systems	14
6.4.3.4	Instrumentation and calibration	14
6.4.3.5	Precautions	15
6.4.4	Strain/displacement measurement devices	15
6.4.4.1	Introduction	15
6.4.4.2	LVDT (Linear Variable Differential Transformer) deflectometers	16
6.4.4.3	Contacting extensometers	16
6.4.4.3.1	Contacting extensometers, applications	16
6.4.4.4	Bondable resistance strain gages	17
6.4.4.4.1	Strain gage selection	17
6.4.4.4.2	Surface preparation and bonding of strain gages	17
6.4.4.4.3	Strain gage circuits	17
6.4.4.4.4	Strain gage instrumentation	18
6.4.4.4.5	Strain gage instrumentation calibration	19
6.4.4.5	Other methods	19
6.4.4.5.1	Optical methods of extensometry	19
6.4.4.5.2	Capacitative extensometers	20
6.4.4.6	Special considerations for textile composites	20
6.4.5	Temperature measurement devices	20
6.4.5.1	Introduction	20
6.4.5.2	Thermocouples	20
6.4.5.3	Metallic resistive temperature devices	21
6.4.5.4	Thermistors	22
6.4.5.5	Bimetallic devices	22
6.4.5.6	Liquid expansion devices	22
6.4.5.7	Change-of-state devices	22
6.4.5.8	Infrared detectors	23
6.4.5.9	Calibration of temperature measurement devices	23
6.4.6	Data acquisition systems	26
6.5	TESTING ENVIRONMENTS	26
6.5.1	Introduction	26
6.5.2	Laboratory ambient test environment	26
6.5.3	Non-ambient testing environment	26
6.5.3.1	Introduction	26
6.5.3.2	Subambient testing	27
6.5.3.3	Above ambient testing	27
6.6	THERMAL/PHYSICAL PROPERTY TESTS	28
6.6.1	Introduction	28
6.6.2	Extent of cure	28
6.6.3	Glass transition temperature	29

6.6.3.1	Overview.....	29
6.6.3.2	T _g Measurements.....	29
6.6.3.2.1	Differential scanning calorimetry (DSC).....	29
6.6.3.2.2	Thermomechanical analysis (TMA).....	30
6.6.3.2.3	Dynamic mechanical analysis (DMA).....	32
6.6.3.3	Glass transition test methods for MIL-HDBK-17 data submittal.....	33
6.6.3.4	Crystalline melt temperature.....	33
6.6.4	Density.....	34
6.6.4.1	Overview.....	34
6.6.4.2	ASTM D 792, Standard Test Method for Density and Specific Gravity (Relative Density) of Plastics by Displacement.....	34
6.6.4.3	ASTM D 1505, Standard Test Method for Density of Plastics by the Density-Gradient Technique.....	35
6.6.4.4	Use of helium pycnometry to determine density of composites.....	36
6.6.4.4.1	Helium pycnometry test procedure for determining composite density.....	38
6.6.4.5	Summary of helium pycnometry experimental results.....	39
6.6.4.6	Density test methods for MIL-HDBK-17 data submittal.....	40
6.6.5	Cured ply thickness.....	40
6.6.5.1	Overview.....	41
6.6.5.2	Thickness measurement using direct means.....	41
6.6.5.3	Thickness measurement using indirect means.....	41
6.6.5.4	SRM 10R-94, SACMA Recommended Method for Fiber Volume, Percent Resin Volume and Calculated Average Cured Ply Thickness of Plied Laminates.....	42
6.6.5.5	Cured ply thickness test methods for MIL-HDBK-17 data submittal.....	42
6.6.6	Fiber volume (V _f) fraction.....	42
6.6.6.1	Introduction.....	42
6.6.6.2	Matrix digestion.....	42
6.6.6.3	Ignition loss.....	43
6.6.6.4	Areal weight/thickness.....	43
6.6.6.5	Determination of fiber volume using image analysis.....	45
6.6.6.5.1	Background.....	45
6.6.6.5.2	Apparatus.....	45
6.6.6.5.3	Specimen preparation.....	45
6.6.6.5.4	Image analysis.....	46
6.6.6.5.5	Sources of error.....	47
6.6.7	Void volume (V _v) fraction.....	48
6.6.7.1	Introduction.....	48
6.6.7.2	Digestive evaluation.....	48
6.6.7.3	Determination of void volume using image analysis.....	49
6.6.7.3.1	Background.....	49
6.6.7.3.2	Sources of Error.....	50
6.6.8	Moisture/diffusivity.....	52
6.6.8.1	Standard test methods.....	53
6.6.8.2	Moisture diffusion property test methods for MIL-HDBK-17 data submittal.....	54
6.6.9	Dimensional stability (Thermal and Moisture).....	54
6.6.9.1	Dimensional stability (thermal).....	55
6.6.9.1.1	Introduction.....	55
6.6.9.1.2	Existing test methods.....	55
6.6.9.1.3	Test specimens.....	56
6.6.9.1.4	Test apparatus and instrumentation.....	57
6.6.9.1.5	CTE test methods for MIL-HDBK-17 data submittal.....	57
6.6.9.2	Dimensional stability (moisture).....	58
6.6.9.2.1	Introduction.....	58

6.6.9.2.2	Specimen preparation	59
6.6.9.2.3	Test apparatus and instrumentation	59
6.6.9.2.4	CME test methods for MIL-HDBK-17 data submittal	60
6.6.10	Thermal conductivity	60
6.6.10.1	Introduction	60
6.6.10.2	Available methods	60
6.6.10.2.1	ASTM C177-97	61
6.6.10.2.2	ASTM E1225-99	62
6.6.10.2.3	ASTM C518-98	63
6.6.10.2.4	Fourier thermal conductivity test method for flat plates	64
6.6.10.3	Thermal conductivity test methods for MIL-HDBK-17 data	68
6.6.11	Specific heat	68
6.6.11.1	Introduction	68
6.6.11.2	Available method	68
6.6.11.2.1	ASTM E1269-95	68
6.6.11.3	Specific heat test methods for MIL-HDBK-17 data submittal	70
6.6.12	Thermal diffusivity	70
6.6.12.1	Introduction	70
6.6.12.2	Available test methods	71
6.6.12.2.1	ASTM E1461-92	71
6.6.12.2.2	ASTM C714-85	76
6.6.12.3	Thermal diffusivity test methods for MIL-HDBK-17 data submittal	76
6.6.13	Outgassing	76
6.6.14	Absorptivity and emissivity	77
6.6.15	Thermal cycling	77
6.6.16	Microcracking	77
6.6.16.1	Introduction	77
6.6.16.2	Microcracking due to the manufacturing process	77
6.6.16.3	Microcracking due thermal cycling	78
6.6.16.4	Microcracking due to mechanical loading/cycling	78
6.6.17	Thermal oxidative stability (TOS)	78
6.6.18	Flammability and smoke generation	78
6.6.18.1	Introduction	78
6.6.18.2	Fire growth test methods	78
6.6.18.2.1	ASTM E 84 - Surface burning characteristics of building materials	79
6.6.18.2.2	ASTM E 162 - Surface flammability of materials using a radiant heat energy source	80
6.6.18.2.3	ISO 9705 fire test – full-scale room test for surface products	81
6.6.18.2.4	ASTM E 1321 - Determining material ignition and flame spread properties	81
6.6.18.3	Smoke and toxicity test methods	82
6.6.18.3.1	ASTM E 662 - Specific optical density of smoke generated by solid materials	82
6.6.18.3.2	NFPA 269 - Developing toxic potency data for use in fire hazard modeling	83
6.6.18.4	Heat release test methods	84
6.6.18.4.1	ASTM E-1354 - Heat and visible smoke release rates for materials and products using an oxygen consumption calorimeter	84
6.6.18.4.2	ASTM E 906 – Heat and visible smoke release rates for materials and products	85
6.6.18.5	Fire resistance test methods	86
6.6.18.5.1	ASTM E-119 - Fire tests for building construction and materials	86
6.6.18.5.2	ASTM E-1529 - Determining effects of large hydrocarbon pool fires on structural members and assemblies and UL 1709 - Rapid rise fire tests of protection materials for structural steel	87
6.7	ELECTRICAL PROPERTY TESTS	87

6.7.1	Introduction	87
6.7.2	Electrical permittivity	88
6.7.3	Dielectric strength	88
6.7.4	Magnetic permeability	88
6.7.5	Electromagnetic interference	88
6.7.6	Electrostatic discharge	88
6.8	STATIC UNIAXIAL MECHANICAL PROPERTY TESTS	88
6.8.1	Introduction	88
6.8.2	Tensile properties	89
6.8.2.1	Overview	90
6.8.2.2	In-plane tension test methods	91
6.8.2.2.1	Straight-sided specimen tension tests	91
6.8.2.2.2	Filament-wound tubes	94
6.8.2.2.3	Width tapered specimens:	94
6.8.2.2.4	Split-disk ring tension test	95
6.8.2.2.5	Sandwich beam test	95
6.8.2.3	Out-of-plane tensile test methods	97
6.8.2.3.1	Introduction	97
6.8.2.3.2	Direct out-of-plane loading adaptations of ASTM C 297/C 633/D 2095	97
6.8.2.3.3	Curved beam approach to out-of-plane tensile strength	102
6.8.2.4	Tension test methods for MIL-HDBK-17 data submittal	102
6.8.3	Compressive properties	104
6.8.3.1	Overview	104
6.8.3.2	In-plane compression tests	105
6.8.3.2.1	ASTM D 3410/D 3410M, Compressive Properties of Polymer Matrix Composite Materials With Unsupported Gage Section by Shear Loading	105
6.8.3.2.2	ASTM D 6484, Compressive Properties of Polymer Matrix Composite Laminates Using a Combined Loading Compression (CLC) Test Fixture	106
6.8.3.2.3	ASTM D 5467, Compressive Properties of Unidirectional Polymer Matrix Composites Using a Sandwich Beam	109
6.8.3.2.4	ASTM C 393, Flexural Properties of Flat Sandwich Constructions	110
6.8.3.2.5	ASTM D 695, Compressive Properties of Rigid Plastics	111
6.8.3.2.6	SACMA SRM 1R, Compressive Properties of Oriented Fiber-Resin Composites	112
6.8.3.2.7	SACMA SRM 6, Compressive Properties of Oriented Cross-Plied Fiber-Resin Composites	113
6.8.3.2.8	Through-thickness compression tests	114
6.8.3.3	Compressive test methods for developing MIL-HDBK-17 data submittal	114
6.8.4	Shear properties	116
6.8.4.1	Overview	116
6.8.4.2	In-plane shear tests	117
6.8.4.2.1	$\pm 45^\circ$ tensile shear tests	117
6.8.4.2.2	Iosipescu shear test	119
6.8.4.2.3	Rail shear tests	123
6.8.4.2.4	Ten-degree off-axis shear test	123
6.8.4.2.5	Tube torsion tests	124
6.8.4.3	Out-of-plane shear tests	125
6.8.4.3.1	Short-beam strength tests	125
6.8.4.3.2	Iosipescu shear test	126
6.8.4.3.3	ASTM D 3846-79, Test Method for In-Plane Shear Strength of Reinforced Plastics	126
6.8.4.4	Shear test methods for MIL-HDBK-17 data submittal	127
6.8.5	Flexural properties	128

6.8.6	Fracture toughness properties.....	128
6.8.6.1	Overview.....	128
6.8.6.2	General discussion.....	129
6.8.6.3	Mode I test methods.....	131
6.8.6.3.1	Double cantilever beam (DCB) test, ASTM D 5528.....	131
6.8.6.3.2	Other mode I tests.....	133
6.8.6.4	Mode II test methods.....	133
6.8.6.4.1	End notched flexure (ENF) test.....	133
6.8.6.4.2	Other mode II tests.....	134
6.8.6.5	Mode III test methods.....	134
6.8.6.6	Mixed mode test methods.....	135
6.8.6.6.1	Mixed mode specimen or crack lap shear (CLS).....	135
6.8.6.6.2	Mixed mode bending (MMB) test.....	135
6.8.6.6.3	Edge delamination test.....	136
6.8.6.7	Fracture toughness tests for MIL-HDBK-17 data submittal.....	137
6.9	UNIAXIAL FATIGUE TESTING.....	137
6.10	MULTIAXIAL MECHANICAL PROPERTY TESTING.....	137
6.11	VISCOELASTIC PROPERTIES TESTS.....	138
6.11.1	Introduction.....	138
6.11.2	Creep and stress relaxation.....	138
6.12	FORM-SPECIFIC MECHANICAL PROPERTY TESTS.....	139
6.12.1	Tests unique to filament winding.....	139
6.12.1.1	Overview.....	139
6.12.1.2	History.....	139
6.12.1.3	Tension tests for uniaxial material properties.....	140
6.12.1.3.1	Zero degree tension.....	140
6.12.1.3.2	Transverse tension.....	140
6.12.1.4	Compression tests for uniaxial material properties.....	140
6.12.1.4.1	Zero degree compression.....	140
6.12.1.4.2	Transverse compression.....	140
6.12.1.5	Shear tests for uniaxial material properties.....	140
6.12.1.5.1	In-plane shear.....	140
6.12.1.5.2	Transverse shear.....	140
6.12.1.6	Test methods for MIL-HDBK-17 data submittal.....	140
6.12.2	Tests unique to textiles composites.....	141
6.12.2.1	Overview.....	141
6.12.2.2	Background.....	142
6.12.2.3	Fabric and two-dimensional weaves.....	142
6.12.2.3.1	Physical property tests.....	142
6.12.2.3.2	Mechanical testing.....	143
6.12.2.3.3	Impact considerations.....	143
6.12.2.4	Complex braiding considerations.....	143
6.12.2.4.1	Three-dimensional weave and braids.....	144
6.12.2.4.2	Through the thickness test methods.....	144
6.12.2.5	Test methods for submission to MIL-HDBK-17.....	144
6.12.3	Tests unique to thick-section composites.....	145
6.13	SPACE ENVIRONMENTAL EFFECTS ON MATERIAL PROPERTIES.....	146
6.13.1	Introduction.....	146
6.13.2	Atomic oxygen.....	146
6.13.3	Micrometeoroid Debris.....	146
6.13.4	Ultraviolet radiation.....	146
6.13.5	Charged particles.....	146
	REFERENCES.....	147

CHAPTER 7	STRUCTURAL ELEMENT CHARACTERIZATION	1
7.1	INTRODUCTION	1
7.2	SPECIMEN PREPARATION	1
7.2.1	Introduction	1
7.2.2	Mechanically fastened joint tests	1
7.2.3	Bonded joint tests	2
7.3	CONDITIONING AND ENVIRONMENTAL EXPOSURE	2
7.3.1	Introduction	2
7.3.2	General specimen preparation	2
7.3.2.1	Strain gaging	2
7.3.2.2	Notched laminates and mechanically fastened joint specimens	3
7.3.3	Bonded joints	3
7.3.4	Damage characterization specimens	4
7.3.5	Sandwich Structure	4
7.4	NOTCHED LAMINATE TESTS	6
7.4.1	Overview and general considerations	6
7.4.2	Notched laminate tension	7
7.4.2.1	Open-hole tensile test methods	8
7.4.2.2	Filled-hole tensile test methods	8
7.4.3	Notched laminate compression	8
7.4.3.1	Open-hole compressive test methods	10
7.4.3.2	Filled-hole compressive test methods	11
7.4.4	Suggested notched laminate test matrix	11
7.4.5	Notched laminate test methods for MIL-HDBK-17 data submittal	13
7.5	MECHANICALLY-FASTENED JOINT TESTS	13
7.5.1	Overview	13
7.5.1.1	Definitions	13
7.5.1.2	Failure modes	14
7.5.1.3	Design requirements	15
7.5.2	Bearing Tests	15
7.5.2.1	Overview	15
7.5.2.2	Double shear bearing tests	16
7.5.2.2.1	ASTM D 953 bearing strength of plastics	16
7.5.2.2.2	ASTM D 5961, Procedure A	17
7.5.2.3	Single shear bearing tests	19
7.5.2.3.1	Overview	19
7.5.2.3.2	ASTM D 5961, Procedure B	19
7.5.2.4	Suggested joint bearing test matrices	21
7.5.2.5	Effects of thickness/gaps/shimming	25
7.5.2.6	Failure modes	27
7.5.3	Bearing/by-pass evaluation	30
7.5.3.1	Overview and rationale	30
7.5.3.2	Specimen design and testing	31
7.5.3.3	Suggested bearing/bypass test matrix	33
7.5.3.4	Data reduction	33
7.5.4	Shear-out strength	34
7.5.5	Fastener pull-thru strength (MIL-HDBK-17 test method)	36
7.5.5.1	Scope	36
7.5.5.2	Summary of test methods	36
7.5.5.3	Significance	41
7.5.5.4	Apparatus	41
7.5.5.5	Test specimen	41
7.5.5.6	Specimen assembly	41
7.5.5.7	Test matrix	42
7.5.5.8	Report	42

7.5.6	Fastener-in-composite qualification tests	42
7.5.6.1	Overview	42
7.5.6.2	Fastener shear tests	44
7.5.6.3	Fastener tension tests	44
7.5.6.4	Fastener Pull-thru tests.....	44
7.5.6.5	Bearing tests	45
7.5.6.6	Data presentation	45
7.5.7	Bearing/mechanical joint test methods for MIL-HDBK-17 data submittal.....	45
7.6	BONDED JOINT TESTS	46
7.6.1	Overview	46
7.6.2	Adhesive characterization tests	46
7.6.2.1	Shear tests.....	47
7.6.2.1.1	ASTM D 5656 (thick adherend specimen)	47
7.6.2.1.2	ASTM E 229 (tubular specimen)	49
7.6.2.1.3	ASTM D 1002 (thin single lap spec. - QA test only)	49
7.6.2.2	Tension tests	50
7.6.2.2.1	ASTM D 2095.....	50
7.6.2.3	Fracture mechanics properties	50
7.6.2.4	Suggested adhesive characterization test matrix.....	50
7.6.3	Bonded joint characterization tests.....	50
7.6.3.1	Honeycomb to face sheet flatwise tension test (ASTM C 297)	51
7.6.3.2	Skin to stiffener bond tests	52
7.6.3.3	Double overlap joint tests	54
7.6.3.4	Single overlap joint tests.....	56
7.6.3.4.1	ASTM D 3165.....	56
7.6.3.4.2	European Aircraft Industry Standard EN 6066	57
7.6.3.4.3	Other examples	59
7.7	DAMAGE CHARACTERIZATION	60
7.7.1	Overview	60
7.7.2	Damage resistance	61
7.7.2.1	Falling weight impact	61
7.7.2.2	Izod and charpy impact.....	62
7.7.2.3	Quasi-static indentation	62
7.7.2.4	Other damage resistance tolerance tests.....	62
7.7.3	Damage tolerance tests.....	63
7.7.3.1	Compression after impact tests	63
7.7.3.1.1	Overview	63
7.7.3.1.2	SACMA SRM 2R-94 "Compression after Impact Properties of Oriented Fiber-Resin Composites".....	64
7.7.3.1.3	NASA 1142, B.11 "Compression After Impact Test"	65
7.7.3.1.4	Test methods for MIL-HDBK-17 data submittal.....	65
	REFERENCES	65
 CHAPTER 8 STATISTICAL METHODS		1
8.1	INTRODUCTION	1
8.1.1	Overview of methods for calculating statistically-based properties	1
8.1.2	Computer software	1
8.1.3	Symbols	1
8.1.4	Statistical terms.....	3
8.2	BACKGROUND	7
8.2.1	Statistically-based design values	7
8.2.2	Basis values for unstructured data.	7
8.2.3	Basis values in the presence of batch-to-batch variability.....	8
8.2.4	Batches, panels, and confounding.....	9

8.2.5	Sample size guidelines for determining basis values.....	10
8.2.5.1	Example.....	11
8.2.5.2	Mean and standard deviations of normal basis values.....	11
8.2.5.3	Basis values using the ANOVA method.....	13
8.3	CALCULATION OF STATISTICALLY-BASED MATERIAL PROPERTIES.....	14
8.3.1	Guide to computational procedures.....	14
8.3.2	Subpopulation compatibility - structured or unstructured.....	16
8.3.2.1	Notation for grouped data.....	16
8.3.2.2	The k-sample Anderson-Darling test.....	17
8.3.3	Detecting outliers.....	18
8.3.3.1	The maximum normed residual.....	18
8.3.4	Basis values for unstructured data.....	19
8.3.4.1	Goodness-of-fit tests.....	19
8.3.4.2	Two-parameter Weibull distribution.....	20
8.3.4.2.1	Estimating the shape and scale parameters of a Weibull distribution.....	20
8.3.4.2.2	Goodness-of-fit test for the two-parameter Weibull distribution.....	23
8.3.4.2.3	Basis values for the two-parameter Weibull distribution.....	23
8.3.4.3	Normal distribution.....	23
8.3.4.3.1	Estimating the mean and standard deviation parameters for the normal distribution.....	24
8.3.4.3.2	Goodness-of-fit test for the normal distribution.....	24
8.3.4.3.3	Basis values for the normal distribution.....	24
8.3.4.4	Lognormal distribution.....	25
8.3.4.5	Nonparametric basis values.....	25
8.3.4.5.1	Nonparametric basis values for large samples.....	25
8.3.4.5.2	The Hanson-Koopmans method.....	26
8.3.5	Basis values for structured data.....	26
8.3.5.1	Regression analysis of linear statistical models.....	26
8.3.5.2	Analysis of variance.....	28
8.3.5.2.1	Levene's test for equality of variances.....	29
8.3.5.2.2	The F-test for equality of means.....	30
8.3.5.2.3	One-way ANOVA computations based on individual measurements.....	30
8.3.5.2.4	One-way ANOVA computations based on summary statistics.....	31
8.3.5.2.5	The ANOVA table for a one-way model.....	31
8.3.5.2.6	Calculation of summary statistics for one-way ANOVA basis values.....	32
8.3.5.2.7	Calculations for three or more batches.....	32
8.3.5.2.8	Calculations for two batches.....	33
8.3.5.3	Simple linear regression.....	33
8.3.5.4	Basis values using pooling of structured data.....	35
8.3.6	Exploratory data analysis.....	36
8.3.6.1	The quantile box plot.....	36
8.3.6.2	The informative quantile function.....	38
8.3.7	Examples of computational procedures.....	40
8.3.7.1	Problem 1 - Outlier detection, multiple-sample tests, and the Weibull distribution.....	40
8.3.7.2	Problem 2 - Normal distribution.....	45
8.3.7.3	Problem 3 - Lognormal distribution.....	49
8.3.7.4	Problem 4 - Nonparametric method.....	51
8.3.7.5	Problem 5 - Hanson-Koopmans method.....	51
8.3.7.6	Problem 6 - Analysis of variance (ANOVA) method.....	52
8.3.7.7	Problem 7 - Linear regression.....	56
8.3.7.8	Problem 8 - Simple linear regression with a random effect.....	61
8.3.7.9	Problem 9 - One-way mixed-model ANOVA: basis values with data from multiple sources.....	63

8.4	STATISTICAL METHODS	65
8.4.1	Tests for determining equivalency between an existing database and a new dataset for the same material	65
8.4.2	Alternate material statistical procedures.....	68
8.4.2.1	Comparing two groups of batches.....	68
8.4.3	Confidence intervals for the coefficient of variation.....	71
8.4.3.1	Example of CV confidence interval calculation	71
8.4.3.2	Comment on the approximation	72
8.4.4	Statistical procedures for process control.....	72
8.4.4.1	\bar{x} bar chart including batch effect.....	72
8.4.4.2	s^2 chart for the within-batch component of variance	75
8.4.4.3	Test for trend in batch means	75
8.4.5	Average stress-strain curves and bearing load-deformation curves	77
8.4.5.1	Fitting equations	79
8.5	STATISTICAL TABLES AND APPROXIMATIONS	81
8.5.1	Quantiles of the F-distribution.....	81
8.5.2	Quantiles of the χ^2 distribution	82
8.5.3	Upper-tail quantiles for the t-distribution.....	82
8.5.4	Two-tail probabilities for the t-distribution	82
8.5.5	Upper-tail probabilities for the standard normal distribution	82
8.5.6	Critical values for the k-sample Anderson-Darling test at the $\alpha = 0.05$ significance level.....	82
8.5.7	Critical values for the MNR outlier test	82
8.5.8	One-sided B-basis tolerance factors, V_B , for the Weibull distribution.....	82
8.5.9	One-sided A-basis tolerance factors, V_A , for the Weibull distribution.....	83
8.5.10	One-sided B-basis tolerance factors, k_B , for the normal distribution	83
8.5.11	One-sided A-basis tolerance factors, k_A , for the normal distribution	84
8.5.12	Ranks, r_B , for determining nonparametric B-basis values	84
8.5.13	Ranks, r_A , for determining nonparametric A-basis values	84
8.5.14	Nonparametric B-basis values for small sample sizes	84
8.5.15	Non-parametric A-basis values for small sample sizes	84
8.5.16	Critical values for approximate confidence limits on the coefficient of variation	84
8.5.17	One-sided tolerance factors for acceptance limits on mean values, for normal distribution.....	84
8.5.18	One-sided tolerance factors for acceptance limits on individual values, for normal distribution.....	85
8.5.19	Upper and lower tail quantiles for two-sided t-distribution.....	85
	REFERENCES	110

LIST OF TABLES

TABLE 8.5.1	Quantiles of the F-distribution	86
TABLE 8.5.2	Quantiles of the χ^2 distribution	88
TABLE 8.5.3	Upper-tail quantiles for the t-distribution.....	89
TABLE 8.5.4	Two-tail probabilities for t-distribution.	90
TABLE 8.5.5	Upper-tail probabilities for the standard normal distribution.....	91
TABLE 8.5.6	Critical values for the k-sample Anderson-Darling test at the $\alpha = 0.05$ significance level.....	92
TABLE 8.5.7	Critical values for the MNR outlier test	93
TABLE 8.5.8	One-sided B-basis tolerance factors, V_B , for the Weibull distribution	94
TABLE 8.5.9	One-sided A-basis tolerance limit factors, V_A , for the Weibull distribution,	96
TABLE 8.5.10	One-sided B-basis tolerance limit factors, k_B , for the normal distribution.....	98
TABLE 8.5.11	One-sided A-basis tolerance limit factors, k_A , for the normal distribution,	100
TABLE 8.5.12	Ranks, r_B for determining nonparametric B-basis values	102
TABLE 8.5.13	Ranks, r_A , for determining nonparametric A-basis values	103
TABLE 8.5.14	Nonparametric B-basis factors for small sample sizes.....	104

Volume 1, Foreword / Table of Contents

TABLE 8.5.15 Non-parametric A-basis factors for small sample sizes 105

TABLE 8.5.16 Critical values for confidence limits on the coefficient of variation 106

TABLE 8.5.17 Constants for test on mean and minimum individual values (values for
mean) 107

TABLE 8.5.18 Constants for test on mean and minimum individual values (values for
minimum individual)..... 108

TABLE 8.5.19 Constants for $t_{a,n}$ 109

INDEX..... I-1

CONCLUDING REMARKS C-1

SUMMARY OF CHANGES

Chapter	Section	Title	Change type
1	1.2	Purpose	revision
	1.7	Definitions	revision
	1.4.1	Roadmaps for use of Volumes 1-3	new
2	2.1.2.2	Data application categories	revision
	2.2.12	Data documentation	new
	2.3.7	Data substantiation for use of MIL-HDBK-17 Basis Values	revision
	2.4.4	Disposition of outlier data	new
	2.5	Material testing for submission of data for MIL-HDBK-17	revision
	2.5.1	Introduction	new
	2.5.3	Sampling Requirements	revision
	2.5.6	Data documentation requirements	revision
4	4.6.1	Introduction	new
	4.6.2	Tension	revision
	4.6.2.1	Introduction	new
	4.6.2.2	Specimen preparation	
	4.6.2.3	Test apparatus	
	4.6.2.4	Tensile test methods for MIL HDBK 17	
	4.6.3	Compression	revision
	4.6.3.1	Introduction	new
	4.6.3.2	Specimen preparation	
	4.6.3.3	Test apparatus	
	4.6.3.4	Compressive test methods for MIL HDBK 17	
	4.6.5	Flexure	revision
	4.6.5.1	Introduction	new
	4.6.5.2	Specimen preparation	
	4.6.5.3	Test apparatus	
	4.6.5.4	Flexural test methods for MIL HDBK 17	
	4.5.6	Volatiles content	revision
	4.5.7	Moisture content	revision
6	Outline	Refer to chapter outline	revision
	6.2	Specimen preparation	revision
	6.4 (to include all subsections)	Instrumentation and calibration	new-incorporates Section 6.7.2 Instrumentation from Rev E
	6.5 (to include all subsections)	Testing environments	new-incorporates Section 6.7.3 Non-ambient testing from Rev E
	6.6.4	Density	revision

Chapter	Section	Title	Change type
	6.6.5	Cured ply thickness	
	6.6.6	Fiber volume fraction	revision
	6.6.6.5	Determination of fiber volume using image analysis	new
	6.6.7	Void volume fraction	revision
	6.6.7.3	Determination of void volume using image analysis	new
	6.6.8	Moisture/fluid diffusivity and equilibrium content	revision
	6.6.9.1	Dimensional Stability (Thermal)	revision-incorporates Section 6.4.9 Dimensional stability from Rev E
	6.6.9.2	Dimensional Stability (Moisture)	revision-incorporates Section 6.4.9 Dimensional stability from Rev E
	6.6.10	Thermal Conductivity	new
	6.6.11	Specific heat	new
	6.6.12	Thermal Diffusivity	new
	6.6.13	Outgassing of composites for spacecraft	new
	6.6.18	Flammability and smoke generation	new
	6.12.2 (to include all subsections)	Tests unique to textile composites	new
7	7.2 (to include all subsections)	Specimen preparation	new
	7.4 (to include all subsections)	Notched laminate tests	new
	7.7	Damage Characterization	New-incorporates Section 7.4 Other Topics from Rev E
8	Chapter 8	Statistical Methods	revision
	8.3.1	Guide to Computational Procedures	new
	8.4	reorganized	revision
	8.5.17	Constants for Test on Mean and Minimum Individual values (Values for Mean)	new
	8.5.18	Constants for Test on Mean and Minimum Individual values (Values for Minimum Individual)	new
	8.5.19	Upper and Lower Tail Quantiles for Two-Sided t-Distribution	new

CHAPTER 1 OBJECTIVES

This handbook documents engineering methodologies for the development of standardized, statistically-based material property data for polymer matrix composite materials. Also provided are data summaries for a number of relevant composite material systems for which available data meets specific MIL-HDBK-17 requirements for publication. Additionally, supporting engineering and manufacturing technologies and common practices related to composite materials are summarized.

1.1 INTRODUCTION

It is generally understood that standardized, statistically-based, material property data are essential to an efficient engineering development process; such data are needed by material suppliers, engineering users, and system end-users alike. Since the inherent properties of materials are independent of specific applications, data development methodologies and material property data are applicable to a wide variety of industries; they also form much of the technical basis for establishment of statistically-based design values acceptable to procuring or certifying agencies.¹ This evaluation of the inherent properties of composite materials, as shown in Figure 1.1, is the focus of MIL-HDBK-17.

While the source and context for much of the handbook has historically come from experience with aerospace flight-critical structures, all transportation industries (aerospace, ground, rail, and marine), whether commercial or military, as well as other applications including general industrial products, will find the handbook useful. Incorporation of additional information related to broader applications is ongoing.

This handbook has been developed and is maintained as a joint effort of the US Department of Defense (DOD) and the US Federal Aviation Administration (FAA). The data contained herein, or appearing as approved items² in the minutes of MIL-HDBK-17 coordination group meetings, while not mandatory, are acceptable for use in the development of structural design values to the FAA and to all branches of the DOD. Note however, that methods for incorporating handbook data into structural design values for specific applications generally require additional procurement or certification agency approval.

1.2 PURPOSE

The primary purpose of MIL-HDBK-17 is the standardization of engineering data development methodologies related to characterization testing, data reduction, and data reporting of properties for polymer matrix composite materials. In support of this objective MIL-HDBK-17 publishes properties on composite material systems for which data meeting specific requirements is available. In addition, MIL-HDBK-17 provides selected guidance on other technical topics related to composites, including material selection, material specification, material processing, design, analysis, quality control and repair of typical polymer matrix composite materials. Thus, MIL-HDBK-17 is published in three volumes, and serves as a source for the following:

- *Volume 1:* Documents material characterization, data development, and methodology guidelines adaptable to a wide variety of needs, as well as specific requirements to be met by data published in the handbook. Most procuring and certifying agencies prefer, and some may require, that composite material systems used in critical applications either be characterized in accordance with Volume 1 guidelines or selected from material systems published in Volume 2.

¹An example of a procuring agency is a branch of the US Department of Defense (DOD). An example of a certifying agency is an office of the US Federal Aviation Administration (FAA).

²Accepted as of the MIL-HDBK-17 Coordination Committee approval date.

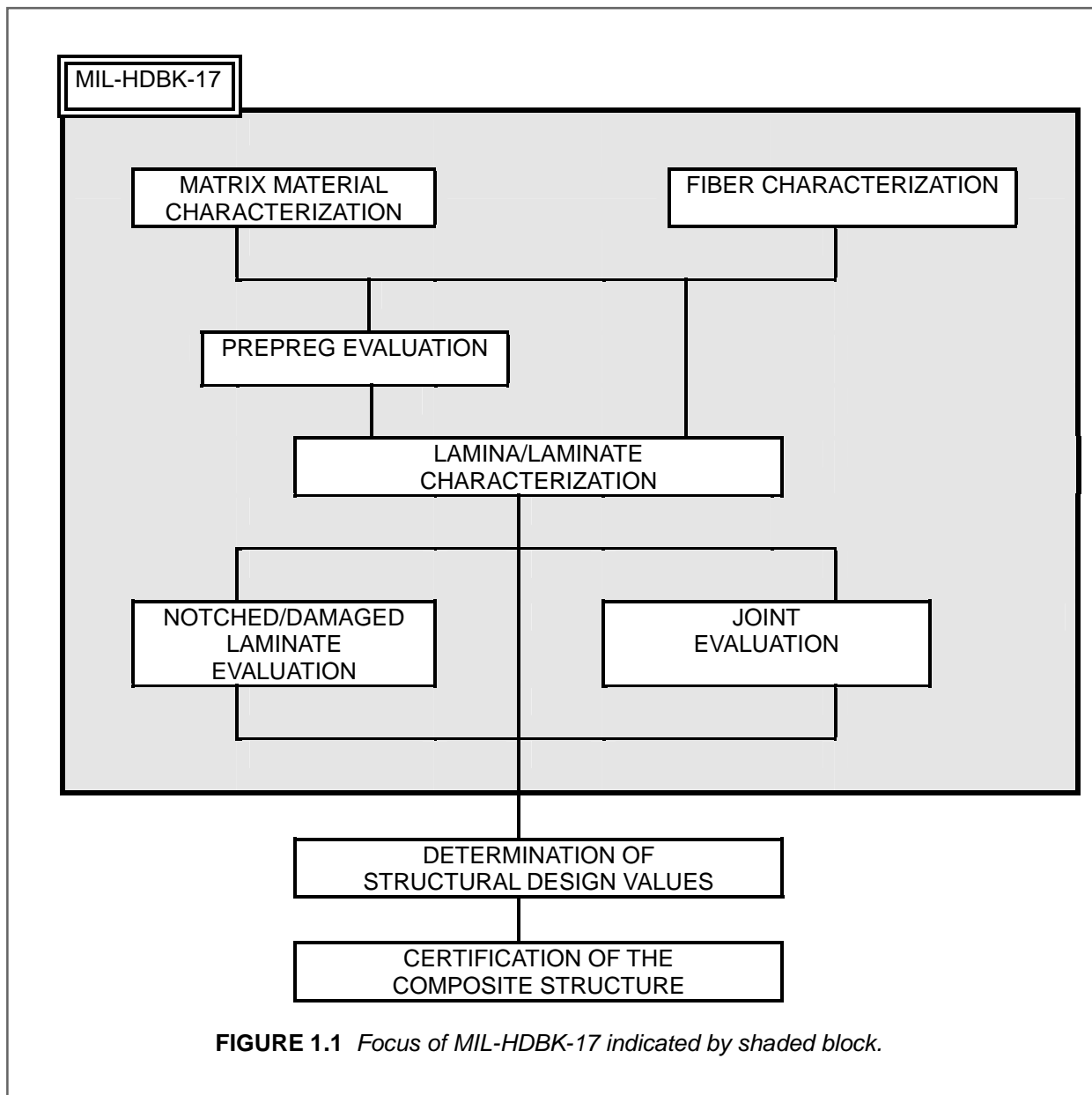

- *Volume 2:* Provides a repository of potential design data. The documented property summaries for material systems provide data meeting the criteria for any of the MIL-HDBK-17 data classes.
- *Volume 3:* Source for additional technical guidance on a wide variety of disciplines related to polymer matrix composites.

1.3 SCOPE

For Department of Defense purposes, this handbook is for guidance only. This handbook cannot be cited as a requirement. If it is, the contractor does not have to comply. This mandate is a DoD requirement only; it is not applicable to the Federal Aviation Administration (FAA) or other government agencies.

The three volumes of MIL-HDBK-17 serve as a general reference source for technical information on polymer matrix composites, including:

1.3.1 Strength properties and allowables data

Statistically-based strength property data are defined for each composite material system over a range of potential usage conditions. The intent is to provide data at the upper and lower limits of the potential environmental conditions for a particular material, so that application issues do not govern the mechanical property characterizations. If data are also available at intermediate environmental conditions, they are used to more exactly define the relationship between the mechanical properties and the effect of the environment on those properties.

The statistically-based strength data that are available are tabulated in Volume 2. These data are useful as a starting point for establishing structural design allowables when stress and strength analysis capabilities permit lamina level margin of safety checks. Where such cases exist, the MIL-HDBK-17 statistically reduced strength data may be used in determining material design allowables. Depending on the application, some structural design allowables will have to be determined empirically by laminate, element, or higher level of testing, since MIL-HDBK-17 does not provide these data.

Additional information and properties are added as they become available and are demonstrated to meet the guideline criteria. Typical property values, as well as S-values (see definitions) are included if they meet the approval of the MIL-HDBK-17 Coordination Group.

When the guidelines or data requirements of MIL-HDBK-17 cannot be followed, the certifying or procuring government agency should be contacted to determine data requirements and other documentation which may be necessary to justify data values proposed or used by the manufacturer.

1.3.2 Volume 1: Guidelines for Characterization of Structural Materials

This volume contains guidelines for determining the properties of composite material systems, their constituents, and generic structural elements, including test planning, test matrices, sampling, conditioning, test procedure selection, data reporting, data reduction, statistical analysis, and other related topics. Special attention is given to the statistical treatment and analysis of data. Volume 1 contains *guidelines* for general development of material characterization data as well as *specific requirements* for publication of material data in MIL-HDBK-17.

It must be emphasized that this handbook differentiates between material basis values (material allowables) and design allowable values. Material basis values, being an intrinsic property of a composite material system, are the focus of this handbook. Design allowable values, while often rooted in material basis values, are application dependent, and consider and include specific additional considerations that may further affect the strength or stiffness of the structure. Also, when establishing application design values there may be additional certification or procurement agency requirements that go beyond MIL-HDBK-17.

1.3.3 Volume 2: Material Properties

Volume 2 contains statistically-based data meeting specific MIL-HDBK-17 population sampling and data documentation requirements, covering constituents and material systems of general interest. Data published in Volume 2 are under the jurisdiction of the Data Review Working Group and are approved by the overall Coordination Group (The MIL-HDBK-17 Coordination Group and Working Groups are discussed in Section 1.5). New material systems will be included and additional material data for existing systems will be added as data becomes available and are approved. Selected historical data from the MIL-HDBK-17A version of the handbook that do not meet current data sampling, test methodology, or documentation requirements, but that still are of potential interest to the industry, are also documented in an appendix to this volume.

The material properties in Volume 2 are defined over a range of potential use conditions, focusing, when possible, on the upper and lower material environmental limits so that application-specific environ-

ments do not limit use of the data. Data at intermediate environmental conditions, when available, provide additional definition of the relation between material response and environment.

While the process of establishing structural design values for specific applications can begin with the data contained in Volume 2, most applications require collection of additional data, especially if there are requirements for data from the laminate or higher structural complexity levels (structural complexity level is discussed in 2.1.2.1). Also, the ability to manufacture material equivalent to that from which the data in Volume 2 were obtained typically must be proven to the procuring or certifying agency, which usually involves limited testing and data comparison. General guidelines for such material/process equivalence evaluation are presented in Volume 1; however, many of the details of such an evaluation remain at the discretion of the procuring or certifying agency.

1.3.4 Volume 3: Materials Usage, Design, and Analysis Guidelines

Volume 3 provides methodologies and lessons learned for the design, manufacture, analysis, and supportability of composite structures, and for utilization of the material data provided in Volume 2 consistent with the guidance provided in Volume 1. Topics discussed in Volume 3 include materials and processing, quality control, design and analysis, joints, reliability, thick composites, and supportability.

1.4 USE OF THE DOCUMENT AND LIMITATIONS

1.4.1 Roadmaps for use of Volumes 1 - 3

The following pages provide summary roadmaps that are intended to be brief guides to relevant sections of this document pertaining to the following topics. The roadmaps are brief guides to the handbook, and while they indicate a general process flow for the topics, they do not show the detailed process flows, interactions and loops that are required in the actual process implementation. In some cases there are overlaps between the various roadmaps. Some minor sections have not been included; for these the reader is referred to the complete handbook table of contents.

Roadmap #1: Use of New Material in Design and Structural Substantiation

This roadmap covers the qualification of a new material, development of material allowables and structural design values, and designing, analyzing and certifying a structure with the new material. This roadmap would be typically used by a design organization.

Roadmap #2: Qualification of New Material

This roadmap covers the process for qualifying a new material and establishing the corresponding material procurement specification. This roadmap would be typically used by an design organization.

Roadmap #3: Development of Lamina Allowables

This roadmap covers the process for developing lamina level material allowables for a material. This roadmap could be used by a material supplier who wishes to provide allowables to customers or by a design organization.

Roadmap #4: Development of Data for New Material for Submittal to Volume 2

This roadmap covers the process for developing material data for submittal to the Handbook for the calculation of material properties and allowables, and subsequent publication in Volume 2. This roadmap could be used by a material supplier or by a design organization.

Roadmap #5: Use of Volume 2 Data for Design and Structural Substantiation

This roadmap covers the process for obtaining Volume 2 data, and for performing "equivalency" testing to validate use of the material in the manufacturer's fabrication process.

Roadmap #6: Demonstration of Equivalency for Revised Material and/or Process

This roadmap covers the process for demonstrating the "equivalency" of a minor change to a material or to a part fabrication process. This roadmap could be used by a material supplier or by a design organization.

Roadmap #7: Demonstration of Application Acceptance for "2nd Source" Material

This roadmap covers the process for demonstrating the acceptability of substituting a new material for the original material used to design and certify a part. "New" material refers to a different fiber or resin material, or to a major change to the original material. This roadmap would be typically used by an design organization.

Roadmap #8: Bolted Joint Tests and Analysis Methods

This roadmap covers development of allowables and design values for, and the design and analysis of bolted joints.

Roadmap #9: Bonded Joint Tests and Analysis Methods

This roadmap covers development of allowables and design values for, and the design and analysis of bonded joints.

Roadmap #10: Design, Analysis and Fabrication of Repairs

This roadmap covers development of allowables and design values for, the design and analysis, and the fabrication of repairs to composite laminates.

Roadmap #1: Use of New Material in Design and Structural Substantiation

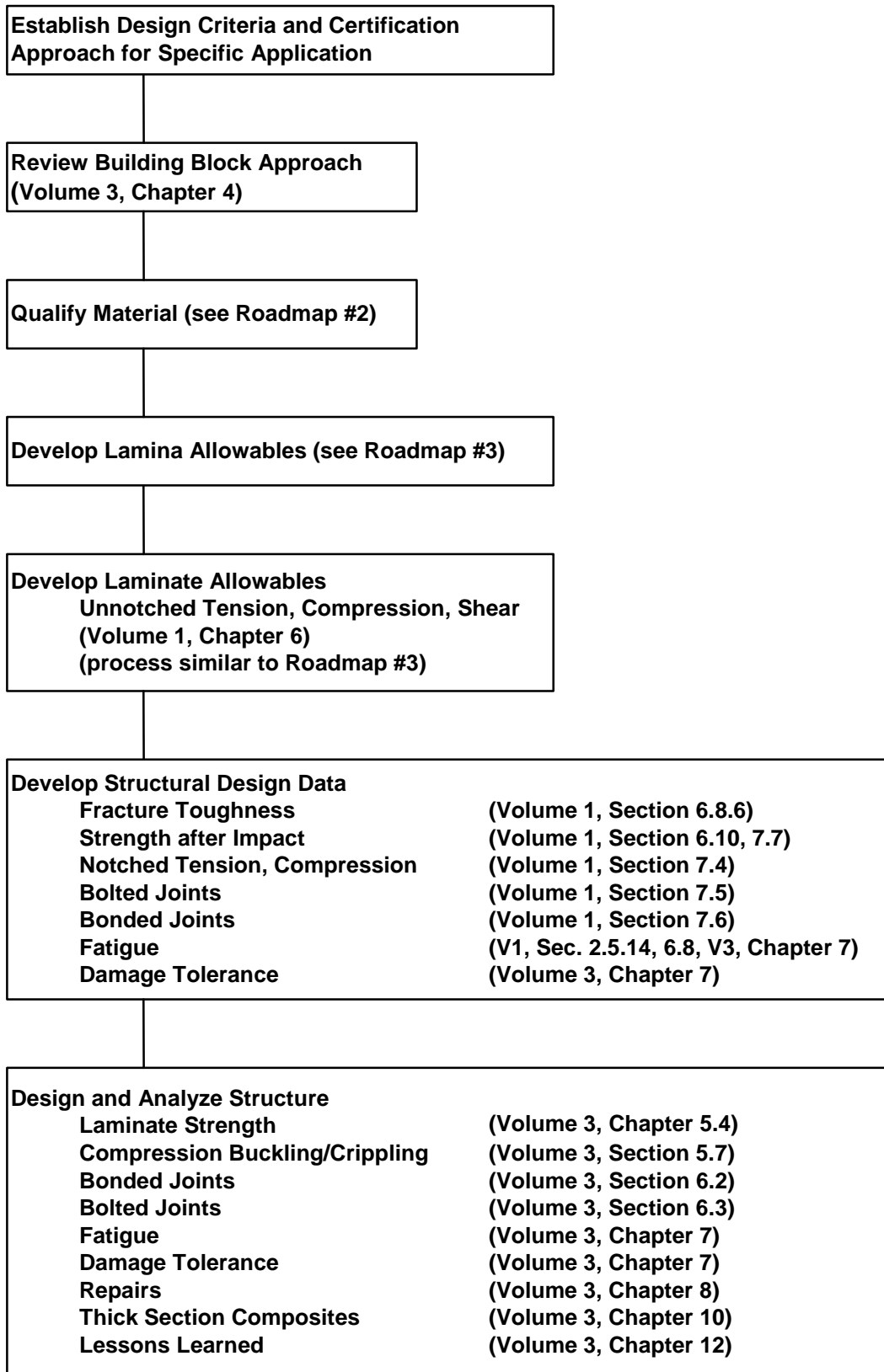

Roadmap #2: Qualification of New Material

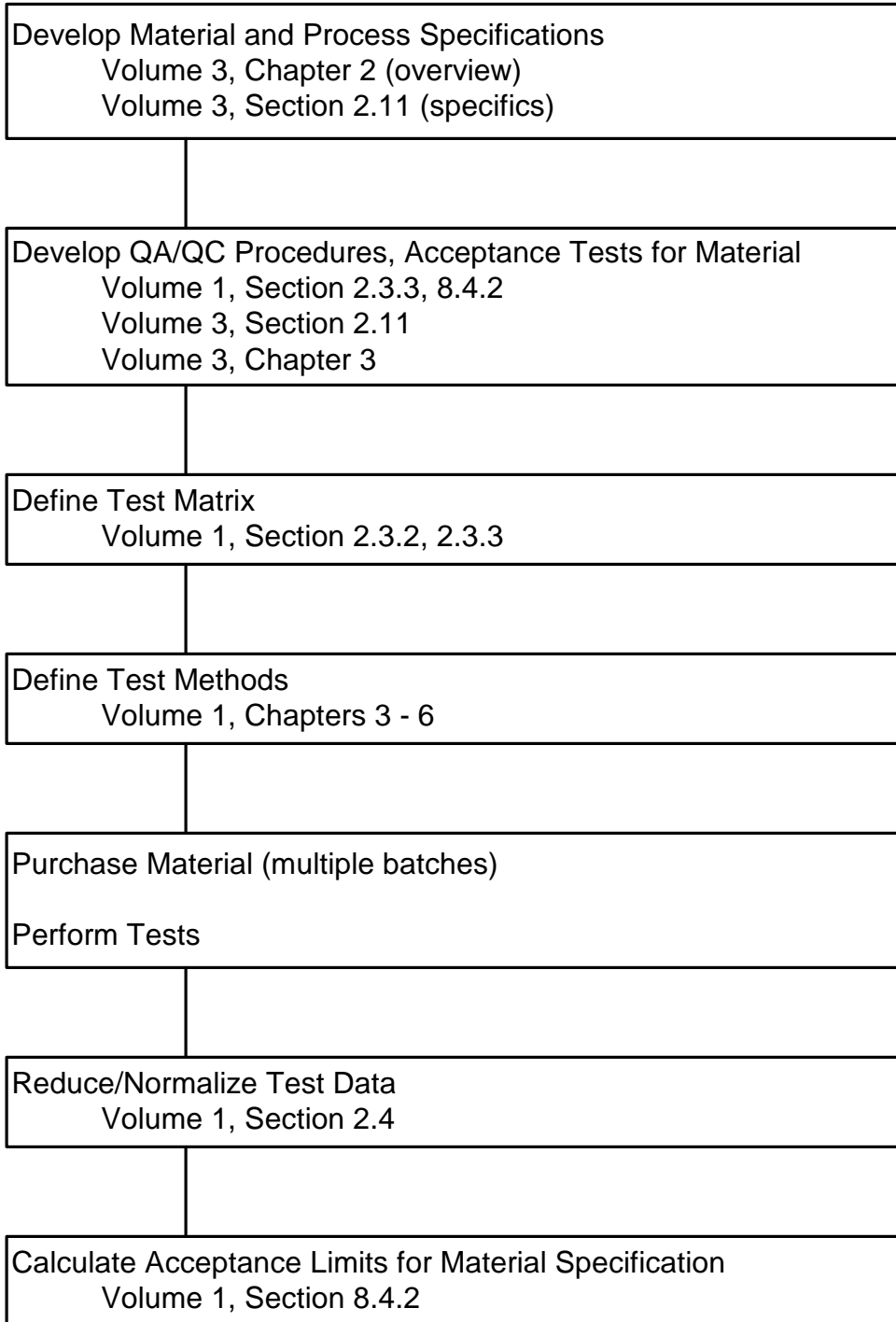

Roadmap #3: Development of Lamina Allowables

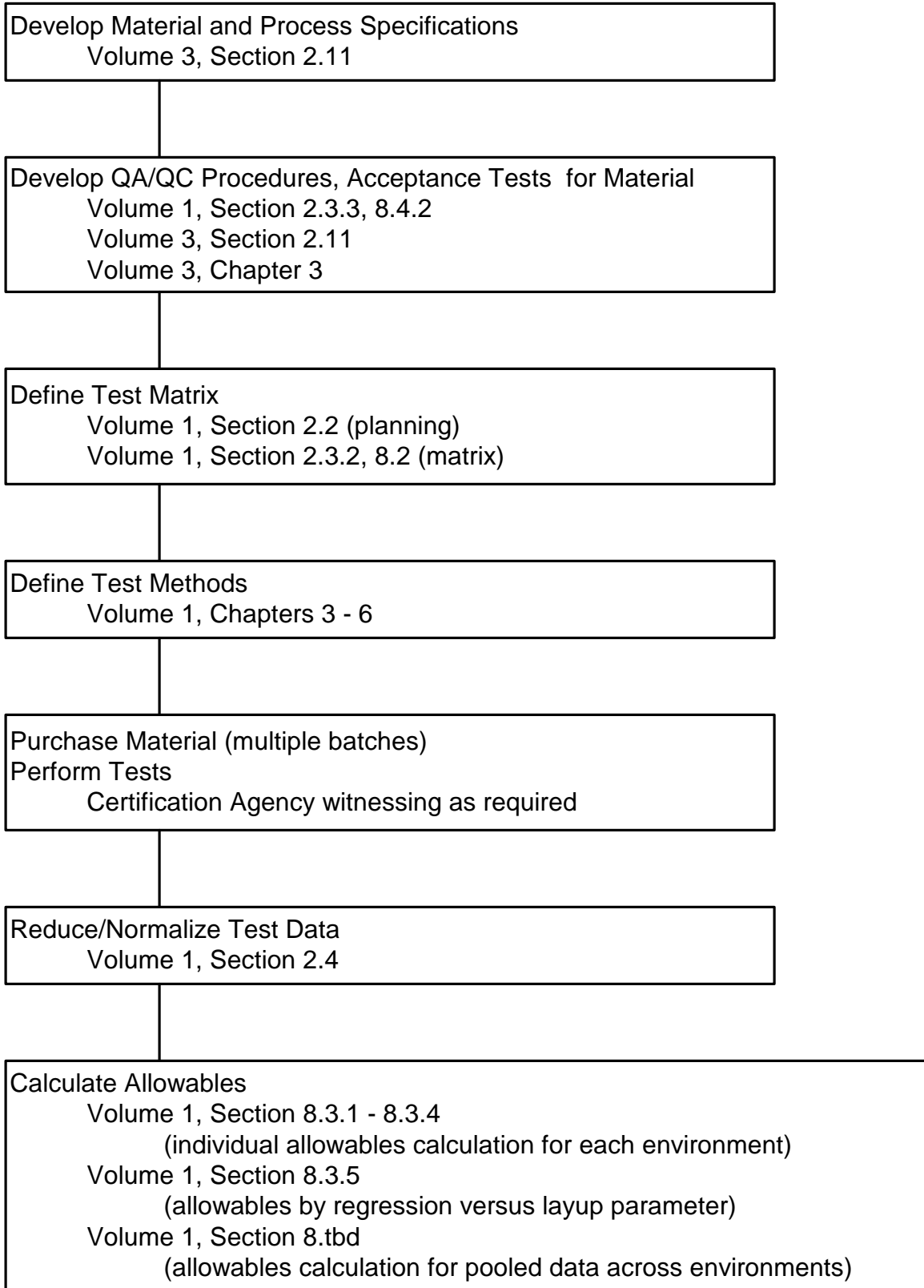

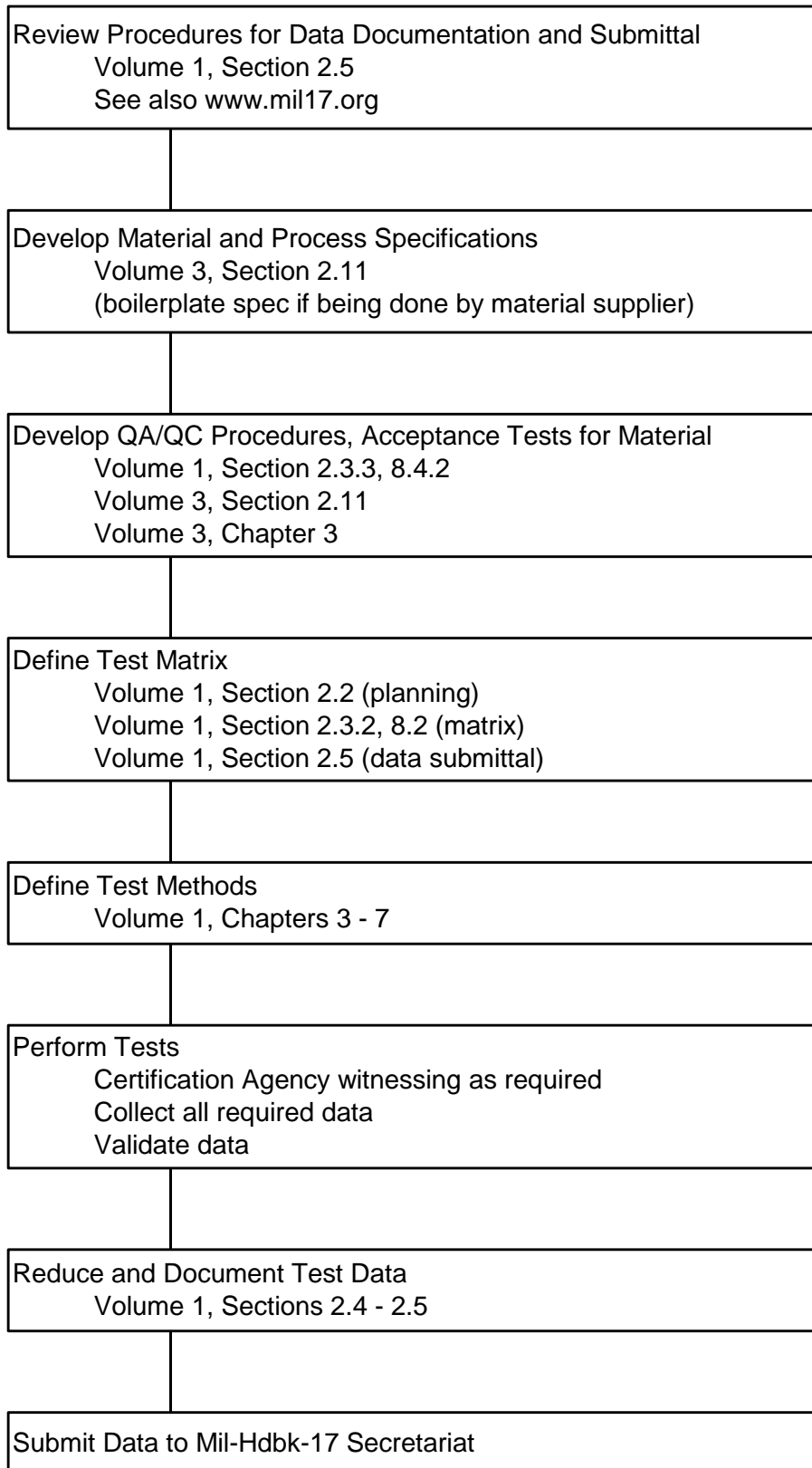
Roadmap #4: Development of Data for New Material for Submittal to Volume 2

Roadmap #5: Use of Volume 2 Data for Design and Structural Substantiation

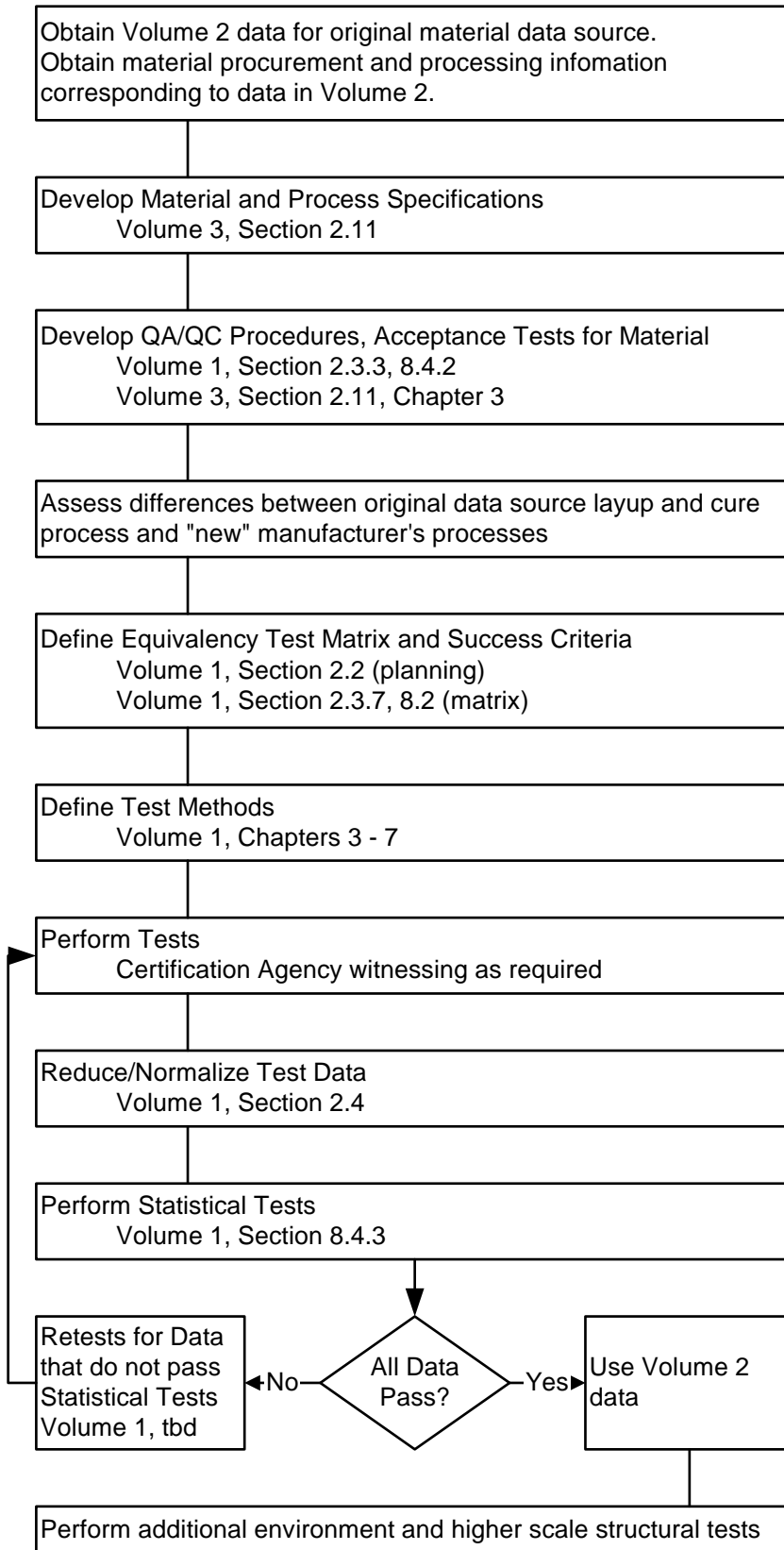

Roadmap #6: Demonstration of Equivalency for Revised Material and/or Process

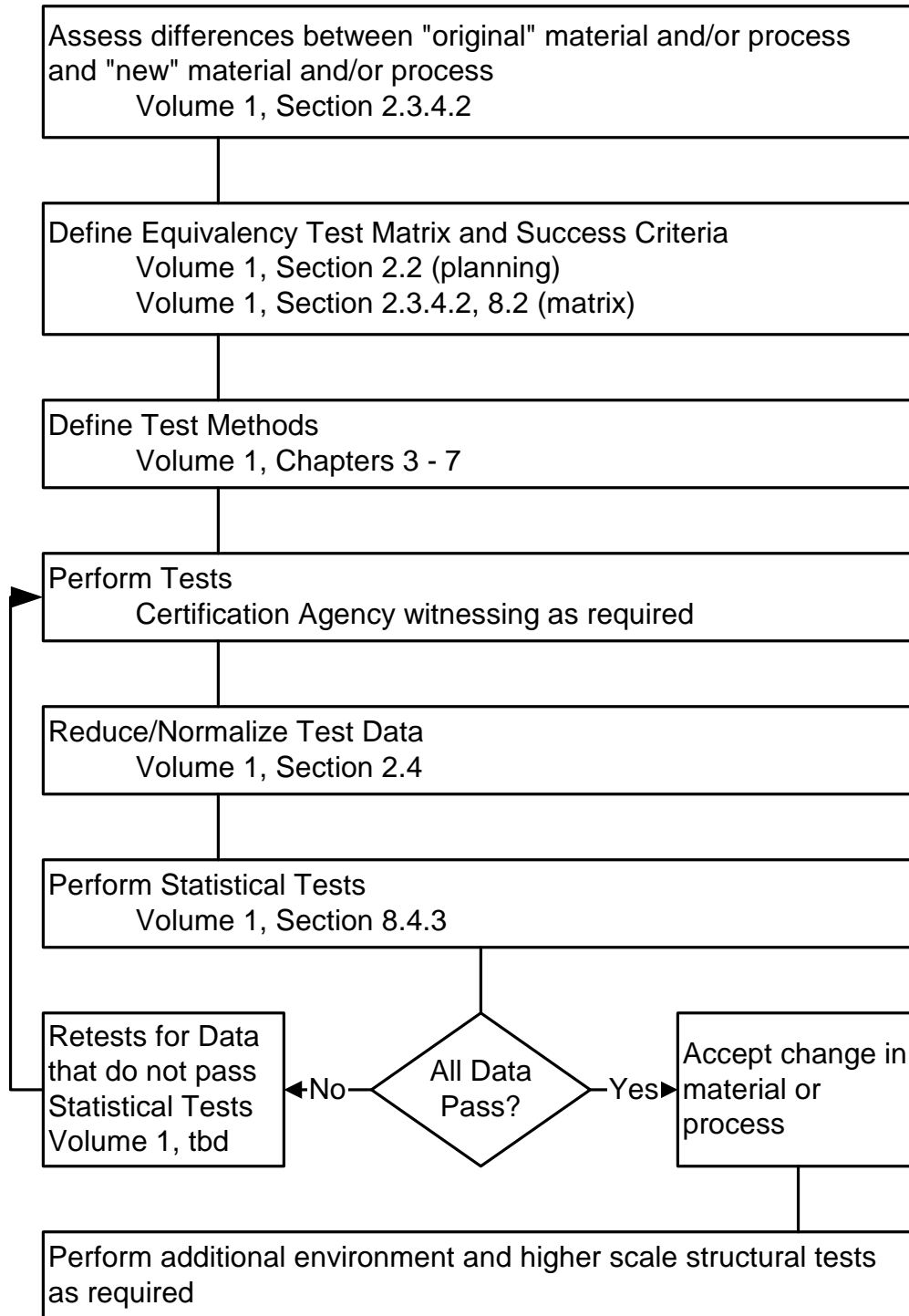

Roadmap #7: Demonstration of Application Acceptance for "2nd Source" Material

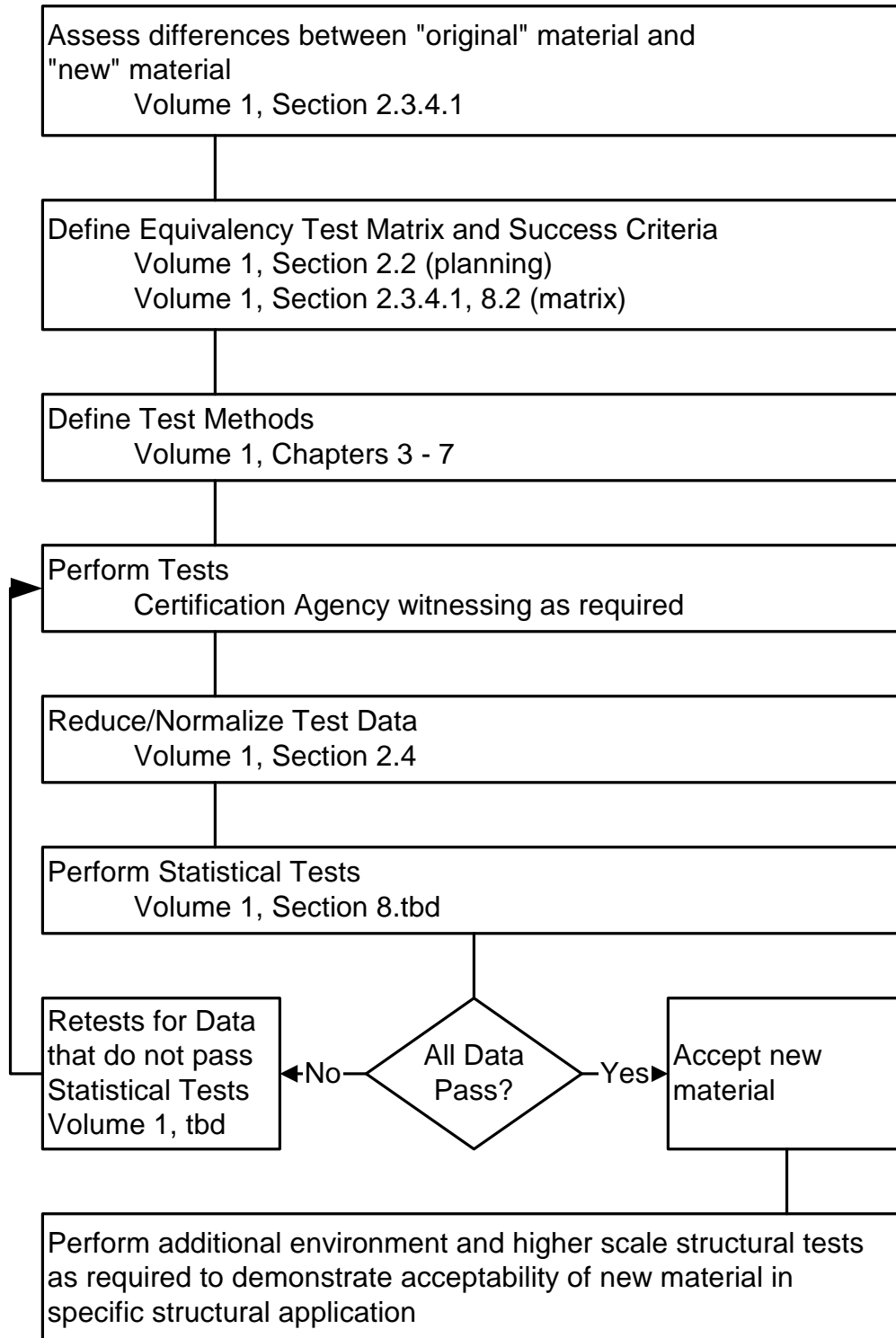

Roadmap #8: Bolted Joint Tests and Analysis Methods

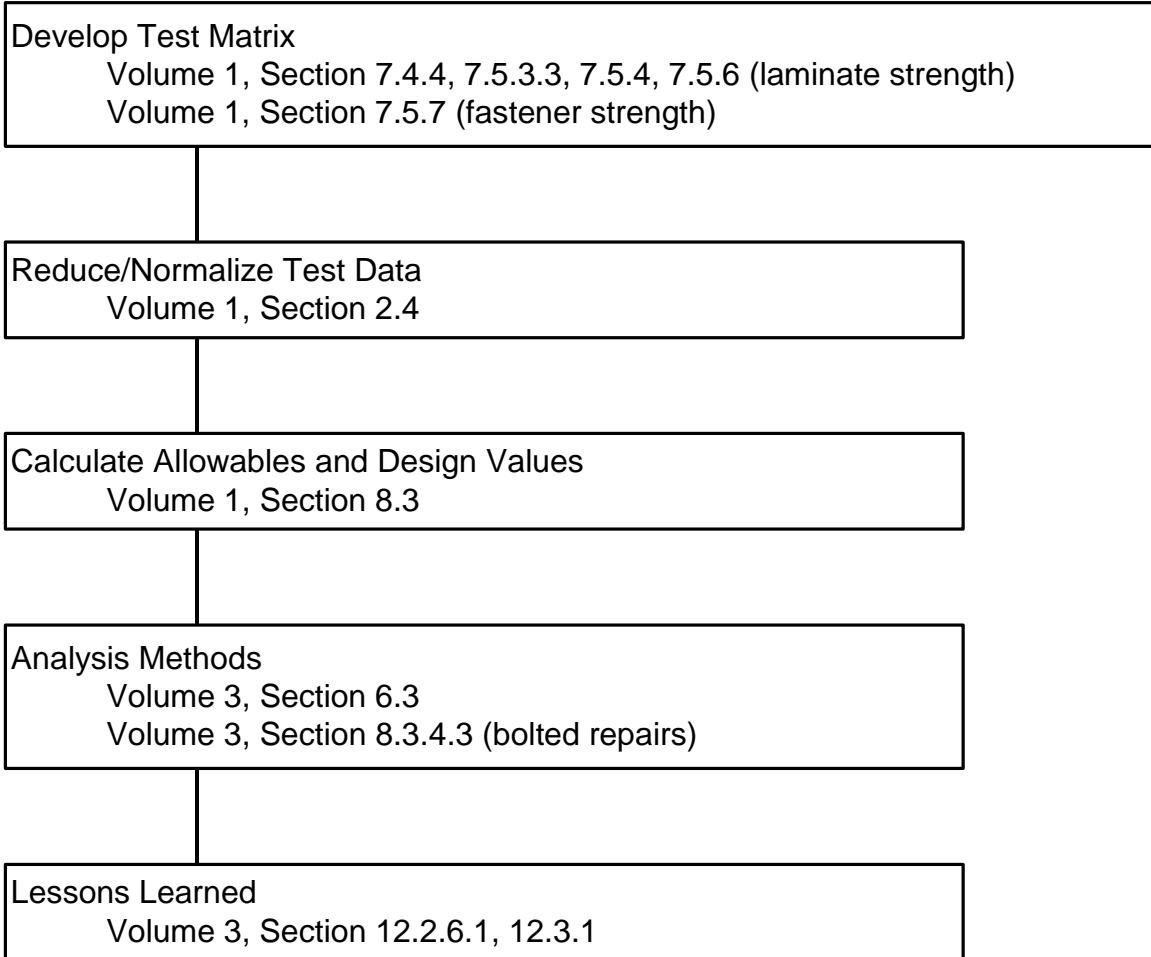

Roadmap #9: Bonded Joint Tests and Analysis Methods

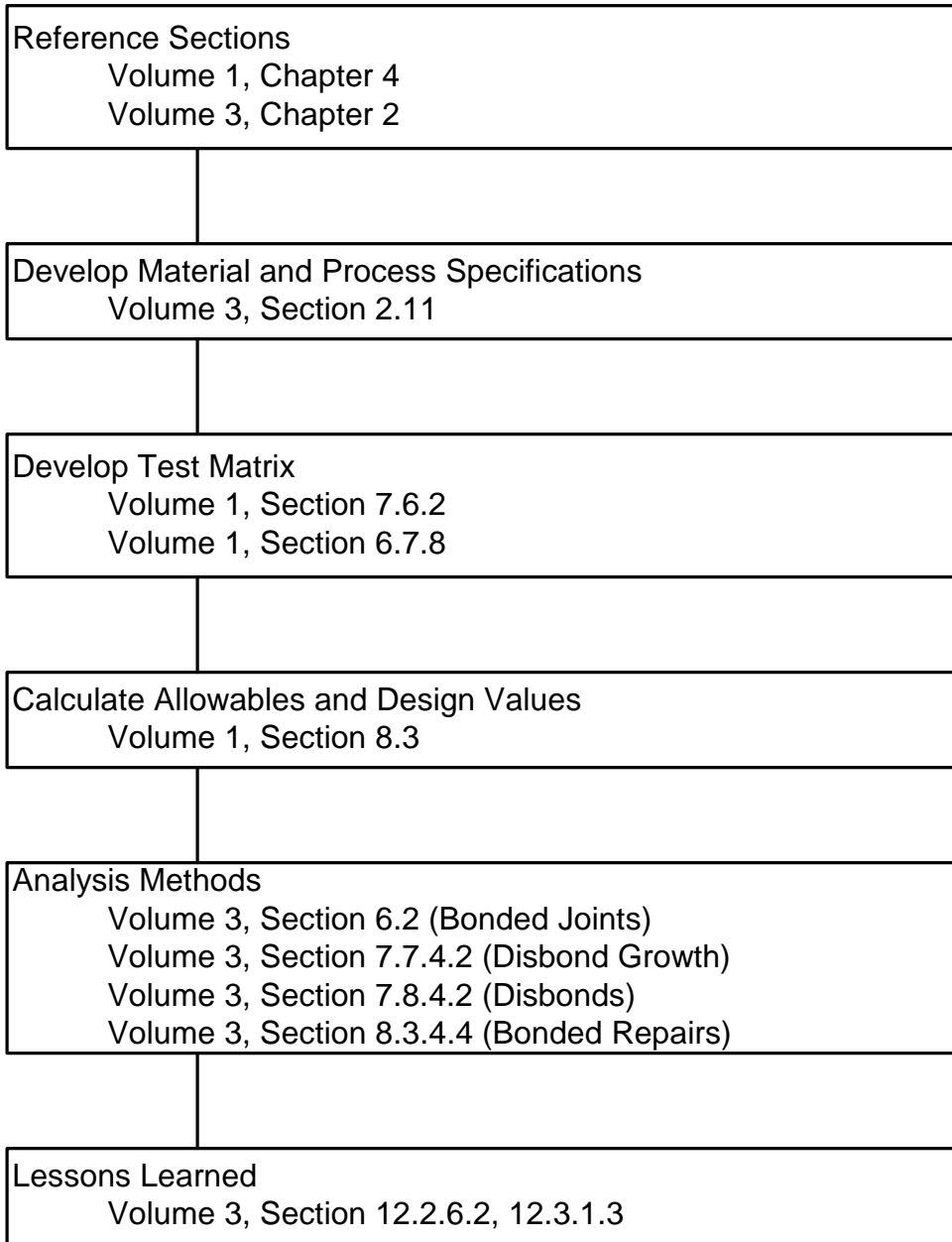

Roadmap #10: Design, Analysis and Fabrication of Repairs

Characterize Repair Materials

- Develop Material and Process Specifications, Volume 3, Section 2.11
- Develop Lamina Allowables (see Roadmap #3)
- Develop Laminate Allowables (similar to Roadmap #3)
- Develop Bolted Joint Allowables, Volume 1, Sections 7.4 - 7.5
- Develop Adhesive Allowables, Volume 1, Section 7.6.2
- Develop Bonded Joint Allowables, Volume 1, Section 7.6.3
- Calculate Allowables and Design Values, Volume 1, Section 8.3

Design for Repair

Volume 3, Section 8.2

Repair Design

Volume 3, Section 8.3

Bonded Repair Analysis Methods

- Volume 3, Chapter 5
- Volume 3, Section 6.2 (Bonded Joints)
- Volume 3, Section 7.7.4.2 (Disbond Growth)
- Volume 3, Section 7.8.4.2 (Disbonds)
- Volume 3, Section 8.3.4.4 (Bonded Repairs)

Bolted Repair Analysis Methods

- Volume 3, Chapter 5
- Volume 3, Section 6.3
- Volume 3, Section 8.3.4.3 (Bolted Repairs)

Lessons Learned

Volume 3, Chapter 12

1.4.2 Source of information

The information contained in MIL-HDBK-17 is obtained from materials producers and fabricators, the aerospace industry, reports on government-sponsored research, the open literature, direct contacts with researchers, and from participants in MIL-HDBK-17 coordination activities. All information published in this document has been coordinated and reviewed by representatives from industry, the US Army, the US Navy, the US Air Force, NASA, and the US Federal Aviation Administration. Every effort has been made to reflect the most up-to-date information on the use of composite materials, with particular emphasis on use of composites in structures. The handbook is continually reviewed and revised to keep current with the state-of-the-art and insure completeness and accuracy.

1.4.3 Use of data and guidelines in applications

All data contained herein are based on small-scale test specimens for specific environmental conditions, largely limited to uniaxial quasi-static loading.¹ It is the user's responsibility to determine if handbook data is appropriate for a given application, and if selected, to translate or scale the data as necessary for use:

- in a multi-directional laminate,
- on a structure of different characteristic size and geometry,
- under a multi-directional stress state,
- when exposed to a different environment, and/or
- when subjected to non-static loading.

Further discussions of these and other issues are provided in Volume 3. Specific uses of handbook data are beyond the scope and responsibility of MIL-HDBK-17, and applicability and interpretation of specific provisions of this handbook may require approval by an appropriate procurement or certification agency.

1.4.4 Strength properties and allowables terminology

The handbook intent is to provide guidelines for generating material property data, including statistically-based strength data at environmental extremes that bracket most intermediate application-specific environments. The philosophy is to avoid having application-specific issues govern generic material property characterization programs. If data are also available at intermediate environmental conditions, they can be used to more completely define the relationship between the property and the effect of the environment on that property. However, in some cases an environmental limit for a composite material system may be application dependent, and in others, data at environmental limits may not be available.

Available statistically-based strength data are tabulated in Volume 2. These data are useful as a starting point for establishing structural design allowable values when stress and strength analysis capabilities permit lamina-level margin-of-safety calculations. For such cases the MIL-HDBK-17 strength basis value may also be termed a material design allowable. Depending on the application, some structural design allowables may have to be empirically determined from additional laminate, element, or higher-level test data not provided by MIL-HDBK-17.

1.4.5 Use of references

While many references are provided at the end of each chapter, note that the information in these citations may not necessarily comply in every respect either with the general guidelines for data development or with the specific requirements for publication of data in the handbook. The references are simply

¹Unless otherwise noted, tests were conducted in conformance with the particular test method noted. The emphasis is on data obtained from ASTM standard test methods for advanced composites, but where an ASTM test method has been deemed inappropriate or is not yet available, or when data from a nonstandard but commonly practiced test procedure is available, then data from a non-standard test method may have been accepted for publication. The specific test method used is noted in the data documentation. See also the statement on test method acceptance criteria in Section 2.5.5.

intended to be helpful, but not necessarily complete or authoritative sources of additional related information on specific subject areas.

1.4.6 Use of tradenames and product names

Use of tradenames or proprietary product names does *not* constitute an endorsement of those products by the US Government or by the MIL-HDBK-17 Coordination Group.

1.4.7 Toxicity, health hazards, and safety

Certain processing and test methods discussed in MIL-HDBK-17 may involve hazardous materials, operations, or equipment. These methods may not address safety problems, if any, associated with their use. It is the responsibility of the user of these methods to establish appropriate safety and health practices and to determine the applicability of regulatory limitations prior to use. The user is referred to the Advanced Composite Materials US Army Interim Health and Safety Guidance for a discussion of the health and safety issues involved in the processing and use of composite materials. This document is generated by the US Army Environmental Hygiene Agency, Aberdeen Proving Ground, MD. Material manufacturers, as well as various composites user groups, may also provide guidance on health and safety issues pertinent to composite materials.

1.4.8 Ozone depleting chemicals

Restrictions on the use of ozone depleting chemicals are detailed in the US Clean Air Act of 1991.

1.5 APPROVAL PROCEDURES

The content of the handbook is developed and approved by the MIL-HDBK-17 Coordination Group, which meets twice yearly to consider changes and additions to the handbook. This Group consists of the handbook Co-Chairs, Coordinator, Secretariat, Working Group Chairs, and the active Working Group participants, which include representatives from various US and international procuring and certifying agencies, in addition to the producing industries and academic and research institutions. MIL-HDBK-17 Coordination Group meetings are announced to participants by mail about eight weeks prior to the scheduled meeting date, and minutes of the meetings are mailed eight weeks following the close of the meeting.

While each of the Working Groups functions similarly, they are of three types: *Executive*, a single Working Group with oversight responsibility composed of the Working Group Chairs, the handbook Co-Chairs, Coordinator, and Secretariat; *Standing*, including Data Review, Guidelines, Materials and Processing, Statistics, and Testing Working Groups; and *Specialty*, which varies with time but currently includes the Braiding and Filament Winding, Supportability, Structural Joints, and Thick-Sections Working Groups. The makeup and organization of the Coordination Group and Working Groups, as well as the procedures followed for document change approval, are summarized in the MIL-HDBK-17 Coordination Group Member's Guide, separately published and available from either the Coordinator or Secretariat.

Proposals for addition to, deletion from, or modification to the handbook should be submitted to both the appropriate Working Group and the Secretariat well in advance of the announcement mailing date, and should include specific notation of the proposed changes and adequate documentation of supporting data or analytical procedures. Reproducible copies of figures, drawings, or photographs proposed for publication in the document should be furnished to the Secretariat. Following approval by the appropriate Working Group, the proposed changes are published in the next minutes of the Coordination Group, in a special section of the minutes called the "yellow pages", and all participants are allowed comment on the proposed changes. If no substantive comments are received on any individual item by the posted response date, then that item is considered approved by the Coordination Group and is considered effective as of that date. (Prior to publication in the next revision of the handbook the collected changes are reviewed by various branches of the US DOD. Additional proposals for revision may result from this US DOD review.)

Requests for inclusion of material property data into MIL-HDBK-17 should be submitted to either the Coordinator or the Secretariat, accompanied by the documentation specified in Section 2.5.5. A Data Source Information Package has been created to aid those considering submitting data for inclusion in MIL-HDBK-17, and is available from either the Coordinator or the Secretariat. The Secretariat reviews and analyzes each data submission and at the next available meeting of the Coordination Group presents a summary for evaluation by the Data Review Working Group. The choice of new materials to be included herein is governed by the MIL-HDBK-17 Coordination Group. Practical considerations preclude inclusion of all advanced composite materials, but reasonable attempts will be made to add new material systems of interest in a timely manner.

1.6 SYMBOLS, ABBREVIATIONS, AND SYSTEMS OF UNITS

This section defines the symbols and abbreviations which are used within MIL-HDBK-17 and describes the system of units which is maintained. Common usage is maintained where possible. References 1.6(a), 1.6(b), and 1.6(c) served as primary sources for this information.

1.6.1 Symbols and abbreviations

The symbols and abbreviations used in this document are defined in this section with the exception of statistical symbols. These latter symbols are defined in Chapter 8. The lamina/laminate coordinate axes used for all properties and a summary of the mechanical property notation are shown in Figure 1.6.1.

- The symbols f and m , when used as either subscripts or superscripts, always denote fiber and matrix, respectively.
- The type of stress (for example, c_y - compression yield) is always used in the superscript position.
- Direction indicators (for example, x , y , z , 1, 2, 3, etc.) are always used in the subscript position.
- Ordinal indicators of laminae sequence (e.g., 1, 2, 3, etc.) are used in the superscript position and must be parenthesized to distinguish them from mathematical exponents.
- Other indicators may be used in either subscript or superscript position, as appropriate for clarity.
- Compound symbols (such as, basic symbols plus indicators) which deviate from these rules are shown in their specific form in the following list.

The following general symbols and abbreviations are considered standard for use in MIL-HDBK-17. Where exceptions are made, they are noted in the text and tables.

A	- (1) area (m^2, in^2) - (2) ratio of alternating stress to mean stress - (3) A-basis for mechanical property values
a	- (1) length dimension (mm, in) - (2) acceleration ($m/sec^2, ft/sec^2$) - (3) amplitude - (4) crack or flaw dimension (mm, in)
B	- (1) B-basis for mechanical property values - (2) biaxial ratio
Btu	- British thermal unit(s)
b	- width dimension (mm, in), e.g., the width of a bearing or compression panel normal to load, or breadth of beam cross-section

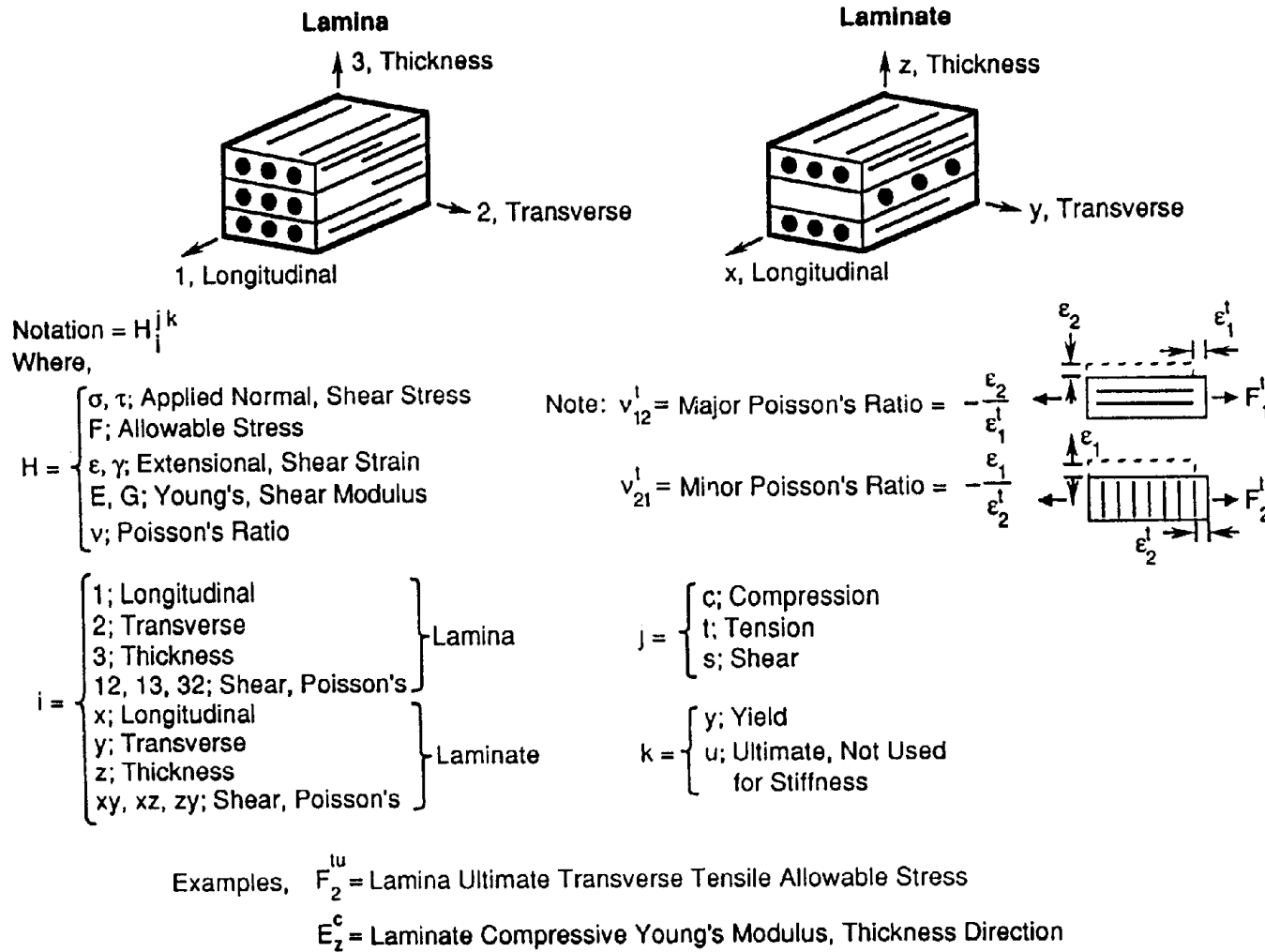

FIGURE 1.6.1 Mechanical property notation.

Volume 1, Chapter 1 Objectives

C	- (1) specific heat (kJ/kg °C, Btu/lb °F) - (2) Celsius
CF	- centrifugal force (N, lbf)
CPF	- crossply factor
CPT	- cured ply thickness (mm, in.)
CG	- (1) center of mass, "center of gravity" - (2) area or volume centroid
\mathcal{C}	- centerline
c	- column buckling end-fixity coefficient
\bar{c}	- honeycomb sandwich core depth (mm, in)
cpm	- cycles per minute
D	- (1) diameter (mm, in) - (2) hole or fastener diameter (mm, in) - (3) plate stiffness (N-m, lbf-in)
d	- mathematical operator denoting differential
E	- modulus of elasticity in tension, average ratio of stress to strain for stress below proportional limit (GPa, Msi)
E'	- storage modulus (GPa, Msi)
E''	- loss modulus (GPa, Msi)
E _c	- modulus of elasticity in compression, average ratio of stress to strain for stress below proportional limit (GPa, Msi)
E _c '	- modulus of elasticity of honeycomb core normal to sandwich plane (GPa, Msi)
E ^{sec}	- secant modulus (GPa, Msi)
E ^{tan}	- tangent modulus (GPa, Msi)
e	- minimum distance from a hole center to the edge of the sheet (mm, in)
e/D	- ratio of edge distance to hole diameter (bearing strength)
F	- (1) stress (MPa, ksi) - (2) Fahrenheit
F ^b	- bending stress (MPa, ksi)
F ^{cr}	- crushing or crippling stress (upper limit of column stress for failure) (MPa, ksi)
F ^{su}	- ultimate stress in pure shear (this value represents the average shear stress over the cross-section) (MPa, ksi)
FAW	- fiber areal weight (g/m ² , lb/in ²)
FV	- fiber volume (%)
f	- (1) internal (or calculated) stress (MPa, ksi) - (2) stress applied to the gross flawed section (MPa, ksi) - (3) creep stress (MPa, ksi)
f ^c	- internal (or calculated) compressive stress (MPa, ksi)
f _c	- (1) maximum stress at fracture (MPa, ksi) - (2) gross stress limit (for screening elastic fracture data) (MPa, ksi)
ft	- foot, feet
G	- modulus of rigidity (shear modulus) (GPa, Msi)
GPa	- gigapascal(s)
g	- (1) gram(s) - (2) acceleration due to gravity (m/s ² , ft/s ²)
H/C	- honeycomb (sandwich)
h	- height dimension (mm, in) e.g. the height of a beam cross-section
hr	- hour(s)
I	- area moment of inertia (mm ⁴ , in ⁴)
i	- slope (due to bending) of neutral plane in a beam, in radians
in.	- inch(es)
J	- (1) torsion constant (= I _p for round tubes) (m ⁴ , in ⁴) - (2) Joule

Volume 1, Chapter 1 Objectives

K	- (1) Kelvin - (2) stress intensity factor (MPa/m,ksi/in) - (3) coefficient of thermal conductivity (W/m °C, Btu/ft ² /hr/in/°F) - (4) correction factor - (5) dielectric constant
K _{app}	- apparent plane strain fracture toughness or residual strength (MPa/m,ksi/in)
K _c	- critical plane strain fracture toughness, a measure of fracture toughness at point of crack growth instability (MPa/m,ksi/in)
K _{Ic}	- plane strain fracture toughness (MPa/m,ksi/in)
K _N	- empirically calculated fatigue notch factor
K _s	- plate or cylinder shear buckling coefficient
K _t	- (1) theoretical elastic stress concentration factor - (2) t _w /c ratio in H/C sandwich
K _v	- dielectric strength (KV/mm, V/mil)
K _x ,K _y	- plate or cylinder compression buckling coefficient
k	- strain at unit stress (m/m,in/in)
L	- cylinder, beam, or column length (mm,in)
L'	- effective column length (mm,in)
lb	- pound
M	- applied moment or couple (N-m,in-lbf)
Mg	- megagram(s)
MPa	- megapascal(s)
MS	- military standard
M.S.	- margin of safety
MW	- molecular weight
MWD	- molecular weight distribution
m	- (1) mass (kg,lb) - (2) number of half wave lengths - (3) metre - (4) slope
N	- (1) number of fatigue cycles to failure - (2) number of laminae in a laminate - (3) distributed in-plane forces on a panel (lbf/in) - (4) Newton - (5) normalized
NA	- neutral axis
n	- (1) number of times in a set - (2) number of half or total wavelengths - (3) number of fatigue cycles endured
P	- (1) applied load (N,lbf) - (2) exposure parameter - (3) probability - (4) specific resistance (Ω)
P ^u	- test ultimate load, (N,lb per fastener)
P ^y	- test yield load, (N,lb per fastener)
p	- normal pressure (Pa,psi)
psi	- pounds per square inch
Q	- area static moment of a cross-section (mm ³ ,in ³)
q	- shear flow (N/m,lbf/in)
R	- (1) algebraic ratio of minimum load to maximum load in cyclic loading - (2) reduced ratio
RA	- reduction of area
R.H.	- relative humidity
RMS	- root-mean-square
RT	- room temperature

Volume 1, Chapter 1 Objectives

r	- (1) radius (mm,in) - (2) root radius (mm,in) - (3) reduced ratio (regression analysis)
S	- (1) shear force (N,lbf) - (2) nominal stress in fatigue (MPa,ksi) - (3) S-basis for mechanical property values
S_a	- stress amplitude in fatigue (MPa,ksi)
S_e	- fatigue limit (MPa,ksi)
S_m	- mean stress in fatigue (MPa,ksi)
S_{max}	- highest algebraic value of stress in the stress cycle (MPa,ksi)
S_{min}	- lowest algebraic value of stress in the stress cycle (MPa,ksi)
S_R	- algebraic difference between the minimum and maximum stresses in one cycle (MPa,ksi)
S.F.	- safety factor
s	- (1) arc length (mm,in) - (2) H/C sandwich cell size (mm,in)
T	- (1) temperature ($^{\circ}\text{C}$, $^{\circ}\text{F}$) - (2) applied torsional moment (N-m,in-lbf)
T_d	- thermal decomposition temperature ($^{\circ}\text{C}$, $^{\circ}\text{F}$)
T_F	- exposure temperature ($^{\circ}\text{C}$, $^{\circ}\text{F}$)
T_g	- glass transition temperature ($^{\circ}\text{C}$, $^{\circ}\text{F}$)
T_m	- melting temperature ($^{\circ}\text{C}$, $^{\circ}\text{F}$)
t	- (1) thickness (mm,in) - (2) exposure time (s) - (3) elapsed time (s)
V	- (1) volume (mm^3 , in^3) - (2) shear force (N,lbf)
W	- (1) weight (N,lbf) - (2) width (mm,in) - (3) Watt
x	- distance along a coordinate axis
Y	- nondimensional factor relating component geometry and flaw size
y	- (1) deflection (due to bending) of elastic curve of a beam (mm,in) - (2) distance from neutral axis to given point - (3) distance along a coordinate axis
Z	- section modulus, I/y (mm^3 , in^3)
α	- coefficient of thermal expansion (m/m/ $^{\circ}\text{C}$, in/in/ $^{\circ}\text{F}$)
γ	- shear strain (m/m,in/in)
Δ	- difference (used as prefix to quantitative symbols)
δ	- elongation or deflection (mm,in)
ϵ	- strain (m/m,in/in)
ϵ^e	- elastic strain (m/m,in/in)
ϵ^p	- plastic strain (m/m,in/in)
μ	- permeability
η	- plasticity reduction factor
$[\eta]$	- intrinsic viscosity
η^*	- dynamic complex viscosity
ν	- Poisson's ratio
ρ	- (1) density (kg/m^3 , lb/in^3) - (2) radius of gyration (mm,in)
ρ_c	- H/C sandwich core density (kg/m^3 , lb/in^3)
Σ	- total, summation
σ	- standard deviation
σ_{ij} , τ_{ij}	- stress in j direction on surface whose outer normal is in i direction (i, j = 1, 2, 3 or x, y, z) (MPa,ksi)

Volume 1, Chapter 1 Objectives

T	- applied shear stress (MPa,ksi)
ω	- angular velocity (radians/s)
∞	- infinity

1.6.1.1 *Constituent properties*

The following symbols apply specifically to the constituent properties of a typical composite material.

E^f	- Young's modulus of filament material (MPa,ksi)
E^m	- Young's modulus of matrix material (MPa,ksi)
E_x^g	- Young's modulus of impregnated glass scrim cloth in the filament direction or in the warp direction of a fabric (MPa,ksi)
E_y^g	- Young's modulus of impregnated glass scrim cloth transverse to the filament direction or to the warp direction in a fabric (MPa,ksi)
G^f	- shear modulus of filament material (MPa,ksi)
G^m	- shear modulus of matrix (MPa,ksi)
G_{xy}^g	- shear modulus of impregnated glass scrim cloth (MPa,ksi)
G_{cx}	- shear modulus of sandwich core along X-axis (MPa,ksi)
G_{cy}	- shear modulus of sandwich core along Y-axis (MPa,ksi)
l	- filament length (mm,in)
α^f	- coefficient of thermal expansion for filament material (m/m/°C,in/in/°F)
α^m	- coefficient of thermal expansion for matrix material (m/m/°C,in/in/°F)
α_x^g	- coefficient of thermal expansion of impregnated glass scrim cloth in the filament direction or in the warp direction of a fabric (m/m/°C,in/in/°F)
α_y^g	- coefficient of thermal expansion of impregnated glass scrim cloth transverse to the filament direction or to the warp direction in a fabric (m/m/°C,in/in/°F)
ν^f	- Poisson's ratio of filament material
ν^m	- Poisson's ratio of matrix material
ν_{xy}^g	- glass scrim cloth Poisson's ratio relating to contraction in the transverse (or fill) direction as a result of extension in the longitudinal (or warp) direction
ν_{yx}^g	- glass scrim cloth Poisson's ratio relating to contraction in the longitudinal (or warp) direction as a result of extension in the transverse (or fill) direction
σ	- applied axial stress at a point, as used in micromechanics analysis (MPa,ksi)
τ	- applied shear stress at a point, as used in micromechanics analysis (MPa,ksi)

1.6.1.2 *Laminae and laminates*

The following symbols, abbreviations, and notations apply to composite laminae and laminates. At the present time the focus in MIL-HDBK-17 is on laminae properties. However, commonly used nomenclature for both laminae and laminates are included here to avoid potential confusion.

A_{ij} (i,j = 1,2,6)	- extensional rigidities (N/m,lbf/in)
B_{ij} (i,j = 1,2,6)	- coupling matrix (N,lbf)
C_{ij} (i,j = 1,2,6)	- elements of stiffness matrix (Pa,psi)
D_x, D_y	- flexural rigidities (N-m,lbf-in)
D_{xy}	- twisting rigidity (N-m,lbf-in)
D_{ij} (i,j = 1,2,6)	- flexural rigidities (N-m,lbf-in)
E_1	- Young's modulus of lamina parallel to filament or warp direction (GPa,Msi)
E_2	- Young's modulus of lamina transverse to filament or warp direction (GPa,Msi)
E_x	- Young's modulus of laminate along x reference axis (GPa,Msi)

Volume 1, Chapter 1 Objectives

E_y	- Young's modulus of laminate along y reference axis (GPa,Msi)
G_{12}	- shear modulus of lamina in 12 plane (GPa,Msi)
G_{xy}	- shear modulus of laminate in xy reference plane (GPa,Msi)
h_i	- thickness of i^{th} ply or lamina (mm,in)
M_x, M_y, M_{xy}	- bending and twisting moment components (N-m/m, in-lbf/in in plate and shell analysis)
n_f	- number of filaments per unit length per lamina
Q_x, Q_y	- shear force parallel to z axis of sections of a plate perpendicular to x and y axes, respectively (N/m,lbf/in)
$Q_{ij} (i,j = 1,2,6)$	- reduced stiffness matrix (Pa,psi)
u_x, u_y, u_z	- components of the displacement vector (mm,in)
u_x^0, u_y^0, u_z^0	- components of the displacement vector at the laminate's midsurface (mm,in)
V_v	- void content (% by volume)
V_f	- filament content or fiber volume (% by volume)
V_g	- glass scrim cloth content (% by volume)
V_m	- matrix content (% by volume)
V_x, V_y	- edge or support shear force (N/m,lbf/in)
W_f	- filament content (% by weight)
W_g	- glass scrim cloth content (% by weight)
W_m	- matrix content (% by weight)
W_s	- weight of laminate per unit surface area (N/m ² ,lbf/in ²)
α_1	- lamina coefficient of thermal expansion along 1 axis (m/m/°C,in/in/°F)
α_2	- lamina coefficient of thermal expansion along 2 axis (m/m/°C,in/in/°F)
α_x	- laminate coefficient of thermal expansion along general reference x axis (m/m/°C, in/in/°F)
α_y	- laminate coefficient of thermal expansion along general reference y axis (m/m/°C, in/in/°F)
α_{xy}	- laminate shear distortion coefficient of thermal expansion (m/m/°C,in/in/°F)
θ	- angular orientation of a lamina in a laminate, i.e., angle between 1 and x axes (°)
λ_{xy}	- product of ν_{xy} and ν_{yx}
ν_{12}	- Poisson's ratio relating contraction in the 2 direction as a result of extension in the 1 direction ¹
ν_{21}	- Poisson's ratio relating contraction in the 1 direction as a result of extension in the 2 direction ¹
ν_{xy}	- Poisson's ratio relating contraction in the y direction as a result of extension in the x direction ¹
ν_{yx}	- Poisson's ratio relating contraction in the x direction as a result of extension in the y direction ¹
ρ_c	- density of a single lamina (kg/m ³ ,lb/in ³)
$\bar{\rho}_c$	- density of a laminate (kg/m ³ ,lb/in ³)
ϕ	- (1) general angular coordinate, (°) - (2) angle between x and load axes in off-axis loading (°)

1.6.1.3 Subscripts

The following subscript notations are considered standard in MIL-HDBK-17.

1, 2, 3	- laminae natural orthogonal coordinates (1 is filament or warp direction)
A	- axial
a	- (1) adhesive - (2) alternating
app	- apparent

¹The convention for Poisson's ratio should be checked before comparing different sources as different conventions are used.

Volume 1, Chapter 1 Objectives

byp	- bypass
c	- composite system, specific filament/matrix composition. Composite as a whole, contrasted to individual constituents. Also, sandwich core when used in conjunction with prime (')
	- (4) critical
cf	- centrifugal force
e	- fatigue or endurance
eff	- effective
eq	- equivalent
f	- filament
g	- glass scrim cloth
H	- hoop
i	- i th position in a sequence
L	- lateral
m	- (1) matrix
	- (2) mean
max	- maximum
min	- minimum
n	- (1) n th (last) position in a sequence
	- (2) normal
p	- polar
s	- symmetric
st	- stiffener
T	- transverse
t	- value of parameter at time t
x, y, z	- general coordinate system
Σ	- total, or summation
o	- initial or reference datum
()	- format for indicating specific, temperature associated with term in parentheses. RT - room temperature (21°C,70°F); all other temperatures in °F unless specified.

1.6.1.4 *Superscripts*

The following superscript notations are considered standard in MIL-HDBK-17.

b	- bending
br	- bearing
c	- (1) compression
	- (2) creep
cc	- compression crippling
cr	- compression buckling
e	- elastic
f	- filament
g	- glass scrim cloth
is	- interlaminar shear
(i)	- i th ply or lamina
lim	- limit, used to indicate limit loading
m	- matrix
ohc	- open hole compression
oht	- open hole tension
p	- plastic
pl	- proportional limit
rup	- rupture
s	- shear
scr	- shear buckling
sec	- secant (modulus)
so	- offset shear

Volume 1, Chapter 1 Objectives

T	- temperature or thermal
t	- tension
tan	- tangent (modulus)
u	- ultimate
y	- yield
'	- secondary (modulus), or denotes properties of H/C core when used with subscript c
CAI	- compression after impact

1.6.1.5 Acronyms

The following acronyms are used in MIL-HDBK-17.

AA	- atomic absorption
AES	- Auger electron spectroscopy
AIA	- Aerospace Industries Association
ANOVA	- analysis of variance
ARL	- US Army Research Laboratory
ASTM	- American Society for Testing and Materials
BMI	- bismaleimide
BVID	- barely visible impact damage
CAI	- compression after impact
CCA	- composite cylinder assemblage
CFRP	- carbon fiber reinforced plastic
CLS	- crack lap shear
CMCS	- Composite Motorcase Subcommittee (JANNAF)
CPT	- cured ply thickness
CTA	- cold temperature ambient
CTD	- cold temperature dry
CTE	- coefficient of thermal expansion
CV	- coefficient of variation
CVD	- chemical vapor deposition
DCB	- double cantilever beam
DDA	- dynamic dielectric analysis
DLL	- design limit load
DMA	- dynamic mechanical analysis
DOD	- Department of Defense
DSC	- differential scanning calorimetry
DTA	- differential thermal analysis
DTRC	- David Taylor Research Center
ENF	- end notched flexure
EOL	- end-of-life
ESCA	- electron spectroscopy for chemical analysis
ESR	- electron spin resonance
ETW	- elevated temperature wet
FAA	- Federal Aviation Administration
FFF	- field flow fractionation
FGRP	- fiberglass reinforced plastic
FMECA	- Failure Modes Effects Criticality Analysis
FOD	- foreign object damage
FTIR	- Fourier transform infrared spectroscopy
FWC	- finite width correction factor
GC	- gas chromatography
GSCS	- Generalized Self Consistent Scheme
HDT	- heat distortion temperature
HPLC	- high performance liquid chromatography
ICAP	- inductively coupled plasma emission

Volume 1, Chapter 1 Objectives

IITRI	- Illinois Institute of Technology Research Institute
IR	- infrared spectroscopy
ISS	- ion scattering spectroscopy
JANNAF	- Joint Army, Navy, NASA, and Air Force
LC	- liquid chromatography
LPT	- laminate plate theory
LSS	- laminate stacking sequence
MMB	- mixed mode bending
MOL	- material operational limit
MS	- mass spectroscopy
MSDS	- material safety data sheet
MTBF	- Mean Time Between Failure
NAS	- National Aerospace Standard
NASA	- National Aeronautics and Space Administration
NDI	- nondestructive inspection
NMR	- nuclear magnetic resonance
PEEK	- polyether ether ketone
RDS	- rheological dynamic spectroscopy
RH	- relative humidity
RT	- room temperature
RTA	- room temperature ambient
RTD	- room temperature dry
RTM	- resin transfer molding
SACMA	- Suppliers of Advanced Composite Materials Association
SAE	- Society of Automotive Engineers
SANS	- small-angle neutron scattering spectroscopy
SEC	- size-exclusion chromatography
SEM	- scanning electron microscopy
SFC	- supercritical fluid chromatography
SI	- International System of Units (Le Système International d'Unités)
SIMS	- secondary ion mass spectroscopy
TBA	- torsional braid analysis
TEM	- transmission electron microscopy
TGA	- thermogravimetric analysis
TLC	- thin-layer chromatography
TMA	- thermal mechanical analysis
TOS	- thermal oxidative stability
TVM	- transverse microcrack
UDC	- unidirectional fiber composite
VNB	- V-notched beam
XPS	- X-ray photoelectron spectroscopy

1.6.2 System of units

To comply with Department of Defense Instructive 5000.2, Part 6, Section M, "Use of the Metric System," dated February 23, 1991, the data in MIL-HDBK-17 are generally presented in both the International System of Units (SI units) and the U. S. Customary (English) system of units. ASTM E-380, Standard for Metric Practice, provides guidance for the application for SI units which are intended as a basis for worldwide standardization of measurement units (Reference 1.6.2(a)). Further guidelines on the use of the SI system of units and conversion factors are contained in the following publications (References 1.6.2(b) - (e)):

- (1) DARCOM P 706-470, *Engineering Design Handbook: Metric Conversion Guide*, July 1976.
- (2) NBS Special Publication 330, "The International System of Units (SI)," National Bureau of Standards, 1986 edition.

- (3) NBS Letter Circular LC 1035, "Units and Systems of Weights and Measures, Their Origin, Development, and Present Status," National Bureau of Standards, November 1985.
- (4) NASA Special Publication 7012, "The International System of Units Physical Constants and Conversion Factors", 1964.

English to SI conversion factors pertinent to MIL-HDBK-17 data are contained in Table 1.6.2.

TABLE 1.6.2 *English to SI conversion factors.*

To convert from	to	Multiply by
Btu (thermochemical)/in ² -s	watt/meter ² (W/m ²)	1.634 246 E+06
Btu-in/(s-ft ² -°F)	W/(m K)	5.192 204 E+02
degree Fahrenheit	degree Celsius (°C)	T = (T - 32)/1.8
degree Fahrenheit	kelvin (K)	T = (T + 459.67)/1.8
foot	meter (m)	3.048 000 E-01
ft ²	m ²	9.290 304 E-02
foot/second	meter/second (m/s)	3.048 000 E-01
ft/s ²	m/s ²	3.048 000 E-01
inch	meter (m)	2.540 000 E-02
in. ²	meter ² (m ²)	6.451 600 E-04
in. ³	m ³	1.638 706 E-05
kilogram-force (kgf)	newton (N)	9.806 650 E+00
kgf/m ²	pascal (Pa)	9.806 650 E+00
kip (1000 lbf)	newton (N)	4.448 222 E+03
ksi (kip/in ²)	MPa	6.894 757 E+00
lbf-in	N-m	1.129 848 E-01
lbf-ft	N-m	1.355 818 E+00
lbf/in ² (psi)	pascal (Pa)	6.894 757 E+03
lb/in ²	gm/m ²	7.030 696 E+05
lb/in ³	kg/m ³	2.767 990 E+04
Msi (10 ⁶ psi)	GPa	6.894 757 E+00
pound-force (lbf)	newton (N)	4.488 222 E+00
pound-mass (lb avoirdupois)	kilogram (kg)	4.535 924 E-01
torr	pascal (Pa)	1.333 22 E+02

* The letter "E" following the conversion factor stands for exponent and the two digits after the letter "E" indicate the power of 10 by which the number is to be multiplied.

1.7 DEFINITIONS

The following definitions are used within MIL-HDBK-17. This glossary of terms is not totally comprehensive but it does represent nearly all commonly used terms. Where exceptions are made, they are noted in the text and tables. For ease of identification the definitions have been organized alphabetically.

A-Basis (or A-Value) -- A statistically-based material property; a 95% lower confidence bound on the first percentile of a specified population of measurements. Also a 95% lower tolerance bound for the upper 99% of a specified population.

A-Stage -- An early stage in the reaction of thermosetting resins in which the material is still soluble in certain liquids and may be liquid or capable of becoming liquid upon heating. (Sometimes referred to as **resol**.)

Absorption -- A process in which one material (the absorbent) takes in or absorbs another (the absorbate).

Accelerator -- A material which, when mixed with a catalyzed resin, will speed up the chemical reaction between the catalyst and the resin.

Accuracy -- The degree of conformity of a measured or calculated value to some recognized standard or specified value. Accuracy involves the systematic error of an operation.

Addition Polymerization -- Polymerization by a repeated addition process in which monomers are linked together to form a polymer without splitting off of water or other simple molecules.

Adhesion -- The state in which two surfaces are held together at an interface by forces or interlocking action or both.

Adhesive -- A substance capable of holding two materials together by surface attachment. In the handbook, the term is used specifically to designate structural adhesives, those which produce attachments capable of transmitting significant structural loads.

ADK -- Notation used for the k-sample Anderson-Darling statistic, which is used to test the hypothesis that k batches have the same distribution.

Aliquot -- A small, representative portion of a larger sample.

Aging -- The effect, on materials, of exposure to an environment for a period of time; the process of exposing materials to an environment for an interval of time.

Ambient -- The surrounding environmental conditions such as pressure or temperature.

Anelasticity -- A characteristic exhibited by certain materials in which strain is a function of both stress and time, such that, while no permanent deformations are involved, a finite time is required to establish equilibrium between stress and strain in both the loading and unloading directions.

Angleply -- Any balanced laminate consisting of plus and minus theta plies where theta is an acute angle with respect to a reference direction.

Anisotropic -- Not isotropic; having mechanical and/or physical properties which vary with direction relative to natural reference axes inherent in the material.

Aramid -- A manufactured fiber in which the fiber-forming substance consisting of a long-chain synthetic aromatic polyamide in which at least 85% of the amide (-CONH-) linkages are attached directly to two aromatic rings.

Areal Weight of Fiber -- The weight of fiber per unit area of prepreg. This is often expressed as grams per square meter. See Table 1.6.2 for conversion factors.

Artificial Weathering -- Exposure to laboratory conditions which may be cyclic, involving changes in temperature, relative humidity, radiant energy and any other elements found in the atmosphere in various geographical areas.

Aspect Ratio -- In an essentially two-dimensional rectangular structure (e.g., a panel), the ratio of the long dimension to the short dimension. However, in compression loading, it is sometimes considered to be the ratio of the load direction dimension to the transverse dimension. Also, in fiber micro-mechanics, it is referred to as the ratio of length to diameter.

Autoclave -- A closed vessel for producing an environment of fluid pressure, with or without heat, to an enclosed object which is undergoing a chemical reaction or other operation.

Autoclave Molding -- A process similar to the pressure bag technique. The lay-up is covered by a pressure bag, and the entire assembly is placed in an autoclave capable of providing heat and pressure for curing the part. The pressure bag is normally vented to the outside.

Axis of Braiding -- The direction in which the braided form progresses.

B-Basis (or B-Value) -- A statistically-based material property; a 95% lower confidence bound on the tenth percentile of a specified population of measurements. Also a 95% lower tolerance bound for the upper 90% of a specified population. (See Volume 1, Section 8.1.4)

B-Stage -- An intermediate stage in the reaction of a thermosetting resin in which the material softens when heated and swells when in contact with certain liquids but does not entirely fuse or dissolve. Materials are usually precured to this stage to facilitate handling and processing prior to final cure. (Sometimes referred to as **resitol**.)

Bag Molding -- A method of molding or laminating which involves the application of fluid pressure to a flexible material which transmits the pressure to the material being molded or bonded. Fluid pressure usually is applied by means of air, steam, water or vacuum.

Balanced Laminate -- A composite laminate in which all identical laminae at angles other than 0 degrees and 90 degrees occur only in \pm pairs (not necessarily adjacent).

Batch (or Lot) -- For fibers and resins, a quantity of material formed during the same process and having identical characteristics throughout. For prepreps, laminae, and laminates, material made from one batch of fiber and one batch of resin.

Bearing Area -- The product of the pin diameter and the specimen thickness.

Bearing Load -- A compressive load on an interface.

Bearing Yield Strength -- The bearing stress at which a material exhibits a specified limiting deviation from the proportionality of bearing stress to bearing strain.

Bend Test -- A test of ductility by bending or folding, usually with steadily applied forces. In some instances the test may involve blows to a specimen having a cross section that is essentially uniform over a length several times as great as the largest dimension of the cross section.

Binder -- A bonding resin used to hold strands together in a mat or preform during manufacture of a molded object.

Binomial Random Variable -- The number of successes in independent trials where the probability of success is the same for each trial.

Birefringence -- The difference between the two principal refractive indices (of a fiber) or the ratio between the retardation and thickness of a material at a given point.

Bleeder Cloth -- A nonstructural layer of material used in the manufacture of composite parts to allow the escape of excess gas and resin during cure. The bleeder cloth is removed after the curing process and is not part of the final composite.

Bobbin -- A cylinder or slightly tapered barrel, with or without flanges, for holding tows, rovings, or yarns.

Bond -- The adhesion of one surface to another, with or without the use of an adhesive as a bonding agent.

Braid -- A system of three or more yarns which are interwoven in such a way that no two yarns are twisted around each other.

Braid Angle -- The acute angle measured from the axis of braiding.

Braid, Biaxial -- Braided fabric with two-yarn systems, one running in the $+\theta$ direction, the other in the $-\theta$ direction as measured from the axis of braiding.

Braid Count -- The number of braiding yarn crossings per inch measured along the axis of a braided fabric.

Braid, Diamond -- Braided fabric with an over one, under one weave pattern, (1 x 1).

Braid, Flat -- A narrow bias woven tape wherein each yarn is continuous and is intertwined with every other yarn in the system without being intertwined with itself.

Braid, Hercules -- A braided fabric with an over three, under three weave pattern, (3 x 3).

Braid, Jacquard -- A braided design made with the aid of a jacquard machine, which is a shedding mechanism by means of which a large number of ends may be controlled independently and complicated patterns produced.

Braid, Regular -- A braided fabric with an over two, under two weave pattern (2 x 2).

Braid, Square -- A braided pattern in which the yarns are formed into a square pattern.

Braid, Two-Dimensional -- Braided fabric with no braiding yarns in the through thickness direction.

Braid, Three-Dimensional -- Braided fabric with one or more braiding yarns in the through thickness direction.

Braid, Triaxial -- A biaxial braided fabric with laid in yarns running in the axis of braiding.

Braiding -- A textile process where two or more strands, yarns or tapes are intertwined in the bias direction to form an integrated structure.

Broadgoods -- A term loosely applied to prepreg material greater than about 12 inches in width, usually furnished by suppliers in continuous rolls. The term is currently used to designate both collimated uniaxial tape and woven fabric prepreps.

Buckling (Composite) -- A mode of structural response characterized by an out-of-plane material deflection due to compressive action on the structural element involved. In advanced composites, buckling may take the form not only of conventional general instability and local instability but also a micro-instability of individual fibers.

Bundle -- A general term for a collection of essentially parallel filaments or fibers.

C-Stage -- The final stage of the curing reaction of a thermosetting resin in which the material has become practically infusible and insoluble. (Normally considered fully cured and sometimes referred to as **resite**.)

Capstan -- A friction type take-up device which moves braided fabric away from the fell. The speed of which determines the braid angle.

Carbon Fibers -- Fibers produced by the pyrolysis of organic precursor fibers such as rayon, polyacrylonitrile (PAN), and pitch in an inert atmosphere. The term is often used interchangeably with "graphite"; however, carbon fibers and graphite fibers differ in the temperature at which the fibers are made and heat-treated, and the amount of carbon produced. Carbon fibers typically are carbonized at about 2400°F (1300°C) and assay at 93 to 95% carbon, while graphite fibers are graphitized at 3450 to 5450°F (1900 to 3000°C) and assay at more than 99% elemental carbon.

Carrier -- A mechanism for carrying a package of yarn through the braid weaving motion. A typical carrier consists of a bobbin spindle, a track follower, and a tensioning device.

Caul Plates -- Smooth metal plates, free of surface defects, the same size and shape as a composite lay-up, used immediately in contact with the lay-up during the curing process to transmit normal pressure and to provide a smooth surface on the finished laminate.

Censoring -- Data is right (left) censored at M , if, whenever an observation is less than or equal to M (greater than or equal to M), the actual value of the observation is recorded. If the observation exceeds (is less than) M , the observation is recorded as M .

Chain-Growth Polymerization -- One of the two principal polymerization mechanisms. In chain-growth polymerization, the reactive groups are continuously regenerated during the growth process. Once started, the polymer molecule grows rapidly by a chain of reactions emanating from a particular reactive initiator which may be a free radical, cation or anion.

Chromatogram -- A plot of detector response against peak volume of solution (eluate) emerging from the system for each of the constituents which have been separated.

Circuit -- One complete traverse of the fiber feed mechanism of a winding machine; one complete traverse of a winding band from one arbitrary point along the winding path to another point on a plane through the starting point and perpendicular to the axis.

Cocuring -- The act of curing a composite laminate and simultaneously bonding it to some other prepared surface during the same cure cycle (see **Secondary Bonding**).

Coefficient of Linear Thermal Expansion -- The change in length per unit length resulting from a one-degree rise in temperature.

Coefficient of Variation -- The ratio of the population (or sample) standard deviation to the population (or sample) mean.

Collimated -- Rendered parallel.

Compatible -- The ability of different resin systems to be processed in contact with each other without degradation of end product properties. (See **Compatible**, Volume 1, Section 8.1.4)

Composite Class -- As used in the handbook, a major subdivision of composite construction in which the class is defined by the fiber system and the matrix class, e.g., organic-matrix filamentary laminate.

Composite Material -- Composites are considered to be combinations of materials differing in composition or form on a macroscale. The constituents retain their identities in the composite; that is, they do not dissolve or otherwise merge completely into each other although they act in concert. Normally, the components can be physically identified and exhibit an interface between one another.

Compound -- An intimate mixture of polymer or polymers with all the materials necessary for the finished product.

Condensation Polymerization -- This is a special type of step-growth polymerization characterized by the formation of water or other simple molecules during the stepwise addition of reactive groups.

Confidence Coefficient -- See **Confidence Interval**.

Confidence Interval -- A confidence interval is defined by a statement of one of the following forms:

- (1) $P\{a < \theta\} \leq 1 - \alpha$
- (2) $P\{\theta < b\} \leq 1 - \alpha$
- (3) $P\{a < \theta < b\} \leq 1 - \alpha$

where $1 - \alpha$ is called the confidence coefficient. A statement of type (1) or (2) is called a one-sided confidence interval and a statement of type (3) is called a two-sided confidence interval. In (1) a is a lower confidence limit and in (2) b is an upper confidence limit. With probability at least $1 - \alpha$, the confidence interval will contain the parameter θ .

Consolidation -- 1) *in metal matrix composites*, the diffusion bonding operation in which an oriented stack of preplies is transformed into a finished composite laminate; 2) *in thermoplastic composites*, a processing step in which fiber and matrix are compressed by one of several methods to reduce voids and achieve desired density.

Constituent -- In general, an element of a larger grouping. In advanced composites, the principal constituents are the fibers and the matrix.

Continuous Filament -- A yarn or strand in which the individual filaments are substantially the same length as the strand.

Coupling Agent -- Any chemical substance designed to react with both the reinforcement and matrix phases of a composite material to form or promote a stronger bond at the interface. Coupling agents are applied to the reinforcement phase from an aqueous or organic solution or from a gas phase, or added to the matrix as an integral blend.

Coverage -- The measure of the fraction of surface area covered by the braid.

Crazing -- Apparent fine cracks at or under the surface of an organic matrix.

Creel -- A framework arranged to hold tows, rovings, or yarns so that many ends can be withdrawn smoothly and evenly without tangling.

Creep -- The time dependent part of strain resulting from an applied stress.

Creep, Rate Of -- The slope of the creep-time curve at a given time.

Crimp -- The undulations induced into a braided fabric via the braiding process.

Crimp Angle -- The maximum acute angle of a single braided yarn's direction measured from the average axis of tow.

Crimp Exchange -- The process by which a system of braided yarns reaches equilibrium when put under tension or compression.

Critical Value(s) -- When testing a one-sided statistical hypothesis, a critical value is the value such that, if the test statistic is greater than (less than) the critical value, the hypothesis is rejected. When testing a two-sided statistical hypothesis, two critical values are determined. If the test statistic is either less than the smaller critical value or greater than the larger critical value, then the hypothesis is rejected. In both cases, the critical value chosen depends on the desired risk (often 0.05) of rejecting the hypothesis when it is true.

Crossply -- Any filamentary laminate which is not uniaxial. Same as Angleply. In some references, the term crossply is used to designate only those laminates in which the laminae are at right angles to one another, while the term angleply is used for all others. In the handbook, the two terms are used synonymously. The reservation of a separate terminology for only one of several basic orientations is unwarranted because a laminate orientation code is used.

Cumulative Distribution Function -- See Volume 1, Section 8.1.4.

Cure -- To change the properties of a thermosetting resin irreversibly by chemical reaction, i.e., condensation, ring closure, or addition. Cure may be accomplished by addition of curing (cross-linking) agents, with or without catalyst, and with or without heat. Cure may occur also by addition, such as occurs with anhydride cures for epoxy resin systems.

Cure Cycle -- The schedule of time periods at specified conditions to which a reacting thermosetting material is subjected in order to reach a specified property level.

Cure Stress -- A residual internal stress produced during the curing cycle of composite structures. Normally, these stresses originate when different components of a lay-up have different thermal coefficients of expansion.

Debond -- A deliberate separation of a bonded joint or interface, usually for repair or rework purposes. (See **Disbond**, **Unbond**).

Deformation -- The change in shape of a specimen caused by the application of a load or force.

Degradation -- A deleterious change in chemical structure, physical properties or appearance.

Delamination -- The separation of the layers of material in a laminate. This may be local or may cover a large area of the laminate. It may occur at any time in the cure or subsequent life of the laminate and may arise from a wide variety of causes.

Denier -- A direct numbering system for expressing linear density, equal to the mass in grams per 9000 meters of yarn, filament, fiber, or other textile strand.

Density -- The mass per unit volume.

Desorption -- A process in which an absorbed or adsorbed material is released from another material. Desorption is the reverse of absorption, adsorption, or both.

Volume 1, Chapter 1 Objectives

Deviation -- Variation from a specified dimension or requirement, usually defining the upper and lower limits.

Dielectric Constant -- The ratio of the capacity of a condenser having a dielectric constant between the plates to that of the same condenser when the dielectric is replaced by a vacuum; a measure of the electrical charge stored per unit volume at unit potential.

Dielectric Strength -- The average potential per unit thickness at which failure of the dielectric material occurs.

Disbond -- An area within a bonded interface between two adherends in which an adhesion failure or separation has occurred. It may occur at any time during the life of the structure and may arise from a wide variety of causes. Also, colloquially, an area of separation between two laminae in the finished laminate (in this case the term "delamination" is normally preferred.) (See **Debond, Unbond, Delamination.**)

Distribution -- A formula which gives the probability that a value will fall within prescribed limits. (See **Normal, Weibull, and Lognormal Distributions**, also Volume 1, Section 8.1.4).

Dry -- a material condition of moisture equilibrium with a surrounding environment at 5% or lower relative humidity.

Dry Fiber Area -- Area of fiber not totally encapsulated by resin.

Ductility -- The ability of a material to deform plastically before fracturing.

Elasticity -- The property of a material which allows it to recover its original size and shape immediately after removal of the force causing deformation.

Elongation -- The increase in gage length or extension of a specimen during a tension test, usually expressed as a percentage of the original gage length.

Eluate -- The liquid emerging from a column (in liquid chromatography).

Eluent -- The mobile phase used to sweep or elute the sample (solute) components into, through, and out of the column.

End -- A single fiber, strand, roving or yarn being or already incorporated into a product. An end may be an individual warp yarn or cord in a woven fabric. In referring to aramid and glass fibers, an end is usually an untwisted bundle of continuous filaments.

Epoxy Equivalent Weight -- The number of grams of resin which contain one chemical equivalent of the epoxy group.

Epoxy Resin -- Resins which may be of widely different structures but are characterized by the presence of the epoxy group. (The epoxy or epoxide group is usually present as a glycidyl ether, glycidyl amine, or as part of an aliphatic ring system. The aromatic type epoxy resins are normally used in composites.)

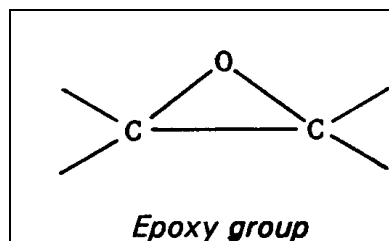

Extensometer -- A device for measuring linear strain.

F-Distribution -- See Volume 1, Section 8.1.4.

Fabric, Nonwoven -- A textile structure produced by bonding or interlocking of fibers, or both, accomplished by mechanical, chemical, thermal, or solvent means, and combinations thereof.

Fabric, Woven -- A generic material construction consisting of interlaced yarns or fibers, usually a planar structure. Specifically, as used in this handbook, a cloth woven in an established weave pattern from advanced fiber yarns and used as the fibrous constituent in an advanced composite lamina. In a fabric lamina, the warp direction is considered the longitudinal direction, analogous to the filament direction in a filamentary lamina.

Fell -- The point of braid formation, which is defined as the point at which the yarns in a braid system cease movement relative to each other.

Fiber -- A general term used to refer to filamentary materials. Often, fiber is used synonymously with filament. It is a general term for a filament of finite length. A unit of matter, either natural or manmade, which forms the basic element of fabrics and other textile structures.

Fiber Content -- The amount of fiber present in a composite. This is usually expressed as a percentage volume fraction or weight fraction of the composite.

Fiber Count -- The number of fibers per unit width of ply present in a specified section of a composite.

Fiber Direction -- The orientation or alignment of the longitudinal axis of the fiber with respect to a stated reference axis.

Fiber System -- The type and arrangement of fibrous material which comprises the fiber constituent of an advanced composite. Examples of fiber systems are collimated filaments or filament yarns, woven fabric, randomly oriented short-fiber ribbons, random fiber mats, whiskers, etc.

Fiber Volume (Fraction) -- See fiber content.

Filament -- The smallest unit of a fibrous material. The basic units formed during spinning and which are gathered into strands of fiber, (for use in composites). Filaments usually are of extreme length and of very small diameter. Filaments normally are not used individually. Some textile filaments can function as a yarn when they are of sufficient strength and flexibility.

Filamentary Composite -- A composite material reinforced with continuous fibers.

Filament winding -- See **Winding**.

Filament Wound -- Pertaining to an object created by the filament winding method of fabrication.

Fill (Filling) -- In a woven fabric, the yarn running from selvage to selvage at right angles to the warp.

Filler -- A relatively inert substance added to a material to alter its physical, mechanical, thermal, electrical, and other properties or to lower cost. Sometimes the term is used specifically to mean particulate additives.

Finish (or Size System) -- A material, with which filaments are treated, which contains a coupling agent to improve the bond between the filament surface and the resin matrix in a composite material. In addition, finishes often contain ingredients which provide lubricity to the filament surface, preventing abrasive damage during handling, and a binder which promotes strand integrity and facilitates packing of the filaments.

Fixed Effect -- A systematic shift in a measured quantity due to a particular level change of a treatment or condition. (See Volume 1, Section 8.1.4.)

Flash -- Excess material which forms at the parting line of a mold or die, or which is extruded from a closed mold.

Former Plate -- A die attached to a braiding machine which helps to locate the fell.

Fracture Ductility -- The true plastic strain at fracture.

Gage Length -- the original length of that portion of the specimen over which strain or change of length is determined.

Gel -- The initial jelly-like solid phase that develops during formation of a resin from a liquid. Also, a semi-solid system consisting of a network of solid aggregates in which liquid is held.

Gel Coat -- A quick-setting resin used in molding processes to provide an improved surface for the composite; it is the first resin applied to the mold after the mold-release agent.

Gel Point -- The stage at which a liquid begins to exhibit pseudo-elastic properties. (This can be seen from the inflection point on a viscosity-time plot.)

Gel Time -- The period of time from a pre-determined starting point to the onset of gelation (gel point) as defined by a specific test method.

Glass -- An inorganic product of fusion which has cooled to a rigid condition without crystallizing. In the handbook, all reference to glass will be to the fibrous form as used in filaments, woven fabric, yarns, mats, chopped fibers, etc.

Glass Cloth -- Conventionally-woven glass fiber material (see **Scrim**).

Glass Fibers -- A fiber spun from an inorganic product of fusion which has cooled to a rigid condition without crystallizing.

Glass Transition -- The reversible change in an amorphous polymer or in amorphous regions of a partially crystalline polymer from (or to) a viscous or rubbery condition to (or from) a hard and relatively brittle one.

Glass Transition Temperature -- The approximate midpoint of the temperature range over which the glass transition takes place.

Graphite Fibers -- See **Carbon Fibers**.

Greige -- Fabric that has received no finish.

Hand Lay-up -- A process in which components are applied either to a mold or a working surface, and the successive plies are built up and worked by hand.

Hardness -- Resistance to deformation; usually measured by indentation. Types of standard tests include Brinell, Rockwell, Knoop, and Vickers.

Heat Cleaned -- Glass or other fibers which have been exposed to elevated temperatures to remove preliminary sizings or binders which are not compatible with the resin system to be applied.

Heterogeneous -- Descriptive term for a material consisting of dissimilar constituents separately identifiable; a medium consisting of regions of unlike properties separated by internal boundaries. (Note that all nonhomogeneous materials are not necessarily heterogeneous).

Homogeneous -- Descriptive term for a material of uniform composition throughout; a medium which has no internal physical boundaries; a material whose properties are constant at every point, in other

words, constant with respect to spatial coordinates (but not necessarily with respect to directional coordinates).

Horizontal Shear -- Sometimes used to indicate interlaminar shear. This is not an approved term for use in this handbook.

Humidity, Relative -- The ratio of the pressure of water vapor present to the pressure of saturated water vapor at the same temperature.

Hybrid -- A composite laminate comprised of laminae of two or more composite material systems. Or, a combination of two or more different fibers such as carbon and glass or carbon and aramid into a structure (tapes, fabrics and other forms may be combined).

Hygroscopic -- Capable of absorbing and retaining atmospheric moisture.

Hysteresis -- The energy absorbed in a complete cycle of loading and unloading.

Inclusion -- A physical and mechanical discontinuity occurring within a material or part, usually consisting of solid, encapsulated foreign material. Inclusions are often capable of transmitting some structural stresses and energy fields, but in a noticeably different manner from the parent material.

Integral Composite Structure -- Composite structure in which several structural elements, which would conventionally be assembled by bonding or with mechanical fasteners after separate fabrication, are instead laid up and cured as a single, complex, continuous structure; e.g., spars, ribs, and one stiffened cover of a wing box fabricated as a single integral part. The term is sometimes applied more loosely to any composite structure not assembled by mechanical fasteners.

Interface -- The boundary between the individual, physically distinguishable constituents of a composite.

Interlaminar -- Between the laminae of a laminate.

Discussion: describing objects (e.g., voids), events (e.g., fracture), or fields (e.g., stress).

Interlaminar Shear -- Shearing force tending to produce a relative displacement between two laminae in a laminate along the plane of their interface.

Intermediate Bearing Stress -- The bearing stress at the point on the bearing load-deformation curve where the tangent is equal to the bearing stress divided by a designated percentage (usually 4%) of the original hole diameter.

Intralaminar -- Within the laminae of a laminate.

Discussion: describing objects (for example, voids), event (for example, fracture), or fields (for example, stress).

Isotropic -- Having uniform properties in all directions. The measured properties of an isotropic material are independent of the axis of testing.

Jammed State -- The state of a braided fabric under tension or compression where the deformation of the fabric is dominated by the deformation properties of the yarn.

Knitting -- A method of constructing fabric by interlocking series of loops of one or more yarns.

Knuckle Area -- The area of transition between sections of different geometry in a filament wound part.

k-Sample Data -- A collection of data consisting of values observed when sampling from k batches.

Laid-In Yarns -- A system of longitudinal yarns in a triaxial braid which are inserted between the bias yarns.

Lamina -- A single ply or layer in a laminate.

Discussion: For filament winding, a lamina is a layer.

Laminae -- Plural of lamina.

Laminate -- for fiber-reinforced composites, a consolidated collection of laminae (plies) with one or more orientations with respect to some reference direction.

Laminate Orientation -- The configuration of a crossplied composite laminate with regard to the angles of crossplying, the number of laminae at each angle, and the exact sequence of the lamina lay-up.

Lattice Pattern -- A pattern of filament winding with a fixed arrangement of open voids.

Lay up, v -- To stack plies of material in specified sequence and orientation.

Lay-up, n -- 1) the stack of plies in specified sequence and orientation prior to cure or consolidation; 2) the complete stack of plies, bagging material, breather material, and so on, prior to cure or consolidation; 3) a description of the component materials, geometry, and so on, of a laminate.

Lognormal Distribution -- A probability distribution for which the probability that an observation selected at random from this population falls between a and b ($0 < a < b < B$) is given by the area under the normal distribution between $\log a$ and $\log b$. The common (base 10) or the natural (base e) logarithm may be used. (See Volume 1, Section 8.1.4.)

Lower Confidence Bound -- See **Confidence Interval**.

Macro -- In relation to composites, denotes the gross properties of a composite as a structural element but does not consider the individual properties or identity of the constituents.

Macrostrain -- The mean strain over any finite gage length of measurement which is large in comparison to the material's interatomic distance.

Mandrel -- A form fixture or male mold used for the base in the production of a part by lay-up, filament winding or braiding.

Mat -- A fibrous material consisting of randomly oriented chopped or swirled filaments loosely held together with a binder.

Material Acceptance -- The testing of incoming material to ensure that it meets requirements.

Material Qualification -- The procedures used to accept a material by a company or organization for production use.

Material System -- A specific composite material made from specifically identified constituents in specific geometric proportions and arrangements and possessed of numerically defined properties.

Material System Class -- As used in this handbook, a group consisting of material systems categorized by the same generic constituent materials, but without defining the constituents uniquely; e.g., the carbon/epoxy class.

Material Variability -- A source of variability due to the spatial and consistency variations of the material itself and due to variation in its processing. (See Volume 1, Section 8.1.4.)

Matrix -- The essentially homogeneous material in which the fiber system of a composite is embedded.

Matrix Content -- The amount of matrix present in a composite expressed either as percent by weight or percent by volume.

Discussion: For polymer matrix composites this is called resin content, which is usually expressed as percent by weight

Mean -- See **Sample Mean** and **Population Mean**.

Mechanical Properties -- The properties of a material that are associated with elastic and inelastic reaction when force is applied, or the properties involving the relationship between stress and strain.

Median -- See **Sample Median** and **Population Median**.

Micro -- In relation to composites, denotes the properties of the constituents, i.e., matrix and reinforcement and interface only, as well as their effects on the composite properties.

Microstrain -- The strain over a gage length comparable to the material's interatomic distance.

Modulus, Chord -- The slope of the chord drawn between any two specified points on the stress-strain curve.

Modulus, initial -- The slope of the initial straight portion of a stress-strain curve.

Modulus, Secant -- The slope of the secant drawn from the origin to any specified point on the stress-strain curve.

Modulus, Tangent -- The ratio of change in stress to change in strain derived from the tangent to any point on a stress-strain curve.

Modulus, Young's -- The ratio of change in stress to change in strain below the elastic limit of a material. (Applicable to tension and compression).

Modulus of Rigidity (also Shear Modulus or Torsional Modulus) -- The ratio of stress to strain below the proportional limit for shear or torsional stress.

Modulus of Rupture, in Bending -- The maximum tensile or compressive stress (whichever causes failure) value in the extreme fiber of a beam loaded to failure in bending. The value is computed from the flexure equation:

$$F^b = \frac{Mc}{I} \quad 1.7(a)$$

where M = maximum bending moment computed from the maximum load and the original moment arm,
 c = initial distance from the neutral axis to the extreme fiber where failure occurs,
 I = the initial moment of inertia of the cross section about its neutral axis.

Modulus of Rupture, in Torsion -- The maximum shear stress in the extreme fiber of a member of circular cross section loaded to failure in torsion calculated from the equation:

$$F^s = \frac{Tr}{J} \quad 1.7(b)$$

where T = maximum twisting moment,
 r = original outer radius,
 J = polar moment of inertia of the original cross section.

Moisture Content -- The amount of moisture in a material determined under prescribed condition and expressed as a percentage of the mass of the moist specimen, i.e., the mass of the dry substance plus the moisture present.

Moisture Equilibrium -- The condition reached by a sample when it no longer takes up moisture from, or gives up moisture to, the surrounding environment.

Mold Release Agent -- A lubricant applied to mold surfaces to facilitate release of the molded article.

Molded Edge -- An edge which is not physically altered after molding for use in final form and particularly one which does not have fiber ends along its length.

Molding -- The forming of a polymer or composite into a solid mass of prescribed shape and size by the application of pressure and heat.

Monolayer -- The basic laminate unit from which crossplied or other laminates are constructed.

Monomer -- A compound consisting of molecules each of which can provide one or more constitutional units.

NDE -- Nondestructive evaluation. Broadly considered synonymous with NDI.

NDI -- Nondestructive inspection. A process or procedure for determining the quality or characteristics of a material, part, or assembly without permanently altering the subject or its properties.

NDT -- Nondestructive testing. Broadly considered synonymous with NDI.

Necking -- A localized reduction in cross-sectional area which may occur in a material under tensile stress.

Negatively Skewed -- A distribution is said to be negatively skewed if the distribution is not symmetric and the longest tail is on the left.

Nominal Specimen Thickness -- The nominal ply thickness multiplied by the number of plies.

Nominal Value -- A value assigned for the purpose of a convenient designation. A nominal value exists in name only.

Normal Distribution -- A two parameter (μ, σ) family of probability distributions for which the probability that an observation will fall between a and b is given by the area under the curve

$$f(x) = \frac{1}{\sigma\sqrt{2\pi}} \exp\left[-\frac{(x-\mu)^2}{2\sigma^2}\right] \quad 1.7(c)$$

between a and b . (See Volume 1, Section 8.1.4.)

Normalization -- A mathematical procedure for adjusting raw test values for fiber-dominated properties to a single (specified) fiber volume content.

Normalized Stress -- Stress value adjusted to a specified fiber volume content by multiplying the measured stress value by the ratio of specimen fiber volume to the specified fiber volume. This ratio may be obtained directly by experimentally measuring fiber volume, or indirectly by calculation using specimen thickness and fiber areal weight.

Observed Significance Level (OSL) -- The probability of observing a more extreme value of the test statistic when the null hypotheses is true.

Offset Shear Strength --- (from valid execution of a material property shear response test) the value of shear stress at the intersection between a line parallel to the shear chord modulus of elasticity and the shear stress/strain curve, where the line has been offset along the shear strain axis from the origin by a specified strain offset value.

Oligomer -- A polymer consisting of only a few monomer units such as a dimer, trimer, etc., or their mixtures.

One-Sided Tolerance Limit Factor -- See **Tolerance Limit Factor**.

Orthotropic -- Having three mutually perpendicular planes of elastic symmetry.

Oven Dry -- The condition of a material that has been heated under prescribed conditions of temperature and humidity until there is no further significant change in its mass.

PAN Fibers -- Reinforcement fiber derived from the controlled pyrolysis of poly(acrylonitrile) fiber.

Parallel Laminate -- A laminate of woven fabric in which the plies are aligned in the same position as originally aligned in the fabric roll.

Parallel Wound -- A term used to describe yarn or other material wound into a flanged spool.

Peel Ply -- A layer of resin free material used to protect a laminate for later secondary bonding.

pH -- A measure of acidity or alkalinity of a solution, with neutrality represented by a value of 7, with increasing acidity corresponding to progressively smaller values, and increasing alkalinity corresponding to progressively higher values.

Pick Count -- The number of filling yarns per inch or per centimeter of woven fabric.

Pitch Fibers -- Reinforcement fiber derived from petroleum or coal tar pitch.

Plastic -- A material that contains one or more organic polymers of large molecular weight, is solid in its finished state, and, at some state in its manufacture or processing into finished articles, can be shaped by flow.

Plasticizer -- A material of lower molecular weight added to a polymer to separate the molecular chains. This results in a depression of the glass transition temperature, reduced stiffness and brittleness, and improved processability. (Note, many polymeric materials do not need a plasticizer.)

Plied Yarn -- A yarn formed by twisting together two or more single yarns in one operation.

Ply Count -- *In laminated composite materials*, the number of plies or laminae used to construct the composite.

Poisson's Ratio -- The absolute value of the ratio of transverse strain to the corresponding axial strain resulting from uniformly distributed axial stress below the proportional limit of the material.

Polymer -- An organic material composed of molecules characterized by the repetition of one or more types of monomeric units.

Polymerization -- A chemical reaction in which the molecules of monomers are linked together to form polymers via two principal reaction mechanisms. Addition polymerizations proceed by chain growth and most condensation polymerizations through step growth.

Population -- The set of measurements about which inferences are to be made or the totality of possible measurements which might be obtained in a given testing situation. For example, "all possible ultimate tensile strength measurements for carbon/epoxy system A, conditioned at 95% relative humidity and room temperature". In order to make inferences about a population, it is often necessary to make assumptions about its distributional form. The assumed distributional form may also be referred to as the population. (See Volume 1, Section 8.1.4.)

Population Mean -- The average of all potential measurements in a given population weighted by their relative frequencies in the population. (See Volume 1, Section 8.1.4.)

Population Median -- That value in the population such that the probability of exceeding it is 0.5 and the probability of being less than it is 0.5. (See Volume 1, Section 8.1.4.)

Population Variance -- A measure of dispersion in the population.

Porosity -- A condition of trapped pockets of air, gas, or vacuum within a solid material, usually expressed as a percentage of the total nonsolid volume to the total volume (solid plus nonsolid) of a unit quantity of material.

Positively Skewed -- A distribution is said to be positively skewed if the distribution is not symmetric and the longest tail is on the right.

Postcure -- Additional elevated temperature cure, usually without pressure, to increase the glass transition temperature, to improve final properties, or to complete the cure.

Pot Life -- The period of time during which a reacting thermosetting composition remains suitable for its intended processing after mixing with a reaction initiating agent.

Precision -- The degree of agreement within a set of observations or test results obtained. Precision involves repeatability and reproducibility.

Precursor (for Carbon or Graphite Fiber) -- Either the PAN or pitch fibers from which carbon and graphite fibers are derived.

Preform -- An assembly of dry fabric and fibers which has been prepared for one of several different wet resin injection processes. A preform may be stitched or stabilized in some other way to hold its A shape. A commingled preform may contain thermoplastic fibers and may be consolidated by elevated temperature and pressure without resin injection.

Preply -- Layers of prepreg material, which have been assembled according to a user specified stacking sequence.

Prepreg -- Ready to mold or cure material in sheet form which may be tow, tape, cloth, or mat impregnated with resin. It may be stored before use.

Pressure -- The force or load per unit area.

Probability Density Function -- See Volume 1, Section 8.1.4.

Proportional Limit -- The maximum stress that a material is capable of sustaining without any deviation from the proportionality of stress to strain (also known as Hooke's law).

Quasi-Isotropic Laminate -- A balanced and symmetric laminate for which a constitutive property of interest, at a given point, displays isotropic behavior in the plane of the laminate.

Discussion: Common quasi-isotropic laminates are $(0/\pm 60)_s$ and $(0/\pm 45/90)_s$.

Random Effect -- A shift in a measured quantity due to a particular level change of an external, usually uncontrollable, factor. (See Volume 1, Section 8.1.4.)

Random Error -- That part of the data variation that is due to unknown or uncontrolled factors and that affects each observation independently and unpredictably. (See Volume 1, Section 8.1.4.)

Reduction of Area -- The difference between the original cross sectional area of a tension test specimen and the area of its smallest cross section, usually expressed as a percentage of the original area.

Refractive Index - The ratio of the velocity of light (of specified wavelength) in air to its velocity in the substance under examination. Also defined as the sine of the angle of incidence divided by the sine of the angle of refraction as light passes from air into the substance.

Reinforced Plastic -- A plastic with relatively high stiffness or very high strength fibers embedded in the composition. This improves some mechanical properties over that of the base resin.

Release Agent -- See **Mold Release Agent**.

Resilience -- A property of a material which is able to do work against restraining forces during return from a deformed condition.

Resin -- An organic polymer or prepolymer used as a matrix to contain the fibrous reinforcement in a composite material or as an adhesive. This organic matrix may be a thermoset or a thermoplastic, and may contain a wide variety of components or additives to influence; handleability, processing behavior and ultimate properties.

Resin Content -- See **Matrix content**.

Resin Starved Area -- Area of composite part where the resin has a non-continuous smooth coverage of the fiber.

Resin System -- A mixture of resin, with ingredients such as catalyst, initiator, diluents, etc. required for the intended processing and final product.

Room Temperature Ambient (RTA) -- 1) an environmental condition of $73\pm 5^\circ\text{F}$ ($23\pm 3^\circ\text{C}$) at ambient laboratory relative humidity; 2) a material condition where, immediately following consolidation/cure, the material is stored at $73\pm 5^\circ\text{F}$ ($23\pm 3^\circ\text{C}$) and at a maximum relative humidity of 60%.

Roving -- A number of strands, tows, or ends collected into a parallel bundle with little or no twist. In spun yarn production, an intermediate state between sliver and yarn.

S-Basis (or S-Value) -- The mechanical property value which is usually the specified minimum value of the appropriate government specification or SAE Aerospace Material Specification for this material.

Sample -- A small portion of a material or product intended to be representative of the whole. Statistically, a sample is the collection of measurements taken from a specified population. (See Volume 1, Section 8.1.4.)

Sample Mean -- The arithmetic average of the measurements in a sample. The sample mean is an estimator of the population mean. (See Volume 1, Section 8.1.4.)

Sample Median -- Order the observation from smallest to largest. Then the sample median is the value of the middle observation if the sample size is odd; the average of the two central observations if n is even. If the population is symmetric about its mean, the sample median is also an estimator of the population mean. (See Volume 1, Section 8.1.4.)

Sample Standard Deviation -- The square root of the sample variance. (See Volume 1, Section 8.1.4.)

Sample Variance -- The sum of the squared deviations from the sample mean, divided by $n-1$. (See Volume 1, Section 8.1.4.)

Sandwich Construction -- A structural panel concept consisting in its simplest form of two relatively thin, parallel sheets of structural material bonded to, and separated by, a relatively thick, light-weight core.

Saturation -- An equilibrium condition in which the net rate of absorption under prescribed conditions falls essentially to zero.

Scrim (also called **Glass Cloth, Carrier**) -- A low cost fabric woven into an open mesh construction, used in the processing of tape or other B-stage material to facilitate handling.

Secondary Bonding -- The joining together, by the process of adhesive bonding, of two or more already-cured composite parts, during which the only chemical or thermal reaction occurring is the curing of the adhesive itself.

Selvage or Selvedge -- The woven edge portion of a fabric parallel to the warp.

Set -- The strain remaining after complete release of the force producing the deformation.

Shear Fracture (for crystalline type materials) -- A mode of fracture resulting from translation along slip planes which are preferentially oriented in the direction of the shearing stress.

Shelf Life -- The length of time a material, substance, product, or reagent can be stored under specified environmental conditions and continue to meet all applicable specification requirements and/or remain suitable for its intended function.

Short Beam Strength (SBS) -- a test result from valid execution of ASTM test method D 2344.

Significant -- Statistically, the value of a test statistic is significant if the probability of a value at least as extreme is less than or equal to a predetermined number called the significance level of the test.

Significant Digit -- Any digit that is necessary to define a value or quantity.

Size System -- See **Finish**.

Sizing -- A generic term for compounds which are applied to yarns to bind the fiber together and stiffen the yarn to provide abrasion-resistance during weaving. Starch, gelatin, oil, wax, and man-made polymers such as polyvinyl alcohol, polystyrene, polyacrylic acid, and polyacetates are employed.

Skewness -- See **Positively Skewed, Negatively Skewed**.

Sleeving -- A common name for tubular braided fabric.

Slenderness Ratio -- The unsupported effective length of a uniform column divided by the least radius of gyration of the cross-sectional area.

Sliver -- A continuous strand of loosely assembled fiber that is approximately uniform in cross-sectional area and has no twist.

Solute -- The dissolved material.

Specific Gravity -- The ratio of the weight of any volume of a substance to the weight of an equal volume of another substance taken as standard at a constant or stated temperature. Solids and liquids are usually compared with water at 39°F (4°C).

Specific Heat -- The quantity of heat required to raise the temperature of a unit mass of a substance one degree under specified conditions.

Specimen -- A piece or portion of a sample or other material taken to be tested. Specimens normally are prepared to conform with the applicable test method.

Spindle -- A slender upright rotation rod on a spinning frame, roving frame, twister or similar machine.

Standard Deviation -- See **Sample Standard Deviation**.

Staple -- Either naturally occurring fibers or lengths cut from filaments.

Step-Growth Polymerization -- One of the two principal polymerization mechanisms. In step-growth polymerization, the reaction grows by combination of monomer, oligomer, or polymer molecules through the consumption of reactive groups. Since average molecular weight increases with monomer consumption, high molecular weight polymers are formed only at high degrees of conversion.

Strain -- the per unit change, due to force, in the size or shape of a body referred to its original size or shape. Strain is a nondimensional quantity, but it is frequently expressed in inches per inch, meters per meter, or percent.

Strand -- Normally an untwisted bundle or assembly of continuous filaments used as a unit, including slivers, tow, ends, yarn, etc. Sometimes a single fiber or filament is called a strand.

Strength -- the maximum stress which a material is capable of sustaining.

Stress -- The intensity at a point in a body of the forces or components of forces that act on a given plane through the point. Stress is expressed in force per unit area (pounds-force per square inch, megapascals, etc.).

Stress Relaxation -- The time dependent decrease in stress in a solid under given constraint conditions.

Stress-Strain Curve (Diagram) -- A graphical representation showing the relationship between the change in dimension of the specimen in the direction of the externally applied stress and the magnitude of the applied stress. Values of stress usually are plotted as ordinates (vertically) and strain values as abscissa (horizontally).

Structural Element -- a generic element of a more complex structural member (for example, skin, stringer, shear panels, sandwich panels, joints, or splices).

Structured Data -- See Volume 1, Section 8.1.4.

Surfacing Mat -- A thin mat of fine fibers used primarily to produce a smooth surface on an organic matrix composite.

Symmetrical Laminate -- A composite laminate in which the sequence of plies below the laminate midplane is a mirror image of the stacking sequence above the midplane.

Tab -- A piece of material used to hold the laminate specimen in a grip or fixture for testing so that the laminate is not damaged, and is adequately supported.

Tack -- Stickiness of the prepreg.

Tape -- Prepreg fabricated in widths up to 12 inches wide for carbon and 3 inches for boron. Cross stitched carbon tapes up to 60 inches wide are available commercially in some cases.

Tenacity -- The tensile stress expressed as force per unit linear density of the unstrained specimen i.e., grams-force per denier or grams-force per tex.

Tex -- A unit for expressing linear density equal to the mass or weight in grams of 1000 meters of filament, fiber, yarn or other textile strand.

Thermal Conductivity -- Ability of a material to conduct heat. The physical constant for quantity of heat that passes through unit cube of a substance in unit time when the difference in temperature of two faces is one degree.

Thermoplastic -- A plastic that repeatedly can be softened by heating and hardened by cooling through a temperature range characteristic of the plastic, and when in the softened stage, can be shaped by flow into articles by molding or extrusion.

Thermoset -- A class of polymers that, when cured using heat, chemical, or other means, changes into a substantially infusible and insoluble material.

Tolerance -- The total amount by which a quantity is allowed to vary.

Tolerance Limit -- A lower (upper) confidence limit on a specified percentile of a distribution. For example, the B-basis value is a 95% lower confidence limit on the tenth percentile of a distribution.

Tolerance Limit Factor -- The factor which is multiplied by the estimate of variability in computing the tolerance limit.

Toughness -- A measure of a material's ability to absorb work, or the actual work per unit volume or unit mass of material that is required to rupture it. Toughness is proportional to the area under the load-elongation curve from the origin to the breaking point.

Tow -- An untwisted bundle of continuous filaments. Commonly used in referring to man-made fibers, particularly carbon and graphite fibers, in the composites industry.

Transformation -- A transformation of data values is a change in the units of measurement accomplished by applying a mathematical function to all data values. For example, if the data is given by x , then $y = x + 1$, x , $1/x$, $\log x$, and $\cos x$ are transformations.

Transition, First Order -- A change of state associated with crystallization or melting in a polymer.

Transversely Isotropic -- Descriptive term for a material exhibiting a special case of orthotropy in which properties are identical in two orthotropic dimensions, but not the third; having identical properties in both transverse directions but not the longitudinal direction.

Traveller -- A small piece of the same product (panel, tube, etc.) as the test specimen, used for example to measure moisture content as a result of conditioning.

Twist -- The number of turns about its axis per unit of length in a yarn or other textile strand. It may be expressed as turns per inch (tpi) or turns per centimeter (tpcm).

Twist, Direction of -- The direction of twist in yarns and other textile strands is indicated by the capital letters S and Z. Yarn has S twist if, when held in a vertical position, the visible spirals or helices around its central axis are in the direction of slope of the central portion of the letter S, and Z twist is in the other direction.

Twist multiplier -- The ratio of turns per inch to the square root of the cotton count.

Typical Basis -- A typical property value is a sample mean. Note that the typical value is defined as the simple arithmetic mean which has a statistical connotation of 50% reliability with a 50% confidence.

Unbond -- An area within a bonded interface between two adherends in which the intended bonding action failed to take place. Also used to denote specific areas deliberately prevented from bonding in order to simulate a defective bond, such as in the generation of quality standards specimens. (See **Disbond, Debond**).

Unidirectional Fiber-Reinforced Composite -- Any fiber-reinforced composite with all fibers aligned in a single direction.

Unit Cell -- The term applied to the path of a yarn in a braided fabric representing a unit cell of a repeating geometric pattern. The smallest element representative of the braided structure.

Unstructured Data -- See Volume 1, Section 8.1.4.

Upper Confidence Limit -- See **Confidence Interval**.

Vacuum Bag Molding -- A process in which the lay-up is cured under pressure generated by drawing a vacuum in the space between the lay-up and a flexible sheet placed over it and sealed at the edges.

Variance -- See **Sample Variance**.

Viscosity -- The property of resistance to flow exhibited within the body of a material.

Void - Any pocket of enclosed gas or near-vacuum within a composite.

Void Content -- The volume percentage of voids in a composite.

Warp -- The longitudinally oriented yarn in a woven fabric (see **Fill**); a group of yarns in long lengths and approximately parallel.

Warp Surface -- The ply surface that shows the larger area of warp tows with respect to filling tows.

Discussion: Fabrics where both surfaces show an equal area of warp tows with respect to filling tows do not have a warp surface.

Wet Lay-up -- A method of making a reinforced product by applying a liquid resin system while or after the reinforcement is put in place.

Weibull Distribution (Two - Parameter) -- A probability distribution for which the probability that a randomly selected observation from this population lies between a and b ($0 < a < b < \infty$) is given by Equa-

tion 1.7(d) where α is called the scale parameter and β is called the shape parameter. (See Volume 1, Section 8.1.4.)

$$\exp\left[-\left(\frac{a}{\alpha}\right)^\beta\right] - \exp\left[-\left(\frac{b}{\alpha}\right)^\beta\right] \quad 1.7(d)$$

Wet Lay-up -- A method of making a reinforced product by applying a liquid resin system while the reinforcement is put in place.

Wet Strength -- The strength of an organic matrix composite when the matrix resin is saturated with absorbed moisture. (See **Saturation**).

Wet Winding -- A method of filament winding in which the fiber reinforcement is coated with the resin system as a liquid just prior to wrapping on a mandrel.

Whisker -- A short single crystal fiber or filament. Whisker diameters range from 1 to 25 microns, with aspect ratios between 100 and 15,000.

Winding -- A process in which continuous material is applied under controlled tension to a form in a predetermined geometric relationship to make a structure.

Discussion: A matrix material to bind the fibers together may be added before, during or after winding. Filament winding is the most common type.

Work Life -- The period during which a compound, after mixing with a catalyst, solvent, or other compounding ingredient, remains suitable for its intended use.

Woven Fabric Composite -- A major form of advanced composites in which the fiber constituent consists of woven fabric. A woven fabric composite normally is a laminate comprised of a number of laminae, each of which consists of one layer of fabric embedded in the selected matrix material. Individual fabric laminae are directionally oriented and combined into specific multiaxial laminates for application to specific envelopes of strength and stiffness requirements.

Yarn -- A generic term for strands or bundles of continuous filaments or fibers, usually twisted and suitable for making textile fabric.

Yarn, Plied -- Yarns made by collecting two or more single yarns together. Normally, the yarns are twisted together though sometimes they are collected without twist.

Yield Strength -- The stress at which a material exhibits a specified limiting deviation from the proportionality of stress to strain. (The deviation is expressed in terms of strain such as 0.2 percent for the Offset Method or 0.5 percent for the Total Extension Under Load Method.)

X-Axis -- In composite laminates, an axis in the plane of the laminate which is used as the 0 degree reference for designating the angle of a lamina.

X-Y Plane -- In composite laminates, the reference plane parallel to the plane of the laminate.

Y-Axis -- In composite laminates, the axis in the plane of the laminate which is perpendicular to the x-axis.

Z-Axis -- In composite laminates, the reference axis normal to the plane of the laminate.

REFERENCES

- 1.6(a) Military Standardization Handbook, Metallic Materials and Elements for Aerospace Vehicle Structures, MIL-HDBK-5F, 1 November 1990.
- 1.6(b) DOD/NASA Advanced Composites Design Guide, Air Force Wright Aeronautical Laboratories, Dayton, OH, prepared by Rockwell International Corporation, 1983 (distribution limited).
- 1.6(c) ASTM E 206, "Definitions of Terms Relating to Fatigue Testing and the Statistical Analysis of Fatigue Data," 1984 Annual Book of ASTM Standards, Vol 3.01, ASTM, Philadelphia, PA, 1984.
- 1.6.2(a) ASTM E 380, "Standard for Metric Practice," 1984 Annual Book of ASTM Standards, Vol 14.01, ASTM, Philadelphia, PA, 1984.
- 1.6.2(b) Engineering Design Handbook: Metric Conversion Guide, DARCOM P 706-470, July 1976.
- 1.6.2(c) The International System of Units (SI), NBS Special Publication 330, National Bureau of Standards, 1986 edition.
- 1.6.2(d) Units and Systems of Weights and Measures, Their Origin, Development, and Present Status, NBS Letter Circular LC 1035, National Bureau of Standards, November 1985.
- 1.6.2(e) The International System of Units Physical Constants and Conversion Factors, NASA Special Publication 7012, 1964.

CHAPTER 2 GUIDELINES FOR PROPERTY TESTING OF COMPOSITES

2.1 INTRODUCTION

This chapter provides guidelines for the experimental characterization of polymer matrix composites and documents the requirements for publishing material property data in MIL-HDBK-17. Recommended test matrices for a number of uses are presented and discussed. Potential problem areas in testing and test matrix planning are highlighted and helpful options are provided. The chapter sections cover the following:

- Section 2.1 introduces the chapter and presents an approach to categorizing testing needs.
- Section 2.2 discusses a wide variety of factors that affect test results and basis values, focusing on issues of particular importance during test planning, whether for a single test or for a large testing program requiring the evaluation of hundreds or thousands of test specimens.
- Section 2.3 presents a number of preplanned test matrices organized by the key categories introduced in Section 2.1, covering the characterization of specific sets of properties at recommended test environments, and including requirements for batch and specimen quantities.
- Section 2.4 describes procedures for normalizing, reducing, and reporting test data.
- Section 2.5 describes detailed test population sampling requirements, and specific test data normalization and documentation requirements for inclusion of data into MIL-HDBK-17 Volume 2.

2.1.1 Building-block approach to substantiation of composite structures

Analysis alone is generally not considered adequate for substantiation of composite structural designs. Instead, the "building-block approach" to design development testing is used in concert with analysis. This approach is often considered essential to the qualification/certification¹ of composite structures due to the sensitivity of composites to out-of-plane loads, the multiplicity of composite failure modes and the lack of standard analytical methods.

The building-block approach is also used to establish environmental compensation values applied to full-scale tests at room-temperature ambient environment, as it is often impractical to conduct these tests under the actual moisture and temperature environment. Lower-level tests justify these environmental compensation factors. Similarly, other building-block tests determine truncation approaches for fatigue spectra and compensation for fatigue scatter at the full-scale level.

The building-block approach is shown schematically in Figure 2.1.1 and discussed in detail in References 2.1.1(b) and (c). The approach can be summarized in the following steps:

1. Generate material basis values and preliminary design allowables.
2. Based on the design/analysis of the structure, select critical areas for subsequent test verification.
3. Determine the most strength-critical failure mode for each design feature.
4. Select the test environment that will produce the strength-critical failure mode. Special attention should be given to matrix-sensitive failure modes (such as compression, out-of-plane shear, and bondlines) and potential "hot-spots" caused by out-of-plane loads or stiffness tailored designs.
5. Design and test a series of test specimens, each one of which simulates a single selected failure mode and loading condition, compare to analytical predictions, and adjust analysis models or design allowables as necessary.
6. Design and conduct increasingly more complicated tests that evaluate more complicated loading situations with the possibility of failure from several potential failure modes. Compare to analytical predictions and adjust analysis models as necessary.

¹Design substantiation is often called "qualification" in U.S. DOD applications and "certification" in civilian applications involving the U.S. FAA. All three terms describe a similar process, but "substantiation" can be considered the more generic term, with "qualification" and "certification" often limited to the foregoing more restricted senses.

7. Design (including compensation factors) and conduct, as required, full-scale component static and fatigue testing for final validation of internal loads and structural integrity. Compare to analysis.

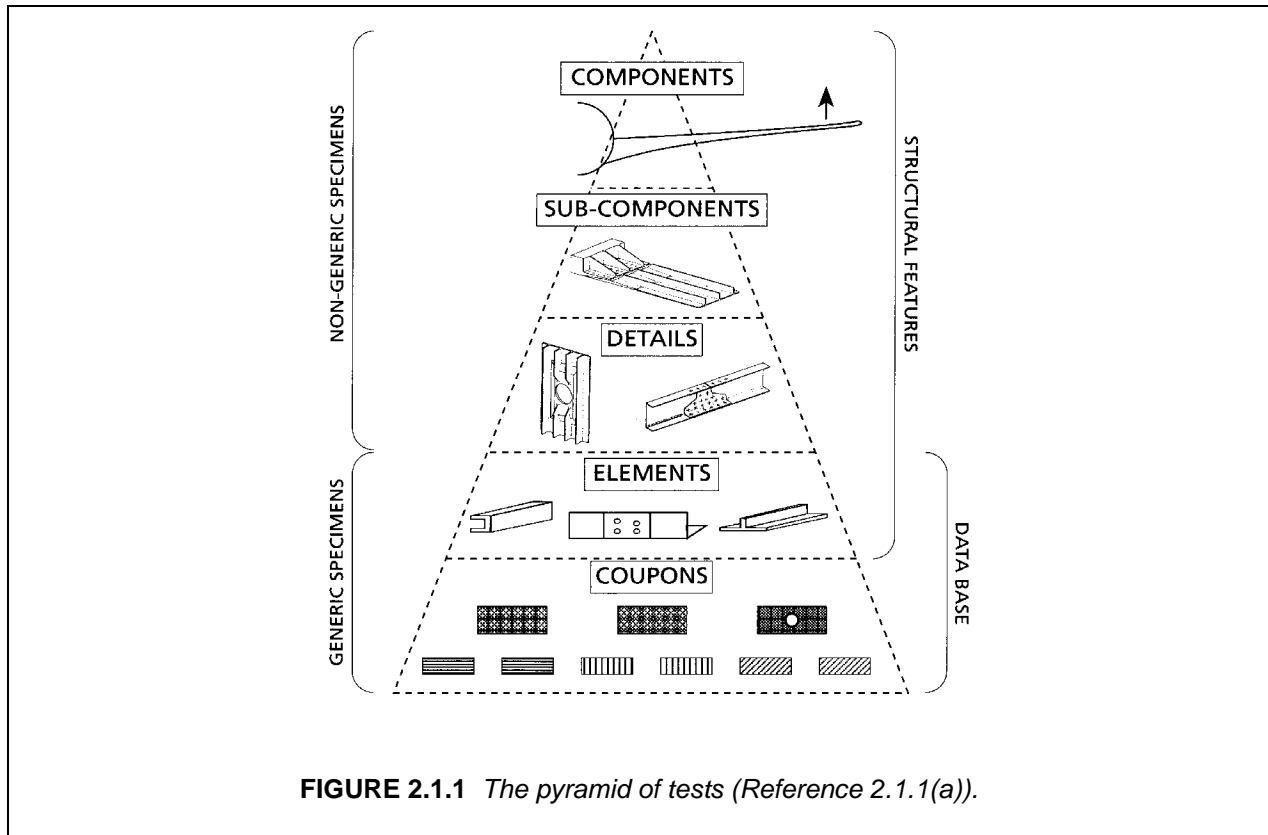

FIGURE 2.1.1 The pyramid of tests (Reference 2.1.1(a)).

2.1.2 Test levels and data uses

Testing activities can be defined in two basic ways, Structural Complexity Level and Data Application Category. The classes within each are discussed in more detail in the sections that follow, and can be used to map large-scale testing programs as an aid to test planning, as illustrated in Section 2.1.2.3.

2.1.2.1 Structural complexity levels

The five Structural Complexity Levels¹ are each geometry or form-based: constituent, lamina, laminate, structural element, and structural subcomponent. The material form(s) to be tested, and the relative emphasis placed on each level, should be determined early in the material data development planning process, and will likely depend upon many factors, including: manufacturing process, structural application, corporate/organizational practices, and/or the procurement or certification agency. While a single level may suffice in rare instances, most applications will require at least two levels, and it is common to use all five in a complete implementation of the building-block approach. Regardless of the Structural Complexity Level selected, physical and chemical property characterization of the prepreg (or the matrix,

¹Due to the popularity of lamina-level testing and analysis, discussions in this handbook often emphasize development of a lamina-level database; however, this is not intended to inhibit use of any of the other Structural Complexity Levels, either singly or in combination. Also, this handbook does not emphasize the structural subcomponent category since it is so strongly application dependent; however, many of the test planning and data documentation concepts for coupon testing contained herein can be extended to structural subcomponent (or higher) testing.

if it is added as part of the process, as with resin transfer molding) is necessary to support physical and mechanical property test results. Each procurement or certification agency has specific minimum requirements and guidelines for use of data. Users of MIL-HDBK-17 are advised to coordinate with the procuring or certifying agency before planning and conducting any testing that supports structural qualification or certification.

The five Structural Complexity Levels cover the following areas:

Constituent Testing:

This evaluates the individual properties of fibers, fiber forms, matrix materials, and fiber-matrix preforms. Key properties, for example, include fiber and matrix density, and fiber tensile strength and tensile modulus.

Lamina Testing:

This evaluates the properties of the fiber and matrix together in the composite material form. For the purpose of this discussion prepreg properties are included in this level, although they are sometimes broken-out into a separate level. Key properties include fiber areal weight, matrix content, void content, cured ply thickness, lamina tensile strengths and moduli, lamina compressive strengths and moduli, and lamina shear strengths and moduli.

Laminate Testing:

Laminate testing characterizes the response of the composite material in a given laminate design. Key properties include tensile strengths and moduli, compressive strengths and moduli, shear strengths and moduli, interlaminar fracture toughness, and fatigue resistance.

Structural Element Testing:

This evaluates the ability of the material to tolerate common laminate discontinuities. Key properties include open and filled hole tensile strengths, open and filled hole compressive strengths, compression after impact strength, and joint bearing and bearing bypass strengths.

Structural Subcomponent (or higher) Testing:

This testing evaluates the behavior and failure mode of increasingly more complex structural assemblies. These are application specific and not specifically covered by MIL-HDBK-17.

2.1.2.2 Data application categories

Material property testing can also be grouped by data application into one or more of the following five categories: screening,¹ qualification, acceptance, equivalence, and structural substantiation. The starting point for testing most material systems is usually material screening. Material systems intended for use in engineering hardware are subjected to further testing to obtain additional data. While structural substantiation requirements, the last category, are not specifically addressed by MIL-HDBK-17 data generated in accordance with MIL-HDBK-17 guidelines may form part of these requirements. The five Data Application Categories cover the following areas:

Screening Testing:

This is the assessment of material candidates for a given application, often with a given application in mind. The purpose of screening testing is initial evaluation of new material systems under worst-case environmental and loading test conditions. This handbook provides guidelines for screening new material systems based on key properties for aerospace structural applications. The MIL-HDBK-17 screening test matrix provides average values for various strength, moduli, and physical properties, includes both lamina

¹A more limited form of screening testing for the characteristic response of a limited number of specific properties (often only one property) is not explicitly named as a testing category, but is commonly performed. Such limited testing usually consists of small test populations of three to six, usually from a single material batch, and often focuses on a specific environmental condition. As each instance of testing of this type has a specific but widely varying purpose MIL-HDBK-17 does not provide explicit test matrix recommendations; however, the guidance provided for the remaining testing categories remains a useful reference for test planning.

and laminate level testing, and is designed both to eliminate deficient material systems from the material selection process and to reveal promising new material systems before planning subsequent, more in-depth, evaluations.

Material Qualification Testing:

This step proves the ability of a given material/process to meet the requirements of a material specification; it is also the process of establishing the original specification requirement values. Rigorous material qualification testing considers the statistics of the data and is ideally a subset of, or directly related to, the design allowables testing performed to satisfy structural substantiation requirements. (However, while a material may be qualified to a given specification, it still must be approved for use in each specific application.) The objective is quantitative assessment of the variability of key material properties, leading to various statistics that are used to establish material acceptance, equivalence, quality control, and design basis values. Since there are various sampling and statistical approaches used within the industry, the approach used must be explicitly defined. While a generic basis value can be obtained many ways, a MIL-HDBK-17 basis value carries with it well-defined sampling requirements and a specific statistical determination process, and emphasizes additional considerations like test methodology, failure mode, and data documentation.

Acceptance Testing:

This is the task of verifying material consistency through periodic sampling of material product and evaluation of key material properties. Test results from small sample sizes are statistically compared with control values established from prior testing to determine whether or not the material production process has changed significantly.

Equivalence Testing:

This task assesses the equivalence of an alternate material to a previously characterized material, often for the purpose of utilizing an existing material property database. The objective is evaluation of key properties for test populations large enough to provide a definitive conclusion, but small enough to provide significant cost savings as compared to generating an entirely new database. A significant use includes evaluation of possible second-sources of supply for a previously qualified material. However, the most common uses for this process are: 1) evaluation of minor constituent, constituent processing, or fabrication processing changes for a qualified material system, and 2) substantiation of previously established MIL-HDBK-17 basis values.

Structural Substantiation Testing:

This is the process of assessing the ability of a given structure to meet the requirements of a specific application. The development of design allowables, ideally derived or related to material basis values obtained during a material qualification task, is considered a part of this effort. When performed for the U.S. DOD this task is called structural qualification, and when the U.S. FAA is the certifying agency it is called structural certification.

2.1.2.3 Test program definition

A matrix is shown in Table 2.1.2.3 that can be used in test planning for large-scale testing programs. The material property tests from the Structural Complexity Levels and Data Application Categories are listed on the axes of an array, with each intersecting cell describing a distinct testing activity (though certain combinations will rarely be used). Groups of cells can be used to summarize the scope of entire building-block testing programs. The array shown in Table 2.1.2.3 illustrates a common (but by no means universal) testing sequence in the substantiation of a composite-based aerospace structural application. The sequence begins with the hatched cells at the upper left of the array and proceeds, with time, toward the cells at the lower right, with the numbered notes indicating the approximate order in the sequence. (The structural substantiation category and structural subcomponent level are shaded to indicate that they are not specifically addressed by MIL-HDBK-17).

TABLE 2.1.2.3 *Test program definition.*

STRUCTURAL COMPLEXITY LEVEL	DATA APPLICATION CATEGORIES				
	Material Screening	Material Qualification	Material Acceptance	Material Equivalence	Structural Substantiation
Constituent	1	-	-	-	-
Lamina	2	4		-	-
Laminate	-	5		-	7
Structural Element	3	6		-	8
Structural Subcomponent	-	-	-	-	9

This handbook defines a number of recommended test matrices in Section 2.3, organized by Data Application Category.

2.2 TEST PROGRAM PLANNING

2.2.1 Overview

Section 2.2 discusses a number of testing objectives that affect the execution of testing programs. The next section, 2.3 on Recommended Test Matrices, completes these items by providing recommended test matrices (types of tests and test quantities at various environments) for a number of composite material forms and objectives. These pre-defined test matrices may have to be customized for use with a specific application.

Characterization of composite material properties is distinctly different than for either metals or unreinforced plastics. Section 2.2 provides information on many of the critical differences that affect testing and test planning, including:

- testing matrices,
- material sampling and pooling issues,
- statistical calculations,
- test method selection,
- material and processing variation,
- conditioning and non-ambient testing issues,
- alternative coupon configurations,
- data normalization and documentation, and
- application-specific testing.

All significant testing programs should begin with preparation of a detailed test plan document. A test plan specifies material properties to be evaluated, selects tests methods, eliminates options offered by

standard test methods by selecting specific specimen and test configurations, and defines success criteria. It is prepared by the contractor, approved by the certifying agency, and is the focal point for understanding between the contractor and certifying agency. A clearly written, well-prepared test plan is also a primary management tool to define the scope of the work, degree of success, and progress toward completion.

2.2.2 Baseline and alternate approaches for statistically-based properties

Much of MIL-HDBK-17 focuses on guidelines for establishing basis values for strength and strain-to-failure properties¹. A specific statistical methodology for calculating basis values from test results, illustrated in Figure 8.3.1, has been developed by this handbook, is recommended for general use in reducing data, and is required for evaluation of data published in Volume 2.

Additional requirements imposed on data published within this handbook include: specific population sampling methods and reporting of supporting data. For the purposes of obtaining a reasonable evaluation of material variation, basis values published in this handbook are based on a minimum of thirty specimens from at least five batches of a material per environment and direction as discussed in Sections 2.2.5 and 2.5.3. These data are normalized (where appropriate) as discussed in Sections 2.2.11 and 2.4.3, statistically evaluated in accordance with the process described by Figure 8.3.1 and discussed in Section 8.3, and reported in accordance with Volume 2, Section 1.4.2.

This same statistical procedure can be used on populations of fewer batches and/or replicates, but, if data from such populations are submitted to the handbook for publication, the published data summary will not include a basis value.

Depending on both the application and the procuring or certifying agency, modifications to the baseline MIL-HDBK-17 approach may be justified when developing new material data. In such cases the handbook guidelines remain useful for support and reference. Alternate sampling and statistical approaches to development of basis values may be justified in certain instances, though they are less commonly used. These alternate approaches directly affect test matrix development and generally require a relatively sophisticated knowledge of both statistics and of the material behavior of the specific material system. An introduction to one type of alternate approach is provided in Section 2.3.6.1, with the related statistical background summarized in Section 8.3.5.3. When using such alternate approaches, advance approval of the procurement or certification agency is strongly recommended.

2.2.3 Issues of data equivalence

Evaluation for data pooling (whether data from two possibly different subpopulations are enough alike to be combined) and material equivalence (whether a material with common characteristics to another is sufficiently alike to use its data for design) are similar issues of data equivalence. Both require statistical procedures to assess the similarities and differences between two subpopulations of data². These, and other related issues, are covered in more detail in Sections 2.3.4.1, 2.3.7, and 2.5.3.4. Assessment of the equivalence of data begins by examining key properties for various within-batch and between-batch statistics (see Section 8.3.2).

The ability to pool different subpopulations of test data is highly desirable, if for no other reason than to obtain larger populations that are more representative of the universe (see Section 2.2.5 for a summary discussion of sample size effects). Equally desirable is the ability to show one material without basis values equivalent to another that already has established basis values (see Sections 2.3.4.1, 2.3.7, and

¹A B-basis value, as defined in Section 1.7, is the value above which at least 90 percent of the population of values is expected to fall, with a confidence of 95 percent. Statistical estimates of basis values for material properties are considered by the handbook to be material properties unto themselves.

²If some properties are found similar and others not, engineering judgment must assess the criticality for the given application of the dissimilar properties before the alternate material can be deemed equivalent. The equivalence then only applies to that application and must be reassessed for a different application.

2.5.3.4). Requirements for the use of pooled data or equivalent materials are normally established for each application during discussions with the certifying agency or, for data being considered for publication in MIL-HDBK-17, by the MIL-HDBK-17 Data Review Working Group.

Before determining statistical degree of equivalence, basic engineering considerations should be satisfied; the two materials should be of the same chemical, microstructural, and material form families. To some extent the criteria for this may be application dependent. For example, property data from two composite systems with the same matrix and similar fibers may not warrant pooling if the fiber/matrix interface is distinctly different, even if the fibers have similar modulus and tensile strength. Data equivalence is typically evaluated for data sets that differ due only to relatively minor changes in precursor manufacturing or material processing, such as:

- minor changes in constituents or constituent manufacturing processes,
- identical materials processed by different component manufacturers,
- identical materials processed at different locations of the same manufacturer,
- slight changes in processing parameters, or
- some combination of the above.

Statistical data equivalence methods currently assume that between- and within-laboratory test method variation is negligible. When this assumption is violated this test method-induced artificial variation severely weakens the ability of the statistical methods to meaningfully compare two different detests. This is discussed further in Sections 2.2.4 and 2.2.5.

2.2.4 Test method selection

Test results in an empirical determination of either an intrinsic material property (like material compressive modulus or tensile strength) or a generic structural response (like quasi-isotropic laminate open hole tensile strength) from a small and relatively simple specimen are often used as input to a simulation of the response of a larger and more complicated specific structure. Test methods historically developed for metals or plastics, in most cases, cannot be directly applied to advanced composite materials. While the basic physics of test methods for composites may be similar to their unreinforced counterparts, the heterogeneity, orthotropy, moisture sensitivity, and low ductility of typical composites often lead to significant differences in testing requirements, particularly with the mechanical tests, including:

- the strong influence of constituent content on material response, creating a need to measure the material response of every specimen,
- a need to evaluate properties in multiple directions,
- a need to condition specimens to quantify and control moisture absorption and desorption,
- increased importance of specimen alignment and load introduction method, and
- a need to assume consistency of failure modes.

Other distinguishing characteristics of many composite materials also contribute to testing differences, including:

- compressive strength often lower than tensile strength (though specific material systems like boron/epoxy may behave counter to this),
- operating temperatures relatively closer to material property transition temperatures (compared to metals),
- shear stress response uncoupled from normal stress response, and
- heightened sensitivity to specimen preparation practices.

One measure of a test method is the theoretical ability of a perfect test to produce a desired result, such as a uniform uniaxial stress state throughout the conduct of the test. However, the above factors tend to increase the sensitivity of composites to a wider variety of testing parameters than is seen with conventional materials. Therefore test method robustness, or relative insensitivity to minor variations in

specimen and test procedure, is just as important as theoretical perfection. Robustness, or lack thereof, is assessed by interlaboratory testing, and is measured by *precision* (variation in the sample population) and *bias* (variation of the sample mean from the true average).¹ The precision and bias of test methods are evaluated by comparison testing (often called "round-robin" testing) both within-laboratory and between laboratories. The obvious ideal is high precision (low variation) and low bias (sample mean close to true average) both within-laboratory and between laboratories. Such a test method would repeatedly produce reproducible results without regard to material, operator, or test laboratory. However, quantification of bias requires a material standard for each test; none of which are currently available for composites. As a result, bias of composite test methods can currently only be qualitatively assessed.

Somewhat separate from the precision and bias of a test method (for a given specimen) is the effect on precision and bias of variation in test specimen size and geometry. For heterogeneous materials, physically larger specimens can be expected to contain within the coupon a more representative sample of the material microstructure. While desirable, a larger specimen is more apt to contain a greater number of micro- or macro-structural defects than a smaller specimen, and thus can be expected to produce somewhat lower strengths (though possibly also with lower variation). Variations in specimen geometry can also create differing results. *Size* and *geometry* effects can produce statistical differences in results independent of the "degree of perfection" of the remaining aspects of a test method or its conduct; such effects should be expected. Therefore, even though the specimen response may not (and probably won't) be identical to that of the structure, the "ideal" test method will incorporate a specimen geometry that can be consistently *correlated* with structural response.

As the criticality of various test parameters are still being researched and understood (even for relatively common tests) and as "standard laboratory practices," upon close examination, are actually found to vary from laboratory to laboratory, it is critical to control or document as many of these practices and parameters as possible. ASTM Committee D-30, responsible for standardization of advanced composite material test methods, tries to consider all of these factors when improving existing and developing new standard test methods (see Reference 2.2.4). Due to both their completeness and their status as full-consensus standards, ASTM D-30 test methods, where applicable, are emphasized by this handbook.

Failure to minimize test method sensitivities, whatever the cause, can cause the statistical methods contained within MIL-HDBK-17 to break-down, as all variation in data is implicitly assumed by the statistical methods to be due to material or process variation. Any additional variation due to specimen preparation or testing procedure is added to the material/process variation, which can result in extraordinarily conservative, or even meaningless, basis value results.

Test methods, with emphasis on ASTM standards for advanced composites, are discussed in Chapters 3 through 7. The advantages and disadvantages of the various test methods for composites are discussed, including, for completeness, non-standard but often referenced methods that have appeared in the literature. Chapters 3 and 4 cover constituent testing. Chapter 5 covers prepreg test methods. Chapter 6 covers lamina and laminate testing. Chapter 7 covers structural element test methods. Data produced by the following test methods (Table 2.2.4) are currently being accepted by MIL-HDBK-17 for consideration for inclusion in Volume 2.

¹The term "accuracy" is often used as a generic combination of aspects of both precision and bias. The terms "precision" and "bias", being more specific, are preferred for use where appropriate.

TABLE 2.2.4 Summary of test methods for MIL-HDBK-17 data submittal
(continued on next page).

Test Category	Source of Test Method	
	ASTM	SACMA
Prepreg Tests		
Resin Content	D 3529, C 613, D 5300	RM 23, RM 24
Volatiles Content	D 3530	---
Resin Flow	D 3531	RM 22
Resin Gel Time	D 3532	RM 19
Fiber Areal Weight	D 3776	RM 23, RM 24
Moisture Content	D 4019	---
Tack	---	---
HPLC	---	RM 20
IR	E 1252, E 168	---
DMA (RDS)	D 4065, D 4473	RM 19
DSC	E 1356	RM 25
Lamina Physical Tests		
Moisture Conditioning	D 5229	RM 11
Fiber Volume	D 3171, D 2734	RM 10
Resin Content	D 3171, D 2734	RM 10
Void Content	D 2584	---
Density	D 792, D 1505	---
Cured Ply Thickness (CPT)	---	RM 10
Glass Transition Temperature, dry	D 4065	RM 18
Glass Transition Temperature, wet	---	RM 18
CTE, out-of-plane	E 831	---
CTE, in-plane	D 696, E 228	---
Equilibrium Moisture Content	D 5229	RM 11
Moisture Diffusivity	D 5229	---
Thermal Diffusivity	E 1461	---
Specific Heat	E 1269	---

TABLE 2.2.4 Summary of test methods for MIL-HDBK-17 data submittal, concluded.

Test Category	Source of Test Method	
	ASTM	SACMA
Lamina/Laminate Mechanical Tests		
0°/Warp Tension	D 3039	RM 4, RM 9
90°/Fill Tension	D 3039, D 5450	RM 4, RM 9
0°/Warp Compression	D 3410, D 5467	RM 1, RM 6
90°/Fill Compression	D 3410, D 5449	RM 1, RM 6
In-Plane Shear (1)	D 3518, D 5448, D 5379	RM 7
Interlaminar Shear	D 5379	---
Short Beam Strength	D 2344	RM 8
Flexure (7)	---	---
Open-Hole Compression	(draft)	RM 3
Open-Hole Tension	D 5766	RM 5
Single-Shear Bearing (2)	(draft)	---
Double-Shear Bearing (2)	(draft)	---
Compression after Impact	(draft)	RM 2
Mode I Fracture Toughness	D 5528	---
Mode II Fracture Toughness	(draft)	---
Tension/Tension Fatigue	D 3479	---
Tension/Compression Fatigue	---	---

Notes:

- 1) ASTM D 4255 will also be accepted for in-plane shear modulus of flat panels.
- 2) Bearing test procedures are presented in Chapter 7 until the draft ASTM test method that is based on them are released. These Chapter 7 test methods will also be accepted.
- 3) Certain material forms or processes (like filament winding) may, for a specific material property, be restricted to a single test method. See the detailed test method descriptions in Chapters 3 through 7, or the test methods themselves, for a more complete explanation.
- 4) SACMA test methods, in many cases, are subsets or supersets of the referenced ASTM test methods, and in other cases have either a different scope or use a different testing methodology. For cases where a SACMA test method exists, and either there is no ASTM test method covering the same property or the existing ASTM test method uses a different methodology, ASTM is considering adopting a form of the SACMA test method. Where ASTM and SACMA test methods overlap, ASTM and SACMA are working to consolidate the test methods into the next release of the ASTM standard.
- 5) For properties where there are more than one test method listed for either ASTM or SACMA, the different test methods either apply to different material forms or use different testing methodologies.
- 6) Data from other test methods not listed may be considered by the Testing and Data Review Working Groups, following the guidelines described in Section 2.5.5.
- 7) See Section 6.7.7.

2.2.5 Population sampling and sizing

Unlike MIL-HDBK-5 for metals, MIL-HDBK-17 for composites does not require simultaneous determination of B-basis values and A-basis values from the same population. This is not because of any fundamental difference in material behavior, but due to a relative lack of need for A-basis properties, to date, for composites. As a result, the composite material B-basis sample population (30+) is much smaller than the MIL-HDBK-5 A/B-basis sample population (100-300) for metals. Unfortunately, since there are usually more composite properties and directions under test, and since testing matrices for composites are often fully populated not only at room temperature but also at the environmental extremes, the total number of specimens in a B-basis composite testing program often exceeds the total number of coupons in an A/B-basis metals testing program.¹ However, included in and allowed by MIL-HDBK-17 are advanced statistical regression techniques that offer the possibility, in specific instances and when combined with different sampling distributions, of being able to reliably determine A-basis values from a total number of composite material specimens similar in quantity to those previously needed for B-basis values (see Section 2.3.6.1).

The sampling approach required for MIL-HDBK-17 B-basis nonregression data, and described in detail in Section 2.5.3, includes at least five batches of production material, using a minimum of 30 specimens distributed among the batches, and fully tests each property at each environment under consideration. The first five prepreg batches are each made using distinct fiber and matrix constituent lots (not required of batch numbers greater than five). For each condition and property, batch replicates are sampled from at least two different test panels covering at least two separate processing cycles. Test panels are non-destructively evaluated using ultrasonic inspection or another suitable non-destructive inspection technique. Test coupons are not extracted from panel areas having indications of questionable quality. A test plan (or report) documents laminate design, specimen sampling details, fabrication procedures (including material traceability information), inspection methods, specimen extraction methods, labeling schemes, and test methods.

For general data development, sampling techniques and sample sizes may be application or qualification/certification agency dependent. A desirable goal of any sampling scheme making use of MIL-HDBK-17 statistical methods is to have multiple batches composed of uniformly-sized subpopulations. The five-batch minimum requirement only applies to material properties that are to be incorporated in MIL-HDBK-17. An alternate number of replicates and batches may be employed upon approval of the procuring or certifying agency. However, mechanical strength data should be evaluated by the statistical methods recommended by this handbook to ensure statistically acceptable basis values.

2.2.5.1 Sample size selection

Regardless of the sampling scheme, for small sample populations, the result of any basis value calculation is strongly dependent on the sample size. Smaller sample populations are obviously less costly to test, but there is a price of a different kind to pay since, as the population size decreases, so does the calculated basis value. Figure 2.2.5.1 shows, for a hypothetical example, the effect of sample size on the calculated B-basis value² for samples of various sizes drawn from a given infinite population normally distributed. In the limit, for very large sample sizes, the B-basis (ten percentile) value for this example would be 87.2. The dotted line in the figure is the mean of all possible B-basis values for each sample size; this line can also be interpreted as the estimated B-basis value as a function of population size for a fixed sample coefficient of variation (CV) of 10%. The dashed lines represent the one-sigma limits for any given sample size (a two-sigma limit would approximately bound the 95% confidence interval).

¹MIL-HDBK-5, the metals handbook, focuses on A-basis values and requires a minimum of 100 tensile specimens, but uses small populations of compressive shear, bearing, and non-ambient tests ratioed to the room temperature tensile properties to estimate compressive, shear, bearing and non-ambient basis values. MIL-HDBK-17 requires at least 30 specimens for each direction, for each property, and for each environment to determine B-basis values. The MIL-HDBK-17 requirement increases to 90 coupons for A-basis values. However, when using MIL-HDBK-17 advanced statistical regression techniques, the specimen populations can sometimes be spread over all of the environments under test, thus reducing the total number of test specimens needed.

²Any statistical calculation based on a subpopulation is only an estimate of the real value for the entire population, although the larger and more representative the sample, the better the estimate.

Not only does the estimated B-basis value increase with larger sample sizes, but, as the one-sigma limits illustrate, the expected variation in estimated B-basis value significantly decreases. The lower one-sigma limit is farther from the mean B-basis value than the upper one-sigma limit, illustrating a skew in calculated B-basis value that is particularly strong for small sample sizes. As a result of this skew, for small populations the calculated B-basis value is substantially more likely to be overly conservative than under-conservative, increasing the significant penalty in B-basis value paid by use of small populations. While similar examples for non-normal distributions would have different quantitative results the trends with sample size can be expected to be similar. Additional discussions on effects of sample size are located in Section 8.2.5.

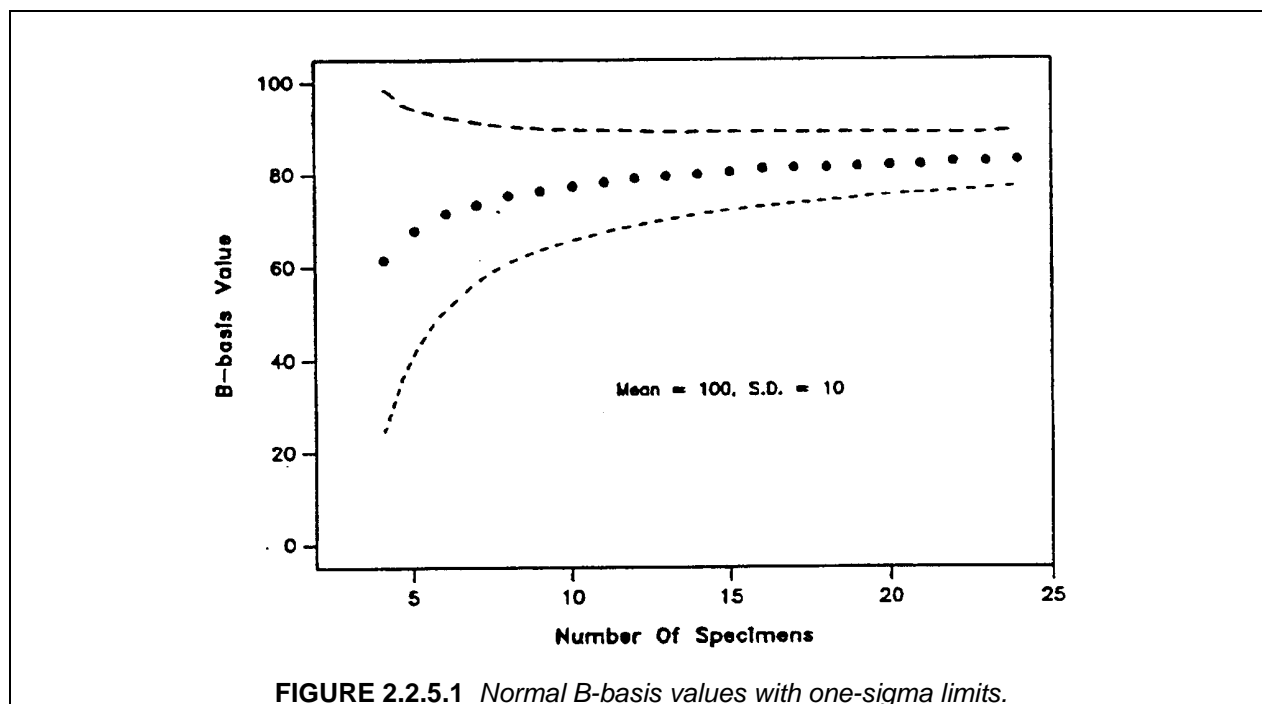

2.2.5.2 Batch quantity effects on ANOVA

The MIL-HDBK-17 statistical methodology (Figure 8.3.1) includes a statistical test to assess the degree of batch-to-batch variation. If the resulting statistic indicates excessive batch-to-batch variation, the data are not conventionally pooled but are instead evaluated using an Analysis of Variance (ANOVA) approach. However, the statistical methods are only as good as the quality and quantity of data that they evaluate.

Small numbers of batches can cause the ANOVA approach to produce extremely conservative basis values, since it essentially treats the average of each batch as a single data point for input to a conventional normal distribution technique for basis value determination (Section 2.2.5.1 describes the effect of small samples on basis values). As the MIL-HDBK-17 statistical methods assume that testing variation is negligible, variation caused by testing (see related discussion in Section 2.2.4), either within or between batch, is treated as real material/process variation and can result in unrealistically low basis values.

Also, the between-batch variation test becomes progressively weaker as the number of batches decreases, or as the variation between batches decreases, or both. For example, when only a small number of batches are sampled, a batch variation test result indicating no significant batch variation may be deceptive. Additional batch samples may indicate that batch variation really exists, but was masked by the small original number of batches.

The above should be understood when batch variation exists and ANOVA basis values are calculated on fewer than five batches.

2.2.6 Material and processing variation, specimen preparation and NDE

In the sections of Volume 1 that follow in the handbook, the reader will find an extensive compilation of test methods for a variety of fibers, resins and composite material forms and structural elements. In most cases these materials or structural elements are the products of complex multi-step materials processes. Figures 2.2.6(a) and 2.2.6(b) illustrate the nature of the processing pipeline from raw materials to composite end item. (Each rectangle in Figure 2.2.6(b) represents a process during which additional variability may be introduced into the material.) These processes may require elevated temperature, stress or pressure. They often involve evolution of volatiles, resin flow and consolidation, and readjustment of reinforcing fibers. If the measured properties of composite materials are to be interpreted correctly and used appropriately, the variability of the properties of the materials must be understood. This variability arises during routine processing and may be increased by any of the legion of anomalies which may occur during processing.

2.2.6.1 Materials and material processing

The constituents of the composite materials covered in this handbook are organic matrices (either thermosetting or thermoplastic) and organic or inorganic reinforcing fibers. Variation in the mechanical properties of the reinforcing fibers can arise from many sources, such as flaws in fiber microstructure, or variations in degree of orientation of the polymer chains in an organic fiber.

Thermoplastic matrices can exhibit variations in molecular weight and molecular weight distribution as a result of processing. The melt viscosity and subsequent processability of the thermoplastic matrix may be strongly affected by such variability. Thermosetting resins are often applied to fibers in a prepregging operation and some forms partially cured to what is referred to as a B-stage. Other methods for stabilizing thermoset resin systems may also be employed prior to the prepregging operation. Stability of these materials is important because there are many potential sources of variability during packaging, shipping and storage of improperly, or even properly, stabilized intermediate forms such as prepreg tape, fabrics and roving.

The placement of reinforcing fibers may be accomplished through many manual or automated processes. Lack of precision in fiber placement or subsequent shifting of reinforcing fibers during matrix flow and consolidation can introduce variability. Depending on the process (e.g., pultrusion compared to RTM), cure and/or consolidation can occur simultaneously with fiber placement, or after fiber placement has occurred. This step in the process is especially vulnerable to the introduction of variability.

As an example, consider the cure of a composite part from B-staged prepreg tape in an autoclave, a press or an integrally heated tool. When the resin is heated and has begun to flow, the material consists of a gas phase (volatiles or trapped air), a liquid phase (resin), and a solid (reinforcement) phase. To avoid variability in material properties due to excessive void volume, void producing gas phase material must be either removed or absorbed by the liquid phase. In order to avoid variability due to variations in fiber volume fraction, the resin must be uniformly distributed throughout the part. The fiber must maintain its selected orientation in order to avoid variability or loss of properties due to fiber misalignment.

Pertinent process parameters and material effects should always be documented to aid in process control and troubleshooting. If potential processing and manufacturing pitfalls are not identified and avoided in this way, resources may be wasted in testing materials which are not representative of those which will occur in an actual part or application. In addition, heavy weight penalties may be paid to allow for avoidable material variability. A better understanding of these processing parameters and their potential effect on material properties will also allow a composites manufacturer to avoid the considerable expenses involved in the production of materials, parts or end items with unacceptable properties.

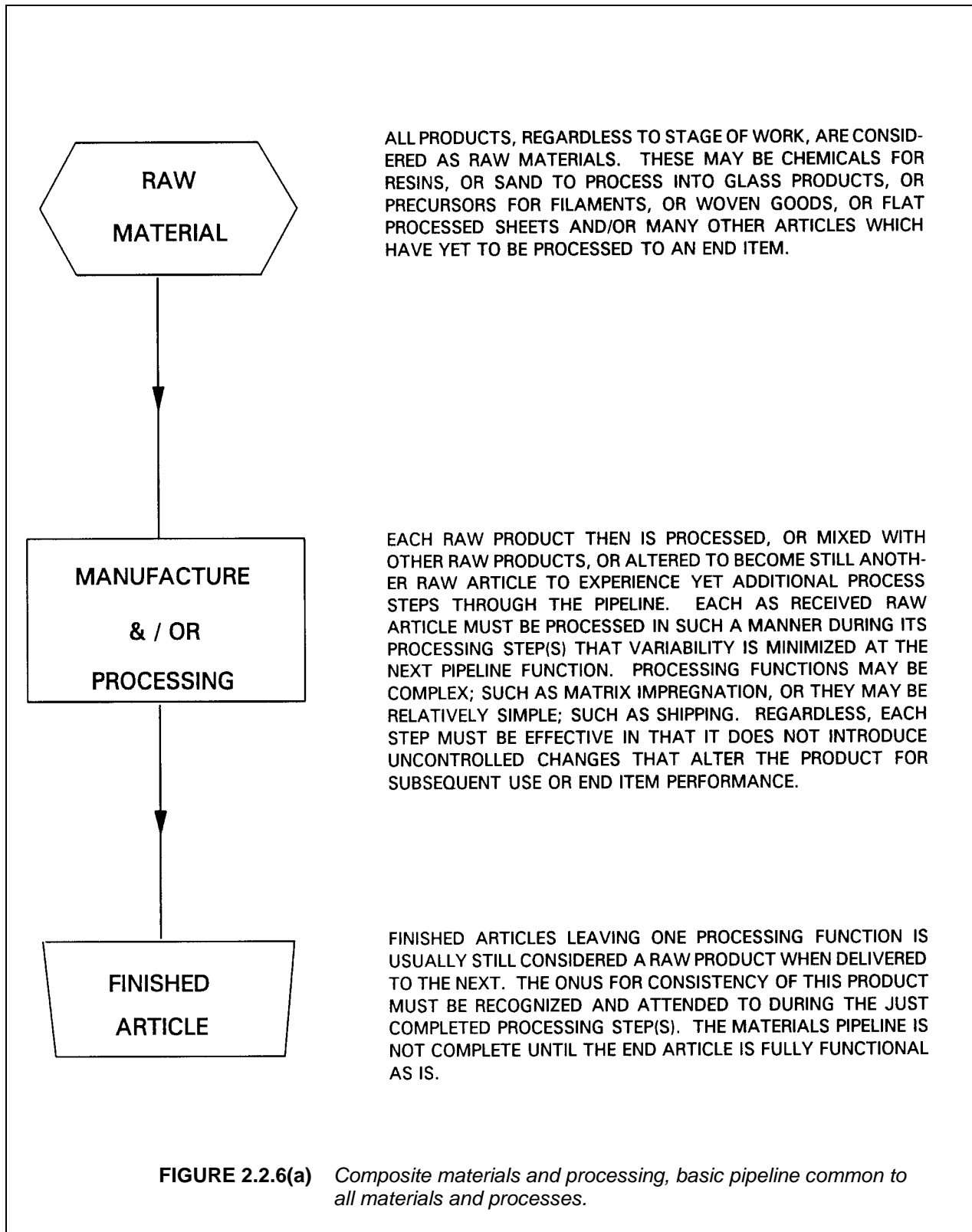

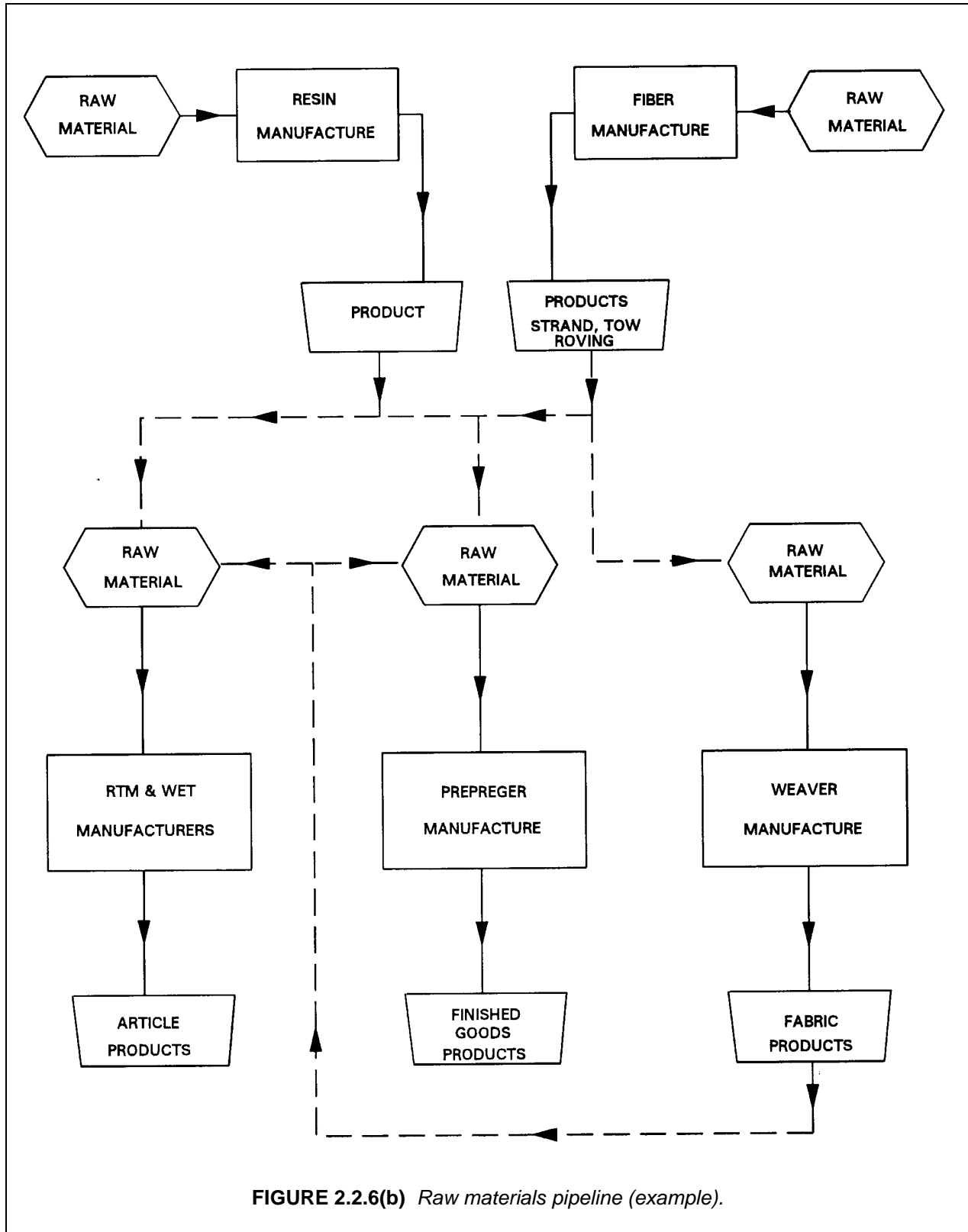

FIGURE 2.2.6(b) Raw materials pipeline (example).

This section is meant to be a brief discussion of variability in composite properties arising from the various processes which are encountered in the materials and processing pipeline. For a more extensive and detailed treatment of this subject, the reader is referred to the broader discussion of these issues which may be found in Volume 3, Chapter 2 entitled Materials and Processes - The Effect of Variability on Composite Properties. Volume 3, Chapter 2 also includes a discussion of preparation of materials and processing specifications. The composite end item manufacturer has no direct control over the processing of incoming materials, and the use of such specifications is essential in minimizing materials variability.

2.2.6.2 Specimen preparation and NDE

This section is reserved for future use.

2.2.7 Moisture absorption and conditioning factors.

Most polymeric materials, whether in the form of a composite matrix or a polymeric fiber, are capable of absorbing relatively small but potentially significant amounts of moisture from the surrounding environment.¹ The physical mechanism for moisture gain, assuming there are no cracks or other wicking paths, is generally assumed to be mass diffusion following Fick's Law (the moisture analog to thermal diffusion). While material surfaces in direct contact with the environment absorb or desorb moisture almost immediately, moisture flow into or out of the interior occurs relatively slowly. The moisture diffusion rate is many orders of magnitude slower than heat flow in thermal diffusion. Nevertheless, after a few weeks or months of exposure to a humid environment, a significant amount of water will eventually be absorbed by the material. This absorbed water may produce dimensional changes (swelling), lower the glass transition temperature of the polymer, and reduce the matrix and matrix/fiber interface dependent mechanical properties of the composite (effectively lowering the maximum use temperature of the material---see Section 2.2.8). Because absorbed moisture is a potential design concern for many applications, material testing should include evaluation of properties after representative moisture exposure. Since the amount of moisture absorbed by a material is thickness and exposure time-dependent, fixed-time conditioning methods should not be followed.² Instead, a conditioning procedure such as ASTM D 5229/D 5229M (Reference 2.2.7(c)) should be followed that accounts for the diffusion process and terminates with the moisture content nearly uniform through the thickness.³

There are two moisture properties of a Fickian material: moisture diffusivity and moisture equilibrium content (weight percent moisture). These properties are commonly determined by a gravimetric test method (such as ASTM D 5229/D 5229M Procedure A) that exposes an initially dry specimen to a humid environment and documents moisture mass gain versus the square-root of time. During early weighings this mass-time relation will be linear, the slope of which is related to the rate of absorption (the moisture diffusivity). As the moisture content in a substantial volume of the exterior of the material begins to approach equilibrium the mass gain versus square-root time slope becomes increasingly smaller. Eventually, as the interior of the material approaches equilibrium, the difference between subsequent weighings will approach zero and the slope will be nearly parallel to the time axis. The weight percent mass gain at this point is the moisture equilibrium content. This process is illustrated in Figures 2.2.7(a) and (b). Figure 2.2.7(a) shows the total mass gain versus root-time during specimen moisture exposure, also showing the difference in response due to different temperatures. For the 150°F condition (the diamonds in Figure 2.2.7(a)), Figure 2.2.7(b) shows the moisture profile through the thickness of the specimen for

¹While certain polymers, like polybutadiene, resist moisture absorption to the point that moisture conditioning may not be required, these materials are still considered rare exceptions. On the other hand, a great many reinforcements, including those in the carbon, glass, metallic, and ceramic fiber families, are not hygroscopic. As a result, except for polymeric fibers like aramid, it is usually assumed that any moisture absorption is limited to the polymer matrix.

²Examples of fixed-time conditioning methods include ASTM D 618 (Reference 2.2.7(a)) and D 570 (Reference 2.2.7(b)) for plastics.

³The discussion focuses on through the thickness moisture absorption; however, in-plane moisture absorption will locally dominate near edges, and may even dominate the overall absorption process in those cases where edge area is a substantial portion of the total exposed area. As the in-plane moisture absorption response may be substantially different than the through the thickness response, due to non-Fickian moisture wicking provided by the presence of the fibers, one should not assume that edge effects will be negligible except for very small ratios of edge area to surface area.

several early time periods, illustrating the rapid moisture uptake near the surface together with the relatively slow uptake of moisture in the middle of the specimen.

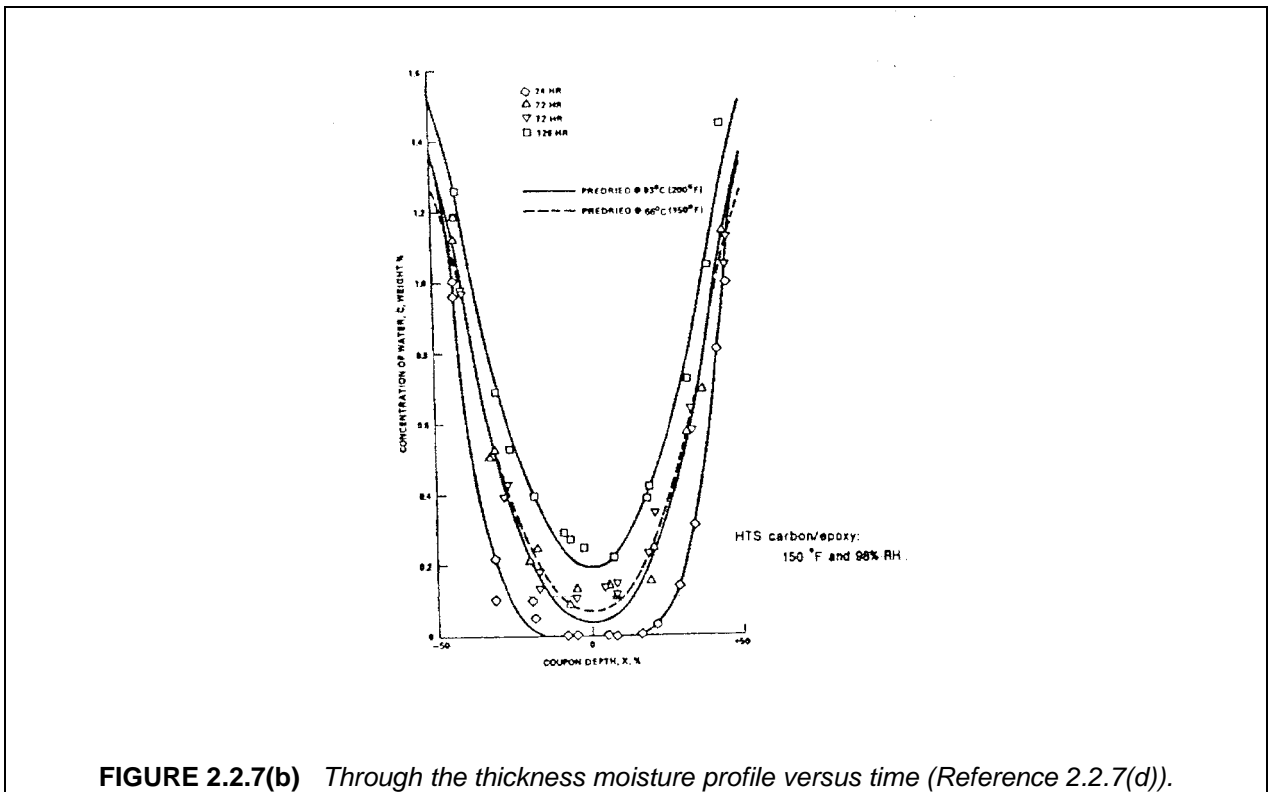
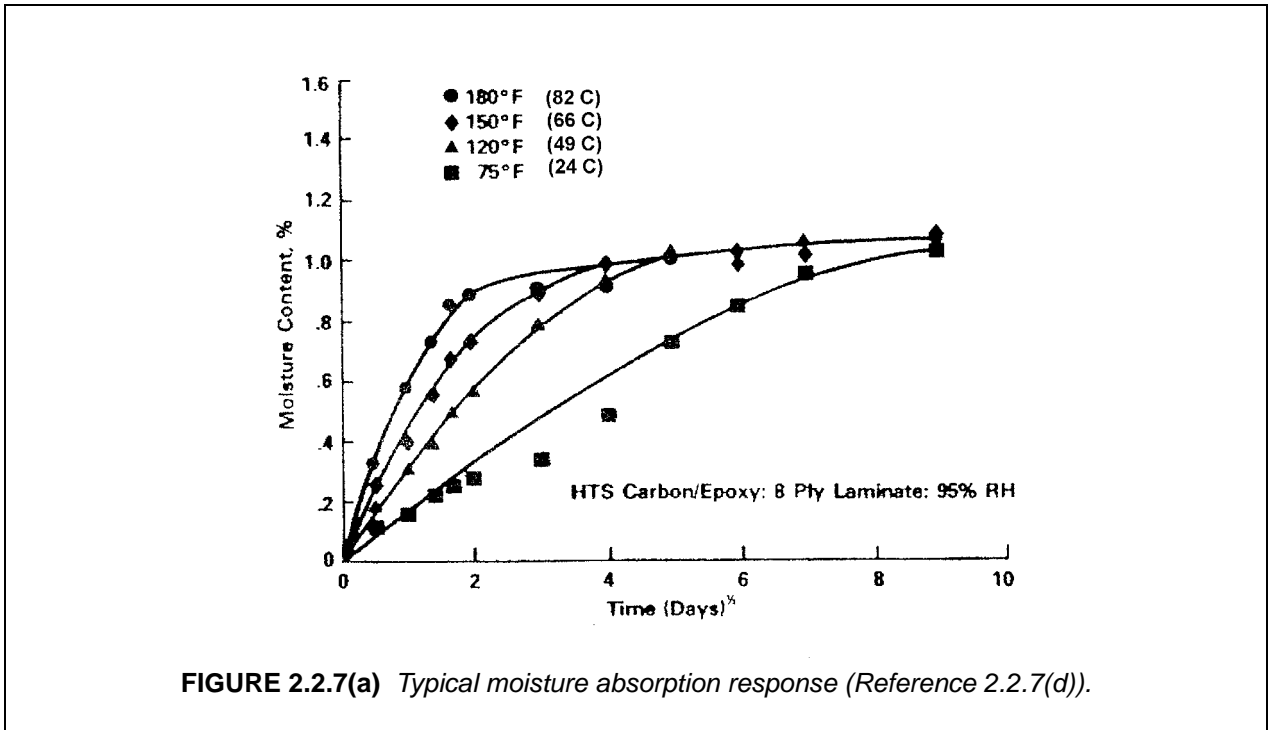

2.2.7.1 Moisture diffusivity

The rate of moisture absorption is controlled by the material property called moisture diffusivity. Moisture diffusivity is usually only weakly related to relative humidity and is often assumed to be a function only of temperature, usually following an Arrhenius-type exponential relation with inverse absolute temperature. This strong temperature dependence is illustrated in Figure 2.2.7.1(a), which shows moisture diffusivity versus temperature for a particular type of carbon/toughened epoxy. Figure 2.2.7.1(b) illustrates, for a different material system, a family of moisture mass gain curves obtained at several temperatures. For this material system, a decrease in conditioning temperature of 60°F (33°C) increased the time required to absorb 1% moisture by a factor of five.

2.2.7.2 Moisture equilibrium content

Moisture equilibrium content is only weakly related to temperature and is usually assumed to be a function only of relative humidity. The largest value of moisture equilibrium content for a given material under humid conditions occurs at 100% relative humidity and is also often called the saturation content. The moisture equilibrium content at a given relative humidity has been found to be approximately equal to relative humidity times the material saturation content; however, as illustrated by Figure 2.2.7.2, this linear approximation does not necessarily hold well for every material system. Regardless, if a material does not reach the moisture equilibrium content for the given relative humidity, then the local moisture content is not uniform through-the-thickness. Another point to be emphasized is that moisture absorption properties under atmospheric humid conditions are generally not equivalent to exposure either to liquid immersion or to pressurized steam. These latter environments alter the material diffusion characteristics, producing a higher moisture equilibrium content, and should not be used unless they simulate the application environment in question.

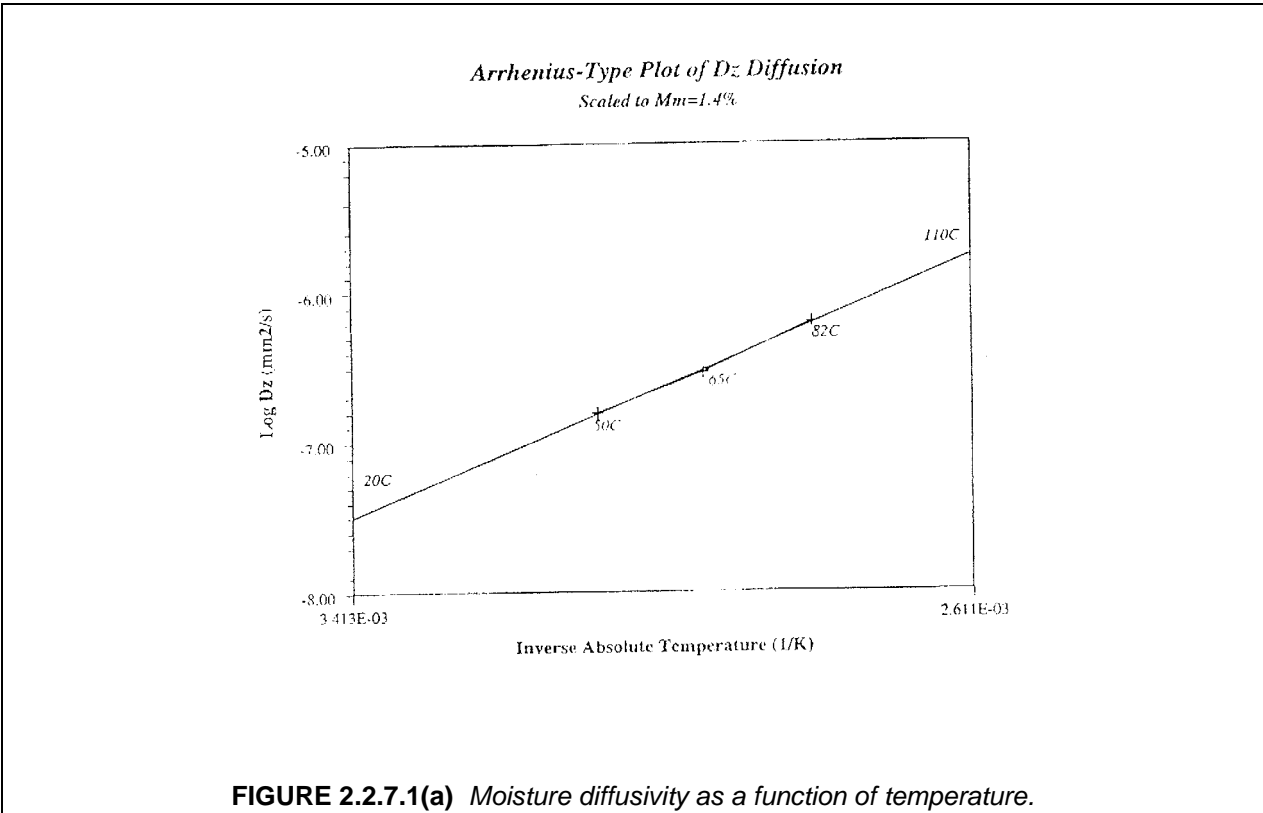

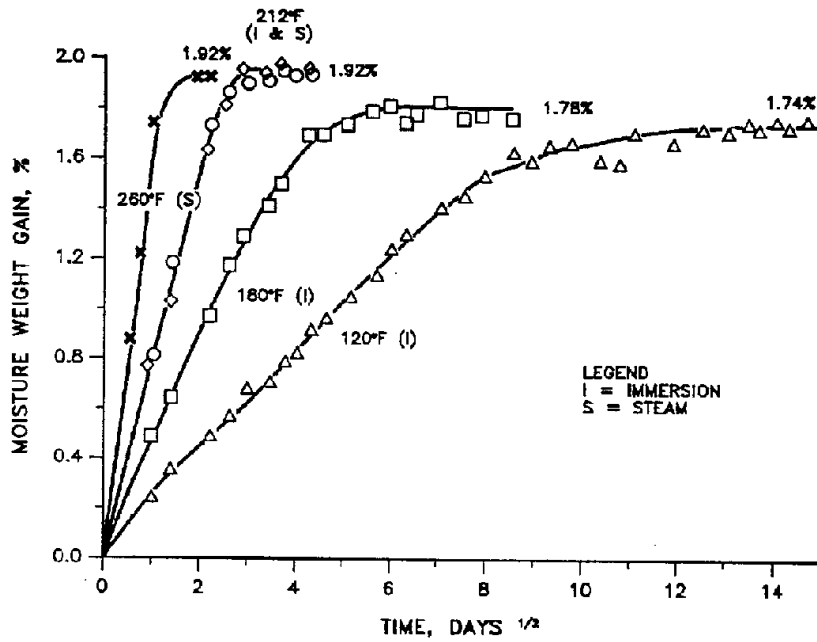

FIGURE 2.2.7.1(b) Effect of temperature on moisture absorption rate in hybrid boron-graphite/epoxy (5505-AS/3501) laminate (3.0 x 0.5 x 12 in., 76 x 13 x 3.0 mm) (Reference 2.2.7.1).

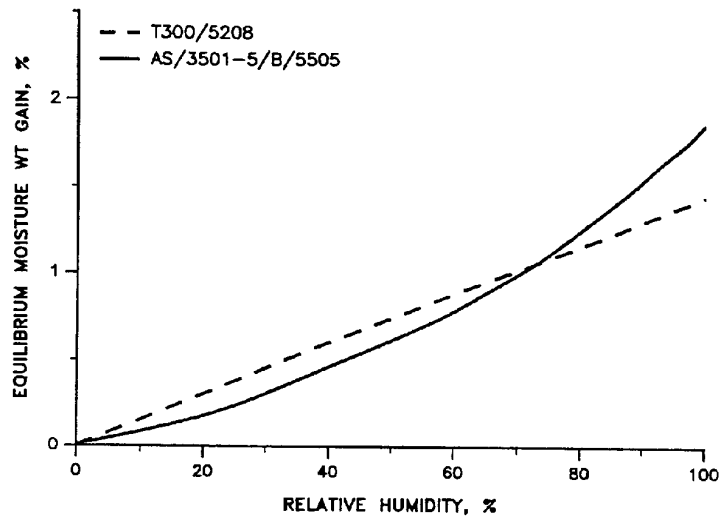

FIGURE 2.2.7.2 Equilibrium moisture content versus relative humidity.

2.2.7.3 Conditioning and test environment

To evaluate worst-case effects of moisture content on material properties, tests are performed with specimens preconditioned to the design service (end-of-life) moisture content (assumed equivalent to equilibrium at the design service relative humidity). The preferred conditioning methodology uses ASTM D 5229/D 5229M, the process of which is summarized in Section 6.3.

The design service moisture content is determined (if it is not specified by the procuring or certifying agency) from semi-empirical calculations that consider secondary effects on a particular type of structure, or more conservatively established by simpler assumptions. An example of the first case is documented in Reference 2.2.7.3(a), where worldwide climatic data and USAF aircraft-basing data were combined to define runway storage environmental spectra for each of the three classes of USAF air vehicles: fighters, bombers, and cargo/tankers. The study applied a ranking procedure to select baseline and worst-case locations with respect to the absorption of moisture by typical carbon/epoxy composite structures. Such data can be used to establish design service moisture content for a particular application; a typical specific design service relative humidity might be 81% RH for a tropically-based supersonic aircraft. Another, more conservative, approach is to use the average relative humidity for a selected diurnal cycle taken from a reference such as MIL-STD-210 (Reference 2.2.7.3(b)), the U.S. military guide to worldwide environmental exposure conditions. This usually leads to a higher design service relative humidity (88% RH being typical), since dry-out due to solar radiation, flight excursions (supersonic in particular), and seasonal climatic changes are not considered.

Given these and other historical considerations, the MIL-HDBK-17 Coordination Group has agreed that a reasonable upper-bound value for aircraft design service relative humidity is 85%, and that this value may be used when a specific determination of design service moisture content has not been established for a specific aircraft application. Use of a design service moisture content of 85% RH will obviate extrapolation of data when test specimens are conditioned to equilibrium at this moisture level. Accepted design service moisture levels for other applications have not yet been established.

Hot-wet test data being submitted to MIL-HDBK-17 should have specimens conditioned to an equilibrium moisture content and tested at the material operational limit (MOL) temperature or below (see Figures 2.2.8(a)-(c)). As can be seen in Figure 2.2.8(a), the effect of environment is generally small for matrix-dependent properties at temperatures below room temperature. However, the fiber-dependent properties of many material systems experience a steady degradation with increasingly colder temperatures, though without a cold MOL. A comparison of tensile (fiber-dominated) and compressive (matrix-influenced) response to varying temperature is shown in Figure 2.2.7.3. Due to these factors, qualification/certification testing programs typically do not require moisture conditioning below room temperature, and since there is generally no need to determine a cold MOL, are simply tested at the coldest design service temperature (often -55°C (-67°F)).

2.2.8 Material operational limit (MOL)

As noted earlier, properties of polymer matrix composites are influenced markedly by temperature and moisture. Generally, matrix-dominated mechanical property values decrease with increases in moisture content and increases in temperature above room temperature. For properties that are highly dominated by reinforcement (fiber) properties (unidirectional tension, for example), this reduction may be reversed, not occur, or be minimal over reasonable temperature ranges. For properties influenced by the organic matrix (shear and compression, for example), the degradation of properties can be significant. Furthermore, the degradation is not linear. At a given moisture content, it becomes more severe with increasing temperature until a temperature is reached where dramatic property reductions begin to occur, and beyond which these reductions may become irreversible. It is desirable to specify this onset of dramatic reduction as a "characteristic temperature", which is also defined to be the material operational limit (MOL), or the maximum operating temperature.

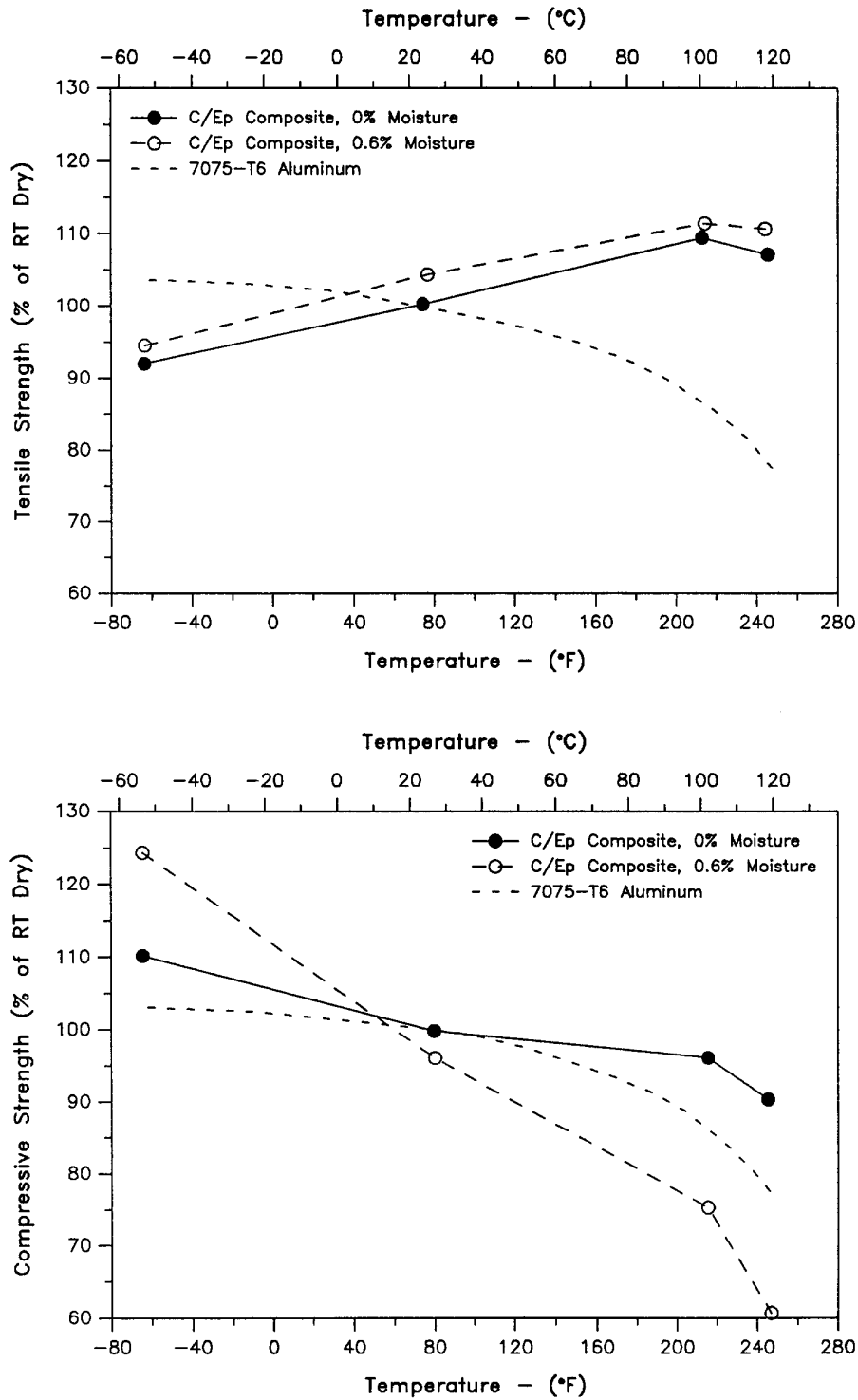
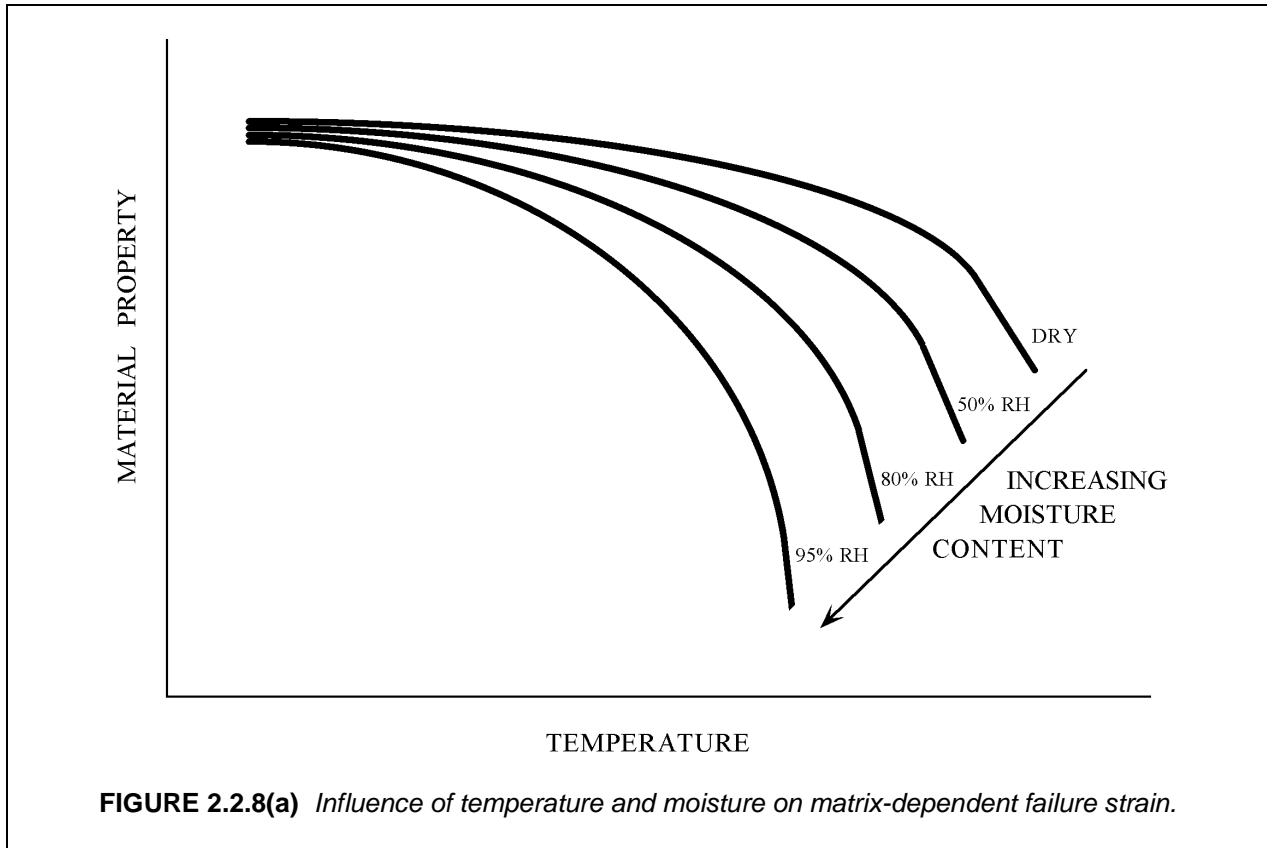

FIGURE 2.2.7.3 Effect of temperature and moisture on strength (Reference 2.2.7.3(c)).

The amount of absorbed moisture in the composite has a significant effect on property reduction with increasing temperature. As shown in Figure 2.2.8(a), property degradation at a given temperature is generally more severe with increasing moisture content. Thus, the MOL becomes lower as moisture content increases. Although different MOLs could be determined at a number of moisture levels, the general practice is to establish a single wet MOL at a "worst-case" moisture content. For some applications, a dry MOL may also be established.



The purpose of establishing the MOL is to assure that materials are not operated in service under conditions where a *slight* increase in temperature might cause a significant loss in strength or stiffness, and to absolutely avoid irreversible property changes.

It should be noted that fiber-dependent properties may degrade as temperature decreases below room temperature. However, since these properties do not typically show a sharp falloff as temperature decreases, testing at the lowest anticipated service temperature is sufficient, and there is no need to establish a generic minimum operational temperature, as discussed in Section 2.2.7.3, and illustrated by Figure 2.2.7.3.

Although the upper limits of specific application environments might be below the established MOL temperature(s) for the material(s) used, each material should be characterized at its MOL temperature for a moisture level corresponding to equilibrium at the highest practical relative humidity. For aircraft, 85% is typically considered to be a worst-case relative humidity. Testing at the MOL (in addition to room temperature and cold temperature) will ensure that materials will be used in appropriate applications, and that maximum advantage will be taken of each material's capabilities. Properties at specific application environments may be conservatively estimated using linear interpolation. Limited testing at specific applica-

tion conditions may be added at a program level for verification and reduction of conservatism if required. Figure 2.2.8(b) depicts this process.

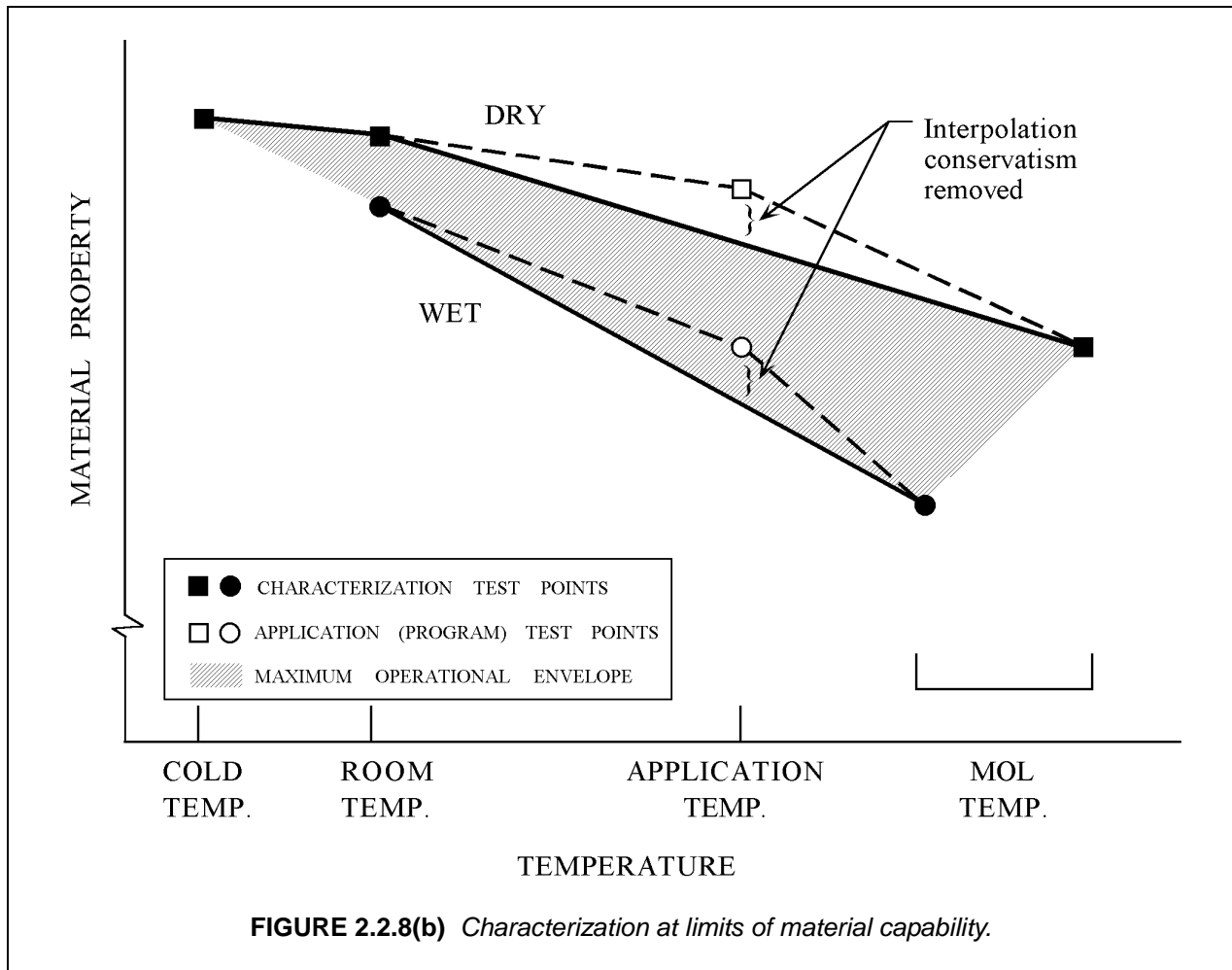

There are not yet any fixed criteria for establishment of a MOL. One method (References 2.2.8(a) - 2.2.8(c)) utilizes the glass transition temperature (T_g) as determined from DMA or similar data, reduced by some temperature margin ΔT . For epoxy matrix composites, 50 F° (28 C°) is commonly used for the value of the temperature margin, but it can be argued that smaller margins may be acceptable for particular applications when supported by other data. While glass transition temperature (T_g) is a useful tool, it should not be the sole basis for establishing MOL. Glass transition frequently occurs over a range of temperatures, and it is well known that measurement of T_g is test method dependent (see Section 6.4.3 on Glass Transition Temperature). Other data which are useful in establishing MOL include field experience (for established materials) and mechanical testing conducted over a temperature range which includes the $\pm\Delta T$ range around the measured T_g .

Evaluating the behavior of a matrix-dependent mechanical property (in the appropriate wet condition) as a function of temperature is considered a reliable method for verifying a MOL which has tentatively been determined from T_g data. Various investigators have used short beam strength, in-plane shear strength, in-plane shear modulus, and quasi-isotropic open hole compressive strength for this purpose, with the latter two being most successful as MOL indicators. Four or five temperatures are typically chosen to provide trend lines for the selected property. Figure 2.2.8(c) shows three possible scenarios when

mechanical testing is used to verify the MOL determined from T_g data. In the first instance, mechanical data corroborate the chosen T_g . In the second case, mechanical data suggest that the MOL predicted by T_g is conservative. In the third example, mechanical data do not support the MOL determined from T_g data, and indicate that a lower MOL should be chosen. One approach to determining the MOL from mechanical property data is to use the temperature at which the property versus temperature plot deviates from linearity by a given percentage. An example of this can be found in Reference 2.2.8(d). However, a specific criterion for determining MOL that includes results from both T_g and mechanical testing has not been standardized and is still being discussed. Nevertheless, the MOL value predicted from T_g measurements verified or modified by mechanical property data provides a practical approach for defining the MOL of a material.

The foregoing described a generic approach to MOL, based on T_g and mechanical property reduction. In addition, there are other factors which should be considered, and which might further reduce the effective MOL for specific applications and/or material types. Two such factors are of particular importance: steam pressure delamination and use of "high temperature" composite systems. These are discussed in the following sections.

2.2.8.1 Steam pressure delamination

A moisture/temperature failure mode (no mechanical loads) that must be considered in establishing the maximum operational temperature for a polymer matrix composite laminate is the steam pressure delamination failure (References 2.2.8.1(a) - 2.2.8.1(c)). As previously noted, polymer matrix composites (thermosets and thermoplastics) contain some degree of porosity and absorb moisture. As the matrix absorbs moisture from the environment by the process of diffusion, the voided areas will partially fill with water. If the laminate is exposed to temperatures above the boiling point of water, the water converts to steam. When the temperature and associated steam pressure reaches the level where it exceeds the laminate wet interlaminar (i.e., flatwise) tensile strength of the material, delamination occurs.

The steam pressure delamination mode can occur over a range of temperatures depending on the amount of absorbed moisture as indicated in Figure 2.2.8.1(a). Failure can be predicted when the wet flatwise tensile strength curve (which is a function of the design relative humidity and moisture equilibrium level) intersects the steam pressure curve. To determine the maximum operational temperature for a new material system for a range of design relative humidity, an experimental program similar to Figure 2.2.8.1(b) is recommended.

Panels should be preconditioned to equilibrium at three relative humidity levels plus a dry condition. These panels are then exposed to the mission time-temperature profiles. One issue in conducting the panel thermal exposure test is that the time-temperature exposure should simulate the actual in-service heating conditions so that laminate moisture drying is representative of the design application. Panels that see a slower heating rate than the design condition may have more dryout and attain a fictitious higher temperature before delamination occurs. For high heating rates such as those seen in missile applications, quartz lamps are recommended. For slower heating rates, a computer-controlled oven exposure may be acceptable. The allowable design temperature curve selected should include a safety tolerance (50°F in this example) below the temperature at which delaminations do occur.

2.2.8.2 MOL considerations for high temperature composite systems

The MOL for high temperature composite systems is dependent on other service environment conditions besides moisture. MOL is dependent on the mission life requirements of the actual applications. The life of the part is a function of time, temperature, pressure, and mechanical loading.

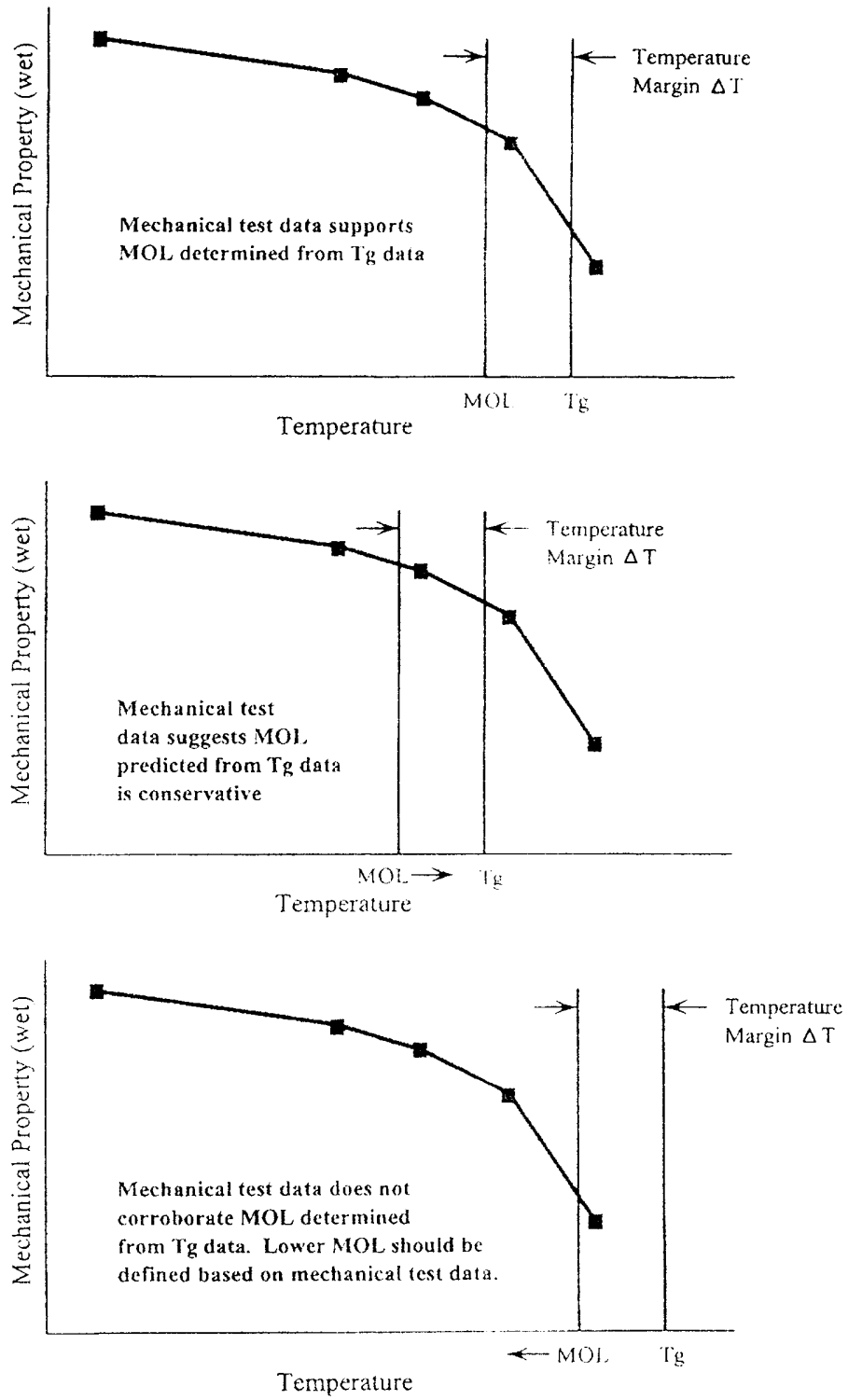

FIGURE 2.2.8(c) Use of mechanical and T_g data to determine MOL.

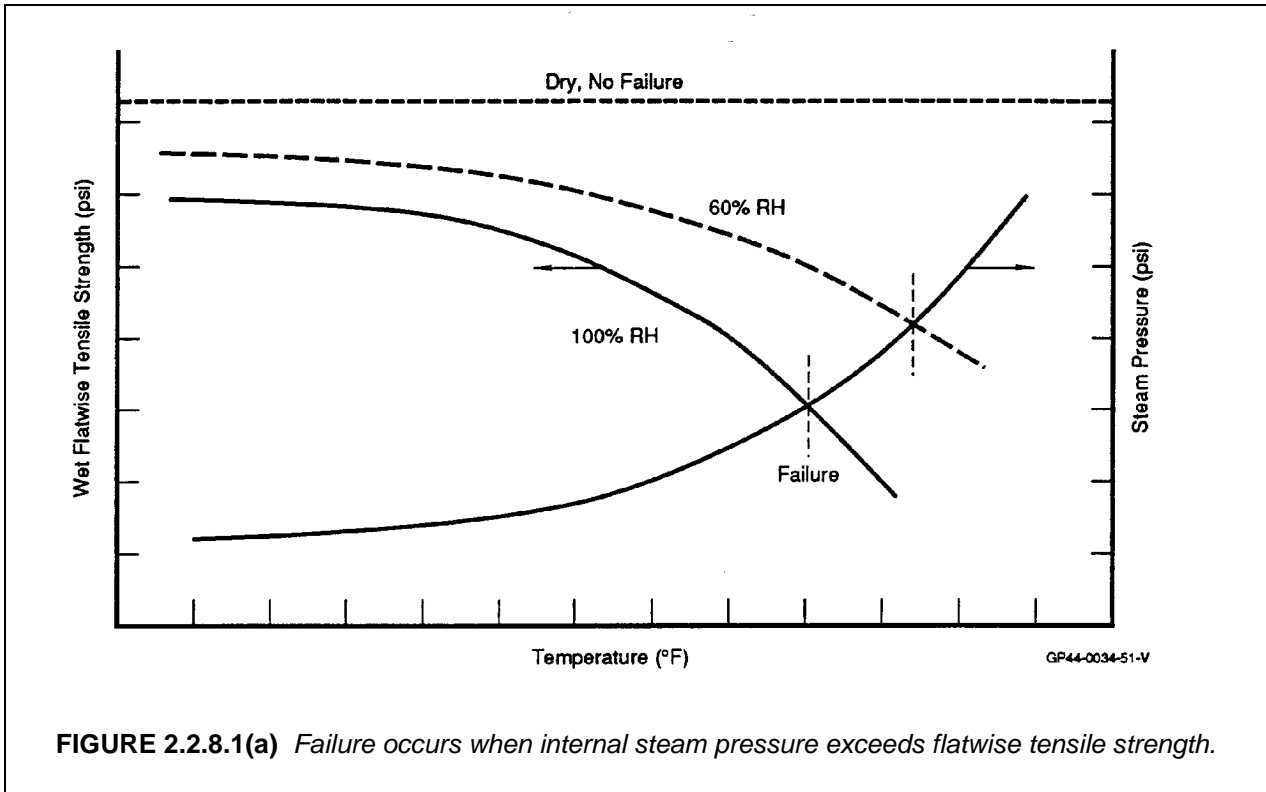

FIGURE 2.2.8.1(a) Failure occurs when internal steam pressure exceeds flatwise tensile strength.

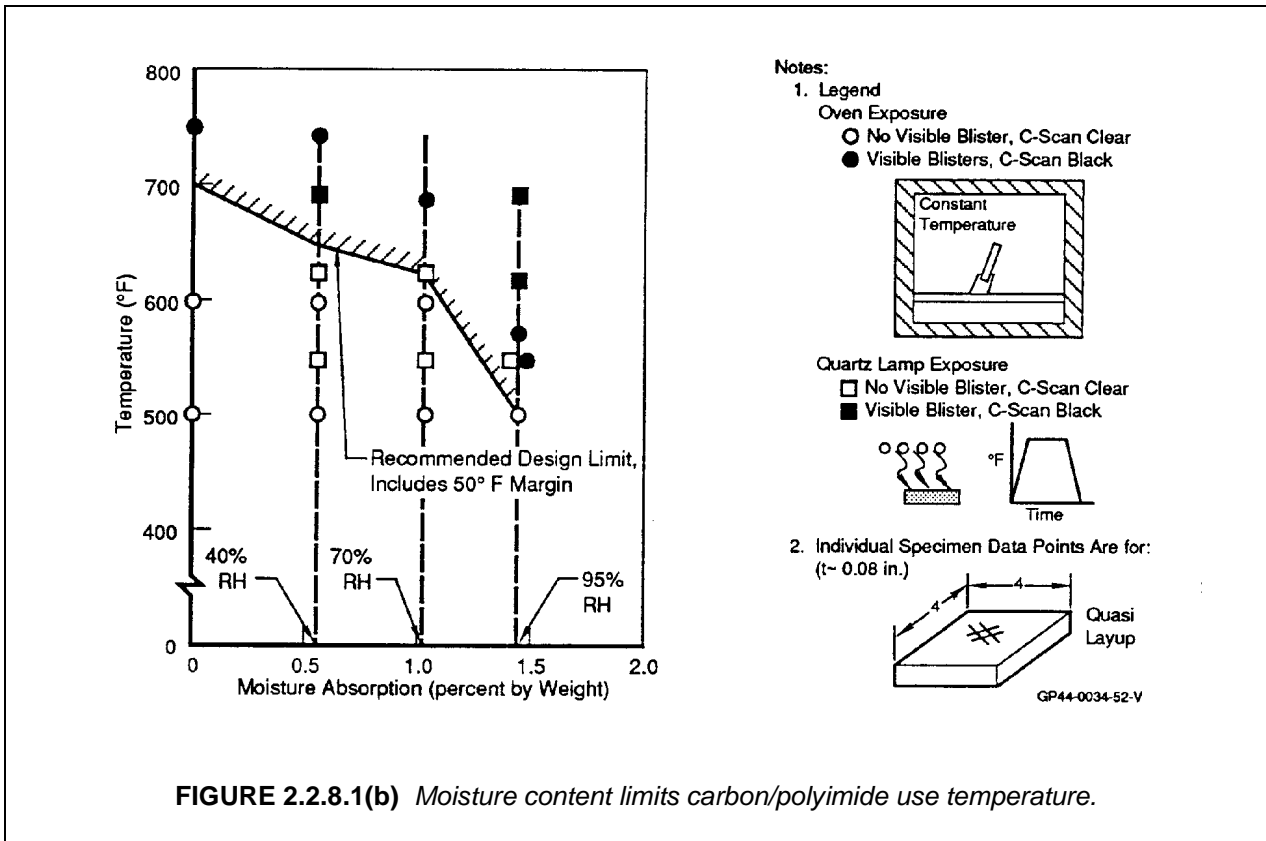

FIGURE 2.2.8.1(b) Moisture content limits carbon/polyimide use temperature.

The wet T_g is one of the indicators of a high temperature composite material's MOL. Humidity does affect the elevated temperature properties and can induce thermal blistering in a thick laminate cross section. Thermal blister resistance is a function of the moisture content and thickness of the part, and the heat up rate the part will encounter.

The other indicators of a high temperature composite material's MOL are the transverse microcrack (TVM) resistance and thermal oxidative stability (TOS) properties. TVM occurs due to thermal cycling of the laminate over a temperature range. TVM can develop because of the large difference in coefficient of expansion between the fiber and resin, and the relative low ductility of most high temperature resins. These thermal stresses can cause 90° ply failure, which occurs at the fiber-matrix interface. This degradation primarily affects the resin/interface dominated properties like compression strength, in-plane shear strength, and interlaminar properties. The magnitude of TVM that will occur depends on the application temperature range, maximum operating temperature, and number of thermal cycles.

TOS is a measure of the oxidation rate of materials, and is also an important property for high temperature composite systems. The thermal oxidation characteristics of a polymeric composite are a function of fiber, sizing, and resin. The constituents can be evaluated individually for thermal oxidative stability on a qualitative basis. The actual performance should be evaluated at the laminate level, since the fiber-matrix interface is the primary area that is degraded. All properties can be affected by TOS, although the interface dependent properties are most affected. The weight loss of a laminate is a good indication of the amount of thermal oxidation that has occurred for a particular system, although some mechanical property degradation may occur prior to significant weight loss. The TOS performance of a material is a function of the time, temperature, and oxygen flow rate/pressure.

There can be synergistic effects among TVM, TOS, and hot/wet exposures for high temperature polymeric composites. In order to get an accurate assessment of a material's MOL, it is recommended these effects be combined in a realistic manner that reflects the actual application environment. For short term applications, the amount of degradation can be determined experimentally by exposing laminates to combined conditions of thermal cycling, aging at temperature, and humidity conditioning to the part's specific mission life. Specimens can be machined and tested from this environmentally exposed material, and the residual strength of the material can be assessed.

For long term applications, it may be difficult to perform this environmental exposure in real time. Durability modeling and accelerated testing may be required in order to predict end-of-life properties for these applications. Durability modeling can be used to predict the amount of damage that is generated as a function of mission exposure conditions, and the subsequent residual strength properties. Mission exposure testing can be accelerated by aging the material at higher temperature or pressures, in order to accelerate the oxidation of the material. It is important that the accelerated tests produce realistic damage mechanisms that will be evidenced in real time exposures. For this reason, it is recommended that some limited real time exposure testing be done in order to confirm the damage mechanisms and also be used to confirm the durability model's accuracy.

2.2.8.3 Hot Wet Testing - Report Moisture Content at Failure

Laminate specimens to be static strength tested hot, wet are usually preconditioned to an equilibrium moisture content. Frequently, the test results report the equilibrium moisture content rather than the actual content at failure. This phenomena is illustrated in Figure 2.2.8.3. The sandwich beam specimens with the wet carbon/epoxy facesheet in compression were tested at room temperature (RT) and at 350 °F. The five RT beam compression specimens average moisture content at failure (1.25%) shown in Figure 2.2.8.3 is same as the moisture content before test since at RT there was no measurable dry out during testing. This was verified by cutting out a piece of the facesheet immediately after failure, measure the weight, drying out the piece, and calculating the moisture content at failure. The 350 °F test specimens which were at the test temperature for 9 minutes until failure, dried out ~ 0.5% from 1.25% to 0.75%. The moisture content for each specimen was determined by cutting out a piece of the facesheet immediately after failure, measuring the weight, drying out the piece, and calculating the moisture content at failure. One issue that must be understood is that at the initial moisture equilibrium condition of 1.25 %, every ply

through the thickness of the facesheet is at the 1.25 % moisture content. The 0.75 % moisture level at failure is an average moisture content for a facesheet that has a severe moisture distribution through the thickness (dry on surface, wet at the center).

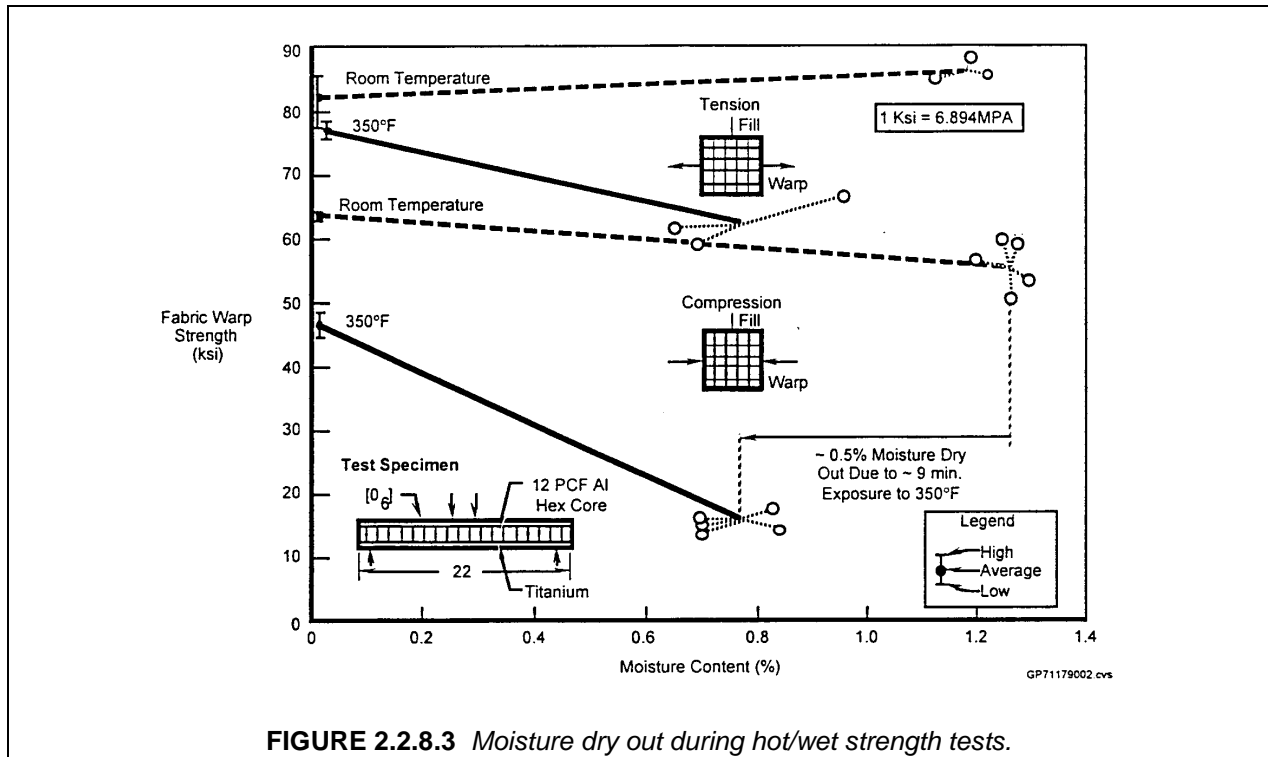

FIGURE 2.2.8.3 Moisture dry out during hot/wet strength tests.

The test goal should be to minimize dry out during testing and the potential severe moisture distribution at failure. There are several ways to minimize the moisture dry out during hot wet testing. If the strength tests are being conducted at a test temperature below 212 °F, the before test moisture equilibrium can be maintained (no dry out) by surrounding the specimen during test with a humidity cabinet at the same relative humidity used during the original moisture preconditioning. This method will not work if the test temperature is above 212 °F. Another method to minimize moisture dry out is to minimize the time at the elevated test temperature. Using contact heaters or quartz lamps (instead of forced hot air chambers) can minimize the time for the specimen surface temperature to reach the test temperature. When using accelerated heating devices, the mechanical load should not be applied until the center of the test specimen thickness has been stabilized at the test temperature. Finally, the moisture dry out can also be minimized by selecting a thicker specimen since the dry out occurs in the surface plies first.

Even though steps have been taken to minimize moisture dry out during hot wet testing, the moisture content at failure still must be determined and reported with the strength data. There are three approaches to obtaining the moisture content at failure. One approach is to use moisture monitoring specimens that mimic the material, lay-up, width and thickness of the test section of the test specimen. The monitoring specimen must follow the identical fabrication and moisture preconditioning steps as the test specimen. The monitoring specimen should be in the same test chamber as the specimen to follow the identical thermal history as the specimen during hot wet testing. As soon as the test specimen fails, the monitoring specimen must immediately be pulled out of the hot environment to preclude additional dry out. The specimen is weighed, dried out, re-weighed and the moisture content at failure is calculated. A second approach to obtaining the moisture content at failure is to predict the moisture dry out during hot wet testing using the documented time temperature history during test and subtract this moisture content from the moisture content before test to obtain the moisture content at failure. This approach assumes

that the moisture diffusion constant for the test temperature is known as well as the detail thermal history of the specimen during test. The third approach, which is the most accurate and preferred approach, is to cut a section out of the gage region of the specimen immediately after failure, weigh, dry out, re-weigh and calculate the moisture content at failure.

2.2.9 Nonambient testing

This section is reserved for future use.

2.2.10 Unidirectional lamina properties from laminates

Though feasible, it is frequently difficult to produce valid or reproducible results on mechanical tests of unidirectional single-orientation specimens, particularly at testing laboratories lacking the testing volume to dedicate technicians solely to preparation and conduct of such tests. An alternate approach tests a crossply laminate, usually from the [90/0]_ns-family, and calculates via lamination theory an equivalent unidirectional lamina strength and stiffness. Crossply laminates have been found to be much more forgiving of troublesome secondary variations in specimen preparation and testing practice, often yielding higher mean strengths and lower data scatter. The material response of a crossply laminate is also believed by many to be more representative of a structural laminate. The basis of test data reduction for this approach is discussed in Section 2.4.2.

2.2.11 Data normalization

Data normalization is a post-test data manipulation process that attempts to eliminate unrealistic artificial variation in test data caused by local changes in fiber volume. The details of this process of adjusting fiber dominated results to a fixed reference fiber volume is summarized below and described in detail in Section 2.4.3.

Most material properties of composites are dependent on the relative proportion of reinforcement and matrix. In the characterization of properties of a continuously reinforced composite, a portion of the variation of a property value within a like sample population is simply due to locally changing fiber volume, rather than due to any variation in fiber, matrix, or fiber/matrix interface properties. For many composite properties measured in the direction parallel to reinforcing fiber¹, the relation between property and fiber volume is essentially linear. This makes possible a simple adjustment of certain measured properties to a fixed reference fiber volume, resulting in what is called a *normalized* property value.

While a minor variation in fiber volume content may be partly due to variation in the absolute amount of the fiber (and even, to void variation), most fiber volume variation is attributable to locally varying matrix content as a result of processing.

2.2.12 Data documentation

Planning data documentation requirements and methods prior to the start of a test program is a necessary step for the data to be fully useful for its intended purpose. Before deciding on the scope of data documentation, the initial purpose for acquiring the data and potential long-term uses of the data must be determined. Testing requirements may range from obtaining a quick estimate for preliminary material screening where one or more specimens may suffice to establishing long-term material property values for an organization's database and submission to MIL-HDBK-17 where large numbers of specimens may be needed. Different data documentation may be required at different stages of data recording and evaluation. In the laboratory, raw data, even raw transducer signals, may be stored. For evaluated and reviewed material properties, less detailed testing information may be needed, particularly if the information can be traced back to the original source. *Evaluation* is used in the sense defined by ASTM Committee E-49 as "the process of establishing the accuracy and reliability of property data" (Reference 2.2.12(a)). The expectation for MIL-HDBK-17 data is that documentation should be sufficient so that

¹The so-called "fiber-dominated" properties.

Volume 1, Chapter 2 Guidelines for Property Testing of Composites

1. Traceability and a historical record (identified by manufacture, testing, and evaluation dates) are established.
2. The material pedigree and associated process specification are well defined.
3. Testing procedures can be identified.
4. Variables that influence test results are identified.

Other programs that establish reference data should have documentation requirements at least as stringent as those in Table 2.5.6.

In any testing program, for future use of the data to be possible, data documentation should be complete enough so that the material and testing can be reproduced.

Documentation may be recorded in a computerized database for raw data or in a lab notebook or other hard copy form. The earlier computerization is implemented in the process of storing and evaluating data, the easier it is to maintain traceability and limit transcription errors. The use of computers does not eliminate the need for error checking and review. Regardless of how much computerization is involved in the process, each organization should have its own protocol for data recording and review. Considerations for such a protocol include who is responsible for recording particular information - material identification, processing, specimen preparation, inspection, testing, and archiving of failed specimens and contact information for each of these steps. It is quite common for each testing laboratory to have limited access to material identification information. In this case, responsibility for coordinating material identification information with testing laboratory data records must be established if any long-term use of the data is planned.

Guidance for establishing data documentation requirements is available from several sources. MIL-HDBK-17, Volume 1, Section 2.5.6 lists data documentation required for data submission to the handbook as well as a few items that are recommended for in-house recordkeeping. Two ASTM guides (References 2.2.12(b) and (c)) provide primary guidance for data recording and database development. ASTM E 1309 addresses identification of all composite materials. ASTM E 1434 provides guidance for test information and results for mechanical properties of continuous-fiber polymer matrix composite materials. These two documents should be used together in a modular approach. First the material is identified and then the test method and results information is recorded. Each data element has a level of importance established by the following categories:

- required for test validity
- required for material traceability
- recommended for test validity
- recommended for material traceability
- optional

These levels of importance divide data documentation requirements into two subsets: one for material traceability and one for test validity. A test laboratory can meet requirements for test validity without access to material identification information. Responsibility for the material traceability should be assigned to someone who does have access to the necessary information (as noted above). The approach used in developing these and similar ASTM guides is to provide assistance for data recording and for the contents of computerized databases without unduly limiting database structure.

These ASTM guides are implicitly included in the MIL-HDBK-17 data documentation requirements, since Table 2.5.6 specifies that all sections of the test method are to be followed unless deviations are reported. Several of the ASTM methods for mechanical properties refer to E 1309 and E 1434 for data recording. Consequently, the reference flows from Table 2.5.6 to the ASTM test methods to the data-recording guides.

Another source for guidance is the Composite Material Test Data Schema (CMTDS) developed within MacNeal Schwendler's MVISION™ database structure (Reference 2.1.12(d)). Focused on continuous-fiber polymer matrix composites, this schema establishes specific fields in a defined database structure

including field names, synonyms, and values sets for expected field entries without defining levels of requirements. A much larger range of potential properties, including thermal and physical properties, is incorporated. The recommendations of MIL-HDBK-17 and the ASTM guides were considered in the development of the schema, which functions both as a source of guidance and a specific implementation of more general recommendations. The released version addresses test data. A draft schema for property level information is under development. The experience of the CMTDS development is serving as feedback into revision of ASTM E 1309 and E 1434 currently underway.

General guidance on the development of material property databases is found in References 2.2.12(e) and (f).

2.2.13 Application specific testing needs

This section is reserved for future use.

2.3 RECOMMENDED TEST MATRICES

2.3.1 Material screening test matrices

The objective of the screening process is to reveal key mechanical property attributes and/or inadequacies in new material system candidates, while keeping testing to a minimum. The screening process identifies, for a particular composite material system, the critical test and environmental conditions as well as any other special considerations. Proper test matrix design enables comparison with current production material systems.

The general approach to screening test matrix design is selection of key static tests that provide sufficient data to assess mean values of stiffness and strength at both the lamina and laminate levels. The lamina-level tests provide intrinsic material stiffness and strength properties commonly used in classical lamination plate point stress analysis, including tension, compression, and shear loadings. Both the lamina-level tension tests and open-hole compression tests are also performed at key environments. The laminate-level tests provide screening strength data on application issues relating to stress discontinuities such as fastener holes, bolt bearing, or impact damage. Additional laminate level tests provide screening stiffness data to verify the use of lamina data with classical lamination plate theory for laminate stiffness predictions. Tests are generally performed at room temperature. Environmental effects are estimated from the key lamina-level tension and open-hole compression tests.

An example of a typical mechanical property screening test matrix is shown and discussed in Section 2.3.1.1. Under extreme environments, additional factors may have to be considered, as discussed in the example for high-temperature materials in Section 2.3.1.2. Sensitivity to exposure to operational fluids and other special issues may justify including additional special tests in the screening evaluation. An example of a fluid sensitivity screening test matrix is shown and discussed in Section 2.3.1.3. (Specific applications may require modifications to the above test matrices.)

2.3.1.1 Mechanical property screening

Table 2.3.1.1 shows a recommended mechanical property screening test matrix developed for epoxy-based resin systems but also useful for other material systems. In the screening test matrix, 0° axial tensile tests examine fiber dominant properties and 0° axial compression tests monitor fiber/matrix interactions;¹ both provide static strength and stiffness properties. The ±45° tensile test specimens are used to evaluate matrix characteristics, determining shear modulus and effective shear strength. Finally, damage resistance is assessed using compression after impact testing. The testing is conducted under three environmental conditions: cold temperature ambient (CTA), room temperature ambient (RTA), and elevated temperature wet (ETW). These test conditions are recommended based on results for current epoxy

¹The 0° axial tensile tests may reveal fiber/matrix interaction in some materials at high strain rates.

resin systems that show the CTA environment as critical for fiber dominated properties and the ETW environment as the most severe condition for matrix dominated properties. The ETW specimens are conditioned to moisture equilibrium at the specified relative humidity.

TABLE 2.3.1.1 Composite material static strength screening test matrix.

Test	Number of Specimens			Evaluation Emphasis
	CTD	RTA	ETW	
Lamina:				
0° Tension	3	3	3	fiber
0° Compression		3		fiber/matrix
±45° Tension		3		fiber/matrix (0°/90° shear - lamina) (±45° - laminate)
Laminate:				
Open Hole Compression ¹		3	3	stress riser
Open Hole Tension ¹		3		stress riser
Bolt-Bearing ¹		3		bearing
Compression after Impact ²		3		impact damage

¹Fastener hole effects

²per NASA Reference Publication 1092.

2.3.1.2 Mechanical property screening for high-temperature material systems

Table 2.3.1.2 shows a typical mechanical property test matrix intended for high temperature polymer matrix composites. The changes were made to Table 2.3.1.1 in order to properly assess the durability of high temperature polymer matrix composites during the screening stages of an evaluation. The test matrix may vary depending on the purpose of the investigation, but it is important that all exposure conditions be evaluated.

Prior to the mechanical test evaluation, it is necessary to evaluate prepreg physical and laminate properties. Test laminates should be carefully inspected for porosity content, dry T_g , and wet T_g . The recommended mechanical tests cover fiber-dominated, interface/resin-dominated, and damage tolerance properties. The elevated test temperature static test conditions should be set below the wet T_g of the system.

The wet exposure condition is 160°F (71°)/ 85% relative humidity to an equilibrium weight gain. It is very important that specimen dry-out be measured and kept to a minimum during the elevated temperature wet tests.

TABLE 2.3.1.2 Composite material test matrix for high temperature PMC's.

Mechanical Property	Dry Test Temperature			Wet ¹	TOS ²	Thermal Cycle ³
	Minimum Temp	75°F (24°C)	ET1			
Tension	3	3	3	-	3	-
Compression or OHC	-	3	3	3	3	3
In-Plane Shear	-	3	3	3	-	3
Mode I Fracture Toughness or CAI	-	3	3	-	3	3

- 1 - ET1 Elevated test temperature should be less than the Wet Glass Transition Temperature of the material
- 2 - Laminates are to be thermally aged at a temperature greater than ET1 but less than the dry T_g for a minimum of 1000 hours or an accelerated test condition that represents a 1000 hour exposure. Weight loss should be recorded as a function of time, i.e., 100, 250, 500, 750 and 1000 hours. Microscopy should be performed after exposure. Specimens are to be machined after exposure.
- 3 - Laminates are to be thermal cycled from Min Temp to a temperature greater than ET1 but less than the dry T_g . Laminates are to be cycled for a minimum of 500 thermal cycles. Microcrack density is to be measured after cycling. Specimens are to be machined from the laminate after exposure.

The thermal oxidative stability (TOS) test should be performed for a minimum of 1000 hours. Weight loss should be measured during testing at specified intervals of 100, 250, 500, 750, and 1000 hours. This test provides a measurement of the oxidation rate of the material.

Thermal cycling should be done for a minimum of 500 thermal cycles. The purpose of the test is to determine the rate of microcracking, not only if microcracking will occur. The minimum temperature should represent the minimum temperature of the potential application, for example, -65°F (-54°C) for aircraft.

The maximum exposure temperature for both the TOS and thermal cycling test should be between the wet T_g and dry T_g of the material system. If the exposure temperature is below the wet T_g , the test may not be discriminating enough and longer exposure times may be necessary. Exposures above the dry T_g of a material normally provide an unrealistic damage mechanism that does not occur below the dry T_g of the material. Prior to the machining of specimens, laminates should be non-destructively inspected for porosity and delaminations. Microscopy should also be done in order to understand the damage mechanism associated with the specific exposure. This will include the measurement of microcrack density.

2.3.1.3 Fluid sensitivity screening

Historically, the concern over exposure of structural composite materials to commonly encountered service related fluids other than water or moisture has not been a major concern. This is because the majority of structural composites have had an epoxy resin matrix which has inherently been very fluid resistant. With the epoxies, in general, the allowance for property degradation caused by absorption of atmospheric moisture has been sufficient to cover degradation which might be caused by other pertinent fluids, e.g., fuel, hydraulic oil, etc. Although epoxy resin systems are subject to accelerated degradation in the presence of highly acidic media, the majority of service fluids tend to be basic in nature, e.g., clean-

ing solvents and hydraulic fluids. The poor resistance of epoxies to methylene chloride, a common ingredient in paint strippers, is an exception. Methylene chloride also aggressively attacks other structural polymers. Consequently, the use of chemical paint strippers on polymer matrix composites is generally not allowed.

With due consideration of the above, it is still important to evaluate the resistance of new polymer materials to fluids with which they might come in contact. Many new epoxies have components, added to improve properties such as toughness, which might affect their solvent resistance. Many other polymers, which have different solvent sensitivities, are also now being used or are being considered for use. An example of a problem encountered in the past was that associated with the developmental evaluation of polysulfone thermoplastic structural parts and their abandonment due to poor resistance to phosphate ester based hydraulic fluids (Reference 2.3.1.3(a)). Some other structural thermoplastics, although they have excellent resistance to moisture and hydraulic oils, have poorer resistance to fuels. Fuels with higher aromatic content, e.g., JP-4 as compared to JP-8, seem to cause the worst problems (Reference 2.3.1.3(b)). In the referenced case, the fuel exposure seemed mostly to effectively lower the material's (PEEK) glass transition temperature (Reference 2.3.1.3(c)). The result was comparable lowering of the material's maximum use temperature.

Higher service temperature resin systems such as bismaleimides (BMI's) and polyimides are susceptible to degradation by fluids with high alkalinity. Both polymer formulations are susceptible to a cleavage of the functional imide rings in the presence of high concentrations of hydroxide ions. This is significant for two reasons. First, cleaning solvents and hydraulic fluids used by most airlines are alkaline by nature and second, hydroxide ions are produced locally at the resin boundary during galvanic coupling between carbon fibers and active metals and can cause degradation. The galvanic corrosion situation should be satisfactorily manageable with an attentive design. The incorporation of an isolation mechanism such as a resin/fiber ply between the carbon/resin and metal structure is one approach to mitigating the risk associated with the electrolytic driven degradation. Exposure can be lessened by providing drainage, etc. It is important that the laminate edges be well sealed if there is exposure in a sump area. In general, the exposure of these materials to alkaline solutions may be sufficiently incidental that this also may not be a problem.

The following evaluation procedure is suggested to assess the suitability of polymer resin systems for application where they might be exposed to a harmful fluid environment.

The evaluation should account for different exposure levels of aircraft structure to fluids. Two fluid exposure classifications are suggested, with example fluids cited for each group:

Group I

Fluids that have the potential for *pooling* or will contact the material for an extended period of time.

JP-4 Jet Fuel	MIL-T-5624
JP-5 Jet Fuel	MIL-T-5624
JP-8 Jet Fuel	MIL-T-83133
Hydraulic Fluid	MIL-H-5606
Hydraulic Fluid ¹	MIL-H-83282
PAO (Poly Alphaolefin) Cooling Fluid	MIL-C-87252
Engine Lubricating Oil	MIL-L-7808
Engine Lubricating Oil	MIL-L-23699
Ethylene Glycol/Urea Deicer (Class I)	SAE AMS 1432 (superseding MIL-D-83411)
Sump Water ²	MIL-S-8802 section 4.8.15
Methylene Chloride ³	ASTM D4701 (superseding MIL-D-6998)
SO ₂ /Salt Spray ³	---

¹ Monsanto low-density aviation hydraulic fluid, commercial.

²A mixture of SAE AMS 2629 Jet Reference Fluid and 3% sodium chloride/water solution.

³U.S. Navy requirement.

Group II

Fluids that are *wiped on and off* (or evaporate) or will not contact the material for an extended period of time.

Alkaline Cleaner (Types 1 and 2)	MIL-C-87936
MEK Washing Liquid	ASTM D740 (superseding TT-M-261)
Dry Cleaning Solvent (Type 2)	P-D-680
Hydrocarbon Washing Liquid	TT-S-735
Polypropylene Glycol Deicer (Type 1)	MIL-A-8243
Isopropyl Alcohol Deicing Agent	TT-I-735

More information on these fluids is found in References 2.3.1.3(d) - (t).

Exposure by immersion prior to test or to evaluate weight loss is also recommended, using a different exposure level for each group:

- Group I Immerse material in fluid until it reaches equilibrium weight gain (saturation). (Except for the MIL-S-8802 Sump Water corrosion test.)
- Group II Immerse material in fluid for 15 days to determine worst case effects. Then follow-up with tests that simulate a more realistic exposure including accidental extended exposure.

Both mechanical and physical testing should be done. Mechanical testing should include open hole compression tests on quasi-isotropic lay-up specimens and $\pm 45^\circ$ tension specimens. The open hole compression test has a meaningful relation to design values and is sensitive to matrix degradation. The use of a $\pm 45^\circ$ tension test is commonplace in industry for comparison of matrix properties. It is a sensitive test which will identify "potentially" harsh fluids. It provides an indication of whether necessary shear stiffness has been retained to ensure acceptable resin to fiber property transfer. While a material stiffness loss criterion is material and application specific, a 20-40% loss in shear modulus from that of the unexposed material is generally considered significant, and should be further investigated. A minimum of five specimens should be tested after exposure at room temperature and at the maximum use temperature. The results should be compared with unexposed controls.

A more economical alternative to open hole compression and $\pm 45^\circ$ tension testing is interlaminar or short beam shear tests. These specimens are easily fabricated, machined, conditioned, and tested. Although not as generally related to design properties, short beam strength tests are sensitive to matrix degradation and can be valuable indicators for material evaluation. As with the $\pm 45^\circ$ tension tests, results after exposure should be compared to unexposed controls at room and elevated temperature to obtain fluid exposure effects.

Physical testing should include weighing to measure weight change, photomicrographs to examine for microcracks, and, where practical, scanning electron microscopy to examine for surface crazing. Relative to the former, it must be warned that because a saturation condition has apparently been reached, it *does not* automatically follow that further degradation of properties has ceased. Especially where new resin systems are involved, test with long term exposure to critical fluids should be conducted. An example of such testing is given in Reference 2.3.1.3(u). Due to the long exposure times involved, these tests should be started early in the evaluation process.

It has been the procedure in the past that if water or moisture has been proven to be the most property-degrading fluid, then fluid exposure tests involving other than moisture conditioning were not included in subsequent design testing. Such a procedure for Group I pooling fluids is presented in Figure 2.3.1.3(a). In effect, if the properties of the material after fluid exposure are better than after moisture exposure, then subsequent testing accounts for moisture only. If a fluid other than water is more critical, then subsequent testing must include evaluation with that fluid.

In the case of Group II wipe on/wipe off fluids, the procedure is somewhat different since water is not a good comparison. Consequently, comparison to a resin that has an acceptable service history is recommended. This is illustrated by the decision tree in Figure 2.3.1.3(b) where comparison with the performance of 3501-6 epoxy resin system is suggested.

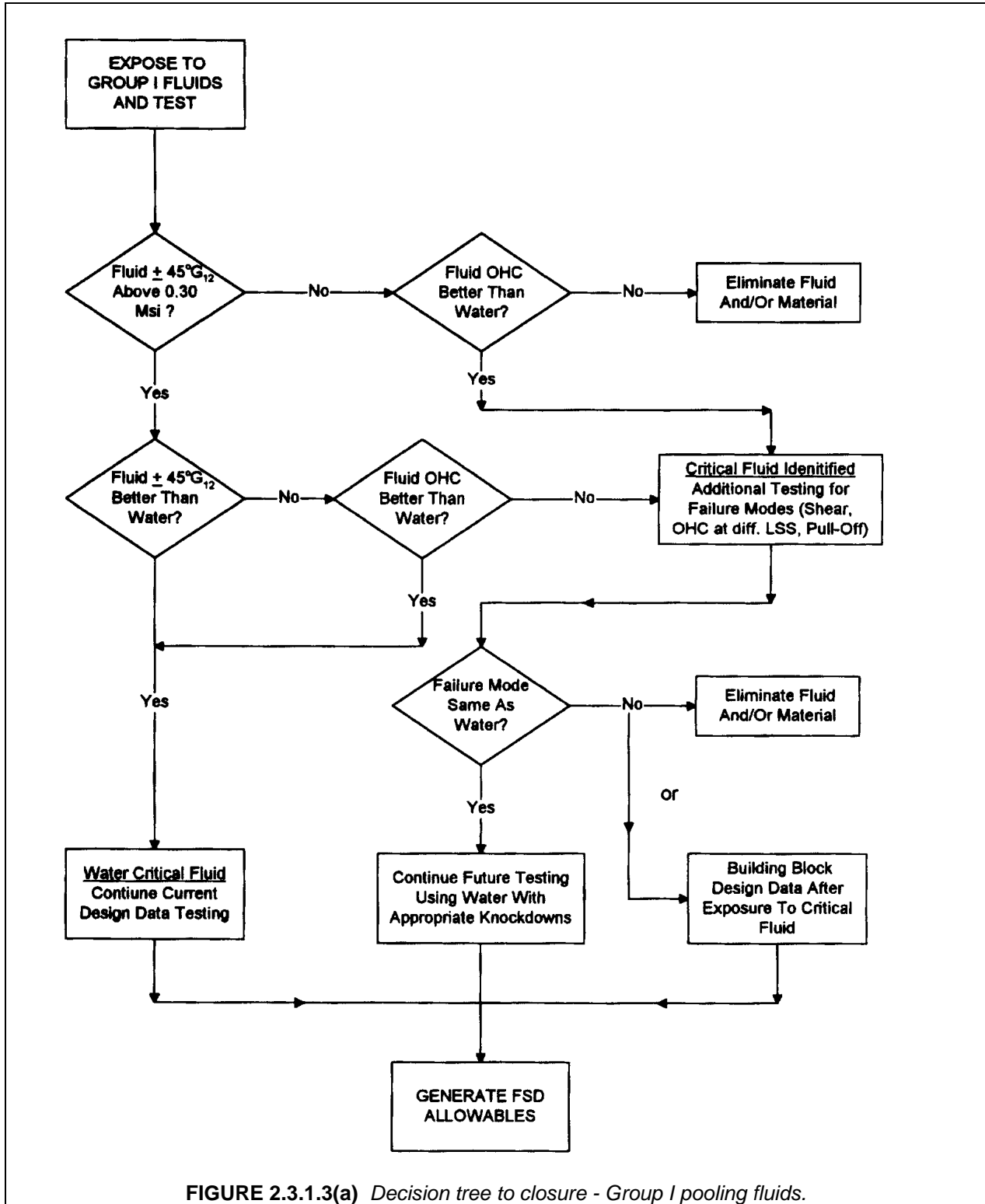

FIGURE 2.3.1.3(a) Decision tree to closure - Group I pooling fluids.

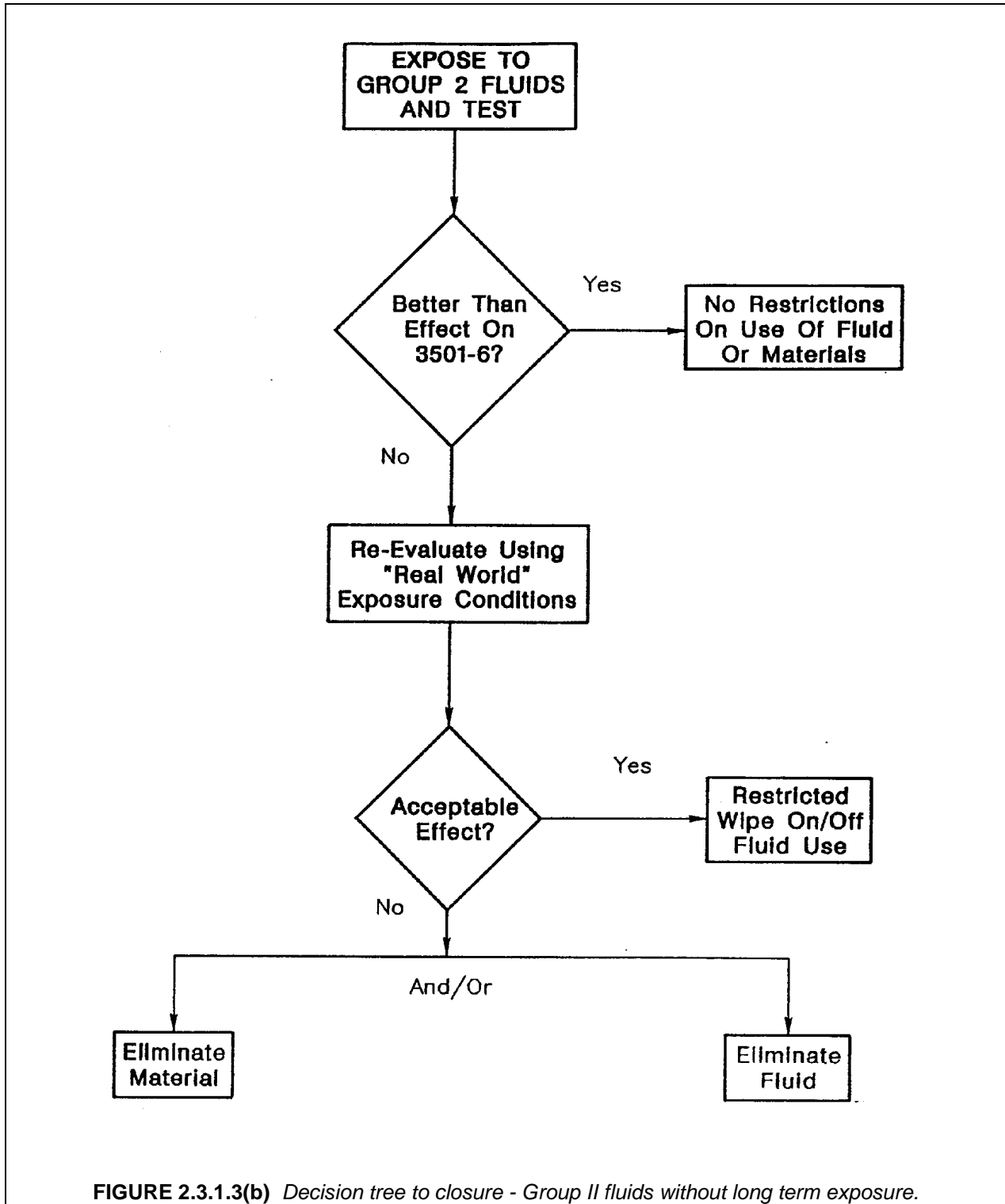

FIGURE 2.3.1.3(b) Decision tree to closure - Group II fluids without long term exposure.

2.3.2 Material qualification test matrices*2.3.2.1 Constituent test matrix*

This section is reserved for future use.

2.3.2.2 Prepreg test matrix

The recommended test matrix for prepreg materials is shown in Table 2.3.2.2. The table is based on thermosetting matrices and requires modification for thermoplastic matrices.

TABLE 2.3.2.2 *Recommended physical and chemical property tests to be performed by material supplier and prime contractor.*

Test Property	Suggested Test Procedure ¹	Number of Tests per Batch ²	Total Number of Tests
Resin Content	ASTM D 3529	3	15
Volatile Content	ASTM D 3530	3	15
Gel Time	ASTM D 3532	3	15
Resin Flow	ASTM D 3531	3	15
Fiber Areal Wt.	†	3	15
Moisture Content	†	3	15
Tack	†	3	15
HPLC (High Performance Liquid Chromatography)	†	3	15
IR (Infrared Spectroscopy)	†	3	15
DMA (Dynamic Mechanical Analysis, neat resin only)	†	3	15
DSC (Differential Scanning Calorimetry)	†	3	15
RDS (Rheological Dynamic Spectroscopy)	†	3	15

¹ Test procedures should be coordinated and agreed to prior to manufacture of prepreg material.

² Tests should be performed on each of the five batches of prepreg material.

† Test procedures to be described at a later date.

2.3.2.3 Lamina test matrices

Recommended physical and mechanical property test matrices for statistical evaluation of lamina-level materials are shown in Tables 2.3.2.3(a) and 2.3.2.3(b).

The mechanical test matrix shown in Table 2.3.2.3(b) is based on a minimum of thirty tests per condition per property (at least six replicates for each of at least five batches) to provide for parametric/nonparametric analysis when determining B-basis properties. Fewer replicates or batches may be acceptable if agreed to between the contractor and the procuring or certifying agency.

TABLE 2.3.2.3(a) Cured lamina physical property tests.

Physical Property	Suggested Test Procedure	Number of Tests Per Prepreg Batch ¹	Total Number of Tests
Fiber Volume	ASTM D 3171	3	15
Resin Volume	ASTM D 3171	3	15
Density	ASTM D 792	3	15
Cured ply thickness	-	10	50
Glass Transition Temperature (dry) ²	-	3	15
Glass Transition Temperature (wet) ²	-	3	15

1. Tests should be performed on each of the five batches.
2. Dry specimens are "as fabricated" specimens which have been maintained at ambient conditions in an environmentally-controlled test laboratory. Wet specimens are environmentally conditioned by exposing them in an elevated temperature humidity chamber until they attain an equilibrium moisture content agreed to by the contractor and customer, then packaged in a heat-sealed aluminumized polyethylene bag until required for test. Tests should be performed in a manner which maintains the moisture content in specimens at the levels agreed to by the contractor and certifying agency.

TABLE 2.3.2.3(b) *Cured lamina mechanical property tests.*

Mechanical Property	Test Methods ¹	Test Condition ² and Number of Tests Per Batch ³			Number of Tests
		Min. Temp Dry	RT Dry	Max. Temp Wet	
0° Tension (warp)	6.7.4.4 ⁴	6	6	6	90
90° Tension (fill)	6.7.4.4 ⁴	6	6	6	90
0° Compression (warp)	6.7.5.4	6	6	6	90
90° Compression (fill)	6.7.5.4	6	6	6	90
In-plane Shear	6.7.6.4	6	6	6	90
0° Short Beam Shear	6.7.6.4	-	6	-	<u>30</u>
					480

1. MIL-HDBK-17 is not currently in a position to make exclusive test method recommendations, but the referenced Handbook sections identify methods that are currently deemed acceptable for data submittals to MIL-HDBK-17.
2. Minimum and maximum temperature tests should be performed within $\pm 5^{\circ}\text{F}$ ($\pm 2.8^{\circ}\text{C}$) of the nominal test temperature. Nominal test temperatures will be as agreed to by contractor and certifying agency. Dry specimens are "as-fabricated" specimens which have been maintained at ambient conditions in an environmentally-controlled test laboratory. Wet specimens are environmentally-conditioned by exposing them in a humidity chamber until they attain an equilibrium moisture content agreed to by the contractor and certifying agency, and then packaging them in a heat-sealed aluminized polyethylene bag until required for test. Tests should be performed in a manner which maintains the moisture content in specimens at the levels agreed to by the contractor and certifying agency.
3. Tests should be performed on each of the five batches.
4. For 0° and 90° tension, ASTM D 3039 and SACMA Recommended Method (SRM) 4-88 are acceptable test methods for MIL-HDBK-17 data submittals.
5. Short Beam Shear is for screening and quality control purposes only.

2.3.2.4 *Filament-wound materials test matrix*

The test matrix shown in Table 2.3.2.4 contains the suggested mechanical property tests for filament wound structures.

TABLE 2.3.2.4 *Filament-wound materials property tests.*

Mechanical Property Condition ³	Suggested Test Procedure ¹	Test Condition and Number of Tests Per Batch ²			Number of Tests
		Min. Temp Dry	RT Dry	Max. Temp Wet	
0° Tension	ASTM D 3039	6	6	6	90
90° Tension	ASTM D 5450	6	6	6	90
0° Compression	ASTM D 3410 (Method B)	6	6	6	90
90° Compression	ASTM D 5449	6	6	6	90
In-plane Shear	ASTM D 5448	6	6	6	90
Interlaminar Shear	ASTM D 5379	6	6	6	<u>90</u> 540

- 1 Reader is referred to Section 6.7 Mechanical Property Tests for more information on these ASTM test methods
- 2 Tests should be performed on each of the five batches.
- 3 Minimum and maximum temperature tests should be performed within $\pm 5^{\circ}\text{F}$ ($\pm 2.8^{\circ}\text{C}$) of the nominal test temperature. Nominal test temperatures will be as agreed to by contractor and certifying agency. Dry specimens are "as-fabricated" specimens which have been maintained at ambient conditions in an environmentally-controlled test laboratory. Wet specimens are environmentally-conditioned by exposing them in a humidity chamber until they attain an equilibrium moisture content agreed to by the contractor and certifying agency, and then packaging them in a heat-sealed aluminized polyethylene bag until required for test. Tests should be performed in a manner which maintains the moisture content in specimens at the levels agreed to by the contractor and certifying agency.

The JANNAF Composite Motorcase Subcommittee has recommended to filament wind the flat laminates used for the test articles for ASTM D 3039, ASTM D 3410 and ASTM D 5379 for the uniaxial material properties used in the design and analysis of filament wound structures. However, there are no universal standards describing the process. Consequently there are numerous methods used by industry and Government to manufacture the flat laminates, (References 2.3.2.4(a) and (b)). At these two meetings filament winders, both industry and government, presented their techniques to prepare flat laminates for the purpose of testing for uniaxial mechanical material properties.

One main issue is whether to use a cylindrical or a rectangular winding mandrel. If a cylindrical mandrel is used, the diameter of the mandrel is a factor. The larger the diameter, the less the effects of shear when the laminates are removed from the winding mandrel and flattened for curing. If the mandrel is rectangular, the main concern is how tension of the fiber is maintained during winding.

The following issues have been identified as concerns for filament wound laminates:

- autoclave vs. non-autoclave cure
- cutting of fibers before or after cure
- whether to cure on the winding mandrel or to remove and cure on a separate fixture
- whether to use a caul plate
- whether to wind single layers, cut and stack versus winding entire thickness before cutting

Currently the winders appear to be using the technique that produces a panel that most closely simulates the process used on their finished part. The ASTM Task Group D30.04.05 is discussing and pursuing these same issues and developing a standard method to prepare filament wound laminates.

2.3.3 Material acceptance test matrices

This section is reserved for future use.

2.3.4 Alternate material equivalence test matrices

2.3.4.1 Qualification of alternate source composite materials

2.3.4.1.1 Introduction

These guidelines apply to the situation where one composite material system from a single supplier has been qualified and it is necessary or desirable to qualify an alternate system and/or supplier. The approach assumes the existence of a body of data and experience developed with the original material (none exists for the alternate system) from which the mechanical property basis values have been developed. It also assumes higher level tests have been performed to qualify a product and verify its performance.

A drastic change, such as switching fiber from E-glass to aramid, is not covered by this guideline. The focus is on materials that will meet the original material specification. A fiber class change, or comparable substitution, is considered a major revision or redesign. Processing and tooling changes are also considered beyond the scope of this section.

2.3.4.1.2 Goal and approach

The ultimate goal in qualifying an alternate material is to be able to exchange this material with the original system without compromising manufacturing or structural performance. To accomplish this goal it is necessary to define the key material parameters that govern performance during specific phases, such as processing, manufacturing, and service. The ideal is to perform this evaluation at the material constituent or composite lamina levels by measurement and comparison of parameters like chemical composition, fiber strength, matrix strength, and composite strength. This may be possible in the future, but is not adequate with current technology.

Successful qualification of an alternate material will not, in itself, be sufficient to permit mixing of this system with the original material within a given part. Intermixing of two different material systems within the same part is not recommended unless appropriate evaluations are carried out to demonstrate compatibility.

The focus of MIL-HDBK-17 is B-basis lamina properties. Adequate alternate material qualification may require going beyond this level of evaluation into more complex demonstrations involving analysis and tests. These may include laminate, specimen, element, and subcomponent tests such as open hole, filled hole, bolt bearing, low velocity impact, fatigue, and panel buckling. The general approach to be followed for qualification of an alternate material is as follows:

1. Identify the key material performance parameters and why they are crucial.

Volume 1, Chapter 2 Guidelines for Property Testing of Composites

2. Define appropriate tests, measurements, or evaluations for each of the parameters. These must correspond exactly to the tests, measurements, or evaluations performed on the original material (for example: same specimen type and same conditions).
3. Define pass/fail (success) criteria for the tests, measurements, and evaluations.
4. Prepare a test plan and obtain necessary approvals.
5. Perform tests and document results.
6. Accept or reject.

2.3.4.1.3 *Material compatibility*

The extent to which an alternate material used in hardware applications must be evaluated to demonstrate equivalence, or superiority, with the original system is first, a function of its material compatibility and second, a function of hardware structural complexity and loading. Material compatibility is defined by the criteria shown in Table 2.3.4.1.3. The baseline system is a material from a single prepregger using a specific prepreg production line. For example, AS4/3501-6 produced from line 3 at Hercules, Inc. The most compatible alternate material, and the one requiring the minimum to demonstrate equivalence would be AS4/3501-6 produced from line 4 at Hercules, Inc. The least compatible material system would be one from a different prepregger with a different matrix and fiber. Thus, Fiberite C12K/934 is a less compatible system and requires more effort to demonstrate equivalence. Situations not included in Table 2.3.4.1.3 must be evaluated with respect to their appropriate compatibility scale.

2.3.4.1.4 *Key material or structural performance parameters*

Key material or structural performance parameters are those measurable quantities which, if compared to the original values, can be used to quantify any difference in manufacturing or structural performance parameters, are material and hardware dependent, and may change with design, tooling, manufacturing, and usage factors. However, five categories of parameters have been defined in Table 2.3.4.1.4. This table lists examples of typical performance parameters appropriate for each category.

2.3.4.1.5 *Success criteria*

The relative importance and completeness of performance parameters varies with the part design, loading, and application. In some cases it is sufficient merely to report a measured value. In other cases the value must meet or exceed the original measurement. And in some cases the value must not vary significantly either higher or lower than the original value. As an example, this is generally true for modulus, fiber areal weight, matrix content, and cured ply thickness.

Success criteria for each parameter must be defined at the beginning of the qualification program. Justification for each success criteria imposed must be provided. A tolerance on a given measurement should be part of the success criteria.

TABLE 2.3.4.1.3 *Material compatibility criteria.*

	MOST COMPATIBLE			LEAST COMPATIBLE		
MATERIAL FACTOR	1	2	3	4	5	6
Fiber Type	Y	N	Y	N	Y	N
Fiber Tow Size	Y	Y/N	Y	Y/N	Y	N
Resin	Y	Y	N	Y	N	N
Prepregger	N	Y	Y	N	N	N
Production Line	N	Y	Y	N	N	N

Y - remains the same in alternate material
 N - changes in alternate material

- a) Column 1 is a change in prepreg supplier and production line. This situation is becoming more common today as resin systems are licensed between prepreg manufacturers; for example, the Navy's A-6 re-wing and V-22 Osprey programs where Hercules 3501-6 is licensed to ICI Fiberite. This cooperative licensing allows competitive bidding for prepreg supplies and provides the customer with nearly identical prepreg for production usage.
- b) Column 2 represents a change in fiber type based on a new fiber with properties similar to the originally qualified fiber. This situation may occur for economic reasons or in the event of discontinued fiber supply.
- c) Column 3 is a change in resin. This would be justified by development of new resin systems by the prepregger that would offer improved pricing and/or properties, such as damage tolerance, for the customer's program.
- d) Columns 4 and 5 represents a change in prepreg supplier, production line, and fiber or resin. This situation would occur when a customer needs an additional supplier but wishes to use the same fiber or resin due to second-source qualification budget constraints (assumes existing data base on the resin and/or fiber). Again, economic reasons justify this situation.
- e) Column 6 involves qualifying a new source prepregger using a different fiber and resin system. An example of this situation is qualifying Fiberite C12K/934 to replace Hercules AS4/3501-6. This is the least compatible situation and would require the greatest effort to demonstrate acceptability.

TABLE 2.3.4.1.4 *Examples of key material or structural performance parameters.*

PHYSICAL	PROCESSING	MECHANICAL	MANUFACTURING	HARDWARE SCALE-UP
TACK	CURED PLY THICKNESS	LAMINA PROPERTIES	DRILLING	STATIC STRENGTH
RESIN CONTENT	CURE CYCLE	ENVIRONMENTAL EFFECTS	TOOLING	FATIGUE STRENGTH
AREAL WEIGHT	SENSITIVITY	DAMAGE TOLERANCE	NONDESTRUCTIVE INSPECTION	STIFFNESS
FLOW	FIBER VOLUME	INTERLAMINAR SHEAR	COST	FAILURE MODES
GLASS TRANSITION TEMPERATURE	THERMAL CYCLING	FLATWISE TENSION	LEAD TIME	QUALITY
FORM	DENSITY	FLAW GROWTH	AVAILABILITY	BEARING
OUT TIME	EXOTHERM	EFFECT OF DEFECTS	REPEATABILITY	CRIPPLING
SHELF LIFE	TOXICITY	PRESSURE BOTTLE TESTS	MACHINABILITY	OPEN HOLE TENSION
STORAGE REQUIREMENTS			UNIFORMITY	OPEN HOLE COMPRESSION
MOISTURE ABSORPTION				PANEL TESTS
SOLVENT RESISTANCE				FATIGUE TESTS

2.3.4.1.6 Lamina-level test matrices for alternate material assessment

Section 2.5 defines minimum requirements for B-basis lamina property values for MIL-HDBK-17 data, which can be quickly summarized as thirty specimens from at least five batches of material for each environment and property of interest. Since an alternate material qualification program is not intended to establish basis values, but rather to show compliance with them, a reduced number of lamina tests can be allowed for a second population of data to be compared to the original data. The actual number of equivalency tests needed depends on the degree of compatibility between the two material systems. Recommendations for test quantities and properties for tape and fabric material forms are shown in Tables 2.3.4.1.6(a) and (b). The equivalency check tests must be performed in the same way, and using the same test methods, as the tests used to determine the basis values. Following testing, (see Section 8.4.3) appropriate statistical analysis must be performed to evaluate the test results and assess equivalency.

TABLE 2.3.4.1.6(a) *Alternate material lamina test requirements - tape.*

Lamina Property	No. of Batches						Replicates						Environments ²						Total					
	Compatibility ¹						Compatibility ¹						Compatibility ¹						Compatibility ¹					
	1	2	3	4	5	6	1	2	3	4	5	6	1	2	3	4	5	6	1	2	3	4	5	6
0° Tension	2	3	3	3	3	3	4	4	4	5	5	6	2	2	2	2	2	2	16	24	24	30	30	36
90° Tension	2	3	3	3	3	3	4	4	4	5	5	6	2	2	2	2	2	2	16	24	24	30	30	36
0° Compression	2	3	3	3	3	3	4	4	4	5	5	6	2	2	2	2	2	2	16	24	24	30	30	36
90° Compression	2	3	3	3	3	3	4	4	4	5	5	6	2	2	2	2	2	2	16	24	24	30	30	36
In-Plane Shear	2	3	3	3	3	3	4	4	4	5	5	6	2	2	2	2	2	2	16	24	24	30	30	36
																			80	120	120	150	150	180

¹ Compatibility is defined in Table 2.3.4.1.3.

² The environments should be RTD and the worst case.

Quality assurance tests must be performed per individual specification.

TABLE 2.3.4.1.6(b) *Alternate material lamina test requirements - fabric.*

Lamina Property	No. of Batches						Replicates						Environments ²						Total					
	Compatibility ¹						Compatibility ¹						Compatibility ¹						Compatibility ¹					
	1	2	3	4	5	6	1	2	3	4	5	6	1	2	3	4	5	6	1	2	3	4	5	6
Warp Tension	2	3	3	3	3	3	4	4	4	5	5	6	2	2	2	2	2	2	16	24	24	30	30	36
Fill Tension	-	3	3	3	3	3	-	4	4	5	5	6	-	2	2	2	2	2	-	24	24	30	30	36
Warp Compression	2	3	3	3	3	3	4	4	4	5	5	6	2	2	2	2	2	2	16	24	24	30	30	36
Fill Compression	-	3	3	3	3	3	-	4	4	5	5	6	-	2	2	2	2	2	-	24	24	30	30	36
In-Plane Shear	2	3	3	3	3	3	4	4	4	5	5	6	2	2	2	2	2	2	16	24	24	30	30	36
												48	120	120	150	150	180							

¹ Compatibility is defined in Table 2.3.4.1.3.

² The environments should be RTD and the worst case.

Quality assurance tests must be performed per individual specification.

2.3.4.1.7 Laminate-level test matrices for alternate material assessment

The next higher level of testing that should be considered for qualification of an alternate material system is laminate mechanical properties. This level of testing confirms strength (strain) basis values for strategic design parameters and should be performed using the same laminate tested for the original material. The recommended tests are shown in Table 2.3.4.1.7(a). The extent to which the Table 2.3.4.1.7(a) tests are performed is governed by the material compatibility factor. The recommended number of tests is given in Table 2.3.4.1.7(b).

TABLE 2.3.4.1.7(a) *Extent of laminate testing.*

Material Compatibility Factor	Laminate Tests	Total	
		Tape	Fabric
1	Unnotched Laminates	12	12
2, 3	All Static Test, Two Environments	36	36
4, 5	All Static Test, Two Environments	36	36
6	All Required	42	42

2.3.4.1.8 Alternate material evaluation summary

Many of the handbook recommendations on key material performance parameters, such as physical and processing characteristics, are commonly included in material and process specifications. Other parameters are more application related and may be difficult to demonstrate at the material level. The reader should not infer from lack of discussion that a particular topic is unimportant; all key performance parameters for a specific project or product must be considered.

Guidelines for substantiating lamina and laminate material property requirements, given some change in the material system or process, were provided. Higher level mechanical element/subcomponent substantiation tests may also be required, depending on the degree of change in the key material or structural parameter, and on the application.

Statistical methods for comparing batches are discussed in Section 8.4.3.

2.3.4.2 Evaluation of changes made to previously qualified materials

This section defines guidelines for evaluating changes made by a material supplier to a material system provided as a qualified source. A drastic change is not covered herein. The focus is to meet original (existing) material specification requirements. Potential changes at all levels should be considered.

The goal of the recommended evaluations is to verify that intended changes do not compromise physical, structural, or manufacturing requirements. This guideline provides a list of potential changes and appropriate experiments/tests to evaluate the effects of a particular change. Specific evaluations are tailored to the nature and severity of proposed changes.

TABLE 2.3.4.1.7(b) Number of suggested laminate tests.

Design Property	Loading		No. of Laminate Types		No. of Environments ¹	Replicates ²	Total Number of Specimens	
	Tension	Compression	Tape	Fabric			Tape	Fabric
<u>Static</u>								
Unnotched laminate, strength and stiffness	X	X	1	1	2	3	12	12
Open Hole		X	1	1	2	3	6	6
Filled Hole	X		1	1	2	3	6	6
Impact Damage	X	X	1	1	1	3	6	6
Double Shear Bearing	X		1	1	1	3	3	3
Single Shear Bearing	X		1	1	1	3	3	3
							36	36
<u>Fatigue³</u>								
Open Hole	-	-	1	1	1	3	3	3
Impact Damage	-	-	1	1	1	3	3	3
							6	6
							42	42

¹ Where two environments are required, they should be RTD and worst case. Where one is required, it should be RTD.

² One batch of material is sufficient.

³ Repeated load and residual strength: constant amplitude, $R = -1$, $n = 1 \times 10^6$ cycles.

A documented quality plan is an assumed prerequisite for this procedure. It should describe the manufacturing process from raw materials receiving to final product shipment. This document should be kept current. It should be in accordance with ISO 9002 or Mil-Q-9858A. The quality plan should reference raw materials used, show key manufacturing steps in proper sequence, and list critical process control documentation as well as quality inspection or testing.

At the time of a proposed modification, a process analysis should be done to determine if the proposed change warrants further consideration. This can be done by an appropriate technical specialist. Guidelines for screening possible modifications should be established prior to embarking on an evaluation program. For example, routine or ongoing maintenance of equipment, changes in personnel, or upgrading control instrumentation would not normally require formal evaluation. Proposed changes in product formulation, elimination of process steps, changes in manufacturing equipment, or changes in sequence of operations are the types of significant modifications that would require formal evaluation.

The relative importance or category of a proposed process modification is determined by a logical system of in-depth process and product impact analysis. It is recommended that a process review team (PRT) be established to perform the process analysis. The process analysis must identify:

- Key process steps (including sequence)
- Key equipment used at each process step.
- Quality-critical processing parameters for each piece of equipment (time, temperature, rate, pressure).
- Quality-critical operating ranges for each critical process parameter.
- Quality-critical instrumentation used for monitoring and/or controlling each critical process parameter.

2.3.4.2.1 *Modification categories*

When a proposed process modification is identified for consideration, a comprehensive review of all related information should be conducted. This includes the rationale for making the process modification. An appraisal should be made as to the impact that the change could have on the next product user as well as upon the product's performance in the final application.

The foundation of the review is derived from the knowledge obtained from the product/process analysis described previously. Based upon this product impact review, the process modification will be placed into one of the following three categories:

Category 1: "No Impact"

The modification is minor in nature. It is known not to impact the product's quality, physical or chemical properties or performance. Additionally, the modification is not likely to cause operational or product performance deficiencies for subsequent customers. This type of process modification is therefore classified as "No Impact".

Category 2: "Unknown"

If upon review of available information there is not enough known about the proposed change, then the modification must be classified as "Unknown".

Category 2 is a temporary classification which is held until additional information is made available. No modification classified as Category 2 should be implemented. All Category 2 classifications must eventually become Category 1 or 3 before the modification is implemented.

Category 3: "Change"

If upon review of available information it is decided that the proposed modification may result in a significant change to the product's properties, quality, performance, or may have an impact on subsequent customers, then the modification must be classified as a "change".

2.3.4.2.2 *Actions required for each modification category*

Category 1 modifications should be formally approved. The change should be documented and an appropriate process change follow-up or monitoring file initiated. This releases manufacturing to implement the modification at an agreed upon schedule with appropriate monitoring for a specified time.

If the change is to a raw material ingredient, the "No Impact" classification can be applied if it is demonstrated as equivalent using a minimum of three lots of the ingredient both before and after the modification to that ingredient. The testing matrix used to demonstrate this should be agreed upon by the raw material manufacturer and the composite manufacturer as representing all significant characteristics of that material.

If the proposed modification is classified as "Unknown", additional information or testing should be identified for further review and action.

Manufacturing should not implement the proposed modification until the additional information or testing has been reviewed and status updated to either Category 1 or 3.

If the proposed modification is classified as a Category 3 "Change" then:

- (a) The process modification is not implemented or
- (b) An equivalency test plan is defined according to Tables 2.3.4.2.2(a) through (h).

When equivalency testing is performed, the data should be compared to the existing product data per statistical procedures given in Section 8.4.1. If the data analysis shows equivalency, the resulting data report should be submitted to the customer(s) for concurrence. If the data analysis shows that the modification resulted in non-equivalent products, the manufacturer will either:

- (a) Not implement the change or
- (b) Review the data documentation report with the customer to determine actions required for implementation.

2.3.4.2.3 *Implementation*

Category 1, "No Impact", process modifications can be implemented immediately based on the review approval. Normal acceptance testing should continue to be monitored to confirm that there has been no product impact.

Category 2, "Unknown", process modifications can not be implemented until additional information is available. Category 2 process modifications may only be implemented after conversion to and approval of either a Category 1 or 3 classification.

Category 3, "Change", process modifications require appropriate validation testing and written customer notification and concurrence prior to implementation or product shipment.

TABLE 2.3.4.2.2(a) Validation requirements versus changes fiber.

Change Description	Testing Requirements - Number of lots to be tested (A) (B)										
	Component Property		Prepreg Properties			Laminate Mechanical Properties					
	Level 1	Level 2	Physical	Process	Mechanical Accept	Comp ETW	±45 ETW	OHC ETW	OHT	CAI	(C)
	Table 2.3.4.2.2(d)		Table 2.3.4.2.2(f)	Table 2.3.4.2.2(g)	Table 2.3.4.2.2(g)						
New line	3	3	2	-	1	1	1	-	-	-	-
Precursor relocation	3	3	3	-	3	3	3	2	2	-	2
Sizing	3	3	3	1	3	3	3	2	2	-	2
Weaver	2	-	-	-	1	-	-	-	-	-	-
Relocation	2	-	-	-	1	-	-	-	-	-	-
Major on-line equipment	2	(D)	-	-	1	1	1	-	-	-	-
Process	2	(D)	-	-	1	1	1	-	-	-	-
Raw material	2	(D)	-	-	1	1	1	-	-	-	-

- NOTES: (A) Prepreg tests made using most representative resin system.
 (B) Chemical and physical tests use 3 specimens per sample. Mechanical tests use 5 specimens per sample.
 (C) Fracture toughness or interfacial bonding test.
 (D) Decision based on degree of change.

TABLE 2.3.4.2.2(b) Validation requirements versus changes formulated resin.

Change Description	Testing Requirements - Number of lots to be tested (A) (B)										
	Component Property		Prepreg Properties			Laminate Mechanical Properties					
	Level 1	Level 2	Physical	Process	Mechanical Accept	Comp ETW	±45 ETW	OHC ETW	OHT	CAI	(C)
	Table 2.3.4.2.2(e)		Table 2.3.4.2.2(f)	Table 2.3.4.2.2(g)	Table 2.3.4.2.2(g)						
Ingredient	3	3	2	1	2	2	2	2	-	1	1
Source for ingredient	3	3	1	1	1	1	1	-	-	-	-
Process	3	3	2	1	2	2	2	-	-	-	-
Equipment	3	3	2	1	2	2	2	-	-	-	-
Relocation	2	-	1	-	1	1	1	-	-	-	-

NOTES: (A) Prepreg tests made using most representative resin system.
 (B) Chemical and physical tests use 3 specimens per sample. Mechanical tests use 5 specimens per sample.
 (C) Fracture toughness or interfacial bonding test.

TABLE 2.3.4.2.2(c) *Validation requirements versus changes prepreg.*

Change Description	Testing requirements - number of lots to be tested (A) (B)								
	Prepreg Properties			Laminate Mechanical Properties					
	Physical	Process	Mechanical Accept	Comp ETW	±45 ETW	OHC ETW	OHT	CAI	(C)
	Table 2.3.4.2.2(f)	Table 2.3.4.2.2(g)	Table 2.3.4.2.2(g)						
Process/equipment	3	1	2	2	2	2	2	-	2
New line	3	1	2	2	2	2	2	-	2
Relocation	2	1	1	1	1	-	-	-	-
New fiber and/or resin	3	2	3	3	3	3	3	3	3

NOTES: (A) Prepreg tests made using most representative resin system.
 (B) Chemical and physical tests use 3 specimens per sample. Mechanical tests use 5 specimens per sample.
 (C) Fracture toughness or interfacial bonding test.

TABLE 2.3.4.2.2(d) *Fiber testing matrix.*

TEST	LEVEL 1	LEVEL 2
Tow Tensile	X	
Tow Modulus	X	
Density	X	
Mass per Unit Length	X	
Surface Characterization Such as ESCA/Interfacial Energy/Microscopic Evaluation		X

TABLE 2.3.4.2.2(e) *Neat resin testing matrix*

PROPERTY	LEVEL 1	LEVEL 2
HPLC	X	
Infrared		X
DSC		X
Gel Time	X	
Flexural Modulus		X
Glass Temperature, Dry and Wet		X
Viscosity		X
Moisture Absorption		X

TABLE 2.3.4.2.2(f) *Prepreg physical testing.*

PROPERTY	
Resin Content/Areal Weight Variability	X
Flow	X
Glass Transition Temperature, Dry and Wet	X
Moisture Absorption	X

TABLE 2.3.4.2.2(g) *Prepreg Processibility testing.*

Microcracking/Thermal Cycling of Cured Laminate	X
Morphology/Microstructure of Cured Laminate	X

TABLE 2.3.4.2.2(h) *Mechanical acceptance testing.*

PROPERTY	ROOM TEMPERATURE	ELEVATED TEMPERATURE DRY
Tensile Strength and Modulus	X	
Compression Strength	X	X
Shear, either SBS or ± 45	X	X

2.3.4.2.4 Validation test matrices

Tables 2.3.4.2.2(a) through (h) define the validation testing recommended as a function of the type of change proposed. Table 2.3.4.2.2(a) provides the guidance for fiber changes. Table 2.3.4.2.2(b) is the overview and guidance for resin changes. Table 2.3.4.2.2(c) describes the recommendations for prepreg changes. Refer to the left hand column in each table for the change description which best represents the modification being proposed.

After the appropriate change description has been identified, the recommended testing is shown in the horizontal row to the right. The number of separate batches of material recommended for validation at each level are shown in Tables 2.3.4.2.2(a) through (c).

The test types are shown in Table 2.3.4.2.2(a) through (c) and are further delineated in the subsequent tables (Tables 2.3.4.2.2(d) through (h)).

All chemical and physical tests should use three specimens per sample. Five specimens per sample are recommended for all mechanical tests.

Prepreg testing can be performed with the most representative resin or fiber (whichever is independent of the change). That choice should be based on that material having the most credible data base. For example, if a change is being made to AS4 fiber, the validation could be performed by testing the fiber with 3501-6 resin, since that fiber/resin combination has the most complete data base.

2.3.5 Generic laminate/structural element test matrices

2.3.5.1 Introduction

A simplified flow chart, Figure 2.3.5.1, overviews the building-block flow of a typical material/structural qualification process. A series of evaluations is required to assess the adequacy of a material system for

production usage. These multi-purpose assessments, often performed in parallel, range from material performance to producibility and cost.

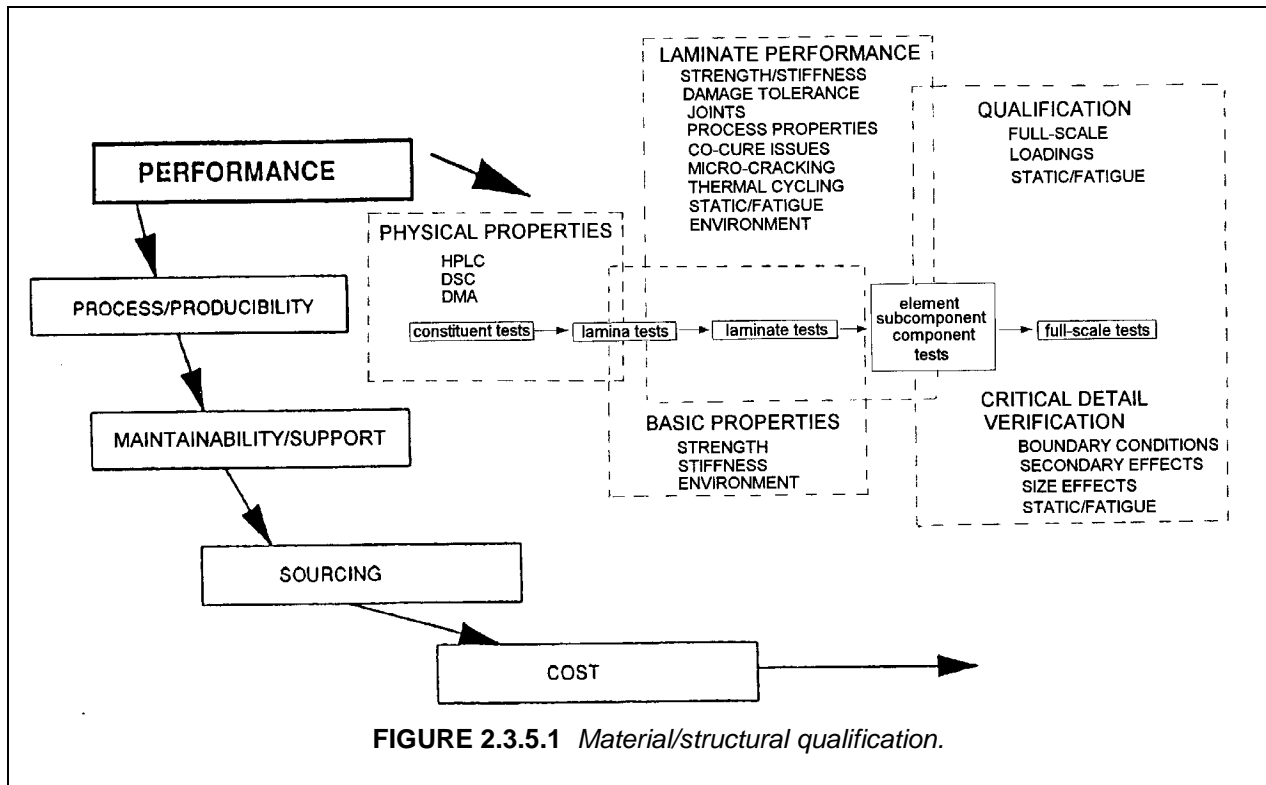

Depending on the sophistication of the application design concept (e.g., a flat monolithic panel versus an integrally cocured semi-monocoque fuselage section), an extensive, progressively more complex, building-block approach to certification testing may be required to evaluate and reduce material and structural design risks. It is recognized that the complete structural qualification of composite material systems for design allowables is often highly dependent on the application for which the material will be used. The historical lessons-learned dictate that composite production hardware design programs must evaluate and discover material, structural, and producibility design deficiencies early in the design development program to meet cost, performance, and schedule goals. Toward this end, it is extremely desirable on any program to establish early, with high confidence, the material design allowables. If this is successfully accomplished, the design development program can then focus on detail design, higher level design development tests, and producibility issues. The most *adverse* situation for any program to experience is a material development or reselection effort *in parallel* with detail design development.

This section addresses that part of the Figure 2.3.5.1 process which assesses the mechanical property characterization at the laminate level. The intent is to define a series of laminate level test matrices that complements both the ply level mechanical property characterization test matrix and the lamina/laminate screening test matrix, previously defined in Sections 2.3.2.3 and 2.3.1.1.

The basis for the test matrices of this section is that a significant number of similar, laminate level, specimen tests are performed in almost all hardware design development programs prior to extended production. The additional laminate level test data are necessary for theory/test correlations to substantiate mathematical models used to predict design allowables. Often these models employ lamina (ply) stiffness and strength input data (Section 2.3.2.3). Alternatively, laminate test data are needed to establish empirical trending where mathematical models do not exist or are deemed deficient. In either case,

some specimen laminate-level data have been historically required to substantiate or establish the design allowables essential to structural qualification. These costly and time-consuming tests are often repeated in each new application program. Because a significant number of these tests are performed at the specimen level, *the test data generated should, once generated, apply to a wide range of applications, and be acceptable to certifying agencies in other application programs.*

These generic characterization tests, once performed (with test matrices in Sections 2.3.2.3 and 2.3.1.1), are intended to further reduce the cost and time of new material characterization efforts, and *establish a generic database for the tested material system applicable to other proposed applications.*

2.3.5.2 Overview

Two laminate level test matrices are defined: (1) laminate strength, and (2) bolt bearing and bearing/bypass strength. Together, these test matrices should provide a statistically significant laminate-level database. The test matrices are defined for selective 3-batch assessments of either tape or fabric prepreg materials. Dependent upon the availability of *validated* analytic models for strength prediction, and the degree to which they use only ply-level strength and stiffness input data, batch effects may be accounted for at the lamina level and not require multiple batch testing in the following test matrices. Thus, with certification agency approval, a single-batch test plan variation may be proposed with replicates of 5 specimens per test condition as implied in Chapter 7. Additionally, it is noted that other load conditions, such as in-plane shear, may require additional testing at higher levels in the building-block assessment and are not covered by these test matrices.

2.3.5.2.1 Laminate strength test matrix

As detailed in Table 2.3.5.2.1, a series of selected orientation laminate unnotched strength tests are recommended for both tensile and compressive loadings at selective cold temperature dry (CTD), room temperature dry (RTD), and elevated temperature wet (ETW) test conditions. For two laminate configurations, three replicate tests are repeated for each of three batches of the material system. Two additional laminates are selectively tested with 5 specimens per test condition using one batch of material. The matrix emphasizes fiber dominant laminate evaluations at the extremes of material environmental capabilities (CTD and ETW) and provides baseline data at room temperature dry (RTD) test conditions. The intent is to provide data to permit a selective validation of stiffness and strength analytic models over a representative range of application relevant laminates and test conditions.

The limited number of tests implies that data pooling using regression analysis across test conditions will be employed (Section 8.3.5.3). The exact specification of critical temperatures and moisture conditioning is determined either by the minimum/maximum material operational capabilities (MOL) established for lamina level tests (Sections 2.3.1.1 and 2.3.2.3) or application considerations jointly established by the manufacturer and the procuring agency.

Four general laminate configurations are specified for tape characterization testing; three laminates for fabric material forms. As illustrated in the carpet plot of Table 2.3.5.2.1, the selection of the four laminates is intended to span the usual application range of structural laminates with emphasis on the fiber dominant orthotropic and quasi-isotropic laminate constructions. Additionally, the solid circles indicate the solely 0-degree, 90-degree, or ± 45 -degree (lamina level) evaluations specified in Section 2.3.2.3. For fabric characterization testing, the bold line in the carpet plot of Table 2.3.5.2.1 represents the reduced range of possible laminate constructions and the 50/40/10 and 40/40/20 tape laminates are replaced by a 40/20/40 fabric laminate construction in the test matrix of Table 2.3.5.2.1. Stacking sequences as specified in Section 7.2 on mechanically fastened joints are also recommended for laminates in this section.

TABLE 2.3.5.2.1 Laminate strength test matrix.

OBJECTIVE:

Create a generic, laminate-level, database to assess an application range of unnotched laminates for correlation of laminate stiffness and strength analytic models and establishment of a selective, but statistically significant, database for empirical approaches.



LAY-UP (%0, %±45, %90 degree plies)	THICK- NESS	LOAD ANGLE Φ	COMPR RTD	COMPR ETW	TENS CTD	TENS RTD
25/50/25	T1	0	9	9	9	9
	T2	0	9	9	9	9
	T1	22.5	-	5	5	-
50/40/10	T1	0	9	9	9	9
	T2	0	9	9	9	9
	T1	22.5	-	5	5	-
40/40/20	T1	0	-	5	5	-
10/80/10	T1	0	-	5	5	-
SUBTOTALS -			36	56	56	36
TOTALS =						184

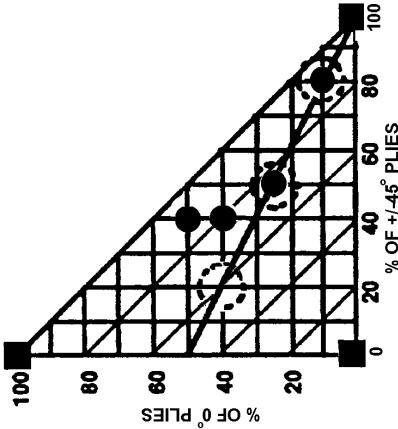

- PLY (LAMINA) LEVEL TEST POINTS (VOL. I, SECT. 2.4)
- LAMINATE LEVEL TEST POINTS (THIS TEST MATRIX)
RTD - room temp., dry test condition
CTD - cold temp., dry test condition
ETD - elevated temp., dry test condition
- FABRIC TEST POINTS

NOTES:
 Assumes 0, +45, -45, & 90 degree family of ply orientations; balanced & symmetric
 9 implies 3 specimens/batch; 3 batches
 5 implies 5 specimens/batch; 1 batch
 T1 represents laminate thickness of approximately 2.0-6.0 mm (.08-.25 inch)
 T2 represents second laminate thickness; may be optional depending on upper bound
 of application laminates
 For fabric — 40/40/20 replaces 50/40/10 laminate and 40/40/20 is deleted

The test matrix also requires two of the laminates to be tested at 22.5 degrees off the principal material axis to assess off-axis material behavior at the critical environmental test conditions. Additionally, if the application range of thickness exceeds significantly (say by a factor greater than two) the basic "T1" thickness range of 0.08-0.24 inches (2-6 mm), a second three-batch series of "T2" laminate thickness tests is specified in Table 2.3.5.2.1 for all test conditions. However, if the application range of laminate thickness are contained within a 0.16 inch (4 mm) variation, it is believed only one test matrix thickness is required (perhaps different from the "T1" range suggested in Table 2.3.5.2.1). This would reduce the matrix to a total of 114 tests for tape laminates (104 for fabric). If the range of application thickness is significantly broader, the second series (T2) of laminate thickness tests should also be performed. This would result in a total of 184 tests for tape laminates (174 for fabric).

2.3.5.2.2 Bolt bearing and bearing/bypass strength test matrix

The test matrix, detailed in Table 2.3.5.2.2, is intended to provide strength data to assess the effects of under bearing and bearing/bypass strain concentrations on laminate strength. In addition to generating design data to establish allowables for composite bolted joint analysis, the filled-hole strength can be used as a reference strength for the effect of manufacturing anomalies and impact damage on laminate strength. The test recommendations in this section include all tests found in Chapter 7, Tables 7.5.2.4(a), 7.4.4, and 7.5.5.3. However, there are additional tests required by Table 2.3.5.2.2 because of the desire to empirically obtain laminate design allowables directly from these data. This necessitates selective testing of three batches of material at the worst environments.

Three of the laminate constructions previously tested under the unnotched laminate strength matrix of Section 2.3.5.2.1 are also specified for testing tape and fabric materials under tensile and compressive bolt bearing and bearing/bypass loadings. Single fastener joint evaluations cover a range of fastener load transfer test conditions including filled hole (100% bypass), bearing/bypass interactions (75% and 50% bypass), and pure bearing (0% bypass). The test matrix is designed to emphasize critical material environmental conditions with most test data collected at either the hot-wet (ETW) condition for matrix-dominated failure modes or the cold-dry (CTD) condition for fiber-dominated failure modes. Sufficient data are also specified to establish a room temperature dry baseline condition. Tension and compression load conditions are specified. Pure bearing tests are only performed under tensile loadings.

The test philosophy is to first evaluate the effect of hole size on laminate strength. Three fastener diameters which span the range of application hardware are specified. Tensile and compressive strength data are gathered for filled hole tension/compression, bearing/bypass, and pure bearing test conditions. Specimens detailed in Figures 7.4.2, 7.5.3.2(d), and 7.5.3.2(a) of Section 7.5, respectively, should be employed. The fastener diameter which represents the majority of application fastener diameters should be selected as the baseline diameter D1 in Table 2.3.5.2.2. The remaining two fastener diameters (D2 and D3 of Table 2.3.5.2.2) should bound all other application fastener usage. Based on historical aerospace industry practice with carbon/epoxy, a baseline joint geometry of width/diameter (W/D) of 6 and edge-distance/diameter (e/D) of 3 is recommended for almost all test specimens (two additional W/D ratios tested for the 25/50/25 lay-up; these values may change as carbon/epoxy systems evolve or for other material systems). The fastener head style, protruding or countersink, that represents the majority of application usage should also be selected as the baseline (H1 in Table 2.3.5.2.2) for all specimen configurations. The "T1" laminate thickness, discussed in Section 2.3.5.2.1, is used as the baseline thickness for all specimens¹. If necessary to cover application design variations, a second series of laminate specimens, of thickness T2 in Table 2.3.5.2.2, may be required. Stacking sequences as specified in Section 7.2 on mechanically fastened joints are also recommended for laminates in this section.

The initial testing should be performed on the isotropic (25/50/25) laminate specimens for the 100% bypass and pure bearing (0% bypass) load conditions at RTD environment. *This should permit initial correlation (or calibration) of analytic or empirical models used for strength prediction of laminates under tensile or compressive loadings.* It is anticipated that these calibrated strength prediction models will then be used to predict, prior to test, the results to be obtained from the remaining bearing/bypass tests of the iso-

¹T1 is specified as 0.2 in. (5 mm) in Section 7.2.5.3

tropic laminate and the full range of tests on the remaining two orthotropic laminates (tape - 50/40/10 and 10/80/10, and fabric - 40/20/40 and 10/80/10). These initial evaluations would be followed by the full range of environmental (CTD or ETW) tests and provide the statistical validation or basis for establishing critical design condition allowables. These same tests, compared to RTD test results, would verify consistency and types of laminate failure modes. Finally, if required, the second series of laminate thicknesses (T2 and T3) and fastener head style (H2) tests would be performed at the critical environmental test conditions to establish additional calibration of analytic models or empirical "knockdown" factors for design allowables.

Based on typical design considerations, pure bearing tests under tensile loading conditions provide conservative strength values and similar failure modes as compared to pure bearing tests under compressive loading, as long as the specimen edge distance/diameter (e/D) ratio is specified as 3 or greater. Accordingly, this test matrix requires pure bearing tests (0% bypass) only under tensile loading conditions. Similarly, design values based on the intermediate 50% level of bearing/bypass load interactions under compressive loading are generally conservative compared to design values based on the 75% level or intermediate levels of tensile loading. Thus, in some cases, only tests of 50% bearing/bypass load interaction under compressive loading may be sufficient and the compressive tests at 75% levels and the tests of 50% bearing/bypass conditions under tensile loading may be eliminated. For current composite material systems, this is felt to be realistically conservative for both the acknowledged nonlinear behavior under compressive bearing/bypass load conditions and the relatively linear material behavior under tensile bearing/bypass load conditions. Should material behavior or design weight goals require a less conservative approach, more experimental evaluation would be necessary and other bearing/bypass ratio test conditions should be tested. The reader is referred to Section 7.5.3 for additional guidance.

As for the unnotched laminate test matrix of Section 2.3.5.2.1, the limited number of tests implies that data pooling using regression analysis across environmental test conditions will be employed (see Section 8.3.5). The exact specification of critical temperatures and moisture conditioning is determined either by the minimum/maximum material operational capabilities (MOL) established for lamina level tests (Sections 2.3.1.1 and 2.3.2.3) or application considerations jointly established by the manufacturer and the procuring agency. To assure upper limits of temperature effects are understood for application laminates, an additional set of "ETW+ DT" tests are performed selectively on the matrix sensitive open hole compression test specimens.

A total of 395 tests are specified if only one laminate thickness and one fastener head style are required to cover application design variables. As in Section 2.3.5.2.1, for two laminate configurations, three replicate tests are repeated for each of three batches of the material system at critical environmental test conditions. Two additional laminates are selectively tested with 5 specimens per test condition using one batch of material. An additional 124 tests are recommended to cover a second fastener head style, and a further set of 206 tests are recommended if a second (191 tests) and third (15 tests) thickness evaluation is required.

TABLE 2.3.5.2.2 Bearing/bypass

LAY-UP	THICKNESS	HOLE SIZE DIAMETER	FASTENER HEAD TYPE	COMPRESSION BEARING/BYPASS						
				100% BYPASS			75% BYPASS		50% BYPASS	
				RTD	ETW	ETW+ΔT	RTD	ETW	RTD	ETW
25/50/25	T1	D1	H1	5	9	9	5		5	5
25/50/25	T1	D2	H1	5	9					5
25/50/25	T1	D2,W/D=8	H1	5						
25/50/25	T1	D3	H1	5	9					5
25/50/25	T1	D3,W/D=4	H1	5						
25/50/25	T1	D1	H2	5	9					5
25/50/25	T2	D1	H1		9	9				5
25/50/25	T2	D2	H1							
25/50/25	T2	D3	H1		9					5
25/50/25	T3	D1	H1							
25/50/25	T3	D2	H1							
25/50/25	T3	D3	H1							
50/40/10	T1	D1	H1	5	9	9	5		5	5
50/40/10	T1	D2	H1	5	9					5
50/40/10	T1	D1	H2	5	9					5
50/40/10	T1	D3	H1	5	9					5
50/40/10	T2	D1	H1		9	9				5
50/40/10	T2	D2	H1							
50/40/10	T2	D3	H1		9					5
10/80/10	T1	D1	H1	5	5		5		5	
10/80/10	T1	D1	H2	5	5					
10/80/10	T2	D1	H1		5					
TOTALS				60	123	36	15	0	15	60

NOTES:

1. T1, D1, and H1 are the primary values of laminate thickness, fastener diameter, and fastener head type. T2, T3, D2, D3 and H2 *may be optional* depending on the range of laminate thicknesses and fastener geometries.

laminare strength test matrix.

TENSION BEARING/BYPASS								NUMBER OF TESTS
100% BYPASS		75% BYPASS		50% BYPASS		0% BYPASS		
CTD	RTD	CTD	RTD	CTD	RTD	RTD	ETW	
9	5		5		5	5	9	76
9	5					5	9	47
	5							10
9	5					5	9	47
	5							10
9	5					5	9	47
9						5	9	46
						5	5	10
9							9	32
						5		5
						5		5
						5		5
9	5		5		5	5	9	76
9						5	9	42
9	5					5	9	47
9							9	37
9						5	9	46
						5	5	10
9							9	32
5	5		5		5	5	5	50
5	5					5	5	30
5							5	15
123	50	0	15	0	15	80	133	725

2. "9" represents 3 specimens/batch with 3 batches tested; "5" represents 5 specimens/batch with only 1 batch tested.

2.3.6 Alternate approaches to basis values

2.3.6.1 Lamina mechanical property test matrix for regression analysis

The test matrix of Table 2.3.2.3(b) can be modified for use with regression analysis. Regression analysis allows the pooling of data obtained at different environmental parameters such as temperature, potentially improving the understanding of intermediate temperature effects. It has the added benefit, when used with a suitably sized population of 90 or more datapoints over five or more material batches, of allowing calculation of A-basis statistics for a property, over an environmental range, with a smaller total test population than would otherwise be required.¹ The approach is also particularly useful when an application design temperature changes over the life of the product design, resulting in smaller amounts of data at each of several temperatures.

However, one should be aware of several fundamental assumptions made in statistical regression analysis of strength data, including:

- the failure mode remains constant over the change in the parameter,
- variation remains essentially unaffected by the parameter, and
- parameters that are not included as independent variables (such as moisture content in a regression on temperature) are fixed.

The example regression analysis lamina test matrix shown in Table 2.3.6.1 differs from the point specific test matrix of Table 2.3.2.3(b) in that the "maximum temperature wet" condition has been replaced with three elevated temperature test conditions, providing a more uniform distribution of test data over the temperature range. ET2 represents the maximum operating temperature of a given application. ET1 represents an intermediate elevated temperature above room temperature but below ET2, while ET3 represents an upper end temperature of the material system, such as the MOL. All temperatures are less than either the dry T_g for dry testing or the wet T_g for wet testing. All temperatures represent either a dry material condition or a wet material condition; dry and wet material conditions are not mixed within a given regression analysis. Specific examples of distributed test temperatures include:

!	(350°F epoxy)	-65°F, 73°F, 180°F, 220°F, and 250°F (-50°C, 23°C, 80°C, 100°C, and 120°C)
!	(450°F BMI)	-65°F, 73°F, 250°F, 350°F, and 400°F (-50°C, 23°C, 120°C, 180°C, and 200°C)
!	(600°F polyimide)	-65°F, 73°F, 350°F, 450°F, and 550°F (-50°C, 23°C, 180°C, 230°C, and 290°C)

For data submission for handbook publication the standard population sampling and data documentation requirements discussed in Section 2.5 remain in effect.

¹This assumes the data have a coefficient of variation no higher than 15%. If the CV is larger, more data points will need to be added to the test matrix in order to calculate an A-basis value. If B-basis values are to be calculated, only 30 data points are needed over the temperature range to achieve the same confidence level. Each batch should be distributed over the temperature range as uniformly as possible, and at least three batches must be represented at any one test condition.

TABLE 2.3.6.1 Cured laminate mechanical property test matrix designed for regression analysis.

A-basis level matrix - 5 batches/90 data points per property

Mechanical Property	Test Methods ¹	Test Condition ² and Number of Tests Per Batch ³					Number of Tests
		Min	RT	ET1	ET2	ET3	
	See Handbook Section	Temp					
0° Tension (warp)	6.7.4.4 ⁴	3	4	3	4	4	90
90° Tension (fill)	6.7.4.4 ⁴	3	4	3	4	4	90
0° Compression (warp)	6.7.5.4	3	4	3	4	4	90
90° Compression (fill)	6.7.5.4	3	4	3	4	4	90
In-plane Shear	6.7.6.4	3	4	3	4	4	90
0° Short Beam Shear ⁵	6.7.6.4	-	6	-	-	-	<u>30</u> 480

1. MIL-HDBK-17 is not currently in a position to make exclusive test method recommendations, but the referenced Handbook sections identify methods that are currently deemed acceptable for data submittals to MIL-HDBK-17.
2. Minimum and maximum temperature tests should be performed within $\pm 5^{\circ}\text{F}$ ($\pm 2.8^{\circ}\text{C}$) of the nominal test temperature. Nominal test temperatures will be as agreed to by contractor and certifying agency. Dry specimens are "as-fabricated" specimens which have been maintained at ambient conditions in an environmentally-controlled test laboratory. Wet specimens are environmentally-conditioned by exposing them in a humidity chamber until they attain an equilibrium moisture content agreed to by the contractor and certifying agency, and then packaging them in a heat-sealed aluminized polyethylene bag until required for test. Tests should be performed in a manner which maintains the moisture content in specimens at the levels agreed to by the contractor and certifying agency.
3. Tests should be performed on each of the five batches.
4. For 0° and 90° tension, ASTM D 3039 and SACMA Recommended Method (SRM) 4-88 are acceptable test methods for MIL-HDBK-17 data submittals.
5. Short Beam Shear is for screening and quality control purposes only.

Important Note: This matrix is intended for the generation of dry coupon data. Wet data can be generated by duplicating this test matrix in the wet condition or by generating hot/wet data at the application specific temperature.

Other important notes: Min Temperature is normally -65°F
 ET2 is the maximum application temperature
 ET3 should be less than T_g temperature of the material,
 dry T_g if testing is done dry, wet T_g if testing is done wet.

2.3.7 Data substantiation for use of basis values from MIL-HDBK-17 or other large databases

To reduce development costs for new composite applications, designers and manufacturers need to make use of basis values and properties from large, existing composite materials databases without having to perform tests that essentially duplicate the database. To do this, the user must demonstrate the equivalency of the properties of the composite material processed per their processing parameters and in their design configuration to the properties of the original database material. The demonstration of equivalency is a crucial step in the concept of shared databases. If unable to establish equivalency, the user will not likely be able to use the larger, shared material database for certification purposes without significantly increased amounts of testing.

To use basis values from MIL-HDBK-17 (or from other databases) in design, the using organization should demonstrate the ability to consistently produce the same material as that evaluated during the material testing program. As a minimum, the substantiation tests identified in Table 2.3.2.3(b) should be conducted for this purpose. A total of six specimens per loading condition are required, either using two independently processed material batches or two panels from a single material batch, processed independently. This amounts to twelve specimens per condition. Other test matrices may be acceptable (for example, see Reference 2.3.7) if replication is sufficient to evaluate critical mechanical properties. The statistical procedures used to validate that the data are from the same population as that for which the original basis value was determined are summarized in Section 8.4.1. The use of basis values from any MIL-HDBK-17 data class depends on agreement between the manufacturer and the certifying agency. Deviations from the recommended lamina-level substantiation testing, for example, a reduction or increase in the number of loading conditions evaluated, also depend upon such agreements.

The recommended test matrices and statistical procedures to demonstrate material equivalency are only applicable to the following specific situations:

- (a) An identical material processed by the same part manufacturer using identical fabrication process at a different location,
- (b) An identical material processed by a different part manufacturer using a process that is equivalent to the original database process,
- (c) An identical material processed by the same part manufacturer using a follow-on process that is slightly different from the original process,
- (d) Minor changes by the material supplier in the prepreg constituent(s) and/or constituent manufacturing process, or
- (e) Combinations of the above.

The specific types of changes to the follow-on material system and/or process that may be considered as minor changes include but are not limited to:

- (a) Increasing the cure pressure or vacuum level for the follow-on process. This includes changing from oven curing (vacuum only) to autoclave curing. Decreasing the cure pressure or vacuum level for the follow-on process, however, is generally considered a major change.
- (b) Minor change in cure parameters such as dwell time and heat-up rate.
- (c) Prepreg tack.

The types of changes to the follow-on material system that are considered as major changes, which are not covered by this section but are addressed in Section 2.3.4 Alternate Materials, include:

- (a) Change of fiber (for example, changing from AS4 to T300 or IM7 fibers)
- (b) Change of resin (for example, changing from 3501-6 to E7K8 resin)
- (c) Fabric weave style (for example, changing from 8 harness satin weave to plain weave)
- (d) Tow size of fabric (for example, changing from 6K tow to 3K tow)

Further evaluation or testing may be required depending on the extent of the changes. For example, increasing the prepreg tack may result in higher volatile content. Higher volatile content has been known

to cause higher void content and lower glass transition temperature in the cured laminate. Sections 2.3.4, 2.5.3.4 and 8.4.2 provide further guidance on this subject.

A successful material equivalency demonstration does not imply that the follow-on material and/or follow-on process will also yield equal properties at laminate, element and sub-component levels, as the manufacturing complexity of a particular application may result in different properties. Tests at these levels are typically needed to fulfill the remaining parts of the structural substantiation requirements.

Engineering judgment is a critical element of the equivalency demonstration process. If a mechanical property at one temperature does not show statistical equivalence, the importance of that property and the size of the discrepancy should be investigated before declaring that the material is not equivalent to the shared database material. For example, for fiber dominated laminates tensile strength and modulus and elevated temperature, wet compressive strength and modulus are examples of properties that are usually design critical and more importance should be placed on the statistical test results of these properties.

In addition to the use of material equivalency testing to take advantage of shared databases, similar testing is used to determine whether the natural variations in the material or process alter key properties. Another form of equivalency testing is the material batch acceptance testing using to control materials. Such continuous sampling is performed to ensure the material meets specification requirements, and, when used with a statistical process control system, that the material properties are not changing over time.

2.4 DATA REDUCTION AND DOCUMENTATION

2.4.1 Introduction

This section is reserved for future use.

2.4.2 Lamina properties from laminates

The mechanical properties of composites have increased markedly as materials have evolved. Carbon fiber composite tensile strengths and strains at failure, for example, nearly doubled during the 1980's (Reference 2.4.2(a)). As properties have improved, however, some test methods that were adequate for previous generations of composites are no longer suitable for characterizing the full capabilities of high strength advanced material systems.

The most serious problems relate to accurate determination of basic lamina (ply) tension and compression strengths which, traditionally, have been characterized using unidirectional test specimens for tape and similar form composites. As material capabilities have advanced, the deficiencies associated with these specimens have been greatly amplified. While it is possible in some cases to generate acceptable strength data with unidirectional specimens, extreme care is required in their design and fabrication, thus adding significant cost. As an alternative, data from the testing of crossply¹ laminates have been used by an increasing number of workers to indirectly calculate lamina properties by classical lamination theory.

There are numerous arguments that support this approach. The most frequently claimed advantages are higher (more realistic) strength values with lower data scatter, both of which have been demonstrated by a number of investigators (e.g., References 2.4.2(a) and (b)). Higher values are attributed to reduction or elimination of premature failures stemming from various causes which are discussed later. Lower variability is associated with less sensitivity to specimen quality fluctuation and small manufacturing defects. This reduction in sensitivity reflects more closely the response of structural configurations.

¹The term "crossply" is used as defined in Section 1.7, which differs from other definitions used in the industry. Here it is synonymous with "angleply" and "multi-directional," and is not restricted to laminates of the [0/90] family.

Perhaps the most compelling reason for using crossply testing is that it is more closely representative of application laminates used in actual structural components. Since, in general, a ply may respond to loads differently when adjacent to plies of different orientation than when in isolation (or adjacent to plies of the same directionality), it makes sense to characterize ply properties in their end-use setting. In this way, ply values used in laminate analysis will be more representative of properties expected of the ply in the laminate being analyzed, not those of a ply in isolation.

Although this approach is not a panacea for all testing difficulties, it is becoming quite common in the advanced composites industry, and standardization activities are in progress. The method does offer advantages and should be considered when planning test programs. For additional information the reader is referred to References 2.4.2(c) and (d).

2.4.2.1 Methodology

The general approach for determining longitudinal lamina strength is to select, fabricate, and test a suitable multidirectional laminate, and then calculate 0° ply tensile or compressive strength using classical lamination theory. This methodology makes some assumptions:

1. The laminate fails by the same mechanism and at the same strain as the plies in a unidirectional specimen that does not fail prematurely.
2. The stress-strain curves for both the laminate and lamina are essentially linear elastic to failure (a methodology for use when this does not hold is briefly discussed).
3. The values of E_1 , E_2 , and ν_{12} for the ply used in the equations are valid at incipient failure.
4. Effects of ply residual stresses and damages such as ply cracks are negligible.

Given these assumptions, it is clear that not all laminates are suitable. A family of laminates that has been found useful, and for which the bulk of test data exists, is the $[0_x/90_y]_{ns}$. In this family the $[0/90]_{ns}$ is most widely used. While this laminate is not commonly used for actual structure, it does provide an environment where adjacent plies are of different orientation. In addition, the calculated factor (discussed below) is reasonably low. Quasi-isotropic laminates have also been used successfully, but the factor is almost twice as high as for the $0^\circ/90^\circ$ laminates, giving somewhat less confidence. Laminates with so many $\pm 45^\circ$ plies as to cause ν_{12} for the laminate to exceed ν_{12} for the lamina are not preferred because the strain to failure may not be as great as for the unidirectional specimens. Some composites with very brittle resin matrices do not permit the fabrication of quality $0^\circ/90^\circ$ laminates due to splitting during cool-down after cure. In such cases some $\pm 45^\circ$ plies must be included. Within a family of laminates, stacking sequence will have an effect. Laminates with several plies of the same orientation stacked together (thick layers) will generally yield lower compressive strength values than more homogeneous lay-ups (Reference 2.4.2.1). Obviously, symmetric laminates must be used in all cases to preclude bending.

The third assumption presumes that E_1 , E_2 , and ν_{12} have been obtained from other tests (most likely, unidirectional specimens). This does not present a serious problem, since the shortcomings of unidirectional specimens do not affect modulus measurements to the same degree as strength measurements. It can be argued that E_2 (and to some degree E_1) is not linear to failure, and is usually calculated significantly below the failure load. However, as discussed in detail later, this is not a significant issue due to the rather low sensitivity of this methodology to variation in E_2 .

To calculate lamina strength, the measured test laminate strength is multiplied by a crossply factor (CPF) generated from classical lamination theory:

$$F_1 = \text{CPF} \cdot F_x \quad 2.4.2.1(a)$$

For the $[0_x/90_y]_{ns}$ family of laminates this factor, based on the assumption of uniform strains in each ply, is calculated according to the following formula:

$$CPF = \frac{E_1 [mE_2 + (1-m)E_1] - (\nu_{12}E_2)^2}{[mE_1 + (1-m)E_2][mE_2 + (1-m)E_1] - (\nu_{12}E_2)^2} \quad 2.4.2.1(b)$$

where m is the fraction of 0° plies in the laminate (E_1 , E_2 , and ν_{12} are for tension or compression as appropriate).

For $[0/90]_{ns}$ laminates (equal numbers of 0° and 90° plies), the formula reduces to:

$$CPF = \frac{E_1 \left(\frac{E_1 + E_2}{2} \right) - (\nu_{12}E_2)^2}{\frac{(E_1 + E_2)^2}{4} - (\nu_{12}E_2)^2} \quad 2.4.2.1(c)$$

As stated above, these equations are not very sensitive to variability in E_2 , and show very little response to changes in ν_{12} . For $[0/90]_{ns}$ laminates with $E_1 = 20$ Msi, a 20% change in E_2 results in less than 2% change in the factor, and a 20% change in ν_{12} has negligible effect. Therefore, E_2 and ν_{12} do not have to be quantified with great accuracy (the precise effect on the factor will, of course, depend on the actual ratio of E_1 to E_2). The shear moduli of a ply are a function of stress. Since these moduli affect stability, and hence compressive strength, there may be some difficulties with soft matrix materials.

Many times a value for E_2 may not be available at all. If this is the case, there is an alternate approach, which may be preferable even if E_2 has been determined. This method involves measuring only E_1 from a unidirectional specimen, and E_x of the crossply laminate being tested. Under assumption 1 that the test laminate fails at the same strain as a unidirectional specimen, the lamina strength may be calculated as follows:

$$F_1 = \frac{E_1}{E_x} F_x \quad 2.4.2.1(d)$$

Very good agreement has been reported between the E_1/E_x ratio and the factor, F , obtained as described above (Reference 2.4.2(a)).

All of the methodology described thus far assumes linear stress-strain behavior to failure. If this is not the case (as in some crossply glass/epoxy laminates, for example), the fiber direction lamina strength can be calculated as follows:

$$F_1 = E_1(\varepsilon_x + \nu_{21}\varepsilon_y) / (1 - \nu_{12}\nu_{21}) \quad 2.4.2.1(e)$$

where the strains (ε) in the x and y directions are those measured at failure.

If Poisson effects can be neglected, the above equation reduces to:

$$F_1 \approx E_1 \varepsilon_x \approx F_x \frac{E_1}{E_x^*} \quad 2.4.2.1(f)$$

where E_x^* is the secant modulus of the laminate at failure. This equation is useful when E_2 are not known.

2.4.2.2 Tension strength tests

Well designed and fabricated unidirectional tensile specimens can give good results for advanced composites, but this is generally the exception rather than the rule. One major problem is premature failure at the tips of adhesive bonded tabs, particularly when they are tapered gently rather than square cut and gripped over their entire length. The higher loads required to test advanced composites often result in high peel forces at the tab ends and subsequent interlaminar tension failure of the first ply of the composite. Once this has occurred, most of the load is taken by this outer ply, which then fails in tension and results in tab loss. Since lower loads are required to test crossply specimens, this is much less likely to happen.

Rawlinson (Reference 2.4.2(a)) and others have investigated various laminate stacking sequences. Both 0/90 and 0/±45 balanced laminates yielded mean strength values comparable to those measured from the best quality unidirectional specimens, and had significantly less data scatter. In addition, it has been demonstrated that some of these laminates can be tested successfully without bonded tabs using hydraulic grips, thus offering additional testing economy. What have sometimes been referred to as "tab-less" specimens actually require an interlayer between the grips and the specimen: for example, a sheet of emery paper with the abrasive side in contact with the specimen, or an abrasive-coated wire mesh with a sheet of plastic to protect the jaws of the test machine. If bonded tabs are not used, 0° plies should not be on the outside surfaces of the laminate since damage may be inflicted by the grips. Thus, for crossply testing without bonded tabs, a [90/0]_{ns} laminate would be preferred over [0/90]_{ns}. It should be noted that surface strain measurements are more sensitive to matrix cracking of the outer 90° plies in the [90/0]_{ns} configuration. If bonded tabs are used, the stacking sequence of the tab material is important to consider (Reference 2.4.2(b)) (see Section 6.7.4). For coupons with tabs there appears to be little difference between results from [90/0]_{ns} and [0/90]_{ns} laminates.

2.4.2.3 Compression strength tests

As in tensile testing, the high loads needed to test advanced composites cause problems in compression testing of unidirectional specimens. In compression, end "brooming" and longitudinal splitting are common modes of premature failure. Occurrence of these modes is greatly reduced or eliminated by crossply specimens, which tend to fail in microbuckling or ply buckling (Reference 2.4.2.3). Furthermore, low sensitivity to methods of loading and end constraint has been reported for quasi-isotropic laminates (Reference 2.4.2.3). The same result has been reported by others for [0/90]_{ns} laminates. This suggests that the capability of the material is being evaluated, not the capability of the test method.

There is currently no consensus regarding the "best" laminate stacking sequence to be used, although [0/90]_{ns} has been commonly employed. These specimens are reported to give high strength values and low data scatter. Data from several sources (yet unpublished) indicate that [90/0]_{ns} laminates yield higher mean values than [0/90]_{ns}. The reason for this increase has not been conclusively established, but has been attributed to several factors. First, there is speculation that the 90° outer plies act to protect the load bearing 0° plies from damage which might be inflicted during specimen fabrication or testing. Such damage could provide sites for initiation of premature failure if inflicted on 0° plies. Second, it is thought that the presence of the outer 90° plies enhances the stability of the otherwise outer 0° plies. If this is true, structural analysts will have to determine if design properties derived from [90/0]_{ns} laminates are appropriate for specific applications where outer 0° plies are aligned with the primary compressive load direction. Third, it is known that 0° outer plies increase stress concentrations at the ends of the gage area for tabbed test specimens, and this is suspected to contribute to premature failure. Fourth, outer 0° plies might split as a result of transverse tensile stresses induced by Poisson effects.

2.4.2.4 Other properties

Transverse strengths of unidirectional composites have always been difficult to characterize because of premature failures due to extreme notch sensitivity. In an effort to improve this situation, a few studies using crossply laminates have been undertaken, but these are not well documented. There is relatively low interest in pursuing this since, for the analysis of most structure, the accuracy of these strength values does not significantly affect the result unless the transverse strength used in the analysis is so low as to cause a false prediction of a "first ply" failure.

[+45/-45]_{ns} laminates tested in tension have commonly been used to derive [0/90] (matrix-dominated) in-plane shear strength and modulus properties. This method generally produces a strength result that is a lower bound of the true material shear capability. See Section 6.7.4 of this volume for more detail.

2.4.3 Data normalization

Data analysis is performed on mechanical test data for a variety of reasons that include determination of multi-batch statistics and statistically based property values (allowables), comparison of materials from

different sources, material selection, evaluation of processing parameters, and quality assurance evaluation. Such calculations or direct comparisons may not be valid if test specimens having different fiber volume contents were tested. Normalization is a procedure for adjusting raw test values to a single (specified) fiber volume content. The following sections discuss the theory, methodology, and practical application of normalization.

2.4.3.1 Normalization theory

Mechanical properties that are dominated by the properties of the reinforcing fiber are dependent on the volume fraction of fiber in the laminate. In the commonly used "rule of mixtures" model, 0° tensile strength of a unidirectional laminate, for example, is assumed equal to the matrix tensile strength at 0% fiber volume, and equal to the fiber strand tensile strength at 100% fiber volume. Neglecting the effects of resin starvation at high fiber contents, the relationship between fiber volume fraction and ultimate laminate strength is, therefore, linear over the entire range of fiber/resin ratios. This follows from the fact that volume percent fiber is the same as the area percent fiber in the specimen cross-section. Tensile modulus is expected to follow the same behavior. Thus, test specimens having different fiber volume contents have fiber-dominated properties that vary linearly with fiber volume fraction.

Two factors can cause laminate fiber volume fraction to vary: (1) the amount of matrix resin present relative to the amount of fiber (resin content), and (2) the amount of porosity (void volume). These factors give rise to changes in fiber volume fraction from material to material, batch to batch, panel to panel, and even specimen to specimen within a panel. In order to perform data analysis that compares materials, batches, panels, or specimens, the data for fiber-dominated properties must be adjusted to a common fiber volume fraction. If this is not done, an additional source of variability will be included in the data that might lead to erroneous conclusions. The process of data normalization attempts to remove or reduce this source of variability in fiber-dominated properties.

2.4.3.2 Normalization methodology

Since, in theory, fiber-dominated strength and stiffness properties vary linearly with fiber volume fraction, an obvious first approach would be to determine the actual fiber volume fractions of the test specimens by an appropriate method (matrix digestion, ignition, optical techniques, etc.), and to adjust raw data values by the ratio of a common fiber volume fraction (chosen or specified) to the actuals as shown in Equation 2.4.3.2(a).

$$\text{Normalized value} = \text{Test value} \times \frac{FV_{\text{normalizing}}}{FV_{\text{specimen}}} \quad 2.4.3.2(a)$$

where

$$\begin{aligned} FV_{\text{normalizing}} &= \text{chosen common fiber content (volume fraction or \%)} \\ FV_{\text{specimen}} &= \text{actual specimen fiber content (volume fraction or \%)} \end{aligned}$$

Although this would appear to be the most direct approach, it has limitations. The most serious deficiency is that fiber volume is not commonly measured for each individual test specimen. At best, representative pieces from each test panel are used to estimate the average panel fiber volume fraction. Since resin content might vary significantly within a panel (due to resin movement during processing and other factors), the fiber volume fraction might not be the same for all specimens cut from the panel. As a result, accurate normalization of each individual specimen is not possible. In addition, digestion methods can be problematic with some material systems, and considerable skill is required for accurate, repeatable results (see Section 6.4.6 for information on fiber volume methods).

A preferred method of data normalization employs an approach that accounts for the fiber volume variation between individual test specimens. The basis of this method is the relationship between fiber volume fraction and laminate cured ply thickness. As stated earlier, laminate fiber volume fraction is a function of resin content and void content. At a given void content, laminate fiber volume fraction is entirely dependent upon resin content. Furthermore, for a given void content and fiber areal weight, panel

thickness (and hence cured ply thickness) is also dependent only upon resin content. Thus, it follows that cured ply thickness is solely dependent upon fiber volume fraction for constant fiber areal weight and void content. This dependency permits normalization of each individual test specimen by its ply thickness (total thickness divided by number of plies). An example of this relationship between cured ply thickness and fiber volume fraction (which is virtually linear within the 0.45 to 0.65 fiber volume fraction range of usual interest for structural composites) is shown in Figure 2.4.3.2.

The following describes the derivation of an equation for normalizing each individual test specimen. Using the relationships discussed in the previous paragraph, expressions for $FV_{normalizing}$ and $FV_{specimen}$ are developed and substituted into Equation 2.4.3.2(a). For illustrative simplicity compatible units of measure are assumed.

The first step is to define an equivalent thickness of fiber which would result if the fiber material could be shaped into a solid sheet of uniform thickness with no air space between filaments:

$$t_f = \frac{FAW}{\rho_f} \tag{2.4.3.2(b)}$$

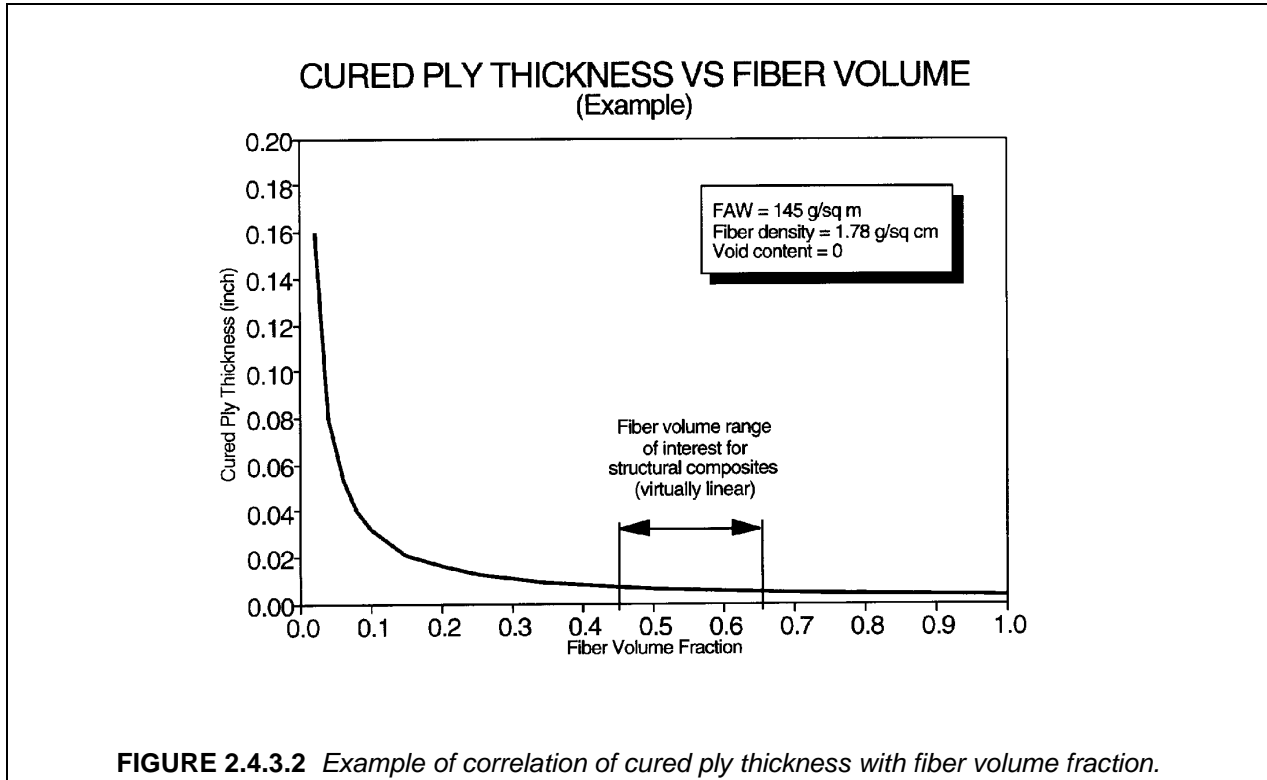

where

- t_f = equivalent thickness of a solid layer of fiber
- FAW = reinforcement fiber areal weight
- ρ_f = fiber density

The fraction of fiber in a laminate is then the thickness of this fiber layer divided by the total laminate thickness:

$$FV = \frac{t_f}{CPT} \tag{2.4.3.2(c)}$$

where

- FV = fiber volume fraction

CPT = laminate cured ply thickness

From Equations 2.4.3.2(b) and 2.4.3.2(c) it follows that

$$FV = \frac{FAW}{\rho_f \times CPT} \quad 2.4.3.2(d)$$

This is the equation that was plotted for the example in Figure 2.4.3.2. It then follows that

$$FV_{normalizing} = \frac{FAW_{nominal}}{\rho_f \times CPT_{normalizing}} \quad 2.4.3.2(e)$$

and

$$FV_{specimen} = \frac{FAW_{specimen}}{\rho_f \times CPT_{specimen}} \quad 2.4.3.2(f)$$

where

- FV_{normalizing} = fiber volume fraction specified or chosen for normalizing
- FV_{specimen} = fiber volume fraction of the specimen
- FAW_{nominal} = nominal fiber areal weight from a material specification or other source
- FAW_{specimen} = specimen actual fiber areal weight
- CPT_{normalizing} = cured ply thickness corresponding to normalizing fiber volume fraction
- CPT_{specimen} = actual specimen ply thickness (specimen thickness divided by number of plies)

Combining Equations 2.4.3.2(e) and 2.4.3.2(f), the following is obtained:

$$\frac{FV_{normalizing}}{FV_{specimen}} = \frac{FAW_{nominal}}{FAW_{specimen}} \times \frac{CPT_{specimen}}{CPT_{normalizing}} \quad 2.4.3.2(g)$$

and substituting 2.4.3.2(g) into 2.4.3.2(a) produces:

$$\text{Normalized value} = \text{Test value} \times \frac{FAW_{nominal}}{FAW_{specimen}} \times \frac{CPT_{specimen}}{CPT_{normalizing}} \quad 2.4.3.2(h)$$

Thus, each specimen can be normalized by multiplying the test value by the ratios of fiber areal weight and cured ply thickness shown. The normalizing cured ply thickness is calculated by rearranging Equation 2.4.3.2(e) as follows:

$$CPT_{normalizing} = \frac{FAW_{nominal}}{FV_{normalizing} \times \rho_f} \quad 2.4.3.2(i)$$

While Equation 2.4.3.2(h) is illustrative of the model initiated in Equation 2.4.3.2(a), it is not necessary to calculate CPT_{normalizing} if Equation 2.4.3.2(h) is transformed to:

$$\text{Normalized value} = \text{Test value} \times \frac{FV_{normalizing} \times CPT_{specimen} \times \rho_f}{FAW_{specimen}} \quad 2.4.3.2(j)$$

The value for FAW_{specimen} is defined as the actual fiber areal weight for each individual specimen, but this measurement is not made on a specimen basis. However, since fiber areal weight does not usually vary greatly within a batch of material, the batch average (or roll average, if available) fiber areal weight is generally sufficient for normalization. In the case of laminates made by resin transfer molding (RTM) or other non-prepreg processes, lot or roll average areal weights for the fabric or preforms should be used. With this assumption that batch fiber areal weight approximates specimen fiber areal weight within a batch, Equation 2.4.3.2(j) becomes:

$$\text{Normalized value} = \text{Test value} \times \frac{FV_{normalizing} \times CPT_{specimen} \times \rho_f}{FAW_{batch}} \quad 2.4.3.2(k)$$

In actual practice, fiber areal weight is commonly reported in g/m² and fiber density in g/cm³, while ply thickness may be in inches or millimeters. For these units, Equation 2.4.3.2(k) requires a conversion factor of 25,400 in the numerator if ply thickness is in inches, or a factor of 1000 if in millimeters. With these factors included, Equation 2.4.3.2(k) becomes:

$$\text{Normalized value} = \text{Test value} \times \frac{25,400 \times FV_{normalizing} \times CPT_{specimen} \times \rho_f}{FAW_{batch}} \quad 2.4.3.2(l)$$

or

$$\text{Normalized value} = \text{Test value} \times \frac{1000 \times FV_{\text{normalizing}} \times CPT_{\text{specimen}} \times \rho_f}{FAW_{\text{batch}}} \quad 2.4.3.2(m)$$

where

- $FV_{\text{normalizing}}$ = fiber volume fraction specified or chosen for normalizing
- CPT_{specimen} = actual specimen ply thickness (specimen thickness divided by number of plies), inch (Equation 2.4.3.2(l)) or mm (Equation 2.4.3.2(m))
- ρ_f = fiber density, g/cm³
- FAW_{batch} = batch average fiber areal weight, g/m²

As stated earlier, void content affects fiber volume fraction. If porosity is "added" to a laminate, the thickness will increase and the fiber volume fraction will decrease. However, for a given fiber areal weight, the change in fiber volume fraction will be the same regardless of the source of a thickness change (resin content change or void content change). Thus, when normalizing using Equation 2.4.3.2(l) or 2.4.3.2(m), there is no need to make any adjustment for void volume. This assumes, of course, that the void content is not so large or localized that basic load carrying capability is reduced.

A hybrid method uses both individual specimen thickness and fiber volume data obtained by experimental methods (matrix digestion, ignition, optical techniques, etc.). This approach is shown by Equation 2.4.3.2(n):

$$\text{Normalized value} = \text{Test value} \times \frac{CPT_{\text{specimen}}}{CPT_{\text{batch avg.}}} \times \frac{FV_{\text{normalizing}}}{FV_{\text{batch avg.}}} \quad 2.4.3.2(n)$$

where

- CPT_{specimen} = actual specimen ply thickness (specimen thickness divided by number of plies)
- $CPT_{\text{batch avg.}}$ = batch average cured ply thickness calculated from a number of panel or specimen thickness measurements
- $FV_{\text{normalizing}}$ = fiber volume fraction specified or chosen for normalizing
- $FV_{\text{batch avg.}}$ = batch average fiber volume fraction calculated from a number of experimental fiber volume determinations from panels within the batch

In Equation 2.4.3.2(n), the test value is first adjusted by specimen ply thickness to an average batch ply thickness. This essentially normalizes the data to a common fiber volume fraction, presumably the batch average fiber volume fraction. The second ratio in Equation 2.4.3.2(n) then makes a further adjustment from the batch average fiber volume fraction to the normalizing fiber volume fraction. This method can be useful when fiber areal weights are not available. However, this approach requires another assumption: that the specimens used to experimentally determine batch average fiber volume fraction had an average ply thickness equal to $CPT_{\text{batch avg.}}$. This is not generally the case, since batch average cured ply thickness may be determined from many measurements over a number of panels, while batch average fiber volume fraction may be obtained from comparatively few specimens. If fiber volume specimens are selected carefully so they are representative of batch ply thickness, this method may be used successfully.

2.4.3.3 Practical application of normalization

Common practice is to normalize fiber-dominated lamina and laminate strengths (both unnotched and notched) and moduli for laminates fabricated from tapes, fabrics, and rovings. Although fiber volume effects on various matrix-dominated properties (in-plane and interlaminar shear, for example) have been observed, there is no clear model for these effects, and such properties are not normalized. In Volume 2 of this Handbook, normalized values are presented for all mechanical strength and stiffness properties *except*: 90° (transverse) tension and compression of unidirectional laminates, interlaminar (3- or z-direction) tension, interlaminar shear, in-plane shear, short beam strength, bearing, bearing/bypass, strain energy release rate, and Poisson's ratio.

Laminates fabricated from rovings and similar forms using a winding process present a unique situation relative to normalization. Such constructions do not have plies in the usual sense: the wound "ply" thickness depends upon tow band width, wind spacing, and tow spread during winding. Since nominal ply thickness and fiber areal weight are not directly applicable, normalization by ply thickness and fiber areal weight is not possible. Test data for these materials must be normalized using the ratio of normalizing fiber volume fraction to the average measured panel fiber volume fraction (Equation 2.4.3.2(a)).

When fiber-dominated properties are normalized, data scatter should decrease compared to the unnormalized values since variability due to fiber volume fraction differences is being reduced. Thus, coefficients of variation should be lower after normalization. However, this is not always observed, and there are a number of reasons why the reduction in scatter expected from normalization is not invariably realized:

1. If measured cured ply thicknesses are close to the normalizing thickness and fiber areal weight is close to nominal, correction factors will be small, and may be nearly the same magnitude as errors in measuring these quantities.
2. The mode of failure initiation may change as a function of fiber volume. As an example, measured (unnormalized) compression strength may increase as fiber volume fraction increases over a given range. However, at some point additional fiber may not increase strength because the ability of the matrix to support the fibers has been exceeded, and a stability failure occurs on a macro scale. In this case, the relationship between strength and fiber volume breaks down, and data scatter is not necessarily reduced by normalization.
3. Flaws in test specimens might cause premature failures. If some specimens fail because of flaws and others at the true material limit, results of normalization will not be predictable.
4. If the coefficient of variation is already small (less than 3%, for example), further reduction as a result of normalization should not be expected, since this level of variability is about the minimum usually observed for most composite properties.

No change in data scatter after normalization is usually not a cause for concern. However, if data scatter *increases* significantly after normalization, the reason should be investigated.

2.4.4 Dispositioning of Outlier Data

Detection of outlier data points (observations which are much lower or much higher than other observations in a data set) is part of statistical analysis and is discussed in Volume 1, Section 8.3.3. Although Section 8.3.3 cautions against discarding outlier data for which no clear cause for its erroneous nature has been found, there are cases where outliers can (and should) be removed based on judgment. The following paragraphs attempt to attach some degree of structure to the judgment process so that outliers that should be retained are not casually discarded, and those which should be deleted are not retained.

For purposes of this discussion, it is assumed that the objective of testing is to characterize the properties of a material when processed, conditioned, and tested in accordance with specified procedures and parameters. If this is the case, variability within the test data should (ideally) reflect only material variability (raw material quality, constituent process variability, mix ratios, etc.), processing parameter variability (within the control ranges for the specimen fabrication process), variability in the environmental history of the specimens prior to test (within control limits), and variability within the tolerances of the test machine parameters. In reality there is also unavoidable random variability due to unknown and uncontrollable factors. However, beyond these inevitable and acceptable sources of variability are sources of error that inflate the observed data scatter. This additional variability may be due to inferior fabrication practices, process parameters that exceed allowed control limits, test fixture or test machine deficiencies, and any number of other factors both detectable and undetectable. The task in dealing with outlier data is to determine (based on physical evidence and judgment) whether the data variability is from a source that re-

flects accepted material and process variability (in which case the outlier data is retained), or from an erroneous external source (in which case the outlier data is discarded).

When outlier data is detected (either by visual inspection of the data or by statistical tests), the first action should be to identify the cause through physical evidence. The following list gives some examples of conditions that could be used as the basis for discarding outlier data (the list is not exhaustive):

1. The material (or a constituent) was out of specification
2. One or more panel or specimen fabrication parameters were outside the specified tolerance range
3. Test specimen dimensions or orientation were outside the specified tolerance range
4. A defect (not under study) was detected in the test specimen
5. An error was made in the specimen preconditioning (or conditioning parameters were out of specified tolerance ranges)
6. The test machine and/or test fixture was improperly set up in some specific and identifiable manner
7. The test specimen was improperly installed in the test fixture in some specific and identifiable manner
8. Test parameters (speed, test temperature, etc.) were outside the specified range
9. The test specimen slipped in the grips during test
10. The test specimen failed in a mode other than the mode under test (loss of tabs, unintended bending, failure outside the gage section, etc.)
11. A test was purposely run to verify conditions suspected to have produced outlier data
12. Data were improperly normalized

Once the search for physical causes has been completed without success, the judgment process begins. There are many approaches to assessing outlier data for which no physical cause has been identified. The following is suggested as one possible process, and follows the flow chart shown in Figure 2.4.4.

When an outlier is detected, it may or may not be a cause of concern. If its inclusion in the data does not significantly affect calculated basis values and does not raise other engineering issues, it may simply be retained without further consideration.

If an outlier data point was detected in a single batch or set of data, and if additional data sets are available (same fabrication, conditioning, and test conditions), there are a number of considerations that can be used to support a judgment call. If, on the other hand, additional data sets are not available, or if the outlier was detected only after combining (pooling) several data sets (see Volume 1, Section 8.3.1), there are fewer options to consider and judgment is more subjective.

In the case of a single data set outlier where additional data sets are available, the first consideration is to determine if the outlier in question is within the range of the non-outliers of the other data set(s). If it is within the non-outlier range of the other data, it is recommended that the outlier be retained.

If a single data set outlier is outside of the non-outlier range of other data, the next option is to obtain retest data using specimens from the same part or panel as the original data that contained the outlier. If the retest data refutes the outlier data, the retest data set may be used to replace the entire original data set. The replacement set is then combined with the other data sets. If outliers still exist in the retest data, the original data is retained and combined with the other data sets. The retest data set may also be added to the body of data. Regardless of whether the original data was replaced or not, the combined set is then tested for outliers. If no outliers are detected in the combined set of data, no deletions from the combined set are made.

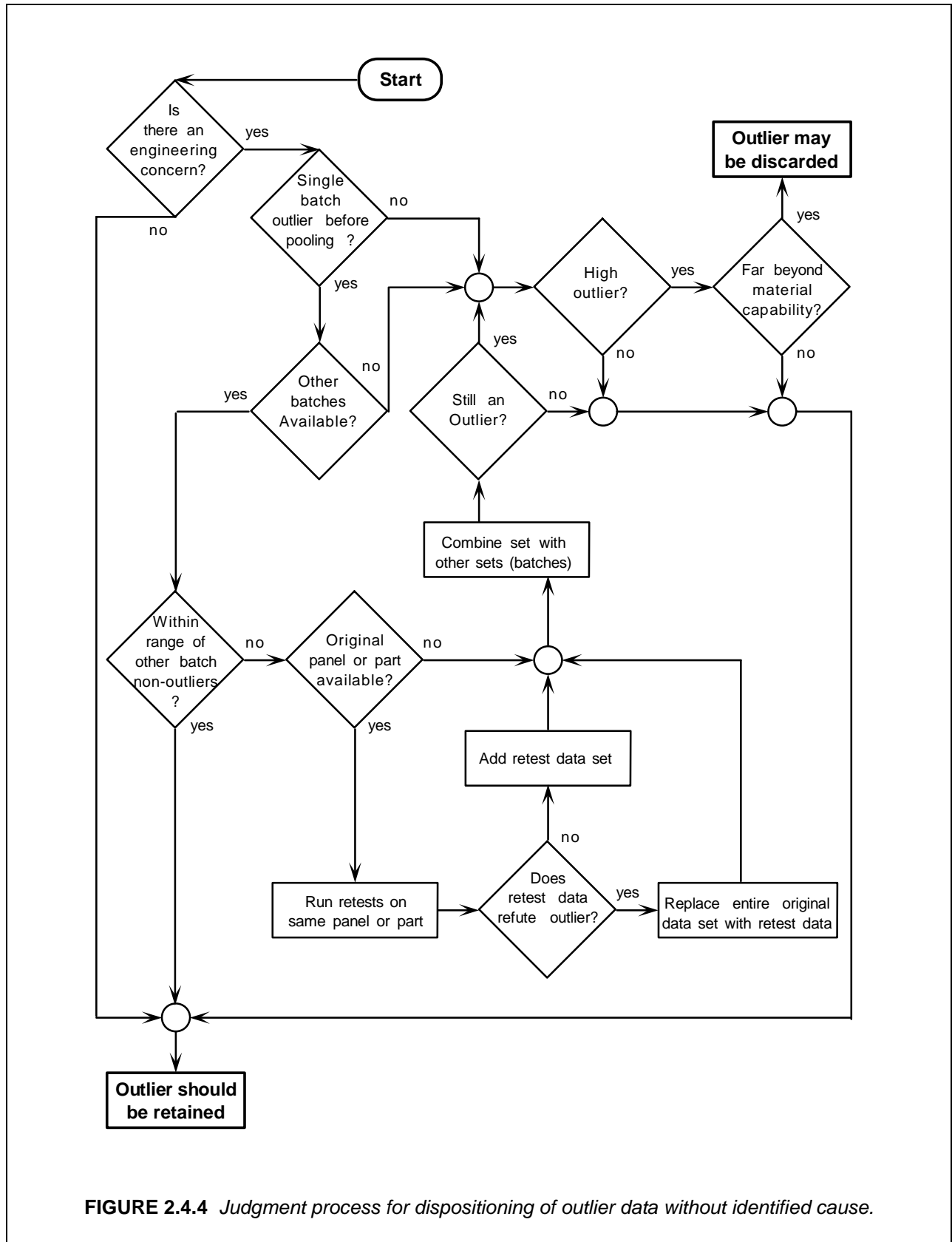

FIGURE 2.4.4 Judgment process for dispositioning of outlier data without identified cause.

If there are outliers in the combined data set (or in a single set where no additional sets were available), the judgment process becomes even more subjective. In this case it is recommended that only high outliers be considered for deletion. Generally, if a high outlier is so high that, based on experience and similar test results from other sources, it is clearly beyond the known or expected capability of the material, it may be discarded. If low outliers exist in single data sets and no additional sets are available, additional batches should be tested and the judgment process repeated. Retests of the same single batch are not considered sufficient without additional batch information.

Note that the judgment process does not specifically identify a cause, and does not really prove that the questionable data resulted from erroneous variability. The judgment process attempts to build a body of information that leads to the conclusion that it is highly likely that erroneous variability (caused by something other than expected material, process, or testing variations) was responsible for the outlier. This approach to outlier disposition should only be used after all attempts to identify and quantify physical causes have failed. The rationale for any data deletions made by the judgment process should be fully documented.

2.4.5 Data documentation

This section is reserved for future use.

2.5 MATERIAL TESTING FOR SUBMISSION OF DATA TO MIL-HDBK-17

2.5.1 Introduction

Section 2.5 describes the requirements for publication of material property data in MIL-HDBK-17 Volume 2. A Data Source Information Package is available from the MIL-HDBK-17 Coordinator or Secretariat to aid data suppliers in submitting data to the Handbook. This package provides recommendations on data preparation and transfer and a diskette containing ASCII text and spreadsheet files containing suggested formats for specimen, batch, and material information. The overall data submittal and review process is described in Section 1.5 and summarized in Figure 2.5.1.

Material property data sets submitted for possible publication are classified by one of the MIL-HDBK-17 data classes described below, and are examined to see that material and process (Section 2.5.2), sampling (Section 2.5.3), conditioning (Section 2.5.4), test methods (Section 2.5.5), and data documentation (Section 2.5.6) requirements are met for the properties discussed in Sections 2.5.7-2.5.11. B-basis values are presented in the handbook only for B and A data classes. (If sufficient data are available, an A class designation is used and both A- and B-values are presented). The MIL-HDBK-17 data classes are:

- **A75 – Robust Sampling Data**
Statistically-based material properties that meet the most stringent handbook level of population sampling, data documentation and test method requirements. A- and B-values are presented in the handbook. The upper-case letter A is used for summary tables.
- **A55 – Reduced Sampling Data**
Statistically-based material properties that meet the most stringent handbook level of data documentation and test method requirements with reduced sampling appropriate for certain applications (See Volume 3, Chapter 4, [Building Block Approach]). A- and B-values are presented in the handbook. The lower-case letter a is used for summary tables.

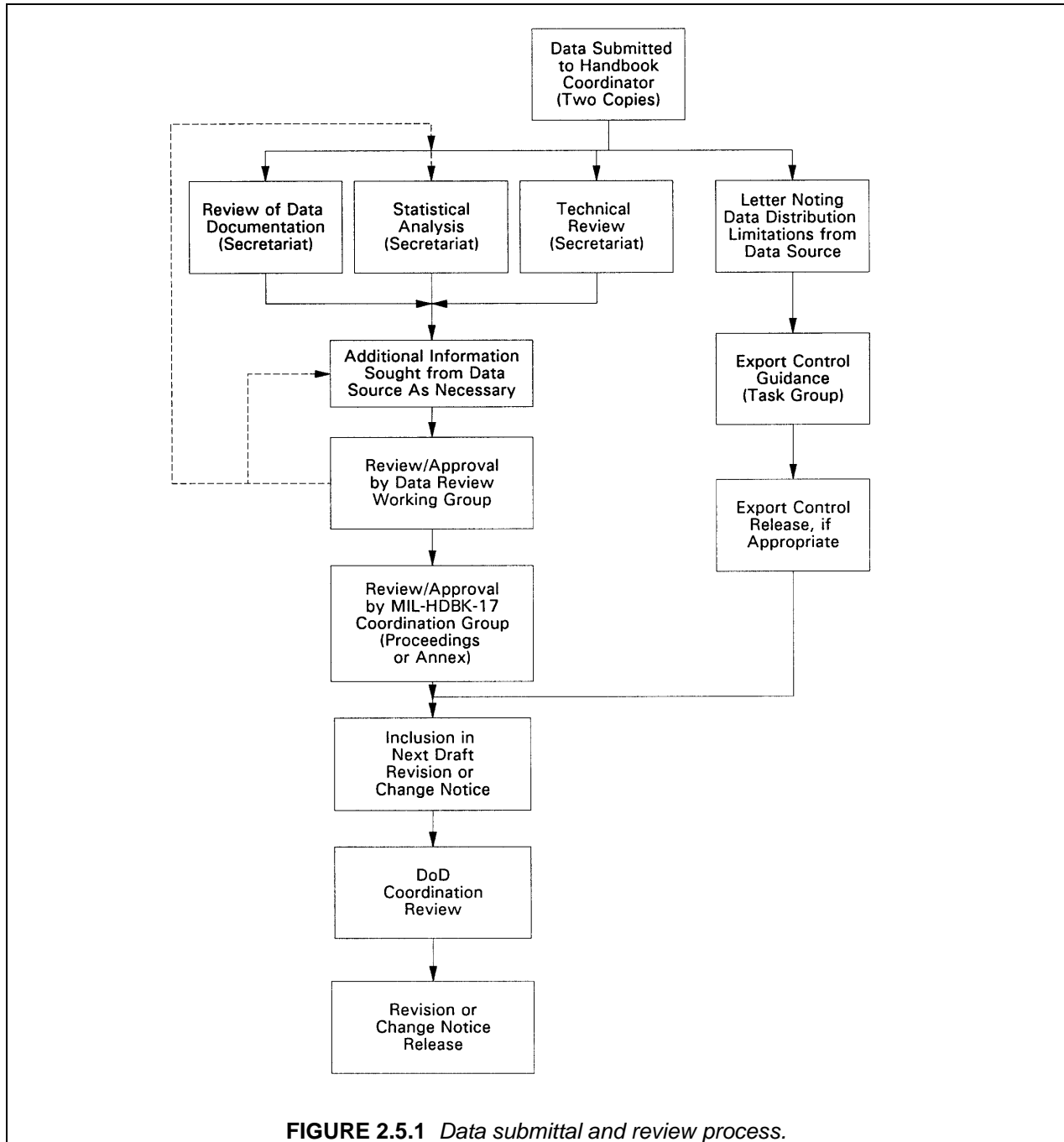

FIGURE 2.5.1 Data submittal and review process.

- B30 – Robust Sampling Data¹
Statistically-based material properties that meet the most stringent handbook level of population sampling for B-values, data documentation and test method requirements. B-values are presented in the handbook. The upper-case letter B is used for summary tables.

¹ The B30 data class corresponds to the Fully Approved class in MIL-HDBK-17 versions B through E.

- **B18 – Reduced Sampling Data**
Statistically-based material properties that meet the most stringent handbook level of data documentation and test method requirements with reduced sampling appropriate for B-values for certain applications (See Volume 3, Chapter 4 (Building Block Approach)). B-values are presented in the handbook. The lower-case letter b is used for summary tables.
- **M – Mean Data**
Mean material properties that meet the most stringent handbook level of data documentation and test method requirements. This data class generally applies to modulus and Poisson's ratio data and other properties for which basis values are not typically used. The upper case letter M is used for summary tables.
- **I – Interim Data**
Data that do not meet the specific sampling or data documentation requirements required of B and A data classes. Interim data can be subdivided into two categories:
 1. Data that meet data documentation requirements for B and A data classes, but for which insufficient batches or replicates were tested. These data may potentially be pooled with other data to create a properly-sampled population that meets the B and A data requirements.
 2. Data which fail to meet the data documentation requirements for B and A data, even if the population sampling is adequate for those data classes. Such data cannot be used for subsequent pooling.
- **S – Screening Data**
Data representing fewer than three batches, or data resulting from a test method limited to the screening level of approval. The screening data class is intended to provide for rapid inclusion in the handbook of data for new materials and other information that is useful even with a limited data set as described in Section 2.1.2.2 and as illustrated by the recommended test matrix of Table 2.3.1.1.

Note that, for uses other than inclusion in MIL-HDBK-17, selection of a material data class for use in an application is subject to agreement between the contractor and the certifying agency.

2.5.2 Material and process specification requirements

All materials submitted to the handbook should be manufactured in accordance with a material specification that imposes requirements on key physical and mechanical properties and should be processed in accordance with a process specification that adequately controls key processing parameters.

2.5.3 Sampling requirements

As noted in Section 2.2.5.1, the magnitude of a basis value is a function of the amount of data obtained, the number of batches represented, and the uniformity of the batches produced. Basis values are presented in the handbook only for B and A data classes. The minimum sampling requirements for each class are shown in Table 2.5.3.

The essence of documentation requirements is complete traceability and control of the database development process from material production, through procurement, fabrication, machining, environmental conditioning, gaging, testing, data acquisition, data normalization, and final statistical interpretation. The key items of information from this process for lamina/laminate mechanical testing are summarized in Table 2.5.6 and should be documented as part of any such material property determination. The items marked (●) should be included with any data submitted to the Secretariat. The items marked (⊗), as well as all items marked (●), must be included in the submission in order for submitted data to qualify for B, A, and M data classes. All other information should be traceable and available to the Secretariat for validation of statistical outliers. This list is based on the information necessary for lamina/laminate level me-

chanical property testing. Individual documentation items or documentation groups are not required where they are not applicable¹.

TABLE 2.5.3. *Minimum sampling requirements for MIL-HDBK-17 data classes.*

Designation	Symbol	Description	Minimum Requirements	
			Number of Batches	Number of Specimens
A75	A	A-Basis – Robust Sampling	10	75
A55	a	A-Basis – Reduced Sampling	5	55
B30	B	B-Basis – Robust Sampling	5	30
B18	b	B-Basis – Reduced Sampling	3	18
M	M	Mean	3	18
I	I	Interim	3	15
S	S	Screening	1	5

2.5.3.1 *Additional requirements for B and A data classes*

The prepreg batches should be prepared by the material supplier using production facilities. The first prepreg batches, up to five, should each be made using distinct fiber and matrix constituent lots (not required for batch numbers greater than five). For each condition and property, batch replicates should be sampled from at least two different test panels covering at least two separate processing cycles. Test panels should be nondestructively evaluated using ultrasonic inspection or another suitable nondestructive inspection technique. Test specimens should not be extracted from panel areas having indications of questionable quality. A test plan (or report) should document laminate design, specimen sampling details, fabrication procedures (including material traceability information), inspection methods, specimen extraction methods, labeling schemes, and test methods.

2.5.3.2 *Data pooling*

The ability to pool multiple similar but not identical data sets is desirable in order to obtain sufficient data to calculate material property basis values. Data sets for pooling may be available for materials from different fabricators, different locations of a single fabricator, or slightly different processes from the same fabricator.

Decisions on suitability of pooling will be made by the MIL-HDBK-17 Data Review working group, which will examine all tested properties for batch-to-batch variability (Section 8.3.2.2). Advance approval of the MIL-HDBK-17 Data Review working group is recommended before starting a new testing program that relies on pooling. However, MIL-HDBK-17 Data Review approval of a specific pooling process will not guarantee that the material data sets will, when testing is completed, be found to be poolable. Preliminary investigations into poolability are recommended before committing significant resources to large-scale testing.

¹ For example, fastener type and torque-up conditions are applicable to the bolt-bearing test but not to a tension test. Consequently, the reporting of this information is required for the bearing test and is not required for the tension test.

MIL-HDBK-17 Data Review has already pre-approved a pooling process for the case when several different fabricators wish to jointly develop B-basis data for MIL-HDBK-17 submission. Standard material and process specifications must be used and available. Sampling requirements are a minimum of three fabricators, each producing panels from at least three different batches of material. The minimum of nine batches must be sampled from five distinct prepreg batches, as discussed in Section 2.5.3.3. The batch replicate, processing, inspection, planning, and reporting requirements of Section 2.5.3.3 also hold.

2.5.4 Conditioning requirements

This section is reserved for future use.

2.5.5 Test method requirements

Specific test method criteria apply when submitting data to MIL-HDBK-17 for consideration for inclusion in Volume 2 of the Handbook, based on the following concepts. Ideally, a test method should have undergone a rigorous review of its applicability, precision and bias by an independent voluntary consensus standards organization that may include representatives from material suppliers, end-users, academia, or government. This review, and the test method, should be available in a referenceable, open-literature publication, and include interlaboratory (round robin) testing. Many times test methods meeting the above criteria are not available, and methods which meet less rigorous criteria (2 or 3 below) must be selected for data submittal.

The MIL-HDBK-17 Coordination Group has identified specific test methods, based on the material's structural complexity level (Section 2.1.2.1) and property, to be used when submitting data for consideration for inclusion in Volume 2 of the Handbook. These methods are designated or described in Chapters 3 through 7, and meet one or more of the following criteria:

1. Methods, applicable to advanced composites and in common use, which have completed the following:
 - Round robin testing under sponsorship of a recognized standards-making organization
 - Rigorous review of precision and bias
 - Publication in the open literature of a recognized standards-making organization
2. "Common practice" methods, which have not been standardized as in (1) above, but which are in common usage in the composite materials industry, are available in referenceable, open-literature publications, and have begun the process toward formal standardization.
3. Where no standards meeting the above criteria exist for specific structures or process/product forms, other test methods may have been selected by consensus of the MIL-HDBK-17 Coordination Group. Such methods may have been developed within the MIL-HDBK-17 Working Groups, or by other organizations, and will have begun the process toward formal standardization.

The test methods used for data submittal to the handbook must meet the handbook recommendations, summarized in Table 2.2.4, at the time the tests were performed. Fully Approved test methods are required for B and A data classes. Interim test methods are acceptable for I class data and Screening test methods are acceptable for S class data.

2.5.6 Data documentation requirements

This section outlines data documentation requirements necessary for the inclusion of data in MIL-HDBK-17 Volume 2. Data must meet the data documentation requirements that are in effect on the date of submission to the handbook. The data documentation requirements in effect at the time of publication of the handbook are provided in Table 2.5.6. Note that these requirements are subject to subsequent modification and that the latest authoritative data documentation requirements, which may differ slightly from Table 2.5.6, must be obtained from either the Secretariat or the Coordinator.

TABLE 2.5.6 *Documentation requirements*

Material identification - required for all composite materials
<ul style="list-style-type: none"> ● material identification ● material class (e.g., C/EP) ▼ material procurement specification
Matrix material - required for all composite materials
<ul style="list-style-type: none"> ● commercial designation ● manufacturer ● date of manufacture, earliest and latest ● lot number for each lot ● nominal density and test method
Reinforcement - required for all composite materials
<ul style="list-style-type: none"> ● precursor type (i.e., PAN, Rayon) ● commercial designation ● manufacturer ● date of manufacture, minimum and maximum ● lot number for each lot ● surface treatment (Y/N) ▼ surface treatment type ● surface finish (sizing) identification and amount ● density (average per lot) and test method ● nominal filament count ● twist
Preform
<ul style="list-style-type: none"> ● preform architecture ● preform identifier ● preform manufacturer ● preform method of manufacture - molded, stitched, RFI, etc. ● number of preform layers 2-D Fabric ▼ fabric manufacturer/weaver ● fabric family (weave pattern) ● fabric standard style number (particularly for glass fabrics) ● fabric sizing identification ● fabric sizing content ● fabric warp and fill tow count per inch ● fiber areal weight per batch¹ ● fabric fill fiber (if different) 3-D Woven Materials (including triaxial fabric) ● interlock description ● warp fiber filament count ● weft fiber filament count ● angle fiber filament count ● weaver yarn filament count ● percentage of warp yarn ● percentage of weft yarn ● angle of angle yarn (positive with respect to axial yarn) ● percentage of angle yarn ● percentage of weaver yarn

¹ See Part Description, fiber areal weight

<ul style="list-style-type: none"> ● percentage of through-thickness yarn ● pitch length ● warp end count ● weft end count Stitching Information ● stitch type ● stitch thread ● stitch axial pitch ● stitch row spacing ▼ stitch denier ● stitch filament count ● bias yarn end count ● bias yarn angle Braiding Information ● braid description ● axial fiber type ● braid fiber type ● axial fiber filament count ● braid fiber filament count ● braid angle ● percentage of axial yarn ● percentage of braid yarn ▼ axial yarn spacing in braids Winding Description ● winding description
Prepreg
<ul style="list-style-type: none"> ● ply manufacturer ● date of manufacture ● material lot number ● commercial designation ● material form - tape/fabric ● fiber areal weight per batch¹ ● total resin content per lot ▼ volatile content ● scrim material class ● scrim fabric style
Processing - required for all composite materials
<ul style="list-style-type: none"> ▼ process specification ● lay-up schematic (including bagging, scrim, bleeder, etc.) ⊗ part manufacturer ● date of manufacture (date completed) ● reinforcement application process (how the fiber/preform was put together) - see Volume 2, Table 1.4.2(b) ● cure process type (how the part was cured/molded) - see Volume 2, Table 1.4.2(b) ▼ tackifier common name ▼ tackifier material class (e.g., epoxy) ▼ tackifier form - aerosol/liquid ▼ tackifier manufacturer

¹ See Part Description, fiber areal weight

<p>Process Description - appropriate group required for all composite materials</p> <ul style="list-style-type: none"> ● Autoclave/oven/press cure <ul style="list-style-type: none"> ● near-net or extra resin process ● temperature for putting uncured part into autoclave/oven/press (including range) ● ramp rate to cure conditions ● cure conditions - temperature, pressure, duration, ● ramp rate to postcure ● postcure conditions - temperature, pressure, duration, ● cooling rate ● part removal temperature ● other critical control parameters RTM (not applicable to RFI) <ul style="list-style-type: none"> ● degas steps on the resin prior to injection ● initial tool temperature ● preform insertion temperature ● heat-up rate, soak time and temperature before injection ● vacuum used (Y/N) and inches Hg ● injection rate (cm³/min), temperature, and pressure ● cure temperature, pressure, and duration ● cooling rate and part removal temperature ● additional postcure (Y/N) - temperature, duration, in-tool/free-standing
<p>Part Description- required for all composite materials</p> <ul style="list-style-type: none"> ● form (panel, tube, etc.) ● ply count ● lay-up code ● fiber areal weight¹, nominal, by batch or part, and test method ● nominal fiber volume¹ and test method ▼ resin content (weight or volume), nominal and test method ⊗ void content, nominal, by batch or part, and test method ● density, nominal, by batch or part, and test method ● ply thickness, nominal, by batch or part, and test method ● glass transition temperature (wet and dry, nominal) and test method
<p>Specimen preparation- required for all composite materials</p> <ul style="list-style-type: none"> ● specimen orientation ⊗ tab adhesive curing temperature (nominal)
<p>Mechanical testing- required for mechanical testing of all composite materials</p> <ul style="list-style-type: none"> ● number of specimens ● test procedure (citing <i>all</i> deviations from standard procedures including reporting requirements. It is assumed that, other than the deviations reported, the test method was followed.) ● date of applicable standard ● date of testing ● specimen thickness for each specimen ● specimen conditioning standard method ● conditioning temperature² ● conditioning humidity ● conditioning time ● conditioning environment (if not lab air), standard designation of fluids if available

¹ Fiber volume or fiber areal weight (FAW) for each batch or panel is required. For prepregs, batch or roll average FAW is acceptable. For other materials, lot or roll average FAW of the assembled reinforcement (fabric, braid, or preform) is acceptable. If additional out-of-plane reinforcement, such as stitching is used, the lot or roll average FAW can be obtained for the reinforcement assembly prior to the out-of-plane reinforcement (e.g., unstitched fabric).

² If multi-step conditioning method was used, provide conditioning information for each step.

- equilibrium (Y/N)
 - ⊗ moisture content, specify whether moisture content or uptake
 - test temperature
 - soak time at test conditions prior to load initiation
 - fastener type and torque-up conditions (bearing, mechanically fastened joint (MFJ), filled hole)
 - hole diameter (open/filled hole, bearing, MFJ)
 - ▼ hole clearance, countersink angle and depth (filled hole, bearing, MFJ)
 - nominal thickness, width, and material for each member (bearing, MFJ)
 - edge distance (bearing, MFJ)
 - fixture torque-up (e.g., SACMA RM-1)
 - shear strain at which test was truncated (shear)
 - failure mode identification and location
 - all non-normalized (raw) data
 - method of calculating modulus and Poisson's ratio
 - method of finding offset strength (bearing)
 - method of finding proportional limit (bearing)
 - method of calculating fracture toughness (fracture toughness)
 - method of finding proportional limit (bearing)
 - method of calculating fracture toughness (fracture toughness)
-
- Required for submission to Secretariat
 - ⊗ Required submission to the Secretariat for B and A data classes
 - ▼ Requested for submission to the Secretariat, presented if available

General recommendations on data documentation are provided in Section 2.2.12. The essence of documentation requirements is complete traceability and control of the database development process from material production, through procurement, fabrication, machining, environmental conditioning, gaging, testing, data acquisition, data normalization, and final statistical interpretation. The key items of information for mechanical testing of composite materials are summarized in Table 2.5.6 and should be documented as part of any such material property determination. The items marked (●) should be included with any data submitted to the Secretariat. The items marked (⊗), as well as all items marked (●), must be included in the submission in order for submitted data to qualify for B and A data classes. Items marked (▼) are requested for submission to the Secretariat; this information will be presented in Volume 2 if available. Recommendations for in-house documentation are discussed in Volume 1, Section 2.2.12. All reasonable information should be traceable and available to the Secretariat for validation of statistical outliers.

This list is based on the information necessary for mechanical property testing. The documentation requirements are grouped by possible forms at various stages of fabrication. Groups required for all composite materials are identified. Material Identification, Matrix Material, and Reinforcement groups are required for all types of materials. The items in the Preform and Prepreg groups are required based on additional steps in fabricating the material as indicated for each fabrication form. For example, a (2-D) fabric prepreg would require the 2-D Fabric portion of the Preform group and the Prepreg group. The appropriate section within Process Description should be used. The remaining groups apply to all mechanical property testing. Note that items are grouped by whether or not they are needed to include relevant information for a particular stage of fabrication. For most items, this also is the fabrication form from which the information is obtained. There are a few exceptions to the latter grouping. For example, information on scrim is included with Prepreg since that is the form which requires scrim information. Fiber areal weight should be measured at the most appropriate stage of fabrication. Individual documentation items are not required where they are not applicable¹.

¹ For example, fastener type and torque-up conditions are applicable to the bolt-bearing test but not to a tension test. Consequently, the reporting of this information is required for the bearing test and is not required for the tension test.

The information required for other types of tests or material levels is similar. For instance, prepreg property testing would require the prepreg, reinforcement, matrix, and possibly fabric information, as well as appropriate information on specimen preparation and testing procedures.

2.5.7 Data normalization

Certain types of data should be normalized to provide consistent presentation of properties and to allow for reasonable material comparison. For mechanical properties, data are normalized by the Secretariat for lamina/laminate strength and stiffness properties *except* 90° (transverse) tension and compression of unidirectional laminates, interlaminar (3- or z-direction) tension, interlaminar compression, interlaminar shear, in-plane shear, short beam strength, bearing and bearing/bypass, strain energy release rate, and Poisson's ratio. The procedures from Section 2.4.3 should be used for normalization of handbook mechanical data, in the following order of preference:

1. By fiber volume as measured on the test specimen as shown in Equation 2.4.3.2(a),
2. By specimen cured ply thickness and batch average fiber areal weight as shown in Equation 2.4.3.2(k)
3. By specimen cured ply thickness and batch average fiber volume as shown in Equation 2.4.3.2(n)

Data for unidirectional tape are normalized to 60% fiber volume and data for fabric are normalized to 57% fiber volume unless another value is considered more appropriate by the Data Review working group. Normalization procedures for other properties have not yet been approved.

2.5.8 Statistical analysis

All data for the handbook are analyzed according to the flowchart in Section 8.3.1. Where batch-to-batch variability can be neglected (based on Section 8.3.2) the data model used is the first data model with an observed significance level greater than 0.05. Models are considered in the following order - Weibull, normal, lognormal, and nonparametric. Selection of statistical approach including consideration of pooling (Section 2.5.3) is subject to review and approval by the Data Review working group.

2.5.9 Mechanical properties of laminae and laminates

Handbook values for mechanical properties of each material will be listed in the data summary in Volume 2.

2.5.9.1 Unidirectional properties from laminates

A laminate "backing-out" approach for unidirectional material lamina mechanical properties is documented in Section 2.4.2. Data by this approach will be considered for inclusion in the handbook according to the procedures in Figure 2.5.1. While the Section 2.4.2 approach is applicable to many lay-ups and other possibilities continue to be explored, to date only [90/0]_ns laminates have been considered acceptable by the MIL-HDBK-17 Coordination Group.

2.5.9.2 Strength and strain-to-failure

Handbook values for strength, and strain-to-failure should meet the sampling requirements in Section 2.5.3 for each property and at each condition. For the data to be included in the population, failure modes must be considered acceptable in accordance with the test method used. Strengths will be normalized according to Sections 2.4.3 and 2.5.7. Strengths and strains-to-failure will receive the full statistical treatment described in Section 8.3.1 including outlier detection, data pooling testing, determination of distribution, and B-basis value calculation.

2.5.9.3 *Elastic moduli, Poisson's ratios, and stress/strain curves*

Handbook values for elastic moduli (Young's moduli or shear moduli) and Poisson's ratios, calculated over a fixed strain range, should meet the sampling requirements in Section 2.5.3 for each property and at each condition. The elastic moduli should be normalized according to Sections 2.4.3 and 2.5.7 and all results receive the statistical analysis outlined in Section 8.3.1. Minimum, average, maximum, and coefficient of variation (CV) values will be tabulated for moduli, and the average value tabulated for Poisson's ratio. The report should include the calculation method and strain ranges for each property. If stress/strain data are provided an average stress/strain curve will be calculated using the procedures described in Section 8.4.4 and reported as shown in Volume 2, Section 1.4.2.

2.5.10 **Chemical properties**

This section is reserved for future use.

2.5.11 **Physical properties of laminae and laminates**

Handbook values for physical properties (at $73\pm 5^\circ\text{F}$ ($23\pm 3^\circ\text{C}$), if available) will be listed in the data summary for each material. Additional values as a function of temperature or other parameters, if available, will be presented graphically.

2.5.11.1 *Density*

The handbook value for density should be determined at a specified temperature (in the absence of a specific requirement use $73\pm 5^\circ\text{F}$ ($23\pm 3^\circ\text{C}$)) from the average of a minimum of three specimens for each batch used in the determination of any mechanical properties.

2.5.11.2 *Composition*

This section is reserved for future use.

2.5.11.3 *Equilibrium moisture content*

Handbook values for equilibrium moisture content should be determined for specified relative humidity and temperature values (in the absence of a specific requirement, use 85%RH, 180°F (82°C)) from the average of a minimum of three specimens at each condition. If additional information is available for equilibrium moisture content as a function of temperature and relative humidity, those values will be presented graphically.

2.5.11.4 *Moisture diffusivity*

Handbook values for moisture diffusivity should be determined for specified temperatures (in the absence of a specific requirement use 180°F (82°C)) from the average of a minimum of three specimens at each temperature. If additional information is available for moisture diffusivity as a function of temperature and relative humidity, those values will be presented graphically.

2.5.11.5 *Coefficient of moisture expansion*

Handbook values for moisture expansion coefficient should be obtained and will be reported in the same way as those for thermal expansion coefficient (Section 2.5.12.1).

2.5.11.6 *Glass transition temperature*

Handbook values for glass transition temperature should be determined for dry and wet material conditions from the average of a minimum of three specimens at each condition. Guidelines for glass transition temperature testing and maintenance of a wet condition are discussed in Section 6.4.3.

2.5.12 Thermal properties

Thermal property room temperature values will be listed in the data summary. Additional values as a function of temperature, if available, will be presented graphically in a single figure according to Volume 2, Section 1.4.3. Each property should be determined for a specified temperature or temperature range. Default values, to be used when temperatures are not otherwise specified, are provided for different matrix materials in Table 2.5.12. The room temperature default value for all materials is 73°F (23°C). The tolerance on all default temperatures is $\pm 5^\circ\text{F}$ ($\pm 3^\circ\text{C}$).

TABLE 2.5.12 *Default temperatures for handbook thermophysical data.*

Matrix Material Family	Default Elevated Temperature		Default Temperature Range	
	°F	°C	°F	°C
Epoxy	220	104	73 - 275	23 - 135
Bismaleimide	350	177	73 - 450	23 - 232
PEEK	220	104	73 - 250	23 - 121
Polyimide	550	288	73 - 600	23 - 315

2.5.12.1 Coefficient of thermal expansion

Handbook values for average coefficient of linear thermal expansion (CTE) should be determined for specified temperature ranges (in the absence of a specific requirement, use the default temperature range for the appropriate matrix material family in Table 2.5.12) from the average of a minimum of five specimens for each temperature range. The reference temperature for thermal expansion should be clearly noted.

2.5.12.2 Specific heat

Handbook values for constant pressure specific heat should be determined at specified temperatures (in the absence of a specific requirement use the room temperature default) from the average of a minimum of three specimens for each temperature.

2.5.12.3 Thermal conductivity

Handbook values for average thermal conductivity should be determined for specified temperature ranges (in the absence of a specific requirement, use the default temperature range for the appropriate matrix material family in Table 2.5.12) from a minimum of three specimens for each temperature range.

2.5.12.4 Thermal diffusivity

Handbook values for thermal diffusivity should be determined for specified temperatures (in the absence of a specific requirement, use the default elevated temperature for the appropriate matrix material family in Table 2.5.12 as the median temperature) from the average of a minimum of three specimens for each temperature.

2.5.13 Electrical properties

This section is reserved for future use.

2.5.14 Fatigue

Fatigue is defined as the change in property as a result of repeated mechanical loading in the appropriate environmental conditions. This is not normally considered a design limiting property for PMC structures that have been designed with fiber dominated lay-ups and have minimal out-of-plane loading conditions. The exceptions to this generalization are high cycle fatigue components like rotor blades, propeller blades, and engine fan blades. These structures encounter a high number of cyclic loads (up to 5×10^8) and should not be sized for static and damage considerations alone. In these applications, fatigue is an important property. The "building block" design/validation approach using coupon, element, and component testing can be used to assure adequate fatigue life.

Fatigue should be addressed at various levels of development:

- Basic material property screening- Primary purpose is to compare various materials to aid in the selection process.
- Design allowables-Purpose is to characterize the specific material selected with sufficient replicate testing and conditions to ensure adequate performance of the completed design by analysis. An additional use of this level of testing is to define fatigue enhancement factors for conducting higher level (more complex) element and component tests.

There is no established practice of using laminae fatigue data to construct laminate fatigue allowables, so it is recommended that application specific laminate based allowables be generated. ASTM D3479, "Tension-Tension Fatigue Oriented Fiber, Resin Matrix Composites" is a generalized coupon testing method that can be used as a guide for a fatigue test method. Note, this published test method approach is for tension-tension fatigue. Compression-compression and tension-compression fatigue are typically more critical in composites.

The following are some general guidelines for specimen fatigue testing. Fatigue data is generated at the design critical test conditions, i.e. -65F, room temperature, or hot/wet. Design critical test conditions are very application dependent. For hot/wet testing, specimens should be brought to their desired moisture level prior to testing, and maintained at this moisture level during the actual fatigue test. The desired moisture level is again application dependent. It may be an equilibrium moisture level for a specified relative humidity, a percentage of an equilibrium level, or some other condition defined by the specific application environment, part geometry, and projected service life. As an example, Reference 2.5.14(a) (J. Rouchon) contains the methodology used by one certifying agency.

Like the generation of static design allowables, notches can be used for fatigue testing as well. This approach could be non-conservative, in that a notched specimen has a greatly reduced volume of material at the maximum stress cross-section when compared to an unnotched specimen. If the purpose of the specimen test is to account for material and process variation effects on fatigue performance, the unnotched specimen is a more appropriate configuration. Unnotched specimen failures will initiate at random failure sites that are inherent in the specimen, whereas notched specimen failures are constrained to initiate at the manufactured notch.

If the purpose of the fatigue testing is to provide a structural level assessment of process variation, the use of actual manufacturing anomalies may be more appropriate. Composite structure based manufacturing anomalies, such as delaminations, disbonds, fiber breaks, are important in a cyclic load environment because it must be shown they will not grow significantly in the no growth damage tolerance approach or they will not grow to a critical length during the life of the component or before they are detected by inspection in the growth approach. Element, component, and sub-component level fatigue tests are usually recommended to substantiate allowable manufacturing anomaly limits and also to establish in-service inspection requirements.

Fatigue data for in-plane material property performance can be evaluated with three R-ratios: $R=0.1$ (tension-tension), $R=10.0$ (compression-compression), and $R=-1.0$ (tension-compression). Design fatigue loading conditions may not dictate the full spectrum of loading conditions, but with these three R-ratios a Goodman diagram (Reference 2.5.14(b)) can be constructed to aid in predicting fatigue at any given R-ratio. For interlaminar properties, it is recommended two R-ratios be run, $R=0.1$ and $R=-1.0$. $R=10.0$ is not necessary for flatwise (through the thickness) fatigue, since this is not typically a viable failure mode. The loading conditions are the same for $R=10.0$ and $R=0.1$ for interlaminar shear fatigue, so $R=10.0$ tests are not performed.

Tests are typically run in load control. Strain control tests are not generally necessary because of PMC's linear elastic behavior. Unless test frequencies are set to be the same as in-service frequencies, test frequencies should be set so that any temperature rise in the specimen is limited to $5F$. Generally, test frequencies of 5-10 hertz are used. All specimens should be thermo-coupled to ensure specimen heating is insignificant during all fatigue testing. The use of in-service frequencies during testing can be important, since it has been shown that increased test frequencies can increase fatigue life in some materials/test configurations.

Failure mode evaluation of fatigue test specimens are just as important as for static test specimens. Erroneous data can be generated if an improper failure mode occurs. The typical undesirable failure modes to avoid include, tab debonding, non-gauge section failures, and fiber splitting in geometry transition areas. Fatigue specimen design and fabrication quality are very significant in achieving the proper gauge section failure modes in specimen fatigue tests.

Stress levels selected for testing should provide good data spacing on a semi-log fatigue stress vs. cycles plot (S/N plot), and provide failure points in the cycle regime of interest. An example of a cycle range for a low cycle fatigue (LCF) 40,000 cycle structure, would be to generate failure points from 10^3 to 10^5 cycles. The number of data points required per curve varies depending on its desired use. For materials screening, 8 data points are usually sufficient to establish the fatigue performance. For design allowables, 15 data points are recommended over three batches. Regression analysis or Sendekyj's method (References 2.5.14(c) and (d)) are efficient approaches for analyzing this data and establishing B-basis and A-basis design allowable lines.

The fatigue design allowable curves can be used for two purposes. The first is to establish maximum stress values for a specific number of cycles by using a B-basis or A-basis value. The other purpose is to use the data distribution from the fatigue data of the critical design property to establish a load/life enhancement magnification factor used for element or component testing. Since only a small number of elements or components are usually fatigue tested, the load/life of the test must be enhanced to account for material and process scatter. Even though there are empirically based techniques to predict the life of PMC structures, the element or component fatigue test is required for verification because of feature dependent effects like ply drops and manufacturing complexities not accounted for in the specimen testing or the design analysis. The load/life enhancement approach is outlined in the FM report (Reference 2.5.14(e)) and provides a sound statistical approach to ensure application durability with a limited number of test articles. Load/life enhancement approach may also be used to account for environmental effects that are difficult to reproduce in element or component tests.

As discussed previously, most fatigue concerns in composites apply to high cycle applications. Most aircraft structure is subjected to a range of loads with various amplitudes and maxima (spectra loading). These structures are not characteristically high cycle. The spectrum loading introduces another complexity that has proved difficult to account for in life prediction. Cumulative damage approaches developed for metallic structure have been shown to be ineffective in composites. This has necessitated an increased reliance on empirical procedures for life verification rather than life prediction.

REFERENCES

- 2.1.1(a) Rouchon, J., "Certification of Large Aircraft Composite Structures, Recent Progress and New Trends in Compliance Philosophy," presented at the 17th ICAS, Stockholm, Sweden, 1990.
- 2.1.1(b) Whitehead, R. S., Ritchie, G. L., and Mullineaux, J. L., "Qualification of Primary Composite Aircraft Structures," presented at the USAF ASIP Conference, Macon, GA, 27-29 November, 1984.
- 2.1.1(c) Whitehead, R. S., and Deo, R. B., "A Building Approach to Design Verification Testing of Primary Composite Structures," *Proceedings of the 24th AIAA/ASME/AHS SDM Conference*, Lake Tahoe, NV, May 1983, pp. 473-477.
- 2.2.4 Fields, R. E., "Improving Test Methods for Composites," *ASTM Standardization News*, Oct. 1993, pp. 38-43.
- 2.2.7(a) ASTM Test Method D 570 "Water Absorption of Plastics," *Annual Book of ASTM Standards*, Vol. 8.01, American Society for Testing and Materials, West Conshohocken, PA.
- 2.2.7(b) ASTM Practice D 618 "Conditioning Plastics and Electrical Insulating Materials for Testing," *Annual Book of ASTM Standards*, Vol. 8.01, American Society for Testing and Materials, West Conshohocken, PA.
- 2.2.7(c) ASTM Test Method D 5229/D 5229M "Moisture Absorption Properties and Equilibrium Conditioning of Polymer Matrix Composite Materials," *Annual Book of ASTM Standards*, Vol. 15.03, American Society for Testing and Materials, West Conshohocken, PA.
- 2.2.7(d) Ryder, J.T., "Effect of Load History on Fatigue Life", AFWAL-TR-80-4044, July 1980.
- 2.2.7.1 Hedrick, I. G., and Whiteside, J. B., "Effects of Environment on Advanced Composite Structures," *AIAA Conference on Aircraft Composites: Emerging Methodology for Structural Assurance*, San Diego, CA, 1977.
- 2.2.7.3(a) Whiteside, J. B., et al, "Environmental Sensitivity of Advanced Composites," Volume 1, Environmental Definition, AFWAL-TR-80-3076.
- 2.2.7.3(b) MIL-STD-210C, *Climatic Information to Determine Design and Test Requirements for Military Systems and Equipment*.
- 2.2.7.3(c) Sanger, K.B., "Certification Testing Methodology Structures", Naval Air Development Center Report NADC-86132-60 on Federal Aviation Administration Report DOT/FAA/CT-36/38, Jan 1986, p. 38.
- 2.2.8(a) Hedrick, I.G., and Whiteside, J.B., "Effects of Environment on Advanced Composite Structures," *AIAA Conference on Aircraft Composites: Emerging Methodology for Structural Assurance*, San Diego, CA, 1977.
- 2.2.8(b) Schneider, P.J., *Conduction Heat Transfer*, Addison-Wesley, 1955.
- 2.2.8(c) Whiteside, J.B., et al., "Environmental Sensitivity of Advanced Composites," Vol. I Environmental Definition, AFWAL-TR-80-3076.
- 2.2.8(d) Whitehead, R.S. and Kinslow, R.W., "Composite Wing/Fuselage Program," Vol. IV Test Results and Qualification Recommendations, AFWAL-TR-88-3098.

Volume 1, Chapter 2 Guidelines for Property Testing of Composites

- 2.2.8.1(a) Garrett, R.A., Bohlmann, R.E., and Derby, E.A., "Analysis and Test of Graphite/ Epoxy Sandwich Panels Subjected to Internal Pressures Resulting From Absorbed Moisture," *Advanced Composite Material Environmental Effects Symposium*, Sept. 1977.
- 2.2.8.1(b) Ashford, L.W., "Analysis and Test of Carbon/Bismaleimide Laminates Subjected to Internal Pressures Resulting From Trapped Moisture," *Proceedings of the 18th International SAMPE Technical Conference*, Oct. 1986.
- 2.2.8.1(c) Kim, H.J., Bohlmann, R.E., "Thermal Shock Testing of Wet Thermoplastic Laminates," *Proceedings of the 37th International SAMPE Symposium*, March 1992.
- 2.2.12(a) ASTM Guide E 1485, "Development of Material and Chemical Property Database Descriptions," *ASTM Annual Book of Standards*, Vol. 15.03, American Society for Testing and Materials, West Conshohocken, PA.
- 2.2.12(b) ASTM Guide E 1309, "Identification of Composite Materials in Computerized Material Property Databases," *ASTM Annual Book of Standards*, Vol. 15.03, American Society for Testing and Materials, West Conshohocken, PA.
- 2.2.12(c) ASTM Guide E 1434, "Development of Standard Data Records for Computerization of Mechanical Test Data for High-Modulus Fiber-Reinforced Composite Materials," *ASTM Annual Book of Standards*, Vol. 15.03, American Society for Testing and Materials, West Conshohocken, PA.
- 2.2.12(d) Composite Material Test Data Schema, Version 1.0, 2 February 1996, available from <http://mil-17.udel.edu/>.
- 2.2.12(e) Rumble, Jr., J. R., and Smith, F. J., *Database Systems in Science and Engineering*, Adam Hilger, Philadelphia, 1990.
- 2.2.12(f) *The Building of Materials Databases*, ASTM Manual 19, C. H. Newton, ed., American Society for Testing and Materials, West Conshohocken, PA, 1993.
- 2.3.1.1 "Standard Tests for Toughened Resin Composites, Revised Edition," NASA Reference Publication 1092 - Revised, July 1983, Available NTIS.
- 2.3.1.3(a) NASA Contract NAS1-11668.
- 2.3.1.3(b) Curliss, D. B., Carlin, D. M., and Arnett, M. S., "The Effect of Jet Fuel Absorption on Advanced Aerospace Thermoset and Thermoplastic Composites," Wright Patterson Air Force Base.
- 2.3.1.3(c) Corrigan, E., Thermoplastics Conference, February 1990.
- 2.3.1.3(d) MIL-T-5606, Hydraulic Fluid, Petroleum Base; Aircraft, Missile, and Ordnance.
- 2.3.1.3(e) MIL-T-5624, Turbine Fuel, Aviation, Grades JP-4, JP-5, and JP-5/JP-8 ST.
- 2.3.1.3(f) MIL-L-7808, Lubricating Oil, Aircraft Turbine Engine, Synthetic Base.
- 2.3.1.3(g) MIL-A-8243, Anti-Icing and Deicing-Defrosting Fluid.
- 2.3.1.3(h) MIL-S-8802, Sealing Compound, Temperature-Resistant, Integral Fuel Tanks and Fuel Cell Cavities, High Adhesion.

Volume 1, Chapter 2 Guidelines for Property Testing of Composites

- 2.3.1.3(i) MIL-L-23699, Lubricating Oil, Aircraft Turbine Engine, Synthetic Base, NATO Code Number O-156.
- 2.3.1.3(j) MIL-T-83133, Turbine Fuels, Aviation, Kerosene Type, NATO F-34 (JP-8) and NATO F-35.
- 2.3.1.3(k) MIL-H-83282, Hydraulic Fluid, Fire Resistant, Synthetic Hydrocarbon Base, Aircraft, Metric, NATO Code Number H-537.
- 2.3.1.3(l) MIL-C-87252, Coolant Fluid, Hydrolytically Stable, Dielectric.
- 2.3.1.3(m) MIL-C-87936, Cleaning Compounds, Aircraft Exterior Surfaces, Water Dilutable.
- 2.3.1.3(n) P-D-680, Dry Cleaning and Degreasing Solvent.
- 2.3.1.3(o) TT-I-735, Isopropyl Alcohol.
- 2.3.1.3(p) TT-S-735, Standard Test Fluids, Hydrocarbon.
- 2.3.1.3(q) ASTM Specification D 740, "Methyl Ethyl Ketone," *Annual Book of ASTM Standards*, Vol. 6.04, American Society for Testing and Materials, West Conshohocken, PA. (supersedes TT-M-261).
- 2.3.1.3(r) ASTM Specification D 4701, "Technical Grade Methylene Chloride," *Annual Book of ASTM Standards*, Vol. 15.05, American Society for Testing and Materials, West Conshohocken, PA. (supersedes MIL-D-6998).
- 2.3.1.3(s) SAE AMS 1432, "Fluid, Deicing/Anti-icing, Runways and Taxiways, Potassium Acetate Base," SAE, Warrendale, PA. (supersedes MIL-D-83411).
- 2.3.1.3(t) SAE AMS 2629, "Jet Reference Fluid for Sealants," SAE, Warrendale, PA.
- 2.3.1.3(u) Tanimoto, E. Y., "Effects of Long Term Exposure to Fuels and Fluids on Behavior of Advanced Composite Materials," NASA Contract Report 165763, August 1981.
- 2.3.2.4(a) JANNAF CMCS Test & Inspection Panel Meeting, 23 May 1991.
- 2.3.2.4(b) Military Handbook 17 Filament Winding Working Group Meeting, 18 September 1991.
- 2.3.7 Tomblin, John S., Ng, Yeow C., and Raju, K. Suresh, "Material Qualification and Equivalency for Polymer Matrix Composite Material Systems" DOT/FAA/AR-00/47, April, 2001.
- 2.4.2(a) Rawlinson, R.A., "The Use of Crossply and Angleply Composite Test Specimens to Generate Improved Material Property Data," *Proceedings of the 36th International SAMPE Symposium*, April, 1991, pp. 1058-1068.
- 2.4.2(b) Hart-Smith, L.J., "Generation of Higher Composite Material Allowables using Improved Test Coupons," *Proceedings of the 36th International SAMPE Symposium*, April, 1991, pp. 1029-1044.
- 2.4.2(c) Wilson, D.W., Prandy, J., and Altstadt, V., "An Analytical and Experimental Evaluation of 0/90 Laminate Tests for Compression Characterization," presented at the D-30 Symposium, ASTM Spring Meeting, Pittsburgh, PA, 1992.
- 2.4.2(d) "Standardization of Test Methods for Laminated Composites," Materials Sciences Corporation Technical Progress Report, MSC TPR 3244/1706-002, AMTL Contract No. DML04-89-C-0023, July, 1992.

Volume 1, Chapter 2 Guidelines for Property Testing of Composites

- 2.4.2.1 Farley, G.L., Smith, B.T., and Maiden, J., "Compression Response of Thick Layer Composite Laminates with Through-the-Thickness Reinforcement," *Journal of Reinforced Plastics and Composites*, Vol. 11, July 1992, pp. 787-810.
- 2.4.2.3 Chatterjee, S.N., Wung, E.C.J., Ramnath, V., and Yen, C.F., "Composite Specimen Design Analysis - Volume 1: Analytical Studies," Technical Report AMTL TR 91-5, prepared by Materials Sciences Corporation, January, 1991.
- 2.5.14(a) J. Rouchon, " Certification of Large Airplane Composite Structures, Recent Progress and New Trends in Compliance Philosophy", 17 ICAS Congress, Stockholm 1990
- 2.5.14(b) John Goodman, "Mechanics Applied to Engineering" Longmans, Green, & Co., Ltd. London, 1899
- 2.5.14(c) Sendeckyj, G.P. "Fitting Models to Composite Materials Fatigue Data," ASTM STP734, 1981, p.p. 245-260
- 2.5.14(d) Sendeckyj, G.P. "Effect of Stress Ratio Effect on Fatigue Life of Composites" presented at 8th Annual Mechanics of Composites Review, Dayton, OH, 5-7 October, 1982, AF-WAL-TR-83-4005 (April 1983)
- 2.5.14(e) Whitehead, R.S., Kan H.P., Cordero, R., and Saether, E. "Certification Testing Methodology for Composite Structures" D.O.T/F.A.A./CT-86-39 October 1986

This page intentionally left blank

CHAPTER 3 EVALUATION OF REINFORCEMENT FIBERS

3.1 INTRODUCTION

This chapter describes techniques and test methods that are generally used to characterize the chemical, physical, and mechanical properties of reinforcement fibers for application in organic matrix composite materials. Reinforcements in the form of unidirectional yarns, strands, or tows, and bidirectional fabrics are covered. Sophisticated experimental techniques generally are required for fiber characterization, and test laboratories must be well-equipped and experienced for measuring fiber properties. It is also recognized that in many cases the measurement of a fiber property that manifests itself in the reinforced composite can best be accomplished with the composite. Sections 3.2 through 3.5 recommend general techniques and test methods for evaluating carbon, glass, organic (polymeric), and other specialty reinforcement fibers. Section 3.6 contains examples of test methods that can be used for evaluating fibers.

Most reinforcement fibers are surface treated or have a surface treatment (e.g., sizing) applied during their production to improve handleability and/or promote fiber-resin bonding. Surface treatments affect wettability of the fiber during impregnation as well as the dry strength and hydrolytic stability of the fiber-matrix bond during use. Because of the direct relation to composite properties, the effectiveness of any treatments to modify surface chemistry is generally measured on the composite itself by means of mechanical tests. The amount of sizing and its compositional consistency are significant in quality control of the fiber and measurement of these parameters is part of the fiber evaluation.

3.2 CHEMICAL TECHNIQUES

A wide variety of chemical and spectroscopic techniques and test methods are available to characterize the chemical structures and compositions of reinforcement fibers. Carbon fibers are found to range from 90-100% carbon. Typically, standard and intermediate modulus PAN carbon fibers are 90-95% carbon, with most of the remaining material being nitrogen. Minor constituents and trace elements can be extremely important when composites containing these fibers are considered for use at elevated temperatures (above 500°F or 260°C). Organic fibers usually contain significant amounts of hydrogen and one or more additional elements (e.g., oxygen, nitrogen, and sulfur) which can be identified by spectroscopic analysis. Glass fibers contain sulfur dioxide and usually aluminum and iron oxide. Depending upon the type of glass, calcium oxide, sodium oxide, and oxides of potassium, boron, barium, titanium, zirconium, sulfur, and arsenic may be found.

3.2.1 Elemental analysis

A variety of quantitative wet gravimetric and spectroscopic chemical analysis techniques may be applied to analyze the compositions and trace elements in fibers. ASTM Test Method C 169 may be used to determine the chemical compositions of borosilicate glass fibers (Reference 3.2.1(a)).

A suitable standardized method for carbon and hydrogen analysis, modified to handle carbon and polymeric fibers is provided by ASTM D 3178 (Reference 3.2.1(b)). Carbon and hydrogen concentrations are determined by burning a weighed quantity of sample in a closed system and fixing the products of combustion in an absorption train after complete oxidation and purification from interfering substances. Carbon and hydrogen concentrations are expressed as percentages of the total dry weight of the fiber. ASTM Method D 3174 (Reference 3.2.1(c)) describes a related test in which metallic impurities may be determined by the analysis of ash residue.

Alternatively, a variety of commercial analytical instruments are available which can quickly analyze carbon, hydrogen, nitrogen, silicon, sodium, aluminum, calcium, magnesium and other elements in reinforcement fibers. X-ray fluorescence, atomic absorption (AA), flame emission, and inductively coupled plasma emission (ICAP) spectroscopic techniques may be employed for elemental analysis. Operating instructions and method details are available from the instrument manufacturers.

Trace metallic constituents are significant in carbon and polymeric fibers because of their possible effect on the rate of fiber oxidation. The presence of metals is usually expressed as parts per million in the original dry fiber and can be determined by analyzing the ash residue. Semi-quantitative determinations are generally made using flame emission spectroscopy. When quantitative values are desired, atomic absorption methods are used. With respect to oxidation of carbon fibers, sodium is usually of most concern because of its tendency to catalyze the oxidation of carbon.

3.2.2 Titration

The potential chemical activity of surface groups on fibers may be determined by titration techniques. For example, the relative concentration of hydrolyzable groups introduced during the manufacture or post treatment of carbon fibers may be determined by measuring the pH (section 3.6.1). However, titration techniques are typically not used on commercial carbon fibers due to the low levels of surface functionality.

3.2.3 Fiber structure

X-Ray diffraction spectroscopy may be used to characterize the overall structure of crystalline or semi-crystalline fibers. The degree of crystallinity and orientation of crystallites have a direct effect on the modulus and other critical properties of carbon and polymeric fibers.

X-ray powder diffraction using commercial power supplies and diffractometer units is used to characterize the structure of carbon fibers. The fiber is ground into a fine powder and then the X-ray powder diffraction pattern is taken using $\text{CuK}\alpha$ radiation. The patterns generally undergo computer analysis to determine the following parameters:

- (a) Average graphite layer spacing: from the 002 peak position.
- (b) Average crystal size L_c : from the 002 peak width
- (c) Average crystal size L_a : from the 100 peak width.
- (d) Average lattice dimension a-axis: from the 100 peak position.
- (e) The ratio of peak area to the diffused area.
- (f) The 002 peak area to the total diffraction area.
- (g) The 100 peak area to the total diffraction area.
- (h) The ratio of the 100 to 002 peak areas.
- (i) Crystallinity index: from a comparison of the X-ray diffraction of known crystallized and amorphous carbons.

X-ray scattering of crystalline fibrous materials shows the presence of sharp and diffuse diffraction patterns which are indicative of crystal phases interdispersed with amorphous regions. The concept of the crystallinity index is derived from the fact that a portion of the scattering from a fiber is diffuse and thereby contributes to the so-called amorphous background. Thus, a simple method of estimating crystallinity is obtained by separating the diffraction pattern into crystalline (sharp) and amorphous (diffuse) components. The crystallinity index is a relative measure of crystallinity, and not an absolute numerical result, useful for correlating with physical properties of fibers.

Wide angle X-ray spectroscopy and infrared spectroscopy techniques have also been developed to determine the crystallinity and orientation of molecules in polymeric fibers. Testing and interpretation of results requires specialized equipment, sophisticated computer models, and a high level of technical expertise.

3.2.4 Fiber surface chemistry

Fibers generally are given a surface treatment to improve the adhesion between the fibers and resin matrix materials. Gases, plasmas, liquid chemical or electrolytic treatments are employed to modify fiber

surfaces. Introducing surface oxidation is perhaps the most common approach to modifying fiber surfaces.

Fiber surface structure, the modifications which surfaces undergo as a result of the different fiber surface treatments, and the relative importance of these modifications for composite properties are not well understood. This arises because of the small surface areas involved (0.5 to 1.5 m²/g) and the very low concentrations of functional groups. If 20% of the surface was covered by one particular species, this would only amount to 1 μmole of chemical groups per gram of fiber. Surface characterization should be carried out on fibers which have not been sized. Residual size from solvent desized fiber can interfere with most techniques, while pyrolysis techniques may alter the fiber surface due to oxidation and char products.

The following techniques have been used for characterizing fiber surfaces:

- (a) X-ray diffraction - provides information relating to crystallite size and orientation, degree of graphitization, and micropore characteristics.
- (b) Electron diffraction - gives crystallite orientation, three-dimensional order, and degree of graphitization. (better for surfaces since penetration is only 1000 Å).
- (c) Transmission Electron Microscopy (TEM) - provides the highest resolution of any of the microscopic techniques routinely available. Ultramicrotomy can be used to prepare specimens, typically about 50 nanometers thick, for direct TEM analysis of the fiber surfaces. TEM provides information about surface fine structure and show fibrils and needle-like pores.
- (d) Scanning Electron Microscopy (SEM) - Gives structural and surface features. SEM is a useful technique for determining fiber diameters and identifying morphological characteristics (scales, chips, deposits, pits) on fiber surfaces.
- (e) Electron Spin Resonance (ESR) Spectroscopy - gives crystallite orientation.
- (f) X-ray Photoelectron Spectroscopy (XPS) or Electron Spectroscopy for Chemical Analysis (ESCA) - measures the binding energy of core electrons in atoms excited by low energy X-rays. Changes in the chemical environment of a surface region 10-15 nanometers thick (the first few atomic layers) are revealed by slight shifts in the energy of these core electrons giving information on functional group types and concentrations. The surface sensitivity arises because the depth of the electrons is between 1 and 2 nanometers.

The ratios of total oxygen to total carbon and of oxidized carbon (including hydroxyl, ether, ester, carbonyl and carboxy functional groups) to total carbon may be determined in carbon fibers using XPS or ESCA.

- (g) Auger Electron Spectroscopy (AES) - directs high energy electrons (1-5 KeV) onto surfaces to create vacancies in the core levels of atoms. These vacancies represent excited ions which may undergo de-excitation and thereby create Auger electrons. By analyzing the characteristic energies of all the back-scattered Auger electrons in the energy range 0-1 KeV, the elemental composition of the first 30 or 40 atomic layers (about 30 nanometers) is possible and in some cases molecular information can be obtained from analysis of data.
- (h) Ion Scattering Spectroscopy (ISS) - uses an ion as a molecular probe to identify elements on the outermost surface layer. Only atomic information can be obtained and sensitivity depends upon the atomic element.

Volume 1, Chapter 3 Evaluation of Reinforcement Fibers

- (i) Secondary Ion Mass Spectroscopy (SIMS) - uses a controlled sputtering process with accelerated ions to remove surface atomic layers for direct analysis by mass spectroscopy. SIMS can be used to identify surface molecules and determine their concentrations.
- (j) Infrared Spectroscopy (IRS) or Fourier Transform IRS (FTIRS) - absorption vibrational spectroscopy technique to obtain molecular information about surface composition. IRS yields both qualitative and quantitative information relating to the chemical composition of surface molecules. The quality of the IR analysis depends on the fiber composition and is directly related to the care taken during sample preparation.

For fibers with diameters between 0.015 and 0.03 mm, no sample preparation is required if an IR microscope is available to examine fibers directly. Organic fibers may be pressed (up to 1000/m²) into a film of fiber grids.

- (k) Laser Raman spectroscopy - absorption/vibrational spectroscopic technique which complements IR and is relatively simple to apply. Little or no sample preparation is necessary. Fibers can be oriented in the path of the incident beam for direct analysis. Fiber sample must be stable to the high intensity incident light and should not contain species that fluoresce.
- (l) Contact angle and wetting measurements - provide an indirect measurement of fiber surface free energy for use in predicting interfacial compatibility and thermodynamic equilibrium with matrix materials. Contact angle and wetting measurement information can be obtained by direct measurement of contact angle, mass pick-up, or surface velocity. Measurement of contact angles on small diameter fibers (< 10 microns) is difficult if done optically. If a fiber's dimensions are known, a simple force balance may be used to determine the contact angle by measuring the force induced by immersing the fiber into a liquid of known surface free energy. The apparatus usually employed for this test is the Wilhelmy balance (Reference 3.2.4(a)).

Contact angles θ also may be measured indirectly by the micro-Wilhelmy technique (References 3.2.4(b-e)). A single fiber is partially immersed in a liquid and the force exerted on the fiber due to the surface tension of the liquid is measured. The contact angle is determined from the relationship $F = C\gamma_{LV} \cos\theta$ where F is the force measured corrected for buoyancy, C is the circumference of the fiber, and γ_{LV} is the surface tension of the liquid. The results may be used to determine the fiber surface free energy and the contributions of polar and dispersive components to the free energy (References 3.2.4(c) and (d)).

- (m) Physisorption and chemisorption measurements - adsorption of inert gas or organic molecules can be used to measure fiber surface area. To obtain accurate estimates of surface area, it is important that there is complete monolayer coverage of the surface, that the area occupied by the adsorbed gas is known and that significant amounts of the gas are not taken up in micropores. Additional complications arise when the adsorption of organic molecules is used in place of gas adsorption, since it may be necessary to know the orientation of the adsorbed molecules to calculate surface area. Adsorption may also occur only at specific active sites and, if solutions are used, solvent molecules may be adsorbed as well.

The chemical reactivity of fiber surfaces can be determined by oxygen chemisorption and desorption measurements. Topographical changes (e.g., pores, cracks and fissures) caused by surface treatments often can be readily detected by adsorption measurements. Flow microcalorimetry is a useful technique for directly measuring heats of adsorption (Reference 3.2.4(f)).

- (n) Thermal desorption measurements - desorption of volatile products from fibers by heat treatment in vacuo. Thermal gravimetric analysis (TGA), gas chromatography (GC), mass spectroscopy (MS), infrared spectroscopy (IRS) analysis or combinations of pyrolysis GC/MS or TGA/IRS may be used to identify components desorbed from fiber surfaces. Below 150°C, CO, NH, CH and various organic molecules are observed depending upon the fiber type.

- (o) Chemical identification of functional groups by titrimetric, coulometric and radiographic techniques.

3.2.5 Sizing content and composition

The amount of sizing contained on fibers is expressed as a percentage of the dry sized fiber weight. It is generally determined by extracting the fibers with a heated solvent; then the cleaned fibers are washed, dried, and weighed. ASTM Test Method C 613 (Reference 3.2.5) describes a suitable method utilizing Soxhlet extraction equipment; however, similar extractions using a laboratory hot plate and beaker are also common. The selection of a solvent which quantitatively removes all the sizing but not does dissolve the fiber is essential for accuracy in this determination.

Thermal removal techniques are also utilized and are most practical for the more difficult soluble sizings. Time, temperature, and atmosphere conditions must be predetermined to ensure the sizing is removed without seriously affecting the fiber. The precise amounts of residue from decomposition of the sizing and weight loss of the fibers due to oxidation must also be known from control tests for greatest accuracy. SACMA recommended test method SRM 14-90 "Determination of Sizing Content on Carbon Fibers" describes a pyrolysis technique for carbon fibers.

Sizing compositions and lot-to-lot chemical consistency may be determined by spectroscopic and chromatographic analysis of materials isolated by extracting the fibers with a suitable solvent. Acetone, tetrahydrofuran and methylene chloride are commonly used solvents for extraction. Liquid and gas chromatography and diffuse infrared spectroscopy are used to analyze or "fingerprint" the chemical compositions of extracts.

3.2.6 Moisture content

The moisture content or moisture regain of fibers or textiles may be determined using the procedure shown in Section 3.6.3. Care must be taken when applying the procedure since volatile materials in addition to moisture may be removed. If possible, tests should be performed on fibers that have not been sized. Moisture content is expressed as weight percentage moisture based upon the dry weight of the specimen.

3.2.7 Thermal stability and oxidative resistance

The susceptibility of fibers and fiber surface to oxidation is measured as weight loss under given conditions of time, temperature, and atmosphere. This is especially important in the evaluation of carbon and organic fibers considered for use in plastics exposed to elevated temperatures since it contributes to the long term degradation of composite properties. Thermal gravimetric analysis (TGA) may be used to determine the thermal decomposition temperature T_d of carbon and organic fibers and estimate the relative amounts of volatile, organic additives and inorganic residues.

A standard method for determining the weight loss of carbon fibers is given in ASTM Test Method D 4102 (Reference 3.2.7(a)). Variations in this test method regarding exposure of fibers have been studied and give similar results (Reference 3.2.7(b)). In order to minimize variability in test results, proper control of gas flow rates and currents is critical when performing TGA analyses.

3.2.8 Chemical resistance

This section reserved for future use.

3.3 PHYSICAL TECHNIQUES (INTRINSIC)

The physical properties of fibers of importance in their applications in polymer matrix composites fall into two categories - those inherent in the filament itself (intrinsic), and those derived from the construction of filaments into yarns, tows, or fabrics (extrinsic). The former includes density, diameter, and electrical resistivity; the latter includes yield, cross-sectional area, twist, fabric construction and areal weight. Density and the derived properties are used in the calculations required for the construction and analysis of the composite products. Density and yield are useful measures of quality assurance. Filament diameter and electrical resistivity are important for the nonstructural aspects of aerospace and aircraft applications.

3.3.1 Filament diameter

The average diameter of fibers may be determined by using an indexing microscope fitted with an image splitting eyepiece or from a photomicrograph of the cross-sectional view of a group of mounted fibers. Since fibers are not always true cylinders, effective diameters may be calculated from the total cross-sectional area of the yarn or tow and dividing by the number of filaments in the bundle. The cross-sectional area may also be estimated from the ratio of mass per unit length to density. For irregular, but characteristically-shaped, fibers an area factor may be required in calculating the average fiber diameter.

Optical microscopy can provide information about fiber diameter and variation in diameter with length. The upper limit of resolution of the optical microscope is about one-tenth of a micron; hence features less than one micron can not be well-characterized by optical microscopy. A detailed procedure for the determination of fiber diameter is described in Section 3.6.4.

Other techniques, such as scanning electron microscopy (SEM), provide much higher resolution than optical microscopy for determining fiber diameter and cross-sectional characteristics. Features of fiber surfaces down to the 5 nanometer level can be observed. In addition, the large depth of field provided by SEM helps defined three-dimensional characteristics on fiber surfaces and define fiber topography.

3.3.2 Density of fibers

3.3.2.1 Overview

Fiber density is not only an important quality control parameter in fiber manufacture, it is required for determination of the void content of the fibrous composite, as described in ASTM D 2734, "Void Content of Reinforced Plastics" (Reference 3.3.2.1(a)). Fiber density can also be used as a distinguishing parameter to identify a fiber. For example, fiber density results can readily differentiate between E and S-2 glass (E glass is 2.54 g/cm^3 (0.092 lb/in^3), S-2 is 2.485 g/cm^3 (0.090 lb/in^3)).

With few exceptions, the determination of density is accomplished indirectly by measuring the volume and weight of a representative sample of the fiber, and then combining these values to calculate density. The weight measurement is most easily obtained by using a quality analytical balance. To determine volume, however, there are several approaches used. The most common approach uses simple Archimedes methods involving displacement of liquids of known density. Direct measurement of density can be made by observation of the level to which the test material sinks in a density-graded liquid (Reference 3.3.2.1(b)).

Liquids are used almost exclusively in displacement techniques for the determination of volume. However, there are advantages to using a gas medium in place of liquid to determine the volume of fiber. One advantage is minimization of errors associated with liquid surface tension. The gas displacement approach is often referred to as helium pycnometry. When a gas displacement approach is used, the test specimen volume is determined by measuring pressure changes of a confined amount of a gas that behaves as an ideal gas at room temperature (preferably high purity helium). Helium pycnometry is not a recognized test method for measuring the volume and density of fibers, yet it has been demonstrated to be a viable technique (References 3.3.2.1(c) and (d)). As no test standard or guidelines exist for this

method as applied to fiber, a test procedure has been developed within the MIL-HDBK-17 Testing Working Group (see Section 6.4.4.4.1).

ASTM Test Method D 3800 (Reference 3.3.2.1(e)) deals specifically with obtaining the density of fibers. This standard covers three different liquid displacement procedures: Procedure A, which is very similar to the D 792 liquid displacement method (Reference 3.3.2.1(f)); Procedure B, in which a low-density liquid is slowly mixed with a high-density liquid (containing the fibers) until the fibers become suspended; and Procedure C, which simply references D 1505, which is a density-gradient method.

For detailed guidance on D 1505 and helium pycnometry, the reader is referred to Sections 6.4.4.3 through 6.4.4.5 of this volume of the Handbook. Note that Section 6.4.4 refers specifically to composites, but the methods discussed are fully applicable to fiber measurement except as noted below in Sections 3.3.2.2 through 3.3.2.3.

3.3.2.2 *ASTM D 3800, Standard Test Method for Density of High-Modulus Fibers*

The approach taken in ASTM D 3800 is threefold. Procedure A is identical to D 792 except that the immersion fluids recommended have only fibers in mind. The concern is complete fiber wetting and avoiding entrapped microbubbles. Procedure B relies on careful mixing of two liquids of different densities (with the fiber immersed). When the fibers are suspended in the mixed liquid a hydrometer or liquid pycnometer is used to determine the density of the liquid. The density of the suspended fiber is equal to that of the liquid. Procedure C is D 1505 inserted as a part of D 3800 by reference.

Given that apparatus and procedures are identical to D 792 for the liquid displacement procedure (Procedure A), and that Procedures B and C have much in common with D 1505, the reader is referred to Sections 6.4.4.2 through 6.4.4.5. Here, only those test aspects peculiar to fibers are discussed.

The experimenter needs to be mindful to avoid entrapped bubbles, liquid absorption, and problems involving the fiber sizing coating (if any). Common sense immediately flags roving as a difficult fiber form to wet out, yet complete wetout is required to produce meaningful data. Pay close attention to the inter-filament regions. In D 1505 the problem is not as severe because the fibers can be cut and/or spread out prior to insertion. Since the measurement is direct the size of the fiber sample is irrelevant. Immersing many small fiber fragments allows for direct verification of density variations of the fiber, keeping in mind that small fragments may take hours to sink to their equilibrium density level. It can not be emphasized enough that complete wetout must be achieved. Use of high-wetting, vacuum-degassed liquids go a long way to this end. Remember that the fibers are a prime geometry for nucleation of gas bubbles out of solution. If the liquid is not fully degassed a bubble-free roving can quickly form new bubbles.

The surface area to volume ratio of composite fibers is extremely high. For cylindrical shapes, $S.A./V=2/R$, where R, the radius, is only several microns. For a 0.028 mil (7 micron) fiber the ratio is 143,000 to 1. It is, therefore, very important to ensure compatibility between the fiber and liquid. Glass and polyethylene fibers are fairly immune in this regard; however, aramid, for example, is certainly not. The liquid immersion time should be kept to a minimum to avoid liquid diffusion into the fiber.

The mistake is often made of thinking of the fiber by itself, when in reality it is usually coated with an interfacial sizing agent (to promote improved bonding with the matrix resin). It is good practice to research the sizing agent, as it is a completely different material than the fiber (with different absorption and chemical characteristics). Since the sizing is applied to the outer surface of the fiber even the volume of a thin coat quickly becomes significant. For example, a 0.028 mil (7 micron) diameter carbon fiber with a typical coating of 1% sizing agent on a weight basis (with assumed density of 1.2 g/cm³ (0.043 lb/in³)) gives a final product which is 98.5% fiber and 1.5% sizing on a volume basis. For precision work, strip the sizing agent off the fiber before measuring fiber density.

3.3.2.3 Recommended procedure changes to Section 6.6.4.4.1 (helium pycnometry) for use in measuring fiber density

In general, it would seem that helium pycnometry lends itself to the measurement of fiber volume/density (although this has yet to be rigorously tested). This is mainly due to the fact that the inert gas medium circumvents the issue of fiber wetout, which is a concern when using any of the liquid immersion methods. Recommended changes to the procedure in Section 6.6.4.4.1 are as follows:

- To prepare the fiber specimens, cut them to the height of the sample cell and stand them on end to get best packing.
- Fill the cell volume to a minimum of 30% of its full capacity.
- Precondition the fibers in the same manner as for immersion testing.
- Follow the instructions under step 2.

3.3.2.4 Density test methods for MIL-HDBK-17 data submittal

Data produced by the following test methods (Table 3.3.2.4) are currently being accepted by MIL-HDBK-17 for consideration for inclusion in Volume 2.

TABLE 3.3.2.4 Fiber density test methods for MIL-HDBK-17 data submittal.

Property	Symbol	Fully Approved, Interim, and Screening Data	Screening Data Only
Density	ρ	D 3800A, D 3800C, D 1505, 3.3.2.3*	D 3800B**

*When this method is used to generate data for subsequent determination of composite void volume, the test specimen must occupy at least 30% of the test cell volume.

**Data from this method is not recommended for use in determining void volume of composites due to precision limitations.

3.3.3 Electrical resistivity

The determination of electrical resistivity is recommended as a control measure for checking processing temperature and to determine compliance with specific resistance specifications, where required. Electrical resistivity is one of the properties dramatically affected by the structural anisotropy of carbon fibers. Measurements can be made on either a single filament or a yarn. The measured value is resistance per given length of fiber as read on an ohm meter or similar device. The contact resistance can be eliminated by obtaining the resistance for two different lengths of fiber and calculating the difference due to the longer length. This difference is then converted to resistance per unit length and then multiplied by the area of the fiber or yarn bundle expressed in consistent units. Resistivity is expressed as ohm-centimeter, ohm-meter, or ohm-inches and refers to the value in the axial direction. Transverse resistivity is seldom reported. A procedure for determining the electrical resistance of carbon cloth or felt is described in Section 3.6.5.

3.3.4 Coefficient of thermal expansion

Standardized methods for measuring the coefficient of thermal expansion (CTE) of the fibers are not generally available although good correlations between laboratories making these measurements do exist. CTE's are directionally dependent, highly influenced by the anisotropy of fibers. Carbon fibers typically have a negative axial CTE and a slightly positive transverse CTE. Commercial instruments (e.g., DuPont Model 943 Thermomechanical Analyzer, or equivalent) can be used directly or modified to measure axial CTE.

The CTE of the fiber can also be derived from measurements made on composites with unidirectional reinforcement. Laser interferometry and dilatometry are the techniques most frequently used. Other techniques, including some applied to the unimpregnated fiber, have also been found satisfactory. When testing the composite, the unidirectional fibers may be oriented parallel or perpendicular to the direction of measurement to obtain the axial or transverse CTE. To perform the analysis, the modulus of the fiber, the modulus and CTE of the matrix, and the fiber loading must be known. It may be desirable to perform the measurements on composites with different fiber loadings in order to check the results.

3.3.5 Thermal conductivity

The thermal conductivity of fibers is generally determined analytically from measurements of axial thermal conductivity on unidirectional reinforced composites. However, some measurements have been made on both fiber bundles and single filaments. These have agreed quite well with values determined from composite measurements (Reference 3.3.5(a)). Both types of measurements require considerable operator skill and sophisticated equipment, and are perhaps best left to the thermophysics laboratory. A well defined relationship between axial thermal conductivity and axial electrical conductivity (or resistivity) has been developed for a wide range of carbon fibers. Since electrical resistivity is relatively easy to measure, reasonable estimates of thermal conductivity can be made for electrical resistivity measurements (Reference 3.3.5(b)). Transverse thermal conductivity can be determined for thin composites using a pulsed laser technique to measure thermal diffusivity. The thermal conductivity can then be calculated if the specific heat of the fiber is known.

3.3.6 Specific heat

This property is measured in a calorimeter such as described in ASTM D 2766 (Reference 3.3.6). This also is not a simple measurement and is best left to the experienced laboratory.

3.3.7 Thermal transition temperatures

Differential scanning calorimetry (DSC), differential thermal analysis (DTA) or thermal mechanical analysis (TMA) instrumentation may be applied to measure the glass transition temperature T_g and, if the fiber is semi-crystalline, its crystalline melting temperature T_m . General procedures for measuring T_g and T_m of organic fibers are given in ASTM standards D 3417 and D 3418 (References 3.3.7(a) and (b)).

3.4 PHYSICAL TECHNIQUES (EXTRINSIC)

3.4.1 Yield of yarn, strand, or roving

Yield is generally expressed as length per unit weight, such as yards per lb, or as its reciprocal, linear density, expressed as weight per unit length. The latter is normally the measured value and is determined by accurately weighing in air a precise length of yarn, strand, and roving.

3.4.2 Cross-sectional area of yarn or tow

This property is calculated rather than measured. However, it is very useful in subsequent calculations of fiber loadings in prepregs and composites as well as in calculations for other physical and thermophysical properties. Often it is considered a quality assurance criterion for fiber manufacture. The cross-sectional area is determined by dividing the linear density, weight per unit length, by the volumetric density, weight per unit volume, using consistent units. It should be noted that this value includes only the cumulative total of the cross-sectional areas of all the individual filaments within the bundle. The cross-sectional area is not affected by any space between filaments nor related to any calculations based on yarn or bundle "diameter".

3.4.3 Twist of yarn

Twist is defined as the number of turns about its axis per unit length in a yarn or other textile strand. Twist is sometimes desirable to improve handleability and, at other times, undesirable because it restricts spreading of the yarn or tow. It can be measured according to the direct procedure described in ASTM D 1423 (Reference 3.4.3).

3.4.4 Fabric construction

Properties of fabrics such as handleability, drapability, physical stability, thickness, and the effectiveness of the translation of fiber properties to the fabric are all dependent on fabric construction. For the purpose of this document, fabric construction is defined according to the fiber used (by type and filament count), the weave style such as "plain" or "satin", and the number of yarns per inch of fabric in both warp and fill directions. The most common weave styles employed for carbon fabrics used in aircraft and aerospace applications are plain weave, crowfoot satin, five harness satin, and eight harness satin. For a given yarn, fabric physical stability decreases and drapability increases progressively from the plain weave to the eight harness satin weave. In order to maintain a satisfactory level of stability, more yarns per inch must be added progressively toward the 8-harness satin weave fabric, thus the lightest weight fabrics are of plain weave style. There are many construction-related tests applied in the textile industry which are beyond the scope of this document. Essential standards for measure of construction are Determination of Yarn Count (ASTM D 3775), Length (ASTM D 3773), Width (ASTM D 3774) and Weight (ASTM D 3776) (References 3.4.4(a) - (d)). Additional information on weaves is provided in Volume 3, Section 2.5.1.

3.4.5 Fabric areal density

This property, although related to the yarn count previously described, is itself useful in calculations for composite construction and analysis. Expressed as weight per unit area of fabric, fabric areal density along with the fiber density governs the thickness of a cured ply of impregnated fabric at a given fiber volume loading. It is measured according to the method described in ASTM D 3776 (Reference 3.4.4(d)).

3.5 MECHANICAL TESTING OF FIBERS

3.5.1 Tensile properties

It is important to note that the fiber stress at specimen failure is test dependent. For example, Table 3.5.1 shows the difference in fiber tensile stress at failure for typical carbon fibers tested as a filament, an impregnated tow, and a unidirectional laminate. These data reflect the fact that composite tensile strength depends upon many factors, including interface characteristics, as well as fiber and matrix properties. These data emphasize the need to define the objective of fiber testing. Thus, for acceptance testing, it is recommended that fiber strength be measured on a material form representative of composite behavior. For carbon fibers, an impregnated tow test is recommended; for boron fibers, single filament tests are recommended.

TABLE 3.5.1 *Effect of test method on measured tensile strength.*

TEST	Nominal Measured Fiber Tensile Strength			
	Typical Carbon Fiber Standard Modulus		Typical Carbon Fiber Intermediate Modulus	
	ksi	MPa	ksi	MPa
Filament	595	4100	780	5380
Tow	580	4000	790	5450
Laminate	555	3830	665	4590

3.5.1.1 Filament tensile testing

Single filament tensile properties can be determined using ASTM D 3379, Tensile Strength and Young's Modulus for High-Modulus Single-Filament Materials (Reference 3.5.1.1). The following summarizes this method:

A random selection of single filaments is made from the material to be tested. The filaments are centerline mounted on special slotted tabs. The tabs are gripped so that the test specimen is aligned axially in the jaws of a constant speed movable crosshead test machine, and stressed to failure.

For this test method, filament cross-sectional areas are determined by planimeter measurements of a representative number of filament cross-sections as displayed on highly magnified photomicrographs. Alternative methods of area determination, such as optical gages, image-splitting microscope, linear weight-density method, etc., may also be used.

Tensile strength and Young's modulus are calculated from the load-elongation records and the cross-sectional area measurements. The specimen is shown in Figure 3.5.1.1.

3.5.1.2 Tow tensile testing

ASTM D 4018, Tensile Properties of Continuous Filament Carbon and Graphite Yarns, Strands, Rovings, and Tows (Reference 3.5.1.2) or its equivalent is recommended for carbon and graphite. The following summarizes this method:

Properties are determined by tensile loading to failure of resin impregnated yarns, strands, rovings, or tows. The purpose of the impregnating resin is to provide the yarn, strand, roving, or tow, when cured, with sufficient mechanical strength to produce a rigid test specimen capable of sustaining uniform loading of the individual filaments in the specimen. To minimize the effects of the impregnating resin on the tensile properties, the following should be observed:

- The resin should be compatible with the fiber.
- The amount of resin in the cured specimen (resin content) should be the minimum required to produce a useful test specimen.
- The individual filaments of yarn, strand, roving, or tow should be well collimated.
- The strain capability of the resin should be significantly greater than the strain capability of the filaments.

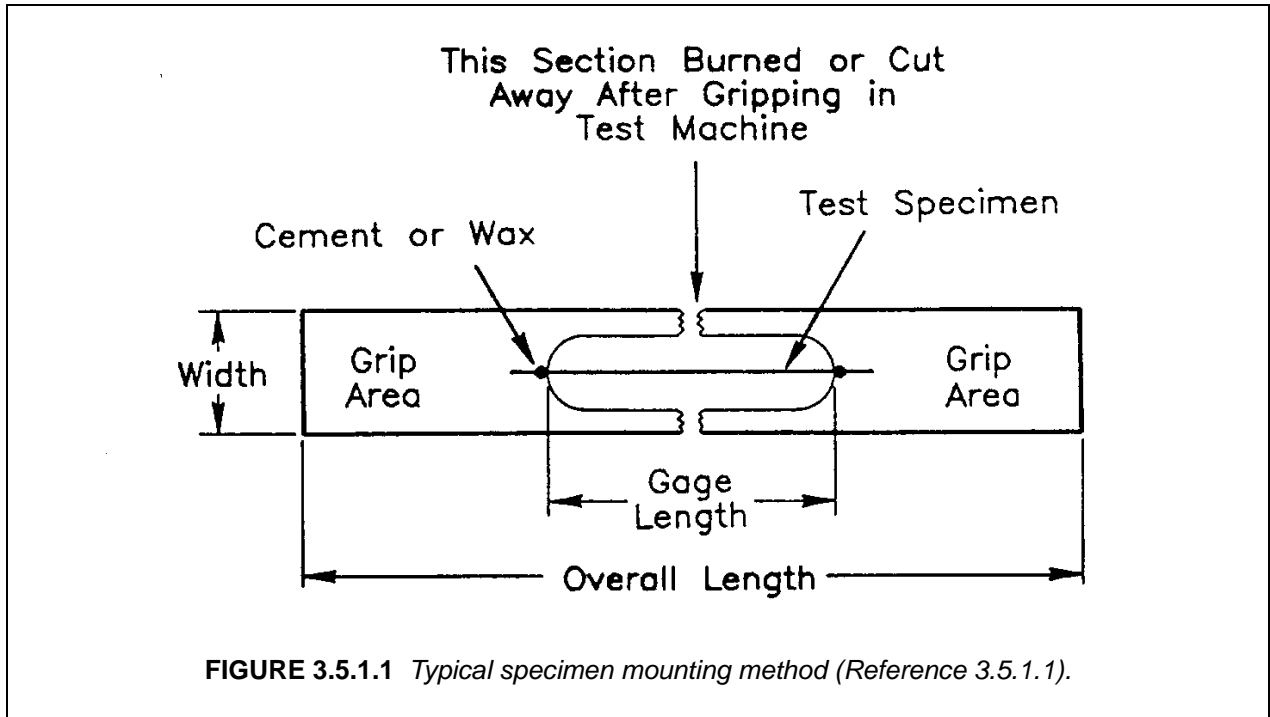

ASTM D 4018 Method I test specimens require a special cast-resin end tab and grip design (Figures 3.5.1.2(a) and (b)), to prevent specimen slippage in the grips under high loads. Alternative methods of specimen mounting with end tabs are acceptable, provided that test specimens maintain axial alignment on the test machine centerline, and they do not slip in the grips at high loads.

Method II test specimens require no special gripping mechanisms. Standard rubber-faced jaws should be adequate.

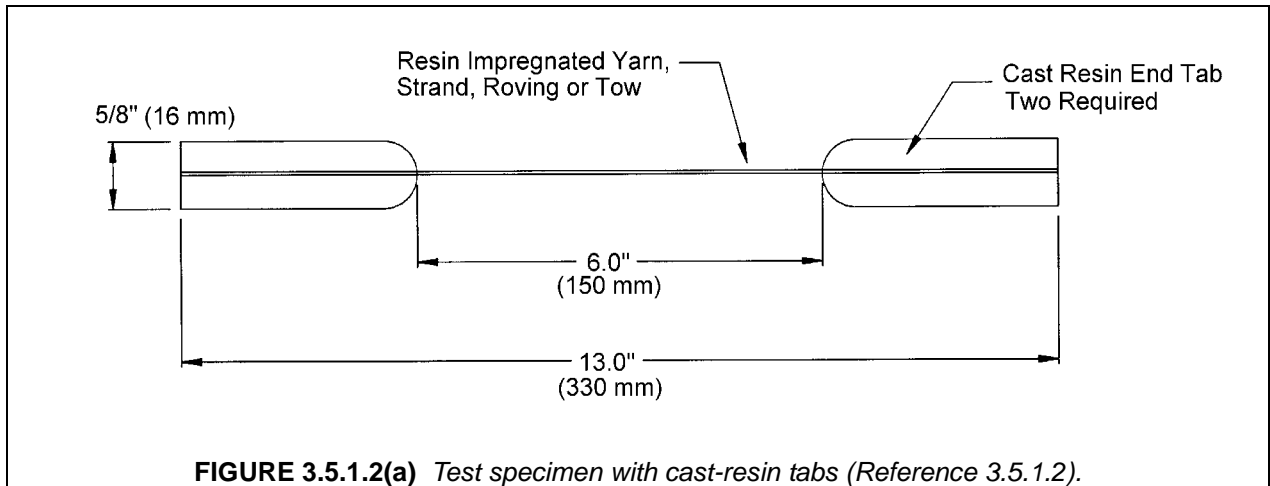

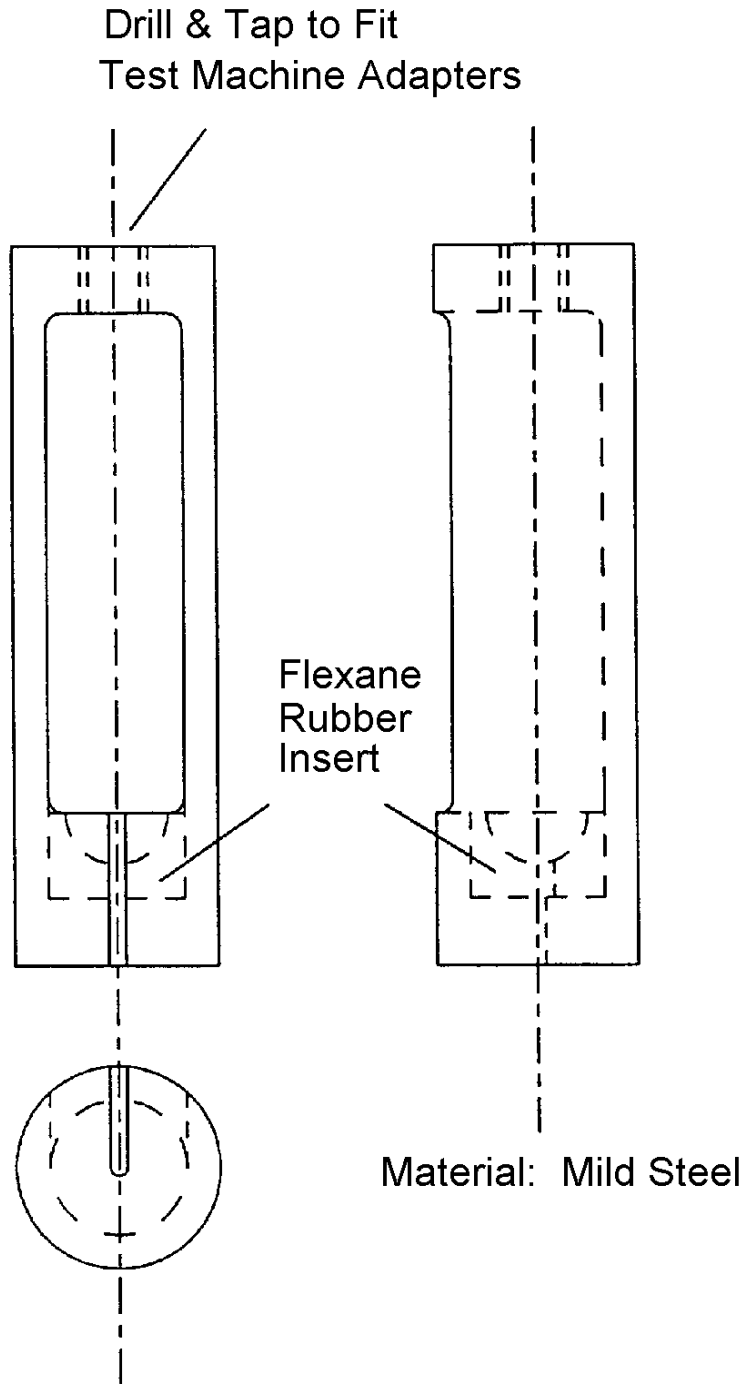

FIGURE 3.5.1.2(b) Grips for high load tensile specimen (Reference 3.5.1.2).

3.5.1.3 Fiber properties from unidirectional laminate tests

The most general representative procedure for the measurement of composite properties is to combine fiber and resin and test as a cured laminate. It is important to understand that laminate properties are a function of both fiber and resin. Table 3.5.1.3 shows the dependence of measured mechanical properties with various modified epoxy resins. Another factor to consider is the fiber volume fraction of the laminate. A fiber volume of 55% to 65% has been found to allow consistent measurement of normalized fiber properties for carbon fiber laminates. Since the objective is to determine fiber properties, the data must be normalized to 100% fiber volume. This is done simply by the following equation:

$$\text{Property (100\%)} = \frac{\text{Property} \times 100}{\text{Fiber Volume}} \quad 3.5.1.3$$

Laminate testing should be conducted per ASTM D 3039 (Reference 3.5.1.3). Laminate mechanical testing is further discussed in Section 6.6.

TABLE 3.5.1.3 Effects of resin on laminate properties.

FIBER	RESIN	TENSILE STRENGTH,		TENSILE MODULUS,	
		(ksi)	(MPa)	(Msi)	(GPa)
AS4	A	527	3630	32.1	221
AS4	B	500	3450	32.7	225
AS4	C	435	3000	32.4	223
AS4	D	432	2980	31.9	220

Tensile strength and modulus data normalized to 100% fiber volume

3.5.2 Filament compression testing

Dynamic recoil tests can be utilized to measure compressive strengths of single filaments. The test method is currently under development and is not in general use.

3.6 TEST METHODS

3.6.1 Determination of pH

(Reference 3.6.1)

3.6.1.1 Scope

This method describes a procedure for determining the pH of carbon and graphite fibers and fabrics by means of a pH meter. Measurements should be made on fibers that have not been sized. Due to the small amount of surface functionality on commercial fibers, these measurements require extreme care.

3.6.1.2 Apparatus

The apparatus needed for this procedure is as follows:

1. A pH meter equipped with glass and calomel electrodes or a single combination electrode which is preferable. It should have an accuracy of ± 0.005 pH and conform to the requirements in the Method for Determination of pH of Aqueous Solutions with the Glass Electrode ASTM E-70.
2. Lipless beakers 100-ml. capacity with cover glasses.
3. Hot plate.
4. Shears for cutting samples.
5. Large pyrex flask one to two liters capacity for boiled distilled water. The pH of this water should be between 6.9 and 7.1 at 77°F (25°C). If it is impossible to meet these limits by boiling, the pH may be adjusted with extremely weak NaOH or HCl.

3.6.1.3 Procedure

1. Prepare cloth samples by shearing into small (1/2" to 3/4") squares sufficient quantity to make 3.0 grams. Prepare yarn by cutting the sample into pieces 1/2" to 3/4" in length.
2. To 3 grams of sample add 30 ml. of the boiled distilled water, cover with a watch glass and boil very gently for 15 minutes. The use of Berzelius or lipless beakers prevents excessive loss of water. At the end of 15 minutes approximately 4 or 5 ml. of slurry should remain.
3. Set the covered beakers in a tray of cold water and cool to room temperature. Keep the beakers covered to prevent the absorption of chemical fumes that may be present in the room. After cooling remove the cover glasses but do not wash down.
4. When all is in readiness for the test, standardize the pH meter by use of a reliable buffer. Place buffer in a beaker, immerse the electrodes and adjust the meter to exactly the same value. A buffer should be chosen with a pH value in the same range as the sample to be tested. The temperature of the buffer and the sample should be the same temperature within $\pm 1^\circ$.
5. After the meter is adjusted, remove the electrodes from the buffer, rinse thoroughly with distilled water and wipe dry with clean absorbent tissue.
6. Place the electrodes in the slurry and rotate the beaker gently in alternate directions until a constant pH value is obtained.

3.6.2 Determination of amount of sizing on carbon fibers

3.6.2.1 Scope

This method describes the procedures for determining the sizing on carbon fibers, expressed as a percent of yarn weight.

3.6.2.2 Apparatus

The following equipment is needed for this procedure:

1. Balance - Analytical, Mettler Model B5-H26. Scientific Products Catalog No. B1253, or equivalent.
2. Desiccator - Scheibler including Coors desiccator plate, 250 mm I.D. Scientific Products Catalog No. D1450-5, or equivalent.

Volume 1, Chapter 3 Evaluation of Reinforcement Fibers

3. Crucible - Coors, 40 ml Cap, 47mm rim dia., 40 ml h. Scientific Products Catalog No. C8450-8, or equivalent.
4. Muffle Furnace - Thermolyne, Model No. F-A1730. Maximum temp. 2000°F. Chamber Dimensions: 9 1/2"W x 8 1/2"H x 13 1/2"D, or equivalent.
5. Sagger - Stainless steel (16 gage). Dimensions: 9"W x 3"H x 10"D, with a snug fitting stainless steel cover having a 1/2" hangover on all sides. Sagger must have a 1/8" stainless steel tube connected into it for purposes of nitrogen purging. In house fabricated.

3.6.2.3 *Materials*

The following materials are needed for this procedure:

1. Drierite or equivalent - Both indicating and non-indicating crystals.
2. Nitrogen Gas - Standard purity.

3.6.2.4 *Procedure*

1. Wind approximately .003 lb. (1.5g) of sample yarn into a small ~.98-1.57 in. dia. (25-40 mm dia.) coil and place it in a desiccator for 2 hours.
2. Using clean dry forceps, remove the sample coiled from the desiccator and weigh to nearest 0.1 mg. Record as W_1 .
3. Obtain a clean dry crucible from the desiccator and place the sample coil in it. Weigh crucible plus yarn and record as W_2 . NOTE: Wear clean dry cotton gloves to prevent any moisture from being picked up by the crucible.
4. Place the crucible plus sample in the sagger and cover it with lid. A stainless steel shelf with twelve 1-3/4" Dia. holes located 3/4" from the bottom of the sagger is suggested to prevent crucibles from overturning.
5. Purge the sagger with nitrogen at a rate of 7.5 S.C.F.H. for a minimum of 45 minutes.
6. While system is purging, set the control on the muffle furnace to 842°F (450°C) and turn on.
7. When purging time is complete and the furnace is at temperature, place the sagger in the furnace and heat for 1 hour. Note, for safety, wear protective asbestos gloves or equivalent when inserting or removing the sagger from the hot muffle furnace. The N_2 purge is continued throughout the heating and cool-down phases of this test.
8. After heating for 1 hour, remove the sagger from the furnace and place it in protected cool-down area.
9. Remove the crucible from the sagger and place it in the desiccator to cool to room temperature.
10. When cool, weigh crucible plus sample and record as W_3 .

3.6.2.5 *Calculation*

Calculate the amount of sizing by determining the percent weight loss as follows:

$$\text{Sizing Content} = \frac{W_2 - W_3}{W_1} \times 100 \quad 3.6.2.5$$

3.6.2.6 *Preparation of crucibles for reuse*

Before reusing crucibles, burn off any residue by placing them in the muffle furnace and heating them at 1292°F (700°C) in air for at least 2 hours. After the crucibles are removed from the furnace and cool to room temperature, blow them out with clean compressed air. Store clean crucibles in the desiccator.

3.6.3 **Determination of moisture content or moisture regain**

3.6.3.1 *Scope*

This method may be used to determine the amount of moisture in a textile either as it is received or when it is in moisture equilibrium for testing in the standard atmosphere as defined in the definitions of Terms Relating to Textile Materials (ASTM D 123, Reference 3.6.3.1).

3.6.3.2 *Apparatus*

The following equipment is needed for this procedure:

1. Weighing Bottle, glass, approximately 100-ml. capacity, fitted with a ground-glass cover, or an aluminum weighing can, approximately 100-ml. capacity, and having a tight-fitting cover.
2. Desiccator, containing anhydrous calcium chloride (CaCl_2) or other suitable dehydrating agent.
3. Chemical Balance, capable of weighing to 0.5 mg.
4. Oven, maintained at 221-230°F (105-110°C). Note that special equipment for drying specimens to constant weight, which is generally available in textile laboratories (conditioning ovens, etc.) may also be used. The apparatus here and the procedure described in Section 3.6.3.4 are provided for laboratories without such special equipment.

3.6.3.3 *Sample preparation*

1. Cut samples for test. Approximately 2 grams are required. When sampling cloth use the Alfred Sutler Company sample cutter or equivalent, which cuts a circular disc slightly over two inches in diameter. Four discs will usually weigh about two grams. When sampling yarn, form sample into small coil. Hold in place by tying with one of the ends.

3.6.3.4 *Procedure*

1. Dry the glass weighing bottle at 221-230°F (105-110°C) to constant weight. Place the weighing bottle and cover separately in the oven. After heating for 1 hour, replace the cover, transfer the weighing bottle to the desiccator and allow it to cool to room temperature. Remove the cover momentarily to equalize the pressure, and with the cover in place, weigh the container. Repeat the heating, cooling, and weighing until the weight of the empty weighing bottle is constant to within ± 0.001 g.
2. Place the specimen to be tested in the container, cover, and weigh. Subtract the weight of the empty container (1.) from this weight to obtain the air-dry weight of the specimen, weight A.
3. Place the uncovered weighing bottle and specimen in the oven for 1 1/2 hours at a temperature of 221-230°F (105-110°C). Cover and transfer the container to a desiccator. When the container has cooled to room temperature, remove the cover momentarily to adjust the pressure, replace the cover, and weigh. Repeat the heating for periods of not less than 20 minutes, cooling and weighing until the weight is constant to within ± 0.001 g. Subtract the weight of the empty container from this weight to obtain the oven-dry weight of the specimen, weight B. When textiles are

Volume 1, Chapter 3 Evaluation of Reinforcement Fibers

heated under the conditions described, volatile materials, in addition to moisture, may be removed. If this possibility is known or suspected, it should be reported that the percentage loss in weight of the textile does or may include volatile substances as well as moisture.

3.6.3.5 Calculations

Calculate the moisture content of the specimen as follows:

$$\text{Moisture content, percent} = \frac{A-B}{A} \times 100 \quad 3.6.3.5(a)$$

Calculate the moisture regain of the specimen as follows:

$$\text{Moisture regain, percent} = \frac{A-B}{B} \times 100 \quad 3.6.3.5(b)$$

where:

A = air-dry weight of the specimen

B = Oven-dry weight of the specimen

3.6.4 Determination of fiber diameter

3.6.4.1 Description and application

This method describes a procedure for determining the average diameter of fibers by means of a microscope fitted with an image splitting eyepiece. This instrument measures the distance across an object as it lays upon a glass slide. Therefore, this is a valid diameter measurement only if the fibers are essentially true cylinders. Since different types of fibers have characteristic shapes it is possible to use this procedure for irregularly shaped fibers by determining an area factor for the particular type of fiber being measured by means of microphotography.

Figure 3.6.4.1 is a sketch showing the optical scheme incorporated in the instrument. In the Image Splitter a prism system is interposed between microscope objective and eyepiece to produce a double image of the microscope field of view. This prism system is precisely rotatable by a micrometer screw. Upon rotation of the prisms double images of objects in the field of view transverse one another. Measurement is accomplished by reading off the micrometer the amount of prism rotation required to place on object's double images exactly edge to edge in the axis of desired measurement. Measurement is accomplished in the plane of the object.

The accuracy which can be obtained and the size limits for various conventional microscope objectives are shown in Table 3.6.4.1.

3.6.4.2 Apparatus

The following equipment is needed for this procedure:

1. Microscope, Unitron monocular model MLU with 5X, 10X, 20X and 40X objectives, fitted with a Vickers AEI 10X image splitting eyepiece, or equivalent.
2. Microscope lamp, A.O. Spencer, Fisher Catalog #12-394, or equivalent.
3. Glass microscope slides (e.g., Fisher Catalog No. 12-550).
4. Sharp knife or razor blade for cutting sample.

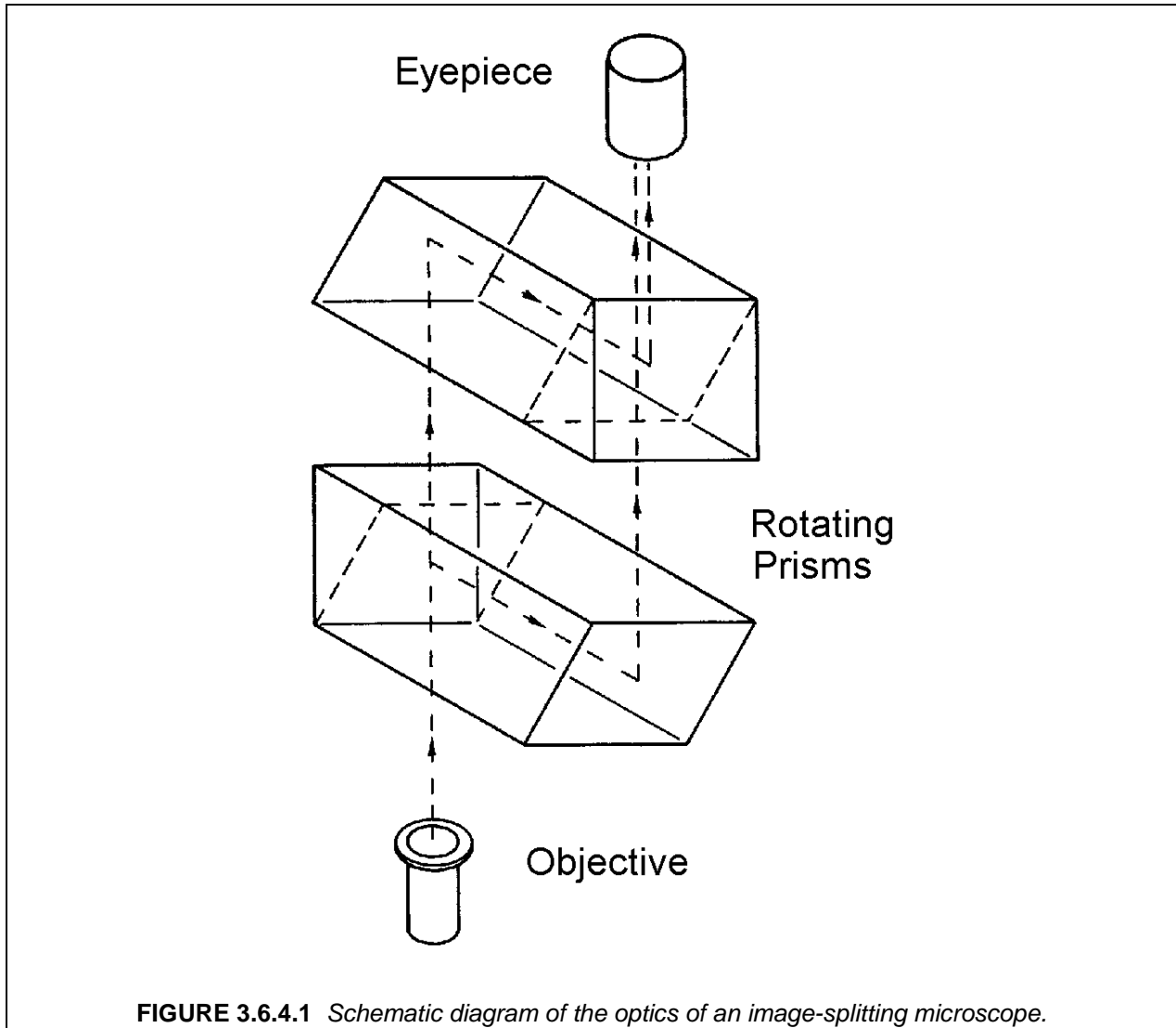

FIGURE 3.6.4.1 Schematic diagram of the optics of an image-splitting microscope.

TABLE 3.6.4.1 Accuracy and size limits.

OBJECTIVE POWER		READING ACCURACY		MAXIMUM SIZE OBJECT WHICH CAN BE COMPLETELY SHEARED	
5X	(N.A. 0.15)	0.00008"	2.0 μ m	0.04"	1.0 mm
10X	(N.A. 0.28)	0.00004"	1.0 μ m	0.02"	0.5 mm
20X	(N.A. 0.50)	0.000026"	0.6 μ m	0.01"	0.25 mm
40X	(N.A. 0.65)	0.0000128"	0.325 μ m	0.005"	0.12 mm

3.6.4.3 Calibration

Assemble and calibrate the microscope following the directions supplied with the instrument. If for any reason a different eyepiece or objective is used, the instrument must be recalibrated for the new part.

3.6.4.4 Prepare slide

Select representative strands from the sample and align in an even bundle. Place the bundle on a spare glass slide and hold it in place with the top of the finger. Cut the strands with a sharp instrument to secure smooth even ends. Place the strands on a clean slide so that the even ends are near one edge of the slide. (See Figure 3.6.4.4.) Cut the strands so that the pieces approximately .19 in. (0.5 mm) will be produced. The pieces will dust in a fine spray over the surface of the slide in an even pattern.

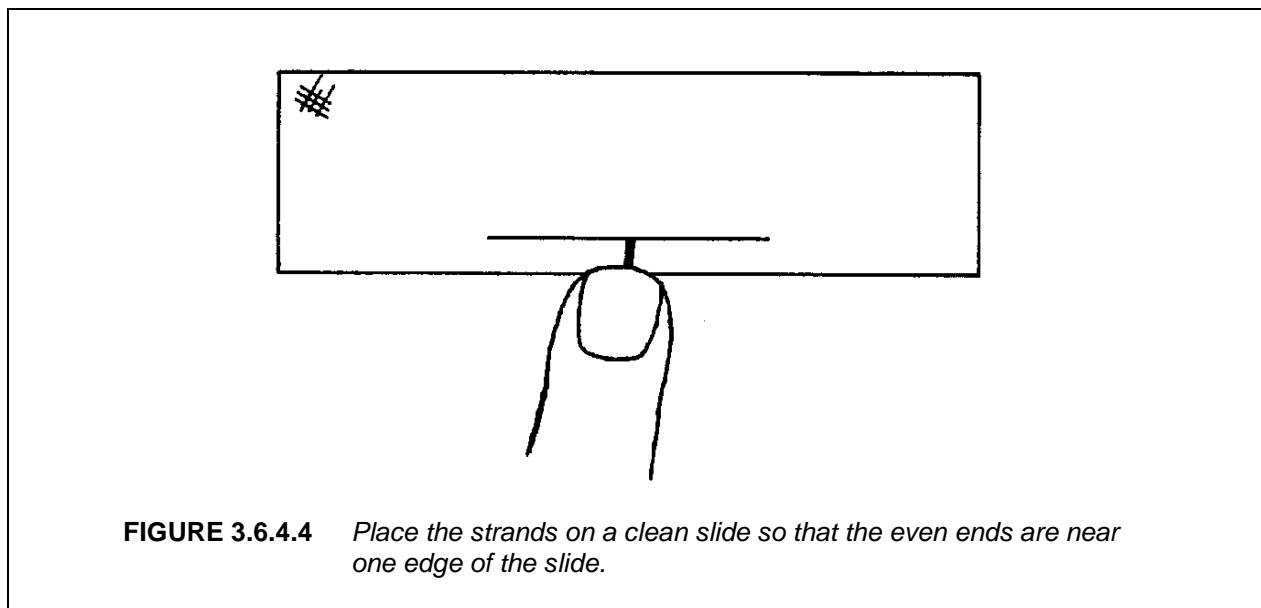

3.6.4.5 Measuring procedure

1. Place the slide under the microscope and select at random a single fiber. The fiber will appear as parallel red and green lines.
2. Rotate the image splitter until the fiber is parallel with the axis of the micrometer barrel and the ends of the two image are even.
3. Bring into sharp focus. Rotate the micrometer until the red and green images overlap forming a single black line. Continue the rotation until the red and green lines again separate and a band of light shows between them. Reverse the rotation and slowly bring the colored images back together until they just touch. Neither a thin light nor black line should be visible. Record the micrometer reading. If the micrometer should be turned too far so that the black line appears back off and start over. This will eliminate the effect of any backlash in the mechanism.
4. Continue to rotate the micrometer until the images have completely overlapped and are just ready to separate on the opposite side. Turn the micrometer very slowly until the thick black line completely disappears. At this point the red and green images should be just touching with no light

Volume 1, Chapter 3 Evaluation of Reinforcement Fibers

showing between them. Record the micrometer reading. The difference between the two readings is equal to twice the width of the object being measured.

5. Select other fibers and continue the measurements until twenty pieces have been measured. Move the slide in a uniform pattern to eliminate the possibility of measuring the same piece twice.

3.6.4.6 Calculation

List the difference in micrometer readings obtained in Paragraph 5 for each of the twenty measurements. Divide this number by two then multiply the result by the calibration factor for the microscope to obtain diameter measurement in microns. Calculate the average for the twenty measurements.

If the diameter measurement calculated above is to be used to calculate cross sectional area for strength determinations see Section 3.6.4.1. For example, the area of Thornel 25™ fibers may be calculated as follows: calculate the area using the average diameter determined in this procedure. Multiply this area by the area factor to obtain the actual area. (An area factor of 0.66 has been determined for Thornel 25™.)

3.6.5 Determination of electrical resistivity

3.6.5.1 Scope

This method describes a procedure for determining the electrical resistance of carbon and graphite cloth and felt. It is used as a control measure for checking temperature of processing and to determine compliance of materials with specific resistance specifications.

3.6.5.2 Apparatus

The following equipment is needed for this procedure:

1. Jig for clamping cloth.
2. Vacuum tube volt-ohmmeter. Triplet #850 or equivalent.
3. Scissors or other implement for cutting samples.

3.6.5.3 Sample preparation

For cloth, obtain a 1/2 yard long (45.7 cm), full width piece of each roll of cloth to be tested. Cut five warp and five fill direction strips 1-1/4" wide and 11" to 12" (27.9 to 30.5 cm) long. Distribute the location of the strips over the entire area of the cloth sample. Ravel each strip to the nearest thread to one inch width. For felt samples, obtain a 1/2 yard long (45.7 cm), full width piece of each roll of felt to be tested. Cut five strips in "warp" direction and five strips in "fill" direction using a 1" x 12" (25 mm x 305 mm) metal template. Distribute the location of strips over the entire area of the felt sample.

3.6.5.4 Procedure

1. Adjust the silver jaws of the resistance jig to provide a test length of 10".
2. Clamp sample in jig and measure resistance.

3.6.5.5 Calculation

Divide observed resistance by 10 to obtain ohms/square value. (See Section 3.6.5.7.) Determine the average resistance for five strips and record on data sheet as ohms per inch per inch width.

3.6.5.6 Calibration and maintenance

Vacuum tube volt-ohmmeters are used for fabric and felt measurement. The meter and jig should be calibrated every six months with a standard resistance box, certified to NBS standards. Any incident requiring meter maintenance (tube replacement, etc.) should be followed by recalibration regardless of the six month routine check.

The zero and full scale adjustment should be checked each shift the meter is used. If meter fails to adjust properly to zero and full scale, it must be checked by the electrical maintenance department. The zero adjustment compensates for lead wire and meter resistance errors.

3.6.5.7 Definition of units of measurement

The electrical resistance measurement on cloth and felt is expressed in ohms per square (unit area). This is not the same value as the specific resistance measured on bulk carbon. The fabric resistance value is proportional to specific resistance when a given grade is considered. For example, carbon cloth has higher resistance than graphite cloth, the same material after graphitization.

The size of the square (unit area) does not influence the resistance value of the cloth or felt. This can be demonstrated with the standard equation for the relation between sample resistance and specific resistance for a solid rectangular shape.

$$P = \frac{RTW}{L} \text{ or } R = \frac{PL}{TW} \quad 3.6.5.7(a)$$

where

- P = specific resistance
- R = sample resistance
- L = sample length
- T = sample thickness
- W = sample width

For materials with identical specific resistance (P) such as copper, the resistance of one square inch of a given thickness would be:

$$R = \frac{PL}{TW} = \frac{P}{T} \cdot \frac{L}{W} \quad 3.6.5.7(b)$$

Since T and P are constant, the resistance of the one inch square can be written:

$$R = K \frac{L}{W} = K \frac{1}{1} = K \quad 3.6.5.7(c)$$

If the square is made twice as large (2 x 2), the resistance of the square will remain the same.

$$R = K \frac{L}{W} = K \frac{2}{2} = K \quad 3.5.6.7(d)$$

Therefore, the resistance of fabrics is reported as ohms/square. The user can use any unit for the square he chooses, inch, centimeter, foot or yard.

REFERENCES

- 3.2.1(a) ASTM C 169, "Chemical Analysis of Soda Lime and Borosilicate Glass," *1984 ASTM Book of Standards*, Vol 15.02, ASTM, Philadelphia, PA, 1984.
- 3.2.1(b) ASTM D 3178, "Carbon and Hydrogen in the Analysis Sample of Coal and Coke," *1984 ASTM Book of Standards*, 5.05, ASTM, Philadelphia, PA, 1984.
- 3.2.1(c) ASTM D 3174, "Ash in the Analysis Sample of Coal and Coke from Coal," *1984 ASTM Book of Standards*, 5.05, ASTM, Philadelphia, PA, 1984.
- 3.2.4(a) Adamson, A.W., *Physical Chemistry of Surfaces*, Wiley, New York, 1980, p. 344.
- 3.2.4(b) Hammer, G.E. and Drzal, L.T., "Graphite Fiber Surface Analysis by X-ray Photoelectron Spectroscopy and Polar/Dispersive Free Energy Analysis," *Applications of Surface Science*, Vol 4, 1980, p. 340.
- 3.2.4(c) Dynes, P.J. and Kaeble, D.H., "Surface Energy Analysis of Carbon Fibers and Films," *J. Adhesion*, Vol 6, 1974, p. 195.
- 3.2.4(d) Kaeble, D.H., "Surface Energy Analysis of Treated Graphite Fibers," *J. Adhesion*, Vol 6, 1974, p. 239.
- 3.2.4(e) Drzal, L.T., Mescher, J.A., and Hall, D.L., "The Surface Composition and Energetics of Type HM Graphite Fibers," *Carbon*, Vol 17, 1979, p. 375.
- 3.2.4(f) Rand, B. and Robinson, R., "A Preliminary Investigation of PAN Based Carbon Fiber Surfaces by Flow Microcalorimetry," *Carbon*, Vol 15, 1977, p. 311.
- 3.2.5 ASTM C 613-67, "Resin Content of Carbon and Graphite Prepregs by Solvent Extraction," *1988 ASTM Book of Standards*, Vol 15.03, ASTM, Philadelphia, PA, 1988.
- 3.2.7(a) ASTM D 4102-82, "Thermal Oxidative Resistance of Carbon Fibers," *1988 ASTM Book of Standards*, Vol 15.03, ASTM, Philadelphia, PA, 1988.
- 3.2.7(b) Eckstein, B.H., "Weight Loss of Carbon Fibers in Air," *18th International SAMPE Technical Conference*, 1986.
- 3.3.2 ASTM D 3800-79, "Density of High Modulus Fibers," *1988 ASTM Book of Standards*, Vol 15.03, ASTM, Philadelphia, PA, 1988.
- 3.3.2.1(a) ASTM D 2734, "Standard Test Method for Void Content of Reinforced Plastics," *Annual Book of ASTM Standards*, ASTM, West Conshohocken, PA.
- 3.3.2.1(b) ASTM D 1505, "Standard Test Method for Density of Plastics by the Density-Gradient Technique," *Annual Book of ASTM Standards*, ASTM, West Conshohocken, PA.
- 3.3.2.1(c) Ghiorse, S.R., data presented to MIL Handbook 17 Testing Working Group, Santa Fe, NM, March 1996.
- 3.3.2.1(d) Ghiorse, S.R. and Tiffany, J., "Evaluation of Gas Pycnometry as a Density Measurement Method," Proceedings of the 34th MIL-HDBK-17 PMC Coordination Group, Schaumburg, IL, September 1996.
- 3.3.2.1(e) ASTM D 3800, "Standard Test Method for Density of High-Modulus Fibers," *Annual Book of ASTM Standards*, ASTM, West Conshohocken, PA.

- 3.3.2.1(f) ASTM D 792, "Standard Test Method for Density and Specific Gravity (Relative Density) of Plastics by Displacement," *Annual Book of ASTM Standards*, ASTM, West Conshohocken, PA.
- 3.3.5(a) Piraux, L., Nysten, B., Haquenne, A., and Issi, J.P., "Temperature Variation of the Thermal Conductivity of Benzene-Derived Fibers," *Solid State Comm.*, Vol 50(8), pp. 697-700, 1984.
- 3.3.5(b) Kalnin, I.L., "Thermal Conductivity of High Modulus Carbon Fibers," ASTM STP 580 *Composite Reliability*, 1975.
- 3.3.6 ASTM D 2766, "Specific Heat of Liquids and Solids," *1984 ASTM Book of Standards*, Vol 05.02, ASTM, Philadelphia, PA, 1984.
- 3.3.7(a) ASTM D 3417-83, "Heats of Fusion and Crystallization of Polymers by Thermal Analysis," *1987 ASTM Book of Standards*, Vol 08.03, ASTM, Philadelphia, PA, 1987.
- 3.3.8(b) ASTM D 3418-82, "Transition Temperatures of Polymers by Thermal Analysis," *1987 ASTM Book of Standards*, Vol 08.03, ASTM, Philadelphia, PA, 1987.
- 3.4.3 ASTM D 1423, "Twist in Yarns by the Direct Counting Method," *1984 ASTM Book of Standards*, Vol 07.01, ASTM, Philadelphia, PA, 1984.
- 3.4.4(a) ASTM D 3775, "Fabric Count of Woven Fabric," *1984 ASTM Book of Standards*, Vol 07.01, ASTM, Philadelphia, PA, 1984.
- 3.4.4(b) ASTM D 3773, "Length of Woven Fabric," *1984 ASTM Book of Standards*, Vol 07.01, ASTM, Philadelphia, PA, 1984.
- 3.4.4(c) ASTM D 3774, "Width of Woven Fabric," *1984 ASTM Book of Standards*, Vol 07.01, ASTM, Philadelphia, PA, 1984.
- 3.4.4(d) ASTM D 3776, "Weight (Mass Per Unit Area) of Woven Fabric," *1984 ASTM Book of Standards*, Vol 07.01, ASTM, Philadelphia, PA, 1984.
- 3.5.1.1 ASTM D 3379-75, "Tensile Strength and Young's Modulus for High-Modulus Single Filament Materials," *1990 Annual Book of ASTM Standards*, Vol 15.03, American Society for Testing and Materials, Philadelphia, 1990.
- 3.5.1.2 ASTM D 4018-81, "Tensile Properties of Continuous Filament Carbon and Graphite Yarns, Strands, Rovings, and Tows," *1990 Annual Book of ASTM Standards*, Vol 15.03, American Society for Testing and Materials, Philadelphia, 1990.
- 3.5.1.3 ASTM D 3039-76, "Tensile Properties of Fiber-Resin Composites," *1990 Annual Book of ASTM Standards*, Vol 15.03, American Society for Testing and Materials, Philadelphia, 1990.
- 3.6.1 "Determination of pH," Union Carbide Corp., Carbon Products Div., WC-2090, 12-6-66
- 3.6.3.1 ASTM D 123-86, "Terminology Relating to Textiles," *1987 ASTM Book of Standards*, Vol 07.01, ASTM, Philadelphia, PA, 1987.

CHAPTER 4 MATRIX CHARACTERIZATION

4.1 INTRODUCTION

The function of the matrix in a composite is to hold the fibers in the desired position, and to provide a path for introducing external loads into the fibers. Since the strengths of matrix materials are generally lower than fiber strengths by an order of magnitude or more, it is desirable to orient the fibers within a composite structure so that they will carry the major external loads. Although the success of composites is largely due to this ability, the strength and other properties of matrix materials cannot be ignored. Matrix material properties can significantly affect how a composite will perform, particularly with respect to in-plane compression, in-plane shear, resistance to impact damage, and other interlaminar behavior, and especially when exposed to moisture and elevated temperatures.

A wide range of polymeric resin systems are used as the matrix portion of fiber reinforced composites. These systems generally fall into two broad categories: thermoplastic materials and thermosetting materials. The thermoplastics are non-reactive solids designed to soften, melt, and intimately infiltrate reinforcement fiber bundles at appropriate processing temperatures and pressures, and to solidify into a desired shape upon cooling. Thermosets are reactive materials comprised of organic resins and other constituents required for chemical "curing." They may exist in various forms (liquid, solid, film, powder, pellets, etc.) in the uncured state, and may be partially reacted prior to combining with the reinforcing fibers. During composite processing they react irreversibly to form solids. In addition to the organic constituents, thermoset systems may also contain additives such as catalysts, fillers, and processing aids, which may be inorganic or contain metals. Thermoplastic or elastomeric fillers may also be incorporated. Due to their reactive nature, most uncured thermosets must be stored under refrigeration, although some multi-part systems designed for component mixing just prior to use may not require cold storage. Both thermoplastics and thermosets can be used to preimpregnate reinforcing fibers to produce prepreg, while processes like RTM (resin transfer molding) are generally more suited to thermosets.

This chapter focuses on methods of testing and characterizing matrix materials and their constituents. Chemical, physical, thermal, and mechanical properties are considered, as well as methods for test specimen preparation and environmental conditioning of test specimens. Tests of thermosets (in both the cured and uncured states), and thermoplastics are addressed.

The properties covered in this chapter will largely be of interest to resin formulators and material suppliers. The composite end user will also find some matrix properties useful, particularly for process cycle development and, to a lesser extent, for initial screening and material selection. A number of matrix properties and tests are also applicable to quality assurance, especially if resins are purchased separately from the reinforcement for use in RTM or similar processes.

4.2 MATRIX SPECIMEN PREPARATION

4.2.1 Introduction

Specimens of unreinforced (neat) matrix material are required for physical and/or mechanical characterization of these polymers in the solid (cured) state. Methods available for specimen preparation are strongly dictated by the type of matrix material being studied. Primary variables include thermoset vs thermoplastic, viscosity at various processing stages, processing temperature, amount of volatiles evolved, and degree of brittleness in the fabricated state. When working with uncured polymers, personal safety is always a concern, and the appropriate Material Safety Data Sheets (MSDS) should be consulted.

4.2.2 Thermoset polymers

Thermoset polymers of interest, i.e., those used as matrices in composites, are typically of sufficiently low viscosity at some point during the cure process to flow. Thus, they may be cast into plate forms to provide blanks from which finished specimens can be machined, or molded into even more complex geometries if necessary to create net- dimension specimens directly.

When casting neat (unreinforced) polymers for use as mechanical test specimens, it is critical that voids, inclusions, and similar defects be minimized, both in size and number. Most thermoset polymers used as matrices, even those considered to be toughened, tend to be relatively brittle, and thus their ultimate strengths are strongly dictated by critical flaw size.

Inclusions can be present in impure resin as obtained from the supplier, or introduced during the fabrication process (e.g., inadequately cleaned molds, airborne dirt particles, inadequate mixing of components, etc.). Caution also must be exercised when using release agents, to avoid contamination of the polymer.

Defects can be in the form of surface scratches, edge chips, and mold marks. Voids are typically caused by trapped volatiles which evolve during the initial stages of the curing process. The evolution of volatiles can be suppressed, or at least minimized, by subjecting the polymer to pressure during the curing process. However, it is more common to apply a vacuum during the initial stage of the cure cycle, either while the polymer is still in the mixing container or already in the mold. This is done at one or more points in time as the temperature is being elevated, and while the viscosity is at its lowest. Thus, a vacuum oven is useful.

The vacuum can evoke a strong evolution of volatiles, requiring that the container or mold have sufficient volume to contain the frothy polymer until the gas bubbles burst. If a single flat panel is to be fabricated, a simple box mold consisting of five steel plates, viz., a bottom and four sufficiently high sides, held together with screws, works well. This box can be disassembled after cure, for ease of polymer matrix plate removal, and easy clean-up. Individual strips of polymer can also be made in this manner, by placing thin steel strips of width equal to the desired polymer matrix specimen width upright on one long edge, spaced apart to the desired polymer specimen thickness.

Since volatiles are being evacuated, the vacuum pump itself should be protected, by the use of a cold trap to condense these vapors before they pass through the pump.

If a cavity mold is being used to produce individual specimens of net dimensions, an elastomeric funnel works well to contain the volume of volatiles; the polymer will flow back down into the mold as the bubbles collapse. The funnel can then be left in place during the remainder of the cure. During clean-up, the funnel can be flexed to easily remove the cured polymer residue on it.

The individual specimen cavity molds can be fabricated of metal, usually steel rather than aluminum because of its lower thermal expansion and higher surface hardness. These are typically two-piece split molds, to permit cured specimen removal. Elastomeric molds, themselves easily fabricated by casting around a permanent pattern, are an attractive alternative. The cured mold can be slit along its length to remove it from around the pattern, this slit also permitting it to be later pried open to easily remove the polymer specimen cast in it. In any case, the individual specimen molds are typically ganged together for efficiency. The as-molded specimens are ready for testing with little or no further preparation. At most, and primarily for aesthetic reasons, the mold seam(s) may be lightly sanded off.

If vacuum is not being subsequently used to remove volatiles, the molds can be filled from the bottom, to minimize trapped air, but this adds complication and is usually not necessary. Likewise, if the viscosity of the polymer is too high for gravity fill, pressure can be used to force it into the mold. Again, this is not usually necessary considering the composite processing requirements of these polymers as matrix materials anyway.

As an alternative to a box mold for fabricating flat neat matrix plates, the polymer can be cast between two vertically positioned flat plates, held the desired cast polymer plate thickness apart by spacers, and sealed around three edges. The polymer is then poured into the open top edge. The plates may be metal or glass. However, this technique is not always successful. Because of the constraint of the mold at both surfaces of the polymer, and the difficulty of achieving full release, the cast polymer plate may crack due to the stresses induced by differential thermal contraction during cooldown from the cure temperature. Also, the polymer, which typically has a higher coefficient of thermal expansion than the mold, may contract away from the mold surfaces, producing a mottled surface. These local depressions are typically very shallow and can be removed by subsequent surface grinding of the cast plate. However, thermal residual strains associated with the formation of these surface irregularities remain (as can be observed under polarized light), and are very difficult to anneal out. Also, the very long path length that any trapped air bubbles or volatiles must travel to reach the free surface makes the production of void-free polymer plates more difficult to achieve.

4.2.3 Thermoplastic polymers

Thermoplastic polymers used in composites are typically high processing temperature (620-840°F (325-450°C)) systems and higher temperature mold materials must be used. Matrix polymers for use in fabricating neat specimens tend to be available in film or granular forms. Pressure injection or compaction is typically necessary, which is complicated by the fact that the minimum viscosities achievable tend to be higher than for thermosets. Although volatile evolution is usually not an issue when molding thermoplastics since they are typically fully polymerized, trapped air can still be a problem. Thus, the use of vacuum during forming may still be desirable.

These high temperature thermoplastics tend to be less brittle than the thermoset polymer matrix materials. Thus, cracking of the polymer plate during the molding operation due to differential contraction of plate and mold is less of a problem, but it can still occur.

4.2.4 Specimen machining

For both thermosets and thermoplastics, if the neat matrix specimen has been molded to final shape, no additional preparation is needed. Dogbone cylindrical specimens, typically for use in solid-rod torsion testing, but sometimes used for tension and compression testing, are one such example.

Tension, compression, and Iosipescu shear specimens of thermoset polymers are typically machined from flat plates or strips rather than being molded to net dimensions. Although individual dogbone flat specimens of commodity thermoplastics are commonly (injection-) molded to final dimensions, high temperature thermoplastic matrix materials are usually not. Rather, flat rectangular blanks are molded, and dogbone specimens are machined from them.

The various polymers are relatively easy to machine using abrasive wheels. If desired, the surfaces of as-molded plates can be ground prior to cutting individual specimens from them. The plates are cut into strips and specimen blanks using thin abrasive blades, although sometimes diamond wheels, or even toothed band saw blades, are used. Dogbone specimens can then be ground to final dimensions. The notches in Iosipescu shear specimens can likewise be ground in, using shaped grinding wheels and multiple passes. Specimens can be stacked together for this operation, mutually supporting each other.

Most polymer matrix specimens will tolerate minor grinding-induced scratches and chipped edges, even though this is never desirable. However, some polymers are extremely sensitive to these surface defects. All surfaces and edges within the specimen gage length must then be carefully smoothed with fine (e.g., down to 600-grit) emery cloth. When working with a new polymer matrix, both as-ground and surface-polished tensile specimens should initially be tested, to determine the polymer's sensitivity to surface defects. Since final polishing adds additional labor cost, it is desirable to only do so when necessary.

4.3 CONDITIONING AND ENVIRONMENTAL EXPOSURE

These issues as applied to the matrix materials themselves (after cure or consolidation) are very similar to the same issues applied to the composite materials using these matrices. The latter case is discussed in detail in Volume 1, Section 6.3. Despite this there are several distinct differences that affect how the information in Section 6.3 is applied to unreinforced matrix material. These include the following:

1. Without reinforcement, most matrix materials are nearly isotropic. In such cases, conditioning restrictions or concerns based on consideration of anisotropy, such as specimen aspect ratio concerns due to moisture absorption through the edge of a specimen, need no longer apply.
2. The transport properties (thermal and moisture) of the unreinforced matrix materials are significantly different than those of the composite. For example, an unreinforced ("neat") epoxy has both a significantly higher diffusivity constant and a significantly higher equilibrium moisture content, as compared to a fiber reinforced composite containing the same resin system.
3. Additional test methods for properties of the matrix material are available that are not typically applied to the composite, such as the moisture content test methods for matrix materials discussed in Section 4.5.7.

4.4 CHEMICAL ANALYSIS TECHNIQUES

Chemical characterization techniques are listed in Table 4.4. Elemental analysis and functional group analysis provide basic and quantitative information relating to chemical composition. Spectroscopic analysis provides detailed information about molecular structure, conformation, morphology, and physical-chemical characteristics of polymers. Chromatographic techniques separate sample components from one another, and thereby simplify compositional characterization and make a more accurate analysis possible. Employing spectroscopic techniques to monitor components separated by gas or liquid chromatography greatly enhances characterization, providing a means to identify and quantitatively analyze even the most minor components.

4.4.1 Elemental analysis

Elemental analysis techniques such as ion chromatography, atomic absorption (AA), X-ray fluorescence, or emission spectroscopy can be applied to analyze specific elements, such as boron or fluorine. When necessary, X-ray diffraction may also be used to identify crystalline components, such as fillers, and to determine the relative percent crystallinity for certain resins.

4.4.2 Functional group and wet chemical analysis

The analysis of reactive functional groups is particularly important in determining equivalent weights of prepolymers. Titration and wet chemical analysis for specific functional groups are useful techniques for characterizing individual epoxy components but have limited application and may provide misleading results when complex resin formulations are analyzed.

4.4.3 Spectroscopic analysis

Infrared spectroscopy (IRS) provides more useful information for identifying polymers and polymer precursors than any other absorption or vibrational spectroscopy technique and is generally available in most laboratories. IR yields both qualitative and quantitative information concerning a polymer sample's chemical nature, i.e., structural repeat units, end groups and branch units, additives and impurities (Reference 4.4.3(a)). Computerized libraries of spectra for common polymeric materials exist for direct comparison and identification of unknowns. Computer software allows the spectrum of a standard polymer to be subtracted from an unknown to estimate its concentration and perhaps to determine whether another type of polymer is also present in the sample.

TABLE 4.4 *Techniques for chemical characterization.*

Elemental Analysis -	Conventional Analytical Techniques X-Ray Fluorescence Atomic Absorption (AA) ICAP EDAX Neutron Activation Analysis
Functional Group Analysis -	Conventional Wet Chemical Techniques Potentiometric Titration Coulometry Radiography
Spectroscopic Analysis -	Infrared (Pellet, Film, Dispersion, Reflectance), Fourier Transform IR (FTIR), Photoacoustic FTIR, Internal Reflection IR, IR Microscopy, Dichroism Laser Raman Nuclear Magnetic Resonance (NMR) ¹³ C, ¹ H, ¹⁵ N; Conventional (Soluble Sample), Solid State (Machined or Molded Sample) Fluorescence, Chemiluminescence, Phosphorescence Ultraviolet-Visible (UV-VIS) Mass Spectroscopy (MS), Election Impact MS, Field Desorption MS, Laser Desorption MS, Secondary Ion Mass Spectroscopy (SIMS), Chemical Ionization MS Electron Spin Resonance (ESR) ESCA (Electron Spectroscopy for Chemical Analysis) X-Ray Photoelectron X-Ray Emission X-Ray Scattering (Small Angle-Saxs) Small-Angle Neutron Scattering (SANS) Dynamic Light Scattering
Chromatographic Analysis -	Gas Chromatography (GC) or GC/MS (Low MW Compounds) Pyrolysis-GC and GC/MS (Pyrolysis Products) Headspace GC/MS (Volatiles) Inverse GC (Thermodynamic Interaction Parameters) Size-Exclusion Chromatography (SEC), SEC-IR Liquid Chromatography (LC or HPLC), HPLC-MS, Multi-Dimensional/Orthogonal LC, Microbore LC Supercritical Fluid Chromatography (SFC) Thin-Layer Chromatography (TLC), 2-D TLC

Infrared (IR) spectroscopy is sensitive to changes in the dipole moments of vibrating groups in molecules and, accordingly, yields useful information for the identification of resin components. IR spectroscopy provides a fingerprint of the resin composition and is not limited by the solubility of resin components (References 4.4.3(b) - 4.4.3(d)). Indeed, gases, liquids and solids may be analyzed by IR spectroscopy. Advances in technology have led to the development of Fourier transform infrared spectroscopy (FTIR), a computer-supported IR technique for rapidly scanning and storing infrared spectra. Multiple scans and Fourier transformation of the infrared spectra enhance the signal-to-noise ratio and provide improved

spectra for interpretation. In addition, the FTIR attenuated total reflection (ATR) and diffuse reflectance techniques may be applied for quality assurance of thermoset composite materials to assess their state of cure; i.e., residual epoxide concentration. (See Section 5.5.3)

Although not as popular as IR, laser Raman spectroscopy complements IR as an identification technique and is relatively simple to apply (Reference 4.4.3(a)). As long as the specimen is stable to the high intensity incident light and does not contain species that fluoresce, little or no sample preparation is necessary. Solid specimens need only be cut to fit into the sample holder. Transmission spectra are obtained directly with transparent specimens. For translucent specimens, a hole may be drilled into the specimen for passage of the incident light and a transmission spectra obtained by analyzing light scattered perpendicular to the incident beam. The spectrum of a turbid or highly scattering specimen is obtained by analyzing the light reflected from its front surface. Powdered samples are simply tamped into a transparent glass tube and fibers can be oriented in the path of the incident beam for direct analysis.

4.4.4 Chromatographic analysis

High performance liquid chromatography (HPLC) is the more versatile and economically viable quality assurance technique for soluble resin materials (References 4.4.4(a) - 4.4.4(g)). HPLC involves the liquid-phase separation and monitoring of separated resin components. Dilute solutions of resin samples are prepared and injected into a liquid mobile phase which is pumped through column(s) packed with a stationary phase to facilitate separation and then into a detector. The detector monitors concentrations of the separated components, and its signal response, recorded as a function of time after injection, provides a "fingerprint" of the sample's chemical composition. Quantitative information may be obtained if the sample components are known and sufficiently well-resolved, and if standards for the components are available. Size exclusion chromatography (SEC), an HPLC technique, is particularly useful in determining the average molecular weights and molecular weight distributions of thermoplastic resins (Reference 4.4.4(g)). Recent advances have resulted in improved and automated HPLC instrumentation that is relatively low cost and simple to operate and maintain.

A powerful, but technically more demanding, technique for directly analyzing polymers is pyrolysis GC/MS (gas chromatography/mass spectroscopy). In this case, the sample only needs to be rendered sufficiently small to fit onto the pyrolysis probe. Not only can the polymer type be identified by comparing the resulting spectrum with standards, but volatiles and additives can be identified rapidly and quantitatively, and polymer branching and crosslink density can sometimes be measured.

Other chromatographic and spectroscopic techniques have also been considered (References 4.4.3(a), 4.4.4(h) - 4.4.4(l)). Gas chromatography (GC), GC head-space analysis, and GC-mass spectroscopy are useful for analyzing residual solvents and some of the more volatile resin components. Combined thermal analysis - GC-mass spectroscopy can be used to identify volatile reaction products during cure (References 4.4.4(m) and 4.4.4(n)).

4.4.5 Molecular weight and molecular weight distribution analysis

Techniques for evaluating polymer molecular weight (MW), molecular weight distribution (MWD), and chain structure are listed in Table 4.4.5. Size-exclusion chromatography (SEC) is the most versatile and widely used method for analyzing polymer MW and MWD. Once the solubility characteristics of a polymer are known, a suitable solvent can be selected for dilute solution characterization. THF is most often the solvent of choice for SEC, however, toluene, chloroform, TCB, DMF (or DMP) and m-cresol are also used. If the polymer's Mark-Houwink constants, K and a , in the solvent are known, size-exclusion chromatography (SEC) can be applied to determine the polymer's average MW and MWD (Reference 4.4.5(a)). If the constants are unknown or the polymer has a complex structure (e.g., branched, a copolymer, or mixture of polymers), SEC still may be used to estimate the MWD and other parameters relating to the structure and composition of the polymer. Although SEC indicates the presence of soluble non-polymeric components, high performance liquid chromatography (HPLC) is the better technique for characterizing residual monomers, oligomers, and other soluble, low MW sample components.

Light scattering, osmometry, and viscometry are also used to analyze polymer MW. Although seldom applied to synthetic polymers, sedimentation is an excellent technique for characterizing the MW of polymers having very large MW. The "special" techniques tend to be somewhat empirical or have limited utility and therefore are used less often.

New techniques which show great promise for characterizing polymer chain structure also are listed in Table 4.4.5. One of the most promising new techniques is dynamic laser light scattering. Unlike SEC, dynamic light scattering can be applied to any soluble polymer, regardless of temperature or solvent, and does not require polymer standards for calibration. Figure 4.4.5 illustrates the MWD of poly(1,4-phenylenetereph-thalamide) (i.e., Kevlar™) measured by the laser light scattering (Reference 4.4.5(b)).

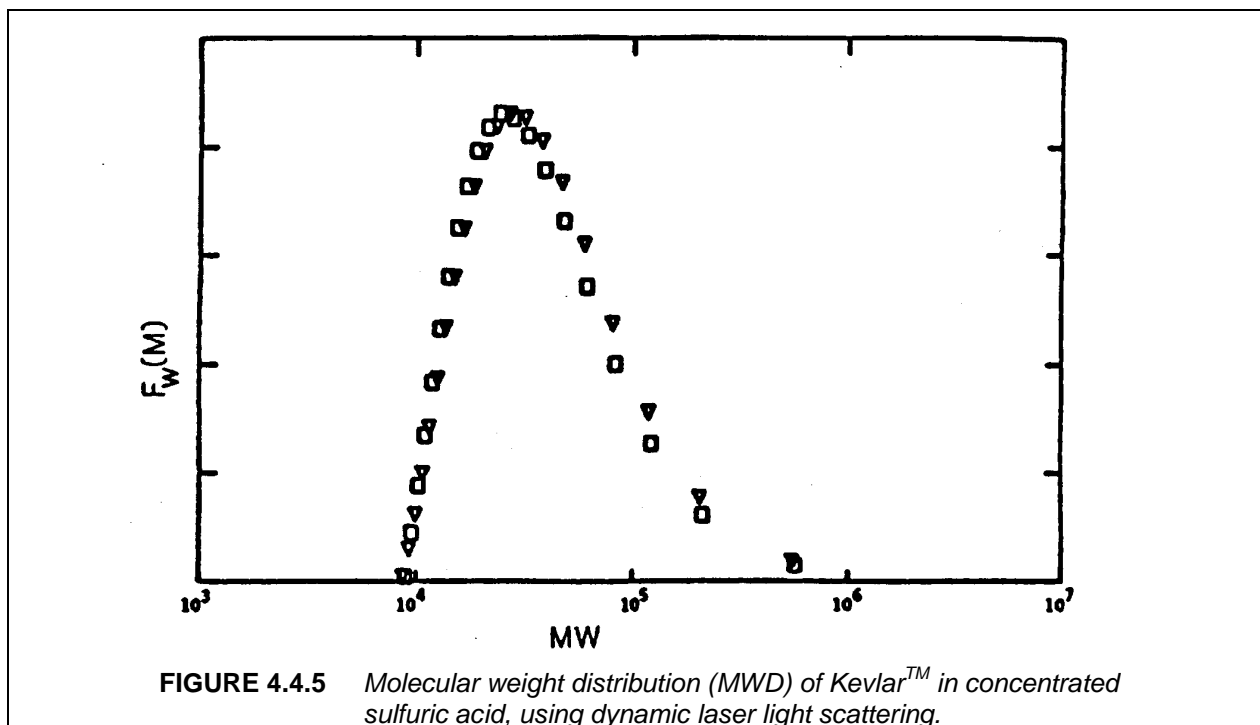

As indicated, the polymer's MWD can be fully characterized using very little sample and a single solution with concentrated sulfuric acid as the solvent.

Dilute solution viscometry is a simple technique for determining the limiting viscosity number or intrinsic viscosity $[\eta]$ of soluble polymers (Reference 4.4.5(a)). The apparatus is inexpensive and simple to assemble and operate. The $[\eta]$ of a polymer depends upon its hydrodynamic volume in the solvent and is related to the MW of the polymer.

4.4.6 General scheme for resin material characterization

The following questions deserve careful consideration when developing procedures for preparing and characterizing polymer and polymer precursor (thermosetting resins and resin formulations) samples -

What are the inherent characteristics of the polymer or prepolymer?

Will certain operations cause irreversible changes in the sample?

TABLE 4.4.5 *Polymer molecular weights, molecular*

Standard Techniques	Parameters Measured
Size-Exclusion Chromatography	Mol. wgt. averages and MWD, also provides (SEC) information relating to polymer chain branching, copolymer composition, and polymer shape.
Light Scattering (Rayleigh)	Weight-average mol. wgt. M_w (g/mol), virial coefficient A_2 (mol. cc/g ²), radius of gyration $\langle R_g \rangle_z(A)$, polymer structure, anisotropy, polydispersity.
Membrane Osmometry	Number-average mol. wgt. M_n (g/mol), virial coefficient A_2 (mol cc/g ²). Good for polymers with MW's in the range $5000 < MW < 10^6$, lower MW species must be removed.
Vapor Phase Osmometry	Same as membrane osmometry except that the technique is best suited for polymers with MW < 20,000 g/mol.
Viscometry (dilute solution)	Viscosity-average mol. wgt. M_η (g/mol) as determined by intrinsic viscosity $[\eta]$ (ml/g) relationship $[\eta] = KM_v$ where K and a are constants.
Ultracentrifugation or Sedimentation	Sedimentation-diffusion average mol. wgt. M_{sd} as defined by the relationship $M_{sd} = S_w/D_w$. Number- and z-average mol. wgt., M_n and M_z . MWD determined by the relation $S = kM^a$ where k and a are constants. Also provides information on the size and shape of polymer molecules.
Special Techniques	Parameters Measured
Ebulliometry	Number-average mol. wgt. M_n (g/mol) for $M_n < 20,000$ g/mol.
Cryoscopy	Number-average mol. wgt. M_n (g/mol) for $M_n < 20,000$ g/mol.
End Group Analysis	Number-average mol. wgt. M_n (g/mol) generally for $M_n < 10,000$. Upper limit depends on the sensitivity of the analytical method used.
Turbidimetry	Weight-average mol. wgt. M_w (g/mol) and MWD based upon solubility considerations and fractional precipitation of polymers in very dilute solutions

weight distribution and chain structure.

Principle

Liquid chromatography technique. Separates molecules according to their size in solution and employs various detectors to monitor concentrations and identify sample components. Requires calibration with standard polymers.

Measurement of scattered light intensities from dilute polymer solutions dependent upon solute concentration and scattering angle. Requires solubility, isolation, and in some cases fractionation of polymer molecules.

Measurement of pressure differential between dilute polymer solution and solvent separated by a semi-permeable membrane. Colligative property method based upon thermodynamic chemical potential for polymer mixing.

Involves isothermal transfer of solvent from a saturated vapor phase to a polymer solution and measurement of energy required to maintain thermal equilibrium. A colligative property.

Employs capillary or rotational viscometer to measure increase in viscosity of solvent caused by the presence of polymer molecules. Not an absolute method, requires standards.

Strong centrifugal field is employed with optical detection to measure sedimentation velocity and diffusion equilibrium coefficients S_w and D_w . Sedimentation transport measurements of dilute polymer solutions corrected for pressure and diffusion provides the sedimentation coefficient S . Permits analysis of gel containing solutions.

Principle

Measures boiling point elevation by polymer in dilute solution. A colligative property.

Measures freezing point depression by polymer in dilute solution. A colligative property.

The number or concentration of polymer chain end groups per weight or concentration of polymer are determined by specific chemical or instrumental techniques.

Optical techniques are applied to measure the extent of precipitation as polymer solution is titrated with a non-solvent under isothermal conditions or as the solution prepared with a poor solvent is slowly cooled.

TABLE 4.4.5 *Polymer molecular weights, molecular*

Special Techniques	Parameters Measured
Chromatographic Fractionation	Molecular weight distribution. An absolute MW technique is needed to analyze fractions.
Melt Rheometry	Weight-average mol. wgt. M_w (g/mol) and weight-fraction differential molecular weight distribution semi-empirical method.
Gel-Sol Analysis of Crosslinked Polymers	Gel fraction, Crosslink density
Swelling Equilibrium	Network structure, crosslink density, number- average mol. wgt. of chains between crosslinks M_c .
Promising Techniques	Parameters Measured
Laser Light Scattering (quasi-elastic, line-broadening or dynamic)	Same as Rayleigh light scattering plus trans-diffusion coefficient, molecular weight distribution, and information relating to gel structure.
Field Flow Fractionation (FFF)	Mol. wgt. averages and MWD. Requires calibration.
Non-Aqueous Reverse-Phase High Performance Liquid Chromatography HPLC and Thin-Layer Chromatography TLC	Mol. wgt. averages and MWD. Requires calibration.
Supercritical Fluid Chromatography (SFC)	Mol. wgt. averages and MWD. Requires calibration.
Neutron Scattering Small Angle (SANS)	Weight-average mol. wgt. M_w (g/mol), Virial coefficient A_2 (mol-cc/g ²), Radius of gyration $\langle R_g \rangle_z$ (Å)

weight distribution and chain structure.

Principle

Polymer is coated onto silica particles packed in thermostated column and separated according using solvent gradient elution. Polymer solubility decreases with increasing MW.

Dynamic melt rheological method involving measurement of spectrum of diffusional relaxation times for polymer during oscillatory deformation.

Extraction, filtration, and centrifugation are employed to isolate soluble polymer from gel. MW of soluble polymer is determined separately.

Molar volume of crosslinked polymer immersed in swelling liquid and density of the swollen polymer are determined. Theory of partial molar free energy of mixing is applied.

Principle

Same as above but also involves measurement of the low-frequency line broadening of the central Rayleigh line of the scattered light. The structure of polymers in both dilute and concentrated solutions can be analyzed.

Separates polymers according to their size and shape in solution. An elution technique, like chromatography, except that a field/gradient (thermal, gravitational, flow, electrical, etc.) is applied perpendicular to the axis of solution flow through a capillary or ribbon-shaped channel and a single phase is employed.

Liquid chromatography technique based upon equilibrium distribution of polymer molecules between a non-aqueous binary solvent mobile phase and a nonpolar stationary (packing) phase.

Liquid chromatography technique involving the use of a mobile phase under supercritical conditions (100 bars, 250°C).

Measurement of amplitude of neutron scattering momentum vector for polymer in dilute solution or blend with another polymer. Scattering angle and polymer concentration are varied. Deuterated solvents are used. Dilute solid solutions and polymer blends have been studied.

What requirements does the characterization technique impose upon the sample?

Is it necessary to isolate the polymer or prepolymer from other sample components?

It should be recognized that the properties of polymer compounds and prepolymer formulations are often quite different from those of the pure polymers and polymer precursors. Polymer properties are greatly influenced by the presence of other components, e.g., fillers, additives, processing aids, dyes, residual catalysts, impurities, solvents and other polymers, low MW oligomers and monomers.

One must decide whether the specimen needs to be modified or specially treated for a particular analysis. Chemical structure, thermal transition behavior and solubility determine what can be done with a specimen. Operations, such as heating or extraction, may alter morphology or change the chemical composition of a specimen and thereby affect its properties and compromise the validity of certain tests. Many characterization techniques require polymer specimens to be modified or have a particular shape or form. If a specimen does not conform precisely to test criteria, the test may be invalid. On the other hand, in order to apply certain techniques (e.g., light scattering and membrane osmometry for MW analysis), it is essential that the polymer be totally isolated from nonpolymeric components.

Knowledge of the type of polymer or prepolymer is important in developing characterization procedures. If the material is unidentified, a simple series of tests (Level I in Figure 4.4.6(a)) may be applied, first to answer the question of whether the sample actually contains polymer, and then to determine its characteristics and identify the polymer or prepolymer.

Specimen modification for Level I merely involves breaking or cutting a small section from the sample and, if possible, further reducing the specimen size by grinding. To facilitate thermal and spectroscopic analysis and solubility testing, the specimen should have a large surface area. Liquid and heterogeneous specimens should be thoroughly mixed before removing an aliquot for analysis. Each test can be run using as little as 10 mg sample.

Structural and compositional information obtained by the tests in Level I is used to help develop more sophisticated specimen preparation schemes and support the application of more detailed or specialized characterization techniques. The major concern of Level II is representative sampling and insuring that specimen modification procedures (cutting, grinding, molding, etc.) do not compromise polymer characteristics to be evaluated. Level II also addresses the "quantitative" aspects of sample composition (percent polymer, additives, volatiles, and inorganic and other organic residues) and, if necessary, deals with the identification of nonpolymeric components.

A general scheme for polymer analysis is illustrated in Figure 4.4.6(b). The polymer sample should be uniform and have a large surface area. Once volatile components are removed, the polymer can be directly analyzed, or a variety of techniques (e.g., extraction, precipitation, filtration, liquid chromatography) may be applied to isolate the polymer. If required, special procedures are applied to prepare the polymer sample for chemical characterization - molecular weight, molecular weight distribution, and chain structure evaluation, and bulk characterization (Level III in Figure 4.4.6(a)).

Whenever possible, complementary techniques should be used for the chemical quality assurance of resin materials. Techniques, such as HPLC and IR spectroscopy, are fundamentally different from one another and provide direct, but different, information about a resin's composition. If appropriate test methods are applied, HPLC and IR spectroscopy are usually powerful enough to detect differences or changes in the chemical compositions of resins. DTA and DSC complement HPLC and IR spectroscopy by providing information relating to the handleability (i.e., the T_g and extent of reaction of the resin) and the processability of the prepreg. TGA and GC head-space analysis techniques for volatile components are secondary, but important, techniques. Special techniques for analyzing specific components or elements should be used if knowledge of the concentrations of the components is critical for processing the resin or if their presence could adversely effect the performance and durability of the cured composite. The information provided by mechanical, rheological, and dielectric analysis techniques is related to the chemical composition of the prepreg resin and thereby complements the more direct chemical techniques.

However, caution is recommended in applying non-chemical techniques since the information obtained is complex and frequently ambiguous when attempts are made to relate measured parameters to chemical composition. (See Section 5.5)

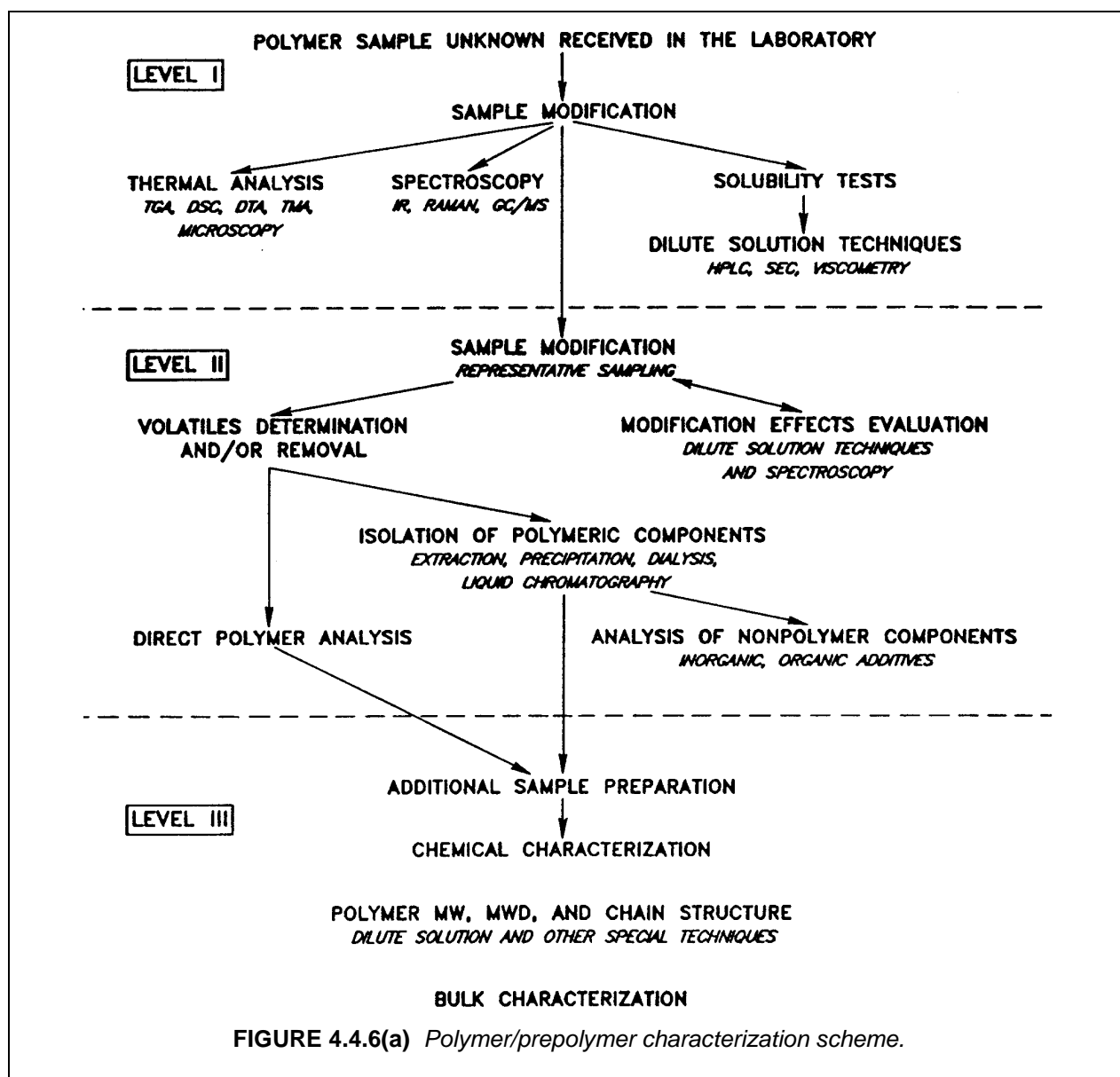

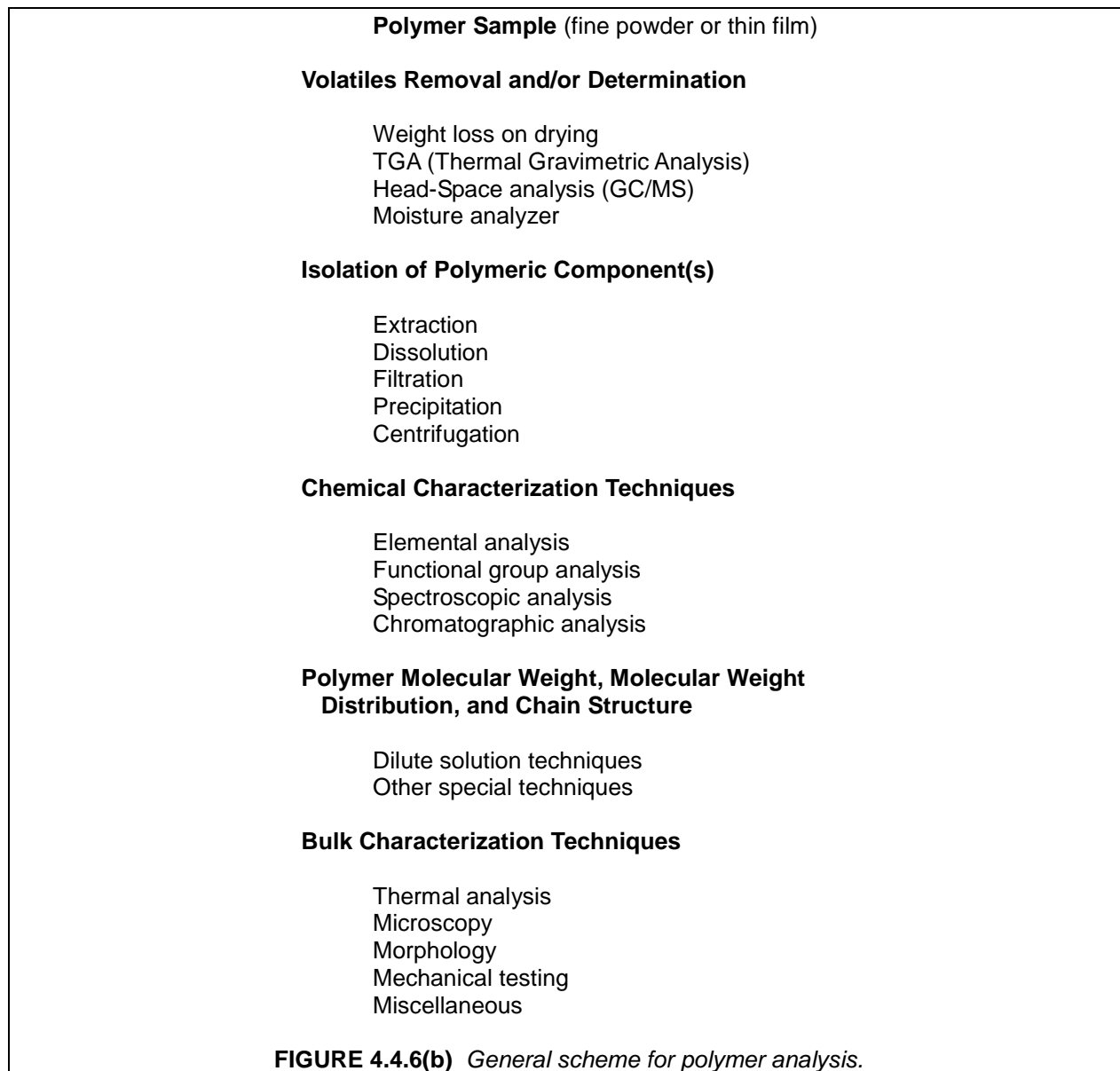

4.5 THERMAL/PHYSICAL ANALYSIS AND PROPERTY TESTS

The physical properties of the matrix material will influence the processing method as well as determine the type of application appropriate for the fabricated composite. Thermal analysis methods are used to determine glass transition and crystalline melt temperatures, thermal expansion, thermal decomposition, heat of reaction, and other thermal events in matrix materials. Rheological methods provide information on the temperature-dependent flow behavior. In addition, the cure-dependent characteristics of thermosetting resins can also be evaluated. Other methods can be employed to determine the morphology and density of the matrix material. The analysis techniques discussed in the following sections are used to determine the physical properties of thermoplastic and thermosetting materials.

4.5.1 Introduction

This section is reserved for future work.

4.5.2 Thermal analysis

Thermal analytical techniques, such as thermal gravimetric analysis (TGA), differential thermal analysis (DTA), differential scanning calorimetry (DSC), thermal mechanical analysis (TMA), dynamic mechanical analysis (DMA), and torsional braid analysis (TBA) provide useful information relating to the composition and processability of resins.

Thermal gravimetric analysis (TGA) monitors the weight changes in a sample as a function of temperature. Although primarily used for studying the degradation processes, TGA can also be applied as a quality assurance technique to provide information about the volatiles, resin, fiber, and inorganic residue content of prepreg materials (Reference 4.5.2(a)). Since dissimilar materials often degrade and volatilize at different temperature and rates, compositional differences may be reflected by differences in their TGA thermograms. Thermal oxidative degradation rates determined by TGA are useful for estimating the life cycles of resin materials (Reference 4.5.2(b)).

Differential scanning calorimetry (DSC) and differential thermal analysis (DTA) techniques are frequently employed for characterizing resins and composite materials (References 4.4.4(g), 4.4.3(b), 4.5.2(c), and 4.5.2(d)). Both DSC and DTA monitor enthalpy changes in materials as a function of temperature (DSC directly and DTA indirectly) and thereby provide similar information useful for quality assurance of prepreg materials. DTA measures the temperature difference (ΔT) between the epoxy resin specimen and a reference material; whereas DSC measures the rate of heat evolution (dH/dt) or enthalpy absorption of the specimen relative to a reference. DTA and DSC measure thermal changes (1) as a function of time with both the specimen and reference material held at the same temperature (isothermal), or (2) as a function of temperature with both the specimen and reference material heated at the same heating rate (dynamic).

For quality assurance applications, DTA and DSC are usually run in the dynamic mode with the weighed specimen in an aluminum specimen holder and an empty holder used as the reference. Dynamic DTA and DSC measure the glass transition temperature T_g and heat of reaction ΔH of the prepreg resin but do not provide information about chemical composition directly. By monitoring the fraction of heat evolved as a function of temperature or time, information relating to the extent of cure and curing kinetics can be obtained. DSC and DTA may also be applied to evaluate the melting temperature T and to estimate the degree of crystallinity of thermoplastic resins and composites. Since the average specimen size used in DSC is only about 10 mg (0.00002 lb), special care must be taken in obtaining representative materials. Multiple specimens runs are advisable.

Thermal mechanical analysis (TMA) is used in conjunction with DTA and DSC to study the thermal transition behavior (e.g., T_g) of prepreg resins and cured laminates. TMA simulates a linear dilatometer to measure the thermal expansion and contraction of specimens under dynamic or isothermal heating conditions. Adjustable loads are applied via a specially designed probe resting upon the specimen surface. Sensitive displacement devices are employed to monitor the "nominal" thermal response of a material. Since thermal transition behavior is related to the chemical composition and extent of cure of a prepreg resin, TMA can be applied as a quality assurance technique.

As previously discussed, TGA provides an indication of a sample's thermal decomposition temperature T_d and is used to estimate the relative amounts of volatiles, polymer, nonpolymeric additives, and inorganic residues. DSC or DTA is applied to evaluate the extent of cure and curing characteristics of thermoset resins, to determine a polymer's T_g , and, if the polymer is semi-crystalline, to determine its crystalline melting temperature T_m . Suggested procedures for measuring T_g and T_m are given in ASTM Standards D 3417 and D 3418 (References 4.5.2(e) and 4.5.2(f)). TMA can also be used to determine the T_g and to obtain further information about a polymer's heat distortion temperature and thermal expansion coefficient. For pelletized or molded samples, a razor blade or microtome can be used to cut sam-

ples to approximately fit the dimensions (thickness and diameter) of the sample holder. If the sample has been cut or is already in film or sheet form with a thickness no greater than 0.015 in (0.04mm), a punch or cork borer may be used to cut disks of an appropriate size.

Alternatively, a hot stage microscope may be used to observe the heat distortion temperature and onset of flow of powdered samples. Initially the powder particles have sharp, rough edges. As the sample is heated and the heat distortion temperature is approached, the edges first become blurred and then the particles start to agglomerate. Finally, at T_m , for semi-crystalline polymers, or T_g , in the case of glassy polymers, flow occurs and a clear melt or liquid forms. Microscopes equipped with cross polarizers are useful for defining crystal-crystal transitions and the onset of melting of semi-crystalline polymers.

4.5.3 Rheological analysis

The processing characteristics of a thermoplastic or thermosetting resin are dependent upon flow behavior, which is characterized by rheological analysis. Methods which measure the temperature-dependent viscosity under constant shear conditions are used to obtain information on flow behavior. These methods include the use of viscometers or capillary rheometers. Since the viscosity of thermosetting materials also depends on the degree of cure, other methods may be used to obtain rheological information during cure.

Dynamic mechanical analysis (DMA), torsional braid analysis (TBA), and various mechanical spectrometers may be used to measure the rheological response of resins as a function of frequency, temperature, and/or state of cure. Both DMA and TBA can provide information relating to the storage modulus, loss modulus, complex viscosity, and tan delta of polymers. In addition, information relating to gelation, vitrification, and the T_g of cured thermosetting resins can be obtained (References 4.3.1(c) and 4.5.3(a) - (c)). Rheological techniques are most often used to optimize processing parameters. However, since rheological properties are related to resin composition and morphology, rheological techniques may also be applied for the quality assurance of resins.

Dynamic dielectric analysis (DDA) techniques can provide information on the flow behavior and curing characteristics of matrix materials. DDA involves the use of electrical measurements to monitor changes in the dielectric constant, the dissipation factor, capacitance, and/or conductance of the resin during processing as a function of frequency, time, and temperature. Measured electrical parameters are highly responsive to changes in resin viscosity and are often employed to investigate and optimize prepreg processing parameters such as resin flow and gelation time/temperature. Since chemical composition affects the electrical properties and curing behavior of thermosetting resins, DDA techniques may also be applied for their quality assurance (References 4.5.3(c) - 4.5.3(j)).

ASTM test methods which are applicable for rheological analysis (References 4.5.3(k) - (o)) include:

ASTM D 2393 "Viscosity of Epoxy Resins and Related Components". Method for measuring the viscosity of the liquid components of an epoxy resin system and/or the mixed formulation.

ASTM D 3835 "Rheological Properties of Thermoplastics with a Capillary Rheometer". Method describes the measurement of the rheological characteristics of thermoplastics at temperatures and shear conditions common to processing equipment.

ASTM D 4065 "Determining and Reporting Dynamic Mechanical Properties of Plastics". Practice for obtaining rheological information by free vibration and resonant or nonresonant forced vibration techniques.

ASTM D 4440 "Rheological Measurement of Polymer Melts Using Dynamic Mechanical Procedures". Practice for determining the rheological properties of thermoplastics over a range of temperatures by nonresonant forced-vibration techniques.

ASTM D 4473 "Measuring the Cure Behavior of Thermosetting Resins Using Dynamic Mechanical Procedures". Practice is intended to provide means for determining the cure behavior of supported and unsupported thermosetting resins over a range of temperatures by free vibration and resonant and nonresonant forced-vibration techniques.

Definitions of terms related to dynamic mechanical analysis are provided in ASTM D 4092 (Reference 4.5.3(p)).

4.5.4 Morphology

The morphology of the matrix material will be dependent upon the type of polymer. The formation of a highly cross-linked network in thermosetting materials is controlled by the degree of conversion and the functionality of the components involved in the cure. Their degree of cross-linking is described in terms of the degree of cure which can be determined by thermal analysis and spectroscopic methods.

On a microscopic scale, the semi-crystalline thermoplastics contain regions of three-dimensional order (crystalline) and regions which lack long-range order (amorphous). Typically the crystalline regions consist of spherulites, which are aggregates of lamellar crystals that radiate from a nucleation site. The thermal history of the material, as well as the presence of fibers and/or fillers will affect the size and number of spherulites and the degree of crystallinity (References 4.5.4(a) - 4.5.4(b)). Differences in the crystalline region may also have an effect on mechanical properties (References 4.5.4(c) - 4.5.4(d)).

The analysis of the crystalline region is achieved by a variety of techniques. The size and degree of orientation of crystals can be studied by X-ray diffraction, electron microscopy, and birefringence methods, while a polarizing microscope is typically used for the analysis of spherulites. The degree of crystallinity can be determined by X-ray diffraction, specific volume, and heat of fusion. The specific volume method requires determining the specific volume of the sample as well as completely amorphous and crystalline samples of the material. The heat of fusion method involves ratioing the heat of fusion of the sample and a completely crystallized sample of the material. The heats of fusion can be determined using ASTM D 3417 (Reference 4.5.2(e)).

The noncrystalline thermoplastics may exhibit different levels of molecular orientation. The liquid crystal polymers may have regions of one- and/or two-dimensional order which can be evaluated by thermal analysis. The amorphous thermoplastics, typically lacking any long-range order, can undergo orientation depending upon the processing technique. In general, molecular orientation can produce anisotropic properties in the material. However, the morphological characteristics of a neat resin sample may be quite different from those found in a fabricated composite.

4.5.5 Density/specific gravity

4.5.5.1 Overview

The matrix density is required when determining the approximate void content of the composite as described in ASTM D 2734 "Void Content of Reinforced Plastics" (Reference 4.5.5.1(a)). Density is also used to identify or characterize matrix material within a given class of polymers. For example, in semi-crystalline thermoplastic matrices, the degree of crystallinity of a particular polymer will change the density of that polymer.

The density of the composite matrix is almost always assumed to be the same whether it is in the composite or is a cast neat resin plate and the neat resin value is always used in practice. It is important to point out that the composite matrix density and the cast neat resin density may not be identical due to differences in their processing history. In the composite the matrix experiences a different thermal, pressure, and spatial environment, including surface conditions in the fiber/matrix interphase. Theoretical thought has led many to believe that the bulk matrix density value is lower than that found in the composite (Reference 4.5.5.1(a)). However, there is no known experimental verification of this assumption. Fur-

ther, if a density difference does exist, the question arises as to whether it is significant enough to be of consequence.

With few exceptions, the determination of density is accomplished indirectly by measuring the volume and weight of a representative sample of the cured matrix resin, and then combining these values to calculate density. The weight measurement is most easily obtained by using a quality analytical balance. To determine volume, however, there are several approaches used. The most common approach uses simple Archimedes methods involving displacement of liquids of known density.¹ Direct measurement of density can be made by observation of the level to which the test material sinks in a density-graded liquid (Reference 4.5.5.1(b)).

Liquids are used almost exclusively in displacement techniques. However, there are advantages to using a gas medium in place of liquid to determine specimen volume. One advantage is minimization of errors associated with liquid surface tension. The gas displacement approach is often referred to as helium pycnometry. When helium pycnometry is used the test specimen volume is determined by measuring pressure changes of a confined amount of helium. Helium pycnometry is not yet a standardized test method for measuring the volume and density of cured matrix resins, yet it has been demonstrated to be a viable technique (References 4.5.5.1(c) and (d)). As no test standard or guidelines exist for this method as applied to resins, a test procedure has been developed within the MIL-HDBK-17 Testing Working Group (see Section 6.6.4.4.1).

At present there are two ASTM standards which deal specifically with obtaining the density of cured matrix resins. These are test methods D 792 (Reference 4.5.5.1(e)), covering the liquid displacement method, and D 1505 (Reference 4.5.5.1(b)), covering the density gradient method.

For detailed guidance on how to experimentally obtain the density of cured matrix resins the reader is referred to Sections 6.6.4.7 through 6.6.4.6 of this volume of the Handbook. Note that Section 6.4.4 refers specifically to composites, but the methods discussed are fully applicable to cured matrix resins except as noted in Section 4.5.5.2 below.

4.5.5.2 Recommended procedure changes to Sections 6.6.4.2, 6.6.4.3 and 6.6.4.4 (D 792, D 1505 and helium pycnometry) for use in measuring cured resin density

Differences between measuring composite density as opposed to the density of a neat resin sample are slight and occur in the area of specimen preparation. The neat resin specimen will typically be more fragile and may crack during machining operations. Due to the relative softness (compared to a composite) and isotropic nature of the resin, good edge quality is easier to obtain using fine grit sandpaper.

4.5.5.3 Density test methods for MIL-HDBK-17 data submittal

Data produced by the following test methods (Table 4.5.5.3) are currently being accepted by MIL-HDBK-17 for consideration for inclusion in Volume 2.

¹For a quick and convenient, but less accurate density determination method, the reader is referred to the micrometer technique as specified in ASTM D 2734, Test Method C. This method obtains specimen volume by simple dimensional measurement and is only appropriate for precision work in limited specific cases.

TABLE 4.5.5.3 Resin density test method for MIL-HDBK-17 data submittal.

Property	Symbol	Fully Approved, Interim, and Screening Data	Screening Data Only
Density	ρ	D 792, D 1505, 4.5.5.2*	D 2734C

*When this method is used to generate data for subsequent determination of composite void volume, the test specimen must occupy at least 30% of the test cell volume.

4.5.6 Volatiles content

The volatiles content of resin materials is of interest to prepreg manufacturers, RTM fabricators, and manufacturers using wet lay-up techniques. Inadequate control of volatiles may effect handling of pre-pregs and final laminate quality. The property is most relevant where materials have a solvent incorporated into the formulation. The volatile content represents the solvent(s), resin components, and other constituents that volatilize at the test temperature. The remainder is commonly known as resin solids and filler. The resin solids include the materials that can be dissolved in an organic solvent (usually polymer constituents) and the filler is generally insoluble inorganic material. The test for volatiles is commonly performed as a quality control check.

Specific methods are material dependent, but they generally involve placing the materials in an air circulating or vacuum oven at a specified temperature for a specified time. Weight loss is measured gravimetrically. The time and temperature are selected such that volatiles completely evaporate and resin solids do not volatilize or degrade. ASTM D 3530 "Volatiles Content of Carbon-Fiber Prepreg" (Reference 4.5.6.a) represents the standard oven exposure test method intended for carbon/epoxy fiber prepregs. The procedure may also be used as a guideline for most thermosetting resins, though the user is cautioned that the temperature may not be appropriate for other resin systems. In the ASTM standard, the time is fixed but the temperature is selected to represent the part process cycle.

Thermogravimetric analysis (TGA) is sometimes used instead of an oven exposure method. TGA is an instrumented procedure where a small specimen is placed on a microbalance. The instrument is automated to gradually increase the temperature while continuously monitoring the specimen weight. A TGA procedure for volatiles content should specify heating rate, gas and flow rate, specimen size, and the temperature range used to define volatile content. While there is no established ASTM procedure for TGA to determine volatiles in resins, ASTM E 1131 "Compositional Analysis by Thermogravimetry" (Reference 4.5.6.b) gives general guidance. Other techniques such as TGA-FTIR and Headspace Gas Chromatography (Reference 4.5.6.c) may be used in a research or problem-solving environment for qualitative/quantitative determination of volatiles.

4.5.7 Moisture content

Depending on the resin system, moisture may retard cure, create volatiles or cause other undesirable reactions during processing. For those resin systems affected, control and measurement of the moisture content is required. Automated moisture meters based on the Karl Fischer titration method are commonly used to determine moisture content in most types of resins. A small sample, typically 5 grams of liquid resin, is introduced to a cell containing the Karl Fischer Reagent and a solvent, typically methanol. A current is passed between two electrodes, creating iodine in a quantitative series of reactions with water and

the Karl Fischer Reagent. The reaction and test are described in ASTM D 4672 "Polyurethane Raw Materials: Determination of Water Content in Polyols" (Reference 4.5.7.a).

An alternate method for determining moisture content uses an instrument that heats a small specimen, typically 10 grams of solid. The moisture is volatilized and transported to an electrolytic cell by a nitrogen carrier gas. The water reacts to form phosphoric acid, which is then quantitatively measured by passing current through the cell. A standard for this test is ASTM D 4019, "Method for Moisture in Plastics by Coulometric Regeneration of Phosphorous Pentoxide" (Reference 4.5.7.b).

4.6 STATIC MECHANICAL PROPERTY TESTS

4.6.1 Introduction

Knowing the static mechanical properties of the matrix material can be very useful when choosing among various candidate systems for use in a composite material. If a particular composite property must be enhanced, the proper selection of an alternate matrix material may be sufficient to meet the need. For example, substituting a matrix with only a slightly higher modulus of elasticity may reduce a fiber microbuckling problem to an acceptable level. A matrix with an enhanced shear strength, or shear strain to failure, will enhance the corresponding composite property.

Likewise, detailed knowledge of the static mechanical properties of the matrix material is mandatory if a micromechanics analysis is to be used to predict composite properties from constituent properties. Even those polymers that are termed "brittle" often exhibit nonlinear tensile and compressive stress-strain responses, the nonlinear nature of which is non-negligible. Even more important is the very significant nonlinear shear stress-strain response exhibited by most polymers. Thus, not only must the initial stiffness properties (E^m , ν^m , G^m) be determined, but also the complete stress-strain curves to failure. This can present special strain instrumentation challenges, as discussed in the following sections.

In general, the polymers used as matrix materials in composites are not formulated to be used in the neat (unreinforced) form. Thus, their viscosities and volatile contents may not be particularly amenable to casting into the void-free neat resin sheets, plates, and other forms required for mechanical test specimen preparation, as discussed in Section 4.2. Nevertheless, obtaining the quality specimens required for the mechanical tests described in the following sections is particularly critical, and must be given special attention.

4.6.2 Tension

$$F_m^{tu}, F_m^{ty}, E_m^t, \nu_m^t, \epsilon_m^{tu}$$

4.6.2.1 Introduction

Neat (unreinforced) matrix tensile testing is typically performed per ASTM D 638 (Reference 4.6.2.1(a)). Although this standard was originally written (in 1941) for commodity thermoplastics, it can be followed directly for the testing of high performance thermosets and high temperature thermoplastics used as matrices in composites. Another standard, ASTM D 882 (Reference 4.6.2.1(b)), intended for testing thin plastic sheeting, is also available. It is stated in this standard that the "tensile properties of plastics 1.0 mm (0.04 in.) or greater in thickness should be determined according to Test Method D 638." That is, ASTM D 882 typically does not apply to neat matrix testing.

4.6.2.2 Specimen preparation

Most commonly, flat dogbone (i.e., dumbbell-shaped, per the terminology of ASTM D 638) specimens are used. As discussed in Section 4.2, these specimens are typically machined from cast flat plate material rather than being individually molded to final dimensions. It is important to observe the plate fabrica-

tion precautions discussed in Section 4.2, to help ensure that adequate material quality will be maintained. Likewise, the quality of specimen machining must be controlled. As discussed in Section 4.2, some matrix polymers, being relatively brittle, are very sensitive to surface scratches and edge chips accidentally induced during machining. In fact, some matrix polymers are very sensitive to roughness of machined surfaces in general, and require polishing as a final preparation step. Neat polymer tensile specimens are not usually tabbed, the dog-boning making this unnecessary.

As recommended in ASTM D 638, the Type I specimen geometry, or something very similar, is preferred, and most commonly used, when testing the high performance composite matrix materials. This geometry is recommended for testing specimens 0.28 in. (7.0 mm) or less in thickness, which is usually the case. As shown in Figure 4.6.2.2, this 6.50 in. (165 mm) long specimen is 0.75 in. (19 mm) wide, reduced to 0.50 in. (13 mm) in the 2.25 in. (57.0 mm) long gage length region, with an ample 3.0 in. (76 mm) transition radius. Should this specimen not fail in the gage section, the Type II specimen is recommended. It is of similar geometry, but with a gage section width of only 0.25 in. (6.0 mm) rather than 0.50 in. (13 mm). That is, it has a more severely reduced gage cross section than the Type I specimen. Three other specimen types are also defined in ASTM D 638, but these are not normally applicable to matrix polymer testing.

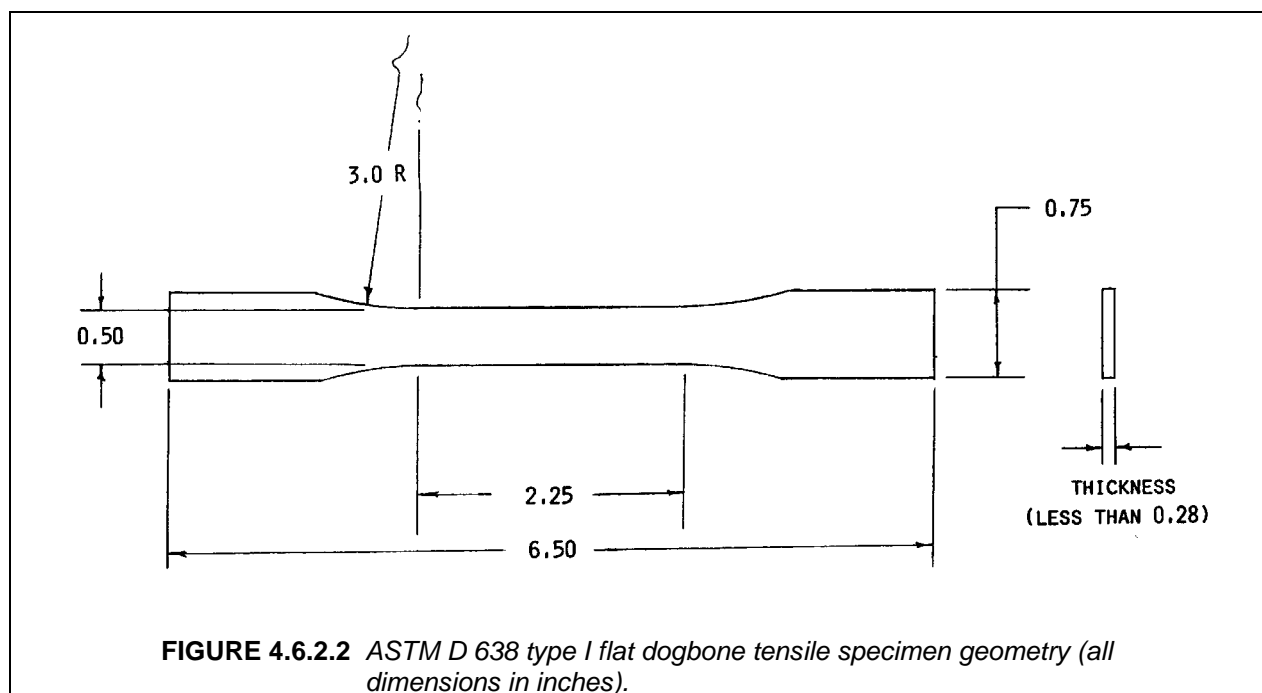

Occasionally, dogbone solid circular cylindrical specimens are used for tensile testing, as discussed in ASTM D 638, but such specimens tend to be more difficult to fabricate, and to grip, than flat specimens. A detailed experimental investigation of the influence of solid circular cylindrical specimen size and geometry is presented in References 4.6.2.2(a) and 4.6.2.2(b). Thin-walled tubes can also be tensile tested. However, this specimen geometry is even more difficult to fabricate and grip than a solid cylindrical specimen. Details of thin-walled tube specimen geometry and gripping are included in ASTM D 638.

4.6.2.3 Test apparatus and instrumentation

The flat dogbone specimens are usually tested using wedge grips. Mechanical and hydraulically-actuated grips usually function equally well. Although not as frequently used, screw-actuated grips can also perform satisfactorily since the tensile strength of neat polymer specimens is not very high and thus

only moderate grip forces are required. Correspondingly, slipping in the fixed-position screw-actuated grips due to Poisson contraction is usually not a serious problem.

Screw-actuated grips often incorporate smooth metal or rubber gripping surfaces, while most wedge grip inserts have aggressive serrations. Thus, it is common to use some type of padding material between the specimen and these wedge grip faces. One or two layers of emery cloth works well. ASTM D 638 also discusses the use of abrasive wire mesh and plastic sheet.

The so-called flame-sprayed grip faces that are finding increasing use in test laboratories, although not yet referred to in the ASTM D 638 standard, are proving to be particularly effective. These grip faces are typically coated with tungsten carbide particles in a nickel (or cobalt) matrix. These grip faces are usually very smooth and nonaggressive, having a surface roughness similar to that of about 150 grit emery cloth. However, they have excellent holding power, equivalent to that of serrated grips. Such grip faces would be a good choice for screw-actuated grips as well.

Although extensometers are recommended in ASTM D 638 for measuring strains, strain gages have been shown to perform at least as well (References 4.6.2.2(a) and 4.6.2.2(b)), even on relatively brittle polymers. If Poisson's ratio is to be determined, a biaxial extensometer (or two linear extensometers) must be used. Correspondingly, a biaxial strain gage is convenient for this purpose.

4.6.2.4 Tensile test methods for MIL-HDBK-17 data submittal

Data produced by the following test method are currently being accepted by MIL-HDBK-17 for consideration for inclusion in Volume 2:

TABLE 4.6.2.4 Resin tensile test methods for MIL-HDBK-17 data submittal.

Tensile Property	Symbol	Fully Approved, Interim, and Screening Data	Screening Data Only
Ultimate Strength	F_m^{tu}	ASTM D 638	
Yield Strength	F_m^{ty}	"	
Modulus	E_m^t	"	
Poisson's Ratio	ν_m^t	"	
Strain to Failure	ϵ_m^{tu}	"	

4.6.3 Compression

F_m^{cu} , F_m^{cy} , E_m^c , ν_m^c , ϵ_m^{cu}

4.6.3.1 Introduction

Compressive testing of neat polymer matrix materials tends to be performed much less frequently than tensile and shear testing, although there does not appear to be any intrinsic reason. Compressive testing is usually no more difficult. The elastic response of most polymer matrices does tend to be similar in tension and compression (References 4.6.3.1(a) and 4.6.3.1(b)), although the ultimate strength in compression is typically much higher since "critical flaw size" does not influence failure as severely.

ASTM D 695 (Reference 4.6.3.1(c)) governs the compressive testing of rigid plastics, and is the test method commonly used. It defines the axial compressive loading of a short prism (or tube), or a dogbone flat specimen laterally restrained against column buckling.

The short prism specimen is commonly used. This specimen for measuring compressive strength may be square or circular in cross section, having a length twice the transverse dimension (i.e., a specimen with an aspect ratio of 2). A recommended specimen size for strength determination is 0.50 in. (12.7 mm) in cross-sectional dimensions and 1.0 in. (25.4 mm) long. A specimen of the same cross-sectional dimensions but twice as long is recommended for modulus and offset yield stress measurement.

4.6.3.2 Specimen preparation

Circular rather than square cross section short prism specimens are commonly used. Particularly for thermoset polymers, it can be difficult to cast a void-free 0.50 in. (12.7 mm) thick plate (as discussed in Section 4.2) from which to cut square specimens. Also, excessive heat-up due to exothermic reactions during cure can be a problem when casting such thick plates. As a secondary consideration, any remaining material from this thick casting is not particularly useful for other neat matrix testing, e.g., tensile, shear, thermal, or moisture expansion testing.

It is often more practical to cast 0.50 in. (12.7 mm) diameter cylinders to net diameter and then simply cut them to the desired length. Of course square specimens could be cast, but a mold with a circular cavity is usually easier to fabricate.

Since specimens machined from neat polymer plates typically 0.12 in. (3.2 mm) thick or less are commonly used for both tensile and Iosipescu shear testing, it is often convenient to fabricate compression specimens from these same cast plates. In this case, ASTM D 695 suggests the use of dogbone flat specimens similar to those used for tensile testing (per ASTM D 638), but only about half as long.

Whether short prism or flat dogbone specimens are being prepared, particular attention must be given to the parallelism of the specimen ends, and their perpendicularity to the specimen longitudinal (loading) axis. Recommended tolerances are given in ASTM D 695 (Reference 4.6.3.1(c)). The influence on compressive strength of roughness of the specimen surfaces, whether as-cast or machined, must also be evaluated. Some polymers are much more sensitive to surface imperfections than others. ASTM D 695 simply states, "All machining operations should be done carefully so that smooth surfaces result."

4.6.3.3 Test apparatus and instrumentation

The short prism specimens are simply loaded in compression between two flat platens. If testing machine platens are used, it is important that they be flat and parallel, and well-aligned perpendicular to the loading axis of the testing machine. ASTM D 695 describes a compression subpress which is a very convenient alternative. This self-contained unit includes a rigid frame with linear ball bushings guiding a hardened steel loading plunger free to move axially but carefully aligned with a hardened steel specimen support anvil.

When testing the flat dogbone compression specimens in axial compression, lateral support must be provided to prevent gross column buckling. A support jig is defined for this purpose in ASTM D 695. SACMA Recommended Method SRM 1 (Reference 4.6.3.3) describes an improved fixture which serves the same purpose but is much easier to use.

Although extensometers are recommended in ASTM D 695 for measuring strains, strain gages have been shown to perform at least as well (References 4.6.3.1(a) and 4.6.3.1(b)), even on relatively brittle polymers. If Poisson's ratio is to be determined, a biaxial extensometer (or two linear extensometers) must be used. Correspondingly, a biaxial strain gage is convenient for this purpose.

4.6.3.4 Limitations

Short Prism Compression Specimens: Either a special 0.50 in. (12.7 mm) thick plate must be molded from which to cut 0.50 in. x 0.50 in. (12.7 mm x 12.7 mm) square cross section specimens, or a special 0.50 in. (12.7 mm) square or circular cross section mold must be available. If ASTM D 695 is adhered to, specimens of two different lengths must be tested, to measure compression strength and modulus, respectively. Also, either special care must be taken to align the testing machine, or a compression subpress must be used.

Laterally Supported Flat Dogbone Specimens: Specimen preparation is slightly more time consuming since the specimen must be dogbone. Also, a special lateral support fixture is required.

4.6.3.5 Compressive test methods for MIL-HDBK-17 data submittal

Data produced by the following test method are currently being accepted by MIL-HDBK-17 for consideration for inclusion in Volume 2:

TABLE 4.6.3.5 Resin compressive test methods for MIL-HDBK-17 data submittal.

Compression Property	Symbol	Fully Approved, Interim, and Screening Data	Screening Data Only
Ultimate Strength	F_m^{cu}	ASTM D 695*	
Yield Strength	F_m^{cy}	"	
Modulus	E_m^c	"	
Poisson's Ratio	ν_m^c	"	
Strain to Failure	ϵ_m^{cu}	"	

* The SACMA SRM 1 test fixture is also an acceptable supporting jig.

4.6.4 Shear

F^{su} , F^{sy} , G^m

4.6.4.1 Test methods available

The shear properties of resin matrix materials are typically determined by testing either a solid circular cylinder rod in torsion or a standard Iosipescu (V-Notched Beam) specimen in a standard test fixture. In the former case, ASTM E 143 is applicable (Reference 4.6.4.1(a)). In the latter case, ASTM D 5379 ap-

plies (Reference 4.6.4.1(b)). Dynamic mechanical analysis (DMA) (Reference 4.5.3(m)) is also available, but is not commonly utilized.

4.6.4.2 *Torsion specimen preparation*

Originally, solid rods were cast as rods of uniform diameter, either in a glass tube which could then be broken away after cure, or in a plunger-in-cavity steel mold and pushed out the end after cure. Currently, dog-boned cylindrical specimens are usually used. These solid rods are typically cast in either steel or silicon rubber molds, although other mold materials can be used also. The metal mold is typically split along its diameter, to permit removal of the cured specimen. The silicon rubber mold is typically split along a radius, so that it can be spread open to remove the cured specimen (and to remove the pattern it itself was originally molded from). The lower end of the mold is closed off and the resin poured in from the top (or sometimes injected from the bottom, under pressure if necessary for low viscosity systems). Cored specimens have also been infrequently utilized, using a silicon rubber core of constant diameter which can then be pulled out one end after cure to form a tubular specimen.

4.6.4.3 *Iosipescu shear specimen preparation*

Iosipescu specimens are typically machined from flat plates either cast in an open mold or injection molded in the case of low viscosity resins, e.g., the high temperature thermoplastics. Specimens could also be molded to net dimensions but this is not known to have been done to date.

4.6.4.4 *Test apparatus and instrumentation*

A torsion testing device of relatively low torque capacity is used to test solid rod specimens, while a standard Iosipescu shear test fixture is used with the Iosipescu specimen. Strain gages, typically $\pm 45^\circ$ biaxial rosettes, bonded to the surface of either the solid rod or the Iosipescu specimen, are utilized to determine shear modulus, and the complete shear stress-shear strain curve to failure.

4.6.4.5 *Limitations*

Solid Rod Torsion Test (ASTM E 143): The shear strain varies from zero at the specimen axis of twist to a maximum at the specimen surface. Almost all resin materials, even those generally considered to be brittle, exhibit significant nonlinearity in shear beyond the elastic limit, and thus the strain variation is not linear. The shear strain being measured by the strain gages is the surface strain. Correspondingly, the calculation of shear stress in the nonlinear range must account for this nonlinearity. (The shear strain is uniform in the gage section of the Iosipescu specimen and thus no special consideration is required when testing nonlinear materials.)

Solid (or hollow) rod specimens must be specially prepared rather than being cut from the same plate material as tensile and compression specimens.

A torsion testing machine in the required torque range is not available in many laboratories.

Iosipescu Shear Test (ASTM D 5379): A standard Iosipescu shear test fixture must be available. For very ductile resins, the fixture may bottom out (very large shear strains) before the specimen fails. For very brittle resins, crushing of the specimen at the loading points may require the use of tabs.

4.6.4.6 *Shear testing methods for MIL-HDBK-17 data submittal*

Data produced by the following test methods are currently being accepted by MIL-HDBK-17 for consideration for inclusion in Volume 2:

TABLE 4.6.4.6 Shear testing methods for MIL-HDBK-17 data submittal.

Shear Property	Symbol	Fully Approved, Interim, and Screening Data	Screening Data Only
Ultimate Strength	F^{su}	ASTM E 143 & D 5379	
Yield Strength	F^{sy}		
Modulus	G^m		

4.6.5 Flexure

F_m^{fu} , F_m^{fy} , E_m^f

4.6.5.1 Introduction

As previously noted in Section 4.6.3, the measured ultimate tensile strength of a neat polymer is typically much less than the ultimate compressive strength, because of the greater critical flaw size sensitivity in tension. Therefore, polymer flexure specimens tend to fail at or near the tensile surface (depending on where a critical flaw is located). Thus, it is usually more logical to test for tensile strength directly, by performing a polymer matrix tensile test as described in Section 4.6.2.

Because of this, flexural testing of neat polymers is not commonly performed, even though flexural testing of composite materials is. For composites, flexural testing tends to persist because of the simplicity of the test specimen and test apparatus, not because of the general value of the data obtained, which is often limited. One exception is when the composite material is to be actually used in service in a similar geometric configuration and loading.

If flexural testing of a neat polymer is to be performed, ASTM Standard D 790 (Reference 4.6.5.1) is available for general guidance.

4.6.5.2 Specimen preparation

The flexure test specimen is a simple rectangular strip of polymer matrix, of constant width and thickness. Thus, it can be readily machined from a molded plate of the appropriate thickness, using the techniques and precautions described in Section 4.2. The ASTM D 790 recommendation of a span length to specimen thickness ratio of 16 for polymers dictates the length of the specimen, allowing for at least 10 percent overhang (but not less than 0.25 in., 6.4 mm) at each end. Specimen width should not exceed one-fourth of the support span, except that the minimum width should not be less than 0.50 in. (12.7 mm). For example when testing a 0.10 in. (2.5 mm) thick polymer matrix material, the test span would be 1.6 in. (41 mm), and thus the overall specimen length about 2.1 in. (53 mm) and the specimen width 0.50 in. (12.7 mm).

4.6.5.3 Test apparatus and instrumentation

ASTM D 790 permits either three-point or four-point loading, with no preference indicated. It will be noted that for three-point loading the maximum tensile stress occurs locally at the surface opposite the loading point. For four-point loading the maximum tensile stress occurs over the entire surface between the loading points, again at the surface opposite that where the loading points are applied. Thus, based

upon the higher probability of a critical flaw being present, statistically it can be expected that four-point flexure will result in lower measured flexural strengths. However, very often this difference is less than the normal data scatter, particularly for less brittle polymer matrix materials.

ASTM D 790 does suggest that the specimen be supported and loaded via circular cylinders of diameters which may be up to three times the specimen thickness, but not less than 0.25 in. (6.4 mm). Thus, for the 0.10 in. (2.5 mm) thick polymer specimen used as an example in Section 4.6.5.2, the cylinders should be between 0.25 in. (6.4 mm) and 0.30 in. (7.6 mm) in diameter. Since fixtures are typically supplied with cylinders of standard sizes, e.g., likely 0.25 in. (6.4 mm) or 0.50 in. (12.7 mm) in the present case, the 0.25 in. (6.4 mm) diameter cylinders would be appropriate. In all cases, the goal is to use cylinders of sufficient diameter so as to minimize excessive indentation of the specimen, or local failures due to stress concentrations directly under the cylinders.

ASTM Standard D 790 suggests the use of either testing machine crosshead displacement or specimen midlength deflection to determine flexural strain and/or modulus. A strain gage bonded to the tensile surface of the specimen at midlength can also be used.

4.6.5.4 Flexural test methods for MIL-HDBK-17 data submittal

Data produced by the following test method (Table 4.6.5.4) are currently being accepted by MIL-HDBK-17 for consideration for inclusion in Volume 2:

TABLE 4.6.5.4 Resin flexural test methods for MIL-HDBK-17 data submittal.

Flexural Property	Symbol	Fully Approved, Interim, and Screening Data	Screening Data Only
Ultimate Strength	F_m^{fu}	ASTM D 790	
Yield Strength	F_m^{fy}	"	
Modulus	E_m^f	"	

4.6.6 Impact

This section is reserved for future work.

4.6.7 Hardness

This section is reserved for future work.

4.7 FATIGUE TESTING

Fatigue testing of unreinforced resins is performed by cyclic loading of a test specimen below failure load to determine time or number of cycles to failure. A wide variety of loading conditions may be employed, including bending, crack opening, tension, compression, or tension-compression reverse loading. The loading is often characterized by the ratio of the minimum to maximum load, for example, tension-tension fatigue, $R=0.1$. A series of tests are usually conducted at a loading frequency chosen to be low

enough to avoid heating of the specimen. This heating can lead to thermally-induced failure. Load or deformation is cycled between selected values until failure, and maximum load or some other indication of load intensity is plotted against the log of the number of cycles to failure. Multiple tests are performed at each of several load levels, and the plot of the results of these tests is referred to as an S-N curve.

Since the fatigue resistance of a fiber-reinforced composite does not depend in a predictable way on the fatigue resistance of the unreinforced matrix, detailed recommendations for such tests are not included in this handbook. A discussion of fatigue testing of composite materials may be found in Section 6.9.

4.8 TESTING OF VISCOELASTIC PROPERTIES

Testing of viscoelastic, as opposed to elastic, properties involves characterization of the time dependence of these properties. This time dependence arises from the viscoelastic nature of polymeric resins. These tests may be conducted by measuring deformation as a function of time at constant load (creep testing), by measuring load as a function of time at constant deformation (stress relaxation), or by subjecting the material to some more complex load or deformation history to determine the elastic and viscous components of the material response. Dynamic mechanical analysis is an example of cyclic loading for viscoelastic material characterization. A discussion of dynamic mechanical analysis may be found in Section 6.6.3.

Since the viscoelastic or time-dependent properties of a fiber-reinforced composite do not depend in a predictable way on the viscoelastic response of the unreinforced matrix, detailed recommendations for such tests are not included in this handbook. A discussion of viscoelastic testing of composite materials may be found in Section 6.11.

REFERENCES

- 4.4.3(a) Siesler, H.W., and Holland-Moritz, K., *Infrared and Raman Spectroscopy of Polymers*, Marcel Dekker, New York, 1980.
- 4.4.3(b) May, C.A., Hadad, D.W., and Browning, C.E., "Physiochemical Quality Assurance Methods for Composite Matrix Resins," *Polymer Eng. Sci.*, Vol 19, 1979, pp. 545-551.
- 4.4.3(c) Koenig, J.L., "Quality Control and Nondestructive Evaluation Techniques for Composites Part II: Physiochemical Characterization Techniques. A State-of-the-Art Review," U.S. Army Aviation R & D Command, AVRADCOM TR 83-F-6, May 1983.
- 4.4.3(d) Garton, A., "FTIR of the Polymer-Reinforcement Interphase in Composites," *Polymer Preprints*, Vol 25(2), 1984, pp. 163-164.
- 4.4.4(a) Hagnauer, G.L., "Quality Assurance of Epoxy Resin Prepregs Using Liquid Chromatography," *Polymer Composites*, Vol 1, 1980, pp. 81-87.
- 4.4.4(b) Hagnauer, G.L., and Dunn, D.A., "Quality Assurance of an Epoxy Resin Prepreg Using HPLC," *Materials 1980 (12th National SAMPE Tech. Conf.)*, Vol 12, 1980, pp. 648-655.
- 4.4.4(c) Hagnauer, G.L., "Analysis of Commercial Epoxies by HPLC and GPC," *Ind. Res. Dev.*, Vol 23(4), 1981, pp. 128-188.
- 4.4.4(d) Hagnauer, G.L., and Dunn, D.A., "High Performance Liquid Chromatography: A Reliable Technique for Epoxy Resin Prepreg Analysis," *Ind. Eng. Chem., Prod. Res. Dev.*, Vol 21, 1982, pp. 68-73.
- 4.4.4(e) Hagnauer, G.L., and Dunn, D.A., "Quality Assurance of Epoxy Resin Prepregs," *Plastics in a World Economy, ANTEC '84*, Society of Plastics Engineers 42nd Annual Technical Conference and Exhibition, 1984, pp. 330-333.
- 4.4.4(f) Mestan, S.A., and Morris, C.E.M., "Chromatography of Epoxy Resins," *J. Macromol. Sci., Rev. Macromol. Chem. Phys.*, Vol C24(1), 1984, pp. 117-172.
- 4.4.4(g) ASTM Test Method D 5296, "Molecular Weight Averages and Molecular Weight Distribution of Polystyrene by High Performance Size-Exclusion Chromatography," Annual Book of ASTM Standards, Vol 8.03, American Society for Testing and Materials, West Conshohocken, PA.
- 4.4.4(h) Kowalsha, M. and Wirsen, A., "Chemical Analysis of Epoxy Prepregs - Market Survey and Batch Control," *Natl. SAMPE Symp. Exhib. [Proc.]*, Vol 25 (1980's Payoff Decade Adv. Mater.), 1980, pp. 389-402.
- 4.4.4(i) Lu, C.S., and Koenig, J.L., "Raman Spectra of Epoxies," *Am. Chem. Soc., Div. Org. Coat. Plast. Chem.*, Vol 32(1), 1972, p. 112.
- 4.4.4(j) Poranski, C.F. Jr., Moniz, W.B., Birkle, D.L., Kopfle, J.T., and Sojka, S.A., "Carbon-13 and Proton NMR Spectra for Characterizing Thermosetting Polymer Systems I. Epoxy Resins and Curing Agents," Naval Research Laboratory, NRL Report 8092, June, 1977.
- 4.4.4(k) Happe, J.A., Morgan, R.J., and Walkup, C.M., "NMR Characterization of Boron Trifluoride-Amine Catalysts Used in the Cure of Carbon Fiber/Epoxy Prepregs," *Compos. Technol. Rev.*, Vol 6(2), 1984, pp. 77-82.

Volume 1, Chapter 4 Matrix Characterization

- 4.4.4(l) Morse, G.A., "Primary Amine Analysis in Polymers," *J. Polm. Sci., Chem. Ed.*, Vol 22, 1984, pp. 3611-3615.
- 4.4.4(m) Hunter, A.B., "Analysis of Reaction Products of Polyimide by High Pressure DSC with GC/MS," *Proc. 12th N. American Thermal Conf.*, Williamsburg, VA, September 1983, p. 527.
- 4.4.4(n) Chen, J.S., and Hunter, A.B., "Chemical Characterization of Composites," *Polymer Pre-prints*, Vol 22, August 1981, p. 253.
- 4.4.5(a) ASTM Test Method D 2857 "Dilute Solution Viscosity of Polymers," *Annual Book of ASTM Standards*, Vol 08.02, American Society for Testing and Materials, West Conshohocken, PA.
- 4.4.5(b) Naoki, M., Park, I-H., Bunder, S.L., and Chu, B., "Light Scattering Characterization of Poly(ethylene terephthalate)," *J. Polym. Sci., Polym. Phys. Ed.*, Vol 23, 1985, p. 2567.
- 4.5.2(a) Bellenger, V., Fontaine, E., Fleishmann, A., Saporito, J., and Verdu, J., "Thermogravimetric Study of Amine Cross-Linked Epoxies," *Polym. Degrad. Stab.*, Vol 9(4), 1984, pp. 195-208.
- 4.5.2(b) Flynn, J.H., and Wall, L.A., "General Treatment of the Thermogravimetry of Polymers," *J. Res. Nat. Bur. Stds.*, Vol 70A, Nov/Dec 1966, p. 487.
- 4.5.2(c) Carpenter, J.F., "Assessment of Composite Starting Materials: Physiochemical Quality Control of Prepregs," *AIAA/ASME Symp. on Aircraft Composites*, San Diego, CA, March 1977.
- 4.5.2(d) Schnieder, N.S., Sprouse, J.F., Hagnauer, G.L., and Gillham, J.K., "DSC and TBA Studies of the Curing Behavior of Two Dicy-Containing Epoxy Resins," *Polymer Eng. Sci.*, Vol 19, 1979, p. 304.
- 4.5.2(e) ASTM Test Method D 3417 "Heats of Fusion and Crystallization of Polymers by Thermal Analysis"; *Annual Book of ASTM Standards*, Vol 08.02, American Society for Testing and Materials, West Conshohocken, PA.
- 4.5.2(f) ASTM Test Method D 3418 "Transition Temperatures of Polymers by Thermal Analysis," *Annual Book of ASTM Standards*, Vol 08.02, American Society for Testing and Materials, West Conshohocken, PA.
- 4.5.3(a) Gillham, J.K., "Characterization of Thermosetting Materials by TBA," *Polymer Eng. Sci.*, Vol 16, 1976, p. 353.
- 4.5.3(b) Enns, J.B., and Gillham, J.K., "Time-Temperature-Transformation (TTT) Cure Diagram: Modeling the Cure Behavior of Thermosets," *J. Appl. Polym. Sci.*, Vol 28, 1983, pp. 2567-2691.
- 4.5.3(c) Zukas, W.X., MacKnight, W.J., and Schneider, N.S., "Dynamic Mechanical and Dielectric Properties of an Epoxy Resin During Cure," *Chemorheology of Thermosetting Polymers*, ACS Symp. Ser., Vol 227, Am. Chem. Soc., Washington, DC, 1983, pp. 223-250.
- 4.5.3(d) Crozier, D., and Tervet, F., "Rheological Characterization of Epoxy Prepreg Resins," *SAMPE J.*, Nov/Dec 1982, pp. 12-16.

Volume 1, Chapter 4 Matrix Characterization

- 4.5.3(e) May, C.A., Dusi, M.R., Fritzen, J.S., Hadad, D.K., Maximovich, M.G., Thrasher, K.G., and Wereta, A., Jr., "Process Automation: A Rheological and Chemical Overview of Thermoset Curing," *Chemorheology of Thermosetting Polymers*, ACS Symp. Ser., Vol 227 Am. Chem. Soc., Washington, DC, 1983, pp. 1-24.
- 4.5.3(f) Hinrichs, R.J., "Rheological Cure Transformation Diagrams for Evaluating Polymer Cure Dynamics," *Chemorheology of Thermosetting Polymers*, ACS Symp. Ser., Vol 227 Am. Chem. Soc., Washington, DC, 1983, pp. 187-200.
- 4.5.3(g) Roller, M.B., "Rheology of Curing Thermosets: Critique and Review," in *Plastics in a World Economy*, ANTEC '84, Society of Plastics Engineers 42nd Annual Technical Conference and Exhibition, 1984, pp. 268-269.
- 4.5.3(h) Baumgartner, W.E., and Ricker, T., "Computer Assisted Dielectric Cure Monitoring in Material Quality and Cure Process Control," *SAMPE J.*, Jul/Aug 1983, pp. 6-16.
- 4.5.3(i) Senturia, S.D., Sheppard, N.F., Jr., Lee, H.L., and Marshall, S.B., "Cure Monitoring and Control with Combined Dielectric/ Temperature Probes," *SAMPE J.*, Jul/Aug 1983, pp. 22-26.
- 4.5.3(j) Chowdhury, B.B., "Significance of Thermally Stimulated Discharge Current for Epoxy Resins," *Am. Lab.*, January 1985, pp. 49-53.
- 4.5.3(k) ASTM Test Method D 2393, "Viscosity of Epoxy Resins and Related Components," *Annual Book of ASTM Standards*, Vol 8.02, American Society for Testing and Materials, West Conshohocken, PA.
- 4.5.3(l) ASTM Test Methods D 3835, "Rheological Properties of Thermoplastics with a Capillary Rheometer," *Annual Book of ASTM Standards*, Vol 8.02, American Society for Testing and Materials, West Conshohocken, PA.
- 4.5.3(m) ASTM Practice D 4065, "Determining and Reporting Dynamic Mechanical Properties," *Annual Book of ASTM Standards*, Vol 8.02, American Society for Testing and Materials, West Conshohocken, PA.
- 4.5.3(n) ASTM Practice D 4440, "Rheological Measurement of Polymer Melts Using Dynamic Mechanical Procedures," *Annual Book of ASTM Standards*, Vol 8.03, American Society for Testing and Materials, West Conshohocken, PA.
- 4.5.3(o) ASTM Practice D 4473, "Measuring the Cure Behavior of Thermosetting Resins Using Dynamic Mechanical Properties," *Annual Book of ASTM Standards*, Vol 8.03, American Society for Testing and Materials, West Conshohocken, PA.
- 4.5.3(p) ASTM Terminology D 4092, "Definitions and Descriptions of Terms Relating to Dynamic Mechanical Measurements on Plastics," *Annual Book of ASTM Standards*, Vol 8.02, American Society for Testing and Materials, West Conshohocken, PA.
- 4.5.4(a) Cebe, P. and Hong, S.D., "Crystallization Behavior of Poly(ether-ether-ketone)," *Polymer*, Vol 27, August 1986, p.1183.
- 4.5.4(b) Blundell, D.J. and Osborn, B.N., "The Morphology of Poly(ether-ether-ketone)," *Polymer*, Vol 24, August 1983, p. 953.
- 4.5.4(c) Lee, Y. and Porter, R.S., "Crystallization of Poly(etherether-ketone) (PEEK) in Carbon Fiber Composites," *Polymer Eng. Sci.*, Vol 26, 1986, p. 633.

Volume 1, Chapter 4 Matrix Characterization

- 4.5.4(d) Seferis, J.C., "Polyetheretherketone (PEEK): Processing-Structure and Properties Studies for a Matrix in High Performance Composites," *Polymer Composites*, Vol 7, 1986, p. 158.
- 4.5.5.1(a) ASTM D 2734, "Standard Test Method for Void Content of Reinforced Plastics," *Annual Book of ASTM Standards*, ASTM, West Conshohocken, PA.
- 4.5.5.1(b) ASTM D 1505, "Standard Test Method for Density of Plastics by the Density-Gradient Technique," *Annual Book of ASTM Standards*, ASTM, West Conshohocken, PA.
- 4.5.5.1(c) Ghiorse, S.R., data presented to MIL Handbook 17 Testing Working Group, Santa Fe, NM, March 1996.
- 4.5.5.1(d) Ghiorse, S.R. and Tiffany, J, "Evaluation of Gas Pycnometry as a Density Measurement Method," Proceedings of the 34th MIL-HDBK-17 PMC Coordination Group, Schaumburg, IL, September 1996.
- 4.5.5.1(e) ASTM D 792, "Standard Test Method for Density and Specific Gravity (Relative Density) of Plastics by Displacement," *Annual Book of ASTM Standards*, ASTM, West Conshohocken, PA.
- 4.5.6(a) ASTM Test Method D 3530. "Volatiles Content of Carbon-Fiber Prepreg," *Annual Book of ASTM Standards*, Vol 15.03, American Society for Testing and Materials, West Conshohocken, PA.
- 4.5.6(b) ASTM Test Method E 1131. "Compositional Analysis by Thermogravimetry" *Annual Book of ASTM Standards*, Vol 14.02, American Society for Testing and Materials, West Conshohocken, PA.
- 4.5.6(c) ASTM Test Method D 4526. "Determination of Volatiles in Polymers by Headspace Gas Chromatography" *Annual Book of ASTM Standards*, Vol 8.03, American Society for Testing and Materials, West Conshohocken, PA.
- 4.5.7(a) ASTM D 4672 "Polyurethane Raw Materials: Determination of Water Content in Polyols" American Society for Testing and Materials, West Conshohocken, PA.
- 4.5.7(b) ASTM Test Method D 4019, "Moisture in Plastics by Coulometry," *Annual Book of ASTM Standards*, Vol 8.02. American Society for Testing and Materials, West Conshohocken, PA.
- 4.6.2.1(a) ASTM Test Method D 638, "Standard Test Method for Tensile Properties of Plastics", *Annual Book of ASTM Standards*, Vol 8.01, American Society for Testing and Materials, West Conshohocken, PA.
- 4.6.2.1(b) ASTM D 882, "Standard Test Methods for Tensile Properties of Thin Plastic Sheeting", *Annual Book of ASTM Standards*, Vol 8.01, American Society for Testing and Materials, West Conshohocken, PA.
- 4.6.2.2(a) Odom, E.M., and Adams, D.F., "Specimen Size Effect During Tensile Testing of an Unreinforced Polymer," *Journal of Materials Science*, Vol 27, No. 7, 1992, pp. 1767-1771.
- 4.6.2.2(b) Odom, E.M., and Adams, D.F., "The Mechanical Response of a Thermosetting Polymer," Report UW-CMRG-R-91-104, Composite Materials Research Group, University of Wyoming, Laramie, Wyoming, May 1991.

Volume 1, Chapter 4 Matrix Characterization

- 4.6.3.1(a) Odom, E.M., and Adams, D.F., "Specimen Size Effect During Tensile Testing of an Unreinforced Polymer," *Journal of Materials Science*, Vol 27, No. 7, 1992, pp. 1767-1771.
- 4.6.3.1(b) Odom, E.M., and Adams, D.F., "The Mechanical Response of a Thermosetting Polymer," Report UW-CMRG-R-91-104, Composite Materials Research Group, University of Wyoming, Laramie, Wyoming, May 1991.
- 4.6.3.1(c) ASTM D 695, "Standard Test Method for Compressive Properties of Rigid Plastics," *Annual Book of ASTM Standards*, Vol 8.01, American Society for Testing and Materials, West Conshohocken, PA.
- 4.6.3.3 SACMA Recommended Method SRM 1, "Compressive Properties of Oriented Fiber-Resin Composites," Suppliers of Advanced Composite Materials Association, Arlington, Virginia.
- 4.6.5.1 ASTM D 790, "Standard Test Methods for Flexural Properties of Unreinforced and Reinforced Plastics and Electrical Insulating Materials," *Annual Book of ASTM Standards*, Vol 8.01, American Society for Testing and Materials, West Conshohocken, PA.
- 4.6.4.1(a) ASTM Test Method E 143-87, "Shear Modulus at Room Temperature," *Annual Book of ASTM Standards*, Vol 3.01, American Society for Testing and Materials, West Conshohocken, PA.
- 4.6.4.1(b) ASTM Test Method D 5379-93, "Shear Properties of Composite Materials by the V-Notched Beam Method," *Annual Book of ASTM Standards*, Vol 15.03, American Society for Testing and Materials, West Conshohocken, PA.

This page intentionally left blank

CHAPTER 5 PREPREG MATERIALS CHARACTERIZATION

5.1 INTRODUCTION

The processability and properties of high performance composites depend upon the composition of the fiber/resin preimpregnated materials (prepregs) from which they are manufactured. In general, prepregs consist of "modified" or surface-treated glass, graphite, or aramid fibers impregnated with 28-60 weight-percent of a reactive and chemically-complex thermoset resin formulation or a thermoplastic resin. A typical thermoset resin formulation may contain, for example, several different types of epoxy resins, curing agents, diluents, rubber modifiers, thermoplastic additives, accelerators or catalysts, residual solvents, and inorganic materials, plus various impurities and synthetic by-products. Furthermore, such resins are often "staged" or partially reacted during the prepregging process and may undergo compositional changes during transport, handling, and storage. Although less likely to undergo compositional changes, polymer molecular weight (MW), molecular weight distribution (MWD), and crystalline morphology have major effects on the processability and properties of thermoplastic prepregs and composites. Inadvertent or minor changes in resin composition may cause problems in processing and have deleterious effects on the performance and long-term properties of composites.

Modern analytical techniques and detailed knowledge relating to fibers, fiber surface treatments, and resin types and formulations are needed to characterize prepregs and composite materials. Characterization involves the identification and quantification of the fiber, fiber surface, and major resin components and should include information about the presence of impurities or contaminants. For thermoset resins and composites, characterization should include a description of the nature and extent of the prepreg resin reaction and the thermal/rheological and thermal/mechanical behavior. In the case of thermoplastics, the polymer molecular weight distribution, crystallinity, and time/temperature viscosity profile should also be analyzed. However, few laboratories are equipped or have the knowledgeable technical personnel to characterize prepregs and composites completely, and few studies have been published describing how variations in fiber type and resin chemistry/morphology affect the physical properties and long-term performance of composites. Also, until recently, prepreg compositions were considered proprietary, processing conditions were only recommended, and acceptance was based primarily upon mechanical testing of fabricated specimens. The purpose of this chapter is to provide an overview of characterization techniques and, more specifically, to address the application of state-of-the-art techniques for the chemical and physical characterization of resins and prepreg materials used in the manufacture of high performance organic matrix composites.

5.2 CHARACTERIZATION TECHNIQUES - OVERVIEW

According to a recent survey (Reference 5.2(a)), the most widely utilized techniques for the characterization and quality assurance of composite material precursors are -

1. High Performance Liquid Chromatography (HPLC)
2. Infrared (IR) Spectroscopy
3. Thermal Analysis
4. Rheological Analysis

HPLC and IR spectroscopy provide the capability for rapid screening and quality control fingerprinting of individual resin constituents as well as of the prepreg resin and, therefore, may be used advantageously by both the prepregger and composite manufacturer (References 5.2(b) - (f)). Thermal analytical techniques, such as thermal gravimetric analysis (TGA), differential thermal analysis (DTA), differential scanning calorimetry (DSC), thermal mechanical analysis (TMA), dynamic mechanical analysis (DMA), and torsional braid analysis (TBA) are not strictly chemical analysis techniques; however, they provide useful information relating to the composition and processability of resins (Reference 5.2(g)). Similarly, rheological and dielectric techniques are used frequently to evaluate the chemoviscosity properties of

thermoset resins during cure (Reference 5.2(h)), and there is increasing interest in applying such techniques for process monitoring and process control of both thermoset and thermoplastic resins.

Many of the chemical and physical analytical techniques described in Chapter 4 are also applicable to the characterization of prepreg materials. HPLC, IR spectroscopy, thermal analytical techniques and rheological methods are described in Section 5.5.

5.3 SAMPLING

Prepregs are commonly described by the purchaser's requirements which may include the manufacturer's trade name, resin type (e.g., 250°F) and lot number, fiber type and form (tape, fabric, roving, etc.), prepreg lot and roll numbers, and date of manufacture. The shipping date and expected shelf life are also usually designated along with recommended processing conditions. Generally, prepregs are shipped as rolls of impregnated woven fabric or unidirectional tape. (Typical widths are 38" (~97 cm) for woven aramid and glass, 42" (~107 cm) for woven graphite, and 12" (~30 cm) for tapes.) The prepreg layers are separated by thin, removable plastic or coated paper films which are removed when the prepregs are analyzed.

To check uniformity, it is recommended that sections be cut from the center and each side of the front-end (first off) of designated prepreg rolls. The amount and number of samples required for a particular analysis or test depends upon the homogeneity of the resin and the uniformity of the prepreg fibers. For some techniques, such as HPLC, 0.5 to 2.0 grams of prepreg may be needed to provide a representative sample. Other techniques (e.g., DSC) which utilize relatively small specimens (10 to 20 milligrams) may demand multiple specimens to provide an "average" value or test result.

Care must be taken not to contaminate or in any way alter samples during handling and storage. The samples should be placed in clean, dry, sealable containers and be carefully labeled. The containers must not react with the samples and precautions must be taken not to expose the prepregs to moisture nor allow them to stand unrefrigerated for long periods of time. For reactive prepreg resins such as epoxies, it is recommended that the prepregs be stored in hermetically sealed packaging at -0°F (-18°C). Upon removing the containers from cold storage, they should be allowed to achieve room temperature before opening to prevent condensation of moisture on the samples.

5.4 PHYSICAL CHARACTERISTICS AND PROPERTY TESTS

5.4.1 Physical description of reinforcement

The physical description of the reinforcement used in a composite should be described using the standard definitions of ASTM D 3878 (Reference 5.4.1). The filaments in the prepreg should be uniformly wetted by the resin. No particulates should be observable upon visual examination.

5.4.1.1 Alignment

In unidirectional prepregs, the filament bundles must be parallel to the longitudinal direction of the prepreg within an angle of 0.5° when examined visually using appropriate aids to measure angular alignment.

5.4.1.2 Gaps

Any gap within or between filament bundles in unidirectional prepregs generally should comply with the specifications. General guidelines are provided as follows:

- a. No gap should exceed 0.030 inch (0.76 mm) in width.

Volume 1, Chapter 5 Prepreg Materials Characterization

- b. The length of any portion of the gap with an average width of 0.030 inch (0.76) should not exceed 24 inches (0.61 m).
- c. Gaps in line with each other and no more than one inch (25 mm) apart should be considered as one gap, regardless of number.
- d. Gaps with excessive width or length should be considered defective and will be the basis for flagging or replacing the prepreg.

5.4.1.3 Width

Width tolerance for unidirectional prepreg tape should be as specified, typically ± 0.030 inch (0.76 mm).

5.4.1.4 Length

The length of each roll of prepreg should be provided. Limits on the length of prepreg on any single roll should be specified. Alternatively, suppliers and users may agree on limits for the prepreg weight or area per roll.

5.4.1.5 Edges

Acceptable waviness of edges should be specified. A typical acceptance value for any 12-inch (30-cm) length of tape should be 0.030 inch (0.76 mm) from the edge when measured with an appropriate straight edge.

5.4.1.6 Splices

Prepreg splices may be permitted on any roll of tape where processing is continuous without change in fiber or resin batch. Such splices should be appropriately marked as a nonconforming area.

5.4.2 Resin content

The resin content of prepreps may be determined by extracting the resin from the prepreg fibers using a solvent in which the resin material is fully soluble and the fibers are not dissolved. Soxhlet extraction procedures are described in ASTM C 613 (Reference 5.4.2(a)). Procedures for determining the resin content of carbon fiber-epoxy prepreps are provided in ASTM D 3529 (Reference 5.4.2(b)). Special procedures and solvents may be required to extract high molecular weight or thermoplastic resins. An alternate procedure for determining the resin content in epoxy resin prepreps is outlined in Section 5.5.1.

5.4.3 Fiber content

Procedures used to determine resin content often provide information about the fiber content of prepreps. Alternatively, acid digestion methods (ASTM D 3171) may be applied to remove the matrix resin from the fibers as long as the fibers are not degraded (Reference 5.4.3). Digestion methods are not preferred for graphite and aramid fiber prepreps since such fibers are subject to oxidative degradation. Section 5.5.1 describes a procedure for determining the fiber and resin contents of glass, carbon, and aramid fiber/epoxy resin prepreps.

5.4.4 Volatiles content

The volatiles content of prepreps may be determined by ASTM D 3530 (Reference 5.4.4). Thermogravimetric analysis (TGA) may also be applied to estimate weight percent volatiles in a prepreg.

5.4.5 Moisture content

The moisture content of prepregs may be determined by coulometry in accordance with ASTM D 4019 (Reference 5.4.5) or by automated moisture meters based on the Karl Fischer titration method.

5.4.6 Inorganic fillers and additives content

The quantitative determination of inorganic fillers and additives in the prepreg resin requires considerable care. For example, the weight percent inorganic fillers and additives in a prepreg resin may be determined according to the procedure described in Section 5.5.1. Assuming that the organic resin material is fully soluble in tetrahydrofuran (THF) and that the inorganic fillers and additives are insoluble, the solution prepared in step 6 can be centrifuged to precipitate the insoluble components. The precipitate is washed at least three times with the solvent, dried, and then weighed.

5.4.7 Areal weight

The areal weight (mass per unit area) of a prepreg material may be determined using ASTM D 3776 (Reference 5.4.7).

5.4.8 Tack and drape

Tack refers to the ability of a prepreg to adhere to itself or to other material surfaces and is a key factor in determining prepreg suitability for component/part fabrication. There is no quantitative method for measuring tack. Subjective terms such as high, medium, and, low are often used in describing tack. Although there is no generally accepted method for measuring tack, some composite manufacturer's use a Monsanto Tack Tester™ to obtain a relative index for prepreg tack. Drape is also a subjective term which relates to the ease of handling and conforming prepregs to complex surfaces.

5.4.9 Resin flow

Resin flow under specified test conditions relates to the composition, extent of reaction, and/or morphology of the prepreg resin, as well as the resin content. Prepreg processability and resin content in the processed laminate are affected by resin flow. Test conditions (temperature, pressure, layers of prepreg, number of bleeder plies) depend upon the type of resin. The resin flow of prepreg materials may be determined by ASTM D 3531 (Reference 5.4.9).

5.4.10 Gel time

Gel time relates to the chemical composition and extent of reaction of thermosetting prepreg resins. Prepreg processability is affected by the resin gel time. The test temperature depends upon the type of resin. The gel times of prepregs may be determined by ASTM D 3532 (Reference 5.4.10).

5.5 TEST METHODS

The following methods are examples of analytical techniques that can be used for prepreg characterization.

5.5.1 Resin extraction procedure for epoxy resin prepregs

This procedure is applicable for determining the fiber and resin contents of glass, carbon, and aramid fiber/epoxy resin prepregs. Solutions prepared according to this procedure can be used directly for HPLC analysis provided appropriate grade solvents are used. Recommended sampling, specimen handling procedures, and standard laboratory safety procedures should be followed.

Volume 1, Chapter 5 Prepreg Materials Characterization

1. Cut a rectangular specimen (approx. 1 g) from prepreg section and weigh on analytical balance (± 0.001 g or better). Record weight as W_o (grams).
2. Place specimen in 25 mL Erlenmeyer flask (fitted with a ground-glass stopper) and add about 20 mL THF (tetrahydrofuran, fresh, HPLC grade, distilled-in-glass, with no inhibitor added).
3. Stopper the flask and allow the specimen to soak in the THF for at least 4 hours.
4. Place flask on vortex mixer and agitate for 1 minute.
5. Carefully decant the THF solution into a 50 mL volumetric flask. The fibers should remain bunched together in the 25 mL flask.
6. Add about 10 mL THF to rinse the fibers in the 25 mL flask, mix on the vortex mixer, and decant the THF into the 50 mL volumetric flask containing the primary solution (step 5).
7. Repeat step 6.
8. Add THF to fill the volumetric flask to the 50 mL mark.
9. Carefully remove the graphite fibers from the 25 mL Erlenmeyer flask (using forceps), wrap fibers in Kimwipes™ or equivalent, place in labeled paper envelop, place the envelope in fume hood air stream, and allow fibers to dry overnight. Alternatively, residual THF may be removed by placing the envelope with fibers in a vacuum oven (fitted an appropriate vapor trap) set at 40°C and maintaining a vacuum for at least 1 hour.
10. The fibers are removed from the Kimwipes™ and weighed on an analytical balance. Record the fiber weight as W_f (grams).
11. Calculate the concentration of the resin solution (see step 8) and record concentration as C_o ($\mu\text{g}/\mu\text{L}$). This concentration will be useful in the analysis of HPLC data.

$$C_o = \frac{(W_o - W_f)}{0.050} \mu\text{g}/\mu\text{L} \quad 5.5.1(a)$$

12. Mix resin solution (from step 11) on vortex mixer and immediately filter about 4 mL of the resin sample solution through a 0.2 μm Teflon™ membrane filter into a dry, clean glass vial. Immediately cap the vial to prevent contamination and solvent loss. This solution will be used for HPLC analysis. The remaining (unfiltered) solution in the flask can be used to determine soluble resin content and insoluble content (steps 16 and 17).
13. The extractable resin content and fiber content, not corrected for the presence of volatiles and insoluble components in the prepreg resin and remaining on the fibers, are calculated -

$$\text{wt- \% extractable resin} = 100\% \times \frac{(W_o - W_f)}{W_o} \quad 5.5.1(b)$$

$$\text{wt- \% fiber} = 100\% - \text{wt \% extractable resin} \quad 5.5.1(c)$$

14. Glass fibers may be placed in a muffle furnace and heated at 650 to 800°C to remove nonextractable surface material. After cooling to room temperature, the fibers are reweighed and their weights are recorded as W_f .
15. The amount of nonextractable fiber surface material in glass fiber prepreps is calculated -

$$\text{wt- \% nonextractables} = 100\% \times \frac{(W_f - W_f')}{W_o} \quad 5.5.1(d)$$

16. Insoluble content. The extractable or THF-soluble resin content may also be determined by filtering the solution prepared in step 8 through a 0.2 μm Teflon™ membrane filter. Using a volumetric pipet,

an aliquot (e.g., 10 mL) of the filtered solution is transferred to a pre-weighed aluminum pan (weight W_A) which is then placed into a fume hood to evaporate the solvent. A stream of filtered air or nitrogen can be directed over the surface of the pan to accelerate evaporation. After 9 mL or more of the solvent is removed leaving an oily residue of resin, the pan can be placed in a vacuum oven and heated at about 50°C for several hours to remove residual solvent. After cooling to room temperature, the pan is reweighed (W'_A) and the resin content is calculated -

$$\text{wt- \% soluble resin} = 100\% \times (W'_A - W_A) \times \frac{5}{W_o} \quad 5.5.1(e)$$

Differences in the weight-percent resin determined using Equations 5.6.1(b) and 5.6.1(e) may be attributed to the presence of volatiles and insoluble (nonfibrous) components in the prepreg.

17. Insoluble content. The amount of insoluble components may be determined by the following procedure. An aliquot of the solution from step 12 can be centrifuged to precipitate the insoluble components. The precipitate is washed at least three times with the solvent, dried, and weighed.

5.5.2 Procedure for HPLC/HPSEC analysis of glass, aramid, and graphite fiber prepreps

Mix resin solution (prepared in Section 5.5.1, step 12) on a vortex mixer and immediately filter about 4 mL of the resin sample solution through a 0.2 μm Teflon™ membrane filter into a dry, clean glass vial.

Immediately cap the vial to prevent contamination and solvent loss. The sample is now ready for HPLC analysis.

If the HPLC analysis is not run immediately, the sample solution should be kept in a cool, dark location. If care is taken during storage, the THF solution will remain stable and may be analyzed weeks after its preparation with no apparent effect on the HPLC analysis.

5.5.2.1 Reverse phase HPLC analysis

The epoxy resin prepreg analysis can be run using any of a number of commercially available HPLC instruments. An integrator/recorder or state-of-the-art HPLC data analysis system is recommended for data acquisition, plotting, and reporting. HPLC operating conditions were selected for simplicity and compatibility with most commercial HPLC equipment.

HPLC System: Waters Associates model-244 instrument with M6000A solvent delivery systems, M720 system controller, 710B WISP auto-injection system, M440 UV detector, and M730 data module. Similar systems available from other manufacturers may also be used.

Solvents: Acetonitrile (distilled-in-glass) and reagent grade water prepared from distilled water using a Millipore Milli-Q2 (Millipore Corp., Bedford, MA) or equivalent water purification system. Purging the solvents with helium is recommended.

Column: Waters Associates $\mu\text{Bondapak}$ C18. (Similar columns available from other manufacturers may also be used).

Injection Volume: 10 mL

Flow Rate: 2.0 mL/min

Mobile Phase (solvent program):

Time	% Acetonitrile	% Water	Curve
0	45	55	*
12 min	100	0	7
16 min	100	0	*
20 min	45	55	6

Detector: UV 254nm Run Time: 20 minutes

5.5.2.2 Size Exclusion Chromatography (SEC) analysis

The SEC analysis of the prepreg resins can be run using HPLC instrumentation as described above.

Solvent: THF (distilled-in-glass) A helium purge should be maintained on THF for optimum results.

Columns: IBM SEC type A and type C, 5 micron (columns from other manufacturers, such as the Waters μ Styragel 1000, 500, 100, 100 \rightarrow , are also acceptable).

Injection Volume: 10 μ L

Flow Rate: 1 mL/min

Detector: UV 254nm

Run Time: 15 minutes

Calculations: Integrated peak areas are converted to area percentages (% area).

5.5.3 Procedure for Fourier transform infrared spectroscopy (FTIR)

Several droplets of the resin/THF solution (prepared in Section 5.5.1, step 12) are placed on the surface of a polished salt plate (preferably KBr). The sample is analyzed as soon as the THF has evaporated. A Perkin Elmer model 1550 or 1700 FTIR spectrometer with model 7500 computer or an equivalent instrument is used to scan and record the spectrum (500 to 4000 cm^{-1}) of the salt plate with and without the sample on its surface. The analysis should be conducted with the salt plate and sample in a purged, dry nitrogen atmosphere at room temperature. Depending upon the sample, 100 to 200 scans of the spectrum may be required to optimize spectral resolution. It also may be necessary to deposit more or less sample on the salt plate. The spectrum of the sample obtained by subtracting that of the salt plate is plotted, reported, and stored on a computer disk.

5.5.4 Procedure for differential scanning calorimetry (DSC)

This test can be performed using a DuPont Instruments 9900 Thermal Analyzer/Controller and model 912 DSC accessory or an equivalent instrument.

Volume 1, Chapter 5 Prepreg Materials Characterization

Specimen:	Prepreg (10 to 30 mg) in an aluminum sample pan
Reference:	Empty sample pan
Heating Rate:	10°C/min
Temperature Range:	Room temperature to 350°C
Atmosphere:	Dry nitrogen gas purge
Data Handling:	Data is stored on a computer disk and a plot of heat flow dH/dt ($\mu\text{W}/\text{sec}$) vs temperature ($^{\circ}\text{C}$) is produced.
Heat of Reaction:	The calibration routine and integration program provided with the thermal analyzer is used to calculate heats of reaction ΔH of thermoset prepreg resins.

Glass Transition: A cooling device attached to the DSC cell may be needed to facilitate glass transition temperature T_g measurements of thermoset prepreg resins; i.e., it is often necessary to initiate temperature scans at -50°C or lower since such resins typically have T_g values below room temperature. The thermal ana-

lyzer

may have a software routine to assist in determining T_g values.

5.5.5 Procedure for dynamic mechanical analysis (DMA)

A single ply of prepreg is cut into a 1.1 cm x 1.7 cm strip and the strip is mounted in a DuPont model 982 or 983 DMA accessory. A DuPont 9900 or 1090 controller is used to run the test and plot the results. Equivalent instruments may also be used.

Heating Rate:	5°C/min
Temperature Range:	Room temperature to 350°C
Atmosphere:	Dry, nitrogen gas purge
Data Handling:	Data is stored on a computer disk and a plot of storage modulus and $\tan \delta$ is plotted as a function of temperature.
Glass Transition:	The temperature of the damping peak maximum is assigned as the T_g value.
Gelation:	Gelation occurs when the Young's modulus starts increasing rapidly (several orders of magnitude) over a narrow temperature range. Gelation temperature depends upon heating rate and mechanical frequency. Therefore, both heating rate and frequency should be included when DMA gelation temperatures are reported.
Gelation Time:	In the isothermal mode, the time to gelation is determined by rapidly heating a sample to the desired temperature, holding the temperature constant and monitoring the change in Young's modulus with time. Gelation time is defined as the time it takes for the modulus to start rapidly increasing (several orders of magnitude).

5.5.6 Procedure for rheological characterization

A Rheometrics Dynamic Spectrometer (RDS) or equivalent system is used for this test. Samples are prepared by cutting three 25-mm diameter circles from a single ply of prepreg. The three plies are stacked and placed between the rheometer's parallel plates.

Heating Rate:	2°C/min
Temperature Range:	Room temperature to the onset of gelation (for thermosets)
Atmosphere:	Air or a blanket of nitrogen gas
Geometry:	25-mm diameter parallel plate
Gap:	Typically 0.8 mm, but may be adjusted according to sample characteristics.
Data Reporting:	Shear moduli (storage and loss) and complex viscosity are plotted as a function of temperature.

REFERENCES

- 5.2(a) Kaelble, D.H., "Quality Control and Nondestructive Evaluation Techniques for Composites - Part 1: Overview of Characterization Techniques for Composite Reliability," U.S. Army Aviation R & D Command, AVRADCOM TR 82-F-3, May 1982.
- 5.2(b) Hagnauer, G.L., "Quality Assurance of Epoxy Resin Prepregs Using Liquid Chromatography," *Polymer Composites*, Vol 1, 1980, pp. 81-87.
- 5.2(c) Hagnauer, G.L., and Dunn, D.A., "Quality Assurance of an Epoxy Resin Prepreg Using HPLC," *Materials 1980 (12th National SAMPE Tech. Conf.)*, Vol 12, 1980, pp. 648-655.
- 5.2(d) Hagnauer, G.L., and Dunn, D.A., "High Performance Liquid Chromatography: A Reliable Technique for Epoxy Resin Prepreg Analysis," *Ind. Eng. Chem., Prod. Res. Dev.*, Vol 21, 1982, pp. 68-73.
- 5.2(e) Hagnauer, G.L., and Dunn, D.A., "Quality Assurance of Epoxy Resin Prepregs," *Plastics in a World Economy*, ANTEC '84, Society of Plastics Engineers 42nd Annual Technical Conference and Exhibition, 1984, pp. 330-333.
- 5.2(f) Kowalsha, M. and Wirsén, A., "Chemical Analysis of Epoxy Prepregs - Market Survey and Batch Control," *Natl. SAMPE Symp. Exhib. [Proc.]*, Vol 25 (1980's Payoff Decade Adv. Mater.), 1980, pp. 389-402.
- 5.2(g) Carpenter, J.F., "Assessment of Composite Starting Materials: Physicochemical Quality Control of Prepregs," *AIAA/ASME Symp. on Aircraft Composites*, San Diego, CA, March 1977.
- 5.2(h) Crozier, D., and Tervet, F., "Rheological Characterization of Epoxy Prepreg Resins," *SAMPE J.*, Nov/Dec 1982, pp. 12-16.
- 5.4.1 ASTM Terminology D 3878, "Definitions of Terms Relating to High-Modulus Reinforcing Fibers and Their Composites," *Annual Book of ASTM Standards*, Vol 15.03, American Society for Testing and Materials, West Conshohocken, PA.
- 5.4.1.7 ASTM Practice D 3951, "Commercial Packaging," *Annual Book of ASTM Standards*, Vol 15.09, American Society for Testing and Materials, West Conshohocken, PA.
- 5.4.2(a) ASTM Test Method C 613, "Resin Content of Carbon and Graphite Prepregs by Solvent Extraction," *Annual Book of ASTM Standards*, Vol 15.03, American Society for Testing and Materials, West Conshohocken, PA.
- 5.4.2(b) ASTM Test Method D 3529/D 3529M, "Resin Solids Content of Carbon Fiber-Epoxy Prepreg," *Annual Book of ASTM Standards*, Vol 15.03, American Society for Testing and Materials, West Conshohocken, PA.
- 5.4.3 ASTM Test Method D 3171, "Fiber Content of Resin-Matrix Composites by Matrix Digestion," *Annual Book of ASTM Standards*, Vol 15.03, American Society for Testing and Materials, West Conshohocken, PA.
- 5.4.4 ASTM Test Method D 3530/D 3530M, "Volatiles Content of Carbon Fiber-Epoxy Prepreg," *Annual Book of ASTM Standards*, Vol 15.03, American Society for Testing and Materials, West Conshohocken, PA.

Volume 1, Chapter 5 Prepreg Materials Characterization

- 5.4.5 ASTM Test Method D 4019, "Moisture in Plastics by Coulometry," *Annual Book of ASTM Standards*, Vol 08.02, American Society for Testing and Materials, West Conshohocken, PA.
- 5.4.7 ASTM Test Method D 3776, "Weight (Mass) per Unit Area of Woven Fabric," *Annual Book of ASTM Standards*, Vol 07.02, American Society for Testing and Materials, West Conshohocken, PA.
- 5.4.9 ASTM Test Method D 3531, "Resin Flow of Carbon Fiber-Epoxy Prepreg," *Annual Book of ASTM Standards*, Vol 15.03, American Society for Testing and Materials, West Conshohocken, PA.
- 5.4.10 ASTM Test Method D 3532, "Gel Time of Carbon Fiber-Epoxy Prepreg," *Annual Book of ASTM Standards*, Vol 15.03, American Society for Testing and Materials, West Conshohocken, PA.

CHAPTER 6 LAMINA, LAMINATE, AND SPECIAL FORM CHARACTERIZATION

6.1 INTRODUCTION

The use of composite materials continues to increase as new performance, reliability, and durability requirements drive hardware designs to higher levels of structural efficiency. Additionally, government requirements are becoming more stringent to ensure proper levels of structural integrity are maintained. These design drivers, among others, have resulted in a growing recognition that certification or qualification of aerospace structure requires an extensive combination of analysis, testing, and documentation.

Further, because of the large number of design variables inherent to composite structure, analytic models are even more necessary than for metallic structure to ensure completeness of the hardware qualification process. Inherent in all structural analysis models are material, physical, and mechanical property characterization data. Ideally, these analytic models would permit analysts to predict full-scale structural response (e.g. stability, deflections, strength, life) directly from a generic (lamina) material database. In truth, test data is required at design development (element, subcomponent, component) and full-scale article test levels as well as the generic (coupon) levels of evaluation.

The purpose of Chapter 6 is to provide guidelines of testing procedures for characterization of physical and mechanical lamina (ply) and laminate properties.

A laminate is a product made by bonding together two or more layers of material or materials, and a lamina is a single ply or layer in a laminate. The material forming each layer typically consists of a carbon, glass, or organic (polymeric) fiber reinforcement embedded in a thermoplastic or thermosetting resin matrix. While retaining their identities in the composite, the constituents combine to provide specific characteristics and properties.

Many techniques are used to characterize the chemical, physical, and mechanical properties of composite materials. The purpose of this chapter is to provide information on techniques that may be used to analyze and evaluate these properties. The test methods discussed in each section may not be appropriate for all types of composite materials. Currently, more studies are being conducted to investigate how variations in reinforcement and resin chemistry and morphology may affect the physical properties and long term performance of composites. Where possible, the limitations of existing test methods are discussed.

6.2 SPECIMEN PREPARATION

6.2.1 Introduction

This section provides general recommendations for the fabrication and preparation of the test specimens detailed in this document. These recommendations cover specimen traceability, test article¹ fabrication, specimen location, configuration, and machining.

The validity of material properties used in design of structure is dependent on the quality of the specimens being tested. If the objective of the testing is to provide comparative information of different materials, it is crucial that variability due to specimen preparation be kept to a minimum. If the data being generated are intended to be used to generate allowables, the goal is to reflect the interaction of the base material and processing which is expected to occur in production. In either case care must be taken in the specimen preparation process to minimize the variation which naturally occurs during the process. Specimen fabrication should be performed in compliance to ASTM D 5687 (Standard Guide for Preparation of Flat Composite Panels with Processing Guidelines for Specimen Preparation). Even test articles that are not flat can benefit from the ASTM guide.

¹ A test article is any construction from which individual specimens are extracted. Such a test article may be a flat panel fabricated specifically to develop material properties, or it may be a production part set aside for test purposes.

6.2.2 Traceability

All specimens should be traceable to the material batch, lot, roll, process and test article. The requesting organization may choose to require traceability of each specimen to its location within the test article.

The specification, or purchasing paperwork, should require batch, lot, roll traceability and lot acceptance test information. It is recommended that when uncured material is purchased it be required that all available traceability information, including vendor certifications and material receiving inspection data of acceptance test results, be delivered with the material. The organization conducting the investigation should review the information to ensure there is enough traceability information to proceed with test article and specimen fabrication.

All prepreg material that is stored before fabrication should have a storage history record. Information such as accumulated time in and out of refrigeration should be recorded.

For the test article, the prepreg batch number, lot number, roll number, and processing information should be recorded. Another piece of information which needs to be maintained throughout specimen fabrication is ply orientation. One method by which this may be accomplished is through the use of a witness line, as discussed in the next section.

6.2.3 Test article fabrication

The following is a list of important items that should be considered when fabricating test articles:

- a. Test articles should be built according to engineering drawing requirements or sketches. The drawing requirements or sketches should specify: ply materials, test article reference orientation, ply orientation, material and process specifications or equivalent process document, and inspection requirements.
- b. Vital material and process identification, such as prepreg batch number, lot number, roll number, autoclave run, press, or other consolidation method and lay-up stacking sequence, should be recorded. This information is stored to maintain traceability of the test articles. This same traceability should be maintained on any excess material left after the specimens have been removed.
- c. The test article identification code and witness line should be permanently identified on each test article. A witness line should be established on the fabrication tool to act as a reference to the fiber orientation on the test article. For hand lay-up methods a witness line which will be maintained during the lay-up and curing process must be identified as the reference orientation. The angular tolerance between the plies put down and this line depends on the processing specification by which the material is being processed. In automated processes some other method of establishing the reference orientation must be established. Once established, the witness line should be transferred to the test article, and maintained throughout specimen extraction.
- d. It is generally recommended that for cured test articles at least 1 in. (25 mm) of material be trimmed from the edges. One of the machined edges of the test article may be used to permanently maintain the reference orientation on the article.
- e. The requesting organization (or if required, the appropriate quality assurance organization) should inspect test articles. This inspection should be done before the specimens are fabricated to ensure they meet all requirements in the controlling process specification or appropriate equivalent document. If the test article does not meet all requirements, the requesting organization and, when applicable, the customer representative, should provide the final disposition of the test article.

6.2.4 Specimen fabrication

The following is a list of important items that should be considered when fabricating specimens.

- a. Specimens should be extracted from test articles in the region that meets all process, engineering drawing, and specimen drawing requirements.
- b. Specimens should be located on the test article according to the cutting diagram provided by the requesting organization. If a test article does not pass the inspection criteria, the requesting organization may choose to cut specimens relative to identified test article defects to make the effect of the defects on the specimen response representative of the full-scale item.

NOTE: When defining specimen locations, allow for material removed in the cutting operation.

- c. A specimen identification code should be defined in the test plan, referenced in the test instructions, and recorded in the data sheets. The specimen identification code should be permanently marked on each specimen. Care should be taken to keep the code outside the failure area of the specimen.
- d. For specimens too small to mark the complete code, mark only the unique serial number on the specimen. It is recommended that care be taken to place small specimens in bags properly labeled with that specimen's full identification.
- e. If it is required that the location of the specimen on the test article be known, specimens should be labeled before being extracted. This labeling should allow all specimen and excess material locations to be known after cutting.
- f. The reference edge of the specimen should be aligned within the specified orientation using the witness line. In instances where a smaller subtest article is machined and used to make several specimens at once, a reference line or edge should be transferred to this subtest article from the witness line. This transferred line should be orientated within $\pm 0.25^\circ$ with respect to the witness line.
- g. Before cutting, the specimen location and orientation should be verified by the requesting organization or an independent reviewer.
- h. Specimens should be extracted from the fabricated test articles according to the appropriate machining procedure as specified. Specimens may be machined with a variety of machining tools. In general the final cutting tool should have a fine grit, be hardened, and run at a high tool speed without wobble. The cut itself should be executed to minimize excess heating of the laminate.
- i. The added cost and manufacturing associated with tabbed specimens should be considered when selecting specimen type. The limitations and problems associated with the tabbing of specimens is stated in each individual test method. If bonded tabs are required, the cure of the adhesive should be evaluated to determine if it is compatible with the composite system and tab material (if different). If the tab configuration produced in the bonding process is not within the geometry requirements of the specimen configuration, further machining of the tabs may be required.
- j. Holes in specimens should be drilled in accordance to the applicable process specification.
- k. Any fasteners that are required should be installed in accordance to the applicable process specification.
- l. Completed specimens should be inspected prior to testing to ensure conformance with the standards being used. Variations in individual specimen thickness should be within the applicable test method tolerances. Larger variations may cause improper loading when used with close tolerance test fixtures. These variations may indicate that the specimen was fabricated improperly (e.g., ply drop-off or resin bleed).

6.3 CONDITIONING AND ENVIRONMENTAL EXPOSURE

6.3.1 Introduction

Conditioning is the process of exposure of material to a potentially property-altering environment prior to subsequent test.¹ This section focuses on conditioning of materials subjected to moisture exposure (immersion in all types of fluids, but especially humid air). There are, of course, many other types of conditioning environments. An incomplete list includes: subambient (moderately low temperatures), cryogenic (very low temperatures), elevated temperature (dry), oxidizing, low-Earth orbit simulation (including exposure to monatomic oxygen), and exposure to various types of radiation. Conditioning issues in these other environments will not be explicitly discussed in this section. A related, but much more difficult, extension of material conditioning is associated with the issue of *long-term aging* (for example, 10,000 to 80,000 or more hours of exposure), which for practical engineering purposes requires development of procedures for accelerated conditioning. While some very limited and restricted guidelines for acceleration of basic moisture conditioning are discussed in the following subsections, acceleration of long-term aging processes is a state-of-the-art topic that is beyond the scope of this section.

Most polymeric materials, whether unreinforced resin, polymeric composite matrix, or a polymer-based fiber, are capable of absorbing relatively small but potentially significant amounts of moisture from the surrounding environment.² The physical mechanism for moisture mass change, assuming there are no cracks or other wicking paths, is generally assumed to be mass diffusion following Fick's Law (the moisture analog to thermal diffusion is discussed in Section 6.4.8). Fickian moisture diffusion into or out of the interior occurs relatively slowly; many orders of magnitude slower than heat flow in thermal diffusion. Nevertheless, given enough exposure-time in a moist environment, a significant amount of moisture may be absorbed into the material. This absorbed moisture may cause material swelling, and, particularly at higher temperatures, may soften and weaken the matrix and matrix/fiber interface, which is deleterious to many mechanical properties that are often design drivers for structural applications. Absorbed moisture effectively lowers the maximum use temperature of the material (see Sections 2.2.7 and 2.2.8). The effect is demonstrated by a lowering of the glass transition temperature (thus the particular interest in T_g test results).

The two main types of basic moisture conditioning of materials are: *fixed-time conditioning*, where a material specimen is exposed to a conditioning environment for a specified period of time; and *equilibrium conditioning*, where a specimen is exposed until the material reaches equilibrium with the conditioning environment. While fixed-time conditioning is still in common use when screening materials, it usually results in a material condition that is substantially non-uniform through the thickness; subsequent test results are, therefore, considered only a qualitative assessment rather than a quantitative result. Except for certain screening-level purposes, or as part of application-specific structural-level tests, fixed-time conditioning as summarized in Section 6.3.2 is not considered sufficient or representative; only equilibrium conditioning as discussed in Section 6.3.3 provides a true assessment of comparable material response.

When absorbed moisture is a potential design concern, a material testing program should evaluate both the moisture absorption material properties (diffusion rate and equilibrium content) and the effect of absorbed moisture on key design properties after equilibrium moisture exposure. An ASTM moisture absorption conditioning/material property test method, ASTM D 5229/D 5229M (Reference 6.3.1), has been created to define the conditioning parameters and procedures needed to assure that uniform through-

¹Nonambient testing is another subject, and, for mechanical testing, is covered in Section 6.5.3.

²While certain polymers, like polybutadiene, resist water vapor absorption to the point that humidity conditioning may not be required, these materials are still considered rare exceptions. On the other hand, most reinforcements, including those of the carbon, glass, metallic, and ceramic fiber families, are not hygroscopic. As a result, except for polymeric fibers like aramid, it is usually assumed that any water vapor absorption is limited to the polymer matrix.

thickness equilibrium¹ is obtained during conditioning. ASTM D 5229/D 5229M also defines how to determine the moisture absorption properties, and its use for this purpose is discussed in more detail in Section 6.6.8.

6.3.2 Fixed-time conditioning

As stated above, fixed-time conditioning is only of limited usefulness², it cannot generally provide the desired uniform moisture condition through the thickness of the material. The shortcomings of the fixed-time approach are illustrated in Figure 6.3.2 for a simulated 30-day exposure of IM6/3501-6 carbon/epoxy at 140°F (60°C) and 95% RH. Using known values for moisture diffusivity and moisture equilibrium content, the calculated average moisture content of various laminate thicknesses is plotted and shown as a smooth curve. From this curve, it can be seen that the maximum laminate thickness that can reach equilibrium at this temperature during this fixed, though fairly lengthy, conditioning exposure, is 0.035 in. (0.89 mm). For greater thicknesses, the moisture distribution through the thickness will *not be uniform*, as the interior moisture levels will be below equilibrium moisture content. This is further illustrated by an example in Section 6.3.3.

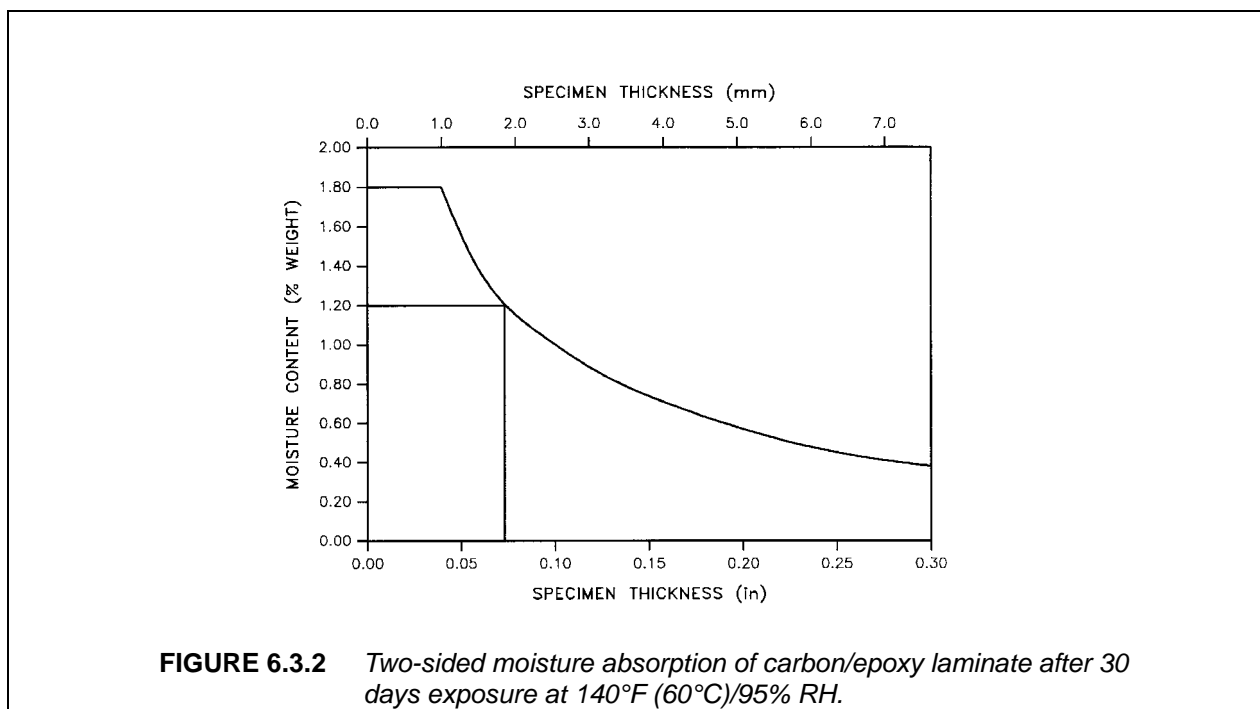

As will be discussed in Section 6.3.3.1, with lower target relative humidity levels, it is common to try to accelerate conditioning by subjecting the material to a higher relative humidity level for a shorter period of time. The objective is to introduce the same average moisture content in the material as would be seen in equilibrium conditioning at the lower relative humidity level, although the distribution of moisture content distribution will be less uniform through the thickness. Using a single-humidity level, fixed-time conditioning example, again illustrated by Figure 6.3.2, equilibrium at 78% RH (1.2% equilibrium moisture content for this material) can be approximated only at a thickness of 0.070 in. (1.8 mm). For a thickness greater than 0.070 in. (1.8 mm), the average moisture content will be insufficient, and for a thickness less than

¹The discussion focuses on through the thickness moisture absorption; however, in-plane moisture absorption will locally dominate near edges, and may even dominate the overall absorption process in those cases where edge area is a substantial portion of the total exposed area.

²Examples of fixed-time conditioning methods that should specifically be avoided include: ASTM D 618 (Reference 6.3.2(a)), ASTM D 570 (Reference 6.3.2(b)), and SACMA RM 11-88 Method I (Reference 6.3.2(c)).

0.070 in. (1.8 mm), the moisture content will be higher than desired. Again, the fixed-time conditioning approach is inadequate.

As seen from the examples above, total moisture content resulting from fixed-time conditioning is thickness dependent. However, since fluids diffuse through different materials at different rates, fixed-time conditioning cannot produce a uniform material condition for all materials,¹ even if thickness is held constant. Therefore, test results based on fixed-time conditioning should not be used for design values, and generally should not even be used in qualitative comparisons between different materials. However, fixed-time conditioning can serve a purpose when combined with a flexure test (which is sensitive to surface exposure) for qualitative aerospace fluids assessment, as discussed in Section 2.3.1.3.

6.3.3 Equilibrium conditioning

To evaluate worst-case effects of moisture content on material properties, tests are performed with specimens preconditioned to the design service (end-of-life) moisture content (hereinafter assumed equivalent to equilibrium at the design service relative humidity). The preferred conditioning methodology uses ASTM D 5229/D 5229M (Reference 6.3.1), a test method that includes procedures for conditioning as well as for determining the two Fickian moisture material properties: moisture diffusivity and moisture equilibrium content (weight percent moisture).

ASTM D 5229/D 5229M is a gravimetric test method that exposes a specimen to a moisture environment and plots moisture mass gain versus the square-root of elapsed time. The early portion of the mass/square-root-time relationship is linear, the slope of which is related to the moisture diffusivity. As the moisture content of the material near the surface begins to approach equilibrium, the slope of this curve becomes increasingly smaller. Eventually, as the interior of the material approaches equilibrium, the difference between subsequent weighings will be very small and the slope will be nearly zero. At this point the material is said to be at equilibrium moisture content. This process is illustrated in Figures 6.3.3(a) and (b). Figure 6.3.3(a) shows the total mass gain versus square-root-time during specimen moisture exposure; the different curves illustrate the difference in response due to different temperatures. For the 150°F condition (the diamonds in Figure 6.3.3(a)), Figure 6.3.3(b) shows the moisture profile through the thickness of the specimen for several early time periods, illustrating the rapid moisture uptake near the surface together with the relatively slow update of moisture in the middle of the specimen.

A similar, but more limited and not fully equivalent, procedure for conditioning and equilibrium moisture content (but not diffusivity) is documented by SACMA RM 11R-94 (Reference 6.3.3(b)), which first brings three specimens to moisture equilibrium at 85% RH.² The actual SACMA conditioning process on test specimens is then subsequently conducted, and terminated when the weight gain of the conditioned specimens reaches 90% of the moisture equilibrium content, resulting in a lower moisture content in the test specimen as compared to that resulting from ASTM D 5229/D 5229M. As an example, a 0.1 in. (2.5 mm) thick laminate with a diffusivity of $1.6\text{E-}09\text{ in}^2/\text{s}$ ($1.0\text{E-}06\text{ mm}^2/\text{s}$) and a true (very long-term) equilibrium moisture content of 1.50%, when evaluated by the two approaches, would reach effective equilibrium at 1.45% in 24 days (ASTM), or at 1.43% in 21 days (SACMA). In subsequent conditioning, the ASTM procedure would reproduce the same 1.45% moisture content in 24 days, while the SACMA conditioning procedure would produce a moisture content of 1.29% (0.9×1.43) in 13 days.

¹Including a specific material system produced at different resin contents.

²While the 1988 version of SACMA RM 11 used a different definition of equilibrium, the 1994 edition adopted the ASTM definition, with one difference: the reference time period (minimum weighing time interval for equilibrium) was fixed at 24 hours. For sufficiently high diffusion rates there is no difference. For example, for the SACMA RM 11R-94 preferred thickness of 0.040 in. (1 mm), the two definitions begin to deviate when the moisture diffusivity is slower (smaller in value) than $3.6\text{E-}10\text{ in}^2/\text{s}$ ($2.3\text{E-}07\text{ mm}^2/\text{s}$). As the rate of diffusion slows below $3.6\text{E-}10\text{ in}^2/\text{s}$ ($2.3\text{E-}07\text{ mm}^2/\text{s}$), the SACMA calculated equilibrium moisture content will begin to deviate from the ASTM value. This diffusivity crossover point is a function of thickness; for the maximum SACMA thickness of 0.080 in. (2 mm), the crossover point increases to a diffusivity of $1.4\text{E-}09\text{ in}^2/\text{s}$ ($9.3\text{E-}7\text{ mm}^2/\text{s}$). When determining the moisture equilibrium content of low diffusivity materials, the ASTM definition, which is sensitive to both diffusion rate and coupon thickness, should be used.

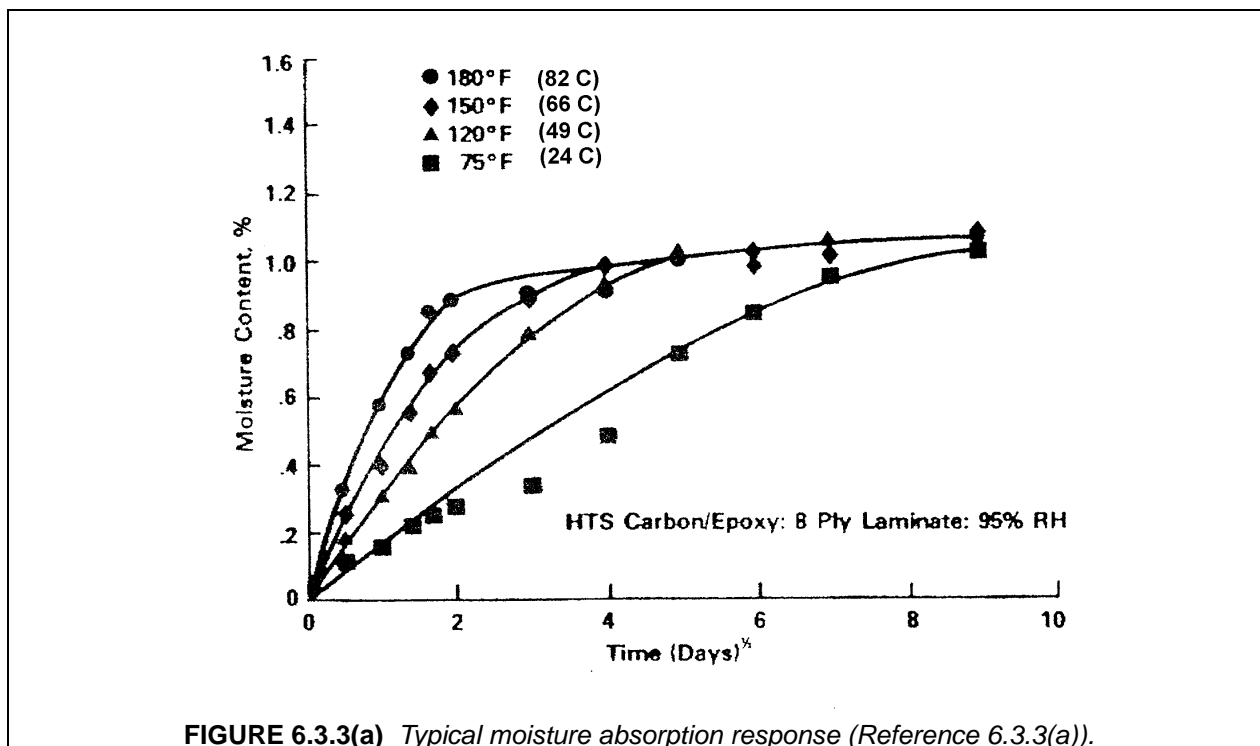

FIGURE 6.3.3(a) Typical moisture absorption response (Reference 6.3.3(a)).

The relative humidity level to be used when moisture conditioning is application dependent. As discussed in more detail in Section 2.2.7.3, the MIL-HDBK-17 Coordination Group has agreed that a reasonable upper-bound value for aircraft design service relative humidity is 85%, and that this value may be used when a specific determination of design service moisture content has not been established for a specific aircraft application. Accepted design service moisture levels for other applications have not yet been established.

6.3.3.1 Accelerating conditioning times

Because equilibrium moisture conditioning can take a very long time, there is a strong desire to attempt to accelerate the process. While certain two-step, accelerated conditioning cycles are considered acceptable, such as use of an initial high-humidity step (95+% RH) to speed up moisture gain, followed by completion to equilibrium at a lower final humidity level (85% RH), one must be careful not to select an accelerating environment that changes the material, alters the physics of diffusion, or both. Since the moisture diffusion rate is so strongly dependent on temperature, there is a temptation to accelerate the process by increasing the conditioning temperature.¹ However, long exposures to high temperatures combined with moisture may alter the chemistry of the material.² 350°F (177°C) cure epoxy-based materials are typically not conditioned above 180°F (82°C) in order to avoid this problem; materials that cure at lower-temperatures may need to be conditioned below 180°F (82°C). And while an initial high relative humidity step is acceptable, the extreme cases of exposure to pressurized steam or immersion in hot/boiling water are *not* accepted methods of accelerating humidity absorption, as they have been found to produce different results from that of 100% humidity.³

¹As an example, for the material illustrated by Figure 2.2.7.1(a), increasing the temperature from 150°F (65°C) to 180°F (82°C) increased the moisture diffusivity of the material from 4.5E-10 in²/s (2.9E-07 mm²/s) to 9.8E-10 in²/s (6.3E-07 mm²/s), resulting in substantially reduced conditioning times.

²The definition of "high" temperature, is, of course, relative to the material system in question, and cannot properly be addressed here.

³The differences reported in the literature are probably due in part to excessively-high conditioning temperatures, but even at moderate temperatures water immersion appears to produce a different response in many polymers than water vapor. In some cases, matrix components have been known to dissolve into the water.

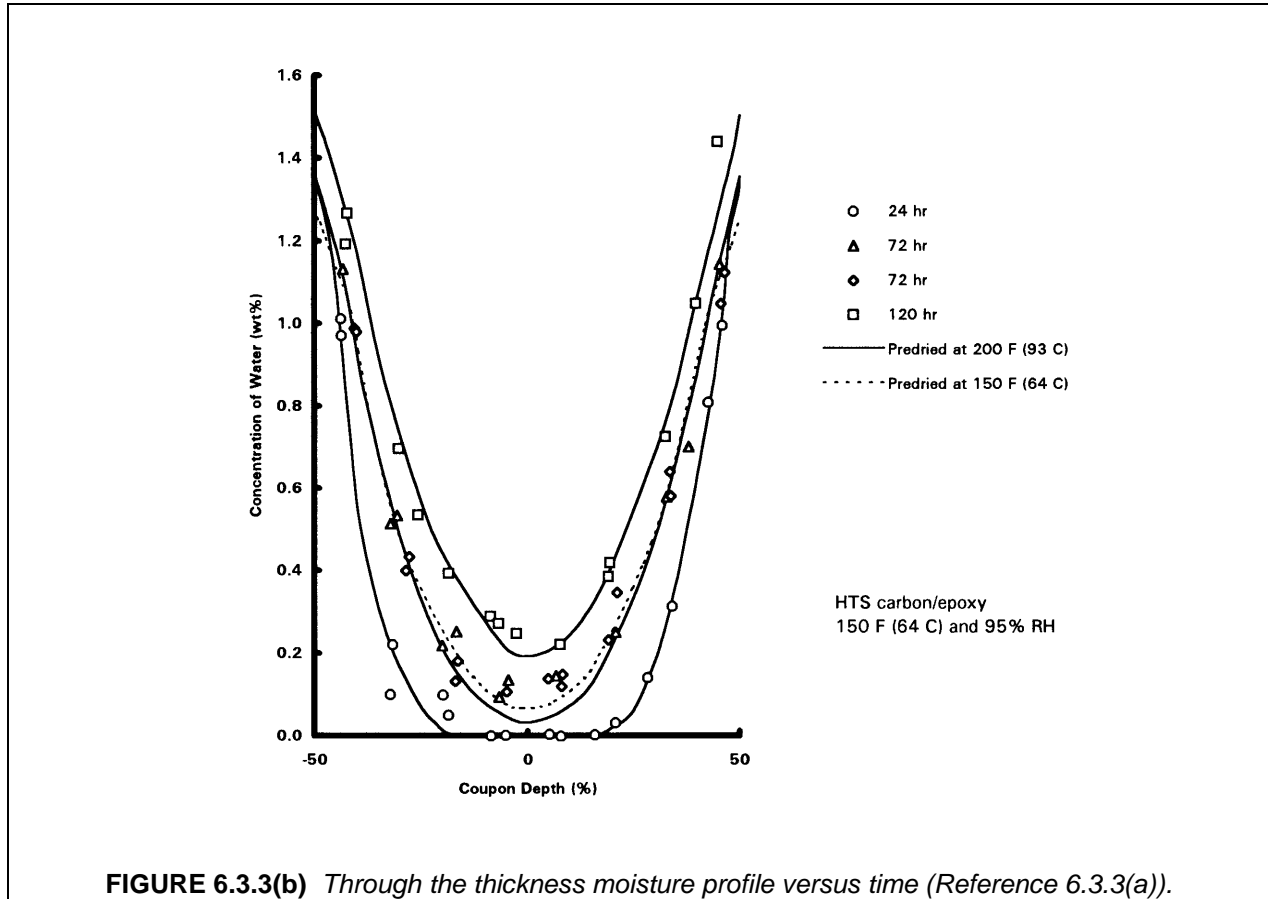

6.3.3.2 Procedural hints

While the procedural description and requirements for ASTM D 5229/D 5229M are fairly complete, the following items justify emphasis:

1. It is highly recommended that some knowledge of the material moisture response be obtained prior to starting conditioning, either from the literature, or from prior test.
2. In moisture property measurement the actual specimen must be initially dry, and the precision and timing of early mass measurements are critical. But for material conditioning needs, knowledge of the initial moisture content may not be important, or may adequately be separately determined from other specimens in parallel. Therefore, it is common not to begin moisture conditioning with a material dry-out step. Moisture conditioning also does not require the repetitive, precise weighings early in the exposure process that are needed to determine the moisture diffusivity. Thus, conditioning without simultaneous determination of the moisture absorption properties is faster and less labor intensive.
3. If the moisture properties are desired, it is faster and less labor intensive to create two other sets of specialized moisture property specimens: a "thin" set that will reach equilibrium quickly, and a "thick" set from which a stable slope to the moisture weight gain versus square-root-time curve can be reliably obtained with minimum test sensitivity. This process is discussed in more detail in Section 6.6.8.

While the procedures for both moisture property determination and equilibrium moisture conditioning are similar, there are some practical reasons why simultaneous determination of moisture properties during a moisture conditioning phase is rarely desirable.

Moisture content measurements are taken either by weighing the actual specimens, or by weighing in their place “travelers,” which are material conditioning specimens cut from the same panel and conditioned at the same time as the specimens. Travelers are required when the specimen is either too small, too large, or includes other materials, such as specimens with tabs, or sandwich specimens. A traveler, when used, accompanies the specimen, or group of related specimens, throughout all subsequent conditioning history.

Because the weight gain of typical polymeric composites is relatively small (on the order of 1%), mass measurement equipment must be selected accordingly. For larger specimens (>50 g), a balance accurate to 0.001 g is generally adequate. For smaller specimens with mass down to 5 g, a precision analytical balance capable of reading to 0.0001 g is required. Direct moisture mass monitoring of coupons weighing less than 5 g is not recommended; a traveler should be used instead.

Near the end of conditioning, minor weighing errors or small relative humidity excursions of the environmental chamber, particularly slight depressions in relative humidity, may artificially cause the material to appear to have reached equilibrium, when, in fact, the material is still absorbing moisture. The lower the temperature (lower the diffusion rate), the more important these errors become. Despite the literal definition of equilibrium expressed by ASTM D 5229/D 5229M, in view of the likely possibility of these experimental errors, the prudent engineer should do the following:

1. Even after the material satisfies the definition of equilibrium, review the chamber records to ensure that a depression in chamber relative humidity did not occur during the reference time period (weighing time interval). If such a depression is found to have occurred, continue the exposure until the chamber has stabilized, then go to item 2.
2. Even after the material satisfies the definition of equilibrium, maintain the exposure, and show satisfaction of the criterion for several consecutive reference time periods.

If the required reference time period does not match a reasonable human time schedule for weighing, then a more regular time interval may be adopted and the ASTM D 5229/D 5229M requirement (less than 0.01% mass change over the reference time period) pro rated to the adjusted time interval. For example, if a required reference time period for equilibrium is determined to be 115,000 s (32 hours), the coupons may be weighed at either 24 hour intervals or 48 hour intervals, with the mass change requirement adjusted from 0.01% to either 0.0075% ($24/32 \times 0.01$) or 0.015% ($48/32 \times 0.01$), respectively.

While many newer models have solid-state controls, a great many environmental chambers control the chamber humidity via monitoring of “dry-bulb” (actual) and “wet-bulb” (moisture depressed) temperatures, which are converted to equivalent relative humidity via a table or algorithm supplied by the manufacturer. The ability of these chambers to control relative humidity is dependent on the accuracy of the thermometer readings. Particularly important in these chambers is regular cleaning of the water reservoir, replacement of the wick, and maintenance of a proper contact between the wick and the wet-bulb thermometer (Reference 6.3.3.2). Chambers that control the dry-bulb temperature and the *differential* between the dry-bulb and wet-bulb temperatures generally have improved control of chamber relative humidity over those that control the dry-bulb and wet-bulb temperatures.

If a drying step is included, whether as an initial step prior to moisture conditioning, or has part of an oven-dry experiment, care should be taken to avoid excessively high drying temperatures and high thermal excursions that may induce thermal cracking in the material.

A variant of equilibrium conditioning uses equilibrium conditioning test data, for a specific material and relative humidity, to establish a table or plotted-curve of minimum exposure time required to achieve equilibrium versus laminate thickness. This approach requires some up-front testing and calculation, but eliminates much of the repetitive weighing otherwise required. A continuous record of the chamber environment must be maintained to prove that proper exposure was achieved.

6.4 INSTRUMENTATION AND CALIBRATION

6.4.1 Introduction

The ability to accurately and repeatably measure deformation and displacement is critical to the testing and characterization of composite materials. This section will discuss the various types of instrumentation used to make strain measurements, and provide guidelines to help determine the appropriate methods for various test types, material forms, test conditions, and data requirements. Only those extensometers which can be classified as ASTM E 83 Class B-2 or better are acceptable for generating data to be included in MIL-HDBK-17 (Reference 6.4.1).

6.4.2 Test specimen dimensional measurement

6.4.2.1 Introduction

Virtually all mechanical property testing requires that dimensional measurements of the test specimen be made. The types of measurements vary depending upon the particular specimen geometry and test requirements, and may include specimen length, width, thickness, gage length, hole diameter, and fastener diameter. Required precision is usually specified by the test method or specification, but generally depends on how a measurement will be used. Some measurements are simply informational, while others are used in calculations (to convert load to stress, for example), and still others are needed to verify conformance to a required geometry. The following five sections discuss (in order of decreasing precision) the various devices commonly used to measure specimen dimensions. Following this is a section on special hole diameter measuring devices. The final section discusses calibration of dimensional measurement devices.

6.4.2.2 Calibrated microscopes

Microscopes with calibrated scales in their eyepieces can provide an extremely accurate means for measuring small specimen dimensions. Resolutions down to 0.0001 inch (2.5 μm) can routinely be attained using magnifications in the range of 50x - 200x. Although this technique is usually more time consuming than micrometer measurement, there are some instances where optical methods may be the only practical option. For example, the thickness of a tabbed specimen may be in question after destruction of the gage section during test. Thickness may be measured and/or verified by optically measuring the thickness of the laminate remaining intact under the bonded tabs. Under the calibrated microscope the laminate thickness between the adhesive bondlines of the tabs can easily be seen and measured (although there is a bias on rough textured specimens). Except for such special cases, however, direct micrometer measurement is usually preferable.

6.4.2.3 Micrometers

Micrometers are precision instruments that are most commonly used for measuring small dimensions. Although some models are available for measurements up to several inches, or even several feet, they generally can only measure continuously over a one inch (25 mm) interval, and require extension rods for different intervals. For this reason calipers are often more convenient for measuring dimensions larger than one inch.

The standard one inch micrometer (25.4 mm)¹ is the most popular instrument for measuring specimen thicknesses. For wide specimens, deep reach micrometers are available for making thickness measurements several inches or more from the specimen edges. The readout may be a scale engraved around the barrel (optionally with a vernier scale), a mechanical digital display, or an electronic digital display. Most instruments indicate in 0.0001 inch graduations and digital models often estimate a fifth decimal place.

¹Note that the SI equivalent dimensions provided in this section are Asoft≡ conversions, that is SI dimensions for measuring instruments and graduations are provided but sizes are not necessarily converted to SI standard sizes.

Several styles of measuring faces are available. These generally fall into four categories: flat, spherical, blade, and pointed. Both faces on a given instrument may be the same style or different (one face flat and one spherical, for example). Pointed faces are not recommended for use with composites, as they may penetrate the surface (pointed faces are typically used to measure the root diameter of threads). Blade (knife edge) faces are convenient for measuring specimen thickness between bonded tabs on short gage section length specimens. However, such specimens should be carefully inspected for the presence of tab bonding adhesive in the gage section. If adhesive is present the measured laminate thickness will be erroneously inflated.

Flat and spherical (ball) faces are appropriate for most specimen width and thickness measurements, but laminate surface texture should be considered when choosing between these two face styles. For "glass smooth" surfaces, double flat, double ball, or ball-flat faces are all appropriate. However, if the surface is textured (due to coarse weave fabrics, or from use of peel ply during processing, as examples) a flat face will contact the "hills" of the texture, and the resulting measurement will be falsely inflated. A ball face, which will settle somewhat into the "valleys" of the texture or compress the "hills," is therefore preferred. Although the percentage error can vary with specific surface conditions, it is usually not significant for thick specimens. However, for thin (2-3 ply) specimens, measurements may be significantly biased since differences of 0.0015 to 0.0030 inch (0.038 to 0.076 mm) may typically be observed between measurements made with double ball and double flat micrometers. Test specimens that are smooth on one surface and textured on the other may be evaluated by a ball/flat micrometer.

In addition to "stand-alone" micrometers, some testing machines have micrometers integrated into their systems, permitting direct electronic input of specimen dimensions. The system generally prompts the user to position the specimen in the micrometer for width, thickness, and possibly other measurements, and later uses these measurements for calculations. Since the measuring faces fall into the same categories as discussed above, the same considerations apply.

6.4.2.4 Scaled calipers

Scaled calipers are devices with parallel, jaw-like measuring faces and a scale for reading the distance between the stationary face and the movable face. Although models are available for measuring dimensions up to several feet, 6 inch and 12 inch (15 cm and 30 cm) lengths are most common for measuring composite test specimens. The scale may be engraved along the length of the caliper, or may take the form of a dial or digital electronic readout. Although an engraved scale (with auxiliary vernier scale) and the digital readout have 0.0001 inch (2.5 μm) resolution, accuracy is more commonly limited to ± 0.001 inch (0.025 mm).

Calipers are convenient for measuring specimen lengths and widths, particularly in the range of 1 - 12 inches (2.5 - 30 cm), since this range exceeds the capability of the common 1 inch micrometer. In addition, some calipers have measuring tips (nibs) designed in such a way that internal as well as external measurements may be made. With this design, calipers may be used to measure hole diameters (in open hole tension and compression specimens, for example). Typically, nibs designed for internal measurement can fit into a 0.25 inch (6.35 mm) or larger hole. Some can read an internal dimension as small as 0.125 inch (3.18 mm).

Calipers may not be particularly suited for measuring specimen thicknesses, especially if the specimen surface(s) is textured. For such measurements a ball-faced instrument is generally preferred (see Section 6.4.2.3 above) as opposed to calipers (which have flat or blade shaped measuring faces).

6.4.2.5 Precision scales

Precision scales are available in various lengths, with 6 inch and 12 inch (15 cm and 30 cm) being common. These tools are similar to rulers, but are usually made of steel and are more precisely and finely graduated. Each instrument typically has four scales, one along each edge of each side. The finest graduations are commonly 1/64 inch or 1/100 (0.01) inch (0.4 mm or 0.25 mm). Reading to 1/100 inch

(0.25 mm) generally requires use of a magnifying glass to discern the graduations clearly. While precision scales may be used for any measurements requiring this resolution, calipers or other instruments are usually easier to use.

6.4.2.6 Rulers and tape measures

These tools are commonly marked in 1/16 inch (1.6 mm) divisions, though some are marked in 1/32 inch (0.79 mm) increments for at least part of their total length. They are generally used for measurements that are recorded for descriptive purposes, but not for more precise measurements. For example, a ruler might be used to identify two groups of specimens: one group with four inch nominal gage lengths, and another group with six inch nominal gage lengths.

6.4.2.7 Special hole diameter measuring devices

Although, as noted above in Section 6.4.2.4, some calipers are designed for inside diameter measurement, special instruments are also available for such measurements. These include telescoping gages, small hole gages, and calibrated pins. Telescoping gages are "T" shaped devices with two spring loaded plungers forming the top of the "T." The measuring faces at the plunger ends are curved and they self-center against the inside walls of the hole. Once in position they are locked by turning a knurled screw on the stem of the "T," and the instrument is withdrawn from the hole. Hole diameter is then determined by measuring the distance between the locked plunger faces using a standard micrometer. The disadvantages of telescoping gages are (1) a set of several gages must be used to cover a range of hole sizes and (2) because of their size, gages are not available for holes smaller than about 5/16 inch (8 mm) diameter.

Small hole gages are similar to telescoping gages except that an adjustable split ball is used instead of plungers. The split ball is placed in the hole and is enlarged by turning the barrel of the device until the ball just contacts the hole walls. The instrument is then removed from the hole and measured with a standard micrometer in the same manner as the telescoping gage. These gages must also be used in sets to cover a wide range of hole sizes but, unlike the telescoping gages, holes down to about 1/8 inch diameter can be measured.

Sets of calibrated pins of known diameter may also be used to measure hole diameters. Pins of various sizes are inserted into the hole until a close, but not tight, fit is obtained. The hole diameter is then taken as the pin diameter. Pins are available in virtually any size, and are generally graduated in 0.0005 inch increments. Very extensive sets are needed to cover a range of nominal hole sizes.

Of the devices available, calipers or small hole gages are most useful and economical for measuring hole diameters in composite test specimens.

6.4.2.8 Calibration of dimensional measurement devices

In order to maintain the stated accuracy of mechanical measuring devices such as micrometers and calipers, they must be periodically calibrated. In general, there are no detailed calibration procedures available in high level (ASTM, ANSI, etc.) U.S. standards. Typically these instruments are calibrated using gage blocks, and specific procedures are contained in company internal specifications. Some ISO documents address aspects of this subject, and the reader is referred to standards under the jurisdiction of ISO Technical Committee 3 on Limits and Fits, as well as to ISO 10012-1 (Reference 6.4.2.8).

6.4.3 Load measurement devices

6.4.3.1 Introduction

The ability to accurately and repeatably measure load (force) is critical to the testing and characterization of composite materials. This section will discuss the various types of instrumentation used to make load measurements, and provide guidelines to insure the accuracy of those measurements. Load meas-

urement device classification and verification is discussed in ASTM E4 "Standard Practices for Force Verification of Testing Machines" (Reference 6.4.3.1(a)), ASTM E74 "Standard Practice of Calibration of Force-Measuring Instruments for Verifying the Force Indication of Testing Machines" (Reference 6.4.3.1(b)), and ASTM E467 "Standard Practice for Verification of Constant Amplitude Dynamic Loads on Displacements in an Axial Load Fatigue Testing System" (Reference 6.4.3.1(c)). Calibration of load devices is also discussed in ISO 5893 "Rubber and plastics test equipment – Tensile, flexural and compressive types (constant rate of traverse) – Description" (Reference 6.4.3.1(d)).

Note: Force in the case of testing machines is defined as pound-force, or Newton where one pound force is the force required to provide a one pound mass an acceleration of 32.1740 ft/sec^2 (9.80665 m/sec^2), and a Newton is the force required to provide a one kilogram mass an acceleration of 1 m/sec^2 . This force is used to determine the load applied on test specimens. Load is commonly used interchangeably with force in mechanical testing specifications and in MIL-HDBK-17.

6.4.3.2 Load cells

The most common type of force measurement device in the mechanical properties testing laboratory is the strain-gage instrumented load cell. These devices consist of an elastic member that deflects in a uniform, consistent, and repeatable manner under the application of load. The elastic member in the load cell is instrumented with strain gages so as to measure the deflection. The output of the strain gage circuit can easily be read by a variety of recording devices and data acquisition systems. The strain gages in the load cell form a complete bridge, carefully balanced, so that the load cell can be calibrated using a reference excitation voltage, and thereafter the output of the bridge circuit will be dependent only upon the external conditioning circuitry. The bridge is, therefore, guaranteed to be in a balanced condition (at thermal equilibrium) when no load is applied. Load cells with internal signal conditioning circuitry should be avoided when circumstances may require the heating and/or cooling of the load cell. An important factor in the design or choice of a load cell is the ability of the load cell to reject spurious inputs generated by improper but inevitable misuse, such as off-axis loading and heating/cooling of the load cell during a test. The ability of a load cell to reject off-axis loads and thermal drift is dependent on the design of the elastic member and the placement of the strain gages upon that member. (See Section 6.4.2.4 on strain gages). A well designed load cell can have a repeatability of 0.01% (of the full-scale output of the load cell), and a thermal stability of 0.001% (full scale) per degree F.

6.4.3.2.1 Design and specification considerations

Load cells should be chosen to provide the greatest degree of accuracy consistent with the required data. An indicated load accurate to within 0.1% of the actual load at critical points in the test (modulus chord points, failure load) will guarantee high quality test results. A variety of load cell configurations is available:

1. Bending beam load cells are constructed as a simple cantilever beam, with strain gages attached to measure deflection. The beam may be instrumented with a single strain gage (quarter bridge), two gages (half bridge), or four gages (full bridge). When two gages are used, they are connected in such a manner that the strains in the gages are summed, effectively doubling the sensitivity of the circuit. When four gages are used, they may be arranged so as to quadruple the sensitivity, or to compensate for the nonlinearity of the strain gradient in the beam. Bending beam load cells are used when cost is a factor, as when destruction of the load cell is a possibility. High accuracy is possible with this type of load cell when it is used correctly. The "S" beam load cell is a special form of the bending beam load cell which permits "in-line" loading to be used with an inexpensive load cell design. Bending beam load cells can reject torsional loading of the beam, and thermal effects, but at higher strains some designs become markedly nonlinear while still producing repeatable results.
2. Shear beam load cells, in their simplest form, utilize the uniform shear condition in the web of an I-beam shaped member as the surface of measurement. Precision load cells commonly utilize eight or twelve mechanical elements of the shear beam type arranged in a radially symmetric pattern,

which combined with a well designed bridge circuit utilizing four of the shear beams, allows the load cell to reject off-axis loads.

3. Ring load cells, essentially so-called proving rings, consist of an elastic member of a ring shape, which when loaded at diametrically opposite points deforms elliptically. This type of load cell can be of high accuracy, but does a poor job of rejecting off axis loads.

6.4.3.3 Other load measuring systems

The following is a brief summary of other types of load measuring devices sometimes used. These systems are generally for highly specialized uses, or are based on older technology, and are not preferred for obtaining MIL-HDBK-17 data.

LVDT Devices -- A load cell which uses an LVDT (linear variable differential transformer, see 6.7.2.4.4) as a strain measuring device may occasionally be seen. This type of load cell may be as accurate as a bonded strain gage type cell, but is somewhat less rugged.

Solid state load transducers -- Special purpose load cells utilizing piezoelectric or piezoresistive semiconductor strain measuring elements (see "Strain Gage Technology" (Reference 6.4.3.3) are available for measuring load during impact, when the strain change rate might exceed the ability of a bonded foil strain gage load cell to accurately indicate load. Semiconductor strain gages are extremely sensitive to temperature changes, and will yield rapid zero shifts with changing temperature. Therefore, they must be used only at thermal equilibrium.

Bourdon tubes, etc. -- There are older test machines in everyday use which rely on Bourdon tubes and other ingenious mechanisms for indicating load. A Bourdon tube is a sealed tube, formed in a spiral, semi-circle or helical shape and filled with fluid. When pressurized, the fluid causes the tube to move in a reproducible manner, mechanically acting on a readout device or indicating needle. The indicating dials on these machines should be relied on only as relative indicators of load level. In all cases, these machines should be retro-fitted with electronic load cells and indicators which can be calibrated more readily, and to greater degrees of accuracy.

Calibrated weights -- Creep testing machines are commonly of the unequal arm dead-weight loading type. The weights used on these machines are commonly cast iron and should be calibrated to Class 6 of ASTM E 617 (note this is the least precise class given in ASTM E 617 and has a tolerance of 0.01%). The measurement of the length of the arms and the condition of the knife-edges should be verified per the machine manufacturers instructions.

Levers -- Test machines with an integral system of levers and knife edges for indicating load as on a beam balance or compound scale should be retrofitted with electronic load indicators to simplify calibration and data acquisition.

6.4.3.4 Instrumentation and calibration

Calibration (more properly, verification) of test machines and load cells requires a "CLASS A" load standard. Those standards are commonly high precision load cells or proving rings. The load standard must have an uncertainty not exceeding 0.25% of the load being measured. Therefore, the minimum load which it may be used to calibrate must be at least 400 times the uncertainty. ASTM E 4 allows the uncertainty of a load device used for testing to be up to 1% of full scale. ASTM E 74 contains a detailed explanation and analysis of the calibration of load measuring devices, and it should be studied closely by anyone responsible for calibrating these devices. Machines meeting the ISO requirements have a sliding scale of allowable error with a maximum of $\pm 1.0\%$ at full scale for Grade A machines and $\pm 2.0\%$ of full scale for grade B machines. A load cell calibrated to ISO 5893, Grade A meets the load cell requirements of ASTM E 4, though there are additional requirements in ASTM E 4 for test machines that are not covered in the ISO standard. The ISO and ASTM standards both include other details such that they are not strictly interchangeable.

6.4.3.5 Precautions

Certain precautions should be observed to insure the accuracy of load cell readings.

- a. In all cases, scrutinize the specifications of a commercial load cell, or carefully analyze the bridge circuit of a self manufactured load cell. Curve fitting of nonlinear output is possible, but care should be taken to insure that the fitting equation is correct, and that it is applied correctly.
- b. The load cell should be calibrated at regular intervals to verify its performance per ASTM E 4 and E 74. The calibration device should be traceable to a national standard such as NIST, and its readout and accuracy should exceed that of the device being calibrated by a factor of 4 or more.
- c. The load cell calibration should be reverified whenever unusual loading conditions occur, such as overloading, impacting, or bending (off-axis loading). Refer to the specification of the individual load cell for overload tolerances.
- d. Load cells not specifically declared to be tolerant of temperature changes during testing should be assumed to be inaccurate at elevated or depressed temperatures. Therefore, care should be taken to isolate the load cell and its cabling, from temperature changes and/or gradients.
- e. Care must be taken to insure that the applied load axis corresponds as nearly as possible to the indicated loading axis of the load cell. Off-axis loads should be avoided and may result in inaccurate readings, and may damage the load cell or other parts of the load train.
- f. In general, the capacity of the load cell to be used for a given test should be determined such that the predicted failure load is between 15% and 85% of the capacity of the load cell. If expected loads are less than 15% of the load cell capacity, the user should insure that adequate calibration has been performed in the test range. Such a calibration may be outside the scope of a routine ASTM E 4 calibration, so special arrangements may need to be made. When the instrumentation used permits the "ranging" of the load cell, for instance where a 100,000 pound load cell might be used over a range of 10,000 pounds through amplification, the load cell must be separately calibrated under those circumstances as a 10,000 pound capacity load cell. Similar individual calibrations must be conducted for all "ranges" provided. Use of a load cell for testing when the expected data is greater than 85% of the load cell capacity is discouraged since an unexpected high load may exceed the capacity of the load cell.

6.4.4 Strain/displacement measurement devices

6.4.4.1 Introduction

The ability to accurately and repeatably measure deformation and displacement is critical to the testing and characterization of composite materials. This section will discuss the various types of instrumentation used to make strain measurements, and provide guidelines to help determine the appropriate methods for various test types, material forms, test conditions, and data requirements. Extensometer classification and verification is discussed in ASTM E 83 (Reference 6.4.1). The class of the extensometer is determined from the maximum expected error. Class A has the least expected error, followed by classes B-1, B-2, C, D, and E in that order. Calibration to class A is very difficult to achieve. Only those extensometers which can be classified as ASTM E 83 Class B-2 or better are acceptable for generating data to be included in MIL-HDBK-17.

6.4.4.2 LVDT (*Linear Variable Differential Transformer*) deflectionometers

LVDT's are electromagnetic devices designed so that as a ferromagnetic core is displaced within a transformer (consisting of three windings), a linearly varying a.c. voltage and phase shift are produced, this signal is demodulated to produce a varying d.c. output. LVDT's are available in both linear and angular configurations. LVDT's are available in lengths to 10 feet (3 meters), their output linearity is about 0.1%, and their maximum resolution is 1 microinch (25 μm). The accuracy of a given LVDT is commonly limited to 0.01% of total travel. An LVDT may be used directly as a deflectionometer with its core contacting the specimen; it can be used with a linkage; or it can be incorporated into a contacting extensometer. High temperature LVDT's may be usable up to the Curie Temperature of the core material, but are generally used with extensions or linkages to avoid exposing them to hostile environments. LVDT's must be calibrated at the temperature to which they will be exposed in use.

6.4.4.3 Contacting extensometers

Contacting extensometers and compressometers are devices that are used to determine the relative displacements of two points on a specimen. The contact extensometer must be clamped to the specimen surface in such a way that the contact points cannot slip, and that the extensometer does not affect the test. Extensometers are relatively complex devices which rely on integral strain gages or LVDT's to convert the relative displacements of their attachment points into linearly related outputs. Extensometers are available in a range of fixed gage lengths from 0.500 to 2.00 in. (12 - 50 mm), their output linearity is 0.1%, and they can resolve displacement to 1 microinch (25 μm). This resolution does not imply accuracy or calibration. A well-made contact extensometer is accurate to 0.01% of full scale, and can measure strain up to 1.00 (100%). Repeatability of contacting extensometers is dependent on their maintaining a constant initial gage length, therefore, when a zero stop is provided it should always be used when attaching the extensometer to a specimen.

Contact extensometers are available which can be used at liquid nitrogen temperatures, others can safely be exposed to temperatures of 500°F (260°C) for extended periods of time. Extensions and linkages are available which allow remote use of extensometers on specimens exposed to temperatures up to 3000°F (1600°C). ASTM E 83 requires that extensometers be calibrated at the temperature at which they will be used. Extensometer calibration should be verified whenever the extensometer is subjected to deflection exceeding the normal range, been exposed to a hostile environment, received rough handling, and whenever the knife edges or points are replaced.

6.4.4.3.1 Contacting extensometers, applications

Extensometers are chosen in preference to bondable strain gages when one or more of the following conditions exist:

1. The price of individual bonded strain gages exceeds the cost of a comparable extensometer.
2. The construction of a laminate will induce a non-uniform strain field under a bonded strain gage.
3. Strains will exceed the practical limit of bonded strain gages (0.03 or 3%).
4. The net deformation of a complex structure or assembly is required (for example a bonded or bolted joint).
5. When specimen conditioning or preconditioning will not allow proper bonding of strain gages.

Extensometers are not recommended when the following circumstances apply:

1. Extensometers fitted with points or knife edges may cause premature failures in notch sensitive materials.
2. Extensometers of large inertial mass respond unpredictably to rapid changes in strain.
3. Catastrophic failure of a specimen while an extensometer is attached will result in damage to the extensometer requiring repair and recalibration or replacement.

6.4.4.4 Bondable resistance strain gages

Strain gages are structures of precisely etched metal foil or wire (usually on a polyimide film substrate) which are permanently bonded to a specimen surface so that the strain field of that surface is immediately transmitted to the gage. In use, the strain gage forms part of a Wheatstone Bridge circuit, which allows strain to be accurately measured as a function of the change in resistance of the grid. Strain gages are made from alloys (Constantan, Karma Alloy) which show relatively small changes in strain sensitivity (ratio of change in resistance to change in length) when they are deformed beyond their proportional limits (Reference 6.4.4.4).

Strain gages have inherently infinite resolution (limited by the accuracy of the gage factor calibration); their ability to indicate small changes in strain accurately is limited only by the instrumentation used.

Strain gages are versatile:

1. Strain gages can be applied directly to a specimen, or can be used to construct extensometers or beam bending deflectometers.
2. Several strain gages can be applied to a single specimen in different orientations to measure simultaneous multi-axial properties.
3. Several strain gages can be applied to a single specimen in various places in similar orientations to identify stress concentrations.

6.4.4.4.1 Strain gage selection

Strain gages are available in a wide range of styles. The selection of the proper strain gage is critical if accurate and repeatable results are to be obtained. Polymeric matrix composites are relatively poor thermal conductors, therefore, 350 Ω or higher resistance gages are usually chosen in preference to 120 Ω gages, higher resistance gages operate at lower currents for a given strain and are less likely to produce errors due to self-heating (Reference 6.4.4.4.1(a)).

Since stresses in woven composites are transmitted by the interaction of relatively large repeating units, the gage must be large enough to integrate any strain gradient associated with the weave. The grid size chosen for a composite specimen will generally be larger than that for a similar metal specimen. Grid sizes of 0.125, 0.250 and 0.500 in. (3.17, 6.35, and 12.7 mm) are commonly used, with specimen size limiting the size of the gage which can be used. The installation of gages very close to specimen edges is to be avoided, as edge effects are difficult to predict. Finally, gages are made to function optimally over a limited range of temperatures, and it is important that the manufacturers' recommendations be heeded regarding maximum operating temperatures of different gage styles (Reference 6.4.4.4.1(b)).

6.4.4.4.2 Surface preparation and bonding of strain gages

Careful evaluation of surface preparation and bonding techniques for strain gages must be done if reliable data are to be obtained. Details of these techniques will be found in Section 6.2 and Reference 6.4.4.4.2. Extreme care should be used when abrading composites to minimize damage to the fibers of the surface laminae. It should be noted that the bonding of strain gages to thermoplastic materials is especially difficult.

6.4.4.4.3 Strain gage circuits

A strain gage or gages function as the variable element(s) in a resistance bridge; the Wheatstone bridge of four elements, shown in Figure 6.4.4.4.3, is the most usual. The diagram illustrates a 1/4 bridge, with a single active gage, 3-wire configuration (the 3-wire configuration removes the effects of lead wire resistance from the circuit). P+ and P- represent the excitation voltage for the bridge, S+ and S- represent the output signal. R1 and R3 are fixed resistors of identical value. When R2 and R_G (the resistance of the strain gage) are identical, the bridge is said to be balanced, and no current flows between S+ and S-. A change in resistance of similar value and sign in *adjacent* elements (e.g., R2, R3) is a null input

to the bridge. A change in resistance of similar value and sign in *opposite* elements (for example, R1, R3) is summed in magnitude. These results are useful in strain measurement: in the first case a gage can be applied to a spare piece of specimen material, and if this second gage is positioned at R1 in the circuit (therefore adjacent to RG) and then exposed to the test conditions, it will compensate for the thermal responses of the specimen and the active gage. In the second case, referred to as a half bridge, a specimen has two active gages both placed within a constant strain field, the second gage is placed at R2 (opposite to RG), then the gage outputs will be summed, and dividing by 2 will give the average strain, with a 2-fold increase in resolution. Contact extensometers are often designed using four gages in a "Full-Bridge" configuration which makes good use of the bridge by effectively summing all elements (adjacent gages are positioned so as to be exposed to strain fields of equal value and opposite sign). In all cases where passive bridge elements exist they are referred to as "Bridge Completion" and are a necessary part of the instrumentation associated with strain gages.

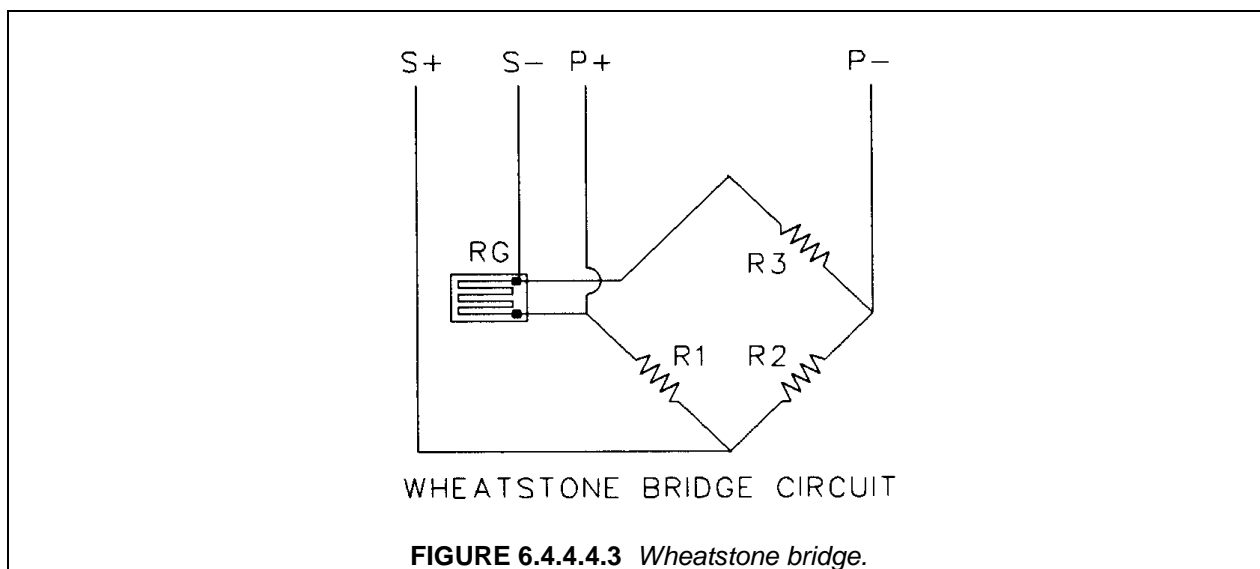

6.4.4.4.4 Strain gage instrumentation

The instrumentation used with strain gages (and extensometers utilizing strain gages as their active elements) is usually of the constant voltage type. The bridge circuit is provided with a stabilized d.c. excitation voltage between 2 and 10 Volts, and the output is on the scale of microvolts. High gain instrumentation amplifiers with low drift and excellent stability are used to scale the outputs up to Volt levels.

The combination of excitation and amplification in a single instrument is called a *conditioner*. Conditioners are available with fixed or variable excitation voltages. A variable excitation conditioner can be used to achieve high resolutions at high excitation voltages (high signal to noise ratio), or extended strain ranges at low voltages. It is a good idea to avoid using excitation voltages greater than 10 Volts for 350Ω gages on polymer matrix composites, which do not dissipate heat efficiently, to avoid "self-heating" of the gage (Reference 6.4.4.4.4). Conditioners with fixed excitation voltages usually offer variable amplifier gains to scale outputs. There is less possibility of overheating the gage with a fixed voltage conditioner.

6.4.4.4.5 Strain gage instrumentation calibration

Strain conditioner linearity is verified by the use of strain simulation. With 350Ω taken as the balance point or zero, strain values can be simulated by using a high accuracy decade resistance box with ranges from 0.01Ω to 100Ω in place of the active gage, and using the following equation to simulate strain values:

$$\Omega = 0.0007 \varepsilon_{\text{sim}} + 350 \quad 6.4.4.4.5$$

where

- Ω = decade resistance box setting to simulate target strain (ohms)
- ε_{sim} = target strain to be simulated (microstrain)

When fixed excitation conditioners have been verified in this way and found acceptable, no further calibration is necessary before testing. The output of the conditioner is simply multiplied by $2/K$, where K is the gage factor reported by the gage manufacturer.

When conditioners offer variable excitation, *shunt calibration* is required.

6.4.4.4.5.1 Shunt calibration (for 1/4 bridge)

When a variable excitation conditioner is used, the excitation voltage is generally chosen to scale the conditioner output (span) to the expected maximum strain level expected in the test. This provides the maximum resolution over the range of the test. With an active gage in the circuit (usually an actual specimen with no load applied), the conditioner output is zeroed. A precision resistor is placed in the circuit parallel with a bridge resistor. The value of the resistor is chosen so that when it is wired parallel to the gage, the combined resistance is exactly that necessary to simulate a known strain, called the shunt value. The excitation voltage is then adjusted so that the conditioner readout shows a value equal to $2/K$ multiplied by the shunt value. After instrument scaling, the indicated strain will be correct at the magnitude of the calibration strain, but slightly in error at other strain levels. The corrected strain at any different strain level can be calculated from Reference 6.4.4.4.1(b) :

$$\varepsilon = 2\varepsilon_i / (2 + K(\varepsilon_s - \varepsilon_i)) \quad 6.4.4.4.5.1$$

where

- ε = corrected strain (microstrain)
- ε_i = indicated strain (microstrain)
- ε_s = shunt cal value (microstrain)
- K = gage factor of strain gage

The topic of shunt calibration of Wheatstone bridges is treated simply here, but is actually a matter of great complexity, and it is recommended that the serious researcher carefully study Reference 6.4.4.4.5.1.

6.4.4.5 Other methods

A number of extensometric methods exist which see limited use in the determination of polymer matrix composite properties due either to unreliability or difficulty of use. However, under appropriate circumstances these techniques yield valuable data which could otherwise not be obtained, therefore, they are described here in limited detail.

6.4.4.5.1 Optical methods of extensometry

A number of methods of strain measurement based on optical phenomena exist: photoelasticity, Moiré interferometry, and laser extensometry. Photoelastic methods and Moiré may be used to verify the results of finite element calculations, and to investigate stress distributions on test specimens or struc-

tures. The application of these techniques to the design of test specimens and fixturing is an important stage in optimization of test geometry.

The non-contact nature of laser extensometry makes it particularly attractive in circumstances where strain gages would be unreliable - at high temperatures, on small radii, and on rough surfaces.

6.4.4.5.2 *Capacitative extensometers*

Contact extensometers are available which utilize the capacitance of an air gap between two probes fixed to the specimen surface to determine strain. These probes are accurate only for very small gage lengths, and cannot be used to record strain to failure as they are easily destroyed. They are used to determine modulus of materials at very high temperatures (>1000°F or 500°C). Capacitative extensometers can be difficult to calibrate and require complicated conditioning instrumentation. They cannot be calibrated better than ASTM E 83 Class B-2.

6.4.4.6 *Special considerations for textile composites*

The inhomogeneity of textile composites requires that strains and displacements are measured over sufficient gage lengths to be representative of bulk (average) specimen response. Results of a study on composites made of 2D triaxial braids, 3D weaves, and stitched uniwoven laminates to determine the effect of strain gage size on strain measurements are given in Reference 6.4.4.6(a).

In general, strain gages should be longer than the unit cell length of the textile and gage width should be no less than half the length. For specific standards in selecting strain gages use Reference 6.4.4.6(b). The gage lengths of extensometers should also be larger than the unit cell size to obtain an average or macroscopic displacement. These recommendations for minimum gage length should apply for thermal loads as well as mechanical loads.

Although not addressed in References 6.4.4.6(a) and (b), several gages might be arranged end to end to avoid more costly special order gages for unit cells longer than .5 in. (12.7 mm).

6.4.5 Temperature measurement devices

6.4.5.1 *Introduction*

Many of the properties that characterize a composite lamina or laminate are temperature dependent. Thus, temperature is one of the variables that must be measured to fully characterize a material. Many tools and techniques exist to measure temperature, but not all will provide the desired results or function in the required environment for the duration of the test. Temperature measurement devices can be divided into two categories: contact and noncontact. Five types of contact temperature measuring devices are commonly encountered: thermocouples, resistive temperature devices (metallic RTDs and thermistors), bimetallic devices, liquid expansion devices, and change of state devices. A noncontact temperature measuring device commonly used is an infrared detector.

6.4.5.2 *Thermocouples*

A thermocouple consists essentially of two strips or wires made of different metal alloys and joined at one end. Referring to Figure 6.4.5.2., changes in the temperature T_1 at that junction induce a change in electromotive force (emf) V_{ab} between the other ends. As temperature goes up, this output emf of the thermocouple rises, though not necessarily linearly. The open-end emf is a function of not only the closed-end temperature T_1 (i.e., the temperature at the point of measurement), but also the temperature T_2 at the open end. Only by holding T_2 at a standard temperature can the measured emf be considered a direct function of the change in T_1 . The industrially accepted standard for T_2 is 32°F (0°C); therefore, most tables and charts assume that T_2 is at that level. In industrial instrumentation, the difference between actual temperature at T_2 and 32°F (0°C) is usually corrected for electronically, within the instrumentation. This emf adjustment is referred to as the cold-junction, or CJ, correction. Temperature

changes in the wiring between the input and output ends do not affect the output voltage, provided that the wiring is of thermocouple alloy or a thermoelectric equivalent. For example, if a thermocouple is measuring temperature in a furnace and the instrument that shows the reading is some distance away, the wiring between the two could pass near another furnace and not be affected by its temperature, unless it becomes hot enough to melt the wire or permanently change its electrothermal behavior.

Thermocouples have advantages over other contact sensors in that they are simple, rugged, inexpensive, require no external power, are available in a wide variety of forms, and can be used over wide temperature ranges. Disadvantages of thermocouples are that they are nonlinear, produce very low voltages, and require an external temperature reference.

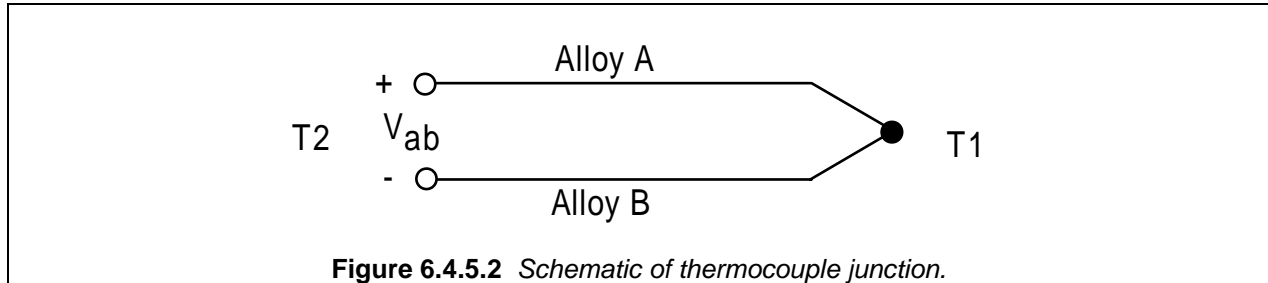

Figure 6.4.5.2 Schematic of thermocouple junction.

Thermocouples must be selected to meet the conditions of the application. Only general recommendations on size and type can be given. Some of the considerations involved are length of service, temperature, atmosphere, and desired response time. Smaller gauge sizes provide faster response at the expense of service life at the elevated temperatures. Larger gauge sizes provide longer service life at the expense of response time. As a rule, it is advisable to protect thermocouple elements with a suitable protecting tube or drilled well.

Thermocouples are available in different combination of metals or 'calibrations'. The four most common calibrations are J, K, T, and E. Each calibration has a different temperature range and environment, although the maximum temperature varies with the diameter of the wire used in the thermocouple.

Type J: [Iron (+) Constantan (-)]

Maximum recommended operating temperature is 1400°F (760°C).

Type K: [CHROMEL (+) ALUMEL (-)]

Maximum recommended operating temperature is 2300°F (1260°C).

Type T: [Copper (+) Constantan (-)]

Recommended operating temperature range is -328 to 662°F (-200 to 350°C).

Type E: [CHROMEL (+) Constantan (-)]

Maximum recommended operating temperature is 1652°F (900°C).

6.4.5.3 Metallic resistive temperature devices

Resistance temperature devices (RTDs) rely on the temperature dependence of a material's electrical resistance. They are usually made of a pure metal having a small but accurate positive temperature coefficient. A typical metallic RTD consists of a fine platinum wire wrapped around a mandrel and encased in a protective coating. Usually, the mandrel and coating are glass or ceramic. The resistance of the platinum wire rises more or less linearly with temperature. By measuring the resistance of the wire, its temperature can be determined. RTDs made of platinum wire are well characterized and linear from -434 to 1112°F (-259 to 600°C).

Although the response of an RTD is more stable and linear than that of a thermocouple, RTDs cannot be used over as broad a temperature range as thermocouples. The large thermal mass and poorer ther-

mal coupling combine to produce slow response to temperature changes. The RTD responds to mechanical, as well as thermal strains, making it sensitive to loads and vibration, in addition to temperature. Unlike the thermocouple, the RTD is not self-powered. Since a current must be passed through the device to provide a voltage that can be measured, the device is prone to self heating. This is particularly true if a large current is employed, a small RTD is employed, or if the RTD is not well coupled thermally.

6.4.5.4 *Thermistors*

Thermistors are generally composed of ceramic semiconductor materials that exhibit a large change in resistance with a change in temperature. There are both positive temperature coefficient (PTC) and negative temperature coefficient (NTC) devices on the market. A PTC thermistor is defined by an increase in resistance with an increase in temperature. A NTC thermistor is defined by a decrease in resistance with an increase in temperature. The majority of thermistors, however, are of type NTC.

Thermistors can generally be classified into two major groups depending upon the method by which electrodes are attached to the ceramic body. The first group consists of bead type thermistors and the second group consists of metallized surface contact thermistors. All of the bead type thermistors have platinum alloy leadwires which are sintered into the ceramic body. As a group, the sealed bead type thermistors are more stable than the metallized surface contact type. The bead types are generally smaller in size and have faster thermal time constant values. That is an advantage in many temperature measurement applications. However, the bead types have lower dissipation values that result in greater self-heating effects in most applications. The metallized surface contact type thermistors are easier to manufacture and, therefore, less expensive than the bead type thermistors. However, the metallized surface contact type thermistors are generally rated at 300°F (150°C) with the best continuous operating temperature stability at 221°F (105°C) or less.

Thermistors are extremely sensitive to temperature changes and can detect temperature changes that could not be observed using other devices. Although thermistors can be very accurate, their measurement range is small in comparison to thermocouples and RTDs. Since a current must be passed through the device to provide a voltage that can be measured, the device is prone to self heating. Thermistors are also somewhat more fragile than other temperature measurement devices.

6.4.5.5 *Bimetallic devices*

Bimetallic temperature indicators take advantage of the difference in the rate of thermal expansion of different metals. Strips of two dissimilar metals are bonded together. When heated, one side of the composite will expand relative to the other. The resulting bending is translated to a temperature reading via mechanical linkages. These devices are portable, and require no power. However, they are not as accurate as other temperature measurement devices, cannot be used to make point measurements, and do not generate data in a form that can be readily recorded. They can be used to acquire a qualitative record of the ambient temperature if a pen is attached to the indicating pointer, and traces a line on a moving chart.

6.4.5.6 *Liquid expansion devices*

Liquid expansion devices, typified by the liquid-column bulb thermometer, require no power, and are stable even after repeated thermal cycling. On the other hand, they do not generate data that can be easily recorded and they do not respond well to transient temperature changes. Since they must be immersed in the medium whose temperature is being measured, they cannot be used to make point measurements. Their primary use is measuring the temperature of the test environment.

6.4.5.7 *Change-of-state devices*

Change-of-state temperature sensors consist of various labels, pellets, crayons, lacquers, or liquid crystals whose appearance changes once a certain temperature is reached. The typical response time is measured in minutes, so they do not respond well to transient temperature changes. The accuracy is

lower than with other types of sensors, and the change in state is irreversible, except in the case of liquid crystal displays. Change-of-state sensors can provide a handy, qualitative confirmation that a material has, or has not, reached or exceeded some temperature.

6.4.5.8 *Infrared detectors*

Infrared (IR) detectors are noncontacting devices that measure the amount of radiation emitted by a surface. At temperatures above absolute zero, all matter radiates electromagnetic energy. The level and frequency of the radiated energy are proportional to temperature. In many engineering situations, much of the radiation is in the infrared region. If the radiating characteristics of the surface are known, its temperature can be inferred from the level of the infrared energy at a specific wavelength. The simplest IR detector design consists of a lens to focus the IR energy onto a detector, that converts the energy to electrical signals that are displayed in units of temperature after being adjusted for ambient temperature variations.

IR thermometers (IRT) come in a wide variety of configurations pertaining to optics, electronics, technology, size, and protective enclosures. The basic IRT design is comprised of a lens to collect the energy emitted from the target; a detector to convert the energy to an electrical signal; an emissivity adjustment to match the IRT calibration to the emissivity characteristics of the object being measured; and an ambient temperature compensation circuit to ensure that the temperature variations within the IRT due to ambient changes are not transferred to the final output.

Single-wavelength thermometry design measures the total energy emitted from a surface at a prescribed wavelength. These devices measure and evaluate the intensity, or brightness, of the intercepted thermal radiation. Intensity, or, more generally, radiance is measured in a narrow wavelength band of the thermal spectrum. Band selection is dictated by the temperature range and the type of material to be measured. The configuration can range from handheld probes with a simple remote meter to sophisticated portables with simultaneous viewing of target and temperature, plus memory and/or printout capabilities.

Dual- and multi-wavelength thermometry are used in applications where absolute accuracy is critical, and where the product is undergoing a physical or chemical change. Dual-wavelength thermometry involves measuring the spectral energy at two different wavelengths. The target temperature can be read directly from the instrument if the emissivity has the same value at both wavelengths. The advantage of ratio measuring is that temperature readings are greatly independent of emissivity fluctuations and/or sight path obscurations. The technique is generally used for temperatures above incandescence (1300°F (700°C)), but measurements down to 400°F (200°C) are possible.

Advantages of infrared detectors are that they are non-contacting, can be used to measure very high temperatures, and can be used to measure temperatures in hostile environments, provided visual access can be obtained. One disadvantage is that the surface emissivity at the temperature of interest must be known (this information is not always known). In addition, the device will average all of the temperatures in its field of view. If a target does not completely fill the field, the temperature of its background will contribute to the reading. If the target is not a perfect emitter, it will reflect infrared energy from other sources that can be detected by the device.

6.4.5.9 *Calibration of temperature measurement devices*

The effectiveness of any temperature measuring equipment is dependent on its accuracy and its repeatability. As with other measuring equipment, temperature devices must be calibrated and periodically verified to maintain confidence that their indicated output is within a certain known tolerance to the true value. Calibration and verification of temperature devices is simple in concept and involves merely exposing the device of interest and a reference device to the same temperature. Any deviation of outputs then can be corrected, in the case of calibration, or noted as in or out of tolerance, in the case of verification. For the purposes of this document, calibration and verification will be considered together and will

both be referred to as “calibration”. General information on temperature measurement can be found in References 6.4.5.9(a) and (b).

Temperature measurement devices are nearly always attached to a readout or control instrument of some type, which must also be calibrated. Often the instrument can be included with the probe and the assembly calibrated as a system. This is preferred because all components of the system are considered together, which leads to greater accuracy and can save considerable time. The user should refer to the specific instrument operations manual for its calibration requirements and procedures. Additionally, good information for temperature device calibration can be found in the following ASTM specifications:

- ASTM E220 Calibration of Thermocouples by Comparison Techniques (Reference 6.4.5.9(c)).
- ASTM E77-92 Standard Test Method for Inspection and Verification of Thermometers (Reference 6.4.5.9(d)).
- ASTM E1502 Use of Freezing Point Cells for Reference Temperatures (Reference 6.4.5.9(e)).

Note that though these standards are generally oriented toward a particular type of sensor, many of the practices can also be applied to other sensor types, particularly when applied in concert with the instructions provided in the owner’s manual for a given temperature sensor or system.

The general calibration procedure for probes involves physically placing them in a known temperature environment together with a reference standard that should be traceable to National Institute of Standards and Technology (NIST) standards. The critical components of a probe calibration setup are shown in Figure 6.4.5.9, and include:

- The “calibrator” (the device used to generate a known temperature).
- The reference standard probe - usually of the same type as the probe being calibrated.
- A readout device (typically a high resolution digital multimeter of 5½ digit resolution or an indicator which provides scaling and cold junction compensation for the probe).
- An ice point reference (used to locate the open end of a thermocouple - T_2 - at the proper reference temperature as discussed in Section 6.4.5.2). This is required when calibrating thermocouple type probes only, and provides the cold junction reference for thermocouple probes not otherwise compensated for the cold junction.

The Calibrator

Calibrators are the heating or cooling sources used to provide the thermal environment into which the instrument to be calibrated is placed. Calibrators must have outstanding temperature control capability, be extremely thermally stable, and free from temperature gradients. Circulating air furnaces are usually not sufficiently stable and exhibit relatively high thermal gradients. The calibrators most often used are specifically designed for probe calibration and are one of three types: block calibrators, circulating liquid baths, and fluidized powder baths.

The block calibrator consists of an electrically powered unit that uniformly heats or cools a solid block of material (often copper) into which the probes are inserted. Block calibrators are clean and easy to maintain, but change temperature relatively slowly. It is also important that the probe fit snugly into the block, so thermal “wells” of many different sizes are often required when calibrating a variety of probes. Typical temperature ranges of block calibrators are -40°F to 1200°F (-40°C to 648°C).

The circulating bath simply circulates a temperature-controlled fluid in a bath into which the probe is inserted. This type of calibrator is the least expensive of the three, but has a relatively limited temperature range, typically -5 to 266°F (-20 to 130°C). More exotic and expensive baths can extend this range to -250 to 1170°F (-160 to 630°C).

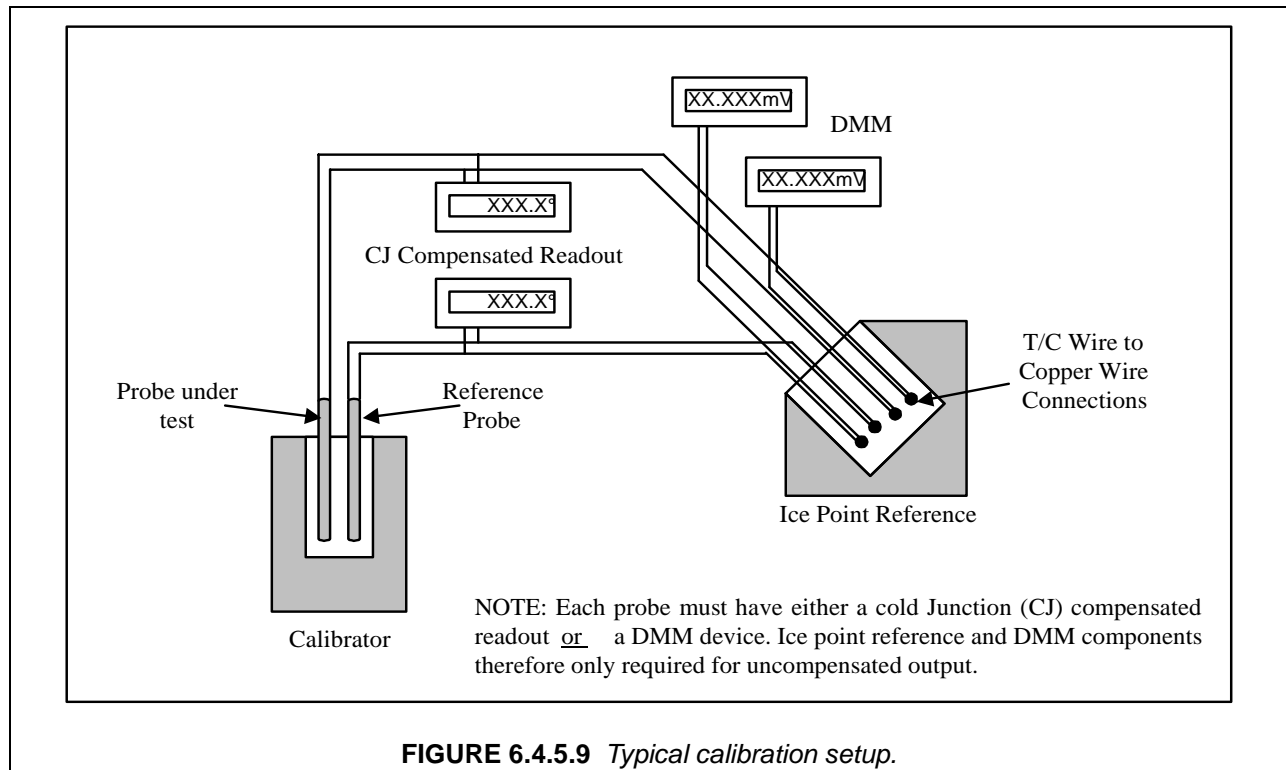

Fluidized powder bath calibrators use a gas, usually low-pressure air or nitrogen, to fluidize dry particles of powder – typically aluminum oxide. These baths have excellent heat transfer characteristics and are clean and easier to maintain than a circulating bath. They also have a significantly higher temperature range, though they are generally not capable of cryogenic temperatures. Common temperature ranges are from 122°F to 1112°F (50°C to 600°C). Extended range powder baths are available from -100 to 1800°F (-70 to 980°C).

The Reference Standard Probe

Reference standard probes are simply temperature probes that are calibrated and traceable to NIST. Obviously the calibration tolerance of the reference probe must be taken into account in the final tolerance of the probe being calibrated. When calibrating a thermocouple probe without an attached readout instrument, it is important that the reference standard be of the same thermocouple type as the probe being calibrated. This insures that both probes behave identically at the T_2 ice point reference. When a system calibration is being performed, this is not essential because the instrument connected to the probe will provide independent cold junction compensation. Similarly, if the reference standard is not a stand-alone probe, but is a calibrated system consisting of a reference probe and a readout device that performs cold junction compensation, the probes need not be of the same type.

All temperature measurement devices have limited temperature ranges over which their response is well behaved. It is therefore essential to verify that the reference standard probe is well behaved and calibrated over the full range of its use.

The Readout Device

Depending on the type of reference standard used, and the probe being calibrated, the readout device can vary considerably. If using reference standards or calibrating temperature probes without a readout device that performs scaling and/or cold junction compensation, the recommended readout device is a 5½ digit digital multimeter (DMM). This precision instrument allows the thermocouple output to be read

to within 0.001 millivolt, which is the precision to which the NIST thermocouple reference tables are published.

If a self-scaling output device is used, its precision (and verified accuracy) must be sufficient to provide at least four times the accuracy desired from the calibration.

The Ice Point Reference

The ice point reference is used to bring the T_2 junction to its standard value of 32°F (0°C) during calibration of the probe. Again, this is only necessary if either the calibration standard or the probe being calibrated does not have another form of cold junction compensation. Ice point reference chambers are often simply a well-controlled and monitored ice bath. Electronic ice points are also available which greatly simplify the setup. It is important to note that the wiring from the T_2 end of the thermocouple (which is at 32°F (0°C) in the ice point reference) to the readout device should be exclusively copper. This ensures that the emf response of the assembly is as-assumed by the thermocouple reference tables.

6.4.6 Data acquisition systems

This section is reserved for future use.

6.5 TESTING ENVIRONMENTS

This section is reserved for future use.

6.5.1 Introduction

This section is reserved for future use.

6.5.2 Laboratory ambient test environment

This section is reserved for future use.

6.5.3 Non-ambient testing environment

6.5.3.1 Introduction

Composite materials can be affected by exposure to non-laboratory ambient environmental conditions and so must be tested to determine those effects. Below laboratory ambient conditions as well as above laboratory ambient conditions must be included in the test matrix to determine each effects. Guidelines for the above and below laboratory ambient test conditions are included below. Many different regimes of testing may be appropriate depending on the usage of the materials. Normal environmental conditions for terrestrial applications would be from as cold as -67°F (-55°C) and up to 350°F (180°C). Conditions in space would widen the band of performance interest from -250°F to 450°F (-160°C to 230°C). Cryogenic conditions (less than -250°F (-160°C)) may be of interest for storage tank usage. Special conditions may dictate the usage of composite materials up to and beyond the short duration limit of 600°F (315°C) around leading edges or engine components. The user must determine what the limits for their particular application may be to allow for proper non-laboratory ambient testing to be completed on the materials used in the application.

The purpose of this section is to give the user some guidance in the testing of materials under other than standard laboratory conditions. Both below and above room temperature test conditions are discussed below. Further guidance related to non-laboratory ambient testing can be received from SACMA SRM 11R-94, Recommended Method for Environmental Conditioning of Composite Laminates.

6.5.3.2 Subambient testing

Testing performed at below laboratory ambient test temperatures can present unique challenges. Special fixturing or lubrication may be needed to ensure that properties measured are material behavior related and not due to freezing or sticking of sliding surfaces. Materials can become more brittle and change their failure modes. Special instrumentation may be necessary to record material properties at the colder temperatures. Adhesives used for tabbing or strain gaging should be types that retain their elongation at the cold temperatures.

Test temperatures as cold as -67°F (-55°C) are common and are discussed here. The test setup in a test chamber must be precooled until stabilized at test temperature. Fixturing should be allowed to stabilize prior to testing. Cooling medium may be liquid nitrogen (LN₂), liquid carbon dioxide (LCO₂), or a refrigerated chamber. Temperature measurements are commonly made with J, K or T type thermocouples (T/C's). See Section 6.4.5 for more information on temperature measurement. A dummy test specimen should be used to determine soak times prior to actual testing. The dummy specimen should be fabricated using the same material and ply orientation as the test specimen. To determine the soak time, a T/C should be inserted into a hole drilled at the centerline of the dummy specimen. Record the time it takes to reach the desired test temperature. This time should be used when testing to regulate when the test specimens are at the appropriate test temperature. Cool down rates should be controlled to minimize thermal shock and possibility of damage and/or microcracking.

Freezing of test fixtures can be a cause of anomalous test results. Fixture clearances must be checked to ensure free sliding surfaces exist. Proper lubricants or no lubricants should be used at the cold temperatures to prevent any fixture related effects on the test results.

A thermocouple (T/C) should be placed in contact with the surface of the test specimen at the time of test. A typical soak time of 5-10 minutes, or the time determined from actual experimentation, should be used, after reaching test temperature. Appropriate safety equipment should always be worn to prevent cold burns. Care must be taken if using LN₂ or LCO₂ when cooling the chamber to ensure that room oxygen is not depleted.

6.5.3.3 Above ambient testing

Testing performed at above ambient temperatures must be done with consideration for the temperature and moisture content of the test sample. Special fixturing may be needed to accommodate the high temperatures. The possibility for adhesive failures and drying of test specimens should be evaluated before proceeding with a test program. Special lubricants may be required to prevent fixturing from sticking or binding. Instrumentation made especially for the required temperatures must be used to ensure valid data is recorded. Strain gages, extensometers, and adhesives with the correct temperature rating must be identified and used. Special strain gage foils or backing materials may be required to withstand the elevated temperatures during testing. Instrumentation may require additional calibration at test temperatures.

The above ambient test temperatures, to 350°F (180°C), are discussed here. The test setup in a test chamber must be heated until stabilized at test temperature. Fixturing should be allowed to stabilize prior to testing. Heating of the test fixture with specimen or only the specimen is usually accomplished with an electrically heated chamber. Temperature measurements are commonly made using J, K, or T type thermocouples (T/C's). A dummy test specimen should be used to determine soak times prior to actual testing. The dummy specimen should be fabricated using the same material and ply orientation as the test specimen. To determine the soak time, a T/C should be inserted into a hole drilled at the centerline of the dummy specimen. Record the time it takes to reach the desired test temperature. This time should be used when testing to regulate when the test specimens are at the appropriate test temperature. Heat up rates should be controlled to minimize thermal shock and possibility of damage and/or microcracking.

Excessive heat up rates may cause charring or melting of test specimens or adhesives. An appropriate lubricant, such as molybdenum disulfide, should be used on sliding surfaces to ensure freedom of movement of test fixtures.

A T/C should be placed in contact with the surface of the test specimen prior to testing. A standard soak time would be 5-10 minutes, after reaching test temperature, if the test condition is dry. A standard soak time would be 2 minutes, after reaching test temperature, if the test condition is wet, to prevent too much dryout of the test specimen.

If moisture content is a testing variable, then the dryout of the test specimen, unless humidity is controlled during test, should be evaluated by weighing a traveler before and after a specimen soak time and test. See Section 6.3 for moisture conditioning guidelines. Appropriate safety equipment should always be worn to prevent burns.

For moderate test conditions, i.e., less than 200°F (93°C), a humidity controlled test chamber is optional for short duration tests. When testing above 200°F (93°C), then a precise humidity control is impractical and specimen dryout is a concern, especially for fatigue testing. Soak times prior to test should be kept short (<3 min.) to minimize the dryout.

Testing performed at temperatures above 350°F (180°C) must use special strain gages and strain gage adhesives, extensometry, and fixturing designed for the elevated temperatures. Special high temperature capable tab materials and tab adhesives will need to be utilized to prevent tab failures. Usage of these materials may be inappropriate at other temperatures.

Thermocouples are the most common transducer for measuring temperatures. Various T/C types may be used but J, K, and T are the most common. Some special conditions may dictate the use of resistance temperature detectors (RTD's). See Section 6.4.5 for more information on temperature measurement.

6.6 THERMAL/PHYSICAL PROPERTY TESTS

The physical analysis methods for laminae and laminates provide information on the integrity of the fabricated composite. Thermal analysis methods are used to determine the glass transition and crystalline melt temperatures, coefficient of thermal expansion, and residual heat of reaction. Additional analytical methods discussed in the following sections are used to determine fiber volume, void volume, density, dimensional stability, and moisture weight gain.

6.6.1 Introduction

The thermal analytical techniques described in Chapter 4, Section 4.5.2 may also be used to evaluate composite materials. Information obtained from thermal analysis includes the glass transition temperature, crystalline melt temperature, expansion/contraction properties, thermal stability, and extent of cure for thermosets.

6.6.2 Extent of cure

Characterization of extent of cure of composite materials has become increasingly important as controlled staging of complex or thick parts has been implemented as part of advanced processing schemes. Debulking and staging of stiffeners or other structural details can be used to facilitate assembly of large complex parts, with the ultimate goal of allowing out-of-autoclave processing. Debulking and staging are also a critically important aspect of the fabrication of thick parts to prevent resin migration and fiber waviness.

Several different thermal analysis techniques are commonly used for extent of cure measurements in fiber reinforced organic matrix composites. There include differential scanning calorimetry (DSC) or dy-

dynamic thermal analysis (DTA) to measure the extent of the residual curing exotherm and dynamic mechanical analysis (DMA) or thermomechanical analysis (TMA) to measure the glass transition temperature. Measurement of T_g is discussed in some detail in Section 6.6.3 below.

6.6.3 Glass transition temperature

6.6.3.1 Overview

The glass transition of a polymer matrix composite is a temperature-induced change in the matrix material from the glassy to the rubbery state during heating, or from a rubber to a glass during cooling. A change in matrix stiffness of two to three orders of magnitude occurs during the glass transition, due to the onset or freezing out of long range molecular mobility of the polymer chains. The temperature at which the glass transition occurs is a function of the molecular architecture and crosslink density of the polymer chains, but it is also dependent on the heating or cooling rate used in the measurement, and on test frequency if a dynamic mechanical technique is employed. In addition to the change in stiffness, the glass transition is marked by a change in the heat capacity and the coefficient of thermal expansion of the material, and so has at least some characteristics of a second order thermodynamic transition (see Reference 6.6.3.1).

The glass transition is frequently characterized by a glass transition temperature (T_g), but since the transition often occurs over a broad temperature range, the use of a single temperature to characterize it may give rise to some confusion. The experimental technique used to obtain the T_g must be described in detail, especially temperature scanning rate and frequency used. The method by which T_g is calculated from the data must also be clearly stated. Reported T_g may reflect onset of the glass transition or mid-point temperature depending on the data reduction method.

Upon exposure to high humidity environments, polymer matrices will absorb environmental moisture and be plasticized by it. One effect of this plasticization is the depression of T_g , frequently by a significant amount. A highly crosslinked resin (one based for instance on a tetrafunctional epoxide such as TGMDA) may have a high initial T_g , but it may be depressed more strongly than that in a less highly crosslinked system. Measurement of the T_g in a composite material plasticized by absorbed moisture poses some difficult experimental challenges. Heating the test specimen as required by the measurement will drive off at least some of the absorbed moisture, thereby affecting the measured properties.

Due to the decrease in matrix stiffness that occurs at the glass transition and to the low strength of these polymer matrices in the rubbery state, the matrix can no longer function effectively to transfer load to the fibers or suppress fiber buckling above the glass transition. T_g is, therefore, frequently used to define the upper use temperature of a composite material, although the time-dependent properties of the material such as creep compliance may be more sensitive to temperature within the glass transition range than are the quasi-static mechanical properties. A safety margin of 50F° (28C°) between the T_g and the material operational limit (MOL) has been proposed for epoxy matrix composites (see Section 2.2.8). This approach is useful for initially estimating the MOL, or for verifying a previously chosen MOL. However, since glass transition frequently occurs over a temperature range, and the measured value of T_g is highly dependent on method, supplemental mechanical property tests should be considered, particularly for new material systems (see Section 2.2.8).

6.6.3.2 T_g Measurements

Several different methods have been used to characterize the glass transition in polymeric materials, and most of these are also applicable to fiber reinforced materials.

6.6.3.2.1 Differential scanning calorimetry (DSC)

Since the heat capacity of a composite material changes at the glass transition, differential scanning calorimetry (DSC) may be used to determine T_g . The glass transition is detected as a shift in the heat flow versus temperature curve (see Figure 6.6.3.2.1). Many calorimeters are supplied with software

which may be used to calculate T_g . T_g of neat resin specimens is relatively easy to detect with DSC, but in composite specimens the resin content in the specimen is small, and the more highly crosslinked the resin, the smaller the change in heat capacity. It is, therefore, sometimes difficult to detect T_g in highly crosslinked cured composites (see Reference 6.6.3.2.1).

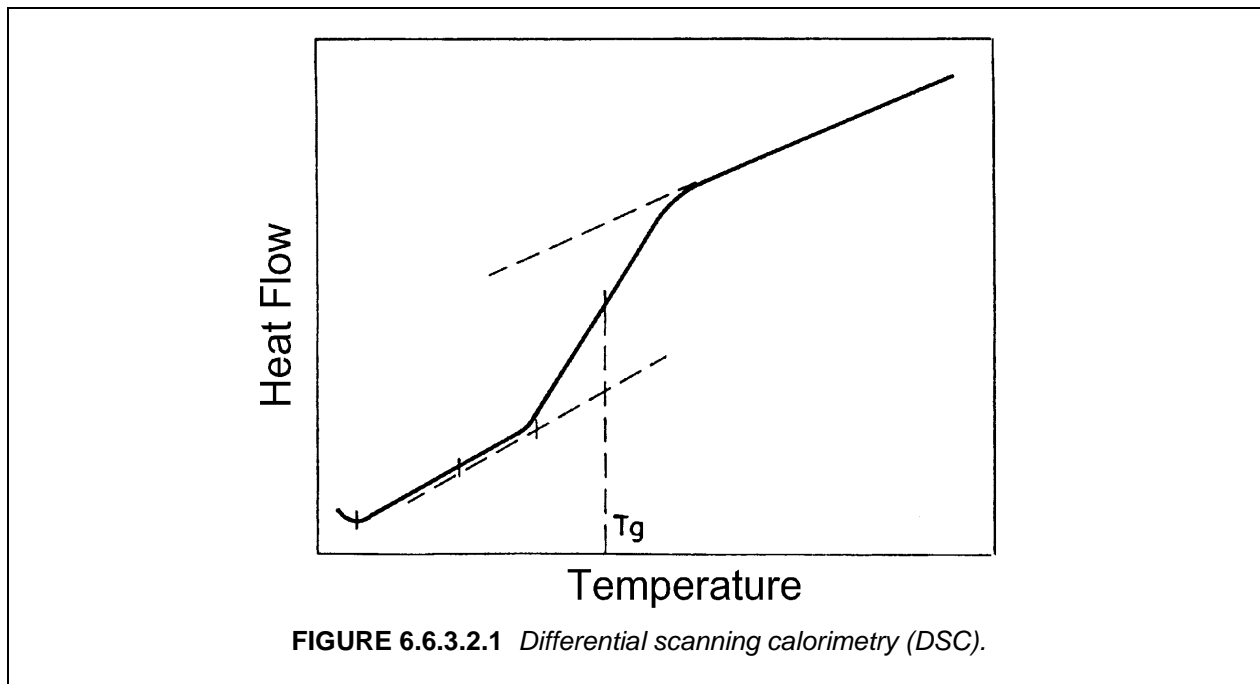

6.6.3.2.2 Thermomechanical analysis (TMA)

Thermomechanical techniques such as expansion, flexure, or penetration thermomechanical analysis (TMA) may also be used to determine T_g . In expansion TMA, the coefficient of thermal expansion α is measured as a function of temperature. As noted above, α undergoes a change during the glass transition, and T_g is determined by the point of intersection of lines fit to the thermal expansion data above and below the glass transition range. Figure 6.6.3.2.2 illustrates the specimen geometries and data reduction methods used for various TMA techniques.

In flexural TMA, a rectangular specimen is loaded in bending and the dimensional change is measured as a function of temperature. A curve fitting technique as illustrated in Figure 6.6.3.2.2 is used to calculate T_g . Flexural TMA measurement of T_g is similar to heat distortion temperature (HDT) measurement, since in both cases the specimens are loaded in flexure. An HDT specimen may be a full-size flexural test specimen, and is loaded in three-point bending or as a cantilever beam. Displacement is measured as a function of temperature, and the HDT is the temperature at which the displacement reaches some predetermined value. Use of a full-size specimen minimizes moisture loss during the HDT test, but flexural TMA and HDT measurement share the disadvantage that values of T_g or HDT obtained will be sensitive to the modulus of the reinforcing fibers in the composite sample and they will give different results depending on the nature of the fiber.

As shown in Figure 6.6.3.2.2, penetration mode TMA measures the hardness of the material. One disadvantage of this technique is that if the probe is touching a reinforcing fiber, an accurate measurement of the T_g of the matrix will not be obtained.

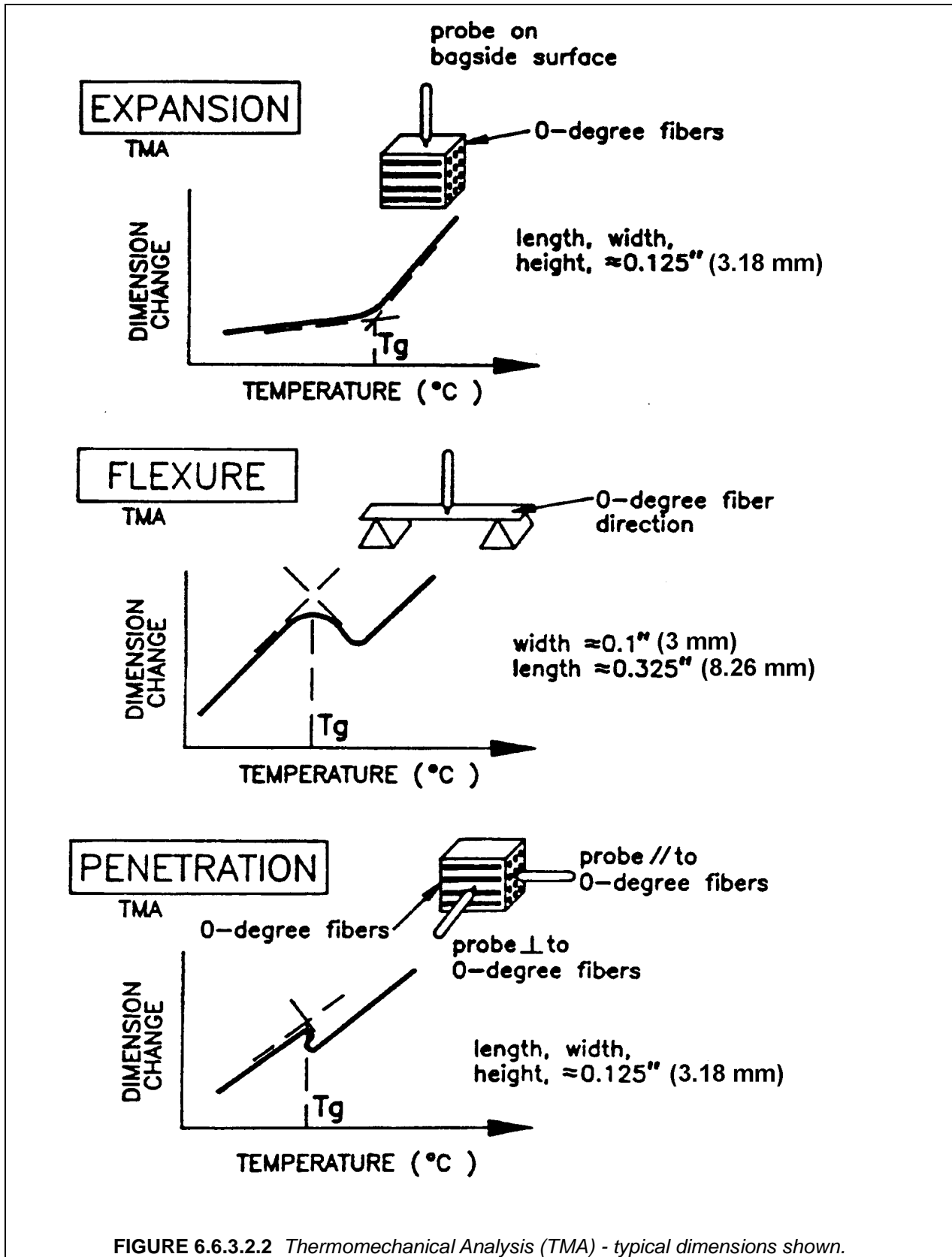
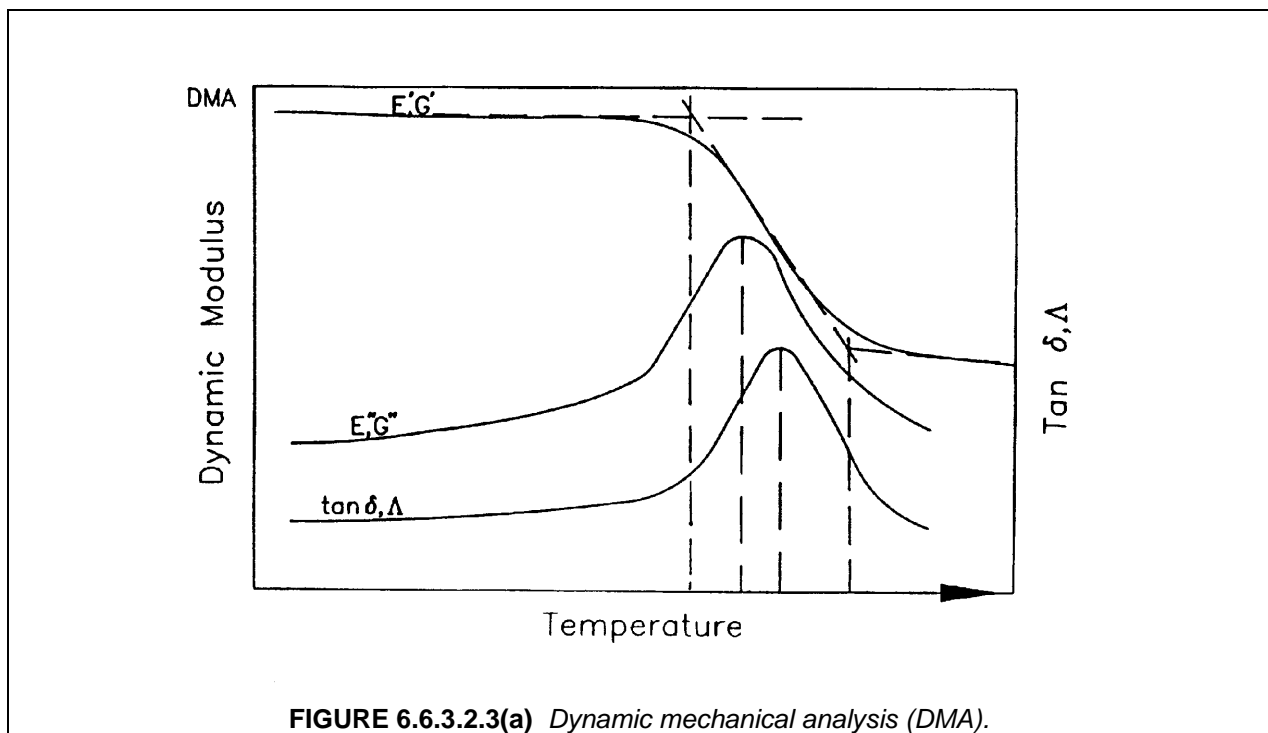

FIGURE 6.6.3.2.2 Thermomechanical Analysis (TMA) - typical dimensions shown.

6.6.3.2.3 Dynamic mechanical analysis (DMA)

Dynamic mechanical analysis (DMA) is the most common and preferred method of characterizing the glass transition of organic matrix composites. There are several types of DMA which have been used with composites, including torsion pendulum analysis (TPA) and other resonant techniques, and forced oscillation measurements in tension, torsion, and shear. These forced measurements are made using a number of DMA instruments, manufactured by DuPont, Perkin Elmer, Polymer Laboratory, Rheometrics, TA Instruments, and others.

All these DMA techniques produce curves of dynamic storage and loss modulus and loss tangent ($\tan \delta$) or log decrement (Λ) as a function of temperature (see Figure 6.6.3.2.3(a)). $\tan \delta$ and Λ are proportional to the ratio of the loss modulus (E'' or G'') to the storage modulus (E' or G'). They reflect the amount of energy dissipated during each cycle of loading, and go through a peak value during the glass transition. T_g may be determined from DMA data in several different ways, and this may be a source of differences in reported values for T_g . As shown in Figure 6.6.3.2.3(a), T_g may be determined as the temperature at the onset or the midpoint of the transition based on the storage modulus curve, at the maximum in $\tan \delta$, or at the maximum in loss modulus. Clearly the method used for calculating T_g could produce markedly different values for the same set of DMA data. The temperature scanning rate and frequency employed will also affect the results, as discussed above.



An ASTM standard (D 4065) is available for DMA of plastics, covering both forced and resonant techniques (Reference 6.6.3.2.3(a)). The test techniques described in this standard practice are the same as those used for fiber reinforced plastics. In addition, a newly released SACMA method (SRM 18R-94) recommends the use of DMA for the measurement of T_g in oriented fiber-resin composites (Reference 6.6.3.2.3(b)). SACMA SRM 18R-94 specifies a forced oscillation measurement at 1 Hz, a heating rate of 5° (9°) per minute, and calculation of an onset T_g from the dynamic storage modulus curve. If a consistent material operational limit (MOL) is to be calculated from T_g , standards for these experimental vari-

ables should be specified along with a temperature safety margin. Otherwise the measured T_g may be shifted by increasing or decreasing heating rate or frequency.

As discussed above, measurement of T_g in a wet composite material is made more difficult by the drying which occurs as the specimen is heated. Techniques which seek to prevent this drying by sealing the specimen in some way may be helpful in slowing the weight loss, but it cannot be prevented completely. If the specimen is sufficiently thick, the drying will occur primarily at the outside surface, resulting in a broadened or even bimodal glass transition (see Figure 6.6.3.2.3(b)). The lower temperature region will reflect the T_g of the interior of the specimen which is still wet, and the higher temperature region will reflect the T_g of the dried material. The loss tangent or log decrement curve will be broadened, or will exhibit two peaks or a peak and a shoulder, with the relative peak heights indicating the amounts of wet and dried material present in the specimen. In measuring T_g of a wet specimen, the lower temperature part of the transition may be the region of interest, suggesting that calculation of an onset T_g would be the appropriate and conservative approach.

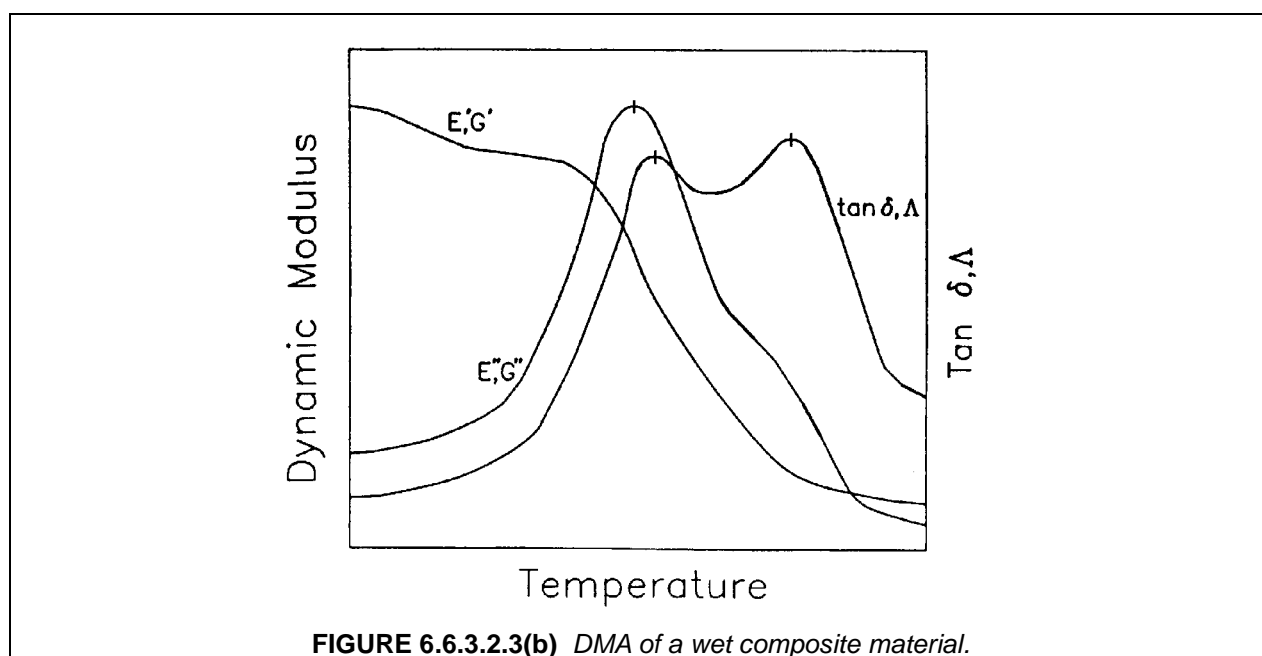

6.6.3.3 Glass transition test methods for MIL-HDBK-17 data submittal

Data generated by DMA as described above are currently being accepted by MIL-HDBK-17 for consideration for inclusion in Volume 2. In addition to the specific apparatus used for the measurement, the heating rate and frequency must be included, and the method used to calculate T_g from the data must be specified. If a resonant method such as torsion pendulum is used, the frequency in the glassy region should be included with the data.

6.6.3.4 Crystalline melt temperature

The crystalline melt temperature (T_m) of semi-crystalline thermoplastic composites can be obtained from DSC or DTA experiments. In addition, an estimate of the degree of crystallinity can be made. This becomes an important parameter since the properties of semi-crystalline thermoplastic composites may be dependent upon the degree of crystallinity of the matrix resin. The heating required for processing prepregs into composite structures may have an affect on the degree of crystallinity as well as the crystal structure.

6.6.4 Density

6.6.4.1 Overview

The density of composite materials is useful both directly, as for estimation of bulk weight or for thermal or dynamic analysis, as well as indirectly, as in derivation of quantities based on other measurements, like thermal conductivity (with specific heat and diffusivity) and void volume (with fiber and resin density). The application will determine the optimum test method, each of which have different levels of precision and bias (see Section 2.2.4) as well as different levels of ease of use. The last application mentioned, void volume determination of composites, probably has the most demanding density determination requirements. In order to accurately determine void volume to within 0.5% or better the density of the composite and the constituents must be known to within about 0.005 g/cm^3 ($1.8 \times 10^{-4} \text{ lb/in}^3$) or better.

Density can be measured directly or calculated from separate volume and mass measurements. From these two approaches the focus will be on the three main density test methods in current use, which are: 1) Archimedes volume determination by liquid (most often water) displacement, as standardized by ASTM D 792 (Reference 6.6.4.1(a)); 2) direct measurement of density by observation of the level at which the test material is suspended in a density gradient column, as standardized by ASTM D 1505 (Reference 6.6.4.1(b)); and 3) measurement of test specimen volume by pressure changes of a known amount of an inert ideal gas (helium pycnometry), as standardized by ASTM D 4892 (Reference 6.6.4.1(c)) for a non-composite material and modified by MIL-HDBK-17 for use with composites as described in Section 6.6.4.4.1.¹

While all three test methods provide generally accurate density values, the helium pycnometry method has not been demonstrated to be sufficiently accurate for use in determining void volume (see evaluation results in Section 6.6.4.5), although this may change in time with future modifications to procedure and instrumentation. For typical applications in composites, the Archimedes method, as described in ASTM D 792 and modified below, is preferred for its low cost, relative simplicity, and high accuracy (when properly performed). While also accurate, the density-gradient technique is less desirable due to the high labor cost and low through-put (since it may take several hours for one determination to stabilize in the column). Also, the long exposure of the specimen to the column fluid may not be desirable for subsequent procedures like matrix digestion. Each of the test methods is described in detail in the sections below.

Liquids are used almost exclusively in displacement techniques. However, there are advantages to using a gas medium in place of liquid to determine specimen volume. One advantage is minimization of errors associated with liquid surface tension. The gas displacement approach is often referred to as helium pycnometry. When helium pycnometry is used, the test specimen volume is determined by measuring pressure changes of a confined amount of gas. Helium pycnometry is not yet a standardized test method for measuring the volume and density of composites, yet it has been demonstrated to be a viable technique (References 6.6.4.1(e) and (f)). As no test standard or guidelines exist for this method as applied to composites, a test procedure has been developed within the MIL-HDBK-17 Testing Working Group. The procedure has been included as Section 6.6.4.4.1. This procedure will remain in effect until such time as a standard method for composites is adopted by ASTM or another standard-certifying organization.

6.6.4.2 ASTM D 792, Standard Test Method for Density and Specific Gravity (Relative Density) of Plastics by Displacement

Density of composites is frequently measured by means of ASTM D 792 which is under the jurisdiction of ASTM Committee D-20 on Plastics. This standard actually describes a means of measuring specimen volume and combines that value with a weight measurement to calculate density. Obtaining an accurate volume measurement is the key to a reliable composite density value.

¹For a quick and convenient, but less accurate density determination method, the reader is referred to the micrometer technique as specified in ASTM D2734, Test Method C (Reference 6.6.4.1(d)). This method obtains specimen volume by simple dimensional measurement and is only appropriate for precision work in limited specific cases.

The method is based on the weight of a specimen in air compared to its weight while completely immersed in a liquid of known density, most often water. When using water as the medium it must be degassed and either deionized or distilled for high accuracy work. A close eye must be kept for nucleated gas bubbles which are most likely to appear on rough surfaces such as machined edges. Also, the machined surfaces are usually more porous and may not wet completely. Close scrutiny of these surfaces is recommended to verify that no visible microbubbles are present within surface cavities. If microbubbles are present, switch to a higher wetting liquid or add a surfactant (for example, add four drops of Cole-Palmer 8790 Micro-Lab Cleaning Solution per 200 ml of water) for optimum results.

In general, the bigger the specimen the better. As specimen size and weight get closer to zero, the measurement limits on volume and weight begin to affect the density value. The recommended minimum test specimen is 1 gram (for carbon/epoxy this is about 0.037 in^3 (0.6 cm^3), for glass/epoxy it is about (0.024 in^3 0.4 cm^3). A balance accuracy of 0.0001 g ($2.2 \times 10^{-7} \text{ lb}$) is required for precision work on a specimen of this size.

The D 792 test method states room temperature testing should be conducted after conditioning the specimens for at least 40 hours at the standard laboratory atmosphere of $73.4 \pm 3.6^\circ\text{F}$ ($23 \pm 2^\circ\text{C}$) with $50 \pm 5\%$ relative humidity. If the test is being performed to referee a disagreement, the tolerances are $\pm 1.8^\circ\text{F}$ ($\pm 1^\circ\text{C}$), and $\pm 2\%$ relative humidity. For cases where immersion liquids other than water are being used, the temperature tolerance is $\pm 0.9^\circ\text{F}$ ($\pm 0.5^\circ\text{C}$). For an improvement in precision, the ASTM D-30 committee recommends bringing the material to oven-dry equilibrium to determine the initial weight (References 6.6.4.2(a) and (b)).

Two techniques are offered: Test Method A, employing water as the immersion liquid; and Test Method B using a liquid other than water, such as kerosene. Test Method B is often used when the specimens are either lighter than water, or when water will cause the specimens to undergo physical changes such as swelling.

Advantages and Limitations of ASTM Test Method D 792

The main advantages to choosing this method are practicality and precision (when carefully performed), and it is by far the most frequently used method. Equipment needed is simple and inexpensive, with the exception of a quality analytical balance. With careful technique, accuracy within $\pm 0.005 \text{ g/cm}^3$ ($\pm 1.8 \times 10^{-4} \text{ lb/in}^3$) is typically obtained. The apparatus includes a balance, a bridge for spanning the balance pan, a wire or filament, beaker, tweezers, thermometer, water or other liquid, and perhaps some sinking weights if the specimen is less dense than the liquid.

After a time investment of about a day for practicing the technique so that reproducible results can be obtained, the tests can begin. Four to six specimens per hour can typically be tested using D 792, however, there is a certain amount of tedium associated with this technique and actual through-put will likely be lower.

As with all the density methods mentioned here, it is good practice to take care in specimen preparation, especially edge quality. Care must be exercised in cutting specimens to avoid density changes. Other issues to be mindful of are specimen size, surface wetting (some experimenters add trace amounts of surfactants to the water), liquid absorption during measurement, and water temperature (vacuum degassing will cool the water, slightly changing its density). D 792 relies on a liquid medium, and problems with entrapped and/or clinging gas bubbles are a concern. High wetting, degassed liquids are required for optimum results.

6.6.4.3 ASTM D 1505, Standard Test Method for Density of Plastics by the Density-Gradient Technique

ASTM D 1505 is significantly different from D 792 in that specimen density is measured directly; no calculations are used. It determines density by floating the test specimen in a glass column containing a liquid mixture of known varied density. Composite specimens work well with this technique as long as the liquid medium selected is inert to the specimens. The test is useful for tracking materials that undergo

physical changes over time, checking uniformity, and identifying materials. It has also been reported to be more precise, and likely, more accurate than the D 792 method (Reference 6.6.4.3).

The method uses two approaches: an incremental varied-density liquid column (Test Method A), and two continuous varied-density liquid columns, Test Method B, progressively less dense liquid, and Test Method C, progressively more dense liquid. When the column is filled correctly the gradient remains remarkably stable and linear. The densities of the starting liquids are first closely approximated using a calibrated volumetric canister (liquid pycnometer). Calibrated sink floats are used to determine the linear variation of liquid density with the height of the column. By noting the level at which the specimen floats, the density of the specimen can be matched to the known density of the column liquid at that height. The accuracy and precision of this test are set by the sink floats along with a highly linear density variation of the column liquid vs. height.

Advantages and Limitations of the ASTM Test Method D 1505

Equipment for this method can be purchased commercially for a few thousand dollars. This includes an assortment of column fluids and sink floats. Alternatively, the apparatus can be assembled from standard lab glassware and components for minimal cost, but expect to spend time on machining and assembly before any testing can be done.

The procedure for filling the column to make a linear gradient is best described as “artful.” Expect to invest several days to a week learning this portion of the procedure. The column sensitivity is under the control of the experimenter. A skilled experimenter can make columns that are in the range of $0.001\text{g/cm}^3/\text{cm}$ ($9.2 \times 10^{-5}\text{ lb/in}^3/\text{in}$). Column sensitivity can be adjusted up or down to match the test need. Sensitivity is set by the density difference of the starting liquids.

Once the column is ready, specimens should be carefully introduced at the top with tweezers. To avoid gas bubbles clinging to the specimen it is helpful to set aside a small amount of the liquid mixture to pre-wet the specimens. As with D 792, if bubbles are present they can often be seen through the glass and transparent liquid, although there is not much that can be done to rectify this in the case of D 1505: once a specimen is immersed it is extremely difficult to retrieve without destroying the gradient.

The D 1505 test itself is rather time-consuming. The column must be filled slowly and carefully to preserve the gradient and typically takes several hours. Once the specimens are immersed it takes time for them to settle to their equilibrated height in the column. If many specimens need to be measured, one column will not be able to handle them all, so several gradient columns will have to be set up, broken down, and refilled.

As with all the density methods mentioned here, care must be exercised in cutting specimens to avoid density changes. The concerns with using a liquid medium are the same as those mentioned for D 792 in the last paragraph of the above Section 6.6.4.2.

6.6.4.4 Use of helium pycnometry to determine density of composites

Technological advances in electronics and automation have made it possible to obtain accurate and reliable volume determinations of composites (as well as fibers and matrix resins) using a gas in place of liquids. Helium pycnometry is a method for measuring the volume of solids of all types, including powders and open and closed cell materials. This flexibility is made possible because the medium used is an inert ideal gas, usually helium, which will penetrate the tiniest pores. High purity helium is the most commonly recommended gas because it is completely inert. High purity nitrogen is a good alternative to helium.

Helium pycnometry is not a new technology. Pycnometers, using both liquids and gases, have been used in ASTM test standards for many years. However, it was not until fairly recently that helium pycnometers became sophisticated enough to be used for high accuracy volume determinations. ASTM adopted standard D 4892 (Reference 6.6.4.4) in 1989, which uses a helium pycnometer to determine the volume/density of a non-composite material to three decimal places.

Interest in using helium pycnometry to measure composite density stems from its potential to be both as accurate and precise as D 1505 while at the same time having a higher through-put and better ease of use than D 792. Another distinct advantage of using a gas medium is that it guarantees reproducible penetration into surface pores. With a liquid medium the experimenter has no way of knowing what percentage of the surface porosity is left unfilled.

In helium pycnometry the volume of solid objects is measured by employing Boyle's Law, which states that the decrease in volume of a confined gas results in a proportionate increase in pressure. Both helium and diatomic nitrogen are used because they behave as ideal gases at room temperature. A helium pycnometer makes use of this by making two precise pressure measurements on two known calibrated volumes. These are the cell volume and the cell volume plus a smaller expansion volume usually called the "added volume." The first pressure is measured with all gas confined in the main measurement cell where the test material is located. After this pressure is determined a valve is opened connecting the main and expansion cells together. This results in a second, lower pressure which is recorded. Using the ideal gas law the volume of the test material in the main cell is determined using the equation below in Section 6.6.4.4.1.

Advantages and Limitations of the Helium Pycnometry Procedure

A distinct advantage of using a gas medium is that it guarantees reproducible penetration into surface pores. With a liquid medium the experimenter has no way of knowing what percentage of the surface porosity is left unfilled.

The accuracy of this method begins to drop off when the ratio of the sample volume to test cell volume (V_s/V_c) is low. Experiments have shown that if this ratio is approximately 30% or higher the pycnometer will be near its optimal performance (References 6.6.4.1(e) and (f)). This is not to say that useful data can not be obtained when the ratio is below 30%. The precision and bias remain quite useful to low ratios below 1% (References 6.6.4.1(e) and (f)). The ratio needed for a particular test is determined by the accuracy needed; for example, if one significant digit is sought, then there would be no restriction on the V_s/V_c ratio. However, if three digits are needed the V_s/V_c ratio becomes important and should be 0.3 or higher.

The gas pressure is sensitive to temperature. Tests were run to detect temperature fluctuation in the measurement cell. It was found that no matter what cell volume was used, the internal temperature of the measurement cell was extremely stable, despite the constant influx and expansion of fresh helium (Reference 6.6.4.1(f)).

The shape of the test specimen can cause problems during insertion into the measurement cell. The cells of off-the-shelf pycnometers sold today are usually cylindrical. If the test specimen is restricted to some rectangular shape it may be difficult to get more than 30% of the cell volume filled due to geometric incompatibility. Commercially available pycnometers are like this because, although capable of working with any solid object, they are designed for their most popular application, which is powders. This problem can be remedied by cutting the composite specimen to match the cell geometry, for example, stacked disk-shaped specimens.

A quality helium pycnometer, such as the one used in this work, is a sophisticated piece of analytical equipment with a base cost in the \$10,000 range. Much like a lab analytical balance, once the equipment is purchased very modest costs are associated with the test thereafter. Expect to spend several days getting familiar with the equipment and procedures.

Pycnometry has an advantage in that much less labor is involved, as the equipment is automated. Aside from sample preparation and conditioning, the experimenter needs to change specimens at the end of each run. Once running, the pycnometer gathers data at a rate of 25 to 30 measurements per hour. An important aspect of automation is that it significantly reduces variations introduced by operator-to-operator skill and "artfulness" which enter into the test results.

As with all the density methods mentioned here, care must be exercised in cutting specimens to avoid density changes.

6.6.4.4.1 Helium pycnometry test procedure for determining composite density

Helium pycnometry is not a formally recognized method for measuring composite density. As no test standard or guidelines exist for this method, a procedural guideline is included here. This procedure will remain in effect until such time as a standard test method is adopted.

Background

Volume and density of solid objects is measured by employing Boyle's Law, which states that the decrease in volume of a confined gas results in a proportionate increase in pressure. Both helium and diatomic nitrogen behave as ideal gases at room temperature. As noted above, the pycnometer makes use of this by making two precise pressure measurements on two known volumes. These are the cell volume and the cell volume plus a smaller expansion volume usually called the "added volume." The working equation used to calculate the test specimen volume is

$$V_s = V_c + \frac{V_a}{1 - (P_1 / P_2)} \quad 6.6.4.4.1$$

where

V_s = specimen volume

V_c = previously calibrated empty specimen cell volume

V_a = previously calibrated added volume

P_1 = pressure when all gas is confined to the main cell

P_2 = second pressure when the gas fills both cells

Before running the pycnometer, V_a and V_c are calibrated by using a volume calibration standard. Assumptions made are that the cell temperature is constant, the two cell volumes are constant, and the moles of gas present is constant. The specimen density is obtained by supplying the pycnometer with a weight measurement of the test material from an analytical balance.

Testing has shown that when the V_s/V_c ratio is approximately 30% or higher the pycnometer will operate near optimal performance. This is not to say that reliable data can not be obtained when the ratio is below 30%, but rather, some loss in performance begins to occur.

It is important to note that the gas medium guarantees filling the tiniest of surface pores, which other liquid immersion methods may or may not do, due to surface tension. This should be kept in mind when comparisons are made. When surface pores are not filled the density data is shifted to some lower value. Therefore, liquid immersion methods may return density data that is biased slightly to the low side when compared to data from the helium pycnometry method. This density shift may or may not be noticeable, depending on such factors as the amount of surface porosity and the wetout between the liquid and the composite.

Apparatus

Helium pycnometer (the pycnometers specified in ASTM D 4892, Footnote 4 are acceptable for use here); volume calibration standard; high purity helium or nitrogen gas cylinder with regulator; analytical balance; desiccator; disposable plastic gloves or tweezers (for specimen handling).

Specimen Preparation

Heat and pressure from the specimen cutting process can locally alter the specimen density. Composite specimens should be sanded with fine grit paper and wiped clean of any remaining loose dust. Specimen shape is irrelevant to the test, but consideration of specimen geometry is required in order to ensure enough material gets into the measurement cell. The recommended shape for a cylindrical cell is

a circular specimen with a diameter nominally 0.080 inches (2.0 mm) less than the cell diameter. Specimen diameter can be larger, but not so large that there is a risk of jamming against the cell walls. The disks should be stacked to fill as much of the cell as possible. If significantly lower precision is acceptable, there is no need to consider what percentage of the cell volume is filled (unless the specimen volume is extremely small). Useful data will result even when V_s/V_c is near 1% (References 6.6.4.1(e) and (f)).

Procedure

1. Precondition the test specimens according to ASTM D 618 "Conditioning Plastics and Electrical Insulating Materials for Testing" (Reference 6.6.4.4.1(a)) or, for improved accuracy, bring the specimen to oven-dry equilibrium as recommended by References 6.6.4.2(a) and described by 6.6.4.2(b). Store the test specimens in a desiccator at 73.4°F (23°C) until they are ready to test.
2. In general, follow the manufacturer's instructions to determine the composite density. A list of, and comments on, the test steps is given here.
 - The helium (or nitrogen) source should be connected to the pycnometer gas input via a gas-tight pressure fitting.
 - The printer and computer (if so equipped) should be connected to the data output interface via an appropriate cable.
 - After the pycnometer power is turned on, let it warm up to its equilibrium operating temperature, which is typically 3.6 to 5.4°F° (2 to 3C°) above ambient temperature.
 - If the pycnometer has not been calibrated, run the calibration procedure specified in the user's manual. From time to time the pycnometer should be recalibrated, especially if the ambient temperature has changed by an appreciable amount or if it fluctuates. The pycnometer is only as good as the calibration standards used to calibrate it. Be sure the standards used meet proper specification. If the accuracy of the standards is in doubt they can be spot-checked using a test such as D 792. Certified standards can be obtained through the National Institute of Standards and Technology (Reference 6.6.4.4.1(b)).
 - Once calibrated, the pycnometer is ready to run. Remove the sealed cap, opening the main cell to the ambient air. Place the pre-weighed test specimen inside the cell. The cap is then replaced and the run started. Before measurement begins the pycnometer typically purges itself for several minutes with helium. This serves two purposes; it ensures that only helium is in the cell and it carries off residual moisture from the specimen surface. At this point the actual measurement runs begin.
 - If the pycnometer is automated it will rerun the same specimen a pre-selected number of times and, when completed, will print a summary of the run, including the average volume and density with their associated standard deviations. Automated machines will download the raw data and the report to a personal computer if desired. Once the download is complete the pycnometer is ready to repeat the measurement cycle.
 - Change out the specimens, re-seal the measurement cell and begin a new run. Recalibration is not necessary for continuous use if the ambient temperature is stable.

6.6.4.5 Summary of helium pycnometry experimental results

A high quality helium pycnometer (Quantachrome Ultrapycnometer 1000) was tested to determine its viability as a tool for measuring the volume/density of composites. Conclusions reached as a result of this testing are as follows (refer to References 6.6.4.1(e) and (f) for all conclusions):

- The D 792 method was more accurate with a maximum deviation of 0.003 g/cm³ (1.1x10⁻⁴ lb/in³) from the certified value for the specimen volumes used. More typically the data varied within 0.001 g/cm³ (3.6x10⁻⁵ lb/in³) of the NIST standard.
- Above 30% fill of the measurement cell the pycnometer data deviated by a maximum of 0.003 g/cm³ (1.1x10⁻⁴ lb/in³). More typically the data varied within 0.002 g/cm³ (7.2x10⁻⁵ lb/in³) of the standard. Below 30% fill the maximum deviation was 0.015 g/cm³ (5.4x10⁻⁴ lb/in³) and a fall off in accuracy with decreasing V_s/V_c was evident.
- The standard deviations of the two techniques are comparable and tight with the pycnometer data showing slightly tighter or equal values for all data points. The typical standard deviation for the D 792 method was 0.001 g/cm³ (3.6x10⁻⁵ lb/in³) while the standard deviations for the helium pycnometer typically ranged from 0.0008 to 0.0002 g/cm³ (2.9x10⁻⁶ to 7x10⁻⁷ lb/in³). The maximum standard deviation recorded by the pycnometer was 0.003 g/cm³ (1.1x10⁻⁴ lb/in³). The largest standard deviation of the D 792 method was 0.004 g/cm³ (1.4x10⁻⁴ lb/in³) recorded in two instances.
- The pycnometer data have a persistent tendency to read slightly below the actual density value as if a constant offset phenomena was occurring. The reason for the low offset is not known at this time.

One difference between gas and liquid mediums is that gases are much more susceptible to temperature variations. The periodic influx of cool helium, and the further cooling of the helium due to expansion was initially a concern as this situation could cause erroneous low pressures to be recorded. Testing showed that the thermal environment in the sample cell is extremely stable, with the helium temperature worst case recovery time of 9 sec. The worst case maximum deviation value reached was -3.8F° (-2.1C°), which occurred within 50 milliseconds after expansion. From this data it is concluded that the gas expansion is not an issue and that the helium is quickly reheated by the thermal mass of the sample cell. Further, 200 repetitions of the gas expansion event showed no change in the temperature recovery curve or any drop in the cell temperature over time, indicating that the sample cell has ample heat capacity to maintain a stable temperature environment for an indefinite period.

6.6.4.6 Density test methods for MIL-HDBK-17 data submittal

Data produced by the following test methods (Table 6.6.4.6) are currently being accepted by MIL-HDBK-17 for consideration for inclusion in Volume 2.

TABLE 6.6.4.6 Composite density test methods for MIL-HDBK-17 data submittal.

Property	Symbol	Fully Approved, Interim, and Screening Data	Screening Data Only
Density	ρ	D 792, D 1505, 6.4.4.4.1*	D 2734C

*When this method is used to generate data for subsequent determination of composite void volume, the test specimen must occupy at least 30% of the test cell volume.

6.6.5 Cured ply thickness

NOTE: Throughout this discussion the term "cured" refers to a fully processed state. For thermosetting materials it means chemically cured. For thermoplastic materials it denotes a fully consolidated condition.

6.6.5.1 Overview

The thickness of a composite part is an important property from the standpoint of weight and dimensional compliance (fit) in hardware applications. Part thickness is governed by the number of plies in the lay-up, the amount of matrix resin present (resin content), the amount of reinforcing fiber (fiber volume), and the amount of porosity (void volume). In the case of resin transfer molding (RTM), the tool dimensions dictate thickness (by controlling resin content). If it is assumed that the amounts of resin, fiber, and porosity do not vary from one ply to another within the structure, then the thickness per ply times the number of plies is representative of the part thickness. In practice, the proportions of resin, fiber, and porosity may vary somewhat from ply to ply. The magnitude of this variation is largely a function of processing parameters. For example, surface bleeding during cure may produce lower resin content in the outer plies compared to interior plies, depending on the mobility of the resin through the part thickness. However, the average cured ply thickness multiplied by the number of plies generally provides a reasonable estimate of part thickness.

Since test panel laminates are typically processed in a manner that simulates a production part process, panel cured ply thickness may also be used to estimate part thicknesses. In addition, cured ply thickness of a test panel may be used in the calculation of fiber volume and subsequent normalization of mechanical test data (see Section 2.4.2 on normalization).

Determination of cured ply thickness generally involves measuring the thickness of a laminate (panel or part) in a number of locations, averaging these thickness values, and dividing by the number of plies in the lay-up. Laminate thickness can be measured by direct means (using devices such as micrometers) or indirectly (using ultrasonic instruments). Sections 6.6.5.2 and 6.6.5.3 below briefly discuss the use of direct and indirect means of measuring laminate thickness. Section 6.6.5.4 discusses SRM 10R-94, which is the only current standard for measuring cured ply thickness.

6.6.5.2 Thickness measurement using direct means

Deep throat micrometers are typically used to directly measure thickness at various locations over the laminate surface. While this is a fairly straight forward procedure, there are several issues to consider.

First is the matter of panel or part size and shape. If the laminate to be measured has large length and width dimensions, the micrometer may not reach far enough into the interior. This problem may be overcome by substituting a dial indicator or similar device suspended from a rigid framework, but accuracy is usually sacrificed. Also, if the laminate has curvature, the micrometer throat may interfere to the extent that the anvils will not reach the laminate surfaces. Laminate surface texture is another significant issue. The reader is referred to Section 6.4.2 for a detailed discussion of this topic. If the size and shape of the laminate do not present a problem, ball-faced micrometers offer an accurate, low cost means of direct thickness measurement.

6.6.5.3 Thickness measurement using indirect means

Pulse-echo type ultrasonic equipment can be used to measure laminate thickness. This technique makes use of the fact that sound can be directed through a laminate, reflected from the opposite surface, and its traverse time measured. If the sound velocity through the laminate material is established by testing specimens of known thickness, then the unknown laminate thickness can be calculated. ASTM E797-90 (Reference 6.6.5.3(a)) describes this practice, but does not include detailed information or any specifics relative to measurement of composite laminates.

One advantage of using an ultrasonic method is that access to only one surface is required. This is important for measuring skin thickness on closed structures, or for measuring large laminates where micrometer measurement is not possible. However, the disadvantages are considerable. First, the equipment can be expensive relative to other options. Second, calibrations must be run on specimens of known thickness. This must be done for each specific material to be tested since sound velocity may be different for each. A further complication is that velocity is also affected by the ratio of fiber to matrix resin

in the laminate and, in fact, SACMA method SRM 24R-94 (Reference 6.6.5.3(b)) takes advantage of this very fact to estimate resin content of prepreg. Third, surface texture is a concern as discussed earlier in Section 6.6.5.2.

Because of the significant disadvantages, this measurement method is not recommended where direct measurement using a micrometer or similar device is possible.

6.6.5.4 SRM 10R-94, SACMA Recommended Method for Fiber Volume, Percent Resin Volume and Calculated Average Cured Ply Thickness of Plied Laminates

The cured ply thickness portion of this method (Reference 6.6.5.4) specifies that thickness readings be taken in at least 10 locations over the surface of the laminate using a ball-faced micrometer. It is recommended that no readings be taken closer than one inch (25 mm) from any edge. The average laminate thickness is calculated and divided by the number of plies to obtain an average cured ply thickness. The method recommends that a laminate be subdivided for the calculation of fiber volume if the variation in laminate thickness exceeds 0.008 inch (0.2 mm). This indirectly suggests that a single cured ply thickness should not be calculated under such conditions.

6.6.5.5 Cured ply thickness test methods for MIL-HDBK-17 data submittal

Methods which meet the requirements of SRM 10R-94 are acceptable when submitting data to MIL-HDBK-17 for consideration for inclusion in Volume 2. In addition, cured ply thickness may be calculated using measured thicknesses of test specimens obtained from a panel provided there are at least 10 specimens distributed over the entire area of the panel (so as to be equivalent to SRM 10R-94).

6.6.6 Fiber volume (V_f) fraction

6.6.6.1 Introduction

The fiber volume (expressed as a fraction or percent) of cured polymer-matrix composites is commonly obtained by matrix digestion, ignition loss, areal weight, and image analysis methods. These methods generally apply to laminates fabricated from most material forms and processes, but the areal weight method cannot be used for filament wound material or other forms that do not consist of discrete individual plies. Each method has its benefits and drawbacks. Other less common methods will not be discussed.

6.6.6.2 Matrix digestion

The method of matrix digestion is covered under ASTM Test Method D 3171 "Fiber Content of Resin-Matrix Composites by Matrix Digestion" (Reference 6.6.6.2). The technique is based on digestion of the matrix by a suitable liquid which does not attack the reinforcing fibers. Depending on the resin, three different procedures are used: Procedure A, concentrated nitric acid; Procedure B, aqueous mixture of sulfuric acid and hydrogen peroxide; and Procedure C, a mixture of ethylene glycol and potassium hydroxide. For example, epoxies generally respond well to all three procedures. Although toughened systems respond better to procedure B, some fiber types are attacked more by B than by A. BMI's, polyimides, and thermoplastics usually respond well to procedure B. Aramid fibers are attacked by both A and B, and therefore, procedure C works best on aramid fiber composites.

Possible causes of error:

If the fiber is significantly attacked by the digestion fluid, results will be erroneous. It is recommended to validate the process by testing a control sample of only fiber to determine mass change of fiber during test.

Some toughened resin systems have additives such as elastomers or thermoplastics. If these additives are not dissolved by the digestion fluid, they may cling to the fiber causing erroneous results.

Incomplete digestion of the resin.

Sample size must be large enough to be representative and weighed accurately.

Accuracy is dependent on accuracy of density measurements.

6.6.6.3 Ignition loss

The method of ignition loss is described in standard test method ASTM D 2584 "Ignition Loss of Cured Reinforced Resins." The technique determines ignition loss of cured polymer-matrix composites which can be considered to be the resin mass. A weighed specimen is heated until the resin matrix is oxidized and converted to volatile materials. After removing any remaining ash, the residue (reinforcing fiber) is weighed and the percent loss is calculated. Fiber density and composite density (to three significant figures) are required in order to calculate fiber volume.

Possible causes of error:

If the fiber gains or loses weight under the conditions of the test, the results will be erroneous. (For this reason, this procedure is not appropriate for aramid fibers and requires special temperature controls for carbon fibers.)

Fillers, if present, must be oxidized with resin.

Incomplete decomposition of resin (and fillers, if present) during the test.

Any volatiles such as water, residual solvent, etc., will cause error unless they are small enough to be ignored.

If the sample is heated too rapidly, mechanical loss of noncombustible residue (fiber) can occur, causing erroneous results.

6.6.6.4 Areal weight/thickness

Sections 6.6.6.2 and 6.6.6.3 discussed methods for determining fiber volume by destructively separating the fibers from the matrix through chemical or thermal means and measuring the mass of the fibers in a sample. As discussed in Section 2.4.3 on data normalization, there is a relationship between laminate (or specimen) thickness and fiber volume for given values of fiber areal weight and fiber density. This fact provides the basis for another method of fiber volume determination, which is not destructive.

In general the method involves measuring the laminate or specimen thickness and calculating the fiber volume using this measured thickness, the number of plies in the laminate, and previously determined values of fiber areal weight and fiber density. Equation 6.6.6.4(a) or an equivalent form is used.

$$V_f = \frac{FAW \times n}{t \times \rho_f} \times k \quad 6.6.6.4(a)$$

where

- V_f = fiber volume fraction
- FAW = fiber areal weight (mass per area per ply)
- n = number of plies in the laminate
- t = measured laminate (or specimen) thickness
- ρ_f = density of the reinforcing fiber
- k = units conversion factor (if required)

The calculated fiber volume is the reinforcing fiber's contribution to the total volume. Although void content does affect the laminate thickness (and hence fiber volume), it is not a factor in the calculation since it contributes to total volume in the same way as the resin or any other non-reinforcement component. Since the calculation requires the number of plies, the method is applicable only to material forms with distinct plies for which fiber areal weight can be determined.

This general procedure is documented in SRM 10R-94 (Reference 6.6.6.4(a)), which references other SACMA Recommended Methods for determination of fiber areal weight and fiber density. The specimen defined by this method is a laminate panel, but the concept could be extended to individual test specimens or to application parts. The method notes that the fiber areal weight and fiber density used in the fiber volume calculation must be representative of the sample (panel, specimen, or part) under evaluation. This is an important point. Although resin content may typically be the major factor affecting fiber volume, fiber areal weight and fiber density variations can also have a significant effect on the accuracy of this method. "Typical" or "data sheet" values for these parameters should not be used in the calculation. SRM 10R-94 recommends that, as a minimum, fiber areal weight of the individual prepreg roll and lot average fiber density be used. If careful thickness measurements are taken (see Section 6.6.5) and appropriate fiber areal weight and fiber density values are used, this method can be quite accurate, and potentially more reliable than destructive methods that depend heavily on laboratory technique.

For certain types of specimens the accuracy of thickness measurements may not be sufficient to yield accurate fiber volumes. In particular, very thin specimens present the problem of obtaining three significant figure precision. In addition, thickness cannot be reliably measured for specimens with irregular surfaces. As an alternate to measuring specimen thickness directly, it may be calculated using equation 6.6.6.4(b):

$$t_c = \frac{M}{A \times \rho_c} \quad 6.6.6.4(b)$$

where

- t_c = calculated laminate (or specimen) average thickness
- M = mass of the specimen
- A = surface area of the specimen
- ρ_c = measured density of the composite specimen

Combining equations 6.6.6.4(a) and 6.6.6.4(b) yields the following expression for fiber volume fraction in terms of laminate specimen mass, density, and area:

$$V_f = \frac{FAW \times A \times \rho_c \times n}{M \times \rho_f} \times k \quad 6.6.6.4(c)$$

When mass is in grams, FAW in g/m^2 , densities in g/cm^3 , and area in in.^2 , then $k = 1/1550$.

For this variation of the method, the specimen must be extracted from the laminate or part such that its edges are cut cleanly without any fraying. Ideally the specimen should be rectangular to permit area calculation from specimen length and width. If possible, the specimen should be cut at least one inch from any laminate (part) edge to minimize edge effects caused by fiber wash. The specimen mass is obtained by weighing on a balance with adequate precision, and density is measured using archemidian or other suitable methods (see Section 6.6.4 of this volume). More detail may be found in Reference 6.6.6.4(b).

Possible causes of error:

Volume 1, Chapter 6 Lamina, Laminate, and Special Form Characterization

- Inaccuracies in measured thickness caused by use of inappropriate measuring equipment, particularly on textured surfaces (see Section 6.4.2).
- Inaccuracies in calculated surface area (for the area variation of this method) caused by edge damage induced during specimen cutting or by inappropriate measuring equipment or technique, especially for irregularly shaped specimens.
- Wide variation in measured thickness across the specimen (in which case the calculated average fiber volume is not representative of all areas of the specimen).
- Significant fiber wash (spreading) during cure (which causes an effective reduction in fiber areal weight in the specimen compared to the value measured for the prepreg).
- Use of fiber areal weight and/or fiber density values that are not representative of the fiber in the specimen.

6.6.6.5 Determination of fiber volume using image analysis

6.6.6.5.1 Background

The method of image analysis offers a technique of measuring fiber volume that eliminates the creation of waste chemicals while providing information about void volume laminate orientation and through thickness fiber distribution. The basic assumption for this technique is that the evaluation of the two dimensional distribution of fibers through a random cross section is representative of the volumetric fiber distribution. This assumption is valid for fibers of constant cross section, such as is found in tape laminates, but is not valid for woven laminates. This technique works well for carbon fibers in a polymer matrix, and for other fiber/matrix combinations where adequate contrast can be achieved. It does not, for example, work as well for glass fibers, since the low contrast between the glass fibers and surrounding matrix makes accurate measurements very difficult. There are no industry standard test methods for this type of evaluation. Therefore, this section will describe the procedure in general terms. Computer software for image analysis is commercially available.

6.6.6.5.2 Apparatus

This technique requires the use of metallographic specimen preparation equipment, a reflected light microscope with a magnification of at least 400 times which has the capability of porting the image to a digital camera, a computer with image acquisition card and image analysis software. While automated image acquisition systems are available, this analysis can also be performed by manual specimen translation and focusing. The use of software macros can reduce the time required to process a fiber volume measurement. Macros allow the user to automate repetitive software instructions.

6.6.6.5.3 Specimen preparation

A small section of laminate is prepared using standard metallographic techniques. A typical specimen is $\frac{3}{4}$ inch (2 centimeters) on a side. The cross section is taken across the thickness of the laminate. The orientation of the cross section with respect to the laminate is dependent on the orientation of the fibers in the laminate being evaluated. The image analysis technique can be used to evaluate fiber volume in laminates with ply orientations from 0 to approximately 60°. At angles above 60 degrees the fiber edge definition becomes distorted by the subsurface fibers. If a laminate with 0/90 lay-up is evaluated, the laminate can be sectioned at 45° to enable evaluation of the fiber volume in all plies. If fiber volume is to be measured on a 0/±60 laminate, the cross section can be oriented at 0° so that all plies can be evaluated.

The surface of the polished specimen should display a clear delineation between the fibers and the matrix. The fiber volume measurement should be made at as high a magnification as possible. This to

some extent depends on the fibers being examined, but for most fibers a magnification of at least 400 to 1000 times should be used. This should get 30 to 100 fibers in the field of view. As these are areal measurements being performed, the partial fibers can be included in the analysis. This would not be true if the individual fiber area were being determined. A typical image is shown in Figure 6.6.6.5.3.

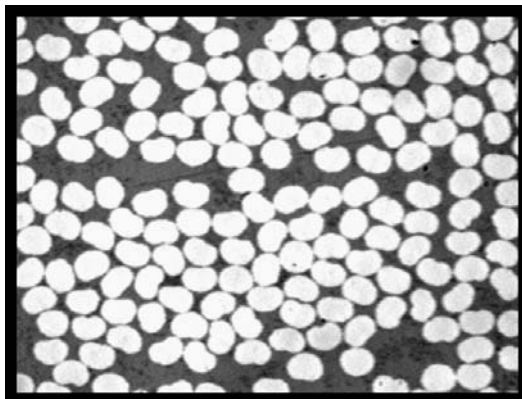

FIGURE 6.6.6.5.3 Typical grayscale image (M55J fibers).

6.6.6.5.4 Image analysis

The objective of the fiber volume image analysis technique is to discriminate between the fibers and matrix. The image is acquired as a gray scale, threshold intensity is used to select the delineation point between the fibers and matrix. The threshold level can be determined by evaluating a histogram of the image as shown in Figure 6.6.6.5.4(a). Typically once the threshold is selected for a given cross section it does not have to be altered as additional images are acquired for that specimen. It is good practice to display the histogram while acquiring images to confirm the veracity of the threshold level. The threshold level is used to convert the grayscale image to a binary image (Figure 6.6.6.5.4(b)) where the fibers will be either black or white and the matrix will be the opposite (white or black). The computer then counts the number of black and white pixels, and the ratio of the fiber pixels to the total number of pixels in the image is the fiber volume.

While automated image systems can be programmed to analyze the entire cross section, this may require as many as 1000 images. Accurate results can be obtained from manually operated systems using from 20 to 50 samples. Testing has shown that where the fibers/resin are evenly distributed, the mean fiber volume converges to a constant value in as few as 20 samples. The manual sampling should be distributed throughout the cross section.

The typical steps in the analysis of a single frame are:

1. Position the specimen. (Manually/automatically move the stage on which the specimen rests.)
2. Focus the microscope. (Manual focusing requires the use of a real time monitor on older computers. Newer computers have acquisition rates fast enough to preclude the use of a monitor.)
3. Acquire an image. (The image used to measure the fiber volume may be a single frame or an average of multiple frames. Integrating several images can offset low luminescence of an image. Examination of the histogram will indicate if the image is suitable for evaluation.)
4. Identify pixels corresponding to fibers. (The histogram should be checked to insure that the correct threshold value has been selected.)
5. Create a binary image. (The pixels with values greater than the threshold value will be black and the pixels with values less than the threshold value will be white.)

6. Count the number of white and black pixels. (Typically it will be necessary to obtain a count of only one of the colors. The total number of pixels in the frame remains constant so the number of fiber pixels for a given image is all that needs to be recorded.)

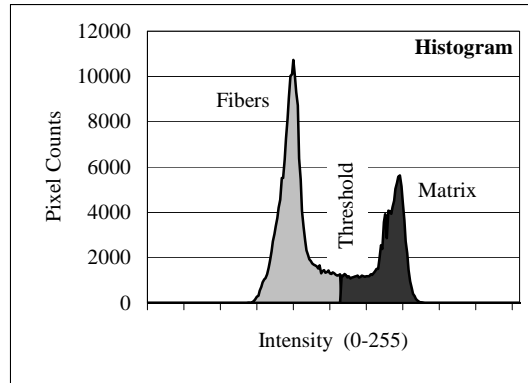

FIGURE 6.6.6.5.4(a) Typical histogram of gray scale fiber and matrix distribution.

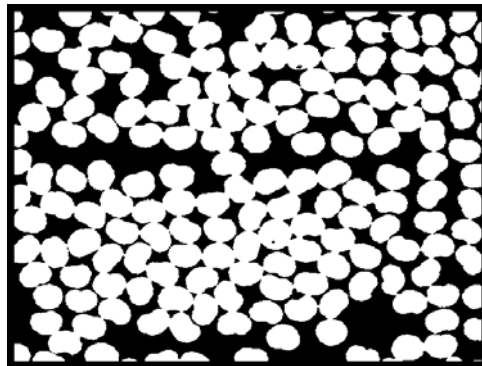

FIGURE 6.6.6.5.4(b) Binary fiber image.

The time required to process a fiber volume measurement can be accelerated by the use of macros within the image analysis program. After the microscope has been focused (step 2), a macro can be initiated via a single keystroke which initiates the acquisition sequence (steps 3 through 6). The histogram can be displayed so that the operator can verify the adequacy of the threshold value selected. Some imaging software programs will have an automatic threshold operation.

6.6.6.5.5 Sources of error

- Out of focus or dirty optics can distort the image which in turn will give inaccurate results.
- Poor metallographic preparation techniques of the cross-section surface makes accurate thresholding difficult.
- Insufficient magnification will result in poor definition of the fibers.

- Poor microscope lighting or incorrect use of blank field image will distort the intensity distribution. The filament in the incandescent bulb used to illuminate the surface may not be uniform. This would result in a non-uniform distribution of light on the specimen surface and yield a distorted histogram. This can be corrected by creating a blank field image that is subtracted from the acquired image. The blank field can be taken either with the microscope slightly out of focus or in focus on a clean area of the polished mounting material surface. Figures 6.6.6.5.5(a) and (b) illustrate this correction.

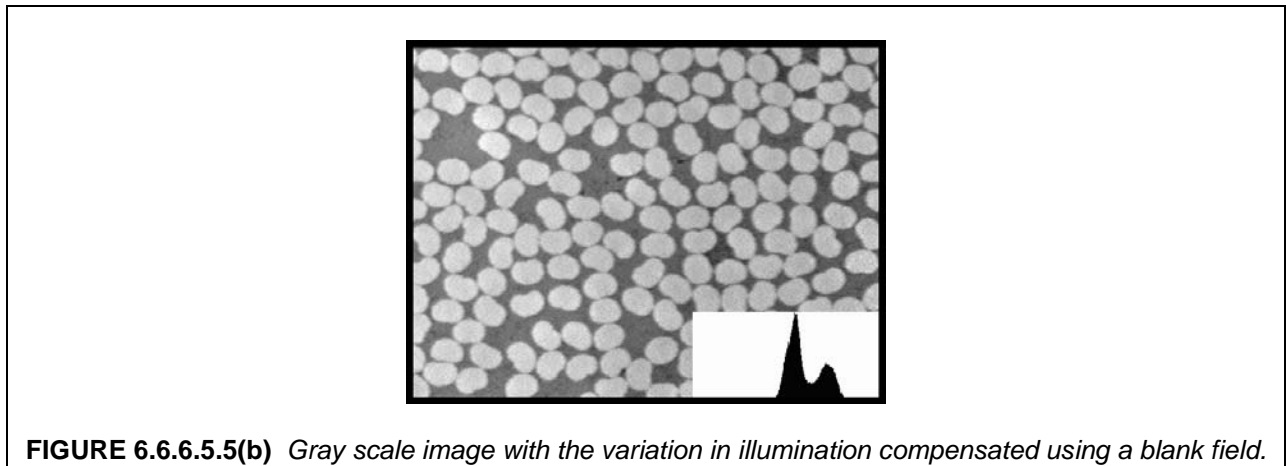
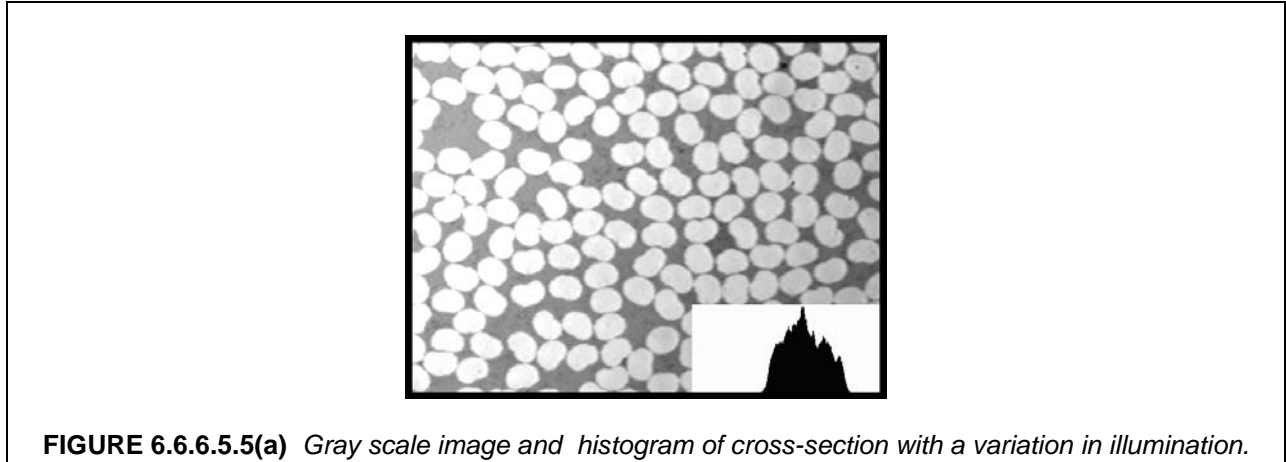

6.6.7 Void volume (V_v) fraction

6.6.7.1 Introduction

Increasing void volume (expressed as a fraction or percent) of a composite material may adversely affect its mechanical properties. The void volume of cured polymer-matrix composites may be obtained by digestive and image analysis assessment. Digestive evaluation uses constituent content and density data to calculate the volumetric void content. Image analysis assessment is obtained by micrographic methods.

6.6.7.2 Digestive evaluation

The most common test method to determine void content is described in ASTM D 2734 "Test Method for Void Content of Reinforced Plastics" (Reference 6.6.7.2). Void content by volume is calculated using

resin and fiber weight percents in the laminate (see Section 6.6.6), along with the densities of the laminate (see Section 6.6.4), fiber (see Section 3.3.2) and resin (see Section 4.5.5). (Fiber and resin densities are commonly obtained from the material supplier.)

This procedure is sensitive to variations in densities and constituent weight percents. Therefore, it is important to use fiber and resin densities that are representative of those constituent densities within the sample tested, and are accurate to three significant figures. Occasionally, negative values of void content may be calculated. Test accuracy is on the order of $\pm 0.5\%$. Therefore, calculated values between -0.5% and 0% are typically considered to be zero. Larger negative values should be investigated for possible errors in technique or procedure. Note that the location and size of the sample should be representative of the material and large enough to minimize experimental error.

Possible causes of error:

Volume measurement may be inaccurate if the sample is not cut with precision.

Laminate density may be inaccurate if the sample is not dried prior to density determination.

Void volumes may not be accurate if density values are determined to less than three significant figures.

6.6.7.3 Determination of void volume using image analysis

6.6.7.3.1 Background

The image analysis technique described in Section 6.6.6.5 can also be used to determine void volume percent. This technique assumes that porosity is essentially the same throughout the laminate and that a random cross-section, therefore, functions as an accurate representative. This assumption is not correct if significant linear (along fiber length) porosity is present. A typical gray scale image is shown in Figure 6.6.7.3.1(a).

The void volume measurement involves using a histogram with three peaks instead of two as shown in Figure 6.6.7.3.1(b). The first peak representing the fibers, the second is the matrix (resin), and the third are the voids. Three colors are then used to represent the areas of the histogram (white, gray, and black, or other user-selected colors). Area percent measurement then proceeds as described in Section 6.6.6.5, with the area of each color measured against the total measured area. The assumption here is that there is adequate contrast between the three areas.

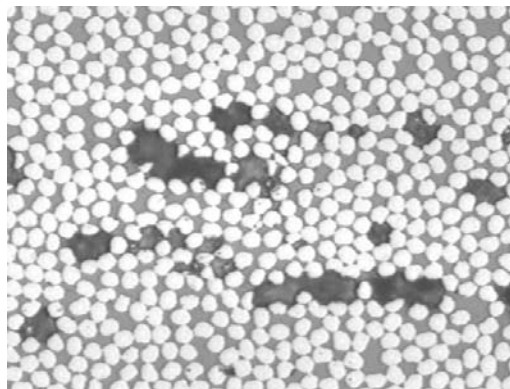

FIGURE 6.6.7.3.1(a) Typical gray scale image of laminate with voids taken at 400X.

The apparatus and specimen preparation are identical to that described in Section 6.6.6.5. A lower magnification, 100 to 200 times, can be used when only void volume is measured or when the void distribution is not uniform. The image analysis is identical to that described in Section 6.6.6.5.

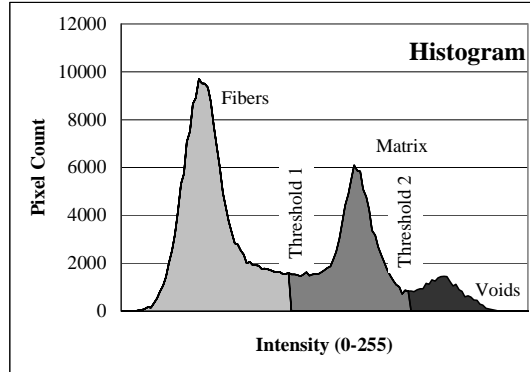

FIGURE 6.6.7.3.1(b) Histogram of intensity distribution of image shown in Figure 6.6.7.3.1(a).

6.6.7.3.2 Sources of Error

- Non-uniform void distribution can lead to significant errors in void volume measurement. Figures 6.6.7.3.2(a) and 6.6.7.3.2(c) show the area around the voids shown in Figure 6.6.7.3.1(a). Figures 6.6.7.3.2(b) and 6.6.7.3.2(d) reflect the histograms for Figures 6.6.7.3.2(a) and 6.6.7.3.2(c), respectively. The void distribution is not uniform across the cross section. Consequently the measured void volume decreases as the magnification is reduced. Using a single image acquired at 400, 200 and 100 times magnification the void volumes were found to be 7.71%, 2.17%, and 0.78%, respectively. As the 100X image encompasses almost the entire thickness of the laminate, the void volume measured from this image is the most accurate. For thicker laminates 100 times magnification would only be a fraction of the laminate thickness. The accuracy of the fiber volume measurement also decreases with decreasing magnification. It is more accurate to perform void volume measurements at lower magnifications than those used for fiber volume measurements.

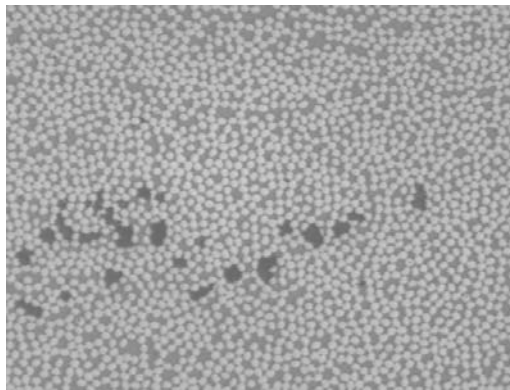

FIGURE 6.6.7.3.2(a) Typical gray scale image of laminate with voids taken at 200X.

- Matrix modifications in a discrete phase (thermoplastic toughening particles) could be confused with voids.
- The lower the magnification used, the lower the effective pixel size.

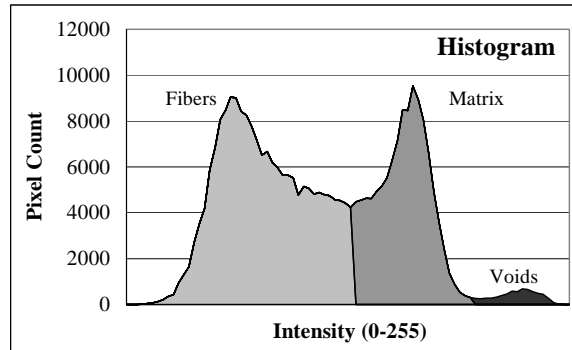

FIGURE 6.6.7.3.2(b) Histogram of intensity distribution of image shown in Figure 6.4.7.3.2(a).

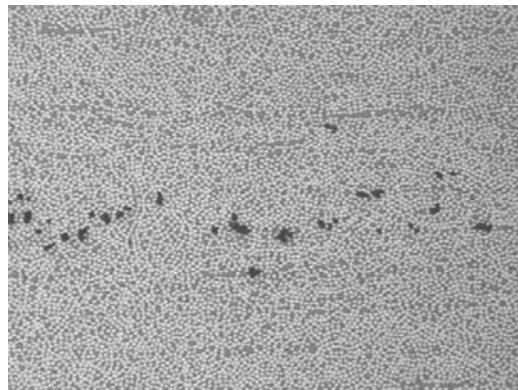

FIGURE 6.6.7.3.2(c) Typical gray scale image of laminate with voids taken at 100X.

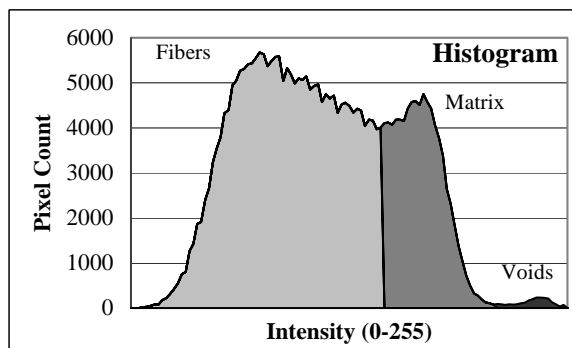

FIGURE 6.6.7.3.2(d) Histogram of intensity distribution of image shown in Fig. 6.4.7.3.2(c).

6.6.8 Moisture/diffusivity

Through-thickness moisture/fluid diffusivity:	D_3 or D_z
Moisture/fluid equilibrium content:	M_m
In-plane moisture/fluid diffusivity:	$D_1, D_2; D_x, D_y$

Many polymeric materials absorb moisture, though in varying amounts and at varying speeds. Moisture is most widely encountered in humid air but is also obviously seen in water (and salt-water) immersion. Other types of fluid exposure, such as hydraulic fluid or jet fuel or even (as in biomedical applications) body fluids, are also encountered during service life in some applications and are considered moisture for the purposes of this discussion.¹

The most commonly adopted moisture diffusion model, and one that many materials have been demonstrated to follow reasonably well, is Fickian diffusion. A one-dimensional example of this model (with a moisture-concentration independent diffusivity) is shown below; it is a direct analog to the more commonly studied thermal diffusion equation:

$$\frac{dc}{dt} = D \left(\frac{d^2c}{dz^2} \right) \quad 6.6.8(a)$$

where:

- c = moisture concentration (g/mm^3)
- t = time (s)
- D = moisture diffusivity (mm^2/s)
- z = coordinate direction of diffusion (mm)

The only standard test method for moisture diffusivity (ASTM Test Method D 5229, discussed in the next section) assumes that the test material behaves as a single-phase Fickian material. The procedure in this test method for calculation of moisture diffusivity will not be accurate for materials that behave otherwise. The prime example of non-Fickian behavior is material containing linked microcracks that allow a direct path for moisture movement. To determine if a material is Fickian, conduct the test, examine the behavior, and calculate the diffusivity, then compare predicted behavior to the test result. If the test behavior does not follow guidelines in the ASTM standard, or the test/analysis correlation is poor, the diffusion may not follow the single-phase Fickian model. However, by procedures not contained in the standard, the data acquired during testing can be used to calculate diffusivity for multi-phase Fickian behavior, if such a model better fits the test results. Also, moisture equilibrium content can be determined by these tests even for materials that do not follow single-phase Fickian behavior.

Other methods of determining moisture content are available but not widely used due to expense, lack of standardization, and/or other limitations, and are not discussed further. One of the newer such methods is nuclear magnetic resonance (NMR) as used in magnetic resonance imaging machines, which, for electrically non-conductive materials (this excludes carbon reinforcement), can non-destructively determine the moisture concentration spacial distribution.

The two primary moisture-related properties of a polymeric composite material are the through-thickness *moisture diffusivity constant*, D_3 or D_z , (speed of moisture diffusion) and *moisture equilibrium content*, M_m . M_m is the total absorbed moisture as a percentage of overall material weight, determined at equilibrium. For a given material, moisture diffusivity is actually a constant only for a given environment and direction of diffusion, as it normally varies very strongly as a function of temperature. Equilibrium

¹ There are several possible definitions of the term "moisture." It has been used to refer to the vapor of a fluid, or its condensate, or even the bulk fluid itself in large quantities. It has been restricted to water itself, in one or more of these forms, or applied to other fluids. While the term "fluid" may arguably be a more precise term for what we are covering in this section, the term "moisture" is retained for general use, largely due to the historical emphasis and use of the term in discussing these problems. For example, the symbol "M" used to describe absorbed fluid equilibrium content is taken from the word "moisture." And so it is convenient for the purposes of this discussion to extend the definition of moisture to all absorbed fluids.

moisture content, on the other hand, does not vary strongly with temperature, but does vary, in the case of humid air, with relative humidity level. (Important background material on the use and application of these properties is located in Volume 1, Sections 2.2.6-8 and 6.3.)

Moisture diffusion of polymeric composites is generally not isotropic. It is not unusual for in-plane moisture diffusivities (D_1 , D_2 ; D_x , D_y) to be an order of magnitude higher than D_3 or D_z . General diffusion models consider moisture diffusivity, like thermal diffusivity and thermal conductivity, to be a second-order tensor quantity that mathematically varies (transforms) as a function of direction in accordance with tensor transformation rules. While it may be tempting to ignore the surface area of edges when they constitute a small proportion of the overall surface area, moisture diffusion through the edges can be significant in a test specimen of limited size. With an understanding of this, the usual procedure is to limit diffusion through the edges so that its effects can be ignored. In-plane moisture diffusion is rarely precisely quantified. No standard test methods for determination of in-plane moisture diffusion currently exist.

Provided the moisture exposure has not cracked or chemically altered the material, the desorption behavior is the reverse of the absorption behavior. In fact, well-behaved desorption is one of the qualitative indications of Fickian behavior.

6.6.8.1 Standard test methods

- 1) ASTM D 5229/D 5229M
- 2) SACMA RM 11R

The only standard test method that rigorously covers determination of the two primary properties is ASTM D 5229/D 5229M (Reference 6.6.8.1(a)). Another test method that covers determination of moisture equilibrium content only is SACMA RM 11R (Reference 6.6.8.1(b)). SACMA RM 11R is based on similar methods used in the ASTM standard, covers determination of properties with somewhat less rigor, and is limited to a single fixed environment of 85% RH humid air. Both of these test methods are gravimetric experiments. A piece of the material is initially weighed and then periodically weighed during exposure to the fluid environment in question. From these data the through-thickness moisture diffusivity (ASTM only) and equilibrium moisture content (both ASTM and SACMA) can be determined.

Both of these test methods, especially ASTM D 5229, cover the subject quite well within the test method documentation. Anyone interested in better understanding this subject should start by reading the test methods, as well as the related sections of this handbook referenced above. The primary reference for these standards is Reference 6.6.8.1(c). Beyond this, further reading would include the other references specified within ASTM D 5229.

Testing issues worth noting that are not currently covered by the test methods themselves include:

1. ASTM D 5229 specifies stringent requirements for a single test specimen that is used to determine, in the same experiment on the same specimen, both moisture diffusivity and moisture equilibrium content. However, it is substantially more practical to test two different test specimen geometries to obtain these properties: a thin specimen from which maximum moisture content can relatively quickly be determined, and a thick specimen from which an extremely stable initial linear slope of the moisture mass gain versus square-root of time plot can be found. The two-specimen approach provides a much more accurate and cost-effective result than that literally described in the 1992 initial release of this standard. ASTM D 5229 is expected to be revised as soon as practical to include this concept.
2. While the ASTM test method uses a diffusivity-based guideline to assess satisfaction of equilibrium (e.g., the maximum allowable change in mass between the last two weighings, which determines when effective equilibrium has been attained, is lower for higher-diffusivity specimens), the SACMA test method uses a fixed reference time period of 24 hours. The approach used by the ASTM test method essentially adjusts the test parameters to result in a fixed maximum error, while the SACMA test method fixes the test parameters and results in variable error.

It is also important to note that there is wide variation in the moisture response of polymers. There are classes of polymers, and their composites, that essentially do not absorb moisture to any appreciable extent due to their molecular structure. These test methods may not produce meaningful results on such materials. One such polymer is polybutadiene.

There are other polymers that, upon cursory examination, *appear* to have no appreciable moisture weight change response, but actually have a low diffusion constant. However, given sufficient exposure time, these polymers will eventually absorb a meaningful amount of moisture. Some high-performance thermoplastics and thermosets fall in this category.

At the other end of the scale are the polymers that absorb (and desorb) moisture so quickly that extreme care must be taken with the gravimetric measurements and with the calibration and control of the environmental chamber, in order to avoid large measurement errors. The most convenient solution for reducing the test sensitivity of these materials is to simply increase the thickness of the test specimen. Polyetherimide is one such material.

While not strictly within the scope of this section, it is worthy to note that most current polymeric matrix sandwich core materials absorb, and are affected by, moisture. When honeycomb core, in particular, is evaluated by itself for moisture absorption response or is mechanically tested as bare core under conditions of controlled moisture content, the surface area is so large relative to the thickness of the cell walls (often as small as 0.003 inch) that the material can absorb/desorb very quickly. Bare honeycomb core is, therefore, very sensitive to experimental procedure for environmental testing or conditioning.

6.6.8.2 Moisture diffusion property test methods for MIL-HDBK-17 data submittal

Data produced by the test methods in Table 6.6.8.2 are currently being accepted by MIL-HDBK-17 for consideration for inclusion in Volume 2.

Table 6.6.8.2

Property	Symbols	Fully Approved, Interim, and Screening Data	Screening Data Only
In-Plane Moisture Diffusivity	D_1, D_2 (lamina) D_x, D_y (laminate)	---	---
Through-Thickness Moisture Diffusivity	D_3 (lamina) D_z (laminate)	D 5229	---
Equilibrium Moisture Content	M_m	D 5229 SRM 11R (85% humid air only)	---

6.6.9 Dimensional stability (Thermal and Moisture)

Dimensional changes in composite materials are typically a function of temperature and/or moisture. Changes in length or volume of a sample can be detected by mechanical, optical or electrical transducer and recorded as a function of temperature or time. Several techniques for measuring linear expansion, such as dial gauges, micrometers, telescopes, linear variable differential transformers, interferometers, and X-ray diffraction patterns, have been used.

6.6.9.1 Dimensional stability (thermal)

α , α_{11} , α_{22}

6.6.9.1.1 Introduction

It is well known that most materials change dimensions with a change in temperature. In fact, most materials expand as the temperature is increased. By definition, isotropic materials, which typically include bulk metals, polymers and ceramics, expand equally in all directions. The reinforcing fibers used to reinforce these bulk materials may or may not be isotropic. For example, inorganic fibers such as glass, boron, and other ceramics are isotropic, while organic fibers such as carbon, aramid (e.g., DuPont's Kevlar), polyethylene (e.g., Allied's Spectra) and others are not.

Even if an isotropic fiber is used in combination with an isotropic matrix, the resulting composite will not be isotropic. The oriented fibers, which are presumably stiffer than the matrix, produce a composite stiffness higher in the direction of orientation than in the transverse direction. Correspondingly, the thermal expansion of the isotropic reinforcing fiber will typically be different than that of the matrix. In the fiber direction the fiber and matrix expand in parallel, while in the transverse direction they expand in series. Thus, in the axial direction the composite thermal expansion is strongly controlled by the thermal deformation of the (stiff) fiber. In the transverse direction the thermal expansion is in proportion to the relative amounts of fiber and matrix in that direction, and their respective thermal expansions. That is, even for isotropic fibers in an isotropic matrix, the composite thermal expansion is anisotropic, and is governed in a complex manner by both the mechanical and thermal properties of each constituent, the fiber orientation, and the relative amounts of fiber and matrix present.

For anisotropic fibers the thermal anisotropy of the resulting composite is even more complex, although no less predictable or measurable. Of special utility is that anisotropic fibers such as carbon, aramid, and polyethylene have negative coefficients of thermal expansion in the fiber axial direction, and relatively high positive coefficients of thermal expansion in the transverse (diametrical) direction. Since the fiber axial stiffness tends to be much higher than that of the matrix, the resulting composite is likely to have a negative coefficient of axial thermal expansion (although the transverse expansion will be positive). In fact, by combining a fiber of the appropriate axial stiffness and negative thermal expansion with a matrix of given stiffness and (positive) thermal expansion, a composite having a zero axial thermal expansion can be achieved (although again a positive transverse expansion will be obtained). Thus, the thermal expansion properties of a composite can be tailored to the specific application just as mechanical properties are.

Thermal stability is customarily defined in terms of a Coefficient of Thermal Expansion (CTE) expressed symbolically as α . Typical units are $10^{-6}/K$ (microstrain per degree Kelvin). Since CTE is calculated as the slope of the expansion versus temperature curve, linear expansion over the temperature range of interest is assumed. However, depending on the material and the temperature range, expansion may not be linear. When expansion over the temperature range of interest is not linear, it is common practice to calculate a separate CTE for each subrange that approximates linearity. Thus, in general, CTE is temperature dependent, and there is not a single value of CTE for a given material.

The classes of polymers used as matrix materials, e.g., epoxies, bismaleimides, polyimides, and high temperature thermoplastics, have higher values of CTE compared to metals and ceramics. At temperatures above their glass transitions, they have larger values of CTE than below their transitions, a behavior which may be used to determine glass transition temperature (see Section 6.6.3). Materials having several polymer constituents may have multiple glass transitions, making the expansion versus temperature curve more complex.

6.6.9.1.2 Existing test methods

There are four ASTM standards governing the experimental determination of the thermal expansion of unreinforced (neat) polymers and their composites. ASTM Standard D 696 (Reference 6.6.9.1.2(a)) is the

simplest of these standards, being applicable only over the relatively narrow temperature range of -20°F to 90°F (-30°C to 30°C). The reason for this narrow range is that the standard is intended primarily for testing (commodity) plastics, which by their nature have a limited range of use temperatures. The apparatus itself, a vitreous silica dilatometer (often termed a fused silica or a quartz tube dilatometer, although not in this ASTM standard), can be used over a much wider range of temperature. In fact, ASTM Standard E 228 (Reference 6.6.9.1.2(b)) utilizes a similar apparatus and specifies a use temperature range of -290°F to 1650°F (-180°C to 900°C), although some minor cautions are given for applications over 900°F (500°C). This standard is intended for a broader range of test materials, including metals, plastics, ceramics, refractories, composites and others.

ASTM E 831 (Reference 6.6.9.1.2(c)) utilizes thermomechanical analysis (TMA) to measure thermal expansion. The principle of operation of TMA is not unlike that of a vitreous silica dilatometer, and thus the applicable temperature range is comparable. ASTM E 831 indicates a range of applicability from -180°F to 1100°F (-120°C to 600°C), and suggests that this range may be extended depending upon the specific instrumentation and calibration materials used.

Per ASTM D 696, the vitreous silica dilatometer is limited to the measurement of thermal expansion coefficients greater than 1 microstrain/K. ASTM E 831 suggests a lower limit of 5 microstrain/K for TMA, this lower resolution being due to the smaller specimen used in a TMA apparatus. In either case, this level of resolution is adequate for most bulk materials, certainly for most metals and polymers, although marginal for some ceramics. Obviously it is not adequate for those composites designed to have a coefficient of thermal expansion near zero, as described above.

ASTM Standard E 289 (Reference 6.6.9.1.2(d)) utilizes interferometry, which permits the measurement of coefficients of thermal expansion as low as 0.01 microstrain/K. ASTM E 289 indicates an applicable temperature range of -240°F to 1300°F (-150°C to 700°C), again with the suggestion that this range may be extended depending on the instrumentation and calibration materials used. Interferometry does require much more operator skill and care, and more complex equipment, than dilatometry.

In addition to the ASTM standard methods, which utilize a dilatometer or interferometer, bonded foil strain gages can also be used to determine CTE. Typically, the measured thermal expansion of the test material is compared to the expansion of a reference material of accurately known CTE in the same chamber. Although not an ASTM or other standard method, Reference 6.6.9.1.2(e) presents complete details of using strain gages to measure thermal expansions. The applicable temperature range depends upon the material being measured, and the type of strain gage utilized. Per Reference 6.6.9.1.2(e), maximum accuracy gages can be used within a temperature range of -50°F to 150°F (-45°C to 65°C), although this range can be extended somewhat by using alternate types of gages. However, an equally important limitation is the stiffness of the test material at temperature relative to the corresponding stiffness of the gage material. A stiff gage can locally reinforce the test material, leading to erroneously low CTE results.

6.6.9.1.3 *Test specimens*

Thermal expansion specimens, whether neat polymer or composite, are typically cylindrical in form, and as long in the direction of measurement as the available material and test apparatus permit. The longer the specimen, the greater the length change, and thus the more precise the measurement of CTE for a given equipment resolution. While the specimen cross-sectional shape is somewhat immaterial, specimens are typically circular, square or rectangular. Some minor axial compressive force is usually applied to the specimen during the test to keep the indexing apparatus in contact with the ends of the specimen. This can induce column buckling in materials that have low stiffness at elevated temperatures, e.g., some unreinforced polymers. In fact, even specimen sag under the force of gravity can induce erroneous deformations in such materials. Thus the specimen cross-sectional shape is kept as compact as practical, e.g., square or circular.

Per the general guidelines of ASTM D 696, specimens tested using a dilatometer are typically 2 to 5 in. (50 to 130 mm) long and 0.25 to 0.50 in. (6 to 13 mm) in lateral dimensions. Per ASTM E 831, TMA specimens should be between 0.08 and 0.40 in. (2 to 10 mm) in length, with lateral dimensions not exceeding 0.39 in. (10 mm), although other lengths are permitted if noted in the report. The TMA apparatus configuration itself typically limits the specimen size. For interferometry, ASTM E 289 states that the optimal length is between 0.4 and 0.8 in. (10 to 20 mm) and the lateral dimensions between 0.2 and 0.5 in. (5 to 12 mm).

These small sizes are recommended mainly because of the geometry of a Fizeau interferometer and the advisability to have minimal internal temperature gradients in reference and test samples. The Michelson approach is much more versatile and is not limited to any sample size or shape except via the coherence length of the laser itself. This in turn is dependent on the frequency stability of the particular laser employed. A typical application is to place reflecting (e.g., mirror) surfaces on, at or near the ends of a sample separated by distances of anything from near zero to about 200m. In most cases it is advisable not to use sample ends. This is because many materials, especially composites, laminates or sandwich structures, have changing stress states near edges or ends and these regions will exhibit different CTE values than internal or bulk regions.

Work is ongoing to modify ASTM D289 accordingly.

6.6.9.1.4 Test apparatus and instrumentation

The three general types of apparatus in use, dilatometers, thermomechanical analyzers and interferometers, are fully described in the corresponding ASTM standards, as already introduced in Section 6.4.9.1.2.

6.6.9.1.5 CTE test methods for MIL-HDBK-17 data submittal

Data produced by the following test methods (Table 6.6.9.1.5) are currently being accepted by MIL-HDBK-17 for consideration for inclusion in Volume 2:

TABLE 6.6.9.1.5 Coefficient of thermal expansion test methods for MIL-HDBK-17 data submittal.

Material Type	Property (symbol)	Fully Approved, Interim, and Screening Data	Screening Data Only
Polymer Matrix (unreinforced)	α_m	ASTM E 228 ASTM E 831 ASTM E 289*	ASTM D 696
High Fiber Axial Expansion Composites	α_{11}, α_{22}	ASTM E 228 ASTM E 831 ASTM E 289**	ASTM D 696 (α_{22} only)
Low Fiber Axial Expansion Composites	α_{11} α_{22}	ASTM E 289 ASTM E 228 ASTM E 831 ASTM E 289*	ASTM D 696 ASTM D 696

* This level of resolution is not required.

** This level of resolution is not required for α_{22}

6.6.9.2 Dimensional stability (moisture)

$$\beta, \beta_{11}, \beta_{22}$$

6.6.9.2.1 Introduction

Dimensional stability due to moisture absorption is customarily defined in terms of a Coefficient of Moisture Expansion (CME), which is expressed symbolically as β (the second letter in the Greek alphabet, following α , which is typically used to symbolically express the Coefficient of Thermal Expansion, CTE, the analogous quantity for thermal dimensional stability). Composites can have different CME's in different directions, whereas unreinforced (neat) polymers typically expand equally in all directions.

Coefficients of moisture expansion of unreinforced polymers are conveniently expressed in units of $10^{-3}/\text{wt}\%M$, whereas CME values for fiber reinforced polymers are expressed in units of $10^{-6}/\text{wt}\%M$ or $\text{ppm}/\Delta M$. (Coefficients of thermal expansion are typically expressed as $10^{-6}/^{\circ}\text{C}$ (microstrain/ $^{\circ}\text{C}$). The strains induced due to temperature changes and moisture changes are proportional to $\alpha \Delta T$ and $\beta \Delta M$, respectively. The effect on dimensional stability of moisture expansion can be considerably greater than the effect of thermal expansion.

The absorption of moisture in polymers and polymer-matrix composites usually causes volumetric expansion (swelling). Most natural fibers, and aromatic polyamide fibers, such as aramid (Reference 6.6.9.2.1(a)), absorb moisture. There are indications that many carbon fibers such as AS4, IM6 and IM7 (References 6.6.9.2.1(b) and (c)) also absorb moisture. In addition, many man-made fibers appear to have negative coefficients of moisture expansion. Polyethylene fibers (e.g., Allied's Spectra) may also absorb moisture but they remain relatively stable dimensionally, particularly in the fiber axial direction, because of the rigid molecular structure. In general, it is the polymer matrix that dictates the amount of swelling due to moisture absorption. For a unidirectional carbon fiber polymer matrix composite, CME values are typically 50-60 parts per million per percent weight change ($\text{ppm}/\Delta M$) in the (carbon) fiber direction and 3000-8000 $\text{ppm}/\Delta M$ in the transverse (cross fiber) direction, and also in the through-thickness direction. For laminates such as quasi-isotropic lay-ups, the in-plane CME values are typically in the 200-500 $\text{ppm}/\Delta M$ range.

No ASTM or other standard for moisture dimensional stability testing presently exists. A detailed presentation of test procedures, types of apparatuses used, and typical experimental results for both unreinforced (neat) polymers and their composites, is included in Reference 6.6.9.2.1(d). This information is summarized in Reference 6.6.9.2.1(e). Coefficient of Moisture Expansion (CME) measurements for solid laminates are also described in (Reference 6.6.9.2.1(f)), and for composite sandwich panels in (References 6.6.9.2.1(g) and (h)). ASTM C 481 (Reference 6.6.9.2.1(i)), ASTM D 5229 (Reference 6.6.9.2.1(j)), and ASTM E 104 (Reference 6.6.9.2.1(k)) provide assistance with general test techniques, including establishing relevant humidity conditions. The significance of maintaining a uniform moisture content through the laminate thickness when measuring moisture-induced strains is discussed in Reference 6.6.9.2.1(l).

The various classes of polymers used as matrix materials, e.g., epoxies, polycyanates, bismaleimides, polyimides, and high temperature thermoplastics (PEEK, PEKK, PPS, PAS, polyamide-imide, etc.) exhibit various magnitudes of coefficient of moisture expansion. However, it is equally important to recognize that there can also be a significant variation of moisture expansion coefficient from one polymer to another within a given class of polymers.

As discussed in Section 6.6.8, the various polymer matrices absorb moisture at significantly different rates (moisture diffusivity), and contain widely differing amounts of moisture at saturation. That is, it is important to recognize that the total influence of moisture on dimensional stability is the product of CME and weight percent moisture absorption; and the rate at which this influence occurs is dependent on the moisture diffusivity. This in turn varies significantly with temperature, stress level and damage state, such as

microcracking. Sudden changes in temperature (thermal spiking) or stress (mechano-absorptive effect) have major effects on properties such as moisture absorption, creep rates, and mechanical stiffness.

6.6.9.2.2 *Specimen preparation*

Moisture expansion specimens, whether neat polymer or composite, are typically very thin, to minimize the time required to absorb a significant fraction of their moisture equilibrium levels. The moisture diffusion coefficient can be determined from the initial part of a weight change versus time curve, but the coefficient of moisture expansion requires knowledge of the equilibrium or total weight change. A specimen thickness on the order of 0.050 in. (1.27 mm) is typical. The other dimensions of the specimen are made large enough (e.g., 3 – 10 inches long by 1 – 3 inches wide) so that both weight change and dimensional changes can be measured accurately. This specimen geometry, with its large areas on two opposing surfaces combined with minimal edge area, also exhibits the secondary advantage of permitting a one-dimensional diffusion assumption when reducing the experimental data.

Moisture expansion specimens can be fabricated to the thickness required, or machined from thicker material. Surface grinding usually works well for this purpose.

6.6.9.2.3 *Test apparatus and instrumentation*

Two quantities must be measured to obtain the coefficient of moisture expansion, viz., the total dimensional change and a total weight change. The CME, analogous to the CTE, is a thermodynamic property so a reproducible and equilibrium value of both these quantities must be established. This in turn requires a means for extrapolating partial strain and weight changes to infinite time, where no strain or mass gradients exist in the sample.

One measurement technique is to use two identical specimens in the same environmental chamber, one specimen being weighed on an analytical balance while the length of the other is monitored by some type of dilatometer. An analytical balance weighing to the nearest 0.1 milligram and a dilatometer (or interferometer) measuring microinches are generally suitable. It may be desirable to keep both the analytical balance and the dilatometer electronics outside of the environmental chamber. For example, the weight gain specimen can be suspended inside the chamber by a thin wire attached to the analytical balance. A quartz tube dilatometer can extend into the chamber, with the electronic components remaining on the outside. It is also possible to measure weight and length simultaneously on the same sample. To avoid erroneous readings, it is important that no moisture be allowed to condense on either the specimen or the suspension wire. Small heating elements can be located in these critical locations as required to keep the local temperature slightly higher than the surroundings, thus avoiding condensation in these critical locations.

The specimens should be dried thoroughly, following the general guidelines of Section 6.3 of Volume 1, so that subsequent measurements are referenced to the zero moisture state. Since the rate of moisture absorption increases rapidly with increasing temperature, to reduce the testing time it is customary to perform the test in a heated chamber, while maintaining a prescribed level of relative humidity. This may be as high as 98 %RH (staying sufficiently below 100 %RH so that moisture condensation on the specimen or support wire does not become an overwhelming problem). The acceptable chamber temperature is dictated to some extent by that which is allowable for the type of material being tested. However, since the rate of moisture diffusion is a strong function of temperature, and most polymers swell significantly with absorbed moisture, large moisture (and, therefore, strain) gradients can be induced through the thickness of the specimen, even though it is relatively thin. These strain gradients can induce surface microcracking, leading to erroneous dimensional change measurements (and nonrepresentative moisture weight gains also). For example, for a carbon/epoxy composite, as a general guideline conditioning chamber temperatures do not exceed about 170°F (77°C), with about 150°F (66°C) being a safer upper limit.

Although the use of elevated temperature accelerates the moisture absorption test, there is no assurance that the measured CME is independent of temperature. Thus, a measurement made at one tem-

perature may not be representative of the CME at other temperatures. This can only be determined by testing at multiple temperatures.

For a given test, conducted at a prescribed temperature, the plot of moisture expansion versus moisture content may not be linear, although it usually is relatively so. Since CME is the slope of this plotted curve, it will then not be a constant value.

6.6.9.2.4 CME test methods for MIL-HDBK-17 data submittal

At the present time there is no ASTM or other standard for coefficient of moisture expansion testing. Data submitted for consideration must include a detailed description of the test method.

6.6.10 Thermal conductivity

6.6.10.1 Introduction

The thermal conductivity for polymer-matrix composites is a required thermal response property applicable to all heat flow conditions. Measurement methods are available for either steady state or transient heat flow conditions. The steady state methods are described in this section.

On reaching a steady state, the thermal conductivity λ of a specimen in the thickness direction is determined from the Fourier relation:

$$\lambda = Q / (A \cdot \Delta T / L) \quad 6.6.10.1$$

where

- Q = heat flow rate in the metered section
- A = metered section area normal to heat flow
- ΔT = temperature difference across the specimen
- L = specimen thickness

The units of the parameters of Eq (6.4.10.1) are:

- Q - W
- A - m²
- ΔT - K
- L - m
- λ - W/m•K

Transient methods actually are determinations of the thermal diffusivity, from which the thermal conductivity may be derived, and are described in Section 6.6.12.

6.6.10.2 Available methods

Several ASTM test methods are available for steady state thermal transmission characterizations. They can be categorized as one of two types: as an absolute (or primary) method of measurement in which no heat flux reference standards are required except to confirm accuracy or to establish traceability to recognized standards (C177); or, as a comparative (or secondary) method in which the results are directly dependent on heat flux reference standards (E1225, C518). The methods are briefly described below.

The choice of the measurement method for polymer-matrix laminates often depends upon the measurement direction. Out-of-plane measurements can be performed with the C177 method, but occasionally the E1225 comparative method is used also. In-plane measurements performed on thin laminates require that the specimen diameter be built up by stacking several laminates together. The C177 method is

usually preferred but results on specimens using the E1225 method are occasionally reported. The flash diffusivity method (E1461) is also a viable choice for laminates in either orientation (see Section 6.6.12). Advantages include shorter test times and smaller specimen sizes.

6.6.10.2.1 ASTM C177-97

ASTM C177-97, known as the guarded hot-plate method (Reference 6.6.10.2.1(a)), is an absolute determination method which covers the measurement of heat flux and associated test conditions for flat-slab specimens when their surfaces are in contact with solid, parallel boundaries held at constant temperatures. This test method is good for low thermal conductivity materials and is applicable to a wide variety of specimens and a wide range of environmental conditions.

Figure 6.6.10.2.1 shows the main components of the idealized system: two isothermal cold surface units and a guarded-hot-plate. The guarded-hot-plate is composed of the metered area centerpiece and a concentric guard ring. Some apparatus have a coplanar secondary guard. Sandwiched between these three units is the material to be measured. Figure 6.6.10.2.1 depicts the double-sided mode of measurement, i.e., the specimen is actually composed of two pieces. The measurement in this case produces a result that is an average of the two pieces and, therefore, it is important that the two pieces be as identical as possible. For guidance in the use of the single-sided mode of operation, in which the specimen consists of one piece placed on one side of the hot-surface assembly, see Reference 6.6.10.2.1(b), describing ASTM Practice C1044.

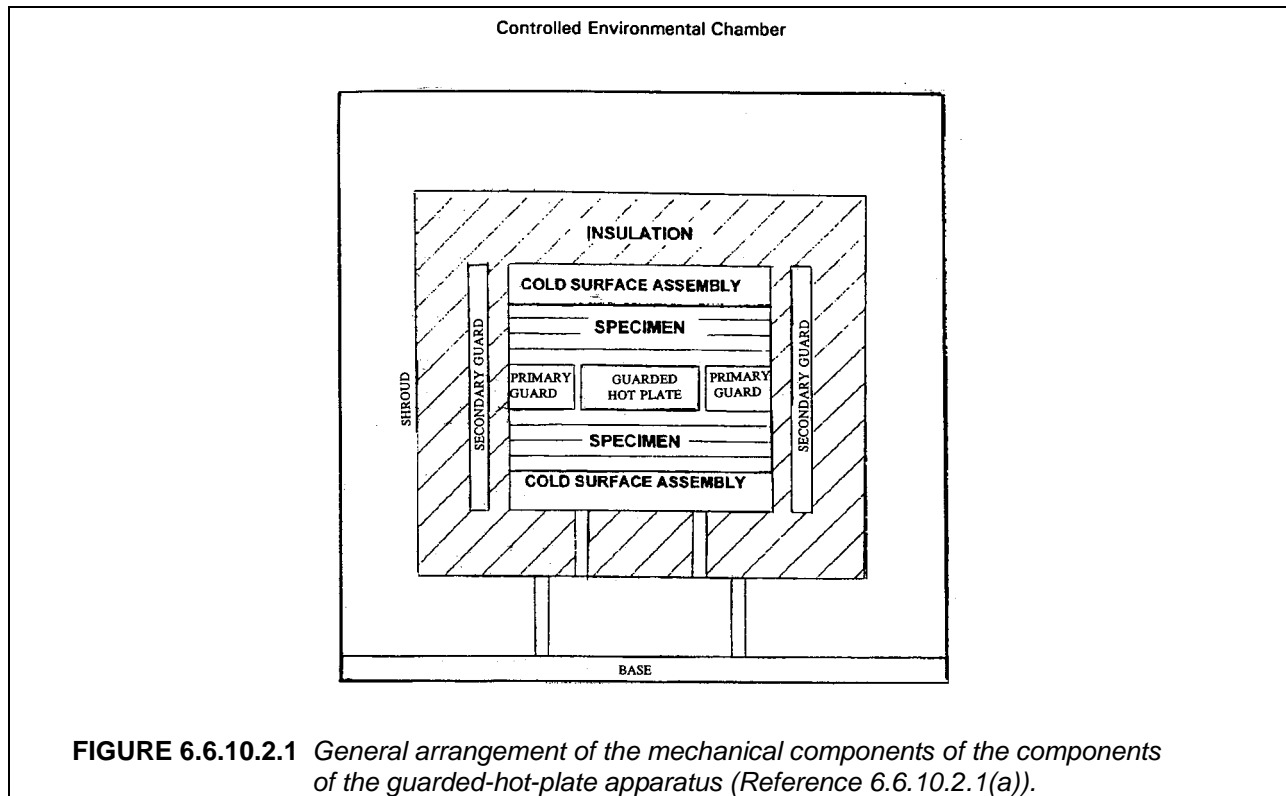

FIGURE 6.6.10.2.1 General arrangement of the mechanical components of the components of the guarded-hot-plate apparatus (Reference 6.6.10.2.1(a)).

The arrangement of Figure 6.6.10.2.1 demands that precautions be exercised concerning heat flux losses and proper use of the thermal guard ring, and concerning the accurate measurement of temperature differences and the temperature sensor separation. The guarded-hot-plate provides the power for the measurement and defines the actual test volume, that is, that portion of the specimen that is actually being measured. The function of the primary guard ring is to reduce lateral heat flow within the appara-

tus. The proper (idealized) conditions are illustrated in Figure 6.6.10.2.1 by the configuration of the isothermal surfaces and lines of constant heat flux within the specimen.

Steps must be taken to ensure that the heat flows uniformly into the specimen. Under vacuum conditions the slightest space between plate and specimen is an infinite thermal resistance except for radiative heat transfer. Good thermal contact between the hot and cold assemblies and the specimen surfaces is promoted by applying a reproducible constant clamping force to the guarded-hot-plate apparatus, such as the pressure produced by using constant force springs. Another potential solution is to mount a compressible thin sheet of conductive soft material or fibrous pad between the plates and specimen to improve the uniformity of the thermal contact.

Compliance with this test method requires the establishment of steady-state conditions and the measurement of the unidirectional heat flow Q in the metered section, the metered section area A , the temperature of the hot and cold surfaces, T_h and T_c (in Equation (6.6.10.1) $\Delta T = T_h - T_c$), the thickness of the specimen L , and any other parameters which may affect the heat flux in the metered region.

6.6.10.2.2 ASTM E1225-99

ASTM E1225-99, or the guarded longitudinal heat flow technique (Reference 6.6.10.2.2), is a comparative test method. Hence, reference materials or transfer standards with known thermal conductivities must be used. This test method is for materials with effective conductivities in the approximate range $0.2 < \lambda < 200 \text{ W/m}\cdot\text{K}$ over the approximate temperature range between 90 and 1300 K. It can be used outside these ranges with decreased accuracy.

The general features of the technique are shown in Figure 6.6.10.2.2. A test specimen is inserted under load between two similar specimens of a material of known thermal properties (meter bars). A temperature gradient is established in the test stack by maintaining the top at an elevated temperature and seating the bottom on a heat sink. Heat losses are minimized by use of a longitudinal guard heater having approximately the same temperature gradient. At steady state equilibrium, the thermal conductivity is derived in terms of the measured temperature gradients in the respective specimens and the thermal conductivity of the reference materials.

The thermal conductance (ratio of thermal conductivity to length) of the reference material should match the thermal conductance of the specimen as closely as possible to ensure similarity in temperature gradients and better accuracy. When the meter bars and the specimen are right circular cylinders of equal diameter the technique is described as the cut-bar method. When the cross-sectional dimensions are larger than the thickness it is described as the flat slab comparative method. Essentially any shape can be used as long as the meter bars and specimen have the same conduction areas.

This test method requires uniform heat transfer at the meter bar to specimen interfaces, which is normally attained by use of an applied axial load in conjunction with a conducting medium at the interfaces. The stack is surrounded by an insulator and enclosed in a guard shell. At steady state, the temperature gradients along the sections are calculated from the measured temperatures along the two meter bars and the specimen. The value of the thermal conductivity in the specimen, λ_s , can then be determined using Equation (6.6.10.2.2) where Z_i = position of a thermocouple as measured from the upper end of the column (see Figure 6.6.10.2.2), T_i = the temperature at position Z_i , λ_m^1 = the thermal conductivity of the top meter bar, and λ_m^2 = the thermal conductivity of the bottom meter bar.

$$\lambda_s = \frac{[(Z_4 - Z_3) \lambda_m^1 (T_2 - T_1)] / [(T_4 - T_3) 2 (Z_2 - Z_1)]}{+ [\lambda_m^2 (T_6 - T_5)] / [2 (Z_6 - Z_5)]} \quad 6.6.10.2.2$$

This result is a highly idealized situation since it assumes no heat exchange between the column and insulation and uniform heat transfer at each meter bar-to-specimen interface. The errors caused by these assumptions are discussed in Reference 6.6.10.2.2.

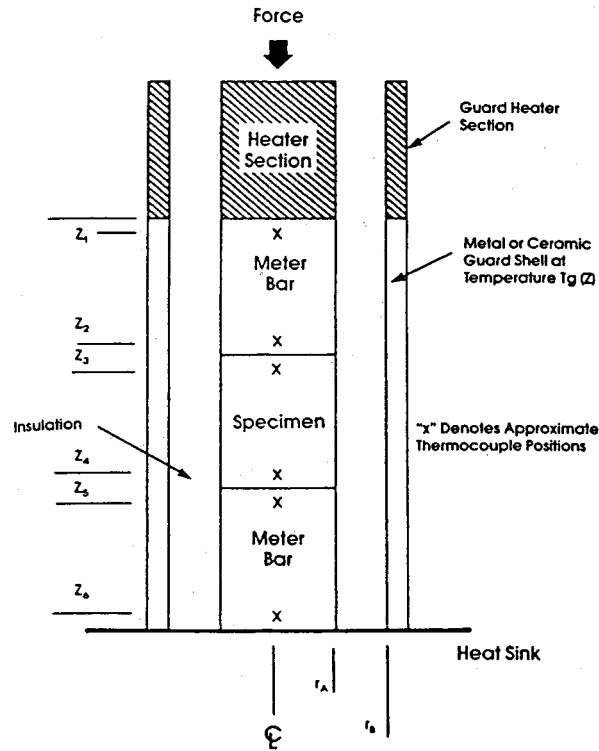

FIGURE 6.6.10.2.2 Schematic of a comparative-guarded-longitudinal heat flow system showing possible locations of temperature sensors.

6.6.10.2.3 ASTM C518-98

ASTM C518, Reference 6.6.10.2.3(a), describes the measurement of the steady state thermal transmission through flat slab specimens using a heat flow meter apparatus. This is a comparative, or secondary, method of measurement since specimens of known thermal transmission properties are required to calibrate the apparatus. The test applies to low conductivity materials. To meet the requirements of this test the thermal resistance of the test specimen should be greater than $0.10 \text{ m}^2 \cdot \text{K/W}$ in the direction of the heat flow and edge heat losses should be controlled using edge insulation and/or a guard heater.

The important features of the heat flow meter apparatus are two isothermal plate assemblies, one or more heat flux transducers, and equipment to measure temperature and the output of the heat flux transducers. Either one or two specimens are used. Three common experimental configurations are depicted in Figure 6.6.10.2.3. Equipment to control the environmental conditions is employed when needed.

A heat flux transducer is a device that produces a voltage output which is a function of the heat flux passing through it. The various types of heat flux transducers are described in Test Method C1046, Reference 6.6.10.2.3(b). The gradient type, commonly used in Test C518-98, consists of a core across which the voltage is measured, normally with a thermopile. Appropriate calibration of the heat flux transducer(s) with calibration standards, and accurate measurement of the plate temperatures and plate separation are required. The procedures are detailed in C518-98.

The experimental procedure is to establish a steady state unidirectional heat flow through the test specimen(s), held between the two isothermal parallel plates, a hot plate and a cold plate. The heat flow

rate, Q , is obtained from the measured voltage output over the heat flux transducer. Equation (6.6.10.1) is then applied to calculate the thermal conductivity through the determination of Q , the separation between the hot and cold plates, L , the cross-sectional area, A , and the temperature difference across the specimen, ΔT .

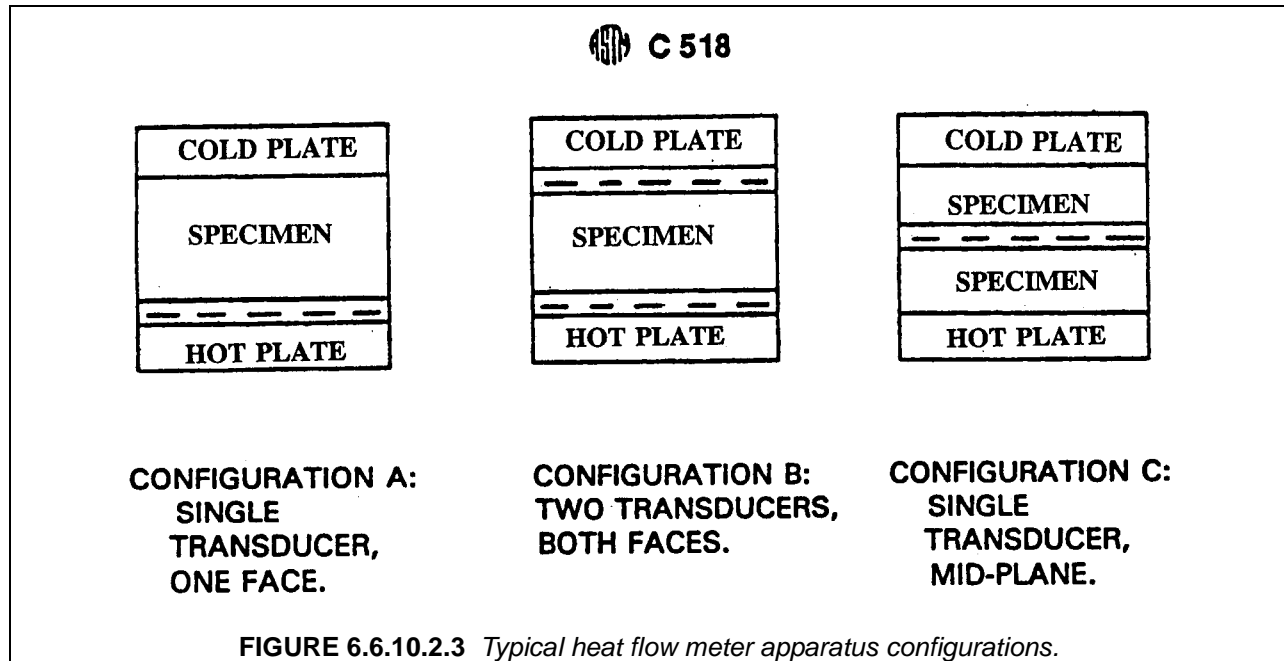

The C518-98 method has been utilized at ambient conditions of 10 to 40°C with specimen thickness up to approximately 25 cm and with plate temperatures from -195°C to 540°C at 2.5 cm thickness. Test Method E1530-93, Reference 6.6.10.2.3(c), is similar in concept to C518-98 but is modified to accommodate smaller test specimens having a higher thermal conductance. This method is relevant to specimens having a thickness less than 1.2 cm with a thermal conductivity in the range $0.1 < \lambda < 5 \text{ W/m}\cdot\text{K}$.

6.6.10.2.4 Fourier thermal conductivity test method for flat plates

One additional procedure applicable to thermal conductive panel materials will be given here. The method is not an ASTM standard. This test method is specifically tailored to determine the thermal conductivity of material whose thickness is much less than its lateral dimensions and which exhibits a thermal conductivity of at least 30 W/m•K. The upper limit can be as high as 1500 W/m•K depending on sensor location and geometry. Although the method is an absolute one as written, it is strongly recommended that results be correlated to a known standard of equivalent size tested with the same experimental arrangement.

This method evaluates the steady state one dimensional heat transfer characteristics in terms of the differential temperature as a function of distance. This is accomplished by acquiring the necessary data off the face of the panel as heat flows from one end of the panel where heat is applied, to the other end where heat exits via a heat sink. This method is applicable to panels where the cross sectional area of heat flow remains constant. Thermal conductivity is calculated using Equation (6.6.10.1).

The goal of this method is to satisfy the need for non-destructive thermal conductivity measurements that determine the overall thermal performance of the component rather than assessing only localized values. Multiple simultaneous measurements allow data to be generated over a large area. This is par-

ticularly important for materials such as composites where the distribution of the conductive reinforcement may vary locally on the component. The non-destructive nature of this method is accomplished through the use of removable heaters and temperature sensors. Also, the use of a liquid immersion heat sink allows for various sized components to be immersed without any machining or specimen sizing. This is particularly important where expensive or end use hardware is being evaluated.

This method also lends itself to being useful in evaluating materials that exhibit anisotropic properties. The method, which employs unidirectional heat transfer, allows for easy measurement of directional properties without the need for complex data reduction.

The apparatus consists of a liquid immersion heat sink; liquid chiller (5°C to 30°C range); Kapton laminated thermal-foil heaters; platinum resistive temperature devices (RTD's); pressure sensitive film adhesive; coated fiberglass insulation (five cm thick and with a thermal conductivity less than 0.1 W/m·K); a well regulated dc power supply (e.g., not less than 60 V dc at a current of at least 2 A); instrumentation for accurately measuring the voltage and current; and signal conditioning for the temperature sensors. The use of a computer data acquisition system is optional but desirable.

The liquid immersion heat sink must be a closed loop system that is hooked to a chiller which will allow near infinite sinking of heat from the test specimen. Figure 6.6.10.2.4(a) shows a schematic view of the system. This system acts as a heat exchanging device in which the specimen is clamped. A suitable liquid such as an equal parts mixture of ethylene glycol and water should be used for the recirculating coolant.

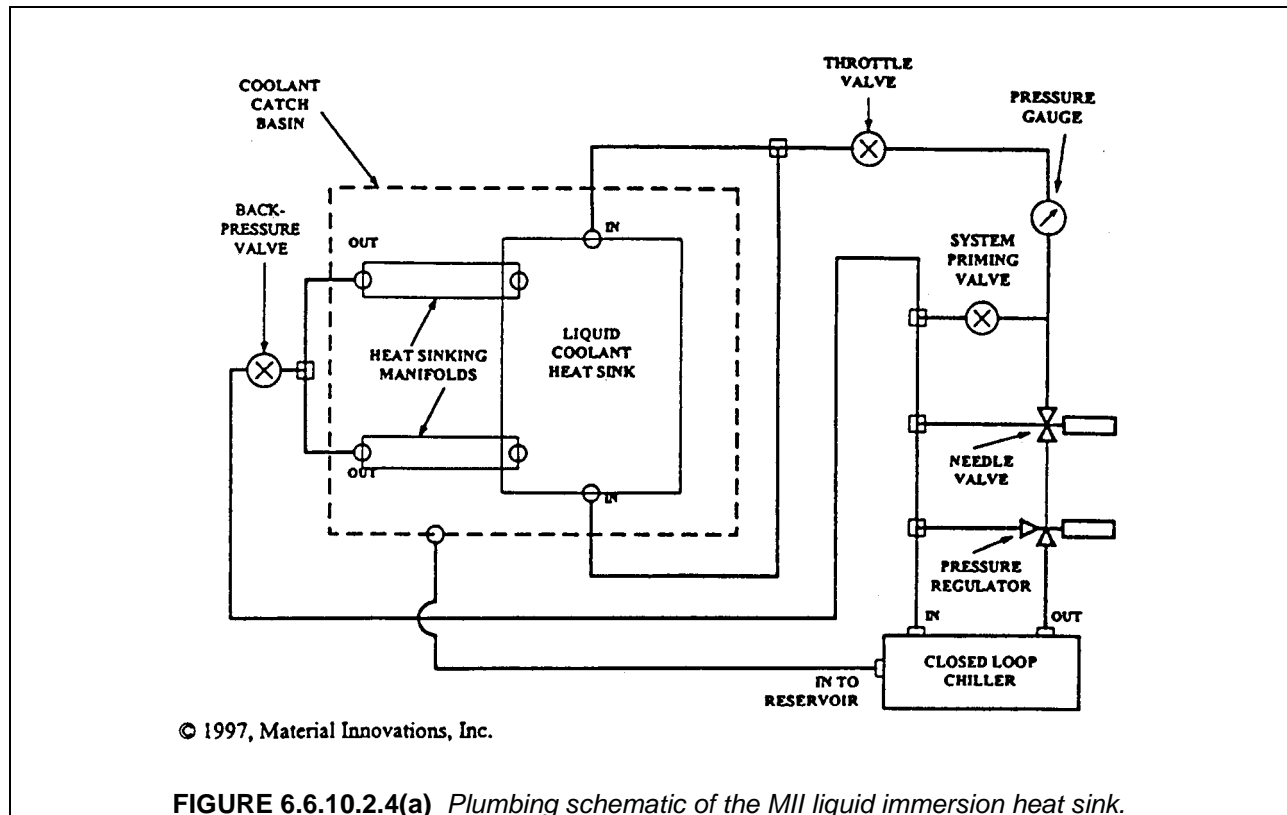

The heat source should employ foil heaters with densely spaced elements. These heaters should be able to tolerate at least 200°C. Aluminum backing may be necessary for anisotropic materials exhibiting poor heat spreading. This will insure uniform heat flow along the specimen surface.

The instrumentation should be capable of measuring voltage with a resolution of 1 mV; measuring current with a resolution of 1 mA; measuring temperatures with a resolution of 0.01°C; and the ability to transfer data to a data acquisition system if used.

The test specimen should be in a rectangular or square configuration with the sides 90° relative to each other. The cross sectional area in any place should not deviate more than 5% from the average cross sectional area. All surfaces should be clean from dirt and oils. It is recommended that the minimum width be at least one inch (25 mm), the minimum thickness at least 0.075 cm, and the minimum length in the direction of heat flow be at least ten cm. Larger surface dimensions will typically yield additional temperature resolution in the measurement. Smaller surface areas should be analyzed for adequate resolution prior to testing.

Thermal foil heaters and RTD's are attached to the surface via a thermally conductive pressure sensitive adhesive. In cases where the specimen thickness exceeds 0.50 cm heating end-on is required. This procedure is required in order to avoid temperature gradients through the thickness of the test specimen in the temperature measurement area. A typical arrangement is shown in Figure 6.6.10.2.4(b).

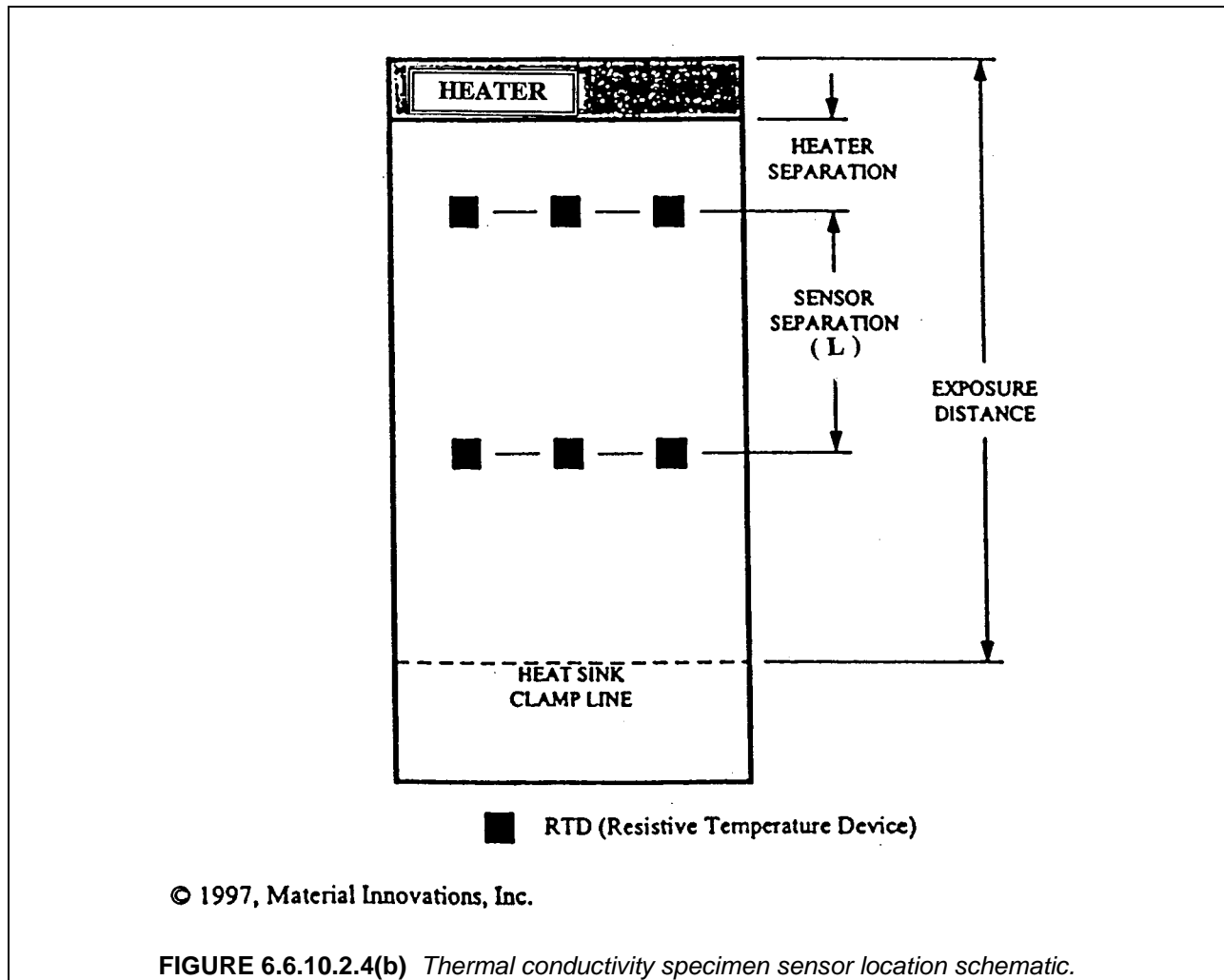

The heating location should be at the top edge of the panel with heaters mounted on both faces of the test specimen. The RTD's are mounted as two rows. The top row needs to be at a measured distance from the heater such that the RTD's are observing uniform heat flow. RTD's too close to the heater may be influenced by heat input effects. The bottom row needs to be a measured distance from the top row such that the temperature gradient during the test exceeds 1.50°C. Both rows of RTD's, as a set, should be placed approximately half way between the heat source and heat sink. It is important to ensure that there are no air bubbles or delaminations in the adhesive bond line.

All wiring should exit the specimen surface horizontally such that temperature gradients along the wire near the specimen are minimized. This will minimize thermal shorts.

The test procedure is to first measure all necessary dimensional data. This survey should include at least five measurements of thickness and width; measurement of RTD spacing relative to the heating elements; and reference data such as test distance, horizontal RTD spacing, and overall panel length.

Then immerse the test specimen into the liquid cooled heat sink and clamp between the heat sinking manifolds. At least one inch (25 mm) of panel material should be in contact with the liquid coolant heat sink to insure adequate heat sinking.

Adequately insulate the test specimen's exposure distance with fiber insulation. This step is required to insure an adiabatic system at equilibrium.

Allow the test stand to equilibrate at the heat sinking temperature. Record all initial RTD temperatures at the heat sinking temperature. These data will be used to normalize any zero offset of the sensor.

Energize the test specimen to a heat flux of approximately 100 kW/m². Other heat fluxes can be used based on the thermal conductivity of the test specimen and the test temperature that is targeted. The only requirement on determining heat flux is that there must be enough power for adequate resolution of the temperature gradients and that heat losses relative to total heat input be insignificant.

Record final temperatures and power parameters upon equilibrium at the heated state. Equilibrium should be defined as less than a degree change in temperature for every ten minutes of test time on all temperature sensors.

The record of test data should include all information describing the material; all dimensional data; initial and final temperatures taken at steady state conditions; voltage and current data; ambient and heat sink temperatures; and the average of all final RTD temperatures.

Thermal conductivity is calculated from Equation (6.6.10.1). The quantity Q is obtained as the product of the voltage and current of the heater. The cross-sectional area A is calculated as the thickness and width product. Separation of the two lines of RTD's in the heat flow direction, L , is measured directly. The temperature data are analyzed by first converting each data point value recorded by an individual RTD to a normalized value. The normalization is accomplished by taking the difference in temperature between the initial (steady state) measurement at the heat sink temperature and the final (steady state) measurement at the heated test temperature. The normalized values are averaged for each of the two rows of RTD's. Taking the temperature difference of the averaged normalized values of the two rows of RTD's yields the change in temperature ΔT to be used in Equation (6.6.10.1).

The final report should include the thermal conductivity in SI units (W/m·K), the average test temperature, and the ambient temperature.

Results must be correlated to a known "standard" of equivalent size tested with the same experimental arrangement, conditions, and power parameters. The "standard" should be a widely accepted material which has been well characterized and should have a thermal conductivity as close as possible to the test

specimen. (Typical "standards" are plates of aluminum or copper.) The conductivity result is normalized by using the correction factor (CF) given in the following equation.

$$CF = [(accepted\ value\ of\ "standard") / (measured\ value\ of\ "standard")] * [measured\ value\ of\ unknown]$$

Typical normalization of test results usually requires a correction of 3% to 6%, which accounts for heat losses in the wiring and through the insulation. Heat losses in excess of 10% should be considered questionable and a detailed analysis should be performed prior to acceptance of data.

6.6.10.3 Thermal conductivity test methods for MIL-HDBK-17 data

Data produced by the following test methods (Table 6.6.10.3) are currently being accepted by MIL-HDBK-17 for inclusion in Volume 2.

TABLE 6.6.10.3 Thermal conductivity test methods for MIL-HDBK-17 data submittal.

PROPERTY	SYMBOL	FULLY APPROVED, INTERIM AND SCREENING DATA
Thermal Conductivity	λ	C 177 E 1225 C 518 Fourier Test Method

6.6.11 Specific heat

6.6.11.1 Introduction

The definition of specific heat is the change in the internal energy of a material per degree temperature change per unit mass of material. In practice, the specific heat at constant pressure or enthalpy, C_p , is the measured quantity, with values reported in J/(kg·K) in SI units.

6.6.11.2 Available method

The standard test method for measuring the specific heat of polymer matrix composites is ASTM E1269-95, Reference 6.6.11.2, and is based on Differential Scanning Calorimetry (DSC). This test is generally applicable to thermally stable solids and has a normal operating range from -100 to 600 EC. The temperature range can be extended depending upon the instrumentation and specimen holders used.

6.6.11.2.1 ASTM E1269-95

A brief summary of the DSC test method is as follows. Empty aluminum pans are placed in the specimen and reference holders. An inert gas atmosphere, such as nitrogen or argon, is typically used as the blanketing atmosphere. An isothermal baseline is recorded at the lower temperature and the temperature is then increased by adding heat, Q (W), in a programmed manner over the range of interest. An isothermal baseline is recorded at the higher temperature, as indicated in the lower part of Figure

6.6.11.2.1, Reference 6.6.11.2.1. The procedure is then repeated with a known mass of specimen, M , in the specimen pan and a trace of energy absorbed against time is again recorded.

The data so produced at this point are theoretically sufficient to calculate the specific heat of the specimen, but in practice a calibration procedure is important and is discussed below. Heating rates in the range of 5-20°C/min are recommended with a rate of 10°C/min being commonly employed.

A quantitative measurement of energy imparted to a test specimen as a function of temperature must be obtained to determine specific heat. Thus, the instrument used for these measurements must be calibrated in both the heat flow and temperature modes.

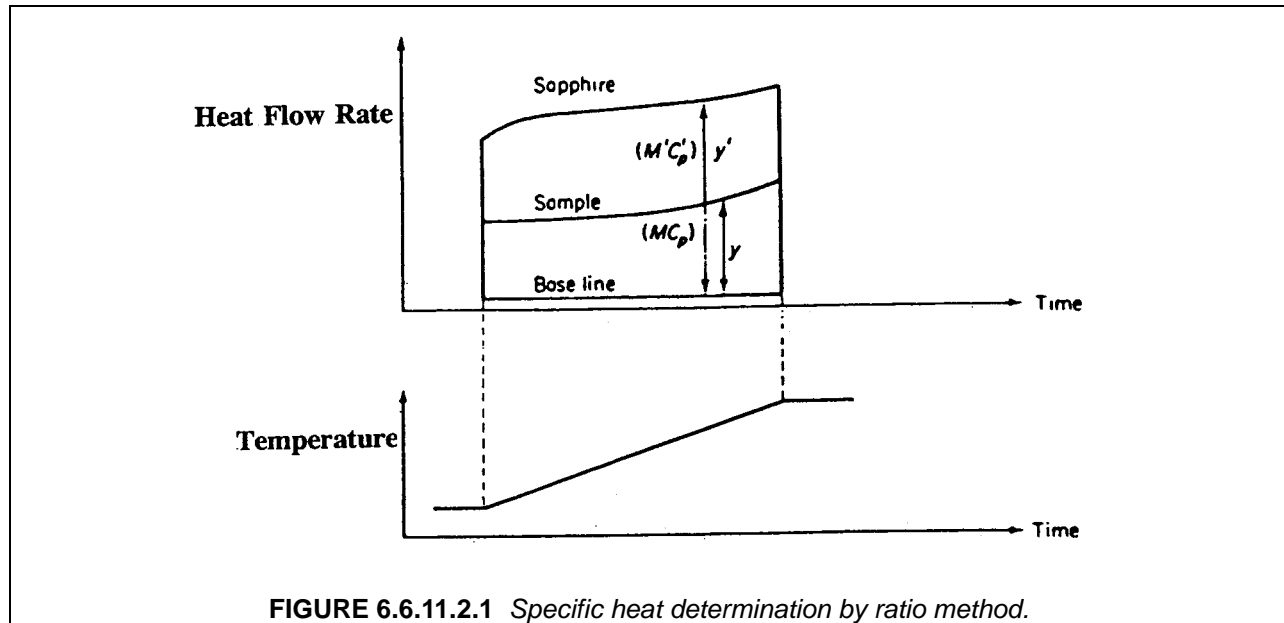

FIGURE 6.6.11.2.1 Specific heat determination by ratio method.

Since specific heat is not a quickly changing function of temperature, the instrument's temperature mode is ordinarily calibrated and checked only occasionally. Temperature calibration is achieved by observing the melting transition of reference materials. This calibration should be performed over the temperature range to be covered in the unknown specimen specific heat measurement. Materials suitable for use as DSC temperature calibration standards are listed in Table 6.6.11.2.1 (Reference 6.6.11.2).

The heat flow information is critical and calibration in this mode is achieved through the use of a standard material whose specific heat is well established. The calibration procedure is known as the Ratio Method. The recommended standard material is synthetic sapphire (α -aluminum oxide). Specific heat capacities for synthetic sapphire, C_p' , are given in Reference 6.6.11.2.

The thermal scan procedure described above is now repeated with a known mass of sapphire, M' , and a new trace is recorded. The two ordinate deflections at the same temperature, Figure 6.6.11.2.1, and the mass ratios are used to calculate the specimen specific heat, according to the formula

$$C_p = C_p' \cdot (y/y') \cdot (M'/M) \quad 6.6.11.2.1$$

where

y = vertical displacement between the specimen holder and the specimen thermal curves at a given temperature

y' = vertical displacement between the specimen holder and the sapphire thermal curves at a given temperature

Notable features of the DSC method are comparatively short test times and milligram specimen sizes. Since such small quantities of specimen material are used, it is essential that specimens be homogeneous and representative. The latter condition may be difficult to achieve if specimens are removed from a polymer matrix composite panel of large size due to manufacturing variabilities from one area of the panel to another. The problem may be addressed by measuring a number of specimens taken from different panel locations and averaging the results.

TABLE 6.6.11.2.1 *Melting temperature of calibration material.*

Calibration Material	Melting Temperature	
	(°C)	(K)
Benzoic Acid	122.4	395.5
Indium	156.6	429.8
Tin	232.0	505.1
Lead	327.5	600.7
Zinc	419.6	692.7

Application of the DSC test method to polymer matrix composites may also encounter difficulties due to specimen mass loss from either moisture evolution or material decomposition, but this problem can be overcome by taking proper precautions.

6.6.11.3 Specific heat test methods for MIL-HDBK-17 data submittal

Data generated by DSC, Procedure E1269, are currently being accepted by MIL-HDBK-17 for consideration for inclusion in Volume 2.

PROPERTY	SYMBOL	FULLY APPROVED, INTERIM, AND SCREENING DATA
Specific Heat	C_p	E1269

6.6.12 Thermal diffusivity

6.6.12.1 Introduction

Thermal diffusivity is a thermal response property of a material derived from transient heat-flow conditions. If the density and specific heat are known, the thermal diffusivity, α , may be used to determine the thermal conductivity of a material from the relationship

$$\lambda = \rho \cdot c_p \cdot \alpha$$

6.6.12.1

where

λ = thermal conductivity

ρ = density

C_p = specific heat

The units of the parameters of Equation (6.4.12.1) are

λ = W/m·K

ρ = kg/m³

C_p = J/kg·K

α = m²/s

6.6.12.2 Available test methods

A standard test method, the flash method, ASTM E1461-92, exists for the determination of thermal diffusivity of homogeneous opaque solid materials (Reference 6.6.12.2(a)). With special precautions, the method can also be used on some transparent and composite materials. Thermal diffusivity values ranging from 0.1 to 1000 mm²/s have been measured by this technique and measurements can be made from about 100 to 2500 K, normally in a vacuum or inert gas environment. The flash method is the most common method reported in the literature for measurement of thermal diffusivity of polymer-matrix composites.

Test E1461-92 is a more detailed form of Test Method C714, Reference 6.6.12.2(b), but has applicability to much wider ranges of materials, applications, and temperatures with improved accuracy of measurement. The C714 method applies only to carbon and graphite.

6.6.12.2.1 ASTM E1461-92

This test method is considered an absolute method of measurement since no heat flux reference standards are required. The essential features of the apparatus used in the flash method are shown in Figure 6.6.12.2.1(a). These are the flash source, sample holder and environmental control chamber, temperature response detector, and data collection and analysis system. The flash source may be a laser, a flash lamp, or an electron beam. The usual specimen is a thin circular disc with a front surface area less than that of the flash beam. The initial temperature of the specimen is controlled by a furnace or cryostat. The detector can be a calibrated thermocouple attached to the rear face of the specimen or an infrared sensor or optical pyrometer focused on the rear face and filter protected from the flash beam.

To conduct the flash test, the source is pulsed on the front surface of the specimen and energy is absorbed by the specimen. The resulting rear face temperature rise is recorded. The measured temperature rise curve is examined to determine the base line temperature, the maximum temperature rise, ΔT_{\max} , and the time of initiation of the thermal pulse.

Thermal diffusivity values are calculated from the specimen thickness L and the time required for the rear face temperature to reach a certain percentage of its maximum value. The equation is

$$\alpha = k_x \cdot L^2 / t_x \quad 6.6.12.2.1(a)$$

where k_x is a constant corresponding to $x\%$ temperature rise and t_x is the time required for the temperature rise to reach x percent of ΔT_{\max} . Values of k_x are given in Table 6.6.12.2.1(a), taken from Reference 6.6.12.2(a). The rear face temperature rise is typically 1 to 2 Kelvin.

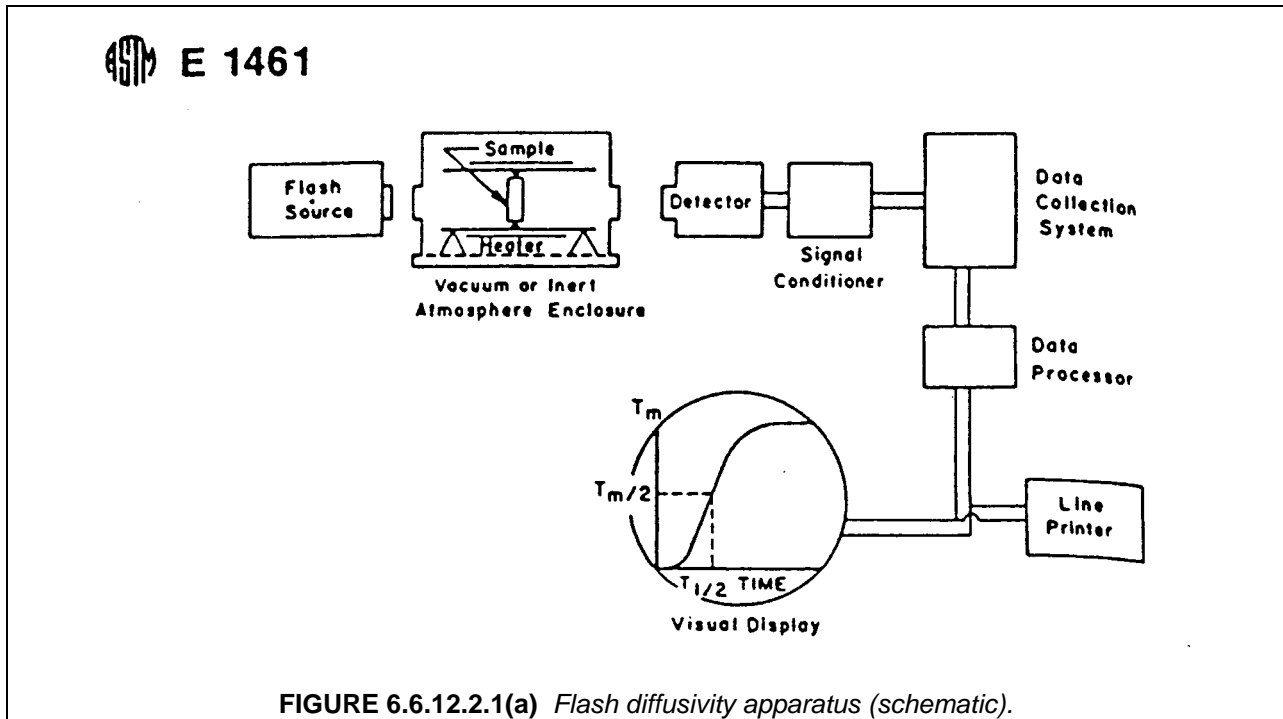

FIGURE 6.6.12.2.1(a) Flash diffusivity apparatus (schematic).

TABLE 6.6.12.2.1(a) Value of the constant k_x for various percent rises.

x(%)	k_x	x(%)	k_x
10	0.066108	60	0.162236
20	0.084251	66.67	0.181067
25	0.092725	70	0.191874
30	0.101213	75	0.210493
33.33	0.106976	80	0.233200
40	0.118960	90	0.303520
50	0.13879

Commonly, the half-rise time (one half the time to reach ΔT_{max}) is used in which case Equation (6.6.12.2.1(a)) becomes

$$\alpha = 0.13879 \cdot L^2/t \tag{6.6.12.2.1(b)}$$

The experimental results may be normalized in temperature rise and in half-rise time and compared to a theoretical model to check for effects of finite pulse time, radiation heat loss, or non-uniform heating. This is done by dividing the temperature rise by the maximum rise, thus non-dimensionalizing the ordinate. Times are divided by the half time to non-dimensionalize the abscissa. The values of normalized temperature versus time for the theoretical model are given in Table 6.6.12.2.1(b). Examples of the normalized plots are shown for an experiment that approximates the ideal case, Figure 6.6.12.2.1(b). Tests in which there is a finite pulse time effect and in which there are radiation heat losses are depicted in Figures 6.6.12.2.1(c) and (d), respectively. After examination of the temperature response data for the test specimen, any needed corrections are made following the procedures outlined in Reference 6.6.12.2(a).

TABLE 6.6.12.2.1(b) Value of normalized temperature versus time for theoretical model.

$\Delta T / \Delta T_{\max}$	$t / t_{1/2}$	$\Delta T / \Delta T_{\max}$	$t / t_{1/2}$
0	0	0.7555	1.5331
0.0117	0.2920	0.7787	1.6061
0.1248	0.5110	0.7997	1.6791
0.1814	0.5840	0.8187	1.7521
0.2409	0.6570	0.8359	1.8251
0.3006	0.7300	0.8515	1.8981
0.3587	0.8030	0.8656	1.9711
0.4140	0.8760	0.8900	2.1171
0.4660	0.9490	0.9099	2.2631
0.5000	1.0000	0.9262	2.4091
0.5587	1.0951	0.9454	2.6281
0.5995	1.1681	0.9669	2.9931
0.6369	1.2411	0.9865	3.6502
0.6709	1.3141	0.9950	4.3802
0.7019	1.3871	0.9982	5.1102
0.7300	1.4601

Typically, specimens are 0.2 to 0.7 in. (0.6 to 1.8 cm) in diameter, with thickness in the 0.06 to 0.16 in. (0.15 to 0.4 cm) range. Thinner specimens are desired at higher temperatures to minimize heat loss corrections. The optimum specimen thickness depends on the magnitude of the estimated diffusivity and should be chosen so that the time for the rear face to reach one-half of its maximum value falls within the 40 to 200 ms range. The duration of the energy flash should be less than 0.02 of the time for the rear face to reach one-half of its maximum value. If this condition is not met, the data must be corrected for the finite pulse time effect.

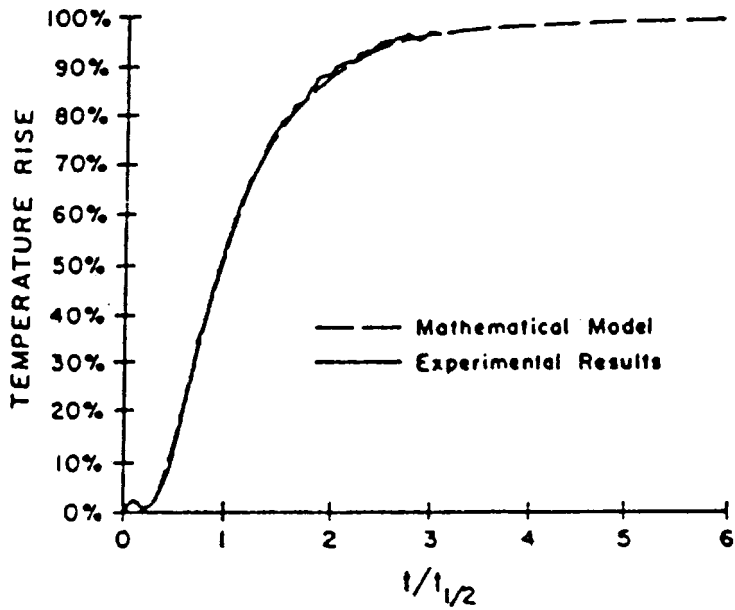

FIGURE 6.6.12.2.1(b) Comparison of non-dimensional temperature response curve to mathematical model.

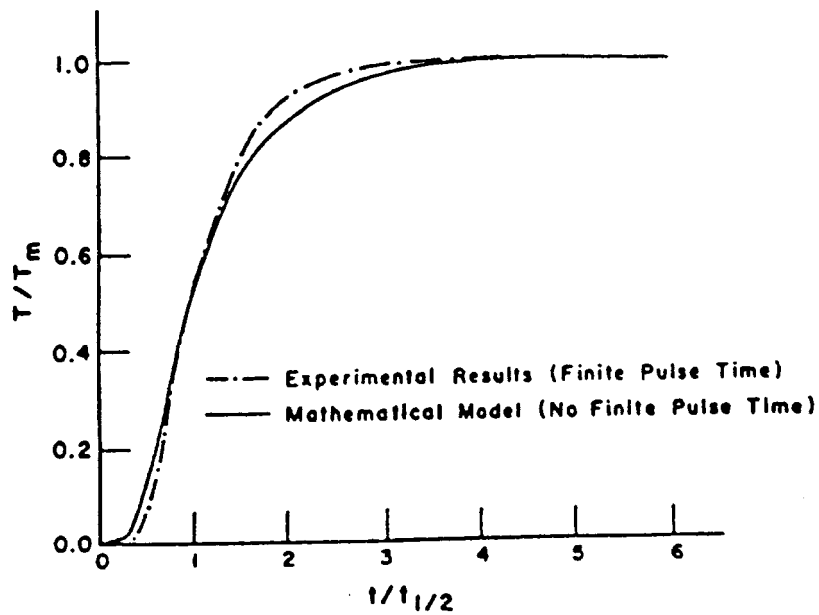

FIGURE 6.6.12.2.1(c) Normalized rear face temperature rise: comparison of mathematical model (no finite pulse time effect) to experimental values with finite pulse time.

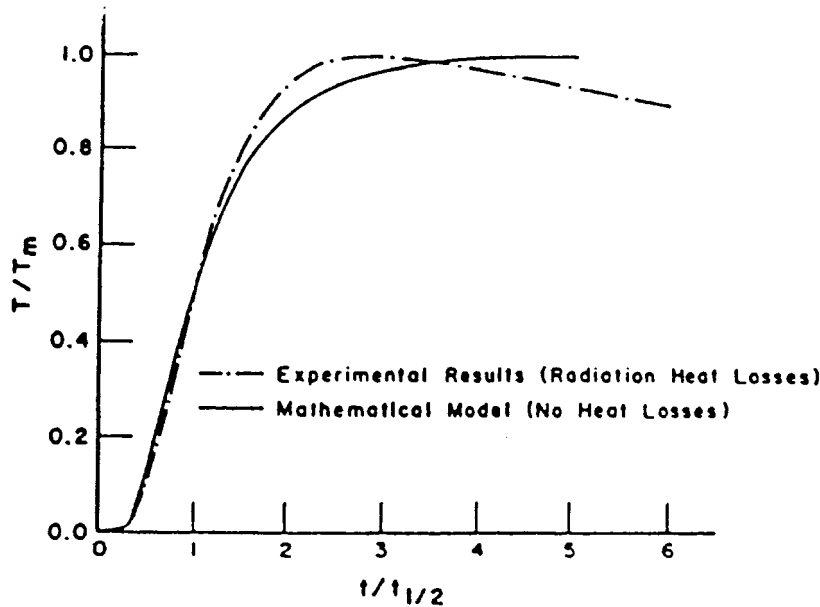

FIGURE 6.6.12.2.1(d) Normalized rear face temperature rise: comparison of mathematical model (no heat loss) to experimental values radiation heat losses.

Round robin test arrangements have shown that a measurement precision of $\sqrt{5}\%$ can be attained for the thermal diffusivity of a variety of materials. Two major sources of experimental uncertainty exist. One lies in the determination of L . This uncertainty is significant because test specimens are relatively thin and the thickness enters as a squared term. A second source is the response time of the detector and its associated amplifiers, which must be no more than 0.1 of the half time value. In general, optical instruments have an acceptable response time. Thermocouples tend to be slower and should be carefully checked for response time against a calibrated source or chopped beam.

Advantages of the flash method are the simple specimen geometry, small specimen size, rapidity of measurement, and ease of handling materials having a wide range of thermal diffusivity values with a single apparatus. Furthermore, the short measurement time reduces chances of contamination and change of specimen properties due to exposure to high temperatures. The flash method has been extended to two-dimensional heat flow so that large samples can be measured and the diffusivity in both the axial and radial directions can be measured.

Problems that can arise when applying the flash diffusivity method are: (1) partial transparency to the light beam exhibited by a specimen material, and (2) different magnitudes of heat transmission manifested by the components of a multi-phase specimen material, such as the reinforcement fiber and matrix of a composite. The first situation is commonly dealt with by coating the front surface of the specimen with a thin layer of a light absorbing material, e.g., graphite. If the second situation exists, the thermal pulse tends to move preferentially through the component phase having the higher thermal diffusivity, with the result that the temperature profile may be non-planar at the specimen rear surface and depart noticeably from the theoretical model. This effect is sometimes observed in practice for composites having a large fraction of high thermal conductivity fibers oriented along the heat flow direction. In this event, the flash method is not applicable.

6.6.12.2.2 ASTM C714-85

This test method covers the determination of the thermal diffusivity of carbon and graphite to $\nabla 5$ percent at temperatures up to 500EC. It requires a circular disk specimen of the order of one cm diameter and one half cm thick. The method has the sensitivity to analyze very low sulfur contents in graphite using small samples and, therefore, is relevant to nuclear reactors where sulfur, even in low concentrations, is a concern.

The method is summarized as follows. A high-intensity short-duration thermal pulse from a flash lamp is absorbed on the front surface of a specimen and the rear surface temperature change as a function of time is recorded. Thermal diffusivity is calculated from the specimen thickness and the time required for the temperature of the back surface to rise to one half of its maximum value, Equation (6.4.12.2.1(b)). The theoretical considerations and experimental caveats of Test E1461-92 apply directly to Test C714-85 and should be consulted at this point, Reference 6.6.12.2(a).

6.6.12.3 Thermal diffusivity test methods for MIL-HDBK-17 data submittal

Data generated by the flash method, Procedure E1461, are currently being accepted by MIL-HDBK-17 for consideration for inclusion in Volume 2.

PROPERTY	SYMBOL	FULLY APPROVED, INTERIM, AND SCREENING DATA
Thermal Diffusivity	α	E1461

6.6.13 Outgassing

Space-based optical payloads and components are exposed to a wide variety of particulate and molecular contamination sources. Many sources of this contamination are not within the scope of this handbook; but the molecular contamination created by outgassing of materials must be analyzed when choosing or specifying materials. Molecular contamination can lower the power output of the solar arrays, and can drastically decrease the throughput of optical components, particularly in the ultraviolet (UV). For example, the Hubble Space Telescope's WF/PC-1 pickoff mirror, returned by the first servicing mission, had developed a thick molecular contamination that had been photopolymerized by exposure to earth atmosphere. As a result, the reflectance at the UV wavelength 1216Å dropped from 0.72 to 0.005. While any molecular contaminant on a mirror tends to lower the UV reflectance, experiments and flight data have shown that the reflectance is especially degraded when the contaminated mirror is exposed to ultraviolet light of sufficient intensity (Reference 6.6.13(a)).

Contamination control engineering is a discipline under the continuous support of NASA. A good introduction is given in Reference 6.6.13(a). There are two ASTM test methods that measure the amount of molecular contamination likely to be produced by outgassing from the tested material. ASTM E 1559 is used to obtain data useful in modeling outgassing and contamination in a designed optical system. ASTM E595 is primarily a screening technique, and is used by NASA to construct tables that help material selectors sort out likely contaminators. (Reference 6.6.13(b)).

ASTM E 595 (1999). "Standard Test Method for Total Mass Loss and Collected Volatile Condensable Materials from Outgassing in a Vacuum Environment"

In this test, the material is first ground to a powder and brought to a standard moisture content. Then the material is placed in the apparatus. The sample is held at 257°F (125°C) in a vacuum lower than 7×10^{-3} Pa (5×10^{-5} torr) for 24 h., after which two parameters are measured: total mass loss (TML) and

collected volatile condensable materials (CVCM). CVCM is that mass which condenses on a plate held at 77°F (25°C). An additional parameter, the amount of water vapor regained (WVR), can also be obtained after completion of exposures and measurements required for TML and CVCM. This test method is primarily a screening technique for materials and is not valid for computing actual contamination on a system or component, because of differences in configuration and temperatures. In NASA RP 1124 (Reference 6.6.13(b)), a distinction is made by listing in Section C only those materials having TML and CVCM equal to or lower than a maximum 1.0 percent TML and a maximum 0.10 percent CVCM. Choosing, where possible, materials with TML and CVCM lower than these limits is always recommended and may be required, depending on the program.

ASTM E 1559-93, "Standard Test Method for Contamination Outgassing Characteristics of Spacecraft Materials".

This ASTM test method can be used for measuring the outgassing rate data that are necessary to develop kinetic expressions for use in models that predict the evolution of molecular contaminants and the migration and deposition of these contaminants on spacecraft surfaces. These mathematical models are described in Reference 6.6.13(a).

The measurements are made by placing the material sample in an effusion cell so that the outgassing flux leaving the cell orifice will impinge on three Quartz Crystal Microbalances (QCMs) which are arranged to view the orifice. A fourth QCM is optional. The effusion cell is held at a constant temperature in the high vacuum chamber and has a small orifice directed at the QCMs. The QCMs are controlled to selected temperatures. The total outgassing rate is determined from the collection rate on a cryocooled QCM. At the end of the isothermal test, the QCMs are heated in a controlled manner in order to determine the evaporation characteristics of the deposits.

While E595 makes one total measurement each of TML and CVCM, E1559 measures the mass loss of the sample over time, the mass condensed at several different temperature QCMs over time, and the mass evaporated from these QCMs over time as the temperature is raised. The mass loss and condensed material are measured indirectly, as a function of the resonant frequencies of the QCMs.

Test method A is the standard procedure using prescribed configurations and temperatures. An online database that includes this data for many materials (Reference 6.6.13(c)) is maintained by the Marshall Space Flight Center. Test Method B allows for the use of spacecraft system specific temperatures, configurations, and QCM collector surface finishes.

6.6.14 Absorptivity and emissivity

This section is reserved for future use.

6.6.15 Thermal cycling

This section is reserved for future use.

6.6.16 Microcracking

This section is reserved for future use.

6.6.16.1 Introduction

This section is reserved for future use.

6.6.16.2 Microcracking due to the manufacturing process

This section is reserved for future use.

6.6.16.3 *Microcracking due thermal cycling*

This section is reserved for future use.

6.6.16.4 *Microcracking due to mechanical loading/cycling*

This section is reserved for future use.

6.6.17 **Thermal oxidative stability (TOS)**

This section is reserved for future use.

6.6.18 **Flammability and smoke generation**

6.6.18.1 *Introduction*

A significant concern in any application of organic matrix based composites in occupied spaces is the possibility that an accidental (or deliberate) fire may impinge on the structure. This is potentially problematic for two reasons. First, heat weakens the polymer binder. Thermoplastic binders begin to creep and then to flow as the impinging flames raise their local temperature past the glass transition temperature. Thermoset binders degrade to a char or gasify or both. The functioning of the binder is thus diminished and the composite loses strength. If the structure is one in which the composite forms only a secondary or repair role, the consequences of a local, heat-induced composite failure are not likely to be serious; time is available to repair the damaged material. However, if the affected composite component is part of a primary critical structure, such as the wing of an aircraft, the structure may collapse.

The second aspect of the problem can greatly magnify the first. The binder may ignite and support the spread of flame on the composite surface and also release heat and generate potentially toxic smoke. Thus the localized, external fire may cause a larger structural fire involving the composite which now becomes the fuel for the growing fire. In confined or enclosed spaces such as ships and aircraft, the growing fire could lead to a flashover condition in which all combustible materials within the enclosure begin to burn. In open spaces such as bridges, a growing fire clearly increases the chance of structural collapse. Again the consequences are less threatening when the composite merely serves a secondary role as opposed to being a primary structure. For earthquake reinforcement, the problem is somewhat more complex. Fires accompany earthquakes but they tend to lag the initial shock. If a quake induced fire did destroy the composite reinforcement on a structure, the structure might readily survive the initial quake only to fall victim to an aftershock occurring after the fire.

Compared to many flammable materials, composites have a built-in advantage that helps resist the worst consequences (extensive fire involvement). This is a result of their (usually) inert fiber content of as high as 70% by weight in some cases. The fibers displace polymer resin, making less fuel available to the fire. When the outermost layers of a composite lose their resin due to heat induced gasification, they act as an insulating layer, slowing heat penetration into and evolution of gases from the depth of the composite (References 6.6.18.1(a)-(c)).

6.6.18.2 *Fire growth test methods*

For most applications of composites, fire growth potential should be the first issue addressed and overcome for habitable environments. Rather surprisingly, this issue has received relatively little attention, except for a limited number of compartment fire growth studies. Much of the sparse work on fire spread on the surface of a composite has employed tests for lateral or downward flame spread. These are relatively slow modes of fire growth and they differ mechanistically from upward flame spread, which tends to be much faster. Good performance in the lateral/downward mode does not necessarily imply good performance in upward spread. The converse, however, is likely to hold true, i.e., resistance to upward spread should carry over to yield resistance to lateral or downward spread.

Suppression of fire growth potential calls for measures which either preclude the heat from an external fire getting to the surface of a composite or which dampen the inherent response of the resin to this heat. At one extreme is total fire insulation of the composite. This has been suggested as a solution for both the hazard of fire involvement and for the threat of structural collapse. A sufficiently thick layer (e.g., 1.97 in. (5 cm)) of fiber insulation can keep the temperature of the composite below its ignition temperature (reducing hazard of fire involvement) and also below its glass transition temperature for periods of 30 minutes or more (reducing threat of structural collapse).

Flame retarded resins are a potential solution to fire growth problems but they only lessen the flammability of a composite. This translates into resistance to a bigger external fire source before fire growth ensues. In unpublished NIST tests, brominated vinyl ester/glass composites exhibited essentially unchanged ignition behavior but required somewhat stronger external heat fluxes to sustain full height flame spread (3.94 ft. (1.2 m)); the increase was from 3-5 kW/m² to approximately 10 kW/m². Whether this is sufficient depends on the use of the composite and the ignition sources it is likely to experience. Choice of a strongly charring resin such as a phenolic can provide greater benefits if other properties are compatible with the application.

As noted previously, intumescent coatings are an established fire protection technology for non-composite applications. Limited work has been done on their ability to protect composites. These studies looked at the ability of various coatings, including certain intumescent, to delay ignition, lower the rate of heat release, suppress lateral flame spread, and extend the duration of fire resistance of composites in a standard temperature-time exposure. These studies revealed that only a limited minority of commercial coatings have the needed ability to remain in place during intense heat exposures characteristic of large fires (References 6.6.18.2(a)-(c)).

Flammability requirements for transport aircraft are prescribed in Federal Aviation Regulation 25.853. Test methods, additional requirements and other information needed to implement the methods are contained in "Aircraft Materials Fire Test Handbook" DOT/FAA/AR-00/12 (Reference 6.6.18.2(d)).

6.6.18.2.1 *ASTM E 84 - Surface burning characteristics of building materials* (Reference 6.6.2.1)

Interior applications of composites in earth-based structures are likely to come under existing building or construction code requirements. Most frequently this means a requirement for some specified level of performance in the ASTM E 84 tunnel test.

The E 84 tunnel measures the spread of flame in a concurrent air flow. The tunnel does not use a radiant heater to preheat the sample, but instead the air that is flowing through the system is heated by the ignition burners and by the flame as it advances down the length of the sample. This hot air passing over the surface of the sample provides the necessary energy to bring the unburnt material up to its ignition temperature.

The ignition source for the apparatus is two burners located below the sample at the 12 in. (305 mm) position. The burners project a methane diffusion flame upward which impinges on the sample for about 2.95 ft. to 3.93 ft. (0.9 to 1.2 m) down the length of the sample from the 12 in. (305 mm) position. The layout of the test chamber and components can be found in Figure 6.6.18.2.1.

The sample is rectangular in shape, measuring 23.95 ft. x 1.67 ft. (7.3 x 0.51 m). The sample and holder become the roof of the tunnel when in place. The remaining walls are lined with fire brick. Thermocouples are located at the 13.12 ft. and 23.62 ft. (4.0 m and 7.2 m) positions. Fresh air flow is regulated with a damper at the inlet end of the tunnel. The flow rate is controlled so that the velocity in the tunnel is 47.64 in. (121 cm/s).

Attached to the exhaust end of the tunnel is a steel exhaust system. Air flow through the exhaust system is a continuation of the flow through the test chamber. Measurements of smoke obscuration are

taken in the exhaust stack. Reduction of light transmittance is measured using a photometer system. The light path is across the stack, perpendicular to the flow of the exhaust gases.

Values which are measured include time for flame to travel a measured distance, exhaust gas temperature, and percent light transmitted. Values that are often calculated include flame spread and smoke development indexes.

The test has been shown to rank "well-behaved" materials in the same order as the fire behavior measured in full scale enclosures. The term "well-behaved" here means essentially materials which behave like wood in a fire (i.e., materials which char and stay in place on the top of the tunnel for the majority of the test time). Correctly ranking the order of fire behavior of materials in a given type of full-scale test is a minimum requirement for a test method.

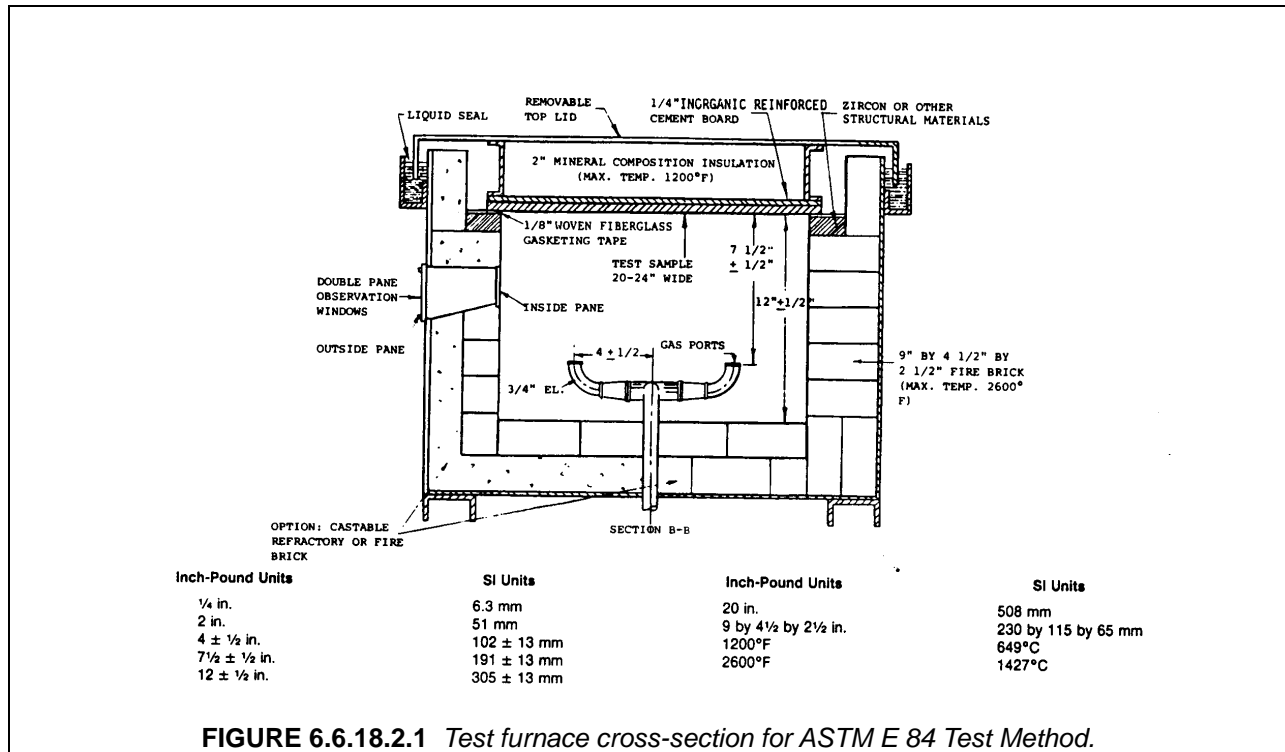

6.6.18.2.2 ASTM E 162 - Surface flammability of materials using a radiant heat energy source (Reference 6.6.18.2.2)

Another bench scale measurement of flame spread is ASTM E 162. The procedure in ASTM E 162 involves the measurement of a flame spread index (Is) which is a product of rate of energy released and average flame spread velocity in the downward direction. Although these quantities change with time as the material burns, the index is formulated to be a constant in order to provide a common scale for ranking different materials.

A sample is fixed in the test apparatus such that it is at an angle to the radiant heat source. This forces ignition at the specimen's upper edge, and if there is flame spread, it progresses downward.

A specimen 6 inches wide by 18 inches long and no greater than 1.0 inch thick is placed in the sample holder. This is located in front of a 12-inch by 18-inch radiant panel using air and gas as the fuel supply. The radiant panel consists of a porous refractory material and should be capable of operating up to

1500°F (815°C). A small pilot flame about 2 inches long is applied to the top center of the specimen at the start of the test. The test is completed when the flame front has traveled 15 inches or after an exposure time of 15 minutes.

The exposure time and whether the specimen was destroyed are reported, as well as any visual characteristics of the burning, such as running or dripping. An average flame spread index is reported.

6.6.18.2.3 ISO 9705 fire test – full-scale room test for surface products (Reference 6.6.18.2.3)

At present there are no small scale tests for upward flame spread potential. The closest pertinent test is full-scale and it involves both lateral and concurrent flame spread (an analog of upward flame spread). This is ISO 9705 which has been recommended for interior surface materials (including composites) in high speed craft. This is a full room test and can be quite expensive for assessing composites. As an enclosure test, it may be unnecessarily severe for composites which are utilized in open spaces, such as in bridges or piers. However, for enclosed spaces such as deckhouse on a ship, this test is quite appropriate. The enclosure provides an enhanced heat feedback effect, due to accumulating hot smoke which is not present in an open fire exposure.

This full-scale room corner fire test method was developed to evaluate material potential for flame spread within and beyond a realistic compartment. Although the procedures were developed primarily for lining materials, the test is also applicable to testing complete construction assemblies. The test provides data from the early stages of material ignition to flashover.

The standard room consists of an enclosure 11.81 ft. x 7.87 ft. (3.6 x 2.4 meters) by 7.87 ft. (2.4 meters) high with a doorway centered on one 7.87 ft. (2.4-meter) wall. The ISO 9705 "standard method" uses a propane gas burner at 100 kW for the first 10 minutes and 300 kW for a further 10 minutes. A 176 kW propane burner is specified in a similar proposed ASTM standard. Each method requires the gas burner to be placed in a corner so that its flames contact the walls and ceiling.

The "standard" configuration requires that the candidate material cover the walls (excluding the doorway wall) and the ceiling. The specimens are mounted on a framing or support system comparable to that intended for their field use, using backing materials, insulation, or air gaps, as appropriate to the intended application.

The test determines the extent to which wall and ceiling materials or assemblies may contribute to fire growth. Therefore, instrumentation within the room and exhaust system are specified for measurement of the: (a) heat flux in the room; (b) total heat release generated by the fire; and (c) if flashover occurs, time that flames emerge through the doorway. Provisions are also provided for measurement of smoke and toxic gas hazards.

6.6.18.2.4 ASTM E 1321 - Determining material ignition and flame spread properties (Reference 6.6.18.2.4)

The LIFT Method, ASTM E 1321, combines two separate test procedures: one to determine ignition and the other to determine lateral flame spread.

The sample holder fixes the specimen in a vertical orientation. A radiant panel is positioned parallel to the sample at a 75° angle from the perpendicular. The layout is represented in Figure 6.6.18.2.4. The ignition test requires samples, 5.90 x 5.90 in. (150 x 150 mm), which are exposed to a nearly uniform heat flux. A series of tests at different flux levels are used to develop an ignition time versus the radiant flux profile. From this profile, the minimum flux for ignition is determined.

The flame spread tests use 5.90 x 31.49 in. (150 x 800 mm) samples. These samples are exposed to a spatially graduated heat flux which is 10 kW/m² higher than the minimum flux calculated above at the hot end. The flux decays in a well-defined manner to low levels at the opposite end of the sample. The

specimens are preheated for a time which is based upon ignition test results. A horizontal pilot is ignited after the preheat time is over. The flame spread rate on the sample as a function of heat flux is then recorded.

Data reported includes minimum flux for ignition, surface temperature necessary for ignition, thermal inertia value, a flame heating parameter, and flame front velocities versus heat flux.

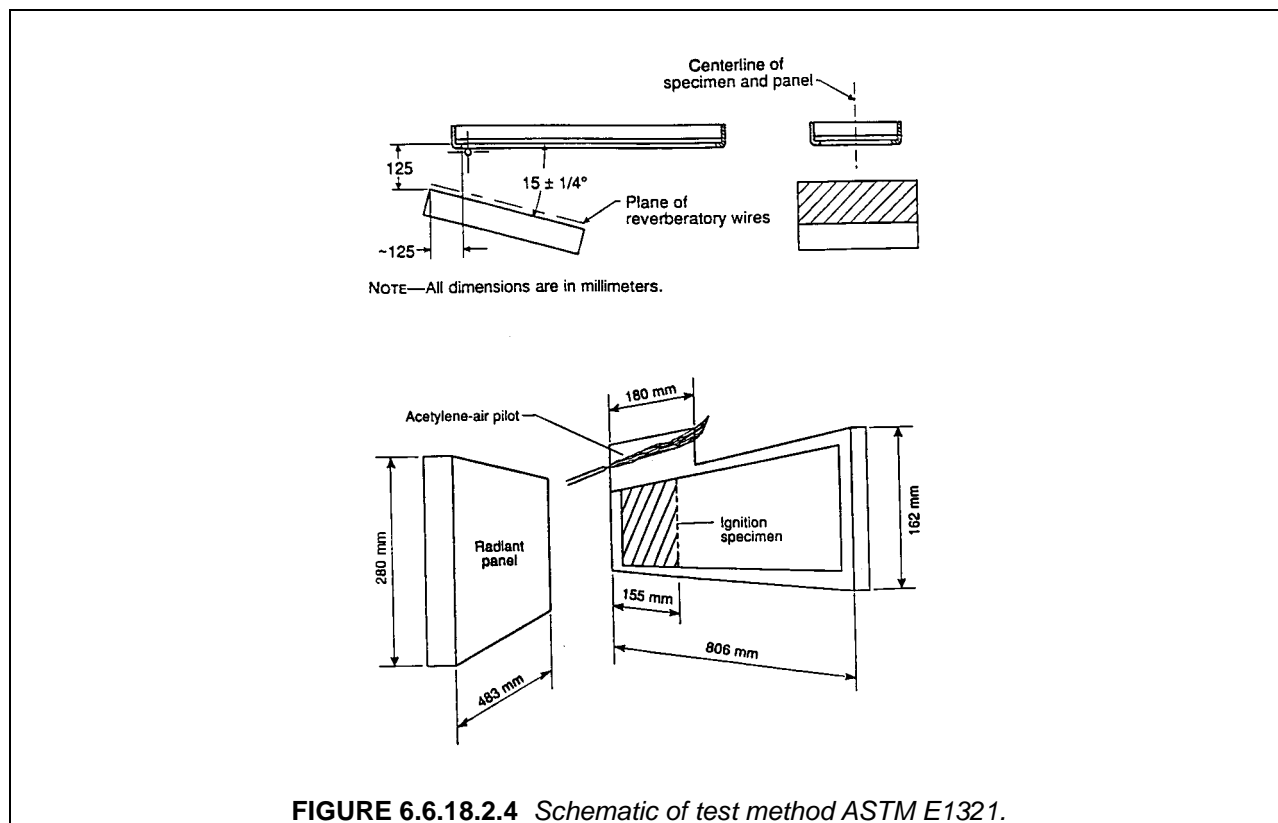

6.6.18.3 Smoke and toxicity test methods

Combustion gas generation is defined as the gases evolved from materials during the process of combustion. The most common gases evolved during combustion are carbon monoxide and carbon dioxide along with HCL, HCN and others depending upon the chemistry of the matrix resin of a given composite material. Historically, more people have been injured and died from fire combustion products than from direct heat/flame exposure. Various test methods have been developed to assess the toxic potential of smoke from burning materials. These test methods are sensitive to the fire exposure (non-flaming vs flaming). Test methods use either bioassay methodologies (animal testing) or analytical techniques to establish toxic potency of burning materials (References 6.6.18.3(a) and (b)).

6.6.18.3.1 ASTM E 662 - Specific optical density of smoke generated by solid materials (References 6.6.18.3.1)

The NBS smoke chamber, identified as ASTM E 662, is used to examine the smoke produced by materials in the flaming or non-flaming modes. The sample is exposed either to a radiant heat source alone (non-flaming mode), or in conjunction with a pilot flame (flaming mode). The radiant heat is supplied by an electrical radiant heater. The heater is circular, measuring 76 mm in diameter, and is mounted in a

vertical orientation parallel to the sample. The heater applies a flux of 25 kW/m^2 to the surface of the sample.

Piloted ignition of the sample is accomplished with a multiple flamelet premixed propane/air burner. The burner is located at the bottom of the sample. It is designed so that some of the flamelets will directly impinge on the surface of the sample and some will be projected up parallel to the surface of the sample. The apparatus is shown in Figure 6.6.18.3.1.

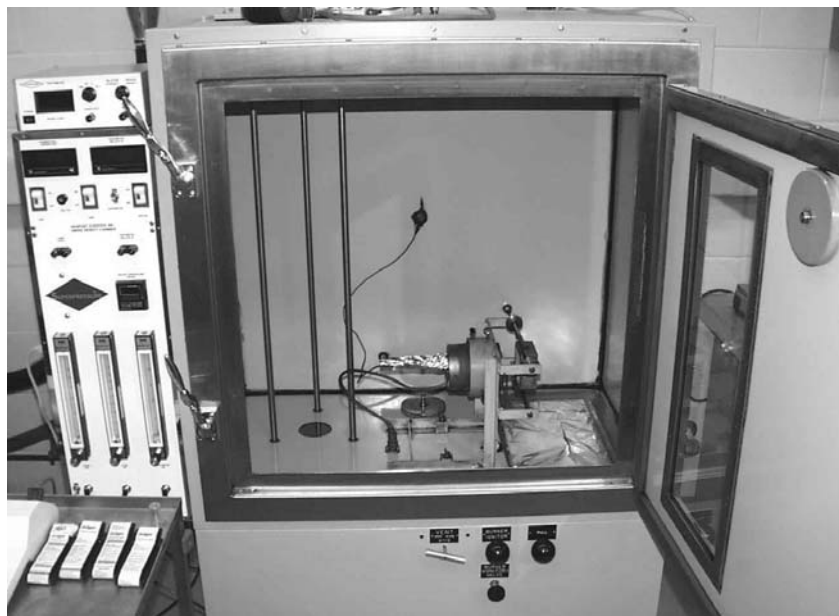

FIGURE 6.6.18.3.1 Photograph of ASTM E662 smoke chamber.

The sample is square in shape, measuring 2.99×2.99 in. (76×76 mm). The thickness may be varied up to 25 mm. The sample is supported in a vertical orientation. The sample, holder, burner, and heater are located inside a test enclosure which measures $2.99 \text{ ft.} \times 2.00 \text{ ft.} \times 2.99 \text{ ft.}$ ($914 \times 610 \times 914$ mm) high. The enclosure is sealed except for ventilation openings at the bottom and top. The ventilation openings are only open if the pressure inside the chamber goes negative.

Smoke obscuration is measured using a photometric system which transverses a vertical path from the bottom to the top of the enclosure. An incandescent lamp is used for the light source. A photomultiplier tube is used as the receiver.

Values which are measured include externally applied flux and light transmitted. Values which are then calculated include specific optical density.

6.6.18.3.2 NFPA 269 - Developing toxic potency data for use in fire hazard modeling (Reference 6.6.18.3.2)

The National Fire Protection Association (NFPA) has adopted NFPA 269 for Use in Fire Hazard Modeling. This is a small-scale test method that uses both analytical and bioassay techniques. In the test, a specimen is subjected to electric spark ignition during exposure to a 50 kW/m^2 radiant flux for 15 minutes. The smoke produced is collected for 30 minutes in a sealed chamber. The concentrations of CO , CO_2 and O_2 are measured over the test period, and a value for the concentration-time product (Ct) is calcu-

lated by integration of the area under the concentration-time curves. Measurement of HCN, HCL, and HBr is optional based on the material composition. The Ct product and the mass loss of the test specimen are used to calculate the Fractional Effective Dose (FED) for the test, and this value is used in a calculation to predict the 30-minute LC₅₀ of the specimen. LC₅₀ is a measure of the lethal toxic potency. It is the concentration of gas or smoke statistically calculated from concentration-response data to produce lethality in 50% of test animals within a specified exposure and post exposure time. This predicted LC₅₀ is then confirmed in a comparable test by exposing six rats to the smoke produced by a specimen sized to produce the predicted LC₅₀ of the smoke in the exposure chamber. The number of rats which die during the 30-minute exposure period and the subsequent 14 day post-exposure period determine the validity of the predicted LC₅₀. In this manner, it is possible to ensure that the monitored toxicants actually account for the observed effects. The LC₅₀ value that is developed is for a pre-flashover fire and additional calculations are provided such that an LC₅₀ for a post-flashover fire is calculated. This correction factor is based on the increased CO concentration that occurs during post-flashover fires that are ventilation controlled.

6.6.18.4 Heat release test methods

In recent years, developments in fire research and understanding of fire dynamics have highlighted the importance of heat release rate (HRR) as the primary fire hazard indicator. Fire hazard under a given set of conditions of fuel load, geometric configurations, and ventilation conditions can be expressed in terms of heat release rate and the fire hazard analysis should include the relevant fire response parameter(s) of a material obtained from small scale heat release rate tests. The assessment of potential fire hazard based on heat release rate measurements extends to composite materials also. The rate of heat release, especially the peak amount, is the primary characteristic determining the size, growth, and suppression requirements of a fire environment (References 6.6.18.4(a) and (b)).

6.6.18.4.1 ASTM E-1354 - Heat and visible smoke release rates for materials and products using an oxygen consumption calorimeter (Reference 6.6.18.4.1)

ASTM E-1354 measures the response of a small sample of material exposed to controlled levels of radiant heating and is used to determine the heat release rates, ignitability, mass loss rates, effective heat of combustion, and visible smoke development. Commonly referred to as the cone calorimeter, this bench scale fire test method involves an application of the oxygen consumption principle and is schematically shown in Figure 6.6.4.1. The oxygen consumption principle states that for most combustibles there is a unique constant, 13.1 MJ/kg O₂, relating the amount of heat released during a combustion reaction and the amount of oxygen consumed from the air. Thus, using this principle, it is only necessary to measure the concentration of oxygen in the combustion system along with the flow rate. The air-flow past the specimen is generally set at 24 liter/s. This results in a highly fuel-lean combustion condition.

Specimens of a material or product to be tested are cut into a 3.94 x 3.94 in. (100 x 100 mm) size. The thickness depends on the type of product tested and can range from .24 to 1.96 in. (6 to 50 mm). The specimen edges are protected from burning, and the specimen can be oriented either horizontally or vertically. The specimen is heated by an electric heater in the shape of a truncated cone, hence, the name cone calorimeter. The irradiance to the specimen can be set to any desired value from zero to 110 kW/m², but specific thermal insults of 25, 50, 75, and 100 kW/m² are required. These thermal insults correspond to a small Class A fire, a large trash can fire, a significant fire, and an oil pool fire. Piloted ignition of the specimen is provided by an electric spark. Since a uniform, controlled irradiance is provided, the ignition times themselves, as measured, constitute a suitable test for ignitability. The specimen is mounted on a load cell, and its mass, along with all other instrument data, is recorded to provide mass loss rate data. The smoke measuring system is comprised of a He-Ne laser beam projected across the exhaust duct. The monochromatic light is monitored by a solid-state detector. A second detector serves as a reference to guard against effects of drift and of laser power fluctuations. The optical system is designed to be self-purging and does not use optical windows. Full specification of test conditions requires specifying the irradiance, the specimen orientation, the use of spark ignition, the test irradiance, and any special specimen preparation techniques.

The data derived from tests in the cone calorimeter constitute a very large set and can be analyzed in a multitude of ways. The data reported include the following:

- (a) Peak rate of heat release (kW/m^2)
- (b) Rates of heat release averaged over various time periods, starting with the time of ignition (kW/m^2)
- (c) Effective heat of combustion (MJ/kg). This will be less than the oxygen-bomb value of the heat of combustion since the combustion is incomplete (as it is in real fires)
- (d) Percent specimen mass lost (%)
- (e) Time to ignition (s)
- (f) Average smoke obscuration (m^2/kg). Smoke production from a material has the rational units of m^2 , representing the extinction cross-section of the smoke. This is normalized by the amount of specimen mass lost (kg)
- (g) Average yields of each of the measured gas species (kg/kg)

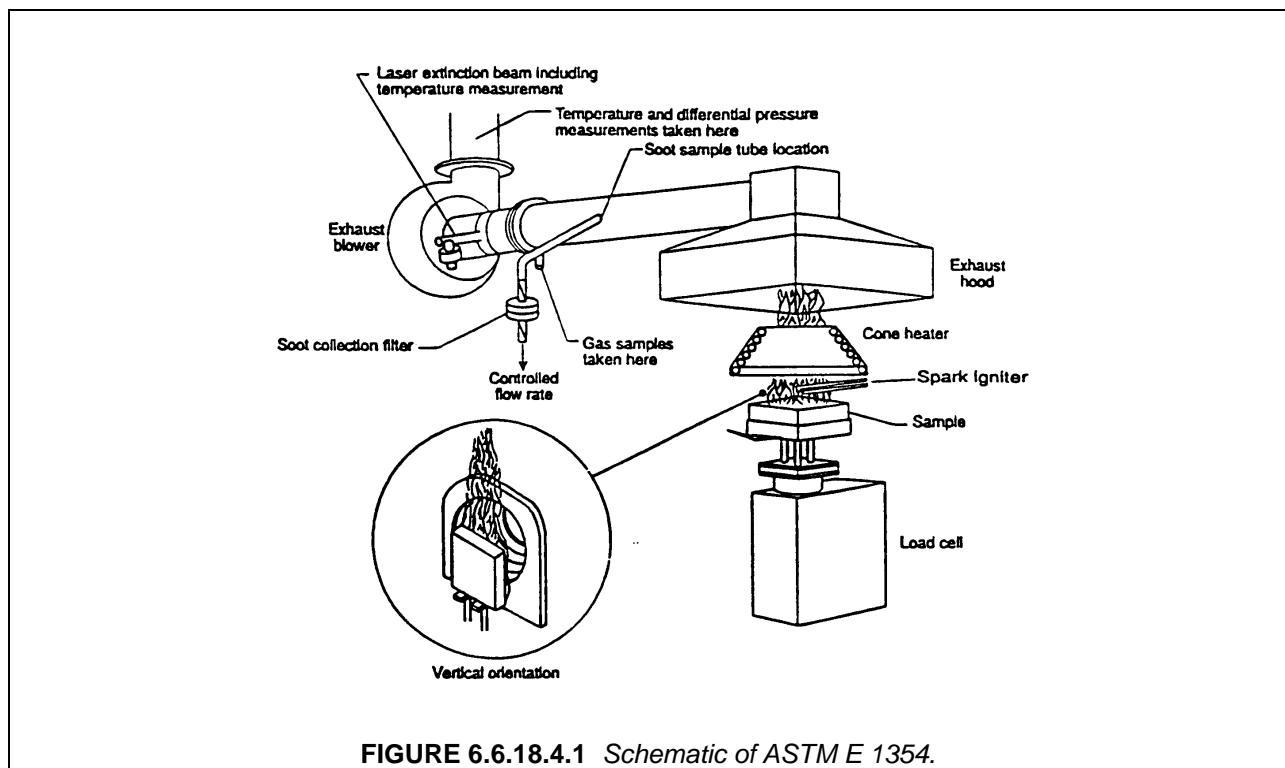

6.6.18.4.2 ASTM E 906 – Heat and visible smoke release rates for materials and products
(Reference 6.6.18.4.2)

ASTM E 906 is based on a thermopile method where the temperature rise is used to determine the heat release rate of materials. This thermopile method measures the heat release of materials at a radiant heat flux of $35 \text{ kW}/\text{m}^2$. The apparatus consists of a combustion chamber inside an insulated metal box. The radiant source comprises four silicon carbide heating elements of nominal resistance of 1.4 ohms. Specimens are exposed to the radiant heater source inside the chamber at an irradiance of $35 \text{ kW}/\text{m}^2$.

Samples are 59 x 59 in. (150x150 cm) in size and a minimum of three specimens are tested for each material. The ignition is caused by a pilot flame from a methane burner placed above the specimen

holder. The total airflow rate through the apparatus is 40 liter/s airflow of which 10 liter/s passes through the combustion chamber. The remaining 30 liter/s flows through the hollow wall section. The temperatures of inflowing air and outflowing gases are measured with a thermopile consisting of 5 type K thermocouples. The hot junctions of the thermocouples are distributed along the diagonals of the stack above a baffle plate. The increase in temperature of the gases exiting the stack with respect to the air temperature entering the combustion zone gives a measure of the heat release rate of the material.

6.6.18.5 Fire resistance test methods

The intensity and duration of a fire can vary over a wide range. It is important to have some understanding of the resistance of building assemblies to different fire threats in order to choose those which more closely match the potential fire threat in a given compartment. Fire resistance here means the ability of a material to continue to serve its structural role during a fire (References 6.6.18.5(a) and (b)).

6.6.18.5.1 ASTM E-119 - Fire tests for building construction and materials (Reference 6.6.18.5.1)

One test method for fire resistance is ASTM E-119, which uses what is often referred to as the standard time-temperature curve. Underwriters Laboratory utilizes this test method to provide fire ratings for all assemblies used in building construction.

In this test, structural components are subjected to a heated furnace environment for the desired duration. If the endpoint criteria are not reached prior to the end of the test period, the assembly is rated as acceptable for that test period, e.g., 30 or 60 minutes. The furnace is heated in such a manner so that the temperature inside the furnace follows a standard time-temperature curve. This curve, shown in Figure 6.6.18.5.1, is intended to relate to conditions in a fully developed room fire. Assemblies may be tested with or without load. If the assembly is tested under load, the assembly is loaded to induce maximum design stress levels calculated based on theory. Floor and roof assemblies and bearing walls are always tested under load. In addition, a second specimen must be exposed to a hose stream to simulate manual fire fighting and rapid cooling.

Sample sizes for this test are specified as follows: bearing walls and partitions, 9.3 m²; nonbearing walls and partitions, 9.3 m²; columns, 2.7 m; floors and roofs, 16.7 m².

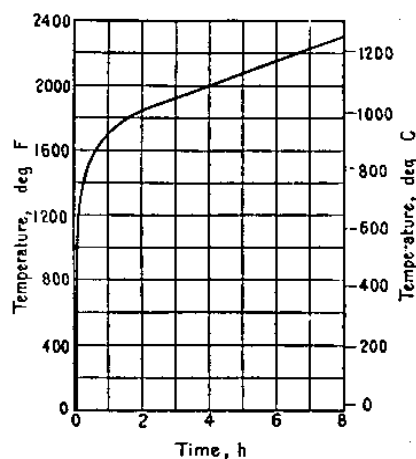

FIGURE 6.6.18.5.1 ASTM E-119 Time temperature curve.

6.6.18.5.2 ASTM E-1529 - Determining effects of large hydrocarbon pool fires on structural members and assemblies and UL 1709 - Rapid rise fire tests of protection materials for structural steel (References 6.6.18.5.2(a) and (b)).

One of the distinguishing features of a post flashover fire is the rapid development of high temperatures and heat fluxes that can subject exposed structural members to thermal shock much more readily than they see in ASTM E-119. The ASTM E-1529 fire curves address this issue. The performance of structural members and assemblies exposed to fire conditions resulting from large, free-burning fluid-hydrocarbon-fueled pool fires is the focus of this test. The exposure scenario which is simulated by this test is the condition of total, continuous engulfment of a member or assembly in the luminous flame area of a large free-burning-fluid-hydrocarbon pool fire.

The test setup provides an average surface heat flux on all exposed surfaces of the test specimen of $158 \pm 8 \text{ kW/m}^2$. This heat flux is attained within the first 5 minutes of test exposure and maintained for the duration of the test. The test environment reaches a temperature of at least 1500°F (815°C) after the first 3 minutes of the test and remains between 1850°F and 2150°F (1010°C and 1176°C) at all times after the first 5 minutes of the test. Because hydrocarbon pool fires often occur in outdoor environments, procedures for accelerated weathering and aging tests are set forth to simulate weathering and aging in outdoor environments. Fire endurance ratings are given for the time period during which the assembly withstands the fire scenario without allowing the passage of flame or hot gases capable of igniting cotton waste.

The temperature conditions described in UL 1709 (Standard for Rapid Rise Fire Tests of Protection Materials for Structural Steel) are similar to those described above for ASTM E-1529. However, heat fluxes described in UL 1709 ($204 \pm 16 \text{ kW/m}^2$) are higher than those described in ASTM E-1529 ($158 \pm 8 \text{ kW/m}^2$). The UL 1709 fire curve rises to at least 1500°F (815°C) after the first 3 minutes of the test and is between 1850°F (1010°C) and 2150°F (1180°C) at all times after the first 5 minutes of the test. In contrast to ASTM E-1529 and UL 1709, the ASTM E-119 fire curve rises to only 1000°F (538°C) at the end of the first 5 minutes, and to 1700°F (927°C) at the end of 60 minutes.

6.7 ELECTRICAL PROPERTY TESTS

6.7.1 Introduction

In certain applications, the electrical properties of a composite are important. The properties that are of interest include dielectric constant, dielectric strength, volume resistivity, surface resistivity, are resistance, dissipation and loss factors. The values can be affected by temperature and environment, as well as the type of curing agent, filler, and fiber used in the composite. The following ASTM test methods can be used for determining the electrical properties of polymer matrix composite laminae and laminates:

ASTM D 149 "Standard Test Method for Dielectric Breakdown Voltage and Dielectric Strength of Solid Electrical Insulating Materials at Commercial Power Frequencies". Method for determining the dielectric strength of solid insulating materials.

ASTM D 150 "Standard Test Method for A-C Loss Characteristics and Permittivity (Dielectric Constant) of Solid Electrical Insulating Materials". Method used for determining the relative permittivity, dissipation factor, loss index, power factor, phase angle, and loss angle of solid insulating materials when the standards are lumped impedances.

ASTM D 495 "Standard Test Method for High-Voltage, Low-Current, Dry Arc Resistance of Solid Electric Insulation". This test method is intended for preliminary screening of material and should not be used in material specifications.

ASTM D 2303 "Standard Test Methods for Liquid-Contaminant, Inclined Plane Tracking and Erosion of Insulating Materials". Test methods for the quantitative evaluation of the relative ability of insulating

materials to withstand the action of electrical discharges on the surface, similar to what may occur in service under the influence of dirt and moisture condensed from the atmosphere.

6.7.2 Electrical permittivity

This section is reserved for future use.

6.7.3 Dielectric strength

This section is reserved for future use.

6.7.4 Magnetic permeability

This section is reserved for future use.

6.7.5 Electromagnetic interference

This section is reserved for future use.

6.7.6 Electrostatic discharge

This section is reserved for future use.

6.8 STATIC UNIAXIAL MECHANICAL PROPERTY TESTS

6.8.1 Introduction

Section 6.8 discusses test methods for determining the static uniaxial mechanical properties of laminated composites. The purpose of this section is to provide brief commentaries on the most commonly used methods, to alert the reader to the limitations of the various methods, and to encourage uniformity in the use of standard test methods with the ultimate goal of combinability of experimental data obtained from multiple sources. The reader is referred to Chapter 8 for statistical data analysis requirements for reporting of data to MIL-HDBK-17.

The section reflects the current dynamic state of test methods development for composite materials. Many of the methods were originally developed for testing of reinforced plastics, and modifications have been (or are being) made for applicability to advanced composites. In recent years there has been a tendency for users to unilaterally modify existing standards without a formal standardization process, leading to uncontrolled test results. In general, these modified standards are not discussed in Section 6.8 except where a specific modification is in common use, and where discussion of the technique is deemed constructive. The test methods included are representative of procedures used in the composite materials industry, and were selected after review of standards documents and user material specifications. Specific test methods may cover lamina-level testing, laminate-level testing, or both, depending upon the test method. The scope of each test method is discussed in the appropriate section.

It is important to make a distinction between methods that are discussed in Section 6.8, and methods for data submittal to MIL-HDBK-17:

- Test methods used by contractors are agreed upon with customers and/or certifying agencies. Section 6.8 reviews many methods in order to provide the reader with awareness of the broad range of procedures in common use. Some of these have been formally standardized (ASTM and other standards) and some are "common practice" methods. Some have distinct limitations, and these are indicated as a matter of information. Mention or omission of a particular method does not, of itself, require or restrict usage. Specific methods are included to allow the user to

perform tests consistent with industry practice; however, inclusion of these standards should not be considered an endorsement of any standard or organization by MIL-HDBK-17.

- When submitting data to MIL-HDBK-17 for consideration for inclusion in Volume 2 of the Handbook, specific methods must be used. Tables at the end of most subsections of 6.8 indicate which methods are acceptable for such submittals. These methods have been chosen in accordance with the criteria given in Section 2.5. Readers are encouraged to also use these methods in contract and internal work to promote standardization.

When selecting and using a particular mechanical strength test method, the importance of obtaining the proper failure mode cannot be overemphasized. While universal definitions of "proper" and "valid" have not been established for most types of tests, further analysis must be employed when unexpected or questionable modes are observed or suspected. If the type of failure is different from what is expected from the test, the data may not represent the property being evaluated. Furthermore, if the failure mode varies within a group of specimens, statistical analysis of the resulting data will not be meaningful due to the introduction of an additional source of variability not related to the property being tested. Therefore, it is crucial that failure modes be reported, and that data be disqualified and discarded when analysis has indicated an unacceptable mode.

It should be noted that failure mode analysis is not necessarily limited to physical examination of the failed test specimens. Other evidence might be obtained from review of additional factors such as:

1. Bending curves from back-to-back strain gage data
2. A check of test machine and/or test fixture alignment
3. A review of the exact procedure used to install and properly align the specimens in the test fixture
4. A check for possible damage to, or malfunction of, the test fixture

ASTM has begun to incorporate failure mode examples and codes into its standard test methods. For example, the 1993 revision of ASTM D 3039 (*Standard Test Method for Tensile Properties of Polymer Matrix Composite Materials*) depicts nine types of failures of the specimen, and defines a three-character coding system that describes various failures. The first letter of the code identifies the type of failure (angled, grip, delamination, etc.), the second indicates the area of the failure (gage, at grip, etc.), and the third denotes the failure location (top, bottom, middle, etc.). In the particular case of tension testing, a failure of the tab or tab adhesive would be an unacceptable mode since the ultimate tensile strength of the laminate was not measured.

Rather than duplicate failure mode examples within the subsections of Section 6.8, the reader is advised to be conscientious regarding the documentation of failure modes, and to refer to examples provided within specific test methods where such examples exist.

6.8.2 Tensile properties

In-Plane Tensile Properties:

Lamina

$$E_1^t, F_1^t, \epsilon_1^t, \nu_{12}^t$$

$$E_2^t, F_2^t, \epsilon_2^t, \nu_{21}^t$$

Laminate

$$E_x^t, F_x^t, \epsilon_x^t, \nu_{xy}^t$$

$$E_y^t, F_y^t, \epsilon_y^t, \nu_{yx}^t$$

Out-of-Plane Tensile Properties:

Lamina

$$E_3^t, F_3^t, \varepsilon_3^t, \nu_{31}^t, \nu_{32}^t$$

Laminate

$$E_z^t, F_z^t, \varepsilon_z^t, \nu_{zx}^t, \nu_{zy}^t$$

6.8.2.1 Overview

The basic physics of most tensile test methods are very similar: a prismatic specimen with a straight-sided gage section is gripped at the ends and loaded in uniaxial tension. The principal differences between these tensile test specimens are the specimen cross-section and the load-introduction method. The cross-section of the specimen may be rectangular, round, or tubular; it may be straight-sided for the entire length (a “straight-sided” specimen) or width- or diameter-tapered from the ends (a larger area) into the gage section (a smaller area).¹ Straight-sided specimens may, in some cases, utilize tabbed load application points.

There are three notable exceptions to the uniaxially loaded prismatic specimen: 1) a sandwich beam test that relies upon gross flexure of a sandwich beam to create an in-plane stress state in the facesheets, making the tensile facesheet, in effect, the specimen; 2) a ring test that applies, via a fixture, a diametrical expansion (or an approximation of such) to a narrow, high radius-to-thickness ratio ring, creating a membrane (in-plane) tensile stress in the ring; and 3) a solid-laminate curved beam test that applies, via a fixture, an opening bending moment, producing a through the thickness tensile stress in the bend region.

While there are a number of existing or developing standards for in-plane tensile properties of laminated materials, this is not the case for out-of-plane properties. Test methods potentially suitable to become standards for through the thickness tensile properties of laminates have only recently begun to receive substantial attention, and so are relatively immature.

By changing the specimen configuration, many of the tensile test methods are able to evaluate different material configurations, including unidirectional laminates, woven materials, and general laminates. However, some specimen/material configuration combinations are more robust (less sensitive to specimen preparation and testing variations) than others. The least robust (most user-sensitive) configuration is the unidirectional specimen. As an example, fiber/load misalignment in a 0° unidirectional specimen, which can occur due to either specimen preparation or testing problems, or both, can reduce strength as much as 30% due to an initial 1° misalignment. This specimen is also very sensitive to load-introduction upsets and requires a high degree of laboratory sophistication, both in specimen preparation as well as testing, to achieve satisfactory results. And bonded end-tabs, which were introduced in the late 1960's to *minimize* load-introduction problems in high-strength unidirectional materials, can actually *cause* premature specimen failure (even in non-unidirectional specimens), if not applied and used precisely and with great art. Since most 0° unidirectional specimens fail with an explosive shatter that obscures the true failure mode, physical evidence of poor testing/specimen preparation practices is usually unavailable.

These difficulties with the testing of unidirectional materials have led to the increased use of a much more robust [90/0]_{ns}-type laminate specimen (also known as the “crossply” specimen). From the laminate strength of a crossply specimen (when the lamina elastic properties are known), the equivalent unidirectional F_1^t lamina strength can be derived, using the procedure discussed in Section 2.4.2. When previously undocumented improvements in testing technique are combined with use of crossply test specimens, much simpler untapered tabs, or even tabless specimens, are now feasible, allowing laboratories that are generally qualified, but inexperienced in unidirectional testing, to produce results equivalent to the best attainable unidirectional data. While unidirectional testing is still performed, and in certain cases may be preferred or required, a straight-sided, tabless, [90/0]_{ns}-type specimen is now generally believed to be the lowest cost, most reliable configuration for lamina tensile testing of unidirectional materials. This straight-sided tabless configuration also works equally well for non-unidirectional material forms and for

¹Though there have been many different types of tapered specimens, they are often called, as a class, Adogbone≡ specimens.

other general laminates. Another advantage is that, unlike with 0° unidirectional specimens, $[90/0]_{ns}$ -type specimen failures do not usually mask indicators of improper testing/specimen preparation practices.

6.8.2.2 *In-plane tension test methods*

6.8.2.2.1 *Straight-sided specimen tension tests*

- 1) ASTM D 3039/D 3039M, Standard Test Method for Tensile Properties of Polymer Matrix Composites
- 2) ISO 527, Plastics --- Determination of Tensile Properties
- 3) SACMA RM 4, Tensile Properties of Oriented Fiber-Resin Composites
- 4) SACMA RM 9, Tensile Properties of Oriented Cross-Plied Fiber-Resin Composites
- 5) ASTM D 5083, Standard Test Method for Tensile Properties of Reinforced Thermosetting Plastics Using Straight-Sided Specimens

ASTM Test Method D 3039/D 3039M (Reference 6.8.2.2.1(a)), originally released in 1971, is the original standard test method for straight-sided rectangular specimens. As a result of a major re-write of D 3039, approved in 1993, tabs were made optional, and a significant number of previously ambiguous, undocumented, and/or optional test and reporting parameters were clarified, documented, and/or made mandatory. ISO 527 (Reference 6.8.2.2.1(b)) parts 4 and 5 (currently in the draft international standard phase) and the two SACMA (Suppliers of Advanced Composite Materials Association) tensile test methods, SRM 4 (Reference 6.8.2.2.1(c)) and SRM 9 (Reference 6.8.2.2.1(d)) are substantially based on ASTM D 3039 and, as a result, quite similar.

While there are still a number of minor differences between ASTM D 3039 and ISO 527, there is a coordinated effort underway to harmonize ASTM D 3039 and ISO 527 and make them technically equivalent. SRM's 4 and 9, while originally intended to be restricted subsets of ASTM D 3039, deviate from ASTM D 3039 enough that they are not exactly equivalent test methods; an ASTM/SACMA harmonization effort is being discussed but has not yet begun.¹ The last of the straight-sided test methods, ASTM D 5083 (Reference 6.8.2.2.1(e)), is the straight-sided equivalent of the ASTM D 638 dogbone tension test for plastics (discussed in Section 6.8.2.2.3). While ASTM D 5083 is conceptually similar to ASTM D 3039, D 5083 was not developed for use with advanced composites, and therefore, cannot be recommended.

In all of these test methods, a tensile stress is applied to the specimen through a mechanical shear interface at the ends of the specimen, normally by either wedge or hydraulic grips. The material response is measured in the gage section of the specimen by either strain gages or extensometers, and the elastic material properties subsequently determined.

End tabs, if used, are intended to distribute the load from the grips into the specimen with a minimum of stress concentration. A schematic example of an appropriate failure mode of a multidirectional laminate using a tabbed tensile specimen is shown in Figure 6.8.2.2.1(a). However, design of the tabs remains somewhat of an art, and an improperly designed tab interface will produce an unacceptable proportion of failures near the tab and result in very low specimen strengths. For this reason a single standard tab design has not been mandated by ASTM, although, when tabs are necessary, the easier-to-apply, less expensive, unbeveled 90° tabs are preferred if the results are acceptable. Recent comparisons confirm that success of a tab design is more dependent on use of a sufficiently ductile adhesive than on the tab angle. An unbeveled tab applied with a ductile adhesive will outperform a tapered tab that has been applied with a insufficiently ductile adhesive. Adhesive selection is therefore most critical to bonded tab use.

The simplest way to avoid bonded tab problems is to not use them. Many laminates (mostly non-unidirectional) can be successfully tested without tabs, or with friction tabs. An example of a high-strength carbon/epoxy material being tested in an untabbed, $[90/0]_{ns}$ -type laminate configuration using an emery

¹ASTM D 3039 contains bending and failure mode restrictions not present in SRM=s 4 and 9, and is different in other respects like thickness measurement, conditioning, and data reporting. ASTM D 3039 is also significantly more detailed than SRM=s 4 and 9. The sum of these differences may produce a different test result.

cloth interface in finely serrated wedge grips is shown in Figure 6.8.2.2.1(b). Flame-sprayed unserrated grips have also been successfully used in tabless tension testing.

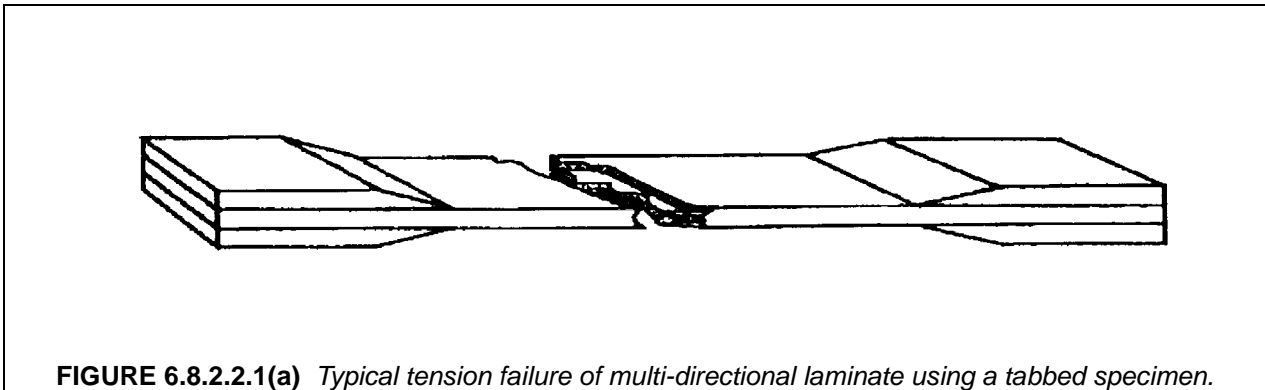

Other important factors that affect tension testing results include control of specimen preparation, specimen design tolerances, control of conditioning and moisture content variability, control of test machine-induced misalignment and bending, consistent measurement of thickness, appropriate selection of transducers and calibration of instrumentation, documentation and description of failure modes, definition of elastic property calculation details, and data reporting guidelines. These factors are described in detail, and controlled, where appropriate, by ASTM D 3039/D 3039M. While ISO 527 parts 4 and 5 and SRM's 4 and 9 are similar to ASTM D 3039/D 3039M in most respects, they do not provide the same degree of guidance or control as ASTM D 3039. For this reason ASTM D 3039 is preferred.

In summary, with proper attention to detail and reasonable care the straight-sided specimen test is generally straightforward and gives good results. However, test parameters must be properly selected for the material and configuration under test, which requires training and experience.

Limitations of the straight-sided specimen tensile test:

Bonded Tabs: The stress field near the termination of a bonded tab is significantly three-dimensional, and critical stresses tend to peak at this location. Design of bonded tabs for the purpose of minimizing peaking stresses is not well-understood and is material and configuration dependent; improperly designed tabs can significantly degrade results. As a result, tables or unbonded tabbed configurations are becoming more popular, when the resulting failure mode is appropriate.

Specimen Design: There are, particularly within ASTM D 3039, a large number of specimen design options included in the standard, needed to cover the wide range of material systems and lay-up configurations within the scope of the test method. These options can be very confusing to the novice, and can lead to the selection of an inappropriate specimen design that negatively affects test results.

Specimen Preparation: Specimen preparation is very important to the test results. While this can probably be said to be true for almost all composite mechanical tests, it is particularly important for unidirectional tests, and unidirectional tension tests are no exception. Fiber alignment, control of specimen taper, and specimen machining (while maintaining alignment) are the most critical steps. For very low strain-to-failure material systems or test configurations, like the 90° unidirectional test, flatness is also particularly important. Edge machining techniques (avoiding machining-induced damage) and edge surface finish are also particularly critical to strength results from the 90° unidirectional test.

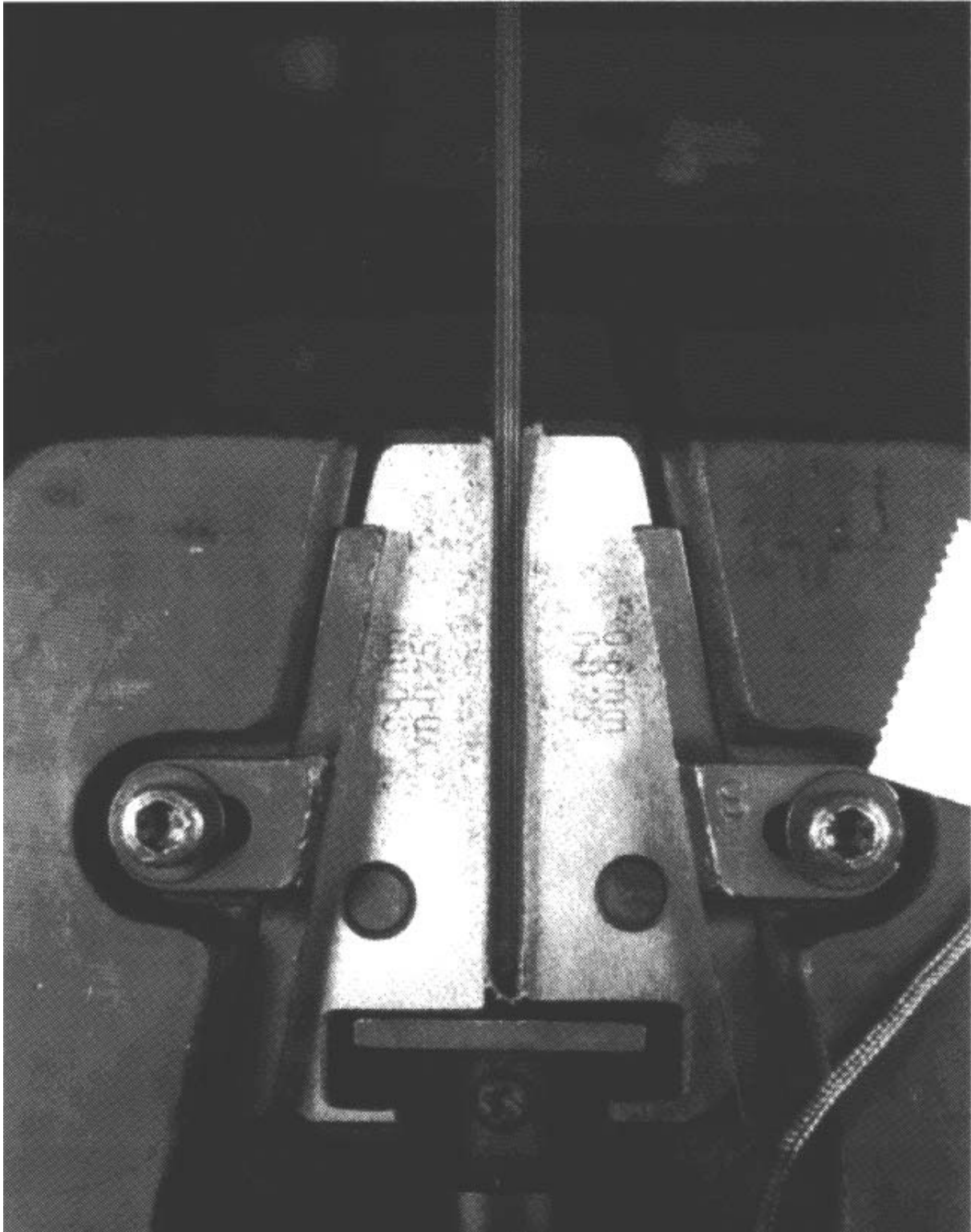

FIGURE 6.8.2.2.1(b) *Tension testing of untabbed specimen using an emery-cloth gripping interface.*

6.8.2.2.2 *Filament-wound tubes*

ASTM Standard Test Method D 5450/D 5450M, Transverse Tensile Properties of Hoop Wound Polymer Matrix Composite Cylinders

ASTM D 5450 describes a test for 90° tensile properties, specifically for a hoop-wound unidirectional cylinder. This test method is discussed in more detail in Section 6.12.1 on test methods for filament wound materials.

6.8.2.2.3 *Width tapered specimens:*

- 1) ASTM Standard Test Method D 638, Tensile Properties of Plastics
- 2) SAE AMS "Bowtie" Tension Specimen

ASTM Test Method D 638 (Reference 6.8.2.2.3(a)), developed for and limited by scope to use with plastics, uses a flat, width-tapered tension specimen with a straight-sided gage section. Despite its heritage, this specimen has also been evaluated on and applied to composite materials. The specimen taper is accomplished by a large cylindrical radius between the wide gripping area at each end and the narrower gage section, resulting in a shape that justifies the specimen nickname of the "dogbone" specimen. The taper makes the specimen particularly unsuited for testing of 0° unidirectional materials, since about half of the gripped fibers terminate prior to the gage section, resulting in failure by splitting at the radius due to inability of the matrix to shear the load from terminated fibers into the gage section.

While the ASTM D 638 specimen configuration has sometimes been successfully used for fabric reinforced composites and with general non-unidirectional laminates, some material systems remain sensitive to the stress concentration at the radius. While, for its intended use with plastics, the specimen is molded to shape, for laminated materials the specimen must be machined, ground, or routed to shape. The specimen also has the drawback of having a relatively small gage volume and is poorly suited for characterization of coarse weaves with repeating units larger than the gage width of 0.25-0.50 in. (6.4-13 mm). The standardized procedure, due to the intended scope, does not adequately cover the testing parameters required for advanced composites.

The bowtie tension test specimen, so-called because of its planform shape with a reduced cross-section, is similar in many respects to the ASTM D 638 specimen, though it has never been released as a standard test method. The bowtie specimen has achieved indirect standardization through use in several SAE AMS composite material (fabric-based) specifications¹. It is also still contained within a number of existing corporate internal material specifications for fabric-based materials, though it is rarely used now in new material specifications. With the geometric similarity to the ASTM D 638 specimen come a similar set of limitations and restrictions. The shape fundamentally restricts use to fabric reinforced materials and/or non-unidirectional laminates. Specimen preparation is extremely important since the reduced cross-section is prepared by machining, routing, or grinding, and both surface finish of the edge and machining of the tangent radii at the transition region to the reduced area are critical. The specimen also does not work well with coarse fabrics, since the gage section is only 0.5-in. (13 mm) wide.

To its credit, the bowtie specimen is reportedly somewhat less sensitive to failures in the transition section than the D 638 specimen, and has also been employed as a resource of last resort, particularly when the severity of non-ambient test environments creates otherwise difficult gripping problems for straight-sided specimens.

Other width-tapered specimen configurations have been proposed, but to date each has been shown, after study, to have at least one shortcoming that renders the method undesirable for general application, and so will not be further discussed.

¹The four known SAE specifications containing the bowtie coupon at the time of this writing were: AMS 3844A (Reference 6.8.2.2.3(b)), AMS 3845A, AMS 3847B, and AMS 3849A. Only the first, as an example, is completely referenced.

Limitations of the width-tapered tension tests for advanced composites:

Standardization: While the ASTM D 638 test is standardized, it was not developed for advanced composites, and is primarily applicable to relatively low modulus, unreinforced materials, or low reinforcement volume materials incorporating randomly oriented fibers. The bowtie test is standardized only in the sense of continued use in a limited number of SAE AMS material specifications. It has not been standardized for general use.

Specimen preparation: Special care is required to machine the taper into a laminated coupon.

Cost: Specimen fabrication is more expensive than untabbed straight-sided coupons.

Stress state: The radius transition region can dominate the failure mode and result in reduced strength results. The width-tapered specimen is not suitable for unidirectional laminates, and is limited to fabrics or non-unidirectional laminates when gage section failures can be attained.

Limited gage section volume: The limited gage width makes it unsuitable for coarse fabrics.

6.8.2.2.4 Split-disk ring tension test

ASTM Standard Test Method D 2290, Apparent Tensile Strength of Ring or Tubular Plastics and Reinforced Plastics by Split Disk Method

Procedure A (Procedures B and C apply only to plastics) of ASTM D 2290 (Reference 6.8.2.2.4) loads a hoop-wound narrow ring using a split-disk loading fixture that applies a hoop-direction tensile stress to the test ring. This test method was developed in the early years of composites, primarily for tensile properties of filament wound materials. It has long since been superseded by more reliable and more representative test methods. The disadvantages will not be dwelled upon, but include the material form/process limitation, the presence of an unaccounted bending moment at the fixture split, the extremely small gage volume, and the inability to monitor strain response. This test is not recommended for MIL-HDBK-17 data, but it still sees some limited usage as a quality control test in the filament winding industry.

6.8.2.2.5 Sandwich beam test

ASTM Standard Test Method C 393, Flexural Properties of Flat Sandwich Constructions

The sandwich beam test, shown schematically in Figure 6.8.2.2.5 is standardized as ASTM C 393 (Reference 6.8.2.2.5). While primarily intended as a flexure test for sandwich core shear evaluation, the scope also allows use for determination of facing tensile strength. While this use is not well documented within the test method, it has been used for tension testing of composite materials, particularly for 90° properties of unidirectional materials, or for fiber-dominated testing in extreme non-ambient environments.

An example of practical use of this test method for 90° unidirectional tape properties follows. A piece of 0.5-in. thick, 1/8-in. cell, 8.1 lbm/ft³ (13 mm thick, 3 mm cell, 130 kg/m³) aluminum honeycomb core is bonded to the test laminate using a suitable adhesive. A compressive faceskin is also bonded to the other side of the core, normally during the same bonding step. To minimize thermal expansion problems from dissimilar materials, the compressive faceskin is often chosen to be of the same material and orientation, but at twice the thickness of the tensile faceskin to assure failure in the tensile faceskin. The test specimen is then cut with a wet-diamond saw from the sandwich laminate. Specimen dimensions are 1 inch (25 mm) wide and 8 inch (200 mm) long, with the core ribbon direction aligned with the length of the specimen. The test setup uses a support span of 7 inch (180 mm) and a four-point loading span of 3 inch (76 mm). The load is both applied and reacted at all points using 1-inch (25 mm) square, 1/8-inch (3 mm) thick rubber pads, which are in turn each loaded by a 1/4-inch (6 mm) thick steel loading plate of the same area. The load is applied to each loading plate via a 1/2-inch (13 mm) diameter steel roller that rides in a transverse slot in the loading plate. This loading mechanism distributes the load into the beam

and prevents out-of-plane crushing of the core. The specimen and loading fixturing are shown schematically in Figure 6.8.2.2.5.

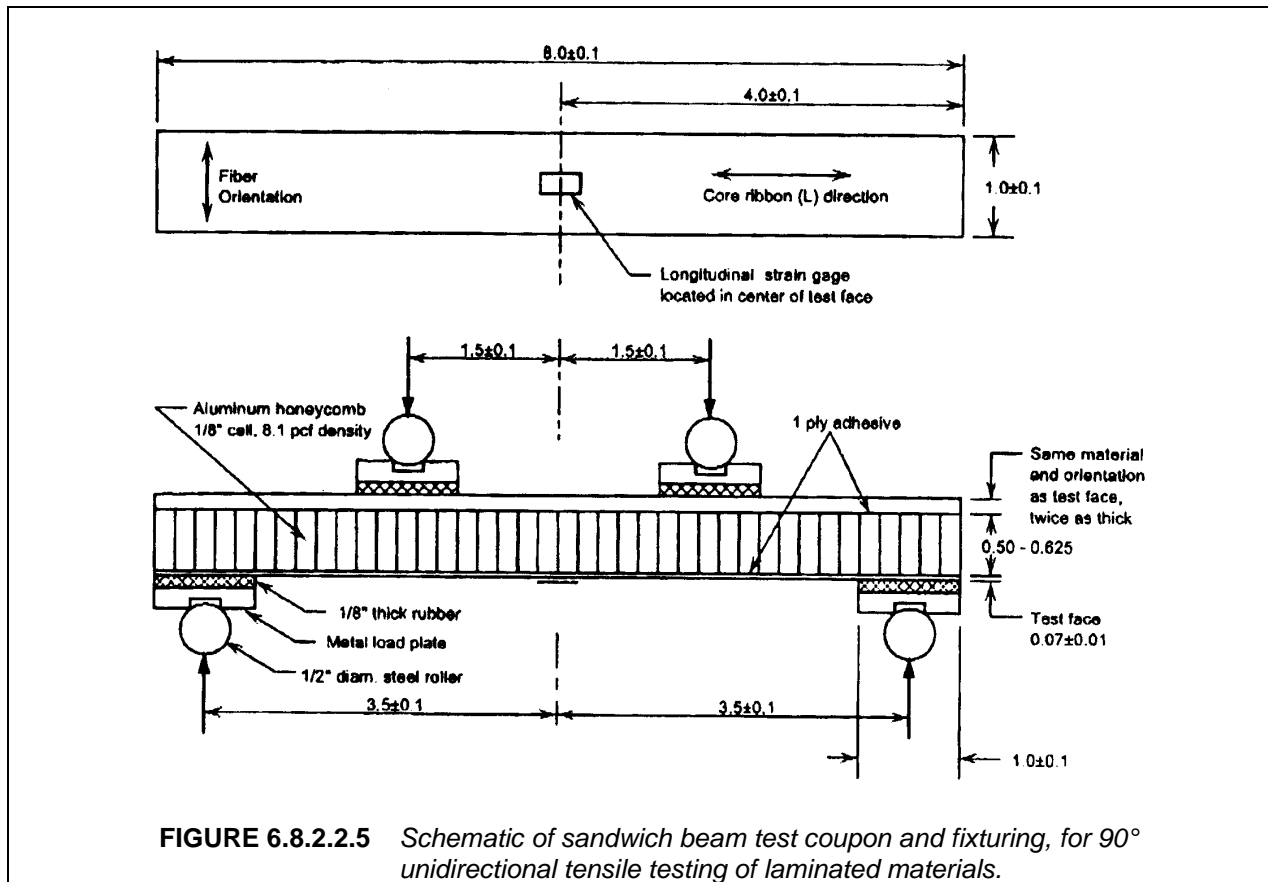

This test specimen is claimed by some to be less susceptible to handling and specimen preparation damage than D 3039-type 90° specimens, resulting in higher strengths and less test-induced variation. However, the one-sided environmental conditioning of this specimen is a problem, since the required conditioning times are longer by a factor of four or more, and such conditioning can create adhesive bond failures. Adhesive selection is, therefore, important and masking of the adhesive from the environmental conditioning may be required. In such cases, conditioning travelers are required that must be twice the test skin thickness in order to simulate the single-sided exposure of the specimen itself.

Limitations of the sandwich beam test for tensile properties:

Cost: Specimen fabrication is relatively expensive.

Stress State: The effect on the stress state of the sandwich core has not been studied in tension, and could be a concern.

Standardization: While this test technically is standardized, its practical application and limitations are not well studied or documented.

Conditioning: Conditioning is more difficult, as described above.

6.8.2.3 *Out-of-plane tensile test methods*

6.8.2.3.1 *Introduction*

There are currently no published standards for out-of-plane tensile test methods specifically relating to composites. Two basic approaches are presently in use, or being studied, by the aerospace industry include: direct out-of-plane loading of a laminated specimen bonded between two fixture blocks (based on modifications to similar non-composite test methods) and indirect out-of-plane loading of a curved beam. Both concepts are being considered for possible standardization in composite use by ASTM.

6.8.2.3.2 *Direct out-of-plane loading adaptations of ASTM C 297/C 633/D 2095*

- 1) using square cylinder loading blocks, or
- 2) using circular cylinder loading blocks

Three similar ASTM standard test methods already used for out-of-plane loading of other material systems have been adapted to composites: ASTM C 297 (Reference 6.8.2.3.2(a)), ASTM C 633 (Reference 6.8.2.3.2(b)), and ASTM D 2095 (Reference 6.8.2.3.2(c)). In the adaptations to composites a laminated specimen is bonded to cylindrical metal loading blocks which are pulled in the out-of-plane direction by a tensile test machine. The metal loading cylinders are either square or circular. The square specimens are typically 2-in. (50 mm) in width, while the circular specimens range in diameter from 0.8-in. to 2-in (20-50 mm). Strength is determined simply by dividing maximum load prior to failure by the specimen gage area.

If the specimen is sufficiently thick, strain gages may be used to determine elastic modulus. A thick specimen may also allow a reduced diameter gage section, which may be required if the out-of-plane strength exceeds the bond strength of the specimen/loading-block interface.

It has been argued by some that a circular specimen achieves a more uniform stress distribution (lower stress concentration). However, either configuration is extremely sensitive to specimen preparation factors, especially surface finish of the specimen edge and alignment of the load and loading blocks. Two typical specimen configurations are shown in Figure 6.8.2.3.2(a).

Each of the ASTM test methods uses a different method of introducing the load to the loading blocks. ASTM C 297 uses what is essentially a universal joint at each end. ASTM C 633 (circular only) applies a thread to the opposite end of each loading block and depends upon test machine alignment to eliminate bending. ASTM D 2095 uses a fixture that eliminates one of the bending degrees of freedom at one end, and the other bending degree of freedom at the other end. These three approaches are shown in Figures 6.8.2.3.2 (b-d).

Limitations of the direct out-of-plane tensile test methods:

Standardization: Despite the existence of three similar standards intended for use on other material systems, there is currently no standard for application of the methodology to laminated composites. This approach is still being studied.

Cost: Due to tight tolerances required for repeatable representative data, specimen preparation is relatively expensive.

Specimen preparation: Results are extremely sensitive to alignment of the loading blocks during bonding, as well as the machining quality and surface finish of the laminate edges. This implies that the laminate itself must be flat. An additional consideration is CTE-mismatch induced thermal stresses caused by a significant difference between the laminate in-plane CTE and the end-block CTE. This is especially important during end-block bonding, as well as during non-ambient testing.

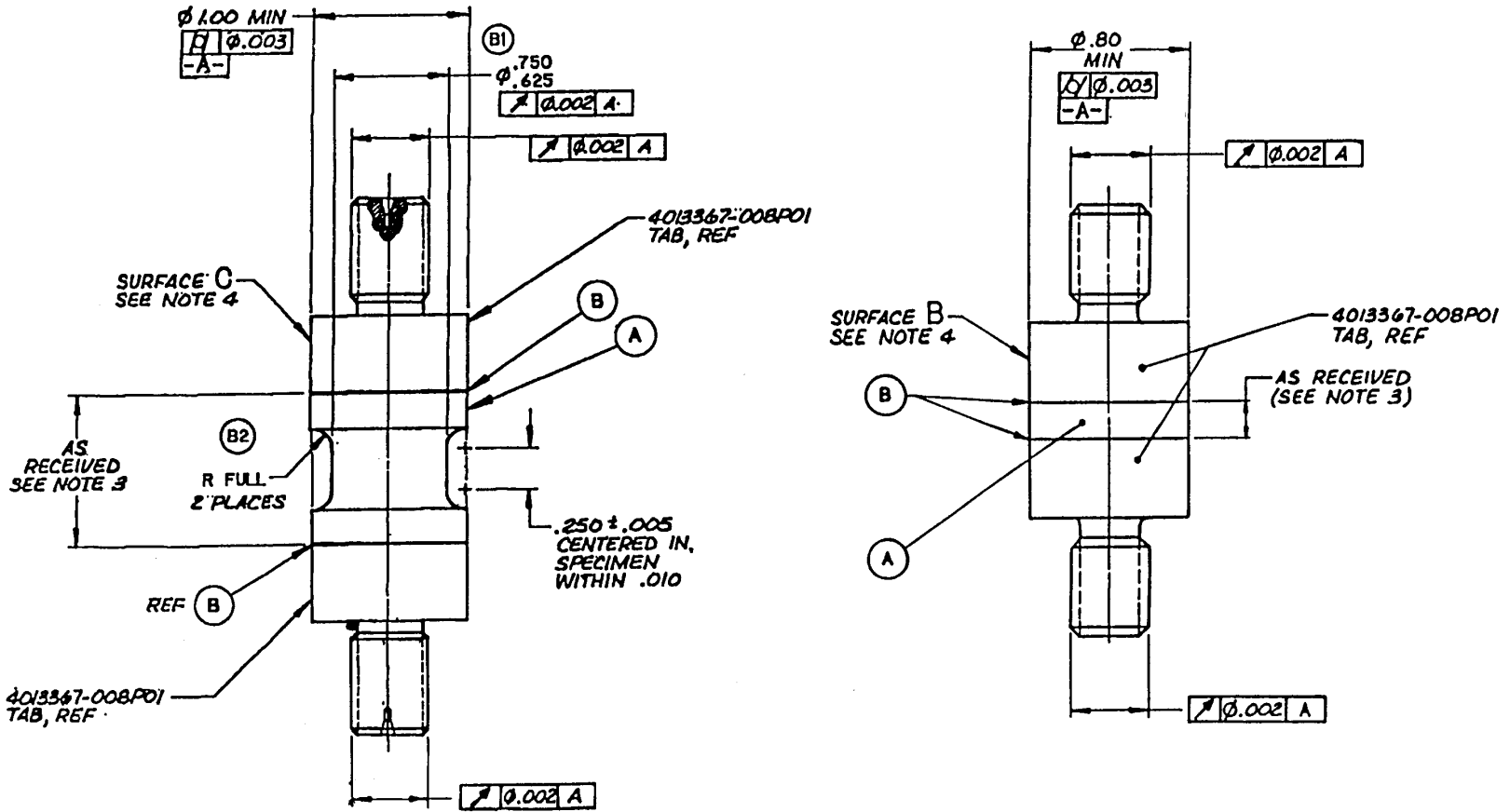

FIGURE 6.8.2.3.2(a) Two typical direct out-of-plane tensile specimen configurations.

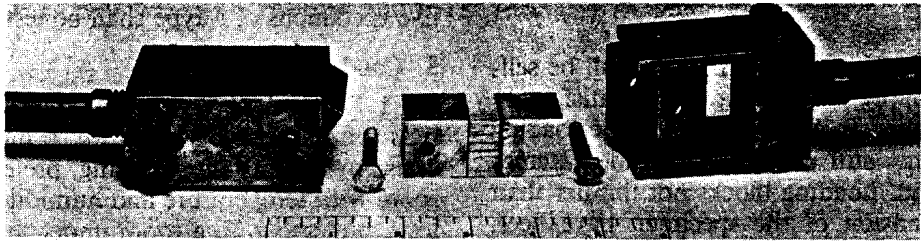
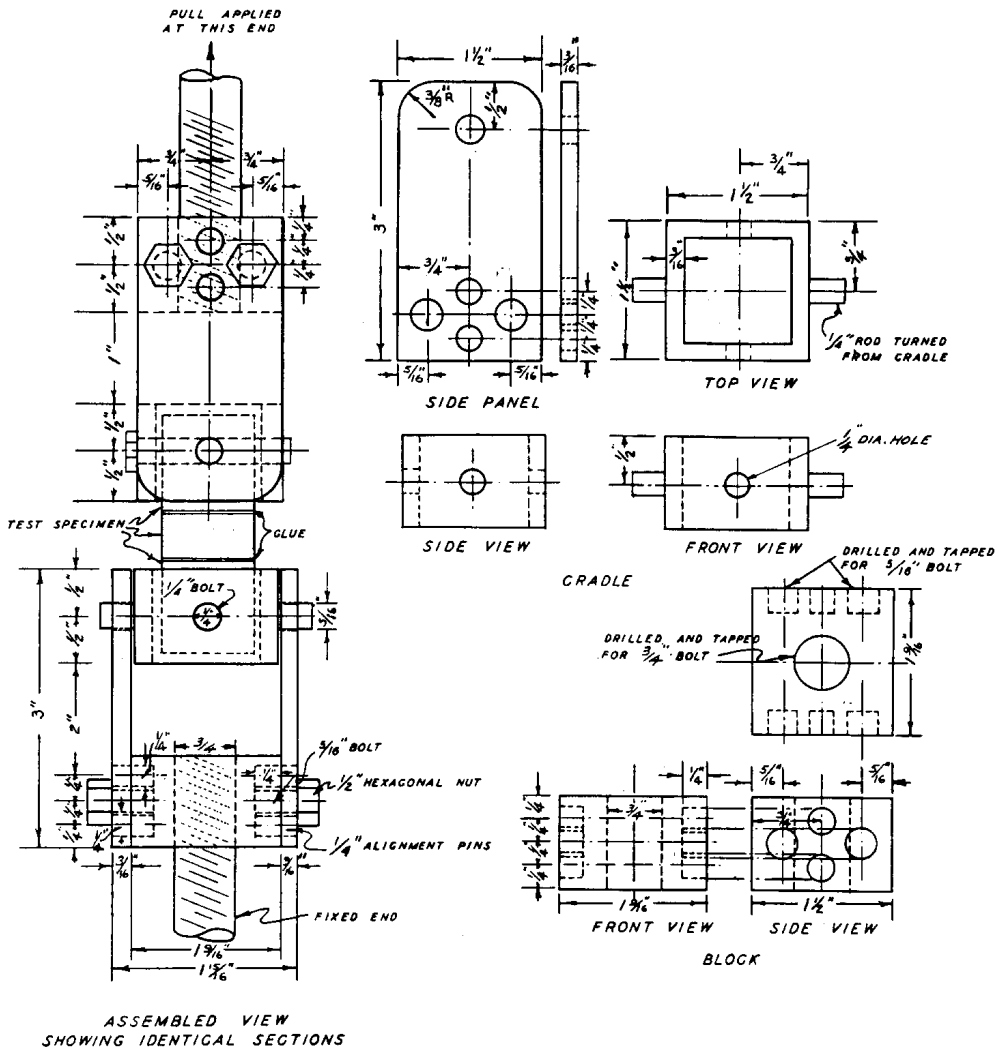

FIGURE 6.8.2.3.2(b) The ASTM C 297 loading fixture.

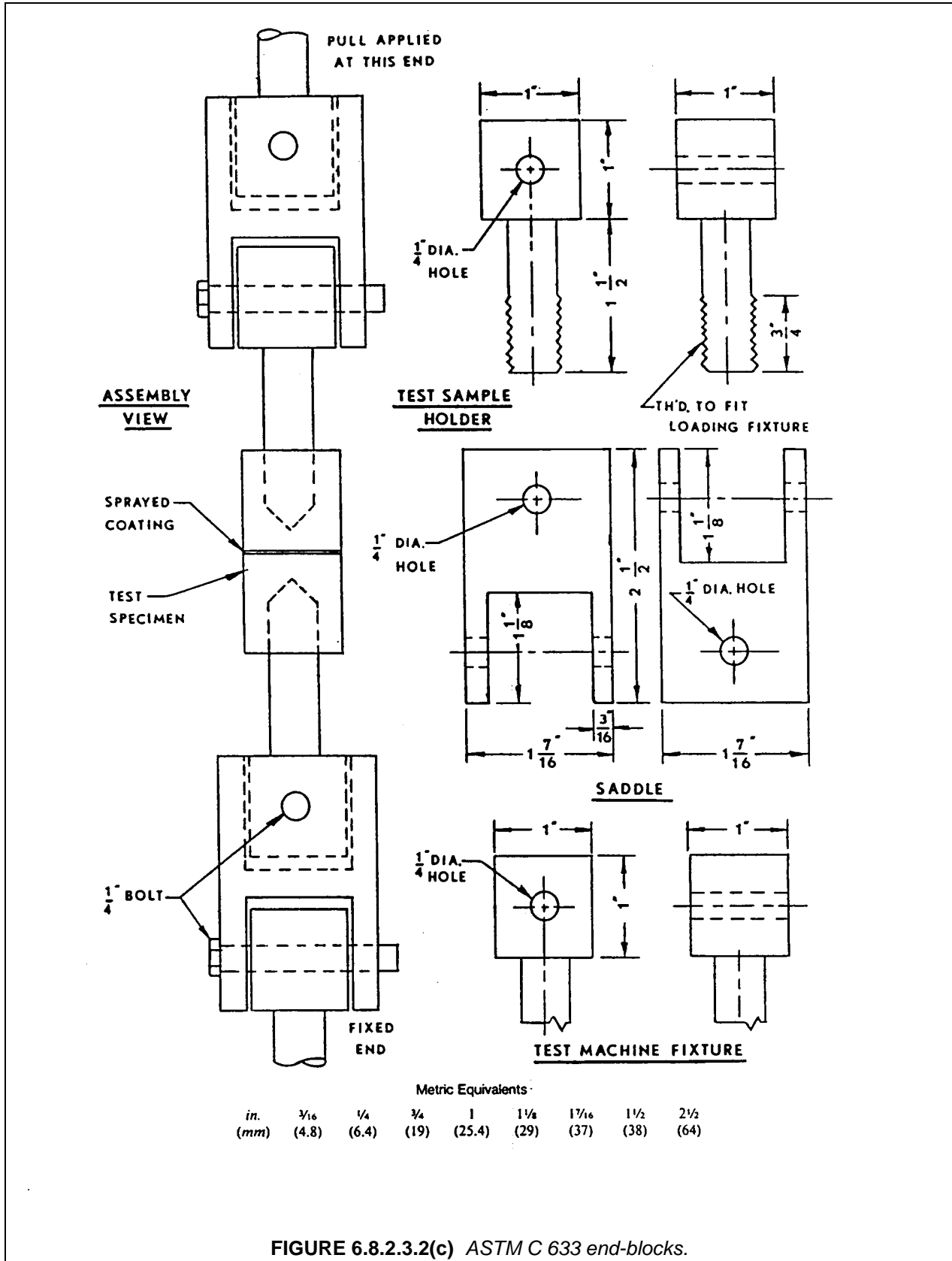

FIGURE 6.8.2.3.2(c) ASTM C 633 end-blocks.

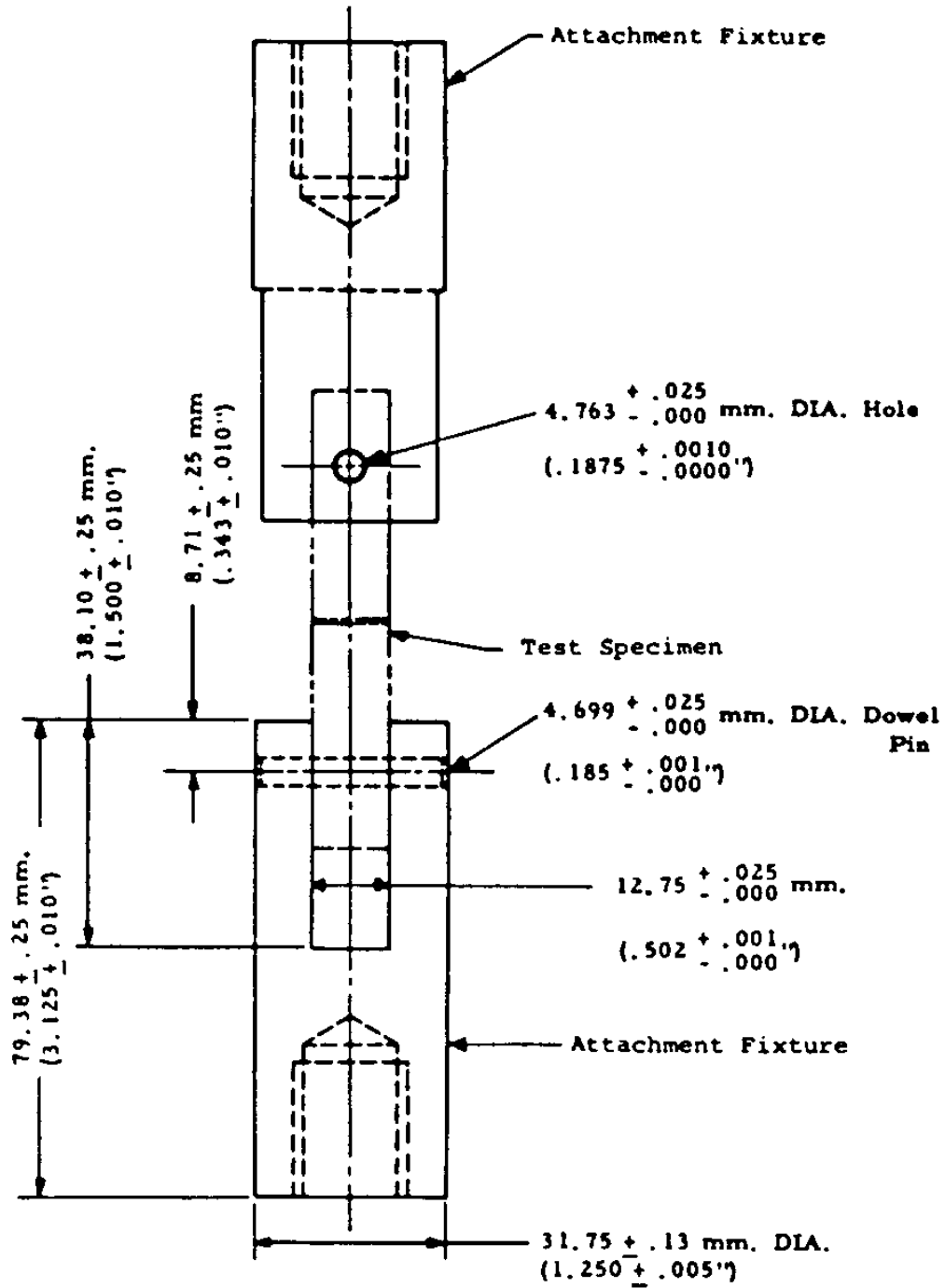

FIGURE 6.8.2.3.2(d) The ASTM D 2095 loading fixture.

6.8.2.3.3 Curved beam approach to out-of-plane tensile strength

This technique takes advantage of the out-of-plane tensile loading induced in the elbow of a curved laminate beam subjected to an opening moment. Several researchers have published investigations of different variations of this technique, exploring specimen size, specimen shape (90° small radius or “C”-shaped), and loading methods (attachment fixture used to apply an opening tensile load, or a four-point flexural fixture) (e.g., Reference 6.8.2.3.3). Typical specimen configurations are conceptually illustrated by Figure 6.8.2.3.3.

Limitations:

Standardization: Currently non-standard, although it is being evaluated for possible standardization by ASTM D-30.

Inconsistent results: Early investigations indicate results are strongly geometry and size dependent.

Material response: Unlike the direct out-of-plane loading method with a thick laminate, the specimen cannot be instrumented for out-of-plane strain and therefore modulus cannot be determined.

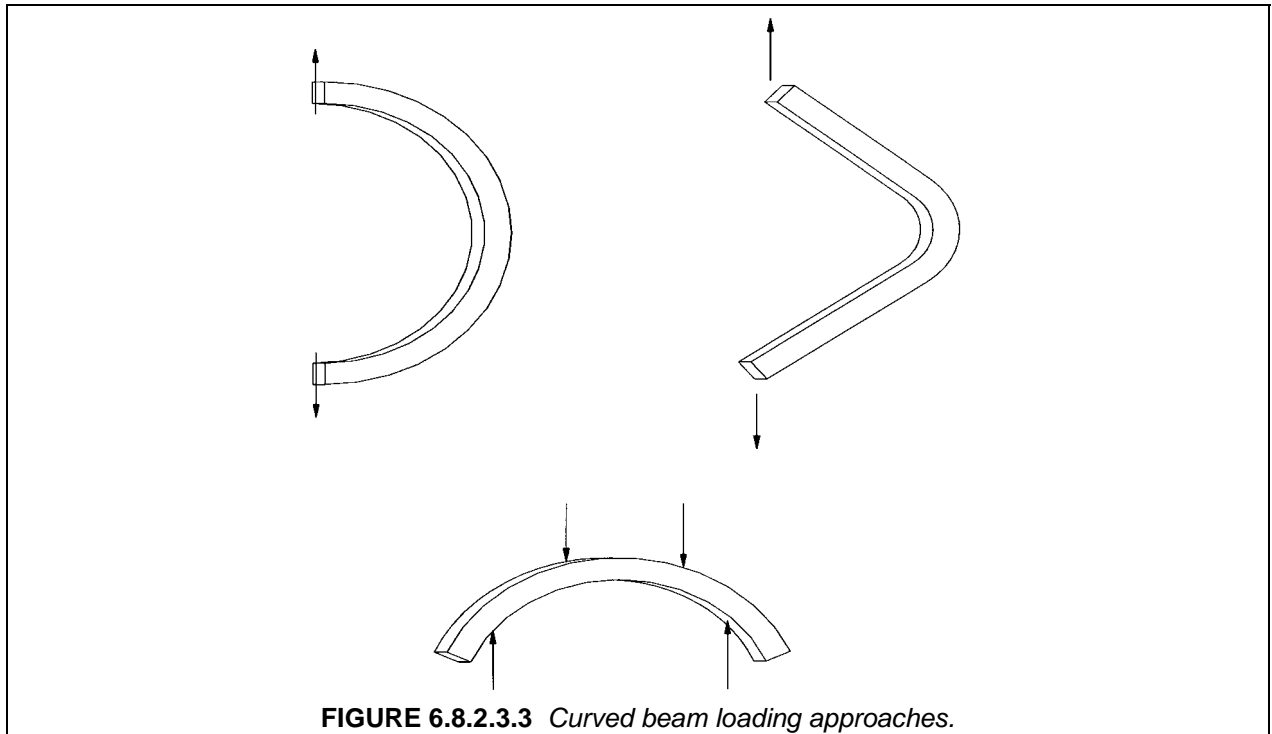

6.8.2.4 Tension test methods for MIL-HDBK-17 data submittal

Data produced by the following test methods (Table 6.8.2.4) are currently being accepted by MIL-HDBK-17 for consideration for inclusion in Volume 2.

TABLE 6.8.2.4 Tension test methods for MIL-HDBK-17 data submittal.

	Symbols	Fully Approved, Interim, and Screening Data	Screening Data Only
LAMINA PROPERTIES			
0° In-Plane Strength	$F_1^{tu}, \epsilon_1^{tu}$	D 3039, SRM 4, SRM 9 (crossply only)	---
0° In-Plane Modulus, Poisson's Ratio	E_1^t, ν_{12}^t	D 3039, SRM 4	---
90° In-Plane Strength	$F_2^{tu}, \epsilon_2^{tu}$	D 3039, SRM 4, D 5450	---
90° In-Plane Modulus	E_2^t	D 3039, SRM 4, D 5450	---
Out-of-Plane Strength	$F_3^{tu}, \epsilon_3^{tu}$	(no recommendation)	---
Out-of-Plane Modulus, Poisson's Ratios	$E_3^t, \nu_{31}^t, \nu_{32}^t$	(no recommendation)	---
LAMINATE PROPERTIES			
x In-Plane Strength	$F_x^{tu}, \epsilon_x^{tu}$	D 3039	---
x In-Plane Modulus, Poisson's Ratio	E_x^t, ν_{xy}^t	D 3039	---
y In-Plane Strength	$F_y^{tu}, \epsilon_y^{tu}$	D 3039	---
y In-Plane Modulus	E_y^t	D 3039	---
Out-of-Plane Strength	$F_z^{tu}, \epsilon_z^{tu}$	(no recommendation)	---
Out-of-Plane Modulus, Poisson's Ratios	$E_z^t, \nu_{zx}^t, \nu_{zy}^t$	(no recommendation)	---

6.8.3 Compressive properties

In-Plane Compressive Properties

Lamina

$$E_1^c, \nu_{12}^c, F_1^{cu}, \epsilon_1^{cu}$$

$$E_2^c, \nu_{21}^c, F_2^{cu}, \epsilon_2^{cu}$$

$$E_3^c, \nu_{31}^c, F_3^{cu}, \epsilon_3^{cu}, \nu_{32}^c$$

Laminate

$$E_x^c, \nu_{xy}^c, F_x^{cu}, \epsilon_x^{cu}$$

$$E_y^c, \nu_{yx}^c, F_y^{cu}, \epsilon_y^{cu}$$

$$E_z^c, \nu_{zx}^c, F_z^{cu}, \epsilon_z^{cu}, \nu_{zy}^c$$

6.8.3.1 Overview

The compressive response of composite materials has been the subject of research efforts and test programs since the early 1970's. Yet there remain numerous methods in use for testing composites in compression and no consensus as to which should be recommended.

Compression tests are conducted on composite materials, utilizing appropriate instrumentation, to determine compressive modulus, Poisson's ratio, ultimate compressive strength and/or strain-at-failure. These properties are determined through use of test fixturing that is typically designed 1) to introduce a uniform state of uniaxial stress in the specimen test section, 2) to minimize stress concentrations, 3) to be as simple to use and fabricate as possible, and 4) to minimize specimen volume. Compressive data are used for various purposes including research, quality control and generation of design allowables.

Measures of quality for a particular compressive test method include low coefficients of variation for strength and modulus, as well as the value of the modulus obtained relative to that from other compression test methods. While relative compressive strength is also often used as another measure of compression test quality, the inherent differences in compression response between the different compression tests mean that the test fixture, the resulting failure modes, and the application must be considered along with the resulting strengths. Compressive strengths from some methods may be considered "artificially high" due to fixture/coupon restraints that may suppress certain "real world" failure modes. Typically, fixtures are designed to induce failure in the test section and to intentionally inhibit some failure modes such as end brooming and column buckling that, if permitted to occur, would result in "artificially low" strengths. This tradeoff between just enough restraint versus too much restraint, and artificially high versus artificially low compressive strength, is the reason for the myriad of possible test methods and the lack of agreement on one acceptable method. There are differences of opinion on how to balance these tradeoffs. Final selection of a compressive test method depends on the goals of the testing program.

The measured compressive strength for a single material system has been shown to differ when determined by different test methods. Other parameters found to be significant contributors to the variations in results include fabrication practices, control of fiber alignment, improper and/or inaccurate specimen machining, improper tabbing procedures if tabs are used, poor quality of the test fixture, improper placement of the specimen in the test fixture, improper placement of the fixture in the testing machine, and an improper test procedure.

A review of the numerous compression test methods available reveals they can be broadly classified into three groups: 1) those that introduce load into the specimen test section through shear, 2) those that introduce load into the specimen test section through direct compression (end-loading), and 3) those that introduce load into the specimen test section through a combination of end-loading and shear. The two compressive test methods for fiber-reinforced composites currently published by ASTM Committee D-30 in D 3410-95 (Reference 6.8.3.1(a)) and the one method in D 5467-97 (Reference 6.8.3.1(b)) introduce load into the test section of the specimen primarily by shear. ASTM D 695 (Reference 6.8.3.1(c)),

SACMA SRM-1R-94 (Reference 6.8.3.1(d)), and SRM-6-94 (Reference 6.8.3.1(e)) utilize end loading. ASTM D 6484 (Reference 6.8.3.1(f)) is a combined loading test method.

Compressive test methods can be further classified as having a supported or an unsupported test section. An unsupported test section is defined as one with nothing in contact with the surfaces of the specimen in the test section throughout the entire compression test. A supported test section is one with support on the specimen faces and/or edges in the test section provided by the test fixture or ancillary equipment. All of the test methods discussed in this section utilize specimens with unsupported test sections, with the exception of ASTM D 5467, the Sandwich Beam method. A more complete discussion of compression test methodology and a description of test methods not covered here can be found in References (6.8.3.1(g) - (h)).

6.8.3.2 *In-plane compression tests*

The in-plane compressive test methods described below are typically used to generate the ultimate compressive strength, strain-at-failure, modulus, and Poisson's ratio of axially or transversely loaded unidirectional composite specimens, over a typical thickness range of 0.040 to 0.400 in. (1 to 10 mm). With the exception of the D 5467 (sandwich beam) method, all of the test methods discussed below will also accommodate specially orthotropic laminates, including [0/90]_{ns} style laminates. The testing of [0/90]_{ns} laminates has become a particularly popular means of eliminating specimen- and fixture-related sensitivities associated with the use of unidirectional specimens. If lamina compressive data are desired from [0/90]_{ns} laminates, data reduction procedures are required. A discussion of the use of [0/90] laminates for determining lamina properties, and the associated data reduction methods, can be found in Section 2.4.2, and in SACMA SRM 6.

The test methods discussed here can often be used for specimen thicknesses greater than those indicated above. Additional information on testing laminates thicker than 0.400 in. (10 mm) can be found in Volume 3, Chapter 6.

General Limitations of In-Plane Compression Testing

Test Method Sensitivity - Measured compressive strength for a single material system has been shown to differ when determined by different test methods. Such differences can be attributed to specimen alignment effects, specimen geometry effects and fixture effects, even though efforts have been made to minimize these effects. Examples of the differences in test results between the two procedures in ASTM D 3410-95 and the one procedure in ASTM D 5467-97 can be found in References 6.8.3.2(a) and (b).

Material and Specimen Preparation - Compressive modulus, and especially compressive strength, are sensitive to poor material fabrication practices, damage induced by improper specimen machining and lack of control of fiber alignment. Fiber alignment relative to the specimen coordinate axis should be maintained as carefully as possible, although no standard procedure to ensure this alignment exists. Procedures found satisfactory include the following: fracturing a cured unidirectional laminate near one edge parallel to the fiber direction to establish the 0° direction, or laying in small filament count tows of contrasting color fiber (aramid in carbon laminates and carbon in aramid or glass laminates) parallel to the 0° direction either as part of the prepreg production or as part of panel fabrication.

6.8.3.2.1 *ASTM D 3410/D 3410M, Compressive Properties of Polymer Matrix Composite Materials With Unsupported Gage Section by Shear Loading*

Two compression procedures are published by ASTM in Test Method D 3410 (Reference 6.8.3.1 (a)) and have historically been called the Celanese (D 3410, Procedure A), and the IITRI (Illinois Institute Technology Research Institute, D 3410, Procedure B). The Celanese and IITRI procedures, as with many other published procedures, originally carried the names of the organizations under which the procedure

was developed. The Celanese and IITRI procedures address the use of tabbed or untabbed rectangular specimens and transfer load via wedge-type grips.

Limitations of ASTM D 3410

Material Form - Limited to continuous-fiber or discontinuous-fiber reinforced composites for which the elastic properties are specially orthotropic with respect to the test direction.

Test Fixture Characteristics - Although both Procedures A and B transmit load to the specimen via tapered wedge grips, the wedge surfaces in Procedure A are conical and those in Procedure B are flat. The conical wedges in Procedure A are known to be prone to cone-to-cone seating problems (Reference 6.8.3.2(a)). The flat wedge grip design used in Procedure B was employed to eliminate this wedge-seating problem (Reference 6.8.3.2(a)). A fixture characteristic that can have a significant effect on test results is the surface finish of the mating surfaces of the wedge grip assemblies. Since these surfaces undergo sliding contact they must be polished, lubricated, and free of nicks and other surface damage.

Strain Measuring Devices - While compressometers are not ruled out, available space considerations make use of strain gages essentially required. Back-to-back gages are required for a minimum number of specimens for both Procedures A and B.

ASTM D 3410, Procedure A

Procedure A is not used very extensively, and is being considered for removal from ASTM D 3410. Thus it will not be discussed further here. Details are available in ASTM D 3410-95.

ASTM D 3410, Procedure B

The fixture for this test method was designed principally to eliminate the seating problems associated with the conical wedge grips in Procedure A (Reference 6.8.3.2(a)). In place of conical wedge grips, the fixture for this test method consists of flat wedge grips seated in a rectangular housing (Figure 6.8.3.2.1). The fixture for this method is much larger and heavier than that for Procedure A, and can accommodate much larger specimens. The test specimen used in this fixture is typically a tabbed specimen of rectangular cross section with recommended dimensions of 5.5 - 6.0 in. (140 - 155 mm) long, 0.50 - 1.0 in. (10 - 25 mm) wide, and with a of 0.5 - 1.0 in. (10 - 25 mm) gage length. Specimens tested using this procedure have a minimum required thickness, specified as a function of gage length, material moduli, and expected material strength. As with Procedure A, the load applied to the fixture is transferred from the wedge grips to the specimen tabs through shear, and from the tabs to the test specimen through shear. The complex stress state in the tabbed region of the specimen changes to uniaxial compression in the specimen test section. Compression strength is determined from load at failure while modulus and strain-at-failure are determined when strain gages or compressometers are employed.

Limitations of ASTM D 3410, Procedure B

Tabbing and Tolerances - The data resulting from this test method have been shown to be sensitive to the flatness and parallelism of the tabs, so care should be taken to assure that the specimen tolerance requirements are met. This may require precision grinding of the tab surfaces after bonding them to the specimen. The fixture used for this procedure must also be precision machined and assembled, and accurately installed in the testing machine.

6.8.3.2.2 ASTM D 6484, *Compressive Properties of Polymer Matrix Composite Laminates Using a Combined Loading Compression (CLC) Test Fixture*

As the title implies, this test method applies a combination of end loading and shear loading to the test specimen. A typical test fixture is shown in Figure 6.8.3.2.2. It consists of four blocks clamped in

pairs to either end of the test specimen. The surfaces of the fixture blocks in contact with the specimen are roughened, to increase the effective coefficient of friction and hence the shear load transfer. By adjusting the torque applied to the four screws in each pair of blocks, the ratio of shear loading to end loading can be controlled. The goal is to apply sufficient torque so that the ends of the specimen are not crushed or otherwise fractured by the end loading, but only a minimum more than necessary. Increasing the clamping force on the ends of the specimen increases the through-thickness stresses induced, and the axial stress concentration at the gage section ends of the fixture blocks. While this is the goal, it has been shown (Reference 6.8.3.2.2.(a)) that there is considerable tolerance on the upper end of screw torque (clamping force).

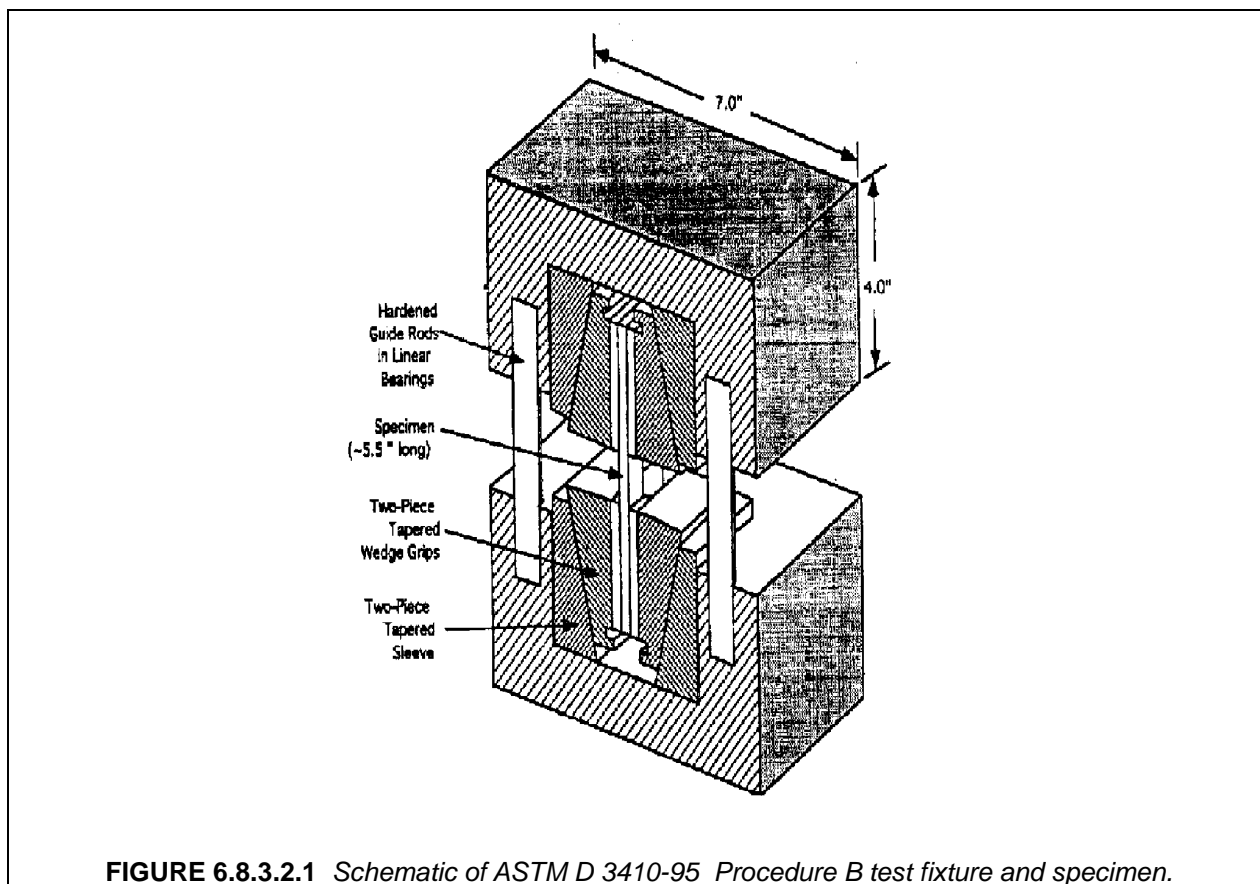

Because of the favorable load introduction aspects of combined loading, it is possible to test many types of composite materials and laminates without the use of tabs. Tabs always introduce an additional stress concentration in the specimen at the ends of the gage section (References 6.8.3.2.2(b)-(d)). Eliminating tabs also significantly reduces the cost of specimen preparation, and eliminates several inherent factors that are potential sources of error and data scatter. These include variations in tabbing material thickness and adhesive bondline thickness. As an example, untabbed $[0/90]_{ns}$ cross-ply laminates cannot be reliably tested using end loading methods. Crushing of the specimen ends is likely. Such laminates are readily tested using combined loading.

The standard CLC specimen is 5.5 in. (140 mm) long. This produces a 0.50 in. (12.7 mm) gage length (unsupported length). Longer or shorter gage sections can be obtained by simply altering the total length of the specimen. A specimen width of 0.50 in. (12.7 mm) is recommended for most applications. However, the standard fixture will accommodate a specimen of any width up to 1.2 in. (30.5 mm). A specimen thickness on the order of 0.080 to 0.100 in. (0.020 to 0.025 mm) is commonly used. However,

the fixture will accommodate a specimen of any practical thickness. Specimens that are too thin will buckle. Thick specimens will end-crush if the orthotropy ratio of the material being tested is too high (a high enough shear component of the combined loading cannot be attained).

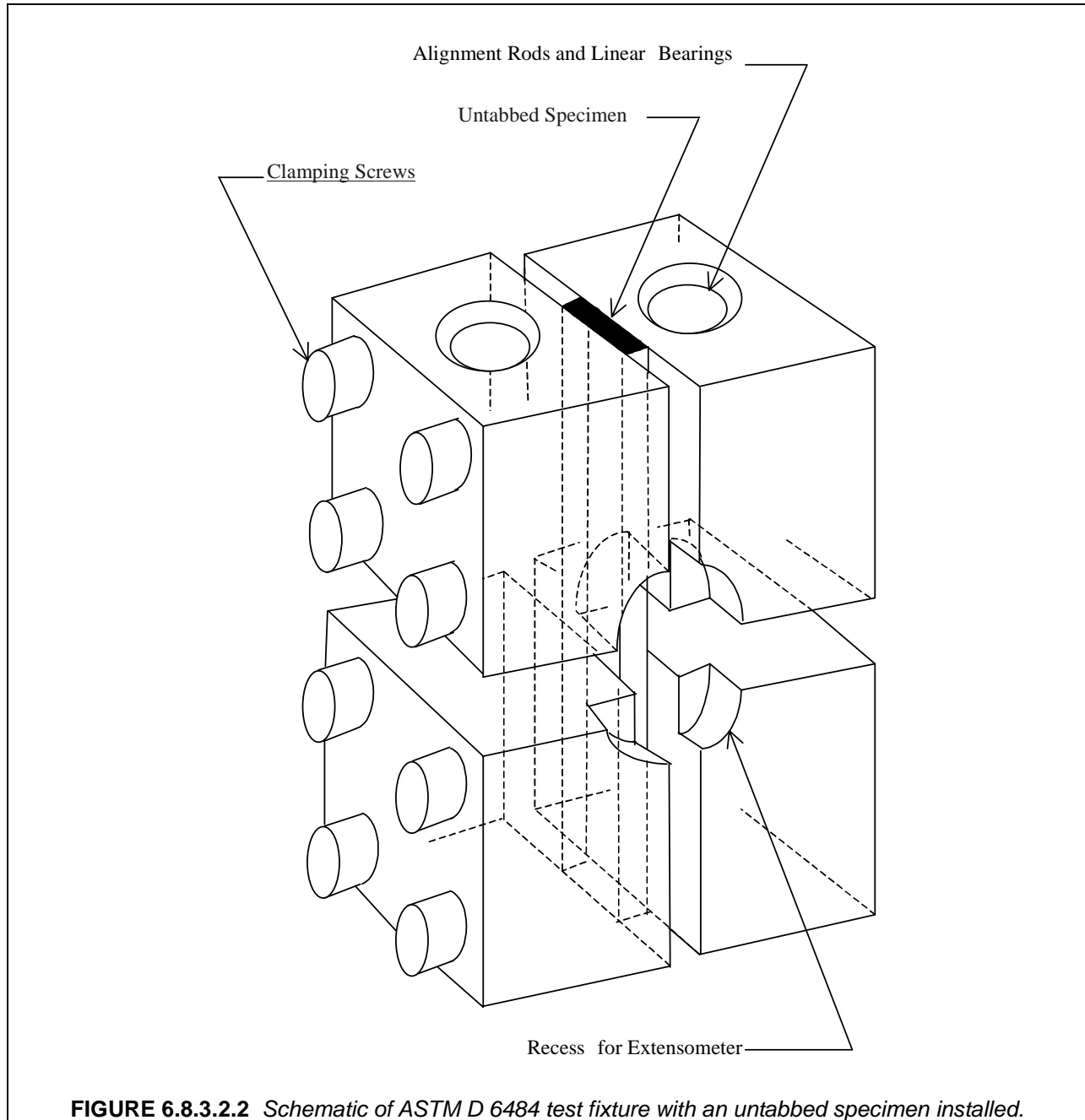

As for ASTM D 3410, tabbed specimens, even unidirectional composites, can be tested. There is a slight advantage of using combined loading rather than shear loading of tabbed specimens in that the clamping forces do not have to be as high and thus the stress concentrations previously noted are not as high.

Material Forms - most specially orthotropic laminate configurations can be tested using untabbed specimens. Exceptions are laminates with high percentages of 0° plies. Testing laminates with more than 50 percent 0° plies may induce end crushing. Untabbed fabric and braided composites can also be tested. Highly orthotropic unidirectional composite specimens must be tested with tabs.

Test Fixture Characteristics - The test method relies on a high effective coefficient of friction at the specimen-fixture interface, to transmit a significant shear force while keeping the clamping force to a minimum. Thermal-sprayed tungsten carbide particle grip surfaces perform well. Each pair of fixture end blocks must be properly machined and well matched at their outer ends so that when clamped on to the specimen ends they form flat planes perpendicular to the axis of the test specimen. The specimens must also be prepared with flat ends perpendicular to the specimen axis. A specimen is installed in the fixture such that each end of the specimen is flush with the outer ends of a pair of clamping blocks. Then when a compressive force is applied via flat platens, this force is transmitted both by the fixture end blocks and the specimen ends.

Strain Measuring Devices - A typical Combined Loading Compression test fixture is provided with a recess on one side so that a compressometer can be attached to one edge of the specimen in the gage section (Figure 6.8.3.2.2). However, as in ASTM D 3410, the unsupported section is typically only about .50 in (12.7 mm) long, limiting the attachment space available. Attaching extensometers to each face of the test specimen, as recommended to monitor specimen bending and buckling under load, is even more difficult because of the long reach length required. Thus, strain gages are commonly used instead. These can have a very short active gage section length and thus fit into a confined space. Back-to-back gages are required for a minimum number of specimens, to check for specimen bending and buckling.

Limitations of ASTM D 6484

Specimen Dimensions - The standard fixture is designed to grip each end of the untabbed specimen over a length of 2.5 in. (63.5 mm). Thus the specimen must be longer than 5.0 in. (127 mm) in order to establish a gage section. The maximum specimen width the standard fixture will accommodate is 1.2 in. (30.5 mm). As specimen thickness is increased, the through-thickness distribution of the axial compressive stress will become more nonuniform. This may dictate a practical upper limit even though the fixture can accommodate thicker specimens.

Material Forms - Highly orthotropic composite materials cannot be tested using untabbed specimens. The very high clamping forces required to prevent end crushing induce stress concentrations of unacceptable magnitudes at the gage section ends of the clamping blocks.

6.8.3.2.3 ASTM D 5467, *Compressive Properties of Unidirectional Polymer Matrix Composites Using a Sandwich Beam*

The sandwich beam method (Reference 6.8.3.1(b)) consists of a honeycomb-core sandwich beam that is loaded in four-point bending, placing the upper face sheet in compression (Figure 6.8.3.2.3). The compression face sheet (upper sheet) is a 6-ply unidirectional laminate and the lower face sheet should be the same material and twice as thick. The two face sheets are separated by, and bonded to, a deep aluminum honeycomb core. The upper face sheet is designed to fail in compression when the beam is subjected to four-point bending. The beam is loaded to failure in bending, resulting in the measurement of compressive strength, compressive modulus and strain-at-failure if strain gages or compressometers are employed.

Limitations of ASTM D 5467

Material Form - This test procedure is limited to unidirectional materials.

Specimen Complexity - The sandwich beam specimen is much larger, and specimen preparation is more complex and expensive, than for those in ASTM D 3410 and ASTM D 6484.

Poisson's Ratio - The validity of Poisson's ratio obtained from this method has been questioned due to anticlastic bending.

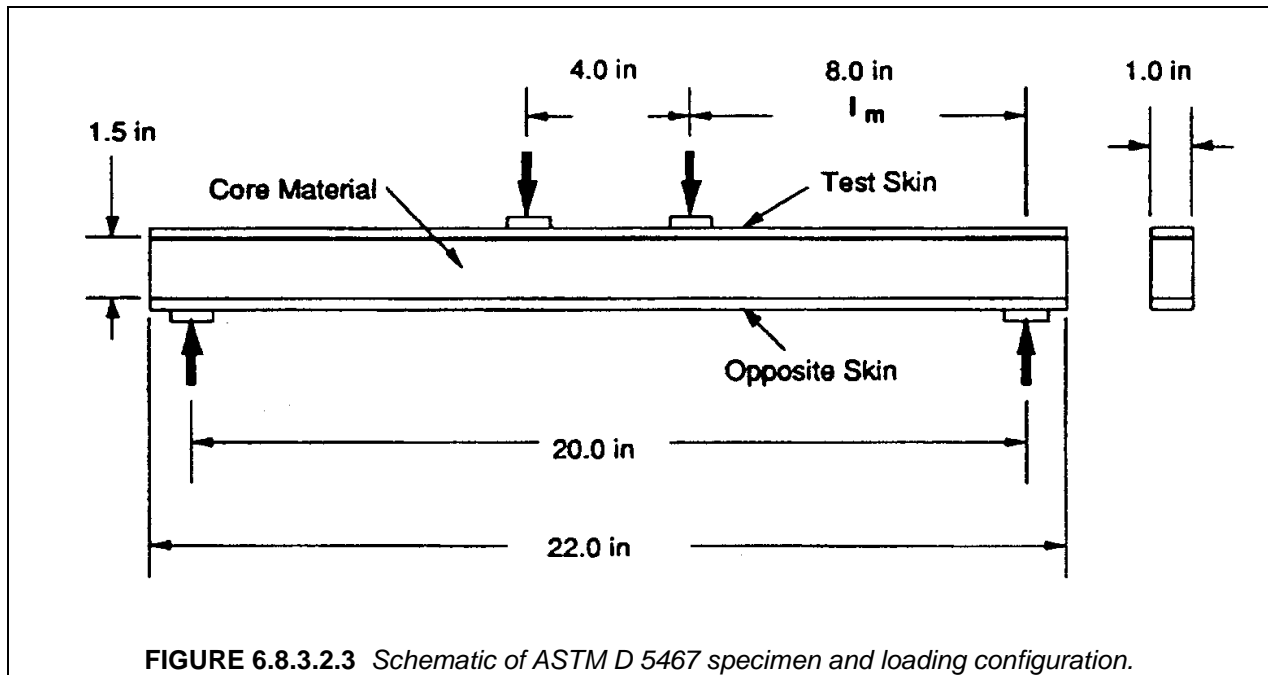

6.8.3.2.4 ASTM C 393, Flexural Properties of Flat Sandwich Constructions

This test method (Reference 6.8.3.2.4) is one of a series designed to test sandwich constructions, and covers the determination of the properties of flat, sandwich constructions subjected to flatwise flexure in the same manner as ASTM D 5467. While D 5467 is designed to provide data for the compressively loaded face sheet only, ASTM C 393 is used to determine the flexural and shear stiffness of the entire sandwich, shear modulus and shear strength of the core, or compressive or tensile strength of the face sheets. There are no limitations on the core or skin materials for this test method, the specimen is rectangular in cross section, and the core, face, and span geometries are determined to achieve the desired failure mode as a function of material properties. While not widely used for the determination of composite material properties, this test method does allow for the design of a test specimen not covered by ASTM D 5467. Caution should be exercised in using this test for composite material properties since the equations for determining the material properties may not be applicable for some specimen geometries or core/face sheet combinations.

The use of this test method to determine the tensile properties of [90°] laminates is covered in Volume 1, Section 6.8.2.2.5.

Limitations of ASTM C 393

Material Form - This test method is not limited in the material form of the core material or face sheet material. Equations for determining the material properties may not be applicable for some specimen geometries or core/face sheet combinations.

Specimen Geometry - This test method is limited to rectangular sandwich construction and the core, face, and span geometries are allowed to vary in order to achieve the desired failure mode as a function of material properties. Equations for determining the material properties may not be applicable for some specimen geometries or core/face sheet combinations.

6.8.3.2.5 ASTM D 695, Compressive Properties of Rigid Plastics

This method was developed by ASTM Committee D-20 for compression testing of unreinforced and reinforced rigid plastics. Two types of specimens can be used for this method. The first is typically used for unreinforced plastics and is in the form of a right cylinder or prism whose length is twice its principal diameter or width. Preferred specimen sizes are 0.50 in. by 0.50 in. by 1 in. (12.7 mm by 12.7 mm by 25.4 mm) for a prism and 0.50 in. dia. by 1 in. (12.7 mm dia. by 25.4 mm) for a cylinder. Smaller diameter rods or tubes may also be tested provided they are of sufficient length to allow a specimen slenderness ratio of 11:1 to 16:1. The specimen is tested by placing it between the hardened steel faces of a compressive subpress and loading it to failure.

The second test specimen configuration in the standard is documented as being for "reinforced plastics, including high-strength composites and highly orthotropic laminates" < 0.125 in. (6.4 mm) thick. It uses a flat, untabbed dogboned specimen 3.13 in. (79.5 mm) long having a 0.50 in. (12.7 mm) reduced width test section. Two I-shaped (anti-buckling) support plates, slightly shorter than the specimen, and with longitudinal grooves, are lightly clamped to the faces of the specimen, at most a negligible portion of the applied force is transmitted through the support plates (a redundant load path). After positioning the specimen between the support plates, a compressive load is applied directly to the ends of the specimen until failure, to determine compression strength.

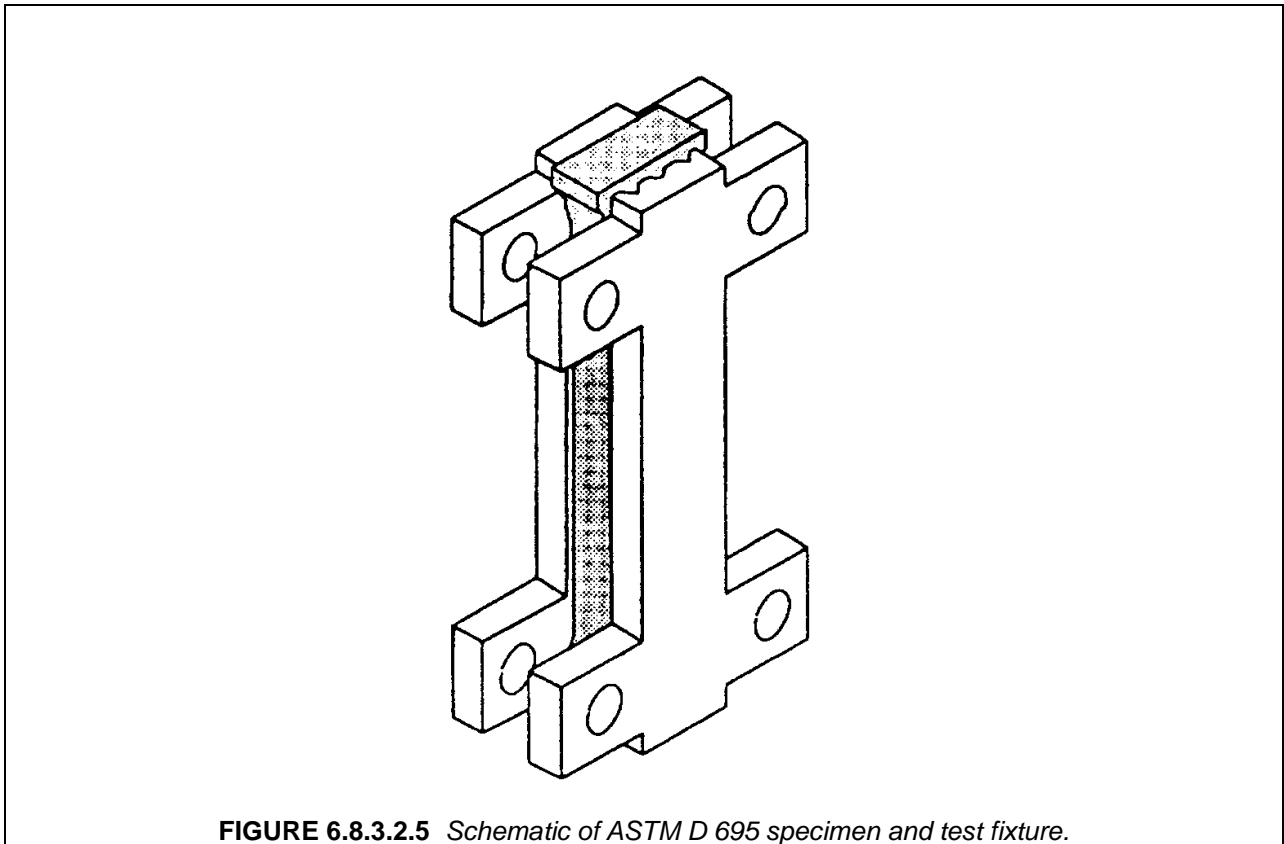

FIGURE 6.8.3.2.5 Schematic of ASTM D 695 specimen and test fixture.

The flat dogboned specimen, fixture-supported method was evaluated in a D-30 round robin for [0] AS/3501 and [0] E-Glass/1002 laminates (Reference 6.8.3.2(b)). The conclusion from this study was that this test method is not adequate for determining the compressive strength of high-modulus composite materials in the forms studied in this investigation. (Other forms, such as E-glass fabric-reinforced com-

posites, can be successfully tested using this test method.) In an attempt to modify this portion of the ASTM D 695 test method for use with high-modulus composites, a straight-sided, tabbed coupon has been developed. In addition, an L-shaped base to support the fixture-specimen assembly has also been added to the test method. These modifications were not made by ASTM, nor incorporated into ASTM D 695. A discussion of these modifications is included below in the section on the SACMA SRM 1R test method.

Limitations of the ASTM D 695 Compressive Test Method

Material Form - The published scope of this document states that it is limited to unreinforced and reinforced rigid plastics, including high-modulus composites. But round-robin testing conducted by ASTM Committee D-30 found this method to be unacceptable for the measurement of strength of high modulus composites (Reference 6.8.3.2(b)). However, it should be noted that there was some question as to the validity of the round-robin testing (Reference 6.8.3.2(b)).

6.8.3.2.6 SACMA SRM 1R, Compressive Properties of Oriented Fiber-Resin Composites

A variation of the ASTM D 695 "Standard Test Method for Compressive Properties of Rigid Plastics" for high-modulus continuous fiber composites has been developed and documented by SACMA as SRM 1R (Reference 6.8.3.1(d)). While essentially retaining the simple fixturing of the D 695 method, the variation utilizes straight-sided tabbed specimens for compression strength and an L-shaped base for support of the fixture-specimen assembly. A separate, untabbed specimen must be used for the measurement of modulus. Both specimens are shorter than the D 3410 specimens, being 3.18 in. (80 mm) long, 0.5 in. (6.4 mm) wide and 0.040 to 0.120 in. (1 to 3 mm) thick. Although the test section is unsupported, it is very short (0.188 in. (4.8 mm)).

This test method tends to produce slightly higher average values of compression strength (5 to 10 percent) than ASTM D 3410 Procedures A and B. One probable reason is the slightly more uniform stress state in the gage section produced by the end loading. However, as for ASTM D 695, a fixture-induced redundant load path through the lateral supports can be significant if the clamping force is too high. SRM-1R specifies that the clamping screws be torqued to 6-10 in-lb (0.7-1.0 Joules). This is discussed further in (Reference 6.8.3.1(d)). A schematic of this test method with the compressive strength specimen in place is shown in Figure 6.8.3.2.6.

Limitations of the SACMA SRM 1R Compressive Test Method

General - Separate strength and modulus specimens are required for this test method. The short specimen gage length results in a small test section volume for the strength specimen.

Material Form - The specific scope of this test method is interpreted by the Handbook coordination group to be for 0° direction properties of unidirectional specimens, and 0° and 90° direction properties of fabric specimens only. This test method is applicable to fabric-based materials only when the unit cell size of the specimen weave/braid is smaller than the 0.188 inch (4.8 mm) gage length of the specimen.

Compressive Strength - Measured compressive strengths obtained using this test method are typically higher than those obtained using the methods in ASTM D 3410, as previously discussed. It is important to avoid a redundant load path induced by using clamping screw torques that are too high.

Strain-at-failure - This test method will not provide strain-at-failure since the gage region of the strength specimen is not large enough for a strain gage, and the (untabbed) modulus specimen geometry is not suitable for loading to failure. Consequently, stress-strain response, including monitoring of specimen bending strains as commonly done to assess proper gage section loading, cannot be observed over most of the actual stress-strain response.

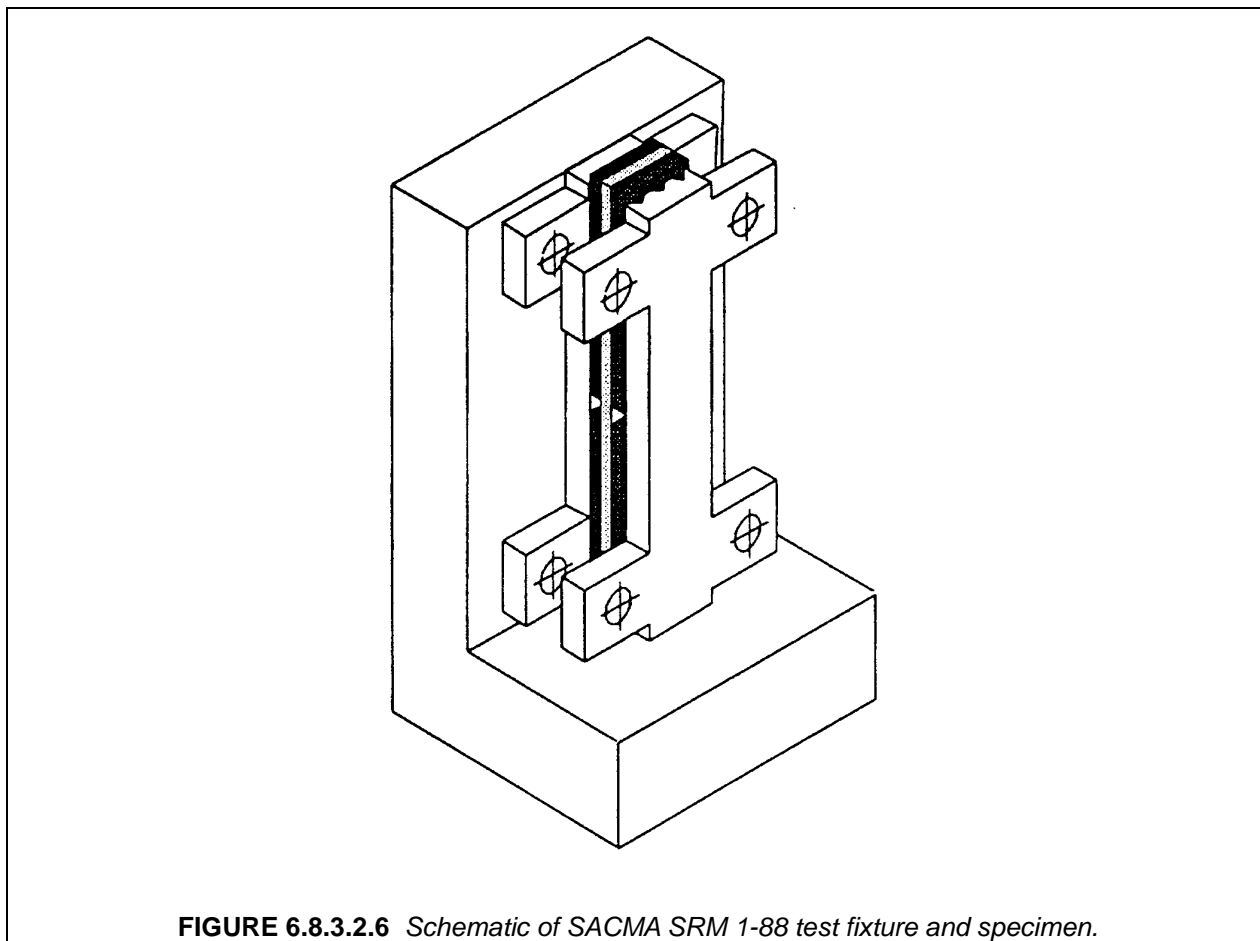

FIGURE 6.8.3.2.6 Schematic of SACMA SRM 1-88 test fixture and specimen.

6.8.3.2.7 SACMA SRM 6, Compressive Properties of Oriented Cross-Plied Fiber-Resin Composites

This test method (Reference 6.8.3.1(e)) is identical to SACMA SRM 1R with the exception that it is limited in material form to cross-ply laminates. This limitation is applied since the method is intended for the determination of unidirectional composite compressive strength by applying a back-out factor to the strength determined from the cross-ply laminate.

The procedure is to test a $[90/0]_{ns}$ (e.g., $n=3$ or 6) laminate¹ to failure in compressive as outlined in this method (which is the same as in SACMA SRM 1R). The compressive strength of this laminate is then multiplied by a factor to determine the effective strength of the unidirectional plies that make up the $[90/0]_{ns}$ laminate, as follows:

$$\sigma_{c,uni} = F \times \sigma_{c,lam}$$

$$\text{where } F = \frac{2E_{11}}{E_{11} + E_{22}}$$

The moduli (E_{11} and E_{22}) of the unidirectional composite material must be determined by separate tests of a unidirectional composite material. A more complete discussion of the limitations and assumptions associated with the use of cross-ply laminate data to back out unidirectional composite data is presented in Section 2.4.2. The strength back-out factor in SACMA SRM 6 is an approximation and is not the same as the factors recommended in Section 2.4.2.

¹ For example, for a carbon/epoxy composite, $n = 3$ is typically used for the laminate lay-up when a prepreg material with an areal weight greater than or equal to 100 g/m^2 is tested, and $n=6$ for areal weights less than 100 g/m^2 .

Limitations of the SACMA SRM 6 Compressive Test Method

General - Separate strength and modulus specimens are required for this test method. The short specimen gage length results in a small test section volume for the strength specimen. The use of the back-out factor in this test method assumes linear elastic response of the material it is being applied to.

Material Form - Limited to cross-plyed, polymer matrix composites reinforced with oriented, continuous fibers, and made primarily of prepreg or similar product forms. The short gage length prohibits its use for fabric-based and braided materials when the unit cell size of the specimen weave/braid is larger than the 0.188 in. (4.8 mm) gage length.

Compressive Strength - As for ASTM D 595 and SACMA SRM 1R, a fixture-induced redundant load path through the lateral supports can be significant if the clamping force is too high. As for SRM-1R, SRM 6 specifies that the clamping screws be torqued to 6-10 in-lb. (017-1.0 Joules). This is discussed further in (Reference 6.8.3.1(*l*)).

Strain-at-failure - This test method does not provide strain-at-failure since the gage region of the strength specimen is not long enough for a strain gage, and the (untabbed) modulus specimen geometry is not suitable for loading to failure. Consequently, stress-strain response, including monitoring of specimen bending strains, as is commonly done to assess proper gage section loading, cannot be observed over most of the actual stress-strain response.

6.8.3.2.8 *Through-thickness compression tests*

Due to an historical lack of need for through-thickness compressive data, there are no standardized or widely accepted test methods to determine the through-thickness (*z*-direction) compressive strength, modulus or Poisson's ratio of composite laminates. These data have been reported to a limited extent in the literature (References 6.8.3.2.8(a) and (b)), and simple rectilinear specimens cut from thick-section laminates have been used to obtain these properties.

6.8.3.3 *Compressive test methods for developing MIL-HDBK-17 data submittal*

Data provided by the following test methods (Table 6.8.3.3) are currently being accepted by MIL-HDBK-17 for consideration for inclusion in Volume 2.

TABLE 6.8.3.3 Compressive test methods for MIL-HDBK-17 data submittal.

	Symbol	Fully Approved, Interim and Screening Data	Screening Data Only
<u>Lamina Properties</u>			
0° In-Plane Strength	$F_1^{cu}, \epsilon_1^{cu}$	D 3410, D 6484, D 5467, SRM 1R ^{1,2} , SRM 6 ^{1,2}	---
0° In-Plane Modulus, Poisson's Ratio	E_1^c, ν_{12}^c	D 3410, D 5467 ³ , SRM 1R ²	---
90° In-plane Strength	$F_2^{cu}, \epsilon_2^{cu}$	D 3410, D 6484, SRM 1R ^{1,2,4}	---
90° In-Plane Modulus, Poisson's Ratio	E_2^c, ν_{21}^c	D 3410, D 6484, D 5467 ³ , SRM 1R ^{2,4}	---
Out-of-Plane Strength	$F_3^{cu}, \epsilon_3^{cu}$	no recommendation	---
Out-of-Plane Modulus, Poisson's Ratio	$E_3^c, \nu_{31}^c, \nu_{32}^c$	no recommendation	---
<u>Laminate Properties</u>			
x In-Plane Strength	$F_x^{cu}, \epsilon_x^{cu}$	D 3410, D 6484	---
y In-Plane Strength	$F_y^{cu}, \epsilon_y^{cu}$	D 3410, D 6484	---
x In-Plane Modulus, Poisson's Ratio	E_x^c, ν_{xy}^c	D 3410, D 6484	---
y In-Plane Modulus, Poisson's Ratio	E_y^c, ν_{yx}^c	D 3410, D 6484	---
Out-of-Plane Strength	$F_z^{cu}, \epsilon_z^{cu}$	no recommendation	---
Out-of-Plane Modulus, Poisson's Ratio	$E_z^c, \nu_{zx}^c, \nu_{zy}^c$	no recommendation	---

¹ Not approved for ϵ_1^{cu} nor ϵ_2^{cu} ² Not approved for fabric-based materials when the unit cell size of the specimen weave/braid is larger than the 0.188 inch (4.8 mm) gage length.³ Not approved for ν_{12}^c nor ν_{21}^c ⁴ Approved for fill direction properties in cross-ply fabric based specimens only.

6.8.4 Shear properties

6.8.4.1 Overview

In-Plane Shear Properties: ^{1,2}

$$G_{12}, F_{12}^{so}, F_{12}^{su}, \gamma_{12}^{su}$$

$$G_{xy}, F_{xy}^{so}, F_{xy}^{su}, \gamma_{xy}^{su}$$

Out-of-Plane Shear Properties:

$$G_{23}, F_{23}^{so}, F_{23}^{su}, \gamma_{23}^{su}$$

$$G_{yz}, F_{yz}^{so}, F_{yz}^{su}, \gamma_{yz}^{su}$$

$$G_{31}, F_{31}^{so}, F_{31}^{su}, \gamma_{31}^{su}$$

$$G_{zx}, F_{zx}^{so}, F_{zx}^{su}, \gamma_{zx}^{su}$$

Short-Beam Strength Properties:

$$F_{31}^{sbs}, F_{zx}^{sbs}$$

Shear testing of composite materials has proven to be one of the most difficult areas of mechanical property testing in which to define a rigorously correct test, especially in the out-of-plane direction. A number of test methods have been devised, only some of which are described herein. Many of these methods were originally developed for materials other than continuous fiber reinforced composites, such as metal, plastic, wood, or adhesive. Several of the methods are not yet fully standardized for composite materials, and none of the methods is without deficiency or limitation, though some are clearly more desirable than others.

While there is general agreement regarding the accuracy of shear modulus measurements (for properly conducted tests), the biggest difficulty with shear testing of composites is determination of shear strength. The presence of edge effects, material coupling effects, nonlinear behavior of the matrix or the fiber/matrix interface, imperfect stress distributions, or the presence of normal stresses make shear strength determination from existing shear test methods highly questionable; depending on the test, results may under- or over-estimate shear strength. Due to this uncertainty, shear strength data to be used structural applications should be reviewed on a case-by-case basis for each given application.

A growing body of experience with composite shear testing, both published and unpublished, has led to a greater understanding of the strengths and weaknesses of each test method. At the Fall 1991 ASTM Committee D30 meetings, discussions in the D30.04.03 Section on Shear Test Methods led to the first two of the following conclusions. During the Spring 1993 meetings, this group added the third conclusion. These philosophies are being included in existing and future ASTM standard shear test methods:

1. There are no known standard (or non-standard) test methods that are capable of producing a perfectly pure shear stress condition to failure for every material system, although some test methods can come acceptably close on specific material systems, as judged by the end-user for a given engineering purpose.
2. The strengths resulting from test methods that do not consistently produce a reasonable approximation of pure shear, or that do not fail via a shear failure mode, should not be termed "shear strength."
3. Since ultimate strength values from existing shear tests are no longer believed able to provide an adequate criterion for comparison of material systems, the addition of an offset strength is now recommended (0.2% offset, unless otherwise specified).

¹ Note that shear properties generally assume subscript independence, where, for example, $F_{23}^{su}=F_{32}^{su}$, etc. For common engineering materials in the principal material coordinate system, this is a commonly accepted and generally accurate assumption. However, in unbalanced, multi-directional laminates, the shear stiffness, shear strength, or both, can be direction dependent. In such laminates this arises primarily from the difference in behavior between tension and compression of the fibers that are oriented off-axis relative to the loading direction.

² Transverse isotropy, a common assumption for many material systems, implies that $G_{12}=G_{13}$.

With the highly nonlinear stress-strain behavior of many filamentary composites, and especially with high-elongation material systems, it is common to terminate a shear test prior to actual specimen failure. Following the lead of MIL-HDBK-17, ASTM D30 currently recommends ending shear testing at 5% shear strain, if failure has not previously occurred. The rationale for this is included in the following discussions.

Practical usage in structural laminates---Typical structural laminates are designed to have fibers aligned with major load-carrying directions. In the case of shear, the shear loads are usually carried in fiber tension or compression by plies oriented at the appropriate angle. Since, from basic mechanics of materials, the shear strain in the matrix of a given ply cannot be more than twice the fiber axial strain of another ply oriented at 45° to the first ply, we can see that an upper bound on the useful engineering value of shear strain is twice the tensile or compressive fiber strain. As the most ductile structural fibers currently fail well below 2.5%, a practical upper limit for shear strain in a structural laminate would be 5%. Terminating shear test data at this shear strain value is a practical recommendation that saves time in testing and yields a more structurally attainable, and therefore more meaningful, lower-bound estimate of ultimate shear strength.

Limitations of common shear test methods---There are kinematic limitations with both the $\pm 45^\circ$ tensile shear test and the V-notched beam (Iosipescu) shear test, due to excessive scissoring of the fibers. The work of Kellas et al (Reference 6.8.4.1) showed that the initial condition of $\pm 45^\circ$ ply geometry changes significantly at high shear strains. Based on their estimate of the relationship between fiber scissoring and shear strain, the test results for these tests become questionable past 5% shear strain, which then becomes a practical upper strain limit for these test methods.

A different issue that results in a similar restriction involves the use of typical strain gages. If gages are used for strain measurement, as is feasible with some tests and required by others, the typical gage limit of about 3% extensional strain equates to roughly 6% shear strain, making this a practical limit for shear strain measurement that is similar in value to the kinematic restriction.

Laminate Testing --- Certain shear test methods, like the $\pm 45^\circ$ tensile shear test, are by their very nature capable of testing only certain types of laminates. And, as difficult as determination of ultimate material shear strength is for current shear test methods, shear strength of a multi-directional laminate is even more problematic. While several of the shear test methods discussed herein are capable of determining a substantial portion of a laminate stress-strain curve and with it a shear modulus, there is no standard test method that has been shown to adequately determine the ultimate shear strength of a multi-directional laminate. A modification of ASTM D4255 (rail shear test method) using bonded, tapered, tabs have been suggested for shear strength testing of multi-directional laminates, but interest to date has not been sufficient to either standardize this modification or allow MIL-HDBK-17 to recommend it for widespread use. MIL-HDBK-17 Testing Working Group will continue to follow developments in this area.

6.8.4.2 *In-plane shear tests*

6.8.4.2.1 *$\pm 45^\circ$ tensile shear tests*

- 1) ASTM D 3518/D 3518M-94, Test Method for In-Plane Shear Response of Polymer Matrix Composites by Tensile Test of a $\pm 45^\circ$ Laminate
- 2) SACMA SRM 7R-94, In-plane Shear Stress-Strain Properties of Oriented Fiber-Resin Composites.

This test (References 6.8.4.2.1(a) and (b)) for in-plane shear properties consists of a modified ASTM Test Method D3039 tensile test of a specimen having a ply lay-up of the $[\pm 45]_n$ s family. Away from the gripping region the in-plane shear stress in this specimen can be shown to be a simple function of the average applied tensile stress, allowing for straightforward calculation of the shear response of the material. This test method has the advantages of a simple test specimen, requires no fixturing, and measurement of strain can be performed using either extensometers or strain gages.

Originally applied only to unidirectional materials, the 1994 release of the standard now includes many woven fabric materials, but the test method is inherently restricted to determination of properties in the 1-2 material plane. The SACMA version has historically been a restricted subset of the ASTM standard; though there have been minor differences between current releases of the two methods in the past. However, the versions listed herein have several significant differences. The 1994 SACMA test method does not include several significant changes that were made to D 3518 in 1994, and though the basic physics of the test remain identical, the details of data reduction are now distinctly different so the two versions are not fully equivalent. D 3518 now defines the chord modulus from 2000 to 6000 shear microstrain (versus 500-3000 in SRM 7R-94), and terminates the test at 5% shear strain (or failure, whichever comes first), while SRM 7R-94 still defines strength based only on ultimate load. D 3518 also has added an offset strength, which SRM 7R-94 does not include.

Good modulus agreement has been shown between the $\pm 45^\circ$ test method and other shear test methods (References 6.8.4.2.1(c) through (e)), although the stress-strain response has been shown to be underestimated at shear strain levels above 1.3% (Reference 6.8.4.2.1(f)). There is a feeling by many in the aerospace composite structures community that while the stress state of this specimen may not be "pure," it does respond in a manner that mimics the actual stress state and ply interaction within a structural laminate. The resulting response yields an "effective" shear modulus that may be preferred by the designer.

Previous versions of the ASTM standard lacked sufficient definition of several test parameters that have since been found to have significant effects on the ultimate strength of this specimen. It has been shown (Reference 6.8.4.1) that this specimen does not fail due to in-plane shear, but rather due to complicated interactions that are sensitive to material toughness, ply stacking sequence, ply count, ply thickness, edge effects, and surface ply constraints. The 1994 release of D 3518 provides additional controls that improve this situation:

- "Ultimate shear strength" has been replaced with "shear stress at 5% shear strain", since it is now agreed that this test cannot determine a true ultimate material strength. This new quantity is analogous to the old ultimate strength value, but since it is calculated differently, for many material systems they will not be exact equivalents, and may be significantly different.
- Adds an offset shear strength (a more meaningful quantity for material comparison than the previous "ultimate" shear strength).
- Terminates the test at 5% shear strain, if the specimen has not already failed by rupture.
- Changes the chord shear modulus to use a strain range (2000-6000 shear microstrain) that is consistent with the tensile chord modulus strain range (1000-3000 microstrain).
- Provides requirements for ply lay-up that assure that the most brittle modes of failure will be avoided, and increase the likelihood that data comparisons will be more meaningful.

Refer to the references, or to the discussion within the ASTM standard itself, for more details.

Limitations of the $\pm 45^\circ$ tensile shear test:

Material and Laminate Form---Limited to materials available in a fully balanced and symmetric $\pm 45^\circ$ specimen. As discussed above, the stacking sequence, ply count, and ply thickness have a direct effect on specimen strength. Low ply count laminates and repeating (or very thick) plies have a deleterious effect on strength and are restricted in the new standard.

Inhomogeneous Materials---The material is assumed homogenous with respect to the size of the test section. Material forms with features that are relatively coarse with respect to the test section width, such as woven or braided textiles with a coarse repeating pattern, require a larger, currently non-standard, specimen width.

Impurity of Stress State---The material in the gage section is not in a state of pure in-plane shear, as an in-plane normal stress component is present throughout the gage section, and a complex stress

field exists near the free edges. Although the specimen is believed to provide reliable initial material response, and can establish shear stress-strain response well into the nonlinear region, the calculated shear stress at failure does not represent the material strength, which is why the ASTM standard now terminates the test at 5% shear strain.

Effects of Large Deformation---The extreme fiber scissoring that can occur in this specimen in ductile specimens changes the fiber orientation progressively with increasing strain, conflicting with the fiber orientation assumptions used in the calculation of results. This is a second reason why the test is now terminated 5% shear strain.

6.8.4.2.2 *Iosipescu shear test*

ASTM D 5379/D 5379-93, Test Method for Shear Properties of Composite Materials by the V-Notched Beam Method.

The V-notched beam shear test (often called the Iosipescu test in the literature) has been standardized for composites by ASTM Committee D-30 in ASTM D 5379/D 5379M-93 (Reference 6.8.4.2.2(a)). The concept for the v-notched beam shear test for strength and modulus was originally identified in the late 1950's and early 1960's by Arcan (References 6.8.4.2.2(b) through 6.8.4.2.2(d)) and Iosipescu (Reference 6.8.4.2.2(e) through 6.8.4.2.2(g)) for use on metals. Subsequent usage was limited until detailed investigations were begun on an improved specimen and fixture at the University of Wyoming under NASA funding during the early 1980's (References 6.8.4.2.2(h) and (i)). The fixture was subsequently modified (References 6.8.4.2.2(j) and (k)), and this latter Wyoming configuration formed the basis for the ASTM standard. This method has been investigated extensively; see References 6.8.4.2.2(l) through 6.8.4.2.2(r)) for additional investigations. Early historical perspectives are given in References 6.8.4.2.2(h) and 6.8.4.2.2(s). However, the remainder of the discussion focuses on the configuration that has been standardized.

In this method, a material specimen in the form of a rectangular flat strip with symmetrical centrally located v-notches, shown schematically in Figure 6.8.4.2.2(a), is loaded in a mechanical testing machine by a special fixture, shown schematically in Figure 6.8.4.2.2(b). Either in-plane or out-of-plane shear properties may be evaluated, depending upon the orientation of the material coordinate system relative to the loading axis.

While the standard only addresses determination of properties in the material coordinate system, the initial stress-strain response of general multi-directional laminates may also be determined. However the method of load introduction into the specimen is generally not capable of reacting the much higher loads sustainable by a multi-directional laminate, and therefore for most material systems this test method is limited, for multi-directional laminates, to characterization of elastic modulus and the initial portion of the stress-strain curve. A few multi-directional materials have been successfully tested, such as the discontinuously reinforced, multi-directional, molded material commonly called sheet-molding compound (SMC), but such materials remain the exception rather than the rule.

The specimen is inserted into the fixture with the notch located along the line-of-action of loading via an alignment tool that centers the specimen in the fixture. The upper head of the fixture is attached to and driven downward by the cross-head of the testing machine, while monitoring load. The relative displacement between the two fixture halves loads the notched specimen. By placing two strain gage elements, oriented at $\pm 45^\circ$ to the loading axis, in the middle of the specimen (away from the notches) and along the loading axis, the shear response of the material can be measured.

The object of the VNB concept can be seen in the idealization of the applied loading as asymmetric flexure, shown in the shear and bending moment diagram of Figure 6.8.4.2.2(c). The specimen gage area is in the region of constant shear and zero moment. The specimen notches influence the shear strain along the loading direction, making the shear distribution more uniform than would be seen without

the notches.¹ The degree of uniformity in the shear distribution is a function of material orthotropy; the best overall in-plane shear results have been obtained on [0/90]_ns-type laminates. However, while the point-loading idealization indicates constant shear loading and zero bending moment in the gage section of the specimen, in practice the fixture applies distributed loads to the specimen that contribute to an asymmetry in the shear strain distribution and to a component of normal stress which is particularly deleterious to [90]_n specimens.

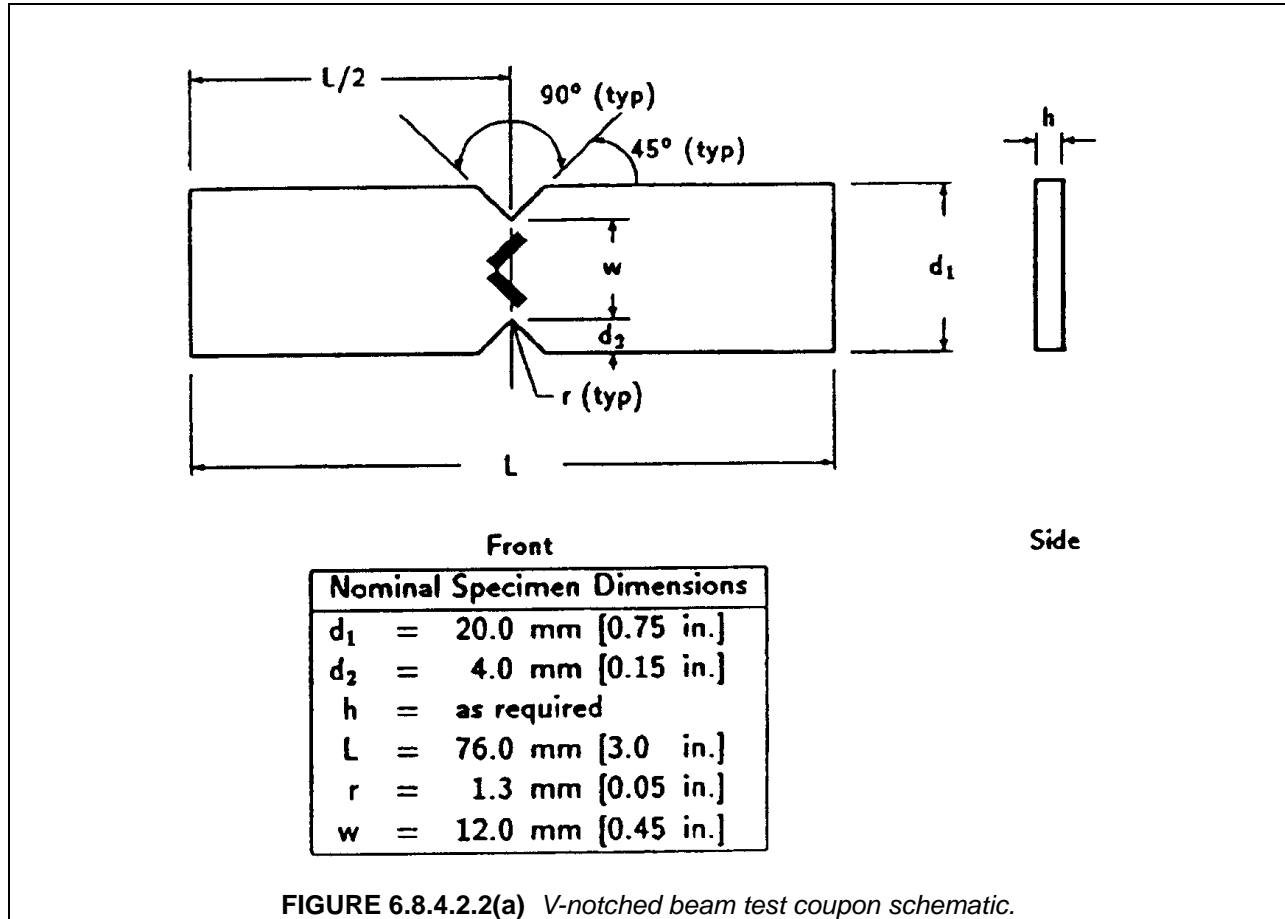

FIGURE 6.8.4.2.2(a) V-notched beam test coupon schematic.

Limitations of the v-notched beam shear test:

Inhomogeneous Materials--- The material is assumed homogeneous with respect to the size of the test section. Materials that have relatively coarse features with respect to the test section dimensions, such as fabrics using large filament count tows (such as tows of 12000 filaments or more) or certain braided structures, should not be tested with this specimen size.

Uniformity of Strain Field--- The calculations assume a uniform shear strain state between the notches. The actual degree of uniformity varies with the level of material orthotropy and the direction of loading. A new strain gage grid configuration has recently been developed specially for use with this test method. The active grid on this gage extends from notch-to-notch and provides an improved estimation of the average strain response. When using conventional strain gages the most accurate measurements of in-plane shear modulus for unidirectional materials have been shown to result from the [0/90]_ns specimen.

¹ An isotropic beam in shear has a parabolic shear stress profile.

Load Eccentricity--- Twisting of the specimen during loading can occur, affecting strength results, and especially, elastic modulus measurement. It is recommended that at least one specimen of each sample be tested with back-to-back rosettes to evaluate the degree of twist.

Determination of Failure--- Failure is not always obvious in certain materials or configurations. See the standard test method (Reference 6.8.4.2.2(a)) for more information.

Instrumentation: Strain gages are required.

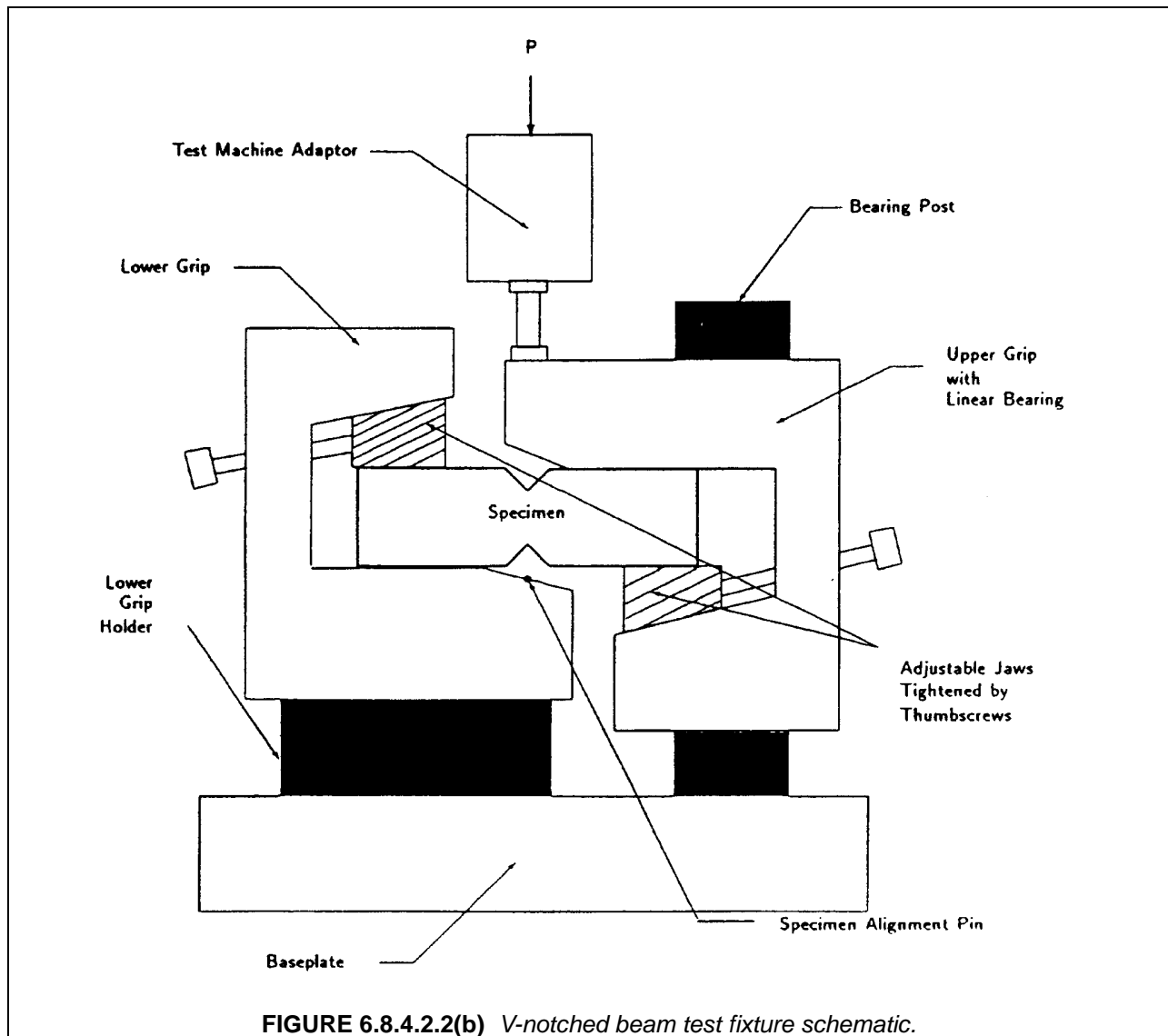

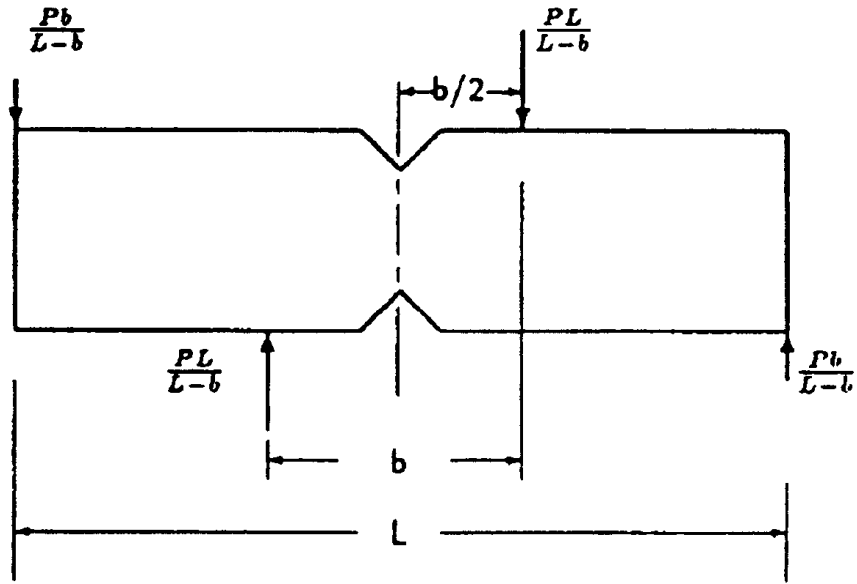

Force Diagram

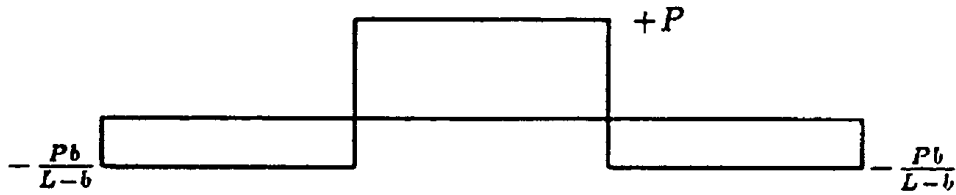

Shear Diagram

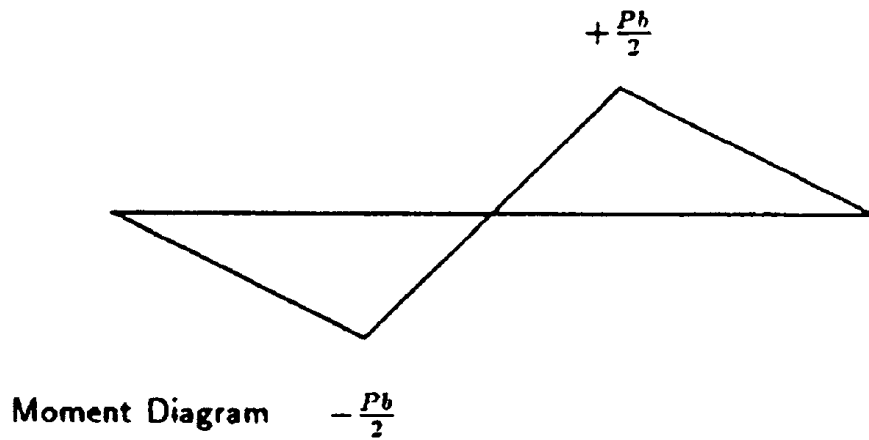

Moment Diagram $-\frac{Pb}{2}$

FIGURE 6.8.4.2(c) Idealized force, shear, and moment diagram.

6.8.4.2.3 Rail shear tests

ASTM D 4255-83, Guide for Testing for In-plane Shear Properties of Composite Laminates.

In 1983, ASTM Committee D-30 published D 4255 (Reference 6.8.4.2.3(a), a standard covering in-plane shear properties of composite laminates by either of two rail shear methods. The round-robin testing conducted by D-30 to understand the precision and bias of these methods found, at the time, a large amount of variability in results between laboratories. While the sources of this variability were not well understood at the time, a standard for this test method was strongly desired since rail shear tests were in wide use. The standard was completed and released, though with caveats, in order to provide a common ground for the users.

Since the initial release of D 4255, several testing factors that could have contributed to the scatter in the initial round-robin data have become better understood, and a revision to this standard is in progress at this writing (1997) that will correct several obvious shortcomings in the initial release. Whether the revised standard will have improved/reduced variability and gain the confidence of new users, particularly in the face of the substantial research that has since improved competing simpler and less expensive test methods, remains to be seen.

While the standard is restricted to in-plane testing, it is capable of testing for either material shear or multi-directional laminate shear properties. However the current version of the standard is limited, as is the D 5379 Iosipescu shear test, to characterization of modulus or initial shear stress-strain response, since the standard means of applying load to the specimen generally cannot sustain the higher strengths of multi-directional laminates. Development of standard rules for application of bonded, tapered tabs to multi-directional laminates is needed, since this approach is one of the most promising for shear strength determination of off-axis configurations. However, more work remains to be done before a bonded, tapered, tab modification to D 4255 can be standardized or recommended by MIL-HDBK-17.

As the shear stress state is not uniform through the specimen, and as failures are often noted to begin outside the center of gage section (such as at the restrained corners of the plate) this test as currently standardized does not always produce reliable shear strength data (Reference 6.8.4.2.3(b)). The three-rail test has a purer state of stress (Reference 6.8.4.2.3(c)), although it requires a larger specimen size of approximately 150 mm by 150 mm (6 in. by 6 in.)

Limitations of the D 4255-83 rail shear tests:

Specimen Size: Both version require larger specimens than other shear tests.

Instrumentation: Strain gages are required.

Stress State: The stress state is known to be non-uniform, and the failure mode is typically influenced by non-shear failures starting outside of the gage section.

Data Scatter: High data scatter from round-robin tests cast doubt upon the ability of these methods to produce repeatable data, at least in their current form.

6.8.4.2.4 Ten-degree off-axis shear test

This method, first reported by Chamis and Sinclair (Reference 6.8.4.2.4) uses a straight-sided, rectangular unidirectional tensile specimen with the fiber oriented at ten degrees to the loading direction (Figure 6.8.4.2.4). Note that the material specimen is limited to unidirectional filamentary laminates. This specimen, like the ASTM D 3518 specimen above, is also not under a state of pure shear and suffers from the effects of a combined stress state. This test produces results of generally higher modulus and significantly lower strengths than the other shear test methods such as ASTM Test Methods D 3518 or D

5379. This test method is inherently restricted to evaluation of the shear response in the 1-2 plane, and is therefore not applicable to shear evaluation of laminates.

Limitations of the 10° off-axis shear test:

Material Form: Limited to unidirectional laminates.

Stress State: Known to have a significantly biased stress state producing an overly stiff initial response and premature failure.

Lack of Standardization: Has never been standardized.

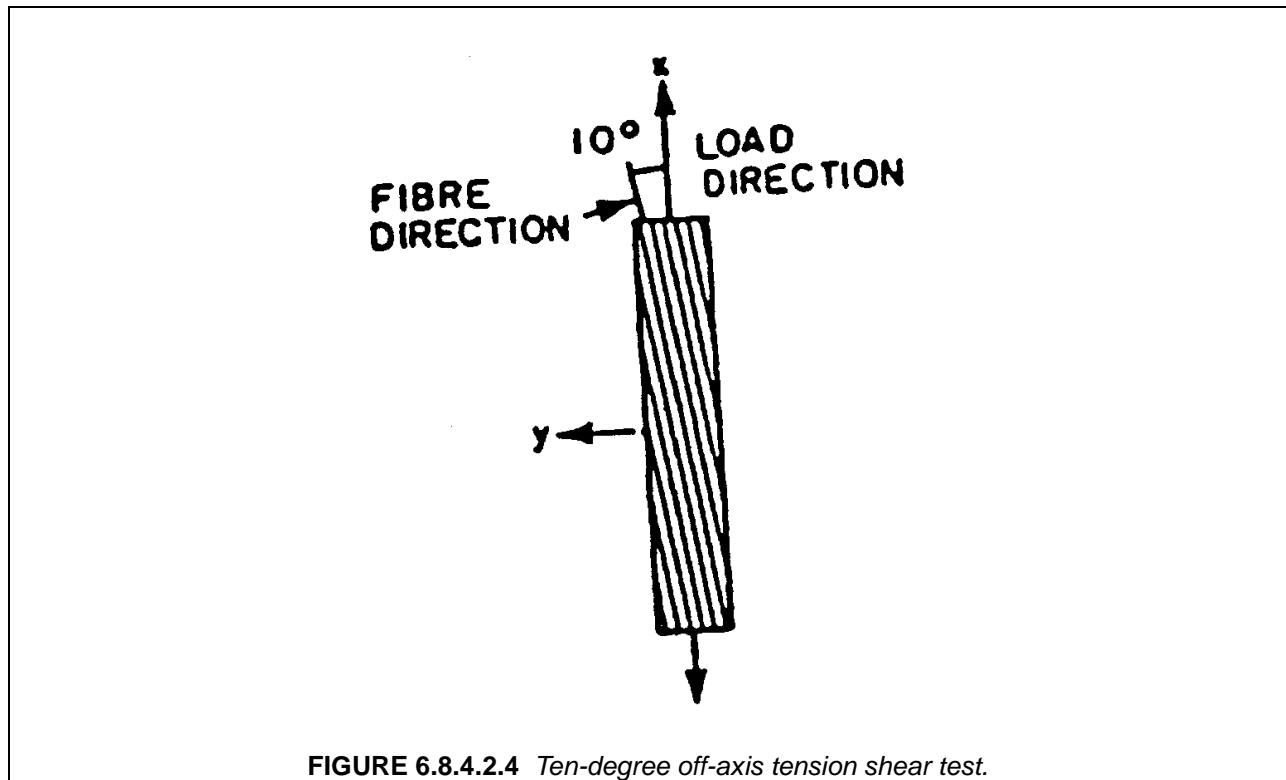

6.8.4.2.5 Tube torsion tests

1. ASTM E143-87, Test Method for Shear Modulus at Room Temperature
2. MIL-STD-375, Test Method for In-Plane Shear Properties of Hoop Wound Polymer Matrix Composite Cylinders
3. ASTM D 5448/D 5448M-93, Test Method for In-Plane Shear Properties of Hoop Wound Polymer Matrix Composite Cylinders

Torsion testing of tubes has been standardized by ASTM since 1959 by Test Method E143-87 (Reference 6.8.4.2.5(a)). While broad in scope, and technically not exclusive of composites, Test Method E143 was primarily developed for metals. However the concept has also been applied to composites, where the challenge becomes in applying load to the specimen without producing a grip-induced failure; a typical gripping arrangement is shown in Figure 6.8.4.2.5. A torsion test specifically for wound composite tubes was developed and released as Military Standard, MIL-STD-375 (Reference 6.8.4.2.5(b)). MIL-STD-375 was submitted to ASTM for non-military standardization, and with minor changes was approved as ASTM D 5448/D 5448M-93. Test Method D 5448 (Reference 6.8.4.2.5(c)) consists of a 100 mm (4 in.) nominal

diameter hoop-wound tube, which is gripped at each end and twisted via a fixture until failure. This test has been shown to produce good results and is the theoretical ideal for determining both in-plane shear strength and modulus. Note that since the MIL-STD test method has since been withdrawn by the U.S. DOD it should no longer be referenced; it has been superseded by the ASTM test method.

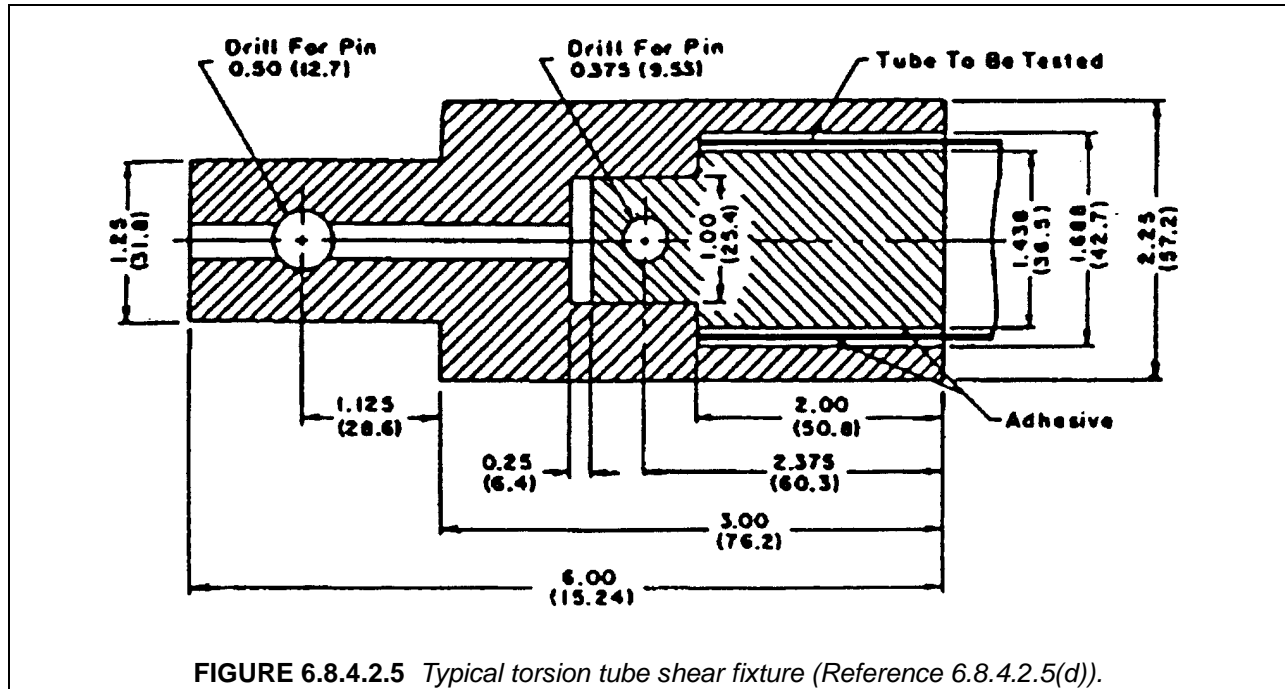

While not within the scope of current test standards, these tests, which are inherently restricted to in-plane usage, can be applied to laminate testing as well as lamina testing. However, gage section specimen failures may be difficult to achieve in the multi-directional laminates, due to the higher loads developed in the presence of off-axis fibers. Loading point modifications will usually be required for laminate testing.

Limitations of the torsional tube methods:

Material Form: If not using filament-wound materials the process required to create the tube may be significantly different than that used in the structure.

Cost of Specimen Fabrication: Fabrication of the specimen can be a significant undertaking requiring unusual expense.

Stress Concentration: A stress concentration exists at the end grips, as noted by Guess and Haizlip (Reference 6.8.4.2.5(d)), tending to result in failures in the gripping area, unless extreme precautions are taken.

Instrumentation: Strain gages are required.

6.8.4.3 Out-of-plane shear tests

6.8.4.3.1 Short-beam strength tests

- 1) ASTM D 2344-84, Test Method for Apparent Interlaminar Strength of Parallel Fiber Composites by Short-Beam Method

2) SACMA SRM 8R-94, Apparent Interlaminar Shear Strength of Oriented Fiber-Resin Composites by the Short-Beam Method

ASTM Test Method D 2344 (Reference 6.8.4.3.1(a), commonly known as the short-beam strength (SBS) test, attempts to quantify the interlaminar (out-of-plane) shear strength of parallel fiber reinforced composites.¹ The specimen for this test is a short, relatively deep beam cut from a flat laminate. The specimen is mounted as a simply supported beam and loaded at the midpoint of the span of the specimen. The intent is to minimize bending stresses while maximizing out-of-plane shear stresses by using a short, deep "beam."

However, the contact stresses induced at the load points greatly interfere with the strain distribution both through the depth of the beam and axially along the length of the beam. The resulting failure is rarely, if ever, a true pure shear failure but instead results from the complex stress state present in the specimen, as shown by Berg *et al* (Reference 6.8.4.3.1(b)) and others.

Unfortunately this test has commonly been used in the past (and is still used by some) to develop design allowables for structural design criteria. In the absence of any other choice this is understandable, though regrettable. However, the availability of the v-notched beam method, discussed in Section 6.8.4.3.2, makes the use of the short-beam strength test for property determination obsolete.

The short beam strength test should only be used for qualitative testing such as material process development and control. As a quality control test use of laminate configurations other than unidirectional are common, though currently non-standard.

The ASTM standard is currently being revised and updated to allow the standard SBS testing of balanced and symmetric laminates. A related method is SACMA SRM 8R-94 (Reference 6.8.4.3.1(c)).

Limitations of the short beam strength test include:

Stress State: The stress state is known to be significantly disruptive and three-dimensional. The resultant strengths are a poor estimation of the out-of-plane shear strength.

Failure Mode: The failure mode is most often multi-mode.

No Modulus/Material Response: Instrumentation of this specimen is not practical, therefore modulus and stress-strain data cannot be obtained.

6.8.4.3.2 *Iosipescu shear test*

This test method and the specimen geometry are described for in-plane shear testing in Section 6.8.4.2.2. When testing for out-of-plane shear properties the orientation of the fibers in the laminate is changed so as to cause a shearing action in the desired transverse plane. This test method is the only acceptable out-of-plane shear test available. The out-of-plane testing of laminates with fibers off-axis to the test direction, such as 3-dimensional textiles, are subject to the same restrictions and limitations that are discussed in the section on in-plane Iosipescu testing (6.8.4.2.2).

6.8.4.3.3 *ASTM D 3846-79, Test Method for In-Plane Shear Strength of Reinforced Plastics*

ASTM Test Method D 3846 (Reference 6.8.4.3.3), despite the title, is *not* normally used as an in-plane shear strength test (using the most common definition of in-plane in the terminology of advanced composites) but is in fact an out-of-plane shear strength test and as such is covered in this section on out-of-plane shear tests.

¹ A currently fully equivalent, but more restricted, subset of ASTM D2344 has been promulgated by the composite materials suppliers as SRM 8R-94 (Reference 6.8.4.3.1(c)). However, it is expected that, barring a parallel revision to SRM 8R-94, the two documents will diverge as a result of the on-going revision to ASTM D2344.

This test is primarily intended for use on randomly-dispersed fiber-reinforced thermosetting sheet plastics as a substitute to the short-beam strength test, Test Method D 2344 (Reference 6.8.4.3.1(a)), described in Section 6.8.4.3.1. The test consists of a doubly notched specimen loaded compressively in a supporting jig (the same fixture used in the Test Method D 695 compression test). Failure occurs in out-of-plane shear in the plane of the specimen between the two centrally located opposing square notches. While this specimen can be (and has been) used for testing continuous-fiber laminated reinforced plastics, it is not recommended for use on advanced composite laminates. The notches, which are machined into the specimen to force failure of the laminate in shear, were found by Herakovich *et al* (Reference 6.8.4.2.2(n)) to negatively influence the stress distribution in the specimen. As a result, a non-uniform, multiaxial stress state exists in the gage section, making a true strength calculation suspect at best.

Limitations of the D 3846 notched compression test:

Stress State: A highly three-dimensional, non-uniform stress state in the gage section cause strength values from this test to be unusually poor estimations of the true out-of-plane shear strength.

No Modulus/Material Response: Instrumentation of this specimen is not practical, therefore modulus and stress-strain data cannot be obtained.

6.8.4.4 Shear test methods for MIL-HDBK-17 data submittal

Data produced by the test methods in Table 6.8.4.4 are currently being accepted by MIL-HDBK-17 for consideration for inclusion in Volume 2.

TABLE 6.8.4.4 Shear test methods for MIL-HDBK-17 data submittal.

Property	Symbols	Fully Approved, Interim, and Screening Data	Screening Data Only
In-Plane Shear Strength (lamina)	F_{12}^{SO}, F_{12}^{SU}	D 3518 SRM 7 D 5379 D 5448	---
In-Plane Shear Strength (laminate)	F_{xy}^{SO}, F_{xy}^{SU}	---	---
In-Plane Shear Modulus (lamina)	G_{12}	D 3518 SRM 7 D 5379 D 4255 D 5448	---
In-Plane Shear Modulus (laminate)	G_{xy}	D 5379 D 4255	---
Out-of-Plane Shear Strength	F_{23}^{SO}, F_{23}^{SU} F_{31}^{SO}, F_{31}^{SU}	D 5379	---
Out-of-Plane Shear Modulus	G_{31}, G_{23} G_{xz}, G_{yz}	D 5379	---
Short Beam Strength	F_{31}^{SBS} F_{zx}^{SBS}	---	D 2344 SRM 8

6.8.5 Flexural properties

There is not a recommended test method for determining the flexural properties of composite laminates. Even though there are approved flexural test methods, there is some debate as to the validity of the results.

Within the aerospace industry, flexure testing is primarily used for quality control. ASTM Test Method D 790, "Flexural Properties of Unreinforced and Reinforced Plastics and Electrical Insulating Materials", was originally written for plastics but has since been modified and approved for composites (Reference 6.8.5). In some cases, ASTM Test Method C 393, "Flexure Test of Flat Sandwich Constructions", has been adapted for use with composite laminates (Reference 6.8.2.2.5).

6.8.6 Fracture toughness properties

6.8.6.1 Overview

Fracture in structural solids, such as wood, glass, metals, rock and concrete, is usually initiated by some crack or notch-like flaws, which cause high stresses in the neighborhood of such flaws. Inglis (Reference 6.8.6.1(a)) pointed out the significance of the localized concentration of stress near the tip of a sharp notch. A criterion of fracture based on the first law of thermodynamics was proposed by Griffith (Reference 6.8.6.1(b)), who postulated that the reduction in strain energy due to propagation of a crack is used to create new crack surfaces. Strain energy release rate, G , is defined as the reduction in strain energy (or increase in potential energy) due to an infinitesimal self-similar extension of the crack and catastrophic propagation of the crack will occur when this rate reaches a critical value, G_c . For a through crack of length $2a$ in a thin or a thick plate, subjected to a tensile stress σ , the energy release rate can be expressed in terms of σ , a and the properties of the material. Irwin (Reference 6.8.6.1(c)) pointed out that in isotropic materials, three independent kinematic movements are possible, by which the upper and lower crack surfaces can displace with respect to each other. These movements are schematically depicted in Figure 6.7.8.1. Only the first mode (Mode I or opening mode) was considered by Griffith. Irwin showed that the crack tip stresses can be expressed by a three parameter set of equations. These parameters, K_I , K_{II} , K_{III} , called the Mode I, Mode II and Mode III stress intensity factors, are functions of the crack dimensions and the applied loads and critical values of these parameters govern the phenomenon of unstable crack growth. The concept of failure based on the critical value of a stress intensity factor has been shown to be equivalent to that proposed by Griffith in terms of the critical strain energy release rate (G_{Ic} , G_{IIc} , or G_{IIIc}). Irwin also suggested the use of the critical value of the total energy release rate as the parameter governing failure, provided failure occurs by self-similar crack propagation. These concepts have also been extended to orthotropic materials (Reference 6.8.6.1(d)).

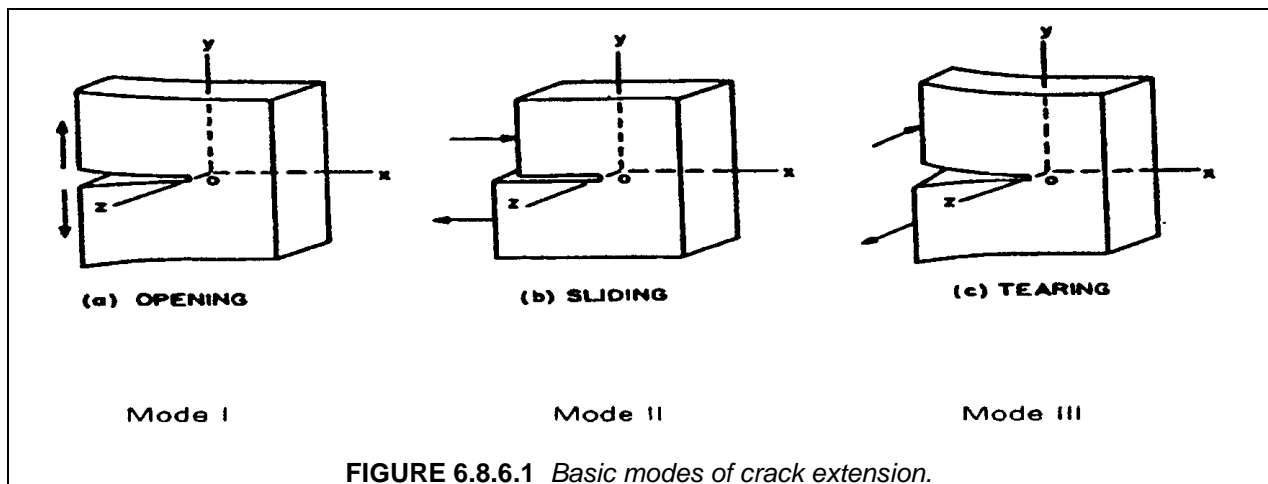

Use of fracture mechanics has gained wide acceptance in predicting failure in metal structures (References 6.8.6.1(e)-(g)) and various test methods have been developed for determining K_{Ic} (or G_{Ic}) as well as crack growth resistance curves for cases when stable crack growth is possible. Further, over the years, there has emerged a fracture mechanics design procedure for fatigue of metal aeronautical structures, which is based on periodic inspection for monitoring visible cracks and predicting residual life using crack growth laws of the power law type (References 6.8.6.1(h) and (i)). Various attempts have been made to use fracture mechanics based methods for predicting failure of thin laminates with through cracks or notches (Reference 6.8.6.1(j)). However, it has been found that linear elastic fracture mechanics treating the thin laminates as orthotropic or isotropic plates is not useful because of considerable sub-critical surface damage near the crack tips. Semi-empirical corrections are often employed for predicting strength of thin notched laminates (Reference 6.8.6.1(k)). On the other hand, fracture mechanics approaches appear to yield better results for thick laminates containing through cracks or deep surface flaws (References 6.8.6.1(l) through 6.8.6.1(n)). It has also been shown that crack growth resistance or the R-curve concept, originally proposed for modeling stable crack growth (with increasing load) in metals, is useful for predicting fracture in notched chopped fiber composites (Reference 6.8.6.1(o)). Although use of fracture mechanics in the problems just described has been very limited, it is now being widely used in the industry for dealing with various problems involving delamination fracture. Delaminations (in resin rich regions between the plies in a laminate) can exist as manufacturing defects or can be created due to various reasons; namely, (i) coalescence of small voids at interfaces, (ii) foreign object impact and (iii) peculiar stress fields near discontinuities such as free edges, holes, ply drops, transverse ply cracks or bonded joints. The basic concepts of delamination fracture are the same as those discussed earlier. However, the strain energy release rate, which is the energy released due to infinitesimal extension (as described earlier for through cracks in a plate) of a delamination is commonly used for prediction of catastrophic fracture and various test methods have been proposed for determination of its critical value (often called the toughness) for each of the three modes of loading (I, II, and III as shown in Figure 6.8.6.1). Some tests have also been devised for determining the criteria of failure (mode interaction) under mixed mode conditions. The next section gives some general discussions on the test methods and use of the properties in practical applications. Subsequent sections deal with some of the test methods.

6.8.6.2 General discussion

It should be noted that although the subject is quite advanced at this point and various attempts have also been made to obtain (i) R curves for modeling stable delamination growth under increasing load and (ii) delamination growth law for predicting delamination extension under cyclic loading, only one test method has been standardized. The test specimens usually contain an implanted delamination in the form of a nonadhesive insert and have been used widely for unidirectional glass or carbon fiber reinforced composites. The tests are designed such that delamination growth direction coincides with the fiber direction. Toughness values or other characteristics may sometimes vary depending on the tendency of the delamination to wander around various phases of multiple phase matrix materials. Also, brittle matrix composites with tough adhesive interleaves may yield different properties depending on the region where the delamination propagates, i.e., interleaves, brittle matrix or the interface. Use of non-unidirectional specimens with implanted delaminations between two off-axis plies of the same orientation or between two plies of different orientations may cause the delamination to shift its path through ply cracks and interpretation of data for such cases is difficult. It is also likely that the properties will differ if the delamination propagates in a direction other than the fiber direction, even though it remains coplanar. Woven fabric composites may show more scatter as compared to that for unidirectional laminates and increasing tendency of stable delamination growth (R-curve) because of the typical structural arrangement in such materials.

The main reason for observed resistance to delamination growth (for stable growth commonly observed in Mode I tests) in unidirectional brittle matrix composites is the phenomenon of fiber bridging across the delamination plane. Such bridging is caused by fiber nesting that is typically present in unidirectional composites and, hence, the toughness value for initiation should be identified separately from those at later stages of delamination growth. This value should be representative of the toughness for a natural delamination and it is often used to obtain a conservative design criterion. R-curves obtained from tests are not commonly used to obtain generic material property data. They are, however, often used to

compare the degree of fiber matrix bonding between specimens, panels or batches of the same material or to compare composites with the same fiber, but different matrices. Poor bonding usually results in greater fiber bridging and, hence, a greater increase in G_c with delamination length.

In materials not strongly influenced by fiber bridging, a competing mechanism may dominate. When the delamination starts to grow from the insert, a pop-in type of behavior (yielding higher toughness values than that for subsequent growth) is observed. For Mode I tests, the first point is neglected in such cases and results for subsequent growth (made possible by displacement controlled tests) are utilized. For Mode II or mixed mode tests, failure is usually catastrophic and for this reason precracking (extension of the delamination beyond the insert) by Mode I loading, wedge insertion, or other methods is usually employed.

Most of the tests utilize beam type specimens with a single delamination tip. As the load is increased, load point deflections are measured and delamination growth is observed visually or using other aids or devices. In some cases, catastrophic delamination growth is observed (as in Mode II tests) and the maximum load reached is noted. Otherwise (in displacement controlled tests), load-displacement plots remain linear up to a point beyond which the delamination extends and a load drop occurs. In some materials, the onset of nonlinearity may be noticed before any delamination growth is noticeable. Such behavior may occur due to inelastic material response or subcritical damage growth ahead of the tip. The measured values of loads, deflections, and delamination lengths at the point of onset of nonlinearity or delamination growth are utilized to compute the critical energy release rates associated with fracture or subcritical damage growth. In some cases, approximate closed form expressions of energy release rates in terms of load, deflection, delamination length and/or material (or beam) stiffnesses are utilized for data reduction. When the deflection can not be measured and there is some uncertainty about the stiffness, an alternate approach is to first perform a compliance calibration on the specimen (or similar specimens) where the compliance

$$C = \frac{\delta}{P} \quad 6.8.6.2(a)$$

δ being the deflection associated with the applied load P , for various values of delamination, length a is fitted to an exact or approximate relation (based on the principles of mechanics or a polynomial). The energy release rate is given by

$$G = -\frac{1}{b} \frac{dU}{da} \quad 6.8.6.2(b)$$

or

$$G = \frac{1}{b} \frac{dV}{da} \quad 6.8.6.2(c)$$

where b is the specimen width and a the delamination length. U and V are the strain and potential energies, respectively, both expressed in terms of displacements.

Now,

$$U = \frac{1}{2} P \delta = \frac{1}{2} \frac{\delta^2}{C} \quad 6.8.6.2(d)$$

and

$$V = -\frac{1}{2} P \delta = -\frac{1}{2} \frac{\delta^2}{C} \quad 6.8.6.2(e)$$

Therefore, it follows that for displacement controlled tests (δ prescribed)

$$G = \frac{\delta^2}{2bC^2} \frac{dC}{da} = \frac{P^2}{2b} \frac{dC}{da} \quad 6.8.6.2(f)$$

It can be shown that the same relation holds for load controlled tests. This approach is not suitable for mixed mode tests because the individual components of the energy release rates can not be calculated in this manner, unless their contribution to the total energy release rate is known.

As discussed in the previous section, catastrophic fracture in a single mode can be predicted using the critical strain energy release rate for the particular mode provided, of course, the energy release rate

is constant along the delamination front. If these rates vary over the front, a conservative estimate can be obtained by equating the maximum value of this quantity at a point as determined from finite element or other stress analyses to the critical value (numerous investigations are reported in literature for such calculations, but they are beyond the scope of this section). Such estimates are often adequate for design purposes unless the delamination gets arrested because of structural or other constraints. A similar approach can be employed for estimating stable growth pattern and instability point using the R-curve concept. Growth of such delaminations under cyclic loading can be estimated using experimentally determined power law type growth laws, where the maximum value (or range) of the energy release rate is the controlling parameter. Uses of R-curves for predicting stable crack growth and power laws for estimating growth per cycle are, however, not yet accepted in the industry, since there exists some evidence that they do not always yield generic characterizations (Reference 6.8.6.2(a)).

The problem becomes more complicated when mixed mode conditions are present and the toughness values for the three modes differ significantly from one another. Various fracture criteria have been proposed for prediction of quasistatic fracture. A survey of such criteria for combined action of Modes I and II can be found in Reference 6.8.6.2(b). Power law type growth laws with the maximum value (or the range) of a scalar function f of the energy release rates ($f = G_I + G_{II} + G_{III}$ is a simple example) or the stress intensity factors have been suggested in different studies for modeling growth of delaminations under cyclic loading.

6.8.6.3 Mode I test methods

6.8.6.3.1 Double cantilever beam (DCB) test, ASTM D 5528 (Reference 6.8.6.3.1(a))

The test set up is schematically shown in Figure 6.8.6.3.1(a), which illustrates two types of loading attachments. The specimen is about 5 in. (125 mm) long, 0.8 - 1 in. (20-25 mm) wide and 0.12 - 0.20 in. (3-5 mm) thick. The applied load P to the two arms, the corresponding displacement δ , and typical load-displacement traces obtained are shown in Figure 6.8.6.3.1(b). The numbers on these traces indicate results for various delamination lengths and are obtained as the delamination progresses. NL indicates the onset of nonlinearity, which is usually caused by subcritical crack growth or material nonlinearities. The traces are often utilized to perform a compliance calibration. Various procedures for data reduction, other details, and restriction on specimen dimensions to avoid geometric nonlinearities are documented in References 6.8.6.3.1(a) and (b). As mentioned in the previous section, this test has been found to be adequate for unidirectional specimens. Some care should be taken when it is to be used for other lay-ups or material forms. Midplane symmetry is a requirement for pure Mode I deformation.

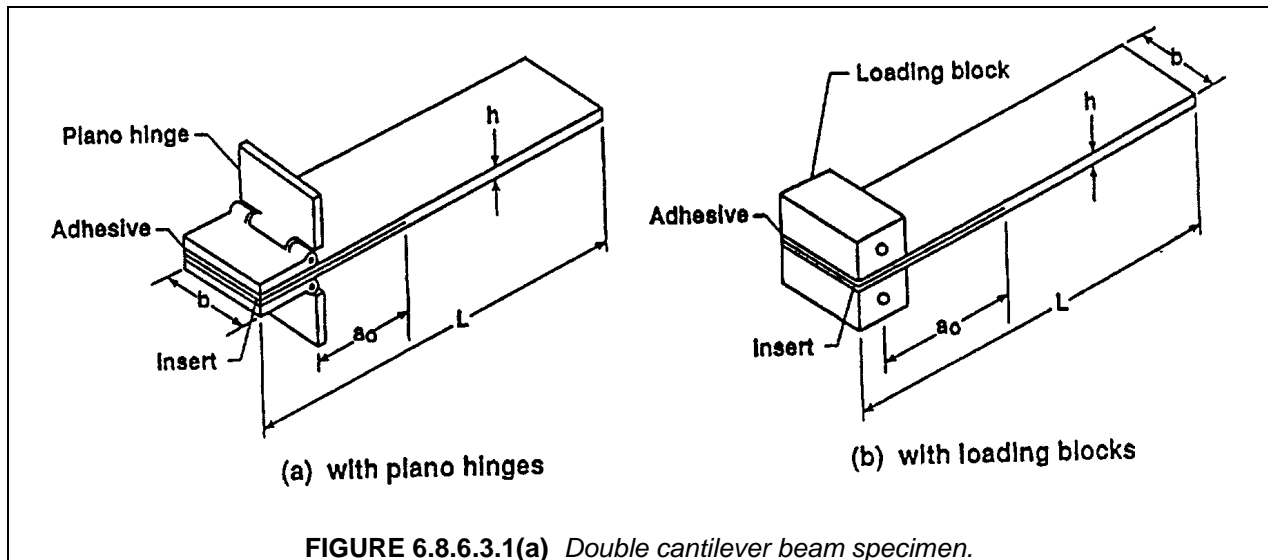

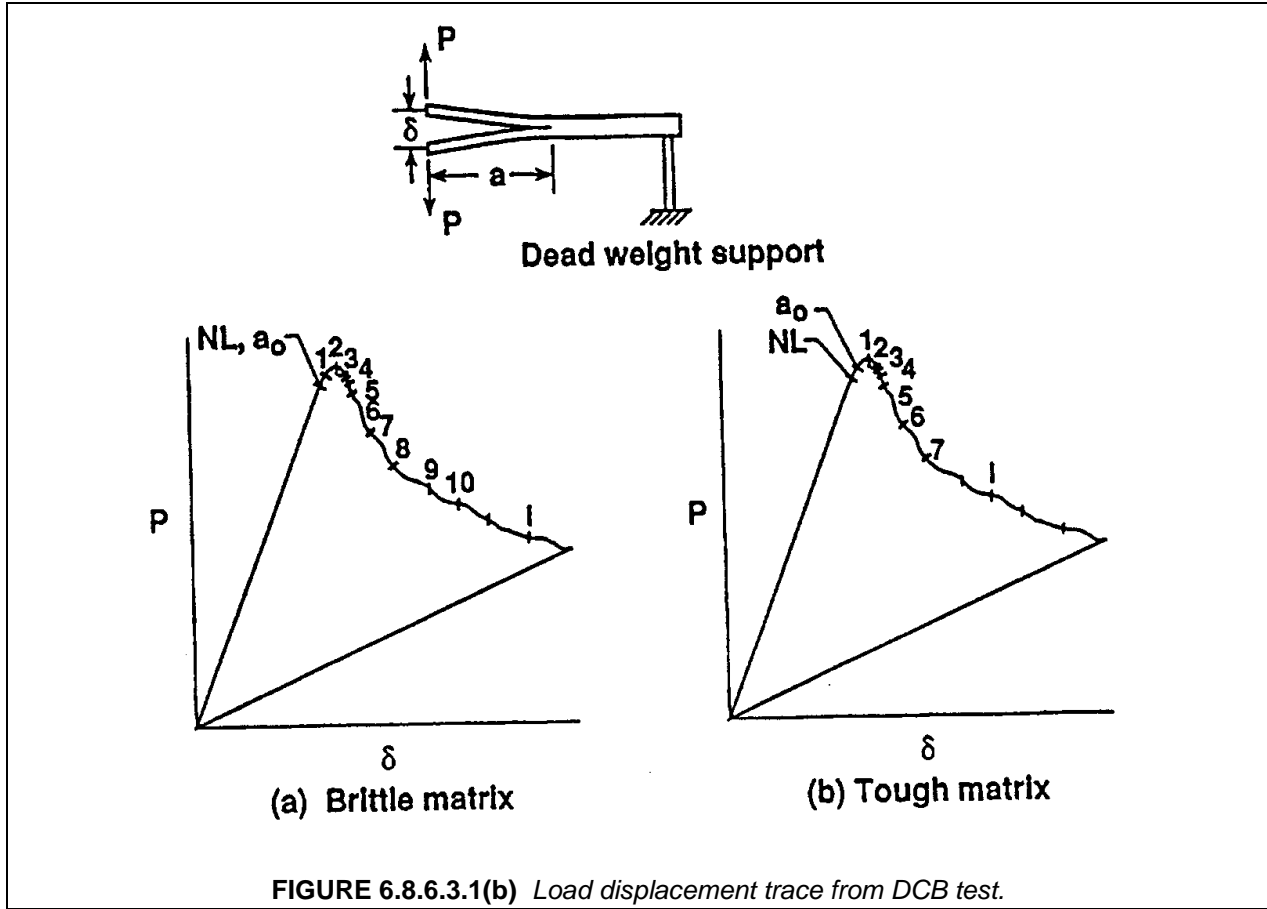

An asymptotic expression for the energy release rate for large a/h (a being the delamination length and h is the laminate thickness) is given by References 6.8.6.3.1(c) and (d).

$$G_I = \frac{96P^2(a + \alpha h)^2}{E_{11}b^2h^3} \quad 6.8.6.3.1(a)$$

where b is the beam width, E_{11} is the axial Young's modulus of the unidirectional composite and α is a constant which depends on the ratio of the axial shear and Young's moduli. The relation in Equation 6.8.6.2(e) can also be used when each of the beam arms are balanced midplane symmetric laminates without any bending twisting coupling if E is replaced by the equivalent flexural modulus for the arms. Substituting Equation 6.8.6.2(e) in Equation 6.8.6.2(d) and integrating with respect to a , one obtains the following equation for the compliance C for large a/h .

$$C = C_0 + \frac{64(a + \alpha h)^3}{E_{11}b^3h^3} \quad 6.8.6.3.1(b)$$

where C_0 is the integration constant. The constant α can be chosen as

$$\alpha \approx 1.45 \sqrt{\frac{E_{11}}{G_{13}}} \quad 6.8.6.3.1(c)$$

where G_{13} is the through the thickness shear modulus.

It has been suggested (References 6.8.6.3.1(b) and 6.8.6.3.1(d)) that for common glass and carbon fiber reinforced composites C_0 can be chosen equal to zero. Also h and the term in the denominator in the second term of Equation 6.8.6.3.1(b) or (a) should be determined by fitting measured compliances to Equation 6.8.6.3.1(b). Therefore, if a straight line is made to fit $C^{1/3}$ versus a plot (a being the abscissa

then the line when extended will cut the abscissa, x at $x = -\alpha h$) and the slope of the line gives the value of $(64/E_{11} b h^3)^{1/3}$. These values can then be substituted in Equation 6.8.6.3.1(a) to calculate G_I . It should be pointed out that in many cases αh can be neglected in comparison to length a and the results of Equations 6.8.6.3.1(a) and (b) are the same as those obtained if the two arms are treated as cantilever beams clamped at the end.

Another method, which is suggested in the ASTM standard (Reference 6.8.6.3.1(a)) for calculation of G_I , when both P and δ can be measured at the point of delamination propagation, is to use the formula

$$G_I = \frac{3P\delta}{2b(a+\alpha h)} \quad 6.8.6.3.1(d)$$

$$\approx \frac{3P\delta}{2ba}$$

The second expression is valid when αh can be neglected in comparison to a . This approach is called the modified beam theory method. Various other data reduction methods have been suggested in the literature (Reference 6.8.6.3.1(b)). It may be noted that if P and δ , measured at the point of onset of non-linearity, are inserted in Equation 6.8.6.3.1(d), the value of G_I yields a conservative estimate of its critical value.

6.8.6.3.2 Other mode I tests

The double cantilever beam test is the most widely used method for determining the Mode I toughness. In cases where joining loading attachments is a problem, wedge insertion between the two beams has been suggested. Another method which has been used is liquid pressure loading over a circular delamination between a thin film bonded to a substrate, which may be useful for some special applications.

6.8.6.4 Mode II test methods

6.8.6.4.1 End notched flexure (ENF) test

The ENF specimen is schematically shown in Figure 6.8.6.4.1. Typically, the specimens are 6 inches (150 mm) long, 1 inch (25 mm) wide and 0.12 - 0.20 inch (3 to 5 mm) thick. The insert is about 1 inch (25 mm) long. The span $2L$ of the three-point loaded beam is of the order of 4 inches (100 mm) leaving about a 1 inch (25 mm) overhang beyond the end supports. It is designed such that a delamination will propagate through the midplane of a laminate specimen loaded in three point bending (Reference 6.7.8.4.1(a)). The laminate should be symmetric about the midplane. Implanted and precracked delaminations grow in an unstable manner and, therefore, only the toughness for onset of Mode II fracture can be measured. Recently a stabilized version has been proposed (Reference 6.8.6.4.1(b)), where the test is controlled to a constant shear displacement at the delamination front. However, subcritical shear damage ahead of the front may influence the measurements after the onset.

An asymptotic expression for the energy release rate for large a/h (a being the delamination length and h is the laminate thickness) is given by (Reference 6.8.6.4.1(c)) as

$$G_{II} = \frac{9}{2} \frac{P^2(a+\alpha h)^2}{E_{11}b^2h^3} \quad 6.8.6.4.1(a)$$

where P is the load at midspan, b and E_{11} are the beam width and axial Young's modulus of the unidirectional composite. α is constant which can be chosen as

$$\alpha \approx 0.065 \sqrt{\frac{E_{11}}{G_{13}}} \quad 6.8.6.4.1(b)$$

G_{13} being the through the thickness shear modulus. Use of similar expressions for laminates whose top and bottom halves have no bending-twisting and shear-extension coupling, but may have bending-extension coupling have also been suggested (Reference 6.8.6.4.1(c)). Using the procedure described in Section 6.8.6.3.1 for the DCB test, the compliance C for large a/h can be shown to be given by

$$C = C_0 + \frac{3(a + \alpha h)^3}{E_{11} b h^3} \quad 6.8.6.4.1(c)$$

where C_0 is an integration constant.

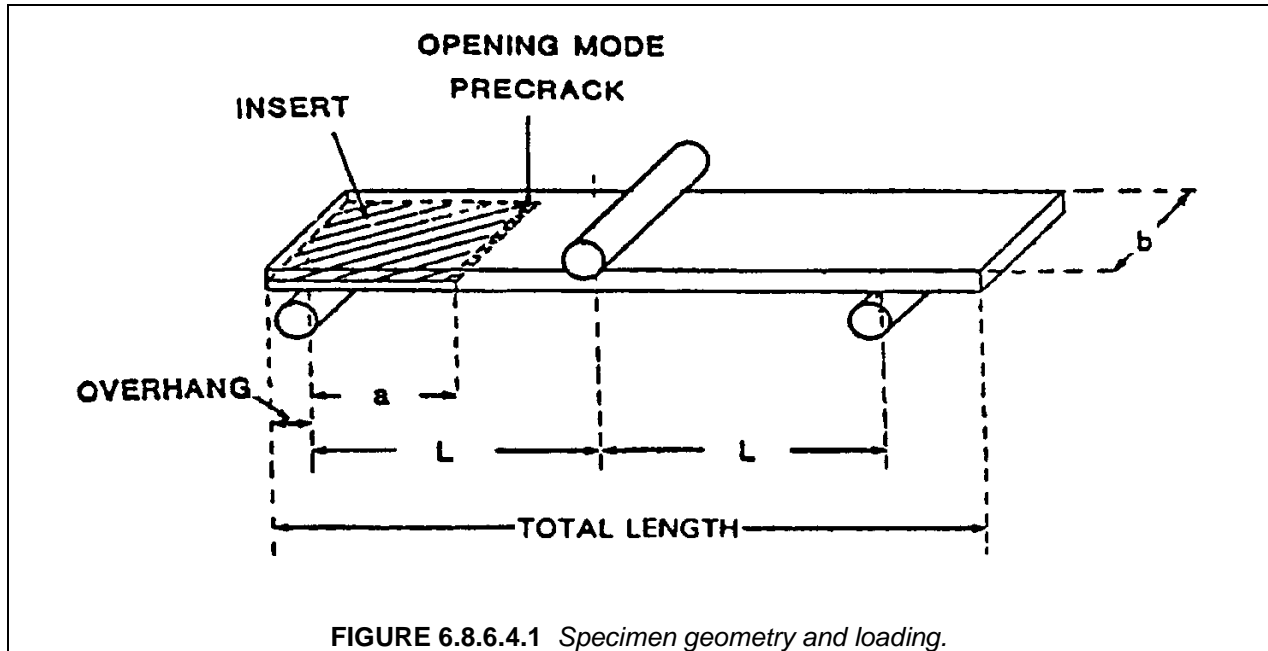

FIGURE 6.8.6.4.1 Specimen geometry and loading.

Use of a curve-fitting procedure to fit Equation 6.8.6.4.1(c) with estimated values of α close to that given by Equation 6.8.6.4.1(b) has been suggested in Reference 6.8.6.4.1(c). According to other investigators, C_0 can be chosen as the compliance of the beam without any delaminations and fitting a straight line to $C^{1/3}$ vs. length a can, therefore, be performed to determine α and $(3/E_{11} b h^3)^{1/3}$. Compliance measurements are easily performed by taking a long beam with an implanted delamination and shifting the beam on the supports to obtain various values of a .

An ASTM "round robin" test program is planned for the ENF test and ASTM subcommittee D30.06 plans to draft a proposed standard test method based on this test program. Effects of material nonlinearity and tough adhesive interlayers on Mode II fracture have also been studied (Reference 6.8.6.4.1(c)).

6.8.6.4.2 Other mode II tests

Flexural loading of a thick laminated beam of the same form used in the ENF test, but with delaminations implanted between the support and the central load, has also been suggested (see Reference 6.8.6.4.1(c)), but compliance measurements and precracking are difficult for this specimen. However, a wider plate type specimen with implanted delaminations of circular and elliptic shapes has been found to be useful to characterize growth of such delaminations under a combined mode, the contribution from each mode varying along the delamination boundary (Reference 6.8.6.4.2).

6.8.6.5 Mode III test methods

Presently there are no commonly accepted methods for measuring Mode III toughness. A split cantilever beam has been proposed (Reference 6.8.6.5(a)) but there appears to be some Mode II contribution in this specimen (Reference 6.8.6.5(b)). A cone torsion test has been used to characterize adhesive bonds (Reference 6.8.6.5(c)), which showed that Mode III toughness can be higher than that in Mode II.

It is a common practice in composites industry to use Mode II value to estimate the criticality of Mode III fracture.

6.8.6.6 Mixed mode test methods

As discussed in Section 6.8.6.2, in natural delaminations with curved fronts, the energy release rates not only vary along the front, but mixed mode conditions are also present. Mixed mode effects are also present in delaminations with straight fronts (edge delaminations and adhesive joints are examples). In such cases, Mode I and Mode II contributions are dominant, although small Mode III effects may also be present. For this reason, various attempts have been made to characterize delamination fracture under combined action of Mode I and Mode II effects and some of them are discussed next.

6.8.6.6.1 Mixed mode specimen or crack lap shear (CLS)

The CLS specimen (Reference 6.8.6.6.1) was patterned after a similar specimen used for bonded joints. The specimen is a tension coupon, where some of the plies are terminated in the middle of the coupon (Figure 6.8.6.6.1). This specimen has been used widely in the industry. Mode I and II components are computed based on stress analyses (finite element or other methods). Effects of geometric nonlinearities have also been studied.

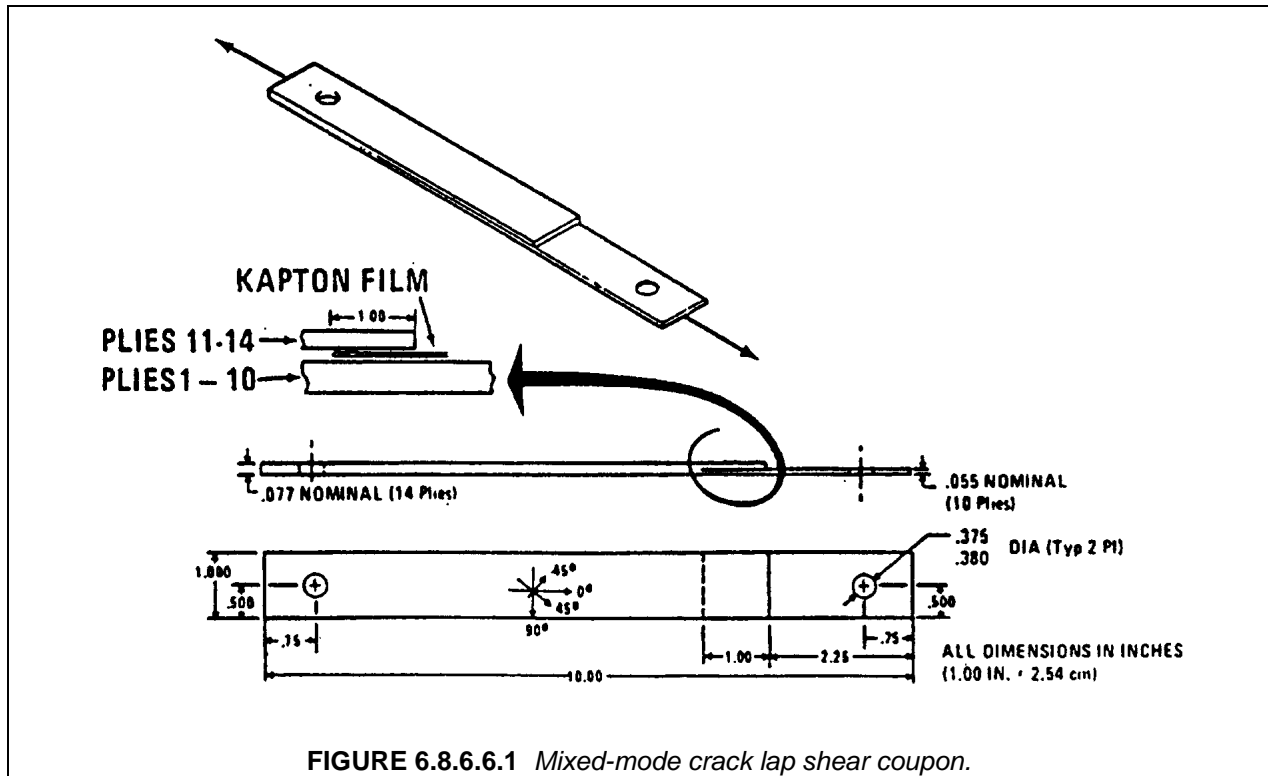

6.8.6.6.2 Mixed mode bending (MMB) test

This test has recently been proposed (References 6.8.6.6.2(a) and (b)) by combining the schemes used for DCB and ENF tests and the specimen is of the same form as that used in those tests. A special loading device is utilized, which can produce a wide range of the ratio of Mode I and Mode II components by changing the lever arm of the device shown in Figure 6.8.6.6.2. Use of the following equations has been suggested

$$G_I = \frac{3P^2}{4b^2 h^3 L^2 E_{11}} A_1 B_1 \quad 6.8.6.6.2(a)$$

$$G_{II} = \frac{9P^2}{16b^2 h^3 L^2 E_{11}} A_2 B_2$$

A_1 , B_1 , A_2 , and B_2 are expressed by the following equations when a modified linear beam theory is used for analysis

$$A_1 = a^2 + \frac{2a}{\lambda} + \frac{1}{\lambda^2} + \frac{h^2 E_{11}}{10G_{13}}$$

$$A_2 = a^2 + \frac{h^2 E_{11}}{5G_{13}} \quad 6.8.6.6.2(b)$$

$$B_1 = (3C-L)^2$$

$$B_2 = (C+L)^2$$

An ASTM "round robin" test program is planned using the MMB specimen. ASTM subcommittee D3.06 plans to draft a proposed standard test method based on the results of this test program.

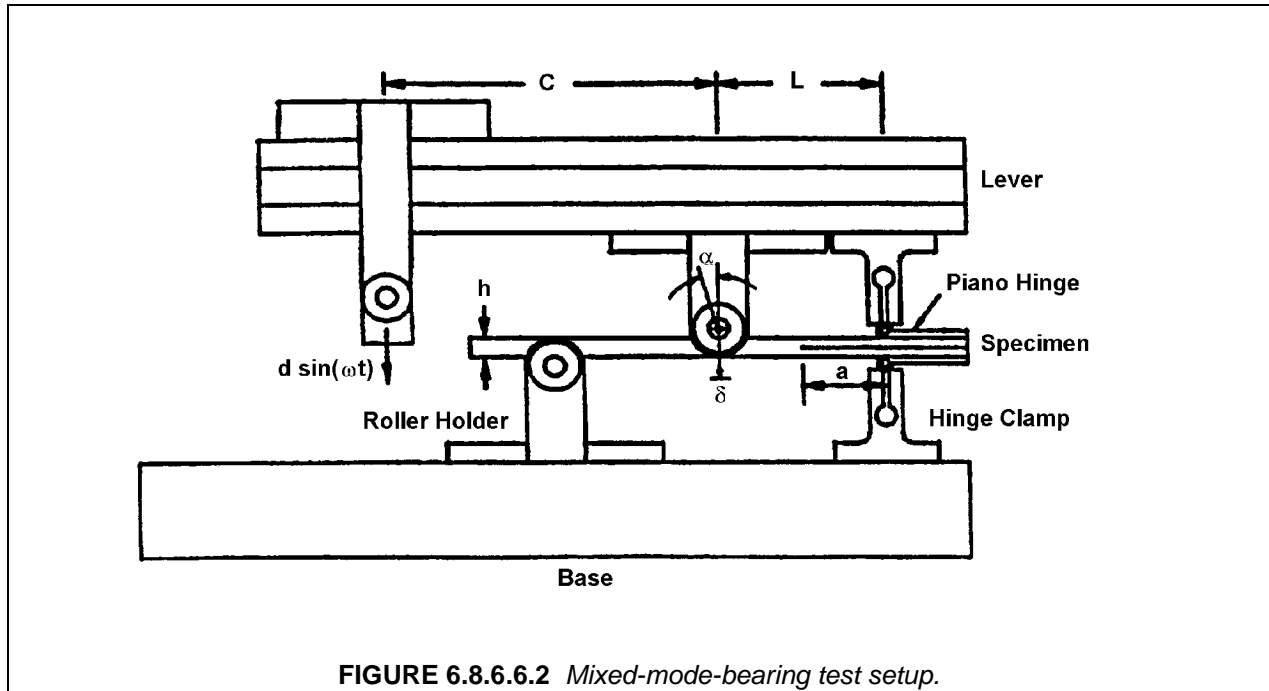

6.8.6.6.3 Edge delamination test

This test specimen makes use of a $(\pm\theta_2/90_2)_s$ tension specimen, in which the free edge effect causes growth of delamination from the edges (Reference 6.8.6.6.3(a)). However, the delamination growth is neither uniform nor symmetric, since it does not remain in the midplane, but oscillates vertically between the $90^\circ/\theta$ interfaces. A modified version of the specimen with a starter delamination has been proposed (Reference 6.8.6.6.3(b)). Data reduction procedures are discussed in References 6.8.6.6.3(a) and (b). The test has not gained wide acceptance for toughness property determination.

6.8.6.7 Fracture toughness tests for MIL-HDBK-17 data submittal

Data produced by the following test methods (Table 6.8.6.7) are currently being accepted by MIL-HDBK-17 for consideration for inclusion in Volume 2.

TABLE 6.8.6.7 Fracture toughness test methods for MIL-HDBK-17 data submittal.

Property	Symbols	Fully Approved, Interim and Screening Data	Screening Data Only
Mode I Toughness	G_{IC}	ASTM D 5528	--
Mode II Toughness	G_{IIC}	ENF	--
Mode III Toughness	G_{IIIC}	--	--
Mixed Mode I, II Fracture	$f_c (G_I, G_{II})$	--	MMB

6.9 UNIAXIAL FATIGUE TESTING

Static testing of unidirectional composite specimens is useful for material characterization, comparison of materials, and for prediction of application laminate properties through the use of lamination plate theory. In the area of fatigue, however, no generalized methodology has yet been devised to predict laminate behavior from unidirectional specimen data. Hence, the development of fatigue design values becomes a unique problem for each application lay-up. Many studies have been undertaken, and much has been written concerning life prediction for specific laminates under cyclic loading spectra. Even at this level, empirical methods have been favored due to the inadequacy of results obtained from cumulative damage models, fracture mechanics analyses, and other theoretical approaches (References 6.9(a) and (b)).

ASTM Test Method D 3479, "Tension - Tension Fatigue of Oriented Fiber, Resin Matrix Composites", is a generalized coupon testing method (Reference 6.9(c)). However, because composite fatigue is so application dependent, it is important that the laminates represent the application and that the laminates testing account for the service load spectra and environmental conditions. Currently this is accomplished in composite hardware programs through a "building block" test approach involving coupon, element, and component specimens, all representative of full-scale structural details.

It is important to note that, for the majority of current aircraft composite structure, fatigue capability does not become a limiting factor if all static strength concerns have been thoroughly and successfully addressed. Exceptions to this are high-cycle components such as those found in helicopter dynamic systems.

6.10 MULTIAXIAL MECHANICAL PROPERTY TESTING

Multiaxial tests, including biaxial and triaxial loadings, can be performed to experimentally evaluate the effect of combined stress states on composite material response. No standard test methods exist to

guide multiaxial testing, and little data is available. A discussion of multiaxial testing can be found in Volume 3, Section 10.2.3.2.

6.11 VISCOELASTIC PROPERTIES TESTS

6.11.1 Introduction

The time dependence of the properties of organic matrix composites arises primarily from the viscoelastic nature of the polymeric matrix resins, which these materials contain. Although these properties are matrix-dependent, they cannot be simply predicted based upon the viscoelastic properties of the unreinforced matrix. Creep compliance, relaxation modulus and even measured glass transition temperature can vary widely as a function of the content and orientation of reinforcing fibers.

6.11.2 Creep and stress relaxation

Creep is the time-dependent strain exhibited by a material under the action of a constant stress. Creep is characterized as a function of time by measurement of the creep compliance which is determined by dividing the time-dependent strain by the level of constant stress. Similarly, stress relaxation is the time-dependent stress exhibited by a material under the action of a constant strain. The relaxation modulus is determined by dividing the time-dependent stress by the constant applied strain. Creep and stress relaxation are different manifestations of the same underlying mechanisms of molecular mobility. At low levels of applied stress or strain these time-dependent effects may be completely recoverable when the forcing function is removed, but at higher levels irrecoverable deformations may occur under load. Irrecoverable strain, sometimes called permanent set, may be accompanied by time-dependent damage development such as the formation and growth of transverse matrix cracking.

Viscoelastic effects should be considered if the end use involves high stresses in a matrix-dominated direction, high temperature or exposure to a harsh chemical environment. Composite structural designs should be evaluated for potential time-dependent effects if the working load involves significant shear loading. Since high shear loads can be generated near a structural discontinuity, these are areas of potential concern. It should be noted that viscoelastic effects can be beneficial in some of these instances, since stress relaxation in high stress regions can help prevent catastrophic failure. When a thermoplastic matrix is employed, time-dependent behavior may be a problem, especially if the service temperature is at or near T_g . The extent of creep should be smaller in thermoset composites due to cross-linking.

In fiber-reinforced plastics (composites), one can assume that creep will be more important when the composite is loaded in a matrix-dominated manner than in a fiber-dominated manner. For instance, the creep of a unidirectional specimen tensile loaded in the fiber direction is expected to be small and hence only of secondary importance. However, loading a specimen in a matrix-dominated manner is not as straight forward as one would expect. Testing a unidirectional specimen in a transverse tensile manner one would think must essentially load the matrix, and this is not so. There are several explanations. One of the explanations is that loading a transverse specimen puts the matrix in a bidirectional state of stress (tensile) because the fibers prevent the matrix from laterally contracting (i.e., Poisson's effect) and thus the amount of creep response is restricted. Another argument for low creep response in transverse specimens is that the specimens are weak and the strains are small, so the change in strain would also be small. Another way to load the matrix is in shear where the creep response should be large. The most convenient way to load the matrix in shear is to load a [+45] specimen in tension. Although there is some argument that this test does not produce pure intralaminar shear, it at least produces some shearing and can be thought analogous to loading a unidirectional laminate in shear.

Experience has shown that the resulting creep is significant. Other loadings that would be interesting to examine with respect to creep response would be compression of unidirectional specimens in the fiber direction and three-point bend loading of unidirectional specimens (in both of these methods shear plays a role).

A common experimental procedure is to apply a dead weight tensile load to a [+45] specimen at 5, 10, or 15 ksi (35 MPa, 70 MPa, or 105 MPa) and monitor the strain as a function of time. The strain reading at the first application of the full load is designated as the strain at zero time. Subsequent measurements are timed from that zero time reading. Readings are taken at 1, 2, 3, 10, 20, 30, 60, 100, and 200 minutes, and then as convenience dictates. Strain as a function of time is plotted on semi-log axes and the test continued for at least 30,000 minutes (or 3 weeks). Testing should be done at controlled (constant) humidity and temperature conditions (References 6.11.2(a) and (b)). Generally, specimens are 1 in. wide, 6 in. long, and ~0.04 – 0.06 in. thick (25 mm wide, 150 mm long and ~1-1.5 mm thick). These dimensions are open to question; there is some evidence that wider samples will creep less than narrow samples.

6.12 FORM-SPECIFIC MECHANICAL PROPERTY TESTS

6.12.1 Tests unique to filament winding

6.12.1.1 Overview

The mechanical behavior of filament wound structures is typically different from the behavior of flat laminated structures. Some noted differences result from the type of cure, resin void content, microcracking, and free edge construction. However, filament wound structures require the same mechanical property data for design and analysis as used for general laminated structures. The majority of filament wound structures are used in the rocket motorcase community, and consequently, most of the test specimens are in the form of cylinders or bottles that more closely simulate the geometry of the structures to be designed and analyzed.

6.12.1.2 History

In November 1983, the Joint Army, Navy, NASA, and Air Force (JANNAF) Interagency Propulsion Committee chartered by the Department of Defense formed the Composite Motorcase Subcommittee (CMCS) (Reference 6.12.1.2.(a)). The CMCS was concerned with the application of composite materials in the construction of rocket motorcases for strategic and tactical missiles, space propulsion systems, and cartridge cases for gun propulsion. The CMCS consisted of four working panels two of which were the Testing and Inspection (T&I) panel and the Design and Analysis (D&A) panel.

The T&I panel surveyed industry on test methods which resulted in seventeen different tension tests, seventeen different compression tests and sixteen different shear tests that were being used to obtain mechanical property data. The T&I and D&A panels joined to evaluate the test methods via a JANNAF Workshop (Reference 6.12.1.2(b)). A panel of experts in filament wound composites was selected and tasked to make recommendations for test methods. A joint T&I and D&A Workshop was held in April 1986 to discuss the panel of experts' recommendations and to have an industry selection of JANNAF interim test standards to be used for the determination of uniaxial material properties.

The CMCS conducted a Design Round Robin (DRR) and a Testing Round Robin (TRR) for three of the interim tests: 1) Transverse Tension, 2) Transverse Compression and 3) In-plane Shear of ninety degree filament wound cylindrical specimens. The participants in the DRR and the TRR were paid and were determined through competitive procurement. The manufacturing of the ninety degree filament wound cylinders and strain gaging were also determined through competitive procurement. Each of the test specimens were ultrasonically C-scanned for any anomalies. The TRR was conducted in accordance with ASTM E 691 (Reference 6.12.1.2(c)). The DRR and TRR were successful and resulted in three Military Standards in the fall of 1992. The three Military Specifications were put into ASTM format, run through the balloting phases and approved as ASTM test methods in the fall of 1993. The JANNAF efforts were coordinated with MIL-HDBK-17, ASTM Committee D-30, SACMA, and the DOD Standardization Program for Composites Technology.

6.12.1.3 *Tension tests for uniaxial material properties*

6.12.1.3.1 *Zero degree tension*

The test method selected for the zero degree tension test is ASTM D 3039 entitled "Standard Test Method for Tensile Properties of Fiber-Resin Composites" (Reference 6.8.2.2.1(a)). It is recommended that the test specimens be obtained from a filament wound laminate. The JANNAF CMCS initially voted on either the pressurized NOL ring or a pressurized ninety degree filament wound tube. There were several attempts to obtain valid data from each technique but with little repeatable success.

6.12.1.3.2 *Transverse tension*

The test method selected to determine the uniaxial material properties for transverse tension is ASTM D 5450 entitled "Test Method for Transverse Tensile Properties of Hoop Wound Polymer Matrix Composite Cylinders" (Reference 6.12.1.3.2). This test method was approved as MIL-STD-373 entitled "Transverse Tensile Properties of Unidirectional Fiber/Resin Composite Cylinders" in the fall of 1992, and was subsequently approved as an ASTM test method in the fall of 1993.

6.12.1.4 *Compression tests for uniaxial material properties*

6.12.1.4.1 *Zero degree compression*

The test method selected to determine zero degree uniaxial material properties is ASTM D 3410 entitled "Test Method for Compressive Properties of Unidirectional or Crossply Fiber-Resin Composites" (Reference 6.8.3.1(a)). Method B, also known as the IITRI method, is recommended. It is further recommended that the test specimens be obtained from a filament wound laminate.

6.12.1.4.2 *Transverse compression*

The test method selected to determine the uniaxial material properties for transverse compression is ASTM D 5449 entitled "Test Method for Transverse Compressive Properties of Hoop Wound Polymer Matrix Composite Cylinders" (Reference 6.12.1.4.2). This test method was approved as MIL-STD-374 entitled "Transverse Compressive Properties of Unidirectional Fiber/Resin Composite Cylinders" in the fall of 1992, and was subsequently approved as an ASTM test method in the fall of 1993.

6.12.1.5 *Shear tests for uniaxial material properties*

6.12.1.5.1 *In-plane shear*

The test method selected for the determination of in-plane shear properties is a ninety degree, four inch diameter filament wound torsion tube described in ASTM D 5448 entitled "Test Method for In-plane Shear Properties of Hoop Wound Polymer Matrix Composite Cylinders" (Reference 6.12.1.5.1). This test method was approved as MIL-STD-375 entitled "In-plane Shear Properties of Unidirectional Fiber/Resin Composite Cylinders" in the fall of 1992, and was subsequently approved as an ASTM test method in the fall of 1993.

6.12.1.5.2 *Transverse shear*

The test method selected to determine transverse shear material properties is ASTM D 5379 entitled "Test Method for Shear Properties of Composite Materials by the V-notched Beam Method" (Reference 6.8.4.2.2(a)).

6.12.1.6 *Test methods for MIL-HDBK-17 data submittal*

Data produced by the following test methods (Table 6.12.1.6) are currently being accepted by MIL-HDBK-17 for consideration for inclusion in Volume 2 (an element of orientation is shown for clarity).

TABLE 6.12.1.6 *Filament wound test methods for MIL-HDBK-17 data submittal.*

Property	Symbols	Fully Approved, Interim, and Screening Data	Screening Data Only
0° Tension*	$F_1^{tu}, E_1^t, \nu_{12}^t, \epsilon_1^{tu}$	ASTM D 3039	---
90° Tension*	$F_2^{tu}, E_2^t, \nu_{21}^t, \epsilon_2^{tu}$	ASTM D 5450	---
0° Compression*	$F_1^{cu}, E_1^c, \nu_{12}^c, \epsilon_1^{cu}$	ASTM D 3410B	---
90° Compression*	$F_2^{cu}, E_2^c, \nu_{21}^c, \epsilon_2^{cu}$	ASTM D 5449	---
In-Plane Shear**	$F_{12}^{su}, G_{12}, \gamma_{12}$	ASTM D 5448	---
Transverse Shear***	$F_{23}^{isu}, G_{23}, \gamma_{23}$ $F_{31}^{isu}, G_{31}, \gamma_{31}$	ASTM D 5379	---

* Strength, modulus, Poisson's Ratio, and strain

** Strength, modulus, and strain

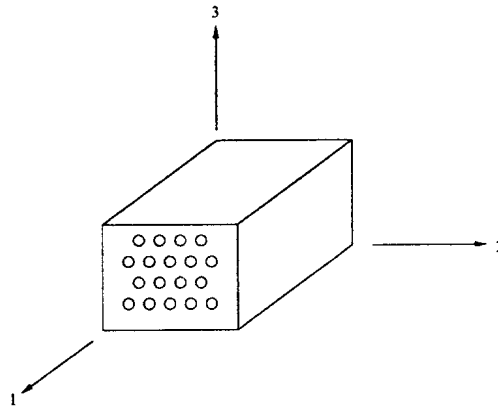

6.12.2 Tests unique to textiles composites

6.12.2.1 Overview

The physical and mechanical behavior of common textile composites is in many ways similar to that of the unidirectional materials. Many of the same test methods work in the determination of properties of the textile composite. This is only applicable to weaves that are homogenous in nature over a small repeat length and width. A designer must analyze very large coarse weaves for specific situations that repeat over several inches on an individual basis.

In two-dimensional weaves, typical testing concerns are associated with specimen size that defines the representative structure. In most commercially available fabrics, the repeat is over a small square. The use of very coarse or odd weave patterns complicates the simplicity of testing allowed by using unidi-

rectional laminate tests. In these large or irregular patterns, it is required to account for repeat sequence in specimen size selection. Coordinating this within the appropriate test method limitations is sometimes difficult.

In testing of textile composites, a major factor to consider is z-axis reinforcing. Cross-stitching of two dimensional textile composites or interconnection of all axes in 3D weaves accomplishes this reinforcement. The cross-stitching and weaving applications introduce reinforcement in the Z-axis to provide better properties in the out-of-plane direction. In these textile products, testing must address the characterization of the third direction. Although a number of programs are investigating the characterization in the z-direction there is no agreed standard as with the in-plane methods.

For textile processes, the most likely manufacturing defects are associated with porosity and with "dry" regions from insufficient resin flow. Large planes of weak bonds are unlikely. Conventional ultrasonic techniques can detect large areas of porosity. Small areas masked by the inhomogeneous structure of 3D textiles are possible. The dry regions tend to be on the surface and visually detectable.

There is the possibility of microcracks in the resin rich areas near the tow intersections even in toughened systems. The 3D nature of the materials does not allow for contraction in the Z direction as do 2D composites so you put a significant 3D stress state on the resin rich areas, hence the potential for cracks forming.

6.12.2.2 Background

The testing of textile composites is not a new topic. In fact, most of the first composite materials were reinforced with woven materials. There are numerous reviews of the test methods for unidirectional materials, but typically the woven materials are as often part of a design as the unidirectional materials. As discussed previously, test methods for textile composites must account for the pattern associated with woven textiles to be representative of woven structures.

In typical woven materials, the repeat pattern is less than one tenth of an inch. In these cases testing per the standard unidirectional methods yields values that are representative of the bulk properties of the weave. In most instances since the repeating pattern is small, normal testing specimens will accommodate the weaving. When using a standard test method developed for a unidirectional laminate, compare the repeat size to the maximum and typical specimen sizes per the standard test method. If the repeat pattern is 10X smaller than the specimen test length, no problem should result.

For woven textile fabrics, the pattern is part of the style designation. In glass fabrics, the weavers number also assigns yarn properties, refer to Reference 6.12.2.2(a) for definition of style numbers of glass fabric.

In two-dimensional and triaxial braiding this is also true, but the weave comes in the form of a sock. The reinforcement properties of the sock are created by the tows that are used, the mandrel feed speed and the diameter and shape of the mandrel. The specimens from a braiding operation require care to assure the weaving pattern is not changed during the lay-up and impregnation phase of test coupon fabrication.

Tests conducted to evaluate the test specimens used for dry textile preforms and RTM process composites are included in References 6.12.2.2(b) and (c). Section 6.12.2.4 presents discussion of the peculiarities of complex braiding.

6.12.2.3 Fabric and two-dimensional weaves

6.12.2.3.1 Physical property tests

For measuring density and fiber volume fraction of dry composites, the sample should be an order of magnitude larger than the unit cell size to obtain an average density. For textile composites with average

fiber volume fractions of 0.50 - 0.55, the fiber volume fraction within the yarn can be as large as 0.7. Thus, use the actual fiber volume fraction in analyses that model the yarns and resin discretely, not average fiber volume fraction for the textile composite.

Composites made with dry two-dimensional textile preforms used in RTM processes are quasi-laminar in nature. Thus, a cured ply thickness could be calculated and used for scaling strength with thickness. For molded parts, the tool volume controls the thickness. The bulk factor (unrestrained thickness/restrained thickness) for a dry preform should be slightly greater than 1:1 to obtain the desired fiber volume fraction. For bulk factors significantly greater than one, autoclave or press pressures may be required to close the tool, resulting in unacceptable distortion of the preform. For bulk factors less than one, the fiber volume fraction will obviously be less than optimum.

6.12.2.3.2 *Mechanical testing*

The standard test methods found in the static uniaxial mechanical test section (6.8) provide good results for textile composites made from two-dimensional woven prepreg. However, any testing must take into account the scale effects associated with the use of textile reinforcements. The repeat size of the weave dominates this scale effect. If the test specimen size is small enough to be unbalanced, the results will be unrepresentative of the characterized parts.

As the complexity of the repeat pattern increases, so does the need for larger test specimens. No specific rule of thumb for this is available and the investigator should evaluate this as part of the program to establish mechanical values. There are many studies that the reader is encouraged to review as part of the characterization of the particular weave.

6.12.2.3.3 *Impact considerations*

The present test methods to measure impact damage tolerance are just as suitable for composite specimens made from dry textile preforms and a RTM process as composites made from prepreg laminates. One must understand impact response to apply the data. A discussion of impact response is in Reference 6.12.2.3.3.

6.12.2.4 *Complex braiding considerations*

The goal of testing braided specimens is to produce mechanical property data that mimics the performance of that section of the braided structure in a representative manner. Often this is difficult to achieve due to the local contour or details not accurately formed into the test specimens. Therefore, certain assumptions as to the applicability of the specimens to the final part are necessary before the start of testing.

Most specimens assume pristine manufacturing in producing the specimen and this is representative of the final part. This initial coupon may or may not mimic the final product depending upon care and reproducibility in the design of the part. Test specimens for tension, compression, shear, pin bearing, interlaminar shear and interlaminar tension are described in other sections of this handbook. In some cases, the actual shape of the zone may more accurately represent specimen geometry, i.e., a tapered specimen (preferably symmetric) that contains the essential geometry of the actual tapered braid.

In general, the specific mechanical properties of interest are torsional stiffness and strength, shear stiffness and strength, tensile, compressive and flexural moduli and strengths, bearing strength for bolted assemblies, and adhesive bond strength where required. In the event exposure of the braided parts to damage or degradation by the environment is possible, a series of tests to provide a measure of the damage tolerance and environmental effects on braided materials must be included. Damage criteria must include manufacturing defects that are not detectable by non-destructive evaluations.

Several candidate configurations for these types of tests are listed in NASA CR 1092 (Reference 6.12.2.4) and should be considered as part of a design allowables program based upon intended use and environment.

Fatigue and creep tests of braided composites are important considerations whenever the part is a dynamic component. The highly complex courses followed by the braided yarns through the matrix create fiber load paths for which stiffnesses and strengths are difficult to predict. The chance that the matrix is loaded beyond the level predicted by laminated design is high. Therefore, a lower confidence in understanding how a braided part behaves will require a rigorous fatigue and creep test plan to characterize the complex interweave of the braided yarns in the part. Tests designed to determine fatigue or creep effects are part specific and should be conducted on a braided specimen that is identical to the finished product. Scaling effects and the use of similitude in test specimen design should be avoided whenever possible. Otherwise, the results may not mimic a critical defect, which results in a failure of the part before the predicted value.

In general, it is accurate to state that for both two- and three-dimensional braided composites, defects are the single most important factor in the design of the part and the corresponding application of the allowables. This is due to the nature of braided preforms as well as physical limitations in the ability of the yarns to cover an area of rapid change in contour. The good news is that net-shape braided parts do provide a means to build these parts without intensive hand labor. This makes braiding suitable to production environments and fully capable of doing the intended job. This is true when the designer or analyst has made the correct choices in the type of specimens used for determining braided allowables.

6.12.2.4.1 *Three-dimensional weave and braids*

Three-dimensional textile composites are typically very complex application driven weavings. The testing associated with them determines the specific properties addressed by special weavings or cross-stitching of two-dimensional weaves. Some conventional tests performed on representative sections of the weave determine and characterize the capabilities of these processes. Currently there are many investigations under way to standardize tests in the z-axis but no industry standard has yet been set.

6.12.2.4.2 *Through the thickness test methods*

Many methods have been developed to characterize the through the thickness properties. Interlaminar test methods are desirable for optimizing the type and amount of through the thickness reinforcement in textile composites; Table 6.12.2.4.2 shows commonly used methods. These test methods must have additional work before recommending them for standardization. None of the in-plane shear test methods was totally acceptable. A review of those investigations is in Reference 6.12.2.3.3.

6.12.2.5 *Test methods for submission to MIL-HDBK-17*

In general, the methods described in the preceding sections on unidirectional materials should be used to characterize textile composites. These are only applicable to weaves that are homogenous in nature over a small repeat length and width. Very large coarse weave repeats developed for specific situations are beyond the scope of this section and the handbook. Analyze these weaves for testing on an individual basis.

For appropriate test methods for individual test conditions see the following sections:

Tension test methods	6.8.2.4
Compression test methods	6.8.3.4
Shear test methods	6.8.4.4
Fracture toughness tests	6.8.6.7

6.12.3 Tests unique to thick-section composites

No standard test methods exist to guide thick-section testing, and little data is available. Mechanical tests, including uniaxial, biaxial, and triaxial loadings, can be performed to experimentally evaluate the effect of combined stress states on composite material response. A discussion of thick-section testing can be found in Volume 3, Section 7.2.3.

TABLE 6.12.2.4.2 *Proposed in-plane shear tests methods for 3D reinforced composites.*

Test method type	Test Method Specification	Test Method Title	Comments
Shear	ASTM E 143	Standard Test Method for Shear Modulus at Room Temperature	Reference 6.12.2.4.2
	ASTM D 4255	Standard Guide for Testing In-plane Shear Properties of Composite Laminates	
	None	Compact Shear	
Interlaminar tension	ASTM D 6415	Standard Test Method for Measuring the Curved Beam Strength of a Fiber-Reinforced Polymer-Matrix Composite	
Interlaminar fracture toughness	ASTM D 5528	Standard Test Method for Mode I Interlaminar Fracture Toughness of Unidirectional Fiber-Reinforced Polymer Matrix Composites	Reasonable for 2-D braids and stitched uniweaves
Interlaminar fracture toughness	See 6.8.6.4.1	End Notched Flexure (Mode II)	Reasonable for 2-D braids
Interlaminar tension	ASTM C 297	Standard Test Method for Flatwise Tensile Strength of Sandwich Constructions	Reasonable for elastic constants
Interlaminar compression	ASTM D 3410, Procedure B	Standard Test Method for Compressive Properties of Polymer Matrix Composite Materials with Unsupported Gage Section by Shear Loading	Reasonable for elastic constants and strength
Interlaminar shear	None	Compact	Reference 6.12.2.4.2, Thick composites Thin composites
	ASTM D 3846	Standard Test Method for In-Plane Shear Strength of Reinforced Plastics	
Interlaminar shear - transverse	ASTM D 2344	Standard Test Method for Short-Beam Strength of Polymer Matrix Composite Materials and Their Laminates	Reasonable for 2-D braids and 3-D weaves

6.13 SPACE ENVIRONMENTAL EFFECTS ON MATERIAL PROPERTIES

This section is reserved for future use.

6.13.1 Introduction

This section is reserved for future use.

6.13.2 Atomic oxygen

This section is reserved for future use.

6.13.3 Micrometeoroid Debris

This section is reserved for future use.

6.13.4 Ultraviolet radiation

This section is reserved for future use.

6.13.5 Charged particles

This section is reserved for future use.

REFERENCES

- 6.3.1 ASTM Test Method D 5229/D 5229M, "Moisture Absorption Properties and Equilibrium Conditioning of Polymer Matrix Composite Materials," *Annual Book of ASTM Standards*, Vol 15.03, American Society for Testing and Materials, West Conshohocken, PA.
- 6.3.2(a) ASTM Practice D 618, "Conditioning of Plastics and Electrical Insulating Materials for Testing," *Annual Book of ASTM Standards*, Vol 8.01, American Society for Testing and Materials, West Conshohocken, PA.
- 6.3.2(b) ASTM Test Method D 570, "Water Absorption of Plastics," *Annual Book of ASTM Standards*, Vol 8.01, American Society for Testing and Materials, West Conshohocken, PA.
- 6.3.2(c) SACMA Recommended Method (SRM) 11-88, "Recommended Procedure for Conditioning of Composite Test Laminates," Suppliers of Advanced Composite Materials Association, Arlington, VA.
- 6.3.3(a) Ryder, J. T., "Effect of Load History on Fatigue Life," AFWAL-TR-80-4044, July, 1980.
- 6.3.3(b) SACMA Recommended Method (SRM) 11R-94, "Recommended Method for Environmental Conditioning of Composite Test Laminates," Suppliers of Advanced Composite Materials Association, Arlington, VA.
- 6.3.3.2 Weisman, S., "Relative Humidity Measurement Errors in Environmental Test Chambers," *Test Engineering & Management*, October/November 1990, pg. 16-17.
- 6.4.1 ASTM Practice E 83-94, "Practice for Verification and Classification of Extensometers," *Annual Book of ASTM Standards*, Volume 3.01, American Society for Testing and Materials, West Conshohocken, PA .
- 6.4.2.8 ISO 10012-1:1992 "Quality Assurance Requirements for Measuring Equipment -- Part 1: Metrological Confirmation System for Measuring Equipment."
- 6.4.3.1(a) ASTM E-4, "Standard Practices for Force Verification of Testing Machines," *Annual Book of ASTM Standards*, Vol 3.01, American Society for Testing and Materials, West Conshohocken, PA, ISBN 0-8031-1915-1.
- 6.4.3.1(b) ASTM E-74, "Standard Practice of Calibration of Force-Measuring Instruments for Verifying the Force Indication of Testing Machines," *Annual Book of ASTM Standards*, Vol 3.01, American Society for Testing and Materials, West Conshohocken, PA, ISBN 0-8031-1915-1.
- 6.4.3.1(c) ASTM E-467, "Standard Practice for Verification of Constant Amplitude Dynamic Loads on Displacements in an Axial Load Fatigue Testing System," *Annual Book of ASTM Standards*, Vol 3.01, American Society for Testing and Materials, West Conshohocken, PA, ISBN 0-8031-1915-1.
- 6.4.3.1(d) ISO 5893, "Rubber and Plastics Test Equipment – Tensile, Flexural and Compressive Types (Constant Rate of Traverse) – Description," International Organization for Standardization, Geneva, Switzerland.
- 6.4.3.3 Window and Hollister, "Strain Gage Technology," Applied Science Publishers, Essex, England, ISBN 0-85334-118-4, p. 267.
- 6.4.4.4 G. Sines, *Elasticity and Strength*, Allyn & Bacon Inc. 470 Atlantic Ave, Boston MA LCCN: 69-14637.

- 6.4.4.4.1(a) "Temperature Induced Apparent Strain and Gage Factor Variation in Strain Gages," Tech Note TN-504-1. Available free of charge from: Measurements Group Inc. P.O. Box 27777 Raleigh, NC 27611. Measurements Group makes available an extensive collection of tech notes and tips relating to strain measurement, all are available at no charge.
- 6.4.4.4.1(b) "Strain Gage Selection Criteria, Procedures, Recommendations," Tech Note TN-505-2. Available free of charge from: Measurements Group Inc. P.O. Box 27777 Raleigh, NC 27611
- 6.4.4.4.2 "Surface Preparation for Strain Gage Bonding," M-LINE ACCESSORIES Instruction Bulletin B-129-6, Micro-Measurements Division, Measurements Group Inc. P.O. Box 27777, Raleigh, NC 27611, USA
- 6.4.4.4.4 "Optimizing Strain Gage Excitation Levels," Tech Note TN-502. Available free of charge from: Measurements Group Inc. P.O. Box 27777 Raleigh, NC 27611.
- 6.4.4.4.5.1 "Shunt Calibration of Strain Gage Instrumentation," Tech Note TN-514. Available free of charge from: Measurements Group Inc. P.O. Box 27777 Raleigh, NC 27611.
- 6.4.4.6(a) Mechanics of Textile Composites Conference. NASA CP 3311, Parts 1 & 2, Oct. 1995.
- 6.4.4.6(b) Masters, John E., and Portanova, Marc A., "Standard Test Methods for Textile Composites," NASA CR-4751, Sept. 1996 (URL <http://techreports.larc.nasa.gov/ltrs>).
- 6.4.5.9(a) "The Temperature Handbook", Volume 29, Omega Engineering, Inc. 1995.
- 6.4.5.9(b) "Guidelines for Realizing the International Temperature Scale of 1990 (ITS-90), B.W. Magnum and G.T. Furukawa, National Institute of Standards and Technology.
- 6.4.5.9(c) ASTM E220-86 (reapproved 1996) Calibration of Thermocouples by Comparison Techniques.
- 6.4.5.9(d) ASTM E77-92 Standard Test Method for Inspection and Verification of Thermometers.
- 6.4.5.9(e) ASTM E1502- ASTM E1502 Use of Freezing Point Cells for Reference Temperatures.
- 6.6.3.1 Young, R.J., *Introduction to Polymers*, Section 4.4.2, Chapman and Hall, 1981, pp. 199-202.
- 6.6.3.2.1 ASTM Test Method E 1356-91, "Glass Transition Temperatures by Differential Scanning Calorimetry or Differential Thermal Analysis," *Annual Book of ASTM Standards*, Vol 14.02, American Society for Testing and Materials, West Conshohocken, PA.
- 6.6.3.2.3(a) ASTM Practice D 4065-85, "Standard Practice for Determining and Reporting Dynamic Mechanical Properties of Plastics," *Annual Book of ASTM Standards*, Vol 8.02, American Society for Testing and Materials, West Conshohocken, PA.
- 6.6.3.2.3(b) SACMA Recommended Method (SRM) 18R-94, "Recommended Method for Glass Transition Temperature (T_g) Determination by DMA of Oriented Fiber-Resin Composites," Suppliers of Advanced Composite Materials Association, Arlington, VA.
- 6.6.4.1(a) ASTM D 792, "Standard Test Method for Density and Specific Gravity (Relative Density) of Plastics by Displacement," *Annual Book of ASTM Standards*, ASTM, West Conshohocken, PA.

- 6.6.4.1(b) ASTM D 1505, "Standard Test Method for Density of Plastics by the Density-Gradient Technique," *Annual Book of ASTM Standards*, ASTM, West Conshohocken, PA.
- 6.6.4.1(c) ASTM D 4892, "Standard Test Method for Density of Solid Pitch (Helium Pycnometer Method)," *Annual Book of ASTM Standards*, ASTM, West Conshohocken, PA.
- 6.6.4.1(d) ASTM D2734, "Standard Test Method for Void Content of Reinforced Plastics," *Annual Book of ASTM Standards*, ASTM, West Conshohocken, PA.
- 6.6.4.1(e) Ghiorse, S.R., data presented to MIL-HDBK-17 PMC Testing Working Group, Santa Fe, NM, March 1996.
- 6.6.4.1(f) Ghiorse, S.R. and Tiffany, J, "Evaluation of Gas Pycnometry as a Density Measurement Method," Proceedings of the 34th MIL-HDBK-17 PMC Coordination Group, Schaumburg, IL, September 1996.
- 6.6.4.2(a) In-progress revision of ASTM D 3171, currently titled, "Standard Test Method for Fiber Content of Resin-Matrix Composites by Matrix Digestion," D-30 Committee, Spring 1997 D30.03 subcommittee ballot.
- 6.6.4.2(b) ASTM D 5229/D 5229M, "Standard Test Method for Moisture Absorption Properties and Equilibrium Conditioning of Polymer Matrix Composites," *Annual Book of ASTM Standards*, ASTM, West Conshohocken, PA.
- 6.6.4.3 Ghiorse, S.R., "A Comparison of Void Measurement Methods for Carbon/Epoxy Composites," U.S. Army Materials Technology Laboratory, TR 91-13, April 1991.
- 6.6.4.4 ASTM D 4892, "Standard Test Method for Density of Solid Pitch (Helium Pycnometer Method)," *Annual Book of ASTM Standards*, ASTM, West Conshohocken, PA.
- 6.6.4.4.1(a) ASTM D 618, "Standard Practice for Conditioning Plastics and Electrical Insulating Materials for Testing," *Annual Book of ASTM Standards*, ASTM, West Conshohocken, PA.
- 6.6.4.4.1(b) Standard Reference Materials Program, National Institute of Standards and Technology, Gaithersburg, MD 20899-0001.
- 6.6.5.3(a) ASTM E 797-90 "Standard Practice for Measuring Thickness by Manual Ultrasonic Pulse-Echo Contact Method," *1993 Annual Book of ASTM Standards*, Vol 3.03, Philadelphia, PA, 1993.
- 6.6.5.3(b) SACMA Recommended Method (SRM) 24R-94, "Recommended Method for Determination of Resin Content, Fiber Areal Weight and Flow of Thermoset Prepreg by Combined Mechanical and Ultrasonic Methods," Suppliers of Advanced Composite Materials Association, Arlington, VA.
- 6.6.5.4 SACMA Recommended Method (SRM) 10R-94, "Recommended Method for Fiber Volume, Percent Resin Volume and Calculated Average Cured Ply Thickness of Plied Laminates," Suppliers of Advanced Composite Materials Association, Arlington, VA.
- 6.6.6.2(a) ASTM Test Method D 3171-76, "Fiber Content of Resin-Matrix Composites by Matrix Digestion," *Annual Book of ASTM Standards*, Vol 15.03, American Society for Testing and Materials, West Conshohocken, PA.

Volume 1, Chapter 6 Lamina, Laminate, and Special Form Characterization

- 6.6.6.4(a) SACMA Recommended Method (SRM) 10R-94, "Recommended Method for Fiber Volume, Percent Resin Volume and Calculated Average Cured Ply Thickness of Plied Laminates," Suppliers of Advanced Composite Materials Association, Arlington, VA.
- 6.6.6.4(b) Kelly, K.M. and Ciriscioli, P.R., "A Non-Destructive Test Method for the Determination of Percent Resin Content, Fiber Areal Weight and Percent Fiber Volume of Composite Materials," Proceedings of the 43rd SAMPE Symposium and Exhibition, Anaheim, CA, June, 1998.
- 6.6.7.2 ASTM Test Method D 2734-70 "Void Content of Reinforced Plastics," *Annual Book of ASTM Standards*, Vol 8.02, American Society for Testing and Materials, West Conshohocken, PA.
- 6.6.8.1(a) ASTM D 5229/D 5229M-92, Test Method for Moisture Absorption Properties and Equilibrium Conditioning of Polymer Matrix Composite Materials.
- 6.6.8.1(b) SACMA SRM 11R-94, Environmental Conditioning of Composite Test Laminates.
- 6.6.8.1(c) Environmental Effects on Composite Materials, George S. Springer, Ed., Technomic Publishing Co., 1981.
- 6.6.9.1.2(a) ASTM Test Method D 696-98, "Test Method for Coefficient of Linear Thermal Expansion of Plastics Between -300C and 30C," *Annual Book of ASTM Standards*, Vol. 8.01, American Society for Testing and Materials, West Conshohocken, PA.
- 6.6.9.1.2(b) ASTM Test Method E 228-95, "Test Method for Linear Thermal Expansion of Solid Materials With a Vitreous Silica Dilatometer," *Annual Book of ASTM Standards*, Vol. 14.02, American Society for Testing and Materials, West Conshohocken, PA.
- 6.6.9.1.2(c) ASTM Test Method E 831-93, "Test Method for Linear Thermal Expansion of Solid Materials by Thermomechanical Analysis," *Annual Book of ASTM Standards*, Vol. 4.11, American Society for Testing and Materials, West Conshohocken, PA.
- 6.6.9.1.2(d)) ASTM Test Method E 289-99, "Test Method for Linear Thermal Expansion of Rigid Solids with Interferometry," *Annual Book of ASTM Standards*, Vol. 14.02, American Society for Testing and Materials, West Conshohocken, PA.
- 6.6.9.1.2(e) Yaniv, G., Peimanidis, G., and Daniel, I.M., "Method for Hygromechanical Characterization of Graphite/Epoxy Composite," *Journal of Composites Technology & Research*, Vol. 9, 1987, pp. 21-25.
- 6.6.9.2.1(a) Fukuda, M., Ochi, M., Miyagawa, M., and Kawai, H., "Moisture Sorption Mechanism of Aromatic Polyamide Fibers: Stoichiometry of the Water Sorbed in Poly(para-phenylene Terephthalamide) Fibers," *Textile Research Journal*, Vol. 61, No. 11, 1991, pp. 668-680.
- 6.6.9.2.1(b) Piggott, M.R., "Water Absorption in Carbon and Glass Fibre Composites," Paper No. 4.180, *Proceedings of ICCM/VI and ECCM/II*, Elsevier Applied Science, Publishers, London, 1987.
- 6.6.9.2.1(c) Tsai, C-L, and Chiang, C-H., "Characterization of the Hygric Behavior of Single Fibers," *Composites Science and Technology*, Vol. 60, 2000, pp. 2725-2729.
- 6.6.9.2.1(d) Cairns, D.S., and Adams, D.F., "Moisture and Thermal Expansion of Composite Materials," Report UWME-DR-101-104-1, Department of Mechanical Engineering, University of Wyoming, Laramie, WY, November 1981.

- 6.6.9.2.1(e) Cairns, D.S., and Adams, D.F., "Moisture and Thermal Expansion Properties of Unidirectional Composite Materials and the Epoxy Matrix," *Journal of Reinforced Plastics and Composites*, Vol. 2, No. 4, October 1983, pp. 239-255.
- 6.6.9.2.1(f) Norris, M.A., and Wolff, E.G., "Moisture Expansion Measurement and Data Analysis Techniques for Composite Structures," *Materials Challenge, Diversification and the Future*, D. Hamston, R. Carson, G.D. Bailey, and F.J. Riel, Editors, 40th International SAMPE Symposium, Anaheim, CA, May 8-11, 1995, pp. 1867-1878.
- 6.6.9.2.1(g) Wolff, E.G., Chen, H., and Oakes, D.W., "Hygrothermal Deformation of Composite Sandwich Panels," *Advanced Composite Letters*, Vol. 9, No. 1, 2000, pp. 35-43.
- 6.6.9.2.1(h) Wolff, E.G., Chen, H., and Oakes, D.W., "Hygrothermal Deformation of Composite Sandwich Panels," *Proceedings of the 12th International Conference on Composite Materials (ICCM/XII)*, 1999; also, Society of Manufacturing Engineers Technical Paper No. EM00-246, Dearborn, MI, 2000.
- 6.6.9.2.1(i) ASTM Test Method 481-99, "Test Method for Laboratory Aging of Sandwich Constructions," *Annual Book of ASTM Standards*, Vol. 15.03, American Society for Testing and Materials, West Conshohocken, PA.
- 6.6.9.2.1(j) ASTM D 5229/D 5229M-92 (1998), "Test Method for Moisture Absorption Properties and Equilibrium Conditioning of Polymer Matrix Composite Materials," *Annual Book of ASTM Standards*, Vol. 15.03, American Society for Testing and Materials, West Conshohocken, PA.
- 6.6.9.2.1(k) ASTM E 104-85 (1996), "Practice for Maintaining Constant Relative Humidity by Means of Aqueous Solutions," *Annual Book of ASTM Standards*, Vol. 11.03, American Society for Testing and Materials, West Conshohocken, PA.
- 6.6.9.2.1(l) Wolff, E.G., "Prediction of Non-Mechanical Transient Strains in Polymer Matrix Composites," Paper No. 32-S, *Composites, Design, Manufacture and Applications, Proceedings of the 8th International Conference on Composite Materials (ICCM/VIII)*, S.W. Tsai and G.S. Springer, Editors, 1991.
- 6.6.10.2.1(a) ASTM C177-97 "Steady-State Heat Flux Measurements and Thermal Transmission Properties by Means of the Guarded-Hot-Plate Apparatus," 1997 Annual Book of ASTM Standards, Vol 04.06, ASTM, Philadelphia, PA.
- 6.6.10.2.1(b) ASTM C1044-97, "Practice for Using the Guarded-Hot-Plate Apparatus in the One-Sided Mode to Measure Steady-State Heat Flux and Thermal Transmission Properties," Annual Book of ASTM Standards, Vol 04.06, ASTM, Philadelphia, PA.
- 6.6.10.2.2 ASTM E1225-99 "Thermal Conductivity of Solids by Means of the Guarded-Comparative-Longitudinal Heat Flow Technique," Annual Book of ASTM Standards, Vol 14.02, ASTM, Philadelphia, PA.
- 6.6.10.2.3(a) ASTM C518-98 "Steady-State Thermal Transmission Properties by Means of the Heat Flow Meter Apparatus," Annual Book of ASTM Standards, Vol 04.06, ASTM, Philadelphia, PA.
- 6.6.10.2.3(b) ASTM C1046-98 "Practice for In-Situ Measurement of Heat Flux and Temperature of Building Envelope Components," Annual Book of ASTM Standards, Vol 04.06, ASTM, Philadelphia, PA.

- 6.6.10.2.3(c) ASTM E1530-93 "Standard Test Method for Evaluating the Resistance to Thermal Transmission of Thin Specimens of Materials by the Guarded Heat Flow Meter Technique," Annual Book of ASTM Standards, Vol 04.06, ASTM, Philadelphia, PA.
- 6.6.11.2 ASTM E1269-95, "Determining Specific Heat Capacity by Differential Scanning Calorimetry," 1995 Annual Book of ASTM Standards, 14.02, ASTM, Philadelphia, PA.
- 6.6.11.2.1 Differential Scanning Calorimetry, J. L. McNaughton and C. T. Mortimer, Perkin Elmer Order Number L-604, reprinted from "IRS; Physical Chemistry Series 2, 1975, Volume 10," which was taken with permission of the publisher Butterworths, London, p. 12.
- 6.6.12.2(a) ASTM E1461-92 "Thermal Diffusivity of Solids by the Flash Method," Annual Book of ASTM Standards, Vol 14.02, ASTM, Philadelphia, PA.
- 6.6.12.2(b) ASTM C714-85 "Thermal Diffusivity of Carbon and Graphite By a Thermal Pulse Method," Annual Book of ASTM Standards, 15.01 ASTM, Philadelphia, PA.
- 6.6.13(a) NASA CR-4740, "Contamination Control Engineering Design Guidelines for the Aerospace Community", AC Tribble et al, eds., NASA CASI, Linthicum Heights, MD, 1996
- 6.6.13(b) NASA RP-1124, Revision 3, "Outgassing Data for Selecting Spacecraft Materials", WA Campbell, JJ Scialdone, eds., NASA CASI, Linthicum Heights, MD, 1993, maintained online by the Goddard Space Flight Center at <http://epims.gsfc.nasa.gov/og/>
- 6.6.13(c) MAPTIS, online database maintained by the Marshall Space Flight Center at <http://map1.msfc.nasa.gov>
- 6.7.1(a) ASTM Test Method D 149-93a, "Dielectric Breakdown Voltage and Dielectric Strength of Solid Electrical Insulating Materials," *Annual Book of ASTM Standards*, Vol 10.01, American Society for Testing and Materials, West Conshohocken, PA.
- 6.7.1(b) ASTM Test Method D 150-93, "A-C Loss Characteristics and Permittivity (Dielectric Constant) of Solid Electrical Insulating Materials," *Annual Book of ASTM Standards*, Vol 10.01, American Society for Testing and Materials, West Conshohocken, PA.
- 6.7.1(c) ASTM Test Method D 495-89, "High-Voltage, Low-Current, Dry Arc Resistance of Solid Electrical Insulation," *Annual Book of ASTM Standards*, Vol 10.01, American Society for Testing and Materials, West Conshohocken, PA.
- 6.7.1(d) ASTM Test Method D 2303-90, "Liquid Contaminant, Inclined-Plane Tracking, and Erosion of Insulating Materials," *Annual Book of ASTM Standards*, Vol 10.01, American Society for Testing and Materials, West Conshohocken, PA.
- 6.6.18.1(a) Sorathia, U., Lyon, Richard, Ohlemiller, Thomas, and Grenier, Lt. Andrew, "A Review of Fire Test Methods and Criteria for Composites", SAMPE Journal, Vol 33, No.4, July/August 1997.
- 6.6.18.1(b) Ohlemiller T., and Cleary, T., "Upward Flame Spread on Composite Materials", Chapter 28 in *Fire and Polymers II- Materials And Tests for Hazard Prevention*, (G. L. Nelson, ed.) American Chemical Society, Washington, DC, 1995, pp. 422-434.
- 6.6.18.1(c) Ohlemiller, T., Cleary, T. and Shields, J., "Effect of Ignition Conditions on Upward Flame Spread on a Composite Material in a Corner Configuration", *Proceedings of the 41st International SAMPE Symposium*, Society for the Advancement of Material and Process Engineering, Covina, CA, 1996, p. 734.

Volume 1, Chapter 6 Lamina, Laminate, and Special Form Characterization

- 6.6.18.2(a) Grand, A, "Fire Evaluation of Coatings for Glass-Reinforced Polymeric Composites", Proceedings of Fire and Materials, 2nd International Conference, Interscience Communications Ltd., London, 1993, p. 144.
- 6.6.18.2(b) Sorathia U., and Beck, C., "Fire Protection of Glass/vinyl Ester Composites for Structural Applications", Proceedings of the 41st International SAMPE Symposium, Society for the Advancement of Material and Process Engineering, Covina, CA, 1996.
- 6.6.18.2(c) Ohlemiller, T and Shields, J., "The Effect of Surface Coatings on Fire Growth over Composite material", National Institute of Standards and Technology NISTIR 5940, December 1996.
- 6.6.18.2(d) DOT/FAA/AR-00/12, Aircraft Material Fire Test Handbook, U.S. Department of Transportation, Federal Aviation Administration Technical Center, Atlantic City, NJ 08405.
- 6.6.18.2.1 ASTM E 84-00a, "Standard Test Method for Surface Burning Characteristics of Building Materials," *Annual Book of ASTM Standards*, Vol 4.07, American Society for Testing and Materials, West Conshohocken, PA.
- 6.6.18.2.2 ASTM E 162-98, "Standard Test Method for Surface Flammability of Materials Using a Radiant Heat Energy Source," *Annual Book of ASTM Standards*, Vol 4.07, American Society for Testing and Materials, West Conshohocken, PA.
- 6.6.18.2.3 ISO 9705, Fire tests-Full-scale room test for surface products, International Organization for Standardization, Geneva, Switzerland.
- 6.6.18.2.4 ASTM E 1321-97a, "Standard Test Method for Determining Material Ignition and Flame Spread Properties," *Annual Book of ASTM Standards*, Vol 4.07, American Society for Testing and Materials, West Conshohocken, PA.
- 6.6.18.3(a) Babrauskas, V., Levin, B., Gann, R., Paabo, M., Harris, R., Peacock, R., and Yusa, S., "Toxic Potency Measurement for Fire Hazard Analysis", National Institute of Standards and Technology Special Publication 827, December 1991.
- 6.6.18.3(b) Sorathia, U., Lyon, R., Gann, R.G., Gritz, L., "Materials and Fire Threat", Fire Technology, Vol 33, Number 3, Sept/Oct 1997.
- 6.6.18.3.1 ASTM E 662-97, "Standard Test Method for Specific Optical Density of Smoke Generated by Solid Materials," *Annual Book of ASTM Standards*, Vol 4.07, American Society for Testing and Materials, West Conshohocken, PA.
- 6.6.18.3.2 NFPA 269, Standard Test Method for Developing Toxic Potency Data for Use in Fire Hazard Modeling, National Fire Protection Association, 1 Batterymarch Park, Quincy, MA 02269-9101.
- 6.6.18.4(a) IMO Resolution MSC.40(64), "Standard for Qualifying Marine Materials for High Speed Craft as Fire-Restricting Materials", International Maritime Organization, London, December, 1994.
- 6.6.18.4(b) MIL-STD-2031(SH), "Fire and Toxicity Test Methods And Qualification Procedure For Composite Material Systems Used in Hull, Machinery, and Structural Applications Inside Naval Submarines", February 1991.
- 6.6.18.4.1 ASTM E 1354-99, "Standard Test Method for Heat and Visible Smoke Release Rates for Materials and Products Using an Oxygen Consumption Calorimeter," , *Annual Book of*

ASTM Standards, Vol 4.07, American Society for Testing and Materials, West Conshohocken, PA.

- 6.6.18.4.2 ASTM E 906-99, "Standard Test Method for Heat and Visible Smoke Release Rates for Materials and Products," *Annual Book of ASTM Standards*, Vol 4.07, American Society for Testing and Materials, West Conshohocken, PA.
- 6.6.18.5(a) Sarkos, C.P., and Hill, R.G., "Heat Exposure and Burning Behavior of Cabin Materials During an Aircraft Post-Crash Fuel Fire", National Materials Advisory Board, National Research Council, NMAB Report 477-2, National Academy Press, 25, 1995.
- 6.6.18.5(b) Petrie, George L., Sorathia, Usman, Warren, L. Will, "Testing and Analysis of Marine Composite Structures in Elevated Temperature Conditions", Proceedings of the 44th International SAMPE Symposium, Vol 44, May 23-27, 1999.
- 6.6.18.5.1 ASTM E-119-00a, "Standard Test Method for Fire Tests of Building Construction and Materials," , " *Annual Book of ASTM Standards*, Vol 4.07, American Society for Testing and Materials, West Conshohocken, PA.
- 6.6.18.5.2(a) ASTM E-1529-00, "Standard Test Method for Determining Effects of Large Hydrocarbon Pool Fires on Structural Members and Assemblies," , " *Annual Book of ASTM Standards*, Vol 4.07, American Society for Testing and Materials, West Conshohocken, PA.
- 6.6.18.5.2(b) UL 1709, Rapid Rise Fire Tests of Protection Materials for Structural Steel, Underwriters Laboratories Inc., 333 Pfingsten Road, Northbrook, IL 60062-2096.
- 6.8.2.2.1(a) ASTM Test Method D 3039/D 3039M, "Tensile Properties of Polymer Matrix Composites," *Annual Book of ASTM Standards*, Vol 15.03, American Society for Testing and Materials, West Conshohocken, PA.
- 6.8.2.2.1(b) ISO 527, "Plastics --- Determination of Tensile Properties," American National Standards Institute, available from ANSI, 11 W. 42nd Street, New York, NY, 10036.
- 6.8.2.2.1(c) SACMA Recommended Method (SRM) 4, "Tensile Properties of Oriented Resin-Matrix Composites," Suppliers of Advanced Composites Materials Association, Arlington, VA.
- 6.8.2.2.1(d) SACMA Recommended Method (SRM) 9, "Tensile Properties of Oriented Resin-Matrix Crossply Laminates," Suppliers of Advanced Composite Materials Association, Arlington, VA.
- 6.8.2.2.1(e) ASTM Test Method D 5083, "Tensile Properties of Reinforced Thermosetting Plastics Using Straight-Sided Specimens," *Annual Book of ASTM Standards*, Vol 8.03, American Society for Testing and Materials, West Conshohocken, PA.
- 6.8.2.2.3(a) ASTM Test Method D 638, "Tensile Properties of Plastics," *Annual Book of ASTM Standards*, Vol 8.01, American Society for Testing and Materials, West Conshohocken, PA.
- 6.8.2.2.3(b) SAE AMS 3844A, "Cloth, Type 'E' Glass, Style 7781 Fabric, Hot-Melt, Addition-Type, Polyimide Resin Impregnated," Society of Automotive Engineers, Warrendale, PA.
- 6.8.2.2.4 ASTM Test Method D 2290, "Apparent Tensile Strength of Ring or Tubular Plastics and Reinforced Plastics by Split Disk Method," *Annual Book of ASTM Standards*, Vol 8.04, 15.03, American Society for Testing and Materials, West Conshohocken, PA.

- 6.8.2.2.5 ASTM Test Method C 393, "Flexural Properties of Flat Sandwich Constructions," *Annual Book of ASTM Standards*, Vol 15.03, American Society for Testing and Materials, West Conshohocken, PA.
- 6.8.2.3.2(a) ASTM Test Method C 297, "Tensile Strength of Flat Sandwich Constructions in the Flatwise Plane," *Annual Book of ASTM Standards*, Vol 15.03, American Society for Testing and Materials, West Conshohocken, PA.
- 6.8.2.3.2(b) ASTM Test Method C 633, "Adhesive or Cohesive Strength of Flame Sprayed Coatings," *Annual Book of ASTM Standards*, Vol 15.03, American Society for Testing and Materials, West Conshohocken, PA.
- 6.8.2.3.2(c) ASTM Test Method D 2095, "Tensile Strength of Adhesives by Means of Bar and Rod Specimens," *Annual Book of ASTM Standards*, Vol 15.06, American Society for Testing and Materials, West Conshohocken, PA.
- 6.8.2.3.3 Jackson, W. C. and Martin, R. H, "An Interlaminar Tensile Strength Specimen," ASTM STP 1206, American Society for Testing and Materials, 1993.
- 6.8.3.1(a) ASTM Test Method D 3410-95, "Compressive Properties of Polymer Matrix Composite Materials with Unsupported Gage Section by Shear Loading," *Annual Book of ASTM Standards*, Vol 15.03, American Society for Testing and Materials, West Conshohocken, PA.
- 6.8.3.1(b) ASTM Test Method D 5467-97, "Compressive Properties of Unidirectional Polymer Matrix Composites Using a Sandwich Beam," *Annual Book of ASTM Standards*, Vol 15.03, American Society for Testing and Materials, West Conshohocken, PA.
- 6.8.3.1(c) ASTM Test Method D 695-96, "Compressive Properties of Rigid Plastics," *Annual Book of ASTM Standards*, Vol 8.01, American Society for Testing and Materials, West Conshohocken, PA.
- 6.8.3.1(d) SACMA Recommended Method (SRM) 1R-94, "Compressive Properties of Oriented Fiber-Resin Composites," Suppliers of Advanced Composite Materials Association, Arlington, VA.
- 6.8.3.1(e) SACMA Recommended Method (SRM) 6-94, "Compressive Properties of Oriented Cross-Plied Fiber-Resin Composites," Suppliers of Advanced Composite Materials Association, Arlington, VA.
- 6.8.3.1(f) ASTM Test Method D 6484, "Compressive Properties of Polymer Matrix Composite Laminates Using a Combined Loading Compression (CLC) Test Fixture," American Society for Testing and Materials, West Conshohocken, PA.
- 6.8.3.1(g) Berg, J.S. and Adams, D.F., "An Evaluation of Composite Material Compression Test Methods," *Journal of Composites Technology and Research*, Vol. 11, No. 2, Summer 1989, pp. 41-46.
- 6.8.3.1(h) Schoeppner, G.A. and Sierakowski, R.L., "A Review of Compression Test Methods for Organic Matrix Composites", *Journal of Composites Technology and Research*, Vol 12 (1), 1990, pp. 3-12.
- 6.8.3.1(i) Camponeschi, E.T., Jr., "Compression of Composite Materials: A Review," *Fatigue and Fracture of Composite Materials (Third Conference)*, ASTM STP 1110, ed., T.K O'Brien, ASTM, 1991, pp. 550-580.

Volume 1, Chapter 6 Lamina, Laminate, and Special Form Characterization

- 6.8.3.1(j) Chatterjee, S.N., Adams, D.F., and Oplinger, D.W., "Test Methods for Composites, a Status Report, Vol. II. Compression Test Methods," Report No. DOT/FAA/CT-93/17, II, Federal Aviation Administration Technical Center, Atlantic City, NJ, June 1993.
- 6.8.3.1(k) Adams, D.F., "Current Status of Compression Testing of Composite Materials," Proceedings of the 49th International SAMPE Symposium, May 1995, pp. 1831-1843.
- 6.8.3.1(l) Welsh, J.S., and Adams, D.F., "Current Status of Compression Test Methods for Composite Materials," SAMPE Journal, Vol. 33, No. 1, January 1997, pp. 35-43.
- 6.8.3.2(a) Hofer, K.E. and Rao, P.N., "A New Static Compression Fixture for Advanced Composite Materials," Journal of Testing and Evaluation, Vol 5(4)1977.
- 6.8.3.2(b) Adsit, N.R., "Compression Testing of Graphite/Epoxy," Compression Testing of Homogeneous Materials and Composites, ASTM STP 808, ed., Chait and Papirno, American Society for Testing and Materials, 1983, pp. 175-186.
- 6.8.3.2.2(a) Wegner, P.M., and Adams, D.F., "Verification of the Combined Load Compression (CLC) Test Method," Report No. DOT/FAA/AR-00/26, Federal Aviation Administration Technical Center, Atlantic City, NJ, August 2000.
- 6.8.3.2.2(b) Tan, S.C., "Stress Analysis and the Testing of Celanese and IITRI Compression Specimens," Composites Science and Technology, Vol. 44, 1992, pp. 57-70.
- 6.8.3.2.2(c) Tan, S.C., and Knight, M., "An Extrapolation Method for the Evaluation of Compression Strength of Laminated Composites," Compression Response of Composite Structures, ASTM STP 1185, S.E. Groves and A.L. Highsmith, Eds., American Society for Testing and Materials, West Conshohocken, PA, 1994, pp. 323-337.
- 6.8.3.2.2(d) Adams, D.F., "Tabbed Versus Untabbed Compression Specimens," Composite Materials: Testing, Design, and Acceptance Criteria, ASTM STP 1416, A.T. Nettles and A. Zureick, Eds., American Society for Testing and Materials, West Conshohocken, PA, 2002.
- 6.8.3.2.4 ASTM Test Method C 393-94, "Flexural Properties of Sandwich Constructions," Annual Book of ASTM Standards, Vol 15.03, American Society for Testing and Materials, West Conshohocken, PA.
- 6.8.3.2.8(a) Knight, M., "Three-Dimensional Elastic Moduli of Graphite/Epoxy Composites," Journal of Composite Materials, Vol 16, 1982, pp. 153-159.
- 6.8.3.2.8(b) Peros, V., "Thick-Walled Composite Material Pressure Hulls: Three Dimensional Laminate Analysis Considerations," Masters Thesis, University of Delaware, Newark, DE, December 1987.
- 6.8.4.1 Kellas, S., Morton, J., and Jackson, K., "Damage and Failure Mechanisms in Scaled Angle-Ply Laminates," Presented at the ASTM Symposium on Fatigue and Fracture, Indianapolis, May 1991.
- 6.8.4.2.1(a) ASTM D 3518/D 3518M-94, "Test Method for In-Plane Shear Response of Polymer Matrix Composites by Tensile Test of a $\pm 45^\circ$ Laminate".
- 6.8.4.2.1(b) SRM 7R-94, "In-plane Shear Stress-Strain Properties of Oriented Fiber-Resin Composites," Suppliers of Advanced Composite Materials Associate.
- 6.8.4.2.1(c) Terry, G., "A Comparative Investigation of Some Methods of Unidirectional, In-Plane Shear Characterization of Composite Materials," *Composites*, Vol 10, October 1979, p. 233.

- 6.8.4.2.1(d) Petit, P.H., "A Simplified Method of Determining the In-plane Shear Stress-Strain Response of Unidirectional Composites," *Composite Materials: Testing and Design*, ASTM STP 460, American Society for Testing and Materials, Philadelphia, PA, 1969, p. 83.
- 6.8.4.2.1(e) Sims, D.F., "In-Plane Shear Stress-Strain Response of Unidirectional Composite Materials," *Journal of Composite Materials*, Vol 7, January 1973, p. 124.
- 6.8.4.2.1(f) Yeow, Y.T., and Brinson, H.F., "A Comparison of Simple Shear Characterization Methods for Composite Laminates," *Composites*, Vol 9, January 1978, p. 161.
- 6.8.4.2.2(a) ASTM Test Method D 5379/D 5379M-93, "Shear Properties of Composite Materials by the V-Notched Beam Method," *Annual Book of ASTM Standards*, Vol 15.03, American Society for Testing and Materials, West Conshohocken, PA.
- 6.8.4.2.2(b) Arcan, M., and Goldenberg, N., "On a Basic Criterion for Selecting a Shear Testing Standard for Plastic Materials," (in French), ISO/TC 61-WG 2 S.P. 171, Burgenstock, Switzerland, 1957.
- 6.8.4.2.2(c) Goldenberg, N., Arcan, M., and Nicolau, E., "On the Most Suitable Specimen Shape for Testing Shear Strength of Plastics," *Proceedings of the International Symposium on Plastics Testing and Standardization*, ASTM STP 247, American Society for Testing and Materials, Philadelphia, PA, 1959, pp. 115-121.
- 6.8.4.2.2(d) Arcan, M., Hashin, Z., and Voloshin, A., "A Method to Produce Uniform Plane-stress States with Applications to Fiber-reinforced Materials," *Experimental Mechanics*, Vol 18, No. 4, April 1978, pp. 141-146.
- 6.8.4.2.2(e) Iosipescu, N., "Photoelastic Investigations on an Accurate Procedure for the Pure Shear Testing of Materials," (in Romanian), *Studii si Cercetari de Mecanica Aplicata*, Vol 13, No. 3, 1962.
- 6.8.4.2.2(f) Iosipescu, N., "Photoelastic Investigations on an Accurate Procedure for the Pure Shear Testing of Materials," *Revue de Mecanique Appliquée*, Vol 8, No. 1, 1963.
- 6.8.4.2.2(g) Iosipescu, N., "New Accurate Procedure for Single Shear Testing of Metals," *Journal of Materials*, Vol 2, No. 3, September 1967, pp. 537-566.
- 6.8.4.2.2(h) Walrath, D.E., and Adams, D.F., "The Iosipescu Shear Test as Applied to Composite Materials," *Experimental Mechanics*, Vol 23, No. 1, March 1983, pp. 105-110.
- 6.8.4.2.2(i) Walrath, D.E., and Adams, D.F., "Analysis of the Stress State in an Iosipescu Test Specimen," University of Wyoming Department Report UWME-DR-301-102-1, June 1983.
- 6.8.4.2.2(j) Walrath, D.E., and Adams, D.F., "Verification and Application of the Iosipescu Shear Test Method," University of Wyoming Department Report UWME-DR-401-103-1, June 1984.
- 6.8.4.2.2(k) Adams, D.F., and Walrath, D.E., "Further Development of the Iosipescu Test Method," *Experimental Mechanics*, Vol 27, No. 2, June 1987, pp. 113-119.
- 6.8.4.2.2(l) Bergner, H.W., Davis, J.G., and Herakovich, C.T., "Analysis of Shear Test Methods for Composite Laminates," VPI-E-77-14, Virginia Polytechnic Institute and State University, Blacksburg, VA, April 1977; also NASA CR-152704.
- 6.8.4.2.2(m) Sleptez, J.M., Zagaeksi, T.F., and Novello, R.F., "In-Plane Shear Test for Composite Materials," AMMRC TR 78-30, Army Materials and Mechanics Research Center Watertown MA, July 1978.

- 6.8.4.2.2(n) Herakovich, C.T., Bergner, H.W., and Bowles, D.E., "A Comparative Study of Composite Shear Specimens Using the Finite-Element Method," *Test Methods and Design Allowables for Fibrous Composites*, ASTM STP 734, American Society for Testing and Materials, Philadelphia, PA, 1981, pp. 129-151.
- 6.8.4.2.2(o) Sullivan, J.L., Kao, B.G., and Van Oene, H., "Shear Properties and a Stress Analysis Obtained from Vinyl-ester Iosipescu Specimens," *Experimental Mechanics*, Vol 24, No. 3, 1984, pp. 223-232.
- 6.8.4.2.2(p) Wilson, D.W., "Evaluation of the V Notched Beam Shear Test Through an Interlaboratory Study," *Journal of Composite Technology and Research*, Vol 12, No. 3, Fall 1990, pp. 131-138.
- 6.8.4.2.2(q) Ho, H., Tsai, M.Y., Morton, J., and Farley, G.L., "An Experimental Investigation of Iosipescu Specimen for Composite Materials," *Experimental Mechanics*, Vol 31, No. 4, December 1991, pp. 328-336.
- 6.8.4.2.2(r) Morton, J., Ho, H., Tsai, M.Y., and Farley, G.L., "An Evaluation of the Iosipescu Specimen for Composite Materials Shear Property Measurement," *Journal of Composite Materials*, Vol 26, No. 5, 1992, p. 708.
- 6.8.4.2.2(s) Arcan, M., "The Iosipescu Shear Test as Applied to Composite Materials -- Discussion," *Experimental Mechanics*, Vol 24, No. 1, March 1984, pp. 66-67.
- 6.8.4.2.3(a) ASTM Guide D 4255-83, "Guide for Testing In-plane Shear Properties of Composite Laminates," *Annual Book of ASTM Standards*, Vol 15.03, American Society for Testing and Materials, West Conshohocken, PA.
- 6.8.4.2.3(b) Garcia, R., Weisshaar, T.A., and McWithey, R.R., "An Experimental and Analytical Investigation of the Rail Shear-Test Method as Applied to Composite Materials," *Experimental Mechanics*, August 1980.
- 6.8.4.2.3(c) Tarnopol'skii, Y.M., and Kincis, T., *Static Test Methods for Composites*, Van Nostrand Reinhold Company, New York, 1985.
- 6.8.4.2.4 Chamis, C.C. and Sinclair, J.H., "Ten-deg Off-Axis Test for Shear Properties in Fiber Composites," *Experimental Mechanics*, September 1977.
- 6.8.4.2.5(a) ASTM Test Method E 143-87, "Test Method for Shear Modulus at Room Temperature," *Annual Book of ASTM Standards*, Vol 3.01, American Society for Testing and Materials, West Conshohocken, PA.
- 6.8.4.2.5(b) MIL-STD-375, Test Method for In-Plane Shear Properties of Hoop Wound Polymer Matrix Composite Cylinders.
- 6.8.4.2.5(c) ASTM Test Method D 5448/D 5448M-93, "Test Method for In-Plane Shear Properties of Hoop Wound Polymer Matrix Composite Cylinders," *Annual Book of ASTM Standards*, Vol 15.03, American Society for Testing and Materials, West Conshohocken, PA.
- 6.8.4.2.5(d) Guess, T.R. and Haizlip, C.B. Jr., "End-Grip Configurations for Axial Loading of Composite Tubes," *Experimental Mechanics*, January 1980.
- 6.8.4.3.1(a) ASTM Test Method D 2344-84, "Test Method for Apparent Interlaminar Shear Strength of Parallel Fiber Composites by Short-Beam Method," *Annual Book of ASTM Standards*, Vol 15.03, American Society for Testing and Materials, West Conshohocken, PA.

- 6.8.4.3.1(b) Berg, C.A., Tirosh, J. and Israeli, M., "Analysis of Short Beam Bending of Fiber Reinforced Composites," *Composite Materials: Testing and Design, Second Conference* ASTM STP 497, American Society for Testing and Materials, Philadelphia, PA, 1972, p. 206.
- 6.8.4.3.1(c) SRM 8R-94, "Short Beam Shear Strength of Oriented Fiber-Resin Composites," Suppliers of Advanced Composite Materials Association.
- 6.8.4.3.3 ASTM Test Method D 3846-79, "Test Method for In-Plane Shear Strength of Reinforced Plastics," *Annual Book of ASTM Standards*, Vol 8.02, American Society for Testing and Materials, West Conshohocken, PA.
- 6.8.5 ASTM Test Method D 790-86, "Flexural Properties of Unreinforced and Reinforced Plastics and Electrical Insulating Materials," *Annual Book of ASTM Standards*, Vol 8.01, American Society for Testing and Materials, West Conshohocken, PA.
- 6.8.6.1(a) Inglis, C.E., "Stresses in a Plate due to the Presence of Cracks and Sharp Corners," *Trans. Royal Inst. Naval Architects*, Vol 55, 1913, pp. 219-230.
- 6.8.6.1(b) Griffith, A.A., "The Theory of Rupture," in *Proc. 1st Int. Cong. Applied Mechanics*, J. Waltman, Sr., Delft, 1924, pp. 55-63.
- 6.8.6.1(c) Irwin, G.R., "Fracture," in *Handbuch der Physik*, Vol 6, Springer, Berlin, 1958, pp. 551-590.
- 6.8.6.1(d) Sih, G.C., and Liebowitz, H., "Mathematical Theories of Brittle Fracture," in *Fracture -An Advanced Treatise, Volume II*, Edited by Liebowitz, H., Academic, New York, 1968, pp. 67-190.
- 6.8.6.1(e) *Fracture Toughness Testing*, ASTM STP 410, edited by Brown, W.F., Jr., and Srawley, J.E., ASTM, Philadelphia, 1966.
- 6.8.6.1(f) *Review of Developments In-plane Strain Fracture Toughness Testing*, ASTM STP 463, ASTM, edited by Brown, W.F., Jr., Philadelphia, 1970.
- 6.8.6.1(g) 1991 Annual Book of ASTM Standards, Section 3, Metals Test Methods and Analytical Procedures.
- 6.8.6.1(h) Pellini, W.S., "Principles of Structural Integrity Technology," ONR, Arlington, VA, 1976.
- 6.8.6.1(i) *Fatigue Crack Growth Measurement and Data Analysis*, ASTM STP 738, Edited by Hudak, S.J., Jr., and Bucci, R.J., ASTM, Philadelphia, 1981.
- 6.8.6.1(j) *Fracture Mechanics of Composites*, ASTM STP 593, Edited by Sendekyj, G.P., ASTM, Philadelphia, 1975.
- 6.8.6.1(k) Awerbuch, J., and Madhukar, M., "Notched Strength of Composite Laminates: Predictions and Experiments: A Review," *J. Reinf. Plast, Comp.*, Vol 4, 1985, pp. 3-159.
- 6.8.6.1(l) Harris, C.E., Morris, D.H., and Nottorf, E.W., "Analytical and Experimental Investigation of the Notched Strength of Thick Laminates with Surface Notches," *Composite Materials, Testing and Design (Eighth Conference)*, ASTM STP 972, edited by Whitcomb, J.D., ASTM, Philadelphia, 1988, pp. 298-321.
- 6.8.6.1(m) Poe, C.C., Jr., Illg, W., and Garber, D.P., "A Program to Determine the Effect of Low Velocity Impact on Strength of Filament Wound Motor Cases," NASA TM 87771, July 1986.

Volume 1, Chapter 6 Lamina, Laminate, and Special Form Characterization

- 6.8.6.1(n) Chatterjee, S.N., "Surface Cracks in Thick Laminated Fiber Composite Plates," in *Surface-Crack Growth: Models, Experiments and Structures*, ASTM STP 1060, edited by Reuter, W.G., Underwood, J.H., and Newman, J.C., Jr., ASTM, Philadelphia, 1990, pp. 177-193.
- 6.8.6.1(o) Agarwal, B.D., Patro, B.S., and Kumar, P., "Prediction of Instability Point During Fracture of Composite Materials," *Comp. Tech. Rev.*, Vol 6, p. 173, 1984.
- 6.8.6.2(a) O'Brien, T.K., "Generic Aspects of Delamination Fatigue of Composite Materials," *J. American Helicopter Society*, Vol 32, 1987, pp. 13-18.
- 6.8.6.2(b) Reeder, J.R., "A Bilinear Failure Criterion for Mixed Mode Delamination," in *Composite Materials: Testing and Design, Eleventh Volume*, ASTM STP 1206, ASTM, Philadelphia, 1993, pp. 303-322.
- 6.8.6.3.1(a) ASTM Test Method D 5528-94a "Mode I Interlaminar Fracture Toughness of Unidirectional Continuous Fiber Reinforced Composite Materials," *Annual Book of ASTM Standards*, Vol 15.03, American Society for Testing and Materials, West Conshohocken, PA.
- 6.8.6.3.1(b) O'Brien, T.K. and Martin, R.H., "Round Robin Testing for Mode I Interlaminar Fracture Toughness of Composite Materials," *ASTM Journal of Composite Technology and Research*, Vol 15, Winter 1994, pp. 269-281.
- 6.8.6.3.1(c) Chatterjee, S.N., and Ramnath, V., "Modeling Laminated Composite Structures as an Assemblage of Sublaminates," *Int. J. Solids and Struct.*, Vol 24, 1988, pp. 439-458.
- 6.8.6.3.1(d) Hashemi, S., Kinloch, A.J., and Williams, J.G., "Corrections Needed in Double Cantilever Beam Tests for Assessing the Interlaminar Failure of Fiber Composites," *J. Mat. Sci. Letters*, Vol 8, 1989, pp. 125-129.
- 6.8.6.4.1(a) Russell, A.J., "On the Measurement of Mode II Interlaminar Fracture Energies," Defense Research Establishment Pacific (Canada) Materials Report II 82-0, British Columbia, December 1982.
- 6.8.6.4.1(b) Kageyama, K., Kikuchi, M., and Yanagisawa, N., "Stabilized End Notched Flexure Test: Characterization of Mode II Interlaminar Crack Growth," *Composite Materials: Fatigue and Fracture, Third Volume*, ASTM STP 1110, 1991, pp. 210-225.
- 6.8.6.4.1(c) Chatterjee, S.N., "Analysis of Test Specimens for Interlaminar Mode II Fracture Toughness, Parts 1 and 2," *J. Comp. Mater.*, Vol 25, 1991, pp. 470-493 and pp. 494-511.
- 6.8.6.4.2 Chatterjee, S.N., Ramnath, V., Dick, W.A., and Chen, Y.Z., "Growth of Elliptic Delaminations in Laminates under Cyclic Transverse Shear Stresses," *Composite Materials: Testing and Design (Eighth Conference)*, ASTM STP 972, edited by Whitcomb, J.D., ASTM, Philadelphia, 1988, pp. 281-297.
- 6.8.6.5(a) Donaldson, S.L., "Mode III Interlaminar Fracture Characterization of Composite Materials," *Comp. Sci. Tech.*, Vol 32, 1988, pp. 225-249.
- 6.8.6.5(b) Martin, R.H., "Evaluation of Split Cantilever Beam for Mode III Delamination Testing," in *Composite Materials: Fatigue and Fracture, Third Volume*, ASTM STP 1110, 1991, pp. 243-266.
- 6.8.6.5(c) Anderson, G.P., Bennet, S.J., and Devries, K.L., *Analysis and Testing of Adhesive Bonds*, Academic, New York, 1977.

Volume 1, Chapter 6 Lamina, Laminate, and Special Form Characterization

- 6.8.6.6.1 Wilkins, D.J., Eisenmann, J.R., Camin, R.A., Margolis, W.S., and Benson, R.A., "Characterizing Delamination Growth in Graphite-Epoxy," *Damage in Composite Materials*, ASTM STP 775, edited by Reifsnider, K.L., ASTM, Philadelphia, 1982, pp. 168-183.
- 6.8.6.6.2(a) Reeder, J.R., and Crews, J.C., Jr., "Mixed Mode Bending Method for Delamination Testing," *AIAA J.*, Vol 28, 1990, pp. 1270-1276.
- 6.8.6.6.2(b) Reeder, J.R., and Crews, J.C., Jr., "Redesign of the Mixed Mode Bending Test for Delamination Toughness," *Proc. ICCM 8*, edited by Tsai, S.W., and Springer, G.S., SAMPE, July 1991, pp. 36-B-01 - 36-B-10.
- 6.8.6.6.3(a) O'Brien, T.K., "Characterization of Delamination Onset and Growth in Composite Laminates," *Damage in Composite Materials: Basic Mechanisms, Accumulation, Tolerance, and Characterization*, ASTM STP 775, edited by Reifsnider, K.L., ASTM, Philadelphia, 1982, pp. 140-167.
- 6.8.6.6.3(b) Whitney, J.M., and Knight, M., "A Modified Free-Edge Delamination Specimen," ASTM STP 876, p. 298, ASTM, Philadelphia, 1985.
- 6.9(a) Saff, C.R., "Compression Fatigue Life Prediction Methodology for Composite Structures -- Literature Survey," Report No. NADC-78203-60, prepared by McDonnell Aircraft Company, June 1980.
- 6.9(b) Garbo, S.P. and Ogonowski, M., "Effects of Variances and Manufacturing Tolerances on the Design Strength and Life of Mechanically Fastened Composite Joints," Technical Report AFFDL-TR-78-179, prepared by McDonnell Aircraft Company, December 1978.
- 6.9(c) ASTM Test Method D 3479-76, "Tension - Tension Fatigue of Oriented Fiber, Resin Matrix Composites," *Annual Book of ASTM Standards*, Vol 15.03, American Society for Testing and Materials, West Conshohocken, PA.
- 6.11.2(a) ASTM Test Method D 2990-77, "Tensile, Compressive, and Flexural Creep and Creep-Rupture of Plastics," *Annual Book of ASTM Standards*, Vol 8.02, American Society for Testing and Materials, West Conshohocken, PA.
- 6.11.2(b) ASTM Practice E 139-83, "Conducting Creep, Creep-Rupture, and Stress-Rupture Tests of Metallic Materials," *Annual Book of ASTM Standards*, Vol 3.01, American Society for Testing and Materials, West Conshohocken, PA.
- 6.12.1.2(a) "JANNAF (Joint Army, Navy, NASA, Air Force) Interagency Propulsion Committee Annual Report: January-December 1984," CPIA Publication 419, Chemical Propulsion Information Agency, Johns Hopkins University, Laurel, MD.
- 6.12.1.2(b) "Test Methods for The Mechanical Characterization of Filament Wound Composites," CPIA Publication 488, Chemical Propulsion Information Agency, Johns Hopkins University, Laurel, MD, February 1986.
- 6.12.1.2(c) ASTM Practice E 691, "Practice for Conducting an Interlaboratory Study to Determine the Precision and Bias of a Test Method," *Annual Book of ASTM Standards*, Vol 14.02, American Society for Testing and Materials, West Conshohocken, PA.
- 6.12.1.3.2 ASTM Test Method D 5450/D 5450M, "Transverse Tensile Properties of Hoop Wound Polymer Matrix Composite Cylinders," *Annual Book of ASTM Standards*, Vol 15.03, American Society for Testing and Materials, West Conshohocken, PA.

Volume 1, Chapter 6 Lamina, Laminate, and Special Form Characterization

- 6.12.1.4.2 ASTM Test Method D 5449/D 5449M, "Transverse Compressive Properties of Hoop Wound Polymer Matrix Composite Cylinders," *Annual Book of ASTM Standards*, Vol 15.03, American Society for Testing and Materials, West Conshohocken, PA.
- 6.12.1.5.1 ASTM Test Method D5448/D 5448M, "In-Plan Shear Properties of Hoop Wound Polymer Matrix Composite Cylinders," *Annual Book of ASTM Standards*, Vol 15.03, American Society for Testing and Materials, West Conshohocken, PA.
- 6.12.2.2(a) MIL-G-9084, Cloth, Glass, Finished, for Resin Laminates
- 6.12.2.2(b) Minguet, Pierre J., Fedro, Mark J., and Gunther, Christian K., "Test Methods for Textile Composites", NASA CR-4609, July 1994, p. 228.
- 6.12.2.2(c) Jackson, Wade C., and Portanova, Marc A., Mechanics of Textile Composites Conference, NASA CP 3311, Part 2, October 1995, pp. 315-348.
- 6.12.2.3.3 Poe, C. C., Jr., "Mechanics Methodology for Textile Preform Composite Materials," *Proceedings of the 28th International SAMPE Technical Conference*, Nov. 1996, pp. 324-338.
- 6.12.2.4 NASA RP-1092, "Standard Test for Toughened Resin Composites", 1982.
- 6.12.2.4.2 Morton, John and Ho, Henjen, NASA-CR-193808, "A Comparative Evaluation of In-Plane Shear Test Methods for Laminated Graphite-Epoxy Composites", 1992.

CHAPTER 7 STRUCTURAL ELEMENT CHARACTERIZATION

7.1 INTRODUCTION

The material in this chapter focuses on test methods and matrices for experimental characterization of composite structures at a laminate/element level of complexity of the building block approach described in Volume 3, Chapter 4. The test elements, discussed here, provide data on notched laminates, bolted and bonded joints, and damage tolerance behavior that is needed for analysis and design of composite structures. General discussion on analysis and design of bolted and bonded joints can be found in Volume 3, Chapter 6, while damage tolerance is covered in Volume 3, Chapter 7.

Any joint in a composite structure is a potential failure site. Without proper design a joint can act as a failure initiation point, which can lead to a loss in structural strength and eventual failure of the component. Two types of joints are in common use: (1) mechanically-fastened joints and (2) adhesively-bonded joints. These guidelines define test types, laminates, environments, and replication that are needed for structurally sound joint design.

For mechanically bolted joints, tests are described that characterize the joint for various failure modes: notched tension/compression, bearing, bearing/by-pass, shear-out, and fastener pull-thru. The tests are drawn from ASTM standards when available. Otherwise common usage tests are recommended. In addition, suggested test matrices are provided that characterize the joint properties for the different variables that affect those properties. The suggested matrices should be considered as the least amount of testing required to obtain design properties. The test matrices are derived from the generic laminate/structural element test matrices in Section 2.3.5, and are included here for completeness. A detailed analysis of the stress distribution around a fastener hole is not presented here but is available in Volume 3, Section 6.3.

For bonded joints, two types of tests are described. One type determines adhesive properties that are needed in design. These tests provide adhesive stiffness and strength properties needed for analysis and design methods of Volume 3, Section 6.2. The second type is used to verify specific designs. Examples of such tests are shown.

The tests in the damage tolerance section are of two types. One type characterizes the damage resistance of a given laminate and the second the damage tolerance of that laminate. The Compression after Impact (CAI) test, an example of the latter type, is used widely in the aerospace industry to gauge damage tolerance potential of composite materials.

7.2 SPECIMEN PREPARATION

7.2.1 Introduction

The general topic of specimen preparation has been described adequately in Section 6.2 of this volume and in ASTM D 5687 for standard flat specimens. This section provides specific guidance for elements that represent mechanically fastened and bonded joints. Additionally, for tests where an ASTM standard exists the standard contains specific specimen preparation guidelines. Specimens for damage tolerance tests are flat plates which require no special specimen preparation procedures other than those in Section 6.2.

7.2.2 Mechanically fastened joint tests

The main concerns with mechanically fastened joint specimens are hole drilling and fastener installation. Holes should be drilled undersized and reamed to final dimensions. Drill back-up plates should be used to prevent delaminations at the drill exit side. Hole diameters should be verified as to their conformity to the specimen drawing. Specimen hole preparation methods should be recorded.

Proper fastener installation procedures are critical for determination of mechanical joint properties. These are specific to each type of bolt tested and are provided either by the bolt manufacturer or part fabricator. Unless finger tight bolt torque is specified, test specimens containing fasteners must be installed per company specification for the data to be meaningful for a given application. Correct grip sizes must also be selected based on the thickness of the mating parts. All bolt installations must be inspected for proper seating and fit.

7.2.3 Bonded joint tests

Test specimens for bonded joint characterization must be fabricated using processing specifications for bonding surface preparation and cure. This requirement is reiterated in the ASTM standards for bonded joint tests described in this chapter (7.6). For the bonded joint data to have any practical use, the specimens must be fabricated to strict processing controls which are the same as for fabrication of actual parts.

7.3 CONDITIONING AND ENVIRONMENTAL EXPOSURE

7.3.1 Introduction

The objective of testing environmentally conditioned specimens is to quantify property changes caused by exposure to humidity, liquid water, or other fluids (gaseous or liquid) under controlled (or at least defined) conditions. In general, the considerations and procedures presented in Section 6.3 of this volume apply to structural elements as well as to the simpler laminate specimens. However, there are some additional issues associated with environmental exposure of structural elements. These special considerations are discussed in the following sections, and cover general specimen preparation (strain gaging, notched laminates, and mechanically fastened joints), bonded joints, damage characterization, and sandwich structure. For the purposes of these discussions, the term "moisture" refers to any absorbed medium (water vapor, liquid water, or other fluid).

7.3.2 General specimen preparation

7.3.2.1 Strain gaging

Structural element tests may involve the use of more strain gages than for small specimens. These gages are frequently applied after exposure to the conditioning medium to prevent the gages from interfering with the conditioning process or to preclude environmental degradation of the gage adhesive leading to premature gage failure. When multiple gages are applied, the test articles are likely to be at ambient conditions for a considerable period of time during the gage bonding process, increasing the risk of significant moisture loss. To minimize this risk, gages should be applied as quickly as possible, and articles should be returned to the conditioning environment or suitable storage container as soon as gaging is complete. If all gages cannot be applied in a single, short session, articles should be returned to the environment or storage between gaging sessions. It is also possible to bag all or portions of the article together with moist towels. Small areas can then be exposed to allow local gaging while minimizing moisture loss of the overall article.

In instances where an elevated temperature cure is required for the gage bonding adhesive, it may be possible to accomplish the cure by returning the specimens to the elevated temperature conditioning environment rather than curing in dry air and risking moisture loss. However, it must be determined if the conditioning environment will have a detrimental effect on the cure reaction.

In some cases it may be necessary to bond gages prior to exposure (for example, if a conditioning fluid like oil would render the specimen surface unsuitable for adhesive bonding). Judgment must be used in determining whether to condition before or after gage bonding. Strain gage and/or gage adhesive manufacturers can often provide valuable advice in making this decision.

7.3.2.2 *Notched laminates and mechanically fastened joint specimens*

Specimens with drilled holes, such as used for open hole, filled hole, and mechanically fastened joint tests, should be conditioned after drilling to avoid local dry-out around the holes due to heat generated by the drilling process.

7.3.3 Bonded joints

Bonded joint configurations fall into three categories when considering environmental conditioning: articles with thin composite adherends, articles with thick composite adherends, and articles with metallic (non-absorbing) adherends. Thin adherends are defined as those capable of reaching a moisture equilibrium condition within a reasonable period of time. Since bonding adhesives generally absorb at a faster rate than fiber-resin composites, the adhesive is usually at equilibrium when the composite adherends reach equilibrium. In such cases no modifications to the guidelines in Section 6.3 are needed.

Bonded joints which employ thick composite adherends are defined as those geometries which will not reach moisture equilibrium within a time period that is practical for a test program. Indeed, some geometries may require years or even decades for equilibrium to be reached throughout the bond. In such cases, the test articles must be treated in the same manner as joints with metallic (non-absorbing) adherends.

For joints with metallic adherends (and, for practical purposes, thick composite adherends), moisture diffusion can only occur through the edges of the bond. In many cases, the bond length and width dimensions may be such that moisture equilibrium of the adhesive cannot be achieved within a reasonable time period. Estimates of the required diffusion time can be calculated if the diffusivity of the adhesive has been previously determined from neat adhesive specimens (see Section 6.6.8 on moisture diffusivity). Even if it is estimated that moisture equilibrium can be achieved within the timeframe of the test program, tracking of moisture uptake is another problem. Since the mass of non-absorbent metal adherends may be several orders of magnitude greater than the mass of the bonding adhesive, accuracy in determining equilibrium from periodic weighings is poor at best. Travelers consisting of aluminum foil adherends bonded together with the same adhesive as the test article, and in the same bondline thickness and same bond length and width dimensions as the test article, have been used in an attempt to reduce the mass of the adherends relative to the adhesive while still limiting absorption to the bond edges. Theoretically these travelers, when placed in the conditioning environment along with the test articles, offer increased accuracy in determining when moisture equilibrium has been reached. However, the foil and adhesive masses must be known accurately, and foil corrosion introduces another potential interference. Thus, this practice has not been widely adopted. A possible work-around for the corrosion issue is the use of stainless steel or other corrosion-resistant foil, although this has not been documented.

Since conditioning to equilibrium is often either impractical or inaccurate, fixed time conditioning is the only real option in many cases. Although the entire bondline does not, in general, reach a constant moisture content, the region near the edges of the bond will be at, or close to, the equilibrium moisture level. This is the same region where shear and peel stresses are typically highest in a bonded joint under load, and from which the failure of the test article will initiate. Therefore it can be argued that, although the entire bondline is not at the desired moisture level, the areas where bond failures will initiate are at the desired level. 1000 hour exposures at 85-95% relative humidity and elevated temperature (up to 185°F (85°C) for 350°F (177°C) curing epoxies) have been used by some labs as an accelerated fixed time condition for relatively short overlaps. However, this approach and rationale should not be used as a general excuse for short exposure times. Since structural tests of bonded joints evaluate the joint as a system, and not just the bonding adhesive in isolation, other effects of conditioning, such as metal adherend surface preparation degradation, may also contribute to bond failure. Such effects should be taken into consideration when selecting a fixed time environmental condition.

7.3.4 Damage characterization specimens

For testing of post-damage specimens (such as compression after impact), a different result may be obtained depending on whether conditioning was performed prior to or subsequent to the damage event. This may be due to several effects:

1. A moisture conditioned panel may have a different compliance and/or matrix hardness compared to the same panel prior to conditioning. This difference in compliance and/or hardness may result in different types and/or levels of damage for the same test parameters and energy. For example, the delamination area may be less for the conditioned panel due to increased compliance, whereas the front surface dent depth might be higher due to matrix softness.
2. A panel which is conditioned after the damage event might absorb moisture in a non-Fickian manner. That is, in addition to Fickian absorption at the molecular level, liquid water (or other fluid) may start to accumulate in matrix cracks and delaminations. This phenomenon could interfere with weight gain measurements, as these measurements may not accurately represent moisture absorbed by the matrix polymer. Consequently, this will affect the accuracy of moisture equilibrium and moisture content determinations. Non-damaged travelers are recommended in this case.

While there may be valid reasons within a design development or qualification program for conditioning either before or after impact, it is important to keep these effects in mind and to document the order in which impacting, conditioning, and testing were performed.

7.3.5 Sandwich Structure

Conditioning of sandwich structures requires consideration of several issues, depending upon the specific materials of construction and the failure mode under test. Table 7.3.5 shows 12 common combinations of materials and failure modes.

TABLE 7.3.5 Sandwich materials and failure modes.*

	Non-perforated Metallic Face Sheets		Composite Face Sheets	
	Metallic Core	Organic Core	Metallic Core	Organic Core
Face Sheet Failure (Tension / Compression)	1	2	3	4
Core Failure (Tens. / Comp. / Shear)	5	6	7	8
Adhesive Bond Failure (Tension / Shear)	9	10	11	12

*Note: Table entries refer to numbered notes which follow

If the core is metallic (aluminum honeycomb, for example) (as in Combinations 1, 3, 5, 7, 9, and 11 in Table 7.3.5), then only the environmental condition of the face sheets and bonding adhesive applies. If the core contains organic constituents (such as in polyamide/phenolic, glass/phenolic, or foam cores, as in Combinations 2, 4, 6, 8, 10, and 12), then the condition of the core material may be of interest, unless core failure is not an expected mode. The following lists each of the 12 combinations in Table 7.3.5, and suggests specific considerations and approaches relative to environmental conditioning.

1. Here everything (except the adhesive) is metallic, and failure is expected in the face sheets. There is no need to condition such test articles since the face sheet strength is not usually affected by moisture exposure (except for corrosion effects, which are not within the scope of MIL-HDBK-17). Even if an unanticipated failure occurs in the adhesive, conditioning would have had a minimal effect on the outcome, since the adhesive is shielded by the skins (except at the edges) from the conditioning medium.
2. As in Combination 1, the metallic face sheets shield the adhesive and core from the conditioning medium. Therefore, even though the core is organic, there is no need to condition such articles, assuming that edge absorption can be ignored.
3. In this combination the face sheets are composite and are expected to fail. Therefore the moisture condition of the skins is of interest and conditioning to moisture equilibrium is desirable. For this configuration, it is difficult to track the test article itself (or even sandwich travelers) during conditioning because of possible liquid accumulation within the metallic cells (assuming the core is a cellular material). In such cases (where there is the assumption of one-sided exposure of the face sheets), it is convenient to prepare solid laminate travelers made of the same material and stacking sequence as the face sheets but twice the thickness. These travelers are placed in the conditioning environment along with the test article. Two sided exposure of the double thick travelers is equivalent to one-sided exposure of the skins on the test article. When the traveler has reached equilibrium, so have the face sheets on the test article.
4. When failure is expected in the face sheets and the core and face sheets are organic, the moisture content of the core is not of particular interest. Therefore, the technique of using solid laminate travelers twice the face sheet thickness (as discussed in 3 above) can be used. This has the added benefit of precluding accumulation of condensation in the cells of the core. Since liquid accumulation in the organic core cells is less likely than with metallic core, moisture tracking of the test article or sandwich travelers can usually be employed as an alternate method.
5. In this case core failure is anticipated. Since the core is metallic, testing of conditioned articles is not needed.
6. See Combination 2.
7. In this combination the face sheets are composite (allowing moisture to reach the interior of the sandwich), but the core (which is expected to fail) is metallic. Assuming an insignificant moisture effect on the metallic core properties, no conditioning should be needed for this configuration.
8. Both the face sheets and the core are absorptive in this combination, and the moisture level of the core (which is expected to fail) is of primary interest. This can be a difficult configuration to assess relative to moisture conditioning. The mass of the skins is frequently greater than the mass of the core; however, the equilibrium moisture content of some core materials may be greater than that of the composite skins. In addition, absorption through the edge of small sandwich travelers may represent a significant proportion of the total moisture absorbed (which may not be the case for test articles with higher surface to edge ratios). Whether tracking is done using the test article or travelers which mimic the test article geometry, accurate determination of equilibrium in the core will be compromised if face sheet absorption is dominant. One possible procedure is as follows:
 - Determine the equilibrium moisture content of the core material alone for the environment of interest using methods discussed in Section 6.4.8 (with modifications as needed).
 - Prepare a large quantity of sandwich travelers that mimic the geometry of the test article.
 - If the surface to edge ratio of the test article is much larger than the travelers, mask the edges of the travelers with foil tape or other suitable barrier material.
 - Place the test article(s) and the travelers in the conditioning environment.

- Periodically remove a traveler and destructively remove the face sheets and adhesive quickly, cleanly, and without generating heat. Weigh the core portion, and then determine the moisture content of the core by desorption.
 - Compare the traveler core moisture level to the previously determined equilibrium level.
 - When the traveler core reaches the equilibrium level within a defined tolerance, the test article(s) is also at equilibrium.
9. As in Combinations 1 and 5, the metallic face sheets shield the adhesive from the conditioning medium. Therefore, even though the adhesive is expected to fail, there is no need to condition such articles (assuming that edge absorption into the bondline is not significant).
 10. As in Combinations 2 and 6, the metallic face sheets shield the adhesive and core from the conditioning medium. Therefore, even though failure is expected in the adhesive, there is no need to condition such articles (assuming that edge absorption into the bondline and organic honeycomb is not significant).
 11. In this combination the face sheets are composite, allowing moisture to reach the adhesive (which is expected to fail). Since the adhesive layer is relatively thin and in contact with the face sheets, it is reasonable to assume that the adhesive will be near equilibrium when the composite skins have reached equilibrium. Therefore, the approach of using solid laminate travelers that are twice the thickness of the face sheets can be used (as described for Combination 3 above).
 12. See Combination 11.

7.4 NOTCHED LAMINATE TESTS

7.4.1 Overview and general considerations

The most common method of assembling composite structure is by the use of mechanical fasteners, even though bolted joints are relatively inefficient. The stress concentration due to the hole will cause substantial reduction in both the notched tensile and compressive strength of a composite laminate. The magnitude of this reduction varies considerably with a multitude of factors. All composite materials that exhibit a linear elastic stress-strain relationship to failure will be very sensitive to notches. Unlike metallic materials, the effects of the notch on strength will vary with the size of the notch but are relatively independent of notch geometry. Under uniaxial load, large holes will produce a stress concentration factor approaching the theoretical factor for wide plates given by the relationship:

$$K_t = 1 + \left\{ 2 \left[\left(\frac{E_x}{E_y} \right)^{\frac{1}{2}} - \nu_{xy} \right] + \frac{E_x}{G_{xy}} \right\}^{\frac{1}{2}} \quad 7.4.1(a)$$

For a quasi-isotropic laminate, the above relationship reduces to the well-known value $k_t = 3.0$ for a circular hole. This relationship also indicates that holes in high modulus laminates have a much greater effect on strength than holes in low modulus laminates. The stress concentration factor described by the above equation is reasonably proportional to the parameter E/G , the laminate axial modulus divided by the laminate shear modulus.

Considerable research literature exists regarding the influence of holes on the strength of composite laminates. An excellent summary of this literature is given in Reference 7.4.1 which includes over 300 citations. While the influence of holes in composites has been researched and reported extensively, there are additional effects to be considered. Two of these effects relate to the influence a fastener has in "filling" a hole in a laminate. The fastener, particularly in tight or interference holes, can induce a biaxial stress field by preventing ovalization of the hole under load. The factor tends to decrease the notch tensile strength of 0° -ply dominated laminates and increase the strength of laminates with predominantly 45°

plies. The second effect is when clamp-up of the fastener prevents damage in the form of longitudinal slits and delaminations from occurring around the hole. These delaminations are the result of "free edge" stresses and are very sensitive to stacking sequence. When damage is suppressed by the fastener, no stress concentration relief occurs and the notch sensitivity increases.

Filled hole compressive strengths are significantly higher than open hole strengths and, in some cases, approach the unnotched strength. This is particularly true with close-fitting holes where load can be transferred through the hole by direct bearing through the fastener. Fabric laminates, because of the balanced nature of fabric materials, tend to have lower stress concentration factors and are less prone to free edge delaminations. The influence of free edge stresses and stacking sequence on delaminations are discussed in Volume 3, Sections 5.6.3 and 5.6.5.

When holes are placed together as in a bolted joint, the stress concentrations at the holes start to interact and the notch strength of the composite laminate decreases. A finite width correction factor is used to account for this interaction effect. For isotropic materials the "finite width correction" factor (FWC) is given by:

$$FWC = \frac{2 + \left(1 + \frac{D}{W}\right)^3}{3 \left(1 - \frac{D}{W}\right)} \quad 7.4.1(b)$$

where D = fastener diameter
 W = fastener spacing

The correction factor for orthotropic materials cannot be expressed in a closed form. In most cases, the isotropic correction has been found to be reasonably accurate.

When the hole diameter is significantly greater than the laminate thickness, the stress concentration is two-dimensional in nature. Most of the research on holes in laminates is for this case. The notch strength of composites is much more difficult to predict when the thickness of the laminate significantly exceeds the hole diameter. The stress concentration at the hole becomes three-dimensional in nature and stacking sequence effects become more dominant.

There have been many failure models proposed for describing the notch strength of composite laminates. All of the models require some form of empirical "calibration" factor such as a "characteristic dimension". Characteristic dimensions have been used as a measure of notch sensitivity. Once calibrated, all of the models are reasonably accurate in describing the notch strength of composites. The drawback to these models is that many parameters such as laminate composition, temperature, and even hole size require re-calibration of the failure model. Some of the calibration factors are reasonably consistent, over a wide range of application laminates, among various material systems of similar characteristics. Low strength or stiffness fibers, or highly nonlinear toughened resins are examples of material constituents which can produce widely different "calibration" factors. Progressive damage failure models have shown some promise in not being overly dependent on empirical factors. For more discussion on this topic see Volume 3, Chapter 7 (bolted joints).

7.4.2 Notched laminate tension

A uniaxial tension test of a balanced, symmetric laminate with a centrally located 0.250 inch (6.35 mm) diameter hole is performed to determine the notched laminate tensile strength. The test consists of loading an untabbed, straight-sided, 1.5 inch (3.8 cm) wide, 12 inch (30 cm) long laminate specimen in tension until two-part failure occurs. The head travel and load on the specimen are recorded during the test. The tensile load is applied to the specimen through a mechanical shear interface at the ends of the specimen, normally by either wedge or hydraulic grips. The test machine grip wedges must be at least the same width as the specimen, and must be able to grip at least 2.0 inch (5 cm) of each end of the specimen. The recommended specimen configuration is shown in Figure 7.4.2. Both open hole and fastener filled hole specimens are tested. There is no need for tabbing or special gripping treatments unless ex-

tremely coarse serrated grips or excessive pressure are used. Normally the large stress concentration at the hole will eliminate problems with grip failures. The test is normally run without instrumentation, recording only maximum load, specimen dimensions, and failure mode and location. The test methods are also applicable to specimens with different fastener types, width/diameter ratios, and hole sizes. The open-hole and filled-hole tensile strength is presented in terms of gross-area strength without any finite-width correction. The following equations are used to calculate the notched tensile strengths:

$$F^{oh} = \frac{P_{max}}{(W)(t)} \quad \text{and} \quad F^{fh} = \frac{P_{max}}{(W)(t)}$$

Where

- P_{max} = maximum tensile load
- W = measured width at midsection
- t = calculated nominal laminate thickness

The calculated nominal thickness is calculated by summing the nominal per-ply thickness of the individual plies in the laminate.

7.4.2.1 Open-hole tensile test methods

ASTM D 5766 "Standard Test Method for Open Hole Tensile Strength of Polymer Matrix Composite Laminates". This test method determines the open hole tensile strength of polymer matrix composite laminates reinforced by high-modulus fibers. The composite material forms are limited to continuous-fiber or discontinuous-fiber reinforced composites in which the laminate is balanced and symmetric with respect to the test direction. The standard test laminate is of the $[45/90/-45/0]_{ns}$ stacking sequence family, where the sublaminar repeat index is adjusted to yield a laminate thickness within the range of 0.080 to 0.160 inch (2.03 to 4.06 mm). The standard specimen width is 1.5 inch (3.8 cm) and the length is 8.0 to 12.0 inches (20 to 30 cm). The notch consists of a 0.250 inch (6.35 mm) diameter centrally located hole. Other laminates may be tested provided the laminate configuration is reported with the results, however, the test method is unsatisfactory for unidirectional tape laminates containing only one ply orientation.

7.4.2.2 Filled-hole tensile test methods

The filled-hole tensile test typically uses the open-hole tensile test method procedures to conduct the test. The standard specimen width is 1.5 inch (3.8 cm) and the length is 8.0 to 12.0 inches (20 to 30 cm). The notch consists of a 0.250 inch (6.35 mm) diameter centrally located hole. The standard specimen configuration for this test should have a protruding head, hex drive fastener installed in the hole prior to testing. Filled-hole tensile strength is dependent upon the amount of fastener clamp-up, with a higher clamp-up force generally producing a lower filled-hole tensile strength. Fastener clamp-up is a function of fastener type, nut or collar type, and installation torque. In general, the strengths obtained using this fastener should be conservative relative to most fastener installations in composite structure. The test method procedures are also applicable to specimens with different fastener types, width/diameter ratios, and fastener/hole sizes.

7.4.3 Notched laminate compression

A uniaxial compressive test of a balanced, symmetric laminate with a centrally located 0.250 inch (6.35 mm) diameter hole is performed to determine the notched laminate compressive strength. The test involves loading an untabbed, straight-sided, 1.5 inch (3.8 cm) wide, 12 inch (30 cm) long laminate specimen in compression until two-part failure occurs. The head travel and load on the specimen are recorded during the test. The recommended specimen is shown in Figure 7.4.2 with recommended thickness greater than 0.08 inch (2.0 mm) but less than 0.25 inch (6.3 mm). The multi-piece bolted compressive support fixture shown in Figure 7.4.3 is used to stabilize the specimen from general column buckling failures. The specimen/fixture assembly is clamped in the hydraulic grips and the load is sheared into the specimen. The grips must apply enough lateral pressure to prevent slippage without locally crushing the specimen. Boeing has recently updated the compressive support fixture configuration that has been in common use throughout industry for some time. This update was done to correct some errors and omis-

sions that were found in the original Boeing drawings for these support fixtures. The updated details are contained in the proposed ASTM Open-Hole Compression Test Method and have been supplied to some vendors (MTS and Wyoming Test Fixture Inc.) and test laboratories (Intec and Delson) for incorporation into their fixtures. The open-hole and filled-hole compressive strength is presented in terms of gross-area strength without any finite-width correction. The following equations are used to calculate the notched compressive strengths:

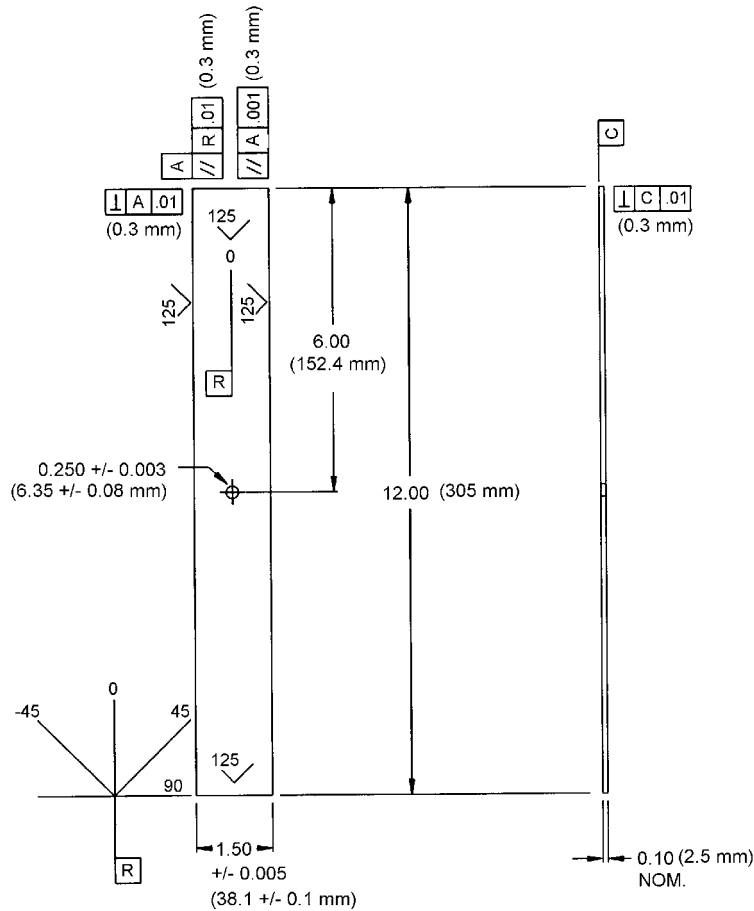

NOTES:

1. UNLESS NOTED ALL TOLERANCES ARE ± 0.100
EDGE ROUGHNESS IN ACCORDANCE WITH ANSI B46.1
2. HOLE MUST NOT HAVE DELAMINATION OR OTHER
DAMAGE.
3. ALL DIMENSIONS IN INCHES. (MILLIMETERS IN PARENTHESES.)
4. CONFIGURATION SHOWN IS FOR 0.25 in. DIAMETER
HOLE. FOR ALL OTHER HOLE SIZES, THE WIDTH
WOULD CHANGE TO MAINTAIN W/D = 6.

FIGURE 7.4.2 Notched tensile/compressive strength specimen (based on Reference 7.4.1).

$$F^{ohc} = \frac{P_{max}}{(W)(t)} \quad \text{and} \quad F^{fhc} = \frac{P_{max}}{(W)(t)}$$

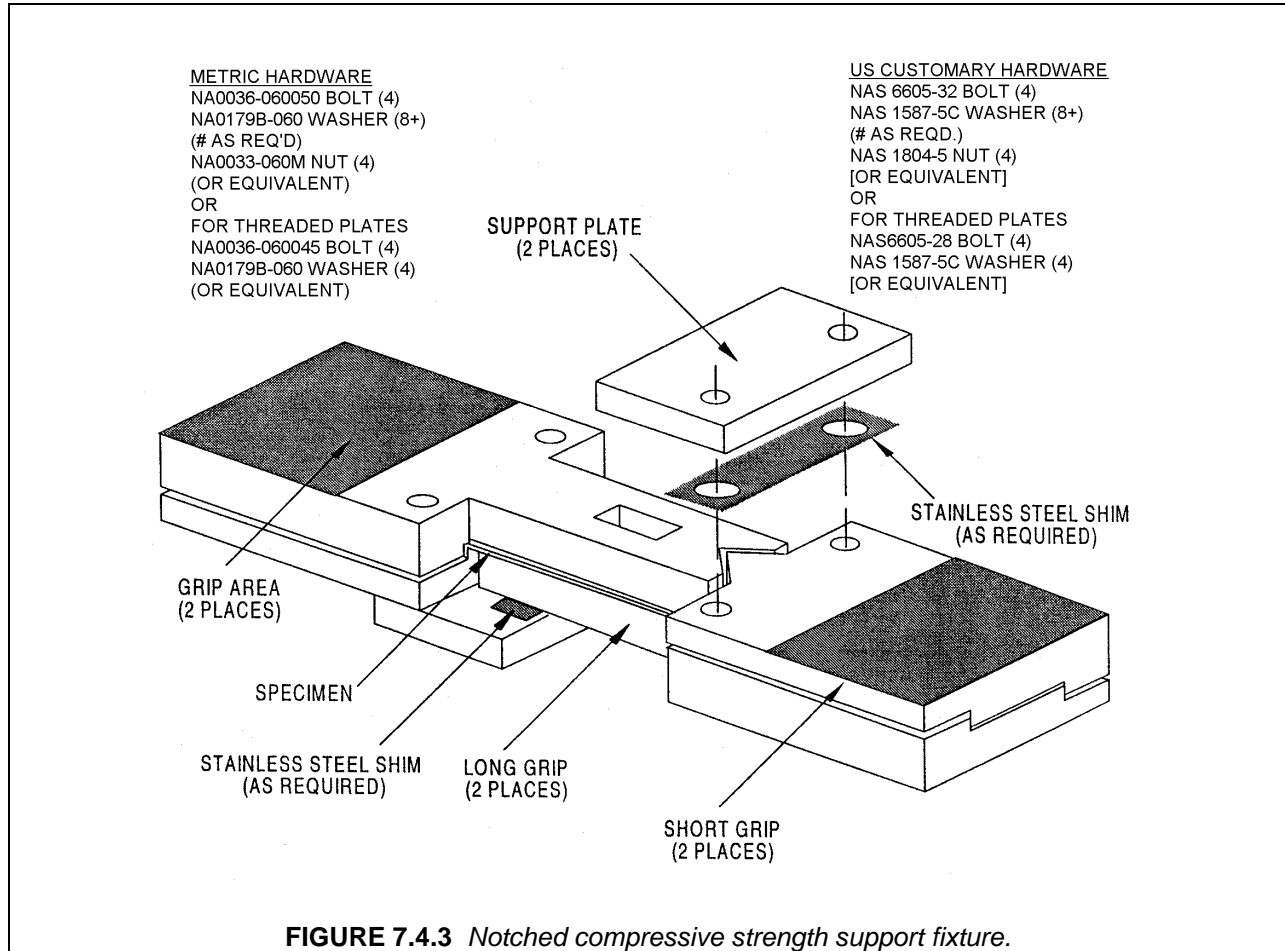

Where

- P_{max} = maximum tensile load
 W = measured width at midsection
 t = calculated nominal laminate thickness

The calculated nominal thickness is calculated by summing the nominal per-ply thickness of the individual plies in the laminate.

7.4.3.1 Open-hole compressive test methods

SACMA SRM 3 "Open-Hole Compression Properties of Oriented Fiber-Resin Composites". This method covers the procedure for the determination of the compressive properties of oriented fiber-resin composites laminates reinforced by continuous, high modulus, >3Msi (>20Gpa), fibers containing a circular hole. The standard test laminate for unidirectional tape composites is of the [45/0/-45/90]_{2S} stacking sequence. The standard specimen width is 1.5 inch (3.8 cm) and the length is 12.0 inches (30 cm). The notch consists of a 0.250 inch (6.35 mm) diameter centrally located hole. The commonly used compressive support fixture is used to stabilize the specimen from general column buckling failures. The preferred test method is to hydraulically grip the specimen/fixture assembly, but the test method allows the speci-

men to be ended loaded as an option. This option was required because many test laboratories did not have the very large hydraulic grips needed to handle the 3 inch (8 cm) wide support fixture. The new side-load hydraulic grips can easily handle the support fixture. The option to end-load the specimen required the tolerances on the ends of the specimen to be much tighter and also required the fixture to be modified.

ASTM D 6484 "Standard Test Method for Open-Hole Compressive Strength of Polymer Matrix Composite Laminates". This method determines the open hole compressive strength of multi-directional polymer matrix composite laminates reinforced by high-modulus fibers. The composite material forms are limited to continuous-fiber or discontinuous-fiber (tape and/or fabric) reinforced composites in which the laminate is balanced and symmetric with respect to the test direction. The standard test laminate is of the [45/90/-45/0]_{ns} stacking sequence family, where the sublaminar repeat index is adjusted to yield a laminate thickness within the range of 0.125 to 0.200 inch (3.17 to 5.08 mm). The standard specimen width is 1.5 inch (3.8 cm) and the length is 12.0 inches (30 cm). The notch consists of a 0.250 inch (6.35 mm) diameter centrally located hole. Figure 7.4.3 compressive support fixture is used to stabilize the specimen from general column buckling failures. The test method uses hydraulic wedge grips to load the specimen/fixture assembly. Other laminates may be tested provided the laminate configuration is reported with the results, however, the test method is unsatisfactory for unidirectional tape laminates containing only one ply orientation.

7.4.3.2 Filled-hole compressive test methods

The filled-hole compression test typically uses the open-hole compressive test method procedures to conduct the test. The standard specimen width is 1.5 inch (3.8 cm) and the length is 12.0 inches (30 cm). The notch consists of a 0.250 inch (6.35 mm) diameter centrally located hole. The standard specimen configuration for this test should have a protruding head, hex drive fastener installed in the hole prior to testing. Filled-hole compressive strength is dependent upon the amount of fastener hole clearance with tighter holes producing a higher filled-hole compressive strength. The test method procedures are also applicable to specimens with different fastener types, width/diameter ratios, and fastener/hole sizes.

7.4.4 Suggested notched laminate test matrix

The minimum recommended test matrix for initial empirical assessment of "calibration" of the various theoretical models and determination of notch strength data for a range of laminates is given in Table 7.4.4. This matrix is just part of the overall development test plan. The matrix requires selective tests to be performed under tensile and compressive loadings in various environments applicable to the design of structural components. The test matrix is for open holes but bolted joint design criteria will also require filled hole test data to be generated. It is recommended that portions of the matrix in Table 7.4.4 be used to spot test for filled hole strengths, particularly in tension. For filled hole strengths, a reduction factor is applied to the open hole strength and the predictive model is not re-calibrated. The matrix represents the range of laminates commonly used in bolted joint designs. This assures that important interactions between laminate stiffness, failure modes, and joint parameters are assessed. If the laminate of interest is significantly outside the range of behavior of the test laminates, open hole tests for that laminate should be added to that matrix.

The procedure, often used to calibrate single-fastener-hole laminate strength methodology, such as for the "characteristic dimension" approaches, starts by evaluating the effect of hole-size on strength data for the isotropic (25/50/25) laminate, using a baseline specimen width/diameter ratio of six. Three fastener diameter sizes are selected for testing which will span the usual application range of fastener hardware. The trend of the effect of hole size on tensile and compressive strength data is established. The characteristic dimension that produces the trend line which best fits the test data is then selected. All other test case predictions now use that selected characteristic dimension.

TABLE 7.4.4 Notch tensile/compressive strength test matrix.

Lay-up	Diameter in. (mm)	Width in. (mm)	W/D Ratio	CTD Tension	RTD Tension	RTD Compression	ETW Compression	Total Number of Tests
(10/80/10)	0.250 (6.35)	1.5 (38)	6.0	5	5	5	5	20
(25/50/25)	0.125 (3.18)	1.0 (25)	6.0		5	5		10
		1.5 (38)	8.0		5	5		10
(25/50/25)	0.250 (6.35)	1.5 (38)	6.0	5	5	5	5	20
(25/50/25)	0.500 (12.7)	2.0 (51)	4.0		5	5		10
		2.5 (64)	6.0		5	5		10
(50/40/10) _{Tape} or (40/20/40) _{Fabric}	0.250 (6.35)	1.5 (38)	6.0	5	5	5	5	20
Total				15	35	35	15	100

Lay-up

Ply Stacking Sequence

Conditions

(10/80/10)
(25/50/25)
(50/40/10)
(40/20/40)

[45/-45/90/45/-45/45/-45/0/45/-45]_{ns}
[45/0/-45/90]_{ns}
[45/0/-45/90/0/0/45/0/-45/0]_{ns}
[0_f/90_f/0_f/90_f/45_f/-45_f/90_f/0_f/90_f/0_f]_n

CTD Cold Temperature Dry
RTD Room Temperature Dry
ETW Elevated Temperature Wet

See Section 2.2.7

n selected so that total laminate thickness is between 0.1 to 0.2 inches (2.5 to 5.0 mm)

Further correlations between the model and the data are then performed to assess the generality of this single characteristic dimension. Additional tests provide data for correlation with predicted effects of laminate composition, temperature variation, and finite width variations. The hole-size effect data, used initially to select a characteristic dimension, "builds in" a correlation for finite width of $W/D = 6$. If subsequent theory/test correlations are inconsistent or errors too large, further fitting of the "characteristic" dimension may be required. If still unacceptable, for the application range of variables, the test data will be the basis for other analytical or purely empirical approaches, but significantly more testing may be required to offset the loss of predictive methodology which provided an analytical bridge among the limited test conditions defined in Table 7.4.4.

7.4.5 Notched laminate test methods for MIL-HDBK-17 data submittal

Data provided by the following test methods (Table 7.4.5) are currently being accepted by MIL-HDBK-17 for consideration for inclusion in Volume 2.

TABLE 7.4.5 *Notched laminate test methods for MIL-HDBK-17 data submittal.*

Property	Symbol	All Data Classes	Screening Data Only
Open Hole Tension Strength	F_x^{ohT}	D 5766	–
Filled Hole Tension Strength	F_x^{fht}	D 5766 as modified by Section 7.4.2.2	–
Open Hole Compression Strength	F_x^{ohc}	D 6484	–
Filled Hole Compression Strength	F_x^{fhc}	D 6484 as modified by Section 7.4.3.2	–

7.5 MECHANICALLY-FASTENED JOINT TESTS

7.5.1 Overview

7.5.1.1 Definitions

The following definitions are relevant to this section.

Bearing Area -- The diameter of the hole multiplied by the thickness of the specimen.

Bearing Load -- A compressive load on an interface.

Bearing Strain -- The ratio of the deformation of the bearing hole in the direction of the applied force to the pin diameter.

Bearing Strength -- The bearing stress value corresponding to total failure of the test specimen.

Bearing Stress -- The applied load divided by the bearing area.

Bypass Strength -- The load that transfers around a hole divided by the laminate gross section area.

Edge Distance Ratio -- The distance from the center of the bearing hole to the edge of the specimen in the direction of the applied load, divided by the diameter of the hole.

Offset Bearing Strength -- The bearing stress at the intersection of the bearing load-deformation curve with the tangent modulus drawn from a pre-selected offset value. Offset may be 1, 2 or 4% of the nominal hole diameter.

Proportional Limit Bearing Stress -- The bearing stress value corresponding to the deviation from linearity of the bearing stress versus hole elongation curve.

Ultimate Bearing Strength -- The maximum bearing stress that can be sustained.

7.5.1.2 Failure modes

An important consideration in joint testing and analysis is the selection of the type of test method with due attention to the failure mode which is likely to result with a specific joint design in a particular composite system. A brief discussion on various failure modes is provided in this section. The occurrence of a particular failure mode is dependent primarily on joint geometry and laminate lay-up. Composite bolted joints may fail in various modes as shown in Figure 7.5.1.2. The likelihood of a particular failure mode is influenced by bolt diameter (D), laminate width (w), edge distance (e), and thickness (t). The type of fastener used can also influence the occurrence of a particular failure mode. A more detail classification of the failure modes is in Section 7.5.2.6.

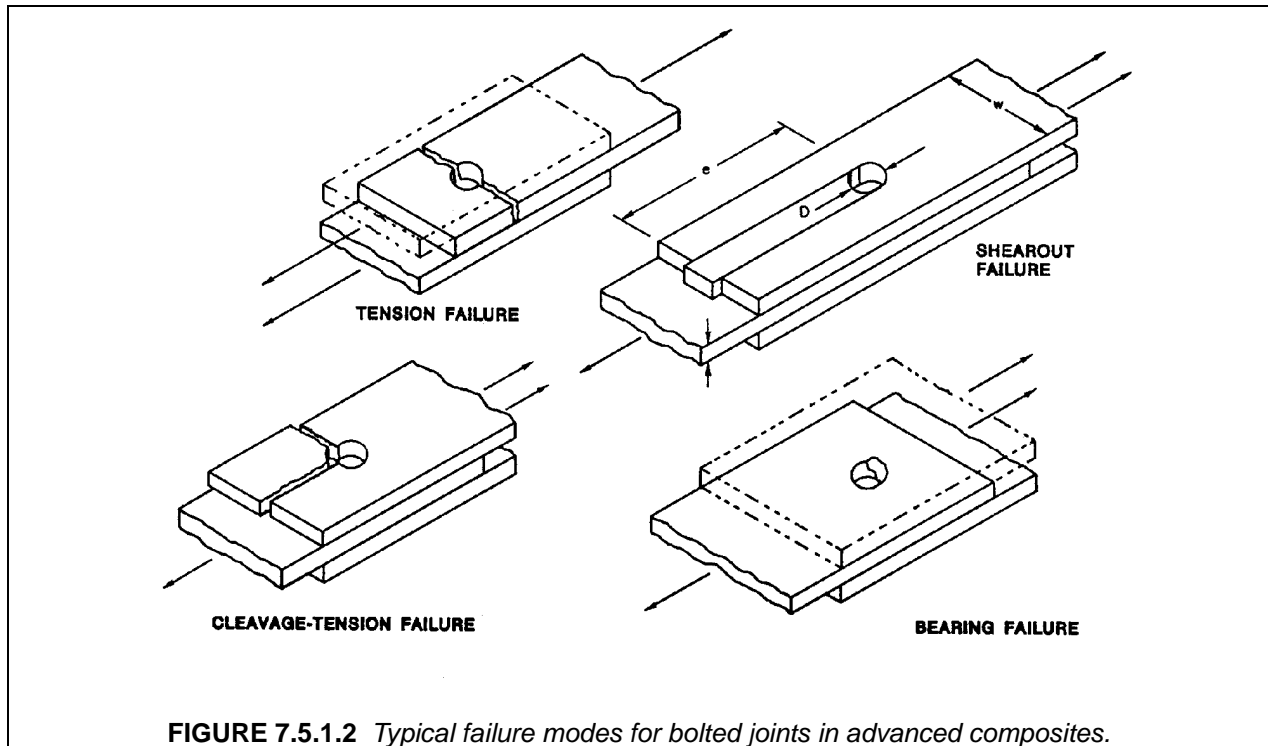

Net section tensile/compressive failures occur when the bolt diameter is a sufficiently large fraction of the strip width. This fraction is about one-quarter or more ($w/D \leq 4$) for near-isotropic lay-ups in graphite/epoxy systems. It is characterized by failure of the plies in the primary load direction. Cleavage failures occur because of the proximity of the end of the specimen. A cleavage failure can be triggered from a net-section tension failure. This type of failure often initiates at the end of the specimen rather than adjacent to the fastener. In some instances the bolt head may be pulled out through the laminate after the bolt is bent and deformed. This mode is frequently associated with countersunk fasteners and is highly dependent on the particular fastener used. Finally, it is important to note that for any given geometry, the failure mode may vary as a function of lay-up and stacking sequence.

7.5.1.3 Design requirements

In order to design against the different failure modes and the interactions between them, the capability of the composite has to be determined by test for:

- Notch/Net Tension/Compression
- Bearing
- Bearing/By-Pass
- Shear-Out

These are described in Sections 7.4.2, 7.4.3 and 7.5.2 to 7.5.4. The amount of testing will vary among manufacturers and certifying agencies depending on the confidence assigned to the analysis capability of each company. The philosophy of MIL-HDBK-17 is to provide guidance as to amount of testing that would be typical, but not necessarily the minimum or maximum. The bearing, net tension/compression, and bearing/by-pass failure mode criticality is best illustrated by a plot shown in Figure 7.5.1.3. This figure, which is typically used by airframe designers, encompasses five failure possibilities as a function of bolt load and strain in the joining members. This plot is usually determined by tests that are described in Section 7.5.3 to 7.5.4. At zero bearing (no bolt load), the failure is in net tension or compression (points A and E). Open-hole or filled-hole specimens described in Sections 7.4.2 and 7.4.3 are used to determine this property. The line between A and C represents the reduction of net tension strength due to the bearing load. Similarly the line from E to C¹ represents the effect of bolt load on net compression strength. Points C and C¹ are the strengths of a single fastener joint where the load is reacted by the bolt. Section 7.5.3 describes the tests required to establish this design point for different joint variables. In practice, joints C and C¹ are not much different so that a tension-bearing test is usually sufficient. Plots such as Figure 7.5.1.3 may be different for each distinct laminate, fastener type, and environmental condition, but many application ranges may be covered by one plot. The shape of the curves could also change depending on the percentage of 0°, 90° or ±45° direction plies in the laminate. The intent of the sections that follow is to provide guidance on how to establish by test the critical points of Figure 7.5.1.3. The number of laminates to be tested is governed by analysis capability and degree of confidence in extrapolation. The shear-out mode of failure is usually avoided in design by providing sufficient edge distance between the holes or the free edge and balanced laminate configuration. However, in certain rework situations shear-out critical joints cannot be avoided. In those situations, a test program must be undertaken to establish design values (see Section 7.5.4).

7.5.2 Bearing Tests

7.5.2.1 Overview

Bearing tests are used to determine bearing response of composites. From the experimental load displacement curve, the bearing strength at maximum load and at some intermediate value (identified as yield or offset) are calculated using the following equation

$$F^{br} = P/tD \quad 7.5.2.1$$

where

- F^{br} = bearing strength, psi (Pa)
- P = bearing load, lb_f (N)
- D = bearing hole diameter, in. (m)
- t = specimen thickness, in. (m)

Superscripts bry and bru are commonly used to differentiate between yield and ultimate bearing strengths. An offset bearing strength may be determined to represent the yield value. In that case, the subscript bro should be used.

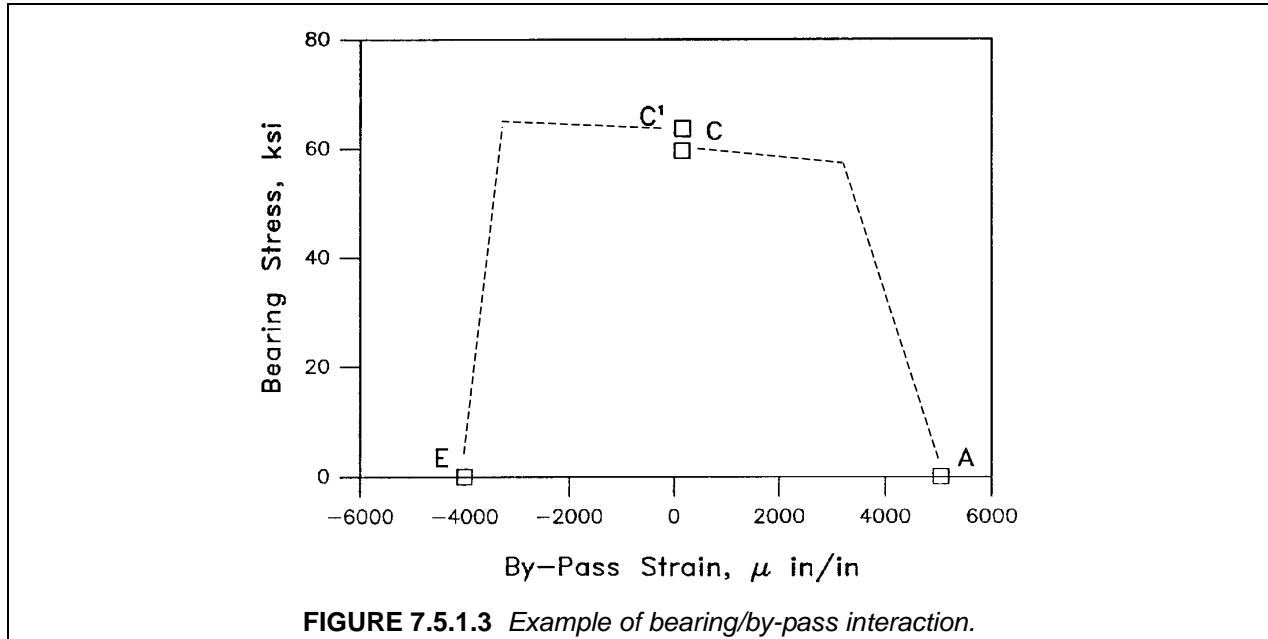

FIGURE 7.5.1.3 Example of bearing/by-pass interaction.

The bearing test is conducted either in double or single shear with configurations that range from simple pin to a two bolt single shear load introduction, the latter being the closest to representing an actual joint. A suggested test matrix is described in Section 7.5.2.4 that can be used to establish bearing design values. The bearing tests to be used in conjunction with the test matrix are the ASTM D 5961 Procedure A, if the joints used in the application are in double shear, or ASTM D 5961 Procedure B two bolt specimen, if the joints are in single shear.

7.5.2.2 Double shear bearing tests

The two tests described in this section introduce the bearing load in a double shear configuration. In actual applications, load transfer in a single shear configuration is more commonplace, resulting in larger stress concentrations in the thickness direction, and lowering the realizable bearing strength; these single-shear tests are discussed in Section 7.5.2.3. In other words, the bearing strength values measured by the double-shear tests cannot be applied to single shear joints.

The main difference between the two test standards described below is how the bearing load is applied. ASTM D 953 uses a pin, where ASTM D 5961, Procedure A uses a bolt with torque. As the clamp-up force is a significant factor for increasing the bearing strength, ASTM D 953 provides a lower bound on the bearing strength for the double shear configuration. Furthermore, as the pin is not representative of a bolted joint, the results of this test are usually not used for design but as a material property for comparison purposes of different materials.

7.5.2.2.1 ASTM D 953 bearing strength of plastics

This test method (Reference 7.5.2.2.1) is the oldest method to measure the bearing response of a composite material. It is the only method available to measure pure bearing strength of a material without the intrusion of bolt influences, such as clamping and washer. As such it is useful for comparison of bearing properties of different materials. The test can obtain bearing strength under tension and compression loading.

Limitations of this test are:

Pin Loading – Introduction of bearing load by a pin is not representative of most structural joints.

Fixturing – The test apparatus is unnecessarily complicated. ASTM D 5961 has a much simpler arrangement.

Specimen Geometry – The geometry of the specimen is inconsistent in e/D and W/D ratios for the two specimen thicknesses specified. As these ratios have a significant influence on bearing strength, a user may find differences in bearing strength for the two thickness where such difference does not exist in the material.

Specimen Configuration – The lay-up of the specimen is not specified and may lead users to test unidirectional material with disastrous results.

Data Reduction – The data reduction mandated by the standard is specifically tied to a parabolic shape that does not reflect actual load-displacement curves. The use of template is antiquated in this computer age. The data reduction method of ASTM D 5961 is more general and useful.

In summary, this test is useful to differentiate between materials as to their bearing strength, but the bearing properties, ultimate strength, yield strength, and the load-displacement response do not relate to the bearing properties of an actual double shear joint. Bearing strength, as measured by the test in this section, is considered a material property for relative evaluation and design. Furthermore D 5961 allows use of pins and hence can be used instead of D 953 and take advantage of simpler fixturing. In realistic structural joints, factors like geometry, fastener type, and load eccentricity will significantly influence the realizable fraction of the bearing strength measured in the proposed test. Bearing strength tests more appropriate in design of joints are discussed in Sections 7.5.2.2.2 and 7.5.2.3.

7.5.2.2.2 ASTM D 5961, Procedure A

This recently developed standard has addressed all of the deficiencies of ASTM D 953 while still permitting a test with a load introduction by a close tolerance pin. ASTM is a standardized adaptation of, and taken in large part from previous MIL-HDBK-17 work. The flexibility built-in in the ASTM D 5961 allows for testing to a standard configuration or to a variation that may be representative of the particular user's application. The loading clevice is simple to make and the test procedures and data requirements are clearly described. Only a tensile loading condition is proposed for evaluating bearing failures; under compression, the larger edge distance ($e \gg 3D$) should only influence the bearing stress at failure minimally unless a shear-out mode of failure is possible (e.g., a laminate with a large percent of 0° plies). The data generated by this standard is acceptable to be included in MIL-HDBK-17. Bearing and joint strength values are reported in MIL-HDBK-17 as typical or average values. Therefore, bearing and joint strength values that are available for each specific condition should be analyzed to produce typical property values as described in Chapter 8. Test data must include the data documentation required by Table 2.5.6 and will be published in property tables per Volume 2, Section 1.4.2. Bearing data developed at a specific fiber volume may not be applicable for fiber volumes that are much different because of failure mode changes.

The standard test specimen and the fixture assembly are reproduced here from ASTM D 5961 as Figures 7.5.2.2.2(a) and (b). For the standard test, bearing load is applied by the lightly torqued bolt. In this test it is mandatory to measure average displacement across the loaded hole as the function of load. An example of the resulting bearing stress/bearing strain curve is shown in Figure 7.5.2.2.2(c). The bearing strain was obtained by normalizing by bolt diameter. Thus, the 2% offset measurement, which is the default in this standard, is in actuality 2% of the bolt diameter. There is no general consensus as to what the value of the offset should be. The usage in the aerospace industry varies from 1%D, for stiff double shear joints to 4%D for single shear joints, the latter being a standard for metal bearing tests in MIL-HDBK-5. Before selecting an offset measurement, for both aerospace and non-aerospace applications, the user should decide how it would be used. If the goal is to use it to represent bearing yield strength, the offset value should be close to $0.67F^{bnu}$, relating to the aircraft industry's safety factor of 1.5. Another measure of the offset value could be the amount of deformation a given design was limited to.

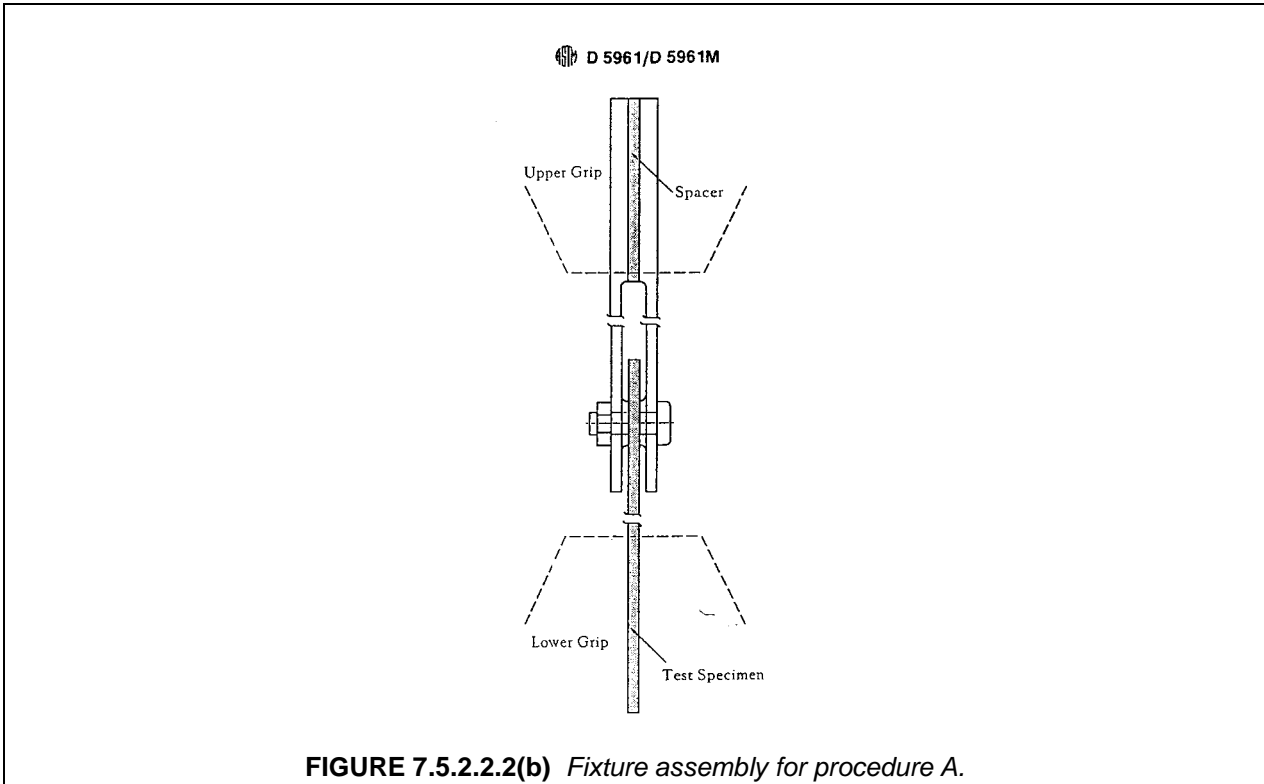
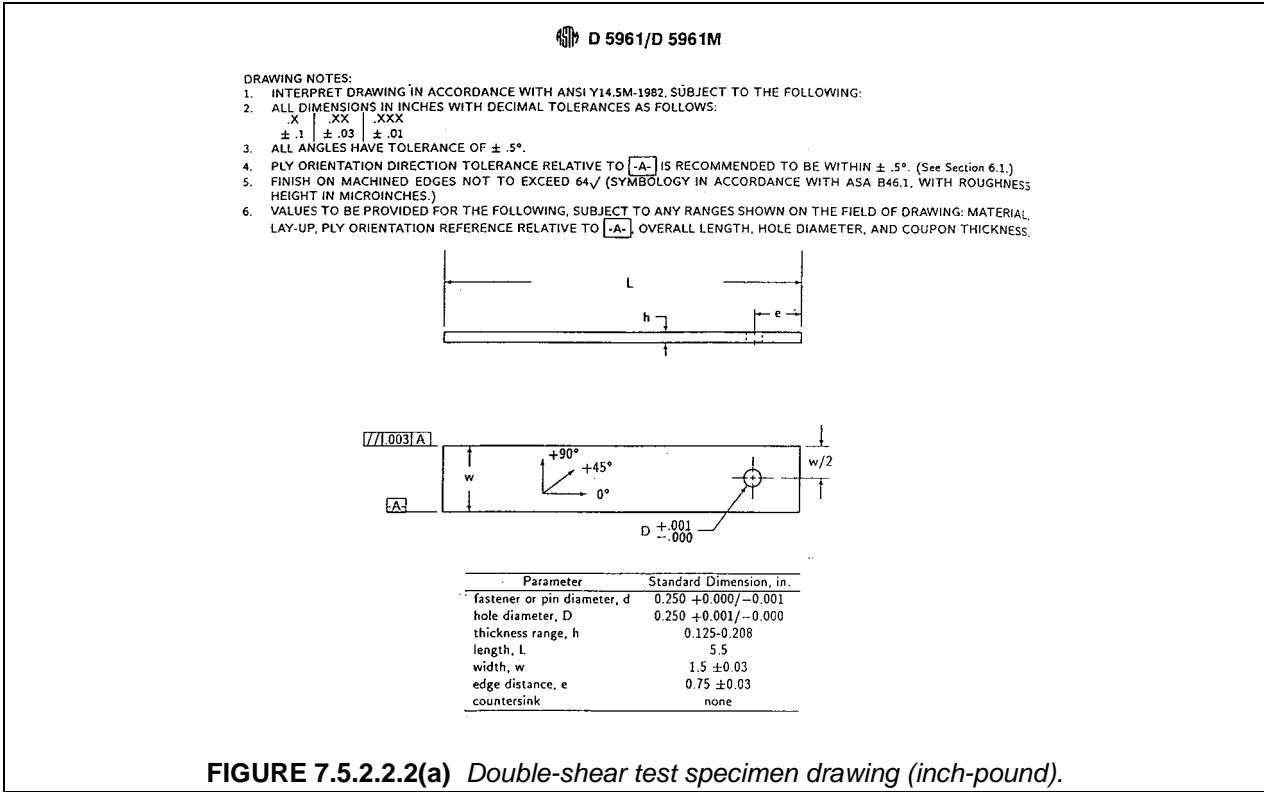

It should be noted that in laboratory practice, the bearing response is usually recorded in terms of bolt load versus average displacement and not as shown in Figure 7.5.2.2.2(c).

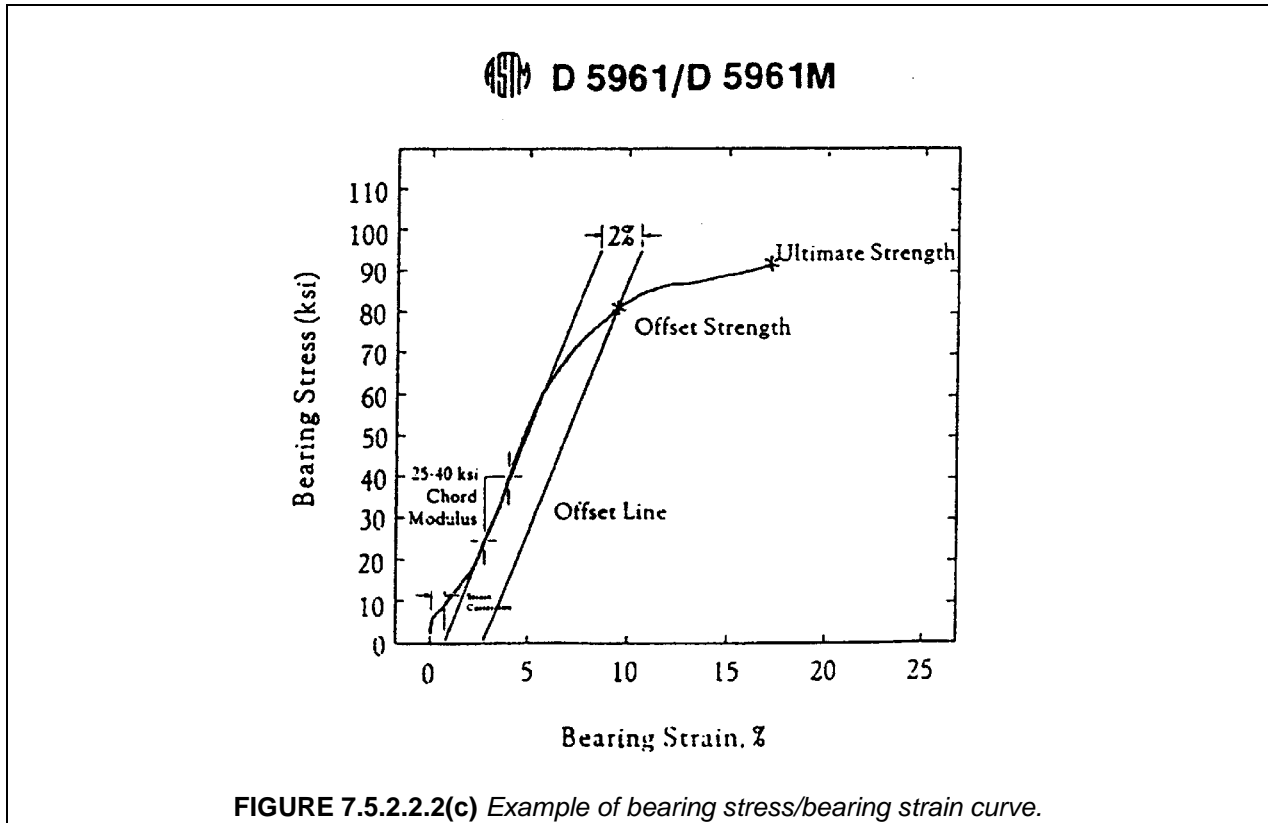

7.5.2.3 Single shear bearing tests

7.5.2.3.1 Overview

The single shear bearing test configuration is more representative of most aircraft bolted joint applications than the double shear tests described in Section 7.5.2.2. The single lap induces both bending and shear loads on the fastener, while the double lap induces mostly shear loads. Two types of single shear specimens are used, one with one bolt and the second with two bolts. The latter being closer to replicating a multi-fastener joint. Both specimens need to be tabbed to assure the load line alignment at the faying surface of the two joining plates. As such the specimens are somewhat more complex than for the double shear configuration. On the other hand, there is no need to fabricate a clevice.

7.5.2.3.2 ASTM D 5961, Procedure B

By developing Procedure B of ASTM D 5961, ASTM recognized the need for a bearing test that is representative of single lap joints found in realistic structures. Single bolt and two bolt configurations are allowed by the standard.

The recommended single fastener joint configuration is shown in Figure 7.5.2.3.2(a). This is the same specimen specified in MIL-STD-1312-X (Reference 7.5.2.3.2). It should be recognized that this joint configuration is subject to high bending due to the load eccentricity transmitted through the bolt. The bending can be reduced by increasing the stiffness of the two laps, either through increased thickness, and/or material stiffness. It should also be noted that the single fastener joint is generally not representa-

tive of multi-fastener joint applications because of excessive joint rotation and deflection. Therefore, it is generally used for screening purposes or for fastener development.

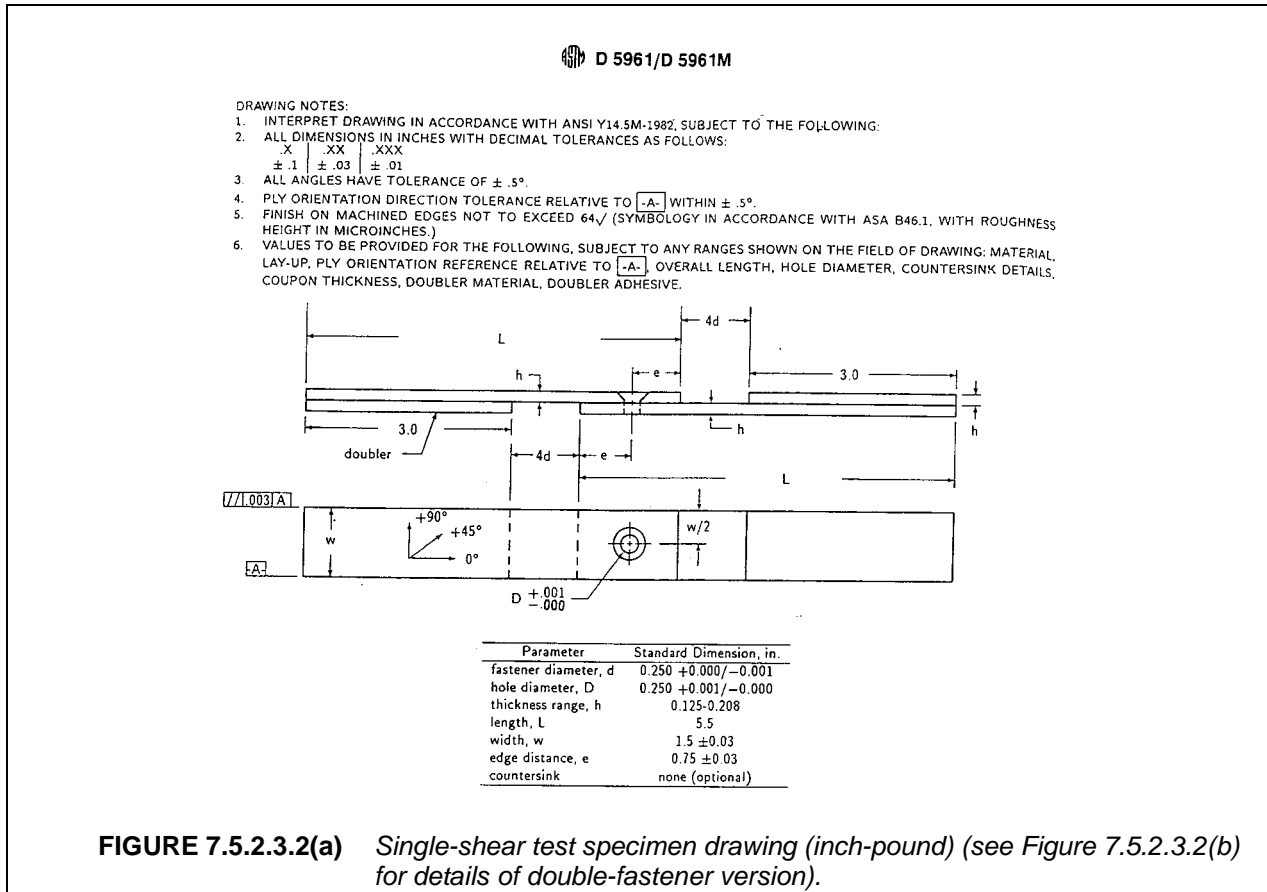

The two bolt lap configuration shown in Figure 7.5.2.3.2(b) may be used to generate both design and fastener screening data. When tested, the specimen geometry shown in Figure 7.5.2.3.2(b) is intended to result in composite bearing failures (as opposed to tension or cleavage failures). It should be noted that this specimen configuration is not pure bearing but has a by-pass load resulting in tensile strain in the two laps. The tensile bypass strain level will be low for the configuration specified in the standard, however, any configuration variations should be checked to make sure that the by-pass strain is not greater than 0.2% to prevent tensile failure of the laps. Fastener pull-thru's and fastener failures, although not acceptable as a measure of composite bearing strength, do provide a measure of joint strength for a particular fastener type.

Both the single bolt specimen, Figure 7.5.2.3.2(a), and the two bolt specimen, Figure 7.5.2.3.2(b), can be adopted to test metal to composite joints. A one-piece metal tongue can be machined for one lap or the tab can be bonded to a metal strip with dimensions so as to align the load path along the interface between the two laps.

Limitations of the test(s) are

Shim Allowance – The standard does not discuss the use of shims between the composite laps to simulate mating gaps occurring in actual joints. The thickness of the shim has a large influence on the bearing strength as discussed in Section 7.5.2.5. A common aerospace practice is to place

an unbonded aluminum shim between laps of the thickness equivalent to the allowable liquid shim dimension, 0.03 in. for aircraft structures.

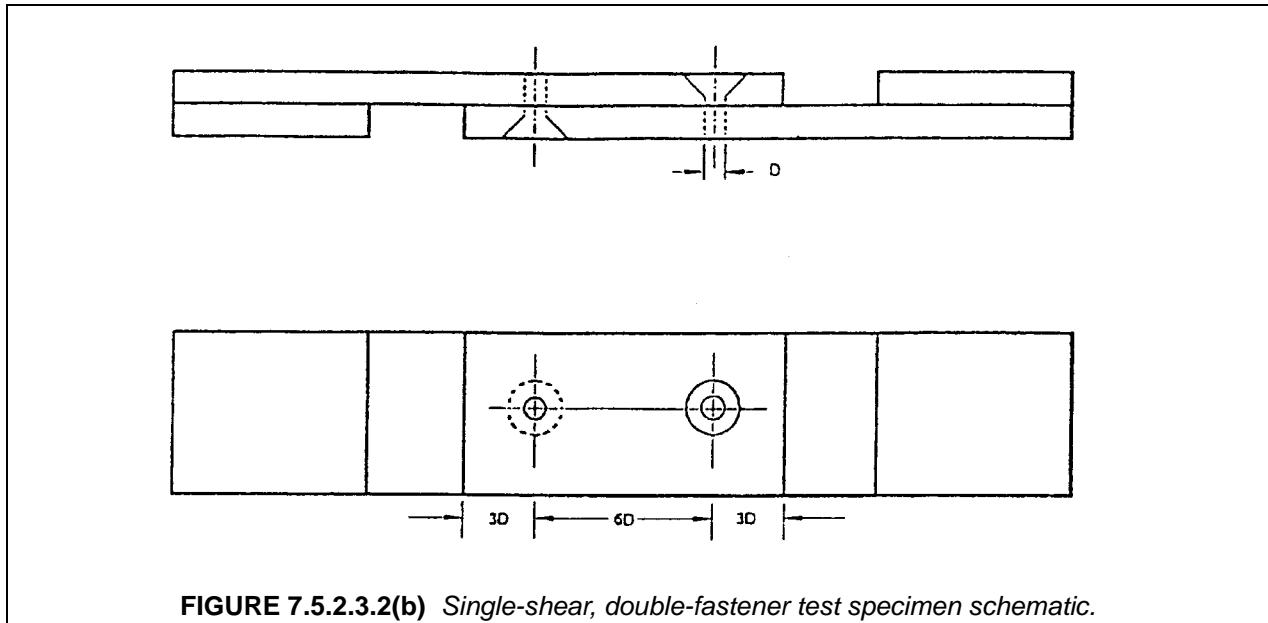

FIGURE 7.5.2.3.2(b) *Single-shear, double-fastener test specimen schematic.*

7.5.2.4 Suggested joint bearing test matrices

This section describes test matrices required to obtain design values for the bearing strength of single or double lap joints. Imbedded in the test matrices are smaller matrices, whose resulting test data can be applicable for the selection and screening of fasteners. The recommended test methods and specimens are the ASTM D 5961 Procedure A if the actual joint configuration is in double shear, and the two bolt test specimen and procedure of ASTM D 5961 Procedure B for single shear.

Bearing strength is a function of joint geometry and stiffness of the members and the fastener. It should be noted that for a $0/\pm 45/90$ family of laminates with 20-40% of 0° plies and 40-60% of $\pm 45^\circ$ plies, the bearing strength is essentially constant. In addition, fastener characteristics such as clamp-up force, and head and tail configuration have a significant effect. However, for a specific laminate family, a specific fastener, and equal thickness lamina joining members, the parameter with the greatest influence is t/D . This was recognized by the aircraft designers and all the bearing data for metals is presented in MIL-HDBK-5 (Reference 7.5.2.4) in terms of the t/D parameter, Figure 7.5.2.4. The slope of this non-dimensional curve is the bearing strength which decreases with increased t/D until for sufficiently thick laminates shear failure occurs in the bolt. The data generated using the recommended test specimens, procedures, and test matrices will produce equivalent data for composite joints.

In the design process there may be instances where the joint configuration may not correspond to the test configurations recommended here, i.e., unequal joining members, gaps, solid shims, fuel sealing provisions. These effects on bearing strengths should be evaluated by modifying the specimen geometry as needed. The test procedures presented here are still applicable.

For composite-to-composite bolted joints, the recommended test matrix for single shear bearing strength testing is given in Table 7.5.2.4(a) and the associated test specimen configuration is given in Figure 7.5.2.3.2(b).

The test data generated from the full test matrix of Table 7.5.2.4(a) will be sufficient to design composite-to-composite mechanical joints against bearing failure for one material and one fastener type. For

other fasteners, the tests with note (1) should be sufficient to provide correction factors that would be applicable to all other not-tested conditions. These are labeled as fastener supplier tests or screening tests. For screening tests, in addition to t_2 thickness, a third thickness specimen (t_3) is shown so that sufficient test data would be generated to construct Figure 7.5.2.4. For composites, this type of normalized plot is only valid for bearing data on a specific laminate.

TABLE 7.5.2.4(a) Composite-to-composite mechanically fastened joint test matrix for bearing strength.

GEOMETRY	SKIN MEMBER THICKNESS in. (mm)	LAY-UP	BOLT DIAMETER in. (mm)	ENVIRONMENT (TEMP/% MOIST)	NUMBER OF TESTS
COMPOSITE TO COMPOSITE	0.2 (5)	25/50/25	0.25 (6.4) D2	RT/ambient RT/ambient	10 ^{1,2} 5 ¹
	0.2 (5)	50/40/10	0.25 (6.4) D2	RT/ambient RT/ambient	5 5
	t_2	25/50/25	0.25 (6.4) D2	RT/ambient RT/ambient	5 ¹ 5 ¹
	t_2	50/40/10	0.25 (6.4) D2	RT/ambient RT/ambient	5 5
	t_3	25/50/25	0.25 (6.4) D2	RT/ambient RT/ambient	5 ¹ only 5 ¹ only
COMPOSITE TO COMPOSITE	0.2 (5)	25/50/25	0.25 (6.4) D2	hot/wet hot/wet	5 5
	0.2 (5)	50/40/10	0.25 (6.4) D2	hot/wet hot/wet	5 5
	t_2	25/50/25	0.25 (6.4) D2	hot/wet hot/wet	5 5
	t_2	50/40/10	0.25 (6.4) D2	hot/wet hot/wet	5 5

Notes:

¹ Supplier fastener screening tests

² Contains additional 5 specimens with 0.03 ± 0.003 in. (0.76 ± 0.08 mm) liquid shim gap between members (optional)

Single shear configuration per Figure 7.5.2.3.2(b) or double shear configuration per Figure 7.5.2.2.2(a).

Tests should be conducted at room temperature ambient conditions, and one hot, wet condition. The hot, wet test should be conducted on specimens after they are preconditioned to equilibrium level moisture content (see Section 2.2.7.2). The recommended temperature for the hot, wet test is $T_g - 50F^\circ$ ($T_g - 28C^\circ$), based on the wet glass transition temperature. Hot/wet tests are conducted after specimens have been preconditioned.

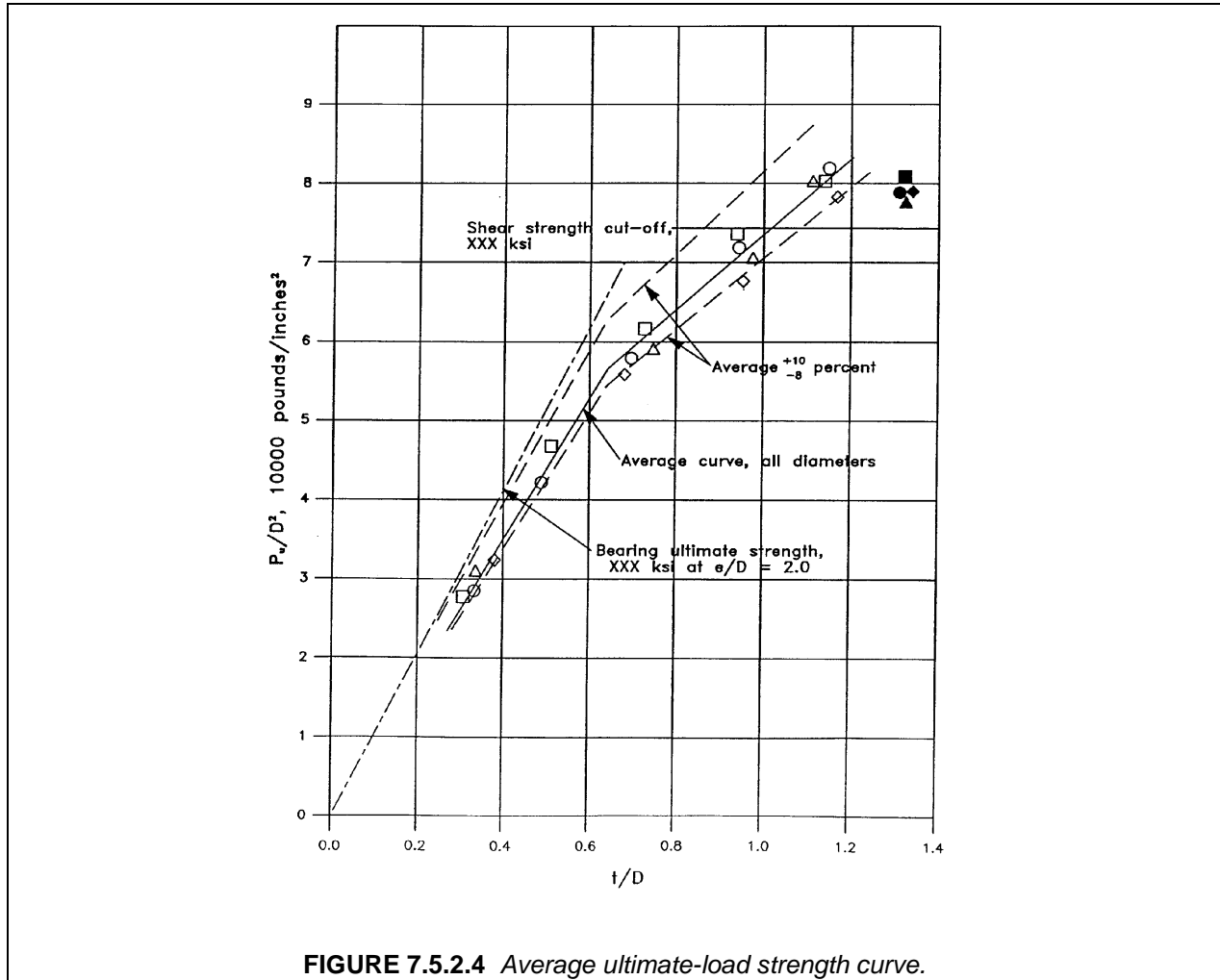

FIGURE 7.5.2.4 Average ultimate-load strength curve.

In the design test matrix two different composite lay-ups are shown at each thickness. The lay-up varies from quasi-isotropic $(45/0-45/90)_{ns}$ to an orthotropic lay-up of 50% 0° plies in the load direction $(45/0/-45/90/0_2/45/0/-45/0)_{ns}$. For a fabric material, the lay-up percentages for the latter laminate have been modified to $(40/20/40)$. One other thickness (t_2) and bolt diameter (D_2) are left unspecified; their choice should be dependent on the application. Two environments should be tested, room temperature as received and hot/wet. The selection of hot/wet temperature and moisture content should be guided by Section 2.2.8.

The baseline 0.2 inch (5 mm) thick quasi-isotropic lay-up with the 0.25 inch (6.4 mm) bolt diameter could be used to evaluate the effect of a 0.03 inch (0.8 mm) thick or thicker liquid shim gap between the two members (option Note (2); also see Section 7.2.5.1). A metal spacer can be used instead of the liquid shim if the spacer is unbonded to the composite.

For composite-to-metal bolted joints, the recommended test matrix for single shear bearing strength testing is given in Table 7.5.2.4(b). The general comments from the composite-to-composite bolted joints section also apply to the composite-to-metal bolted joints since the test matrices are the same. The composite-to-composite configuration is more critical than the composite-to-metal joint with respect to the design of the fastener tail; therefore, the composite-to-composite test specimen is more useful for the evaluation of fasteners by the fastener supplier. Because of the above reason, note (1) in Table 7.5.2.4(b) has been designated as tests required for a different fastener.

TABLE 7.5.2.4(b) Composite-to-metal mechanically fastened joint test matrix for bearing strength.

GEOMETRY	SKIN MEMBER THICKNESS in. (mm)	LAY-UP	BOLT DIAMETER in. (mm)	ENVIRONMENT (TEMP/% MOIST)	NUMBER OF TESTS
COMPOSITE TO METAL	0.2 (5)	25/50/25	0.25 (6.4) D2	RT/ambient RT/ambient	10 ^{1,2} 5 ¹
	0.2 (5)	50/40/10	0.25 (6.4) D2	RT/ambient RT/ambient	5 5
	t2	25/50/25	0.25 (6.4) D2	RT/ambient RT/ambient	5 ¹ 5 ¹
	t2	50/40/10	0.25 (6.4) D2	RT/ambient RT/ambient	5 5
COMPOSITE TO METAL	0.2 (5)	25/50/25	0.25 (6.4) D2	hot/wet hot/wet	5 5
	0.2 (5)	50/40/10	0.25 (6.4) D2	hot/wet hot/wet	5 5
	t2	25/50/25	0.25 (6.4) D2	hot/wet hot/wet	5 5
	t2	50/40/10	0.25 (6.4) D2	hot/wet hot/wet	5 5

Notes: ¹ Alternate fastener tests

² Contains additional 5 specimens with 0.03 ± 0.003 liquid shim gap required between members (optional)

Single shear configuration per Figure 7.5.2.3.2(b).

The recommended fatigue matrix is given in Table 7.5.2.4(c). Constant amplitude fatigue is suggested with a stress ratio of $R = -0.2$ (compressive load is 20 percent of tensile load). Frequency of loading should be selected so as to avoid excessive heating at the joint area of the specimen. For current material systems this translates to 5 Hz. This test matrix should be repeated for each fastener under consideration. The fifteen replicates per test will allow three replicates at each of the five stress levels. A load level of half the static strength is a good starting point. All tests should be conducted at room temperature/ambient environment.

The specimens with specified thickness and bolt diameter ($t = 0.2$ in. (5 mm) and $D = 0.25$ in. (6.4 mm)) have been sized to fail in bearing. Specimens should be selected based on assuring bearing failure and avoiding bolt shearing, or net tension failures either in composite or metal members.

TABLE 7. 5.2.4(c) *Mechanically fastened joint fatigue test matrix for bearing fatigue.*

GEOMETRY	THICKNESS	LAY-UP	TOTAL NUMBER OF TESTS
COMPOSITE TO COMPOSITE	t1	25/50/25	15 ¹
	t1	50/40/10	15
COMPOSITE TO COMPOSITE	t1	25/50/25	15 ¹
	t1	50/40/10	15

Notes: ¹ Supplier fastener screening tests

² Constant amplitude fatigue (R=-0.2) to 4% hole elongation measured across a single hole
Specimen geometry is the same as for static tests.

7.5.2.5 Effects of thickness/gaps/shimming

Although in most composite applications, the use of bonded joints appears more weight-efficient, bolted joints still predominate due to their higher joint reliability and the need to disassemble some joints. In the assembly of composite structure, gaps between mating surfaces will occur and the disposition of these gaps is required prior to clamp-up of the fastener. Closing excessive unshimmed gaps when installing fasteners can cause delaminations in the composite structure, however, residual gaps of any size may reduce joint performance.

Test data show that the strength of bolted composite joints depends partially on bolt diameter, composite thickness, shimmed gap thickness, and the type of shimming material used. Examples of strength reduction curves are shown in Figures 7.5.2.5(a) and (b) for the diameter to thickness ratio and shimmed gap effects for a single shear composite joint in a multiple bolt splice. These are not generic curves and generation of similar data would be required for specific user application. The reduction factors are then used to reduce the nominal allowable bearing stress. The nominal bearing allowable for a particular material system would be obtained using tests with configurations minimizing bolt bending to obtain uniformity of stress through the thickness (a large diameter to thickness ratio clevis or multi-fastener test) and using all pertinent statistical and environmental knockdowns. Joint strength reduction factors are greater for joints using liquid shims for filling the gaps than joints using metal or composite solid shims.

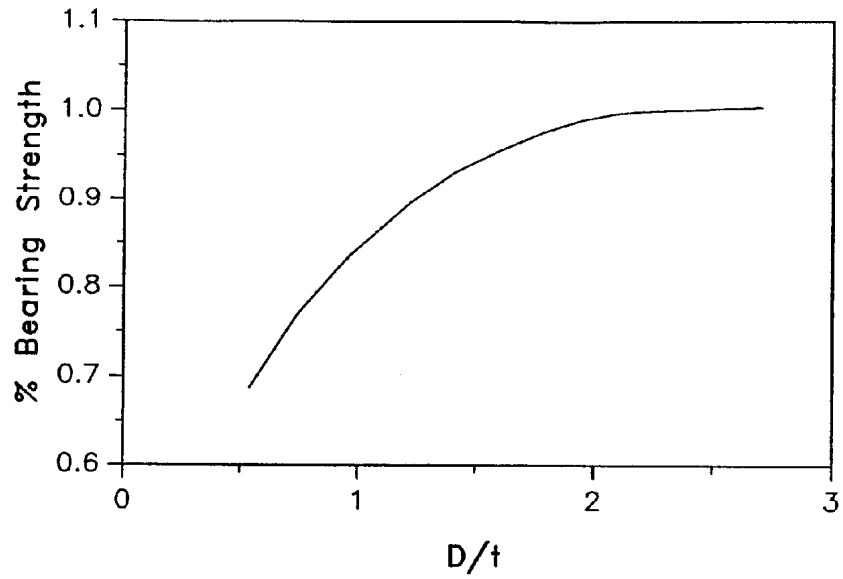

FIGURE 7.5.2.5(a) Bearing strength reduction vs D/t.

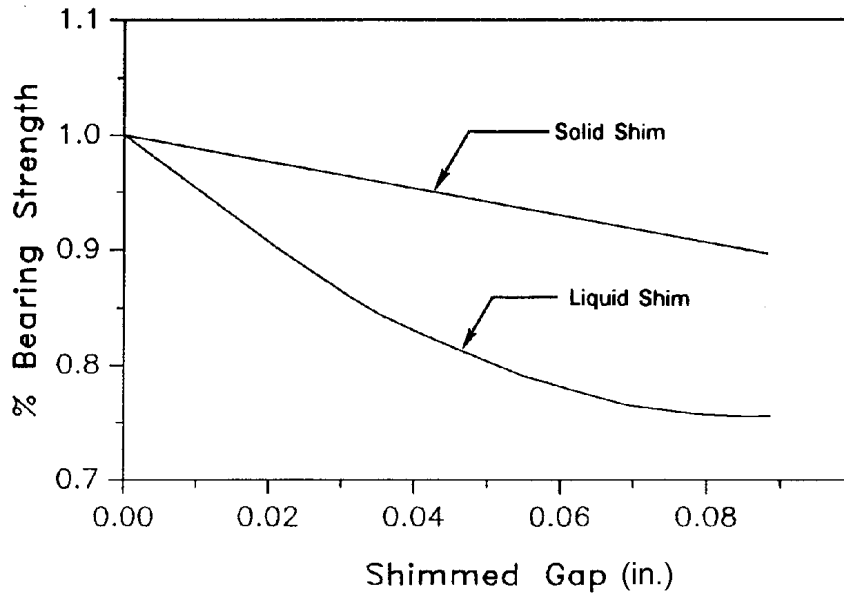

FIGURE 7.5.2.5(b) Bearing strength reduction vs shimmed gap.

7.5.2.6 Failure modes

Descriptions for failure modes are provided in Figures 7.5.2.6(a) - (d).

Laminate Failures

L-NT:	Laminate Net Section Tensile Failure
L-NC:	Laminate Net Section Compressive Failure
L-OC:	Laminate Off-Set Compressive Failure
L-BR:	Laminate Bearing Failure
L-SO:	Laminate Shear-Out Failure
L-MM:	Mixed Mode Failure
L-PT:	(Laminate allowing) Fastener Pull-Through Failure

Fastener Head/Collar Failures

F-HD:	Fastener Head Dished
F-FS:	Fastener Flange Shear Failure
F-HS:	Fastener Head, Blind or Formed Head Shear Failure
F-BH:	Fastener Blind Head Deformed
F-NF:	Fastener Collar Fracture Failure
F-NS:	Fastener Collar Stripped

Fastener Shank Failures

F-STH:	Fastener Shank Tensile Failure at Shank/Head or Formed Head Junction
F-STT:	Fastener Shank Tensile Failure in Threads
F-ST:	Fastener Shank Tensile Failure
F-SST:	Fastener Sleeve or Stem Tensile Failure
F-SSH:	Fastener Shank Shear Failure at Shank/Head Junction
F-SS:	Fastener Shank Shear Failure

FIGURE 7.5.2.6(a) Failure mode descriptions for mechanical fastened joints.

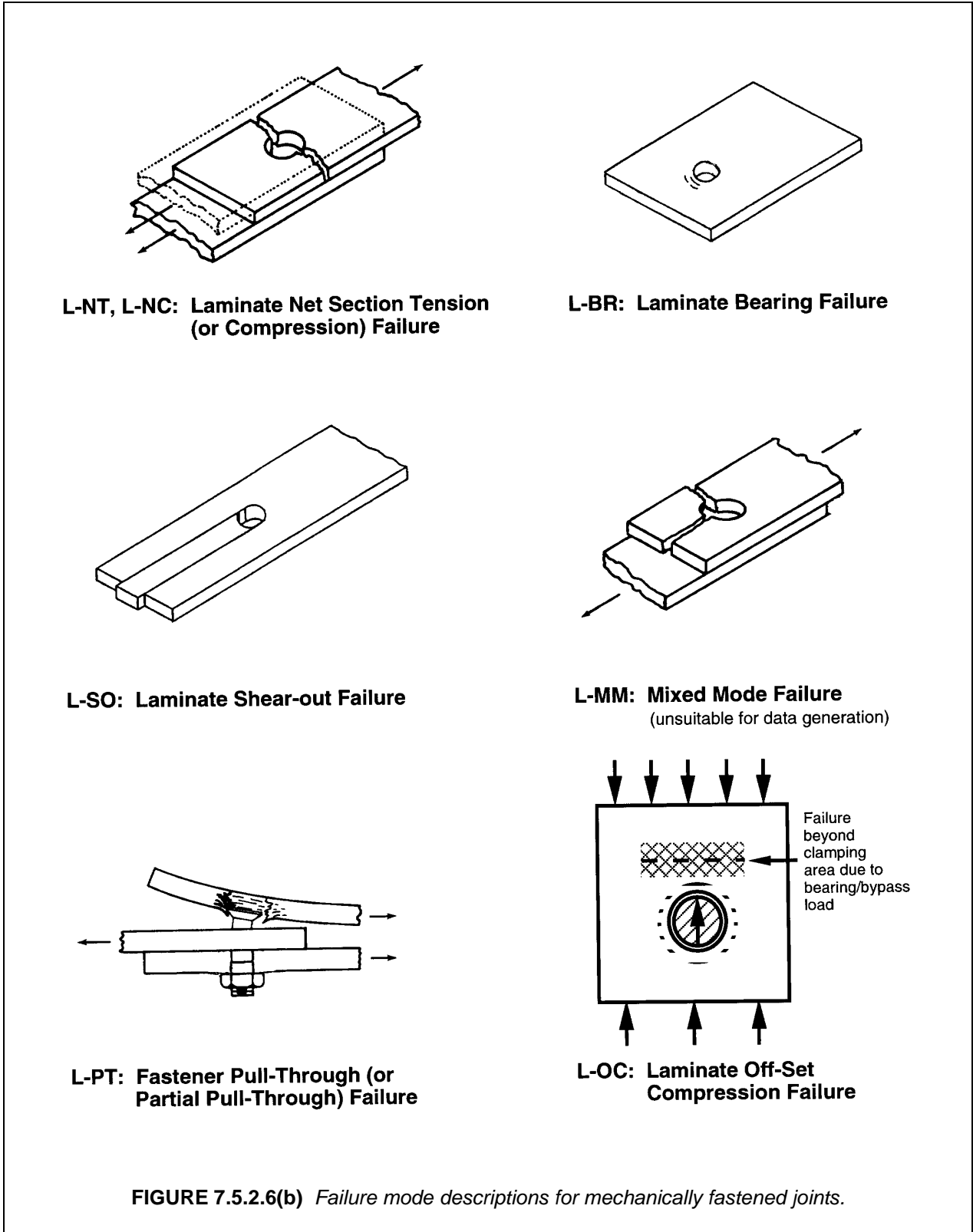

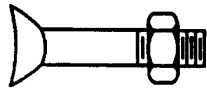

F-HD: Fastener Head Dished

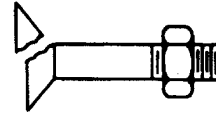

F-FS: Fastener Flange Shear Failure

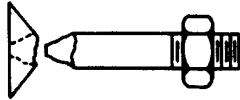

F-HS: Fastener Head Shear Failure

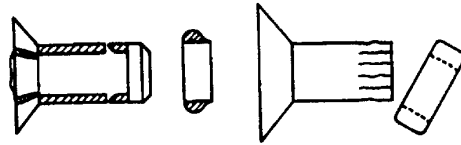

F-HS: Blind or Form Head Shear Failure

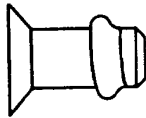

F-BH: Fastener Blind Head Deformed



F-NF: Fastener Collar Fracture Failure

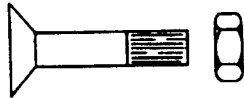

F-NS: Fastener Collar Stripped

FIGURE 7.5.2.6(c) Failure mode descriptions for mechanically fastened joints .

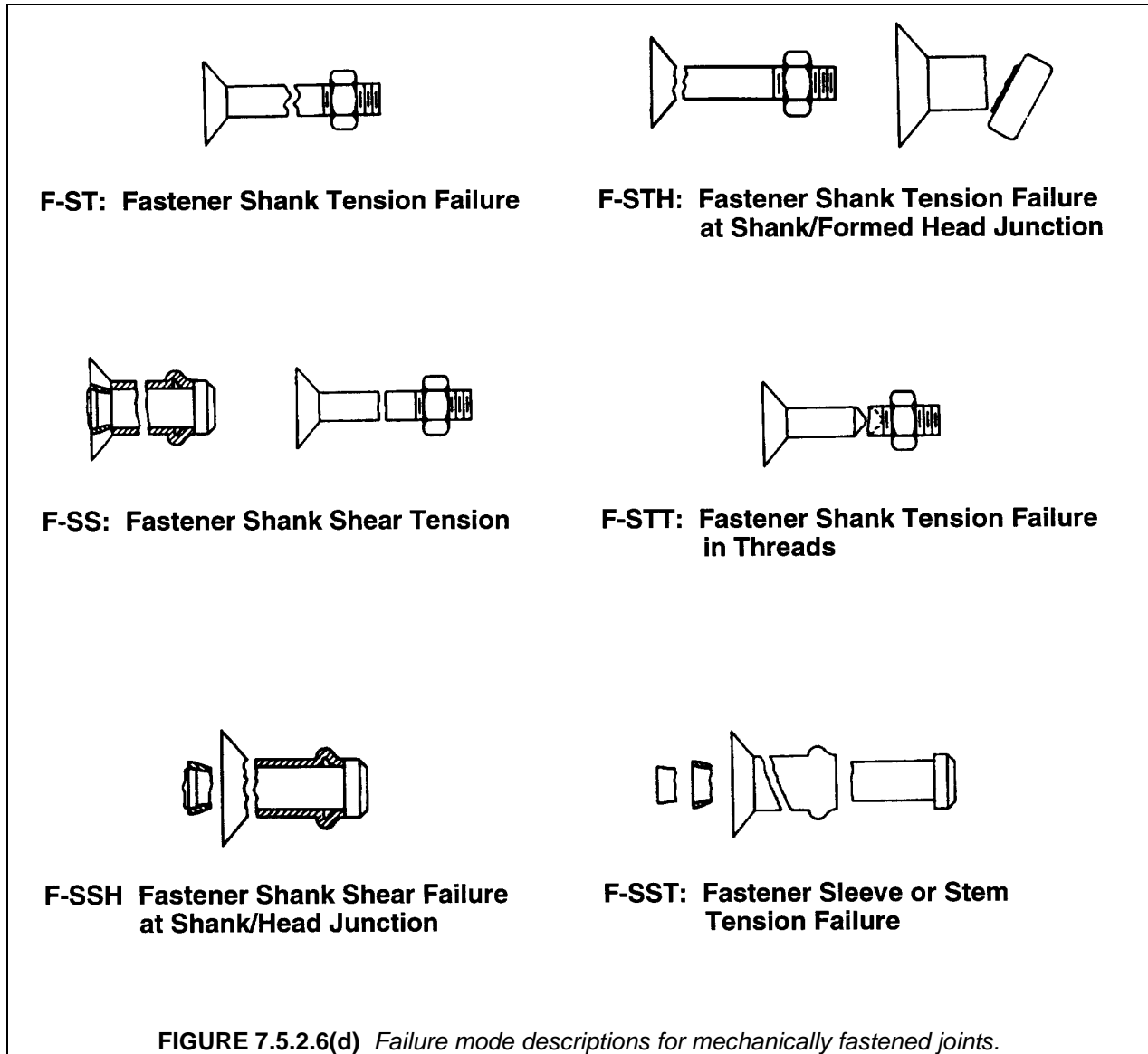

7.5.3 Bearing/by-pass evaluation

7.5.3.1 Overview and rationale

Designs of composite structure containing bolted joints in which the load transfer is greater than 20% of the total load at an individual bolt may require test substantiation. The purpose of this section is to provide guidance on how to obtain these data. Specifically, this section describes specimen geometries, test procedures, and test matrices to sufficiently define experimental lines AC and EC' in Figure 7.5.1.3 to B-basis significance for the variability and environmental dependence of the material is known *a priori*.

Analytical procedures, *e.g.*, see Reference 7.5.3.1, are being developed to reduce testing requirements. Progress has been made in the net tension/by-pass quadrant (line AC) for the failure mode characterized as net tension. For this failure mode, a good correlation was obtained using linear interaction for combined bearing/by-pass loading.

7.5.3.2 Specimen design and testing

Various specimens and test fixtures have been utilized by the aerospace industry to obtain bearing/by-pass strengths. All can be classified into three general categories: (1) passive, (2) independent bolt load, and (3) coupled bolt load/by-pass load. In the passive method, load is transferred through the bolt into an additional strap, as shown in Figure 7.5.3.2(a). The magnitude of the transferred load, and hence the bearing/by-pass ratio, is thus a function of metal strip stiffness and the details of bolt installation. Without a significant amount of strain gauging, it is difficult to establish how much bearing load will be transferred. This method/specimen is not recommended without experimental verification of load transfer parameters. Because of geometrical limitations, this method is most applicable with low load transfer usually not greater than 40%, which may not be where significant interaction effects occur. The major advantage of the passive method is that it does not need special fixturing. The testing itself is equivalent to a standard tension or in-plane stabilized compression test.

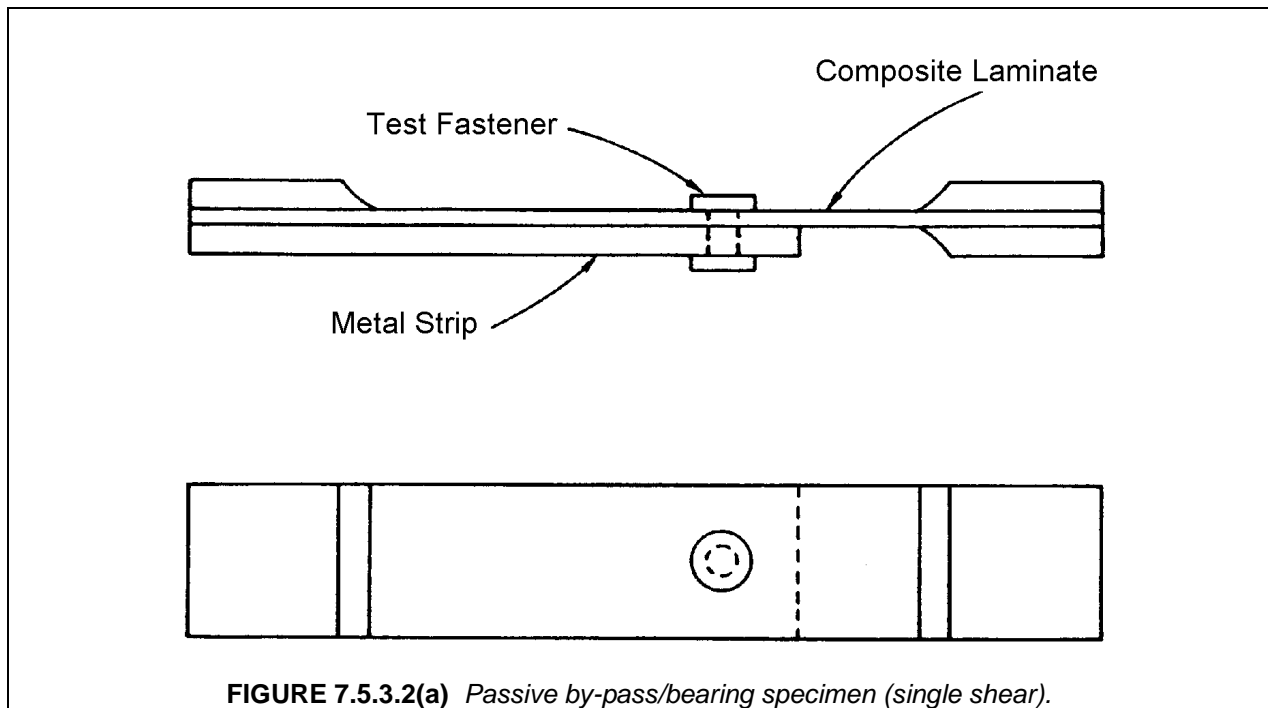
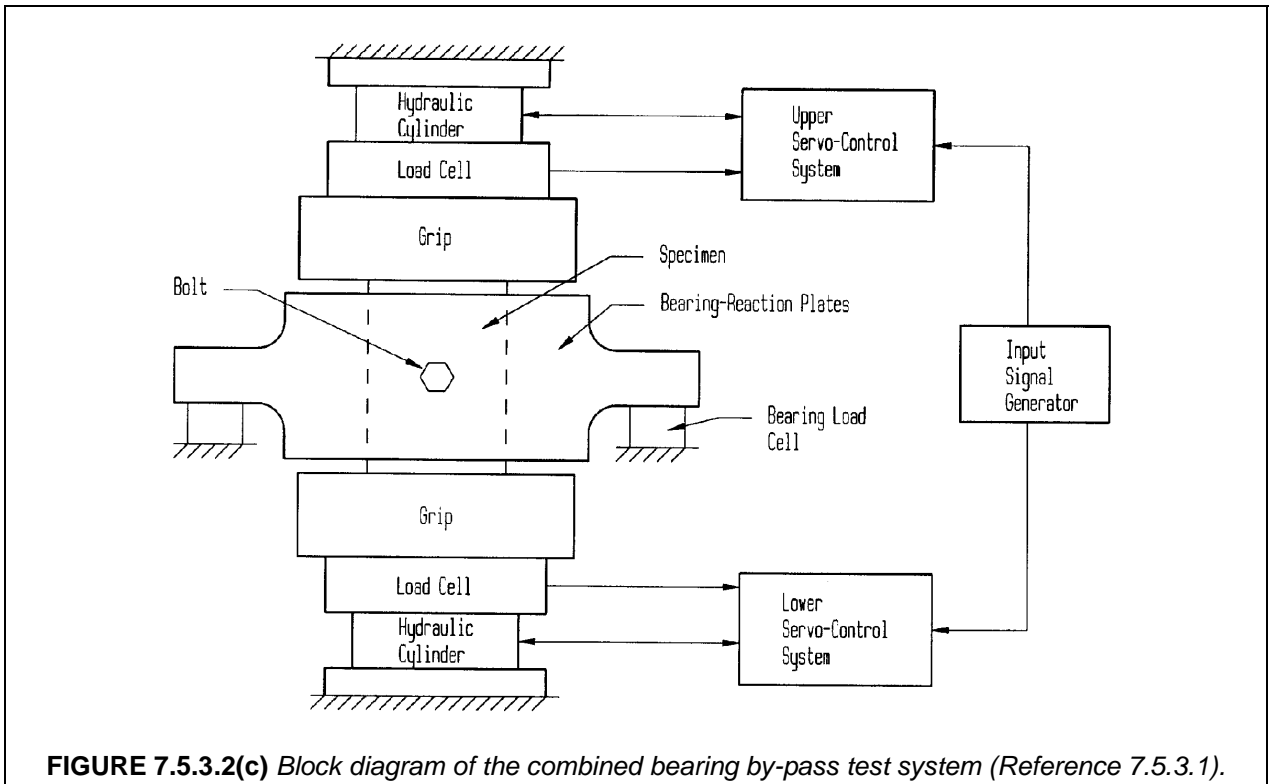
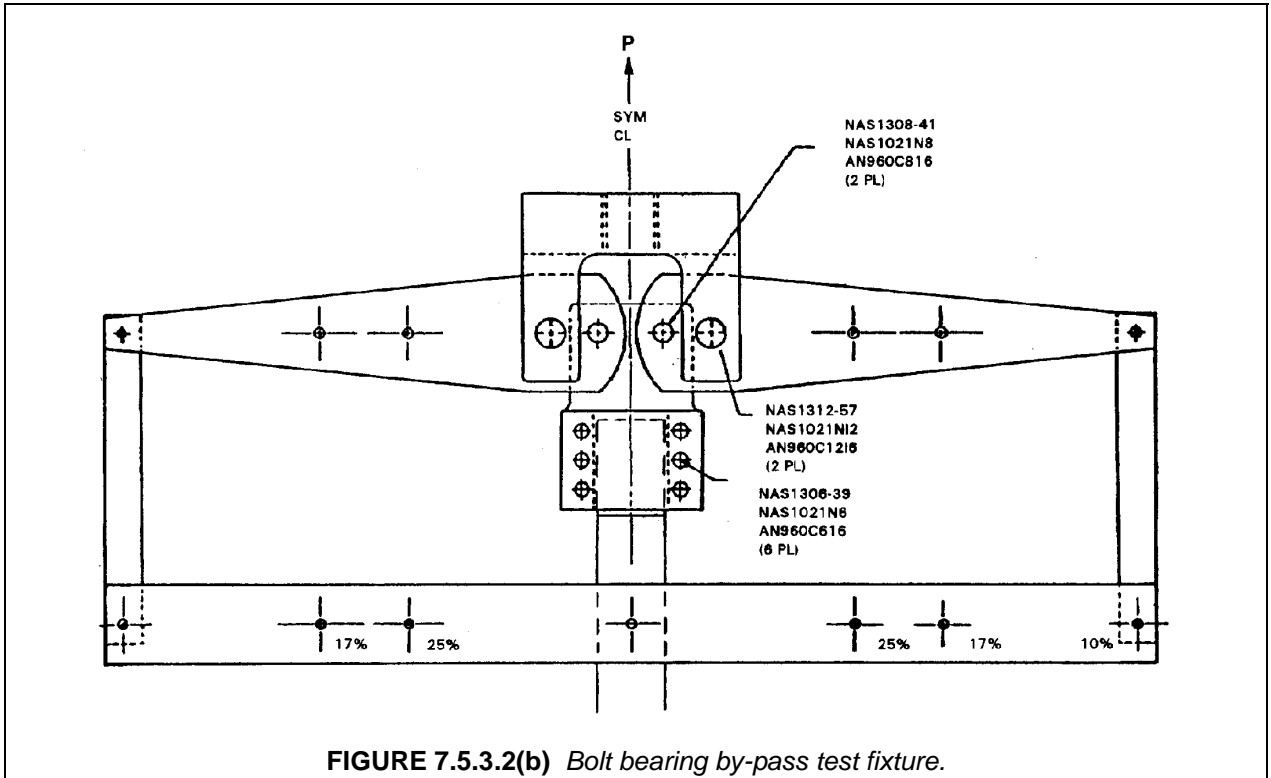
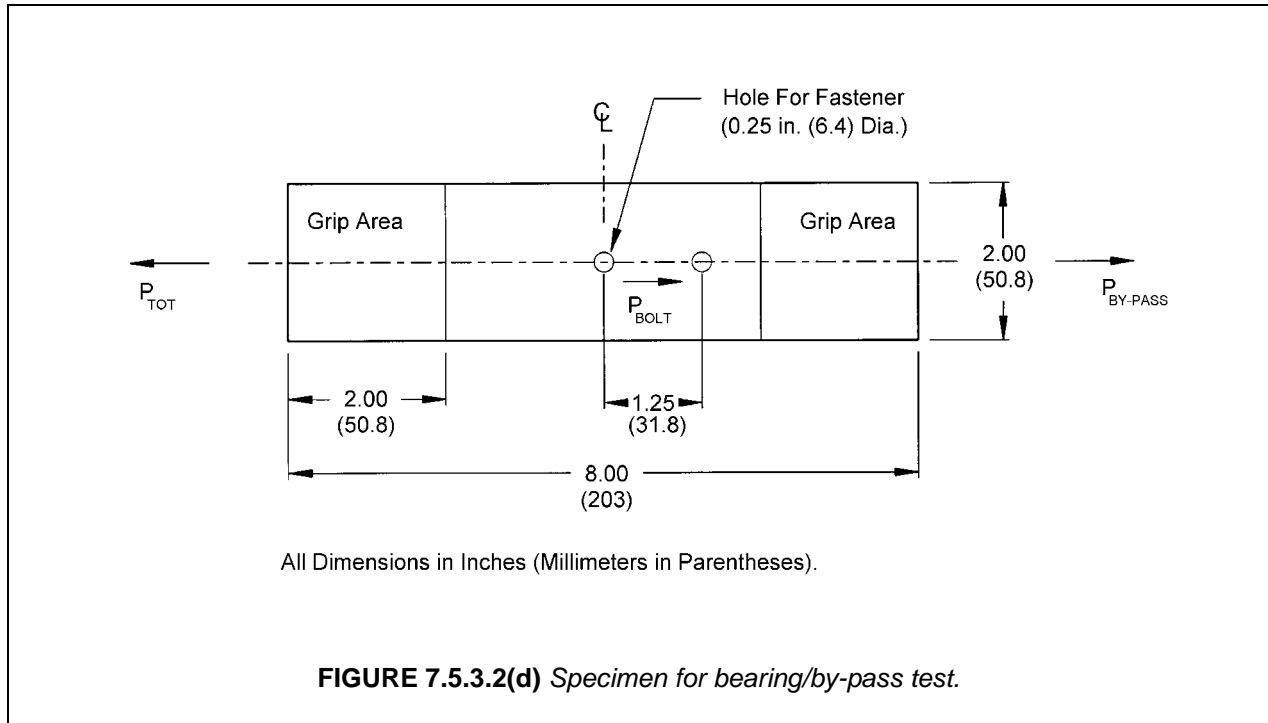

FIGURE 7.5.3.2(a) *Passive by-pass/bearing specimen (single shear).*

In the coupled bolt load/by-pass load method, the bolt is loaded by mechanical linkages attached to the test machine (Figure 7.5.3.2(b)). By locating the vertical link at different locations, different bearing/by-pass ratios can be tested. This ratio will remain constant until failure during each particular test. Because of this constraint and the complexities of test fixturing, this method is also not recommended as the primary method of obtaining bearing/by-pass data.

The recommended test method for bearing/by-pass should load the bolt independently, with the bolt load measured directly, so that the bearing stress can be calculated without resorting to backing out a value from strain gage readings on joining members. Test fixtures to accomplish this require a loading cell(s) separate from the testing machine which complicates the test procedures. Specialized test fixturing has been developed by the industry to synchronize the loading between the bolt and the specimen. One well-documented test system has been developed by the NASA Langley Research Center (Reference 7.5.3.1). Figure 7.5.3.2(c), taken from this reference, illustrates the complexities of the fixturing. The coupon from Reference 7.5.3.1 is shown in Figure 7.5.3.2(d), modified with an additional hole to alert the tester if any shear-out failures occurred. It is typical of all independently loaded test systems in the industry. It should be noted that for compressive loading, the specimen is stabilized to prevent buckling.





7.5.3.3 Suggested bearing/bypass test matrix

The minimum testing requirements necessary to construct the bearing/by-pass interaction plot of Figure 7.5.1.3 for a particular polymer matrix composite material are outlined in Table 7.5.3.3. The test matrix assumes that the end points (A and E) have been or will be obtained from no bolt load notch tension/compression tests recommended in Section 7.4. It also assumes that the points C and C₁ are obtained from the bearing strength tests enumerated in Section 7.5.2 for single shear and Section 7.2.4 for double shear. As no environmental tests other than that at room temperature have been specified in Table 7.5.3.3, the environmental effects on the bearing/by-pass strength are to be deduced from the interaction curves' endpoints. The laminate called out are the same as in Section 7.4.2 and 7.4.3. For completeness, the laminate lay-ups should be as follows: [+45/0/-45/(±45)₃/90]_{ns} for 10/80/10, [+45/0/-45/90]_{ns} for 25/50/25, and [+45/0/-45/90/0₂/+45/0]_{ns} for 50/40/10.

The test specimen and procedures to fulfill the test requirements of Table 7.5.3.3 should use an individually loaded bolt method such as described in Reference 7.5.3.1 and shown in Figures 7.5.3.2(c) and (d), or similar. The test matrix can be applied to either a single shear or double shear joint. In the event that both types of joints exist in the structure the test matrix should be repeated.

7.5.3.4 Data reduction

The data reduction procedures of notched tension and bearing tests are applicable to bearing/by-pass tests. The bolt load versus displacement plot should be obtained as for the bearing test. In addition, total of by-pass load must be recorded. Failure mode must also be described.

TABLE 7.5.3.3 *Bearing/by-pass test matrix.*

Lay-up	Environment (Temp/% Moist)	Tension		Compression		Total No. of Tests
		Bearing/By-pass ratio		Bearing/By-pass ratio		
		0.75	0.50	0.75	0.50	
10/80/10	RT/ambient	5	5	5	5	20
25/50/25	RT/ambient	5	5	5	5	20
50/40/10	RT/ambient	5	5	5	5	20
TOTAL		15	15	15	15	60

7.5.4 Shear-out strength

The shear-out strength of a material is its ability to withstand shear-out failure of the type shown in Figure 7.5.1.2. Composite joints are usually designed to avoid this mode of failure. However, by reducing the edge distance from the typical value of three times the fastener diameter ($3D$), the bearing specimens of Sections 7.2.4 and 7.2.5 can be induced to fail by shear-out. Thus these specimens and procedures are used to determine the joint shear-out strength. The shear-out strength is calculated as $P/2et$ based on the gross section. Definitions of e , D , and t are described in Figure 7.5.4(a). The shear-out failure mode in composite bolted joints can be avoided by having sufficient edge distance and interspersed stacking sequence with adequate numbers of $\pm 45^\circ$ and 90° plies. Indeed, it is virtually impossible to create a design limiting shear-out failure mode at a $3D$ edge distance without clustering together an excessive number of plies of the same direction. On the other hand, in some situations, particularly in rework or repair, short edge distances cannot be avoided. Thus the capability of laminates in shear-out must be known, even when the laminate would not fail by shear-out at the nominal edge distance.

Because a pure bearing test specimen is used to determine the shear-out strength, misinterpretations have occurred in reports that claim that the smaller e/D ratios reduce the bearing strength of the joint. While the shear lap specimens with small e/D ratios do fail at lower joint bearing stresses than the laminate bearing strength, it is because a lower joint failure has occurred in the shear-out failure mode in the shearing surfaces, preempting the bearing mode of failure.

How the failure mode changes as a function of e/D and laminate lay-up is illustrated in Figure 7.5.4(b). In this figure, failure test data for e/D ratios between 1.5 and 2.5 and for different laminates are plotted with bearing stress as the ordinate and shear-out stress as the abscissa. The plotted results show a constant shear-out failure stress irrespective of bearing stress or e/D ratio. For one laminate, even at an e/D ratio of 2.5, sufficiently high joint load was reached to fail the joint by bearing failure. The data of Figure 7.5.4(b) also show a reduction in shear-out strength when the grouping of the same direction plies are doubled from four to eight. Typical failures are shown in Figure 7.5.4(a) where a plug of material is displaced parallel to the fiber direction without any crushing of fibers ahead of the bolt. As this shear-out failure mode is a matrix failure, it is susceptible to degradation with environment.

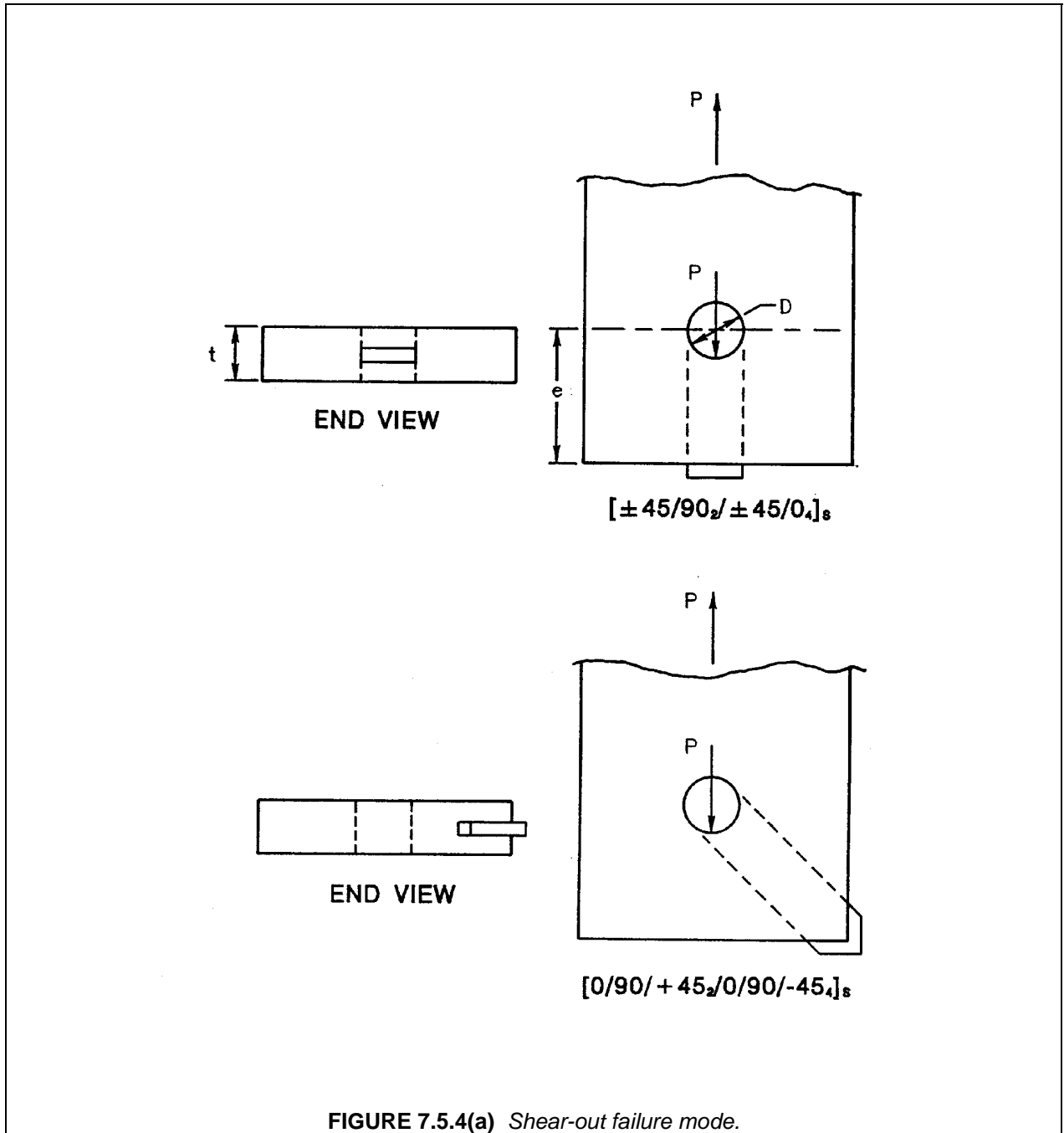

Yet other data, for laminates with fifty percent or more of concentrated plies in the bearing load direction show shear-out failures at the same load irrespective of whether the edge distance (e) is $2D$ or $8D$. So additional edge distance alone cannot be relied upon to enhance shear-out resistance of highly orthotropic laminates. To avoid shear-out failure, one must avoid large concentrations of same direction plies. The conclusion is that the shear-out strength is more dependent on the laminate and stacking order than on the edge distance.

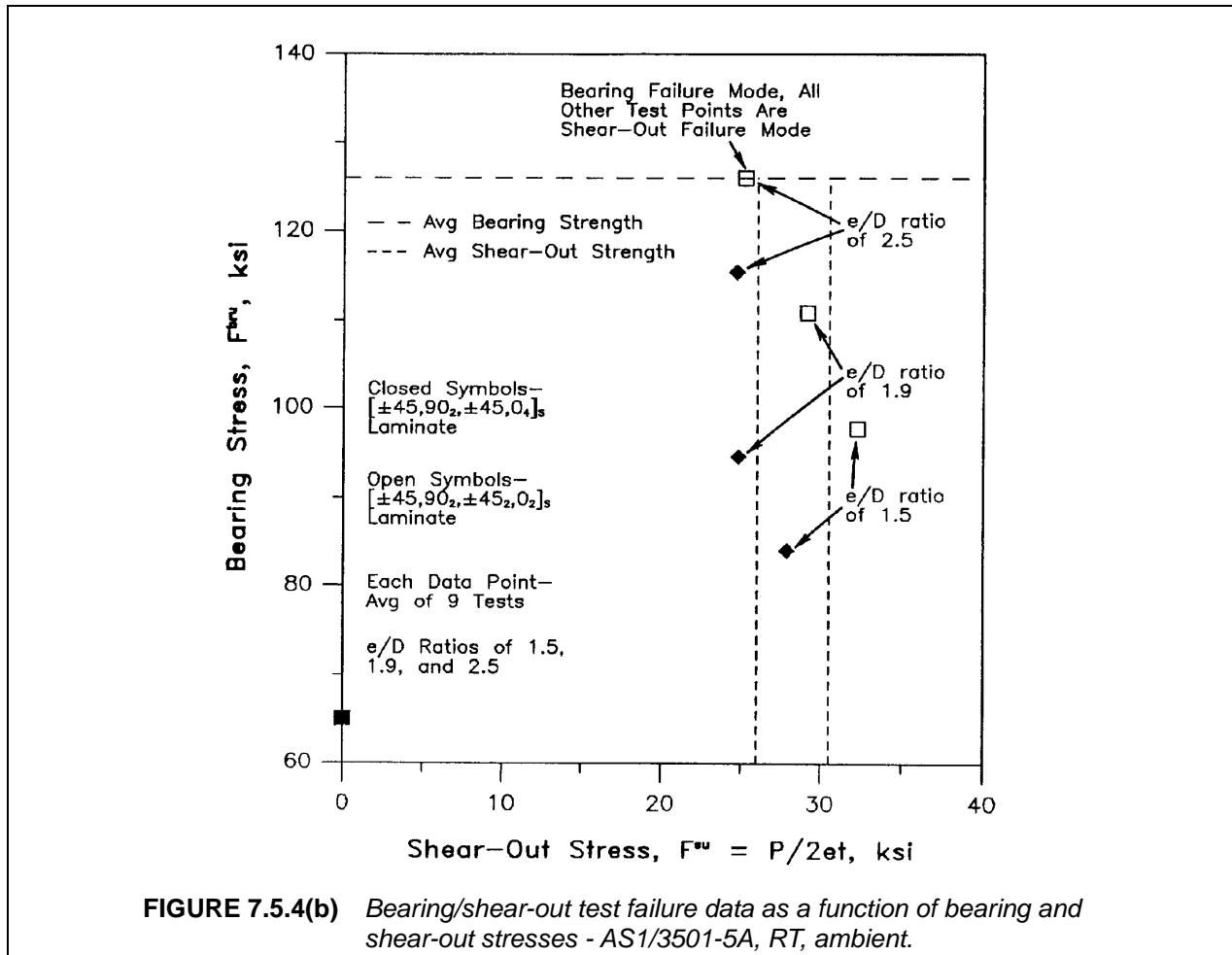

7.5.5 Fastener pull-thru strength (MIL-HDBK-17 test method)

7.5.5.1 Scope

Test procedures for determining the sheet pull-thru characteristics of mechanically fastened composite joints are described in this section. Sheet pull-thru is defined as the load level at which two composite plates attached by a mechanical fastener can no longer support an increase in load when the plates are pulled apart perpendicular to the plates' plane. Two methods are suggested; one method, an adaptation of MIL-STD-1312 Test 8 for Tensile Strength (recently being adopted by AIA Standards Committee as NAS M1312), is described in detail and for the purposes of this handbook will be called Procedure A. This method is suitable for screening and fastener development purposes. The second method, Procedure B, is suitable to establish design values, but as this test is more configuration dependent only a sketch of possible testing configuration is provided. Both methods can be utilized to perform comparative evaluations (with baseline fasteners having established usage) of the candidate fasteners/fastener system designs. It is understood that the specimens described herein may not be representative of actual joints which might contain one or more free edges adjacent to the fastener or contain multi-fasteners that change the actual boundary conditions.

7.5.5.2 Summary of test methods

Both procedures use a flat square specimen with a constant rectangular cross-section. A centrally located hole is used to install a fastener, see Figures 7.5.5.2(a) and (b). For Procedure A additional 4 holes are needed on the periphery of the specimen to accommodate the test fixture, Figure 7.5.5.2(c).

Additionally, as can be seen from Figure 7.5.5.2(a), Procedure A requires two such square plates. The two plates are joined together by the fastener, with one plate being rotated 45° degrees with respect to the second plate, Figure 7.5.5.2(d). These plates are pried apart by compressive loads that are transmitted by the fixture of Figure 7.5.5.2(c) resulting in a tensile load on the fastener and compressive load on the composite plate. For Procedure B one plate is connected to a yoke, Figure 7.5.5.2(e). The yoke loads the fastener in tension creating a pull-thru force on the joint.

Both the applied load and the associated deformation are monitored in both procedures. A typical load deflection curve is shown in Figure 7.5.5.2(f). The deflection can be measured either by the relative cross-head displacement or by an extensometer. The first peak load observed on the load displacement curve defines the structural failure load.

Procedure A test is easily performed as most test laboratories have the fixture shown in Figure 7.5.5.2(c). The only critical point is the correct installation of the test fastener. Additionally the composite plates must be sufficiently stiff to transmit the compressive fixture loading without excessive plate bending or bearing damage.

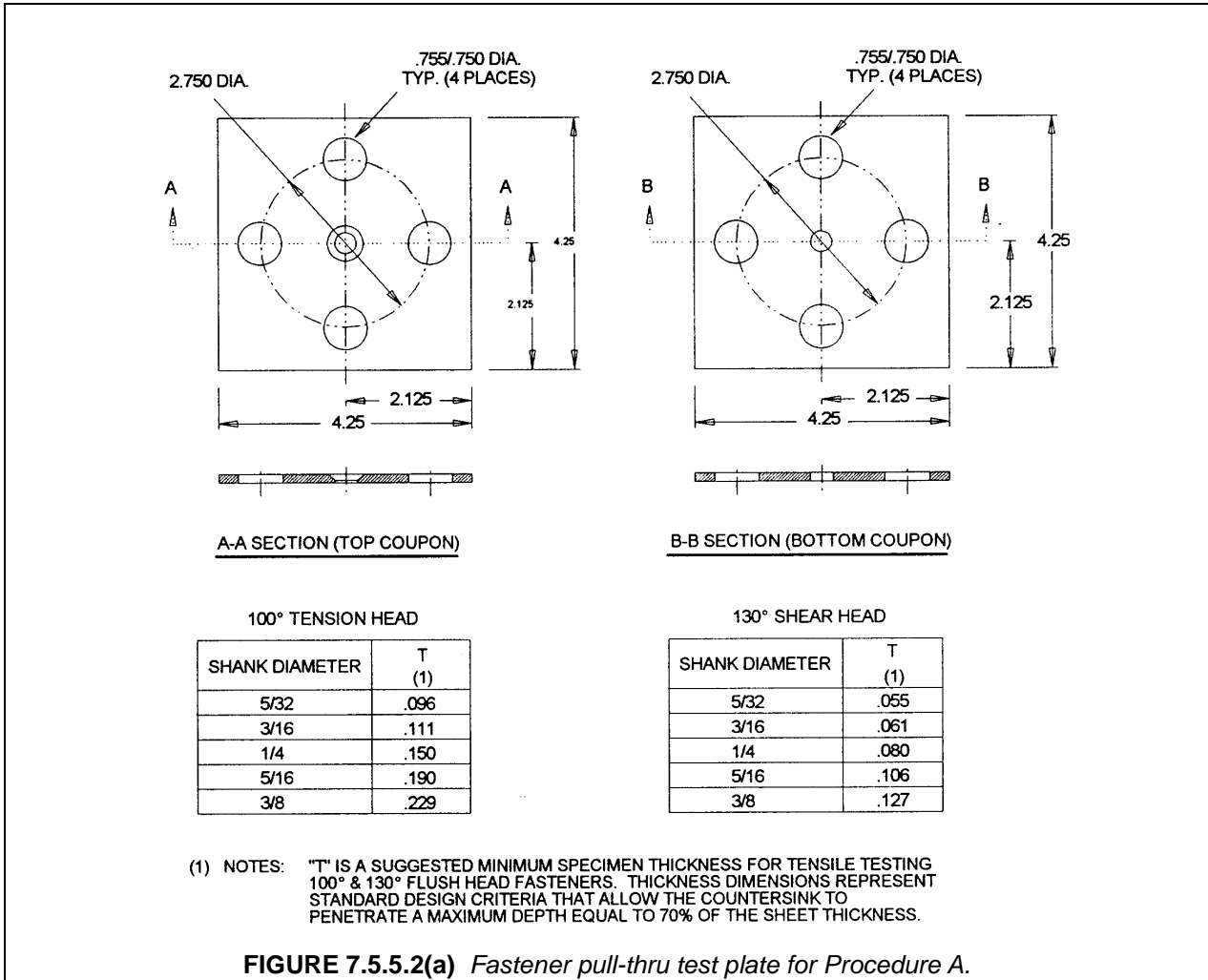

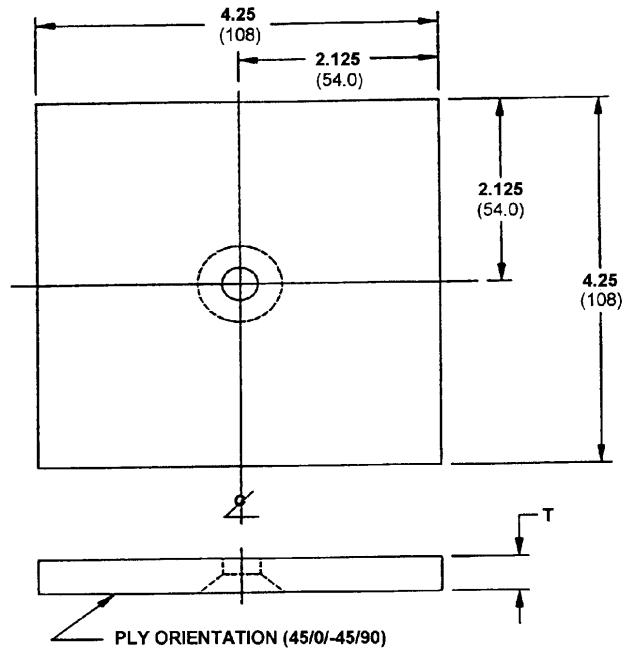

NOMINAL FASTENER SHANK DIA.	100° (1) TENSION HEAD "T"	130° (1) SHEAR HEAD "T"	CLEARANCE HOLE
5/32	0.096	0.055	1.312
3/16	0.111	0.061	1.500
1/4	0.150	0.080	2.000
5/16	0.190	0.106	2.500
3/8	0.229	0.127	3.000

(1) NOTES: "T" IS A SUGGESTED MINIMUM SPECIMEN THICKNESS FOR TENSILE TESTING 100° & 130° FLUSH HEAD FASTENERS. THICKNESS DIMENSIONS REPRESENT STANDARD DESIGN CRITERIA THAT ALLOW THE COUNTERSINK TO PENETRATE A MAXIMUM DEPTH EQUAL TO 70° OF THE SHEET THICKNESS.

ALL DIMENSIONS IN INCHES (MILLIMETERS)

FIGURE 7.5.5.2(b) Fastener pull-thru test plate for Procedure B.

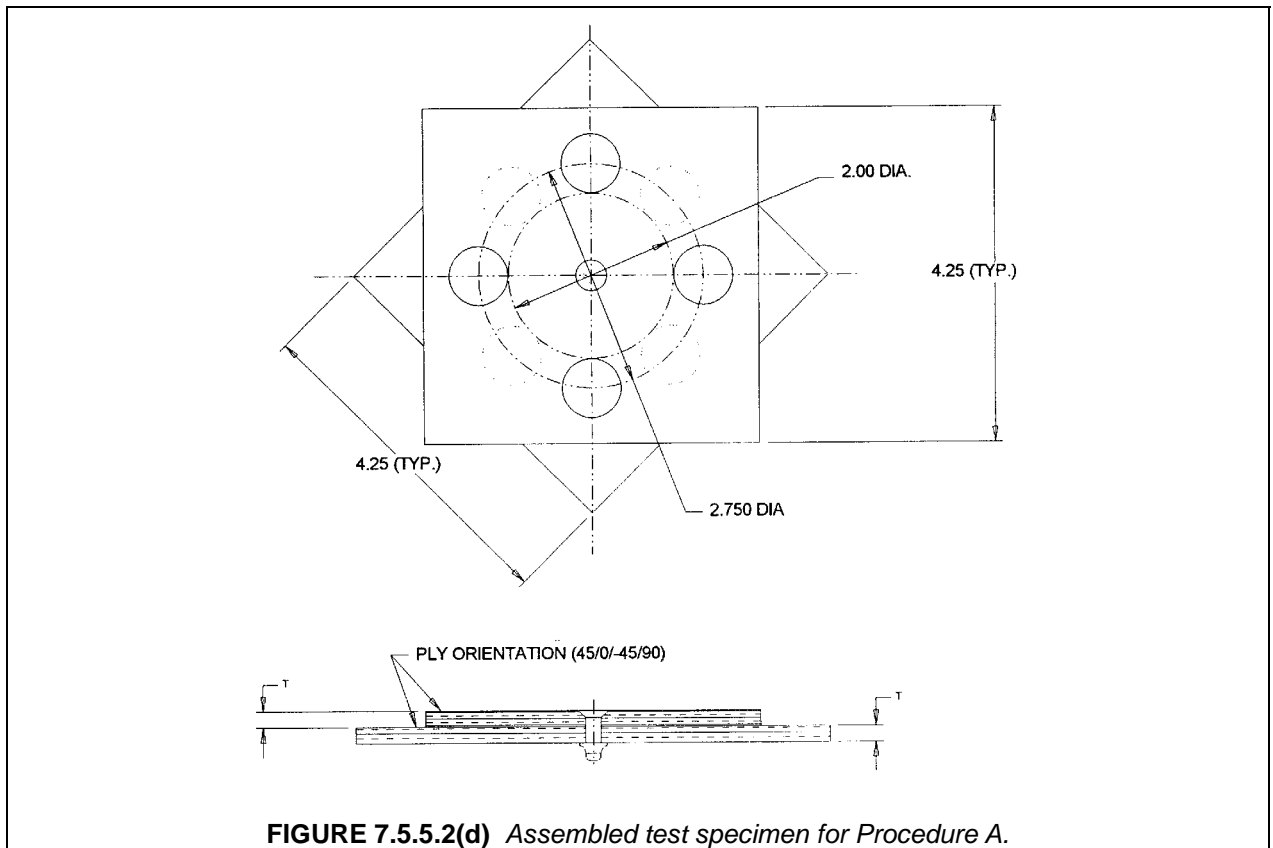
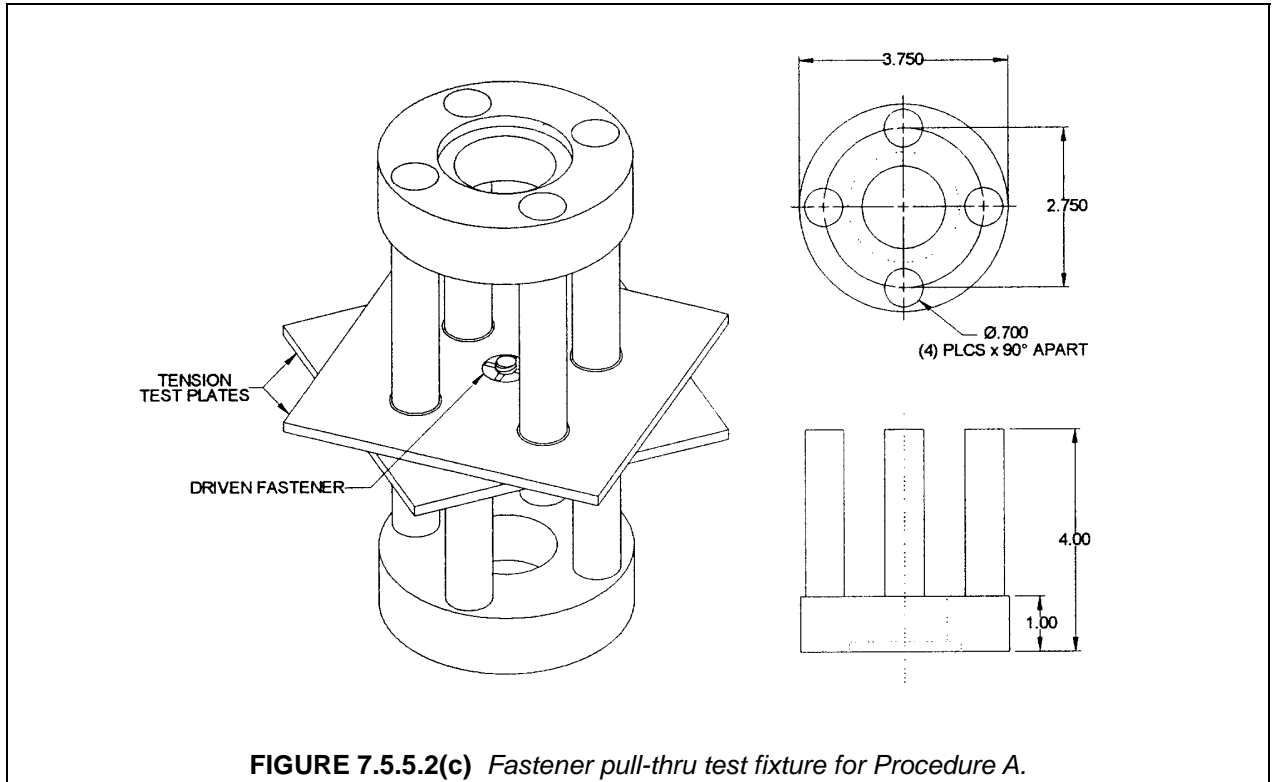

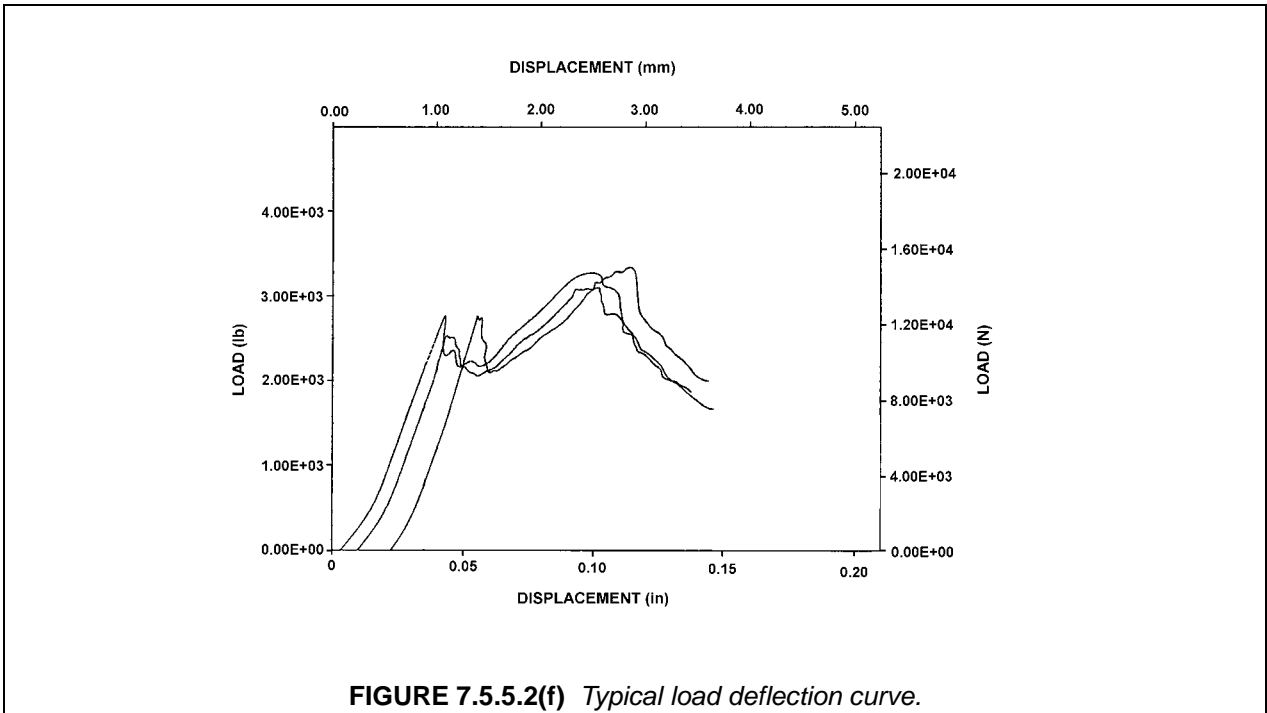
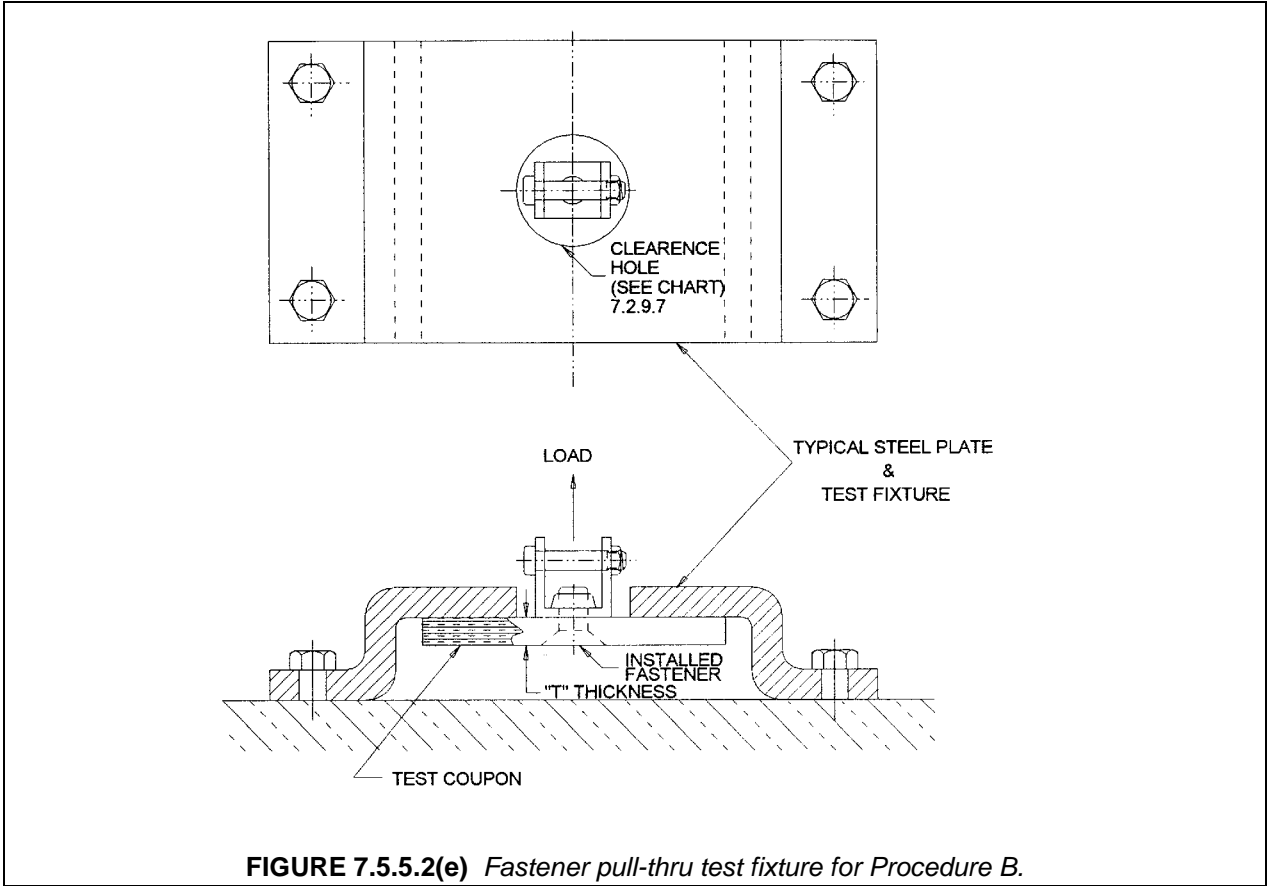

7.5.5.3 Significance

Polymeric composites are weak in the transverse direction, therefore, the test to establish pull-thru characteristics has acquired more significance than for metal mechanical joints. Early tests using fasteners common to metal structures led to premature joint failures and resulted in development of fasteners specific for composite applications. These fasteners have larger heads and tails to reduce transverse compression stress on the composite laminate. Determination of the pull-thru strength of a particular composite/fastener joint design has become a normal requirement in the design and verification of a composite structure.

In addition to determining the pull-through strength of a particular composite plate/fastener combination, these procedures can also be utilized for evaluation of different fastener components such as bolt/nuts, pin/collars, or washers to satisfy pull-thru strength requirements.

7.5.5.4 Apparatus

Test Machine - Testing should be conducted using a universal test machine capable of applying tension or compression load at a controlled rate per ASTM E 8 guidelines (Reference 7.5.5.4(a)). The calibration system for the machine should conform to ASTM E 4, its accuracy verified every 12 months by a method complying with ASTM E 4 (Reference 7.5.5.4(b)). The ultimate failing loads of the fasteners/joints should be within the load range of the test machine as defined in ASTM E 4.

Deflection Measurement – Load-deflection response should be recorded autographically. The movement sensor should be installed to measure the relative motion between the movable cross-head and the stationary cross-head. If a measuring device is used it should be an averaging, differential transformer extensometer or equivalent. It should be used in conjunction with an autographic recorder and should have an accuracy of 0.5% of indicated joint deflection at loads equivalent to 70% of the anticipated joint's strength and be calibrated per ASTM E 83 (Reference 7.5.5.4(c)). Load and deflection ranges should be used that give the initial part of the load-extension curve a slope between 45° and 60°. Load and deflection ranges and scales should be held constant for each test group (test group is defined as specimens of the same configuration, fastener type and size and their baseline counterparts).

Test Fixture - The test fixture for the screening test should be as described in Figure 7.5.5.2(c) capable of transmitting compression loads to the test specimen. The fixtures should be parallel within 15 minutes of arc and capable of loading the specimen to fastener failure without experiencing local compressive deformation. The test schematic for a more structure-representative test is shown in Figure 7.5.5.2(e). A load cell capable of applying a tensile load is required.

7.5.5.5 Test specimen

Test specimen configuration should be in accordance with Figure 7.5.5.2(a) for Procedure A or Figure 7.5.5.2(b) for Procedure B. For Procedure A, the composite ply lay up should be similar to Figure 7.5.5.2(d). The ply orientation provides a balanced laminate having a quasi-isotropic (25%, 50%, 25%) distribution. The lay-up for Procedure B has been left open and should closely mimic the actual application.

7.5.5.6 Specimen assembly

Fastener Installation – Fasteners should be installed per the manufacturer's recommendation or applicable process specification.

Grip Length – Fastener grip lengths should be selected to ensure full shank bearing through the total specimen thickness. Fasteners with load bearing tails that are formed during installation and bear against the composite test surface should be tested in both minimum and maximum grip conditions. This is because the effective bearing area may vary from one grip condition to the other.

Fasteners with manufactured heads used in conjunction with nuts or collars that do not change shape affecting the bearing surface being tested, should be tested in nominal grip condition.

Head Flushness – Unless otherwise specified flush head fasteners should be installed within ± 0.005 inches (± 0.1 mm) from the composite surface.

7.5.5.7 Test matrix

A suggested test matrix to be used for fastener screening or development is shown in Table 7.5.5.7. Procedure A test specimen (Figure 7.5.5.2(d)) is to be used in conjunction with this test matrix that represents the required testing for one fastener configuration. The testing should be performed at room temperature, ambient and hot, wet conditions. The latter is defined as the highest temperature and moisture content for the composite material (see Section 2.2.8). The test matrix is to be repeated for a different fastener, head or tail configuration, and installation hole clearance. As used in Table 7.5.5.7, Class 1 is reserved for interference fit, Class 2 for aircraft quality, usually $+0.003$ in ($+0.08$ mm), and Class 3 for clearance fit.

A test matrix similar to Table 7.5.5.7 should be constructed for the Figure 7.5.5.2(e) test (Procedure B). However, as the test is more design-oriented, fewer variables need to be tested. The replication of 5 should be maintained.

7.5.5.8 Report

The test results should be reported in terms of structural failure load, load-deflection curve, and the observed failure mode.

7.5.6 Fastener-in-composite qualification tests

7.5.6.1 Overview

A first step in design of composite bolted joints is the identification of fasteners that are suitable for use with composites. The data generated by tests outlined in this section will provide a realistic basis for selection as the tests will give a good estimate of joint strength. Composites require fasteners with larger tail footprints (than metals), especially for blind fasteners; the tests described here will interrogate this feature. After fastener selection additional test data, enumerated in Sections 7.5.2 and 7.5.6, will be needed to design bolted joints for other laminates and failure modes that are not a function of specific fastener characteristics.

The test requirements and methods have been extracted from Sections 7.5.2 and 7.5.6, thus details of testing procedures can be obtained from those sections. Testing for fastener-in-composite qualification uses only one laminate lay-up (quasi-isotropic), but more than one thickness. Also, the testing is limited to room temperature as the environment is not a driver for fasteners as it is for composites. The test program is based on the assumption that the plates to be joined are both composites. If the particular fastener is also intended for use in metal/composite combinations, testing should be performed for that configuration. The test matrices reflect two properties most affected by fastener properties: joint bearing and pull-thru strengths. It is suggested that pull-thru tests be conducted first to determine the suitability of the fastener for composites. Once that property is satisfactory, the more expensive bearing tests can be undertaken. In aircraft industry, there is also a requirement established by aircraft manufacturers and certifying agencies that 25% of bearing and pull-thru tests be tested by someone other than the manufacturer of the fastener. For inclusion of data in the MIL-HDBK-5, the fastener must be in-use by at least one aircraft manufacturer. For completeness, test requirements for fastener shear and tensile strengths are included here, although these properties are independent of joining members.

TABLE 7.5.5.7 Fastener pull-thru test matrix.

GEOMETRY	COMPOSITE SHEET THICKNESS in. (mm)	LAY-UP	FASTENER NOMINAL SHANK DIAMETER in. (mm)	INSTALLATION HOLE CLASS	ENVIRONMENT (TEMP/% MOIST)	NUMBER OF TESTS (1)
COMPOSITE TO COMPOSITE	0.190 (4.83) Head side	25/50/25	0.250 (6.35)	Class 2	RT/ambient hot/wet	5 5
COMPOSITE TO COMPOSITE	0.120 (3.05) Tail side	25/50/25	0.250 (6.35)	Class 2	RT/ambient hot/wet	5 5
COMPOSITE TO METAL (2) (Metal on head side)	0.190 (4.83)	25/50/25	0.250 (6.35)	Class 3	RT/ambient hot/wet	5 5
COMPOSITE TO METAL(2) (Metal on tail or nut side)	0.160 (4.06)	25/50/25	0.250 (6.35)	Class 2	RT/ambient hot/wet	5 5

- Notes: (1) Each grip condition where applicable (see Section 7.2.9.4).
(2) Metal thickness can be varied to accommodate fastener grip length.

Fasteners for use with carbon fiber composites should be titanium, A286 CRES or Monel to reduce the potential for galvanic corrosion. In some applications, particularly space applications, galvanic corrosion is not a problem. This limitation does not apply to aramid or fiberglass composites.

The data generated by the test program presented here will not be sufficient by itself to qualify a fastener for use in aircraft structures. Fatigue testing, manufacturing tolerances studies (grip lengths, seating angles, hole diameters) are the other criteria that have to be satisfied to complete fastener qualification requirements.

7.5.6.2 Fastener shear tests

These tests are conducted using steel plates per MIL-STD-1312, Test 13 for double shear and Test 20 for single shear (Reference 7.5.2.3.2). Evidence of previous valid qualification tests could be accepted here.

7.5.6.3 Fastener tension tests

These tests are conducted in steel plates per MIL-STD-1312, Test 8 (Reference 7.5.2.3.2). Evidence of previous valid qualification tests could be accepted here.

7.5.6.4 Fastener Pull-thru tests

Test specimen configuration to determine pull-thru strength should be in accordance with Figures 7.5.5.2(a), (b), and (c). The test procedures are given in Section 7.5.5. The test matrix, Table 7.5.6.4, requires testing for three different diameters representative of the applicability of the fastener. One diameter should be 0.25 in. This may require adjustments in laminate thickness; however, the laminate lay-up must be maintained as (45/0/-45/90)_{ns}. The test matrix is to be repeated for each fastener under consideration.

TABLE 7.5.6.4 Fastener qualification pull-thru test matrix¹.

Geometry	Composite Sheet Thickness in. (mm)	Lay-Up	Fastener Nominal Shank Diameter in. (mm)	Number of Tests ²
Composite to Composite	0.190 (4.83) ³ Head Side	25/50/25	0.25 (6.4)	5
	0.120 (4.83) ³ Tail Side	25/50/25	0.25 (6.4)	5
	t2 Head Side	25/50/25	D2	5
	t2 Tail Side	25/50/25	D2	5
	t3 Head Side	25/50/25	D3	5
	t3 Tail Side	25/50/25	D3	5

Notes: ¹All tests to be performed at RT/ambient and with installation hole Class 2.

²Each grip condition where applicable (see Section 7.5.5.4).

³May be different for other diameters.

7.5.6.5 Bearing tests

The composite-to-composite two bolt bearing specimen geometry shown in Figure 7.5.2.3.2(b) is suggested. This single shear configuration is more representative of multi-fastener joints found in the industry. With an acceptable fastener, composite bearing failure should be achieved, although secondary fastener rotation about its longitudinal axis may be evident. The test matrix for fastener qualification is shown in Table 7.5.6.5. Three different thicknesses of one lay-up (45/0/-45/90)_{ns} and three fastener diameters are suggested. One diameter should be 0.25 in. (6.35 mm) and the other two reflecting the range of available fastener sizes. Selection of additional thicknesses of the composite members should stay within these guidelines to assure maximum usefulness of data: (1) $0.8 < D/t < 2$ and (2) countersink depth should not exceed 0.67 of total laminate thickness. The goal of the tests is to obtain a family of three curves of bearing stress versus D/t ratio for each diameter tested. There should be 15 data tests for each diameter. The test matrix is to be repeated for each fastener under consideration.

TABLE 7.5.6.5 Fastener qualification bearing test matrix¹.

Geometry	Thickness in. (mm)	Lay-Up	Bolt Diameter in. (mm)	Number of Tests
Composite to Composite	0.2 (5)	25/50/25	0.25 (6.4)	5
	0.2 (5)	25/50/25	D2	5
	0.2 (5)	25/50/25	D3	5
Composite to Composite	t2	25/50/25	0.25 (6.4)	5
	t2	25/50/25	D2	5
	t2	25/50/25	D3	5
Composite to Composite	t3	25/50/25	0.25 (6.4)	5
	t3	25/50/25	D2	5
	t3	25/50/25	D3	5

Note: ¹ All tests are to be performed at RT, ambient.

7.5.6.6 Data presentation

Data presentation should follow the guidelines of Volume 2, Section 1.4.2. Additionally, bearing data should be presented as plots of bearing strength vs. D/t for each diameter tested.

7.5.7 Bearing/mechanical joint test methods for MIL-HDBK-17 data submittal

For bearing strength, test data obtained from ASTM D 5961 are publishable in MIL-HDBK-17 either as double shear values, Procedure A, or single shear values, Procedure B. For design values the two bolt specimen is more representative of actual joints.

No bearing/by-pass method is recommended, however, a test method that measures the by-pass load directly will produce acceptable data for MIL-HDBK-17.

Shear-out strength values are acceptable for MIL-HDBK if obtained from the bearing tests of ASTM D 5961. The failure mode for these tests must be distinctly observed as shear-out and not bearing.

Pull-thru strength test data from Procedure A of Section 7.5.5 is acceptable for inclusion in MIL-HDBK-17. Data obtained using Procedure B, although acceptable for establishing design values, may be very configuration dependent and hence not usable for others.

7.6 BONDED JOINT TESTS

7.6.1 Overview

In principle, bonded joints are structurally more efficient than those that are mechanically fastened. Bonded joints eliminate hole drilling for fastener installation resulting in a structure without notches that cause stress concentrations. Composite structures can have bonded joints fabricated by three different processes: secondary bonding, co-bonding, and co-curing. Secondary bonding uses a layer of adhesive to bond two pre-cured composite parts. Thus, this type is most similar to metal bonded joints in structural behavior and fabrication method. Co-curing is a process wherein two parts are simultaneously cured. The interface between the two parts may or may not have an adhesive layer. In the co-bonding process one of the detail parts is pre-cured with the mating part being cured simultaneously with the adhesive. Surface preparation is a critical step in any bonded joints and must be clearly defined before any bonding is performed. This is particularly important in secondary and co-bonding processes. More detail on bonded joint fabrication is given in Volume 3, Section 2.9.

The type of bonded joints addressed in this section are secondarily bonded and co-bonded. For these types of joints, knowledge of mechanical properties, particularly stiffness of the adhesive, is a design imperative. Well designed adhesive joints in aircraft structures are not critical in the adhesive layer but in the adherends, whether they be metal or composites, but this does not obviate the need to know the strength capability of the adhesive in shear and tension. The composite adherends are in most instances well constructed laminates with sufficient number of plies in the principal load directions ensuring that the failure mode is fiber dominated. The properly selected adhesives are formulated to be much more ductile than the resins used as matrices in composites as they are not required to provide support to fibers, particularly under compressive loading, thus steering the joint failure to the adherends. The fibers also constrain the resin so that the behavior of the matrix is also more brittle than the resin by itself. This may shift the composite bonded joint failure to a transverse, through the thickness, tensile failure of the composite laminate.

Two distinct type of tests are needed to characterize the behavior of a bonded joint and obtain sufficient mechanical data to perform structural analysis. It is assumed that the mechanical properties of the composite adherends are known. For simplicity and standardization goals, the tests to determine adhesive properties make use of metal adherends. The results of these tests provide properties of adhesive for design and analysis, comparative data, surface preparation effectiveness, but in no way represent the strength of a composite structural bonded joint. This is obtained by testing specimen configurations with composite and/or honeycomb adherends that are more application representative. Both types of testing are discussed in the sections that follow.

7.6.2 Adhesive characterization tests

Adhesive strength and stiffness data is required if successful bonded joints are to be designed. As adhesive behavior is elastic-plastic, it is not sufficient to characterize the adhesive by ultimate strength and initial tangent modulus. The data that are needed include stress-strain curves in shear and tension at the service temperature and humidity environments.

The test methods that are currently favored by the industry to obtain these data are the thick adherend test for the shear properties that was pioneered by Krieger (Reference 7.6.2 (a) and 7.6.2 (b)) and resulted in ASTM D 5656, and the ASTM D 2095 (Reference 7.6.2 (c)) test for the tensile strength by means of bar and rod specimen. None of the tests are completely satisfactory for various reasons. However, as they have gained widespread usage, it is deemed useful to have them referenced in this chapter.

Moisture conditioning of adhesive specimens to equilibrium (uniform moisture content of the entire bondline) before wet testing requires prohibitive duration times - several years. This is because of low values of moisture diffusivity of common adhesives and the use of test specimens with moisture impervious metal adherends for which water can only enter the adhesive through exposed bondline edges. For-

unfortunately, adhesive failures usually initiate at bond edges, due either to shear stress peaking or to peel (tensile) stresses. Thus, as long as a reasonable depth of adhesive near the edges has approached the desired equilibrium moisture level, test results will be representative of a fully equilibrated bondline. The common practice of exposing test specimens to the required relative humidity at reasonably high temperatures (160 to 180°F (71-82°C) for epoxies) for 1000 hours (42 days) achieves this goal. An alternative method to determine the effect of absorbed moisture on adhesives is to use cast adhesive neat resin specimens and perform tension and compression tests. As in this case the entire specimen is exposed, the times to reach equilibrium are significantly less.

7.6.2.1 Shear tests

7.6.2.1.1 ASTM D 5656 (thick adherend specimen)

This test method uses the KGR-1 extensometer that is attached to a specimen of geometry shown in Figure 7.6.2.1.1(a). Typical data obtained by this test is shown in Figure 7.6.2.1.1(b) for one adhesive at different temperatures. Because of KGR-1 design and use of aluminum adherends, the test method is limited to 300°F (150°C). For higher temperature applications titanium adherends have been used to increase the usable temperature of the method.

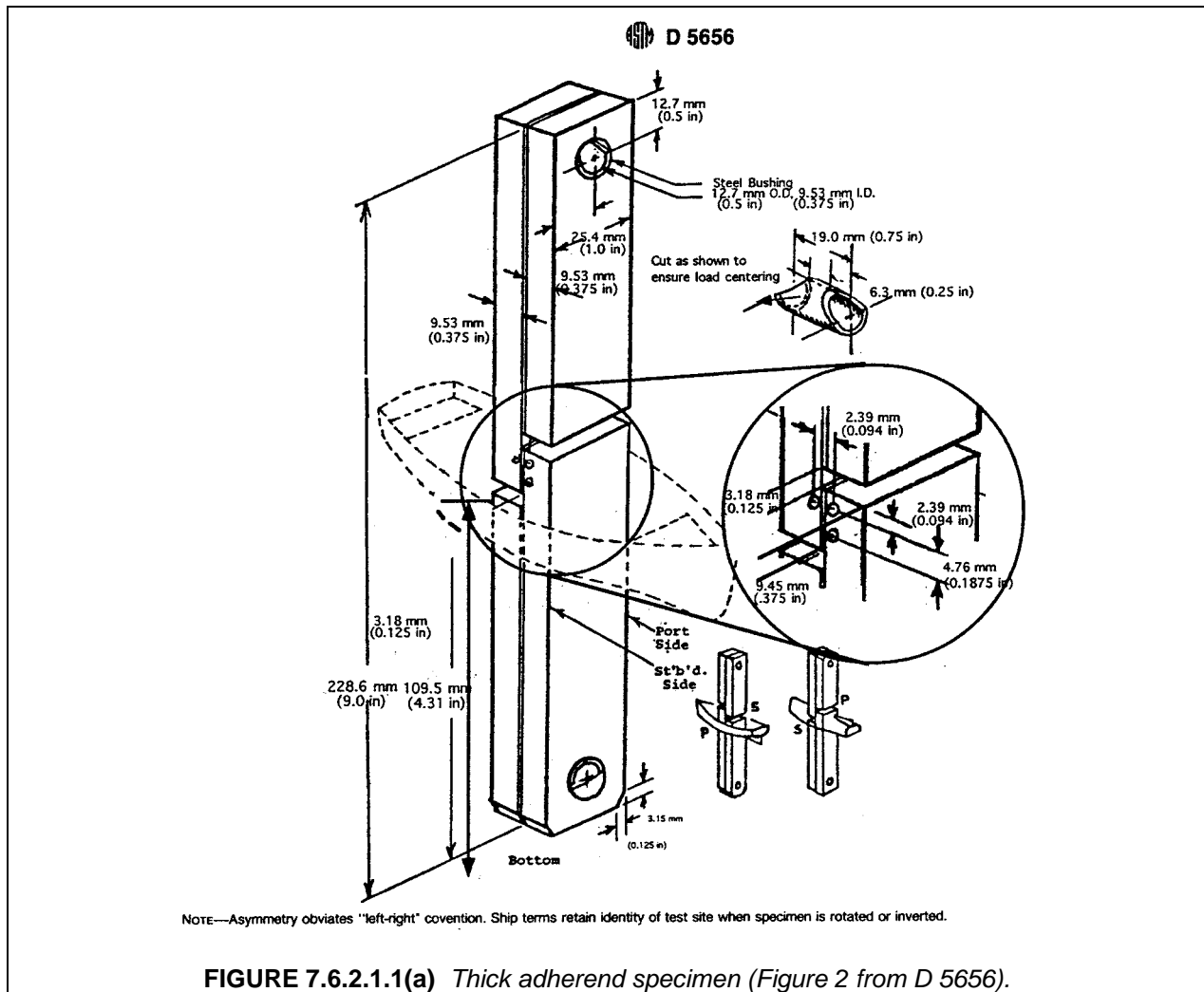

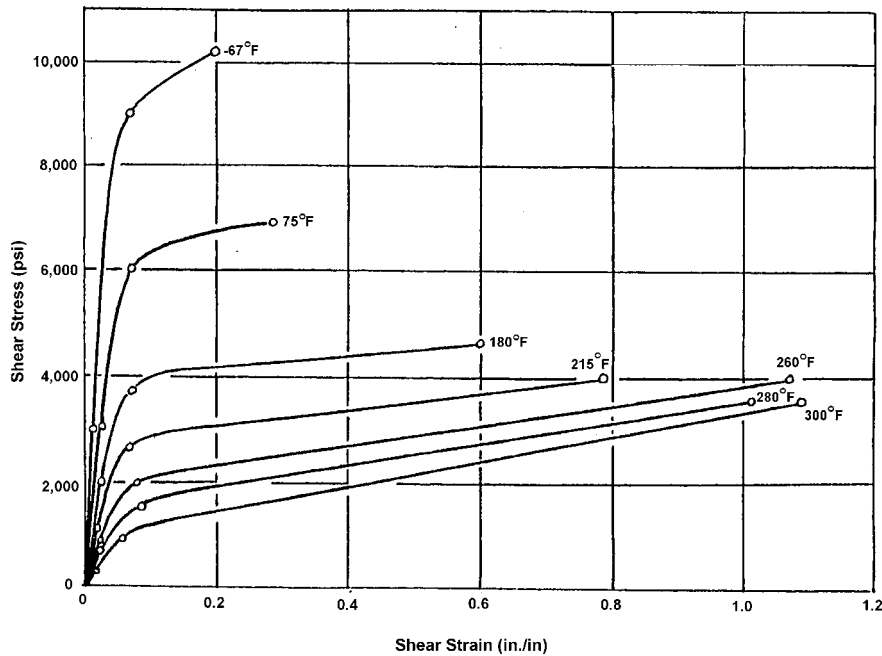
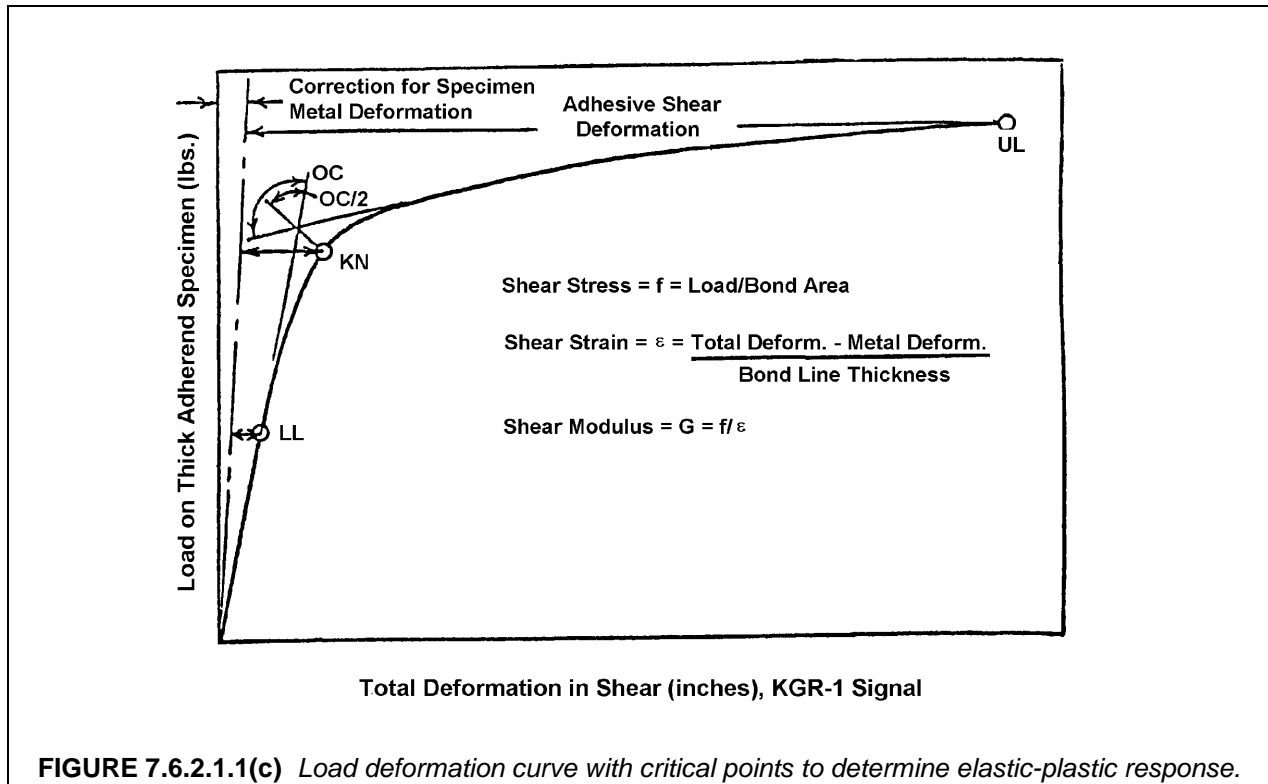

FIGURE 7.6.2.1.1(b) *Shear stress-strain response of FM 300 K adhesive at different temperatures in °F.*

How to interpret the shear stress-strain curves of Figure 7.6.2.1.1(b) in terms of adhesive shear modulus has been a subject of numerous papers. Krieger in Reference 7.6.2(a) states that only a small correction for adherend deformation is needed to obtain adhesive properties and that by characterizing the stress-strain curve using three points, all the necessary information for design of bonded joints with the particular adhesive is determined. These three points are shown in Figure 7.6.2.1.1(c). A more extensive analysis of the test method and the associated measurement device was performed by Kassapoglou and Adelman in Reference 7.6.2.1.1(a). They found the method to be reasonably accurate for soft adhesives, but suggest some improvements for other situations. However, their conclusions are limited to the elastic range and the method is considered quite adequate for measuring stress-strain response in the plastic (large deformation) region. Reference 7.6.2.1.1(b), using Moire' fringe interferometry, validated Krieger measurements, but found the method susceptible to loading eccentricities which causes early failure and large scatter in modulus measurement. Reference 7.6.2.1.1(b) also suggested using a strain gage at the geometrical center of the bondline instead of the KGR-extensometer if the data of interest is the initial tangent modulus.

For bonded joint stress analysis, the test stress-strain curves of Figure 7.6.2.1.1(b) are sometimes further simplified to a perfect elastic-plastic material response, as described in Reference 7.6.2.1.1(c). Thus, the stress-strain data as obtained by the thick adherend test, although not 100% correct, is of sufficient accuracy for the current design and analysis methodology.



7.6.2.1.2 ASTM E 229 (tubular specimen)

An alternate method to obtain shear strength and stiffness is by use of a tubular specimen loaded in torsion. The basis of the test is a narrow, annular ring of adhesive subjected to uniform shear loads around the circumference. Because the thickness of the tube is small compared to its radius, the shear stress across it is considered constant. Although the test provides pure shear distribution, the test apparatus is complex and specialized testing know-how is required which have led to the disuse of this test method. A test method utilizing the tubular specimen is the ASTM E 229 Standard Test Method (Reference 7.6.2.1.2). It uses narrow but large diameter adherend tubes and measures angle of twist by an Amsler Mirror Extensometer. Details of the test are described in the standard.

7.6.2.1.3 ASTM D 1002 (thin single lap spec. - QA test only)

The single lap shear test described in the ASTM D 1002 is a test that is widely used for comparative evaluation of the adhesive and for qualification and incoming inspection purposes. The test is also useful to evaluate surface preparation procedures as this test uses metal adherends. The main attribute of this test is that it is easy to fabricate and test.

Limitations of this test are

Shear Strength – The maximum shear stress obtained from this test (maximum load divided by bond area) has no relation to the adhesive shear strength. The stress field in the adhesive has a large component of peel stress that contributes to the specimen failure. The apparent shear strength will also be a function of the adherend modulus and its thickness. Because the apparent shear strength will vary with adherend modulus and thickness, for comparative purposes, the specimen configuration should be kept constant. ASTM D 4896 should be consulted for interpretation of test results.

Shear Stiffness – The test cannot measure adhesive stiffness because of large bending inherent in the specimen.

Joint Realism – Because the adherends are metal, the test cannot simulate failure modes of a composite to composite bonded joint. Surface preparation and adhesion are completely unrepresentative of a composite to composite bonded joint. Furthermore, as the process to fabricate composite bonded joint will be quite different to the fabrication of this metal to metal lap joint, this specimen cannot be used for in-process control.

To address the problem of joint realism, the ASTM D 1002 has been modified to admit composite adherends. ASTM D 3163 is the resulting standard. This standard, however, has all the other limitations of ASTM D 1002. When using this standard, in addition to thickness, the lay-up of the composite material must approximate the joint laminate as the apparent shear strength will vary with lay-up. For composite applications, the use of this standard is preferable if the properties of the adhesive/adherend interface characterization are of interest. If the primary purpose is adhesive characterization, then ASTM D 5656 should be used.

7.6.2.2 Tension tests

7.6.2.2.1 ASTM D 2095

Tensile strength of the adhesive can be obtained by the ASTM D 2095 method, Figure 7.6.2.2.1 (Reference 7.6.2(c)). Either bar or a rod specimen can be used in this test method. The design of the specimens and specimen preparation is described in ASTM Recommended Practice D 2094 (Reference 7.6.2.2.1(a)). The tensile strengths obtained by this test method should be used with caution as the test specimen is susceptible to peel initiated failure at the specimen edges. The adhesive failure strength can be used in an approximate peel analysis as proposed in Reference 7.6.2.2.1(b). As good bonded joint design practice minimizes peel stresses, the exact knowledge of tensile strength capability is not that critical.

An independent measurement of the Young's modulus of the adhesive is needed as the adhesive often does not obey laws of isotropic materials and can not be obtained from shear modulus measurement, i.e., $G = E / 2(1 + \nu)$.

7.6.2.3 Fracture mechanics properties

Another approach to determining the behavior of bonded joints is to use fracture mechanics. This analysis and failure criteria requires testing to obtain critical strain energy release rates in modes I and II. The tests to be performed are described in Section 6.8.6.

7.6.2.4 Suggested adhesive characterization test matrix

Tests for adhesive properties should be performed at room temperature, ambient conditions, and at low and high usage temperature extremes as discussed in Section 2.2.8. The replication should be a minimum of five at each test condition.

7.6.3 Bonded joint characterization tests

Tests of bonded joint configurations representative of actual joints must be tested to validate the structural integrity of the joint. As these specimens quickly become point design oriented, it is difficult to standardize. Thus the discussion will be limited to the simplest specimens which contain the important parameters of the bonded composite joint: geometry, composite laminates and/or metal adherends, adhesive, fabrication process, and quality control procedures.

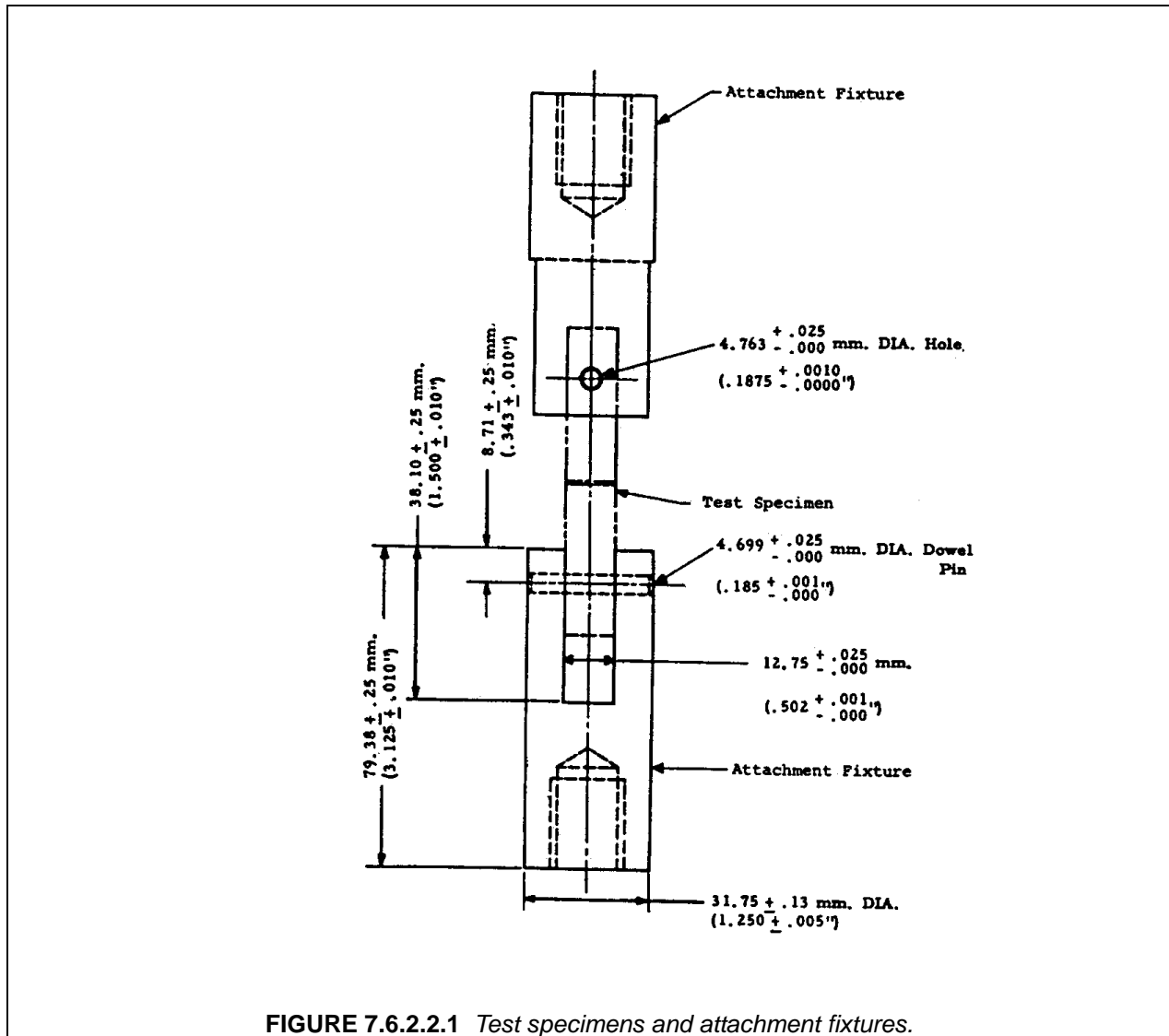

7.6.3.1 Honeycomb to face sheet flatwise tension test (ASTM C 297)

For honeycomb construction there is a need to determine the strength of the bond between the core and the facings of an assembled sandwich panel. ASTM C 297 is the test most commonly used by the industry (Reference 7.6.3.1). The specimen and test assembly is shown in Figure 7.6.3.1. The specimen size is usually 2 by 2 in., but can be round. It is important to use the same processing to fabricate the specimen as for the actual component in order to have meaningful results. This test does not determine adhesive tensile strength, but does give an indication how well the adhesive wets the walls of the honeycomb. The failure mode should be recorded, as for some configurations the bond has a higher tensile strength than the honeycomb itself. In most applications the honeycomb-to-facesheet bond has higher strength than the core, but for this test, to induce bond failures higher strength core should be used. The main difficulties encountered with this specimen are bonding of the fixture to the face sheet, especially at elevated, wet environmental conditions, and maintaining parallelism between the fixtures and the specimen.

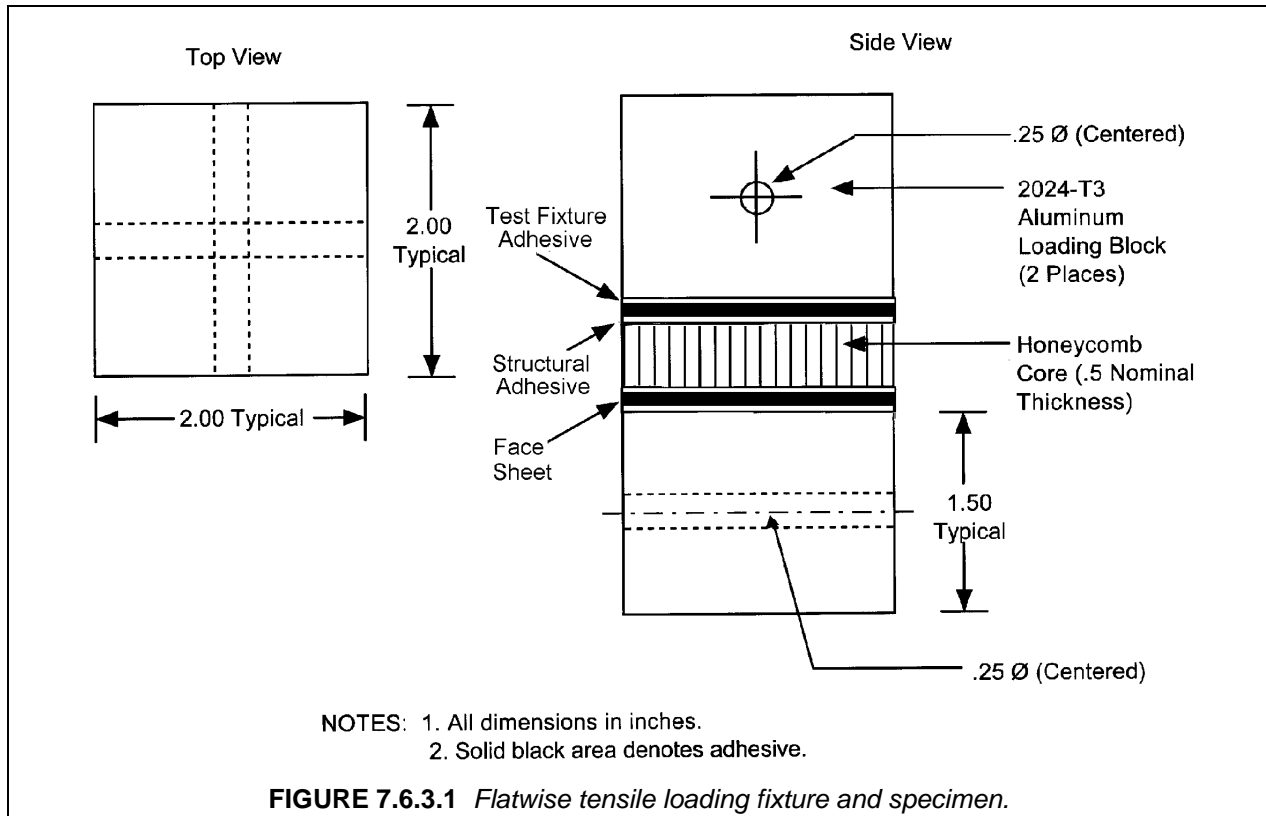

7.6.3.2 Skin to stiffener bond tests

To assess the strength of skin-to-stiffener bonded joints in situations where out-of-plane loads are being developed, i.e., fuel pressure, post-buckling, fairly simple tests are being used in the industry. Although these tests cannot completely represent the behavior of the actual structure, they provide design data and early assessment of the adequacy of selected materials and geometry before commitment to large component validation tests. The maximum benefits from these tests are obtained when the specimens represent as closely as possible the geometry and fabrication processes of the simulated component. The schematics of two such tests are presented here. The "T" pull-off test shown in Figure 7.6.3.2(a) is similar to the ASTM C-297 except that only one block is needed. Because the bending of the skin and stiffener flanges are suppressed by the rigid loading block, the disbond failure will generally occur in the heel of the stiffener and not at the flange ends. This is a serious deficiency of the specimen, if in component tests the failure is at flange ends. The location of the failure is strongly dependent on the ratio of stiffener/skin stiffness; the lower the ratio, the more useful is the test.

Using rollers to resist the pull-off load instead of the rigid block, Figure 7.6.3.2(b), can be a better method if the skin is more flexible. There is the problem how far apart to place the rollers to match the skin displacement. The specimen in Figure 7.6.3.2(b) can be used to apply a moment to the bonded joint. This is represented by P1 loads and R1 reactions in Figure 7.6.3.2(b). Post-buckling of shear panels introduces significant twisting moments in the interface and the capability of the joint against them must be determined as part the structural analysis.

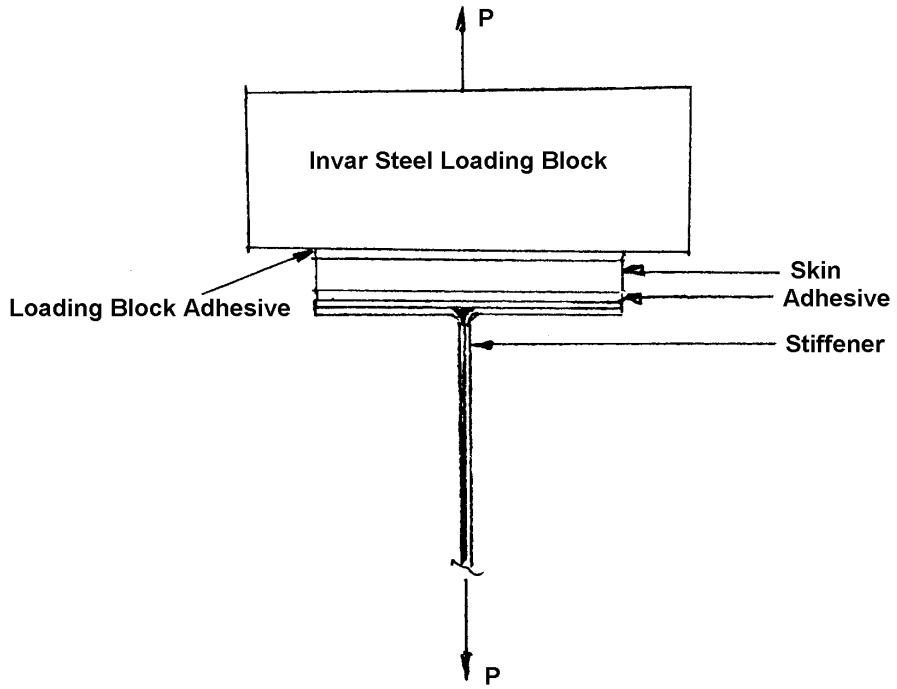

FIGURE 7.6.3.2(a) "T" pull-off specimen.

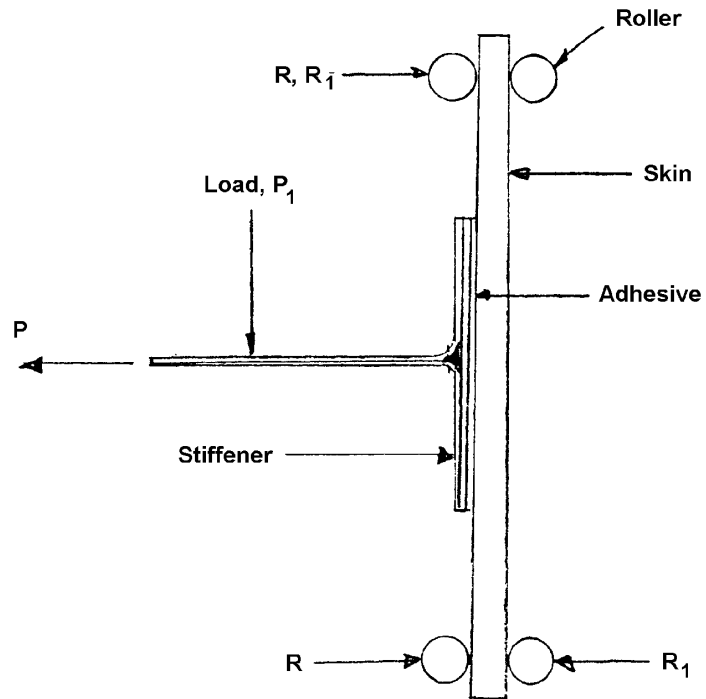

FIGURE 7.6.3.2(b) "T" twist-off specimen.

7.6.3.3 Double overlap joint tests

Double overlap specimens range between single step type to ones containing many steps and are usually loaded in tension. The complexity being dependent on what type of data is to be obtained or the structural application. An example of a specimen derived from ASTM D 3528 - 92 (Reference 7.6.3.3) is shown in Figure 7.6.3.3(a). This test specimen is useful for determining adhesive shear strength as the double shear configuration reduces peel stresses. This configuration is not usually used in design, as the load transfer capability can be increased significantly by tapering the outside adherends.

For higher load transfer, double lap joints will contain many steps. To validate such a joint, specimens of a type shown in Figure 7.6.3.3(b) have been used. These type of specimens are quite expensive to fabricate and hence are not replicated in large numbers. As these specimens are to represent a particular design, care must be taken that the specimen is manufactured using the same processes as the actual joint. Another example of a joint verification specimen is shown in Figures 7.6.3.3(c) and (d). It represents a chordwise connection between a composite skin and a titanium spar and is a double lap two-step joint.

The multi-step joint specimen could be converted to scarf joint specimen if that was the actual design.

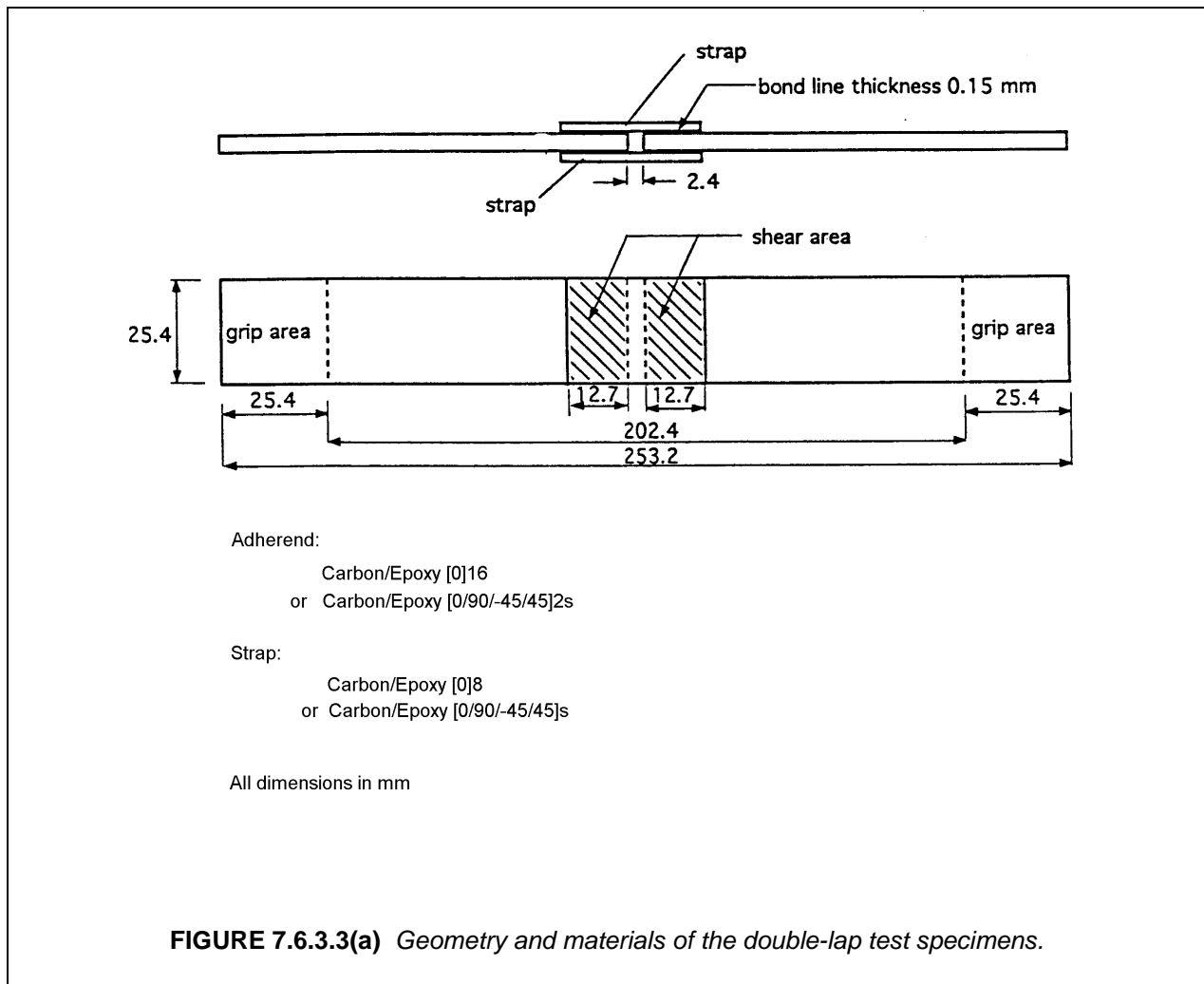

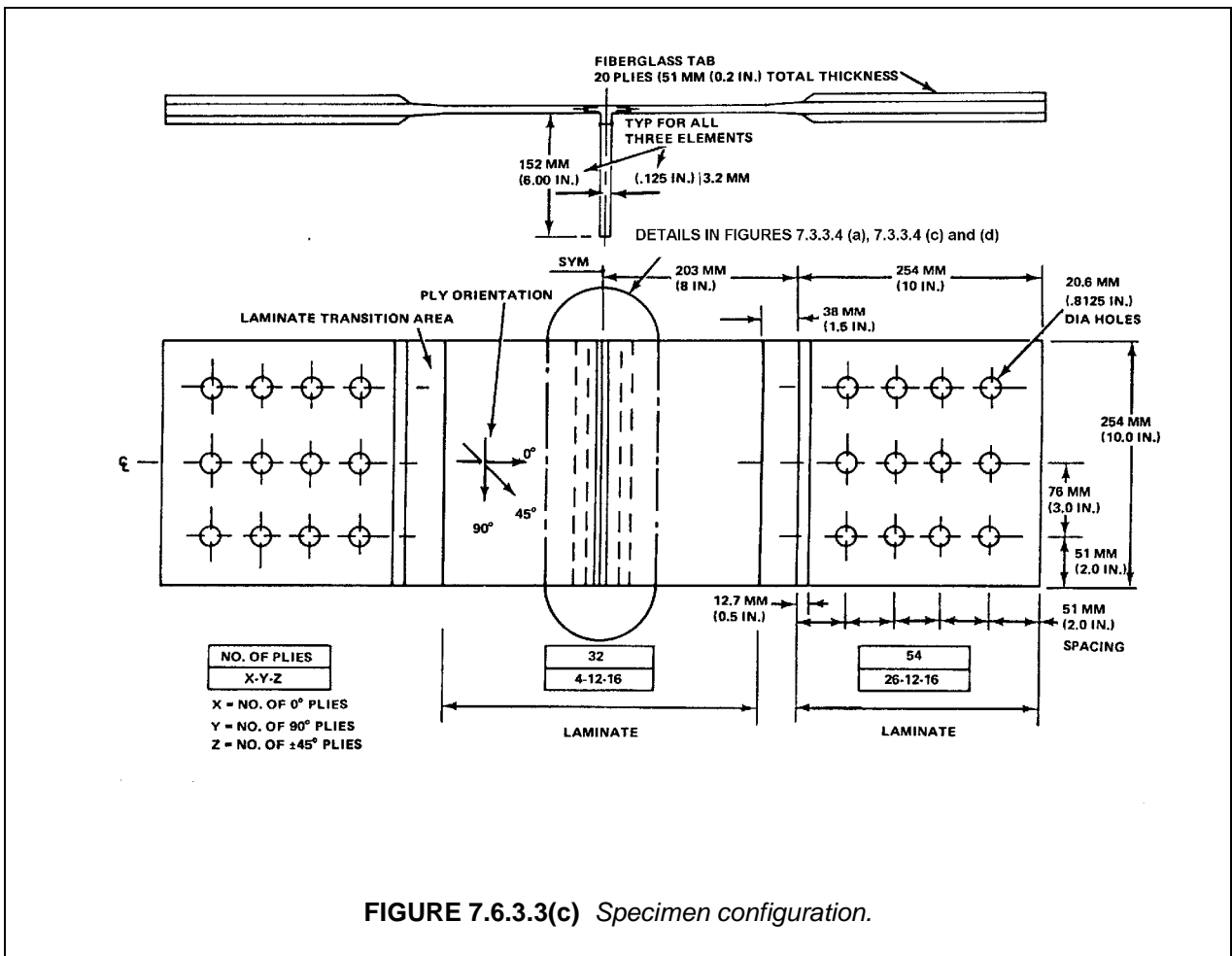
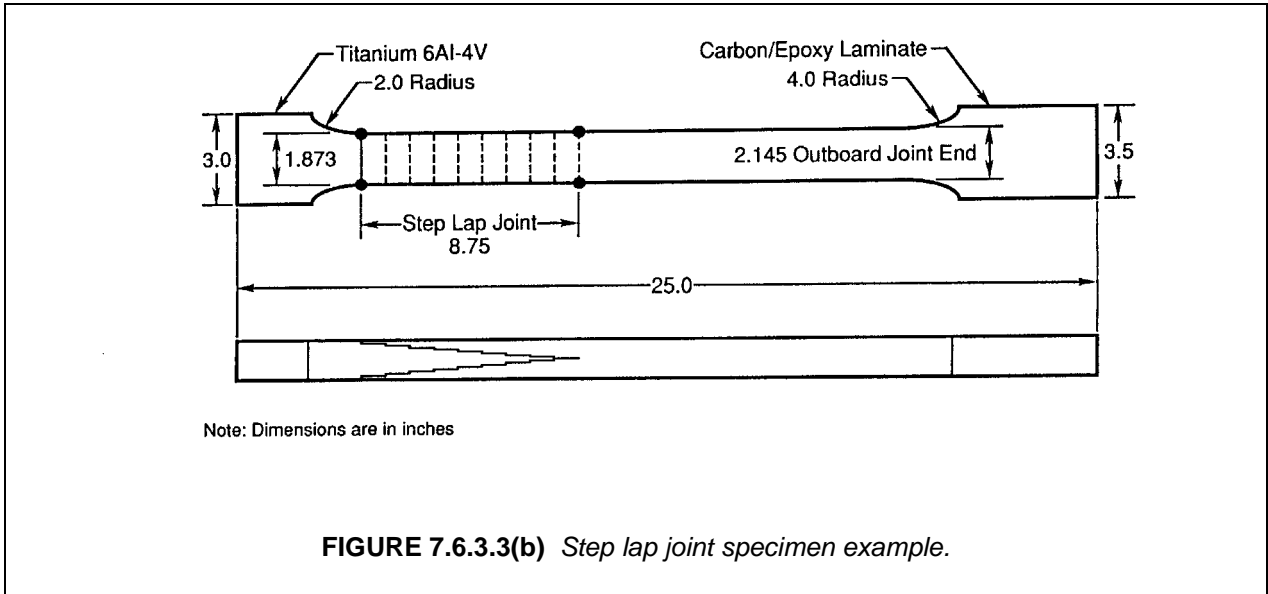

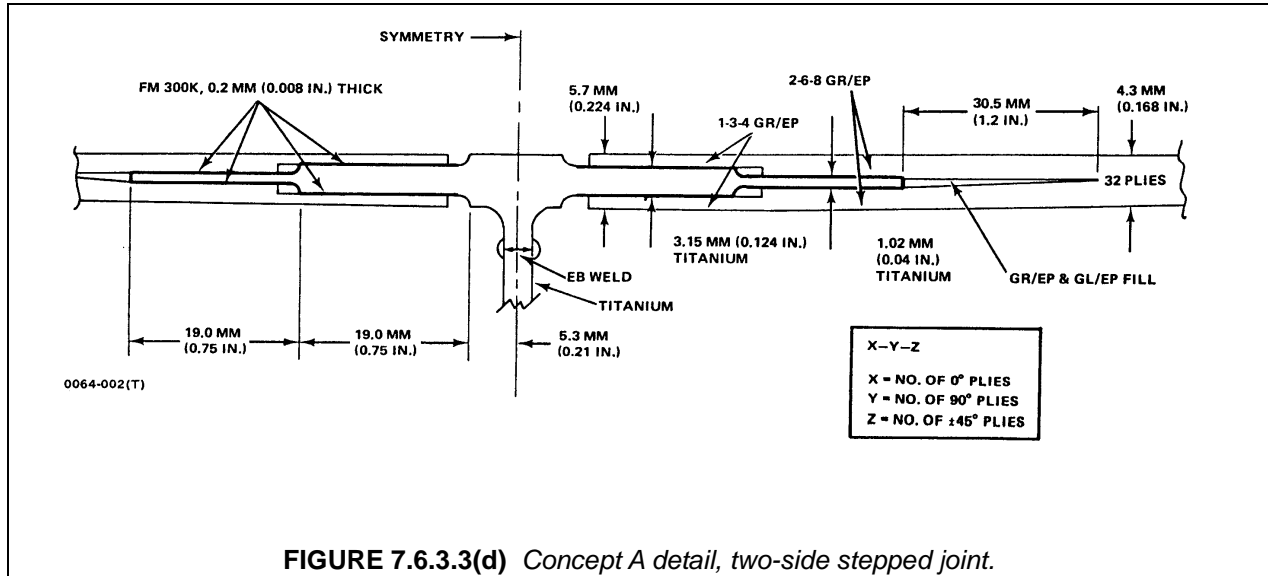

7.6.3.4 Single overlap joint tests

Single overlap specimens are similar to those described in the above section. However, because single overlap specimens induce additional peel stresses due to bending, the length of the joint must be longer to minimize that effect. This effectively eliminates usefulness of single step specimens to determine strength property of realistic joints. Single step single overlap joints, however, are used for comparison between different adhesives and for quality control. Two different approaches to minimize peel stresses in single lap test specimen are described in this section. The ASTM D 3165 method minimizes peel by keeping the load line in the adhesive layer similarly to the single shear bearing tests of ASTM D 5961, Procedure B. The second approach, exemplified by European Aircraft Industry Standard prEN 6066, reduces peel stresses by easing the load into the joint by scarfing or by multiple small steps.

7.6.3.4.1 ASTM D 3165

This method measures comparative shear strength of adhesive joint when tested using single lap specimen of Figure 7.6.3.4.1. This specimen is used widely in the industry as an alternative to the ASTM D 1002 or ASTM D 3163 as it reduces the peel stresses in the lap while retaining the interface realism of a composite bonded joint. All the limitations enumerated for ASTM D 1002 in Section 7.6.2.1.3 are applicable here. For composites, there is an additional difficulty in fabricating this type of specimen. The usual procedure of machining the notch can be substituted by placing a spacer in the notch area and laying-up separate laminates. Both manufacturing methods need trained composite engineers and mechanics to establish a manufacturing process that will result in useful specimens.

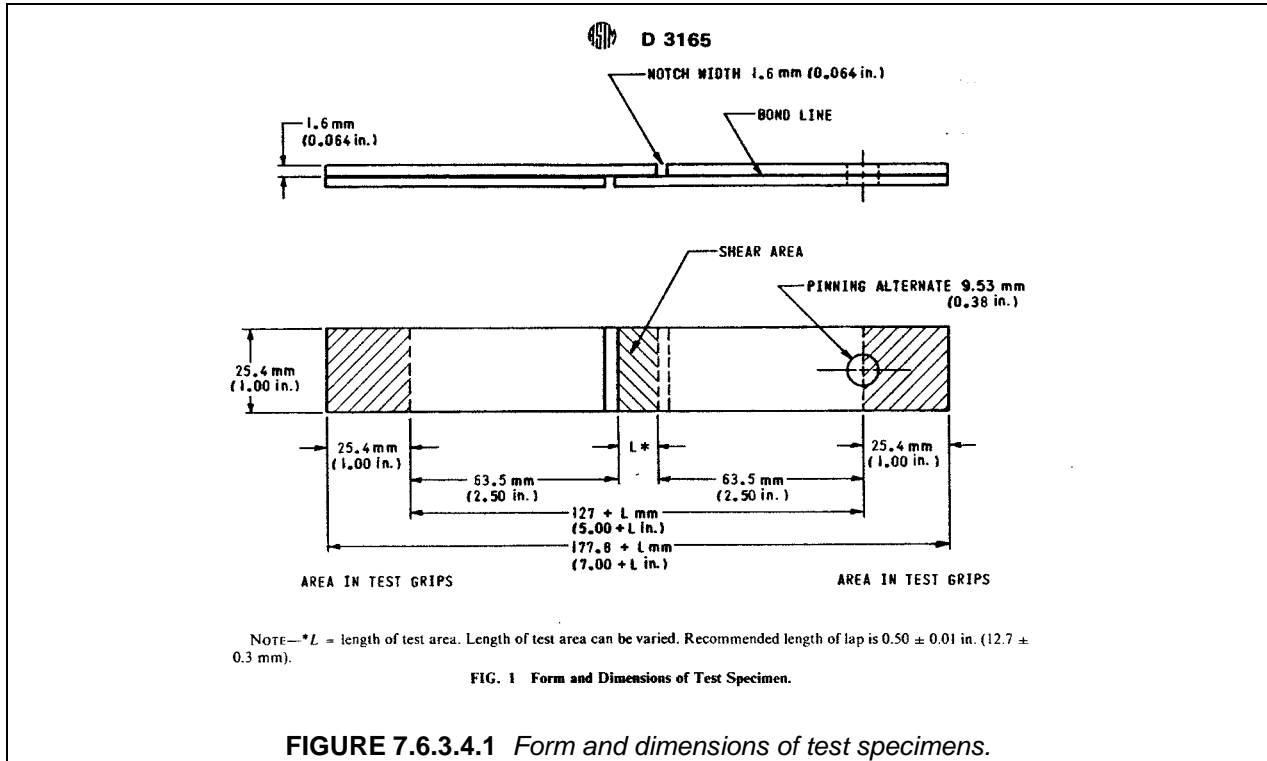

7.6.3.4.2 European Aircraft Industry Standard EN 6066

A 1 in. (25 mm) wide multi-step or scarfed specimen has been developed for bonded joint characterization. This specimen, shown in Figure 7.6.3.4.2(a) is referenced in a preliminary European Aircraft Industry Standard EN 6066 (Reference 7.6.3.4.2). This standard also defines types of failures that are possible with such a specimen, Figure 7.6.3.4.2 (b). This testing standard has been called out for obtaining qualification data for a wet lay-up repair material.

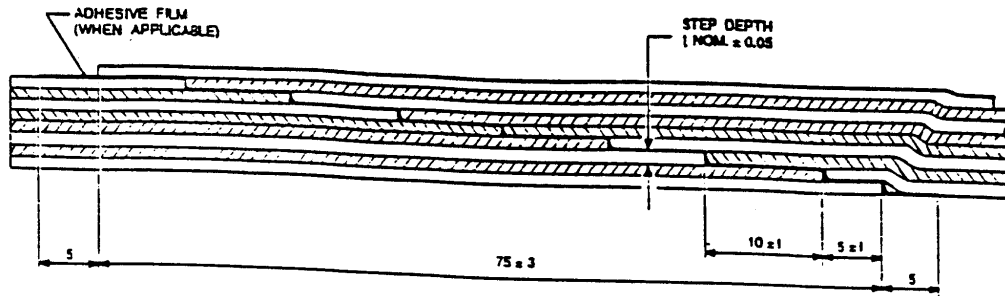

DETAIL "B"
(STEPPED JOINT)

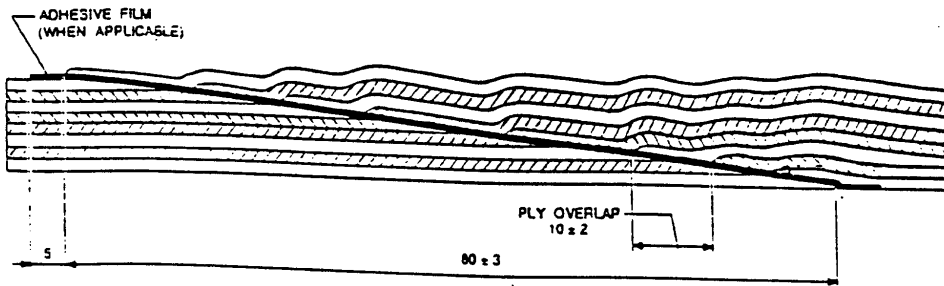

DETAIL "A"
(SCARFED JOINT)

DIMENSIONS IN mm

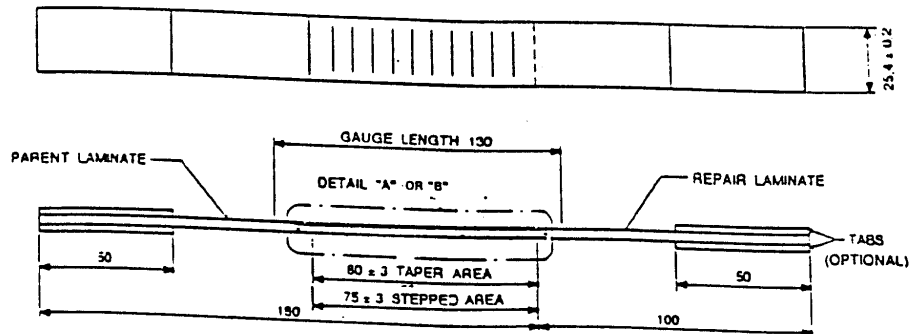
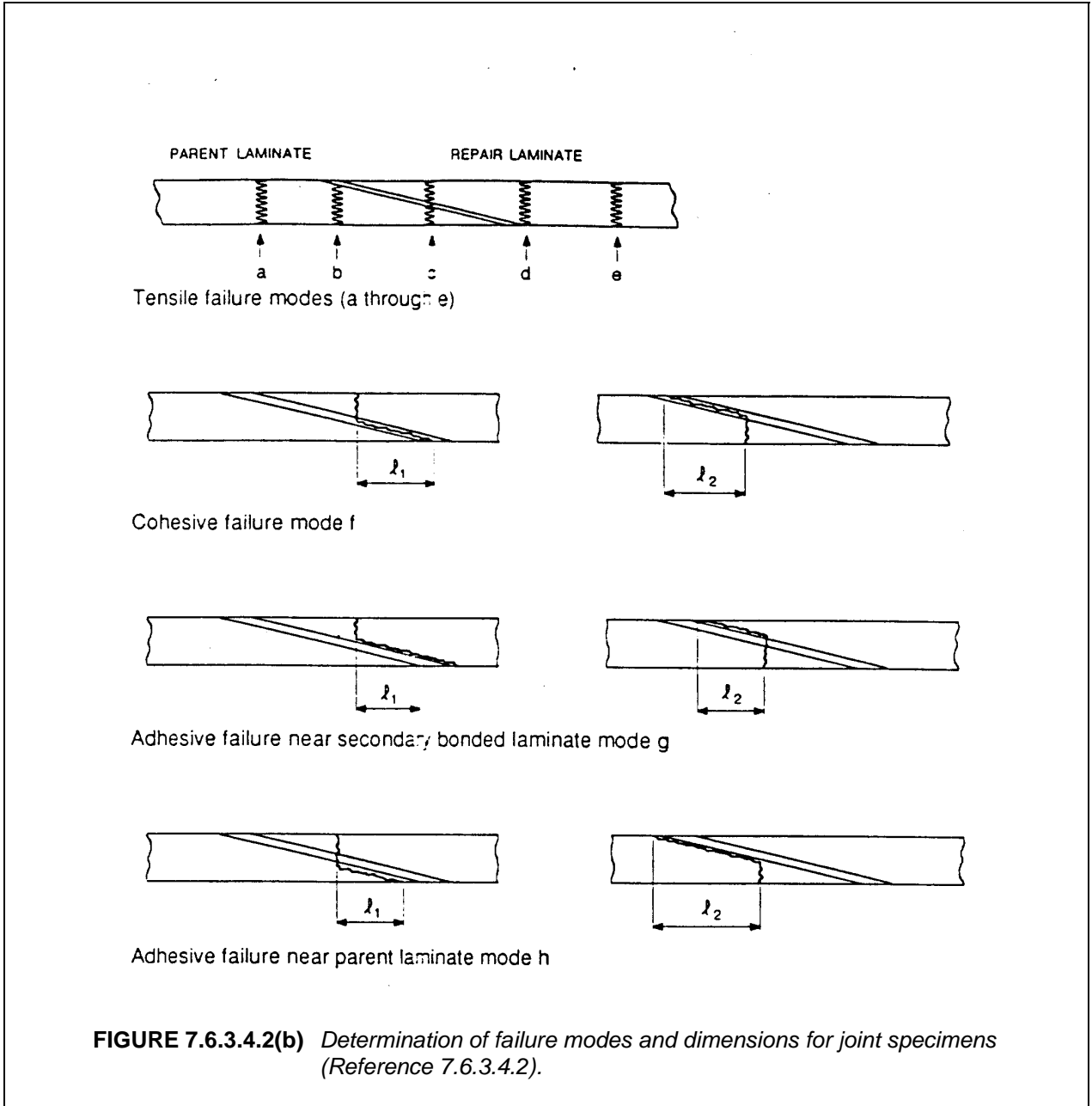
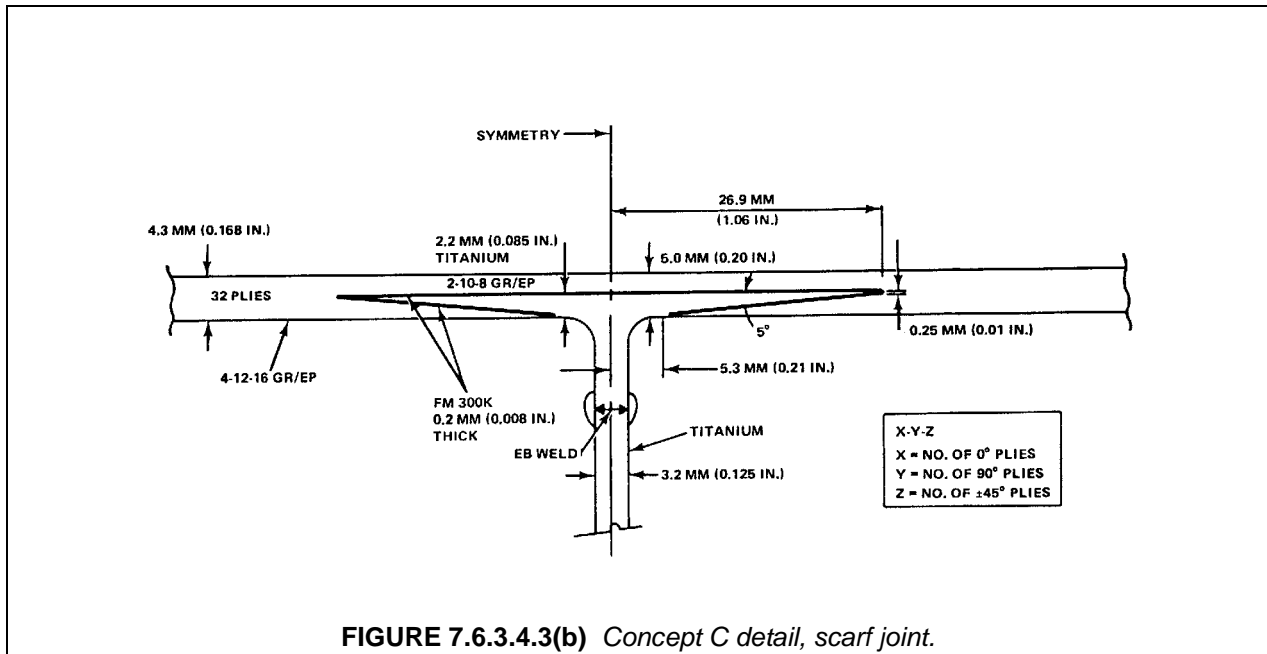
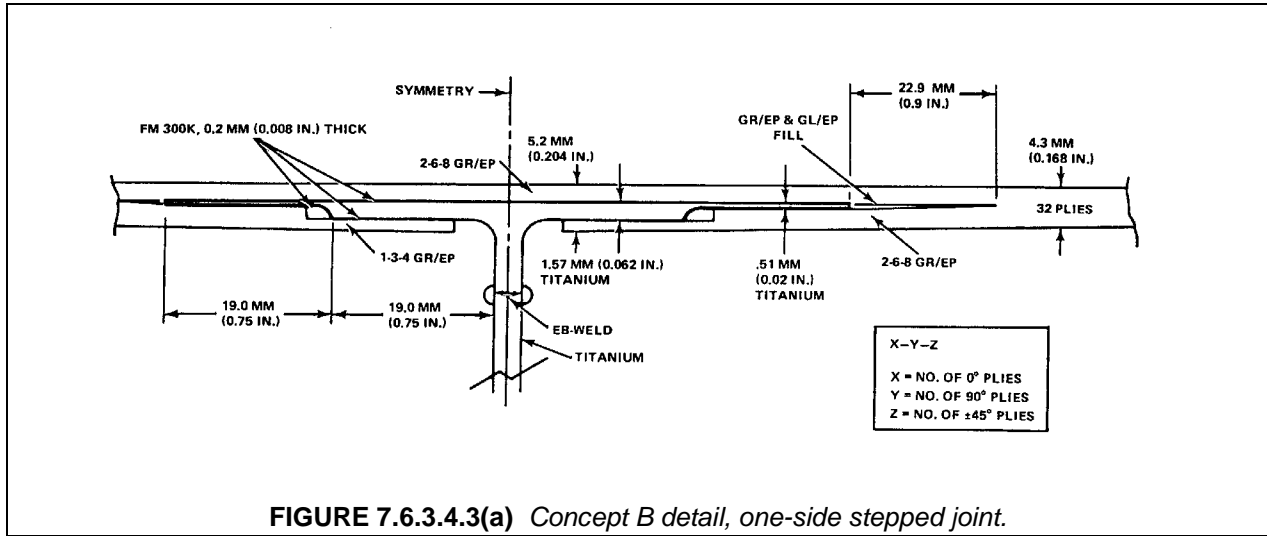

FIGURE 7.6.3.4.2(a) Scarfed and stepped joint specimens.



7.6.3.4.3 Other examples

Two-step and scarfed verification specimens are shown in Figures 7.6.3.4.3(a) and (b) for the same spar to skin joint shown in Figure 7.6.3.3.3(b). Such specimen should be developed to validate any major joint design.



7.7 DAMAGE CHARACTERIZATION

7.7.1 Overview

Damage characterization is a key parameter in the use of composite materials in aerospace applications. Unlike traditional metallic materials, composites vary in strength depending on direction and lay-up. They can also be relatively brittle. Interlaminar tensile and shear strengths are especially low compared to isotropic metallic materials. Damage such as internal delaminations may not even be visually apparent. This combination of attributes makes consideration of damage characterization a key factor in the use of composite materials. Approaches for consideration of damage in design and certification are found in Section 5.0 of Volume 3.

Damage characterization can be divided into two issues, the resistance of a material to damage from impact (damage resistance), and the ability of a material or structure to perform safely after damage (damage tolerance). Damage can occur while handling during the manufacturing process, while in use or during maintenance procedures. This damage can be the result of manufacturing defects, foreign body impacts such as rocks or ice, or tool drops. This section will outline impact and indentation tests that are commonly performed to evaluate the damage resistance and tolerance of candidate materials. Crack growth, micro-cracking and fatigue tests are discussed elsewhere in this handbook.

7.7.2 Damage resistance

Damage resistance of a material is commonly considered to be the resistance of the material to impact damage in aerospace applications. Impacts may arise from dropped tools, foreign objects such as rocks on runways, from hail and ice, and from ballistics. Impact testing is commonly used to screen materials for damage resistance and tolerance and as a part of larger sub-element and element tests performed during certification.

Simulation of all these conditions may require testing at differing energy levels, velocities, impactor geometries, and support conditions.

7.7.2.1 Falling weight impact

Another common method for investigating impact resistance is the falling weight test. This type of impact is included as a portion of the Compression After Impact (CAI) testing discussed in Section 7.7.3. Generally, a flat panel is impacted normal to its surface. Commonly, 0.5 inch to 1 inch (12.7 to 25.4 mm) diameter hemispherical tups are used. Quasi-isotropic laminates approximately 0.2 to 0.4 inch (5.08 to 10.16 mm) thick are often used to screen materials for aircraft structural applications. The energy of the weight at impact is given by the classical equation.

$$E = \frac{1}{2} mv^2 = mgh$$

E = energy

m = mass

v = velocity

g = gravitational constant of 9.8 m/sec² or 32 ft/sec²

h = drop height

Since g is constant, energy levels for the falling weight test are generally given in foot-pounds or foot-pounds per inch of thickness. With variations of velocity of the falling weight, the damage may vary with even constant energy. This phenomenon is related to the type of damage, the rate it propagates in the specimen and the deformation of the specimen during impact.

The falling weight used for CAI testing is generally dropped from a few feet, with a mass of 10 to 20 pounds, and is considered a low velocity impact. Low velocity tests such as a falling weight do not adequately simulate ballistic damage. Occasionally investigators may accelerate the drop with elastic cords to gain a somewhat higher velocity. If very low velocity impacts are to be studied, a long fulcrum pendulum may be used to impact the specimen with a much higher mass.

Following the impact, an assessment of the damage must be performed. Criteria for damage assessment may include measurement of the visually apparent damage area, measurement of dent depth, and non-destructive evaluation, such as C-Scan, for the internal damage area. Following this assessment, additional mechanical tests such as CAI or fatigue may be performed.

Sources of Experimental Error

1. The velocity may be slower than predicted due to friction on the guide rails/tube. To ensure accuracy the actual weight velocity should be measured just prior to impact.
2. Steps should be taken so the weight does not bounce and impact the specimen more than once.
3. The amount of damage will be dependent on the specimen support conditions, such as clamping arrangements. These must be reproduced very carefully. The overall stiffness of the base of the machine and even the flooring under the impactor may influence the test results.

7.7.2.2 Izod and Charpy impact

Izod and Charpy impact are common classical tests performed on plastic and metallic materials. These tests are described in ASTM D 256. Within the ASTM standard, five procedures are given. The Izod test is discussed in procedures A, C and D of the standard and uses a notched rectangular bar 2.5" X 0.5" X 0.25" to 0.5" (6.35 cm x 1.27 cm x .635 cm x 1.27 cm) thick. One end of the specimen is held in a vise as a vertical cantilever and impacted on the same face as the notch, at a fixed distance above the notch and vise, by a weighted pendulum. The energy lost by the pendulum during impact is measured and the Izod impact strength is calculated. Procedure C contains a correction factor for the energy required to toss the broken specimen part. This factor is considered significant for materials with Izod impact strengths less than 0.5 ft-lbsf/inch of notch.

The Charpy test was formerly discussed in Procedure B, but has been removed as of 1997 and has been issued as a new standard, ASTM D 6110. It also uses a notched rectangular bar 2.5" X 0.5" X 0.25" to 0.5" (6.35 cm x 1.27 cm x .635 cm x 1.27 cm) thick. In this test the specimen is supported as a horizontal simple beam and is broken by the pendulum with the impact site halfway between the supports and directly opposite the notch.

Procedure D is a variation on the Izod tests, but with differing notch radii. This can give an indication of the notch sensitivity of the material.

Procedure E is a reversed-notched Izod test. It is similar to Procedure A except the specimen is impacted on the face opposite the notch. This procedure gives an indication of the unnotched impact strength of the plastic.

None of the tests in ASTM D 256 are generally appropriate for continuously reinforced composite materials, and data from these tests will not be accepted into MIL-HDBK-17.

7.7.2.3 Quasi-static indentation

Quasi-static indentation tests may be performed by supporting a flat panel in a frame and indenting the center of the panel with a tup attached to a universal-testing machine. This method is described in ASTM D 6264. The most common test specimen is a 6" X 6" (15.24 x 15.24 cm) quasi-isotropic laminate, approximately 0.17" (4.32 mm) thick. The specimen may be simply supported on a frame with a 5-inch diameter cutout, or on a solid, flat, rigid support. Load and cross-head displacement are measured during the test and the resulting curve is reported. A predefined level of damage or cross-head displacement is used to define where to take data during the test and where to stop the test in the case of the rigidly supported configuration. In the case of the simple support configuration, the maximum indentation force is also reported. Dent depth and damage are evaluated after the specimen is unloaded.

7.7.2.4 Other damage resistance tolerance tests

Other impact tests are often included at higher levels of the building block approach. These may include ballistic impact, ice/hail simulation, bird strike simulation and other program specific tests. These

are often accomplished through use of an air gun that fires a projectile at the test specimen. Details of these tests have not been standardized, and are not discussed in detail here.

Specialized tests are also performed to evaluate a materials performance and durability in specific applications. These include roller cart and spiked heel resistance tests for flooring.

7.7.3 Damage tolerance tests

7.7.3.1 Compression after impact tests

7.7.3.1.1 Overview

The compression after impact (CAI) test is an empirical evaluation of the degradation of laminate compressive strength due to out-of-plane impact. Investigators use many different impact and damage tolerance tests depending on material form, application and expected damage. Although the CAI tests proposed here were developed by the airframe industry for comparing the damage tolerance of candidate composite materials, they may be generally applicable to other industries. The possible damage scenarios the test was designed to simulate include dropped tools, runway debris kickup, etc. Because the impact is relatively low velocity, the test is not commonly used to assess ballistic damage tolerance.

Several methods are commonly used in the composite industries to determine CAI. Though none are currently ASTM standards all of the methods involve impacting a flat laminate plate. The plate is constrained by a support system with a cutout opposite to the impact site. The impactor is normally a hemispherical tup (falling dart, rod or ball). The most common methods are SACMA SRM 2R-94 (Reference 7.7.3.1.1(a)) and NASA 1092 and 1142, B.11 (References 7.7.3.1.1(b) and (c)).

Sandwich panels are also commonly evaluated for damage tolerance. There are currently no industry wide standards for CAI on sandwich panels. However, for qualification or screening tests, many firms impact a flat sandwich panel under controlled conditions and then perform an evaluation. This evaluation may consist of NDI, water intrusion, residual compressive strength or shear strength testing. A more detailed discussion may be found in Reference 7.7.3.1.1(d).

The impact level is generally selected to cause visual damage to the laminate, but such that the damage is localized at the center of the plate. Other levels of damage such as "barely visible impact damage" (BVID) have been used. If the damage extends to over one half the width of the specimen or if the impactor penetrates through the laminate, the damage level is too large to meaningfully evaluate with a subsequent compression test. Impact levels are specified in the methods but may be varied for experimental purposes.

After impact, the level of damage may be characterized by the apparent damage area (front and back), indentation depth, and nondestructive evaluation by ultrasonic C-Scan or similar techniques. Prior to compression testing, NASA methods require an additional machining step to reduce the specimen size and insure the ends are flat and parallel. Compression testing is then performed in a fixture that stabilizes the specimen near the edges, but does not constrain transverse deformation due to Poisson's effect.

Limitations of CAI testing (all methods) are as follows:

Materials with differing thicknesses or lay-ups should not be directly compared.

Users should be cautioned that damage mechanisms in these test specimens may not scale up to larger parts. This is particularly true with composites made from toughened resin systems.

The level of impact damage is dependent on the rigidity of the specimen support system during impact. Lab to lab variation may be encountered due to differing support systems. Generally less rigid support will result in less impact damage and higher CAI strength.

There may be variation among testers regarding the impact mass used to obtain a given energy level. Data and theoretical models are not sufficient to state the significance of varying mass/velocity at a given energy.

Reliable results are not obtained if the failure is not in the impact area. Soft laminates may fail by buckling above or below the side supports. End brooming is also possible. Both are unacceptable failure modes.

Like most composite tests, proper specimen preparation is critical. End flatness and parallelism are particularly important.

7.7.3.1.2 SACMA SRM 2R-94 "Compression after Impact Properties of Oriented Fiber-Resin Composites"

SACMA SRM 2-88 method was developed from Boeing BSS 7260. The test specimen is a 4"x 6" (100 mm x 150 mm) quasi-isotropic specimen nominally 0.25" (6 mm) thick. If C-Scan will be used after impact, an initial C-Scan should be performed as a baseline. The specimen is clamped to an aluminum support base with a 3"x 5" (76.2 mm x 127 mm) cut out. The specimen is then impacted with an impactor having 0.625" (15.75 mm) diameter hemispherical tup at a height to provide a target impact energy of specimen thickness. The mass of the impactor is not specified but is between 10 and 12 pounds (4.5 and 5.5 kilograms) in normal practice. The impact energy is determined by one of the following methods:

Method 1: Energy = drop weight x drop height/specimen thickness

Method 2: Energy = 1/2 mass (velocity)² /specimen thickness

The specified impact energy level is 1500 inch-pounds/inch thickness (6.7 Joules/mm thickness). The velocity is measured just prior to impact. The velocity measurement is corrected for any travel between the flag and the specimen. Since Method 2 takes into account friction losses, it is the preferred method.

Rebound impacts of the specimen must be avoided. If instrumentation is used during impacting, the actual impact energy can be calculated, and impact force versus time can be recorded. The impacted specimen is inspected via an ultrasonic scan. The area and the general configuration of the delamination can be recorded.

Specimen testing -- A compressive loading fixture is used to ensure axial loading in the desired plane. The method requires four axial strain gages to be used to measure the strain although the strain gages are not always used in industry practice. The testing speed is 0.05 inches/min (1 mm/min). The output of each gage is plotted individually to check for unusual loading conditions. CAI is calculated as follows:

$$F^{CAI} = \frac{P}{tw} \quad 7.7.3.1.2$$

where

P = load

t = thickness

w = width

Advantages: Requires much less material than the NASA methods and the elimination of a secondary machining step saves cost.

Disadvantage: There is no machining step after impact to remove possible damage in the clamp areas or ends.

7.7.3.1.3 NASA 1142, B.11 "Compression After Impact Test"

The NASA CAI methods are described in NASA 1092, ST-1 and NASA 1142, B.11

The NASA 1142, B.11 method is a later version of NASA 1092.

The test specimen is 7"x 12" (180 mm x 300 mm) quasi-isotropic composite plate prior to impacting. Thickness is 0.25" (6 mm) in normal practice. Ultrasonic C-Scan should be performed prior to impact for a baseline. The specimen is clamped to a steel support plate with a 5"x 5" (130 mm x 130 mm) cutout opposite to the impact site. The specimen is impacted with an impactor equipped with a 0.5" (13 mm) diameter hemispherical tip. The mass of the impactor is 10 to 12 lbs (4.5-5.5 kg). The required impact energy is 20 foot-pounds (27 Joules).

Following the impact, the specimen is visually examined, ultrasonically inspected and then machined to its final compression test dimensions of 5"x 10" (130 mm x 250 mm). This final machining step eliminates any damage sustained by the specimen in the clamped area during impact and allows for ends to be machined flat after impact.

The specimen is then instrumented with back-to-back axial gages. The gages are used to monitor for unusual loading conditions during the test. The strain gages are not always used in industry practice. CAI is calculated as follows:

$$F^{CAI} = \frac{P}{tw} \tag{7.7.3.1.3}$$

where

P = load

t = thickness

w = width

7.7.3.1.4 Test methods for MIL-HDBK-17 data submittal

Data produced by the following test methods (Table 7.7.3.1.4) are currently being accepted by MIL-HDBK-17 for consideration for inclusion in Volume 2:

TABLE 7.7.3.1.4 Compression after impact test method for MIL-HDBK-17 data submittal.

PROPERTY	SYMBOL	ALL DATA TYPES	SCREENING
Compression after impact strength	F^{CAI}		SACMA SRM 2R-94 NASA 1192, B.11

REFERENCES

- 7.4.1 SRM 3-88, "SACMA Recommended Test Method for Open-Hole Compression Properties of Oriented Fiber-Resin Composites," Suppliers of Advanced Composite Materials Association, Arlington, VA, 1988.

Volume 1, Chapter 7 Structural Element Characterization

- 7.5.2.2.1 ASTM D 953, "Standard Method of Test for Bearing Strength of Plastics," *Annual Book of ASTM Standards*, Vol 8.01, American Society for Testing and Materials, West Conshohocken, PA.
- 7.5.2.3.2 MIL-STD-1312/B, "Fasteners Test Methods".
- 7.5.2.4 Military Standardization Handbook, *Metallic Materials and Elements for Aerospace Structures*, MIL-HDBK-5E, 1 June 1987.
- 7.5.3.1 Crews, J.H. and Naik, R.A., "Combined Bearing and Bypass Loading on a Graphite/Epoxy Laminate," *Composite Structures*, Vol 6, 1986, pp. 21-40.
- 7.5.5.4(a) ASTM Test Method E 8, "Test Methods for Tension Testing of Metallic Materials," *Annual Book of ASTM Standards*, Vol. 3.01, American Society for Testing and Materials, West Conshohocken, PA.
- 7.5.5.4(b) ASTM Practice E 4, "Force Verification of Testing Machines," *Annual Book of ASTM Standards*, Vol. 3.01, American Society for Testing and Materials, West Conshohocken, PA.
- 7.5.5.4(c) ASTM Practice E 83, "Verification and Classification of Extensometers," *Annual Book of ASTM Standards*, Vol. 3.01, American Society for Testing and Materials, West Conshohocken, PA.
- 7.6.2(a) Krieger, Raymond B. Jr., "Stress Analysis of Metal-to-Metal Bonds in Hostile Environments", *Proceedings of the 22nd National SAMPE Symposium*, San Diego, CA, April 26-28, 1977.
- 7.6.2(b) Krieger, Raymond B. Jr., "Stress Analysis Concepts for Adhesive Bonding of Aircraft Primary Structure," *Adhesively Bonded Joints: Testing, Analysis and Design*, ASTM STP 981, W.S. Johnson, Ed. American Society for Testing and Materials, Philadelphia 1988, pp. 264-275.
- 7.6.2(c) ASTM Test Method D 2095, "Test Method for Tensile Strength of Adhesives by Means of Bar and Rod Specimens," *Annual Book of ASTM Standards*, Vol. 15.06, American Society for Testing and Materials, West Conshohocken, PA.
- 7.6.2.1.1(a) Kassapoglou, Christos and Adelman, John C., "KGR-1 Thick Adherend Specimen Evaluation for the Determination of Adhesive Mechanical Properties", *SAMPE Quarterly*, October 1992.
- 7.6.2.1.1(b) Tsai, Ming-Yi, Morton, J., and Oplinger, D., "Determination of Thin-Layer Adhesive Shear Properties Using Strain Gages", *Experimental Mechanics*, (to be published).
- 7.6.2.1.1(c) Hart-Smith, L.J., "Adhesively Bonded Joints for Fibrous Composite Structures," *Proceedings of International Symposium on Joining and Repair of Fibre-Reinforced Plastics*, London, Great Britain, September, 1986.
- 7.6.2.1.2 ASTM Test Method E 229, "Shear Strength and Shear Modulus of Structural Adhesives," *Annual Book of ASTM Standards*, Vol. 15.06, American Society for Testing and Materials, West Conshohocken, PA.
- 7.6.2.2.1(a) ASTM Practice D 2094, "Preparation of Bar and Rod Specimens for Adhesion Testing," *Annual Book of ASTM Standards*, Vol. 15.06, American Society for Testing and Materials, West Conshohocken, PA.
- 7.6.2.2.1(b) Hart-Smith, L.J., "Adhesive Bonded Single Lap Joints", NASA CR-11236, January, 1973.

- 7.6.3.1 ASTM Test Method C 297, "Tensile Strength of Flat Sandwich Constructions in Flatwise Plane," *Annual Book of ASTM Standards*, Vol. 15.03, American Society for Testing and Materials, West Conshohocken, PA.
- 7.6.3.3 ASTM Test Method D 3528-92, "Strength Properties of Double Lap Shear Adhesive Joints by Tension Loading," *Annual Book of ASTM Standards*, Vol. 15.06, American Society for Testing and Materials, West Conshohocken, PA.
- 7.6.3.4.2 European Aircraft Industry Standard EN 6066, "Determination of Tensile Strength of Tapered and Stepped Joints".
- 7.7.3.1.1(a) SACMA SRM 2R-94 "SACMA Recommended Test Method for Compression After Impact Properties of Oriented Fiber-Resin Composites" Suppliers of Advanced Composite Materials Association, 1600 Wilson Blvd. Suite 1008, Arlington, VA 22209.
- 7.7.3.1.1(b) NASA Reference Publication 1092-Revised. "Standard Tests for Toughened Resin Composites, Revised Edition," 1983.
- 7.7.3.1.1(c) NASA Reference Publication 1142, "NASA/Aircraft Industry Standard Specification for Graphite Fiber/Toughened Thermoset Resin Composite Material," compiled by ACEE Composites Project Office, Langley Research Center, Hampton, VA, 1985.
- 7.7.3.1.1(d) Caldwell, Borris, Fallabella, "Impact Damage Tolerance Testing of Bonded Sandwich Panels," SAMPE Technical Conference, November 1990.

This page intentionally left blank

CHAPTER 8 STATISTICAL METHODS

8.1 INTRODUCTION

Variability in composite material property data may result from a number of sources including run-to-run variability in fabrication, batch-to-batch variability of raw materials, testing variability, and variability intrinsic to the material. It is important to acknowledge this variability when designing with composites and to incorporate it in design values of material properties. Procedures for calculating *statistically-based* material properties are provided in this chapter. With a properly designed test program (Chapter 2), these statistical procedures can account for some, but not all, of these sources for variability. A fundamental assumption is that one is measuring the desired properties. If this is not the case, then no statistical procedure is sufficient to account for other technical inadequacies.

Section 8.2 provides introductory material and guidance for the methods used in the remainder of the chapter. Readers unfamiliar with the statistical methods in the chapter should read Section 8.2 before the remainder of the chapter; more experienced readers may find it useful as a reference. Section 8.3 provides methods for evaluating data and calculating statistically-based properties. Section 8.4 contains other statistical methods, including methods for confidence intervals for a coefficient of variation, stress-strain curves, quality control, and alternate material evaluation. Section 8.5 contains statistical tables and approximate formulas.

8.1.1 Overview of methods for calculating statistically-based properties

Section 8.3 describes computational methods for obtaining A- and B-basis values from composite material data. Different approaches are used depending on whether the data can be grouped in a natural way (for example, because of batches or differences in environmental conditions). Data sets which either cannot be grouped, or for which there are negligible differences among such groups, are called *unstructured*. Otherwise, the data are said to be *structured*. The statistical methods in Section 8.3.2, which examine if the differences among groups of data are negligible, are useful for determining whether the data should be treated as structured or unstructured. Unstructured data are modeled using a Weibull, normal, or lognormal distribution, using the methods in Section 8.3.4. If none of these are acceptable, nonparametric basis values are determined. Structured data are modeled using *linear statistical models*, including *regression* and the *analysis of variance* (ANOVA), using the methods in Section 8.3.5.

8.1.2 Computer software

Non-proprietary computer software useful for analyzing material property data is available. *STAT17*, available from the MIL-HDBK-17 Secretariat upon request (see page ii), performs the calculations in the flowchart in Figure 8.3.1 with the exception of linear regression. *RECIPE* (REgression Confidence Intervals on PERcentiles), available from the National Institute of Standards and Technology, performs calculations that find material basis values from linear models including regression and analysis of variance. *RECIPE* can be obtained by anonymous ftp from 'ftp.nist.gov', directory 'recipe'. A non-proprietary general statistical analysis and graphics package *DATAPLOT* is also available from NIST by anonymous ftp from 'scf.nist.gov', directory 'pubs/dataplot'¹.

8.1.3 Symbols

The symbols that are used in Chapter 8 and not commonly used throughout the remainder of this handbook are listed below, each with its definition and the section in which it is first used.

¹ Contact Stefan Leigh, Statistical Engineering Division, NIST, Gaithersburg, MD, 20899-0001, email: stefan.leigh@nist.gov.

SYMBOL	DEFINITION	SECTION
A	A-basis value	-
a	distribution limit	8.1.4
ADC	critical value of ADK	8.3.2.2
ADK	k-sample Anderson-Darling statistic	8.3.2.2
B	B-basis value	8.2.5.1
b	distribution limit	8.1.4
C	critical value	8.3.3.1
CV	coefficient of variation	8.2.5.2
e	error, residual	8.3.5.1
F	F-statistic	8.3.5.2.2
F(x)	cumulative distribution function	8.1.4
f(x)	probability density function	8.1.4
F ₀	standard normal distribution function	8.3.4.3.2
IQ	informative quantile function	8.3.6.2
J	number of specimens per batch	8.2.5.3
k	number of batches	8.2.3
k _A	(1) one-sided tolerance limit factor, A-basis (2) Hanson-Koopmans coefficient, A-basis	8.3.4.3.3 8.3.4.5.2
k _B	(1) one-sided tolerance limit factor, B-basis (2) Hanson-Koopmans coefficient, B-basis	8.3.4.3.3 8.3.4.5.2
MNR	maximum normed residual test statistic	8.3.3.1
MSB	between-batch/group mean square	8.3.5.2.5
MSE	within-batch/group mean square	8.3.5.2.5
n	number of observations in a data set	8.1.4
n'	effective sample size	8.3.5.2.6
\tilde{n}	number of specimens required for comparable reproducibility	8.2.5.3
n*	see Equation 8.3.5.2.6(b)	8.3.5.2.6
n _i	number of observations in batch/group i	8.3.2.1
OSL	observed significance level	8.3.1
p(s)	fixed condition	8.3.5.1
Q	quantile function	8.3.6.1
\hat{Q}	quantile function estimate	8.3.6.1
r	rank of observation	8.3.4.5.1
RME	relative magnitude of error	8.5
s	sample standard deviation	8.1.4
s ²	sample variance	8.1.4
s _L	standard deviation of log values	8.3.4.4
s _y	estimated standard deviation of errors from the regression line	8.3.5.3
SSB	between-batch/group sum of squares	8.3.5.2.3
SSE	within-batch/group sum of squares	8.3.5.2.3
SST	total sum of squares	8.3.5.2.3
T	tolerance limit factor	8.3.5.2.7
t	quantile of the t-distribution	8.3.3.1
T _i	temperature at condition i	8.3.5.1

SYMBOL	DEFINITION	SECTION
$t_{\gamma,0.95}(\delta)$	0.95 quantile of the non-central t-distribution with non-centrality parameter δ and degrees of freedom γ	8.3.5.3
TIQ	truncated informative quantile function	8.3.6.2
u	(1) ratio of mean squares (2) batch	8.3.5.2.7 8.3.5.1
V_A	one-sided tolerance limit factor for the Weibull distribution, A-basis	8.3.4.2.3
V_B	one-sided tolerance limit factor for the Weibull distribution, B-basis	8.3.4.2.3
w_{ij}	transformed data	8.3.5.2.1
\bar{x}	sample mean, overall mean	8.1.4
x_i	observation i in a sample	8.1.4
\tilde{x}_i	median of x values	8.3.5.2.1
x_{ij}	j^{th} observation in batch/group i	8.3.2.1
x_{ijk}	k^{th} observation in batch j at condition i	8.2.3
x_L	mean of log values	8.3.4.4
$x_{(r)}$	r^{th} observation, sorted in ascending order; observation of rank r	8.3.4.5.1
$z_{0.10}$	tenth percentile of the underlying population distribution	8.2.2
$z_{(i)}$	ranked independent values	8.3.2.1
$z_{p(s),u}$	regression constants	8.3.5.1
α	(1) significance level (2) scale parameter of Weibull distribution	8.3.3.1 8.1.4
$\hat{\alpha}$	estimate of α	8.3.4.2.1
β	shape parameter of Weibull distribution	8.1.4
$\hat{\beta}$	estimate of β	8.3.4.2.1
β_i	regression parameters	8.3.5.3
$\hat{\beta}_i$	least squares estimate of β_i	8.3.5.3
γ	degrees of freedom	8.3.5.3
δ	noncentrality parameter	8.3.5.3
θ_i	regression parameters	8.3.5.1
μ	population mean	8.1.4
μ_i	mean at condition i	8.2.3
ρ	correlation between any two measurements in the same batch	8.2.5.3
σ	population standard deviation	8.1.4
σ^2	population variance	8.1.4
σ_b^2	population between-batch variance	8.2.3
σ_e^2	population within-batch variance	8.2.3

8.1.4 Statistical terms

Definitions of the most often used statistical terms in this handbook are provided in this section. This list is certainly not complete; the user of this document with little or no background in statistical methods should also consult an elementary text on statistical methods such as Reference 8.1.4. Definitions for additional statistical terms are included in Section 1.7.

Volume 1, Chapter 8 Statistical Methods

Population -- The set of measurements about which inferences are to be made or the totality of possible measurements which might be obtained in a given testing situation. For example, "all possible ultimate tensile strength measurements for Composite Material A, conditioned at 95% relative humidity and room temperature". In order to make inferences about a population, it is often necessary to make assumptions about its distributional form. The assumed distributional form may also be referred to as the population.

Sample -- The collection of measurements (sometimes referred to as observations) taken from a specified population.

Sample size -- The number of measurements in a sample.

A-basis Value -- A statistically-based material property; a 95% lower confidence bound on the first percentile of a specified population of measurements. Also a 95% lower tolerance bound for the upper 99% of a specified population.

B-basis Value -- A statistically-based material property; a 95% lower confidence bound on the tenth percentile of a specified population of measurements. Also a 95% lower tolerance bound for the upper 90% of a specified population.

Compatible -- Descriptive term referring to different groups or subpopulations which may be treated as coming from the same population.

Structured data -- Data for which natural groupings exist, or for which responses of interest could vary systematically with respect to known factors. For example, measurements made from each of several batches could reasonably be grouped according to batch, and measurements made at various known temperatures could be modeled using linear regression (Section 8.3.5.2); hence both can be regarded as structured data.

Unstructured data -- Data for which all relevant information is contained in the response measurements themselves. This could be because these measurements are all that is known, or else because one is able to ignore potential structure in the data. For example, data measurements that have been grouped by batch and demonstrated to have negligible batch-to-batch variability (using the subsample compatibility methods of Section 8.3.2) may be considered unstructured.

Location parameters and statistics:

Population mean -- The average of all potential measurements in a given population weighted by their relative frequencies in the population. The population mean is the limit of the sample mean as the sample size increases.

Sample mean -- The average of all observations in a sample and an estimate of the population mean. If the notation x_1, x_2, \dots, x_n is used to denote the n observations in a sample, then the sample mean is defined by:

$$\bar{x} = \frac{x_1 + x_2 + \dots + x_n}{n} \quad 8.1.4(a)$$

or

$$\bar{x} = \frac{1}{n} \sum_{i=1}^n x_i \quad 8.1.4(b)$$

Sample median -- After ordering the observations in a sample from least to greatest, the sample median is the value of the middle-most observation if the sample size is odd and the average of the two middle-most observations if the sample size is even. If the population is symmetric about its mean, the sample median is also a satisfactory estimator of the population mean.

Dispersion statistics:

Sample variance -- The sum of the squared deviations from the sample mean, divided by $n-1$, where n denotes the sample size. The sample variance is defined by:

$$s^2 = \frac{1}{n-1} \sum_{i=1}^n (x_i - \bar{x})^2 \quad 8.1.4(c)$$

or

$$s^2 = \frac{1}{n-1} \sum_{i=1}^n x_i^2 - \frac{n}{n-1} \bar{x}^2 \quad 8.1.4(d)$$

Sample standard deviation -- The square root of the sample variance. The sample standard deviation is denoted by s .

Probability distribution terms:

Probability distribution -- A formula which gives the probability that a value will fall within prescribed limits. When the word *distribution* is used in this chapter, it should be interpreted to mean *probability distribution*.

Normal Distribution -- A two parameter (μ, σ) family of probability distributions for which the probability that an observation will fall between a and b is given by the area under the curve

$$f(x) = \frac{1}{\sigma\sqrt{2\pi}} e^{-(x-\mu)^2/2\sigma^2} \quad 8.1.4(e)$$

between a and b . A normal distribution with parameters (μ, σ) has population mean μ and variance σ^2 .

Lognormal Distribution -- A probability distribution for which the probability that an observation selected at random from this population falls between a and b ($0 < a < b < \infty$) is given by the area under the normal distribution between $\ln(a)$ and $\ln(b)$.

Two-Parameter Weibull Distribution -- A probability distribution for which the probability that a randomly selected observation from this population lies between a and b ($0 < a < b < \infty$) is given by

$$e^{-(a/\alpha)^\beta} - e^{-(b/\alpha)^\beta} \quad 8.1.4(f)$$

where α is called the scale parameter and β is called the shape parameter.

Probability function terms:

Cumulative Distribution Function -- A function, usually denoted by $F(x)$, which gives the probability that a random variable lies between any prescribed pair of numbers, that is

$$\Pr(a < x \leq b) = F(b) - F(a) \quad 8.1.4(g)$$

Such functions are non-decreasing and satisfy

$$\lim_{x \rightarrow +\infty} F(x) = 1 \quad 8.1.4(h)$$

The cumulative distribution function, F , is related to the probability density function, f , by

$$f(x) = \frac{d}{dx}F(x) \quad 8.1.4(i)$$

provided that $F(x)$ is differentiable.

F-distribution -- A probability distribution which is employed in the analysis of variance, regression analysis, and tests for equality of variance. Tables of this distribution are readily available.

Probability Density Function -- A function $f(x) \geq 0$ for all x with

$$\int_{-\infty}^{\infty} f(x)dx = 1 \quad 8.1.4(j)$$

The probability density function determines the cumulative distribution function $F(x)$ by

$$F(x) = \int_{-\infty}^x f(t)dt \quad 8.1.4(k)$$

Note that the limits $(-\infty, \infty)$ may be conventional; for example, the exponential distribution satisfies the definition by defining its probability density function as

$$f(x) = \begin{cases} 0 & \text{for } x \leq 0, \text{ and} \\ e^{-x} & \text{for } x > 0 \end{cases} \quad 8.1.4(l)$$

The probability density function is used to calculate probabilities as follows:

$$\Pr(a < x \leq b) = \int_a^b f(x)dx \quad 8.1.4(m)$$

Error and Variability:

Fixed Effect -- A systematic shift in a measured quantity due to a particular level change of a treatment or condition. The change in level for a treatment or condition is often under the control of the experimenter. A measured quantity could be compressive strength or tensile modulus. A treatment or condition could be test temperature, fabricator, and so on. For a fixed effect, the shift in the measured quantity is to be interpreted as a consistent change not only in the context of the observed data but also with respect to future data under the same treatment or condition.

Random Effect -- A shift in a measured quantity due to a particular level change of an external, usually uncontrollable, factor. The level of this factor is regarded as a random draw from an infinite population. The specific level of a random effect is never under the control of the experimenter, however it may remain fixed within a limited subgroup of observed data. A measured quantity could be compressive strength or tensile modulus. An external factor could be batch production leading to batch-to-batch differences. Fabricator-to-fabricator differences may be considered a random effect if the number of fabricators involved are considered to be a small sample of all present and future fabricators. For a random effect, the shift in the measured quantities is viewed as a random variable having mean zero and a non-zero variance. Within a subgroup experiencing a fixed level of an external factor, the measured quantities are correlated (shifting as a cluster around a population average with the magnitude of the shift depending on the level of the factor). Therefore, to obtain the most independent information concerning the

population of response values, it is better to have more subgroups than to have more measurements per subgroup.

Random Error -- That part of the data variation that is due to unknown or uncontrolled external factors and that affects each observation independently and unpredictably. It is the residual error in a model under analysis, the variability remaining after the variability due to fixed and random effects has been removed. Random error is a special case of a random effect. In both cases, the level of the random effect or error is uncontrollable but random errors vary independently from measurement to measurement (i.e., there are no random error shifts shared in common by several measurements). An important example of random error is the specimen-to-specimen variability occurring within a subgroup experiencing constant levels of treatment, condition, batch, and other external factors (fixed and random effects).

Material Variability -- A source of variability due to the spatial and consistency variations of the material itself and due to variations in its processing (e.g., the inherent microstructure, defect population, cross-link density, etc.). Components of material variability can be any combination of fixed effects, random effects, and random error.

8.2 BACKGROUND

This section provides introductory material and guidance for the methods used in the remainder of the chapter. Readers unfamiliar with the statistical methods in the chapter should read this section before the remainder of the chapter. For more experienced readers, this section may be a useful reference for the approach and use of terminology.

8.2.1 Statistically-based design values

A *design value* for a material is the minimum value of a material property expected to be used in the fabrication of the structure. The value can be deterministic or statistically based. S-basis value is the usual designation of a deterministic value; this implies that any material when test-sampled is rejected if any of its properties fall below the established S-value. Statistically-based design values acknowledge the stochastic nature of the material properties and, in general, will reduce the amount of incoming material testing. Deterministic and statistically based material design values are used in the same way in the deterministic design of the structure. For structural integrity, actual (including appropriate safety factors) stresses or strains in the structure can not exceed the material design values. If the structure is designed using probabilistic methods (by making reliability estimates) only statistically-based design values can be used.

To understand the definitions of 'statistically-based' design values, it is necessary to regard the material property of interest, not as a constant, but as a *random variable*, a quantity that varies from specimen to specimen according to some probability distribution. A reasonable first attempt at definitions of B-basis and A-basis material properties are the 10th and 1st percentiles of a material property distribution. One expects the property to usually be above these values, so these definitions are reasonable statistically-based counterparts to the traditional deterministic notion of a design value. Of course, there is an obvious problem in practice; one doesn't know the probability distribution of a material property. So far only simple ideas of probability theory have been used in these definitions; it is in addressing uncertainty in these percentiles that statistical inference plays an essential role.

8.2.2 Basis values for unstructured data.

Before breaking n specimens, imagine them each to have a strength value which can be represented as belonging to a common probability distribution. After breaking the specimens, one observes n numbers, and if n is large enough, a histogram of these numbers will approximate the unknown distribution. This probability distribution is referred to as a *population*, and the n numbers are a realization of a *random sample* of this population. Conceptually, one can do this thought-experiment many times, obtaining different sets of n numbers. A statistically-based B-basis material property is a *statistic*, calculated from a

random sample n , such that if one were to repeatedly obtain random samples of n specimens and calculate many of these basis values, 95% of the time the calculated values would fall below the (unknown) 10th percentile. An A-basis value is defined similarly, replacing the 10th percentile with the 1st. In statistical parlance, basis values are 95% lower confidence limits on prescribed percentiles, which are also sometimes referred to as *tolerance limits*.

Note that the definitions of statistically-based material properties have been developed in two steps. First a deterministic property was modeled with a probability distribution in order to take into account observed scatter in the property, and tentative definitions of basis values in terms of percentiles of this distribution were made. This takes into account uncertainty that remains, however much data on the property one obtains. But there is additional uncertainty, since instead of unlimited data, one has only n specimens. So the percentiles of our tentative definitions are replaced with conservative 'under-estimates' of these percentiles, thereby taking into account the additional uncertainty in a random material property due to limited data.

An example will help fix ideas. Let the tensile strength of a material have a normal distribution with a mean of 1000 MPa and a standard deviation of 125 MPa. The 10th percentile of this population is

$$z_{0.10} \doteq 1000 - (1.282)125 \doteq 840 \text{ MPa}$$

This would be the B-basis value if one had unlimited data, and hence knew the population. Assume instead that only $n=10$ specimens are available. A B-basis value can be calculated for these n specimens (see Section 8.3.4.3), and if one were to obtain many such sets of 10 specimens from the same population, this basis value would be less than 840 MPa for 95% of these repeated samples. Substantial scatter is characteristic of basis values determined from small data sets, due primarily to uncertainty in the population variance (see Section 8.2.5).

The present discussion provides a fairly complete description of material basis values, if one is willing to make two simplifying assumptions: first that between-batch material property variability is negligible, and second that all of the data are obtained from tests at identical conditions. In Section 8.3.2, such data are defined to be *unstructured*. However, composite material properties often do vary substantially from batch to batch, and data on properties are usually obtained, not for a single set of fixed conditions but over a test matrix of some combination of temperatures, humidities, and stacking sequences. Data that exhibit these additional complexities will be called *structured* (see Section 8.3.2), and are analyzed using *regression* and *analysis of variance*. Regression analysis in general is discussed in Section 8.3.5.

8.2.3 Basis values in the presence of batch-to-batch variability

Composite materials typically exhibit considerable variability in many properties from batch to batch. Because of this variability, one should not indiscriminately pool data over batches and apply the unstructured data procedures discussed above and in Section 8.3.4. Basis values should incorporate the variability to be expected between batches or panels of a material, particularly when one has data on only a few batches or panels, or when one has a particular reason for suspecting that this variability could be non-negligible. Pooling batches involves the implicit assumption that this source of variability is negligible, and in the event that this is not the case, the values which result from pooling can be too optimistic. Before pooling data, the subsample compatibility methods of Section 8.3.2 should be applied. The interpretation of material basis values in the presence of between-batch (or panel, and so on) variability is discussed below for the simplest case of a one-way ANOVA model (Section 8.3.5.2).

The data for the present discussion consist of n measurements, all of the same property, of the same material, and tested under the same conditions. The only structure apparent in the data under this hypothetical scenario is that each specimen has been fabricated from one of k batches of raw material. (Equivalently, one might imagine material made from the same batch, but for which several autoclave runs had been required, resulting in non-negligible variability in properties between *panels* of specimens.) Each data value can be regarded as a sum of three parts. The first part is the unknown mean, the second

part is a shift in the mean due to the batch from which the specimen was obtained, and the third part is a random perturbation due to the scatter in measurements made on different specimens from the same batch.

The unknown constant mean corresponds to a set of fixed conditions (for example, 8-ply unidirectional tensile strength for a specific material, tested according to a well-defined test method, and at prescribed test conditions). If one were to produce batches endlessly, preparing specimens from each batch according to these fixed conditions, breaking specimens from each batch, and obtaining measurements of the property of interest, then the average of all of these measurements would approach this unknown constant in the limit of infinitely many batches. This unknown mean can be parameterized as a function of the conditions under which the specimens were prepared and tested, where the form of this function is known except for some constants; this is related to the notion of a *regression model*, which will be discussed in some detail in Section 8.3.5.1.

Imagine, however, that one were to test many specimens from a single batch. The average strength approaches a constant in this situation as well, but this constant will not be the same as in the case where each specimen comes from a different batch. In the situation discussed in the previous paragraph, the average converges to an overall population mean (a 'grand mean'), while the average converges to the population means for a *particular batch* in the present case. The difference between the overall population mean and the population mean for a particular batch is the second component of a material property measurement. This difference is a random quantity; it will vary from batch to batch in an unsystematic way. This random 'batch effect' is assumed to follow a normal probability distribution with a mean of zero, and some unknown variance called the *between-batch component of variance*, and denoted by σ_b^2 .

Even when specimens are made from the same batch and tested under identical conditions, one will not get the same value every time. In addition to the population mean and the random 'batch effect' there is a third component to any measurement, which is also random, but which differs from specimen to specimen within a batch. This random quantity is called the *within-batch variability*, and it is modeled as a normally distributed random variable with a mean of zero and a variance σ_w^2 , referred to as the *within-batch component of variance*.

To summarize, a measurement made on data on a particular specimen from a specific batch is modeled as a sum of three parts:

$$x_{ijk} = \mu_i + b_j + e_{ijk} \quad 8.2.3$$

where x_{ijk} is the k^{th} measurement on data from batch j at a set of fixed conditions labeled by i . The random variables b_j and e_{ijk} have normal distributions with mean zero and variances σ_b^2 and σ_w^2 , respectively. For the present discussion, there is only one set of fixed conditions, hence the subscript 'i' can be omitted. For the general regression and analysis of variance models discussed in Sections 8.3.5.1 and 8.3.5.2 there can be many combinations of fixed factors; there the 'i' subscript in Equation 8.2.3 must be retained.

If data from more than one batch are available, then *RECIPE* (Section 8.1.2) will use the data to determine basis values which with 95% confidence are less than the appropriate percentile of a randomly chosen observation from a randomly chosen *future* batch, for a particular set of fixed conditions. Such values protect against the possibility of batch-to-batch variability resulting in future batches which have lower mean properties than those batches for which data are available.

8.2.4 Batches, panels, and confounding

The model described in Equation 8.2.3 and Section 8.3.5 is based on the assumption of at most two sources of variability; these are referred to as 'between-batch variability' and 'within-batch variability'. In

the manufacturing of composites, however, there are typically at least three sources of variability. For composites made from prepreg, the additional source is due to the fact that several specimens are typically manufactured together as a 'panel', consequently a third source can be referred to as 'between-panel' variability.

When one has data on a material from several batches, but at only one set of fixed conditions, one cannot estimate batch and panel variabilities separately. Whenever data are obtained from a new batch, that data also comes from a different panel. (In statistical terminology, the batch and panel variances are confounded.) So what we call 'between-batch variability' in such cases is actually the sum of the between-batch and between-panel variances. Unless the between-panel variability is negligible, the between-batch variance will be over-estimated in such cases. This can result in material basis properties that are lower than they should be.

Next consider the situation where data are available from several batches at more than one set of fixed conditions (see Section 8.3.7.8). If one assumes also that data at different conditions from the same batch are from different panels, then one is able, in principle, to estimate the between-batch and between-panel variances separately. However, the regression models in this chapter and the `RECIPE` software include only one source of such variability. Consequently, the between-panel variance is confounded, not with the between-batch variance as above, but with the within-batch variance. This can result in material basis values that are somewhat higher than they should be. This is likely to be a less serious problem than the case where panel and batch variances are confounded for several reasons. Perhaps the most important of these is that of the sources of variability, that due to batches is the primary concern, and is being treated appropriately. Another reason is that there is typically considerable variability within panels, and if the between-panel variance is small with respect to the within-panel variability, then the material basis properties will not be substantially higher than they should be.

8.2.5 Sample size guidelines for determining basis values.

Material basis values are often regarded as material properties, that is, these values are interpreted as constants which can be used to help characterize the material and processing. Since basis values will *always* vary from one set of data to the next, even if the material, conditioning, and test remain unchanged, treating them as material constants is always an approximation.

However, if the calculations are based on 'enough' data, the basis values should be reproducible, to within engineering accuracy, across comparable data sets. The objective of this section is to illustrate the small-sample reproducibility problem and to provide guidance on how many data are necessary in basis value calculations in order for these values to be approximately reproducible.

How many data are 'enough' depends on many factors, including

1. The statistical model which is used to approximate the population from which the data is sampled,
2. The degree of reproducibility which is desired,
3. The variability in the property being measured, and
4. Variability in measurements of the property due to the test method

Because of this, it is impossible to give firm recommendations. The discussion in this section has another purpose. It is intended to provide background information and guidelines to assist the user of this handbook in making a sample size decision. We emphasize that this section deals *only* with the stability of basis values with respect to sample size. Another important issue relevant to the choice of a sample size, which deserves separate consideration, is the effect on basis values of statistical model assumptions - since there is considerable uncertainty in model selection from small samples. Additional discussion of the effect of sample size selection is found in Section 2.2.5.

8.2.5.1 Example

Table 8.2.5.1 presents tensile strength data (in ksi) for a unidirectional composite material, tested under room temperature dry conditions.

TABLE 8.2.5.1 Room temperature dry tensile strength for a unidirectional composite material.

226	227	226	232	252
-----	-----	-----	-----	-----

The mean and standard deviation for these data are $\bar{x} = 232.6$ and $s = 11.13$. Using the normal model (Section 8.3.4.3), a B-basis value for these data is

$$B = \bar{x} - k_B s = 232.6 - 3.407(11.13) = 195 \qquad 8.2.5.1$$

The first point to be made is that a B-basis value determined from as few as five specimens is not likely to be sufficiently reproducible for it to be regarded as a material constant for most applications. For the present discussion, the plausible assumption is made that the above data are a sample from a normal distribution with a mean of 230 and a standard deviation of 10.

The theoretical population of B-basis values which corresponds to this assumed normal population of strength measurements can be calculated, and is displayed in Figure 8.2.5.1. Note that the observed basis value is near the mean of this population of basis values. This is to be expected since the parameters of the hypothetical normal distribution have been based on the same set of data from which the basis value was determined. However, note also that values within ± 20 ksi of the basis value are also likely to be observed. Based on this analysis, one cannot rule out the possibility of the B-basis value of the next sample of five being as low as 180 ksi or as high as 220 ksi.

8.2.5.2 Mean and standard deviations of normal basis values

Basis values calculated from small samples exhibit high variability. One way of quantifying this is to calculate the theoretical mean, standard deviation, and coefficient of variation of basis values from hypothetical populations as functions of the number of specimens. Of course, these calculations are going to depend on the statistical model chosen and the parameters selected for this model. However, the objective of these calculations is not to provide rigid criteria, but rather to inform the user of the qualitative behavior of basis values.

A normal population with a mean of 100 and a standard deviation of 10 will be considered for the discussion in this subsection. The 10% coefficient of variation is typical of what is observed for many material properties, and the mean of 100 is within an order of magnitude of most strength measurements (in ksi) for unidirectional composite materials. The choice of the normal population is made because the normal basis values procedures have broad appeal, and because the required calculations can be done in closed form. Sample sizes for basis values from Weibull populations should as a rule be larger than those for normal populations in order to achieve the same degree of reproducibility. Only basis values for a simple random sample are considered here; ANOVA basis values are discussed in the next subsection.

The mean and one standard deviation limits for B-basis values from a normal population with a mean of 100 and a standard deviation of 10 is displayed in Figure 8.2.5.2(a) as a function of the number of specimens. Note the extremely high variability for sample sizes of ten or less.

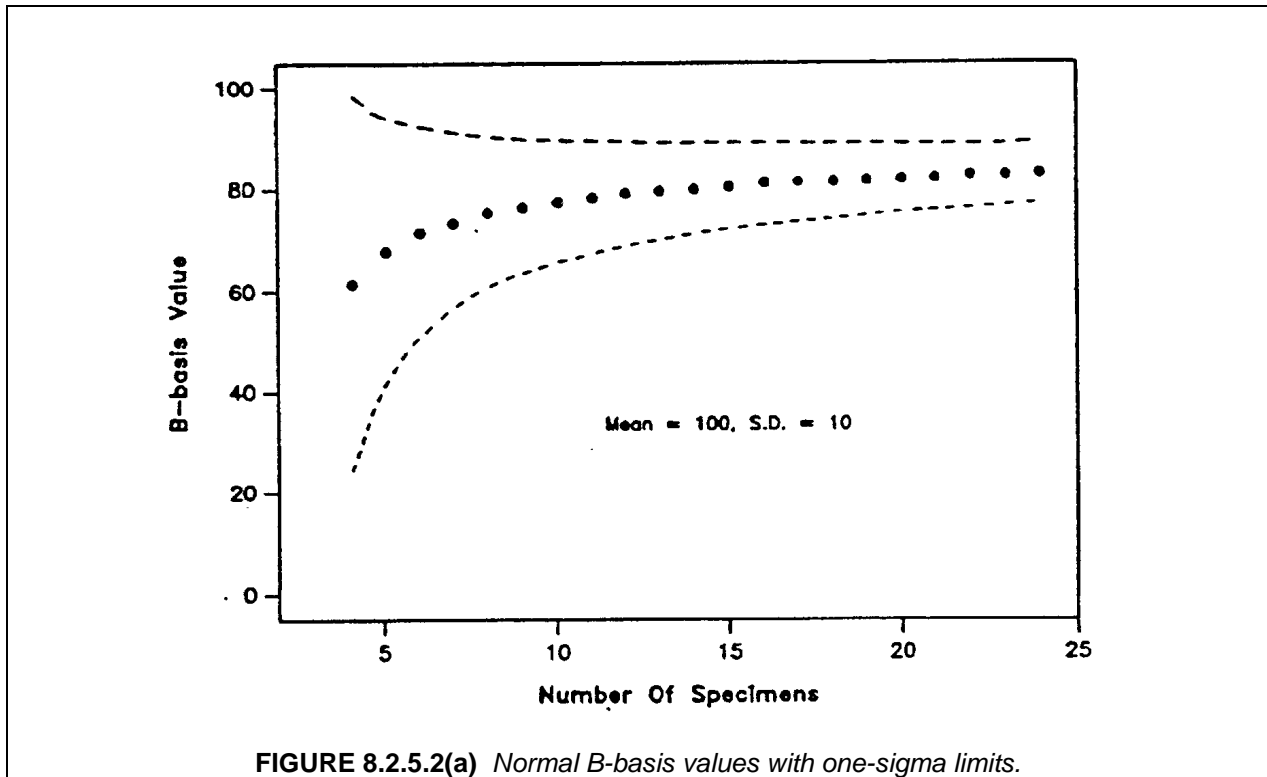
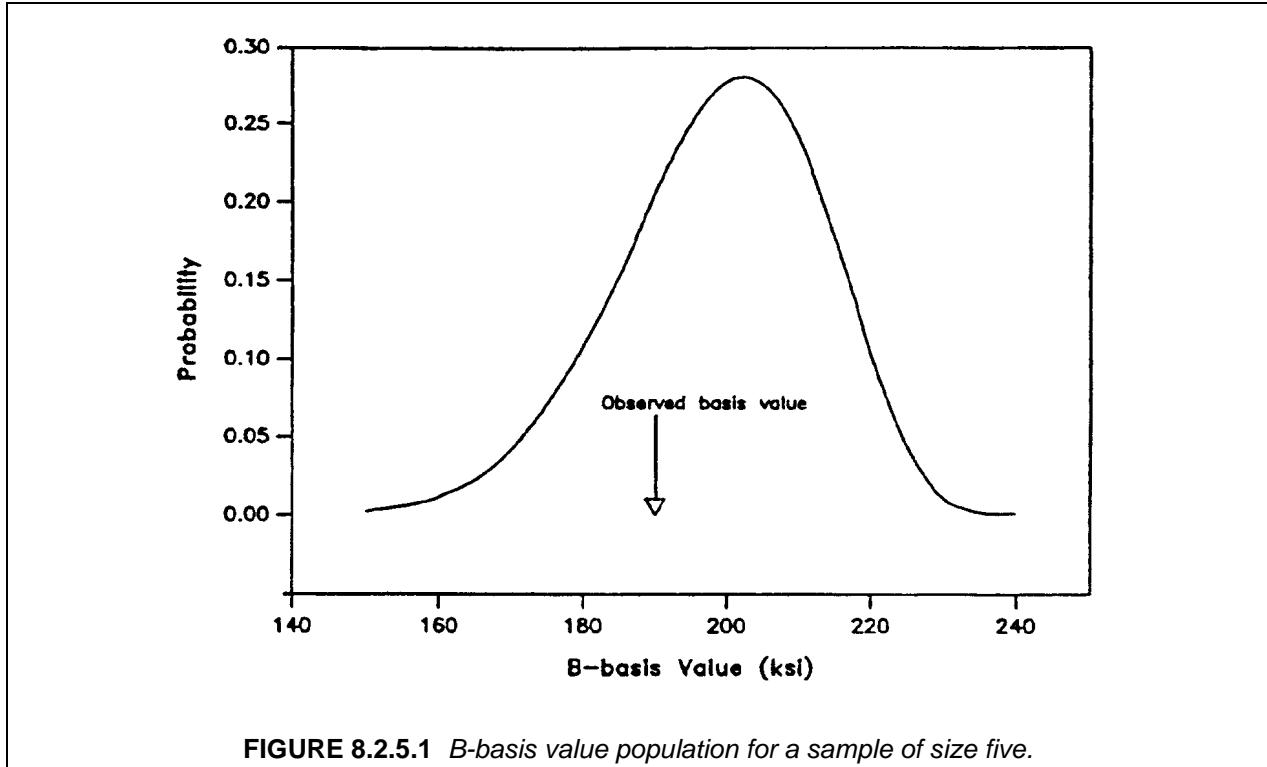

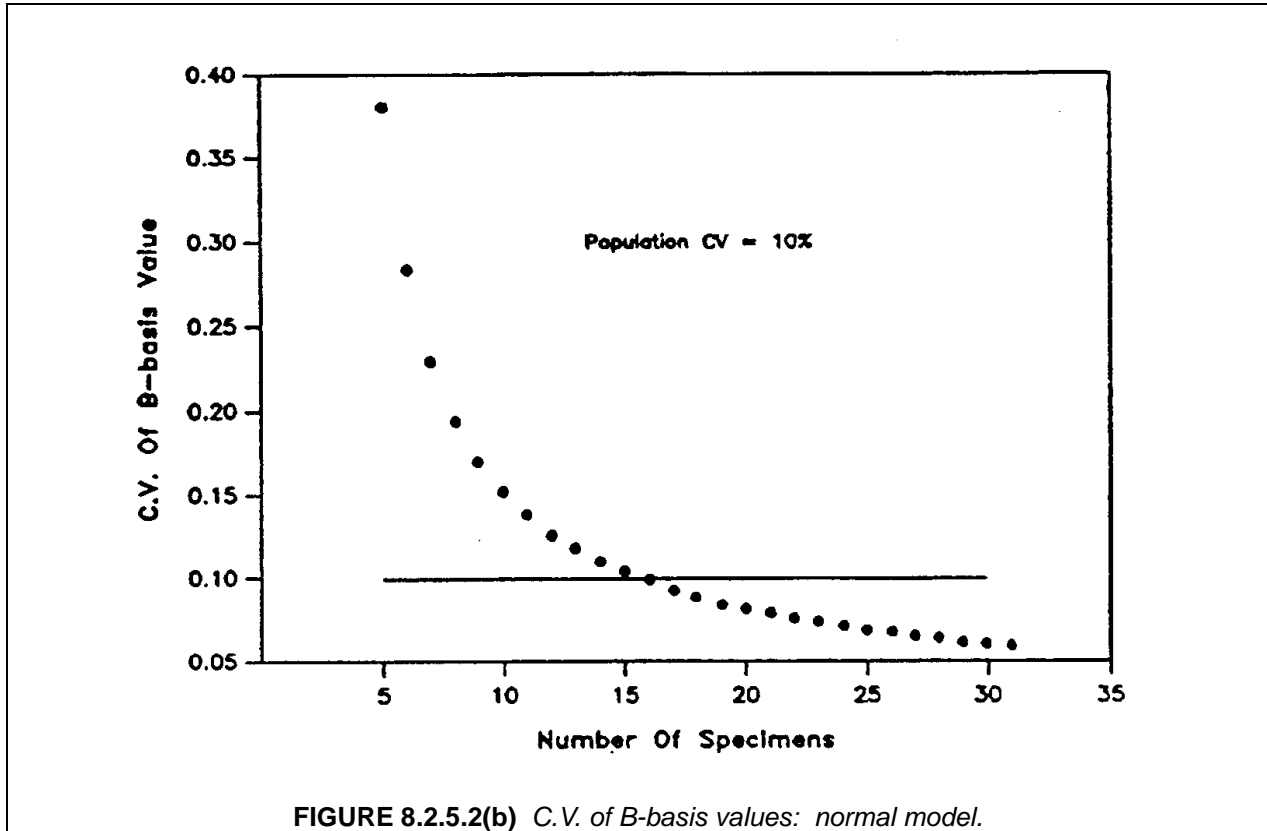

The coefficient of variation (CV) is the ratio of the standard deviation to the mean. It is, therefore, easy to obtain the CV as a function of sample size from the information in Figure 8.2.5.2(a). Figure 8.2.5.2(b) displays these CV values, with a horizontal line at 10% provided for reference.

Since an A-basis value is a 95% lower confidence limit on the *first* population percentile, while a B-basis value is a 95% lower confidence limit on the *tenth* percentile, it is obvious that, for a given amount of reproducibility in the basis values, substantially more data is required for A-basis than for B-basis. If one assumes that the measurements are a sample from a normal distribution, then it is reasonable to decide on the number of specimens as for B-basis and then multiply the resulting n by three to get an A-basis sample size. This is based on the assumption that the population coefficient of variation is less than 15%.

8.2.5.3 Basis values using the ANOVA method

When the data come from several batches, and the between-batch variability is substantial, the flow-chart (Figure 8.3.1) might indicate that the ANOVA method of Section 8.3.5.2 should be used. To decide how many specimens are required when the data are to come from several batches, begin by acting as if the data were from a single batch, and selecting a sample size, say n , based on the discussion of the previous subsection. If J is the number of specimens per batch (assumed equal for all batches) and ρ is the correlation between any two measurements taken on specimens from the same batch, then the number of specimens required for comparable reproducibility in the multi-batch case is approximately

$$\tilde{n} = [J\rho + 1 - \rho] n \quad 8.2.5.3$$

If $\rho = 0$, there is no between-batch variability; hence $\tilde{n} = n$. At the other extreme, if $\rho = 1$, there is perfect correlation within each batch (that is, each batch consists of J copies of a single value), and $\tilde{n} = Jn$, one needs n batches to have the same degree of reproducibility as n specimens in the uncorrelated ($\rho = 0$) case. In practice, ρ is unknown. For sample size guidelines, letting $\rho = 1/2$ in Equation 8.2.5.3 is adequate for most applications. This suggests that $(n(J+1)/(2J))$ batches of size J are necessary for the same degree of reproducibility as a single sample of size n . It is usually preferable to divide a fixed number of specimens among as many batches as is possible. However, testing a new batch is much more expensive than testing several more specimens within a single batch. It is sometimes the case that the variability between two panels from the same batch, processed and tested separately, is comparable to the variability between two panels from different batches. When this is the case, it is reasonable to substitute multiple panels within a batch for multiple batches.

Suppose that an A-basis ANOVA value is desired which has the same degree of reproducibility as a B-basis value would have for a single sample of size $n = 5$. First, make the adjustment to an A-basis sample size: $n_A = 3 \cdot 5 = 15$, as described in Section 8.2.5.2. Next, assuming moderate between-batch variability and a batch size of (say) $J = 3$, calculate that $n_A[(J+1)/(2J)] = 10$ batches are required for the desired degree of reproducibility, for a total of 30 specimens.

8.3 CALCULATION OF STATISTICALLY-BASED MATERIAL PROPERTIES

Section 8.3 contains computational methods for obtaining B- and A-basis values from composite material test data.

8.3.1 Guide to computational procedures

The procedure used to determine a basis value depends on the characteristics of the data. The step-by-step procedure for selecting the appropriate computational method is illustrated by the flowchart in Figure 8.3.1. Details for the specific computational methods are provided in later sections.

Two approaches are used, with the selection dependent on whether the data are structured or not. The k-sample Anderson-Darling test in Section 8.3.2 examines the differences among groups of data to determine if they are significant or negligible, which also determines whether the data should be treated as structured or unstructured. The difference between structured and unstructured data is considered in Section 8.3.2. Briefly, data sets which either cannot be grouped, or for which there are negligible differences among such groups, are called *unstructured*. Otherwise, the data are said to be *structured*. All data should be examined for outliers, using the test in Section 8.3.3. From this point, different approaches are used for analysis depending on whether the data are unstructured or structured.

The approach for unstructured data is described first. If unstructured data were grouped and the differences among the groups found to be negligible, the groups are combined. The test for outliers should be performed again on the combined data. Tests for goodness-of-fit (Section 8.3.4.1) are performed for the Weibull, normal, and lognormal distributions in succession. If the observed significance level (OSL) for the Weibull distribution is greater than 0.05, indicating an adequate fit for the data to the Weibull distribution, then a Weibull basis value is recommended (Section 8.3.4.2). If the OSL for the Weibull distribution is less than 0.05 and the OSL for the normal distribution is greater than 0.05, then the normal basis value should be used (Section 8.3.4.3). If the OSL's from both the Weibull and normal goodness-of-fit tests are less than 0.05, and the OSL for the lognormal distribution is greater than 0.05, then a lognormal basis value is recommended (Section 8.3.4.4). If none of the three OSL's are greater than 0.05, then the nonparametric basis value procedures are recommended (Section 8.3.4.5). Section 8.3.4 provides the rationale for the order of the distribution selection. An alternative approach is to use the basis values corresponding to the best-fitting model. Exploratory data analysis (EDA) techniques, described in Section 8.3.6, can provide graphical illustrations of the data distribution in support of the goodness-of-fit tests.

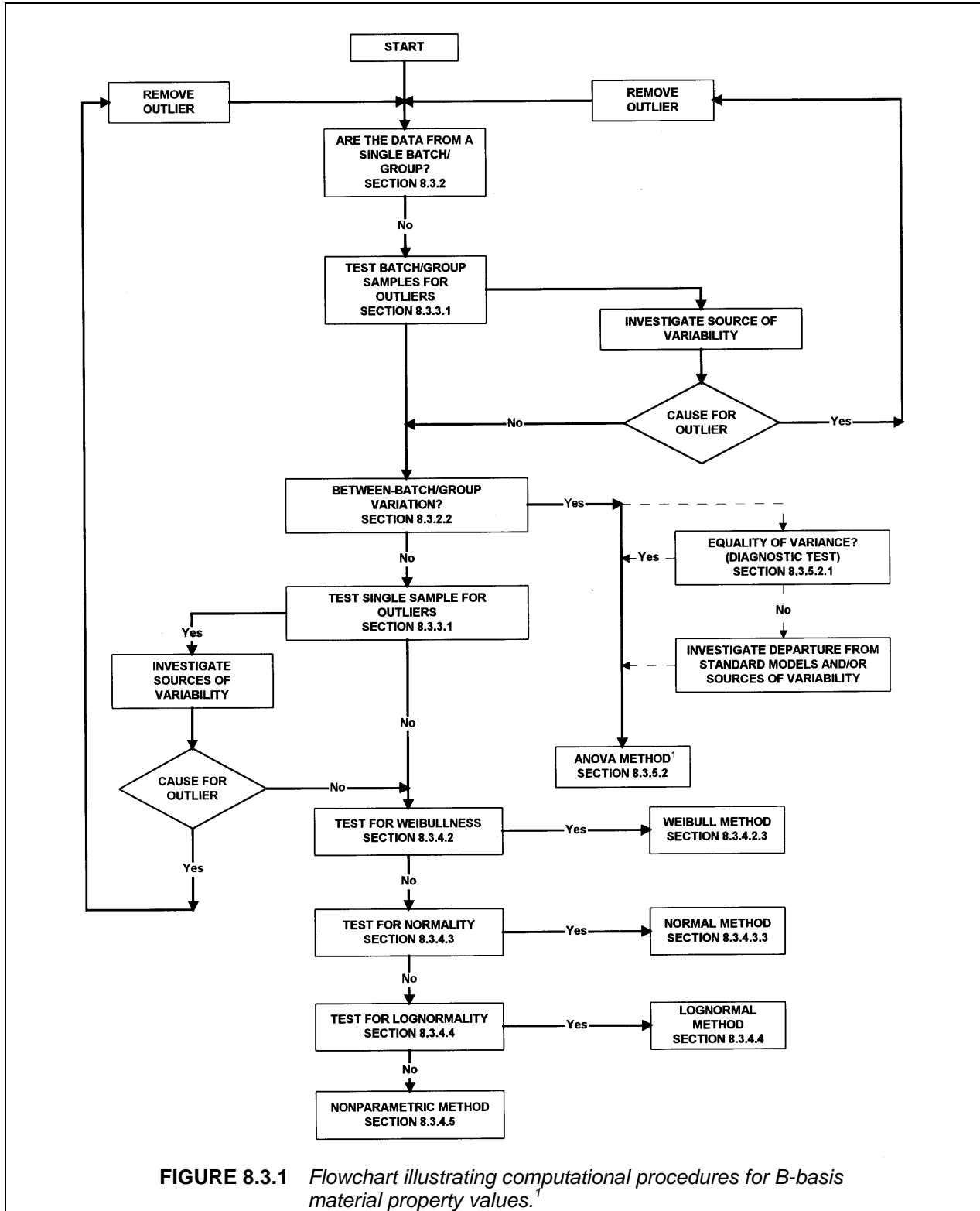

FIGURE 8.3.1 Flowchart illustrating computational procedures for B-basis material property values.¹

¹The ANOVA method applies to the simple multiple-batch case. Other scenarios may be addressed by linear regression (RECIPE). The acceptance of data analyzed by linear regression for inclusion in MIL-HDBK-17 is under consideration.

The approach for structured data divides the grouping of data according to fixed and random effects. A fixed effect is where an independent variable is set or measured. An example of a fixed effect is data obtained, by design or by chance, at different measured test temperatures. A random effect is the result of variability where the cause is unknown or unmeasurable. An example of a random effect is data obtained from several batches with significant batch-to-batch variability. (See definitions in Section 8.1.4.) Data sets with random effects, fixed effects or combinations of fixed and random effects require a basic understanding of linear models for regression and the analysis of variance. While a detailed exposition of this topic is beyond the scope of the handbook, an introduction with elementary references is provided in Section 8.3.5.1. The simplest case of structured data is where the only grouping is by a random effect, such as batches or panels. For this situation, basis values should be calculated by the analysis of variance (ANOVA) procedure (Section 8.3.5.2). Before basis values are calculated, a diagnostic test for equality of variances should be applied. Note that there is a special approach for determining basis values when the data consist of only two groups.

The case of one fixed effect and no random effects is linear regression (Section 8.3.5.3). For cases with no or one random effect and an arbitrary number of fixed effects, basis values from regression models can be calculated using the computer program *RECIPE*. A method for pooling small data sets from multiple environmental conditions is described in Section 8.3.5.4.

8.3.2 Subpopulation compatibility - structured or unstructured

Expected and unexpected behavior should be considered in determining whether there are natural or logical groupings of the data. Data for which natural groupings exist, or for which responses of interest could vary systematically with respect to known factors, are *structured* data. For example measurements made from each of several batches could reasonably be grouped according to batch, and measurements made at various known temperatures could be modeled using linear regression (Section 8.3.5); hence both can be regarded as structured data. In many ways, it is easier to analyze data which are *unstructured*; hence, it is often desirable to be able to show that a natural grouping of data has no significant effect. Data are considered unstructured if all relevant information is contained in the response measurements themselves. This could be because these measurements are all that is known, or else because one is able to ignore potential structure in the data. For example, data measurements that have been grouped by batch and demonstrated to have negligible batch-to-batch variability may be considered unstructured. An unstructured data set is a *simple random sample*.

The following section describes the k-sample Anderson-Darling test for showing the subpopulations are *compatible*, that is, the natural groupings have no significant effect. Compatible groups may be treated as part of the same population. Thus, a structured data set, with a natural grouping identified, can become an unstructured data set by showing that the natural grouping has no significant effect using the k-sample Anderson-Darling test.

For composite materials, it is recommended that batches (and panels where possible) be treated as natural groupings and tested for compatibility. Other groupings may result from expected behavior. Ply count might have a significant effect on ± 45 shear test; thus specimens with different ply counts naturally fall into groupings for this test. The decision regarding grouping the data may also be affected by the purpose of the test program. As an example, consider the influence of strain rate on material properties. A test program may be designed to evaluate the effects of strain rate on a given property. That program would obtain data at selected and controlled values of strain rate. These would provide the natural grouping for the data. A subpopulation compatibility test could be used to determine if there was a significant effect; or a structured data approach, such as linear regression, could be used.

8.3.2.1 Notation for grouped data

For structured data, each data value belongs to a particular group, and there will generally be more than one value within each group. Therefore, double subscripts will be used to identify the observations. Let the data be denoted by x_{ij} for $i = 1, \dots, k$ and $j = 1, \dots, n_i$, where i is the group and j is the observation within that group. There are n_i data values in the i th of k groups. Then the total number of observations is

$n = n_1 + n_2 + \dots + n_k$. The distinct values in the combined data set, ordered from smallest to largest, is denoted $z_{(1)}, z_{(2)}, \dots, z_{(L)}$, where L will be less than n if there are tied observations.

8.3.2.2 The *k*-sample Anderson-Darling test

The *k*-sample Anderson-Darling test is a nonparametric statistical procedure that tests the hypothesis that the populations from which two or more groups of data were drawn are identical. The test requires that each group be an independent random sample from a population. For more information on this procedure, see Reference 8.3.2.2.

The *k*-sample Anderson-Darling statistic is

$$ADK = \frac{n-1}{n^2(k-1)} \sum_{i=1}^k \left[\frac{1}{n_i} \sum_{j=1}^L h_j \frac{(nF_{ij} - n_i H_j)^2}{H_j(n - H_j) - n h_j / 4} \right] \tag{8.3.2.2(a)}$$

where

- h_j = the number of values in the combined samples equal to $z_{(j)}$
- H_j = the number of values in the combined samples less than $z_{(j)}$ plus one half the number of values in the combined samples equal to $z_{(j)}$, and
- F_{ij} = the number of values in the *i*th group which are less than $z_{(j)}$ plus one half the number of values in this group which are equal to $z_{(j)}$.

Under the hypothesis of no difference in the populations, the mean and variance of ADK are approximately 1 and

$$\sigma_n^2 = \text{Var}(ADK) = \frac{an^3 + bn^2 + cn + d}{(n-1)(n-2)(n-3)(k-1)^2} \tag{8.3.2.2(b)}$$

with

$$a = (4g-6)(k-1) + (10-6g)S \tag{8.3.2.2(c)}$$

$$b = (2g-4)k^2 + 8Tk + (2g-14T-4)S - 8T + 4g - 6 \tag{8.3.2.2(d)}$$

$$c = (6T+2g-2)k^2 + (4T-4g+6)k + (2T-6)S + 4T \tag{8.3.2.2(e)}$$

$$d = (2T+6)k^2 - 4Tk \tag{8.3.2.2(f)}$$

where

$$S = \sum_{i=1}^k \frac{1}{n_i} \tag{8.3.2.2(g)}$$

$$T = \sum_{i=1}^{n-1} \frac{1}{i} \tag{8.3.2.2(h)}$$

and

$$g = \sum_{i=1}^{n-2} \sum_{j=i+1}^{n-1} \frac{1}{(n-i)j} \tag{8.3.2.2(i)}$$

If the critical value

$$ADC = 1 + \sigma_n \left[1.645 + \frac{0.678}{\sqrt{k-1}} - \frac{0.362}{k-1} \right] \tag{8.3.2.2(j)}$$

is less than the test statistic in Equation 8.3.2.2(a), then one can conclude (with a five percent risk of being in error) that the groups were drawn from different populations. Otherwise, the hypothesis that the groups were selected from identical populations is not rejected, and the data may be considered unstructured with respect to the random or fixed effect in question. Table 8.5.6 contains the critical values (Equation 8.3.2.2(j)) for the case of where all of the n_i are equal. The example problem in Section 8.3.7.1, Step 2 demonstrates this procedure.

8.3.3 Detecting outliers

An *outlier* is an observation that is much lower or much higher than most other observations in a data set. Often outliers are erroneous values, perhaps due to clerical error, to the incorrect setting of environmental conditions during testing, or to a defective test specimen. Data should routinely be screened for outliers, since these values can have a substantial influence on the statistical analysis. In addition to the quantitative screening for outliers (Section 8.3.3.1), the data should also be examined visually, since no statistical procedure can be completely reliable for outlier detection.

The Maximum Normed Residual (MNR) method is used for quantitative screening for outliers. This test screens for outliers in an unstructured data set. If the data can be grouped naturally into subgroups (due to batches, manufacturers, temperatures, and so on), then one should form the smallest subgroups possible and screen each of these separately. Data from compatible subgroups, based on the previous section, should be combined and the screening test performed on the larger group. Of course, data should only be pooled when it makes sense to do so. For example, batches of data for the same property and environmental condition can be combined, but tension and compression data should never be pooled.

All values identified as outliers should be investigated. Those values for which a cause can be determined should be corrected if possible, and otherwise discarded. When error in data collection or recording are discovered, all data should be examined to determine whether similar errors occurred; these values should also be corrected or discarded. If no cause can be found for an outlier, it should be retained in the data set. If an outlier is clearly erroneous, it can be removed after careful consideration provided that the subjective decision to remove a value is documented as part of the data analysis. If any observations are corrected or discarded, both the statistical outlier test and the visual inspection should be repeated.

8.3.3.1 The maximum normed residual

The maximum normed residual (MNR) test is a screening procedure for identifying an outlier in an unstructured set of data. A value is declared to be an outlier by this method if it has an absolute deviation from the sample mean which, when compared to the sample standard deviation, is too large to be due to chance. This procedure assumes that observations which are not outliers can be regarded as a random sample from a normal population. The MNR method can only detect one outlier at a time, hence the significance level pertains to a single decision. Additional information on this procedure can be found in References 8.3.3.1(a) and (b).

Let x_1, x_2, \dots, x_n denote the data values in the sample of size n , and let \bar{x} and s be the sample mean and sample deviation, defined in Section 8.1.4. The MNR statistic is the maximum absolute deviation, from the sample mean, divided by the sample standard deviation:

$$\text{MNR} = \max_i \frac{|x_i - \bar{x}|}{s}, \quad i = 1, 2, \dots, n \quad 8.3.3.1(a)$$

The value of Equation 8.3.3.1(a) is compared to the critical value for the sample size n from Table 8.5.7. These critical values are computed from the following formula

$$C = \frac{n-1}{\sqrt{n}} \sqrt{\frac{t^2}{n-2+t^2}} \quad 8.3.3.1(b)$$

where t is the $[1 - \alpha/(2n)]$ quantile of the t -distribution with $n - 2$ degrees of freedom and α is the significance level. The recommended significance level for this test is $\alpha = 0.05$.

If MNR is smaller than the critical value, then no outliers are detected in the sample; otherwise the data value associated with the largest value of $|x_i - \bar{x}|$ is declared to be an outlier.

If an outlier is detected, this value is omitted from the calculations and the MNR procedure is applied again. This process is repeated until no outliers are detected. Note that the j th time that a sample is screened for an outlier, the mean, standard deviation, and critical value are computed using a sample size of $n - j - 1$. It should be noted that for small samples, for example a batch containing five or six data, this procedure may identify most of the data as outliers, particularly if two or more of the values are identical. The example problem in Section 8.3.7.1, Step 1 demonstrates this procedure.

8.3.4 Basis values for unstructured data

The method employed in calculating basis values for unstructured data depends on the distributional form which is assumed. Section 8.3.4 contains procedures for performing a goodness-of-fit test for the Weibull, normal, and lognormal distributions.

As shown in Figure 8.3.1, it is recommended that the Weibull model be used if it adequately fits the data, even if other models apparently fit the data better. This preference for the Weibull distribution is based on two factors:

1. Theory suggests that the Weibull distribution is appropriate for the strength distribution of brittle materials such as composite fibers (see, for example, Reference 8.3.4(a)).
2. The "Chain-of-Bundles" model for the strength of two- and three-dimensional unidirectional composites suggests that the Weibull model is appropriate for the strength distribution of such composites. This result is stated in References 8.3.4(b) and (c).

If the Weibull model cannot be shown to adequately fit the data, then the normal and lognormal tests are performed in succession. If none of these three population models can be demonstrated to adequately fit the data, then nonparametric procedures should be used to compute basis values.

The exploratory data analysis (EDA) techniques of Section 8.3.6 should also be used to graphically display the data, highlighting potential difficulties and providing graphical evidence of goodness-of-fit to support the quantitative conclusions of the tests in this section.

8.3.4.1 Goodness-of-fit tests

Each distribution is considered using the Anderson-Darling test statistic which is sensitive to discrepancies in the tail regions. The Anderson-Darling test compares the cumulative distribution function for the distribution of interest with the cumulative distribution function of the data. The data are first converted to a common representation for the distribution under consideration. For example, for a normal distribution, the data are normalized to a mean of 0 and a standard deviation of 1. An observed significance level (OSL) based on the Anderson-Darling test statistic is computed for each test. The OSL measures the probability of observing an Anderson-Darling test statistic as least as extreme as the value calculated if the distribution under consideration is in fact the underlying distribution of the data. The OSL is the probability of obtaining a value of the test statistic at least as large as that obtained if the hypothesis that the data are actually from the distribution being tested is true. If the OSL is less than or equal to 0.05, the hypothesis is rejected (with at most a five percent risk of being in error) and one proceeds as if the data are not from the distribution being tested.

In what follows, unless otherwise noted, the sample size is denoted by n , the sample observations by x_1, \dots, x_n , and the sample observations ordered from least to greatest by $x_{(1)}, \dots, x_{(n)}$.

8.3.4.2 Two-parameter Weibull distribution

In order to compute a basis value for a two-parameter Weibull population, it is first necessary to obtain estimates of the population shape and scale parameters. Section 8.3.4.2.1 contains a step-by-step procedure for calculating maximum likelihood estimates of these parameters. Calculations specific to the goodness-of-fit test for the Weibull distribution are provided in Section 8.3.4.2.2. The computational procedure for calculating basis values using these estimates is outlined in Section 8.3.4.2.3. The example problem in Section 8.3.7.1 demonstrates these procedures. For further information on these procedures, see Reference 8.3.4.2.

8.3.4.2.1 Estimating the shape and scale parameters of a Weibull distribution

The section describes the *maximum likelihood* method for estimating the parameters of the two-parameter Weibull distribution. The maximum-likelihood estimates of the shape and scale parameters are denoted $\hat{\beta}$ and $\hat{\alpha}$. The estimates are the solution to the pair of equations:

$$\hat{\alpha}\hat{\beta}n - \frac{\hat{\beta}}{\hat{\alpha}^{\hat{\beta}-1}} \sum_{i=1}^n x_i^{\hat{\beta}} = 0 \quad 8.3.4.2.1(a)$$

and

$$\frac{n}{\hat{\beta}} - n \ln \hat{\alpha} + \sum_{i=1}^n \ln x_i - \sum_{i=1}^n \left[\frac{x_i}{\hat{\alpha}} \right]^{\hat{\beta}} (\ln x_i - \ln \hat{\alpha}) = 0 \quad 8.3.4.2.1(b)$$

Equation 8.3.4.2.1(a) can be rewritten as

$$\hat{\alpha} = \left(\frac{\sum_{i=1}^n x_i^{\hat{\beta}}}{n} \right)^{\frac{1}{\hat{\beta}}} \quad 8.3.4.2.1(c)$$

By substituting Equation 8.3.4.2.1(c) into Equation 8.3.4.2.1(b), the following equation is obtained.

$$\frac{n}{\hat{\beta}} + \sum_{i=1}^n \ln x_i - \frac{n}{\sum_{i=1}^n x_i^{\hat{\beta}}} \sum_{i=1}^n x_i^{\hat{\beta}} \ln x_i = 0 \quad 8.3.4.2.1(d)$$

Equation 8.3.4.2.1(d) can be solved numerically for $\hat{\beta}$, which can then be substituted into Equation 8.3.4.2.1(c) to obtain $\hat{\alpha}$.

Figure 8.3.4.2.1 shows FORTRAN source code for three routines which compute the estimates of $\hat{\alpha}$ and $\hat{\beta}$ by the method described above. WBLEST is a subroutine which returns the estimates of the parameters, $\hat{\beta}$ and $\hat{\alpha}$. FNALPH is a function which calculates the estimate of the scale parameter, $\hat{\alpha}$. GFUNCT is a function which evaluates Equation 8.3.4.2.1(d). Arguments to WBLEST are

X	=	a vector of length NOBS containing the data (input),
NOBS	=	the number of data values, n (input),
BETA	=	estimate of the shape parameter (output),
ALPHA	=	estimate of the scale parameter (output).

The algorithm by which the FORTRAN code computes the estimates is described in the following paragraph.

```

C-----
C          SUBROUTINE WBLEST(X,NOBS,ALPHA,BETA)
C
C          COMPUTE MLES FOR SHAPE PARAMETER (BETA) AND SCALE PARAMETER
C          (ALPHA) BY SOLVING THE EQUATION G(BETA) = 0, WHERE G IS
C          A MONOTONICALLY INCREASING FUNCTION OF BETA.
C          THE INITIAL ESTIMATE IS: RI=(1.28)/(STD. DEV. OF LOG(X)'S)
C          AND THE TOLERANCE IS : 2*RI/(10**6).
C
C          DIMENSION X(NOBS)
C
C          RN = FLOAT(NOBS)
C          SUMY = 0.0
C          SUMYSQ = 0.0
C          DO 2 I = 1, NOBS
C              Y = ALOG(X(I))
C              SUMY = SUMY + Y
C              SUMYSQ = SUMYSQ + (Y**2)
C          2 CONTINUE
C          YSTD = SQRT((SUMYSQ - (SUMY**2)/RN)/(RN - 1.0))
C          XGM = EXP(SUMY/RN)
C          RI = 1.28/YSTD
C          TOL = 2.0*.000001*RI
C          BETAM = RI
C          GFM = GFUNCT(X,NOBS,BETAM,XGM)
C
C          IF G(BETAM) .GE. 0, DIVIDE THE INITIAL ESTIMATE BY 2 UNTIL
C          THE ROOT IS BRACKETED BY BETAL ND BETAH.
C
C              IF(GFM .GE. 0.0) THEN
C                  DO 3 J = 1, 20
C                      BETAH = BETAM
C                      BETAM = BETAM/2.0
C                      GFM = GFUNCT(X,NOBS,BETAM,XGM)
C                      IF (GFM .LE. 0.0) GO TO 4
C                  3          CONTINUE
C                  STOP 'GFM NEVER LE 0'
C                  4          CONTINUE
C                  BETAL = BETAM
C              ENDIF
C
C          IF G(BETAM) .LT. 0, MULTIPLY THE INITIAL ESTIMATE BY 2
C          UNTIL THE ROOT IS BRACKETED BY BETAL AND BETAH
C
C              IF(GFM .LT. 0.0) THEN
C                  DO 7 J = 1, 20
C                      BETAL=BETAM
C                      BETAM=BETAM*2.0
C                      GFM=GFUNCT(X,NOBS,BETAM,XGM)
C                      IF(GFM .GE. 0.0) GO TO 8
C                  7          CONTINUE
C                  STOP 'GFM NEVER GE 0'
C                  8          CONTINUE
C                  BETAH = BETAM
C              ENDIF
C
C          SOLVE THE EQUATION G(BETA) = 0 FOR BETA BY BISECTING THE
C          INTERVAL (BETAL,BETAH) UNTIL THE TOLERANCE IS MET
C
C          10 CONTINUE
C              BETAM = (BETAL + BETAH) / 2.0
C              GFM = GFUNCT(X,NOBS,BETAM,XGM)
C              IF(GFM .GE. 0.0) THEN
C                  BETAH = BETAM
C              ENDIF
C              IF(GFM .LT. 0.0) THEN
C                  BETAL = BETAM
C              ENDIF
C              IF((BETAH - BETAL) .GT. TOL) GO TO 10

```

FIGURE 8.3.4.2.1 FORTRAN routines for calculating two-parameter Weibull shape and scale parameter, estimates, continued on next page.

```

C
      BETA = (BETAL + BETAH) / 2.0
      ALPHA = FNALPH(X,NOBS,BETA,XGM)
      RETURN
      END
-----
C
      FUNCTION FNALPH(X,NOBS,BETA,XGM)
C
C     COMPUTE MLE FOR TWO-PARAMETER WEIBULL SCALE PARAMETER (ALPHA)
C     XGM IS THE GEOMETRIC MEAN OF THE X'S
C
      DIMENSION X(NOBS)
      RN = FLOAT(NOBS)
C
      SUMZ = 0.0
      DO 20 I = 1, NOBS
        SUMZ = SUMZ + (X(I)/XGM)**BETA
20 CONTINUE
C
      FNALPH = XGM*(SUMZ/RN)**(1./BETA)
C
      RETURN
      END
-----

C
-----
C
      Function GFUNCT(X,NOBS,BETA,XGM)
C
C     COMPUTE G FUNCTION USED IN ESTIMATING THE TWO-PARAMETER WEIBULL
C     SHAPE PARAMETER (BETA).
C     XGC IS THE GEOMETRIC MEAN OF THE X'S USED IN ESTIMATING ALPHA.
C
      DIMENSION X(NOBS)
      RN = FLOAT(NOBS)
C
      ALPHA = FNALPH(X,NOBS,BETA,XGM)
      SUMYZ = 0.0
      DO 10 I = 1, NOBS
        SUMYZ = SUMYZ + ALOG(X(I))*((X(I)/ALPHA)**BETA - 1.)
10 CONTINUE
C
      GFUNCT = (SUMYZ/RN) - 1.0/BETA
C
      RETURN
      END
-----

```

FIGURE 8.3.4.2.1 FORTRAN routines for calculating two-parameter Weibull shape and shale parameter, estimates, concluded.

Equation 8.3.4.2.1(d) is a monotonically decreasing continuous function of $\hat{\beta}$. Designate the left-hand side of Equation 8.3.4.2.1(d) divided by n as $G(\hat{\beta})$ and obtain a solution for $\hat{\beta}$ by the following iterative procedure. Let S_y denote the standard deviation of y_1, \dots, y_n where $y_i = \ln(x_i)$ for $i = 1, \dots, n$. Calculate $I = 1.28/S_y$ as an initial guess at the solution and calculate $G(I)$. If $G(I) > 0$, then find the smallest positive integer k such that $G(1/2^k) < 0$ and let $L = I/2^2$ and $H = I/2^{k-1}$. If $G(I) < 0$, then find the smallest positive integer k such that $G(2^k I) > 0$ and let $L = 2^{k-1} I$ and $H = 2^k I$. In either case, the interval (L, H) contains the solution to $G(\hat{\beta}) = 0$. Now calculate $G(M)$ where $M = (L + H)/2$. If $G(M) = 0$, then the solution is $\hat{\beta} = M$. If $G(M) > 0$, then let $H = M$. If $G(M) < 0$ then let $L = M$. The new interval (L, H) still contains the solution to $G(\hat{\beta}) = 0$ but is only half as long as the old interval. Calculate a new M -value and begin the process of interval halving again. The process is repeated until $H - L < 2I/10^6$. The solution to $G(\hat{\beta}) = 0$ is then taken to be $M = (L + H)/2$. The solution is in error by at most $I/10^6$.

8.3.4.2.2 Goodness-of-fit test for the two-parameter Weibull distribution

The two-parameter Weibull distribution is considered by comparing the cumulative Weibull distribution function (Section 8.1.4) that best fits the data with the cumulative distribution function of the data. Using the shape and scale parameter estimates from Section 8.3.4.2.1, let

$$z_{(i)} = \left[x_{(i)} / \hat{\alpha} \right]^{\hat{\beta}}, \quad \text{for } i = 1, \dots, n \quad 8.3.4.2.2(a)$$

The Anderson-Darling test statistic is

$$AD = \sum_{i=1}^n \frac{1-2i}{n} \left[\ln \left[1 - \exp(-z_{(i)}) \right] - z_{(n+1-i)} \right] - n \quad 8.3.4.2.2(b)$$

and the observed significance level is

$$OSL = 1 / \left\{ 1 + \exp[-0.10 + 1.24 \ln(AD^*) + 4.48 AD^*] \right\} \quad 8.3.4.2.2(c)$$

where

$$AD^* = \left(1 + \frac{0.2}{\sqrt{n}} \right) AD \quad 8.3.4.2.2(d)$$

This OSL measures the probability of observing an Anderson-Darling statistic at least as extreme as the value calculated if in fact the data are a sample from a two-parameter Weibull distribution. If $OSL \leq 0.05$, one may conclude (at a five percent risk of being in error) that the population does not have a two-parameter Weibull distribution. Otherwise, the hypothesis that the population has a two-parameter Weibull distribution is not rejected. For further information on this procedure, see Reference 8.3.4.2.

8.3.4.2.3 Basis values for the two-parameter Weibull distribution

If the unstructured data set is from a population with a two-parameter Weibull distribution, the B-basis value is

$$B = \hat{q} \exp \left\{ \frac{-V}{\hat{\beta} \sqrt{n}} \right\} \quad 8.3.4.2.3(a)$$

where

$$\hat{q} = \hat{\alpha} (0.10536)^{1/\hat{\beta}} \quad 8.3.4.2.3(b)$$

and V is the value in Table 8.5.8 corresponding to a sample of size n. A numerical approximation to the V values is given in Equation 8.5.8(h).

To calculate the A-basis value, use the appropriate V value from Table 8.5.9 substituting 8.3.4.2.3(c) for 8.3.4.2.3(b).

$$\hat{q} = \hat{\alpha} (0.01005)^{1/\hat{\beta}} \quad 8.3.4.2.3(c)$$

8.3.4.3 Normal distribution

In order to compute a basis value for a normally distributed population, it is necessary to obtain estimates of the population mean and standard deviation. Section 8.3.4.3.1 gives the equations for calculating these parameters. Section 8.3.4.3.2 provides the procedure for goodness-of-fit for the normal distri-

bution, and Section 8.3.4.3.3 gives the procedure for calculating basis values. The example problem in Section 8.3.7.2 demonstrates these procedures.

8.3.4.3.1 Estimating the mean and standard deviation parameters for the normal distribution

The population mean and standard deviation are estimated using the sample mean \bar{x} and sample standard deviation s .

$$\bar{x} = \frac{1}{n} \sum_{i=1}^n x_i$$

$$s = \frac{1}{n-1} \sum_{i=1}^n (x_i - \bar{x})^2$$

8.3.4.3.2 Goodness-of-fit test for the normal distribution

The normal distribution is considered by comparing the cumulative normal distribution function (Section 8.1.4) that best fits the data with the cumulative distribution function of the data. Let

$$z_{(i)} = \frac{\bar{x}_{(i)} - \bar{x}}{s}, \quad \text{for } i = 1, \dots, n \quad 8.3.4.3.2(a)$$

where $x_{(i)}$ is the i th smallest sample observation, \bar{x} is the sample average, and s is the sample standard deviation.

The Anderson-Darling test statistic is

$$AD = \sum_{i=1}^n \frac{1-2i}{n} \left\{ \ln[F_0(z_{(i)})] + \ln[1 - f_0(z_{(n+1-i)})] \right\} - n \quad 8.3.4.3.2(b)$$

where F_0 is the standard normal distribution function (Equation 8.1.4(e)). The observed significance level is

$$OSL = 1 / \{1 + \exp[-0.48 + 0.78 \ln(AD^*) + 4.58 AD^*]\} \quad 8.3.4.3.2(c)$$

where

$$AD^* = \left(1 + \frac{0.2}{\sqrt{n}}\right) AD \quad 8.3.4.3.2(d)$$

This OSL measures the probability of observing an Anderson-Darling statistic at least as extreme as the value calculated if in fact the data are a sample from a normal distribution. If $OSL \leq 0.05$, one may conclude (at a five percent risk of being in error) that the population is not normally distributed. Otherwise, the hypothesis that the population is normally distributed is not rejected. For further information on this procedure, see Reference 8.3.4.2.

8.3.4.3.3 Basis values for the normal distribution

If the unstructured data set is from a population with a normal distribution, the B-basis value is

$$B = \bar{x} - k_B s \quad 8.3.4.3.3(a)$$

where k_B is the appropriate one-sided tolerance-limit factor from Table 8.5.10. A numerical approximation to the k_B values is given in Equation 8.5.10.

Volume 1, Chapter 8 Statistical Methods

To calculate the A-basis value, replace k_B with the appropriate value of k_A from Table 8.5.11 or the numerical approximation in Equation 8.5.11.

8.3.4.4 Lognormal distribution

The lognormal distribution is a positively skewed distribution that is simply related to the normal distribution. If something is lognormally distributed, then its logarithm is normally distributed. The natural (base e) logarithm is used in MIL-HDBK-17. See Section 8.1.4 for the definition of the lognormal distribution. The example problem in Section 8.3.7.3 demonstrates the application of the procedures in Section 8.3.4.3 for a lognormal distribution.

In order to fit test the goodness-of fit of the lognormal distribution, take the logarithm of the data and perform the Anderson-Darling test for normality from Section 8.3.4.3. Using the natural logarithm, let

$$z_{(i)} = \frac{\ln(\bar{x}_{(i)}) - \bar{x}_L}{s_L}, \quad \text{for } i = 1, \dots, n \quad 8.3.4.4(a)$$

where $x_{(i)}$ is the i th smallest sample observation, \bar{x}_L and s_L are the mean and standard deviation of the $\ln(x_i)$ values.

The Anderson-Darling statistics is computed using Equation 8.3.4.3(b) and the observed significance level (OSL) is computed using Equation 8.3.4.3(c). This OSL measures the probability of observing an Anderson-Darling statistic at least as extreme as the value calculated if in fact the data are a sample from a lognormal distribution. If $OSL \leq 0.05$, one may conclude (at a five percent risk of being in error) that the population is not lognormally distributed. Otherwise, the hypothesis that the population is lognormally distributed is not rejected. For further information on this procedure, see Reference 8.3.4.2.

The following procedure should be used to calculate basis values for unstructured data that is assumed to be a sample from a lognormal population. The equations presented in Section 8.3.4.3 are used to calculate the basis values. However, the calculations are performed using the logarithms of the data rather than the original observations. The computed B-basis value must then be transformed back to the original units by applying the inverse of the log transformation which was used.

8.3.4.5 Nonparametric basis values

These procedures should be used to compute basis values for unstructured data when one is unwilling to assume a particular population model, usually because the Weibull, normal, and lognormal models all provide inadequate fits to the data. One of two methods should be used, depending on the sample size.

8.3.4.5.1 Nonparametric basis values for large samples

To calculate a B-basis value for $n > 28$, determine the value r corresponding to the sample size n from Table 8.5.12. For sample sizes between tabulated values, select the r value associated with the largest tabulated sample size that is smaller than the actual n . The B-basis value is the r th lowest observation in the data set. For example, in a sample of size $n = 30$, the lowest ($r = 1$) observation is the B-basis value. A numerical approximation to the tabulated r values as a function of n is given in Section 8.5.12. The example problem in Section 8.3.7.4 demonstrates this procedure. Further information on this procedure may be found in Reference 8.3.4.5.1.

For $n > 298$, an A-basis value can be calculated using the sample procedure, with the r value selected from Table 8.5.13.

8.3.4.5.2 The Hanson-Koopmans method

The following procedure (References 8.3.4.5.2(a) and (b)) can be a useful method for obtaining a B-basis value for sample sizes not exceeding 28. This procedure requires the assumption that the observations are a random sample from a population for which the logarithm of the cumulative distribution function is concave, an assumption satisfied by a large class of probability distributions. There is substantial empirical evidence that suggests the composite strength data satisfies this assumption, consequently this procedure can usually be recommended for use when n is less than 29. However, in view of the required assumption, this is not an unconditional recommendation.

The Hanson-Koopmans B-basis value is

$$B = x_{(r)} \left[\frac{x_{(1)}}{x_{(r)}} \right]^k \quad 8.3.4.5.2(a)$$

where $x_{(1)}$ is the smallest and $x_{(r)}$ is the r th largest data value. The values of r and k depend on n and are tabulated in Table 8.5.14. This equation for the B-basis value should not be employed if $x_{(r)} = x_{(1)}$. The example problem in Section 8.3.7.5 demonstrates these procedures.

The Hanson-Koopmans method can be used to calculate A-basis values for n less than 299. Find the value k_A corresponding to the sample size n in Table 8.5.15. Let $x_{(n)}$ and $x_{(1)}$ be the largest and smallest data values. The A-basis value is

$$A = x_{(n)} \left[\frac{x_{(1)}}{x_{(n)}} \right]^k \quad 8.3.4.5.2(b)$$

8.3.5 Basis values for structured data

Where possible, it is advantageous to reduce structured data to unstructured cases as discussed in Section 8.3.2. The analysis of unstructured data is possible for distributions other than a normal probability model, which is assumed by the procedures for structured data. Where the data are structured and cannot be combined according to the test in Section 8.3.2.2, the procedures in this section should be used. These procedures for basis value calculations for structured data assume a normal probability model. All of these procedures can be considered in terms of regression analysis. A general description of regression analysis of linear statistical models is provided in Section 8.3.5.1. Included in this section is a discussion of checking the required assumptions. Analysis of variance is a special case with one random effect and no fixed effects (Section 8.3.5.2). A case of one fixed effect and no random effects is *simple linear regression* (Section 8.3.5.3).

8.3.5.1 Regression analysis of linear statistical models

The objective of a regression analysis for material basis properties is to obtain basis values for a particular response (for example, tensile strength) as functions of fixed factors (such as temperature, lay-up, and humidity). The measured response values will be called *observations*, and the values which describe the conditions corresponding to these observations will be referred to as *covariates*. For example, if a linear relationship is assumed between tensile strength and temperature, then the mean strength at a temperature T_i is, in the limit of infinitely many observations at this temperature, equal to $\theta_0 + \theta_1 T_i$. The constants θ_0 and θ_1 are generally unknown and must be estimated from the data. The values that these constants multiply, here 1 and T_i , are covariates; together they describe the fixed conditions under which the i th strength observation was made. Linear regression refers to a method for the analysis of relationships which are linear functions of *unknown parameters* (here θ_0 and θ_1). These relationships need not be linear in *covariates*. For example, a quadratic model in which squared temperature (T^2) is introduced as an additional covariate can be analyzed using linear regression.

Assume that the data being analyzed consist of n observations at ℓ fixed conditions (or levels), and number these conditions $1, 2, \dots, \ell$. In the example of linear regression on temperature, there are ℓ temperatures, and ℓ corresponding sets of covariates: $(1, T_1), (1, T_2), \dots, (1, T_\ell)$. It is necessary to indicate which fixed condition corresponds to each observation (recall the subscript i in Equation 8.2.3, so let the fixed conditions for observation s be $p(s)$. Also each observation is made on a specimen from one of m batches. These batches are numbered $1, 2, \dots, m$, and $q(s)$ indicates the batch corresponding the s th observation. Denote the observations by x_s , for $s = 1, 2, \dots, n$, where the s th value comes from fixed level $p(s)$ and from batch $q(s)$.

Assume that the $\{x_s\}$ represents a sample from a normal distribution with mean

$$\mu_{p(s)} = \theta_1 z_{p(s),1} + \theta_2 z_{p(s),2} + \dots + \theta_r z_{p(s),r} \quad 8.3.5.1(a)$$

where the $\{z_{p(s),u}\}$, for $1 \leq p(s) \leq \ell$ and $u = 1, \dots, r$, are known constants and the $\{\theta_u\}$ are parameters to be estimated. For example, if mean strength is assumed to vary linearly with temperature, and if condition $p(s) = 1$ corresponds to 75 degrees, then

$$\mu_1 = \theta_1 + \theta_2 75 \quad 8.3.5.1(b)$$

so $r = 2$, $z_{11} = 1$, and $z_{12} = 75$. Recall that the covariates $z_{p(s),u}$ are not required to be linear. For example, a quadratic relationship between strength and temperature would have covariates, $1, T_i$, and T_i^2 .

The means $\mu_{p(s)}$ can never be observed, but must be estimated from limited data. Each data value consists of the sum of $\mu_{p(s)}$ plus a random quantity $b_{q(s)} + e_s$, where $b_{q(s)}$ takes on a different value for each batch $q(s)$ and e_s takes on a different value for each observation. The random variables $\{b_{q(s)}\}$ and $\{e_s\}$ are assumed to be random samples from normal populations with means zero and variances σ_b^2 and σ_e^2 . The variance σ_b^2 is the *between-batch variance*, and σ_e^2 is referred to as the *within-batch (or error) variance*. (For a more elementary discussion of these ideas, see Section 8.2.3.)

The model for the data can now be written as

$$x_s = \mu_{p(s)} + b_{q(s)} + e_s = \theta_1 z_{p(s),1} + \dots + \theta_r z_{p(s),r} + b_{q(s)} + e_s \quad 8.3.5.1(c)$$

where the $\{z_{p(s),u}\}$ are known, the $\{\theta_u\}$ are unknown fixed quantities, and the $\{b_{q(s)}\}$ and $\{e_s\}$ are random quantities with unknown variances. Equation 8.3.5.1(c) is called a *regression model*. Every regression analysis begins with the choice of a regression model.

Special cases of Equation 8.3.5.1(c) are frequently useful. If the levels correspond to data groups, with the covariates indicating which group is associated with each observation, then the regression model is an analysis of variance (ANOVA) (Section 8.3.5.2). This case is most frequently used to calculate basis values when there is significant batch-to-batch variability. When there is one continuous covariate, the case is called the simple linear regression model (Section 8.3.5.3). Details of the analysis are provided for these special cases in the following sections. The analysis of the more general case is beyond the scope of this handbook; however, the *RECIPE* software is available to perform the analysis and examples are shown in Sections 8.3.7.6 - 8.3.7.9.

The power gained by using regression models for basis values is obtained at the expense of additional assumptions. A *residual* is defined to be the difference between a data point and its fitted value. Using the residuals, the following assumptions need to be checked:

Volume 1, Chapter 8 Statistical Methods

1. Check the validity of the assumed curvilinear relation between property and predictor variables, for example, straight line, quadratic, or other assumed relationship;
2. Check homogeneity of variance (variances are assumed constant over the range of predictor variables);
3. Check normality of regression residuals; and
4. Check for independence of residuals.

Also, one should not extrapolate beyond the range of the predictor variables without good cause.

A detailed discussion of the validation of a regression model is beyond the scope of this handbook; however it is discussed at length in most elementary texts, including References 8.3.5.1(a) - (d). Some elaboration at this point, though, might be helpful.

If a model fits well, then the residuals should be as likely to be positive as negative, and so they will alternate in sign every few values. They will have no apparent structure, and ideally will look like 'white noise'. If a model fits poorly, then there will often be long sequences of residuals that have the same sign, and curved patterns will typically be apparent in the residuals.

If the variance is high for a group of residuals, then these values will appear more scattered, and conversely for the case of low variability. This behavior can often be detected by examining residual plots. For example, if a simple linear regression has been performed of strength of specimens as a function of temperature, and if strength becomes more variable as temperature increases, then a plot of residuals against temperature might have a 'megaphone' shape.

There are also graphical procedures for checking the normality assumption for residuals. These can be found in most textbooks. It is also possible to apply the Anderson-Darling goodness-of-fit test for normality (Section 8.3.4.3) to the ratio of residuals to the standard deviation about the regression line (that is, e_i/s_y). A justification for this procedure can be found in Reference 8.3.5.1(e).

It is difficult to test for independence graphically. One possibility is to plot the odd-numbered residuals against the even-numbered ones, and to see if a trend is apparent. Further discussion can be found in the referenced textbooks. One form of lack of independence, 'clustering' due to batch effects, is addressed in the example in Section 8.3.7.9.

8.3.5.2 Analysis of variance

This section contains a discussion of one-way analysis of variance (ANOVA) procedures. Although these models can be written using the general notation of Equation 8.3.5.1(c), for the present discussion it is simpler to write the one-way ANOVA model as

$$x_{ij} = \mu + b_i + e_{ij}, \quad \begin{array}{l} i = 1, \dots, k \\ j = 1, \dots, n_i \end{array} \quad 8.3.5.2$$

where n_i is the number of values in the i th group, and x_{ij} represents the j th observation in the i th of k groups. The overall average of the population is μ , b_i is the effect attributed to the i th group, and e_{ij} is a random error term representing unexplained sources of variation. The error terms, e_{ij} , are assumed to be independently distributed normal random variables with mean zero and variance σ_e^2 (the within-group variance). The b_i may be regarded as fixed (unknown) constants, or else they may be modeled as realizations of a random variable, which is generally taken to be normally distributed with mean zero and variance σ_b^2 (the between-group variance).

The case of fixed b_i is called a *fixed-effects* analysis of variance, and it is appropriate for situations where the group means $\mu + b_i$ are *not* to be considered as samples from a population of means. For example, the groups might consist of strength measurements on composite material specimens having different numbers of plies. If the groups differ substantially in mean strength, one might consider determining basis values for the various numbers of plies. However, it clearly makes no sense to consider hypothetical random populations of specimens with different number of plies, and to regard the k groups which appear in the data as a random sample from such a population.

If the group means $\mu + b_i$ are considered to be a sample from a population of group means, then the model is a *random-effects* analysis of variance. For example, the data might come from k batches. In this case, one would typically be concerned as much with future batches as with those represented in the data. If one intends to use future batches in fabrication, then it does not make much sense to calculate basis values for each of the k observed batches. Rather, one might choose to determine basis values based on the populations of a random observation from an as yet unobtained batch. In this way, protection against batch-to-batch variability can be incorporated into design values. Reference 8.3.5.2(a) provides more information on analysis of variance procedures. The effect of sample size on an analysis of this type should be considered in test program design (Section 2.2.5.2).

The following calculations address batch-to-batch variability. In other words, the only grouping is due to batches and the compatibility test (Section 8.3.2) indicate that unstructured data methods should not be used. The method is based on the one-way analysis of variance (ANOVA) random-effects model and the procedure is documented in Reference 8.3.5.2(b).

The assumptions are that

1. The data from each batch are normally distributed,
2. The within-batch variance is the same from batch to batch, and
3. The batch means are normally distributed.

There is no test available for the first assumption. Simulation studies, however, suggest that moderate violation of this assumption does not have an adverse effect on the properties of the ANOVA method. The second assumption should be validated by performing the test described in Section 8.3.5.2.1. This test is currently recommended as a diagnostic, since extensive simulation suggests that violation of this assumption will likely result in conservatism, although non-conservatism can arise in some situations. There is no useful test for the third assumption unless data from many (twenty or more) batches are available.

In this analysis, all batches are treated the same (for example, no distinction is made between batches from different fabricators). If the batches are not from a single fabricator, then the approach shown in Section 8.3.7.9 should be used.

The organization of this subsection is as follows. The test for equality of variance is documented in the first two subsections. The next three subsections present computational procedures for statistics used in the ANOVA procedures. Next, a method for three or more batches, which should cover most cases of practical importance, is presented. The case of two batches is discussed separately.

8.3.5.2.1 *Levene's test for equality of variances*

The ANOVA method is derived under the assumption that the variances within each batch are equal. This section describes a widely-used test suggested by Levene (References 8.3.5.2.1(a) - (c)) for determining whether the sample variances for k groups differ significantly. This test is nonparametric; that is, it does not require strong assumptions about the form of the underlying populations.

To perform this test, form the transformed data

$$w_{ij} = |x_{ij} - \tilde{x}_i| \quad 8.3.5.2.1$$

where \tilde{x}_i is the *median* of the n_i values in the i th group. Then perform an F-test on these *transformed* data (Section 8.3.5.2.2). If the test statistic is greater than or equal to the tabulated F-distribution quantile, then the variances are declared to be significantly different. If the statistic is less than the tabulated value, then the hypothesis of equality of variance is not rejected.

If the test does reject the hypothesis that the variances are equal, it is recommended that an investigation of the reason for the unequal variances be carried out. This may reveal problems in the generation of the data or in the fabrication of the material. Basis values calculated using the ANOVA method are likely to be conservative if the variances differ substantially.

8.3.5.2.2 The F-test for equality of means

To test the assumption that the populations from which the k samples were drawn have the same mean, calculate the following F statistic:

$$F = \frac{\sum_{i=1}^k n_i (\bar{x}_i - \bar{x})^2 / (k-1)}{\sum_{i=1}^k \sum_{j=1}^{n_i} (x_{ij} - \bar{x}_i)^2 / (n-k)} \quad 8.3.5.2.2$$

where \bar{x}_i is the average of the n_i values in the i th group, and \bar{x} is the average of all n observations. If Equation 8.3.5.2.2 is greater than the $1 - \alpha$ quantile of the F-distribution having $k - 1$ numerator and $n - k$ denominator degrees of freedom, then one concludes (with a five percent risk of making an error) that the k population means are not all equal. For $\alpha = 0.05$, the required F quantiles are tabulated in Table 8.5.1.

This test is based on the assumption that the data are normally distributed; however, it is well known to be relatively insensitive to departures from this assumption.

8.3.5.2.3 One-way ANOVA computations based on individual measurements

When all of the observations in a sample are available, the first step is to compute the means.

$$\bar{x} = \sum_{i=1}^k \sum_{j=1}^{n_i} x_{ij} / n \quad 8.3.5.2.3(a)$$

and

$$\bar{x}_i = \sum_{j=1}^{n_i} x_{ij} / n_i, \quad \text{for } i = 1, \dots, k \quad 8.3.5.2.3(b)$$

where

$$n = \sum_{i=1}^k n_i \quad 8.3.5.2.3(c)$$

is the total sample size. The required sums of squares can now be computed. The between-batch of squares is computed as

$$SSB = \sum_{i=1}^k n_i \bar{x}_i^2 - n \bar{x}^2 \quad 8.3.5.2.3(d)$$

and the total sum of squares is

$$SST = \sum_{i=1}^k \sum_{j=1}^{n_i} x_{ij}^2 - n\bar{x}^2 \tag{8.3.5.2.3(e)}$$

The within-batch, or error, sum of squares is computed by subtraction

$$SSE = SST - SSB \tag{8.3.5.2.3(f)}$$

8.3.5.2.4 One-way ANOVA computations based on summary statistics

It is often the case that only summary statistics are available for each group. If these summary statistics contain the sample averages \bar{x}_i , the standard deviations of the data from each group (s_i) and the group sizes (n_i), the sums of squares can be computed as follows. First, compute the overall mean,

$$\bar{x} = \sum_{i=1}^k n_i \bar{x}_i / n \tag{8.3.5.2.4(a)}$$

The between-batch sum of squares is computed using Equation 8.3.5.2.3(d). In terms of the s_i^2 , the within-batch sum of squares is

$$SSE = \sum_{i=1}^k (n_i - 1) s_i^2 \tag{8.3.5.2.4(b)}$$

The total sum of squares, SST, is the sum of SSB and SSE.

8.3.5.2.5 The ANOVA table for a one-way model

An ANOVA table displays the information about sources of variation that is contained in the sums of squares. A typical ANOVA table, which is used for both the fixed effects and random effects models, is shown below. The first column identifies the source of variation. The degrees of freedom and the computed sums of squares are listed in the second and third columns. The fourth column contains mean squares which are defined as the sum of squares divided by its degrees of freedom. The final column contains an F statistic which is equal to the ratio of the mean squares. This statistic is used to test the hypothesis that there is significant sample-to-sample variation (Section 8.3.5.2.2). The statistic is compared to the upper 0.95th quantile of an F distribution with $k - 1$ numerator degrees of freedom and $n - k$ denominator degrees of freedom. Table 8.5.1 contains these critical F values. If the computed statistic is greater than the tabulated F value, this indicates that there is statistically significant sample-to-sample variation. If the computed statistic is less than the tabulated value, then the variation between samples is not statistically significant at the chosen significance level.

Source	Degrees of Freedom	Sum of Squares	Mean Squares	F Test
Samples	$k-1$	SSB	$MSB = SSB/(k-1)$	$F = MSB/MSE$
Error	$n-k$	SSE	$MSE = SSE/(n-k)$	
Total	$n-1$	SST		

8.3.5.2.6 Calculation of summary statistics for one-way ANOVA basis values

The first step in computing an ANOVA basis value is to compute summary statistics, including the batch averages, an estimate of the overall population mean, and estimates of the between-batch and within-batch variances. Since the batches need not have equal numbers of specimens, an 'effective batch size, is defined as

$$n' = \frac{n - n^*}{k - 1} \quad 8.3.5.2.6(a)$$

where

$$n^* = \sum_{i=1}^k \frac{n_i^2}{n} \quad 8.3.5.2.6(b)$$

and

$$n = \sum_{i=1}^k n_i \quad 8.3.5.2.6(c)$$

is the total sample size.

Next, the batch means (\bar{x}_i), overall mean (\bar{x}), and between- and within-batch sums of squares should be calculated as in Section 8.3.5.2.3 or 8.3.5.2.4) The between-batch mean square (MSB) and the within-batch mean square (MSE) are then obtained by dividing these sums of squares by the appropriated degrees of freedom, as in Section 8.3.5.2.5.

Using these two mean squares, an estimate of the population standard deviation is

$$S = \sqrt{\frac{MSB}{n'} + \left(\frac{n' - 1}{n'}\right)MSE} \quad 8.3.5.2.6(d)$$

8.3.5.2.7 Calculations for three or more batches

Let the tolerance limit factor for a simple random sample from a normal distribution with sample size n be denoted k_0 , and let the tolerance limit factor for a simple random sample from a normal distribution of size k be denoted k_1 . These tolerance limit factors can be obtained from Table 8.5.10 (for B-basis values) or 8.5.11 (for A-basis values). Denote the ratio of mean squares by

$$u = \frac{MSB}{MSE} \quad 8.3.5.2.7(a)$$

If u is less than one, set u equal to one. The tolerance limit factor is

$$T = \frac{k_0 - k_1 / \sqrt{n'} + (k_1 - k_0) w}{1 - \frac{1}{\sqrt{n'}}} \quad 8.3.5.2.7(b)$$

where

$$w = \sqrt{\frac{u}{u + n' - 1}} \quad 8.3.5.2.7(c)$$

The basis value is

$$B = \bar{x} - TS \quad 8.3.5.2.7(d)$$

Whether this value is an A- or B-basis value depends only on whether k_0 and k_1 are taken from Table 8.5.10 or Table 8.5.11.

8.3.5.2.8 Calculations for two batches

If data on only two batches are available, then the ANOVA method is not useful. One has two alternatives:

1. Obtain more batches, or
2. Pool the two batches and use unstructured-data methods.

In order to decide which of these actions to take, look at the data from the two batches. If the difference between the two batch means is large when compared to the standard deviation of \bar{x}

$$s_{\bar{x}} = \sqrt{\frac{MSB}{n}} \quad 8.3.5.2.8$$

and if this difference in means is also large enough to be of practical importance, then pooling cannot be advised. However, if the batches overlap substantially, or if the difference in batch means is too small to be of engineering importance, then one might be able to justify pooling and using the methods of Section 8.3.4. However, since the compatibility test (Section 8.3.2) has already indicated that the batches are not from the same population, it is probable that this visual inspection will not provide convincing evidence for combining the data and using the methods of Section 8.3.4. In this case, whenever possible, data from new batches should be obtained before proceeding. If this is not possible, then calculate the basis values for each batch separately, according to the methods in Section 8.3.4, and choose the lower of these numbers as an interim basis value, ideally to be replaced when more data can be obtained.

8.3.5.3 Simple linear regression

Simple linear regression is the special case of the general regression model (Equation 8.3.5.1(c)), in which the covariates are 1 and z , and there is no random effect, such as batch-to-batch variability:

$$x_s = \mu_{p(s)} + e_s = \theta_1 + \theta_2 z_{p(s),2} + e_s \quad 8.3.5.3(a)$$

Putting this in more familiar notation and assuming that β_0 and β_1 are fixed unknown parameters,

$$Y = \beta_0 + \beta_1 X + \varepsilon \quad 8.3.5.3(b)$$

Assume that the experimenter chooses n values of x , x_1, x_2, \dots, x_n which need not be distinct, and observes the corresponding y values; thus the data consist of the n pairs

$$(x_1, y_1), (x_2, y_2), \dots, (x_n, y_n)$$

In order for the statistical analysis to be valid we must have $n \geq 3$ and at least two distinct x values. Let $\hat{\beta}_0$ and $\hat{\beta}_1$ denote estimates of β_0 and β_1 . Then for any x , which need not be one of the experimental values x_1, x_2, \dots, x_n , a predicted or fitted value denoted \hat{y} is obtained, that is

$$\hat{y} = \hat{\beta}_0 + \hat{\beta}_1 x \quad 8.3.5.3(c)$$

It is customary to estimate β_0 and β_1 using the principle of least squares, which may be defined as follows. Let β_0^* and β_1^* be any estimates of β_0 and β_1 . Let

$$Q(\beta_0^*, \beta_1^*) = \sum_{i=1}^n (y_i - \hat{y}_i^*)^2 \quad 8.3.5.3(d)$$

where $\hat{y}_i^* = \beta_0^* + \beta_1^* x_i$.

The least squares estimates $\hat{\beta}_0$ and $\hat{\beta}_1$ are the values of β_0^* and β_1^* which minimize $Q(\beta_0^*, \beta_1^*)$. They are given by

$$\hat{\beta}_0 = \bar{y} - \hat{\beta}_1 \bar{x} \quad 8.3.5.3(e)$$

and

$$\hat{\beta}_1 = \frac{\sum_{i=1}^n (x_i - \bar{x})(y_i - \bar{y})}{\sum_{i=1}^n (x_i - \bar{x})^2} \quad 8.3.5.3(f)$$

where

$$\bar{y} = \sum_{i=1}^n y_i / n \quad 8.3.5.3(g)$$

and

$$\bar{x} = \sum_{i=1}^n x_i / n \quad 8.3.5.3(h)$$

It is sometimes more convenient to calculate $\hat{\beta}_1$ by the following equivalent formula

$$\hat{\beta}_1 = \frac{\sum_{i=1}^n x_i y_i - n \bar{x} \bar{y}}{\sum_{i=1}^n x_i^2 - n \bar{x}^2} \quad 8.3.5.3(i)$$

Statistical significance (at level α) of this regression means that there is evidence the $\beta_1 \neq 0$ (with a probability of $\leq \alpha$ of reaching this conclusion when $\beta_1 = 0$). If $\beta_1 \neq 0$, then X is of value as a linear predictor of Y. In order for the usual test of significance to be valid, the following additional assumption is required; the Y's are independently normally distributed random variables with common variance σ^2 and means $\beta_0 + \beta_1 x_i$, for $i = 1, 2, \dots, n$.

To test whether the regression is significant at level α , let

$$s_Y^2 = \frac{\sum_{i=1}^n (y_i - \hat{\beta}_0 - \hat{\beta}_1 x_i)^2}{n-2} \quad 8.3.5.3(j)$$

and define

$$SSE = \sum_{i=1}^n (y_i - \hat{\beta}_0 - \hat{\beta}_1 x_i)^2 \quad 8.3.5.3(k)$$

$$SST = \sum_{i=1}^n (y_i - \bar{y})^2 \quad 8.3.5.3(l)$$

and

$$SSR = SST - SSE \quad 8.3.5.3(m)$$

Then define

$$F = \frac{SSR}{s_{\hat{Y}}^2} \quad 8.3.5.3(n)$$

which has the F-distribution with 1 and $n - 2$ degrees of freedom. The regression is considered significant if the value in Equation 8.3.5.3(n) exceeds the $1 - \alpha$ quantile of the F-distribution with $\gamma_1 = 1$ and $\gamma_2 = n - 2$ degrees of freedom. Table 8.5.1 provides these values for $\alpha = 0.05$.

For given x_0 , the B-basis value satisfies the condition that $B(x_0)$ is a B-basis value for the normal population with mean $f(x_0) = \beta_0 + \beta_1 x_0$ and variance σ^2 . A B-basis, value, in the case of simple linear regression, can be determined as follows. For $x = x_0$, compute B as

$$B = (\hat{\beta}_0 + \hat{\beta}_1 x_0) - k_B s_y \quad 8.3.5.3(o)$$

where s_y is the square root of $s_{\hat{Y}}^2$ in Equation 8.3.5.3(j),

$$k_B = t_{\gamma,0.95}(\delta) \sqrt{\frac{1+\Delta}{n}} \quad 8.3.5.3(p)$$

and $t_{\gamma,0.95}(\delta)$ is the 95th percentile of the non-central t-distribution with $\gamma = n - 2$ degrees of freedom and non-centrality parameter

$$\delta = \frac{1.282}{\sqrt{\frac{1+\Delta}{n}}} \quad 8.3.5.3(q)$$

with

$$\Delta = \frac{n(x_0 - \bar{x})^2}{\sum_{i=1}^n (x_i - \bar{x})^2} \quad 8.3.5.3(r)$$

The following approximation to k_B can be used when n is greater than or equal to 10 and $0 \leq \Delta \leq 10$:

$$k_B = 1.282 + \exp \left[0.595 - 0.508 \ln(n) + \frac{4.62}{n} + \left(0.488 - \frac{0.988}{n} \right) \ln(1.82 + \Delta) \right] \quad 8.3.5.3(s)$$

To adapt Equation 8.3.5.3(o) to A-basis values, replace 1.282 by 2.326 in Equation 8.3.5.3(q). For A-basis values, k_A can be approximated by

$$k_A = 2.326 + \exp \left[0.659 - 0.514 \ln(n) + \frac{6.58}{n} + \left(0.481 - \frac{1.42}{n} \right) \ln(3.71 + \Delta) \right] \quad 8.3.5.3(t)$$

The example problem in Section 8.3.7.7 demonstrates the simple linear regression procedures. This case is expanded to linear regression with batch effects in Section 8.3.7.8.

8.3.5.4 Basis values using pooling of structured data

For small data sets (less than eighteen (18) per environmental condition) the utility of the approach described in Figure 8.3.1 can be increased by pooling data from tests at different environmental conditions. When using pooling procedures to expand the utility of small data sets to obtain higher basis values, the associated assumptions and limits must be validated in the data analysis (see References 8.3.5.4(a) and (b)). If the statistical checks and engineering data analysis described in these references

indicate that pooling is invalid, the other standard statistical methods described in this handbook should be applied. Unfortunately, some penalty is inherent when applying the standard methods with small data sets.

The general methodology is described in Reference 8.3.5.4(a) if the Weibull distribution fits the data and in (Reference 8.3.5.4(b)) if the use of normal distribution is desired. Either statistical distribution can be used, depending on the best fit to the data, although, in general, the use of the Weibull distribution will result in more conservative material basis values. In this data reduction method, data from multiple environments, batches, and panels are pooled to obtain population variability factors for each test type and failure mode, i.e., tension, compression, shear. Essentially the method uses the larger pooled data set to estimate variability but uses only the test sample at each environment to estimate the mean property value at that environment. As the large sample size is used to calculate the probabilities and confidence, the resulting basis values are generally less conservative than those obtained without resorting to pooling.

However, the pooling data reduction methodology requires the validation of several underlying assumptions in order to generate a valid material basis value (see References 8.3.5.4(a) and (b)). In order to pool the data sets, the variability across environments must be statistically equivalent and the failure modes for each environment should not significantly change.

8.3.6 Exploratory data analysis

Exploratory Data Analysis (EDA) techniques are simple, visual, qualitative procedures which often point out important features of data early in the analysis. Where possible, conclusions based on EDA should be used to supplement quantitative statistical methods. Two EDA techniques are described below; the *quantile box plot* and the *informative quantile functions*. A more complete treatment of this subject can be found in Reference 8.3.6.

8.3.6.1 The quantile box plot

The quantile box plot provides a graphical summary of the sample values. This procedure depicts the symmetry, tail sizes, and median value of the sample as well as indicating the possible existence of outliers and inhomogeneous data.

Let $F(x)$ be the underlying distribution function. The u th quantile of $F(x)$, q_u , is the solution to the equation $F(q_u) = u$. The quantile function, $Q(u)$, is defined by

$$Q(u) = F^{-1}(u) \quad 0 < u < 1 \tag{8.3.6.1(a)}$$

(see Figure 8.3.6.1(a)). Letting $x_{(1)} \leq x_{(2)} \leq \dots x_{(n)}$ denote the ordered measurements for a sample of size n , $Q(u)$ is estimated by the piecewise linear function

$$\hat{Q}(u) = (nu - j + \frac{1}{2})x_{(j+1)} + (j + \frac{1}{2} - nu)x_{(j)} \tag{8.3.6.1(b)}$$

for

$$\frac{2j-1}{2n} \leq u < \frac{2j+1}{2n} \tag{8.3.6.1(c)}$$

Figure 8.3.6.1(b) is an example of a quantile box plot. The boxes are used to examine the symmetry and tail sizes of the underlying distribution. Flat spots in $Q(u)$ indicate modal values. Sharp rises in $Q(u)$ for u in the vicinity of 0 or 1 indicate the possible presence of outliers in the data. Sharp rises in $Q(u)$ within the boxes indicate the possible existence of two (or more) populations or gaps in the data. A thorough treatment of the use of the Quantile Box plot can be found in Reference 8.3.6.1.

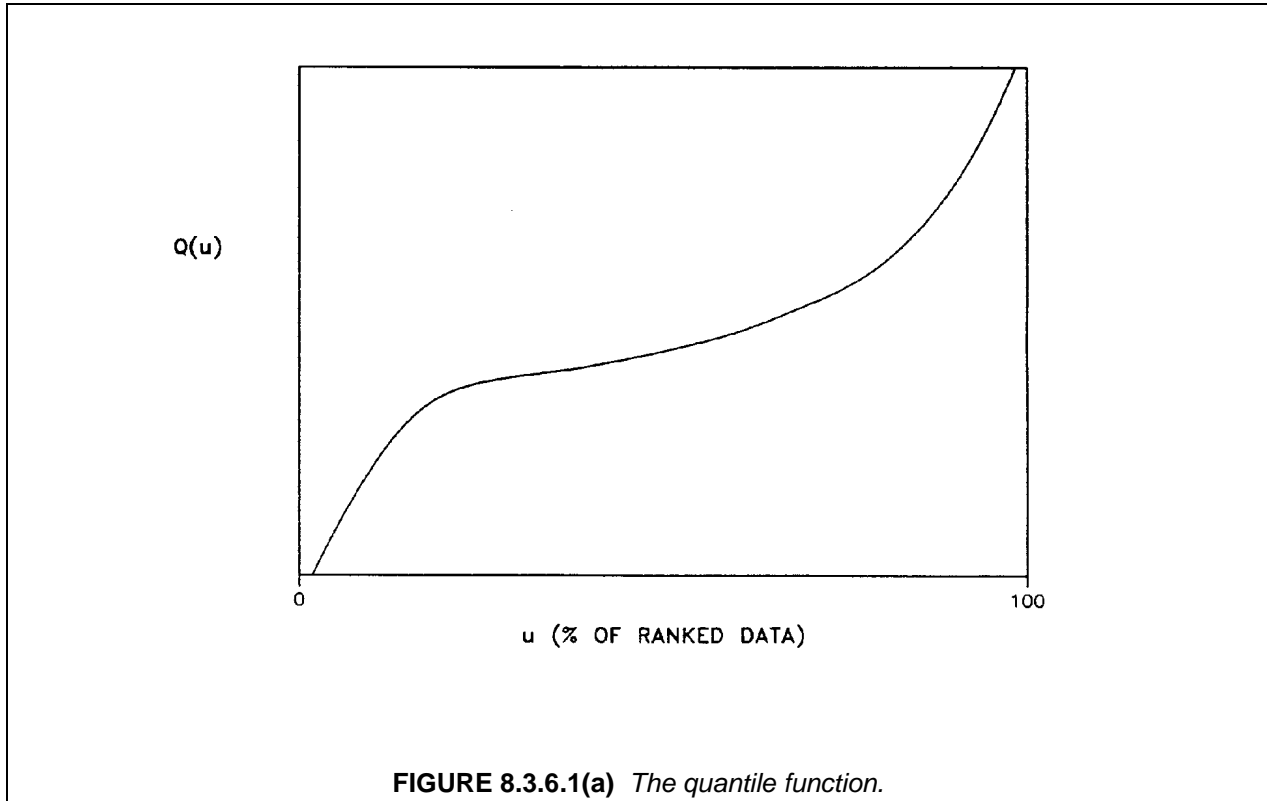

FIGURE 8.3.6.1(a) The quantile function.

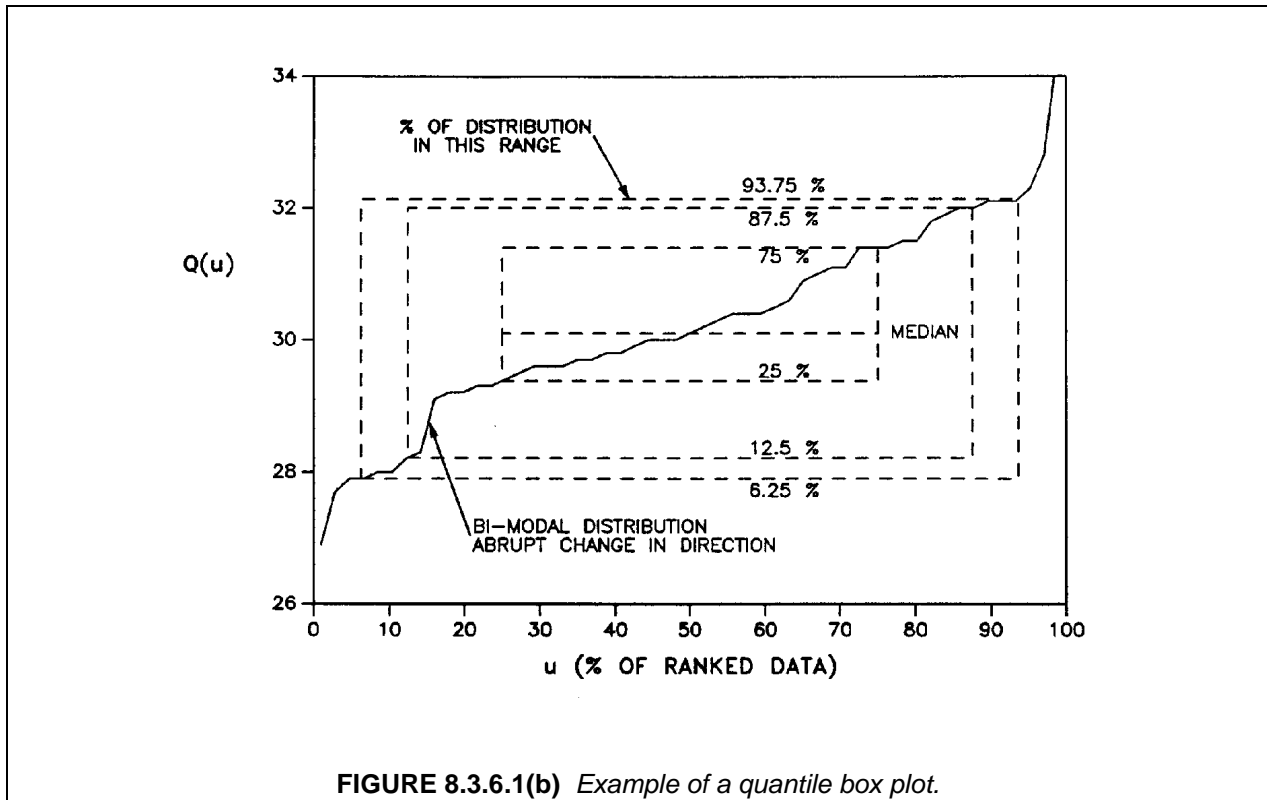

FIGURE 8.3.6.1(b) Example of a quantile box plot.

8.3.6.2 The informative quantile function

Techniques for obtaining B-basis values for unimodal data can be divided into two main categories: techniques for specific parametric families, and nonparametric techniques. The *Informative Quantile* (IQ) function can be used as an aid in identifying a parametric model which provides a satisfactory fit to the data. Parametric techniques have been most thoroughly discussed for the normal, lognormal, and two-parameter Weibull parametric families; thus only these techniques will be considered here. Henceforth in this section, any reference to the Weibull parametric family should be interpreted as a reference to the two-parameter Weibull parametric family.

The IQ function was developed to identify which univariate location-scale parametric distribution best describes an ordered group of data. A univariate location-scale parametric distribution is one whose distribution function $F(x)$ can be expressed as

$$F(x) = F_o[(x - a) / b] \tag{8.3.6.2(a)}$$

where a and b are the location and scale parameters respectively, and $F_o(x)$ is the "standard" distribution with $a = 0$ and $b = 1$. The IQ function identifies the standard distributional form and is thus independent of the values of the location and scale parameters.

The Weibull and lognormal parametric families are not location-scale parametric families. However, these distributions are simply related to two location-scale families: the normal and the extreme value families.

The estimated IQ function is defined as

$$\hat{I}Q(u) = \frac{\hat{Q}(u) - \hat{Q}(0.5)}{2[\hat{Q}(0.75) - \hat{Q}(0.25)]} \tag{8.3.6.2(b)}$$

where $Q(u)$ is the estimated quantile function defined in Equation 8.3.6.1(b). The corresponding exact IQ function is denoted $IQ(u)$ and defined by Equation 8.3.6.2(a) with $\hat{Q}(u)$ replaced by $Q(u)$. In order to determine whether the data can be adequately modeled by either the normal or extreme value distribution, a plot of the estimated truncated IQ function, defined by

$$\hat{T}IQ(u) \begin{cases} -1 & \text{if } \hat{I}Q(u) \leq -1 \\ \hat{I}Q(u) & \text{if } -1 < \hat{I}Q(u) \leq 1 \\ 1 & \text{if } \hat{I}Q(u) > 1 \end{cases} \tag{8.3.6.2(c)}$$

is compared to the graph of the exact TIQ plots for these distributions (see Figures 8.3.6.2(a) and (b)). Though the TIQ plots for the data will be considerably less smooth than the exact TIQ plots, they may be compared for general shape and tail behavior.

In order to determine the adequacy of either the lognormal or the Weibull distribution, use the natural logarithms of the data to define the quantile function. Thus, Equation 8.3.6.1(b) becomes

$$\hat{Q}(u) = (nu - j + \frac{1}{2}) \ln(x_{(j+1)}) + (j + \frac{1}{2} - nu) \ln(x_{(j)}) \tag{8.3.6.2(d)}$$

for

$$\frac{2j-1}{2n} \leq u < \frac{2j+1}{2n} \tag{8.3.6.2(d)}$$

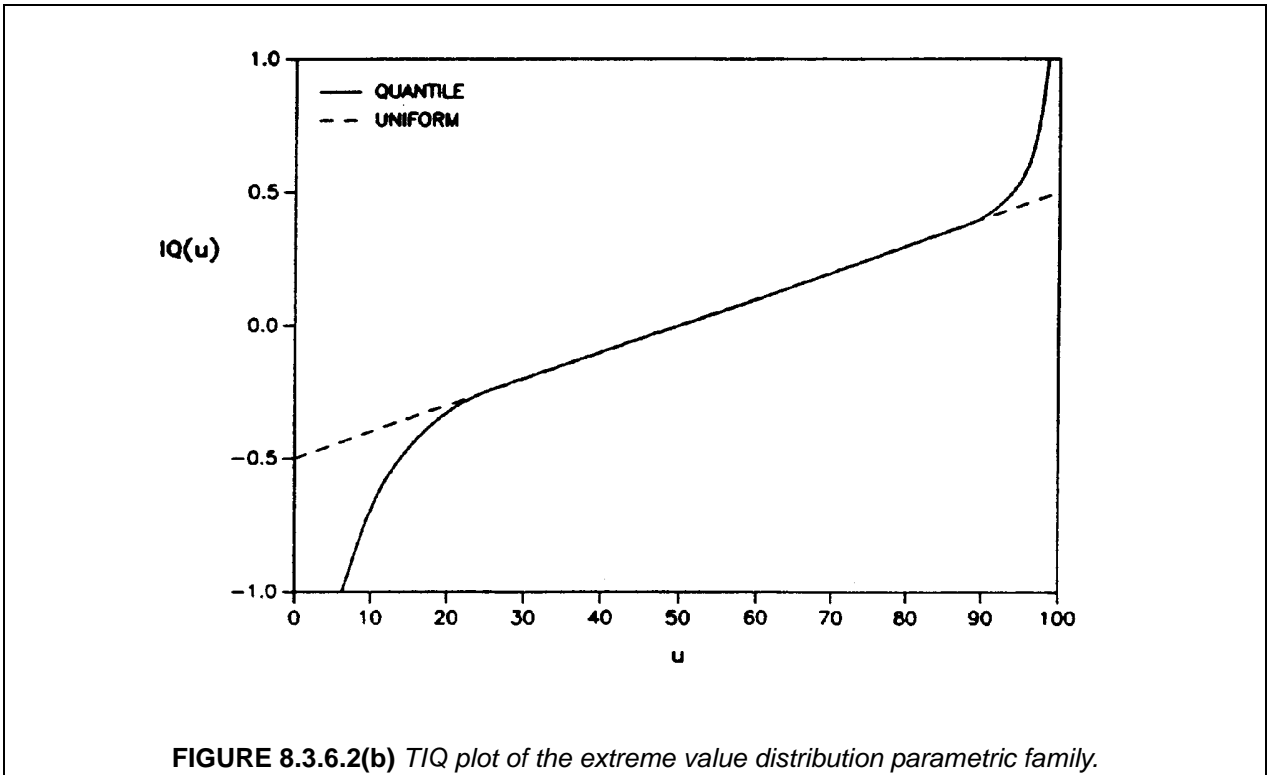
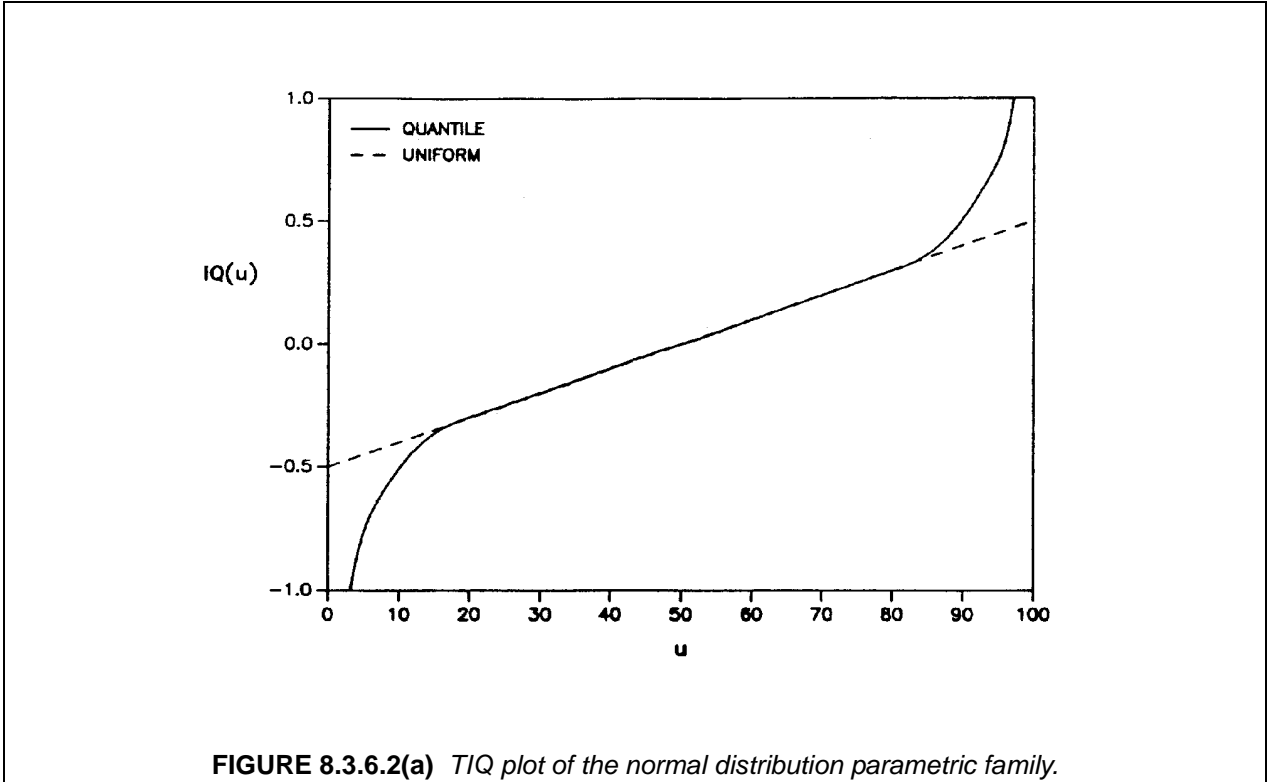

The IQ and TIQ functions in Equations 8.3.6.2(b) and 8.3.6.2(c) are defined using this quantile function.

Thus, to determine whether the data can be adequately modeled by the normal distribution, compare the $\hat{\text{TIQ}}$ plot for the original data to the exact TIQ plot for the normal distribution in Figure 8.3.6.2(a). To determine whether the data can be adequately modeled by the lognormal distribution, compare the $\hat{\text{TIQ}}$ plot for the log data to the exact TIQ plot for the normal distribution in Figure 8.3.6.2(a). The adequacy of the two-parameter Weibull distribution is determined by comparing the $\hat{\text{TIQ}}$ plot for the log data to the exact TIQ plot for the extreme value distribution in Figure 8.3.6.2(b). For further information concerning the quantile function and the informative quantile function, the reader is referred to References 8.3.6.2(a) and 8.3.6.2(b).

8.3.7 Examples of computational procedures

This section illustrates the computational procedures using mechanical property data sets. In progressing through the example problems, the flowchart in Figure 8.3.1 are followed, and appropriate references to specific sections are made. Each example notes which software, STAT17 or RECIPE or both, provides the calculation for each step (see Section 8.1.2). All example data sets are listed in Table 8.3.7. Data files provided with the software are identified for each example.¹

8.3.7.1 Problem 1 - Outlier detection, multiple-sample tests, and the Weibull distribution

The data set for this problem consists of compressive strength measurements from ten batches of material. This problem illustrates the outlier detection procedure, the k-sample Anderson-Darling test, the two-parameter Weibull goodness-of-fit test and the calculation of B-basis values by the Weibull method. Calculations for all steps may be performed by STAT17 and may be demonstrated using example data set, `example.d01`.

Problem 1 - Step 1. The first step is to screen the data for outliers using the MNR procedure as described in Section 8.3.3.1. The screening procedure is performed separately on each batch. The relevant calculations for the first batch, with a sample mean of 568.8 and a sample standard deviation of 757.9, are shown in the table below.

x_i	$ r_i = \left \frac{x_i - \bar{x}}{s} \right = \left \frac{x_i - 568.8}{757.9} \right $
125.9	0.584
136.6	0.570
1444	1.155

The MNR statistic is the largest absolute residual, or 1.155. Since this is greater than the $n = 3$ critical value of 1.154 from Table 8.5.7, the third observation is identified as an outlier. An examination of the laboratory record shows a measured value of 144.4. The data point was corrected and the MNR test repeated. The batch mean was recalculated as 135.7 and the batch standard deviation as 9.31. No outliers were detected. Similar calculations for the remaining batches identify no other outliers in this set of data. Visual inspection of the data also does not identify any outliers.

¹Note that the example data sets identified for STAT17 correspond to those distributed with Version 5.0.

TABLE 8.3.7 Example data sets for Section 8.3.7, concluded.

Problem 6		Problem 8			Problem 8		
Batch	Data	Temperature	Batch	Data	Temperature	Batch	Data
1	328.1174	75	1	328.1174	-67	4	315.2963
1	334.7674	75	1	334.7674	-67	4	322.8280
1	347.7833	75	1	347.7833	-67	5	340.0990
1	346.2661	75	1	346.2661	-67	5	348.9354
1	338.7314	75	1	338.7314	-67	5	331.2500
2	297.0387	75	2	297.0387	-67	5	330.0000
2	293.4595	75	2	293.4595	-67	5	340.9836
2	308.0419	75	2	308.0419	-67	5	329.4393
2	326.4864	75	2	326.4864	-67	7	330.9309
2	318.1297	75	2	318.1297	-67	7	328.4553
2	309.0487	75	2	309.0487	-67	7	344.1026
3	337.0930	75	3	337.0930	-67	7	343.3584
3	317.7319	75	3	317.7319	-67	7	344.4717
3	321.4292	75	3	321.4292	-67	7	351.2776
3	317.2652	75	3	317.2652	-67	8	331.0259
3	291.8881	75	3	291.8881	-67	8	322.4052
4	297.6943	75	4	297.6943	-67	8	327.6699
4	327.3973	75	4	327.3973	-67	8	296.8215
4	303.8629	75	4	303.8629	-67	8	338.1995
4	313.0984	75	4	313.0984			
4	323.2769	75	4	323.2769			
5	312.9743	75	5	312.9743			
5	324.5192	75	5	324.5192			
5	334.5965	75	5	334.5965			
5	314.9458	75	5	314.9458			
5	322.7194	75	5	322.7194			
6	291.1215	75	6	291.1215			
6	309.7852	75	6	309.7852			
6	304.8499	75	6	304.8499			
6	288.0184	75	6	288.0184			
6	294.1995	75	6	294.1995			
Problem 7		-67	1	340.8146	Problem 9		
Temperature	Data	-67	1	343.5855	Source	Batch	Data
75	328.1174	-67	1	334.1746	1	1	75.8
75	334.7674	-67	1	348.6610	1	1	78.4
75	347.7833	-67	1	356.3232	1	1	82.0
75	346.2661	-67	1	344.1524	1	2	68.8
75	338.7314	-67	2	308.6256	1	2	70.9
75	340.8146	-67	2	315.1819	1	2	73.5
-67	343.5855	-67	2	317.6867	1	3	74.5
-67	334.1746	-67	2	313.9832	1	3	74.8
-67	348.6610	-67	2	309.3132	1	3	78.8
-67	356.3232	-67	2	275.1758	2	4	81.3
-67	344.1524	-67	3	321.4128	2	4	87.7
		-67	3	316.4652	2	4	89.0
		-67	3	331.3724	2	5	88.2
		-67	3	304.8643	2	5	91.2
		-67	3	309.6249	2	5	94.2
		-67	3	347.8449			
		-67	4	331.5487			
		-67	4	316.5891			
		-67	4	303.7171			
		-67	4	320.3625			

Problem 1 - Step 2. The k-sample Anderson-Darling test described in Section 8.3.2.2 will be employed next to determine whether or not the data from the ten batches should be combined. The first step is to order the pooled sample. Table 8.3.7.1 lists the 27 sorted, distinct values in the column labeled $z_{(j)}$. The

remaining columns show the h_j , H_j , and F_{1j} values used in calculating the terms in the statistic arising from the first batch ($i = 1$). The column labeled f_{1j} shows the number of times that $z_{(j)}$ is represented in the first batch and is used in calculating F_{1j} . From these numbers, it follows that

$$\frac{1}{n_i} \sum_{j=1}^L h_j \frac{(nF_{1j}n_iH_j)^2}{H_j(n-H_j) - \frac{nh_j}{4}} = \frac{1}{3} \sum_{j=1}^{27} h_j \frac{(30F_{1j}3H_j)^2}{H_j(30H_j)30 - \frac{h_j}{4}} = 363.33$$

When these calculations are repeated for the remaining nine batches, the k-sample Anderson-Darling statistic is computed as

TABLE 8.3.7.1 Illustration of k-sample Anderson-Darling statistic calculations for the first batch.

j	$z_{(j)}$	h_j	H_j	f_{1j}	F_{1j}
1	107.8	1	0.5	0	0.0
2	109.5	1	1.5	0	0.0
3	110.7	1	2.5	0	0.0
4	114.6	1	3.5	0	0.0
5	118.3	1	4.5	0	0.0
6	118.7	1	5.5	0	0.0
7	118.8	1	6.5	0	0.0
8	119.0	1	7.5	0	0.0
9	119.3	1	8.5	0	0.0
10	120.0	1	9.5	0	0.0
11	121.2	1	10.5	0	0.0
12	121.9	1	11.5	0	0.0
13	124.6	2	13.0	0	0.0
14	125.5	1	14.5	0	0.0
15	125.8	1	15.5	0	0.0
16	125.9	3	17.5	1	0.5
17	126.1	1	19.5	0	1.0
18	126.6	1	20.5	0	1.0
19	127.5	1	21.5	0	1.0
20	127.9	1	22.5	0	1.0
21	130.0	1	23.5	0	1.0
22	131.2	1	24.5	0	1.0
23	132.6	1	25.5	0	1.0
24	134.4	1	26.5	0	1.0
25	136.6	1	27.5	1	1.5
26	139.4	1	28.5	0	2.0
27	144.4	1	29.5	1	2.5

$$ADK = \frac{n-1}{n^2(k-1)} \sum_{i=1}^k \left\{ \frac{1}{n_i} \sum_{j=1}^L h_j \frac{(nF_{ij} - n_iH_j)^2}{H_j(n-H_j) - \frac{nh_j}{4}} \right\}$$

$$= \frac{30-1}{30^2(10-1)} \times \text{the sum in } \Sigma$$

$$= 1.24$$

The computed value of the statistic is compared to the critical value from Equation 8.3.2.2(j), which is 1.37. Since the computed value of 1.24 is less than the critical value of 1.37, the hypothesis that the populations from which these groups were drawn are identical is not rejected. Conclude that the data from these batches may be combined into a single sample.

Problem 1 - Step 3. The maximum normed residual (MNR) test is performed on the pooled data. No potential outliers are detected in the pooled data. (see Problem 1 - Step 1 for details of the outlier detection procedure.)

Problem 1 - Step 4. In order to perform the two-parameter Weibull goodness-of-fit test described in Section 8.3.4.2.2, it is necessary to compute estimates of the scale and shape parameters, $\hat{\alpha}$ and $\hat{\beta}$. A procedure for doing this is described in Section 8.3.4.2.1. The geometric mean of the data is computed as

$$\bar{x}_G = \exp\left[\frac{1}{n} \sum_{i=1}^n \ln(x_i)\right] = \exp\left[\frac{1}{53} \sum_{i=1}^{53} \ln(x_i)\right] = 67.501$$

For a given value of $\hat{\beta}$, $\hat{\alpha}$ is calculated as

$$\hat{\alpha} = \bar{x}_G \left[\frac{1}{n} \sum_{i=1}^n \left(\frac{x_i}{\bar{x}_G} \right)^{\hat{\beta}} \right]^{\frac{1}{\hat{\beta}}}$$

$$\hat{\alpha} = 67.501 \left[\frac{1}{31} \sum_{i=1}^{31} \left(\frac{x_i}{67.501} \right)^{\hat{\beta}} \right]^{\frac{1}{\hat{\beta}}}$$

In order to calculate $\hat{\beta}$, define the function $G(\hat{\beta})$ by

$$G(\hat{\beta}) = \frac{1}{n} \sum_{i=1}^n \ln(x_i) \left(\left[\frac{x_i}{\hat{\alpha}} \right]^{\hat{\beta}} - 1 \right) - \frac{1}{\hat{\beta}}$$

$$= \frac{1}{30} \sum_{i=1}^{30} \ln(x_i) \left(\left[\frac{x_i}{\hat{\alpha}} \right]^{\hat{\beta}} - 1 \right) - \frac{1}{\hat{\beta}}$$

where $\hat{\alpha}$ is calculated as above. The estimate, $\hat{\beta}$, is the solution to the equation $G(\hat{\beta})=0$. An iterative technique for solving this equation is given in Section 8.3.4.2.1, and begins by setting

$$\hat{\beta} = \frac{1.28}{S_y} = \frac{1.28}{0.0673} = 19.02$$

The solution is $\hat{\beta}=15.35$, which in turn gives $\hat{\alpha}=128.39$.

The first five ordered observations are listed below with the transformations necessary to compute the goodness-of-fit test statistic.

x_i	$z_{(i)} = \left(\frac{x_{(i)}}{\hat{\alpha}}\right)^{\hat{\beta}} = \left(\frac{x_{(i)}}{128.39}\right)^{15.35}$
107.8	0.0684
109.5	0.0869
110.7	0.1027
114.6	0.1748
118.3	0.2847

The Anderson-Darling goodness-of-fit statistic and observed significance level are calculated according to Section 8.3.4.2.2 as follows.

$$\begin{aligned} AD &= \sum_{i=1}^n \frac{1-2i}{n} \left\{ \ln[1 - \exp(-z_{(i)})] - z_{(n+1-i)} \right\} - n \\ &= \sum_{i=1}^{30} \frac{1-2i}{30} \left\{ \ln[1 - \exp(-z_{(i)})] - z_{(31-i)} \right\} - 30 \\ &= 0.699 \end{aligned}$$

$$AD^* = \left(1 + 0.2/\sqrt{n}\right) AD = \left(1 + 0.2/\sqrt{30}\right) 0.699 = 0.7245$$

$$\begin{aligned} OSL &= 1/\left\{1 + \exp[-0.10 + 1.24\ln(AD^*) + 4.48AD^*]\right\} \\ &= 1/\left\{1 + \exp[-0.10 + 1.24\ln(0.7245) + 4.48(0.7245)]\right\} \\ &= 0.0576 \end{aligned}$$

Since the Weibull goodness-of-fit test yields an OSL value greater than 0.05, there is insufficient evidence to contradict the assumption that the data follow a two-parameter Weibull distribution. Hence, the two parameter Weibull method in Section 8.3.4.2.3 should be used to compute the B-basis value.

Problem 1 - Step 5. The parameter estimates $\hat{\alpha}$ and $\hat{\beta}$ calculated in the previous step are used to compute the B-basis value for the sample as described in Section 8.3.4.2.3. The quantities necessary to compute the B-basis value are:

$$\begin{aligned} V_B &= 5.057 \text{ (from Table 8.5.8)} \\ \hat{\alpha} &= 128.39 \\ \hat{\beta} &= 15.35 \\ \hat{Q} &= \hat{\alpha}(0.10536)^{1/\hat{\beta}} = (128.39)(0.10536)^{1/15.35} = 110.88 \end{aligned}$$

The B-basis value is calculated as

$$B = \hat{Q} \exp\left(\frac{-V_B}{\hat{\beta}\sqrt{n}}\right) = 110.88 \exp\left(\frac{-5.057}{15.35\sqrt{30}}\right) = 104.41$$

For presentation in MIL-HDBK-17, this B-basis value would be rounded to 104.

8.3.7.2 Problem 2 - Normal distribution

The data set for this problem consists of compressive test measurements from four batches of material. This problem illustrates the normal goodness-of-fit test and the calculation of B-basis values by the

Volume 1, Chapter 8 Statistical Methods

normal method. Calculations for all steps may be performed by *STAT17* and may be demonstrated using example data set, *example.d02*. Calculations for Step 6 may be performed by *RECIPE* and may be demonstrated using example data set, *pr2.dat*. This also provides an example of the use of *RECIPE* for a simple random sample.

Problem 2 - Step 1. There are no detected outliers in this set of data. (See Problem 1 for details of the outlier detection calculations.)

Problem 2 - Step 2. The k-sample Anderson-Darling test statistic is $ADK = 1.01$ (see Problem 1 for a detailed computation of the k-sample statistic). Since this is less than the critical value of 1.73, conclude that the data from the batches may be combined and treated as a single sample. The next step is to investigate the form of the distribution.

Problem 2 - Step 3. The maximum normed residual (MNR) test is performed on the pooled data. No potential outliers are detected in the pooled data. (see Problem 1 - Step 1 for details of the outlier detection procedure.)

Problem 2 - Step 4. The Weibull goodness-of-fit test yields an observed significance level of 0.008. (See Problem 3 for details of the computation for the Weibull goodness-of-fit test.) Since this is less than 0.05, the normal goodness-of-fit test described in Section 8.3.4.3.2 is performed.

Problem 2 - Step 5. The mean and standard deviation of the sample are 103.1 and 6.175, respectively. The first five ordered observations are listed below with the z-values and the values of the standard normal distribution necessary for calculation of the normal Anderson-Darling statistic.

$x_{(i)}$	$z_{(i)} = \frac{x_{(i)} - \bar{x}}{s} = \frac{x_{(i)} - 106.5}{6.436}$	$F_0(z_{(i)})$
98.0	-1.313	0.0951
99.0	-1.158	0.1235
100.0	-1.002	0.1582
100.0	-1.002	0.1582
100.0	-1.002	0.1582
..

$$\begin{aligned}
 AD &= \sum_{i=1}^n \frac{1-2i}{n} \left\{ \ln[F_0(z_{(i)})] + \ln[1 - F_0(z_{(n+1-i)})] \right\} - n \\
 &= \sum_{i=1}^{20} \frac{1-2i}{20} \left\{ \ln[F_0(-z_{(i)})] + \ln[1 - F_0(z_{(21-i)})] \right\} - 20 \\
 &= 0.570 \\
 AD^* &= \left[1 + \frac{4}{n} - \frac{25}{n^2} \right] AD = \left[1 + \frac{4}{20} - \frac{25}{20^2} \right] (0.570) = 0.648 \\
 OSL &= 1 / \left\{ 1 + \exp[-0.48 + 0.78 \ln(AD^*) + 4.58 AD^*] \right\} \\
 &= 1 / \left\{ 1 + \exp[-0.48 + 0.78 \ln(0.648) + 4.58(0.648)] \right\} \\
 &= 0.163
 \end{aligned}$$

Since the normal goodness-of-fit test yields an OSL value (0.163) greater than 0.05, there is insufficient evidence to contradict the assumption that the data are normally distributed. Hence, the normal method in Section 8.3.4.3.3 is used to compute a B-basis value.

Problem 2 - Step 6. From Table 8.5.10, the one-sided tolerance limit factor, k_B , is 1.93. The B-basis value for a normally distributed sample is computed as

$$B = \bar{x} - k_B s = 103.1 - (1.927)(6.175) = 91.2$$

For presentation in MIL-HDBK-17, this B-basis value would be rounded to 91, since this corresponds to the number of significant figures obvious in the data.

RECIPE can also be used to calculate this basis value. Since it has been shown that the batches may be pooled, this problem represents an unstructured (that is, simple random) sample of n observations from a single batch at a fixed set of conditions. For this case, there $\ell = 1$ is condition, and $m = 1$ batch, so $p(s) = q(s) = 1$ for each s . This model can be written

$$y_s = \theta_1 + e_s$$

Note that $b_{q(s)}$ does not appear in this equation since the between-batch variability has been shown to be negligible (Step 3).

```
#
# RECIPE Problem #2: Random sample of 4 batches with no
#       batch-to-batch variability
#
# -- For this example, we have 20 observations: all at the same
#    fixed level and from one population. RECIPE is a very
#    general program which is here used for a very simple
#    example. This example might seem confusing because it
#    is so special. If so, consider the more complicated
#    examples, particularly Example #4. Ironically, the
#    simpler examples may then be easier to understand.
#
# -- ntot, nlvl, nbch, npar, npts, prob, conf
#
20 1 1 1 1 .9d0 .95d0
#
# -- Fixed levels. Here nlvl=1 and npar=1; that is there is only
#    one fixed level and one regression parameter (a constant mean),
#    so this part of the input consists of one row and one column,
#    containing just the number '1'.
#
1
#
# -- Fixed level, batch number, response value. Note that there
#    is only one level (nlvl=1) and one batch (nbch=1).
#
1 1 99.
1 1 100.
1 1 106.
# (this just shows that comments can be put anywhere: even among
# the data values. This is useful, for example, if a data value
# is to be removed from the analysis. Simply put a '#' at the
# beginning of the appropriate line, and decrease 'ntot' by 1
# in the first noncomment line)
1 1 107.
1 1 110.
1 1 98.
1 1 103.
1 1 111.
```

Volume 1, Chapter 8 Statistical Methods

```

1 1 119.
1 1 121.
1 1 100.
1 1 100.
1 1 104.
1 1 108.
1 1 116.
1 1 103.
1 1 104.
1 1 106.
1 1 106.
1 1 108.
#
# -- Points at which to evaluate tolerance limit. Here the only fixed
#    effect is a constant mean, so this part of the input is trivial.
1

```

Lines which begin with a '#' are *comment lines* which are ignored by the program. Comment lines can be inserted anywhere and are intended to make RECIPE data files self-documenting. The input to this program is free-format, so it doesn't matter which column values are in, so long as they are in the correct order and separated by spaces. The sole exception to this is that comment lines must have a '#' in column 1.

The first non-comment line of any RECIPE files has seven constants:

RECIPE mnemonic	Symbol	Definition
ntot	n	total number of observations
nlevel	l	number of fixed levels
nbch	m	number of batches
npar	r	number of fixed parameters
npts	-	number of basis values to be calculated
prob	-	content
conf	-	confidence

It is necessary to specify the number of points at which the basis values will be determined. For example, if a linear regression model relates strength to temperature, then a basis value can be calculated at any number of temperatures, that is, the temperatures at which basis values are determined need not correspond to values for which data are available. The fifth number *npts* specifies the number of basis values which are to be calculated. The sixth and seventh values, *prob* and *conf*, give the *content* and *confidence* which are to be used. For purpose of basis calculations, one need only remember that *prob* should be 0.99d0 for A-basis values and 0.90d0 for B-basis values, and that *conf* should be 0.95d0.

In this example, note that there are *n*=20 observations, at *l*=1 fixed level, from *m*=1 batch, with *r*=1 fixed parameter, and that a single B-basis value is to be calculated. (Since this corresponds to a simple random sample, it only makes sense to calculate one B-basis value.)

The next *l*=1 noncomment lines specify the fixed levels; for this example there is only one fixed level, and it is just the mean, so this part of the file has only one line with a '1' in it. The following *n*=20 noncomment lines each gives, from left to right, a fixed level *p*(*s*) (here *p*(*s*)=1), batch *q*(*s*) (here *q*(*s*)=1), and observation (strength *y_s* for *s*=1,...,20). The next *npts* = 1 noncomment lines give the *z*'s

Volume 1, Chapter 8 Statistical Methods

corresponding to each point at which a basis value is to be calculated. Again, because this example is a simple random sample, this part of the file consists of only a single line with a '1'.

RECIPE is executed as follows:

recipe

Filename (without .dat extension) ?

ex2

RECIPE : One-Sided Random-Effect Regression Tolerance Limits
(Version 1.0, April 1995)

*** Simulated pivot critical value file ex2.crt not found.
Satterthwaite approximation will be used.

Probability	Confidence	Regression	Tolerance Limit
0.90	0.95	104.400000	88.312898

The first two columns of the output indicate a B-basis value has been calculated. The third column gives the value of a point on the least squares regression line (here just the sample mean) and the fourth column gives the corresponding basis value (here the usual normal B-basis value for a single sample of five specimens). These results provide a mean of 104 and a B-basis value of 88 (Note the number of significant figures). This approach can also be used for data from one batch. A warning is provided as a reminder that one cannot estimate between-batch variability with data from a single batch, and consequently a basis value has been calculated under the assumption that there is no between-batch variability.

There are two methods that RECIPE can use to calculate allowable. One involves the use of a Satterthwaite approximation (Reference 8.3.7.2(a)) and the other requires using an auxiliary program SIMPVT to obtain a quantile of a pivotal random variable for which the probability distribution cannot be determined in analytical form. Usually, these two methods will give very nearly the same answers, at least for material basis value calculations. The simpler Satterthwaite approximation is therefore recommended for general use. Auxiliary programs SIMPVT and SIMCOV, which use simulation to approximate the appropriate pivoted quantile and to assess the quality of the Satterthwaite approximate, respectively, are available with RECIPE (Section 8.1.2). For more information see References 8.3.7.2(a) and (b).

8.3.7.3 Problem 3 - Lognormal distribution

The data set for this problem consists of transverse tension test measurements from five batches of material. This problem illustrates the lognormal goodness-of-fit test and the calculation of B-basis values by the lognormal method. Calculations for all steps may be performed by STAT17 and may be demonstrated using example data set, `example.d03`.

Problem 3 - Step 1. There are no detected outliers in this set of data. (See Problem 1 for details of the outlier detection calculations.)

Problem 3 - Step 2. The k-sample Anderson-Darling test statistic is $ADK = 1.27$. (See Problem 1 for details of the computation of the k-sample statistic.) Since this is less than the critical value of 1.64, conclude that the data from the batches may be combined into a single sample.

Problem 3 - Step 3. The maximum normed residual (MNR) test is performed on the pooled data. No potential outliers are detected in the pooled data. (see Problem 1 - Step 1 for details of the outlier detection procedure.)

Problem 3 - Step 4. The observed significance levels (OSL) for the two-parameter Weibull and the normal goodness-of-fit tests are given below:

Distribution	OSL
Two-parameter Weibull	0.001
Normal	0.042

(See Problems 1 and 2 for details of the computations for these tests.) Since the OSL 's are both less than 0.05, neither of the distributions adequately describe the data. Thus, the lognormal goodness-of-fit test is performed.

Problem 3 - Step 5. In order to perform the lognormal goodness-of-fit test described in Section 8.3.4.4, the natural logarithms of the data are used. The average and standard deviation of the transformed data are

$$\bar{x}_L = 4.57 \quad s_L = 1.6050$$

The first five ordered observations are listed below with the transformations necessary to compute the goodness-of-fit statistic. The goodness-of-fit statistic and observed significance level are calculated as:

$x_{(i)}$	$\ln(x_{(i)})S$	$z_{(i)} = \frac{\ln(x_{(i)}) - \bar{x}_L}{s_L} = \frac{\ln(x_{(i)}) - 4.57}{1.6050}$	$F_o[z_{(i)}]$
85.39	4.447228998	-1.727771002	0.042014598
86.11	4.455625549	-1.719374451	0.042773061
86.18	4.456438132	-1.718561868	0.042847046
90.72	4.50777784	-1.66722216	0.047735087
90.86	4.50931986	-1.66568014	0.047888539
..

$$\begin{aligned} AD &= \sum_{i=1}^n \frac{1-2i}{n} \{ \ln[F_o(z_{(i)})] + \ln[1 - F_o(z_{(n+1-i)})] \} - n \\ &= \sum_{i=1}^{30} \frac{1-2i}{30} \{ \ln[F_o(-z_{(i)})] + \ln[1 - F_o(z_{(31-i)})] \} - 31 \\ &= 0.597 \\ AD^* &= \left[1 + \frac{4}{n} - \frac{25}{n^2} \right] AD = \left[1 + \frac{4}{30} - \frac{25}{30^2} \right] (0.597) = 0.177S \end{aligned}$$

$$\begin{aligned} OSL &= 1 / \{ 1 + \exp[-0.48 + 0.78 \ln(AD^*) + 4.58 AD^*] \} \\ &= 1 / \{ 1 + \exp[-0.48 + 0.78 \ln(0.177) + 4.58(0.177)] \} \\ &= 0.098 \end{aligned}$$

Since the lognormal goodness-of-fit test results in an OSL value greater than 0.05, there is insufficient evidence to contradict the assumption that the data are lognormally distributed. Hence, the lognormal method in Section 8.3.4.5.1 is used to compute a B-basis value.

Problem 3 - Step 6. The B-basis value for lognormally distributed data is computed as

$$B = \exp[\bar{x}_L - k_{BSL}] = \exp[4.57 - 1.78(1.6050)] = 85.09$$

For presentation in MIL-HDBK-17, this B-basis value would be rounded to 85.1.

Volume 1, Chapter 8 Statistical Methods

8.3.7.4 Problem 4 - Nonparametric method

The data set for this problem consists of transverse tensile strain-to-failure measurements for three batches of material. This problem illustrates the calculation of B-basis values by the nonparametric method. Calculations for all steps may be performed by STAT17 and may be demonstrated using example data set, `example.d04`.

Problem 4 - Step 1. There was one detected outlier, 1300, in this set of data. No reason could be found so it was retained in the data set (See Problem 1 for details of the outlier detection calculations.)

Problem 4 - Step 2. The k-sample Anderson-Darling test statistic is $ADK = 1.44$. (See Problem 1 for details of the computation of the k-sample statistic.) Since this is less than the critical value of 1.86, conclude that the data from the batches may be combined into a single sample.

Problem 4 - Step 3. The maximum normed residual (MNR) test is performed on the pooled data. The outlier detected in Step 1 was again identified as an outlier in the pooled data. (see Problem 1 - Step 1 for details of the outlier detection procedure.)

Problem 4 - Step 4. The results of the goodness-of-fit tests for the three distributions are:

Distribution	OSL
Two-parameter Weibull	0.003
Normal	0.011
Lognormal	0.000

(See problems 1, 2, and 3 for details of the computations for each of these tests.)

Since all of the observed significance levels are less than 0.05, it is concluded that the data do not follow any of the three distributions. Thus, the nonparametric method described in Section 8.3.4.5.1 must be used to calculate the B-basis value.

Problem 4 - Step 5. The first step in computing a B-basis value by the nonparametric method is to order the data values from smallest to largest. The five smallest values are 1300, 5500, 5500, 5700, and 5900. The next step is to obtain the appropriate rank from Table 8.5.12 corresponding to the sample of size n . With an n of 97, the rank of the observation to be used as a B-basis value is $r = 5$. Thus, the fifth observation, or 5900, is the B-basis value for this sample.

8.3.7.5 Problem 5 - Hanson-Koopmans method

The data set for this problem consists of compressive strength measurements for three batches of material. This problem illustrates the situation where none of the standard distributions adequately fit the data, and there is insufficient data to perform the nonparametric method. Calculations for all steps may be performed by STAT17 and may be demonstrated using example data set, `example.d05`.

Problem 5 - Step 1. There are no detected outliers in this set of data. (See Problem 2 for details of the outlier detection calculations.)

Problem 5 - Step 2. The k-sample Anderson-Darling test statistic is $ADK = 0.60$. (See Problem 1 for details of the computation of the k-sample statistic.) Since this is less than the critical value of 1.89, conclude that the data from the batches may be combined into a single sample.

Problem 5 - Step 3. The maximum normed residual (MNR) test is performed on the pooled data. No potential outliers are detected in the pooled data. (see Problem 1 - Step 1 for details of the outlier detection procedure.)

Problem 5 - Step 4. The results of the goodness-of-fit tests for the three distributions are:

Distribution	OSL
Two-parameter Weibull	0.047
Normal	0.039
Lognormal	0.035

(See problems 1, 2, and 3 for details of the computations for each of these tests.)

Since all of the observed significance levels are less than 0.05, it is concluded that the data do not follow any of the three distributions. The Hanson-Koopmans method should be used to calculate a B-basis value for these data, since there are only 15 data values.

Problem 5 - Step 5. Following the procedure described in Section 8.3.4.5.2, a B-basis value can be estimated. For $n = 15$, from Table 8.5.14 it is determined that $r = 8$ and $k = 1.54$. After ranking the data in ascending order, the first and eighth values are found.

$$x_{(1)} = 114.6 \quad x_{(8)} = 133.4$$

The B-basis value is calculated as

$$B = x_{(r)} \left[\frac{x_{(1)}}{x_{(r)}} \right]^k = 133.4 \left[\frac{114.6}{133.4} \right]^{1.54} = 104.365$$

These data can be included in MIL-HDBK-17 as interim data, but the B-value would not be reported in the handbook.

8.3.7.6 Problem 6 - Analysis of variance (ANOVA) method

The data set for this problem consists of tensile strength measurements from six batches of material. This problem illustrates the test for normality of multiple samples, the equality of variance test, and the calculation of basis values by the analysis of variance (ANOVA) method. Calculations for all steps may be performed by STAT17 and may be demonstrated using example data set, `example.d06`. Calculations for Step 4 may be performed by RECIPE and may be demonstrated using example data set, `ex2.dat`.

Problem 6 - Step 1. There are no detected outliers in this set of data. (See Problem 1 for details of the outlier detection computations.)

Problem 6 - Step 2. The k-sample Anderson-Darling test statistic is $ADK = 2.45$. (See Problem 1 for details of the computation of the k-sample statistic.) Since ADK is greater than the critical value of 1.56, the hypothesis that the populations from which these groups are drawn are identical is rejected.

Problem 6 - Step 3. The equality of variance test described in Section 8.3.5.2.1 is used to determine if the within-batch variances are significantly different. The sample sizes (n_i), group medians (\tilde{x}_i), and group averages of $w_{ij} = |x_{ij} - \tilde{x}_i|$ are tabulated below.

Batch	n_i	\bar{x}_i	\bar{w}_i
1	5	338.7	6.233
2	6	308.5	9.187
3	5	317.7	9.874
4	5	313.1	9.823
5	5	322.7	6.239
6	5	294.2	7.099

The transformed data are $w_{11} = |328.1 - 338.7| = 10.6$, $w_{12} = |334.8 - 338.7| = 3.9$, ..., $w_{65} = |294.2 - 294.2| = 0$. The test statistic is

$$\begin{aligned}
 F &= \frac{\sum_{i=1}^k n_i (\bar{w}_i - \bar{w})^2 / (k-1)}{\sum_{i=1}^k \sum_{j=1}^{n_i} (w_{ij} - \bar{w}_i)^2 / (n-k)} \\
 &= \frac{\sum_{i=1}^6 n_i (\bar{w}_i - \bar{w})^2 / (6-1)}{\sum_{i=1}^6 \sum_{j=1}^{n_i} (w_{ij} - \bar{w}_i)^2 / (31-6)} \\
 &= 0.29
 \end{aligned}$$

95th percentile of an F random variable with $\gamma_1 = k - 1 = 5$ and $\gamma_2 = n - k = 25$ degrees of freedom from Table 8.5.1 is 2.60. Since 0.29 is less than 2.60, the hypothesis that within-group variances are equal is not rejected.

Since the equality of variance test is a diagnostic test, a B-basis value may still be calculated, even when the hypothesis that higher group variances are equal is rejected. However, a nonconservative B-basis value can result in some instances when the variances are unequal. Unequal variances suggest potential problems with consistency in fabrication or processing of the different batches. The B-basis value calculated in such cases should be used with caution.

Problem 6 - Step 4. Summary statistics for the data are given in the table below.

Batch	n_i	\bar{x}_i	s_i
1	5	339.133	8.159
2	6	308.701	12.443
3	5	317.081	16.236
4	5	313.066	12.556
5	5	321.951	8.614
6	5	297.595	9.307

Preliminary ANOVA calculations covered in Section 8.3.5.2.6 are:

$$n^* = \sum_{i=1}^k n_i^2 / n = (5^2 + \dots + 5^2) / 31 = 5.19$$

$$n' = (n - n^*) / (k - 1) = (31 - 5.19) / (6 - 1) = 5.16$$

Volume 1, Chapter 8 Statistical Methods

$$\bar{x} = \sum_{i=1}^k n_i \bar{x}_i / n = [5(339.133) + \dots + 5(297.595)] / 31 = 316$$

$$MSB = \sum_{i=1}^k \frac{n_i (\bar{x}_i - \bar{x})^2}{k-1} = \frac{1}{6-1} [5(339-316)^2 + \dots + 5(298-316)^2] = 983.0$$

$$MSE = \sum_{i=1}^k \sum_{j=1}^{n_i} \frac{(x_{ij} - \bar{x}_i)^2}{n-k} = \frac{1}{n-k} \sum_{i=1}^k (n_i - 1) s_i^2 = \frac{1}{31-6} [4(8.159)^2 + \dots + 4(9.307)^2] = 134.8$$

The following tolerance limit factors are obtained from Table 8.5.10 (for B-basis values).

$$k_0 = 1.768 \quad k_1 = 3.007$$

Note that the approximation to Table 8.5.10 is not used for small degrees of freedom. The tolerance limit factor is calculated as follows. Denote the ratio of mean squares by

$$\begin{aligned} S &= \sqrt{\frac{MSB}{n'} + \left(\frac{n'-1}{n'}\right) MSE} \\ &= \sqrt{\frac{983.0}{5.16} + \left(\frac{5.16-1}{5.16}\right) 134.8} \\ &= 17.297 \end{aligned}$$

$$u = \frac{MSB}{MSE} = \frac{983.0}{134.8} = 7.292$$

(If u is less than one, set u equal to one.)

$$w = \sqrt{\frac{u}{u+n'-1}} = \sqrt{\frac{7.292}{7.292+5.16-1}} = 0.7980$$

The tolerance limit factor is

$$\begin{aligned} t &= \frac{k_0 - k_1 / \sqrt{n'} + (k_1 - k_0) W}{1 - \frac{1}{\sqrt{n'}}} \\ &= \frac{1.768 - 3.007 / \sqrt{5.16} + (3.007 - 1.768) 0.798}{1 - \frac{1}{\sqrt{5.16}}} \\ &= 2.560 \end{aligned}$$

Thus, a B-basis value is calculated as

$$B = \bar{x} - ts = 316 - 2.560(17.297) = 271.72$$

For presentation in MIL-HDBK-17, this B-basis value would be rounded to 272.

The calculations for Step 4 can be performed using RECIPE, when batch-to-batch variability is significant or the ANOVA approach is desired. In this example, there are data on several batches, each tested

Volume 1, Chapter 8 Statistical Methods

under the same set of fixed conditions. Since there is only one set of fixed conditions, the model for this example has a constant mean, but now there are both between-batch and within-batch components of variance. So $l=1$, and

$$y_s = \theta_1 + b_{q(s)} + e_s$$

This is the usual random-effects ANOVA (or simply 'ANOVA') model of Section 8.3.5.2.

```
#
# RECIPE Example #2: Basis value from a one-way ANOVA model
# This corresponds to MIL-HDBK-17, Problem #6
#
# -- This example has 31 observations in 6 batches, for which
#    an ANOVA B-basis value is to be determined
#
# -- ntot, nlvl, nbch, npar, npts, prob, conf
# 31 1 6 1 1 .9d0 .95d0
#
# -- Fixed levels. Here we are fitting a one-way ANOVA model, so there
#    is only one fixed level, and only one fixed parameter (the mean)
#    to estimate.
#
# 1
#
# -- Fixed level number, batch number, strength. Since we have
#    only one fixed level, the first column is all ones. The
#    second column gives the batch number, and the third column
#    gives the strength values.
#
# 1 1 328.1174
# 1 1 334.7674
# 1 1 347.7833
# 1 1 346.2661
# 1 1 338.7314
# 1 2 297.0387
# 1 2 293.4595
# 1 2 308.0419
# 1 2 326.4864
# 1 2 318.1297
# 1 2 309.0487
# 1 3 337.0930
# 1 3 317.7319
# 1 3 321.4292
# 1 3 317.2652
# 1 3 291.8881
# 1 4 297.6943
# 1 4 327.3973
# 1 4 303.8629
# 1 4 313.0984
# 1 4 323.2769
# 1 5 312.9743
# 1 5 324.5192
# 1 5 334.5965
# 1 5 314.9458
# 1 5 322.7194
# 1 6 291.1215
# 1 6 309.7852
# 1 6 304.8499
# 1 6 288.0184
# 1 6 294.1995
#
# -- Points at which to evaluate tolerance limit. For the one-way
#    ANOVA model used here, there is only one point at which the
#    evaluation can be done: it corresponds to the one fixed
#    level of the model.
#
# 1
```

Volume 1, Chapter 8 Statistical Methods

The output is similar in form to the example in Problem 2, Step 6.

```

recipe
  Filename (without .dat extension) ?
ex2

RECIPE : One-Sided Random-Effect Regression Tolerance Limits
(Version 1.0, April 1995)

*** Simulated pivot critical value file ex2.crt not found.
    Satterthwaite approximation will be used.

      Probability      Confidence      Regression      Tolerance Limit
      0.90              0.95          316.010884      271.672860

```

The results include a mean of 316 and a B-basis value of 272. Note, however, that the warning message that was output for Problem 2 does not appear. The between-batch variability can be estimated since there are six batches. The fourth column gives the one-way random effects ANOVA basis value.

8.3.7.7 Problem 7 - Linear regression

The data set for this problem consists of tensile test measurements at two fixed temperatures. This problem illustrates the regression analysis procedures presented in Section 8.3.5.3. Calculations for Step 1 may be performed by STAT17 and may be demonstrated using example data set, *example.d07*. Calculations for Steps 2 through 5 may be performed by RECIPE and may be demonstrated using example data set, *ex3.dat*. Note that a linear relationship between strength and temperature is not appropriate for all temperature ranges.

Problem 7 - Step 1. In this example, x represents the temperature and y the tensile strength determined from a group of tension tests. Outlier detection is useful applied to each temperature or fixed condition. There are no detected outliers for either temperature in this set of data.

Problem 7 - Step 2. From the data in Table 8.3.7, the following quantities may be calculated:

$$\begin{array}{ll}
 n = 11 & (\Sigma x)^2 = 13225 \\
 \Sigma x = 115 & (\Sigma y)^2 = 14163006 \\
 \Sigma y = 3763 & (\Sigma x)(\Sigma y) = 432788.3 \\
 \Sigma x^2 = 56195 & \Sigma xy = 37033.94 \\
 \Sigma y^2 = 1288172 &
 \end{array}$$

$$S_{xx} = \Sigma x^2 - (\Sigma x)^2 / n = 56195 - (13225) / 20 = 54992$$

$$S_{xy} = \Sigma xy - (\Sigma x)(\Sigma y) / n = 37033.94 - (115)(3763) / 11 = 2310.459$$

$$S_{yy} = \Sigma y^2 - (\Sigma y)^2 / n = 1288172 - (14163006) / 11 = 626.5063$$

The slope of regression line is:

$$b = \frac{S_{xy}}{S_{xx}} = \frac{-2310.459}{54992} = 0.0420$$

The y-intercept of the regression line is:

$$a = \frac{\Sigma y - b \Sigma x}{n} = \frac{3763 - (-0.0420)(115)}{11} = 342.1 - (-0.438) = 342.5644$$

Thus, the final equation of the least squares regression line is:

$$y^* = a + b\bar{x} = 342.5644 - 0.0420\bar{x}$$

Using this equation, the values of y^* in the table below are computed for the values of x in the data set.

x	y	y^*	$e = y - y^*$
75	328.1174	339.4134	-11.2959667
75	334.7674	339.4134	-4.6459667
75	347.7833	339.4134	8.3699333
75	346.2661	339.4134	6.8527333
75	338.7314	339.4134	-0.6819667
75	340.8146	339.4134	1.4012333
-67	343.5855	345.3793	-1.7938400
-67	334.1746	345.3793	-11.2047400
-67	348.6610	345.3793	3.2816600
-67	356.3232	345.3793	10.9438600
-67	344.1524	345.3793	-1.2269400

The root mean square error is computed as follows:

$$s_Y = \sqrt{\frac{\Sigma(y - y^*)^2}{n-2}} = \sqrt{\frac{529.5}{9}} = 7.669818$$

and R^2 is computed as follows:

$$R^2 = \frac{b^2 S_{xx}}{S_{yy}} = \frac{(-0.0420)^2 (54992)}{626.5063} = 0.1549$$

Thus, 15% of the variability in the y data about its average is explained by the linear relationship between y and x .

Problem 7 - Step 3. One of the assumptions made in linear regression analysis is that the residuals are normally distributed about the regression line. The validity of this assumption may be checked by performing a normal goodness-of-fit test on the residuals as discussed in Section 8.3.5.1. Note that the $z_{(i)}$ values used in the Anderson-Darling statistic are defined as $z_{(i)} = e_{(i)} / s_Y$, where $e_{(i)}$ is the i^{th} ordered residual and s_Y is the root-mean-square error from the regression. The eleven ordered residuals and the preliminary goodness-of-fit calculations are shown in the following table.

$e(i)$	$z(i) = \frac{e(i)}{S_y} = \frac{e(i)}{58.83}$
-11.2959667	-1.47278162
-4.6459667	-0.60574667
8.3699333	1.09128187
6.8527333	0.89346752
-0.6819667	-0.08891563
1.4012333	0.18269447
-1.7938400	-0.23388299
-11.2047400	-1.46088734
3.2816600	0.42786674
10.9438600	1.42687349
-1.2269400	-0.15996990

The normal goodness-of-fit test statistic is 0.222 with an OSL of 0.590. (See Problem 2 for details of the computation for the normal goodness-of-fit test.) Since the OSL is greater than 0.05, there is insufficient evidence to contradict the assumption that the residuals are normally distributed.

Problem 7 - Step 4. There are multiple y observations for several of the x values. Thus, it is possible to construct an analysis of variance table to test the adequacy of the regression as discussed in Section 8.3.5.3. The sums of squares for the three primary lines of the analysis of variance table are calculated as follows:

$$\begin{aligned} SSR &= b^2 S_{xx} = (-0.0420)^2 (54992) = 97.7138 \\ SST &= S_{yy} = 626.5063 \\ SSE &= SST - SSR = 626.5063 - 97.7138 = 529.4349 \end{aligned}$$

The mean squares are calculated as shown below.

$$\begin{aligned} MSR &= SSR = 97.07138 \\ MSE &= SSE/n-2 = 529.4349/9 = 58.82611 \\ F &= MSR/MSE = 97.07138/58.82611 = 1.650141 \end{aligned}$$

The analysis of variance table is shown below.

Source of Variation	Degrees of Freedom	Sum of Squares, SS	Mean Squares, MS	F_{calc}
Regression	1	97.07	97.07	F = 1.65
Error	9	529.4	58.83	
Total	10	626.5		

The F value of 1.65 with 1 and $n-2=9$ degrees of freedom is less than the value of 5.12 from Table 8.5.1 corresponding to 1 and 9 degrees of freedom, so the regression may be negligible.

Problem 7 - Step 5. With the linear regression equation from step 1, lower tolerance limits may be calculated at any temperature (x value) by the procedure in Section 8.3.5.3. Details for computing a B-basis value at $x = 25$ are given below.

The average temperature value in the data set is:

$$\bar{x} = \sum x/n = 115/11 = 10.45$$

The Δ factor required to compute the tolerance limit factor, k' , is:

$$\Delta = \frac{(x_0 - \bar{x})^2}{\sum_{i=1}^n (x_i - \bar{x})^2 / n} = \frac{(25 - 10.45)^2}{(54992)/11} = 0.0423$$

The approximation for the k' factor is:

$$\begin{aligned} k'_B &= 1.282 + \exp \left[0.595 - 0.508 \ln(n) + \frac{4.62}{n} + \left(0.486 - \frac{0.986}{n} \right) \ln(1.82 + \Delta) \right] \\ &= 1.282 + \exp \left[0.595 - 0.508 \ln(11) + \frac{4.62}{11} + \left(0.486 - \frac{0.986}{11} \right) \ln(1.82 + 0.0423) \right] \\ &= 2.33 \end{aligned}$$

Thus, a B-basis value at $x = 25$ is computed as

$$B = (a + b x_0) - k_{Bsy} = [342.5 + (-0.0420)(20) - 2.33(7.669818)] = 323.64339$$

For presentation in MIL-HDBK-17, this value would be rounded to 324.

RECIPE provides the linear regression calculations for this problem. There are data from a single batch, so that $m=1$; but the possibility of several conditions ($1 > 1$) is included. To fix ideas, assume that there are several sets of unidirectional tensile strength data from a single batch, with each set being tested at a different temperature, and with all other conditions held constant. Assume further that the strength for this material is believed to vary linearly with temperature, at least for temperatures within the range of the data. With only one batch, the between-batch variability cannot be estimated. The regression model appropriate for this situation is

$$y_s = \theta_1 z_{p(s),1} + \theta_2 z_{p(s),2} + e_s$$

This is the simple linear regression model of Section 8.3.5.3.

The file `ex3.dat`, which corresponds to this problem, is:

```
#
# RECIPE Example #3: Regression model with data from a single batch
# This corresponds to MIL-HDBK-17, Problem #7
#
# -- This dataset has 11 observations at two fixed levels. The
# data come from 1 batch, there are two fixed parameters to
# estimate (the slope and intercept of a straight line), and
# a B-basis value is to be calculated at 7 points on this line.
#
# -- ntot, nlvl, nbch, npar, npts, prob, conf
# 11 2 1 2 7 .9d0 .95d0
#
# -- We are fitting a model y=a+bT at two levels: T=75 degrees and
# T=-67 degrees. The first column corresponds to 'a' in this
# linear equation; the second column corresponds to 'b'. Note
# that these values need not be given in any special order,
# for example (1, -67) need not come before (1, 75). The
# important thing is that the order of the rows given here
# must correspond to the level indicator, p(s), given with each
# response value.
```

Volume 1, Chapter 8 Statistical Methods

```

1 75
1 -67
#
# -- Now we have the 11 observations.  The first column is the
# level (=1 for 75 degrees, =2 for -67 degrees), the second
# column is the batch (always 1), and in the third column are
# the strength observations.
#
1 1 328.1174
1 1 334.7674
1 1 347.7833
1 1 346.2661
1 1 338.7314
1 1 340.8146
2 1 343.5855
2 1 334.1746
2 1 348.6610
2 1 356.3232
2 1 344.1524
#
# -- Finally, we give the seven points at which basis
# values are to be determined.  These correspond
# to seven different temperatures -67,...,50. Note
# that the first column of ones is required because
# of the intercept in the regression model
1 -67
1 -50
1 -25
1 0
1 25
1 50
1 75

```

Note that the first noncomment line of `ex3.dat` indicates (in order, from left to right) that there are 11 observations in all, that the data are at 2 fixed levels, that all of the data are from a single batch, that the fixed part of the model involves 2 unknown parameters (actually, a straight line is being fit to the data), that the basis value curve will be evaluated at 7 points, and that the tolerance limits to be calculated are B-basis values.

This example illustrates a simplification of the common situation where a material basis value is required as a function of temperature. One has data at two fixed levels, corresponding to the temperatures -67 and 75 °F, and one would like to determine basis values at the 7 temperatures -67, -50, -25, 0, 25, 50, and 75 °F. The intercept of the linear function is, of course, constant for all temperatures, so the first column equals 1 for the 2 rows that give the levels of the fixed effect, as well as the 7 rows that give the points at which the basis values are to be evaluated. The output from running `RECIPE` on these data is

```

recipe
  Filename (without .dat extension) ?
ex3

RECIPE : One-Sided Random-Effect Regression Tolerance Limits
(Version 1.0, April 1995)

*** Simulated pivot critical value file ex3.crt not found.
Satterthwaite approximation will be used.

regini : Warning: between-batch variance cannot
be estimated from these data. Results
will be based on the assumption that the
between-batch variability is negligible.

Probability    Confidence    Regression    Tolerance Limit

```

Volume 1, Chapter 8 Statistical Methods

0.90	0.95	345.379340	325.887099
0.90	0.95	344.665104	325.747683
0.90	0.95	343.614756	325.338699
0.90	0.95	342.564409	324.619436
0.90	0.95	341.514062	323.538853
0.90	0.95	340.463714	322.102027
0.90	0.95	339.413367	320.366619

Each of the last seven lines gives a point on the regression line, and the corresponding point on the B-basis curve for each of the seven sets of covariates (temperatures) in the file `ex3.dat`. Note that there is a warning message, since one cannot estimate between-batch variability using data from a single batch. The basis values calculated are valid under the assumption that the between-batch variability is zero (or at least negligible).

8.3.7.8 Problem 8 - Simple linear regression with a random effect

The data set for this problem consists of compression test measurements at two temperatures with several batches represented at each temperature. This problem illustrates the same situation as Problem 7 except data are available for more than one batch. Calculations for Step 1 can be performed by STAT17 and can be demonstrated using example data set, `example.d08`. Calculations for Step 2 are demonstrated by example data set, `ex4.dat`. and `RECIPE`. Note that a linear relationship between strength and temperature is not appropriate for all temperature ranges.

Problem 8 - Step 1. In this example, x represents the temperature and y the tensile strength determined from a group of tension tests. Outlier detection is useful applied to each temperature or fixed condition. There are no detected outliers for either temperature in this set of data.

Problem 8 - Step 2. The random batch effect $b_{q(s)}$ can now be introduced into the model, leading to

$$y_s = \theta_1 z_{p(s),1} + \theta_2 z_{p(s),2} + b_{q(s)} + e_s$$

where $z_{p(s),1} = 1$, $z_{p(s),2} = T_i$, the i^{th} test temperature, and $b_{q(s)}$ is the batch mean for the $q(s)^{\text{th}}$ batch. The file `ex4.dat`, which corresponds to this problem, is

```
#
# RECIPE Example #4: Regression model with data from several
# batches
# This corresponds to MIL-HDBK-17, Problem #8
#
# -- In this example, we have 72 strength observations on data
# from 8 batches. A straight-line regression is fit with
# two fixed levels (temperatures). B-basis values are calculated
# for 7 points along this curve.
#
# -- ntot, nlvl, nbch, npar, npts, prob, conf
72 2 8 2 7 .9d0 .95d0
#
# -- There are two fixed levels, corresponding to
# 75 and -67 degrees.
1 75
1 -67
#
# -- The following 72 rows give the fixed level in the
# first column, the batch in the second column, and the
# strength observation in the third column.
1 1 328.1174
1 1 334.7674
1 1 347.7833
```

Volume 1, Chapter 8 Statistical Methods

1	1	346.2661
1	1	338.7314
1	2	297.0387
1	2	293.4595
1	2	308.0419
1	2	326.4864
1	2	318.1297
1	2	309.0487
1	3	337.0930
1	3	317.7319
1	3	321.4292
1	3	317.2652
1	3	291.8881
1	4	297.6943
1	4	327.3973
1	4	303.8629
1	4	313.0984
1	4	323.2769
1	5	312.9743
1	5	324.5192
1	5	334.5965
1	5	314.9458
1	5	322.7194
1	6	291.1215
1	6	309.7852
1	6	304.8499
1	6	288.0184
1	6	294.1995
2	1	340.8146
2	1	343.5855
2	1	334.1746
2	1	348.6610
2	1	356.3232
2	1	344.1524
2	2	308.6256
2	2	315.1819
2	2	317.6867
2	2	313.9832
2	2	309.3132
2	2	275.1758
2	3	321.4128
2	3	316.4652
2	3	331.3724
2	3	304.8643
2	3	309.6249
2	3	347.8449
2	4	331.5487
2	4	316.5891
2	4	303.7171
2	4	320.3625
2	4	315.2963
2	4	322.8280
2	5	340.0990
2	5	348.9354
2	5	331.2500
2	5	330.0000
2	5	340.9836
2	5	329.4393
2	7	330.9309
2	7	328.4553
2	7	344.1026
2	7	343.3584
2	7	344.4717
2	7	351.2776

Volume 1, Chapter 8 Statistical Methods

```

2 8 331.0259
2 8 322.4052
2 8 327.6699
2 8 296.8215
2 8 338.1995
#
# -- The following 7 rows give the points at which
# the B-basis value is to be calculated: these
# correspond to 7 temperatures -67,-50,...,75.
1 -67
1 -50
1 -25
1 0
1 25
1 50
1 75

```

A run of RECIPE produces the output:

```

recipe
Filename (without .dat extension) ?
ex4

RECIPE : One-Sided Random-Effect Regression Tolerance Limits
(Version 1.0, April 1995)

*** Simulated pivot critical value file ex4.crt not found.
Satterthwaite approximation will be used.

      Probability      Confidence      Regression      Tolerance Limit
      0.90              0.95          327.537310      286.895095
      0.90              0.95          326.157386      285.580736
      0.90              0.95          324.128085      283.557672
      0.90              0.95          322.098785      281.470595
      0.90              0.95          320.069485      279.335972
      0.90              0.95          318.040184      277.119935
      0.90              0.95          316.010884      274.783636

```

The input and output files have the same form as Problem 7. The important distinction between Problem 7 and Problem 8 is that the basis values in Problem 8 account for between-batch variability, while in Problem 7 the calculated basis values are strictly valid for a specific batch. Note also that the warning message that appeared in Problem 7 does not appear here, since there are data from several batches.

8.3.7.9 Problem 9 - One-way mixed-model ANOVA: basis values with data from multiple sources

The data set for this problem consists of tensile test measurements for several batches each from more than one manufacturer. Calculations for Steps 1 and 2 may be performed by *STAT17* and may be demonstrated using example data set, *example.d09*. Calculations for Step 3 are demonstrated by example data set, *ex5.dat*, and *RECIPE*.

Suppose that one has several batches of data from each of several manufacturers, and that these manufacturers wish to combine their resources to determine basis values. If one is absolutely certain that the manufacturing and testing are identical for all of the data, then one can ignore the fact that the data came from multiple sources. Often, however, there will be slight differences among the manufacturers in the way that the material was fabricated, tested, or both. In such cases, if one is unwilling to assume that the variability between and within batches are close to being the same for all manufacturers, there is no alternative to applying the usual ANOVA method (as in Section 8.3.5.2) separately to each manufacturer's data. However, if one is willing to assume that each set of data exhibits the same variability (with a possible different mean for each manufacturer), then *all* of the batches can be used to deter-

Volume 1, Chapter 8 Statistical Methods

mine a basis value for *each* manufacturer. These basis values will often be substantially higher, and closer together, than if each manufacturer had acted alone.

Problem 9 - Step 1. As in Problem 6, each batch should be examined for outliers. No outliers were identified for these batches.

Problem 9 - Step 2. For this case, it may also be worthwhile to group the data by manufacturer, and evaluate each group for outliers. The outlier detection procedure is demonstrated in Problem 1.

Problem 9 - Step 3. To develop a regression model for this example, let the mean for the i^{th} manufacturer be μ_i . If there are l manufacturers, we have $r=l$ unknown fixed parameters, $\mu_1, \mu_2, \dots, \mu_l$ in addition to the components of variance σ_b^2 and σ_e^2 . Hence, the regression model is of the form

$$\begin{aligned} y_s &= \theta_1 z_{p(s),1} + \theta_2 z_{p(s),2} + \theta_3 z_{p(s),3} + \dots + \theta_l z_{p(s),l} + b_{q(s)} + e_s \\ &= \mu_{p(s)} + b_{q(s)} + e_s \end{aligned}$$

The z 's are taken to be $z_{p(s),u} = \delta_{p(s),u}$, where $\delta_{p(s),u}$ (the Kronecker δ) equals one where $p(s) = u$, and zero otherwise. The fixed parameters are $\theta_i = \mu_i$.

The example data set `ex5.dat`, which corresponds to this problem, contains data on several batches of the same material from each of two manufacturers. For this example, assume that the variability is the same for each manufacturer. The number of fixed levels $l=r=2$.

```
#
# RECIPE Example #5: Basis values using data from multiple sources
# This corresponds to MIL-HDBK-17, Problem #9
#
# -- In this example, we have five batches of data: three from
# one source, and two from a second source. We would like
# to use all five batches of data to get a tolerance limit
# for each source.
#
# -- ntot, nlvl, nbch, npar, npts, prob, conf
#
15 2 5 2 2 .9d0 .95d0
#
# -- The fixed part of this model is a different mean for
# each of the two sources
#
1 0
0 1
#
# -- Here are the 15 data values. Column 1 indicates the
# fixed level (data source), and column 2 indicates the
# number of the batch. The third column gives the strength
# values.
1 1 75.8
1 1 78.4
1 1 82.0
1 2 68.8
1 2 70.9
1 2 73.5
1 3 74.5
1 3 74.8
1 3 78.8
2 4 81.3
2 4 87.7
2 4 89.0
```

Volume 1, Chapter 8 Statistical Methods

```

2 5 88.2
2 5 91.2
2 5 94.2
#
# -- The tolerance limit are to be calculated at two
#    points, which correspond to the two sources. So
#    we just repeat the two lines for the fixed part
#    of the model here.
1 0
0 1

```

From the file `ex5.dat` one can see that there are 15 data values, and that a regression model is being used with $r=2$ parameters. The first column of the 15 rows of `ex5.dat` that contain data indicates the fixed level, the second column for these rows indicates the batches, and the third column gives the strength values. The fixed part of the model has two means, one for each data source. So the rows that give the fixed levels, and the rows that give the points at which basis values are to be evaluated have a '1' in one column and a '2' in the other. Contrast this with Problems 2 and 6 where there is only one fixed level and so the corresponding rows have just one column having a single value, 1.

The RECIPE output for this example is:

```

recipe
  Filename (without .dat extension) ?
ex5

RECIPE : One-Sided Random-Effect Regression Tolerance Limits
(Version 1.0, April 1995)

*** Simulated pivot critical value file ex5crt not found.
    Satterthwaite approximation will be used.

      Probability      Confidence      Regression      Tolerance Limit
        0.90             0.95             75.27778         59.401536
        0.90             0.95             88.600000        71.902179

```

The B-basis values are therefore 59.4 and 71.9 for the two manufacturers. As a simple exercise in using RECIPE, one can show (following Problem 6, using the data from this problem) that if each manufacturer had used only their own data, then the B-basis values would be 52.8 and 34.6, respectively. Note that the mixed model gives basis values which are higher and closer together. In particular, the very low value 34.6 is due to the second manufacturer having data from only two batches.

8.4 STATISTICAL METHODS

8.4.1 Tests for determining equivalency between an existing database and a new dataset for the same material

There are several situations where it is required to determine whether a sample of test data is equivalent to a baseline data set for the same raw material:

- For material batch certification and acceptance, it must be shown that the properties of the batch are "equivalent" to the qualification database; i.e., the batch data meet the material specification acceptance limits.
- A material supplier wishes to modify the production process for the raw material.
- A part manufacturer wants to design using a common database of material properties and basis values that was developed by another organization. Whether they are using the exact same fabrication process as was used for the laminates used to obtain the shared database, or are using a

modified fabrication process, the manufacturer must demonstrate the "equivalency" of its production methods in obtaining the same material properties.

- A part manufacturer who has established a database of material properties, specification values and basis values, and who wants to modify its fabrication process without regenerating the property database.

This section is intended to provide the statistical procedures for determining data "equivalency" in the above types of situations. These procedures are not intended for use in determining the acceptability for use of an alternate ("second source") material; for this situations refer to Section 8.4.2. In the following procedures, a probability level of rejecting a "good" material, α , must be selected. Other sections of this Volume recommend the appropriate value of α for particular situations; for instance, see Section 2.3.7 for requirements to substantiate the use of MIL-HDBK-17 Volume 2 data.

The mechanical and chemical properties of material specimens are subject to random variability. Hence, one must accept the possibility of making an error in declaring a "good" material property to have failed a statistical test. For a fixed number of test specimens in a sample, the probability of this undesirable event occurring (defined as α in the following statistical tests) can only be made small at the expense of decreased likelihood of detecting failures in material when failure should be declared. The selection of the value for the probability of failing a statistical test in error, α , is a compromise between the two types of errors. If the statistical tests are being used with test programs where retests of "failed" properties are allowed, then a slightly higher value for α can be used, as the α after one retest will be effectively α^2 .

The criteria used to determine equivalency between a large database of a given composite material and a subsequent test sample of the same material are selected based on the material properties of interest.

The criterion for modulus or physical properties such as per ply thickness require that the mean value be within an acceptable range; neither a high nor a low mean is desirable. The criterion for these properties is designed to reject either a high or a low mean value. The appropriate statistical method is given below as "Test for Change in Mean".

The criterion for strength properties, on the other hand, must reject either a low mean or a low minimum individual value. The appropriate statistical method for strength properties is given below as "Test for Decrease in Mean or Minimum Individual". This test was developed to have equal probability of rejecting a "good" set of data with either the test on the mean or on the minimum individual property. This balance between the two conditions of the test gives the maximum "statistical power", and is an improvement over the ad-hoc methods used in industry to set material specification acceptance limits.

The criterion for certain chemical and physical properties, such as volatile content or porosity level, must reject a high mean value, as the desired property value is 0. The appropriate statistical method for these properties is given below as "Test for a High Mean".

Test for Decrease in Mean or Minimum Individual – The mean, and standard deviation are approximated by \bar{x} and s , from the individual test condition (environment) of the original material qualification database. The pass/fail thresholds for mean properties, W_{mean} , are determined by equation 8.4.1(a). The k_n^{Mean} values are given in Table 8.5.17. The mean values from experimental tests must meet or exceed

$$W_{\text{mean}} = \bar{x} - k_n^{\text{Mean}} S \quad 8.4.1(a)$$

The pass/fail thresholds for minimum individual properties, $W_{\text{minimum individual}}$, are determined by equation 8.4.1(b). The k_n^{Indv} values are given in Table 8.5.18. The minimum individual values from experimental tests must meet or exceed

$$W_{\text{Minimum Individual}} = \bar{x} - k_n^{\text{Indv}} S \quad 8.4.1(b)$$

Test for Change in Mean - Since the sample sizes of the original database, n_1 , and the new data sample, n_2 , are different, a pooled standard deviation, S_p , is used as an estimator of common population standard deviation.

$$S_p = \sqrt{\frac{(n_1 - 1)s_1^2 + (n_2 - 1)s_2^2}{n_1 + n_2 - 2}} \quad 8.4.1(c)$$

Using the pooled standard deviation and the mean values of the original and new data sets, the test statistic, t_0 , is calculated using:

$$t_0 = \frac{\bar{x}_1 - \bar{x}_2}{S_p \cdot \sqrt{\frac{1}{n_1} + \frac{1}{n_2}}} \quad 8.4.1(d)$$

Since this is a two-sided t-test, the required t value is $t_{a,n} = t_{\alpha/2, n_1 + n_2 - 2}$. Note that $a = \alpha/2$ for the two-sided test. $t_{a,n}$ is obtained from Table 8.5.19.

For a material to pass the this test, the test statistic, t_0 , must satisfy:

$$-t_{\alpha/2, n_1 + n_2 - 2} \leq t_0 \leq t_{\alpha/2, n_1 + n_2 - 2} \quad 8.4.1(e)$$

Test for a High Mean - For this test, the test statistic, t_0 , is obtained using equation 8.4.1(d). This test is designed to detect undesirably high mean values such as in the case of volatile content of prepreg. The mean of the "follow-on" property is said to be less than or equal to the mean of the "original" property if equation 8.4.1(f) is satisfied, an indication of an acceptable material and/or process. This is a one-sided t-test so $t_{a,n} = t_{\alpha, n_1 + n_2 - 2}$. Note that $a = \alpha$ for one-sided test. $t_{a,n}$ is obtained from Table 8.5.19. Thus, for a material to pass this test, the test statistic, t_0 , must satisfy:

$$t_0 \leq t_{\alpha, n_1 + n_2 - 2} \quad 8.4.1(f)$$

Recommended Values for α

For determining batch acceptance limits for material specifications, setting the probability of rejecting a good property (α) to 0.01 (1%) is recommended for all test methods that utilize the test statistics. A minimum of five specimens for strength properties and three specimens for modulus properties is recommended for material batch acceptance testing.

For determining material equivalency (such as the second through fourth situations listed in the introduction to this section), setting the probability of rejecting a good property (α) to 0.05 (5%) is recommended for all test methods that utilize the test statistics. One retest is allowed for each property, reducing the actual probability to 0.0025 (0.25%). A minimum of eight specimens is recommended for strength property comparisons (typically four specimens from two separate panels and processing cycles). A minimum of four specimens is recommended for modulus comparisons (typically two specimens from two separate panels and processing cycles). In the case where one or more properties fail the appropriate criteria, one may choose to retest only those properties that failed the criteria.

8.4.2 Alternate material statistical procedures

Considerable data, including allowables, are often available on the in-house fabrication of a particular material system with raw material obtained from a particular supplier. A change in some aspect of the material system is contemplated, such as a switch to a new supplier. The additional testing which is required is specified in Sections 2.3.4. The present section describes statistical procedures which will help determine when the original and alternative materials differ to an extent that is too large to be plausibly attributed to chance. If the methods of this section indicate a statistically significant difference, and if the magnitude of this difference is meaningful from an engineering standpoint, then the alternative material probably should not be qualified without further testing.

This section assumes that data as required by Section 2.3.4 are available. Because differences in materials are usually observed to be differences in the mean of a property, the methods of this section focus on the comparison of means. It is important to note that, although no formal test for comparing variances is provided, differences in variability which are substantially larger than what is consistent with experience with similar materials should be investigated.

The means for each mechanical property for which data are available for both the original and the alternative material are compared using a two sample t-test which allows for a random batch effect (Section 8.4.2.1). This analysis will result in a set of observed significance levels and confidence intervals. Any of the mean differences which are statistically significant at the five percent level should be investigated.

To get a single number which measures the difference between the materials, let p_i be the OSL for the i th property as determined in Section 8.4.2.1, and let m be the number of properties compared. Calculate the following:

$$P = -2 \sum_{i=1}^m \ln(p_i) \quad 8.4.2$$

The larger P is, the more evidence there is in the data for a difference between the materials. Compare P with the 95th percentile of a chi-square distribution with $2m$ degrees of freedom (Table 8.5.2) in order to determine if the differences in the means is significant at the five percent significance level.

This combined test is strictly valid only when the m sets of data are statistically independent of each other. However, since the tests are on the same material and the same batches, this independence will never exactly hold. In many situations, the tests will be approximately independent and the combined value P will provide a useful measure of the extent to which the two sets of tests differ. If it is apparent from examining the data that some batches are consistently high and others low, i.e. that independence does not hold, then the combined test should be interpreted with caution.

8.4.2.1 Comparing two groups of batches

This section considers the problem of testing whether a statistically significant difference exists between the means of two sets of measurements, where each set consists of several batches. The methods of this section might be applied, for example, to compare the mean room temperature tensile strength of specimens made from three batches at one site to another set of measurements on the same mechanical property consisting of five batches manufactured at another site.

The two sets of data are represented by x_{ij} and y_{ij} where the first subscript indicates the batch and the second subscript denotes the values within each batch. We assume here that both the x and y sets of data are sampled from one-way, balanced, random effects models (see Section 8.3.5.2):

$$x_{ij} = \mu^{(1)} + b_i^{(1)} + e_{ij(1)} \quad 8.4.2.1(a)$$

Volume 1, Chapter 8 Statistical Methods

where $i = 1, \dots, k_1$ and $j = 1, \dots, n_1$ and

$$y_{ij} = \mu^{(2)} + b_1^{(2)} + e_{ij(2)} \quad 8.4.2.1(b)$$

where $i = 1, \dots, k_2$ and $j = 1, \dots, n_2$. The number of batches and batch size are k_1 and n_1 for the x's and k_2 and n_2 for the y's.

The ANOVA model represents each observation as the sum of three components; $\mu^{(\ell)}$ is the overall mean, $\mu^{(\ell)} + b_1^{(\ell)}$ is the population average for the i th batch, and $e_{ij(\ell)}$ represents the variation within each batch, where ℓ equals one for the x data and two for the y data. The error terms $e_{ij(\ell)}$ are assumed to be independently distributed normal random variables with mean zero and variance σ_e^2 (the within batch variance).

The batch means $b_1^{(\ell)}$ are assumed to be independent random variables following a normal distribution with zero and a variance of σ_b^2 (the between batch variance). The within-batch variance is assumed to be the same for all batches.

Denote the batch averages for the x's by \bar{x}_i , for $i = 1, \dots, k_1$, and the batch averages for the y's by \bar{y}_i , for $i = 1, \dots, k_2$. the test statistic uses the following four quantities:

$$\bar{x} = \frac{1}{k_1} \sum_{i=1}^{k_1} \bar{x}_i \quad 8.4.2.1(c)$$

$$\bar{y} = \frac{1}{k_2} \sum_{i=1}^{k_2} \bar{y}_i \quad 8.4.2.1(d)$$

$$s_x^2 = \frac{n_1}{k_1 - 1} \sum_{i=1}^{k_1} (\bar{x} - \bar{x}_i)^2 \quad 8.4.2.1(e)$$

$$s_y^2 = \frac{n_2}{k_2 - 1} \sum_{i=1}^{k_2} (\bar{y} - \bar{y}_i)^2 \quad 8.4.2.1(f)$$

If $k_1 = 1$, then let $s_x^2 = 0$; if $k_2 = 1$, let $s_y^2 = 0$; if $k_1 = k_2 = 1$, then the method of this subsection should not be used. In terms of the statistics in Equations 8.4.2.1(c) - (f), the test statistic is

$$T = \frac{|\bar{x} - \bar{y}|}{\left(\frac{s_x^2}{k_1 n_1} + \frac{s_y^2}{k_2 n_2} \right)^{0.5}} \quad 8.4.2.1(g)$$

To test the hypothesis that $\mu^{(1)} = \mu^{(2)}$ at the α significance level, compare T with $t_{1-\alpha/2, \gamma}$, the $100(1 - \alpha/2)$ quantile of a central t random variable with $\gamma = k_1 + k_2 - 2$ degrees of freedom (Table 8.5.3). If T does not exceed this t quantile, then conclude that the data are consistent with the hypothesis that the population means are equal, otherwise conclude that there is a statistically significant difference in the population means (at the α level of significance).

A $100(1 - \alpha)$ confidence interval is

$$|\bar{x} - \bar{y}| \pm t_{1-\alpha/2, \gamma} \left(\frac{s_x^2}{k_1 n_1} + \frac{s_y^2}{k_2 n_2} \right)^{0.5} \tag{8.4.2.1(h)}$$

The observed significance level, or OSL, is the probability of observing a value of T as large or larger than the T actually observed if indeed the hypothesis of equal means is true. An OSL which is less than the significance level α indicates that the null hypothesis can be rejected at the α level of significance. The OSL is a function of T and $\gamma = k_1 + k_2 - 2$. For γ greater than ten, the following approximation is usually adequate. Calculate

$$u = \frac{T(1 - \frac{1}{4\gamma})}{\left(1 + \frac{T^2}{2\gamma}\right)} \tag{8.4.2.1(i)}$$

Determine the probability P that a standard normal random variable is less than u. This probability can be determined from a table of the normal distribution, such as Table 8.5.5. The OSL is equal to $2(1 - P)$. If γ is less than 10, then the above approximation is not sufficiently accurate and the OSL should be obtained from Table 8.5.4.

For example, consider the strength measurements in Table 8.4.2.1. The specimens tested to give these data were taken from a group of three consecutive batches and a group of five consecutive batches. The second group of batches was produced more than a year after the first group. Because of this time difference, one should not consider these data to be eight random batches from a single population without justification. A more prudent approach is to regard these test results as a random sample of three batches from one population and a random sample of five batches from a possible different population.

TABLE 8.4.2.1 Strength measurements from two groups of consecutive batches.

Set 1			Set 2		
Mean	Variance	n	Mean	Variance	n
402.2	138.7	5	408.4	40.8	5
387.8	1002.2	5	395.8	113.2	5
389.4	321.8	5	357.2	451.7	5
			376.2	119.7	5
			377.0	189.5	5

For the data in Table 8.4.2.1, Equations 8.4.2.1(c) - (g) give the following:

$$\bar{x} = 393 \tag{8.4.2.1(j)}$$

$$\bar{y} = 383 \tag{8.4.2.1(k)}$$

$$s_x^2 = 311 \tag{8.4.2.1(l)}$$

$$s_y^2 = 1946 \tag{8.4.2.1(m)}$$

$$T = \frac{|393 - 383|}{\left(\frac{311}{(3)(5)} + \frac{1946}{(5)(5)} \right)^{0.5}} = 1.007 \tag{8.4.2.1(n)}$$

Volume 1, Chapter 8 Statistical Methods

From Table 8.5.3, the 97.5 percentile of the t distribution with $5 + 3 - 2 = 6$ degrees of freedom is $t_{0.975,6} = 2.45$. Since 1.007 is less than 2.45, one concludes that there is no statistically significant difference in the mean strength for the two sets of data at the five percent significance level. Because $k_1 + k_2 - 2 = 6$ is less than ten, use Table 8.5.4 to obtain an OSL of 0.0.36. A 95 percent confidence interval for the difference in the means is given by

$$|393 - 383| \pm (2.45) \left(\frac{311}{(3)(5)} + \frac{1946}{(5)(5)} \right)^{0.5} \quad 8.4.2.1(o)$$

$$10 \pm 24.3$$

Note that the confidence interval must contain zero for this example since the difference in the means is not significant at the 95 percent level.

8.4.3 Confidence intervals for the coefficient of variation

The coefficient of variation is the ratio of the population standard deviation to the population mean. This section provides a method for calculating confidence intervals for a coefficient of variation, assuming that the underlying distribution is normal. The coefficient of variation of the population is estimated by the sample coefficient of variation

$$c = \frac{s}{\bar{x}} \quad 8.4.3(a)$$

where s is the sample standard deviation and \bar{x} is the sample mean.

An approximate $100\gamma\%$ confidence interval for the coefficient of variation has lower limit

$$c_l = c \left[\left(\frac{u_1 + 2}{n} - 1 \right) c^2 + \frac{u_1}{n+1} \right]^{-\frac{1}{2}} \quad 8.4.3(b)$$

and upper limit

$$c_h = c \left[\left(\frac{u_2 + 2}{n} - 1 \right) c^2 + \frac{u_2}{n+1} \right]^{-\frac{1}{2}} \quad 8.4.3(c)$$

where u_1 and u_2 are $100(1+\gamma)/2$ and $100(1-\gamma)/2$ percentiles of the χ^2 distribution with $n-1$ degrees of freedom. Values of u_1 and u_2 are tabulated in Table 8.5.16 for γ equal to 0.9, 0.95, and 0.99.

8.4.3.1 Example of CV confidence interval calculation

A sample of five specimens has sample mean $\bar{x} = 103.8$, sample standard deviation $s = 4.161$, and sample coefficient of variation

$$c = \frac{4.161}{103.8} = 0.0400 \quad 8.4.3.1$$

The constants u_1 and u_2 are, from Table 8.5.16, found to be $u_1 = 5(2.2287) = 11.1435$ and $u_2 = 5(0.0968883) = 0.48444$. By substituting in Equations 8.4.3(a) and (b), an interval, which contains the population coefficient of variation, with 95% confidence, is determined to have lower limit $c_l = 0.0240$ and upper limit, $c_h = 0.115$.

8.4.3.2 Comment on the approximation

This approximate method is adequate for situations where the population coefficient of variation is less than 35%. It is usually extremely accurate, and it is exact in the limit of large samples and also in the limit of small population coefficient of variation. For details of the derivation and properties of this approximation, see Reference 8.4.3.2. For measurements made on populations with coefficients of variation substantially larger than this, an exact (but somewhat complicated) method is available. However, if one is willing to consider the possibility of a population C.V. much larger than 35%, then in order for the normal model to make sense, one must also accept the possibility of negative values. Hence, if a quantity is necessarily positive, then a very large C.V. implies that the normal model does not make physical sense. Consequently for those cases where this approximation fails, one would usually not want to assume a normal model anyway, so one would seldom, if ever, need the complicated exact procedure.

8.4.4 Statistical procedures for process control

8.4.4.1 \bar{x} bar chart including batch effect

Assume that the data are a sample from a one-way, balanced random effects analysis of variance model (see Section 8.3.5.2):

$$x_{ij} = \mu + b_i + e_{ij}, \quad i=1,\dots,k \quad j=1,\dots,k \quad 8.4.4.1(a)$$

where k is the number of accepted batches, n is the number of specimens in each batch, and x_{ij} represents the j th specimen in the i th batch.

This ANOVA model represents each observation as the sum of three components; μ is the overall average of the population, b_i is the population average for the i th batch, and e_{ij} is a random error term which represents variation within each batch. The error terms, e_{ij} , are assumed to be independently distributed normal random variables with a mean of zero and a variance of σ_e^2 (the within-batch variance). The batch means, b_i , are assumed to be independent random variables following a normal distribution with a mean of zero and a variance of σ_b^2 (the between-batch variance).

The acceptability of a new batch is to be tested using the data in the k previously accepted batches. This new batch is referred to as the $(k+1)$ th batch. Denote the grand mean on the basis of k batches as

$$\bar{x}^{(k)} = \frac{\sum_{i=1}^k \sum_{j=1}^n x_{ij}}{(kn)} \quad 8.4.4.1(b)$$

The batch means are computed as

$$\bar{x}_i = \sum_{j=1}^n x_{ij} / n \quad \text{for } i = 1, \dots, k \quad 8.4.4.1(c)$$

In this section, a superscript in parentheses indicates the number of batches of data used to calculate a statistic. For example, $\bar{x}^{(k)}$ is the grand mean based on all batches up to and including the k th batch. From these quantities, the required sums of squares can be computed. The between-batch mean square is computed as

$$MSB^{(k)} = \frac{1}{k-1} \sum_{i=1}^k n(\bar{x}_i - \bar{x}^{(k)})^2 \quad 8.4.4.1(d)$$

Assume that the $(k+1)^{\text{th}}$ batch is also described by the model in Equation 8.4.4.1(a). The mean of the $(k+1)^{\text{th}}$ batch has a normal distribution with mean μ and a variance of

$$\frac{1}{n}(n\sigma_b^2 + \sigma_e^2)$$

It follows that the difference between the grand mean and the $(k+1)^{\text{th}}$ mean,

$$\bar{x}^{(k)} - \bar{x}_{k+1}$$

has a normal distribution with a mean of zero and a variance of

$$\frac{k+1}{k} \frac{(n\sigma_b^2 + \sigma_e^2)}{n}$$

Also,

$$\frac{k+1}{kn} \text{MSB}^{(k)} \sim \frac{k+1}{k(k-1)} \frac{(n\sigma_b^2 + \sigma_e^2)}{n} \chi_{k-1}^2 \tag{8.4.4.1(e)}$$

where the \sim indicates "is distributed as" and χ_{k-1}^2 denotes the χ^2 distribution with $k-1$ degrees of freedom. Dividing the difference between the grand mean and the $(k+1)^{\text{th}}$ batch mean by the left hand side of Equation 8.4.4.1(e) gives

$$V^{(k+1)} = \frac{\bar{x}^{(k)} - \bar{x}_{k+1}}{\left[\frac{k+1}{k(k-1)} \sum_{i=1}^k (\bar{x}_i - \bar{x}^{(k)})^2 \right]^{1/2}} \sim t_{k-1} \tag{8.4.4.1(f)}$$

where t_{k-1} denotes the central t-distribution with $k-1$ degrees of freedom. This last relationship is the basis of the control chart. $V^{(k+1)}$, calculated from the new mean and all previously accepted batch means, is compared to the t-distribution limits. Specifically, $V^{(k+1)}$ is compared to the a quantile of the central t-distribution with $k-1$ degrees of freedom, $t_{k-1,\alpha}$, from Table 8.5.3. If the absolute value of $V^{(k+1)}$ exceeds $t_{k-1,\alpha}$, the $(k+1)^{\text{th}}$ batch is not accepted. These limits approach the normal distribution limits as the number of batches increases. Because of the variable control limits, it should be possible to start using this chart after very few batches. It may be reasonable to use it after data from four or five batches have been obtained.

If the $(k+1)^{\text{th}}$ batch is accepted, the grand mean and the between-batch mean square are updated as follows:

$$\bar{x}^{(k+1)} = \frac{k\bar{x}^{(k)} - \bar{x}_{k+1}}{k+1} \tag{8.4.4.1(g)}$$

$$\text{MSB}^{(k+1)} = \frac{k-1}{k} \text{MSB}^{(k)} + \frac{n}{k+1} (\bar{x}^{(k)} - \bar{x}_{k+1})^2 \tag{8.4.4.1(h)}$$

Finally, note that this procedure can fail if there is a trend in the means. Such a trend would inflate the estimate of the variance and result in limits which are too wide. Because of this, the above procedure is used with a "runs" test for trends. Example charts are shown in Figure 8.4.4.1(a) and (b). These figures show the limits, $t_{k-1,\alpha}$ and $-t_{k-1,\alpha}$, and $V^{(k+1)}$ for each successive batch.

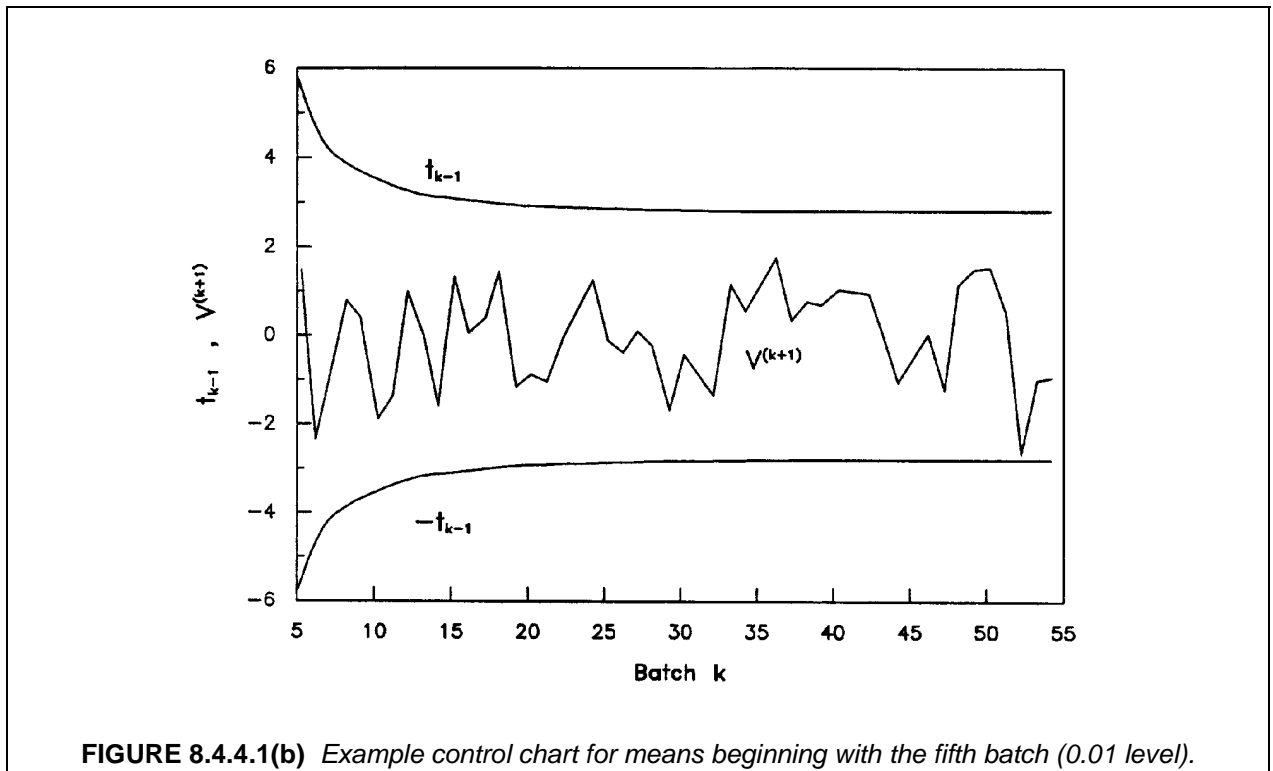
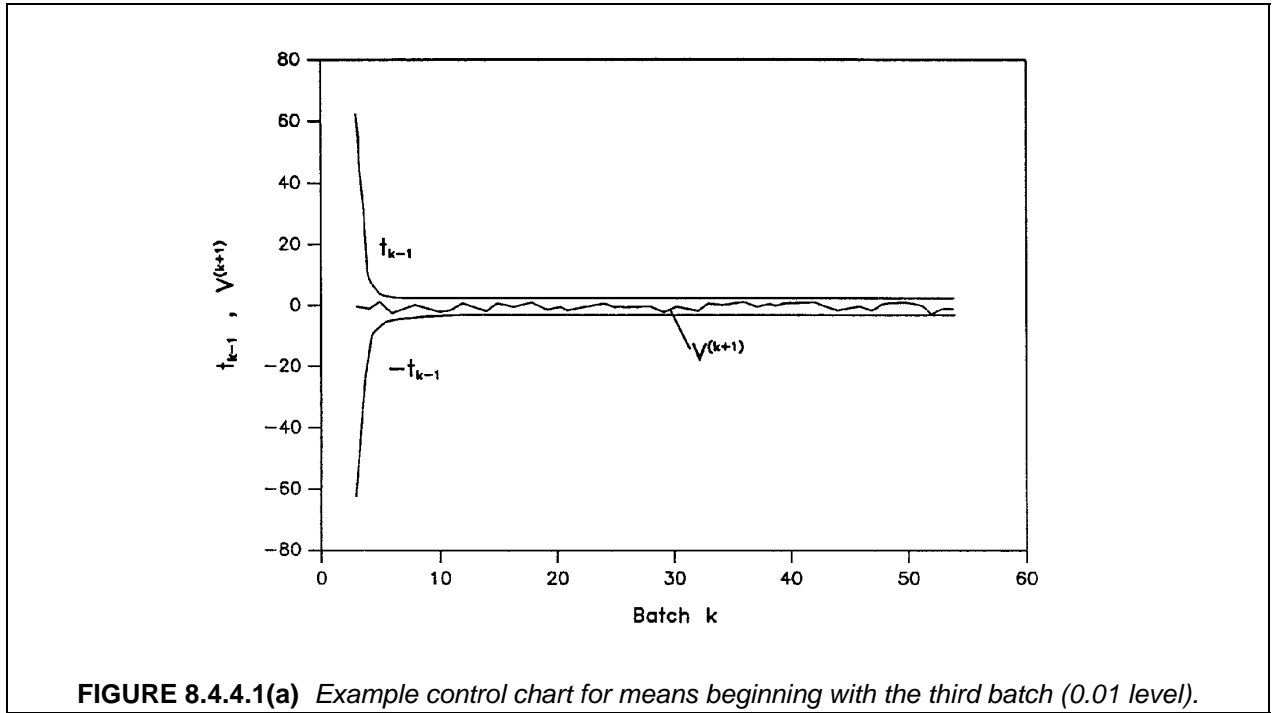

8.4.4.2 s^2 chart for the within-batch component of variance

Let s^2 be the sample variance of the j th accepted batch. Test the $(k+1)$ th batch variance using the following statistic:

$$U_{k+1} = \frac{s_{k+1}^2}{\sum_{j=1}^k s_j^2 / k} \sim F \tag{8.4.4.2}$$

where F denotes the standard F -distribution with $n - 1$ numerator degrees of freedom and $k(n - 1)$ denominator degrees of freedom. Compare U_{k+1} to the α quantile of the F -distribution for $n - 1$ numerator degrees of freedom and $k(n - 1)$ denominator degrees of freedom, F_α . These values are provided in Table 8.5.1 for the 0.95 level. If the statistic U_{k+1} exceeds F_α , the $(k+1)$ th batch is not accepted. The control limits will approach constants as the denominator degrees of freedom for the F statistic become large. As with the means chart, this variance chart should be useful after data have been obtained from a few batches. An example S^2 chart is shown in Figure 8.4.4.2. This figure shows the limit, F_α , and U for each successive batch.

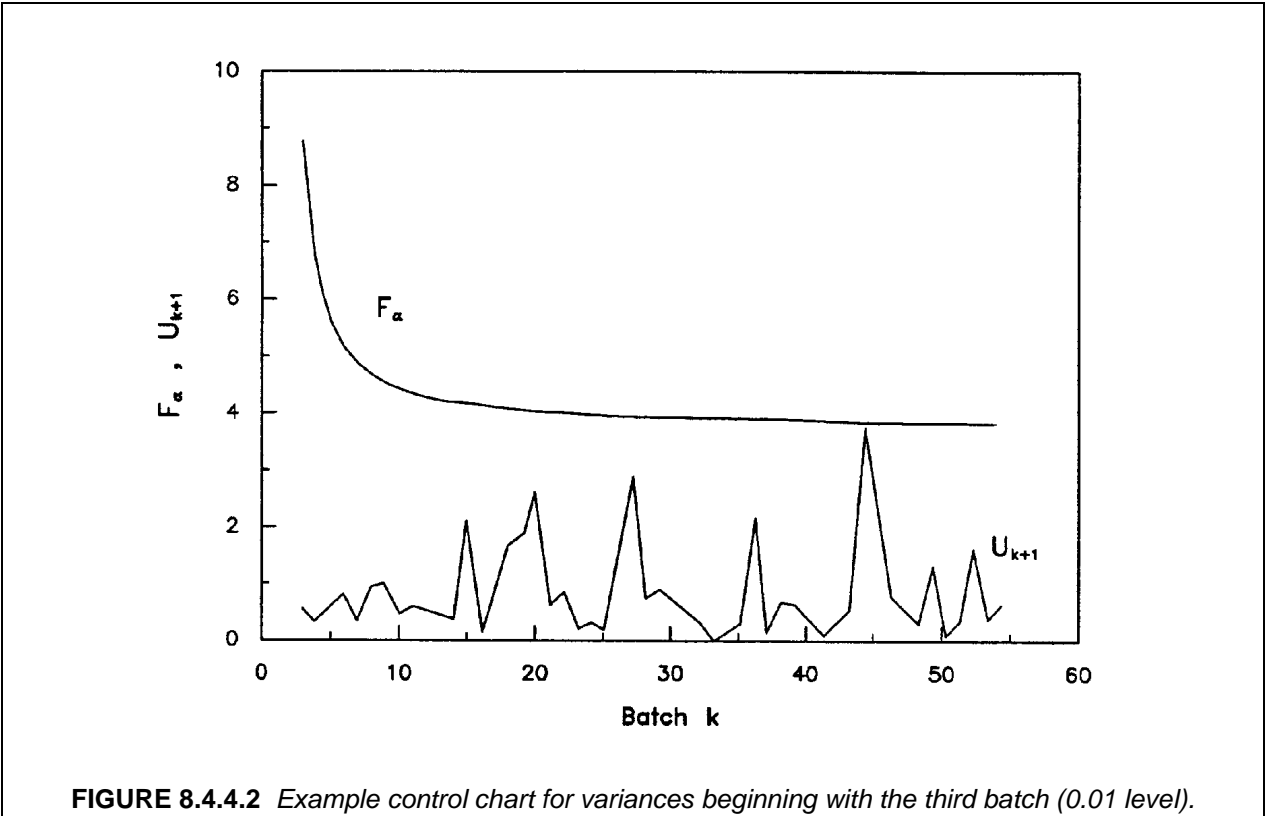

FIGURE 8.4.4.2 Example control chart for variances beginning with the third batch (0.01 level).

8.4.4.3 Test for trend in batch means

The \bar{x} chart including batch effect of Section 8.4.4.1 may not perform properly if there is a systematic trend, either upward or downward, in the batch means for the initial batches received. Such a trend would make $\bar{v}^{(k+1)}$ (Equation 8.4.4.1(f)) too small by inflating the denominator. This could result in batches being accepted which would have been rejected had there been no trend. If a trend is detected in the batch means before the control limits have leveled off (e.g., before the 25th batch; see Figure

Volume 1, Chapter 8 Statistical Methods

8.4.4.1(b)) then caution should be used when accepting batches, especially if the trend can be seen to be downward. A diagnostic test is given in this subsection which should be performed on the first 25 batches received in order to determine whether a statistically significant trend exists. After 25 batches, this diagnostic should be discontinued, since the control limits will no longer be substantially effected by any trend which might be present, so the validity of the test in Section 8.4.4.1 need no longer be questioned. The idea behind this test is to fit a straight line through the batch means by least squares, and to determine if this line has a statistically significant slope.

Let the mean for the i th accepted batch be denoted \bar{x}_i , and let t_i be a time associated with the arrival of this batch. For example, the time of arrival of the first batch may be represented by $t_1 = 0$, and the remaining t_i may be the number of days which have elapsed since the first batch arrived. Assume that k batches have been accepted thus far, and that the following quantities have been calculated and therefore are available:

$$\bar{\bar{x}}^{(k)} = \sum_{i=1}^k \bar{x}_i / k \quad 8.4.4.3(a)$$

$$\bar{t}^{(k)} = \sum_{i=1}^k t_i / k \quad 8.4.4.3(b)$$

$$S_{tt}^{(k)} = \sum_{i=1}^k (t_i - \bar{t}^{(k)})^2 \quad 8.4.4.3(c)$$

$$S_{xx}^{(k)} = \sum_{i=1}^k (\bar{x}_i - \bar{\bar{x}}^{(k)})^2 \quad 8.4.4.3(d)$$

$$S_{tx}^{(k)} = \sum_{i=1}^k (t_i - \bar{t}^{(k)})(\bar{x}_i - \bar{\bar{x}}^{(k)}) \quad 8.4.4.3(e)$$

$$b^{(k)} = \frac{S_{tx}^{(k)}}{S_{tt}^{(k)}} \quad 8.4.4.3(f)$$

$$S_R^{(k)} = S_{xx}^{(k)} - 2b^{(k)}S_{tx}^{(k)} + [b^{(k)}]^2 S_{tt}^{(k)} \quad 8.4.4.3(g)$$

The slope of the least squares line based on k batches is $b^{(k)}$, and the standard deviation about the least squares line is

$$SD^{(k)} = [S_R^{(k)} / (k-2)]^{1/2} \quad 8.4.4.3(h)$$

When the $(k+1)$ st batch arrives, at time t_{k+1} , the following steps should be performed.

Step 1 Update $S_{tt}^{(k)}$, $S_{tx}^{(k)}$, and $S_{xx}^{(k)}$.

$$S_{tt}^{(k+1)} = S_{tt}^{(k)} + \frac{k}{k+1} (\bar{t}^{(k)} - t_{k+1})^2 \quad 8.4.4.3(i)$$

$$S_{xx}^{(k+1)} = S_{xx}^{(k)} + \frac{k}{k+1} (\bar{\bar{x}}^{(k)} - \bar{x}_{k+1})^2 \quad 8.4.4.3(j)$$

$$S_{tx}^{(k+1)} = S_{tx}^{(k)} + \frac{k}{k+1} (\bar{t}^{(k)} - t_{k+1}) \bar{x}_{k+1} \quad 8.4.4.3(k)$$

Step 2 Calculate $b^{(k+1)}$ and $S_R^{(k+1)}$.

$$b^{(k+1)} = \frac{S_{tx}^{(k+1)}}{S_{tt}^{(k+1)}} \quad 8.4.4.3(l)$$

$$S_R^{(k+1)} = S_{xx}^{(k+1)} - 2b^{(k+1)} S_{tx}^{(k+1)} + b^{(k+1)^2} S_{tt}^{(k+1)} \quad 8.4.4.3(m)$$

Step 3 Calculate the trend statistic.

$$U^{(k+1)} = b^{(k+1)} \sqrt{\frac{(k-1)S_{tt}^{(k+1)}}{S_R^{(k+1)}}} \quad 8.4.4.3(n)$$

Step 4 Determine $t_{k-1, \alpha/2}$, the α quantile of the central t distribution with k-1 degrees of freedom (Table 8.5.3). If $|U^{(k+1)}|$ is greater than $t_{k-1, \alpha/2}$, then a statistically significant trend has been detected and should be investigated.

The level α of the test is somewhat arbitrary, but probably should be taken to be small (e.g., 0.001) in order to make small the probability of making an error by declaring a trend when no trend exists.

Step 5 Update the means.

$$\bar{x}^{(k+1)} = \frac{k\bar{x}^{(k)} + \bar{x}_{k+1}}{k+1} \quad 8.4.4.3(o)$$

$$\bar{t}^{(k+1)} = \frac{k\bar{t}^{(k)} + t_{(k+1)}}{k+1} \quad 8.4.4.3(p)$$

The following remarks should be made concerning this test:

- 1) The test should not be performed once the control limits in the \bar{x} chart including batch effect (Section 8.4.4.1) have leveled off. This should occur at or before 25 batches have been accepted.
- 2) This trend test is only designed to detect situations where the validity of the test in Section 8.4.4.1 is called into question. It is not suitable as a general purpose trend test.
- 3) The updating Equations 8.4.4.3(i - k) and 8.4.4.3(o - p) make it unnecessary to use Equations 8.4.4.3(a - e) after each batch. Calculating quantities for a test on the $(k+1)^{\text{th}}$ batch based on the results from the test on the kth batch requires only a hand calculator.
- 4) A control chart analogous to Figure 8.4.4.1 may be prepared for the trend test as well, and it could provide useful information.

8.4.5 Average stress-strain curves and bearing load-deformation curves

It is highly desirable to have average stress-strain curves for tension, compression, and in-plane shear loading and to have average bearing load-deformation curves. However, the equations suggested below to represent the average curves are continuous and cannot represent discontinuities that may be caused by initiation of damage. Thus, it is also desirable to have graphs of actual data sets that are representative of individual tests.

Average curves will be determined using a best fit procedure with a minimum of two data sets from each batch. The best fit of each data set will be obtained to each of the seven algebraic functions below using the procedure described in References 8.4.5(a) and (b).

Volume 1, Chapter 8 Statistical Methods

- 1) linear
- 2) parabolic
- 3) inverse parabolic
- 4) Ramberg-Osgood exponential
- 5) bilinear
- 6) parabolic-linear
- 7) parabolic-exponential

The equations for each function are given in the Section 8.4.5.1. The average error of fit is determined by the product of the root mean square (RMS) stress (load) error and the RMS percent stress (load) error. By using the product of these two values, sensitivity to errors for high stress (load) values and for the initial portion of the data set is provided. The function with the smallest average error of fit is chosen for each data set.

An average curve for all the data sets is determined up to the minimum strength of all data sets using the best-fit functions with smallest average error and the following procedure. At increments of one hundredth of the minimum strength, the average strain (deformation) for each best-fit function is determined. These average strains (deformations) and stresses (loads) are again fit to the seven algebraic functions to obtain an average curve. The function with the smallest average error of fit and the constants for this function will be reported with the average curve in Volume 2.

All of the strengths and strain- and deformation-to-failure values, not just those used in determining the average curve will be included as a scatter plot at the top of the average curve. Example stress-strain curves which include the scatter plot are shown in Figures 8.4.5(a) and (b).

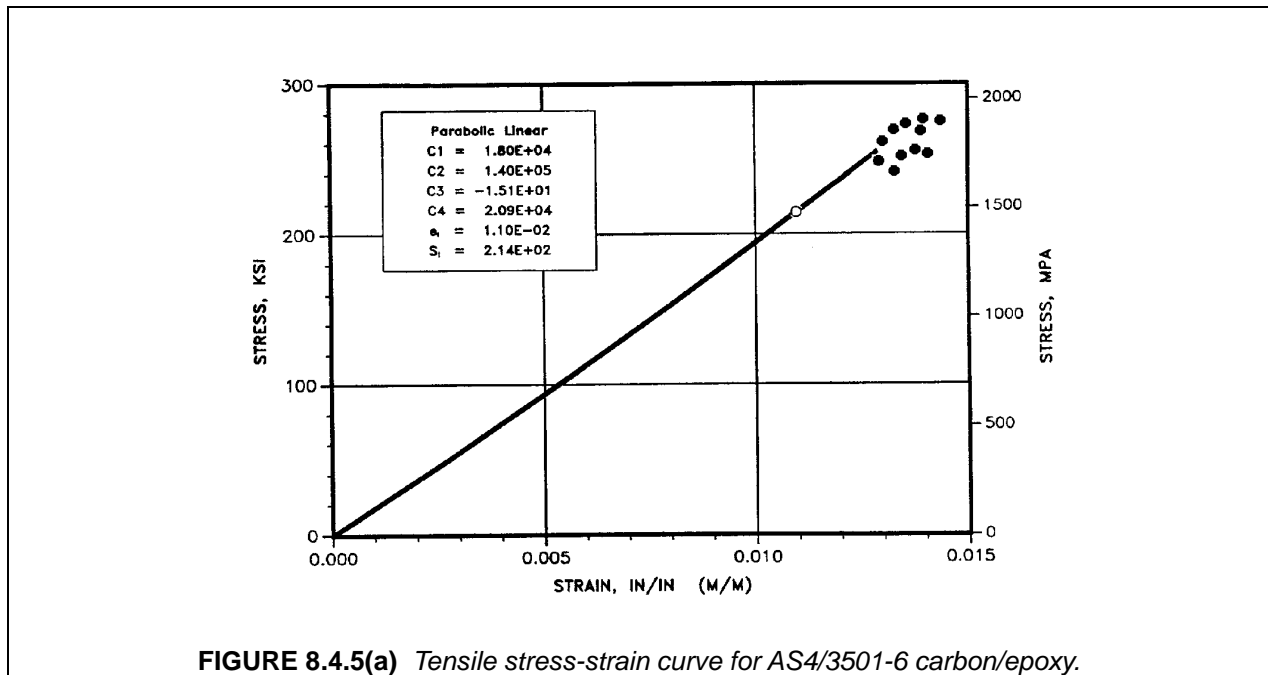

FIGURE 8.4.5(a) Tensile stress-strain curve for AS4/3501-6 carbon/epoxy.

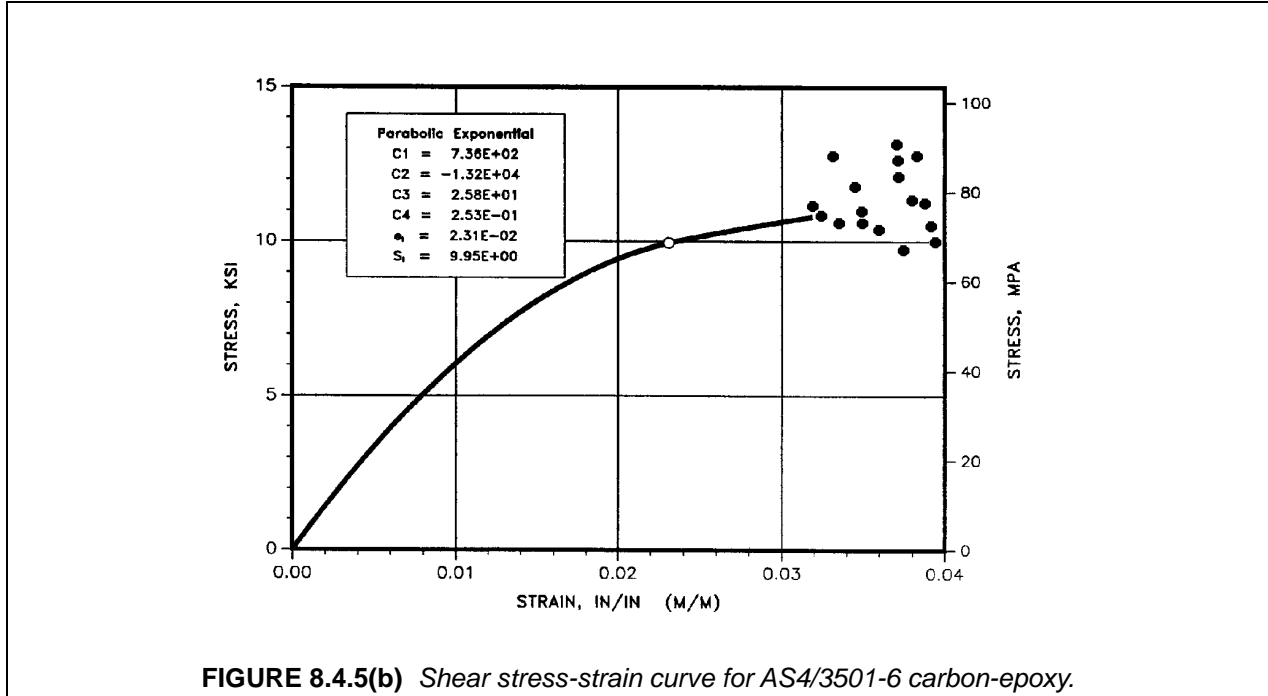

FIGURE 8.4.5(b) Shear stress-strain curve for AS4/3501-6 carbon-epoxy.

8.4.5.1 Fitting equations

The fitting equations for the stress-strain curves based on References 8.4.5(a) and (b) are presented below. Also included with each type of curve are the equations for the secant modulus and tangent modulus curves. These curves will be presented in MIL-HDBK-17 as discussed in Section 8.4.4. Each of the functions are based on the terms stress (s) and strain (e). The secant modulus functions are calculated as the secant modulus between the current value of strain and zero strain.

$$E_s = \frac{s(e) - s(0)}{e - 0} = \frac{s(e)}{e} \tag{8.4.5.1(a)}$$

The equation for the tangent modulus at any value of strain is:

$$E_t = \frac{ds}{de} \tag{8.4.5.1(b)}$$

Linear:

$$s = C_1 e \tag{8.4.5.1(c)}$$

$$E_t = E_s = C_1 \tag{8.4.5.1(d)}$$

Parabolic:

$$s = C_1 e + C_2 e^2 \tag{8.4.5.1(e)}$$

$$E_t = C_1 + 2 C_2 e \tag{8.4.5.1(f)}$$

$$E_s = C_1 + C_2 e \tag{8.4.5.1(g)}$$

Inverse Parabolic:

$$e = C_2 s + C_3 s^2 \tag{8.4.5.1(h)}$$

$$E_t = \pm(C_2^2 + 4 C_3 e)^{-1/2} \tag{8.4.5.1(i)}$$

$$E_s = \frac{C_2 \pm (C_2^2 + 4C_3e)^{1/2}}{2C_3e} \quad 8.4.5.1(j)$$

The \pm symbol has the same sign as the constant C_3 .

Ramberg-Osgood Exponential:

$$e = \frac{s}{C_2} + 0.002 \left[\frac{s}{C_1} \right]^n, \quad n = C_3 \quad 8.4.5.1(k)$$

Both secant modulus and tangent modulus values for the Ramberg-Osgood exponential function are found numerically.

The remaining functions have two fitted portions of the curves. The intersection of these two portions (e_i, s_i) is found as part of the fitting procedure.

Bilinear:

Below (e_i, s_i)

$$s = C_1 e \quad 8.4.5.1(c)$$

$$E_t = E_s = C_1 \quad 8.4.5.1(d)$$

Above (e_i, s_i)

$$s = C_2 + C_3 e \quad 8.4.5.1(l)$$

$$E_t = C_3 \quad 8.4.5.1(m)$$

$$E_s = \frac{C_2}{e} + C_3 \quad 8.4.5.1(n)$$

Parabolic - Linear:

Below (e_i, s_i)

$$s = C_1 e + C_2 e^2 \quad 8.4.5.1(e)$$

$$E_t = C_1 + 2C_2 e \quad 8.4.5.1(f)$$

$$E_s = C_1 + C_2 e \quad 8.4.5.1(g)$$

Above (e_i, s_i)

$$s = C_3 + C_4 e \quad 8.4.5.1(o)$$

$$E_t = C_4 \quad 8.4.5.1(p)$$

$$E_s = \frac{C_3}{e} + C_4 \quad 8.4.5.1(q)$$

Parabolic - Exponential:

Below (e_i, s_i)

$$s = C_1 + C_2 e^2 \quad 8.4.5.1(e)$$

$$E_t = C_1 + 2C_2 e \quad 8.4.5.1(f)$$

$$E_s = C_1 + C_2 e \quad 8.4.5.1(g)$$

Above (e_i, s_i)

$$s = C_3 e^n, \quad n = C_4 \quad 8.4.5.1(r)$$

$$E_t = nC_3 e^{n-1} \quad 8.4.5.1(s)$$

$$e_s = C_3 e^{n-1} \quad 8.4.5.1(t)$$

In all cases, the type of curve and the values of the constants will be shown on the typical stress-strain curve figures. When there are two regions in a stress-strain curve, the value of the strain and stress and the intersection of the two regions is also shown on the figure.

8.5 STATISTICAL TABLES AND APPROXIMATIONS

This section contains a number of tables which are required for the analyses described in Section 8.3. Tables 8.5.1, 8.5.4 through 8.5.6, and 8.5.14 were generated specifically for MIL HDBK-17. The remaining tables were adapted from MIL-HDBK-5 (see Reference 8.3.4.5.1).

For some of the tabulated values, theoretical derivations and numerical approximations are provided below. The approximations are useful in computer applications when the software required to generate the tabulated values is not available. The accuracy of the approximations is measured by the relative magnitude of error (RME). The RME is defined as

$$\text{RME} = \frac{|\text{approximate value} - \text{actual value}|}{\text{actual value}} \quad 8.5$$

and measures the percentage error in the approximate value with respect to the actual value.

8.5.1 Quantiles of the F-distribution

An approximation to the $F_{0.95}$ values in Table 8.5.1 is

$$F_{0.95} = \exp \left(2\delta \left[1 + \frac{z^2 - 1}{3} - \frac{4\sigma^2}{3} \right] + 2\sigma z \sqrt{1 + \frac{\sigma^2(z^2 - 3)}{6}} \right) \quad 8.5.1(a)$$

where

$$\delta = 0.5 \{ 1/(\gamma_2 - 1) - 1/(\gamma_1 - 1) \} \quad 8.5.1(b)$$

$$\sigma^2 = 0.5 \{ 1/(\gamma_2 - 1) + 1/(\gamma_1 - 1) \} \quad 8.5.1(c)$$

$$z = 1.645$$

γ_1 = numerator degrees of freedom

γ_2 = denominator degrees of freedom.

Equations 8.5.1(a-c) are not valid when either γ_1 or γ_2 equals one. The following equations are to be used for these special cases:

For $\gamma_1 = 1$

$$F_{0.95} = \left[1.95996400 + \frac{2.37227200}{\gamma_2} + \frac{2.82250000}{\gamma_2^2} + \frac{2.555585200}{\gamma_2^3} + \frac{1.58953600}{\gamma_2^4} \right]^2 \quad 8.5.1(e)$$

For $\gamma_2 = 1$

$$F_{0.95} = \left[0.06270671 + \frac{0.01573832}{\gamma_1} + \frac{0.00200073}{\gamma_1^2} - \frac{0.00243852}{\gamma_1^3} - \frac{0.00064811}{\gamma_1^4} \right]^{-2} \quad 8.5.1(f)$$

8.5.2 Quantiles of the χ^2 distribution

An approximation to the chi-squared quantiles ($\chi_{0.95}^2$) in Table 8.5.2 is:

$$\chi_{0.95}^2 = \gamma \left[1 - \frac{2}{9\gamma} + 1.645 \left(\frac{2}{9\gamma} \right)^{\frac{1}{2}} \right]^3 + \frac{9}{100\gamma} \quad 8.5.2$$

where γ is the degrees of freedom. This approximation is accurate to within 0.2% of the tabulated values. (See Reference 8.5.2.)

8.5.3 Upper-tail quantiles for the t-distribution

Table 8.5.3 was generated specifically for MIL-HDBK-17.

8.5.4 Two-tail probabilities for the t-distribution

Table 8.5.4 was generated specifically for MIL-HDBK-17.

8.5.5 Upper-tail probabilities for the standard normal distribution

Table 8.5.5 was generated specifically for MIL-HDBK-17.

8.5.6 Critical values for the k-sample Anderson-Darling test at the $\alpha = 0.05$ significance level

The k-sample Anderson-Darling test critical values in Table 8.5.6 were calculated using Equation 8.3.2.2(j) for the case of samples of equal size n.

8.5.7 Critical values for the MNR outlier test

The critical values in Table 8.5.7 are computed by the following formula:

$$V_c = \frac{n-1}{\sqrt{n}} \sqrt{\frac{t^2}{n-2+t^2}} \quad 8.5.7$$

where t is the $[1 - \gamma/(2n)]$ quantile of the t-distribution with n - 2 degrees of freedom, γ is the significance level of the test, and n is the sample size. Numbers in Table 8.5.7 are computed with a significance level of $\gamma = 0.05$. (See Reference 8.3.3.1(b).)

8.5.8 One-sided B-basis tolerance factors, V_B , for the Weibull distribution

The V values in Table 8.5.8 are calculated using the following statistical results. First, define the random variables

$$A_i = \frac{\ln(x_i) - \ln(\hat{\alpha})}{1/\hat{\beta}} \quad i = 1, \dots, n \quad 8.5.8(a)$$

where x_i is a Weibull random variable with unknown shape and scale parameters β and α and $\hat{\alpha}$ and $\hat{\beta}$ are the maximum likelihood estimators (MLE's) of β and α given by Equations 8.3.4.2.1(a) and 8.3.4.2.1(c). For a particular n , the V_B value is the 0.95th quantile of the conditional distribution of the random variable

$$V_B = \frac{\sqrt{n}[\ln(\hat{Q}) - \ln(Q)]}{1/\hat{\beta}} \quad 8.5.8(b)$$

given that

$$A_i = \frac{\ln(x'_i) - \ln(\hat{\alpha}')}{1/\hat{\beta}'} \quad 8.5.8(c)$$

where

$$x'_i = -\ln\left(1 - \frac{i-0.5}{n+0.25}\right) \quad i = 1, \dots, n \quad 8.5.8(d)$$

$$\hat{Q} = \hat{\alpha}(0.10536)^{1/\beta} \quad 8.5.8(e)$$

$$Q = \alpha(0.10536)^{1/\beta} \quad 8.5.8(f)$$

and $\hat{\alpha}'$ and $\hat{\beta}'$ are the MLE's of the two-parameter Weibull scale and shape parameters for the sample x'_1, \dots, x'_n . The conditional distribution of V_B is determined by the relationship

$$V_B = \sqrt{n}[Z + \ln(0.10536)] \quad 8.5.8(g)$$

where the distribution of Z is given in Theorem 4.1.3 on page 150 of reference 8.3.4.2. Numerical integration was used to determine the V values in Table 8.5.8 based on these results.

An approximation to the V values in Table 8.5.8 is:

$$V_B \approx 3.803 + \exp\left\{1.79 - 0.516\ln(n) + \frac{5.1}{n-1}\right\} \quad 8.5.8(h)$$

This approximation is accurate to within 0.5% of the tabulated values for n greater than or equal to 16.

8.5.9 One-sided A-basis tolerance factors, V_A , for the Weibull distribution

The V_A values in Table 8.5.9 are calculated as described in Section 8.5.8 (Reference 8.5.9). An approximation to the V_A values is:

$$V_A \approx 6.649 + \exp\left[2.55 - 0.526\ln(n) + \frac{4.76}{n}\right] \quad 8.5.9$$

This approximation is accurate within 0.5% of the tabulated values for n greater than or equal to 16.

8.5.10 One-sided B-basis tolerance factors, k_B , for the normal distribution

The k_B values in Table 8.5.10 are calculated as $1/\sqrt{n}$ times the 0.95th quantile of the noncentral t-distribution with noncentrality parameter $1.282\sqrt{n}$ and $n - 1$ degrees of freedom. An approximation to the k_B values in Table 8.5.10 is:

$$k_B \approx 1.282 + \exp\{0.958 - 0.520 \ln(n) + 3.19/n\} \quad 8.5.10$$

This approximation is accurate to within 0.2% of the tabulated values for n greater than or equal to 16.

8.5.11 One-sided A-basis tolerance factors, k_A , for the normal distribution

The k_A values in Table 8.5.11 are calculated as $1/\sqrt{n}$ times the 0.95th quantile of the noncentral t-distribution with noncentrality parameter $2.326\sqrt{n}$ and $n - 1$ degrees of freedom (Reference 8.5.11). An approximation to the k_A values in Table 8.5.11 is:

$$k_A \approx 2.326 + \exp\left(1.34 - 0.522 \ln(n) + \frac{3.87}{n}\right) \quad 8.5.11$$

This approximation is accurate to within 0.2% of the tabulated values for n greater than or equal to 16.

8.5.12 Ranks, r_B , for determining nonparametric B-basis values

For $n > 29$, an approximation to the ranks for B-basis values in Table 8.5.12 is

$$r_B = \frac{n}{10} - 1.645 \sqrt{\frac{9n}{100}} + 0.23 \quad 8.5.12$$

rounded to the nearest integer. This approximation is exact for all but 12 values of n in the range of the table ($29 \leq n \leq 10499$). For this small percentage of n values (0.1%), the approximation errs by one rank on the conservative side.

8.5.13 Ranks, r_A , for determining nonparametric A-basis values

For $n \geq 299$, an approximation to the ranks for A-basis values in Table 8.5.13 is:

$$r_A \approx \frac{n}{100} - 1.645 \sqrt{\frac{99n}{10,000}} + 0.29 + \frac{19.1}{n} \quad 8.5.13$$

For n less than 299, an A-allowable cannot be computed. This approximation is exact for all but 23 values of n in the range of the table ($299 \leq n \leq 11691$). For this small percentage of n values (0.2%), the approximation errs by one rank on the conservative side (Reference 8.3.4.5.1).

8.5.14 Nonparametric B-basis values for small sample sizes

The values in Table 8.5.14 are based on Reference 8.3.4.5.2(a).

8.5.15 Non-parametric A-basis values for small sample sizes

The values in Table 8.5.15 are based on Reference 8.3.4.5.2(b).

8.5.16 Critical values for approximate confidence limits on the coefficient of variation

Values for u_1 and u_2 , $100(1+\gamma)/2$ and $100(1-\gamma)/2$ percentiles of the χ^2 distribution with $n-1$ degrees of freedom, are tabulated in Table 8.5.16 for γ equal to 0.9, 0.95, and 0.99.

8.5.17 One-sided tolerance factors for acceptance limits on mean values, for normal distribution

The values listed in Table 8.5.17 are used for determining equivalency between two data sets and for the establishment of material specification requirements for minimum average values. These constants are used for equivalency tests that are designed to detect a decrease in the mean value. The values in the table were obtained from Reference 8.3.5.4(b) and reference 8.5.17.

8.5.18 One-sided tolerance factors for acceptance limits on individual values, for normal distribution

The values listed in Table 8.5.18 are used for determining equivalency between two data sets and for the establishment of material specification requirements for minimum individual values. These constants are used for equivalency tests that are designed to detect a decrease in an individual value. The values in the table were obtained from Reference 8.3.5.4(b) and Reference 8.5.17.

8.5.19 Upper and lower tail quantiles for two-sided t-distribution

The values listed in Table 8.5.19 are used for determining equivalency between two data sets and for the establishment of material specification requirements for minimum and/or maximum mean values. These constants are used for equivalency tests that are designed to detect an increase in a mean value, or to detect a change in a mean value (either up or down). The values in the table were obtained from Reference 8.3.5.4(b) and Reference 8.5.17.

TABLE 8.5.1 *Quantiles of the F-distribution, continued on next page.*

		γ_1 numerator degrees of freedom								
		1	2	3	4	5	6	7	8	9
γ_2	1	161.45	199.50	215.71	224.58	230.16	233.99	236.77	238.88	240.54
	2	18.51	19.00	19.16	19.25	19.30	19.33	19.35	19.37	19.38
	3	10.13	9.55	9.28	9.12	9.01	8.94	8.89	8.85	8.81
	4	7.71	6.94	6.59	6.39	6.26	6.16	6.09	6.04	6.00
	5	6.61	5.79	5.41	5.19	5.05	4.95	4.88	4.82	4.77
d	6	5.99	5.14	4.76	4.53	4.39	4.28	4.21	4.15	4.10
	7	5.59	4.74	4.35	4.12	3.97	3.87	3.79	3.73	3.68
	8	5.32	4.46	4.07	3.84	3.69	3.58	3.50	3.44	3.39
	9	5.12	4.26	3.86	3.63	3.48	3.37	3.29	3.23	3.18
	10	4.96	4.10	3.71	3.48	3.33	3.22	3.14	3.07	3.02
n	11	4.84	3.98	3.59	3.36	3.20	3.09	3.01	2.95	2.90
	12	4.75	3.89	3.49	3.26	3.11	3.00	2.91	2.85	2.80
	13	4.67	3.81	3.41	3.18	3.03	2.92	2.83	2.77	2.71
	14	4.60	3.74	3.34	3.11	2.96	2.85	2.76	2.70	2.65
	15	4.54	3.68	3.29	3.06	2.90	2.79	2.71	2.64	2.59
e	16	4.49	3.63	3.24	3.01	2.85	2.74	2.66	2.59	2.54
	17	4.45	3.59	3.20	2.96	2.81	2.70	2.61	2.55	2.49
	18	4.41	3.55	3.16	2.93	2.77	2.66	2.58	2.51	2.46
	19	4.38	3.52	3.13	2.90	2.74	2.63	2.54	2.48	2.42
	20	4.35	3.49	3.10	2.87	2.71	2.60	2.51	2.45	2.39
s	21	4.32	3.47	3.07	2.84	2.68	2.57	2.49	2.42	2.37
	22	4.30	3.44	3.05	2.82	2.66	2.55	2.46	2.40	2.34
	23	4.28	3.42	3.03	2.80	2.64	2.53	2.44	2.37	2.32
	24	4.26	3.40	3.01	2.78	2.62	2.51	2.42	2.36	2.30
	25	4.24	3.39	2.99	2.76	2.60	2.49	2.40	2.34	2.28
o	26	4.23	3.37	2.98	2.74	2.59	2.47	2.39	2.32	2.27
	27	4.21	3.35	2.96	2.73	2.57	2.46	2.37	2.31	2.25
	28	4.20	3.34	2.95	2.71	2.56	2.45	2.36	2.29	2.24
	29	4.18	3.33	2.93	2.70	2.55	2.43	2.35	2.28	2.22
	30	4.17	3.32	2.92	2.69	2.53	2.42	2.33	2.27	2.21
f	40	4.08	3.23	2.84	2.61	2.45	2.34	2.25	2.18	2.12
	60	4.00	3.15	2.76	2.53	2.37	2.25	2.17	2.10	2.04
	120	3.92	3.07	2.68	2.45	2.29	2.18	2.09	2.02	1.96
	∞	3.84	3.00	2.61	2.37	2.21	2.10	2.01	1.94	1.88

TABLE 8.5.1 *Quantiles of the F-distribution, concluded.*

		γ_1 numerator degrees of freedom									
		10	12	15	20	24	30	40	60	120	∞
γ_2	1	241.88	243.91	245.95	248.01	249.05	250.10	251.14	252.20	253.25	254.31
	2	19.40	19.41	19.43	19.45	19.45	19.46	19.47	19.48	19.49	19.51
	3	8.79	8.74	8.70	8.66	8.64	8.62	8.59	8.57	8.55	8.53
	4	5.96	5.91	5.86	5.80	5.77	5.75	5.72	5.69	5.66	5.63
	5	4.74	4.68	4.62	4.56	4.53	4.50	4.46	4.43	4.40	4.37
d e n o m i n a t o r	6	4.06	4.00	3.94	3.87	3.84	3.81	3.77	3.74	3.70	3.67
	7	3.64	3.57	3.51	3.44	3.41	3.38	3.34	3.30	3.27	3.23
	8	3.35	3.28	3.22	3.15	3.12	3.08	3.04	3.01	2.97	2.93
	9	3.14	3.07	3.01	2.94	2.90	2.86	2.83	2.79	2.75	2.71
	10	2.98	2.91	2.85	2.77	2.74	2.70	2.66	2.62	2.58	2.54
	11	2.85	2.79	2.72	2.65	2.61	2.57	2.53	2.49	2.45	2.40
	12	2.75	2.69	2.62	2.54	2.51	2.47	2.43	2.38	2.34	2.30
	13	2.67	2.60	2.53	2.46	2.42	2.38	2.34	2.30	2.25	2.21
	14	2.60	2.53	2.46	2.39	2.35	2.31	2.27	2.22	2.18	2.13
	15	2.54	2.48	2.40	2.33	2.29	2.25	2.20	2.16	2.11	2.07
d e g r e e s	16	2.49	2.42	2.35	2.28	2.24	2.19	2.15	2.11	2.06	2.01
	17	2.45	2.38	2.31	2.23	2.19	2.15	2.10	2.06	2.01	1.96
	18	2.41	2.34	2.27	2.19	2.15	2.11	2.06	2.02	1.97	1.92
	19	2.38	2.31	2.23	2.16	2.11	2.07	2.03	1.98	1.93	1.88
	20	2.35	2.28	2.20	2.12	2.08	2.04	1.99	1.95	1.90	1.84
	21	2.32	2.25	2.18	2.10	2.05	2.01	1.96	1.92	1.87	1.81
	22	2.30	2.23	2.15	2.07	2.03	1.98	1.94	1.89	1.84	1.78
	23	2.27	2.20	2.13	2.05	2.01	1.96	1.91	1.86	1.81	1.76
	24	2.25	2.18	2.11	2.03	1.98	1.94	1.89	1.84	1.79	1.73
	25	2.24	2.16	2.09	2.01	1.96	1.92	1.87	1.82	1.77	1.71
o f f r e e d o m	26	2.22	2.15	2.07	1.99	1.95	1.90	1.85	1.80	1.75	1.69
	27	2.20	2.13	2.06	1.97	1.93	1.88	1.84	1.79	1.73	1.67
	28	2.19	2.12	2.04	1.96	1.91	1.87	1.82	1.77	1.71	1.65
	29	2.18	2.10	2.03	1.94	1.90	1.85	1.81	1.75	1.70	1.64
	30	2.16	2.09	2.01	1.93	1.89	1.84	1.79	1.74	1.68	1.62
	40	2.08	2.00	1.92	1.84	1.79	1.74	1.69	1.64	1.58	1.51
	60	1.99	1.92	1.84	1.75	1.70	1.65	1.59	1.53	1.47	1.39
	120	1.91	1.83	1.75	1.66	1.61	1.55	1.50	1.43	1.35	1.25
	∞	1.83	1.75	1.67	1.57	1.52	1.46	1.39	1.32	1.22	1.00

TABLE 8.5.2 *Quantiles of the χ^2 distribution.*

γ	$\chi^2_{0.95}$
1	3.84
2	5.99
3	7.82
4	9.49
5	11.07
6	12.60
7	14.07
8	15.51
9	16.93
10	18.31
11	19.68
12	21.03
13	22.37
14	23.69
15	25.00
16	26.30
17	27.59
18	28.88
19	30.15
20	31.42
21	32.68
22	33.93
23	35.18
24	36.42
25	37.66
26	38.89
27	40.12
28	41.34
29	42.56
30	43.78

TABLE 8.5.3 *Upper-tail quantiles for the t-distribution.*

γ	0.75	0.90	0.95	0.975	0.99	0.995
1	1.0000	3.0777	6.3137	12.7062	31.8205	63.6568
2	0.8165	1.8856	2.9200	4.3027	6.9646	9.9248
3	0.7649	1.6377	2.3534	3.1825	4.5407	5.8409
4	0.7407	1.5332	2.1318	2.7764	3.7470	4.6041
5	0.7267	1.4759	2.0150	2.5706	3.3649	4.0322
6	0.7176	1.4398	1.9432	2.4469	3.1427	3.7074
7	0.7111	1.4149	1.8946	2.3646	2.9980	3.4995
8	0.7064	1.3968	1.8595	2.3060	2.8965	3.3554
9	0.7027	1.3830	1.8331	2.2622	2.8214	3.2498
10	0.6998	1.3722	1.8125	2.2281	2.7638	3.1693
11	0.6974	1.3634	1.7959	2.2010	2.7181	3.1058
12	0.6955	1.3562	1.7823	2.1788	2.6810	3.0545
13	0.6938	1.3502	1.7709	2.1604	2.6503	3.0123
14	0.6924	1.3450	1.7613	2.1448	2.6245	2.9768
15	0.6912	1.3406	1.7530	2.1314	2.6025	2.9467
16	0.6901	1.3368	1.7459	2.1199	2.5835	2.9208
17	0.6892	1.3334	1.7396	2.1098	2.5669	2.8982
18	0.6884	1.3304	1.7341	2.1009	2.5524	2.8784
19	0.6876	1.3277	1.7291	2.0930	2.5395	2.8609
20	0.6870	1.3253	1.7247	2.0860	2.5280	2.8453
21	0.6864	1.3232	1.7207	2.0796	2.5176	2.8314
22	0.6858	1.3212	1.7171	2.0739	2.5083	2.8188
23	0.6853	1.3195	1.7139	2.0687	2.4999	2.8073
24	0.6848	1.3178	1.7109	2.0639	2.4922	2.7969
25	0.6844	1.3163	1.7081	2.0595	2.4851	2.7874
30	0.6828	1.3104	1.6973	2.0423	2.4573	2.7500
40	0.6807	1.3031	1.6839	2.0211	2.4233	2.7045
60	0.6786	1.2958	1.6706	2.0003	2.3901	2.6603
120	0.6765	1.2886	1.6577	1.9799	2.3578	2.6174
∞	0.6745	1.2816	1.6449	1.9600	2.3263	2.5758

TABLE 8.5.4 Two-tail probabilities for *t*-distribution.

T	degrees of freedom, γ									
	1	2	3	4	5	6	7	8	9	10
0.00	1.0000	1.0000	1.0000	1.0000	1.0000	1.0000	1.0000	1.0000	1.0000	1.0000
0.25	0.8440	0.8259	0.8187	0.8149	0.8125	0.8109	0.8098	0.8089	0.8082	0.8076
0.50	0.7048	0.6667	0.6514	0.6433	0.6383	0.6349	0.6324	0.6305	0.6291	0.6279
0.75	0.5903	0.5315	0.5077	0.4950	0.4870	0.4816	0.4777	0.4747	0.4724	0.4705
1.00	0.5000	0.4226	0.3910	0.3739	0.3632	0.3559	0.3506	0.3466	0.3434	0.3409
1.25	0.4296	0.3377	0.2999	0.2794	0.2666	0.2578	0.2515	0.2466	0.2428	0.2398
1.50	0.3743	0.2724	0.2306	0.2080	0.1939	0.1843	0.1773	0.1720	0.1679	0.1645
1.75	0.3305	0.2222	0.1784	0.1550	0.1405	0.1307	0.1236	0.1182	0.1140	0.1107
2.00	0.2952	0.1835	0.1393	0.1161	0.1019	0.0924	0.0856	0.0805	0.0766	0.0734
2.25	0.2662	0.1534	0.1099	0.0876	0.0743	0.0654	0.0592	0.0546	0.0510	0.0482
2.50	0.2422	0.1296	0.0877	0.0668	0.0545	0.0465	0.0410	0.0369	0.0339	0.0314
2.75	0.2220	0.1107	0.0707	0.0514	0.0403	0.0333	0.0285	0.0251	0.0225	0.0205
3.00	0.2048	0.0955	0.0577	0.0399	0.0301	0.0240	0.0199	0.0171	0.0150	0.0133
3.25	0.1900	0.0831	0.0475	0.0314	0.0227	0.0175	0.0141	0.0117	0.0100	0.0087
3.50	0.1772	0.0728	0.0395	0.0249	0.0173	0.0128	0.0100	0.0081	0.0067	0.0057
3.75	0.1659	0.0643	0.0331	0.0199	0.0133	0.0095	0.0072	0.0056	0.0046	0.0038
4.00	0.1560	0.0572	0.0280	0.0161	0.0103	0.0071	0.0052	0.0039	0.0031	0.0025
4.25	0.1471	0.0512	0.0239	0.0132	0.0081	0.0054	0.0038	0.0028	0.0021	0.0017
4.50	0.1392	0.0460	0.0205	0.0108	0.0064	0.0041	0.0028	0.0020	0.0015	0.0011
4.75	0.1321	0.0416	0.0177	0.0090	0.0051	0.0032	0.0021	0.0014	0.0010	0.0008
5.00	0.1257	0.0377	0.0154	0.0075	0.0041	0.0025	0.0016	0.0011	0.0007	0.0005
5.25	0.1198	0.0344	0.0135	0.0063	0.0033	0.0019	0.0012	0.0008	0.0005	0.0004
5.50	0.1145	0.0315	0.0118	0.0053	0.0027	0.0015	0.0009	0.0006	0.0004	0.0003
5.75	0.1096	0.0289	0.0104	0.0045	0.0022	0.0012	0.0007	0.0004	0.0003	0.0002
6.00	0.1051	0.0267	0.0093	0.0039	0.0018	0.0010	0.0005	0.0003	0.0002	0.0001
6.25	0.1010	0.0247	0.0083	0.0033	0.0015	0.0008	0.0004	0.0002	0.0001	0.0001
6.50	0.0972	0.0229	0.0074	0.0029	0.0013	0.0006	0.0003	0.0002	0.0001	0.0001
6.75	0.0936	0.0213	0.0066	0.0025	0.0011	0.0005	0.0003	0.0001	0.0001	0.0001
7.00	0.0903	0.0198	0.0060	0.0022	0.0009	0.0004	0.0002	0.0001	0.0001	0.0000
7.25	0.0873	0.0185	0.0054	0.0019	0.0008	0.0003	0.0002	0.0001	0.0000	0.0000
7.50	0.0844	0.0173	0.0049	0.0017	0.0007	0.0003	0.0001	0.0001	0.0000	0.0000
7.75	0.0817	0.0162	0.0045	0.0015	0.0006	0.0002	0.0001	0.0001	0.0000	0.0000
8.00	0.0792	0.0153	0.0041	0.0013	0.0005	0.0002	0.0001	0.0000	0.0000	0.0000

TABLE 8.5.5 Upper tail probabilities for the standard normal distribution.

x	0.00	0.25	0.50	0.75	1.00	1.25	1.50	1.75	2.00	2.25
0.00	0.50000	0.59871	0.69146	0.77337	0.84134	0.89435	0.93319	0.95994	0.97725	0.98778
0.01	0.50399	0.60257	0.69497	0.77637	0.84375	0.89617	0.93448	0.96080	0.97778	0.98809
0.02	0.50798	0.60642	0.69847	0.77935	0.84614	0.89796	0.93574	0.96164	0.97831	0.98840
0.03	0.51197	0.61026	0.70194	0.78230	0.84850	0.89973	0.93699	0.96246	0.97882	0.98870
0.04	0.51595	0.61409	0.70540	0.78524	0.85083	0.90147	0.93822	0.96327	0.97932	0.98899
0.05	0.51994	0.61791	0.70884	0.78814	0.85314	0.90320	0.93943	0.96407	0.97982	0.98928
0.06	0.52392	0.62172	0.71226	0.79103	0.85543	0.90490	0.94062	0.96485	0.98030	0.98956
0.07	0.52790	0.62552	0.71566	0.79389	0.85769	0.90658	0.94179	0.96562	0.98077	0.98983
0.08	0.53188	0.62930	0.71904	0.79673	0.85993	0.90824	0.94295	0.96637	0.98124	0.99010
0.09	0.53586	0.63307	0.72240	0.79955	0.86214	0.90988	0.94408	0.96712	0.98169	0.99036
0.10	0.53983	0.63683	0.72575	0.80234	0.86433	0.91149	0.94520	0.96784	0.98214	0.99061
0.11	0.54380	0.64058	0.72907	0.80511	0.86650	0.91309	0.94630	0.96856	0.98257	0.99086
0.12	0.54776	0.64431	0.73237	0.80785	0.86864	0.91466	0.94738	0.96926	0.98300	0.99111
0.13	0.55172	0.64803	0.73565	0.81057	0.87076	0.91621	0.94845	0.96995	0.98341	0.99134
0.14	0.55567	0.65173	0.73891	0.81327	0.87286	0.91774	0.94950	0.97062	0.98382	0.99158
0.15	0.55962	0.65542	0.74215	0.81594	0.87493	0.91924	0.95053	0.97128	0.98422	0.99180
0.16	0.56356	0.65910	0.74537	0.81859	0.87698	0.92073	0.95154	0.97193	0.98461	0.99202
0.17	0.56749	0.66276	0.74857	0.82121	0.87900	0.92220	0.95254	0.97257	0.98500	0.99224
0.18	0.57142	0.66640	0.75175	0.82381	0.88100	0.92364	0.95352	0.97320	0.98537	0.99245
0.19	0.57535	0.67003	0.75490	0.82639	0.88298	0.92507	0.95449	0.97381	0.98574	0.99266
0.20	0.57926	0.67364	0.75804	0.82894	0.88493	0.92647	0.95543	0.97441	0.98610	0.99286
0.21	0.58317	0.67724	0.76115	0.83147	0.88686	0.92785	0.95637	0.97500	0.98645	0.99305
0.22	0.58706	0.68082	0.76424	0.83398	0.88877	0.92922	0.95728	0.97558	0.98679	0.99324
0.23	0.59095	0.68439	0.76730	0.83646	0.89065	0.93056	0.95818	0.97615	0.98713	0.99343
0.24	0.59483	0.68793	0.77035	0.83891	0.89251	0.93189	0.95907	0.97670	0.98745	0.99361

Note: To find the probability that a standard normal random variable is less than x , enter the table at the cell for which the sum of the row and column headings equals x (e.g., for $x = 0.73 = 0.5 + 0.23$, we have, from row 23 and column 2, $P = 0.76730$). If x is less than zero, use the absolute value of x to get a value P' , and let the probability be $P = 1 - P'$ (e.g., for $x = -0.73$, $P = 1 - 0.76730 = 0.23270$)

TABLE 8.5.6 Critical values for the k -sample Anderson-Darling test at the $\alpha = 0.05$ significance level.

		k*														
		2	3	4	5	6	7	8	9	10	11	12	13	14	15	
n*	3	2.11	1.80	1.65	1.56	1.50	1.46	1.42	1.39	1.37	1.35	1.33	1.32	1.31	1.29	
	4	2.20	1.86	1.70	1.60	1.54	1.49	1.45	1.42	1.39	1.37	1.36	1.34	1.33	1.31	
	5	2.25	1.89	1.73	1.63	1.56	1.51	1.47	1.43	1.41	1.39	1.37	1.35	1.34	1.32	
	6	2.29	1.92	1.74	1.64	1.57	1.52	1.48	1.45	1.42	1.40	1.38	1.36	1.34	1.33	
	7	2.32	1.94	1.76	1.65	1.58	1.53	1.49	1.45	1.43	1.40	1.38	1.36	1.35	1.34	
	8	2.34	1.95	1.77	1.66	1.59	1.53	1.49	1.46	1.43	1.41	1.39	1.37	1.35	1.34	
	9	2.35	1.96	1.78	1.67	1.59	1.54	1.50	1.46	1.43	1.41	1.39	1.37	1.36	1.34	
	10	2.37	1.97	1.78	1.67	1.60	1.54	1.50	1.47	1.44	1.41	1.39	1.37	1.36	1.35	
	11	2.38	1.97	1.79	1.68	1.60	1.55	1.50	1.47	1.44	1.42	1.39	1.38	1.36	1.35	
	12	2.39	1.98	1.79	1.68	1.60	1.55	1.51	1.47	1.44	1.42	1.40	1.38	1.36	1.35	
	13	2.39	1.98	1.80	1.68	1.61	1.55	1.51	1.47	1.44	1.42	1.40	1.38	1.36	1.35	
	14	2.40	1.99	1.80	1.69	1.61	1.55	1.51	1.47	1.44	1.42	1.40	1.38	1.37	1.35	
	15	2.41	1.99	1.80	1.69	1.61	1.55	1.51	1.48	1.45	1.42	1.40	1.38	1.37	1.35	
	16	2.41	2.00	1.80	1.69	1.61	1.56	1.51	1.48	1.45	1.42	1.40	1.38	1.37	1.35	
	17	2.42	2.00	1.81	1.69	1.61	1.56	1.51	1.48	1.45	1.42	1.40	1.38	1.37	1.35	
	18	2.42	2.00	1.81	1.69	1.62	1.56	1.51	1.48	1.45	1.42	1.40	1.39	1.37	1.35	
	19	2.42	2.00	1.81	1.70	1.62	1.56	1.52	1.48	1.45	1.43	1.40	1.39	1.37	1.36	
	20	2.43	2.01	1.81	1.70	1.62	1.56	1.52	1.48	1.45	1.43	1.40	1.39	1.37	1.36	
			2.49	2.05	1.84	1.72	1.64	1.58	1.53	1.50	1.46	1.44	1.42	1.40	1.38	1.37

TABLE 8.5.7 Critical values for the MNR outlier test.

n	CV	n	CV	n	CV	n	CV	n	CV
-	-	41	3.047	81	3.311	121	3.448	161	3.539
-	-	42	3.057	82	3.315	122	3.451	162	3.541
3	1.154	43	3.067	83	3.319	123	3.453	163	3.543
4	1.481	44	3.076	84	3.323	124	3.456	164	3.545
5	1.715	45	3.085	85	3.328	125	3.459	165	3.547
6	1.887	46	3.094	86	3.332	126	3.461	166	3.549
7	2.020	47	3.103	87	3.336	127	3.464	167	3.551
8	2.127	48	3.112	88	3.340	128	3.466	168	3.552
9	2.215	49	3.120	89	3.344	129	3.469	169	3.554
10	2.290	50	3.128	90	3.348	130	3.471	170	3.556
11	2.355	51	3.136	91	3.352	131	3.474	171	3.558
12	2.412	52	3.144	92	3.355	132	3.476	172	3.560
13	2.462	53	3.151	93	3.359	133	3.479	173	3.561
14	2.507	54	3.159	94	3.363	134	3.481	174	3.563
15	2.548	55	3.166	95	3.366	135	3.483	175	3.565
16	2.586	56	3.173	96	3.370	136	3.486	176	3.567
17	2.620	57	3.180	97	3.374	137	3.488	177	3.568
18	2.652	58	3.187	98	3.377	138	3.491	178	3.570
19	2.681	59	3.193	99	3.381	139	3.493	179	3.572
20	2.708	60	3.200	100	3.384	140	3.495	180	3.574
21	2.734	61	3.206	101	3.387	141	3.497	181	3.575
22	2.758	62	3.212	102	3.391	142	3.500	182	3.577
23	2.780	63	3.218	103	3.394	143	3.502	183	3.579
24	2.802	64	3.224	104	3.397	144	3.504	184	3.580
25	2.822	65	3.230	105	3.401	145	3.506	185	3.582
26	2.841	66	3.236	106	3.404	146	3.508	186	3.584
27	2.859	67	3.241	107	3.407	147	3.511	187	3.585
28	2.876	68	3.247	108	3.410	148	3.513	188	3.587
29	2.893	69	3.252	109	3.413	149	3.515	189	3.588
30	2.908	70	3.258	110	3.416	150	3.517	190	3.590
31	2.924	71	3.263	111	3.419	151	3.519	191	3.592
32	2.938	72	3.268	112	3.422	152	3.521	192	3.593
33	2.952	73	3.273	113	3.425	153	3.523	193	3.595
34	2.965	74	3.278	114	3.428	154	3.525	194	3.596
35	2.978	75	3.283	115	3.431	155	3.527	195	3.598
36	2.991	76	3.288	116	3.434	156	3.529	196	3.599
37	3.003	77	3.292	117	3.437	157	3.531	197	3.601
38	3.014	78	3.297	118	3.440	158	3.533	198	3.603
39	3.025	79	3.302	119	3.442	159	3.535	199	3.604
40	3.036	80	3.306	120	3.445	160	3.537	200	3.606

TABLE 8.5.8 One-sided B-basis tolerance factors, V_B , for the Weibull distribution, continued on next page

n = 10 - 192							
n	V_B	n	V_B	n	V_B	n	V_B
10	6.711	45	4.764	80	4.477	130	4.309
11	6.477	46	4.751	81	4.471	132	4.305
12	6.286	47	4.738	82	4.466	134	4.301
13	6.127	48	4.725	83	4.462	136	4.296
14	5.992	49	4.713	84	4.457	138	4.292
15	5.875	50	4.702	85	4.452	140	4.288
16	5.774	51	4.691	86	4.448	142	4.284
17	5.684	52	4.680	87	4.443	144	4.280
18	5.605	53	4.670	88	4.439	146	4.277
19	5.533	54	4.659	89	4.435	148	4.273
20	5.469	55	4.650	90	4.431	150	4.269
21	5.412	56	4.640	91	4.427	152	4.266
22	5.359	57	4.631	92	4.423	154	4.262
23	5.310	58	4.622	93	4.419	156	4.259
24	5.265	59	4.631	94	4.415	158	4.256
25	5.224	60	4.605	95	4.411	160	4.253
26	5.186	61	4.597	96	4.407	162	4.249
27	5.150	62	4.589	97	4.404	164	4.246
28	5.117	63	4.582	98	4.400	166	4.243
29	5.086	64	4.574	99	4.396	168	4.240
30	5.057	65	4.567	100	4.393	170	4.237
31	5.030	66	4.560	102	4.386	172	4.234
32	5.003	67	4.553	104	4.380	174	4.232
33	4.979	68	4.546	106	4.373	176	4.229
34	4.956	69	4.539	108	4.367	178	4.226
35	4.934	70	4.533	110	4.361	180	4.224
36	4.913	71	4.527	112	4.355	182	4.221
37	4.893	72	4.521	114	4.349	184	4.218
38	4.875	73	4.515	116	4.344	186	4.216
39	4.857	74	4.509	118	4.339	188	4.213
40	4.840	75	4.503	120	4.334	190	4.211
41	4.823	76	4.498	122	4.328	192	4.208
42	4.807	77	4.492	124	4.323		
43	4.792	78	4.487	126	4.317		
44	4.778	79	4.482	128	4.314		

TABLE 8.5.8 One-sided B-basis tolerance factors, V_B , for the Weibull distribution, concluded.

n = 194 - ∞					
n	V_B	n	V_B	n	V_B
194	4.206	300	4.119	850	3.992
196	4.204	310	4.113	875	3.989
198	4.201	320	4.108	900	3.986
200	4.199	330	4.103	925	3.983
204	4.195	340	4.098	950	3.981
208	4.191	350	4.093	975	3.979
212	4.186	360	4.089	1000	3.976
216	4.182	370	4.085	1100	3.968
220	4.179	380	4.081	1200	3.960
224	4.175	390	4.077	1300	3.954
228	4.171	400	4.073	1400	3.948
232	4.168	425	4.076	1500	3.943
236	4.164	450	4.067	1600	3.939
240	4.161	475	4.060	1700	3.934
244	4.157	500	4.053	1800	3.931
248	4.154	525	4.047	1900	3.927
252	4.151	550	4.041	2000	3.924
256	4.148	575	4.035	3000	3.901
260	4.145	600	4.030	4000	3.887
264	4.142	625	4.025	5000	3.878
268	4.140	650	4.020	6000	3.872
272	4.137	675	4.016	7000	3.866
276	4.134	700	4.012	8000	3.862
280	4.131	725	4.008	9000	3.859
284	4.129	750	4.005	10000	3.856
288	4.126	775	4.001	15000	3.846
292	4.124	800	3.998	20000	3.840
296	4.121	825	3.995	∞	3.803

TABLE 8.5.9 *One-sided A-basis tolerance limit factors, V_A , for the Weibull distribution, (Reference 8.5.11), continued on next page.*

n	V_A	n	V_A	n	V_A	n	V_A
10	12.573	44	8.629	78	8.038	124	7.706
11	12.093	45	8.600	79	8.028	126	7.697
12	11.701	46	8.573	80	8.017	128	7.687
13	11.375	47	8.547	81	8.007	130	7.678
14	11.098	48	8.522	82	7.997	132	7.669
15	10.861	49	8.498	83	7.988	134	7.660
16	10.654	50	8.474	84	7.978	136	7.652
17	10.472	51	8.452	85	7.969	138	7.643
18	10.311	52	8.430	86	7.960	140	7.635
19	10.166	53	8.409	87	7.951	142	7.627
20	10.035	54	8.389	88	7.942	144	7.619
21	9.917	55	8.369	89	7.933	146	7.612
22	9.809	56	8.349	90	7.925	148	7.604
23	9.710	57	8.330	91	7.916	150	7.597
24	9.619	58	8.313	92	7.908	152	7.590
25	9.535	59	8.295	93	7.900	154	7.583
26	9.457	60	8.278	94	7.892	156	7.576
27	9.385	61	8.262	95	7.884	158	7.569
28	9.318	62	8.246	96	7.877	160	7.563
29	9.251	63	8.230	97	7.867	162	7.556
30	9.195	64	8.215	98	7.862	164	7.550
31	9.139	65	8.200	99	7.855	166	7.544
32	9.087	66	8.186	100	7.845	168	7.538
33	9.037	67	8.172	102	7.834	170	7.532
34	8.990	68	8.158	104	7.820	172	7.526
35	8.946	69	8.145	106	7.811	174	7.520
36	8.904	70	8.132	108	7.795	176	7.515
37	8.863	71	8.119	110	7.783	178	7.509
38	8.825	72	8.107	112	7.771	180	7.504
39	8.789	73	8.095	114	7.759	182	7.499
40	8.754	74	8.083	116	7.748	184	7.493
41	8.721	75	8.071	118	7.737	186	7.488
42	8.689	76	8.060	120	7.727	188	7.483
43	8.658	77	8.049	122	7.717	190	7.478

TABLE 8.5.9 *One-sided A-basis tolerance limit factors, V_A , for the Weibull distribution, (Reference 8.5.11), concluded.*

n	V_A	n	V_A	n	V_A	n	V_A
192	7.473	268	7.333	475	7.152	1000	6.989
194	7.469	272	7.328	500	7.138	1100	6.972
196	7.454	276	7.322	525	7.126	1200	6.958
198	7.459	280	7.317	550	7.114	1300	6.945
200	7.455	284	7.312	575	7.103	1400	6.934
204	7.446	288	7.307	600	7.093	1500	6.924
208	7.437	292	7.302	625	7.084	1600	6.915
212	7.429	296	7.297	650	7.075	1700	6.907
216	7.421	300	7.292	675	7.066	1800	6.899
220	7.413	310	7.280	700	7.058	1900	6.892
224	7.404	320	7.270	725	7.051	2000	6.886
228	7.397	330	7.259	750	7.044	3000	6.841
232	7.390	340	7.249	775	7.037		
236	7.383	350	7.240	800	7.031		
240	7.376	360	7.229	825	7.025		
244	7.370	370	7.222	850	7.019		
248	7.363	380	7.214	875	7.013		
252	7.357	390	7.206	900	7.008		
256	7.351	400	7.198	925	7.003		
260	7.345	425	7.183	950	6.998		
264	7.339	450	7.167	975	6.993		

TABLE 8.5.10 One-sided B-basis tolerance limit factors, k_B , for the normal distribution, continued on next page.

N = 2 - 137							
n	k_B	n	k_B	n	k_B	n	k_B
2	20.581	36	1.725	70	1.582	104	1.522
3	6.157	37	1.718	71	1.579	105	1.521
4	4.163	38	1.711	72	1.577	106	1.519
5	3.408	39	1.704	73	1.575	107	1.518
6	3.007	40	1.698	74	1.572	108	1.517
7	2.756	41	1.692	75	1.570	109	1.516
8	2.583	42	1.686	76	1.568	110	1.515
9	2.454	43	1.680	77	1.566	111	1.513
10	2.355	44	1.675	78	1.564	112	1.512
11	2.276	45	1.669	79	1.562	113	1.511
12	2.211	46	1.664	80	1.560	114	1.510
13	2.156	47	1.660	81	1.558	115	1.509
14	2.109	48	1.655	82	1.556	116	1.508
15	2.069	49	1.650	83	1.554	117	1.507
16	2.034	50	1.646	84	1.552	118	1.506
17	2.002	51	1.642	85	1.551	119	1.505
18	1.974	52	1.638	86	1.549	120	1.504
19	1.949	53	1.634	87	1.547	121	1.503
20	1.927	54	1.630	88	1.545	122	1.502
21	1.906	55	1.626	89	1.544	123	1.501
22	1.887	56	1.623	90	1.542	124	1.500
23	1.870	57	1.619	91	1.540	125	1.499
24	1.854	58	1.616	92	1.539	126	1.498
25	1.839	59	1.613	93	1.537	127	1.497
26	1.825	60	1.609	94	1.536	128	1.496
27	1.812	61	1.606	95	1.534	129	1.495
28	1.800	62	1.603	96	1.533	130	1.494
29	1.789	63	1.600	97	1.531	131	1.493
30	1.778	64	1.597	98	1.530	132	1.492
31	1.768	65	1.595	99	1.529	133	1.492
32	1.758	66	1.592	100	1.527	134	1.491
33	1.749	67	1.589	101	1.526	135	1.490
34	1.741	68	1.587	102	1.525	136	1.489
35	1.733	69	1.584	103	1.523	137	1.488

TABLE 8.5.10 One-sided B-basis tolerance limit factors, k_B , for the normal distribution, concluded.

n = 138 - ∞							
n	k_B	n	k_B	n	k_B	n	k_B
138	1.487	172	1.464	230	1.438	400	1.398
139	1.487	173	1.464	235	1.436	425	1.395
140	1.486	174	1.463	240	1.434	450	1.391
141	1.485	175	1.463	345	1.433	475	1.388
142	1.484	176	1.462	250	1.431	500	1.386
143	1.483	177	1.461	255	1.430	525	1.383
144	1.483	178	1.461	260	1.428	550	1.381
145	1.482	179	1.460	265	1.427	575	1.378
146	1.481	180	1.460	270	1.425	600	1.376
147	1.480	181	1.459	275	1.424	625	1.374
148	1.480	182	1.459	280	1.422	650	1.372
149	1.479	183	1.458	285	1.421	675	1.371
150	1.478	184	1.458	290	1.420	700	1.369
151	1.478	185	1.457	295	1.419	725	1.367
152	1.477	186	1.457	300	1.417	750	1.366
153	1.476	187	1.456	305	1.416	775	1.364
154	1.475	188	1.456	310	1.415	800	1.363
155	1.475	189	1.455	315	1.414	825	1.362
156	1.474	190	1.455	320	1.413	850	1.361
157	1.473	191	1.454	325	1.412	875	1.359
158	1.473	192	1.454	330	1.411	900	1.358
159	1.472	193	1.453	335	1.410	925	1.357
160	1.472	194	1.453	340	1.409	950	1.356
161	1.471	195	1.452	345	1.408	975	1.355
162	1.470	196	1.452	350	1.407	1000	1.354
163	1.470	197	1.451	355	1.406	1500	1.340
164	1.469	198	1.451	360	1.405	2000	1.332
165	1.468	199	1.450	365	1.404	3000	1.323
166	1.468	200	1.450	370	1.403	5000	1.313
167	1.467	205	1.448	375	1.402	10000	1.304
168	1.467	210	1.446	380	1.402	∞	1.282
169	1.466	215	1.444	385	1.401		
170	1.465	220	1.442	390	1.400		
171	1.465	225	1.440	395	1.399		

TABLE 8.5.11 *One-sided A-basis tolerance limit factors, k_A , for the normal distribution, Reference 8.5.11), continued on next page.*

n	k_A	n	k_A	n	k_A	n	k_A
2	37.094	36	2.983	70	2.765	104	2.676
3	10.553	37	2.972	71	2.762	105	2.674
4	7.042	38	2.961	72	2.758	106	2.672
5	5.741	39	2.951	73	2.755	107	2.671
6	5.062	40	2.941	74	2.751	108	2.669
7	4.642	41	2.932	75	2.748	109	2.667
8	4.354	42	2.923	76	2.745	110	2.665
9	4.143	43	2.914	77	2.742	111	2.663
10	3.981	44	2.906	78	2.739	112	2.662
11	3.852	45	2.898	79	2.736	113	2.660
12	3.747	46	2.890	80	2.733	114	2.658
13	3.659	47	2.883	81	2.730	115	2.657
14	3.585	48	2.876	82	2.727	116	2.655
15	3.520	49	2.869	83	2.724	117	2.654
16	3.464	50	2.862	84	2.721	118	2.652
17	3.414	51	2.856	85	2.719	119	2.651
18	3.370	52	2.850	86	2.716	120	2.649
19	3.331	53	2.844	87	2.714	121	2.648
20	3.295	54	2.838	88	2.711	122	2.646
21	3.263	55	2.833	89	2.709	123	2.645
22	3.233	56	2.827	90	2.706	124	2.643
23	3.206	57	2.822	91	2.704	125	2.642
24	3.181	58	2.817	92	2.701	126	2.640
25	3.158	59	2.812	93	2.699	127	2.639
26	3.136	60	2.807	94	2.697	128	2.638
27	3.116	61	2.802	95	2.695	129	2.636
28	3.098	62	2.798	96	2.692	130	2.635
29	3.080	63	2.793	97	2.690	131	2.634
30	3.064	64	2.789	98	2.688	132	2.632
31	3.048	65	2.785	99	2.686	133	2.631
32	3.034	66	2.781	100	2.684	134	2.630
33	3.020	67	2.777	101	2.682	135	2.628
34	3.007	68	2.773	102	2.680	136	2.627
35	2.995	69	2.769	103	2.678	137	2.626

TABLE 8.5.11 *One-sided A-basis tolerance limit factors, k_A , for the normal distribution, Reference 8.5.11), concluded.*

n	k_A	n	k_A	n	k_A	n	k_A
138	2.625	172	2.591	230	2.552	400	2.494
139	2.624	173	2.590	235	2.549	425	2.489
140	2.622	174	2.589	240	2.547	450	2.484
141	2.621	175	2.588	245	2.544	475	2.480
142	2.620	176	2.587	250	2.542	500	2.475
143	2.619	177	2.587	255	2.540	525	2.472
144	2.618	178	2.586	260	2.537	550	2.468
145	2.617	179	2.585	265	2.535	575	2.465
146	2.616	180	2.584	270	2.533	600	2.462
147	2.615	181	2.583	275	2.531	625	2.459
148	2.613	182	2.583	280	2.529	650	2.456
149	2.612	183	2.582	285	2.527	675	2.454
150	2.611	184	2.581	290	2.525	700	2.451
151	2.610	185	2.580	295	2.524	725	2.449
152	2.609	186	2.580	300	2.522	750	2.447
153	2.608	187	2.579	305	2.520	775	2.445
154	2.607	188	2.578	310	2.518	800	2.443
155	2.606	189	2.577	315	2.517	825	2.441
156	2.605	190	2.577	320	2.515	850	2.439
157	2.604	191	2.576	325	2.514	875	2.438
158	2.603	192	2.575	330	2.512	900	2.436
159	2.602	193	2.575	335	2.511	925	2.434
160	2.601	194	2.574	340	2.509	950	2.433
161	2.600	195	2.573	345	2.508	975	2.432
162	2.600	196	2.572	350	2.506	1000	2.430
163	2.599	197	2.572	355	2.505	1500	2.411
164	2.598	198	2.571	360	2.504	2000	2.399
165	2.597	199	2.570	365	2.502	3000	2.385
166	2.596	200	2.570	370	2.501	5000	2.372
167	2.595	205	2.566	375	2.500	10,000	2.358
168	2.594	210	2.563	380	2.499	∞	2.326
169	2.593	215	2.560	385	2.498		
170	2.592	220	2.557	390	2.496		
171	2.592	225	2.555	395	2.495		

TABLE 8.5.12 Ranks, r_B , for determining nonparametric B-basis values.

n	R_b	n	r_B	n	r_B
28	†	660	54	3901	360
29	1	682	56	4005	370
46	2	704	58	4109	380
61	3	726	60	4213	390
76	4	781	65	4317	400
89	5	836	70	4421	410
103	6	890	75	4525	420
116	7	945	80	4629	430
129	8	999	85	4733	440
142	9	1053	90	4836	450
154	10	1107	95	4940	460
167	11	1161	100	5044	470
179	12	1269	110	5147	480
191	13	1376	120	5251	490
203	14	1483	130	5354	500
215	15	1590	140	5613	525
227	16	1696	150	5871	550
239	17	1803	160	6130	575
251	18	1909	170	6388	600
263	19	2015	180	6645	625
275	20	2120	190	6903	650
298	22	2226	200	7161	675
321	24	2331	210	7418	700
345	26	2437	220	7727	730
368	28	2542	230	8036	760
391	30	2647	240	8344	790
413	32	2752	250	8652	820
436	34	2857	260	8960	850
459	36	2962	270	9268	880
481	38	3066	280	9576	910
504	40	3171	290	9884	940
526	42	3276	300	10191	970
549	44	3380	310	10499	1000 ¹
571	46	3484	320		
593	48	3589	330		
615	50	3693	340		
638	52	3797	350		

†B-value does not exist for $n < 28$.¹For $n > 10499$, use Equation 8.5.12.

TABLE 8.5.13 Ranks, r_A , for determining non-parametric A-basis values (Reference (8.6.8 (c))).

n	r_A	n	r_A	n	r_A	n	r_A
≤298	†	3603	27	6657	54	9627	81
299	1	3719	28	6769	55	9736	82
473	2	3834	29	6879	56	9854	83
628	3	3949	30	6990	57	9954	84
773	4	4064	31	7100	58	10063	85
913	5	4179	32	7211	59	10172	86
1049	6	4293	33	7322	60	10281	87
1182	7	4407	34	7432	61	10390	88
1312	8	4521	35	7543	62	10498	89
1441	9	4635	36	7653	63	10607	90
1568	10	4749	37	7763	64	10716	91
1693	11	4862	38	7874	65	10824	92
1818	12	4975	39	7984	66	10933	93
1941	13	5088	40	8094	67	11041	94
2064	14	5201	41	8204	68	11150	95
2185	15	5314	42	8314	69	11258	96
2306	16	5427	43	8423	70	11366	97
2426	17	5539	44	8533	71	11475	98
2546	18	5651	45	8643	72	11583	99
2665	19	5764	46	8753	73	11691	100 ¹
2784	20	5876	47	8862	74		
2902	21	5988	48	8972	75		
3020	22	6099	49	9081	76		
3137	23	6211	50	9190	77		
3254	24	6323	51	9300	78		
3371	25	6434	52	9409	79		
3487	26	6545	53	9518	80		

† A-value does not exist for $n < 299$ ¹
 For $N > 11691$, use Equation 8.5.13

TABLE 8.5.14 *Nonparametric B-basis factors for small sample sizes (Reference 8.3.4.5.2(a)).*

n	r_B	k_B
2	2	35.177
3	3	7.859
4	4	4.505
5	4	4.101
6	5	3.064
7	5	2.858
8	6	2.382
9	6	2.253
10	6	2.137
11	7	1.897
12	7	1.814
13	7	1.738
14	8	1.599
15	8	1.540
16	8	1.485
17	8	1.434
18	9	1.354
19	9	1.311
20	10	1.253
21	10	1.218
22	10	1.184
23	11	1.143
24	11	1.114
25	11	1.087
26	11	1.060
27	11	1.035
28	12	1.010

TABLE 8.5.15 *Nonparametric A-basis factors for small sample sizes (Reference 8.3.4.5.2(b)).*

n	k_A	n	k_A	n	k_A
2	80.00380	38	1.79301	98	1.31553
3	16.91220	39	1.77546	100	1.30806
4	9.49579	40	1.75868	105	1.29036
5	6.89049	41	1.74260	110	1.27392
6	5.57681	42	1.72718	115	1.25859
7	4.78352	43	1.71239	120	1.24425
8	4.25011	44	1.69817	125	1.23080
9	3.86502	45	1.68449	130	1.21814
10	3.57267	46	1.67132	135	1.20620
11	3.34227	47	1.65862	140	1.19491
12	3.15540	48	1.64638	145	1.18421
13	3.00033	49	1.63456	150	1.17406
14	2.86924	50	1.62313	155	1.16440
15	2.75672	52	1.60139	160	1.15519
16	2.65889	54	1.58101	165	1.14640
17	2.57290	56	1.56184	170	1.13801
18	2.49660	58	1.54377	175	1.12997
19	2.42833	60	1.52670	180	1.12226
20	2.36683	62	1.51053	185	1.11486
21	2.31106	64	1.49520	190	1.10776
22	2.26020	66	1.48063	195	1.10092
23	2.21359	68	1.46675	200	1.09434
24	2.17067	70	1.45352	205	1.08799
25	2.13100	72	1.44089	210	1.08187
26	2.09419	74	1.42881	215	1.07595
27	2.05991	76	1.41724	220	1.07024
28	2.02790	78	1.40614	225	1.06471
29	1.99791	80	1.39549	230	1.05935
30	1.96975	82	1.38525	235	1.05417
31	1.94324	84	1.37541	240	1.04914
32	1.91822	86	1.36592	245	1.04426
33	1.89457	88	1.35678	250	1.03952
34	1.87215	90	1.34796	275	1.01773
35	1.85088	92	1.33944	299	1.00000
36	1.83065	94	1.33120		
37	1.81139	96	1.32324		

TABLE 8.5.16 Critical values for approximate confidence limits on the coefficient of variation.

n	Confidence level					
	Lower limit C_l			Upper limit C_u		
	0.99	0.95	0.90	0.90	0.95	0.99
2	0.3562	0.4461	0.5101	15.989	31.999	160.051
3	0.4344	0.5207	0.5778	4.415	6.285	14.124
4	0.4834	0.5665	0.6196	2.920	3.729	6.467
5	0.5188	0.5991	0.6493	2.372	2.874	4.396
6	0.5464	0.6242	0.6720	2.089	2.453	3.485
7	0.5688	0.6444	0.6903	1.915	2.202	2.980
8	0.5875	0.6612	0.7054	1.797	2.035	2.660
9	0.6036	0.6755	0.7183	1.711	1.916	2.439
10	0.6177	0.6878	0.7293	1.645	1.826	2.278
20	0.7018	0.7604	0.7939	1.370	1.461	1.666
30	0.7444	0.7964	0.8255	1.280	1.344	1.487
40	0.7718	0.8191	0.8453	1.232	1.284	1.397
50	0.7914	0.8353	0.8594	1.202	1.246	1.341
60	0.8065	0.8476	0.8701	1.181	1.220	1.303
70	0.8185	0.8574	0.8785	1.165	1.200	1.274
80	0.8284	0.8654	0.8855	1.152	1.185	1.252
90	0.8368	0.8722	0.8913	1.142	1.172	1.235
100	0.8440	0.8780	0.8963	1.134	1.162	1.220
125	0.8583	0.8895	0.9062	1.118	1.142	1.193
150	0.8692	0.8982	0.9137	1.106	1.128	1.173
200	0.8849	0.9106	0.9243	1.090	1.109	1.147
250	0.8959	0.9193	0.9317	1.080	1.096	1.129
500	0.9243	0.9416	0.9507	1.055	1.066	1.088

TABLE 8.5.17 *One-sided tolerance factors for acceptance limits on mean values, for normal distribution.*

α	Number of Samples (n)								
	2	3	4	5	6	7	8	9	10
0.5	0.1472	0.1591	0.1539	0.1473	0.1410	0.1354	0.1303	0.1258	0.1217
0.25	0.6266	0.5421	0.4818	0.4382	0.4048	0.3782	0.3563	0.3379	0.3221
0.1	1.0539	0.8836	0.7744	0.6978	0.6403	0.5951	0.5583	0.5276	0.5016
0.05	1.3076	1.0868	0.9486	0.8525	0.7808	0.7246	0.6790	0.6411	0.6089
0.025	1.5266	1.2626	1.0995	0.9866	0.9026	0.8369	0.7838	0.7396	0.7022
0.01	1.7804	1.4666	1.2747	1.1425	1.0443	0.9678	0.9059	0.8545	0.8110
0.005	1.9528	1.6054	1.3941	1.2488	1.1411	1.0571	0.9893	0.9330	0.8854
0.0025	2.1123	1.7341	1.5049	1.3475	1.2309	1.1401	1.0668	1.0061	0.9546
0.001	2.3076	1.8919	1.6408	1.4687	1.3413	1.2422	1.1622	1.0959	1.0397
0.0005	2.4457	2.0035	1.7371	1.5546	1.4196	1.3145	1.2298	1.1596	1.1002
0.00025	2.5768	2.1097	1.8287	1.6363	1.4941	1.3835	1.2943	1.2203	1.1578
0.0001	2.7411	2.2429	1.9436	1.7390	1.5877	1.4701	1.3752	1.2966	1.2301
0.00005	2.8595	2.3389	2.0266	1.813	1.6553	1.5326	1.4337	1.3517	1.2824
0.000025	2.9734	2.4313	2.1065	1.8844	1.7204	1.5928	1.4900	1.4048	1.3327
0.00001	3.1179	2.5487	2.2079	1.9751	1.8031	1.6694	1.5616	1.4723	1.3968

TABLE 8.5.18 *One-sided tolerance factors for acceptance limits on individual values, for normal distribution.*

α	Number of Samples (n)								
	2	3	4	5	6	7	8	9	10
0.5	0.7166	1.0254	1.2142	1.3498	1.4548	1.5400	1.6113	1.6724	1.7258
0.25	1.2887	1.5407	1.6972	1.8106	1.8990	1.9711	2.0317	2.0838	2.1295
0.1	1.8167	2.0249	2.1561	2.2520	2.3272	2.3887	2.4407	2.4856	2.525
0.05	2.1385	2.3239	2.4420	2.5286	2.5967	2.6527	2.7000	2.7411	2.7772
0.025	2.4208	2.5888	2.6965	2.7758	2.8384	2.8900	2.9337	2.9717	3.0052
0.01	2.7526	2.9027	2.9997	3.0715	3.1283	3.1753	3.2153	3.25	3.2807
0.005	2.9805	3.1198	3.2103	3.2775	3.3309	3.3751	3.4127	3.4455	3.4745
0.0025	3.1930	3.3232	3.4082	3.4716	3.5220	3.5638	3.5995	3.6307	3.6582
0.001	3.4549	3.5751	3.6541	3.7132	3.7603	3.7995	3.8331	3.8623	3.8883
0.0005	3.6412	3.7550	3.8301	3.8864	3.9314	3.9690	4.0011	4.0292	4.0541
0.00025	3.8188	3.9270	3.9987	4.0526	4.0958	4.1319	4.1628	4.1898	4.2138
0.0001	4.0421	4.1439	4.2117	4.2629	4.304	4.3384	4.3678	4.3936	4.4166
0.00005	4.2035	4.3011	4.3664	4.4157	4.4554	4.4886	4.5172	4.5422	4.5644
0.000025	4.3592	4.4530	4.5160	4.5637	4.6022	4.6344	4.6620	4.6863	4.7079
0.00001	4.5573	4.6466	4.7069	4.7527	4.7897	4.8206	4.8473	4.8707	4.8915

TABLE 8.5.19 Upper and lower tail quantiles for two-sided *t*-distribution.

n	a									
	0.4	0.25	0.1	0.05	0.025	0.01	0.005	0.0025	0.001	0.0005
1	0.325	1	3.078	6.314	12.706	31.821	63.657	127.32	318.31	636.62
2	0.289	0.816	1.886	2.920	4.303	6.965	9.925	14.089	23.326	31.598
3	0.277	0.765	1.638	2.353	3.182	4.541	5.841	7.453	10.213	12.924
4	0.271	0.741	1.533	2.132	2.776	3.747	4.604	5.598	7.173	8.610
5	0.267	0.727	1.476	2.015	2.571	3.365	4.032	4.773	5.893	6.869
6	0.265	0.718	1.440	1.943	2.447	3.143	3.707	4.317	5.208	5.959
7	0.263	0.711	1.415	1.895	2.365	2.998	3.499	4.029	4.785	5.408
8	0.262	0.706	1.397	1.860	2.306	2.896	3.355	3.833	4.501	5.041
9	0.261	0.703	1.383	1.833	2.262	2.821	3.250	3.690	4.297	4.781
10	0.260	0.700	1.372	1.812	2.228	2.764	3.169	3.581	4.144	4.587
11	0.260	0.697	1.363	1.796	2.201	2.718	3.106	3.497	4.025	4.437
12	0.259	0.695	1.356	1.782	2.179	2.681	3.055	3.428	3.930	4.318
13	0.259	0.694	1.350	1.771	2.160	2.650	3.012	3.372	3.852	4.221
14	0.258	0.692	1.345	1.761	2.145	2.624	2.977	3.326	3.787	4.140
15	0.258	0.691	1.341	1.753	2.131	2.602	2.947	3.286	3.733	4.073
16	0.258	0.690	1.337	1.746	2.120	2.583	2.921	3.252	3.686	4.015
17	0.257	0.689	1.333	1.740	2.110	2.567	2.898	3.222	3.646	3.965
18	0.257	0.688	1.330	1.734	2.101	2.552	2.878	3.197	3.610	3.922
19	0.257	0.688	1.328	1.729	2.093	2.539	2.861	3.174	3.579	3.883
20	0.257	0.687	1.325	1.725	2.086	2.528	2.845	3.153	3.552	3.850
21	0.257	0.686	1.323	1.721	2.080	2.518	2.831	3.135	3.527	3.819
22	0.256	0.686	1.321	1.717	2.074	2.508	2.819	3.119	3.505	3.792
23	0.256	0.685	1.319	1.714	2.069	2.500	2.807	3.104	3.485	3.767
24	0.256	0.685	1.318	1.711	2.064	2.492	2.797	3.091	3.467	3.745
25	0.256	0.684	1.316	1.708	2.060	2.485	2.787	3.078	3.450	3.725
26	0.256	0.684	1.315	1.706	2.056	2.479	2.779	3.067	3.435	3.707
27	0.256	0.684	1.314	1.703	2.052	2.473	2.771	3.057	3.421	3.690
28	0.256	0.683	1.313	1.701	2.048	2.467	2.763	3.047	3.408	3.674
29	0.256	0.683	1.311	1.699	2.045	2.462	2.756	3.038	3.396	3.659
∞	0.253	0.674	1.282	1.645	1.960	2.326	2.576	2.807	3.090	3.291

REFERENCES

- 8.1.4 Moore, D.S. and McCabe, G.P., *Introduction to the Practice of Statistics*, Second Edition, W.H. Freeman, New York, 1993.
- 8.3.2.2 Scholz, F.W. and Stephens, M.A., "K-Sample Anderson-Darling Tests of Fit," *Journal of the American Statistical Association*, Vol 82, 1987, pp. 918-924.
- 8.3.3.1(a) Snedecor, G.W. and Cochran, W.G., *Statistical Methods*, 7th ed., The Iowa State University Press, 1980, pp. 252-253.
- 8.3.3.1(b) Stefansky, W., "Rejecting Outliers in Factorial Designs," *Technometrics*, Vol 14, 1972, pp. 469-479.
- 8.3.4(a) Bury, K.V., *Statistical Models in Applied Science*, John Wiley and Sons, 1975, reprinted by Krieger, 1989, pp. 585-589.
- 8.3.4(b) Smith, R.L., et al., "Lower Tail Approximations for the Probability of Failure of Three-Dimensional Fibrous Composites with Hexagonal Geometry," *Proc. Royal Society London*, Vol A388, 1983, pp. 353-391.
- 8.3.4(c) Phoenix, S.L. and Smith, R.L. "A Comparison of Probabilistic Techniques for the Strength of Fibrous Materials under Local Load Sharing Among Fibers," *International Journal of Solids and Structures*, Vol 19, 1983, pp. 479-496.
- 8.3.4.2 Lawless, J.F., *Statistical Models and Methods for Lifetime Data*, John Wiley & Sons, 1982, pp. 150, 452-460.
- 8.3.4.5.1 *Metallic Materials and Elements for Aerospace Vehicle Structures*, MIL-HDBK-5E, Naval Publications and Forms Center, Philadelphia, Pennsylvania, 1 June 1987, pp. 9-166,9-167.
- 8.3.4.5.2(a) Hanson, D.L. and Koopmans, L.H., "Tolerance Limits for the Class of Distribution with Increasing Hazard Rates," *Annals of Math. Stat.*, Vol 35, 1964, pp. 1561-1570.
- 8.3.4.5.2(b) Vangel, M.G., "One-Sided Nonparametric Tolerance Limits," *Communications in Statistics: Simulation and Computation*, Vol. 23, 1994, p. 1137.
- 8.3.5.1(a) Draper, N.R. and Smith, H., *Applied Regression Analysis*, 2nd ed., John Wiley & Sons, 1981.
- 8.3.5.1(b) Hinkelmann, K and Kempthorne, O., *Design and Analysis of Experiments Volume 1: Introduction to Experimental Design*, New York, John Wiley & Sons, 1994.
- 8.3.5.1(c) Scheffé, H., *The Analysis of Variance*, John Wiley & Sons, 1959.
- 8.3.5.1(d) Box, G.E.P., Hunter, W.G., and Hunter, J.S., *Statistics for Experimenters*, John Wiley & Sons, 1981.
- 8.3.5.1(e) Pierce, D.A. and Kopecky, K.J., "Testing Goodness-of-Fit for the Distribution of Errors in Regression Models," *Biometrika*, Vol 66, 1979, pp. 1-5.
- 8.3.5.2(a) Searle, S.R., *Linear Models*, John Wiley & Sons, 1971, pp. 473-474.
- 8.3.5.2(b) Vangel, M.G., "New Methods for One-Sided Tolerance Limits for a One-Way Balanced Random Effects ANOVA Model," *Technometrics*, Vol 34, 1992, pp. 176-185.

Volume 1, Chapter 8 Statistical Methods

- 8.3.5.2.1(a) Lehmann, E.L., *Testing Statistical Hypotheses*, John Wiley & Sons, 1959, pp. 274-275.
- 8.3.5.2.1(b) Levene, H., "Robust Tests for Equality of Variances," in *Contributions to Probability and Statistics*, ed. I. Olkin, Palo, Alto, CA: Stanford University Press, 1960.
- 8.3.5.2.1(c) Conover, W.J., Johnson, M.E., and Johnson, M.M., "A Comparative Study of Tests for Homogeneity of Variances, with Applications to the Outer Continental Shelf Bidding Data," *Technometrics*, Vol. 23, pp. 351-361, 1981
- 8.3.5.4(a) Shyprykevich, P., "The Role of Statistical Data Reduction in the Development of Design Allowables for Composites," *Test Methods for Design Allowables for Fibrous Composites: 2nd Volume*, ASTM STP 1003, C.C. Chamis, ed., American Society for Testing and Materials, Philadelphia, PA, 1989, pp. 111-135.
- 8.3.5.4(b) Tomblin, John S., Ng, Yeow C., and Raju, K. Suresh, "Material Qualification and Equivalency for Polymer Matrix Composite Material Systems," DOT/FAA/AR-00/47, March 2001.
- 8.3.6 Tukey, J.W., *Exploratory Data Analysis*, Addison-Wesley Publishing Company, 1977
- 8.3.6.1 Parzen, E., "A Density-Quantile Function Perspective on Robust Estimation," *Robustness in Statistics*, Academic Press, New York, 1979
- 8.3.6.2(a) Parzen, E., "Entropy Interpretation of Tests for Normality by Shapiro-Wilk Statistics," presented at the Twenty-Eighth Conference on the Design of Experiments in Army Research, Development, and Testing, 20-22 October 1982, Monterey, California
- 8.3.6.2(b) Parzen, E., "Informative Quantile Function and Identification of Probability Distribution Types," Technical Report A-26, Department of Statistics, Texas A&M University (August 1983)
- 8.3.7.2(a) Vangel, M.G., "One-Sided β -Content Tolerance Intervals for Mixed Models with Two Components of Variance," *Technometrics*, submitted
- 8.3.7.2(b) Vangel, M.G., "Design Allowables From Regression Models Using Data From Several Batches," in *12th Symposium on Composite Materials: Testing and Design*, American Society of Testing and Materials, to appear, 1996
- 8.4.3.2 Vangel, M.G., "Confidence Intervals for a Normal Coefficient of Variation," *The American Statistician*, Vol. 14, pp. 21-26, 1996
- 8.4.5(a) Papiro, R., "Average Stress-Strain Curves for Resin Matrix Composites," *Composite Technology Review*, 1986, pp. 107-116
- 8.4.5(b) Papiro, R., "Algebraic Approximations of Stress-Strain Curves for Kevlar-Reinforced Composites," *Journal of Testing and Evaluation*, Vol 13, 1985, pp. 115-122
- 8.5.2 Johnson, N.L. and Kotz, S., *Distributions in Statistics: Continuous Univariate Distributions - 1*, John Wiley & Sons, 1970, p. 176
- 8.5.9 Jones, R.A., Ossiander, M., Scholz, F.W., and Shorack, G.R., "Tolerance Bounds for Log-gamma Regression Model," *Technometrics*, Vol 27, May 1985, pp. 109-118
- 8.5.11 Odeh, R.E. and Owen, D.B., *Tables of Normal Tolerance Limits, Sampling Plans and Screening*, Marcel Dekker, 1980.

- 8.5.17 Vangel, Mark, "Acceptance and Compliance Testing Using the Sample Mean and an Extrema", submitted to Technometrics, 2001.

Abbreviations	Ch 1-18, 23
Acceptance	
Material	Ch 2-4, 42
Acronyms	Ch 1-26
Additives	Ch 5-1, 4
Aging	Ch 6-4
Alignment	Ch 5-2
Alternate material	Ch 2-4, 6, 42, 43, 44, 45, 48, Ch 8-1, 68
Alternate source	Ch 2-42, Ch 8-68
Analysis of variance (ANOVA)	Ch 2-12, 13, Ch 8-1, 6, 8, 9, 11, 13, 14, 15, 16, 27, 28, 29, 30, 31, 32, 33, 52, 53, 54, 55, 56, 58, 63, 69, 72
Multiple sources	Ch 8-63
Table	Ch 8-31, 58
Aramid fiber	Ch 7-44
Area	
Cross-sectional	Ch 3-6, 10, 11, 21
Areal weight	Ch 3-6, Ch 5-4, 43
Basis values ...	Ch 8-1, 7, 8, 9, 10, 11, 12, 13, 14, 16, 19, 20, 23, 24, 25, 26, 27, 29, 32, 35, 38, 40, 45, 48, 49, 51, 52, 54, 60, 61, 63, 64, 65, 84, 102, 103
Batch effects	Ch 8-28, 35
Bearing	Ch 2-3, 11, 31, 32, 42, 58, 60, 61, 70, 74, 87, Ch 7-1, 7, 15, 16, 17, 20, 21, 22, 23, 24, 25, 26, 30, 31, 32, 33, 34, 35, 36, 41, 42, 45
Bearing area	Ch 7-41
Bearing strength	Ch 7-15, 16, 17, 20, 21, 22, 23, 24, 26, 33, 34, 45
Bearing/bypass	Ch 7-30
Bias	Ch 2-8, 82
Bismaleimide	Ch 2-34, 64
Braiding	Ch 1-17, 30, 31, 34, 37, 39, Ch 6-141
Building-block approach	Ch 2-1, 2, 57
Capacitative extensometers	Ch 6-20
Carbon fiber	Ch 3-1, 2, 3, 5, 7, 8, 9, 10, 14, 15, Ch 7-44
PAN	Ch 3-1
Certification	Ch 2-1, 2, 4, 6, 11, 20, 57, 58
ch ² - distribution	Ch 8-84, 88
Chemical properties	Ch 2-2, 38, 50
Chemical techniques	
Fiber	Ch 3-1
Matrix	Ch 4-4
Chromatography	Ch 2-9, 38, 55, Ch 4-4, 5, 6, 8, 9, 10, 11, 12, 14, Ch 5-1, 2, 4, 5, 6, 7
Coefficient of thermal expansion	Ch 6-55
Coefficient of variation	Ch 8-1, 2, 11, 13, 71, 72, 84, 106
Compatibility	
Material	Ch 2-43, 44
Statistical	Ch 8-4, 16
Composition	
Fiber	Ch 3-1
Compression after impact tests	Ch 7-1, 63
Compression tests	
Filament	Ch 3-14
Filament winding	Ch 6-140
Lamina/laminate	Ch 2-70, Ch 6-104
Computer software	Ch 8-1

Volume 1, Index

Conditioning	Ch 2-5, 9, 16, 18, 20, 27, 35, 58, 61, Ch 6-4, 5, 6, 7, 8, 9, 16, 20, 26, 28, 35, 37, 39, 91, 92, 96
Accelerated.....	Ch 6-4, 7
Equilibrium.....	Ch 6-4, 5, 6, 9
Fixed-time.....	Ch 6-4, 5, 6
Confidence interval.....	Ch 8-1, 68, 69, 71
Confidence limits.....	Ch 8-8, 84, 106
Confounding.....	Ch 8-9
Control chart.....	Ch 8-73, 74, 75, 77
Coordination Group.....	Ch 1-3, 17, 18, Ch 2- 20, 82, 87
Crack lap shear (CLS).....	Ch 6-135
Creep tests	
Lamina/laminate.....	Ch 6-138
Crystalline melt temperature.....	Ch 6-28, 33
Cured ply thickness (CPT).....	Ch 2-3, 9, 43, 71, 72, 73, 74, 75, 87, Ch 6-40
Damage tolerance.....	Ch 2-32, 44, Ch 7-1, 63
Data.....	Ch 1-1, 2, 3, 4, 16, 17, 18, 20, 27, 28, 39, 44, 47, Ch 2-1, 2, 3, 4, 5, 6, 7, 8, 9, 10, 11, 12, 20, 23, 25, 29, 31, 40, 42, 44, 45, 51, 56, 57, 58, 60, 61, 64, 65, 67, 68, 70, 71, 74, 75, 81, 82, 87, 88, 89
Class.....	Ch 2-78
Review process.....	Ch 2-79
Sampling requirements.....	Ch 2-80
Data application categories.....	Ch 2-2, 5
Data documentation.....	Ch 2-2, 4, 30, 51, 64, 82
Data leveraging.....	Ch 2-66
Data pooling.....	Ch 2-6, 58, 61, 87, Ch 8-17
Data submission.....	Ch 1-18, Ch 2- 64, 82
Data substantiation.....	Ch 2-66
Definitions.....	Ch 1-29, Ch 7-13, 34, Ch 8-3, 6, 7, 8, 16, 25, 48
Delamination.....	Ch 2-24
Density.....	Ch 2-9, 39, 55, 88, Ch 6-28, 29, 34, 35, 36, 37, 38, 39, 40, 43, 48, 49
Fiber.....	Ch 3-6
Matrix.....	Ch 4-17
Design.....	Ch 7-1, 11, 15, 17, 20, 21, 23, 31, 34, 36, 42, 46, 47, 48, 50, 52, 54, 59
Differential scanning calorimetry (DSC).....	Ch 2-9, 38, 55, Ch 4-9, 12, 15, Ch 5-1, 2, 7, 8, 29, 30, 33
Differential thermal analysis (DTA).....	Ch 4-9, 12, 15
Dimensional stability (moisture).....	Ch 6-58
Double.....	Ch 7-16, 21, 33, 44, 54
Double cantilever beam (DCB).....	Ch 6-131, 133
Drape.....	Ch 5-4
Dynamic mechanical analysis (DMA).....	Ch 2-9, 23, 38, Ch 5-1, 8, Ch 6-32
Heat distortion.....	Ch 6-32
Electrical properties.....	Ch 6-87
Electrical resistivity	
Fiber.....	Ch 3-8, 21
Elemental analysis.....	Ch 4-4, 5, 14
End notched flexure (ENF).....	Ch 6-133
Environmental effects.....	Ch 2-20, 24, 33, 58
Epoxy.....	Ch 2-7, 18, 19, 20, 23, 31, 33, 36, 60, 64, 69, Ch 6-5, 7, 29, 35, 91
Equality of variance.....	Ch 8-6, 16, 29, 30, 52, 53
Equivalence.....	Ch 8-68
Material.....	Ch 2-66
Exploratory data analysis.....	Ch 8-14, 19, 36
Extensometers.....	Ch 6-10, 15, 16, 17, 18, 20, 27, 91, 117

Extent of cure.....	Ch 6-28
Fabric.....	Ch 3-6, 10, 22
Failure modes.....	Ch 2-1, 7, 60, 61, 87, Ch 6-27, 89, 92, Ch 7-1, 11, 14, 27, 42, 59, 64
Fastener.....	Ch 2-60, Ch 7-1, 6, 7, 11, 17, 19, 20, 21, 22, 23, 24, 25, 34, 36, 37, 38, 39, 40, 41, 42, 43, 44, 45, 46
Fatigue tests	
Lamina/laminate.....	Ch 6-137
F-distribution.....	Ch 8-6, 30, 35, 75, 81, 86, 87
Fiber	
Physical properties.....	Ch 3-2, 6
Fiber areal weight.....	Ch 2-9
Fiber content.....	Ch 2-9, 71, Ch 5-3, 5
Fiber diameter.....	Ch 3-3, 6, 18
Fiber properties.....	Ch 3-1, 10, 14
Fiber volume.....	Ch 2-9, 13, 29, 39, 71, 72, 73, 74, 75, 87, Ch 6-28, 41, 42, 43, 46
Filament winding.....	Ch 2-10, 41, 42, Ch 6-95, 139
Fillers.....	Ch 5-4
Fire growth.....	Ch 6-79
Fixed effect.....	Ch 8-6, 7, 16, 17, 26, 31, 60
Flame spread.....	Ch 6-81
Flame spread properties.....	Ch 6-81
Flexure tests.....	Ch 6-6, 128
Fluid sensitivity.....	Ch 2-33
Fracture mechanics.....	Ch 6-129, 137
Fracture toughness.....	Ch 6-128, 137
Fracture toughness tests	
Lamina/laminate.....	Ch 6-129
F-test.....	Ch 8-30
Fuels.....	Ch 2-34
Gaps.....	Ch 5-2, 3
Gel time.....	Ch 2-9, 38, 55, Ch 5-4, 8
Glass fiber.....	Ch 3-1, Ch 7-44
Glass transition temperature.....	Ch 2-9, 23, 33, 55, Ch 3-9, 14, 15, Ch 5-8, Ch 6-4, 28, 29
Goodness-of-fit test.....	Ch 8-14, 19, 20, 23, 24, 28, 40, 44, 45, 46, 49, 50, 51, 52, 57, 58
Hanson-Koopmans method.....	Ch 8-26, 51, 52
Health hazards.....	Ch 1-17
Helium pycnometry.....	Ch 6-36
Specimen preparation.....	Ch 6-38
High temperature.....	Ch 2-24, 27, 32, 33
Image analysis.....	Ch 6-45
Impact.....	Ch 7-1, 63, 64, 65
Informative quantile function.....	Ch 8-2, 3, 36, 38, 40
Infrared spectroscopy.....	Ch 2-9, 38, Ch 3-2, 4, 5, 4, 5, 6, 12, Ch 5-1, 7
Instrumentation.....	Ch 6-10, 15, 17, 18, 19, 20, 27, 34, 92, 121, 125, 126, 127
Joint	
Double shear.....	Ch 7-17, 33
Single.....	Ch 7-44
Single shear.....	Ch 7-16
k-sample Anderson-Darling test.....	Ch 8-14, 16, 17, 40, 42, 46, 49, 51, 52, 82, 92

Volume 1, Index

Lamina	Ch 6-1, 88, 90
Mechanical properties	Ch 2-31, 39, 87
Physical properties	Ch 2-39, 88, Ch 6-28
Properties from laminates	Ch 2-29, 67, 87, Ch 6-90
Thermal properties	Ch 6-28
Laminate	Ch 6-1, 5, 6, 9, 10, 11, 16, 41, 42, 49, 88, 89, 90, 91, 92, 95, 97, 102, 118, 126, 127, 129, 132, 133, 137, 138, 140
Mechanical properties	Ch 2-58, 87
Physical properties	Ch 2-88, Ch 6-28
Thermal properties	Ch 6-28
Laminate characterization.....	Ch 2-58
Lognormal distribution	Ch 8-1, 14, 25, 40, 49
LVDT deflectometers	Ch 6-16
Material operational limit (MOL).....	Ch 2-20, 22, 23, 24, 25, 27, 58, 61, 64, Ch 6-29, 32
Matrix	
Thermal properties	Ch 4-14
Mechanical properties.....	Ch 2-3, 13, 16, 20, 23, 24, 27, 31, 32, 39, 40, 41, 42, 48, 57, 64, 65, 67, 80, 87, 88
Mechanically-fastened joints.....	Ch 7-22, 24, 28, 29, 30
Mixed mode	Ch 6-129, 130, 131, 135
Mixed mode bending (MMB).....	Ch 6-135, 136, 137
Moisture content	Ch 2-9, 16, 18, 19, 20, 22, 27, 38, 39, 40, 41, 64, 65, 88, Ch 6-5, 6, 7, 8, 27, 28, 92
Fiber	Ch 3-5
Matrix.....	Ch 4-4, 20
Prepreg.....	Ch 5-4
Moisture diffusion.....	Ch 6-4, 5, 6, 7, 8
Moisture diffusivity	Ch 2-9, 18, 52
Moisture effects.....	Ch 2-20
Moisture expansion.....	Ch 2-16, 88
Molecular weight.....	Ch 4-6, 7, 8, 10, 12
Morphology	
Matrix.....	Ch 4-17
Multiaxial tests	Ch 6-137
Nonparametric method	Ch 8-84, 102, 104
Large samples.....	Ch 8-25, 51
Small samples	Ch 8-26, 51
Normal distribution.....	Ch 8-2, 5, 8, 9, 11, 13, 14, 19, 23, 24, 25, 27, 32, 39, 40, 45, 46, 69, 70, 72, 73, 82, 83, 84, 91, 98, 99, 100, 101
Normalization	Ch 6-1, 5, 29, 70, 71, 73, 74, 75, 87
Notched compression strength.....	Ch 7-1
Notched compressive strength	Ch 7-12
Notched tensile strength	Ch 7-12
Notched tension strength.....	Ch 7-1
Optical extensometers	Ch 6-19
Outgassing.....	Ch 6-76
Outlier	Ch 8-14, 18, 19, 36, 40, 44, 46, 49, 51, 52, 56, 61, 64, 82, 93
Disposition	Ch 2-75
Ozone depleting chemicals.....	Ch 1-17
Panel effects	Ch 8-9
pH	
Fiber	Ch 3-2, 14, 15

Volume 1, Index

Physical properties.....	Ch 2-3, 38, 39, 88
Fiber	Ch 3-2, 6
Physical techniques	
Matrix.....	Ch 4-14
Polyimide	Ch 2-26, 34, 64
Precision	Ch 2-8, 13, 82
Prepregs	Ch 5-1, 2, 3, 4, 5, 6
Process control	Ch 8-72
Processing	Ch 2-4, 5, 7, 11, 13, 14, 16, 29, 42, 48, 50, 71, 80, 81, 82
Pull-thru strength.....	Ch 7-36
Qualification	Ch 2-1, 3, 4, 11, 20, 38, 42, 43, 44, 45, 48, 56, 57, 58, Ch 7-42, 44, 45, 63
Alternate material	Ch 8-68
Alternate source	Ch 8-68
Alternate supplier	Ch 2-42
Material.....	Ch 8-4, 5
Quantile box plot.....	Ch 8-36, 37
Random effect.....	Ch 8-6, 7, 16, 26, 31, 33, 56, 61, 68, 72
RECIPE.....	Ch 8-1, 9, 10, 15, 16, 27, 40, 46, 47, 48, 49, 52, 54, 55, 56, 59, 60, 61, 63, 64, 65
Linear with random effect.....	Ch 8-61
Multiple sources.....	Ch 8-63, 64
Table.....	Ch 8-54, 59
Regression.....	Ch 2-11, 58, 61, 64, 65, Ch 8-1, 2, 3, 4, 6, 8, 9, 10, 15, 16, 26, 27, 28, 33, 34, 35, 47, 48, 49, 56, 57, 58, 59, 60, 61, 63, 64, 65, 111
Assumptions	Ch 8-27
Linear.....	Ch 8-33, 56
Linear with random effect.....	Ch 8-61
Model.....	Ch 8-27
Residuals	Ch 8-27, 28, 57, 58
Linear.....	Ch 8-57
Resin content.....	Ch 2-9, 38, 55, 71, 74, Ch 5-3, 4, 5
Resin flow	Ch 2-9, 13, 38, Ch 5-4
Rheological analysis	Ch 4-16, 32, Ch 5-1, 8
Roadmaps.....	Ch 1-4
S ² chart	Ch 8-75
Safety.....	Ch 1-16, 17, 21, 22, 27
Sample size	Ch 2-4, 6, 11, 12, 80, 82, Ch 8-2, 4, 5, 10, 11, 13, 14, 18, 19, 25, 26, 29, 30, 32, 52, 82, 84, 104, 105
Sampling	Ch 5-2, 4
Sandwich beam	Ch 6-90, 95, 96
Scale parameter.....	Ch 8-3, 5, 20, 23, 38, 83
Screening.....	Ch 2-3, 31, 32, 33, 50, 57, 65, Ch 7-20, 21, 22, 25, 36, 41, 63
Secretariat.....	Ch 1-17, 18
Shape parameter	Ch 8-3, 5, 20, 44, 83
Shear tests.....	Ch 6-116, 117, 123, 126, 139, 140
Filament winding.....	Ch 6-140
Lamina/laminate	Ch 6-116
Matrix.....	Ch 4-24
Short-beam strength tests	Ch 6-125, 126, 127
Sizing	Ch 3-1, 5, 7, 15, 16
Software	Ch 8-1, 10, 27, 40, 81
Solvents	Ch 2-34
Specific heat.....	Ch 2-89, 68
Fiber	Ch 3-9

Braiding	Ch 6-141
Compression	Ch 6-105, 114
CTE	Ch 6-57
Cured ply thickness	Ch 6-42
Filament winding.....	Ch 2-10, 41, 42, Ch 6-139
Filament wound	Ch 6-141
Fire growth.....	Ch 6-78
Fire resistance	Ch 6-86
Fourier thermal conductivity	Ch 6-64
Fracture toughness	Ch 6-137
Heat release	Ch 6-84
Lamina.....	Ch 2-39, Ch 6-1
Laminate.....	Ch 6-1
Mechanically-fastened joints	Ch 7-17
Moisture diffusion	Ch 6-54
Open-hole compression	Ch 7-10
Open-hole tension	Ch 7-8
Shear	Ch 6-127
Smoke and toxicity	Ch 6-82
Specific heat.....	Ch 6-70
Tension.....	Ch 6-103
Thermal conductivity	Ch 6-68
Thick-section composites.....	Ch 6-145
Test program planning	Ch 2-4, 5
Thermal analysis.....	Ch 4-6, 14, 15, 17, Ch 6-28
Prepregs	Ch 5-1
Thermal conductivity.....	Ch 2-89, Ch 6-60
Fiber	Ch 3-9
Thermal cycling.....	Ch 2-27, 33
Thermal diffusivity.....	Ch 2-89, Ch 6-70
Thermal expansion	Ch 2-88, 89, Ch 6-28, 29, 30, 95
Fibers.....	Ch 3-9
Thermal gravimetric analysis (TGA)	Ch 3-4, 5, Ch 5-12, 14, 15
Thermal mechanical analysis (TMA)	Ch 3-9, 15
Thermal oxidative stability	Ch 2-27, 33
Thermal properties.....	Ch 2-89, Ch 4-14
Thermocouple	Ch 6-20, 28
Thermomechanical analysis (TMA)	Ch 6-30, 31
Thickness.....	Ch 2-9
Thick-section composites	Ch 6-27, 145
Torsion tests.....	Ch 6-124
Torsional braid analysis (TBA)	Ch 4-15, 16
Toxicity	Ch 1-17
Transverse microcrack resistance	Ch 2-27
Trend in test	Ch 8-75
Truncated IQ function	Ch 8-38
Twist.....	Ch 3-6
Unit.....	Ch 1-18, 27, 36, 41, 42, 43, 47
Conversion	Ch 1-27, 28, 30, 46
Unstructured data	Ch 8-1, 4, 7, 8, 14, 16, 18, 19, 23, 24, 25, 26, 29
Material.....	Ch 8-7
Variability.....	Ch 2-4, 13, 16, 67, 69, 71, 75, 81, 87, Ch 8-1, 4, 6, 7, 8, 9, 10, 11, 13, 14, 16, 27, 28, 29, 33, 47, 49, 54, 56, 57, 59, 60, 61, 63, 64, 68
Material.....	Ch 8-7, 8

Volume 1, Index

Viscoelastic properties **Ch 6-138**
Void content **Ch 2-9, Ch 6-48, 49, 139**
Void volume fraction..... **Ch 6-48**
Volatiles content..... **Ch 2-9, 19, Ch 5-3**

Weibull distribution..... **Ch 8-3, 5, 14, 19, 20, 23, 38, 40, 45, 82, 83, 94, 95, 96, 97**

x-bar chart..... **Ch 8-72**

Yield **Ch 3-6**

CONCLUDING MATERIAL

Custodians:

Army - MR
Navy - AS
Air Force - 11

Preparing activity:

Army - MR

(Project CMPS-0171)

Review activities:

Army - AR, AT, AV, MI
Navy - SH
Air Force - 13
DLA-IS

STANDARDIZATION DOCUMENT IMPROVEMENT PROPOSAL

INSTRUCTIONS

1. The preparing activity must complete blocks 1, 2, 3, and 8. In block 1, both the document number and revision letter must be given.
2. The submitter of this form must complete blocks 4, 5, 6, and 7.
2. The preparing activity must provide a reply within 30 days from receipt of the form.

NOTE: This form may not be used to request copies of documents, nor to request waivers, or clarification of requirements on current contracts. Comments submitted on this form do not constitute or imply authorization to waive any portion of the referenced document(s) or to amend contractual requirements.

I RECOMMEND A CHANGE:	1. DOCUMENT NUMBER MIL-HDBK-17-1F	2. DOCUMENT DATE (YYYYMMDD) 20020617
3. DOCUMENT TITLE COMPOSITE MATERIALS HANDBOOK – VOLUME 1, Polymer Matrix Composites, Guidelines for Characterization of Structural Materials		
4. NATURE OF CHANGE <i>(Identify paragraph number and include proposed rewrite, if possible. Attach extra sheets as needed)</i>		
5. REASON FOR RECOMMENDATION		
6. SUBMITTER		
a. NAME (Last, First, Middle Initial)	b. ORGANIZATION	
c. ADDRESS (Include Zip Code)	d. TELEPHONE (Include Area Code) (1) Commercial (2) DSN (If applicable)	7. DATE SUBMITTED (YYYYMMDD)
8. PREPARING ACTIVITY		
a. NAME US Army Research Laboratory Weapons & Materials Research Directorate	b. TELEPHONE (Including Area Code) (1) Commercial (410) 306-0725 (2) DSN 458-0725	
c. ADDRESS (Include Zip Code) ARL/WMRD ATTN: AMSRL-WM-MA Aberdeen Proving Ground, MD 21005-5069	IF YOU DO NOT RECEIVE A REPLY WITHIN 45 DAYS, CONTACT: Defense Standardization Program Office (DLSC-LM) 8725 John J. Kingman Road, Suite 2533, Fort Belvoir, VA 22060-6221 Telephone (703) 767-6888 DSN 427-6888	