



GRADUATE EDUCATION
 (301) 295-3913
 FAX: (301) 295-6772

APPROVAL SHEET

Title of Dissertation: "The bionomics and vector competence of Anopheles albimanus and Anopheles vestitipennis in southern Belize, Central America"

Name of Candidate: John P. Grieco
 Doctor of Philosophy
 20 November 2000

Dissertation and Abstract Approved:

Richard G. Andre

Richard Andre, Ph.D.
 Department of Preventive Medicine & Biometrics
 Committee Chairperson

22 Nov. 2000
 Date

Donald Roberts

Donald Roberts, Ph.D.
 Department of Preventive Medicine & Biometrics
 Committee Member

23 Nov 2000
 Date

LTC Scott Gordon

LTC Scott Gordon, USA
 Department of Preventive Medicine & Biometrics
 Committee Member

22 NOV 2000
 Date

John Cross

John Cross, Ph.D.
 Department of Preventive Medicine & Biometrics
 Committee Member

22 Nov 2000
 Date

Susan Langreth

Susan Langreth, Ph.D.
 Department of Microbiology & Immunology
 Committee Member

22 Nov 2000
 Date

Report Documentation Page

Form Approved
OMB No. 0704-0188

Public reporting burden for the collection of information is estimated to average 1 hour per response, including the time for reviewing instructions, searching existing data sources, gathering and maintaining the data needed, and completing and reviewing the collection of information. Send comments regarding this burden estimate or any other aspect of this collection of information, including suggestions for reducing this burden, to Washington Headquarters Services, Directorate for Information Operations and Reports, 1215 Jefferson Davis Highway, Suite 1204, Arlington VA 22202-4302. Respondents should be aware that notwithstanding any other provision of law, no person shall be subject to a penalty for failing to comply with a collection of information if it does not display a currently valid OMB control number.

1. REPORT DATE 20 NOV 2000		2. REPORT TYPE N/A		3. DATES COVERED -	
4. TITLE AND SUBTITLE "The Bionomics and Vector Competence of Anopheles Albimanus and Anopheles Vestitipennis in Southern Belize, Central America"				5a. CONTRACT NUMBER	
				5b. GRANT NUMBER	
				5c. PROGRAM ELEMENT NUMBER	
6. AUTHOR(S)				5d. PROJECT NUMBER	
				5e. TASK NUMBER	
				5f. WORK UNIT NUMBER	
7. PERFORMING ORGANIZATION NAME(S) AND ADDRESS(ES) Uniformed Services University of the Health Sciences 4301 Jones Bridge Road Bethesda, MD 20814-4799				8. PERFORMING ORGANIZATION REPORT NUMBER	
9. SPONSORING/MONITORING AGENCY NAME(S) AND ADDRESS(ES)				10. SPONSOR/MONITOR'S ACRONYM(S)	
				11. SPONSOR/MONITOR'S REPORT NUMBER(S)	
12. DISTRIBUTION/AVAILABILITY STATEMENT Approved for public release, distribution unlimited					
13. SUPPLEMENTARY NOTES					
14. ABSTRACT					
15. SUBJECT TERMS					
16. SECURITY CLASSIFICATION OF:			17. LIMITATION OF ABSTRACT UU	18. NUMBER OF PAGES 468	19a. NAME OF RESPONSIBLE PERSON
a. REPORT unclassified	b. ABSTRACT unclassified	c. THIS PAGE unclassified			

The author hereby certifies that the use of any copyrighted material in the thesis manuscript entitled:

"The bionomics and vector competence of Anopheles albimanus and Anopheles vestitipennis in southern Belize, Central America"

is appropriately acknowledged and, beyond brief excerpts, is with the permission of the copyright owner.

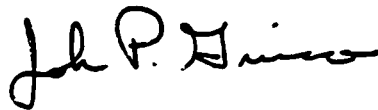

**John P. Grieco
Department of Preventive Medicine and Biometrics
Uniformed Services University of the Health Sciences**

ABSTRACT

The bionomics and vector competence of Anopheles albimanus Weidemann and Anopheles vestitipennis Dyar and Knab (Diptera: Culicidae) in southern Belize, Central America

John Paul Grieco, Doctor of Philosophy, 2001

Dissertation directed by: Donald R. Roberts, Professor, Department of Preventive Medicine and Biometrics

During an 18 month study period (1997-1998) in the Toledo District, southern Belize, a series of studies were undertaken to evaluate the vector competence of the Anopheles mosquitoes. At both Golden Stream and Rancho, the population densities of An. vestitipennis showed positive correlation with human cases of P. vivax. and tested positive for P. vivax 210 (MFIR of 0.01 and MFIR of 0.0004, respectively). Population densities of An. darlingi from Golden Stream showed a negative correlation with high numbers of malaria cases but also tested positive for P. vivax 210 (MFIR of 0.001). Population abundance of An. albimanus from Rancho showed a negative correlation with malaria transmission and was not found naturally infected with malaria parasites.

The feeding preference study showed An. vestitipennis to prefer feeding on human blood while An. albimanus showed a strong tendency for feeding on cattle and non-human hosts.

Human landing collections showed An. albimanus exhibited a bimodal biting pattern with an O:I ratio of 1:0.1. Anopheles vestitipennis, however, exhibited a high level of biting activity throughout the night and a strong endophagic behavior (O:I ratio

of 1:0.9). Post spray, deltamethrin functioned primarily as an irritant, causing premature exiting behavior. DDT exerted a powerful repellency effect resulting in a 97% post-spray reduction of An. vestitipennis females entering the hut.

Results from the comparative susceptibility study showed An. darlingi maintains a high salivary gland infection rate (41.0%) with P. falciparum (NF-54). Anopheles vestitipennis had a low salivary gland infection rate of 9.3% with moderate numbers of sporozoites (i.e. 85.7% containing 50-250 sporozoites). Anopheles albimanus was the least susceptible to salivary gland infection (Golden Stream, 0.0% and Buena Vista, 2.2%).

Although the rate of infection for An. vestitipennis is low, its strong endophagic and anthropophagic behaviors augment its overall vector potential. This species clearly demonstrates characteristics of an important vector of malaria in Belize. The opposite appears to be true of An. albimanus. A low infection rate and both exophagic/zoophagic behaviors reveal this species to be a poor vector of P. falciparum.

Key Words (Indexing): Anopheles albimanus, Anopheles vestitipennis, DDT, deltamethrin, comparative susceptibility, experimental huts, Belize.

The bionomics and vector competence of *Anopheles albimanus* Weidemann and *Anopheles vestitipennis* Dyar and Knab (Diptera: Culicidae) in southern Belize, Central America

By

John Paul Grieco

Dissertation submitted to the Faculty of the Department of Preventive Medicine and Biometrics Graduate Program of the Uniformed Services University of the Health Sciences in Partial fulfillment of the requirements for the degree of Doctor of Philosophy
2000

Acknowledgments

I would like to thank all of the member of the various committees for their guidance and input during the writing of this dissertation: my major professor, Donald R. Roberts, my committee chairman, Dr. Richard G. Andre and committee members Dr. Scott Gordon, Dr. John Cross and Dr. Susan Langreth. Thanks are also extended Dr. Paul Hshieh for providing valuable statistical advice, Dr. Robert Wirtz for the Plasmodium-specific monoclonal antibodies for the sprozoite ELISA, Megan Dowler and Dr. Jack Williams for providing Plasmodium falciparum (NF-54) cultured parasites for the comparative susceptibility tests, Ms. Caroline Korves and Ms. Margaret Pickerel for providing support when equipment was needed, and all of the members of the USUHS community who provided guidance and support throughout this project. I would also like to thank Dr. Eliska Rejmankova for her assistance on numerous occasions which got us out of a jam.

Special thanks and appreciation to Mr. Herbert Lenares, former Director of the Vector Control Program for supporting and permitting this research to take place in Belize. Thanks to Mr. Orlando Chen (Toledo Malaria Supervisor) for providing his support and use of the spray teams to treat the experimental huts. A special thanks to Ms. Yvette Alonzo for providing invaluable support and assistance without which many of the things accomplished in this project would never have been completed. Thanks to Mr. Britt (Manager of Voice of America - Belize) for his friendship and for providing safe storage for our equipment. Thanks to Mr. Clive Geno for maintaining our vehicle in proper working order.

I would like to thank the people of the Toledo District and especially the people of Golden Stream and Rancho villages for allowing us into their homes to do our work. Never once were we made to feel not welcomed. I would particularly like to thank Ignacio and Nola from Golden Stream who helped us in numerous ways. I would like to thank the member of my field teams who spent many hours performing difficult, tedious tasks without complaining: the team from Rancho Village-Santiago Chen (Head Technician), Maria Chen, Maria Sho, Martin Mis, Pedro Sho, Camilio Sho, the team from Golden Stream Village -Antonio and Crispino.

And lastly but most importantly I would like to thank Ms. Nicole Achee for her continued support and devotion throughout this entire endeavor, for without her constant support, both in an intellectual and spiritual sense, this project would never have been completed.

Dedication

This dissertation is dedicated to my father, Angelo John Grieco, who passed away from cancer during my research in Belize. Only now am I realizing his true wisdom.

Table of Contents

	Page
Chapter 1	
General Introduction	1
Chapter 2	
Colonization and Life Table Attributes of a Field Collected Population of <u>Anopheles albimanus</u> (Weidemann) from the Toledo District, Southern Belize.	68
Chapter 3	
Malaria Transmission and Seasonal Prevalence of <u>Anopheles</u> Mosquitoes in Association with Ecological Factors in Southern Belize.	115
Chapter 4	
Use of a Vehicle Mounted Trap for the Collection of <u>Anopheles</u> Mosquitoes (Diptera: Culicidae) from the Toledo District, Belize, Central America.	189
Chapter 5	
Host Feeding Preference of <u>Anopheles</u> (Diptera: Culicidae) Species Collected from Manual Aspiration, Mechanical Aspiration and a Vehicle Mounted Trap in Toledo, Southern Belize, Central America	245
Chapter 6	
A Comparison Study of House Entering and Exiting Behavior of <u>Anopheles vestitipennis</u> (Diptera: Culicidae) Using Experimental Huts Sprayed with DDT or Deltamethrin in the Southern District of Toledo, Belize, Central America.	305

	Page
Chapter 7	
Comparative Susceptibility of Four Species of <u>Anopheles</u> from Belize, Central America to <u>Plasmodium falciparum</u> (NF-54)	358
Chapter 8	
Conclusion	413

List of Tables

	Page
Chapter 1	
Table 1: Malaria incidence and district population data for 1995. Data is separated by district with a calculation of the API (Annual Parasite Index) (Vector Control Program 1997).	59
Table 2: The break down by age and sex of the malaria cases reported in the Toledo District during 1995 (Siez et al. 1997).	59
Table 3: Childhood malaria cases from 1995 separated on the basis of month. Highest numbers of cases occur between the months of July and November which coincides with the rainy season (Siez et al. 1997).	60
Table 4: Classification of the 10 villages with the highest number of malaria cases during 1993, 1994 and 1995. Also shown are the total numbers of Thick Blood Films (TBF) examined and the total number of positives recorded for the entire Toledo District (Siez et al. 1997).	61
Chapter 2	
Table 1: The daily feeding regimen which was provided to the <u>Anopheles albimanus</u> larvae.	99
Table 2: Life table attributes of <u>Anopheles albimanus</u> in colony from southern Belize, Central America conducted from February to November of 1998.	100
Table 3: Life table attributes of <u>Anopheles albimanus</u> , male and female, from Trial 1. Studies were conducted from February to November of 1998 in Punta Gorda, Belize.	101
Table 4: Life table attributes of <u>Anopheles albimanus</u> , male and female, from Trial 2. Studies were conducted from February to November of 1998 in Punta Gorda, Belize.	102

Table 5: Longevity of Anopheles albimanus adults shown by two rearing trials. A trial consisted of four cages of 100 mosquitoes each (50 males and 50 females) from a single generation. Female mosquitoes were offered a source of blood meals and sugar water every day. Studies were conducted from July to August of 1998 in Punta Gorda, Belize. 103

Table 6: Eggs collected from four types of oviposition containers during two trials using Anopheles albimanus colony reared mosquitoes. A trial consisted of four cages of 100 mosquitoes each (50 males and 50 females) from a single generation. Comparisons consisted of white and dark oviposition containers, with and without plant material. Studies were conducted from July to August of 1998 in Punta Gorda, Belize. 104

Chapter 3

Table 1: Total number of adult anophelines collected in adult landing collections in Belize presented by species, by village and by location (I=Indoor collection and O=Outdoor collection). Collections conducted at Rancho were done over a 17 month time span (July 1997-December 1998), all other locations were sampled for 12 months (July 1997-June 1998). 163

Table 2: Total number of adult anophelines collected during two hour adult landing collections at Rancho Village in Belize and displayed by month in which they were collected. Collections were conducted during a 17-month period from July 1997 to November 1998. 164

Table 3: Total number of adult anophelines collected during two hour adult landing collections at Golden Stream Village in Belize and displayed by month in which they were collected. Collections were conducted during a 12-month period from July 1997 to November 1998. 165

	Page
Table 4: Average number of larvae collected per 30 dips per habitat type from locations adjacent to the Rancho site in Belize. Collections were made from November of 1997 to July of 1998.	166
Table 5: Spearman's rho values for the 5 main anopheline species collected at Golden Stream Village, Belize in relation to precipitation, river level and <u>P. vivax</u> infections.	168
Table 6: Spearman's rho values for the 5 main anopheline species collected at Rancho Village, Belize in relation to precipitation, and <u>P. vivax</u> infections.	168
Table 7: <u>Plasmodium</u> infected <u>Anopheles</u> detected by ELISA from seasonal field survey conducted from July 1997-November 1998 from all other localities in the Toledo District, Belize. Numbers of infected pools have been separated based on the month in which they were found.	169
Table 8: <u>Plasmodium</u> infected <u>Anopheles</u> detected by ELISA from seasonal field survey conducted from July 1997-June 1998 at Golden Stream Village, Toledo District.	170
Table 9: <u>Plasmodium</u> infected <u>Anopheles</u> detected by ELISA from seasonal field survey conducted from July 1997-November 1998 at Rancho Village, Toledo.	171
Table 10: <u>Plasmodium</u> infected <u>Anopheles</u> detected by ELISA from seasonal field survey conducted from July 1997-June 1998 from all other localities in the Toledo District, Belize.	172
Table 11: Other aquatic insects found in association with <u>An. albimanus</u> in wet rice field habitat during larval collections from November 1997 to July 1998.	173
Table 12: Other aquatic insects found in association with <u>An. vestitipennis</u> and <u>An. punctimacula</u> in flooded forest habitat during larval collections from November 1997 to July 1998.	174

	Page
Chapter 4	
Table 1: Spearman's rho values for the 3 anopheline species collected in the mobile car trap in relation to temperature, relative humidity, periods of rain and wind speed. Collections were conducted from June to November of 1998.	221
Chapter 5	
Table 1: Number of non-anopheline mosquitoes collected in a resting box which tested positive, using the blood meal ELISA, for hosts found at the site of collection. Values in parentheses indicated the percentage of a species that tested positive for a particular host.	297
Table 2: Number of non-anopheline mosquitoes collected with a backpack aspirator which tested positive, using the blood meal ELISA, for hosts found at the site of collection. Values in parentheses indicated the percentage of a species that tested positive for a particular host.	297
Table 3: A sample of non-anopheline mosquitoes collected with a mobile car top trap which tested positive, using the blood meal ELISA, for hosts found at the site of collection. Values in parentheses indicated the percentage of a species that tested positive for a particular host.	298
Table 4: Numbers of multiple blood meals determined by the ELISA and separated on the basis of collection method.	299
Table 5: Number of multiple blood meals determined by ELISA and separated on the basis of species	299
Table 6: Number of <u>Anopheles</u> testing positive, using the blood meal ELISA, for hosts found at the site of collection. Mosquitoes have been separated on the basis of collection method. Values in parentheses indicated the percentage of a species that tested positive for a particular host.	300
Table 7: Numbers of animals observed from within 100 meters of the study site area where the indoor/outdoor collections and the backpack aspirations were conducted.	301

	Page
Table 8: Feeding Indices for <u>Anopheles vestitipennis</u> based on method of collection of blood engorged specimens	302
Table 9: Feeding Indices for <u>Anopheles albimanus</u> based on method of collection of blood engorged specimens	303
Table 10: Feeding Indices for <u>Anopheles punctimacula</u> based on method of collection of blood engorged specimens	303
Table 11: Foraging ratios for anopheline mosquitoes collected using three different collection techniques. <u>Anopheles</u> have been separated on the basis of collection method.	304
Chapter 6	
Table 1: Summary of the monthly meteorological data collected from March 1998 to December 1998 at the Rancho site, Toledo District, southern Belize.	340
Table 2: Spearman's rho values showing the relationship between entrance and exit intercept trap collections and meteorological conditions during all night collections at the Rancho site.	341
Chapter 7	
Table 1: Infection data from a comparative susceptibility study conducted using <u>Plasmodium falciparum</u> (NF-54). Data based on two membrane feeds conducted with two culture populations (E5 and E7) ^a .	403
Table 2: Salivary gland infection data showing the level of infection based on an estimate of the number of sporozoites observed in the glandular tissue. Data based on two membrane feeds conducted with two culture populations (E5 and E7) ^a .	403
Table 3: A break down of the proportion of mosquitoes which exhibited oocyst counts in designated categories and intensity of infection based on mean number of oocysts per midgut. Data based on one membrane feed.	404

Table 4: Oocyst diameters of Plasmodium falciparum (NF-54) in 4 groups of Anopheles mosquitoes fed from cultured parasites via a membrane feeder. Measurements were made under 400x and are presented in microns.

405

List of Figures

Chapter 1	Page
Figure 1. Map of the Toledo District in Southern Belize showing the location of the two research sites, Golden Stream and Rancho.	62
Figure 2: Increasing trend in cases of malaria between the years 1991-1995 (Source: Vector Control Program of Belize).	63
Figure 3: Number of malaria cases in 1995 broken down by district (Source: Vector Control Program of Belize).	63
Figure 4: Numbers of <u>Plasmodium falciparum</u> malaria cases recorded in 1995 separated by district (Source: Vector Control Program of Belize).	64
Figure 5: Seasonal trends for all malaria cases for the years 1993, 1994 and 1995 (Source: Vector Control Program of Belize).	65
Figure 6: Geographic distribution of <u>Anopheles albimanus</u> in the Americas (Faran 1980).	66
Figure 7: Geographic distribution of <u>Anopheles vestitipennis</u> in the Americas (Arredondo-Jimenez et al. 1980).	67
 Chapter 2	
Figure 1: Age specific survivorship of adult <u>Anopheles albimanus</u> maintained in cages (50 males and 50 females/cage). Cages were maintained at an average temperature of 32°C and adults were provide both a daily blood meal and 10% sugar source. Data represents Trial 1, Cage A.	105
Figure 2: Age specific survivorship of adult <u>Anopheles albimanus</u> maintained in cages (50 males and 50 females/cage). Cages were maintained at an average temperature of 32°C and adults were provide both a daily blood meal and 10% sugar source. Data represents Trial 1, Cage B.	106

	Page
Figure 3: Age specific survivorship of adult <u>Anopheles albimanus</u> maintained in cages (50 males and 50 females/cage). Cages were maintained at an average temperature of 32°C and adults were provide both a daily blood meal and 10% sugar source. Data represents Trial 1, Cage C.	107
Figure 4: Age specific survivorship of adult <u>Anopheles albimanus</u> maintained in cages (50 males and 50 females/cage). Cages were maintained at an average temperature of 32°C and adults were provide both a daily blood meal and 10% sugar source. Data represents Trial 1, Cage D.	108
Figure 5: Age specific survivorship of adult <u>Anopheles albimanus</u> maintained in cages (50 males and 50 females/cage). Cages were maintained at an average temperature of 32°C and adults were provide both a daily blood meal and 10% sugar source. Data represents Trial 2, Cage A.	109
Figure 6: Age specific survivorship of adult <u>Anopheles albimanus</u> maintained in cages (50 males and 50 females/cage). Cages were maintained at an average temperature of 32°C and adults were provide both a daily blood meal and 10% sugar source. Data represents Trial 2, Cage B.	110
Figure 7: Age specific survivorship of adult <u>Anopheles albimanus</u> maintained in cages (50 males and 50 females/cage). Cages were maintained at an average temperature of 32°C and adults were provide both a daily blood meal and 10% sugar source. Data represents Trial 2, Cage C.	111
Figure 8: Age specific survivorship of adult <u>Anopheles albimanus</u> maintained in cages (50 males and 50 females/cage). Cages were maintained at an average temperature of 32°C and adults were provide both a daily blood meal and 10% sugar source. Data represents Trial 2, Cage D.	112
Figure 9: Expected days of life remaining per day after emergence. Data pertaining to Trial 1 only.	113
Figure 10: Expected days of life remaining per day after emergence. Data pertaining to Trial 2 only.	114

	Page
Chapter 3	
Figure 1: Map of the Toledo District in Southern Belize depicting the two main sites sampled during the seasonality study: ● - Rancho Village ● - Golden Stream Village.	175
Figure 2: Average number of <u>Anopheles vestitipennis</u> collected per night in 2-hour paired indoor:outdoor human landing collections conducted at the village of Golden Stream. Collections were conducted from 6:00-8:00 pm from July 1997-June of 1998. The average number of mosquitoes collected for each month is displayed in conjunction with the monthly precipitation, monthly river level and number of cases of <u>P. vivax</u> . Confirmation of malaria cases was determined at the Punta Gorda hospital by microscopic examination of blood smears.	176
Figure 3: Average number of <u>Anopheles darlingi</u> collected per night in 2-hour paired indoor:outdoor human landing collections conducted at the village of Golden Stream. Collections were conducted from 6:00-8:00 pm from July 1997-June of 1998. The average number of mosquitoes collected for each month is displayed in conjunction with the monthly precipitation, monthly river level and number of cases of <u>P. vivax</u> . Confirmation of malaria cases was determined at the Punta Gorda hospital by microscopic examination of blood smears.	178
Figure 4: Average number of <u>Anopheles albimanus</u> collected per night in 2-hour paired indoor:outdoor human landing collections conducted at the village of Golden Stream. Collections were conducted from 6:00-8:00 pm from July 1997-June of 1998. The average number of mosquitoes collected for each month is displayed in conjunction with the monthly precipitation, monthly river level and number of cases of <u>P. vivax</u> . Confirmation of malaria cases was determined at the Punta Gorda hospital by microscopic examination of blood smears.	180
Figure 5: Average number of <u>Anopheles punctimacula</u> collected per night in 2-hour paired indoor:outdoor human landing collections conducted at the village of Golden Stream. Collections were conducted from 6:00-8:00 pm from July 1997-June of 1998. The average number of mosquitoes collected for each month is displayed in conjunction with the monthly precipitation, monthly river level and number of cases of <u>P. vivax</u> . Confirmation of malaria cases was determined at the Punta Gorda hospital by microscopic examination of blood smears.	182

Figure 6: Average number of Anopheles apicimacula collected per night in 2-hour paired indoor:outdoor human landing collections conducted at the village of Golden Stream. Collections were conducted from 6:00-8:00 pm from July 1997-June of 1998. The average number of mosquitoes collected for each month is displayed in conjunction with the monthly precipitation, monthly river level and number of cases of P. vivax. Confirmation of malaria cases was determined at the Punta Gorda hospital by microscopic examination of blood smears. 184

Figure 7: Average number of An. vestitipennis collected per night in 2-hour human landing collections conducted at the village of Rancho. Collections were conducted from 6:00-8:00 p.m. from July 1997-November 1998. The average number of mosquitoes collected for each month is displayed in conjunction with the monthly precipitation, and number of cases of P. vivax. Confirmation of malaria cases was determined at the hospital in Punta Gorda by microscopic examination of a blood smear. 186

Figure 8: Average number of An. albimanus collected per night in 2-hour human landing collections conducted at the village of Rancho. Collections were conducted from 6:00-8:00 p.m. from July 1997-November 1998. The average number of mosquitoes collected for each month is displayed in conjunction with the monthly precipitation, and number of cases of P. vivax. Confirmation of malaria cases was determined at the hospital in Punta Gorda by microscopic examination of a blood smear. 187

Figure 9: Average number of An. punctimacula collected per night in 2-hour human landing collections conducted at the village of Rancho. Collections were conducted from 6:00-8:00 p.m. from July 1997-November 1998. The average number of mosquitoes collected for each month is displayed in conjunction with the monthly precipitation, and number of cases of P. vivax. Confirmation of malaria cases was determined at the hospital in Punta Gorda by microscopic examination of a blood smear. 188

Chapter 4	Page
Figure 1: Map of the Toledo District in Southern Belize showing the location of the vehicle mounted trap site in Rancho Village.	222
Figure 2: Illustration of the route driven in the car trap collection. The distance between turn-around points was approximately 1 mile and took 10 minutes to drive at 5-10 mph.	223
Figure 3: Illustration of the car top trap and PVC coupler used for the collection of in-flight mosquito populations at the Rancho site.	224
Figure 4: Average meteorological data over the 15 trap nights on which the mobile car trap was conducted. Average temperature, relative humidity and wind speed are presented at the midpoint of each 15 minute collection interval.	225
Figure 5: Number of <u>An. albimanus</u> , <u>An. punctimacula</u> and <u>An. vestitipennis</u> collected in a mobile car trap on 10 June 1998. Sample period was every 15 minutes and encompassed a 1 mile section of road in Rancho Village of the Toledo District, Belize.	226
Figure 6: Number of <u>An. albimanus</u> , <u>An. punctimacula</u> and <u>An. vestitipennis</u> collected in a mobile car trap on 12 June 1998. Sample period was every 15 minutes and encompassed a 1 mile section of road in Rancho Village of the Toledo District, Belize.	227
Figure 7: Number of <u>An. albimanus</u> , <u>An. punctimacula</u> and <u>An. vestitipennis</u> collected in a mobile car trap on 18 June 1998. Sample period was every 15 minutes and encompassed a 1 mile section of road in Rancho Village of the Toledo District, Belize.	228
Figure 8: Number of <u>An. albimanus</u> , <u>An. punctimacula</u> and <u>An. vestitipennis</u> collected in a mobile car trap on 8 August 1998. Sample period was every 15 minutes and encompassed a 1 mile section of road in Rancho Village of the Toledo District, Belize.	229
Figure 9: Number of <u>An. albimanus</u> , <u>An. punctimacula</u> and <u>An. vestitipennis</u> collected in a mobile car trap on 18 August 1998. Sample period was every 15 minutes and encompassed a 1 mile section of road in Rancho Village of the Toledo District, Belize.	230

Figure 10: Number of An. albimanus, An. punctimacula and An. vestitipennis collected in a mobile car trap on 27 August 1998. Sample period was every 15 minutes and encompassed a 1 mile section of road in Rancho Village of the Toledo District, Belize. 231

Figure 11: Number of An. albimanus, An. punctimacula and An. vestitipennis collected in a mobile car trap on 2 September 1998. Sample period was every 15 minutes and encompassed a 1 mile section of road in Rancho Village of the Toledo District, Belize. 232

Figure 12: Number of An. albimanus, An. punctimacula and An. vestitipennis collected in a mobile car trap on 5 September 1998. Sample period was every 15 minutes and encompassed a 1 mile section of road in Rancho Village of the Toledo District, Belize. 233

Figure 13: Number of An. albimanus, An. punctimacula and An. vestitipennis collected in a mobile car trap on 11 September 1998. Sample period was every 15 minutes and encompassed a 1 mile section of road in Rancho Village of the Toledo District, Belize. 234

Figure 14: Number of An. albimanus, An. punctimacula and An. vestitipennis collected in a mobile car trap on 17 September 1998. Sample period was every 15 minutes and encompassed a 1 mile section of road in Rancho Village of the Toledo District, Belize. 235

Figure 15: Number of An. albimanus, An. punctimacula and An. vestitipennis collected in a mobile car trap on 11 October 1998. Sample period was every 15 minutes and encompassed a 1 mile section of road in Rancho Village of the Toledo District, Belize. 236

Figure 16: Number of An. albimanus, An. punctimacula and An. vestitipennis collected in a mobile car trap on 16 October 1998. Sample period was every 15 minutes and encompassed a 1 mile section of road in Rancho Village of the Toledo District, Belize. 237

Figure 17: Number of An. albimanus, An. punctimacula and An. vestitipennis collected in a mobile car trap on 3 November 1998. Sample period was every 15 minutes and encompassed a 1 mile section of road in Rancho Village of the Toledo District, Belize. 238

	Page
Figure 18: Number of <u>An. albimanus</u> , <u>An. punctimacula</u> and <u>An. vestitipennis</u> collected in a mobile car trap on 5 November 1998. Sample period was every 15 minutes and encompassed a 1 mile section of road in Rancho Village of the Toledo District, Belize.	239
Figure 19: Number of <u>An. albimanus</u> , <u>An. punctimacula</u> and <u>An. vestitipennis</u> collected in a mobile car trap on 8 November 1998. Sample period was every 15 minutes and encompassed a 1 mile section of road in Rancho Village of the Toledo District, Belize.	240
Figure 20: Total number of gravid <u>An. vestitipennis</u> and <u>An. albimanus</u> combined from 15 trap nights made between June and November of 1998 using the mobile car trap. Samples were taken every 15 minutes.	241
Figure 21: Total number of male <u>An. punctimacula</u> and <u>An. vestitipennis</u> combined from 15 trap nights made between June and November of 1998 using the mobile car trap. Samples were taken every 15 minutes.	242
Figure 22: Comparison of the times of collection of all <u>An. albimanus</u> collected in the mobile car trap versus times of collection of blood engorged <u>An. albimanus</u> .	243
Figure 23: Comparison of the times of collection of all <u>An. punctimacula</u> collected in the mobile car trap versus times of collection of blood engorged <u>An. punctimacula</u> .	243
Figure 24: Comparison of the times of collection of <u>An. vestitipennis</u> collected in the mobile car trap which tested positive for human blood versus times of collection for <u>An. vestitipennis</u> testing positive for non-human blood and unfed <u>An. vestitipennis</u> .	244

Chapter 5

Figure 1: Map of the Toledo District in Southern Belize showing the location sites sampled during the host feeding preference study: ● - Rancho Village ● - Golden Stream Village.	293
Figure 2: Diagram illustrating the dimensions of the resting box used for the collection of blood engorged mosquitoes at the Rancho site.	294

	Page
Figure 3: Illustration of the route driven in the car trap collection. The distance between turn-around points was approximately 1 mile and took 10 minutes to drive at 5-10 mph.	295
Figure 3: Illustration of the car top trap and PVC coupler used for the collection of in-flight mosquito populations at the Rancho site.	296
Chapter 6	
Figure 1: Map of the Toledo District in Southern Belize. The location of the experimental hut site is indicated by the star.	342
Figure 2: Basic design of the experimental hut used in the study conducted at Rancho Village, Toledo District, Southern Belize showing the placement of the one door and three windows fitted with exit intercept traps.	343
Figure 3: Experimental hut study site located in Rancho Village, Toledo District, Southern Belize showing the placement of huts (A, B and C), surrounding man-made structures and environmental habitats.	344
Figure 4: Illustration of the window and door intercept traps.	345
Figure 5: Average temperature readings over 36 collection nights during which collections were made at the experimental huts from March to December of 1998. Range bars indicate the maximum and minimum temperatures recorded at that time during any collection.	346
Figure 6: Average wind speeds recorded over 36 collection nights during which collections were made at the experimental huts from March to December of 1998.	346
Figure 7: Average relative humidity readings over 36 collection nights during which collections were made at the experimental huts from March to December of 1998. Range bars indicate the maximum and minimum humidity recorded at that time during any collection.	347
Figure 8: Average number of <i>Anopheles vestitipennis</i> collected from human baited collections during 26 collection nights at Rancho, Toledo District, Belize, from March to November of 1998. Each collection was conducted for 15-hours by two collectors collecting for 30 minutes each hour throughout the night. Data is plotted against the midpoint of each 30-minute sample period.	348

	Page
Figure 9: Average number of <u>Anopheles albimanus</u> collected from human baited collections during 26 collection nights at Rancho, Toledo District, Belize, from March to November of 1998. Each collection was conducted for 15-hours by two collectors collecting for 30 minutes each hour throughout the night. Data is plotted against the midpoint of each 30- minute sample period.	349
Figure 10: Average number of <u>Anopheles punctimacula</u> collected from human baited collections during 26 collection nights at Rancho, Toledo District, Belize, from March to November of 1998. Each collection was conducted for 15-hours by two collectors collecting for 30 minutes each hour throughout the night. Data is plotted against the midpoint of each 30-minute sample period.	350
Figure 11: Comparison of the average number of <u>Anopheles vestitipennis</u> collected under pre- and post-spray conditions from entrance interception traps conducted during 21 and 5 collection nights, respectively, at Rancho, Toledo District, Belize, from August to December of 1998. Each collection was conducted for 15 hours by two collectors collecting for 30 minutes each hour throughout the night. Data is plotted against the midpoint of each 30-minute sample period. During a single night's collection, both sprayed huts were affixed with entrance traps, and a human baited collection was conducted at the control hut.	351
Figure 12: Comparison of the average number of <u>Anopheles vestitipennis</u> collected under pre- and post-spray conditions from exit interception traps conducted during 21 and 5 collection nights, respectively, at Rancho, Toledo District, Belize, from August to November of 1998. Each collection was conducted for 15 hours by two collectors collecting for 30 minutes each hour throughout the night. Data is plotted against the midpoint of each 30-minute sample period. During a single night's collection, both sprayed huts were affixed with exit traps, and a human baited collection was conducted at the control hut.	352
Figure 13: Percentage of total <u>Anopheles vestitipennis</u> populations collected from entrance interception traps during 21 nights of collections. Window and door traps represent collection from entire portal region while the eaves and wall trap represent only 1/8 of the total surface area for that mode of entry.	353

	Page
Figure 14: Average number of <u>Anopheles vestitipennis</u> collected from human baited collections conducted post-spray during 10 night collections at Rancho, Toledo District, Belize, from November to December of 1998. Each collection was conducted for 15-hours by two collectors collecting for 30 minutes each hour throughout the night. Data is plotted against the midpoint of each 30- minute sample period.	354
Figure 15: A comparison of entrance and exit times for <u>Anopheles vestitipennis</u> post-spray with deltamethrin. Entrance and exit collections were conducted on different nights. Average number of mosquitoes collected per 30-minute sample period are plotted against the midpoint of that sample period.	355
Figure 16: ANCOVA analysis showing the relationship between increasing population density and increasing entrance trap collection for <u>Anopheles vestitipennis</u> . An increase in the number of mosquitoes collected from the traps is positively correlated with all treatments except the DDT treated hut where the slope of the line is not significantly different from zero ($P>0.05$).	356
Figure 17: Illustration of the possible scenarios available to endophagic host seeking <u>Anopheles</u> mosquitoes (Roberts et al. 2000). Conditional probabilities can be assigned to each value to evaluate behavioral changes exerted by various insecticides.	357
 Chapter 7	
Figure 1: Digital images of oocysts of <u>Plasmodium falciparum</u> in infected midguts of <u>An. vestitipennis</u> . Top most image shows oocysts on midgut at 4 days post infection (200 x). Bottom image shows an oocyst at 8 days post infection (200 x).	406
Figure 2: Digital images of oocysts of <u>Plasmodium falciparum</u> in infected midguts of <u>An. vestitipennis</u> . Top most image shows oocysts on midgut at 9 days post infection (200 x). Bottom image shows an oocyst at 11 days post infection (200 x).	407
Figure 3: Digital images of oocysts of <u>Plasmodium falciparum</u> in infected midguts of <u>An. vestitipennis</u> . Top most image shows oocysts on midgut at 12 days post infection (400 x). Bottom image shows a ruptured oocyst and release of sporozoites from a differentiated oocyst at 13 days post infection (400 x).	408

	Page
Figure 4: Digital images of <u>Plasmodium falciparum</u> infected salivary glands of <u>An. vestitipennis</u> . Numerous sporozoites can be seen being released from two separate sets of salivary glands. Top (200 x), Bottom (400 x)	409
Figure 5: Mean oocyst diameters for <u>Plasmodium falciparum</u> (NF-54) in <u>An. vestitipennis</u> compared to the control population of <u>An. stephensi</u> . Maximum and minimum range bars are displayed to illustrate the daily variation in oocyst diameters.	410
Figure 6: Mean oocyst diameters for <u>Plasmodium falciparum</u> (NF-54) in <u>An. albimanus</u> (BV) compared to the control population of <u>An. stephensi</u> . Maximum and minimum range bars are displayed to illustrate the daily variation in oocyst diameters.	411
Figure 7: Mean oocyst diameters for <u>Plasmodium falciparum</u> (NF-54) in <u>An. albimanus</u> (GS) compared to the control population of <u>An. stephensi</u> . Maximum and minimum range bars are displayed to illustrate the daily variation in oocyst diameters.	412

Chapter 1

General Introduction

INTRODUCTION

Malaria

Throughout history, malaria has remained a serious medical threat to the inhabitants of endemic regions of the world. The number of people who live in these regions presently exceeds 2.1 billion people (WHO 1991). Control measures that have been directed at the vector population have shown the greatest success (Russell et al. 1963). Despite large sums of money and massive, organized control efforts over many decades, malaria continues to be a major health threat. Malaria transmission has increased in recent years due in part to drug resistant parasite strains, decreased or sporadic use of effective insecticides, movement of susceptible human populations into endemic areas, and political/socioeconomic constraints hampering established control and prevention efforts.

With the present international pressure to limit the use of DDT (Curtis 1994, PAHO 1994, WHO 1994, Lopez-Carrillo et al. 1996), a key weapon available to mosquito control programs around the world is being eliminated. Historically, the use of DDT in house spray campaigns has been singled out as a major reason why control of malaria demonstrated a high degree of success (WHO 1995). Increasing incidence of malaria in many tropical areas of the world has recently been accompanied by a decline in the use of DDT for residual house spraying (WHO 1977). Fears are largely associated with the environmental impact created by large-scale agricultural use of DDT in the 1950's and unfounded claims of human health risks. Instead, the focus of vector control has been placed on short lived, expensive alternatives such as the synthetic pyrethroids or have overestimated the effectiveness of insecticide treated bed nets (Miller 1988).

Renewed emphasis has also been placed on case detection and treatment. Effectively, these new strategies have resulted in a reduction of residual house spraying as a control method and, therefore, an increasing trend in malaria cases. The increasing trends of malaria transmission that have recently been observed throughout the tropical regions of the world have been attributed to the reduction of vector control operations (Roberts et al. 1997, Mouchet et al. 1998).

Given the severity of the global malaria problem, renewed efforts must be made to better understand the epidemiology of malaria. The success or failure of any vector control approach hinges on a better understanding of the dynamics of malaria transmission as it occurs in the field (Collins and Paskewitz 1995). A critical aspect of malaria epidemiology is the bionomics of the vector populations (Tonn 1983, Zimmerman 1992). The various life history and behavioral strategies (i.e. host preference, longevity, flight patterns, endophagy and malaria susceptibility) of the Anopheles populations vary between species and thereby create varying vector potential (Gillies 1956, Elliott 1969, Zimmerman 1992). Literature pertaining to the ecology of the anopheline species in Latin America is sparse. Continuing research is presently filling in gaps in our understanding of the dynamics of malaria in these countries, but many questions remain unanswered. One area of particular interest is the effect that insect behavior has on the transmission of disease (Klowden 1996). Numerous studies have been conducted on the behavior of malaria vectors in Africa and Southeast Asia but little is known of these behaviors in the America's.

Because each area is unique in its vector population and because characteristics of these populations are so varied, a control strategy must be developed to deal with the

specific needs and lifestyles for that region (WHO 1995). Therefore, studies should be undertaken prior to implementing a control strategy. With our increased knowledge of genetic variation within species that are linked to behavioral and vectoral differences, it is imperative that we reevaluate malaria transmission dynamics over its entire range.

An estimated 1 million cases of malaria are reported each year from the Americas (WHO 1995). The Pan American Health Organization, in 1994, classified Belize as the only country in Latin America to be at “high risk” for malaria transmission. This same year, Belize reported 9,957 cases of malaria with the majority of these cases coming from the Districts of Cayo, Corozal and Toledo. Research efforts have intensified in the country of Belize where the incidence of malaria has shown a dramatic increase since 1991 (Roberts et al. 1996). The focus of this research has been on the bionomics of the various native anopheline species found throughout the country. A number of recent studies have looked at the behavioral effect that various insecticides used in house spraying elicit on a vector population. The old school of thought was that the main goal of a residual insecticide was to kill the vector population and thereby break the transmission cycle (Macdonald 1950, 1957). Some have even gone so far as to state that any behavioral alteration elicited on the mosquito that does not directly result in its death could serve to increase malaria transmission. Our present understanding indicates that the true action of an effective insecticide is one in which there is a disruption in the host-vector interaction. This is achieved through the repellent and contact irritant action of the chemical (Roberts et al. 2000) which prevents the vector from entering a house and biting during hours of activity. These types of behavioral evaluations of anopheline vectors can

provide vital information pertaining to the role various control measures play in the reduction of malaria transmission.

Research Site

Belize is a country located in Central America with an estimated land area of 23,000 square kilometers and an estimated population of 230,000 individuals. A large percentage of these individuals occupy the coastal region of Belize City. The country shares common borders with both Mexico to the north and Guatemala to the west and south. Geologically, Belize is composed of both low-lying coastal plains and mountainous highlands. The interior regions of the country that border Guatemala are the location of a low series of mountains called the Maya Mountains. The average elevation of this range is approximately 850 m with a peak elevation of 1122 m. The northern portion of the country is more typically low coastal planes that are utilized for sugar cane plantations, as well as limited banana and citrus farming. The southern regions of the country support some primary growth rain forest and agricultural production of citrus, banana and the beginnings of wet rice farming (Rubio-Palis and Zimmermand 1997).

The climate of the country is described as sub-tropical and is characterized by high humidity and annual temperatures with a mean of 26.1°C. Temperatures in Belize range from 10°C to 35°C. The months from November to January are traditionally the coolest months with the temperatures averaging about 23.8°C. May through September are generally the warmest months with temperatures averaging 27.2°F.

There are definite wet and dry seasons patterns associated with the country of Belize. The onset of the dry season typically begins in late December but varies from year to year. The amount of rainfall that occurs during dry season, however, is often very

predictable. The wet season typically commences at the beginning of April and the amount of rainfall that occurs varies with year and location. The more northern and central districts in the country such as the Cayo District average about 125 days of rain a year with an accumulation of between 177.8 cm and 254 cm. The more centrally located districts such as the Belize District and the Stann Creek District average 171 and 183 days of rain respectively. This accounts for between 254 and 330 cm of rain a year. The most southern portion of the country, the Toledo District, often has over 200 days of rain a year. The town of Punta Gorda located in the southern portion of the Toledo District often records rainfall totals in excess of 406.4 cm a year.

Throughout the majority of the year (January through August) the warm moisture-laden winds blow off the ocean from the southeast. These winds shift and begin to blow from the North and West between the months of September through December, bringing in cooler air from the North.

An ecological prospective of Belize conducted to characterize regions based on malaria transmission potential, classify this area as falling between two ecoregions: coastal and piedmont. The coastal regions are located in the northern portions of Belize and extend down to the southern aspects of the country where they extend inland from the coast approximately 20 to 30 km. The definition of a coastal ecoregion is land that is less than 500 m above sea level and less than 100 km from a significant body of water. These regions show malaria transmission associated with forest swamps, mangroves and riverine environments. The primary vector species that has been associated with this type of ecotype in the neotropics has historically been An. albimanus.

The western and southern most regions of the country of Belize have been classified a piedmont ecoregion. This ecotype is characterized as the interface between coastal and high valley ecoregions. Elevations typically range from 200 to 1500 m above sea level with vegetation ranging from tropical rain forest to desert shrub. In the piedmont regions of Mexico and Central America, the predominate malaria vectors are *An. albimanus* and *An. pseudopunctipennis* (Rodriguez and Loyola 1989), *An. vestitipennis*, and *An. darlingi* (Rodriguez and Loyola 1990, Loyola et al. 1991 and Wilkerson and Strickman 1990).

The studies conducted as part of this research project were primarily at two sites, Golden Stream (N 16 21.820, W 88 47.936) and Rancho (N 16 09.954, W 88 50.529) (Figure 1). Both Golden Stream and Rancho were listed as two of the 5 villages with the highest number of malaria cases in the Toledo District. Golden Stream is a village of approximately 422 individuals and 94 homes as determined by a 1998 census estimation. The ethnicity is predominately Mopan Indian and Ketchi. The village is situated inland from the coast, along the southern highway. It is located on a clean fast flowing river which is fed by both natural spring water and mountain rain runoff. Homes were constructed of plank wood with Cahon palm thatch roofing and dirt flooring. All homes in the village had been sprayed with DDT at least six months prior to the beginning of the study.

The 1998 census estimates the population of Rancho to be 824 individuals living in approximately 166 houses with an ethnic composition of Ketchi, East Indian and Garafuna. The village is located about 4 miles from the Gulf of Honduras and is situated on the outskirts of the town of Punta Gorda. Houses in this village were constructed of

both plank wood and thatch roofing or cinder block and corrugated tin roofing. Several of the houses that were sampled in this area also had been sprayed with DDT at least six months prior to the beginning of the study. Three additional huts that were sampled were experimental huts constructed for the purpose of conducting behavioral studies. None of the three experimental huts were sprayed during the course of this study.

Malaria in Belize:

The malaria data for the countries of Central America reveal that there are more than 1 million cases of malaria per year (WHO 1995). The number of cases in this region are bound to increase as the international pressure continue to limit control options through the banning of successful, cheap residual sprays such as DDT. The Central American country of Belize has historically battled with the problem of malaria. Scott (1932) reported that the 10 % of all hospital deaths were the result of malaria or complications from malaria. Shortly after this finding was reported, Faust (1949) estimated that 50% of the population of the rural population of Belize was infected with malaria. Even as early as 1994, the entire population of Belize was classified as being at high risk for malaria (PAHO 1994).

The specific malaria statistics for Belize for 1993 showed an incidence rate of 42 cases per 1000 individuals (WHO 1996, 1997). The total number of cases rose to 9,957 during 1994 (47.4 cases per 1000 individuals). If we look back even further, this same increasing trend in malaria is apparent from 1991 through 1995 (Figure 2). Records maintained by PAHO indicate that the number of cases, the number of positive localities, the number of P. falciparum cases and the number of malaria cases seen in children all showed an increase during the years 1992-1994. These increases coincide with a period

of time when house spraying was stopped (1990-1991) and a period of low house spray coverage (1993-1996) (Bangs 1999). A 10% decrease in the number of malaria cases was reported between 1994 and 1995.

Significant amounts of data have been compiled for the 1995 malaria season. Data collected during 1995 showed that 56% of the cases in the Toledo District occurred in children under the age of 14 while in other districts the majority of the cases occurred in young adult males. In terms of total numbers of malaria cases, three districts accounted for 81% of all cases reported (Figure 3). These districts were Cayo (40%), Toledo (23%) and Stann Creek (18%). When the population malaria rates were compared to the population estimates for each district, the Toledo District exhibits a much higher rate (Table 1). Almost 95% of the 1995 cases were due to *P. vivax*. Of the *P. falciparum* cases that occurred during 1995, the majority of cases occurred in either Cayo (264 cases), Stann Creek (143 cases) or Toledo (38 cases) (Figure 4).

Looking specifically at the Toledo District during 1995, 47 of the 63 villages in the district reported cases of malaria. Of the malaria, 51% of all cases were reported from children below the age of 12 (Table 2). The numbers of males and females infected in this population was the same. This data can be further broken down by month to give an indication of time of transmission (Table 3). From all indications, the highest numbers of cases occur during the months of July through November. The historical data also shows a similar season trend associated with the malaria transmission in entire country of Belize. By plotting the malaria data for 1993, 1994 and 1995 (Figure 5), it is clear that the majority of transmission occurs during the months of June through November (the

rainy season). This also coincides with production of breeding habitats conducive for Anopheles vectors in the region.

For the purposes of this study, it was necessary to gather vector information from villages considered having a history of high malaria transmission. Looking back to those years when malaria transmission was highest (1993-1995), the villages of Golden Stream and Rancho were always in the top 10 (Table 4). The 1997 census data for the Toledo District showed that Golden Stream and Rancho ranked among the top 5 villages in terms of positive cases of malaria.

Malaria Control in Belize:

The Ministry of Health (MOH) in Belize incorporates both passive and limited active case detection for malaria (MOH 1993). These efforts rely mainly on passive detection with ill patients reporting to village health collaborators or to the district hospital. If the patient reports to a health collaborator, a thick blood film is taken and the slide is sent to the district hospital. Thick blood films are made from the suspected patient's blood and the individual immediately begins chloroquine treatment. The slide is read by technician at the hospital and if the patient is confirmed to be positive, the full course of chloroquine is administered. As recently as 1995, chloroquine remains effective against the Plasmodium species in Belize with no reports of resistance to date. If Plasmodium falciparum is diagnosed, the village is targeted for immediate residual spraying.

The main focus of malaria control efforts in Belize as well as throughout the Americas has been on the use of residual insecticides for house spraying. The primary insecticide of choice has traditionally been DDT. The World Health Organization reported that in 1992 the majority of the countries in the Americas relied heavily on the use of DDT for residual house spraying (WHO 1995). Other chemicals such as deltamethrin also have been used in malaria control campaigns but at a cost. The price of DDT is 3 to 4 times less expensive than alternatives such as deltamethrin or fentrothion (WHO 1990).

The use of DDT as a control measure for malaria in Belize began as early as 1950 with a UNICEF funded program when it was used extensively in a residual house spraying campaign (Brown et al. 1976). The malaria rates showed an 80% drop by 1957.

Since this time, however, the spraying coverage that was maintained on a nationwide basis has fluctuated dramatically. These fluctuations have gone from complete coverage to almost no control measures at all. These yearly changes often coincide with both political and international policy change. One major policy change was the ban on the use of DDT for agricultural purposes in 1988. This was precipitated by growing international pressure that was based on findings during the 1960's and 1970's from the United States that showed a number of adverse effects on local wildlife, particular the thinning of avian eggshells (Lundholm 1997, Lundholm and Bartonek 1992, Khan and Cutkomp 1982, Lindvall and Low 1980). The 1988 ban, also, was coupled with a decrease in the use of DDT for public health purposes. By 1989, the nationwide spray campaign essentially came to an end. A few concessions were made, however, for the use of residual insecticides for public health purposes which basically translated to limited spraying areas which demonstrated high rates of malaria (PAHO 1994). This low level of chemical control continued throughout the early 1990's. Coincidentally, this same period of time experienced increasing rates of malaria throughout Belize (Vector Control Program 1997).

Continued pressures from the international community resulted in a complete termination of the use of DDT in Belize by 1993. The end of DDT in Belize marked the end of effective vector control (Vanzie 1995). Alternative chemicals like deltamethrin proved to be too costly and less effective, leaving Belize with no viable substitute for DDT. The Mexican government in 1993 became concerned about the resurgence of malaria on their southern border. The increasing malaria rates in Belize and Guatemala prompted Mexico to provide limited spray coverage of Belize's northern districts (Bangs

1999). These efforts were continued until 1995 when the Belizean government returned to the use of DDT for residual house spraying on a restricted basis. In 1999, the international community again placed pressure on the Belizean government and under the fear of loosing much needed monetary funding was forced to abandon the use of DDT in their vector control program. Presently, only small in-country stores of DDT are maintained for the purposes of major outbreaks of disease. No plans are presently in place to replenish these stores and the chemical could quickly become depleted.

Affects of Residual Insecticides:

The reliance on residual spraying of insecticides for the control of malaria requires that evaluations of these insecticides be made. In order to accomplish this, it is necessary to determine the mode in which these chemicals work. Many researchers have suggested that the only effective insecticides are those that kill the vector (De Zulueta 1959, Hadaway et al. 1970, Sharp et al. 1990, Hamon et al. 1970). The idea of behavioral avoidance of residual insecticides was seen as a negative characteristic that would do nothing for the control of malaria. The issue of behavioral avoidance and excito-repellency has been re-examined in recent years due to continued effectiveness of these chemicals despite the presence of physiological resistance in the mosquito population (Haworth 1988, Roberts and Andre 1994). Our present understanding of the true mode of action of these chemicals is that they don't work by killing but by reducing the human-vector contact by reducing the number of mosquitoes entering a house and biting (Hudson 1984, Roberts et al. 2000).

A number of terms, such as behavioral resistance, repellency, irritancy, and excito-repellency, have been used in the literature to describe the behavior of vectors in response to insecticide application. A brief description of these terms is required to understand their effect on the vector population. The term, behavioral resistance, implies an evolutionary basis in which the insect has evolved the ability to protect itself against lethal contact with naturally occurring plant toxins (Chareonviriyaphap et al. 1997), and has been documented in early studies dealing with anopheline vectors and malaria transmission (Kennedy 1947, Muirhead-Thomson 1960, Elliott and De Zulueta 1975, Gilles 1988, Cullen et al. 1975). The term repellency is used to describe oriented

movements of avoidance made by the insect in response to a chemical stimulant without having made tarsal contact with the chemical (Roberts et al. 2000). Irritancy refers to oriented movements by the insect away from a chemical stimulus only after making tarsal contact with the chemical (Roberts et al. 2000). Excito-repellency is a chemical stimulus, which induces a series of oriented avoidance behavior with or without having made tarsal contact with the chemical (Roberts and Andre 1994).

Experimental Huts:

The use of experimental huts for the evaluation of the effects of insecticides on entering and exiting populations of mosquitoes have been performed since the 1950's. In order to obtain an accurate assessment of the affects these chemicals have on the mosquito population, it is desirable to construct experimental huts in a natural setting with local materials (Smith 1964, Muirhead-Thomson 1968). Although experimental huts operate under the constraints of natural fluctuations in environmental conditions and mosquito populations, if enough repetitions are conducted, an accurate representation of house entering and exiting behavior can be made (Service 1993).

A number of hut designs have been constructed over time for the purpose of evaluating the residual effect of insecticides being used malaria control campaigns. These designs must closely resemble the structure and environmental conditions of the typical village huts in the region to insure that the behavior of the mosquitoes is not altered due to construction differences. Muirhead-Thomson in 1947 constructed mud walled huts with thatched roofs in Nigeria to most accurately resemble other huts in the region (Muirhead-Thomson 1948, 1950, Davidson 1953). Other huts using wood planking and thatch have been employed throughout Central and South America (Symes and Hadaway 1947, Giglioli 1948, Muirhead-Thomson and Mercier 1952, De Zulueta and Garrett-Jones 1965, Rachou et al. 1965, 1973, Elliott 1972, Roberts et al. 1984, 1987, Hudson 1984, Bown et al. 1986, 1987, Cases et al. 1994).

On occasion, in order to save time and money, local huts are modified to accommodate exit or entry traps (Bown et al. 1986, 1987, Coz et al. 1966, Pant et al 1969, Kuhlow 1959, Mpofo et al. 1988). This may not be the best situation for

conducting these types of studies due to the lack of control of the use of the huts. Several conditions may alter the collections and may comparison under ideal conditions difficult. These conditions may be previous spray history of the huts, number of people occupying the hut and activities conducted in the hut (i.e. cooking, building fires and keeping pets) (Service 1993). Bar-Zeev et al. in 1966 found that soot deposits on the interior walls of Nigeria homes increased the residual life of insecticides by slowing down the adsorption rate of the chemical.

These studies work off the premise that various portals of entry into a house such as windows, doors, eaves and cracks in walls can be sampled with traps in order to observe altered behavioral patterns after spraying a house with different types of chemicals. Therefore, studies conducted using experimental huts also rely on the use of various exit and entry traps affixed to open portals (Worth 1953). The most obvious of these portals are windows, doors and eaves, however, a wide variety of traps have been designed to evaluate these behaviors such as louver, verandah and wall (Colombia curtain) traps (Smith 1963, 1965, Coz et al. 1965, Elliott 1972, WHO 1975, Taylor et al. 1981, Bown et al. 1985, 1986).

In order to more easily assess the effects insecticides have on the mortality of mosquitoes entering or exiting a sprayed house, a number of techniques have been developed. This task is made more difficult by the fact that dying mosquitoes inside a house are often difficult to locate on hut floors and are often quickly carried off by ants and other scavengers (Taylor et al. 1981). In order to counteract these types of predators, Rapley (1961) constructed huts raised on cement pillars that were surrounded by water filled moats. This presumably cut down on scavengers entering the hut. Others have

utilized white sheets on the floor of the hut to facilitate the location and collection of dead and dying mosquitoes before they could be removed by other predatory insects (Hudson and Esozed 1971, Ree 1988). In order to assess the mortality of window and door exit trap collections, it is advisable to hold mosquitoes removed from these traps for 24 hours and record the number of dead or moribund adults (Bown et al. 1986).

Anopheles in Belize:

Faunistic studies conducted on the anopheline mosquitoes of Central America and Mexico have identified 14 species which inhabit the country of Belize (Wilkerson et al. 1990). These 14 species fall into two genera and 5 subgenera. Four Anopheles species have been strongly incriminated as the primary vectors in Central America: An. albimanus, An. argyritarsis, An. pseudopunctipennis and An. darlingi (Kumm and Ram 1941, Bertram 1971, White 1982, Roberts et al. 1993). In addition to these primary vectors, other anophelines identified from Belize also have been incriminated as secondary vectors either in Belize or in other areas of their range. These include An. vestitipennis (Kumm and Ram 1941) and An. punctimacula (White 1982).

The geology and ecology of the southern district of Toledo is quite different from the rest of Belize. The abundance and type of mosquitoes found in this region also are quite different. Data from surveys conducted in Belize found only 7 of the 14 Anopheles species in the Toledo District (Pecor unpub. data 1997). The present study adds an additional 5 species to the this list: Ch. bathana, An. punctimacula, An. pseudopunctipennis, An. darlingi and An. neivai.

The present study focuses on 4 of these species due to their abundance and potential as vectors of malaria in Belize: An. albimanus, An. vestitipennis, An. darlingi and An. punctimacula. Data obtained on the other Anopheles species collected during the course of this study will be dealt with in the appropriate chapter of this dissertation.

Anopheles - Target species:

Although the vector potential of the mosquitoes of Central and South America have been documented by a number of researchers, additional information is clearly needed for certain anopheline species (Roberts and Andre, 1994). Anopheles albimanus Weidemann is considered one of the most important vectors in Central America and northern South America (Komp 1942, Horsfall 1955, Ramsey et al. 1994, Faran 1980, Breeland 1980). This species has been documented from throughout the Caribbean (Figure 6) including Belize (Rejmankova et al. 1992, Roberts et al. 1993), Colombia (Elliott 1968, Marten et al. 1996), Costa Rica (Kumm et al. 1940), Cuba (Carr and Hill 1942), Dominican Republic (Mekuria et al. 1990), El Salvador (Breeland 1972, Breeland et al. 1974), Guatemala (Zamora and Calderon 1991), Haiti (Taylor 1966, Hobbs et al. 1986), Jamaica (Boyd and Aris 1929, Belkin et al. 1970), Mexico (Savage et al. 1990, Rodriguez et al. 1996), Panama (Simmons et al. 1939) and Venezuela (Gabaldon 1949). Anopheles albimanus is primarily characterized as being a lowland species, in particular lowland coastal areas (Rubio-Palis and Zimmerman 1997).

Anopheles albimanus is considered to be a strong flier with wind aided flight distances for this species recorded at up to 12 miles (Curry, 1934). Non-wind aided flight is considered to be considerably shorter. Ranges have been documented between 1.5 miles (Eyles, 1944) to less than 0.6 miles (Lowe et al 1975). Hobbs et al. (1974) conducted a mark/release study in which the maximum flight distance recorded for An. albimanus was 1.8 miles.

Morphological variations have been observed in the larval stages of An. albimanus (Georghiou et al. 1967, Warren et al. 1975). This has led to the identification

of at least four different strains of An. albimanus: white-striped, green, brown striped and brown (Warren et al. 1979). In studies conducted on the susceptibility of these various strains to Plasmodium infection, there seemed to be distinct differences (Eyles and Young 1950, Warren et al. 1977, Warren et al. 1979, Gonzalez-Ceron et al. 2000). In all of these studies, An. albimanus exhibited a higher infection rate with P. vivax than with P. falciparum. Gonzalez-Ceron (2000) demonstrated an adaptation between local strains of An. albimanus and local strains of malaria parasites.

This species also has demonstrated a weak anthropophagic behavior (Bangs 1999). Anopheles albimanus has demonstrated throughout its range to be primarily exophagic and zoophilic (Elliott 1969, 1972, Garrett-Jones 1964, Breeland 1972, Garrett-Jones et al. 1980, Frederikson 1993, Roberts et al. 1993, Roberts et al. 2000, Bangs 1999). Achee et al. (2000) showed that 8 out of 10 sporozoite-infected An. albimanus were collected from outside the house and both P. falciparum infected An. albimanus also were collected outdoors. In previous studies (Horsfall 1955, Warren et al. 1975, Ramsey et al. 1986, Fredrickson 1993), the natural sporozoite infection rates were extremely low (1-2%). It is believed that this species exhibits effective malaria transmission only when it occurs at high population densities (Elliott 1972, Loyola et al 1993). In addition, this species also has demonstrated a clear avoidance behavior to particular insecticides such as DDT (Gabaldon 1952, Brown 1958, Hecht and Hernandez 1960, Quinones and Suarez 1989, Chareonviriyaphap et al. 1997).

Anopheles albimanus can occur in high densities depending on environmental conditions. One condition important to increased population density is heavy rainfall usually associated with the wet season (Kumm and Zuniga, 1944). In addition, this

species demonstrates the ability to breed in a number of different habitats. In particular this species in Belize shows an association with mats of cyanobacteria and precipitated levels of calcium carbonate (Remanjakova 1995, 1993). Conditions that favor these types of communities are permanent impoundments of water such as marshes and open swamps. Savage et al. (1990) found an association of An. albimanus breeding sites with bodies of water that were exposed to ample sunlight and which produced large amounts of food reserves for developing larvae. During the dry season, many of the breeding sites dry out and the larvae are confined to the margins of permanent lakes, ponds and roadside ditches (Orr and Resh 1989). The presence of standing water on a wet rice field creates all of the conditions favorable for An. albimanus breeding. These conditions are artificially maintained through irrigation channels, which allows this species to breed during times of year when population levels may normally be low. Anopheles albimanus shows an opportunistic behavior in its selection of breeding habitats.

Anopheles vestitipennis has, until recently, only been suspected as a vector of malaria. This species is found throughout the coastal regions of Mexico, Central America (Wilkerson et al 1990), regions of northern South America, Cuba and Puerto Rico (Loyola et al. 1991, Mekuria et al. 1991, Padilla et al. 1992, Marquetti et al. 1992)(Figure 7). It appears to be most common along coastal areas of the Atlantic and Gulf coast regions (Komp 1942) and can be found in large numbers throughout the Yucatan, southern Mexico and Guatemala (Kumm et al. 1943, Loyola et al. 1991, Arredondo-Jimenez et al. 1996).

Throughout its range, the larvae of An. vestitipennis have been found in clean, heavily shaded water containing large amounts of emergent vegetation (Komp 1942,

Horsfall 1955, Belkin et al. 1965, Loyola et al 1991, Rejmankova et al 1998). Anopheles vestitipennis has demonstrated preferences for breeding in flooded forests often times in association with An. punctimacula (Rejmenkova 1998). Larvae of An. vestitipennis also have been found breeding in aquatic areas with cattails (Arredondo-Jimenez 1995) and tall dense macrophytes (Rejmankova et al 1998). This species appears to require plant material or detritus as a nutritional source as well as plant cover for shade. Anopheles vestitipennis exhibits its highest numbers during the rainy season, predominately after periods of heavy rain (Komp 1942, Arredondo-Jimenez et al 1996, Rejmankova et al 1998). This was confirmed by adult collections conducted in the Lacandon forest of Mexico where higher population levels were observed during the rainy season (Arredondo-Jimenez 1995).

Although some investigators downplay the role that An. vestitipennis plays in the transmission of malaria (Boyd 1949), others have shown it to be a probable vector based on favorable vector characteristics (Kumm and Ram 1941, Padilla et al. 1992, Rodriguez and Loyola 1990, Loyola et al. 1991, Arredondo-Jimenez et al. 1998, Roberts et al. 1993). Loyola et al. (1991) observed this species to exhibit both endophilic and endophagic behavioral patterns. Others also have documented this endophagic and anthropophilic behavior throughout its range: Mexico (Loyola et al. 1991), Costa Rica (Kumm et al. 1940), Guatemala (Richards et al. 1994) and Belize (Roberts et al. 1993). Arredondo-Jemenez et al. 1998 showed the high longevity and multiple blood feeding habits to increase the vector potential of An. vestitipennis. Studies conducted in the Dominican Republic showed that An. vestitipennis readily fed on humans and demonstrated a higher human biting index than An. albimanus (Mekuria et al. 1991).

These behaviors were coupled with positive ELISA results for *P. vivax* in a native populations of *An. vestitipennis* collected from Chiapas, Mexico. Positive results such as these confirmed earlier findings by Kumm and Ram (1941) who found 1 of 41 specimens of *An. vestitipennis* collected from Belize to be positively infected with *Plasmodium* spp. by salivary gland dissection. Achee et al. (2000) found this species to have a relatively high MFIR (Minimum Field Infection Rate) in relation to the other anopheline species collected in a survey conducted in Belize. In this study, the MFIR for *An. vestitipennis* was (0.282%) which was higher than either *An. albimanus* (0.126%) or *An. darlingi* (0.261%). Only few infection studies have been conducted using *An. vestitipennis* and with little success (Simmons 1941, Horsfall, 1955). However, Carr and Hill (1942) did demonstrate the development of oocysts in the midgut from 1 of 12 mosquitoes fed off an infective patient in Cuba.

Anopheles darlingi was first incriminated as vector of malaria in 1931 in the Para state of Brazil based upon finding sporozoites in the salivary glands of dissected specimens (Davis 1931). Since that time, others have confirmed these findings using radioimmunoassays and enzyme linked immunosorbent assays (ELISA) (Deane et al. 1946, Causey et al. 1946, Arruda et al. 1989, Tadei et al. 1988, Deane et al. 1988, Lourenco-de Oliveira et al. 1989). The assay data, along with other behavioral factors, strongly incriminated *An. darlingi* as a malaria vector in Central and South America. This species showed both a strong attraction for feeding on humans as well as demonstrating a strong endophagic behavior (Deane et al 1946, Roberts et al. 1987, Klein and Lima 1990, Rozendaal 1989). Klein et al. (1991) stated that *An. darlingi* was the primary vector of malaria in Costa Marques, Rondonia, Brazil based upon seasonal

distribution, relative abundance, peridomiciliary and biting behavior, host contact and high natural field infection rates. This species has recently been re-described taxonomically for the country of Belize after its initial description in 1946 (Harbach 1994, Roberts et al. 1993). In a survey of anophelines conducted in Belize from 1994 to 1997, Achee et al. (2000) demonstrated that An. darlingi had a higher MFIR than An. albimanus (0.261% and 0.126%, respectively). This same study showed that a pool which tested positive for P. falciparum occurred in a sample of An. darlingi which was obtained in an indoor collection.

Anopheles darlingi has been characterized as a riverine species that utilizes breeding sites in and around river systems (Rozendaal 1990). The volatile dynamics of these rivers during the rainy season make it critical for this species to be flexible in its choice of breeding habitats. During the dry season, An. darlingi has been found breeding in creeks and between roots and fallen trunks along river margins. It has also been found in shaded areas of debris and floating vegetation in the river where the flow of the river has been impeded (Fleming 1963; Panday 1980; Hudson, 1984). These breeding sites change during the rainy season when water levels flood the rivers out of their banks and flush out these sites. It is during the rainy season that An. darlingi has been observed to breed in vegetation and floating debris in flooded forest areas near the river (Bonne&Bonne-Wepster 1925; Van der Kuyp 1950; Bruyning 1952; Hudson 1984; Rozendaal 1987; Rozendaal 1992).

Rozendaal clearly showed that An. darlingi utilized a variety of breeding habitats within the country of Suriname, South America. These habitats were dependent on the river level and precipitation. He demonstrated that in the coastal regions of Suriname, the

breeding conditions are unfavorable due to the tidal action of the rivers. In these areas, the breeding sites were found limited to flooded depressions near the banks of the river, which occurred during the rainy season. The rainy season also coincided with high population densities of *An. darlingi* as determined by human landing collections. Times of heavy rain also bring about outbreaks of malaria. In coastal areas of Guyana, a similar situation occurred (Giglioli 1951). Malaria transmission began during the rainy season when breeding sites were formed for *An. darlingi* in flooded depressions adjacent to irrigation canals.

In more densely forested regions that are found in the interior of the Amazon rainforest, the flow dynamics of the rivers are different and the heavy rains may be responsible for the flushing out of breeding sites. This would result in a reduction in the numbers of *An. darlingi* present in the area (Rozendaal 1992). It was presumed that only when the rivers began to recede in the months between the wet and dry season that breeding sites were exposed, coinciding with peaks of malaria transmission in these regions (Ferraroni and Hayes 1979; Charlwood 1980).

Insecticides:

Numerous insecticides have been used to control a wide variety of insects. The general classes of insecticides used are the organophosphates, carbamates, pyrethroids and organochlorines. The present study focused on two commonly used compounds that are used for the purposes of malaria control throughout the world. The organochlorine DDT (Dichloro-Diphenyl-Trichloroethane) has been the primary weapon against malaria since its insecticidal properties were first realized in 1939 (Bruce-Chwatt 1985). Since that time, it has widely been used for the control of a number of mosquito species and more specifically for the control of the anopheline vectors of malaria.

The primary mode of action of DDT is the binding of the compound to the axonal region of the insect nerve. The axons associated with the sensory part of the peripheral nervous system appear to be most susceptible to the toxic effects of DDT. This binding creates a situation in which the ion channels become leaky resulting in a continuous firing of action potentials. There seems to be a specificity for disruption of the sodium channels which causes the sodium gates to remain open, thereby allowing sodium ions to continuously flow into the cell. The axon will begin a continuous succession of firing and, at the same time, never return to its original resting state. The outward results of these physiological changes are a hyperexcitability characterized by hyperactivity, tremors, tetany and paralysis. Death is most often attributed to this paralysis which is believed to result in respiratory failure and suffocation.

The pyrethroid, deltamethrin ((S)- α -cyano-m-phenoxybenzyl (1R,3R)-3-(2,2-dibromovinyl)-2,2-dimethylcyclopropanecarboxylate) has become the alternative insecticide of choice for residual house spraying for malaria control. This chemical falls

under the broad category of synthetic pyrethroids, which are esters that have evolved from a natural product pyrethrin extracted from *crasanthamums*. These natural esters have been altered by the incorporation of phenoxybenzyl alcohols which protect the molecule from environmental and metabolic breakdown. A unique aspect of the synthetic pyrethroids is their ability to affect both the peripheral and central nervous systems. In many regards their modes of action are similar to that of DDT. There seems to be an interaction of the chemical with sodium channels and the axonal membrane surface. This again leads to the leaky channel process and eventual paralysis. There also appear to be effects on the motor nerve terminals. Deltamethrin appears to increase the release of neurotransmitters (Salgado et al 1982) increasing repetitive discharge. This is what is believed to be responsible for the temperature reversible knockdown effect often seen associated with this compound.

There also are indications that deltamethrin has stimulatory effects on the neuroendocrine system and may alter the release of hormones. A number of researchers (Orchard 1980, Normann 1980, Orchard and Osborne, 1979) have shown that the synthetic pyrethroids increased the release of a number of hormones within the insect system. Within the *Diptera*, it was shown that this increase in hormonal levels was correlated with an increase in the levels of trehalose, a sugar often used by rapidly firing flight muscles, in the blood of poisoned flies.

Research Goals

The goals of this study were to gain insight into the vector bionomics of the main anopheline species that have been incriminated in the transmission of malaria in southern Belize. A variety of field techniques were used for acquiring data on the seasonality, flight behavior, host feeding preference and house entering and exiting behavior in the presence and absence of both DDT and deltamethrin. Additional information was obtained on the colonization and life table attributes of An. albimanus and the natural circumsporozoite infectivity rates of field collected specimens. These studies will provide vital information for vector control efforts which could lead to more effective labor and cost saving control strategies.

Colonization of An. albimanus:

Anopheles albimanus has maintained its status as an important vector of malaria throughout much of Mexico, Central America, parts of northern South America and Haiti (Rachou et al. 1965). This species, however, has demonstrated only a low level of natural field infectivity to P. vivax (Ramsey et al. 1986). This finding has led many researchers to conclude that the transmission potential for this species occurs only when the population levels are high (Breeland 1972 and Weidhaas et al. 1974). The potential of any anopheline species to be a competent vector of malaria, however, depends upon a number of physical and physiological components associated with the life history of the mosquito. Various biological characteristics such as fecundity and larval and adult mortality are critical aspects of disease transmission potential of any vector species and constitute information that could contribute to potential control strategies (Seawright et al. 1979, Rodriguez et al. 1992).

Information pertaining to *An. albimanus* has been well documented throughout Central America. Additional information, however, about this species in the country of Belize is needed to determine its true vector potential in relation to the other *Anopheles*. The goals of this study were two fold: 1) gain preliminary information on laboratory rearing of *An. albimanus* for use in future colonization efforts, 2) obtain life table data on *An. albimanus* to clarify the longevity and fecundity of this malaria vector species.

Seasonality of Vectors in Belize:

Vector behavior influences the dynamics of malaria transmission by governing the intensity time and place of host-vector interactions (Elliott 1972). Vector behaviors also can inhibit disease transmission through behavioral modifications that are stimulated by the repellent/irritant actions of insecticides (Roberts et al. 2000, Grieco et al. 2000, Roberts and Andre 1994). Clarification of the effects vector behaviors have overall on malaria transmission can give insight into the vector potential of different anopheline species. To understand the vector competence of a given species, one must know the temporal and spatial distributions of host-vector interactions, outdoor/indoor biting patterns and natural field infection rates.

Arthropod-borne disease rates in tropical regions often correlate with seasonal patterns of vector populations. The cycles of these arthropod populations are bound by environmental conditions, which govern their ability to propagate and survive. Insects are able to survive under harsh conditions in their environment by undergoing both physiological and behavioral adaptations. In more temperate regions of the world, these adaptations result in winter diapause and summer aestivation. In more tropical regions

these adaptations are often associated with wet and dry seasons or seasonal variation in land use practices.

The purpose of the present study was to quantify seasonal abundance of each Anopheles species in the study area during the 18-month study period and examine the relationship between abundance and various ecological and disease related factors. The correlation between population abundance of An. albimanus, An. punctimacula, An. darlingi, and An. vestitipennis and rates of sporozoite positive specimens were important components of this investigation.

Flight activity:

Vehicle mounted traps have been used as a means of obtaining non-attractant motivated samples of in-flight mosquito populations (Chamberlin and Lawson, 1945; Stage 1947; Provost 1952; Provost 1957). A key aspect of collections made with a mobile truck trap is that the collections are considered to be the least affected by human manipulation and the physical environment (Bidleingmayer (1964, 1967, 1974, 1975, 1981). These types of collections are critical when trying to determine natural flight patterns of mosquito species without artificially altering behavior in any way. It has been noted by Bidleingmayer (1966, 1971) that mosquitoes do not maintain continuous flight throughout the night and, therefore, hourly collections from a vehicle-mounted trap are representative of natural flight patterns occurring in the population. Information pertaining to unbiased changes in the number of in-flight mosquitoes can be used by mosquito control programs in designing a spray schedule which will most optimally affect exposed mosquitoes. The main purpose of this study was to determine the natural flight patterns of An. vestitipennis, An. albimanus and An. punctimacula in a village in

the Toledo District of Belize. The effects of various environmental conditions such as wind speed, relative humidity and temperature on the car trap collection were also evaluated. A side benefit of this trapping method was the collection of a relatively unbiased sample of blood engorged females.

Host feeding preference:

A key component of arthropod-borne disease epidemiology is the specific host range of the vector species in question. It is important to determine the proportion of feeds that occur on humans in order to assess vectorial capacity. Care must be taken to account for factors that may alter the true estimate of feeding preference. Examples of these factors are the sensitivity and specificity of the bloodmeal assay, the host and vector dynamics and the type of statistical treatment applied to the research data.

Studies conducted on the feeding preference of An. vestitipennis are few in number. This species may be composed of sibling species that exhibit different feeding patterns and preferences (Arredondo-Jimenez et al. 1995). Overall, however, these same researchers have shown that An. vestitipennis more strongly prefers a human host than does An. albimanus. Bangs (1999) also suggested that the foraging ratios for An. vestitipennis indicate a preference for human hosts and that An. albimanus prefer cattle. The main focus of the present research project was to utilize a variety of collection techniques for sampling resting mosquito populations in an effort to collect blood engorged specimens and thereby define the specific host feeding preference of the malaria vectors in southern Belize.

Experimental Hut Studies:

The resurgence of malaria in tropical regions of Central and South America has created a renewed urgency for information pertaining to Anopheles vectors (PAHO 1994). This is evident in Belize and many other countries of the Americas where the prevalence of malaria has increased. Roberts et al. (2000) showed that this increase was associated with a reduced emphasis on vector control measures, primarily house spraying with residual insecticides.

An investigation of the house entering and exiting behavior of Anopheles vestitipennis was undertaken in the Toledo District of Belize, Central America between March and December of 1998. Three untreated experimental huts were fitted with either exit or entrance interception traps or used as a control for human landing collections. In the later part of the study (November and December of 1998), one hut was sprayed with DDT, one with deltamethrin and the third hut was left untreated to serve as a control. Throughout these collections, meteorological data was collected to determine if behavior was affected by a number of environmental parameters to include temperature, relative humidity, wind speed and periods of rain. This study was designed to clarify the entering and exiting behavior of An. vestitipennis before and after spray and to determine the true affects elicited by each chemical on these behavioral patterns.

Vector Incrimination:

Four criteria (modified versions of Koch's postulates) must be fulfilled in order to incriminate an Anopheles mosquito as a vector of malaria (Eldridge 2000). The first criterion is that the disease agent must be found naturally in the suspected vector species. Kumm and Ram (1941) and Loyola et al. (1991) reported finding sporozoites in the salivary glands of An. vestitipennis. The identity of the parasite was not determined and

therefore the possibility exists that the parasites found were of a non-human infecting species. Other researchers have found members of this species to be infected with the *P. vivax* circumsporozoite protein using the enzyme-linked immunosorbent assay (Bangs 1999, Achee et al 2000). One method used to insure the identity of the parasite involves the use of a membrane feeder, blood infected with a known *Plasmodium* species and a non-infected colony of mosquitoes.

The second criterion is to find the vector species feeding on humans. Typically these types of studies involve the determination of host preference. One method used to determine feeding preference is the use of baited traps placed closely together (Blackmore and Dow 1958, Scherer et al. 1959, Service 1971). A determination of attractiveness was made based on the number and type of mosquito collected from around each host type. With the increased use of the ELISA technique for the identification of vector blood meals, systematic collections of resting, blood engorged specimens have been used for the determination of host preference. In this regard very little has been reported on the host feeding patterns of *An. vestitipennis*. What has been reported for populations of *An. vestitipennis* from southern Mexico indicate a considerable variation in feeding preference within a region (Arredondo-Hemenez 1999). This led the researchers to consider the possibility of a sibling species. Other researchers (Bangs 1999) have indicated a preference for *An. vestitipennis* to feed on humans in the northern Belize. No definitive information has surfaced, however, regarding this issue.

The third criterion involves the susceptibility of the mosquito species to infection with the malaria parasite. Until now, this issue has not been addressed for *An.*

vestitipennis. In order to insure accurate information, it is vital to compare infection rates with other suspected vector species from the same region, as well as a control species which is known to maintain high infection rates.

The fourth and final criterion requires the transmission of the malaria parasite to an uninfected person/animal model or to a clean blood sample offered to a mosquito from a membrane feeder. This procedure has never been performed in the country of Belize and is not commonly performed. The detection of sporozoites in the salivary glands by microscopic examination is often the evidence used to incriminate a mosquito species as a vector of malaria.

In order to confirm the ability of An. albimanus, An. vestitipennis and An. darlingi to become infected with P. falciparum (Criterion 1) and to compare between species the level of infection obtained (Criterion 3), the need to perform patient feeds or artificial membrane feeds is necessary. The goals of this study were to 1) confirm, by finding sporozoites in the salivary glands by microscopic examination, the ability of An. vestitipennis to become infective by membrane feeding cultured P. falciparum and 2) compare between species the level of infectivity and thus shed light on the vector potential of these species in Belize.

REFERENCES CITED

- Achee, N.L., C.T. Korves, M.J. Bangs, E. Rejmankova, M. Lege, D. Curtin, H. Lenares, Yvette Alonzo, R.G. Andre, and D.R. Roberts. 2000. Plasmodium vivax polymorphs and Plasmodium falciparum circumsporozoite proteins in Anopheles (Diptera: Culicidae) from Belize, C.A. *J. Vect. Ecology*.
- Arredondo-Jimenez, J.I. 1995. Comparative ecology of allopatric populations of Anopheles (Anopheles) vestitipennis (Diptera: Culicidae). Ph.D. Dissertation, Department of Entomology, University of California at Davis. 172 pp.
- Arredondo-Jimenez, J.I., M.H. Gimnig, M.H. Rodriguez, and R. K. Washino. 1996. Genetic differences among Anopheles vestitipennis subpopulations collected using different methods in Chiapas state, southern Mexico. *J. Am. Mosq. Contr. Assoc.* 12: 396-401.
- Arredondo-Jimenez, J.I., M.H. Rodriguez and R.K. Washino. 1998. Gonotrophic cycle and survivorship of Anopheles vestitipennis (Diptera: Culicidae) in two different ecological areas of southern Mexico. *J. Med. Entomol.* 35:937-942.
- Arruda, M., M.B. Carvalho, R.S. Nussenzweig, M. Maracic, A.W. Ferreira and A.H. Cochrane. 1986. Potential vectors of malaria and their different susceptibility to Plasmodium falciparum and Plasmodium vivax in northern Brazil identified by immunoassay. *Am. J. Trop. Med Hyg* 35: 873-881.
- Bangs, M.J. 1999. The susceptibility and behavioral response of Anopheles albimanus Weidemann and Anopheles vestitipennis Dyar and Knab (Diptera: Culicidae) to insecticides in northern Belize. Ph.D. Thesis, Uniformed Services University of the Health Sciences, Bethesda, Maryland. 489 pp.

- Bar-Zeev, M., P. Bracha and L.S. Self. 1966. The effect of 'soot' on the residual toxicity of Bayer 39007 on mud surfaces of southern Nigerian huts. *Riv. Parassit.* 27: 33-38.
- Belkin, J.N., R.X. Schick and S.J. Heinemann. 1965. Mosquito studies (Diptera: Culicidae). V. Mosquitoes originally described from Middle America. *Contr. Am. Entomol. Inst.* 1: 1-95.
- Belkin, J.N., S.J. Heinemann and W.A. Page. 1970. The Culicidae of Jamaica. *Cont. Am. Entomol. Inst.* 6: 1-458.
- Bertram, D.S. 1971. Mosquitoes of British Honduras, with some comments on malaria, and on arbovirus antibodies in man and equines.
- Bidlingmayer, W.L. 1971. Mosquito flight paths in relation to the environment. I. Illumination levels, orientation, resting areas. *Ann. Entomol. Soc. Am.* 64: 1121-1131.
- Bidlingmayer, W.L. 1974. The influence of environmental factors and physiological stage on flight patterns of mosquitoes taken in the vehicle aspirator and truck, suction, bait and New Jersey light traps. *J. Med. Entomol.* 11: 119-146.
- Bidlingmayer, W.L. 1964. The effect of moonlight on the flight activity of mosquitoes. *Ecology.* 45: 87-94.
- Bidlingmayer, W.L. 1966. Use of the truck trap for evaluating adult mosquito populations. *Mosq. News* 26: 139-143.
- Bidlingmayer, W.L. 1967. A comparison of trapping methods for adult mosquitoes: species response and environmental influence. *J. Med. Ent.* 4: 200-220.

- Bidlingmayer, W.L. 1975. Mosquito flight paths in relation to the environment. Effect of vertical and horizontal visual barriers. *An. Entomol. Soc. Am.* 68: 51-57.**
- Bidlingmayer, W.L. 1981. Mosquito flight paths in relation to the environment, effect of the forest edge upon trap catches in the field. *Mosq. News.* 55: 55-59.**
- Blackmore, J.S. and R.P. Dow. 1958. Differential feeding of *Culex tarsalis* on nestling and adult birds. *Mosq. News.* 18: 15-17.**
- Bonne, C. and Bonne-Webster, J. 1925. Mosquitoes of Surinam. *Mede. K. Vereen. Indisch. Inst. Amst. No. 21.* 558 pp. *Afd. Trop. Hyg. No. 13.***
- Bown, D.N., J.R. Rios, C. Frederickson, G. del Angel Cananas and J.F. Mendez. 1986. Use of an exterior curtain-net: evaluate insecticide/mosquito behavior in houses. *J. Am. Mosq. Control Assoc.* 2: 99-101.**
- Bown, D.N., C. Frederickson, G. del Angel Cananas and J.F. Mendez. 1987. An evaluation of bendicarb and deltamethrin applications in the same Mexican village and their impact on populations of *Anopheles albimanus*. *Bull. Pan.-Am. Hlth Org.* 21: 121-135.**
- Boyd, M.F. 1949. Epidemiology factors related to the definitive host. In: *Malariology*, Boyd, M.F. (Editor). Philadelphia: W.B. Saunders, pp. 608-697.**
- Boyd, M.F. and F.W. Aris. 1929. A malaria survey of the islands of Jamaica, B.W.I. *Am. J. Trop. Med.* 9: 309-399.**
- Breeland, S.G. 1972. Studies on the ecology of *Anopheles albimanus*. *Am. J. Trop. Med. Hyg.* 21: 751-754.**
- Breeland, S. 1980. A bibliography to the literature of *Anopheles albimanus* (Diptera:Culicidae). *Mosq. Syst.* 12: 50-150.**

- Breeland, S.G., G.M. Jeffery, C.S. Lofgren and D.E. Weidhaas. 1974. Release of chemosterilized males for the control of Anopheles albimanus in El Salvador. I. Characteristics of the test site and the natural population, *Am. J. Trop. Med. Hyg.* 23: 274-281.
- Brown, A.W.A. 1958. Laboratory studies on the behavioural resistance of Anopheles albimanus in Panama. *Bull. Wld. Hlth. Organ.* 19: 1053-1061.
- Brown, A.W.A., J. Haworth and A.R. Zahar. 1976. Malaria eradication and control from a global standpoint. *J. Med. Entomol.* 13: 1-25.
- Bruce-Chwatt, L.J. 1985. *Essential malariology*, 2nd ed. John Wiley&Sons, New York.
- Bruyning, C.F.A. 1952. Some observations on the distributions of A. darlingi Root in the savanna region of Surinam. *Documenta Med. Geogr. Trop.* 4: 171-174.
- Casas, M., D.N. Bown and M.H. Rodriguez. 1994. Intradomicillary pre-and postfeeding behavior of Anopheles pseudopunctipennis of southern Mexico: Implications for malaria control. *J. Am. Mosq. Control Assoc.* 10: 348-354.
- Carr, H.P. and R.B. Hill. 1942. A malaria survey of Cuba. *Am. J. Trop. Med.* 22:587-607.
- Causey, O.R., L.M. Deane and M.P. Deane. 1946. Studies on Brazilian anophelines from the Northeast and Amazon Regions. *Am. J. Hyg.* 18.
- Chamberlin, J.C. and F.R. Lawson. 1945. A mechanical trap for the sampling of aerial insect populations. *Mosq. News.* 5: 4-7.
- Chareonviriyaphap, T., D.R. Roberts, R.G. Andre, H.H. Harlan, S. Manguin and M.J. Bangs. 1997. Pesticide avoidance behavior in Anopheles albimanus, a malaria vector in the Americas. *J. Am. Mosq. Control Assoc.* 13: 171-183.

- Charlwood, J.D. 1980. Observations on the bionomics of Anopheles darlingi Root (Diptera: Culicidae) from Brazil. *Bull. Entomol. Res.* 70: 685-692.
- Collins, F.H. and S.M. Paskewitz. 1995. Malaria: current and future prospects for control. *Annu. Rev. Entomol.* 40: 195-219.
- Coz, J., M. Eyraud, P. Vernard, B. Attiou, D. Somda and V. Ouedraogo. 1965. Experience en Haute-Volta sur l'utilisation de cases pieges pour la mesure d l'activite du DDT contre les moustiques. *Bull. Wld. Hlth. Org.* 33: 435-452.
- Coz, J., P. Venard, B. Attiou and D. Somda. 1966. Etude de la remanence de deux nouveaux produits insecticides: O.M.S. 43 et O.M.S. 658. *Cah. ORSTOM, ser. Entomol. Med.* 4:3-12.
- Cullen, J.R. and J. de Zulueta. 1975. Observations on the irritability of mosquitoes to DDT in Uganda. *Bull. Wld. Hlth. Organ.* 27: 239-250
- Curry, D.P. 1934. Breeding of anopheline mosquitoes among aquatic vegetation of Gatun Lake, accompanied by periodic long flights of A. albimanus Wied. *Southern Med. J.* 27: 644-651.
- Curtis, C.F. 1994. Should DDT continue to be recommended for malaria vector control? *Med. Vet. Entomol.* 8: 107-112.
- Davidson, G. 1953. Experiments on the effects of residual insecticides in houses against Anopheles gambiae and A. funestus. *Bull. Ent. Res.* 44: 231-254.
- Davis, N.C. 1931. A note on the malaria-carrying anophelines in Belem, Para, and in Natal, Rio Grande do Norte, Brazil. *Riv. Malar.* 10: 1-11.
- Deane, L.M., O.R. Causey and M.P. Deane. 1946. An illustrated key by adult female characteristics for identification of thirty-five species of Anophelini from

- Northeast and Amazon regions of Brazil with notes on the malaria vectors
(Diptera: Culicidae). *Am. J. Hyg.* 18: 1-18.
- Deane, L.M. 1988. Malaria studies and control in Brazil. *Am. J. Trop. Med. Hyg.* 38:
223-230.
- De Zulueta, J. 1959. Insecticide resistance in *Anopheles sacharovi*. *Bull. W.H.O.* 20:
797-822.
- De Zulueta, J. and C. Garrett-Jones. 1965. An investigation of the persistence of malaria
transmission in Mexico. *Am. J. Trop. Med. Hyg.* 14: 63-77.
- Eldridge, B.F. and J.D. Edman (eds.) 2000. *Medical Entomology*. Kluwer Academic
Publishers. Netherlands. pp 165-168.
- Elliott, R. 1968. Studies on man-vector contact in some malarious areas in Colombia.
Bull. Wld. Hlth. Organ. 38: 239-253.
- Elliott, R. 1969. Ecology and behaviour of malaria vectors in the American region.
Cah. ORSTOM., ser. Ent. Med. Et Parasitol. 7: 29-33.
- Elliott, R. 1972. The influence of mosquito behavior on malaria transmission. *Am. J.*
Trop. Med. Hyg. 21: 755-763.
- Elliott, R. and J. De Zulueta. 1975. Ethological resistance in malaria vectors.
Behavioral response to intradomestic residual insecticides. WHO/VBC (75.569:
1-15).
- Eyles, D.E. 1944. A critical review of the literature related to the flight and dispersion
habits of anopheline mosquitoes. *Pub. Hlth. Rep., No. 287.* 39pp.

- Eyles, D.E. and M.D. Young. 1950. The comparative susceptibility of Anopheles albimanus and An. quadrimaculatus to a South Carolina strain of Plasmodium falciparum. J. Infect. Dis. 87: 189-193.
- Faran, M.E. 1980. Mosquito studies (Diptera:Culicidae) 34. A revision of Albimanus section of the subgenus Nyssorhynchus of Anopheles. Contrib. Am. Entomol. Inst. 15: 1-215.
- Faust, E.C. 1949. Malaria incidence in North America. In: Malariology: A Comprehensive Survey of All Aspects of this Group of Diseases. M.F. Boyd. (ED.) Saunders, Philadelphia, Pennsylvania. pp. 749-763.
- Ferraroni, J.J. and J. Hayes. 1979. Drug-resistant falciparum malaria among the Mayongong Indians in the Brazilian Amazon. Am. J. Trop. Med. Hyg. 1979. 28: 909-911.
- Fleming, G. 1986. Biology and Ecology of Malaria Vectors in the Americas. J. Pan Am. Hlth. Org. PNSP/86-72.
- Frederikson, E.C. 1993. Bionomics and control of Anopheles albimanus. Tech. Paper 34. Pan Am. Hlth. Organ. Washington, D.C. 76pp.
- Gabaldon, A. 1952. The effect of DDT on the population of anopheline vectors in Venezuela. Riv. Parasitol. 13:29-41.
- Gabaldon, A. 1949. The nation-wide campaign against malaria in Venezuela. Trans. Roy. Soc. Trop. Med. Hyg. 43: 113-160.
- Garrett-Jones, C. 1964. The human blood index of malaria vectors in relation to epidemiological assessment. Bull. WHO 30: 241-261.

- Garrett-Jones, C., P.F.L. Boreham and C.P. Pant. 1980. Feeding habits of anophelines (Diptera: Culicidae) in 1971-78, with references to the human blood index: a review. *Bull. Entomol. Res.* 70: 165-185.
- Georghiou, G.P., F.E. Gidden, and J.W. Cameron. 1967. A strip character in Anopheles albimanus (Diptera: Culicidae) and its linkage relationships to sex and dieldrin resistance. *Ann. Entomol. Soc. Am.* 60: 323-328.
- Giglioli, G. 1948. An investigation of the house-frequenting habits of mosquitoes of the British Guiana coastland in relation to the use of DDT. *Am. J. Trop. Med.* 28: 43-70.
- Giglioli, G. 1951. Eradication of Anopheles darlingi from the inhabited areas of British Guiana by DDT residual spraying. *J. Nat. Malaria Soc.* 10: 142-161.
- Gillies, M.T. 1956. The problems of exophily in Anopheles gambiae. *Bull. Wld. Hlth. Organ.* 15: 437-449.
- Gillies, M.T. 1988. Anopheline mosquitoes: vector behaviour and bionomics. In: *Malaria, Principles and Practice of Malariology*. W.H. Wernsdorfer and I. McGregor, (editors). Churchill Livingstone, New York. pp. 453-485.
- Gonzalez-Ceron, L, M.H. Rodriguez, F.V. Santillan, Juan E. Hernandez and R.A. Wirtz. 2000. Susceptibility of three laboratory strains of Anopheles albimanus (Diptera: Culicidae) to coindigenous Plasmodium vivax circumsporozoite protein phenotypes in southern Mexico. *J. Med. Entomol.* 37: 331-334.
- Googwin, M.H. 1942. Studies on artificial resting places of Anopheles quadrimaculatus Say. *J. Nat. Malar. Soc.* 1: 93-99.

- Grieco, J.P., N.L. Achee, R.G. Andre and D.R. Roberts. 2000. A comparison study of house entering and exiting behavior of *Anopheles vestitipennis* (Diptera:Culicidae) using experimental huts sprayed with DDT or deltamethrin in the southern district of Toledo, Belize, C.A. *J. Vector Ecol.* 25: 62-73.
- Hadaway, A.B., F. Barlow, J.E. Grose, C.R. Turner and L.S. Flower. 1970. Evaluation of compounds for insecticidal activity on adult mosquitoes. 1. Responses of adult mosquitoes to some new insecticides. *Bull. W.H.O.* 42: 353-368.
- Hamon, J. J. Mouchet, J. Brengues and G. Chauvet. 1970. Problems facing anopheline vector control; vector ecology and behavior before and after application of control measures. In: *Conference of Anopheline Biology and Malaria Eradication. Misc. Pubs. Entomol. Soc. Amer.* 7(1): 28-41.
- Harbach, R.E. 1994. review of the internal classification of the genus *Anopheles* (Diptera:Culicidae): the foundation for comparative systematics and phylogenetic research. *Bull. Entomol. Res.* 84: 331-342.
- Haworth, J. 1988. The global distribution of malaria and the present control effort. In: *Malaria, Principles and Practice of Malariology.* W.H. Wernsdorfer and I McGregor, (eds.) Churchill Livingstone, New York pp. 1379-1420.
- Hecht, O. and J. Hernandez. 1960. Resna de las investigaciones sobre la irritacion de anofelinos por el contacto con superficies cubiertas con DDT. *CNEP Boletin.* 4: 93-106.
- Hobbs, J. R. Lowe and C. Schreck. 1974. Studies of the flight range and survival of *Anopheles albimanus* Wiedemann in El Salvador. I. Dispersal and survival during the dry season. *Mosq. News* 34: 389-393.

- Hobbs, J.H., J.D. Sexton, Y. St. Jean and J.R. Jacques. 1986. The biting and resting behavior of Anopheles albimanus in northern Haiti. J. Am. Mosq. Control. Assoc. 2:150-153.
- Horsfall, W. 1955. Mosquitoes: Their Bionomics and Relation to Disease. Ronald, New York. 723pp.
- Hudson, J.E. 1984. Anopheles darlingi Root (Diptera:Culicidae) in the Suriname rain forest. Bull. Entomol. Res. 74: 129-142.
- Hudson, J.E. and S. Esozed. 1971. The effects of smoke from mosquito coils on Anopheles gambiae Giles and Mansonia uniformes (Theo.) in verandah-trap huts at Magugu Tanzania. Bull. Ent. Res. 61: 247-265.
- Kennedy, J.S. 1947. The excitant and repellent effects on mosquitoes of sublethal contacts with DDT. Bull. Entomol. Res. 37: 593-607.
- Khan H.M. and L.K. Cutkomp. 1982. In vitro studies of DDT, DDE, and ATPase as related to avian eggshell thinning. Arch. Environ. Contam. Toxicol. 11: 627-633.
- Klein, T.A. and J.B.P. Lima. 1990. Seasonal distribution and biting patterns of Anopheles mosquitoes in Costa Marques, Rondonia, Brazil. J. Am. Mosq. Control Assoc. 6: 700-707.
- Klein, T.A., J.B.P. Lima and M.S. Tada. 1991b. Comparative susceptibility of anopheline mosquitoes to Plasmodium falciparum in Rodonia, Brazil. Am. J. Trop. Med. Hyg. 44: 598-603.
- Klowdon, M.J. 1996. Vector behavior. In : The biology of disease vectors. B.J. Beaty and W. C. Marquardt (Editors). University Press, Colorado. pp. 34-50.

- Komp, W.H.W. 1942. The anopheline mosquitoes of the Caribbean region. U.S. Public Health Service, Nat. Inst. Hlth. Bull. No. 179. 195 pp.
- Kuhlow, F. 1959. On the behavior of Anopheles funestus in unsprayed and DDT sprayed houses. Z. Tropenmed. Parasit. 10: 328-333.
- Kumm, H.W., W.H.W. Komp and H. Ruiz. 1940. The mosquitoes of Costa Rica. Am. J. Trop. Med. 20: 385-422.
- Kumm, H.W. and L.M. Ram. 1941. Observations on the Anopheles of British Honduras. Am. J. Trop. Med. 21: 559-566.
- Kumm, H.W., M.E. Bustamante and J.R. Herrera. 1943. Report concerning certain anophelines found near the Mexican-Guatemalan frontier. Am. J. Trop. Med. 23: 373-376.
- Kumm, H.W. and H. Zuniga. 1944. Seasonal variations in the numbers of Anopheles albimanus and A. pseudopunctipennis caught in stable traps in Central America. Am. J. Hyg. 39: 8-15.
- Laarman, J.J. 1959. A new species of Anopheles from a rain forest in eastern Belgian Congo. Acta Leidensia. 29: 200-211.
- Lindvall, M.L. and J.B. Low. 1980. Effects of DDE, TDE and PCBs on shell thickness of western grebe eggs, Bear River Migratory Bird Refuge, Utah—1973-74. Pestic Monit. J. 14: 108-111.
- Lopez-Carrillo, L., L. Torres-Arreola, I. Torres-Sanchez, R. Espinosa-Torres, C. Jimenez, M. Cebrian, S. Waliszewski and O. Saldate. 1996. Is DDT use a public health problem in Mexico? Environ. Hlth. Persp. 104: 584-588.

- Lowe, R.E., C.E. Schreck, J.H. Hobbs, D.A. Dame and C.S. Lofgren. 1975. Studies of flight range and survival of Anopheles albimanus Wiedemann in El Salvador. II. Comparisons of release methods with sterile and normal adults in wet and dry seasons. *Mosq. News.* 35: 160-168.
- Loyola, E.G., J.I. Arredondo, M.H. Rodriguez, D.N. Brown and M.A. Vaca-Marin. 1991. Anopheles vestitipennis, the probable vector of Plasmodium vivax in the Lacadon forest of Chiapas, Mexico. *Trans. R. Soc. Trop. Med. Hyg.* 85: 171-174.
- Loyola, E.G., L. Gonzalez-Ceron, M.H. Rodriguez, J.I. Arredondo-Jimenez, S. Bennett, and D.N. Brown. 1993. Anopheles albimanus (Diptera: Culicidae) host selection patterns in three ecological areas of the coastal plains of Chiapas, Southern Mexico. *J. Med. Ent.* 30: 518-523.
- Lourenco-de-Oliveira, R. 1989. Some observations on the mosquitoes of Indian settlements in Xingu National Park, Mato Grosso State, Brazil, with emphasis on malaria vectors. *Rev. Bras. Biol.* 49: 393-397.
- Lundholm, C.D. 1997. DDE-induced eggshell thinning in birds: effects of p,p'-DDE on the calcium and prostaglandin metabolism of the eggshell gland. *Comp. Biochem. Phy. C. Pharmacol. Toxicol. Endocrinol.* 118: 113-128.
- Lundholm, C.E. and M. Bartonek. 1992. Effects of p,p'-DDE and some other chlorinated hydrocarbons on the formation of prostaglandins by the avian eggshell gland mucosa. *Arch. Toxicol.* 66: 387-391.
- Macdonald, G. 1950. Epidemiological basis of malaria control. *Bull. Wld. Hlth. Org.* 15: 613-626.

- Macdonald, G. 1957. *The epidemiology and control of malaria*. Oxford University Press, Amen House, London, 201 pp.
- Marquetti, M., A. Navarro, J. Bisset and F.A. Garcia. 1992. Comparisons of three catching methods for collecting anopheline mosquitoes. *Mem. Inst. Oswaldo Cruz Rio J.* 87:457-458.
- Marten, G.G., M.F. Suarez and R. Astaeza. 1996. An ecological survey of Anopheles albimanus larval habitats in Colombia. *J. Vec. Ecol.* 21: 122-131.
- Mekuria, Y., M.A. Tidwell, D.C. Williams, and J.D. Mandeville. 1990. Bionomic studies of the Anopheles of Dajabon, Dominican Republic. *J. Am. Mosq. Control Assoc.* 6: 651-657.
- Mekuria, Y., R. Granados, M.A. Tidwell, D.C. Williams, R.A. Wirtz and D.R. Roberts. 1991. Malaria transmission potential of Anopheles mosquitoes of Dajabon, Dominican Republic. *J. Am. Mosq. Control. Assoc.* 7:456-461.
- Miller, T.A. 1988. Mechanisms of resistance to pyrethroid insecticides. *Parasitol. Today.* 4: 8-12.
- [MOH] Ministry of Health (Belize). 1993. Evaluation of program activities. *Vector Control Program*.
- Mouchet, J., S. Manguin, J. Sircoulon, S. Laventure, O. Faye, A.W. Onapa, P. Carnevale, J. Julvez and D. Fontenille. 1998. Evolution of malaria in Africa for the past 40 years: impact of climatic and human factors. *J. Am. Mosq. Control. Assoc.* 14: 121-130.
- Mpofu, S.M., P. Taylor and J. Govere. 1988. An evaluation of the residual lifespan of DDT in malaria control. *J. Am. Mosq. Control Assoc.* 2: 529-535.

- Muirhead-Thomson, R.C. 1947. The effects of house spraying with pyrethrum and with DDT on Anopheles gambiae and A. melas in West Africa. Bull. Entomol. Res. 38: 449-464.
- Muirhead-Thomson, R.C. 1948. Studies on Anopheles gambiae and A. melas in and around Lagos. Bull. Ent. Res. 38: 527-558.
- Muirhead-Thomson, R.C. 1950. DDT and gammexane as residual insecticides against Anopheles gambiae in African houses. Trans. R. Soc. Trop. Med. Hyg. 43: 401-412.
- Muirhead-Thomson, R.C. 1960. The significance of irritability, behavioristic avoidance and allied phenomena in malaria eradication. Bull. W.H.O. 22: 721-734.
- Muirhead-Thomson, R.C. 1968. Ecology of Insect Vector Populations. Academic Press, London. 174 pp.
- Muirhead-Thomson, R.C and E.C. Mercier. 1952. Factors in malaria transmission by Anopheles albimanus in Jamaica. Part I. Ann. Trop. Med. Parasitol. 46: 103-116.
- Orr, B.K. and V.H. Resh. 1989. Experimental test of the influence of aquatic macrophyte cover on the survival of Anopheles larvae. J. Am. Mosq. Control Assoc. 5: 579-585.
- Padilla, N., P. Molina, J. Juarez, D.M. Brown and C. Cordon-Rosales. 1992. Potential malaria vectors in northern Guatemala. J. Am. Mosq. Control Assoc. 8: 307-308.
- Pan American Health Organization. 1994. Status of malaria programs in the Americas. XLII report, CSP24/INF/2(Eng.) Washington, D.C. 116 pp.

- Panday, R.S. 1980. Medical entomological aspects of the malaria problem in Surinam. *Surinaams Medisch. Bull.* 3: 52-58.
- Pant, C.P., G. P. Joshi, P. Rosen, J. A. Pearson, P. Renaud, M. Ramasamy and M. Vandekar. 1969. A village-scale trial of OMS-214 (Dicapthon) for the control of *Anopheles gambiae* and *Anopheles funestus* in northern Nigeria. *Bull. Wld. Hlth. Org.* 41: 311-315.
- Provost, M.W. 1952. The dispersal of *Aedes taeniorhynchus* I. Preliminary studies. *Mosq. News.* 12(3): 174-191.
- Provost, M.W. 1957. The dispersal of *Aedes taeniorhynchus* II. The second experiment. *Mosq. News* 17(4): 233-247.
- Quinones, M.L. and M.F. Suarez. 1989. Irritability to DDT of natural populations of the primary malaria vectors in Colombia. *J. Am. Mosq. Control Assoc.* 5: 56-59.
- Rachou, R.G., G. Lyons, M. Maura Lima, and J.A. Kerr. 1965. Synoptic epidemiological studies of malaria in El Salvador. *Am. J. Trop. Med. Hyg.* 14:1-62.
- Ramsey, J.M., D.N. Brown, J.L. Aron, R.L. Beaudoin and J.F. Mendez. 1986. Field trials in Chiapas, Mexico, of a rapid detection method for malaria in anopheline vectors with low infection rates. *Am. J. Trop. Med. Hyg.* 35: 234-238.
- Ramsey, J.M., E. Salinas, D.M. Brown and M.H. Rodriguez. 1994. *Plasmodium vivax* sporozoite rates from *Anopheles albimanus* in southern Chiapas, Mexico. *J. Parasitol.* 80: 489-493.

- Rachou, R.G., G. Lyons, M. Moura-Lima, and J.A. Kerr. 1965. Synoptic epidemiological studies of malaria in El Salvador. *Am. J. Trop. Med. Hyg.* 14: 1-62.
- Rachou, R.G., L.A. Schinazi and M. Moura-Lima. 1973. An extensive epidemiological study of the causes for the failure of residual DDT-spraying to interrupt the transmission of malaria in Atalaya and Falla, two villages on the coastal plain of El Salvador, Central America. *Rev. Bras. Malariol. Doencas Trop.* 25: 3-293.
- Rapley, R.E. 1961. Notes on the construction of experimental huts. *Bull. Wld. Hlth. Org.* 24: 659-663.
- Ree, H.I. 1988. Studies on control effect of the pyrethrin-impregnated mosquito net against *Anopheles farauti* in the experimental hut. *Jap. J. Sanit. Zool.* 39: 113-118.
- Rejmankova, H.M. Savage, M.H. Rodriguez, D.R. Roberts, and M. Rejmanek. 1992. Aquatic vegetation as a basis for classification of *Anopheles albimanus* Weideman (Diptera: Culicidae) larval habitats.
- Rejmankova, E., D.R. Roberts, R.E. Harbach, J. Pecor, E.L. Peyton, S. Manguin, R. Krieg, J. Polanco and L. Legters. 1993. Environmental and regional determinants of *Anopheles* (Diptera: Culicidae) larval distribution in Belize, Central America. *Environ. Entomol.* 22: 978-992.
- Rejmankova, E., D.R. Roberts, A. Pawley, S. Manguin and J. Polanco. 1995. Predictions of adult *Anopheles albimanus* densities in villages based on distances to remotely sensed larval habitats. *Am. J. Trop. Med. Hyg.* 53: 482-488.

- Rejmankova, E., K.O. Pope, D.R. Roberts, M.G. Lege, R. Andre, J. Greico, and Y. Alonzo. 1998. Characterization and Detection of Anopheles vestitipennis and Anopheles punctimacula (Diptera: Culicidae) larval habitats in Belize with field survey and SPOT satellite imagery. *J. Vector Ecol.* 23: 74-88.
- Richards, F.O., Jr., R.Z. Flores, J.D. Sexton, R.F. Beach, D.L. Mount, C. Cordon-Rosales, M. Gatica and R.E. Klein. 1994. Effects of permethrin-impregnated bed nets on malaria vectors in northern Guatemala. *Bull. Pan. Am. Hlth. Org.* 28: 112-121.
- Roberts, D.R., W.D. Alecrim, P. Hsieh, J.P. Grieco, M. Bangs, R.G. Andre and T. Chareonviriphap. 2000. A probability model of vector behavior: effects of DDT repellency, irritancy and toxicity in malaria control. *J. Vector Ecol.* 25: 48-61.
- Roberts, D.R., W.D. Alecrim, A.M. Tavares and K.M. McNeill. 1984. Influence of physiological condition on the behavioral responses of Anopheles darlingi to DDT. *Mosq. News.* 44: 357-362.
- Roberts, D.R., W.D. Alecrim, A.M. Tavares and M.G. Radke. 1987. The house frequenting, host-seeking and resting behavior of Anopheles darlingi in southeastern Amazonas, Brazil. *J. Am. Mosq. Control Assoc.* 3: 433-441.
- Roberts, D.R. and R. Andre. 1994. Insecticide resistance issues in vector-borne disease control. *J. Am. Trop. Med. Hyg.* 50: 21-34.
- Roberts, D.R., J.F. Paris, S. Manguin, R.E. Harbach, R. Woodruff, E. Rejmankova, J. Polanco, B. Wullschleger and L.J. Legters. 1996. Predictions of malaria vector distribution in Belize based on multispectral satellite data. *Am. J. Trop. Med. Hyg.* 54: 304-308.

- Roberts, D.R., O. Chan, J. Pecor, E. Rejmankova, S. Manguin, J. Polanco and L.J. Letgers. 1993. Preliminary observations on the changing roles of malaria vectors in southern Belize. *J. Am. Mosq. Control Assoc.* 9: 456-459.
- Roberts, D.R., L.L. Laughlin, P. Hsheih and L.J. Letgers. 1997. DDT: global strategies and a malaria control crisis in South America. *Emerg. Inf. Dis.* 3:295-302.
- Rodriguez, A.D., M.H. Rodriguez, J.E. Hernandez, S.W. Dister, L.R. Beck, E. Rejmankova and D. Roberts. 1996. Landscape surrounding human settlements and Anopheles albimanus (Diptera:Culicidae) abundance in southern Chiapas, Mexico. *J. Med. Entomol.* 33: 39-48.
- Rodriguez, M.H., D.N. Bown, J.I. Arredondo-Jimenez, C. Villarreal, E.G. Loyola and C.E. Frederickson. 1992. Gonotrophic cycle and survivorship of Anopheles albimanus (Diptera: Culicidae) in southern Mexico. *J. Med. Entomol.* 29: 395-399.
- Rodriguez, M.H. and E.G. Loyola. 1990. Malaria in Mexico. *Proc. 58th Ann. Conf. Calif. Mosq. Vec. Control Assoc.* pp. 49-52.
- Rozendaal, J.A. 1987. Observations on the biology and behaviour of anophelines in the Suriname rainforest with special reference to Anopheles darlingi Root. *Cah. ORSTOM, Ser. entomol. Med. Parasitol.* 25: 33-43.
- Rozendaal, J. A. 1990. Observations on the distribution of anophelines in Suriname with particular reference to the malaria vector Anopheles darlingi. *Mem. Inst. Oswaldo Cruz.* 85: 221-234.

- Rozendaal, J. A. 1992. Relations between Anopheles darlingi breeding habitats, rainfall, river level and malaria transmission rates in the rain forest of Suriname. Med. Vet. Entomol. 6: 16-22.
- Rozendaal, J.A., J.P.M. van Hoof, J. Voorham and B.F.J Oostburg. 1989. Behavioral responses of Anopheles darlingi in Suriname to DDT residues on house walls. J. Am. Mosq. Control Assoc. 5: 339-350.
- Rubio-Palis, Y. and R.H. Zimmerman. 1997. Ecoregional classification of malaria vectors in the neotropics. J. Med. Entomol. 34: 499-510.
- Russell, P.F., L.S. West, R.D. Manwell and G. Macdonald. 1963. Practical Malariology. 2nd Ed. Oxford University Press, London, England. 750 pp.
- Savage, H.M., E. Rejmankova, J.I. Arredondo-Jimenez, D.R. Roberts and M.H. Rodriguez. 1990. Limnological and botanical characterizations of larval habitats of two primary malaria vectors, Anopheles albimanus and Anopheles pseudopunctipennis, in coastal areas of Chiapas state, Mexico. J Am. Mosq. Control Assoc. 6: 612-620.
- Scherer, W.F., E.L. Buescher, M.B. Flemings, A. Noguchi and J. Scanlon. 1959. Ecologic studies of Japanese encephalitis virus in Japan. III. Mosquito factors. Zootropism and vertical flight of Culex tritaeniorhynchus with observations on variations in collections from animal-baited traps in different habitats. Am. J. Trop. Med. Hyg. 8: 665-677.
- Scott, H.H. 1932. Medical and sanitary reports from British colonies, protectorates and dependencies for the year 1930. Trop. Dis. Dull. 29: 127-129.

- Seawright, J.A., D.G. Haile, M.G. Rabbani and D.E. Weidhaas. 1979. Computer simulation of the effectiveness of male-linked translocations for the control of Anopheles albimanus Weidmann. *Am. J. Trop. Med. Hyg.* 28: 155-160.
- Service, M.W. 1993. *Mosquito Ecology: Field sampling methods* 2nd Ed. Chapman and Hall, London. 988 pp.
- Service, M.W. 1971. Feeding behaviour and host preferences of British mosquitoes. *Bull. Ent. Res.* 60: 653-661.
- Sharp, B.L., D. le Sever and P. Bekker. 1990. Effects of DDT on survival and blood feeding success of Anopheles arabiensis in Northern KwaZulu, Republic of South Africa. *J. Am. Mosq. Control Assoc.* 6: 197-202.
- Siez, A., C. Rodriguez, Y. Arzu and O. Chan. 1995. Morbidity of malaria in children in Toledo District. *Vector Control Program.* 12 pp.
- Simmons, J.S. 1941. The transmission of malaria by the Anopheles mosquitoes of North America. In: *A symposium on human malaria with special reference to North America and the Caribbean region.* F.R. Moulton, Ed. *Am. Assoc. Adv. Sci.* Pub. No. 15. Washington, D.C. pp. 113-130.
- Simmons, J.S., G.R. Callender, D.P. Curry, S.C. Schwartz and R. Randall. 1939. *Malaria in Panama.* *Am. J. Hyg. Monogr. Ser. No. 13.* 326pp.
- Smith, A. 1963. Principles in assessment of insecticides by experimental huts. *Nature, Lond.* 198: 171-173.
- Smith, A. 1964. A review of the origin and development of experimental hut techniques used in the study of insecticides in East Africa. *E. Afr. Med. J.* 41: 361-374.

- Smith, A. 1965. A verandah-trap hut for studying the house-frequenting habits of mosquitoes and for assessing insecticides. I. A description of the verandah-trap hut and of the studies on the egress of Anopheles gambiae Giles and Mansonia uniformis (Theo.) from and untreated hut. Bull. Ent. Res. 56: 161-167.
- Stage, H.H. 1947. DDT to control insects affecting man and animals in a tropical village. J. Econ. Entomol. 40: 759-762.
- Symes, C.B. and A.B. Hadaway. 1947. Initial experiments in the use of DDT against mosquitoes in British Guiana. Bull. Entomol. Res. 37: 399-430.
- Tadei, W.P., B.D. Thatcher, J.M. Santos, V.M. Scarpassa, I.B. Rodrigues and M.S. Rafael. 1998. Ecological observations on anopheline vectors of malaria in the Brazilian Amazon. Am. J. Trop. Med. Hyg. 59: 325-335.
- Taylor, R.N. M.N. Hill, D.C. Stewart, R. Slatter and M. Gichanga. 1981. A field evaluation of permethrin (OMS 1821) and NRDC 161 (OMS 1998) for residual control of mosquitoes. Mosq. News. 41: 423-434.
- Taylor, R.T. 1966. The ecology of Anopheles albimanus (Wied.) in Haiti. Mosq. News 26: 393-397.
- Tonn, R.J. 1983. Recent developments in Latin America and the Caribbean. Bull. Soc. Vect. Ecol. 8: 3-22.
- Vale, G.A. 1971. Artificial refuges for tsetse flies (Glossina spp). Bull. Ent. Res. 61: 331-350.
- Van der Kuyp, E. 1950. Contributions to the study of the malarial epidemiology in Surinam. Afd. Trop. Hyg. 18: 146pp.

- Vanzie, E. 1995. Situation analysis of the vector control program: Magnitude and trend of malaria transmission. Vector Control Programme, Ministry of Health, Belize. 17 pp.
- Warren, McW, W.E. Collins, B.B. Richardson and J.C. Skinner. 1977. Morphological phenotypes of Anopheles albimanus and susceptibility to Plasmodium vivax and Plasmodium falciparum. Am. J. Trop. Med. Hyg. 26: 607-611.
- Warren, McW, W.E. Collins, B.B. Richardson and J.C. Skinner. 1979. Naturally occurring pupal phenotypes of Anopheles albimanus and their susceptibility to Plasmodium vivax and P. falciparum. Mosq. News 39: 472-477.
- Warren, McW, J. Mason and J. Hobbs. 1975. Natural infections of Anopheles albimanus with Plasmodium in a small malaria focus. Am. J. Trop. Med. Hyg. 24: 545-546.
- Weidhaas, D.E., S.G. Breeland, C.S. Lofgren, D.A. Dame and R. Kaiser. 1974. Release of chemosterilized males for the control of Anopheles albimanus in El Salvador. IV. Dynamics of the test population. Am. J. Trop. Med. Hyg. 23: 298-308.
- White, G.B. 1982. Malaria vector ecology and genetics. Br. Med. Bull. 38: 207-211.
- Wilkerson, R.C. and D. Strickman. 1990. Illustrated key to the female anopheline mosquitoes of Central America and Mexico. J. Am. Mosq. Control Assoc. 6: 7-33.
- World Health Organization. 1975. Manual on practical entomology in malaria. II. Methods and techniques. WHO Offset Publication, Geneva, No. 13, 191 pp.
- World Health Organization. 1990. Control of the leishmaniases. Report of a WHO Expert Committee. Geneva, WHO Technical Report Series, No. 793.

- World Health Organization. 1991. World Health Organization expert committee on biological standardization. Techn. Rep. Ser. 610:1977.
- World Health Organization. 1994. Use of DDT in vector control. Med. Vet. Entomol. 8:113.
- World Health Organization. 1995. Vector control for malaria and other mosquito-borne diseases. Wld. Hlth. Organ. Tech. Rep. Ser. No. 857. 91pp.
- World Health Organization. 1996. World malaria situation in 1993. Part II. Weekly Epidemiol. Rec. 71: 25-29.
- World Health Organization. 1997. World malaria situation in 1994. Part I. Weekly Epidemiol. Rec. 72: 269-276.
- Worth, C.B. 1953. Construction and use of a simplified window trap for insects. Mosq. News. 13: 204-206.
- Zamora, F.V. and M.L. Calderon. 1991. Biology and vectorial capacity of Anopheles albimanus on the southern coast of Guatemala. J. Am. Mosq. Control Assoc. 7: 635.
- Zimmerman, R.H. 1992. Ecology of malaria vectors in the Americas and future direction. Mem. Inst. Oswaldo Cruz. 87: 371-383.

Table 1: Malaria incidence and district population data for 1995. Data is separated by district with a calculation of the API (Annual Parasite Index) (Vector Control Program 1997).

Malaria Incidence by District (1995)			
District	Population	Number of Cases	API
Corozal	32,134	670	20.8
Orange Walk	34,663	621	17.9
Belize	64,377	505	7.8
Cayo	42,458	3,738	88.0
Stann Creek	20,416	1,741	85.2
Toledo	19,685	2,138	108.6

Table 2: The break down by age and sex of the malaria cases reported in the Toledo District during 1995 (Siez et al. 1997).

Age	Sex		Total	% of Total
	Female	Male		
<1 yr.	22	23	45	2.1%
1-4 yr.	185	192	377	17.6%
5-12 yrs	324	346	670	31.4%
>12	NA	NA	1046	48.9%
Total			2138	100%

Table 3: Childhood malaria cases from 1995 separated on the basis of month. Highest numbers of cases occur between the months of July and November which coincides with the rainy season (Siez et al. 1997).

Age	Months												Total
	Jan	Feb	Mar	Apr	May	Jun	Jul	Aug	Sep	Oct	Nov	Dec	
< 1yr	1	4	1	2	4	3	8	3	3	7	8	1	45
1-4 yrs	26	31	27	22	29	20	42	32	29	51	43	25	377
5-12 yrs	51	45	47	33	41	50	65	72	63	90	80	33	670
Total	78	80	75	57	74	73	115	107	95	148	131	59	1092

Table 4: Classification of the 10 villages with the highest number of malaria cases during 1993, 1994 and 1995. Also shown are the total numbers of Thick Blood Films (TBF) examined and the total number of positives recorded for the entire Toledo District (Siez et al. 1997).

Rank	1993		1994		1995	
	Village	Number of cases	Village	Number of cases	Village	Number of cases
1	Punta Gorda	35	Punta Gorda	80	Indian Creek	82
2	Columbia	24	Big Falls	63	Columbia	75
3	Big Falls	14	Golden Stream	43	Aguacate	59
4	Golden Stream	11	Columbia	4	Golden Stream	55
5	Rancho	10	Indian Creek	32	Big Falls	54
6	Blue Creek	7	Deep River	25	Punta Gorda	39
7	Silver Creek	6	Aguacate	24	Bladden	31
8	Laguna	6	Rancho	20	San Lucas	30
9	Bladden	5	Laguna	19	Rancho	23
10	Criquet Sarco	5	San Antonio	17	Otoxha	19
Total TBFs		1,955	3,905		5,188	
Positives		173 (8%)	589 (15%)		684 (13%)	

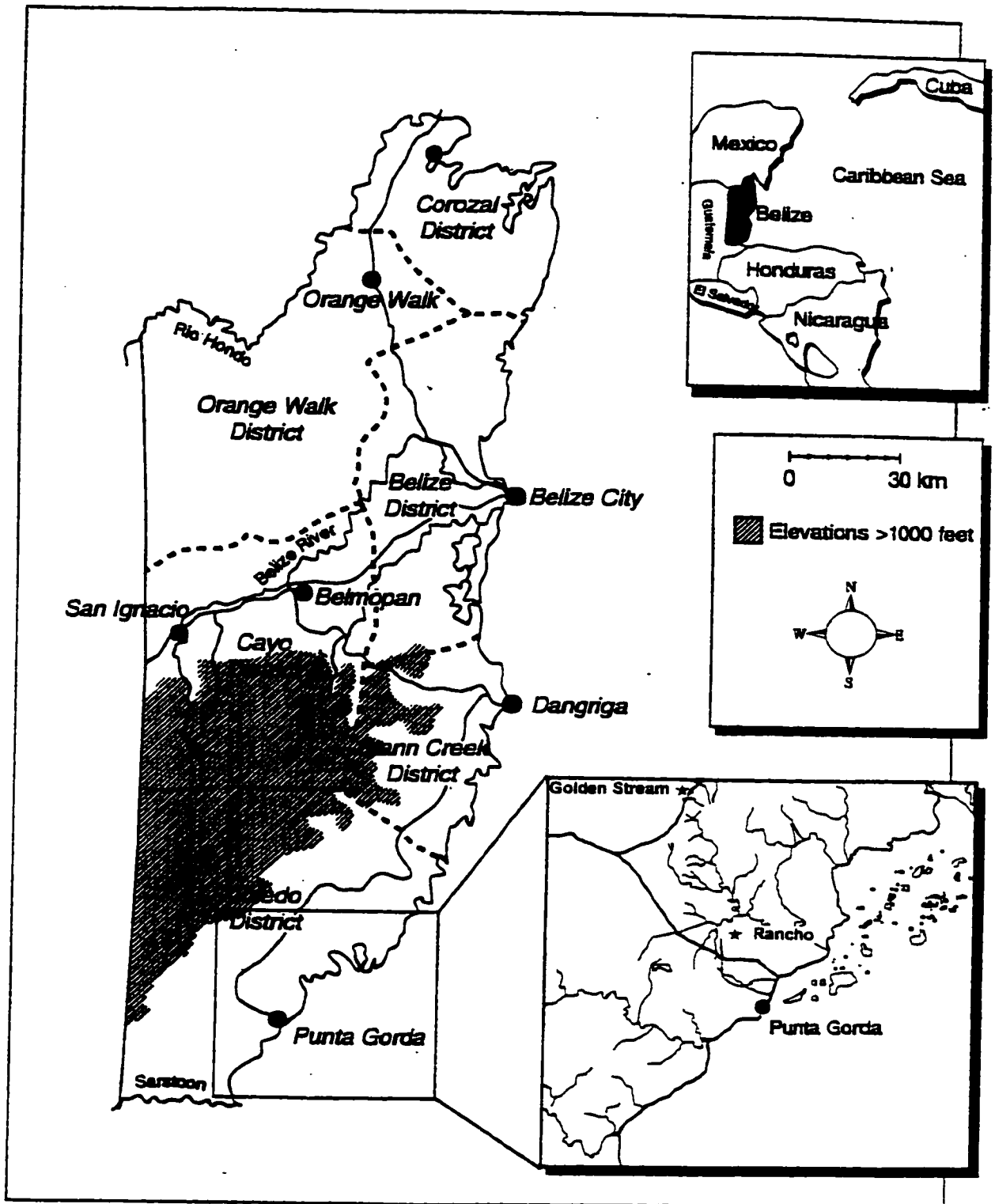

Figure 1. Map of the Toledo District in Southern Belize showing the location of the two research sites, Golden Stream and Rancho

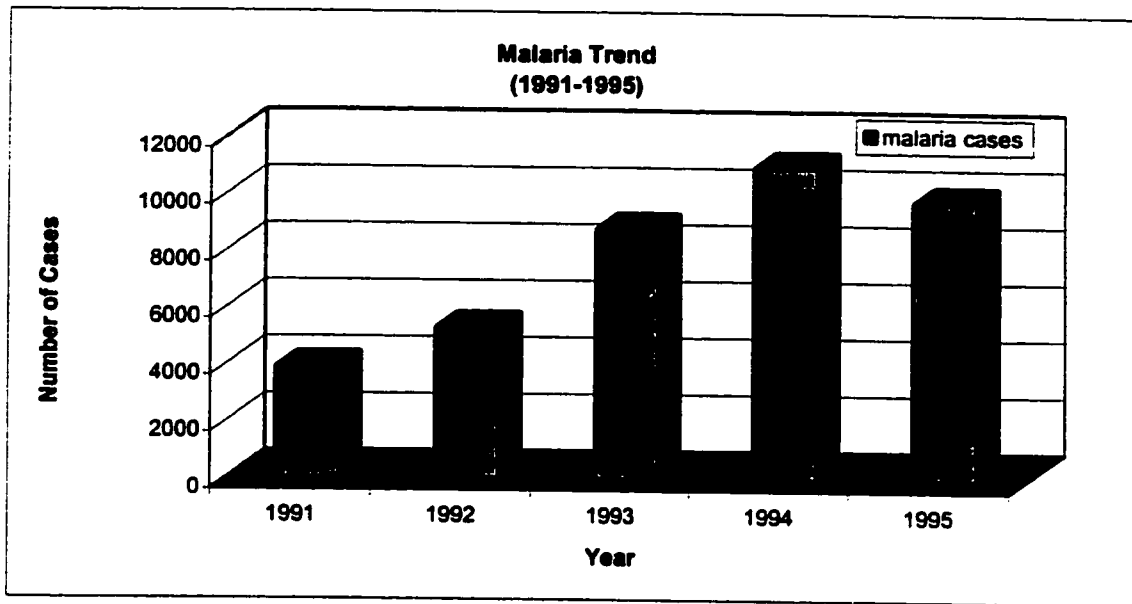

Figure 2: Increasing trend in cases of malaria between the years 1991-1995 (Source: Vector Control Program of Belize).

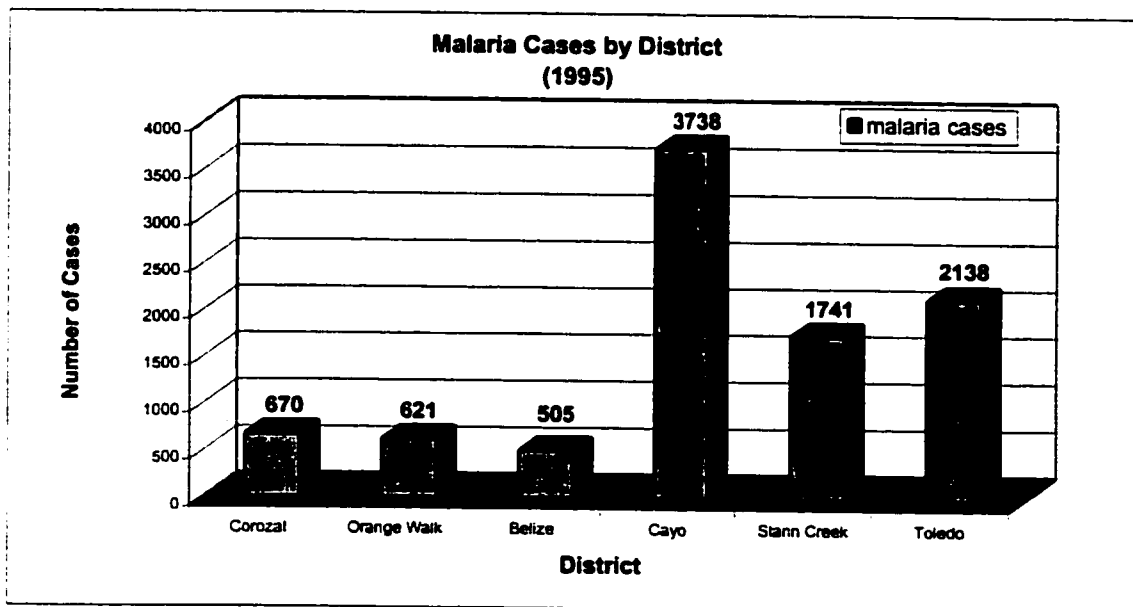

Figure 3: Number of malaria cases in 1995 broken down by district (Source: Vector Control Program of Belize).

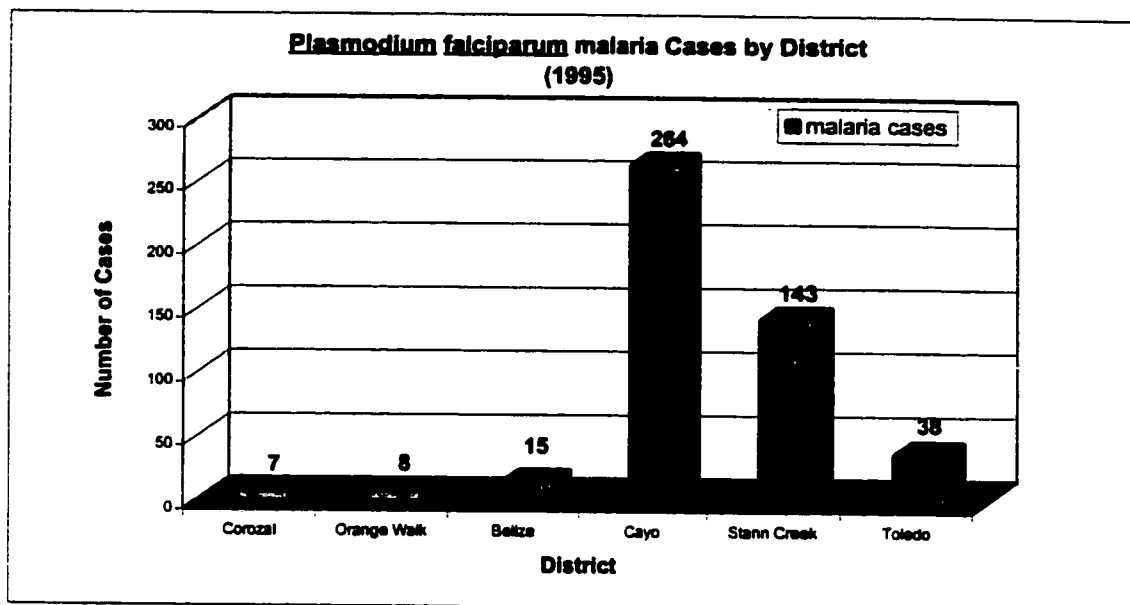

Figure 4: Numbers of *Plasmodium falciparum* malaria cases recorded in 1995 separated by district (Source: Vector Control Program of Belize).

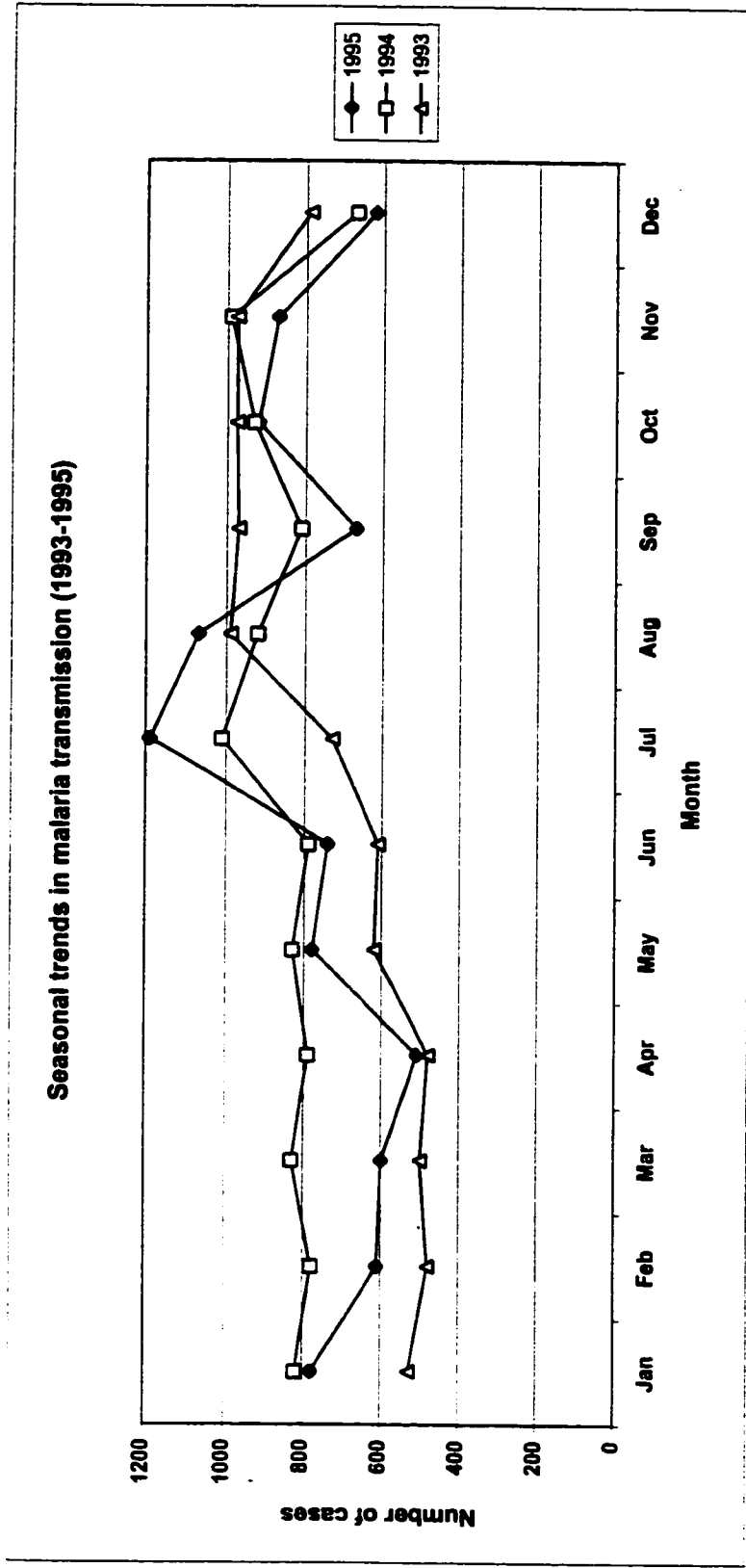

Figure 5: Seasonal trends for all malaria cases for the years 1993, 1994 and 1995 (Source: Vector Control Program of Belize).



Figure 6. Geographic distribution of *Anopheles albimanus* in the Americas (Faran 1980)

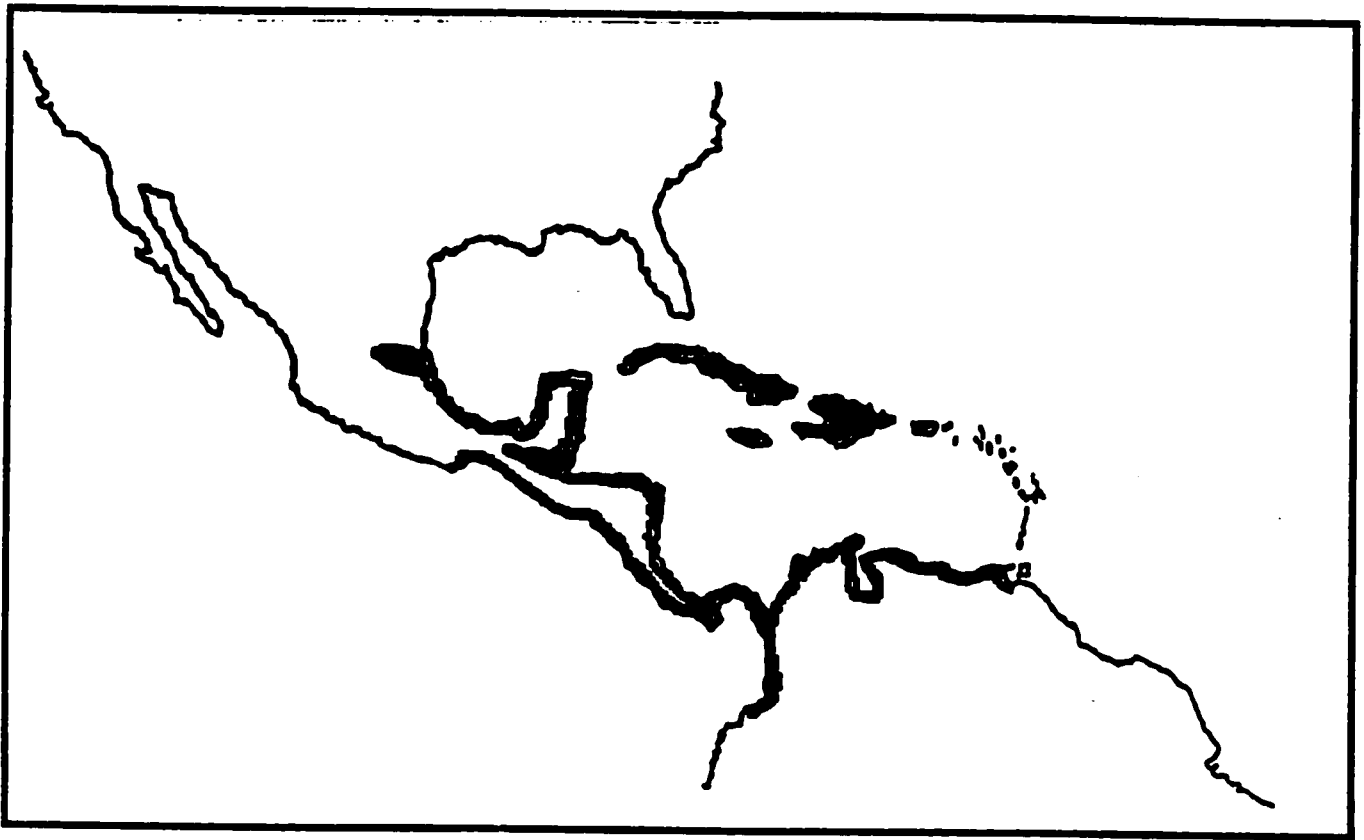

Figure 7: Geographic distribution of *Anopheles vestitipennis* in the Americas (Arredondo-Jimenez et al. 1980)

Chapter 2

Colonization and Life Table Attributes of a Field Collected Population of *Anopheles albimanus* (Weidemann) from the Toledo District, Southern Belize.

ABSTRACT

A life table study was conducted for a recently established colony of Anopheles albimanus in Belize, Central America. The colony was obtained and reared in the southern Toledo District under uncontrolled environmental conditions (29-35°C, 87-90% RH, and 13:11 L:D photoperiod). The mean time of larval development was determined to be 10.87 days with adult emergence occurring approximately 1.33 days later. The length of the pupal stage was found to be longer for the males (30.47 hours) than for the females (30.16 hours) although the overall female development took longer. Adult emergence success was 94% and the sex ratio was not significantly different from 1:1. Adult males lived for an average of 15.21 days while the females lived for an average of 19.39 days. The r/B and B/D ratios of 0.71 and 1.96, respectively, indicate that this species has a low potential for colonization.

In terms of oviposition preference, there was a definite preference for darkly colored containers with 87% of all eggs oviposited in the black containers. In the white containers, there was a preference for the plant over non-plant containing cups. On average, 318.35 eggs were laid per female.

INTRODUCTION

Anopheles albimanus has maintained its status as an important vector of malaria throughout much of Mexico, Central America, parts of northern South America and Haiti (Rachou et al. 1965). This species, however, has demonstrated only a low level of natural field infectivity to Plasmodium vivax (Ramsey et al. 1986). This finding has led many researchers to conclude that the transmission potential for this species occurs only when the population levels are high (Breeland 1972 and Weidhaas et al. 1974). The potential of any anopheline species to be a competent vector of malaria, however, depends on a number of physical and physiological components associated with the life history of the mosquito. Various biological characteristics such as fecundity and larval and adult mortality are critical aspects of disease transmission potential of any vector species and constitute information that could contribute to potential control strategies (Seawright et al. 1979).

The longevity of a population is an extremely important facet of vector potential. The malaria parasite requires a certain amount of time under specific temperature regimes to penetrate the gut lining of the mosquito, develop into oocysts and finally have the sporozoites rupture out of the mature oocysts and infect the salivary glands of the mosquito. If the life span of the mosquito is not sufficiently long, the parasite will be unable to complete its sporogonic life cycle and transmission cannot take place. When the temperature is held at a constant 24°C, the process of sporogony takes 9 days for P. vivax and 11 days for P. falciparum to complete (Sandosham and Thomas 1983).

Information pertaining to the natural longevity of a species is often difficult to obtain. Both predators and adverse weather conditions can reduce the life span of mosquitoes. These factors are difficult if not impossible to accurately measure. For this reason, it is important to make inferences about the life span of particular species by collecting data on colony reared populations. When conditions are held constant or semi-constant, the attributes associated with the colony can be used to represent the level of survivorship under those constant conditions. This will give some clue as to the vector potential for a given species given constant environmental parameters.

Larval mortality and fecundity of a species also are important components in the vector potential of a particular mosquito species. Within the framework of this study, fecundity is defined as the potential innate reproductive capacity of the individual mosquito. The combined effects of mortality and fecundity determine the potential for rapid population growth, which could increase a mosquito species ability to transmit malaria. This is particularly true for a species like *An. albimanus* which appears to have weak vector characteristics and plays a role in malaria transmission only when at high population densities (Breeland 1972 and Weidhaas et al. 1974).

Measuring the reproductive potential of a species can also provide useful information for application of non-chemical control strategies such as natural competition. This concept entails using a non-vector species to out-compete (particularly in the larval stage) a known vector species and thereby reduce the population density of the vector species. This concept was tested using *Ae. aegypti* populations that were suppressed by *Ae. albopictus* populations in Asia (Gilotra et al. 1967). Gubler (1972) also experimented with *Ae. albopictus*, a non-vector of filariasis,

and its ability to out-compete and suppress populations of Ae. polynesiensis, a known vector of filariasis.

In addition to determining the life history attributes of a species, there is a great need for colonized mosquitoes for conducting experiments in which a control population of known origin and history are needed. This is particularly true in the case of insecticide susceptibility studies. Studies examining comparative susceptibilities to various Plasmodium species also rely on the use of colonized specimens to provide baseline data (Collins et al. 1973; Collins et al. 1974; Collins et al. 1985; Klein et al. 1990; Klein et al. 1991a; Klein et al. 1991b; Klein et al. 1991c).

In laboratory studies, An. albimanus has proven to be a poor host for the malaria parasite (Warren et al 1977). In host preference studies this species exhibits a greater tendency to feed on cattle than on humans (Breeland, 1972). Differences occur within and between populations of An. albimanus. This suggests the presence of genetic variants within the population. A susceptibility study of three strains of An. albimanus (white-striped, green and brown) to two phenotypes of P. vivax (VK210 and VK247) was conducted in southern Mexico (Gonzalez-Ceron et al. 2000). The white-stripe phenotype had a higher susceptibility to P. vivax parasites than either of the green or brown phenotypes (Chan et al. 1994; Gonzalez-Ceron et al. 2000) had. The presence of variants within a mosquito population may explain the differences seen in the behavioral patterns as well as differences in susceptibility to P. vivax and P. falciparum. This intraspecific variation has been demonstrated for the An. maculipennis complex in Europe and more prominently in the An. gambiae complex in Africa. For all of these

studies, it is desirable to use a colonized source of mosquitoes so that a known genetic line can be used and compared to various field strains.

The use of *An. albimanus* in a variety of other studies has required that it be established in colony (Baily et al. 1979). Dame et al. (1974) described a procedure, utilizing techniques established by Ford and Green in 1972, for the colonization of large numbers of *An. albimanus* for the purposes of mass sterile release experiments. Others also have used colonization for the mass rearing of mosquitoes for the purpose of sterile release experiments (Baily et al. 1980, Savage 1980). Rabbani et al. (1976) adapted a technique for rearing isofemale lines of *An. albimanus* for genetic studies on phenotypic characteristics of single families.

The short viability period in which the eggs of *An. albimanus* can be maintained dry have led some researchers to investigate better methods of long-term egg storage. Baily et al. (1979) adapted a previous storage technique to enable researchers to store eggs for up to 5 days at a temperature of 10-12°C with little loss of viability. Others have looked at this drying process to determine other possible oviposition substrates (Dame et al. 1978). Breeland et al. (1970) examined mud as an alternate ovipositional substrate. They found that eggs could be held for up to 15 days and would hatch immediately when inundated with water. They reported that a delay in eclosion had little effect on egg viability.

Different oviposition containers also have been investigated in order to maximize egg production. This has led to the experimental addition of various chemical compounds to the water. Many of these compounds are derivatives of plant extracts. Within the anophelines, it has been well documented that plant material is

required for egg deposition and for larval development (Ancona 1930; Hall 1972; Balling and Resh 1985; Orr and Resh 1989). This association has been attributed to the compounds in the plant material which provided an additional source of nutrients for developing larvae. Plant material also may provide protection from predatory insects. Recent studies have demonstrated a strong association between plant life and algal mats found in particular aquatic habitats and their association with An. albimanus larvae (Rejmankova et al. 1992).

Age-specific horizontal life tables can be used to summarize the mortality and reproductive characteristics of a given species (Reisen et al. 1979, Reisen and Mahmood 1980). When all of the variables are controlled for, this information can provide characterizations about the population which represent the maximum expression of these attributes for a given population or species. This type of study has been applied to a number of species including Ae. aegypti (L.) (Crovello and Hacker 1972), Culex quinquefasciatus Say (Walter and Hacker 1974), An. culicifacies and An. stephensi (Reisen and Mahmood 1980) and An. albimanus (Mahmood 1997)

Differences in the behavior of An. albimanus and its susceptibility to malaria parasites may be due to different environment pressures placed on this species as a consequence of its extensive habitat range. These local, co-evolutionary, adaptation to specific phenotypes of the malaria parasite may result in varying abilities to transmit malaria throughout its range (Jeffery et al. 1954; Collins et al. 1976; Collins et al. 1980; Ramsey et al. 1988; Kain et al. 1992).

Information pertaining to An. albimanus has been well documented throughout Central America. Additional information, however, about this species in the country of

Belize is needed to determine its true vector potential in relation to the other Anopheles present in the region. The goals of this study were two fold: 1) gain preliminary information on laboratory rearing of An. albimanus for use in future colonization efforts, 2) obtain life table data on An. albimanus to clarify the longevity and fecundity of this malaria vector species.

MATERIALS AND METHODS

Insectary:

One room of a house in the town of Punta Gorda in the Toledo District of Belize was modified into a temporary mosquito insectary. Initial inquiries pertaining to the spray history of the house revealed that the house had not been sprayed with insecticide in at least several years. The insectary measured 10 ft by 10 ft and had windows on two of the four walls. These windows were screened and had heavy metal slats which could be closed to seal off the room from the outside environment. Ultra low volume (ULV) spraying occasionally took place in town; therefore, additional measures were taken to ensure that no harmful chemical entered the room. Solid plastic curtains were constructed which could be lowered and provide a double barrier to the outside environment. Under normal conditions, the slats and the curtain could be opened to allow ventilation and maintain the temperature within the room at a constant range (i.e. if temperatures were too hot the slats and curtain would be raised). One doorway led into the room from the interior of the house. With the door closed, the insectary was shut off from the rest of the house. Shoes were routinely removed prior to entering the room to ensure that no harmful chemicals were tracked into the insectary.

Within the insectary, a series of wooden shelves was constructed to accommodate the larval pans and adult cages. A total of nine adult cages measuring 30.5 x 30.5 x 30.5 cm were used for to house the adult population. A set of 24 white enamel pans measuring 34.3 x 25.4 cm with a depth of 4.4 cm were used for rearing larvae. All cages and rearing pans were positioned a maximum distance from the windows. All pans were washed in hot water and weak bleach solution to prevent

contamination and larval mortality during the study. Wet towels were kept on top of the cages to maintain high levels of humidity within the adult cages.

Temperature and relative humidity were recorded in the room using a Davis Instrument's Weather Monitor II. A Max/Min thermometer also was used in the room in case of a power outage. This was critical for accurate measurement of the conditions inside the insectary due to the inability to control these conditions within the rearing room.

Field population:

Initially, colonization attempts were made with several Anopheles species but due to a number of reasons only An. albimanus was pursued. Eggs also were obtained from blood engorged populations of An. vestitipennis and An. darlingi. The An. vestitipennis were obtained from human landing collections conducted at Rancho Village, and the An. darlingi were collected from human landing collections at Golden Stream Village. Both villages are located near rivers and forested areas within the Toledo District of Belize. A field population of An. albimanus larvae was collected from a rice field (N 16°09.975 W 88°50.618) in the village of Rancho in the Toledo District of Belize. Various developmental stages were collected using a larval dipper, plastic disposable pipettes and 4 oz. Whirl Pacs. Whirl Pacs are 100 ml plastic collection bags with imbedded wires at the open end that facilitate a tight seal when the bag is twirled. All larvae were transported back to the insectary where they were separated by stage and placed in white enamel pans filled with 1.5 gallons of tap water.

No more than 200 larvae were placed in any one pan. Pans were labeled with date and location of collection.

Larvae were fed a diet of ground rabbit chow and brewer's yeast mixed in a 3:1 (weight/weight) ratio. The mixture was made into a suspension with regular tap water in approximately a 10% suspension (weight/volume). This suspension was applied to each pan using a 3ml disposable plastic pipette. One full pipette of suspension was applied to the pans on a daily basis until day 5 when the amount added to each pan was increased. The feeding schedule is presented in Table 1. Pans were checked for pupae each day.

Pupae were removed from rearing pans and placed into separate clear styrene 9 dram tubes. An inverted 5-dram clear styrene tube was inserted in the top of the larger tube to form a sealed rearing vial. The vial was labeled using a wax pencil with information from the pan from which the pupae had been picked. Upon emergence, adults were briefly placed in a freezer to knock the specimen down for species identification. All *An. albimanus* adults were placed into an adult cage with the date and location of larval collection as well as date of first emergence. All adults that had emerged within three days of the initial emergence were placed into the same cage to insure that all members of the population were within the same age range. Vials containing cotton wicks soaked in a 10% sugar solution were placed in each adult cage to provide a source of sugar. The vials containing the sugar solution and the cotton wicks were replaced every three days to prevent the growth of mold and bacteria.

Beginning 24 hours after adult emergence, sugar solutions were removed from cages for a period of 24 hours. Mosquitoes were then offered a blood meal from the

researcher. Small plastic cups lined with filter paper were filled with tap water and placed in the cages to provide oviposition sites for the mosquitoes. These cups were checked on a daily basis. When eggs were observed, the filter paper was lifted from the cups allowing the water to slowly drain off. This process would leave only the eggs clinging to the paper. The eggs were transferred to a pan filled with tap water, which had been labeled with the date of oviposition and generation number.

Life Table Analysis:

The colony was allowed to reach the F4 generation prior to beginning life table observations. Upon reaching the F4 generation, 10 pans were set up with 100 An. albimanus 1st stage larvae (all larvae were within 12 hours of hatch) per pan. The pans were labeled with a letter designation (A-J). Each pan was provided with a standard amount of food, and pans were examined for any signs of contamination.

Once the immatures became 4th stage larvae, the pans were checked every 30 minutes. Pupae were picked every 30 minutes and were placed into separate clear styrene 9 dram tubes with an inverted 5 dram clear styrene tube inserted in the top of the larger tube to form a sealed rearing vial. Each vial contained approximately 5 ml of water which came from the pan of origin for each pupa. These vials were labeled with the date and time of pupation. Each pupa was designated with a number from 1 to 100 and the time of pupation was recorded on a data sheet next to the corresponding pupa.

Rearing vials were checked every 30 minutes for signs of adult emergence. Upon emergence, the sex of the mosquitoes was determined and recorded along with the time of adult emergence on the data sheet next to the corresponding pupal number.

Mosquitoes which died in the process of emerging also were recorded. This experiment was duplicated and resulted in observations on a total of 2,000 *An. albimanus* larvae.

Adult Lifespan:

After identification, the adult mosquitoes were promptly placed in adult rearing cages (50 females and 50 males). Four cages of 100 specimens were set up to quantify adult longevity. Cages had white paper placed on the bottom of the cage to make location and removal of dead specimens easier. The cages were examined on a daily basis in order to locate, record and promptly remove dead mosquitoes. For every dead mosquito, information regarding their cage number, sex and date of death was recorded on a data sheet. If a mosquito was located on the bottom but did not appear dead, a light puff of air from a mouth aspirator was blown onto it. If no movement was observed within a three-hour period, it was determined to be dead. Adult feeding followed the same procedure as was used for the regular colony. Both a 10% sugar solution and a bloodmeal were offered to the mosquitoes every day. This procedure was repeated until all mosquitoes had been removed from the cage.

Oviposition Selection:

Four types of oviposition containers were used in the study. Four cages were supplied with one white container, one white container with plant material, one black container and one black container with plant material. These containers were placed in the interior four corners of the cage in various arrangements to remove position as a confounding variable. Containers filled approximately 3/4 full with regular tap water

were placed in the cages immediately after the mosquitoes blood-fed . This allowed the water in the cage to stabilize at room temperature and allowed compounds in the plant material to disseminate into the water prior to the time females would oviposit.

Containers were removed from the cages on a daily basis and examined for eggs. When eggs were observed they were counted, removed with a small piece of filter paper and transferred to a pan for hatching. The pans were labeled with the cage number they were removed from, the cup type and the date of oviposition. This same information was recorded in a laboratory note book. Two trials of this study were conducted using four cages during each trial.

Data Analysis:

Standard life table analysis was performed on the colony data (Mahmood 1997). The median times for pupation and eclosion were calculated by fitting a regression line to the pupation and emergence data as a Probit equation in the form of $(p) = a + b \ln x$, where p was the cumulative proportion either pupating or emerging on each day and x being equal to the age in days. The median values were obtained by solving the equation for 50% pupation or 50% emergence. The median length of pupation was calculated in the same manner except the scale was in hours rather than days. These values were obtained for each pan and for each trial to check for variations between pans.

Larval survival was determined by counting the number of larvae reaching the pupal stage and dividing that value by the total number of 1st stage larvae placed in the pan (i.e. 100 larvae). The same procedure was used for those 1st stage larvae that

emerged as adults. The sex ratio was calculated by dividing the number of males by the total number of adults that emerged.

Age specific survivorship was calculated as $l_x = y_x / y_0$, where y_x was the number of mosquitoes which were alive on day x and y_0 was the starting number of mosquitoes in the population. This provided an estimate of the daily survivorship of the species.

Age specific life expectancy was calculated as,

$$e_x = Tx / l_x, \text{ where}$$

$$Tx = \sum_{x=0}^w L_x, \text{ and where}$$

$$L_x = (l_x + l_{x+1}) / 2; \text{ with}$$

w being equal to the final day a mosquito was still alive in the cage.

For example, the value of e_1 represents the total number of days a mosquito would be expected to live after it emerges as an adult on day 1.

The true measure of a population's fecundity is the number of females which are produced by an individual. For this reason, it is critical to know the number of females produced by each member of a specific cohort or generation. This was accomplished by solving for R_0 in the following equation,

$$R_0 = a \sum_{x=0}^w l_x m_x.$$

In this equation, a equals the proportion of the population which survives from egg to adult. The value m_x can be calculated using the following equation,

$$m_x = E_x p.$$

In this equation, E_x equals the mean number of larvae that are produced per female per time interval (i.e. the number of days after adult emergence, as designated by x). The

value p equals the proportion of the emerging adult population which will be female (i.e. this value is equal to the female sex ratio).

Another critical statistic is instantaneous rate of increase per female and is designated as r . The equation used in this determination is a modified version of the Euler-Lotka equation (Dobzhansky et al. 1964; Mahmood 1997). This equation is as follows,

$$1.0 = a \sum_{x=0}^w l_x m_x e^{-r(x)},$$

Where e is the natural logarithm.

To calculate the instantaneous birthrate (B), the equation used was

$$B = \ln(1+b) \text{ where}$$

$$1/b = \sum_{x=0}^w l_x m_x e^{-r(x)}.$$

The death rate (D) was then calculated as $D = B-r$.

The analysis of preference between oviposition containers was calculated with a Chi-square analysis for multiple samples. This was calculated in order to quantify variation among and between cups.

RESULTS

Temperatures within the insectary ranged from 29°C to 35°C with an average temperature of 32°C throughout the course of the study. The low temperatures occurred at night, and the high temperatures occurred during the day. The relative humidity recorded within the cages ranged from 87%-90% with an average of 89%. The light:dark cycle was recorded as 13L:11D within the insectary.

Tables 2 shows the median length of time required to go from 1st stage larvae to pupae and the median time from pupation to adult emergence. The Male/Female sex ratio for trial one was 0.468 and for trial two 0.473 for an overall sex ratio of 0.471 in favor of the females (Table 2). The overall mean survival rate from eclosion to pupation was 95% and from eclosion to adult was 93.7%. On average, it took 10.65 days for male An. albimanus to go from eclosion to pupation while the females took 11.09 days (Table 2). Data from the individual pans can be found in Tables 3 and 4. A statistical analysis showed that there were no significant differences between pans or between trials ($p > .05$, p -value = .43). The amount of time spent in the pupal stage favored the males. It took an average of 30.46 hours for the males to emerge and on average 30.16 hours for females to emerge. Analysis of data obtained from individual pans indicates that there were no significant differences between pans or between trials (Tables 3 and 4).

Figures 1-8 show adult specific survivorships for both male and female An. albimanus separated by cage and by trial. In all instances the males demonstrated a shorter adult life span than the females. The males lived for an average of 15.21 days while the females lived for 19.39 days (Table 5). The net result was that the females

lived slightly more than 4 days longer than males. Figures 1-8 show in conjunction with the adult specific survivorship, the average number of offspring produced per female per day of life. The r -value (r being the rate of instantaneous female growth per female per day of life) was calculated to be 3.22. The instantaneous birth and death rates were 4.55 and 2.31, respectively. This leads to the r/B and B/D ratios of 0.71 and 1.96, respectively.

Figures 1-8 present the average number of eggs produced per female per day of life. The highest average number of females were produced between days seven and nine with a gradual decrease in egg production after this time period. In almost all cases, egg production decreased to zero or almost zero, 2 to 3 days prior to death of the last female mosquito. Only in one instance did egg production continue until the final day of female life (Figure 4). On several occasions, egg production terminated considerably in advance of the last female's death (Figures 2, 5 and 7).

Figures 9 and 10 give the expectation of adult life, beginning from time of eclosion. Each figure contains data for both male and female members of the population and is separated for the two cohort trials. Both trials show that the expectation of life gradually decreases with the age of the mosquito until a critical time, around day 21 for, both sexes in trial 1 and around day 31 in females in trial 2. After this critical time period, the expectation of life increased slightly. The males in trial 2 showed no increase throughout their life span and demonstrated a continuous decline in the expected days of life throughout their aging process.

The oviposition containers yielded 127,340 eggs from 400 females (Table 6). This equated to an average of 318.35 eggs per female. A total of 110,734 eggs were

collected from the black containers which represented 87% of all eggs collected. Only 16,606 eggs were collected from the white containers which constituted 13% of the total number of eggs collected.

After conducting a Chi-square analysis, the results showed that there were no differences between cages in the number of eggs produced ($p > 0.05$, $p\text{-value} = 0.862$) as well as no significant difference between the number of eggs between trials 1 and 2 ($p > 0.05$, $p\text{-value} = 0.069$). There was, however, a statistically significant difference between different treatment containers ($p < 0.05$, $p\text{-value} = 0.001$).

Of those eggs collected from the white containers, the plant container yielded twice as many eggs as the non-plant infused container. This, however, was not the case for the black containers where the numbers collected from both plant infused and non-plant infused were almost identical. After running a statistical analysis on the oviposition cups, there were no significant differences between the number of eggs laid in the black cups with plant material and black cups without plant material ($p > 0.05$, $p\text{-value} = 0.37$). The results did, however, show that there was a significant difference between the white oviposition containers with and without plant material ($p < 0.05$, $p\text{-value} = 0.002$). There was also a significant difference between the white containers and the black containers ($p < 0.05$, $p\text{-value} = 0.022$). When the plant containers (black and white) and non-plant containers (black and white) were combined, however, no significant difference was detected ($p > 0.05$, $p\text{-value} = 0.34$).

DISCUSSION

Attempts to colonize An. vestitipennis and An. darlingi were not successful. These attempts will be described, however, in order to help with any future colonization attempts. The blood-fed An. darlingi which had been obtained from human landing collections yielded only small numbers of eggs (approximately 100 per female) of which there was a hatch rate of approximately 20%. Eggs were placed in pans that both did and did not contain plant material. Those that were reared in conjunction with plant material did considerably better, with almost a 75% survival rate as compared to a 32% survival rate for those reared in pans with no plant material. Overall, only small numbers of immatures reached the adult stage. The resulting females took a blood meal but did not produce fertile eggs. The adults do not readily mate in colony, and this is the probable reason for the lack of egg production. No attempts were made at forced mating, but forced mating might be necessary to colonize this species in Belize.

The attempts at colonizing An. vestitipennis were slightly more successful. Field collected adults produced large numbers of eggs after receiving a blood meal. The hatch rate was 89%. Rearing of larvae was difficult, and the survival rate from 1st instar to adult was approximately 67%. Larvae in pans with plant material did much better than larvae in pans without plant material. Adults of An. vestitipennis that reached maturity took blood meals and produced small numbers of eggs. None of the eggs of the second generation hatched and this result suggests that there was a failure to mate in the cage. It is possible that mating would occur if large numbers of mosquitoes were placed in a cage. The relatively large number of offspring produced from the field population suggest that this species has potential for colonization. The obstacle which

must be overcome is the high mortality observed in the larval stage. It appears that some type of diet requirement is not being met which leads to high mortality.

The life table attributes of *An. albimanus* in this study are slightly different from those of previous studies conducted with *An. albimanus* (Mahmood 1997). The mean time of larval development was determined to be 10.87 days which is considerably longer than reported by Mahmood (7.5 days) or by Haile and Weidhaas (6.0 days). These differences could be due to differences in environmental conditions for larval development. One consistent finding, however, was that males developed more quickly than females. The overall developmental time for males was considerably longer in this experiment than in previous studies. One departure from the traditional life table study was the measurement of duration of the pupal stage. This parameter was determined to be longer for males than for females (30.46 hrs. and 30.16 hrs. respectively). The average time of development from 1st instar to adult continued to show that females required a longer developmental time regardless of the discrepancy observed in the pupal developmental time. This was due primarily to the developmental time for the males during the larval stage.

The total number of eggs obtained from the 400 females was 127,340 for an average of 318.35 eggs per female. The average number per female is considerably lower than was previously reported for this species. This is probably due to the recent establishment of the colony and there was a stress induced reduction in fecundity due to artificial environmental conditions.

Females showed a definite preference for dark oviposition containers. More than 80% of all eggs were deposited in the two dark containers. This agrees with

previous studies with other mosquito species which indicate that mosquitoes prefer to oviposit in dark colored containers. There was no difference, however, between the black container with plant infusion and black container without plant infusion. Between the two light colored oviposition containers, however, there was a preference shown for the container with the plant infusion. This most likely can be explained by there being a higher nutrient content in the plant infused water which would provide food for developing larvae. The only problem with this explanation is that the same situation did not occur in the dark cups. An alternate explanation would be that the plant material created shadows as well as an overall darker appearance of the white container, thus making it more attractive. The largest number of eggs from a female can be obtained by offering an ovipositing female a darkly colored container. I do not suggest adding plant material because plant material did not contribute to egg production and quickly fouled the water.

The trend of aging males succumbing before females, as reported by other investigators (Reisen and Mahmood 1980) also was seen in the present study. The males in this study lived for an average of 15.24 days and the females lived for an average of 19.36 days. This equates to the females living slightly longer than four days more than males. The r/B and B/D ratios of 0.71 and 1.96 are low but are considerably higher than those reported by Mahmood in 1997. Based on these values, An. albimanus has a low potential for colonization. These numbers indicate that the population is subject to very slow growth and that minor contamination of the water with bacteria will result in a slight increase in mortality and could severely impact a colony, to the

point of complete elimination. However, the ease with which this species goes into colony shows that this evaluation is not accurate.

The varying age composition of the female members of a species as well as the length of the adult survivorship plays important roles in the vectoral capacity of a particular species. In nature, each blood meal represents an additional chance for a female mosquito to become infected with malaria parasites. Therefore, the vectoral importance of each age grouping becomes greater in relation to the physiological age of an individual mosquito (Detinova 1962). The relationship between age and probability of being infected is countered by the cumulative increase in adult mortality which is associated with an individual mosquito reaching the upper limits of its expected life span. Factors which play a role in this cumulative mortality are predation, environmental conditions and increased physiological age. Therefore it must be stressed that the earlier that a mosquito acquires malaria parasites in a blood meal, the greater the likelihood that transmission will take place. This is particularly true for short-lived species.

Based on the number of females produced per female per day, indications are that the first seven days for an adult female encompass the time for almost 60% of her egg producing potential. With the female living on average 19.36 days, the last 12 days of life are not as critical to sustaining population density as the first week of her adult life. When applied to a natural setting, it is understandable that there will be a reduction in the length of the adult life span due to predation and other adverse environmental factors. Therefore, high reproductive activity during the first few days of life is necessary for the species to be successful.

For multivoltine species with overlapping generations, the r -value reflects the growth potential per unit of time. The r -value is a better reflection of this growth because it takes into account both the number of progeny produced and the times at which these progeny were produced (Hacker 1972). The r -value for An. albimanus was higher than in previous studies due to a shorter time before initial reproduction and a longer adult life span. Both of these conditions resulted in increases in the overall growth potential as measured by the r -value.

If we concede that after emergence it requires a maximum of 3 days for mating and blood feeding, then from the calculation of expectation of life, An. albimanus can be expected to survive for an additional 16 days under laboratory conditions. The gonotrophic cycle of this species has been recorded at between 2 and 3 days (Rodriguez et al. 1992; Weidhaas et al. 1974). Taking all available data into consideration, An. albimanus would feed an additional five to six times, thus increasing the chance of malaria transmission if the female took an infectious blood meal soon after emerging.

Additional studies are required to determine the life table attributes for the other species found in Belize, specifically An. vestitipennis and An. darlingi. When true side by side comparisons can be made between these species, we will better understand their respective potentials for malaria transmission.

REFERENCES CITED

- Ancona, A.H. 1930. Las Lemnaces y las larvas de los mosquitos. An. Inst. Biol. Mex. 1: 33-37.
- Bailey, D.L., J.E.F. Fowler and R.E. Lowe. 1979. Production efficiency and rate of increase of mass reared laboratory colony of Anopheles albimanus Wiedemann. Mosq. News. 39: 640-644.
- Bailey, D.L., R. E. Lowe and Pe. Kaiser. 1980. A reliable technique for rapid colonization of Anopheles albimanus Wiedemann. Mosq. News. 40: 410-412.
- Bailey, D.L., J.A. Thomas, W.L. Munroe and D.A. Dame. 1979. Viability of eggs of Anopheles albimanus and Anopheles quadrimaculatus when dried and stored at various temperatures. Mosq. News. 39: 113-116.
- Balling, S.S. and V.H. Resh. 1985. Seasonal pattern of pondweed standing crop and Anopheles occidentalis densities in Coyote Hills marsh. Proc. Calif. Mosq. Vector Control Assoc. 52: 122-125.
- Breeland, S.G. 1972. Studies on the ecology of Anopheles albimanus. Am. J. Trop. Med. Hyg. 21: 751-754.
- Breeland, S.G., D.L. Pletsch and K.D. Quarterman. 1970. Laboratory studies on the suitability of mud as an oviposition substrate for An. albimanus Wiedemann. Mosq. News. 30: 81-88.
- Chan, A.S.T., M.H. Rodriguez, J.A. Torres, M.C. Rodriguez and C. Villarreal. 1994. Susceptibility of three laboratory strains of Anopheles albimanus (Diptera: Culicidae) to coindigenous Plasmodium vivax in southern Mexico. J. Med. Entomol. 31: 400-403.

- Collins, W.E., P.G. Contacos, P.S. Stanfill and B.B. Richardson. 1973. Studies on human malaria in Aotus monkeys. I. Sporozoite transmission of Plasmodium vivax from El Salvador. *J. Parasitol.* 59: 606-608.
- Collins, W.E., J.C. Skinner, B.B. Richardson, P.S. Stanfill and P.G. Contacos. 1974. Studies on human malaria in Aotus monkeys. V. Blood-induced infections of Plasmodium vivax. *Am. Soc. Parasitol.* 60:393-398.
- Collins, W.E., J.C. Skinner, McW. Warren and B.B. Richardson. 1976. Studies on human malaria in Aotus monkeys. VII. Comparative infectivity of tow strains of Plasmodium vivax to Anopheles freeborni, A. maculatus, and four strains of A. albimanus. *J. Parasitol.* 62: 190-194.
- Collins, W.E., McW. Warren, P.G. Contacos, J.C. Skinner, B.B. Richardson and T.S. Kearse. 1980. The Chesson strain of Plasmodium vivax in Aotus monkeys and anopheline mosquitoes. *J. Parasitol.* 66: 488-497.
- Collins, W.E., J.C. Skinner, W.A. Krotoski, F.B. Cogswell, R.W. Gwatz, J.R. Broderson, N.S.F. Ma, P. Mehaffey and Bettye B. Sutton. 1985. Studies on the North Korean strain of Plasmodium vivax in Aotus monkeys and different anophelines. *Am. Soc. Parasitol.* 71: 20-27.
- Crovello, T.J. and C.S. Hacker. 1972. Evolutionary strategies in life table characteristics among feral and urban strains of Aedes aegypti (L.). *Evolution* 26: 185-196.
- Dame, D.A., D.G. Haile, C.S. Lofgren, D.L. Bailey and W.L. Munroe. 1978. Improved rearing techniques for larval Anopheles albimanus. Use of dried mosquito eggs and electric heating tapes. *Mosq. News.* 38: 68-74.

- Dame, D.A., C.S. Lofgren, H.R. Ford, M.D. Boston, K.F. Baldwin and G.M. Jeffery.
1974. Release of chemosterilized males for the control of An. albimanus in El Salvador. II Methods of rearing sterilization and distribution. *Am. J. Trop. Med. Hyg.* 23: 282-286.
- Detinova, T.S. 1962. Age grouping methods in Diptera of medical importance. *Wld. Hlth. Org. Monogr.* 47: 1-216.
- Dobzhansky, T., R.C. Lewontin and O. Pallovsy. 1964. The capacity for increase in chromosomally polymorphic and monomorphic populations of Drosophila pseudoobscura. *Heredity* 19: 597-614.
- Ford, H.R. and E. Green. 1972. Laboratory rearing of Anopheles albimanus Wiedemann. *Mosq. News.* 32: 509-513.
- Gilotra, S.K., L.E. Rozenboom and N.C. Bhattacharya. 1967. Observations on possible competitive displacement between populations of Aedes aegypti Linnaeus and Aedes albopictus Skuse in Calcutta. *Bull. WHO.* 37: 437-446.
- Gonzalez-Ceron, L, M.H. Rodriguez, F.V. Santillan, Juan E. Hernandez and R.A. Wirtz. 2000. Susceptibility of three laboratory strains of Anopheles albimanus (Diptera: Culicidae) to coindigenous Plasmodium vivax circumsporozoite protein phenotypes in southern Mexico. *J. Med. Entomol.* 37: 331-334.
- Gubler, D.J. and N.C. Bhattacharya. 1972. Swarming and mating of Aedes (S.) albopictus in nature. *Mosq. News.* 32: 219-223.
- Hacker, C.S. 1972. Measuring reproductive potential in populations. *Mosq. News.* 32: 193-196.

- Hall, T.F. 1972. The influence of plants on anopheline breeding. *Am. J. Trop. Med. Hyg.* 21: 787-794.
- Jeffery, G., R. Burgess and D. Eyles. 1954. Susceptibility of Anopheles quadrimaculatus and Anopheles albimanus to domestic and foreign strains of Plasmodium vivax. *Am. J. Trop. Med. Hyg.* 3: 821-824.
- Kain, K.C., A.E. Brown, H.K. Webster, R.A. Wirtz, J.S. Keystone, M.H. Rodriguez, J. Kinahan, M. Rowland and D.E. Lanar. 1992. Circumsporozoite genotyping of global isolates of Plasmodium vivax from dried blood specimens. *J. Clin. Microbiol.* 30: 1863-1866.
- Klein, T.A., J.B.P. Lima and A. Toda-Tang. 1990. Colonization and maintenance of Anopheles deaneorum in Brazil. *J. Am. Mosq. Control. Assoc.* 6: 510-513.
- Klein, T.A., B.A. Harrison, S.V. Dixon and J.R. Burge. 1991a. Comparative susceptibility of Southeast Asian Anopheles mosquitoes to the simian malaria parasite Plasmodium cynomolgi. *J. Am. Mosq. Control Assoc.* 7: 481-487.
- Klein, T.A., A. Toda-Tang and J.B.P. Lima. 1991b. Infection of Anopheles darlingi fed on patients with Plasmodium falciparum before and after treatment with quinine or quinine plus tetracycline. *Am. J. Trop. Med. Hyg.* 44: 604-608.
- Klein, T.A., A. Toda-Tang, J.B.P. Lima and T.H. Katsuragawa. 1991c. Infection of Anopheles darlingi fed on patients infected with Plasmodium vivax before and during treatment with chloroquine in Costa Marques, Rondonia, Brazil. *Am. J. Trop. Med. Hyg.* 45: 471-478.
- Mahmood, F. 1997. Life-table attributes of Anopheles albimanus (Weidemann) under controlled laboratory conditions. *J. Vec. Ecology.* 22(2): 103-108.

- Orr, B.K. and V.H. Resh. 1989. Experimental test of the influence of aquatic macrophyte cover on survival on the survival of Anopheles larvae. J. Am. Mosq. Control Assoc. 5: 579-585.
- Rachou, R.G., G. Lyons, M. Moura-Lima, and J.H. Kerr. 1965. Synoptic epidemiological studies of malaria in El-Salvador. Am. J. Trop. Med. Hyg. 14: 1-62.
- Rabbani, M.G., J.A. Seawright and L.B. Leatherwood. 1976. A method of culturing single families of Anopheles albimanus. Mosquito News. 36: 100-102.
- Ramsey, J.M., D.N. Brown, J.L. Aron, R.L. Beaudoin and J.F. Mendez. 1986. Field trials in Chiapas, Mexica, of a rapid detection method for malaria in anopheline vectors with low infection rates. Am. J. Trop. Med. Hyg. 35: 234-238.
- Ramsey, J.M., E. Salinas, J.R. Lopez, G. Del Angel-Cabanas, L. Martinez and D.N. Brown. 1988. Laboratory ovipostion, fecundity and egg hatching ability of colonized Anopheles albimanus from Southwestern Mexico. Am. J. Trop. Med. Hyg. 23:282-286.
- Reisen, W.K. and F. Mahmood. 1980. Horizontal life table characteristics of the malaria vector Anopheles culicifacies and Anopheles stephensi (Diptera:Culicidae). J. Med. Entomol. 17: 211-217.
- Reisen, W.K., T.F. Siddique, Y. Aslam and G.M. Malik. 1979. Geographic variations among the life table characteristics of Culex tritaeniorynchus Giles from Asia. Ann. Entomol. Soc. Am. 72: 700-779.

- Rejmankova, H.M. Savage, M.H. Rodriguez, D.R. Roberts, and M. Rejmanek. 1992. Aquatic vegetation as a basis for classification of Anopheles albimanus Weideman (Diptera: Culicidae) larval habitats.
- Rodriguez, M.H., D.N. Brown, J.I. Arredondo, C. Villarreal, E.G. Loyola and C.E. Frederickson. 1992. Gonotrophic cycle and survivorship of Anopheles albimanus (Diptera: Culicidae) in southern Mexico. *J. Med. Entomol.* 29: 395-399.
- Savage, K.E., R.E. Lowe, D.L. Bailey and D.A. Dame. 1980. Mass rearing of Anopheles albimanus. *Mosq. News.* 40: 185-190.
- Sandosham, A.A. and V. Thomas. 1983. Malariology. Singapore University Press. Ket Ridge, Singapore. 382 pp.
- Seawright, J.A., D.G. Haile, M.G. Rabbani and D.E. Weidhaas. 1979. Computer simulation of the effectiveness of male-linked translocations for the control of Anopheles albimanus Weidmann. *Am. J. Trop. Med. Hyg.* 28: 155-160.
- Walter, N.M. and C.S. Hacker. 1974. Variations in life table characteristics among three geographic strains of Culex pipiens quinquefasciatus. *J. Med. Entomol.* 11: 541-550.
- Warren, McW, W.E. Collins, B.B. Richardson and J.C. Skinner. 1977. Morphological phenotypes of Anopheles albimanus and susceptibility to Plasmodium vivax and Plasmodium falciparum. *Am. J. Trop. Med. Hyg.* 26: 607-611.

Weidhaas, D.E., S.G. Breeland, C.S. Lofgren, D.A. Dame and R. Kaiser. 1974.

Release of chemosterilized males for the control of Anopheles albimanus in El Salvador. IV. Dynamics of the test population. Am. J. Trop. Med. Hyg. 23: 298-308.

Table 1. The daily feeding regimen which was provided to the *Anopheles albimanus* larvae.

Days After Hatch	Amount of Food Suspension Added to Larval Pan
1	3.0ml
2	3.0ml
3	3.0ml
4	0.0ml
5	3.0ml
6	6.0ml
7	0.0ml
8	6.0ml

Table 2. Life table attributes of *Anopheles albimanus* in colony from southern Belize, Central America conducted from February to November of 1998.

Attribute	<i>An. albimanus</i> (Trial 1)	<i>An. albimanus</i> (Trial 2)	<i>An. albimanus</i> (Average)
Days to Median Pupation^a			
Males	10.677	10.627	10.652
Females	11.242	10.929	11.086
Days to Median Emergence^a			
Males	11.952	11.893	11.923
Females	12.417	12.186	12.302
Duration of Pupal Stage (Hours)^b			
Males	30.55	30.37	30.46
Females	30.12	30.19	30.16
Mean Survival from Hatching to Pupation	0.949	0.951	0.950
Mean Survival from Hatching to Adult Emergence	0.93	0.943	0.937
Sex Ratio males/total	0.468	0.473	0.471

^a Measured as median number of days for completion of development.

^b Measured as median number of hours for completion of the pupal stage.

Table 3. Life table attributes of *Anopheles albimanus*, male and female, from Trial 1. Studies were conducted from February to November of 1998 in Punta Gorda, Belize.

Pan	Male		Female	
	Days ^a for larval development	Hours ^b for completion of the pupal stage	Days ^a for larval development	Hours ^b for completion of the pupal stage
A	10.22	30.64	10.3	30.04
B	10.48	30.86	10.65	30.09
C	10.5	30.14	11.09	29.67
D	10.69	31.49	11.65	30.27
E	11.25	29.99	11.7	30.15
F	10.6	31.2	11.19	30.46
G	10.62	30.24	11.26	30.17
H	10.71	30.24	11.31	30.12
I	10.68	30.63	11.62	30.31
J	11.02	30.12	11.65	29.95

^a Measured as median number of days from hatching to pupation.

^b Measured as median number of hours from pupation to adult emergence.

Table 4. Life table attributes of *Anopheles albimanus*, male and female, from Trial 2. Studies were conducted from February to November of 1998 in Punta Gorda, Belize.

Pan	Male		Female	
	Days ^a for larval development	Hours ^b for completion of the pupal stage	Days ^a for larval development	Hours ^b for completion of the pupal stage
A	10.19	30.55	10.45	30.47
B	10.52	30.46	10.82	30.35
C	10.46	30.36	10.73	30.21
D	10.44	30.21	10.81	30.07
E	10.35	30.51	10.68	30.36
F	10.74	30.33	11.23	30.03
G	11.08	29.89	11.42	29.54
H	11.26	30.73	11.36	30.59
I	10.57	30.4	10.88	30.27
J	10.66	30.22	10.91	29.98

^a Measured as median number of days from hatching to pupation.

^b Measured as median number of hours from pupation to adult emergence.

Table 5. Longevity of *Anopheles albimanus* adults shown by two rearing trials. A trial consisted of four cages of 100 mosquitoes each (50 males and 50 females) from a single generation. Female mosquitoes were offered a source of blood meals and sugar water every day. Studies were conducted from July to August of 1998 in Punta Gorda, Belize.

Cage-Sex	Days from Adult Emergence to Death (Trial 1) ^a	Days from Adult Emergence to Death (Trial 2) ^b	Days from Adult Emergence to Death (Average)
A-Male	14.64	15.32	14.98
A-Female	19.56	19.34	19.45
B-Male	19.56	16.33	17.95
B-Female	21.08	19.97	20.53
C-Male	13.56	14.44	14.00
C-Female	16.68	18.30	17.49
D-Male	13.65	14.41	14.03
D-Female	20.11	19.87	19.99

^a Trial 1 began on July 11, 1998.

^b Trial 2 began on August 5, 1998.

Table 6. Eggs collected from four types of oviposition containers during two trials using *Anopheles albimanus* colony reared mosquitoes. A trial consisted of four cages of 100 mosquitoes each (50 males and 50 females) from a single generation. Comparisons consisted of white and dark oviposition containers, with and without plant material. Studies were conducted from July to August of 1998 in Punta Gorda, Belize.

Cage (Trial)	Total number of eggs collected from each oviposition container				TOTAL
	White (no plant)	White (Plant)	Black (no Plant)	Black (Plant)	
A (1) ^a	636	850	7506	6302	15294
B (1) ^a	794	2493	5838	5178	14303
C (1) ^a	416	582	3240	3524	7762
D (1) ^a	616	1766	6983	7235	16600
A (2) ^b	773	1573	8990	8571	19907
B (2) ^b	532	832	7630	7023	16017
C (2) ^b	679	896	6211	7211	14997
D (2) ^b	823	2345	9739	9553	22460
Total	5269	11337	56137	54597	127,340

^a Trial 1 began on July 11, 1998.

^b Trial 2 began on August 5, 1998.

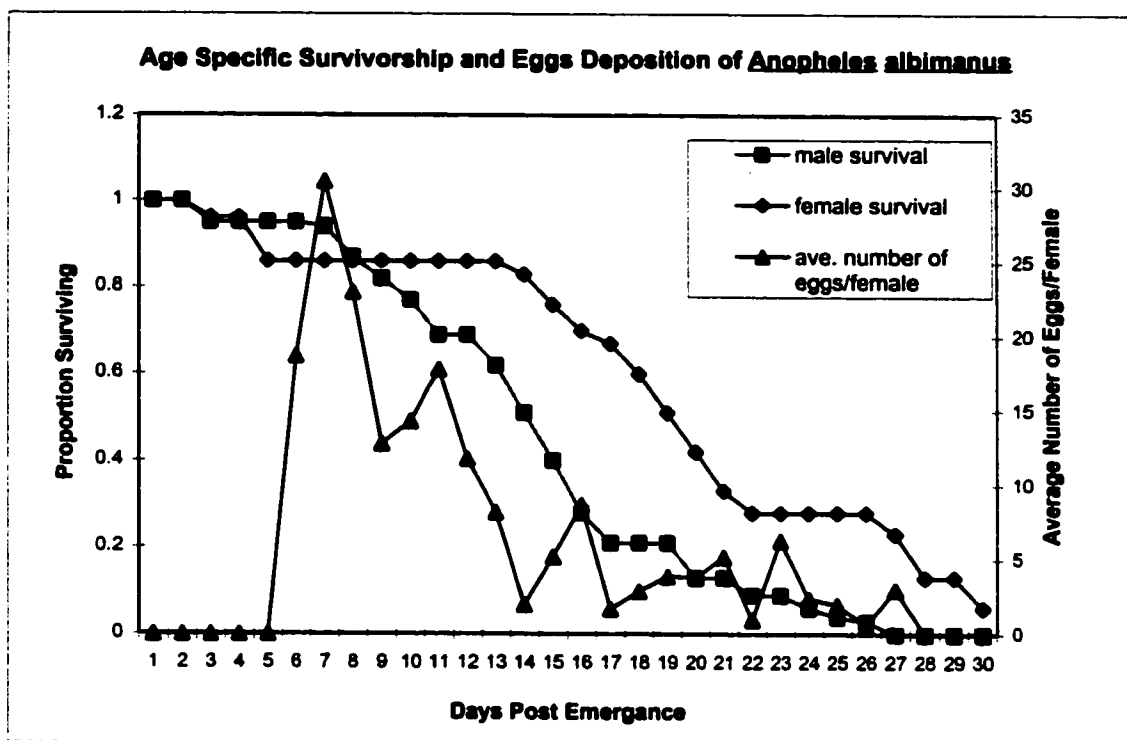

Figure 1. Age specific survivorship of adult *Anopheles albimanus* maintained in cages (50 males and 50 females/cage). Cages were maintained at an average temperature of 32°C and adults were provided both a daily blood meal and 10% sugar source. Data represents Trial 1, Cage A.

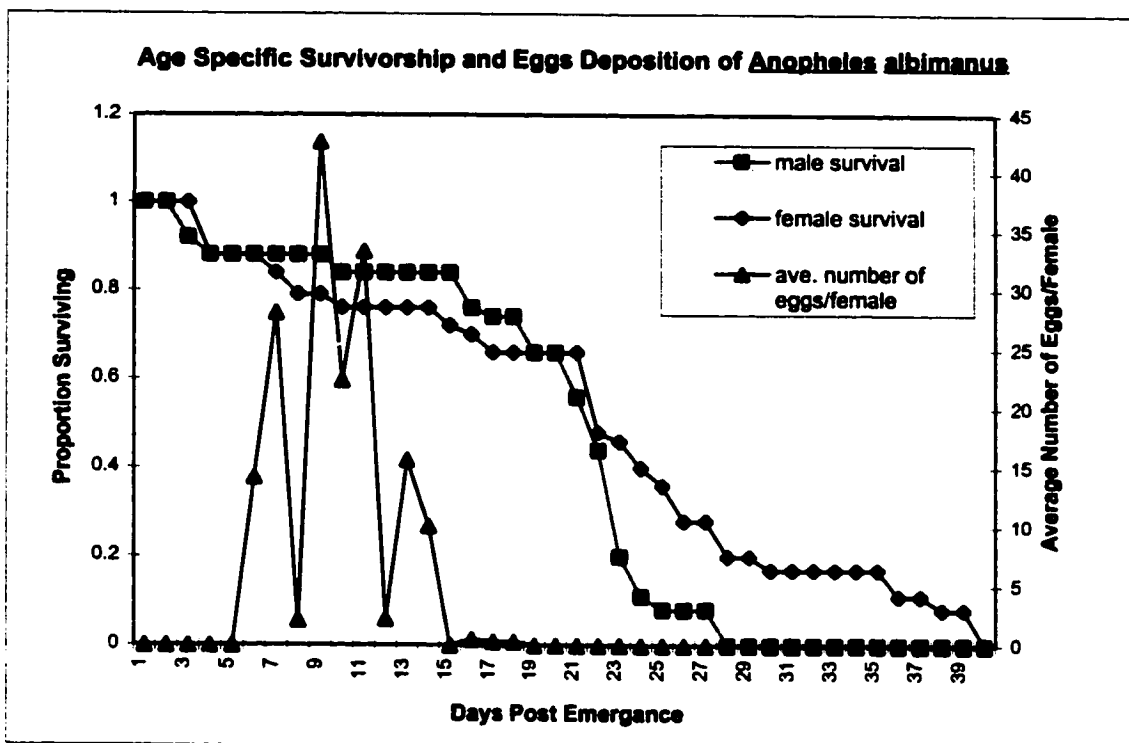

Figure 2. Age specific survivorship of adult *Anopheles albimanus* maintained in cages (50 males and 50 females/cage). Cages were maintained at an average temperature of 32°C and adults were provided both a daily blood meal and 10% sugar source. Data represents Trial 1, Cage B.

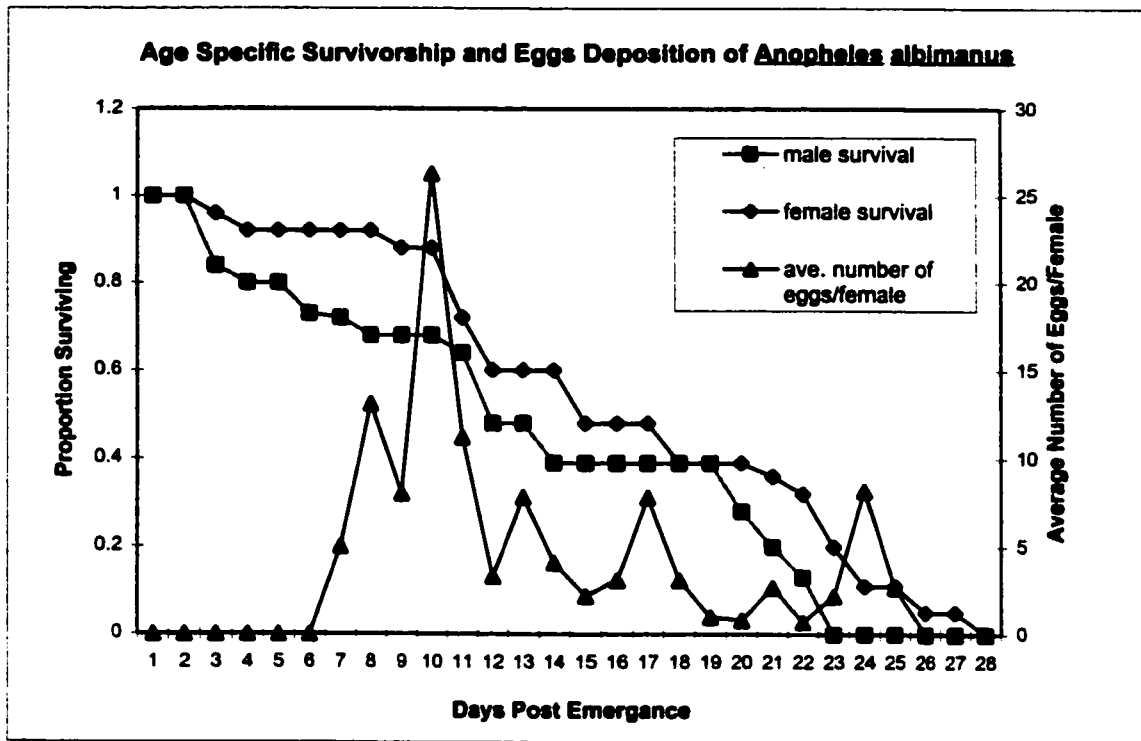

Figure 3. Age specific survivorship of adult *Anopheles albimanus* maintained in cages (50 males and 50 females/cage). Cages were maintained at an average temperature of 32°C and adults were provided both a daily blood meal and 10% sugar source. Data represents Trial 1, Cage C.

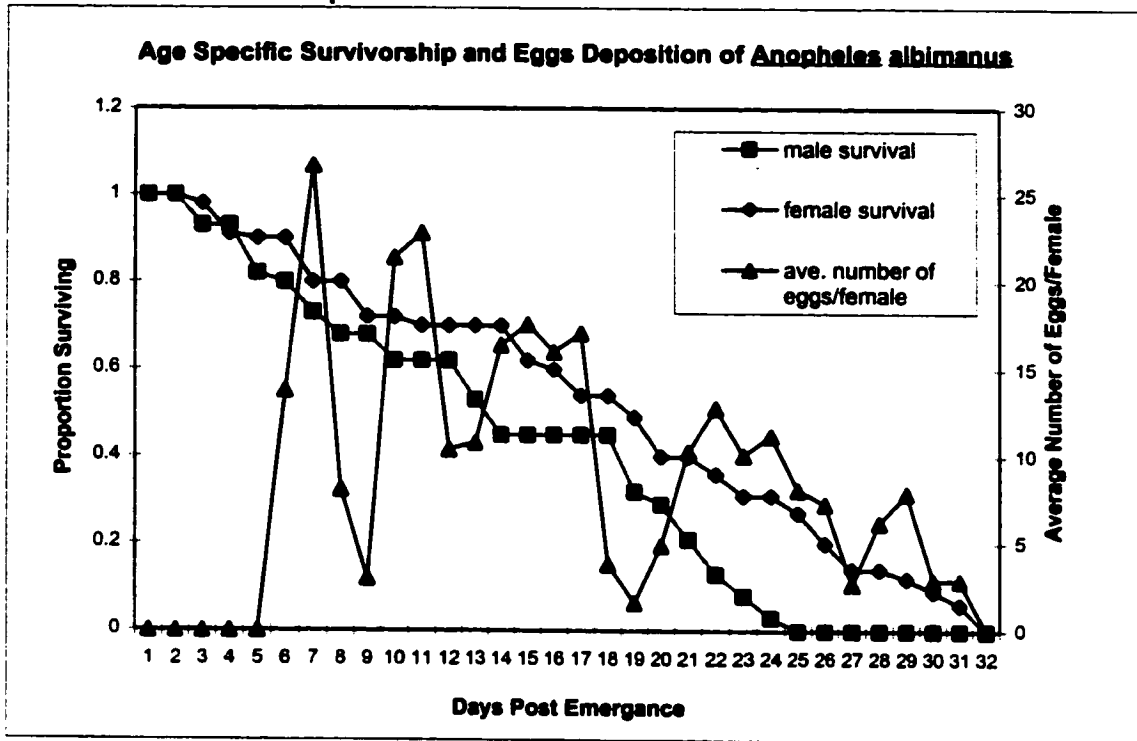

Figure 4. Age specific survivorship of adult *Anopheles albimanus* maintained in cages (50 males and 50 females/cage). Cages were maintained at an average temperature of 32°C and adults were provided both a daily blood meal and 10% sugar source. Data represents Trial 1, Cage D.

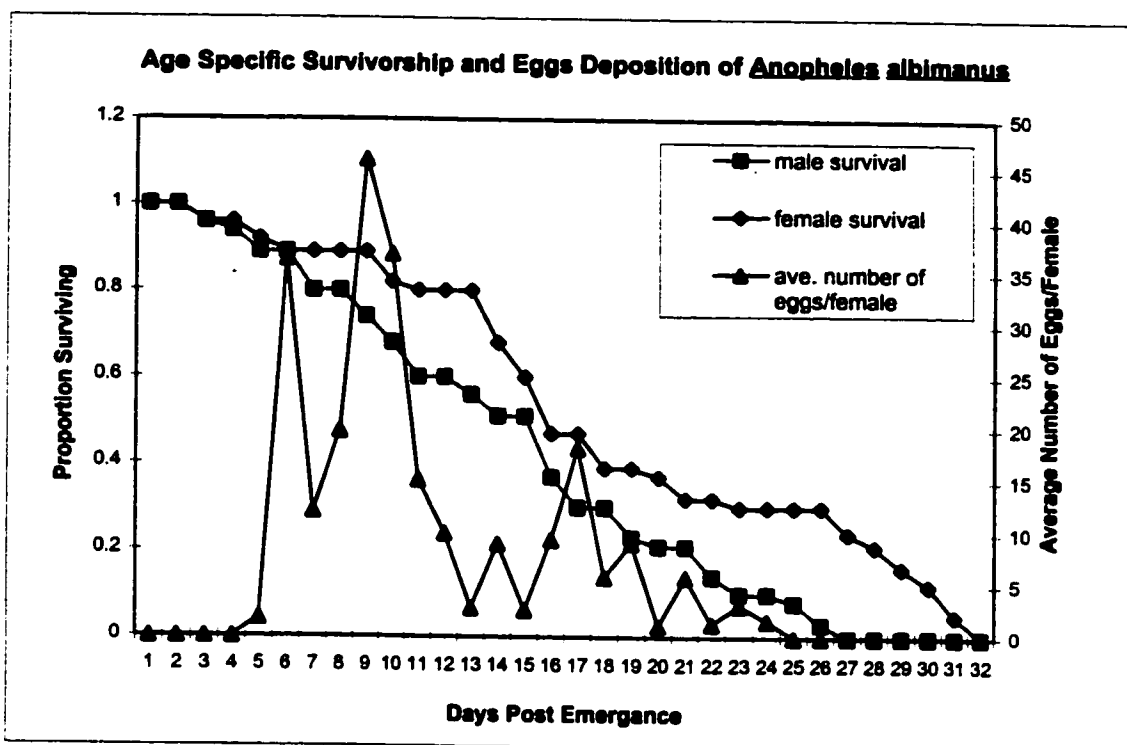

Figure 5. Age specific survivorship of adult *Anopheles albimanus* maintained in cages (50 males and 50 females/cage). Cages were maintained at an average temperature of 32°C and adults were provided both a daily blood meal and 10% sugar source. Data represents Trial 2, Cage A.

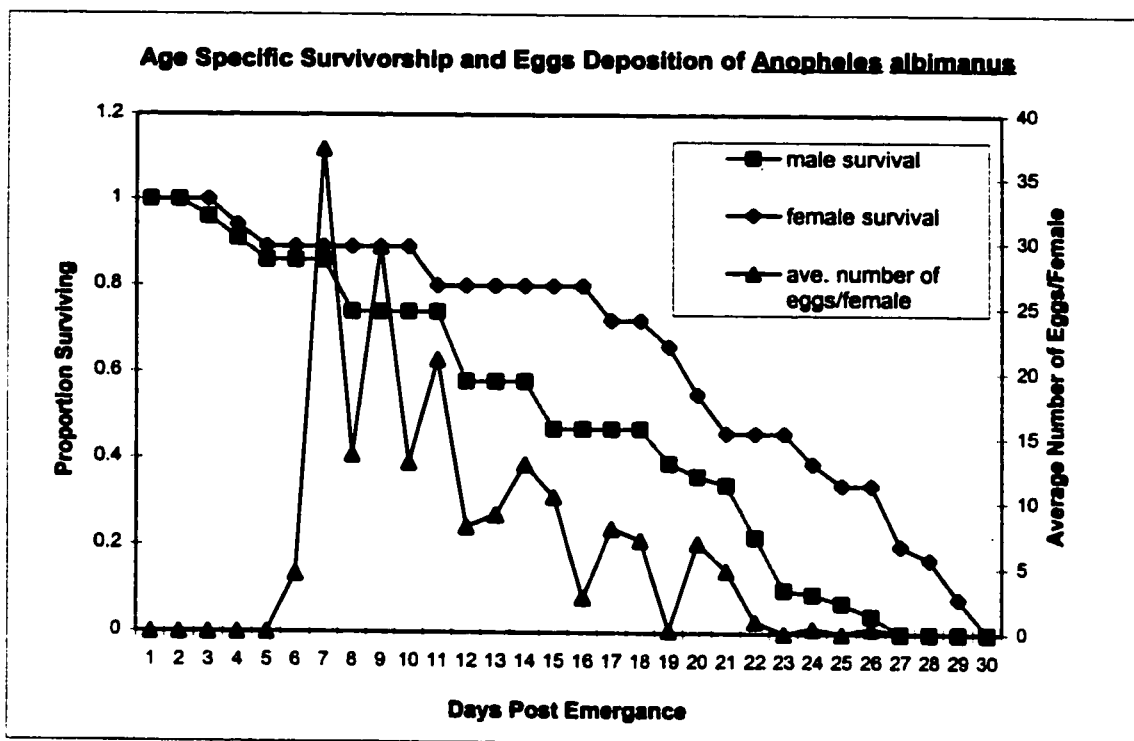

Figure 6. Age specific survivorship of adult *Anopheles albimanus* maintained in cages (50 males and 50 females/cage). Cages were maintained at an average temperature of 32°C and adults were provided both a daily blood meal and 10% sugar source. Data represents Trial 2, Cage B.

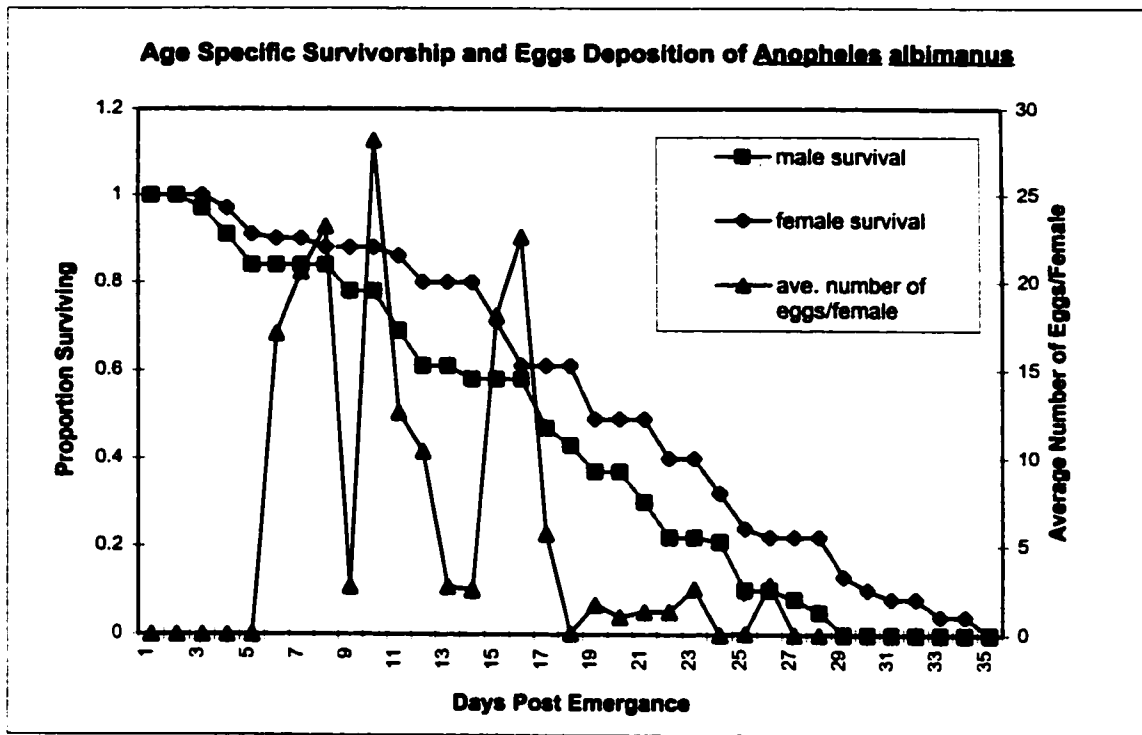

Figure 7. Age specific survivorship of adult *Anopheles albimanus* maintained in cages (50 males and 50 females/cage). Cages were maintained at an average temperature of 32°C and adults were provided both a daily blood meal and 10% sugar source. Data represents Trial 2, Cage C.

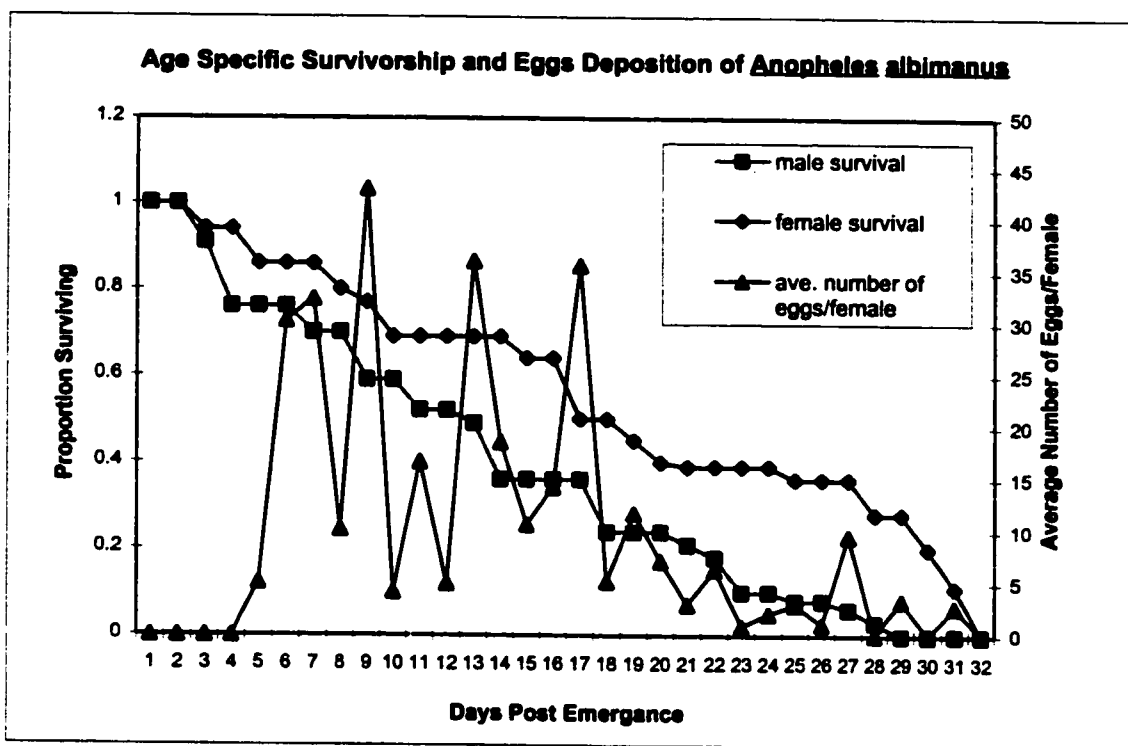

Figure 8. Age specific survivorship of adult *Anopheles albimanus* maintained in cages (50 males and 50 females/cage). Cages were maintained at an average temperature of 32°C and adults were provided both a daily blood meal and 10% sugar source. Data represents Trial 2, Cage D.

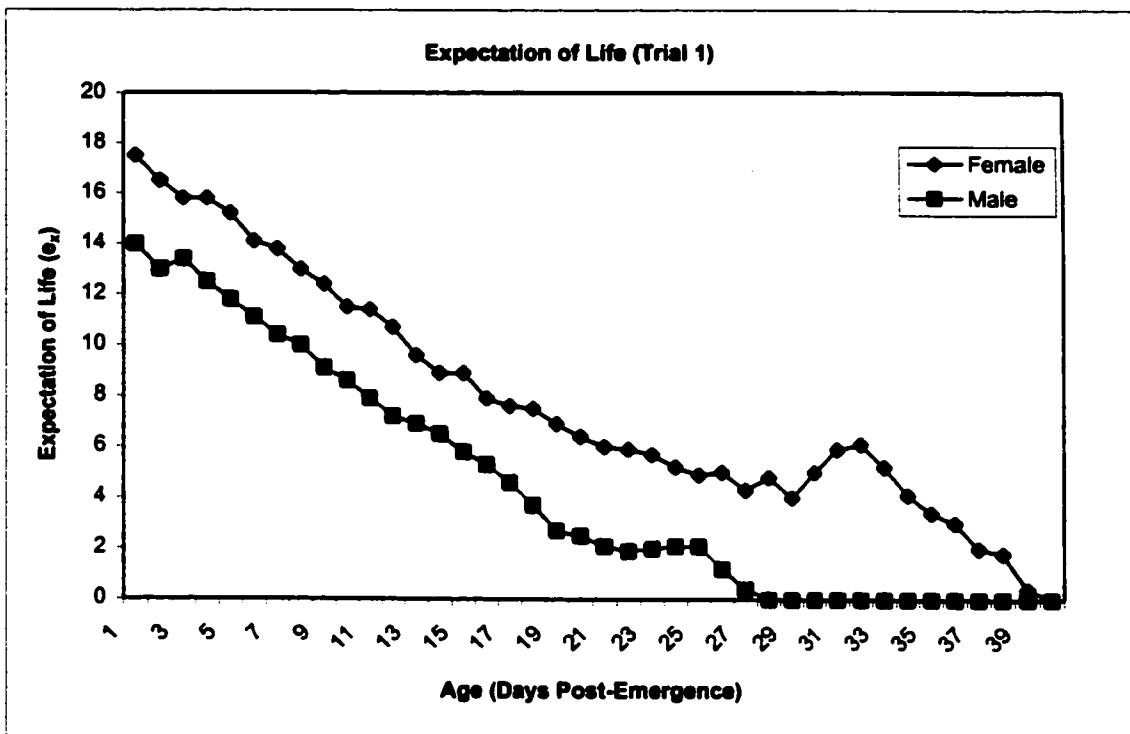

Figure 9: Expected days of life remaining per day after emergence. Data pertaining to Trial 1 only.

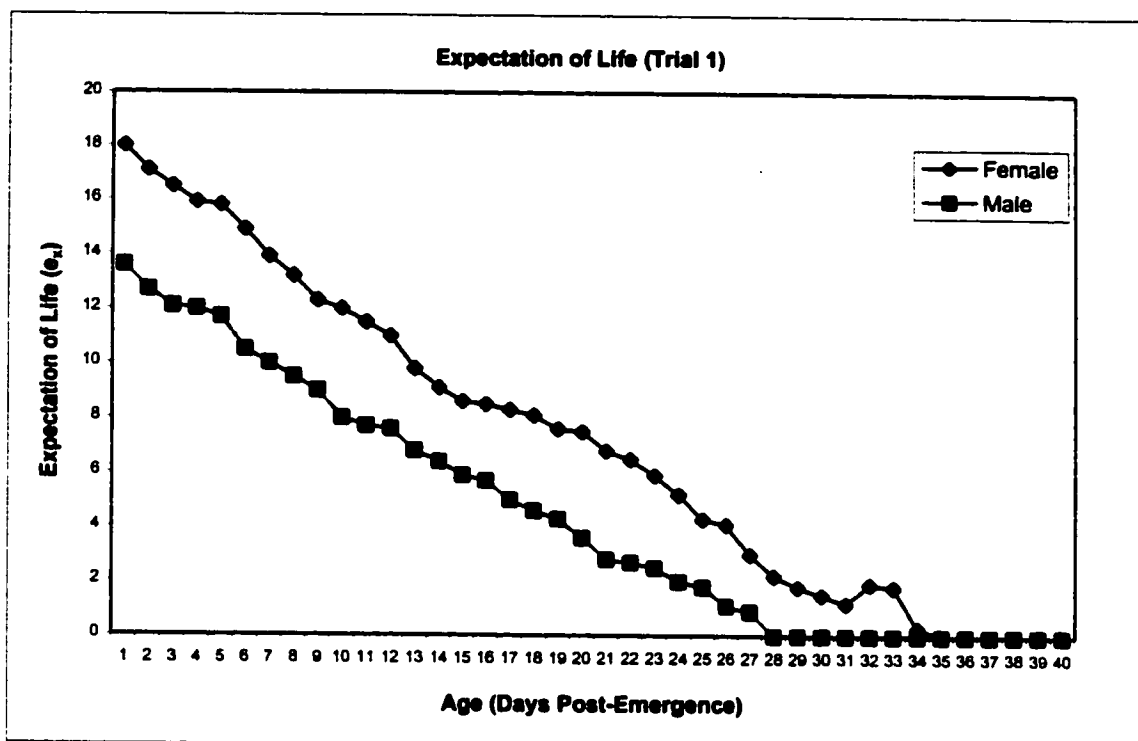

Figure 10: Expected days of life remaining per day after emergence. Data pertaining to Trial 2 only.

Chapter 3

Malaria Transmission and Seasonal Prevalence of Anopheles Mosquitoes in Association with Ecological Factors in Southern Belize.

ABSTRACT

The ability to identify the seasonal abundance of potential insect vector species is a priority for understanding the epidemiology and control of arthropod-borne diseases such as malaria. Abundance studies can be used to predict the intensity of outbreaks, the time and place of outbreaks as well as the type and intensity of vector control measures. In areas where the vector/vectors responsible for transmission are not known, abundance studies can give insight into the concordance between abundance of potential vector species, frequency of sporozoite antigen in wild-caught populations and numbers of malaria cases.

The present study utilized two-hour, evening, human landing collections as an indicator of seasonal vector abundance for two main sites in the Toledo District in southern Belize, Rancho Village and Golden Stream Village. Population abundance patterns were compared to several ecological parameters such as precipitation, river level and number of malaria cases. This information is presented in conjunction with sporozoite ELISA data. All adult female anophelines collected in this study were tested (ELISA) for presence of sporozoite antigen.

At Golden Stream, the population densities of *Anopheles albimanus*, *An. vestitipennis* and *An. punctimacula* showed positive correlation with the river level and all except *An. punctimacula* showed a positive correlation with precipitation. All three species showed an increase in population density shortly after periods of heavy rain. These periods of heavy rain coincide with high numbers of malaria cases, which may explain the correlation of all three *Anopheles* species with high malaria transmission. Only *An. vestitipennis* tested positive for *P. vivax* 210 with 3 pools testing positive

(minimum field infection rate (MFIR) of 0.01). Two of the three pools came from indoor collections.

Population densities of *An. darlingi* showed a negative correlation with precipitation, river level and high numbers of malaria cases. The negative correlation is most likely due to high flow rates as characterized by a high Froude index created by the general stream ecology characteristic of the Golden Stream river system. In this river, heavy rains create a flushing action which eliminate suitable larval habitats for this species. *Anopheles darlingi* also tested positive for *P. vivax* 210 (MFIR of 0.001) from an indoor collection.

At Rancho, the three dominant adult *Anopheles* species were *An. albimanus*, *An. punctimacula* and *An. vestitipennis*. As at Golden Stream, all three species were most common in both adult and larval collections during the rainy season. Population densities of *Anopheles vestitipennis* showed a correlation with high numbers of *P. vivax* cases as did *An. punctimacula*, but only *An. vestitipennis* tested positive for *P. vivax* sporozoites. The MFIR at this location was very low (0.0004) due mainly to the large numbers of specimens collected. *Anopheles albimanus* showed an interesting pattern of adult abundance. The abundance of this species showed a negative correlation with rainfall. High population densities of *An. albimanus* during the dry season probably reflects the presence of wet rice fields close to the study site which provided suitable breeding habitat during the dry season. Regardless, population abundance of *An. albimanus* showed a negative correlation with malaria transmission and was not found infected with any of the malaria parasites screened for in this study.

Additional collections of 406 specimens of *An. albimanus* from the Toledo District produced one positive sample for *P. vivax* 247 and it was in a pool of mosquitoes from an outdoor collection. The single positive collection was from the village of Big Falls. All other species tested (represented by 6 species and 650 specimens) negative in the sporozoite ELISA.

Introduction

Vector behavior influences the dynamics of malaria transmission by governing the intensity, time and place of host-vector interactions (Elliott 1972). Vector behaviors can also inhibit disease transmission through behavioral modifications stimulated by repellent/irritant actions of insecticides (Roberts et al. 2000, Grieco et al. 2000, Roberts and Andre 1994). Clarification of the effects vector behaviors have overall on malaria transmission can give insight into the vector potential of different anopheline species. To understand the vector competence of a given species, one must know the temporal and spatial distributions of host-vector interactions, outdoor/indoor biting patterns and natural field infection rates.

Arthropod-borne disease rates in tropical regions often correlate with seasonal patterns of vector populations (Shililu et al. 1998, Torres et al. 1997, Prakash et al. 1997, Rattanarithikul et al. 1996, Sarkar and Pramanik 1996, Chadee 1994, Szumilas 1975.) The cycles of these arthropod populations are bound by environmental conditions, which govern their ability to propagate and survive. Insects are able to survive under harsh conditions in their environment by undergoing both behavioral and physiological adaptations. In more temperate regions of the world, the latter adaptations result in winter diapause and summer aestivation. In more tropical regions, behavioral adaptations are often associated with wet and dry seasons or adaptations to seasonal variation in land use practices.

This is particularly true of those arthropods, which spend a portion of their life in an aquatic environment, such as mosquitoes. Mosquitoes are greatly influenced by precipitation and river levels that either create or flush out suitable breeding habitats.

These conditions determine the population density of a given species and influence the patterns of malaria transmission during the wet/dry seasons within tropical regions. In many regions, however, it is not eminently clear as to the true vector species responsible for malaria transmission. Therefore, entomological studies conducted to determine the seasonal occurrence of anopheline species in association with the seasonal incidence of malaria can help define the role of potential vector species. To obtain a true indication of seasonal patterns, one must collect samples throughout the course of the year. Ideally, several years of collections are required to deal with yearly fluctuations in environmental conditions.

Although the potential malaria vectors of Central and South America have been studied by a number of researchers, additional information is needed for several Anopheles species (Roberts and Andre, 1994). Anopheles albimanus Weidemann is considered one of the most important vectors in Central America and northern South America (Ramsey et al. 1994, Faran 1980, Breeland 1980) even though this species exhibits a weak endophagic behavior (Elliott 1972, Frederikson 1993, Roberts et al. 1993, Roberts et al. 2000, Bangs 1999). In Belize, An. albimanus shows a distinct preference for feeding on domestic animals over humans (Bangs 1999). Achee et al. (2000) showed that 8 out of 10 Plasmodium vivax sporozoite infected An. albimanus were collected from outside the house and two P. falciparum positive specimens were collected outdoors (i.e. 10 of 12 positive specimens were collected outside in paired indoor/outdoor collections). In addition, this species has also demonstrated a clear avoidance behavior to various insecticides such as DDT (Gabaldon 1952, Brown 1958, Hecht and Hernandez 1960, Quinones and Suarez 1989, Chareonviriyaphap et al. 1997).

Anopheles darlingi was first incriminated as a vector of malaria in 1931 in the state of Para, Brazil based on finding sporozoites in the salivary glands of dissected specimens (Davis 1931). Since that time others have confirmed these findings using radioimmunoassays and enzyme linked immunosorbent assays (ELISA) (Deane et al. 1946, Causey et al. 1946, Arruda et al. 1986, Tadei et al. 1988, Deane et al. 1988, Lourenco-de Oliveira 1989). Positive dissections, assay data, laboratory infection studies and other behavioral factors define An. darlingi as a major malaria vector in Central and South America. This species shows both a strong tendency to feed on humans as well as demonstrates a strong endophagic behavior (Deane et al. 1946, Roberts et al. 1987, Klein and Lima 1990, Rozendaal 1989). Klein et al. (1991) stated that An. darlingi is the primary vector of malaria in Costa Marques, Rondonia, Brazil based on seasonal distribution, relative abundance, peridomiliary and biting behavior, host contact and high natural field infection rates. This species was recently taxonomically re-described for the country of Belize after its initial description in 1946 (Harbach 1994, Roberts et al. 1993). In a 1994-1997 survey of Anopheles mosquitoes conducted throughout Belize, Achee et al. (2000) demonstrated that An. darlingi had a higher minimum field infection rate (MFIR) than An. albimanus (0.261% and 0.126% respectively). This same study showed that a P. falciparum positive specimen occurred in a sample of An. darlingi collected indoors.

Anopheles vestitipennis has, until recently, only been suspected of being a malaria vector. This species is found throughout the coastal regions of Mexico, Central America, regions of northern South America, Cuba and Puerto Rico (Loyola et al. 1991, Mekuria et al. 1991, Padilla et al. 1992, Marquetti et al. 1992). Some authors have even

gone so far as to downplay the role that this species plays in the transmission of malaria (Boyd 1949). Loyola et al. (1991), however, observed this species to exhibit both endophilic and endophagic behaviors. These behaviors were coupled with positive ELISA results for *P. vivax* in a native population of *An. vestitipennis* collected from Chiapas, Mexico. The positive results from studies in Mexico confirm earlier findings by Kumm and Ram (1941) who found 1 of 41 specimens of *An. vestitipennis* collected from Belize to be positively infected with *Plasmodium* spp. by salivary gland dissection. Achee et al. (2000) found this species to have a relatively high MFIR in relation to the other *Anopheles* species collected in a survey conducted in Belize. In this study the MFIR for *An. vestitipennis* (0.282%) was higher than rates for either *An. albimanus* (0.126%) or *An. darlingi* (0.261%).

Anopheles darlingi has been characterized as a riverine species that utilizes breeding sites in and around river systems (Rozendaal 1990). The volatile dynamics of these rivers during the rainy season make it critical for this species to be flexible in its choice of breeding habitats. During the dry season, *An. darlingi* has been found breeding in creeks, between roots and fallen trunks along river margins. It has also been found in shaded areas of debris and floating vegetation in the river where the flow of the river has been impeded (Fleming 1986; Panday 1980; Hudson, 1984). These breeding sites change during the rainy season when rivers flood and flush these sites out. It is during the rainy season that *An. darlingi* has been observed to breed in vegetation and floating debris in flooded forest areas near the river (Bonne&Bonne-Wepster 1925; Van der Kuyp 1950; Bruyning 1952; Hudson 1984; Rozendaal 1987; Rozendaal 1992).

Manguin et al. (1996) characterized the larval habitat of An. darlingi for the country of Belize. They found that the main habitat for this species in the Sibun River was defined by floating mats of debris and submerged plants which were shaded by overhanging vegetation. Observations were also made concerning the flooding action of the river. It was observed that the larvae would follow the floating debris as the river receded from a heavy rain. This would result in the stranding and eventual demise of some of the larvae. These observations were made in a lagoon off of the main river and did not represent the conditions which might occur in the increased flow rate of the main river system. Manguin et al. (1996) collected larvae and adult An. darlingi during both wet and dry seasons in Belize.

Rozendaal clearly showed that An. darlingi utilized a variety of breeding habitats within the country of Suriname, South America. These habitats were dependent on the river level and precipitation. He demonstrated that in the coastal regions of Suriname the breeding conditions are unfavorable due to the tidal action of the rivers. In these areas, the breeding sites were found limited to flooded depressions near the banks of the river which occurred during the rainy season. The rainy season also coincided with high population densities of An. darlingi as determined by human landing collections. Periods of heavy rain also brought about outbreaks of malaria. In coastal areas of Guyana, a similar situation occurred (Giglioli 1951). Malaria transmission began during the rainy season when breeding sites were formed for An. darlingi in flooded depressions adjacent to irrigation canals.

In more densely forested regions found in the interior of the Amazon Basin, the flow dynamics of the rivers are different and the heavy rains may be responsible for

flushing out breeding sites. This would result in a reduction in the numbers of An. darlingi present in the area (Rozendaal 1992). It is presumed that only when the rivers began to recede in the months between the wet and dry season that the breeding sites were exposed and this often coincided with peaks of malaria transmission in these regions (Ferraroni and Hayes 1979; Charlwood 1980).

Anopheles albimanus is a species, which has demonstrated the ability to breed in a number of different habitats. In particular this species shows an association with floating mats of cyanobacteria (Rejmenkova et al. 1995, 1993). Conditions which favor these types of communities are permanent impoundments of water such as marshes and open swamps. Savage et al. (1990) found an association of An. albimanus breeding sites with bodies of water that were exposed to ample sunlight and which produced large amounts of food reserves for developing larvae. During the dry season, many of the breeding sites dry out, and the larvae are confined to the margins of permanent lakes, ponds and roadside ditches (Orr and Resh 1989). The presence of standing water on a wet rice field creates all of the conditions favorable for An. albimanus breeding. These conditions are artificially maintained through irrigation channels which permit this species to breed during times of year when their population levels may naturally be low. Overall, An. albimanus seems to show an opportunistic behavior in its selection of breeding habitats.

Anopheles vestitipennis and An. punctimacula have demonstrated preferences for breeding in flooded forests (Rejmenkova et al. 1998). The larvae of the two species have been found frequently in swamp forest habitats and often occur sympatrically. Larvae of An. vestitipennis also have been found in tall dense macrophyte marsh habitats. This

species appears to require plant material or detritus as a nutritional source as well as plant cover for shade. Both species also have a clear seasonal pattern which coincides with increased larval habitat produced during the rainy season. This was confirmed by adult collections conducted in the Lacandon forest of Mexico where higher population levels were observed during the rainy season (Arredondo-Jimenez et al. 1996).

This issue of land use practices has been postulated as a potential factor influencing the increase in numbers of disease carrying mosquitoes. One of these land use practices which most clearly demonstrates this association is large scale wet rice farming. It has been noted that amplification of breeding sites results from irrigation of rice fields and that this is associated with increased prevalence of malaria, filariasis and a number of arboviral diseases. A number of factors have been given for this increased prevalence of disease. In traditionally arid climates, irrigation expands larval habitats, increases host availability (both human and non-human), and elevates humidity (Lacey and Lacey, 1990). Rice field cultivation in central Japan resulted in increased population densities of Culex tritaeniorhynchus Giles (Mogi 1978, 1979). Practices involved in rice production can also create large populations of mosquitoes during times of the year when they may normally be kept in check by dry conditions such as with Culex salinarius and Psorophora columbae (Olson and Meek 1980, Chambers et al 1981). Allowing large amounts of fresh water to sit on a field which contains ample amounts of plant material and fertilizer creates an ideal situation for many anopheline species, as well. Some anophelines that have been found in association with rice fields include An. pharoensis (Mukiama and Mwangi, 1989), An. freeborni (Kramer and Garcia, 1989), An. funestus (Gillies and Coetzee, 1987) and An. albimanus (Bruce-Chwatt, 1985). Plant material

provides the surface of the water with both shade and protection from wind and wave action. Plant material also moderates the temperature to create a suitable larval habitat. These favorable conditions for mosquito production are generally aggravated by the presence of cattle and other readily available blood meal sources in the immediate vicinity of rice fields.

Anopheles spp. have been examined for malaria sporozoites using a variety of laboratory techniques. The most common technique has been the dissection and microscopic examination of mosquito salivary glands (WHO 1975). This technique remains the most definitive method of detecting infection, as well as, the most accurate method of quantifying infections for comparative susceptibility tests (Klein et al. 1991a, 1991b, 1991c, 1991d). This method, however, requires a skilled microscopist and a considerable amount of time which make other techniques such as the enzyme linked immunosorbent assay (ELISA) more practical for analyzing large numbers of specimens collected in the field. Another limitation of the dissection technique is that a species determination for the Plasmodium parasite can not be made.

The ability to produce monoclonal antibodies to malaria sporozoite antigens has enabled researchers to develop species specific immunological tests that are sensitive enough to detect sporozoite infections in pools of Anopheles mosquitoes. A number of techniques have been employed for this purpose. Tests such as immunoradiometric assays (Collins et al. 1995, 1984), indirect immunofluorescent assays and enzyme linked immunosorbent assays (ELISAs) have all been successful in the identification of sporozoite infected mosquitoes. Immunoradiometric assays utilize short lived radioactive reagents that require proper handling and disposal. Immunofluorescent assays require

equipment and power supplies that make them difficult to operate in the field.

Alternatively, the ELISA relies on stable reagents which elicit a color change that can be read visually, making this test very useful in a field setting (Wirtz et al. 1985). The ELISA technique also has advantages over the traditional dissection techniques e.g. the ability to identify sporozoites to species level and maintain specimens dried on desiccating silica gel for long periods of time prior to processing. The ELISA can also be used to give rough estimates of the number of sporozoites present in a given sample (Beier et. al 1987) by comparing absorbance wave length values of the positive samples to a standard curve.

ELISA assays have been developed for the three types of malaria parasite common to Central America: Plasmodium vivax 247, P. vivax 210 and P. falciparum (Rosenberg et al 1989). The heterogeneity which occurs within P. vivax was first described by Rosenberg et al in 1989. This phenotypic heterogeneity has been attributed to a repetitive region of the circumsporozoite (CS) protein. The monoclonal antibodies produced to the two P. vivax CS protein isolates did not bind to other P. vivax isolates or other species of human or simian malaria. This enabled a specific ELISA test to be developed for each P. vivax phenotype.

The purpose of the present study was to quantify seasonal abundance of each Anopheles species in the study area during the 18 month study period and examine the relationship between abundance of mosquitoes and various parameters of disease ecology. The correlation between population abundance of An. albimanus, An. punctimacula, An. darlingi, and An. vestitipennis and rates of sporozoite positive specimens was an important component of this investigation.

Materials and Methods

From July of 1997 until December of 1998, a series of 2-hour outdoor:indoor human landing collections were conducted at two sites in the Toledo District of southern Belize. These human landing collections were conducted at two separate sites, Golden Stream (N 16 21.820, W 88 47.936) and Rancho (N 16 09.954, W 88 50.529) (Figure 1). Both Golden Stream and Rancho were listed as two of the 5 villages with the highest number of malaria cases in the Toledo District. Golden Stream is a village of approximately 422 individuals and 94 homes as determined by a 1998 census. The ethnicity is predominately Mopan Mayan and Ketchi. The village is situated inland from the coast, along the Southern Highway. It is located on a clean fast flowing river which is fed by both natural spring water and mountain rain runoff. Homes are constructed of plank wood with Cahon palm thatch roofing and dirt flooring. All homes in the village had been sprayed with DDT at least six months prior to the beginning of the study.

The 1998 census estimates the population of Rancho at 824 individuals living in approximately 166 houses with an ethnic composition of Ketchi, East Indian and Garafuna. The village is located about 4 miles from the Gulf of Honduras and is situated on the outskirts of Punta Gorda (the largest urban area in the Toledo District). Houses in Rancho were constructed of either plank wood and thatch roofing or cinder block and corrugated tin roofing. Several of the houses that were sampled in this area had also been sprayed with DDT at least six months prior to the beginning of the study. Three additional experimental huts were constructed for the purpose of conducting behavioral

studies and were sampled throughout the study. None of the three experimental huts had been sprayed.

Additional collections were conducted at various locations throughout the Toledo District to include Big Falls (N 16 15.702, W 88 53.082), Indian Creek (N 16 18.788, W 88 50.012), Esso Landing (N 16 09.822, W 88 50.622) and Punta Gorda (N 16 06.240, W 88 50.550) (Figure 1).

Prior to conducting a collection, a data sheet (Appendix I) was filled out to record information about the house at which the collection was being conducted. Information which was collected include the GPS coordinates of the location, the number of family members in the house, number of door and window openings, type of construction and the spray history of the house. Additional meteorological information was also recorded such as the relative humidity and high/low temperatures at the time of collection. The numbers and types of mosquitoes collected were also recorded on the corresponding data sheet. All information was later entered into a database for further analysis.

Collectors consisted of two researchers and trained recruits from the local indigenous population. A signed consent form (Appendix II), stating the task to be performed and the risks involved, was required of all collectors prior to beginning any collection. A series of training nights was conducted prior to the beginning of the study to instruct collectors on the proper sampling methods. These were paid workers, over 16 years of age, who were not allowed to use repellent or smoke cigarettes while collecting mosquitoes. A weekly dose of chloroquine was also provided to all collectors, as well as, all other materials needed for the collection (i.e. flashlights, batteries, aspirator, paper

cartons etc.). The medication was made available but was not required for participation in the evening collections.

The collections were conducted by two individuals, one positioned inside a hut and one positioned outside the hut. On a given night, either one or two huts were sampled depending on the number of collectors available. A human landing collection was conducted from 6:00 p.m.-8:00 p.m. with the collectors switching their positions half way through the collection. Anopheles mosquitoes were collected from the exposed lower legs (i.e. from below the knee to the lower ankle) (WHO, 1975) of the collector using a flashlight and mouth aspirator. All collected mosquitoes were placed in modified 1-pint cardboard cartons which were labeled with either "inside" or "outside" and the location. At the conclusion of the collection the mosquitoes were returned to the laboratory in Punta Gorda and promptly knocked down with vapors from a chloroform soaked cotton ball and were identified to species using keys specific to the region (Wilkerson and Strickman 1990). Mosquitoes from each night's collection were pooled by species and indoor or outdoor location, and placed into labeled vials (no more than 10 mosquitoes per vial). The vials and their contents were stored in air tight containers with desiccating silica gel until they were safely transported back to the Uniformed Services University of the Health Sciences where they were analyzed using a modified sporozoite ELISA.

Larval collections were also conducted in and around the Rancho site as part of establishing a working colony of the various Anopheles species. The GPS coordinates of larval habitats were recorded as well as the number of larvae obtained per dip. These collections were performed from November of 1997 through July of 1998. A total of 30

dips were made at each habitat several times a month by two to three collectors.

Averages were obtained for the number of anophelines of each species collected per dip and were recorded for data processing. All anopheline larvae were removed and placed in labeled Whirl Pac collection bags. The contents of the bags were returned to the insectary where the larvae were placed in labeled, enamel rearing pans. The larvae were fed and monitored until pupation at which time they were placed in separate rearing vials until adult emergence. The adults that emerged were momentarily placed in the freezer to knock them down long enough for species identification. Information was recorded as to date, location and species identity. Any larvae which died during rearing were slide mounted, identified and recorded with the previously mentioned collection information. Identifications were made based on morphological characteristics using the keys of Clark-Gil and Darsie (1983) for the mosquitoes of Guatemala.

Five separate habitats at the Rancho site were sampled for larvae in the previously mentioned manner. The habitats were wet rice field (N 16 09.939, W 88 50.565), flooded forest (N 16 09.953, W 88 50.520), roadside ditch (N 16 09.952, W 88 50.522), flooded field (N 16 09.955, W 88 50.527) and temporary pools in the dry rice field (N 16 09.941, W 88 50.563). The wet rice field was approximately one km² in area and was partitioned off into a series of smaller 25 m² plots. Each plot was surrounded by a levee system where the water level was maintained by a series of irrigation canals and gates that channeled water from the Jacinto River. The planting of rice began during the dry season with flooding of fields beginning in early March and harvesting in early August. During the remainder of the year the gates and canals remained open to drain the fields and prevent the rain water from flooding the surrounding area. The canals contained a wide

variety of plant material which provided limited shade and protection from the wind. Predatory and non-predatory aquatic insects invaded these areas when water was allowed to stand on the fields. In proximity to the rice fields were open pastures occupied by approximately 45 head of cattle as well as a single house with two adults and 4 children. Approximately 1000 meters separated the rice fields and the site where the human landing collections were conducted.

The flooded forest habitat was a low depression area located beneath a fairly thick-forest canopy. The area was fed by a fresh water spring and contained water throughout the year. The water level varied, however, with high water levels occurring during the rainy season. This location also contained large numbers of aquatic insects when water levels were high. The water remained in this area during the dry season, but as water levels dropped, the water became muddy and a surface film of plant oils and algae made it unsuitable for mosquito breeding. This site was located approximately 100 meters from the site where human landing collections were conducted.

The roadside ditch was located close to the margin of the flooded forest and contained water only during the wet season. This habitat was approximately 1 m wide by 10 m long and contained areas which were both exposed to the sun and areas which were shaded. All areas contained ample amounts of grasses and other vegetation. The water was also present during the dry season but contained large amounts of sediment and had an oily surface film, which made it unsuitable for mosquito larvae. This site was approximately 25 meters from the site where human landing collections were conducted.

The flooded field was located in a low lying area at the bend of the Jacinto River. The field covered an area of approximately 30 m² and was prone to flooding during the

wet season. Once the field was flooded it remained so until the flood waters were able to drain into the river. Depending on the severity of the rain, this process could take from days to weeks to complete. A large amount of non-aquatic vegetation became submerged in this area during times of flooding. The entire area was exposed to the sun, and the only shade came from the heads of submerged vegetation. During the dry season this area was completely devoid of water. In addition, cattle were rotated in and out of this field at various times throughout the year. The breeding sites at this location range in distance from 20 to 100 meters from the research site where human-landing collections were conducted. Distances varied depending on the severity and duration of the rainfall.

The dry rice field was similar in composition to the flooded field except that the dry field had sparse vegetation (i.e. weeds and a few remaining rice stalks) during the dry season. Water was present in this field only during the wet season which also coincided with the planting of rice. The majority of the water quickly drained from the field but some remained in low lying depressions throughout the field. The collection of all mosquito larvae occurred in these depressions. The surface of the water was primarily exposed to the sun except in small areas where the rice and other vegetation provided sufficient shade. The dry rice field was located approximately 500 meters from where human landing collections were conducted.

Blood films were examined for each village in the area of Punta Gorda. These data related to malaria cases were obtained from the hospital in Punta Gorda.

Meteorological information was obtained from the Belize Hydrology Center in Belize City and this information included precipitation, river levels and temperature, for the various study sites in the Toledo district. Aquatic insects associated with the various

larval habitats were identified using the keys to aquatic insects of North America (Merritt and Cummins 1996).

A modified sandwich sporozoite ELISA (Wirtz et al. 1987; Beach et al 1992) was performed on all adult, female Anopheles collected from this study. All procedures conducted in the course of this assay were performed at room temperature (23-26°C). The mosquitoes were dissected, and only the heads and thoraxes were used in the ELISA assay. A maximum of 10 individual specimens of the same species were pooled for the assay. All samples were ground in 50 ul of blocking buffer (BB) and an additional volume of 150 ul was added to bring total volume to 200 ul. The blocking buffer was made by dissolving 0.5% casein in 0.01 M Dulbecco's phosphate-buffer saline (PBS) and was adjusted to a pH of 7.4. An aliquot of 0.002% phenol red was added to the BB solution to serve as an indicator of a change in pH. The BB also contained 0.5% Igepal CA-630 (Sigma, St. Louis, MO). Samples were stored in the -20°C freezer for no more than 2 weeks prior to testing in the assay.

The sandwich sporozoite ELISA was performed in polyvinyl chloride, U-shaped 96-well microtiter plates (Costar, Cambridge, MA). All outside wells were left empty to reduce the effects of evaporation and to cut down on background when reading the final plate. Separate plates for each Plasmodium species were initially coated for one hour with 50 ul of capture monoclonal antibodies of the following Plasmodium species: Plasmodium falciparum (2A10; 4ug/ ml PBS), P. vivax 210 (NSV3; 0.5 ug/ ml PBS) and P. vivax VK247 (2471G12; 2ug/ ml PBS). The capture antibodies were aspirated from the wells and replaced with 250 ul of BB. The blocking buffer was allowed to incubate for the period of one hour at the end of which it was aspirated and replaced with 50 ul

aliquots of either the unknown mosquito sample, a negative control or a positive control. Five negative controls were tested per plate. The negative controls consisted of 10 pooled, laboratory reared *An. albimanus* from the Walter Reed Army Institute of Research which were ground in 50 ul of BB with an additional 150 ul of BB added after grinding (total volume = 200 ul). In addition, five positive controls were tested per plate. Positive controls consisted of lyophilized recombinant proteins from *P. falciparum* 100pg/50ul BB; *P. vivax* 210 40pg/50ul BB or synthetic peptide *P. vivax* VK247 2000pg/50ul BB. The samples and positive/negative controls were covered and allowed to incubate for 2 hours.

At the end of the 2-hour incubation, the plates were aspirated, and the wells were washed three times with PBS containing the detergent Tween 20. To each well on their respective plate was added 50 ul of a homologous monoclonal antibody conjugated to horseradish peroxidase (Kirkegaard & Perry Laboratory, Gaithersburg, MD) (1ug/ml BB *P. falciparum* and *P. vivax* 210; 2 ug/ml BB *P. vivax* VK247). The conjugate was allowed to remain in the plate for 1 hour after which time it was aspirated, and the plate was washed three times with PBS containing Tween-20. The final step in the analysis was the addition of 100 ul of an enzyme substrate solution (2,2'-azino-di (3-ethyl-benzthiazolinesulfonicacid [ABTS]) in buffered hydrogen peroxide (Kirkegaard & Perry Laboratory, Gaithersburg, MD). Those samples testing positive elicited a green color change.

After addition of the peroxidase substrate, absorbency values were read at a wavelength of 414nm at 15, 30 and 60 minutes using an ELISA plate reader (Titertek Multiskan, Flow Laboratories, McLean, VA). Values obtained at the 30-minute time

interval were used in determining positive samples. Those mosquito triturates whose absorbency values were equal to or greater than 3 times the standard deviation of the 5 negative controls were determined to be positive and were re-tested. Samples testing positive a second time were deemed to be true positives.

The field infectivity rate is a calculation of the number of mosquitoes which test positive for malaria in relation to the entire population of specimens tested for a given species. For the purpose of this study, it was necessary to calculate a minimum field infectivity rate (MFIR). This was required because pools of mosquitoes were tested rather than individual samples. Therefore, when a positive sample was detected in a pool of 10 mosquitoes, it was not known whether one or more mosquitoes in that pool were positive. The low level of malaria present in Belize makes it very unlikely that more than one mosquito in a pool would be infected, however, this can not be ruled out. Therefore, a positive result indicates the minimum number of mosquitoes which tested positive and thus the term MFIR. The MFIR value was calculated for each species and for each site separately due to the unique ecology associated with each site.

Statistical analysis were performed using the SPSS version 9.0 statistical package (SPSS® vs. 9.0, SPSS Inc., Chicago, IL). A nonparametric, bivariate analysis was performed on collection, meteorological and malaria data to obtain Spearman's rho coefficients. These values were used to identify relationships between species densities and factors associated with the environment and malaria transmission. A multiple linear regression was performed on the hut factor data to determine house attributes which are associated with positive mosquito collections.

Results

From all locations sampled, a total of 11,264 anophelines was collected. The collections consisted of the following species: 1,736 *An. albimanus*, 381 *An. apicimacula*, 1,046 *An. darlingi*, 50 *An. gabaldoni*, 2 *An. eisini*, 1 *An. neivai*, 611 *An. punctimacula*, 1 *An. pseudopunctipennis*, 7,532 *An. vestitipennis* and 1 *Chagasia* spp (Tables 1, 2 and 3).

The numbers of *Anopheles* collected both outdoors and indoors from human landing collections are displayed in Table 1. The outdoor:indoor biting ratios were only calculated for species if more than 10 specimens were collected. The following overall outdoor:indoor ratios were calculated: *An. albimanus* (1:0.37), *An. apicimacula* (1: 0.09), *An. darlingi* (1:0.53), *An. gabaldoni* (1:0.04), *An. punctimacula* (1:0.25) and *An. vestitipennis* (1:0.45). The data from the Rancho site was separated into two data sets, those collections conducted at sprayed houses and those that were conducted at unsprayed houses. The sprayed houses were determined to have been sprayed at least 6 months prior to the beginning of collections by a dated spray card which was posted in each hut by the Ministry of Health's house spray teams. The outdoor:indoor ratios for *An. vestitipennis* at sprayed and unsprayed houses were significantly different. The outdoor:indoor ratio was 1:0.32 for the sprayed houses and 1:0.78 for the unsprayed houses.

The results of the larval survey are presented in Table 4. The largest number of larvae sampled during the study were *An. albimanus* from the wet rice field. These numbers were highest during the dry season (March-July) with greater than 14 larvae per dip. During May and June of 1998, more than 20 larvae per dip were collected with

counts ranging from >14 in March to >20 in May and June. There was, however, no statistical significance in the level of precipitation and the monthly number of larvae collected from the rice field (Spearman's $\rho = -0.643$; $p > 0.05$). During the rainy season large numbers of larvae were also found in roadside ditches, flooded forests, flooded fields and the dry rice fields when these areas contained suitable water levels for mosquito breeding. Only the flooded fields showed a positive correlation between high levels of precipitation and increased numbers of larvae collected (Spearman's $\rho = 0.867$; $p < .05$). Many of the sites which demonstrated relatively high levels of An. albimanus larvae during the wet season were dry from March to July (dry season).

The data for An. vestitipennis show high numbers of larvae being collected from the flooded forest and roadside ditch habitat (Table 4). These high numbers occurred during the rainy season (November 1997 to January 1998) when clean water was present. The highest number of larvae were collected in November which coincides with the highest rainfall measured during the survey. Although these trends were recognizable, after statistical analysis, there was no correlation between level of rainfall and number of An. vestitipennis larvae collected (Spearman's $\rho = 0.607$; $p > 0.05$). A similar trend was seen for An. punctimacula which demonstrated a high larval density in flooded forest during the rainy season. These trends also showed that there was no significant correlation between rainfall and number of larvae collected (Spearman's $\rho = 0.630$; $p > 0.05$). Small numbers of An. punctimacula larvae were also collected from temporary pools in the dry rice field and the road-side ditch during the rainy season. Periods when large numbers of An. vestitipennis and An. punctimacula larvae were collected coincided with periods when high numbers of adults were collected in human landing collections.

Data from adult collections conducted at Golden Stream indicate that there is an association between the abundance of An. vestitipennis and the precipitation level (Spearman's rho = 0.573; p=0.044), as well as, a positive association with river level (Figure 2; Table 5) (Spearman's rho = 0.812; p=0.006). A slight time lag occurred between high levels of precipitation and increases in population density. There is also a direct association between high population densities of An. vestitipennis and an increase in the number of P. vivax cases (Spearman's rho = 0.905; p = 0.009) confirmed by the local hospital (Figure 2; Table 5). The association between vector population and case data was further strengthened by the ELISA analysis which confirmed three pools of An. vestitipennis testing positive for P. vivax (1 in the month of August 1997 and two occurring in the month of December of 1997) (Table 7). This resulted in an MFIR of 0.01 (Table 8), which is particularly high for this area. Two of the positive pools were from indoor collections and the remaining positive was from an outdoor collection.

Figure 3 and Table 5 show the relationship between abundance of An. darlingi with precipitation, river level and monthly cases of P. vivax. This species demonstrates a negative association with precipitation (Spearman's rho = -0.587; p < 0.05) and river level (Spearman's rho = -0.0804; p < 0.01). High population densities of An. darlingi were recorded during the dry season (February through June of 1998). It is during this same time when the river levels were at their lowest. During this same period of time, hospital confirmed cases of P. vivax were also at their lowest and there was a negative correlation between An. darlingi population densities and malaria transmission (Spearman's rho = -0.728; p < 0.01). Regardless of the negative correlation, one pool of

An. darlingi tested positive for P. vivax, which resulted in an MFIR of 0.001 (Table 8).

This positive also came from an indoor collection.

Figure 4 and Table 5 show the relationship between the abundance of An. albimanus with precipitation (Spearman's rho = 0.813; p = 0.001), river level (Spearman's rho = 0.774; p < 0.01) and monthly cases of P. vivax (Spearman's rho = 0.835; p = 0.007) at the village of Golden Stream. This species seems to show a positive association with both river level and precipitation. High population densities of An. albimanus were also encountered in association with high levels of P. vivax transmission. However, in December when the highest number of cases of P. vivax were recorded, population levels of An. albimanus were extremely low. In addition, out of 854 mosquitoes tested, none produced a positive result in the sporozoite ELISA (Table 8).

Figures 5 and 6 show the relationship between these same ecological factors and the other two Anopheles species collected in highest abundance at Golden Stream, An. apicimacula and An. punctimacula. Anopheles punctimacula shows a similar pattern to that seen for An. vestitipennis at both the Rancho and Golden Stream sites (Tables 5 and 6). There appears to be an association of this species with increasing river levels (Spearman's rho = 0.663; p < 0.05) and high levels of malaria (Spearman's rho = 0.792; p < 0.01). However, no An. punctimacula from the Golden Stream site tested positive for malaria. Low numbers of An. apicimacula (164) were collected from this location and 96% (158 mosquitoes) were collected in the months of October and November. These low numbers made it difficult to run further statistical tests for this species. No pools of An. apicimacula tested positive for malaria sporozoite antigen (Table 8).

Data collection from the Rancho site was carried out for an additional 5 months. River level data from this site was not available from the Belize Hydrology Center. At Rancho, An. vestitipennis was the most common Anopheles species, comprising 6962 of the 8187 (85%) anophelines collected at this site. Population levels of An. vestitipennis showed a lag time between high levels of precipitation and high population densities (Figure 7 and Table 6). Without adjusting for the time lag, there was no correlation between precipitation and mosquito abundance (Spearman's $\rho = 0.327$; $p = 0.15$). By adjusting data to account for a three week lag in larval development, emergence and maturation there was a positive correlation demonstrated (Spearman's $\rho = 0.648$; $p = 0.043$). Population levels begin to increase approximately 1 month after the heavy rains begin and densities peak in the month of December. Again, there was an association with the high population density of An. vestitipennis and increased number of cases of P. vivax reported from the area (Spearman's $\rho = 0.688$; $p < 0.01$). Also, the only pool, which tested positive at Rancho was from specimens of An. vestitipennis from outdoor collections. This resulted in an MFIR of 0.0004 (Table 9). This low MFIR is due mainly to the very large numbers of An. vestitipennis specimens collected at this site.

An. albimanus shows an inverse association with precipitation at the Rancho site (Spearman's $\rho = -0.667$; $p < 0.01$) (Figure 8 and Table 6). The greatest number of adult An. albimanus was collected in highest numbers during the dry season. This does, however, coincide with the largest number of An. albimanus larvae collected from locations in the Rancho area. The presence of An. albimanus and the occurrence of malaria also shows an inverse relationship with the number of cases of P. vivax (Spearman's $\rho = -0.619$; $p < 0.01$). The highest number of malaria infections occurred

when the *An. albimanus* populations were at their lowest. Not surprisingly no pools of *An. albimanus* tested positive for malaria sporozoites by ELISA assay at Rancho (Table 9).

Fairly high population densities of *An. punctimacula* were also present at the Rancho site (Figure 9 and Table 6). This species showed trends of adult abundance similar to those of *An. vestitipennis* with similar statistical results (i.e. no statistical correlation). Population densities of *An. punctimacula* increased during periods just after the heavy rains and were statistically correlated with high numbers of *P. vivax* confirmed by the hospital for the village of Rancho and patterns of occurrence show a statistical correlation (Spearman's $\rho = 0.482$; $p < 0.05$). Even though population densities of *An. punctimacula* and high numbers of malaria cases occurred in conjunction with one another, no pools of this species tested positive for malaria from the Rancho Site (Table 9).

The data for collections at other sites are shown in Table 10. The most abundant species collected from the 4 other locations in the Toledo district were *An. albimanus* (406) followed by *An. vestitipennis* (186), *An. punctimacula* (73), *An. apicimacula* (27) and *An. darlingi* (21). Trends observed from these locations are purely observational due to the small sample sizes and the lack of accurate meteorological data from each specific collection site. *An. albimanus* showed similar ecological trends as populations of this same species exhibited at the Golden Stream site. Their population levels were highest during the rainy season, which also coincides with high levels of *P. vivax* transmission. There was one pool of *An. albimanus* which tested positive for *P. vivax* VK247 from the

remaining four locations. This came from a pool of mosquitoes collected outdoors at the village of Big Falls and resulted in an MFIR of 0.002 for An. albimanus.

Due to the limited number of collections conducted at these sites and the low numbers obtained in these collections, it was difficult to make an evaluation of the abundance of these species in relation to the same ecological factors as was done with the two primary collection sites. Therefore, any further evaluations will be made on the basis of the outdoor:indoor biting ratios and the level of infection within the mosquito population. The following O:I ratios were recorded for those mosquitoes collected at the remaining four sites: An. albimanus (1:0.28), An. apicimacula (1:0.17), An. darlingi (1:0.23), An. punctimacula (1:0.12) and An. vestitipennis (1:0.47)

After running a multiple linear regression with the hut attributes in association with the infected mosquito pools collected indoors at Golden Stream, the only factor that proved to be significant was the number of windows and doors that remained open. All other factors either did not contribute significantly to the collection of infected mosquitoes or were removed due to confounding or non-biological significance.

The data collected on the other aquatic insects found in association with wet rice field and flooded forest habitats are presented in Tables 11 and 12. Because the aquatic insects of Central America are poorly studied and not well represented in the literature, there are few taxonomic keys to the aquatic insects of Belize. For this reason the identification of these organisms to species and often to genus was very difficult. Although limited, this information provides essential data about the ecological communities found in association with these anopheline species. The numbers of each

type of aquatic insect collected are presented in order to give an indication as to the abundance of these organisms within mosquito larval habitats.

Discussion

The outdoor:indoor biting ratios reported in this study are consistent with what is found in the literature. The outdoor:indoor biting ratios are, however, slightly misleading due to the two-hour duration of the paired collections. To gain insight into the indoor/outdoor biting ratios, all-night collections are preferable. The two-hour collections do give some indication of early evening biting behavior but the pattern of biting may change throughout the night. All-night collections conducted in the village of Rancho show a much stronger indoor biting activity for An. vestitipennis (Chapter 6) where as the two-hour collections show a less endophagic biting behavior. This emphasizes the need for doing all-night collections when trying to evaluate behavioral patterns based on spatial and temporal parameters.

The larval collections of An. vestitipennis confirm findings in the literature which state that this species is a flooded forest species. The highest larval densities of this mosquito occurred during the rainy season in low-lying areas beneath a heavy forest canopy. During the dry season these same waters, although present, became muddied and polluted making them inhospitable to mosquito larvae. Periods of high larval population densities also coincided with high adult populations as determined by human landing collections. This same seasonal pattern is also characteristic of An. punctimacula. High larval populations occur during the wet season in heavily shaded flooded forests and drop off drastically during the dry season when these areas become fouled or dry out.

Anopheles darlingi exhibits an unusual pattern of behavior that has been shown to occur in other regions of its range. This species has demonstrated preferences for

breeding in riverine environments. Rozendaal (1992) suggested that this species occurs in high population densities at various times of the year due to flow dynamics of the river with which it is associated. In coastal areas this species occurs during the wet season in flooded regions adjacent to the river. In forested areas where the river dynamics provide a more severe flushing action, this species occurs during the dry season when river flow declines and breeding sites are exposed by low river levels. This appears to be the case with *An. darlingi* in Belize. At Golden Stream, the high densities of *An. darlingi* occur during the dry season when the rivers are at their lowest levels. Numerous larval collections conducted at Golden Stream yielded only small numbers of *An. darlingi* larvae. Those that were collected came during the months between the wet and dry season and occurred in small pools 10 to 15 meters from the river.

The high adult population levels of *An. darlingi* during the dry season suggested that their breeding site is in close association with river levels. Golden Stream River is a narrow river with steep sloping sides. During the rainy season the flow of the river is high and fast. The torrential rains, which occur on a nightly basis, flood the surrounding area but generally drain into the river within 24 hours. This continuous flooding and draining throughout the rainy season creates a constant flushing action which washes larvae from their breeding sites. The low river levels which occur during the dry season may expose breeding sites along the margin of the river that are normally flushed out when river levels are high. This phenomenon may not occur in other areas of Belize where flow dynamics of the larger rivers (e.g. Belize River, Rio Hondo etc.) are different. Additional studies are needed in order to determine the preferred breeding sites of this

important vector species. This would entail a thorough sampling of a variety of river systems throughout the country of Belize.

By graphing the population densities of the adult populations in conjunction with the occurrence of malaria at the same site, it is clear that the highest levels of malaria in Golden Stream occur when *An. darlingi* population densities are low. The converse can be said for *An. albimanus*, *An. punctimacula* and *An. vestitipennis*. The three species breed in flooded areas which are more prevalent during the rainy season. Although high levels of malaria in Golden Stream village coincide with high levels of these species, results of the ELISA performed on the mosquitoes collected indicate that only 3 *An. vestitipennis* and 1 *An. darlingi* tested positive for *P. vivax*. No pools of *An. albimanus* collected from Golden Stream tested positive for malaria infection. The fact that the adult population levels of *An. vestitipennis* show strong correlation with malaria transmission and that this species tested positive for sporozoites during times of transmission indicates that this species plays a greater role in malaria transmission in southern Belize than previously believed.

At the Rancho site it is not possible to make any conclusions regarding *An. darlingi* due to the low numbers (total of 5) which were collected. It is possible, however, to show an association between heavy rain and high populations of both *An. vestitipennis* and *An. punctimacula*. These correlations occur only when collection times are adjusted by 3 weeks to account for larval development. This most likely reflects the production of adequate breeding sites in the form of flooded forests, which are favored by both of these species. These primary breeding sites disappear during the dry season resulting in the low adult collections for these two species.

Populations of An. albimanus show moderate densities throughout the wet season but increase dramatically during the dry season. This is most likely due to the wet rice production, which is practiced during this time period approximately 1000 meters from the study site. This issue is of some concern to the country of Belize which is testing the prospect of increasing wet rice field production. Because An. albimanus is a suspected vector of malaria when it occurs in high densities, expansion of wet rice would greatly increase the breeding habitat for this species. This is borne out by the collection of large numbers of larval An. albimanus from these fields during the dry season when the majority of breeding sites has dried.

There are two population peaks of Anopheles albimanus, which occur during the year. One is associated with a period of time after the heavy rains when natural breeding sites are available in many different types of settings. The second peak, however, occurs during the latter part of the dry season when most, if not all, of these sites have dried. In the process of collecting larvae for colonization attempts, a number of larval collections were made in and around the Rancho site. Throughout the wet season, small numbers of An. albimanus were collected from a variety of habitats to include marshy depressions, road-side ditches, water filled canoes and flooded fields. During the dry season, however, most of these sites were dry. However, large numbers of larvae were collected from wet rice fields, which were approximately 1000 yards from the adult collection site.

The importance of wet rice fields can be noted in the relatively low numbers of An. albimanus found in other regions of the Toledo district during the same period of time. In the case of a competent vector, such changes in seasonal abundance could potentially lead to focal outbreaks of malaria transmission. Creation of year round

breeding sites through increased rice cultivation may also provide a means of maintaining malaria transmission at a low level in the area with a mosquito species that has proven to be a poor vector except when it occurs in high population densities, such as An. albimanus.

When examining data from the Rancho site it is important to look at the differences between the established huts that had a previous spray history and the experimental huts which had not been sprayed. By looking at the differences in the outdoor and indoor proportions it is clear that the unsprayed experimental huts had a much higher proportion of An. vestitipennis biting indoors than out of doors (1:0.73). This is true even of houses that had not been sprayed in over a year (1:0.32). The residual effect of the DDT, remained in the huts and continued to exert a repellent effect that deterred house entering activity months after the last spray cycle. This is an important concept because there is a misconception in the literature that the malaria vectors in the Americas do not feed indoors and that malaria transmission mainly occurs outdoors. These studies are, however, typically conducted in areas where the houses have a previous spray history, and mosquitoes are deterred from entering the house. The other species collected during this study all demonstrated a much greater outdoor biting behavior at huts that have, at some point, been sprayed. The overall O:I ratio for An. albimanus at sprayed houses is 1:0.27, where as, at unsprayed houses it is 1:0.34. This same phenomenon can also be shown for An. punctimacula (1:0.22 - sprayed; 1:0.38 - unsprayed). This clearly demonstrates that the sprayed surfaces (all were sprayed with DDT) continue to exhibit a repellency effect on host-seeking mosquitoes 1 year past the date of spraying.

An. vestitipennis demonstrated a much higher MFIR than the other mosquitoes collected in this study. This is particularly true of the mosquitoes collected at the Golden Stream site. A total of 3 samples tested positive for P. vivax resulting in an MFIR of 0.011 from this site. This is equivalent to 3 mosquitoes out of 292 An. vestitipennis collected. The more revealing aspect of these data is that 2 of 3 positive samples came from indoor collections. For an area of low malaria endemicity, this level of infection in mosquito populations is very high. Anopheles vestitipennis was the only species to test positive for P. vivax at the Rancho site. Only one pool tested positive, resulting in the low MFIR of 0.0004 and these specimens came from an outdoor collection. This is essentially one infected mosquito out of 6962 An. vestitipennis tested.

In conclusion, these data improve our understanding of the role that An. vestitipennis has in the transmission of malaria in Belize, Central America. Both this study and previous studies (Achee et al. 2000) show An. vestitipennis populations to be naturally infected with P. vivax and to have higher MFIRs than other species. Fifty percent of all infected An. vestitipennis mosquitoes were collected indoors. High population densities of An. vestitipennis correlate with high levels of P. vivax malaria. This information incriminates An. vestitipennis as an important and competent vector of malaria in southern Belize. These data also show that An. albimanus had O:I ratios that clearly demonstrate the exophagic behavior of this species. In addition, a very low MFIR (one mosquito from an outdoor collection) for this species in regards to P. vivax suggests a weak vector role for this species in southern Belize. Further more, Kumm and Ram in 1941 found sporozoites in only An. vestitipennis and An. darlingi in the country of Belize. Anopheles albimanus clearly has the potential for being an amplifying vector, but

it appears that the majority of malaria transmission is occurring due to vectors such as An. vestitipennis and An. darlingi.

References Cited

- Achee, N.L., C.T. Korves, M.J. Bangs, E. Rejmankova, M. Lege, D. Curtin, H. Lenares, Yvette Alonzo, R.G. Andre, and D.R. Roberts. 2000. Plasmodium vivax polymorphs and Plasmodium falciparum circumsporozoite proteins in Anopheles (Diptera: Culicidae) from Belize, C.A. J. Vect. Ecology.
- Arredondo-Jimenez, J.I., M.H. Gimnig, M.H. Rodriguez, and R. K. Washino. 1996. Genetic differences among Anopheles vestitipennis subpopulations collected using different methods in Chiapas state, southern Mexico. J. Am. Mosq. Contr. Assoc. 12: 396-401.
- Arruda, M., M.B. Carvalho, R.S. Nussenzweig, M. Maracic, A.W. Ferreira and A.H. Cochrane. 1986. Potential vectors of malaria and their different susceptibility to Plasmodium falciparum and Plasmodium vivax in northern Brazil identified by immunoassay. Am. J. Trop. Med Hyg 35: 873-881.
- Bangs, M.J. 1999. The susceptibility and behavioral response of Anopheles albimanus Weidemann and Anopheles vestitipennis Dyar and Knab (Diptera: Culicidae) to insecticides in northern Belize. Ph.D. Thesis, Uniformed Services University of the Health Sciences, Bethesda, Maryland. 489 pp.
- Beach, R.F., C. Cordon-Rosales, E. Molina, and A. Wirtz. 1992. Field evaluation of an enzyme-linked immunosorbent assay for estimating the sporozoite rate in Anopheles albimanus. Am. J. Trop. Med. Hyg. 47: 478-483.

- Beier, J.C., P.V. Perkins, R.A. Wirtz, R.E. Whitmire, M. Mugambi and W.T. Hockmeyer. 1987. Field evaluation of an enzyme-linked immunosorbent assay (ELISA) for Plasmodium falciparum sporozoite detection in anopheline mosquitoes from Kenya. *Am. J. Trop. Med. Hyg.* 36: 459-468.
- Berti, A.L. and M. Montesinos. 1946. Cultivo de arroz en relacion con la malaria, el problema de Venezuela. III Conferencia Interamericana de Agricultura. Vargas, Caracas.
- Bonne, C. and Bonne-Webster, J. 1925. Mosquitoes of Surinam. Mede. K. Vereen. Indisch. Inst. Amst. No. 21. 558 pp. Afd. Trop. Hyg. No. 13.
- Boyd, M.F. 1949. Epidemiology factors related to the definitive host. In: *Malariology*, Boyd, M.F. (Editor). Philadelphia: W.B. Saunders, pp. 608-697.
- Breeland, S. 1980. A bibliography to the literature of Anopheles albimanus (Diptera:Culicidae). *Mosq. Syst.* 12: 50-150.
- Bruce-Chwatt, L.J. 1985. *Essential malariology*, 2nd ed. John Wiley&Sons, New York.
- Brown, A.W.A. 1958. Laboratory studies on the behavioural resistance of Anopheles albimanus in Panama. *Bull. Wld. Hlth. Organ.* 30: 97-111.
- Bruyning, C.F.A. 1952. Some observations on the distributions of A. darlingi Root in the savanna region of Surinam. *Documenta Med. Geogr. Trop.* 4: 171-174.
- Causey, O.R., L.M. Deane and M.P. Deane. 1946. Studies on Brazilian anophelines from the Northeast and Amazon Regions. *Am. J. Hyg.* 18.
- Chadee, D.D. 1994. Seasonal abundance, biting cycle, and parity of the mosquito Anopheles homunculus in Trinidad, West Indies. *J. Am. Mosq. Control Assoc.* 10: 522-526.

- Chambers, D.M., C.D. Steelman and P.E. Schilling. 1981. The effect of cultural practices on mosquito abundance and distribution in the Louisiana riceland ecosystem. *Mosq. News* 41: 233-240.
- Chareonviriyaphap, T., D.R. Roberts, R.G. Andre, H.H. Harlan, S. Manguin and M.J. Bangs. 1997. Pesticide avoidance behavior in Anopheles albimanus, a malaria vector in the Americas. *J. Am. Mosq. Control Assoc.* 13: 171-183.
- Charlwood, J.D. 1980. Observations on the bionomics of Anopheles darlingi Root (Diptera: Culicidae) from Brazil. *Bull. Entomol. Res.* 70: 685-692.
- Clark-Gil, S. and R.F. Darsie. 1983. The mosquitoes of Guatemala. *Mosq. Syst.* 15(3): 1-284.
- Collins, F.H. and S.M. Paskewitz. 1995. Malaria: current and future prospects for control. *Annu. Rev. Entomol.* 40: 195-219.
- Collins, F.H., F. Zavala, P.M. Graves, A.H. Cochrane, R.W. Gwadz, J. Akoh and R.S. Nussenzweig. 1984. First field trial of an immunoradiometric assay for the detection of malaria sporozoites in mosquitoes. *Am. J. Trop. Med. Hyg.* 33: 538-543.
- Davis, N.C. 1931. A note on the malaria-carrying anophelines in Belem, Para, and in Natal, Rio Grande do Norte, Brazil. *Riv. Malar.* 10: 1-11.
- Deane, L.M., O.R. Causey and M.P. Deane. 1946. An illustrated key by adult female characteristics for identification of thirty-five species of Anophelini from Northeast and Amazon regions of Brazil with notes on the malaria vectors (Diptera:Culicidae). *Am. J. Hyg.* 18: 1-18.

- Deane, L.M. 1988. Malaria studies and control in Brazil. *Am. J. Trop. Med. Hyg.* 38: 223-230.
- Elliott, R. 1972. The influence of vector behavior on malaria transmission. *Am. J. Trop. Med. Hyg.* 21: 755-763.
- Faran, M.E. 1980. Mosquito studies (Diptera: Culicidae) 34. A revision of Albimanus section of the subgenus Nyssorhynchus of Anopheles. *Contrib. Am. Entomol. Inst.* 15: 1-215.
- Ferraroni, J.J. and J. Hayes. 1979. Drug-resistant falciparum malaria among the Mayongong Indians in the Brazilian Amazon. *Am. J. Trop. Med. Hyg.* 1979. 28: 909-911.
- Fleming, G. 1986. Biology and Ecology of Malaria Vectors in the Americas. *J. Pan Am. Hlth. Org. PNSP/86-72.*
- Flores-Mendoza, C. and R. Lourenco-de-Oliveira. 1996. Bionomics of Anopheles aquasalis Curry 1932, in Guarai, State of Rio de Janeiro, southeastern Brazil I. Seasonal distribution and parity rates. 91: 265-270.
- Frederikson, E.C. 1993. Bionomics and control of Anopheles albimanus. Tech. Paper 34. Pan Am. Hlth. Organ. Washington, D.C. 76pp.
- Gabalton, A. 1952. The effect of DDT on the population of anopheline vectors in Venezuela. *Riv. Parasitol.* 13:29-41.
- Giglioli, G. 1951. Eradication of Anopheles darlingi from the inhabited areas of British Guiana by DDT residual spraying. *J. Nat. Malaria Soc.* 10: 142-161.
- Gillies, M.T. and M. Coetzee. 1987. A supplement to the Anophelinae of Africa south of the Sahara (Afrotropical region). 2nd ed. S. Afr. Inst. Med. Res. Publ. 54.

- Grieco, J.P., N.L. Achee, R. Andre and D.R. Roberts. 2000. A comparison study of the house entering and exiting behavior of An. vestitipennis (Diptera:Culicidae) before and after spraying with DDT and Deltamethrin in the southern district of Toledo, Belize, C.A. *J. Vec. Ecology*. 25: 62-73.
- Harbach, R.E. 1994. review of the internal classification of the genus Anopheles (Diptera:Culicidae): the foundation for comparative systematics and phylogenetic research. *Bull. Entomol. Res.* 84: 331-342.
- Hecht, O and J. Hernandez. 1960. Resena de las investigaciones sobre la irritacion de Anofelinos por el contacto con superficies cubiertas con DDT. [Review of investigations on the irritation of anopheles mosquitoes by contact with DDT-treated surfaces.] *Bol. Com. Nac. Errad. Paludismo*. 4: 93-106.
- Hudson, J.E. 1984. Anopheles darlingi Root (Diptera:Culicidae) in the Suriname rain forest. *Bull. Entomol. Res.* 74: 129-142.
- Klein, T.A., B.A. Harrison, S.V. Dixon and J.R. Burge. 1991a. Comparative susceptibility of southeast Asian Anopheles mosquitoes to the simian malaria parasite Plasmodium cynomolgi. *J. Am. Mosq. Control Assoc.* 7: 481-487.
- Klein, T.A., J.B.P. Lima and M.S. Tada. 1991b. Comparative susceptibility of anopheline mosquitoes to Plasmodium falciparum in Rodonia, Brazil. *Am. J. Trop. Med. Hyg.* 44: 598-603.
- Klein, T.A. M.S. Tada and J.B.P. Lima. 1991c. Infection of Anopheles darlingi fed on patients with Plasmodium falciparum before and after treatment with quinine or quinine plus tetracycline. *Am. J. Trop. Med. Hyg.* 44: 604-608.

- Klein, T.A. M.S. Tada, J.B.P. Lima and T.H. Katsuragawa. 1991d. Infection of Anopheles darlingi fed on patients with Plasmodium vivax before and after treatment with chloroquine in Costa Marques, Rondonia, Brazil. *Am. J. Trop. Med. Hyg.* 45: 471-478.
- Klein, T.A. and J.B.P. Lima. 1990. Seasonal distribution and biting patterns of Anopheles mosquitoes in Costa Marques, Rondonia, Brazil. *J. Am. Mosq. Control Assoc.* 6: 700-707.
- Kramer, V.L. and R. Garcia. 1989. An analysis of factors affecting mosquito abundance in California wild rice fields. *Bull. Soc. Vector Ecol.* 14: 87-92.
- Kumm, H.W. and L.M. Ram. 1941. Observations on the Anopheles of British Honduras. *Am. J. Trop. Med.* 21: 559-566.
- Lacey, L.A. and C.M. Lacey. 1990. The medical importance of riceland mosquitoes and their control using alternatives to chemical insecticides. *J. Am. Mosq. Control. Assoc. Suppl.* 2. pp. 1-93.
- Lourenco-de-Oliveira, R. 1989. Some observations on the mosquitoes of Indian settlements in Xingu National Park, Mato Grosso State, Brazil, with emphasis on malaria vectors. *Rev. Bras. Biol.* 49: 393-397.
- Loyola, E.G., J.I. Arredondo, M.H. Rodriguez, D.N. Broqn and M.A. Vaca-Marin. 1991. Anopheles vestitipennis, the probable vector of Plasmodium vivax in the Lacadon forest of Chiapas, Mexico. *Trans. R. Soc. Trop. Med. Hyg.* 85: 171-174.
- Manguin, S., D.R. Roberts, R.G. Andre, E. Rejmankova, and S. Hakre. 1996. Characterization of Anopheles darlingi (Diptera:Culicidae) larval habitats in Belize, Central America. *J. Med. Entomol.* 33: 205-211.

- Marquetti, M., A. Navarro, J. Bisset and F.A. Garcia. 1992. Comparison of three catching methods for collecting anopheline mosquitoes. Mem. Inst. Oswaldo Cruz Rio J. 87: 457-458.
- Mekuria, Y., R. Granados, M.A. Tidwell, D.C. Williams, R.A. Wirtz and D.R. Roberts. 1991. Malaria transmission potential by Anopheles mosquitoes of Dajabon, Dominican Republic. J. Am. Mosq. Control. Assoc. 7: 456-461.
- Merritt, R.W. and K.W. Cummins. 1996. An introduction to the aquatic insects of North America. Kendall/Hunt Publishing Company, Dubuque, Iowa, USA. 862pp.
- Mogi, M. 1978. Population studies on mosquitoes in the rice field area of Nagasaki, Japan, especially on Culex tritaeniorhynchus. Trop. Med. 20: 173-263.
- Mogi, M. 1979. Dispersal of Culex tritaeniorhynchus larvae (Diptera:Culicidae) by water currents in rice fields. Trop. Med. 21: 115-126.
- Molez, J.F., P. Desenfant and J.R. Jacques. 1998. Bioecology in Haiti of Anopheles albimanus Wiedemann, 1820 (Diptera: Culicidae). Bull. Soc. Pathol. Exot. 91: 334-339.
- Mukiama, T.K. and R.W. Mwangi. 1989. Seasonal population changes and malaria transmission potential of Anopheles pharoensis and the minor anophelines in Mwea Irrigation Scheme, Kenya. Acta Trop. 46: 181-189.
- Olson, J.K. and C.L. Meek. 1980. Variations in the egg horizons of Psorophora columbiae on levees in Texas ricelands. Mosq. News 40: 55-56.
- Orr, B.K. and V.H. Resh. 1989. Experimental test of the influence of aquatic macrophyte cover on the survival of Anopheles larvae. J. Am. Mosq. Control Assoc. 5: 579-585.

- Padilla, N., P. Molina, J. Juarez, D.M. Brown and C. Cordon-Rosales. 1992. Potential malaria vectors in northern Guatemala. *J. Am. Mosq. Control Assoc.* 8: 307-308.
- Panday, R.S. 1980. Medical entomological aspects of the malaria problem in Surinam. *Surinaams Medisch. Bull.* 3: 52-58.
- Prakash, A., D.R. Bhattacharyya, P.K. Mohapatra and J. Mahanta. 1997. Seasonal prevalence of Anopheles dirus and malaria transmission in a forest fringed village of Assam, India. *Indian J. Malariol.* 34: 117-125.
- Quinones, M.L. and M.F. Suarez. 1989. Irritability to DDT of natural populations of the primary malaria vectors in Colombia. *J. Am. Mosq. Control Assoc.* 5: 56-59.
- Ramsey, J.M., E. Salinas, D.M. Brown and M.H. Rodriguez. 1994. Plasmodium vivax sporozoite rates from Anopheles albimanus in southern Chiapas, Mexico. *J. Parasitol.* 80: 489-493.
- Rattarithikul, R., K.J. Linthicum and E. Konishi. 1996. Seasonal abundance and parity rates of Anopheles species in southern Thailand. *J. Am. Mosq. Control Assoc.* 12: 75-83.
- Rejmankova, E., D.R. Roberts, R.E. Harbach, J. Pecor, E.L. Peyton, S. Manguin, R. Krieg, J. Polanco and L. Legters. 1993. Environmental and regional determinants of Anopheles larval distribution in northern Belize. *Environ. Entomol.* 22: 978-992.
- Rejmankova, E., D.R. Roberts, A. Pawley, S. Manguin and J. Polanco. 1995. Predictions of adult Anopheles albimanus densities in villages based on distances to remotely sensed larval habitats. *Am. J. Trop. Med. Hyg.* 53: 482-488.

- Rejmankova, E., K.O. Pope, D.R. Roberts, M.G. Lege, R. Andre, J. Greico, and Y. Alonzo. 1998. Characterization and Detection of Anopheles vestitipennis and Anopheles punctimacula (Diptera: Culicidae) larval habitats in Belize with field survey and SPOT satellite imagery. *J. Vector Ecol.* 23: 74-88.
- Roberts, D.R., W.D. Alecrim, P. Hshieh, J.P. Grieco, M. Bangs, R.G. Andre and T. Chareonviriphap. 2000. A probability model of vector behavior: effects of DDT repellency, irritancy and toxicity in malaria control. *J. Vector Ecol.*
- Roberts, D.R. and R. Andre. 1994. Insecticide resistance issues in vector-borne disease control. *J. Am. Trop. Med. Hyg.* 50: 21-34.
- Roberts, D.R., O. Chan, J. Pecor, E. Rejmankova, S. Manguin, J. Polanco and L.J. Legters. 1993. Preliminary observations on the changing roles of malaria vectors in southern Belize. *J. Am. Mosq. Control Assoc.* 9: 456-459.
- Roberts, D.R., W.D. Alecrim, A.M. Tavares and M.G. Radke. 1987. The house frequenting, host-seeking and resting behavior of Anopheles darlingi in southeastern Amazonas, Brazil. *J. Am. Mosq. Control Assoc.* 3: 433-441.
- Rosenberg, R., R.A. Wirtz, D.E. Lanar, J. Sattabongkot, T. Hall, A. P. Waters and C. Prasittisuk. 1989. Circumsporozoite protein heterogeneity in the human malaria parasite Plasmodium vivax. *Science.* 245: 973-976.
- Rozendaal, J.A. 1987. Observations on the biology and behaviour of anophelines in the Suriname rainforest with special reference to Anopheles darlingi Root. *Cah. ORSTOM, Ser. entomol. Med. Parasitol.* 25: 33-43.

- Rozendaal, J.A., J.P.M. van Hoof, J. Voorham and B.F.J Oostburg. 1989. Behavioral responses of Anopheles darlingi in Suriname to DDT residues on house walls. J. Am. Mosq. Control Assoc. 5: 339-350.
- Rozendaal, J. A. 1990. Observations on the distribution of anophelines in Suriname with particular reference to the malaria vector Anopheles darlingi. Mem. Inst. Oswaldo Cruz. 85: 221-234.
- Rozendaal, J. A. 1992. Relations between Anopheles darlingi breeding habitats, rainfall, river level and malaria transmission rates in the rain forest of Suriname. Med. Vet. Entomol. 6: 16-22.
- Savage, H.M., E. Rejmankova, J.I. Arredondo-Jimenez, D.R. Roberts and M.H. Rodriguez. 1990. Limnological and botanical characterization of larval habitats for two primary malaria vectors, Anopheles albimanus and An. pseudopunctipennis, in coastal areas of Chiapas State Mexico. J. Am. Mosq. Control Assoc. 6: 612-620.
- Sarkar, S., and M.K. Pramanik. 1996. Seasonal prevalence of common anophelines in Sugar Island. Indian J. Malariol. 33: 154-158.
- Shililu, J.I., W.A. Maier, H.M. Seitz and A.S. Orago. 1998. Seasonal density, sporozoite rates and entomological inoculation rates of Anopheles gambiae and Anopheles funestus in a high-altitude sugarcane growing zone in Western Kenya. Trop. Med Int Health. 3: 706-710.
- Surtees, G. 1975. Mosquitoes, arboviruses and vertebrates. In: Man-made lakes and human health, N.F. Stanley and M.P. Alpers (Eds.), Academic Press, London. pp 21-34.

- Szumlas, D.E., C.S. Apperson and E.E. Powell. 1996. Seasonal occurrence and abundance of Aedes triseriatus and other mosquitoes in a La Crosse virus-endemic area in western North Carolina. *J. Am. Mosq. Assoc.* 12: 184-193.
- Tadei, W.P., B.D. Thatcher, J.M. Santos, V.M. Scarpassa, I.B. Rodrigues and M.S. Rafael. 1998. Ecological observations on anopheline vectors of malaria in the Brazilian Amazon. *Am. J. Trop. Med. Hyg.* 59: 325-335.
- Torres, E.P., N.P. Salazar, V.Y. Belizario, and A. Saul. 1997. Vector abundance and behaviour in an area of low malaria endemicity in Bataan, the Philippines. *Acta Trop.* 63: 209-220.
- Van der Kuyp, E. 1950. Contributions to the study of the malarial epidemiology in Surinam. *Afd. Trop. Hyg.* 18: 146pp.
- Wilkerson, R.C. and D. Strickman. 1990. Illustrated key to the female anopheline mosquitoes of Central America and Mexico. *J. Am. Mosq. Assoc.* 6: 7-33.
- Wirtz, R.A., T.R. Burkot, R.G. Andre, R. Rosenberg, W.E. Collins and D.R. Roberts. 1985. Identification of Plasmodium vivax sporozoites in mosquitoes using an enzyme-linked immunosorbent assay. *Am. J. Trop. Med. Hyg.* 34: 1048-1054.
- World Health Organization. 1975. Manual on Practical Entomology in Malaria, Part II, WHO Offset Publ. No. 13, Geneva. 191 pp.

Table 1: Total number of adult anophelines collected in adult landing collections in Belize presented by species, by village and by location (I=Indoor collection and O=Outdoor collection). Collections conducted at Rancho were done over a 17 month time span (July 1997-December 1998), all other locations were sampled for 12 months (July 1997-June 1998).

Location	An. albimanus	An. apicimacula	An. darlingi	An. gabaldoni	An. punctimacula	An. vestitipennis
	I O	I O	I O	I O	I O	I O
Rancho	115 361	26 164	2 3	2 12	106 217	2165 4797
Golden Stream	241 613	2 162	356 664	0 34	10 205	82 210
Big Falls	17 40	0 0	0 0	0 0	3 18	1 5
Indian Creek	1 9	0 1	4 17	0 0	2 5	6 12
Esso Landing	87 164	3 18	0 0	0 0	0 35	37 64
Punta Gorda	15 73	1 4	0 0	0 0	3 7	16 45
Total:	476 1260	32 349	362 684	2 48	124 487	2339 5193

Table 2: Total number of adult anophelines collected during two hour adult landing collections at Rancho Village in Belize and displayed by month in which they were collected. Collections were conducted during a 17-month period from July 1997 to November 1998.

Species	J-97	A-97	S-97	O-97	N-97	D-97	J-98	F-98	M-98	A-98	M-98	J-98	J-98	A-98	S-98	O-98	N-98	D-98	Total	
Rancho																				
<i>An. albimanus</i>	2	5	67	12	28	23	11	53	43	65	103	41	6	2	7	4	0	4	476	
<i>An. apicimacula</i>	0	0	5	7	40	68	30	15	2	14	2	0	0	4	0	3	0	0	190	
<i>An. darlingi</i>	0	0	0	1	0	1	0	1	1	1	0	0	0	0	0	0	0	0	5	
<i>An. gabaldoni</i>	0	0	0	0	3	5	2	0	0	0	0	0	0	2	0	2	0	0	14	
<i>An. neivei</i>	0	0	0	0	0	0	0	0	0	1	0	0	0	0	0	0	0	0	1	
<i>An. punctimacula</i>	0	13	25	2	38	30	14	20	10	21	2	0	0	52	38	65	28	24	323	
<i>An. vestitipennis</i>	37	94	681	433	2095	1917	341	398	99	1	0	9	0	292	138	1228	139	401	6962	

Table 4: Average number of larvae collected per 30 dips per habitat type from locations adjacent to the Rancho site in Belize. Collections were made from November of 1997 to July of 1998.

Average number of anopheline larvae collected per dip ^a									
Species	NOV-97	DEC-97	JAN-98	FEB-98	MAR-98	APR-98	MAY-98	JUN-98	JUL-98
Rice Field									
<i>An. albimanus</i>	2.3	1.4	3.2	4.7	14.3	18.4	20+	20+	17.4
<i>An. crucians</i>	0	0	0	0	0.03	0.45	0	0	0
Flooded Forest									
<i>An. albimanus</i>	0.6	0.6	0.3	1.0	.13	.27	0	0	.03
<i>An. punctimacula</i>	3.0	2.6	0.3	0	0	0.6	0	0	0
<i>An. vestitipennis</i>	2.4	3.2	1.5	.06	.04	.07	.03	0	.03
Roadside Ditch									
<i>An. albimanus</i>	3.0	.06	.03	.03	0.0	0.0	0.0	0.0	.13
<i>An. punctimacula</i>	.16	.3	0.0	0.0	.03	0.0	0.0	.03	0.0
<i>An. vestitipennis</i>	.63	.6	.27	.16	0.0	0.0	0.0	0.0	0.0
Flooded Field									
<i>An. albimanus</i>	1.7	1.03	.6	0.0	0.0	0.0	0.0	0.0	0.0
Dry Rice Field									
<i>An. albimanus</i>	4.5	5.2	3.3	.06	0	0	0	0	0
<i>An. punctimacula</i>	.20	.20	0	0	0	0	0	0	0

^a Average number of *Anopheles* spp. collected from 30 consecutive dips in a particular habitat type.

Table 5: Spearman's rho values for the 5 main anopheline species collected at Golden Stream Village, Belize in relation to precipitation, river level and *P. vivax* infections.

	Spearman's rho values				
	<i>An. albimanus</i>	<i>An. apicimacula</i>	<i>An. darlingi</i>	<i>An. punctimacula</i>	<i>An. vestitipennis</i>
Precipitation	(0.774;p<0.01)	(0.148;p>0.05)	(-0.587;p<0.05)	(0.467;p>0.05)	(0.573;p<0.05)
River Level	(0.813;p<0.01)	(0.543;p>0.05)	(-0.804;p<0.01)	(0.663;p<0.05)	(0.812;p<0.01)
<i>P. vivax</i>	(0.835;p<0.01)	(0.653;p<0.05)	(-0.728;p<0.01)	(0.792;p<0.01)	(0.905;p<0.01)

Table 6: Spearman's rho values for the 5 main anopheline species collected at Rancho Village, Belize in relation to precipitation, and *P. vivax* infections.

	Spearman's rho values				
	<i>An. albimanus</i>	<i>An. apicimacula</i>	<i>An. darlingi</i>	<i>An. punctimacula</i>	<i>An. vestitipennis</i>
Precipitation	(-0.667;p<0.01)	(-0.139;p>0.05)	(-0.576;p<0.05)	(-0.091;p>0.05)	(0.327;p>0.05) (0.648;p<0.05) ^a
<i>P. vivax</i>	(-0.619;p<0.01)	(-0.503;p>0.05)	(-0.164;p>0.05)	(0.482;p<0.05)	(0.688;p<0.01)

^a Value obtained after adjusting the collection data by 3 weeks to account for the maximum length of time required for larval development.

Table 8: *Plasmodium* infected *Anopheles* detected by ELISA from seasonal field survey conducted from July 1997-June 1998 at Golden Stream Village, Toledo District, Belize.

Species	No. Tested	Number of reactive pools ^a (indoor(I)/outdoor(O)) ^b			Minimum Field Infection Rate (MFIR) ^c
		<i>P. falciparum</i>	<i>P. vivax</i> 210	<i>P. vivax</i> VK247	
<i>An. albimanus</i>	854	0	0	0	0
<i>An. apicimacula</i>	164	0	0	0	0
<i>An. darlingi</i>	1020	0	1(I)	0	0.001
<i>An. eisini</i>	2	0	0	0	0
<i>An. gabaldoni</i>	34	0	0	0	0
<i>An. pseudopunctipennis</i>	1	0	0	0	0
<i>An. punctimacula</i>	215	0	0	0	0
<i>An. vestitipennis</i>	292	0	2(I),1(O)	0	0.01
<i>Chagasia</i> spp.	1	0	0	0	0
TOTAL	2383	0	4	0	

^a 1-10 mosquitoes/pool.

^b All collections were conducted as paired indoor-outdoor collections from 6:00-8:00 p.m. (I) indoor, (O) outdoor.

^c Field-caught specimens were pooled for testing. Overall low infection rates suggest that presence of more than one infected specimen per pool was unlikely. However, since this possibility cannot be excluded, the term infection rate has been replaced with minimum field infection rate (MFIR) i.e. if more than one infected specimen were included in a pool of specimens, then the actual infection rate would be higher than the MFIR estimate.

Table 9: *Plasmodium* infected *Anopheles* detected by ELISA from seasonal field survey conducted from July 1997-November 1998 at Rancho Village, Toledo District, Belize.

Species	No. Tested	Number of reactive pools ^a (indoor(I)/outdoor(O)) ^b			Minimum Field Infection Rate (MFIR) ^c
		<i>P. falciparum</i>	<i>P. vivax</i> 210	<i>P. vivax</i> VK247	
<i>An. albimanus</i>	476	0	0	0	0
<i>An. apicimacula</i>	190	0	0	0	0
<i>An. darlingi</i>	5	0	0	0	0
<i>An. neivai</i>	14	0	0	0	0
<i>An. gabaldoni</i>	217	0	0	0	0
<i>An. punctimacula</i>	323	0	0	0	0
<i>An. vestitipennis</i>	6962	0	1(O)	0	0.0004
TOTAL	8187	0	1	0	

^a 1-10 mosquitoes/pool.

^b All collections were conducted as paired indoor-outdoor collections from 6:00-8:00 p.m. (I) indoor, (O) outdoor.

^c Field-caught specimens were pooled for testing. Overall low infection rates suggest that presence of more than one infected specimen per pool was unlikely. However, since this possibility cannot be excluded, the term infection rate has been replaced with minimum field infection rate (MFIR) i.e. if more than one infected specimen were included in a pool of specimens, then the actual infection rate would be higher than the MFIR estimate.

Table 10: Plasmodium infected Anopheles detected by ELISA from seasonal field survey conducted from July 1997-June 1998 from all other localities in the Toledo District, Belize

Species	No. Tested	Number of reactive pools ^a (indoor(I)/outdoor(O)) ^b			Minimum Field Infection Rate (MFIR) ^c
		<u>P. falciparum</u>	<u>P. vivax</u> 210	<u>P. vivax</u> VK247	
<u>An. albimanus</u>	406	0	0	1(O)	0.002
<u>An. apicimacula</u>	27	0	0	0	0
<u>An. darlingi</u>	21	0	0	0	0
<u>An. gabaldoni</u>	0	0	0	0	0
<u>An. punctimacula</u>	73	0	0	0	0
<u>An. vestitipennis</u>	186	0	0	0	0
TOTAL	713	0	0	1	

^a 1-10 mosquitoes/pool.

^b All collections were conducted as paired indoor-outdoor collections from 6:00-8:00 p.m. (I) indoor, (O) outdoor.

^c Field-caught specimens were pooled for testing. Overall low infection rates suggest that presence of more than one infected specimen per pool was unlikely. However, since this possibility cannot be excluded, the term infection rate has been replaced with minimum field infection rate (MFIR) i.e. if more than one infected specimen were included in a pool of specimens, then the actual infection rate would be higher than the MFIR estimate.

Table 11: Other aquatic insects found in association with *An. albimanus* in wet rice field habitat during larval collections from November 1997 to July 1998.

Order	Family	Genus
Ephemeroptera	Ephemeridae	<i>Heagenia spp.</i> (5)
	Ephemerellidae	unknown (2)
Odonata (Anisoptera)	Aeshnidae	<i>Aeshna spp.</i> (2)
		<i>Coryphaeschna spp.</i> (6)
(Zygoptera)	Gomphidae	unknown (1)
	Coenagrionidae	<i>Acanthagrion spp</i> (3)
Hemiptera	Belostomatidae	unknown (12)
	Macroveliidae	unknown (2)
	Veliidae	<i>Microvelia spp</i> (16)
	Corixidae	<i>Centrocorisa</i> (6)
		<i>Sigara</i> (3)
	Pleidae	unknown (1)
	Notonectidae	<i>Buenoa</i> (2)
		<i>Notonecta</i> (7)
Gelastocoridae	unknown (3)	
Coleoptera	Gyrinidae	<i>Dineutus</i> (3)
	Dytiscidae	<i>Acilius</i> (1)
		<i>Brachyvatis</i> (4)
		<i>Hygrotus</i> (6)
		Unknown (2)
		Unknown (1)
		Unknown (1)
	Hydrophilidae	<i>Derallus</i> (4)
		<i>Berosus</i> (1)
		<i>Tropisternus</i> (15)
	Hydraenidae	unknown (2)
<i>Limnebus</i> (2)		
<i>Ochthebius</i> (1)		

Table 12: Other aquatic insects found in association with An. vestitipennis and An. punctimacula in flooded forest habitat during larval collections from November 1997 to July 1998.

Order	Family	Genus
Odonata		
(Anisoptera)	Aeshnidae	<i>Coryphaeschna spp.</i> (1)
	Libellulidae	<i>Macrothemis spp.</i> (3)
(Zygoptera)	Coenagrionidae	<i>Acanthagrion spp</i> (6) <i>Enallagma spp</i> (4) <i>Ischnura spp</i> (2)
Hemiptera		
	Belostomatidae	unknown (1)
	Corixidae	<i>Centrocorisa</i> (3)
	Notonectidae	<i>Buenoa</i> (1) <i>Notonecta</i> (2)
Coleoptera		
	Gyrinidae	<i>Dineutus</i> (1)
	Dytiscidae	<i>Acilius</i> (3) <i>Brachyvatis</i> (6) <i>Unknown</i> (1)
	Hydrophilidae	<i>Derallus</i> (2) <i>Tropisternus</i> (4) <i>unknown</i> (1)
	Hydraenidae	<i>Limnebus</i> (5)

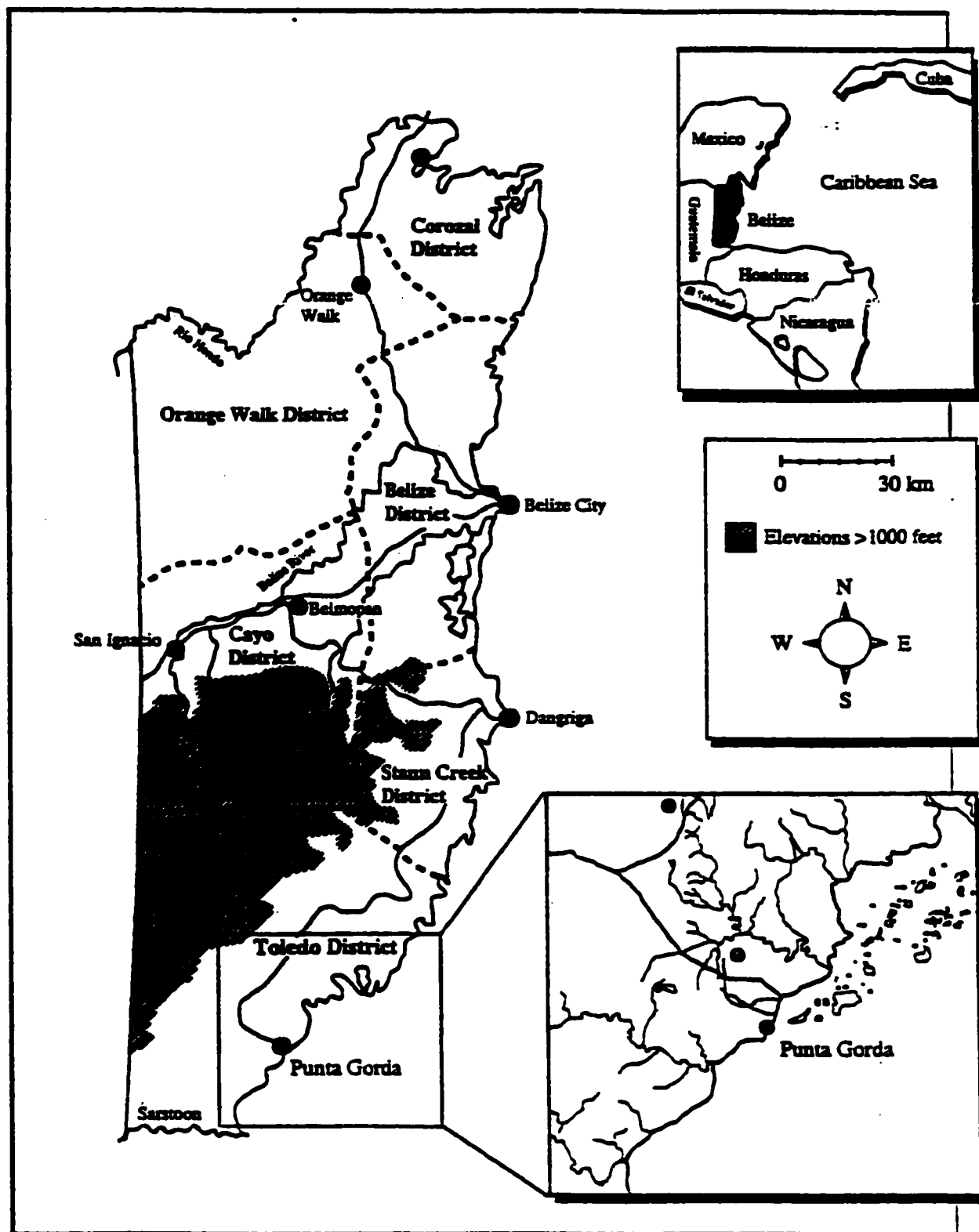
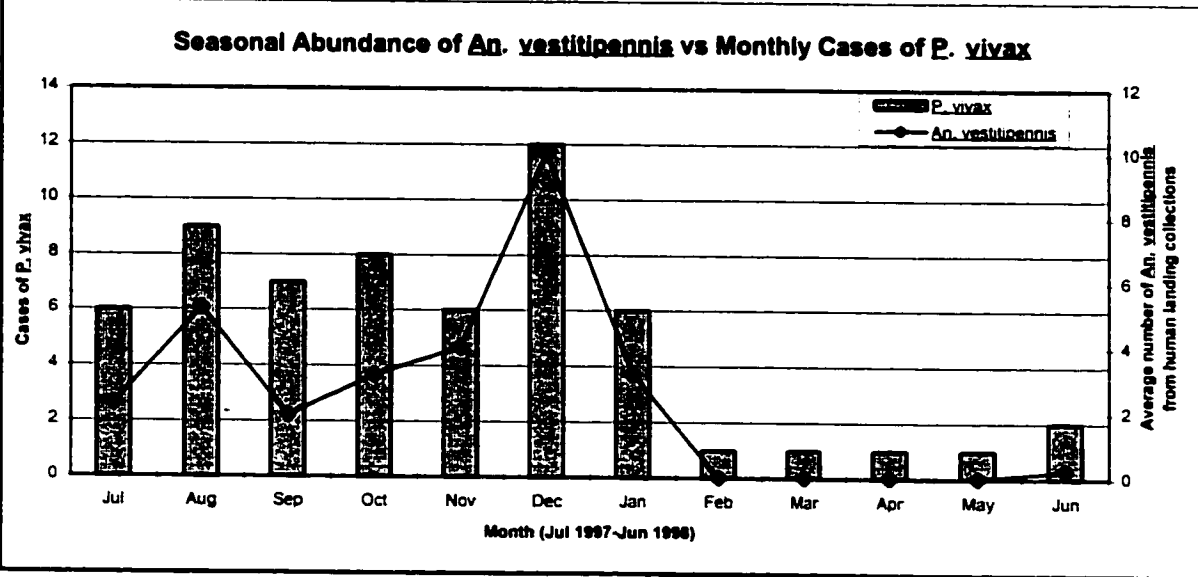
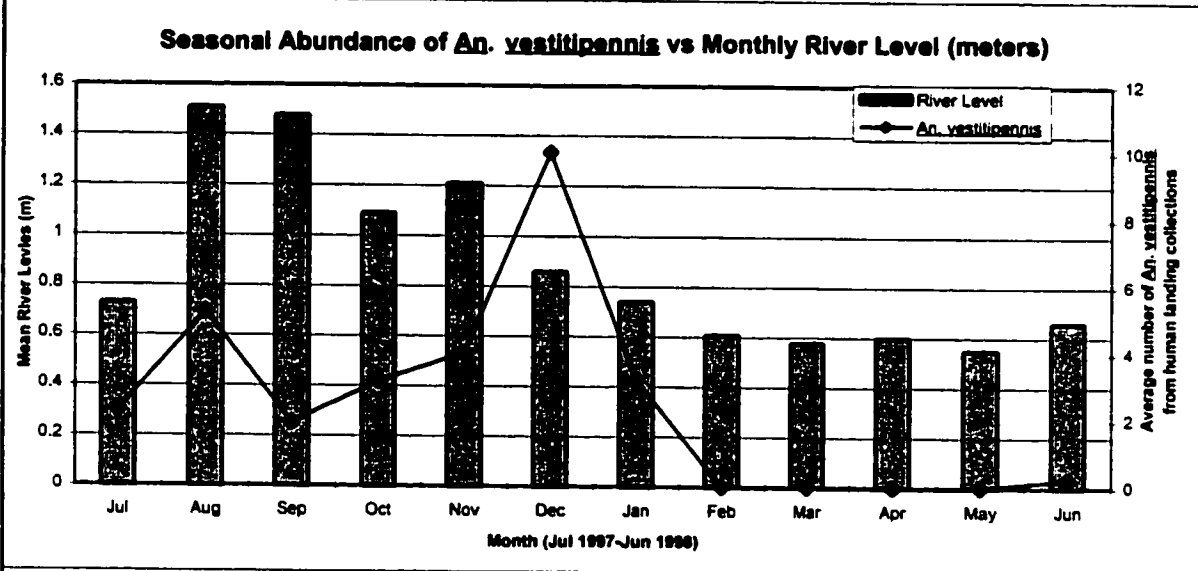
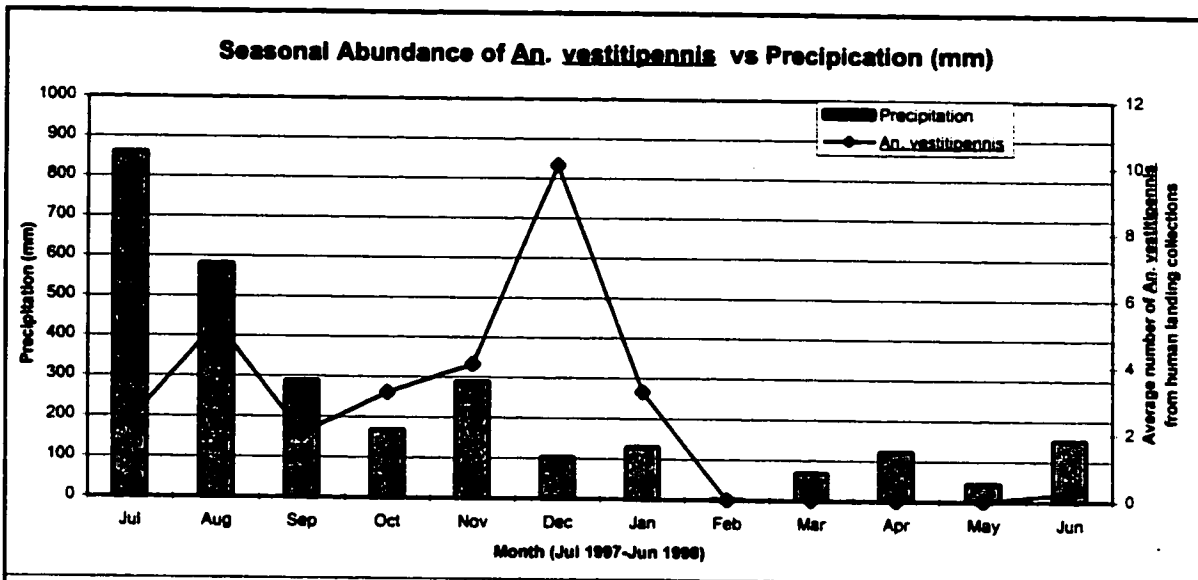
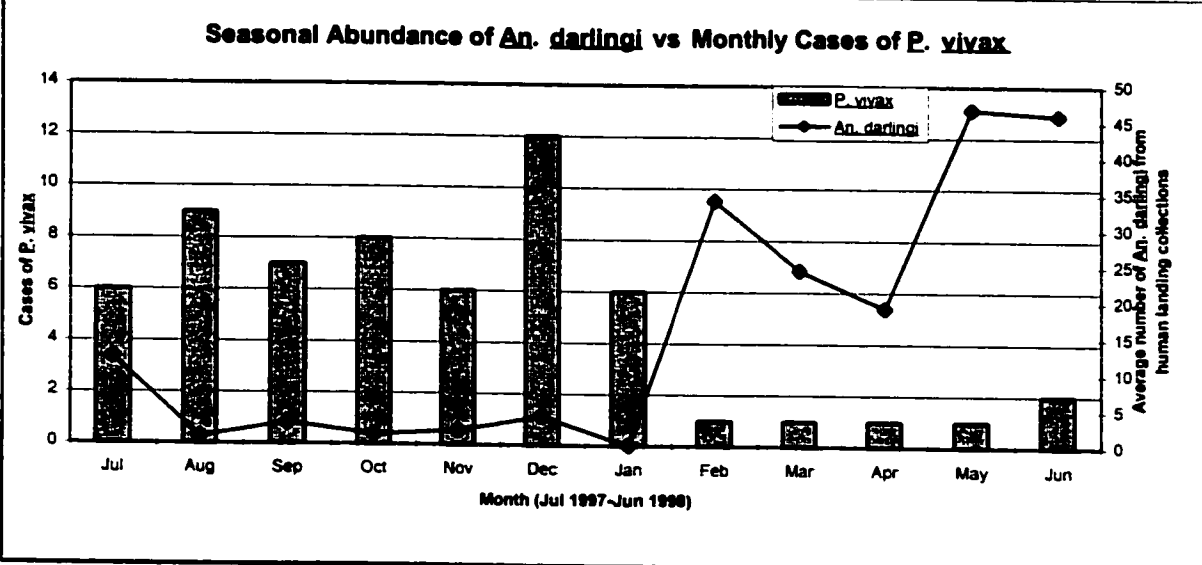
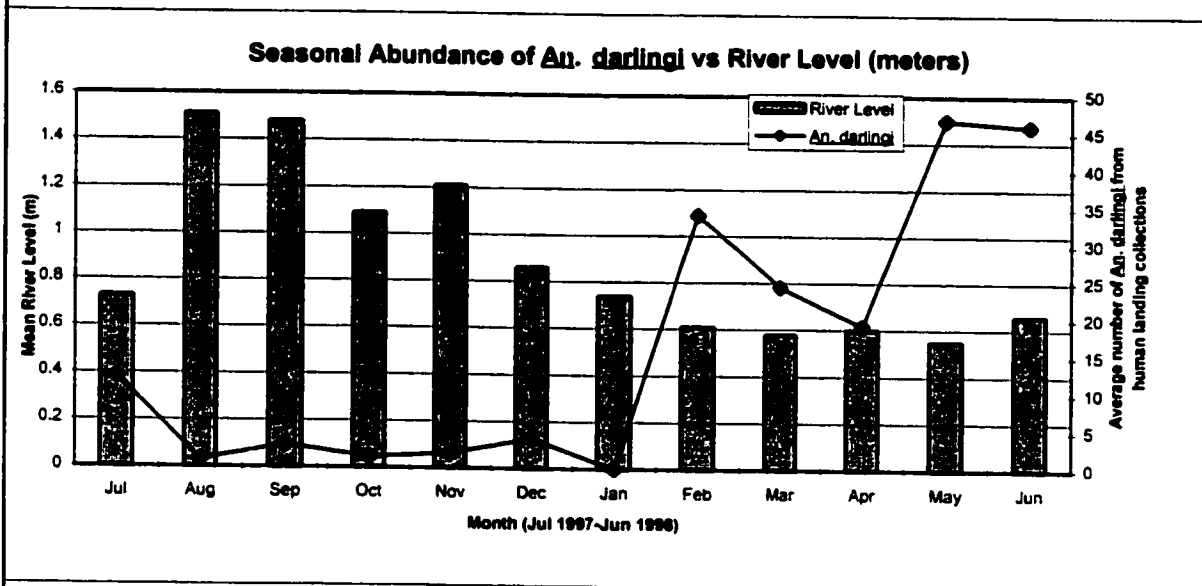
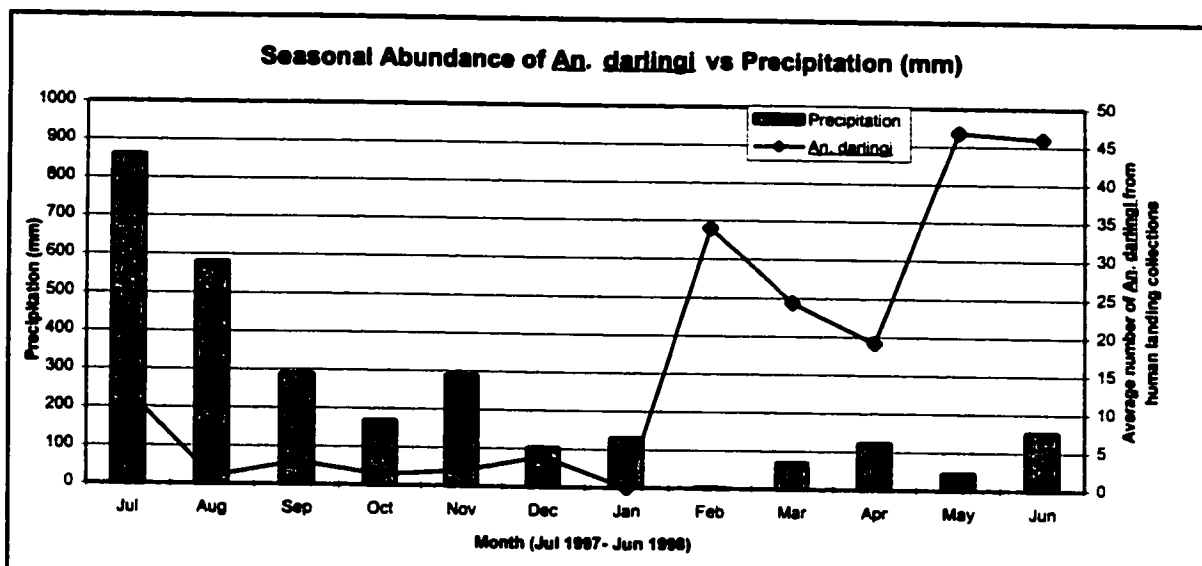
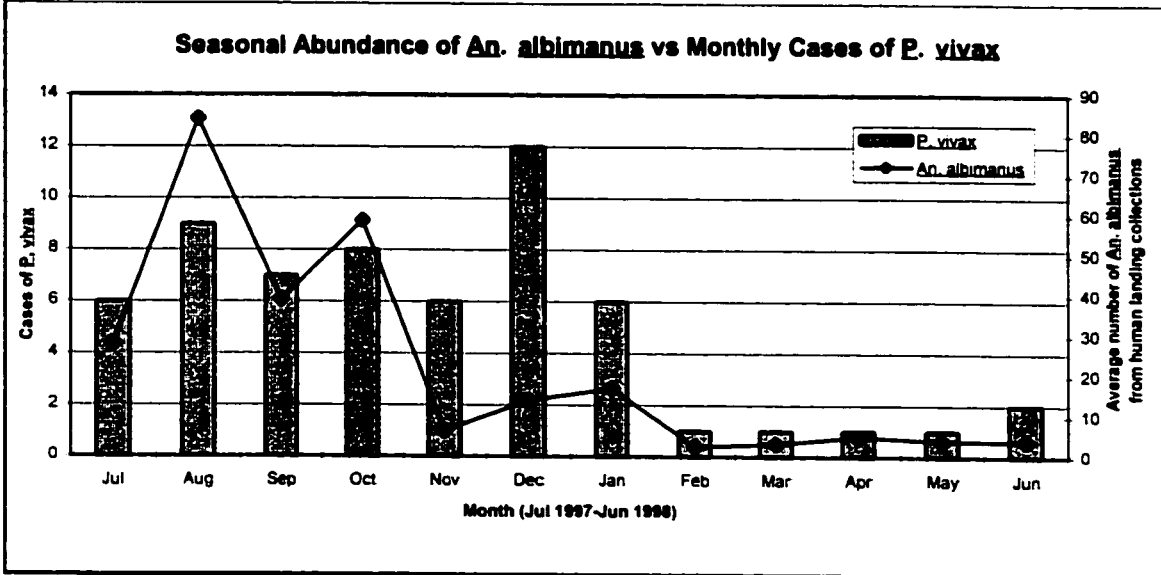
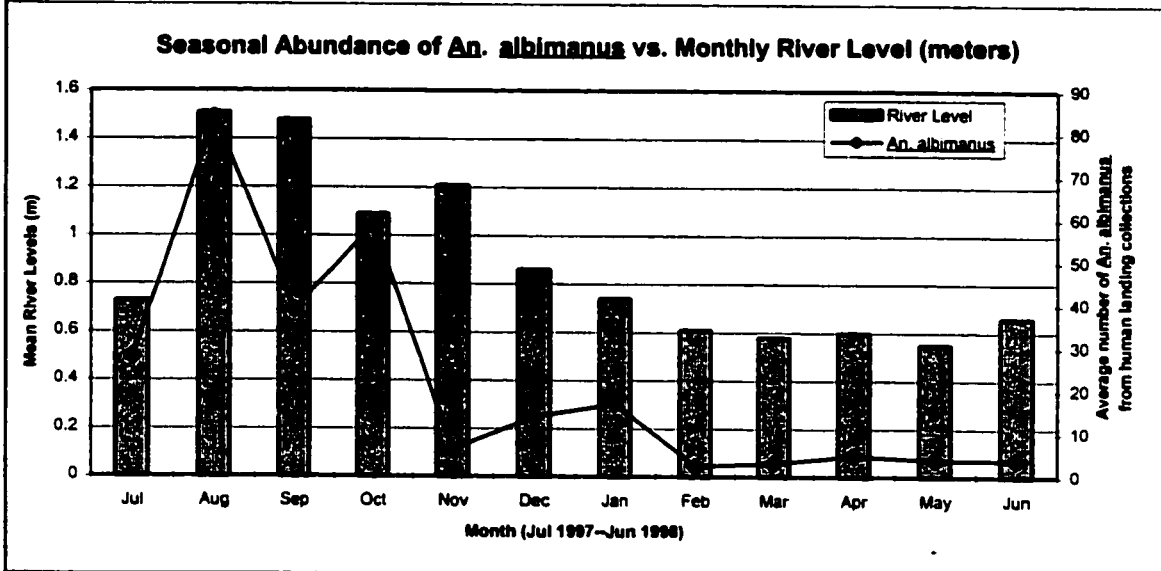
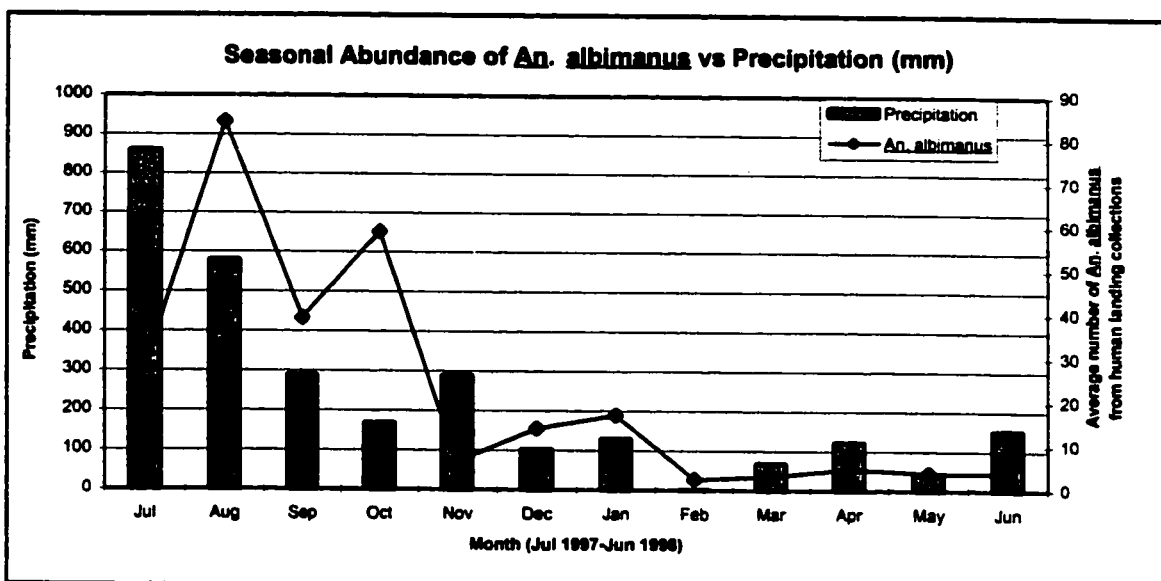
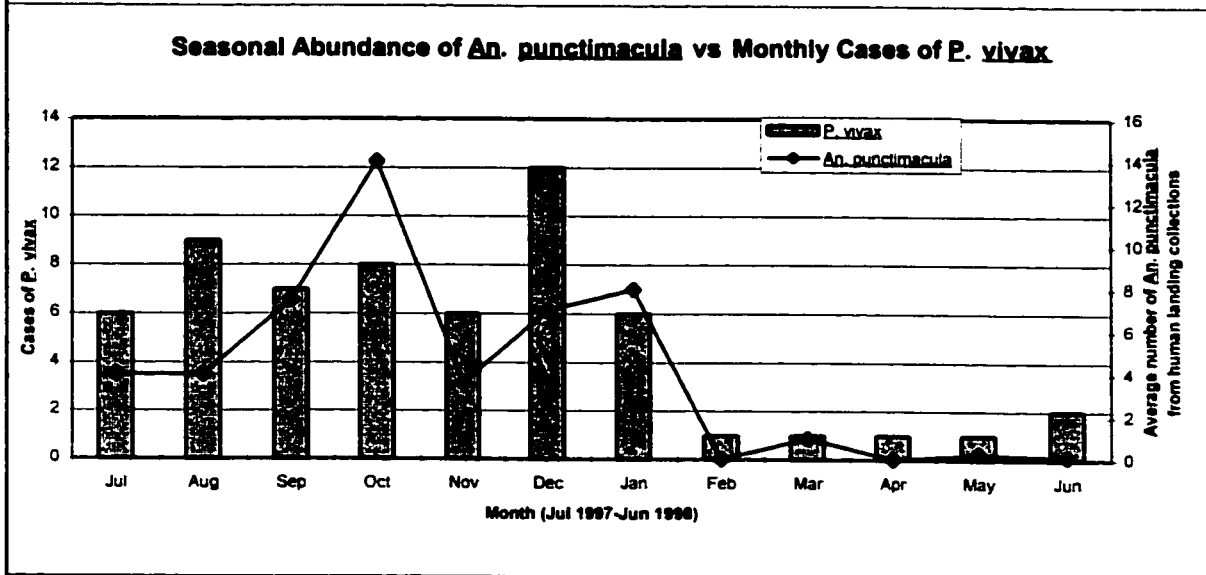
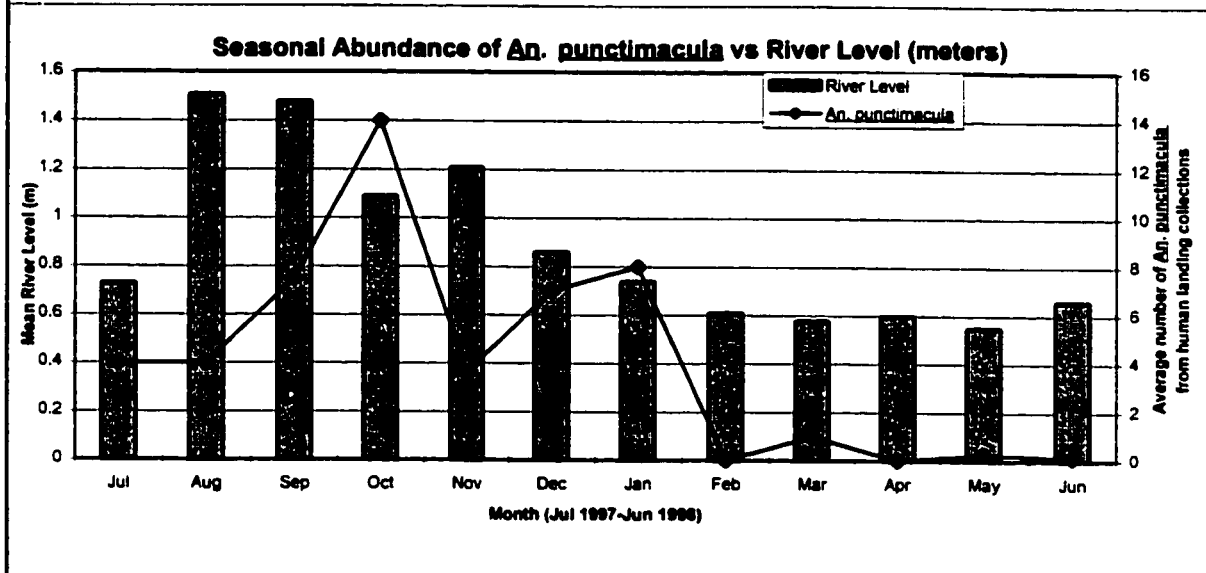
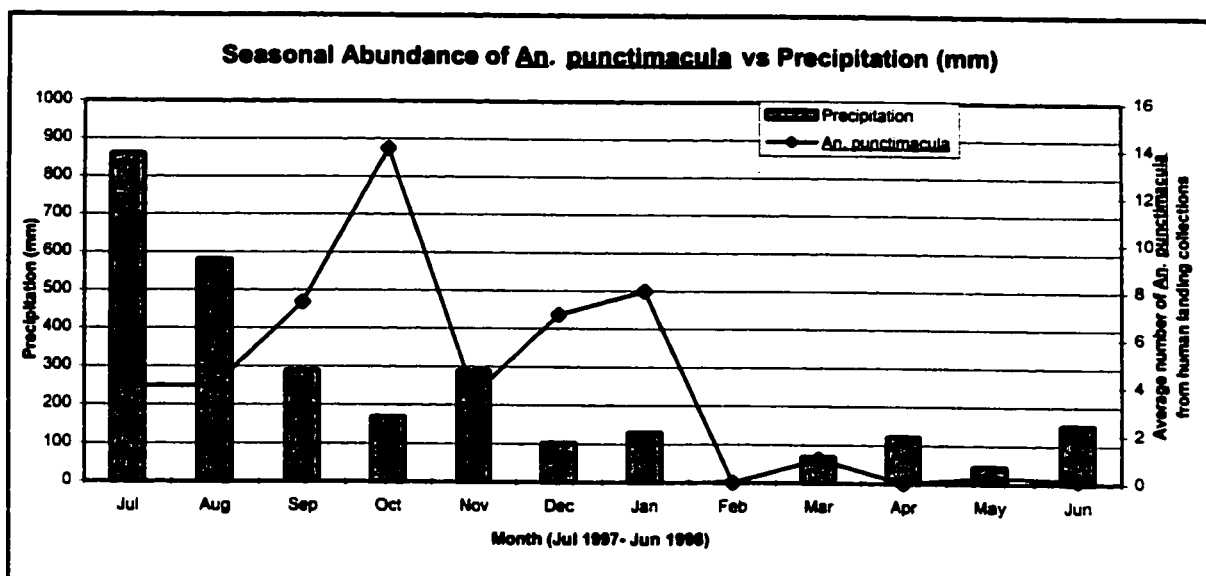

Figure 1: Map of the Toledo District in Southern Belize depicting the two main sites sampled during the seasonality study: ● - Rancho Village, ■ - Golden Stream Village









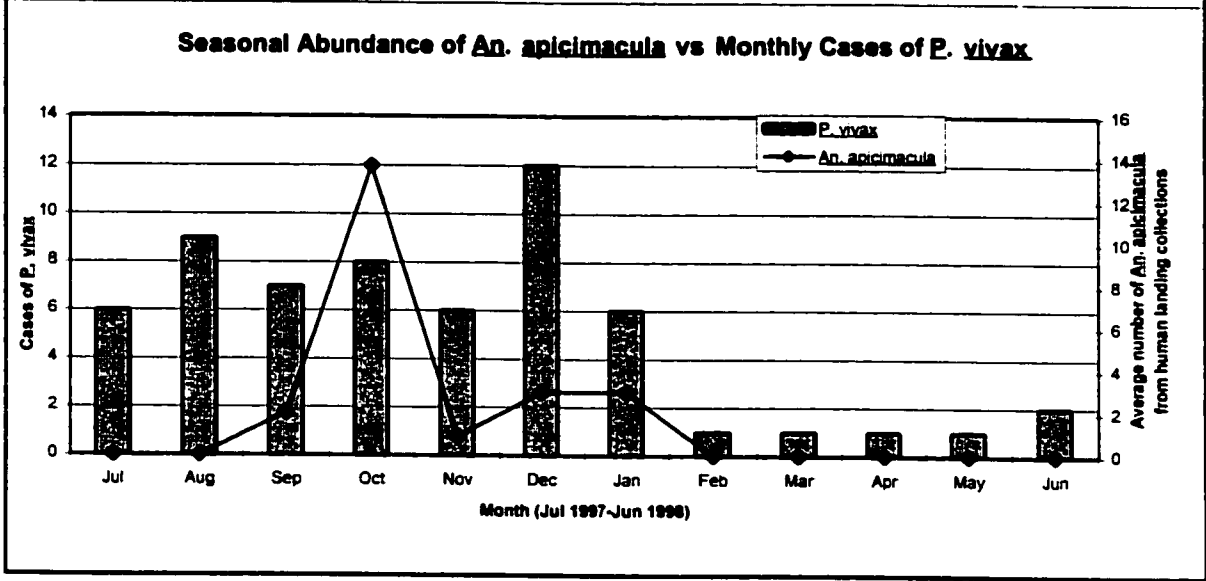
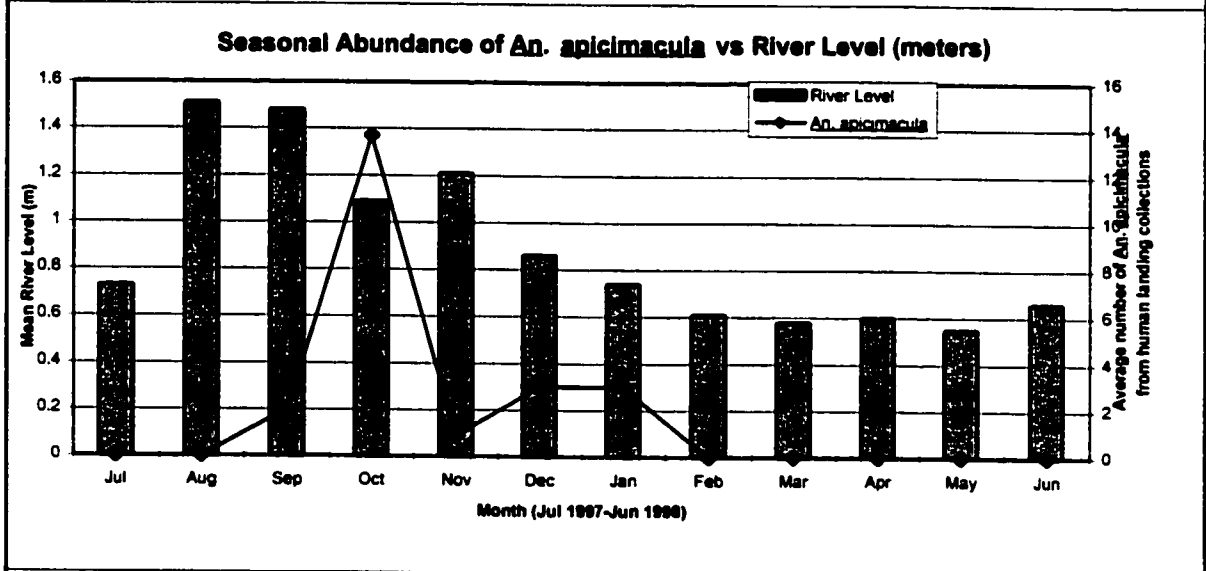
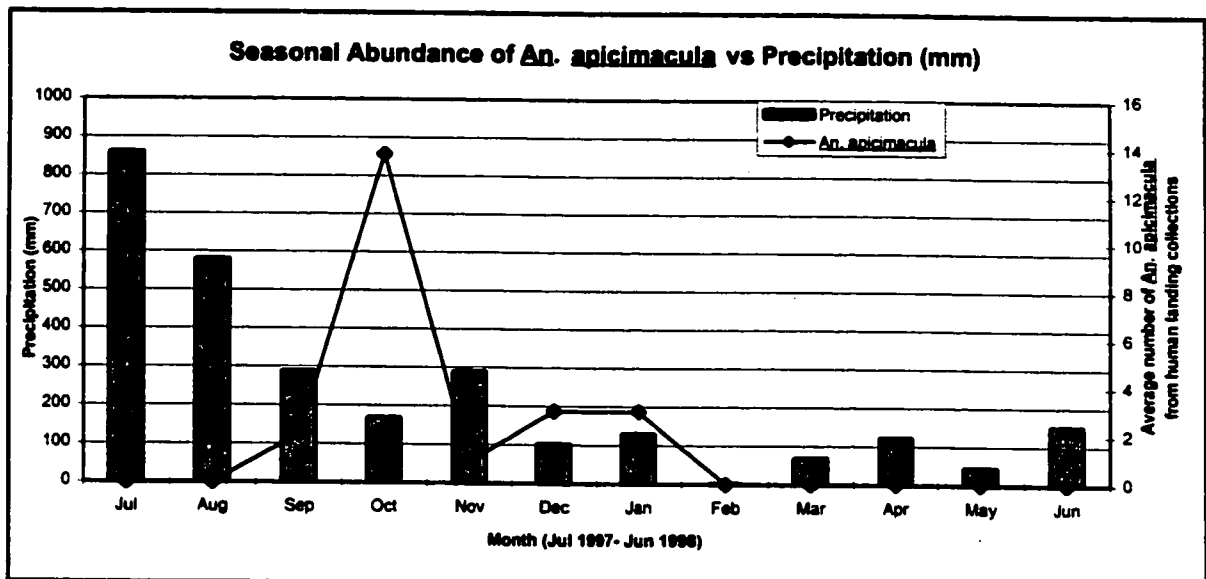

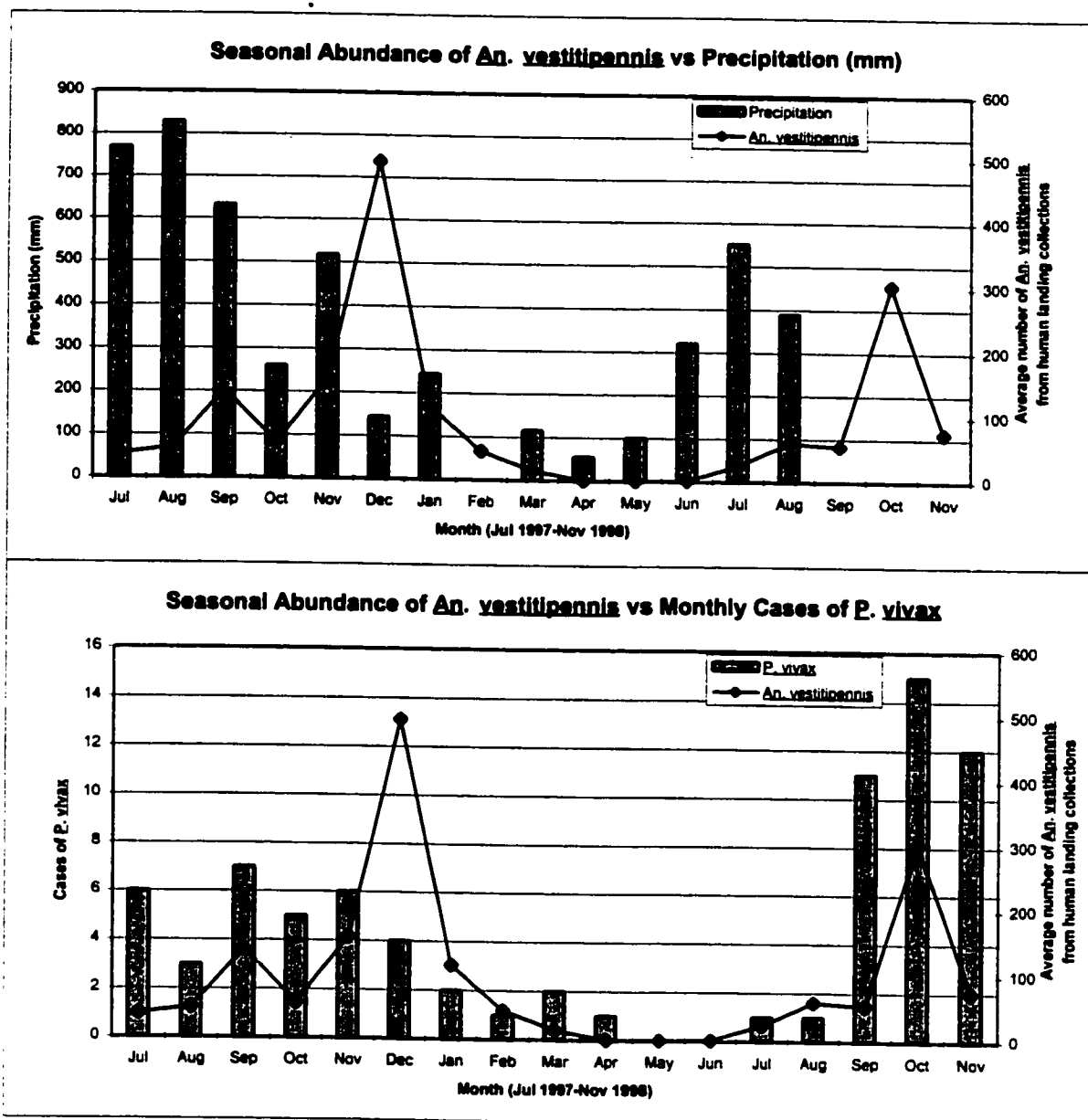

Figure 7: Average number of *An. vestitipennis* collected/night in 2-hour human landing collections conducted at the village of Rancho. Collections were conducted from 6:00-8:00 pm from July 1997-November 1998. The average number of mosquitoes collected for each month is displayed in conjunction with the monthly precipitation, and number of cases of *P. vivax*. Confirmation of malaria cases was determined at the hospital in Punta Gorda by microscopic examination of blood smears.

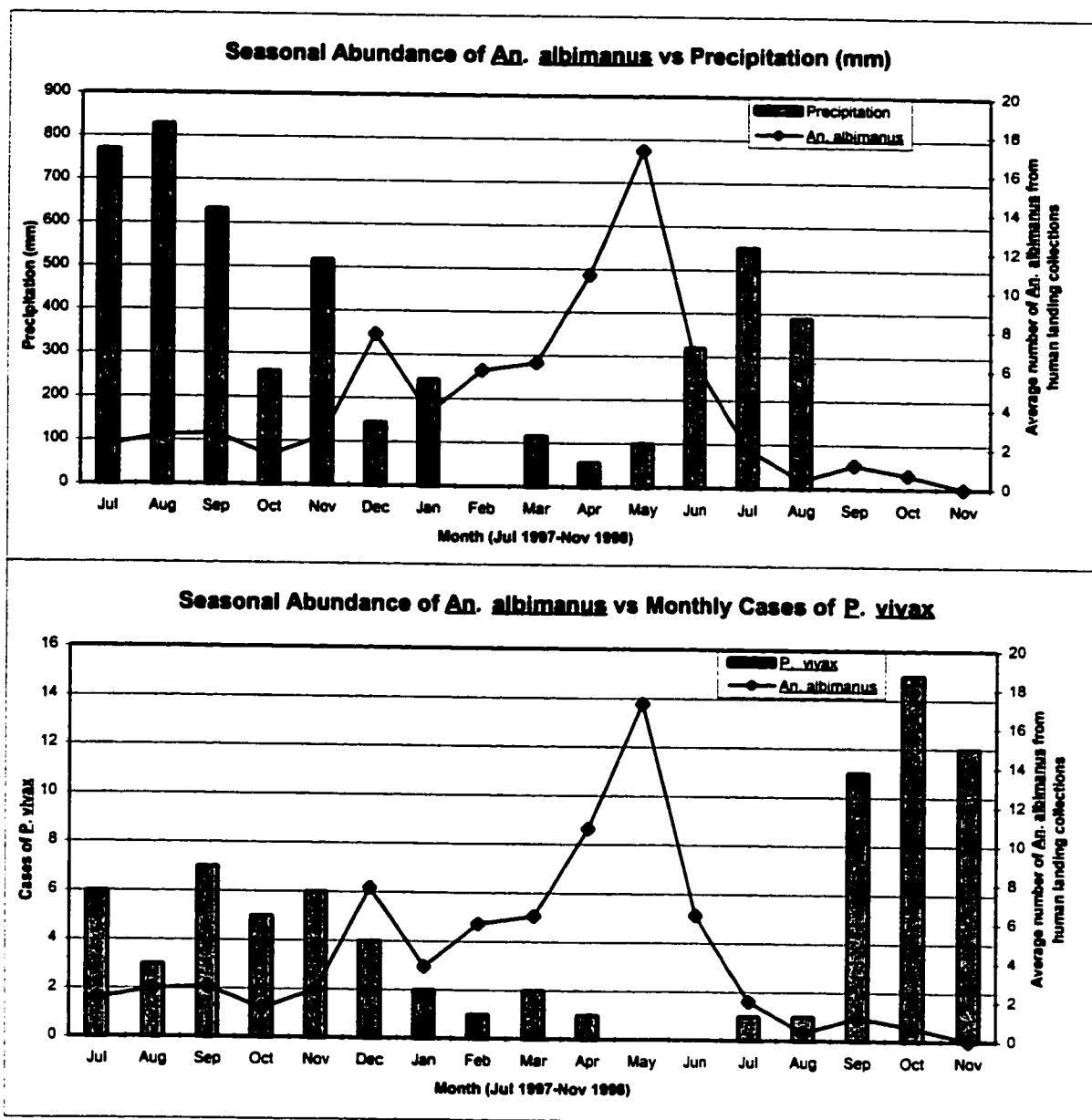

Figure 8: Average number of *An. albimanus* collected/night in 2-hour human landing collections conducted at the village of Rancho. Collections were conducted from 6:00-8:00 pm from July 1997-November 1998. The average number of mosquitoes collected for each month is displayed in conjunction with the monthly precipitation, and number of cases of *P. vivax*. Confirmation of malaria cases was determined at the hospital in Punta Gorda by microscopic examination of blood smears.

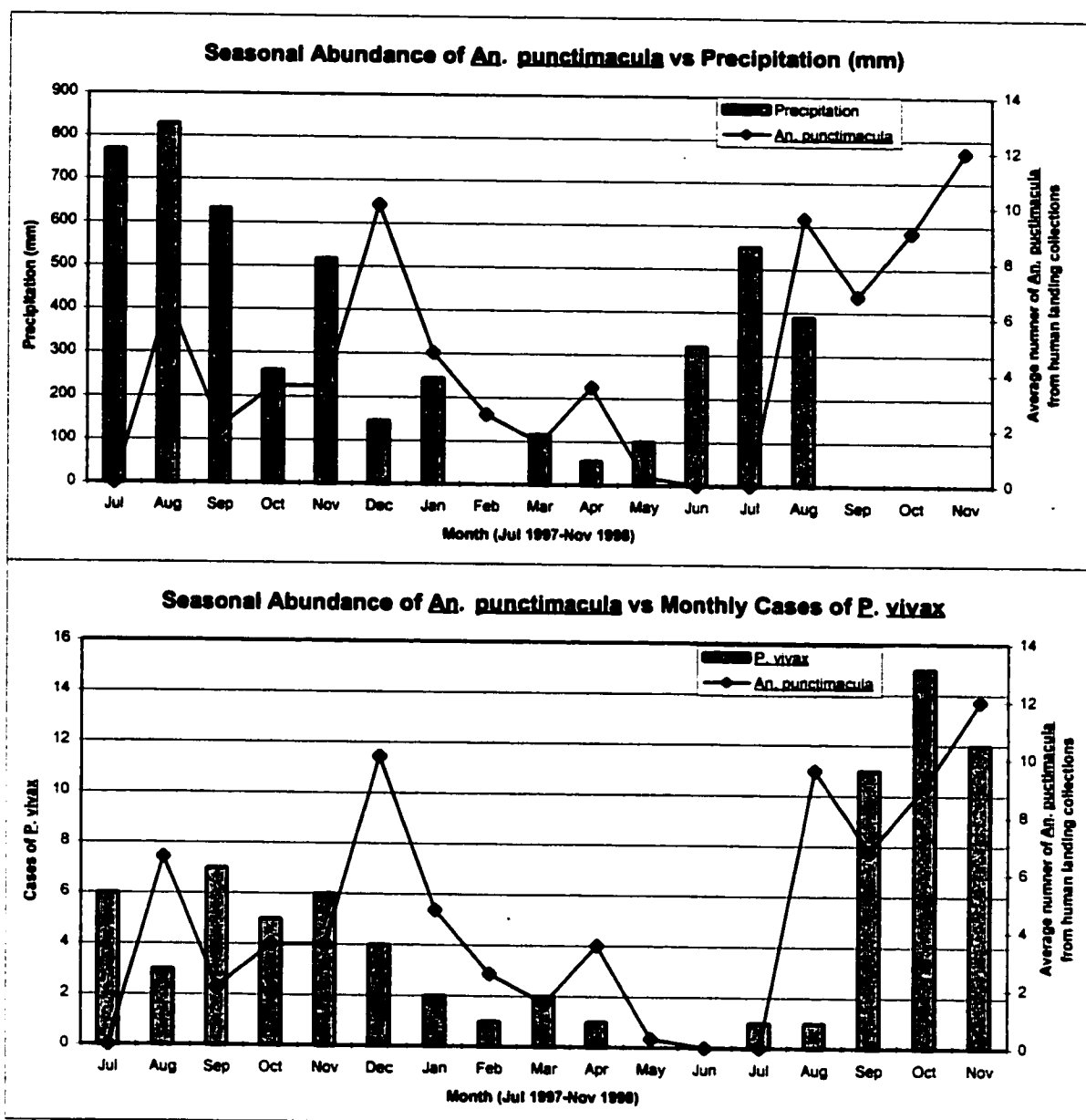

Figure 9: Average number of *An. punctimacula* collected/night in 2-hour human landing collections conducted at the village of Rancho. Collections were conducted from 6:00-8:00 pm from July 1997-November 1998. The average number of mosquitoes collected for each month is displayed in conjunction with the monthly precipitation, and number of cases of *P. vivax*. Confirmation of malaria cases was determined at the hospital in Punta Gorda by microscopic examination of blood smears.

Chapter 4

Use of a Vehicle Mounted Trap for the Collection of Anopheles spp. (Diptera: Culicidae) from the Toledo District, Belize C.A.

ABSTRACT

Knowledge of the flight patterns of various mosquito species is important for determining flight distances and activity patterns as well as for collecting unbiased samples of blood engorged and gravid females (Bidleingmayer 1964). The use of a mobile car trap is seldom used for collecting Anopheles mosquitoes, although collections of An. quadrimaculatus (Bidleingmayer 1966), An. crucians (Carroll and Bourg 1977) and An. annulipes (Muller et al. 1981) have been described by other researchers. In the present study, the mobile car trap was utilized exclusively for the determination of anopheline flight patterns, as well as, for the purpose of collecting blood engorged samples of An. vestitipennis, An. albimanus and An. punctimacula from the Toledo District of Belize, Central America.

A number of environmental parameters were examined to determine their association with the nightly anopheline flight patterns. Meteorological conditions such as temperature, relative humidity and periods of rainfall had no effect on the numbers of anopheline mosquitoes collected in the mobile car trap. Wind speed did, however, show an inhibitory effect on flight behavior with collection totals decreasing as wind speeds increased. Collection of all three species decreased with winds greater than 5 mph and stopped altogether at speeds greater than 10 mph.

All three anopheline species demonstrated flight patterns that agreed with their biting activity as determined by human biting collections conducted at near by experimental huts (Chapter 6). Anopheles albimanus has a bimodal peak of flight behavior with an evening peak occurring just after sunset (5:15 and 8:00 p.m.) and a smaller morning peak just prior to sunrise (4:00 and 5:30 a.m.). The An. punctimacula

also showed a bimodal peak with the first peak of activity occurring just after sunset (6:00 and 8:30 p.m.) and the second peak occurring just prior to midnight (10:00 p.m. to 12:30 a.m.) . Anopheles vestitipennis showed no distinct peak of activity but exhibited a constant, low level of flight throughout the night beginning shortly after sunset (6:00 p.m.) and continuing until just prior to sunrise (5:30 a.m.). The male An. punctimacula showed a peak in flight activity in the early evening just after sunset.

Information obtained on the time of collection and the physiological state of the blood meal was used to approximate the time of feeding. Anopheles albimanus (90.4%) appeared to feed predominately in the hours after sunset (5:15-9:15 p.m.). All of the blood meals tested positive for non-human hosts. Anopheles punctimacula appeared to feed throughout its activity cycle (6:00 p.m.-12:30 a.m.). Blood engorged specimens were collected from 6:30 p.m. until 12:30 a.m. with the majority of blood meals also testing for non-human blood. An. vestitipennis was the only anopheline which tested positive for a significant number of human blood meals. Greater than 82.7% of the blood engorged specimens testing positive for human blood were captured during the second half of the night (12:00 a.m.-5:00a.m.). Almost all other specimens which tested positive for non-human blood meals (75.9%) were collected during the first half of the night.

Introduction

Vehicle mounted traps have been used as a means of obtaining samples of in-flight mosquito populations (Chamberlin and Lawson 1945; Stage 1947; Provost 1952; Provost 1957). A key aspect of collections made with a mobile truck trap is that the collections are considered to be the least effected by human manipulation and the physical environment (Bidlingmayer 1964, 1967 and 1974). These types of collections are critical when trying to determine natural flight patterns of mosquito species without artificially altering behavior in any way. It has been noted by Bidlingmayer (1966) that mosquitoes do not maintain continuous flight throughout the night and, therefore, hourly collections from a vehicle-mounted trap are representative of natural flight patterns occurring in the population. Information pertaining to unbiased changes in the number of in-flight mosquitoes can be used by mosquito control programs in designing a spray schedule that will most optimally affect exposed mosquitoes. A side benefit of this trapping method is acquisition of a relatively unbiased sample of blood-engorged females.

Mosquito flight is often the focus of studies which seek to determine the flight range (Headlee 1932, Edman and Bidlingmayer 1969), natural dispersion patterns (Provost 1952, Provost 1957, Janousek and Olson 1994) or host seeking flight patterns (Gillies and Wilkes 1975) of target mosquito populations. All of these studies rely on one basic premise: mosquito flight is motivated by both intrinsic and extrinsic stimuli (Provost, 1953.) Provost goes further and breaks these behaviors down into two distinct patterns: appetential and migratory flight behaviors. He defines appetential flight as an active process of seeking out a particular stimuli. Examples of this type of behavior are

searches initiated for a blood meal source, a compatible oviposition site or a suitable resting site. Provost groups all other types of flight into migratory flight.

Others (Clements 1999) have separated flight into three categories; trivial movement, dispersal and migratory flight. Trivial movement is described as all flight which displaces an individual from its immediate area but which does not take the individual out of the general area occupied by the local population. Examples of this behavior would be flight initiated in the search for suitable blood meal sources or resting sites, the return of an ovipositing female to a larval habitat or a female engaged in a mating flight. This flight behavior would essentially be analogous to Provost's appetential flight.

One component of trivial movements is described as "return flight" (Clements, 1999). This is used to describe flights, usually made over long distances, to areas which have been previously frequented. An example of this can be observed within the Hymenoptera which will return from nectar foraging to a hive. This type of behavior usually is associated with a chemical or visual stimuli that serves as an orientation marker. This same behavioral pattern has been observed in ovipositing females in the family Culicidae which will return to the breeding site from which they completed their own larval development. This has been demonstrated with populations of Anopheles melas and Aedes niphadopsis. Return flights are also exhibited by crepuscular or diurnal mosquitoes which move from resting sites to a blood source and then back to the resting site.

The term dispersal typically refers to a random scattering of individuals. In order to accurately characterize this term within the framework of a biological system one must

separate it into three distinct behavioral patterns: 1) the spread of individuals of particular genetic type into the area of another genetically different population; 2) the spread of individuals out from a central point of release as associated with a mark release experiment; and 3) the displacement of a species away from its natural range as a result of a chance event.

Migratory flight within insect populations is seen as non-goal oriented flight in which the insect is engaged in persistent locomotor movements which are directed by environmental conditions such as wind or topography (Clements 1999). Provost uses the example of a newly emerged mosquito that flies from the breeding site. This mosquito has ample energy stores which have been carried with it from its larval development to sustain it for some time. The drive of this mosquito to disperse from its site of emergence and be carried by the wind to other locations is what can be referred to as migratory flight. Three features which are always associated with migratory behavior are 1) persistent locomotion, 2) straight line flight paths which are associated with wind driven flight (note: this does not always send individuals to favorable locations but it does facilitate widespread movement of a species) and 3) inhibition of station-keeping responses. Station keeping responses are defined as stimuli such as food sources, sexual stimuli or resting places which fail to illicit a response in migratory individuals. The migratory movements are eventually terminated by the response to one or more of these stimuli. Johnson in 1966 noted that migratory flight was usually undertaken by young, reproductively immature females in their movement from their larval habitats.

Meteorological Effects on Flight Behavior:

The flight activity of a mosquito population can be effected by a number of environmental factors. These environmental factors include light intensity (Haddow 1964, Haddow et al. 1968; Bates 1941), temperature (Bradley and McNeel 1935; Bidlingmayer 1974, Carroll and Bourg 1977), relative humidity (Braack et al. 1994), wind speed (Bradley and McNeel 1935, Service 1980) and periods of heavy rain (Chadee and Tikasingh 1989, Sharp 1983). Other meteorological conditions have also shown to influence the flight patterns of various mosquito species, such as, lunar phase (Ribbands 1946, Bidlingmayer 1967, Charlwood et al. 1986, Janousek and Olson 1994).

The effect of temperature on mosquito behavior has been characterized as being inhibitory or permissive (Clements 1999). A mosquito that exhibits a crepuscular behavior with two activity peaks , one at dusk and one at dawn, must be able to cope with a dual temperature regime. Typically the temperatures are lower at dawn than they are at dusk. This usually results in an decrease in flight activity in the hours prior to sun rise. For this reason, it has been noted (Corbet 1965) that there are larger numbers of mosquito species that exhibit both dusk and dawn flight activity in tropical regions of the world. Corbet believes this is due to the less extreme temperature fluctuations which occur during the course of the night, thus permitting pre dawn flight patterns. This same phenomenon has been noticed in suction trap collections conducted in Florida where a larger number of mosquitoes were collected in the early evening hours than in the early morning hours (Bidlingmayer 1967). Again, this is believed to be attributed to an inhibition of flight activity resulting from lower pre-dawn temperatures.

A detailed investigation of this behavioral pattern was undertaken by Bidlingmayer in 1985 when he compared the truck trap collections of Culex nigripalpus from both evening and morning collection intervals. Between the temperatures of 20°C and 12°C, Bidlingmayer found a 12-14% decrease in the collection totals with every 1 degree decrease in temperature. This clearly explains the typically smaller peak in flight activity often seen in morning collections.

Temperature may also alter the effects of other environmental stimuli such as light intensity. The light induced threshold required for swarming can be shifted to either earlier or later based on the temperature. Depending on the species, high temperatures have demonstrated the capacity to either advance or delay the swarming behavior. Cambornac and Hill (1940) showed Anopheles atroparvus delayed their swarming until later in the evening at higher temperatures. At the same time, cooler temperatures will cut short the duration of the swarming behavior.

Relative humidity is directly influenced by temperature as well. Night-time humidity levels will generally increase throughout the night until dawn and can reach humidity levels of 100% during pre-dawn hours (Braack et al 1994). There is a relationship between increasing humidity to decreasing temperatures. In low land rainforest areas, the humidity levels may decrease during the day with readings around 60% high in the canopy and yet remain at fairly high levels (80-90%) on the forest floor (Richards, 1996). It is not clear how these humidity levels effect flight behavior. What is known is that there is an avoidance behavior exhibited for extremely low and high relative humidity. Muirhead-Thomson (1938) showed this avoidance behavior to be strongest at the highest humidity levels. Changes in relative humidity (from 100%-70%)

have resulted in increased flight activity of *Aedes vexans* Meigen (Platt et al. 1958). At saturation level during periods of both light and heavy rainfall, no effect on flight activity was observed for a number of mosquito species including *Culex caudelli* (Chadee and Tikasingh 1989), *An. gambiae* and *An. melas* (Bertram and McGregor, 1956) and *An. merus* (Sharp 1983).

Extensive studies have been conducted on the effect that wind speed has on the flight patterns of mosquitoes. To obtain an accurate depiction of how wind alters flight patterns, one must conduct studies in the lab where wind speeds can be kept at a constant velocity. Observation made in the field by way of trap collection data are not as reliable due to natural fluctuations in wind velocity. The threshold for inhibition of mosquito flight has been demonstrated to occur at very low wind velocities. Nielsen and Nielsen in 1966 showed that *Aedes impiger* demonstrated a reduction in flight activity at speeds greater than 2 meters per second (ms) and flight activity was completely inhibited at speeds greater than 3 ms. Sharp (1983) showed that collections of *An. merus* at human bait did not occur in winds greater than 2.5 ms. A series of suction and truck traps were performed in Florida which demonstrated that collection totals decreased with increasing wind velocities (Bidlingmayer 1967, 1974, 1985). It was found that wind speeds of 0.1 to 0.9 mph reduced the collection of *Aedes taeniorhynchus* and *Culex nigripalpus* by 58% and by 80% in winds greater than 1 mph. Bidlingmayer et al. (1995) also showed that wind velocities were negatively correlated with suction trap collections for a number of different species of mosquito. He postulated that the wind slowed the rate at which the mosquitoes arrived at the trap and reduce numbers captured.

Collection of Blood Engorged Mosquitoes

The use of a vehicle mounted trap has demonstrated mixed success in the collection of blood engorged specimens. This method collected only small numbers of non-engorged, rice field mosquitoes in Texas as compared to a backpack aspirator (Kunz et al. 1982). Williams and Meisch (1983) also employed a vehicle mounted trap for the collection of blood engorged mosquitoes. Although the trap proved useful for the collection of a large number of species and had larger collections over all, only a small proportion were blood fed. Some researchers have shown success using the vehicle mounted trap to collect large numbers of blood engorged mosquitoes. Muller et al. (1981) collected relatively large numbers of blood fed Anopheles annulipes (40.3%) and Culex annulirostris using a vehicle mounted trap in Australia.

Vehicle mounted traps have rarely been used in areas outside of the United States (Service 1993). The few examples of use are those conducted by Muller et al. (1981) in Australia and by in India. Although this type of trapping method has not been specifically used for Anopheles mosquitoes, a number of researchers have documented the collection of the following species: An. quadrimaculatus (Bidlingmayer 1966), An. crucians (Carroll and Bourg 1977) and An. annulipes (Muller et al. 1981).

Blood Meal ELISA

The most widely accepted technique presently in use for identifying arthropod blood meals is the sandwich ELISA (Service et al. 1986; Chow et al. 1993). The sandwich ELISA is seen as the most sensitive and specific of the ELISA analyses (Chow et al. 1993). This procedure has been successful in identifying small amounts of antigen,

such as would be found in a partial blood meal (Kirkegaard and Perry Laboratories 1990). This technique employs the use of capture antibodies which are plated onto a microtiter plate. These antibodies capture homologous antigen found in the blood meal sample. This antigen/antibody complex is then recognized by a second antigen specific enzyme conjugated antibody. This enzyme elicits a color change when in the presence of an enzymatic substrate.

There are several advantages of using a sandwich blood meal ELISA over other techniques. The main advantage is the high level of specificity and sensitivity compared to either the direct or indirect ELISA (Chow et al. 1993). When tested on blood meals of known origin, the sandwich ELISA was able to identify 100% of blood meals taken ≤ 32 hours after feeding and 80% of blood meals taken ≤ 42 hours after feeding. This compares with 100% of blood meals being detectable ≤ 26 hours after engorgement and only 50% ≤ 40 hours after engorgement using the direct ELISA analysis. Overall, Chow et al. (1993) found that the sandwich ELISA was able to correctly detect 88% of samples tested. The direct ELISA was able to detect only 41% of samples tested.

One goal of the present study was to determine the nightly flight patterns of the three main Anopheles species found at the study site (i.e. Anopheles vestitipennis, An. albimanus and An. punctimacula). Another goal was to collect data on a number of meteorological parameters to define conditions that influence the nightly flight behaviors. The primary goal of the study was to collect blood-engorged females of the three species as relatively unbiased samples to measure host feeding preferences.

Material and Methods

Site Selection:

A series of collections were conducted from June to November of 1998 on a 1 mile stretch of road near the town of Rancho (N 16 09.954 W 88 50.529) in the Toledo District of Belize (Figure 1). The study site was selected based on the following criteria: 1) a series of preliminary larval collections confirmed that the collection route was adjacent to larval habitats of *Anopheles vestitipennis*, *An. albimanus* and *An. punctimacula*, 2) the presence of both human habitations and cattle pastures interspersed along the route and 3) a low volume of vehicle traffic permitting uninterrupted collection runs throughout the night.

A depiction of the collection route sampled with the mobile car trap can be seen in Figure 2. Three separate larval breeding habitats were identified prior to the start of the study. *Anopheles albimanus* larvae were found in a wet rice field at the southern end of the route. Larval collections conducted in April and May of 1998 resulted in an average of 35 larvae per dip. In the center of the route were located two separate larval habitats. To the west of the route was a flooded forest area where larvae of *An. punctimacula* were collected. Larval collections conducted during this same time period resulted in an average of 3 larvae per dip. This site also resulted in the collection of minimal numbers of *An. albimanus*. Directly opposite the flooded forest on the eastern side of the road was a *Typha* marsh where larvae of *An. vestitipennis* were collected. Initial collections conducted during the summer of 1998 resulted in the average collection of 0.7 larvae per dip.

Two human dwellings were also located along the collection route. Both were Mayan structures composed of wood plank walls and thatch roofs. The most southerly structure housed a family of five individuals (2 adults and 3 children) and was located approximately 15 feet from the road. A variety of animals were located at the house, including 2 dogs, chickens, turkeys, pigs and on various occasions, cattle. The most northerly structure housed a family of 7 individuals (3 adults and 4 children) and was located approximately 100 feet from the road. The house also had a variety of animals located on the premises, including 2 dogs, chickens, turkeys and pigs.

Two large cattle pastures were located on the eastern side of the road. Cattle and horses were rotated between these two pastures at various times throughout the year. Approximately 45 head of cattle and 2 horses were present. The remainder of the land surrounding the collection site was composed of wet or dry rice fields or flooded forest.

A portable weather station (Davis Instruments, Weather Monitor II) was affixed to a cattle gate located approximately in the middle of the 1 mile section of road. Meteorological data, to include temperature, wind speed and direction, relative humidity and barometric pressure were collected every 15 minutes to coincide with collection intervals. The data was later downloaded to a computer database (PC compatible Weatherlink software.)

Car Trap Construction:

The modified vehicle mounted trap was based on the design of Bidlingmayer (1974) (Figure 3). The frame of the trap was constructed with sections of 1/2 inch PVC pipe to which a laterally positioned, pyramid shaped piece of green polyester netting (Bioquip Products) was attached. This pyramid shaped netting tapered back to a plastic

funnel encased in a PVC pipe coupler that had an interior diameter measurement of 4 inches. The end of the funnel terminated in an opening 1 inch in diameter. The mouth of the trap measured 4 feet wide by 3 feet high. The structure was positioned so that the mouth of the trap was located 6 inches above the roof of the vehicle in line with the leading edge of the front windshield. The trap was secured to the roof by sliding the two 6 inch legs of the trap into a wood base. The base was secured to the hood using bunge cords. The uppermost top corners were secured with nylon cord to the front of the vehicle and the anterior end of the trap was secured in a similar fashion to the rear of the vehicle.

The collection cups consisted of pint sized cardboard ice cream cartons and were modified to fit the 4 inch PVC coupler (Figure 3). The bottom portion of the cartons were removed and replaced with two alternating pieces of dental dam with single 1 inch slits cut in their center. The center portions of the lids were removed and replaced with polyester netting to allow for adequate airflow. The outer diameter of the cartons measured 4-inches and they fit snugly into the PVC coupler. The constant forward motion of the vehicle created sufficient airflow to keep mosquitoes in the collection cup.

Collections:

A "sample run" consisted of collecting mosquitoes as the vehicle was driven at 10 mph over a 1-mile section of road. At the beginning of each run, a collection cup was inserted into the rear of the trap. A complete run required approximately 10 minutes. Although there does not seem to be any evidence that the headlights of the vehicle influence the collection (Bidlingmayer, 1966), only the flashing hazard lights were used to minimize the possibility of the lights attracting mosquitoes. At the end of each run, the collection cup was removed and replaced with an empty cup. Cup contents were knocked down using chloroform vapors applied from a soaked cotton ball. Collected specimens were emptied onto a white plate and examined using a flashlight and forceps. All anopheline mosquitoes were removed to labeled 5-dram clear styrene vials with snap-tops. Small holes were punched in the lids and the vials were placed in a large screw top jar, which contained desiccating silica gel. This stopped moisture from condensing in the container and prevented growth of mold on specimens. The examination process took about 5 minutes at the end of which the next run was begun. Collection runs were conducted every 15 minutes through the night, beginning 1 hour before sunset and continuing 1 hour after sunrise.

At the conclusion of a night of collection runs, specimens were identified to species and recorded on a data sheet along with the collection time. The physiological state of each specimen was also recorded (i.e. whether there was blood present in the mosquito abdomen and the corresponding Sella's stage, i.e., stage of blood digestion (Detinova 1962). The assessment of Sella's stage was calibrated with observations on blood fed colony specimens to try and give an accurate time of blood meal acquisition

versus the time specimens were captured. Those mosquitoes that contained red blood and were of Sella's stage 1-3 were considered to have fed recently (within 3-5 hours). If the blood meal was black in color and Sella's stage 4 or greater then the meal was considered to have been acquired more than 6 hours prior to time of capture. Those mosquitoes which contained either a partial or full blood meal were separated into individual vials and the blood meal was determined using a ELISA assay. A data also sheet was kept during each collection which allowed for the recording of other observations such as the occurrence of rain, presence or absence of cattle in the pasture, moon phase or any other unusual event or weather condition.

Blood Meal ELISA

The anopheline specimens were returned to the laboratory at the Uniformed Services University of the Health Sciences where they were processed in the blood meal ELISA. The identification of each specimen was reconfirmed by microscopic examination. The blood engorged abdomens were removed and placed in Eppendorf vials and labeled with an identifying number which linked it to data on method of collection, date of collection, location of collection and species identification. The head and thorax also were removed from the specimens and placed in separately labeled Eppendorf vials with a similar identifying number, which linked it to its corresponding abdomen. The head and thorax were processed in the sporozoite ELISA to identify possible infection with *P. vivax* (210), *P. vivax* (247) or *P. falciparum*.

To each abdomen was added 50ul of a blocking buffer solution which contained the detergent Igepal. The abdomens were then ground using a plastic pestle which was

attached to a foot operated Fordem drill. Two 350 ul washes were used to wash any remaining material off of the pestle into the corresponding eppendorf vial. This resulted in a total of 750ul of ground blood meal solution with which to run the blood meal ELISA. The samples were tested against 8 different animals which required 50ul/animal type. Therefore a total of 400ul was required to run a single sample. The remaining 350ul was kept frozen at -80°C in case the sample required re-testing. A series of five negative controls were also ground. The negative controls consisted of ground An. albimanus which were obtained from a colony which had been established at Walter Reed. Five female An. albimanus were collected immediately after emergence to insure that they had not blood fed. They were processed and stored in the same manner as the blood engorged samples. Between grindings, the pestle was washed twice with distilled water and wiped clean using a KemWipe towel. All ground specimens were stored at -20°C for no more than one week before being tested in the ELISA analysis. A series of positive controls were also used in the analysis. These consisted of known sera samples for each of the animal groups that were being tested in the analysis. The sera was diluted down to a 1:300,000 dilution in blocking buffer. The sera was stored at -80°C during the course of testing.

Reagents for the blood meal ELISA were obtained from Kirkegaard & Perry. The specimens were tested against the following animals: human, rat, mouse, chicken, bovine, canine, feline, and horse. The blood meal ELISA utilizes a two antibody system which is run in a 96 well (u-shaped) plate. Four specimens could be run per plate in addition to a series of five negative and eight positive controls (one for each animal species). The outer wells of the plate were left empty to reduce the occurrence of evaporation and to cut

down on background disturbance. A capture antibody (50ul) was first plated down for each of the animal groups listed above in a plate. After incubating for one hour, the capture antibody was removed and blocking buffer (200ul) was added to the wells to eliminate the possibility of non specific binding of antigen to the plate thus resulting in false positives. After an hour of incubation the blocking buffer was removed and an aliquot of 50ul of sample was added to each of the eight test wells. This was allowed to incubate for two hours before being removed and discarded. All the wells were then washed three times with a phosphate buffer solution containing the detergent Tween-20. Upon completion of the third wash, the enzyme for the eight previously listed animal types were added to their corresponding wells and allowed to incubate for one hour after which time it was aspirated from the plate. The plate was again washed three times with the PBS solution. The final step required the addition of 100ul of a substrate solution which produced a color change when a positive reaction was detected. At room temperature this test was read after a 30 minute incubation using a plate reader with a wavelength filter of 414.

Those samples whose wavelength value were three times the standard deviation of the mean of the negatives were determined to be positive. The results of the analysis were transferred to a data sheet containing the corresponding sample number and all of the data was then transferred to a relational data base.

Results

A total of 1199 female anopheline mosquitoes was collected between June and November of 1998. These were composed of three species; 668 (56%) Anopheles vestitipennis, 326 (27%) An. albimanus and 205 (17%) An. punctimacula. A large percentage of the anophelines collected contained a blood meal. The following totals represent the number of blood engorged specimens collected of each anopheline species: 167 (25%) An. vestitipennis, 103 (31%) An. albimanus, and 90 (44%) An. punctimacula. An additional 74 male anophelines were also collected. The majority of which (68 or 91%) were An. punctimacula and the remaining 6 (9%) were An. vestitipennis. Large numbers of other species were also collected with the mobile car trap but due to time constraints, only a representative sample of the blood engorged specimens were kept for processing in the blood meal ELISA. These included 7 Aedes seratus, 16 Culex coronator, 15 Cx. educator, 28 Cx erraticus, 37 Cx. nigripalpus, 23 Cx. theobaldi, 43 Mansonia titillans, 26 Psorophora colombia and 5 Ps. ferox.

The average temperature, relative humidity and wind speeds were obtained for each 15-minute sampling period and graphed to indicate the mean values over all collection nights. These values are presented in graphical form in Figure 4. The average range of values over the 15 trap nights were as follows: temperature (32.5°– 25° C), relative humidity (74 – 100%), wind speed (0-15 mph).

A correlation analysis was run on the data to determine the effects of environmental factors on the collection totals obtained in the car trap (Table 1). The temperature, relative humidity and periods of rain showed no correlation with the number of mosquitoes collected in the trap. There was, however, a negative correlation which

occurred between the collection total of all species with wind velocity: An. vestitipennis (-0.133; $p < 0.01$), An. albimanus (-0.588; $p < 0.01$) and An. punctimacula (-0.731; $p < 0.05$). A reduction in the number of mosquitoes collected in the trap occurred with wind velocities greater than 5 mph and there was a complete inhibition of flight at wind speeds greater than 10 mph.

A nightly comparison of the three anopheline species collected in the study are presented in figures 5-19. An. albimanus demonstrates a bimodal peak of flight behavior with an evening peak occurring at just after sunset (6:00 and 8:00 p.m.) and a smaller morning peak occurring just prior to sunrise (4:00 and 5:00 a.m.). The An. punctimacula also showed a bimodal peak with the first peak of activity occurring just after sunset (6:30 and 8:30 p.m.) and the second peak occurring just prior to midnight (11:00 p.m. to 12:30 a.m.). An. vestitipennis showed no distinct peak of activity but exhibited a constant, low level of flight throughout the night beginning shortly after sunset (6:00 p.m.) and continuing until just prior to sunrise (5:15 a.m.).

Graphical presentation of times that gravid females were collected are presented in Figure 20. The majority of gravid females of An. vestitipennis were collected early in the evening. A total of 7 (70%) of the gravid females of this species were collected between 7:00 and 8:00 p.m. The remaining 3 (30%) gravid females were collected between 8:00 and 9:45 p.m. Only 3 gravid females of Anopheles albimanus were collected and these occurred in the trap during the first activity peak of this species (between 6:45 and 7:45 p.m.). A total of 5 gravid female An. punctimacula were collected in the car trap with 4 occurring between 7:15 and 9:00 p.m. and 1 occurring at midnight.

The male population of *An. vestitipennis* collected in this study were too few in number to give an accurate depiction of the male flight activity. The males of this species were also collected in the early evening with a slight peak at approximately 8:00 p.m. (Figure 21). The male *An. punctimacula*, however, were collected in modest numbers and show a tendency to be active just after sunset (Figure 21). Almost all (67 or 98.5%) male *An. punctimacula* were collected between 6:00 p.m. and 8:00 p.m.

Times of collection for blood engorged females are presented in Figures 22, 23 and 24. All blood meals were determined to be freshly acquired (2-3 hours old) based on the color of the blood meal and the Sella's stage of the distended abdomen as compared to colony reared specimens of engorged *An. albimanus*. The majority (93 mosquitoes or 90.4%) of blood engorged females of *An. albimanus* were collected during the first peak of activity. The meals were composed almost exclusively of cattle blood. The remaining 11 (10.6%) were collected between midnight and 5:00 a.m. These also contained cattle and dog blood.

The blood engorged females of *An. punctimacula* were collected in almost equal numbers during both nightly peaks of activity. Blood engorged *An. vestitipennis* females were collected throughout the night. After performing the blood meal ELISA on the *An. vestitipennis* specimens, however, an interesting pattern was observed. The majority (88 or 75.9%) of the non-human containing blood meals were collected prior to midnight. These were composed primarily of cattle and dog. A different situation was observed in regard to the human containing blood meals. A total of 43 (82.7%) of the human containing blood meals were collected after midnight between the hours of 12:00 a.m.

and 5:00 a.m. There were a small number (9 or 17.3%) of human blood meals collected between 8:00 p.m. and 12:00 a.m.

Discussion

The mobile car top trap was operated on 15 different occasions for 13 hours at a time. This resulted in a total of 195 man-hours of collection. This translates into the collection of 6.15 anophelines per man-hour or 1.85 blood engorged anophelines per man-hour. Although these values appear to be quite low, the unbiased nature of the collection method makes the data obtained from these samples extremely valuable. In addition, these values would be considerably higher if all other blood engorged mosquito species collected by the trap were included in the study. This collection method also showed signs of being an effective method for the collection of swarming male populations of An. punctimacula.

After examining a number of environmental variables, it was determined that most meteorological factors had no effect on the flight patterns of the anopheline species collected in this study. Temperature, relative humidity and bouts of rain showed no association with collection totals. Wind speed did, however, show an inhibitory effect on flight behavior with collection totals of all three anopheline species decreasing as wind speeds increased. Collection of all three species decreased with winds greater than 5 mph and stopped altogether at speeds greater than 10 mph. This finding is consistent with other researchers (Bidlingmayer 1967, 1974, 1985) who found increasing wind speeds to be inhibitory to mosquito flight.

The flight patterns for the three anopheline species are strikingly similar to their biting patterns (Chapter 6). Annopheles albimanus exhibited a crepuscular pattern of behavior with in-flight mosquitoes being collected at both dusk and dawn. The collection totals for this species were consistently higher at dusk than at dawn, with 30% more An.

albimanus being collected after sunset than in the predawn hours. This coincides with previous studies (Corbet 1965, Bidlingmayer 1967) which suggest that the cooler morning temperatures may act to inhibit predawn activity. The blood-feeding pattern indicated that this species shows a stronger tendency to feed in the evening (30% more blood engorged collected before midnight than after midnight) when they are more likely to feed on non-human hosts such as cattle and dogs. The lack of large numbers of blood engorged females in the morning peak may also be a reflection of the cooler temperatures. Temperatures in the upper 60's and low 70's may inhibit the host seeking behavior or feeding response.

An. punctimacula also showed a dual peak of night-time flight activity. This species demonstrated a peak of activity just after dusk and then a second at around midnight. This is also similar to its biting activity which commences shortly after sunset and then continues at low levels until midnight (Chapter 6). At midnight, this species appears to terminate its appetitional flight behavior and commences with the search for suitable resting sites in preparation for the advent of morning. There does not appear to be a specific time during these periods of activity when they are more prone to acquire a blood meal. Results indicate that blood engorged specimens were collected throughout their nightly activity. The percentage of specimens that were engorged at each time interval increased later in the night. This would be expected based on a non-blood fed, host seeking population occurring in the evening and a blood fed population would predominate later in the night.

The constant all night biting activity exhibited by An. vestitipennis was consistent with this species flight patterns which seemed to be at low levels all night long. There

were no distinct times in which the flight activity of this species seemed to be more active than another. Collection of *An. vestitipennis* began shortly after sunset (6:00 p.m.) and continued at low levels until just prior to sunrise (5:15 a.m.). The results of the blood meal analysis show that the majority (75%) of the human blood meals were collected in the latter half of the night. The majority (82%) of non-human blood meals were collected during the first half of the night.

The movement of mosquitoes to a house appears to take place in a series of leaping flights from resting sites in the surrounding habitat. At each stage, the mosquito will adopt a resting posture before continuing on. This process may take minutes or hours. Upon reaching a house, the mosquito will land on the exterior wall surfaces and thatch before entering. Once the mosquito enters, it will generally alight on interior aspects of the house for a period of time before actually acquiring a blood meal from a human host. This entire process may take considerable amounts of time to complete. A host seeking mosquito will generally take the first available blood meal source which is presented to it. Therefore, the source of a mosquito blood meal is determined by the parameters which govern mosquito/host contact.

The patterns of host feeding exhibited by these three species appears to be a direct function of their nightly activity patterns. Those species which exhibit host seeking flight during distinct windows of time, such as *An. albimanus* and *An. punctimacula* show a stronger tendency to feed on non-human hosts. This may be more a function of timing rather than feeding preference. These mosquitoes most likely leave their outdoor resting sites in search of a blood meal and make contact with non-human hosts first (ie cattle and dogs). This is primarily due to the presence of these types of hosts outdoors in close

proximity to the mosquitoes' resting sites. During this time when the mosquito begins its blood meal search, humans have retired to the interior of their homes. As the night progresses, these early evening feeders terminate their feeding behavior, thus preventing the progression indoors and the acquisition of a human blood meal.

Due to the very large numbers of *An. vestitipennis* present at the research site and this species' all night activity pattern, the conditions are favorable for indoor feeding on a human host. They have sufficient time in which to make their move toward a human dwelling, enter, take a blood meal and leave in search of an outdoor resting site. This is bolstered by the fact that those *An. vestitipennis*, which were collected early in the evening contained mostly non-human blood. These mosquitoes represent that percentage of the population which have taken flight from their daytime resting habitats in search of a blood meal and have first made contact with a non human host. As the night progresses, movement towards and into a house continue, thus resulting in increased collection of blood engorged *An. vestitipennis* later in the night. Therefore, the probability of an unfed, female *An. vestitipennis* entering a house and taking a human blood meal increase as the search time increases.

All of these assumptions hinge on whether the species in question exhibits an endophagic behavior. Based on other aspects involved in this study and from information obtained by other researchers, *An. albimanus* and *An. punctimacula* exhibit an exophagic behavior. This increases the likelihood that the majority of blood meals will be of non-human origin. *An. vestitipennis*, on the other, exhibits a strong endophagic behavior which increases the likelihood that this progression of events would occurring.

The potential to utilize the data from this research to implement a more effective control effort in areas where these anopheline species occur is great. Present efforts in Belize focus on two strategies for the control of the adult population: ULV spraying and residual house spraying. The use of ULV spraying is often used to control a crepuscular mosquito species that has a very specific time of activity. The flight patterns of these different anophelines indicate that the use of ULV spraying would only be practical for An. albimanus. This method of control would only target a small proportion of the populations of An. punctimacula and even more so with An. vestitipennis and would have little impact on the indoor biting population. For control of the latter two species, it is critical to maintain a diligent residual house spray campaign. This is particularly true for An. vestitipennis which shows a strong tendency to both rest and feed indoors.

The ability of the mobile car trap to collect unbiased samples of in-flight mosquitoes makes it a valuable tool in studying the behavior of a number of vector species. The added advantage of collecting a large proportion of samples which were blood engorged increases the scope of studies in which this trapping method can be used. The fact that the flight patterns of all three anopheline species mirrored their respective biting patterns as determined by the experimental hut studies shows that a strong correlation can be made between times of peak flight activity and of biting behavior. This trapping method could also be used to model mosquito movement to and from human habitations. This is of particular interest given that there appears to be a time component involved with the acquisition of human blood meals by An. vestitipennis.

References Cited

- Bates, M. 1941. Laboratory observations on the sexual behavior of anopheline mosquitoes. *J. Exp. Zool.* 86: 153-173.
- Bertram, D.S. and I.A. McGregor. 1956. Catches in The Gambia, West Africa, of *Anopheles gambiae* Giles and *A. gambia* var. *melas* Theobald in entrance traps of a baited portable wooden hut, with special reference to the effect of wind direction. *Bull. Entomol. Res.* 47: 669-681.
- Bidlingmayer, W.L. 1964. The effect of moonlight on the flight activity of mosquitoes. *Ecology.* 45: 87-94.
- Bidlingmayer, W.L. 1966. Use of the truck trap for evaluating adult mosquito populations. *Mosq. News* 26: 139-143.
- Bidlingmayer, W.L. 1967. A comparison of trapping methods for adult mosquitoes: species response and environmental influence. *J. Med. Ent.* 4: 200-220.
- Bidlingmayer, W.L. 1974. The influence of environmental factors and physiological stage on flight patterns of mosquitoes taken in the vehicle aspirator and truck, suction, bait and New Jersey light traps. *J. Med. Ent.* 11(2): 119-146.
- Bidlingmayer, W.L. 1985. The measurement of adult mosquito population changes - some considerations. *J. Am. Mosq. Control Assoc.* 1; 328-348.
- Bidlingmayer, W.L., J.F. Day and D.G. Evans. 1995. Effects of wind velocity on suction trap catches of some Florida mosquitoes. *J. Am. Mosq. Control Ass.* 11: 295-301.

- Braack, L.E.O., M. Coetzee, R.H. Hunt, H. Biggs, A. Cornel and A. Gericke. 1994. Biting pattern and host-seeking behavior of Anopheles arabiensis (Diptera: Culicidae) in northeastern South Africa. *J. Med. Ent.* 31: 333-339.
- Bradley, G.H. and T.E. McNeal. 1935. Mosquito collections in Florida with the New Jersey light trap. *J. Econ. Entomol.* 28: 780-786.
- Cambournac, F.J.C. and R.B. Hill. 1940. Observations on the swarming of Anopheles maculipennis, var atroparvus. *Am. J. Trop. Med.* 20: 133-140.
- Carroll, M.K. and J.A. Broug. 1977. The night-time flight activity and relative abundance of fifteen species of Louisiana mosquitoes. *Mosq. News* 37: 661-664.
- Chadee, D.D. and E.S. Tikasingh. 1989. Diel biting activity of Culex (Melanoconion) caudelli in Trinidad, West Indies. *Med Vet Entomol.* 3: 231-237.
- Chamerlin, J.C. and F.R. Lawson. 1945. A mechanical trap for the sampling of aerial insect populations. *Mosq. News.* 5: 4-7.
- Charlwood, J.D., R. Paru, H. Dagoro and M. Lagog. 1986. Influence of moonlight and gonotrophic age on biting activity of Anopheles farauti (Diptera: Culicidae) from Papua New Guinea. *J. Med. Ent.* 23: 132-135.
- Chow, E., R.A. Wirtz and T.W. Scott. 1993. Identification of blood meals in Aedes aegypti by antibody sandwich enzyme-linked immunosorbent assay. *J. Am. Mosq. Control. Ass.* 9: 196-205.
- Clements, A.N. 1999. *The Biology of Mosquitoes: Sensory Reception and Behavior.* CABI publishing. New York City, New York. 740pp.

- Corbet, P.S. 1965. Asymmetry in ecocrepuscular diel periodicities of insects. *Can. Entomol.* 97: 878-880.
- Detinova, T.S. 1962. Age-grouping methods in Diptera of medical importance. WHO Geneva. 216pp.
- Edman, J.D. and W.L. Bidlingmayer. 1969. Flight capacity of blood-engorged mosquitoes. *Mosq. News* 29: 386-392.
- Gilles and Wilkes. 1975. Long range orientation of Mansonia (Mansonioides) males to animal hosts. *Mosq. News.* 35: 226-227.
- Headlee, T.J. 1932. The development of mechanical equipment for sampling the mosquito fauna and some results of its use. *Proc. Ann. Mtg N. J. Mosq. Exterm. Assoc.* P. 106-126.
- Haddow, A.J. 1954. Studies of the biting habits of African mosquitoes. An appraisal of methods employed, with special reference to the twenty-four hour catch. *Bull. Entomol. Res.* 45: 199-242.
- Haddow, A.J. 1964. Observations on the biting habits of mosquitoes in the forest canopy at Zika, Uganda, with special reference to the crepuscular periods. *Bull. Entomol. Res.* 55: 589-608.
- Janousek, T.E. and J.K. Olson. 1994. Effect of a lunar eclipse on the flight activity of mosquitoes in the upper gulf coast of Texas. *J. Am. Mosq. Control Assoc.* 10(2): 222-224.
- Johnson. 1966. A functional system of adoptive dispersal by flight. *Ann. Rev. Entomol.* 11: 233-260.

- Kirkegaard and Perry Laboratories, Inc. 1990. Types of solid phase enzyme immunoassays. Gaithersburg, MD.
- Kuntz, K.J., J.K. Olson and B.J. Rade. 1982. Role of domestic animals as hosts for blood-seeking females of Psorophora columbiae and other mosquito species in Texas rice fields. Mosq. News. 42: 202-210.
- Muller, M.J., M.D. Murray and J.A. Edwards. 1981. Blood sucking midges and mosquitoes feeding on mammals at Beatrice Hill, N.T. Aust. J. Zool. 29: 573-588.
- Muirhead-Thomson, R.C. 1938. The reactions of mosquitoes to temperature and humidity. Bull. Entomol. Res. 29: 125-150.
- Nielsen, H.T. and E.T. Nielsen. 1962. Swarming of mosquitoes. Laboratory experiments under controlled conditions. Entomol. Exp. Applic. 5: 14-32.
- Platt, R.B., G.J. Love and E.L. Williams. 1958. A positive correlation between relative humidity on the distribution and abundance of Aedes vexans. Ecology 39: 167-169.
- Provost, M.W. 1952. The dispersal of Aedes taeniorhynchus I. Preliminary studies. Mosq. News. 12(3): 174-191.
- Provost, M.W. 1953. Motives behind mosquito flight. Mosq. News 13(2): 106-109.
- Provost, M.W. 1957. The dispersal of Aedes taeniorhynchus II. The second experiment. Mosq. News 17(4): 233-247.
- Ribbands, C.R. 1946. Moonlight and house haunting habits of female anophelines in west Africa. Bull. Entomol. Res. 36: 395-417.

- Richards, P.W. 1996. *The Tropical Rain Forest*, 2nd edition. Cambridge University Press. 598pp.
- Service, M.W. 1980. Effects of wind on the behaviour and distribution of mosquitoes and blackflies. *Int. J. Biometeorol.* 24: 347-353.
- Service, M.W. 1993. *Mosquito Ecology: Field sampling methods* 2nd Ed. Chapman and Hall, London. 988 pp.
- Service, M.W., A. Voller and D.E. Bidwell. 1986. The enzyme linked immunosorbent assay (ELISA) test for the identification of blood meals of haematophagus insects. *Bull. Entomol. Res.* 76: 321-330.
- Sharp, B.L. 1983. *Anopheles merus* (Donitz) its biting cycle in relation to environmental parameters. *J. Entomol. Soc. Southern Africa.* 46: 367-374.
- Stage, H.H. 1947. DDT to control insects affecting man and animals in a tropical village. *J. Econ. Entomol.* 40: 759-762.
- Williams, D.C. and M.V. Meisch. 1983. Collection methods for a blood host study of riceland mosquitoes. *Mosq. News.* 43: 355-356.

Table 1: Spearman's rho values for the 3 anopheline species collected in the mobile car trap in relation to temperature, relative humidity, periods of rain and wind speed. Collections were conducted from June to November of 1998.

Spearman's rho values			
	<i>An. albimanus</i>	<i>An. punctimacula</i>	<i>An. vestitipennis</i>
Temperature	(0.662; p>0.05)	(0.437; p>0.05)	(0.793; p>0.05)
Relative Humidity	(0.811; p>0.05)	(-0.470; p>0.05)	(0.328; p>0.05)
Rain	(0.527; p>0.05)	(0.693; p>0.05)	(-0.576; p>0.05)
Wind Speed	(-0.588; p<0.01)	(-0.731; p<0.05)	(-0.133; p<0.01)

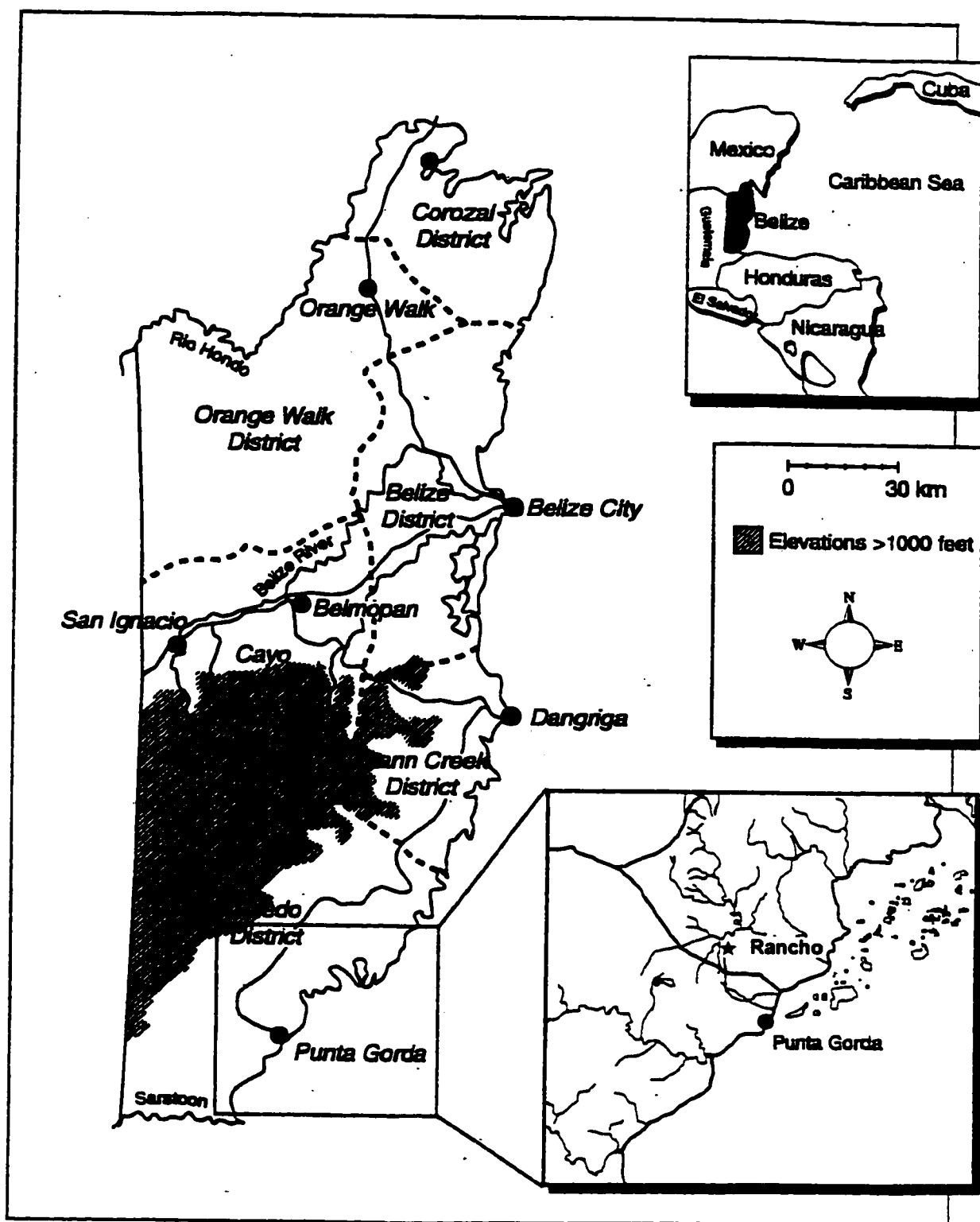

Figure 1: Map of the Toledo District in Southern Belize showing the location of the vehicle mounted trap site in Rancho Village.

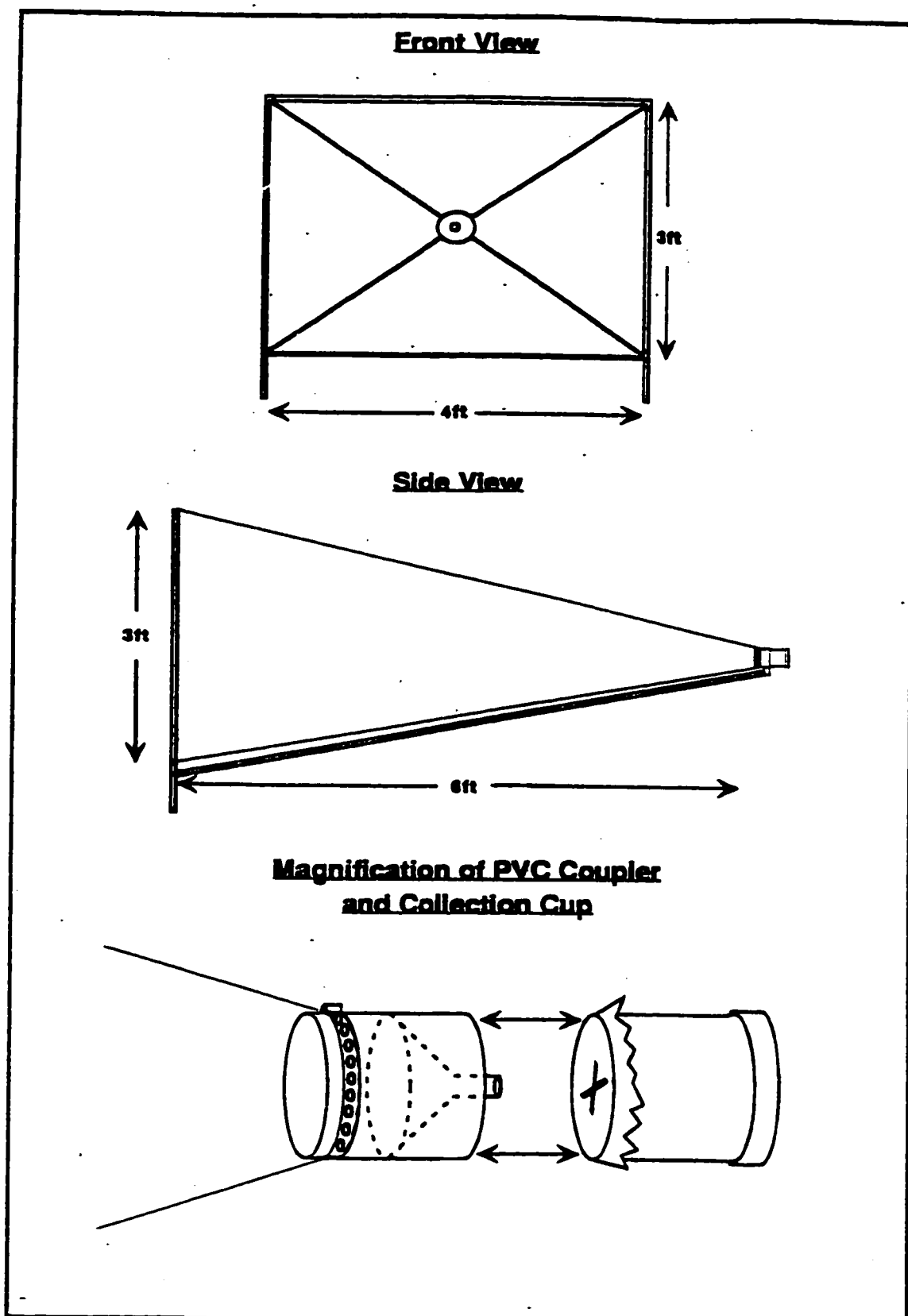

Figure 3: Illustration of the car top trap and PVC coupler used for the collection of in-flight mosquito populations at the Rancho site.

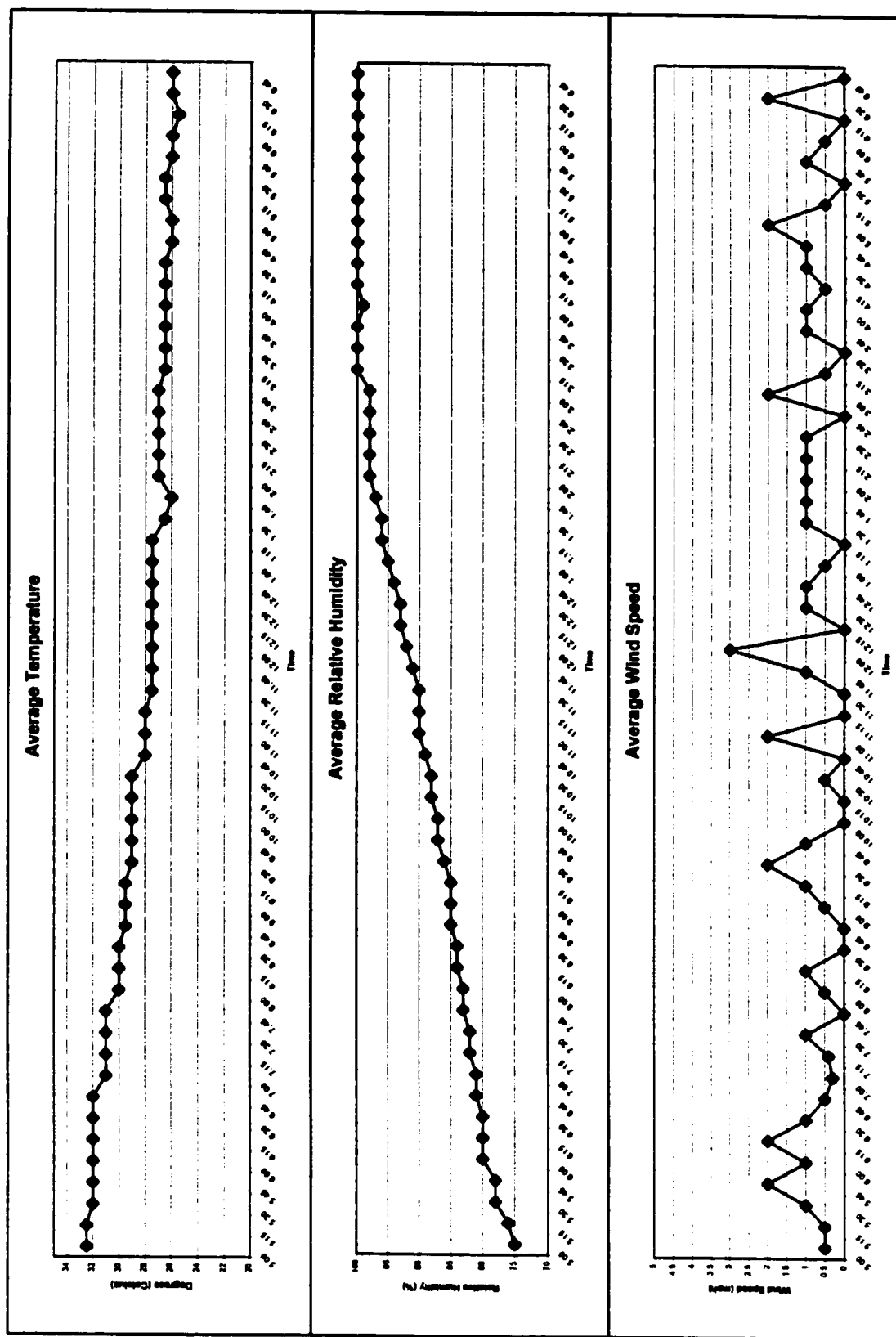

Figure 4: Average meteorological data over the 15 trap nights on which the mobile car trap was conducted. Average temperature, relative humidity and wind speed are presented at the midpoint of each 15 minute collection interval.

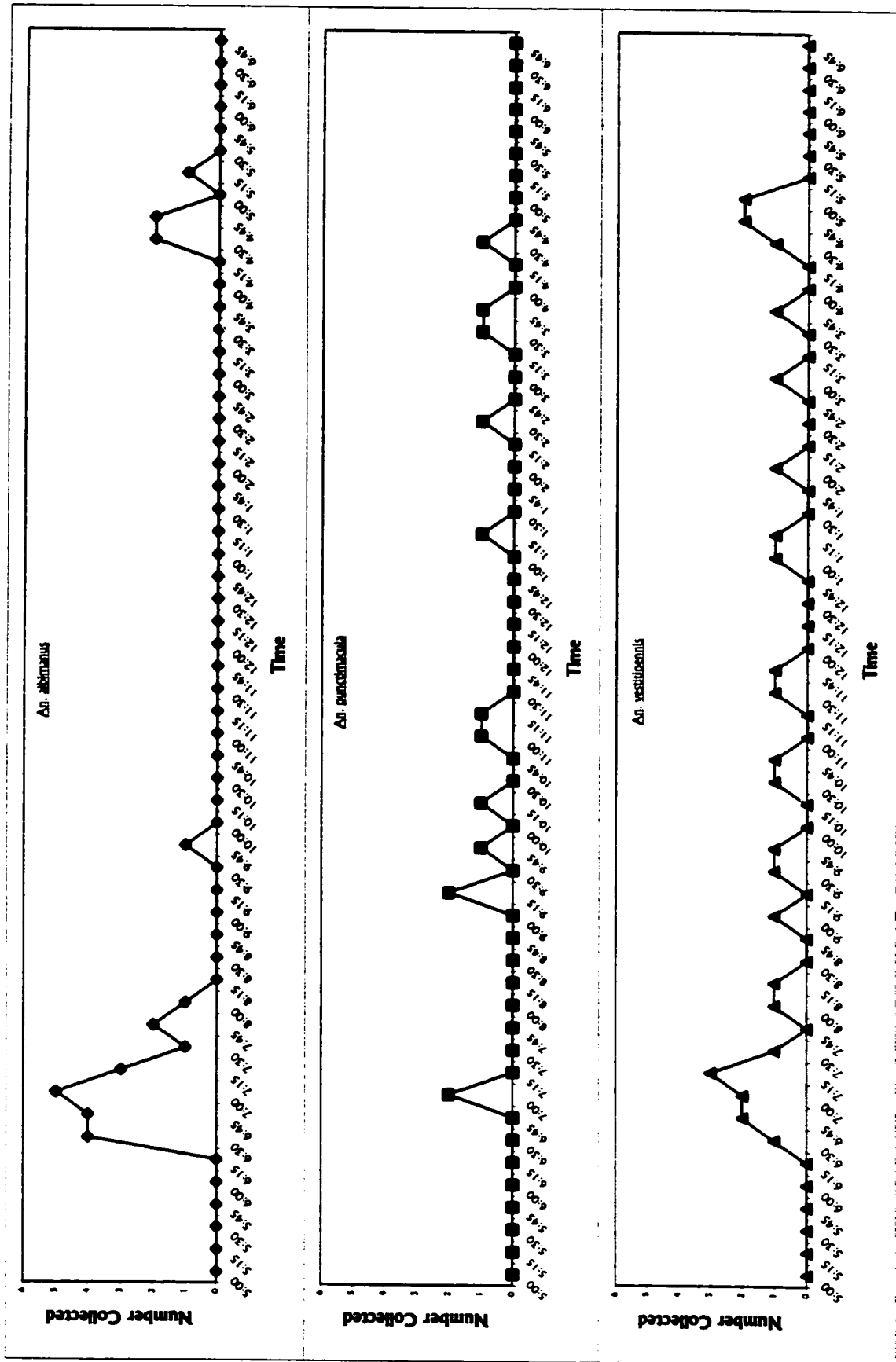

Figure 5: Number of *An. albimanus*, *An. punctimacula* and *An. vestitipennis* collected in a mobile car trap on 10 June 1998. Sample period was every 15 minutes and encompassed a 1 mile section of road in Rancho Village of the Toledo District, Belize.

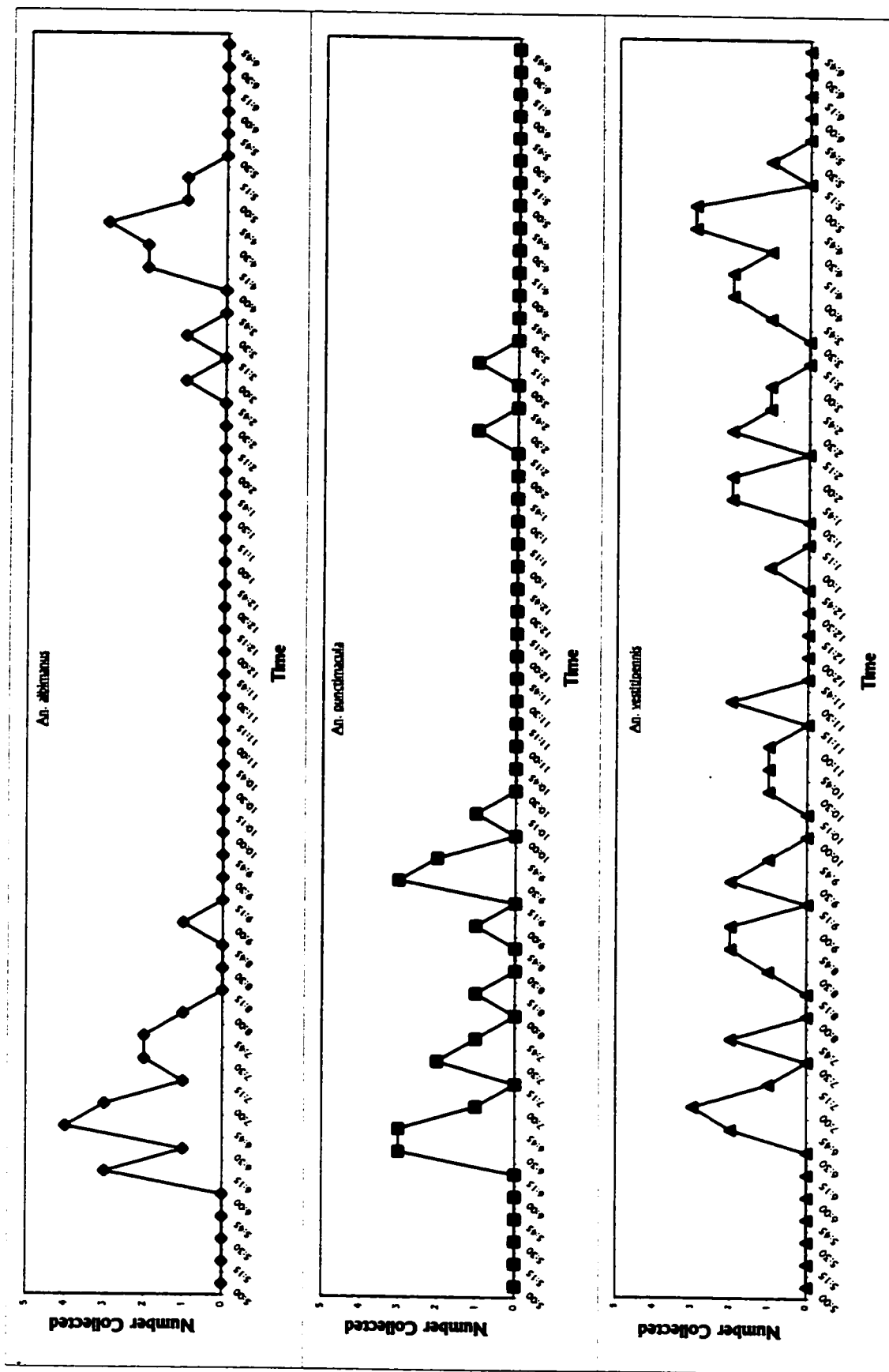

Figure 6: Number of *An. albimanus*, *An. punctumacula* and *An. vestitipennis* collected in a mobile car trap on 12 June 1998. Sample period was every 15 minutes and encompassed a 1 mile section of road in Rancho Village of the Toledo District, Belize.

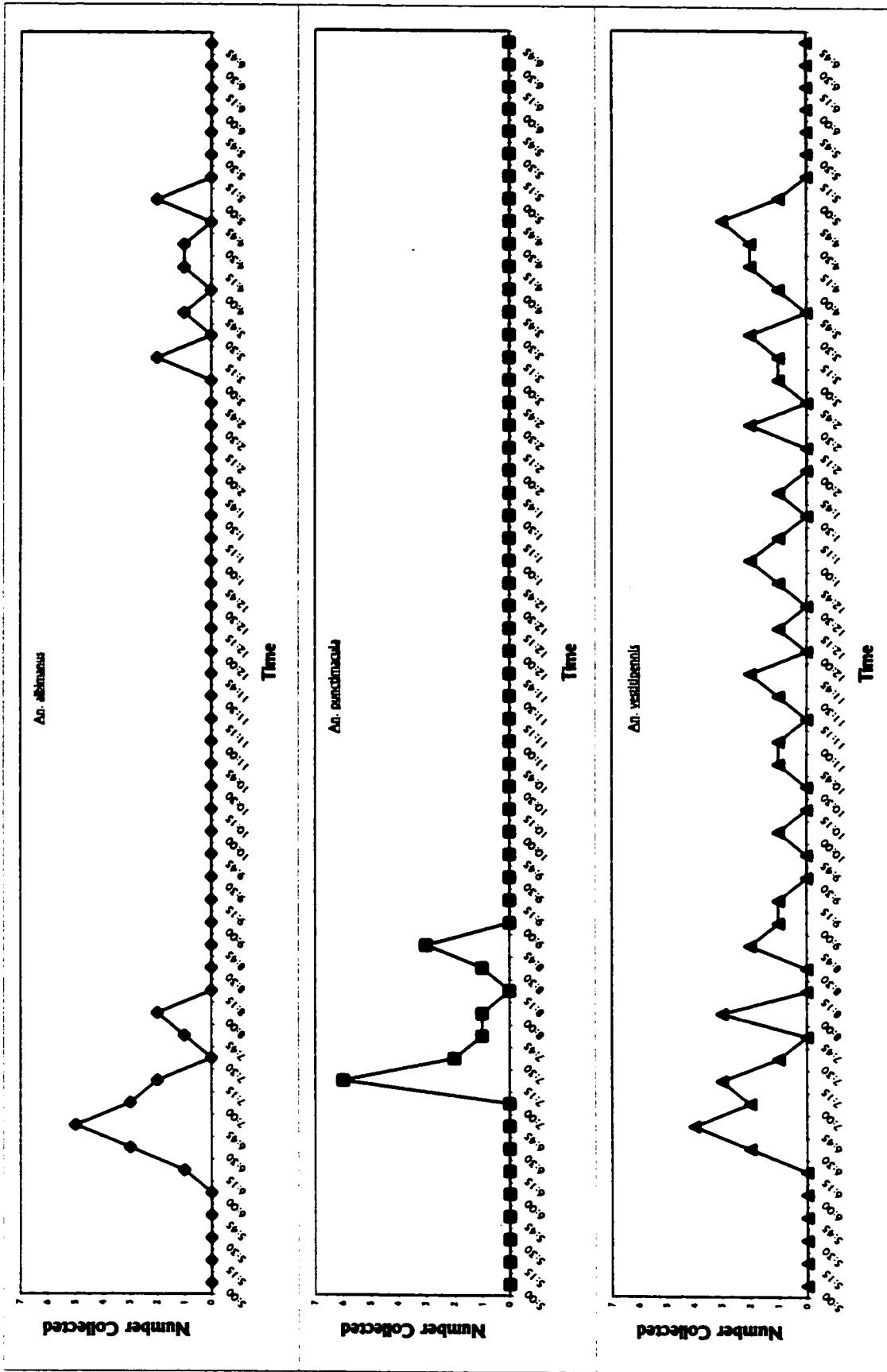

Figure 7: Number of *An. albimanus*, *An. punctumacula* and *An. vestitipennis* collected in a mobile car trap on 18 June 1998. Sample period was every 15 minutes and encompassed a 1 mile section of road in Rancho Village of the Toledo District, Belize.

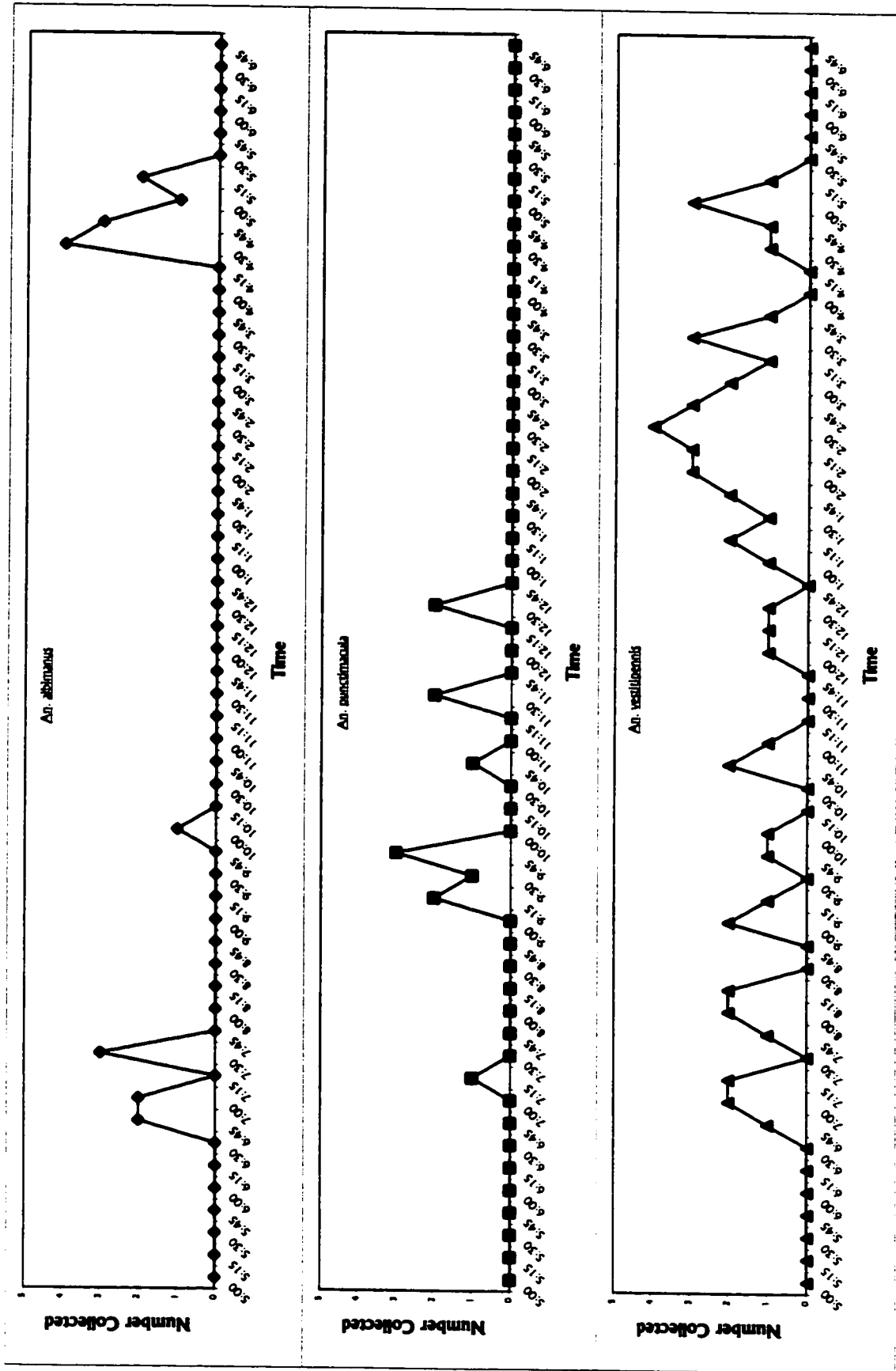

Figure 8: Number of *An. albimanus*, *An. punctimacula* and *An. vestipennis* collected in a mobile car trap on 8 August 1998. Sample period was every 15 minutes and encompassed a 1 mile section of road in Rancho Village of the Toledo District, Belize.

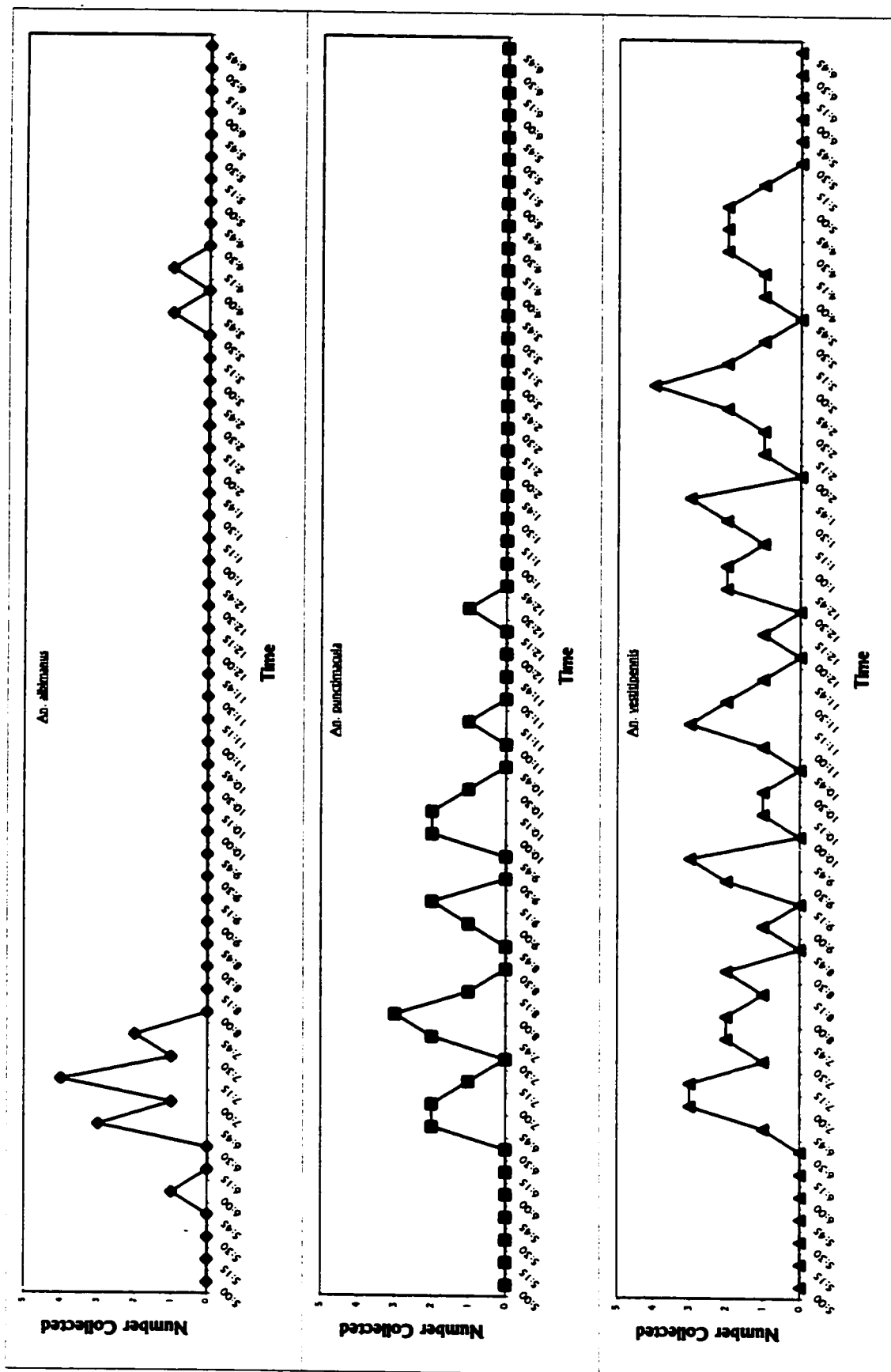

Figure 9: Number of *An. albimanus*, *An. punctimacula* and *An. vestitipennis* collected in a mobile car trap on 18 August 1998. Sample period was every 15 minutes and encompassed a 1 mile section of road in Rancho Village of the Toledo District, Belize.

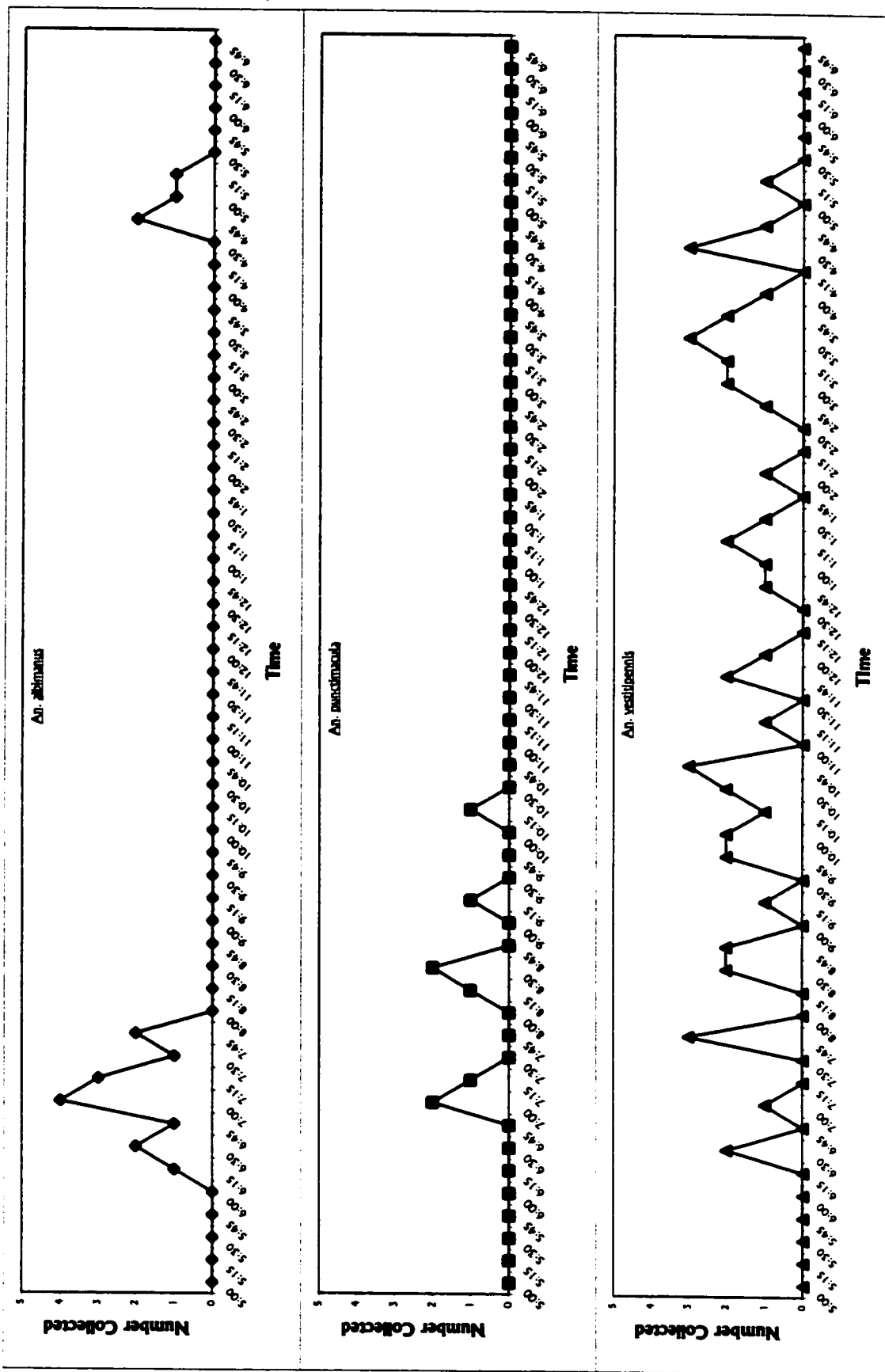

Figure 10: Number of *An. albimanus*, *An. punctumacula* and *An. vestitipennis* collected in a mobile car trap on 27 August 1998. Sample period was every 15 minutes and encompassed a 1 mile section of road in Rancho Village of the Toledo District, Belize.

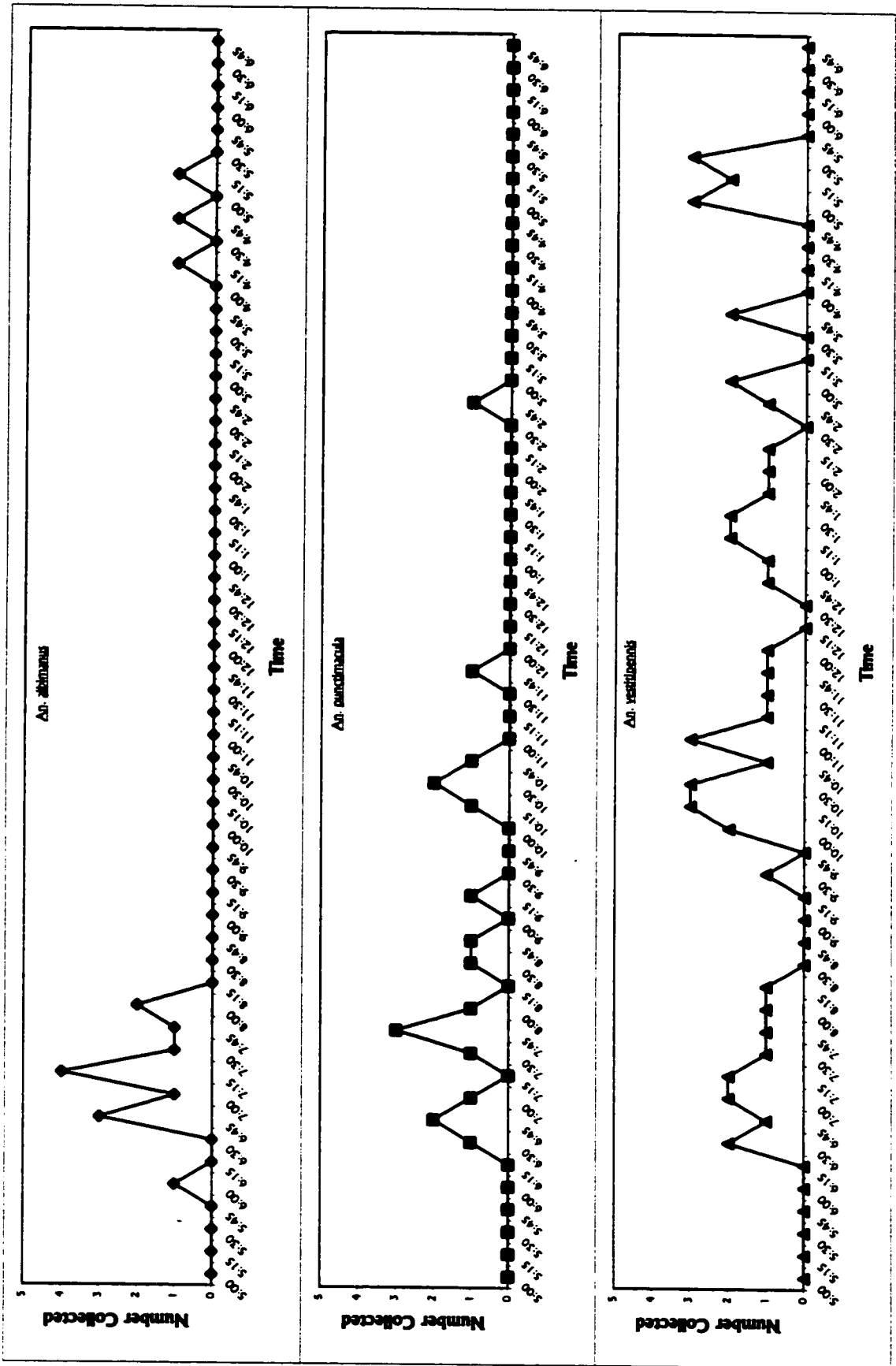

Figure 12: Number of *An. albimanus*, *An. punctimacula* and *An. vestitipennis* collected in a mobile car trap on 5 September 1998. Sample period was every 15 minutes and encompassed a 1 mile section of road in Rancho Village of the Toledo District, Belize.

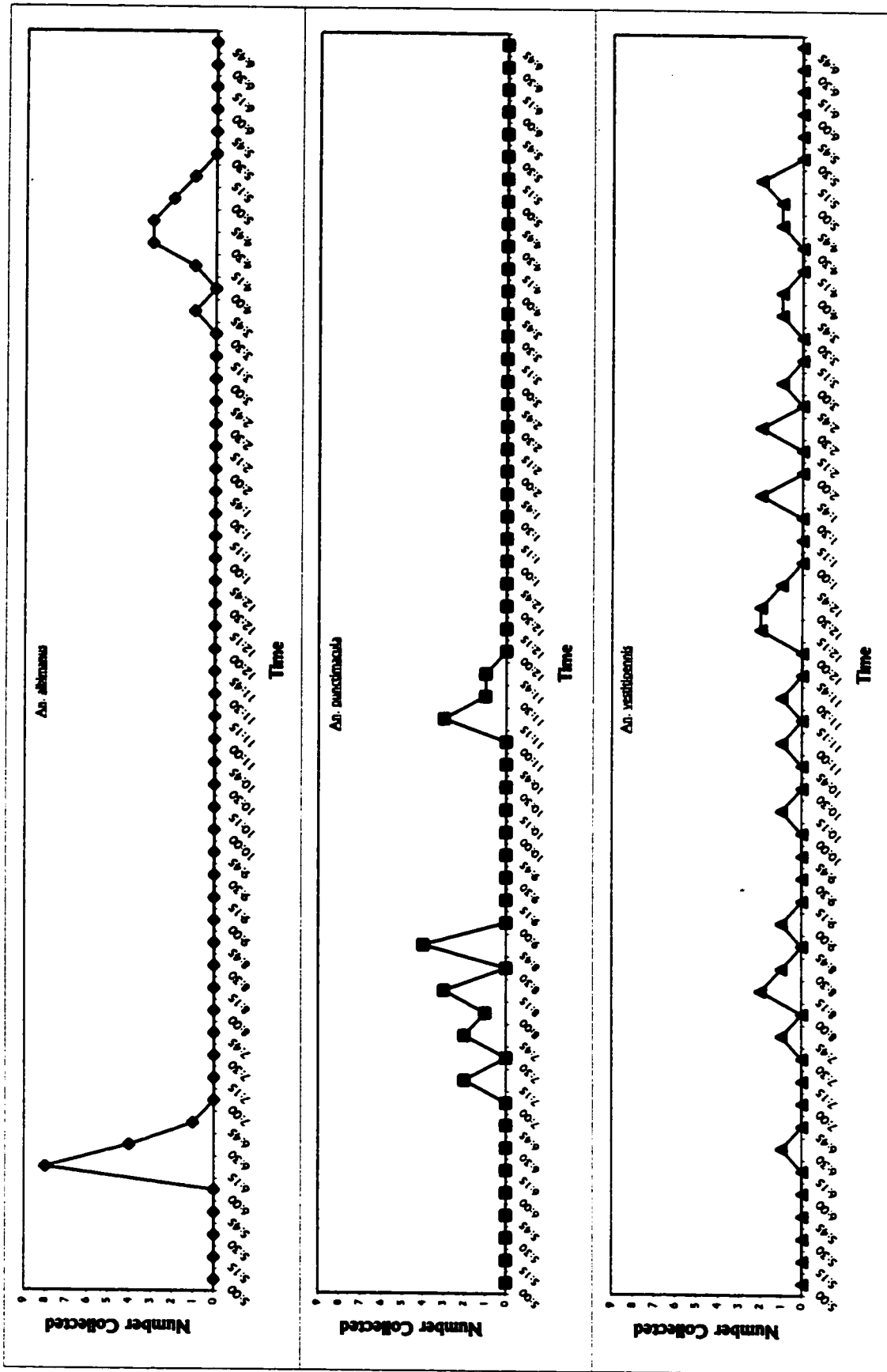

Figure 13: Number of *An. albimanus*, *An. punctimacula* and *An. vestitipennis* collected in a mobile car trap on 11 September 1998. Sample period was every 15 minutes and encompassed a 1 mile section of road in Rancho Village of the Toledo District, Belize.

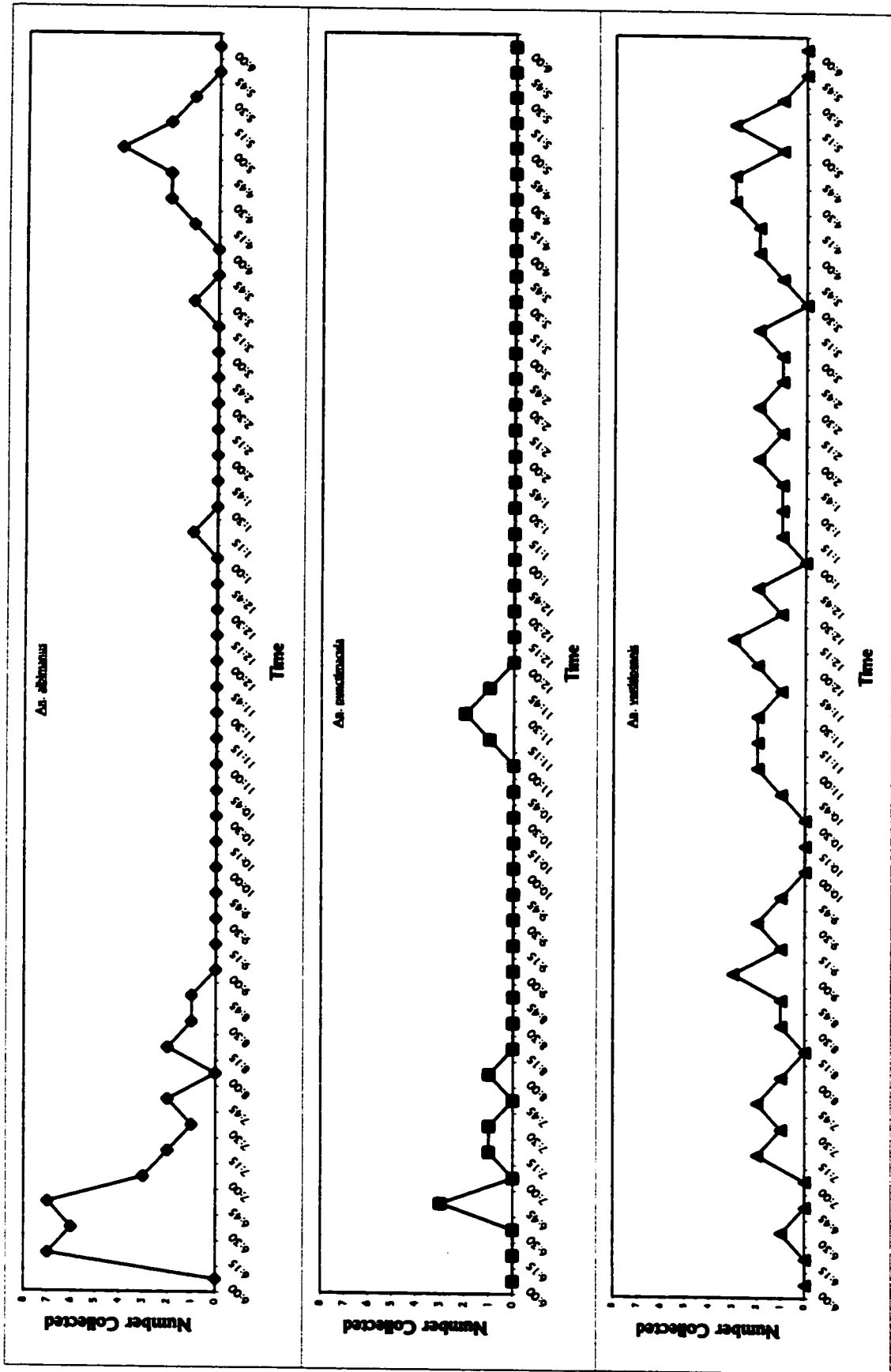

Figure 14: Number of *An. albimanus*, *An. punctimacula* and *An. vestitipennis* collected in a mobile car trap on 17 September 1998. Sample period was every 15 minutes and encompassed a 1 mile section of road in Rancho Village of the Toledo District, Belize.

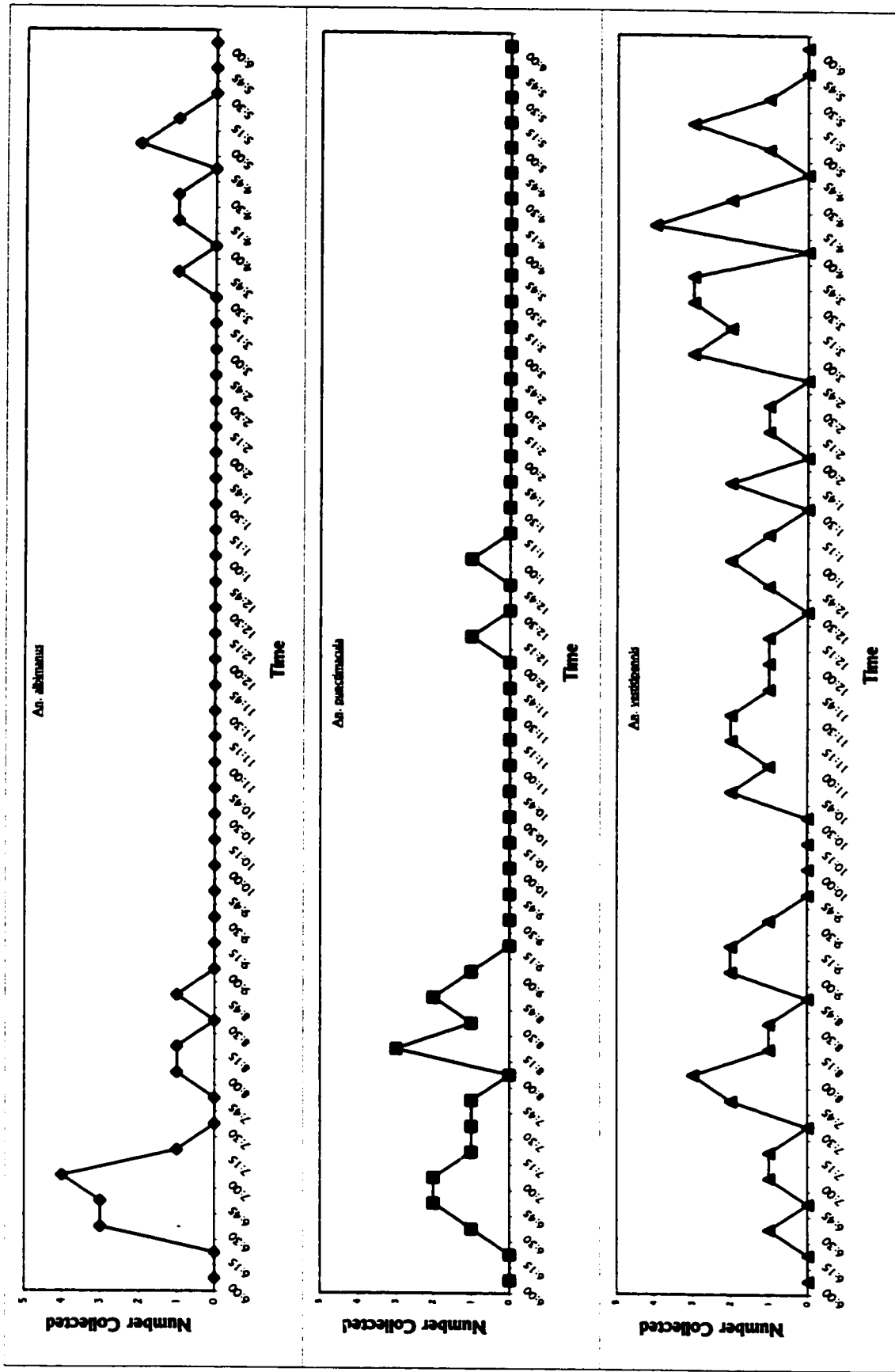

Figure 15: Number of *An. albimanus*, *An. punctimacula* and *An. vestitipennis* collected in a mobile car trap on 11 October 1998. Sample period was every 15 minutes and encompassed a 1 mile section of road in Rancho Village of the Toledo District, Belize.

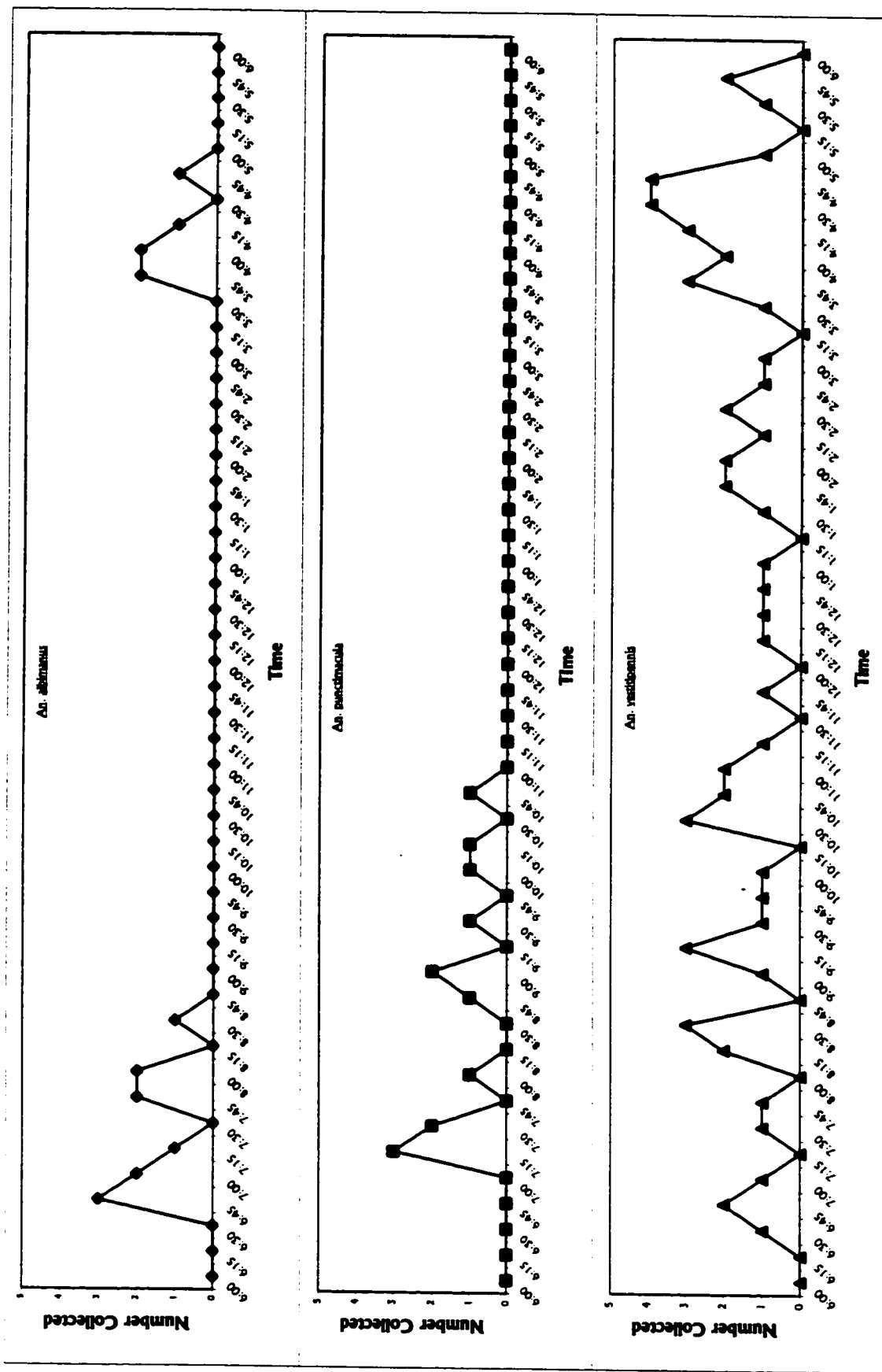

Figure 16: Number of *An. albimanus*, *An. punctimacula* and *An. vestitipennis* collected in a mobile car trap on 16 October 1998. Sample period was every 15 minutes and encompassed a 1 mile section of road in Rancho Village of the Toledo District, Belize.

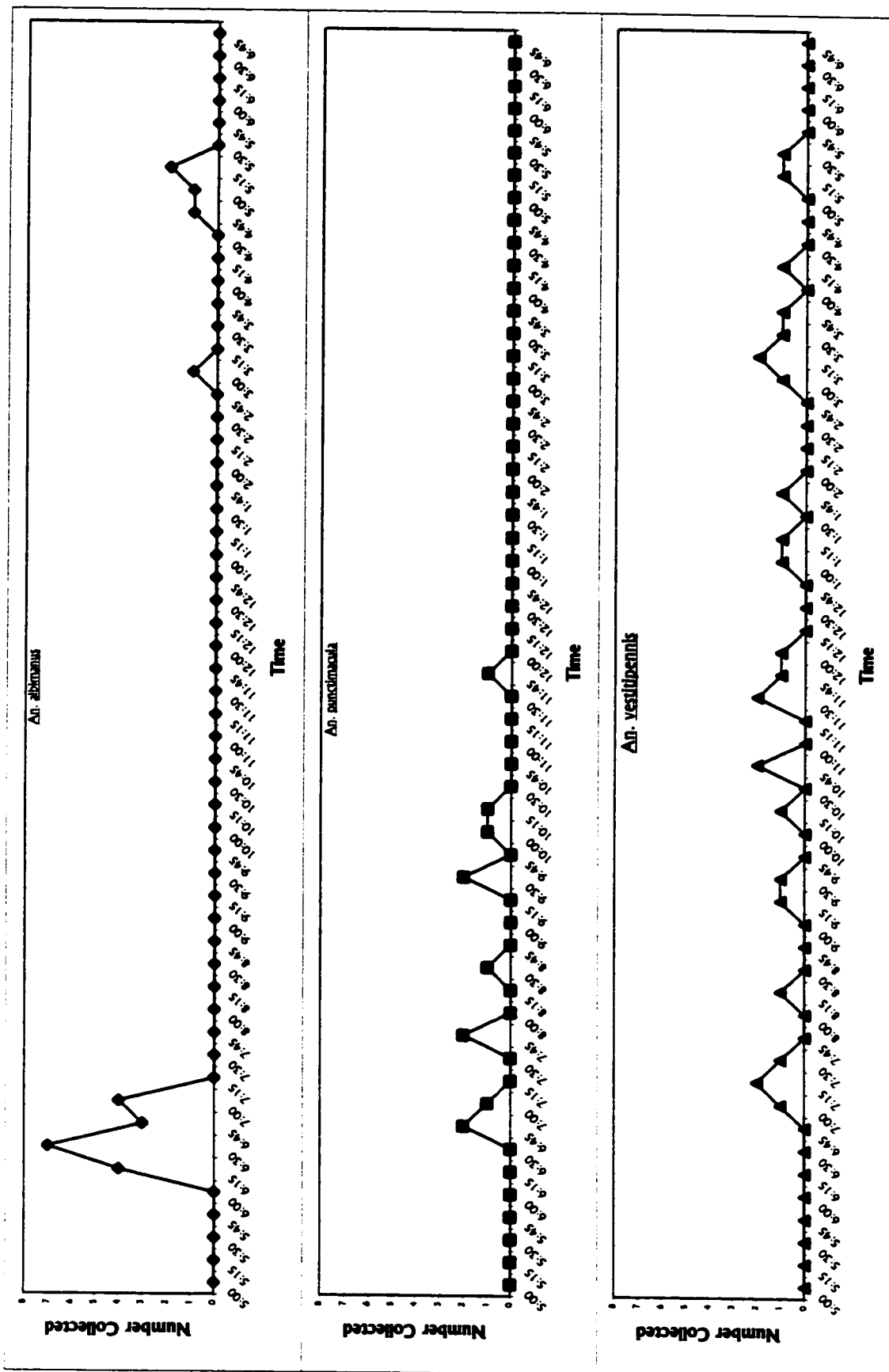

Figure 17: Number of *An. albimanus*, *An. punctimacula* and *An. vestitipennis* collected in a mobile car trap on 3 November 1998. Sample period was every 15 minutes and encompassed a 1 mile section of road in Rancho Village of the Toledo District, Belize.

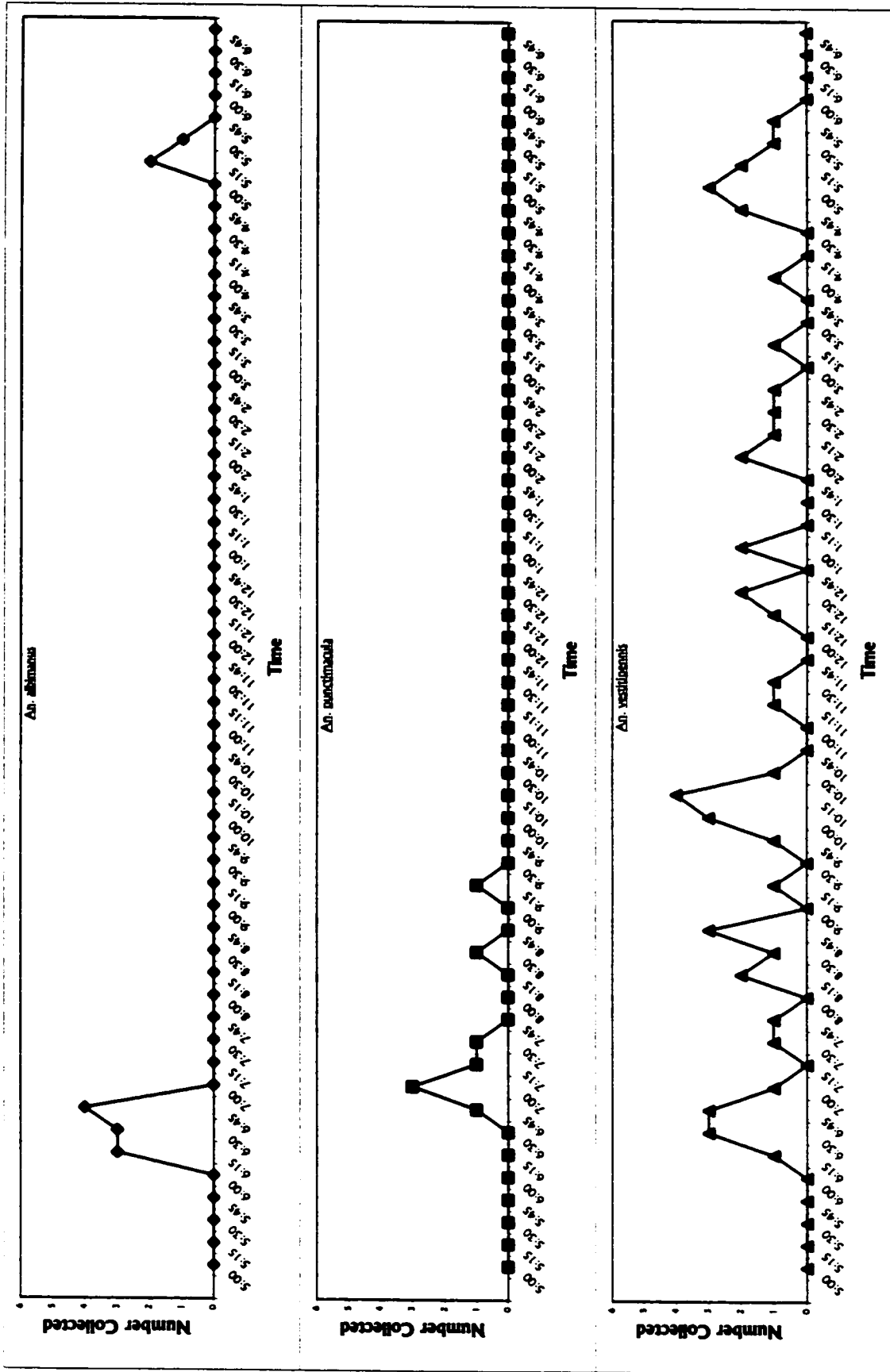

Figure 18: Number of *An. albimanus*, *An. punctimacula* and *An. vestitipennis* collected in a mobile car trap on 5 November 1998. Sample period was every 15 minutes and encompassed a 1 mile section of road in Rancho Village of the Toledo District, Belize.

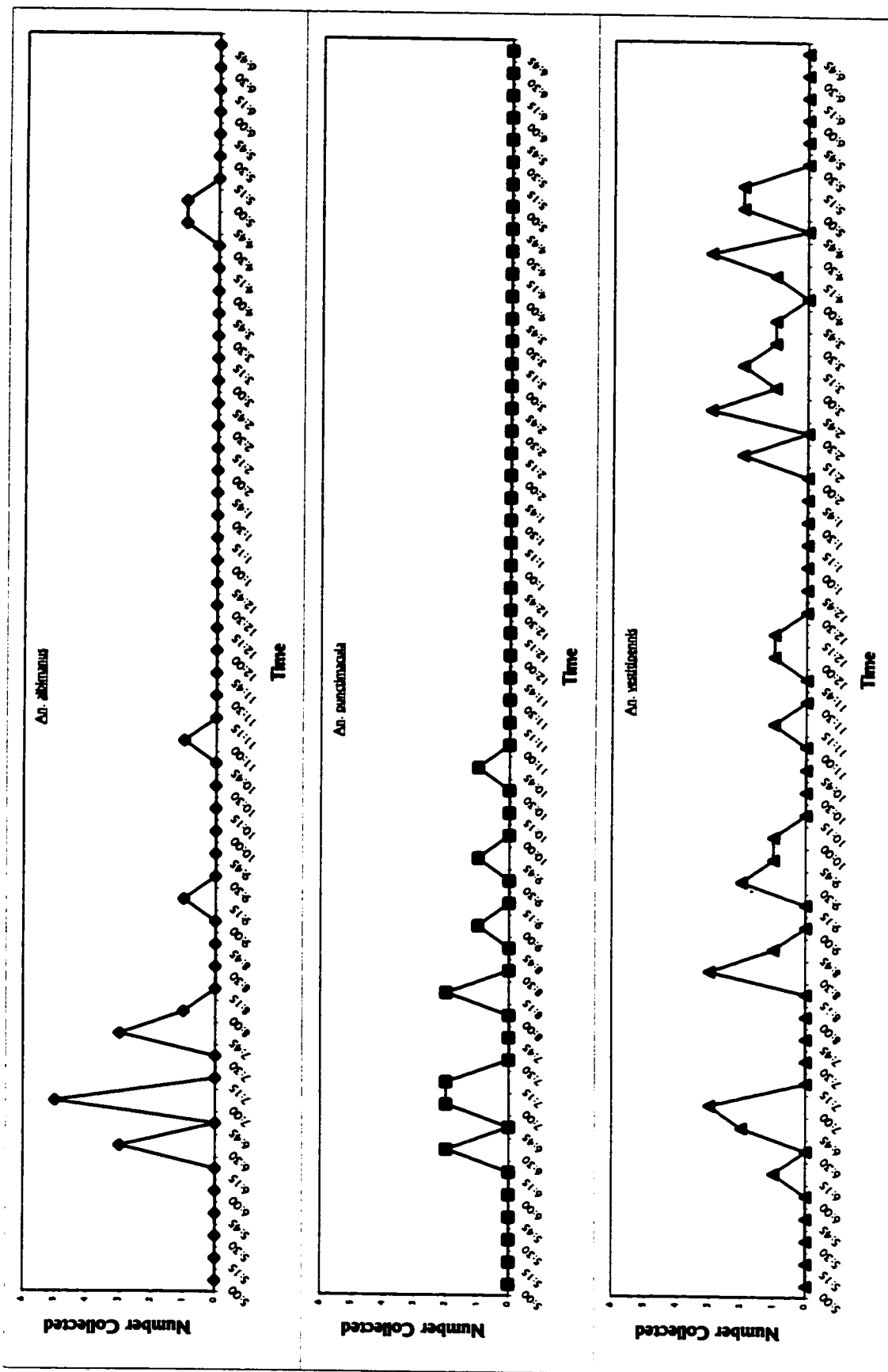

Figure 19: Number of *An. albimanus*, *An. punctumacula* and *An. vestitipennis* collected in a mobile car trap on 8 November 1998. Sample period was every 15 minutes and encompassed a 1 mile section of road in Rancho Village of

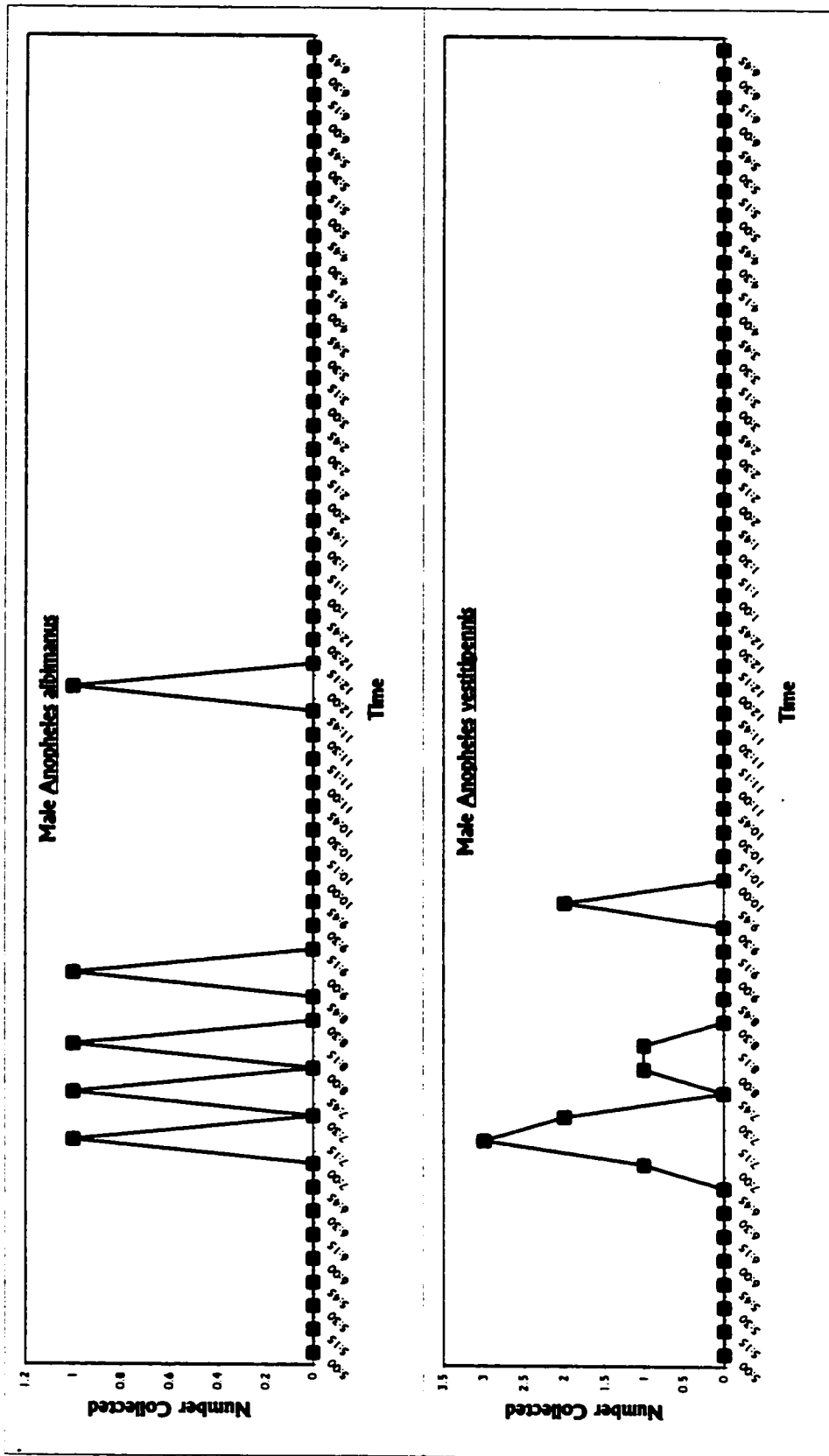

Figure 20: Total number of gravid *An. vestitipennis* and *An. albimanus* combined from 15 trap nights made between June and November of 1998 using the mobile car trap. Samples were taken every 15 minutes.

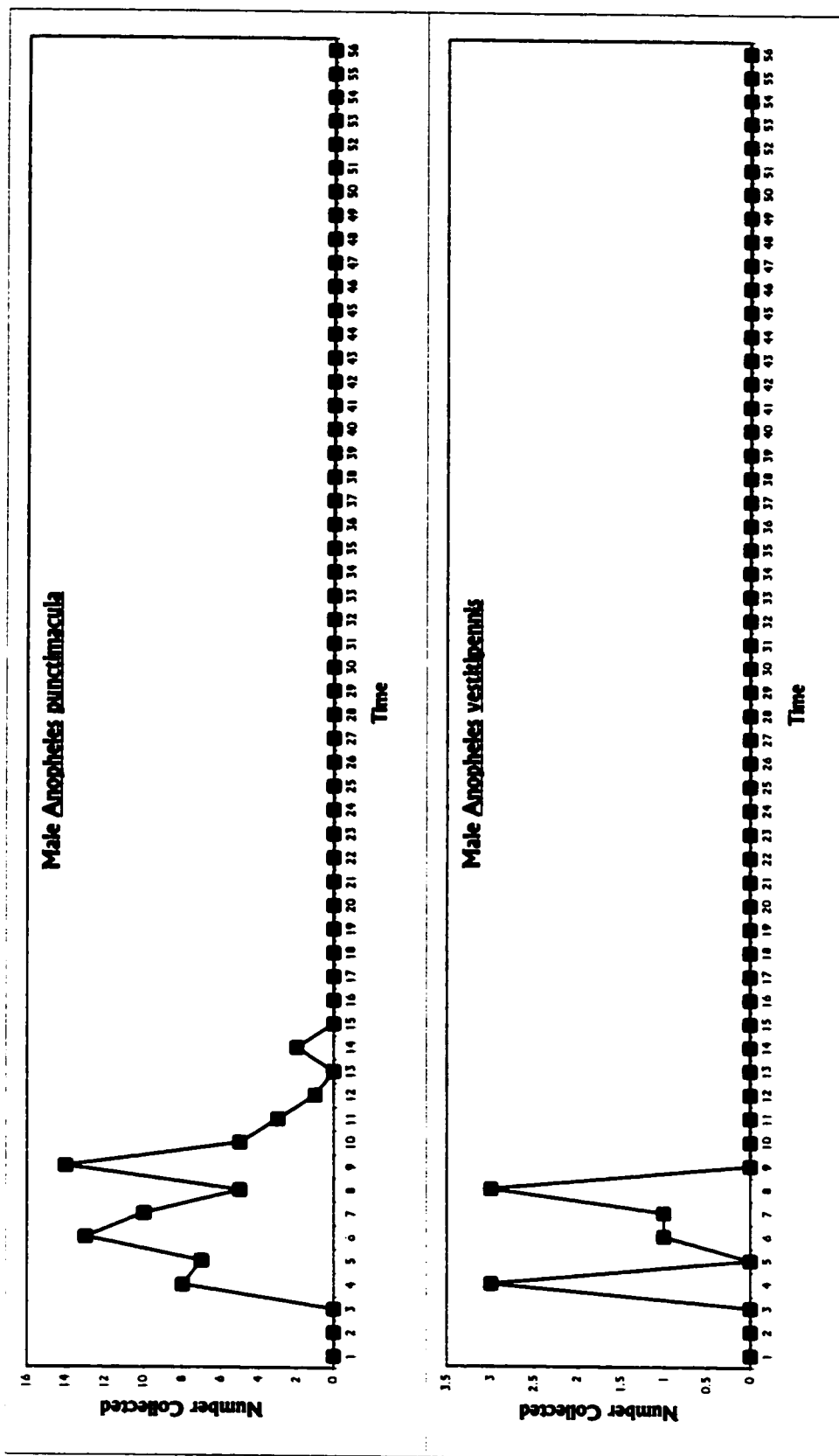

Figure 21: Total number of male *An. punctimaculata* and *An. vestitipennis* combined from 15 trap nights made between June and November of 1998 using the mobile car trap. Samples were taken every 15 minutes.

Blood Meal Collection - *Anopheles albimanus*

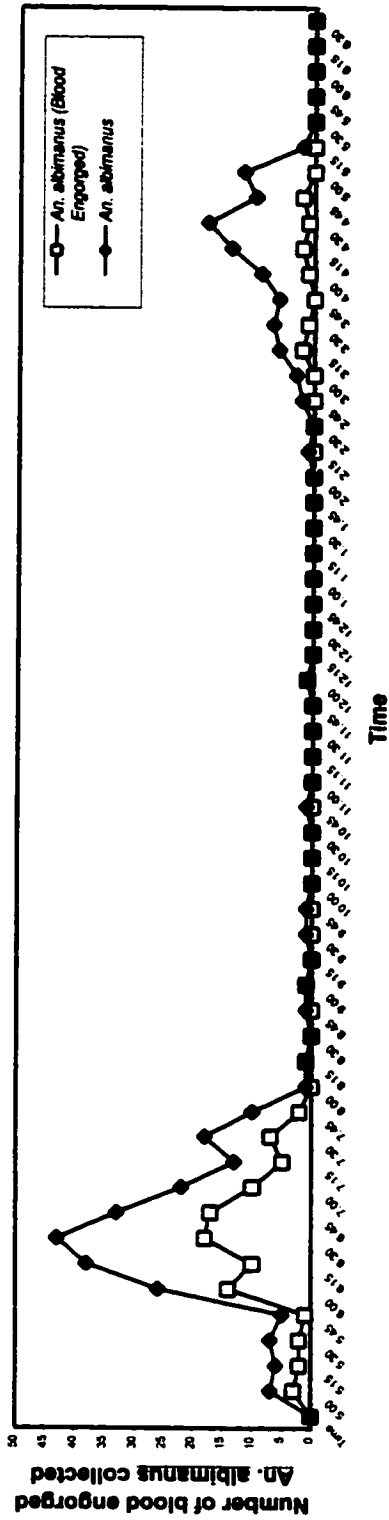

Figure 22. Comparison of the times of collection of all *An. albimanus* collected in the mobile car trap versus times of collection of blood engorged *An. albimanus*.

Blood Meal Collection *Anopheles punctimaculata*

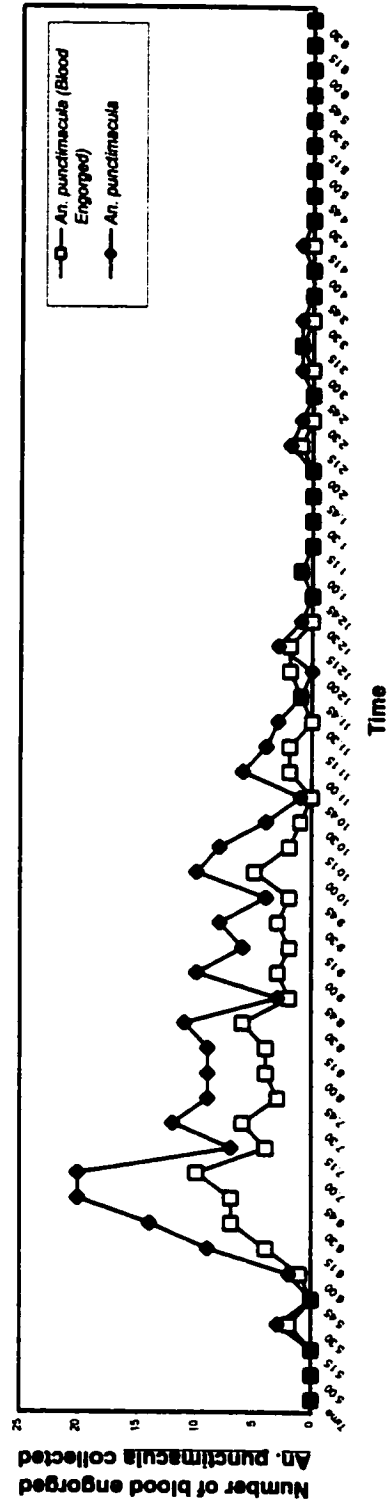

Figure 23. Comparison of the times of collection of all *An. punctimaculata* collected in the mobile car trap versus times of collection of blood engorged *An. punctimaculata*.

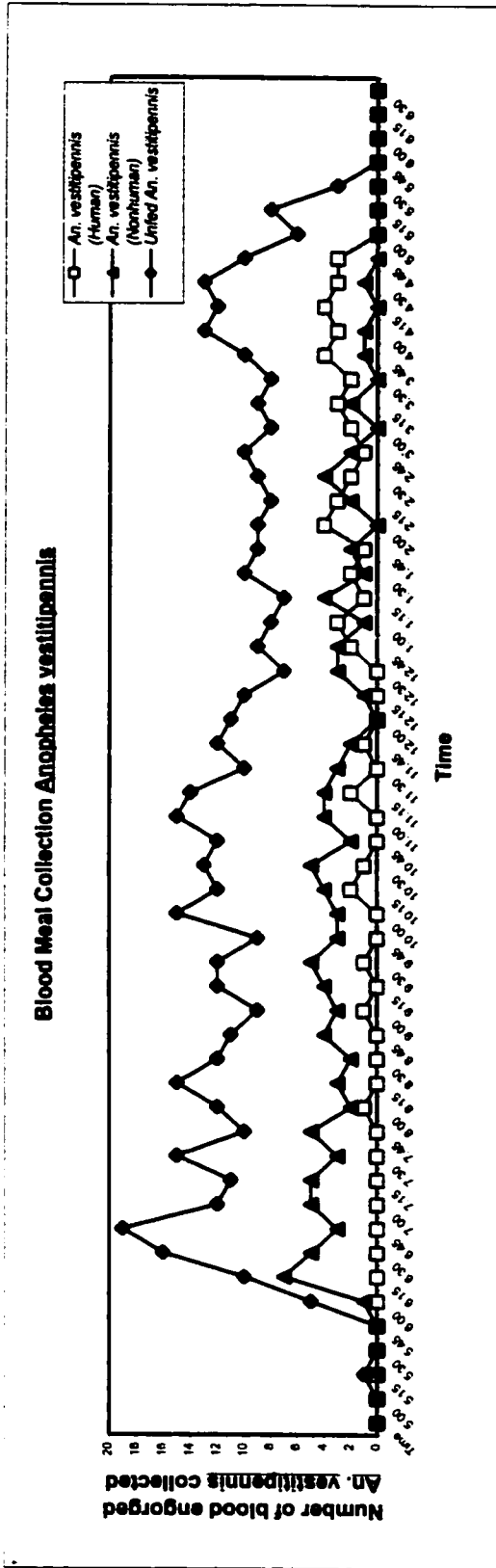

Figure 24. Comparison of the times of collection of *An. vestitipennis* collected in the mobile car trap which tested positive for human blood versus times of collection for *An. vestitipennis* testing positive for non-human blood and unfed *An. vestitipennis*.

Chapter 5

Host Feeding Preferences of Anopheles (Diptera:Culicidae) species Collected by Manual Aspiration, Mechanical Aspiration and from a Vehicle Mounted Trap in Toledo, Southern Belize, Central America

ABSTRACT

In October of 1997, a study was conducted to determine the feeding preference of the Anopheles found in southern Belize, Central America. This was an attempt to better define the vector potential of these species for the human malaria parasites Plasmodium vivax and P. falciparum. To accomplish this goal, a number of collection methods were employed for obtaining blood-engorged populations. These collection methods included manual aspiration from the interior and exterior surfaces of houses, backpack aspiration of vegetation and a mobile truck trap for sampling in flight mosquito populations. Blood-engorged specimens were then processed by blood meal ELISA.

A majority of An. vestitipennis collected both indoors and outdoors by manual aspiration tested positive for a human blood meal (88% and 67%, respectively). Seven additional specimens of An. darlingi collected in this manner also tested positive for human blood.

Specimens collected with the backpack aspirator showed that An. vestitipennis fed in almost equal numbers on humans and cattle (44% and 43%, respectively) with only limited numbers feeding on pigs and dogs. A large proportion of the An. albimanus specimens (68%) collected in this manner tested positive for cattle blood while the remaining specimens tested positive for (in order of importance) pigs, humans and dogs.

The car top trap collections resulted in the second largest number of blood engorged An. albimanus and the largest number of An. punctimacula. Specimens of An. vestitipennis tested positive for cow blood (108) and human blood (52). The remaining specimens tested positive for dog and pig blood. Almost all specimens of An. albimanus were positive for cow (98) with only 4 and 1 testing positive for dog and pig,

respectively. Anopheles punctimacula specimens also tested high for bovine blood (87), with the rest testing positive for canine (2) and human (1) blood.

After analyzing the data from the An. vestitipennis samples using the feeding index, the ratio of human blood to all other sources showed indices greater than 1 in all relationships except for the human:cow ratio for specimens collected from the car top trap. After adjustment for differences in host size, however, this value also showed that the human host was preferred over cattle. Anopheles albimanus showed a strong tendency to feed on cattle. In all instances, except for samples collected by backpack aspiration there was a preference for feeding on cattle over humans, pigs and dogs. Anopheles punctimacula also showed a strong tendency for feeding on cattle over humans and other domesticated animals. The exception occurred with specimens collected with the backpack aspirator which showed a preference for feeding on pigs.

The foraging ratio does not allow adjustments for vector and host factors, such as variations in host body size, but does allow for comparisons of one host versus all other species. Foraging ratios for the three Anopheles species were very similar to the feeding indexes. The samples which came from all three collection methods showed that An. vestitipennis exhibits a strong preference for human blood. The strength of this association decreased as the area of collection was expanded outward from an area of human habitation. The foraging ratios for An. albimanus consistently demonstrated a feeding preference for non-human hosts. As with previous studies, An. albimanus seemed to prefer cattle and pigs to almost all other host species. This feeding pattern is consistent with An. albimanus' crepuscular, exophagic feeding behavior. During times when this species is feeding, most humans are inside their homes eating or preparing for

sleep. Therefore, the only hosts available to be fed upon are non-human in nature. The same appears to hold true for An. punctimacula which also showed a preference for cattle and pigs.

INTRODUCTION

A key component of arthropod-borne disease epidemiology is the specific host range of the vector species in question. More importantly, one must determine the proportion of feeds which occur on humans in order to assess capacity of arthropods to transmit disease to humans (vectorial capacity). Care must be taken to account for factors which may alter the true estimate of feeding preference. Examples of these factors are the sensitivity and specificity of the blood meal assay, the host and vector dynamics and the type of statistical treatment applied to the research data.

A variety of laboratory techniques have been used for mosquito host preference studies. These techniques range from non-serological approaches such as the use of animal-baited traps (Nelson et al. 1976, Weitz 1960, Mitchell and Millian 1981) to serological tests such as the precipitin test (Nuttall 1904, Bull and King 1923, Weitz 1960; Tempelis and Lofy 1963; Tesh et al. 1971; Eliason 1971; Crans 1969), the fluorescent antibody technique (FA) (McKinney et al. 1972), the passive hemagglutination inhibition test (PHI) (Boreham 1975, Weitz 1963, Tempelis and Rodrick 1972), the use of DNA fingerprinting (Coulson et al. 1990), DNA dot blot hybridization (Sato et al 1992) and the enzyme-linked immunosorbent assay (ELISA) (Burkot et al. 1981, Edrissian and Hafizi 1982, Chow et al. 1993).

In the past, mosquito blood meal identification relied on the use of nonspecific serological techniques such as the modified precipitin test utilized by Tempelis and Lofy in 1963. The precipitin test employs a known antiserum which is placed in a microhematocrit tube and then overlaid with the unknown blood meal. The formation of a precipitate at the interface of the two liquids is indicative of a positive reaction for that

host species. Mosquito blood meals also have been identified using an agar gel diffusion known as the Ouchterlony test (Crans 1969), the microplate method (Tesh et al. 1971) and the gel surface precipitin test (Eliason 1971). Although these tests are cheap and easily performed, they lack both sensitivity and specificity (Washino and Tempelis 1983). A lack of sensitivity is a problem when testing samples that contain only a small quantity of blood, as in the case of a small insect like Culicoides or partial blood meal in mosquitoes. A lack of specificity has been reported by some researchers (Tempelis 1975) which has resulted in the misidentification of multiple blood meals. It was apparent that a more accurate test that maintained a high level of both sensitivity and specificity was needed to correctly identify the composition of arthropod blood meals.

The use of the enzyme linked immunosorbent assay (ELISA) for the study of malaria was first postulated by Voller et al. (1974). This indirect ELISA was later modified by Burkot et al. (1981) for the identification of laboratory-fed Aedes triseriatus. Other ELISA methods include the direct ELISA and the sandwich ELISA. The direct ELISA (Edrissian et al. 1985, Beier et al. 1988) depends on the blood meal antigen adhering directly to the wells of a microtiter plate. A primary host-specific labeled antibody, which has been conjugated to an enzyme is added to the well. The bound antigen/antibody complex can then be visualized by way of a color change elicited by an enzymatic substrate. This procedure is primarily used when the antigens in the sample are in great abundance and when labeled antibodies are readily available.

If labeled antibodies are not available then the indirect method (Burkot et al. 1981, Burkot and DeFoliart 1982, Burkot et al. 1988, Tesh et al. 1988, Chow et al. 1993) is more appropriate for blood meal analysis. The indirect ELISA utilizes an unlabeled

primary antibody which reacts with the blood meal antigen. This product is reacted with a second labeled antibody which reacts to the primary antibody and, it turn, elicits a color change in the presence of an enzyme substrate.

The most widely used technique is the sandwich ELISA (Service et al. 1986, Chow et al. 1993). The sandwich ELISA is seen as the most sensitive and specific blood meal analysis (Chow et al. 1993). It successfully identifies small amounts of antigen such as that found in a partial blood meal (Kirkegaard and Perry Laboratories 1990). The sandwich ELISA uses capture antibodies that are plated in a 96-well microtiter plate. The most widely used antibodies are IgG and IgM due to their ability to remain active for an extended period of time (Tesh et al. 1988). These antibodies are responsible for capturing homologous antigen found in the blood sample. This antigen/antibody complex is then recognized by a second antigen-specific-enzyme-conjugated antibody. Once again, this enzyme elicits a color change when in the presence of an enzymatic substrate.

There are several advantages of using a sandwich blood meal ELISA over other techniques. The main advantage is its high level of specificity and sensitivity as compared to either the direct or indirect ELISA (Chow et al 1993). When tested on blood meals of known origin, the sandwich ELISA was able to identify 100% of blood meals taken ≤ 32 hours after feeding and 80% of blood meals taken ≤ 42 hours after feeding. This compares with 100% of blood meals being detectable ≤ 26 hours after engorgement and only 50% ≤ 40 hours after engorgement using the direct ELISA. Overall, Chow et al. (1993) found that the sandwich ELISA was able to correctly identify 88% of samples tested; whereas, the direct ELISA was able to identify only 41% of samples tested.

Foraging Strategy

To understand feeding preference behavior, one must first understand the driving forces behind that behavior. Organisms must maximize the energy gained from their food source in relation to the amount of energy that is expended in finding and consuming that food source. The net nutritional gain must be greater than or equal to the gross caloric intake minus the total daily caloric expenditure (Alcock 1989). Applying this to mosquitoes, larger animals may be easier to obtain a blood meal from but be less abundant and require more energy to locate (except in the case of an animal which congregates in herds such as cattle). The alternate condition may also hold true in that a smaller animal may be more difficult to obtain a blood meal from but be more common, so finding smaller hosts requires a minimal energy expenditure. The difficulty in acquiring a blood meal from a smaller host may be due to a limited availability of host surface area from which to feed or the animal may be less tolerant of even moderate numbers of biting insects (Cully et al. 1991).

In addition to energy constraints, consideration must be given to the time the organism must spend exposed to predators and other detrimental conditions, such as inclement weather. These conditions are often referred to as nutritional constraints. Alcock (1989) stated that organisms will opt for a less profitable, but safer feeding behavior, if unfavorable conditions such as predation and adverse weather exist. Another nutritional constraint on foraging behavior is the defensive postures that a potential host exhibits when being fed upon. Large animals such as cattle exhibit less defensive behavior in the presence of a moderate mosquito attack (20-30 mosquitoes) than would a smaller animal such as a mouse or chipmunk (Reeves 1971, Cully et al. 1991). Culex

tarsalis Coq. will switch its feeding preference from avian hosts to larger mammals, like cattle, when the mosquito populations are at high density (Reeves 1971). Most birds are intolerant of large numbers of attacking mosquitoes and will actively defend themselves against being fed upon.

There are underlying physiological benefits associated with a particular feeding preference. The nutritional properties of various types of host blood can determine the protein content of the mosquito egg and thereby affect the overall fecundity of an individual mosquito. This was demonstrated by Briegal et al. in 1990 when they fed *Ae. aegypti* on either human blood or guinea pig blood. Eggs produced from the human blood showed a lower level of protein acquisition than did the eggs produced from the guinea pig blood. The level of protein in the egg is a determining factor in the size and health of the developing larva. For this reason, it is beneficial to the survival and success of a mosquito species to select blood sources that will provide a high level of nutrition to its offspring and yet require a low expenditure of energy in blood meal acquisition.

Feeding Behavior

A variety of terms have been used to describe mosquito feeding patterns associated with host selection. These patterns are defined as the relative frequency of various types of blood meals in a population of mosquitoes in a defined location during a defined period of time (Boreham and Garrett-Jones 1973). Feeding patterns can be associated with a number of factors which include feeding preference (Boreham and Garrett-Jones 1973), host availability (Hess et al. 1968), host density (Edman and Webber 1975) and host defensive behavior or host irritability (Edman and Kale 1971).

Host preference is defined as a choice made on the part of a mosquito population to select one host species over other species that are equally available (Boreham and Garrett-Jones 1973). Feeding patterns often fall under two distinct categories. The first is described as “opportunistic” (Edman et al. 1972). This type of behavior is characterized as nonspecific feeding in which the mosquito feeds on the most available host at a particular time and place. Opportunistic feeding behaviors often results in different feeding patterns associated with changing availability of the host population in different seasons and location. A second type of feeding behavior was given the term “fixed” (Edman et al. 1972). It is characterized by host selection, which is not influenced by host availability. A mosquito population that exhibits a fixed pattern of feeding will feed on one host regardless of season and availability of possible alternative host. McCrae et al. in 1976 showed that a forest dwelling anopheline, Anopheles implexus (Theobald), feeds primarily on cattle. This species left the forest on a hunting flight pattern in order to obtain a blood meal from cattle. Humans were fed on by this species but only when the humans traveled into forested areas where resting populations of An. implexus were located. Thus humans were an opportunistic host, which was only fed on due to the proximity of the host to the mosquito in its natural resting habitat. Given the natural behavior of the mosquito, however, An. implexus preferred to feed on cattle.

The importance of determining the host range of various mosquito species was discussed by Chandler et al. (1976) in a study conducted on mosquitoes from Kenya. They concluded that species with a narrow range of hosts are more likely to be vectors of parasitic diseases such as malaria and those with a wide range of hosts are more likely to be involved in arboviral transmission.

The occurrence of multiple feedings within a single gonotrophic cycle was emphasized by research of Boreham and Garrett-Jones in 1973. They described multiple blood feeding as the acquisition of two or more blood meals, the last of which had been taken before the first had been digested beyond the point of identification. Multiple blood meals have been identified for a number of mosquito species (Boreham and Garrett-Jones 1973, Downe 1960, Edman and Down 1964, Rempel et al. 1946, Senior-White 1952, Shemanchuk et al. 1963). Most multiple blood meals have contained only two components. Senior-White in 1952, however, found that some specimens of An. aquasalis collected from Trinidad contained blood from three and four different host sources.

Within the framework of mixed blood meals is the concept of a “cryptic” multiple blood meal. The components of this type of blood meal are from the same host species but come from two different individuals (Boreham and Garrett-Jones 1973). Researchers have attempted to identify multiple human blood feeds by utilizing novel serological techniques for blood meal analysis. One of these tests utilized the agglutination technique for typing of ABO blood groups (Boreham and Lenahan 1976). This technique successfully identified the components of cryptic blood meals in Ae. aegypti up to 30 hours after feeding and in An. stephensi for between 24 and 30 hours.

The epidemiological implication of multiple blood meals is increased potential for disease transmission by mosquito populations. If an infectious mosquito is prevented from acquiring a full blood meal and is forced to complete its feeding on one or several additional hosts, the potential for transmitting disease to multiple hosts is increased. In addition to increased host contact, Downe (1965) showed that the length of time taken to

digest the first component of a partial blood meal is increased by 2 to 12 hours after the second component is ingested. This increase allows for additional time for malarial parasites acquired in the first meal to penetrate the gut and infect the mosquito. Boreham and Garrett-Jones (1973), on the other hand, postulated that the first meal would be encased in the second meal creating a barrier through which ookinetes may not be able to penetrate.

Data Analysis

Various approaches to host preference studies have been discussed in the literature. Researchers have suggested that there are inherent biases associated with blood meal identification studies. The main focus of controversy has been on the bias of host availability at the collection site. This is commonly referred to as a problem of host availability versus host preference. A clear distinction should be made between a true preference for a given host type and an opportunistic feeding behavior.

Presentation of blood meal data is particularly problematic. Historically, the data was crudely presented as percentages. Garrett-Jones (1964) developed the concept of the Human Blood Index (HBI) which he defined as the proportion of freshly fed anophelines found to contain human blood. This was problematic due to the inability to obtain a representative sample for the HBI. He suggested that the best way to obtain an accurate estimate was by taking the unweighted mean of samples collected from human living quarters and from other mosquito resting habitats. The HBI can also be adjusted by ranking availability of human and animal hosts, and converting the ranks into a modified foraging ratio (Loyola et al. 1993).

The foraging ratio was initially designed to determine the food preference of herring (Savage 1931) and stream food gradients as they apply to trout habitat (Hess and Rainwater 1939). This foraging ratio was later adapted to the feeding habits of other species, including mosquitoes (Hess et al. 1968). The foraging ratio is more specifically defined as the percent of blood-fed mosquitoes that fed on a particular vertebrate host divided by the percent which the particular host represents out of the total population of available hosts in the range of the mosquito. Values greater than 1 indicate a feeding preference, less than 1 a feeding avoidance, and a value of 1 represents an opportunistic feeding behavior.

A number of difficulties arise when trying to analyze data using the foraging ratio. These difficulties were reviewed by Edman (1971). He stated that the foraging ratio does not take into account differences in defensive behavior exhibited by different hosts or any temporal differences in the availability of the hosts. In addition, the foraging ratio requires a numerical census of all animals in the study area, a difficult task to accomplish.

The inability of the foraging ratio to be adjusted for other variables such as defensive behavior and variations in host body size, led Kay et al. in 1979 to propose the Feeding Index (FI). They defined the Feeding Index as the proportion of feeds on one host with respect to another divided by the expected comparative proportion of feeds on those 2 hosts based on factors affecting feeding. The expected comparative proportion is actually the ratio of population density of host one in relation to population density of host two. The analysis of this type of data is similar to the foraging ratio in that values greater than one are taken to be a feeding preference, values less than one a feeding avoidance and values equal to one indicate no preference.

The Feeding Index takes into account the temporal and spatial occurrence of vector species, defensive behavior, host size and mosquito abundance. It also eliminates the need for the researchers to obtain a detailed census of all possible hosts within a study area. The one drawback, however, with this analysis is that it only compares the feeding preference associated between two particular species; whereas, the foraging ratio takes into account the preference for one species in comparison to all other species at the same time.

Studies conducted on the feeding preference of *An. albimanus* (Garrett-Jones 1964; Breeland 1972; Garrett-Jones et al. 1980; Loyola et al. 1993) all conclude that this species is zoophagic, with a particular opportunistic feeding behavior favoring mammalian hosts. Additionally, it appears to prefer feeding on large domestic animals such as horses, cattle and pigs rather than on humans (Loyola et al. 1993). Preference for feeding on cattle and other non-human hosts was also shown by Bangs (1999).

Studies conducted on the feeding preference of *An. vestitipennis* are few in number. While species may be composed of sibling species that exhibit different feeding patterns and preferences (Arredondo-Jimenez et al. 1995), overall, *An. vestitipennis* was shown to more strongly prefer human hosts than *An. albimanus*. Bangs (1999) also suggested that the foraging ratios show *An. vestitipennis* prefer human hosts and *An. albimanus* prefer cattle. The main focus of the present research was to define the specific host feeding preference of malaria vectors in southern Belize.

Material and Methods

In October of 1997, experimental trials were conducted to determine effective methods for the collection of blood-engorged female anophelines. These initial trials were conducted at two separate sites, Golden Stream (N 16 21.820, W 88 50.529) and Rancho (N 16 09.954, W 88 50.529) (Figure 1). Golden Stream is a village of approximately 422 individuals and 94 homes. The ethnicity of the village is predominately Mopan Indian and Kethci. The village is situated inland from the coast, along the Southern Highway in the Toledo District, Belize. It is located on a clean fast flowing river which is fed by both natural spring water and mountain rain runoff.

The second site was the village of Rancho. A 1998 census estimated the population of Rancho to be 824 individuals living in approximately 166 houses with an ethnic composition of Ketchi, East Indian and Garfuna. The village is located about 4 miles from the Gulf of Honduras and is situated on the outskirts of the town of Punta Gorda in the Toledo District, Belize. Both sites were among the 5 villages with the highest number of malaria cases in Toledo District for 1997. Results from initial trials showed Rancho to be more secluded and to provide greater opportunities for conducting a series of uninterrupted studies. Consequently, all resources and efforts were then focused on the village of Rancho.

Attempts were made using a hand-held sweep net to collect resting populations in vegetation surrounding human habitations. The net loop was a standard 16-inch diameter ring that was fitted with a heavy canvas collection bag. This type of material

was required to ensure that the net would not tear in the heavy underbrush. A collection sample came from small plots of vegetation which were 15 paces by 15 paces square (approximately 30 ft by 30 ft). Two forceful sweeps were conducted per pace for a total of 450 sweeps per plot. Usually, two to three plots were sampled per day.

At the end of 30 sweeps, a ball of cotton soaked with chloroform was quickly placed in the sweep net, and the net was tied off to prevent any mosquitoes from escaping. While the contents of the first net were being knocked down, a second net was used to make another pass of 30 sweeps, and the above procedure was repeated. At the end of the second pass, the first net was untied, the contents poured into a white enamel pan, and the contents were examined for blood-engorged female mosquitoes. Mosquitoes were removed with forceps and placed into labeled eppendorf vials. Holes were punctured in the lids of the vials and the vials were placed in a larger container of desiccating silica gel. At the laboratory, the mosquitoes were identified to species and placed into separately labeled eppendorf vials, placed on silica gel, and processed for the blood meal and sporozoite ELISA.

Initial attempts were also made to use resting boxes for collecting blood-engorged females. Two identical boxes were constructed and placed at sites in both Golden Stream and Rancho. The box in Golden Stream was placed in an open field adjacent to the river. The box was destroyed by vandals shortly after construction and was not replaced. The second box was placed at Rancho along a fence line within 100 feet of human habitation. These resting boxes (Figure 2) were a modified pyramid style design of Janousek (per comm.). The main body of the resting box measures 2 ft by 2ft by 2 ft with a pyramid style roof. The bottom of the trap was left open to allow for mosquitoes seeking a resting

site to enter the box. One side of the roof was hinged and latched to allow for access to the interior of the box, allowing spider webs, wasp nests and other intruders to be easily removed. Legs (2 ft high) were attached to the box in order to keep the underside of the trap exposed and elevated above tall vegetation. A mechanical aspirator was used to sample from the box in both the morning and the evening. Mosquitoes collected in the resting boxes were processed in the same manner as described for specimens obtained through sweep netting.

Another method employed for collecting blood-engorged specimens was the inverted refuse container designed by Weathersbee and Meisch (1988). Two darkly colored, 5-gallon rectangular Rubbermaid® refuse containers were placed on their side. Funnels constructed of wire and black plastic were placed in the openings of the containers. Both containers were placed at the Rancho Village location. One container was placed adjacent to the experimental huts while the other was placed against an existing fence line. The fence line was located about 20 meters from several human dwellings as well as from three experimental huts. Earlier, numerous blood engorged specimens had been collected from this area using the backpack aspirator and thus it was considered to be a suitable location for a resting box.

Indoor and outdoor resting collections were also made at the Rancho location. These collections consisted of two collectors searching the interior and exterior surfaces of a house for two hours immediately after sunset. One collector searched the exterior of the house (to include the walls, thatch, stools, woodpile, bicycles etc.) while the other collector searched all aspects of the interior of the hut (to include walls, thatch, tables, chairs, grain bags etc.). To eliminate bias, collectors switched positions (indoor/outdoor)

every 10 minutes. Sampling of resting mosquitoes would continue in this manner for a period of 2 hours. Blood-engorged mosquitoes were aspirated with a mouth aspirator and placed in a cardboard carton labeled with the location (IN or OUT), and date of collection. When collectors switched their position the carton would remain in its original location. At the end of the collection, cotton balls soaked with chloroform were placed on top of the cartons in order to kill the mosquitoes. The mosquitoes were returned to the laboratory where they were identified and placed in labeled eppendorf vials. They were then placed on silica gel, until they were processed using the blood meal ELISA.

The most successful collection method was the use of a backpack aspirator to sample vegetation and other outdoor resting sites for blood-fed anopheline mosquitoes. A 12V DC backpack aspirator (BioQuip Products, Inc. 1997) was used to sample a variety of outdoor resting sites. These sites included localities along tree and fence lines, off of the walls of animal sheds, from under inverted canoes and along fallen logs and other thick stands of vegetation. The aspirator was operated for 5 minutes, then the contents of the collection cup was examined for blood engorged mosquitoes. If an engorged mosquito was found, it would be removed and placed in an eppendorf vial. The label would contain information about the location, date and area in which the mosquito was found. Captured specimens were returned to the laboratory where they were identified and preserved dry on silica gel for later processing.

Site Selection for Car Top Trap

A series of collections was conducted from June to November of 1998 on a 1-mile stretch of road near the town of Rancho (Figure 1 and 3). The study site was selected based on the following attributes: 1) a series of preliminary larval collections confirmed it to be adjacent to breeding sites of Anopheles vestitipennis, An. albimanus and An. punctimacula, 2) the presence of both human habitations and cattle pastures interspersed along the route and 3) a low volume of vehicle traffic allowing for uninterrupted collection runs.

Three separate breeding sites were identified prior to the start of the study. An. albimanus was found to be breeding in a wet rice field at the southern end of the route. Larval collections conducted in April and May of 1998 resulted in an average of 35 larvae per dip. In the center of the route were located two separate breeding sites. To the west of the route was a flooded forest area where An. punctimacula were collected. Larval collections conducted in the flooded forest during this same time period resulted in an average of 3 larvae per dip. This site also yielded minimal numbers of An. albimanus larvae. Directly opposite the flooded forest on the eastern side of the road was a Typha marsh which was populated with An. vestitipennis larvae. Collections made during the summer of 1998 resulted in the average collection of 0.7 larvae per dip.

Two human dwellings were also located along the collection route. Both were Mayan structures composed of wood plank walls and thatch roofs. The most southerly structure housed a family of five individuals (2 adults and 3 children) and was located approximately 15 feet from the road. A variety of animals were located at the house including dogs, chickens, turkeys, pigs and on various occasions, cattle. The most northerly structure housed a family of 4 individuals (2 adults and 2 children) and was

located approximately 100 feet from the road. The house also had a variety of animals located on the premises including dogs, chickens, turkeys and pigs.

Two large cattle pastures were located on the eastern side of the road.

Approximately 45 head of cattle and 2 horses were rotated between these two pastures at various times throughout the year. The remainder of the land surrounding the collection site is either agricultural (i.e. wet or dry rice fields) or natural (i.e. flooded forest.)

A portable weather station (Davis Instruments, Weather Monitor II) was affixed to a cattle gate located in the middle of the 1-mile section of road. Meteorological data, to include temperature, wind speed and direction, relative humidity and barometric pressure were collected every 15 minutes to coincide with the collection intervals. The data were later downloaded to a computer database (PC compatible Weatherlink software.)

Car Trap Construction

The modified vehicle mounted trap was based on the design of Bidlingmayer (1974) (Figure 4). The frame of the trap was constructed using sections of 1/2 inch PVC pipe to which a pyramid shaped piece of green polyester netting with a mesh size of 530 μ (Bioquip Products) was attached. This pyramid shaped netting tapered back to a plastic funnel encased in a PVC pipe coupler that had an interior diameter measurement of 4 inches. The end of the funnel terminated in an opening 1 inch in diameter. The mouth of the trap measured 4 feet wide by 3 feet high. The structure was positioned so that the mouth of the trap was located 6 inches above the roof of the vehicle in line with the leading edge of the front windshield. The trap was secured to the roof by sliding the

two 6 inch legs of the trap into a wooden base. The base was secured to the hood using bunge cords. The uppermost top corners were secured with nylon cord to the front of the vehicle and the posterior end of the trap was secured in a similar fashion to the rear of the vehicle.

The collection cups consisted of pint-sized, cardboard ice cream cartons and were modified to fit the 4-inch PVC coupler (Figure 4). The bottom portion of the cartons were removed and replaced with two alternating pieces of dental dam with single 1 inch slits cut in their center. The center portions of the lids were removed and replaced with polyester netting to allow for adequate airflow. The outer diameter of the cartons measured 4-inches which allowed for them to be snugly fit into the PVC coupler. The constant forward motion of the vehicle created sufficient airflow to keep mosquitoes in the collection cup.

Collections

At the beginning of each sampling run, a collection cup was inserted into the rear of the trap and the vehicle moved at 10 mph down the 1-mile section of road. This took approximately 10 minutes. Although there does not seem to be any evidence that the headlights of the vehicle effect the collection (Bidlingmayer 1966), only the flashing hazard lights were used during the collection to minimize the possibility of the lights serving as an attractant for mosquitoes. At the end of each run, the collection cup was replaced with an empty cup. The contents of the cup were knocked down using chloroform vapors applied from a soaked cotton ball. Once the contents were down, they were emptied onto a white plate and examined using a flashlight and forceps. All

anopheline mosquitoes were removed to labeled, 5-dram, clear styrene vials with snap-tops. This examination process took about 5 minutes at the end of which the next run was begun. Representative samples of non-anopheline mosquitoes also were collected. Small holes were punched in the lids and the vials were placed in a large screw top jar containing desiccating silica gel. This stopped moisture from condensing in the container and prevented the growth of mold on the specimens. Collection runs were conducted every 15 minutes throughout the night beginning 1 hour before sunset and continuing 1 hour after sunrise.

At the conclusion of a nightly collection, the specimens were identified and recorded on a data sheet along with the time they were collected. The physiological state of the specimens was also recorded (i.e. whether there was blood present in the mosquito abdomens or whether the mosquito was fully or partially gravid.) A data sheet was also completed for each collection that noted the occurrence of rain, presence or absence of cattle in the pasture, moon phase or anything that may have been out of the ordinary.

Blood meal Analysis

All field specimens were returned to the Uniformed Services University of the Health Sciences where they were processed in the blood meal ELISA. The identification of each specimen was reconfirmed by microscopic examination using a key by Wilkerson and Strickman (1990). Abdomens with blood were removed and placed in eppendorf vials and labeled with an identifying number which linked it to a data base by method of collection, date of collection, location of collection and species identification. The head and thorax were removed from each specimen and placed in a separate 1.6 ml

microcentrifuge tubes labeled with the identification number linking it to its corresponding abdomen. The head and thorax were processed separately in the sporozoite ELISA to identify possible infection with Plasmodium vivax (210), P. vivax (247) or P. falciparum.

To each abdomen was added 50ul of a blocking buffer solution which contained the detergent Igepal. The abdomens were then ground using a plastic pestle that was attached to a foot-operated Fordem drill. Two 350 ul washes were used to wash any remaining material off the pestle into the corresponding eppendorf vial. This resulted in a total of 750 ul of ground blood meal solution with which to run the blood meal ELISA. The samples are tested against 8 different animals requiring 50 ul of blood meal solution for each animal type. Therefore, a total of 400 ul was required to run a single sample. The remaining 350 ul of solution was stored at -80°C in case the sample required retesting. A series of five negative controls were tested. The negative controls consisted of An. albimanus females obtained from a colony which had been established at Walter Reed Army Institute of Research. Five female An. albimanus were collected immediately after emergence to insure that they had not blood fed. They were processed and stored in the same manner as the blood engorged samples. Between grindings, the pestle was washed twice with distilled water and wiped clean using a KemWipe towel. All ground specimens were stored at -20°C for no more than one week before being tested in the ELISA.

A series of positive controls were also used in the analysis. These consisted of known serum samples for each of the animal groups that were being tested in the analysis. The sera were diluted to 1:30,000 in blocking buffer. The sera were stored at

-80°C during the course of testing. All diluted sera were used for a maximum of one week before making new dilutions.

Reagents for the blood meal ELISA were obtained from Kirkegaard & Perry. The specimens were tested against the following animals: human, rat, mouse, chicken, cow, dog, cat, and horse. The blood meal ELISA utilizes a two-antibody system which is run in a 96-well (U-shaped) plate. The antibodies were all IgG (H+L) or IgG (γ). Four specimens could be run per plate in addition to a series of five negative and eight positive controls (one for each animal species). The outer wells of the plate were left empty to reduce the occurrence of evaporation and to cut down on background disturbance. A capture antibody (50 ul) was first plated down for each of the animal groups listed above. After incubating for one hour, the capture antibody was removed, and blocking buffer (200 ul) was added to the wells to eliminate non specific binding of antigen to the plate, thus preventing false positive readings. After an hour incubation the blocking buffer was removed and a 50 ul aliquot of sample was added to each of the eight test wells. This was incubated for two hours before being removed and discarded. All wells were then washed three times with a phosphate buffer solution which contained the detergent Tween-20. After the third wash, the enzyme for the eight previously listed animal types were added to their corresponding wells and allowed to incubate for one hour and then it was aspirated from the plate. The plate was again washed three times with PBS solution. The final step required the addition of 100 ul of a horseradish peroxidase substrate solution which produces a color change when a positive reaction occurs. At room temperature this test is read after a 30-minute incubation using a micro plate reader with a Labsystems® Multiskan Microplate Reader using a wavelength filter of 414.

Those samples whose wavelength values were greater than three times the standard deviation of the 5 negative values were considered to be positive. The test results were transferred to a data sheet containing the corresponding sample number and all data were then transferred to a relational data base.

Data Analysis

A feeding index (FI) was calculated to show preference to feed on one host type over a second host type. The equation (Kay et al. 1979) for FI was,

$$FI = \frac{Ne/Ne'}{Ef/Ef'}$$

where FI = the feeding index,

Ne = Number of feeds on host I,

Ne' = Number of feeds on host II,

Ef = Expected proportion of feeds on host I, and

Ef' = Expected proportion of feeds on host II.

The expected proportion is actually the number of that host present in the study area.

Feeding Indexes greater than one indicate a preference for host I and FI values less than one indicate preference for the second host. Values close to 1 indicate no host preference. This equation was also calculated with an adjustment for variations in host body size which could account for bias in determining feeding preference. This entailed multiplying the denominator of the feeding index equation by the proportional difference in body size of host I to host II.

The Foraging Ratio (FR) was also performed on the data in order to obtain the proportion of blood meals occurring for each host type in respect to all possible hosts available in the study area. This equation for FR (Hess et al. 1968) was

$$FR = \frac{N_{AE}/N_{TE}}{N_{AP}/N_{TP}}$$

where FR = Foraging Ratio,

N_{AE} = Number of engorged female mosquitoes containing blood from host I,

N_{TE} = Total number of engorged females,

N_{AP} = Number of hosts of type I in the collection area, and

N_{TP} = Total number of hosts of all types in the collection area.

Resulting values are again evaluated in a similar manner as those obtained in the calculation of the feeding index (i.e., values >1 = feeding preference, values <1 = feeding avoidance and values equal to 1 no preference).

A human blood index (HBI) was also calculated for the blood meal data. The calculation of this value is accomplished by adding the proportion of human blood meals obtained from indoors to the proportion of human blood meals obtained from outdoors and dividing by 2 (Garrett Jones 1964). Due to the small sample size of the indoor/outdoor collections, an unweighted mean was used in the calculations. The adjusted HBI was also obtained for the data in order to account for differences in the population density of available hosts in the study area. This was done by assuming a hypothetical situation in which the host population was composed of 50% human hosts and 50% animal hosts. The equation for AHBI (Garrett Jones 1964) becomes

$$AHBI = HBI / HBI + ABI,$$

where AHBI = Adjusted Human Blood Index,

HBI = Human Blood Index (using unweighted means)

ABI = Animal Blood Index (using unweighted means).

The results of this analysis represent the percentage of feedings on humans given the number of all hosts being fed on. This adjustment essentially converts the HBI into a modified foraging ratio (Loyola et al. 1993).

RESULTS

A total of 1,575 blood engorged mosquito specimens were collected from all methods employed in this study. Of these, 1298 were Anopheles mosquitoes. In addition, 277 culicines were collected and tested in this analysis.

Of the non-anopheline specimens, 20 were collected in resting boxes, 57 were collected with the backpack aspirator and the remaining 200 were collected in the car top trap. All mosquitoes collected in the backpack aspiration and resting boxes were tested. The number of blood engorged mosquitoes collected by the car top trap numbered in the thousands and most were not processed. Since Anopheles were the main focus of this study, only a small representative sample of culicines collected in the car top trap were kept and processed in the blood meal ELISA. The following are totals for the other mosquito species collected in the study: Aedes serratus (7), Culex coronator (20), Cx. educator (19), Cx. erraticus (48), Cx. nigripalpus (41), Cx. theobaldi (23), Mansonia titillans (56), Psorophora colombia (55) and Ps. ferox (8). A total of 18 of these samples did not test positive for any of the 8 hosts screened in the blood meal ELISA (Table 1, 2 and 3).

Within the anopheline population, 852 (66.6%) specimens were Anopheles vestitipennis, 320 (25%) were Anopheles albimanus, 97 (7.6%) were Anopheles punctimacula and the remaining 10 (1.0%) were Anopheles darlingi. All but 9 (0.69%) tested positive for one of the animals being screened in the blood meal ELISA. Ten specimens showed signs of multiple feeding (Tables 4 and 5). Of these, 6 were human/cow and one each of human/rat, human/dog, cow/rat and cow/dog.

Indoor/Outdoor Collections:

A total of 30, two-hour indoor/outdoor collections were conducted by two collectors, resulting in a combined 120 man-hours of labor. The indoor collections resulted in 2.95 blood engorged anopheline mosquitoes per man-hour, and the outdoor collections resulted in 1.85 blood engorged anopheline mosquitoes per man-hour. A total of 67, two-hour backpack aspiration sessions were conducted for a total of 134 man-hours. This equates to 4.7 blood engorged anopheline mosquitoes being collected per man-hour. The car top trap was conducted on 15 different occasions for 13 hours each time. This resulted in a total of 195 man-hours of collection. This resulted in 1.85 mosquitoes per man-hour of collection.

The blood meal ELISA results are presented in Table 6 and are separated by method of collection and by species. Of *An. vestitipennis* collected indoors, 150 (88%) tested positive for humans, 8 (5.0%) tested positive for canine hosts and the rest were composed of cat (5), pig (3), rat (2) and mouse (2) (Table 6). Seven specimens of *An. darlingi* were collected indoors and all tested positive for human blood.

Of the *An. vestitipennis* collected outdoors, 67 (62%) contained human blood, 23 contained canine blood and 9 specimens each tested positive for cow and pig. Only 3 *An. darlingi* were collected outdoors. Of these, 2 tested positive for human blood, and 1 tested positive for cow blood.

The use of a backpack aspirator on vegetation surrounding the houses resulted in the largest number of blood-fed *An. vestitipennis* (407) and *An. albimanus* (217) being collected. The *An. vestitipennis* had fed on human (180) and cow (175) in almost equal numbers. Pig blood was found in 48 of the samples and canine blood in another 4

samples. The majority of the *An. albimanus* (148) tested positive for bovine blood. Pig blood comprised the second largest category with 40 samples testing positive, while humans and dogs made up the remaining samples with 24 and 5 positive samples, respectively. All of the samples of *An. punctimacula* tested positive for either cow (4) or pig (3) blood.

The car top trap collections resulted in the second largest number of blood engorged *An. albimanus* and the largest number of *An. punctimacula*. *Anopheles vestitipennis* samples tested positive for cow blood (108) and human blood (52). The remaining samples tested positive for dog and pig blood. Almost all specimens of *An. albimanus* were positive for cow (98) with only 4 and 1 testing positive for dog and pig, respectively. *Anopheles punctimacula* also tested high for bovine blood (87) with the rest testing positive for canine (2) and human (1) blood.

The number of each host type present at the indoor/outdoor and backpack aspiration collection sites are presented in Table 7. The number of hosts present were considered the same because the two sites were close together. The numbers of hosts present at the car top trap collection site are also presented in Table 7. The numbers of animals was larger at this site because the 1-mile track encompassed a large sampling area.

Tables 8, 9 and 10 show the feeding indices for *An. vestitipennis*, *An. albimanus* and *An. punctimacula* for blood engorged specimens separated on the basis of collection method. The first value displayed in each feeding index column is the standard feeding index which has not been adjusted for any factors associated with host or vector populations. The second value which is displayed in parentheses is the feeding index

which has been adjusted for the size difference ratio between humans and the host in question. For this analysis, cattle were taken to be 5 times the size of a human, a pig was taken to be the same size as a human and a dog was taken to be 3 times smaller than a human.

Table 11 shows the results of the foraging ratio analysis. This analysis allows for the comparison of preference for different host species as an entire population. Due to an inability to determine the number of mice and rats at the study sites and the low numbers fed upon, these hosts were not included in the foraging ratio analysis. There were also no samples which tested positive for chicken or horse blood and therefore, these animals were not included in the calculation of the foraging ratio.

No An. albimanus or An. punctimacula were collected from the interior or exterior aspects of the house; and therefore, no foraging ratios could be calculated for these species from human habitations. In collections where these two species were obtained, the preferential foraging ratios for An. albimanus were 2.3 for cattle and 2.0 for pigs from the backpack aspiration and 3.2 for cattle in the car trap collection. The foraging ratios calculated for this species resulted in a feeding avoidance with respect to humans and dogs (0.73 and 0.33, respectively) for samples from backpack aspiration, and resulted in a feeding avoidance with respect to pigs and dogs (0.1 and 0.65, respectively) for samples from the car trap collection. Anopheles punctimacula showed a preference for both cattle and pigs in the samples obtained by backpack aspiration and a preference for cattle in samples from the car trap collection. A feeding avoidance was indicated for human and dog hosts for this mosquito species.

The foraging ratios conducted on the blood meal data for An. vestitipennis showed a strong feeding preference for human blood from all samples collected (indoor, 7.5; outdoor, 5.3; backpack, 3.76; car top trap, 2.0). This species also showed a preference for cattle in the car top collection (2.2) and dogs in the outdoor collection (3.3). Virtually no preference was shown for pigs in either the outdoor collection or the backpack collection. There also appeared to be no preference for dogs in the indoor collection and cattle in the backpack collection. A feeding avoidance was shown for pigs (0.6) and cats (0.6) in the indoor collection, cattle (0.2) in the outdoor collection, dogs (0.16) in the backpack aspiration and pigs (0.2) and dogs (0.4) in the car trap collection.

The human blood indices (HBI) for An. vestitipennis were calculated separately from the indoor / outdoor collections and for the backpack and car trap collections. The HBI for the indoor / outdoor collections was calculated as 75%. The HBI for the backpack and car trap collection was calculated at 37.5%.

Figures 5, 6 and 7 represent the times at which the majority of blood engorged specimens for An. vestitipennis, An. albimanus and An. punctimacula were collected during the all night car top trapping. The points indicate the midpoint of each 15-minute collection period. As the graphs indicate, the greatest number of blood engorged An. vestitipennis that tested positive for human blood were collected later in the evening with a peak in the collection at approximately 2:00 a.m and 3:45-4:15 a.m. The vast majority of An. vestitipennis testing positive for non human blood were collected in the first half of the time (peak at 6:15 p.m.) This species was also collected for a longer period of time throughout the evening. The vast majority of blood engorged An. albimanus were

collected in the early evening with a peak at approximately 6:45 p.m. The peak for An. punctimacula occurred shortly after An. albimanus, at approximately 7:00 p.m.

The graphs displaying the collection totals over time are shown in conjunction with the average meteorological data recorded over all 15 trap-nights. These graphs include the temperature, barometric pressure and relative humidity. Wind speed was not included due to extreme fluctuations in this variable. Wind was, however, evaluated on a night by night basis in regard to the overall flight patterns and will not be presented in this chapter. The trends for temperature and barometric pressure indicate consistent decreasing and increasing patterns, respectively. The relative humidity shows a gradual increase until about 1:00 a.m. and quickly reaches a peak at approximately 3:00 a.m., at which point it levels out and remains at or near the saturation point for the remainder of the morning hours.

The head and thorax from all blood-engorged specimens were tested singularly in the sporozoite ELISA and none of the samples tested positive for P. vivax (210), P. vivax (247) or P. falciparum.

Discussion

The use of the various collection techniques described in the methods section resulted in blood engorged samples being collected from only three methods: the indoor/outdoor resting collection, the backpack aspiration of resting mosquitoes and the car top trap of in flight mosquitoes. The two types of resting boxes used in this study resulted in the collection of only minor numbers of Culex, Psorophora and Culiseta species and use of this collecting method was discontinued. Use of sweep nets produced poor results, e.g., a few blood engorged Culex mosquitoes. In addition, it was extremely difficult to locate mosquitoes in the net and identify damaged specimens. The vegetation, grass seeds and other organic material were coated with dew resulting in a compacted bolus after even a short period of sweep netting. This was the primary source of difficulty and the reason that specimens were damaged. The sweep net method was abandoned after several days of aggravating failures.

The backpack aspiration of vegetation around the houses was by far the most productive method of collecting blood engorged Anopheles. In numbers collected per hour of effort, the car top trap was the least effective method. The raw numbers indicate that this method produced the second largest number of blood engorged Anopheles specimens but also required the largest amount of man-hours. Approximately 1.85 mosquitoes were collected in the car trap per man-hour. The outdoor hand aspiration collection was less productive than the indoor collection due, primarily, to the larger number of outdoor resting sites (i.e. nearby vegetation) making it more difficult to locate blood engorged specimens. In contrast, blood-engorged females rested on some aspect of the interior of the hut and were more easily located and collected by hand aspiration.

One would expect that the proportion of mosquitoes containing human blood would be greater inside and near houses. This appears to be the case for An. vestitipennis. Of females collected on inner walls, 88% contained human blood, compared to 62% that were positive for human blood on the outside walls. Moving slightly further away from the houses, 44% of females collected with the backpack aspirator from vegetation contained human blood. As the radius of collection is extended out from the houses, the human positivity rate declined but still remained fairly high.

The car top trap is the most unbiased collection method in terms of distance from human habitation as well as sampling in-flight mosquito populations. Again, the percentage of mosquitoes feeding on humans dropped to 31% of those samples tested from this collection method. Although the percentage feeding on cattle is much higher (65%), there still remain a large number of specimens feeding on humans.

The evidence of feeding on cattle is more extreme with An. albimanus. A comparison can not be made for the indoor/outdoor collection because there were no blood-engorged samples of this species collected on the interior or exterior surfaces of the houses. A comparison can be made, however, from the results of the backpack aspiration. Even though there were almost twice as many An. vestitipennis collected in this manner, a fairly large number of An. albimanus were also collected. Of these samples, 11% tested positive for human blood and this was considerably lower than the 44% of An. vestitipennis that contained human blood. The results from the car top trap were more dramatic in that out of a sample of 103 blood-engorged specimens, no An. albimanus tested positive for human blood. The proportion feeding on cattle, however, was very high (95%).

After conducting the feeding index analysis on the An. vestitipennis samples, the ratio of human blood to all other sources showed indices greater than 1 in all relationships except for in the human:cow ratio collected from the car top trap. After adjustment for the disparity in host size, however, this value also showed that the human host was preferred over cattle. The feeding index for dogs changed to show a preference for a canine host over humans after the adjustment. When looking at the broad picture, however, there appears to be a strong preference for humans over all other host sources collected from all collection methods.

Anopheles albimanus showed a strong tendency to feed on cattle. In all instances, except for backpack aspiration collections, there was a preference for feeding on cattle over humans, pigs and dogs. This agrees with other researchers (Bangs 1999) who have found this species to favor cattle and other domesticated animals over humans.

Anopheles punctimacula also showed a strong tendency for feeding on cattle over humans and other domesticated animals, except in the case of those samples collected with the backpack aspirator that tested positive for pig blood.

The number of multiple feeds identified in this study was quite low. The vast majority were collected from within 100 meters of the houses in the backpack aspiration collection. A large proportion were An. vestitipennis (6). Of the multiple feeds from this species, all contained human blood as part of the blood meal and 5 of the 6 specimens contained cattle blood as the second component. The incidence of multiple feeding is probably not indicative of the true number of anophelines in the study area which required more than one blood meal to complete a single gonotrophic cycle. Previous studies (Wekesa et al. 1995, Wekesa et al 1994) using a more specific histological assay,

showed that the true number of multiple and cryptic blood meals was actually much higher than previously reported by other researchers. It was shown that almost 10% of blood engorged *An. freeborni* females from California tested positive for a multiple blood meal. This is much higher than the 0.8% reported in the present study. Since *An. vestitipennis* shows the highest degree of multiple feedings, it is possible that a number of human/human cryptic blood meals were missed. An infected mosquito that feeds on two or three humans during a single night increases the potential that the mosquito will transmit the disease. For this reason, it is clear that further studies are required to identify the multiple feeding behaviors of the anopheline species in Belize.

When looking at the foraging ratio which does not allow for the adjustment for vector and host factors such as variations in host size but does allow for the comparison of one host versus all other species, the results were very similar to the feeding indexes. The samples obtained from the three collection methods showed that *An. vestitipennis* exhibits a strong preference for human blood. The strength of this association decreased as the area of collection was expanded outward away from an area of human habitation. This trend is understandable considering that as the area of collection increases, the number of available non human hosts also increases.

A field collection's degree of randomness is an important sampling issue. Collections conducted on the interior and exterior aspects of the house resulted in freshly blood-engorged females. These mosquitoes were resting in close proximity to the hosts on which they fed. The mosquitoes collected in the car top trap, however, contained blood meals that were several hours old, as well as being a considerable distance from their host source. The larger sampling area includes a larger number of available hosts as

well as a larger number of resting sites. These factors combine to make sampling the in-flight population a more random and unbiased (relative to host distributions) sampling method for blood-engorged females. The foraging ratio for *An. vestitipennis* collected with the car top trap indicated a feeding preference for both humans and cattle. The strength of the association was virtually the same for both human and cattle blood (2.0 and 2.2 respectively). Again, it must be stressed that the foraging ratio makes no adjustment for the difference in body size between humans and cattle nor does it adjust for variables like host defensive behavior. This could lead to an unrealistic bias being shown toward cattle which may not truly exist.

The foraging ratios for *An. albimanus* consistently demonstrated a feeding preference for non-human hosts. As with previous studies, *An. albimanus* seemed to prefer cattle and pigs to almost all other host species. The foraging ratios also demonstrate that there is an avoidance of human hosts. This type of feeding pattern is consistent with *An. albimanus*' crepuscular, exophagic feeding behavior. During times when this species is feeding, most humans are inside their homes eating or preparing for sleep. Therefore, the only hosts available to be fed upon are non-human. The same appears to hold true for *An. punctimacula* which also showed a preference for cattle and pigs and an avoidance of human hosts. The association with pigs is weakened by the fact that the sample size on which the data is based is extremely small.

The foraging ratio for *An. darlingi* also is consistent with previously published data which indicate that this species is strongly anthropophagic. Samples taken from the interior and exterior aspects of the houses both indicate a strong feeding preference for

human blood. This association, however, is also weak due to the small numbers of An. darlingi collected in this study.

The Human Blood Indexes for An. vestitipennis were consistent with the foraging ratios and the feeding indices. The high HBI of 75% for the indoor/outdoor collection shows a large proportion of this species contain human blood. Although the number of human hosts in the immediate vicinity was quite high, there were a large number of alternate host sources within flying distance. This indicates that An. vestitipennis has a strong tendency to feed on humans both indoors and outdoors when they are found near human habitations. A high HBI of 37.5% was also calculated for the backpack collection and the car top collection. This HBI is a little more revealing because high proportions of An. vestitipennis populations collected from areas far removed from human habitations contained human blood. These two collection methods combined should provide an accurate representation of the natural population and reveal the true feeding behavior of these Anopheles species.

The data showing the time of collection of the blood-engorged specimens from the car top trap correlate with the times of biting for these species in human biting collections. Most blood engorged An. albimanus were collected early in the evening with only small number being collected in the early pre-dawn hours. Anopheles punctimacula also shows similar patterns. The peak collection time was around 9:00 p.m. while the peak of the blood engorged collection occurred about one hour later.

Anopheles vestitipennis showed the most interesting pattern of blood feeding. Data obtained from the car top collection showed the flight of this species persisted at a low level throughout the night but the majority of the blood engorged mosquitoes showed

up in the collection at about 3:00 a.m. This time period also coincides with a peak in the humidity levels. Blood-engorged, female An. vestitipennis may require suitable environmental conditions (i.e. high relative humidity) before proceeding to an alternate resting site to finish blood meal digestion.

Human biting data indicate that the biting begins shortly after sunset and continues at a high level throughout the night. The majority of An. vestitipennis populations collected in the car trap testing positive for human blood were collected after midnight. It appears that the human feeding An. vestitipennis require a considerable length of time of rest before flying in search of a more permanent outdoor resting site. This was confirmed by the indoor collections where blood engorged An. vestitipennis was the main species found resting on the interior aspects of the house. This endophilic behavior increases the chances of the mosquito picking up a lethal dose of insecticide from the sprayed surface of the hut.

In summary, An. albimanus and An. punctimacula continually demonstrated a feeding preference for non-human hosts such as cattle and pigs. This zoophagic behavior along with a propensity for feeding outdoors makes for a weak vector association. Although An. albimanus has been shown to transmit malaria, it appears that the right environmental conditions (which produce high vector population densities) are required for transmission to occur.

Anopheles vestitipennis, on the other hand, showed a definite preference for humans in all three collection methods. This was further substantiated by the feeding indices which showed a preference for humans over all other host types compared on an individual basis. This association was strengthened by factoring in differences in host

body size. This anthropophagic behavior in conjunction with the fact that this species has demonstrated a natural infection with Plasmodium vivax by the sporozoite ELISA (Achee et al. 2000) and its behavior of readily entering a house to feed further incriminates this species as an important, if not the most important, vector of malaria in Belize.

REFERENCES CITED

- Achee, N.L., C.T. Korves, M.J. Bangs, E. Rejmankova, M. Lege, D. Curtin, H. Lenares, Yvette Alonzo, R.G. Andre, and D.R. Roberts. 2000. Plasmodium vivax polymorphs and Plasmodium falciparum circumsporozoite proteins in Anopheles (Diptera: Culicidae) from Belize, C.A. *J. Vect. Ecology*.
- Arredondo-Jimenez, J.I., M.H. Gimnig, M.H. Rodriguez, and R. K. Washino. 1996. Genetic differences among Anopheles vestitipennis subpopulations collected using different methods in Chiapas state, southern Mexico. *J. Am. Mosq. Contr. Assoc.* 12: 396-401.
- Bangs, M.J. 1999. The susceptibility and behavioral responses of Anopheles albimanus Weidemann and Anopheles vestitipennis Dyar and Knab (Diptera: Culicidae) to insecticides in northern Belize. Ph.D. Thesis, Uniformed Services University of the Health Sciences, Bethesda, Maryland. 489 pp.
- Beier, J.C., P.V. Perkins, R.A. Wirtz, J. Koros, D. Diggs, T.P. Gargan II and D.K. Koeh. 1988. Bloodmeal identification by direct enzyme-linked immunosorbent assay (ELISA), tested on Anopheles (Diptera: Culicidae) in Kenya. *J. Med. Ent.* 25: 9-15.
- Bidlingmayer, W.L. 1966. Use of the truck trap for evaluating adult mosquito populations. *Mosq. News* 26: 139-143.
- Bioquip Products, Inc. 1997. Equipment, supplies, and books for entomology and related sciences. Gardena, C.A.

- Boreham, P. F. L. 1975. Some applications of bloodmeal identifications in relation to the epidemiology of vector-borne tropical diseases. *J. Trop. Med. Hyg.* 78: 83-91.
- Boreham, P.F.L. and J.K. Lenahan. 1976. Methods for detecting multiple blood-meals in mosquitoes (Diptera:Culicidae). *Bull. Ent. Res.* 66: 671-679.
- Boreham, P.F.L. and C. Garrett-Jones. 1973. Prevalence of mixed blood meals and double feeding in a malaria vector (Anopheles sacharovi Favre). *Bull. Wld. Hlth Org.* 48: 605-614.
- Briegel, H. 1990. Fecundity, metabolism, and body size in Anopheles (Diptera: Culicidae), vectors of malaria. *J. Med. Entomol.* 27: 839-850
- Bull, C.G. and W.V. King. 1923. The identification of the blood meal of mosquitoes by means of the precipitin test. *Am. J. Hyg.* 3:491-496.
- Burkot, T.R. and G.R. DeFoliart. 1982. Bloodmeal sources of Aedes triseriatus and Aedes vexans in a southern Wisconsin forest endemic for La Crosse encephalitis virus. *Am. J. Trop. Med. Hyg.* 31: 376-381.
- Burkot, T.R., W.G. Goodman and G.R. DeFoliart. 1981. Identification of mosquito blood meals by enzyme linked immunosorbent assay. *Am. J. Trop. Med. Hyg.* 30: 1336-1341.
- Burkot, T.R., P.M. Graves, R. Paru and M. Lagog. 1988. Mixed blood feeding by the malaria vectors in the Anopheles punctulatus complex (Diptera: Culicidae). *J. Med. Ent.* 25: 205-213.

- Chandler, J.A., P.F.L. Boreham, R.B. Highton and M.N. Hill. 1976. A study of the host selection patterns of the mosquitoes of the Kisumu area of Kenya. *Trans. R. Soc. Trop. Med. Hyg.* 69: 415-425.
- Chow, E., R. A. Wirtz and T. W. Scott. 1993. Identification of blood meals in Aedes aegypti by antibody sandwich enzyme-linked immunosorbent assay. *J. Am. Mosq. Control Assoc.* 9: 196-205.
- Coulson, R.M.R., C.F. Curtis, P.D. Ready, N. Hill and D. F. Smith. 1990. Amplification and analysis of human DNA present in mosquito bloodmeals. *Med. Vet. Ento.* 4: 357-366.
- Crans, W.J. 1969. An agar gel diffusion method for the identification of mosquito blood-meals. *Mosq. News* 29: 563-566.
- Cully, J.F., J.P. Grieco and D. Kissel. 1991. Defensive behavior of eastern chipmunks against Aedes triseriatus (Diptera: Culicidae). *J. Med. Entomol.* 28: 410-416.
- Downe, A.E.R. 1960. Blood-meal sources and notes on host preferences of some Aedes mosquitoes (Diptera:Culicidae). *Can. J. Zool.* 38: 689-699.
- Edman, J.D. 1971. Host feeding patterns of Florida mosquitoes. I. Aedes, Anopheles, Coquillettidia, Mansonia and Psorophora. *J. Med. Entomol.* 8: 687-695.
- Edman, J.D., and A.E.R. Downe. 1964. Host-blood sources and multiple feeding habits of mosquitoes in Kansas. *Mosq. News.* 24: 154-160.
- Edman, J.D and H.W. Kale II. 1971. Host behavior: Its influence on the feeding success of mosquitoes. *Ann. Entomol. Soc. Am.* 64: 513-516.
- Edman, J.D. and L.A. Webber. 1975. Effects of vertebrate size and density on host selection by caged Culex nigripalpus. *Mosq. News.* 35: 508-512.

- Edman, J.D., L.A. Webber and H.W. Kale II. 1972. Host-feeding patterns of Florida mosquitoes. II. Culiseta. J. Med. Entomol. 9: 429-434.
- Edrissian, G.H. and A. Hafizi. 1982. Application of enzyme-linked immunosorbent assay (ELISA) to identification of Anopheles mosquito bloodmeals. Trans. R. Soc. Trop. Med. Hyg. 76: 54-56.
- Eliason, D.A. 1971. Identification of mosquito blood meals: A comparison of selected procedures. Dr. P.H. dissertation. Univ. NC at Chapel Hill. 91pp. Univ. Microfilms, Ann Arbor, Mich.
- Garrett-Jones, C. 1964. The human blood index of malaria vectors in relation to epidemiological assessment. Bull. WHO 30: 241-261.
- Hess, A.D., R.O. Hayes and C.H. Tempelis. 1968. The use of the foraging ratio technique in mosquito host preference studies. Mosq. News. 28: 386-389.
- Kay, B.H., P.F.L. Boreham and J.D. Edman. 1979. Application of the "feeding index" concept to studies of mosquito host-feeding patterns. Mosq. News. 39: 68-72.
- Kirkegaard and Perry Laboratories, Inc. 1990. Types of solid phase enzyme immunoassays. Gaithersburg, MD.
- Loyola, E.G., L. Gonzalez-Ceron, M.H. Rodriguez, J.I. Arredondo-Jimenez, S. Bennett, and D.N. Brown. 1993. Anopheles albimanus (Diptera: Culicidae) host selection patterns in three ecological areas of the coastal plains of Chiapas, Southern Mexico. J. Med. Ent. 30: 518-523.

- McCrae, A.W.R., P.F.L. Boreham and Y Ssenkubuge. 1976. The behavioural ecology of host selection in Anopheles implexus (Theobald) (Diptera:Culicidae). Bull. Entomol. Res. 66: 587-631.
- McKinney, R.M., J.T. Spillane and P. Holden. 1972. Mosquito blood meals: Identification by a fluorescent antibody method. Am. J. Trop. Med. Hyg. 21: 999-1003.
- Mitchell, C.J. and K. Y. Millian Jr. 1981. Continued host seeking by partially engorged Culex tarsalis (Diptera: Culicidae) collected in nature. J. Med. Entomol. 18: 249-250.
- Nelson, R.L., C.H. Tempelis, W.C. Reeves and M.M. Milby. 1976. Relation of mosquito density to bird : mammal feeding ratios of Culex tarsalis in stable traps. Am. J. Trop. Med. Hyg. 25: 644-654.
- Nuttall, G.H.F. 1904. Blood Immunity and Blood Relationships. Cambridge: Univ. Press. 444 pp.
- Rempel, J.G., W.A. Riddell and E.M. McNelly. 1946. Multiple feeding habits of Saskatchewan mosquitoes. Can. J. Res. Sect. E 24: 71-78.
- Reeves, W.C. 1971. Mosquito vector and vertebrate host interaction: The key to maintenance of certain arboviruses. In Ecology and Physiology of Parasites. ed. A.M. Fallis. Toronto. University of Toronto Press. pp 223-231.
- Sato, C., Y Furuya, M. Harada, and S. Suguri. 1992. Identification of human blood in mosquitoes (Diptera: Culicidae) using nonradioactive DNA dot blot hybridization. J. Med. Ent. 29: 1045-1048.

- Savage, R.E. 1931. The relation between feeding of the herring off the East Coast of England and the plankton of the surrounding waters. Fishery Invest. Lond. Ser. 12: 1-88.
- Senior-White, R.A. 1952. Studies on the bionomics of *Anopheles aquasalis* Curry, 1932 (concl.). Pt. 3. Indian J. Malar. 6: 29.
- Service, M.W., A. Voller and D.E. Didwell. 1986. The enzyme-linked immunosorbent assay (ELISA) test for the identification of blood-meals of haematophagous insects. Bull. Ent. Res. 76: 321-330.
- Shemanchuk, J.A., A.E.R. Downe and L. Burgess. 1963. Hosts of mosquitoes (Diptera:Culicidae) from the irrigated areas of Alberta. Mosq. News. 23: 336-341.
- Tempelis, C.H. 1975. Host feeding patterns of mosquitoes, with a review of advances in analysis of blood meals by serology. J. Med. Entomol. 11: 635-653.
- Tempelis, C.H. and F.M. Lofy. 1963. A modified precipitin method for identification of mosquito blood-meals. Am. J. Trop. Med. Hyg. 12: 825-831.
- Tempelis, C.H. and M.L. Rodrick. 1972. Passive hemagglutination inhibition technique for the identification of arthropod blood meals. Am. J. Trop. Med. Hyg. 21: 238-245.
- Tesh, R.B., B.N. Chaniotis, M.D. Aronson and K.M. Johnson. 1971. Natural host preferences of Panamanian phlebotomine sandflies as determined by precipitin test. Am. J. Trop. Med. Hyg. 20: 150-156.

- Tesh, R.B., W.R. Chen and D. Catuccio. 1988. Survival of albumin, IgG, IgM, and complement (C3) in human blood after ingestion by Aedes albopictus and Phlebotomus papatasi. *Am. J. Trop. Med. Hyg.* 39: 127-130.
- Voller, A., D. Bidwell, G. Huldt and E. Engvall. 1974. A microplate method of enzyme-linked immunosorbent assay and its application to malaria. *Bull. W.H.O.* 51: 209-211.
- Washino, R.K. and C.H. Tempelis. 1983. Mosquito host bloodmeal identification: Methodology and data analysis. *Ann. Rev. Entomol.* 28: 179-201.
- Weathersbee, A.A. and M.V. Meisch. 1988. An economical lightweight portable resting unit for sampling adult Anopheles quadrimaculatus populations. *J. Am. Mosq. Contr. Ass.* 4: 89-90.
- Wekesa, J.W., B. Yuval and R.K. Washino. 1994. A histological technique for detecting multiple blood feeding in Anopheles freeborni. *Proc. Calif. Mosq. Vector Control Ass.* 62: 128-130.
- Wekesa, J.W., B. Yuval and R.K. Washino. 1995. Multiple blood feeding in Anopheles freeborni (Diptera: Culicidae). *Am. J. Trop. Med. Hyg.* 52: 508-511.
- Weitz, B. 1960. Feeding habits of blood sucking arthropods. *Exp. Parasitol.* 9: 63-82.
- Weitz, B. 1963. The Feeding habits of Glossina. *Bull WHO* 28: 711-729.
- Wilkerson, R.C. and D. Strickman. 1990. Illustrated key to the female anopheline mosquitoes of Central America and Mexico. *J. Am. Mosq. Control Assoc.* 6: 7-33.

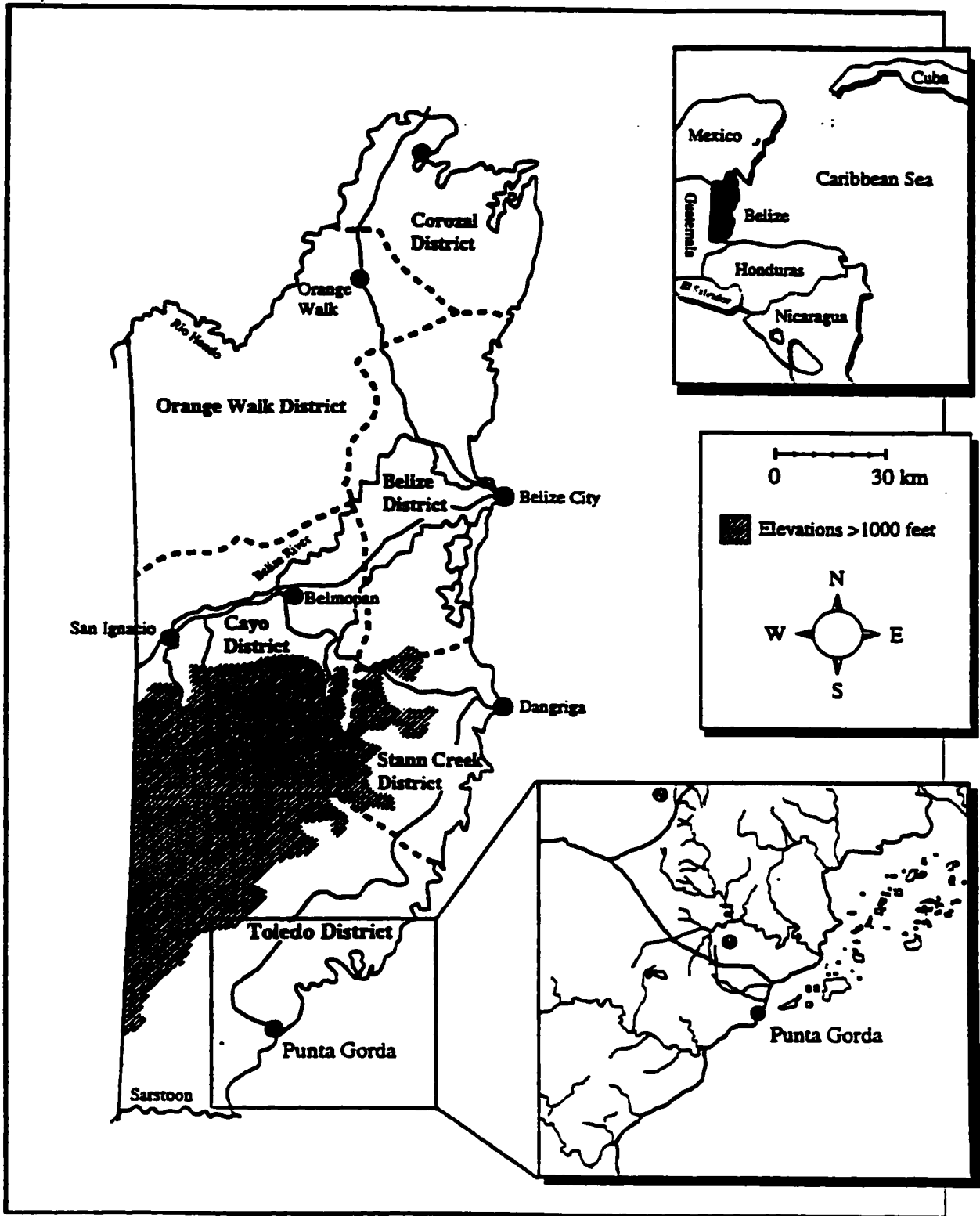

Figure 1: Map of the Toledo District in Southern Belize depicting the two main sites sampled during the seasonality study: ① - Rancho Village, ② - Golden Stream Village

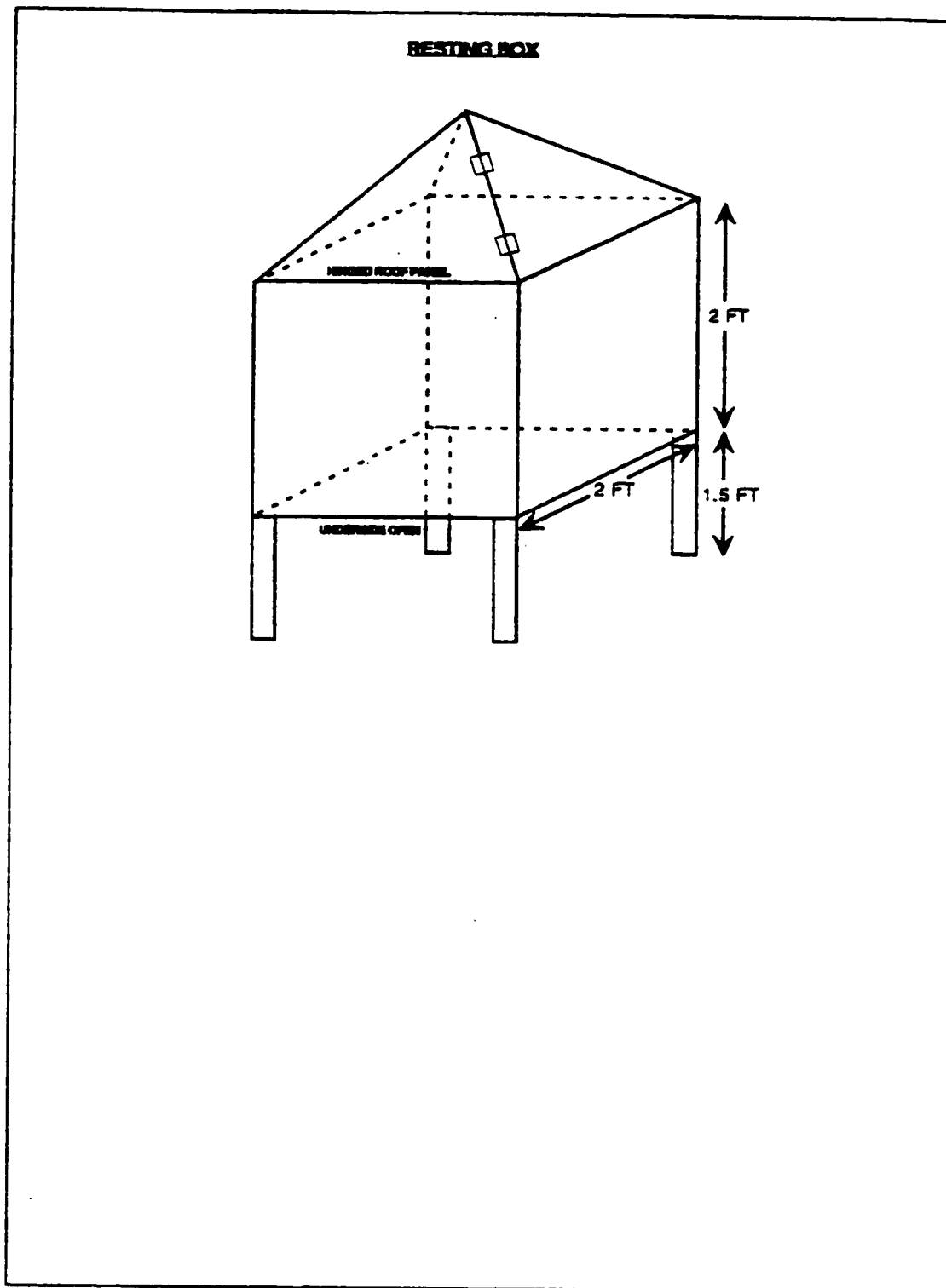

Figure 2. Diagram illustrating the dimensions of the resting box used for the collection of blood engorged mosquitoes at the Rancho site.

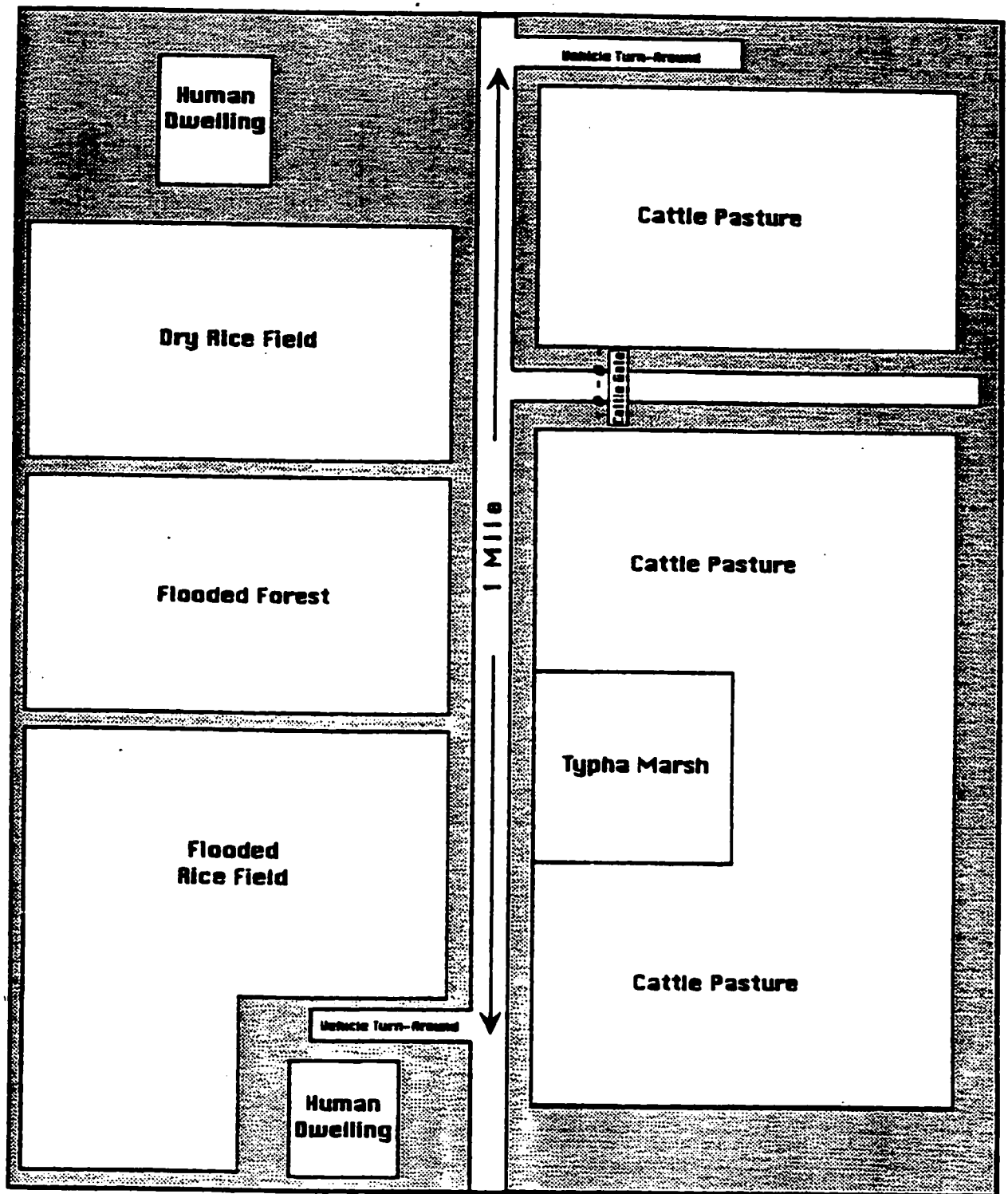

Figure 3. Illustration of the route followed in the car trap collection. The distance between turn-around points was approximately 1 mile and took 10 minutes to drive at 5-10mph.

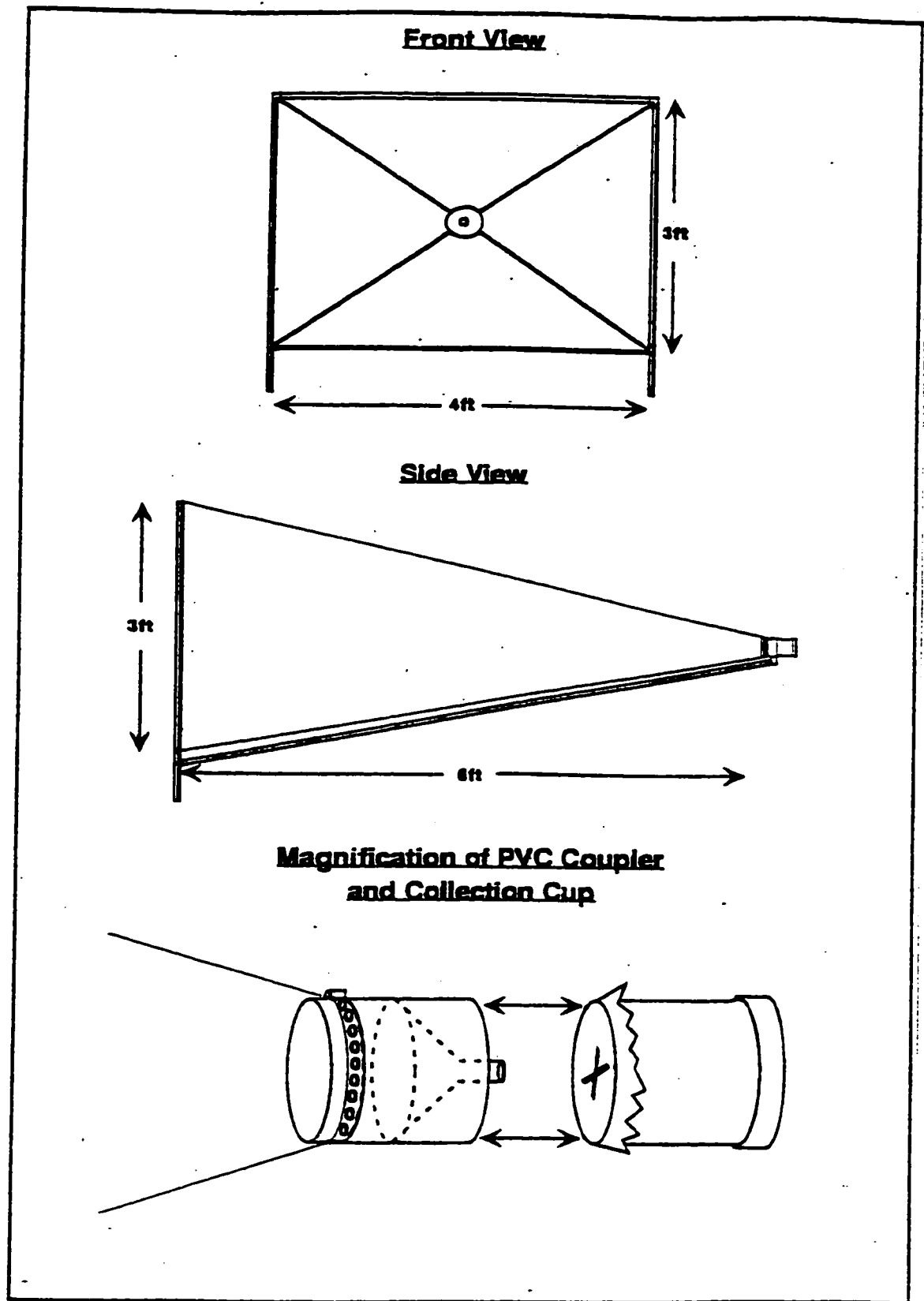

Figure 4. Illustration of the car trap and PVC coupler used for the collection of in-flight mosquito populations at the Rancho site

Table 1: Number of non-anopheline mosquitoes collected in a resting box which tested positive, using the blood meal ELISA, for hosts found at the site of collection. Collections were made from October 1997-November 1998 at the Rancho site in southern Belize. Values in parentheses indicated the percentage of a species that tested positive for a particular host.

	Human	Chicken	Cow	Pig	Dog	Undetermined	Total
<i>Culex coronator</i>	0	0	3 (100%)	0	0	0	3
<i>Cx. erraticus</i>	0	2 (33%)	4 (67%)	0	0	0	6
<i>Cx. nigripalpus</i>	0	0	2 (100%)	0	0	0	2
<i>Mansonia titillans</i>	1 (33%)	0	2 (67%)	0	0	0	3
<i>Psorophora colombiana</i>	0	0	6 (100%)	0	0	0	6

Table 2: Number of non-anopheline mosquitoes collected with a backpack aspirator which tested positive, using the blood meal ELISA, for hosts found at the site of collection. Collections were made from October 1997-November 1998 at the Rancho site in southern Belize. Values in parentheses indicated the percentage of a species that tested positive for a particular host.

	Human	Chicken	Cow	Pig	Dog	Undetermined	Total
<i>Culex coronator</i>	0	1 (100%)	0	0	0	0	1
<i>Cx. educator</i>	0	1 (25%)	2 (50%)	1 (25%)	0	0	4
<i>Cx. erraticus</i>	1 (7%)	2 (14%)	7 (50%)	2 (14%)	1 (7%)	1 (7%)	14
<i>Cx. nigripalpus</i>	0	0	2 (100%)	0	0	0	2
<i>Mansonia titillans</i>	4 (40%)	0	6 (60%)	0	0	0	10
<i>Psorophora colombiana</i>	5 (22%)	0	12 (52%)	1 (4%)	5 (22%)	0	23
<i>Ps. ferox</i>	0	0	3 (100%)	0	0	0	3

Table 3: A sample of non-anopheline mosquitoes collected with a mobile car top trap which tested positive, using the blood meal ELISA, for hosts found at the site of collection. Collections were made from June-November 1998 at the Rancho site in southern Belize. Values in parentheses indicated the percentage of a species that tested positive for a particular host.

	Human	Chicken	Cow	Pig	Dog	Undetermined	Total
<i>Aedes serratus</i>	2 (30%)	0	5 (70%)	0	0	0	7
<i>Culex coronator</i>	0	5 (30%)	6 (40%)	3 (20%)	0	2 (10%)	16
<i>Cx. educator</i>	1 (7%)	3 (20%)	5 (33%)	2 (13%)	2 (13%)	2 (13%)	15
<i>Cx. erraticus</i>	0	1 (4%)	15 (53%)	7 (25%)	0	5 (18%)	28
<i>Cx. nigripalpus</i>	0	4 (11%)	17 (46%)	6 (16%)	2 (5%)	8 (22%)	37
<i>Cx. theobaldi</i>	1 (4%)	6 (26%)	11 (48%)	3 (13%)	2 (9%)	0	23
<i>Mansonia titillans</i>	10 (23%)	0	31 (72%)	0	2 (5%)	0	43
<i>Psorophora colombia</i>	2 (8%)	0	24 (92%)	0	0	0	26
<i>Ps. ferox</i>	0	0	5 (100%)	0	0	0	5

Table 4. Numbers of multiple blood meals determined by the ELISA and separated on the basis of collection method. Collections were made from October 1997 to November of 1998 in southern Belize.

Host Composition of Multiple Feeds	Number of Multiple Feeds From 3 Collection Methods ^a			
	IO	BA	CT	
Human/Cow	1	4	1	
Human/Rat	0	1	0	
Human/Dog	1	0	0	
Cow/Rat	0	1	0	
Cow/Dog	0	1	0	
Total Mixed Meals	2	7	1	

^a = IO are from Indoor/Outdoor collections; BA are from backpack aspirations; CT are from car top trapping.

Table 5. Number of multiple blood meals determined by ELISA and separated on the basis of species.

Host Composition of Multiple Feeds	Multiple Feeds by anopheline species		
	<i>Anopheles vestitipennis</i>	<i>Anopheles albimanus</i>	<i>Anopheles punctimacula</i>
Human/Cow	5	1	0
Human/Rat	0	1	0
Human/Dog	1	0	0
Cow/Rat	0	1	0
Cow/Dog	0	0	1
Total Mixed Meals	6	3	1

Table 6: Number of *Anopheles* testing positive, using the blood meal ELISA, for hosts found at the site of collection. Mosquitoes have been separated on the basis of collection method. Collections were made from October 1997-November 1998 at the Rancho site in southern Belize. Values in parentheses indicated the percentage of a species that tested positive for a particular host.

	Human	Rat	Mouse	Cow	Pig	Dog	Cat	Total
Indoor Collection								
<i>Anopheles vestitipennis</i>	150 (88%)	2 (1%)	2 (1%)	0	3 (2%)	8 (5%)	5 (3%)	170
<i>Anopheles darlingi</i>	7 (100%)	0	0	0	0	0	0	7
Outdoor Collection								
<i>Anopheles vestitipennis</i>	67 (62%)	0	0	9 (8%)	9 (8%)	23 (22%)	0	108
<i>Anopheles darlingi</i>	2 (67%)	0	0	1 (33%)	0	0	0	3
Backpack Aspiration								
<i>Anopheles vestitipennis</i>	180 (44%)	0	0	175 (43%)	48 (12%)	4 (1%)	0	407
<i>Anopheles albimanus</i>	24 (11%)	0	0	148 (68%)	40 (18%)	5 (3%)	0	217
<i>Anopheles punctimacula</i>	0	0	0	4 (57%)	3 (43%)	0	0	7
Car Top Trap								
<i>Anopheles vestitipennis</i>	52 (31%)	0	0	108 (65%)	3 (2%)	4 (2%)	0	167
<i>Anopheles albimanus</i>	0	0	0	98 (95%)	1 (1%)	4 (4%)	0	103
<i>Anopheles punctimacula</i>	1 (1%)	0	0	87 (97%)	0	2 (2%)	0	90

Table 7. Numbers of animals observed from within 100 meters of the Rancho site in southern Belize where the indoor/outdoor collections and the backpack aspirations were conducted from October 1997 to November 1998.

Animal Type	Number of Hosts Observed from Indoor/Outdoor and Back Pack Aspiration Collection Sites	Number of Hosts Observed from Mobile Car Trap Collection Sites
Human	12	21
Rat	NA	NA
Mouse	NA	NA
Cow	40	40
Dog	6	8
Pig	6	12
Cat	2	5
Chicken	25	45
Horse	1	1

Table 9: Feeding Indices for *Anopheles albimanus* based on method of collection of blood engorged specimens. Collections were made from October 1997 to November of 1998 in southern Belize.

Collection Method	Number of Blood Engorged				Feeding Index		
	Human	Cow	Pig	Dog	Cow:Human	Cow:Pig	Cow:Dog
Backpack Aspiration	24	148	40	5	1.85	.55	4.44
Car Top Trap	0	98	1	4	-----	29	4.9

Table 10: Feeding Indices for *Anopheles punctimacula* based on method of collection of blood engorged specimens. Collections were made from October 1997 to November of 1998 in southern Belize.

Collection Method	Number of Blood Engorged				Feeding Index		
	Human	Cow	Pig	Dog	Cow:Human	Cow:Pig	Cow:Dog
Backpack Aspiration	0	4	3	0	-----	.40	-----
Car Top Trap	1	87	0	2	45.8	-----	5.44

Table 11: Foraging ratios for anopheline mosquitoes collected from October 1997 to November 1998 in southern Belize using three different collection techniques. *Anopheles* have been separated on the basis of collection method.

	Human	Cow	Pig	Dog	Cat
Indoor Collections					
<i>Anopheles vestitipennis</i>	7.5	--	0.6	0.8	0.6
<i>Anopheles darlingi</i>	7.69	0	0	0	0
Outdoor Collection					
<i>Anopheles vestitipennis</i>	5.3	0.2	1.3	3.3	--
<i>Anopheles darlingi</i>	5.2	0.8	0	0	0
Backpack Aspiration					
<i>Anopheles vestitipennis</i>	3.76	1.1	1.3	0.16	--
<i>Anopheles albimanus</i>	0.73	2.3	2.0	0.33	--
<i>Anopheles punctimacula</i>	--	1.5	7.2	--	--
Car Top Trap					
<i>Anopheles vestitipennis</i>	2.0	2.2	0.2	0.4	--
<i>Anopheles albimanus</i>	--	3.2	0.1	0.65	--
<i>Anopheles punctimacula</i>	0.07	3.2	--	0.37	--

Chapter 6

A Comparison Study of House Entering and Exiting Behavior of Anopheles vestitipennis (Diptera:Culicidae) Using Experimental Huts Sprayed with DDT or Deltamethrin in the Southern District of Toledo, Belize, C. A.

ABSTRACT

An investigation of the house entering and exiting behavior of Anopheles vestitipennis Dyar and Knab was undertaken in the Toledo District of Belize, Central America between March and December of 1998. Three untreated experimental huts were fitted with either exit or entrance interception traps or used as a control for human landing collections. In the later part of the study (November and December of 1998), one hut was sprayed with DDT, one with deltamethrin and the third hut was left untreated to serve as a control. Throughout these collections, meteorological data were collected to determine if behavior was affected by a number of environmental parameters to include temperature, relative humidity, wind speed and periods of rain.

Pre-spray human landing collections showed that An. albimanus exhibited a bimodal biting pattern with the evening peak commencing 2 hours after sunset and the morning peak occurring 1 hour prior to sunrise. The data is strongest from the outdoor collections due to the very small number of An. albimanus collected indoors. This is evident from the O:I ratio of 1:0.1 calculated for this species. Anopheles punctimacula showed a single peak of activity with continued low levels of biting throughout the remainder of the night. This species began biting 1-2 hours after sunset and then continued at very low levels until 1 hour prior to sunrise. This pattern of activity was exhibited in both the indoor and outdoor collections. This species also showed a stronger exophagic behavior with an O:I ratio of 1:0.4.

Pre-spray human landing collections showed that An. vestitipennis exhibited a high level of biting activity shortly after sunset and continued biting at high levels throughout the night. Anopheles vestitipennis also demonstrates a strong endophagic

behavior with an O:I ratio of 1:0.9. Under unsprayed conditions, the use of exit and entrance interception traps demonstrated that doors, windows and eaves were the primary mode of entry; whereas, cracks in the walls served a secondary role. The peak entrance time for An. vestitipennis occurred between 6:45 P.M. and 9:45 P.M. and a peak exit time occurred between 11:45 P.M. and 4:45 A.M. Additional trials were conducted after spraying one of the huts with DDT and another with deltamethrin. The excito-repellent properties of deltamethrin did not influence entrance times but did result in a peak of exiting behavior that was 5 hours earlier than under pre-spray conditions. Deltamethrin also exhibited a repellency effect, showing 66% fewer An. vestitipennis entering the hut 2 weeks post spray. DDT had an even more powerful repellency effect resulting in a 97% post-spray reduction of An. vestitipennis females entering the hut up to 2 weeks post-spray. The control hut showed only a 37% reduction in human landing collections as compared to pre-spray conditions. This reduction was most likely due to a natural decrease in population densities during this time of year.

Collections conducted both pre- and post-spray showed that house-entering behavior by An. vestitipennis was effected by wind speed and rain. A positive correlation was demonstrated between increased wind speeds and bouts of rain with collection of increased numbers of An. vestitipennis in the entrance traps. This is most likely due to the resting period that was exhibited by the species prior to its feeding. They rested mainly on the thatch and outer wall surfaces prior to entering and feeding. Both rain and wind disturbed these resting sites and motivated the females to move indoors.

Introduction

The resurgence of malaria in tropical regions of Central and South America has created a renewed urgency for information pertaining to *Anopheles* vectors (PAHO 1994). This is evident in Belize and many other countries of the Americas where the prevalence of malaria has increased. This increase is associated with a reduced emphasis on vector control measures, primarily house spraying with residual insecticides (Roberts et al. 1997).

A number of terms, such as behavioral resistance, repellency, irritancy, and excito-repellency, have been used in the literature to describe the behavior of vectors in response to insecticide application. A brief description of these terms is required to understand their effect on the vector population. The term, behavioral resistance, implies an evolutionary basis in which the insect has evolved the ability to protect itself against lethal contact with naturally occurring plant toxins (Chareonviriyaphap et al. 1997), and has been documented in early studies dealing with anopheline vectors and malaria transmission (Kennedy 1947, Muirhead-Thomson 1960, Elliott and de Zulueta 1975). The term repellency is used to describe oriented movements of avoidance made by the insect in response to a chemical stimulant without having made tarsal contact with the chemical (Roberts et al. 2000). Irritancy refers to oriented movements by the insect away from a chemical stimulus only after making tarsal contact with the chemical (Roberts et al. 2000). Excito-repellency is a chemical stimulus, which induces a series of oriented avoidance behavior with or without having made tarsal contact with the chemical (Roberts and Andre 1994).

A long-standing belief was that the only true action of an effective malaria campaign was the reduction of the vector population. This belief is based on Macdonald's early mathematical models (1950, 1957) which emphasize the relationship between decreased vector survival and reduced rates of malaria transmission. These models pointed out that any effect which decreases the probability of a lethal contact with the insecticide would negatively effect the reduction in malaria transmission. This notion led to the assumption that behavioral avoidance of residual insecticides would, in essence, protect the vectors and, therefore, prevent overall reductions in the vector populations (Muirhead-Thomson 1950). This assessment, however, overlooks the possibility that prevention of indoor biting and resting behaviors might be an effective approach to reducing malaria transmission. Others have also stressed the relationship between altered behavioral patterns, due to interaction with insecticides, and the control of vector-borne disease (Cullen and deZulueta 1975, Hamon et al. 1970, Elliott 1972, Gillies 1988). Indeed, present understanding of disease transmission indicates that the disruption of the host-vector interaction may be more important than an actual reduction in mosquito populations.

DDT has demonstrated a long residual life in a number of studies. Taylor et al. in 1981 showed the affects of DDT lasted up to 2 years post-treatment with An. arabiensis. Others have also showed the continued effects of DDT, both contact toxicity and excito-repellency, long after spray (Roberts et al. 1984, Reid and Wharton 1956, Rozendaal 1990). Others (Sharp et al. 1990) showed surfaces treated with DDT 8 to 12 months prior exhibited 100% kill.

Research efforts in Belize have focused on four anopheline species, which have been incriminated in the transmission of human malaria; including: An. albimanus Weidemann; An. darlingi Root; An. pseudopunctipennis Theobald; and An. vestitipennis Dyar and Knab. Both An. darlingi and An. pseudopunctipennis have shown the ability to transmit malaria in areas of Central America (Padilla et al. 1992, Roberts et al. 1987) but Anopheles albimanus is widely believed to be the primary vector in this region (Ramsey et al. 1994). Although this species readily feeds on humans, recent studies in Belize have indicated that it exhibits a weak endophagic behavior (Bangs 1999, Roberts et al., unpub. data). Very little, however, is known of the vectorial capacity of An. vestitipennis.

Although An. vestitipennis is found throughout the coastal regions of Mexico, Central America, regions of northern South America, Cuba, Dominican Republic and Puerto Rico (Loyola et al. 1991, Mekuria et al. 1991, Padilla et al. 1992, Marquetti et al. 1992), until recently, its role as an important vector of human malaria has not been well established. In fact, Boyd (1949) reported that An. vestitipennis is of little importance in the transmission of malaria. Loyola et al. (1991), however, observed this species to be both endophilic and endophagic, and found native populations of An. vestitipennis in Chiapas, Mexico positive for Plasmodium vivax. In a malaria vector survey conducted in Belize, Kumm and Ram (1941) found malaria sporozoites in the salivary glands of An. vestitipennis and An. darlingi, but not in An. albimanus. More recently, natural P. falciparum infections in An. vestitipennis collected from Belize have been identified by sporozoite ELISA (Achee et al. 2000). These data indicate that An. vestitipennis had a higher minimum field infection rate (0.282%) than either An. albimanus (0.126%) or An.

darlingi (0.271%). Evidence for the role of An. vestitipennis as a vector of malaria in Belize has been mounting from thorough documentation of human-vector contact (Roberts et al. 1993, Bangs 1999), documentation of relatively high natural infection rates (Achee et al. 2000), and documentation of malaria sporozoites in naturally infected salivary glands (Kumm and Ram 1941). Taken together, these observations incriminate An. vestitipennis as one of three important malaria vectors in Belize.

In laboratory studies, An. albimanus has proven to be a poor host for the malaria parasite (Warren et al 1977). In host preference studies this species exhibits a greater tendency to feed on cattle than on humans (Breeland, 1972). Differences occur within and between populations of An. albimanus and the differences seemed to be linked to morphologic variants within the species. The susceptibility of three strains of An. albimanus (white-striped, green and brown) to two phenotypes of P. vivax (VK210 and VK247) was examined in southern Mexico (Gonzalez-Ceron et al. 2000). The white-stripe phenotype had a higher susceptibility to P. vivax parasites than either of the green or brown phenotypes (Chan et al. 1994; Gonzalez-Ceron et al. 2000). The presence of variants within a population may explain differences seen in behavioral patterns as well as differences in susceptibility to P. vivax and P. falciparum. This may also explain the differences seen by some researchers who have shown different levels of susceptibility to various insecticides in populations obtained from different regions of Belize (Chareonviriyaphap et al 1997). Similar types of intraspecific variation also has been demonstrated for the Anopheles maculipennis complex in Europe and more prominently in the An. gambiae complex in Africa.

The main goals of this study were to 1) determine the house entering and exiting behavior of *An. vestitipennis* under natural conditions, 2) determine environmental factors associated with increases or decreases in entry/exit behavior and, 3) evaluate the effects spraying with DDT and deltamethrin had on these behaviors. Low population densities of *An. albimanus* and *An. punctimacula* at the experimental hut site, prevented detailed documentation of insecticide impacts on house entering and exiting behaviors. However, data was available for defining the all night biting activity of both species.

Materials and Methods

Study area:

In the early part of 1998, an experimental hut study was undertaken to determine the house entering and exiting behavior of *An. vestitipennis* in the Toledo District, located in southern Belize (Figure 1). The study was conducted in the village of Rancho (N 16° 09.954, W 88° 50.529) which was composed of 166 houses with a total population of approximately 824 people based on survey statistics from 1998. The village was located about 4 miles from the Gulf of Honduras near the town of Punta Gorda. Study site selection was based on the Belize Ministry of Health's classification of Rancho as one of the five most malarious areas within the Toledo District. Site selection was also based on preliminary surveys which detected large numbers of *An. vestitipennis* larvae and adults.

The rainy season in the southern portion of Belize generally begins in late April and continues through December. The average yearly rainfall in the south is generally greater than 4000mm. The coolest temperatures occur from November to December with an average temperature of 24°C. May through September are traditionally the warmest months with temperatures averaging 27°C. The prevailing winds blow off the Gulf of Honduras from the Southeast during January through August. In September the winds shift direction and blow out of the Northwest until the end of December.

A portable weather station (Davis Instruments, Weather Monitor II) was affixed to the control hut for the purpose of collecting measurements of meteorological data, including temperature, wind speed and direction, relative humidity and barometric pressure. Measurements were stored in the archive memory of the weather station at 15

minute intervals to coincide with times mosquitoes were collected. Temperature readings were also obtained from a maximum/minimum thermometer (Taylor®, Model 5458, Fletcher, North Carolina) in case of a power failure on the weather station. The relative humidity at the start and end of each night's collection was also measured using a sling psychrometer (Bacharach Inc., Pittsburgh, PA) in order to determine the accuracy of the weather station. At the end of the collection, the weather station was returned to the laboratory and the data was downloaded to a computer database (PC compatible Weatherlink software).

Three identical huts (Figure 2) were constructed for experimental purposes and for a series of 15-hour collections. Huts were modeled after the basic design of a Mayan house that is common in southern Belize. The walls of the hut measured 7.8 m long x 4.2 m wide x 2.1 m high and consisted of plank wood walls, dirt floor and a thatch roof constructed from cahune palm, *Orbignya cohune*. The apex of the angled roof measured 4.5 m from the floor of the hut. A walkway running lengthwise down the center of each hut was constructed 3 m above the floor to enable examination of the thatch during collection. Each hut had three windows and a north-facing door. In addition, each hut was equipped with a small, auxiliary door (0.5 m wide x 1 m high) through which collectors could enter or exit the huts without removing the traps. This door remained shut and locked except when collectors were rotated. All three huts were constructed to accommodate window and door intercept traps. Each hut was identically furnished with a stool for the collector and a small wooden table for storage of collection equipment.

The huts were situated in a triangle (Figure 3) with the most northern house (Hut A) positioned 15 m from the other two structures and Hut B and Hut C positioned 30 m

from each other. Two additional huts, that housed the collectors and their families and a small animal shed, were located about 40 m and 50 m, respectively, from the experimental hut site. Approximately 100 m to the West of the experimental huts was the Jacinto River. A flooded forest area was located 6 m to the south of Huts B and C. Routine larval collections from this habitat resulted in the collection of moderate numbers of *An. vestitipennis* larvae. To the North of Hut A was located a marshy depression which produced some *An. albimanus* during the rainy season.

Interception Traps:

With minor modifications, window and door intercept traps were constructed according to the design of Muirhead-Thomson (Figure 4). The window traps were 0.6 m x 0.6 m x 0.6 m boxes and were constructed with lengths of 1.3 cm PVC pipe. The door traps were constructed in a similar fashion and measured 1.8 m x 0.9 m x 0.9 m. Both traps types were covered by green polyester insect netting (Bioquip Products Inc.) and were sewn into place. The front of the trap was left open to form a five-sided box. Sleeve material was attached over a hole in the rear of the trap to facilitate the removal of resting mosquitoes. Initial efforts were made using a funnel in the front of the trap to act as a one way baffle. After a number of trials, this apparatus was removed as an obstacle to mosquito passage. Additionally, a 3 m x 0.3 m x 0.3 m eave trap and a 3 m x 1.8 m x 0.8 m wall trap were constructed to aid in determining the mode of entry into the huts. These traps were constructed in a similar fashion to that used for the window and door traps.

Collection Method:

Simultaneous collections were conducted using all three huts. During a single night's collection (4:30 P.M. to 7:30 A.M.), one hut was affixed with exit traps while another was affixed with entrance traps. The third hut was maintained as a control hut at which an indoor/outdoor landing collection was conducted. The type of collection conducted at each hut was rotated on subsequent nights to quantify variation of *An. vestitipennis* behavior and population densities between huts prior to spray. A host presence was established in each hut prior to the collection by placing collectors in the huts one hour before the beginning of the collection period. Two collectors were placed in the center of each trap hut to act as bait during the collection.

Human-baited landing collections at the control hut were conducted for 30 minutes each hour. Indoor collectors were positioned in the center of the hut while outdoor collectors were positioned on the side of the house at least 3 m from any house opening. Collections consisted of collectors aspirating mosquitoes from their exposed, lower legs for a 30-minute time period. Indoor collectors switched with outdoor collectors halfway through each 30-minute collection period. All collectors rotated their positions between huts throughout the night to eliminate the possibility of collector bias. Post-spray collections were conducted with traps being placed in the same position (i.e. both with exit traps or both with entrance traps.) on the two sprayed huts. Post-spray human biting collections were conducted at the control hut in the same manner as described above.

Resting mosquitoes were collected from the interior aspects of the traps using a mouth aspirator for a period of 30 minutes every hour. Collected mosquitoes, from both

human landing and intercept traps, were placed in cardboard cages and labeled with the date, time and hut location for each collection period. Each hour represents the 30-minute sampling period, which occurred beginning at the top of that hour. Mosquitoes were killed with chloroform vapor and species were identified the following morning.

Mosquito Identification and Processing:

All Anopheles collected in both the human landing collections and from the exit/entrance traps were identified to species using standard morphological characteristics (Wilkerson and Strickman 1990). Pools of adults (no more than 20/pool) were placed in eppendorf vials which were labeled with the date, time, species and location of collection. These vials were stored over desiccating silica gel in Rubbermaid screw top containers until they could be tested using the sporozoite enzyme-linked immunosorbent assay (ELISA). An Excel data file containing this information was also maintained to coincide with the vials. Due to the large number of mosquitoes collected in the hut study, only a representative sample (10%) of the Anopheles were tested in the sporozoite ELISA.

Circumsporozoite protein ELISA:

A modified sandwich sporozoite ELISA (Wirtz et al. 1987; Beach et al. 1992) was performed on a sub-sample of the adult, female Anopheles collected from this study. All procedures conducted in the course of this assay were performed at room temperature (23-26°C). The mosquitoes were dissected, and only the heads and thoraxes were used in the ELISA assay. A maximum of 10 individual specimens of the same species were pooled for the assay. All samples were ground in 50 ul of blocking buffer (BB) and an

additional volume of 150 ul was added to bring total volume to 200 ul. The blocking buffer was made by dissolving 0.5% casein in 0.01 M Dulbecco's phosphate-buffer saline (PBS) and was adjusted to a pH of 7.4. An aliquot of 0.002% phenol red was added to the BB solution to serve as an indicator of a change in pH. The BB also contained 0.5% Igepal CA-630 (Sigma, St. Louis, MO). Samples were stored in the -20°C freezer for no more than 2 weeks prior to testing in the assay.

The sandwich sporozoite ELISA was performed in polyvinyl chloride, U-shaped 96-well microtiter plates (Costar, Cambridge, MA). All outside wells were left empty to reduce the effects of evaporation and to cut down on background when reading the final plate. Separate plates for each Plasmodium species were initially coated for one hour with 50 ul of capture monoclonal antibodies of the following Plasmodium species: Plasmodium falciparum (2A10; 4ug/ ml PBS), P. vivax 210 (NSV3; 0.5 ug/ ml PBS) and P. vivax VK247 (2471G12; 2ug/ ml PBS). The capture antibodies were aspirated from the wells and replaced with 250 ul of BB. The blocking buffer was allowed to incubate for the period of one hour at the end of which it was aspirated and replaced with 50 ul aliquots of either the unknown mosquito sample, a negative control or a positive control. Five negative controls were tested per plate. The negative controls consisted of 10 pooled, laboratory reared An. albimanus from the Walter Reed Army Institute of Research which were ground in 50 ul of BB with an additional 150 ul of BB added after grinding (total volume = 200 ul). In addition, five positive controls were tested per plate. Positive controls consisted of lyophilized recombinant proteins from P. falciparum 100pg/50ul BB; P. vivax 210 40pg/50ul BB or synthetic peptide P. vivax VK247

2000pg/50ul BB. The samples and positive/negative controls were covered and allowed to incubate for 2 hours.

At the end of the 2-hour incubation, the plates were aspirated, and the wells were washed three times with PBS containing the detergent Tween 20. To each well on their respective plate was added 50 ul of a homologous monoclonal antibody conjugated to horseradish peroxidase (Kirkegaard & Perry Laboratory, Gaithersburg, MD) (1ug/ml BB *P. falciparum* and *P. vivax* 210; 2 ug/ml BB *P. vivax* VK247). The conjugate was allowed to remain in the plate for 1 hour after which time it was aspirated, and the plate was washed three times with PBS containing Tween-20. The final step in the analysis was the addition of 100 ul of an enzyme substrate solution (2,2'-azino-di (3-ethyl-benzthiazolinesulfonicacid [ABTS]) in buffered hydrogen peroxide (Kirkegaard & Perry Laboratory, Gaithersburg, MD). Those samples testing positive elicited a green color change.

After addition of the peroxidase substrate, absorbency values were read at a wavelength of 414nm at 15, 30 and 60 minutes using an ELISA plate reader (Titertek Multiskan, Flow Laboratories, McLean, VA). Values obtained at the 30-minute time interval were used in determining positive samples. Those mosquito triturates whose absorbency values were equal to or greater than 3 times the standard deviation of the 5 negative controls were determined to be positive and were re-tested. Samples testing positive a second time were deemed to be true positives.

Insecticide Application:

On November 27, 1998, after the initial pre-spray trials had been completed, trained personnel of the Belize Malaria Control Program sprayed two of the huts with insecticide following established protocol. The interior walls, lower 1 meter of thatch and outside eaves of Hut C were sprayed with DDT wettable-powder (75% wdp) which had been suspended in clean water to make a 4% (technical grade) formulation. Spraying was conducted using a Hudson X-Pert compression sprayer equipped with an 8002E Teejet nozzle in order to obtain a fan application to all hut surfaces. Hut B was sprayed in an identical manner as that applied to Hut C except using a 5% deltamethrin wettable-powder. Four ounces of wettable-powder were suspended in 4 gallons of clean water. The application rate is 2 grams per square meter. Both huts were allowed to dry completely (for no less than 12 hours) before a collection was performed.

Results

Meteorological Conditions:

Data presented in Table 1 summarize the temperatures and rainfall from the Rancho area from March to December of 1998. Rainfall levels were not available for the months of September through December. The total rainfall from January to August was recorded at 1780.6 mm with a maximum one-day rain total of 131.3 mm which occurred on 29 June 1998. The wettest months were July and August with rainfall levels of 552.0 and 90.1 mm, respectively. Although there are no official recordings, rainfall levels remained high until December when they dropped off considerably and remained low throughout the dry season. Overall temperatures during the study ranged from 17.2-35.5°C. The coldest temperatures occurred in the predawn hours in early December. The warmest temperatures were recorded during the months of April, May and June with daytime highs reaching the mid- to upper 30's.

The meteorological data gathered during the collections is presented in Figures 5, 6 and 7. The highest temperatures (34°C) readings occurred just prior to sunset. Temperatures showed a gradual decline throughout the course of the night with the coolest temperatures (23°C) occurring just prior to sunrise. Relative humidity levels showed a steady increase throughout the night with humidity levels at the beginning of a collection averaging 80-81% and increasing to complete saturation (100%) by 4:00 A.M. The widely variable ranges observed are due to frequent periods of rain that would periodically occur during the collections. No consistent pattern was observed in the wind speeds. There did seem to be consistently stronger winds just after sunset. As with

the highly variable humidity levels, the wind speeds were greatly influenced by nightly storms over the study site.

Pre-spray collections:

A total of 26 all-night pre-spray human landing collections were conducted from February to December 1998 yielded the following anopheline species, in order of abundance collected: *An. vestitipennis* (23,087), *An. punctimacula* (437), *An. albimanus* (158), *An. apicimacula* (17), *An. gabaldoni* (10), *An. darlingi* (3) and *An. neivai* Howard, Dyar & Knab (1). Analysis of 5 preliminary all night landing human landing collections performed at all three huts simultaneously indicated the mean number of anopheline mosquitoes collected at the three huts were not significantly different (F value = .03; $p < .001$).

Anopheles vestitipennis showed a constant high level of landing/biting activity beginning shortly after sunset and continuing until approximately 1 hour prior to sunrise (6:00 A.M.) (Figure 8). An examination of the indoor/outdoor biting populations showed no significant difference between the number of *An. vestitipennis* collected inside the huts (11,220) compared to outside the hut (11,867), for an O:I ratio of 1:0.9.

The nightly biting activity of the other anophelines found at the study area conform to what is already found in the literature (Hobbs 1989, Taylor 1966, Rachou et al. 1965, Muirhead-Thomson et al. 1952). The majority of *An. albimanus* were collected in the early part of the year (March and April). Populations of this species collected in the human landing collections conducted at the experimental huts dropped off considerably during the months from July to December. Outdoor populations of *An.*

albimanus demonstrated a bimodal pattern of biting activity (Figure 9). The peak occurring shortly after sunset (7:45 P.M.) and a smaller secondary peak of activity occurring at sunrise (5:45 A.M.). The density of outdoor and indoor biting populations exhibited a marked difference with 91% (144) of the population being collected outside and only 9% (14) of the population being collected inside. The O:I ratio for An. albimanus was 1:0.1.

Both indoor and outdoor biting populations of An. punctimacula exhibited a peak of biting activity at sunset (Figure 10). Continued low levels of biting activity, however, persisted throughout the remainder of the night. As demonstrated by An. albimanus, An. punctimacula also exhibited a greater propensity for biting outdoors with 71% (309) of the biting population being collected outdoors and only 29% (128) being collected indoors. These data translate into an O:I ratio of 1:0.4. The remaining four species, An. apicimacula, An. gabaldoni, An. darlingi and An. neivai were all collected in outdoor collections.

Mode of Entry:

Studies on mode of entry into the hut employed the simultaneous use of 3 window traps, 1 door trap, 1 wall trap and 1 eave trap. Overall, intercept traps were effective collecting devices for An. vestitipennis mosquitoes. The traps collected more as exit traps (3929) than as entrance traps (2807).

The pre-spray trap collections of An. vestitipennis were conducted over 21 trap nights between August and November of 1998 and consisted of multiple collections each night. The collection totals were averaged by time period and graphed against the

midpoint for that time interval. Peak entering occurred between 6:45 P.M. and 9:45 P.M. (Figure 11). The vast majority of the entering population was collected in the first half of the night with 91% of the *An. vestitipennis* being collected before midnight. Peak exiting began at approximately 11:45 P.M. and continued until 4:45 A.M. (Figure 12). Exiting *An. vestitipennis* were primarily collected during the latter half of the night. Only 31% of all exiting *An. vestitipennis* were collected prior to midnight while 69% were collected between midnight and 6:45 A.M.

Only 3 anophelines collected from all the traps were blood fed (0.1%). Two of these were *An. punctimacula* and only one was *An. vestitipennis*. For this reason, the gonotrophic status of the mosquitoes collected were classified as unfed. The door and window openings clearly proved to be the preferred mode of entry with 1,044 anopheline mosquitoes (35.3%) being collected from the window traps and 1,760 (59.5%) being collected from the door trap (Figure 13). The eaves and walls appeared to contribute very little to the overall buildup of entering anopheline mosquitoes, with 4.4% (130) entering through the eaves and 0.8% (24) entering through cracks in the wall. These traps only sampled 1/8 of total wall or eave space in the house (3 m of 24 m of wall or eave space). Assuming random movement into the house, the number of mosquitoes entering the other areas of eave or wall should be proportional to that obtained from the trapped portion. For this reason, collections from the eave and wall were adjusted to reflect the true size of these entry points. After adjustment, the doors and windows remained as primary modes of entry (43.6% and 25.9%, respectively). The eaves also showed to be a primary mode of entry after adjustment (25.7%). The walls contributed very little to the overall indoor population of anopheline mosquitoes (4.8%).

An analysis of the affects of temperature, relative humidity, wind speed and rain is presented in Table 2. A positive correlation was demonstrated between increased entrance trap collections and both wind speed and rain fall (Spearman's rho values 0.617; $p < 0.01$ and 0.423; $p < 0.05$, respectively). Temperature and relative humidity seem to have no effect on entrance trap collection totals. None of the meteorological parameters recorded had an effect on the exit trap collection totals.

Entry/Exit Times (Post-spray):

All night post-spray collections (5 entrance and 5 exit) were conducted between November and December of 1998. The pattern of *An. vestitipennis* biting activity was similar to pre-spray patterns of activity. Biting began shortly after sunset (6:45 P.M.) and continued at a high level throughout the remainder of the night in the control hut (Figure 14). The O: I ratio was calculated to be 1:0.8. Numbers of *An. vestitipennis* collected in the unsprayed hut, compared to pre-spray collections, showed a 37.4% reduction.

Both the DDT and the deltamethrin sprayed huts exhibited a reduction in population levels from pre-spray trials. Numbers of *An. vestitipennis* collected in pre-spray traps compared to the numbers trapped post-spray documented a 66% reduction in the deltamethrin hut and a 97% reduction in the DDT hut. Trap data for the DDT hut showed that two of the nights with the largest collections occurred with winds of greater than 5 mph and bouts of heavy rain.

The numbers of *An. vestitipennis* that entered the DDT hut post-spray were very low and only small peaks of entrance/exit activity occurred in the early hours after sunset (5:45 P.M. to 7:45 P.M.) (Figure 11 and Figure 12). The deltamethrin hut, however,

continued to have substantial numbers of *An. vestitipennis* enter the house after spraying. In the deltamethrin-sprayed hut, the peak entrance time generally followed the same pattern as that seen in the pre-spray trials. A peak occurred between 6:45 P.M. and 9:45 P.M. (Figure 11, 12 and 15). The exit times, however, demonstrated a dramatic shift to earlier in the evening. In addition visual examination of the unsprayed portions of the thatch during the collection indicated that there were no mosquitoes resting on these surfaces during the course of the night. After spraying, the peak in exit activity occurred between 8:45 P.M. and 11:45 P.M. Almost all mosquitoes had exited the deltamethrin-sprayed hut by midnight.

An ANCOVA analysis was performed on the entrance activity to examine the affect population density had on trap collection totals (Figure 16). The analysis compared both pre- and post-spray entrance trap collection totals to the population density on the same night based on the human-landing collection from the control hut. As population densities increased, the collection from the entrance traps also increased for both pre-spray huts and for the post-spray deltamethrin hut. The slope of the DDT hut regression line was not significantly different from zero ($P > 0.05$) and therefore represented no increase in entrance activity with increased population density.

Circumsporozoite protein/ blood meal ELISA:

A total of 3051 mosquitoes were tested in the sporozoite ELISA: *An. vestitipennis* (2950), *An. punctimacula* (50), *An. albimanus* (20), *An. apicimacula* (17), *An. gabaldoni* (10), *An. darlingi* (3) and *An. neivai* (1). Of these, none tested positive for *P. vivax* 210, *P. vivax* (247) or *P. falciparum*.

The three, blood-engorged specimens collected from the entrance traps were of two species: An. punctimacula (2) and An. vestitipennis (1). Both of the An. punctimacula tested positive for dog blood. The only An. vestitipennis collected tested positive for human blood. The specimen of An. vestitipennis was collected at a time of high wind and most likely was blown into the trap after taking a blood meal.

Discussion

Experimental hut studies provide critical information on the behavioral activities of vector populations in malarious areas. The present study demonstrates the differences in the biting activities of three anopheline species commonly found in the southern regions of Belize. *Anopheles vestitipennis* more frequently entered houses than other potential vectors. *Anopheles albimanus* showed a stronger exophagic behavior than either *An. vestitipennis* or *An. punctimacula*. *Anopheles punctimacula*, however, showed a greater tendency towards exophagy than *An. vestitipennis*, with only 29% of the biting females collected indoors.

At the Rancho study site, *An. vestitipennis* was collected in the greatest abundance and therefore provided the most data for analysis. Continuous high levels of biting activity occurred throughout the night both indoors and outdoors. Activity began shortly after sunset and continued until just prior to sunrise. This species demonstrated the strongest endophagic behavior with a calculated O:I ratio of 1:0.9, clearly documenting this species' strong tendency to enter a house and feed.

Data on the mode of entry into huts show that the door, window and eaves all contribute to the overall indoor population of *An. vestitipennis*. The door, windows and eaves present very large portals of entry. A host seeking mosquito would find little or no obstacle to house entry when presented with one of these openings. The openings between wall boards, on the other hand, are very narrow (ranging from 1 to 2 cm wide). *Anopheles vestitipennis* were observed to land on the exterior wall surface prior to house entry. After a short outdoor resting period, the mosquito would again take flight, bouncing along the wall in either a horizontal or vertical pattern. It would continue this

movement until it reached either a window, door or eave opening. It is possible that during this behavior a proportion of mosquitoes would locate a suitable opening in the wall and thus account for a small number of anophelines being collected from the wall trap.

Entrance trap collections from unsprayed huts showed that the majority of An. vestitipennis entering the house were collected during the first six hours after sunset. Of those mosquitoes entering the hut, 91% were collected prior to midnight. While peak entering occurred shortly after sunset, the biting activity continued at a high level throughout the night. This implied that a large proportion of the host seeking female population rested within the interior of the hut prior to obtaining a blood meal. Under identical conditions, exiting of An. vestitipennis females occurred during the last 6 hours before sunrise. Those An. vestitipennis, which entered the unsprayed hut, peaked in their exiting behavior at 3 to 4 hours before sunrise, at which time they returned to the outdoor environment in search of suitable resting sites.

Anopheles vestitipennis demonstrates a distinct outdoor resting period prior to feeding. Host seeking females could be observed resting on the exterior aspects of the house, most notably the walls, thatch and stools. After a short resting period, they would either bite the outdoor collector or proceed to enter the house. I observed that disturbances of their outdoor resting posture on the thatch and walls often stimulated a premature entry of the house. These disturbances often came in the form of gusts of wind or downpours of rain. Strong gusts of wind had the added affect of forcing some mosquitoes to enter the house which may not have normally done so. This is demonstrated by the Spearman's values that show a relation between increase entrance

trap collection and both wind and rain. There does not seem to be a meteorological factor that influences the exiting of a house. One factor which needs to be investigated further is the effect that increasing light intensities have on the exiting behavior of An. vestitipennis.

A similar indoor resting behavior also was observed for An. vestitipennis. Once a host-seeking female entered the house, it would adopt a resting posture on the walls or furnishing within the house prior to biting. Most resting females were found resting below 3 meters but occasionally they could be found resting on ceiling posts and wall surfaces which were slightly higher than 3 meters. The central walkway allowed for periodic aspiration of the interior aspects of the thatch with the backpack aspirator. No resting Anopheles mosquitoes were ever collected in this manner.

After deltamethrin application, time of peak exiting of An. vestitipennis populations was shifted to earlier in the night, by approximately 5 hours. Examination of the thatch during the collection indicated that there were no mosquitoes resting on the unsprayed portions of the thatched roof. This shift, in conjunction with very little deviation from pre-spray entrance behavior, indicated that An. vestitipennis was sufficiently irritated or repelled by deltamethrin to leave shortly after entering the hut. Although this effect was observed, there still remained a 2-hour period between peak time of entering and peak time of exiting in which biting occurred, allowing for the possibility of malaria transmission to also occur. It should be noted that a common practice during insecticide application is the removal of personal items from inside the hut prior to spraying the walls, beams and ceiling. When returned to the hut, these items provide suitable untreated resting sites. Any unsprayed surfaces may decrease the overall

irritancy effect, as well as, allow mosquitoes to avoid contact with the chemical, and thereby avoid uptake of a lethal dose of insecticide.

After spraying with DDT, there was a reduction of 97% in the total population of An. vestitipennis coming to the treated hut. This equates to the collection of an average of 4.9 mosquitoes per night at the DDT hut. This is compared to a 66% reduction (or an average nightly collection of 55.4 mosquitoes/night) in the deltamethrin hut and the 37% reduction (or an average nightly collection of 465.9 mosquitoes/night) in the control hut. This illustrates a strong repellency effect due to the DDT, and a lower but, perhaps important level of deltamethrin repellency. A reduction in the number of mosquitoes actually coming into the hut indicates a clear reduction in the vector/host interaction and a potential break in the transmission cycle.

Pre- and post-spray variations in An. vestitipennis collected from the entrance traps were not due to natural changes in population density as determined by the ANCOVA analysis. Both pre-spray huts demonstrated increased trap collections in association with increasing population densities. This same positive linear trend was also seen after deltamethrin application. The DDT treated hut, however, showed no increase in the number of An. vestitipennis collected from the entrance traps as the mosquito population levels increased. This suggests that the number of An. vestitipennis entering both untreated and deltamethrin treated huts will increase as mosquito densities increase. In contrast, An. vestitipennis but will be repelled from entering a DDT treated hut regardless of vector population levels.

Roberts et al. (2000), developed a probability model which illustrates (Figure 17) the endophagic behavior of a host seeking Anopheles mosquito. This model operates on

the premise that an efficient vector will move to a house, enter and bite the inhabitants indoors. There is a probability associated with each of these actions. These are conditional probabilities because each action requires that the previous action has already taken place. When dealing with a sprayed house, an additional probability of leaving the house and surviving is added. By altering an initial step in the process, such as house entering, you greatly reduce the probability for malaria transmission potential. The results of this study and others (Roberts et al. 1984) show that the non-contact repellent actions of DDT alter the transmission cycle by breaking the host/vector interaction at a critical step, house entering. In the case of deltamethrin, even though the vector may pick up a lethal dose of chemical while in the house, the mosquito still has the opportunity of biting and transmitting malaria. There is also the chance that the mosquito will not pick up a lethal dose or land on untreated surfaces such as furnishings and personal belongings.

In conclusion, An. vestitipennis in southern Belize exhibited a strong endophagic behavior. This species readily fed indoors and is a persistent biter throughout the night. The deltamethrin hut showed a definite irritancy effect. Although the chemical did not alter the pattern of house entering activity, it did alter the time of exiting. DDT on the other hand proved to have a very powerful repellency effect. Under normal reduced population levels (37.4% in control hut), deltamethrin only exhibited a 66% reduction while DDT showed a reduction of 97%. This effect goes contrary to earlier observations made by Roberts et al. (1993) that An. vestitipennis was undeterred by DDT residues. These early observations were based on 45 minute indoor/outdoor human landing collections conducted in houses that were last sprayed with DDT months prior to the

actual collection activity. The present study sampled anopheline populations throughout the night and was conducted for 2 weeks after the initial spray. Differences in the house entering behavior of An. vestitipennis documented by these two studies is clearly associated with the duration of the residual effect of DDT. Due to the short time frame of the post spray observations in the present study, it is clear that additional studies are required to examine the residual effects of both DDT and deltamethrin in order to determine their long-term effectiveness.

The repellency effect documented in the DDT-sprayed house essentially excluded human-vector contact within that house. Reduced levels of mosquitoes entering and biting will strongly reduce the potential for malaria transmission. While the irritancy effect of deltamethrin reduced the potential window of opportunity for transmission, it did not preclude transmission from occurring within the house during those few hours in which An. vestitipennis females were in contact with humans.

REFERENCES CITED

- Achee, N.L., C.T. Korves, M.J. Bangs, E. Rejmankova, M. Lege, D. Curtin, H. Lenares, Yvette Alonzo, R.G. Andre, and D.R. Roberts. 2000. Plasmodium vivax polymorphs and Plasmodium falciparum circumsporozoite proteins in Anopheles (Diptera: Culicidae) from Belize, C.A. J. Vect. Ecology.
- Bangs, M. 1999. The susceptibility and behavioral response of Anopheles albimanus Weidemann and Anopheles vestitipennis Dyar and Knab (Diptera:Culicidae) to insecticides in northern Belize. Ph.D Thesis. Uniformed Services University of the Health Sciences. Bethesda, Maryland. 489pp.
- Beach, R.F., C. Cordon-Rosales, E. Molina and R.A. Wirtz. 1992. Field evaluation of an enzyme-linked immunosorbent assay for estimating the sporozoite rate in Anopheles albimanus. Am. J. Trop. Med. Hyg. 47: 478-483.
- Boyd, M.F. 1949. Epidemiology factors related to the definitive host. In: Malariaology, Boyd, M.F. (editor) Philadelphia: W.B. Saunders, pp. 608-697.
- Breeland, S.G. 1972. Studies on the ecology of Anopheles albimanus. Am. J. Trop. Med. Hyg. 21: 751-754.
- Chan, A.S.T., M.H. Rodriguez, J.A. Torres, M.C. Rodriguez and C. Villarreal. 1994. Susceptibility of three laboratory strains of Anopheles albimanus (Diptera: Culicidae) to coindigenous Plasmodium vivax in southern Mexico. J. Med. Entomol. 31: 400-403.
- Chareonviriyaphap, T., D.R. Roberts, R.G. Andre, H.J. Harlan, S. Manguin and M.J. Bangs. 1997. Pesticide avoidance behavior in Anopheles albimanus a malaria vector in the Americas. J. Am. Mosq. Control. Assoc. 13: 171-183.

- Cullen, J.R. and J. de Zulueta. 1975. Observations on the irritability of mosquitoes to DDT in Uganda. *Bull. Wld. Hlth. Organ.* 27: 239-250
- Elliott, R. 1972. The influence of mosquito behavior on malaria transmission. *Am. J. Trop. Med. Hyg.* 21:755-763.
- Elliott R. and J. de Zulueta. 1975. Ethological resistance in malaria vectors. Behavioral response to intradomestic residual insecticides. *WHO/VBC.* (75.569): 1-15.
- Gillies, M.T. 1988. Anopheline mosquitoes: vector behaviour and bionomics. In: *Malaria, Principals and Practice of Malariology.* W.H. Wernsdorfer and I. McGregor, (editors). Churchill Livingstone, New York. pp. 453-485.
- Gonzalez-Ceron, L, M.H. Rodriguez, F.V. Santillan, Juan E. Hernandez and R.A. Wirtz. 2000. Susceptibility of three laboratory strains of *Anopheles albimanus* (Diptera: Culicidae) to coindigenous *Plasmodium vivax* circumsporozoite protein phenotypes in southern Mexico. *J. Med. Entomol.* 37: 331-334.
- Hamon, J., J. Mouchet, J. Brengues and G. Chauvet. 1970. Problems facing anopheline vector control; vector ecology and behavior before and after application of control measures. In: *Conference on Anopheline Biology and Malaria Eradication.* Misc. Pubs. Entomol. Soc. Amer. 7(1): 28-41.
- Hobbs, J.H., J.D. Sexton, Y. St. Jean and J.R. Jacques. 1986. The biting and resting behavior of *Anopheles albimanus* in northern Haiti. *J. Am. Mosq. Control. Assoc.* 2:150-153.
- Kennedy, J.S. 1947. The excitant and repellent effects on mosquitoes of sub-lethal contacts with DDT. *Bull. Entomol. Res.* 37: 593-607.

- Kumm, H.W. and L.M. Ram. 1941. Observations on the Anopheles of British Honduras. *Am. J. Trop. Med.* 21: 559-566.
- Loyola, E.G., J.I. Arredondo, M.H. Rodriguez, D.N. Broqn and M.A. Vaca-Marin. 1991. Anopheles vestitipennis, the probable vector of Plasmodium vivax in the Lacandon forest of Chiapas, Mexico. *Trans. R. Soc. Trop. Med. Hyg.* 85:171-174.
- Macdonald, G. 1950. Epidemiological basis of malaria control. *Bull. Wld. Hlth. Org.* 15: 613-626.
- Macdonald, G. 1957. The epidemiology and control of malaria. Oxford University Press, Amen House, London, 201 pp.
- Marquetti, M., A. Navarro, J. Bisset and F.A. Garcia. 1992. Comparisons of three catching methods for collecting anopheline mosquitoes. *Mem. Inst. Oswaldo Cruz Rio J.* 87:457-458.
- Mekuria, Y., R. Granados, M.A. Tidwell, D.C. Williams, R.A. Wirtz and D.R. Roberts. 1991. Malaria transmission potential of Anopheles mosquitoes of Dajabon, Dominican Republic. *J. Am. Mosq. Control. Assoc.* 7:456-461.
- Muirhead-Thomson, R.C. 1950. DDT and Gammexane as residual insecticides against Anopheles gambia in African houses. *Trans. Roy. Soc. Trop. Med. Hyg.* 43: 401-412.
- Muirhead-Thomson, R.C. and E.C. Mercier. 1952. Factors in malaria transmission by Anopheles albimanus in Jamaica. *Ann. Trop. Med. Parasitol.* 46: 103-116.

- Muirhead-Thomson, R.C. 1960. The significance of irritability, behaviouristic avoidance and allied phenomena in malaria eradication. *Bull. Wld. Hlth. Organ.* 22:721-734.
- Padilla, N., P. Molina, J. Juarez, D. Brown and C. Cordon-Rosales. 1992. Potential malaria vectors in northern Guatemala. *J. Am. Mosq. Control Assoc.* 8:307-308.
- Pan American Health Organization. 1994. Status of malaria programs in the Americas. XLII report, CSP24/INF/2(Eng.) Washington, D.C. 116 pp.
- Rachou, R.G., G. Lyons, M. Maura Lima, and J.A. Kerr. 1965. Synoptic epidemiological studies of malaria in El Salvador. *Am. J. Trop. Med. Hyg.* 14:1-62.
- Ramsey, J.M., E. Salinas, D.M. Brown, and M.H. Rodriguez. 1994. Plasmodium vivax sporozoite rates from Anopheles albimanus in southern Chiapas, Mexico. *J. Parasitol.* 80:489-493.
- Roberts, D.R., W.D. Alecrim, P. Hshieh, J.P. Grieco, M. Bangs, R.G. Andre and T. Chareonviriphap. 2000. A probability model of vector behavior: effects of DDT repellency, irritancy and toxicity in malaria control. *J. Vec. Ecol* (In Press)
- Roberts, D.R., W.D. Alecrim, A.M. Tavares and M.G. Radke. 1987. The house frequenting, host-seeking and resting behavior of Anopheles darlingi in southeastern Amazonas, Brazil. *J. Am. Mosq. Control Assoc.* 3: 433-441.
- Roberts, D.R., W.D. Alecrim, A.M. Tavares and K.M. McNeill. 1984. Influence of physiological condition on the behavioral responses of Anopheles darlingi to DDT. *Mosq. News.* 44: 357-362.

- Roberts, D.R. and R.G. Andre, 1994. Insecticide resistance issues in vector-borne disease control. *Am. J. Trop. Med. Hyg.* 50: 21-43.
- Roberts, D.R., O. Chan, J. Pecor, E. Rejmankova, S. Manguin, J. Polanco and L.J. Letgers. 1993. Preliminary observations on the changing roles of malaria vectors in southern Belize. *J. Am. Mosq. Control Assoc.* 9: 456-459.
- Roberts, D.R., L.L. Laughlin, P. Hsheih and L.J. Letgers. 1997. DDT: global strategies and a malaria control crisis in South America. *Emerg. Inf. Dis.* 3:295-302.
- Rozendaal, J. A. 1990. Observations on the distribution of anophelines in Suriname with particular reference to the malaria vector Anopheles darlingi. *Mem. Inst. Oswaldo Cruz.* 85: 221-234.
- Sharp, B.L., D. le Sever and P. Bekker. 1990. Effects of DDT on survival and blood feeding success of Anopheles arabiensis in Northern KwaZulu, Republic of South Africa. *J. Am. Mosq. Control Assoc.* 6: 197-202.
- Taylor, R.J. 1966. The ecology of Anopheles albimanus (Weid.) in Haiti. *Mosq. News* 26: 393-397.
- Warren, McW, W.E. Collins, B.B. Richardson and J.C. Skinner. 1977. Morphological phenotypes of Anopheles albimanus and susceptibility to Plasmodium vivax and Plasmodium falciparum. *Am. J. Trop. Med. Hyg.* 26: 607-611.
- Wilkerson, R.C. and D. Strickman. 1990. Illustrated key to the female anopheline mosquitoes of Central America and Mexico. *J. Am. Mosq. Control Assoc.* 6: 7-33.

Wirtz, R.A., T.R. Burkot, P.M. Graves and R.G. Andre. 1987. Field evaluation of enzyme-linked immunosorbent assays for Plasmodium falciparum and Plasmodium vivax sporozoites in mosquitoes (Diptera:Culicidae) from Papua New Guinea. J. Med. Entomol. 24: 433-437.

Table 1: Summary of the monthly meteorological data collected from March 1998 to December 1998 at the Rancho site, Toledo District, southern Belize.

Month	Mean Temperature (SD)			Precipitation mm (SD)	Precipitation Max mm
	Max	Min	Range		
March	31.1 (2.3)	23.3 (3.0)	32-21.6	116.3 (13.1)	48.1
April	34 (1.8)	24.4 (2.4)	35.5-23.3	56.1 (10.1)	26.7
May	33.8 (2.2)	25 (3.6)	35-22.7	100.9 (20.4)	49.9
June	33.3 (3.6)	23.3 (2.7)	35.5-21.6	320.8 (31.5)	131.3
July	32.7 (2.5)	23.8 (1.3)	34-23.3	552 (16.8)	60.5
August	31.1 (3.1)	22.2 (4.2)	32.7-20	390.1 (24.7)	97.6
September	30 (3.9)	21 (4.1)	33.3-18.8	NA	NA
October	28.8 (4.6)	20 (3.3)	32.7-18.3	NA	NA
November	27.7 (4.2)	18.8 (2.5)	32-17.7	NA	NA
December	26.6 (5.1)	17.7 (1.2)	31-17.2	NA	NA

Table 2: Spearman's rho values showing the relationship between entrance and exit intercept trap collections and meteorological conditions during all night collections at the Rancho site.

Spearman's rho values		
	Entrance	Exit
Rain	(0.423;p<0.05)	(0.281;p>0.05)
Wind Speed	(0.617;p<0.01)	(0.430;p>0.05)
Relative Humidity	(0.023;p>0.05)	(0.221;p>0.05)
Temperature	(0.241;p>0.05)	(0.522;p>0.01)

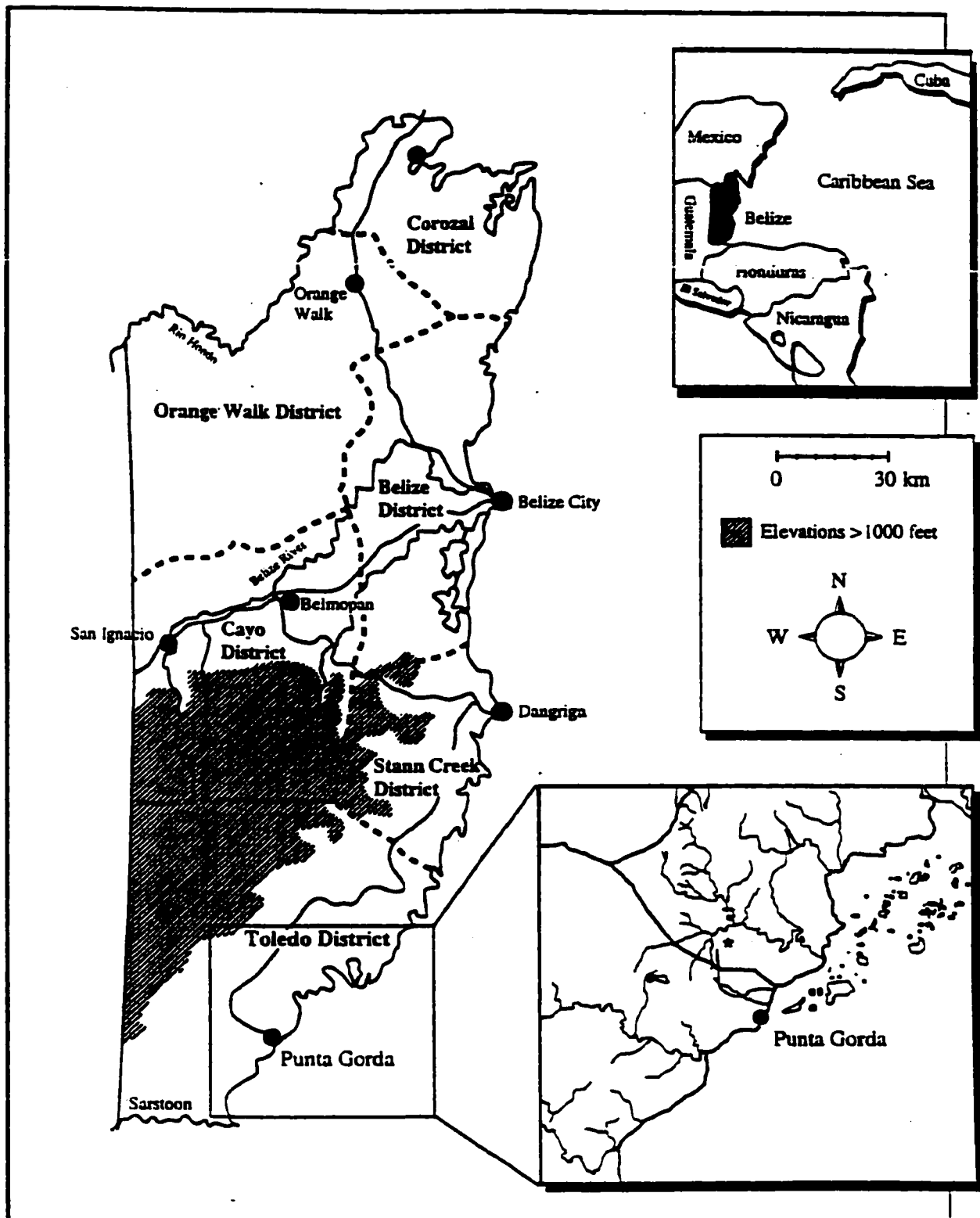

Figure 1. Map of the Toledo District in Southern Belize. The location of the experimental hut site is indicated by the star.

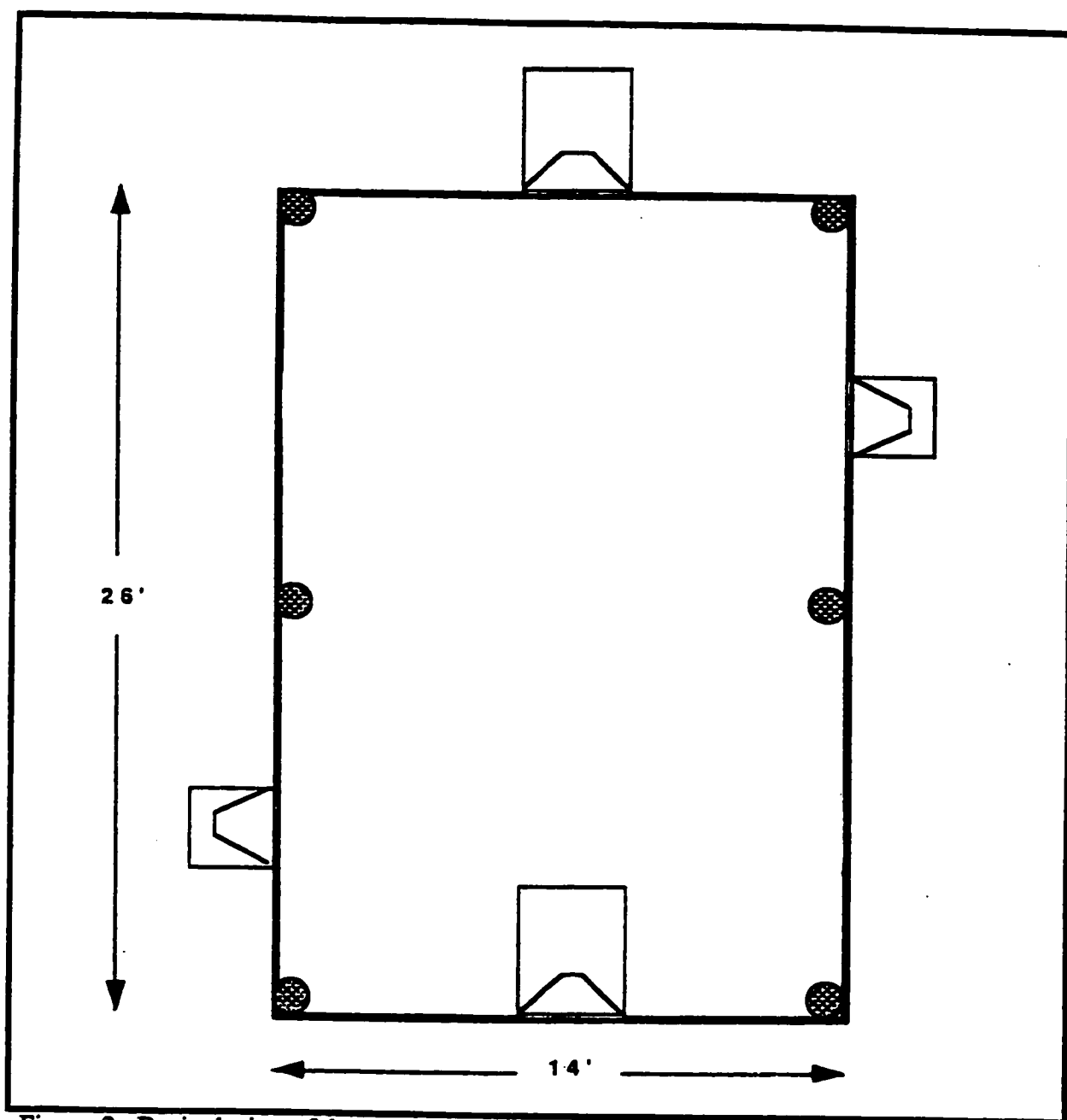

Figure 2. Basic design of the experimental hut study used in the study conducted at Rancho Village, Toledo District, southern Belize showing the placement of the one door and three windows fitted with exit intercept traps.

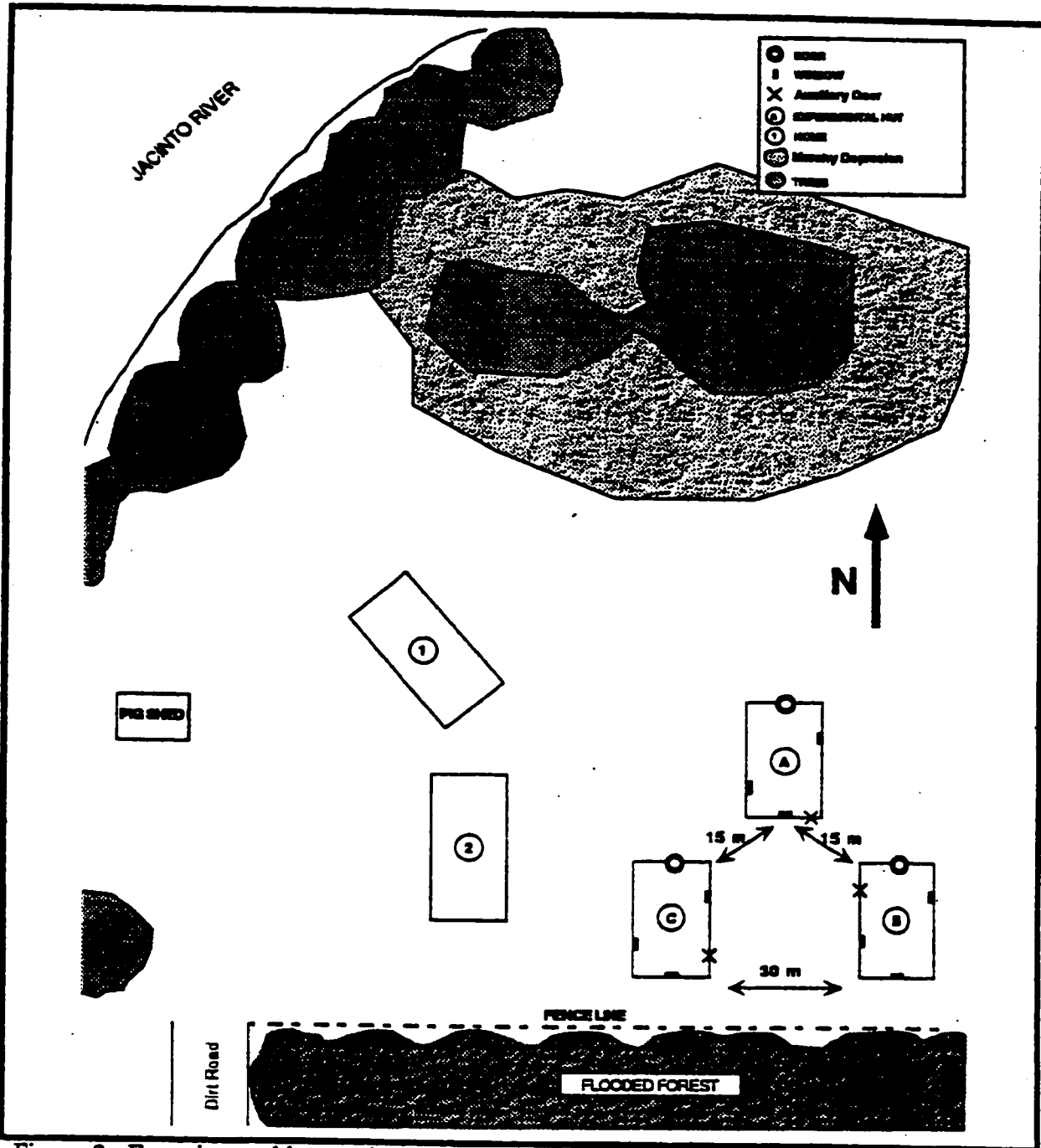

Figure 3. Experimental hut study site located in Rancho Village, Toledo District, southern Belize showing the placement of huts (A, B and C), surrounding man made structures and environmental habitats.

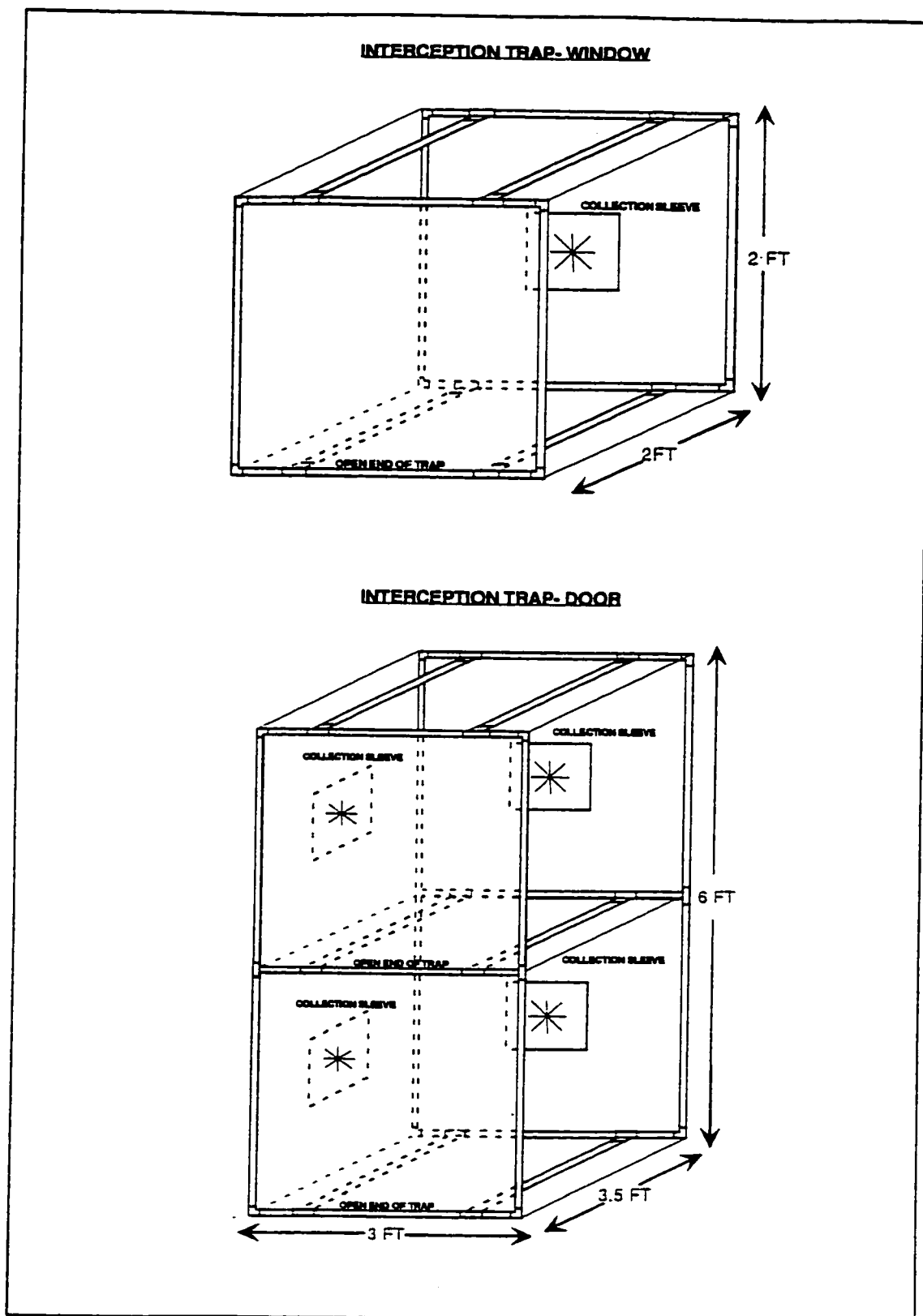

Figure 4: Illustration of the window and door intercept traps.

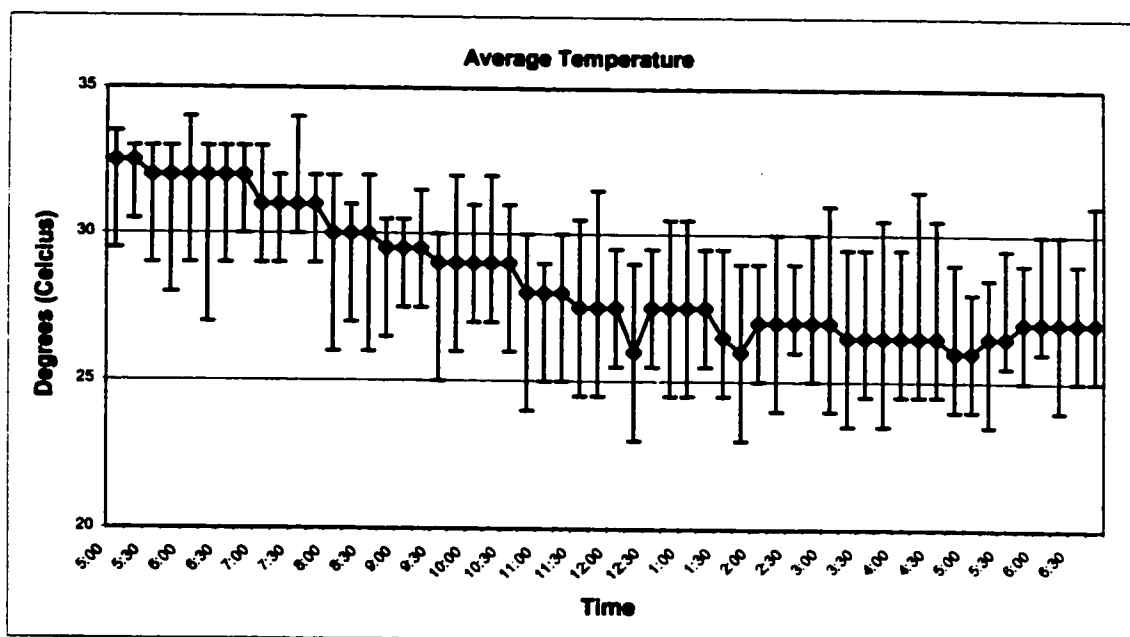

Figure 5: Average temperature readings over 36 collection nights during which collections were made at the experimental huts from March to December of 1998. Range bars indicate the maximum and minimum temperatures recorded at that time during any collection.

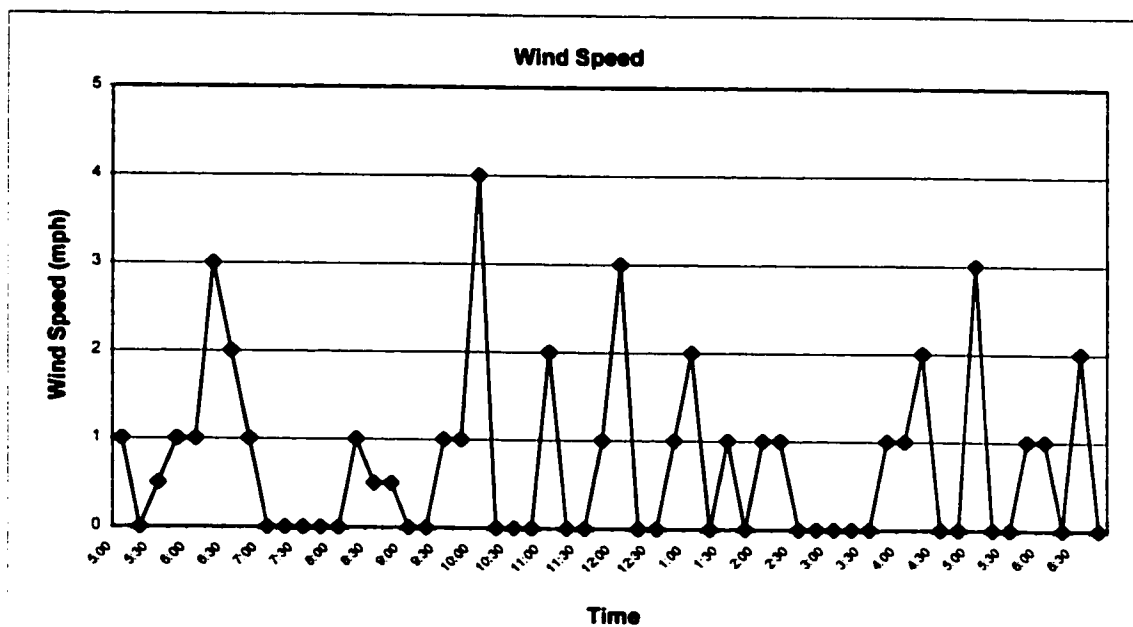

Figure 6: Average wind speeds recorded over 36 collection nights during which collections were made at the experimental huts from March to December of 1998.

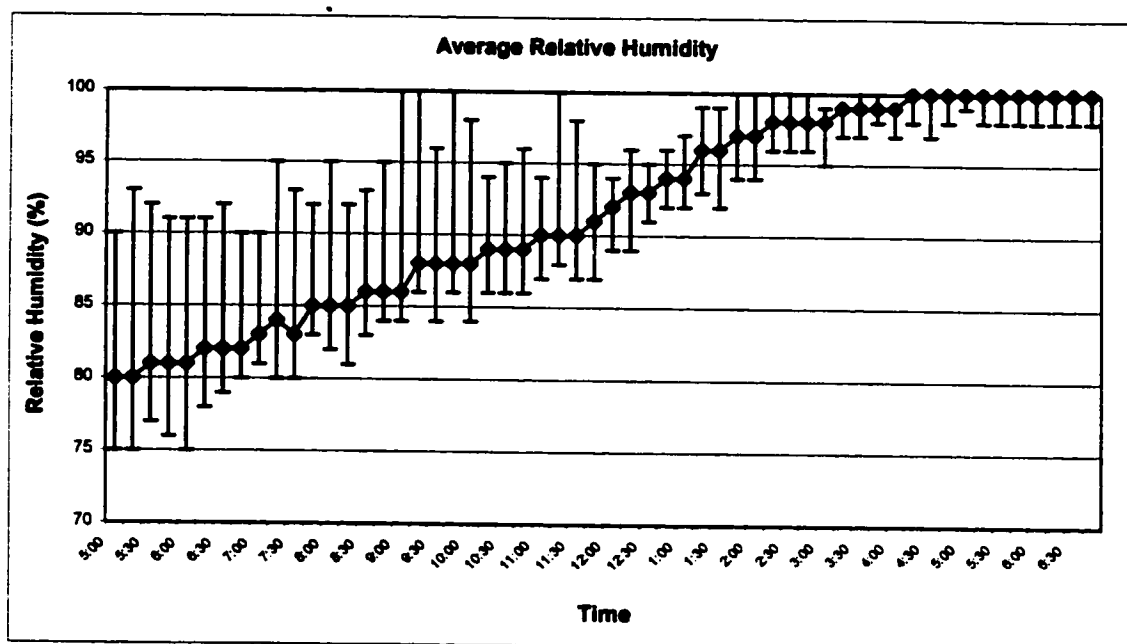

Figure 7: Average relative humidity recorded over 36 collection nights during which collections were made at the experimental huts from March to December of 1998. Range bars indicate the maximum and minimum humidities recorded at that time during any collection.

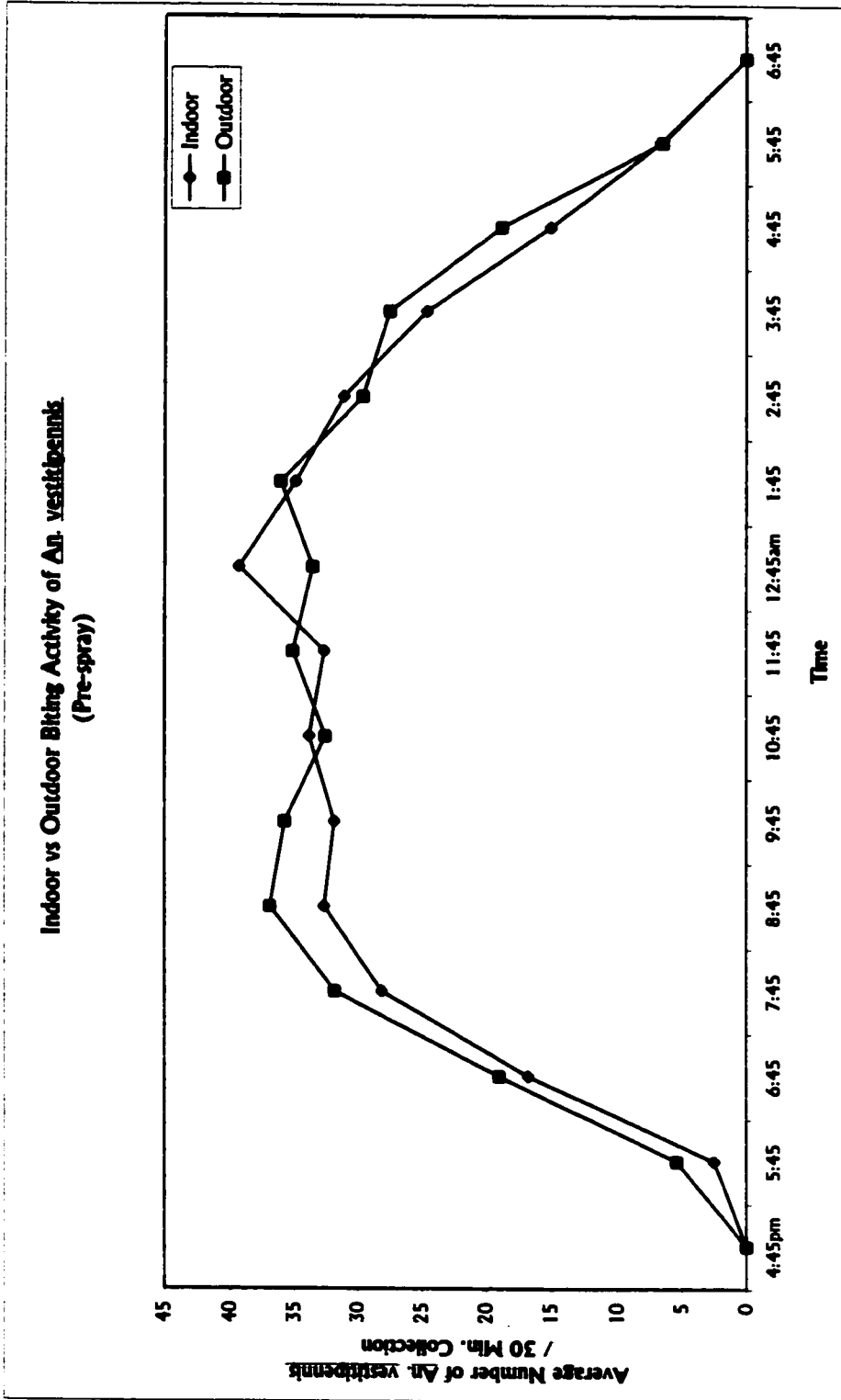

Figure 8: Average number of *Anopheles vestitipennis* collected from human baited collections during 26 collection nights at Rancho, Toledo District, Belize, from March to November of 1998. Each collection was conducted for 15-hours by two collectors collecting for 30 minutes each hour throughout the night. Data is plotted against the midpoint of each 30-minute sample period.

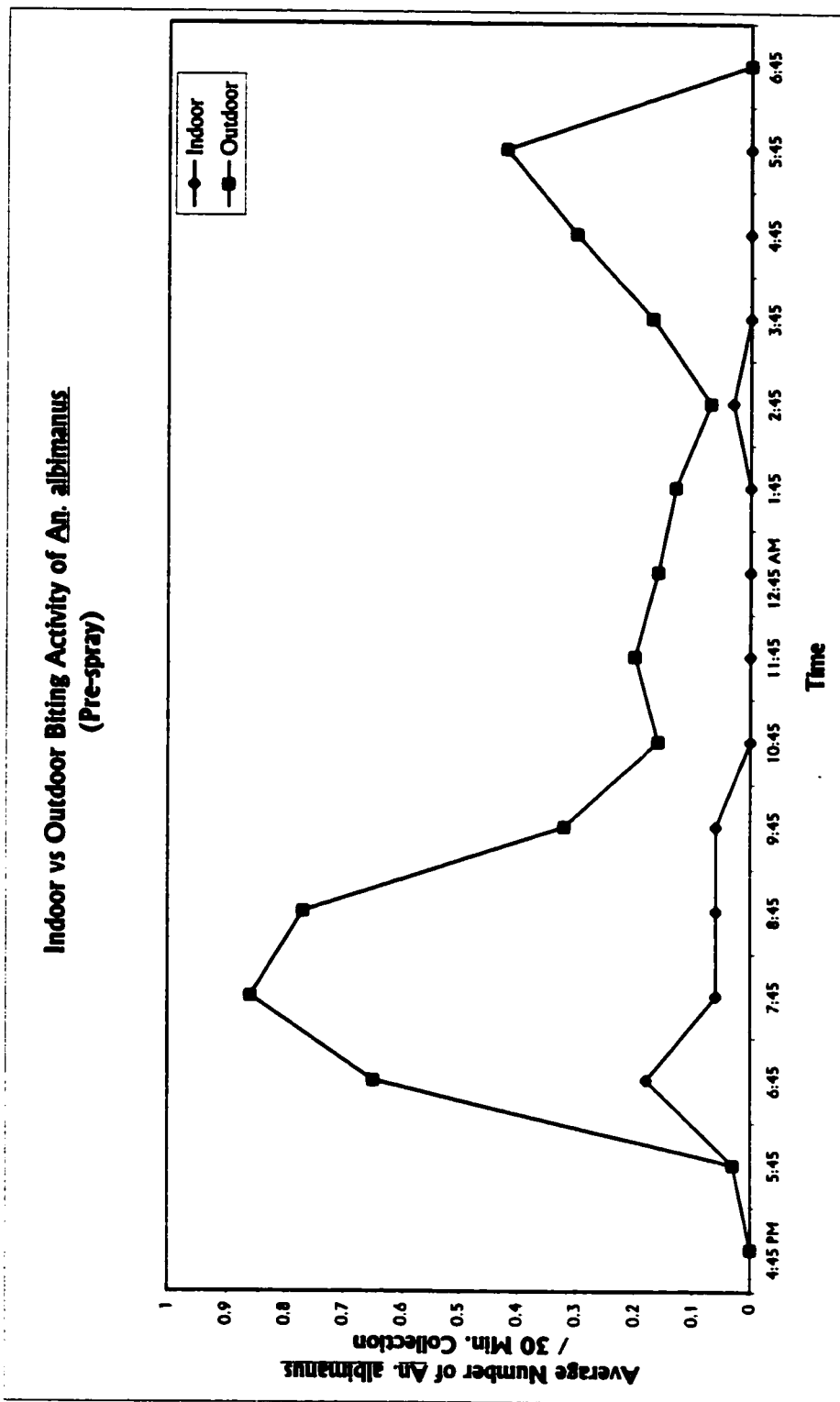

Figure 9: Average number of *Anopheles albimanus* collected from human baited collections during 26 collection nights at Rancho, Toledo District, Belize, from March to November of 1998. Each collection was conducted for 15-hours by two collectors collecting for 30 minutes each hour throughout the night. Data is plotted against the midpoint of each 30-minute sample period.

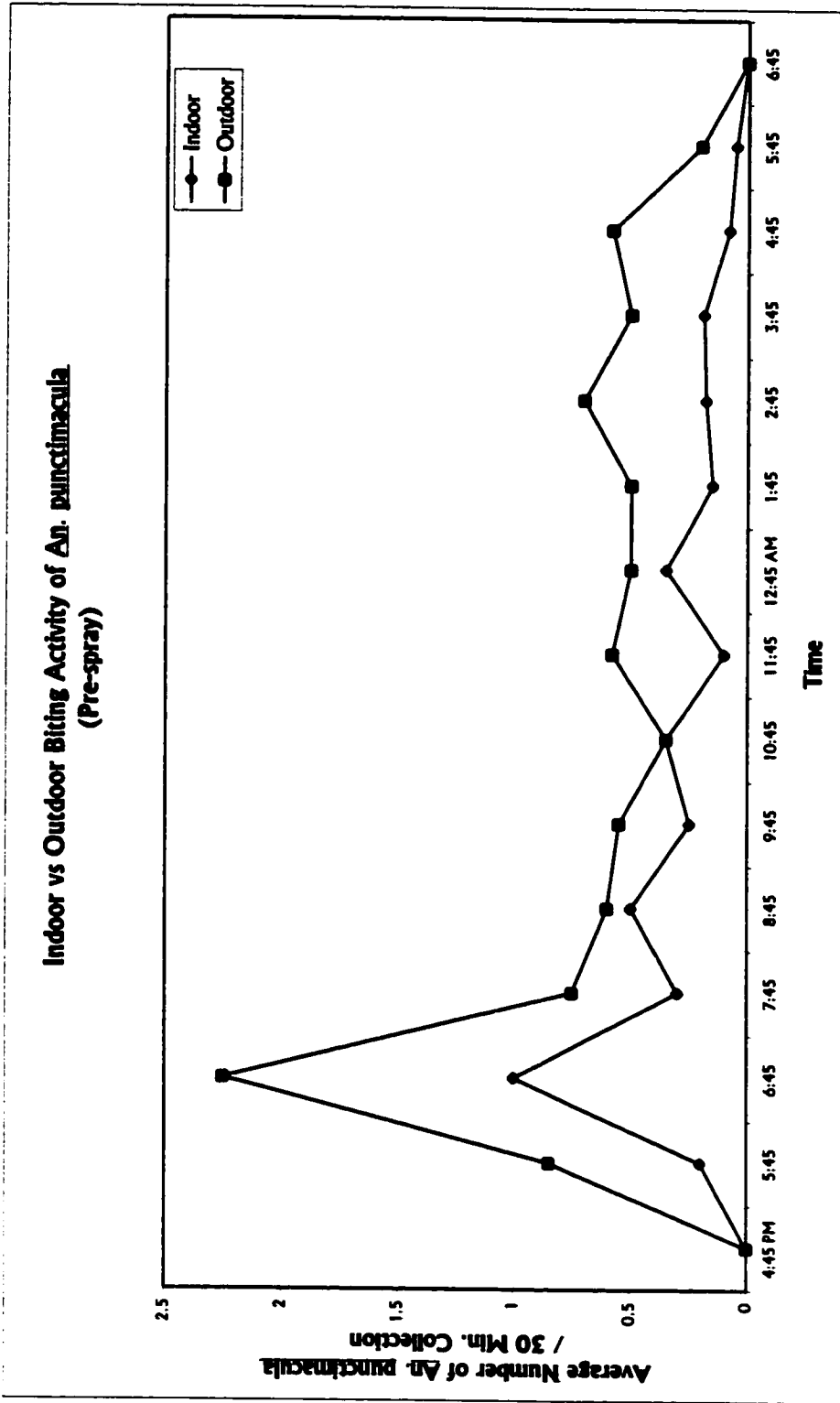

Figure 10: Average number of *Anopheles punctimaculata* collected from human baited collections during 26 collection nights at Rancho, Toledo District, Belize, from March to November of 1998. Each collection was conducted for 15-hours by two collectors collecting for 30 minutes each hour throughout the night. Data is plotted against the midpoint of each 30-minute sample period.

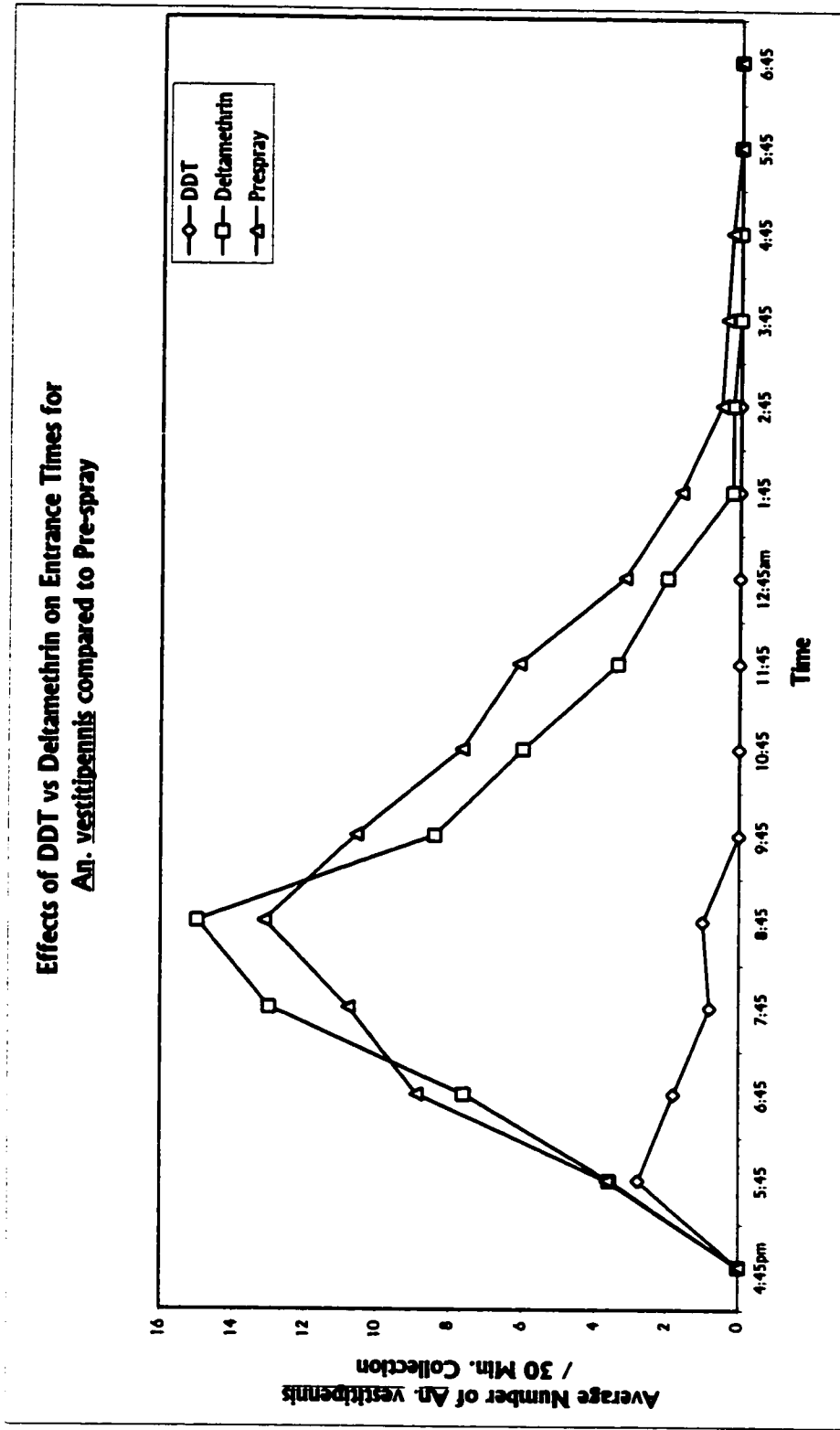

Figure 11: Comparison of the average number of *Anopheles vestitipennis* collected under pre- and post-spray conditions from entrance interception traps conducted during 21 and 5 collection nights, respectively, at Rancho, Toledo District, Belize, from August to December of 1998. Each collection was conducted for 15 hours by two collectors collecting for 30 minutes each hour throughout the night. Data is plotted against the midpoint of each 30-minute sample period. During a single night's collection, both sprayed huts were affixed with entrance traps, and a human baited collection was conducted at the control hut.

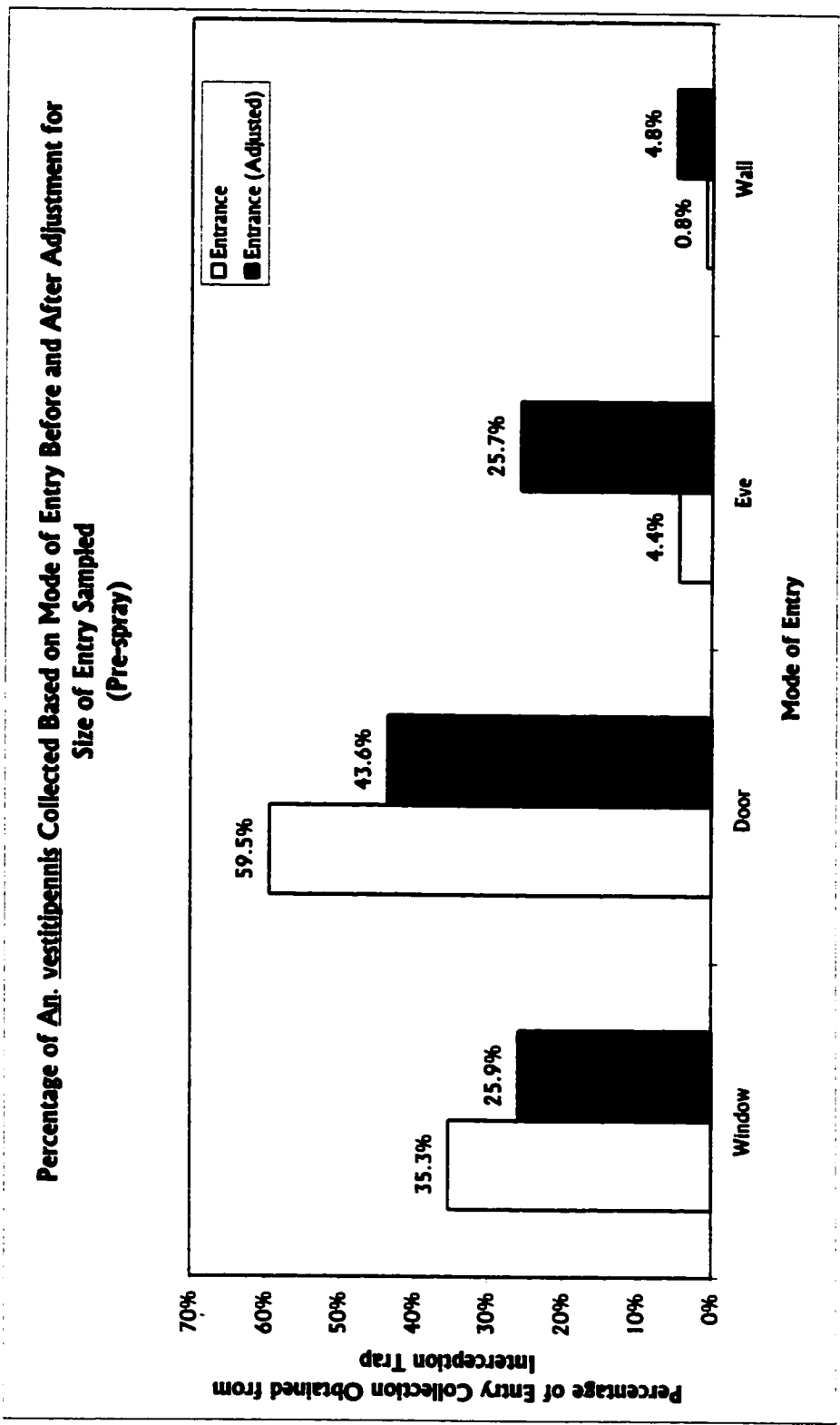

Figure 13: Percentage of total *Anopheles vestitipennis* populations collected from entrance interception traps during 21 nights of collections. Window and door traps represent collection from entire portal region while the eaves and wall trap represent only 1/8 of the total surface area for that mode of entry.

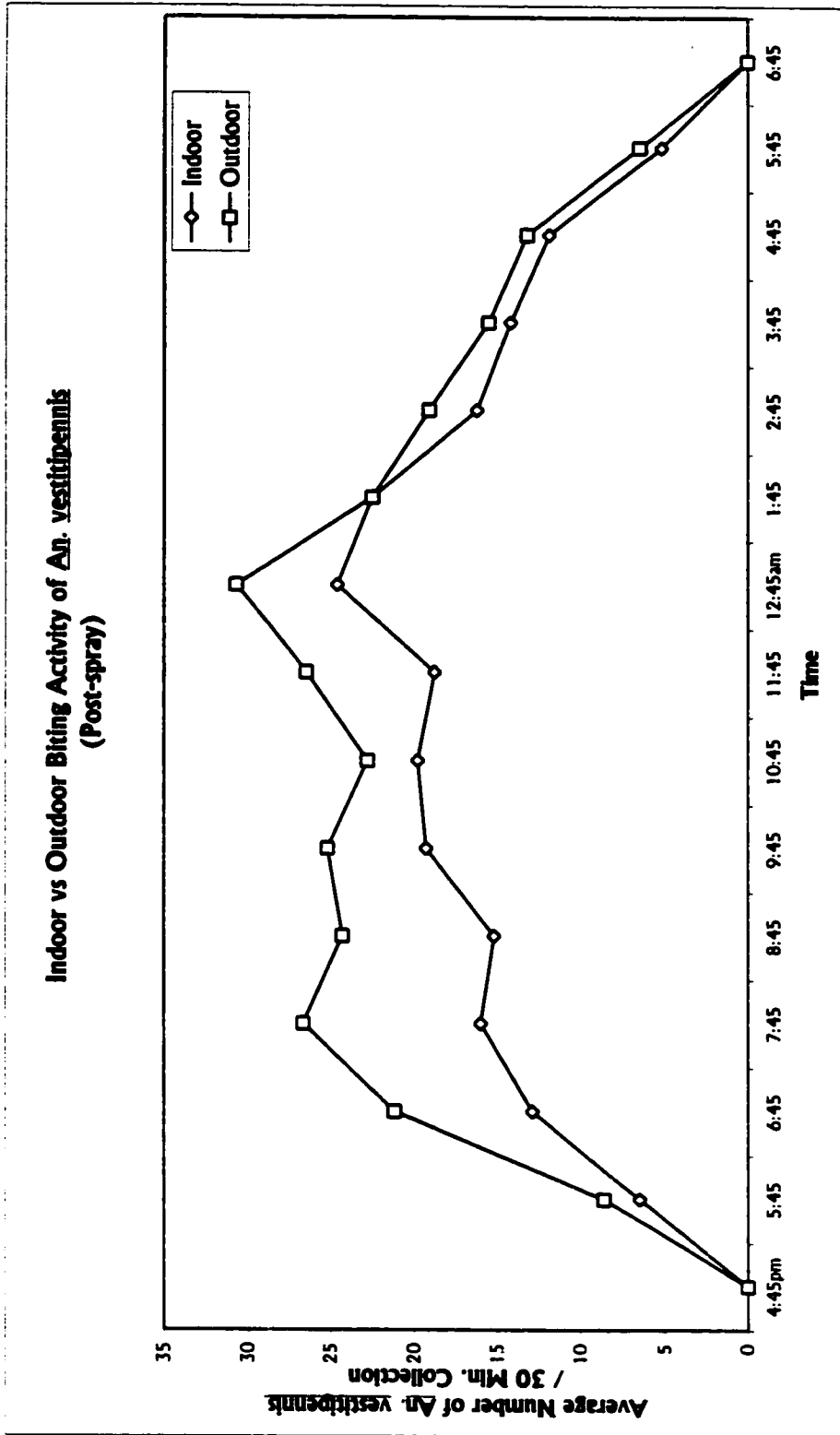

Figure 14: Average number of *Anopheles vestitipennis* collected from human baited collections conducted post-spray during 10 night collections at Rancho, Toledo District, Belize, from November to December of 1998. Each collection was conducted for 15-hours by two collectors collecting for 30 minutes each hour throughout the night. Data is plotted against the midpoint of each 30-minute sample period.

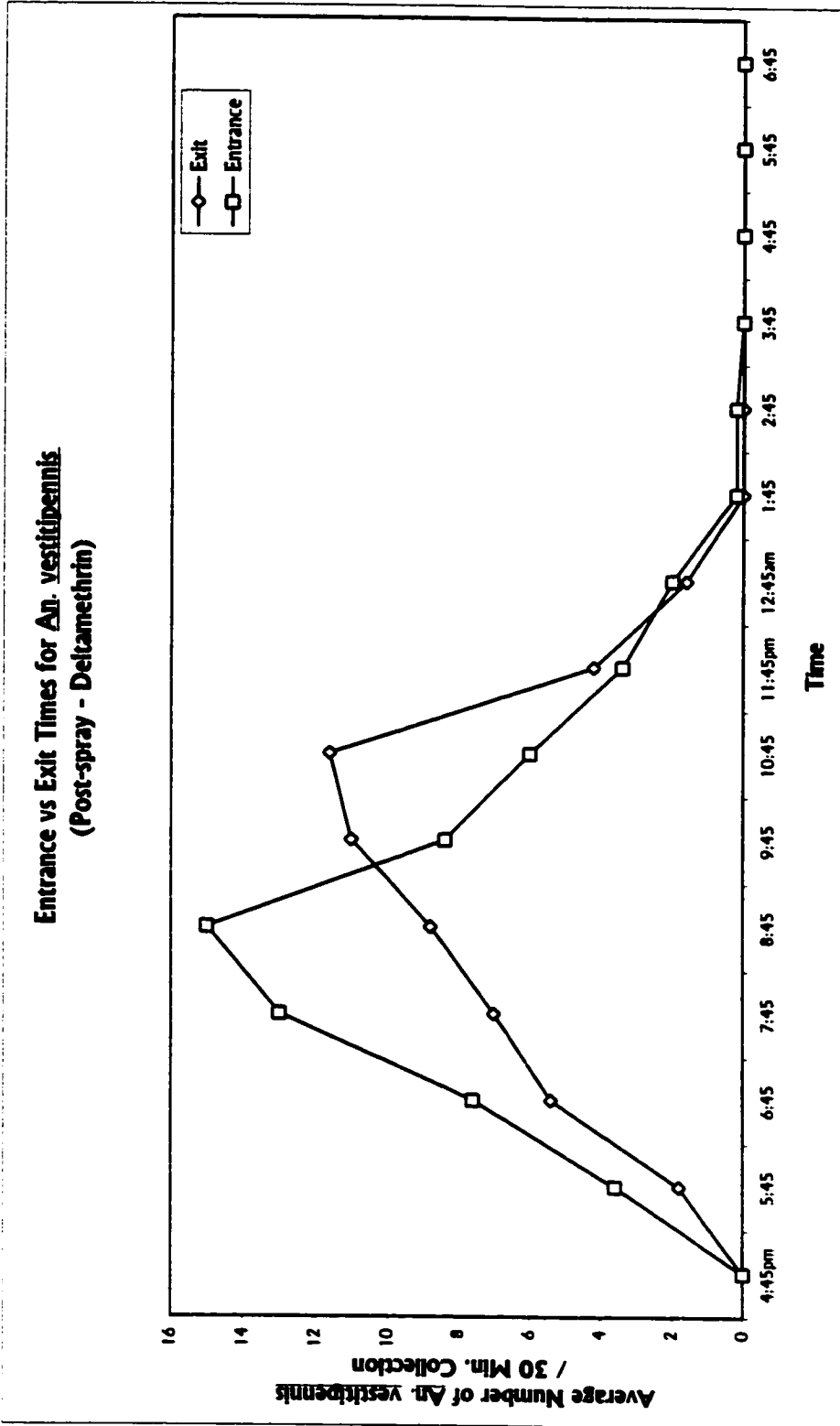

Figure 15: A comparison of entrance and exit times for *Anopheles vestitipennis* post-spray with deltamethrin. Entrance and exit collections were conducted on different nights. Average number of mosquitoes collected per 30-minute sample period are plotted against the midpoint of that sample period.

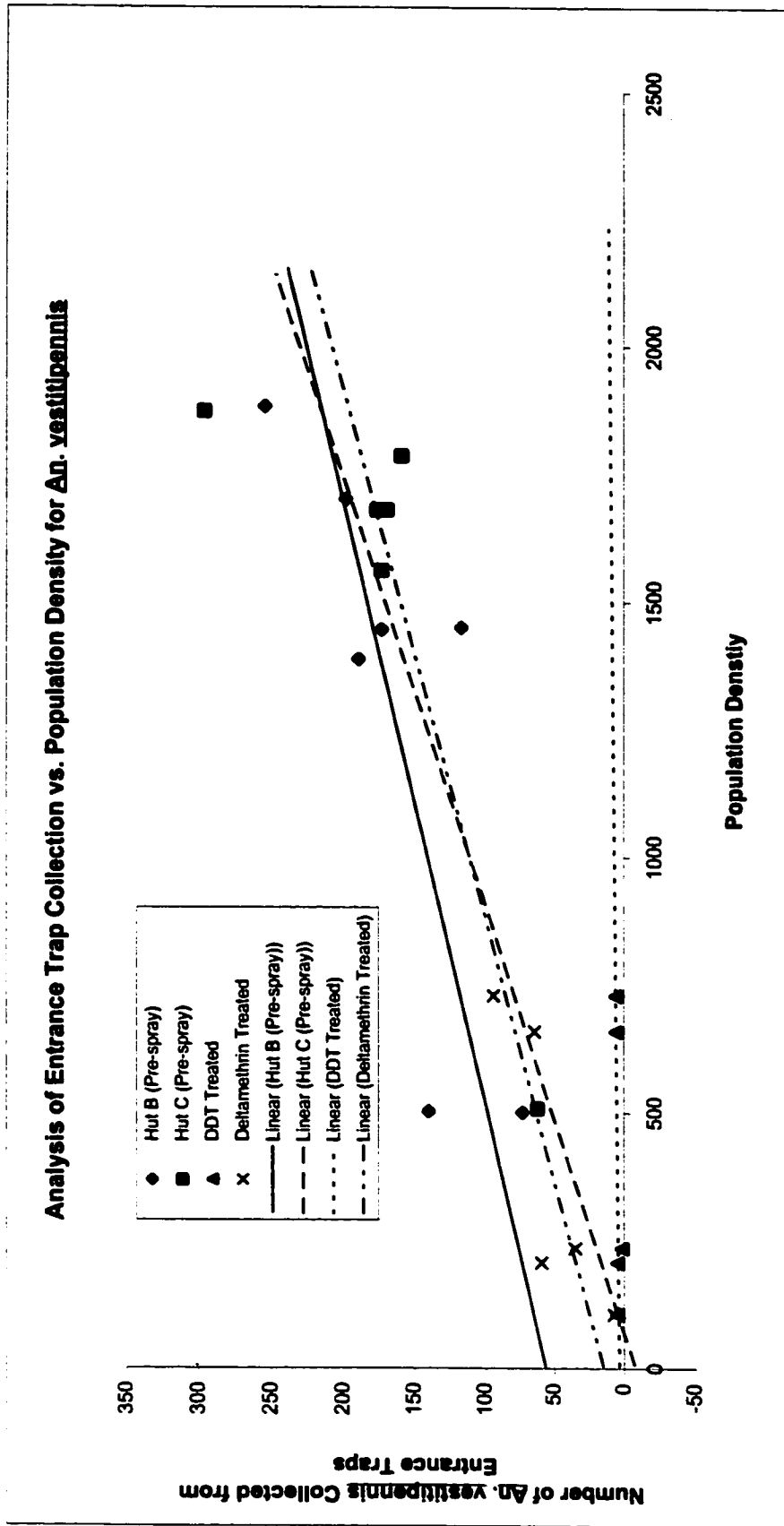

Figure 16: ANCOVA analysis showing the relationship between increasing population density and increasing entrance trap collection for *Anopheles vestitipennis*. An increase in the number of mosquitoes collected from the traps is positively correlated with all treatments except the DDT treated hut where the slope of the line is not significantly different from zero ($P > 0.05$).

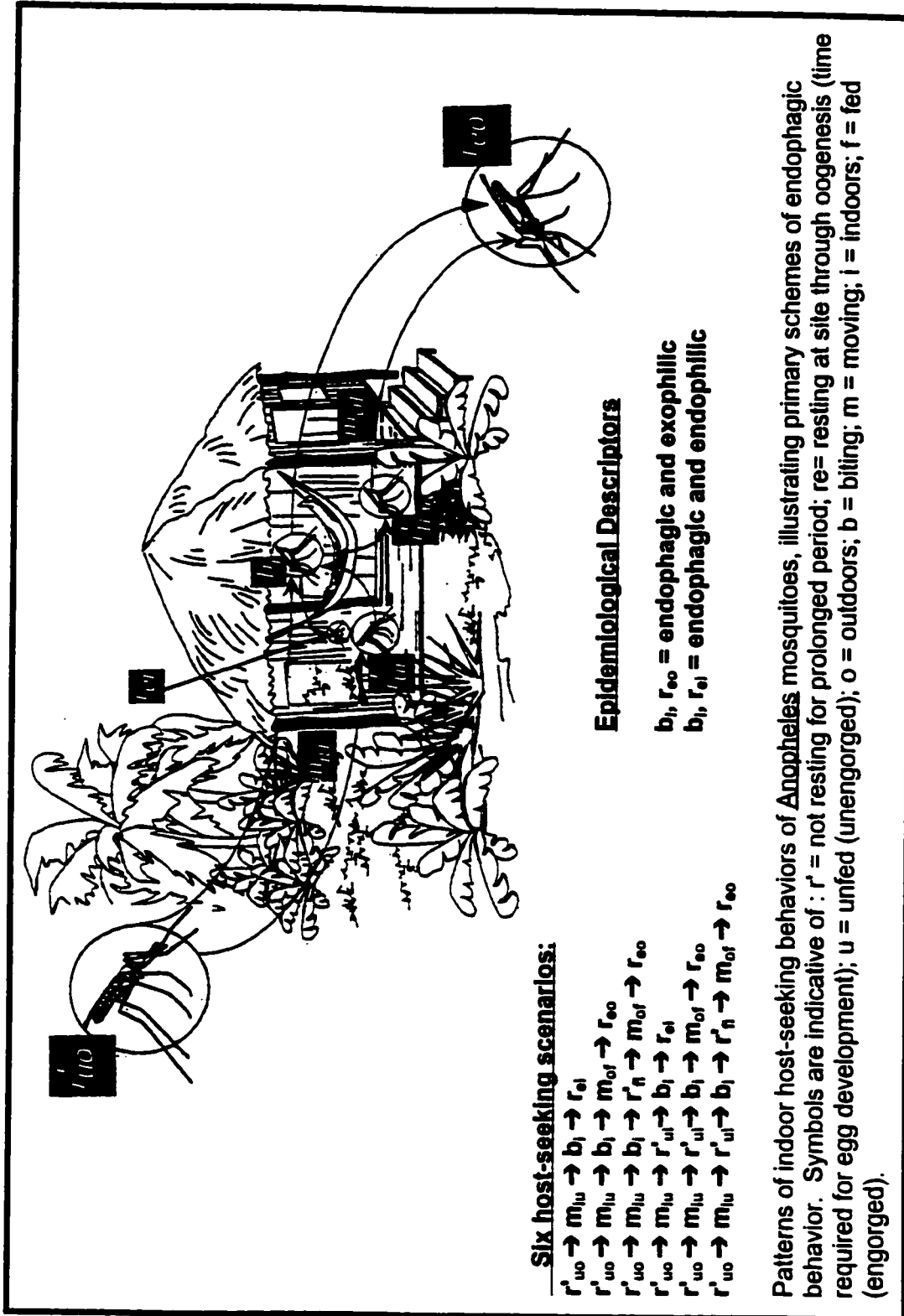

Figure 17: Illustration of the possible scenarios available to endophagic host seeking *Anopheles* mosquitoes (Roberts et al. 2000). Conditional probabilities can be assigned to each value to evaluate the behavioral effects exerted by various insecticides.

Chapter 7

**Comparative susceptibility of three species of Anopheles from Belize,
Central America to Plasmodium falciparum (NF-54)**

Abstract

In August of 2000, a comparative susceptibility study was conducted using 3 species of Anopheles mosquitoes from Belize, Central America and a control species obtained from a colony reared population of An. stephensi. Populations of these mosquitoes were fed infected blood containing a cultured Plasmodium falciparum from a membrane feeder. The main goals of this study were to 1) confirm the ability of An. vestitipennis to become infected by P. falciparum, 2) compare the rates of infection maintained in three vector species from the country of Belize and 3) chart the rate of oocyst development between the three species.

Results indicate that the control population of An. stephensi exhibited the highest level of infectivity with 73.8% of those mosquitoes dissected exhibiting sporozoites in the salivary glands. Those An. stephensi testing positive also showed heavier sporozoite loads with 74.0% of salivary gland infected mosquitoes having greater than 200 sporozoites. Anopheles darlingi showed the next highest infectivity rate with a 41.0% salivary gland infection rate. Again, this species exhibited high numbers of sporozoites in the salivary glands (>200). Anopheles vestitipennis had a low salivary gland infection rate of 9.3% and moderate numbers of sporozoites (i.e. 85.7% containing 50-250 sporozoites). Anopheles albimanus was the least susceptible to infection. No specimens of An. albimanus from the Golden Stream population developed sporozoites in the salivary glands yet 20.7% of those dissected had positive midgut infections. The Buena Vista population showed similar results with only a 2.2% salivary gland infection rate, but a 21.5% midgut infection rate.

The oocyst growth curves in all four mosquito populations show similar patterns of development until day 10 post infectious blood meal. After day 10, the oocysts in An. stephensi show a 20% greater increase in size over its development during the first 10 days. Development peaked at day 12 with a mean oocyst diameter of 58 microns, as well as, first observation of oocyst differentiation. Anopheles vestitipennis showed slower oocyst development until day 10. After day 10, there was a 53% increase in oocyst development over the previous 10 days. Oocyst differentiation was not observed until day 13 post feed. Both populations of An. albimanus showed similar slow rates of oocyst development as that seen in An. vestitipennis, however, no dramatic growth increase occurred after day 10. The oocysts in the Golden Stream An. albimanus population exhibited a cessation of growth after day 10, peaking at a mean of 30 microns. The Buena Vista population did not exhibit the same level of reduced oocyst development. A gradual increase in growth continued until days 13 and 14 (36.7 and 35.7 microns respectively).

As in other parts of its range, An. darlingi shows a high level of susceptibility to Plasmodium falciparum. Susceptibility to infection plus its endophilic and endophagic behaviors incriminate this species as an extremely important vector of P. falciparum in southern Belize. Although the rate of infection for An. vestitipennis is low, its strong endophagic and anthropophagic behaviors augment its overall vector potential. This species clearly demonstrates characteristics of an important vector of malaria in Belize. The opposite appears to be true of An. albimanus. A low infection rate and both exophagic/zoophagic behaviors reveal this species to be a poor vector of P. falciparum. From the oocyst growth curve, it appears that some factor acts on the oocyst and prevents

completion of development. In order to obtain a true picture of the transmission potential of these species, further studies with local strains of the Plasmodium parasite are needed. It would also be valuable to conduct similar studies using the other Anopheles species found in Belize (i.e. An. pseudopunctipennis, An. crucians, An. punctimacula etc.) and both P. vivax 210 and P. vivax 247.

Introduction

The resurgence of malaria in tropical regions of Central and South America has created a renewed urgency for information pertaining to Anopheles vectors (PAHO, 1994). A control program should be based detailed knowledge of the transmission dynamics occurring in the field (Collins and Paskewitz, 1995). An integral part of the transmission dynamics is the bionomics of the vector species. Although behavioral and physiological characteristics of a species can incriminate it as a competent vector, only by coupling this information with finding sporozoites in the salivary glands can a strong argument be made for vector status. Four species have been incriminated in the transmission of malaria in Belize: Anopheles albimanus Weidemann, An. pseudopunctipennis Theobald, An. darlingi Root and An. vestitipennis Dyer and Knab. The aim of this research project was to conduct a comparative susceptibility study on three potentially important vector species in Belize; An. albimanus, An. darlingi and An. vestitipennis. In performing this study, the following goals will be achieved: 1) confirm the ability of An. vestitipennis to become infected by P. falciparum, 2) compare the rates of infection maintained in the three vector species and 3) chart the rate of oocyst development in populations of An. vestitipennis, An. albimanus from Belize, and a colony strain of An. stephensi.

It is still unclear why only a limited number of Anopheles species are able to efficiently transmit malaria parasites. Differences in susceptibility of Anopheles to human Plasmodium, however, have been documented for all taxonomic levels of Anopheles mosquitoes (Warren et al. 1977). Even within a single species, there may be large differences in susceptibility between mosquito strains, as well as, variations in

susceptibility over time (Rutledge et al. 1969, Collins et al. 1986). The high level of behavioral variability associated with these mosquito species adds to the importance of determining local and individual vector potentials so that effective control measures can be developed.

Under ideal conditions, it would be desirable to conduct infection studies using direct feeds on malaria infected patients. Such studies more accurately reflect the true infection potential obtained under natural conditions (Galun 1975). This method of infection is, however, not well received by the study participants and is increasingly difficult to get approved by human use committees (Novak 1995). A membrane feeding system is easier to use and more acceptable to all individuals involved in the study. A major concern, however, of conducting comparative susceptibility studies using a membrane feeding system is the validity of the data as compared to studies conducted using direct patient feeds (Bonnet et al 2000). Reliable comparisons are required to accurately understand the epidemiological differences in malaria transmission. Bonnet et al (2000) compared direct patient feeds to membrane feeds to determine their effectiveness in infecting mosquitoes. They found that direct feeds showed significantly higher infection rates in mosquitoes than did membrane feeding. They did report, however, that the sensitivity of the two techniques was the same. Because proportions of infected mosquitoes between the species are the same for both membrane and direct feed, accurate comparisons can be made without having a concordance between level of infection in the laboratory and from patient fed mosquitoes.

Membrane feeding systems have been extensively used with blood sucking arthropods to conduct transmission studies of bacterial, viral and protozoal agents. This

feeding method reduces the need for having an animal model and allows one the ability to easily manipulate the dosage of the infectious agent (Novak et al. 1991). Not all mosquitoes, however, will membrane feed. Conditions must closely mimic the conditions of a natural system such as temperature and viscosity of the blood meal (Galun 1967). The type of membrane will also influence success of a feeding experiment. A large variety of different membranes were tested by Tarshis (1958). He found that animal derived versus synthetic membranes exhibit the greatest success. Novak et al. (1991) showed that animal derived membranes were more successful than latex condoms. Some success was achieved with Parafilm in feeding An. stephensi (Rutledge et al 1964). This success is increased if the Parafilm is placed in contact with exposed human skin for 30 minutes or more prior to feeding (Dowler pers comm 2000).

One membrane that has shown a great deal of success is the Baudruche membrane. This membrane is made from ox intestine and has demonstrated a high degree of permeability to aqueous substances. The success of animal derived membranes has been attributed to their permeability to water and water soluble materials (Rutledge et al 1964). It is believed that some compound in the blood is able to diffuse across the membrane, activate chemoreceptors and stimulate the mosquitoes to begin probing. Other researchers have demonstrated increases in mosquito probing and feeding due to the simple process of wetting the membrane with tap water prior to using (Awono-Ambene and Robert 1998). Again, this is seen as a means of increasing the diffusion of some volatile chemical across the surface of the membrane. The Baudruche membrane has become a routine and effective medium for achieving successful mosquito feeds (Awono-Ambene and Robert 1998).

Not only does the type of membrane effect the success of experimental feeds but a number of chemical and physical factors also affect the successful engorgement of mosquitoes on a membrane feeder (Galun 1975). The effectiveness of the feeding response was shown to increase in the presence of adenine nucleotides. Galun (1975) demonstrated that adenosine triphosphate (ATP) induced a higher feeding response than did either adenosine diphosphate (ADP) or adenosine monophosphate (AMP). Based on this information, many researchers have incorporated ATP into the blood meal to serve as a phagostimulant (Galun and Rice 1971; Cosgrove and Wood 1995). The membrane feeding response also is influenced by temperature. Cosgrove and Wood (1995) showed a correlation between increased probing and increased temperatures. This feeding response was seen to be associated with a temperature differential between the membrane and the surrounding air temperature rather than the absolute temperature of the membrane. Price et al. in 1979 suggested that there are factors other than CO₂, water and temperature involved in mosquito attraction. One suggestion is that other volatile chemicals that have been isolated from human skin could increase the effectiveness of the membrane feeding system (Schreck et al 1990).

Another factor influencing the success or failure of membrane feeding experiments is the infectivity of blood used in the system. For many years, researchers relied on the use of venous blood obtained from infected patients (Graves 1980). With the advent of cultured Plasmodium parasites, however, it has become easier to conduct susceptibility studies. One such cultured parasite is the Amsterdam airport strain of NF-54. This parasite was first cultured by Ponnudurai et al. in 1982. Since that time it has

been used extensively in a number of vaccine trials and susceptibility studies (Jensen and Trager 1978, Campbell 1984, Trager 1990).

Another parameter that can influence the success of a membrane feeding experiment is the effect of crowding. Edman et al. (1975) reported that blood feeding was prematurely interrupted when too many Culex nigripalpus were kept in the feeding chamber. This same result was observed by Samish et al. (1995) with crowded conditions involving An. stephensi. Interrupted feeding also was shown to occur in mosquito populations that were presented with restrained animals or animals that had an extremely aggressive defensive posture (Klowden and Lea 1979, Waage and Nondo 1982). It is believed that this crowding effect occurs due to host seeking females disturbing actively feeding females. The disturbed female will terminate the feeding session prematurely and not return to the feeder for a considerable length of time. From observations made at Walter Reed Army Institute of Research, where routine feeds are conducted, this crowding affect will occur when a gallon carton contains more than 300 mosquitoes (Dowler pers comm. 2000).

Once a successful feeding system is established, one must turn to the development of the parasite. The sporogonic development of the human malaria parasite can only occur in the midgut of the Anopheles mosquito (Pathak 1993). This process entails the presence of both male and female gametocytes in the infective blood meal. The zygotes formed by the union of the gametes in the midgut of the mosquito, quickly develop into a motile ookinete. The ookinetes travel to the lining of the midgut where they penetrate the gut and develop into haploid oocysts. The oocyst will continue to grow and develop into a mature, sporozoite filled oocyst. Depending on temperature and other environmental

factors, this oocyst will rupture, releasing sporozoites into the hemolymph. The sporozoites will migrate to the salivary glands of the mosquito where they will penetrate the glandular tissue, thus rendering the mosquito infective. Under ideal conditions this process generally takes about 14-16 days, provided the mosquito is susceptible to the parasite.

A refractory mosquito species is one in which this cycle will not be completed (Rosenberg 1985). Some physiological mechanism prevents maturation of the parasite in refractory species. A number of cell free or humoral mechanisms are utilized by the insect in an attempt to defend themselves against bacterial, viral and protozoal agents. Many of these mechanisms, however, are circumvented by the parasite through biochemical pathways (Pathak 1993). The ability to successfully control and impede these parasitic invasions through physiologic mechanisms operates at the population level and thus creates differences in susceptibility between species (Pathak 1993).

A number of factors are involved in the interaction of the malaria parasite and the vector mosquito. Barriers to the parasite can be host related, vector related or even parasite related (Ponnudurai et al 1982). These factors can involve host complement in the blood meal, digestive enzymes in the gut of the mosquito, soluble factors associated with the erythrocyte, the speed of peritrophic membrane formation, factors associated with midgut epithelial cells, or any combination of the above factors (Ponnudurai et al. 1988). Recent research has focus on the function of recognition receptors associated with the peritrophic membrane. Studies have shown that there are lectin-binding sugars associated with the peritrophic membrane which may be used by the parasite to recognize and invade mosquito tissues by the malaria parasite (Ponnudurai et al 1988).

Human host factors also influence the process of mosquito infection. Some component of the vertebrate immune system such as anti-gametocyte antibodies or cytokines are responsible for inhibited infection rates in the vector population (Lensen 1996). These components of the blood meal bind to the parasite in the mosquito midgut and inhibit parasite development.

All of these factors work to create barriers that thwart parasite invasion of vector tissues (Rosenberg 1985). These barriers have been coined for the tissue beyond which the parasite is unable to proceed. Two such barriers occur in the gut and two occur in the salivary glands. The gut barriers can either be infection barriers or escape barriers. The gut infection barrier implies that the parasite can not penetrate the gut lining and begin oocyst development. In this instance, microscopic examination of the midgut would result in an absence of oocysts. The gut escape barrier would indicate that the ookinete would be able to penetrate the gut and begin oocyst formation, however, some biochemical or physiological mechanism would prevent maturation and rupture of the oocysts. The other two barriers involve similar properties in the invasion and escape from the salivary glands.

Rosenberg (1995) investigated the inability of Plasmodium knowlesi to infect the salivary glands of Anopheles freeborni despite formation of large numbers of oocysts in the midgut of infected mosquitoes. Previous studies showed that rarely were sporozoites found in the salivary glands of infected mosquitoes and never was an infected mosquito able to transmit the parasite by bite. Through the transplantation of salivary glands from An. freeborni into a completely susceptible species, An. dirus, and vice versa, Rosenberg found that a recognition factor existed between the sporozoite and the glandular tissue.

Glands from An. dirus which had been transplanted to An. freeborni would become infected but glands of An. freeborni that were transplanted into An. dirus would not.

Mosquito Vectors:

Anopheles albimanus is widely believed to be the primary vector of human malaria in Central America (Ramsey et al. 1994). Morphological variations have been observed in the larval stages of An. albimanus (Georghiou et al. 1967, Warren et al. 1975), leading to the identification of four strains of An. albimanus: white-striped, green, brown striped and brown (Warren et al. 1979). Distinct differences in susceptibility of these various strains to Plasmodium infection have been reported (Warren et al. 1977, Warren et al. 1979, Gonzalez-Ceron et al. 2000). However, in several of these studies researchers have had difficulty in duplicating the experimental results, so further evaluation is required. In one study, the white variant showed the highest susceptibility while in a subsequent study, the green showed the highest susceptibility. In all of these studies, however, An. albimanus exhibited a higher infection rate with P. vivax than with P. falciparum. In addition, Gonzalez-Ceron et al. (2000) demonstrated an adaptation of local strains of An. albimanus to local strains of P. vivax parasites, so differences in strain of parasites and vectors may account for some variability in test results.

The potential for An. albimanus to be a vector of P. vivax has been well documented (Jeffery et al. 1954; Ramsey et al. 1994, 1996; Warren et al. 1975, 1977; Collins et al. 1976; Chan et al. 1994; Gonzalez-Ceron et al. 1999, 2000). Very little has been done with P. falciparum and An. albimanus. Studies that have been conducted have relied on detecting oocysts in the midgut as a confirmation of infection (Warren et al.

1975, 1977). Very few studies have included salivary gland dissections to show the mosquito was infectious, even though finding oocysts on the midgut does not insure salivary gland infection (Warren et al 1977).

Several studies dealing with the susceptibility of An. albimanus to P. falciparum (NF-54) did show that this species could become infected with cultured parasites (Vaughan et al. 1994, Hurtado et al. 1997). Hurtado et al. (1997) isolated sporozoites from the salivary glands of two populations of An. albimanus after dissecting mosquitoes that fed on cultured parasites. One An. albimanus population was obtained from a highly endemic region in Colombia and the other population was from Guatemala. Hurtado et al. (1997) reported that the salivary gland infection rates and the sporozoite loads in infected mosquitoes were relatively low for both populations. They also found that An. albimanus from Colombia had higher infection rates than did the Guatemalan population. They attributed this difference in susceptibility to geographic differences in the 2 populations.

In Belize, populations of An. albimanus have demonstrated weak anthropophagic behaviors (Bangs 1999). Throughout its range, An. albimanus is primarily exophagic and zoophilic (Elliott 1969, 1972, Garrett-Jones 1964, Breeland 1972, Garrett-Jones et al. 1980, Frederikson 1993, Roberts et al. 1993, Roberts et al. 2000, Bangs 1999). Achee et al. (2000) showed that 8 of 10 sporozoite infected An. albimanus were collected from outside the house, and both P. falciparum infected An. albimanus were also collected outdoors. In previous studies (Horsfall 1955, Warren et al. 1975, Ramsey et al. 1986, Fredrickson 1993), the natural sporozoite infection rates have been extremely low (between 1-2%). It is believed that this species is an important vector only when it is

very abundant (Elliott 1972, Loyola et al 1993). In addition, this species has also demonstrated a clear avoidance behavior to particular insecticides such as DDT (Gabaldon 1952, Brown 1958, Hecht and Hernandez 1960, Quinones and Suarez 1989, Chareonviriyaphap et al. 1997).

Anopheles vestitipennis has long been suspected to be a vector of malaria. Although some down play the importance of this species in the transmission of malaria (Boyd 1949), others have shown it to be a probable vector based on favorable vector characteristics (Kumm and Ram 1941, Padilla et al. 1992, Rodriguez and Loyola 1990, Loyola et al. 1991, Arredondo-Jimenez et al. 1998, Roberts et al. 1993). Loyola et al. (1991) observed this species to exhibit both endophilic and endophagic behaviors. Endophagic and anthropophilic behaviors seem characteristic of this species throughout its range: Mexico (Loyola et al. 1991), Costa Rica (Kumm et al. 1940), Guatemala (Richards et al. 1994) and Belize (Roberts et al. 1993). Arredondo-Jemenez et al 1998 showed that female longevity and multiple blood feeding habits increase the vector potential of An. vestitipennis. Studies conducted in the Dominican Republic showed that An. vestitipennis readily fed on humans and demonstrated a higher human biting index than An. albimanus (Mekuria et al. 1991).

Strong endophagic behaviors and positive ELISA results for P. vivax in native populations of An. vestitipennis have served to incriminate An. vestitipennis as an important vector of malaria in Chiapas, Mexico (Loyola et al. 1991). This type of assessment provides a useful perspective for Kumm and Ram's (1941) observation that 1 of 41 specimens of An. vestitipennis collected from Belize were positive for Plasmodium spp. by salivary gland dissection. Achee et al. (2000) found this species to have a

relatively high MFIR (minimum field infection rate) in relation to the other anopheline species collected in Belize. In this study the MFIR for An. vestitipennis was (0.282%) which was higher than either An. albimanus (0.126%) or An. darlingi (0.261%). Few, relatively successful, infection studies have been conducted with An. vestitipennis females (Simmons 1941, Horsfall, 1955); however, Carr and Hill (1942) did demonstrate development of oocysts in the midgut in 1 of 12 mosquitoes fed on an infective patient in Cuba.

Anopheles darlingi was first incriminated as a vector of malaria by finding sporozoites in the salivary glands of dissected specimens, in 1931 in the Para state of Brazil (Davis 1931). Since then others have confirmed these findings using radioimmunoassays and enzyme linked immunosorbent assays (ELISA) (Deane et al. 1946, Causey et al. 1946, Arruda et al. 1989, Tadei et al. 1988, Deane et al. 1988, Lourenco-de Oliveira et al. 1989). The assay data along with other behavioral factors strongly incriminate An. darlingi as a malaria vector in Central and South America. This species shows both a strong attraction for feeding on humans as well as strong endophagic behaviors (Deane et al. 1946, Roberts et al. 1987, Klein and Lima 1990, Rozendaal 1989). Klein et al. (1991a) stated that An. darlingi is the primary vector of malaria in Costa Marques, Rondonia, Brazil based on seasonal distribution, relative abundance, peridomiciliary and biting behavior, host contact and high natural field infection rates. Klein et al. (1991a, 1991b) conducted a comparative susceptibility in Brazil and showed that An. darlingi exhibited high levels of infection after patient feeds with both P. falciparum and P. vivax.

This species has recently been re-described for the country of Belize after its initial description in 1946 (Harbach 1994, Roberts et al. 1993). In a survey of anophelines conducted in Belize from 1994 to 1997, Achee et al. (2000) demonstrated that An. darlingi had a higher minimum field infection rate than An. albimanus (0.261% and 0.126% respectively). This same study showed a single pool tested positive for P. falciparum in a population of female An. darlingi from an indoor collection.

The main goal of the present study were to 1) confirm the ability of An. vestitipennis to become infected with P. falciparum parasites, 2) compare the rates of infection maintained in three vector species from the country of Belize and 3) chart the rate of oocyst development in the three species.

Materials and Methods

Mosquito Collections:

In June of 2000, human landing collections were conducted in Belize to obtain populations of Anopheles for comparative susceptibility testing. Three localities within the country were sampled: Buena Vista, Golden Stream and Rancho. The species collected were Anopheles vestitipennis, An. albimanus, An. darlingi, An. punctimacula and An. crucians. An F1 population was obtained from all species by providing the females with a daily blood meal. Only An. crucians was unable to be tested due to the small number of collected females. Mosquitoes found dead in the field population cartons were removed and promptly identified. The An. albimanus collected from Buena Vista (BV) and from Golden Stream (GS) were kept separate because previous studies reported differences in their susceptibilities to pesticides (Chareonviriyaphap et al 1997).

Mosquitoes collected from these sites were placed in cardboard collection cups that were labeled with the date and locality of collection. To minimize mortality, no more than 50 mosquitoes were placed in each cup to minimize mortality. Each carton of mosquitoes was provided a daily blood meal. Two days after the initial feed, small cups lined with cones of filter paper were placed in each carton for eggs. When eggs were observed on the filter paper, the egg containers were removed and replaced with new clean cups. The egg-laden papers were placed in air-tight containers. These containers were then placed in a Rubbermaid™ cooler for easy transport. Water soaked cotton balls were placed on the tops of the adult mosquito cups and they were placed in an ice chest for transport back to the Uniformed Services University of the Health Sciences in Bethesda, Maryland.

At the university the filter papers were placed in separate pans of deionized water and kept in either a walk-in incubator at 30°C or an exterior holding room at 25-26°C. A higher hatch success rate was observed to occur at the higher temperature and eventually all eggs were hatched in the incubator at 30°C. Once the eggs hatched, larvae were fed a diet of catfish chow which had been ground to a fine powder with a mortar and pestle. After the adults emerged they were identified to species. Groups of F1 females of each species were placed in separate gallon cartons in preparation for the artificial membrane feed. A single cohort consisted of 5-day old mosquitoes. No more than 250 females from a single cohort were placed in a carton to minimize the effects of crowding (Dowler pers comm. 2000). Sugar pads were placed on top of all cartons for 96 hours. All Anopheles were starved for 24 hours prior to membrane feeding. After feeding, both sugar and water pads were placed on top of the cartons. Cartons were placed in clear plastic bags and were maintained at a mean temperature of $25 \pm 2^\circ\text{C}$ and an artificial light cycle of 12:12 light/dark. Separate feeds were conducted for each of two lots of mosquitoes. In addition to the four field populations tested, a colony strain of An. stephensi was used as a control population.

Membrane feeds:

Two lots of mosquitoes were fed on two separate occasions, one feeding per lot. Experimental feeds were conducted with four feeders being used each time. Since only 4 cartons could be fed at one time, the An. darlingi were placed in the carton with a species that could easily be distinguished from it (i.e. An. vestitipennis). After the feed, blood fed An. darlingi specimens which had fully engorged were removed to a separate carton.

Cultured Plasmodium falciparum (NF54-strain) maintained at the Walter Reed Army Institute of Research (WRAIR) was used as the infective blood meal. At each feeding, four groups of mosquitoes were fed simultaneously from feeders joined in series to a circulating water bath. The feeders used in this study were of a modified Rutledge type and had a feeding surface of 3 cm². The temperature of the water bath was maintained at 37°C. The membrane used was a Baudruch membrane which was affixed to the feeder using a rubber band. The feeders remained on the tops of the cartons for a period of 1 hour and 30 minutes. At the end of the feeding session, unfed mosquitoes were removed from the cartons and placed in the freezer.

All mosquitoes were maintained in the gallon cartons in which they had been fed and were sealed in clear plastic bags. Each carton was provided with a sugar pad and a water pad. The sugar pads were changed every 2 days to prevent the buildup of mold and bacteria. A water soaked gauze pad also was placed on the screen to ensure high humidity levels inside the plastic bag and also was changed every 2 days to minimize the growth of mold. The mosquitoes were maintained in a room with a 12:12 light/dark cycle and a temperature of 25-26°C. All mosquitoes were maintained under these conditions until time of dissection.

Preparation of NF-54 parasite:

Cultures of the NF-54 strain of Plasmodium falciparum used in this study were maintained in tissue culture flasks in an incubator at 37°C at the Walter Reed Army Institute of Research. The in-vitro cultures were maintained on units of expired whole blood. In order to insure the production of gametocytes, the cultures were maintained at

37°C with daily changes of the media. Cultures were maintained for 13-16 days until mature gametocytes were obtained. The flasks were checked for gametocytes prior to use to insure that the cultures were infective to the mosquitoes.

On the day of use, the flasks were removed from the incubator and rocked in a gentle fashion to insure all red cells were separated from the interior surface of the flask. The culture was then transferred to a 50 ml centrifuge tube and spun at 1000 rpm for 10 minutes to separate the sera from the red cells. The top layer of sera was then aspirated from the tube using a vacuum aspirator. Fresh sera and whole blood were warmed to 37°C in a water bath. The pelleted red cells were resuspended in 3 ml of the warmed sera and 1 ml of whole blood and the tube was inverted several times to insure a proper mixture. Each feeder was filled with approximately 2.5 mls of the cultured parasites. A thick smear was made from a small amount of the blood and examined immediately in order to determine the level of exflagellation. Throughout the feeding process the feeders were tilted, causing an agitation of the blood and thus preventing settling of the red cells. During the first feed, the culture used was in its fifth pass while the second feed was conducted using a culture in its seventh pass.

Oocyst examination:

Dissection and examination of the midguts began on day 3 after the blood feed. On day 3, fifteen mosquitoes from each species were dissected. A determination was made that this rate of dissection would deplete the infected population prior to day 14. Therefore, the maximum number of each species dissected per day was reduced to 10 mosquitoes. The dissection process entailed small aliquots of mosquitoes from each

species being removed, knocked down on dry ice and their midguts removed.

Dissections for a particular species were stopped for a given day when the total oocyst count reached one hundred. This number was only achieved for An. stephensi. All dissections took place in phosphate buffered saline (PBS) and midguts were stained with a 1.0% mercurochrome solution (Eyles 1950) after which they were examined with a light microscope. The number of infected mosquitoes, the number of oocysts per mosquito and the diameter of the oocysts (under 400x magnification) were measured and recorded. These dissections were continued until day 14 post feed. Those mosquitoes that remained alive until day 16 were dissected to determine salivary gland infection. Electronic images of both the oocysts and the salivary glands were captured using an Olympus DP-10 digital camera system and were downloaded directly to a laptop computer. Manipulation of images was performed using the Digital Vision Software package version 3.0.

Salivary gland examination:

On day 16, the salivary glands were removed from the mosquitoes in PBS. The glands were washed with PBS and cover slipped. A slight pressure was applied to the cover slip with the tip of the forceps to rupture the glands and release the sporozoites. The resulting salivary gland was observed under a light microscope at 400x. The sporozoite positivity rate and level of infection was recorded. The level of infection was categorized based on the number of sporozoites found in the salivary glands: 1 (1-50), 1+ (51-100), 2 (101-150), 2+ (151-200), 3 (201-250), 3+ (251-300), 4 (300+). If a salivary gland was found not to be infected, the gut was dissected to determine midgut infection.

All infected salivary glands and uninfected glands of midgut infected mosquitoes were washed into eppendorf tubes with 150 ul of PBS and were stored at -70°C as a source of known infected material.

Results

Mosquito Collection:

Three sites were sampled during the course of collecting mosquitoes for this research endeavor. A total of 320 Anopheles were obtained from a single collection conducted at Buena Vista of which 296 (92.5%) were An. albimanus, 16 (5.0%) were An. punctimacula and 8 (2.5%) were An. crucians. A single collection at Golden Stream resulted in 123 Anopheles mosquitoes composed of 96 (78.0%) An. albimanus, 17 (13.8%) An. darlingi, 7 (5.7%) An. vestitipennis and 3 (2.5%) An. punctimacula. Two collections were conducted at the Rancho location with a total of 438 Anopheles collected. The majority of the mosquitoes collected were An. vestitipennis (398; 90.9%) with the remaining mosquitoes comprised of 24 (5.5%) An. albimanus and 16 (3.6%) An. punctimacula.

An overview of the salivary gland dissection data is presented in Table 1. The control population of An. stephensi showed the highest salivary gland infection rate at 73.8% as well as the highest midgut infection rate of 78.5%. This equates to 94.1% of An. stephensi females which demonstrated a midgut infection also showing a salivary gland infection.

Of the Belizean populations, An. darlingi exhibited the highest infection rates for both salivary gland (41.0%) and midgut (53.1%) infection rates. In the experimental population of An. darlingi, 76.5% of specimens with midgut infection also demonstrated salivary gland infection. The populations of An. vestitipennis showed a low salivary gland infection rate with only 7 of 75 (9.3%) mosquitoes testing positive. The midgut infection rate was higher (25.3%) and this resulted in only 36.8% of the midgut infected

population obtaining a salivary gland infection. The species which exhibited the lowest infection rates was An. albimanus. Both the Golden Stream and Buena Vista populations showed extremely low salivary gland infection rates (0.0% and 2.2%, respectively) and yet exhibited moderately high midgut infection rates (20.7% and 21.5%, respectively). Only the Buena Vista population exhibited salivary gland infection and only 10% of those with midgut infections also developed salivary gland infections.

Table 2 shows sporozoite load in the salivary glands based on estimates of numbers of sporozoites observed. The An. albimanus (BV) populations had the lowest number of sporozoites of all species dissected. One sample (50%) had a count of 101-150 while the other sample (50%) had a count of 1-50 sporozoites per gland. The other three species dissected in this study presented much higher numbers of sporozoites in the salivary glands. Anopheles vestitipennis and An. darlingi presented similar counts with the majority of both species (42.8% and 38.4%, respectively) containing between 200 to 250 sporozoites per infected mosquito. The level of infection in An. stephensi was higher than all field collected populations. This species had the highest sporozoite counts with 37.5% of the experimental population exhibiting between 250 and 300 sporozoites per infected mosquito.

Table 3 presents the midgut infection rates, percentage of the each population containing categorized oocyst counts and the mean number of oocysts per infected gut. Again, the number of oocysts in the two infected An. albimanus populations were very low. The majority of both populations contained 10 or fewer oocysts per midgut. The mean number of oocyst for the Buena Vista population was 10 while the mean number for the Golden Stream population was even lower, 8 oocysts per midgut. Anopheles

vestitipennis populations varied from 5 to 38 oocysts per midgut. The mean was 22 oocysts per midgut and the majority of specimens (32.4%) contained between 10 and 15 oocysts. Again, Anopheles stephensi showed the highest midgut infection levels, with a mean of 27 oocysts per midgut and the majority had 20 to 25 oocysts.

Table 4 shows the measurements for the oocyst diameters of parasites found in each mosquito species on days 4 through 14 after infection. The mean diameter of oocysts in An. stephensi ranged from 6.2 microns on day 4 up to 56.3 microns on day 14. Anopheles vestitipennis showed similar growth rates with the means ranging from 6.2 microns on day 4 up to 51.3 microns on day 14. Oocyst differentiation was visible on day 12 for An. stephensi and on day 13 for An. vestitipennis. The measurements for the two populations of An. albimanus were similar to each other but different from either An. vestitipennis or An. stephensi. The means ranged from 6.2 microns on day 4 for both populations to 35.7 microns in the Buena Vista population and 30.6 microns in the Golden Stream population on day 14.

Photographs have been included in order to illustrate the chronological development of the parasite in An. vestitipennis. Figure 1 shows the size and intensity of the midgut infection found in An. vestitipennis on days 4 and 8 post infection. The oocysts stain darker than the surrounding midgut tissue in the presence of the 1.0% mercurochrome stain. Figure 2 shows the relative size obtained by the oocysts on days 9 and 11 post infection. There is a 53% increase in rate of oocysts growth after day 10 compared to the first 7 days of growth. Mean size of oocysts on day 9 was 20.2 microns as opposed to 50.4 microns on day 11. On day 11 there was a large variation in oocyst sizes with a range in diameter from 32.1-59.1 microns. Figure 3 illustrates the size of the

oocyst on day 12 and oocyst differentiation on day 13 post infection in midguts of An. vestitipennis. The day 13 photograph shows a ruptured oocyst and the release of sporozoites. Figure 4 illustrates two separate sets of ruptured salivary glands from An. vestitipennis showing the release of sporozoites from infected glands on day 16 post infection. The top photograph is taken at 200x power while the bottom photograph was taken at 400x power.

Figures 5, 6 and 7 graphically illustrate the rate of oocyst growth seen in the three mosquito populations compared to oocyst growth in An. stephensi. Range bars show the wide variation in size of oocysts. Considerable overlap in oocyst growth rates can be seen between mosquito species. Another feature evident from the graphic representation of oocyst growth rates is a retardation of oocyst growth after day 10 in An. albimanus (GS). The An. albimanus (BV) population exhibits slowed growth, but no differentiation was ever observed. The oocysts in An. albimanus (BV) never reached the size of mature oocysts observed in An. vestitipennis or An. stephensi.

The growth curve of An. vestitipennis illustrates a constant growth rate until day 10 post infection. At this point in oocyst development, a considerable increase in size is observed from the growth curve. The growth observed between days 10 and 11 is 53% greater than demonstrated in the previous 10 days. Anopheles stephensi also shows a spurt in growth after day 10, but it is only a 20% increase in growth as compared to the preceding days.

Both An. vestitipennis and An. stephensi show a decrease in the mean oocyst size on day 14, even though the range for both species remains the same. This phenomenon is most likely due to a decrease in the larger, mature oocysts which have released their

sporozoite load and collapsed. This reduces the overall mean of the remaining oocyst diameters.

Discussion

Information on vector competence of An. vestitipennis for human malaria in Central America is sparse. For this reason, vector studies are needed to better understand the transmission dynamics of malaria in areas where An. vestitipennis is present. The comparative susceptibility study described here was conducted to: 1) determine the ability of An. vestitipennis to become infective with a cultured strain of Plasmodium falciparum, 2) compare the susceptibility of An. vestitipennis, An. darlingi, and An. albimanus from Belize and a colony population of An. stephensi and 3) chart the rate of growth of the oocysts in An. vestitipennis, two populations of An. albimanus, and a colony population of An. stephensi.

The control population of An. stephensi clearly shows a high level of susceptibility to the cultured strain of Plasmodium falciparum (NF-54). Clearly there has been an effective selection process to find a species (An. stephensi) that becomes infectious with this strain of parasite. The fact that 78.5% of An. stephensi showed midgut infections and, of those, almost 94% developed salivary gland infections bears this out. In addition to having a high susceptibility to infection, the oocyst and sporozoite loads for infected individuals was extremely high.

Only a few studies have actually found sporozoites in the salivary glands of An. vestitipennis (Kumm and Ram 1941, Carr and Hill 1942). Of these, only Carr and Hill (1942) could confirm that the sporozoites were of human origin (i.e., they fed mosquitoes on infected patients). There have been many more reports of this species testing positive for malaria by the ELISA (Mekuria et al 1991, Bangs 1999, Achee et al. 2000). The present study is the first to document salivary gland infection of An.

vestitipennis with a cultured strain of Plasmodium falciparum. Although the salivary gland infection rate was low (9.3%), the sporozoite loads in those glands were relatively high. Within the infected glands, 57% showed sporozoite counts greater than 200.

Anopheles vestitipennis also demonstrated higher numbers of oocysts in the midgut than did either population of An. albimanus. A total of 55.9% of the An. vestitipennis that had positive midguts, contained between 10 and 25 oocysts per gut. This is in contrast to An. albimanus (BV) in which 83.8% contained 10 or fewer oocysts per gut or An. albimanus (GS) in which 78.8% contained 10 or fewer oocysts per gut. The clear message is that An. vestitipennis can maintain a high midgut infection and is able to carry the infection through to the salivary glands and become infectious.

Although the salivary gland infection rate was quite low for An. vestitipennis, its behavior increases its vector potential. In Belize, An. vestitipennis has demonstrated both an endophagic behavior and a propensity for feeding on humans (Bangs 1999). In light of these behaviors and the fact that this species demonstrates the ability to become infected with a cultured strain of P. falciparum, there is a strong likelihood that An. vestitipennis plays a greater role in the transmission of malaria in southern Belize than previously believed. Additional information must be obtained on the susceptibility of this species in regard to local strains of Plasmodium parasite.

The results for An. albimanus are quite different. This species showed an extremely low level of salivary gland infection (An. albimanus (BV) 2.2%; An. albimanus (GS) 0.0%). In addition, positive mosquitoes exhibited few sporozoites in the salivary glands (<200). The midgut infection rates were similar to those seen in An. vestitipennis, yet the salivary gland infection rates were much lower. Warren et al.

(1975,1977) also showed populations of An. albimanus with similar midgut infection rates. However, Warren et al.(1975, 1977) did not perform salivary gland dissections to determine the rates for complete maturation of the parasite in the vector population.

Low salivary gland infection rates in An. albimanus have been reported by Hurtado et al. (1997). Their conclusion is similar to the one proposed here, i.e., An. albimanus is a poor vector of P. falciparum NF-54 and that there is considerable variability in the susceptibility of geographic isolates of mosquitoes to parasites. The present research indicates that there is some type of gut escape barrier, or some combination of gut escape barrier plus a salivary gland infection barrier acting on the parasite to prevent successful completion of the parasite's development in An. albimanus. Another possible explanation is that the parasite takes more than 16 days to develop in An. albimanus and dissections were not carried out long enough for the parasite to mature to the salivary glands. Again, it was not possible to perform the required number of dissections due to the low number of specimens available.

The extremely low infection rate is evidence enough that An. albimanus is not an efficient vector of P. falciparum (NF-54). Even if low salivary gland infection rates were due to a longer time requirement for oocyst development, this delayed development also would decrease vector potential of An. albimanus populations. The longer it takes a parasite to complete its development in the vector the greater the likelihood that that vector will not survive to transmit the parasite. In addition to poor susceptibility, exophagic and zoophagic feeding behaviors exhibited by this species further decrease the likelihood that An. albimanus is an effective vector of falciparum malaria.

The fourth species tested in this study, Anopheles darlingi, is clearly an efficient vector of P. falciparum. This conclusion is consistent with data from other areas of its geographic range (Deane et al 1946, Causey et al 1946, Arruda et al 1989, Tadei et al 1988, Deane et al 1988, Lourenco-de Oliveira et al 1989, Klein et al 1991a, 1991b). The high salivary gland infection rates and high midgut infection rates observed for An. darlingi indicate that it can readily be infected with P. falciparum (NF-54). The low numbers of An. darlingi available for this study prevented observations on the rate of oocyst growth. Consequently, the study needs to be repeated with larger numbers of specimens to increase the level of confidence in test results.

The oocyst growth curve of An. albimanus (GS) clearly shows a cessation of development after day 10, post infection. Again, this suggests that there is some physiological factor associated with the mosquito which is acting to prevent maturation of the parasite. This is an important issue that requires further study. By identifying the mechanism which prevents the maturation of the parasite in An. albimanus, genetic manipulation of other more competent species may be possible to break the transmission cycle. The most likely place to begin looking is the midgut epithelial cells which seem to allow infection but somehow inhibit oocyst maturation.

The An. albimanus (BV) population is slightly different in that there does appear to be continued slow oocyst growth through day 14. This population also showed low levels of salivary gland infection. These data agree with the salivary gland infection data and may indicate a slower rate of growth that could eventually lead to salivary gland infection, given enough time. Higher salivary gland infection rates may have been observed if the dissections had been carried out for additional days post infection.

Additional days of observation were not possible due to the limited number of mosquitoes available for this study. Survivorship of colonized An. albimanus appears to decrease rapidly after day 14. Reduced survival would be even more likely with natural populations which would be subjected to harsh environmental conditions and predation. Therefore, those An. albimanus which do live long enough to become infective (if even possible) would have only a small window of opportunity to effectively transmit the parasite.

The growth curve of oocysts in An. vestitipennis is very similar to that of the control population of An. stephensi. The only difference is that An. vestitipennis exhibits a slow rate of growth until day 10 after which there is a dramatic increase in size of the oocyst. By day 12, the mean size of oocysts in both An. vestitipennis and An. stephensi were almost identical. A high midgut infection rate and quick oocyst development rate coupled with a low salivary gland infection rate suggest that there may be an inhibitory factor associated with the salivary gland tissue of An. vestitipennis. This apparently allows only a small proportion of the population to become infective. Higher rates of salivary gland infections in An. vestitipennis compared to An. albimanus, appears to result from higher numbers of oocysts developing and maturing on the midgut of An. vestitipennis.

If these susceptibilities hold true for local strains of P. falciparum and if An. albimanus is more susceptible to P. vivax, an interesting scenario presents itself. Given the exophagic behavior of this mosquito species, a spray campaign utilizing indoor house spraying may do little to control biting populations of An. albimanus. It would however control malaria transmission by An. vestitipennis and An. darlingi, which show strong

endophagic behaviors. At the same time these two Anopheles species show higher susceptibilities to P. falciparum. If an extensive indoor spray campaign was undertaken, one would expect to see P. falciparum levels fall while P. vivax levels remain unchanged. This appears to be the case with the data for malaria rates in Central America (Roberts pers comm). Another implication of this research is that residual house spraying must continue in order to effectively target those mosquito species that feed indoors and that are responsible for the transmission of P. falciparum.

Although this information is a valuable indicator of the susceptibility of these 4 Anopheles species to Plasmodium falciparum (NF-54), different outcomes might occur if the study were conducted with a local strain of P. falciparum or with local strains of P. vivax. Several things, however, are clear from the present study. Anopheles vestitipennis can become infected with P. falciparum (NF-54) and can develop large numbers of sporozoites in its salivary glands. Anopheles albimanus appears to exhibit either slowed parasite development or inhibited development of P. falciparum (NF-54) oocysts. Anopheles darlingi from Belize is clearly an efficient vector of P. falciparum (NF-54).

In conclusion, the data suggest that An. darlingi is an efficient vector of malaria in Belize, both from the standpoint of susceptibility to the parasite and conducive behavior that favors malaria transmission (i.e. endophagic and anthropophilic). Anopheles vestitipennis is less susceptible to the parasite but its behavior increases its vector potential by maximizing opportunities for spatial and temporal association with preferred hosts (i.e. indoors while people are sleeping). Although An. albimanus has long been considered the primary vector of malaria in Belize, the results of this infectivity study

and results of other field studies document the low vector potential for this species.

Anopheles albimanus is almost refractory to infection with P. falciparum (NF-54).

Additionally, it bites outdoors and is predominately zoophagic. Finally, it is evident from the data presented here that greater attention must be paid to the vector status of

An. vestitipennis, and further research on this and the other Anopheles in Belize must be conducted.

References Cited

- Achee, N.L., C.T. Korves, M.J. Bangs, E. Rejmankova, M. Lege, D. Curtin, H. Lenares, Yvette Alonzo, R.G. Andre, and D.R. Roberts. 2000. Plasmodium vivax polymorphs and Plasmodium falciparum circumsporozoite proteins in Anopheles (Diptera: Culicidae) from Belize, C.A. J. Vect. Ecology.
- Arredondo-Jimenez, J.I., M.H. Rodriguez and R.K. Washino. 1998. Gonotrophic cycle and survivorship of Anopheles vestitipennis (Diptera:Culicidae) in two different ecological areas of southern Mexico. J. Med. Entomol. 35:937-942.
- Arruda, M., M.B. Carvalho, R.S. Nussenzweig, M. Maracic, A.W. Ferreira and A.H. Cochrane. 1986. Potential vectors of malaria and their different susceptibility to Plasmodium falciparum and Plasmodium vivax in northern Brazil identified by immunoassay. Am. J. Trop. Med Hyg 35: 873-881.
- Awono-Ambene, H.P. and V. Robert. 1998. Gorging response of wild Anopheles arabiensis using membrane feeder with Baudruche or Parafilm. Parasite. 5(3): 294.
- Bangs, M.J. 1999. The susceptibility and behavioral response of Anopheles albimanus Weidemann and Anopheles vestitipennis Dyar and Knab (Diptera: Culicidae) to insecticides in northern Belize. Ph.D. Thesis, Uniformed Services University of the Health Sciences, Bethesda, Maryland. 489 pp.
- Breeland, S.G. 1972. Studies on the ecology of Anopheles albimanus. Am. J. Trop. Med. Hyg. 21: 751-754.

- Bonnet, S., C. Gouagna, I. Safeukui, J. Meunier and C. Boudin. 2000. Comparison of artificial membrane feeding with direct skin feeding to estimate infectiousness of Plasmodium falciparum gametocyte carriers to mosquitoes. *Tran. Roy. Soc. Trop. Med. Hyg.* 94: 103-106.
- Boyd, M.F. 1949. Epidemiology factors related to the definitive host. In: *Malariology*, Boyd, M.F. (Editor). Philadelphia: W.B. Saunders, pp. 608-697.
- Brown, A.W.A. 1958. Laboratory studies on the behavioural resistance of Anopheles albimanus in Panama. *Bull. Wld. Hlth. Organ.* 19: 1053-1061.
- Campbell, J.R. 1984. In vitro culture of Plasmodium falciparum. *J. Parasitol.* 70: 966.
- Carr, H.P. and R.B. Hill. 1942. A malaria survey of Cuba. *Am. J. Trop. Med.* 22:587-607.
- Causey, O.R., L.M. Deane and M.P. Deane. 1946. Studies on Brazilian anophelines from the Northeast and Amazon Regions. *Am. J. Hyg.* 18.
- Chan, A.S.T., M.H. Rodriguez, J.A. Torres, M.C. Rodriguez and C. Villarreal. 1994. Susceptibility of three laboratory strains of Anopheles albimanus (Diptera: Culicidae) to coindigenous Plasmodium vivax in southern Mexico. *J. Med. Entomol.* 31: 400-403.
- Chareonviriyaphap, T., D.R. Roberts, R.G. Andre, H.H. Harlan, S. Manguin and M.J. Bangs. 1997. Pesticide avoidance behavior in Anopheles albimanus, a malaria vector in the Americas. *J. Am. Mosq. Control Assoc.* 13: 171-183.

- Collins, W. E., J.C., Skinner McW. Warren and B.B. Richardson. 1976. Studies on human malaria in Aotus monkey. VII. Comparative infectivity of two strains of Plasmodium vivax to Anopheles freeborni, An. maculatus, and four strains of An. albimanus. J. Parasitol. 62: 190-194.
- Collins, F.H., R.K. Sakai, K.D. Vernick, S.M. Paskewitz, D.C. Seeley, L.H. Miller, W.E. Collins, C.C. Campbell and R.W. Gwadz. 1986. Genetic selection of a Plasmodium-refractory strain of the malaria vector Anopheles gambiae. Science. 234: 607-610.
- Collins, F.H. and S.M. Paskewitz. 1995. Malaria: current and future prospects for control. Annu. Rev. Entomol. 40: 195-219.
- Cosgrove, J. and R.J. Wood. 1995. Probing and gorging responses of three mosquito species to a membrane feeding system at a range of temperatures. J. Am. Mosq. Control Assoc. 11: 339-342.
- Davis, N.C. 1931. A note on the malaria-carrying anophelines in Belem, Para, and in Natal, Rio Grande do Norte, Brazil. Riv. Malar. 10: 1-11.
- Deane, L.M., O.R. Causey and M.P. Deane. 1946. An illustrated key by adult female characteristics for identification of thirty-five species of Anophelini from Northeast and Amazon regions of Brazil with notes on the malaria vectors (Diptera:Culicidae). Am. J. Hyg. 18: 1-18.
- Edman, J.D., E. Cody and H. Lynn. 1975. Blood feeding activity of partially engorged Culex nigripalpus. Entomol. Exp. Appl. 18: 261-268.
- Elliott, R. 1969. Ecology and behaviour of malaria vectors in the American region. Cah. ORSTOM., ser. Ent. Med. Et Parasitol. 7: 29-33.

- Elliott, R. 1972. The influence of mosquito behavior on malaria transmission. *Am. J. Trop. Med. Hyg.* 21: 755-763.
- Eyles, D.E. 1950. A stain for malarial oocysts in temporary preparations. *J. Parasitol.* 36: 501.
- Frederikson, E.C. 1993. Bionomics and control of Anopheles albimanus. Tech. Paper 34. Pan Am. Hlth. Organ. Washington, D.C. 76pp.
- Galun, R. and R.R. Rice. 1971. Role of platelets in haematophagy. *Nature* 223: 110-111.
- Graves, P.M. 1980. Studies on the use of a membrane feeding technique for infecting Anopheles gambiae with Plasmodium falciparum. *Tran. Roy. Soc. Trop. Med. Hyg.* 74: 738-742.
- Harbach, R.E. 1994. review of the internal classification of the genus Anopheles (Diptera:Culicidae): the foundation for comparative systematics and phylogenetic research. *Bull. Entomol. Res.* 84: 331-342.
- Horsfall, W. 1955. Mosquitoes: Their Bionomics and Relation to Disease. Ronald, New York. 723pp.
- Gabalton, A. 1952. The effect of DDT on the population of anopheline vectors in Venezuela. *Riv. Parasitol.* 13:29-41.
- Galun, R. 1967. Feeding Stimuli and Artificial Feeding. *Bull. Wld. Hlth. Org.* 36: 590-593.
- Galun, R., L.C. Koontz and R.W. Gwadz. 1975. Engorgement response of anopheline mosquitoes to blood fractions and artificial solutions. *Physiol. Entomol.* 10: 145-149.

- Garrett-Jones, C. 1964. The human blood index of malaria vectors in relation to epidemiological assessment. *Bull. WHO* 30: 241-261.
- Garrett-Jones, C., P.F.L. Boreham and C.P. Pant. 1980. Feeding habits of anophelines (Diptera: Culicidae) in 1971-78, with references to the human blood index: a review. *Bull. Entomol. Res.* 70: 165-185.
- Georghiou, G.P., F.E. Gidden, and J.W. Cameron. 1967. A strip character in Anopheles albimanus (Diptera: Culicidae) and its linkage relationships to sex and dieldrin resistance. *Ann. Entomol. Soc. Am.* 60: 323-328.
- Gonzalez-Ceron, L, M.H. Rodriguez, J.A. Nettel, C. Villarreal, K.C. Kain and J.E. Hernandez. 1999. Differential susceptibility of Anopheles albimanus and Anopheles pseudopunctipennis to infections with coindigenous Plasmodium vivax phenotypes VK210 and VK247 in southern Mexico. *Infect. Immunol.* 67: 410-412.
- Gonzalez-Ceron, L, M.H. Rodriguez, F.V. Santillan, Juan E. Hernandez and R.A. Wirtz. 2000. Susceptibility of three laboratory strains of Anopheles albimanus (Diptera: Culicidae) to coindigenous Plasmodium vivax circumsporozoite protein phenotypes in southern Mexico. *J. Med. Entomol.* 37: 331-334.
- Hecht, O. and J. Hernandez. 1960. Resna de las investigaciones sobre la irritacion de anofelinos por el contacto con superficies cubiertas con DDT. *CNEP Boletin.* 4: 93-106.

- Hurtado, S., M.L. Salas, J.F. Romero, J.C. Zapata, H. Ortiz, M. Arevalo-Herrera and S. Herrera. 1997. Regular production of infective sporozoites of Plasmodium falciparum and P. vivax in laboratory-bred Anopheles albimanus. *Ann. Trop. Med. Parasitol.* 91: 49-60.
- Jeffery, G., R. Burgess and D. Eyles. 1954. Susceptibility of Anopheles quadrimaculatus and Anopheles albimanus to domestic and foreign strains of Plasmodium vivax. *Am. J. Trop. Med. Hyg.* 3: 821-824.
- Jensen, J.B. and W. Trager. 1978. Plasmodium falciparum in culture: establishment of additional strains. *Am. J. Trop. Med. Hyg.* 27: 743-746.
- Klein, T.A. and J.B.P. Lima. 1990. Seasonal distribution and biting patterns of Anopheles mosquitoes in Costa Marques, Rondonia, Brazil. *J. Am. Mosq. Control Assoc.* 6: 700-707.
- Klein, T.A., J.B.P. Lima and M.S. Tada. 1991b. Comparative susceptibility of anopheline mosquitoes to Plasmodium falciparum in Rodonia, Brazil. *Am. J. Trop. Med. Hyg.* 44: 598-603.
- Klowden, M.J. and A.O. Lea. 1979. Effect of defensive host behavior on the blood meal size and feeding success of natural populations of mosquitoes (Diptera: Culicidae). *J. Med. Entomol.* 15: 514-517.
- Kumm, H.W., W.H.W. Komp and H. Ruiz. 1940. The mosquitoes of Costa Rica. *Am. J. Trop. Med.* 20: 385-422.
- Kumm, H.W. and L.M. Ram. 1941. Observations on the Anopheles of British Honduras. *Am. J. Trop. Med.* 21: 559-566.

- Lensen, A.H.W. 1996. Infectivity of malarial parasites to mosquitoes: the interdependent roles of parasite, vector and host. *Ann. Trop. Med. Parasitol.* 90: 359-365.
- Lourenco-de-Oliveira, R. 1989. Some observations on the mosquitoes of Indian settlements in Xingu National Park, Mato Grosso State, Brazil, with emphasis on malaria vectors. *Rev. Bras. Biol.* 49: 393-397.
- Loyola, E.G., J.I. Arredondo, M.H. Rodriguez, D.N. Brown and M.A. Vaca-Marin. 1991. Anopheles vestitipennis, the probable vector of Plasmodium vivax in the Lacadon forest of Chiapas, Mexico. *Trans. R. Soc. Trop. Med. Hyg.* 85: 171-174.
- Loyola, E.G., L. Gonzalez-Ceron, M.H. Rodriguez, J.I. Arredondo-Jimenez, S. Bennett, and D.N. Brown. 1993. Anopheles albimanus (Diptera: Culicidae) host selection patterns in three ecological areas of the coastal plains of Chiapas, Southern Mexico. *J. Med. Ent.* 30: 518-523.
- Mekuria, Y., R. Granados, M.A. Tidwell, D.C. Williams, R.A. Wirtz and D.R. Roberts. 1991. Malaria transmission potential of Anopheles mosquitoes of Dajabon, Dominican Republic. *J. Am. Mosq. Control. Assoc.* 7:456-461.
- Novak, M.G., W.J. Berry and W.A. Rowley. 1991. Comparison of four membranes for artificially bloodfeeding mosquitoes. *J. Am. Mosq. Control. Assoc.* 7: 327-329.
- Padilla, N., P. Molina, J. Juarez, D.M. Brown and C. Cordon-Rosales. 1992. Potential malaria vectors in northern Guatemala. *J. Am. Mosq. Control Assoc.* 8: 307-308.
- Pan American Health Organization. 1994. Status of malaria programs in the Americas. XLII report, CSP24/INF/2(Eng.) Washington, D.C. 116 pp.

- Pathak, J.P.N. 1993. *Insect Immunity*. Kluwer Academic Publishers, New Delhi, India. 192pp.
- Ponnudurai, T., P.F. Billingsley and W. Rudin. 1988. Differential infectivity of Plasmodium for mosquitoes. *Parasitol. Today*. 4: 319-321.
- Ponnudurai, T., A.H.W. Lensen, G.J.A. Van Genert, M.P.E. Bensink, M. Bolmer and J.H.E.Th. Meuwissen. 1988. Infectivity of cultured Plasmodium falciparum gametocytes to mosquitoes. *Parasitology* 98: 165-173.
- Price, G.D., N. Smith and D.A. Carlson. 1979. The attraction of female mosquitoes (Anopheles quadrimaculatus Say) to stored human emanations in conjunction with adjusted levels of relative humidity, temperature and carbon dioxide. *J. Chem. Ecol.* 5: 383-395.
- Quinones, M.L. and M.F. Suarez. 1989. Irritability to DDT of natural populations of the primary malaria vectors in Colombia. *J. Am. Mosq. Control Assoc.* 5: 56-59.
- Ramsey, J.M., D.N. Brown, J.L. Aron, R.L. Beaudoin and J.F. Mendez. 1986. Field trials in Chiapas, Mexico, of a rapid detection method for malaria in anopheline vectors with low infection rates. *Am. J. Trop. Med. Hyg.* 35: 234-238.
- Ramsey, J.M., E. Salinas, D.M. Brown and M.H. Rodriguez. 1994. Plasmodium vivax sporozoite rates from Anopheles albimanus in southern Chiapas, Mexico. *J. Parasitol.* 80: 489-493.
- Roberts, D.R., O. Chan, J. Pecor, E. Rejmankova, S. Manguin, J. Polanco and L.J. Legters. 1993. Preliminary observations on the changing roles of malaria vectors in southern Belize. *J. Am. Mosq. Control Assoc.* 9: 456-459.

- Roberts, D.R., W.D. Alecrim, P. Hshieh, J.P. Grieco, M. Bangs, R.G. Andre and T. Chareonviriphap. 2000. A probability model of vector behavior: Effects of DDT repellency, irritancy and toxicity in malaria control. *J. Vect. Ecol.* 25: 48-61.
- Roberts, D.R., W.D. Alecrim, A.M. Tavares and M.G. Radke. 1987. The house frequenting, host-seeking and resting behavior of Anopheles darlingi in southeastern Amazonas, Brazil. *J. Am. Mosq. Control Assoc.* 3: 433-441.
- Rodriguez, M.H. and E.G. Loyola. 1990. Malaria in Mexico. Proc. 58th Ann. Conf. Calif. Mosq. Vec. Control Assoc. pp. 49-52.
- Rosenberg, R. 1985. Inability of Plasmodium knowlesi sporozoites to invade Anopheles freeborni salivary glands. *Am. J. Trop. Med. Hyg.* 34: 687-691.
- Rozendaal, J.A., J.P.M. van Hoof, J. Voorham and B.F.J Oostburg. 1989. Behavioral responses of Anopheles darlingi in Suriname to DDT residues on house walls. *J. Am. Mosq. Control Assoc.* 5: 339-350.
- Rutledge, L.C., R.A. Ward and D.J. Gould. 1964. Studies on the feeding response of mosquitoes to nutritive solutions in a new membrane feeder. *Mosq. News.* 24: 407-419.
- Rutledge, L.C., D.J. Gould and B. Tantichareon. 1969. Factors affecting the infection of anophelines with human malaria in Thailand. *Trans. R. Soc. Trop. Med. Hyg.* 63: 613-619.
- Samish, M., A. Kozłowska and K. Maramorosch. 1995. Factors affecting membrane feeding of Anopheles stephensi. *J. Am. Mosq. Control Assoc.* 11: 408-415.
- Schreck, C.E., D.L. Kline and D.A. Carlson. 1990. Mosquito attraction to substances from the skin of different humans. *J. Am. Mosq. Control Assoc.* 6: 406-410.

- Simmons, J.S. 1941. The transmission of malaria by the Anopheles mosquitoes of North America. In: A symposium on human malaria with special reference to North America and the Caribbean region. F.R. Moulton, Ed. Am. Assoc. Adv. Sci. Pub. No. 15. Washington, D.C. pp. 113-130.
- Tadei, W.P., B.D. Thatcher, J.M. Santos, V.M. Scarpassa, I.B. Rodrigues and M.S. Rafael. 1998. Ecological observations on anopheline vectors of malaria in the Brazilian Amazon. Am. J. Trop. Med. Hyg. 59: 325-335.
- Tarshis, I.B. 1958. Feeding techniques for bloodsucking arthropods. Proc. Tenth Int. Congr. Entomol. Montreal. 3: 767-784.
- Trager, W. 1990. On the establishment in culture of isolates of Plasmodium falciparum. Trans. R. Soc. Trop. Med. Hyg. 84: 466.
- Vaughn, J.A., B.H. Noden and J.C. Beier. 1994. Sporogonic development of cultured Plasmodium falciparum in six species of laboratory reared Anopheles mosquitoes. Am. J. Trop. Med. Hyg. 51: 233-243.
- Waage, J.K. and J. Nondo. 1982. Host behaviour and mosquito feeding success: and experimental study. Trans. R. Soc. Trop. Med. Hyg. 76: 119-122.
- Warren, McW, W.E. Collins, B.B. Richardson and J.C. Skinner. 1977. Morphological phenotypes of Anopheles albimanus and susceptibility to Plasmodium vivax and Plasmodium falciparum. Am. J. Trop. Med. Hyg. 26: 607-611.
- Warren, McW, W.E. Collins, B.B. Richardson and J.C. Skinner. 1979. Naturally occurring pupal phenotypes of Anopheles albimanus and their susceptibility to Plasmodium vivax and P. falciparum. Mosq. News 39: 472-477.

Warren, McW, J. Mason and J. Hobbs. 1975. Natural infections of Anopheles albimanus with Plasmodium in a small malaria focus. Am. J. Trop. Med. Hyg. 24: 545-546.

Table 1: Infection data from a comparative susceptibility study conducted using Plasmodium falciparum (NF-54). Data based on two membrane feeds conducted with two culture populations (E5 and E7)^a.

Species	# dissected	# of mosquitoes with infected salivary glands	% salivary gland infection	# infected midguts	% midgut infection
<u>Anopheles vestitipennis</u>	75	7	9.3	19	25.3
<u>Anopheles albimanus</u> (BV)	93	2	2.2	20	21.5
<u>Anopheles albimanus</u> (GS)	111	0	0.0	23	20.7
<u>Anopheles darlingi</u>	32	13	41.0	17	53.1
<u>Anopheles stephensi</u>	130	96	73.8	102	78.5

^a Cultures indicate the number of passes that the parasite had been through before use in the membrane feeding.

Table 2: Salivary gland infection data showing the level of infection based on an estimate of the number of sporozoites observed in the glandular tissue. Data based on two membrane feeds conducted with two culture populations (E5 and E7)^a.

Species	n	% Salivary Gland Infection	Proportion infected						
			1	1+	2	2+	3	3+	4
<u>Anopheles vestitipennis</u>	75	9.3	0.0	14.3	14.3	14.3	42.8	0.0	14.3
<u>Anopheles albimanus</u> (BV)	93	2.2	50.0	0.0	50.0	0.0	0.0	0.0	0.0
<u>Anopheles albimanus</u> (GS)	111	0.0	--	--	--	--	--	--	--
<u>Anopheles darlingi</u>	32	41.0	0.0	0.0	23.1	7.7	38.4	7.7	23.1
<u>Anopheles stephensi</u>	130	73.8	0.0	0.0	14.6	11.4	32.3	37.5	4.2

^a Cultures indicate the number of passes that the parasite had been through before use in the membrane feeding.

^b Salivary gland infection ratings: 1 (1-50), 1+ (51-100), 2 (101-150), 2+ (151-200), 3 (201-250), 3+ (251-300), 4 (>300+).

Table 3: A break down of the proportion of mosquitoes which exhibited oocyst counts in designated categories and intensity of infection based on mean number of oocysts per midgut. Data based on one membrane feed.

Species	n	% Midgut Infection	Proportion infected							Intensity of infection Oocysts per Mosquito ^a
			% positive guts with oocyst counts							
			x ≤ 5	5 < x ≤ 10	10 < x ≤ 15	15 < x ≤ 20	20 < x ≤ 25	25 < x ≤ 30	x > 30	
<u>Anopheles vestitipennis</u>	135	0.20	13.5	7.2	32.4	20.1	13.4	7.6	5.8	22 ± 10.6
<u>Anopheles albimanus (BV)</u>	137	0.17	49.6	34.2	19.7	4.9	1.6	--	--	10 ± 12.3
<u>Anopheles albimanus (GS)</u>	140	0.15	52.3	26.5	12.4	4.6	4.2	--	--	9 ± 14.1
<u>Anopheles stephensi</u>	78	0.71	3.2	5.4	10.6	12.2	29.8	26.7	12.1	27 ± 25.4

^a Means are based on the number of oocysts divided by the number of positive mosquitoes dissected.

Table 4: Oocyst diameters of Plasmodium falciparum (NF-54) in 4 groups of Anopheles mosquitoes fed from cultured parasites via a membrane feeder. Measurements were made under 400x and are presented in microns.

Days after infection	<u>Anopheles vestitipennis</u>			<u>Anopheles albimanus</u> (BV)			<u>Anopheles albimanus</u> (GS)			<u>Anopheles stephensi</u>		
	No. ^a	Range	Mean	No. ^a	Range	Mean	No. ^a	Range	Mean	No. ^a	Range	Mean
4	51	4.1-9.3	6.2	40	3.7-8.0	6.2	47	3.7-8.2	6.2	101	3.7-8.6	6.2
5	80	3.2-14.8	6.6	32	3.7-9.8	6.5	33	4.3-8.8	6.7	104	4.9-13.5	9.4
6	75	4.6-19.7	9.1	31	3.7-12.3	7.8	47	3.9-10.1	8.0	116	7.4-18.4	13.4
7	55	6.6-27.9	16.7	42	9.8-18.4	13.8	33	9.8-14.7	14.0	103	9.8-34.2	20.1
8	82	10.1-31.2	17.9	29	9.8-30.7	17.2	40	9.8-31.8	17.5	108	14.8-38.1	26.8
9	77	13.5-34.3	20.2	45	12.3-30.5	19.7	41	12.3-28.3	18.7	111	17.3-40.2	32.3
10	73	14.6-44.8	26.7	37	10.5-37.4	27.4	28	12.8-40.4	30.4	104	17.4-56.0	38.5
11	79	32.1-59.1	50.4	33	14.8-45.5	30.2	31	15.2-46.1	30.7	102	18.1-65.4	53.6
12	67	44.5-60.8	57.6	22	22.4-49.3	34.2	41	18.6-46.7	29.7	100	18.4-68.2	58.1*
13	69	42.1-61.6	57.5*	32	23.8-50.2	36.7	39	20.1-41.1	30.9	102	24.3-69.0	58.6*
14	70	36.3-59.0	51.3*	25	22.7-47.9	35.7	30	18.5-52.5	30.6	98	22.6-67.3	56.3*

^a Numbers of oocysts measured from a maximum of 10 mosquitoes dissected.

* Point at which oocyst differentiation was observed.

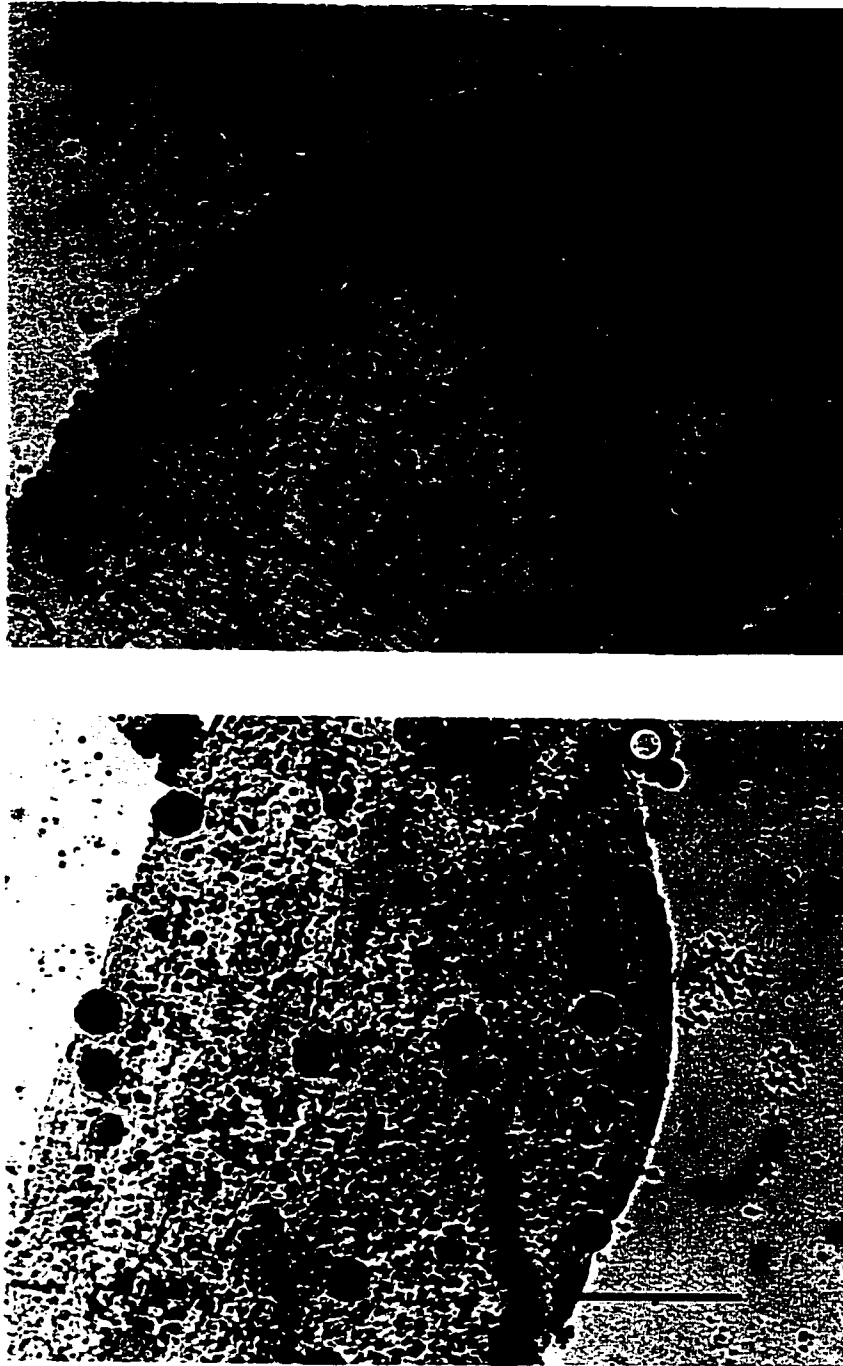

Figure 1: Digital images of oocysts of Plasmodium falciparum in infected midguts of An. vestitipennis. Top most image shows oocysts on midgut at 4 days post infection (200x). Bottom image shows oocysts at 8 days post infection (200x). Scale bar = 50 μ m.

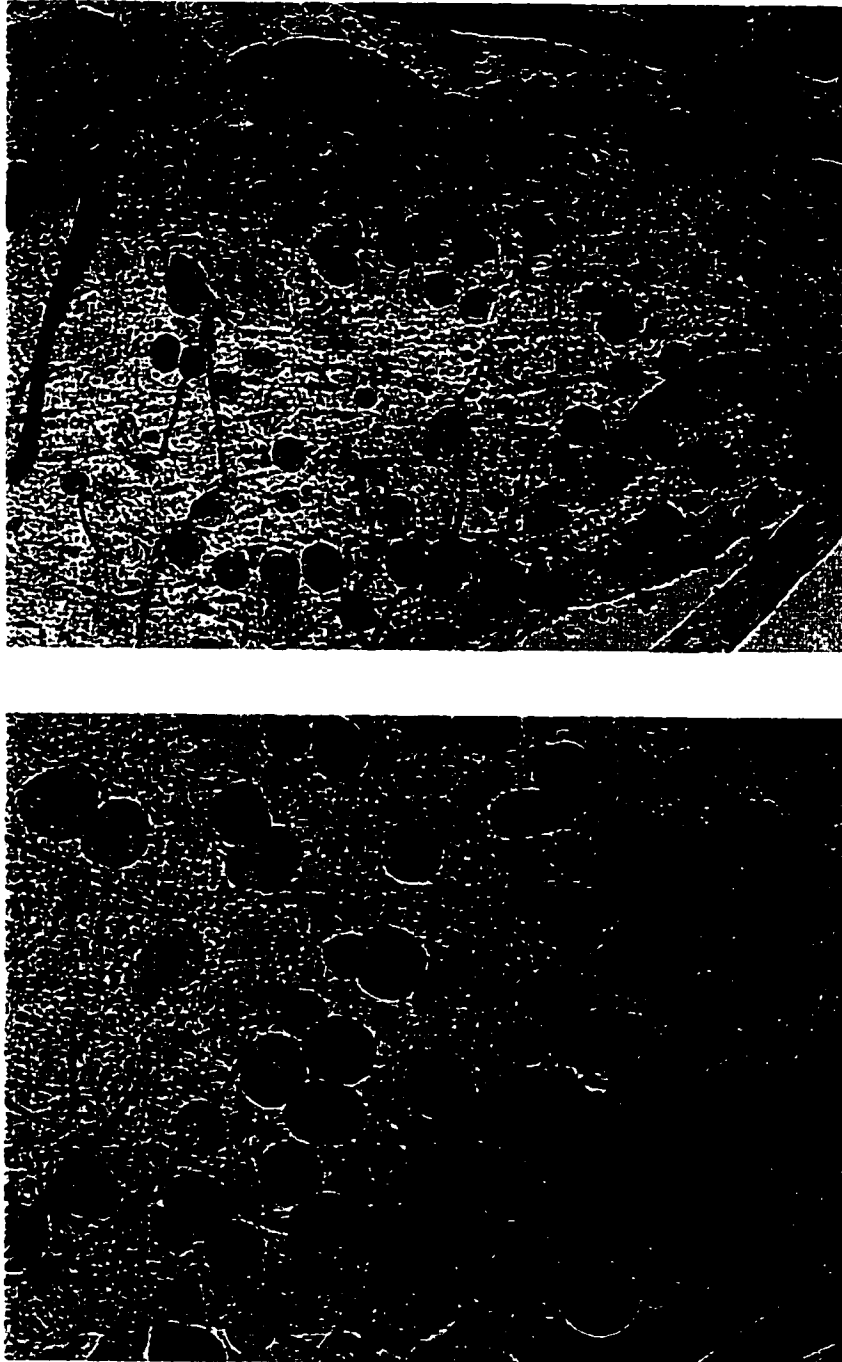

Figure 2: Digital images of oocysts of Plasmodium falciparum in infected midguts of An. vestitipennis. Top image shows oocysts on midgut at 9 days post infection (200x). Bottom image shows oocysts at 11 days post infection (200x). Scale bar = 50 μ m.

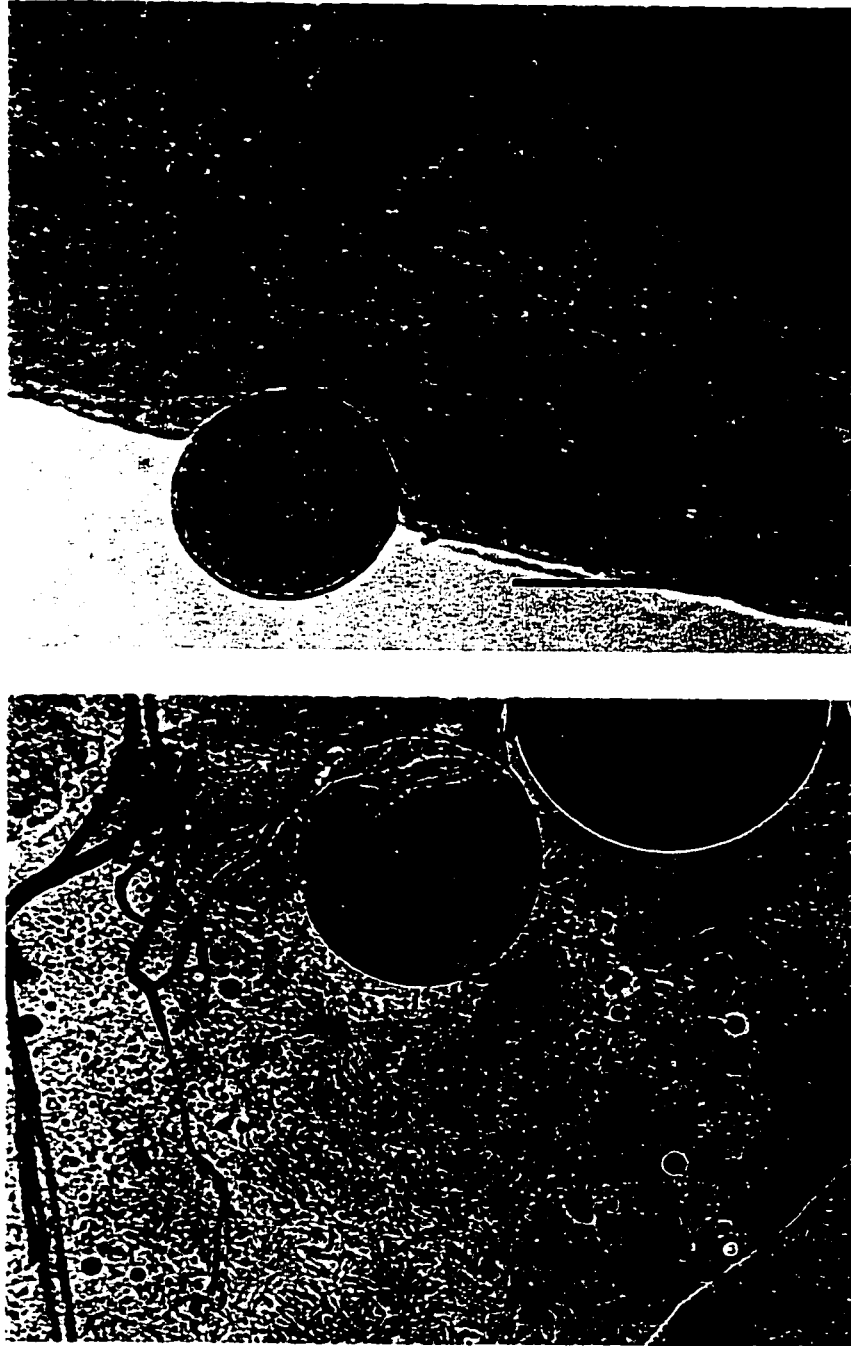

Figure 3: Digital images of oocysts of *Plasmodium falciparum* in infected midguts of *An. vestitipennis*. Top image shows oocysts on midgut at 12 days post infection (400x). Bottom image shows a ruptured oocyst and release of sporozoites from a differentiated oocyst at 13 days post infection (400x). Scale bar = 50 μ m

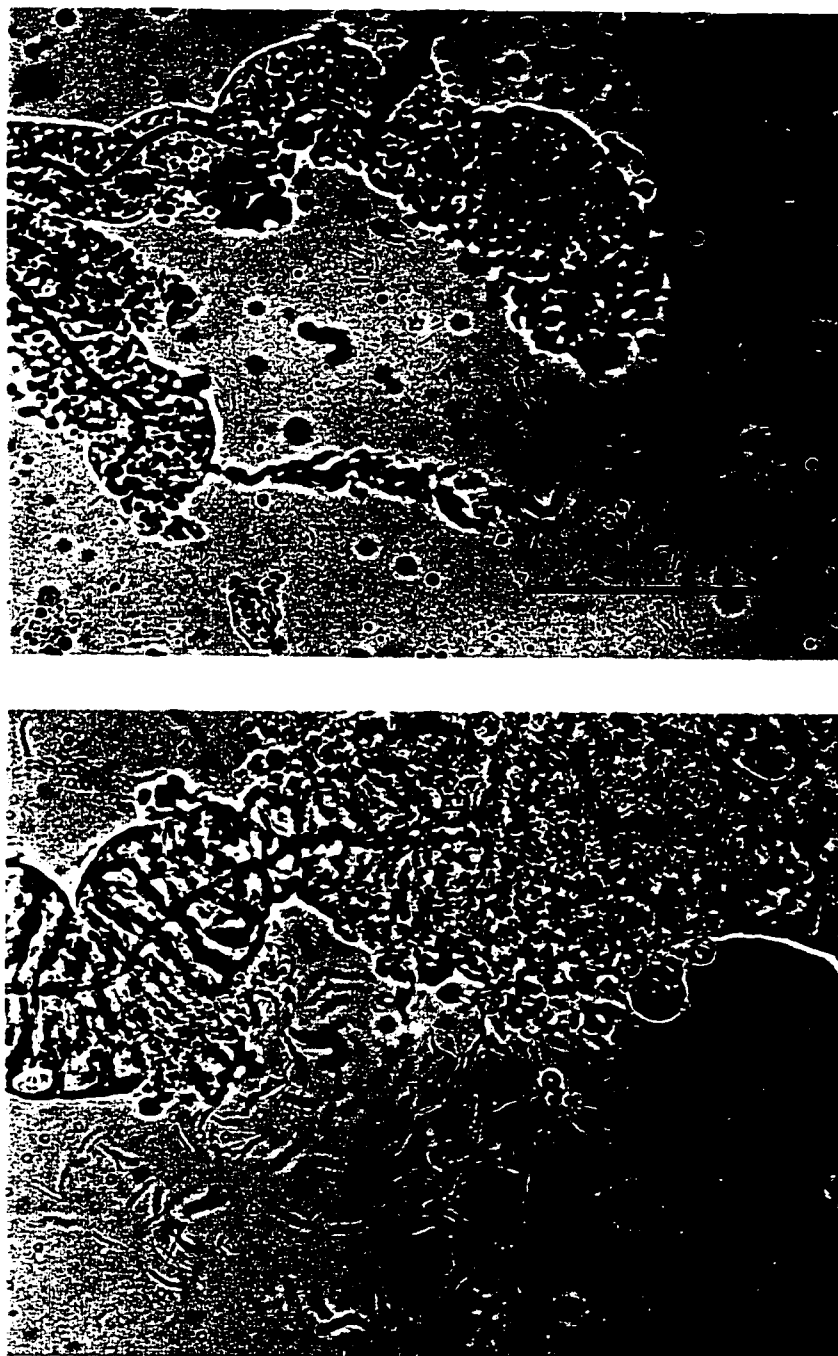

Figure 4: Top image is a digital image of Plasmodium falciparum infected salivary glands of An. vestitipennis (200x). Scale bar = 100 μ m. Bottom image of P. falciparum infected salivary glands of An. vestitipennis (400x). Scale bar = 50 μ m. Numerous sporozoites can be seen being released from both sets of salivary glands.

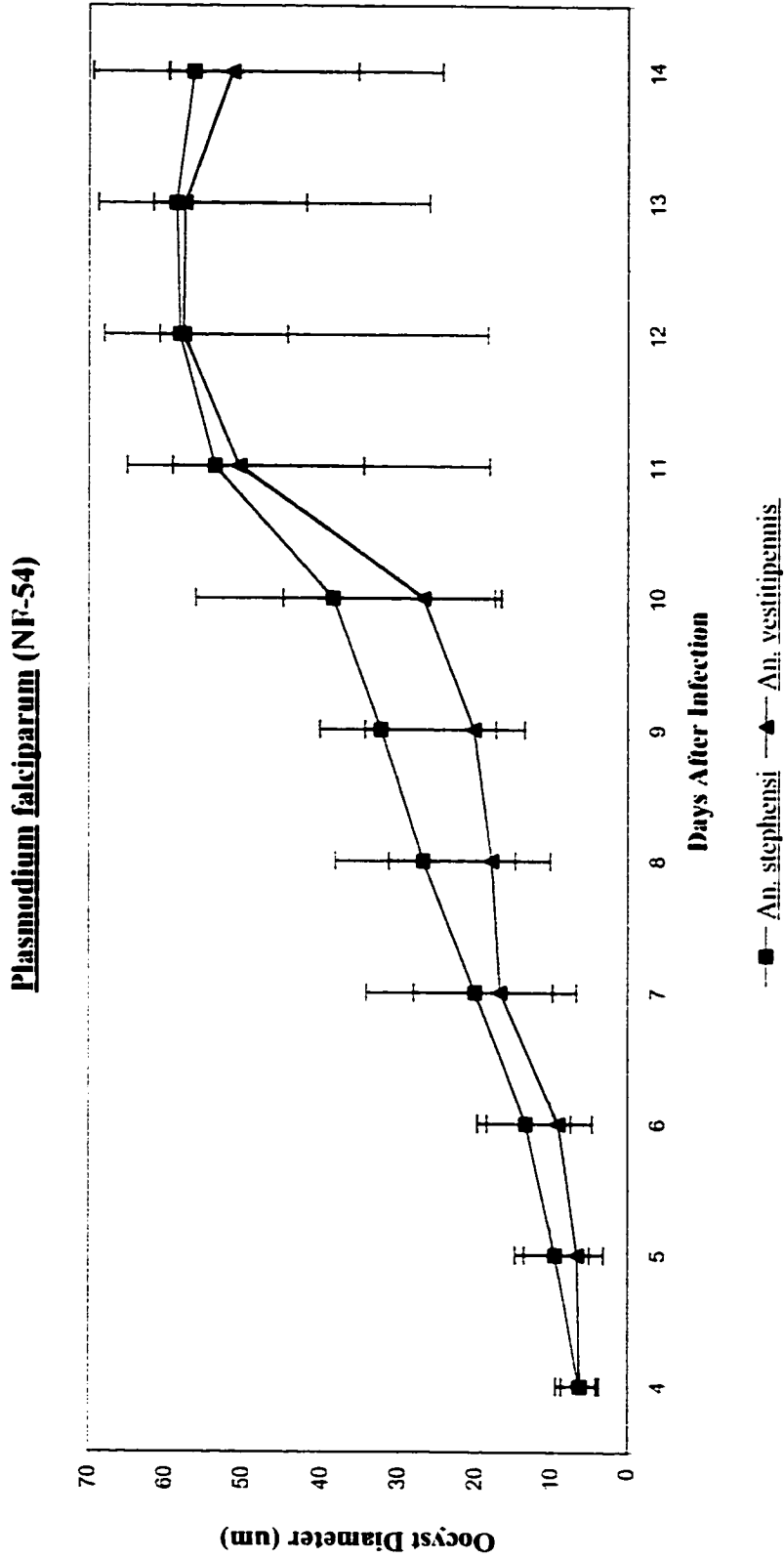

Figure 5: Mean oocyst diameters for *Plasmodium falciparum* (NF-54) in *An. vestitipennis* compared to the control population of *An. stephensi*. Maximum and minimum range bars are displayed to illustrate the daily variation in oocyst diameters.

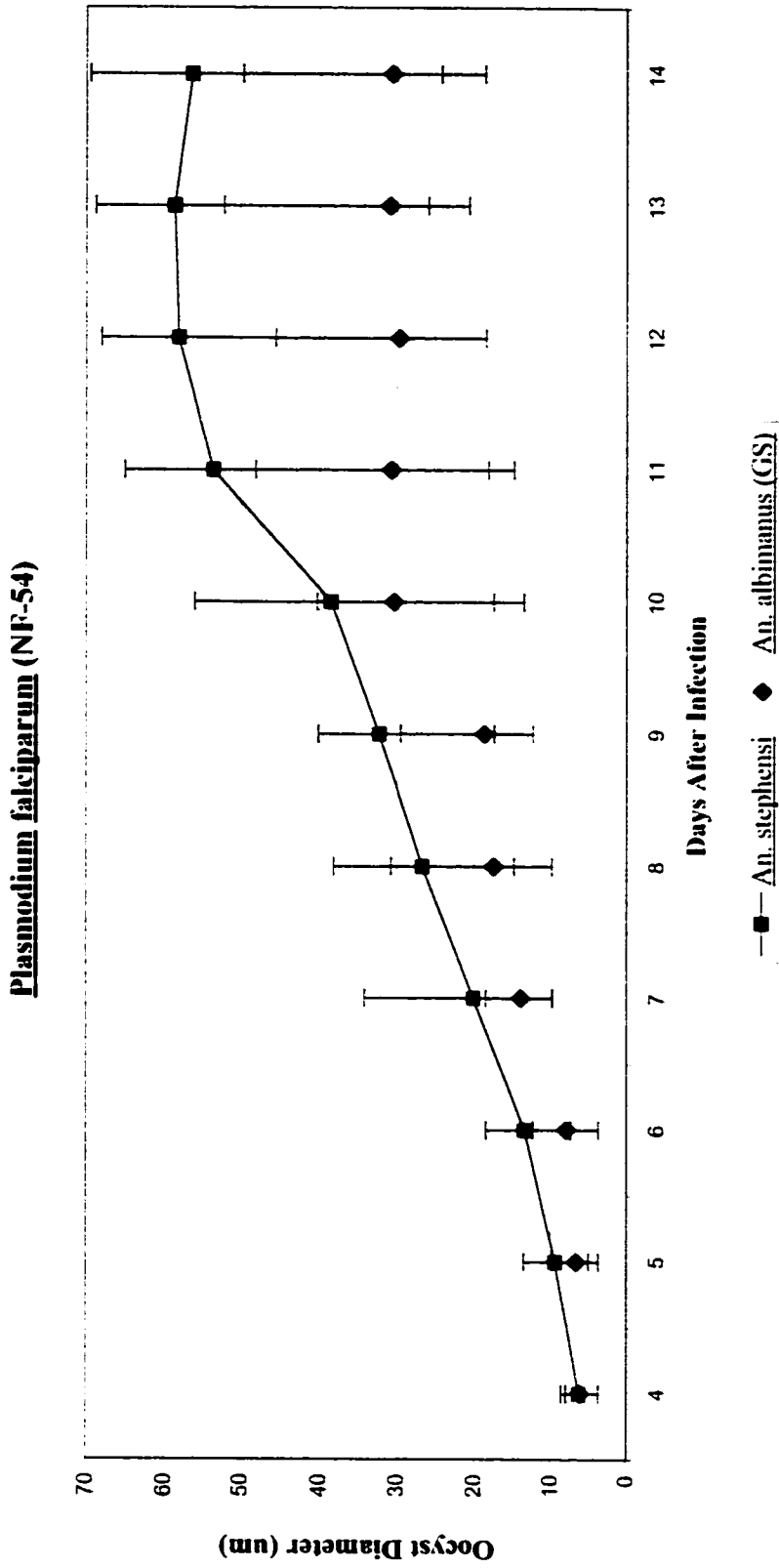

Figure 6: Mean oocyst diameters for *Plasmodium falciparum* (NF-54) in *An. albimanus* (BV) compared to the control population of *An. stephensi*. Maximum and minimum range bars are displayed to illustrate the daily variation in oocyst diameters.

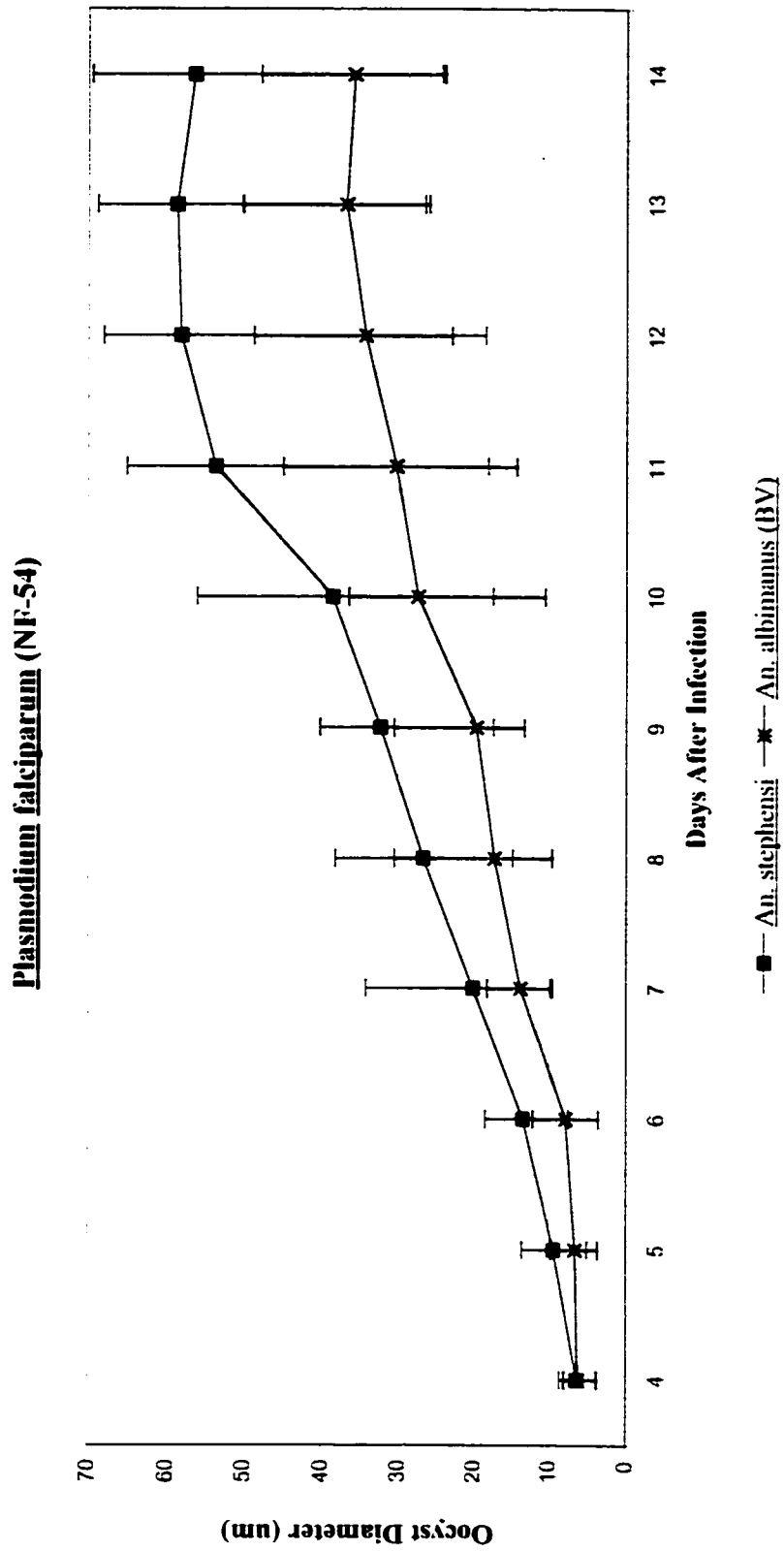

Figure 7: Mean oocyst diameters for *Plasmodium falciparum* (NF-54) in *An. albimanus* (GS) compared to the control population of *An. stephensi*. Maximum and minimum range bars are displayed to illustrate the daily variation in oocyst diameters.

Chapter 8

Conclusion

Conclusion

The present research was undertaken in the hopes of clarifying the malaria vector situation in Belize, Central America. Very little information is available on the mosquito species from this region (Roberts et al. 1993). By gaining additional information on the bionomics and vector competence of the Anopheles species in Belize, it may be easier to focus our control efforts thereby reducing costs while effectively reducing vector/human contact. With the increased international pressure to ban critical elements of our control strategy (i.e., DDT), it becomes imperative to further our understanding of not only the vectors but of the actions and effectiveness of the insecticides that are being using to control them.

Presently, the literature is full of statements that refer to An. albimanus as the primary vector of malaria in Central America (Warren et al. 1975, 1977, Horsfall 1955, Komp 1942, Ramsey et al. 1994, Faran 1980, Breeland 1980). These statements were made even though this species continually exhibits weak vector-associated behaviors such as exophagic and zoophilic feeding behaviors (Elliott 1969, 1972, Garrett-Jones 1964, Breeland 1972, Garrett-Jones et al. 1980, Frederikson 1993, Roberts et al. 1993, Roberts et al. 2000, Bangs 1999). There are statements indicating this species will only transmit malaria when it occurs in high population densities (Elliott 1972, Loyola et al. 1993). This type of statement seems to suggest that this species is not a competent vector of malaria and may serve a secondary role in malaria transmission where it occurs. If this is the case, then there are more efficient vectors in Central America that are responsible for the majority of malaria transmission. It is in the best interest of the public health

community to determine the primary vector species so that a targeted control strategy can be developed to minimize the threat of malaria transmission.

One likely candidate for primary vector status is An. vestitipennis. Previous data have shown An. vestitipennis to be naturally infected with Plasmodium spp. and to exhibit strong vector-associated characteristics such as endophilic and anthropophilic feeding behaviors (Achee et al. 2000). This species also has been classified as a primary vector of malaria in southern Mexico (Loyola et al. 1991) and yet has drawn little attention in other areas of its range. Despite these findings, very little can be found in the literature about this species and this is particularly true for the country of Belize. For this reason, the present research has focused more heavily on the vector potential of An. vestitipennis than of An. albimanus in Belize.

The data presented in this dissertation reveal that An. vestitipennis is a competent vector of malaria based on the criteria for vector incrimination: 1) demonstration that members of the suspected vector species is commonly found feeding on the vertebrate host of the pathogen, 2) demonstration of a biological association in time and space with the suspected vector and clinical or subclinical infection in the host, 3) demonstration that natural populations of the suspected vector contains the infective stage of the pathogen, and 4) demonstration of infection and transmission by the suspected vector under controlled experimental conditions (Eldridge and Edman 2000). This species shows an association in time and space with cases of P. vivax at the village level as demonstrated by the seasonality study. At the house level, this species exhibits a strong tendency to feed indoors throughout the night increasing the likelihood of uncontested feeding off of sleeping inhabitants. The feeding preference study showed this species to feed

preferentially off of humans over other wild and domestic animals at the study site.

Natural populations of An. vestitipennis tested positive for P. vivax by ELISA. This species even shows a high MFIR of 1.0% from a region where the incidence of malaria is fairly low. Finally, confirmation of salivary gland infection was made in the laboratory using a cultured strain of P. falciparum (NF-54). Although transmission studies were unable to be performed, finding high numbers of sporozoites in the salivary glands of this species clearly indicates a strong potential for transmission.

The opposite argument can be made for the vector potential of An. albimanus in Belize. From data presented in this dissertation, it is clear that this species demonstrates a poor vector potential in light of these four criteria. Although an association was determined to exist between abundance of this species and cases of P. vivax, no specimens tested positive by ELISA at either Golden Stream or Rancho, even though these were two of the five highest villages for malaria cases and this species was second in abundance at both locations. This species also demonstrated exophagic and zoophilic feeding behaviors, characteristics that are not indicative of an efficient malaria vector. Finally, laboratory-determined salivary gland infection rates by P. falciparum (NF-54) were extremely low with only 1.0% of all An. albimanus tested showing a salivary gland infection.

Many of the statements that can be found in the literature concerning the vector status of An. albimanus are based on research conducted half a century ago. These early findings have been accepted and broadened to incriminate An. albimanus in all areas where this mosquito species occurs (Warren et al. 1977). With modern technology, however, we are discovering genetic variants in both parasite and mosquito populations.

These variants demonstrate varying levels of infectivity and susceptibility. Therefore, to make blanket statements about the vector potential of particular species over vast and diverse ecological regions would be an egregious error that may detrimentally affect our control efforts. In light of the latest technologies we, as researchers, must strive to continually reevaluate the vector situation in malaria endemic countries. We also must be mindful not to formulate conclusions beyond the scope of the data, for if we do, we may be causing a greater harm to occur.

Much work remains to be done to clarify the transmission dynamics of malaria in Belize. In some regards, this study creates more questions than answers with regards to the vector potential of the Anopheles species. in the southern portion of the country. Although An. albimanus is a vector of malaria in Belize, its behavior and low infectivity rates show this species to have poor vector potential and therefore its role in the transmission of malaria is secondary to other species such as An. vestitipennis and An. darlingi. Therefore, additional information needs to be obtained regarding the bionomics of these other species in order to adjust control efforts to more focally target the primary vectors.

Experimental huts were extensively used in this study to determine times of entering and exiting of houses before and after spraying. This marks only the second time that experimental huts have been used to evaluate the effects of insecticides on vector populations in the country of Belize and the first time they have been used in the southern portion of the country. The experimental huts were critical to our understanding of these behaviors under natural conditions. Although other means may be employed to quantify these behaviors, nothing can compare to what occurs under normal conditions in

a natural setting. These studies clearly show the effects these chemicals exert on the behavior of entering and exiting populations of An. vestitipennis.

Early researchers focused primarily on the killing action of insecticides believing that avoidance behaviors served to reduce the effectiveness of insecticides (Muirhead-Thomson 1947, de Zulueta 1962, MacDonald 1950, 1957). The effects that these chemicals have goes far beyond the reduction of the vector population due to the killing action of the insecticides. Recently there has been a renewed interest in the association between alterations in mosquito behavior and the reduction in malaria transmission (Roberts and Andre 1994). The changes exerted on the behavioral patterns of the mosquitoes are equally as important in disrupting disease transmission as a reduction in mosquito abundance due to chemically induced mortality . These behavioral modifications function by disrupting the vector/host contact thereby reducing the potential for transmission. The ultimate goal needs to remain focused on the reduction of disease and not the reduction of the mosquito population (Gabaldon 1953).

The evaluation of behavioral patterns post-spray documented the strong repellent action exerted by DDT. The reduction on entering populations of An. vestitipennis by 97% clearly shows that this insecticide dramatically interrupts the indoor vector/host contact, thereby preventing transmission of malaria when humans are most vulnerable (i.e., while they are sleeping). Similar changes in behavior have previously been observed after spraying huts with DDT (Roberts et al. 1984). This study, however, is the first study conducted that gives a side by side comparison of the effects of DDT and deltamethrin on both the entering and exiting behavior of Anopheles species in the country of Belize. In regards to the effects exerted by deltamethrin, this study clearly

documents the irritancy effect this insecticide has on An. vestitipennis. Very little alteration of entering behavior was observed while, clearly, a premature exiting behavior occurred. Those An. vestitipennis that entered the hut exited approximately 2 hours later. During this time, however, mosquitoes continued to bite potentially allowing malaria transmission to occur.

A major issue used by groups looking to ban the use of DDT is the concept of insecticide resistance. In some areas where DDT is used as a residual house spray, mosquito populations have become genetically resistant to the killing effects of the insecticide primarily due to agricultural use affecting larval forms. The lack of a lethal consequence associated with insecticide avoidance behavior eliminates the selection pressure that would stimulate genetic selection against this attribute being perpetuated. An argument could be made that the selection pressure placed on the population would be against house entering of sprayed houses due to the killing action exerted on those that are not repelled. Therefore, those individuals who claim that DDT is a less effective chemical because of insecticide resistance are not taking into account its primary mode of action which is as a repellent.

The present claims made about the detrimental effects of DDT on human health as used in the public health arena are largely unfounded (Davidson, 1989). The effects this chemical has on the formation of egg shells in many avian species, however, has been well documented (Lundholm 1997, Lundholm and Bartonek 1992, Khan and Cutkomp 1982, Lindvall and Low 1980). These findings, however, were the result of the large-scale use of the chemical for the control of agricultural pests such as the cotton boll weevil. During the 1940's and 1950's, this chemical was used by the ton to control a

variety of agricultural pests. The use of DDT strictly for the purpose of residual house spraying contributes very little to the environment, and therefore should not accumulate in the food chain as previously observed from its agricultural use. Many countries where DDT is presently used, rely on this chemical because of its low cost, long residual life and high level of effectiveness. International pressures, however, are aimed at banning DDT by threatening to withhold international aid while at the same time offering no viable alternative insecticides to replace it. This leaves third world countries with the choice between decreased international aid or suspension of their residual spray programs. For many countries that rely heavily on international aid there is no real choice to be made. Reductions in residual house spraying have been linked to dramatic increases in malaria rates (Roberts et al. 1997). For this reason, the use of DDT must continue for public health purposes until a more cost effective and sustainable alternative can be found.

This study also documents for the first time the use of a vehicle mounted trap in the country of Belize. This collection method proved valuable for two reasons: 1) it was an unbiased sampling method which allowed for the collection of several Anopheles spp. over a large area, and 2) it proved useful for the collection of blood engorged specimens of all mosquito species sampled. One aspect of this study that requires further investigation is the disparity in collection times for mosquitoes containing human and non-human blood meals. This collection technique could be useful in future studies to determine mosquito movement from breeding or resting sites towards a host source (i.e., houses, stables, etc.) by choosing routes at varying distances from the host source. This

trapping technique also may prove useful for sampling marked populations in order to determine nightly movements.

The colony data presented in this dissertation serve only to add to the large amount of data already available for this species. The true value of this information will come when attempting to colonize this species. Future efforts need to focus on a comparison study of life table attributes using An. albimanus and An. vestitipennis under controlled conditions. It is only through a comparison of these life table attributes for these two species that we can gain valuable information needed regarding the longevity and fecundity of these species.

It is with great hope that the present research has shed light on the transmission dynamics of malaria in the country of Belize. Further studies must be undertaken to bolster the data presented in this study, as well as, to clarify issues that remain unanswered. Specifically, there needs to be additional comparative susceptibility studies conducted using local strains of P. falciparum and P. vivax. It also would be interesting to look at genetic issues involved with those species used in this study. A number of studies (Warren et al. 1975, 1977, Gonzalez-Ceron et al. 2000) have demonstrated varying levels of susceptibility to infection with P. vivax and P. falciparum by different strains of An. albimanus. Verification of genetically different populations may clarify the differences observed between the two An. albimanus populations. It is also important to determine if there are sibling species issues in the An. vestitipennis population as has been previously reported in southern Mexico (Arredondo-Jimenez et al. 1996). Any information pertaining to malaria transmission in the country of Belize will benefit the

control efforts which should, in time, reduce the morbidity and mortality from the disease.

In regards to DDT and deltamethrin, further studies are required to better understand the repellent and irritant effect of these insecticides. It would be desirable to reproduce this study at a location with a greater species diversity to add to our knowledge of the effects that these chemicals have on other Anopheles species. One aspect of particular importance is the long-term residual effects of these chemicals. Additional studies must be conducted to evaluate their effectiveness 6 months to a year after spraying. It is only through a thorough understanding of the mode of action and long term effectiveness of these chemicals that we can hope to design successful, sustainable control strategies.

References Cited

- Achee, N.L., C.T. Korves, M.J. Bangs, E. Rejmankova, M. Lege, D. Curtin, H. Lenares, Yvette Alonzo, R.G. Andre, and D.R. Roberts. 2000. Plasmodium vivax polymorphs and Plasmodium falciparum circumsporozoite proteins in Anopheles (Diptera: Culicidae) from Belize, C.A. *J. Vect. Ecology*.
- Arredondo-Jimenez, J.I., M.H. Gimnig, M.H. Rodriguez, and R. K. Washinc. 1996. Genetic differences among Anopheles vestitipennis subpopulations collected using different methods in Chiapas state, southern Mexico. *J. Am. Mosq. Contr. Assoc.* 12: 396-401.
- Bangs, M.J. 1999. The Susceptibility and Behavioral Response of Anopheles albimanus Weidemann and Anopheles vestitipennis Dyar and Knab (Diptera: Culicidae) to Insecticides in Northern Belize. Ph.D. Thesis, Uniformed Services University of the Health Sciences, Bethesda, Maryland. 489 pp.
- Breeland, S.G. 1972. Studies on the ecology of Anopheles albimanus. *Am. J. Trop. Med. Hyg.* 21: 751-754.
- Breeland, S. 1980. A bibliography to the literature of Anopheles albimanus (Diptera: Culicidae). *Mosq. Syst.* 12: 50-150.
- Davidson, G. 1989. Insecticide usage: An anti-alarmist view of its advantages and disadvantages. *Trop. Dis. Bull.* 6: R1-6.
- de Zulueta, J. and C. Garrett-Jones. 1965. An investigation of the persistence of malaria transmission in Mexico. *Am. J. Trop. Med. Hyg.* 14: 63-77.
- Elliott, R. 1969. Ecology and behaviour of malaria vectors in the American region. *Cah. ORSTOM., ser. Ent. Med. Et Parasitol.* 7: 29-33.

- Elliott, R. 1972. The influence of mosquito behavior on malaria transmission. *Am. J. Trop. Med. Hyg.* 21: 755-763.
- Faran, M.E. 1980. Mosquito studies (Diptera:Culicidae) 34. A revision of Albimanus section of the subgenus Nyssorhynchus of Anopheles. *Contrib. Am. Entomol. Inst.* 15: 1-215.
- Frederikson, E.C. 1993. Bionomics and Control of Anopheles albimanus. Tech. Paper 34. Pan Am. Hlth. Organ. Washington, D.C. 76pp.
- Gabaldon, A. 1953. Possible effects of residual insecticides on the interruption of malaria transmission. *Riv. Malariol.* 32: 155-171.
- Garrett-Jones, C. 1964. The human blood index of malaria vectors in relation to epidemiological assessment. *Bull. WHO* 30: 241-261.
- Garrett-Jones, C., P.F.L. Boreham and C.P. Pant. 1980. Feeding habits of anophelines (Diptera: Culicidae) in 1971-78, with references to the human blood index: a review. *Bull. Entomol. Res.* 70: 165-185.
- Gonzalez-Ceron, L, M.H. Rodriguez, F.V. Santillan, Juan E. Hernandez and R.A. Wirtz. 2000. Susceptibility of three laboratory strains of Anopheles albimanus (Diptera: Culicidae) to coindigenous Plasmodium vivax circumsporozoite protein phenotypes in southern Mexico. *J. Med. Entomol.* 37: 331-334.
- Horsfall, W. 1955. Mosquitoes: Their Bionomics and Relation to Disease. Ronald, New York. 723pp.
- Khan H.M. and L.K. Cutkomp. 1982. *In vitro* studies of DDT, DDE, and ATPase as related to avian eggshell thinning. *Arch. Environ. Contam. Toxicol.* 11: 627-633.
- Komp, W.H.W. 1942. The Anopheline Mosquitoes of the Caribbean Region. U.S. Public Health Service, Nat. Inst. Hlth. Bull. No. 179. 195 pp.

Loyola, E.G., J.I. Arredondo, M.H. Rodriguez, D.N. Brown and M.A. Vaca-Marin. 1991.

Anopheles vestitipennis, the probable vector of Plasmodium vivax in the Lacadon forest of Chiapas, Mexico. *Trans. R. Soc. Trop. Med. Hyg.* 85: 171-174.

Loyola, E.G., L. Gonzalez-Ceron, M.H. Rodriguez, J.I. Arredondo-Jimenez, S. Bennett, and

D.N. Brown. 1993. Anopheles albimanus (Diptera: Culicidae) host selection patterns in three ecological areas of the coastal plains of Chiapas, Southern Mexico. *J. Med. Ent.* 30: 518-523.

Lundholm, C.D. 1997. DDE-induced eggshell thinning in birds: effects of p,p'-DDE on the calcium and prostaglandin metabolism of the eggshell gland. *Comp. Biochem. Phys. C. Pharmacol. Toxicol. Endocrinol.* 118: 113-128.

Lundholm, C.E. and M. Bartonek. 1992. Effects of p,p'-DDE and some other chlorinated hydrocarbons on the formation of prostaglandins by the avian eggshell gland mucosa. *Arch. Toxicol.* 66: 387-391.

Macdonald, G. 1950. Epidemiological basis of malaria control. *Bull. Wld. Hlth. Org.* 15: 613-626.

Macdonald, G. 1957. *The Epidemiology and Control of Malaria.* Oxford University Press, Amen House, London, 201 pp.

Muirhead-Thomson, R.C. 1947. The effects of house spraying with pyrethrum and with DDT. on Anopheles gambiae and A. melas in West Africa. *Bull. Entomol. Res.* 38: 449-464.

Ramsey, J.M., E. Salinas, D.M. Brown and M.H. Rodriguez. 1994. Plasmodium vivax sporozoite rates from Anopheles albimanus in southern Chiapas, Mexico. *J. Parasitol.* 80: 489-493.

- Roberts, D.R. and R. Andre. 1994. Insecticide resistance issues in vector-borne disease control. *J. Am. Trop. Med. Hyg.* 50: 21-34.
- Roberts, D.R., O. Chan, J. Pecor, E. Rejmankova, S. Manguin, J. Polanco and L.J. Letgers. 1993. Preliminary observations on the changing roles of malaria vectors in southern Belize. *J. Am. Mosq. Control Assoc.* 9: 456-459.
- Roberts, D.R., L.L. Laughlin, P. Hsueh and L.J. Letgers. 1997. DDT: global strategies and a malaria control crisis in South America. *Emerg. Inf. Dis.* 3:295-302.
- Roberts, D.R., W.D. Alecrim, P. Hsieh, J.P. Grieco, M. Bangs, R.G. Andre and T. Chareonviriphat. 2000. A probability model of vector behavior: effects of DDT repellency, irritancy and toxicity in malaria control. *J. Vector Ecol.* 25: 48-61.
- Warren, McW, W.E. Collins, B.B. Richardson and J.C. Skinner. 1977. Morphological phenotypes of Anopheles albimanus and susceptibility to Plasmodium vivax and Plasmodium falciparum. *Am. J. Trop. Med. Hyg.* 26: 607-611.
- Warren, McW, J. Mason and J. Hobbs. 1975. Natural infections of Anopheles albimanus with Plasmodium in a small malaria focus. *Am. J. Trop. Med. Hyg.* 24: 545-546.

APPENDIX I

ADULT COLLECTION FORM

**ADULT COLLECTION
DISTRICT:**

Sample Number: _____ Date: ____/____/____

Collectors: INSIDE _____ OUTSIDE _____

Name of Village: _____ Name River/Creek: _____

Village Number: _____

Time started: _____ am/pm Time ended: _____ am/pm

GPS (UTM Coordinates): N _____ W _____

Distance to River _____ m Distance to forest edge _____ m

House Number: _____ Household Name: _____

Elevated House: Y / N

% Enclosure: _____

of Occupants: _____

of Houses
(at family site): _____

of Persons treated
for Malaria in last month: _____

Use Bednets?: Y / N

Insecticide Sprayed?: Y / N

Date Last Sprayed: ____/____/____

Name of Insecticide: _____

Walls planks concrete/cinder bamboo slats sticks plaster	Floor planks concrete split bamboo dirt	Roof thatch concrete metal tile
Windows # _____ # open _____ # screened _____		Doors # _____ # open _____ # screened _____
Wind none light gusts strong	Precip. none light/mist drizzle rain heavy	Cloud clear fog pty cloudy cloudy full overcast

Numbers Collected

	OUTSIDE	INSIDE
An. albimanus		
An. vestitipennis		
An. darlingi		
An. punctimacula		
An. pseudopunct.		
An. gabaldoni		
An. apicimacula		
An. crucians		
An. argyritarsis		
OTHER		

Rel. Humidity: _____

Temperature: _____

#'s & kinds of animals present:

APPENDIX II

HUMAN USE INFORMATION AND AGREEMENT FORM

HUMAN USE INFORMATION AND AGREEMENT

Consent form for voluntary participation in a scientific investigation of malaria mosquito vectors in Southern Belize

Study title: "Comparison study of the house entering and exiting behavior of *An. vestitipennis* before and after spray with DDT and Deltamethrin in the Toledo District, Belize, Central America.

Background:

Malaria is a serious problem in the country of Belize. Because *Anopheles* mosquitoes transmit malaria, the best and most efficient way to control this disease is to control the mosquito. Effective control measures which use insecticides or other means requires detailed knowledge of the biology and behavior of the anopheline mosquitoes involved in transmission. The transmission potential of *An. vestitipennis* is not well documented in Central American but it appears that this species is a competent vector. The purpose of this study is to determine the entering and exiting behavioral response of this species to huts sprayed with DDT and Deltamethrin. Other studies will be carried out in conjunction with this one in order to obtain information on the biology and ecology of this and other anopheline species in the region. The information obtain from this project, with the aid of your participation, will be of great benefit to your community and the country of Belize in their efforts to control malaria.

Participation information:

You have been asked to voluntarily participate in a scientific research study to be conducted in Belize. Please read and understand the following:

- 1) Your participation is voluntary.
- 2) You will be compensated at an agreed upon daily rate for each collection period.
- 3) You may withdraw from participation in this study or any part of the study at any time. Refusal to participate will involve no penalty or loss of benefits to which you are otherwise entitled.
- 4) The details of this study will be explained to you. You will be free to ask questions at any time before or during the study that will allow you to clearly understand aspects of the investigation.
- 5) There will be no cost to you for your participation.

Duration of participation:

The study will last for a period of up to one year, with varying intervals of activity Depending on the study requirements. Your participation can continue until you withdraw, are removed earlier by a physician because of health reasons or for inability to perform the required tasks.

Procedures:

Before agreement to participate, you will be interviewed and informed of the full scope of the activities requirements and risks involved. If acceptable by both parties, you will be given the opportunity to be trained and begin the study.

Activities:

You will be asked to collect mosquitoes from your exposed lower legs using a mouth aspirator and flashlight. Collections will be performed both inside and outside of local houses or specially constructed experimental huts during night time hours. Maximum periods per collection will be 13 hours. You will be provided with all necessary supplies (flashlight, batteries, cups, aspirator, etc.).

Risks, Hazards and Discomforts:

You will be asked to collect mosquitoes landing on your exposed skin. During the collection period, you will not be allowed to apply repellents or smoke tobacco. Depending on the number of mosquitoes landing on your legs and your skill of capturing them, some of these mosquitoes will have the opportunity to bite and cause local irritation. Other exposed parts of your body (i.e. face, hands etc.) may be exposed to bites as well. Depending on the amount of malaria in the study area, you may be at an increasing risk of acquiring malaria parasites from the infective bite of certain mosquitoes.

Benefits:

Upon request or if you fall ill, your blood will be checked for malaria infection. If you are infected, you will be given treatment by a physician monitor until you are completely cured in accordance with the policies of the Belizean Ministry of Health. Malaria treatment will be free of charge.

Confidentially:

All records relating to your participation as a research subject will remain confidential. Your name will not be used in any report resulting from the study without your consent. A statement of your participation in the study will be given to you.

Circumstances under which you participation may be terminated without your consent:

- 1) Conditions which might occur that would make your participation detrimental to your health
- 2) Unable to comply with the activity requirements.

Maximum number of study subjects: 8

Medical care for injury or illness:

You will be entitled to free medical care through a government health care facility for the treatment of clinically diagnosed malaria or injury as a direct result of your participation in this study. Points of contact are available if you have any questions concerning the medical research or your rights as a subject under this agreement. If you become ill during the study, either due to malaria or to the medications used to prevent or treat malaria, please contact one of the listed investigators.

Points of Contact:

John P. Grieco (Principle Investigator)

Herbert Lenares (Director, Vector Control Program)

I have read/ had read to me the Consent Form in a language I understand. Additionally, I have been given the opportunity to ask questions and have received satisfactory answers to all questions. The general purpose of this study, and risks and benefits to me are fully understood. I understand that participation will entitle me to malaria treatment should the need arise and that I may withdraw from this study without prejudice at any time.

Having been fully informed, I consent to participation in this study.

Subject

Signature and Date

Project Supervisor

Signature and Date

Witness

Signature and Date

APPENDIX III

HUT STUDY PUBLICATION

A Comparison Study of House Entering and Exiting Behavior of *Anopheles vestitipennis* (Diptera: Culicidae) Using Experimental Huts Sprayed with DDT or Deltamethrin in the Southern District of Toledo, Belize, C. A.¹

John P. Grieco^{2,3}, Nicole L. Achee², Richard G. Andre², and Donald R. Roberts²

²*Division of Tropical Public Health, Department of Preventive Medicine/Biometrics, Uniformed Services University of the Health Sciences, 4301 Jones Bridge Road, Bethesda, MD 20814, U.S.A.*

³*Corresponding Author.*

Received 27 May 1999; Accepted 11 February 2000

ABSTRACT: An investigation of the house entering and exiting behavior of *Anopheles vestitipennis* Dyar and Knab was undertaken in the Toledo District of Belize, Central America, between March and December of 1998. Three untreated experimental huts were either fitted with exit or entrance interception traps or used as a control for human landing collections. Human landing collections showed that *An. vestitipennis* exhibited a high level of biting activity shortly after sunset and continued biting at high levels throughout the night. Under unsprayed conditions, the use of exit and entrance interception traps demonstrated that doors, windows, and eaves were the primary mode of entry; whereas, cracks in the walls served a secondary role. The peak entrance time for *An. vestitipennis* occurred between 6:45 P.M. and 9:45 P.M. and a peak exit time occurred between 11:45 P.M. and 4:45 A.M. Additional trials were conducted after spraying one of the huts with DDT and another with deltamethrin. The excito-repellent properties of deltamethrin did not affect entrance times but did result in a peak exiting behavior that was five hours earlier than under pre-spray conditions. Deltamethrin also exhibited a repellency effect, showing 66% fewer *An. vestitipennis* entering the hut two weeks post-spray. DDT had an even more powerful repellency effect resulting in a 97% post-spray reduction of *An. vestitipennis* females entering the hut up to two weeks post-spray. The control hut showed only a 37% reduction in *An. vestitipennis* as compared to pre-spray conditions.

Keyword Index: *Anopheles*, behavior, DDT, deltamethrin, Belize.

INTRODUCTION

The resurgence of malaria in tropical regions of Central and South America has created a renewed urgency for information pertaining to *Anopheles* vectors (PAHO 1994). This is evident in Belize and many other countries of the Americas where the prevalence of malaria has increased. This increase is associated with a reduced emphasis on vector control measures, primarily house spraying with residual insecticides (Roberts et al. 1997).

A number of terms, such as behavioral resistance, repellency, irritancy, and excito-repellency, have been used in the literature to describe the behavior of vectors in response to insecticide application. A brief description of these terms is required to understand their affect on the vector population. The term, behavioral resistance, implies an evolutionary basis in which the insect has evolved the ability to protect itself against lethal contact with naturally occurring plant toxins (Chareonviriyaphap et al. 1997), and has been documented in early studies dealing with anopheline vectors and malaria transmission

¹Disclaimer: The views expressed are those of the authors and do not reflect the official policy or position of the USUHS, the Department of Defense, or the United States Government.

(Kennedy 1947, Muirhead-Thomson 1960, Elliott and de Zulueta 1975). The term repellency is used to describe oriented movements of avoidance made by the insect in response to a chemical stimulant without having made tarsal contact with the chemical (Roberts et al. 2000). Irritancy refers to oriented movements made by the insect away from a chemical stimulus only after making tarsal contact with the chemical (Roberts et al. 2000). Excito-repellency implies a series of oriented avoidance behaviors made with or without tarsal contact to a chemical stimulus (Roberts and Andre 1994).

A long-standing belief was that the only true action of an effective malaria campaign was the reduction of the vector population. This belief is based on Macdonald's early mathematical models (1950, 1957), which emphasize the relationship between decreased vector survival and reduced rates of malaria transmission. These models pointed out that any effect that decreases the probability of a lethal contact with the insecticide would negatively effect the reduction in malaria transmission. This notion led to the assumption that behavioral avoidance of residual insecticides would, in essence, protect the vectors and, therefore, prevent overall reductions in the vector populations (Muirhead-Thomson 1950). This assessment, however, overlooks the possibility that prevention of indoor biting and resting behaviors might be an effective approach to reducing malaria transmission. Others have also stressed the relationship between altered behavioral patterns associated with insecticide interaction, and to their implications for control of vector-borne disease (Cullen and De Zulueta 1962, Hamon et al. 1970; Elliott 1972, and Gillies 1988). Indeed, present understanding of disease transmission indicates that the disruption of the host-vector interaction may be more important than an actual reduction in mosquito populations.

Research efforts in Belize have focused on four anopheline species, which have been incriminated in the transmission of human malaria including: *Anopheles albimanus* Weidemann; *An. darlingi* Root; *An. pseudopunctipennis* Theobald; and *An. vestitipennis* Dyar and Knab. Both *An. darlingi* and *An. pseudopunctipennis* have shown the ability to transmit malaria in areas of Central America (Padilla et al. 1992) while *Anopheles albimanus* is widely believed to be the primary vector in this region (Ramsey et al. 1994). Although this species readily feeds on humans, recent studies in Belize have indicated that it exhibits a weak endophagic behavior (Bangs 1999, Roberts et al., unpub. data).

Anopheles vestitipennis is found throughout the coastal regions of Mexico, Central America, regions of northern South America, Cuba, Dominican Republic,

and Puerto Rico (Loyola et al. 1991, Mekuria et al. 1991, Padilla et al. 1992, Marquetti et al. 1992), and until recently, its role as an important vector of human malaria has not been well established. In fact, Boyd (1949) reported that *An. vestitipennis* is of little importance in the transmission of malaria. Loyola et al. (1991), however, observed this species to be both endophilic and endophagic, and found native populations of *An. vestitipennis* in Chiapas, Mexico, positive for *Plasmodium vivax*. In a malaria vector survey conducted in Belize, Kumm and Ram (1941) found malaria sporozoites in the salivary glands of *An. vestitipennis* and *An. darlingi*, but not in *An. albimanus*. More recently, natural *P. falciparum* infections in *An. vestitipennis* collected from Belize have been identified by sporozoite ELISA (Achee et al., unpub. data). This data indicates that *An. vestitipennis* had a higher minimum field infection rate (0.282%) than either *An. albimanus* (0.126%) or *An. darlingi* (0.271%). Evidence for the role of *An. vestitipennis* as a vector of malaria in Belize has been mounting from thorough documentation of human-vector contact (Roberts et al. 1993 and Bangs 1999), relatively high natural infection rates (Achee et al., unpub. data), and confirmation of malaria sporozoites in naturally infected salivary glands (Kumm and Ram 1941). Taken together, these observations incriminate *An. vestitipennis* as one of three important malaria vectors in Belize.

MATERIALS AND METHODS

Study Area

In the early part of 1998, an experimental hut study was undertaken to determine the house entering and exiting behavior of *An. vestitipennis* in the Toledo District, located in southern Belize (Fig. 1). The study was conducted in the village of Rancho (N 16° 09.954, W 88° 50.529), which was composed of 166 houses with a total population of approximately 824 people based on survey statistics from 1998. The village was located about four miles from the Gulf of Honduras near the town of Punta Gorda. Study site selection was based on the Belize Ministry of Health's classification of Rancho as one of the five most malarious areas within the Toledo District and preliminary surveys which detected large numbers of *An. vestitipennis* larvae and adults.

The rainy season in the southern portion of Belize begins in late April and continues through December. The average yearly rainfall in the south is generally greater than 160 inches. The coolest temperatures in the region occur from November to December with an average temperature of 24°C while the warmest temperatures occur May through September (average

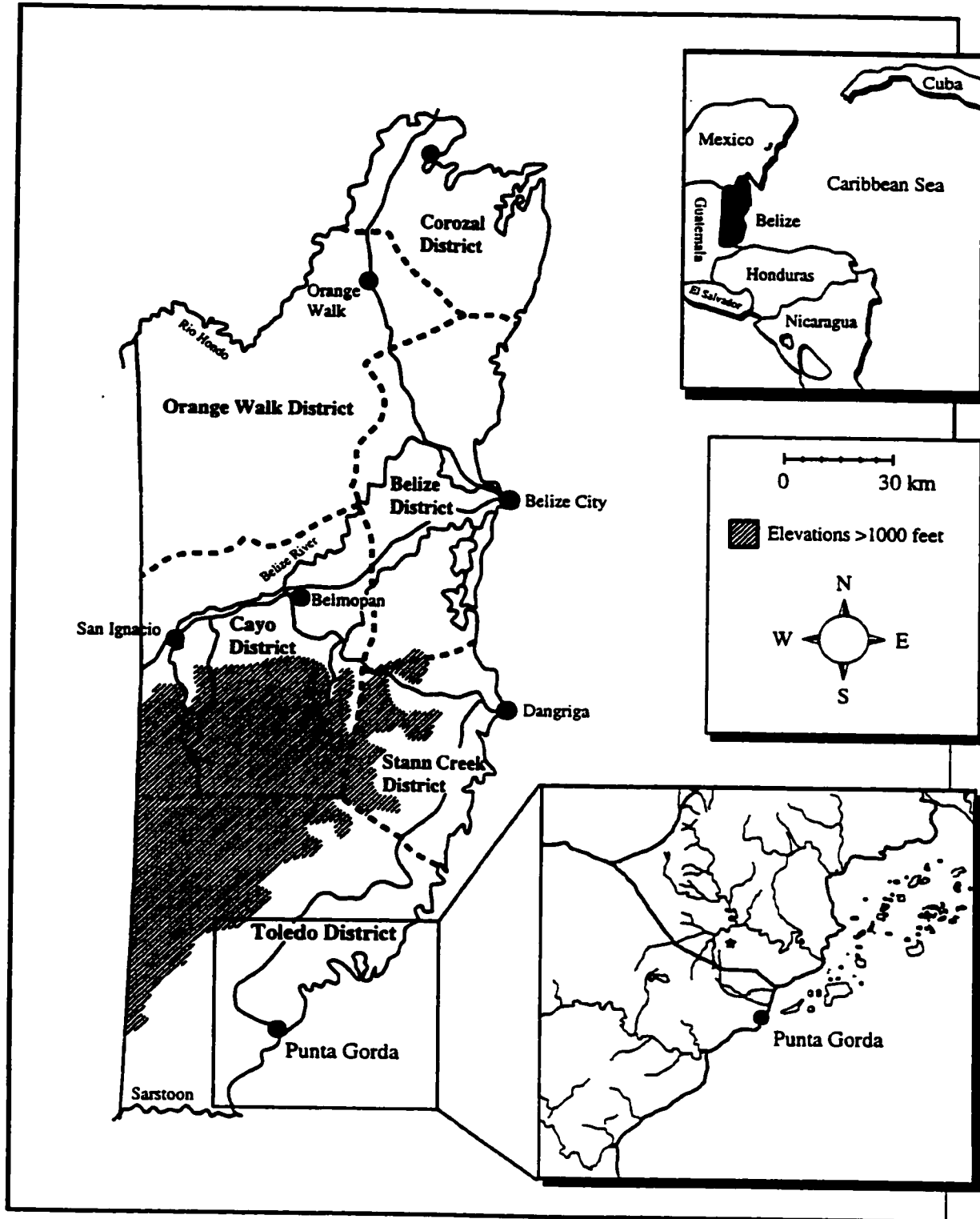

Figure 1. Map of the Toledo District in Southern Belize. The location of the experimental hut site is indicated by the star.

temperature of 27°C). The prevailing winds blow off of the Gulf of Honduras from the Southeast from January through August and shift out of the Northwest beginning in September.

Three identical huts were constructed for experimental purposes and for a series of 15-hour collections. Huts were modeled after the basic design of a Mayan house that is common in southern Belize. The walls of the hut measured 7.8 m long x 4.2 m wide x 2.1 m high and consisted of plank wood walls, dirt floor, and a thatch roof constructed from Cahune palm. The apex of the angled roof measured 4.5 m from the floor of the hut. A walkway running lengthwise down the center of each hut was constructed 3 m above the floor to enable examination of the thatch during collections. Each hut had three windows and a north-facing door. In addition, each hut was equipped with a small auxiliary door (0.5 m wide x 1 m high) through which collectors could enter or exit the huts without removing the traps. This door remained shut and locked except when collectors were rotated. All three huts were constructed to accommodate window and door intercept traps. The huts were situated in a triangle with the most northern house (Hut A) positioned 15 m from the other two structures and Hut B and Hut C positioned 30 m from each other. Two additional huts, that housed the collectors and their families, were located about 40 to 50 m from the experimental hut site.

Interception Traps

With minor modifications, window and door intercept traps were constructed according to the design of Muirhead-Thomson (1950). The window traps were 0.6 m x 0.6 m x 0.6 m boxes and were constructed with lengths of 1.3 cm PVC pipe. The door traps were constructed in a similar fashion and measured 1.8 m x 0.9 m x 0.9 m. Both trap types were covered by green polyester insect netting (BioQuip Products Inc.) and were sewn into place. The front of the traps were left open to form a five-sided box. Sleeve material was attached over a hole in the rear of the trap to facilitate the removal of resting mosquitoes. Initial efforts were made using a funnel in the front of the trap to act as a one way baffle. After a number of trials, this apparatus was removed as an obstacle to mosquito passage. Additionally, a 3 m x 0.3 m x 0.3 m eaves trap and a 3 m x 1.8 m x 0.8 m wall trap were constructed to aid in determining the mode of entry into the huts. These traps were constructed in a similar fashion to that used for the window and door traps.

Collection Method

Simultaneous collections were conducted using all

three huts. During a single night's collection (4:30 P.M. to 7:30 A.M.), one hut was affixed with exit traps while another was affixed with entrance traps. The third hut was maintained as a control hut at which an indoor/outdoor human landing collection was conducted. The type of collection conducted at each hut was rotated on subsequent nights in order to minimize slight variations between the huts. A host presence was established in each hut prior to the collection by placing collectors in the huts one hour before the beginning of the sampling period. Two collectors were placed in the center of each trap hut to act as bait during the collection.

Human landing collections at the control hut were conducted for 30-minutes each hour. Indoor collectors were positioned in the center of the hut while outdoor collectors were positioned on the side of the hut at least 3 m from any openings. Collections consisted of collectors aspirating mosquitoes from their exposed, lower legs for a 30-minute time period. Indoor collectors switched with outdoor collectors halfway through each 30-minute collection period. All collectors rotated their positions between huts throughout the night to eliminate the possibility of collector bias. Post-spray collections were conducted with traps being placed in the same position (i.e., both with exit traps or both with entrance traps) on the two sprayed huts. Post-spray human landing collections were conducted at the control hut in the same manner as described above.

Resting mosquitoes were collected from the interior aspects of the traps using a mouth aspirator for a period of 30 minutes every hour. Collected mosquitoes, from both human landing and intercept traps, were placed in separate cardboard cages and labeled with the date, time, and hut location for each collection period. Each hour represents the 30-minute sampling period, which occurred beginning at the top of that hour. Mosquitoes were killed with chloroform vapor, and species were identified the following morning.

Insecticide Application

On November 27, 1998, after the initial pre-spray trials had been completed, trained personnel of the Belize Malaria Control Program sprayed two of the huts with insecticide following established protocol. The interior walls, lower 1 m of thatch, and outside eaves of Hut C were sprayed with DDT wettable powder (75% wdp) that had been suspended in clean water to make a 4% (technical grade) formulation. Spraying was conducted using a Hudson X-Pert compression sprayer equipped with an 8002E Teejet nozzle in order to obtain a fan application to all hut surfaces. Hut B was sprayed in an identical manner as that applied to Hut C except

using a 5% deltamethrin wettable powder. Four ounces of wettable powder were suspended in 4 gallons of clean water. The application rate was 2 grams per square meter. Both huts were allowed to dry completely (for no less than 12 hours) before a collection was performed.

RESULTS

Pre-Spray Collections

A total of 26 pre-spray human landing collections was conducted from February to December 1998 resulted in the collection of the following anopheline species placed in order of abundance: *An. vestitipennis* (23,087), *An. punctimacula* (437), *An. albimanus* (158), *An. apicimacula* (17), *An. gabaldoni* (10), *An. darlingi* (3) and *An. neivai* Howard, Dyar & Knab (1). Analysis of five preliminary all-night human landing collections performed at all three huts simultaneously indicated the mean number of anopheline mosquitoes collected at the three huts were not significantly different (F value = .03; $p > 0.05$).

Anopheles vestitipennis showed a constant high level of landing/biting activity beginning shortly after sunset and continuing until approximately one hour prior to sunrise (6:00 A.M.) (Fig. 2). An examination of the indoor/outdoor biting populations showed no difference between the number of *An. vestitipennis* collected inside the huts (11,220) compared to outside the hut (11,867), for an O:I ratio of 1:0.9.

The nightly biting activity of the other anophelines found at the study area conforms to what is already found in the literature (Hobbs et al. 1986, Taylor 1966, Rachou et al. 1965 and Muirhead-Thomson and Mercier 1952). Outdoor:indoor ratios, however, were calculated for the other anopheline species collected during this study to document the behavior of these species for the southern portion of Belize, Central America. The density of outdoor and indoor biting populations of *An. albimanus* exhibited a marked difference with 91% (144) of the population being collected outside and only 9% (14) of the population being collected inside. The O:I ratio for *An. albimanus* was 1:0.1. *Anopheles punctimacula* also exhibited a greater propensity for biting outdoors with 71% (309) of the biting population being collected outdoors and only 29% (128) being collected indoors. These data translate into an O:I ratio of 1:0.4. The remaining four species, *An. apicimacula*, *An. gabaldoni*, *An. darlingi*, and *An. neivai* were all collected in outdoor collections.

Mode of Entry

Studies on mode of entry into the hut employed the simultaneous use of three window traps, one door trap,

one wall trap, and one eaves trap. Overall, intercept traps were effective collecting devices for *An. vestitipennis* mosquitoes. The traps were, however, more effective as exit traps (3,929) than as entrance traps (2,807).

The pre-spray trap collections of *An. vestitipennis* were conducted over 21 trap nights between August and November of 1998 and consisted of multiple collections each night. The collection totals were averaged by time period and graphed against the midpoint for that time interval. Peak entering occurred between 6:45 P.M. and 9:45 P.M. (Fig. 4). The vast majority of the entering population was collected in the first half of the night with 91% of the *An. vestitipennis* being collected before midnight. Peak exiting began at approximately 11:45 P.M. and continued until 4:45 A.M. (Fig. 5). Exiting *An. vestitipennis* were primarily collected during the latter half of the night. Only 31% of all exiting *An. vestitipennis* were collected prior to midnight while 69% were collected between midnight and 6:45 A.M.

Only three anophelines collected from all the entrance traps were blood fed (0.1%). Two of these were *An. punctimacula* and only one was *An. vestitipennis*. For this reason, the gonotrophic status of the entering mosquitoes collected was classified as unfed. The door and window openings clearly proved to be the preferred mode of entry with 1,044 anopheline mosquitoes (35.3%) being collected from the window traps and 1,760 (59.5%) being collected from the door trap (Fig. 3). The eaves and walls appeared to contribute very little to the overall buildup of entering anopheline mosquitoes, with 4.4% (130) entering through the eaves and 0.8% (24) entering through cracks in the wall. These traps only sampled 1/8 of total wall or eaves space in the house (3 m of 24 m of wall or eaves space). Assuming random movement into the house, the number of mosquitoes entering through other areas, such as the eaves or walls should be proportional to that obtained from the trapped portion. For this reason, collections from the eaves and wall were adjusted to reflect the true size of these entry points. After adjustment, the doors and windows remained as primary modes of entry (43.6% and 25.9%, respectively). The eaves also showed to be a primary mode of entry after adjustment (25.7%). Only the walls continued to contribute very little to the overall indoor population of anopheline mosquitoes (4.8%).

Entry/Exit Times (Post-Spray)

All night post-spray collections (5 entrance and 5 exit) were conducted between November and December of 1998. The pattern of *An. vestitipennis* biting activity was similar to pre-spray patterns of activity. Biting

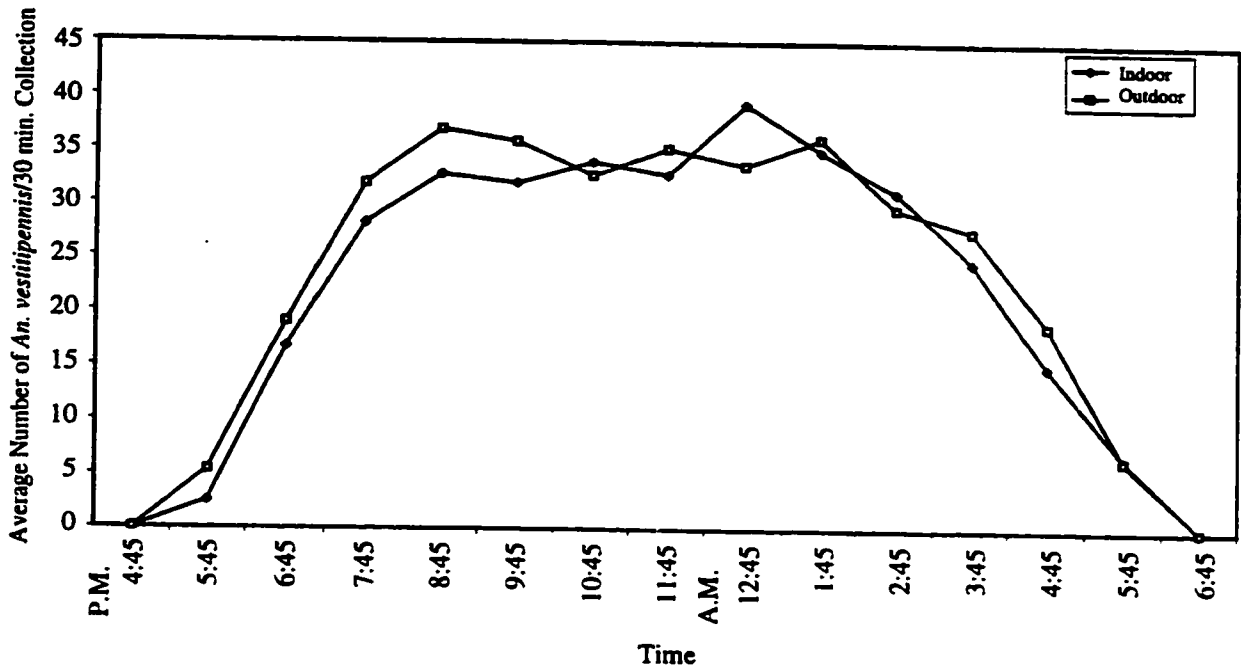

Figure 2. Average number of *Anopheles vestitipennis* collected from human baited collections during 26 collection nights at Rancho, Toledo District, Belize, from March to November of 1998. Each collection was conducted for 15 hours by two collectors collecting for 30 minutes each hour throughout the night. Data is plotted against the midpoint of each 30-minute sample period.



Figure 3. Percentage of total *Anopheles vestitipennis* populations collected from entrance interception traps during 21 nights of collections. Window and door traps represent collection from entire portal region while the eaves and wall trap represent only 1/8 of the total surface area for that mode of entry.

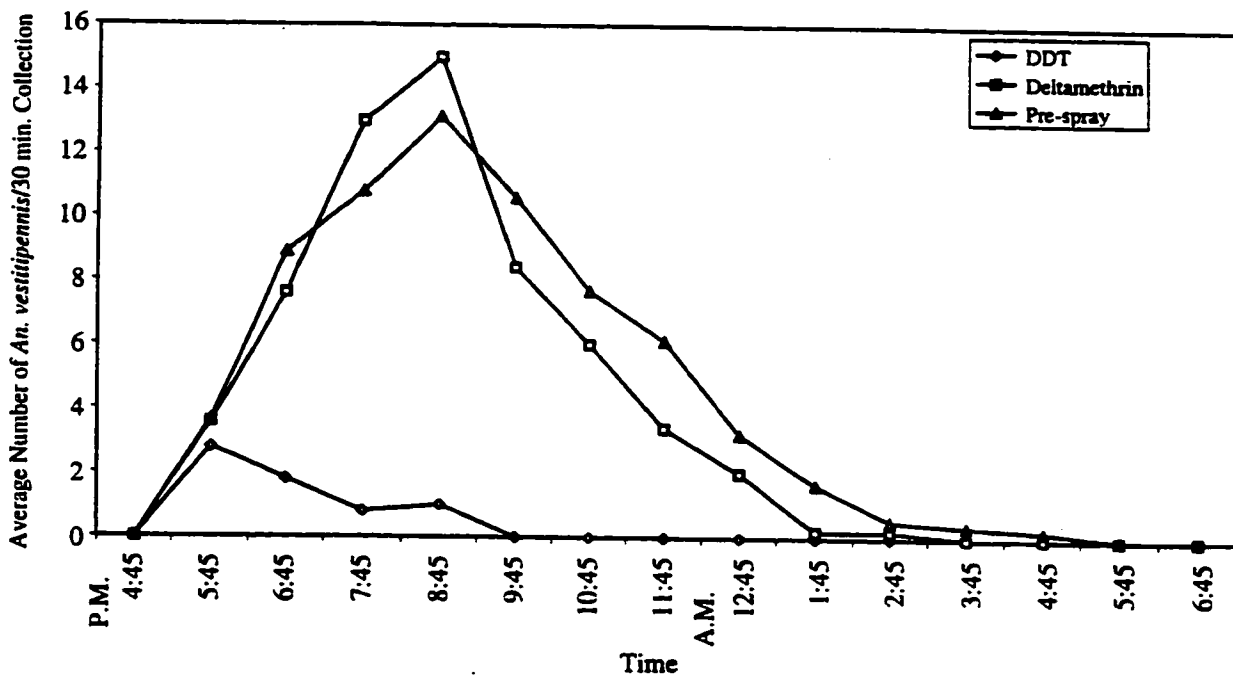

Figure 4. Comparison of the average number of *Anopheles vestitipennis* collected under pre- and post-spray conditions from entrance interception traps conducted during 21 and 5 collection nights, respectively, at Rancho, Toledo District, Belize, from August to December of 1998. Each collection was conducted for 15 hours by two collectors collecting for 30 minutes each hour throughout the night. Data is plotted against the midpoint of each 30-minute sample period. During a single night's collection, both sprayed huts were affixed with entrance traps, and a human baited collection was conducted at the control hut.

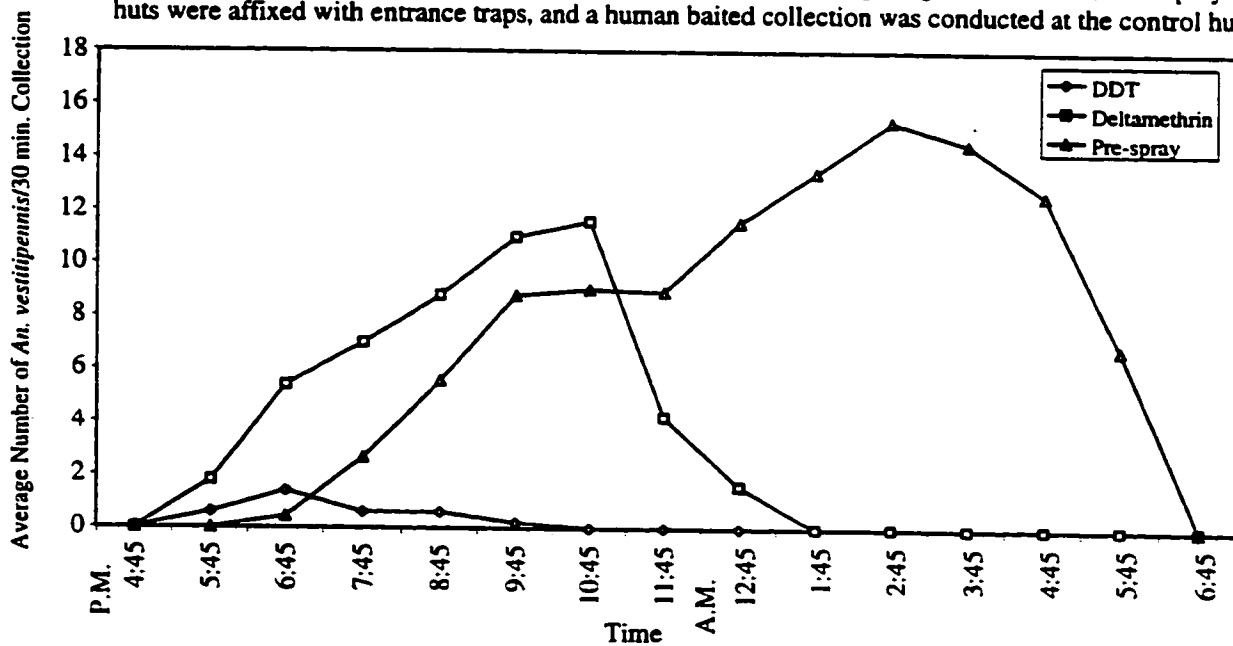

Figure 5. Comparison of the average number of *Anopheles vestitipennis* collected under pre- and post-spray conditions from exit interception traps conducted during 21 and 5 collection nights, respectively, at Rancho, Toledo District, Belize, from August to November of 1998. Each collection was conducted for 15 hours by two collectors collecting for 30 minutes each hour throughout the night. Data is plotted against the midpoint of each 30-minute sample period. During a single night's collection, both sprayed huts were affixed with exit traps and a human baited collection was conducted at the control hut.

began shortly after sunset (6:45 P.M.) and continued at a high level throughout the remainder of the night in the control hut (Fig. 6). The O:I ratio was calculated to be 1:0.8. Numbers of *An. vestitipennis* collected in the unsprayed hut, compared to pre-spray collections, showed a 37.4% reduction.

Both the DDT and the deltamethrin sprayed huts exhibited a reduction in population levels from pre-spray trials. Numbers of *An. vestitipennis* collected in pre-spray traps compared to the numbers trapped post-spray documented a 66% reduction in the deltamethrin hut and a 97% reduction in the DDT hut. Trap data for the DDT hut showed that two of the nights with the largest collections occurred with winds of greater than 5 mph and bouts of heavy rain.

The numbers of *An. vestitipennis* that entered the DDT hut post-spray were very low and only small peaks of entrance/exit activity occurred in the early hours after sunset (5:45 P.M. to 7:45 P.M.) (Figs. 4 and 5). The deltamethrin hut, however, continued to have substantial numbers of *An. vestitipennis* enter the house after spraying. In the deltamethrin-sprayed hut, the peak entrance time generally followed the same pattern as that seen in the pre-spray trials. A peak occurred between 6:45 P.M. and 9:45 P.M. (Figs. 4, 5, and 7). The exit times, however, demonstrated a dramatic shift to earlier in the evening. In addition visual examination of the unsprayed portions of the thatch during the collection indicated that there were no mosquitoes resting on these surfaces during the course of the night. After spraying, the peak in exit activity occurred between 8:45 P.M. and 11:45 P.M. Almost all mosquitoes had exited the deltamethrin-sprayed hut by midnight.

An ANCOVA analysis was performed on the entrance activity to examine the effect population density had on trap collection totals (Fig. 8). The analysis compared both pre- and post-spray entrance trap collection totals to the population density on the same night based on the human-landing collection from the control hut. As population densities increased, the collection from the entrance traps also increased for both pre-spray huts and for the post-spray deltamethrin hut. The slope of the DDT hut regression line, however, was not significantly different from zero ($p > 0.05$) and, therefore, represented no increase in entrance activity with increased population density.

DISCUSSION

Experimental hut studies provide critical information on the behavioral activities of vector populations in malarious areas. The present study demonstrates the differences in the biting activities of three anopheline

species commonly found in the southern regions of Belize. *Anopheles albimanus* showed a much stronger exophagic behavior than either *An. vestitipennis* or *An. punctimacula*. *Anopheles punctimacula*, however, showed a greater tendency towards exophagy than *An. vestitipennis*, with only 29% of the biting females collected indoors.

At the Rancho study site, *Anopheles vestitipennis* was collected in the greatest abundance and, therefore, exhibited the strongest trends. Continuous high levels of biting activity occurred throughout the night both indoors and outdoors. Activity began shortly after sunset and continued until just prior to sunrise. In addition, this species demonstrated the strongest endophagic behavior with a calculated O:I ratio of 1:0.9, clearly documenting this species' strong tendency to enter a house and feed.

Data pertaining to the mode of entry into the huts show that the door, window, and eaves all contribute to the overall indoor population of *Anopheles vestitipennis*. The door, windows, and eaves present very large portals of entry. A host-seeking mosquito would find little or no obstacle to house entry when presented with one of these openings. The gaps between the slates of the wall, on the other hand, are very narrow (ranging from 1 to 2 cm wide). Those few mosquitoes entering through the wall may be host-seeking females that accidentally find one of these cracks in the process of trying to locate a window or door. *Anopheles vestitipennis*, for example, were observed to land on the exterior wall surface prior to house entry. After a short outdoor resting period, the mosquito would again take flight, bouncing along the wall in either a horizontal or vertical pattern. It would continue this movement until it reached either a window, door, or eaves opening. It is possible that during this behavior a proportion of mosquitoes would locate a suitable gap in the wall. This may account for the small number of anophelines that were collected from the wall trap.

Entrance trap collections from unsprayed huts showed that the majority of *An. vestitipennis* entering the house were collected during the first six hours after sunset. Of those mosquitoes entering the hut, 91% were collected prior to midnight. While peak entering occurred shortly after sunset, the biting activity continued at a high level throughout the night. This implied that a large proportion of the host seeking female population rested within the interior of the hut prior to obtaining a blood meal. Under identical conditions, exiting of *An. vestitipennis* females occurred during the last six hours before sunrise. Those *An. vestitipennis*, which entered the unsprayed hut, peaked in their exiting behavior at three to four hours before sunrise, at which time they

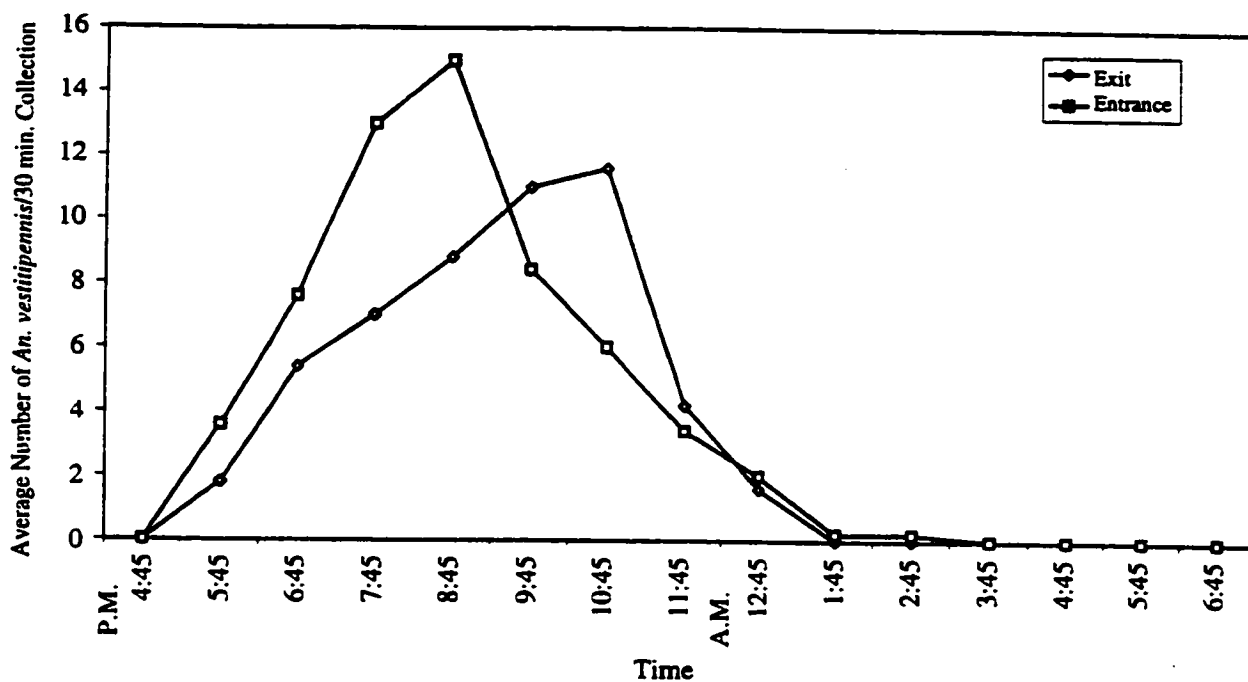

Figure 6. A comparison of entrance and exit times for *Anopheles vestitipennis* post-spray with deltamethrin. Entrance and exit collections were conducted on different nights. Average number of mosquitoes collected per 30-minute sample period are plotted against the midpoint of that sample period.

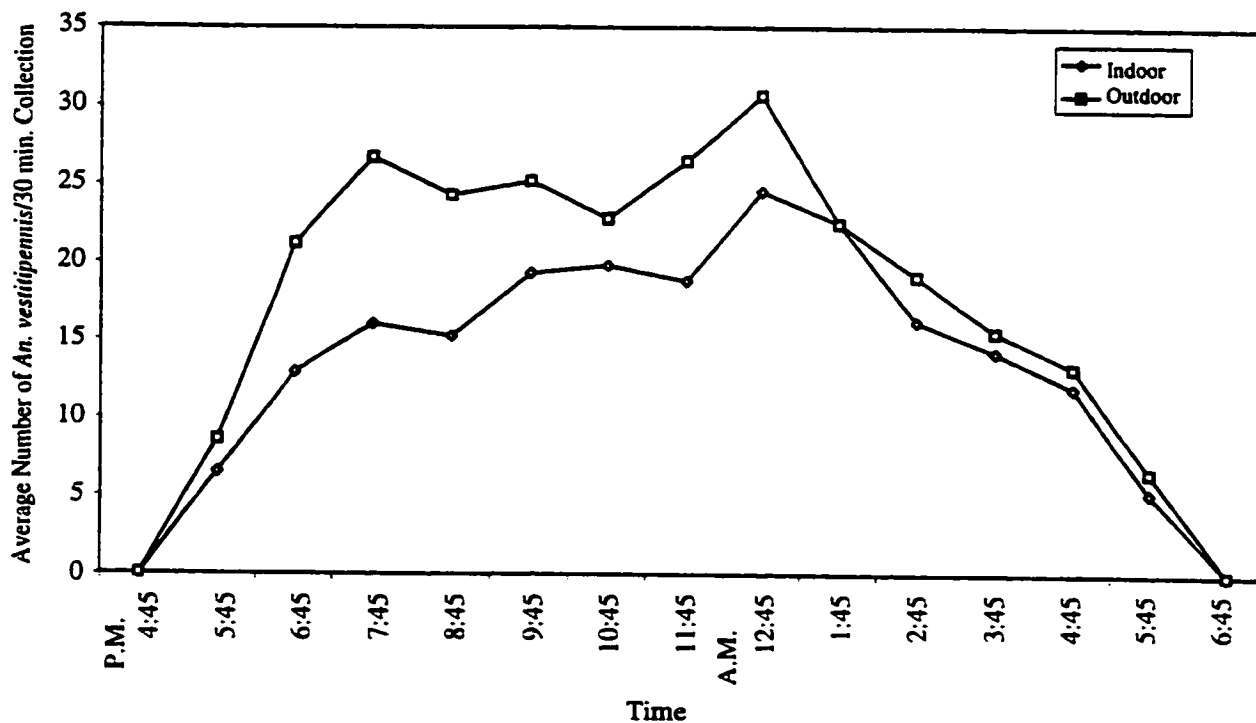

Figure 7. Average number of *Anopheles vestitipennis* collected from human baited collections conducted post-spray during 10 night collections at Rancho, Toledo District, Belize, from November to December of 1998. Each collection was conducted for 15 hours by two collectors collecting for 30 minutes each hour throughout the night. Data is plotted against the midpoint of each 30-minute sample period.

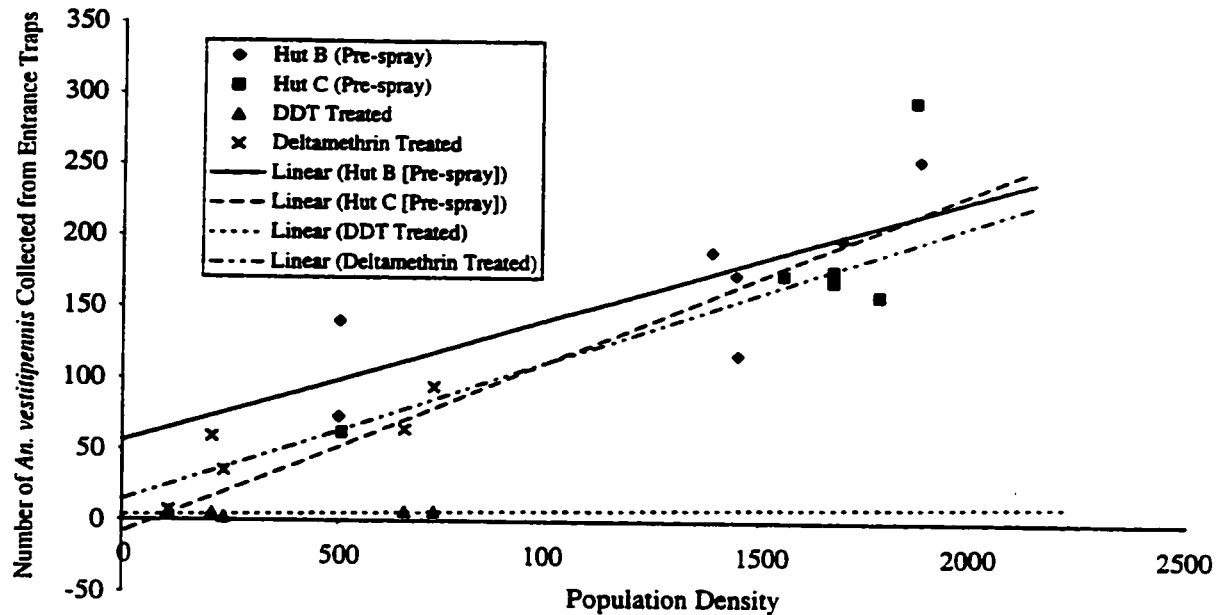

Figure 8. Ancova analysis showing the relationship between increasing population density and increasing entrance trap collection for *Anopheles vestitipennis*. An increase in the number of mosquitoes collected from the traps is positively correlated with all treatments except the DDT treated hut where the slope of the line is not significantly different from zero ($P > .05$).

returned to the outdoor environment in search of suitable resting sites.

After deltamethrin application, time of peak exiting for *An. vestitipennis* populations was shifted to earlier in the night, by approximately five hours. Examination of the thatch during the collection indicated that there were no mosquitoes resting on the unsprayed portions of the thatched roof. This shift, in conjunction with very little deviation from pre-spray entrance behavior, indicated that *An. vestitipennis* was sufficiently irritated or repelled by deltamethrin to leave shortly after entering the hut. Although this effect was observed, there still remained a two-hour period between peak time of entering and peak time of exiting in which biting occurred, allowing for the possibility of malaria transmission to also occur. In addition, it should be noted that a common practice during insecticide application is the removal of personal items from inside the hut prior to spraying the walls, beams, and ceiling. When returned to the hut, these items provide a number of suitable, untreated resting sites. These unsprayed surfaces may decrease the overall irritancy effect, as well as, allow mosquitoes to avoid contact with the chemical, and thereby avoid uptake of a lethal dose of insecticide.

After spraying with DDT, there was a reduction of 97% in the total population of *An. vestitipennis* coming

to the treated hut. This equates to the collection of an average of 4.9 mosquitoes per night in the DDT hut. This is compared to a 66% reduction (or an average nightly collection of 55.4 mosquitoes/night) in the deltamethrin hut and a 37% reduction (or an average nightly collection of 465.9 mosquitoes/night) in the control hut. This illustrates a strong repellency effect due to the DDT, and a lower but, perhaps important level of deltamethrin repellency. A reduction in the number of mosquitoes actually coming into the hut indicates a clear reduction in the vector/host interaction and a potential break in the transmission cycle.

Pre- and post-spray variations in *An. vestitipennis* collected from the entrance traps were not due to natural changes in population density as determined by the ANCOVA analysis. Both pre-spray huts demonstrated increased trap collections in association with increasing population densities. This same positive linear trend was also seen after deltamethrin application. The DDT treated hut, however, showed no increase in the number of *An. vestitipennis* collected from entrance traps as the mosquito population levels increased. This means that the number of *An. vestitipennis* entering a hut will increase in both untreated and deltamethrin treated huts as mosquito densities increase but will be repelled from entering a DDT treated hut regardless of vector

population levels.

In conclusion, *An. vestitipennis* in southern Belize exhibited a strong endophagic behavior. This species readily fed indoors and was a persistent biter throughout the night. The deltamethrin hut showed a definite irritancy effect. Although the chemical did not alter the pattern of house entering activity, it did alter the time of exiting. DDT on the other hand proved to have a very powerful repellency effect. Under normal reduced population levels (37.4% in control hut), deltamethrin only exhibited a 66% reduction, while DDT showed a reduction of 97%. This effect goes contrary to earlier observations made by Roberts et al. (1993) that *An. vestitipennis* was undeterred by DDT residues. These early observations were based on 45 minute indoor/outdoor human landing collections conducted in houses that were last sprayed with DDT months prior to the actual collection activity. The present study sampled anopheline populations throughout the night and was conducted for two weeks after the initial spray. Differences in the house entering behavior of *An. vestitipennis* documented by these two studies are clearly associated with the duration of the residual effect of DDT. Due to the short time frame of the post-spray observations in the present study, it is clear that additional studies are required to examine the residual effects of both DDT and deltamethrin in order to determine their long-term effectiveness.

The repellency effect documented in the DDT-sprayed house essentially excluded human-vector contact within that house. Reduced levels of mosquitoes entering and biting will strongly reduce the potential for malaria transmission. While the irritancy effect of deltamethrin reduced the potential window of opportunity for transmission, it did not preclude transmission from occurring within the house during those few hours in which *An. vestitipennis* females were in contact with humans.

REFERENCES CITED

- Bangs, M. 1999. The susceptibility and behavioral response of *Anopheles albimanus* Weidemann and *Anopheles vestitipennis* Dyar and Knab (Diptera: Culicidae) to insecticides in northern Belize. Ph.D. Thesis. Uniformed Services University of the Health Sciences. Bethesda, Maryland, 489 pp.
- Boyd, M. F. 1949. Epidemiology factors related to the definitive host. Pp. 608-697 in *Malariology* (Boyd, M. F., ed.). Philadelphia: W. B. Saunders, 787 pp.
- Chareonviriyaphap, T., D. R. Roberts, R. G. Andre, H. J. Harlan, S. Manguin, and M. J. Bangs. 1997. Pesticide avoidance behavior in *Anopheles albimanus* a malaria vector in the Americas. *J. Am. Mosq. Control. Assoc.* 13: 171-183.
- Cullen, J. R. and J. DeZulueta. 1962. Observations on the irritability of mosquitoes to DDT in Uganda. *Bull. Wld. Hlth. Organ.* 27: 239-250.
- Elliott, R. 1972. The influence of mosquito behavior on malaria transmission. *Am. J. Trop. Med. Hyg.* 21: 755-763.
- Elliott R. and J. de Zulueta, 1975. Ethological resistance in malaria vectors. Behavioral response to intradomestic residual insecticides. *WHO/VBC. (75.569):* 1-15.
- Gillies, M. T. 1988. Anopheline mosquitoes: vector behaviour and bionomics. Pp. 453-485 in *Malaria, Principals and Practice of Malariology* (W. H. Wernsdorfer and I. McGregor, eds.). Churchill Livingstone, New York, 602 pp.
- Hamon, J., J. Mouchet, J. Brengues, and G. Chauvet. 1970. Problems facing anopheline vector control; vector ecology and behavior before and after application of control measures. Conference on Anopheline Biology and Malaria Eradication. *Misc. Pubs. Entomol. Soc. Am.* 7(1): 28-41.
- Hobbs, J. H., J. D. Sexton, Y. St. Jean, and J. R. Jacques. 1986. The biting and resting behavior of *Anopheles albimanus* in northern Haiti. *J. Am. Mosq. Control. Assoc.* 2: 150-153.
- Kennedy, J. S. 1947. The excitant and repellent effects on mosquitoes of sub-lethal contacts with DDT. *Bull. Entomol. Res.* 37: 593-607.
- Kumm, H. W. and L. M. Ram. 1941. Observations on the *Anopheles* of British Honduras. *Am. J. Trop. Med.* 21: 559-566.
- Loyola, E. G., J. I. Arredondo, M. H. Rodriguez, D. N. Broqn, and M. A. Vaca-Marin. 1991. *Anopheles vestitipennis*, the probable vector of *Plasmodium vivax* in the Lacandon forest of Chiapas, Mexico. *Trans. R. Soc. Trop. Med. Hyg.* 85: 171-174.
- Macdonald, G. 1950. Epidemiological basis of malaria control. *Bull. Wld. Hlth. Org.* 15: 613-626.
- Macdonald, G. 1957. The epidemiology and control of malaria. Oxford University Press, Amen House, London, 201 pp.
- Marquetti, M., A. Navarro, J. Bisset, and F. A. Garcia. 1992. Comparisons of three catching methods for collecting anopheline mosquitoes. *Mem. Inst. Oswaldo Cruz Rio J.* 87: 457-458.
- Mekuria, Y., R. Granados, M. A. Tidwell, D. C. Williams, R. A. Wirtz, and D. R. Roberts. 1991. Malaria transmission potential of *Anopheles* mosquitoes of Dajabon, Dominican Republic. *J. Am. Mosq. Control. Assoc.* 7: 456-461.

- Muirhead-Thomson, R. C. 1950. DDT and Gammexane as residual insecticides against *Anopheles gambiae* in African houses. *Trans. Roy. Soc. Trop. Med. Hyg.* 43: 401-412.
- Muirhead-Thomson, R. C. and E. C. Mercier. 1952. Factors in malaria transmission by *Anopheles albimanus* in Jamaica. *Ann. Trop. Med. Parasitol.* 46: 103-116.
- Muirhead-Thomson, R. C. 1960. The significance of irritability, behaviouristic avoidance and allied phenomena in malaria eradication. *Bull. Wld. Hlth. Organ.* 22: 721-734.
- Padilla, N., P. Molina, J. Juarez, D. Brown, and C. Cordon-Rosales. 1992. Potential malaria vectors in northern Guatemala. *J. Am. Mosq. Control Assoc.* 8: 307-308.
- Pan American Health Organization. 1994. Status of malaria programs in the Americas. XLII report, CSP24/INF/2(Eng.) Washington, D.C., 116 pp.
- Rachou, R. G., G. Lyons, M. Maura Lima, and J. A. Kerr. 1965. Synoptic epidemiological studies of malaria in El Salvador. *Am. J. Trop. Med. Hyg.* 14: 1-62.
- Ramsey, J. M., E. Salinas, D. M. Brown, and M. H. Rodriguez. 1994. *Plasmodium vivax* sporozoite rates from *Anopheles albimanus* in southern Chiapas, Mexico. *J. Parasitol.* 80: 489-493.
- Roberts, D. R., W. D. Alecrim, P. Hshieh, J. P. Grieco, M. Bangs, R. G. Andre, and T. Chareonviriphap. 2000. A probability model of vector behavior: effects of DDT repellency, irritancy and toxicity in malaria control. *J. Vector Ecol.* 25(1): 48-61.
- Roberts, D. R. and R. G. Andre, 1994. Insecticide resistance issues in vector-borne disease control. *Am. J. Trop. Med. Hyg.* 50: 21-43.
- Roberts, D. R., O. Chan, J. Pecor, E. Rejmankova, S. Manguin, J. Polanco, and L. J. Letgers. 1993. Preliminary observations on the changing roles of malaria vectors in southern Belize. *J. Am. Mosq. Control Assoc.* 9: 456-459.
- Roberts, D. R., L. L. Laughlin, P. Hshieh, and L. J. Letgers. 1997. DDT: global strategies and a malaria control crisis in South America. *Emerg. Infect. Dis.* 3: 295-302.
- Taylor, R. J. 1966. The ecology of *Anopheles albimanus* (Weid.) in Haiti. *Mosq. News* 26: 393-397.