



**SPAWAR**  
Systems Center  
San Diego

TECHNICAL DOCUMENT 3186  
August 2004

# Software and Functional Requirements Specification for the Refractivity from Clutter CSCI

L. J. Wagner  
L. T. Rogers

Approved for public release;  
distribution is unlimited.

SSC San Diego

**BEST AVAILABLE COPY**

TECHNICAL DOCUMENT 3186  
August 2004

# Software and Functional Requirements Specification for the Refractivity from Clutter CSCI

L. J. Wagner  
L. T. Rogers

Approved for public release;  
distribution is unlimited.



SSC San Diego  
San Diego, CA 92152-5001

20040927 037

**SSC SAN DIEGO**  
**San Diego, California 92152-5001**

---

---

**T. V. Flynn, CAPT, USN**  
**Commanding Officer**

**R. F. Smith**  
**Executive Director**

**ADMINISTRATIVE INFORMATION**

This document was prepared for Space and Naval Warfare Systems Command (PMW-150) by the Atmospheric Propagation Branch (Code 2858) Space and Naval Warfare Systems Center, San Diego.

Released by  
R. A. Paulus, Head  
Atmospheric Propagation Branch

Under authority of  
B. J. Marsh, Head  
Electromagnetics & Advanced  
Technology Division

Lockheed Martin is a registered trademark of the Lockheed Martin Corporation.  
PowerPC is a registered trademark of the International Business Machines Corporation.  
Windows NT is a registered trademark of Microsoft Corporation.

This is a work of the United States Government and therefore is not copyrighted. This work may be copied and disseminated without restriction. Many SSC San Diego public release documents are available in electronic format at <http://www.spawar.navy.mil/sti/publications/pubs/index.html>

## CONTENTS

1.0 Scope.....	1
1.1 Identification.....	1
1.2 System Overview.....	1
1.3 Document Overview.....	1
2.0 Reference Documents .....	1
3.0 Requirements .....	1
3.1 Required states and modes .....	1
3.2 CSCI Capability Requirements .....	2
3.2.1 Refractivity from Clutter Initialization CSC.....	7
3.2.1.1 RFC Read Evaporation Profiles SU.....	7
3.2.1.2 RFC Read SBD Profiles SU .....	7
3.2.1.3 RFC Read Random Numbers SU .....	8
3.2.1.4 RFC Generate Markov Shifts SU .....	8
3.2.2 Refractivity from Clutter Reader CSC .....	8
3.2.2.1 RFC Read UF SU .....	8
3.2.3 Refractivity from Clutter Data Quality CSC.....	8
3.2.3.1 RFC FindLand SU .....	8
3.2.3.2 RFC FindSectorLumps SU .....	8
3.2.3.3 RFC FindPtTargets SU .....	8
3.2.3.4 RFC Interpolator SU .....	9
3.2.4 Refractivity from Clutter Data Classifier CSC .....	9
3.2.4.1 RFC Data Classifier SU .....	9
3.2.5 Refractivity from Clutter ED CSC .....	9
3.2.5.1 RFC Find Mavg SU .....	9
3.2.5.2 RFC Invert Evaporation SU.....	9
3.2.6 Refractivity from Clutter SBD CSC .....	9
3.2.6.1 RFC Calculate Square Error SU .....	10
3.2.6.2 RFC Get Map Estimate SU.....	10
3.2.7 RFC Output File.....	10
3.3 CSCI External Interface Requirements .....	10
3.3.1 Interface Identification and Diagrams.....	10
3.4 CSCI Internal Interface Requirements .....	11
3.5 CSCI Internal Data Requirements .....	11
3.6 Adaptation Requirements .....	11
3.7 Safety Requirements.....	12
3.8 Security and Privacy Requirements.....	12
3.9 CSCI Environment Requirements .....	12
3.10 Computer Resource Requirements .....	12
3.10.1 Computer Hardware Requirements.....	12
3.10.2 Computer Hardware Resource Utilization Requirements.....	12
3.10.3 Computer Software Requirements .....	12
3.10.4 Computer Interface Requirements .....	13
3.11 Software Quality Factors .....	13
3.11.1 Design .....	13

3.11.2 Performance .....	13
3.11.3 Adaptation .....	13
3.12 Design and Implementation Constraints .....	13
3.13 Personnel-Related requirements .....	13
3.14 Training-Related Requirements.....	13
3.15 Logistics-Related Requirements.....	14
3.16 Other Requirements.....	14
3.17 Packaging Requirements .....	14
3.18 Precedence and Criticality of Requirements .....	14
4.0 Qualification Provisions.....	14
5.0 Requirements Traceability .....	14
6.0 Notes .....	14
6.1 Glossary.....	14
7.0 Appendix.....	15

## FIGURES

1. RFC CSCI program flow .....	2
2. RFC Reader CSC program flow .....	3
3. RFC Data Quality CSC program flow .....	4
4. RFC Classifier CSC program flow .....	5
5. RFC ED CSC program flow .....	6
6. RFC SBD CSC program flow.....	7
7. Test results from USS Normandy .....	15

## TABLES

1. RFC CSCI external data element requirements .....	11
2. Database storage requirements .....	12
3. Test results from IV&V testing by NSWC Dahlgren Division .....	15

## APPENDIX

Attachment to JHU/APL Technical Memo A2A-04-U-3-009.....	16
--	----

## 1.0 Scope

### 1.1 Identification.

The Refractivity from Clutter (RFC) Version 1.0 computer software configuration item (CSCI) uses techniques for inferring atmospheric refractive conditions from radar backscatter. It applies to evaporation ducts (EDs), surface-based ducts (SBDs), and whether the observed backscatter is from the sea, land, or known point targets.

### 1.2 System Overview.

The RFC system will infer atmospheric refractivity from radar sea clutter. The system will use information obtained by going "Through-the-Sensor Means" to provide refractive effects that can characterize the electromagnetic environment. This characterization can enhance the radar and weapons performance assessment to maximize the warfighter's battlespace. The RFC system will be realized as a bootable PowerPC<sup>®</sup> Verification, Execution and Rewrite System (VERSA) Module Eurocard (VME) computer-on-a-board. The system will poll universal format (UF) data files containing the clutter measurements needed for RFC from the Tactical Environmental Processor (TEP) provided by Lockheed Martin<sup>®</sup>.

### 1.3 Document Overview.

The RFC System must meet the software functional requirements specified in this document. The input software requirements are discussed and the internal structure of the RFC CSCI is described as it relates to CSCI's capability.

## 2.0 Reference Documents.

- (a) L. T. Rogers, C. P. Hattan, and J. K. Stapleton. 2000. "Estimating Evaporation Duct Heights from Radar Sea Clutter," *Radio Science*, vol. 35, no. 4 (July–August), pp. 955-966.
- (b) P. Gerstoft, L. T. Rogers, J. Krolik, and W. S. Hodgkiss. 2002. "Inversion for Refractivity Parameters from Radar Sea Clutter," *Radio Science*, vol. 38, no. 3.
- (c) S. Vasuvedan, R. H. Anderson, J. L. Krolik, L. T. Rogers, and P. Gerstoft. "Recursive Bayesian Electromagnetic Refractivity Estimation from Radar Sea Clutter," *IEEE Transactions On Signal Processing*, submitted for publication.
- (d) P. Gerstoft, L.T. Rogers, W. S. Hodgkiss, and L. J. Wagner. 2003. "Refractivity Estimation Using Multiple Elevation Angles," *IEEE Oceanic Engineering*, vol. 28 (July).

## 3.0 Requirements

### 3.1 Required States and Modes.

No states or modes are required.

### 3.2 CSCI Capability Requirements.

The required RFC CSCI algorithms use radar backscatter from Lockheed Martin's TEP system to determine refractivity profiles of the environment. Figure 1 shows the program flow of the required RFC CSCI. Figures 2 through 6 show the program flow for the main computer software components (CSCs), RFC Reader CSC, RFC Data Quality Checks, RFC Classifier CSC, RFC ED CSC, and RFC SBD CSC, respectively.

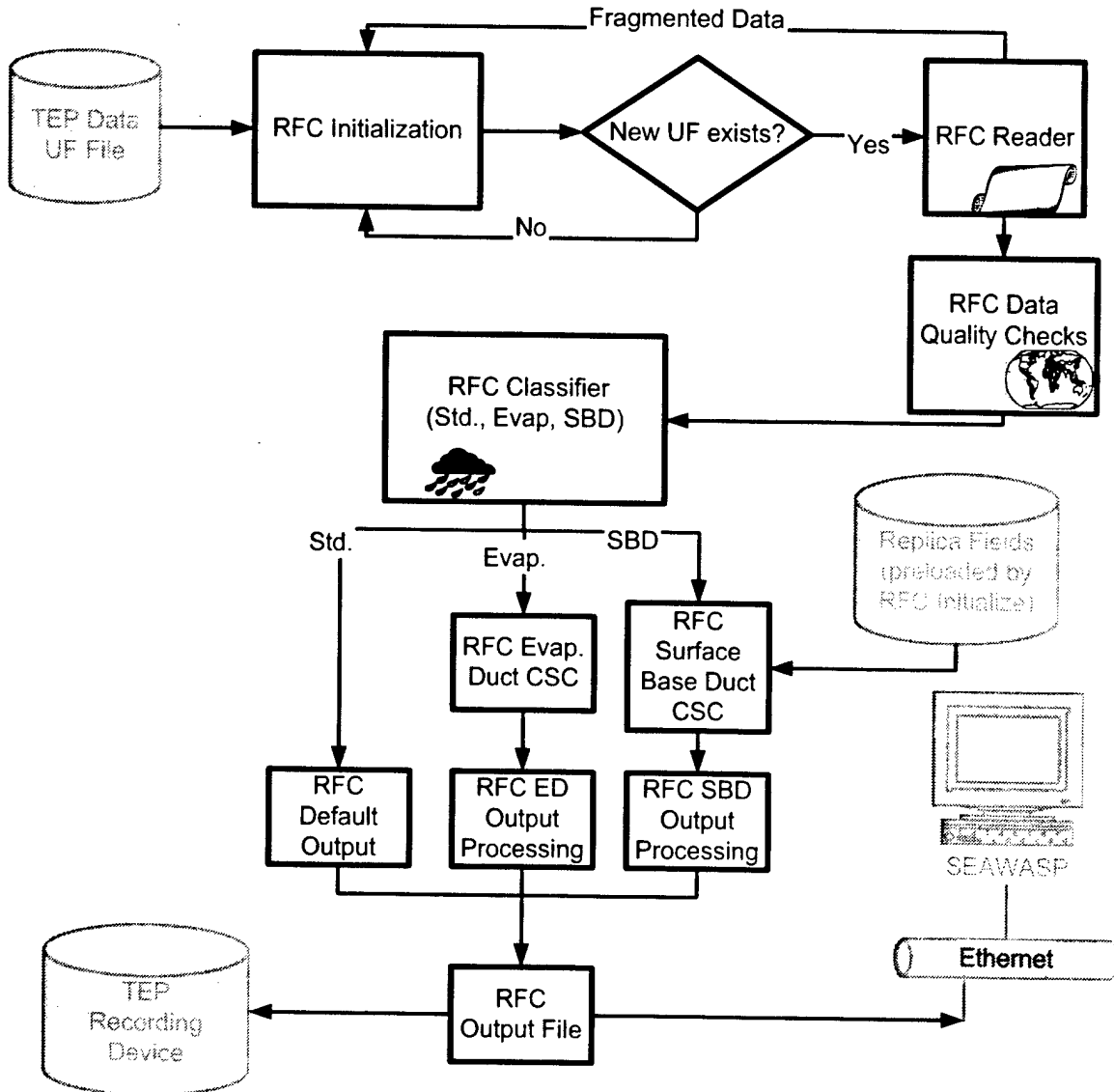

Figure 1. RFC CSCI program flow.

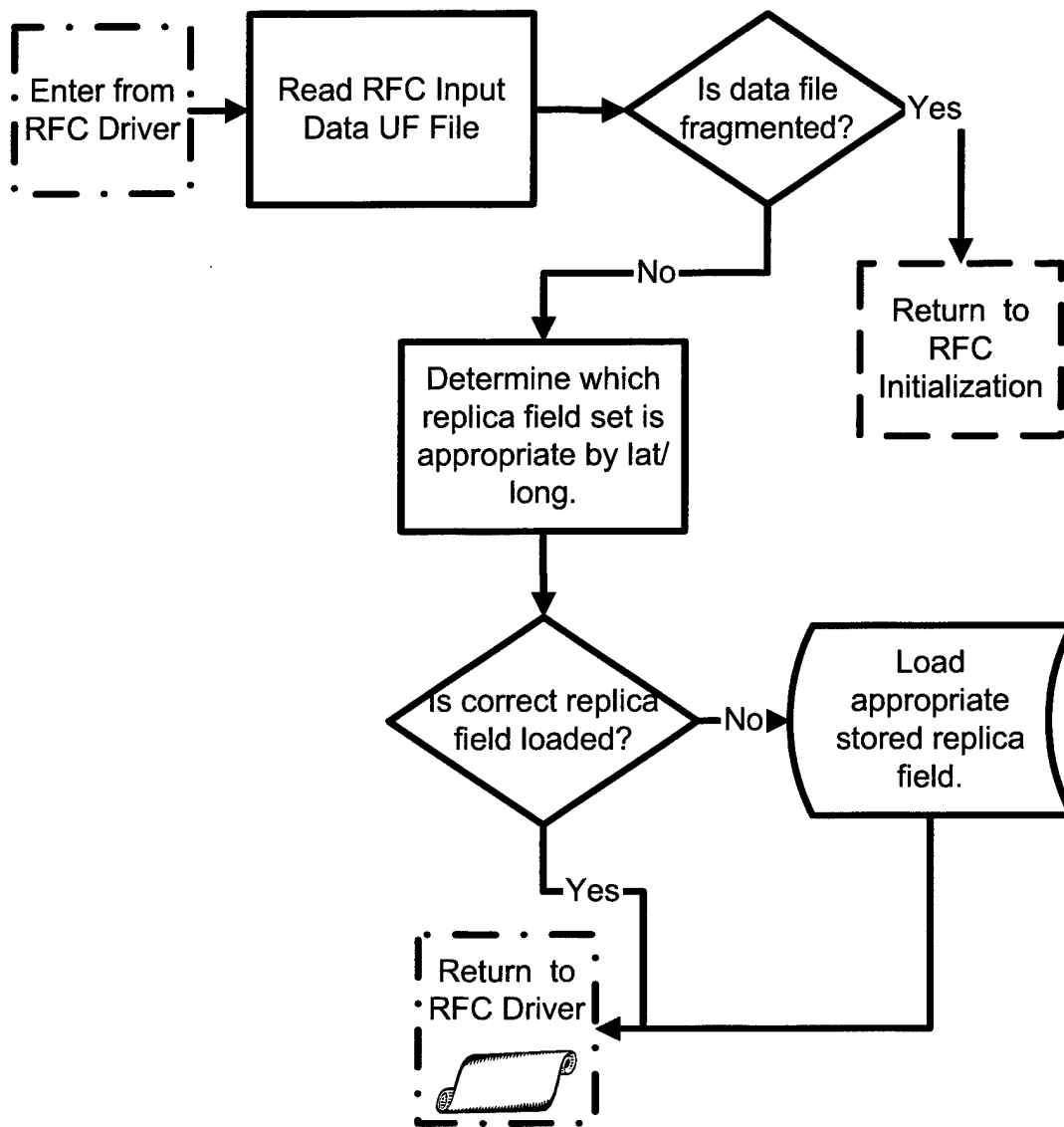

Figure 2. RFC Reader CSC program flow.



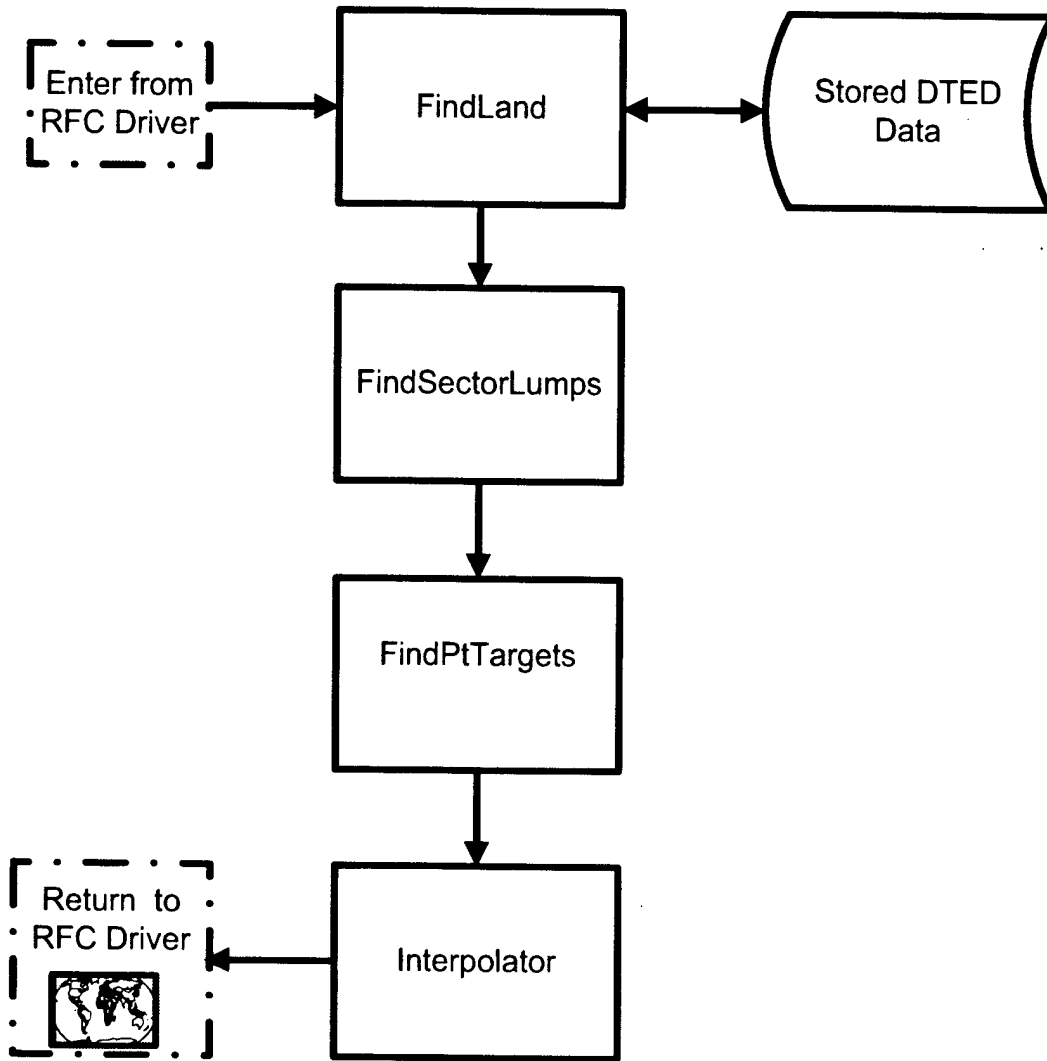

Figure 3. RFC Data Quality CSC program flow.

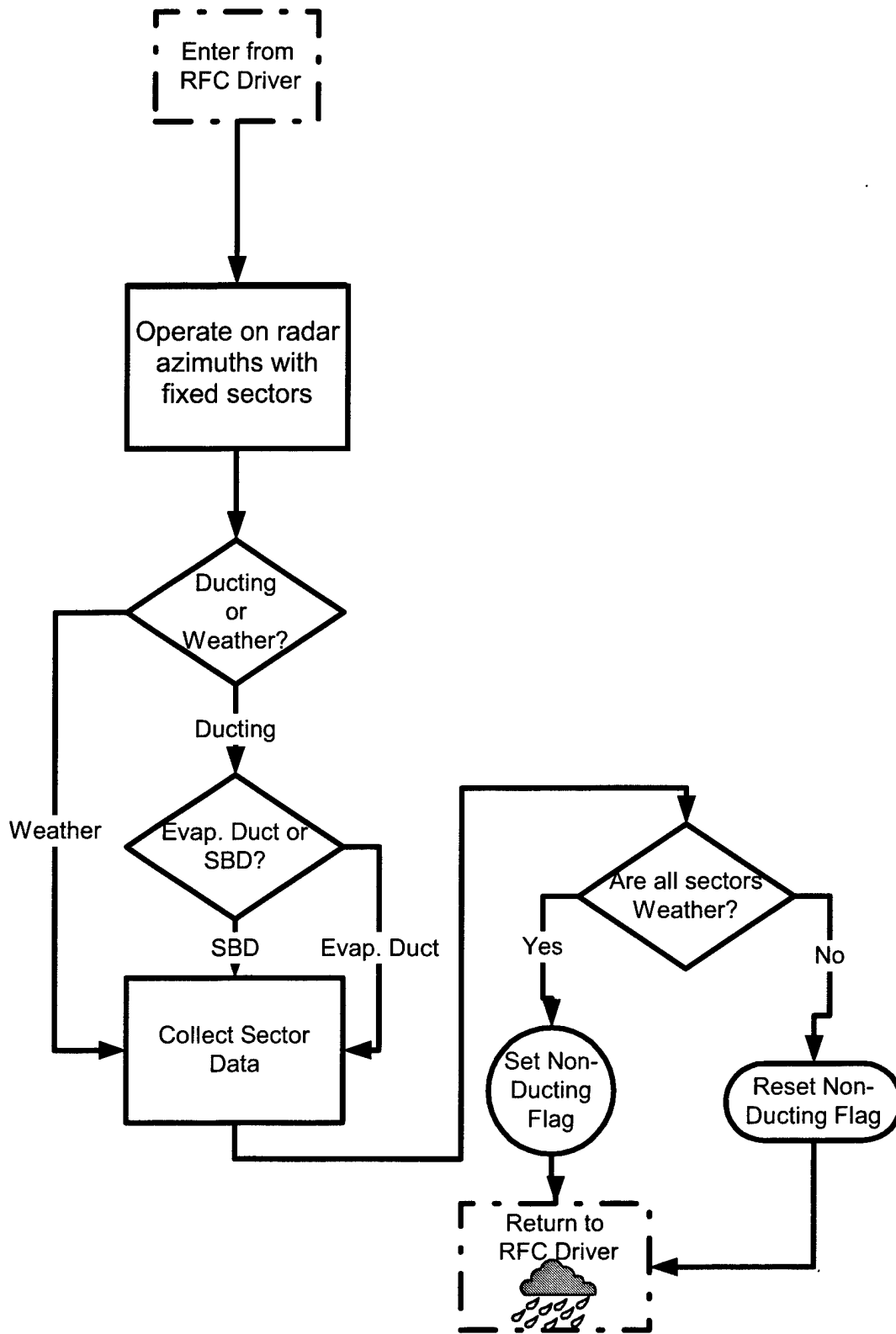

Figure 4. RFC Classifier CSC program flow.

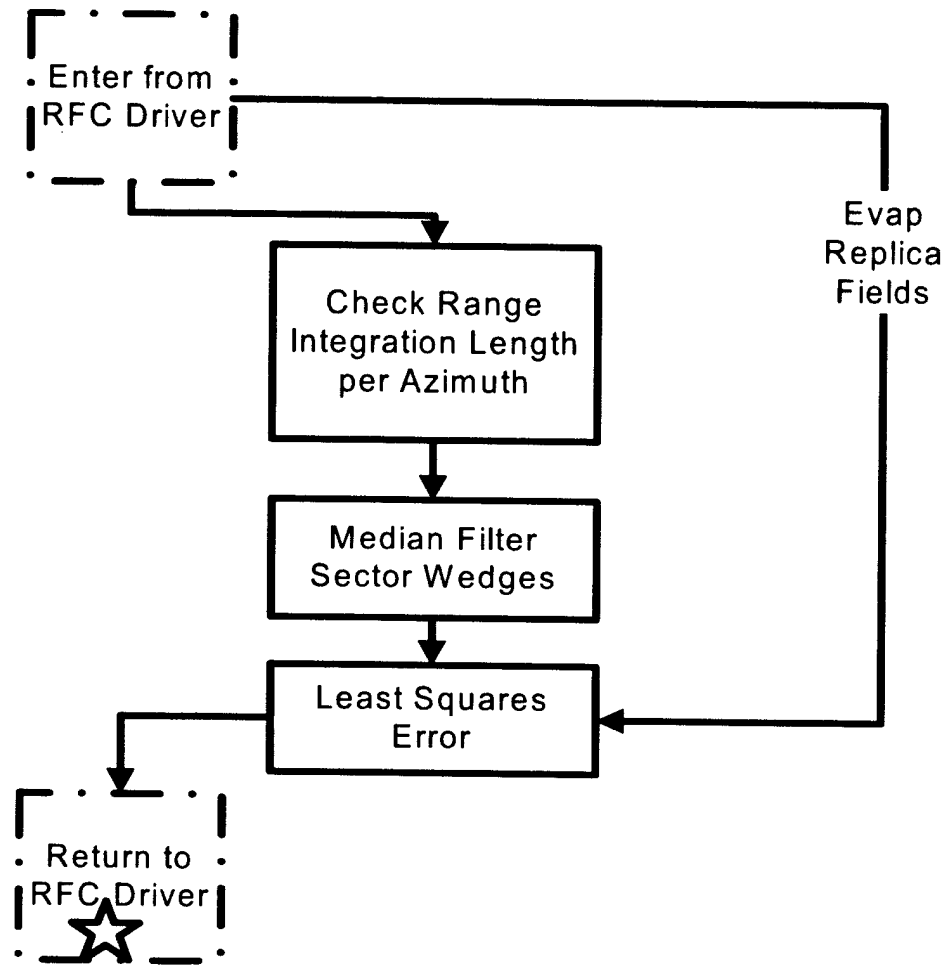

Figure 5. RFC ED CSC program flow.

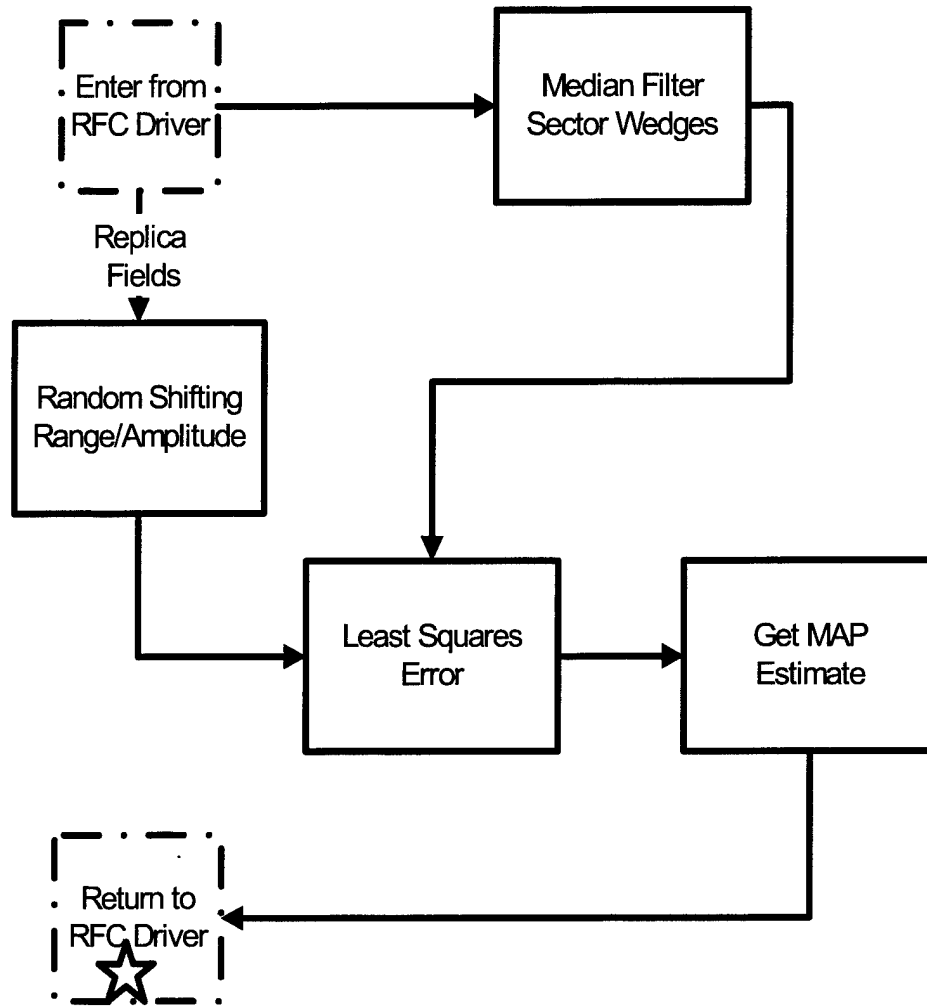

Figure 6. RFC SBD CSC program flow.

### 3.2.1 Refractivity from Clutter Initialization CSC.

The RFC Initialization CSC initializes registers, flags, and checks to see if a new UF file exists on the TEP system. During this time, the stored replica fields of evaporation and SBD refractive profiles are also loaded into memory.

#### 3.2.1.1 RFC Read Evaporation Profiles SU.

The Read Evaporation Profiles SU (software unit) reads the binary file EvapProfiles into memory. This file contains a precompiled set of evaporation duct replica fields that will be used in the RFC ED CSC.

#### 3.2.1.2 RFC Read SBD Profiles SU.

The Read SBD Profiles SU reads the binary file SBDProfiles into memory. This file contains a precompiled set of SBD replica fields that will be used in the RFC SBD CSC.

### 3.2.1.3 RFC Read Random Numbers SU.

The Read Random Numbers SU reads the binary file RandomNumbers into memory. This file contains a set of random numbers that will be used in the Generate Markov Shift SU.

### 3.2.1.4 RFC Generate Markov Shifts SU.

The RFC Generate Markov Shifts SU shifts in range and amplitude each SBD replica field. These newly generated replica fields are then used in the RFC SBD CSC.

## 3.2.2 Refractivity from Clutter Reader CSC.

The RFC Reader CSC reads a binary universal format (UF) file from the TEP weather data processor (WDP). The spectral moments for each dwell are stored for processing. It also checks to see if the file is fragmented (non-usable); if so, it then sends control back to the RFC Initialization CSC. If usable, the data are sent to the RFC Data Quality CSC.

### 3.2.1.1 RFC Read UF SU.

The Read UF SU reads the binary UF file from the TEP system and formats it into an observed data structure. It also checks to see if the file is not fragmented. If fragmented, control is sent back to the RFC Initialization CSC.

## 3.2.3 Refractivity from Clutter Data Quality CSC.

The RFC Data Quality CSC determines what limits and what parts of the data will be used in the RFC ED and RFC SBD algorithms. The data are then stored in memory for other algorithms to retrieve.

### 3.2.3.1 RFC FindLand SU.

The RFC FindLand SU uses Digital Terrain and Elevation Data (DTED) stored on a hard drive to find the range at which land begins. It stores that range in memory.

### 3.2.3.2 RFC FindSectorLumps SU.

The RFC Find Sector Lumps SU finds and stores all protrusions that could possibly be weather, surface-based ducting, or point targets. It also finds the range limit at which the RFC ED algorithm will compare the slope of the observed clutter power to the slope of the modeled clutter power from the replica fields.

### 3.2.3.3 RFC FindPtTargets SU.

The RFC Find Point Targets SU tests all the protrusions that the FindLumps SU flagged to see if they meet the criteria for a possible point target. Point targets are those radar returns that come from other ships at sea. If the protrusion is a point target, it is removed from the interpolated data. These data are then stored in memory.

#### 3.2.3.4 RFC Interpolator SU.

The RFC Interpolator SU interpolates the spectral moment to 1-kilometer-range bins. The interpolated spectral moments are reflectivity, signal-noise ratio (SNR), and radial velocity.

#### 3.2.4 Refractivity from Clutter Data Classifier CSC.

The RFC Classifier CSC determines whether the interpolated spectral moments have individual sectors of surface-based ducting, evaporation ducting, or non-ducting, such as weather, in them. If surface-based ducting is detected, and this information is sent to the RFC-SBD SU. If evaporation ducting is detected, this information is sent to the RFC ED SU. If weather is detected, this sector is then flagged as non-usable in the RFC SBD and RFC ED SUs. A standard atmospheric refractivity profile is output for that particular sector.

##### 3.2.4.1 RFC Data Classifier SU.

The RFC Data Classifier SU distinguishes between weather-related and surface-based ducting data. Data determined to be weather-related is no longer used in the RFC algorithms. Only surface-based ducting data are passed to the RFC SBD SU. Data uncorrupted by weather during the first 20 kilometers are then passed to the RFC ED SU.

#### 3.2.5 Refractivity from Clutter ED CSC.

The RFC ED CSC finds the evaporation duct height by comparing the slope of the interpolated clutter power to the slope of the modeled clutter power obtained from the refractivity replica fields that are precompiled and stored in memory. The best fitting ED replica refractivity profile is then output to an RFC Output File format, which is defined in the RFC–Shipboard Environmental Assessment WeApon System Performance (SEAWASP) Interface Design Specification document. This file is then written to the TEP recorder and passed to SEAWASP via Ethernet.

##### 3.2.5.1 RFC Find Mavg SU.

The RFC Find Mavg SU determines the range cutoff for each individual dwell within each sector used in the RFC InvertEvap SU. This range limitation could result from hitting the noise floor, point target, or weather.

##### 3.2.5.2 RFC Invert Evaporation SU.

The RFC Invert Evaporation SU compares the SNR spectral moment to the precompiled evaporation replica fields that were loaded during the RFC Initialization CSC. A least-squares estimation compared an integration length of no less than 4 kilometers.

#### 3.2.6 Refractivity from Clutter SBD CSC.

The RFC SBD CSC finds the set of refractivity replica fields that best match the fit of the interpolated clutter data to the modeled clutter data. The results are found for those individual sectors that were classified as SBD by the RFC Data Classifier CSC. The

best fit SBD refractive profile is then output to an RFC Output File, which is defined in the RFC-SEAWASP Interface Design Specification document. This file is then written to the TEP recorder and passed to SEAWASP via Ethernet.

#### 3.2.6.1 RFC Calculate Square Error SU.

The RFC Calculate Square Error SU calculates the squared error between the median filtered reflectivity spectral moment and the markov range and amplitude-shifted, precompiled SBD replica fields. This information is then passed to the RFC Get Map Estimate SU.

#### 3.2.6.2 RFC Get Map Estimate SU.

The RFC Get Map Estimate SU chooses the “best matching” field out of the set of precompiled SBD replica fields.

#### 3.2.7 RFC Output File.

The output file from the RFC algorithms shall consist of the following: (1) if an ED is detected, a neutral (ED) refractivity profile will be output; (2) if a SBD is detected, the best matching range-dependent SBD refractive profile for up to three sectors will be output; (3) if no ED or SBD is detected in any of the sectors, then a standard atmospheric refractivity profile will be output along with a flag as to the reason behind defaulting to a standard atmosphere; (4) the start bearing and stop bearing of each individual sector; (5) the confidence level (i.e., High, Medium, and Low) of each classified sector.

The format of the RFC Output File is documented in the Attachment to John Hopkins University (JHU)/Applied Physics Laboratory (APL) Technical Memo A2A-04-U-3-009, which is in the Appendix.

### 3.3 CSCI External Interface Requirements.

The RFC CSCI external data elements consist of the RFC Data Input UF file generated by the Lockheed Martin<sup>®</sup> TEP system.

#### 3.3.1 Interface Identification and Diagrams.

The RFC Initialization CSC polls the TEP system (reference Figure 1) to see if a new UF file was generated. Within this data file is information necessary for the RFC algorithms to process and calculate environmental refractivity profiles necessary for radar performance and assessment to the warfighter. The results from the RFC CSCI are then output to a file for retrieval by SEAWASP over the ship Ethernet and also output to the TEP recorder for storage. Table 1 lists the data elements required from the UF file for the RFC CSCI.

Table 1. RFC CSCI external data element requirements.

Name	Description	Type	Units	Bounds
Date/Time	UTC	Integer	N/A	None
Latitude	Ship Position	Float	Degrees	None
Longitude	Ship Position	Float	Degrees	None
DBZ	Reflectivity	Float	Decibels	None
SNR	Signal-Noise Ratio	Float	Decibels	None
SW	Spectrum Width	Float	meters/sec	None
VR	Radial Velocity	Float	meters/sec	None
MTI_1	1 <sup>st</sup> Pulse MTI	Float	decibels	None
MTI_2	2 <sup>nd</sup> Pulse MTI	Float	decibels	None
MTI_3	3 <sup>rd</sup> Pulse MTI	Float	decibels	None
Az	Azimuth	Float	degrees	0 to 360
EI	Elevation	Float	degrees	0 to 90
Range	Range Bins	Float	meters	None
Range Transition	RFA Range Switch Out	Float	meters	None
Transmit Power	Power Level	Integer	None	High/Low
WvType	Waveform	Integer	None	None
SPY-1 Doctrine	NA	NA	NA	NA

#### 3.4 CSCI Internal Interface Requirements.

Section 3.2 shows the relationship between the RFC CSCI and its five CSCs: RFC Reader, RFC Data Quality, RFC Classifier, RFC ED, and RFC SBD. The required internal interface between these five CSCs and the RFC CSCI is left to the designer. However, Table 2 should be used as a guide to the required internal interfaces in the CSCI.

#### 3.5 CSCI Internal Data Requirements.

The internal data requirements are left to the designer.

#### 3.6 Adaptation Requirements.

The TEP UF file will have parameters that indicate the waveform type transmitted by the radar, whether the radio frequency attenuation (RFA) was used during transmission, and when an RFC-dedicated dwell was transmitted.



### 3.7 Safety Requirements.

None.

### 3.8 Security and Privacy Requirements.

None.

### 3.9 CSCI Environment Requirements.

The RFC CSCI will operate on a bootable PowerPC<sup>®</sup> VME computer-on-a board in the TEP cabinet. The operating system is Linux and the application will be written in C language using Vector Signal Image Processing Library (VSIPL) functions. To use VSIPL functions on a given platform, a VSIPL-compliant library will be available for particular hardware. A tool-set (linker) will also be available for the operating system.

### 3.10 Computer Resource Requirements.

#### 3.10.1 Computer Hardware Requirements.

The RFC CSCI will reside on a bootable PowerPC<sup>®</sup> VME board. The DTED database and refractivity replica fields for ED and SBD will reside on a hard drive in the TEP processor cabinet.

#### 3.10.2 Computer Hardware Resource Utilization Requirements.

Table 2 lists the storage requirements for the databases used in the RFC CSCI.

Table 2. Database storage requirements.

Database	Storage	% Auxiliary Storage
ED replica fields	25 KB	0
SBD replica fields	75 MB	0
Random numbers	300 Kb	0
DTED	5 GB	0

#### 3.10.3 Computer Software Requirements.

The software requirements consist of using a middleware that is open architecture (OA)-compliant. This middleware allows RFC application portability between hardware systems without major code changes. VSIPL is the OA-compliant middleware used for the RFC application.

#### 3.10.4 Computer Interface Requirements.

Lockheed Martin® will incorporate the interface requirements between RFC-TEP in TEP system documentation. The Interface Design Specification document will incorporate the interface requirements between RFC-SEAWASP.

#### 3.11 Software Quality factors.

The primary required quality factors can be divided into the three categories: design, performance, and adaptation.

##### 3.11.1 Design.

The quality factors for the design category should include correctness, maintainability, and verifiability. Correctness describes the extent to which the RFC CSCI conforms to its requirements and is determined from the following criteria: completeness, consistency, and/or traceability. Maintainability specifies the effort required to locate and fix an error in the RFC CSCI. Maintainability is determined from the following criteria: consistency, modularity, and self-documentation. Verifiability characterizes the effort required to test the RFC CSCI to ensure that it performs its intended function. Verifiability is determined from the following criteria: modularity and self-documentation.

##### 3.11.2 Performance.

The quality factor for the performance category is reliability, which shows the confidence that can be placed in the RFC CSCI calculations. Reliability is determined from the following criteria: accuracy and consistency.

The Naval Surface Warfare Center (NSWC) Dahlgren Division uses Wallops Mission 2000 experimental data (Table 3) determines the accuracy and consistency criteria for the RFC SBD SU. Experimental data collected using the TEP system when it was demonstrated on USS O'Kane and USS Normandy (Figure 7) determines the accuracy and consistency criteria for the RFC ED SU.

##### 3.11.3 Adaptation.

None.

#### 3.12 Design and Implementation Constraints.

VSIPL functions and libraries are used as an open architecture for the software.

#### 3.13 Personnel-Related Requirements.

None.

#### 3.14 Training-Related Requirements.

None.

3.15 Logistics-Related Requirements.

SSC San Diego Code 2858 will handle all logistics.

3.16 Other Requirements.

None.

3.17 Packaging Requirements.

None.

3.18 Precedence and Criticality of Requirements.

None.

4.0 Qualification Provisions.

None.

5.0 Requirements Traceability.

None.

6.0 Notes.

6.1 Glossary.

CSC–Computer Software Component

CSCI–Computer Software Configuration Item

DTED–Digital Terrain Elevation Data

ED–Evaporation Duct

JHU/APL–Johns Hopkins University/Applied Physics Laboratory

OA–Open Architecture

RFC–Refractivity from Clutter

SBD–Surface-Based Duct

SU–Software Unit

TEP–Tactical Environmental Processor

UF–Universal Format

VME–VERSA Module Eurocard

VSIPL–Vector, Signal, and Image Processing Library

Table 3. Test results from IV&V testing by NSWC Dahlgren Division.

Confidence Level	Band	RFC	Rocketsonde	Range-Dependent Helicopter	Single Profile Helicopter	Free Space	Standard Atmosphere
50%	S	4.0	5.1	3.4	3.7	4.8	15.7
	C	4.8	3.9	3.5	3.5	4.8	17.7
	X	5.3	4.9	3.7	3.7	3.7	10.9
90%	S	14.3	16.6	10.2	12.2	13.1	51.2
	C	15.9	18.3	12.0	12.3	13.3	55.4
	X	15.4	13.9	11.7	12.3	10.5	51.1

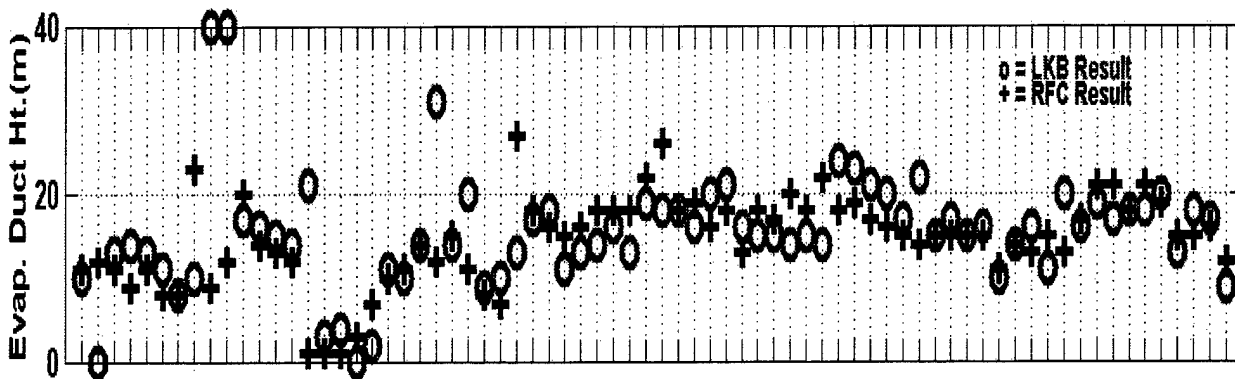

Figure 7. Test results from USS Normandy.

## 7.0 Appendix

### Attachment to JHU/APL Technical Memo A2A-04-U-3-009

#### PURPOSE

This Interface Design Specification (IDS) defines the digital interface between the Refractivity From Clutter (RFC) Module in the Tactical Environmental Processor (TEP) Open Architecture (OA) system, and the Shipboard Environmental Assessment WeAPON System Performance (SEAWASP) system. The IDS has been specifically designed to parallel the interface between the data server process of the Shipboard Meteorological and Oceanographic Observation System (SMOOS) and SMOOS clients, in order to facilitate interface development and to facilitate the use of SMOOS/SEAWASP to validate RFC algorithms.

#### Network Interface Protocol

This section describes the network interface protocol used to manage the flow and processing of information between the TEP RFC module and SEAWASP.

The interface has two sides: a data server residing in the RFC Module and a data client residing in the SEAWASP processor.

### General Protocol Features

The server communicates with the client using the TCP/IP protocol via port 9050 using connected sockets. If the client is external to the TEP processors' cabinet, the client and server processes will require an Ethernet LAN connection.

### Connection Establishment and Validation

The client connects to the server through a TCP stream socket. Once the client establishes connection with the server, it has 10 seconds to identify itself by sending Message Type (MT) 2000. If identification is valid and the client has enabled at least one interface message, the server replies with MT 1000 to indicate that the connection has been accepted and the server is ready for data transactions with the client. If identification fails or the client does not enable any messages within the allowable time frame, the server replies with MT 1001 (connection rejected), closes the socket, terminates the connection, and remains in listening mode waiting for a new connection.

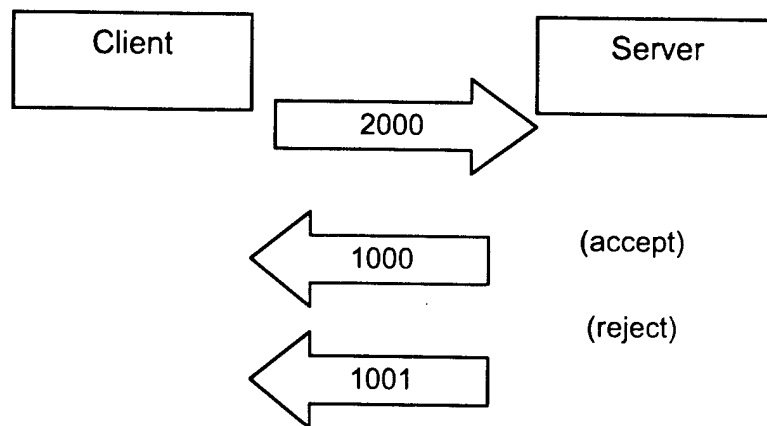

Figure-1. Establishment of Connection.

### Message Exchange

Once a valid connection has been established, the server will periodically send the client all enabled interface messages.

The client can enable or disable interface messages by sending a new message of MT 2001 to the server. The server enables a certain message when the corresponding bit in MT 2001 is set to 1, and continues sending it until the connection is disabled or the client asks to stop receiving the message. The client requests the server to stop sending messages of a specific type by setting the appropriate bit to 0 in MT 2001.

## Message Format

All data messages for communications between the server and the client consist of five distinct data fields: Message Length, Message Type, Message Data, Message Time, and Message Terminator.

Table-1. Message Format.

MSG LENGTH	MSG TYPE	MSG DATA	MSG TIME	MSG TERMINATOR
4 bytes, uint	2 bytes, ushort	Variable	4 bytes, uint	2 bytes, '##'

- **MSG LENGTH** – This binary field is four bytes long and indicates message length in bytes. This field includes only the length of the data contained in **MSG DATA** field.
- **MSG TYPE** – This binary field is two bytes long and identifies type of message. Server-to-client message types start at 1000 while client-to-server message types start at 2000.
- **MSG DATA** – This variable field contains the actual data specific to each message type. The data in this field can be either binary or ASCII depending on message type. All data is in Network Byte Order (NBO) unless noted otherwise.
- **MSG TIME** – (This field is included for compatibility with a “SMOOS-like” system, and can be set to zero, as the data time of interest to SEAWASP will be contained in the **MSG DATA** field.) This binary field is four bytes long and indicates the server’s or client’s system real-time-clock, in milliseconds, at the time the message was written to the socket. The time is reset to zero when the METOC Processor and this server is restarted. Since this time is stored as a four byte data field, to avoid overflow, it will wrap around to zero if the system is run continuously for 49.7 days
- **MSG TERMINATOR** – This ASCII field is two bytes long and indicates end of message. The two bytes in this field are Sharp characters ('##').

## Network Byte Order

Data fields that have a data type of ushort, int, uint, float, double or double uint are converted into network byte order prior to sending the message to the client.

ushort – two-byte unsigned value

int – four-byte integer value

uint – four-byte unsigned integer value

float – four-byte floating-point value

double – eight-byte floating-point value

double uint – eight-byte unsigned integer value

byte – unsigned eight-bit value

char – ASCII NULL terminated string

---

## Message Data Description

The following sections define the **MSG DATA** field format for each message type. The common definitions of the fields comprising each message type are given in Table 2. Message-specific definitions are provided following the message’s field definition table.

Table-2. Data Field Definitions.

Field Type	Range and Units <sup>1</sup>	Format/Description
Alt MSL	0 to 65,000 feet	Altitude as nnnnn which is the measured or calculated height above mean sea-level
Confidence	Table 3	Confidence codes.
Range	0 to ??? NMI	Profile Range to xxx.x nmi
Duct Height	0 to ??? feet	Evaporation Duct Height as nnn.n above sea level
Latitude	-90 to +90 degrees	Latitude as ±nn.nnnn where + indicates North and – indicates South
Longitude	-180 to +180 degrees	Longitude as ±nnn.nnnn where + indicates East and – indicates West
Refractivity	M-units	Modified Refractivity as nnn.nn
UTC	Table 4	UTC (Z) date and time as DateTime Data Type using WindowsNT "Monrovia, Casablanca" time zone setting

Table-3. Confidence Field Codes.

Value	Description
0	Low
1	Medium
2	High
255	Unknown or no Data Available

Table-4. UTC Field Type Subfields.

SubField Name	Description <sup>2</sup>	Beg:Len	Data Type
a. Year	4-digit year (Y2K compliant)	0:4	int
b. Month	month of year (1 to 12)	4:4	int
c. Day	day of month (1 to 31)	8:4	int
d. Hour	hour of day (24-hour clock)	12:4	int
e. Minutes	minutes of hour (0 to 59)	16:4	int
f. Seconds	seconds of minute (0 to 59)	20:4	int
g. Milliseconds	milliseconds of second	24:4	int

<sup>1</sup> The absence of a valid float data type value is indicated by a value equal to -9999.0. The absence of a valid int data type value is indicated by a value equal to -9999.

<sup>2</sup> The absence of a valid UTC is indicated by all subfield values equal to 0.

## Server-to-Client Messages

The server may send the following messages to the client:

- Client Connection Accepted (Type 1000) – page 19
- Client Connection Refused (Type 1001) page 19
- Bearing-Range-Altitude-Refractivity Profile Data (Type 1023) – page 20
- Error (Type 1014) – page 21
- Abort (Type 1015) – page 21

### Client Connection Accepted (Type 1000)

This message is sent to the client in response to the client's sending message type 2000 followed by 2001, indicating that the request to become a client of this server has been granted, and the server is now ready for data transactions. Prior to sending this message, the server ensures that the client has properly identified itself (via message type 2000) and has enabled at least one interface message (via message type 2001) within 10 seconds after establishing connection. This message has the following format:

Table-5. Client Connection Accepted Message.

Field Name	Field Type	Beg:Len	Data Type
a. Connection Accepted	[1]	0:var	char
b. Date/Time	UTC	var:28	DateTime

[1] This message data field has a variable length, formatted as a NULL-terminated ASCII character string, which identifies the server's software version. The field length shall not exceed 200 bytes including the NULL. The byte order is not applicable.

### Client Connection Refused (Type 1001)

This message indicates that the request to become a client of this server has been refused due to the fact that the client failed to follow the protocol or for lack of connection resources (too many clients already connected to the server). The protocol requires the client to identify itself and to enable at least one interface message within 10 seconds after establishing connection. This message has the following format:

Table-6. Client Connection Refused Message.

Field Name	Field Type	Beg:Len	Data Type
a. Connection Refused	[1]	0:var	char
b. Date/Time	UTC	var:28	DateTime

[1] This message data field has a variable length, formatted as a NULL-terminated ASCII character string, which indicates the reason for refusing client connection. The field length shall not exceed 200 bytes including the NULL. The byte order is not applicable.



Bearing-Range-Altitude-Refractivity Profile Data (Type 1023)

This message provides modified refractive index profile data. If enabled, the RFC Module sends this message to the client every 15 minutes or when a new refractivity calculation has been successfully completed. This message has the following format:

Table-7. Bearing-Range-Altitude-Refractivity Profile Data Message.

Field Name	Field Type	Beg:Len	Data Type
a. Profile Date/Time	UTC	0:28	Date/Time
b. Profile Latitude	Latitude	28:4	float
c. Profile Longitude	Longitude	32:4	float
d. Profile Quality	Table 8	36:4	int
e. Profile Type	Table 9	40:4	int
f. Profile Start Bearing	Degrees	44:4	float
g. Profile Stop Bearing	Degrees	48:4	float
h. Evaporation Duct Height	Alt MSL	52:4	float
i. NRanges	[1]	56:4	int
j. Range(1)	NMI	60:4	float
k. NAlts(1)	[2]	64:4	int
l. Altitude(1)	Alt MSL	68:4	float
m. Modified Refractive Index(1)	Refractivity	72:4	float
m. ...		...	
n. Altitude(NAlts(1))	Alt MSL	68+8(NAlts(1)-1):4	float
o. Modified Refractive Index(NAlts(1))	Refractivity	72+8(NAlts(1)-1):4	float
p. ...		...	
q. Range(NRanges)	NMI	68+[8(NAlts(1))]+[8+8(NAlts(2))+...]:4	float
r. NAlts(NRanges)	[2]	Etc.	int
s. Altitude(1)	Alt MSL		float
t. Modified Refractive Index(1)	Refractivity		float
u. ...		...	
v. Altitude(NAlts(NRanges))	Alt MSL		float
w. Modified Refractive Index(NAlts(NRanges))	Refractivity		float

[1] NRanges is the number of range-dependent profiles in this azimuth sector

[2] NAlts is the number of data points in the modified refractive index profile for this range

Table-8. Profile Quality Codes.

Bit	Description
0...7	Data Confidence per Table 3
8...31	Reserved

Table-9. Profile Type.

Value	Description
1	Evaporative Duct Profile
2	Surface-Based Duct Profile
3	Profile calculated using Standard Atmosphere
255	Unknown or No Data Available (Missing)

#### Error (Type 1014)

The server sends this message to the client to indicate that a non-fatal error condition has been detected by server. Always enabled, the server sends this message to the client upon server non-fatal error detection. This message has the following format:

Table-10. Error Message.

Field Name	Field Type	Beg:Len	Data Type
a. Error Message	[1]	0:var	char
b. Date/Time	UTC	var:28	DateTime

[1] This message data field has a variable length, formatted as a NULL-terminated ASCII character string, which identifies the error condition detected by the server. The field length shall not exceed 200 bytes including the NULL. The byte order is not applicable.

#### Abort (Type 1015)

This message is sent to the client to indicate that a fatal error condition has been detected by the server, which will result in the server's terminating processing. This message is sent to client prior to closing the socket connection. Always enabled, the server sends this message to the client upon fatal error detection by the server. This message has the following format:

Table-11. Abort Message.

Field Name	Field Type	Beg:Len	Data Type
a. Abort Message	[1]	0:var	char
b. Date/Time	UTC	var:28	DateTime

[1] This message data field has a variable length, formatted as a NULL-terminated ASCII character string, which identifies the error condition detected by the server. The field length shall not exceed 200 including the NULL. The byte order is not applicable.

## Client-to-Server Messages

The client may send the following messages to the server:

- Request to Become a Client (Type 2000)

### Request to Become a Client (Type 2000)

This is the first message sent by the client after establishing a socket connection with the server. This message identifies the requester. If the server cannot honor this request, it will reply with the Client Connection Refused (Type 1001) message. If the server accepts this request, it will reply with the Client Connection Accepted (Type 1000) message. This message is sent upon establishment of communications with the server. This message has the following format:

Table-12. Request to Become a Client Message.

Field Name	Field Type	Beg:Len	Data Type
a. Request to become a client	[1]	0:var	char
b. Date/Time	UTC	var:28	DateTime

[1] This message data field has a variable length, formatted as a NULL-terminated ASCII character string, which identifies the client and the software version running on the client. The field length shall not exceed 200 bytes including the NULL. The byte order is not applicable.

**REPORT DOCUMENTATION PAGE**

Form Approved  
OMB No. 0704-01-0188

The public reporting burden for this collection of information is estimated to average 1 hour per response, including the time for reviewing instructions, searching existing data sources, gathering and maintaining the data needed, and completing and reviewing the collection of information. Send comments regarding this burden estimate or any other aspect of this collection of information, including suggestions for reducing the burden to Department of Defense, Washington Headquarters Services Directorate for Information Operations and Reports (0704-0188), 1215 Jefferson Davis Highway, Suite 1204, Arlington VA 22202-4302. Respondents should be aware that notwithstanding any other provision of law, no person shall be subject to any penalty for failing to comply with a collection of information if it does not display a currently valid OMB control number.

**PLEASE DO NOT RETURN YOUR FORM TO THE ABOVE ADDRESS.**

<b>1. REPORT DATE (DD-MM-YYYY)</b> 08-2004		<b>2. REPORT TYPE</b> Technical		<b>3. DATES COVERED (From - To)</b>	
<b>4. TITLE AND SUBTITLE</b>  SOFTWARE AND FUNCTIONAL REQUIREMENTS SPECIFICATION FOR THE REFRACTIVITY FROM CLUTTER CSCI				<b>5a. CONTRACT NUMBER</b>	
				<b>5b. GRANT NUMBER</b>	
				<b>5c. PROGRAM ELEMENT NUMBER</b>	
<b>6. AUTHORS</b>  L. J. Wagner L. T. Rogers				<b>5d. PROJECT NUMBER</b>	
				<b>5e. TASK NUMBER</b>	
				<b>5f. WORK UNIT NUMBER</b>	
<b>7. PERFORMING ORGANIZATION NAME(S) AND ADDRESS(ES)</b>  SSC San Diego San Diego, CA 92152-5001				<b>8. PERFORMING ORGANIZATION REPORT NUMBER</b>  TD 3186	
<b>9. SPONSORING/MONITORING AGENCY NAME(S) AND ADDRESS(ES)</b>  Space and Naval Warfare Systems Command (PMW-150) 4301 Pacific Highway San Diego, CA 92110-3127				<b>10. SPONSOR/MONITOR'S ACRONYM(S)</b> SPAWAR	
				<b>11. SPONSOR/MONITOR'S REPORT NUMBER(S)</b>	
<b>12. DISTRIBUTION/AVAILABILITY STATEMENT</b>  Approved for public release; distribution is unlimited.					
<b>13. SUPPLEMENTARY NOTES</b>  This is a work of the United States Government and therefore is not copyrighted. This work may be copied and disseminated without restriction. Many SSC San Diego public release documents are available in electronic format at <a href="http://www.spawar.navy.mil/sti/publications/pubs/index.html">http://www.spawar.navy.mil/sti/publications/pubs/index.html</a> .					
<b>14. ABSTRACT</b>  This document specifies the software functional requirements that must be met by the RFC System. The input software requirements are discussed and the internal structure of the RFC CSCI is described as it relates to computer software configuration item (CSCI) capability.					
<b>15. SUBJECT TERMS</b> Mission Area: Ocean Surveillance refractivity from clutter                      surface-based ducts                      Tactical Environmental Processor Computer software configuration item      evaporation ducts                      software and functional requirements					
<b>16. SECURITY CLASSIFICATION OF:</b>			<b>17. LIMITATION OF ABSTRACT</b>	<b>18. NUMBER OF PAGES</b>	<b>19a. NAME OF RESPONSIBLE PERSON</b>
<b>a. REPORT</b>	<b>b. ABSTRACT</b>	<b>c. THIS PAGE</b>			L. J. Wagner
U	U	U	UU	34	<b>19b. TELEPHONE NUMBER (Include area code)</b> (619) 553-1428

## INITIAL DISTRIBUTION

20012	Patent Counsel	(1)
202753	Archive/Stock	(4)
202752	Library	(2)
2027	G. C. Pennoyer	(1)
20275	R. Roessler	(1)
202753	D. Richter	(1)
2858	L. T. Rogers	(12)
2858	L. J. Wagner	(11)

Defense Technical Information Center  
Fort Belvoir, VA 22060-6218 (4)

SSC San Diego Liaison Office  
C/O PEO-SCS  
Arlington, VA 22202-4804 (1)

Center for Naval Analyses  
Alexandria, VA 22311-1850 (1)

Office of Naval Research  
ATTN: NARDIC  
Philadelphia, PA 19111-5078 (1)

Government-Industry Data Exchange  
Program Operations Center  
Corona, CA 91718-8000 (1)

Office of Naval Research  
Arlington, VA 22043 (1)

Space and Naval Warfare Systems Command  
San Diego, CA 92110-3127 (2)

Naval Research Laboratory Monterey  
Monterey, CA 93943-5502 (1)

Naval Surface Warfare Center  
Dahlgren Division  
Dahlgren, VA 22448-5100 (1)

Johns Hopkins University  
Applied Physics Laboratory  
Laurel, MD 20723-6099 (2)

University of Washington  
Applied Physics Laboratory  
Seattle, WA 98105-6698 (1)

Maritime Systems & Sensors  
Moorestown, NJ 08057 (3)