Marine Physical Laboratory

Bubble and Wave Measurements for the Rough Evaporation Duct (RED) Experiment

Principal Investigator(s) Eric J. Terrill

Supported by the
Office of Naval Research
Grant Number: N00014-01-1-0701

Final Report

August 2003

DISTRIBUTION STATEMENT A
Approved for Public Release
Distribution Unlimited

University of California, San Diego
Scripps Institution of Oceanography

20040809 098

REPORT DOCUMENTATION PAGE			<i>Form Approved OMB No 0704-0188</i>	
Public reporting burden for this collection of information is estimated to average 1 hour per response, including the time for reviewing instructions, searching existing data sources, gathering and maintaining the data needed, and completing and reviewing the collection of information. Send comments regarding this burden estimate or any other aspect of this collection of information, including suggestions for reducing this burden, to Washington Headquarters Services, Directorate for Information Operations and Reports, 1215 Jefferson Davis Highway, Suite 1204, Arlington, VA 22202-4302, and to the Office of Management and Budget, Paperwork Reduction Project (0704-0188), Washington, DC 20503.				
1. Agency Use Only (Leave Blank).	2. Report Date. August 13, 2003	3. Report Type and Dates Covered. Final Report		
4. Title and Subtitle. Bubble and Wave Measurements for the Rough Evaporation Duct (RED) Experiment			5. Funding Numbes. N00014-01-1-0701	
6. Author(s). Eric J. Terrill			Project No. Task No.	
7. Performing Monitoring Agency Name(s) and Address(es). University of California, San Diego Marine Physical Laboratory Scripps Institution of Oceanography 291 Rosecrans Street San Diego, CA 92106			8. Performing Organization Report Number.	
9. Sponsoring/Monitoring Agency Name(s) and Address(es). Office of Naval Research Department of the Navy 800 North Quincy Street Arlington, VA 22217-5660 Atten: Ronald J. Ferek, ONR 322MM			10. Sponsoring/Monitoring Agency Report Number.	
11. Supplementary Notes.				
12a. Distribution/Availability Statement. Approved for public release; distribution is unlimited.			12b. Distribution Code.	
13. Abstract (Maximum 200 words). The long term goals of this project are to better understand the influence of air-sea interaction processes on electromagnetic and electrooptical signal propagation including surface waves, spray generation, and the atmospheric conditions which lead to near-surface ducting of the signal in the atmosphere				
14. Subject Terms. signal propagation, surface gravity field, bubble size distribution,			15. Number of Pages. 4	
			16. Price Code.	
17. Security Classification of Report. Unclassified	18. Security Classification of this Page. Unclassified	19. Security Classification of Abstract. Unclassified	20. Limitation of Abstract. None	

BUBBLE AND WAVE MEASUREMENTS FOR THE ROUGH EVAPORATION DUCT (RED) EXPERIMENT

Eric J. Terrill
Scripps Institution of Oceanography
mail code 0213
La Jolla, CA 92093-0213
phone: (858) 822-3101 fax (858) 534-7132 email: et@mpl.ucsd.edu

W. Kendall Melville
Scripps Institution of Oceanography
mail code 0213
La Jolla, CA 92093-0213
phone: (858) 534-0478 fax (858) 534-7132 email: kmelville@ucsd.edu

Award #: N00014-01-1-0701

LONG-TERM GOALS

The long term goals of this project are to better understand the influence of air-sea interaction processes on electromagnetic and electrooptical signal propagation including surface waves, spray generation, and the atmospheric conditions which lead to near-surface ducting of the signal in the atmosphere.

OBJECTIVES

Electromagnetic and electro-optical propagation near the ocean's surface is dependent on both the atmospheric conditions and the interaction of the propagated signal with the ocean waves. Factors which impact the nature of the propagation of these signals include the profiles of mean and turbulent fluctuations of humidity, temperature, wind speed, ocean surface waves, and aerosols. While the average and fluctuating atmospheric conditions determine the ducting, scintillation, and attenuation of the EM/EO signals, the importance of the ocean waves are two-fold since they provide the bottom boundary condition which scatter the signal as well as modulate the marine atmospheric boundary layer. In addition, marine aerosols generated by both active wave breaking / whitecapping and bubbles bursting at the sea surface will also impact visible and infrared propagation by the aerosol's ability to modify the extinction of the signal. The additional air-sea heat fluxes which result from evaporation of the water component of the aerosols will also impact the near-surface EM propagation duct. It is anticipated that critical to understanding the source function of the aerosols will be an understanding of the spatial and temporal statistics of both the flux of bubbles across the sea-surface and the moments of the kinematics of active whitecapping. Despite the close coupling between these two aerosol generation mechanisms, we make the distinction between the two sources since the two processes will contribute to different size regimes in the total aerosol size distribution. While it is expected that bubbles bursting at the ocean's surface are the dominant source for the smaller particles, the larger aerosols will be introduced to the atmosphere by the active breaking region of the whitecap. The larger aerosol sizes generated by this mechanism will most likely overlap in size ranges with the sizes generated by the bubbles and will extend up through the sea spray regime. Advancements in

measurement technology now allow us to measure these processes independently and couple them to the overlying wind and wave field.

APPROACH

The Rough Evaporation Duct (RED) Experiment was conducted offshore Oahu, HI onboard R/P FLIP from mid-August through mid-September 2001. The electromagnetic and electrooptical signal propagation measurements conducted during the experiment were supported by a wide suite of atmospheric and marine aerosol measurements which will be used for developing coupled meteorological EM/EO propagation models. Our participation provided an added capability of measurements of the subsurface bubble field, whitecap kinematics, and the surface gravity wave field in support of this experiment to provide an increased understanding of the influence of air-sea interaction processes that are relevant to EM/EO signal propagation near the ocean's surface. Our participation in RED was also supported by objectives defined by the Hyperspectral Coupled Ocean Dynamics Experiment (HYCODE), a field sampling program designed for measurements of bubbles and IOPs over a range of sea states. The variability of the bubble field that results from wave breaking necessitates that the bubble and optical field be sampled with sufficient temporal and spatial resolution. Acoustic techniques that have been refined over the last decade (Terrill & Melville, 2000) are used for measuring the bubbles in conjunction with optical measurements to directly measure the bubble field and the resulting optical scattering. The complementary nature of the two measurement programs were brought together during the RED field effort, with the results used in both programs.

WORK COMPLETED

The following measurements were made as part of the RED campaign:

Bubble size distributions and their temporal / spatial statistics. – Bubble size distributions were measured at several different depths using an array of acoustic bubble sizing instrumentation (Terrill & Melville 2000) deployed off the starboard boom of FLIP. This instrumentation was co-located with Jeffrey Reid's aerosol sampling equipment located directly above the water's surface. The bubble sizing instrumentation allows us to resolve bubble radii between 15~1600 μ m over void fractions ranging from $O(10^{-8})$ – $O(10^{-3})$ at sampling rates of a few Hz. The high sampling rate of the instrumentation allows the inherent variability of the bubble field that results from intermittent breaking to be resolved. To determine the total aerosol flux from the sea surface, the spatial distribution of the bubbles in the upper ocean must also be measured. This will be measured directly using high-frequency, range-gated sonars that will be orientated upward and horizontal looking. While the signal returned from the sonar is sensitive to an integral of the entire bubble size distribution (the second moment of the size distribution in this case), range-gated techniques allow us to resolve spatial scales of the bubble field. Two different sonars will be deployed upward looking from FLIP, one fixed to the hull and one off the starboard boom to resolve the vertical bubble length scales from $O(10)$ cm to $O(20)$ m.

Whitecap kinematics and size statistics. – Whitecap kinematics were measured from an aerial platform using the Modular Aerial Sensing System (MASS). The MASS system is a visible imaging (an IR imager has also been used) system which measures the kinematics of wave breaking. A bore sighted laser altimeter is also deployed for direct measurement of the waves. The equipment essentially

consists of video and IR cameras with a 6 d-o-f motion package. Originally developed under ONR funding for the Shoaling Waves Experiment (SHOWEX), the system has been deployed numerous times from several different light aircraft to minimize deployment costs. The principal measurement of the system is the statistical distribution of the average length of breaking front over an increment of speed per unit surface area. Using geometric similarity of the shape of the whitecap and Froude scaling, the area swept out by breaking waves per unit area per unit time and the volume swept out per unit time per unit area can be determined by the first and third moments of the measured distribution. We anticipate that the larger aerosols and sea spray will scale according to these moments which describe the area and volumes of the active regions of breaking. Also provided by the image analysis is total whitecap coverage and whitecap size distributions. This system was flown on Seneca aircraft with Tony Clarke's group from UH in a series of flights during the RED campaign.

Surface waves. – Measurements of the surface wave heights, their directional (and non-directional) spectra, and wave group structure are necessary for understanding the statistics of wave breaking as well as the wave field's influence on EM scatter. Surface waves were measured using an upward looking, 600kHz sonar which mounts to the bow thruster of FLIP. The principle of the wave measurement is the inversion of current velocities measured at a 2Hz rate at a number of locations just below the water's surface measured remote from the sonar unit. The advantage of the sonar is the increased degrees of freedom provided for in the measurement which enables the definition of complex wave fields which may include local seas superimposed upon distant swell from a different direction.

Temperature, salinity, and dissolved gas profiles of the upper ocean. – An understanding of the heat content of the upper ocean is necessary for determining heat fluxes and atmospheric stability. A CTD was profiled periodically from the vessel Wailoa in the vicinity of FLIP during RED. Dissolved gas measurements were also made from FLIP to determine gas saturation levels which influence the lifetimes of the smallest bubbles in solution. Understanding the lifetimes of the smallest bubbles is relevant to the EO/EM propagation since the smallest bubbles will generate the small aerosols which have long atmospheric residence times. An additional complexity to the bubble/aerosol generation mechanism is the potential supersaturation of surface waters during high winds which will introduce a potential positive feedback in the generation of these aerosols.

While this intensive measurement campaign was successful from a data return standpoint, the RED program had difficulty reaching objectives due to the unusually calm weather that was present during the experiment. Significant wave heights never exceeded 2m and winds exceeded 10m/s only once during the experiment. In addition, the coordination of vessels and aircraft flights became very difficult mid-experiment as a result of the September 11 tragedy. However, the data set that was collected during this effort has been analyzed with respect to the EM propagation measurements, confirming the ability of existing models to have satisfactory performance during moderate conditions. In addition, we have one of the first data sets that couple air-sea interaction processes with near-surface aerosol concentrations. While funding under the RED grant has been completed, we continue to analyze the data sets to examine these relationships with support from the HYCODE program and Terrill's ONR Young Investigator award. This involves continued collaboration with Jeffrey Reid - NRL, Tony Clarke - UH, and Kenn Anderson - Spawar.

Results of these efforts were presented in two papers by authors Terrill & Melville and Melville & Terrill at the AMS RED/SEAS special session held in Long Beach, CA 2003.

Note: large array of atmospheric boundary layer measurements conducted by conducted by UCI, SPAWAR, TNO

Surface meteorological package:

- barometric pressure
- air temperature
- relative humidity
- rain

Hull mounted temperature sensors

- 1 m
- 1.6 m
- 2.6 m
- 7 m
- 11.4 m
- 18.5 m
- 30 m
- 49 m
- 80 m

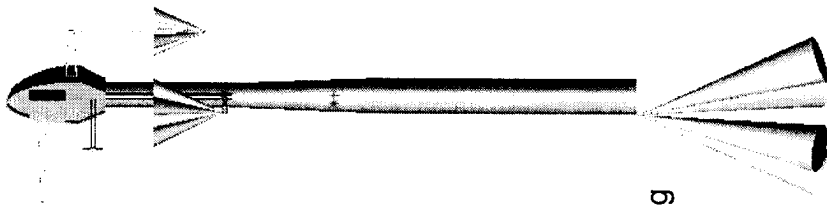

Downward looking 300kHz ADCP

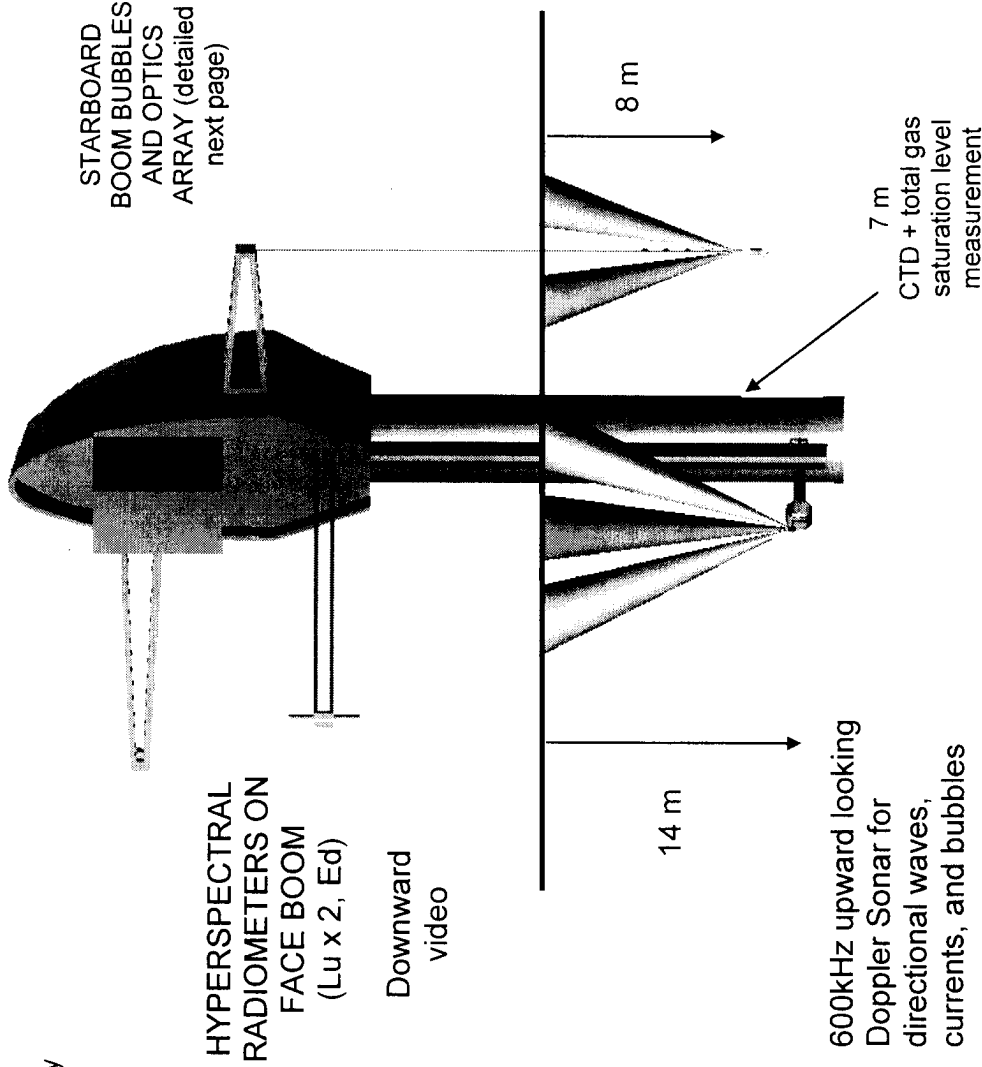

- Surface meteorological package:
- barometric pressure
 - air temperature
 - relative humidity
 - rain

Downward looking
300kHz ADCP

*Note: large array of atmospheric
boundary layer measurements
conducted by conducted by UCI,
SPAWAR, TNO*

Hull mounted temperature sensors

- 1 m
- 1.6 m
- 2.6 m
- 7 m
- 11.4 m
- 18.5 m
- 30 m
- 49 m
- 80 m

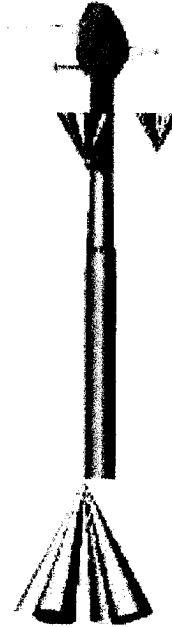

STARBOARD BOOM BUBBLES AND OPTICS ARRAY

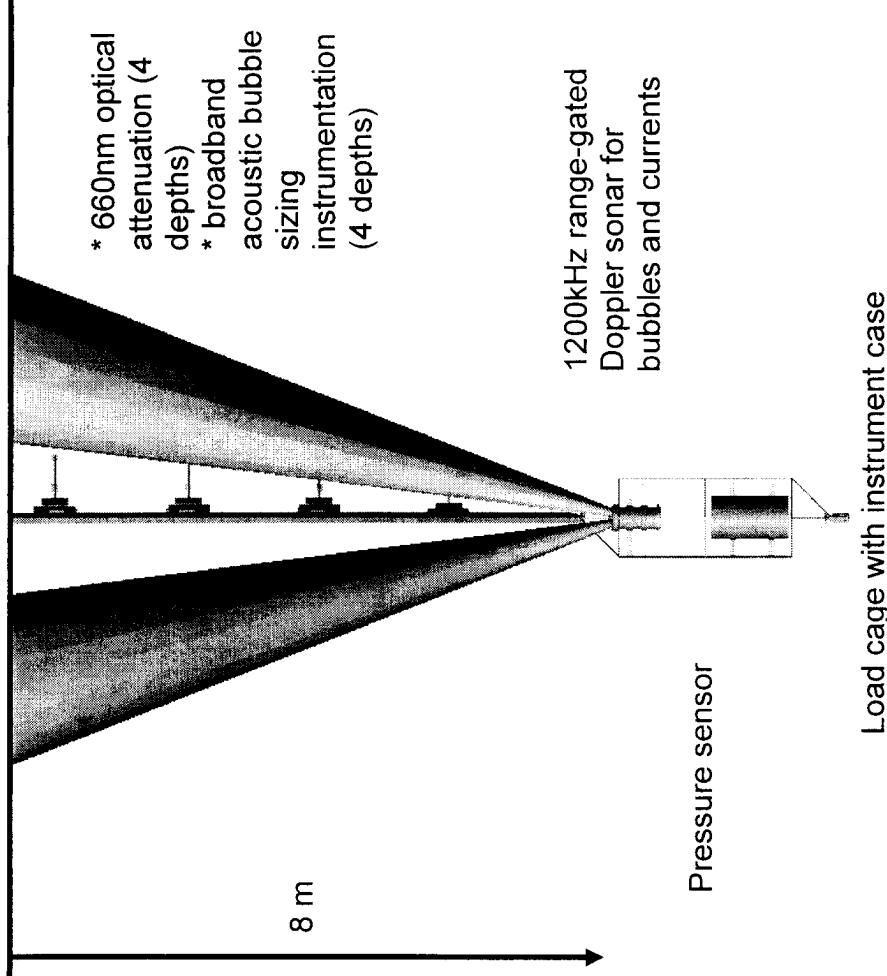
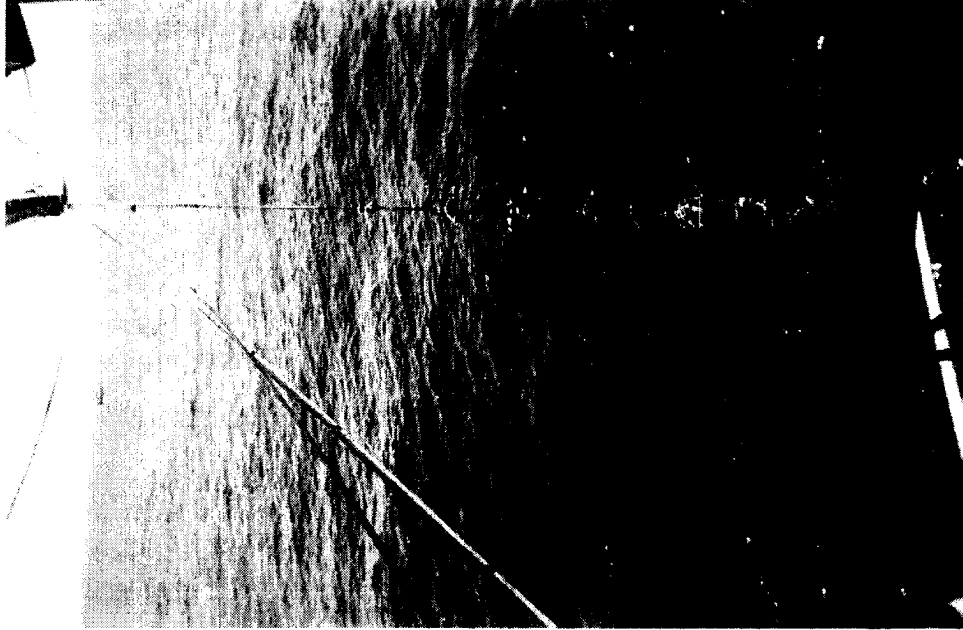

Left Blank

STARBOARD BOOM BUBBLES AND OPTICS ARRAY

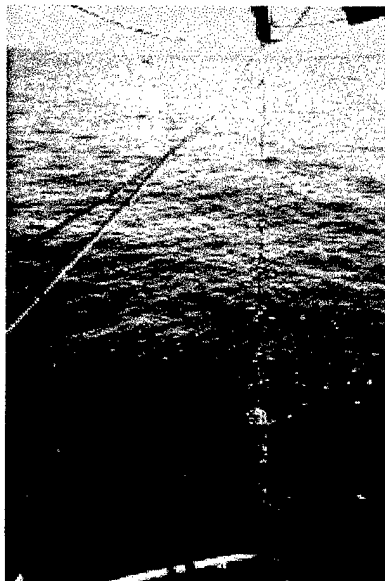
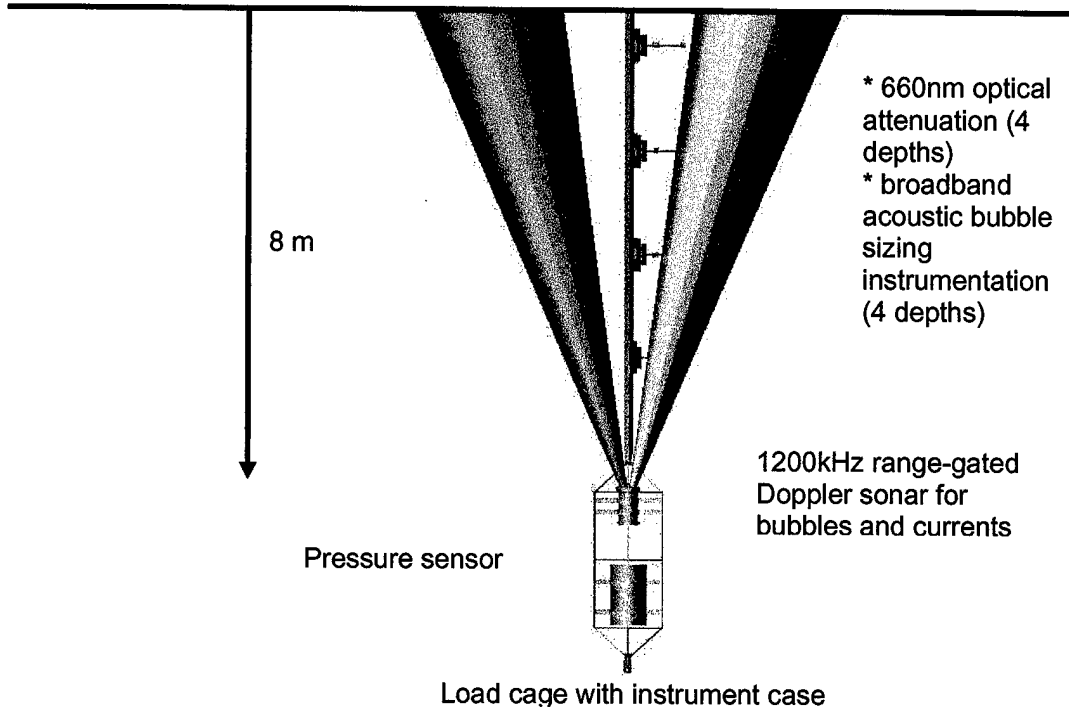

Measurements of the air-sea interface are conducted with a motion compensated, imaging system and a bore-sighted laser altimeter.

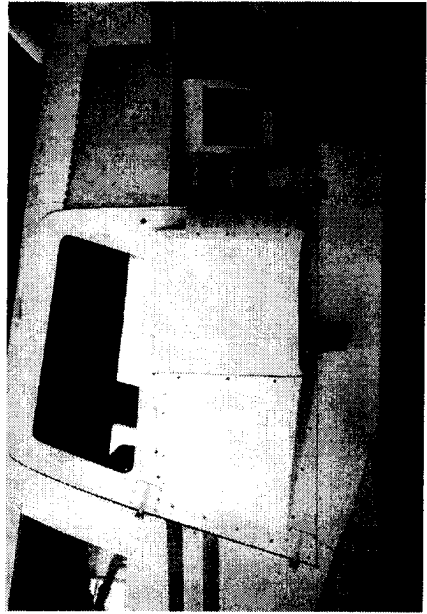
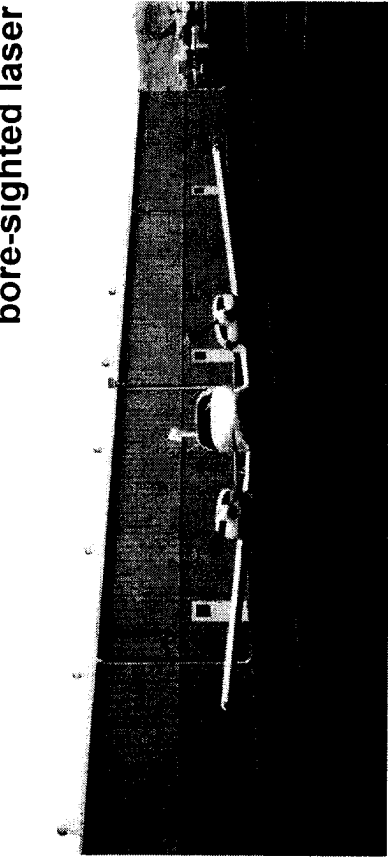

8/30/01 (local afternoon) - measurements near FLIP

Breaking speed statistics scaled by U^3 (wind measurements used from WAILOA)

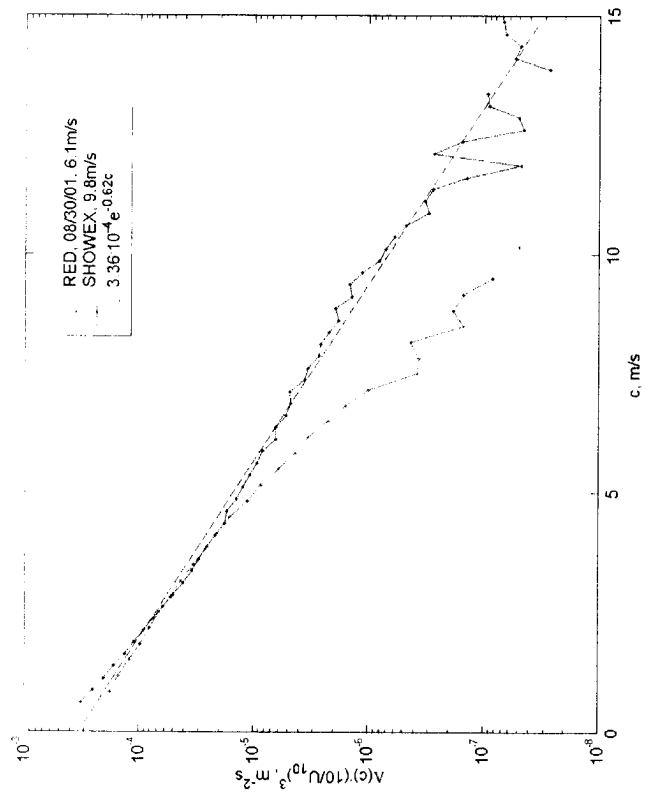

CUMULATIVE DISTRIBUTION OF SECOND MOMENT (WHITE CAP COVERAGE) AS A FUNCTION OF BREAKING SPEED

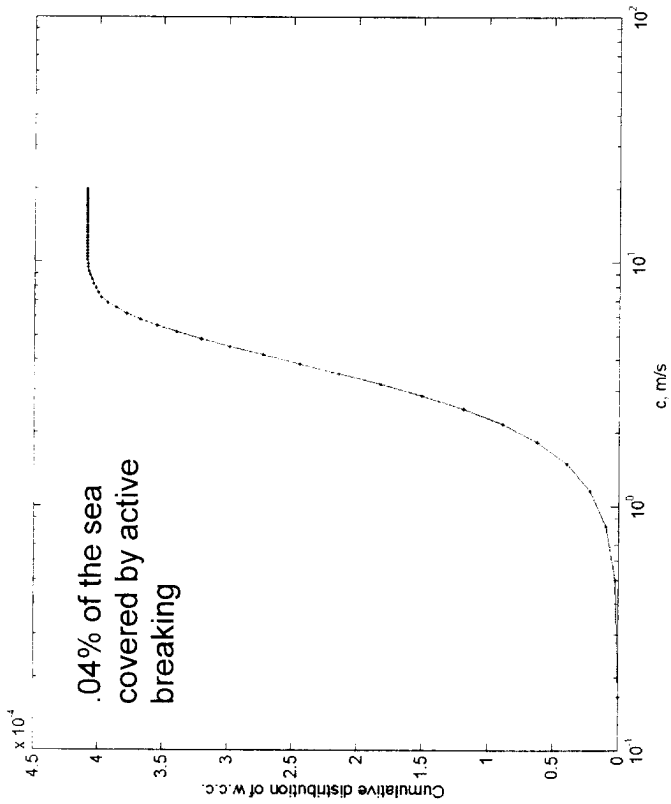

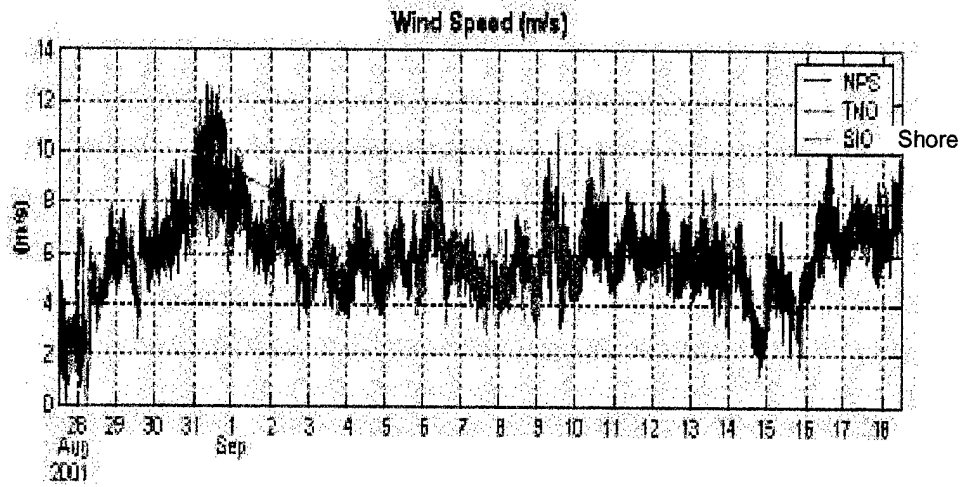
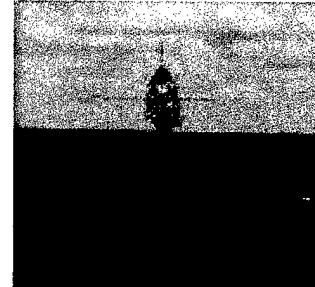
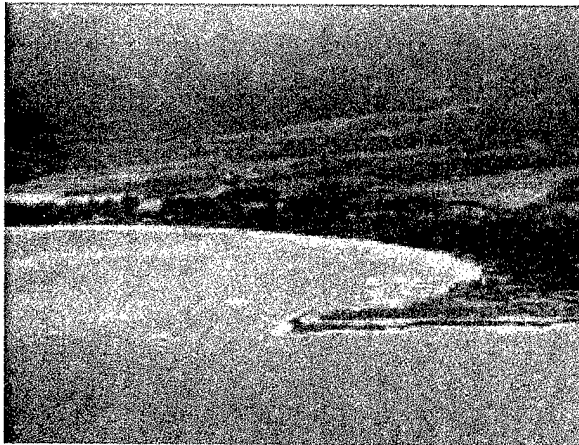

• FLIP: $21^{\circ}42.6'$, $157^{\circ}50.4'$
 $z = 370\text{m}$

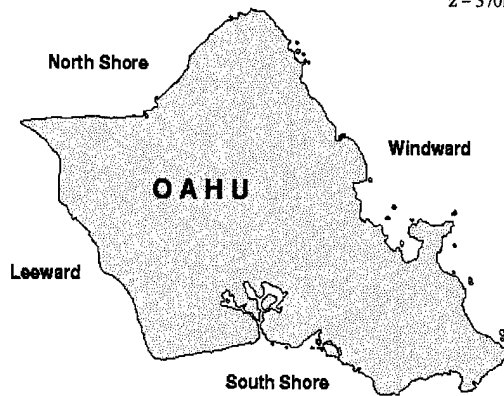

Measurements of the air-sea interface are conducted with a motion compensated, imaging system and a bore-sighted laser altimeter.

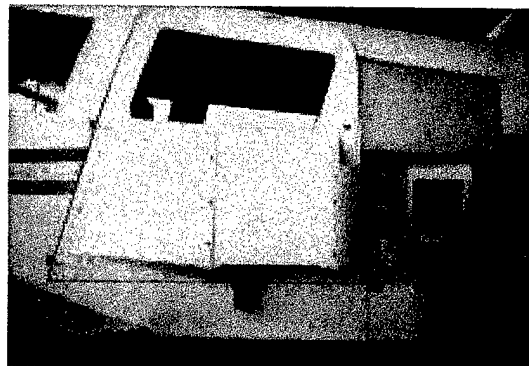
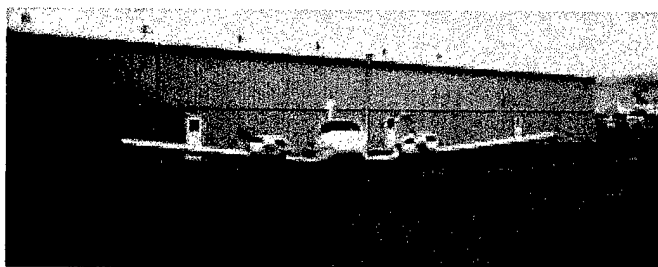

8/30/01 (local afternoon) - measurements near FLIP

Breaking speed statistics scaled by U^3 (wind measurements used from WAILOA)

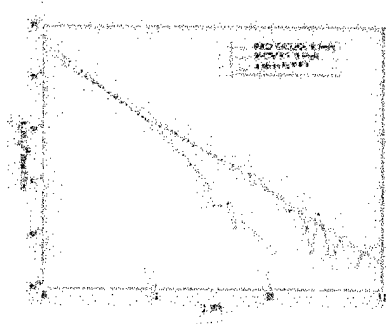

CUMULATIVE DISTRIBUTION OF SECOND MOMENT (WHITE CAP COVERAGE) AS A FUNCTION OF BREAKING SPEED

.04% of the sea covered by active breaking

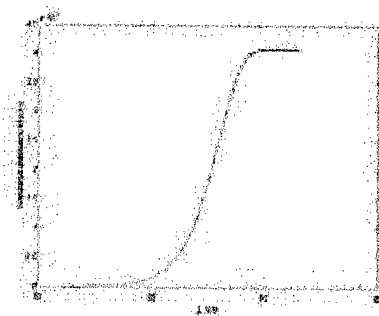

ONR/MPL REPORT DISTRIBUTION

Office of Naval Research (3)
Department of the Navy
Ballston Tower One
800 North Quincy Street
Arlington, VA 22217-5660
Attn: Ronald J. Ferek, ONR 322MM

Regional Director (1)
ONR Detachment
San Diego Regional Office
4520 Executive Drive, Suite 300
San Diego, CA 92121-3019

Commanding Officer (1)
Naval Research Laboratory
4555 Overlook Avenue, S.W.
Attn: Code 2627
Washington, D.C. 20375-5320

Defense Technical Information Center (4)
8725 John J. Kingman Road
Suite 0944
Ft. Belvoir, VA 22060-6218