

REPORT DOCUMENTATION PAGE

*Form Approved
OMB No. 0704-0188*

The public reporting burden for this collection of information is estimated to average 1 hour per response, including the time for reviewing instructions, searching existing data sources, gathering and maintaining the data needed, and completing and reviewing the collection of information. Send comments regarding this burden estimate or any other aspect of this collection of information, including suggestions for reducing the burden, to Department of Defense, Washington Headquarters Services, Directorate for Information Operations and Reports (0704-0188), 1215 Jefferson Davis Highway, Suite 1204, Arlington, VA 22202-4302. Respondents should be aware that notwithstanding any other provision of law, no person shall be subject to any penalty for failing to comply with a collection of information if it does not display a currently valid OMB control number.

PLEASE DO NOT RETURN YOUR FORM TO THE ABOVE ADDRESS.

1. REPORT DATE (DD-MM-YYYY)		2. REPORT TYPE		3. DATES COVERED (From - To)	
4. TITLE AND SUBTITLE				5a. CONTRACT NUMBER	
				5b. GRANT NUMBER	
				5c. PROGRAM ELEMENT NUMBER	
6. AUTHOR(S)				5d. PROJECT NUMBER	
				5e. TASK NUMBER	
				5f. WORK UNIT NUMBER	
7. PERFORMING ORGANIZATION NAME(S) AND ADDRESS(ES)				8. PERFORMING ORGANIZATION REPORT NUMBER	
9. SPONSORING/MONITORING AGENCY NAME(S) AND ADDRESS(ES)				10. SPONSOR/MONITOR'S ACRONYM(S)	
				11. SPONSOR/MONITOR'S REPORT NUMBER(S)	
12. DISTRIBUTION/AVAILABILITY STATEMENT					
13. SUPPLEMENTARY NOTES					
14. ABSTRACT					
15. SUBJECT TERMS					
16. SECURITY CLASSIFICATION OF:			17. LIMITATION OF ABSTRACT	18. NUMBER OF PAGES	19a. NAME OF RESPONSIBLE PERSON
a. REPORT	b. ABSTRACT	c. THIS PAGE			19b. TELEPHONE NUMBER (Include area code)

SBIR Final Report

For SBIR Topic N03-171

***Very Low Volatile Organic Compound Spray
Application Process for Iron Filled Elastomeric Coatings***

Contract No: N00421-03-P-1340

Delivery CLINS/SLIN 0003

Unit Price: \$ 23,328.71

Competitive Proposal Number: N032-0591

Prepared for

Naval Air Warfare Center AD (PAX)

Code 2.5.1.3.2 Building 441

21983 Bundy Road

Patuxent River, MD 20670

by

En'Urga Inc.

1291-A, Cumberland Avenue

West Lafayette, IN 47906

Performance Period: October 1 to March 31, 2004

Distribution:

Attn: Dr. James Adkins

Dr. James Muller

Mr. David Pulley

PI: Yudaya Sivathanu



ANALYSIS OF COMBUSTION SYSTEMS

*Very Low Volatile Organic Compound Spray
Application Process for Iron Filled Elastomeric Coatings*

Summary of Final Report

This Small Business Innovation Research Phase 1 project evaluated the feasibility of a new method for spraying high viscosity coatings. This new method of forming sprays uses very little VOC solvents, and has two distinguishing features: (1) The application of effervescent atomization for producing droplets independent of the fluid viscosity, and (2) a perforated aerator tube insert to control both the Sauter mean diameter (SMD, or D_{32}) and the distribution of drop sizes. These features allow for the reduction (elimination in certain applications) of VOC carrier liquids that are required with current conventional spray nozzles.

The three key tasks of the Phase I project were: (1) to design and fabricate an effervescent atomizer to spray solids filled polymeric liquids with viscosities ranging up to 120 KU, (2) to evaluate the effervescent atomizer with the high viscosity solution to assure that acceptable drop size and distribution performance is achieved, and (3) to evaluate the applicability of the spray to painting processes by measuring transfer efficiencies.

An effervescent atomizer was designed, fabricated and evaluated during the Phase I work. The following are the three major conclusions of the work: (1) The effervescent atomizer provided excellent spray uniformity that it is ideal for painting purposes, (2) the drop size distribution obtained with the effervescent atomizer spraying the surrogate fluid was well within acceptable ranges for painting processes, and (3) transfer efficiencies greater than 80% were achieved with the effervescent atomizer. ***Based on the Phase work, the feasibility of reducing VOCs in MagRAM coating applications at least by a factor of two was completely established.***

For the Phase II project, three major tasks are envisaged. The first is to develop a prototype paint sprayer for MagRAM coatings which is a two component mixture. The second is to evaluate the prototype sprayer with actual MagRAM coatings with different amount of VOCs, so as to quantify the potential savings achieved with the system. The third will be to characterize the coating thickness on the plate using a profilometer. When these three tasks have been completed, the prototype sprayer will be ready for commercialization.

The Phase I work addressed a key technology barrier for both the Navy and Air Force is spraying MagRAM iron-filled elastomeric (IFE) coatings onto surfaces for low observable survivability. Conventional applicator systems (even the latest hydraulic assist HVLV units) require unacceptable quantities of VOC solvents in order to reduce coating viscosities to levels compatible with spray formation. These high solvent levels lead directly to health hazards for workers, a decrease in indoor and outdoor air quality, as well as a reduction in process speed. The proposed method will significantly reduce the VOCs used for forming these sprays. The three major commercial applications of the proposed low VOC spray process are in the painting industry (aircraft, furniture, and automotive), the consumer product industry (deodorants, hair sprays, topical anesthetics and antiseptics/antibiotics, fabric care, etc.), and the chemical industry (spray drying, materials processing, etc.). These industries will benefit from reducing the amount of VOCs used for spraying in a wide variety of consumer and industrial products.

***Very Low Volatile Organic Compound Spray
Application Process for Iron Filled Elastomeric Coatings***

1. Introduction

This SBIR proposal describes a method for forming sprays of high viscosity IFE MagRAM coatings while using very little or no VOC solvents (estimated to be 5% or less). The proposed method takes advantage of a key breakthrough in twin-fluid atomization that has occurred over the last ten years. The breakthrough is based on the use of effervescent atomization, which makes spray formation insensitive to fluid viscosity. Effervescent atomization is based on proven technology developed at Purdue University for use in industrial process industries and consumer products, and has already been demonstrated for solids filled-polymeric liquids (approximately 50 weight-%) having effective viscosities greater than 1500 cP (equivalent to approximately 100 KU) at mass flow rates as high as 60 l/min.

2. Phase I Work Plan

There were three specific tasks for Phase I work. The first task was to design and fabricate an effervescent atomizer based system for spraying high viscosity MagRAM liquids. The second task was to evaluate the characteristics of the spray using a Malvern Spray Analyzer for drop sizing, and an optical patternator for spray surface areas. The third task was to determine the characteristics of the coatings to assess thickness and transfer efficiencies.

3 Work Completed under the Three Tasks

3.1 Design and Fabrication of the Effervescent Atomizer

The first task was the design and fabrication of a typical effervescent atomizer for spraying the high viscosity MagRAM liquids. A solid model design of the effervescent atomizer is shown in Fig. 1.

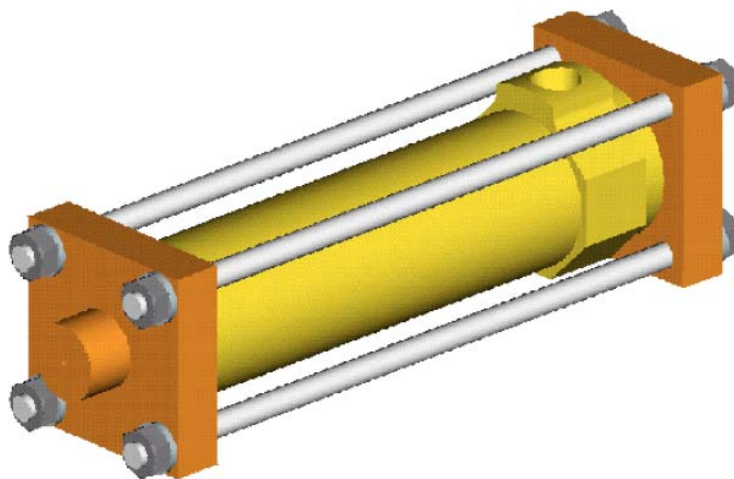

Figure 1. Solid model of the effervescent atomizer.

The solid model was created using the Pro-Engineer software module. The atomizer is constructed primarily out of aluminum. The atomizer has a top plate which is interchangeable for providing different orifice sizes at the exit nozzle. The main body of the atomizer consists of two concentric tubes. Air is admitted to the outer tube and liquid is fed through the inner tube. The inner tube is constructed out of brass. All other parts of the atomizer are made with aluminum. The air bubbles into the inner tube through a perforated tube.

The sectional details of the atomizer are shown in Fig. 2. The inner tube has an ID of

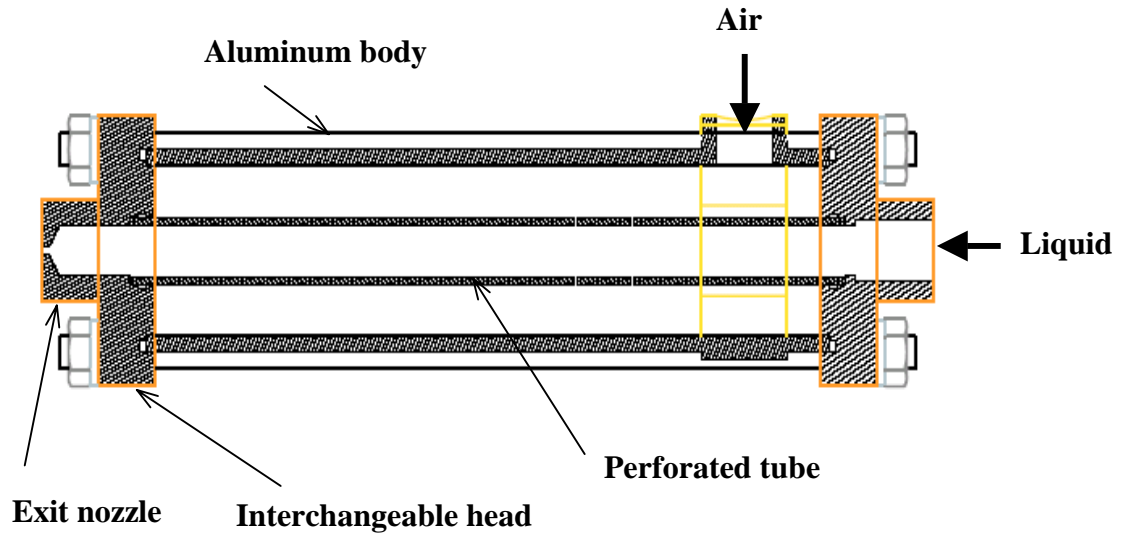

Figure 2. Section drawing of the effervescent atomizer.

9.54 mm and an OD of 12.7 mm. This inner brass tube is 100 mm long and has five rows of holes in them. Each row has four 100 micron holes, spaced 90 degrees apart. The exit orifice is 3 mm in diameter. The exit orifice has a back chamber, 25 mm long with an ID of 9.54 mm. There is a small taper for the last 6 mm of the back chamber as shown in Fig. 2.

A photograph of the effervescent atomizer, mounted on the spray stand is shown in Fig 3.

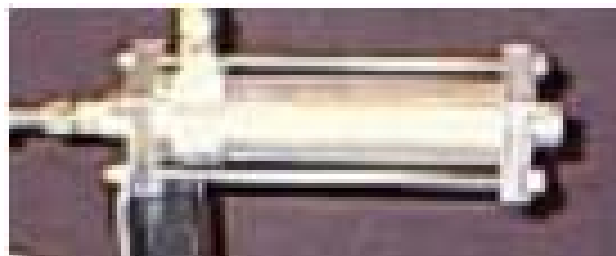

Figure 3. Photograph of the effervescent atomizer.

The effervescent atomizer was initially connected to a commercial air compressor that had a maximum delivery pressure of 150 PSI. After the fourth month, a custom high pressure chamber capable of pressurizing the atomizer to 600 PSI was designed and fabricated. A photograph of the flow system used with the effervescent atomizer is shown in Fig. 4.



Figure 4. Photograph of the high pressure spray system.

The liquid within the high pressure chamber is pressurized using a nitrogen bottle. Liquid is fed through a rotameter to the effervescent atomizer using flexible steel tube. Nitrogen is also fed at the same pressure through a flow control valve to the effervescent atomizer using a flexible steel tube. The nozzle is mounted on a table to enable easy alignment of the nozzle with the optical patternator and the Malvern PDA. After the flow system and atomizer were fabricated, testing of the nozzle was started.

3.2 Evaluation of the Effervescent Atomizer

The initial proposal called for evaluating the atomizer using sample MagRAM coatings obtained from the Navy. However, the coating fluid was unavailable in the short time frame of the Phase I project. An alternate method of directly purchasing and formulating the mixture at En'Urga Inc. was initiated and abandoned as it was clear that the coating used is a two component mixture, which cannot be sprayed using the effervescent atomizer that was fabricated for the Phase I work. Additional modification of the nozzle to handle the two component mixture has been scheduled for the Phase II work.

A surrogate high viscosity fluid (corn syrup with an approximate viscosity of 80 KU) mixed with 5 micron iron carbonyl powder was used to complete the evaluation of the effervescent atomizer. Equal parts by weight of corn syrup and iron powder were mixed using a commercial paint mixer system. The resulting particulate laden solution was uneven in consistency, and very difficult to force through the pressure system. Attempts to spray the

solution resulted in extensive blockage of the 100 micron air holes of the aerator tubes. On examination of the tubes, it could be clearly seen that clumps of iron particles were stuck together since the mixture had a very gummy consistency. Therefore, about 10% by weight of water was added to the mixture to even out the particulate within the solution. The resulting solution was found to be free of particle clumps and could flow easily through the entire plumbing system. The viscosity of the resulting fluid as measured by a Zahn5 cup is roughly about 50 KU. This is below the target KU of 100. However, if the paint mixture was used with the same VOC as recommended by the manufacturer, the KU of the paint and powder solution would be much less than 20KU. So, the viscosity of approx. 50 KU used for the evaluation of the injector would enable reduction of VOC at least by a factor of two. This is sufficient to establish the feasibility of the atomizer to significantly reduce the VOC's used in the application of MagRAM coatings to aircraft.

All evaluations of the nozzle described below were completed with the solution at 50KU. It should be noted that the actual MagRAM coating will have to be formulated with the modified nozzle (capable of handling two components simultaneously) and different VOC contents to quantitatively establish the actual savings in VOCs that will be achieved by the final system.

The first evaluation of the nozzle was to establish that the effervescent atomizer provided a very uniform spray. The evaluation of the nozzle was completed at 200 PSI (the lowest pressure used in the Phase I work) using a SETScan[®] optical patternator. A photograph of the patternator is shown in Fig. 5.



Figure 5. Photograph of the SETScan optical patternator.

The SETScan optical patternator measures path integrated transmittances along 256 parallel paths from six view angles. The measured transmittances are converted to local drop surface area per unit volume using a Statistical Deconvolution algorithm. The optical patternator was developed by En'Urga Inc. for spray performance evaluations using a Phase II SBIR from the National Science Foundation.

The path integrated absorptances measured at six view angles as a function of radial distances are shown in Fig. 6. The measurements were obtained at an axial distance of 100 mm from the nozzle exit, where the spray is fully developed. The path integrated absorptances were deconvoluted to provide the mean local surface areas per unit volume. Typical local drop surface areas per unit volume obtained for the atomizer are shown in Fig. 7.

[®] SETscan is a registered trademark of En'Urga Inc.

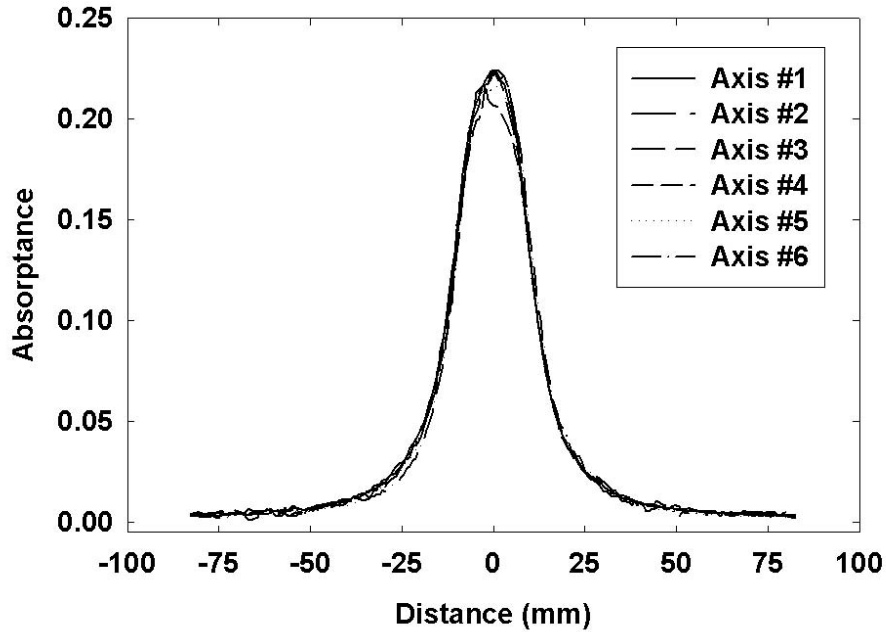

Figure 6. Path integrated absorbances measured using the SETScan patternator.

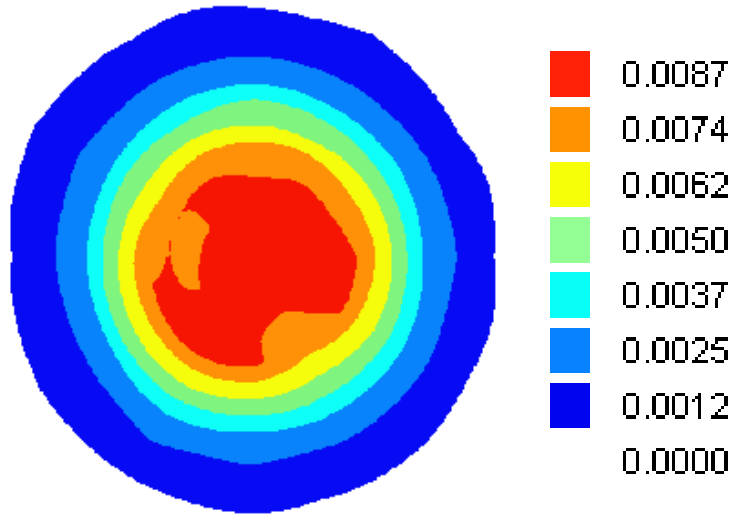

Figure 7. Drop surface area per unit volume obtained from the atomizer.

The particulate laden spray from the effervescent atomizer is extremely uniform. More quantitative information on the uniformity of the spray can be obtained from the integrated drop surface areas as a function of circumferential angle. The integrated drop surface areas as a function of circumferential angles are shown in Fig. 8.

The integrated drop surface areas per unit volume can be used to obtain a patteration number for the nozzle. *The patteration number obtained for the nozzle is 0.0707.* This indicates that there is less than a 10% variation in the uniformity of the spray in the circumferential direction. Similar uniformity of the sprays was obtained at the higher pressures.

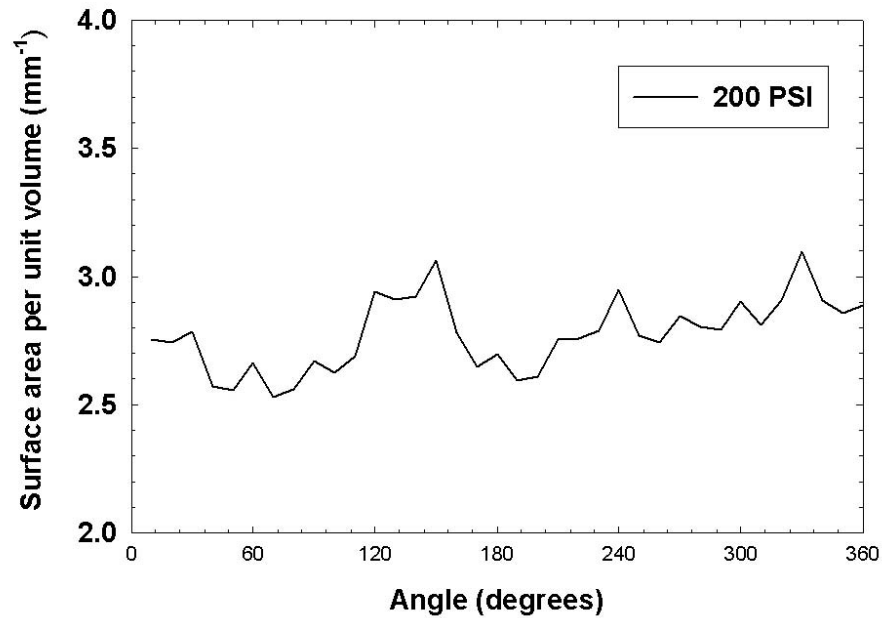

Figure 8. Integrated drop surface area per unit volume as a function of circumferential angle.

Therefore, the results obtained from the patterning of the spray indicates that the atomizer is ideal for painting processes as non-uniformities in the coating thickness will be absent in the finished product.

The second set of evaluation of the spray was completed using a Malvern PDA. A schematic diagram of the Malvern PDA is shown in Fig. 9.

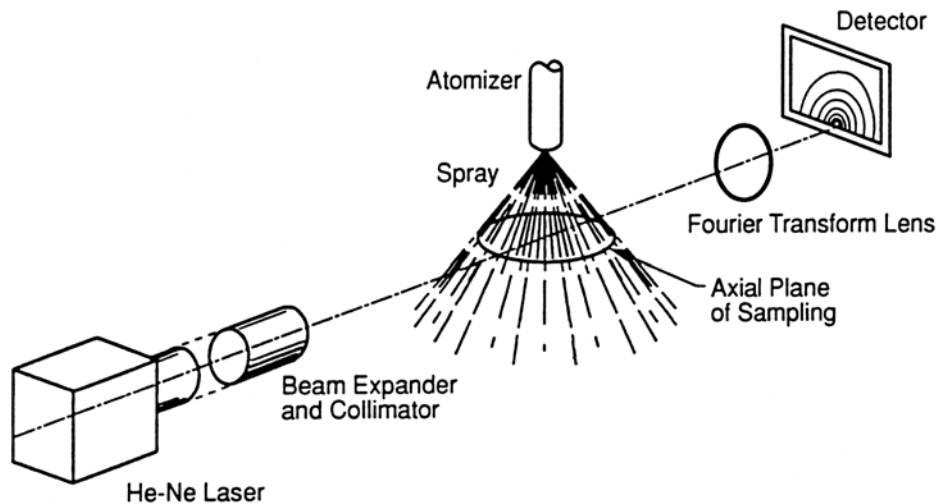

Figure 9. Schematic of the experimental arrangement for measuring drop sizes.

The Malvern PDA utilizes light scattering to provide the drop size distribution in sprays. The drop size distributions were obtained at 4 inches from the nozzle exit where the spray is fully developed. The three characteristic drop sizes that are used in classifying nozzles are the

Sauter Mean Diameter (SMD), the $D_{0.9}$, and the $D_{0.1}$. The SMD is the volume averaged diameter of the spray. $D_{0.9}$ is the diameter below which 90 percent of the drops exist. $D_{0.1}$ is the diameter below which 10% of the drops exist.

The characteristic drop sizes obtained at three pressures from the effervescent atomizer are shown in Fig. 10. The liquid flow rate for the measurements was fixed at 35 g/s. This

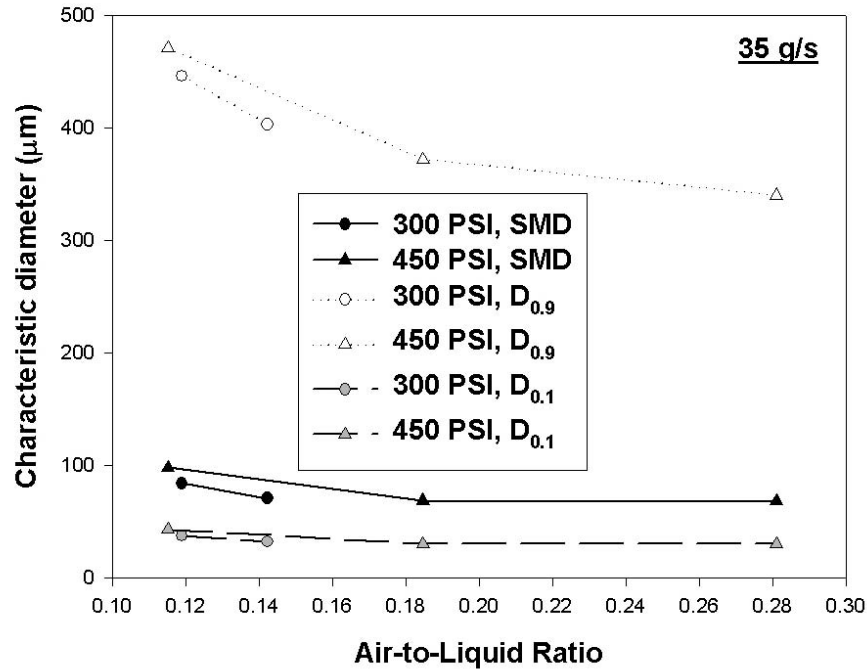

Figure 10. Variation of the characteristic drop sizes with pressure.

corresponds to a volume of approximately 0.12 l/min. A value of 0.1 l/min is close to a desirable value for painting operations. There is some change in the diameter with pressure. There is a more significant change in the bigger drops (drops above 300 microns) with the Air-to-Liquid Ratio (ALR). It is clear that with low ALRs (< 0.2), the SMD of the drops are not sufficiently small for painting operations. For painting operations, a SMD of 50 microns is ideal. Sprays that have significantly larger SMD will lead to paint runs, and sprays that have much smaller SMD will lead to poorer transfer efficiencies and pose a health hazard due to inhalation.

Increasing the pressure to higher values would lead to greater velocities for the drops, which could lead to lower transfer efficiency. Therefore, it was decided to increase the ALR while going to a lower pressure if possible to achieve the required SMD.

Drop sizes obtained with a much lower pressure of 200 PSI, but with higher ALRs are shown in Fig. 11. The ALR for these measurements ranged from approximately 0.5 to 0.9. The SMDs obtained with these higher ALRs all are close to 50 microns, with a few conditions at the higher ALR being lower than 50 microns. The ideal condition seems to be at an ALR of approximately 0.78. At this condition, particularly for the higher liquid flow rate, the SMD of the drops are approximately 44 microns, the $D_{0.9}$ is 277 and the $D_{0.1}$ is 17 microns. This satisfies

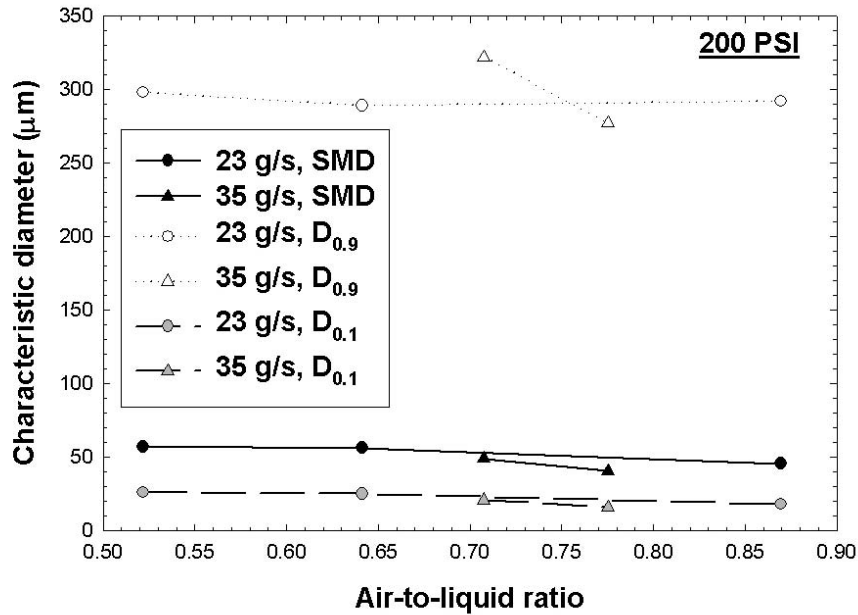

Figure 11. Variation of characteristic drop sizes with pressure.

all three conditions required for the spray. SMDs are approximately 50 microns, 90% of the drop sizes are less than 300 microns and the 10% drop size is greater than 10 microns.

Typical drop size distribution obtained from the spray nozzle is shown in Fig. 12. The

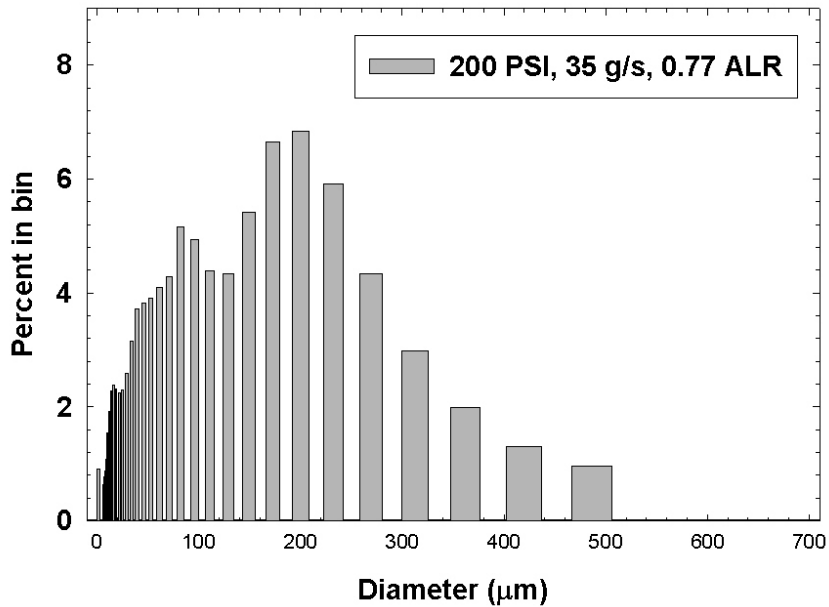

Figure 12. . Drop size distribution obtained from the sprays.

drop size distribution provides the percent volume of the spray within any specific drop size. It can clearly be seen that less than 10% of the volume of the spray is present in drops greater than

300 microns, and less than 10% of the volume of the spray is present in drops less than 17 microns. The distribution in addition is not significantly bimodal. All these conditions suggest that the spray drop size distribution is acceptable for painting applications.

The last evaluation of the spray that was completed was to measure the transfer efficiency of the spray. The spray nozzle was maintained at a distance of 16 inches from a target plate of 18 inches x 18 inches. The spray was turned and the target plate inserted rapidly into the spray region for a duration of ten seconds and then withdrawn. The change in the mass of the target plate was obtained using a chemical balance.

The total mass in 10 seconds collected from the 23 g/s spray onto the target was 189 gms and for the 35 g/s spray was 281 gms. These translate into transfer efficiencies of 82.2% and 80.2%. These transfer efficiencies are excellent. The primary reason for these high transfer efficiencies is the low pressure used for achieving good spray quality, one of the advantages of effervescent atomization.

Conclusions

The following conclusion can be obtained from the Phase I project.

1. An effervescent atomizer was designed and fabricated during the Phase I project.
2. A surrogate fluid that had a lower viscosity than the targeted 100 KU but much higher viscosity than the current paint formulation that has high VOCs was formulated.
3. The effervescent atomizer provided excellent spray uniformity confirming that it is ideal for painting purposes.
4. The drop size distribution obtained with the effervescent atomizer spraying the surrogate fluid was well within acceptable ranges for painting processes.
5. Transfer efficiencies greater than 80% were achieved with the effervescent atomizer.

Based on the above, the feasibility of reducing VOCs in MagRAM coating applications at least by a factor of two was completely established by the Phase I research.

Phase II Plans

The Indiana 21st Century Funds have provided a 100% matching grant to assist En'Urga Inc. in their Phase II application. For the Phase II project, three major tasks are envisaged. The first is to develop a prototype paint sprayer for MagRAM coatings which is a two component mixture. This task involves modification of the effervescent atomizer to mix the two components just prior to the spraying operation. The second is to evaluate the prototype sprayer with actual MagRAM coatings with different amount of VOCs. This will clearly demonstrate the total savings in VOCs used for the application of MagRAM coatings while achieving an acceptable spray. The third will be to characterize the coating thickness on the plate using a

profilometer. This will provide the ideal rate of application of the coating to the aircraft surface. When these three tasks have been completed, the prototype sprayer will be ready for commercialization. The prototype sprayer will also be made available to the Navy, if they so desire, for their evaluations.

En'Urga Inc. has initiated talks with three spray nozzle companies, Hago Nozzles, Spraying Systems, and Nordstorm for the commercialization of the prototype nozzle. Details and supporting letters will be solicited and attached with the Phase II application. En'Urga Inc. will partner with Professor Paul Sojka, primarily through a subcontract to Purdue University, for both the design and the characterization of the prototype effervescent atomizer. A letter stating the availability of Purdue University as a Phase II partner will be included with the Phase II proposal.