

# **IEEE 802.11 Communications Test For Robotic Systems**

Prepared by:  
Narek Manouk  
SPAWAR Systems Center San Diego  
Adaptive Systems Branch (code 2371)  
Phone: (619) 553-7875  
Fax: (619) 553-5578  
[narek@spawar.navy.mil](mailto:narek@spawar.navy.mil)  
<http://www.spawar.navy.mil/robots/>

# Report Documentation Page

Form Approved  
OMB No. 0704-0188

Public reporting burden for the collection of information is estimated to average 1 hour per response, including the time for reviewing instructions, searching existing data sources, gathering and maintaining the data needed, and completing and reviewing the collection of information. Send comments regarding this burden estimate or any other aspect of this collection of information, including suggestions for reducing this burden, to Washington Headquarters Services, Directorate for Information Operations and Reports, 1215 Jefferson Davis Highway, Suite 1204, Arlington VA 22202-4302. Respondents should be aware that notwithstanding any other provision of law, no person shall be subject to a penalty for failing to comply with a collection of information if it does not display a currently valid OMB control number.

1. REPORT DATE <b>JUL 2002</b>		2. REPORT TYPE <b>N/A</b>		3. DATES COVERED <b>-</b>	
4. TITLE AND SUBTITLE <b>IEEE 802.11 Communications Test for Robotic Systems</b>				5a. CONTRACT NUMBER	
				5b. GRANT NUMBER	
				5c. PROGRAM ELEMENT NUMBER	
6. AUTHOR(S) <b>Narek /Manouk</b>				5d. PROJECT NUMBER	
				5e. TASK NUMBER	
				5f. WORK UNIT NUMBER	
7. PERFORMING ORGANIZATION NAME(S) AND ADDRESS(ES) <b>Space and Naval Warfare Systems Center Adaptive Systems Branch (Code 2371) 53406 Woodward Road San Diego, CA 92152</b>				8. PERFORMING ORGANIZATION REPORT NUMBER	
9. SPONSORING/MONITORING AGENCY NAME(S) AND ADDRESS(ES)				10. SPONSOR/MONITOR'S ACRONYM(S)	
				11. SPONSOR/MONITOR'S REPORT NUMBER(S)	
12. DISTRIBUTION/AVAILABILITY STATEMENT <b>Approved for public release, distribution unlimited</b>					
13. SUPPLEMENTARY NOTES <b>The original document contains color images.</b>					
14. ABSTRACT					
15. SUBJECT TERMS					
16. SECURITY CLASSIFICATION OF:			17. LIMITATION OF ABSTRACT	18. NUMBER OF PAGES	19a. NAME OF RESPONSIBLE PERSON
a. REPORT <b>unclassified</b>	b. ABSTRACT <b>unclassified</b>	c. THIS PAGE <b>unclassified</b>			

## **Abstract**

Designing a robust communications structure needed in a robotic system often leads to many difficulties and compromises due to design constraints. Some of the capabilities of an 802.11 Ethernet radio modem can suffer as a direct result of compromises made to allow a robotic system to operate effectively within its established parameters. This was the case in the Man Portable Robotic System (MPRS) project, funded by the Army. The Urban Robot (URBOT) developed under this project had many specific user requirements, which led to challenging problems when designing the communications system. A communications test was conducted to determine the baseline capabilities of the BreezeNET PRO.11 modems that are currently being used in the URBOT. Tests conducted measured the received throughput under different circumstances, such as multi-hop, multi-node, multicast, and variable antenna height and range. Results show that under some circumstances throughput improvements are possible. Lessons learned from the outcome of the communications test will help in designing an improved communications system for future projects.

## **1.0 Introduction**

The following is a summary of a test report concerning the BreezeCOM BreezeNET PRO.11 Wireless Local Area Network (WLAN) Frequency Hopping Spread Spectrum (FHSS) radio modems, which conform to the IEEE 802.11 protocol. These modems are currently being used in the Urban Robot (URBOT) and its companion Operator Control Unit (OCU) shown in Figure 1. The URBOT, designed primarily for the Army to perform tunnel and sewer reconnaissance, can also operate outdoors, and is waterproof. The tests performed were designed to gather data regarding the performance of these modems in different topologies. The information

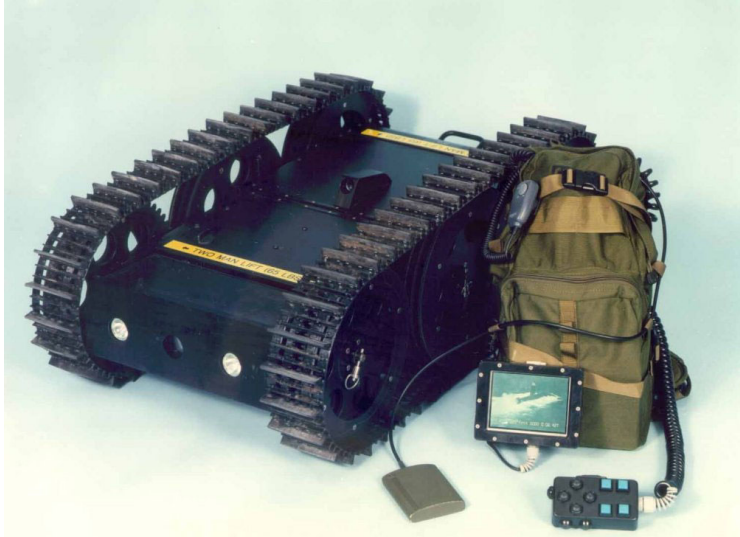

**Figure 1.** URBOT and OCU Backpack

gathered by conducting these tests is important in that it will help in optimizing the communications system used to control and gather information from the robot.

The objective of these tests was to characterize the performance of the BreezeNET PRO.11 modems in terms of received throughput. The throughput

is a function of the transmitted packet size, the data rate at which the packets were transmitted, and the received signal level. The range of packet sizes used varies from 64 bytes – the minimum size of an Ethernet packet – to a maximum of 1518 bytes. According to the IEEE 802.11 protocol standard, the data rates can vary up to 2 Megabits per second (Mbps). BreezeCOM has incorporated a proprietary data rate of 3-Mbps in the BreezeNET PRO.11 modems. This data rate has also been tested.

Three types of BreezeNET PRO.11 modems are used in the URBOT/OCU infrastructure; an Access Point (AP-10), a Workgroup Bridge (WB-10), and a Station Adapter (SA-40). An AP-10 is a wireless hub that connects a wireless network to a wired network, and it also allows communication between SAs and WBs. A WB-10 allows connectivity between different Ethernet networks, while an SA-40 allows up to four wired stations to access a wireless network.

In all laboratory tests, coaxial cables were used in conjunction with variable attenuators to connect the antenna ports of the modems to establish communications channels. The attenuators serve two purposes. First and foremost, they protect the modems from being damaged by a large

input signal. Second, they simulate an increase in distance between two modems as the attenuation level is increased.

The software involved in performing these tests included SmartApplications, SmartWindow, and SmartMulticastIP, which work in conjunction with a SmartBits-200 (SMB-200) chassis using SmartCard 7710 Modules.

The URBOT and the OCU currently communicate using User Datagram Protocol (UDP) packets. A significant portion of these Ethernet packets transmitted from the URBOT contains digitized video. As a result, the Ethernet protocol for all tests was set to UDP.



**Figure 2. BreezeNET PRO.11 Modem**

On average, the size of a packet transmitted by the URBOT is around 500 bytes; this includes audio/video and other telemetry information. The performance of the modems at a packet size of 512 bytes is a point of interest in these tests since it is close to the maximum packet size transmitted by the URBOT.

## 1.1 Overview of Test Cases

The performance of the modems was tested in six different scenarios in which the URBOT could potentially operate. The following briefly explains each scenario.

- **Baseline Throughput** – This is a simple point-to-point communication topology where the URBOT communicates with its companion OCU. This test measures a best-case throughput to which results from the remaining tests are compared.

- **Multi-node Baseline Throughput** – This setup simulates a more realistic situation where more than one URBOT communicates with a single OCU, although currently this feature is not implemented.
- **Throughput in Multi-hop** – Repeater units are used in the URBOT/OCU infrastructure to increase the effective distance. This test measures whether or not the addition of a single and a dual repeater system affects the throughput.
- **Range** – The range test conducted in the laboratory measures the throughput as a function of free-space path loss (simulated by an attenuator), which was converted into an approximate distance using a first-order equation. The range test conducted in the field measures the throughput using different antenna types and heights.
- **Multicast Throughput** – It may be required to view video transmitted by the URBOT on other stations in addition to the OCU. For example, an officer may need to see the video coming from the URBOT in order to make a command decision and relay that to the operator controlling the URBOT. To accomplish this, a multicast session can be started wherein several stations can join the session and receive the appropriate data. This test measures the throughput of multicast packets.
- **Interoperability** – The purpose of this test is to determine if the BreezeNET PRO.11 modems can interoperate with other 802.11-compliant radios. A Symbol Spectrum 24 Ethernet Access Bridge was used in this test.

## 2.0 Summary of Test Results

The following sections summarize the full test report and provide the results obtained from the performance tests.

## 2.1 Baseline Throughput

This test measures the fastest rate at which the modems can communicate. The throughput is measured at each data rate over a range of variable packet sizes. In addition, the Request To Send (RTS) option is enabled/disabled to test the effect on the throughput. RTS is important when multiple nodes are trying to communicate with a single AP. Since only a simple point-to-point topology is used in this test, where only two modems are communicating with one another, RTS is enabled only to show that it does affect the overall throughput, given that it adds some overhead to the transmitted packets.

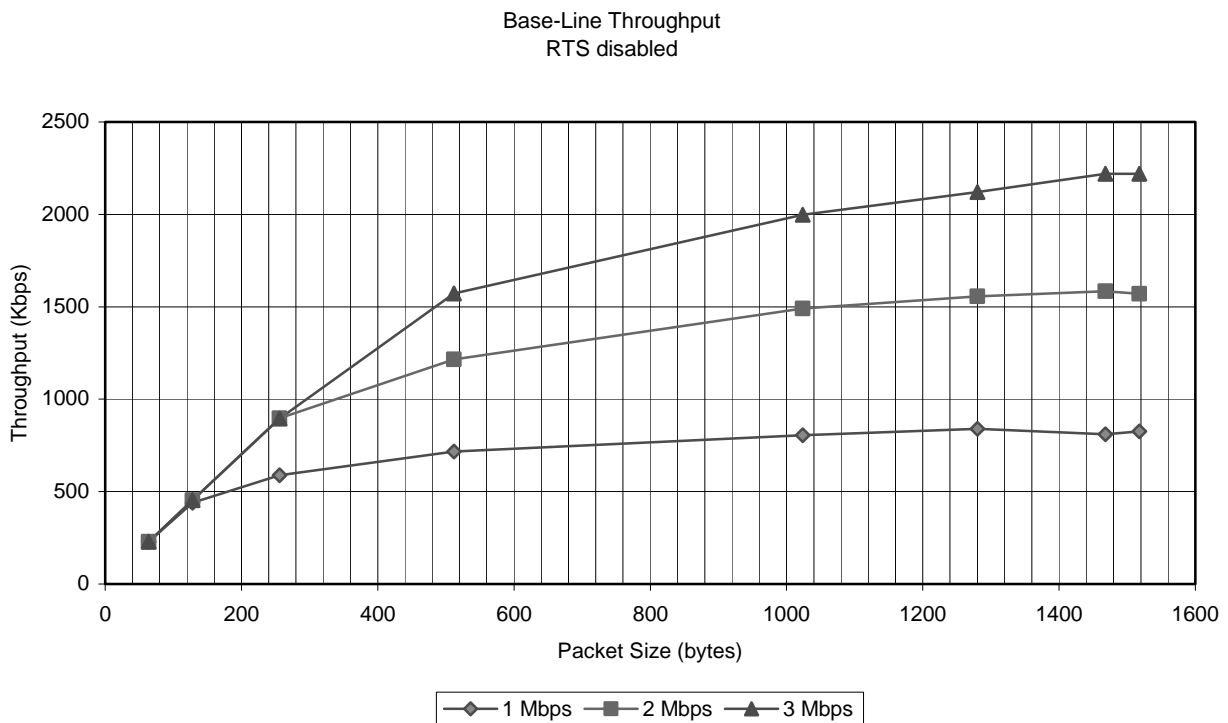

**Figure 3.** Highest Possible Bit Rate With Point-to-Point Communication

The baseline throughput tests were conducted to measure the maximum possible throughput at 1-Mbps, 2-Mbps, and 3-Mbps data rates. Each test was performed with RTS enabled and

disabled. A continuous stream of data at the given rate and packet size was transmitted and the received throughput measured. The results are shown in Figure 3.

As the packet size increases, so does the throughput. The maximum throughput of 2.22-Mbps was achieved at a packet size of 1468 bytes, with the data rate set to 3-Mbps. The BreezeNET modems fragment packets greater than 1468 bytes; as a result, there is a somewhat lower throughput at packet sizes greater than this built-in threshold.

The RTS feature was enabled next and the same test was performed. The RTS feature adds overhead to the packet, thus the overall throughput drops. The drop in throughput is about 250 Kbps at packet sizes of 512 bytes and greater, and less at smaller packet sizes. The advantage of enabling RTS will become evident in Section 2.2.

## **2.2 Multi-Node Baseline Throughput**

The Multi-Node test is performed mainly to show the advantage of enabling the RTS feature. When several nodes are trying to communicate with an AP, they are contending for the same channel. This is especially a problem when the transmitting nodes are hidden from each other due to range or barrier separation, but are within range of the AP. In this case both nodes will sense that the channel is clear and will start transmitting. Packets arriving simultaneously at the AP will collide and drop; therefore, both nodes will back off randomly and retransmit. Eventually one node will capture the channel as its packets get through and acknowledge packets are received from the AP. The packets of the other node will not be acknowledged, and as a result the connection to this node will become progressively worse due to exponential back-offs and timeouts.

With RTS enabled, a fair channel access is achieved. A node transmits an RTS packet requesting a predetermined amount of airtime from the AP. If the AP approves, it sends a Clear To Send (CTS)



packet to all listening nodes, at which time only the approved node can get on the air. At the end of its transmission it will back off for a random amount of time and other nodes will get a chance to send an RTS packet. RTS is generally not justified for small packet sizes, since they are likely to get through to the AP, especially if retransmissions of data packets are performed. However, for this test the RTS is either completely disabled or enabled for all packet sizes.

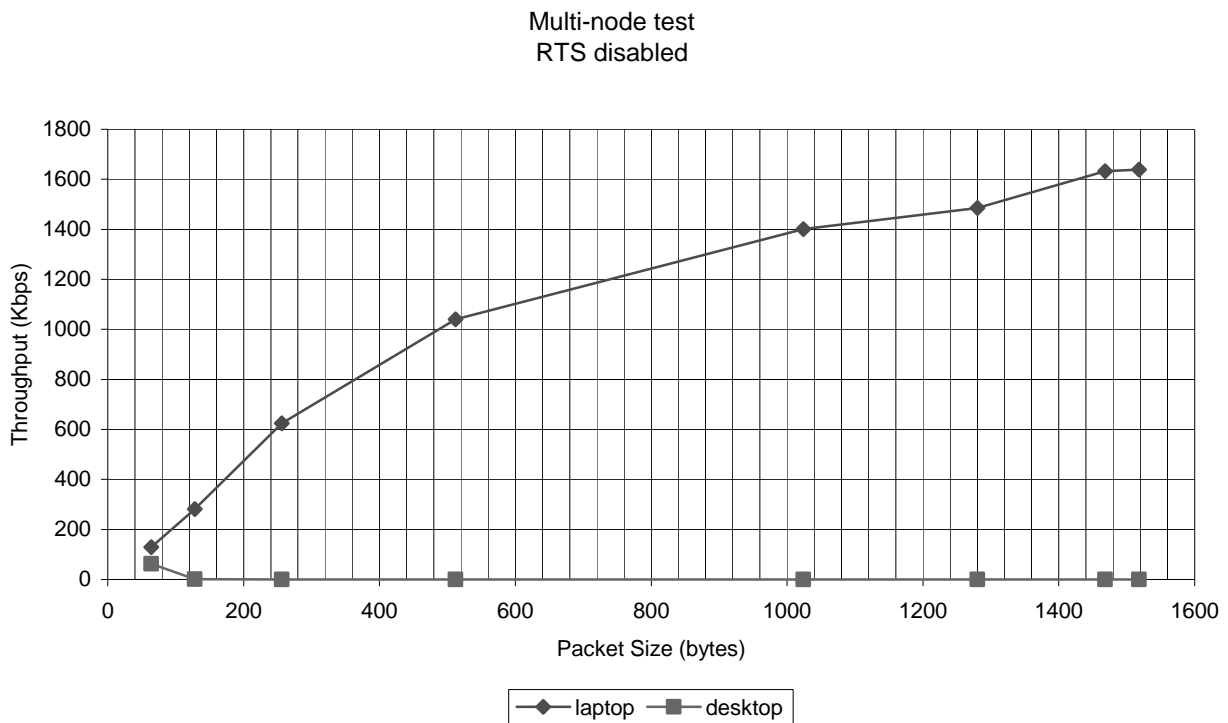

**Figure 4.** Node Channel Capture Effect With RTS Disabled

Attenuators were used to hide the transmitting nodes from each other but not from the AP. The effect of RTS can clearly be seen in Figures 4 and 5. With RTS disabled, one node captured the channel completely when packet sizes were greater than 128 bytes. With RTS enabled, both nodes were able to transmit data, although the throughput of each node is less than the throughput of a single node with RTS disabled. This is due to the limited amount of airtime that is given to each node by the AP. Although the average throughput is approximately half that of a single node

with RTS disabled, both nodes are at least able to transmit at a satisfactory rate. Combining the throughput of each node yields a total throughput that is comparable to what was achieved when a single node captured the channel, as seen in Figure 4.

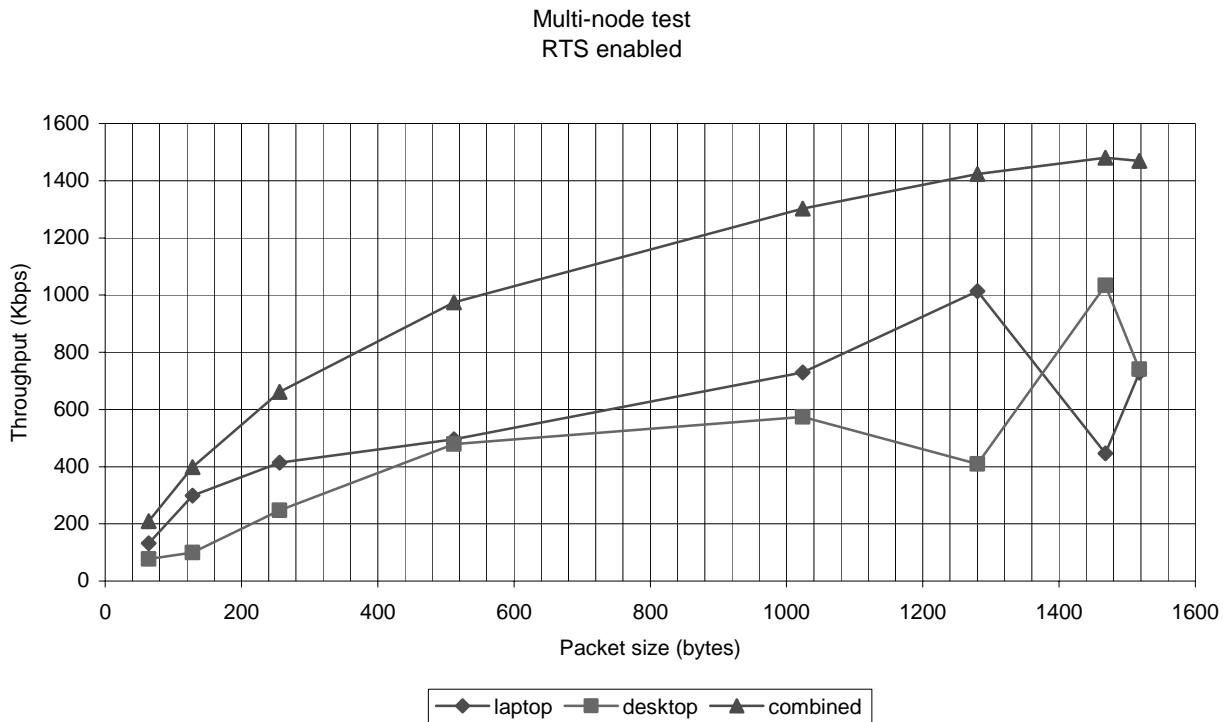

**Figure 5. Fair Channel Access Achieved With RTS Enabled**

### 2.3 Throughput in Multi-hop

A major issue in wireless communications is the effective range between nodes. One way to increase the range is to add amplifiers (See Section 2.4), but the output power amplification at radio frequencies is generally limited due to design constraints, and regulated by the FCC. Another way to increase range between wireless communication points is to introduce repeaters, or hop-points, into the wireless infrastructure. This option in turn will be limited by practicality, cost, and degraded performance. To test the performance in a multi-hop system, repeaters were added

between two communication points. A single repeater was first added, and its effect on the throughput measured. Then a second repeater was added, and the test repeated.

The BreezeNET modems communicate in the following manner: An SA and a WB can only communicate directly with an AP, and not with each other. In order for an SA to communicate with a WB, it must first go through an AP. Therefore, a repeater consists of an AP-WB pair. A sample test topology is shown in Figure 6.

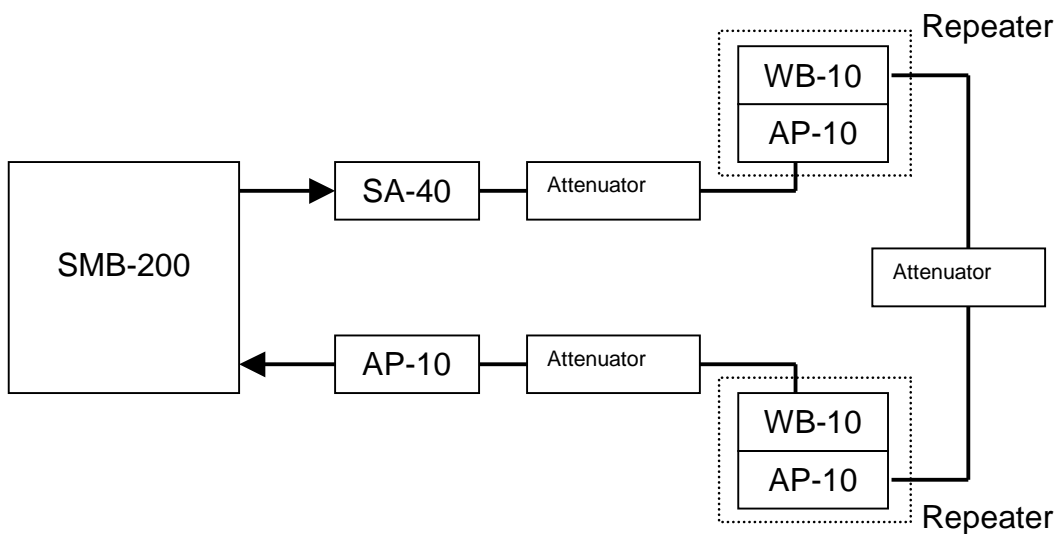

**Figure 6.** Dual Repeater Topology

The result of single and dual repeater topology are almost identical except that there is a slight drop in throughput in the two-repeater topology. For example, the largest difference in throughput, which is approximately 100 Kbps between the two topologies, occurs at a packet size of 1518 bytes. This indicates a drop of about 4.5% from the baseline throughput at this packet size. The percentage difference is reduced at lower packet sizes. The throughput measured in a dual-hop topology is shown in Figure 7.

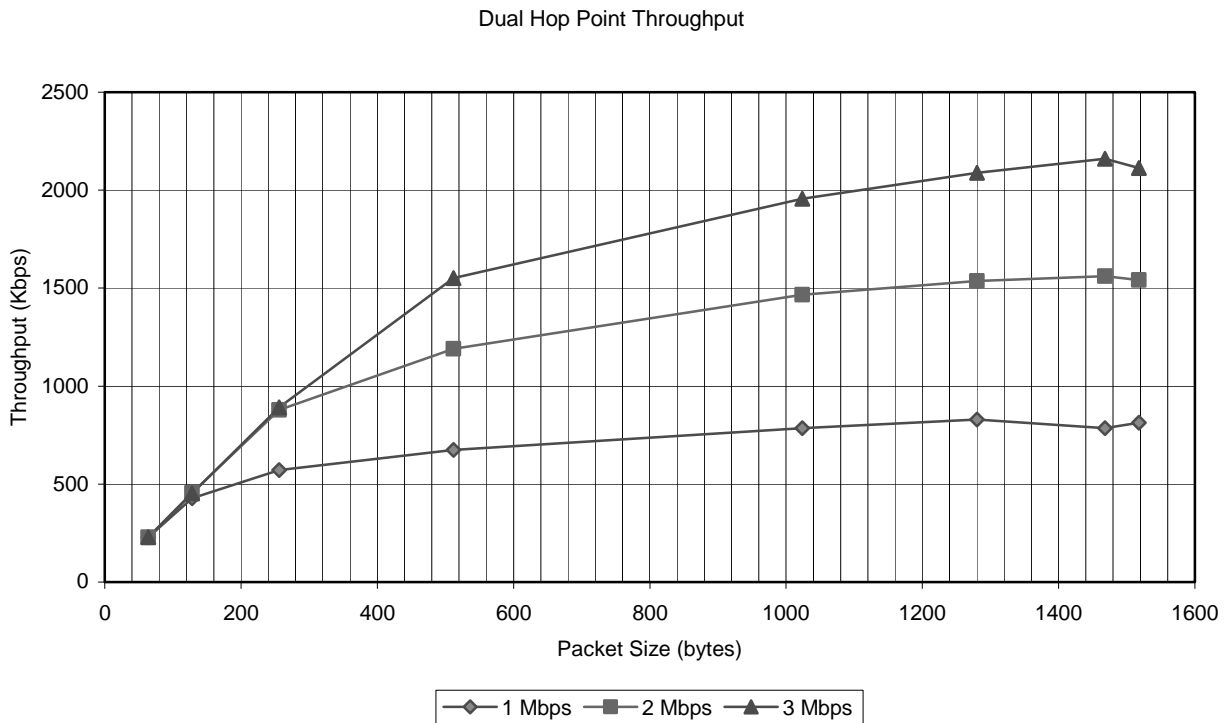

**Figure 7. Throughput Measured of a Two Repeater System**

## 2.4 Range

As stated in Section 2.3, one way to increase the range between communication points is the addition of amplifiers. The amplifiers used in these tests (see Figure 8) consist of a power amplifier for the transmitting end and a low noise amplifier (LNA) for the receiving end. Two different amplifiers were used, but not in every test.

The range tests were conducted both in the laboratory and in the field. The tests performed in the laboratory were conducted solely for the purpose of obtaining best-case scenario data to which the data obtained in the field would be compared.

In the laboratory, the range between the modems was simulated by increasing the attenuation level between two ends. At each level the throughput was recorded and a plot of throughput-versus-distance generated. The distance was derived from a first-order equation that is

a function of frequency measured in MHz and free-space path loss measured in dB. The laboratory test was conducted with and without a 2W amplifier.

Tx Power			Rx Sensitivity Threshold		
without amp	500mW amp	2W amp	without LNA	LNA (in 500mW amp)	LNA (in 2W amp)
17 dBm	27 dBm	33 dBm	-81 dBm: 1 Mbps -75 dBm: 2 Mbps -67 dBm: 3	-85 dBm: 1 Mbps -79 dBm: 2 Mbps -71 dBm: 3 Mbps	-84 dBm: 1 Mbps -78 dBm: 2 Mbps -70 dBm: 3

**Figure 8.** Comparison Between Amplifiers

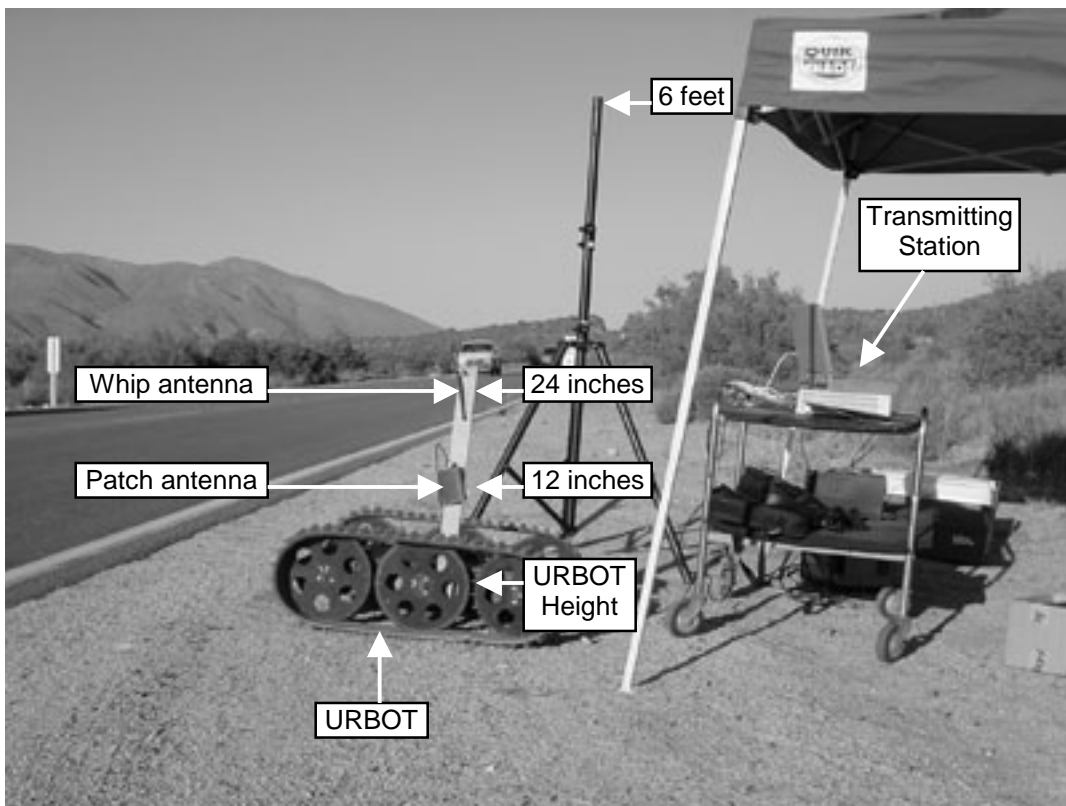

**Figure 9.** Field Range Test Showing The Transmitter Station Setup



**Figure 10.** Mobile Receiver Station in Field Range Test (Simulated OCU)

The field tests were conducted to determine how the throughput changes as a function of antenna height, antenna type, and distance. In order to receive data coming from the URBOT to the OCU at a rate that is fast enough to deliver uninterrupted audio/video and telemetry information, a minimum rate of approximately 400 Kbps is required. As a result, this threshold was used in the field to measure the maximum distance that can be achieved using various antenna types and antenna heights. To take into account the geometry of the URBOT body, which affects the RF signal, the antennae were actually mounted on an URBOT as shown in Figure 9.

To measure the maximum range the throughput was observed as the receiver moved away from the transmitter. When the throughput dropped to approximately 400 Kbps, the separation distance was measured. The block diagram of the field range test is shown in Figure 11.

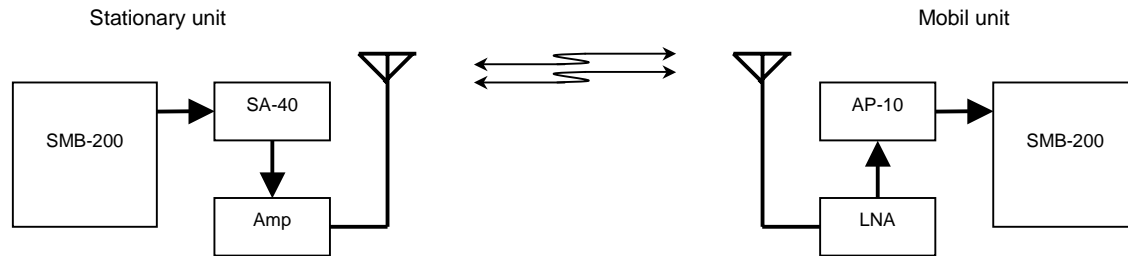

**Figure 11.** Field Range Test Setup

The laboratory test results are shown in Figure 12. It can be seen that the addition of an amplifier improves the distance by a factor of four when comparing the points on both plots where the throughput just drops below the saturation level. This factor decreases as the throughput drops.

The results of the field test are shown in Figure 13. Three different antenna types were used: 5-dBi whip antennae (omni-directional) currently used on the URBOT, 8-dBi patch antennae (directional) currently used on the OCU, and a 13-dBi Yagi antenna (highly directional) used by the OCU when extended range is required. The patch and the Yagi antennae, which were fixed at a height of 6 feet, were used on the receiver (OCU) side. The whip and the patch antennae were used on the transmitter (URBOT) side. They were interchanged and mounted at heights of 6 inches (the current location of URBOT antennae), 12 inches, 24 inches, and in a few cases at 6 feet. A 2W amplifier was used on the transmitter side throughout the tests. A 2W and a 500mW amplifier were used on the receiver side, although not at the same time, to take advantage of their integrated LNA.

The distance values given in the figure are in feet. The + sign indicates distances in excess of what the test area would allow. The “best case” and “worst case” distances apply only to the patch antenna. “Best case” indicates that the patch antenna on the URBOT pointed to the receiver antenna, and “worst case” indicates that the patch pointed 90° away from the receiver antenna. This is best illustrated in Figure 14.

Laboratory Range Test  
Packet size: 512 bytes

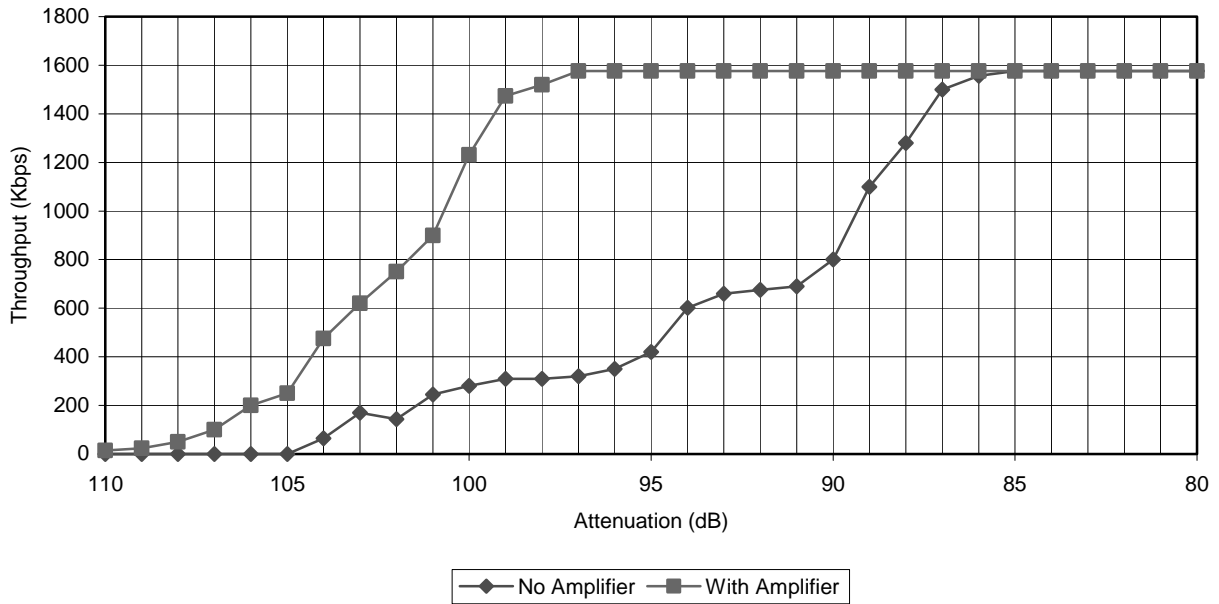

**Figure 12.** Significant Improvement in Distance With the Addition of a 2W Amplifier

In normal operation, the URBOT uses two antennae although only one is operational at a given time. An internal (to the modem) continuous check selects the antenna that receives the stronger signal. That same antenna is used for transmission. If two patch antennae are used, then the worst-case scenario will be when the URBOT antennae are facing 90° away from the OCU. In this state the radiation emanating from the selected patch antenna on the URBOT would come from the weaker side lobes of that antenna and therefore set the range limit. This is clearly seen in Figure 13, where the worst-case scenario always yielded a shorter distance than the best-case scenario.

Directional antennae, such as the patch and the Yagi antennae increase the range. This is due to their ability to concentrate most of the RF energy in one general direction. Increasing the height of the antenna also improved the range. Many factors contribute to this improvement. For



Antenna type		Antenna height on URBOT						
URBOT (2W)	OCU (fixed at 6')	URBOT height		12''		24''		6'
Whip	Patch 500mW	900		1056		1500		3000
	Yagi 500 mW	2142		4671		6921+		
Patch	Patch 500 mW	Best case 3240	Worst case 1680	Best case 3615	Worst case 1500	Best case 5085	Worst case 3348	
	Yagi 500 mW			Best case 6921 +	Worst case 3921			6267
Whip	Patch 2 W	1155		3237		3921		6921+
	Yagi 2 W	1680		4497		6921+		
Patch	Patch 2 W	Best case 2385	Worst case 1110	Best case 4101	Worst case 2775	Best case 4788	Worst case 2049	
	Yagi 2 W	Best case 6921 +	Worst case 3900	Best case 6921 +	Worst case 3921			

**Figure 13.** Maximum Distance at 400 Kbps

example, a height increase allows the RF energy to clear the Fresnel Zone more effectively. Other factors that may improve as the antenna is raised are diffraction and multi-path fading, which depend on the antenna position, surrounding environmental geometry, and environmental conditions. Looking at Figure 13 it is seen that a height increase always improved the effective range.

To further demonstrate the effects of antenna heights, a simulation was conducted using the EREPS (Engineer's Refractive Effects Prediction System) software, where antenna heights and

frequency can be entered and a plot of attenuation vs. propagation loss generated. Results from the simulation show that as the antenna height is increased, the propagation loss is decreased.

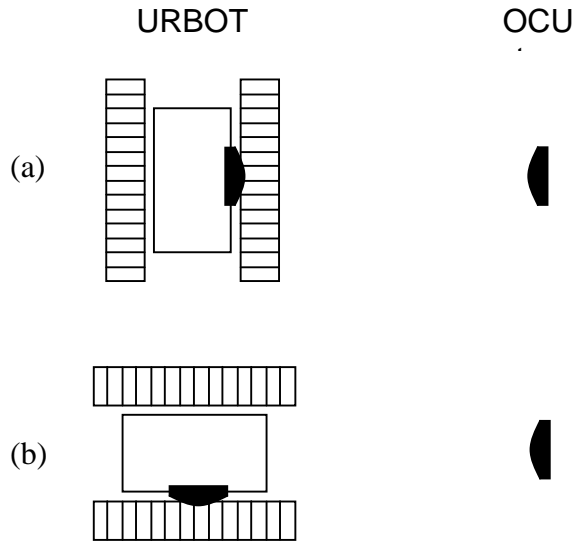

**Figure 14.** a) URBOT Patch Antenna Facing OCU Antenna; b) Facing 90° Away

## 2.5 Multicast Throughput

A popular form of a multicast session is the transmission of live video from one node to others that join the session. It may be desirable to view video coming from the URBOT on several stations, therefore the URBOT must generate and transmit multicast packets. The OCU would receive these frames and forward them to other stations that have joined the multicast session. The purpose of this test is to determine the throughput of received multicast frames. Since multicast packets are not acknowledged when received, they are transmitted at 1-Mbps, in order to decrease excessive bit errors. It is possible, at least in firmware, to increase the multicast data rate of a BreezeNET modem to 3-Mbps. This option was tested to find if the throughput improves.

Another parameter that was tested was the Delivery Traffic Indication Message (DTIM) period. The DTIM period determines on which beacon of the AP the multicast frames are

transmitted. According to the BreezeNET PRO.11 manual, the DTIM period applies to stations in power-save mode and those not in power-save mode (normal mode). The default setting for the DTIM period is 4 beacons, indicating multicast traffic is sent on the 4<sup>th</sup> beacon (approximately once every second). It follows that reducing this period should increase the rate at which the multicast frames are sent.

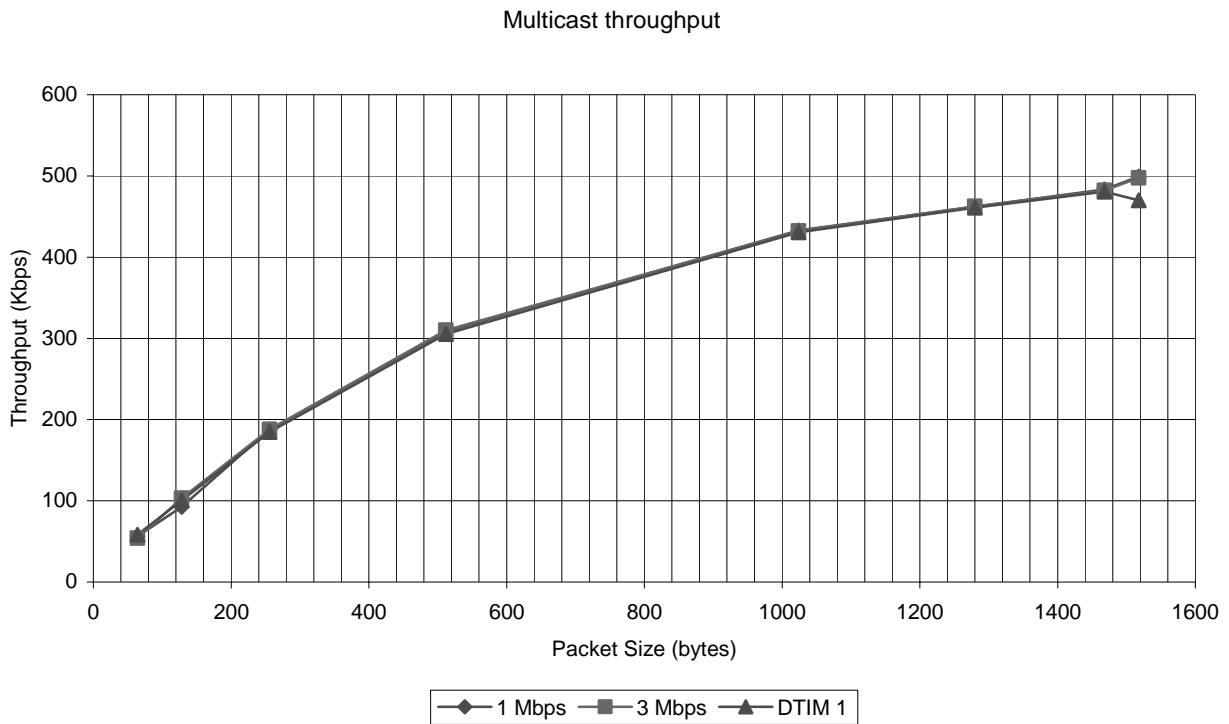

**Figure 15.** Multicast Throughput Using Different Modem Settings

The test setup was designed to simulate the transmission of video from the URBOT being received by the OCU and two additional stations. The throughput was measured at each station and plotted, as shown in Figure 15. Default settings were used to plot the throughput against varying packets sizes, which is shown as the “1 Mbps” plot. Increasing the multicast data rate to 3-

Mbps did not change the throughput rate. Decreasing the DTIM interval to 1 beacon also had no effect.

## 2.6 Interoperability

Wireless modems from different vendors incorporating the IEEE 802.11 protocol should be able to communicate with one another. To test this interoperability and to make throughput measurements, a Symbol Spectrum 24 Ethernet Access Bridge (EAB) was used. The throughput was measured against variable packet sizes.

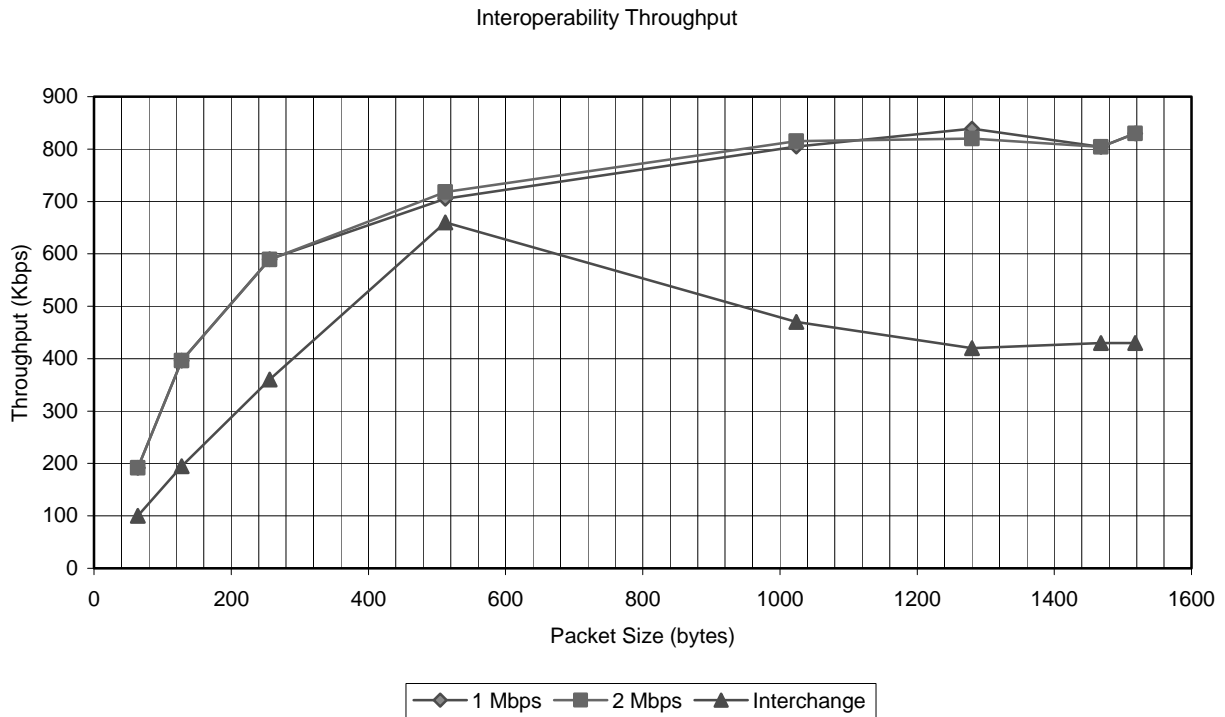

**Figure 16.** Interoperability Results of the BreezeNET AP and the Spectrum 24 EAB

A simple point-to-point topology was used in this test. The EAB operates at the standard data rates of 1-Mbps and 2-Mbps, and does not include a 3-Mbps data rate. The throughput was

only measured for the standard 802.11 data rates. Both modems were also swapped and the test performed at a 2-Mbps data rate, to ensure complete interoperability.

The throughput results of both data rates are shown in Figure 16. The 1-Mbps data rate is comparable to the baseline rate shown in Figure 3. However, the 2-Mbps data rate is not. Enabling both modems to transmit and receive at 2-Mbps did not increase the overall throughput. The modems were then swapped so that the EAB was allowed to transmit and the AP was able to receive. The data rate for each packet was manually adjusted so that the received throughput was measured at its highest level. The plot labeled “Interchange” in Figure 16 shows the throughput result. The input data rate was manually adjusted because a constant stream of data fed into the EAB at 2-Mbps caused the throughput to drop to much lower levels for each packet than that shown in the “Interchange” plot. The EAB did not perform as well as the BreezeNET AP since the AP was able to receive at higher throughput rates (see Section 2.1). However, the purpose of this test is to show that the BreezeNET modems do interoperate with other 802.11 wireless modems.

### **3.0 Conclusions**

Tests show that the throughput is directly related to the packet size, received signal power, and selected data rate. Contrarily, the highest throughput was not achieved at the maximum Ethernet packet size of 1518 bytes. It was achieved at 1468 bytes, the built-in packet fragmentation point. Beyond this packet size the throughput dropped a negligible amount.

The RTS feature was not needed in a simple two-node point-to-point topology, but was absolutely necessary when more than two nodes were present. Without RTS one node can capture the channel and not allow other nodes to communicate. Enabling RTS ensures that fair access is granted to all nodes, although the throughput of each node drops by a factor that is inversely

proportional to the number of nodes requesting to use the channel. Additionally, the throughput is somewhat reduced due to RTS packet overhead.

BreezeNET PRO.11 modems can be configured as repeaters, although two modems (an AP and a WB) are required to set up a repeater set. Only after adding a second repeater pair was there a slight degradation in the overall throughput.

Results obtained in the laboratory tests show that adding a 2W amplifier can increase the range by a factor of four when the throughput is saturated at a packet size of 512 bytes. Field tests show that the range is not only a function of transmission power and received signal level, but also the antenna type, position, and other environmental factors and radio wave properties. Highly directional antennae such as the Yagi and the patch antenna significantly improved the maximum range. The Yagi antenna is much more directional than the patch antenna and as a result there is not much room for play. The patch antenna was able to transmit even when faced 90° away, although the effective range was reduced by about half. Tests also show that raising the antenna from its current position on the URBOT (6") to heights of 12" or more can significantly improve the range even with omni-directional antennae.

The Multicast performance test shows that the data rate does not exceed 1-Mbps. The BreezeNET modem parameters related to the multicast data rate have no effect.

The BreezeNET PRO.11 modems were able to successfully communicate with another 802.11 compliant radio, at a data rate no greater than 1-Mbps.

The overall results show that significant improvements in throughput cannot be made in the URBOT/OCU infrastructure by simply changing the default modem parameters. Removing the small overhead of the RTS packets by disabling the RTS feature can make a slight improvement since it is not needed in the current point-to-point topology used in the URBOT/OCU combination.

A more significant improvement can be made in the effective range by replacing the current whip antennae with patch antennae. Results show that the maximum range obtained from worst-case scenario of the patch antennae is comparable, if not better, than the whip antennae. Raising the antenna height will bring about further improvements. This option, however, is not practical given the requirements of the URBOT (the URBOT is invertible; therefore raising the antenna on one side will hamper its operation should the URBOT turn over).

#### 4.0 References

- [BreezeCOM]            BreezeNET PRO.11 Series User's Guide, BreezeCOM Ltd., Cat. No. 213083, 1999
- [Breyer, Riley]        *Switched, Fast, And Gigabit Ethernet, 3<sup>rd</sup> Edition*, Robert Breyer & Sean Riley, New Riders Publishing, 1999
- [EREPS]                *Engineer's Refractive Effects Prediction System, Program: PROPH version 3.0*, Naval Command, Control and Ocean Surveillance Center (NCCOSC), D833, October 1996
- [Geier]                 *Wireless LANs: Implementing Interoperable Networks, 1<sup>st</sup> Edition*, Jim Geier, Macmillan Technical Publishing, 1999
- [SSC-SD1]             *IEEE 802.11 FHSS System Test Report*, Space and Naval Warfare Systems Center, San Diego (SSC-SD), D855
- [SSC-SD2]             *Wireless Local Area Network Test Plan, v1.01*, Space and Naval Warfare Systems Center, San Diego (SSC-SD), D85