

REPORT DOCUMENTATION PAGE

AFRL-SR-AR-TR-04-

Public reporting burden for this collection of information is estimated to average 1 hour per response, including the time for reviewing instructions, searching existing data sources, gathering the data, reviewing the collection of information. Send comments regarding this burden estimate or any other aspect of this collection of information, including suggestions for reducing the burden, to Washington Headquarters Service, Paperwork Project Office, 1215 Jefferson Davis Highway, Suite 1204, Arlington, VA 22202-4302, and to the Office of Management and Budget, Paperwork Project Office (0301-0188), Washington, DC 20503.

0208

1. AGENCY USE ONLY (Leave blank)

2. REPORT DATE

3. REPORT TYPE AND DATES COVERED

01 May 2003 - 30 Apr 2004 FINAL

4. TITLE AND SUBTITLE

(DURIP 03) Non-Linear Radio frequency Research and Educational Laboratory

5. FUNDING NUMBERS

3484/US

61103D

6. AUTHOR(S)

PROFESSOR ROBLIN

7. PERFORMING ORGANIZATION NAME(S) AND ADDRESS(ES)

OHIO STATE UNIVERSITY

RESEARCH

1960 KENNY ROAD

COLUMBUS OH 43210-1063

8. PERFORMING ORGANIZATION

REPORT NUMBER

9. SPONSORING/MONITORING AGENCY NAME(S) AND ADDRESS(ES)

AFOSR/NE

4015 WILSON BLVD

SUITE 713

ARLINGTON VA 22203

10. SPONSORING/MONITORING
AGENCY REPORT NUMBER

F49620-03-1-0268

11. SUPPLEMENTARY NOTES

12a. DISTRIBUTION AVAILABILITY STATEMENT

DISTRIBUTION STATEMENT A: Unlimited

12b. DISTRIBUTION CODE

13. ABSTRACT (Maximum 200 words)

The AFOSR Durip grant was awarded to OSU in May 2003. A research Foundation account ~ RF744774 was subsequently created. The target of this AFOSR Durip grant was to acquire a Large Signal Network Analyzer (LSNA). A brief description of the activities which took place in the calendar year 2003 following the award are described below. In the Summer 2003 establishing the specifications of the LSNA as required by the OSU bidding process. By the time of the award Agilent which initially developed the LSNA, had contracted with Naurv Microwaves to fabricate and distribute it. OSU being one of the first customer for this new product, no detailed specs were then available and the P1 worked with Maurv Microwaves to develop them. Attached to this report is the resulting list of specifications which were established for the final equipment requisition.

20040423 028

14. SUBJECT TERMS

Non-linear Radio and Educational Lab

15. NUMBER OF PAGES

16. PRICE CODE

17. SECURITY CLASSIFICATION
OF REPORT

Unclassified

18. SECURITY CLASSIFICATION
OF THIS PAGE

Unclassified

19. SECURITY CLASSIFICATION
OF ABSTRACT

Unclassified

20. LIMITATION OF ABSTRACT

UL

Best Available Copy

Final Report

FY2003 DURIP

F49620-03-1-0268

Non-Linear Radio-Frequency Research and Educational Laboratory

Patrick Roblin

Department of Electrical Engineering

The Ohio State University

<http://eewww.eng.ohio-state.edu/~roblin>

email: roblin@ee.eng.ohio-state.edu

phone: 614-292-0998

submitted to

Dr. Gerald Witt

**Air Force Office of Scientific Research
FY2003 DURIP-AFOSR**

Dec 28, 2003

1. Report

1.1 Introduction

The AFOSR Durip grant was awarded to OSU in May 2003. The OSU Research Foundation account # RF744774 was subsequently created. The target of this AFOSR Durip grant was to acquire a Large Signal Network Analyzer (LSNA). A brief description of the activities which took place in the calendar year 2003 following the award are described below.

The ordering of capital equipment follows a rigorous process at OSU which is mandated by Ohio state laws. As part of these regulations, capital equipment has to be submitted to a competitive bidding process. To complete this bidding process detailed specifications of the equipment targeted are required.

The PI spent the Summer 2003 establishing the specifications of the LSNA as required by the OSU bidding process. By the time of the award Agilent which initially developed the LSNA, had contracted with Maury Microwaves to fabricate and distribute it. OSU being one of the first customer for this new product, no detailed specs were then available and the PI worked with Maury Microwaves to develop them. Attached to this report is the resulting list of specifications which were established for the final equipment requisition. Also the LSNA had to be configured for the applications (pulsed RF measurement) targeted in the proposal. The final configuration selected is shown in Figure 1.1.

Maury provided a \$33,930 discount and donated the operating software. However the LSNA also requires various RF sources for the equipment to function. By directly ordering some of these particular pieces of equipment to their manufacturers (Agilent and Anritsu) instead of ordering them via Maury, OSU was able to benefit from an extra educational discount of 20% or more. The LSNA order was therefore broken into three separate orders, each of them requiring at least 3 bids.

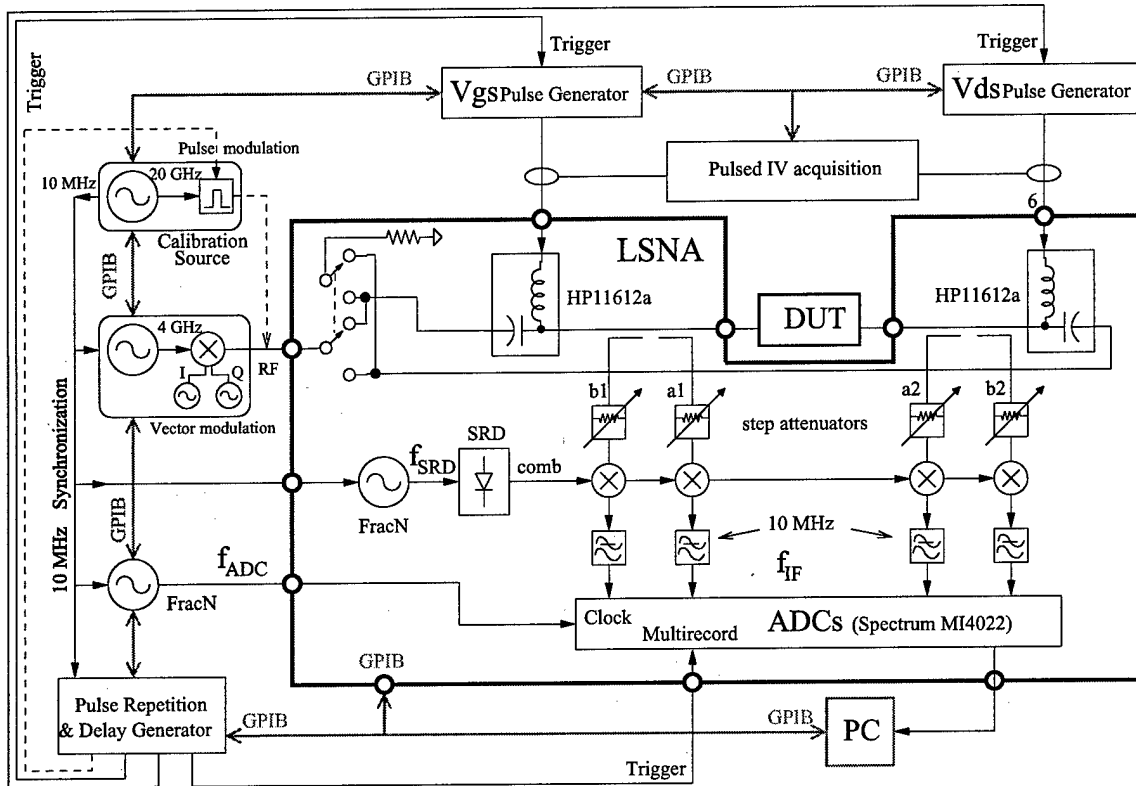

Figure 1.1: Schematic of LSNA configured for pulsed RF measurement.

Equipment	Source	Cost
20 GHz Large Signal Network Analyzer	Maury Microwaves	\$ 235,910
Digital Modulation RF source + Power meter	Agilent	\$ 46,981
2-20 GHz CW Synthesized Generator	Anritsu	\$29,760
TOTAL		\$ 312,651

Note that because of the extra RF source required to operate the LSNA with digitally modulated signals it was not possible to acquire the infrared camera initially targeted.

The 3 requisitions were internally submitted in OSU by the PI in September 4, 17 and 25, 2003 respectively. The cost of the equipment is to be splitted in 5 different ways:

- DOD/Durip RF744774: 50 %
- Ohio Board of Regent (OBOR): 25 %
- OSU: 25 %
 - Depart. of Elect. Eng.: 1/3 of OSU share
 - College of Eng.: 1/3 of OSU share

– Office of Research: 1/3 of OSU share

The equipment specifications were sent to various manufacturers for bidding. The results of the bidding was then reviewed by the PI and the originally proposed manufacturers were selected as they were either the most cost effective (Agilent and Anritsu) or offered the only viable solution (Maury). The requisitions were then sent to various successive auditing steps in OSU and finally to the Controlling Board of the State of Ohio. In December 15, 2003 the Controlling Board of the State of Ohio met and approved the 1/4 cost sharing initially pledged. The 3 purchase orders were then generated and mailed in December 18, 2003. The LSNA is expected to be delivered in late March 2004.

The Durip award specifies that the fund should be spent by March 31, 2004. In the absence of production delay we should be able to meet this schedule.

1.2 Description of the LSNA Acquired and of Potential Applications

OSU will be the first University in the US to acquire an LSNA. The LSNA was developed to measure the non-linear response of electronic devices to radio-frequency (RF) signals from 0.6 to 20 GHz. The RF signals can be continuous wave, multitone or pulsed periodic signals. Note that the control of non-linearities in devices is of critical importance in wireless applications to minimize the pollution of the RF spectrum resource and prevent signal distortion and cross-talk. The LSNA provides the means to reconstruct actual RF waveforms in the time domain for RF signals featuring up to 10,000 tones. The applications of the LSNA itself are various and include semiconductor device model-extraction and model-verification. The LSNA is also useful for designing highly-linear RF power-amplifiers for wireless communication. Finally the LSNA's unique capabilities should make it useful for measuring ultra-wide-band (UWB) periodic RF signals (typically having more than 1 GHz bandwidth). Note that ultra-wide band signals are the basis for novel applications including isothermal device-measurement, UWB communication, UWB radar and UWB detection of breast-cancer tumors.

1.3 Non-Linear RF Laboratory at OSU

The presence of the LSNA at OSU is expected to not-only leverage present research at OSU but also facilitate the development of new collaborative research thrusts with other Industrial, University and Governmental labs.

In expectation for the arrival of the LSNA a letter of intent for the creation of a multi university IUCRC center was submitted by OSU to NSF. The letter of intent is available at: <http://www.eleceng.ohio-state.edu/~roblin/iucrc/>

OSU and its partners Georgia Tech. and University of Colorado declined however the offer made by NSF to join an existing wireless IUCRC center as this would have diluted the research thrust targeted on non-linear RF. Nonetheless this attempt demonstrates the interest of other universities in joining OSU in such a research thrust.

The PI submitted a proposal to NSF for funding seed research focusing on the use of the LSNA for non-linear device and behavioral modeling, pulsed RF measurement and power amplifier linearization. The proposal is available at:

<http://www.eleceng.ohio-state.edu/~roblin/nsf03/nsf03.pdf>

The PI and his Co-PIs intend to submit other proposals in the near future to AFOSR and other agencies such as SRC. Indeed this equipment will permit us to pursue new types of research not conceivable before. In the mean time this equipment will benefit the various DOD, NSF and industrial research projects mentioned in our DURIP proposal. These projects include research in GaN RF power devices and research in linearization of broadband RF systems.

2. Large Signal Network Analyzer

Specifications of LSNA:

General:

Microwave system for measuring the calibrated phase and amplitudes of the harmonics of CW and modulated signals from 0.6 to 20 GHz with upgrade capability to 40 GHz. The LSNA has a 10 MHz bandwidth with 1 kHz resolution and can acquire 10,000 multi-tones. Typical dynamic range is 70 dBc and noise floor of -80 dBm.

Test Set:

2 test ports + power cal port
Frequency range: 0.6 to 40 GHz
Switch for RF input and load
Switch for signal conditioning by-pass
Maximum RF power: 10 W
Attenuators 60 dB, step 10 dB
Coupler Insertion loss: < 1.5 dB below 20 GHz
Connectors: 2.4 mm
All adapter/connector-savers required (8 minimum) for conversion of all the 2.4mm connectors of the testset to operate with 3.5 mm cal-kit/test-cable/power meter/RF-source for 20 GHz operation.

Bias Tee:

10 W RF min
DC input:
0.5 A
+/-40 V

Analog Sampling Converter:

Frequency Range: 50 GHz
Max Bandwidth: 10 MHz
SRD RF source (frac N or sF): 10-20 MHz controllable by user via GPIB.

Digital to Analog Conversion:

4 channels
14 bits
Memory: 250,000 M sample
Sampling rate: 10-20 MHz
ADC RF source (adcF) synchronized with 10 MHz clock.
Synchro and distribution ports for pulsed RF are provided externally with ADC options MI4022-mr and MI4022-gs.

Load Pull:

Controller with 1 tuner.
Frequency: 1.8 to 18.0 GHz
RF power: 50 W
Connector: 7mm
VSWR: 15 dB min
Max Insertion loss: 1.16 dB
Calibration software
Software interface with LSNA
Display: P1dB, PAE, gain contour plots

Software Function:

Equipment (except ADC) are controlled by GPIB.
Calibration (SOLT/LRRM, power, harmonic reference)
Testbed and tuner deembedding.
Harmonics and multisine data acquisition.
Display: load line, time domain, frequency domain.
Generic dll API and header files to allow for example LabView
to connect to LSNA.
Software documentation

Computer:

2.4 or more GHz Pentium 4, 80 GB disk, 512 MB RAM, RW CD
GPIB card High res 17" minimum LCD monitor
Optical mouse with center wheel
Keyboard

System integrated in a rack

All power supply cords.

All GPIB cables to control required equipment delivered

Hardware documentation

Specifications of RF CW Generator:

Synthesized CW Generator 10MHz to 20 GHz

Low phase noise (-80 dBc/Hz at 1kHz, -90 dBc/Hz at 10 kHz)

Low harmonics level (-30 dBc <2 GHz, -50 dBc >2 GHz)

High power output (> 15 dBm)

High stability time based

Pulse modulation (minimum pulse width 10 ns)

Pulse Generator (period: 500 ns to 1 s, width: 100 ns to 1 s, delay: 0 to 1s)

Rack mount configuration

Specifications of Vector Signal Generator:

Vectorial signal generator from 250 kHz to 4 GHz.

High output power from 136 dBm to 10 dBm

SSB phase noise <-130 dBc/Hz at 1 GHz <-115 dBc/Hz at 4GHz for 20 kHz offset

Harmonics below -30 dBc

2 channel baseband generator with 64 Msa and 16 bit resolution

IQ bandwidth of 100 MHz

6 Gbyte drive for waveform storage

3GPP WCDMA protocol

Specification of Power Meter and Sensor:

50 MHz to 26.5 GHz , -30 to 20 dBm

Calibration Kit:

SMA, DC to 26.5 GHz standards for SOLT calibration

Specification of Bias Tees:

1.5 dB Insertion loss from .4 to 26 GHz

14 dB Return loss from .4 to 26.5 GHz

10 W RF min

DC input:

40 MHz input

2 A DC , 10 A pulsed with 3% duty rate & 30ms pulse width max

+/-100 V

3. Quotes

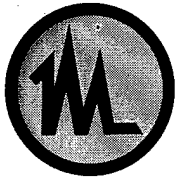

MAURY MICROWAVE CORPORATION

2900 INLAND EMPIRE BLVD. • ONTARIO, CA 91764 USA • TEL: 909-987-4715 • FAX: 909-987-1112

September 16, 2003
Maury Quote No. 03-0066D

Ohio State
Atten: Patrick Roblin
roblin@ee.eng.ohio-state.edu
Tel: 614-270-8737

Dear Patrick

Maury Microwave is pleased to offer the following quotation for a LSNA and Automated Tuner System.

1. LSNA Model Number MT4463Axx \$202,500.
(xx complete model number will be assigned at time of order entry)

a. Model MT4463Axx includes:

1. Sampling Converter, 50GHz
2. Test Set, 40 GHz
3. Harmonic Phase Reference, 20 GHz (calibrated)
4. Rack
5. LSNA Software with 20 hours of software support within first year
6. System Manual
7. Two days On-site Installation
8. One day On-site Training
9. Desktop Computer including:
 - a. 2.4 GHz or faster Pentium 4 Processor
 - b. 512 MB RAM
 - c. 80 GB Hard Drive
 - d. RW CD
 - e. GPIB Card
 - f. 17" Minimum High Resolution LCD Monitor
 - g. Optical Mouse with Center Wheel
 - h. Keyboard

b. The additional equipment needed for an LSNA measurement include the following items.

1. Digitally Modulated Signal Source
2. Power Meter
3. Bias Supply
4. Test Cables
5. Calibration Kit
6. System integration
7. Mathematica Software >= Version 4.2

The customer is responsible for the interconnecting cables, adapters, rack mounting hardware and integration of these additional components. Additionally, the customer supplied hardware must be in compliance with the current LSNA supported instruments at time of installation.

2. Automated Tuner System (ATS)

- a. Model MT980Nxx, 1.8 to 18.0 GHz System including the following items, \$ 58,430
(xx complete model number will be assigned at time of order entry)

- | | |
|------------|---|
| 1 MT982A02 | High Matching Range Tuner 1.8 to 18.0 GHz |
| 1 MT986B01 | Controller for 1 tuner |

- 1 MT993C Power and Noise Characterization Software
- 1 MT980Z06B On-site Installation 3 days
- 1 MT980Z09 2 days training for 2 people at Maury
- 20 Hours Technical Support to be used within 1st year

b. Software Options:

MT993D IMD/ACP Power Option	\$ 8,049
MT956D Fixture Software	4,777
MT993P Post Analysis Option	4,399
MT993F System Control Software	8,686
MT993G DC I-V Software Option	2,316
MT993H Harmonic Software Option	<u>4,053</u>
Subtotal	\$32,280

3. Hardware Options

- a. 2 each Cascade Probes, ACP, 40 GHz,
GSG, 150 Au \$1,000 each 2,000
- Note:** Must specify standard or 45 degree.
- b. MI4022-MR Option to the ADC Card 530
- c. Fractional - N Synthesizer 4,280
- Note:** This is not supported as part of the LSNA or ATS setups
and has no supported interface.
- d. 3.5/2.4mm Adapter Set, 10 pieces, Model 7927N01 2,100

Total Price for the LSNA and ATS Systems, software options, hardware options, installation and training.

LSNA	\$202,500
ATS	58,430
Software Options \$32,280	0 with system purchase
Hardware Options	<u>8,910</u>
Total	\$269,840
Educational System Discount	<u>*33,930</u>
Net Price to Ohio State	\$235,910 (Based upon all of the above being ordered.)

Delivery would be 16-20 weeks ARO. Terms of sale TBD, FOB origin, quote valid 90 days.

*The Educational System Discount is based upon a cooperative effort of Ohio State working with Maury and NMDG to promote the LSNA and ATS technology. This would include at least one technical paper being published (internally or externally) per year for the next five years in which the LSNA and/or ATS is used and referenced. Maury will further support Ohio State by providing at No Charge, ATS Software upgrades during this period. This will result in an additional savings and discount of \$7,153 per year, \$35,765 over five years.

Please don't hesitate to contact me with any questions that you may have.

Sincerely,



Jim Adamson
General Sales Manager
Maury Microwave Corporation

1155 East Collins Blvd.
Richardson, TX 75081

TEL: (800) 267-4878
FAX: (972) 671-1877

IN REPLY PLEASE REFER TO
THIS QUOTE NUMBER:

1-1YX00
Revision:0

Attn: Patrick Roblin
Cc:

Quote Type: Firm
Quote Date: 8/14/03

To: Ohio State University Dept. Of Electrical Engineering
Room 205 Dreese Lab 2015 Neil Avenue
Columbus, OH 43210

Customer Refs:

Terms: NET 30 DAYS
Recom. Shipping Method: FedEx
FOB: Shipping Point

Phone: (614) 292-0998
Fax: (614) 292-7596

Quote Firm For: 60 Days

Line	Qty	Item #	Product Description	Standard Delivery Time (Weeks)	Standard Base Price	List Price	Net Disc %	Net Price	Extended Price
1	1	MG3692A	Synthesized CW Generator, 2 to 20 GHz	10-12 ARO	18,750.00	\$18,750.00	20	\$15,000.00	\$15,000.00
2	1	MG3690A-1A	Option 1A, Rack Mount kit with slides	10-12 ARO	350.00	\$350.00	20	\$280.00	\$280.00
3	1	MG3690A-3	Option 3, Ultra Low Phase Noise, main band, >2 GHz	10-12 ARO	4,500.00	\$4,500.00	20	\$3,600.00	\$3,600.00
4	1	MG3690A-4	Option 4, RF Coverage 0.01 to 2.2 GHz, with DDC for ultra-low phase noise	10-12 ARO	2,450.00	\$2,450.00	20	\$1,960.00	\$1,960.00
5	1	MG3690A-13A	Option 13A, Pulse Modulation External for models up to and including 40 GHz	10-12 ARO	3,500.00	\$3,500.00	20	\$2,800.00	\$2,800.00
6	1	MG3690A-15B	Option 15B, High Power Output, for MG3692A with pulse option 13 (ext. pulse)	10-12 ARO	4,900.00	\$4,900.00	20	\$3,920.00	\$3,920.00
7	1	MG3690A-16	Option 16, High Stability Time Base	10-12 ARO	1,500.00	\$1,500.00	20	\$1,200.00	\$1,200.00
8	1	MG3690A-24	Pulse Generator (not available without Option 13x)	10-12 ARO	1,250.00	\$1,250.00	20	\$1,000.00	\$1,000.00

TOTAL: \$29,760.00

Pricing above reflects a 20% Educational Discount. Please call Dytac East, your Anritsu Company regional sales office at 330-405-8311 or 1-800-ANRITSU with regard to Inquiries and Order Placement.

Unless otherwise specified, our standard shipping method is Fed Ex Economy (two day delivery).

Anritsu offers a broad range of extended calibration and repair options. Please contact us if you have any questions.



Agilent Technologies

Customer Address:

Ohio State University Columbus
 Dreese Labs 234
 2015 Neil Ave
 Columbus OH 43210-1210
 United States

Reference: Patrick Roblin, Phone: 614-292-0998

QUOTATION		
Agilent Quotation No. 374825 .9	Date 24/SEP/2003	Page Number 1 / 3
Expiration Date/ Days 22/NOV/2003 60	Est. Weeks Delivery (All Quoted Items) 8	
Payment Terms NET 30 DAYS	Agreement/Expires EDUCATION-G8X00-31-MAY-09	
Delivery Terms DDP-Duty Paid		

Agilent Technologies Inc. / US
 PO BOX 4026
 ENGLEWOOD CO 80155-4026
 United States

Comments:

To place an order, please contact Yvonne Lehman at 800-829-4444 ext. 4696 or fax, 800-829-4433, email: Yvonne_lehman@agilent.com. To expedite processing of your order, please reference this quotation number on your purchase order.

Item No.	Product/Description	Est. (weeks) Availability	Qty	Unit Price	Adjustment Amount	Extended Price
1	E4438C - ESG Vector signal generator Purchase Agreement Discount-20 % CD of user guide and assembly level service manual Power cord - United States and Canada (120V)	7	1	0.00	0.00	0.00
1	E4438C-504 - 250kHz to 4 GHz Price Adjustment-25 % Special discount applied, expires 11/10/02. See terms and conditions below.		1	22,947.00	-5,736.75	17,210.25
1	E4438C-UNB - High output power with mechanical attenuator Price Adjustment-25 % Special discount applied, expires 11/10/02. See terms and conditions below.		1	1,049.00	-262.25	786.75
1	E4438C-UNJ - Enhanced phase noise performance Price Adjustment-25 % Special discount applied, expires 11/10/02. See terms and conditions below.		1	5,190.00	-1,297.50	3,892.50
1	E4438C-602 - Internal baseband generator, 64 Msa memory with digital bus capability Price Adjustment-25 % Special discount applied, expires 11/10/02. See terms and conditions below.		1	15,022.00	-3,755.50	11,266.50
1	E4438C-005 - 6 Gbyte hard drive Price Adjustment-25 % Special discount applied, expires 11/10/02. See terms and conditions below.		1	525.00	-131.25	393.75
1	E4438C-400 - 3GPP WCDMA (FDD) personalities Price Adjustment-25 % Special discount applied, expires 11/10/02. See terms and conditions below.		1	3,114.00	-778.50	2,335.50



Agilent Technologies

Customer Address:

Ohio State University Columbus
 Dreese Labs 234
 2015 Neil Ave
 Columbus OH 43210-1210
 United States

QUOTATION		
Agilent Quotation No. 374825.9	Date 24/SEP/2003	Page Number 2 / 3
Expiration Date/ Days 22/NOV/2003 60	Est. Weeks Delivery (All Quoted Items) 8	
Payment Terms NET 30 DAYS	Agreement/Expires EDUCATION-G8X00-31-MAY-09	
Delivery Terms DDP-Duty Paid		

Item No.	Product/Description	Est. (weeks) Availability	Qty	Unit Price	Adjustment Amount	Extended Price
1	E4438C-1CP - Rackmount kit with front handles Price Adjustment-25 % Special discount applied, expires 11/10/02. See terms and conditions below. 3 year Return-to-Agilent warranty		1	94.41	-23.60	70.81
					Item Net Total	35,956.06
2	8485A - Power Sensor, 50 MHz to 26.5 GHz, -30 to +20 dBm Purchase Agreement Discount-20 % 1 year Return-to-Agilent warranty	4	1	1,527.00	-305.40	1,221.60
					Item Net Total	1,221.60
3	E4418B - Single Channel EPM series Power Meter Purchase Agreement Discount-20 %	8	1	3,127.00	-625.40	2,501.60
3	E4418B-908 - Rackmount Kit (One Instrument) Purchase Agreement Discount-20 % 3 year Return-to-Agilent warranty		1	57.65	-11.53	46.12
					Item Net Total	2,547.72
4	85052D - 3.5 mm economy calibration kit DC to 26.5 GHz Purchase Agreement Discount-20 % 1 year Return-to-Agilent warranty	7	1	5,793.00	-1,158.60	4,634.40
					Item Net Total	4,634.40
5	11612A - Bias network, 45 MHz - 26.5 GHz Purchase Agreement Discount-20 %	4	2	1,375.00	-275.00	2,200.00
5	11612A-001 - High current bias Purchase Agreement Discount-20 % 1 year Return-to-Agilent warranty		2	263.00	-52.60	420.80
					Item Net Total	2,620.80
Unit Price Total						61,722.06
Adjustment Total						-14,741.48
Quote Net Total						46,980.58
Quote Price Total						USD 46,980.58

Please reference Agilent Technologies quote number, purchase agreement (if applicable) and item sequence on any resulting purchase order. Please contact your Agilent Field Engineer for any technical questions.

Please Submit Purchase Order to:
 Agilent Technologies
 P.O. Box 4026
 Englewood, CO 80155-4026
 Attn: Yvonne Lehman
 Fax: 1-800-829-4433

Net 30 days, subject to credit approval. All list prices are firm for 60 days.

Prices quoted include prepaid Agilent standard transportation. Invoicing on partial shipments will be considered acceptable unless otherwise noted on your purchase order. Please note your order with the requested delivery date.

Prices exclude any sales, value added or similar tax. If the items are exempt from sales tax, please ensure that a valid Tax Exemption Certificate, referencing Agilent Technologies as the vendor, be forwarded to your Agilent Technologies Order Processing

Agilent Financial Services is pleased to provide financing of Agilent products and services to qualified applicants. AFS offers a wide variety of rental, operating and full ownership options. To obtain more information, please contact AFS at 800-236-3508 and ask to speak with a Sales Finance