

# Does the U.S. Army Need Divisions?

A Monograph  
by  
MAJ Lester A. Layman  
U.S. Army



School of Advanced Military Studies  
United States Army Command and General Staff College  
Fort Leavenworth, Kansas  
AY 02-03

SCHOOL OF ADVANCED MILITARY STUDIES

MONOGRAPH APPROVAL

MAJ Lester A. Layman

Title of Monograph: Does the U.S. Army Need Divisions?

Approved by:

\_\_\_\_\_  
LTC Alan M. Mosher

Monograph Director

\_\_\_\_\_  
Robert H. Berlin, Ph.D.

Professor and Director  
Academic Affairs,  
School of Advanced  
Military Studies

\_\_\_\_\_  
Philip J. Brookes, Ph.D.

Director, Graduate Degree  
Program

## **Abstract**

DOES THE U.S. ARMY NEED DIVISIONS? by MAJ Lester A. Layman, ARMY, 65 pages.

Secretary of the Army Thomas White stated in a 2001 interview that he envisions flattening the Army organization along the lines of civilian industry and eventually eliminating divisions. This is not a new idea, but it does represent the highest level of interest put forth in eliminating the division echelon. There exists a debate, both within and outside of the Army, on whether the division echelon is necessary.

This paper examines the need for divisions using the following methodology. The criteria of span of command and control, communications technology, and the role of the division are used to discuss doctrine, history, and theory. A review of current doctrine examines whether there is a hole in the doctrine that requires a change. The history section follows the evolution of the current division by studying the general history of the division, the evolution of the modern division, and studies the 1<sup>st</sup> Infantry Division during the 20<sup>th</sup> Century. The theory section presents the current and recent arguments for both eliminating and retaining the division. The most common argument for eliminating the division is that future technology will enable commanders to increase their span of command and control. Opponents disagree, stating that technology is an enabler, not a replacement.

The review of current doctrine revealed no shortcoming that needs addressed. The history discussion revealed that the span of command and control fluctuated very little over the past century. Span of command and control remains an issue of the human element. What has changed, in some cases drastically, is communications technology and the role of the division. Technological advances allow a significant amount of information to be collected, sent, and received. It also assists a commander and staff in visualization, but does not increase his span of command and control. The role of the division has evolved to include Title X responsibilities, serve as other headquarters such as C/JFLCC and ARFOR, and coordination with other agencies. The conclusion of this paper is that the division is necessary and should not be eliminated.

## TABLE OF CONTENTS

TABLE OF CONTENTS .....	iv
INTRODUCTION.....	1
DEFINITIONS.....	2
Division.....	2
Span of Command and Control.....	2
Technology.....	3
Role of the Division .....	3
ISSUES .....	4
DOCTRINAL REVIEW .....	6
CONCLUSION.....	10
HISTORY.....	11
THE DIVISION ECHELON.....	11
EVOLUTION OF THE MODERN U.S. DIVISION.....	13
THREE WARS WITH 1 <sup>ST</sup> INFANTRY DIVISION.....	22
1 <sup>st</sup> Division in the Great War.....	22
1 <sup>st</sup> Infantry Division in World War II.....	24
The Big Red One in Desert Storm.....	26
CONCLUSION.....	28
THEORY.....	30
ELIMINATE THE DIVISION.....	30
Span of Command and Control.....	32
Technology.....	33
Role of the division .....	35
RETAIN THE DIVISION.....	35
Span of command and control.....	36
Technology.....	39
Role of the division .....	40
CONCLUSION.....	41
ANALYSIS/RECOMMENDATIONS.....	43
HISTORY.....	43
Span of Command and Control.....	43
Technology.....	45
Role of the Division .....	46
THEORY.....	46
Span of Command and Control.....	47
Technology.....	49
Role of the Division .....	50
CONCLUSION.....	53
APPENDIX A .....	56
FIGURE 1.....	56
FIGURE 2.....	57
FIGURE 3.....	57
FIGURE 4.....	58
FIGURE 5.....	59
FIGURE 6.....	59
BIBLIOGRAPHY.....	60

## CHAPTER ONE

### INTRODUCTION

“The Army has had its same hierarchy of forces -- corps, division, brigade, battalion, company -- since Napoleon. Now along comes information technology. The impact of information technology in the private sector is to flatten organizations, widen spans of control, be more horizontal, because everyone can very easily have the same situational awareness.”<sup>1</sup>

Secretary of the Army Thomas E. White

Secretary of the Army Thomas E. White believes that the United States Army needs to incorporate business practices. In a 14 June 2001 interview, Secretary White said the [U.S.] Army is behind the civilian sector in applying technology to the organizational structure and he envisions the Army ‘doing away with’ divisions in ten to fifteen years with brigades reporting directly to corps or through small mobile corps command posts.<sup>2</sup> Does the United States Army need divisions?

Following Desert Storm, the United States Army experienced a drawdown that resulted in the current force design of four corps and ten divisions. While XVIII Airborne Corps has four divisions and a cavalry regiment assigned to it, the remaining three corps have two divisions each and only III Corps has an Armored Cavalry Regiment. Given the ratio of 2.5:1 of division headquarters to corps headquarters, Secretary White’s use of technology to flatten the Army organization, and a changing operational environment, it is time to examine the need for divisions in the U.S. Army.

This paper will review doctrine and then examine history and theory to determine whether the U.S. Army needs divisions. This paper discusses each of these areas in turn using the following

---

<sup>1</sup> Joe Burlas, *White: Army needs better business practices*, (Interview with Secretary of the Army Thomas E. White), ArmyLINK News, Washington, DC: June 14, 2001. Available on the internet: [www.dtic.mil/armylink/news/Jun2001/a20010614white0612.html](http://www.dtic.mil/armylink/news/Jun2001/a20010614white0612.html). Accessed 19 February 2003, 2.

<sup>2</sup> Burlas, 2.

criteria: 1) span of command and control, 2) technology and particularly communications, and 3) the role of the division as a headquarters.

The remainder of chapter one examines the definitions of the terms used throughout the rest of the document, discusses the issues leading to the need for this study, and reviews what doctrine says about the division. Chapter two provides the history of the division and looks at the 1<sup>st</sup> Infantry Division during World War I, World War II, and Desert Storm. Chapter three examines several theories of whether changes need to be made to the force structure pertaining to the division and what those changes should entail. Chapter four analyzes the information previously discussed and provides recommendations. Finally, chapter five is the conclusion. Now let us lay the groundwork for terms used in the remainder of the paper.

## **DEFINITIONS**

### **Division**

It is important to note that when the need for a division is discussed in this document, it refers to the unit as an echelon of command. A division headquarters may have active organic units like the ten standing divisions in the Army or it may exist without organic units, to be filled by reserve units in time of war, like the 7<sup>th</sup> Infantry Division at Fort Carson and the 24<sup>th</sup> Infantry Division at Fort Riley.

### **Span of Command and Control**

Command, as defined by Field Manual (FM) 71-100-2 “is the art of assigning missions, prioritizing resources, guiding and directing subordinates, and focusing the entire division’s energy to accomplish clear objectives.”<sup>3</sup> Control, as defined by the same FM, “is defining limits, computing requirements, allocating resources, prescribing requirements for reports, monitoring performance, identifying and correcting deviations from guidance, and directing subordinate

---

<sup>3</sup> U.S. Department of the Army, FM 71-100-2, *Infantry Division Operations*, Washington D.C., 1993, 2-1.

actions to accomplish the commander's intent."<sup>4</sup> While sometimes referred to as span of control, this ignores the command function of the organization or individual.

In this paper, span of command and control refers to the number of subordinates for which one can maintain positive control. Span of command and control focuses on the number of major subordinate elements a command, and more specifically a commander, can direct in combat. FM 100-15: Corps Operations states that a corps normally commands from two to five divisions of any type.<sup>5</sup> Two to five major subordinates is the base line used throughout the remainder of this paper when examining span of command and control. Major subordinate elements are maneuver units unless otherwise specified in the text.

### Technology

Technology, as defined by the American Heritage Dictionary, is the application of science, especially to industrial or commercial objectives.<sup>6</sup> For this paper, technology refers to the application of science to materiel (the equipment, apparatus, and supplies, as guns and ammunition, of a military)<sup>7</sup> for the purpose of increasing lethality and/or effectiveness. In particular, this paper examines the evolution of communications technology within a division.

### Role of the Division

The role of the division refers to the functions the division (headquarters) serves in a given situation. The division's role in the Army has remained tactically focused, representing the highest tactical echelon. As the nature of warfare changes, the United States no longer fights alone; all operations are combined and/or joint. While remaining tactically oriented, the division has added the possible roles of Army Forces (ARFOR) Command and Combined/Joint Forces

---

<sup>4</sup> FM 71-100-2, 2-1.

<sup>5</sup> U.S. Department of the Army, FM 100-15, *Corps Operations*, Washington D.C. 1996, 1-7.

<sup>6</sup> *American Heritage Dictionary*, 2d ed., s.v. "technology."

<sup>7</sup> *American Heritage Dictionary*, 2d ed., s.v. "materiel."

Land Component Command (C/JFLCC). When discussing the role of the division, this paper verifies the division's tactical focus and any additional role(s) as part of a combined or joint force.

## **ISSUES**

There are three issues that need addressing when examining the need for divisions in the U.S. Army. First, what is the ideal span of control and can it be increased? Eliminating the division echelon infers, as Secretary White pointed out, that brigades would report directly to corps. Is there a limit to the number of brigades a corps can fight?

The span of command and control is established as two to five to seven for well functioning organizations. Major Joseph Martz argues that increases in technology enhance the commander's ability to command and control their forces (to a lower echelon) and precisely monitor those of the enemy.<sup>8</sup> Eliminating a level of command would decrease the time information travels from Corps to Brigades and vice-versa. This is true at face value; however, the same increase in technology also means that the commander is receiving more information at a higher rate than in the past. Currently, XVIII Airborne Corps Commander receives information from corps maneuver assets that constitute 4 Divisions, an Artillery Division, an Aviation Brigade, and a Cavalry Regiment. Attachments of separate brigades and other elements are unknown but possible. The Corps Commander makes decisions from input provided by seven elements as well as intelligence on the enemy. Eliminating divisions would increase this input to as high as twenty-three sources of information without attachments (each division is comprised of three maneuver brigades, and aviation brigade, and an artillery brigade). This is well beyond the accepted size for span of command and control. It is important to remember that every corps is structured differently.

---

<sup>8</sup> Joseph E. Martz, *The Division: Redundant or Necessary?*, Fort Leavenworth, KS. 1991, 4.



Let us look at V Corps as another example. V Corps, which is the only Corps in United States Army Europe (USAREUR), commands two divisions and a separate brigade. Given that a corps should command two to five divisions, V Corps is at the low end of ideal with three subordinate commands, only two of which are divisions.<sup>9</sup> To go one level lower, however, reveals that each division in V Corps only controls two maneuver brigades and an aviation brigade. The third maneuver brigade for each division is located at Fort Riley under the control of the 24<sup>th</sup> Infantry Division. By eliminating these two divisions, V Corps would have direct command and control of five maneuver brigades, three aviation brigades, and seven artillery brigades (V Corps currently has five artillery brigades and each division one). This totals fifteen subordinates in what is considered to be a smaller corps. Again, this is beyond the accepted number of subordinates for span of command and control. Is there a way to alleviate this problem or increase the span of command and control? This question leads directly to the next issue.

The second issue is one of technology. As already discussed, civilian corporations have successfully used improvements in technology to flatten organizations (reduce management levels). Does technology allow the U.S. Army to also flatten the organization by eliminating the division level echelon? Technology is an enabler that supports or changes the greater issue already mentioned, span of command and control. There exists one final issue in eliminating the division level echelon.

The last issue is the role(s) of a division on the modern battlefield. Historically, as we will discuss in chapter 2, the division is the highest tactical echelon. It served as a conduit between the operational corps level and the tactically fighting brigades. Can brigades, working directly for corps, fill the role of the division?

Historically since the Gulf War, the conduct of operations has been by Brigade size elements. When Division Headquarters deployed, they provided, with the exception of the Implementation Force (IFOR) in Bosnia, command and control to one Brigade. Force caps in current operations

---

<sup>9</sup> FM 100-15, 1-7. "A corps normally has from two to five divisions of any type and combination."

often dictate that Brigades are the primary unit in the Area of Operation. Another issue in the current operational environment is that doctrine is evolving to take into consideration non-contiguous, non-linear battlefields. Small units are spread over great a distance, which means a brigade now operates in an Area of Operation that would have previously been a division Area of Operation. This paper examines new and future roles of the division on the battlefield, such as ARFOR and C/JFLCC, and whether brigades and corps' can work without the division.

## **DOCTRINAL REVIEW**

In addition to the history and theory of the U.S. Army division level echelon, this paper also examines past, current, and future doctrine and examines what doctrine says about span of command and control, technology, and the role of the division echelon. 71-100 is the current division doctrine. FM 3-0 is the current operational manual in use by the U.S. Army. TRADOC Pamphlet 525-3-92/O&O provides insight into the proposed doctrine for the Objective Force. In addition, FM 71-100-2, FM 100-7, and FM 100-15 are used to expand upon doctrines consideration of span of command and control, technology, and role of the division.

FM 71-100: Division Operations, from 1996, represents the doctrine of the U.S. Army from the Army of Excellence through today. The basis for FM 71-100, as for all doctrine, is the technology available to employ the doctrine, the accepted span of [command and] control in an operation, and what roles the division plays in the Army.

FM 71-100 does not set a defined limit on the span of command and control. What it does say is that traditionally; divisions comprise nine to twelve maneuver, artillery, and supporting battalions in a corps operation.<sup>10</sup> This equates to two or three maneuver brigades and the Division Support Command (DISCOM).

Concerning technology, FM 71-100 is again vague. "Army divisions exploit advances in technology to include space-based platforms. They maximize the increased range, lethality, and

---

<sup>10</sup> U.S. Department of the Army, FM 71-100, *Division Operations*, Washington, D.C. 1996, 1-2.

accuracy of news systems, conducting simultaneous operations throughout the depth of the battlefield to overwhelm and adversary.’<sup>11</sup> This means the U.S. Army uses technology to its best advantage.

FM 71-100 describes the roles and missions of a modern division. The division’s primary focus is warfighting – the use of force. Divisions must be versatile, though, to conduct the ever-growing number of Operations Other Than War (OOTW) missions conducted.<sup>12</sup> Given the growing number of missions requiring a Joint Task Force (JTF), the division must be prepared to assume additional roles. In situations where a division works directly for a JTF, whether that is a corps element or not, the division’s personnel must know joint doctrine.<sup>13</sup> The division commander must also be prepared to serve in an Area of Operations (AO) as the ARFOR commander or C/JFLCC commander.<sup>14</sup> As the ARFOR commander, the division commander has responsibility for all U.S. Army forces in the AO. As a C/JFLCC commander, the division commander assumes responsibility for all land forces in the AO, whether they are Army, Marine, or Multi-national. These are the roles of the division as outlined in FM 71-100.

Current doctrine is found in FM 3-0: Operations dated 2001. While it does not address span of command and control or the role of the division, it does discuss technology. FM 3-0 addresses technology as part of the operational environment. Technology enhances the capabilities of a soldier; it does not replace the soldier.<sup>15</sup> FM 3-0 also gives three warnings regarding technology. First, fielding technology to only a portion of the force could lead to a hybrid organization if forces with dissimilar capabilities are combined. Next, the United States does not hold a monopoly on technology. The global market makes it cheap and easy for any country to purchase

---

<sup>11</sup> Ibid, vi.

<sup>12</sup> Ibid., 1-2.

<sup>13</sup> Ibid., 1-2.

<sup>14</sup> Ibid., 1-3.

<sup>15</sup> U.S. Department of the Army, FM 3-0, *Operations*, Washington, D.C. 2001, 1-12.

sophisticated weapons. Finally, the application of combat power is what decides the outcome of a war, not the level of technology a side possesses.<sup>16</sup> This seems to point out that technology is not the “silver bullet” but simply another round in the chamber.

TRADOC Pamphlet 525-3-92/O&O: The United States Army Objective Force: Operation and Organizational Plan for Maneuver Units of Action (UA O&O) dated November 2002 covers the latest theory in employing forces. This new theory sees a UA as a brigade sized element and the primary tactical element in the Army. A Unit of Employment (UE) is a division or corps sized organization that is highly tailorable and can integrate and synchronize Army forces for full spectrum operations at higher tactical and operational levels of war. The UE can serve as the ARFOR, JFLCC, or JTF. The O&O does refer to the UE as mainly a division sized element and uses a division symbol to represent it.<sup>17</sup> This divisional UE, like its contemporary counterpart, employs brigade sized Units of Action.

The UA O&O differs from the doctrine examined in that it is based on several key assumptions. Among these is that the acquisition community will develop the technology necessary, and proper resources will be available to support this doctrine.<sup>18</sup> The assumptions made are essential to the success of the UE/UA concept of warfare.

The span of command and control is graphically portrayed for a divisional UE and UA. The span of command and control for a divisional UE is three maneuver UA’s, an aviation a brigade, a divarty brigade, a sustainment brigade, and an engineer regiment.<sup>19</sup> The UA span of command and control includes three maneuver battalions, an aviations detachment, and artillery battalion, a

---

<sup>16</sup> FM 3-0, 1-12 – 1-13.

<sup>17</sup> TRADOC Pamphlet 525-3-90/O&O. *The United States Army Objective Force: Operational and Organizational Plan for Maneuver Unit of Action*. (Fort Monroe, VA: 2002), 7-8.

<sup>18</sup> *Ibid.*, 13-15.

<sup>19</sup> *Ibid.*, B-3.

forward support battalion, and as well as military intelligence and signal companies.<sup>20</sup> No mention is given to the span of command and control of a corps level UE.

FM 100-7: Decisive Force: The Army in Theater Operations addresses span of command and control and the use of technology. The number of subordinates that a commander can control depends on the mission, experience, training, communications abilities, and logistics and will be as broad or narrow as the situation dictates.<sup>21</sup> This shows the thought within the Army that the span of command and control is not a number that can be fixed.

FM 100-7 also discusses technology, specifically information technology. According to FM 100-7, information technology will provide the ability to dominate the battle space in any situation. The use of digital systems by soldiers in combat results in a marked advantage over our adversaries.<sup>22</sup> Information technology in the digitized force will have an increased capability that will result in a tactical advantage over the U.S. Army's opponents.

FM 7-100-2: Infantry Division Operations contains a whole chapter on future technology and increasing soldier capability. The Army tactical command and control system (ATCCS) has increased the Army's capabilities on the battlefield.<sup>23</sup> The manual also discusses future technology as it relates to sensing, lethality, fire support, survivability and endurance.<sup>24</sup> While other manuals briefly mention the uses of emerging technology, it is interesting to note that the Infantry Division manual, which has its focus on light infantry, is the only manual that devotes an entire chapter to technology.

---

<sup>20</sup> Ibid., 26.

<sup>21</sup> U.S. Department of the Army, FM 100-7, *Decisive Force: The Army in Theater Operations*, 1995, 7-14.

<sup>22</sup> Ibid., D-0.

<sup>23</sup> FM 71-100-2, 9-1.

<sup>24</sup> Ibid., 9-2 – 9-3.

## **CONCLUSION**

As the U.S. Army goes through transformation and begins moving to the Interim Force and eventually the Objective Force, it is apparent that the need for Divisions must be addressed. The issues stated in this paper need careful analysis and solutions for the problems raised.

That a need for change exists regarding U.S. Army divisions is obvious. What that change is becomes the issue. It is certain that any change to the U.S. Army division must be examined carefully. An examination of the issue using history, doctrine and theory provides a framework within which to study this problem. Applying the criteria of technology, span of control, and role of the division within the framework focuses the study. The remainder of this paper examines the issue using this framework.

## CHAPTER TWO

### HISTORY

This chapter examines the history of the division. A general background of the division is presented, from its inception in Europe to its development throughout American history. The modern U.S. Army Division is a product of the early twentieth century. A closer study of the U.S. Army Division looks at the 1<sup>st</sup> Infantry Division during World War I, World War II, and the Gulf War. An examination of existing span of command and control, technology, and the role of the division is made during each of these conflicts.

#### THE DIVISION ECHELON

The ideas leading to the modern division began in the 18<sup>th</sup> Century. In 1732,<sup>25</sup> Marshal Maurice de Saxe described his idea of dividing armies into permanently organized legions capable of operating independently.<sup>26</sup> During the Seven Years War, the Duke de Broglie tentatively put together the first divisions.<sup>27</sup> Napoleon finally formalized divisions and corps in Europe in 1794.<sup>28</sup> This allowed an army to divide and travel along parallel routes, increasing mobility while sustaining and often increasing firepower by massing at a single point.

The history of the division in the United States begins during the American Revolution. The Continental Army of 1775 comprised thirty-eight regiments of different sizes. George Washington, upon assuming command of the Continental Army, organized these regiments into six brigades of six or seven regiments each and three divisions of two brigades each.<sup>29</sup> The

---

<sup>25</sup> John B. Wilson, *Maneuver and Firepower: The Evolution of Divisions and Separate Brigades*, (Washington, D.C.: Center of Military History, 1998), 7.

<sup>26</sup> Martin Van Creveld, *Command in War*, (Cambridge, MA: Harvard University Press, 1985), 60.

<sup>27</sup> *Ibid.*, 25.

<sup>28</sup> *Ibid.*, 60.

<sup>29</sup> Russell F. Weigley, *History of the United States Army*, (Bloomington, IN: Indiana University Press, 1984), 62. Russell Weigley is the preeminent authority on the history of the United States Army. Many of

battalion remained the main tactical unit (battalions and regiments were the same body, regiment being the administrative term and battalion the tactical term of the day). Divisions and brigades were administrative in nature.<sup>30</sup> Following the American Revolution, the Army was reduced to approximately one regiment. Not until the Mexican War would the United States Army have a division structure.

The invasion of Mexico required additional soldiers and a change in organizational structure to allow proper command and control. The troops of the Mexican War under Winfield Scott were the first American soldiers to be systematically organized into divisions.<sup>31</sup> Scott used these divisions as autonomous maneuver units, allowing him the flexibility of flanking operations.<sup>32</sup> Following the Mexican War regiments were again the standard unit of organization in the United States Army. The American Civil War revived the need for divisions, and much larger organizations.

During the American Civil War, the United States raised 1,696 regiments of infantry, 272 of cavalry, and 78 of artillery. The most common force structure during this period was five regiments to a brigade and three brigades to a division. Additionally, each division had organic artillery. A corps consisted of three divisions and an army of two or more corps'.<sup>33</sup> The regimental system became the standard between the American Civil War and the Spanish-American War.

Following the American Civil War, the Army returned to frontier duty in the west at a greatly reduced strength. Prior to the Spanish American War, the Regular Army had an authorized

---

the sources examined during the research for this paper cite Weigley's works. For this reason, his work is cited often.

<sup>30</sup> Ibid., 62.

<sup>31</sup> Ibid., 182.

<sup>32</sup> Russell F. Weigley, *The American Way of War: A History of United States Military Strategy and Policy* (Bloomington, IN: Indiana University Press, 1973) 75.

<sup>33</sup> Russell F. Weigley, *History*, 227.



strength of 28,747 officers and men.<sup>34</sup> On April 22, 1898, following the sinking of the Battleship Maine in Havana harbor, Congress authorized the activation of seven corps similar to those of the American Civil War. Three regiments constituted a brigade with three brigades to a division and three divisions to a corps. Authorization of the Regular Army increased to 64,719. National Guard and volunteers comprised the remainder of troops.<sup>35</sup> By war's end, the United States Army was 274,717 men strong. While Congress released National Guard units and volunteers from active service, they voted to maintain the Regular Army at the wartime strength of 65,000. Congress deemed this necessary to have adequate troops available to maintain national security and suppress the Filipino Rebellion.<sup>36</sup> The division soon became a standard echelon in the United States Army.

## **EVOLUTION OF THE MODERN U.S. DIVISION**

Secretary of War Henry Stimson and Army Chief of Staff General Leonard Wood formed the first "Maneuver Division" at San Antonio, Texas in March 1911. They concluded that such an organization would aid in mobilization. Secretary Stimson reorganized the U.S. Army into four divisions in 1913. Three infantry brigades and a cavalry regiment comprised each division.<sup>37</sup> The division structure changed several times over the next eighty-nine years.

The United States declared war on the Triple Alliance on 6 April 1917. As a result of a study conducted, the War College Division of the Army General Staff revised the structure of the division and settled upon a square division.<sup>38</sup> General John J. Pershing, commander of the American Expeditionary Force, sought larger divisions, willing to trade mobility for the

---

<sup>34</sup> Ibid., 295.

<sup>35</sup> Ibid., 306.

<sup>36</sup> Ibid., 308.

<sup>37</sup> Richard W. Kedzior, *Evolution and Endurance: The U.S. Army Division in the Twentieth Century* (Santa Monica, CA: RAND Corp., 2000) 8.

<sup>38</sup> Wilson, *Maneuver* 47.

capability to fight prolonged battles in sustained frontal attacks. The Square Infantry Division of World War I had a fighting strength of 28,061 and a total strength of approximately 40,000 including support personnel.<sup>39</sup> The Square Infantry Division consisted of two infantry brigades, one artillery brigade, one regiment of engineers and a division machine-gun battalion. Each infantry brigade contained two infantry regiments and a machine-gun battalion. The artillery brigade included one regiment of 155mm guns, two regiments of 75mm guns, and a mortar battery<sup>40</sup> (See appendix A figure 1). This resulted in a division span of command and control of five subordinates and the subordinates with an average span of command and control of three and one-third.

Communications technology was just starting to expand beyond messengers. New to the signal battalion was the field telephone (voice wire), wireless communications, though field radios were not available, the airplane, which dropped messages to units, and messengers.<sup>41</sup> Field phones were used primarily in the defense but the wires were susceptible to artillery. Messengers remained the most reliable.

Divisions during World War I served under different corps' as the mission required. This tactical focus gave the division the role of fighting the enemy to it's front. Corps', though also focused on the tactical situation, began working at the operational level; making the division an intermediate level focused solely tactics.

Successful because of the tremendous firepower it possessed, the Square Division lacked coordination and proved unwieldy and difficult to support logistically.<sup>42</sup> GEN Pershing argued after the war that the division should be reduced in size, to one brigade of three regiments, to

---

<sup>39</sup> Kedzior, 10.

<sup>40</sup> Weigley, *History* 386.

<sup>41</sup> *Ibid.*, 334. Weigley mentions testing of wireless communications devices but discusses on page 391 that field radios were not available. The author assumes that wireless radio technology existed but was unreliable in the field.

<sup>42</sup> Kedzior, 11.

increase flexibility and mobility.<sup>43</sup> Secretary of War Newton Baker assigned a special committee to review the structure of the U.S. Army division. The Special Committee met between 22 June and 8 July 1920, and concluded that the wartime infantry division was indeed too large and unwieldy.<sup>44</sup> The wartime division was actually a corps improperly organized. The division's size made it difficult to move by road or rail, and passage of lines was complicated. The Special Committee's solution was not to reorganize the division as GEN Pershing wished to do but to reduce the number of troops at every level.<sup>45</sup> The U.S. Army made no further changes to the division organization for twenty years.

Studies continued during the 1920's and 1930's, incorporating new technological developments such as the airplane, the rapid-firing cannon, automatic small arms, improved motor vehicles and high speed tanks. Influenced by military thinkers like de Gaulle, Guderian, Fuller, Mitchell, and Liddell-Hart, the organization of all armies began to change. From 1936 to 1939, the U.S. Army studied, tested and approved the triangular division concept.<sup>46</sup> This design combined infantry and artillery.

The triangular infantry division centered on three infantry regiments and an artillery regiment (See appendix A figure 2). Each infantry regiment had three infantry battalions of three infantry companies. The primary weapon for an infantryman was the M1 .30 caliber rifle. Each regiment of 6,987 men had 4,311 M1 rifles as well as 72 .30 caliber machine guns, 351 .30 caliber light machine guns, 24 37mm anti-tank guns (bazookas), and an assortment of mortars and heavy

---

<sup>43</sup> John B. Wilson, *Maneuver and Firepower: The Evolution of Divisions and Separate Brigades*, (Washington, D.C.: United States Army Center of Military History, 1998) 87-90.

<sup>44</sup> *Ibid.*, the committee listened to the testimony of approximately 70 officers, including Air Service COL William (Billy) Mitchell and BG Samuel Rothenback, the former chief of staff of the Tank Corps. The testimony of these two individuals addressed incorporating new technology in the division, specifically the airplane and the tank, 90-92.

<sup>45</sup> *Ibid.*, 91-92.

<sup>46</sup> Virgil Ney, *Evolution of the U.S. Army Division 1939-1968*, (Fort Belvoir, VA: United States Army Combat Operations Research Group, 1969) 35.

weapons, including .50 caliber machine guns for air defense. The artillery regiment contained four battalions, three 75mm battalions and one 155mm battalion that remained under division control as general support.<sup>47</sup> This design was specific to the infantry divisions.

Though the triangular infantry division was approved in 1936, it was not until the fall of France in 1940 that U.S. Army divisions were organized thus. The U.S. Army required all National Guard divisions to conform to the triangular division following the Japanese attack on Pearl Harbor.<sup>48</sup> The triangular division maintained a span of command and control of four while subordinate echelons enjoyed a span of command and control of three.

During the studies conducted during the interwar years, tanks were part of the infantry, adding both mobility and firepower to the organization. The Chief of Cavalry had tanks assigned to the Cavalry Arm and designated “combat cars”. In 1939, tanks were removed from infantry divisions and not reentered organically until after World War II.<sup>49</sup> Because of this, U.S. armor divisions developed independently of infantry divisions. An armored division contained a reconnaissance squadron, three armor battalions, three motorized infantry battalions, and three self-propelled artillery battalions. These units were then task organized under two or three combat commands, labeled CCA, CCB, and CCR(eserve) (See appendix A figure 3). The combat commands were the predecessors of the modern brigade.<sup>50</sup> The modern heavy brigade has a habitual task organization of infantry, armor, and artillery. This task organization resulted in a span of command and control of three to four, while subordinate units had a span of command and control of three to five.

---

<sup>47</sup> Ibid., 30-37.

<sup>48</sup> Ibid., 37.

<sup>49</sup> Ibid., 38-39.

<sup>50</sup> Kedzior, 18-21.

Technology improved dramatically during the interwar years. Foremost among advances were those of the tank, the airplane, and the Garand rifle.<sup>51</sup> Communications technology also improved. No longer reliant on wire and messengers, field radios permitted swift movements over large areas while maintaining good contact between officers and troops. Developed during the interwar years, Frequency Modulation (FM) proved invaluable in ground warfare, armored and mechanized warfare, amphibious assaults, air coordination, and ship-to-shore communications. FM radio relay kept front line units in contact with headquarters across the battlefield. Additionally, the SCR-300 walkie-talkie allowed infantrymen to communicate with their superiors and each other during engagements.<sup>52</sup> During World War II, an infantry regiment possessed 81 radio sets.<sup>53</sup> The advances in communications technology supported maneuver warfare in the 1940's and set the stage for future wars.

Despite the changes in technology and the nature of warfare, the division remained a tactically focused organization. Increased mobility and the fluid nature of battle made task organization easier. The division, however, still focused on finding and defeating the enemy with organic ground forces. This remained the division's role until the end of the cold war.

During the 1950's, the Army underwent major changes. President Eisenhower believed that nuclear weapons made large armies obsolete. President Eisenhower stated that actions such as the Korean War were, in effect, a waste of American resources and an Army larger than one million strong was irresponsible. Army Chief of Staff GEN Matthew Ridgway successfully argued that a reliance on nuclear weapons forced the United States into an "all or nothing"

---

<sup>51</sup> Weigley, *History*, 409-414. Weigley discusses the development of the tank in the United States Army as well as the advancements in airplane design and the increased capabilities of the Garand over the 1903 Springfield. He does state that all of these advances were slow to be adopted by the United States Army, while many European countries were excelling in the development of new technologies. Many of these were adopted by American designers such as J.Walter Christie whose revolutionary design for a tank was turned down by the U.S. but adopted by the Soviets and incorporated into the development of the T-34.

<sup>52</sup> Kathy R. Coker and Carol E. Rios, *A Concise History of the U.S. Army Signal Corps*, Office of the Command Historian, U.S. Army Signal Center and Fort Gordon, 1988, 23.

<sup>53</sup> Martin Van Creveld, *Command in War*, 238.

military posture.<sup>54</sup> Nevertheless, the Eisenhower administration decidedly favored nuclear capability. The Department of Defense reduced the U.S. Army from 20 to 14 divisions, and without a nuclear capability the future of the Army was unclear.<sup>55</sup> The Army felt a structural change was needed to avoid losing more of the force structure.

To regain relevance in the Department of Defense, Army Chief of Staff GEN Maxwell Taylor reshaped the U.S. Army for the nuclear battlefield. In 1956, GEN Taylor demanded a division organization that emphasized dispersion, flexibility, and mobility.<sup>56</sup> The Reorganization of Current Infantry Division (ROCID) and Reorganization of Current Armored Division (ROCAD) divisions of 1956 became the better-known Pentomic Divisions of 1958 through 1960.<sup>57</sup> Based on five subordinate elements (See appendix A figure 4), the Pentomic Infantry Division could disperse and consolidate quickly in a nuclear environment, minimizing losses from enemy attacks while maximizing firepower during counterattacks, and exploiting the use of tactical nuclear weapons.<sup>58</sup> Every echelon retained a span of command and control of seven. Obviously, one of the key weapons systems given these constraints was the *Honest John* rocket, equipped with a nuclear warhead. With a range of 22 miles, each division possessed one battery of these rockets, though the launchers were not air mobile. The U.S. Army also introduced the *Little John*, a nuclear rocket with a range of only 10 miles, but airmobile, and the *Davy Crockett*, a small mortar-like nuclear rocket approximately the size of a mortar with a range of 1.25 miles.<sup>59</sup> Employment of nuclear weapons at this range were in a worst case scenario.

---

<sup>54</sup> Stephen E. Ambrose, *Eisenhower, Volume two: The President*, Simon and Schuster, New York, 1985, 171-172.

<sup>55</sup> Wilson, *Maneuver and Firepower*, 286.

<sup>56</sup> Kedzior, 23-25.

<sup>57</sup> Wilson, *Maneuver and Firepower*, ROCID (Reorganization of Current Infantry Division) and ROCAD (Reorganization of Current Armored Division), 281-284.

<sup>58</sup> Ney, 73-74.

<sup>59</sup> A.J. Bacevich, *The Pentomic Era*, National Defense University Press, Washington, D.C. 1986, 94.

Another objective of the Pentomic Division was to enable units to absorb new weapons quickly. Often overshadowed by the nuclear weapons is the fact that during the time of the Pentomic Division, the Army also introduced into its inventory the 7.62 caliber M14 rifle to replace the M1, the carbine, the submachine gun, and the Browning automatic rifle (BAR); the 7.62 caliber M60 machine gun to replace heavier .30 caliber machine guns; the diesel driven M60 tank; M113 armored personnel carrier and the 4.2 inch mortar.<sup>60</sup> This division organization was short lived.

Communications technology also underwent a period of rapid change in response to the threats posed on a nuclear battlefield. The Signal Corps developed the Army Area Communications System. Benefits of this system were mobility, self containment, multiple communications nodes for system redundancy, and a broad coverage to widely dispersed units.<sup>61</sup> A major increase in communications technology occurred with the launching of the Signal Communications via Orbiting Relay Equipment (SCORE) satellite on 18 December 1958.<sup>62</sup> This made voice and teletypewriter communications possible over extensive distances and led to global communications.

In 1961, GEN Taylor, then Chairman of the Joint Chiefs of Staff recognized that the Pentomic Division did not support President Kennedy's policy of "flexible response". GEN Taylor called for further reorganization of the Army. The Army adopted the "Reorganization Objectives, Army Divisions 1965" (ROAD) division structure. Each division consisted of three brigade headquarters, normally ten or eleven combat battalions that were task organized under the brigades, and supporting units<sup>63</sup> (See appendix A figure 5). Division artillery consisted of three

---

<sup>60</sup> Wilson, *Maneuver and Firepower*, 286.

<sup>61</sup> Coker and Rios, 27.

<sup>62</sup> Ibid, 27.

<sup>63</sup> Ney, 75.

105mm battalions, one composite battalion of 155mm and 8-inch howitzers, and one battalion of Honest John and Little John rockets (the missile battalion was dropped later).<sup>64</sup> The division span of command and control under the ROAD structure was six, and subordinate echelons averaged five. The ROAD division structure went to war in Vietnam.

Communications technology continued refinement, but no radical advances were made during this period. One significant change was the proliferation of radios in units. A brigade in 1971 contained 539 radio sets, an increase of 565% over the regiment of 1943, while personnel fell 19% over the same period.<sup>65</sup> This meant that every unit from squad level up communicated with other forces while their World War II counterparts did not.

The late 1970's and early 1980's saw many changes in the United States Army. New technology led to new weapons systems and a new doctrine. The AirLand Battle concept, published in 1982, utilized new weapons, specifically, the M1 Abrams Main Battle Tank, the M2/M3 Bradley Fighting Vehicle, the Multiple Launch Rocket System (MLRS), the Patriot Missile, and the Apache Attack Helicopter. The AirLand Battle doctrine made divisions a truly independent organization capable of conducting operations without immediate corps support.<sup>66</sup> Sustainment support was necessary for extended operations.

The result of the reorganization, in conjunction with the emerging doctrine and new technology, was Army 86. The basic division structure did not change drastically from the ROAD division. Ten battalions (a mix of six and four or five and five for armored and mechanized divisions) were task organized under three brigade headquarters. (See appendix A figure 6). The amount of Combat Support and Combat Service Support grew. Under the "come-as-you-are, fight-as-you-are" approach, combat service support also increased in priority. The

---

<sup>64</sup> Kedzior, 30.

<sup>65</sup> Van Crevald, 238.

<sup>66</sup> Wilson, Evolution, 384.



three support battalions of the division had to “arm, fuel, fix and feed” forward in the brigade areas.<sup>67</sup> Implementation of Army 86 proved to be tough. In the summer of 1983, the issue at hand was the total manpower of the U.S. Army. Budgetary restraints imposed a manpower end strength of 780,000. The Army needed an end strength of 836,000 to fulfill the organizational designs of Army 86. Neither increasing the end strength nor inactivating active Army divisions was an option.<sup>68</sup> Under these limitations the Army of Excellence (AOE) was born.

On 5 July 1983, TRADOC Chief of Staff MG Robert Forman issued a directive to the TRADOC staff to reexamine the Army 86 design given the reality of a 780,000 man end strength. To accomplish this, he proposed the following steps: “further reduce the heavy division; suggest design options for smaller light divisions; examine the design of the special operations forces; and consider new support ratios between divisions, corps, and echelons above corps.”<sup>69</sup> This revision in structure was not the result of new technology or an emerging enemy threat, it was the result of budgetary limitations.

AOE required a reduction of approximately 2,000 personnel in heavy divisions. Recommendations were to cut one tank battalion from every division, reduce every infantry squad from ten men to nine, transfer the 8-inch howitzers to corps (eliminating the divisions nuclear capability), transfer the division’s Chaparrals to corps, transfer one attack helicopter battalion to corps, and eliminate the brigade scout platoons.<sup>70</sup> GEN John A. Wickham Jr., Army Chief of Staff, approved all changes to the heavy division force structure except the elimination of the tenth maneuver battalion and directed further studies to reduce the size of the heavy

---

<sup>67</sup> Ibid., 384.

<sup>68</sup> John L. Romjue, *The Army of Excellence: The Development of the 1980s Army* (Fort Monroe, VA: Office of the Command Historian, 1993) 29.

<sup>69</sup> Ibid., 29.

<sup>70</sup> Ibid., 49.

divisions.<sup>71</sup> The Army later eliminated the tenth maneuver battalion, as well as seven divisions, under a new end strength cap of 485,000 following Operation Desert Storm.

The AOE division had a span of command and control of six including three maneuver brigades, an aviation brigade, division cavalry squadron, and division artillery. Subordinate echelons managed an average span of command and control of five and a half.

This era also witnessed the first advances in communications technology since the satellite was introduced. The Single Channel Ground and Airborne Radio System (SINCGARS), Mobile Subscriber Equipment System (MSE), and the Joint Tactical Information Distribution System (JTIDS) exemplified significant improvements in communications.<sup>72</sup> Secure radios, satellite communications, and navigational systems such as LORAN increased the capabilities of the force and allowed the integration of joint and coalition forces. This increase in capabilities, coupled with a changing world environment, meant a change in the role of the division.

The division's role began to expand as operations became smaller. The division began assuming roles such as ARFOR and C/JFLCC during this period. In some instances, the division became the JTF, particularly in the 1990's when stability operations increased.

### **THREE WARS WITH 1<sup>ST</sup> INFANTRY DIVISION**

#### **1<sup>st</sup> Division in the Great War**

Organized in May, 1917, the First Expeditionary Division, later designated the 1<sup>st</sup> Division, was a Square Infantry Division comprised of units then in service on the Mexican border and throughout the United States. To better understand the structure and capabilities of the 1<sup>st</sup> Division, this section examines the span of command and control, technology utilized, and the role of the division in the Great War. The primary subordinate units of the 1<sup>st</sup> Division were:<sup>73</sup>

---

<sup>71</sup> Ibid., 54.

<sup>72</sup> Coker and Rios, 31-33.

<sup>73</sup> American Battle Monuments Commission, *1<sup>st</sup> Division Summary of Operations in the World War* (Washington, D.C.: GPO, 1944), 1.

*1<sup>st</sup> Infantry Brigade*  
16<sup>th</sup> Infantry Regiment  
18<sup>th</sup> Infantry Regiment  
2<sup>nd</sup> Machine-Gun Battalion

*2<sup>nd</sup> Infantry Brigade*  
26<sup>th</sup> Infantry Regiment  
28<sup>th</sup> Infantry Regiment  
3<sup>rd</sup> Machine-Gun Battalion

*1<sup>st</sup> Field Artillery Brigade*  
6<sup>th</sup> FA Regiment (75mm)  
5<sup>th</sup> FA Regiment (155mm)

7<sup>th</sup> FA Regiment (75mm)  
1<sup>st</sup> Trench-Mortar Battery

*Divisional Troops*  
1<sup>st</sup> Machine-Gun Battalion  
2<sup>nd</sup> Signal Battalion

1<sup>st</sup> Engineer Regiment  
Trains

The actual strength of the 1<sup>st</sup> Division varied from 25,332 on 30 April 1918 to 17,828 on 31 July 1918, minus support troops.<sup>74</sup> The Square Infantry Division gave the 1<sup>st</sup> Division a span of command and control of five: two maneuver brigades, an artillery brigade, a machine-gun battalion and an engineer regiment.

The 2<sup>nd</sup> Signal battalion maintained the communications for the 1<sup>st</sup> Division. This entailed telephone communications with higher headquarters and telegraph communications throughout the divisions area to subordinate units. It is unclear whether the signal battalion provided messengers on the battlefield or just technical services.

As the first American division to arrive in Europe, 1<sup>st</sup> Division initially served as part of the French IX Corps. Over the next several months, 1<sup>st</sup> Division also served as part of the French XXXII Corps, the French VI Corps, the French X Corps and the French XX Corps.<sup>75</sup> More than twice the size of a European division,<sup>76</sup> 1<sup>st</sup> Division increased the firepower of these French Corps' while decreasing the French commanders' span of control. Two French divisions could be pulled from the line and replaced with one American division, reducing the coordination necessary at Corps level while increasing the firepower in the Corps sector.

---

<sup>74</sup> Ibid., 98.

<sup>75</sup> Ibid., 5-18.

<sup>76</sup> Kedzior, 10.

With the formation of the First (U.S.) Army in the summer of 1918, 1<sup>st</sup> Division became part of IV (U.S.) Corps and served the remainder of the war as part of IV (U.S.) Corps or V (U.S.) Corps.<sup>77</sup> The structure of the First Army during an attack on 1 November 1918 exemplifies the span of control for American forces. First Army attacked with three corps, each corps having three divisions,<sup>78</sup> each division having two brigades, and each brigade having two regiments of three battalions.

The role of the 1<sup>st</sup> Division during the Great War was that of an intermediate tactical maneuver unit. Corps' were the largest tactical level. The 1<sup>st</sup> Division never conducted an attack or defense alone but always as part of a larger force under the command of a corps. Not bothered with large scale maneuvering in the trench warfare of the time, divisions focused on the close fight.

### 1<sup>st</sup> Infantry Division in World War II

Several changes occurred during the interwar years, as has been discussed in the evolution of the modern division. Changes to the 1<sup>st</sup> Infantry Division concerning span of command and control, technology, and the role of the division are now examined. Consolidated at Fort Devens, Massachusetts in early 1941, the 1<sup>st</sup> Infantry Division began extensive training that included transport loading and beach landings along the coasts of North Carolina and Puerto Rico.<sup>79</sup> The 1<sup>st</sup> Infantry Division arrived in Scotland on 8 August 1942 and continued training at Tidworth

---

<sup>77</sup> American Battle Monuments Commission, 35-64. 1<sup>st</sup> Division served with IV Corps during the St. Mihiel offensive and with V Corps during the Meuse-Argonne offensive.

<sup>78</sup> *Ibid.*, 81.

<sup>79</sup> *The First – A Brief History of the 1<sup>st</sup> Infantry Division, World War II*, reprinted by the Cantigny First Division Foundation 1996, 3-4.

Barracks, England.<sup>80</sup> The organization of the 1<sup>st</sup> Infantry Division followed the triangular infantry division structure and included the following subordinate units:<sup>81</sup>

	<i>Division Headquarters</i>	
16 <sup>th</sup> Infantry Regiment		18 <sup>th</sup> Infantry Regiment
26 <sup>th</sup> Infantry Regiment		
	<i>Division Artillery</i>	
5 <sup>th</sup> FA Battalion		7 <sup>th</sup> FA Battalion
32 <sup>nd</sup> FA Battalion		3 <sup>rd</sup> FA Battalion
	<i>Division Troops</i>	
1 <sup>st</sup> Reconnaissance Troop		1 <sup>st</sup> Engineer Battalion
1 <sup>st</sup> Medical Battalion		1 <sup>st</sup> Signal Company
1 <sup>st</sup> Ordnance Company		1 <sup>st</sup> Quartermaster Company

The triangular division gave the 1<sup>st</sup> Infantry Division a span of control of three to five organic combat units: three infantry regiments, an artillery regiment, and a reconnaissance troop.

Missions occurred that brought additional units under the control of the 1<sup>st</sup> Infantry Division. When this was the case, the division often divided the available forces into two or three “groups” or “forces”. The first time this happened was during the 1<sup>st</sup> Infantry Division’s participation in “Operation Torch”, the invasion of North Africa by U.S. forces. The 1<sup>st</sup> Infantry Division’s objective, as a part of II Corps, was the city of Oran. MG Allen, commander of the 1<sup>st</sup> Infantry Division, planned to seize Oran using a double envelopment.<sup>82</sup> He accomplished this maneuver by task organizing his forces.

MG Allen organized the 1<sup>st</sup> Infantry Division into two forces. The “Y” force, under command of the Assistant Division Commander BG Theodore Roosevelt, consisted of the 26<sup>th</sup> Infantry Regiment. This force attacked Oran from the west. The “Z” force, directly under division control, consisted of the 16<sup>th</sup> Infantry Regiment, the 18<sup>th</sup> Infantry Regiment, and the Ranger Battalion (LTC Bill Darby, Commanding). U.S. II Corps for Operation Torch tasked the

---

<sup>80</sup> Terry Allen, *Situation and Operations Report of the First Infantry Division During the Period of Its Overseas Movement, North Africa, and Sicilian Campaigns*, United States Army 1951, 1.

<sup>81</sup> *The First*, rear pullout. The First traces the lineage of the three assigned infantry regiments and artillery units early in the text. A fold out map located at the end of the book provides the division structure.

<sup>82</sup> Allen, 2.

Ranger Battalion to the 1st Infantry Division. “Z” force was the main effort and attacked Oran from the east. Span of control normally ranged from three to six subordinate elements. This exemplifies the division’s ability to task organize with additional assets and retain a simple span of control.

The 1<sup>st</sup> Infantry Division utilized the FM capabilities previously discussed. Due to the small numbers of radios available (81 in a regiment), leaders predominantly used them in communicating with each other and led on the battlefield with verbal instructions or signals.

*The First* states that during World War II the 1<sup>st</sup> Infantry Division experienced 443 days of combat as a division and subordinate units experienced an additional 100 days of combat assigned to other headquarters.<sup>83</sup> Following the attack on Oran, the 1<sup>st</sup> Infantry Division dispersed among allied units. MG Allen states that from 20 November 1942 to 1 March 1943 elements of the 1<sup>st</sup> Infantry Division fought detached. The 18<sup>th</sup> Infantry Regiment and 5<sup>th</sup> Field Artillery Battalion fought for the British V Corps. Attached by battalions, the 26<sup>th</sup> Infantry Regiment fought for various U.S. II Corps units. 1<sup>st</sup> Infantry Division, with the remaining subordinate units as well as assigned French units, fought for the French XIX Corps.<sup>84</sup> These examples illustrate that the division of World War II, as a maneuver element, was able to task organize efficiently and quickly. The division’s role was that of the largest strictly tactical maneuver force employed. Corps’ performed both operational and tactical functions.

### The Big Red One in Desert Storm

The 1<sup>st</sup> Infantry Division (Mechanized) was headquartered at Fort Riley, Kansas in 1990. Stationed at Fort Riley with the Division Headquarters were the 1<sup>st</sup> and 2<sup>nd</sup> Brigades. Both of these brigades were armor consisting of two armor battalions and one mechanized infantry battalion. The 3<sup>rd</sup> Brigade, a mechanized infantry brigade, was forward deployed in Europe.

---

<sup>83</sup> *The First*, 55.

<sup>84</sup> Allen, 3.

When the Iraqis invaded Kuwait in 1990, U.S. President George Bush responded with force. Part of the force leveraged against Iraqi forces was the 1<sup>st</sup> Infantry Division. The span of command and control, technology, and role of the division had undergone changes since World War II, some minute and some significant.

Normally a part of the III Corps at Fort Hood, 1<sup>st</sup> Infantry Division served under the VII Corps during Desert Shield/Storm. The Big Red One was about to display the flexibility of the U.S. Division. The 1<sup>st</sup> Infantry Division deployed with 1<sup>st</sup> and 2<sup>nd</sup> Brigades, 1<sup>st</sup> Infantry Division as well as 3<sup>rd</sup> Brigade, 2<sup>nd</sup> Armored Division (forward deployed in Europe). The 3<sup>rd</sup> Brigade was an armored brigade, unlike the 3<sup>rd</sup> Brigade, 1<sup>st</sup> Infantry Division. During part of the ground war, the 1<sup>st</sup> Infantry Division also commanded the 2<sup>nd</sup> Armored Cavalry Regiment. The organization of the 1<sup>st</sup> Infantry Division was as follows:<sup>85</sup>

<i>Division Headquarters</i>			
1 <sup>st</sup> Brigade	2 <sup>nd</sup> Brigade	3 <sup>rd</sup> Brigade (2AD)	2ACR (temporarily)
1/34 AR	3/37 AR	2/66 AR	1 <sup>st</sup> Squadron
2/34 AR	4/37 AR	3/66 AR	2 <sup>nd</sup> Squadron
2/16 IN	5/16 IN	1/41 IN	3 <sup>rd</sup> Squadron
			4 <sup>th</sup> Squadron (AVN)
<i>Division Artillery</i>			
1/5 FA BN (155mm SP)	4/5 FA BN (155mm SP)	4/3 FA BN (155mm SP)	
	B/6 BT (MLRS)		
<i>Division Units</i>			
1/4 Cavalry Squadron	2/3 ADA BN	1 <sup>st</sup> ENG BN	
D/17 Engineer CO	1/1 AVN BN (AH-64)	1 transport helicopter BN	

This represents the doctrinal Army of Excellence organization, with the part time addition of an Armored Cavalry Regiment. The 1<sup>st</sup> Infantry Division thus had a span of control of six or seven depending on the status of the 2ACR. This included three maneuver brigades, an ACR, the division cavalry squadron, division artillery brigade, and the aviation brigade.

---

<sup>85</sup> James F. Dunnigan and Austin Bay, *From Shield to Storm*, (New York: William Morrow and Company, Inc., 1992), 339.

Though habitually assigned to the III Corps, 1<sup>st</sup> Infantry Division fought as a member of the VII Corps. Also within VII Corps was 3<sup>rd</sup> Armored Division, 1<sup>st</sup> Armored Division, 2ACR (when not attached to 1<sup>st</sup> Infantry Division), 1<sup>st</sup> British Armored Division, 1<sup>st</sup> Cavalry Division, 11<sup>th</sup> Aviation Brigade, and VII Corps Artillery consisting of four artillery brigades, as well as several CSS brigades and the Corps Support Command (COSCOM).<sup>86</sup> The span of command and control enjoyed by LTG Franks, the VII Corps commander, was at least eight. Given the current baseline of two to five, it is difficult to imagine extending the span of command and control of either VII Corps or 1<sup>st</sup> Infantry Division further and still maintain the same efficiency and effectiveness.

The United States Army fielded five major combat systems in the 1980's to outfit the Army of Excellence. The 1<sup>st</sup> Infantry Division took four of these systems into combat, the M1A1 Main Battle Tank, the Bradley Fighting Vehicle, the Multi-Launch Rocket System (MLRS), and the Apache attack helicopter. The fifth system, the Patriot (AD) Missile also saw extensive service in the Gulf War. Reliable radios, satellite technology, and navigational aids such as LORAN made control easier and insured a unity of effort.

## **CONCLUSION**

Conceived in 18<sup>th</sup> Century Europe, the division existed in the United States only during times of crisis until the 20<sup>th</sup> Century. Formed in 1911, the "maneuver division" has undergone many changes in organization and equipment. Throughout this period, though, the division remained an important echelon in the United States Army.

Throughout the 20<sup>th</sup> Century, the division had a span of command and control that ranged from three to seven. The shortest-lived structure, the Pentomic Division, coincidentally had the largest span of command and control. The average span of command and control remained within, or just above, the baseline of two to five.

Changes in technology changed the face of battle and the ability to communicate more efficiently on the battlefield. Divisions adapted with the changes, incorporating new technology

---

<sup>86</sup> Tom Clancy, *Into the Storm: A Study in Command*, (New York: G.P Putnam's Sons, 1997), 176.



into the structure. Telegraphs and messengers gave way to FM radios. Satellites and secure technology further advanced the abilities of communications. The proliferation of radios to the lowest level and speed of communications over great distances has increased the division's combat effectiveness. Advances in communications technology is reflected more in a division's ability than in force structure during this period.

As exemplified by the 1<sup>st</sup> Infantry Division during three wars, the division as a tactical echelon instilled great flexibility on the battlefield. During World War I twenty eight thousand fighting men moved from Corps to Corps as a unit. Divisions worked for Corps' based on the mission, and could task organize units under them likewise. By the 1990's, the division not only focused on the close fight but also served in roles as the CFLCC and ARFOR headquarters.

The history of the U.S. Army division during the 20<sup>th</sup> Century is one of change. While the span of command and control remains relatively constant, communications technology and the role of the division changed. These changes exemplify the division's adaptability to the environment. Having examined the history of the modern U.S. division, let us now examine the theories that pertain to the division's future.

## CHAPTER THREE

### THEORY

Since the end of the Cold War, many modern military theorists presented their thoughts on changes to the structure of the United States Army. Several of these theorists wrote specifically on whether the United States Army should retain the division level echelon or eliminate it. At the heart of most arguments is the changing and advanced technology that is currently available or being developed.

Some proponents for eliminating the division echelon cite the need to “flatten” the organization, reducing the number of echelons in the Army. This would, theoretically, increase communications flow and flexibility. Others believe that an increase in lethality allows for a decrease in the force. Those that wish to retain the division echelon believe that span of command and control has a limit and that the division still serves a viable role in the Army.

The different theories presented, both for elimination of the division echelon and retention of the division echelon, are based on philosophies on span of command and control, technological changes pertaining to communications, or thoughts on the U.S. Army division’s role within the U.S. Armed Forces in the future. In most cases, technology is the basis for changes in the span of command and control. While the preponderance of technology is communications based, in some instances, technology refers to weapons platforms such as the Future Combat System (FCS). This is done not as a separate criteria but to give voice to the argument that new weapons technology will make brigades as lethal as divisions. Both aspects are presented to insure full disclosure of arguments for and against change.

#### **ELIMINATE THE DIVISION**

Two of the best known proponents for eliminating the division echelon are COL Douglas A. Macgregor and COL (RET) John R. Brinkerhoff. This paper examines the arguments put forth

by these two gentlemen as well as those of MAJ Joseph E. Martz. All three of these individuals make the case that a brigade, as the highest tactical echelon, could work directly for a corps.

Several assumptions present themselves throughout the works of all three of these authors. The first assumption, according to COL Macgregor, is “recognizing that the two-major-theater-war (MTW) capability strategy based on known threats, doctrines, and orders of battle no longer applies.”<sup>87</sup> He also states that this “requires developing a new strategic formula for the use of American military power that is neither scenario-based nor based on service-centric concepts and structures designed to deploy masses of men and materiel; the focus must be on critical warfighting capabilities.”<sup>88</sup> Another key assumption is that the technology will exist to accomplish this transformation.

Colonel Macgregor wrote Breaking the Phalanx in 1997, and discusses in depth how the land component for the United States Armed Forces failed to change given the increased capabilities brought on by new technology. Admittedly, Macgregor envisions the United States Army restructured on the model of the Roman Legion. That is, Colonel Macgregor wants small, self-contained, mobile armed forces that can deploy instantly to defend American interests. He further argues that current and developing technology would allow the United States Army to effectively adapt a 2000-year-old structure. Specifically, Colonel Macgregor believes that brigades, enhanced by technology, could work directly for corps’.<sup>89</sup> This view, that brigades work directly for corps, eliminating divisions and flattening organizations, is prevalent among all three authors. This paper now examines the positions of these three authors based on span of command and control, technology, and role of the division.

---

<sup>87</sup> Douglas A. Macgregor, *Resurrecting Transformation for the Post-Industrial Era*, (Westport, CT: Praeger, 1997) 2.

<sup>88</sup> *Ibid.*, 2.

<sup>89</sup> Douglas A. Macgregor, *Breaking the Phalanx: A New Design for Landpower in the 21<sup>st</sup> Century*, (Westport, CT: Praeger, 1997), 68-69, 227.

## Span of Command and Control

An examination of the span of command and control is important when discussing the elimination of the division echelon. Though COL Macgregor states that technological advances allow a larger span of command and control within the Army,<sup>90</sup> an opinion that is somewhat supported by the U.S. Army Research Institute, only COL Brinkerhoff and MAJ Martz propose a new span of command and control with the elimination of the division echelon.

COL Brinkerhoff's plan is for a brigade to have a span of command and control of seven. These elements include 4 maneuver battalions as well as a reconnaissance battalion, artillery battalion and aviation battalion. Additionally, there is an engineer battalion, headquarters battalion, support battalion and ADA battery with an end strength of approximately 6,000.<sup>91</sup> Task organizing forces to a brigade raises the span of command and control above the baseline of two to five, a level that stretches the limits of the brigade's ability.

COL Brinkerhoff also suggests that a corps span of command and control is eleven. Six maneuver brigades, a cavalry brigade, combat aviation brigade, and 3 artillery brigades. Additionally, each corps would have an air defense brigade, engineer brigade, signal brigade, military intelligence brigade, military police battalion, chemical battalion, civil affairs brigade, and corps support command with an end strength of 65,000.<sup>92</sup> Under this structure, the 73 divisional and separate brigades in the active and reserve components would be reduced to 62

---

<sup>90</sup> Martz, 31-32. Macgregor's two works, *Breaking the Phalanx* and *Resurrecting Transformation* both talk extensively about the need for a brigade based Army but never commit to the size of a brigade or how many brigades to a corps.

<sup>91</sup> John R. Brinkerhoff, "The Brigade-Based New Army", (*Parameters*, Autumn 1997), 62. The brigade end strength is an approximation because COL Brinkerhoff mentions the aviation battalion but does not list them in the end strength role up. An assumption is that the true end strength is 6,000 plus the personnel in the aviation battalion.

<sup>92</sup> Brinkerhoff, 64.

brigades requiring nine corps headquarters.<sup>93</sup> Additional assets such as joint or coalition forces are not addressed.

MAJ Martz simply proposes that a corps have six separate brigades assigned to it. The separate brigade is a four battalion brigade that is self contained and commanded by a Brigadier General.<sup>94</sup> This brigade is based on the current separate brigades already in the Army.

The U.S. Army Research Institute (ARI) conducted a study on the span of command and control in 1998. It concluded that “technology insertion may increase spans of command and control but at a cost.” Advances in technology related to command, control, communications, computers, intelligence, and information (C4I2) generally facilitated larger spans of command and control. However, it increased stress on the staff to maintain the equipment and manage the data.<sup>95</sup> ARI never concluded with a set span of command and control based on the study.<sup>96</sup> At this time, the only established span of [command and] control is that of a corps at two to five subordinates.

## Technology

The technology most often referred to, but seldom specified, pertains to either communications or weapons systems. COL Brinkerhoff states that the time is now for reducing the size and increasing the flexibility of the fighting formation because new communications and information processing capabilities make it possible.<sup>97</sup> He also states that a 5,000 to 6,000 man

---

<sup>93</sup> Brinkerhoff, 65.

<sup>94</sup> Martz, 35-36.

<sup>95</sup> J. Patrick Ford, William J. Mullen III, and Richard E. Christ, “New Research on Span of Command and Control: Implications for Designing Army Organizations”, ARI Research Note 99-09, December 1998, 45.

<sup>96</sup> Dr. Stanley Halpin, Chief of ARI Leader Development Research Unit, interview 24 March 2003. Dr. Halpin stated that span of command and control is an art, not a science. Because of this, there is no study that can accurately measure it. Span of command and control is dependant upon the individual and technology may increase if the individual is comfortable with technology. Conversely, it may degrade the span of command and control for an individual that is not comfortable with technology. Dr. Halpin was not aware of any study done conducted to establish a set span of command and control.

<sup>97</sup> Brinkerhoff, 60.

brigade, using “modern technology” that is unspecified, could replace a 10,000 to 18,000 man division, retaining as much if not more combat power than the division.<sup>98</sup> In other words, a brigade under this structure has as much combat power and lethality as a current division.

COL Macgregor discusses both weapons technology and communications to support change. COL Macgregor sites American ships, aircraft, satellites, tanks, guns, and rockets as able to support transformation now.<sup>99</sup> COL Macgregor refers to using technology to compensate for an increased span of [command and] control at the corps/JTF level. He then states that the Army should immerse tactical commanders in operational doctrine to help them deal with the inevitable information overload, which will occur regardless of the C4I systems developed.<sup>100</sup> COL Macgregor recognizes the fact that today’s leaders are unprepared for the amounts of information they will receive in the future and seems to admit that changes to the system will result in exceeding a reasonable span of command and control.

MAJ Martz also believes communications technology will enable a greater span of command and control. He suggests creating flat-topped organizations that use C3I technology, thus reducing the command and control levels while supporting a larger span of control.<sup>101</sup> MAJ Martz does use the examples of advances such as the Maneuver Control System (MCS) and Joint Strategic Target Acquisition Radar System (JSTARS)<sup>102</sup> to support his argument that technology will support the elimination of the division echelon. He does not, however, offer evidence that this is true.

---

<sup>98</sup> Brinkerhoff, 63.

<sup>99</sup> Macgregor, *Resurrecting Transformation*, 7.

<sup>100</sup> Macgregor, *Breaking the Phalanx*, 88.

<sup>101</sup> Martz, 29.

<sup>102</sup> Martz, 32.

As for weapons technology, both COL Brinkerhoff and COL Macgregor agree that combat systems will gain in lethality in the future. COL Macgregor states that by reducing two echelons (combining Army and Corps as well as Division and Brigade) the Army could deploy 43,600 troops to Iraq in 30 days with the same or greater firepower than VII Corps did with 110,000 troops over 120+ days.<sup>103</sup> He does not, however, go into details on how this is to be accomplished. COL Brinkerhoff conservatively estimates that using his structure, a new armored brigade would be approximately one-third the size of a current armored division but would possess half of the combat capability.<sup>104</sup> This means that two brigades, using COL Brinkerhoff's model, would possess the same combat power as the current division at roughly two-thirds the size.

### Role of the division

This, understandably, is a very short section. COL Brinkerhoff summarizes the role of the division well when he says that the division level adds little that the corps cannot provide.<sup>105</sup> There is no discussion of the division serving a role that is unique to that echelon in any of the material supporting elimination of the division. It stands to reason that if the position of these authors is to eliminate the division echelon, then they see no role for the division. This is not the case, however, for several who believe the U.S. Army should retain the division echelon.

### **RETAIN THE DIVISION**

Several authors have responded against the call for the elimination of the division echelon. Foremost among them is BG (RET) Huba Wass de Czege. Another proponent of retaining the division echelon is BG David Fastabend. BG Fastabend focuses mainly on the span of command and control aspect while BG (RET) Wass de Czege assumes a more holistic approach. An

---

<sup>103</sup> Macgregor, *Resurrecting Transformation*, 6.

<sup>104</sup> Brinkerhoff, 64.

<sup>105</sup> Brinkerhoff, 62.

underlying theme is that technology should result in changes within the Army, not necessarily to it.

### Span of command and control

“Today’s C2 initiatives have created a gleaming, high-speed pipe, but they still link a human sender to a human receiver.”<sup>106</sup>

This statement exemplifies the human aspect of the span of command and control. This section examines what a span of command and control is and whether technology can expand it. Consideration is given to a corps’ span of command and control when divisions are not in the echelon.

Technology can increase the span of control within an organization, but the span of command is human dependant. There is a point where technology allows information to flow at a rate that overwhelms the human ability to synthesize it.<sup>107</sup> BG Fastabend mentions the rule of five to seven (higher than the baseline two to five) subordinates being the accepted upper limit of a feasible span of [command and] control. This is important because, in response to COL Brinkerhoff’s recommendation of six maneuver brigades per corps, there are a lot more assets that a corps commander must deal with. Also, U.S. doctrine contends that a commander must plan two levels down, making the corps commander responsible for the planning of eighteen maneuver battalions. BG Fastabend raises the issue of coalition forces. MG Nash commanded five brigades in Bosnia; only two were U.S., the remaining three were coalition brigades.<sup>108</sup> Coalition forces in future operations are a consideration when discussing increasing a commander’s span of command and control.

---

<sup>106</sup> Daniel P. Bolger, “Command or Control?”, (Military Review, July 1990), 72.

<sup>107</sup> David Fastabend, “An Appraisal of ‘The Brigade-Based New Army’”, (Parameters, Autumn 97), 78.

<sup>108</sup> Fastabend, 78. BG Fastabend points out that under the structure proposed by COL Brinkerhoff, a corps would be responsible for 19 subordinates. This number is increased by at least a factor of three when planning two levels down.



BG (RET) Wass de Czege contends that the span of command and control should increase not with technological advances but with experience. Companies should have a span of command and control smaller (two) than they currently have. As experience increases, so should the span of control.<sup>109</sup> This supports his position that the span of command and control must be manageable by any single headquarters and that flattening an organization may so enlarge the span of command and control that it “increases organizational sluggishness and operational risk.”<sup>110</sup> The Charter for Information Policy Research of Harvard University published a study by Frank Snyder in which he concluded that effective command and control is dependent upon the individual in command and the technology available to help him.<sup>111</sup> Both of these cases strongly advocate that span of command and control is limited. Technology may increase the effectiveness of command and control, but the individual is the real mark for the span of command and control.

Another issue of having brigades working directly for a corps is the theater structure. In this two tiered system, the communications zone (COMMZ) begins at the brigade rear boundary. The corps commander now coordinates the tactical fight for six to nineteen subordinates, is responsible for logistics back to the United States, exercises Title 10 authority, coordinates for interagency and coalition forces, and serves as the Joint Task Force (JTF), Combined Joint Forces Land Component Command (CJFLCC), and/or Army Command (ARCOM) commander.<sup>112</sup> This scenario requires an iron will and a superb (and highly augmented) staff even though the technology exists to insure the control of all of these elements. Historically, the Corps

---

<sup>109</sup> Huba Wass de Czege, “Enhancing Organizational Performance: Re-engineering the Army’s System of Echelonment”, (*New Paradigms* 4), 47.

<sup>110</sup> Huba Wass de Czege and Richard H. Sinnreich, “Conceptual Foundations of a Transformed U.S. Army”, Land Warfare Paper No. 40, The Institute of Land Warfare, March 2002, 30.

<sup>111</sup> Frank M. Snyder, “*Command and Control: Readings and Commentary*”, (Cambridge, MA: 1984), 123-124.

<sup>112</sup> Fastabend, 78.

Commander worked for a numbered Army and supervised divisions on the battlefield. Today, the scope of duties at corps level is much greater.

BG Wass de Czege proposes the retention of the division echelon, but expanding the span of control within the division. A division with six brigades could establish a “battle rhythm” rotating units between combat, mission staging, and rear area protection.<sup>113</sup> Theoretically, this reduces the number of divisions required for a mission, reducing further the corps’ command responsibilities.

The Army Research Institute (ARI) studied the question of span of control from a purely military perspective. In 1995, ARI published *Span of Effective Command and Control: Implications for New Research for Organizing the Force*. This document outlines Units of Action and Units of Employment at both the division and corps level.<sup>114</sup> Two more studies were published in 1999, *Effective Span of Command and Control by Echelon in Training and Operational Environments* and *New Research on Span of Command and Control: Implications for Designing Army Organizations*. Both of these studies focus on the optimal number of subordinates a commander can effectively control.<sup>115</sup> Both of these studies conclude that the optimal span of command and control is dependent upon the individual.

Span of command and control remains a human endeavor. The best way to understand an intent is not by reading it, it is by knowing the individual that gave the order.<sup>116</sup> Technology can increase the flow of data, and it can increase the flow of data beyond human usefulness. So let us look at how technology fits in with the future force.

---

<sup>113</sup> Huba Wass de Czege, “Toward a Future Army”, 40.

<sup>114</sup> This study was generated by the U.S. Army to study span of control issues within the Objective Force, specifically the Unit of Action and Unit of Employment.

<sup>115</sup> Both of these studies were conducted by the Army Research Institute.

<sup>116</sup> Bolger, 78.

## Technology

“Machines can assist, but warfare will remain an intensely human activity.”<sup>117</sup>

Technology, as defined in this paper, pertains primarily to information systems. In many cases, as seen above under the theories of eliminating the division echelon, technology is difficult to discuss in the future tense. Most theories are based on expected technologies.

Unlike the argument of technology replacing the division echelon, the supporters of retaining the division echelon view technology as enhancing the current force. One example is in the conduct of distributed operations. A commander can attack, at the time and place of his choosing, using improved C2 linked with improved target acquisition capabilities to employ precision weapons striking multiple targets simultaneously.<sup>118</sup> Another application of technology at the division level is the Army Battle Command System (ABCS). The ABCS manages the division database and provides a Relevant Common Picture (RCP) to all brigade equivalents.<sup>119</sup> The RCP gives subordinates better situational awareness, but also led to the elimination of one company per battalion. It remains to be seen if an increase in situational awareness, provided by technology, can increase the commander’s situational understanding.

BG Wass de Czege writes often about what he believes to be the shortcomings of technology. Information Technologies (IT) will help, but are unreliable predictors of moral factors, enemy actions and event outcomes. Fog and friction remain on the battlefield and plans will remain judgment based on assumptions.<sup>120</sup> He warns that combat potential is more than the sum of machine performance and that, “with few exceptions, technology does not lend itself as well to

---

<sup>117</sup> Huba Wass de Czege and Jacob Biever, “Optimizing Future Battle Command Technologies”, (Military Review, March-April 98), 15.

<sup>118</sup> Billy Jordan and Mark Reardon, “Restructuring the Division: An Operational and Organizational Approach”, (Military Review, May-June 98), 21.

<sup>119</sup> John Twohig, Thomas Stokowski, and Bienvenido Rivera, “Structuring Division XXI”, (Military Review May-June 98), 27.

replacing soldiers in close combat missions involving incredible complexity, constant change, and sudden surprises as it does to enhancing their effectiveness.<sup>121</sup> Technology can enhance human performance, but cannot replace it in warfare.

### Role of the division

“Finally, although small units now are capable of conducting sustained operations, these units require an overarching structure to give cohesion to their parts. Independent brigades, for example, might become much like the fabled Army regiments of the late nineteenth century: individually magnificent, but, as demonstrated in the Spanish-American War, incapable of operating together. Therefore, the division likely will remain the basic warfighting organization, but its structure and organization must continue to be reassessed in terms of future battlefield innovations, as well as with an eye on the lessons of the past.”<sup>122</sup>

This statement by John Wilson sums up the role of the division in the past and foreseeable future. As discussed, the division has been the major tactical maneuver unit in the U.S. Army. Given that new technology and an ever changing political environment are constantly causing changes in the United States Military, what is the future role of the division?

BG Wass de Czege offers an answer based on his concept that the brigade would be the combined arms unit of action. Divisions will be rapidly tailorable echelons of tactical employment, diminishing the corps’ span of command and control. It also enhances corps’ ability to tailor ground forces for simultaneous and successive objectives.<sup>123</sup> Corps’ focus divisions on tactical objectives while coordinating the efforts of interagency actors and coalition forces not assigned to a division, while operating as a JTF, CJFLCC, or ARFOR.

---

<sup>120</sup> Huba Wass de Czege, “Optimizing Future Battle Command Technologies”, 16.

<sup>121</sup> Huba Wass de Czege, “Enhancing Organizational Performance: Re-engineering the Army’s System of Echelonment”, (New Paradigms 4), 45 and 60.

<sup>122</sup> John B. Wilson, “Influences on U.S. Army Divisional Organization in the Twentieth Century”, (Information paper for the Federation of American Scientists, December 1995), Available at <http://www.fas.org/man/dod-101/army/unit/docs/influncs.htm> accessed 21 September 2002, 6.

<sup>123</sup> Huba Wass de Czege, “Conceptual Foundations of a Transformed U.S. Army”, 33.

Depending on the forces in an Area of Operation (AO), the role of the division may vary. In an AO where the corps is the JTF headquarters, the division commander is the senior tactical commander, freeing the corps commander to focus on the operational level of conflict.<sup>124</sup> If a corps commander is serving as the JTF commander, a division commander may serve as the CJFLCC or ARFOR commander.<sup>125</sup> In the case of a division headquarters expanding to assume the role of CJFLCC or ARFOR, augmentation is required.

## **CONCLUSION**

Whether contending to eliminate the division echelon or retain it, everyone agrees that emerging technologies will have an impact on the Army. There is an issue of whether technology can help extend the span of command and control or eventually overwhelm the human element of every military system. Those like COL Brinkerhoff believe that communications technology make it possible to increase the number of subordinates and eliminate overhead without diminishing combat potential. Proponents of eliminating the division believe that commanders, with the assistance of computers, can increase their span of command and control beyond the traditionally accepted five to seven subordinates. The result being that a corps can employ brigades directly, eliminating the division echelon. Elimination of an echelon speeds the flow of information and increases the reaction of brigades as the premier tactical unit.

Opponents contend that the span of command and control is dependant upon the human element. As MAJ Bolger stated, no matter how fast the flow of information, there is still a human involved at each end. BG (RET) Wass de Czege suggests that increasing the span of command and control is not as reliant on technology as it is on experience. The span of command and control should increase as you rise up the military hierarchy, but there is a limit for every human being. The average, based on the baseline and historical evidence is three to seven.

---

<sup>124</sup> Fastabend, 78.

<sup>125</sup> John Twohig, Thomas Stokowski, and Bienvenido Rivera, 27-28.

Research and studies conducted does not set a number on the span of command and control. Both studies examined in this paper agreed that technology can influence the span of command and control but the bottom line remains human involvement and commander and staff ability.

Another application of technology that enables eliminating the division echelon is weapons technology. As technology increases lethality, units can decrease in size without compromising combat potential and gain flexibility at the same time. Brigades are able, through technological advances, to bring to bear the same combat potential as a current division.

However, technology should enhance the capabilities of soldiers, not replace them. War is still a human endeavor that is fought by human's using machines to gain an advantage, but what advantage is there if every technological advance is met with reductions in the force? It is also important to remember that the United States does not own a monopoly on technology. That which gives the Army the edge today may be used by our enemies tomorrow.

The role of the division in the future is a one-sided argument. Those that favor eliminating the division echelon see no role for it. After all, the division adds nothing that the corps cannot provide.

The counterargument posed by those in favor of retaining the division echelon cites the implications of joint exercises as one of the biggest reason to keep it. In operations involving a single corps or three star echelon, that level will be, in all likelihood, the JTF. While the JTF is coordinating at the operational level and shaping the tactical fight, the division is the element with prime responsibility for coordinating and conducting the tactical fight. There are also issues like who becomes the CFLCC or ARFOR, who assumes Title X authority, and where does the deep fight begin?

## CHAPTER FOUR

### **ANALYSIS/RECOMMENDATIONS**

This paper has discussed the issue of whether the U.S. Army needs the division echelon by reviewing the history of the division and theories of why the division echelon should be eliminated or retained. This paper examined each of these areas using the criteria of span of command and control, (information) technology, and the role of the division. Analysis is now required in order to establish recommendations and reach a conclusion on whether the U.S. Army needs the division echelon.

### **ANALYSIS**

#### **HISTORY**

An analysis of the history of the division includes the span of command and control, communications technology, and role during the evolution of the division. Comparing the span of command and control for each stage of the division gives an indication of the optimal number of subordinates a division can have. Studying the communications technology of the past may shed light on what is possible and probable in the future. Finally, analyzing the role of the division discusses those functions that another level would do in a time of war.

#### **Span of Command and Control**

In analyzing the span of command and control, this paper looks at the span of command and control of the modern division level. The span of command and control of the corps echelon is not addressed due to the independent structure of corps'. This paper assumes that in order to retain the same capabilities and combat power currently enjoyed, should the division level echelon be eliminated, you must multiply the division span of command and control by the number of divisions and add corps assets such as cavalry, artillery, and attached aviation.

During World War I, the United States Army division was considered a square division. With two infantry brigades, an artillery brigade, an engineer regiment and a machine-gun

battalion, the division had a span of command and control of five. The example of the 1<sup>st</sup> Division in World War I bears this fact out as it did have a span of command and control of five. One can infer that five was the maximum number of subordinates wanted during this time. This structure massed firepower but lacked flexibility, which would prove essential during the next war.

Three developments, the tank, the airplane, and the radio, meant that maneuver and flexibility were essential in World War II. The United States Army adapted the triangular division in an attempt to gain flexibility. This division maneuvered three infantry regiments, an artillery regiment, and a reconnaissance troop. This gave the division a span of command and control of five. Examining the 1<sup>st</sup> Infantry Division during World War II shows that this sometimes changed. MG Allen discussed the 1<sup>st</sup> Infantry Division's participation in "Operation Torch." His official report showed the addition of the Ranger Battalion to the Division for the operation. He then discusses creating a "Y" force and a "Z" force for part of the operation. This meant a span of command and control of six, which MG Allen reduced to two during the invasion of Africa. This was not unlike the Armored Divisions of the same era.

The World War II Armored Division task organized three tank battalions, three mechanized battalions, and three artillery battalions under three brigade size combat commands. This gave the Armored Division a span of command and control of four including the organic cavalry squadron. During World War II, the average span of command and control within an American Division was 4.5 and it appears that if this changed at all, commanders preferred to reduce the number rather than increase it. This is within the two to five subordinates established as the baseline. As the atomic bombs dropped on Japan ended World War II and signaled a new age of warfare, they also signaled a new divisional design for the nuclear age.

The pentomic division was designed to disperse on a nuclear battlefield, increasing the overall survivability of the organization. This dispersion resulted in five infantry battalions, one armored battalion, one reconnaissance troop, and an artillery brigade working directly for



division. With a span of command and control of eight, the pentomic division was not long lived. Because there were only six maneuver battalions, the pentomic division was really under strength and relied on the Honest John rocket with nuclear warhead for firepower on the battlefield. Approximately three years after the pentomic division was adapted, the U.S. Army division changed to the “Reorganization Objectives, Army Divisions” (ROAD) Division Base.

The Army soon changed the division structure to the ROAD framework. This division contained three maneuver brigades, an artillery brigade, an aviation battalion, and a cavalry squadron. With a span of command and control of six, this seems to be an effective structure, still the basis of today’s division. The only difference is that the Army of Excellence division and today’s divisions have an aviation brigade instead of a battalion. During Desert Storm, the 1<sup>st</sup> Infantry Division effectively fought with a span of command and control of seven.

Over the past century, the span of command and control of a division has grown from five to seven. Once reaching eight, this did not last long but there is no evidence to support that the span of command and control was too large. A more likely answer is the lack of conventional strength of the pentomic division. One can conclude that a span of command and control of seven is about right for the current force. This increase in number of subordinates was possible in part due to changes in communications technology.

## Technology

Until 1844, messenger conducted communications on the battlefield or signaling flags. With Samuel Morse’s invention of the telegraph, communications on the battlefield began to change. The first modern divisions of World War I were still using messengers and wire, though the wire now carried voice across field phones. Field phones remained in use until the 1980’s. Radios used during World War II allowed the mechanized forces and air forces to cover greater ranges effectively.

As weapons technology increased, so did communications technology. Radios became secure and satellite links now allow global communications. Today’s communications

technology includes live video feeds and real time imagery. There is no doubt that communications technology will continue to evolve. It is interesting to note that as weapons technology increased during the past century, so did communications technology. Though not discussed in this paper, Secretary White declared that the United States Army “skip” a generation of technology. This is interesting considering that Secretary White suggests, and probably sooner than the ten to fifteen years he stated publicly based on political timelines, that the Army utilize emerging technology to flatten the organization and eliminate divisions. Is it possible to skip a generation of technology and also utilize it for major changes?

### **Role of the Division**

The role of the modern division remained one of a tactical headquarters throughout most of the twentieth century. From World War I through the Vietnam War, the division was the highest purely tactical echelon. Defeat of the enemy using organic and attached forces was the mainstay. That began to change, however, as the United States Army began to fight regularly with joint and coalition forces. Divisions can currently serve the role of ARFOR and/or C/JFLCC. A corps level echelon normally serves as the JTF, though a division may sometimes serve in that role as well. These are vital roles on today’s battlefield and will not go away. As will be discussed again under the analysis of theory, a corps cannot be all things to all people and increase the span of command and control.

### **THEORY**

There are two views on the theory of whether the U.S. Army needs divisions. An analysis of the arguments for eliminating the division as well as an analysis of the arguments for retaining the division is necessary using the established criteria of span of command and control, technology, and role of the division.

## Span of Command and Control

Of the three authors proposing to eliminate the division, COL (RET) Brinkerhoff did the most thorough job of explaining the span of command and control without a division echelon. He contends that current technology increases a commander's span of command and control sufficiently to eliminate the division. COL Brinkerhoff sets the span of command and control for a brigade at approximately seven and the span of command and control of a corps at eleven.

This span of command and control fails to take into consideration joint and coalition forces added to the force structure during an operation. COL Brinkerhoff never addresses how the corps, operating as a JTF, can focus on theater and political issues while coordinating the tactical level of conflict. This shortcoming is common among COL Macgregor and MAJ Martz as well. The issue is even more basic than incorporating joint and coalition forces. The issue becomes how a corps absorbs the brigades organic to it without divisions.

When looking strictly at maneuver units, it is easy to see how a Corps Headquarters could command and control the brigades under it without divisions. However, there is more to a corps, and any organization, than maneuver units. The following example is based on a corps that is task organized with three mechanized or armored divisions, an air assault division, a separate brigade, and a cavalry regiment:

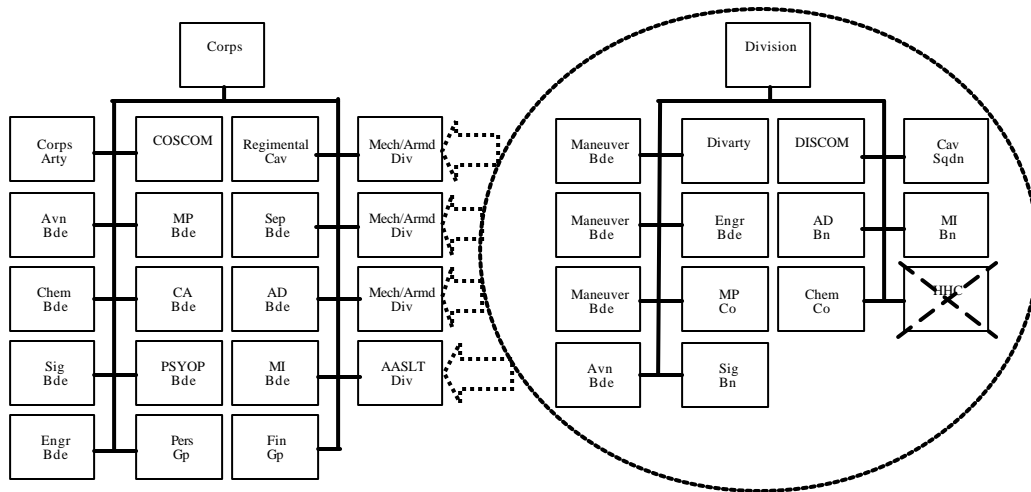

Figures 2-2 and 2-3, CGSC Student Text 100-3, Battle Book

This figure shows all of the current elements of this corps and a typical mechanized or armored division. It is assumed, in order to have a truly stand alone brigade, that all of the capabilities currently enjoyed by a Division Headquarters would be absorbed into the corps, with the exception of the Division HHC. This would more than triple the size of the Corps. The issue then becomes how to best command and control this new, larger organization. One solution could be to increase the size of the Corps staff. Can this be done without losing staff efficiency and creating an artificial layer of command between the Brigades and the Corps Commander? In the diagram above, a Corps Commander, assuming no reduction in the Corps' capability, would command thirteen maneuver brigades, five aviation brigades, seven artillery brigades, and the equivalent of two cavalry regiments (the original cavalry regiment and four cavalry squadrons). This is in addition to all of the other elements shown above. Can a corps commander command and control twenty-seven combat elements in addition to combat support and combat service support elements, possible joint or coalition forces, and serve as the Joint Task Force Commander for an operation?

## Technology

The short coming of using technology to increase the span of command and control as an argument to eliminate the division is the lack of specificity involved. To say that the technology will soon exist to make a change, without elaborating on the technology, is merely a leap of faith. This “leap of faith” is made often in the arguments of COL Macgregor, COL Brinkerhoff, and MAJ Martz. That technology will continue to evolve and increase the capabilities of the Army is unquestionable. However, to try and pin down future capabilities, and change the structure of the Army, before the technology exists compares to building a house on a foundation of sand. The house, and the changes, may firm up or they may collapse. It is more important to view the technology that does exist and utilize it to the fullest. Regardless of what technology is utilized, the human element remains the same.

Currently, systems such as ABCS are used to enhance a commander’s situational awareness. As the commander receives a better visualization of the battlefield using automated sensors and systems that are interlinked, he can increase situational understanding. It is important to keep in mind that technology can be fooled and does not rationalize like the human mind. Current technology also allows interaction at a greater level. The highest levels of command can watch the live feed of an Unmanned Aerial Vehicle (UAV) and give guidance to multiple subordinates. This exemplifies the very problem of relying on technology. If a Regional Combatant Commander can watch the live feed of a UAV over an engagement area and talk directly to the operator of the UAV or the platoon leader engaged in the fight, why not eliminate every echelon in between? Because the Regional Combatant Commander cannot see everything in his Area of Operation (AO), he relies on the synthesis of subordinate commanders to inform him of issues pertaining to his AO. The *Regional* Combatant Commander must not allow himself to be dragged down into platoon level engagements, and intermediate echelons keep him focused on his region.

The arguments of how to use communications technology fall into two distinct categories. One side establishes that communications technology can increase the span of command and control at the corps level, allowing the elimination of the division echelon. The other side argues that communications technology is an enabler, not a replacement for divisions.

### **Role of the Division**

The most obvious mission is that of ARFOR Commander or C/JFLCC Commander in a Theater of Operations. There are no longer operations that are strictly Army. All future operations will be, at a minimum combined and most likely joint. This now leaves two options. The first option is that the Corps Commander assumes the role of ARFOR or C/JFLCC Commander. This assumes that the Theater Commander will always be a Regional or Combatant Commander. The second option is to make the senior Brigade Commander the ARFOR or C/JFLCC Commander. This approach has two major problems that need deeper analysis.

The first problem is that a Brigade staff is busy fighting the Brigade. They are not adequately staffed for this additional mission. The second problem is that of being the junior member of the next higher organization. A Colonel may find his peers to be in a two star billet, whether they are American or Allied. Would a Marine Expeditionary Force Commander or Allied Division Commander agree to a Brigade Commander as the C/JFLCC? The Army could concede this role in future operations without the division level echelon. This means that the Army, the predominant land component of the United States' military forces, would not be the Land Component Command in future operations.

## **RECOMMENDATIONS**

This section gives recommendations based on the evidence and analysis presented. The recommendations pertain to the span of command and control, communications technology, and role of the division.

The span of command and control is dependent upon the individual exercising it. It can and should be expanded somewhat as an individual progresses in their career and gains experience dealing with subordinates. A brigade or division commander should have a greater span of command and control than a company commander or platoon leader, but it is experience and not some magical technology that allows this. Seven seems to be the limit of major subordinates a commander can adequately handle.

Perhaps there is a need to realign the higher echelons of the Army. As stated early in this paper, there are four corps and ten divisions in the Active Army. Instead of eliminating the divisions, a better solution may be to eliminate one corps and realign the divisions so that each of the three remaining corps' would have three or four division subordinates.

There should be a study conducted by the Department of the Army to determine what the effects of eliminating divisions would be on V Corps concerning pending operations in Iraq. It would be interesting to ask the V Corps commander periodically, after commencement of hostilities, what each brigade is doing and how important the division headquarters are in conducting the operation. Flattening an organization in business may save money and be more efficient, but most decisions are not made instantly by an individual with the result being life or death for many. War remains a human endeavor, and humans are easily overwhelmed. Technology may be an answer, but not the answer.

As stated earlier, technological developments allow a commander at any level to monitor a battle or firefight via the live feed of a UAV. In a large scale, high intensity conflict, this is impractical. There is a finite amount of information that an individual can absorb and synthesize. This synthesis he passes on to the next higher echelon. Indeed, echelonment is much about processing and passing information as it is about controlling formations. Technology should continue to be developed as an enabler to the current structure. Instead of trying to do more with less, we should try doing much more with more. Technology continues to increase the Army's capabilities, and as it does, someone says it can downsize or restructure without losing

capabilities or firepower. This paper recommends using technology such as ABCS and FBCB2 to make the Army stronger, not smaller. Technology may not be able to replace the division on current and future battlefields.

The current roles of the division are still valid. As the largest tactical echelon, divisions direct brigade fights while corps orchestrate at the operational level tactical units, allies, non-government organizations and interagency activities. As the doctrine for the Objective Force are solidified and put into effect, there may come a time when the Corps Unit of Employment and Division Unit of Employment merge into one organization with the functions or roles of each being conducted by this new organization or some other organization in the future. This needs to be an evolutionary process, not forced upon the Army. Changes to the Army in general and the division in particular must be evolutionary or the Army may become ineffective at any level above brigade.



## CHAPTER FIVE

### CONCLUSION

“Wars may be fought with weapons, but they are won by men. It is the spirit of the men who follow and of the man who leads that gains the victory.”<sup>126</sup>

GEN George S. Patton Jr.

The need for this monograph was set forth by the Secretary of the Army in a statement proposing using technological advances to flatten the Army organization, increase span of control at some levels, and eventually eliminate the division level echelon. This paper has reviewed doctrine, examined the history of the division, and discussed theories for eliminating the division and for retaining it.

The review of doctrine revealed no holes or shortcomings that require the elimination of the division level echelon. In fact, the Objective Force O&O refers to Units of Employment as either corps size or division size, retaining many of the current characteristics for both of those organizations.

Throughout the history of modern warfare, the division remained an irreplaceable force. The span of command and control increased steadily, occasionally increasing marginally beyond the baseline. Divisions functioned during the 20<sup>th</sup> century with a span of command and control sometimes reaching seven with no noted adverse effects. The baseline established has an upper limit of five subordinates while history shows seven subordinates as about right.

History also showed that communications technology increased with weapons technology, or perhaps increases in communications technology allowed increases in weapons technology. Regardless, the two are tied together. Communications technology advanced throughout the 20<sup>th</sup> Century, the result being an increase in the capability of the division. From telegraphs and messengers to FM radios to SINCGARS and satellites, improvements in communications

---

<sup>126</sup> Peggy Anderson, *Great Quotes from Great Leaders*, (Lombard, Ill.: Great Quotations Publishing Company), 123.

technology improved the capabilities of the force, but never replaced the force. Technological advances in communications will continue in the future, how that will affect the division is in question.

Proponents for eliminating the division level echelon argue that modern and future technology allows for an expanded span of command and control. They state that brigades can work directly for corps. The technology that will allow this, however, is never established. It appears to be a “leap of faith” that the technology will exist. The proponents fail to take into account the human factor of leadership. Technology is only as good or useful as the people operating it and absorbing the information it presents. It may be possible that technology overwhelms a commander and makes him less effective.

Supporters of maintaining the division level echelon also recognize advances in communications technology. They believe, for the most part, that technology should remain an enabler, enhancing a commander’s ability, not replacing him. All supporters of the division agree that there is a limit to the span of command and control, but it is based on the individual and his abilities. There is no proposed magic number that is tied to the span of command and control.

The final issue discussed was the role of the division. Historically, the division was a tactical headquarters, focused on the close fight. Other roles evolved, including, but not limited to, serving as a JFLCC or ARFOR headquarters, Title X responsibility, interagency coordination, and coordination with Non-governmental Organizations (NGOs). These are missions that still have to be completed, and if not by the division then by a higher or lower echelon.

Based on the information examined in this paper, it is imperative that the U.S. Army retain the division echelon. World events ongoing at the time of this paper bear witness to this statement. As the 3<sup>rd</sup> Infantry Division (Mechanized) continues to advance on Baghdad, it is impossible to believe that a war of this magnitude could be conducted using brigades working for V Corps.

There may a point in the future when technological advances or changes in the world facilitate a change to the Army structure. Until that time is realized, no change should be made. Rushing to make a change based on technologies that do not exist, and may never exist, is foolhardy.

# APPENDIX A

FIGURE 1

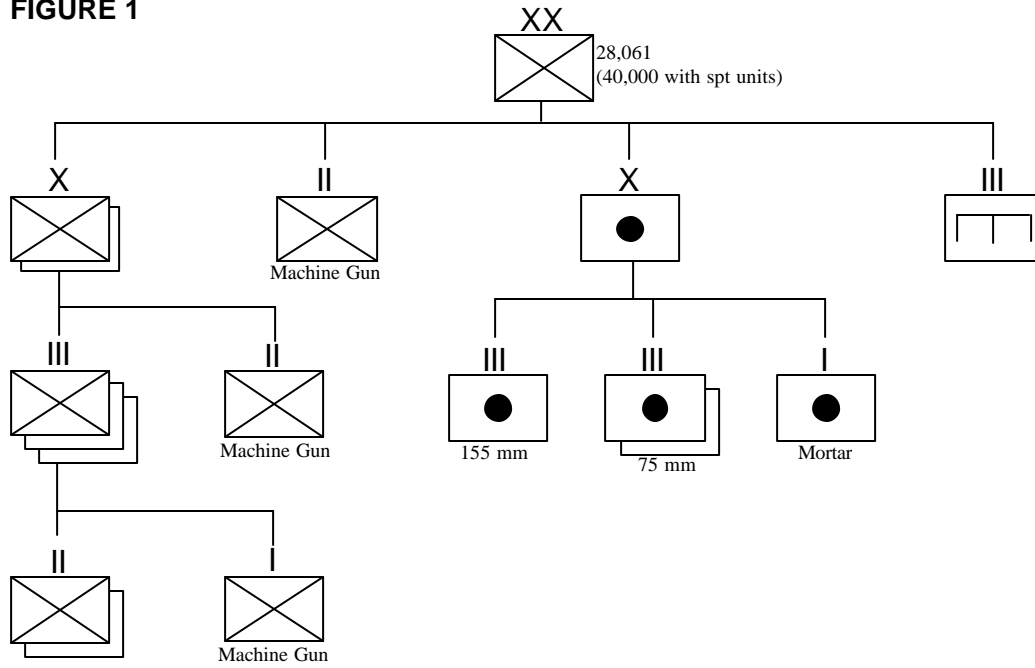

The Square Infantry Division, 1918<sup>127</sup>

<sup>127</sup> Kedzior, 11.

**FIGURE 2**

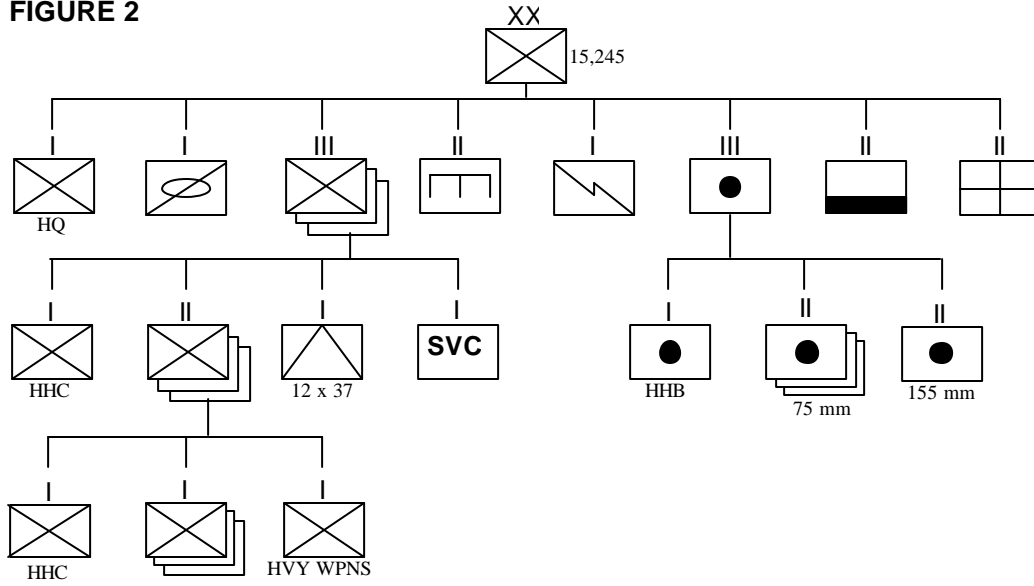

The Triangular Infantry Division, 1940<sup>128</sup>

**FIGURE 3**

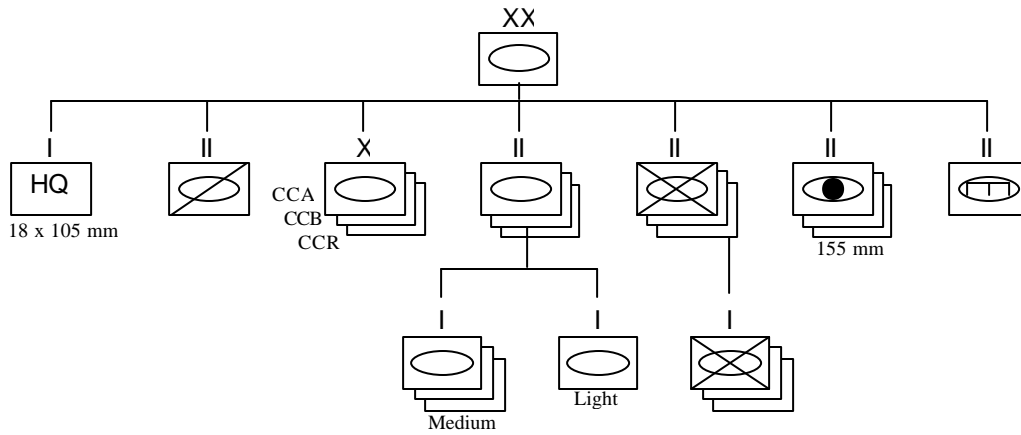

The Armored Division, 1943<sup>129</sup>

<sup>128</sup> Ibid., 17.

<sup>129</sup> Ibid., 19.

FIGURE 4

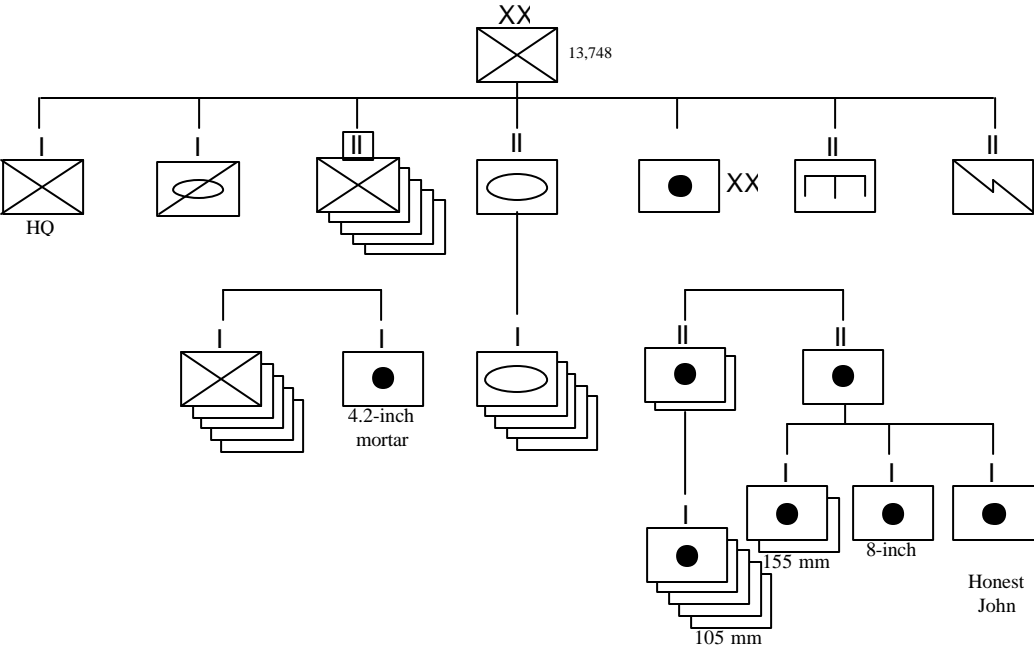

The Pentomic Infantry Division, 1959<sup>130</sup>

<sup>130</sup> Ibid., 23-25.

**FIGURE 5**

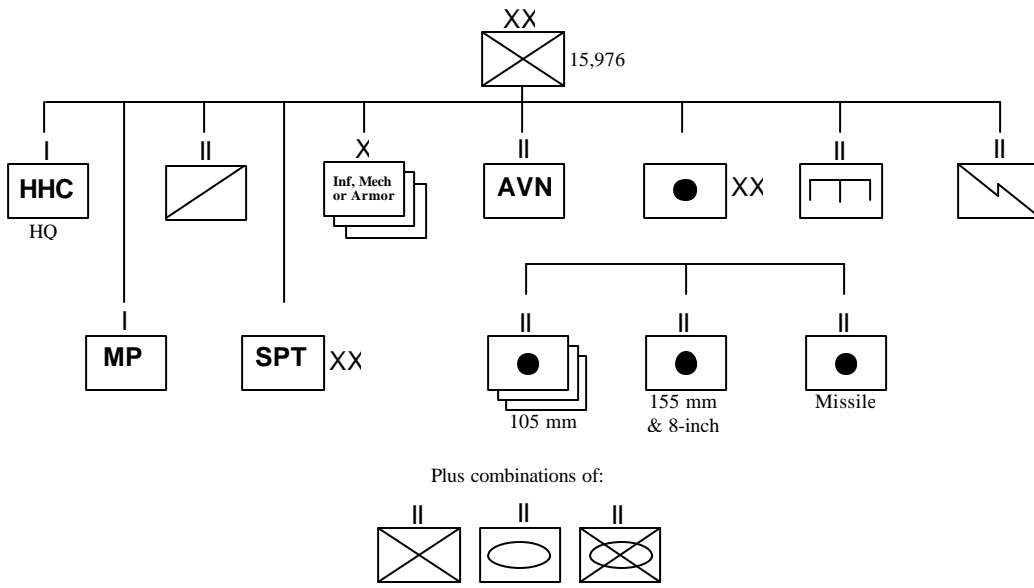

The ROAD Division Base, 1961<sup>131</sup>

**FIGURE 6**

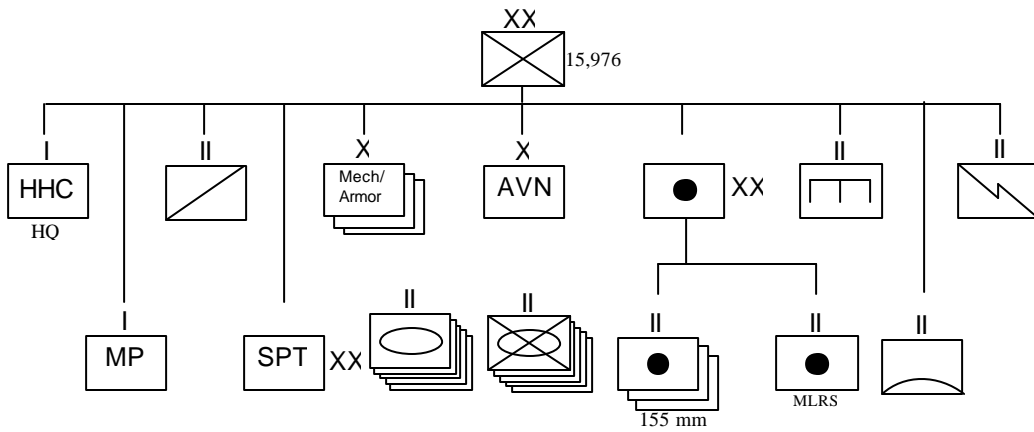

The AOE Infantry Division (Mechanized), 1986<sup>132</sup>

<sup>131</sup> Ibid., 31.

<sup>132</sup> Romjue, *The Army of Excellence*, 140.

## BIBLIOGRAPHY

- Allen, Terry. *Situation and Operations Report of the First Infantry Division during the Period of Its Overseas Movement, North African, and Sicilian Campaigns*. United States Army, 1951.
- Ambrose, Stephen E. *Eisenhower, Volume Two: The President*. New York, NY. Simon and Schuster, 1985.
- American Battle Monuments Commission. *1<sup>st</sup> Division Summary of Operations in the World War*. Washington, D.C.: GPO, 1944.
- Anderson, Peggy. *Great Quotes from Great Leaders*. Lombard, Ill. Great Quotations Publishing Company, 1990.
- Bacevich, A.J. *The Pentomic Era: The U.S. Army Between Korea and Vietnam*. Washington, D.C. National Defense University Press, 1986.
- Bell Jr., Raymond E. "Old Traditions Die Hard: Division Reorganization." Military Review. September-November 1998.
- Bolger, Daniel P. "Command or Control?" Military Review. July 1990.
- Boyes, Jon L. and Andriole, Stephen J. "Principles of Command and Control." Washington, D.C.: Armed Forces Communications and Electronic Association, National Defense University, 1989.
- Brinkerhoff, John R. "The Brigade-Based New Army." Parameters, U.S. Army War College Quarterly, Carlisle PA.: U.S. Army War College, Volume XXVII, No. 3, Autumn 1997.
- Burlas, Joe. "White: Army Needs Better Business Practices." Army Link News. United States Army Public Affairs, 14 June 2001. [on-line]; available from <http://www.dtic.mil/armylink/news/Jun2001/a20010614white0612.html>; Internet; accessed 19 February 2003.
- Clancy, Tom. *Into the Storm: A Study in Command*. New York, NY. G.P. Putnam's Sons, 1997.
- Coker, Kathy R. and Rios, Carol E. *A Concise History of the U.S. Army Signal Corps*. Fort Gordon, GA: U.S. Army Signal Center, 1988.
- Colodney, Lori L. S. "Getting Command and Control Systems Back into the Fight on the Digitized Battlefield." Fort Leavenworth, KS. United States Army Command and General Staff College School of Advanced Military Studies, 1995.
- Combat Studies Institute. *Sixty Years of Reorganizing for Combat: A Historical Trends Analysis*. Fort Leavenworth, KS. 1999.
- Dunnigan, James F. and Bay, Austin. *From Shield to Storm*. New York, NY. William Morrow and Company, Inc. 1992.



- Fastabend, David “An Appraisal of ‘The Brigade-Based New Army’.” Parameters. Autumn 1997, pp.73-81.
- \_\_\_\_\_. “New Research on Span of Command and Control: Implications for Designing Army Organizations.” ARI Research Note 99-09, Fort Leavenworth, KS. U.S. Army Research Institute for the Behavioral and Social Sciences, December 1998.
- The First – A Brief History of the 1<sup>st</sup> Infantry Division, World War II*. Reprinted by the Cantigny First Division Foundation, 1996.
- Ford, J. Patrick, and Mullen III, William J. and Christ, Richard E. “Effective Span of Command and Control by Echelon in Training and Operational Environments.” ARI Research Note 99-03, Fort Leavenworth, KS. U.S. Army Research Institute for the Behavioral and Social Sciences, October 1998.
- Holt, Jimmie F. “The U.S. Army Corps in Europe – Will Its Command and Control System Support Operational Movement?” Fort Leavenworth, KS. United States Army Command and General Staff College School of Advanced Military Studies, 1989.
- Jordan, Billy J. and Reardon, Mark J. “Restructuring the Division: An Operational and Organizational Approach.” Military Review. May-June 98.
- Kedzior, Richard W. “Evolution and Endurance: The U.S. Army Division in the Twentieth Century.” Santa Monica, CA.: RAND Corp., 2000.
- Lewis, Kevin N. “Historical U.S. Force Structure Trends: A Primer.” Santa Monica, CA.: RAND Corp., 1989.
- Macgregor, Douglas A. *Breaking the Phalanx: A New Design for Landpower in the 21<sup>st</sup> Century*. Westport, CT: Praeger, 1997.
- \_\_\_\_\_. “Resurrecting Transformation for the Post-Industrial Era.” Defense Horizons. September 2001.
- Martz, Joseph E. “The Division: Redundant or Necessary?” Fort Leavenworth, KS. United States Army Command and General Staff College School of Advanced Military Studies, 1991.
- Ney, Virgil. “Evolution of the U.S. Army Division 1939-1968.” Fort Belvoir, VA.: United States Army Combat Operations Research Group, 1969.
- Romjue, John L. *A History of the Army 86 Volume II: The Development of the Light Division, The Corps, and Echelons Above Corps*. Fort Monroe, VA.: Historical Office, United States Army Training and Doctrine Command, June 1982.
- \_\_\_\_\_. *The Army of Excellence: The Development of the 1980s Army*. Fort Monroe, VA: Office of the Command Historian, 1993.
- Snyder, Frank M. “Command and Control: Readings and Commentary.” Charter for Information Policy Research. Cambridge, MA.: Harvard University, 1984.

- TRADOC Analysis Center, *Interim Division Design Analysis Final Report*, (TRAC-F-TR-01-017). Fort Leavenworth, KS. July 2001.
- TRADOC Pamphlet 525-3-90/O&O. *The United States Army Objective Force: Operational and Organizational Plan for Maneuver Unit of Action*. Fort Monroe, VA.: U.S. Army Training and Doctrine Command, 2002.
- Turabian, Kate L. *A Manual for Writers of Term Papers, Theses, and Dissertations* 6<sup>th</sup> ed. Chicago: University of Chicago Press, 1996.
- Twohig, John, Stokowski, Thomas J. and Rivera, Bienvenido. "Structuring Division XXI." Military Review. May-June 1998.
- U.S. Army Research Institute for the Behavioral and Social Sciences. *Span of Effective Command and Control: Implications of New Research for Organizing the Force*. ARI Newsletter Volume 5, Number 2, Fort Leavenworth, KS. Summer 1995.
- U.S. Department of the Army. *FM 3-0: Operations*. Washington, D.C., 2001.
- \_\_\_\_\_. *FM 3-90: Tactics*. Washington, D.C., 2001.
- \_\_\_\_\_. *FM 71-100: Division Operations*. Washington, D.C., 28 August 1996.
- \_\_\_\_\_. *FM 71-100-2: Infantry Division Operations*. Washington, D.C., 31 August 1993.
- \_\_\_\_\_. *FM 100-7: Decisive Force: The Army in Theater Operations*. Washington, D.C., May 1995.
- \_\_\_\_\_. *FM 100-15: Corps Operations*. Washington, D.C., 29 October 1996.
- Van Creveld, Martin. *Command in War*. Cambridge, MA: Harvard University Press, 1985.
- Wass de Czege, Huba.. "Enhancing Organizational Performance: Re-engineering the Army's System of Echelonment." New Paradigms 4.
- \_\_\_\_\_. "Toward a Future Army." 2002.
- Wass de Czege, Huba and Sinnreich, Richard H. "Conceptual Foundations of a Transformed U.S. Army." Land Warfare Paper No. 40. The Institute of Land Warfare: Association of the United States Army. March 2002.
- Wass de Czege, Huba and Bieber, Jacob. "Optimizing Future Battle Command Technologies." Military Review. March-April 1998.
- Weigley, Russell F. *The American Way of War: A History of United States Military Strategy and Policy*. Bloomington, IN: Indiana University Press, 1973.
- \_\_\_\_\_. *History of the United States Army*. Bloomington, IN: Indiana University Press, 1984.

Wilson, John B. "Influences on U.S. Army Divisional Organization in the Twentieth Century." December 1995 [on-line]; available from <http://www.fas.org/man/dod-101/army/unit/influncs.htm>; Internet; accessed 21 September 2002.

\_\_\_\_\_. *Maneuver and Firepower: The Evolution of Divisions and Separate Brigades*. Washington, D.C.: United States Army Center of Military History, 1998.

Worley, D. Robert. "W(h)ither Corps?" Carlisle, PA.: Strategic Studies Institute, 2001.