

REPORT DOCUMENTATION PAGE

AFRL-SR-AR-TR-03-

Public reporting burden for this collection of information is estimated to average 1 hour per response, including gathering and maintaining the data needed, and completing and reviewing the collection of information. Send collection of information, including suggestions for reducing this burden, to Washington Headquarters Services, Davis Highway, Suite 1204, Arlington, VA 22202-4302, and to the Office of Management and Budget, Paperw

6281

s,
is
in

| | | | | |
|---|---|--|---|--|
| 1. AGENCY USE ONLY (Leave blank) | | 2. REPORT DATE | 3. REPORT | |
| | | | 01 JUN 2000 - 28 FEB 2002 Final Report | |
| 4. TITLE AND SUBTITLE (DARPA) ULTRA-SLOW LIGHT GENERATION ON A SINGLE CHIP | | | 5. FUNDING NUMBERS 62712E K126/01 | |
| 6. AUTHOR(S) DR VESTERGAARD HAU | | | | |
| 7. PERFORMING ORGANIZATION NAME(S) AND ADDRESS(ES) HARVARD UNIVERSITY 1350 MASSACHUSETTS AVENUE HOLYOKE CENTER, 4TH FLOOR CAMBRIDGE MA 02138-3826 | | | 8. PERFORMING ORGANIZATION REPORT NUMBER | |
| 9. SPONSORING/MONITORING AGENCY NAME(S) AND ADDRESS(ES) AFOSR/NE 4015 WILSON BLVD SUITE 713 ARLINGTON VA 22203 | | | 10. SPONSORING/MONITORING AGENCY REPORT NUMBER F49620-00-1-0325 | |
| 11. SUPPLEMENTARY NOTES | | | | |
| 12a. DISTRIBUTION AVAILABILITY STATEMENT APPROVED FOR PUBLIC RELEASE, DISTRIBUTION UNLIMITED | | | 12b. DISTRIBUTION CODE | |
| 13. ABSTRACT (Maximum 200 words) We plan to create a compact, low power, single chip system for generation of ultra slow light. Such a system would facilitate practical applications of nonlinear optics at light levels millions of times lower than what is presently possible. Potential applications include optical switches controlled by single photons, dynamically programmable optical delay lines with delays that can be pushed into the millisecond regime, and frequency up-conversion at extremely low power Levels. | | | | |
| 14. SUBJECT TERMS | | | 15. NUMBER OF PAGES | |
| | | | 16. PRICE CODE | |
| 17. SECURITY CLASSIFICATION OF REPORT UNCLASSIFIED | 18. SECURITY CLASSIFICATION OF THIS PAGE UNCLASSIFIED | 19. SECURITY CLASSIFICATION OF ABSTRACT UNCLASSIFIED | 20. LIMITATION OF ABSTRACT UL | |

20030731 103

Final Report

Abstract:

We plan to create a compact, low power, single chip system for generation of ultra slow light. Such a system would facilitate practical applications of nonlinear optics at light levels millions of times lower than what is presently possible. Potential applications include optical switches controlled by single photons, dynamically programmable optical delay lines with delays that can be pushed into the millisecond regime, and frequency up-conversion at extremely low power levels.

Statement of objectives:

Recently, we succeeded in reducing the light speed to 17 m/s by creating a laser induced quantum interference in a Bose-Einstein condensate. At the same time we obtained extreme optical properties in our cold atom clouds: we have demonstrated a nonlinear refractive index which is 14 orders of magnitude larger than the nonlinear index in an optical fiber and the largest ever measured by a factor of a million. This has opened up a new regime of nonlinear optics at extremely low light levels.

An important potential application of the large nonlinearities is the creation of extremely sensitive optical switches with switching energies that could be made as low as the energy corresponding to just two photons. The bandwidth of the switch can be tailored both through intensity control of the lasers inducing the quantum interference in the atomic medium, and by manipulating the shape and density of the trapped, cold atom cloud. Other intriguing possible applications include dynamically programmable optical delay lines with delays in the microsecond and even millisecond regimes which are temporal regions hard to access with other means. We also envision that frequency up-conversion at very low light levels would be possible.

Our plan is for a total re-engineering of our system for atom cooling and trapping, with the aim of making practically accessible the extreme nonlinear optical properties obtained in cold atom clouds. With state of the art nanotechnology tools (focused ion beam machine) we can create submicron sized metallic trapping and guiding structures on an insulating substrate that would allow atom manipulation with miniscule electric fields and currents applied to the metal lines. This would give us an unprecedented ability to control the atoms on fast time scales and, consequently, to fully control the properties of the cold-atom based nonlinear medium we plan to create.

Using a quartz substrate we could also create optical wave guides on the same substrate for guiding of the laser beams required for laser cooling and for slow light generation. We'll pick atoms that we can excite with low power diode lasers.

By optimizing the atom and laser guiding structures and with the right choice of atom, we should be able to obtain - on a single 1 cm sized chip - optical nonlinearities as large as those mentioned above.

Technical Proposal

Ultra-slow light generation on a single chip

Recently, we succeeded in reducing the light speed to 17 m/s by optically inducing a quantum interference in a Bose-Einstein condensate (Ref. 1). The low light speeds are obtained in an optical medium created from entangled states between Bose condensed atoms and an optical field created by the 'coupling' laser shown in Fig. 1. The intensity of this light field controls the optical properties for another, pulsed laser beam (the 'probe' laser) sent through the medium. The reported reduction of the pulse propagation speed by a factor of 20 million is associated with a spatial compression of the laser pulses in the medium by the same factor. Furthermore, the presence of the coupling laser allows for loss-less, shape preserving transmission of light pulses through atomic media that would otherwise be totally opaque.

By generating ultra slow light we have at the same time created extreme optical properties of our cold atom clouds: we have demonstrated a nonlinear refractive index which is 14 orders of magnitude larger than the nonlinear index in an optical fiber and the largest ever measured by a factor of a million. This has opened up a new regime of nonlinear optics at extremely low light levels.

An important potential application of the large nonlinearities is the creation of extremely sensitive optical switches with switching energies that could be made as low as the energy corresponding to just two photons. The bandwidth of the switch can be tailored both through intensity control of the lasers inducing the quantum interference in the atomic medium, and by manipulating the shape and density of the trapped, cold atom cloud. Other intriguing possible applications include dynamically programmable optical delay lines with delays in the microsecond and even millisecond regimes which are temporal regions hard to access with other means. A very important aspect of the proposed delay lines is the fact that the delays are dynamically programmable through control of the coupling laser intensity. We also envision that frequency up-conversion at very low light levels would be possible. (Ref. 2)

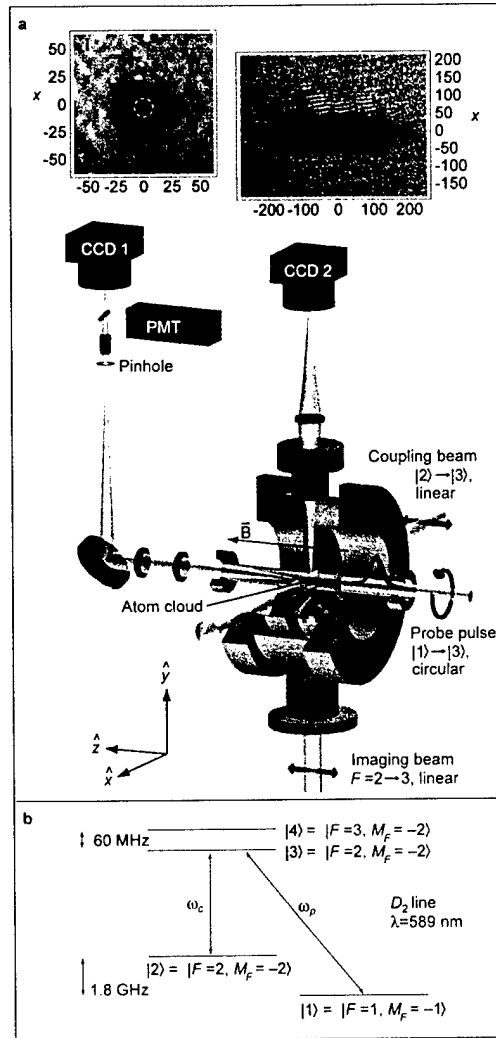

Figure 1: The experimental set-up used to slow light to 17 m/s. A cold atom cloud – or a Bose-Einstein condensate – is trapped by an electromagnet in the center of a vacuum chamber. The cigar-shaped cloud is then illuminated from the side by a ‘coupling’ laser and a new optical medium is formed from entangled states between the trapped, cold atoms and the laser field. The energy states of this coupled system – and thereby its optical properties - can be controlled simply through control of the intensity of the coupling laser. Probe pulses are launched and sent through the cloud along the z direction. To measure the light speed of these pulses, we observe directly, with a photomultiplier (PMT), the time it takes the pulses to go through the medium. To obtain the size of the cloud, we use a vertical laser beam, the ‘imaging beam’, and record an absorption image of the cloud with a charge coupled device camera, CCD 2. In insert (ii) we show an image of a 230 micron long cloud cooled to 450 nK. (Figure taken from Ref. 1).

In our present setup for creating ultra slow light with cold atoms and Bose-Einstein condensates, we laser cool sodium atoms to temperatures in the microkelvin regime and subsequently trap them in a '4 Dee' electromagnet. The trapped atoms are evaporatively cooled to nanokelvin temperatures, resulting in the creation of Bose-Einstein condensates typically containing millions of atoms. The condensates are formed in an ultra high vacuum chamber and we presently generate the laser beams from an argon-ion laser pumped dye laser. The currents we apply in the 4 Dee magnet are typically in the range of 1000 amperes.

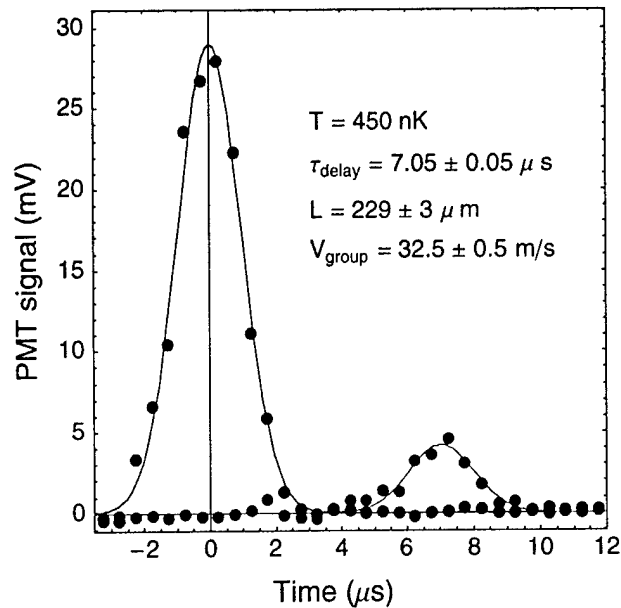

Fig. 2. An example of a pulse delay measurement. The blue pulse is a reference pulse obtained with no atoms in the system. By latching a similar pulse through the 230 micron long cloud shown in insert (ii) in Fig. 1, we obtain the red pulse delayed by 7 microseconds which corresponds to a light speed of 32 m/s. To obtain the same delay with an optical fiber would require a fiber length of 1/2 mile. The presence of the coupling laser also allows for transmission of the probe pulse through an otherwise opaque medium. (In the absence of the coupling laser beam, the transmission of the resonant probe pulse would have been on the order of $\exp(-65)$). We have already demonstrated in the laboratory that the small remnant transmission loss seen in the figure can be mitigated by using the D1 line in sodium rather than the D2 line used here. (Figure taken from Ref. 1).

Our plan is for a total re-engineering of the system for atom cooling and trapping, with the aim of making practically accessible the extreme nonlinear optical properties obtained in cold atom clouds. Our idea is to create a much better match between the size of the atoms and the size of the mechanical structures used for their manipulation. With state of the art nanotechnology tools

we can create submicron sized metallic trapping and guiding structures on an insulating substrate. Atoms could then be trapped right above the surface of the substrate and the close proximity to the guiding structures would allow atom manipulation with miniscule electric fields and currents applied to the metal lines (Refs 3-5) . Using a quartz substrate we could also create optical wave guides on the same substrate for guiding of the laser beams required for laser cooling and for slow light generation. Furthermore we plan to implement far detuned (infrared) laser beams to create a set of 'optical tweezers' (in an optical tweezer an atom is trapped in the focal point of a laser beam). Full control of the atom clouds would be gained from the resulting combination of electric, magnetic, and optical fields.

On a single substrate, with a size of 5-10 mm, we plan to incorporate a magneto-optical trap (MOT) (Ref. 6). Laser beams, tuned slightly below an atomic resonance, create an optical molasses where atoms can be cooled to microkelvin temperatures. A spherical magnetic quadrupole field creates - in the presence of the laser beams - a confining trapping potential. We'll pick atoms that we can excite with low power diode lasers (rubidium is one candidate we are considering). On the same substrate, we'll transfer atoms from the MOT to a spatially separated, second electromagnet for purely magnetic atom trapping, where the nonlinear optical medium will be created. As described in Ref. 1 such a magnet would act as a filter with all atoms trapped in one particular internal quantum state. It is this fact that makes it possible to obtain truly lossless, ultra slow light propagation. Both electromagnets could be created with currents in submicron metallic lines deposited on the substrate. Alternatively, for much tighter trapping, a magnetic material could be deposited. On the size scales we are envisioning we could create single magnetic domains and generate very large magnetic field gradients.

We expect to run the experiment in a pulsed mode with continuous loading of the MOT and a periodic transfer of the atoms - with cold atom waveguides - to the spatially separated purely magnetic trap. The atom guide could be based upon a submicron metallic structure with a time varying electric field interacting with the induced electric dipole moment of the atoms and resulting in dynamically stabilized, guided atomic motion. We could also obtain

magnetic guiding with a current applied to a thin metal line or with a magnetic needle.

By optimizing the trap configuration, with the right choice of atom, and by applying the coupling and probe lasers in a copropagating configuration, we should be able to obtain - on a single chip - optical nonlinearities as large as those reported in Ref. 1.

With access to a focused ion beam machine (Ref. 7) we would be able to produce a wide range of submicron sized atom guiding and trapping structures. This would give us an unprecedented ability to control the atoms on fast time scales and, consequently, to fully control the properties of the cold-atom based nonlinear medium we plan to create. Furthermore, with such a tool we could create a nested set of traps of differing size and we believe that a successive transfer between traps of decreasing size could effect the onset of evaporative cooling and allow for atom cooling to nanokelvin temperatures. Ultimately, we could then obtain - still on a single chip - light speeds in the millimeter/second regime, and nonlinearities larger yet by 4 orders of magnitude than those reported in Ref. 1. Alternatively, by relaxing the constraint of colinear propagation of coupling and probe lasers, we could obtain the same nonlinearities as in Ref. 1, with the ability also to focus the coupling and probe laser beams. This would allow the use of tightly focused laser beams and hence the use of ultra low power laser diodes.

For a prototype system we would generate most of the laser beams from a laser diode pumped Ti:Sa laser. With its large tunability in the infrared spectrum we would maximize our flexibility, particularly for testing the system with different atomic species. The prototype system will have an ion-pumped vacuum system. Ultimately we would use low-power diode lasers, picked for a particular atom, and replace the ion pump/vacuum chamber possibly with a getter material in a sealed, compact, self-contained system.

One of the great challenges in this project will be to co-implement trapping and guiding structures for both light and atoms on a single, small substrate. This process must be controlled well enough to allow for creation of the required laser induced quantum interference in a trapped atom cloud. This quantum interference is greatly sensitive, for example, to propagation direction

and polarization of the laser beams. I believe access to a focused ion beam machine (FIB) will be crucial to meet that challenge. An FIB will provide us with the precision and flexibility necessary for the nano scale machining process.

On longer time scales we imagine that creation of optical switches, controllable at the single photon level, could form the basis for a whole family of logical gates. In particular, NOT and NAND gates could be made and form the basis for a single chip implemented computing structure. Also, quantum computing might be an intriguing possibility. We could include many atom traps on a single substrate and information from one atom cloud to the next could be transmitted along atomic wave guides or through light fields in optical waveguides. One of the crucial issues for quantum computing is control and minimization of the dephasing rate in the system. First of all, our system is based on neutral atoms that – compared to ions - couple very weakly to the surroundings. Secondly, the dephasing time determines the robustness of the quantum interference we set up in our atom clouds, governing the minimum light speeds and maximum nonlinearities we can obtain. Therefore, we have developed great experience in controlling the dephasing time for our cold atom based nonlinear system.

References:

1. Lene Vestergaard Hau, S.E. Harris, Zachary Dutton, and Cyrus H. Behroozi, *Nature* **397**, 594 (1999).
2. S.E. Harris and Lene Vestergaard Hau, *Phys. Rev. Lett.*, **82**, 4611 (1999).
3. Lene Vestergaard Hau, Michael M. Burns, and J.A. Golovchenko, *Phys. Rev. A* **45** 6468 (1992).
4. Lene Vestergaard Hau, J.A. Golovchenko, and Michael M. Burns, *Phys. Rev. Lett.* **74** 3138 (1995) (See also: *Phys. Rev. Lett.* **75** 1426 (1995) for corrections of typesetting errors in the original version).
5. J.D. Weinstein and K.G. Libbrecht, *Phys. Rev. A*, **52**, 4004 (1995).
6. Nobel lectures by S. Chu, C. N. Cohen-Tannoudji, and W.D. Phillips, *Rev. Mod. Phys.* **70**, 685-741 (1998).
7. Diane K. Stewart and J. David Casey, Jr., in *Handbook of Microlithography, Micromachining, and Microfabrication*, Vol. 2: Micromachining and Microfabrication, Chap. 4: Focused Ion Beams for Micromachining and Microchemistry, pages 153-195.