

NPS-97-03-003

NAVAL POSTGRADUATE SCHOOL Monterey, California



**Seventh Fleet Command Post Exercise
Fleet Battle Experiment Kilo
Fires Initiative Final Report**

Gordon Schacher and Shelley Gallup
Wayne E. Meyer Institute of Systems Engineering

May 2003

20030724 021

Approved for public release; distribution is unlimited.

Prepared for: Navy Warfare Development Command

Contributing Authors

Wayne "Doc" Sweitzer

Provided significant material used directly in the Reconstruction Section of this report.

Rich Kimmel

Provided the section on JFACC processes.

Nelson Irvine and Sue Hutchins

Provided editing and material for this report:

NAVAL POSTGRADUATE SCHOOL
Monterey, California 93943-5000

RADM David R. Ellison, USN
Superintendent

Richard Elster
Provost

This report was prepared for: Navy Warfare Development Command

Reproduction of all or part of this report is authorized.

This report was prepared by: Wayne E. Meyer Institute of Systems Engineering

Authors:



Gordon Schacher

Shelley P. Gallup

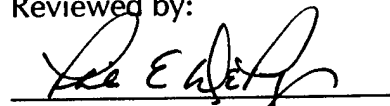
Reviewed by:

Phil DePoy, Director
Wayne E. Meyer Institute of Systems Engineering

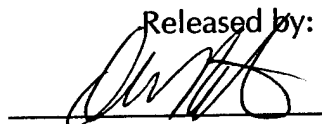
Released by:

D. W. Netzer
Associate Provost and
Dean of Research

REPORT DOCUMENTATION PAGE

Form approved

OMB No 0704-0188

Public reporting burden for this collection of information is estimated to average 1 hour per response, including the time for reviewing instructions, searching existing data sources, gathering and maintaining the data needed, and completing and reviewing the collection of information. Send comments regarding this burden estimate or any other aspect of this collection of information, including suggestions for reducing this burden, to Washington Headquarters Services, Directorate for Information Operations and Reports, 1215 Jefferson Davis Highway, Suite 1204, Arlington, VA 22202-4302, and to the Office of Management and Budget, Paperwork Reduction Project (0704-0188), Washington, DC 20503.

1. AGENCY USE ONLY (Leave blank)		2. REPORT DATE 28 May 03	3. REPORT TYPE AND DATES COVERED Research	
4. TITLE AND SUBTITLE Seventh Fleet Command Post Exercise Fleet Battle Experiment Kilo Fires Initiative Final Report			5. FUNDING Navy Warfare Development Command	
6. AUTHOR(S) Gordon Schacher and Shelley Gallup				
7. PERFORMING ORGANIZATION NAME(S) AND ADDRESS(ES) Wayne E. Meyer Institute of Systems Engineering Naval Postgraduate School 777 Dyer Rd., Room 100D, Monterey, CA 93943			8. PERFORMING ORGANIZATION REPORT NUMBER	
9. SPONSORING/MONITORING AGENCY NAME(S) AND ADDRESS(ES) Navy Warfare Development Command Naval War College Newport, Rhode Island			10. SPONSORING/MONITORING AGENCY REPORT NUMBER	
11. SUPPLEMENTARY NOTES				
12a. DISTRIBUTION/AVAILABILITY STATEMENT Unlimited			12b. DISTRIBUTION CODE	
13. ABSTRACT (Maximum 200 words.) Fleet Battle Experiment was conducted during Seventh Fleet exercise Tandem Thrust 03. During the Command Post Exercise phase, testing of Time Sensitive Targets processes using the Joint Fires Network was carried out. This report covers training and use of the TES-N portion of the Joint Fires Network.				
14. SUBJECT TERMS Time Sensitive Targets, Command and Control, Network Information Systems			15. NUMBER OF PAGES 32	
			16. PRICE CODE	
17. SECURITY CLASSIFICATION OF REPORT Unclassified	18. SECURITY CLASSIFICATION OF THIS PAGE Unclassified	19. SECURITY CLASSIFICATION OF ABSTRACT Unclassified	20. LIMITATION OF ABSTRACT	

Table of Contents

1.0 Principal Results	3
2.0 Introduction	13
2.1 Command Post Exercise	14
2.2 Navy Fires Initiative	14
3.0 Reconstruction	17
3.1 Impacts on the Experiment	17
3.1.1 Reduced Manning Impacts	17
3.1.2 Lack of Sufficient Training Impacts	18
3.1.3 Systems / Data Impacts	19
3.1.4 Equipment Status Matrix	20
3.2 Experiment Planned Events	24
3.2.1 Modifications to Planned Events	28
3.3 Daily Context Summary	29
3.4 Summary of Context Consequences	30
4.0 Results	33
4.1 Simulation Impact on Training	33
4.2 Personnel Capabilities	34
4.3 Operator Acceptance of TES-N	35
4.4 TST Process Performance Times	35
4.5 JFN and the TST Process	36
4.6 Range Of Validity for Results	37
5.0 Recommendations	39
5.1 Fleet Follow-Up	39
5.2 Experimentation Structure	39
5.3 Experimentation Hardware	40
5.4 Experimentation Data	40
5.5 Experiment Planning Stability	41
5.6 Simulation and Training	41
Appendix A TST Timelines	43
Appendix B CJTF TST Process - TT03 CPX	47
Appendix C JFACC TST Process - TT03 CPX	53

This page intentionally left blank.

1.0 PRINCIPAL RESULTS

The following principal results have been extracted from the body of this report. They are those deemed most significant for the objectives of this initiative and for the experiment as a whole.

The format of these results is meant to facilitate their use for presentations. The results for each area of interest are presented on a single page: there are highlights within a box, as might be inserted in a Power Point or view graph, followed below it by a more lengthy explanation of each point.

FBE-Kilo, Command Post Exercise Phase

PR #1 - Achievement of SOP Testing Objective

- Experimentation difficulties prevented an adequate determination.
 - No manning of JFACC Afloat.
 - Lack of JAOC manning.
 - TES-N operators lack of training.
- CPX was modified to be mostly training for FTX.

This initiative was to test JFN support for TST, and the associated SOP, for operations in the three roles for which it will be employed by C7F:

- as an embarked CJTF with other supported staff(s) embarked,
- as an embarked JFMCC/NAVFOR, and
- as the Fleet JFN/JFN supporting deployed RTCs and RTC Lites.

Key equipment components were an afloat JFN (supporting the JTF staff and a JFACC forward) and an ISR-M supporting the JFACC Main.

Key participants include the entire CJTF command structure and Component Commanders. JFACC participation was essential to meet the majority of objectives in addition to supporting examination of USAF ISR Manager (ISRM) to JFN operations.

The CPX was the only time during TT03 that full CJTF manning was to be in place, which is necessary to validate the CONOPS and associated standing procedures.

Not having a manned JFACC Afloat eliminated a major component of SOP testing that was to be accomplished. JAOC personnel shortage also had a detrimental effect on exercising the SOP.

With one exception, personnel in the JIC had no experience with TES-N. The result was that a major portion of CPX was devoted to training rather than initiative experimentation.

Equipment difficulties also played a major role in reducing the ability to obtain results for this initiative (see PR #2).

The basic objectives of this initiative could not be met. Indications of needed SOP development for a JIC, if it is to participate in TST, were determined.

FBE-Kilo, Command Post Exercise Phase

PR #2 - Achievement of JFN Contributions to TST Objective

- No baseline without JFN available, cannot perform an adequate test.
- Equipment difficulties prevented adequate testing of JFN capabilities.
 - Lack of TES-N to ADOCS connectivity.
 - Failure of FBEnet.
- Only TES-N in the JIC was tested.

The stated JFN objective was to determine the contribution of JFN to TST prosecution. In order to determine JFN-unique contributions, or synergistic JFN effects, a baseline of performance without JFN is needed. Such a baseline requires using the same C2 structure and information processes as were used in the experiment. Baseline information is not available.

Equipment problems prevented testing end-to-end JFN performance. Target nominations could not be passed directly from TES-N to ADOCS, or directly to ISRM. FBEnet was not operational due to Ku Band switching problems in Hawaii. The result was that many information paths that are crucial for realizing JFN potential were not operational.

Because of the collection of equipment and manning problems the only comprehensive test of JFN that could be made was of the TES-N component in the JIC.

The basic objectives of this initiative could not be met. Results that could be derived are indications of JFN potential for TST processes within a JIC.

FBE-Kilo, Command Post Exercise Phase

PR #3 - TES-N Capabilities

- Works well for IMINT exploitation.
 - Video screener a major factor in closing TST timeline.
 - Directing tactical imagery assets.
- Inability to drop validated aim points a major drawback.
- Improved sensor control by image analyst required.

Image analysis and processing worked well, essentially creating/producing an efficient assembly line. Operators, with little training, were able to explore images and make both analysis and processing decisions fairly quickly. (Difficulties encountered because of the simulation are covered in a subsequent Principal Result.)

An important capability was for the image analyst to be able to direct tactical sensors. The analyst worked through a sensor manager and the process worked moderately well. There were difficulties with this sensor control, as implemented, in that there was no direct provision for sensor control at the analyst's terminal. A direct link that the analyst can use without interrupting, nor losing sight of, imagery is needed.

There were problems with imagery information content. Transmission of aim points and Lat-Long needs to be improved. This was done verbally or by notes, which slowed the process.

FBE-Kilo, Command Post Exercise Phase

PR #4 - TES-N Personnel Issues

- Only the team leader was an experienced operator.
 - Lack of operator training hindered TST operations.
- New operators learned very fast.
 - Performed quite well with minimal training.
 - Could determine whether performance difficulties were due to equipment or training.
- New operators did not understand full spectrum of TST process.

The TES-N team leader in the JIC was an IS1 who had 9 months of intensive experience with the system. He was the trainer for a team of three Sailors who had no experience or training on the system. On-the-job training was performed during the experiment. It is to be expected that the performance of well-trained operators would be better than those in the midst of training and that this had an impact on TST processes. It was not possible to determine which process performance difficulties were the result of an operator lacking proficiency or due to JFN capability difficulties.

It was surprising how fast the new operators learned how to use TES-N. They were performing image analysis and TST nominations within a few hours of developing familiarity with the system. This speaks well for the performance to be expected with JFN.

Operator performance was hindered by their learning only that portion of the TST process they were performing. Performance will improve when operators understand the full process and how the functions at the node they are working fits into the overall process.

FBE-Kilo, Command Post Exercise Phase

PR #5 - Operator's Acceptance of TES-N

- In spite of lack of familiarity, operators recognized the system's potential for improving performance and efficiency
- User-friendly and easy to learn.
- Much appreciation of several functions combined in one machine.

With the exception of the team leader, the TES-N operators were totally unfamiliar with the system and with TST processes. Their training was on IPB. Thus, they were being introduced to both a new system and a new process. In spite of this they were enthusiastic about TES-N.

They felt the system was easy to learn and that the graphical user interface (GUI) layout and methods of use were fairly intuitive.

The system layout was such that a terminal could be used for image screening, image analysis, or nomination. This allowed those operations to be exchanged or shared. Having multiple functions resident within one machine produced manpower savings as a result of increased work efficiency and direct sharing of information between operators.

FBE-Kilo, Command Post Exercise Phase

PR #6 - TES-N Training Issues

- Current simulation hinders training.
 - Lack of reality interfered with all aspects of training and performance.
 - Simulation designed specifically for TES-N training needed.
- Operators need broad TST process training.

CPX was used to provide TES-N operator training in an operational context. But, the simulation used for the experiment presented unrealistic renderings of battlefield objects. This lack of realism interfered with operator performance and therefore with their training. In addition to low fidelity, the presentation of the battlefield was such that image analysts could not distinguish different instances of the same object type. This produced a situation where operators were moving back and forth between objects to figure out which was which, interfering with training.

A realistic simulation designed specifically for TES-N training is needed.

Operators did not have an understanding of the TST process. Training on the TST process was being conducted at the same time as how to do it. Training on the full TST process is needed as a prerequisite to system "knobology" training.

FBE-Kilo, Command Post Exercise Phase

PR #7 - Experimentation Issues

- Experiment and Exercise were decoupled.
- Greater emphasis needed on learning spirals prior to operational field experimentation.
- Complete exercising of equipment and validation of functions required prior to operational field experimentation.

The exercise proceeded through the MSEL events in good fashion. Due to a number of factors mentioned earlier it was not possible for the experiment to proceed in the same fashion. The result was that the two became decoupled. It was not clear that it was planned for the exercise to depend on information coming out of TES-N in the JIC, but in execution it did not. Thus, the experiment became one that could have been performed anywhere. A shipboard operation and a real operational environment were not needed nor used.

This brings into question the wisdom of having operational field experiments be a principal information collection means. Savings could be realized if Navy experimentation were to concentrate on learning spirals and having operational field experimentation done only when necessary to validate results in an operational environment.

CPX suffered significantly from not having equipment operate properly. A process is needed where an experiment is not undertaken until equipment has been fully tested, determined to be functioning properly, and warranted to be ready to fully support the experiment's objectives.

FBE-Kilo, Command Post Exercise Phase

PR #8 - Fleet Follow-Up

- Little Fleet follow-up has occurred after former FBEs.
 - Operational improvements have been lost.
 - Fleet recommendations for program improvement have not occurred.
- FBE-K opportunities.
 - TST SOP
 - Design of Fleet Flagship as a JFN TST hub.
 - TST processes and SOP for less well-equipped units.

The pace of FBEs formerly has been such that the planning for the next experiment is underway before the current one is concluded, certainly before analysis is completed. This has prevented lessons-learned from being carried forward to the next experiment. It has also precluded investing the effort needed to follow up with the Fleet on system and process improvements. Much of the possible immediate value of FBE results has not been realized.

FBE-K, even the CPX portion, present opportunities for Fleet follow-up. Areas that have been identified as fruitful for doing this are:

- Development of TST SOP for an afloat CJTF
- Design of the processes for a Fleet Flagship to function as a JFN TST hub.
- Developing TST processes and SOP for less well-equipped ships/units.

Undertaking these suggested Fleet follow-up items will require a shift of funds and manpower to this activity.

This page intentionally left blank.

2.0 INTRODUCTION

The following italicized descriptions are taken directly from the Navy Warfare Development Command (NWDC) FBE Kilo Experiment Plan.

Fleet Battle Experiment K (FBE K) will be conducted in the spring of 2003, the 11th experiment in the FBE series. It will be conducted in conjunction with the USPACOM tier 1 level exercise, Tandem Thrust 03 (TT03). TT03 is comprised of two events, a Command Post Exercise (CPX) and a Field Training Exercise (FTX); FBE K will participate in both events.

As part of FBE K, many of the Experiment's initiatives will focus on the command and control (C2) processes centered at the joint force level. A primary goal is to apply the concepts of Network Centric Warfare (NCW) to the processes used to support a Joint Task Force (JTF) staff and a Joint Forces Air Component Commander (JFACC) while they are embarked aboard a Joint Fires Network (JFN) equipped command platform (USS BLUE RIDGE LCC-19). FBE K will concentrate on the allocation / reallocation of both weapons and sensors, target assignment, and fire mission deconfliction in support of the JFACC execution of Time Sensitive Targeting (TST) operations at the joint force and component level. FBE K will use a common set of automated tools and common system architecture aboard the USS BLUE RIDGE that enables effective TST C2 and joint task force coordination. This flexible Joint Fires Initiative C2 architecture is designed to increase the speed and tempo at which the JTF as a whole can conduct TST operations.

In support of these goals, there were two Sea Strike Initiatives, JFN CONOPS and Coalition. The Initiative Statements for each in the Experiment Plan are:

Initiative #1. Refinement Of Commander, Seventh Fleet Joint Fires Network Concept of Operations (C7F JFN CONOPS) and Commander, Seventh Fleet / USS Blue Ridge Time Sensitive Targeting Standing Operating Procedures (C7F TST SOP).

Initiative #2: Establishment and examination of requirements for utilization of a Distributed Maritime Sensor and Fires network that integrates a coalition engagement node within that network.

In October 2002 the C7F Flagship, USS BLUE RIDGE, received a TES-N installation. Upon installation completion, the JFN Virtual Program Office developed a draft Concept of Operations (CONOPS) tailored to C7F needs. C7F requested NWDC assistance in refining the CONOPS and any underlying TT&P and validation of those documents during the Tandem Thrust '03 (TT03) Command Post Exercise (CPX).

The CPX is the only time during TT03 that full CJTF manning will be in place which is necessary to validate the CONOPS and associated standing procedures. For this reason, this report on the CPX Fires Initiative #1 has been prepared. A second report on the FTX portion of FBE-Kilo will be presented at a later date.

Initiative number one's primary goal was to support C7F in refining and validating its C7F JFN CONOPS / C7F TST SOP. This initiative will attempt, to the maximum extent possible, to define JFN support to operations in the three C7F roles for which it will be employed. The roles are as an embarked CJTF with other supported staff(s) embarked, as an embarked JFMCC/NAVFOR, and as the Fleet JFN supporting deployed RTCs and RTC Lites.

Additional benefits of this initiative include providing material to update the JFACC (Afloat) PACAF CONOPS, define personnel and training requirements for X-INT fusion to the Target Data Base, and examination of JFN impact on the Air Tasking Order (ATO) process. Another important objective is to assess the adequacy of USS BLUE RIDGE's legacy communications to support JFN.

2.1 COMMAND POST EXERCISE

The purpose of the CPX was to exercise Commander, U.S. Seventh Fleet operating as the Commander of a Joint Task Force with the U. S. Pacific Command. This was done within the structure and scenarios of Tandem Thrust 03. The exercise scenario involved defense of a fictitious island nation Guppie against an aggressor island nation Piranha. The scenario was complicated by the presence of military forces from the fictitious nation of Orca, which was sympathetic to Piranha but not overtly engaged in aggressive action.

U.S. Joint Task Force tasking included:

- Secure SLOCs/ALOCs within the Joint Operating Area
- Forcible entry. Re-take friendly territory seized by aggressor nation
- Conduct Humanitarian Assistance operations
- Fortify/defend friendly nation(s)
- Establish bases for future combat operations against aggressor
- Eliminate aggressor's ability to threaten region

The command structure for the exercise was to include:

CJTF – COMSEVENTHFLT embarked USS BLUE RIDGE

JFACC - Main at Hickam AFB

- JFACC 80 person liaison detachment embarked USS BLUE RIDGE

JFLCC - embarked USS BLUE RIDGE

JFMCC – CTF 70 embarked USS CARL VINSON

SOF Commander - embarked USS BLUE RIDGE

2.2 NAVY FIRES INITIATIVE

The purpose of the Navy Fires Initiative was primarily to determine the support to TST that can be provided by JFN. The TES-N portion of JFN resided within and was utilized by the Joint Intelligence Center (JIC). ADOCS was to be used for the engagement COP primarily in the Joint Air Operations Center (JAOC) on the BLUE RIDGE. The following equipment and systems were employed in support of the CPX.

Application	Purpose
Gale Lite	On a TES MFWS applied to ELINT analysis.
TES-N	Nomination of TSTs. Sensor management.
JSIPS-N/PTW	Georefinement of TST positions
GCCS-M	COP, track management. Track exchange with TES-N.
Ku-band SATCOM network	Support FBE network
MUSE/AFSERS	Simulated imagery and video for Predator, U-2 and Global Hawk
JSAF	In the CPX, supported imagery generation for MUSE/AFSERS. In FTX, JSAF was the stimulator for the full exercise.
JTLS	CPX stimulator
ADOCS	Cross Component TST collaboration and TST target management
IRC/IWS	Collaboration
IPL	Central imagery repository
Electronic Target Folder	Repository for all TST data.

This page intentionally left blank.

3.0 RECONSTRUCTION

3.1 IMPACTS ON THE EXPERIMENT

Three circumstances significantly affected the ability to obtain the desired data for this Initiative.

Typhoon Kujira forced the ship to depart one day early, leaving many personnel ashore.

The Air Force decided not to man JFACC Afloat.

There were numerous equipment and information failures.

The following reconstruction describes the impact of these events on the ability to meet initiative objectives. Also provided is a listing of the daily TST events from the MSEL.

Events which had major impacts on the experiment began before the experiment. More than a month prior to the experiment, the proposed JFN/TST CONOPS was rejected by 7th Fleet and it was decided to instead use the PACAF TST SOP as its basis. This SOP was not written for a JFACC Afloat with the CJTF so it was not entirely appropriate for carrying out this initiative's objectives. However, it did provide a set of processes that could act as a baseline of sorts. The result was that, rather than CONOPS evaluation and/or validation, the experiment shifted to a focus on observing and evaluating activities in order to formulate workable TTPs.

Prior to the experiment it was also learned that the Air Force would not man a JFACC Afloat as planned, partly due to policy and partly due to demands of the Iraqi Freedom operation. As a result, it was decided that emphasis on the BLUE RIDGE during CPX would shift to assessing the effectiveness of TES-N in the Joint Intelligence Center (JIC). In addition, manning of JFACC rear was reduced due to real-world operations, resulting in adapted form of processing TSTs through to engagement.

This combination of a lack of CONOPS to test, manning changes, and equipment difficulties caused a refocusing of CPX to being mainly training for FTX. Even so, data were obtained that shed light on training needs and on the use of JFN for TST by the Fleet.

3.1.1 Reduced Manning Impacts

Few Intelligence Analysts / TES-N Operators: CPX had far too few intelligence analysts participating (normally one, sometimes three, as many as five -- but the latter two only momentarily and/or part time).

- Cause: This was at least partially due to C7F Staff having to fill TT03 positions left unfilled by lack of requested augmentees (due partially to real world situations such as "Gulf War II", N. Korean activities, and for much of the time, typhoon avoidance which forced ship's sortie from inport Guam prior to the arrival of many augmentees on the island).

- Impact: Information flow and related processes were slowed. The one Intel Analyst (IS1 Karr), who participated consistently throughout, was over tasked and had to perform roles serially (e.g., screening video on TES-N, then acting as the PTW/IPL Operator).

Few "Khaki" Supervisors / Analysts. CPX had far too few intel "khaki" supervisors (no Chiefs, one Officer for one day).

- Impact: C7F Science Advisor (civilian) and NWDC personnel had to fill key roles (e.g., Targeting Officer, JFN Operations Officer, JFN Supervisor, ISR Operations Officer). This not only distracted them from accomplishment of other objectives, but also impacted the quality of the "team interaction" required.

Scaled Back JFACC Participation: CPX had no JFACC FWD personnel aboard (e.g., ISR Operations), and exercise architecture limited JFACC REAR participation during Find, Fix, Track, phases of the F2T2EA process. JFACC ISR Section (ISR-M) was dependent on receiving timely input from BLUE RIDGE ISR Cell (TES-N). ISR data flow connectivity between TES-N suite on BLUE RIDGE and ISR-M suite at AOC was intermittent which prevented JFACC TCT Cell from participating in TCT nomination decisions and other ISR Section responsibilities (e.g. Collections Management) necessary prior to target nomination. The BLUE RIDGE decided to nominate all TSTs at sea and pass relevant details to the JFACC TCT Cell for prosecution. This adaptive process was not realistic nor responsive since the JFACC TCT Cell ISR Section was not included in collections management or control of the ISR missions.

- Impact: The process did not exercise the necessary coordination between the JTF staff and the TST Authority (JFACC) during the critical ISR (Find, Fix, Track) phase.

No NWDC Intel Officer / JECG LNO: Because of typhoon avoidance, the NWDC Intelligence Officer did not make it aboard for the entire CPX.

- Impact: His roles as liaison with both the JECG and the C7F N2 and other Staff had to be picked up by NWDC ISR/Fires personnel, meaning less of their time, focus, and energy devoted to accomplishment of objectives.

3.1.2 Lack of Sufficient Training Impacts

TES-N Operator Experience Level: TES-N was manned by four people: an IS1 team leader, an IS3, an ISSN, and a CTT1. The IS1 had 6-9 months shipboard experience with TES-N, working with the Field Support Representatives. The IS3 had a 4-week PTW training course and is PTW certified. The other two had no previous experience with JFN systems. Although the IS1 had extensive TES-N training, it focused on IPB, and operating the equipment for TST was new for this operator.

No TES-N Mobile Training Team: Because of typhoon avoidance, the TES-N Program Office (PEO IWS) Mobile Training Team (MTT) did not make it aboard for the bulk of the CPX.

- Impact: (1) Lack of training for C7F Staff prior to, and during the majority of, the CPX frequently forced the one dedicated full-time Intel Analyst into the role of TES-N and PTW/IPL systems trainer; (2) Lack of available TES-N expertise, forcing, for instance, NWDC ISR/Fires personnel to learn U-2 Mission Planning on their own, and delaying the one (part-time) ELINT Analyst from learning how to "fuse" ELINT into the TES-N Integrated Tactical Display (ITD).

Team Leader Comments: This exercise was valuable for getting operators to use the JFN system. Under the concept of "train as you fight...fight as you train", it was less useful due to the artificial/lack-of information flow into and out of the JFN system. Information bypassed components of the JFN system at almost all levels in order to make the system work in an artificial environment. Imagery analysts could not provide the mensuration because no geo-data were contained in the simulated image. Nomination data was being dropped out along the path to ADOCS. Using real-world assets is a financial burden but, if we are to train as we would fight, realism must be present. Too many workarounds are needed in an artificial environment. To effectively train, and to effectively test information paths, we must be able to use the same information paths the system will use for a real operation. Workarounds are not the correct way to train. **If the path in place doesn't work, that needs to be corrected** (emphasis by team leader). The only way to identify such shortfalls is testing in a real environment.

Simulation Effects: Lack of realism in the simulation had a strong effect on training. It impeded training because of low fidelity. Early on the operators had a tendency to view the displays as incomprehensible, lowering their capabilities. Their attitude toward TES-N was affected, lowering their desire to learn. They had difficulty separating the system from the simulation.

3.1.3 Systems / Data Impacts

FBE Wide-Area Network (WAN) Connectivity: The FBE WAN was inoperable for the first three days of the CPX (came up approximately 161400 April Guam time, after MSEL Events had ended). The items most affected were: (1) AFSERS "MUSE" ISR video feed from Newport into TES-N afloat; (2) the JSAF M&S "entity" feed from Newport into AFSERS "TENCAP" (U-2 simulator) afloat; (3) NWDC TST Target Folder Server accessibility; and, (4) there was no rapid, reliable means of coordination (e.g., IP phones or chat) between controllers (JECG, M&S, NWDC controllers) -- relied almost entirely upon asynchronous SIPRNET email.

- Impact: Because of these limitations (no video feed, no U-2 simulation, no TST Target Folders, slow JECG coordination), CPX MSEL Events could not be run effectively until day four of the CPX.

No Digital Point Positioning Database (DPPDB). Because of typhoon avoidance, the DPPDB (classified tapes hand-carried by the NWDC Intel Officer) was not available for use in PTW.

- Impact: Could not meaningfully exercise the important TST processes of coordinating geo-refinement / aimpoint generation (e.g., taking video "chips" and conducting the required "visual point transfer" to accurately geoposition the TST).

No Receipt of COMINT In SCI TES-N: C7F does not currently use the SCI side of TES-N for COMINT analysis (etc.).

- Impact: This meant that any COMINT injects, intended as "tippers" for the TST MSEL events had to come to the JFN Team as hardcopy from the COMINT analyst manning the FIC Watch SCI GCCS-M workstation (remote from the JFN Team's positions). This artificiality negatively impacted the timeliness, focus of analysis (i.e., the COMINT Analyst wasn't looking solely for TST tippers), and "fusion".

TES-N Interface with GCCS-M Functionally Inoperative: The TES-N-to-GCCS-M interface remained inoperative for the entire CPX.

- Impact: TST nominations were never “pushed” to the COP. The omission of this important step in the TST process, the Track step, to enhancing the commander’s situational awareness, and to the “context” in which TST engagement decision-making must take place.

TES-N Could Not Attach Images to TST Nominations: The Target Nomination application in TES-N did not provide for the attachment of accompanying images / image “chips” (a shortfall identified during FBE-J that was reportedly to be rectified by FBE-K).

- Impact: During CPX MSEL Events, TST-related images were manually moved (FTP) to PTW, with the nominating analyst providing verbal cueing to the PTW operator as to which Target Block Number related to which image. The PTW analyst then changed the image filename appropriately (much easier to do in PTW than TES-N), and saved the re-named image to a shared network drive. NWDC personnel (due to lack of availability of other manning) then drafted a one-line ATI.ATR message in SIPRNET email (in MS Outlook), and attached the appropriate image(s) from the shared network drive, and sent the email to the NWDC TST Target Folder Server for ingest.

3.1.4 Equipment Status Matrix

The following three pages present the equipment status matrix. It shows the daily status of JFN equipment during CPX.

DATE (Guam time)	COMINT (via SCI bcast)	ELINT (via TDDS)	IMINT (via JCA)	U-2 Imagery (fm AFSERS TENCAP)	U-2 Telemetry (fm AFSERS TENCAP)
	CPX:				
14-Apr	KRSOC scripters not in place [no COMINT analysis tools in TES-N!!]	TRE to TES-N wiring not in place	No access to JCA fm Newport	No mission plan built	No mission plan built
15-Apr	KL rec'd by JIC Watch, but not relayed due to lack of specificity in amp line	No receipt of "XX" TDDS traffic by anyone in force [from either HI or Newport sources]	Images in JCA IPL, but still have wrong country code	No mission plan built	No mission plan built
16-Apr	KL rec'd by JIC Watch, but not relayed due to lack of specificity in amp line	No receipt of "XX" TDDS traffic by anyone in force [from either HI or Newport sources]	Images in JCA IPL, but still have wrong country code	No mission plan built	No mission plan built
17-Apr	KRSOC scripters not given anything to script/inject	Sent by Camp Smith, rec'd in GCCS-M, but time late in TES-N	Successfully pulled from JCA IPL to BLR IPL	Rec'd two SAR images, but too dark.	No telemetry received [FSR told of missing script by Balt. OSF]
18-Apr	KL xmit'd late by JECG; no relay fm Watch due to lack of specificity in amp line	Rec'd from Camp Smith, used as cue by ISR Ops (Doc)	Pre- and post- strike imagery pulled to BLR IPL, FTP'd to TES-N, used by analysts	Rec'd SAR images (despite EO plan); images remain too dark	No telemetry received, FSR and TENCAP rep troubleshooting
19-Apr	Analyst had to be asked (a.m.); KL xmit'd late by JECG (p.m.)	Rec'd from NWDC, used as cue by ISR Ops (Doc)	Successfully pulled from JCA to BLR IPL, used by analysts in PTW and TES-N	Changed base imagery to EO, successfully sent to TES-N, used by analysts	Telemetry rec'd, icon in TES-N, EMPS moved in "real time", etc.
20-Apr	Rec'd from Watch [no analysts on SCI TES-N]	Rec'd from NWDC, used to cue ISR ops (Doc) and Screeners	Successfully pulled from JCA to BLR IPL, used by analysts in PTW and TES-N	Rec'd in TES-N, but not yet used for source of TST nominations	Successful

DATE (Guam time)	Video (from AFSERS MUSE)	Images to PTW for aimpoint refinement	Target nom to ADOCS	Target nom to Target Folder Server	Target (Manual Contact) to GCCS-M COP
14-Apr	No FBE WAN	Can FTP, but no DPPDB	SMTP unsuccessful	No FBE WAN	Attempted, but no indications of success
15-Apr	No FBE WAN	Can FTP, but no DPPDB	SMTP unsuccessful	No FBE WAN	Attempted, but no indications of success
16-Apr	FBE WAN and video up, but too late for use in any MSEL events	FTP good, but no georefinement due to lack of DPPDB	Only when FSR sends to his own SIPR email acct, then fwds to ADOCS	Unable to send, prob due to ships exchange server settings	Not attempted (focus elsewhere)
17-Apr	Video rec'd, chips produced, used for target noms	FTP good, but no georefinement due to lack of DPPDB	Only when FSR sends to his own SIPR email acct, then fwds to ADOCS	Unsuccessful using IP addr for destination	Not attempted (FSR troubleshooting with Baltimore)
18-Apr	Video rec'd, chips produced, used for target noms	FTP good, but no georefinement due to lack of DPPDB	Successful	[TES-N unable to attach images; work around uses Outlook, PTW, shared drive]	Not attempted (FSR troubleshooting with Baltimore)
19-Apr	Video rec'd, chips produced, used for target noms	FTP good, but no georefinement due to lack of DPPDB	Successful	[TES-N unable to attach images; work around uses Outlook, PTW, shared drive]	Not attempted (focus elsewhere)
20-Apr	Video rec'd, chips produced, used for target noms	FTP good, but no georefinement due to lack of DPPDB	On closer investigation, many data fields are not properly populating	[TES-N unable to attach images; work around uses Outlook, PTW, shared drive]	Not attempted (FSR troubleshooting with Baltimore)

DATE (Guam time)	DIOP and file transfers to ISRM	U-2 Msn Plan (to AFSERS TENCAP)	Cross-INT replication fm TES-N to ISRM
14-Apr	ISRM not manned	No mission plan built	Not attempted
15-Apr	Successful FTP [no DIOP due to no U-2 sim]	No mission plan built	Not attempted
16-Apr	Successful FTP [no DIOP due to no U-2 sim]	No mission plan built	Not attempted
17-Apr	Successful FTP [no DIOP due to no U-2 sim]	Doc built SYERS2 plan, but TENCAP could not read SYERS2 format	Not attempted
18-Apr	Successful FTP [no DIOP due to no U-2 sim]	Doc built legacy SYERS plan; TENCAP ingested but treated it as ASARS	Not attempted
19-Apr	Successful FTP [no DIOP due to no U-2 sim]	Doc & IS1 Karr built ASARS2 plan; good play back, but using EO base imagery	Attempted, but ISRM system was up and down
20-Apr	Told by FSRs that sim data from AFSERS cannot be DIOP'd	Plan updated and "played back" successfully	Not attempted

3.2 EXPERIMENT PLANNED EVENTS

The following are sanitized extractions from the Master Scenario Event List (MSEL). These events were designed to provide stimulation to Joint Fires Network (JFN) analysts and operators. The events were designed to start slowly and build in complexity to help "players" gradually learn and understand the analytical processes and information flows required to use JFN to support Joint Task Force (JTF) level operations such as Time Sensitive Targeting (TST). The events were designed to stimulate the JFN operators to perform the following operations:

- Find and Fix** - cross-int analysis to detect, precisely locate, and positively identify TSTs;
- Track** - enter the TSTs into the Common Operational Picture (COP);
- Target** - derive aimpoint coordinates and nominate the TST for engagement;
- Engage and Assess** - monitor the engagement, and conduct preliminary Bomb Hit Assessment / Battle Damage Assessment (BHA/BDA);
- Re-Task** - support ISR collection plan adjustment during execution;
- Re-Engage** - support re-engagement of TST as required.

These objectives were gradually introduced, with an initial schedule:

- 14-16 Apr: Objectives 1 & 2 only [Find & Fix, Track].
- 17-18 Apr: Objectives 1-4 [add Target, Engage & Assess].
- 19-20 Apr: Objectives 1-6 [add Re-Task and Re-Engage].

The 16 MSEL events are laid out by day, with: Event number; target(s) and general location; event start time; ISR data types/sources. A synopsis of the intent of each event is provided, as well as "Smart Notes" (where needed) to indicate specific details needed for the conduct of that event. The following are the planned events by day. The next subsection will describe differences between planned and executed events. All are Guam days.

14 APR - Objectives 1 & 2 [Find & Fix, Track] only.

Event 09952X: SA site: COMINT; ELINT; UAV EO video; EO still imagery.

Collection assets required:

- Aircraft or National for COMINT
- Aircraft or National for ELINT
- Aircraft for EO
- UAV for EO video

SYNOPSIS: Cause various analysts (e.g., CTR, CTT, IS, OS) to rapidly fuse SCI and GENSER data, and get target reflected in GENSER COP.

Event 09953X: Ground force C2 node: COMINT x 2; open source/HUMINT; EO still imagery; EO video.

Collection assets required:

- Aircraft or National COMINT
- Aircraft for EO
- UAV for EO video
- Intelligence summary

SYNOPSIS: Same.

15 APR - objectives 1 & 2 [Find & Fix, Track] only.

Event 09951X: SCUD / support vehicle: HUMINT/SOF; open source; COMINT; EO video (to detect and ID SCUD support vehicle).

Collection assets required:

- SOF SR HUMINT
- National IMINT (EO) via JCA
- Aircraft or National COMINT
- UAV for EO video
- Intelligence summary

SYNOPSIS: Same, adding a "pull" via JCA to get imagery.

Event 09955X: Ground force C2: COMINT (location); COMINT (heavy volumes); COMINT; open source; JCA EO imagery; EO video.

Collection assets required:

- National IMINT (EO) via JCA
- Aircraft or National COMINT
- UAV for EO video
- Intelligence summary

SYNOPSIS: same, adding a "pull" via JCA to get imagery.

16 APR - objectives 1 & 2 [Find & Fix, Track] only.

Event 09956X: SA site: ELINT of SA radar (three transmissions from three locations -- "looks" and moves); EO video.

Collection assets required:

- National IMINT (EO) via JCA
- Aircraft or National COMINT
- UAV for EO video

SYNOPSIS: Same as previous events, but making "tracking" element more complex by trying to follow mobile SAM's "shell game".

Event 09957X: SCUD TEL decoy: COMINT; UAV EO video (of vehicle partially CC&D covered).

Collection assets required:

- National IMINT (EO) via JCA
- Aircraft or National COMINT
- UAV for EO video

SYNOPSIS: same as previous events, but making "find/fix" element more complex by forcing imagery analyst to measure vehicle, which will be too short to be an actual SCUD TEL.

17 APR - objectives 1-4 [add Target, Engage, Assess].

Event 09958X: SA site: COMINT; ELINT x 2 SA radars; P-3 AIP EO video.

Collection assets required:

- Aircraft or National COMINT
- Aircraft or National ELINT

National IMINT (EO) via JCA

Aircraft for EO video (track/orbit just out of SA max range)

SYNOPSIS: Same as previous events, but adding rapid targeting, engagement, and initial BHA/BDA. EO Aircraft gets "lit up" and shot at by SA but is out of range so missile misses; SA is engaged; video enables BHA/BDA by JFN operator.

SMART NOTES:

- (1) EO Aircraft must be tasked in JTF collection plan for ISR (vs. ASW)
- (2) Track/orbit must be just out of SA max range

Event 09959X: CDCM: ELINT of coastal surveillance; HUMINT/SOF; U-2 EO imagery.

Collection assets required:

Aircraft or National ELINT

SOF SR

U-2 for EO (re-task note: aircraft must be within sensor range, but not yet tasked to collect against that site)

SYNOPSIS: ELINT tipper; SOF confirm activity, think it may be a decoy, but can't tell due to revetments and/or stand-off range; EMPS operator will need to dynamically re-task U-2 to get rapid "overhead" imagery.

SMART NOTES:

- (1) U-2 (EO) must be in JTF collection plan, putting aircraft within sensor range, but not yet tasked to collect against that site;
- (2) U-2 mission plan/collection plan must be built and loaded into EMPS;
- (3) JFACC Forward must have the U-2 "token" passed from JFACC Rear.

18 APR - objectives 1-4 [add Target, Engage, Assess].

Event 09954X: SA battery: COMINT; ELINT of SA radar; EO video; JCA Radar still imagery.

Collection assets required:

Aircraft or National COMINT

Aircraft or National ELINT

UAV for EO video

National IMINT (Radar) via JCA

SYNOPSIS: Some obscuration (ground fog?) of targets seen in EO video, requiring analysts to pull Radar imagery via JCA .

Event 09954X-01: Artillery battery: COMINT; ELINT of EW radar; EO video; JCA EO Imagery.

Collection assets required:

Aircraft or National COMINT

Aircraft or National ELINT

UAV for EO video

National IMINT (EO) via JCA

SYNOPSIS: Continue polishing procedures, this time requiring multiple aim points to cover the multiple targets.

19 APR - objectives 1-6 [add Re-Task and Re-Engage].

Event 09957X-01: CDCM. COMINT between HQ and CDCM unit; ELINT of radar; EO video.

-- AND --

Event 09959X-01: a different CDCM. COMINT between HQ and CDCM unit; EO video.

Collection assets required:

Aircraft or National COMINT

Aircraft or National ELINT

UAV for EO video

National IMINT (EO) via JCA

SYNOPSIS: Conduct two TST events simultaneously. Analysts will have to recognize that multiple targets exist; ISR Ops will need to adjudicate use of video sensor to identify and conduct BHA/BDA.

SMART NOTES:

- (1) COMINT should indicate same HQ, but two different firing units;
- (2) ELINT of only one radar, near but not co-located with firing units;
- (3) BHA should show initial engagement missed one of the firing units.

Event 09953X-01: ground force C2 node. COMINT; EO video; JCA EO imagery.

Collection assets required:

Aircraft or National COMINT

UAV for EO video

National IMINT (EO) via JCA

SYNOPSIS: Presence of a variety of vehicles and antennae will require multiple aimpoints. Initial COMINT reports must be transmitted no earlier than 191400 Guam, and Predator must be on station (within sensor range) no earlier than 1415, so that this Event is still "in progress" when SCUD "pops up" in next Event.

-- overlapping with --

Event 093900-10 (AADC MSEL). COMINT; EO video; JCA EO imagery.

Collection assets required:

SOF SR HUMINT

UAV for EO video

SYNOPSIS: SOF observe SCUD TEL on the road; report conveyed rapidly to Intel Watch. Report should force Intel Watch to notify AADC and ISR Ops. ISR Ops (and TST) will need to prioritize between prosecution of C2 node and SCUD (consult TST Guidance Matrix).

20 APR - objectives 1-6 [add Re-Task and Re-Engage].

Event 09915X: SCUD. COMINT between HQ and SCUD battery; EO video (obscured by clouds/ground fog); aircraft SAR imagery.

Collection assets required:

Aircraft or National COMINT

UAV for EO video

Aircraft SAR (Re-Task note: aircraft must be within sensor range, but not yet tasked to collect against that site)

SYNOPSIS: COMINT tippers; ground fog obscures EO video; should force collection adjustment to use U-2(SAR) to locate SCUD TEL.

SMART NOTES:

- (1) EO video must show fog/obscuration
- (2) Aircraft SAR must be in JTF collection plan, putting aircraft within sensor range, but not yet tasked to collect against that site;
- (3) U-2 mission plan/collection plan must be built and loaded into EMPS;
- (4) JFACC FWD must have the U-2 "token" passed from JFACC REAR.

Event 09915X-05: SA site. COMINT; ELINT SA radar; UAV EO video; U-2(SAR) or other "precision" asset

Collection assets required:

SOF SR HUMINT

Aircraft or National COMINT

Aircraft or National ELINT

UAV for EO video

Aircraft SAR (Re-Task note: aircraft must be within sensor range, but not yet tasked to collect against that site)

SYNOPSIS: UAV gets shot down by SA deployed near hospital -- should cause collection plan adjustment and collateral damage consideration.

TIMELINE (20 April, Guam day/time):

1000: COMINT indicates SA-15 deploying near hospital; ISR Ops should vector UAV to head toward the area.

1015? (must be prior to UAV coming into effective sensor range): SA Radar ELINT emission, simultaneous with loss of UAV video

1020? (immediately after loss of UAV video): SOF report of aerial explosion near hospital, indicating that UAV got shot down.

Event 09915X-01: CDCM. COMINT; ELINT; EO video.

Collection assets required:

Aircraft or National COMINT

Aircraft or National ELINT

UAV for EO video (a new one, since prior bird shot down in previous event....should have plenty of time to get from local AFB)

3.2.1 Modifications to Planned Events

During the experiment, modifications made to event details and also wholesale modifications to accommodate to operator training and expertise. The following lists those modifications.

4/14 The events were run as a training exercise for the TES-N operators.

4/15 Events were not run operationally. Rather, they were run to focus on one piece of the information flow at a time, e.g. obtain imagery from JCA, build U-2 mission plan, etc. The TES-N team was down to one person.

- 4/16 Continue events with a one-person TES-N team. Stop data collection at 1300 due to equipment difficulties. Event is not being prosecuted as it would be operationally.
- 4/17 Run events as planned.
- 4/18 Run events as planned.
- 4/19 Change morning event from CDCM to Hind Helos. Afternoon event will be a mobile C2 node and a SCUD TEL as planned. Afternoon, two targets compete for assets.
- 4/20 Change event to the TST being a command post with eight targets.

3.3 DAILY CONTEXT SUMMARY

The following provides summaries of details that were important to the context for each day. This context frames each day's events and provides some insight into cause-and-effect for that day's results. As was pointed out at the start of this section, events were strongly affected by manning and equipment failures. The following context entries list these factors and their impacts. This is done with a broad brush rather than focusing on details.

Equipment difficulties with Ku band, communication between TES-N and ADOCS, and getting TES-N information to the COP were pervasive problems and may be assumed to apply to all days. Lack of JFACC Afloat the low manning at JFACC Main also applies to all exercise days. As was noted above, these factors, and the lack of a baseline CONOPS, forced modification of this initiative to focusing on training observations, some basic information concerning JFN utilization, and preparation for FTX. Thus, the following context will include only factors that relate to training and broad comments concerning JFN use for TST.

4/14 Navy personnel assigned to be TES-N image analysts were untrained and the Mobile Training Team missed the ship's departure, resulting in a serious lack of TES-N proficiency. All except the lead TES-N person (IS1 Karr) were pulled to other JIC duties. Workarounds to compensate for equipment deficiencies were developed, mainly transfer of information by e-mail.

The level of manning is insufficient to support development and refinement of the TST process as had been planned.

4/15 Lack of TES-N manning continued, thus no training could be accomplished.

The TES-ADOCS ATLATR interface was not working so nominations could not be sent directly. Lack of FBEnet, and no Ku connectivity, meant that workarounds were needed for target folders. A full TST operation could not be executed.

4/16 E-mail continued to be the main workaround method. ELINT, U-2 imagery, and posting of event images to JCA IPL were occurring for the first time. The combination of some imagery and workarounds meant that the experiment could proceed.

4/17 Was able to proceed with ELINT, Predator, and national imagery.

The MTT arrived on board (ship pulled into Guam to pick up personnel left ashore due to the typhoon). TES-N personnel returned and proper training proceeded. Only one person was available part time to man ADOCS.

4/18 TES-N was fully manned and the MTT was working alongside the operators.

The experiment deviated from the exercise in order to have the TES-N operators prosecute the desired TSTs. During the experiment operators prosecuted targets that had already been killed in the exercise.

Operators reported that the simulation quality and lat-long problems interfere with their training and with operating TES-N.

4/19 Personnel training progressed to the point where the operators could work with their TES-N station with some independence and were capable of evaluating the usefulness of the system.

Two events were executed completely, from ELINT and COMINT through engagement. Sufficient imagery and Predator control were available to provide chips and nominations. E-mail workarounds for remaining equipment difficulties continued to be in place.

The TST environment was rich enough to stress operator ability to perform sensor management and target identification and location. However, the simulation interfered with evaluating operator capabilities to assess and manipulate imagery and make target decisions.

4/20 A full event day was conducted under the same conditions.

3.4 SUMMARY OF CONTEXT CONSEQUENCES:

The main impact created by the above noted difficulties, with regard to meeting this initiative's objectives, was that JFN was operated in an artificial environment. Procedures used were not what are documented nor what will be used in the future for TST, hence evaluation of these procedures to determine JFN's contribution will have marginal validity.

The experiment became decoupled from the exercise. JFACC Main staff was operating to support the exercise as planned (see Appendix C for a description of this process). The events being run in the BLUE RIDGE JIC for the experiment became mostly uncoupled from JFACC so

that the full TST process from Detect to Engage could not be observed. As a consequence, this report deals almost exclusively with JIC/TES-N processes.

The processes that were being used did not produce results that could be used to evaluate SOPs, as was planned for this initiative. Information was obtained on having an afloat JIC participate directly in the TST process.

This portion of FBE-Kilo operated as a personnel training period and equipment test period for FTX. In that regard it was valuable. TES-N operator training and performance were extensively observed and from those observations, a number of conclusions could be developed concerning training format, personnel capabilities, and human operator acceptance of TES-N.

This page intentionally left blank.

4.0 RESULTS

As was stated in the Reconstruction section (Section 3), obtaining results for this initiative was strongly influenced by equipment and manning issues. The results that have been obtained may be valid for a wider range of circumstances but have proven validity only for the conditions that existed during CPX. The last topic of this Results section describes the range of validity.

4.1 SIMULATION IMPACT ON TRAINING

CPX simulation was designed to support the goals of determining the contribution of JFN (TES-N) to TST and to determine appropriate TST SOPs. TES-N's contribution is strongly dependent on the ability of JIC personnel to operate the system. Thus, it is required that the simulation provide a realistic operating environment or the results will be contaminated by operator/simulation-presentation interaction effects. With regard to SOPs, they cannot be evaluated if operators are modifying procedures on-the-fly in the experiment in order to utilize the simulation output.

The simulation did not provide an appropriate training environment. This point was strongly made by the operators and their supervisor. The following are points made by the person who supervised event execution within the JIC

Simulated Predator Video Quality Shortfalls: There were three issues regarding the quality of the simulated ISR video: (1) Analysts found it hard to read the Lat / Long read-outs on the TES-N screen that was intended to provide the approximate location of the TST.

(2) Analysts found it difficult to distinguish one simulated object from another.

(3) Analysts found the base imagery used in the simulated video to be of insufficient quality to allow for any "contextual" analysis.

- Impacts:

(1) NWDC personnel had to frequently go to a different space on the ship to read the geo-coordinates off of the NWDC Remote Video Server screen (which shows the video before it is fed into TES-N).

(2) NWDC personnel often had to tell the analysts what they were looking at. This removed much of the interaction and analysis required for (for instance) TST positive identification (PID), a significant step in the TST process.

(3) Analysts often could not conduct important tasks in the TST process, for instance collateral damage estimates (CDE).

U-2 Simulation Shortfalls. There were four issues regarding the "stimulation" of TES-N by AFSERS "TENCAP" U-2 simulation:

(1) The simulated Synthetic Aperture Radar (SAR) appeared too dark in the TES-N Screener application, and too grainy in the TES-N imagery manipulation applications (e.g., Remote View) to be of use in CPX TST MSEL events.

(2) The U-2 simulation only operated with mission plans built for the U-2 SAR sensor package (e.g., ASARS2, ASARS2A), but not with mission plans built for the U-2 Electro-Optical (EO)

sensor package (e.g., SYERS2).

(3) The nature of the AFSERS-to-TES-N interface apparently precluded the "DIOP" (Data Input/Output Port) of U-2 imagery and telemetry to the USAF's Intelligence Surveillance Reconnaissance Manager (ISRM) at JFACC REAR (Hickam AFB, HI).

(4) AFSERS "TENCAP" could not simulate the "waterfall" of imagery (either SAR or EO) in the TES-N Screener application that occurs when live U-2 sensors are in "search" mode (many mistake this "waterfall" for being high-resolution "UAV video").

- Impacts:

(1) MSEL events were limited to simulated U-2 EO play (e.g., the watch leader had to modify those events that introduced cloud cover / ground fog, meant to force an ISR Operations adjustment from the EO ISR video to the U-2 SAR sensor).

(2) & (3) had to build ASARS2/2A mission plans, but have the AFSERS output EO base imagery.

(4) Without the "waterfall" (which is functionally like viewing high-resolution slow-motion video) screening for TSTs would have been limited to a series of "still" U-2 images. Due to these factors listed above, and the lack of JFACC REAR mission planning support mentioned above, simulated U-2 data was not used functionally in any CPX TST MSEL events.

4.2 PERSONNEL CAPABILITIES

With the exception of the team leader, personnel in the JIC had no experience with TES-N. This resulted in a CPX philosophy change to using CPX for training in order to be ready for FTX. Thus, most CPX results deal with training issues rather than JFN contributions to TST or SOP evaluation. In perspective, the following five factors influenced all results:

- Operator competence and its change over time with training.

- Simulation artificiality impact on operators.

- JFN system and connectivity failures.

- Lack of applicable SOP.

- C2 structure and manning.

It is not possible to unambiguously sort out the influence of these five factor's on the results.

In spite of developing procedures and workarounds on the fly, training those just developed procedures, and training system button pushing all at the same time, coupled with operator dissatisfaction with the simulation, the operators learned very quickly. After three days of working with the system, operators were able to manipulate imagery, chip images, and make and transmit nominations quite rapidly. It appeared that the limiting factor regarding processing speed was system problems rather than operator capabilities.

Operators never developed an understanding of the full TST process and how TES-N and operators fit into that overall process. They were working at one component of the overall process and developing an understanding of how to perform their component's function. According to the team leader, their competence would improve if they understood the full process. In order to help this situation, the team leader rotated the image analyst's functions so they could train on more than one function.

4.3 OPERATOR ACCEPTANCE OF TES-N

It is interesting that, in spite of dissatisfaction with image realism/quality and lack of familiarity with TES-N and TST processes, the operators were impressed with the system. This can be summarized simply as: They recognized its possibilities.

The ISSN reported the following:

- a. TES-N is a very user-friendly piece of equipment. Never having previously worked on the system, I felt it was very easy to learn.*
- b. Target nominations, downloading maps, and disseminating Predator or U-2 video feeds are very interesting things to be able to do. The hands-on experience is great. To be able to do it yourself, and understand the process, was very helpful. To have combined the use of what used to take a few machines into one system is great.*
- c. The multi-tasking ability of TES-N greatly reduced the time it would take to download an image and annotate. Plus, you could have DBO and ITD and EMPS all up at the same time while working on different projects.*
- d. TES-N helps my job by minimizing the time you would have to wait for imagery. It also helps you in the way that you can pull up different windows to use different systems. I do think that there needs to be more user time, more training for the system. Some times I didn't understand what I was doing, only that I was doing them.*

The IS3 reported:

- a. For IMINT exploitation, the system is good. The remote view ELT is easy to use. That said, so is V. Tec on PTW. A major drawback is the inability to drop validated aim-points.*
- b. Video screener is huge in terms of closing a large gap of time in the TST process. The ability to redirect an asset and receive the real-time feed is a big advantage.*

4.4 TST PROCESS PERFORMANCE TIMES

Most TST execution during CPX was done concurrent with training, fixing equipment problems, and developing process workarounds. Thus, execution times were not representative of prosecution of TSTs with JFN. It would not be appropriate to follow an execution thread through an end-to-end TST prosecution and draw conclusions regarding process capabilities. Even so, there are cases where components of the process are indicative of the enhanced capabilities provided by TES-N for TST.

The time to build and transmit a target nomination after receipt of image chips from the image analyst was as short as 2 min. This best case occurred after previous analysis and nominations for the same area had already provided some of the necessary background information.

After detecting a possible target, directing a tactical sensor to obtain imagery to confirm target location and ID took 20 to 30 min. This was with a UAV already in the area.

Building a tactical sensor collection plan took on the order of 20 min.

After an indication such as ELINT, it took on the order of ½ hour to locate, identify, and nominate a target. This includes obtaining and using national imagery. This observation represents a composite of the times to perform functions when an operation is working well and stations are properly staffed.

The above presents various times to perform TST process segments. These times cannot be strung end-to-end to determine a total processing time. There are interactions and overlaps between them. In order to determine a total processing time, one needs uninterrupted flow through the total TST process. There no such instances available during CPX.

4.5 JFN AND THE TST PROCESS

There are no meaningful CPX results on the use of ADOCS performance within TST. Engagement was not carried out within the JAOC. ADOCS was used occasionally by the 7F Science Advisor both in the JAOC and JIC but only for practice and to determine if TES-N/ADOCS connectivity was working rather than as part of TST prosecution and SOP evaluation. The experiment produced no meaningful results for engagement of targets under the control of JFACC.

Use of TES-N in the JIC was examined extensively, with the results compromised by the contextual factors described earlier in this report. It was observed that the system can make significant contributions to the TST process. However, it was pointed out by the operators that one does not necessarily have to have TES-N or a full JFN to process TSTs efficiently. Components such as JSIPS-N/PTW and GALE-Lite can be used to accomplish much of the TST process that occurs within the JIC.

Operations within a JIC focus on IPB. Participation in the TST process is not part of what they normally do. If this is to become an operational reality, CONOPS and TTPs that focus specifically on a JIC will be needed.

One of the goals of this initiative was to determine the added contributions provided by JFN to the TST process. An adequate job in performing this assessment would require running the same scenarios with and without JFN, which was not done (and cannot be easily done in any venue). An alternate approach is to use CPX, or FTX, results to establish baseline capabilities from which one can determine excursions with subsequent experimentation. This will also be difficult to do because the C2 configuration and processes used in CPX are atypical of what has been done in the past and may never be used again in the future. Thus, the most that can be obtained from these results is an indication of possible JFN contributions to TST.

CPX experimentation focused on a unit fully equipped with JFN. There will be units that will participate in the TST process that will not be so equipped. Also, JFN or some of its component systems could be down or communication links between them could be down. In actuality, this

was the case for CPX for information exchange between TES-N and ADOCS and TES-N and GCCS. Thus, it will not be sufficient to formulate CONOPS and TTPs for JFN. Also needed are procedures for less capable units or situations. Some of these will simply entail developing checklists for actions to take, communications to fulfill, etc. by whatever means is available. In essence, a spectrum of processes needs to be developed.

4.6 RANGE OF VALIDITY FOR RESULTS

Experimentation plans develop a set of conditions within which systems and processes are tested. These conditions define a known range of validity for derived results. If the experiment is designed so that cause-and-effect relationships can be determined (as opposed to merely observations), it is possible to use those relationships to extend the range of validity to untested circumstances.

The special circumstance of the CPX portion of FBE-Kilo is that the planned conditions were largely not achieved. This situation was explained earlier in this report. Thus, it is difficult to determine the range of validity for these results, or even whether they are valid for any operational situation that will be encountered. Rather, we have reported improvements that are needed in training, indications of TST performance using TES-N, and improvements in the experimentation process. Extension of CPX results beyond this could be misleading.

This page intentionally left blank.

5.0 RECOMMENDATIONS

5.1 FLEET FOLLOW-UP

Fleet Battle Experiments have two purposes: (1) to advance and improve the capabilities of systems and processes, and (2) to move new operational capabilities to Navy operating units. Part of the reason for doing number one with operational units is that, at some point, capabilities testing must be done in a realistic, human-in-the-loop environment. Part of the reason for a Fleet participating in an experiment is to improve capabilities and the ensuing "leave-behinds" that can occur. Leave-behinds are not only equipment but also new or improved processes.

To date, most leave-behinds have been transitory rather than permanent improvements. A telling example was a comment made by VADM Metzger, then C7F, during an FBE presentation: "What happened to the processes we put in place following Delta?" The answer was that they had disappeared due to staff changes. The basic problem was that there was no process or program to make the changes permanent.

It is recommended that NWDC institute a process with Seventh Fleet to take the results from FBE-K and develop TST CONOPS and TTPs, in partnership with the Fleet, that will be adopted by the Fleet. Results from CPX indicate that follow-on development would most profitably be in the following areas:

1. Development of TST CONOPS and TTPs for a BLUE RIDGE CJTF.
2. Develop a concept for BLUE RIDGE as a hub for TST information.
3. Following the hub concept, specify what systems are needed for the range of users included in the network, including "disadvantaged" users.
4. Develop procedures and guidelines for TST operations for all users, including situations when full JFN capabilities are not available, or completely unavailable.

Adopting this recommendation will entail a significant shift in the way NWDC does business. To date, personnel have ceased involvement with an FBE once it is completed, moving on to the next event. Following this recommendation means that personnel would continue to work on the initiatives associated with an experiment for some time after it is physically completed. This requires a shift of resources to the follow-up aspect of an experiment. It is believed that doing so will produce a significant improvement in NWDC productivity as well as produce an overall cost savings to the Navy.

5.2 EXPERIMENTATION STRUCTURE

Operational field experiments are expensive, both in terms of real fund expenditures and in terms of the use of platforms and their personnel. Field experimentation as the primary data acquisition means is not cost effective. Also, experience has shown that it is not possible to produce quality results when there is an overlap between analysis for one experiment and planning for the next. With such overlap, lessons learned do not carry over into improvements for the next event.

Another problem involved the mechanics of having a "learning" experiment overlaid on a Fleet exercise. There is a basic incompatibility. Instead, one should have preliminary learning occur before going into the field then an exercise used for human-in-the-loop and operational testing to ensure validity. Using this approach will allow for tighter coupling between experiment and exercise objectives. The goals of the exercise will always be primary and one can adapt the experiment to those goals and produce high quality results that are directly applicable to the Fleet.

It is recommended that a series of appropriate studies be performed to meet learning objectives, including workshops and even laboratory experiments. Going into the field would occur only when needed for validation. Hence, FBEs would not be events that occur on a regular schedule, and perhaps not exist in their current form. Rather, when a particular study area progressed to the point of needing to do so, an appropriate venue for operational field-testing would be sought. This could be identified as an LOE, a culmination event, or whatever would be appropriate.

5.3 EXPERIMENTATION HARDWARE

The experience in past Fleet Battle Experiments has been that there were always some equipment problems. Perhaps this is to be expected, but it should be on a minor scale and the type of problem that can be quickly remedied. FBE-K CPX was perhaps the worst situation encountered over the FBE series, with major equipment problems significantly disrupting the Fires Initiative.

A policy is needed where equipment and interfaces must be fully tested and functionality ensured prior to an experiment. A limited objective experiment (LOE) devoted to equipment testing is recommended. This may be costly, but not be as costly as losing large portions of the desired results during a Fleet Battle Experiment.

5.4 EXPERIMENTATION DATA

Three types of data are typically obtained during an operational field experiment: (1) subjective opinions about the performance of systems and processes, (2) subject matter experts logging event observations, and (3) electronic data logged within and between hardware systems. The latter type includes simulation data.

Planning an experiment requires close coupling between the detailed goals of an initiative and data elements to be captured. Analysis of an experiment requires complete sets of all three types of data so that event chains can be reconstructed and the context within which events occurred can be fully understood. A missing data element, or link, in the event chain breaks it and detracts from the ability to fully understand what occurred and why. Absent context means cause-and-effect relationships cannot be established.

To date it has not been possible to obtain all of the needed electronic data. Part of the reason for this is that doing so is expensive and funds have not been made available. The recommendation is made that the lists of electronic data requirements that have been provided be prioritized, decisions made as to which data will be obtained, system owners directed to obtain the data and make it available for analysis, and that adequate funding be provided for the purpose. In addition, impact statements should be developed for those cases where the data will not be available and deficiencies be taken into account in experiment planning.

5.5 EXPERIMENT PLANNING STABILITY

CPX was an unusual situation in that there were major changes in the experiment structure (e.g. lack of a JFACC Forward) shortly before the experiment, and then personnel shortfalls due to BLUE RIDGE departing early for the typhoon. However, it is not unusual in FBEs to have equipment and process changes occur right up to the beginning of an experiment. Such changes disrupt data capture and analysis plans and can even make it impossible to capture data required to meet Initiative objectives.

It is recommended that an experiment be "locked down" **four** months prior to its start. An exception would be when there is a series of events that includes an equipment testing LOE prior to the field experiment. In this case, the LOE should occur six weeks prior to the operational experiment and the lock-down occur within one week after the LOE.

5.6 SIMULATION AND TRAINING

CPX was different from previous FBEs in that it had a definite training aspect associated with JFN and SOP evaluation. The stated purpose of the evaluations was that they be conducted for a particular C2 configuration and operational situation. Training was to be conducted using TES-N to prosecute TSTs. The operational situation was to be created by simulation. Training and evaluation were significantly negatively affected by the simulation's lack of fidelity.

It is recommended that realistic training modules be developed for TES-N and JFN. This could be done with pre-recorded real imagery and preset scenarios as is done for other systems.

This page intentionally left blank.

Appendix A: TST TIMELINES

The following timelines present the principal occurrences in TST detect-to-engage cycles. They are presented to give a representation of information and decision flow, and the amounts of time various actions take. Only actions that are directly part of the TST process are shown; associated actions such as working on equipment and designing workarounds are not presented. Dates and times are local (GUAM) time for those events that took place on the BLUE RIDGE.

These timelines do not provide an accurate representation of TST times that would be expected in a real operational situation. They are highly compromised by equipment and manning problems and by the training that was occurring. Even so, they are useful as an indication of the types of performance that can be expected because parts of the process occasionally worked well.

14 Apr: No usable data.

15 Apr: No usable data.

16 Apr: No usable Data.

17 Apr: Morning Target

0840 – Receiving Predator video from Newport.

0900 – Attempts to send image chips unsuccessful, discuss target with JFACC.

0914 – JFACC decides to strike without images.

0925 – JFACC requests multi-tasking of sensor for BHA.

0928 – Strike target.

17 Apr: Afternoon Target

1233 – Using EMPS planner to develop U2 collection plan (until 1302, 29 min).

1308 – TENCAP images received.

1314 – Manual insertion of Lat-Long coordinates for nomination preparation.

1324 – E-mail the plan to Newport.

18 Apr: Morning Target

0735 – TES-N Receive ELINT from JTLS.

0810 – Send images to JFACC via FTP and ELINT information.

0818 – Gale check ELINT for Surface-Air site emissions.

0825 – Direct Predator to the area.

0826 – Find SA6 in imagery, chip an image.

0827 – Send chip to JFACC.

0835 – Image analyst nominate the target.

0839 – JFACC decides to strike at 0900, decision to use Predator for BHA.

0857 – Predator feed being received by TES-N .

0900 – Strike target.

0901 – Chip images with smoking targets.

0902 – Send chips to JFACC.

0905 – Send second chip to JFACC.
0906 – Find a second launcher.
0910 – JFACC announces a 40 min window for restrike and BHA.
0915 – National imagery sent to TES-N shows additional targets.
0920 – Analysis of additional targets complete, chips sent to JFACC.
0925 – Send message to JFACC describing targets, restrike set for 0945.
0944 – Restrike confirmed.
0950 – Send new chip showing no damage.
1011 – Confirmation site destroyed, send chip.

18 Apr: Afternoon Target

1250 – Have ELINT but not imagery of artillery.
1258 – TTES-N finds target in imagery, chip image.
1307 – Image analyst has found at least 4 targets.
1309 – Analyst asks for Predator zoom-in.
1332 – TES-N target nomination submitted via ATL.ATR.
1333 – JFACC has nomination, requests via Chat a better description.
1356 – JFACC hasn't accepted nomination because of no images, insufficient information.
1400 – More information provided via voice.
1413 – Targets struck.
1416 – Imagery shows smoke on targets.
1420 – Send BHA chip.

19 Apr: Morning Target

0810 – Video feed received.
0824 – ELINT received.
0836 – Strike underway.
0839 – Predator video shows one target destroyed.
0841 – Chip images.
0844 – JFACC requests national imagery.
0845 – National imagery not available.
0914 – TES-N has national post-strike images via FTP.

19 Apr: Afternoon Target

1405 – Check national imagery.
1407 – Predator flying and recording.
1412 – Look for possible C2 node on video.
1415 – Image analyst looking for target on national image using verbal Lat-Long cue.
1420 – ELINT operator directed to watch for TBM launch.
1422 – Possible targets found on national image.
1424 – JFACC asks for national image.
1425 – National image sent to JFACC.
1430 – HUMINT report of SCUD TEL.
1433 – Moving TEL seen in Predator video.
1434 – Decision to nominate TEL.

1440 – Resent national image to JFACC.
1458 – Report second SCUD which hasn't been nominated.
1503 – New national image, send nomination with image.
1506 – Lat-Long for search given to image analyst via paper note.
1510 – Three TES-N nominations are in ADOCS, DTFs made.
1517 – Third SCUD located.
1535 – BHA images received. New, found 4 school bus-like objects, 1 car on AFSERS images.
1550 – Call strike on all four targets.
1552 – Video shows both damage and that strike missed the target (smoke off target).
1602 – See second TEL burning, Predator goes home.

20 Apr:

0929 – COMINT received for a SCUD from Battle Watch.
0930 – CrossINT being done with Gale.
0933 – Have Bar Lock radar on ITD, not on Gale.
0934 – Image analyst requests Predator zoom in.
0936 – Image analyst found Bar Lock.
0937 – Image analyst directs Predator to go under clouds for better imagery.
0942 – Chip an image.
0944 – Sending national image from JIC JSIPS-N to TES-N.
0948 – Image analyst asks Predator for an exact spot.
0949 – National image reveals two possible targets, verbally gives Lat-Long to image analyst.
0950 – Going below clouds to check another possibility found on national imagery.
0958 – Improved imagery video being received from Predator.
1000 – Chip image of possible radar target.
1003 – Chip image of a truck.
1004 – ID an armored vehicle.
 TES-N sends ATL.ATR nomination for the radar.
1005 – Chip a large tent.
1006 – ELINT IDs four Bar Locks, two in region of interest.
1012 – Second nomination, support vehicles.
1016 – Inquiry about collateral damage danger for nominations 19 and 20, report none.
1025 – Make third nomination.
1029 – Image analyst sends overview chip to PTW.
1030 – Send last four chips to JFACC ISR-M.
1033 – Predator operator zooming in on site.
1035 – MSEL manager directs crew to look for a second radar site.
1037 – Found and chipped second radar site.
xxxx – Fourth nomination sent, arrival confirmed.
1043 – Nomination 0022 sent.
1053 – Nomination 0023 sent.
1055 – Image analyst has image of two vehicles.
1100 – 0024 nomination made (took 5 min to build the nomination).

This page intentionally left blank.

Appendix B: CJTF TCT PROCESS – TT03 CPX

The following material is an extraction from the FBE K Sea Strike Experiment Plan. It is presented here, with the original section numbers (*italicized to distinguish them from this report's numbers*), in order to include in this report a record of the planned TST processes aboard the BLUE RIDGE during CPX.

2.2.1.1 *Concept for TST support to the embarked staff(s)*

During the conduct of FBE K, the JFACC will use the following six-step process. This sequence is in conjunction with the current USAF planning and execution cycles for prosecution of TSTs. The planning to the conduct of TST operations and continued Intelligence Preparation of the Battlespace (IPB) in support of these and any follow-on operations is inferred:

- Find
- Fix
- Track
- Target
- Engage
- Assess

The JFACC Time Critical Targeting (TCT) Cell structure is per the JFACC Afloat SOP and the JTF 507/519 SOP. (*For the purpose of this EXPLAN and FBE K, the terms TCT and TST can be used interchangeably, based on the preference of the particular organization involved.*) This team is lead by a TCT Watch Officer that has various intelligence and offensive operations subject matter experts at his/her disposal. He is a direct representative of the Chief of Combat Operations (CCO) in the JOAC relative to execution of the JTF's TST operations. The organization is depicted below in Figure 1:

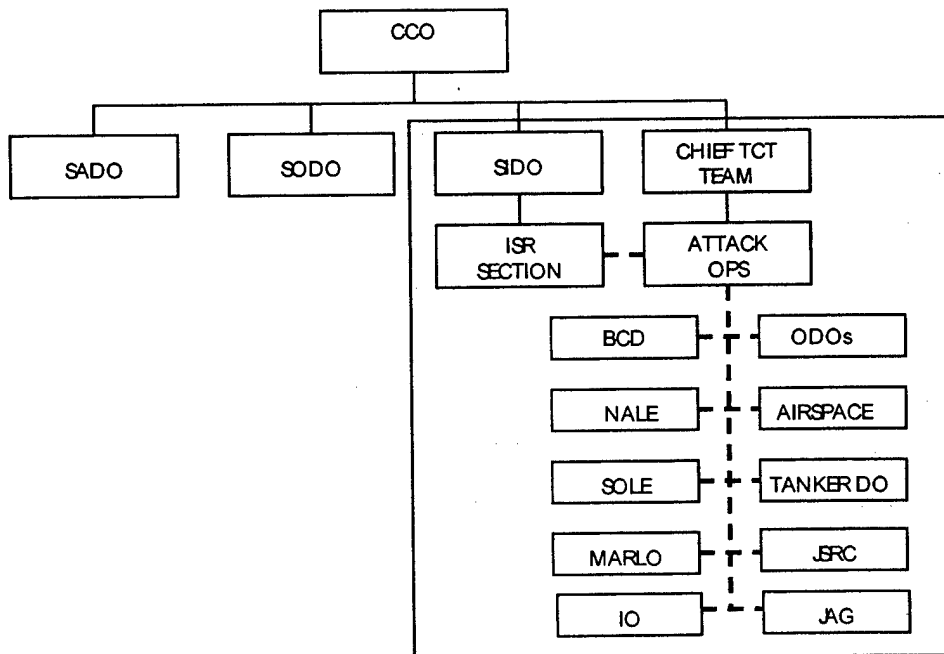

Figure 1. JFACC Afloat TCT Team Structure

2.2.1.2 Supporting Technologies.

During FBE K, the naval Distributed Common Ground Station (DCGS) Navy interface is through the Joint Fires Network – JFN. This is a system of systems anchored by the JFN family of systems, GCCS-M and ADOCS. It will provide the bulk of the TST functionality required by the JFMCC staff to conduct both JOA wide and battlespace specific TST operations. This interoperability provided by the JFI will also enable seamless transition of TST authority/responsibility to the JFC or his designee if required. The components of JFN within the experiment are described below:

2.2.1.2.1 Automated Deep Operations Coordination System (ADOCS) / Land Attack Warfare System (LAWS)

The ADOCS / LAWS is the cornerstone toolset in the processes described in this EXPLAN. It facilitates the timely engagement of fixed and Time Sensitive Targets (TSTs) by facilitating rapid dissemination of targeting data to personnel within the TST process. ADOCS is the base software application, with LAWS being the maritime configuration of that application. ADOCS is the asset management, weapon target pairing, and information dissemination tool used by the JFC/JFACC/AP Cell at the operational level. LAWS is used by the AP Cell and the engagement nodes at the tactical level. The ADOCS/LAWS consists of PC-based workstations distributed aboard the USS BLUE RIDGE and at other remote sites (supporting the engagement nodes) using SIPRNET as the network pathway. ADOCS/LAWS will interface to a number of other to receive situational data and target nominations. ADOCS/LAWS is designed to increase situational awareness, automate processes for weapon-target pairing, and automate coordination between joint forces engaging both preplanned and emergent targets. ADOCS configurations will be used at the JTF and component level. LAWS will be used within the Joint Force Maritime Component Commander command and control hierarchy.

2.2.1.2.2 GCCS Intelligence, Surveillance, Reconnaissance Capability (GISRC)

GISRC will reflect sensor tracks and payload employment for certain airborne sensors. This capability is required in order for the sensor net to provide smart options for flexing. Additionally, GISRC will be used as the ISR screening tool for EO/IR sensors in FBE-K. GISRC will be used on the DD(X), vE-2C, and the vANZAC in FBE K. GISRC is a software suite consisting of five major applications or segments:

- Situational Awareness Segment – displays multiple ISR data sources as iconic Information on NIMA vector map backgrounds.
- Reporting and Dissemination Segment – creates and disseminates multiple ISR/Ops messages types over several different communications paths.
- Video Display and Tracking Segment – displays analog video and provides a capability to initiate

and maintain tracks on targets displayed in the video.

- Situational Awareness Display Client – accepts and displays information being processed on a remote GISRC workstation
- C2PC embedded.
- Will serve as the target nomination clearing point for all target nominations that do not use the FBE K ATIA.ATR standardized format.

2.2.1.2.3 Joint Fires Network (JFN)

The JFN is the centerpiece of a family of systems that includes the Remote Terminal Component and the Remote Terminal Component Lite (RTC/RTC Lite), Precision Targeting Workstation (PTW), The JSIPS Concentrator Architecture (JCA). This family of system provides cross-INT database management, collection planning functionality, target geo-refinement, sensor control capability, image handling and processing capability, targeting data uplink capability, JSTARS MTE (auto tracking), and multi-INT fusion capability to the JTF when embarked aboard USS BLUE RIDGE. It performs tasks at both the TOP SECRET/SCI and the GENSER SECRET level, using Radiant Mercury as the filter. This is the current U.S. Navy segment of the joint Distributed Common Ground Station (DCGS) capability. A detailed description of JFN can be found in the NWDC TACMEMO 2-01.1-02 – Naval Fires Network.

2.2.1.3 The TCT Team Process.

The detailed process used by the TCT Team to prosecute TSTs within the battlespace during the TT03 CPX will be the same as that used during the TT03 FTX / FBE K. The difference between the two events will be that during the FTX, some experimental targeting and collaborative toolsets and supporting techniques will be examined in an effort to see if such toolsets/techniques enhance or detract from the warfighter's ability and effectiveness to conduct TST operations. The PACAF JFACC Afloat TCT Team Process is described below in Figure 2.

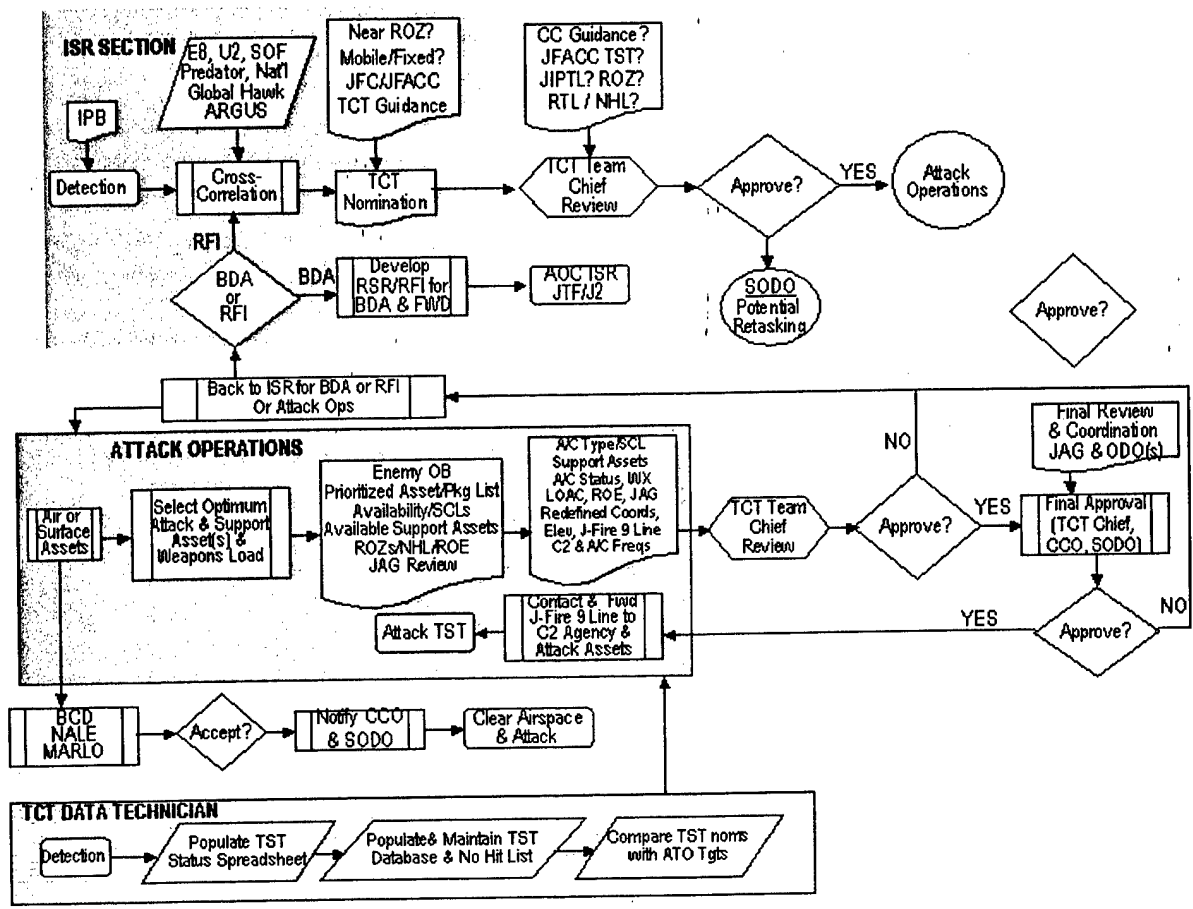

Figure 2. TCT Team Process

2.2.1.4 Integration of FBE K Toolsets / Processes into the TCT Team Process

The functional and system processes described in the process in Figure 3, but enabled through FBE K toolsets and or procedures are graphically depicted below in Figures 3 through 14. These descriptions take track events through the time sensitive targeting process described above and targets through the F2T2EA cycle.

Note: Only Figure 9 is shown below. For the full set see the Experiment Plan.

COP Track Injct. In this sequence a TST “manual contact” is created and sent to GCCS-M. COP Analyst modifies new “track name” to match TST’s target number. TST “track” distro’d to GCCS-M (COP Synch Tools) and to ADOCS (TDBM relay) in an effort to build situational awareness (SA) and allow increased ease of target coordination and prosecution by the appropriate personnel/agencies within the JTF. COP track management for both players and JECG personnel

occurs in the "COP" DCP chatroom. This event correlates to the TRACK portion of the TST engagement cycle.



FBE-K: JFN TST Information Flow *FTX*

COP inject

JECG M&S
(NWDC Newport)

8. TST "manual contact" created, sent to GCCS-M. COP Analyst modifies new "track name" to match TST's target number. TST "track" distro'd to GCCS-Ms (COP Synch Tools) and to ADOCS (TDBM relay).

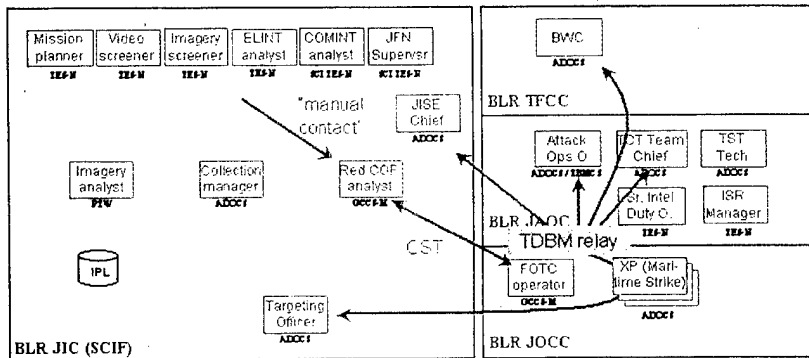

Figure 9. COP Track Inject

This page intentionally left blank.

Appendix C: JFACC TCT PROCESS – TT03 CPX

The following material was written to provide a record of the planned TST processes at JFACC ashore at Hickam Field during CPX. This JFACC TST process was used for the exercise.

JFACC TCT Organization Overview

The Combat Operations Division (COD) reported to the Joint Forces Air Component Commander (JFACC) and had overall responsibility for implementing the TCT prosecution process. The Air Operations Center (AOC) Director was responsible for the COD and provided liaison between the COD staff and the JFACC, during Tandem Thrust 03 (TT03) Command Post Exercise (CPX). Within the COD, the Chief of Combat Operations (CCO) designated a Time-Critical Targeting Chief who established a TCT team to coordinate TST validation and provide attack execution authority. The TCT prosecution process was based on the USAF 'kill chain' concept, illustrated in Figure 1, that is comprised of six operational functions: Find, Fix Track, Target, Engage, and Assess (F2T2EA).

PACOM TST Event Flow

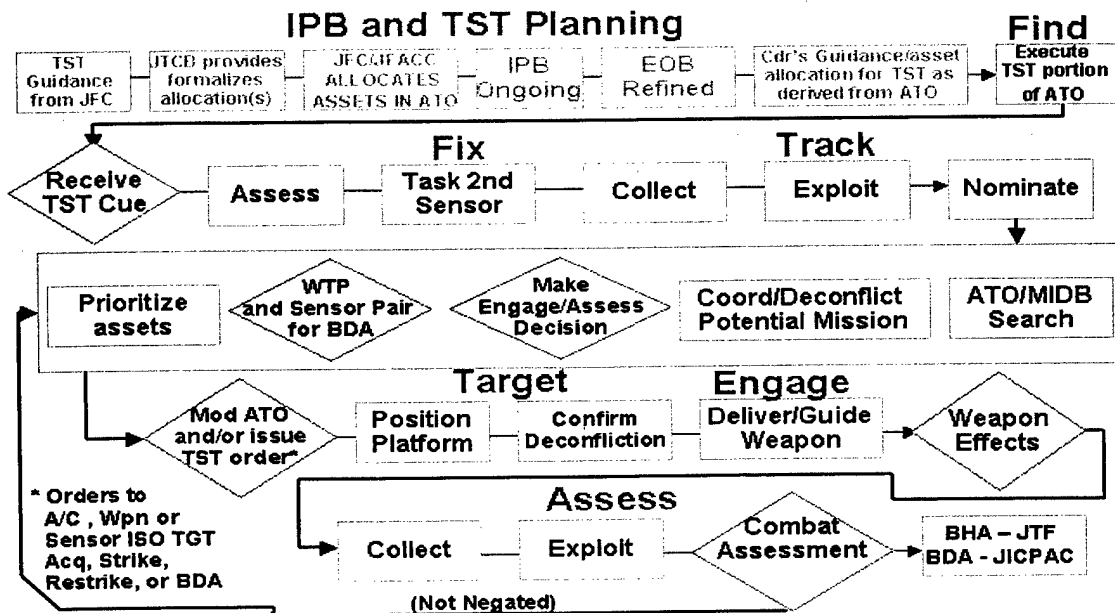

Figure C-1. USAF 'Kill Chain' Concept

The TCT team was tasked to quickly F2T2EA Time Sensitive Targets (TST) within the execution phase of the ATO timeline. TST's were categorized as those critical, scenario specific targets identified in daily commanders guidance and/or intent messages. The Air Force uses the term TCT to describe the TST F2T2EA cycle.

The Time-Critical Targeting Chief was responsible to the CCO for the TCT prosecution process. The CCO worked closely with the AOC Director and the JFACC during TCT operations to ensure all worked from a common situational awareness (SA). Figure 2 provides the overview structure of the JFACC TCT team and includes information flow observed during TT03 CPX.

The TCT team contained two primary support sections: ISR Section and Attack Operations Section. The Senior Intelligence Duty Officer (SIDO) was the focal point for the ISR Section and was responsible for ISR TCT integration and support. The SIDO coordinated with ISR staff and nominated TST's for approval and prosecution to the TCT Chief. The Attack Operations Section coordinated with the TCT Chief, SIDO, and CCO to develop TST engagement options for approved nominations. In a parallel effort during engagement option development, the SIDO coordinated with the ISR team for the Battle Damage Assessment (BDA) mission tasking necessary to complete the cycle after target engagement. It should be noted that during TT03, coordination between TCT Team and senior decision-makers was not serial but was observed to have feedback at nearly every level throughout TCT process as indicted in Figure 2 below.

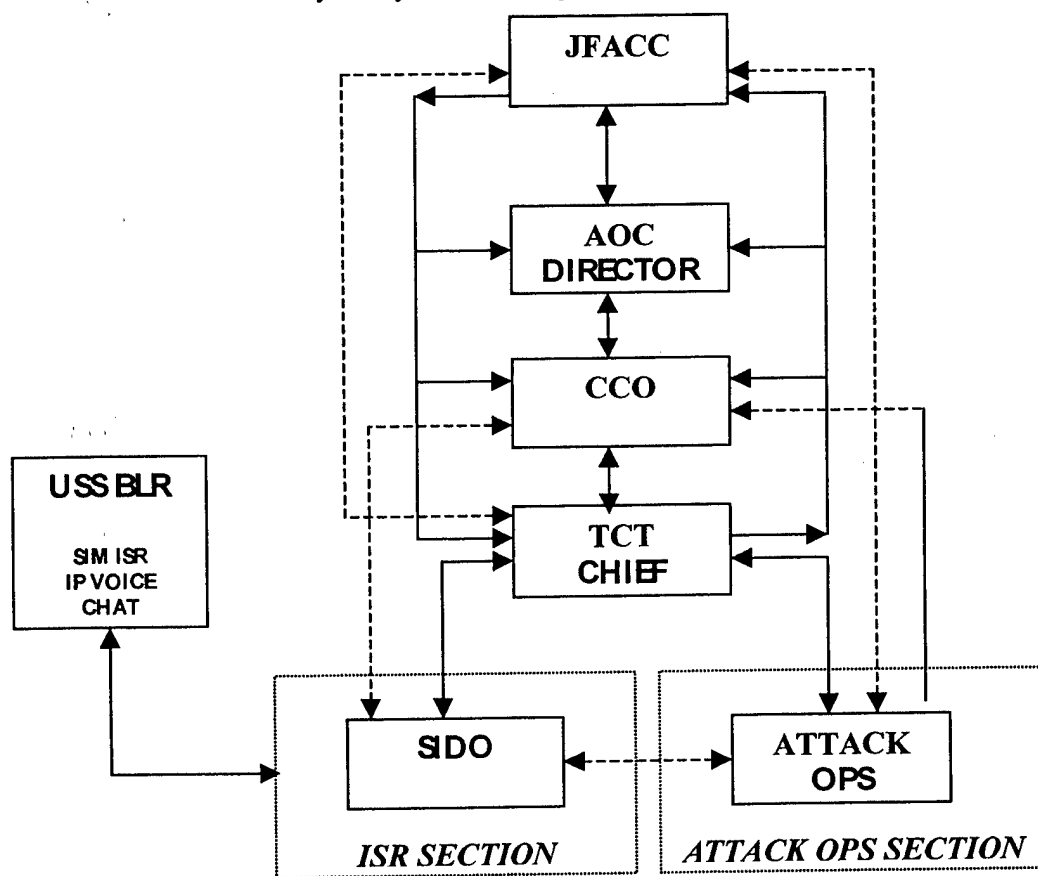

Figure C-2. TT03 TCT Team Organization

ISR Section

The principal role of the ISR Section during TCT operations was to lead the Find, Fix, Track, and Assess functions of the F2T2EA kill chain. Figure 3 provides a Information Flow diagram

of the ISR Section observed during TT03. Key functions of ISR Section observed during TT03 include:

- Conducted Predictive Battle Space Analysis (PBA) for TCT based on Intelligence Preparation of the Battlespace (IPB) conducted for deliberate planning/ATO generation. [Note: PBA was notional during the exercise. Discussions between TCT ISR Section at AOC and JTF ISR staff on BLUE RIDGE was limited during the CPX]
- Conducted dynamic sensor re-tasking for those assets not under direct collection management authority of the TCT team. [Note: TT03 process required ISR Section to request sensor re-tasking through the JECG and USS BLUE RIDGE. In real world, the SIDO would have capability/authority to reposition sensors to Find/Fix TST. If JFACC were afloat then ISR Section would have reach-back capability to support dynamic sensor re-tasking].
- Tracked ISR data and provide TST nomination to the TCT Chief for valuation
- Coordinated with external agencies to fully integrate all possible ISR capabilities in support of TCT (ELINT, COMINT, HUMINT, IMINT)
- Ensured track quality and geo-location support desired weapons options and address any ID conflicts
- Tracked TST's throughout TST "life-cycle" and maintain situational awareness on all active TST's. [Note: Intelligence information regarding TST's was shared between the BLUE RIDGE TES-N and AOC ISR-M.]
- Provided support to Attack Operations Section during target pairing function against a particular TST (e.g. Collateral Damage Assessment (CDA), Refined Mensuration) [Note: In reality the AOC (TST Authority) ISR Section would conduct CDA and target mensuration prior to forwarding TST nomination to Attack Operations, however, during TT03 CPX, CDA was requested from the JECG and target mensuration was sometimes conducted on USS BLUE RIDGE before sending imagery from TES-N to ISR-M (AOC) for TST engagement]
- Compared nominated TST to daily ATO target list
- Coordinated Phase II BDA [Note: SIDO did not have control of ISR assets during the exercise. During TT03, all BDA requirements were coordinated through the Joint Experiment Control Group (JECG) and ISR Cell on USS BLUE RIDGE]

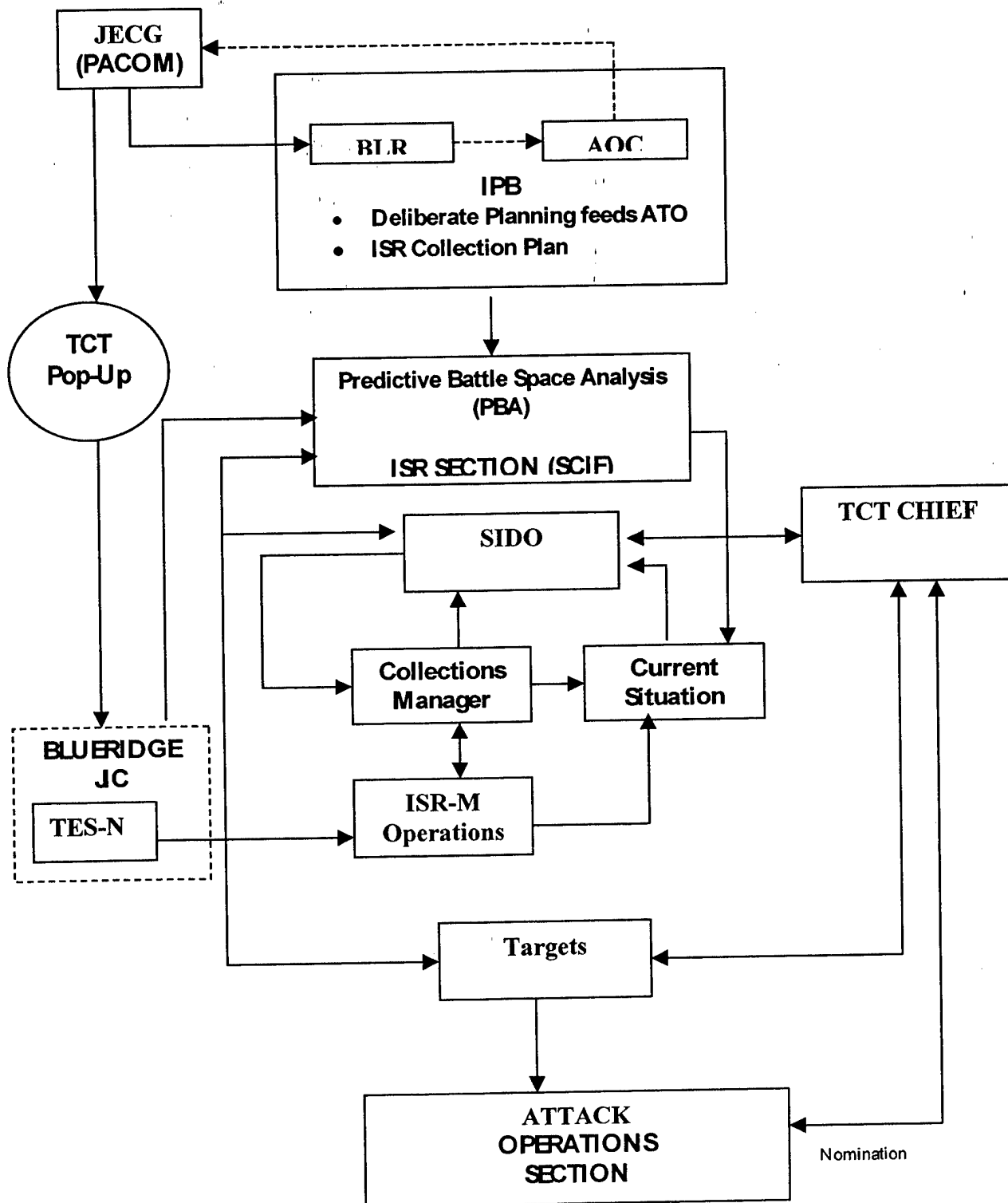

Figure C-3. TT03 ISR Section Information Flow – Find, Fix, Track, Assess

Attack Operations Section

The principal role of the Attack Operations Section during TCT operations was to lead the target and engage function of the F2T2EA kill chain. During TT03, the Deputy CCO was tasked as the Attack Operations Chief with responsibility of coordinating support required to successfully attack nominated TST with AOC personnel (Airspace Management, IO, Tanker Cell, JAG, Joint liaisons, etc.). Figure 4 provides a Information Flow diagram of the Attack Operations Section observed during TT03. Key functions of Attack Operations Section observed during TT03 include:

- Received the approved TST nominations from the TCT Chief and coordinated with the ISR Section (Targets) to develop a list of available assets capable of attacking the target.
- Coordinated with AOC liaison elements (Battlefield Coordination Detachment (BCD), MARLO, NALE, SOLE, for availability of alternative attack options for TST engagement/attack. [Note: MARLO or SOLE representatives did not participate]
- Coordinated with IO Cell for potential non-kinetic kill solutions. [Note: This was not observed during TT03 but step was identified during discussions with TCT Chief and Attack Operations Chief]
- Provided TCT Chief with a prioritized attack asset list and package options for TST.
- Provided TCT Chief with JAG perspective on TST's prior to requesting final approval from JFACC for engagement.

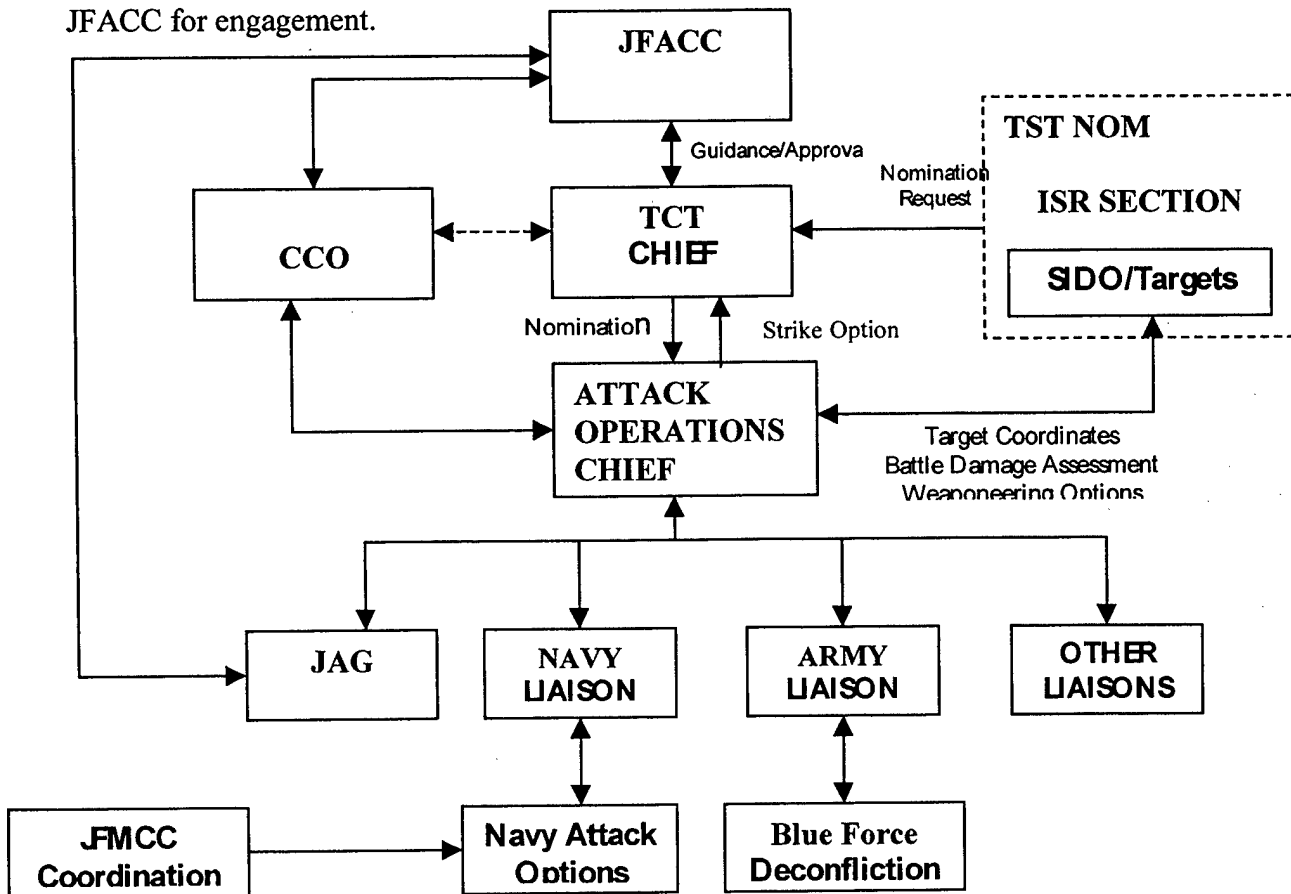
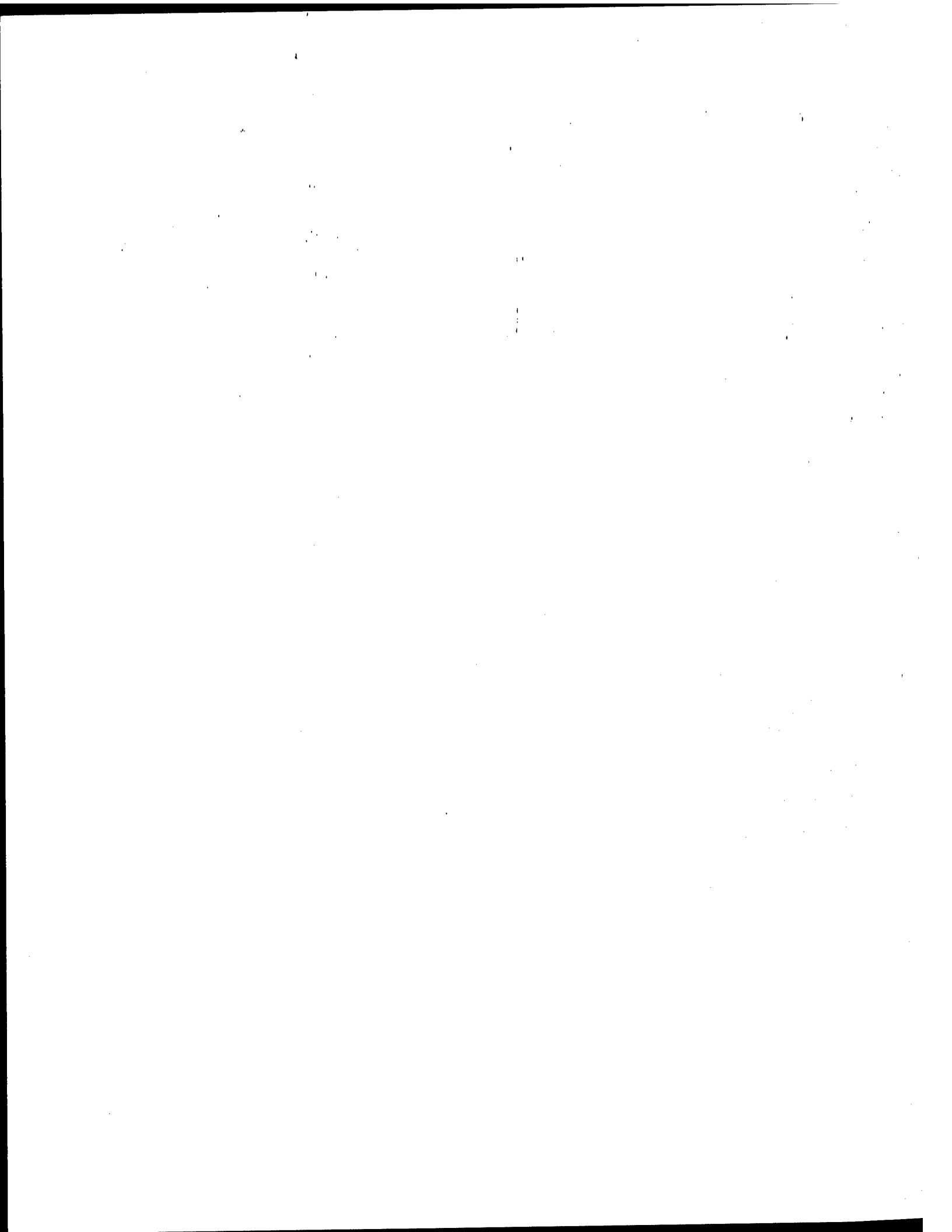

Figure C-4. TT03 Attack Operations Section Information Flow – Target, Engage

TCT Process Summary

1. Based on Commander's Guidance, ISR assets will be resourced on ATO. Emerging targets (ELINT, COMINT, HUMINT, IMINT, etc.) commence TCT process.
2. Ensure TST Targeting Matrix and ROE is available at JIC (BLR), JAOC TST Cell (BLR) and AOC TCT Cell (Hickam)
3. As tippers (sensor cues) flow in from a variety of sources, the ISR Section (SIDO) prioritizes which targets are potentially valid TST's. The SIDO enters potential targets on the 'Emerging Target List' and requests the track data manager to create a JTIDS 3.5 track if a JSTARS unit has not already created. The track data manager in the ISR Section will work with the Joint Stars Work Station (JSWS) operator to ensure tracks are created, updated, and dropped as appropriate.
[NOTE: During TT03, AOC TST Cell (Hickam) received initial target nominations from the ship and acknowledged receipt to the JAOC TST Cell (BLR) via IWS Chat, SIPRnet email or Voice Comm]
4. Targets not categorized as TST's will be forwarded to the Senior Offensive Duty Officer (SODO) for potential retasking of current ATO assets to accommodate, or processed back through Combat Plans for inclusion in subsequent ATO's.
5. SIDO directs TCT personnel (targets and current situation) to conduct a Predictive Battlespace Analysis (PBA) based on sensor cue(s). PBA could be considered a more refined IPB of the specific TST location. Collateral damage assessment is conducted to ensure TST engagement will not violate Commander's Guidance or ROE.
6. SIDO directs Collections Manager to modify collection plans, as required to cross-correlate initial sensor contact. SIDO must coordinate with TCT Chief and CCO prior to re-tasking sensors on current ATO.
7. SIDO evaluates sensor data collected. If target is a TST identified on Joint Integrated Prioritized Target List (JIPTL), the SIDO will nominate the target to the dynamic target list.
8. After a target is nominated to the dynamic target list, the TCT Chief will assign the target a team in the Attack Operations Section.
[NOTE: Real world operations typically include three attack coordination teams to handle multiple high priority TST's simultaneously. CCO and TCT Chief will adjust the number of teams as required by the operational tempo. Instead of creating teams with stovepipe focus (geographic areas or specific target sets), each team should be able to flex to any geographic area/target set as directed by the SIDO and TCT Chief]
9. The attack coordination team is responsible for friendly deconfliction, coordination with SOLE/BCD/MARLO for attack options, asset nomination based on threat, weather, response time, weapons effect, airspace deconfliction, Positive Identification (PID), Rules of Engagement (ROE), and point mensuration, as required.
10. The attack coordinator works closely with the Targeteer (ISR Section) to ensure mensuration and collateral damage assessment is conducted and current; then completes an electronic checklist for the attack as posted on the shared view of selected chat room application. When data form is complete, the attack coordinator presents the attack plan to the TCT Chief for approval. The TCT Chief will review and present recommendations to the CCO, AOC, and JFACC.

11. In parallel to the attack option development, the SIDO coordinates with Collections Manager and Current Situation to identify ISR resources required for a Phase II BDA and plans BDA mission(s), if required. The primary BDA will be conducted and verified by platforms conducting the strike (Phase I). However, if Phase I BDA is unsuccessful, the SIDO will provide recommended approach to dynamically retask assets to conduct Phase II BDA.
12. Once the TST strike package is approved by the JFACC, the TCT Chief directs the C2 duty officer to pass the tasking via SATCOM TCT net to the C2 package Commander in the aircraft.
[Note: All approved strike packages were forwarded through JECG during TT03 CPX]
13. The attack coordinator ensures the strike package/target information is forwarded to the appropriate duty officer (track data manager) to pass up to the attack aircraft.
[Note: Assumes that weapon target pairing is Air Force strike aircraft.]
14. The track data manager sends a 9.0 tasking message to the aircraft and works with the surface track coordinator and the JSWS operator to ensure the track is updated with accurate coordinates and elevation.
15. The C2 Commander on Aircraft will conduct Phase 1 BDA and pass information to the C2 Duty Officer who informs TCT Chief of the results.
16. The TCT Chief coordinates with the SIDO, CCO and JFACC to decide if Phase II BDA or re-strike option is required.



INITIAL DISTRIBUTION LIST

1. Defense Technical Information Center 2
Cameron Station
Alexandria, VA 22314
2. Library, Code 0142 2
Naval Postgraduate School
Monterey, CA 93943
3. Gordon Schacher 2
Wayne E. Meyer Institute of Systems Engineering
Naval Postgraduate School
777 Dyer Rd., Room 100D, Monterey, CA 93943
4. Shelley Gallup 6
Wayne E. Meyer Institute of Systems Engineering
Naval Postgraduate School
777 Dyer Rd., Room 100D, Monterey, CA 93943
5. Nelson Irvine 1
Wayne E. Meyer Institute of Systems Engineering
Naval Postgraduate School
777 Dyer Rd., Room 100D, Monterey, CA 93943
6. Chuck Marashian 1
Wayne E. Meyer Institute of Systems Engineering
Naval Postgraduate School
777 Dyer Rd., Room 100D, Monterey, CA 93943
7. Bill Kemple 1
Information Systems Department
Naval Postgraduate School
789 Dyer Rd., Room 100D, Monterey, CA 93943
8. Rich Kimmel 1
Wayne E. Meyer Institute of Systems Engineering
Naval Postgraduate School
777 Dyer Rd., Room 100D, Monterey, CA 93943
9. Steve Pilnick 1
Wayne E. Meyer Institute of Systems Engineering
Naval Postgraduate School
777 Dyer Rd., Room 100D, Monterey, CA 93943

- 10. Susan Hutchins 1
Information Systems Department
Naval Postgraduate School
789 Dyer Rd., Room 100D, Monterey, CA 93943

- 11. Phil DePoy, Director 1
Wayne E. Meyer Institute of Systems Engineering
Naval Postgraduate School
777 Dyer Rd., Room 100D, Monterey, CA 93943

- 12. CAPT Jeff Kline 1
Wayne E. Meyer Institute of Systems Engineering
Naval Postgraduate School
777 Dyer Rd., Room 100D, Monterey, CA 93943

- 13. RADM Ron Route 1
Navy Warfare Development Command
686 Cushing Rd.
Newport, RI 02841

- 14. CDR Harry Newton 1
Navy Warfare Development Command
686 Cushing Rd.
Newport, RI 02841

- 15. CDR John Covell 1
Navy Warfare Development Command
686 Cushing Rd.
Newport, RI 02841

- 16. Ralph Klingbile 1
Navy Warfare Development Command
686 Cushing Rd.
Newport, RI 02841

- 17. James Miller 4
Navy Warfare Development Command
686 Cushing Rd.
Newport, RI 02841

- 18. CAPT Kevin Morissey 4
Navy Warfare Development Command
686 Cushing Rd.
Newport, RI 02841