



# UNITED STATES AIR FORCE RESEARCH LABORATORY

---

DEVELOPMENT OF HIGH PERFORMANCE  
PNEUMATIC MUSCLE ACTUATOR SYSTEMS

Rupa Purasinghe

CALIFORNIA STATE UNIVERSITY  
LOS ANGELES CA 90032

Maria Feng

FENG ENTERPRISES  
NEWPORT BEACH CA 92657

Masanobu Shinozuka

UNIVERSITY OF SOUTHERN CALIFORNIA  
LOS ANGELES CA 90089

NOVEMBER 1999

FINAL REPORT FOR THE PERIOD 15 MAY 1998 TO 30 NOVEMBER 1999

20030617 048

*Approved for public release; distribution is unlimited*

Human Effectiveness Directorate  
Crew System Interface Division  
2255 H Street  
Wright-Patterson AFB OH 45433-7022

## NOTICES

When US Government drawings, specifications, or other data are used for any purpose other than a definitely related Government procurement operation, the Government thereby incurs no responsibility nor any obligation whatsoever, and the fact that the Government may have formulated, furnished, or in any way supplied the said drawings, specifications, or other data, is not to be regarded by implication or otherwise, as in any manner licensing the holder or any other person or corporation, or conveying any rights or permission to manufacture, use, or sell any patented invention that may in any way be related thereto.

Please do not request copies of this report from the Air Force Research Laboratory. Additional copies may be purchased from:

National Technical Information Service  
5285 Port Royal Road  
Springfield, Virginia 22161

Federal Government agencies and their contractors registered with the Defense Technical Information Center should direct requests for copies of this report to:

Defense Technical Information Center  
8725 John J. Kingman Road, Suite 0944  
Ft. Belvoir, Virginia 22060-6218

### DISCLAIMER

This Technical Report is published as received and has not been edited by the Air Force Research Laboratory, Human Effectiveness Directorate.

### TECHNICAL REVIEW AND APPROVAL

AFRL-HE-WP-TR-2003-0019

This report has been reviewed by the Office of Public Affairs (PA) and is releasable to the National Technical Information Service (NTIS). At NTIS, it will be available to the general public.

This technical report has been reviewed and is approved for publication.

### FOR THE COMMANDER



MARIS M. VIKMANIS  
Chief, Crew System Interface Division  
Air Force Research Laboratory

# REPORT DOCUMENTATION PAGE

Form Approved  
OMB No. 0704-0188

Public reporting burden for this collection of information is estimated to average 1 hour per response, including the time for reviewing instructions, searching existing data sources, gathering and maintaining the data needed, and completing and reviewing the collection of information. Send comments regarding this burden estimate or any other aspect of this collection of information, including suggestions for reducing this burden, to Washington Headquarters Services, Directorate for Information Operations and Reports, 1215 Jefferson Davis Highway, Suite 1204, Arlington, VA 22202-4302, and to the Office of Management and Budget, Paperwork Reduction Project (0704-0188), Washington, DC 20503.

1. AGENCY USE ONLY (Leave blank)	2. REPORT DATE November 1999	3. REPORT TYPE AND DATES COVERED Final, 15 May 1998 - 30 November 1999	
4. TITLE AND SUBTITLE  Development of High Performance Pneumatic Muscle Actuator Systems		5. FUNDING NUMBERS  C: F41624-98-1-001 PR: 7184 TA: 08 WU: LA	
6. AUTHOR(S)  *Rupa Purasinghe, **Maria Feng, ***Masanobu Shinozuka		8. PERFORMING ORGANIZATION	
7. PERFORMING ORGANIZATION NAME(S) AND ADDRESS(ES)  * California State University, Los Angeles CA 90032 ** Feng Enterprises, Newport Beach CA 92657 ***University of Southern California, Los Angeles CA 90089		10. SPONSORING/MONITORING  AFRL-HE-WP-TR-2003-0019	
9. SPONSORING/MONITORING AGENCY NAME(S) AND ADDRESS(ES)  Air Force Research Laboratory Human Effectiveness Directorate Crew System Interface Division Air Force Materiel Command Wright-Patterson AFB OH 45433-7022		11. SUPPLEMENTARY NOTES	
12a. DISTRIBUTION/AVAILABILITY STATEMENT  Approved for public release; distribution is unlimited		12b. DISTRIBUTION CODE	
13. ABSTRACT ( <i>Maximum 200 words</i> ) In this project, a prototype pneumatic muscle actuator system resembling a human arm joint has been designed, fabricated, and tested. System identification of the actuator system with different types, sizes, and characteristics of rubber muscles were performed through static and dynamic tests, and experimental as well as theoretical models were developed. Control algorithms including a feed-forward algorithm suitable for the muscle actuator system was developed and implemented to compensate the time delay otherwise inherent in the response of the actuator system. The time delay of the muscle response depended on the type and size of the muscles. The larger muscle suffered larger time delay, although it provided larger power and stroke. The control algorithm equipped with the feed-forward compensation developed in this research is very effective in reducing the time delay in response. Excellent control performance of the pneumatic muscle actuator system was confirmed by experiments. This research has demonstrated the potential of using pneumatic muscle actuators for enhancing human strength and mobility.			
14. SUBJECT TERMS Pneumatic muscle actuator systems		15. NUMBER OF PAGES 49	
17. SECURITY CLASSIFICATION OF REPORT Unclassified		16. PRICE CODE	
18. SECURITY CLASSIFICATION OF THIS PAGE Unclassified		20. LIMITATION OF ABSTRACT Unlimited	
19. SECURITY CLASSIFICATION OF ABSTRACT Unclassified		20. LIMITATION OF ABSTRACT Unlimited	

**THIS PAGE IS INTENTIONALLY LEFT BLANK**

## Table of Contents

	List of Illustrations	II
	List of Tables	IV
	Acknowledgement of Sponsorship	V
1.	Introduction	1
1.1.	Background	1
1.2.	Objective of this Research	2
2.	Development of a Pneumatic Muscle Actuator System	3
2.1.	Characteristics of Pneumatic Air Muscles	3
2.2.	Experimental Setup of One-Linked Arm Fixture	5
2.3.	Specifications of Devices Used in the Experiment	6
3.	Characteristics of Experimental Fixture	10
3.1.	Theoretical Modeling of Air Muscle	10
3.2.	Experimental Modeling of Air Muscle	16
3.3.	Parameter Identification of Air Muscle	23
3.3.1.	The Equation of Motion	23
3.3.2.	Parameter Identification by Experiment	26
4.	System Control and Response	30
4.1.	PI Control	30
4.2.	Compensation using Feed-Forward Control	32
5.	Summary and Conclusions	38
6.	Bibliography	40
7.	Appendix –List of Publications / Personnel	42

## **List of Illustrations**

Figure 2.1	Structure of McKibben Pneumatic Artificial Muscle	3
Figure 2.2	Schematic Diagram of Fixture	5
Figure 2.3	Photo of Fixture	6
Figure 2.4	Pressure Value	7
Figure 2.5	Pressure Sensor	8
Figure 2.6	Rotary Encoder	8
Figure 2.7	Multifunction I/O Board	9
Figure 2.8	Air Compressor	9
Figure 3.1	Simple Model of Air Muscle	11
Figure 3.2	Geometry of Thread of Muscle	12
Figure 3.3	Circular Force	13
Figure 3.4	Balance of Longitudinal Forces	13
Figure 3.5(a), (b), (c)	Relationship between Force and Contraction Ratio	18
Figure 3.6	Experimental Modeling (RUB-125)	19
Figure 3.7	Error between Model and Experimental Data (RUB-125)	20
Figure 3.8	Experimental Modeling (AM-02)	21
Figure 3.9	Error between Model and Experimental Data (AM-02)	21
Figure 3.10	Experimental Modeling (AM-04)	22
Figure 3.11	Error between Model and Experimental Data (AM-04)	22
Figure 3.12	Construction of Air Muscle Actuator System	23
Figure 3.13	Free Vibration of Link	27
Figure 3.14	Relationship between Angle and Pressure Difference	29

Figure 4.1	Step Response of PI Control	33
Figure 4.2	Control with Feed-Forward Compensation	34
Figure 4.3	Experimental Results of PI Control	36
Figure 4.4	Control with Feed-Forward Compensation	37

## **List of Tables**

Table 2.1	Specifications of each Muscle	4
Table 2.2	Specifications of Magnetic Proportional Pressure Control Value	7
Table 2.3	Specifications of Pressure Sensor	8
Table 2.4	Specifications of Rotary Encoder	8
Table 2.5	Specifications of Multifunction I/O Board	9
Table 2.6	Specifications of Air Compressor	9
Table 3.1	Condition for Experiment	16
Table 3.2	Parameter Values Identified by Free Vibration Experiment	28
Table 4.1	Parameter Values for PI Control	32
Table 4.2	Parameter Values for Control with Feed-Forward Compensation	35



## **Acknowledgement of Sponsorship**

This research effort was sponsored by the AFRL/HECP, Air Force Material Command, USAF, under grant number F41624-98-1-0001, with Dr. Daniel Repperger as the Program Manager.

THIS PAGE INTENTIONALLY LEFT BLANK

## **1. Introduction**

### **1.1. Background**

Pneumatic artificial muscle actuators were first developed in artificial limb research in the 1950's and 1960's (Gavrilovic and Maric, 1969, Schulte, 1961). They were commercialized by the Bridgestone Corporation, Japan, in the 1980's (Inoue, 1988) using rubber as the primary muscle material for robotics applications (e.g., Feng, et al, 1997, Hesselroth, et al, 1994, Uno, 1986, Yamafuji, et al, 1993). These actuators have high power-to-weight and power-to-volume ratios and flexible mechanical features friendly to human as compared to hydraulic and electric actuators. Therefore, these actuators have shown considerable potential for enhancing human strength and mobility for military as well as civilian applications.

However, some features of the pneumatic actuators, namely the compressibility of the air inside the muscles, the delay of the response and its nonlinearity for example, make it difficult to precisely control output displacements and forces of these actuators, which prevents their effective applications in the fields as mentioned above.

Significant efforts have recently been made to overcome such drawbacks. For example, Repperger, et al, (1997) performed static and dynamic tests on a pneumatic muscle actuator system to identify its nonlinear characteristics and to incorporate them into a force control algorithm. Chou et al (1996) developed a linearized model of the McKibben artificial muscle pneumatic actuator. Galdwell et al (1995) applied the adaptive control scheme combined on on-line system identification to improve the accuracy of the position control. Hesselroth, et al (1994) developed a neural learning

algorithm for position control of a robot arm actuated by rubber muscles. The previous, work represented by these papers contributed significantly to the artificial muscle technology. Additional work, however, is needed to further improve the control performance of pneumatic muscles in order to make them implementable.

## **1.2. Objective of this Research**

The objectives of this research are

- i) to develop a prototype pneumatic muscle actuator system reflecting the state of the art technology.
- ii) to study and model its static and dynamic characteristics and
- iii) to develop and apply effective control algorithms to achieve accurate position control.

## 2. Development of a Pneumatic Muscle Actuator System

### 2.1. Characteristics of Pneumatic Air Muscles

The pneumatic muscles used as actuators in this research are called *McKibben Pneumatic Artificial Air Muscles*. The muscle has an internal rubber bladder covered with an external shell formed from interwoven nylon fibers (Figure 2.1). When the internal bladder is pressurized, the high pressure air pushes against its inner surface and its external shell, and thus tends to increase its volume. The bladder and thread are fixed at both ends tightly with fittings. Due to the non extensibility (or very high longitudinal stiffness) of the nylon fibers of the external shell, the muscle shortens according to its volume increase and/or tension force if it is coupled to a mechanical load. By combining a pair of such muscles in different ways and by controlling the pressure difference of the air inside the two muscle bladders, one can provide various actuations.

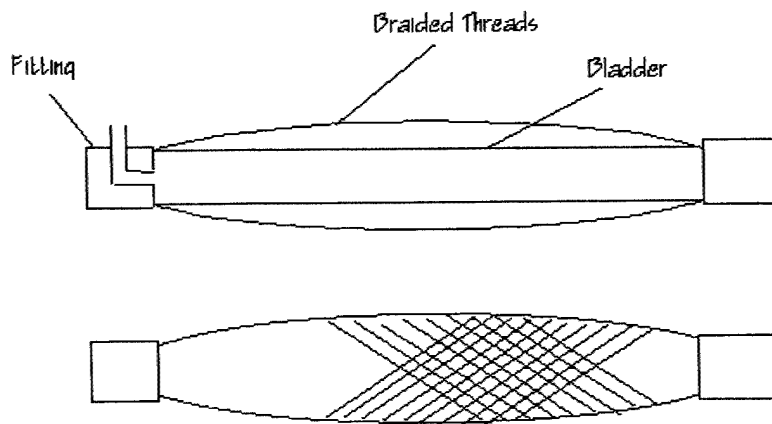
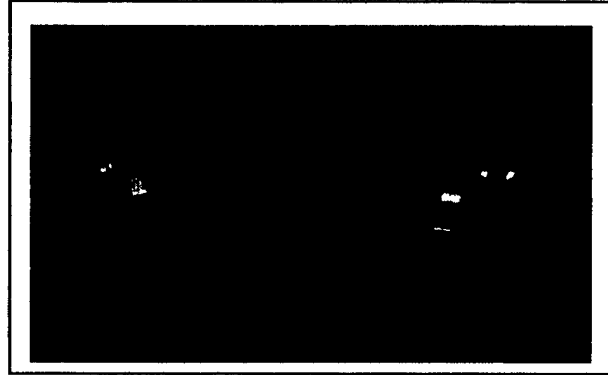

**Figure 2.1: Structure of McKibben Pneumatic Artificial Muscle**

Three types of pneumatic muscles were used for the experiment. The specifications of each muscle are shown in Table. 2.1.

**Table 2.1: Specifications of each Muscle**

<b><i>Model</i></b>	<b><i>AM-02</i></b>
Manufacturer	<b>Shadow Robot Co.</b>
Length	<b>210 [mm]</b>
Diameter	<b>20 [mm]</b>
Load pulled at 50 psi	<b>45 [lb.]</b>
Percent contraction per given load	<b>25% Contraction with load of: 25 [lb.]</b>



<b><i>Model</i></b>	<b><i>AM-04</i></b>
Manufacturer	<b>Shadow Robot Co.</b>
Length	<b>400 [mm]</b>
Diameter	<b>50 [mm]</b>
Load pulled at 50 psi	<b>300 [lb.]</b>
Percent contraction per given load	<b>25% Contraction with load of: 150 [lb.]</b>



<b><i>Model</i></b>	<b><i>RUB-125</i></b>
Manufacturer	<b>Bridgestone</b>
Length	<b>280 [mm]</b>
Diameter	<b>15 [mm]</b>
Load pulled at 50 psi	<b>140 [lb.]</b>
Percent contraction per given load	<b>20% Contraction with load of: 30.8 [lb.]</b>

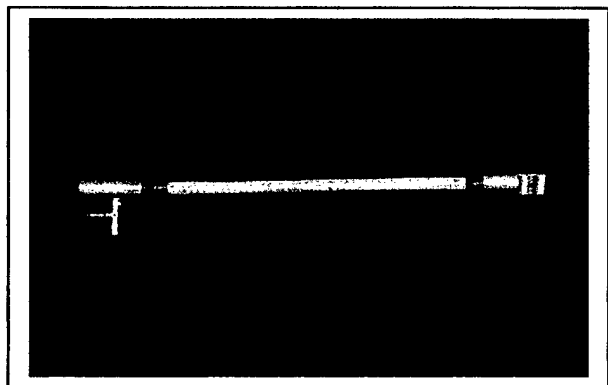

## 2.2. Experimental Setup of One-Linked Arm Fixture

An experimental setup of a one-linked arm fixture was designed and fabricated. As shown in Figure 2.2, the system consists of a pair of muscles, an air compressor, two proportional pressure control valves, an air regulator, an encoder, two pressure sensors, a rotary link, and a computer with AD/DA boards. The muscles are connected through a pulley, which represents an arm joint. The angular position of the joint is controlled by adjusting the longitudinal deformation of each air muscle through controlling the air pressure inside the muscle. The encoder is used to measure the angular position of the joint and the two pressure sensors are used to monitor the air pressure inside each muscle. The measured data from these sensors are sent to the computer through the analog to digital (A/D) converter. The pressure control signals are sent to the air valve from the computer via the digital to analog (D/A) converter. Figure 2.3 is a photo of the fixture.

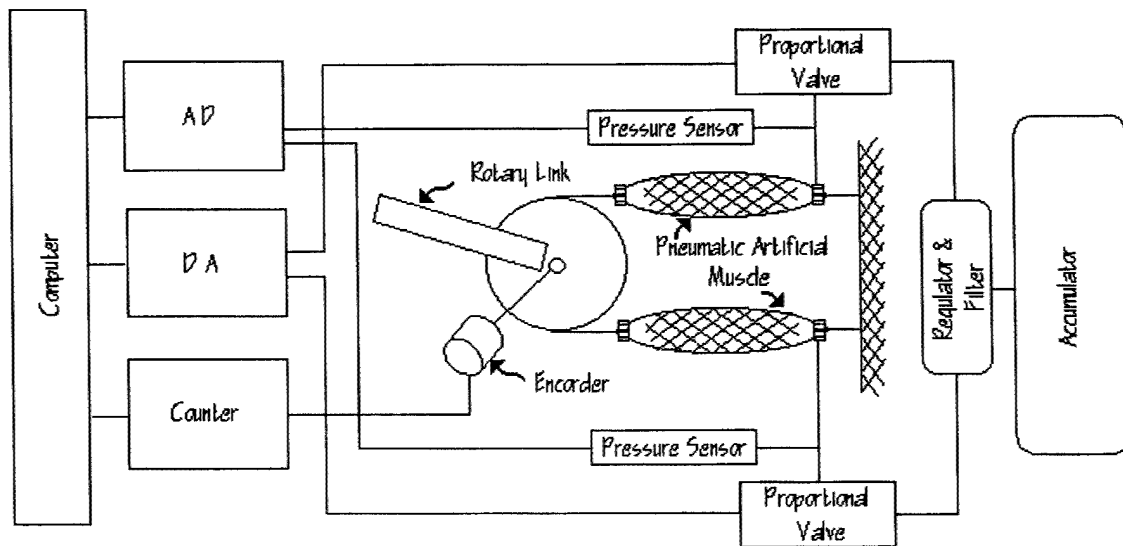
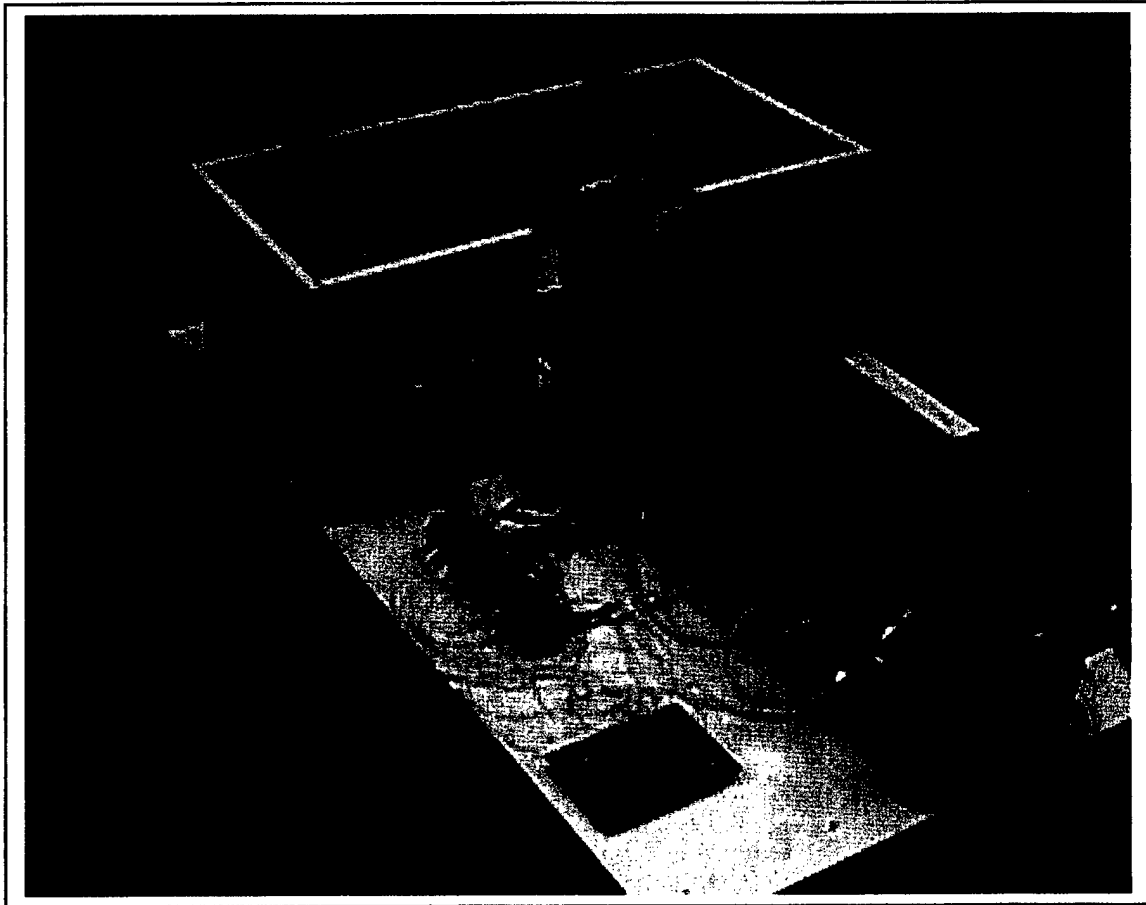

Figure 2.2: Schematic Diagram of Fixture



**Figure 2.3: Photo of Fixture**

### **2.3. Specifications of Devices used in the Experiment**

The specifications of the valves, pressure sensors, encoder, A/D and D/A converters and the air compressor are shown in Table 2.2, through Table 2.6. Figures 2.4 through 2.8 show the photos of these devices.



**Table 2.2: Specifications of Magnetic Proportional Pressure Control Valve**

<b><i>Model</i></b>	<b><i>PPC5B-AAA-AGCA</i></b>
Manufacturer	<b>Fluidtrols Corporation</b>
Pressure Range	<b>100 (psi)</b>
Pressure Reference	<b>Gage Pressure</b>
Overall Accuracy	<b>± 0.5% F.S.</b>
Command signal	<b>0-10 V Differential</b>

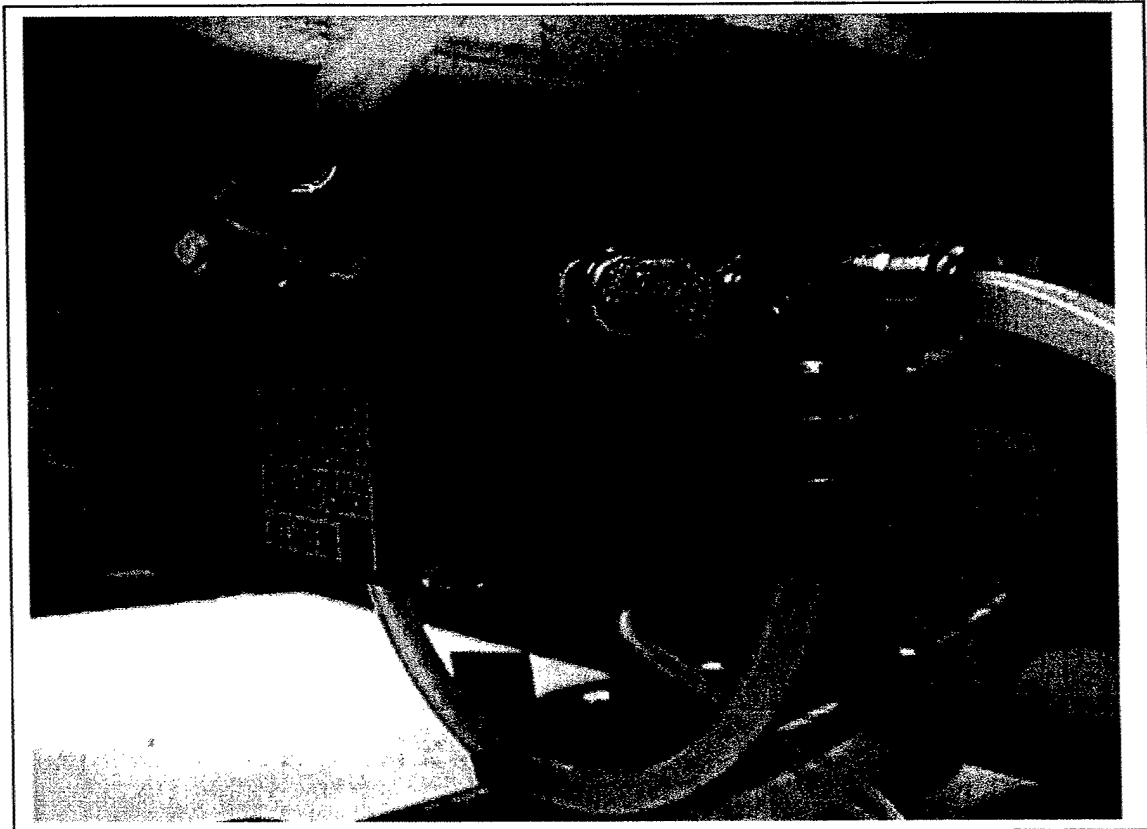

**Figure 2.4: Pressure Valve**

**Table 2.3: Specifications of Pressure Sensor**

<b>Model</b>	<b>DP2-42N</b>
Manufacturer	SUNX
Type of Pressure	Gage Pressure
Rotate Pressure Range	0 ~ 1.000Mpa
Applicable Fluid	Non-corrosive gas
Supply Voltage	12 to 24 V DC $^{-15\%}$ $^{+10\%}$ Ripple P $\square$ P: 105 or less
Output Voltage	1 to 5 V Zero-point: within 1V $\square$ 5% F.S. Span: within 4V $\square$ 5% F.S. Linearity: within V $\square$ 5% F.S.

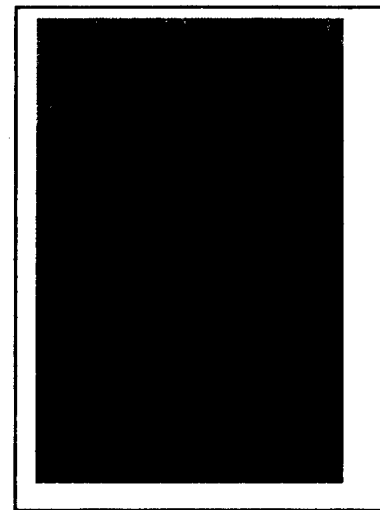

**Figure 2.5: Pressure Sensor**

**Table 2.4: Specifications of Rotary Encoder**

<b>Model</b>	<b>L25G-F1-2500-P4C-8830-LED-SM16</b>
Manufacturer	BEI Sensors & Systems Company
Code	Incremental
Count per Rotate	10,000
Maximum RPM	10,000
Moment of Inertia	$4.1 \times 10^{-4}$ oz-in-sec <sup>2</sup>
Voltage Supply	+5V de
Output Format	2 channels (cw & ccw)
Frequency	100 kHz

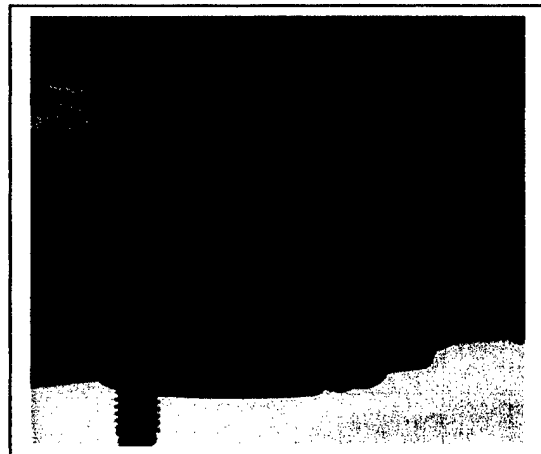

**Figure 2.6: Rotary Encoder**

**Table 2.5: Specifications of Multifunction I/O Board**

<i>Model</i>	<i>PCI-6024E</i>
Manufacturer	<b>National Instruments</b>
Analog Input	<b>16 Single-ended or 8 differential 200kS/s sampling rate 200kS/s stream-to-disk rate 12 bit resolution</b>
Analog Output	<b>2channels 12-bit resolution</b>
Digital I/O	<b>8 (5V/TTL) lines</b>
Counter / Timer	<b>2 up/down 24 bit resolution</b>
Triggering	<b>Digital</b>

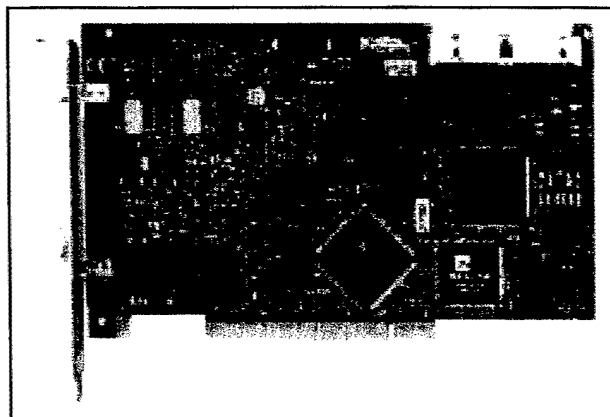

**Figure 2.7: Multifunction I/O Board**

**Table 2.6 Specifications of Air Compressor**

<i>Model</i>	<i>WL340003AJ</i>
Manufacturer	<b>CAMPBELL HAUSFELD</b>
Maximum Pressure	<b>125 psi</b>
Container Volume	<b>13 gallon</b>

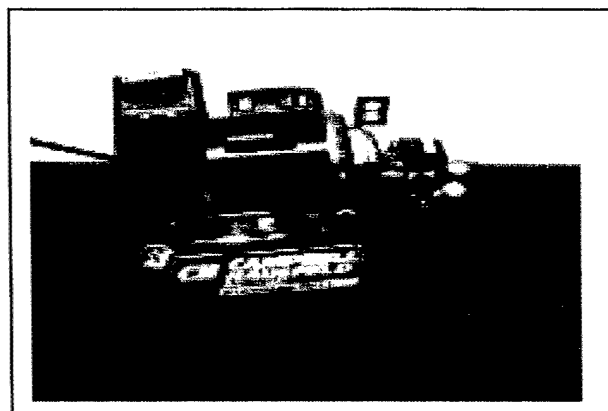

**Figure 2.8: Air Compressor**

### 3. Characteristics of Experimental Fixture

#### 3.1. Theoretical Modeling of Air Muscle

In order to control the angular position or the torque of the arm joint through controlling the pressure of the air muscle, the relationship between the muscle force, air pressure and the contraction ratio of the muscle must be identified. In this research, a theoretical relationship was first derived. In order to simplify the model the following assumptions were made.

- The shape of the braided sleeve is cylindrical.
- The threads in the braided mesh shell are not extensible.
- The elasticity of bladder is ignored.
- The friction of each thread is ignored.

As depicted in Figure 3.1, the length of the muscle,  $L$ , has the following relationships with the contraction ratio  $\varepsilon$ , and the initial length  $L_n$ .

$$\begin{aligned} L &= (1 - \varepsilon)L_n \\ L' &= (1 - \varepsilon)L'_n \end{aligned} \tag{3.1}$$

where

$L$  = Length of the muscle

$L_n$  = Initial length of the muscle

$L'$  = Longitudinal length of the muscle for one turn of thread.

$L'_n$  = Initial longitudinal length of the muscle for one turn of thread.

As such

$$\begin{aligned} L_n &= mL'_n \\ L &= mL' \end{aligned} \tag{3.2}$$

where  $m$  = number of turns of thread

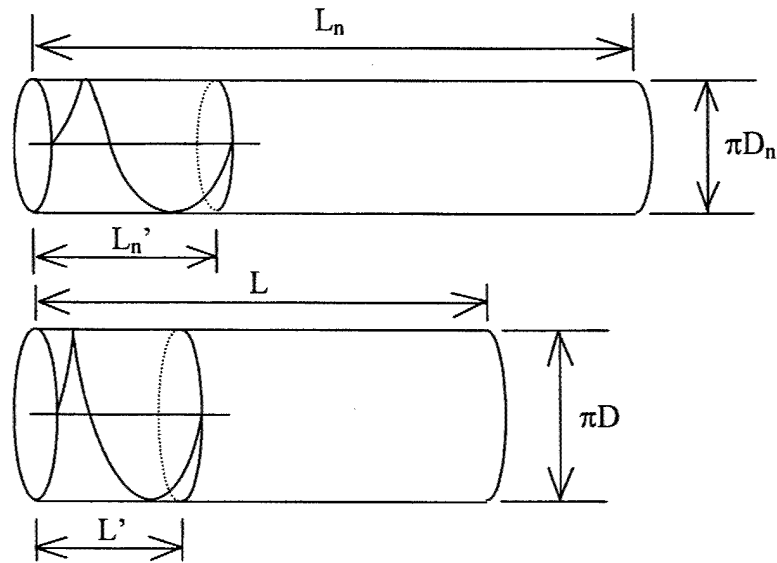

**Figure 3.1: Simple Model of Air Muscle**

The relationship between the above parameters are illustrated in the triangles shown in the Figure 3.2

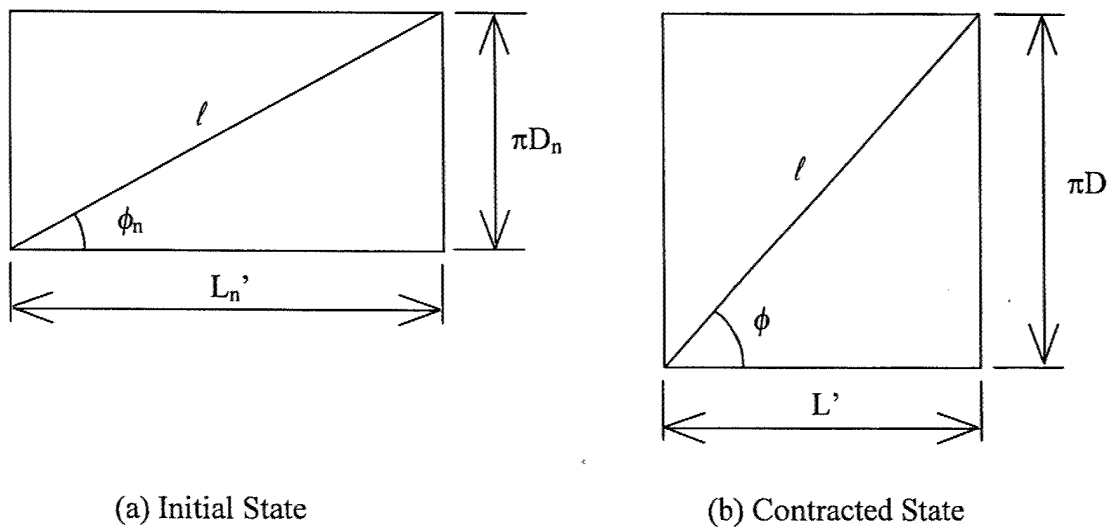

**Figure 3.2: Geometry of Thread of Muscle**

The geometry of the parameters of the triangle is as follows

$$(\pi D_n)^2 + L_n'^2 = (\pi D)^2 + L'^2 = l^2 \quad (3.3)$$

where  $D_n$  and  $D$  are at initial and final conditions of the air muscle, respectively.

By solving for  $D$ , yields

$$D^2 = D_n^2 + \frac{L_n'^2}{\pi^2} \{1 - (1 - \varepsilon)^2\} \quad (3.4)$$

Using the same geometry and solving for the circumference, yields

$$\begin{aligned} \pi D_n &= L_n' \tan \phi_n \\ \pi D &= L' \tan \phi \end{aligned} \quad (3.5)$$

where,  $\phi_n$  and  $\phi$  refer to the gradient angle of each thread at initial and contracted states.

Thus, setting the circumference equal to each other and solving, yields

$$\frac{D}{\tan \phi} = \frac{(1 - \varepsilon) D_n}{\tan \phi_n} \quad (3.6)$$

Similarly,

$$L_n = ml \cos \phi_n \quad (3.7)$$

and

$$l = \frac{\pi D_n}{\sin \phi_n} \quad (3.8)$$

which yields,

$$L_n = \frac{m\pi D_n}{\tan \phi_n} \quad (3.9)$$

By substituting Equation 3.9 into Equation 3.4, yields,

$$D^2 = D_n^2 \left\{ 1 + \frac{(1 - (1 - \varepsilon)^2)}{\tan^2 \phi_n} \right\} \quad (3.10)$$

and,

$$L \tan \phi = m\pi D \quad (3.11)$$

$$L = \frac{m\pi D}{\tan \phi} \quad (3.12)$$

The relationship between circular direction Force  $F_C$  and longitudinal Force  $F_L$  generated by the braided sleeve, can be expressed using angle  $\phi$  as follows:

$$F_C : F_L = \sin \phi : \cos \phi \quad (3.13)$$

Thus,

$$F_C = \tan \phi F_L \quad (3.14)$$

Considering the free body diagram of the air muscle in Figure 3.3, yields

$$2\Delta f_C = P \cdot r \int \sin \phi \, d\phi = PD \quad (3.15)$$

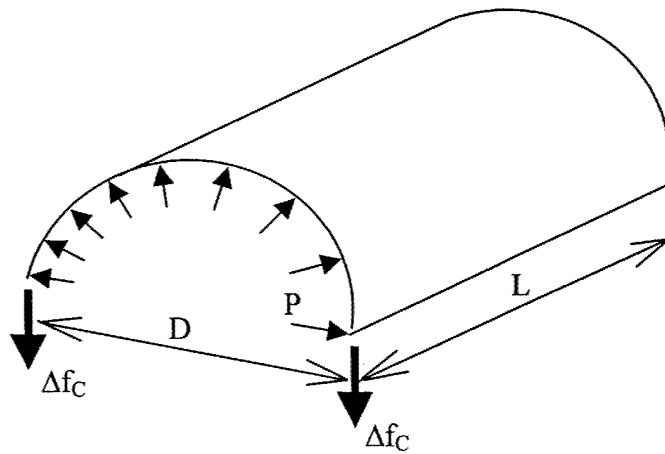

Figure 3.3: Circular Force

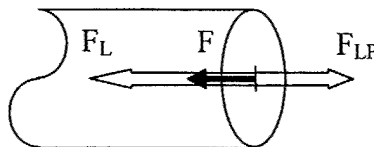

Figure 3.4: Balance of Longitudinal Forces

where,

$\Delta f_C$  = the circular force that act on a small portion of the air muscle.

$P$  = the pressure inside the air muscle.

$r, D$  = the radius and the diameter of the muscle respectively.

Assuming  $F_C$  is the circular Force that is generated in the length of a one turn of thread,

then

$$F_C = \Delta f_C L'$$

Thus,

$$2F_C = PDL' \quad (3.16)$$

Thus,

$$F_C = \frac{PDL'}{2} \quad (3.17)$$

The longitudinal force generated by internal air pressure  $F_{LP}$  is shown as:

$$F_{LP} = -EP \quad (3.18)$$

where, the force pointing towards the inside of the muscle is assumed the positive direction, and

$E$  = cross section of the air muscle.

$$E = \frac{1}{4}\pi D^2 \quad (3.19)$$

Thus,

$$F_{LP} = -\frac{1}{4}\pi D^2 P \quad (3.20)$$

and, the contraction force of air muscle,  $F$  is the balancing force as shown in Figure 3.4.

$$F = F_L + F_{LP} \quad (3.21)$$



i.e.

$$F_L = F + \frac{1}{4}\pi D^2 P \quad (3.22)$$

Now substituting Equation 3.17 and Equation 3.22 into Equation 3.14, yields

$$F + \frac{1}{4}\pi D^2 P = \frac{PDL'}{2 \tan \phi} \quad (3.23)$$

Substituting Equation 3.12 into Equation 3.23 yields the theoretical Equation,

$$F + \frac{1}{4}\pi D^2 P = \frac{\pi P}{2} \cdot \left( \frac{D}{\tan \phi} \right)^2 \quad (3.24)$$

By substituting Equation 3.24 into Equation 3.6, yields

$$F + \frac{1}{4}\pi D^2 P = \frac{\pi D_n^2 (1 - \varepsilon)^2}{2 \tan^2 \phi_n} P \quad (3.25)$$

By substituting Equation 3.25 into Equation 3.10, yields

$$F = \frac{\pi D_n^2 P}{4 \sin^2 \phi_n} \{3 \cos^2 \phi_n (1 - \varepsilon)^2 - 1\} \quad (3.26)$$

Thus, the theoretical model of the relationship of the muscle force, contraction ratio and the pressure can be expressed as

$$F = A(B(1 - \varepsilon)^2 - 1)P \quad (3.27)$$

where,

$$A = \frac{\pi D_n^2}{4 \sin^2 \phi_n} \quad (3.28)$$
$$B = 3 \cos^2 \phi_n$$

### 3.2. Experimental Modeling of Air Muscle

The theoretical model in Equation 3.27, which shows the relationship between the force, pressure and contraction ratio of each muscle is obtained in the Section 3.1. However, theoretical and experimental data do not agree perfectly with each other as shown in Figures. 3.5 a, b, and c. The two curves of the experimental results are for the forward and backward motions respectively. The force value for each contraction ratio from the experiments is generally lower than the value from the theoretical model. The difference may be due to such reasons as the assumption of uniform cross section of the muscle, the friction being ignored for each thread, and the elasticity of the bladder being ignored.

Therefore the experimental models are also obtained for each of the muscles, RUB-125, AM-02 and AM-04. Figures 3.6, 3.8, and 3.10 show the best-fitted straight lines of the experimental data for three different pressure values.

As shown in Figure 3.6, the experimental data approximates a straight line within the tested range of the pressure and contraction ratio (shown in Table 3.1) when hysteresis is ignored. Furthermore, the slope of the line is proportional to the pressure. The force value at  $\epsilon = 0$  is also in proportion to the pressure.

**Table 3.1: Condition for Experiment**

	RUB-125	AM-02	AM-04
Pressure Range[psi]	20 ~ 40	20 ~ 40	20 ~ 50
Range of Contraction Ratio $\epsilon$	0.02 ~ 0.196	0.167 ~ 0.233	0.20 ~ 0.270
Total Stroke Range of $\epsilon$	0.0 ~ 0.2	0.0 ~ 0.3	0.0 ~ 0.3

Therefore, the experimental model showing the relationship among the muscle force, contraction ratio and pressure can be expressed in the Equation shown below.

$$F = (aP + b)\varepsilon + (cP + d) \quad (3.29)$$

where  $P$  = pressure

$a, b, c,$  and  $d$  are constants.

Table 3.1 lists the contraction and pressure ranges for each type of muscles for which the force-contraction ratio relationship can be linearized. Figures 3.7, 3.9 and 3.11 show the amount of error between the above mentioned experimental data and their best fit linear lines.

For the RUB-125 muscle, Figure 3.6 shows the linear relationships at three pressure states; 28.4, 42.6, 56.8[psi] ( 2, 3, 4 [kgf/cm<sup>2</sup>] ). The maximum stroke (contraction ratio) of the RUB-125 muscle is 0.2. The range of the contraction ratio tested in the experiment is 0.02 to 0.196, which covers 97 [%] of the entire range. Choosing the parameters,  $a, b, c$  and  $d$  in the Equation 3.29 to best fit the experimental data, the error between the approximated line and the experimental data of force values can be minimized below 15 [%], as shown in Figure. 3.7.

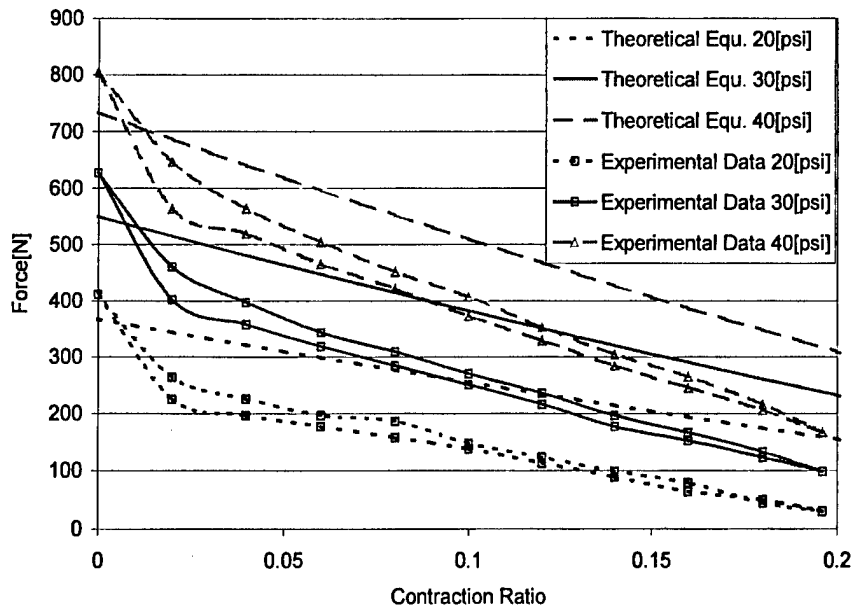

(a) RUB-125 Muscle

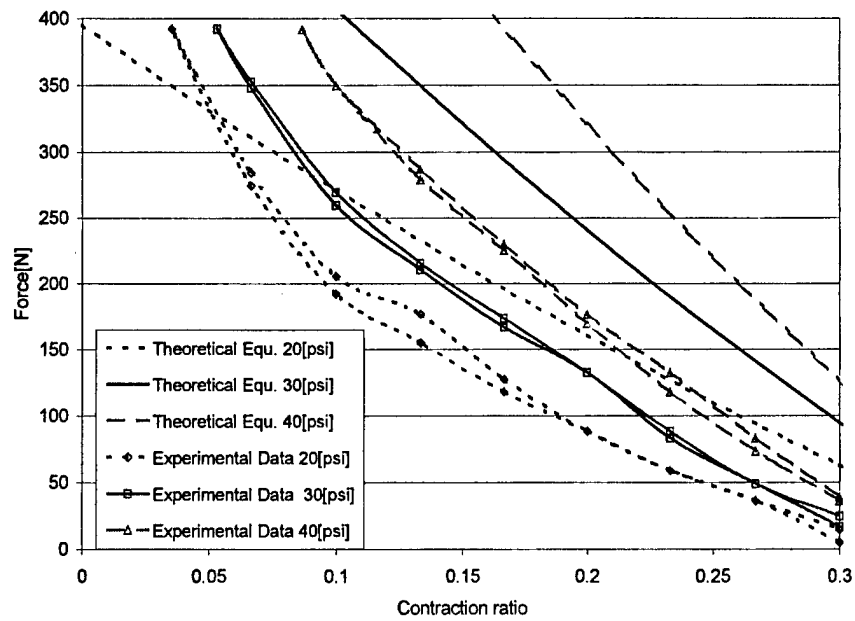

(b) AM-02 Muscle

Figure 3.5 (a) & (b): Relationship between Force and Contraction Ratio

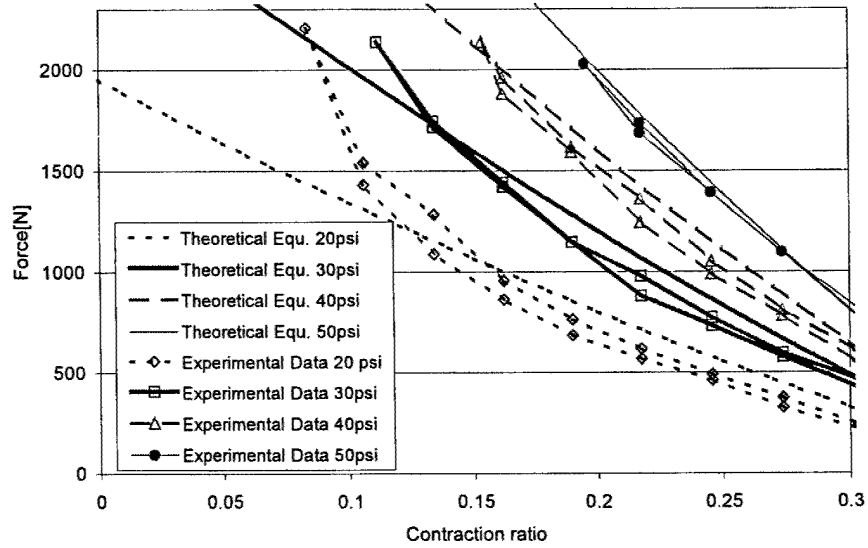

(c) AM-04 muscle

Figure 3.5(c): Relationship between Force and Contraction Ratio

Similarly, for muscles, AM-02 and AM-04, as shown in Figure 3.8 to Figure 3.11, the range of the contraction ratio which results in the error less than 15% are 22% and 23% respectively of the entire range of stroke.

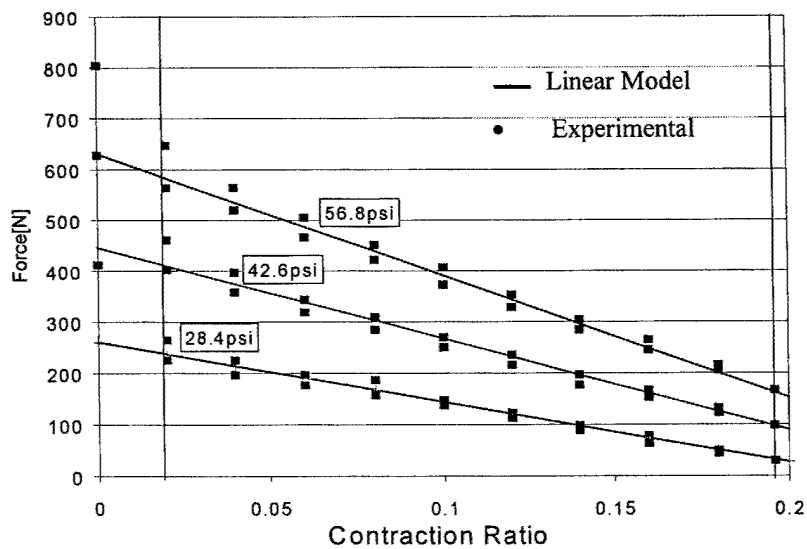
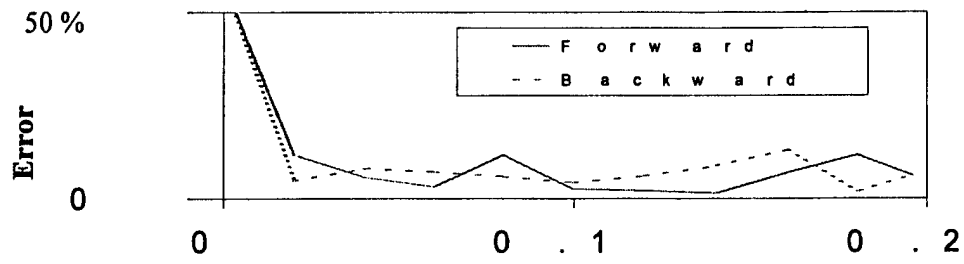
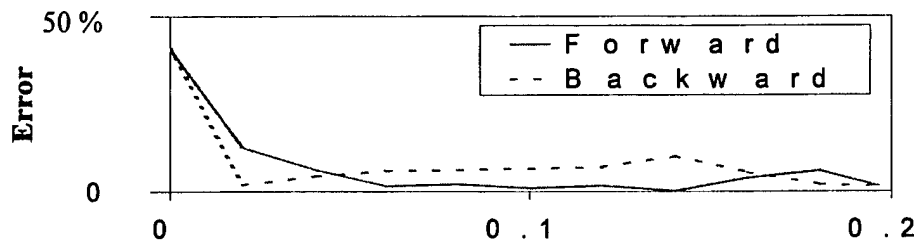

Figure 3.6: Experimental Modeling (RUB-125)



(a) P=28.4[psi]



(a) P=42.6[psi]

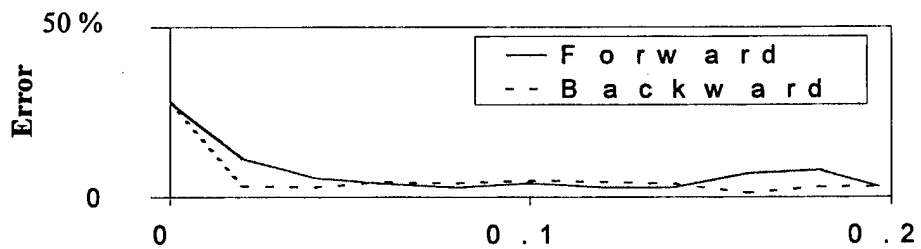

Contraction Ratio

(b) P=56.8[psi]

Figure 3.7: Error between Model and Experimental Data (RUB-125)

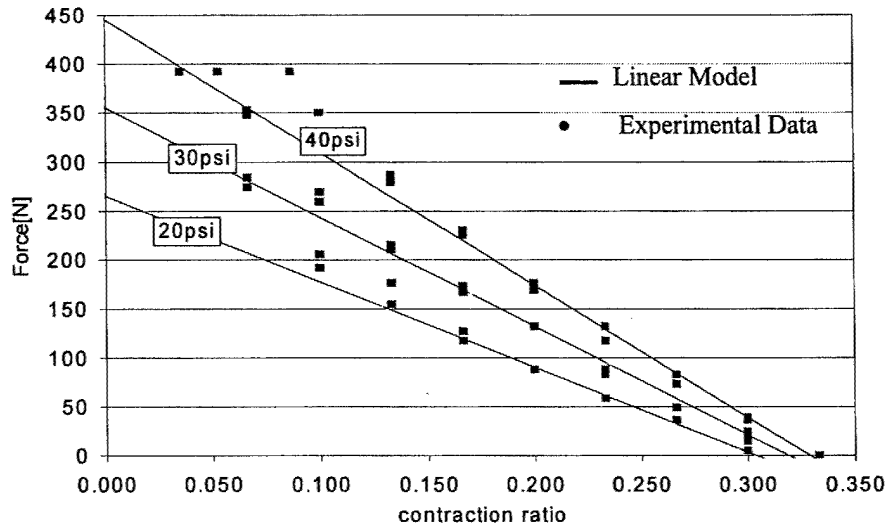

Figure 3.8: Experimental Modeling (AM-02)

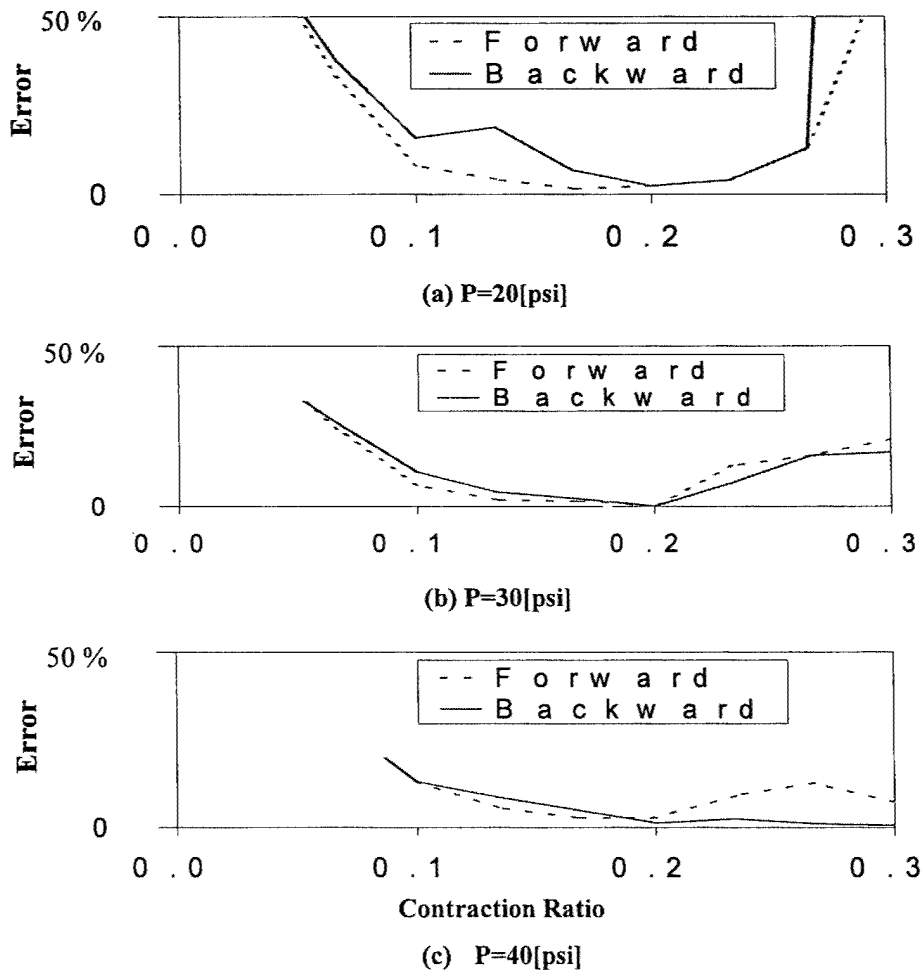

Figure 3.9: Error between Model and Experimental Data (AM-02)

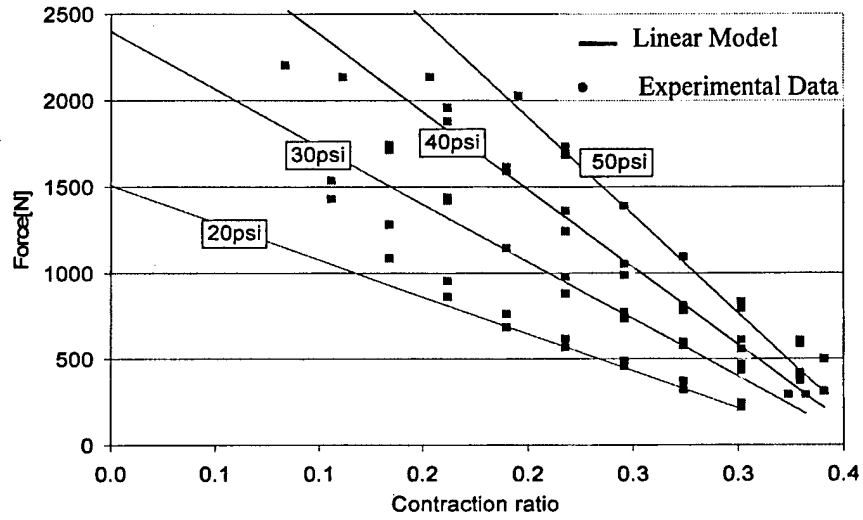

Figure 3.10: Experimental Modeling (AM-04)

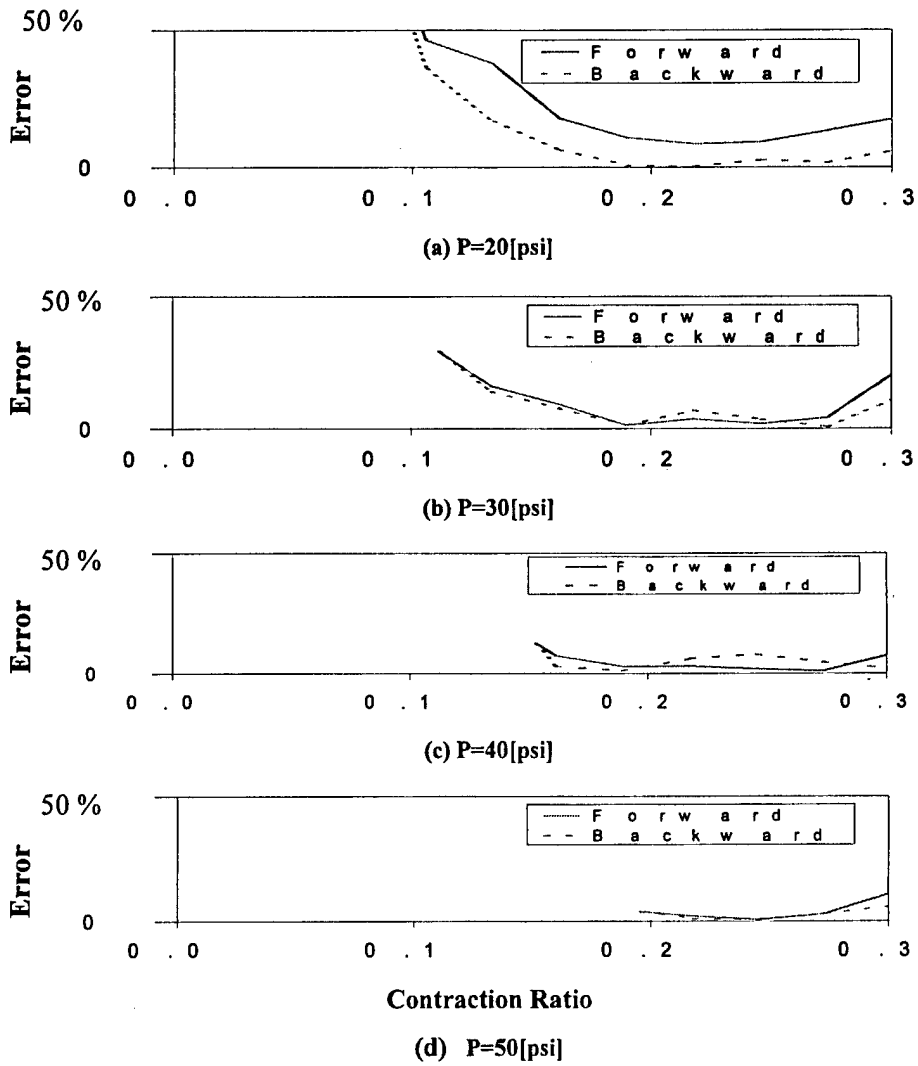
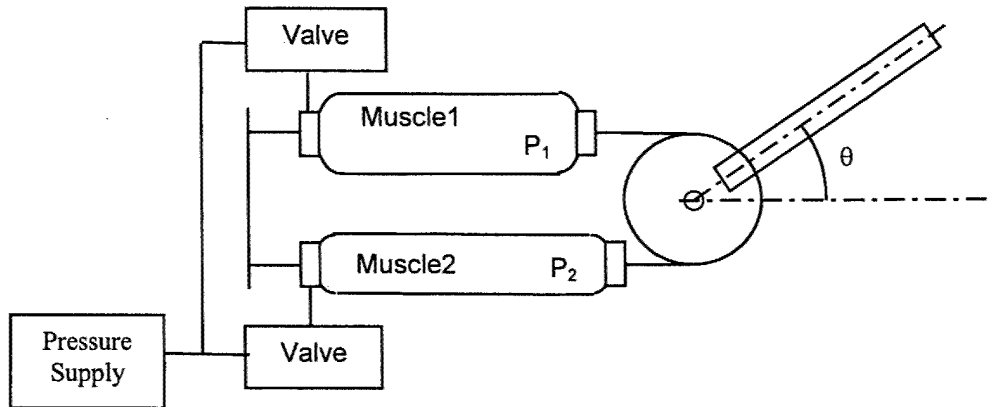

Figure 3.11: Error between Model and Experimental Data (AM-04)



### 3.3. Parameter Identification of Air Muscle

The identification of the parameters of air muscles, were done experimentally using the fixture shown in chapter 2. The simple depiction of the system is shown in Figure. 3.12.



**Figure 3.12: Construction of Air Muscle Actuator System**

In this discussion the displacements were assumed to be small. As mentioned previously, the Equation of force vs. contraction for each *i th* muscle is given by

$$F_i = (aP_i + b)\varepsilon_i + (cP_i + d) \quad (3.30)$$

#### 3.3.1. The Equation of Motion

With the assumption that  $P_i$  and  $\delta_i$  change infinite decimal amounts from the basic pressure  $P_0$  and basic contraction ratio  $\varepsilon_0$  ( $\varepsilon$  under  $P = P_0$ ),

$$P_i = P_{0i} + \delta P_i \quad (3.31)$$

$$\varepsilon_i = \varepsilon_{0i} + \delta \varepsilon_i \quad (3.32)$$

$$\delta\varepsilon_1 = -\delta\varepsilon_2 = \frac{r\theta}{L_n} \quad (3.33)$$

where,

$R$  = The radius of the pulley

$\theta$  = The angle of rotation

$L_n$  = The natural length of the air muscle

Substituting these Equations into Equation 3.30 yields,

$$F_i = (aP_{0i}\varepsilon_{0i} + b\varepsilon_{0i} + cP_{0i} + d) + (a\varepsilon_{0i} + c)\delta P_i + (aP_{0i} + b)\delta\varepsilon_i + a\delta P_i\delta\varepsilon_i \quad (3.34)$$

If it is assumed that

$$F_i = F_{0i} + \delta F_i \quad (3.35)$$

then,

$$\delta F_i = Ka \cdot \delta P_i + Kb \cdot \delta\varepsilon_i \quad (3.36)$$

where,

$$\begin{aligned} F_{0i} &= aP_{0i}\varepsilon_{0i} + b\varepsilon_{0i} + cP_{0i} + d \\ Ka &= a\varepsilon_{0i} + c \\ Kb &= aP_{0i} + b \end{aligned} \quad (3.37)$$

$$a\delta P_i\delta\varepsilon_i \approx 0$$

Using these Equations, the dynamic Equation of motion can be obtained as follows.

The moment  $M$  at the pulley with the link is

$$M = (F_1 - F_2) \cdot r \quad (3.38)$$

where,  $F_1$  and  $F_2$  are the contraction force of muscle 1 and muscle 2 respectively.

If the force of each muscle under basic pressure is  $F_{01} = F_{02}$ , then

$$M = (\delta F_1 - \delta F_2) \cdot r \quad (3.39)$$

Substituting Equation 3.36 into Equation 3.39 yields

$$M = \{Ka(\delta P_1 - \delta P_2) + Kb(\delta \varepsilon_1 - \delta \varepsilon_2)\} \cdot r \quad (3.40)$$

Substituting Equation 3.33 into Equation 3.40 yields

$$M = Ka \cdot r(\delta P_1 - \delta P_2) + Kb \cdot r \cdot \left( \frac{2r\theta}{L_n} \right) \quad (3.41)$$

thus

$$M = Ka \cdot r(\delta P_1 - \delta P_2) + \frac{2Kb r^2}{L_n} \theta \quad (3.42)$$

Finally, the moment M of the rotating parts can be described as

$$M = Kc(\delta P_1 - \delta P_2) - Kd \cdot \theta \quad (3.43)$$

where,

$$\begin{aligned} Kc &= Ka \cdot r \\ Kd &= -\frac{2Kb \cdot r^2}{L_n} \end{aligned} \quad (3.44)$$

The Equation of motion is shown as

$$J\ddot{\theta} + c\dot{\theta} = M \quad (3.45)$$

where,

J= The moment of inertia of the wheel and the link

C= Damping coefficient

Substituting Equation 3.43 into Equation 3.45 yields

$$J\ddot{\theta} + c\dot{\theta} + Kd\theta = Kc(\delta P_1 - \delta P_2) \quad (3.46)$$

### 3.3.2. Parameter Identification by Experiment

The parameters  $K_d$  and  $c$  in Equation 3.46 can be obtained by using the free vibration of our system. The system was subjected to an initial angle while keeping the pressure of both muscles at basic pressure  $P_0$ . The back and forward motion of the link was recorded. The results of each muscle are shown in Figure.3.13.

If both muscles are kept at the same constant pressure, the Equation 3.46 can be expressed as

$$J\ddot{\theta} + c\dot{\theta} + Kd\theta = 0 \quad (3.47)$$

Dividing the Equation by  $J$  yields

$$\ddot{\theta} + 2\zeta\omega_n\dot{\theta} + \omega_n^2\theta = 0 \quad (3.48)$$

where,

$\zeta$ : Damping ratio

$\omega_n$ : Natural frequency

and

$$Kd = J\omega_n^2 \quad (3.49)$$

$$c = 2J\zeta\omega_n \quad (3.50)$$

Also

$$\omega_n = \frac{2\pi}{T} \quad (3.51)$$

Substituting these into Equation 3.49 and Equation 3.50 respectively, yields

$$Kd = \frac{4\pi^2 J}{T^2} \quad (3.52)$$

$$c = \frac{4\pi\zeta J}{T^2} \quad (3.53)$$

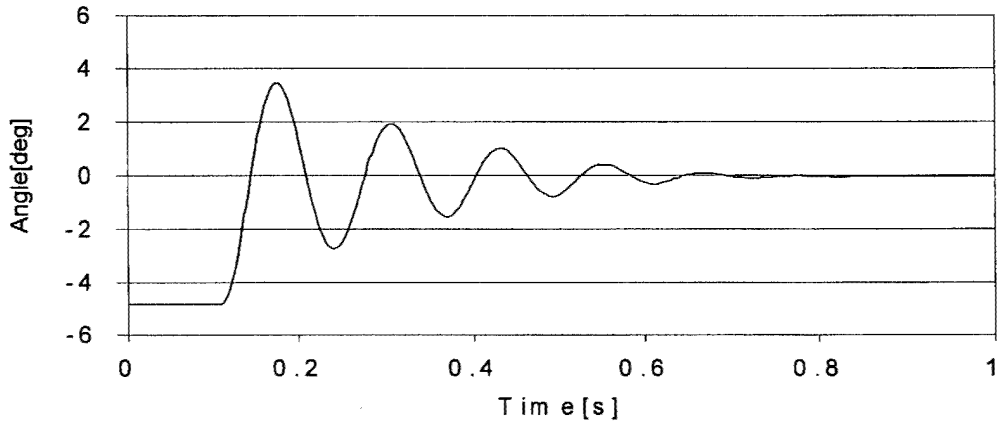

*RUB-125 muscle*

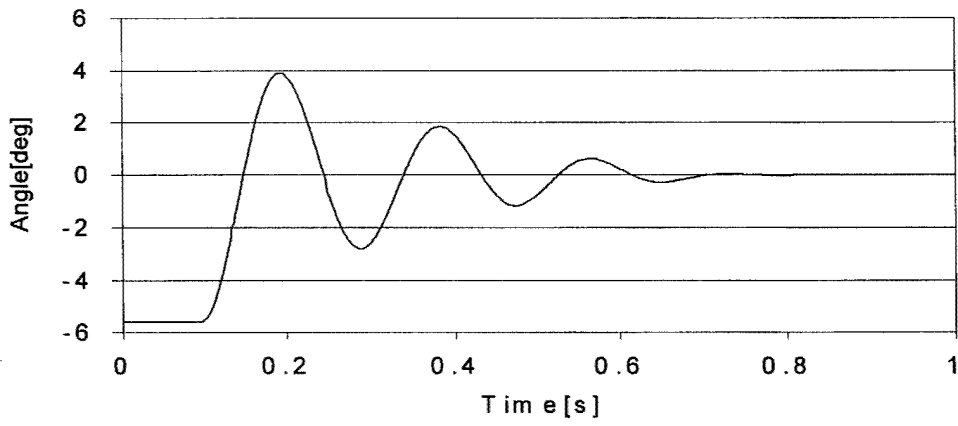

*AM-02 muscle*

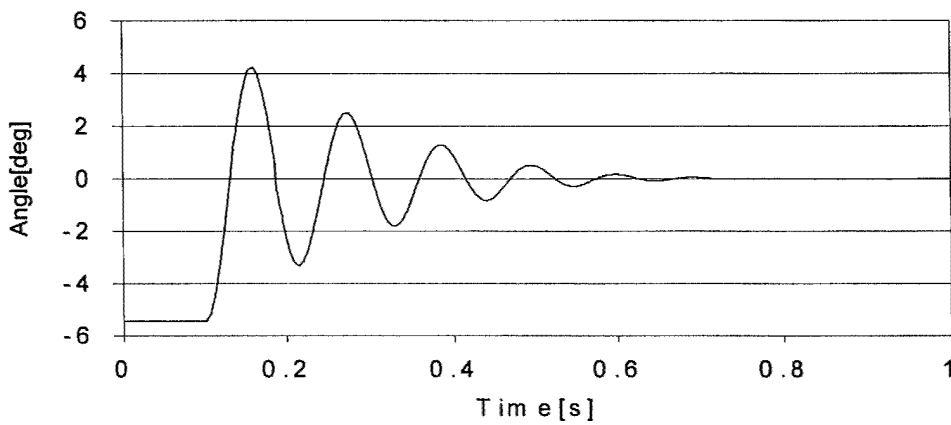

*AM-04 muscle*

**Figure 3.13: Free Vibration of Link**

The period  $T$  and the damping ratio  $\zeta$  are obtained using the recorded data of free vibration. Then substituting these parameters into Equation 3.52 and Equation 3.53 the parameters  $Kd$  and  $c$  are obtained.

The parameter  $Kc$  was determined by performing the static tests to obtain the relationship between the difference of pressure change ( $\delta P_1 - \delta P_2$ ) of each muscle and the angle of  $\theta$ .

If the moment  $M = 0$  then the Equation 3.43 can be simplified as

$$Kc = \frac{Kd}{\delta P_1 - \delta P_2} \theta \quad (3.54)$$

if  $P_{01} = P_{02}$  in Equation 3.31 then

$$\Delta P = \delta P_1 - \delta P_2 = P_1 - P_2 \quad (3.55)$$

Therefore, Equation 3.54 becomes

$$Kc = \frac{\theta}{\Delta P} \cdot Kd \quad (3.56)$$

The experimental results obtained from the relationship between  $\theta$  and  $\Delta P$ , are shown in Figure. 3.14. The values of parameters obtained from three types of muscles using experimental results are shown in Table 3.2.

**Table 3.2: Parameter Values Identified by Free Vibration Experiment**

	<b>Kd[Nm/rad]</b>	<b>c [Nm/(rad/s)]</b>	<b><math>\theta/\Delta P</math>[rad/Pa]</b>
RUB-125	82.2	0.476	-2.0 $10^{-6}$
AM-02	12.7	0.243	-6.76 $10^{-7}$
AM-04	114.5	0.605	-1.77 $10^{-6}$

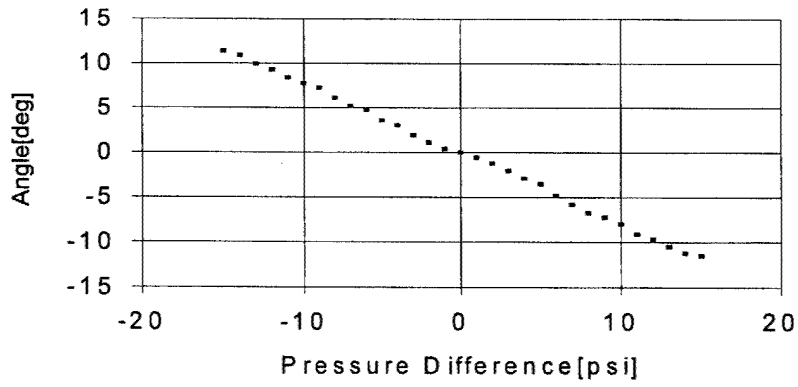

*RUB-125*

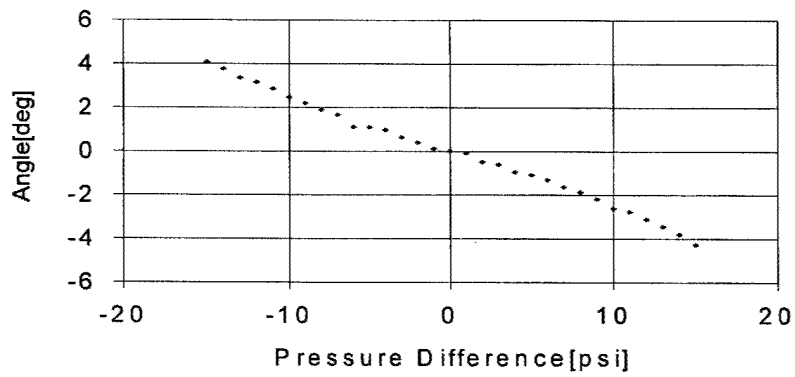

*AM-02*

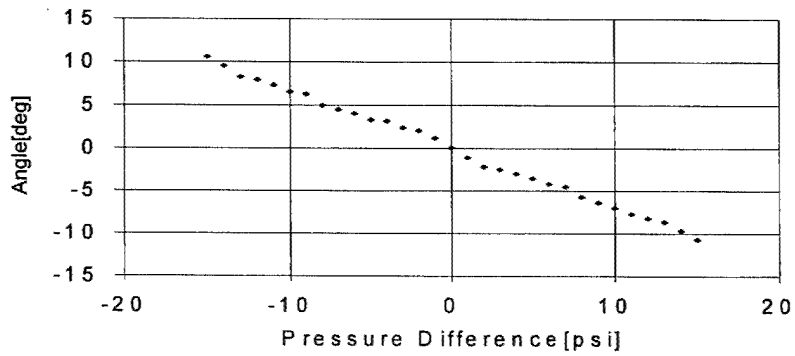

*(c) AM-04*

**Figure 3.14: Relationship between Angle and Pressure Difference**

## 4. System Control and Response

With the analytical model established and its parameters experimentally identified, algorithms were developed for controlling the angular displacement of the link through position control of a pair of pneumatic muscles. First, Proportional Integral (PI) control was applied which resulted in a time delay of desired response. Then a Feed-Forward control algorithm was developed and applied, which successfully compensated the time delay in muscle response.

### 4.1. PI Control

The encoder measured the angular displacement of the pulley and this signal was sent to the computer. The computer then sent a pressure control signal to the proportional pressure control valves of the two muscles based on the difference of the measured angle and a reference angle. The control signal is based on the PI control shown as follows.

$$\delta P_r = K_p \theta_e + K_I \int \theta_e dt \quad (4.1)$$

$$\begin{aligned} P_{r1} &= P_{01} + \delta P_r / 2 \\ P_{r2} &= P_{02} - \delta P_r / 2 \end{aligned} \quad (4.2)$$

where,

$\theta_e = \theta_r - \theta$  : difference between the reference angle and the measured angle

$P_{r1}, P_{r2}$ : pressure control signals for muscle 1 and muscle 2

$K_P$  : proportional gain

$K_I$  : integral gain

The output voltage signals sent to the pressure control valves are



$$V_i = K_v P_{ri}$$

where,

$K_v$  ( $i=1, 2$ ): coefficient of the valve based on the relationship between input voltage and output pressure

Step responses under the PI control were obtained through experiments and compared with the results simulated using the experimental model shown in Equation 3.29. Figure 4.1 show the experimental and simulated results for each type of the muscles, where the reference signal was set at 5 degrees. The parameter values used in the experiments and simulation are shown in Table 4.1.

In the case of RUB-125 and AM-02 muscles, the experimental and simulated responses agreed well, except for their frequencies. Ignoring the friction of threads and the elasticity of bladder when modeling the muscle actuator system, mainly caused the difference in frequencies.

In case of the largest size muscle, AM-04, the experimental result did not well correlate with the simulated one. Due to the large air capacity of the muscle and the small inlet to supply air, the response velocity of muscle was limited, which was, not considered in the analytical model. From the experimental data, it can be confirmed that the maximum contraction velocity under the basic pressure around 35[psi] is 8.64[mm/s]. Therefore, for a step control signal, the required response velocity exceeded the maximum velocity capacity of the muscle and, as a result, the muscle contracts at its maximum velocity.

In summary, the simulated response reasonably agreed well with the experimental response, indicating that the analytical model together with its parameters identified in this study is sufficient.

**Table 4.1: Parameter Values for PI Control**

PARAMETERS	RUB-125	AM-02	AM-04
J [kgm <sup>2</sup> ]	0.029		
r [m]	0.045		
L <sub>n</sub> [m]	0.225	0.160	0.358
C [Nm/(rad/s)]	0.476	0.243	0.605
T [s]	0.118	0.3	0.1
ζ	0.154	0.2	0.166
K <sub>c</sub> [m <sup>3</sup> ]	1.644 × 10 <sup>-4</sup>	8.599 × 10 <sup>-6</sup>	2.029 × 10 <sup>-4</sup>
K <sub>d</sub> [Nm/rad]	82.22	12.72	114.49
K <sub>p</sub> [[psi/rad]	65	120	100
K <sub>i</sub> [[psi/rad.sec]	1000	1300	800

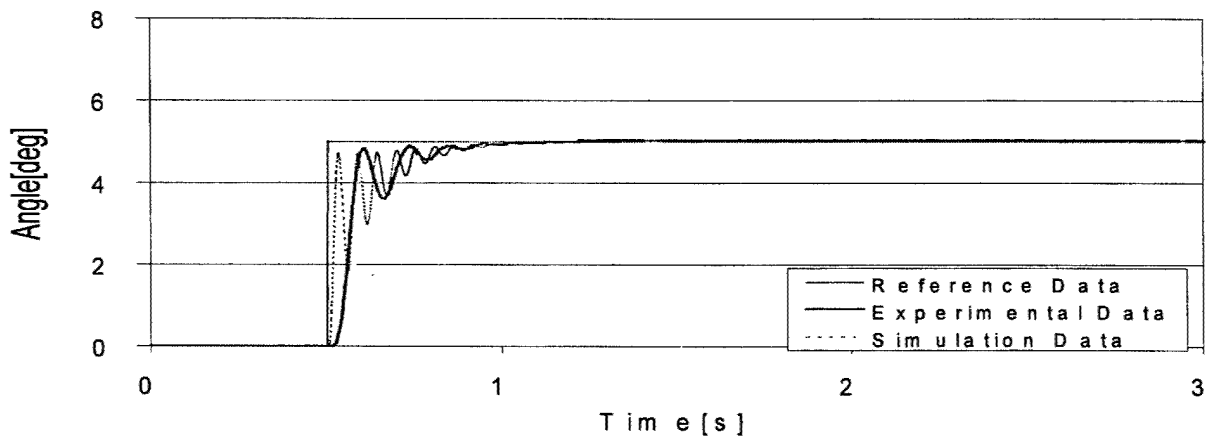

(a) RUB-125

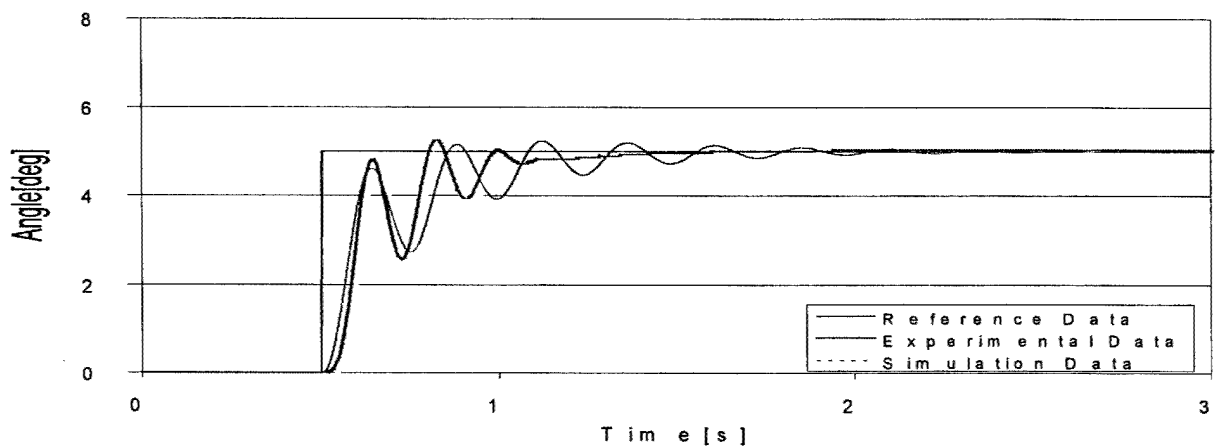

(b) AM-02

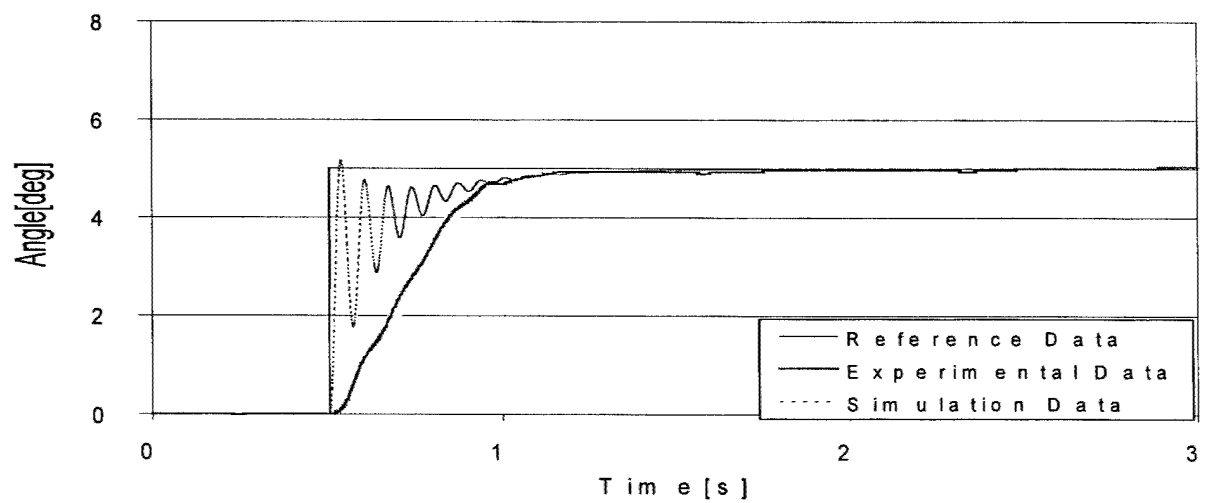

(c) AM-04

Figure 4.1: Step Response of PI Control

## 4.2. Compensation using Feed-Forward Control

This section documents the results of feed-forward control that was used to control the movement of the link arm in a predetermined path. The path sought was a sine curve. Time delay of air muscle system was shown in Figure 4.1. A feed-forward control algorithm was thus developed to compensate the time delay.

The control system equipped with the feed-forward algorithm is shown in Figure. 4.2 (Noritsugu et al, 1986). The gain  $K_{fp}$  was decided by the static relationship between the angular displacement and the difference of pressures  $\Delta P$ , which was discussed in Chapter 3.3.2. In addition, a low pass filter was added with a time constant  $T = 0.125$  seconds to alleviate the rapid change in velocity of motion. Adding a differential motion with gain of  $K_{fv}$  also helped to compensate the delay.

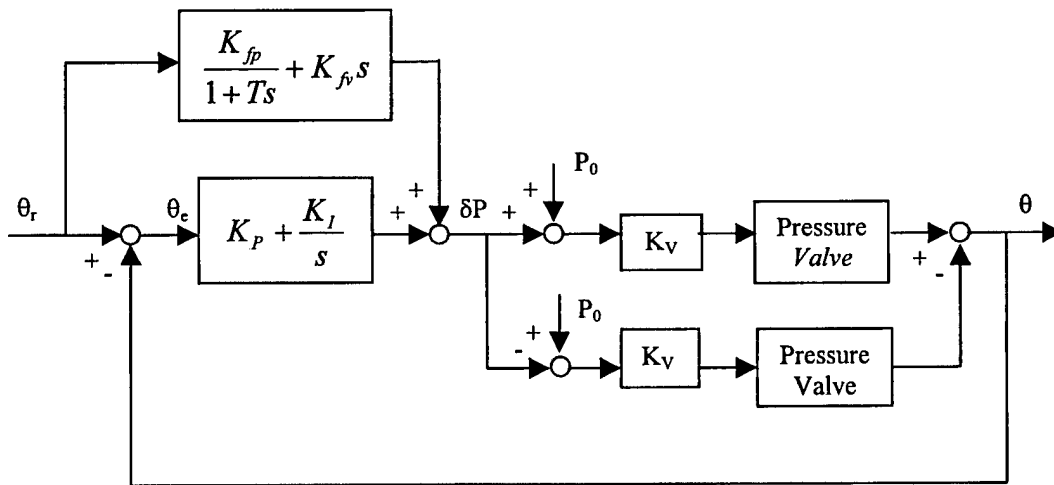

Figure 4.2: Control with Feed-Forward Compensation

The angular displacement of the link arm was controlled to follow a sinusoidal curve with an amplitude of 5 degrees and a period of 2 seconds for muscles RUB-125 and AM-02, and 4 seconds for muscle AM-04. The Figure 4.3 shows the response of each type of muscle system under the PI control without feed-forward compensation. In this case when compared with the reference signal, time delay in response is again demonstrated.

The sinusoidal response under the feed-forward control is shown in Figure.4.4. The parameter values of the control system are shown in Table 4.2. Considering the limited velocity capacity of muscle AM-04, sinusoidal signals with higher frequencies (period less than 4 seconds) were not tested. Compared with the results under the PI control without feed-forward compensation shown in Figure. 4.3, the results under the feed-forward control were significantly better in terms of the reduction of time delay. The maximum error between the reference and measured signals is reduced to about 0.3 degrees. The instability demonstrated at the early stages of the time history is due to the discontinuity of the velocity at the starting point.

**Table 4.2: Parameter Values for Control with Feed-Forward Compensation**

	RUB-125	AM-02	AM-04
$K_{fp}$ [psi/rad]	100	245	102
$K_{fv}$ [psi*s/rad]	20	45	45
$K_p$ [psi/rad]	100	120	1500
$K_i$ [psi/(rad*s)]	20	280	3800

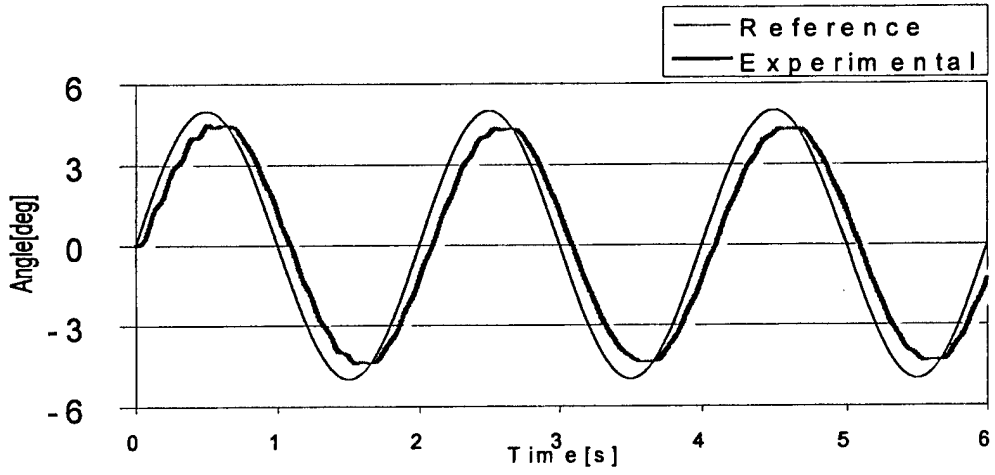

*RUB-125*

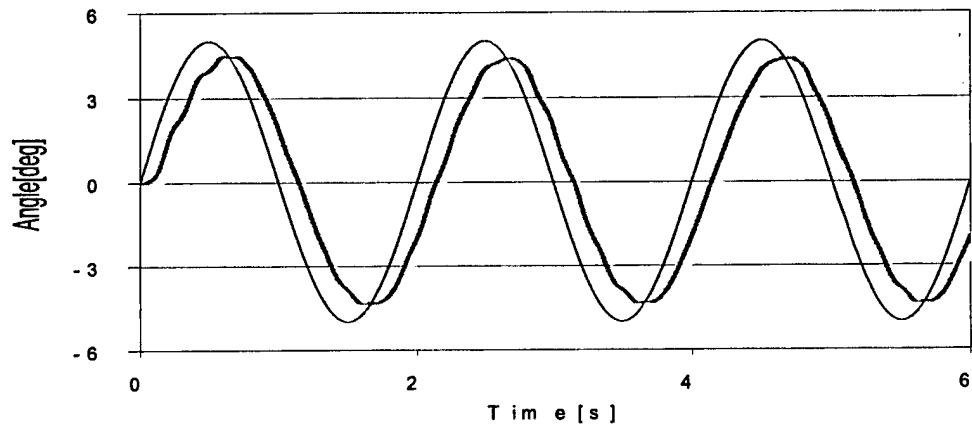

*AM-02*

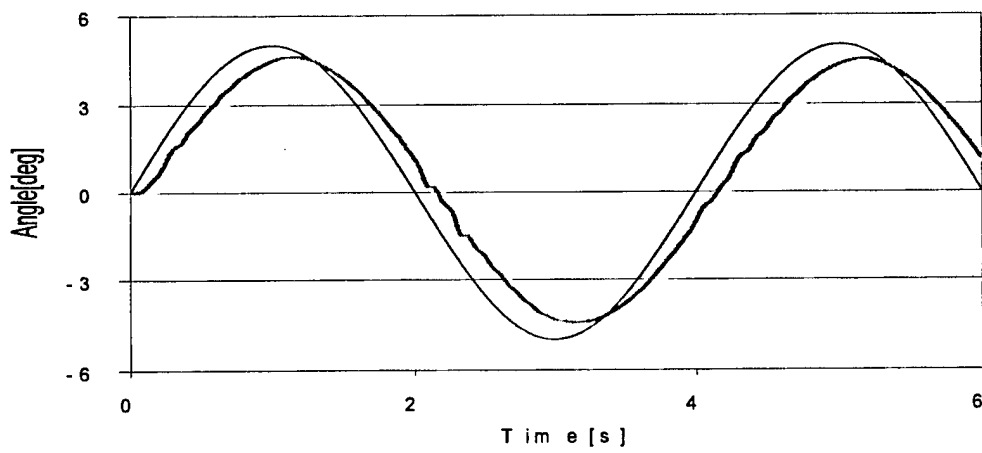

*AM-04*

**Figure 4.3: Experimental Results of PI Control**

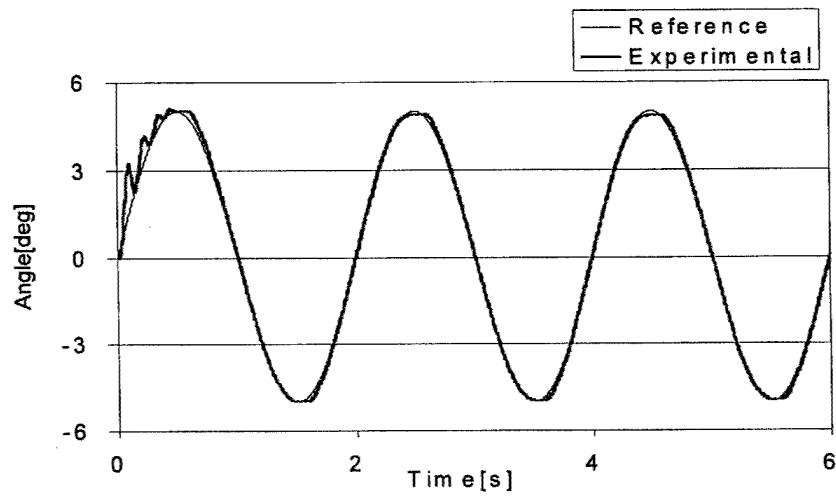

*RUB-125*

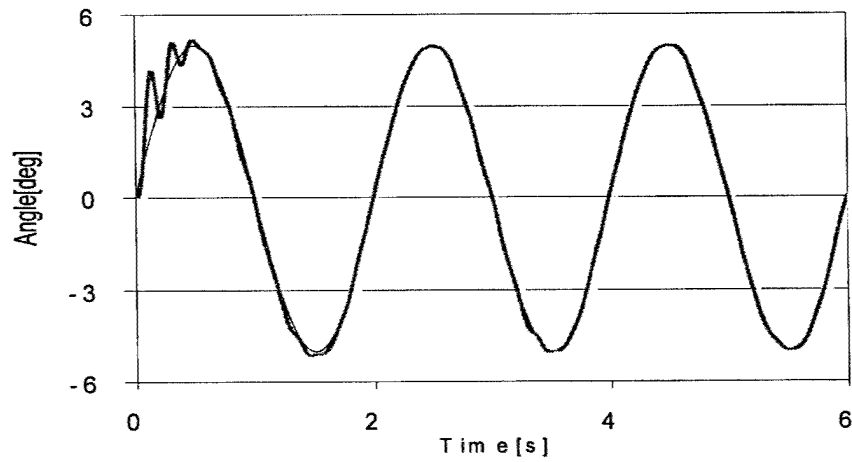

*AM-02*

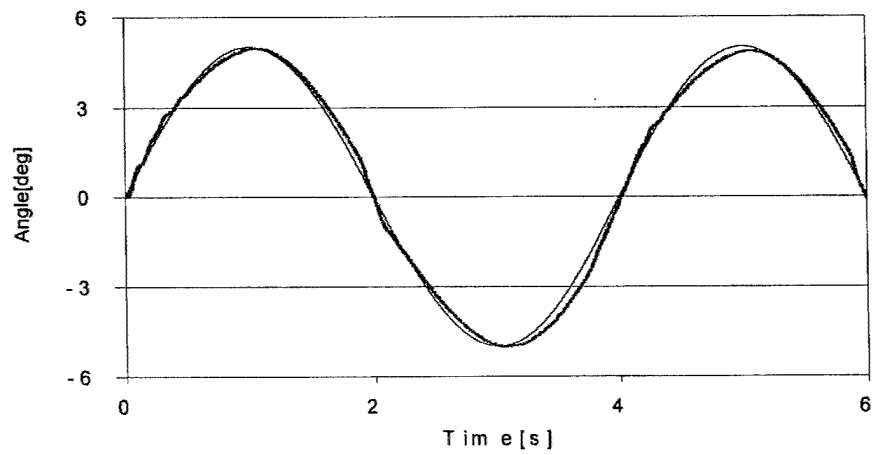

*AM-04*

**Figure 4.4: Control with Feed-Forward Compensation**

## **5. Summary and Conclusions**

The following tasks have been performed in this research project:

1. A prototype pneumatic rubber muscle actuator system has been designed and fabricated which consists a pair of muscles and a pulley, resembling a human arm joint. An encoder was installed to measure the rotation of the pulley driven by the muscles and two pressure sensors to measure the pressure inside the rubber blades. Air was supplied from an air compressor through two servo valves. This system was connected to a computer through I/O boards including A/D and D/A converters.
2. Three types of rubber muscles with different manufacturers and different sizes have been tested.
3. The theoretical model of the muscle system (relationship among the pressure, contraction ratio and force) was found quite different from the experimental data. As a result, experiments were performed to develop a model and to identify its parameter values, rather than using the theoretical model. The developed model was used for designing the control system.
4. Control algorithms were developed including a feed-forward algorithm to compensate the time delay of the muscle system.

The following observations and conclusions can be made from this research:

1. The linearity of the muscle actuator depends on the manufacturing quality. Based on the criterion determined in this study, the linear range of the Bridgestone muscles was found to be as large as 97 [%] of its stroke, while the that of the two Shadow muscles only reached 22 [%] and 23 [%] of their strokes respectively.



2. The accuracy of the analytical model of the muscle system experimentally developed in this study was demonstrated through comparison of the experimental and analytical step responses.
3. The time delay of the muscle response depends on the size of the muscle. The larger muscle suffers from longer time delay, although it provides larger power and stroke.
4. The control algorithm equipped with a feed-forward compensation developed in this research is very effective in reducing the time delay in response.
5. Excellent control performance of the pneumatic muscle actuator system was demonstrated by experiments.

## 6. Bibliography

- C. P. Chou and B. Hannaford, "Measurement and modeling of McKibben pneumatic artificial muscles", *IEEE Transactions on Robotics and Automation*, Vol. 12, No. 1, 1996, pp. 90-102.
- M. Q. Feng, T. Kobayashi, and K. Yamafuji, "An attitude-controllable free-falling robot cat", *To be submitted to IEEE Transactions on Robotics and Automation*, 1997.
- M. M. Gavrilovic and M. R. Maric, "Positional servo-mechanism activated by artificial muscles", *Med. & Biol. Eng.*, Vol. 7, 1969, pp. 77-82.
- D. G. Galdwell, G. A. Medrano-Cerda, and M. Goodwin: "Control of pneumatic muscle actuators", *IEEE Control Systems*, Vol. 15, No. 1, 1995, pp. 40-48
- T. Hesselroth, K. Sarkar, P. v. d. Smagt, and k. Schulten, "Neural network control and a pneumatic robot arm", *IEEE Transactions on Systems. Man. and Cybernetics*, Vol. 24, No. 1, 1994, pp. 28-38
- K. Inoue, "Rubbertuators and applications for robots", *Robotics Research: The 4th Int'l Symp.*, R. Bolles, and B. Roth Eds. Cambridge, MA: MIT Press, 1988.
- D. W. Repperger, C. A. Phippips, R. D. Harmon, and K.R. Johnson, " A study of Pneumatic muscle Technology for Possible Assistance in Mobility," 1997
- H. F. Schulte, Jr., "The characteristics of the McKibben artificial muscle", *The application of External Power in Prosthetics and Orthotics*, Washington, DC: Nat. Acad. Sci - Nat. Res. Council, 1961.
- M. Uno, "Rubber artificial muscles and their applications in robotics", *Hydraulic and Pneumatic Actuation*, Vol, 17, No. 3, 1986, pp. 175-179. (in Japanese)

K. Yamafuji, K. Honda, and T. Kobayashi, "Midair posture detection and landing control of a robot with multiarticulated twin legs", *Transactions of JSME (C)*, Vol. 59, No. 565, 1993, pp. 188-195, (in Japanese)

T. Noritsugu, F. Ando, and T. Yoshikawa, "Control Performance of Rubber Artificial Muscle", Proc. of the 35<sup>th</sup> Symposium of Automatic Control Association, 1991. (in Japanese)

## Appendix

### I). Written publications in technical journals

R. Purasinghe, M Feng, S. Moromugi, M. Shinozuka, A. Bhaumik, X. Wei, E. Mercado, W.Olmedo, "Development of High Performance Actuator Systems," in preparation to be submitted to Transactions on Mechatronics, IEEE and ASME.

### II). A list of professional personnel associated with the research effort

(California State University at Los Angeles)

- i) Rupa Pursinghe, Principle Investigator
- ii) Anjan Bhaumik, Faculty Research Associate
- iii) Xiang Wei, Graduate Student. MS Degree Graduate Directed Study Project  
"Development of a High Performance Pneumatic-Muscle Actuator System"  
M.S. Degree (expected), Winter 2000
- iv) Edgar Mercado, Undergraduate Student
- v) William Olmedo, Undergraduate/Graduate Student

Subcontractors:

- i) Feng Enterprises
- ii) University of Southern California

### III). Papers presented at meetings, conferences, seminars, etc.

"Development of a Pneumatic Muscle Actuator System" Presented at the Civil and Environmental Engineering Conference - New Frontiers and Challenges, Asian Institute of Technology, Bangkok, Thailand, November 1999.