



ONWARD MOVEMENT
TRANSPORTATION MODE SELECTION STUDY
THESIS

Seongkyun Lee, Captain, R.O.K. Army

AFIT/GLM/ENS/03-06

DEPARTMENT OF THE AIR FORCE
AIR UNIVERSITY
AIR FORCE INSTITUTE OF TECHNOLOGY

Wright-Patterson Air Force Base, Ohio

APPROVED FOR PUBLIC RELEASE; DISTRIBUTION UNLIMITED.

The views expressed in this thesis are those of the author and do not reflect the official policy or position of the United States Air Force, Department of Defense, or the United States Government.

AFIT/GLM/ENS/03-06

ONWARD MOVEMENT
TRANSPORTATION MODE SELECTION STUDY
THESIS

Presented to the Faculty
Department of Operational Sciences
Graduate School of Engineering and Management
Air Force Institute of Technology
Air University
Air Education and Training Command
In Partial Fulfillment of the Requirements for the
Degree of Master of Science in Operations Research

Seongkyun Lee, BS
Captain, R.O.K Army

March 2003

APPROVED FOR PUBLIC RELEASE; DISTRIBUTION UNLIMITED.

AFIT/GLM/ENS/03-06

ONWARD MOVEMENT
TRANSPORTATION MODE SELECTION STUDY

Seongkyun Lee, BS
Captain, R.O.K Army

Approved:

Stanley Griffis E, Maj (USAF) (Advisor)

date

William A. Cunningham, III, Ph.D. (Reader)

date

Acknowledgments

I would like to express my sincere appreciation to my faculty advisor, Maj. Stanley E. Griffis, for his generous guidance, patience, and enthusiastic support throughout the course of this thesis effort. Without his help this work could not have been possible. I would, also, like to thank my reader, Dr. William A. Cunningham, for both the support and latitude provided to me in this endeavor. I am also grateful to Dr. Raynold for helping me throughout the research process.

Furthermore, I am deeply indebted to the many transportation experts who spent their valuable time explaining the processes and procedures of the RSO&I especially onward movement. Special thanks goes to the ROK Army Transportation School Instructors who answered whenever I had question.

Special thanks to my English tutor, Mr Black, and members of the International Affair Office who are always very willing to help.

I also want to express my appreciation to each of my classmates. Thank you for the help and motivation. I would not have been able to have completed the last 20 months' journey except by the grace of your kindness and willingness to share knowledge.

Finally, I am indebted to my wife for helping me by doing everything she could to make it easier.

List of Figures

	Page
Figure 1-1 The Deployment Process	3
Figure 1-2 The Army Transformation	4
Figure 2-1 Mobility Requirements Study Required Force Closure.....	10
Figure 3-1 SPOD Onward Movement Process.....	22
Figure 3-2 Onward Movement by HET	30
Figure 4-1 Mobility Requirements Study Required Force Closure.....	37
Figure 4-2 Comparison of Train Model's CI with Heavy Division Force Closure Time .	38
Figure 4-3 Onward Movement Time Comparisons	40
Figure 4-4 Regression Model	42
Figure 4-5 Comparison of Combined Model's CI with Heavy Division Force Closure time.....	44
Figure 4-6 Comparison of Current Onward Movement Time with One HET Company Added Onward Movement Time.....	45

List of Tables

	Page
Table 3-1 Steps in a simulation study	20
Table 3-2 Entities of Armored Division Moved by Train.....	25
Table 3-3 Data for by Train Model	25
Table 3-4 Data for by HET Model	26
Table 3-5 General Assumptions for the Onward Movement Model.....	27
Table 3-6 Loadable Tracked Vehicle and Available Flatcar Number.....	29
Table 3-7 Assumptions for the Train Model.....	29
Table 3-8 Assumption for the Comparison Model.....	31
Table 3-9 Assumptions for the Combined Model.....	33
Table 4-1 The Results of 4 Replications of by Train Model (unit Hour).....	35
Table 4-2 The Results of 10 Replications of by Train Model (unit Hour).....	36
Table 4-3 The Results of 10 Replications of Comparison Model (unit hour).....	39
Table 4-4 Each Mode Mean Time and Difference (unit hour).....	40
Table 4-5 Regression Model's Lack Of Fit.....	41
Table 4-6 Regression Model's Parameter Estimates.....	42
Table 4-7 The Results of 10 Replications of Combined Model.....	43

Abstract

As a result of the global security environmental changes, the US Army's posture has changed from forward deployment to power projection and resulted in the reduction of the Army force structure. These changes also reduced the possibility of the United States' involvement in a large scale war, but require rapid and reliable deployment to stabilize a hostile area.

Force projection is the demonstrated ability to alert, mobilize, deploy rapidly, and operate effectively anywhere in the world, and consists of three deployment segments: fort to port, port to port, and port to foxhole. Reception, Staging, Onward Movement, and Integration (RSO&I) is a detailed process of the port to foxhole segment. Onward movement is the process of moving units and accompanying materiel from reception facilities and staging areas to Tactical Assembly Areas (TAAs).

This study employs simulation models to evaluate whether the current transportation infrastructure can meet the required force closure time and which transportation mode, train versus Heavy Equipment Transporter (HET), is faster to move M1A1 tanks in the Korean Peninsula in the onward movement process.

Table of Contents

	Page
Acknowledgments	iv
List of Figures	v
List of Tables.....	vi
Abstract	vii
Table of Contents	viii
I. Introduction.....	1
Changing environment after the end of the Cold War	1
The Concept of Reception, Staging, Onward Movement, and Integration (RSO&I) ..	2
The Army's Transformation.....	3
Scope of Research	5
Problem Statement	5
Research Objective.....	6
Outline of Thesis	7
II. Literature Review.....	8
Introduction	8
The RSO&I Process	8
Execution of Onward Movement	11
AweSim.....	13
Transportation Mode Selection	14
Summary	15
III. Methodology.....	16
Introduction	16
Military Application of Simulations	16
Arena Simulation Software	17
Formulating the Problems	18
Onward Movement Process Model Design.....	19
Conceptual Model	19
Model Building	23
Data Collection.....	24
Entities.....	24

	Page
Onward Movement by Train.....	24
Onward Movement by HET.....	26
Experimental Design.....	26
General Framework.....	27
Train Model.....	28
Comparison model.....	29
Combined model.....	32
Model Verification and Validation.....	32
IV. Results and Analysis.....	35
Introduction.....	35
Train Model Results and Analysis.....	35
Comparison Model Results and Analysis.....	39
Combined Model Results and Analysis.....	43
V. Conclusions and Recommendations.....	47
Review of Research.....	47
Results of Research and Conclusions.....	45
Limitations.....	48
Recommendations.....	49
Future Research.....	49
Appendix A: The Arena Simulation Model.....	51
A-1 Train Model.....	51
A-2 Comparison Model.....	54
A-3 Combined Model.....	55
Appendix B: Mathematical and Statistical Analysis.....	57
B-1 Calculation of the Required Number of Replications.....	57
B-2 Onward Movement by the Train Model Results and Analysis.....	58
B-3 JMP Liner Regression Analysis.....	59
B-4 Onward Movement by the Combined Model Results and Analysis.....	62
Appendix C. Acronyms and Abbreviation.....	63
Bibliography.....	65
Vita.....	67

ONWARD MOVEMENT
TRANSPORTATION MODE SELECTION STUDY

I. Introduction

Changing environment after the end of the Cold War

As a result of the fall of communism, the world has changed dramatically over the past decade. Global threat, a relic of the Cold War era, has changed to regional threats: “the unitary and relatively predictable adversary we knew in the Cold War, to the diverse, ambiguous and dynamic threats that we confront today” (Gordon R. Sullivan, 1993). The environmental change of global security has reduced the possibility of United States’ involvement in a large scale of warfare “other than on the Korean peninsula or in the Middle East if the rogue nations of Iran and Iraq get anxious and land hungry” (John L. Romjue, 1996). According to U.S Field Manual (FM) 100-17-3,

Today, there is the low probability of warfare in Central Europe. On the other hand, the military situation in the Balkans, Middle East, Central Asia, Africa, and the Asiatic Rim is extremely unstable and unpredictable. These realities cause fundamental changes in the international security situation and US military strategy, resulting in a profound redirection of our military's roles and missions. ... No longer forward deployed at the level maintained during the Cold War, the US Army has become a power projection force. It is smaller than the force that won the Cold War and Desert Storm and based largely in the United States but with a minimal forward presence in Southwest Asia, Korea and Germany.

This environmental change has shifted the US Army's posture from one of forward deployment to power projection and resulted in the reduction of the US Army force structure. Instead of using forward deployment forces, the US Army depends more on the fast and reliable force projection from Continental United States (CONUS) to any potential theater to meet US military requirements. To deal with this change, the US Army has also executed a transformation.

The Concept of Reception, Staging, Onward Movement, and Integration (RSO&I)

The military element of power projection is force projection. Force projection is described as “the demonstrated ability to alert, mobilize, deploy rapidly, and operate effectively anywhere in the world” (FM 55-10 Movement Control, 1999). The US Army must be ready for global force projection to meet wide a range of missions such as humanitarian support operations and major theater wars with a mix of Heavy, Light, and Special Operations forces, with appropriate Combat Support (CS) and Combat Service Support (CSS) as the nation's strategic land force, and the strategic core of US forces for joint or multinational operations (FM 100-17-3, 1999).

As we can see in Figure 1-1, the force projection process, and deployment process, consists of three deployment segments: fort to port, port to port, and port to foxhole. Fort to port and port to port segments are part of strategic deployment and the port to foxhole segment is a combination of operational and tactical deployment. RSO&I is the detailed process of the port to foxhole segment defining “how to receive personnel and equipment

into a theater of operations, rejoin these elements into combat ready units, and integrate these units into the theater's command structure.” (FM 100-17-3, 1999)

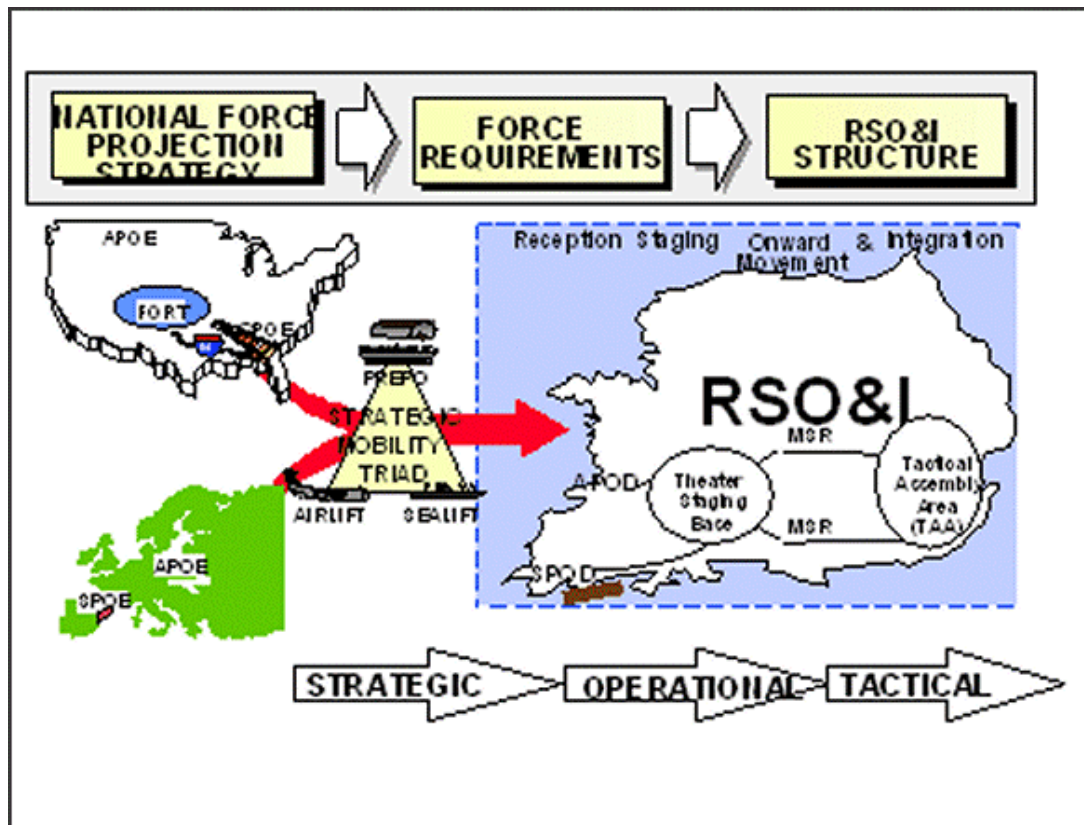

Figure 1-1 The Deployment Process
 Source US FM 100-17-3 P 1-3

The Army's Transformation

The Army has developed and begun executing the Army Transformation Campaign Plan (ATCP) to meet external and internal environmental change. It has three force categories: Legacy Force, Interim Force, and Objective Force. Legacy Force is the Army of today. With a legacy of victories in both the Cold War and the Gulf War, it is a

formidable and capable force, though its equipment is aging. We must recapitalize this force with upgrades, such as the insertion of some digital technologies.

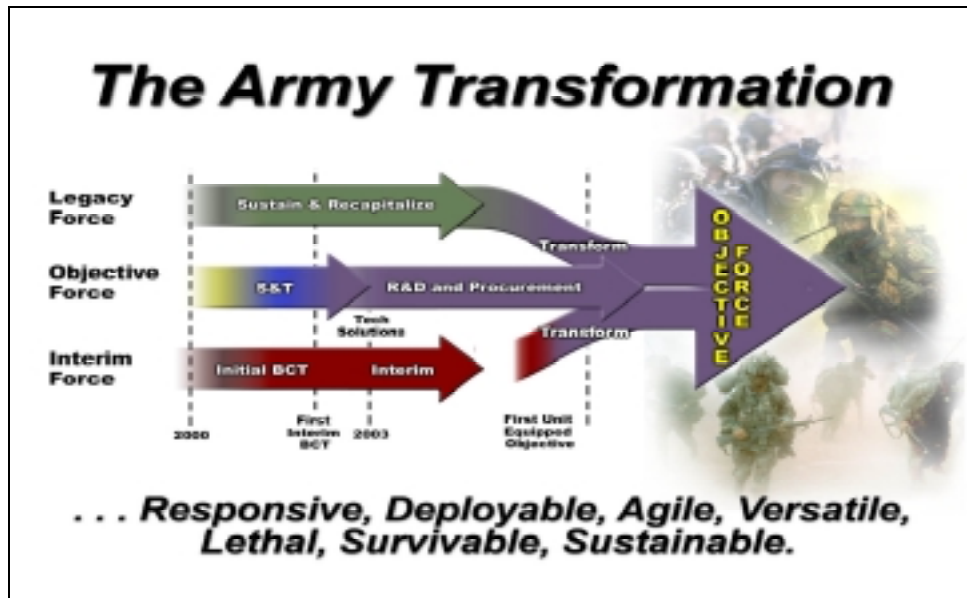

Figure 1-2 The Army Transformation
Source U.S. Army Transformation Brief, 2000

If we were to go to war today, we would fight and win with a Legacy Force. The Objective Force is the Army of Tomorrow. It is more strategically responsive, deployable, agile, versatile, lethal, survivable, and sustainable. Interim Force is the force that bridges the capability gap between the Legacy Force and Objective Force. The first Interim Brigade Combat Teams (IBCTs), equipped with the best off-the-shelf combat vehicles available today, are being formed. This flexible, lethal, and survivable force will be capable of deploying more quickly and to more locations than the current Legacy Force. The IBCTs will also validate organizational and operational concepts for the future Objective Force. The overall transformations will be implemented in three phases: 1)

began with the Initial Force, the initial Brigade Combat Team (BCT) from the Interim Force, in fiscal year 2000, 2) continues with the Interim Force projected for activation in fiscal year 2003, and 3) culminates with the fielding of the Objective Force in 2010 (U.S. Army Transformation Brief, 2000).

Scope of Research

This study will focus on the process of the Reception, Staging, Onward Movement, and Integration, with particular focus upon the onward movement process. During an force projection, the deployed unit's equipment must be moved from the staging area to the integration area as soon as possible with force protection. To secure onward movement, we need to determine what kind of transportation infrastructure is needed, how much, and who is in charge of onward movement. Additional data concerning how much and when the equipment is moved is needed for onward movement planning purpose. Also, analysis is needed to determine the best transportation mode for transporting vehicles, especially the M1A1 tanks, by calculation of onward movement time of each mode such as Heavy Equipment Transport (HET) and rail, and what is the best mixture of mode to increase onward movement speed.

Problem Statement

Every year the U.S. military performs RSO&I exercises. The characteristic exercise is the Command Post Exercise (CPX) or Command Post Maneuver Exercise

(CPMX). Despite these exercises, it is difficult to know what will happen in case of an actual deployment and hard to predict how long it will take to conduct the onward move of deploying units from the staging area to the integration area via current transportation infrastructure. According to US Field Manual (FM) 55-15 Transportation Reference Data, we can calculate onward movement time by itself, by HET, and by rail separately. But, no combined movement time can be calculated. Particularly, we have no way of choosing which mode is the best in certain situations. Currently rules of thumb are used to decide mode selection.

An additional problem is that current manual and operational plans are based on the concept of the Legacy Force. We need to move to the concept of Interim Force and prepare for the Objective Force.

Research Objective

The objective of this research is to analyze the onward movement process to gain a detailed understanding of the process and to make the process more efficient by developing a computer simulation. Based on the simulated onward movement process, we will recommend which transportation mode is better for moving tracked vehicles such as the US Army M1A1/2 Abrams tanks. The model and its resulting output analysis will provide the enhanced RSO&I performance capability and hopefully aid in the development of force deployment activities for current and future Army organizations.

Outline of Thesis

The remaining chapters of this thesis present a literature review, methodology, models results and analysis, and conclusions. The literature review provides additional background on the RSO&I process and detailed analysis of the onward movement process. The literature review also presents related literature on topics such as a simulation studies and transportation mode selection.

Chapter Three describes how onward movement models: 1) train mode, 2) comparison model, and 3) combined model, were built, and, the process for problem formulation, assumption development, and input data selection. Chapter Four, Results and Analysis chapter, presents the experiments and the results of the analysis. Chapter Five reviews the results of the study and presents recommendations for further research.

II. Literature Review

Introduction

The purpose of this chapter is to provide a review of literature relevant to this research. The literature review begins with a look at the process of RSO&I and focuses particularly on the execution of onward movement. A doctrinal review of the RSO&I and onward movement is presented to understand the concept. Then Awesim simulation that was used to find railroad throughput capacity in the Korean Peninsula is presented to show the simulation study of onward movement. Finally the transportation mode selection is presented to understand the academic theory of selecting transportation mode.

The RSO&I Process

Combat power is generated in part through the RSO&I process. RSO&I is often viewed as a logistics problem but it is a critical operational process moving units' equipment and material that is executed by the logistical infrastructure. US FM 100-17-3 Reception, Staging, Onward Movement, and Integration defines RSO&I process as

- Reception: The process of unloading personnel and materiel from strategic transport, marshaling the deploying units, transporting them to staging areas, if required, and providing life support to deploying personnel.
- Staging: The process of assembling, holding, and organizing arriving personnel and equipment into units and forces, incrementally building combat power and preparing units for onward movement, and providing life support for the personnel until the unit becomes self-sustaining.

- Onward Movement: The process of moving units and accompanying materiel from reception facilities and staging areas to Tactical Assembly Areas (TAAs) or other theater destinations, moving arriving non-unit personnel to gaining commands, and moving arriving sustainment materiel from reception facilities to distribution sites.
- Integration: The synchronized transfer of authority over units and forces to a designated component or functional commander for employment in the theater of operations.” (US FM 100-17-3, 1999)

During major deployments like the Persian Gulf War deployment, the US Army has encountered serious delays in the RSO&I. Inefficiencies of RSO&I have caused substantial bottlenecks in the flow of personnel and equipment from sea ports of debarkation (SPOD) to tactical assembly areas (TAAs). The US Army must not have such extended and unopposed RSO&I processes in future contingency operations. After the Persian Gulf War, Congress directed a study of strategic mobility requirements for the post-Cold War Army. The results were as follows,

The Army must provide a Corps of five Divisions that is tailorable, sustainable, and with airborne, vertical insertion capability. The lead Brigade must be on ground by C+4, the lead Division by C+12. Two heavy Divisions (sealifted) arrive from CONUS by C+30 (Armored, Mechanized, Air Assault, [mix per CINC]). The full Corps (five Divisions and a COSCOM) closes by C+75. A fully supported heavy combat Brigade, with sufficient supplies to sustain the Corps until line of communication are established, must be prepositioned afloat. (Mobility Requirements Study Bottom-Up Review Update, 1994)

US Army FM 55-10 defines the Legacy Force deployment closure time needed to meet current strategic requirements (See Figure 2-1). RSO&I planners must define the required force closure time of each of phase of the RSO&I process by checking flows of deploying units into the theater and also must define required the infrastructure to meet

the overall C+75 day (unnamed day on which a deployment operation ends within 75 days) force closure requirement. Usually early entry forces and their supporting units will arrive by air (unless forward-based forces and/or equipment prepositioned ashore or afloat are already in-theater).

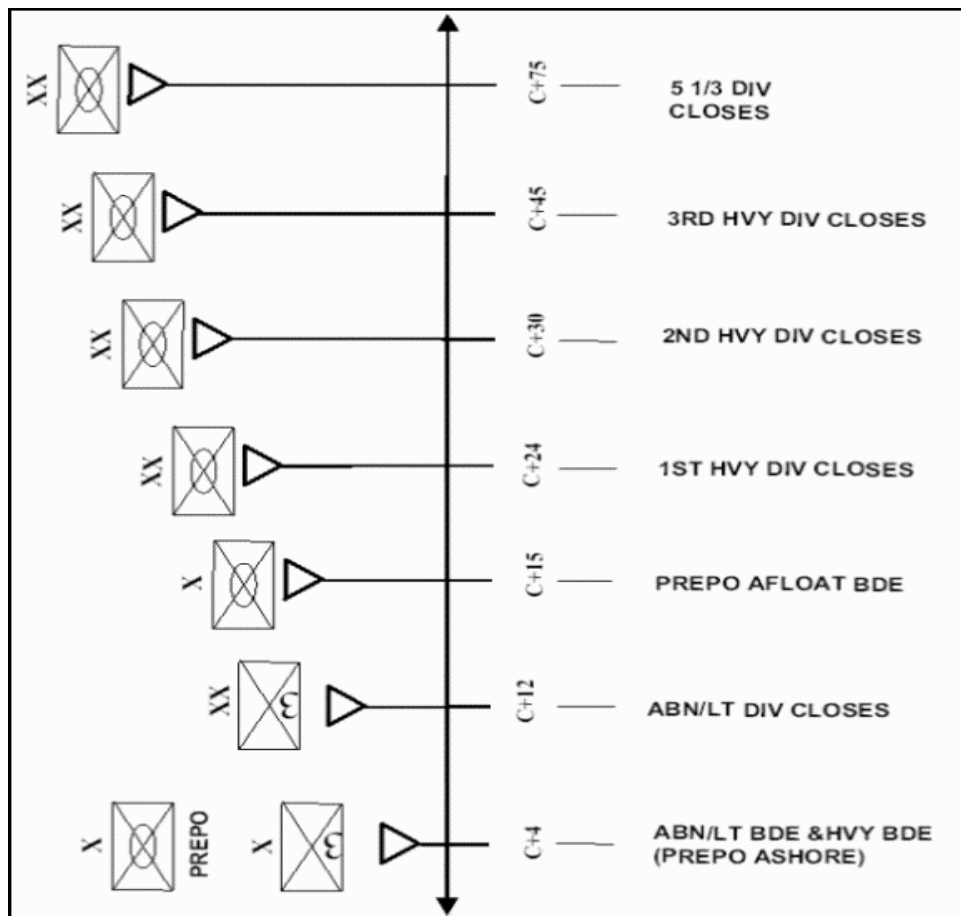

Figure 2-1 Mobility Requirements Study Required Force Closure
 Source US Army FM 55-10 Movement Control
 Note: ABN-Airborne, LT-Light, BDE-Brigade, HVY-Heavy,
 Prepo-Preposition, Div-Division, PREPO AFLOAT
 DBE- 2nd Heavy Brigade

The first heavy brigade arriving in the theater will draw prepositioned ashore stocks if they are available. The next brigade is usually organized as 2 x 2 brigade. It

will be organized based on the task and equipped with APS-3 prepositioned afloat stocks. This unit must be closed by C+15 (US Army FM 100-17-3, 1999, p 1-11). The next arriving unit is a heavy division. It can be an armored division or mechanized division according to the needs of the in theater commander. This unit must be closed by C+24 and the next closed by C+30.

The Objective Force's deployment schedule will be changed dramatically. It will be capable of deploying a combat brigade anywhere in the world in 96 hours, a division on the ground in 120 hours, and five divisions in 30 days. This concept is currently still being examined and is not yet reflected in the US Army Field Manuals.

Execution of Onward Movement

Onward movement is a sub-process of the overall RSO&I process. US Army FM 100-17-3 Chapter 5 Onward Movement and FM 55-10 Chapter 6 Movement Control in the Force Projection Process each explain the general concept of onward movement. These sections' purpose are to present the concept of onward movement and are paraphrased here for clarity.

The onward movement process involves moving reassembled combat-ready units' personnel and equipment from the staging area to the integration area or Tactical Assemble Areas (TAA) based on the Joint Force Command (JFC)'s priorities. Onward movement is a joint, combined service, and multinational, operated by the U.S. and Host nation, efforts to increase deployment speed by enhancing supporting units' capabilities and overall organizational structures utilization of other Services, Allies, Host Nation and

other governmental support activities. It will be repeated until movement is completed in which units advance from one Line of Communication (LOC) node to another. Onward movement occurs when units move from ports to theater staging area to the integration area or TAAs.

Three primary factors affect onward movement they are: Movement Control, Transportation Infrastructure, and Security and Enemy Interdiction. Movement control is defined as planning, routing, scheduling, and control of a units' personnel and cargo over LOC, while maintaining in-transit visibility and force tracking. The controller should execute Movement Control actively. He should analyze requirements verses capabilities and predict shortfalls, bottlenecks, interruptions, and where possible provide alternatives.

The total transportation infrastructure must be coordinated to maximize overall speed of movement. Transportation network capabilities must be balanced according to movement requirements, so the movement planner must coordinate all modes and routes, and should be maintained under the proper utilization. In most cases, other services and allied forces will use the same transportation networks as Army units so uncoordinated execution of onward movement could result in congestion. Planners should expect simultaneous demands on limited infrastructure so they need to allocate limited infrastructure according to JFC's priorities. During the onward movement process, mode selection (rail, HET, barge, and so forth) is considered an operational issue. Ideally, rail and HET should transport tracked vehicles and wheeled vehicles should convoy under own power.

To enhance speed and efficiency of the onward movement, reliable communication that allows in-transit visibility (ITV) and communication with in transit units, well coordinated procedures that ensure unity of effort and uninterrupted flow, and movement control that allows the most effective routes and modes are required.

AweSim

Kirkman used Awesim simulation software to provide a proof of the conceptual model that allows for analysis of the current rail infrastructure and assets availability of conducting RSO&I in Korea. His objectives were determining throughput capability, identifying areas of risk, and developing alternatives to reduce risk based on simulation results. He assumed that the required host nation support were available, the rail system was 100% operational, the tracked vehicles and containers moved via rail and wheeled vehicles moved via road, a 24 hours/day operation, at an average speed of 35 km/hr with the average load/unload time for 15 rail cars was 3.5 hours and for 22 rail cars was 4.4 hours. Limitations were that there were 121 available Heavy Flat Cars (70ST), 216 Flat Cars (54ST), and 221 Container Flat Cars (51ST), and a maximum of 22 rail cars were allowed per train. Moving units were an armored division, an air assault division, an aviation brigade, and a mechanized division. Kirkman hypothesized that trains consisting of 15 rail cars can move units more effectively than trains consisting of 22 rail cars. According to his results, unit movement time for tracked vehicles of an armored division was 13 days with 15 rail cars and 9 days with 22 rail cars so his hypothesis was not

supported. Trains consisting of 22 rail cars had a faster throughput capability and used resources more efficiently (Military Operations Research Society, 2000)

Transportation Mode Selection

Transportation mode choice is based on the transportation rate that the carrier charges the shipper, and on the service level; transit time, reliability, equipment capacity, and responsiveness. All service elements are related to the shipper's cost (Sheffi, 1998). To explain the transportation mode selection, there are four major models; the classical economic model, the inventory-theoretic model, the trade-off model, and the constrained optimization model. The classical economic model is explained as evaluating the fixed cost and variable costs of competing modes. Like rail versus truck, certain theoretical distance is selected as a break-even point. Within below of the break-even distance, one mode has domination in moving freight, usually truck, and beyond that distance, the other mode, train, has domination in moving freight. The inventory-theoretic model considers inventory in transportation, the trade-off model contained non-transportation cost facts, and the constrained optimization model is explained as the optimizing process considering transportation cost and non-transportation cost (Michael A. McGinnis, 1989).

Rate and cost are the most important facts in the civilian industry because they are based on the economical theory. How about military transportation mode selection? Can it be operated based on economical facts only? Yes or No. Military transportation mode selection for administrative movement, moving equipment or material for routine operational purposes, can be based on the economical transportation mode selection

during peacetime, but for the strategic or emergency movement is based on the beyond economical facts like operational response and political issues.

The onward movement process is moving units' equipment and material from the staging area to the integration area. Transportation mode selection for onward movement usually considers which mode is the fastest one to meet force closure times so economical facts like cost and inventory level are less considered.

Summary

RSO&I is the vital combat power generation process in the force projection process. Onward movement is the critical movement process of combat ready deploying units. There are many studies that focus on increasing throughput capacity to secure seamless flow, but there are few studies that cover the onward movement process in South Korea. Even though Major Kirkman evaluated throughput capacity in South Korea, he considered only the train as a transportation mode because, at that time, the train was the only possible transportation mode to move tanks. The situation has changed. The ROK Army will deploy HET to transport tanks. So we need to evaluate which transportation mode (HET or train) is better and the effect of HET on the onward movement process.

III. Methodology

Introduction

This chapter presents the methodology taken in the evaluation of the RSO&I process. The military applications of simulation and Arena software are presented to understand general concept of simulation. Following this the design of experiment is described: the onward movement by train model depicting current onward movement process, the comparison of HET with a train model is presented to find out which is a better transportation mode, and a combined model is presented to figure out the effect of adding one HET company to the current plan. The onward movement process design begins with general issues and steps in designing an experiment, and then goes on to discuss specifics of this study. The information presented was used to determine which aspects of the onward movement actually needed to be included in the simulation model.

Military Application of Simulations

Simulation is widely used in the military. One example is which the Analysis Division of the Air Force Personnel Operations Agency (AFPOA) used simulation to examine a wide range of personnel policy issues, including how the available number of pilots and navigators relates to actual needs. With the results AFPOA was able to examine the impact of changing personnel policies and determine projections of available pilots and navigators before actually making a change. Simulation enabled the analysts to

alter and test different scenarios as they manipulated the data to determine realistic policies to avoid unforeseen costs (Rockwell Automation Arena-AP003A-EN-P, 2002).

Simulation models are used for training personnel, analyzing proposed equipment, and rehearsing missions and allow the analyst to study the behavior of systems for possible implementation (Pew and Mavor, 1998). By using simulation, analysts can create a model of system or process and test variability of input and process to imitate the real system or process. Based on the results of a simulation, an analyst can predict the system and suggest improvements (Wyland et.al, 2000).

Current manual calculation of movement time on the basis of US FM 55-15 Transportation Reference Data does not consider the loading/unloading or delay time for the movement instead focusing only on movement time. This results in restricted onward movement data. Deploying unit commander need more realistic and accurate data to make operational decisions. To validate the manual calculation and provide more accurate onward movement data, this study will build onward movement simulation models by utilizing Arena simulation software.

Arena Simulation Software

To develop and analyze an onward movement model, Arena Simulation Software was used in this study (Rockwell Automation Arena, 2002). During the military exercise, movement of actual unit is a costly activity due to the large scale of the units. Without moving an actual unit, it is hard to predict a true movement time. However, a simulated process can predict estimated movement process time without moving actual large scale

units. Because of this, simulation software can be used as a tool for cost saving or avoidance.

The onward movement process is complicated so it is hard to figure out which processes cause delays, which parts are ineffective, and where to improve total process efficiency. A simulation can depict the onward movement process. Transfer modeling templates facilitate the development of realistic loading, transportation, and unloading procedures for the onward movement model. Realistic onward movement process model can be used to find and eliminate bottlenecks and increase the efficiency and effectiveness of the onward movement process.

Formulating the Problems

The limitation of command post exercise of RSO&I result in the question “what will happen in the case of real deployment”? Real deployment exercises of large-scale actual unit like armored division are impossible because of cost, safety, and political reasons. The best way to solve this problem is using simulation. By building a simulation model, we can predict thing about the deploying process. This study will depict the current onward movement process in RSO&I and predict one armored division’s onward movement time to compare with planned required force closure time.

Currently, only trains are used to move tracked vehicle on the Korean Peninsula in the process of onward movement because there are no alternatives to move tracked vehicles like the M1A1/2 tanks. However, the ROK Army has developed a prototype of heavy equipment transporter (HET) that is capable of moving M1A1/2 and will soon field

one HET company. The problem is, we have no idea which transportation mode is better for moving tracked vehicle. This study will model the tank onward movement by comparing HET and train to figure out which is the better transportation mode to move tanks. Additionally by building one combined HET company and current rail assets model, we will find out the impact on onward movement time of adding one HET company.

Onward Movement Process Model Design

Law and Kelton (1991), and Banks and Carson (1984) each suggested a simulation model development process. These two methods are quite similar but there are differences. For this research, a modified method is established. Table 2-1 shows the major steps of these approaches and modified one. Step 1 already has been discussed in chapter I. This chapter focuses on steps 2, through 6. Steps 7 and 8 are covered in Chapter IV.

Conceptual Model

Military exercises are based on Field Manual (FM) and the onward movement process is part of these military exercises. Building an onward movement model is within the scope of the FM. This section is adopted from related FM: US Army FM 55-65 Chapter 8 Reception and Onward Movement, US Army FM 100-17-3 Chapter 5 Onward Movement, FM 55-20 Rail Transport in a Theater of Operations, FM 55-30 Army Motor Transport Units and

Table 3-1 Steps in a simulation study

Steps	Averill M. Law and W. David Kelton's	Jerry Banks and John S. Carson, II	Modified
1	Formulate problem and plan the study	Problem formulation	Formulate problem and plan the study
2	Collect data and define a model	Setting of objectives and overall project plan	Model building
3	Valid?	Model building	Data collection
4	Construct a computer program and verify	Data collection	Valid?
5	Make pilot runs	Coding	Experimental Design
6	Valid?	Verified?	Make production runs
7	Design experiments	Validated?	Analyze output data
8	Make production runs	Experimental Design	Document, present, and implement results
9	Analyze output data	Production runs and analysis	
10	Document, present, and implement results	More run?	
11		Document program and report results	
12		Implementation	

Operations, and ROK Army FM 22-10-2 Army Motor Transport Operations, to present manual concept of onward movement.

The onward movement process is part of force projection and RSO&I. As vessels arrive at the Sea Port of Debarkation (SPOD), the port commander is responsible for discharging the unit equipment, staging the equipment, maintaining the control and In-Transit Visibility (ITV), and releasing it to the unit. Units receive this equipment and move it to a marshaling area outside of the terminal (US Army FM 55-65 P 8-5). Equipment is then staged based on theater onward movement requirements. As unit

personnel arrive in the theater, they are transported to the SPOD to assume custody of their equipment. Equipment is then assembled and moved to a marshaling area.

The Marshaling Area (MA) is an area located next to the port where units reconfigure their equipment and prepare for onward movement. Prompt clearance of cargo from the terminal is essential to the efficiency and success of the total theater logistics system. It is also necessary to avoid congestion in the terminal staging area. Marshaling areas provide security area for sensitive items and life support facilities and act as a central control and inspection point. It also consolidates movement requirements and submitting movement requests. Since marshaling areas are not always available, units may need to move directly into their area of operations from the port staging area. When this is necessary, the marshaling area functions are performed in the port staging area. This requires additional coordination with the port commander so that these activities do not interfere with discharge operations (US Army FM 55-65 P 8-5). Onward movement occurs when units move from ports to theater staging bases or forward to the TAAs.

The onward movement process beginning from the staging or marshaling area and ends at integration area or TAAs. Onward movement is a joint/multinational effort using capabilities and organizational structures of other services, allies, host nation and other government entities. It is an iterative activity in which units advance from one Line of Communication (LOC) node to another. A comprehensive plan for onward movement requires adherence to a step-by-step process. Planning must estimate the workload at specific transportation nodes to determine requirements for movement control, mode

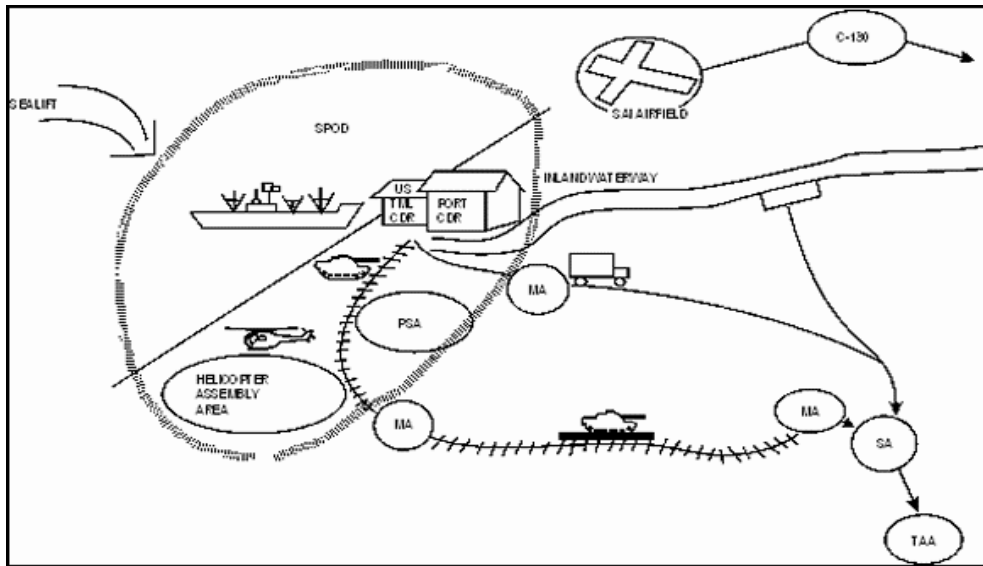

Figure 3-1 SPOD Onward Movement Process
Source US FM 55-10 P6-10

operating, and cargo transfer units. Planning should be done for operational periods for each node. It must identify requirements for materials handling equipment (MHE), container handling equipment (CHE), and host nation support (HNS). The supporting installation (SI) is responsible for support of arriving forces until they arrive at their destination. The SI also assists them in onward movement and may help obtain access to transportation assets as well as required clearances

When moving by road, the unit conducts serial/convoy operations in accordance with standing operating procedures (SOP) and installation guidance, including convoy clearances and movement times. The unit submits status reports as required by higher headquarters. If the unit moves by rail, the unit conducts sequential loading for trains. The port authority or the Military Traffic Management Command (MTMC) develops and publishes the rail load plan. Units conduct rail operations as required by this guidance.

MTMC also organizes for rail loading. The installation with port of debarkation (POD) responsibilities operates railheads at the POD. Units provide drivers, tie-down teams, safety officers/noncommissioned officers (NCOs), and other resources as directed by the installation. Finally, it moves to the railhead and load trains. MTMC issues the Government Bill of Lading (GBL) for all commercial transportation from the POD. Units, in turn, assist MTMC with required documentation, including that associated with frustrated cargo.

Model Building

In case of deploying to the Korean Peninsula, Pusan Port is the port of debarkation (POD). A deploying unit receives equipment and materials and moves it to the staging area: YangSan Inland Container Depot (ICD). The staging area is divided into three marshaling areas: items moved by train, these moved by container, and a wheeled vehicle marshaling area. This study considers only the first area, trains. Current RSO&I in Korea's use only train for tracked vehicles' onward movement because no other transportation mode for transporting tracked vehicles exists and moving tracked vehicle under their own power takes too long. Actual onward movement begins from this marshaling area and ends at integration area. The current RSO&I integration area in South Korea is the Osan vicinity area. Tracked vehicles be loaded on a flatcar are then moved from YangSan ICD to Osan Station according to CINC's priorities. As such YangSan ICD station is the start point of train and Osan Station is the destination because Osan Station is the nearest station from integration area. After arriving Osan Station, the

tracked vehicles are unloaded. After unloading, the tracked vehicles move to Integration area.

Data Collection

Data were needed to build the onward movement model to include entities, movement distances and speeds, and delay times. Data were collected for each model. To gain a better understanding of the process, experts in the ROK Army Transportation school railroad system instructor and Highway Operation instructor, the ROK YangSan ICD Operation manager, the ROK second Army RSO&I Officer, were consulted for these data.

Entities.

The deploying units in the RSO&I process are airborne, armored, and mechanized division. This study focuses only on one armored division. An armored division is made up of headquarters (HQ), two armor brigades, one infantry brigade, an engineer brigade, an aviation brigade, and a division artillery. It has various kinds of vehicles, equipment, and materials, but this study concerns only tracked vehicles moved by train. Table 2-2 shows major tracked vehicles associated with an armored division.

Onward Movement by Train.

In the case of onward moving by train, the train must be prepared for loading. The onward moving unit conducts loading for each train. Safety checks and station

Table 3-2 Entities of Armored Division Moved by Train

Equipment	Quantity	Remarks
M1A2	317	Main Battle Tanks
M2A2	269	Bradley Fighting Vehicle
M88	65	Tank Recovery Vehicle
M109A6	54	Self-propelled Medium Howitzers
M3A2	41	Bradley Fighting Vehicle Systems (BFVS)
BSFV	32	Bradley Stinger Fighting Vehicle
MLRS	12	Multiple Launch Rocket System
M113/M577	280	Armored Personnel Carrier
Total	1,070	

clearance activity typically cause delays. The maximum speed of a 70 ton loaded train is 35 Kilometer in Hour (KIH) because of safety and bridge load limitation. There are also delays associated with loading, unloading, and return. Table 3-3 shows data for by train model.

Table 3-3 Data for by Train Model

Activity	From	To	Distance	Speed	Delay
Delay for preparation					TRA(0.25,0.5,0.75)
Loading					TRA(4,4.4,4.8)
Delay for leaving					TRA(0.2,0.25,0.3)
Onward movement	YangSan ICD	Osan station	400 km	35 KIH	
Delay for unloading					TRA(0.25,0.5,0.75)
Unloading					TRA(4,4.4,4.8)
Delay for return					TRA(0.2,0.25,0.3)
Moving	Osan Station	Integration Area	5 km	10 KIH	

Onward Movement by HET.

In the case of onward moving by HET, HET move from a HET support base and load tanks. There are sufficient spaces to load 22 tanks at one time in the YangSan ICD. The onward moving unit conducts loading for each HET. After safety check, HET units onward move from marshaling area to integration area. Maximum speed of a 70 ton loaded HET is also 35 KIH because of safety and bridge load limitation. There are also delay for loading, unloading, and return. Table 3-4 shows the data for the HET model.

Table 3-4 Data for by HET Model

Activity	From	To	Distance	Speed	Delay (Hour)
Moving	HET Base	Staging Area	5 km	40 KIH	
Loading					TRA(0.5,0.75,1)
Onward movement	YangSan ICD	Integration Area	400 km	35 KIH	Halt $0.17 \times$ every two hours
Delay for leaving					TRA(0.2,0.25,0.3)
Unloading					TRA(0.5,0.75,1)
Delay for return					TRA(0.2,0.25,0.3)

Experimental Design

This section presents the depiction of the process and assumptions used to develop the onward movement model. General structure and assumptions needed to build the onward movement model are presented. Each of the three principle models are then described. Each of the sections describes the process used to develop the model and lists all assumptions.

General Framework.

General framework provides a base line and limitation of the onward movement model. Important features such as the timeframe, location and distance, hours of the operation, moving unit, the type of operation, the external environment, and time and distance units needed for the scenario are presented as model boundaries. Table 3-5 shows general assumption for the onward movement model.

Table 3-5 General Assumptions for the Onward Movement Model

General Condition	Assumptions
Operation Timeframe	Initial Entry Operation
Operation Location	The Korean Peninsula
Operation Distance	400 KM (from Pusan to Osan)
Operation Hours	24 Hours per Day
Moving unit	One Armored division only
Type of Operation	Onward Movement Operation
Political Environment	Friendly “Treated Supported” environment with host nation support assets available for contraction
Threat Level	Minimal; Moving personnel maintain minimal security during the period. NBC = Zero: All personnel maintain a MOPP level zero posture during the period.
Infrastructure	Infrastructure able to provide functional Onward Movement and capable road network.
Time units	Hours
Distance units	Kilometers

Train Model

The purpose of this model is to model current RSO&I plans in the South Korea and evaluate onward movement time. This study assumes one Armored Division has already arrived at the staging area and is ready for onward movement. According to CINC's priority, units' tracked vehicles need to be loaded on the available flatcar for onward movement. There are three kinds of railcars that can be loaded with tracked vehicle. They are 70 short ton (ST) heavy flatcar, 54ST flatcar, and 51ST container flatcar. One M1A1 tanks or two other tracked vehicles or 2 containers can be loaded on the 70ST heavy flat car. The 54ST flat car can load only 2 M113 or M577. A 51ST can load one tracked vehicle of any kind other than M113, M577, or 2 containers. Two M113 or M577 can be loaded on the one 51ST flat car. The available number of flatcar are 121ea 70 ST, 216 ea 54ST, and 221 ea 51ST. Table 3-6 shows loadable tracked vehicle and available flatcar numbers.

The maximum number of rail cars per train is 22 in Korea because of station capacity limitation. Currently two loading and unloading lamp are available at originating and destination station respectively. Mean loading and unloading time for 22 rail cars are 4.4 hours (the results of RSO&I 2000 in Korea). There is space capacity limitation in the station's loading area so units must wait for a call sign in the marshaling area. The railroad system can operate 24 hours per day and locomotive are not limited by locomotive engine availability as there are for more engines than required in the South Korea. Table 3-7 shows assumptions for the Train Model.

Table 3-6 Loadable Tracked Vehicle and Available Flatcar Number

Equipment	70ST	54ST	51ST	Available #
M1A2	1	0	0	121 70ST 216 54ST 221 51ST
M109A6	2	0	1	
M3A2	2	0	1	
M2A2	2	0	1	
BSFV	2	0	1	
MLRS	2	0	1	
M113/M577	2	2	2	
Containers	2	0	2	

Table 3-7 Assumptions for the Train Model

Variable or Process	Assumption
Arrival time for entities	All tracked vehicles already arrived staging area and ready for the onward movement
Making train	Delay TRA(0.25, 0.5, 0.75)
Loading	Two loading lamp are available TRA(4,4.4,4.8)
Preparation for leaving	Delay for leaving TRA(0.2,0.25,0.3)
Onward movement	Distance 400 km Speed 35 KIH
Approaching unloading lamp	Delay for unloading TRA(0.25,0.5,0.75)
Unloading	Two unloading lamp are available TRA(4,4.4,4.8)
Preparation for return	Delay for return TRA(0.2, 0.25, 0.3)
Movement from destination station to TAAs	Distance 5 km speed 10 KIH
Flat car initial location	Starting station

Comparison model

The purpose of this section is to determine which transportation mode is better for moving M1A1/2 Abrams tanks in the onward movement process. There are two kinds of transportation modes available for moving tanks. The most common mode is train, but the US Army has developed a heavy equipment transporter (HET) for the tactical

movement in the cases where no rail system exists. Unfortunately HET has not been considered for tank onward movement mode in the South Korea because HET is not ready for deployment and the ROK Army does not yet have any HET. But the Republic of Korea Army has developed a prototype of HET. Although it has not yet deployed to the field, but we need to estimate its capacity for moving tracked vehicle especially; M1A1 tanks.



Picture 3-2 Onward Movement by HET

The ROK Army HET is similar to the US Army M1070 Heavy Equipment Transporter (HET). It provides line-haul, local-haul and maintenance evacuation on and off road during tactical operations. It is designed to carry both a tank and its crew. Its speed is 70 KIH on highway and 45 KIH with a tank payload. The expected HET company will be equipped with 60 HET and 120 drivers. This study assume that there is

one HET company in the ROK Army and it can be used to onward move deploying US military troops' M1A1 tanks.

Table 3-8 Assumption for the Comparison Model

Variable or Process	Assumption
Arrival time for tanks	All tanks already arrived staging area and ready for the onward movement
HET initial location	The vicinity of staging area
HET failure	HET Availability is 83 % Failure is 27 % (Break down-5%, Maintenance-8%, and Safety rate-4%)
Loading	There are sufficient space for loading Every tanks can be loaded at the same time TRA(0.5,0.75,1)
Onward movement	Distance 400 km, HET speed 40 KIH 10 minutes halts every 2 hours
Delay for leaving	TRA(0.2,0.25,0.3)
Unloading	There are sufficient space for unloading Every tanks can be unloaded at the same time TRA(0.5,0.75,1)
Delay for return	TRA(0.2,0.25,0.3)

The onward movement process by HET depicts the movement associated with moving unit's tanks from staging area to integration areas. When a tank movement requirement occurs, HET move to the start point: staging area, load, and move onward to the destination: integration areas or TAAs. During the onward movement, HET drivers must stop and take a 10-minute rest every 2 hours for safety reasons. Like other motor

transportation company, HET company can operate 20 hours per day and their vehicle availability is anticipated to be 83% (ROK Army FM 22-10-2, 2000, p 3-15). For the comparison reason, we assume that there is one HET company (equipped with 60 HET) and 60 heavy flat cars (70 ST) because both can move one M1A1 tanks at one time. Table 3-8 shows assumptions for the Comparison Model.

Combined model.

The purpose of this model is to find the effect of adding HET to the onward movement process. The onward movement process is executed by a combination of trains and HET instead of using only trains. An assumption is made that all tanks are moved by HET and all other tracked vehicle are moved by trains, and there is one HET company available and 60 heavy flat cars (70 ST). Heavy flat cars can load one M1A1 tanks and two other tracked car, but HET can load one M1A1 tanks or one other tracked vehicles. As such, moving other tracked vehicles by HET is inefficient. Table 3-9 shows assumptions for the Combined Model.

Model Verification and Validation

To get a verified model, the simulation model was debugged until a working model performed as intended: moving one armored division's all tracked vehicles from staging area to integration area according to onward movement process.

Table 3-9 Assumptions for the Combined Model

Variable or Process		Assumption
T R A I N	Arrival time for entities	All tracked vehicles already arrived staging area and ready for the onward movement
	Movement from staging area to start station	Distance 5 km speed 10 KIH
	Making train	Delay TRA(0.25,0.5,0.75)
	Loading	Two loading lamp are available TRA(4,4.4,4.8)
	Preparation for leaving	Delay for leaving TRA(0.2,0.25,0.3)
	Onward movement	Distance 400 km Speed 35 KIH
	Approaching unloading lamp	Delay for unloading TRA(0.25,0.5,0.75)
	Unloading	Two loading lamp are available TRA(4,4.4,4.8)
	Preparation for return	Delay for return TRA(0.2,0.25,0.3)
	Movement from destination station to TAAs	Distance 5 km speed 10 KIH
Flat car initial location	Starting station	
H E T	HET initial location	The vicinity of staging area
	HET failure	HET Availability is 83 % Failure is 27 % (Break down-5%, Maintenance-8%, and Safety rate-4%)
	Loading	There are sufficient space for loading Every tanks can be loaded at the same time TRA(0.5,0.75,1)
	Onward movement	Distance 400 km, HET speed 40 KIH 10 minutes halts every 2 hours
	Delay for leaving	TRA(0.2,0.25,0.3)
	Unloading	There are sufficient space for unloading Every tanks can be unloaded at the same time TRA(0.5,0.75,1)
	Delay for return	TRA(0.2,0.25,0.3)

Getting model validation is one of the most difficult problems to a simulation analyst. If we built invalid model, the conclusion derived will be useless. The easiest way of ensuring validity is to compare pilots run results with an existing system (Law and Kelton, 1991). Unfortunately there are no results of one armored division onward movement exercise in Korea. But we can compare this study pilot run results with a past onward movement study on the RSO&I process (Kirkman, 2000). Pilot run results of the current onward movement model's onward movement time were 206 hours (about 8.6 days) which compared well with past studies (Kirkman, 2000) result of 9 days. This provides support that the model has validity.

IV. Results and Analysis

Introduction

This chapter presents the results and outputs analyses of onward movement using the train model, comparison model, and a combined model. The first level of analysis concerns the current RSO&I plan with the current transportation infrastructure to determine if it can meet required force closure times. The second level of analysis determines which transportation mode is faster and where the breakeven point between them is. Finally we analyze the effect of an additional HET company to the basic model of onward movement process.

Train Model Results and Analysis

We want to estimate the onward movement time with a precision (interval width) of 6 hours and an accuracy of 95% ($\alpha = 0.05$). After 4 runs ($R_0 = 4$), the following results were observed.

Table 4-1 The Results of 4 Replications of by Train Model (unit Hour)

Replication	Result
1	206.32
2	205.47
3	196.08
4	201.92

To determine a proper number of replications, we used following inequality.

$$R \geq \left(\frac{t_{\alpha/2, R-1} S_0}{\epsilon} \right)^2 \quad (\text{Banks and Carson, 1984})$$

R=10 is the smallest integer satisfying the inequality. So six additional replications are needed. More information on calculation of the number of replications is included in Appendix B-1. Ten replications of the train model were performed which resulted in the following results (Table 4-2).

Table 4-2 The Results of 10 Replications of by Train Model (unit Hour)

Replication	Result
1	206.32
2	205.47
3	196.08
4	201.92
5	199.35
6	206.07
7	197.16
8	196.79
9	204.89
10	200.74
Average	201.83
Standard Deviation	4.26

The average onward movement time of one armored division's tracked vehicle is 201.83 hours (8.4 days) with a standard deviation of 4.26 hours. The $\alpha=0.05$ confidence interval (CI) around this mean is [198.7 hrs, 204.4 hrs]. Additional quantitative analysis of the train model are included in Appendix B-2. As we can see in Figure 4-1, the required force closure time between the arrival of the second brigade and the first heavy division is 9 days (216 hours) and the time between the first heavy division and the second heavy division is 6 days (144 hours). This means that the heavy division's

minimum time window for force projection is 6 days. To prevent potential congestion or delay in the RSO&I process, every heavy division needs to be moved within 6 days.

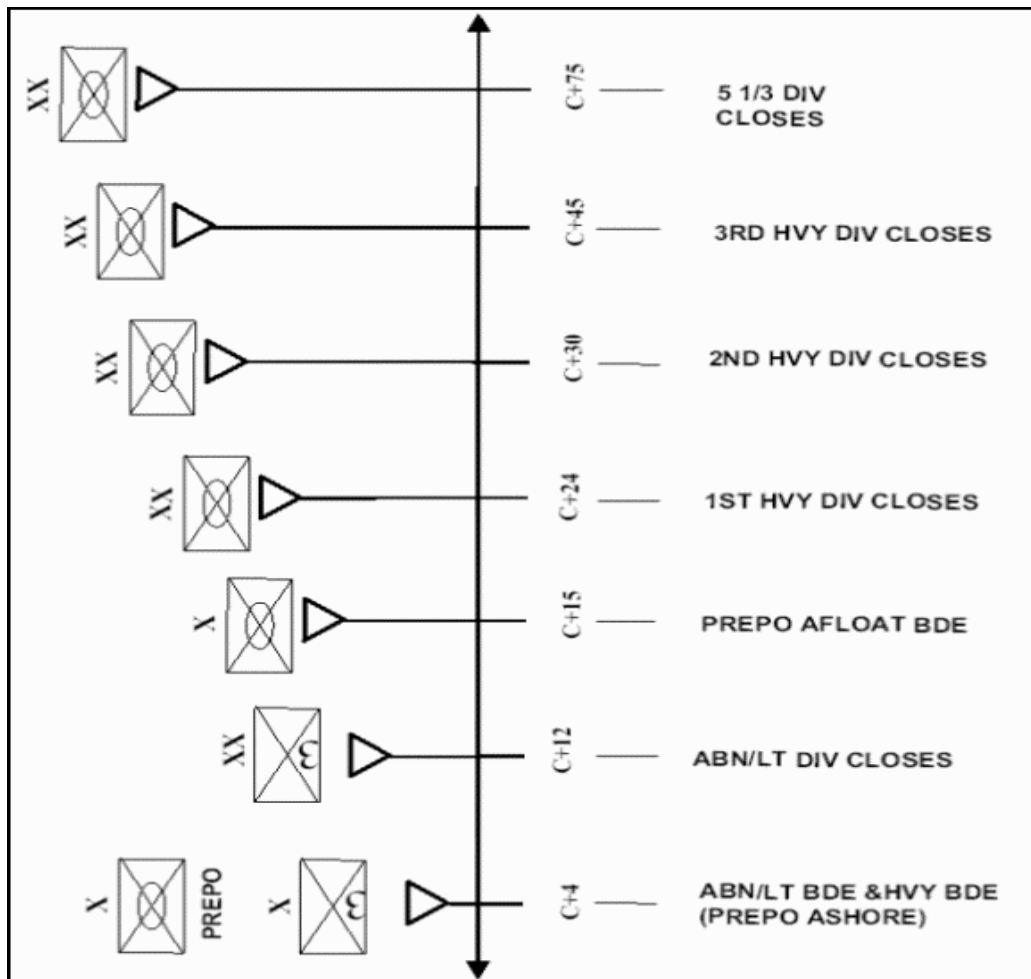

Figure 4-1 Mobility Requirements Study Required Force Closure

Source US Army FM 55-10 Movement Control

Note: ABN-Airborne, LT-Light, BDE-Brigade, HVY-Heavy, Prepo-Preposition, Div-Division, PREPO AFLOAT DBE- 2nd Heavy Brigade

Figure 4-2 depicts the confidence interval resulting from the train model as well as the 6 and 9 days windows. Although the confidence interval for the train model falls

within the 9 days (216 hours) window, it is beyond the 6 days (144 hours) window required by force closure time.

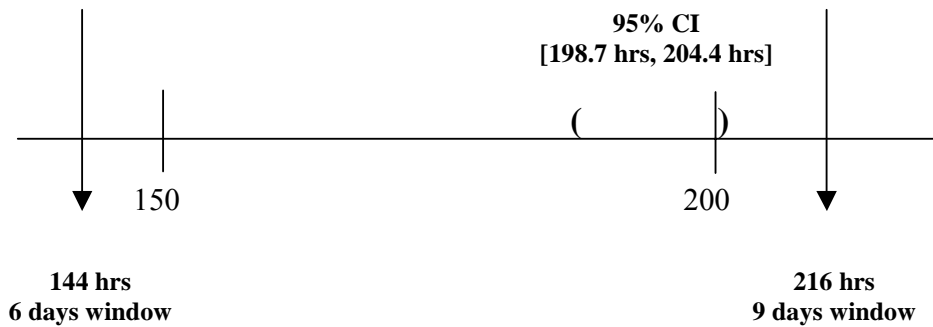

Figure 4-2 Comparison of Train Model's CI with Heavy Division Force Closure Time

Statistically speaking, we cannot say that one armored division can meet its 6 days force closure time with the current transportation infrastructure and RSO&I process in South Korea. You can say that one armored division can meet its 9 days force closure time under the limitations on this study which ignores all material other than tracked vehicles. This limitation is discussed in detail in Chapter 5 Limitations section. Thus, we need to increase onward movement speed to meet required 6 days force closure time. The question becomes, how do we improve the onward movement process to affect the needed reduction in time?

Currently, the ROK Army is considering fielding one HET company to help reducing onward movement time. Before finding the effects of fielding a HET company are and whether this method can meet required force closure time, we will analyze the comparison model to find out which transportation mode (HET or train) is faster to move tanks.

Comparison Model Results and Analysis

Table 4-3 shows the results of 10 replications of comparison model. Table 4-4 shows the mean onward movement time by HET and by Train and the difference. As we can see, HET appears to be a much faster transportation mode when moving tanks less than 200 km. This is primarily due to the reduced loading times and available loading site. Trains take much longer to load (4.4 hours for 22 flat-cars) than HET (45minutes), and also have more limitations on loading sites (currently only 2 loading sites are available) than HET (can be loaded at any site). However, as distance is increased, the operational advantage of trains over distance make up for this, to the point where trains are quicker overall for distances greater than 500 km. Most of this operational difference is because HET can only operate 20 hours per day, must halt every 2 hours because of safety concern, and only has an 83 % vehicle availability. Trains on the other hand can operate 24 hours per day with no stops and a nearly 100 % flat car availability.

Table 4-3 The Results of 10 Replications of Comparison Model (unit hour)

MD	100 km		200 km		300 km		400 km		500 km	
	HET	Train	HET	Train	HET	Train	HET	Train	HET	Train
1	62.0	163.9	107.2	187.8	184.6	207.9	200.6	223.8	247.8	243.6
2	62.5	162.8	107.7	187.7	184.5	203.6	200.7	222.9	248.8	247.6
3	62.5	163.2	107.3	183.2	186.4	208.3	201.6	229.0	248.7	243.3
4	62.5	168.2	108.2	187.6	185.3	207.2	201.3	227.7	248.3	247.8
5	61.1	168.2	106.7	187.8	184.2	208.0	201.9	227.7	249.2	248.2
6	61.6	167.9	107.5	187.5	184.4	207.7	201.0	228.3	248.1	248.4
7	62.9	166.9	106.9	183.4	184.4	207.8	201.2	222.6	248.2	244.3
8	62.0	164.4	106.3	187.8	185.7	208.4	201.5	223.6	249.3	243.3
9	61.6	162.9	107.0	187.6	184.7	208.0	201.9	224.5	247.8	242.9
10	61.4	162.7	107.5	188.5	185.1	207.3	202.4	228.3	248.6	248.8

Note: MD means movement distance, Rep means replication

Table 4-4 Each Mode Mean Time and Difference (unit hour)

Division	100	200	300	400	500
HET	62.01	107.23	184.93	201.41	248.48
Train	165.11	186.89	207.42	225.84	254.82
Difference	103.10	79.66	22.49	24.43	- 6.34

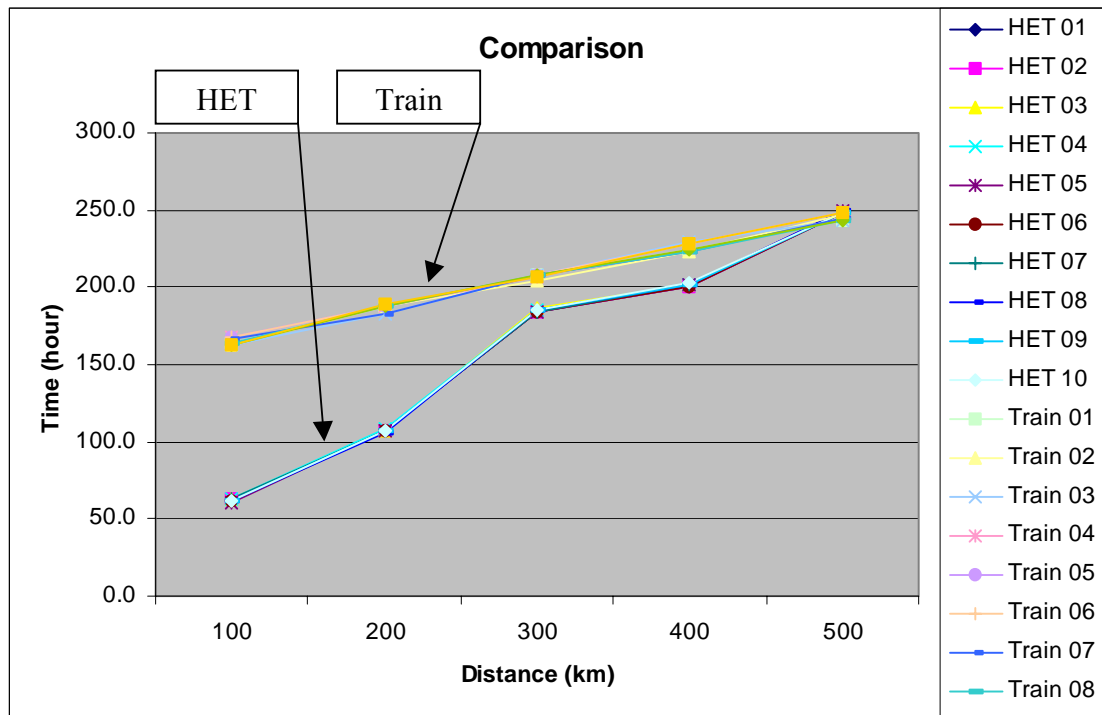

Figure 4-3 Onward Movement Time Comparisons

To find a breakeven distance, a qualitative predictor variables regression analysis was performed. We want to relate the movement time (Y) and movement distance (MD) (X). Variables are possible transportation modes: HET and Train. We shall use variables that take on the values 0 and 1 and might define them as follows:

Types (T): HET = 0

Train = 1

A model would be the following:

$$Y = \beta_0 + \beta_1 MD + \beta_2 T + \beta_3 TMD + \varepsilon_i$$

$$E(y|T = 0) = \beta_0 + \beta_1 MD$$

$$E(y|T = 1) = (\beta_0 + \beta_2) + (\beta_1 + \beta_3) MD$$

$$H_0: \beta_2 = \beta_3$$

Note: β_0 is intercept. β_1 is distance. β_2 is dummy. β_3 is distance*dummy.

Table 4-5 shows parameter estimates of the linear regression analysis. For more detailed information on the linear regression analysis see Appendix B-3.

Table 4-5 Regression Model's Lack Of Fit

Source	DF	Sum of Squares	Mean Square	F Ratio
Lack Of Fit	6	7317.2187	1219.54	470.0770
Pure Error	90	233.4900	2.59	Prob > F
Total Error	96	7550.7087		<.0001
				Max RSq
				0.9993

As we can see Table 4-5, the p-value for significance of the t test is less than 0.0001.

This indicates that the parameters are significantly different from zero so the hypothesis,

$\beta_2 = \beta_3$, was rejected. Managerially speaking, this means the slopes of the two lines

(HET and Train) are different from one another.

The reason why we do this analysis is that the model assumes equal slopes and the same constant error term variance for each type of transportation mode. The common slope β_1 can best be estimated by pooling the two types of transportation modes and other inferences, such as β_0 and β_2 , can be made more precisely by working with one

regression model containing an indicator variable since more degrees of freedom will be associated with MSE (John Neter and others, 1996).

The fitting of the regression model is straightforward. Table 4-6 presents the key results (Parameter Estimates) from the JMP run regressing Y on X. The fitted response function is:

$$E(y|T = 0) = 20.676 + 0.467MD$$

$$E(y|T = 1) = (20.676 + 125.429) + (0.467 - 0.267)MD$$

Table 4-6 Regression Model's Parameter Estimates

Term	Estimate	Std Error	t Ratio	Prob> t
β_0	20.676	2.941403	7.03	<.0001
β_1	0.46712	0.008869	52.67	<.0001
β_2	125.429	4.159773	30.15	<.0001
β_3	-0.26675	0.012542	-21.27	<.0001

Figure 4-4 contains the fitted response function for each type of transportation mode.

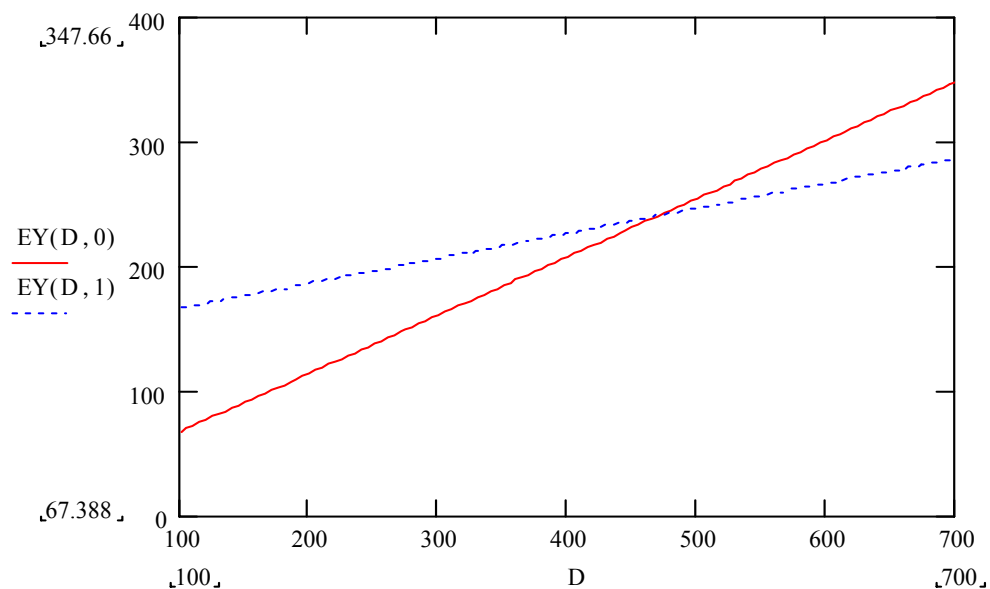

Figure 4-4 Regression Model

According to the regression model, the breakeven point is 470.40 km and 240.41 hours. This means that movement by HET is faster by train when the movement distance is less than 470.40 km but that the train is faster beyond that distance. Given that movement distance in South Korea is usually less than 470.40 km (South Korea is only about 450 km long from north to south), it appears that HET is generally a better transportation mode for moving tanks in South Korea.

Now we want to find the effects of adding HET in the onward movement process in South Korea by analyzing the combined model.

Combined Model Results and Analysis

Ten replications of the combined model were performed which resulted in the following results (Table 4-7).

Table 4-7 The Results of 10 Replications of Combined Model.

Replication	Result
1	137.1
2	149.0
3	144.9
4	132.1
5	145.0
6	140.9
7	138.1
8	146.3
9	141.4
10	145.5
Average	142.0
Standard Deviation	4.85

When we add one HET company to the current onward movement process in South Korea, the onward movement mean time of one armored division's tracked vehicle is 142.0 hours (5.9 days) with a standard deviation 4.85 hours. The $\alpha = 0.05$ confidence interval around this mean is [138.4 hrs, 145.7 hrs]. For more information on the analysis of combined model see Appendix B-4.

As we already mentioned according to Figure 4-1 the Time-Phased Force and Deployment Data Flow, requires force closure times between the second brigade and the first heavy division of 9 days (216 hours) and the first heavy division and the second heavy division of 6 days (144 hours). Figure 4-5 depicts the confidence interval of the Combined model as well as 6 and 9 days windows. As we can see in Figure 4-5, CI and the 6 day window overlapped. This means that the onward movement time of the combined model's confidence interval is not significantly different from 6 days and the onward movement time with one additional HET company cannot meet the required 6 day window with 95% confidence.



Figure 4-5 Comparison of Combined Model's CI with Heavy Division Force Closure time

Despite this the mean time and confidence interval are reduced from 201.83 to 142.0 hours and from [198.7, 204.4] to [138.4, 145.7] respectively as the result of adding

one HET company in the onward movement process. This is illustrated in Figure 4-6. This signifies that the onward movement times decreased by an average of 59.83 hours (2.5 days). Although adding one HET company to the current onward movement process in South Korea is not sufficient to meet the required force closure time 6 day window. There is a clear benefit (2.5 days) to their use.

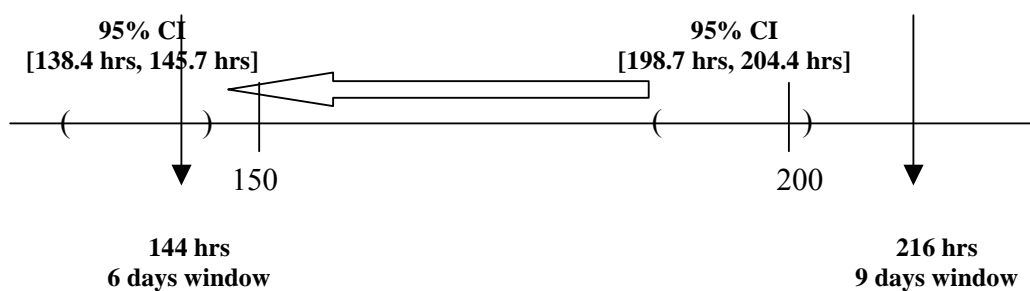

Figure 4-6 Comparison of Current Onward Movement Time with One HET Company Added Onward Movement Time

Results and Analysis Summary

According to the TPFDD Flow, the heavy division's minimum time window for force projection is 6 days (144 hours). To prevent potential congestion or delay in the RSO&I process, every heavy division must be moved within 6 days. Simulated results of the train model showed that onward movement time of one armored division's tracked vehicles was 201.83 hours (8.4 days) with a standard deviation of 4.26 hours. The CI when we use 0.05 as the α level is [198.7, 204.4]. This CI is not within the 6 days (144 hours) window of minimum required force closure time, indicating that the current RSO&I plan with current transportation infrastructure can not meet required force closure times.

According to the results of the Comparison model, HET was a faster transportation mode to move tanks where distances are less than 470.4 km. Beyond this distance, differences in loading time and the characteristic of operation begin to favor trains.

When we add one HET company to the current onward movement process in South Korea, the onward movement mean time of one armored division's tracked vehicles is 142.0 hours (5.9 days) with a standard deviation 4.85 hours. The confidence interval when we use 0.05 as an α level is [138.4, 145.7]. This means that onward movement mean times are decreased by 59.83 hours (2.5 days). But adding one HET company to the current onward movement process in South Korea is not sufficient enough to meet the required force closure time of a 6 day window.

V. Conclusions and Recommendations

Review of Research

The goal of the existence of the military is to be ready for war, fight, and win the war if it takes place. Currently, the US Army is arranging for Objective Force and testing Interim Force for the realization of this goal. But, if we go to war today, we will need to fight and win with a Legacy Force, the Army of today. We must be ready for this. A ready military force means that it can accomplish the operational plan, and is well prepared for current and future combat environments. This study sought to verify current operational plans especially the RSO&I plan in South Korea.

This study simulated the current RSO&I process focusing upon the onward movement process in South Korea. To investigate whether current transportation infrastructure can meet required force closure time or not, a simulation model of the onward movement process using trains was developed. Through the train model, onward movement process of one armored division's tracked vehicles was depicted according to RSO&I exercise 2000 results in South Korea, and consultations of related experts.

The ROK Army has developed HET as a method of the tracked vehicle transportation mode. To figure out which transportation mode is the faster (HET or Train) mode to move tanks by train versus by HET, we built a comparison model. This model depicts the movement associated with moving a unit's tanks from the staging area to the integration areas according to motor transportation company and train operation procedure. We performed a regression analysis and found a breakeven distance.

Finally, we built the combined model to understand the effects of adding one HET company to the current train based RSO&I plan in South Korea as a method of improving the onward movement speed.

Limitations

This study only considered the armored division's tracked vehicles in the onward movement process. When we consider all of the equipment and material of an armored division, and the entire RSO&I process further force projection process, onward movement time will definitely be extended. To evaluate the precise throughput capacity of the current RSO&I plan with the current transportation infrastructure in South Korea to see whether it can meet required force closure time, all of the equipment and material of deploying units, and entire force projection process should be included.

This study assumed that the ROK Army is fielding one HET company as a method of increasing onward movement speed. We compared HET with train to find which transportation mode is faster to move an armored division's M1A1 tanks as a transportation mode selection study. This can be justified only during the wartime scenario in the military, especially rapid deployment are required.

This study only considered the aspect of throughput speed by comparing HET with train as a transportation mode selection study to find which one is faster to move one armored division's tanks in the onward movement process of South Korea. The transportation mode selection study in the military should include all possible aspects,

such as the deploying unit commander's intention, operational environment, and political considerations etc, that effect the transportation mode selection decision.

Recommendations

As we can see in the results of research and conclusions section, current transportation infrastructure can not meet required force closure time, and even the addition of one HET company to the onward movement process will not lower times enough to sufficiently meet required force closure times. However it was shown that HET is a much faster transportation mode to move tanks in the Korean Peninsula for distances less than 470 km and adding one HET company decreases the mean time of the onward movement time from 8.4 days (201.83 hours) to 5.9 days (142.0 hours). This is a decrease in onward movement time of 30% which would be a drastic improvement in any war-fighters opinion. So, we can recommend that one HET company should be fielded and used as the transportation mode for the onward movement process.

Future Research

This study considered only one armored division's tracked vehicles and simulated the onward movement process in the RSO&I process. Future studies should include all of the equipment and material of an armored division to figure out a more accurate onward movement time, and all of the deploying units' flow of RSO&I process further force projection process according to the TPFDD to investigate whether current and

future transportation infrastructure can meet the required force closure times, and find which part of the process causes the most significant delay and congestion.

This study considered only the speed aspect of the onward movement to find which transportation mode is the better one. Future studies should consider all possible aspects of transportation mode selection such as cost, inventory, non-transportation, and cost. Future study also should include the economic aspect of fielding and operating the HET company, and adding 60 more flat car versus 60 HET (one company).

This study considered only that fielding one HET company as a method of increasing onward movement speed. There are many possible way of reducing onward movement time such as reducing loading time, increasing movement speed, and adding loading sites. These leave much room for consideration because some of these may cause notable reduction of movement time with much less cost if the technical problems, safety concerns, and space limitation of loading site are solved. Future study should include all possible aspects of reduction of the onward movement time.

Appendix A: The Arena Simulation Model

A-1 Train Model

Entities arrival and loading process of the train model

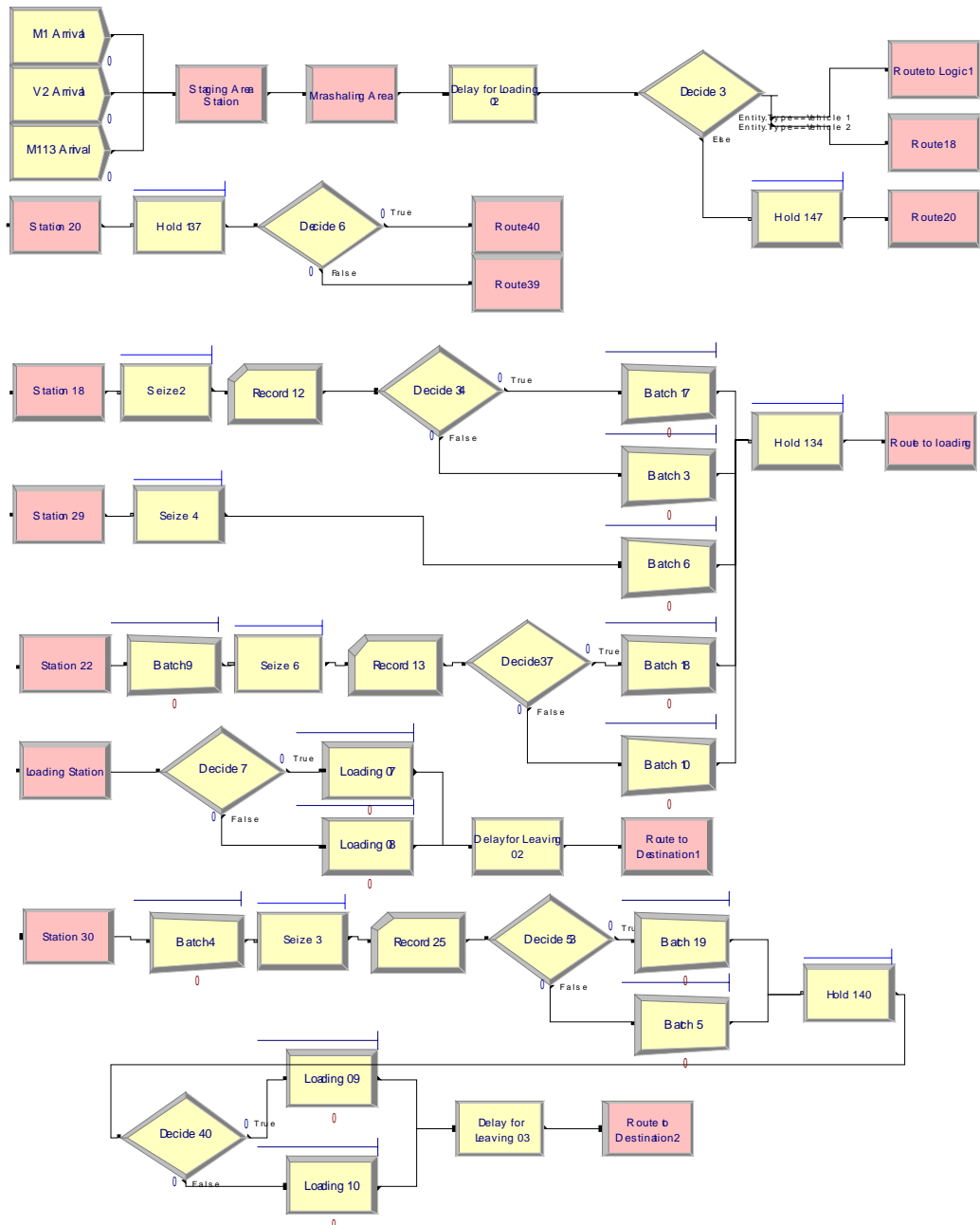

Unloading, separation, and return process of the train model

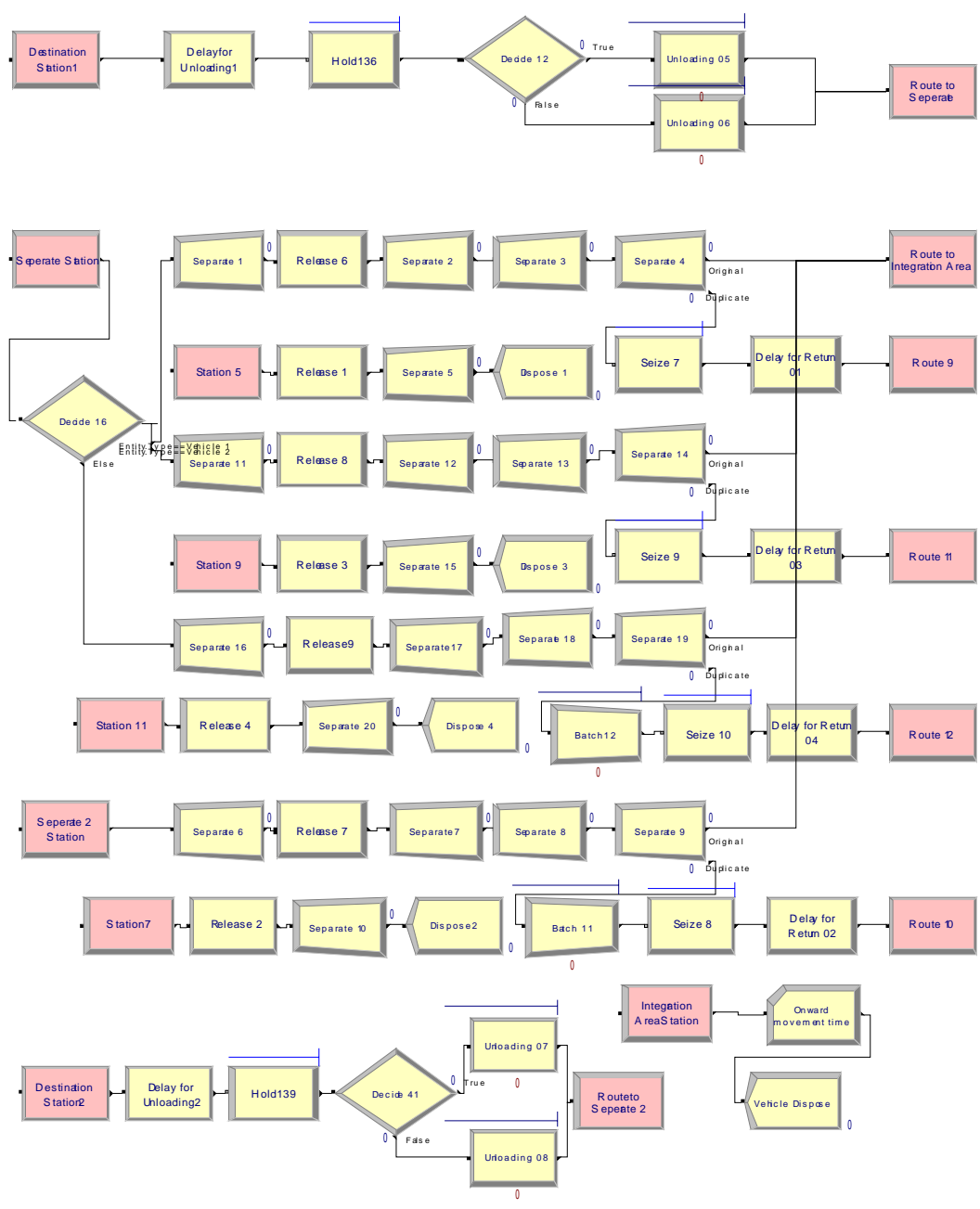

Flatcar allocation logic of the train model

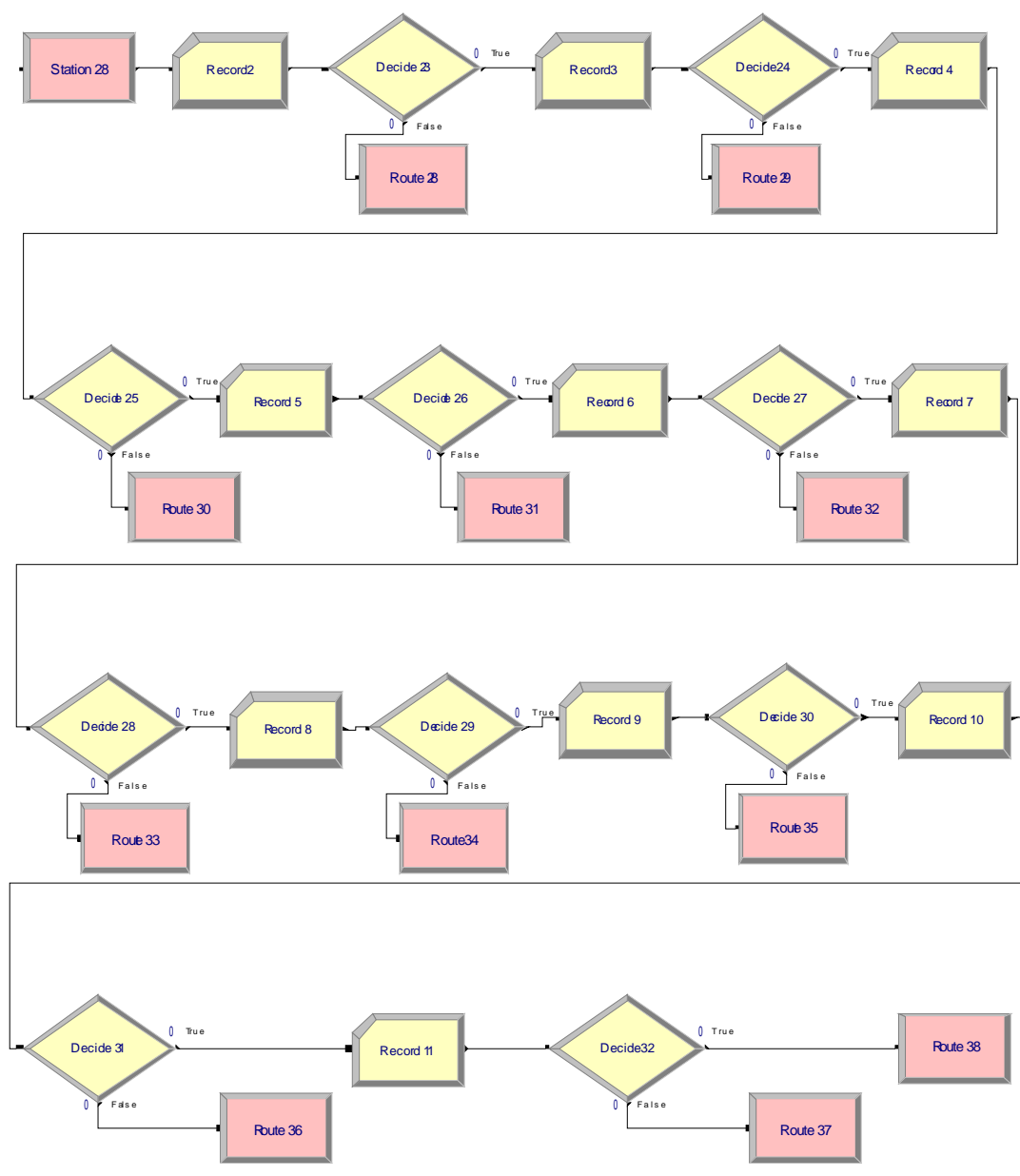

A-2 Comparison Model

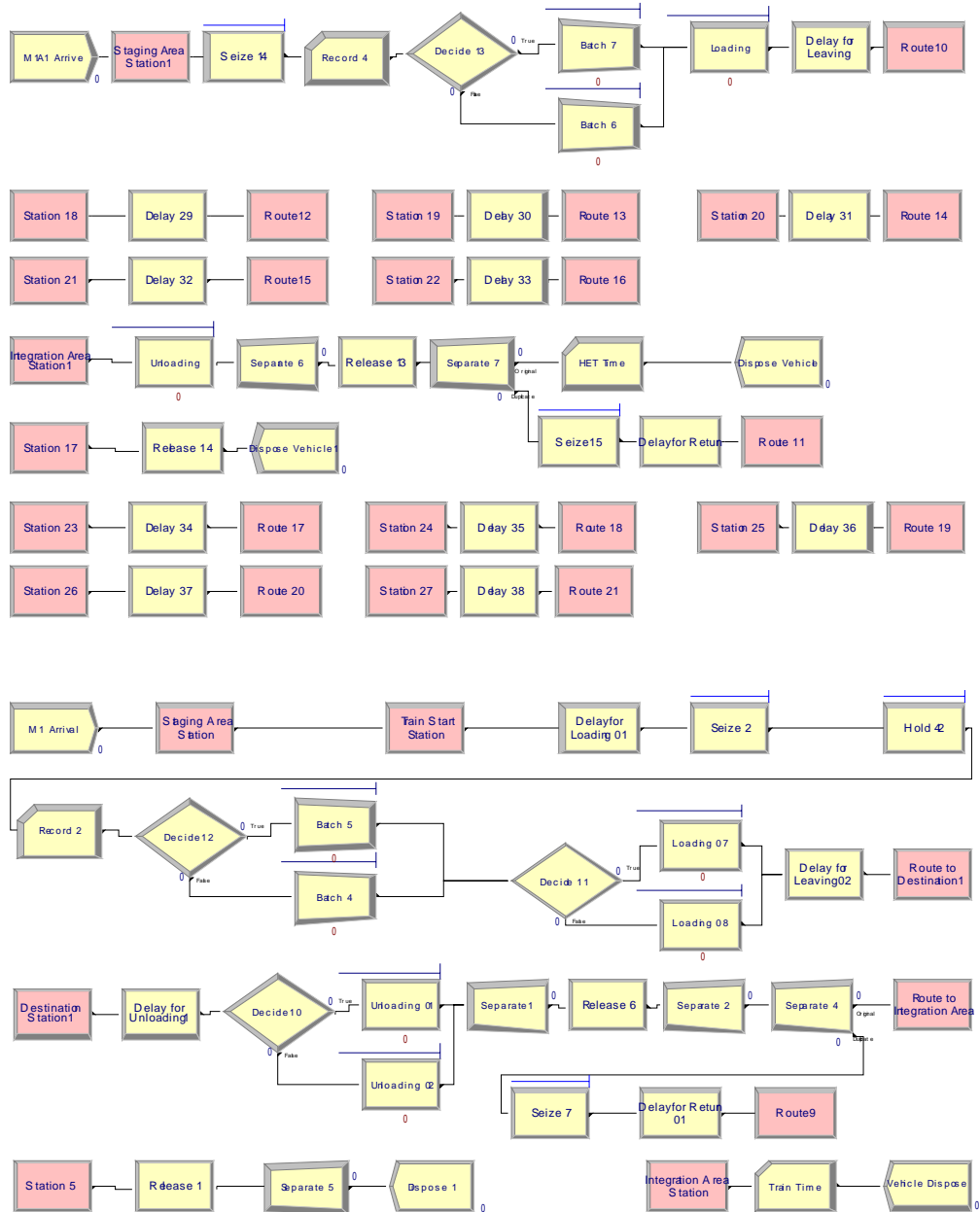

A-3 Combined Model

Entities arrival and loading process of the combined model

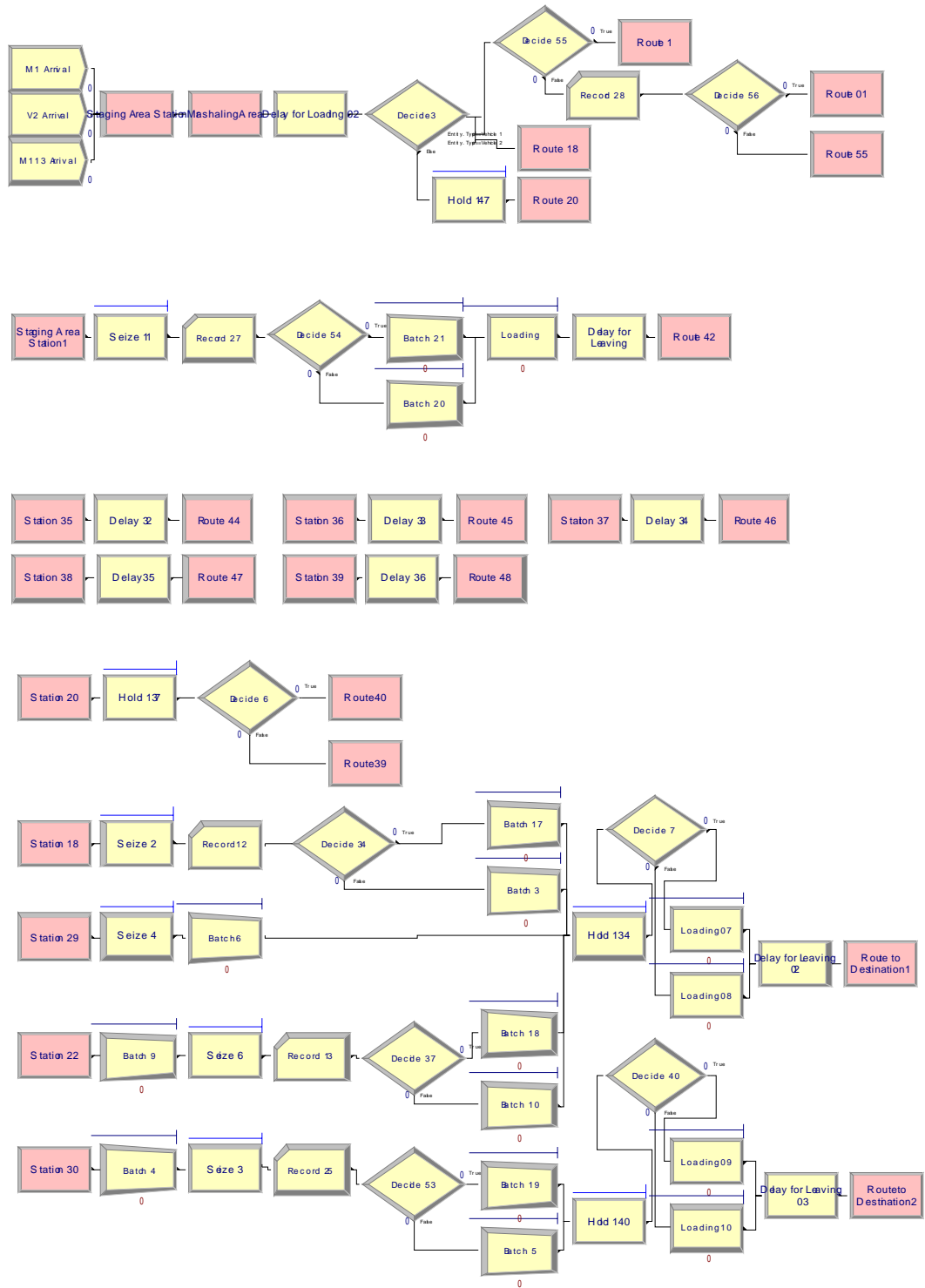

Unloading, separation, and return process of the combined model

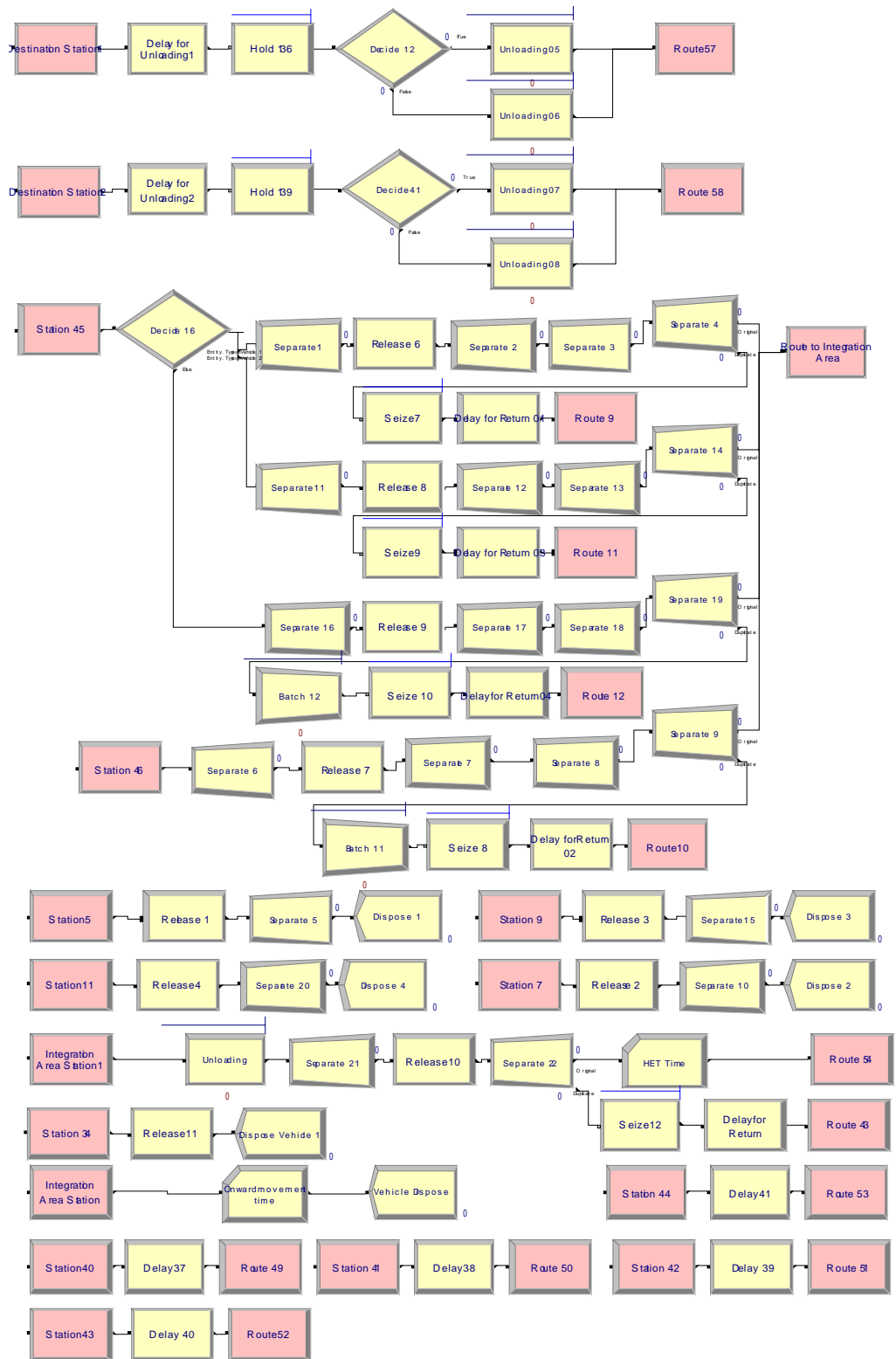

Appendix B: Mathematical and Statistical Analysis

B-1 Calculation of the Required Number of Replications

The general inequality to determine number of replications R is

$$R \geq \left(\frac{t_{\alpha/2, R-1} S_0}{\varepsilon} \right)^2$$

Four replications of the train model are,

$$Ft1 := \begin{pmatrix} 206.3 \\ 205.5 \\ 196.1 \\ 201.92 \end{pmatrix} \quad \text{ORIGIN} \equiv 1$$

Average is $Ft1_{\text{average}} := \text{mean}(Ft1)$ $Ft1_{\text{average}} = 202.455$

Variance is $V_{Ft1} := \text{Var}(Ft1)$ $V_{Ft1} = 21.576$

Standard deviation is $\sigma_{Ft1} := \text{Stdev}(Ft1)$ $\sigma_{Ft1} = 4.645$

$$\sigma := 4.645 \quad w := 1, 1 + 1..10 \quad R(w) := \left(2 \cdot 1.96 \frac{\sigma}{w} \right)^2$$

w =	R(w) =
1	331.546
2	82.886
3	36.838
4	20.722
5	13.262
6	9.21
7	6.766
8	5.18
9	4.093
10	3.315

B-2 Onward Movement by the Train Model Results and Analysis

ORIGIN = 1

$$Ft1 := \begin{pmatrix} 206.3 \\ 205.5 \\ 196.1 \\ 201.9 \\ 199.4 \\ 206.1 \\ 197.2 \\ 196.8 \\ 204.9 \\ 200.7 \end{pmatrix}$$

$n := \text{rows}(Ft1) \quad \alpha := .05$

$Ft1_{\text{average}} := \text{mean}(Ft1) \quad Ft1_{\text{average}} = 201.49$

$V_{Ft1} := \text{Var}(Ft1) \quad V_{Ft1} = 16.301$

$\sigma_{Ft1} := \text{Stdev}(Ft1) \quad \sigma_{Ft1} = 4.037$

$$SE_{Ft1} := \frac{\sigma_{Ft1}}{\sqrt{n}} \quad SE_{Ft1} = 1.277 \quad t_{\text{crit}} := \left| \text{qt} \left(\frac{\alpha}{2}, n - 1 \right) \right| \quad t_{\text{crit}} = 2.262 \quad \varepsilon := t_{\text{crit}} \cdot SE_{Ft1} \quad \varepsilon = 2.888$$

$$t_{\text{crit}Ft1U1} := Ft1_{\text{average}} + t_{\text{crit}} \cdot SE_{Ft1} \quad t_{\text{crit}Ft1U1} = 204.378 \quad t_{\text{crit}Ft1L1} := Ft1_{\text{average}} - t_{\text{crit}} \cdot SE_{Ft1} \quad t_{\text{crit}Ft1L1} = 198.602$$

$$t_{\text{crit}Ft1U1} := Ft1_{\text{average}} + t_{\text{crit}} \cdot SE_{Ft1} \quad t_{\text{crit}Ft1U1} = 204.378 \quad FCMi := 144$$

$$t_{\text{crit}Ft1L1} := Ft1_{\text{average}} - t_{\text{crit}} \cdot SE_{Ft1} \quad t_{\text{crit}Ft1L1} = 198.602 \quad FCMa := 216$$

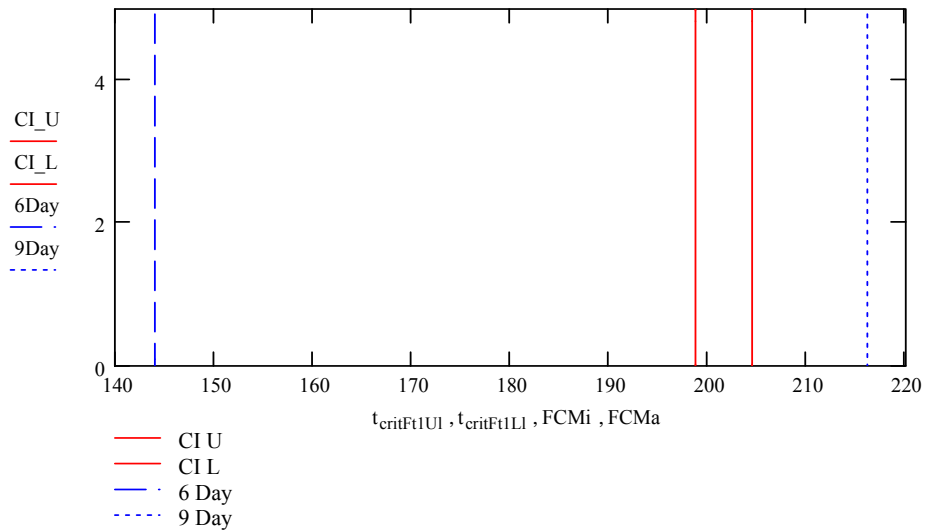

B-3 JMP Liner Regression Analysis

Response Time, Whole Model Actual by Predicted Plot

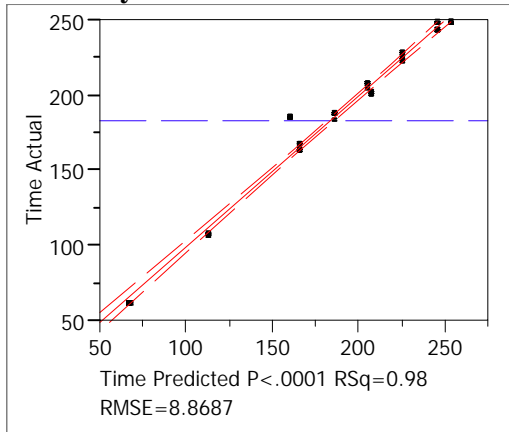

Summary of Fit

RSquare	0.976214
RSquare Adj	0.97547
Root Mean Square Error	8.868665
Mean of Response	183.514
Observations (or Sum Wgts)	100

Analysis of Variance

Source	DF	Sum of Squares	Mean Square	F Ratio
Model	3	309887.31	103296	1313.306
Error	96	7550.71	79	Prob > F
C. Total	99	317438.02		<.0001

Lack Of Fit

Source	DF	Sum of Squares	Mean Square	F Ratio
Lack Of Fit	6	7317.2187	1219.54	470.0770
Pure Error	90	233.4900	2.59	Prob > F
Total Error	96	7550.7087		<.0001
				Max RSq
				0.9993

Parameter Estimates

Term	Estimate	Std Error	t Ratio	Prob> t
Intercept	20.676	2.941403	7.03	<.0001
Distance	0.46712	0.008869	52.67	<.0001
Dummy	125.429	4.159773	30.15	<.0001
Distance*Dummy	-0.26675	0.012542	-21.27	<.0001

Effect Tests

Source	Nparm	DF	Sum of Squares	F Ratio	Prob > F
Distance	1	1	218201.09	2774.217	<.0001
Dummy	1	1	71511.06	909.1944	<.0001
Distance*Dummy	1	1	35577.78	452.3373	<.0001

Residual by Predicted Plot

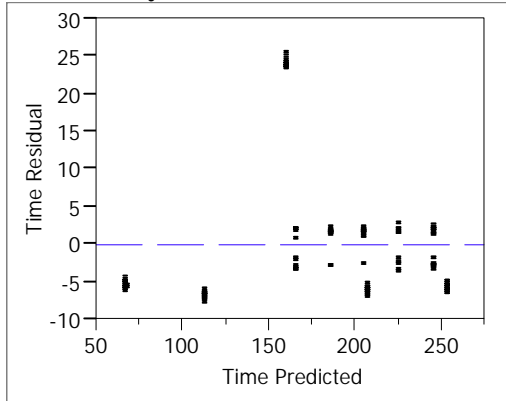

Distance-Leverage Plot

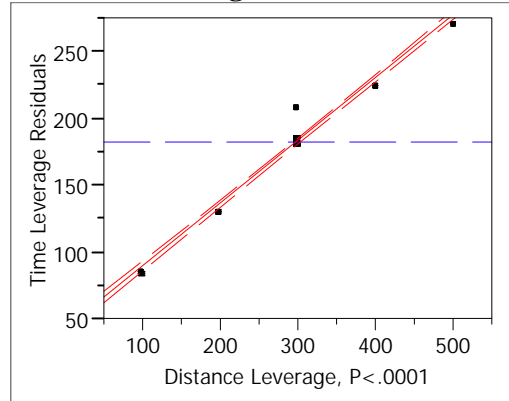

Dummy-Leverage Plot

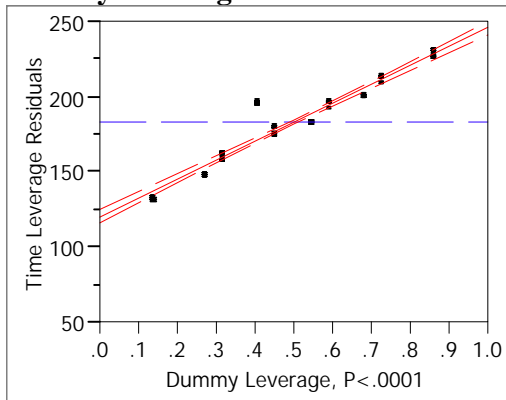

Distance*Dummy-Leverage Plot

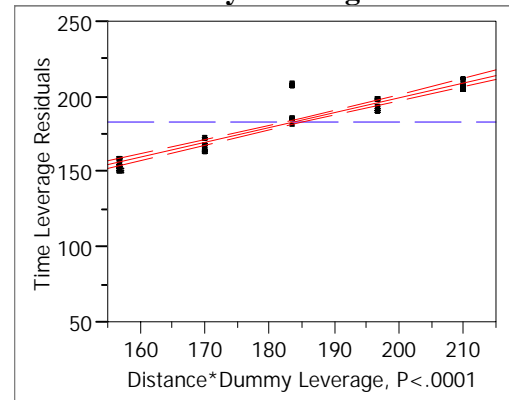

Breakeven Distance

$$\beta_0 := 20.676 \quad \beta_1 := .46712 \quad \beta_2 := 125.479 \quad \beta_3 := -.26675$$

$$EY(D, M) := \beta_0 + \beta_1 \cdot D + \beta_2 \cdot M + \beta_3 \cdot D \cdot M$$

$$D := 100, 105.. 700$$

Given

$$ey = \beta_0 + \beta_1 \cdot d$$

$$ey = \beta_0 + \beta_1 \cdot d + \beta_2 + \beta_3 \cdot d$$

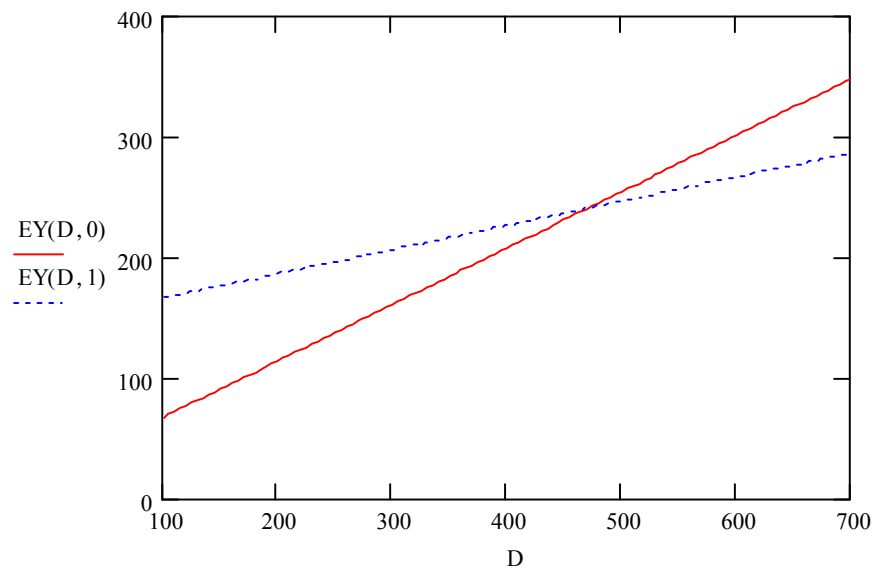

$$\text{Find}(ey, d) \text{ float}, 5 \rightarrow \begin{pmatrix} 240.41 \\ 470.40 \end{pmatrix}$$

B-4 Onward Movement by the Combined Model Results and Analysis

ORIGIN = 1

Rc := $\begin{pmatrix} 137.1 \\ 149.0 \\ 144.9 \\ 132.1 \\ 145.0 \\ 140.9 \\ 138.1 \\ 146.3 \\ 141.4 \\ 145.5 \end{pmatrix}$

n := rows(Rc) α := .05

Rc_{average} := mean(Rc) Rc_{average} = 142.03

V_{Rc} := Var(Rc) V_{Rc} = 26.216

σ_{Rc} := Stdev(Rc) σ_{Rc} = 5.12

$$SE_{Rc} := \frac{\sigma_{Rc}}{\sqrt{n}} \quad SE_{Rc} = 1.619 \quad t_{critl} := \left| qt\left(\frac{\alpha}{2}, n - 1\right) \right| \quad t_{critl} = 2.262 \quad \epsilon := t_{critl} \cdot SE_{Rc} \quad \epsilon = 3.663$$

$$t_{critRcUl} := Rc_{average} + t_{critl} \cdot SE_{Rc} \quad t_{critRcUl} = 145.693 \quad t_{critRcLl} := Rc_{average} - t_{critl} \cdot SE_{Rc} \quad t_{critRcLl} = 138.367$$

$$t_{critRcUl} := Rc_{average} + t_{critl} \cdot SE_{Rc} \quad t_{critRcUl} = 145.693 \quad FCMi := 144$$

$$t_{critRcLl} := Rc_{average} - t_{critl} \cdot SE_{Rc} \quad t_{critRcLl} = 138.367 \quad FCMa := 216$$

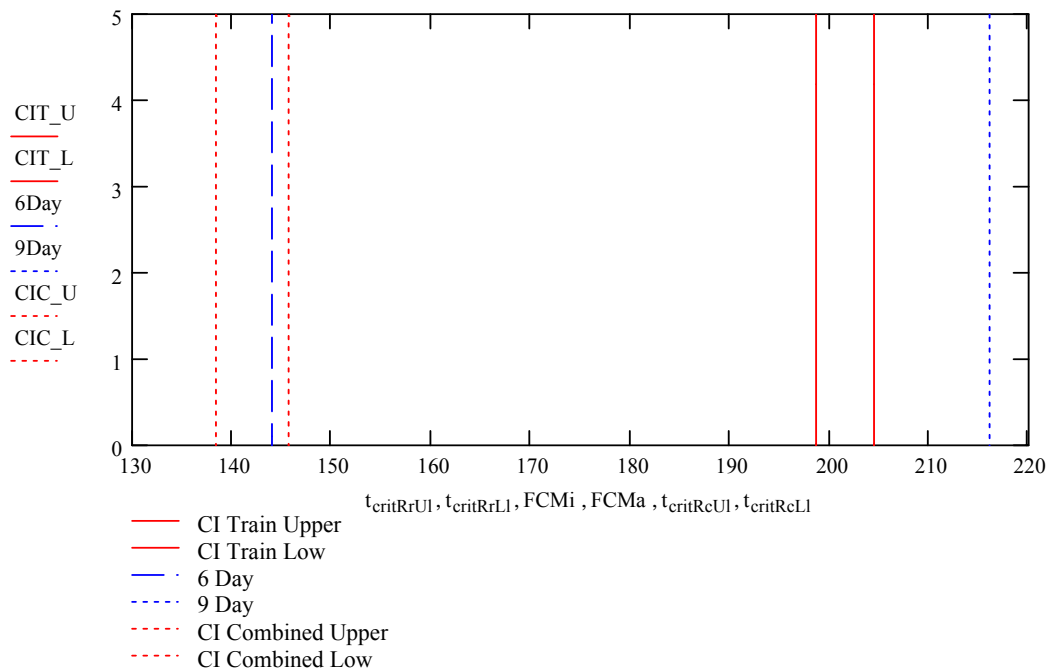

Appendix C. Acronyms and Abbreviation

-A-

AFPOA	Air Force Personnel Operations Agency
APOD	Aerial Port of Debarkation
ATCP	Army Transformation Campaign Plan

-B-

BAO	Brigade Ammunition Officer
-----	----------------------------

-C-

CINC	Commander in chief
CHE	Container Handling Equipment
CI	Confidence Interval
CONUS	Continental United States
COSCOM	Corps Support Command
CPMX	Command Post Maneuver Exercise
CPX	Command Post Exercise
CS	Combat Support
CSS	Combat Service Support

-D-E-

DA	Department of the Army
ECDS	Enhanced Container Delivery System

-F-G-

FM	Field Manual
GBL	Government Bill of Lading
GPS	Global Positioning System

-H-

HET	Heavy Equipment Transport
HNS	Host Nation Support
HQ	Headquarter

-I-

IBCT	Initial or Interim Brigade Combat Team
ICD	Inland Container Depot
ITV	In-Transit Visibility

-J-

JFC	Joint Force Command
JIT	Just-In-Time-Logistics

JTF Joint Task Force

-K-

KIH Kilometer in Hour
KM (Km) Kilometer

-L-

LOC Lines of Communication

-M-

MA Marshaling Area
MD Movement Distance
MHE Materials Handling Equipment
MOPP Mission Oriented Protective Posture
MTMC Military Traffic Management Command

-N-

NBC Nuclear, Biological & Chemical
NCO Noncommissioned Officers

-O-P-Q-R-

O&O Operational and Organizational
POD Port of Debarkation
RSO&I Reception, Staging, Onward Movement, and Integration

-S-

SOP Standing Operating Procedures
SPOD Sea Port of Debarkation
SPOE Sea Port of Embarkation
ST Short Ton

-T-

TAA Tactical Assembly Area
TPFDDF Time-Phased Force and Deployment Data Flow

-U-V-W-X-Y-Z-

Bibliography

- General Gordon R. Sullivan, and Lieutenant Colonel James M. Dubik. *Land Warfare in the 21st Century*. US Army War College Fourth Annual Strategy Conference, 24-25 February 1993.
- John L. Romjue. *American Army Doctrine for the Post-Cold War*. US Army Training and Doctrine Command, Port Monroe VA, 1996, 160 pages.
- U.S. Department of the Army. *Reception, Staging, Onward Movement, and Integration*. FM 100-17-3. Headquarters Department of the Army Washington DC, 17 March 1999. Available at web address:
<http://www.adtdl.army.mil/cgi-bin/atdl.dll/fm/100-17-3/toc.htm>
- U.S. Department of the Army. *Movement Control*. FM 55-10. Headquarters Department of the Army Washington DC, 9 February 1999. Available at web address:
<http://www.adtdl.army.mil/cgi-bin/atdl.dll/fm/55-10/toc.htm>
- U.S. Department of the Army Headquarters. 2000. "Soldiers On Point for the Nation: Army Transformation Brief", 17 October 2000. Slides 4-5. Available at web address:
<http://192.111.52.91/resdoc/doctrine/Transformation/TRANSFORMATION.pdf>.
- U.S. Department of Defense. *Mobility Requirements Study Bottom-Up Review Update*, 1994
- Jean J. O'Reilly, and William R. Lilegdon. "Introduction to AweSim", Winter Simulation Conference, 1999
- Major Christopher W. Kirkman. "RSO&I in South Korea." Available at web address:
http://www.mors.org/education_colloquium/EC2001/Presentations/RSOI_files/frame.htm
- Yosef Sheffi, Babak Eskandari, and Haris N. Koutsopoulos. "Transportation Mode Choice Based on the Total Logistics Costs," *Journal of Business Logistics*, Volume 9, Number 2: 137-154 (1992)
- Michael A. McGinnis. "A Comparative Evaluation of Freight Transportation Choice Models," *Transportation Journal*, Freight Choice Models: 36-46 (1989)
- Rockwell Software. "USAF Uses Arena to Determine Staffing and Make Effective Policy Decisions." Available at web address:
<http://www.arenasimulation.com/pdf/ARENA-AP003A-EN-P.pdf>

Rockwell Automation, "The Arena Product Family -- a white paper." 30 September 2000.
Available at web address:
<http://www.arenasimulation.com/pdf/ArenaWhitePaper.pdf>

Richard W. Pew. and Anne S. Mavor. *Modeling Human and Organizational Behavior: Application to Military Simulation*. Washington, DC: National Academy Press, 1998

Wyland, B. Buxton, K. and B. Fuqua, "Simulating the Supply Chain," *IIE Solutions*, January 2000, 37-42.

U.S. Department of the Army. *Transportation Reference Data*. FM 55-15. Headquarters Department of the Army Washington DC, 27 October 1997. Available at web address:
<http://www.adtdl.army.mil/cgi-bin/atdl.dll/fm/55-15/default.htm>

Law, Averill M. and Kelton, W. David. *Simulation Modeling and Analysis* (3rd Edition). New York NY: McGraw-Hill, 2001.

Jerry Banks and John S. Carson, II. *Discrete-Event System Simulation*. New Jersey Prentice-Hall, 1984

Pegden, C.E., Shannon, R.E., Sadowski, R. *Introduction to Simulation using SIMAN* (2nd Edition). New York: McGraw-Hill, 1995.

U.S. Department of the Army. *Strategic Deployment*. FM 55-65. Headquarters Department of the Army Washington DC, 3 October 1995. Available at web address:
http://usasma.bliss.army.mil/pubs/FM_55-65/PDF/

U.S. Department of the Army. *Army Motor Transport Units and Operations*. FM 55-30. Headquarters Department of the Army Washington DC, 27 June 1997.
Available at web address:
<http://www.adtdl.army.mil/cgi-bin/atdl.dll/fm/55-30/toc.htm>

ROK Army. *Army Motor Transport Operations*. FM 22-10-2. Headquarters Department of the Army ChungNam ROK, 12 March 1999.

John Neter. and others. *Applied linear statistical models 4th Edition*, New York NY: WCB/McGraw-Hill, 1996

Vita

Captain Seongkyun Lee was born in Goryeong, Gyeongbuk Province, Republic of Korea, and graduated from Simin High School in 1988. Seongkyun entered the Korea Military Academy (KMA) in Seoul, and majored in the Mechanical Engineering. In 1993, Seongkyun graduated from KMA with honors and was commissioned a Second Lieutenant in the Republic of Korea Army Transportation Corps.

His initial assignment was the 101st Infantry Brigade as a platoon leader. Following his experience as a infantry platoon leader, Seongkyun was transferred to 63rd Light Transportation Battalion as a transportation platoon leader on 10 November 1994, and reassigned as Battalion S-2 on 4 April 1995. In September 1996, Seongkyun was assigned to 611th Transportation Battalion as the 4th Medium Motor Company Commander.

In December 1998, Seongkyun was selected to attend the US Army's Combined Logistics Captains Career Course (CLCCC), Fort Lee, Virginia. There, he was first exposed to the American culture and military education. After the CLCCC program, he was assigned to the ROK Army Consolidated Logistics School as a Transportation Division Instructor. In September 2000, Captain Lee was selected to come to the Air Force Institute of Technology (AFIT), Wright-Patterson Air Force Base, Ohio, to pursue a Master of Science degree in Logistics (Transportation) Management.

REPORT DOCUMENTATION PAGE

Form Approved
OMB No. 074-0188

The public reporting burden for this collection of information is estimated to average 1 hour per response, including the time for reviewing instructions, searching existing data sources, gathering and maintaining the data needed, and completing and reviewing the collection of information. Send comments regarding this burden estimate or any other aspect of the collection of information, including suggestions for reducing this burden to Department of Defense, Washington Headquarters Services, Directorate for Information Operations and Reports (0704-0188), 1215 Jefferson Davis Highway, Suite 1204, Arlington, VA 22202-4302. Respondents should be aware that notwithstanding any other provision of law, no person shall be subject to a penalty for failing to comply with a collection of information if it does not display a currently valid OMB control number.

PLEASE DO NOT RETURN YOUR FORM TO THE ABOVE ADDRESS.

1. REPORT DATE (DD-MM-YYYY) 03-04-2003		2. REPORT TYPE Master's Thesis		3. DATES COVERED (From - To) August 2002—March 2003	
4. TITLE AND SUBTITLE ONWARD MOVEMENT TRANSPORTATION MODE SELECTION STUDY			5a. CONTRACT NUMBER		
			5b. GRANT NUMBER		
			5c. PROGRAM ELEMENT NUMBER		
6. AUTHOR(S) Seongkyun Lee, Captain, ROK Army			5d. PROJECT NUMBER		
			5e. TASK NUMBER		
			5f. WORK UNIT NUMBER		
7. PERFORMING ORGANIZATION NAMES(S) AND ADDRESS(S) Air Force Institute of Technology Graduate School of Engineering and Management (AFIT/EN) 2950 P Street, Building 640 WPAFB OH 45433-7765			8. PERFORMING ORGANIZATION REPORT NUMBER AFIT/GLM/ENS/03-06		
9. SPONSORING/MONITORING AGENCY NAME(S) AND ADDRESS(ES)			10. SPONSOR/MONITOR'S ACRONYM(S) CASCOM, DCD-CSS		
			11. SPONSOR/MONITOR'S REPORT NUMBER(S)		
12. DISTRIBUTION/AVAILABILITY STATEMENT APPROVED FOR PUBLIC RELEASE; DISTRIBUTION UNLIMITED.					
13. SUPPLEMENTARY NOTES					
14. ABSTRACT As a result of the global security environment change, the US Army's posture has changed from forward deployment to power projection and resulted in the reduction of the Army force structure. This change also reduced the possibility of United States' involvement in a large scale of warfare but requires rapid and reliable deployment to stabilize a hostile area. Force projection is the demonstrated ability to alert, mobilize, deploy rapidly, and operate effectively anywhere in the world and consists of three deployment segments: fort to port, port to port, and port to foxhole. Reception, Staging, Onward Movement, and Integration (RSO&I) is detailed process of port to foxhole segment. Onward movement is the process of moving units and accompanying materiel from reception facilities and staging areas to Tactical Assembly Areas (TAAs). This study employs simulation models to evaluate whether the current transportation infrastructure can meet required force closure time and which transportation mode, trans versus Heavy Transporter Equipment (HET), is faster to move M1A1 tanks in the Korean Peninsula in the onward movement process.					
15. SUBJECT TERMS Reception, Staging, Onward Movement, and Integration; RSO&I; Onward Movement; Discrete-Event Simulation; Simulation; Arena; Heavy Equipment Transporter (HET); Onward Movement by HET and Train; Qualitative Predictor Variables Regression Analysis					
16. SECURITY CLASSIFICATION OF:		17. LIMITATION OF ABSTRACT	18. NUMBER OF PAGES	19a. NAME OF RESPONSIBLE PERSON Stanley Griffis E, Maj, USAF (ENS)	
a. REPO RT	b. ABSTRA CT	c. THIS PAGE	UU	19b. TELEPHONE NUMBER (Include area code) (937) 255.6565 x4339; e-mail: stan.griffis@afit.edu	
U	U	U	78		