

# BIOMEDICAL DATA ACQUISITION SYSTEMS BASED ON SIGMA-DELTA ANALOGUE-TO DIGITAL CONVERTERS

E.V. Aksenov, Yu.M. Ljashenko, A.V. Plotnikov, D.A. Prilutskiy, S.V. Selishchev, E.V. Vetvetskiy  
Biomedical Systems Department, Moscow State Institute of Electronic Technology, Moscow, Russia

**Abstract**-The high resolution of recent sigma-delta analogue-to-digital converters (ADCs) has made possible the direct acquisition of a wide range of biomedical data. Such ADCs allows creating universal systems as for medical research and for clinical practice.

**Keywords** - Sigma-Delta, biomedical data acquisition systems

## INTRODUCTION

The performance of biomedical data acquisition systems is generally limited by precision of the digital input data, which is achieved at the interface between analog and digital signals. The recent developments in digital VLSI technologies provide the practical means to implement the Sigma-Delta ( $\Sigma$ - $\Delta$ ) analogue-to-digital converters (ADCs). The increasing use of digital techniques in biomedical data acquisition systems has also contributed to the recent interest in cost effective high precision ADCs. Sigma-delta modulation based on analog-to-digital conversion technology is cost effective alternative for high resolution (greater than 14 bits) converts, which can be ultimately integrated on digital signal processor ICs [1].

## METHODOLOGY

Electrophysiological acquisition systems must extract and amplify the low - level signal (less than 200  $\mu$ V in EEG and 10 mV in ECG) from a relatively high level (~ hundreds of mV) of common mode interference, electrode artefact etc. Traditional biomedical amplifiers front ends have been based on around instrumentation amplifiers.

The high resolution of sigma-delta converters allows ECG or EEG signals to be acquired directly, without the use of instrumentation amplifiers. The large common mode signals can be digitized without saturation and the small differential signal can be recovered with resolutions comparable to convention methods [2,3,4].

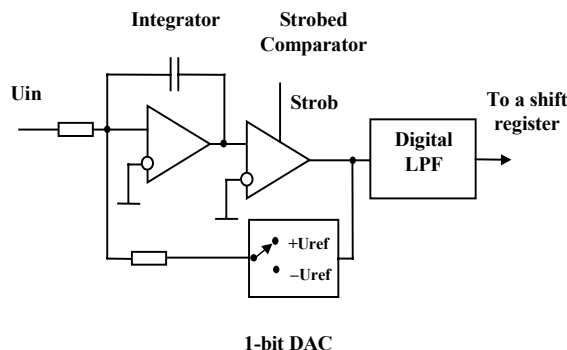

Fig. 1. One channel sigma-delta ADC

One channel sigma-delta ADCs (Fig. 1) employ a negative feedback loop consist of an integrator, comparator and one-bit digital-to-analog converter (DAC). The input analogue signal is first integrated and compared with ground

using a sampling comparator. Its output drives a one bit DAC that switches reference voltages to the summing node of the integrator, minimising the difference of signals. The loop operates at a high oversampling ratio. The output word is retrieved after digital low pass filter.

One from the first sigma-delta ADC chip, prevalent in biomedical systems, was AD7716 of production Analog Devices. On it to a basis the systems for the ECG, EEG, IMG (impedance measure) are developed. On Fig.2 showed digital ECG system on AD7716 for registration standard lead.

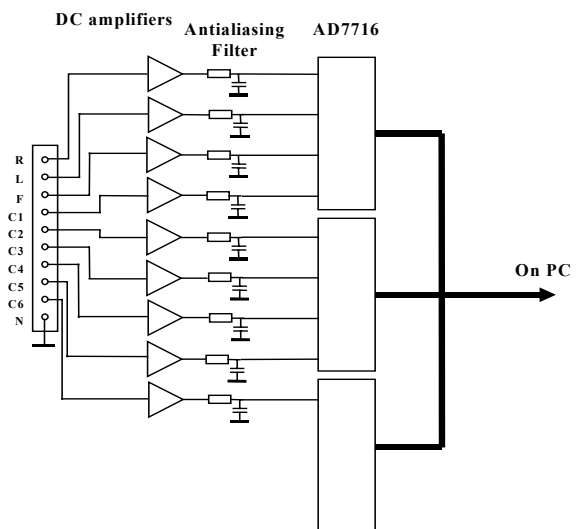

Fig. 2. 12-channel ECG on AD7716

Devices consist of DC amplifiers (gain equals 4 for ECG and 19 for EEG), simply RC antialiasing filters, AD7716 and serial channel to PC. There are sampling rate 512kHz synchronously on all channel, high pass digital filtering and decimation. Output sampling rate may be programmable 1000, 500, 250, 125 Hz. Digital signals processing – correction gain channels, leads calculation and filtration are made on the PC or microprocessor.

The application sigma-delta ADC, intended for digital sound in majority of biomedical systems is poorly effective. As a rule, such ADC is not intended for work on frequencies less than 10-20 Hz, have fixed sampling rate, and high power supply.

However, now a lot of the companies have developed universal sigma-delta ADC for work with signals on frequencies up to 10 kHz. These chips distinguishes as are less expensive, for example – sigma-delta ADC ADS1252 from Burr-Brown (Texas Instrument). The ADS1252 is a precision, wide dynamic range ADC with 24-bit resolution operating from a single +5V supply. The delta-sigma architecture is used for wide dynamic range and to guarantee 24 bits of no missing codes performance. An effective resolution of 19 bits (2.5ppm of rms noise) is achieved for

## Report Documentation Page

<b>Report Date</b> 25 Oct 2001	<b>Report Type</b> N/A	<b>Dates Covered (from... to)</b> -
<b>Title and Subtitle</b> Biomedical Data Acquisition Systems Based on Sigma-Delta Analogue-to Digital Converters	<b>Contract Number</b>	
	<b>Grant Number</b>	
	<b>Program Element Number</b>	
<b>Author(s)</b>	<b>Project Number</b>	
	<b>Task Number</b>	
	<b>Work Unit Number</b>	
<b>Performing Organization Name(s) and Address(es)</b> Biomedical Systems Department Moscow State Institute of Electronic Technology Moscow, Russia	<b>Performing Organization Report Number</b>	
<b>Sponsoring/Monitoring Agency Name(s) and Address(es)</b> US Army Research, Development & Standardization Group (UK) PSC 802 Box 15 FPO AE 09499-1500	<b>Sponsor/Monitor's Acronym(s)</b>	
	<b>Sponsor/Monitor's Report Number(s)</b>	
<b>Distribution/Availability Statement</b> Approved for public release, distribution unlimited		
<b>Supplementary Notes</b> Papers from 23rd Annual International Conference of the IEEE Engineering in Medicine and Biology Society, October 25-28, 2001, held in Istanbul, Turkey. See also ADM001351 for entire conference on cd-rom.		
<b>Abstract</b>		
<b>Subject Terms</b>		
<b>Report Classification</b> unclassified	<b>Classification of this page</b> unclassified	
<b>Classification of Abstract</b> unclassified	<b>Limitation of Abstract</b> UU	
<b>Number of Pages</b> 2		

conversion rates up to 40kHz. On 40 kHz output rate signal passband equals 9kHz.

In modern biomedical acquisitions systems required more resolution on low passband. Theoretically for random noise, the effective resolution can be improved with averaging. The result is the reduction in noise by the factor  $\sqrt{N}$ , where N is the number of averages.

Practically this procedure in progress on Digital Signal Processor (DSP) and consist of *filtering* and *decimation*. Decimation is the process of downshifting the data (sampling) rate to a lower frequency. This then enables digital filtering based on the higher frequency. By increasing the data rate digital filtering can be applied directly at the main passband edge. On Fig.3 showed all acquisition studies.

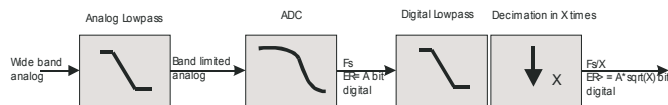

Fig. 3. 12-channel ECG on AD7716

## RESULTS

On base sigma-delta ADC some systems including ECG and EEG were developed.

### ECG device specification:

- input impedance not less than 90 MΩ;
- range of measured signals ±600 mV;
- pass band DC–140Hz (-3 dB) for output rate 500Hz;
- resolution 1.3 μV;
- software filters 0.02, 0.05, 0.1, 0.25, 0.5, 1 Hz;
- software rejecting filter on 50/60 Hz;
- software intellectual system for the channel keeping of the isoline;
- CMRR not less than 100 dB;
- persistent control on «rupture of electrode»;
- II-CF class electro-safety according to IEC601;
- USB interface to PC

### ECG software provides:

- possible lead schemes: 12 standard, Nab, Frank, bipolar orthogonal, McFee;
- standard 12-channel ECG processing;
- high-resolution ECG (Simpson method, wavelet);
- heart rate variability (time and frequency domain, wavelet)
- vectorcardiography;
- ECG mapping on the base of Frank leads (Decarto©).

### EEG device specification:

- 24 or 40 unipolar channel (up 23 or 39 differential channel);
- input impedance not less than 90 MΩ;
- range of measured signals ±130 mV;
- pass band DC–200 Hz (-3 dB) for output rate 250 Hz;
- resolution 0.3 μV;
- CMRR not less than 110 dB;
- persistent control on «rupture of electrode»;

- impedance measurement;
- electro-safety according to IEC601;
- size (200x150x50 mm), connector for EEG cap
- USB interface to PC

### EEG software provides:

- filtering on base FFT;
- 2D and 3D mapping;
- spectral analysis;
- dipole localization;
- overlapping EEG and MRI (CT) data;
- research long evoked potentials (EP);
- sleep research.

## CONCLUSION

Sigma-delta ADCs provide a useful alternative to traditional acquisition systems of electrophysiological signals (Table I).

TABLE I

Classification	Frequency Range	Dynamic Range	Comments
Electro-retinogram (ERG)	0.2–200Hz	0.5μV–1mV	Evoked flash potential
Electro-oculogram (EOG)	DC–100Hz	10μV–5mV	Steady corneal-retinal potential
Electro-encephalogram (EEG)	0.5–100Hz	2μV–200μV	Multichannel (6–32) scalp potential
Visual Evoked potentials (VEP)	1–300Hz	0.1μV–20μV	Response of brain potential to stimulus
Surface EMG (SEMG)	0.01–500Hz	50μV–5mV	Action potential from muscle fiber
Electro-cardiogram (ECG)	0.05–100Hz	1μV–10mV	Recording electrical activity heart.

## REFERENCES

- [1] Principles of Sigma-Delta Modulation for Analog-to-Digital Converters, *Comm. Appl. Manual*, APR8, Motorola, DL411D/REV 1, pp.293-350,1993.
- [2] J.J. McKee, N.E.Evans and D. Wallace. “Sigma-Delta analogue-to-digital converters for ECG signal acquisition,” in *CD-ROM Proc. of 18th Annual International Conference of the IEEE EMBS*.Amsterdam, 1996.
- [3] Kurekov S. F., Prilutski D. A., Selishchev S. V. «Sigma-Delta Analogue-to-Digital converters for Biomedical Data Acquisition Systems,» in *Proc. 4th European conference on engineering and medicine*, 1997, pp.163-164.
- [4] S.F.Kurikov, D.A.Prilutski and S.V.Selishchev, «Use of sigma-delta analog-to-digital converter in multichannel electrocardiographs,» *Biomed. Eng.* Vol.31, No.4., 1997, pp.190–194.
- [5] M. Curtin, «Sigma-Delta techniques reduce hardware count and power consumption in biomedical analog front end», *Anal. Dial. Journal* Vol.28, No.2, 1994, pp.6-7.