



**UNITED STATES AIR FORCE
IERA**

**Clean Air Act Emission Testing
of the T-38C Aircraft Engines**

Tom Gerstle

**Environmental Quality Management, Inc.
1800 Carillon Boulevard
Cincinnati, Ohio 45340**

Mark D. Wade

**Karta Technologies, Inc.
5555 Northwest Parkway
San Antonio, TX 78249**

20030324 034

September 2002

*Approved for public release;
distribution is unlimited.*

**Air Force Institute for Environment, Safety
and Occupational Health Risk Analysis
Risk Analysis Directorate
Environmental Analysis Division
2513 Kennedy Circle
Brooks City-Base TX 78235-5116**

NOTICES

When Government drawings, specifications, or other data are used for any purpose other than in connection with a definitely Government-related procurement, the United States Government incurs no responsibility or any obligation whatsoever. The fact that the Government may have formulated or in any way supplied the said drawings, specification, or other data, is not to be regarded by implication, or otherwise in any manner construed, as licensing the holder or any other person or corporation; or as conveying any rights or permission to manufacture, use, or sell any patented invention that may in any way be related thereto.

The mention of trade names or commercial products in this publication is for illustration purposes and does not constitute endorsement or recommendation for use by the United States Air Force.

The Office of Public Affairs has reviewed this report, and it is releasable to the National Technical Information Service, where it will be available to the general public, including foreign nationals.

The report has been reviewed and is approved for publication.

Government agencies and their contractors registered with Defense Technical Information Center (DTIC) should direct requests for copies to: Defense Technical Information Center, 8725 John J. Kingman Rd., Suite 0944, Ft Belvoir, VA 22060-6218.

Non-Government agencies may purchase copies of this report from: National Technical Information Services (NTIS), 5285 Port Royal Road, Springfield, VA 22161-2103.

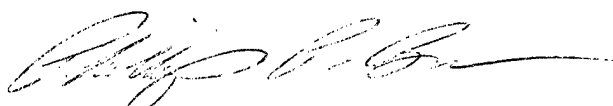

PHILLIP P. BROWN, Major, USAF, BSC
Technical Project Manager

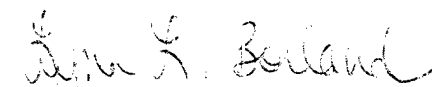

LYNN L. BORLAND, Lt Col, USAF, BSC
Chief, Environmental Analysis Division

REPORT DOCUMENTATION PAGE

Form Approved
OMB No. 0704-0188

Public reporting burden for this collection of information is estimated to average 1 hour per response, including the time for reviewing instructions, searching existing data sources, gathering and maintaining the data needed, and completing and reviewing the collection of information. Send comments regarding this burden estimate or any other aspect of this collection of information, including suggestions for reducing this burden, to Washington Headquarters Services, Directorate for Information Operations and Reports, 1215 Jefferson Davis Highway, Suite 1204, Arlington, VA 22202-4302, and to the Office of Management and Budget, Paperwork Reduction Project (0704-0188), Washington, DC 20503.

| | | | | |
|---|--|---|---|--|
| 1. AGENCY USE ONLY (Leave blank) | | 2. REPORT DATE September 2002 | 3. REPORT TYPE AND DATES COVERED Final | |
| 4. TITLE AND SUBTITLE Clean Air Act Emission Testing of the T-38C Aircraft Engines | | | 5. FUNDING NUMBERS F41624-95-D-9012 | |
| 6. AUTHOR(S) Tom Gerstle, *Mark D. Wade | | | | |
| 7. PERFORMING ORGANIZATION NAME(S) AND ADDRESS(ES) Environmental Quality Management Inc., 1800 Carillon Boulevard, Cincinnati Ohio 45340 *Karta Technologies Inc., 5555 N.W. Parkway, San Antonio TX 78235-5116 | | | 8. PERFORMING ORGANIZATION REPORT NUMBER | |
| 9. SPONSORING/MONITORING AGENCY NAME(S) AND ADDRESS(ES) Air Force Institute for Environment, Safety and Occupational Risk Analysis Risk Analysis Directorate Environmental Analysis Division 2513 Kennedy Circle Brooks City-Base, TX 78235-5116 | | | 10. SPONSORING/MONITORING AGENCY REPORT NUMBER IERA-RS-BR-SR-2003-0001 | |
| 11. SUPPLEMENTARY NOTES | | | | |
| 12a. DISTRIBUTION AVAILABILITY STATEMENT Approved for public release, distribution unlimited | | | 12b. DISTRIBUTION CODE | |
| 13. ABSTRACT (Maximum 200 words) The Report is the product of an emissions testing program designed to document, characterize, and evaluate emissions from the T-38C aircraft engines modifications. The purpose of the emissions testing program was to develop emission factors for the tested engines under representative load conditions. Testing was performed by Environmental Quality Management, Inc. (EQM). Testing was conducted for criteria and hazardous air pollutants. | | | | |
| 14. SUBJECT TERMS T-38, Aircraft Engine Emissions, J85-GE-15 Engine Air Pollutant Emissions | | | 15. NUMBER OF PAGES 252 | |
| | | | 16. PRICE CODE | |
| 17. SECURITY CLASSIFICATION OF REPORT Unclassified | 18. SECURITY CLASSIFICATION OF THIS PAGE Unclassified | 19. SECURITY CLASSIFICATION OF ABSTRACT Unclassified | 20. LIMITATION OF ABSTRACT UL | |

THIS PAGE INTENTIONALLY LEFT BLANK

TABLE OF CONTENTS

| <u>Section</u> | <u>Page</u> |
|---|-------------|
| Figures..... | v |
| Tables | vi |
| Executive Summary..... | x |
| | |
| 1 Introduction..... | 1-1 |
| 1.1 Project Objectives | 1-1 |
| 1.2 Test Engine and Location | 1-2 |
| 1.2.1 J85-GE-5M and -5R..... | 1-2 |
| 1.2.2 Test Facility..... | 1-2 |
| | |
| 2 Facility and Sampling Apparatus Description | 2-1 |
| 2.1 Moody AFB Hush House Overview | 2-1 |
| 2.2 Randolph AFB Hush House Overview..... | 2-2 |
| 2.3 Engine Exhaust Sampling Rake System..... | 2-2 |
| 2.4 Augmenter Tube Slipstream Sampling System | 2-3 |
| | |
| 3 Sampling Procedures and Methods..... | 3-1 |
| 3.1 General Sampling Considerations/Complications | 3-3 |
| 3.1.1 Pollutant Distribution in the Augmenter Tube..... | 3-4 |
| 3.2 Emission Measurement Approach | 3-4 |
| 3.2.1 Flow Rate Measurement | 3-6 |
| 3.2.2 Pretest Measurement..... | 3-7 |
| 3.2.3 Gaseous Emission Measurement | 3-7 |
| 3.2.4 Particulate Measurement..... | 3-8 |
| 3.2.5 Hazardous Air Pollutant Sampling | 3-10 |
| 3.2.6 Direct Engine Exhaust Measurement..... | 3-10 |
| 3.2.7 Emissions Test Methods | 3-10 |
| 3.2.7.1 Particulate Sampling..... | 3-11 |
| 3.2.7.2 Aldehyde and Ketone..... | 3-11 |
| 3.2.7.3 VOCS..... | 3-11 |
| 3.2.7.4 Polynuclear Aromatic Hydrocarbons..... | 3-11 |

TABLE OF CONTENTS (continued)

| <u>Section</u> | <u>Page</u> |
|---|-------------|
| 3.2.7.5 Carbon Monoxide, Carbon Dioxide, Oxides of Nitrogen, and Oxygen..... | 3-11 |
| 3.2.7.6 Methane and Non-methane Hydrocarbons (NMHC) | 3-12 |
| 3.2.8 Hush House Inlet Air Sampling | 3-13 |
| 3.3 Engine Testing Matrix | 3-13 |
| 3.3.1 Engine Shakedown Runs | 3-13 |
| 3.3.2 Engine Test Settings | 3-14 |
| 3.3.3 Engine Emission Trend Development | 3-15 |
| 3.4 Engine Test Cycle Data..... | 3-16 |
| 3.5 JP-8+100 Fuel Sampling and Analysis | 3-17 |
| 3.6 Emission Test Schedule and Responsibilities..... | 3-18 |
| 3.6.1 Personnel Responsibilities | 3-18 |
| 4 Calculation of Airflow | 4-1 |
| 4.1 Calculation of Exhaust Airflow Using a Carbon Balance | 4-1 |
| 4.2 Calculation of Airflow Using F-Factors | 4-5 |
| 5 Results..... | 5-1 |
| 5.1 Gaseous Pollutants..... | 5-2 |
| 5.1.1 Gaseous Emissions..... | 5-2 |
| 5.2 Volatile Organic Compounds | 5-9 |
| 5.2.1 Speciated Pollutant Comparison..... | 5-10 |
| 5.3 Aldehyde and Ketones | 5-10 |
| 5.4 Polynuclear Aromatic Hydrocarbons | 5-17 |
| 5.5 Pollutant Mixing in the Augmenter Tube | 5-17 |
| 5.6 Particulate Matter..... | 5-17 |
| 5.6.1 Particle Characterization..... | 5-23 |
| 5.7 Exhaust Flow Determination | 5-24 |
| 5.8 Fuel Analysis..... | 5-24 |
| 5.9 Engine Operation | 5-26 |

Appendices:

| | |
|---|---------------------------|
| A | Example Calculations |
| B | Emission Sampling Methods |
| C | Field Data |
| D | QA/QC Procedures |
| E | QA/QC – Calibration Data |

FIGURES

| <u>Number</u> | | |
|---------------|---|------|
| 2-1 | Overview of Typical Hush House Physical Layout | 2-6 |
| 2-2 | Overview of T-10 Hush House Physical Layout – Moody AFB | 2-7 |
| 2-3 | Engine Mounted for Testing in T-10 Hush House – Moody AFB..... | 2-8 |
| 2-4 | Exhaust Deflector Plate, T-10 Hush House – Moody AFB | 2-9 |
| 2-5 | Orthogonal View of Slipstream Sampling Apparatus – Moody AFB | 2-10 |
| 2-6 | Testing of T-38 Talon at Randolph AFB Hush House | 2-11 |
| 2-7 | Engine Rake at Randolph AFB (Front View)..... | 2-12 |
| 2-8 | Engine Rake Assembly – Moody AFB..... | 2-13 |
| 2-9 | Engine Sampling Rake – Moody AFB..... | 2-14 |
| 2-10 | Augmenter Tube Slipstream Sampling System (Front View) – Moody AFB | 2-15 |
| 2-11 | Augmenter Tube Sampling Rake (View from Test Engine) – Moody AFB..... | 2-16 |
| 2-12 | Augmenter Tube Slipstream Extraction Tube and Gas Sampling – Moody AFB | 2-17 |
| 2-13 | Augmenter Tube Slipstream Sampling System (Top View) – Moody AFB | 2-18 |
| 2-14 | Slipstream Transition to T-10 Hush House Exit – Moody AFB..... | 2-19 |
| 2-15 | Augmenter Tube Slip-Stream Sampling System Duct – Moody AFB..... | 2-20 |
| 3-1 | Time-Line for J85-GE-5R Engine Testing | 3-19 |
| 5-1 | Gaseous Pollutants vs. Power Setting | 5-4 |
| 5-2 | Augmenter Tube Slipstream Extraction Tube and Gas Sampling | 5-19 |

TABLES

| <u>Number</u> | | <u>Page</u> |
|---------------|---|-------------|
| 3-1 | J85-GE-5M, Moody AFB Target Exhaust Pollutants for Each Engine Setting | 3-2 |
| 3-2 | Percentages of Carbon Particles in Various Diameter Ranges | 3-3 |
| 3-3 | Summary of Source Target Compounds for Volatile Organic Compounds | 3-12 |
| 3-4 | Engine Emission Sampling Matrix – Moody AFB | 3-15 |
| 3-5 | Engine Operating Data | 3-16 |
| 3-6 | JP-8+100 Fuel Analysis Request | 3-17 |
| 3-7 | Summary of Source Target Metals from JP-8+100 Fuel Analysis | 3-17 |
| 3-8 | Breakout of Field Team Personnel and Responsibilities | 3-20 |
| 5-1 | Gaseous Emissions Summary – Emission Trend Summary Engine Rake..... | 5-3 |
| 5-2 | J85-GE-5M (Moody AFB) Slipstream Rake – Emission Factor Summary..... | 5-5 |
| 5-3 | J85-GE-5M (Moody AFB) Engine Rake Emissions Factor Summary | 5-6 |
| 5-4 | J85-GE-5M (Moody AFB) Emissions Factor Comparison – Criteria Pollutants | 5-7 |
| 5-5 | T-38 Talon (Randolph AFB) Engine Rake Emission Factor Summary..... | 5-8 |
| 5-6 | J85-GE-5M (Moody AFB) Emissions Factor Summary – Volatile Organic Compounds (VOCs) – Idle | 5-11 |
| 5-7 | J85-GE-5M (Moody AFB) Emissions Factor Summary – Volatile Organic Compounds (VOCs) – Intermediate | 5-12 |
| 5-8 | J85-GE-5M (Moody AFB) Emissions Factor Summary – Volatile Organic Compounds (VOCs)..... | 5-13 |

TABLES (continued)

| <u>Number</u> | | <u>Page</u> |
|---------------|---|-------------|
| 5-9 | J85-GE-5M (Moody AFB) Engine Rake Emission Factor Summary – Benzene..... | 5-14 |
| 5-10 | J85-GE-5M (Moody AFB) Engine Rake Emission Factor Summary – Formaldehyde..... | 5-15 |
| 5-11 | J85-GE-5M (Moody AFB) Slipstream Rake Emission Factor Summary – Adelhyde/Ketones..... | 5-16 |
| 5-12 | J85-GE-5M (Moody AFB) Slipstream Rake Emissions Factor Summary – Polynuclear Aromatic Hydrocarbons..... | 5-18 |
| 5-13 | J85-GE-5M (Moody AFB) Slipstream Rake Emissions Factor Summary – Sample Point Data Comparison..... | 5-20 |
| 5-14 | J85-GE-5M (Moody AFB) Emissions Factor Summary – Particulate | 5-21 |
| 5-15 | Percentages of Carbon Particles in Various Diameter Ranges | 5-22 |
| 5-16 | JP-8+100 Fuel Analysis..... | 5-25 |
| 5-17 | Summary of Source Target Metals from JP-8 Fuel Analysis..... | 5-25 |
| 5-18 | Engine Operating Data..... | 5-26 |

ACRONYMS

| | |
|-----------------|--|
| AFB | Air Force Base |
| AFIERA | Air Force Institute for Environment, Safety, and Occupational Health Risk Analysis |
| CDRL | Contract Data Requirements List |
| CEM | continuous emissions monitoring |
| CFM | cubic feet per minute |
| CO | Carbon Monoxide |
| CO ₂ | Carbon Dioxide |
| DOT | Department of Transportation |
| DSCFM | dry standard cubic feet per minute |
| EQ | Environmental Quality Management, Inc. |
| FID | flame ionization detector |
| HAP | Hazardous Air Pollutant |
| IATA | International Aviation Transportation Association |
| ICAO | International Civil Aviation Organization |
| IXRF | Iridium X-ray Fluorescence |
| MCE | carbon mass rate – exhaust |
| MCF | carbon mass rate – fuel |
| MCI | carbon mass rate – inlet air |
| NIOSH | National Institute of Occupational Safety and Health |
| NO _x | Nitrogen Oxides |
| NMHC | Non Methane Hydrocarbons |
| PAH | Polynuclear Aromatic Hydrocarbons |
| PIC | product of incomplete combustion |
| PM | Particulate Matter |
| RSEQ | Risk Analysis Environmental Quality |
| SAP | Sampling and Analysis Plan |
| SEM | scanning electron microscopy |
| SPO | System Program Office |
| TPM | Technical Program Manager |
| THC | total hydrocarbon |
| VOC | volatile organic compound |

REFERENCES

- Title 40, Code of Federal Regulations, part 60, Appendix A
- Air Emissions Inventory Guidance Document for Mobile Sources at Air Force Installations, January 2002
- <http://www.epa.gov/ttn/emc/tmethods.html>
- <http://www.epa.gov/epaoswer/hazwaste/test/methdev.thm>
- Aircraft Engine Emissions, International Standards and Recommended Practices-Environmental Protection, Annex 16, Volume II, First Edition

EXECUTIVE SUMMARY

The J85-GE-5R aircraft engine is a modified version of the J85-GE-5M engine which currently powers the T-38 Talon aircraft (T38C and T38A respectively). In order to evaluate the impact of the engine modifications on emissions, a comprehensive emission measurement program was conducted at Moody AFB and Randolph AFB. A single J85-GE-5M engine was tested in a hush house at Moody AFB to measure criteria and select hazardous air pollutants. At Randolph AFB, gaseous emissions were measured directly behind a T-38C test aircraft equipped with two J85-GE-5R engines. The purpose of testing at both locations was to compare on-wing emissions versus test-stand emissions.

The results from this test program will be used to evaluate potential environmental impacts that may be created by the bed down of the modified engine at various Air Force Bases.

I. OBJECTIVES

The purpose of this program was to determine emission factors for the J85-GE-5R and J85-GE-5M engines under representative engine load conditions and compare test-stand emissions with on-wing emissions. In addition, the emissions data were compared to the J85-GE-5H emissions to determine if the engine modifications affected emissions. Testing was conducted for criteria pollutants and select hazardous air pollutants (HAPs).

II. SAMPLING METHODOLOGY

Sampling was performed for criteria pollutants and those HAPs that are products of incomplete combustion (PICs) from the J85-GE-5M engine at Moody AFB. Gaseous criteria pollutants were measured from the T-38 with PMP Aircraft at Randolph AFB. Environmental Protection Agency (EPA) emissions test methods (Title 40, Code of Federal Regulations, Part 60, Appendix A) were followed during this test program. The test methods were modified where necessary due to the unique circumstances encountered during the program: i.e., high flow rates, unique exhaust configuration, and a large volume of dilution (ambient) air in the exhaust gas stream. A custom EPA Method 5 was employed due to the physical configuration of the test

cell. The nature of each test location did not permit a full cross-section traverse; instead, single point sampling was performed via a slipstream and engine sampling rake. A verification was made through the use of a multi-point gaseous sampling system in the hush house augments tube to assure that the sample point was representative of the entire exhaust stream. The following is a list of the constituents of the exhaust stream that were measured at Moody AFB along with the corresponding EPA test methods used:

- Filterable and condensable particulate (EPA Methods 5 and 202¹).
- Aldehydes and ketones (EPA 0011² and TO-05).
- Volatile organic compounds (VOCs) (EPA Method 0030).
- Oxygen and carbon dioxide (EPA Method 3A).
- Carbon monoxide (EPA Method 10).
- Nitrogen oxides (EPA Method 7E).
- Non-methane hydrocarbons (NMHCs) (EPA Method 25A).
- Polynuclear Aromatic Hydrocarbons (NIOSH Method 5506)

Sampling was not performed for sulfur dioxide and metals in the engine exhaust streams. Historic testing of metals provided random results with a number of interferences. Sulfur dioxide emissions are reported based on the procedure documented by AFIERA. ("Air Emissions Inventory Guidance Document for Mobile Sources at Air Force Installations, "January 2002). This procedure estimates that sulfur dioxide emissions can be calculated by assuming all sulfur in the fuel undergoes complete oxidation to SO₂. Dioxins/furans and other HAPs not listed in this report would not have been emitted in significant quantities to be readily detected by conventional sampling methods. Therefore, these compounds were not part of the emissions testing program.

Ambient air samples were collected for total non-methane hydrocarbons, carbon dioxide, oxygen, and carbon monoxide in order to complete the f-factor and carbon balance flow models. Due to historic ambient air monitoring programs and the proximity of the test facilities to contributing sources, correction for ambient pollutants was not performed.

II.1A Engine Testing Considerations/Complications

The engine was tested at four actual flight settings. Nominal engine conditions for emissions sampling are provided below:

¹ Unless otherwise noted, test methods taken from 40 CFR 60, Appendix A;
<http://www.epa.gov/ttn/emc/tmethods.html>.

² From EPA SW-846, <http://www.epa.gov/epaoswer/hazwaste/test/methdev.htm>

- Idle (I)
- Intermediate (N)
- Military (M)
- Afterburner (AB)

Emissions tests at Moody AFB comprised three 2-hour sampling runs for each pollutant at the first three power settings with the exception of the aldehydes/ketones and polynuclear aromatic hydrocarbons tests. Due to sample volume requirements needed to meet method detection limits, aldehydes/ketones were collected over the 6-hour sampling period. At the afterburner setting, a single 10-minute sample run was conducted for gaseous pollutants only.

Testing at Randolph AFB consisted of approximately 15 minutes of sampling time at each engine setting.

III. RESULTS

III.1A Criteria Pollutants

Results of the criteria pollutants are presented in Tables III-1 and III-2. The tables present both emission rates and factors for NO_x, CO, total particulate, NMHC, SO₂, and CO₂ for each engine at each engine test condition. The emissions presented are the average of each of the sampling runs. Results of individual runs are presented in Section 5 of this report. A summary of the historic J85-GE-5H emissions data is provided in Table III-3 for comparison. These data were collected during a separate emission measurement program in March 1997.

Table III-4 is a detail of the particulate emissions from the J85-GE-5M engine tested at Moody AFB. The condensable particulate fraction at idle and intermediate consists mostly of unburned fuel. It was noted in the field that the condensable fraction was heavily discolored (yellow) with fuel. The organic fraction of the condensible particulate has been removed from these results.

III.2B Hazardous Air Pollutants

Table III-5 depicts the average HAP emissions for each power setting. This table summarizes volatile and aldehyde/ketones compounds. The 11 HAPs shown in Table III-5 are the most frequently detected HAPs that are combustion by-products. Within this table, HAPs have been totaled for each power setting. The remaining HAP data that was analyzed during this sampling program is presented in Section 5 of this report.

**TABLE III-1
J85-GE-5M ENGINE (MOODY AFB)
CRITERIA POLLUTANT
EMISSION FACTOR SUMMARY
(lbs/1000 lbs fuel)**

| | Idle | Intermediate | Military | Afterburner |
|--|---------|--------------|----------|-------------|
| Exhaust Flow, dscfm | 118,704 | 293,150 | 544,312 | 611,727 |
| Fuel Flow, lbs/hr | 525 | 1,045 | 2,550 | 7,695 |
| Pollutant | | | | |
| Nitrogen Oxides (NOx) | 0.79 | 1.81 | 1.65 | 1.21 |
| Carbon Monoxide (CO) | 191.41 | 48.90 | 25.35 | 10.19 |
| Total Non Methane Hydrocarbons | 21.11 | 1.62 | 0.45 | 0.65 |
| Carbon Dioxide (CO ₂) | 3,503 | 3,048 | 3,092 | 3,116 |
| Sulfur Dioxide (SO ₂) ^(a) | 0.90 | 0.90 | 0.90 | 0.90 |
| Total Particulate | 6.30 | 10.72 | 3.66 | (b) |

(a) - Sulfur dioxide emissions based on sulfur content in fuel (0.045%).

As noted in "Air Emissions Inventory Guidance Document for Mobile Sources at Air Force Installations, January 2002".

(b) - Particulate sampling not performed at afterburner.

**TABLE III-2
T-38C WITH PMP TALON (RANDOLPH AFB)
CRITERIA POLLUTANT
EMISSION FACTOR SUMMARY
(lbs/1000 lbs fuel)**

| | Idle | Intermediate | Military | Afterburner |
|--|--------|--------------|----------|----------------------|
| Exhaust Flow, dscfm | 24,956 | 82,241 | 120,532 | 141,922 |
| Fuel Flow per Engine, lbs/hr ^(a) | 520 | 1,030 | 2,220 | 7,695 ^(b) |
| Pollutant | | | | |
| Nitrogen Oxides (NOx) | 1.08 | 0.70 | 1.92 | 6.23 |
| Carbon Monoxide (CO) | 177.45 | 65.07 | 30.99 | 53.43 |
| Total Non Methane Hydrocarbons | 14.61 | 2.42 | 0.65 | 6.06 |
| Carbon Dioxide (CO ₂) | 2,838 | 3,025 | 3,084 | 7,423 |
| Sulfur Dioxide (SO ₂) ^(c) | 0.90 | 0.90 | 0.90 | 0.90 |

(a) - Fuel flow per engine. The T-38 with PMP Talon operates on two J85-GE-5R engines.

(b) - Fuel flow is estimated

(c) - Sulfur dioxide emissions based on sulfur content in fuel (0.045%).

As noted in "Air Emissions Inventory Guidance Document for Mobile Sources at Air Force Installations, January 2002".

**TABLE III-3
J85-GE-5H ENGINE (LAUGHLIN AFB)
CRITERIA POLLUTANT
EMISSION FACTOR SUMMARY
(lbs/1000 lbs fuel)**

| | Idle | Intermediate | Military | Afterburner |
|-----------------------------------|--------|--------------|----------|-------------|
| Exhaust Flow, dscfm | 54,302 | 127,046 | 283,270 | 232,850 |
| Fuel Flow, lbs/hr | 434 | 950 | 2,740 | 8,138 |
| Pollutant | | | | |
| Nitrogen Oxides (NOx) | 1.14 | 1.74 | 2.92 | 2.09 |
| Carbon Monoxide (CO) | 211.97 | 123.43 | 36.40 | 14.19 |
| Total Non Methane Hydrocarbons | 34.02 | 5.66 | 0.58 | 2.29 |
| Carbon Dioxide (CO ₂) | 2,732 | 2,953 | 3,106 | 3,129 |
| Total Particulate | 4.70 | 1.79 | 1.13 | 0.25 |

NOTE: These data were obtained during a separate emission measurement program in March 1997.

TABLE III-4
J85-GE-5M (MOODY AFB)
EMISSIONS FACTOR SUMMARY
PARTICULATE

| | Run Number | | | | | | Average | |
|---------------------------------|---------------------|-------|----------------------|-------|-------------------|-------|-------------------|-------|
| | 1 | | 2 | | 3 | | Composite | |
| | 118,704 | 525 | 118,704 | 525 | 118,704 | 525 | 118,704 | 525 |
| Flow Rate, dscfm ^(a) | | | | | | | | |
| Fuel Flow, lbs/hr | lbs/1000 lbs fuel | lb/hr | lbs/1000 lbs fuel | lb/hr | lbs/1000 lbs fuel | lb/hr | lbs/1000 lbs fuel | lb/hr |
| IDLE | | | | | | | | |
| Filterable | 3.06 | 0.86 | 1.64 | 1.26 | 2.39 | 0.73 | 1.39 | 0.95 |
| Condensable ^(b) | 6.12 | 2.36 | 4.49 | 2.21 | 4.21 | 2.51 | 4.79 | 2.36 |
| Total Particulate | 9.17 ^(c) | 3.22 | 6.13 | 3.47 | 6.60 | 3.24 | 6.18 | 3.31 |
| INTERMEDIATE | | | | | | | | |
| Flow Rate, dscfm ^(a) | 293,150 | | 293,150 | | 293,150 | | 293,150 | |
| Fuel Flow, lbs/hr | 1,045 | | 1,045 | | 1,045 | | 1,045 | |
| Filterable | 3.54 | 3.20 | 3.07 | 3.12 | 2.98 | 1.29 | 1.24 | 2.65 |
| Condensable | 7.80 | 14.60 | 13.97 | 10.38 | 9.94 | 7.48 | 7.16 | 8.55 |
| Total Particulate | 11.34 | 17.80 | 17.03 ^(c) | 13.50 | 12.92 | 8.77 | 8.40 | 11.20 |
| MILITARY | | | | | | | | |
| Flow Rate, dscfm ^(a) | 544,312 | | 544,312 | | 544,312 | | 544,312 | |
| Fuel Flow, lbs/hr | 2,550 | | 2,550 | | 2,550 | | 2,550 | |
| Filterable | 9.11 | 9.16 | 3.59 | 8.18 | 3.21 | 4.57 | 1.79 | 7.30 |
| Condensable | 6.30 | ND | ND | ND | ND | 6.08 | 2.39 | 2.03 |
| Total Particulate | 15.41 | 9.16 | 3.59 | 8.18 | 3.21 | 10.65 | 4.18 | 9.33 |

(a) - Exhaust flow rate determined by F-factor

(b) - Exhaust flow rate determined by Carbon Balance

(c) - This run not included in averages.

(d) - Aqueous fraction only, see note below.

NOTE: Particulate measurements not made at Afterburner. It appears that hydrocarbons from unburned fuel are in the impinger solution at the idle and intermediate power settings. This accounts for the majority of the condensable fraction.

TABLE III-5
J85-GE-5M ENGINE (MOODY AFB)
EMISSION FACTOR SUMMARY
(lbs/1000 lbs fuel)

| | Idle | Intermediate | Military |
|----------------------------|-------------|--------------|-------------|
| Exhaust Flow, dscfm | 118,704 | 293,150 | 544,312 |
| Fuel Flow, lbs/hr | 525 | 1,045 | 2,550 |
| Pollutant | | | |
| Formaldehyde | 2.26 | 0.35 | 0.024 |
| Acetaldehyde | 0.24 | 0.02 | 0.002 |
| Acrolein | 0.31 | 0.01 | 0.001 |
| MEK | 0.08 | 0.01 | 0.001 |
| Benzene | 0.03 | 0.02 | 0.003 |
| Toluene | 0.03 | 0.01 | 0.0009 |
| Ethylbenzene | 0.007 | 0.002 | 0.00005 |
| m,p-Xylene | 0.02 | 0.008 | 0.0004 |
| naphthalene | 0.0829 | 0.00595 | 0.00466 |
| o-Xylene | 0.02 | 0.005 | 0.0002 |
| Styrene | 0.008 | 0.002 | 0.00007 |
| Total HAPs | 3.09 | 0.44 | 0.04 |

IV. CONCLUSIONS

During this emission measurement program, several emission phenomena were noted and are summarized below.

- At the idle, intermediate, and military, there was a discoloration in the Method 5 sampling train impingers. The discoloration was heaviest at idle and decreased as power increased. The discoloration was a heavy yellow at the idle setting and was slightly cloudy at military. The yellow material appeared to be unburned JP-8+100 fuel which can be attributed to the engine operating inefficiently at idle. Therefore, the condensible particulate fraction contained unburned fuel. The organic fraction (primarily unburned fuel) of the condensible particulate was approximately 30% at the idle setting and 4% at intermediate. The condensible particulate fraction presented in Table III-4 includes only the aqueous fraction.
- On each particulate filter, the mass collected began to "run" across the filter surface, indicating an organic fraction. When the filter is recovered, a clean ring can be seen on the outer edge of the filter where the filter is held during sampling. This clean ring became discolored over time as the particulate coating was absorbed into the filter material.
- The NO_x data varied the most between the engine and slipstream. This was caused by the high percentage (90%+) of NO₂ in the sample stream behind the engine. The NO₂ converted to N and O₂ by the time the sample reached the slipstream. Therefore, the mass of NO_x at the slipstream was lower. This is not the expected trend. During a past program, the NO_x concentration was predominantly NO at the engine and NO₂ at the slipstream. This is the expected pattern. NO combines with O₂ in the augments tube to form NO₂ at the slipstream.
- The on-wing and test-stand emissions were comparable at all settings with the exception of A/B. At each location the sampling time at afterburner was limited. At Moody AFB, the engine malfunctioned and sampling time was limited to approximately 3 minutes. At Randolph AFB, the engine sampling rake broke after approximately 5 minutes of sampling. Also, the engine sampling rake at Randolph AFB was much closer (approx. 12 feet closer) to the engine exhaust. This position impacts the emission results. In addition, the engine can operate at several different afterburner modes. The engines tested during this program may have operated in different AB modes, resulting in varying emission results.
- During the test program, a field balance accurate to 0.1 mg was used to provide a qualitative measure of particulate gain. During past sampling programs, particulate gain was minimal. Oftentimes the filter weighed less after sampling, due to handling of the filter. The field balance provided an instant indication of particle gain and allowed for sample volume adjustment in the field if necessary.
- The particles in the exhaust stream are predominantly less than 2.5 microns in size (range from 88% - 92% of the total particles). These particles are primarily carbon soot. The larger particles, 2.5 to 10 microns, were found to be agglomerates of smaller combustion particles. These agglomerates accounted for 7% to 12% of the particle total. The largest particles, 7.5 to 10+ microns, were found to be angular particles that are believed to have been cooled and

deposited on a surface and suspended during the test program. Approximately 1% of the particles were greater than 7.5 microns.

- Emissions detected with the use of JP-8+100 were not significantly different from historical emissions detected with the use of JP-8 fuel.

THIS PAGE INTENTIONALLY LEFT BLANK

SECTION 1

INTRODUCTION

This Emissions Summary Report has been prepared by Environmental Quality Management, Inc. (EQ) under Delivery Order 0002 of the Occupational and Environmental Health Assessments Contract (Contract Number F41624-01-D-9012) supporting the Air Force Occupational and Environmental Health programs around the world. This contract is administered by the Air Force Institute for Environment, Safety, and Occupational Health Risk Analysis/Risk Analysis Environmental Quality (AFIERA/RSEQ), Brooks Air Force Base (AFB), Texas.

The project requirements are described in the delivery order and its attached Statement of Work and Contract Data Requirements Lists (CDRL's).

The project includes:

- Preparation of the Sampling and Analysis Plan (SAP) Submitted 15 April 2002, A004).
- Preparation of the Site Survey Report (Submitted 8 April 2002, A011).
- Preparation of monthly progress, status, and management reports (Ongoing, A001).
- Preparation of conference agenda and minutes (A008).
- Preparation of a summary Scientific and Technical Report (this document, A003).

Testing at Moody AFB involved emissions measurement directly behind the engine and at the hush house exhaust for one J85-GE-5M engine operating on a test stand. Testing at Randolph AFB involved gaseous emission measurement directly behind the engine exhaust while a T-38C with PMP aircraft was operating in the hush house. This data was compared to the test-stand emissions data collected at Moody AFB and the historic J85-GE-5H data collected by EQ.

1.1 PROJECT OBJECTIVES

Emission measurement from the J85-GE-5M engine and the T-38C Talon involved several overall project objectives:

- 1) Provide sufficient data to determine engine "bed down" conformity analysis for compliance with state implementation plans and federal implementation plans for the purpose of attaining or maintaining the national ambient air quality standards.
- 2) Determine if emission variances exist between on-wing emissions and test-stand emissions.
- 3) Examine the engine intake modification and its effect on engine emissions.
- 4) Measure emissions directly behind the aircraft engine and at the hush house exhaust to note pollutant mixing in the augmentor tube. Measure emissions directly behind the aircraft engine at Randolph AFB and compare these data to the engine emission results collected at Moody AFB.
- 5) Determine if emissions from the J85-GE-5M and -5R modified engine vary from historic emissions data collected from the J85-GE-5H by EQ.

1.2 TEST ENGINE AND LOCATION

1.2.1 J85-GE-5M and -5R

Two J85-GE-5M single-shaft, turbojet engines power the Northrup T-38 Talon. Two J85-GE-5R engines power the T-38C with PMP Talon. The engines are manufactured by General Electric and used throughout the world. The engines consist of a nine-stage compressor section using axial flow, a two-stage axial flow turbine section, and has afterburning capabilities. The overall pressure ratio is 7.0:1. The T-38 aircraft is used as a trainer aircraft due to its ability to reproduce the flying characteristics of a supersonic operational fighter aircraft.

1.2.2 Test Facility

The J85-GE-5M engine was tested in a T-10 hush house at Moody Air Force Base in Valdosta, Georgia. The T-38C Talon was tested in a T-12 hush house located at Randolph Air Force Base in San Antonio, Texas. Facility hush houses were operated by Air Force personnel during testing.

SECTION 2

FACILITY AND SAMPLING APPARATUS DESCRIPTION

As stated in Section 1, testing of the J85-GE-5R engine was performed at Moody AFB and Randolph AFB utilizing JP-8+100 jet fuel. Due to the physical layout of the hush house testing location, the engine exhaust could not be sampled safely or cost-effectively using traditional EPA-recommended emission testing methodologies (Title 40, Code of Federal Regulations, Part 60, Appendix A). In addition, the traditional International Civil Aviation Organization (ICAO) sampling method (Aircraft Engine Emissions, International Standards and Recommended Practices – Environmental Protection, Annex 26, Volume II, First Edition) does not address particulate or HAP analysis, therefore, unique sampling approaches were developed. A description of the Hush house, sampling system apparatus, and general sampling methodology is provided in this section. A more detailed description of the sampling methodology is provided in Sections 3 and 4.

2.1 MOODY AFB HUSH HOUSE OVERVIEW

Military aircraft jet turbine engines are tested in indoor enclosures designed to restrain the engines or aircraft and to provide suitable environmental protection (i.e., noise reduction) while testing occurs. These facilities are known as hush houses. The building functions include supply air filtration, noise suppression, exhaust diversion, and technical support for various test functions. The layout of a typical hush house interior and exterior are illustrated in Figure 2-1. Exterior layout of the T-10 hush house at Moody AFB is included as Figure 2-2. During the test process, an isolated engine is mounted in the rear of the hangar-like enclosure with the exhaust nozzle pointing toward the augmentor tube and out of the building (Figure 2-3). The engine exhaust is directed out of the test facility and into the ambient air via a horizontal elliptical duct (the augmentor tube) which finally directs the air flow upward via a terminal deflector plate in

the blast box (Figure 2-4). The hush house emits combustion products mixed with filtered dilution air directly to the atmosphere at the augments tube terminus.

For this test program, the test team collected samples directly behind the engine exhaust nozzle and prior to the exit of a T-10 hush house augments tube, near the point of entry into the blast box (Figure 2-5).

2.2 RANDOLPH AFB HUSH HOUSE

As described above, military aircraft jet turbine engines are tested in indoor enclosures designed to restrain the engines or aircraft and to provide suitable environmental protection while testing occurs, namely hush houses. The T-12 hush house utilized for testing at Randolph AFB was smaller than the T-10 hush house used at Moody AFB. During the test process, the aircraft was mounted in the rear of the hangar-like enclosure with the exhaust nozzle pointing toward the augments tube and out of the building (see Figure 2-6).

For this test program, the test team collected samples directly behind the engine exhaust nozzles for gaseous emissions only (see Figure 2-7).

2.3 ENGINE EXHAUST SAMPLING RAKE SYSTEM (MOODY AFB AND RANDOLPH AFB)

As part of the test program at Moody AFB, gaseous emissions directly behind the engine were measured at timed intervals (approximately every 30 minutes) in a similar manner described by ICAO. At each location the engine rake was mounted in front of the augments tube. Engine exhaust sampling was conducted using a cruciform rake mounted approximately 172 inches downstream from the engine exhaust tip. The cruciform could not be sampled directly behind the engine due to the position of the engine on the test stand. A schematic diagram of the rake assembly is illustrated in Figure 2-8. This system was utilized during a previous test program and was obtained by AFIERA for use during this portion of the engine study. The rake contained eight 1/8-inch orifice ports spaced across four rake arms. A mixed exhaust sample was drawn from the 8 ports and transferred via a single stainless steel tube through filtered and heated

Teflon® lines to the combustion and diluent gas conditioning system and analyzers. The photograph in Figure 2-9 shows the rake assembly mounted behind the J85-GE-5M engine. The rake was installed behind the engine during all phases of engine testing except afterburner.

As part of the test program at Randolph AFB, gaseous emissions were measured for approximately 5 minutes at each setting in a similar manner described by ICAO. Engine exhaust sampling at Randolph AFB was conducted using a cruciform rake mounted approximately 16 inches downstream from the exhaust. The rake contained six 1/8-inch orifice ports spaced across four rake arms. A mixed exhaust sample was drawn from the six ports and transferred via a single stainless steel tube through filtered and heated Teflon® lines to the combustion and diluent gas conditioning system and analyzers. The photograph in Figure 2-7 shows the rake assembly mounted behind the T-38C Talon aircraft tested. The rake was constructed to fit the dimensions of the Randolph AFB T-12 hush house and installed behind the engine during all phases of engine testing except afterburner.

2.4 AUGMENTER TUBE SLIPSTREAM SAMPLING SYSTEM (MOODY AFB)

Access to the area of emissions exhaust is restricted during operation of engines in the hush house due to safety concerns including high temperatures, high velocity and vibration, excessive noise, and the potential of exposure to the exhaust gases. It was therefore necessary to devise a sampling scheme that allowed sampling to be conducted from a remote location, requiring modification to existing point source EPA emission test procedures.

The slipstream (or side-stream) sampling system shown in Figures 2-10, 2-11, and 2-12 was constructed to measure jet engine emissions from the Langley AFB hush house as part of the F100-PW-100 jet engine emission tests conducted in November 1996. Similarities between that testing program and the current sampling effort allowed the sampling system to be applied to the J85-GE-5M engine sampling program completed at the Moody AFB T-10 hush house. The system was designed to extract an augmentor tube exhaust sample to permit use of standard source emission test methods that could not be applied immediately behind the test engine or in the augmentor tube.

A stainless steel pipe, 10 inches in diameter, was utilized to extract a side-stream sample of the diluted engine emissions at a point upstream of the augments tube exit. The duct was centered in the augments tube and extended approximately 10 feet into the augments tube. The duct was supported inside the augments tube by two sets of support stands. The duct was directed horizontally toward the rear of the blast box and then turned at an angle out of the blast box to the top of the deflector shield wall, where a transition to a 24-inch by 24-inch square duct occurred. The duct was constructed of stainless steel seamless pipe with flanged ends. Each section was bolted together at the flanged end. Each piece was 10 feet in length except for the inlet and elbows. The larger square duct provided a decrease in gas velocity and a suitable sampling location for applying standard emission testing methods. The inlet to the slipstream was circular, similar to the inlet of a large Method 5 sampling nozzle. At the end of the square duct was a deflector plate to vent emissions upward away from ground activities (see Figures 2-13, 2-14, and 2-15).

The stainless steel slipstream ductwork was supported inside the augments tube by attaching pipe risers to existing bolts in the U-channels inside the augments tube. Four radial arms with sampling ports were used inside the augments tube. Each arm was attached to the hush house wall. Attachments were made to the 10 inch pipe with 10 inch pipe collars and bolts. All bolts were secured with a washer, lock washer, a nut, and a second nut to secure the lock. Bulkhead fittings were used to provide sampling ports through the C-Channel in the first support brace. Sampling lines were directed through an iron pipe conduit to the exit. The conduit was secured to the supporting braces via bolts and U-clamps. The duct was then fastened to the blast box and supporting scaffolding outside the blast box. This approach provided structural integrity, reduced the cross sectional exposure profile of freestanding duct, and subjected the duct only to radial flow forces on the plate, or turbulent forces along the entire exposed length. Scaffolding fixed to the hush house and ground supported the rectangular ductwork outside the hush house. Scaffolding was secured to each other and to 1/2-inch-thick plywood on the ground to provide further vibration support.

This sample collection structure provided full use of the hush house for purposes other than emission testing. Once the sampling structure was installed, the hush house was used for testing of other engines as needed. This structure did not interfere with the normal operation of the hush house.

Engine exhaust samples were collected at multiple locations along the slipstream. Gaseous emission (CO, NO_x, CO₂, and TNMHC) samples were collected at the slipstream crossbrace from 12 sample ports installed in the brace. Particulate and HAP emission samples were collected from sample ports in the slipstream outside of the hush house.

The locations of the sampling points for the slipstream sampling rake were positioned using EPA Method 1 criterion. Since the augments tube is oval shaped and EPA Method 1 does not accommodate this configuration, the points will be determined across the major axis assuming a circular diameter. Similarly, the points across the minor axis were calculated assuming a circular diameter. The slipstream duct was positioned in the center of the augments tube. Although the oval cross sectional shape of the augments tube is not addressed in EPA Method 1, locating the sampling point inlet at least 1/2 diameter prior to the exit of the tube was consistent with the basic tenets of EPA Method 1. Samples of the augments tube exhaust were obtained for combustion and diluent gas analysis using the cruciform rake assembly mounted in the augments tube.

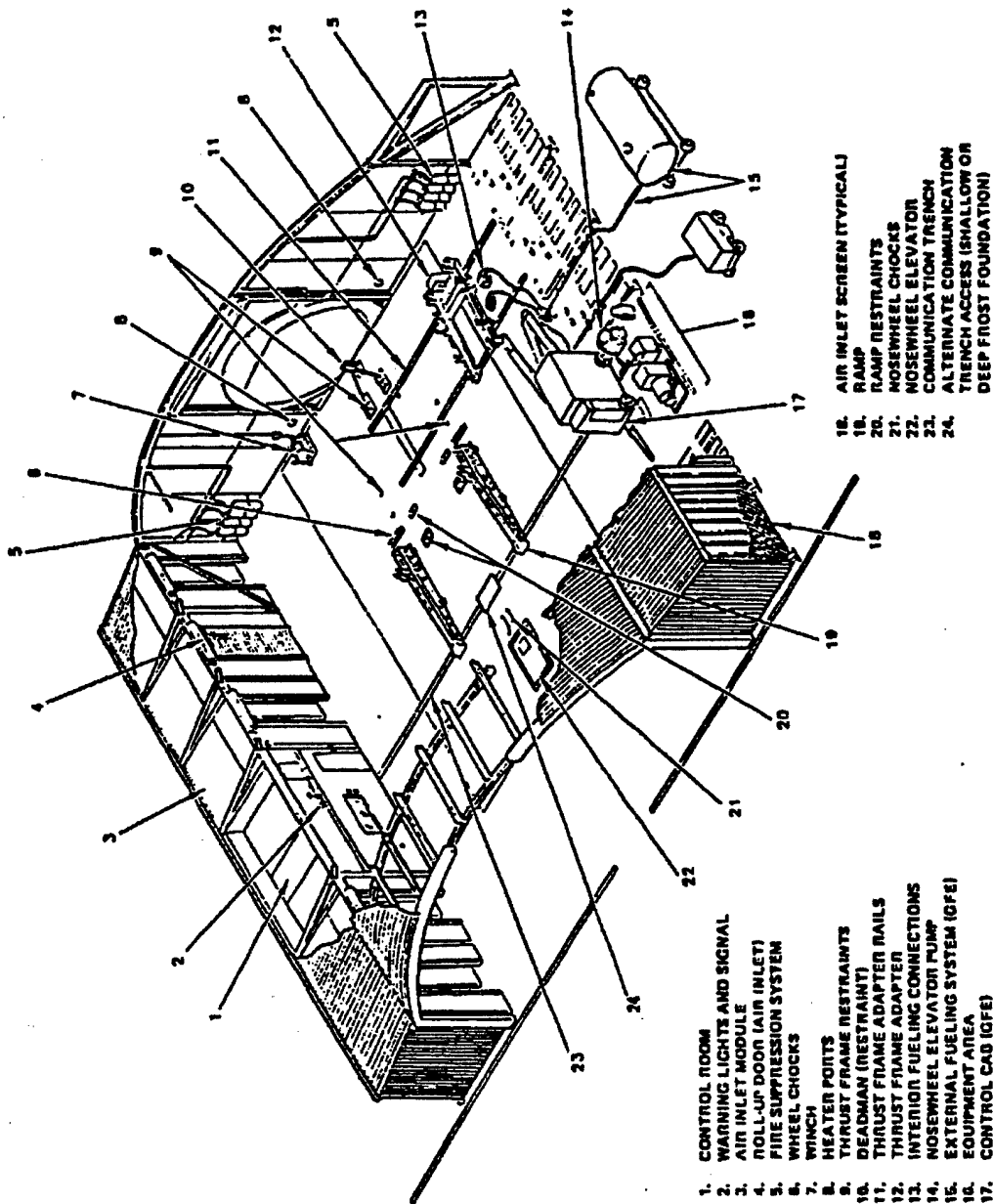

- 1. CONTROL ROOM
- 2. WARNING LIGHTS AND SIGNAL
- 3. AIR INLET MODULE
- 4. ROLL-UP DOOR (AIR INLET)
- 5. FIRE SUPPRESSION SYSTEM
- 6. WHEEL CHOCKS
- 7. WINCH
- 8. HEATER PORTS
- 9. THRUST FRAME RESTRAINTS
- 10. DEADMAN (RESTRAINT)
- 11. THRUST FRAME ADAPTER
- 12. INTERIOR FUELING CONNECTIONS
- 13. NOSEWHEEL ELEVATOR PUMP
- 14. EXTERNAL FUELING SYSTEM (IGFE)
- 15. EQUIPMENT AREA
- 16. CONTROL CAB (IGFE)

- 18. AIR INLET SCREEN (TYPICAL)
- 19. RAMP
- 20. RAMP RESTRAINTS
- 21. NOSEWHEEL CHOCKS
- 22. NOSEWHEEL ELEVATOR
- 23. COMMUNICATION TRENCH
- 24. ALTERNATE COMMUNICATION TRENCH ACCESS (SHALLOW OR DEEP FROST FOUNDATION)

Figure 2-1. Overview of Typical Hush House Physical Layout

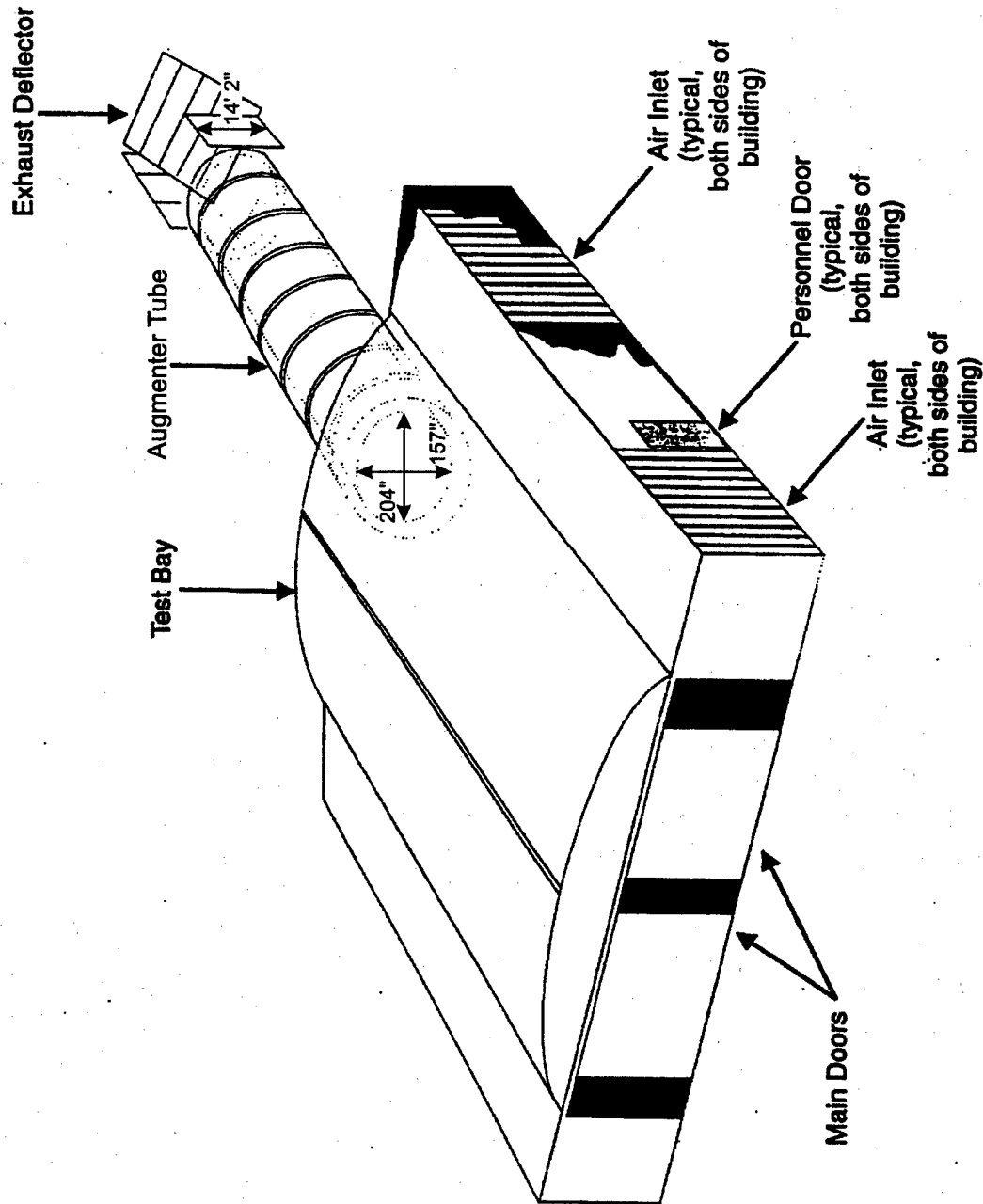

EQ ENVIRONMENTAL QUALITY
MANAGEMENT, INC.

Figure 2-2. Overview of T-10 Hush House Physical Layout
Moody AFB



Figure 2-3. Engine Mounted for Testing in T-10 Hush House at Moody AFB

EQ ENVIRONMENTAL QUALITY
MANAGEMENT, INC.

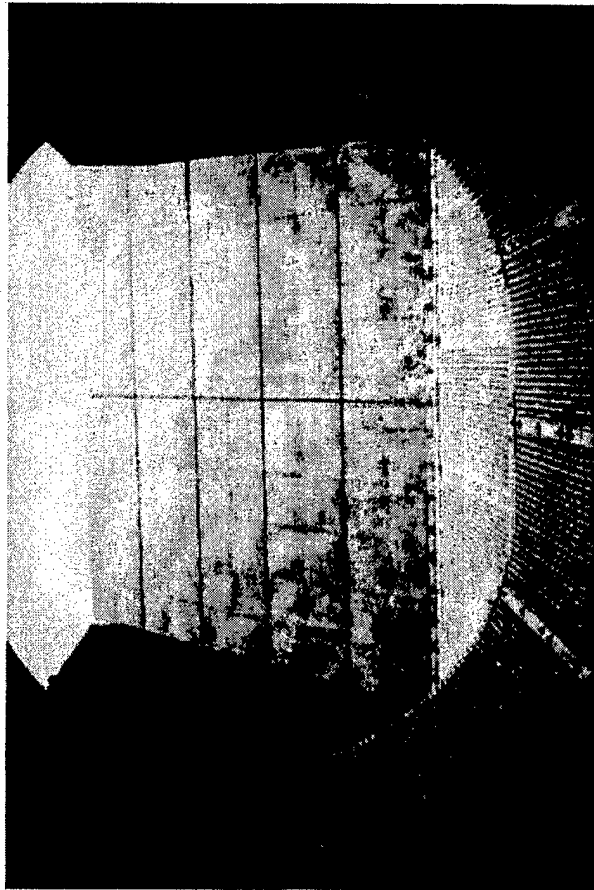

Figure 2-4. Exhaust Deflector Plate, T-10 Hush House at Moody AFB

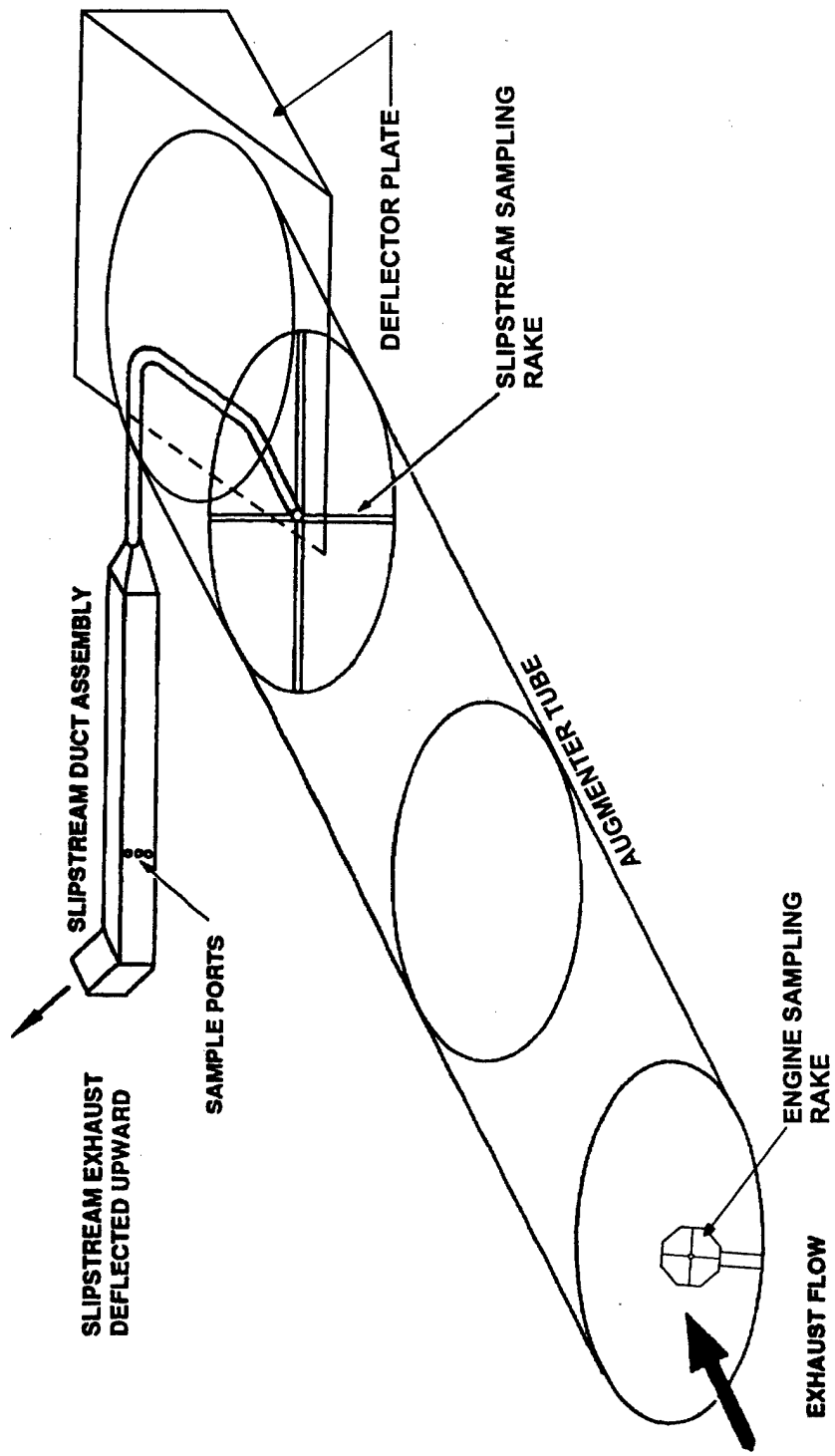

Figure 2-5. Orthogonal View of Slipstream Sampling Apparatus
Moody AFB

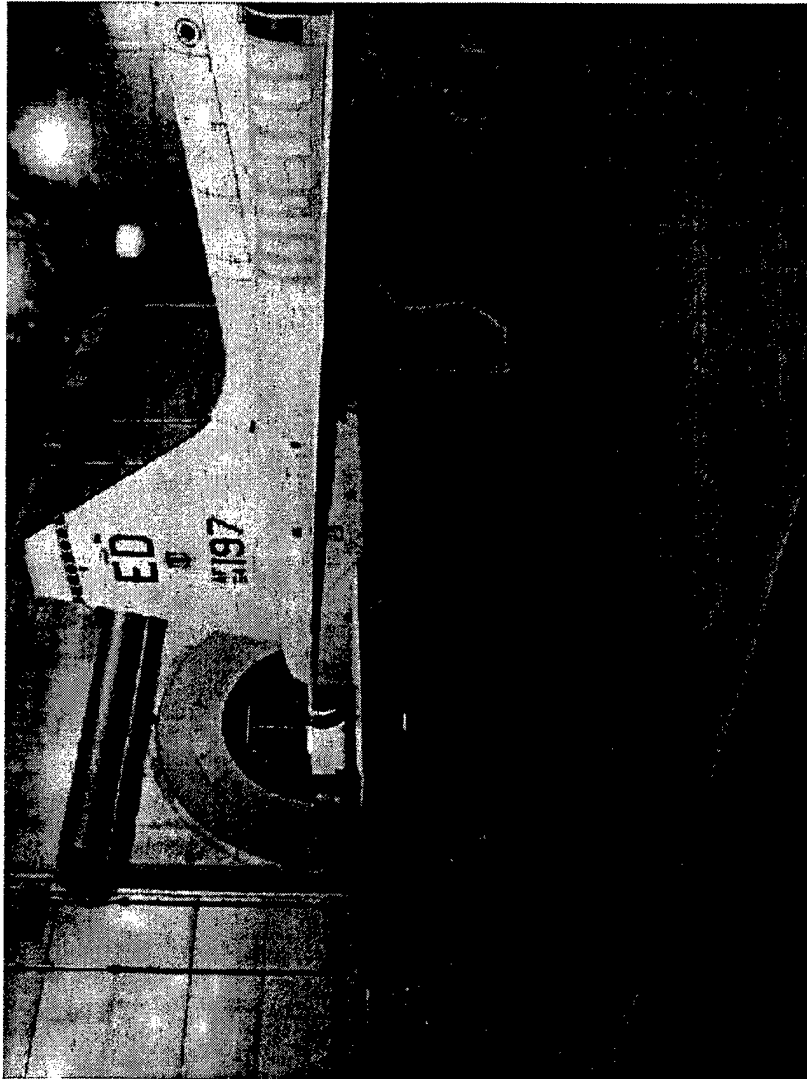

Figure 2-6. Testing of T-38C Talon at Randolph AFB T-12 Hush House

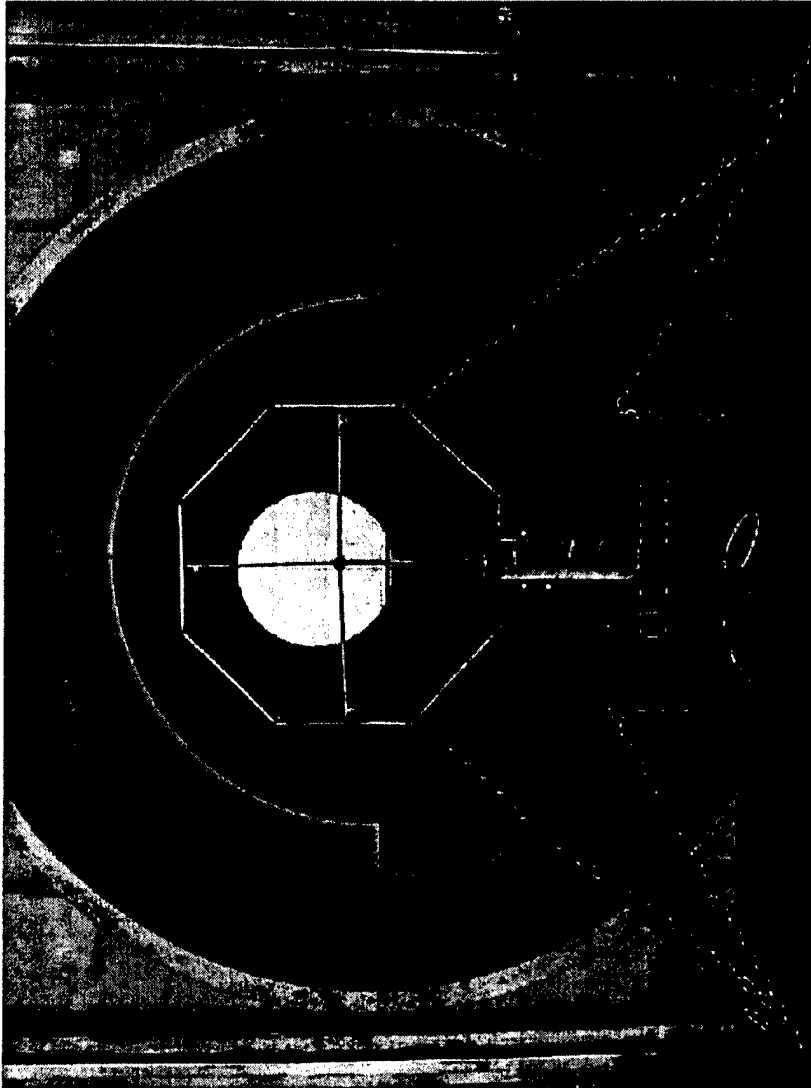
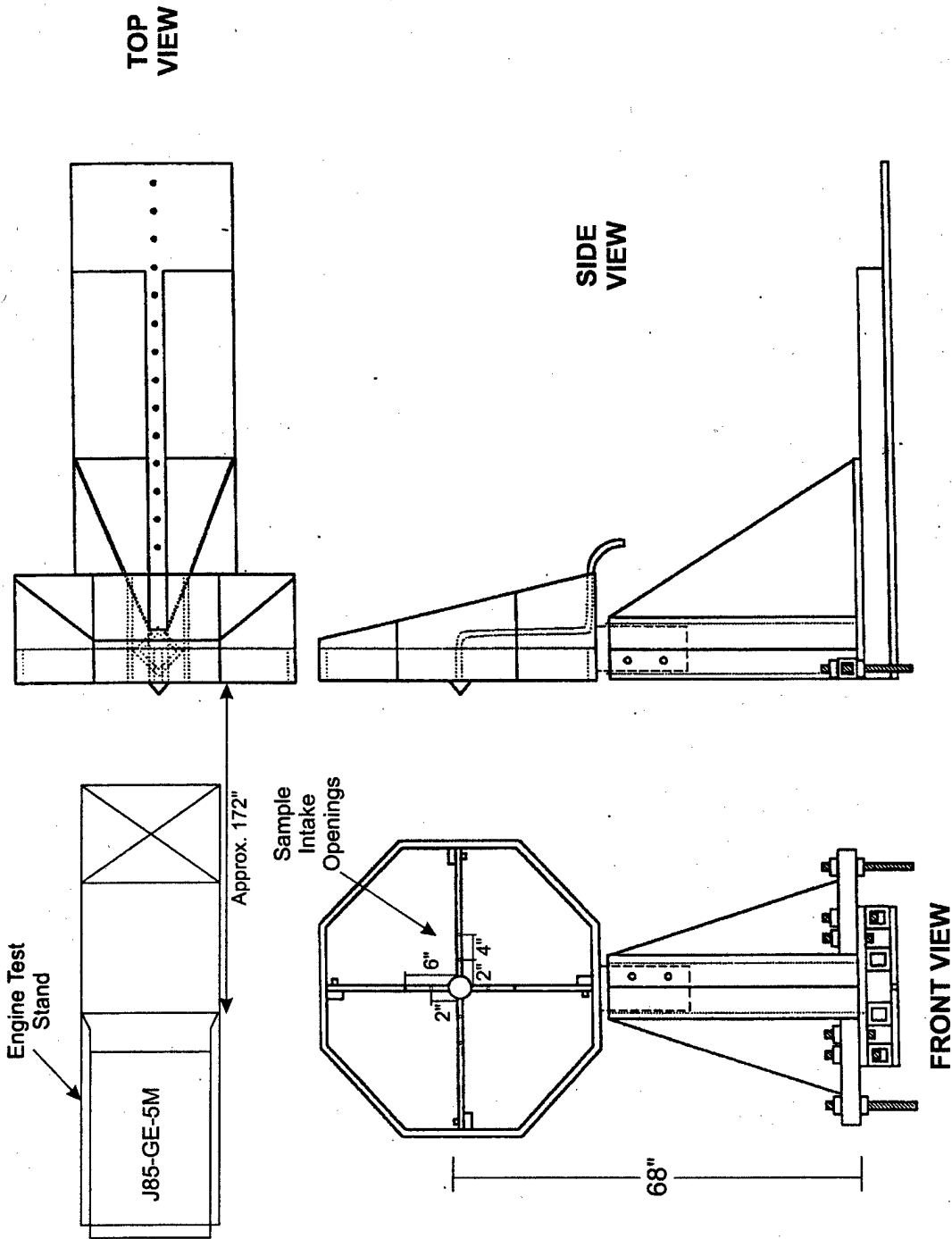
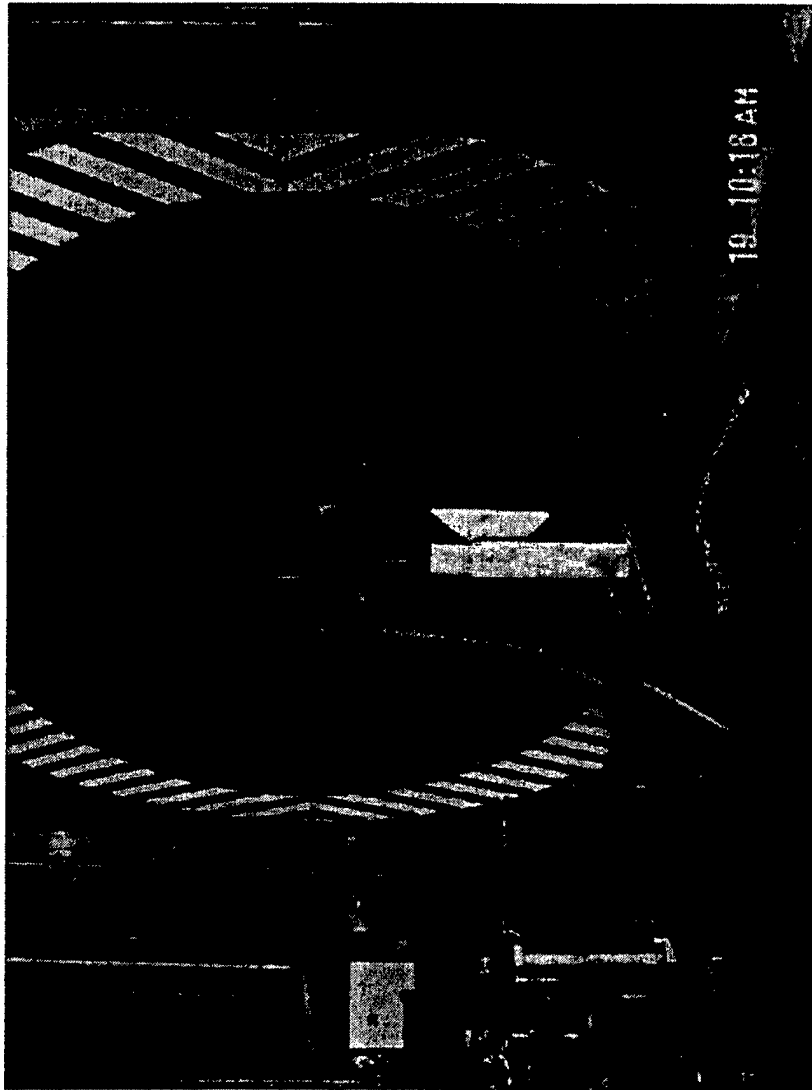

Figure 2-7. Engine Rake at Randolph AFB (Front View into Round Augmenter Tube of T-12 Hush House)



EQ ENVIRONMENTAL QUALITY
MANAGEMENT, INC.

Figure 2-8. Engine Rake Assembly
Moody AFB



EQ ENVIRONMENTAL QUALITY
MANAGEMENT, INC.

Figure 2-9. Engine Sampling Rake
Moody AFB

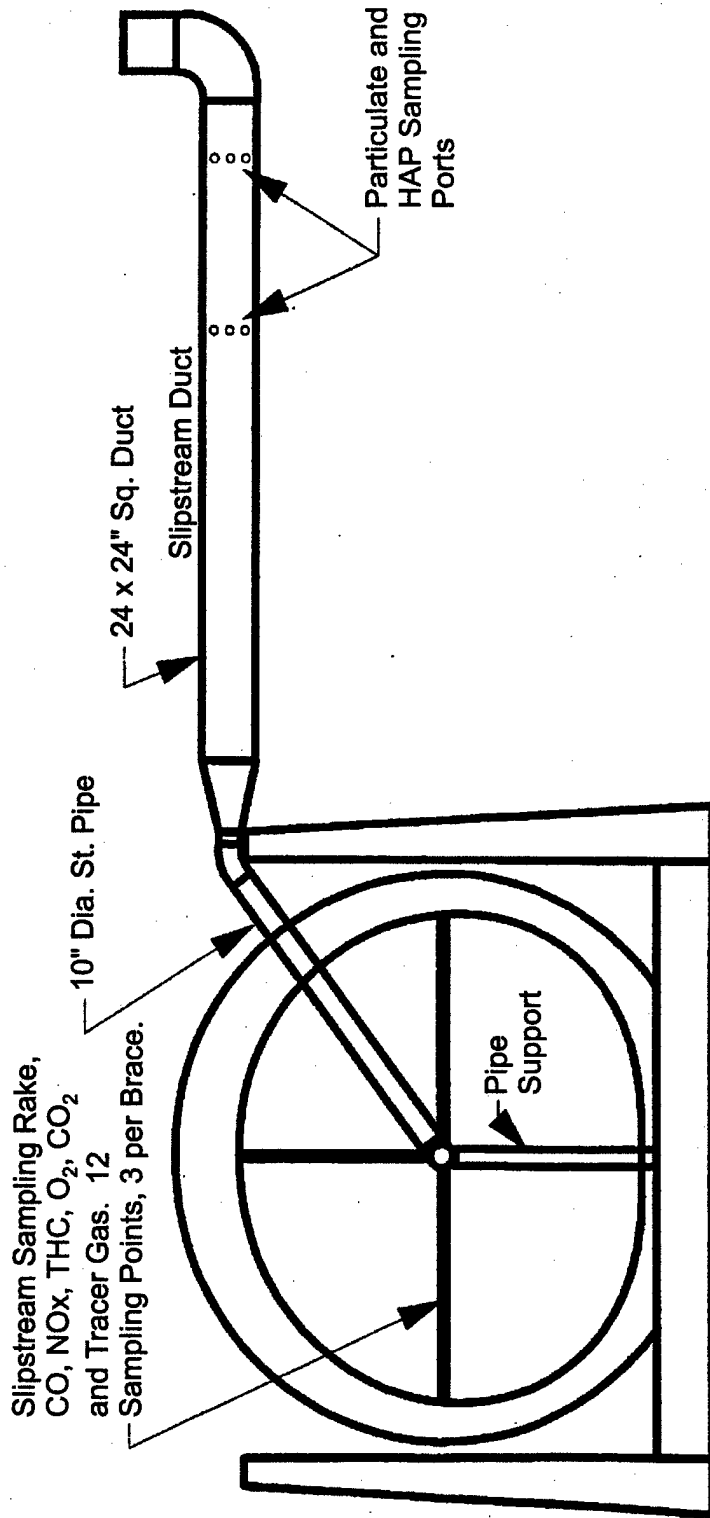

Figure 2-10. Augmenter Tube Slipstream Sampling System
(Front View into Augmenter Tube) at Moody AFB

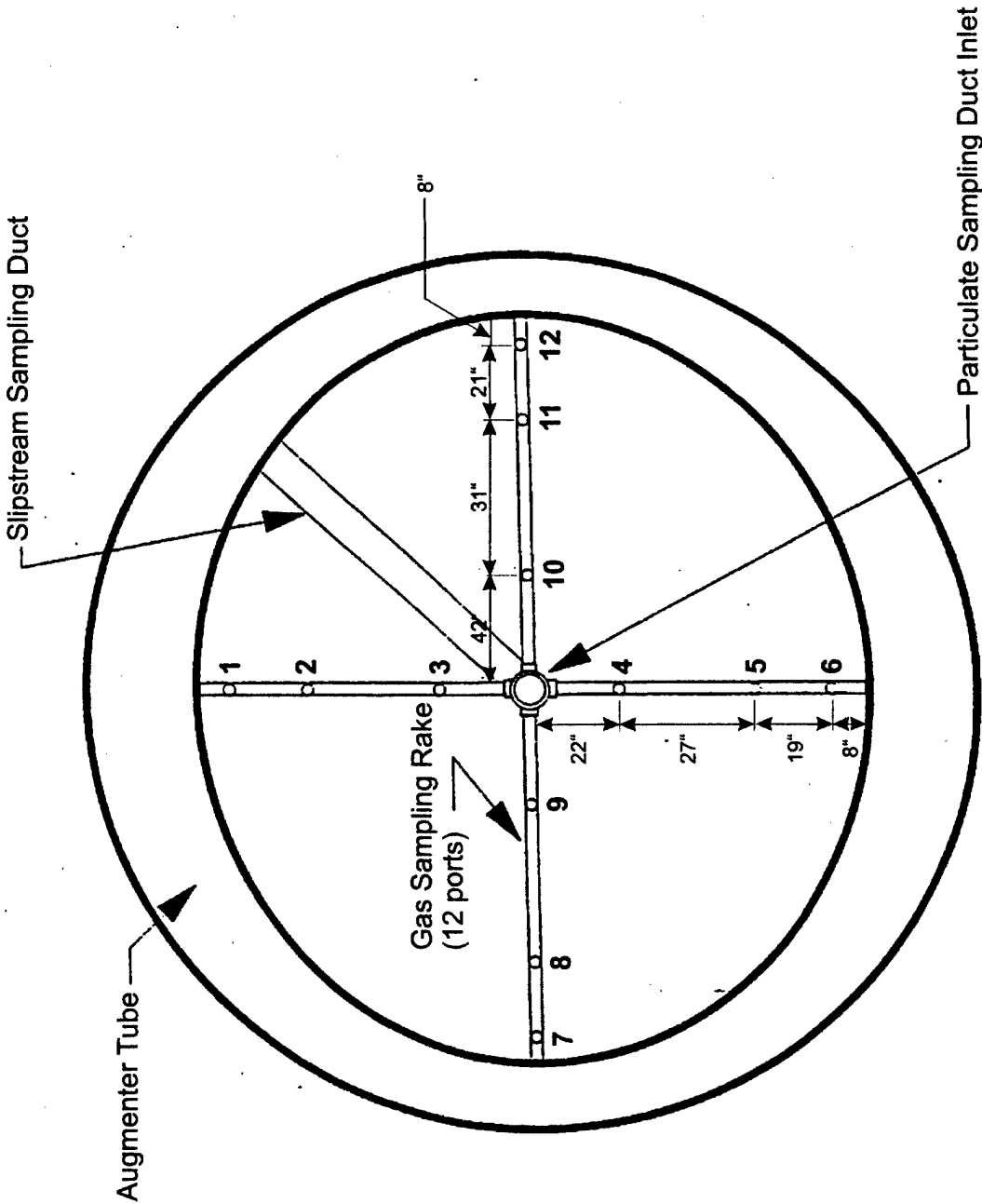

Figure 2-11. Augmenter Tube Slipstream Sampling Rake (View from Test Engine)
Moody AFB

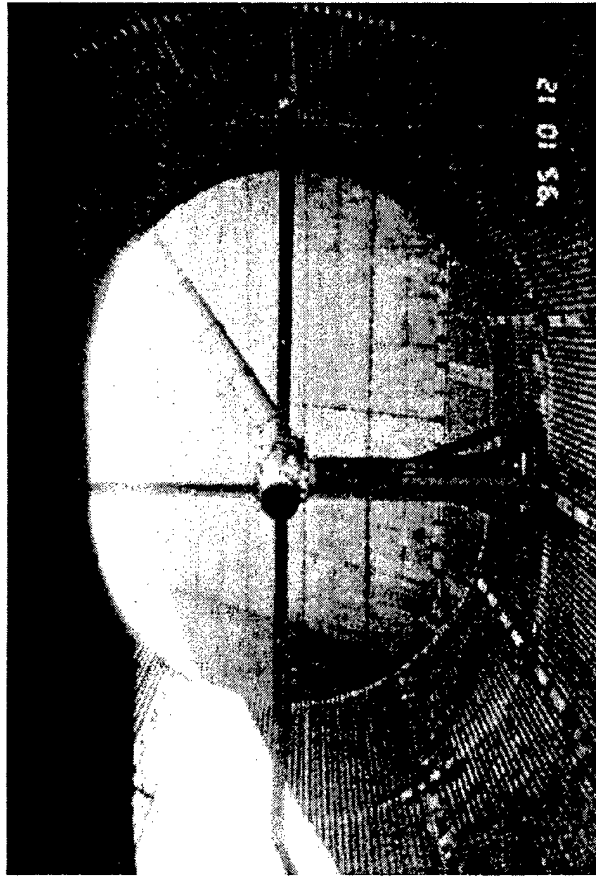

Figure 2-12. Augmenter Tube Slipstream Extraction Tube and Gas Sampling
Moody AFB

EQ ENVIRONMENTAL QUALITY
MANAGEMENT, INC.

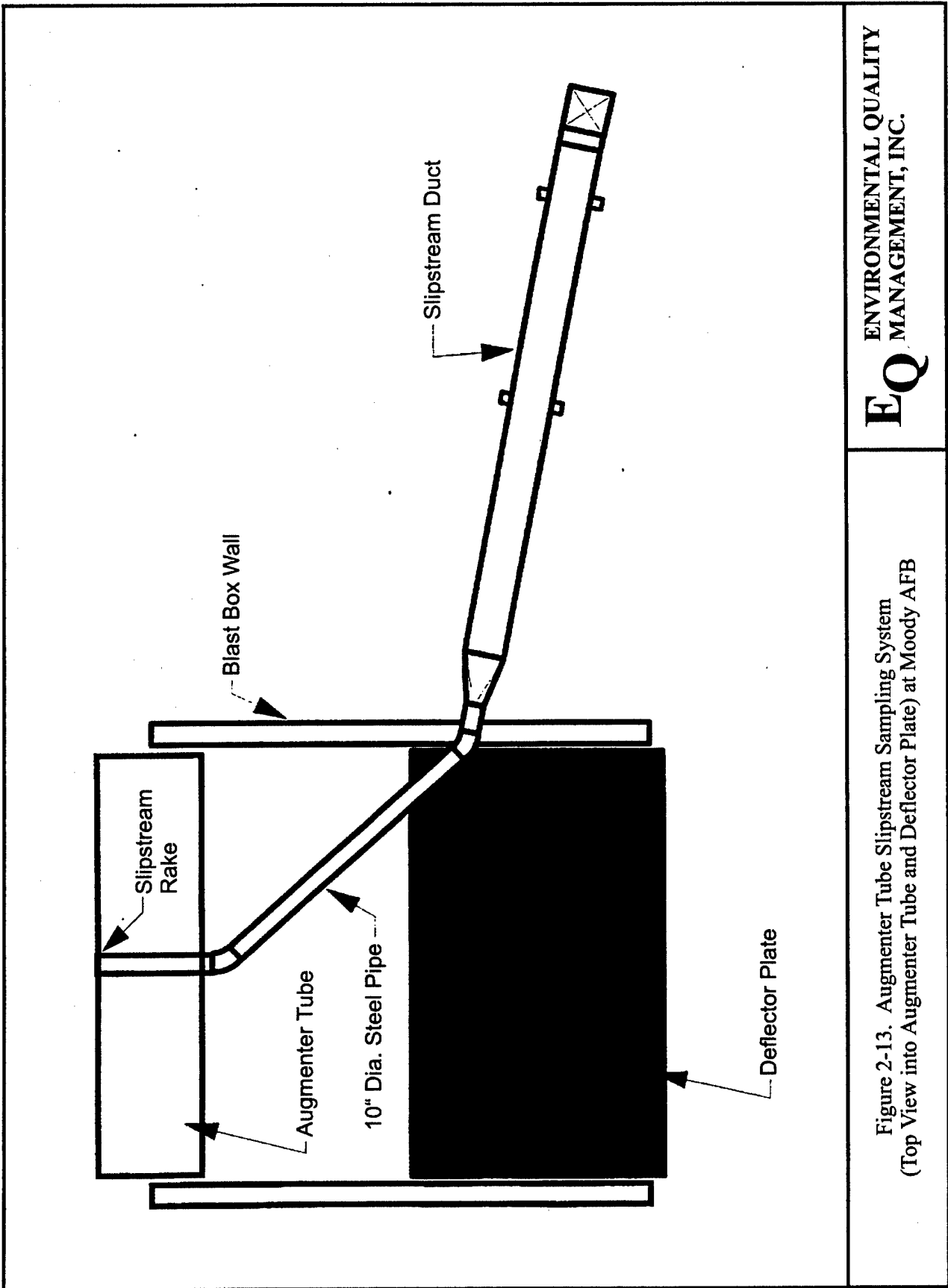

Figure 2-13. Augmenter Tube Slipstream Sampling System
(Top View into Augmenter Tube and Deflector Plate) at Moody AFB

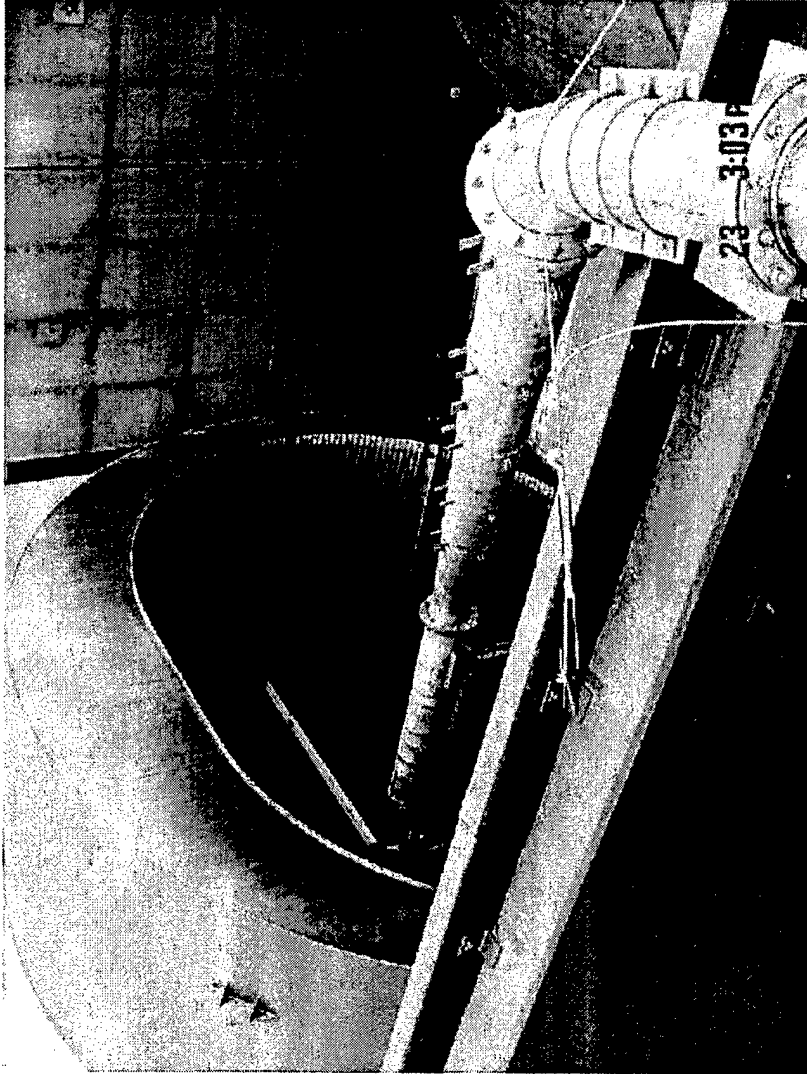
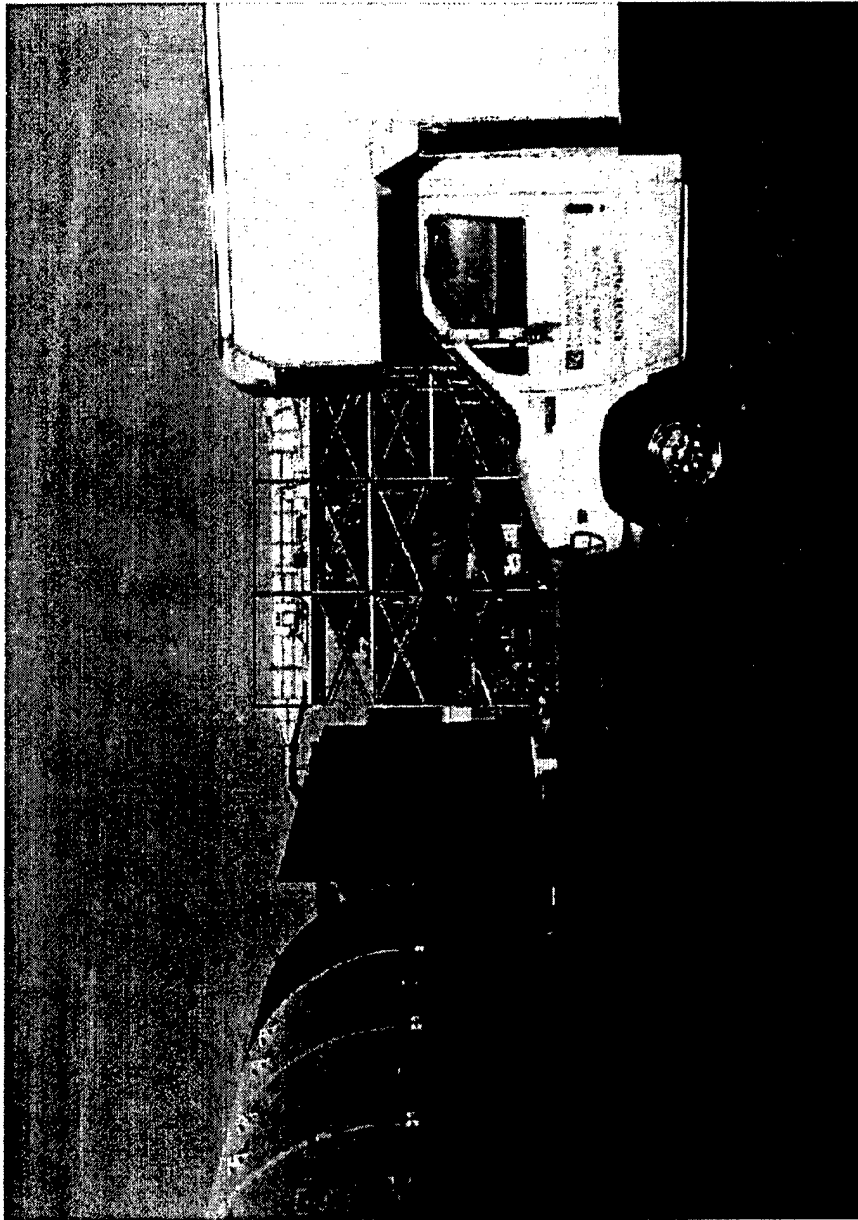

Figure 2-14. Slipstream Transition to T-10 Hush House Exit
Moody AFB

EQ ENVIRONMENTAL QUALITY
MANAGEMENT, INC.



EQ ENVIRONMENTAL QUALITY
MANAGEMENT, INC.

Figure 2-15. Augmenter Tube Slipstream Sampling System Duct
Moody AFB

SECTION 3

SAMPLING PROCEDURES AND METHODS

The sample program completed at Moody AFB involved sample collection of emissions from one J85-GE-5M engine at three locations (see Figure 2-5): 1) directly behind the engine (gaseous emissions and select HAPs), 2) at the hush house augments tube exit (particulate and HAP), and 3) at the intake to the slipstream inside the augments tube (gaseous emissions). The purpose of the multiple sample locations was to note the variance (if any) in gaseous emissions (CO, NO_x, TNMHC) inside the hush house augments tube and to look at pollutant dilution and secondary pollutant formation by sampling directly behind the engine. (The sample program completed at Randolph AFB involved sample collection of gaseous emissions from one J85-GE-5M engine at the first location only.) A breakdown of the target pollutants for each engine setting is provided in Table 3-1.

Due to the complexity of the test program, several items are summarized here for consideration. Each item is discussed in more detail in the following sections.

- The exhaust emissions were diluted with cooling air as they pass through the hush house augments tube. Sample run times were extended in an attempt to attain the lowest detection limits.
- Engine exhaust velocities in the rear of the augments tube at the idle setting were expected to be very low, possibly unmeasurable. A hot wire was used to measure exhaust velocity in the slipstream at the rear of the hush house, and the flow was calculated.
- Particulate measurements at the hush house exhaust were run at an isokinetic sampling rate while attempting to maximize sample volume and retain filter integrity as well as particle catch. Sample run times were 3 hours at the idle setting and 2 hours at the remaining settings.

TABLE 3-1. J85-GE-5M, MOODY AFB TARGET EXHAUST POLLUTANTS FOR EACH ENGINE SETTING

| | Sampling Duration | Particulate Matter | HAPs (VOC, ALD/KEY) | NO _x | TNMHC | CO | CO ₂ | O ₂ |
|--------------|-------------------------------------|--------------------|---------------------|-----------------|-------|----|-----------------|----------------|
| Idle | 9 hours (Three 3-hour test runs) | X | X | X | X | X | X | X |
| Intermediate | 6 hours (Three 2-hour test runs) | X | X | X | X | X | X | X |
| Military | 6 hours (Three 2-hour test runs) | X | X | X | X | X | X | X |
| Afterburner | 25 minutes (Five 5-minute runs) | | | X | X | X | X | X |

Note: Grab samples for benzene and formaldehyde were collected directly behind the engine at idle, intermediate, and military.

- One composite particulate sample was collected at each setting. This sample was collected in conjunction with the three replicate sample runs in an attempt to obtain a measurable quantity of particulate matter.
- One particulate sample at each setting was analyzed by scanning electron microscopy for particle size distribution (by particle count) and morphology (see Table 3-2).
- All sampling was conducted while the aircraft was burning JP-8+100 fuel.

**TABLE 3-2. PERCENTAGES OF CARBON PARTICLES
IN VARIOUS DIAMETER RANGES BY NUMBER OF PARTICLES**

| | Idle | Intermediate | Military | |
|----------------------------|--------------|---------------------|-----------------|--------------|
| Filter Number | PC001 | PC002 | PC003 | Blank |
| Diameter Range (um) | | | | |
| .5-2.5 | 92.4% | 88.2% | 89.4% | NA* |
| 2.5-5.0 | 6.7% | 10.8% | 8.7% | |
| 5.0-7.5 | 1.0% | 1.0% | 1.0% | |
| 7.5-10 | 0.0% | 0.0% | 1.0% | |
| >10 | 0.0% | 0.0% | 0.0% | |

*NA – Insufficient particles for a valid statistical analysis

3.1 GENERAL SAMPLING CONSIDERATIONS/COMPLICATIONS

Access to the interior of the hush house was restricted to periods when the engine/aircraft was not operating. It was therefore necessary to devise a sampling scheme that allowed sampling to be conducted from a remote location, requiring some modification to existing test procedures. The slipstream sampling approach allowed particulate matter and HAP testing personnel to be located outside the exclusion zone.

The physical structure of the exhaust through the augments tube did not allow for use of the traditional isokinetic sampling methodologies (Title 40, Code of Regulations, Part 60, Appendix A, Methods 1-5). Complicating factors included large amounts of dilution air and limited testing windows. Based on these considerations, several assumptions were made to address the unique nature of this program. Assumptions included homogeneous mixing of the exhaust stream (verification of this assumption was made in the field); theoretical methods for determining air flow through the system; and particulate distribution behavior equivalent to gaseous. These assumptions were based on previous engine testing programs.

3.1.1 Pollutant Distribution in the Augmenter Tube

The test program was based on the assumption that, as the exhaust gas exits the test stand through the augmenter tube, the exhaust stream from the engine and the dilution air have reached a homogeneous mixture. A sample drawn from each of the 12 sample points on the slipstream support (Figure 2-11) showed that the gas stream was homogeneous in the hush house augmenter tube at approximately 60 feet behind the jet engine exhaust point. The complete mixing of exhaust gases and the dilution air are the result of the very turbulent flow from the jet engine exhaust and rough (open-pore) augmenter tube surface. Particulate size distribution in the engine exhaust has been shown to be significantly less than 10 microns (μm) in size. Because of the size of the particles, it was assumed that they behaved as an aerosol or gas and that pollutants were distributed evenly throughout the test stand exhaust. Since it was assumed that all particulate (and those contaminants bound to the particulate) would behave as an aerosol, any point in the augmentor tube would have the same concentration of pollutants. This assumption was used as the basis to conduct single-point (center-point) isokinetic sampling at one point in the exhaust, which would be representative of all points in this engine test exhaust.

3.2 EMISSION MEASUREMENT APPROACH

Sampling was performed for criteria pollutants and those HAPs that are products of incomplete combustion (PICs). The following compounds were monitored from the slipstream sampling system at the rear of the hush house augmenter tube (Moody AFB):

- Filterable and condensable particulate (EPA Methods 5 and 202), including particle size distribution.
- Aldehydes and ketones (EPA Method 0011).
- Volatile organic compounds (VOCs) (EPA Method 0030), including 1,3 butadiene.
- Oxygen and carbon dioxide (EPA Method 3A).
- Carbon monoxide (EPA Method 10).
- Nitrogen oxides (EPA Method 7E).

- Total hydrocarbons (THCs) (EPA Method 25A). Total hydrocarbons reported as total non-methane hydrocarbons.
- Methane (EPA Method 25A).
- Polynuclear Aromatic Hydrocarbons (NIOSH Method 5506)
- Benzene and formaldehyde (grab samples directly behind the engine).

The following compounds were monitored from the engine rake sampling (Moody and Randolph AFB):

- Oxygen and carbon dioxide (EPA Method 3A).
- Carbon monoxide (EPA Method 10).
- Nitrogen oxides (EPA Method 7E).
- Total hydrocarbons (THCs) (EPA Method 25A).
- Methane (EPA Method 25A).

The engine exhaust system was not sampled for sulfur dioxide, metals or semi-volatiles. Sulfur dioxide emissions were determined by measuring the sulfur content in the JP-8+100 fuel and converting sulfur mass emissions to sulfur dioxide mass emissions. This is based on the procedure documented by AFIERA ("Air Emissions Inventory Guidance Document for Mobile Sources at Air Force Installations," January 2002). Concentrations of the following metals were determined in the fuel analysis: antimony, arsenic, barium, beryllium, cadmium, cobalt, chromium, copper, lead, manganese, mercury, nickel, phosphorus, selenium, silver, thallium, and zinc. Dioxins, furans, semi-volatiles and HAPs not discussed in the subsequent text were emitted in quantities too small to be detected by the sampling methods proposed in this program. Therefore, these pollutants were not included in the sampling program.

Grab samples were collected behind the engine at the engine rake to determine the concentration of benzene and formaldehyde. This was performed from the idle to military engine settings.

The unique feature in conducting emissions testing for this engine was that the exhaust stream at the T-10 and T-12 hush house exhausts were diluted with ambient air (significantly diluted at the T-10 hush house). This presented two problems: (1) the volume of exhaust gas was significantly increased; and (2) dilution of the exhaust made it difficult to detect various pollutants. Sample run times were extended and analytical methods were revised in order to

reduce the detection limits. During past emission measurement programs, ambient pollutants were monitored in order to correct the measured exhaust parameters. Due to the location of the hush houses at Moody AFB and Randolph AFB, the influence of other pollutant contributing sources was minimal. Therefore, ambient air monitoring was limited to CO₂, CO, and TNMHC in order to complete the carbon balance calculations.

3.2.1 Flow Rate Measurement

As stated previously, standard flow rate measurements could not be performed at the test locations due to the hush house configuration. Engine exhaust flow was determined by theoretical methods (carbon balance and F-factors). An attempt was made to measure the flow directly by fixing a pitot tube to the engine rake at a single point. Velocity readings were taken in this manner while the engine operated at idle and intermediate settings. Flow calculations were questionable, because the volume of air entering the augments tube was not definitive. However, this method provided an additional point for comparison. The use of multiple-flow measurement/calculation methods provided a firm basis for identifying and rejecting outlier data. For example, the calculated exhaust flow using the f-factor methodology showed a decrease in airflow between the military and afterburner settings. Therefore, carbon balance was used as the selected flow methodology. The flow data collected by all methods for the engine at different operating conditions. An established relationship was expected between engine operating level and total flow. All flow measurement methods were anticipated to provide valid data at one or more operating conditions. The data evaluation identified which measurement deviates from that relationship, and whether that deviation can be attributed to a physical parameter such as temperature, oxygen concentration, etc. If the deviation was predicted (e.g., high oxygen concentration impact on F-factor calculation), that data was discarded. If there was no obvious physical explanation, best-fit estimates at other loads were used to identify and reject the outlier methodology.

Inlet concentrations for some compounds were measured as part of the theoretical flow determination method using carbon balance and F-factors. At the inlet location, THC was measured using a hydrocarbon analyzer identical to the one that measured engine exhaust gas THC. An inlet carbon dioxide (CO₂) measurement was also required as input to the theoretical

flow model. An ambient CO₂ monitor was used to measure the inlet CO₂ concentration during each test run.

The J85-GE-5H engine was tested by EQ in the past. The exhaust flow was calculated using identical theoretical methods including tracer gas methodologies. The most representative flow determination method was carbon balance. These flows were used for comparison with the exhaust flows determined in this program.

Section 4 discusses in detail the methodologies that were applied to calculate air flow at the hush house engine test facilities.

3.2.2 Pretest Measurement

Preliminary test data for the Moody AFB sampling program was obtained at the slipstream during the shakedown runs. Preliminary flow rate data and gas composition data were collected. Augmenter tube and slipstream sampling geometry measurements were obtained and recorded, and sampling point distances verified. A preliminary velocity traverse was performed in the slipstream utilizing a calibrated S-type pitot tube and a Dwyer inclined manometer to determine velocity profiles. However, flow was not detectable using this methodology. Therefore, a hot wire anemometer was used to measure velocity and flow was back-calculated. Exhaust gas temperatures were observed with a calibrated direct readout pyrometer equipped with a chromel-alumel thermocouple.

A check for the presence or absence of cyclonic flow ("swirling" stack gas flow that is not flowing parallel to the stack walls) was conducted in the slipstream. Preliminary test data was used for nozzle sizing and sampling rate determinations. Probe nozzles, pitot tubes, metering systems, and temperature measurement devices were calibrated on site as specified in Section 5 of EPA Method 5 test procedures.

3.2.3 Gaseous Emission Measurement

Continuous emission analyzers were utilized to measure gaseous pollutants at several locations during both the Moody and Randolph AFB test programs. NO_x, CO, TNMHC, CO₂, and O₂ were measured continuously according to the procedures in EPA Methods 7E, 10, 25A, and 3, respectively. In order to measure the relatively low concentration of CO₂ in the exhaust stream, an

analyzer equivalent to a Siemens Ultramat SE analyzer, was used. This analyzer meets the specifications established by Pratt & Whitney Engineers during prior test programs.

At Moody AFB, two complete sets of continuous emission analyzers were used to monitor emissions. One set of analyzers was dedicated to the slipstream system. The slipstream intake contained 12 sample intake ports (Figure 2-11). Each port was sampled individually so that pollutant distribution was verified. In addition, a composite sample was collected from all 12 points after pollutant distribution was verified. The second complete set of continuous emission analyzers alternated monitoring between the hush house cooling air intake and the engine cruciform directly behind the engine. The cruciform contained eight sample intake ports (Figure 2-8) that were used to collect a composite sample directly behind the engine. A heated sampling line was run to each location and a tee valve installed so that the sample stream could be diverted at approximately 30-minute intervals.

Similarly, a complete set of continuous emission analyzers was utilized at Randolph AFB to monitor emissions from the engine cruciform directly behind the engine. The cruciform contained six sample intake ports (Figure 2-7) that were used to collect a composite sample directly behind the engine.

3.2.4 Particulate Measurement

The collection of particulate matter from aircraft engines is difficult due to the lack of particulate present in the exhaust stream. The aircraft engines are highly efficient and thus produce minimal particulate matter, and the exhaust stream may be slightly diluted. Due to the difficulty in obtaining a measurable quantity of particulate matter from the engine exhaust using EPA test methodologies, the method was adapted to provide the best opportunity for particle collection. EPA Method 5 was utilized, but the sample run times were extended to three hours in length at the idle setting and two hours in length for the remaining settings. In past programs, a one-hour test duration was utilized and the isokinetic sampling rate was maximized in order to increase the sample volume. This resulted in filter material loss to the impingers and a high vacuum on the filter holder which resulted in filter material adhering to the support frit gasket. This caused filter material loss and a negative net mass gain with respect to filterable particulate matter.

In order to minimize method error and maximize the potential for particle gain, EPA Method 5 was followed in order to gain regulatory acceptance; the sample run time was extended to three hours at idle setting and two hours at intermediate and military while maintaining a steady sample flow rate so the filter material was not pulled to the impinger solutions. A Teflon filter support frit without a rubber gasket was used to minimize filter loss during sample recovery. The entire Method 5 sample was measured as total particulate. Therefore, the filterable fraction and condensible fraction were added together to provide a total particulate matter result. This assisted in accounting for any filter loss that may have carried to the impingers.

EPA Method 5I was considered as part of this program. This method is specific to low particulate concentrations and uses a smaller filter and increased sample rate. This method was considered but was not utilized based on past experience. In past sampling, the smaller filter surface area increased the method error when a small portion of the filter was lost. This resulted in a loss of mass.

In a further attempt to collect a measurable quantity of particulate matter, a composite particulate sample was also conducted at each setting simultaneously with the three sample runs. The composite sample run followed EPA Method 5 procedures for a 9- or 6-hour duration.

In order to assess the success of particle collection in the field, an analytical balance was brought to the test site for field weighing of the sample filters. The field weights were used as a qualitative indication of the particle catch on the filters. This indication allowed the test team to make adjustments in the field to maximize the opportunity for particle collection.

For each engine setting, one particulate sample was analyzed by scanning electron microscopy (SEM) equipped with an Iridium X-ray Fluorescence (IXRF) digital image system to determine the particle size distribution by count and the aerodynamic particle shape. The EPA Method 5 filter media was modified for the sample to accommodate the SEM analysis. A polycarbonate filter media was used. The exact filter media was discussed with the analytical laboratory based on the intent of gaining the highest possible quantity of measurable particulate matter. Based on inspection of the polycarbonate filter at idle setting, run times were shortened to approximately half duration of the remaining two runs. This was completed so that particulate matter collected on the filter did not become so dense that the SEM would not be effective.

3.2.5 Hazardous Air Pollutant Sampling

Sampling for select HAPs was conducted at the slipstream. Based on historical sampling programs, volatile organic compounds, aldehydes and ketones, and Polynuclear Aromatic Hydrocarbons (PAH) were the target of the sampling program. Volatiles were sampled at the slipstream using EPA Method 0030 and aldehydes and ketones were measured according to the procedures in EPA Method 0011. One aldehyde/ketone and PAH sample was collected at each setting in order to maximize sample volume. Three volatile samples were collected at each setting. National Institute of Occupational Safety and Health (NIOSH) Method 5506 was used to collect a sample for PAH at each setting. A sample was drawn through an in-stack filter across an XAD-2 resin trap at approximately 1 lpm. A single 1-hour sample was collected over each setting.

3.2.6 Direct Engine Exhaust Measurement

During each sample run, a single sample was collected directly behind the engine for gaseous pollutant analysis at the idle, intermediate, and military settings. The sample was collected from the engine cruciform situated directly behind the engine. These data were compared to the gaseous emissions data collected at the slipstream to note dilution ratios and possible secondary chemistry with the dilution air.

At the idle, intermediate and military engine settings a single grab sample was collected for Benzene and Formaldehyde. Benzene was collected via TO Method 14 and Formaldehyde was analyzed via TO Method 11.

3.2.7 Emissions Test Methods

The following paragraphs discuss methods that were utilized for emissions testing. Furthermore, Appendix B presents the emissions sampling methods in greater detail, including descriptions of all exhaust emissions test sampling trains, sample preparation, sample procedures, sample recovery, and analytical procedures.

3.2.7.1 Particulate Sampling

EPA Method 5 was used for particulate sampling at the slipstream exhaust at Moody AFB. The sampling train utilized to perform particulate sampling conformed to EPA Reference Methods 5 and 202 for the collection of both filterable particulate and back-half condensable particulate. One particulate sample at each setting was submitted for analysis of particle size distribution and shape. The particulate was analyzed using a scanning electron microscope (SEM) equipped with an IXRF iridium digital image system.

3.2.7.2 Aldehyde and Ketone

The sampling train utilized to perform aldehyde and ketone sampling at Moody AFB conformed to EPA Method 0011. In order to increase sample volume and meet method detection limits, a single sample was collected at each setting. For example, at the idle setting, a 9-hour sample was collected.

3.2.7.3 VOCs

The sampling train utilized to perform VOC sampling at Moody AFB conformed to EPA Reference Method 0030. Table 3-3 lists the VOCs that were analyzed for in each sample. Three VOC samples were collected at each setting and ran simultaneously with the particulate runs.

3.2.7.4 Polynuclear Aromatic Hydrocarbons

National Institute of Occupational Safety and Health (NIOSH) Method 5506 was used to collect a sample for PAH at each setting. A sample was drawn through an in-stack filter across and XAD-2 resin trap at approximately 1 lpm. A single 1-hour sample was collected over each setting.

3.2.7.5 Carbon Monoxide, Carbon Dioxide, Oxides of Nitrogen, and Oxygen

Sampling was performed using a continuous emissions monitoring system (CEM) for oxygen and carbon dioxide (EPA Method 3A), carbon monoxide (EPA Method 10), and nitrogen oxides (EPA Method 7E) at both Moody AFB and Randolph AFB. Due to the expected low concentration of CO₂ in the exhaust stream, Siemens Ultramat 5E was used. The analyzer has

**TABLE 3-3. SUMMARY OF SOURCE TARGET COMPOUNDS FOR
VOLATILE ORGANIC COMPOUNDS**

| VOST Compounds – Clean Air Act List | |
|--|---------------------------|
| Acetone | trans-1,2-Dichloroethene |
| Benzene | 1,2-Dichloropropane |
| Bromodichloromethane | cis-1,3-Dichloropropene |
| Bromomethane | trans-1,3-Dichloropropene |
| Bromoform | Ethylbenzene |
| 2-Butanone | 2-Hexanone |
| 1,3 Butadiene | Methylene chloride |
| Carbon disulfide | 4-Methyl-2-pentanone |
| Carbon tetrachloride | Styrene |
| Chlorobenzene | 1,1,2,2-Tetrachloroethane |
| Chlorodibromomethane | Tetrachloroethene |
| Chloroethane | Toluene |
| Chloroform | 1,1,1-Trichloroethane |
| Chloromethane | 1,1,2-Trichloroethane |
| 1,1-Dichloroethane | Trichloroethene |
| 1,2-Dichloroethane | Trichlorofluoromethane |
| 1,1-Dichloroethene | Vinyl acetate |
| Cis-1,2-Dichloroethene | M,P-Xylene |
| | O-Xylene |

the ability to measure the concentration in several ranges: 0-2%, 0-5%, and 0-10% CO₂ with accuracy to three decimal places.

3.2.7.6 Methane and Non-methane Hydrocarbons (NMHC)

NMHCs were measured directly at Moody AFB and Randolph AFB using a J.U.M. Model 109A methane/non-methane hydrocarbon analyzer. The Model 109A contains two flame ionization detectors (FIDs). The sample is split before being sent to the respective FIDs. One fraction is passed through a catalytic converter to combust all non-methane hydrocarbons (to CO₂) before the sample is measured in the FID. The methane residual in the sample is the only component that is measured by that detector. The other sample fraction is sent to the second FID, which measures the total hydrocarbon concentration of the sample. Both FIDs are initially calibrated with a methane calibration standard, so both the total hydrocarbon and the methane residual are measured as methane. The difference between these two values is automatically determined and reported as non-methane hydrocarbons by the Model 109A.

Any sampling configuration which splits the sample stream, analyzes one fraction for total hydrocarbons and catalyzes the remaining fraction to remove non-methane hydrocarbons before analysis of the methane residual was considered the equivalent of the J.U.M. Model 109A. The equivalent analyzer configurations can employ two parallel hydrocarbon analyzers, with a J.U.M. Model 900 NMHC-cutter treating one fraction of the sample, or using a single hydrocarbon analyzer and catalytic pre-cutter, with the FID alternating between the total and methane residual fractions. The analyzer was challenged with a zero and span gas at the beginning and end of each sample day to calibrate and assess the instrument's calibration.

3.2.8 Hush House Inlet Air Sampling

Due to the location of the Moody T-10 and Randolph T-12 hush houses, the influence of ambient pollutants on the measured concentrations from the engine exhaust were negligible. Therefore, the hush house inlet was monitored for CO, CO₂, O₂, and TNMHC in order to complete the carbon balance and f-factor flow calculation.

Sampling was performed using a continuous emissions monitoring system (CEM) for oxygen and carbon dioxide (EPA Method 3A), carbon monoxide (EPA Method 10), and total non-methane hydrocarbons (EPA Method 25A). Due to the expected low concentration of CO₂ in the exhaust stream at the slipstream, a low concentration CO₂ monitor was utilized to measure CO₂. The CO₂ analyzer had the ability to measure the concentration in several ranges: 0-1,000 ppm, 0-1% and 0-5% CO₂.

3.3 ENGINE TESTING MATRIX

3.3.1 Engine Shakedown Runs

Prior to the commencement of emission testing, a preliminary set of gaseous emission and exhaust flow data were determined at each setting except afterburner. The purpose of the shakedown runs was to determine the expected gaseous pollutant concentrations so that the appropriate calibration gases could be determined. Also, the preliminary flow measurements were used at Moody AFB to select the proper sample nozzle diameter.

During the shakedown runs, several measurements were made at multiple idle settings. The fuel flow was adjusted at small increments and gaseous emissions were measured at the slipstream rake to note the variance in emissions with fuel flow near idle.

3.3.2 Engine Test Settings

Emissions testing was performed on the J85-GE-5R engine at four power settings. These power settings are the following:

- Idle.
- Intermediate.
- Military.
- Afterburner.

At Moody AFB, emissions testing comprised three emissions tests for each pollutant at each power setting where possible. At the idle setting, three 3-hour emission test runs were conducted. Due to sample volume and method detection limit requirements, the aldehyde/ketone sample was composited over the 6- or 9-hour period. The other particulate matter and volatile samples ran for 2 or 3 hours based on the particulate gain. The engine was brought down to a safe operating level so that the test team personnel could access sampling equipment for approximately 10 minutes in between each sample run. All engine settings were defined by engine operators so that the engine could be run continuously (or as long as practical) at idle, intermediate, military, and afterburner. EQ adjusted the sample collection procedure to accommodate the reduced operating time at the afterburner setting. Approximately five 5-minute samples of gaseous pollutants (NO_x, CO, TNMHC, CO₂, O₂) were sampled at the afterburner setting. Table 3-4 lists engine type, number of power settings, and number and types of samples that were collected.

At Randolph AFB, 30-minutes of combined readings at idle, intermediate, military, and afterburner were collected from two engines.

3.3.3 Engine Emission Trend Development

In addition to the settings listed in Table 3-4, a sample run from idle to military was conducted. The purpose of the run was to sample for gaseous pollutants throughout the engine

TABLE 3-4. ENGINE EMISSION SAMPLING MATRIX – MOODY AFB

| Pollutant/Method | Sample Location | | | Sample Duration (A) (Minutes) | Number of Samples per Setting | Total Number of Samples | Engine Setting | | | |
|--|-----------------|-----------------|------------|-------------------------------|-------------------------------|-------------------------|----------------|------|--------------|----------|
| | Engine Rake | Slipstream Rake | Slipstream | | | | Ambient | Idle | Intermediate | Military |
| Particulate/EPA Method 5202 | | | X | 120/180 | 3 | 9 | X | X | X | |
| Aldehydes and Ketones/EPA Method 0011 | | | X | 360/540 | 1 | 3 | X | X | X | |
| VOC/EPA Method 0030 | | | X | 120/180 | 3 | 9 | X | X | X | |
| Carbon Monoxide/EPA Method 10 | X | X | | 120/30 | 3 | 12 | X | X | X | X |
| Carbon Dioxide and Oxygen/ EPA Method 3A | X | X | | 120/30 | 3 | 12 | X | X | X | X |
| Oxides of Nitrogen/EPA Method 7E | X | X | | 120/30 | 3 | 12 | X | X | X | X |
| Total Hydrocarbons/ EPA Method 25A | X | X | X | 120/30 | 3 | 12 | X | X | X | X |
| Methane/EPA Method 25A | X | X | | 120/30 | 3 | 12 | X | X | X | X |
| Benzene/TO-14 | X | | | | | | | | | |
| Formaldehyde/TO-11 | X | | | | | | | | | |

A – 30 minute samples were collected at the engine rake. 180-minute test runs were conducted at idle.
 B – The engine rake was removed prior to sampling at afterburner. The sample times was reduced to 5 minutes.

power band. The engine throttle position was increased in small increments at 10-minute intervals so that gaseous emission data could be collected at the slipstream rake to develop an emission trend for the engine. These data are presented in Table 5-1.

3.4 ENGINE TEST CYCLE DATA

In order to correlate the aircraft engine emissions data with the engine operation, facility personnel compiled selected engine test cycle data during testing. The engine test monitoring system at the test stand constantly monitors a variety of engine parameters during engine testing. For the purpose of emissions sampling, a select number of these parameters were provided to the Support Program Office (SPO) for emission factor development. These parameters will assist in noting the effect of a specific pollutant for a specific engine load condition. The following data was compiled by facility personnel:

- Fuel flow at each load.
- Engine rpm at each load.
- Thrust at each load.
- Test cell temperature.

Table 3-5 presents engine operating data.

TABLE 3-5. ENGINE OPERATING DATA

| Power Setting | Fuel Flow (lbs/hr) | | %RPM (Average) | | lb/Thrust (Average) | Cell Temperature |
|---|-----------------------|--------|-------------------|-----|------------------------|---------------------|
| J85-GE-5M (Moody AFB) | | | | | | |
| Idle | 525 | | 49.5 | | 55 | 83 |
| Intermediate | 1,045 | | 85.5 | | 808 | 86 |
| Military | 2,550 | | 99.7 | | 2,521 | 77 |
| Afterburner | 7,695 | | 99.8 | | 3,450 | 88 |
| T-38 (with PMP) Talon (Randolph AFB) | | | | | | |
| Engine | 1 | 2 | 1 | 2 | Not Recorded | |
| Idle | 520 | 520 | 50 | 49 | | |
| Intermediate | 980 | 1080 | 85 | 85 | | |
| Military | 2,200 | 2,240 | 100 | 100 | | |
| Afterburner | 15,390 | 15,390 | 100 | 100 | | |

3.5 JP-8+100 FUEL SAMPLING AND ANALYSIS

The proximate/ultimate JP-8+100 fuel analysis and level of nitrogen was determined for the facility in order to develop a custom F-factor and to document fuel characteristics during emissions testing. Table 3-6 lists the fuel analysis requirements. One fuel sample at each setting was collected over the period of testing and composited. EQ collected these samples and shipped them to the appropriate laboratory for analysis.

In addition to the proximate/ultimate JP-8+100 fuel analysis, EQ submitted a portion of the composited sample for analysis of the metals listed in Table 3-7.

TABLE 3-6. JP-8+100 FUEL ANALYSIS

| Parameter | Analytical Method | Result |
|--------------|-------------------|---------------|
| Btu/lb | ASTM D-240 | 19,300 Btu/lb |
| Sulfur % | ASTM D-2622 | 0.0496% |
| Carbon % | ASTM D-5291 | 85.52% |
| Nitrogen % | ASTM 4629 | 0.0007% |
| Hydrogen % | ASTM D-5291 | 14.18% |
| Ash % | ASTM D482 | <0.001% |
| Naphthenes % | PONA Analysis | 45.6% |
| Aromatics % | PONA Analysis | 23.5% |
| Parafins % | PONA Analysis | 30.4% |
| Olefins % | PONA Analysis | 0.5% |

TABLE 3-7. SUMMARY OF SOURCE TARGET METALS FROM JP-8 FUEL ANALYSIS

| Metal | Analytical Method | Analytical Result (mg/kg) |
|------------|-------------------|---------------------------|
| Antimony | 6010 | <0.05 |
| Arsenic | 6010 | <0.063 |
| Barium | 6010 | <0.025 |
| Beryllium | 6010 | <0.0025 |
| Cadmium | 6010 | <0.013 |
| Chromium | 6010 | <0.013 |
| Cobalt | 6010 | <0.013 |
| Copper | 6010 | 0.025 (MDL = 0.025) |
| Lead | 6010 | <0.063 |
| Manganese | 6010 | 0.013 (MDL = 0.013) |
| Mercury | 7470 | <0.0005 |
| Nickel | 6010 | 0.038 |
| Phosphorus | 365.2 | 1.2 (MDL = 0.025) |
| Selenium | 6010 | 0.13 |
| Silver | 6010 | 0.013 |
| Thallium | 6010 | 0.075 |
| Zinc | 6010 | 0.025 |

Note: A sample and duplicate were submitted for analysis. The highest concentration is recorded in the table above.

3.6 EMISSION TEST SCHEDULE AND RESPONSIBILITIES

Figure 3-1 shows the time-line for engine testing. The time-lines depict activities and the time each activity required for equipment setup, shakedown runs, emissions testing, and demobilization at the test facility.

The following is a breakout of the general tasks conducted during each of the three phases:

- **Equipment setup** - Setup of the slipstream and calibration of sampling equipment took 5 days. This involved setting up the exhaust rake and slipstream sampling systems, sampling equipment, the flow measurement system, and the mobile laboratory. EQ worked with base personnel so that the facility test schedule was not interrupted.
- **Shakedown** - During this important period, the test team and engine test stand operators became familiar with the operational procedures of the test program. The test team gathered preliminary information at each of the engine test settings. This information was vital to ensure that the scheduled test runs were conducted accurately and efficiently.
- **Testing** - The test team completed three test runs at a single engine setting in one sample day. Testing was completed in 3 days.
- **Teardown** - Teardown of the equipment was accomplished in 2 days.

3.6.1 Personnel Responsibilities

The nature of this test program dictates that the members of the sampling team be highly skilled. The program was staffed at the appropriate level with the necessary skill levels to perform each task. Each team member was actively involved in the collection of emissions samples, fuel samples, sample recovery, data reduction, and sample shipment. Table 3-8 lists the personnel categories and the required qualifications and tasks. The test team functioned as an integrated unit to complete the test program efficiently and without compromising data quality.

MOODY AFB TEST SCHEDULE

| | April 18 | April 19 | April 20 | April 21 | April 22 | April 23 | April 24 | April 25 | April 26 | April 27 | April 28 |
|------------------------------------|----------|----------|----------|----------|----------|----------|----------|----------|----------|----------|----------|
| DAY | Th | F | S | Su | M | T | W | Th | F | S | Su |
| MOODY DAY No. | 1 | 2 | 3 | 4 | 5 | 6 | 7 | 8 | 9 | 10 | 11 |
| Idle | M,S | | | | | | | | | | |
| Intermediate | | | | | | | | | | | |
| Military | | | | | | | | | | | |
| Afterburner | | | | | | | | | | | |
| Engine Trend Curve Idle - Military | | | | | | SD | | | D | D, M | |

RANDOLPH AFB TEST SCHEDULE

| | April 29 | April 30 | May 1 | May 2 |
|--------------|----------|----------|-------|-------|
| DAY | M | T | W | Th |
| DAY No. | 1 | 2 | 3 | 4 |
| Idle | S | S,SD | | D |
| Intermediate | | | | |
| Military | | | | |
| Afterburner | | | | |





Mobilize 
 Setup 
 Shakedown 
 Test 
 Teardown 

Figure 3-1. Time-Line for J85-GE-5R Engine Testing

**TABLE 3-8. BREAKOUT OF MOODY AFB FIELD TEAM
PERSONNEL AND RESPONSIBILITIES**

| Personnel | Responsibilities/Qualifications |
|------------------------------------|---|
| EQ Project Manager | Acted as liaison between Base personnel, sample team, and AFIERA/RSEQ. Coordinated engine operation with testing. Assisted in equipment preparation and sample recovery. Set up and constructed sampling equipment. |
| EQ Team Leaders | Assumed technical responsibility for overall sampling effort and sample recovery. Set up and calibrated equipment. Operated VOST system. Supervised International Aviation Transportation Association (IATA)/DOT certification of shipment of hazardous materials (hazardous sample media, i.e., acetone); and acted as field sample custodian. |
| CEM Operator | Operated and calibrated CEM systems. |
| Particulate Matter Train Operator | Operated particulate matter sampling train and composite train and assisted in sample recovery. |
| Aldehyde and Ketone Train Operator | Operated aldehyde and ketone sampling train. |

**BREAKOUT OF RANDOLPH AFB FIELD TEAM
PERSONNEL AND RESPONSIBILITIES**

| Personnel | Responsibilities/Qualifications |
|---------------------|---|
| EQ Project Manager | Acted as liaison between Base personnel, sample team, and AFIERA/RSEQ. Coordinated engine operation with testing. Assisted in equipment preparation and sample recovery. Set up sampling equipment. |
| CEM Operator | Operated and calibrated CEM system. |
| Sampling Technician | Provided sampling support to the above personnel. |

SECTION 4

CALCULATION OF AIRFLOW

The calculation of emission rates for this test program required accurate measurement of both inlet (ambient) airflow as well as total exhaust flow (combustion products plus excess air). The total exhaust flow was required to quantify mass emission rates for the parameters being measured.

Whenever possible, standard EPA flow measurement methods were used to quantify airflow. However, this test location did not provide adequate measurement locations for traditional flow measurements. Three alternate flow measurement techniques were employed at this location. These measurement techniques were the following:

- Direct measurement.
- Carbon balance for the calculation of inlet and total exhaust flow.
- F-factor for the calculation of inlet and total exhaust flow.

Each method had advantages and disadvantages that varied in significance depending on the specific conditions of each test run. The objective of the test program was to ensure that at least two independent techniques for measuring airflow were available for each test run.

An attempt was made to directly measure the engine exhaust velocity. A pitot tube was attached at a single point to the engine cruciform. This was used as an additional data point for comparison.

4.1 CALCULATION OF INLET AND OUTLET AIRFLOW USING A CARBON BALANCE

This method calculates both inlet and outlet airflow rates using a carbon mass balance. Conservation of matter requires that the total carbon mass rate in the exhaust (MCE) equal the sum of the total carbon mass rate in the fuel (MCF) and the carbon mass rate in the inlet air (MCI).

$$MCE = MCF + MCI$$

Equation 1

A similar conservation of total mass states that the total mass rate in the exhaust (ME) equals the total mass rate in the fuel (MF) plus the total mass rate at the inlet (MI).

$$ME = MF + MI$$

Equation 2

Finally, the mass rate of carbon also can be derived as the total mass rate at each location times the percent carbon by weight (% C_x) in each stream.

$$MCE = ME \times \% C_e / 100$$

Equation 3

$$MCF = MF \times \% C_f / 100$$

Equation 4

$$MCI = MI \times \% C_i / 100$$

Equation 5

The percent carbon by weight was measured in all streams and the mass rate of fuel burned was also measured. This left four unknown variables, ME, MI, MCE, and MCI, and five independent equations.

To solve for inlet mass flow rate, substitute Equation 2 into Equation 3.

$$MCE = (MF \times \% C_e / 100) + (MI \times \% C_e / 100)$$

Then substitute that equation into Equation 1.

$$(MF \times \% C_e / 100) + (MI \times \% C_e / 100) = MCF + MCI$$

Substitute Equations 4 and 5 to get:

$$(MF \times \% C_e / 100) + (MI \times \% C_e / 100) = (MF \times \% C_f / 100) + (MI \times \% C_i / 100)$$

Rearrange factors to get the inlet mass rate.

$$MI = MF \left(\frac{\% C_f - \% C_e}{100} \right) / \left(\frac{\% C_e - \% C_i}{100} \right)$$

By similar derivation, rearrange Equation 2, substitute into Equation 5, substitute the results into Equation 1, and then substitute Equations 3 and 4 to get the following:

$$MI = ME - MF$$

Equation 2

$$\begin{aligned} \text{MCI} &= (\text{ME} \times \% C_i/100) - (\text{MF} \times \% C_i/100) && \text{Equation 5 using Equation 2} \\ \text{MCE} &= \text{MCF} + (\text{ME} \times \% C_i/100) - (\text{MF} \times \% C_i/100) && \text{Equation 1 using Equation 5} \end{aligned}$$

$$\left(\text{ME} \times \frac{\% C_e}{100} \right) = \left(\text{MF} \times \frac{\% C_f}{100} \right) + \left(\text{ME} \times \frac{\% C_i}{100} \right) - \left(\text{MF} \times \frac{\% C_i}{100} \right) \quad \begin{array}{l} \text{Substitute} \\ \text{Equations 3 and 4} \end{array}$$

$$\text{ME} = \text{MF} \left(\frac{\% C_f - \% C_i}{100} \right) / \left(\frac{\% C_e - \% C_i}{100} \right)$$

The mass emission rates can be converted to volumetric flow rates by dividing by molecular weight and multiplying by standard volume. For example:

$$\text{QE} = \frac{\text{ME} \times 385.35}{\text{MW}_e}$$

Where:

$$\text{QE} = \text{Wet standard volumetric flow rate, } \frac{\text{wscf}}{\text{min}}$$

$$\text{ME} = \text{Total exhaust flow rate, } \frac{\text{lb}}{\text{min}}$$

$$\text{MW}_e = \text{Wet molecular weight exhaust stream, } \frac{\text{lb}}{\text{lb mole}}$$

$$385.35 = \text{Standard molar volume, } \frac{\text{scf}}{\text{lb mole}}$$

The fuel mass rate was measured directly during each test run, and the % C_f was determined by the fuel analysis.

The wet molecular weights of the exhaust gas streams were determined by EPA Reference Methods 3A and 4 (40 CFR 60). These methods measure the percent moisture (% M) of the gas stream and percent carbon dioxide (% CO_2) and oxygen (% O_2) in the gas stream on a dry basis, which were used to calculate the molecular weight as follows:

$$\text{MW}_e = \left[\left\{ (\% \text{CO}_2 \times 0.48) + (\% \text{O}_2 \times 0.32) + ((\% \text{CO} + \% \text{N}_2) \times 0.28) \right\} \times \left(1 - \frac{\% \text{M}}{100} \right) \right] + (\% \text{M} \times 0.18)$$

Where:

% M = Moisture content as a percent.

For the purpose of calculating a molecular weight, (% CO + % N₂) was assumed to be (1 - % CO₂ - % O₂). Calculation of the carbon content of the exhaust gas stream used the % CO₂ as determined by Method 3A, plus additional measurements of carbon monoxide (% CO) and total hydrocarbons (% THC) by EPA Reference Methods 10 and 25A (40 CFR 60, Appendix A). The % THC was stated on the basis of methane (CH₄). The carbon monoxide (CO) and carbon dioxide (CO₂) concentrations were measured on a dry basis and must be converted to a wet basis using the measured moisture content of the exhaust gas. THC was measured on a wet basis.

$$\begin{aligned}\% \text{CO}_2 (\text{wet}) &= \% \text{CO}_2 (\text{dry}) \times \left(1 - \frac{\% M}{100}\right) \\ \% \text{CO} (\text{wet}) &= \% \text{CO} (\text{dry}) \times \left(1 - \frac{\% M}{100}\right)\end{aligned}$$

The total carbon content of the exhaust gas stream is equal to the sum of % CO₂, % CO, and % THC on a wet basis times the ratio of carbon molecular weight to the total wet molecular weight of the gas stream.

$$\% C_e = (\% \text{CO}_2 \text{ wet} + \% \text{CO wet} + \% \text{THC}) \times \frac{12.01}{MW_e}$$

A similar calculation was required for the inlet air volumetric flow rate, but the following simplifying assumptions were made:

- Dry ambient air is composed of 20.9% oxygen and 79.1% nitrogen.
- Ambient humidity represents the moisture content of the inlet air.

The major drawback to this measurement method was the use of extremely low carbon concentration values at the inlet, and relatively low concentrations at the exhaust to modify the very high carbon concentrations in the fuel. As excess air increased, the inlet flow would be indistinguishable from the outlet flow. The major advantage of this procedure was that the only additional data that were required to calculate flow were: the inlet flow; CO, CO₂, and THC values; and ambient humidity.

4.2 CALCULATION OF AIRFLOW USING F-FACTORS

F-factors relate the volume of combustion products to the heat content of fuel. F-factors generally are used for combustion sources when the exhaust stream flow rate is known, but the fuel heat input must be determined. In this case, the fuel input was determined easily and the volumetric flow of combustion air was difficult to determine. The F-factor relationship was used to calculate the total airflow based on a fuel firing rate.

F-factors are published for a variety of fuels and usually are expressed in units of dry standard cubic feet per British thermal unit (dscf/Btu or dscm)/joule (J). For this test program, specific F-factors were determined through ultimate analysis of the fuel components on a weight percent basis and fuel density.

- Ultimate analysis of jet fuel (i.e., hydrogen, carbon, sulfur, nitrogen, oxygen, and density (pounds per gallon [lb/gal]) on a mass basis (% wt).

To determine the air volumetric flow rate, the following additional information was required:

- The concentrations of oxygen, carbon monoxide, and moisture content in the exhaust stream after combustion.
- Fuel firing rate, gallons per minute (gal/min).

The F-factor, dry basis, was calculated from the ultimate analysis of the jet fuel as follows:

$$F_d = \frac{K[(K_{hd} \% H) + (K_c \% C) + (K_s \% S) + (K_n \% N) - (K_o \% O)]}{GCV}$$

(Equation 19-13, 40 CFR 60, Appendix A, Method 19)

If the heat input components (K, GCV) are eliminated from the equation, an F-factor based on fuel mass is derived.

$$F_{md} = [(K_{hd} \% H) + (K_c \% C) + (K_s \% S) + (K_n \% N) - (K_o \% O)]$$

Where:

F_d = Volume of combustion components per unit of heat content, scf/million Btu.

F_{md} = Volume of combustion component on a dry basis per pound of fuel, scf/lb.

% H, % C, % S, % N, % O = Weight percents of hydrogen, carbon, sulfur, nitrogen, and oxygen in the jet fuel.

GCV = Gross calorific value of the fuel consistent with the ultimate analysis, Btu/lb.

K = Conversion factor, 10^{-5} .

$K_{hd} = 3.64$ (scf/lb)/(%).

$K_c = 1.53$ (scf/lb)/(%).

$K_s = 0.53$ (scf/lb)/(%).

$K_n = 0.14$ (scf/lb)/(%).

$K_o = 0.46$ (scf/lb)/(%).

Stoichiometric combustion calculations assume that the carbon in the fuel is burned completely to produce carbon dioxide and water with no excess air (and no significant formation of nitrogen dioxide or carbon monoxide). The air stoichiometric volumetric flow rate (dry basis) was determined by simply multiplying the measured fuel firing rate by the F-factors.

$$\left(\text{Fuel firing rate, } \frac{\text{gal}}{\text{min}} \right) \left(\text{fuel density, } \frac{\text{lb}}{\text{gal}} \right) \left(F_{md}, \frac{\text{scf}}{\text{lb}} \right) \\ = \text{dry combustion air flow, } \frac{\text{scf}}{\text{min}}$$

The percent excess air (EA) during actual combustion was calculated using the following formula:

$$\% \text{ EA} = \left[\frac{\% \text{ O}_2 - 0.5\% \text{ CO}}{20.9 - (\% \text{ O}_2 - 0.5\% \text{ CO})} \right] \times 100$$

Where:

% O₂, % CO = Measured percents of oxygen, and carbon monoxide, in the exhaust gas.

20.9 is the percent dry oxygen in ambient air.

Total dry combustion flow (including) excess air equals:

$$\text{Total dry air flow} = \left[(\text{dry combustion air flow}) \left(1 + \frac{\% \text{ EA}}{100} \right) \right]$$

This simplifies to:

$$\text{Total dry combustion flow, } \frac{\text{scf}}{\text{min}} = (\text{dry combustion air}) \\ * \left(\frac{20.9}{20.9 - \% \text{ O}_2 + 0.5 \% \text{ CO}} \right)$$

The inlet airflow is equal to the total dry combustion air plus the fraction of oxygen in the inlet used for the combustion of hydrogen in the fuel. The nitrogen associated with this oxygen fraction of the inlet air was included in the F_d calculation.

This inlet oxygen fraction can be derived from the same F-factor calculations presented in EPA Method 19.

$$F_{mo} = K [K_{hi} \% H]$$

Where:

F_{mo} = Volume of inlet oxygen used to combust hydrogen per unit of fuel fired, scf/lb.

$K_{hi} = 0.96$ (scf/lb)/%.

% H = Weight percent of hydrogen in the fuel as stated previously.

Then the total dry inlet airflow is the following:

$$\text{Dry inlet air} = \left[\text{fuel firing rate, } \frac{\text{gal.}}{\text{min}} \right] \left[\text{fuel density, } \frac{\text{lb}}{\text{gal.}} \right] [F_{md} + F_{mo}] \\ * \left[\frac{20.9}{20.9 - \% \text{ O}_2 + 0.5 \% \text{ CO}} \right]$$

The inlet air then can be corrected back to actual conditions using the ambient temperature and humidity. The total exhaust flow can be adjusted to actual conditions using the measured exhaust moisture content and temperature.

There are limitations to the use of these F-factors for calculations of airflow from jet engines. The concentration of carbon monoxide in the combustion stream normally is so low that it is insignificant in the excess air calculation, but it has been included to cover operation during periods of incomplete combustion. If the combustion is so incomplete that large quantities of the fuel are exhausted as carbon (soot) or volatile hydrocarbons (THC), the % C of the fuel must be reduced to account for the reduced formation of combustion products.

The second limitation arises when high levels of excess air are present. At high excess air levels, the carbon monoxide concentration becomes zero, but the oxygen content of the combustion gas approaches ambient concentrations (20.9 % O₂). The excess air equation becomes unreliable at a concentration of 20.9 % oxygen as this equation is undefined due to division by zero. As a general rule, these F-factor calculations will be unreliable any time the combustion gas contains more than 18.5 % oxygen.

SECTION 5

RESULTS

J85-GE-5R aircraft engine exhaust emissions were characterized to determine the concentration, mass emission rate, and emission factor relative to JP-8+100 fuel flow for criteria and select hazardous air pollutants. A single J85-GE-5M engine was tested on a test stand in a hush house at Moody AFB and the gaseous emissions from a T-38C with PMP Talon were measured directly behind the engine at Randolph AFB. Sampling was performed at Moody AFB for nitrogen oxides (NO_x), carbon monoxide (CO), carbon dioxide (CO₂), non-methane hydrocarbons (NMHC), particulate matter (PM), particle size characterization, aldehyde and ketones, and volatile organic compounds. Also, the condensable particulate matter fraction was analyzed to determine the presence of organics. At Randolph AFB, NO_x, CO, NMHC, CO₂, and O₂ were recorded at each setting. Semi-volatile organic compounds, metals, and sulfur dioxide emissions were not part of the scope or work for this engine. Historical aircraft engine emission sampling has noted that the semi-volatile analysis has provided non-detected and scattered detected values. Metals analysis has also shown mainly non-detect values, which was confirmed by an analysis of the fuel. Sulfur dioxide emissions are reported based on the procedure documented by AFIERA ("Air Emissions Inventory Guidance Document for Mobile Sources at Air Force Installations," January 2002). This procedure estimates that sulfur dioxide in the fuel undergoes complete oxidation to SO₂. The sulfur content in JP-8+100 fuel was determined during testing to assure consistency with published results. Ambient measurements for CO, CO₂, O₂, and NMHC were made in order to complete carbon balance and f-factor calculations. Emission rates were not corrected for ambient pollutants due to the lack of contributing sources in the vicinity of the test facility.

As part of the emission testing program, samples were collected directly behind the aircraft engine at both Moody and Randolph Air Force Bases, at the end of the augmentor tube where the engine exhaust exits the hush house, and in the slipstream duct at Moody AFB. As described in Section 2 and shown in Figure 2-8, a stainless steel rake with multiple sampling

nozzles was installed directly behind the engine to collect gaseous, benzene, and formaldehyde emissions data at the idle, intermediate, and military engine settings. Near the end of the augmentor tube, where the emissions exhaust the hush house, a stainless steel slipstream sampling system was installed to transfer the engine exhaust out of the hush house to a safe location for sampling. The slipstream rake, shown in Figure 2-11, consists of 12 sample intake nozzles that were used to determine pollutant distribution in the augmentor tube and to collect a gaseous emission sample from each of the 12 points. After the slipstream had exited the hush house, the slipstream duct was utilized to extract manual samples for PM, aldehyde and ketones, and volatile organic compounds. These sampling locations are referred to as the engine rake and slipstream rake accordingly. The purpose of sampling at multiple locations was to study the pollutant mass emission rates as they traveled from the engine to the atmosphere and note if any secondary chemistry occurred during the residence time in the augmentor tube.

A similar engine rake was utilized at Randolph AFB to measure emissions directly behind the engine. The emissions data are discussed in this section.

5.1 GASEOUS POLLUTANTS

Gaseous emissions were collected at the engine rake and slipstream rake for the J85-GE-5M engine tested at Moody AFB. Gaseous emissions were collected directly behind the T-38C with PMP aircraft at Randolph AFB. The results of the sampling at each location are provided in the following sections.

5.1.1 Gaseous Emissions

Prior to the actual emission test runs at each engine setting at Moody AFB, a series of shakedown runs were performed to note gaseous pollutant concentrations and the point where CO emissions decrease and NO_x emissions increase. Data was collected at the idle, intermediate, and military power settings as well as at several interim power settings to note the variation of NO_x, CO, CO₂, O₂, and NMHC.

Table 5-1 and Figure 5-1 present the gaseous emissions data collected at various power settings during the shakedown runs. It can be seen that at approximately 25% power (871 lbs/hr fuel flow), the CO emissions begin to decrease significantly.

TABLE 5-1
J85-GE-5M (Moody AFB)
GASEOUS EMISSIONS SUMMARY
EMISSION TREND SUMMARY
ENGINE RAKE

| Power Setting (Fuel Flow, lbs/hr) | O₂ Dry % | CO₂ Dry % | NO_x Dry ppm | NMHC Wet ppm (as CH₄) | CO Dry ppm |
|--|--------------------------------|---------------------------------|-----------------------------------|---|-----------------------|
| Idle (525) | 19.7 | 0.6 | 3.8 | 167 | 687 |
| (698) | 19.9 | 0.5 | 3.9 | 80 | 466 |
| (871) | 19.9 | 0.5 | 4.3 | 46 | 340 |
| (930) | 19.9 | 0.7 | 5.0 | 31 | 309 |
| Intermediate (1,045) | 19.8 | 0.5 | 6.2 | 17 | 231 |
| Military (2,550) | 19.0 | 1.2 | 16.2 | 7 | 184 |

Tables 5-2 and 5-3 contain the gaseous emission summary for the gaseous emission samples collected directly behind the engine and at the slipstream near the end of the augmentor tube for the J85-GE-5R engine tested at Moody AFB. As can be seen in Table 5-4, the CO, NMHC, and CO₂ emission rates compare well, while the NO_x data tended to be higher directly behind the engine. The NO_x concentration directly behind the engine was predominantly NO₂. As the NO₂ traveled down the augmentor tube, the NO₂ dispersed into N and O₂ resulting in a decrease in NO_x at the slipstream. This is confirmed by the high NO concentration at the slipstream and little NO₂.

A summary of the on-wing emissions from the T-38C with PMP Talon Aircraft operated at Randolph AFB is shown in Table 5-5. The emission factors differed slightly from those collected at Moody AFB. The differences are minimal and the emission factors are in the same order of magnitude. The difference in emissions between Moody AFB and Randolph AFB can be attributed to the position of the sampling rake behind the engine. At Randolph AFB the engine rake was positioned approximately 3 feet behind the engine. At Moody AFB the engine

Moody AFB
J85-GE-5A
Gaseous Pollutants vs. Power Setting

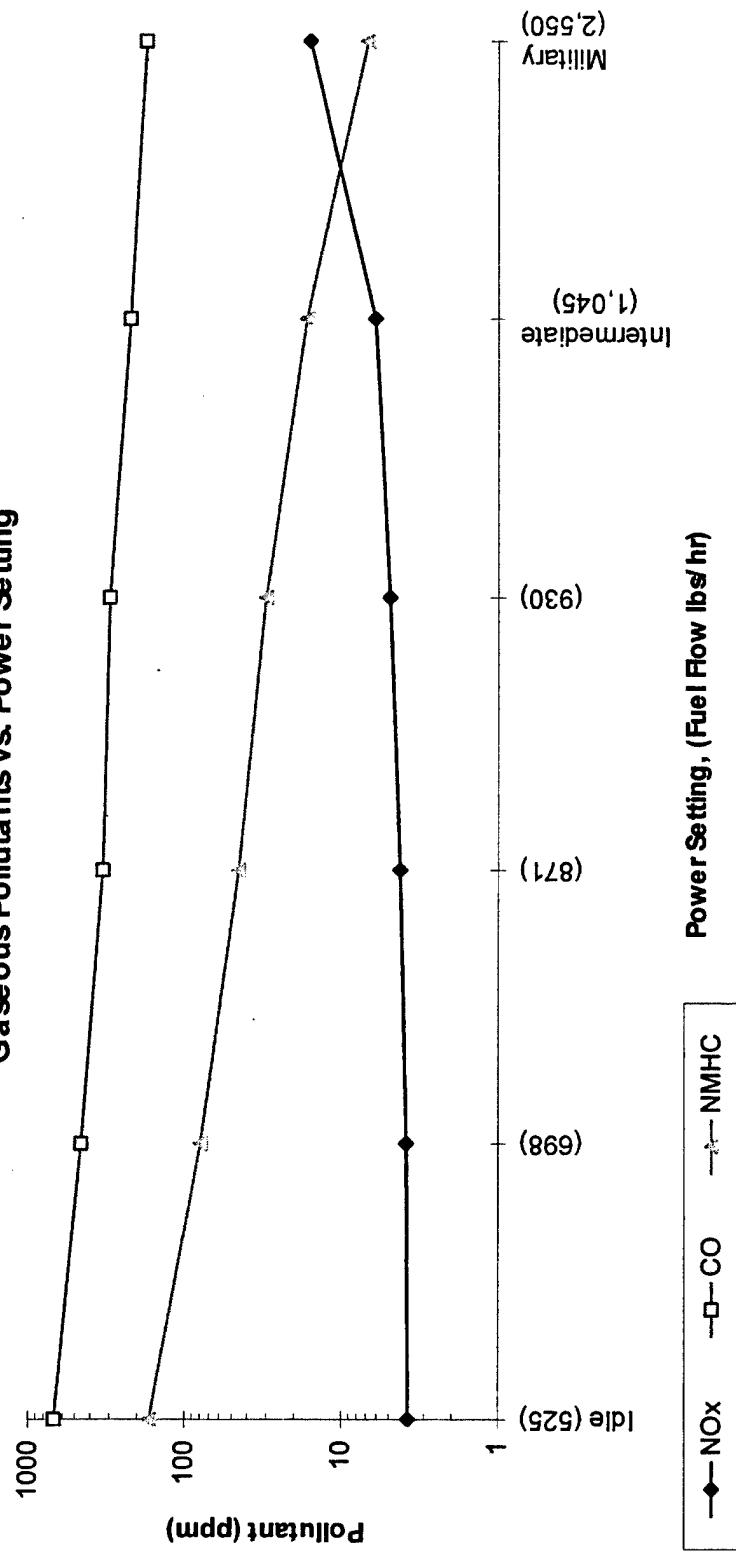

Figure 5-1. Gaseous Pollutants (ppm) vs. Power Setting (Fuel flow, lbs/hr)

**TABLE 5-2
J85-GE-5M (Moody AFB)
SLIPSTREAM RAKE
EMISSION FACTOR SUMMARY**

| Flow Rate dscfm | Idle ^(a) | | | Intermediate ^(b) | | | Military | | | Afterburner | | |
|--|---------------------|--------|--------------------------|-----------------------------|--------|--------------------------|----------|--------|--------------------------|-------------|--------|--------------------------|
| | ppmvd | lbs/hr | lbs/ 1000 lbs fuel | ppmvd | lbs/hr | lbs/ 1000 lbs fuel | ppmvd | lbs/hr | lbs/ 1000 lbs fuel | ppmvd | lbs/hr | lbs/ 1000 lbs fuel |
| | 118,704 | | | 293,150 | | | 544,312 | | | 611,727 | | |
| Fuel Flow lbs/hr | 525 | | | 1,045 | | | 2,550 | | | 7,695 | | |
| Nitrogen Oxides (NO _x) ^(c) | 0.50 | 0.41 | 0.79 | 0.90 | 1.89 | 1.81 | 1.10 | 4.21 | 1.65 | 2.10 | 9.33 | 1.21 |
| Carbon Monoxide (CO) | 188.60 | 100.49 | 191.41 | 40.00 | 51.11 | 48.90 | 27.20 | 64.54 | 25.35 | 29.40 | 78.37 | 10.19 |
| THC (as CH ₄) | 35.80 | 11.08 | 21.11 | 2.30 | 1.69 | 1.62 | 0.80 | 1.16 | 0.45 | 3.30 | 5.02 | 0.65 |
| Carbon Dioxide (CO ₂) ^(d) | 2,200 | 1,839 | 3,503 | 1,600 | 3,185 | 3,048 | 2,100 | 7,868 | 3,092 | 5,700 | 23,980 | 3,116 |

(a) - Idle flow rates calculated by F-Factor methodology.

(b) - Intermediate, Military and Afterburner flow rates calculated using carbon balance methodology.

(c) - The majority (approximately 90%) of the NO_x concentration is NO. This is not the typical NO_x trend.

(d) - Measured CO₂ emissions are approximately 10% higher than the theoretical CO₂ emission rate.

**TABLE 5-3
J85-GE-5M (Moody AFB)
ENGINE RAKE
EMISSION FACTOR SUMMARY**

| | Idle ^(a) | | | Intermediate ^(b) | | | Military | | | Afterburner ^(d) | | | | | |
|--|---------------------|---------------------|---------|-----------------------------|--------|--------------------------|----------|--------|--------------------------|----------------------------|--------|--------------------------|-------|--------|--------------------------|
| | Flow Rate dscfm | Fuel Flow lbs/hr | Analyte | ppmvd | lbs/hr | lbs/ 1000 lbs fuel | ppmvd | lbs/hr | lbs/ 1000 lbs fuel | ppmvd | lbs/hr | lbs/ 1000 lbs fuel | ppmvd | lbs/hr | lbs/ 1000 lbs fuel |
| | 33,249 | | | | | | | | | | | | | | |
| | | 525 | | | | | | | | | | | | | |
| | | | | | | | | | | | | | | | |
| Nitrogen Oxides (NO _x) ^(c) | | | 3.6 | 0.8 | 1.5 | 5.7 | 2.3 | 2.2 | 16.0 | 9.6 | 3.8 | 41.0 | 21.6 | 2.8 | |
| Carbon Monoxide (CO) | | | 693.0 | 92.6 | 176.4 | 211.6 | 52.6 | 50.3 | 187.0 | 68.6 | 27.0 | 170.5 | 54.7 | 7.1 | |
| THC (as CH ₄) | | | 161.4 | 12.4 | 23.6 | 9.7 | 1.4 | 1.3 | 2.0 | 0.4 | 0.2 | 9.2 | 1.7 | 0.2 | |
| Carbon Dioxide (CO ₂) | | | 7000 | 1560 | 3030 | 8000 | 3119 | 3048 | 14000 | 7869 | 3086 | 48000 | 24207 | 3123 | |

(a) - Idle flows calculated by F-Factor methodology.
(b) - Intermediate, Military and Afterburner flow rates calculated using carbon balance methodology.
(c) - The majority (approximately 90%) of the NO_x concentration is NO₂.
(d) - The sampling time at afterburner was limited to 3 minutes due to engine malfunction.

TABLE 5-4
J85-GE-5M (Moody AFB)
EMISSION FACTOR COMPARISON
CRITERIA POLLUTANTS
lbs/1000 lbs fuel

| | ENGINE RAKE | | | | SLIPSTREAM | | | |
|--|---------------------|-----------------------------|----------|-------------|---------------------|-----------------------------|----------|-------------|
| | Idle ^(a) | Intermediate ^(b) | Military | Afterburner | Idle ^(a) | Intermediate ^(b) | Military | Afterburner |
| Flow Rate dscfm | 33,249 | 56,863 | 84,120 | 73,548 | 118,704 | 293,150 | 544,312 | 611,727 |
| Fuel flow lbs/hr | 525 | 1,045 | 2,550 | 7,695 | 525 | 1,045 | 2,550 | 7,695 |
| Nitrogen Oxides (NO _x) ^(c) | 1.63 | 2.22 | 3.79 | 2.81 | 0.79 | 1.81 | 1.65 | 1.21 |
| Carbon Monoxide (CO) | 191.46 | 50.29 | 26.96 | 7.11 | 191.41 | 48.90 | 25.35 | 10.19 |
| THC (as CH ₄) | 25.65 | 1.34 | 0.17 | 0.17 | 21.10 | 1.62 | 0.45 | 0.65 |
| Carbon Dioxide (CO ₂) | 3,030 | 3,048 | 3,086 | 3,123 | 3,504 | 3,048 | 3,092 | 3,116 |
| Sulfur Dioxide (SO ₂) | 1.00 | 1.0 | 1.0 | 1.0 | 1.0 | 1.0 | 1.0 | 1.0 |
| Total Particulate | (d) | (d) | (d) | (d) | 6.30 | 10.72 | 3.66 | (d) |

(a) - Idle flow rates calculated by F-Factor methodology.

(b) - Intermediate, Military and Afterburner flow rates calculated using carbon balance methodology.

(c) - The majority (approximately 90%) of the NO_x concentration is NO₂ at the engine rake; NO at the Slipstream.

(e) - Particulate data not collected.

**TABLE 5-5
T-38 TALON (Randolph AFB)
ENGINE RAKE
EMISSION FACTOR SUMMARY**

| Flow Rate dscfm | Idle ^(a) | | | Intermediate ^(b) | | | Military | | | Afterburner ^(c) | | |
|--|---------------------|--------|--------------------------|-----------------------------|--------|--------------------------|----------|--------|--------------------------|----------------------------|---------|-----------------------------|
| | ppmvd | lbs/hr | lbs/ 1000 lbs fuel | ppmvd | lbs/hr | lbs/ 1000 lbs fuel | ppmvd | lbs/hr | lbs/ 1000 lbs fuel | lbs/hr | | |
| | | 25,101 | | 82,241 | | | 120,532 | | | 141,922 | | |
| Fuel Flow lbs/hr ^(e) | | 1,040 | | 2,060 | | | 4,440 | | | 15,390 | | |
| Analyte | ppmvd | lbs/hr | lbs/ 1000 lbs fuel | ppmvd | lbs/hr | lbs/ 1000 lbs fuel | ppmvd | lbs/hr | lbs/ 1000 lbs fuel | ppmvd | lbs/hr | lbs/ 1000 lbs fuel |
| Nitrogen Oxides (NO _x) ^(d) | 6.30 | 1.12 | 1.08 | 2.40 | 1.44 | 0.70 | 9.90 | 8.53 | 1.92 | 94.30 | 95.94 | 6.23 |
| Carbon Monoxide (CO) | 1,686 | 184.55 | 177.45 | 374.00 | 134.04 | 65.07 | 262.00 | 137.60 | 30.99 | 1,328 | 822.26 | 53.43 |
| THC (as CH ₄) | 2,11.60 | 15.19 | 14.61 | 24.30 | 4.99 | 2.42 | 9.70 | 2.91 | 0.65 | 264.00 | 93.34 | 6.06 |
| Carbon Dioxide (CO ₂) | 17,000 | 2,952 | 2,839 | 11,000 | 6,232 | 3,025 | 17,000 | 13,691 | 3,084 | 117,000 | 114,245 | 7,423 |

- (a) - Idle flow rates calculated by F-Factor methodology.
- (b) - Intermediate, Military and Afterburner flow rates calculated using carbon balance methodology.
- (c) - Due to the limited sample time at Afterburner, the CO₂ and O₂ values at Afterburner are based on the engine rake data at Moody AFB.
- (d) - The majority (approximately 90%) of the NO_x concentration is NO₂.
- (e) - Fuel flow per engine. The T-38 Talon operates on two J85 engines.

rake was positioned approximately 15 feet behind the engine. The difference in position is due to the physical configuration of the engine on the test stand.

A summary of the stock J85-GE-5H emissions data is presented in Table III-3 in the Executive Summary. These data were collected using a slipstream in a test cell at Laughlin AFB. The test cell and slipstream configurations are much different than those in this program, but the data is presented for comparison purposes. The NO_x emission factor of 1.1 lbs/1000 lbs fuel at idle is identical to the NO_x emission index for the T-38. CO is approximately 191 lbs/1000 lbs fuel for the J85-GE-5M and 212 lbs/1000 lbs fuel for the J85-GE-5H. NMHC emissions were higher from the unmodified engine at 34 lbs/1000 lbs fuel compared to 21 lbs/1000 lbs fuel at the idle setting. At the intermediate power setting, the CO and NMHC emissions were higher on the unmodified engine, but the NO_x emissions were similar, 1.7 lbs/1000 lbs fuel (J85-GE-5H) compared to 1.8 lbs/1000 lbs fuel (J85-GE-5M). At military, the historic NO_x emission index was 3 lbs/1000 lbs fuel, but during this program the emission index was 2 lb/1000 lbs fuel. CO was 36 lbs/1000 lbs fuel historically and 31 lbs/1000 lbs fuel for the T-38 aircraft. NMHC were 0.6 and 0.5 lb/1000 lbs fuel for the J85-GE-5H and J85-GE-5M engines respectively.

The afterburner data collected at Moody AFB was comparable to the historic data set. Also, the engine rake data and slipstream data were comparable for the testing conducted at Moody AFB. The afterburner data at Randolph AFB for the T-38C with PMP was not similar to the data collected at Moody AFB. At both locations, the sample time at afterburner was limited. During the J85-GE-5M testing at Moody AFB, the engine reached afterburner for a 3-minute period, but could not return to afterburner due to a failed fuel delivery problem. At Randolph AFB during testing of the T-38C with PMP Talon, the engine sampling rake was destroyed after approximately 5 minutes of sampling. Therefore, the afterburner data collected at Randolph AFB appears to be an outlier since the J85-GE-5M data compares well with the historic J85-GE-5H data set.

5.2 VOLATILE ORGANIC COMPOUNDS

Speciation of volatile organic compounds was performed at the hush house exhaust for the engine at each engine setting with the exception of afterburner. The highest emission rate of volatiles was at the idle setting. This has been the typical trend in historic engine emission

testing. Due to the inefficiencies in engine operation at idle, unburned hydrocarbons tend to be present in the exhaust stream resulting in higher organic emissions. The VOC HAP total at idle was 0.13 lb/1000 lbs fuel. The detected compounds at each setting were similar to the speciated HAPs determined in historical test programs. Typically, naphthalene, benzene, toluene, ethylbenzene, xylene and styrene were detected in the exhaust stream. A summary of the volatile emissions is provided in Tables 5-6 through 5-8.

5.2.1 Speciated Pollutant Comparison

Samples for benzene and formaldehyde were collected directly behind the engine and at the slipstream duct to note the variation in emissions at the idle, intermediate, and military settings. The benzene emissions determined directly behind the engine are summarized in Table 5-9. These data were typically one order of magnitude higher than the benzene emissions at the slipstream shown in Tables 5-6 through 5-8. At idle the emission factor for benzene behind the engine was 0.74 lb/1000 lbs fuel and 0.03 lb/1000 lbs fuel at the slipstream. At the intermediate engine setting, the benzene emission factor was 0.02 lb/1000 lbs fuel at the slipstream and 0.24 lb/1000 lbs fuel at the engine exhaust. Formaldehyde samples collected at the idle, intermediate, and military settings behind the engine were compared to the formaldehyde data collected at the slipstream duct. These data are presented in Tables 5-10 and 5-11. The formaldehyde data collected behind the engine, shown in Table 5-10, provided an engine emission factor of 1.45 lbs/1000 lbs fuel at idle, 1.64 lbs/1000 lbs fuel at intermediate, and 0.18 lb/1000 lbs fuel at military. The formaldehyde data collected at the slipstream, shown in Table 5-11, indicate an emission factor of 2.26 lbs/1000 lbs fuel at idle, 0.35 lb/1000 lbs fuel at intermediate, and 0.02 lb/1000 lbs fuel at military.

5.3 ALDEHYDE AND KETONES

Aldehyde and ketone data was collected at the slipstream duct for the idle, intermediate and military settings. These data are summarized in Table 5-11. The emission rates were highest at the idle setting, which is consistent with the data trends seen in this program. Formaldehyde was the pollutant emitted in the highest quantity at 2.26 lbs/1000 lbs fuel at idle. As the engine

TABLE 5-6.
J85-GE-5M (MOODY AFB)
EMISSION FACTOR SUMMARY
VOLATILE ORGANIC COMPOUNDS (VOCs)
Idle
(Flow by f-factor)

| Flow Rate, defn | Run Number | | | | | | | | | | Average | |
|------------------|-------------------------------------|---------|---------|---------|---------|---------|---------|---------|---------|---------|---------|---------|
| | 1 | | 2 | | 3 | | 4 | | 5 | | | |
| | 11E-04 | 22E-04 | 11E-04 | 22E-04 | 11E-04 | 22E-04 | 11E-04 | 22E-04 | 11E-04 | 22E-04 | | |
| Flow Rate, defn | 11E-04 | 22E-04 | 11E-04 | 22E-04 | 11E-04 | 22E-04 | 11E-04 | 22E-04 | 11E-04 | 22E-04 | 11E-04 | 22E-04 |
| Flow Rate, lb/hr | 2.7E-04 | 5.4E-04 | 2.7E-04 | 5.4E-04 | 2.7E-04 | 5.4E-04 | 2.7E-04 | 5.4E-04 | 2.7E-04 | 5.4E-04 | 2.7E-04 | 5.4E-04 |
| Analysis | Chloroethane* | 74873 | 2.7E-04 | 5.4E-04 | 2.7E-04 | 5.4E-04 | 2.7E-04 | 5.4E-04 | 2.7E-04 | 5.4E-04 | 2.7E-04 | 5.4E-04 |
| | Bromochloroethane* | 74839 | 2.7E-04 | 5.4E-04 | 2.7E-04 | 5.4E-04 | 2.7E-04 | 5.4E-04 | 2.7E-04 | 5.4E-04 | 2.7E-04 | 5.4E-04 |
| | Chloroethane* | 75003 | 2.7E-04 | 5.4E-04 | 2.7E-04 | 5.4E-04 | 2.7E-04 | 5.4E-04 | 2.7E-04 | 5.4E-04 | 2.7E-04 | 5.4E-04 |
| | Flow 11 (1,1,2,2-tetrachloroethane) | 75694 | 2.7E-04 | 5.4E-04 | 2.7E-04 | 5.4E-04 | 2.7E-04 | 5.4E-04 | 2.7E-04 | 5.4E-04 | 2.7E-04 | 5.4E-04 |
| | 1,1-Dichloroethane* | 75343 | 2.7E-04 | 5.4E-04 | 2.7E-04 | 5.4E-04 | 2.7E-04 | 5.4E-04 | 2.7E-04 | 5.4E-04 | 2.7E-04 | 5.4E-04 |
| | Carbon Dioxide* | 75130 | 2.7E-04 | 5.4E-04 | 2.7E-04 | 5.4E-04 | 2.7E-04 | 5.4E-04 | 2.7E-04 | 5.4E-04 | 2.7E-04 | 5.4E-04 |
| | Acetone | 67441 | 2.7E-04 | 5.4E-04 | 2.7E-04 | 5.4E-04 | 2.7E-04 | 5.4E-04 | 2.7E-04 | 5.4E-04 | 2.7E-04 | 5.4E-04 |
| | 1,1,1-Trichloroethane* | 75093 | 2.7E-04 | 5.4E-04 | 2.7E-04 | 5.4E-04 | 2.7E-04 | 5.4E-04 | 2.7E-04 | 5.4E-04 | 2.7E-04 | 5.4E-04 |
| | trans-1,2-Dichloroethane | 136603 | 2.7E-04 | 5.4E-04 | 2.7E-04 | 5.4E-04 | 2.7E-04 | 5.4E-04 | 2.7E-04 | 5.4E-04 | 2.7E-04 | 5.4E-04 |
| | 1,1-Dichloroethane* | 75314 | 2.7E-04 | 5.4E-04 | 2.7E-04 | 5.4E-04 | 2.7E-04 | 5.4E-04 | 2.7E-04 | 5.4E-04 | 2.7E-04 | 5.4E-04 |
| | Vinyl Acetate* | 104934 | 2.7E-04 | 5.4E-04 | 2.7E-04 | 5.4E-04 | 2.7E-04 | 5.4E-04 | 2.7E-04 | 5.4E-04 | 2.7E-04 | 5.4E-04 |
| | cis-1,2-Dichloroethane* | 135393 | 2.7E-04 | 5.4E-04 | 2.7E-04 | 5.4E-04 | 2.7E-04 | 5.4E-04 | 2.7E-04 | 5.4E-04 | 2.7E-04 | 5.4E-04 |
| | 2-Dioxane (N-ethyl Ethyl Ketone)* | 78933 | 2.7E-04 | 5.4E-04 | 2.7E-04 | 5.4E-04 | 2.7E-04 | 5.4E-04 | 2.7E-04 | 5.4E-04 | 2.7E-04 | 5.4E-04 |
| | Chloroform* | 67663 | 2.7E-04 | 5.4E-04 | 2.7E-04 | 5.4E-04 | 2.7E-04 | 5.4E-04 | 2.7E-04 | 5.4E-04 | 2.7E-04 | 5.4E-04 |
| | 1,1,1-Trichloroethane* | 71356 | 2.7E-04 | 5.4E-04 | 2.7E-04 | 5.4E-04 | 2.7E-04 | 5.4E-04 | 2.7E-04 | 5.4E-04 | 2.7E-04 | 5.4E-04 |
| | Carbon Tetrachloride* | 56233 | 2.7E-04 | 5.4E-04 | 2.7E-04 | 5.4E-04 | 2.7E-04 | 5.4E-04 | 2.7E-04 | 5.4E-04 | 2.7E-04 | 5.4E-04 |
| | Benzene* | 71452 | 2.7E-04 | 5.4E-04 | 2.7E-04 | 5.4E-04 | 2.7E-04 | 5.4E-04 | 2.7E-04 | 5.4E-04 | 2.7E-04 | 5.4E-04 |
| | 1,2-Dichloroethane* | 107462 | 2.7E-04 | 5.4E-04 | 2.7E-04 | 5.4E-04 | 2.7E-04 | 5.4E-04 | 2.7E-04 | 5.4E-04 | 2.7E-04 | 5.4E-04 |
| | Bromochloroethane | 75274 | 2.7E-04 | 5.4E-04 | 2.7E-04 | 5.4E-04 | 2.7E-04 | 5.4E-04 | 2.7E-04 | 5.4E-04 | 2.7E-04 | 5.4E-04 |
| | cis-1,2-Dichloroethane* | 1001413 | 2.7E-04 | 5.4E-04 | 2.7E-04 | 5.4E-04 | 2.7E-04 | 5.4E-04 | 2.7E-04 | 5.4E-04 | 2.7E-04 | 5.4E-04 |
| | trans-1,2-Dichloroethane* | 1001424 | 2.7E-04 | 5.4E-04 | 2.7E-04 | 5.4E-04 | 2.7E-04 | 5.4E-04 | 2.7E-04 | 5.4E-04 | 2.7E-04 | 5.4E-04 |
| | 4-Methyl-2-pentanone* | 108101 | 2.7E-04 | 5.4E-04 | 2.7E-04 | 5.4E-04 | 2.7E-04 | 5.4E-04 | 2.7E-04 | 5.4E-04 | 2.7E-04 | 5.4E-04 |
| | Toluene* | 108883 | 2.7E-04 | 5.4E-04 | 2.7E-04 | 5.4E-04 | 2.7E-04 | 5.4E-04 | 2.7E-04 | 5.4E-04 | 2.7E-04 | 5.4E-04 |
| | 1,1,2-Trichloroethane* | 79203 | 2.7E-04 | 5.4E-04 | 2.7E-04 | 5.4E-04 | 2.7E-04 | 5.4E-04 | 2.7E-04 | 5.4E-04 | 2.7E-04 | 5.4E-04 |
| | Tetrahydrofuran* | 127184 | 2.7E-04 | 5.4E-04 | 2.7E-04 | 5.4E-04 | 2.7E-04 | 5.4E-04 | 2.7E-04 | 5.4E-04 | 2.7E-04 | 5.4E-04 |
| | 2-Hexanone | 591786 | 2.7E-04 | 5.4E-04 | 2.7E-04 | 5.4E-04 | 2.7E-04 | 5.4E-04 | 2.7E-04 | 5.4E-04 | 2.7E-04 | 5.4E-04 |
| | Dibromochloroethane | 124481 | 2.7E-04 | 5.4E-04 | 2.7E-04 | 5.4E-04 | 2.7E-04 | 5.4E-04 | 2.7E-04 | 5.4E-04 | 2.7E-04 | 5.4E-04 |
| | Chlorobenzene* | 108907 | 2.7E-04 | 5.4E-04 | 2.7E-04 | 5.4E-04 | 2.7E-04 | 5.4E-04 | 2.7E-04 | 5.4E-04 | 2.7E-04 | 5.4E-04 |
| | Ethyl Benzene* | 108414 | 2.7E-04 | 5.4E-04 | 2.7E-04 | 5.4E-04 | 2.7E-04 | 5.4E-04 | 2.7E-04 | 5.4E-04 | 2.7E-04 | 5.4E-04 |
| | m-xylene* | 108383 | 2.7E-04 | 5.4E-04 | 2.7E-04 | 5.4E-04 | 2.7E-04 | 5.4E-04 | 2.7E-04 | 5.4E-04 | 2.7E-04 | 5.4E-04 |
| | o-xylene* | 51476 | 2.7E-04 | 5.4E-04 | 2.7E-04 | 5.4E-04 | 2.7E-04 | 5.4E-04 | 2.7E-04 | 5.4E-04 | 2.7E-04 | 5.4E-04 |
| | Styrene* | 108425 | 2.7E-04 | 5.4E-04 | 2.7E-04 | 5.4E-04 | 2.7E-04 | 5.4E-04 | 2.7E-04 | 5.4E-04 | 2.7E-04 | 5.4E-04 |
| | Bromofluoride* | 75313 | 2.7E-04 | 5.4E-04 | 2.7E-04 | 5.4E-04 | 2.7E-04 | 5.4E-04 | 2.7E-04 | 5.4E-04 | 2.7E-04 | 5.4E-04 |
| | 1,1,2,2-Tetrachloroethane* | 79345 | 2.7E-04 | 5.4E-04 | 2.7E-04 | 5.4E-04 | 2.7E-04 | 5.4E-04 | 2.7E-04 | 5.4E-04 | 2.7E-04 | 5.4E-04 |
| | 1,2-Dioxane* | 106990 | 2.7E-04 | 5.4E-04 | 2.7E-04 | 5.4E-04 | 2.7E-04 | 5.4E-04 | 2.7E-04 | 5.4E-04 | 2.7E-04 | 5.4E-04 |

* Hazardous Air Pollutant (HAP)
ND - Compound not detected at this detection limit. Compound may be present at a value less than the detection limit.

TABLE 5-7.
J85-GE-5M (MOODY AFB)
EMISSION FACTOR SUMMARY
VOLATILE ORGANIC COMPOUNDS (VOCs)
INTERMEDIATE
(Flow by Carbon Balance)

| Analyte | 1 | | 2 | | 3 | | Average | | | | | |
|------------|---------------------------------------|-------------------|--------------------|-------------------|-------------------|-------------------|--------------------|-------------------|-------------|----------|--------------------|----------|
| | Flow Rate, Acids Feed Flow, Barley | 291,110 1045.0 | 291,110 1045.0 | 291,110 1045.0 | 291,110 1045.0 | 291,110 1045.0 | 291,110 1045.0 | 291,110 1045.0 | | | | |
| CAS number | Description | lb/hr | Per 1,000 lbs Fuel | | Description | lb/hr | Per 1,000 lbs Fuel | | Description | lb/hr | Per 1,000 lbs Fuel | |
| | | | Detailed | Lt/ht | | | Detailed | Lt/ht | | | Detailed | Lt/ht |
| 7447-3 | Chloroform* | 6.31E-04 | 3.17E-04 | 1.01E-04 | 4.80E-07 | 1.01E-04 | 9.66E-04 | 3.49E-04 | 1.01E-04 | 3.26E-04 | 3.17E-04 | 3.17E-04 |
| 7483-9 | Bromochloroform* | 1.09E-04 | 1.04E-04 | 1.01E-04 | 1.01E-04 | 1.01E-04 | 9.66E-04 | 9.18E-05 | 1.01E-04 | 9.18E-05 | 9.18E-05 | 9.18E-05 |
| 7485-2 | Chloroacetaldehyde* | 9.87E-05 | 9.47E-05 | 1.01E-04 | 1.01E-04 | 9.66E-04 | 9.66E-04 | 9.18E-05 | 1.01E-04 | 9.66E-04 | 9.66E-04 | 9.66E-04 |
| 7489-4 | Form II (1,1-Dichloroethane) | 1.39E-03 | 1.31E-03 | 1.01E-04 | 1.01E-04 | 9.66E-04 | 9.66E-04 | 1.01E-04 | 1.01E-04 | 1.15E-03 | 1.01E-04 | 1.01E-04 |
| 75-34-3 | 1,1-Dichloroethane* | 9.89E-05 | 9.87E-05 | 9.87E-05 | 9.87E-05 | 9.87E-05 | 9.66E-04 | 9.66E-04 | 9.66E-04 | 9.66E-04 | 9.66E-04 | 9.66E-04 |
| 75-11-0 | Carbon Disulfide* | 9.89E-05 | 9.87E-05 | 9.87E-05 | 9.87E-05 | 9.87E-05 | 9.66E-04 | 9.66E-04 | 9.66E-04 | 9.66E-04 | 9.66E-04 | 9.66E-04 |
| 75-44-1 | Acetone | 3.41E-03 | 3.41E-03 | 1.79E-03 | 1.79E-03 | 1.79E-03 | 1.40E-03 | 1.51E-03 | 2.37E-03 | 2.37E-03 | 2.37E-03 | 2.37E-03 |
| 75-69-3 | Methyl Isobutyl Ketone* | 3.64E-04 | 3.64E-04 | 5.76E-04 | 5.76E-04 | 5.76E-04 | 5.31E-04 | 5.69E-04 | 5.76E-04 | 5.76E-04 | 5.31E-04 | 5.31E-04 |
| 156-60-3 | trans-1,2-Dichloroethane | 9.89E-05 | 9.87E-05 | 9.87E-05 | 9.87E-05 | 9.87E-05 | 9.66E-04 | 9.66E-04 | 9.66E-04 | 9.66E-04 | 9.66E-04 | 9.66E-04 |
| 75-33-4 | 1,1-Dichloroethane* | 9.89E-05 | 9.87E-05 | 9.87E-05 | 9.87E-05 | 9.87E-05 | 9.66E-04 | 9.66E-04 | 9.66E-04 | 9.66E-04 | 9.66E-04 | 9.66E-04 |
| 108-03-4 | Vinyl Acetate* | 4.97E-04 | 4.97E-04 | 4.97E-04 | 4.97E-04 | 4.97E-04 | 4.97E-04 | 4.97E-04 | 4.97E-04 | 4.97E-04 | 4.97E-04 | 4.97E-04 |
| 156-19-2 | cis-1,2-Dichloroethane* | 9.89E-05 | 9.87E-05 | 9.87E-05 | 9.87E-05 | 9.87E-05 | 9.66E-04 | 9.66E-04 | 9.66E-04 | 9.66E-04 | 9.66E-04 | 9.66E-04 |
| 78-93-3 | 2-Butanone (Methyl Ethyl Ketone)* | 2.19E-03 | 2.09E-03 | 3.77E-04 | 3.77E-04 | 3.77E-04 | 2.73E-04 | 4.99E-04 | 4.78E-04 | 1.15E-03 | 1.15E-03 | 1.15E-03 |
| 67-66-3 | Chloroform* | 9.89E-05 | 9.87E-05 | 9.87E-05 | 9.87E-05 | 9.87E-05 | 9.66E-04 | 9.66E-04 | 9.66E-04 | 9.66E-04 | 9.66E-04 | 9.66E-04 |
| 71-31-4 | 1,1,1-Trichloroethane* | 9.89E-05 | 9.87E-05 | 9.87E-05 | 9.87E-05 | 9.87E-05 | 9.66E-04 | 9.66E-04 | 9.66E-04 | 9.66E-04 | 9.66E-04 | 9.66E-04 |
| 66-33-5 | Carbon Tetrachloride* | 3.86E-04 | 3.69E-04 | 2.93E-04 | 2.93E-04 | 2.93E-04 | 3.17E-04 | 3.03E-04 | 3.32E-04 | 3.32E-04 | 3.17E-04 | 3.17E-04 |
| 71-45-3 | Benzene* | 3.37E-05 | 3.23E-05 | 3.03E-05 | 3.03E-05 | 3.03E-05 | 1.93E-05 | 1.86E-05 | 1.86E-05 | 2.45E-05 | 2.45E-05 | 2.45E-05 |
| 107-06-2 | 1,3-Dichlorobenzene | 9.89E-05 | 9.87E-05 | 9.87E-05 | 9.87E-05 | 9.87E-05 | 9.66E-04 | 9.66E-04 | 9.66E-04 | 9.66E-04 | 9.66E-04 | 9.66E-04 |
| 75-37-4 | Bromochlorobenzene | 9.89E-05 | 9.87E-05 | 9.87E-05 | 9.87E-05 | 9.87E-05 | 9.66E-04 | 9.66E-04 | 9.66E-04 | 9.66E-04 | 9.66E-04 | 9.66E-04 |
| 1081-41-5 | cis-1,2-Dichloroethane* | 9.89E-05 | 9.47E-05 | 1.01E-04 | 1.01E-04 | 1.01E-04 | 9.66E-04 | 9.66E-04 | 9.66E-04 | 9.66E-04 | 9.66E-04 | 9.66E-04 |
| 1061-42-6 | trans-1,2-Dichloroethane* | 9.89E-05 | 9.47E-05 | 1.01E-04 | 1.01E-04 | 1.01E-04 | 9.66E-04 | 9.66E-04 | 9.66E-04 | 9.66E-04 | 9.66E-04 | 9.66E-04 |
| 4160-51-2 | 4-Methyl-2-pentanone* | 4.97E-04 | 4.97E-04 | 4.97E-04 | 4.97E-04 | 4.97E-04 | 4.97E-04 | 4.97E-04 | 4.97E-04 | 4.97E-04 | 4.97E-04 | 4.97E-04 |
| 108-10-1 | Toluene* | 1.64E-02 | 1.57E-02 | 1.01E-04 | 1.01E-04 | 5.05E-04 | 4.83E-04 | 9.13E-03 | 4.83E-04 | 4.83E-04 | 4.83E-04 | 4.83E-04 |
| 78-08-3 | 1,1,2-Trichloroethane* | 9.89E-05 | 9.87E-05 | 9.87E-05 | 9.87E-05 | 9.87E-05 | 9.66E-04 | 9.66E-04 | 9.66E-04 | 9.66E-04 | 9.66E-04 | 9.66E-04 |
| 127-18-4 | Tetrachloroethane* | 9.89E-05 | 9.87E-05 | 9.87E-05 | 9.87E-05 | 9.87E-05 | 9.66E-04 | 9.66E-04 | 9.66E-04 | 9.66E-04 | 9.66E-04 | 9.66E-04 |
| 91-78-6 | 2-Hexanone | 4.97E-04 | 4.97E-04 | 4.97E-04 | 4.97E-04 | 4.97E-04 | 4.97E-04 | 4.97E-04 | 4.97E-04 | 4.97E-04 | 4.97E-04 | 4.97E-04 |
| 124-48-1 | Dibromochloroethane | 9.89E-05 | 9.87E-05 | 9.87E-05 | 9.87E-05 | 9.87E-05 | 9.66E-04 | 9.66E-04 | 9.66E-04 | 9.66E-04 | 9.66E-04 | 9.66E-04 |
| 108-90-7 | Chlorobenzene* | 9.89E-05 | 9.87E-05 | 9.87E-05 | 9.87E-05 | 9.87E-05 | 9.66E-04 | 9.66E-04 | 9.66E-04 | 9.66E-04 | 9.66E-04 | 9.66E-04 |
| 108-41-4 | Ethyl Benzene* | 3.39E-03 | 3.39E-03 | 3.45E-03 | 3.45E-03 | 3.45E-03 | 3.14E-03 | 1.76E-03 | 1.76E-03 | 3.49E-03 | 3.14E-03 | 3.14E-03 |
| 108-39-3 | m,p-Xylene* | 1.03E-02 | 1.03E-02 | 9.27E-03 | 9.27E-03 | 9.27E-03 | 6.96E-03 | 3.66E-03 | 3.66E-03 | 7.97E-03 | 7.97E-03 | 7.97E-03 |
| 93-47-6 | o-Xylene* | 6.53E-03 | 6.53E-03 | 4.60E-03 | 4.60E-03 | 4.60E-03 | 4.41E-03 | 3.69E-03 | 3.69E-03 | 5.03E-03 | 5.03E-03 | 5.03E-03 |
| 106-42-5 | Benzene* | 3.94E-03 | 3.94E-03 | 1.74E-03 | 1.74E-03 | 1.74E-03 | 1.80E-03 | 1.74E-03 | 1.74E-03 | 2.33E-03 | 2.44E-03 | 2.44E-03 |
| 75-31-2 | Bromobenzene* | 9.89E-05 | 9.87E-05 | 9.87E-05 | 9.87E-05 | 9.87E-05 | 9.66E-04 | 9.66E-04 | 9.66E-04 | 9.66E-04 | 9.66E-04 | 9.66E-04 |
| 78-94-3 | 1,1,2-Trichloroethane* | 9.89E-05 | 9.87E-05 | 9.87E-05 | 9.87E-05 | 9.87E-05 | 9.66E-04 | 9.66E-04 | 9.66E-04 | 9.66E-04 | 9.66E-04 | 9.66E-04 |
| 106-99-0 | 1,3-Dioxane* | 9.70E-03 | 9.23E-03 | 4.83E-03 | 4.83E-03 | 4.83E-03 | 4.64E-03 | 4.13E-03 | 4.13E-03 | 6.39E-03 | 6.02E-03 | 6.02E-03 |

* Hazardous Air Pollutant (HAP)
 ND - Compound not detected at this detection limit. Compound may be present at a value less than the detection limit.

TABLE 5-8.
J85-GE-5M (MOODY AFB)
EMISSION FACTOR SUMMARY
VOLATILE ORGANIC COMPOUNDS (VOCs)
Military
(Flow by Carbon Balance)

| Flow Rate, lb/hr | 1 | | | 2 | | | 3 | | | Average | |
|-----------------------------------|------------|----------|-----------------|-------------------|-----------------|----------|-----------------|-------------------|-----------------|----------|-------------------|
| | 544,313 | | | 544,313 | | | 544,313 | | | | |
| | 2350 | | | 2350 | | | 2350 | | | | |
| Analyte | CAS number | lb/hr | | lb/1,000 lbs fuel | | lb/hr | | lb/1,000 lbs fuel | | lb/hr | lb/1,000 lbs fuel |
| | | Detected | Detection Limit | Detected | Detection Limit | Detected | Detection Limit | Detected | Detection Limit | | |
| Chloroethane* | 74-87-3 | 3.31E-04 | 1.73E-04 | 4.60E-07 | 1.73E-07 | 2.43E-04 | 1.09E-04 | 2.43E-04 | 1.09E-04 | 1.91E-04 | 7.79E-05 |
| Bromomethane* | 74-83-9 | | 1.73E-04 | | 1.09E-04 | | 1.09E-04 | | 1.09E-04 | ND | ND |
| Chloroethane* | 74-50-3 | | 1.73E-04 | | 1.09E-04 | | 1.09E-04 | | 1.09E-04 | ND | ND |
| Flow 11 (1,1-Dichloroethane) | 74-60-4 | 8.77E-04 | 1.73E-04 | 8.30E-04 | 2.77E-04 | 2.43E-04 | 1.09E-04 | 2.43E-04 | 1.09E-04 | 9.59E-04 | 3.76E-04 |
| 1,1-Dichloroethane* | 75-34-3 | | 1.73E-04 | | 1.09E-04 | | 1.09E-04 | | 1.09E-04 | ND | ND |
| Carbon Dioxide* | 75-11-0 | | 1.73E-04 | | 1.09E-04 | | 1.09E-04 | | 1.09E-04 | ND | ND |
| Acetone | 67-64-1 | | 1.73E-04 | | 1.09E-04 | | 1.09E-04 | | 1.09E-04 | ND | ND |
| Methylene Chloride* | 74-92-2 | 3.68E-04 | 1.73E-04 | 4.70E-04 | 2.77E-04 | 2.43E-04 | 1.09E-04 | 2.43E-04 | 1.09E-04 | 6.66E-04 | 2.52E-04 |
| trans-1,2-Dichloroethane | 156-60-3 | | 1.73E-04 | | 1.09E-04 | | 1.09E-04 | | 1.09E-04 | ND | ND |
| 1,1-Dichloroethane* | 75-33-4 | | 1.73E-04 | | 1.09E-04 | | 1.09E-04 | | 1.09E-04 | ND | ND |
| Very Aromatic* | 108-03-4 | | 1.73E-04 | | 1.09E-04 | | 1.09E-04 | | 1.09E-04 | ND | ND |
| cis-1,2-Dichloroethane* | 156-59-2 | | 1.73E-04 | | 1.09E-04 | | 1.09E-04 | | 1.09E-04 | ND | ND |
| 2-Butanone (Methyl Ethyl Ketone)* | 78-93-3 | | 1.73E-04 | | 1.09E-04 | | 1.09E-04 | | 1.09E-04 | ND | ND |
| Chloroform* | 67-66-3 | | 1.73E-04 | | 1.09E-04 | | 1.09E-04 | | 1.09E-04 | ND | ND |
| 1,1,1-Trichloroethane* | 71-55-6 | | 1.73E-04 | | 1.09E-04 | | 1.09E-04 | | 1.09E-04 | ND | ND |
| Carbon Tetrachloride* | 56-23-5 | 4.03E-04 | 1.73E-04 | 3.60E-04 | 2.77E-04 | 2.43E-04 | 1.09E-04 | 2.43E-04 | 1.09E-04 | 3.76E-04 | 1.47E-04 |
| Benzene | 71-43-2 | 6.14E-03 | 1.73E-04 | 6.61E-03 | 2.77E-04 | 2.43E-04 | 1.09E-04 | 2.43E-04 | 1.09E-04 | 6.54E-03 | 2.68E-03 |
| 1,2-Dichloroethane* | 107-06-2 | | 1.73E-04 | | 1.09E-04 | | 1.09E-04 | | 1.09E-04 | ND | ND |
| Bromodichloromethane | 73-27-4 | | 1.73E-04 | | 1.09E-04 | | 1.09E-04 | | 1.09E-04 | ND | ND |
| cis-1,2-Dichloroethane* | 10061-01-5 | | 1.73E-04 | | 1.09E-04 | | 1.09E-04 | | 1.09E-04 | ND | ND |
| trans-1,2-Dichloroethane* | 10061-02-6 | | 1.73E-04 | | 1.09E-04 | | 1.09E-04 | | 1.09E-04 | ND | ND |
| 4-Methyl-2-pentanone* | 108-10-1 | | 1.73E-04 | | 1.09E-04 | | 1.09E-04 | | 1.09E-04 | ND | ND |
| Toluene* | 108-88-3 | 2.74E-03 | 1.73E-04 | 2.10E-03 | 2.77E-04 | 2.43E-04 | 1.09E-04 | 2.43E-04 | 1.09E-04 | 2.33E-03 | 9.12E-04 |
| 1,1,2-Trichloroethane* | 79-00-5 | | 1.73E-04 | | 1.09E-04 | | 1.09E-04 | | 1.09E-04 | ND | ND |
| Trichloroethane* | 117-18-4 | | 1.73E-04 | | 1.09E-04 | | 1.09E-04 | | 1.09E-04 | ND | ND |
| 2-Hexanone | 59-178-6 | | 1.73E-04 | | 1.09E-04 | | 1.09E-04 | | 1.09E-04 | ND | ND |
| Dibromochloromethane | 124-81-1 | | 1.73E-04 | | 1.09E-04 | | 1.09E-04 | | 1.09E-04 | ND | ND |
| Chlorobenzene* | 108-90-7 | | 1.73E-04 | | 1.09E-04 | | 1.09E-04 | | 1.09E-04 | ND | ND |
| Ethyl Benzene* | 108-11-4 | 3.68E-04 | 1.73E-04 | 2.77E-04 | 2.77E-04 | 2.43E-04 | 1.09E-04 | 2.43E-04 | 1.09E-04 | 1.31E-04 | 4.89E-05 |
| m,p-Xylene* | 108-38-3 | 1.97E-03 | 1.73E-04 | 1.97E-03 | 2.77E-04 | 2.43E-04 | 1.09E-04 | 2.43E-04 | 1.09E-04 | 1.10E-03 | 4.33E-04 |
| o-Xylene* | 95-47-6 | 2.10E-04 | 1.73E-04 | 2.10E-04 | 2.77E-04 | 2.43E-04 | 1.09E-04 | 2.43E-04 | 1.09E-04 | 2.33E-04 | 8.64E-05 |
| Styrene* | 104-25-2 | 2.10E-04 | 1.73E-04 | 2.10E-04 | 2.77E-04 | 2.43E-04 | 1.09E-04 | 2.43E-04 | 1.09E-04 | 1.84E-04 | 7.32E-05 |
| Bromoform* | 75-32-4 | | 1.73E-04 | | 1.09E-04 | | 1.09E-04 | | 1.09E-04 | ND | ND |
| 1,1,2-Trichloroethane* | 79-34-5 | | 1.73E-04 | | 1.09E-04 | | 1.09E-04 | | 1.09E-04 | ND | ND |
| 1,3-Butadiene* | 106-99-0 | | 1.73E-04 | | 1.09E-04 | | 1.09E-04 | | 1.09E-04 | ND | ND |

* Hazardous Air Pollutant (HAP)
 ND - Compound not detected at this detection limit. Compound may be present at a value less than the detection limit.

TABLE 5-9.
J85-GE-5M (Moody AFB)
ENGINE RAKE
EMISSION FACTOR SUMMARY
BENZENE
(Flow By Carbon Balance)

| | Idle | | Intermediate | | Military |
|-----------------------------------|-------------|-------------------|---------------------|-------------------|-------------------|
| Flow Rate dscfm | 188,704 | | 293,150 | | 544,313 |
| Fuel Flow lbs/hr | 525 | | 1,045 | | 2550 |
| Analyte | lbs/hr | lbs/1000 lbs fuel | lbs/hr | lbs/1000 lbs fuel | lbs/1000 lbs fuel |
| Benzene | 3.90E-01 | 7.42E-01 | 2.46E-01 | 2.35E-01 | 4.63E-02 |
| | | | | | 1.82E-02 |

TABLE 5-10.
J85-GE-5M (Moody AFB)
ENGINE RAKE
EMISSION FACTOR SUMMARY
Formaldehyde
(Flow By Carbon Balance)

| | Idle | | Intermediate | | Military |
|----------------------------|----------|-------------------|--------------|-------------------|-------------------|
| Flow Rate dscfm | 118,704 | | 293,150 | | 544,313 |
| Fuel Flow lbs/hr | 525 | | 1,045 | | 2550 |
| Analyte | lbs/hr | lbs/1000 lbs fuel | lbs/hr | lbs/1000 lbs fuel | lbs/1000 lbs fuel |
| | 7.60E-01 | 1.45E+00 | 1.71E+00 | 1.64E+00 | 4.57E-01 |
| Formaldehyde | | | | | 1.79E-01 |

TABLE 5-11.
J85-GE-5M (Moody AFB)
SLIPSTREAM RAKE
EMISSION FACTOR SUMMARY
ADELHYDE/KETONES

| Flow Rate dscfm | Idle | | Intermediate | | Military |
|--------------------------------------|--------------|--------------------|--------------|--------------------|--------------------|
| | 118,704 | 293,150 | 544,313 | | |
| Fuel Flow lbs/hr | 525 | | 1,045 | | 2,550 |
| Analyte | lbs/hr | lbs/ 1000 lbs fuel | lbs/hr | lbs/ 1000 lbs fuel | lbs/ 1000 lbs fuel |
| | Formaldehyde | 1.19E+00 | 2.26E+00 | 3.64E-01 | 3.48E-01 |
| Acetaldehyde | 1.28E-01 | 2.44E-01 | 2.00E-02 | 1.93E-02 | 4.00E-03 |
| Acrolein | 1.65E-01 | 3.13E-01 | 1.30E-02 | 1.28E-02 | 3.00E-03 |
| Propanal | 4.10E-02 | 7.83E-02 | 1.30E-02 | 1.28E-02 | 3.00E-03 |
| Crotonaldehyde | 6.20E-02 | 1.18E-01 | 1.30E-02 | 1.28E-02 | 3.00E-03 |
| Isobutaldehyde / Methyl Ethyl Ketone | 4.10E-02 | 7.83E-02 | 1.30E-02 | 1.28E-02 | 3.00E-03 |
| Benzaldehyde | 4.10E-02 | 7.83E-02 | 1.30E-02 | 1.28E-02 | 3.00E-03 |
| Isopentanal (Isovaleraldehyde) | 4.10E-02 | 7.83E-02 | 1.30E-02 | 1.28E-02 | 3.00E-03 |
| Pentanal (Valeraldehyde) | 1.28E-01 | 2.44E-01 | 1.30E-02 | 1.28E-02 | 3.00E-03 |
| o-Tolualdehyde | 4.90E-02 | 9.40E-02 | 1.30E-02 | 1.28E-02 | 3.00E-03 |
| Hexanal (Hexaldehyde) | 4.10E-02 | 7.83E-02 | 1.30E-02 | 1.28E-02 | 3.00E-03 |

moved from idle to the higher engine settings the emissions decreased accordingly.

Formaldehyde emissions were 0.02 lb/1000 lbs fuel at military.

5.4 POLYNUCLEAR AROMATIC HYDROCARBONS

Samples for polynuclear aromatic hydrocarbons were collected at the slipstream for the J85-GE-5M engine. A summary of the results for the idle, intermediate, and military settings is provided in Table 5-12. Naphthalene and 2-methylnaphthalene were detected at the idle setting only.

5.5 POLLUTANT MIXING IN THE AUGMENTER TUBE

Pollutant mixing in the augmenter tube was examined at Moody AFB through the use of 12 sampling points within the augmenter tube fixed to the slipstream rake. The points were positioned according to the procedures in EPA Method 1 and are provided in Figure 5-2. By investigating the mixing of emissions from the engine, we could define the profile within the augmenter tube (at the point of collection, the slipstream rake) for the engine emissions. At each engine setting, CO concentrations were compared to each other. As shown in Table 5-13, the concentrations of CO varied by 22%, 12%, and 9% between the highest and lowest values observed from the 12 sampling points at idle, intermediate, and military respectively. This indicated that CO was well distributed with the ambient air entering the hush house and into the augmenter tube. The slight variance in emissions does not impact sample collection since the gaseous emissions were collected at all 12 slipstream rake intake points and averaged and the inorganic and volatile samples were collected from the slipstream duct where there was a slight increase in concentration. The data showed at the tested conditions, that stratification of the engine exhaust was not significant.

5.6 PARTICULATE MATTER

The total particulate emissions are presented in Table 5-14. The results represent the total particulate, condensable (aqueous fraction only), and filterable exiting the hush house.

**TABLE 5-12.
J85-GE-5M (MOODY AFB)
SLIPSTREAM RAKE
EMISSION FACTOR SUMMARY
POLYNUCLEAR AROMATIC HYDROCARBONS**

| Analyte | CAS Number | HAP? | IDLE | | | | INTERMEDIATE | | | | MILITARY | | | | Average | | | | | | | | | | | | |
|------------------------|------------|------|-------------------------------|-----------------|-------------------|-----------------|--------------|-----------------|----------|-----------------|----------|-----------------|----------|-----------------|----------|------------------|----------|-----------------|------------------|----------|-----------------|------------------|----------|-----------------|------------------|----------|----------|
| | | | Flow Rate, decfm ^o | | Fuel Flow, lbs/hr | | 118,704 | | 293,150 | | 544,313 | | 2,550 | | | lbs/1000lbs fuel | lb/hr | Detection Limit | lbs/1000lbs fuel | lb/hr | Detection Limit | lbs/1000lbs fuel | lb/hr | Detection Limit | lbs/1000lbs fuel | | |
| | | | Detected | Detection Limit | Detected | Detection Limit | Detected | Detection Limit | Detected | Detection Limit | Detected | Detection Limit | Detected | Detection Limit | | | | | | | | | | | | | |
| Naphthalene | 91-20-3 | Yes | 4.35E-02 | 4.84E-03 | 8.29E-02 | 9.21E-03 | 6.22E-03 | 5.95E-03 | 6.22E-03 | 6.22E-03 | 6.22E-03 | 6.22E-03 | 6.22E-03 | 6.22E-03 | 1.19E-02 | 4.66E-03 | 4.66E-03 | 1.19E-02 | 4.66E-03 | 4.66E-03 | 1.19E-02 | 4.66E-03 | 4.66E-03 | 1.19E-02 | 4.66E-03 | 2.76E-02 | 4.30E-01 |
| 2-Methylnaphthalene | 91-57-6 | Yes | 6.77E-02 | 4.84E-03 | 1.29E-01 | 9.21E-03 | 6.22E-03 | 5.95E-03 | 6.22E-03 | 6.22E-03 | 6.22E-03 | 6.22E-03 | 6.22E-03 | 6.22E-03 | 1.19E-02 | 4.66E-03 | 4.66E-03 | 1.19E-02 | 4.66E-03 | 4.66E-03 | 1.19E-02 | 4.66E-03 | 4.66E-03 | 1.19E-02 | 4.66E-03 | 4.66E-03 | 4.66E-03 |
| 2-Chloronaphthalene | 91-58-7 | Yes | | 4.84E-03 | | 9.21E-03 | 6.22E-03 | 5.95E-03 | 6.22E-03 | 6.22E-03 | 6.22E-03 | 6.22E-03 | 6.22E-03 | 1.19E-02 | 4.66E-03 | 4.66E-03 | 1.19E-02 | 4.66E-03 | 4.66E-03 | 1.19E-02 | 4.66E-03 | 4.66E-03 | 1.19E-02 | 4.66E-03 | 4.66E-03 | 4.66E-03 | 4.66E-03 |
| Acenaphthene | 83-32-9 | Yes | | 4.84E-03 | | 9.21E-03 | 6.22E-03 | 5.95E-03 | 6.22E-03 | 6.22E-03 | 6.22E-03 | 6.22E-03 | 6.22E-03 | 1.19E-02 | 4.66E-03 | 4.66E-03 | 1.19E-02 | 4.66E-03 | 4.66E-03 | 1.19E-02 | 4.66E-03 | 4.66E-03 | 1.19E-02 | 4.66E-03 | 4.66E-03 | 4.66E-03 | 4.66E-03 |
| Acenaphthylene | 208-96-8 | Yes | | 4.84E-03 | | 9.21E-03 | 6.22E-03 | 5.95E-03 | 6.22E-03 | 6.22E-03 | 6.22E-03 | 6.22E-03 | 6.22E-03 | 1.19E-02 | 4.66E-03 | 4.66E-03 | 1.19E-02 | 4.66E-03 | 4.66E-03 | 1.19E-02 | 4.66E-03 | 4.66E-03 | 1.19E-02 | 4.66E-03 | 4.66E-03 | 4.66E-03 | 4.66E-03 |
| Fluorene | 86-73-7 | Yes | | 4.84E-03 | | 9.21E-03 | 6.22E-03 | 5.95E-03 | 6.22E-03 | 6.22E-03 | 6.22E-03 | 6.22E-03 | 6.22E-03 | 1.19E-02 | 4.66E-03 | 4.66E-03 | 1.19E-02 | 4.66E-03 | 4.66E-03 | 1.19E-02 | 4.66E-03 | 4.66E-03 | 1.19E-02 | 4.66E-03 | 4.66E-03 | 4.66E-03 | 4.66E-03 |
| Phenanthrene | 85-01-8 | Yes | | 4.84E-03 | | 9.21E-03 | 6.22E-03 | 5.95E-03 | 6.22E-03 | 6.22E-03 | 6.22E-03 | 6.22E-03 | 6.22E-03 | 1.19E-02 | 4.66E-03 | 4.66E-03 | 1.19E-02 | 4.66E-03 | 4.66E-03 | 1.19E-02 | 4.66E-03 | 4.66E-03 | 1.19E-02 | 4.66E-03 | 4.66E-03 | 4.66E-03 | 4.66E-03 |
| Anthracene | 120-12-7 | Yes | | 4.84E-03 | | 9.21E-03 | 6.22E-03 | 5.95E-03 | 6.22E-03 | 6.22E-03 | 6.22E-03 | 6.22E-03 | 6.22E-03 | 1.19E-02 | 4.66E-03 | 4.66E-03 | 1.19E-02 | 4.66E-03 | 4.66E-03 | 1.19E-02 | 4.66E-03 | 4.66E-03 | 1.19E-02 | 4.66E-03 | 4.66E-03 | 4.66E-03 | 4.66E-03 |
| Fluoranthene | 206-44-0 | Yes | | 4.84E-03 | | 9.21E-03 | 6.22E-03 | 5.95E-03 | 6.22E-03 | 6.22E-03 | 6.22E-03 | 6.22E-03 | 6.22E-03 | 1.19E-02 | 4.66E-03 | 4.66E-03 | 1.19E-02 | 4.66E-03 | 4.66E-03 | 1.19E-02 | 4.66E-03 | 4.66E-03 | 1.19E-02 | 4.66E-03 | 4.66E-03 | 4.66E-03 | 4.66E-03 |
| Pyrene | 129-00-0 | Yes | | 4.84E-03 | | 9.21E-03 | 6.22E-03 | 5.95E-03 | 6.22E-03 | 6.22E-03 | 6.22E-03 | 6.22E-03 | 6.22E-03 | 1.19E-02 | 4.66E-03 | 4.66E-03 | 1.19E-02 | 4.66E-03 | 4.66E-03 | 1.19E-02 | 4.66E-03 | 4.66E-03 | 1.19E-02 | 4.66E-03 | 4.66E-03 | 4.66E-03 | 4.66E-03 |
| Chrysenes | 218-01-9 | Yes | | 4.84E-03 | | 9.21E-03 | 6.22E-03 | 5.95E-03 | 6.22E-03 | 6.22E-03 | 6.22E-03 | 6.22E-03 | 6.22E-03 | 1.19E-02 | 4.66E-03 | 4.66E-03 | 1.19E-02 | 4.66E-03 | 4.66E-03 | 1.19E-02 | 4.66E-03 | 4.66E-03 | 1.19E-02 | 4.66E-03 | 4.66E-03 | 4.66E-03 | 4.66E-03 |
| Benzo(a)anthracene | 56-55-3 | Yes | | 4.84E-03 | | 9.21E-03 | 6.22E-03 | 5.95E-03 | 6.22E-03 | 6.22E-03 | 6.22E-03 | 6.22E-03 | 6.22E-03 | 1.19E-02 | 4.66E-03 | 4.66E-03 | 1.19E-02 | 4.66E-03 | 4.66E-03 | 1.19E-02 | 4.66E-03 | 4.66E-03 | 1.19E-02 | 4.66E-03 | 4.66E-03 | 4.66E-03 | 4.66E-03 |
| Benzo(b)fluoranthene | 205-99-2 | Yes | | 4.84E-03 | | 9.21E-03 | 6.22E-03 | 5.95E-03 | 6.22E-03 | 6.22E-03 | 6.22E-03 | 6.22E-03 | 6.22E-03 | 1.19E-02 | 4.66E-03 | 4.66E-03 | 1.19E-02 | 4.66E-03 | 4.66E-03 | 1.19E-02 | 4.66E-03 | 4.66E-03 | 1.19E-02 | 4.66E-03 | 4.66E-03 | 4.66E-03 | 4.66E-03 |
| Benzo(k)fluoranthene | 207-08-9 | Yes | | 4.84E-03 | | 9.21E-03 | 6.22E-03 | 5.95E-03 | 6.22E-03 | 6.22E-03 | 6.22E-03 | 6.22E-03 | 6.22E-03 | 1.19E-02 | 4.66E-03 | 4.66E-03 | 1.19E-02 | 4.66E-03 | 4.66E-03 | 1.19E-02 | 4.66E-03 | 4.66E-03 | 1.19E-02 | 4.66E-03 | 4.66E-03 | 4.66E-03 | 4.66E-03 |
| Benzo(e)pyrene | 50-32-8 | Yes | | 4.84E-03 | | 9.21E-03 | 6.22E-03 | 5.95E-03 | 6.22E-03 | 6.22E-03 | 6.22E-03 | 6.22E-03 | 6.22E-03 | 1.19E-02 | 4.66E-03 | 4.66E-03 | 1.19E-02 | 4.66E-03 | 4.66E-03 | 1.19E-02 | 4.66E-03 | 4.66E-03 | 1.19E-02 | 4.66E-03 | 4.66E-03 | 4.66E-03 | 4.66E-03 |
| Indeno(1,2,3-cd)pyrene | 193-3-5 | Yes | | 4.84E-03 | | 9.21E-03 | 6.22E-03 | 5.95E-03 | 6.22E-03 | 6.22E-03 | 6.22E-03 | 6.22E-03 | 6.22E-03 | 1.19E-02 | 4.66E-03 | 4.66E-03 | 1.19E-02 | 4.66E-03 | 4.66E-03 | 1.19E-02 | 4.66E-03 | 4.66E-03 | 1.19E-02 | 4.66E-03 | 4.66E-03 | 4.66E-03 | 4.66E-03 |
| Dibenzo(a,h)anthracene | 53-70-3 | Yes | | 4.84E-03 | | 9.21E-03 | 6.22E-03 | 5.95E-03 | 6.22E-03 | 6.22E-03 | 6.22E-03 | 6.22E-03 | 6.22E-03 | 1.19E-02 | 4.66E-03 | 4.66E-03 | 1.19E-02 | 4.66E-03 | 4.66E-03 | 1.19E-02 | 4.66E-03 | 4.66E-03 | 1.19E-02 | 4.66E-03 | 4.66E-03 | 4.66E-03 | 4.66E-03 |
| Benzo(g,h,i)perylene | 191-24-2 | Yes | | 4.84E-03 | | 9.21E-03 | 6.22E-03 | 5.95E-03 | 6.22E-03 | 6.22E-03 | 6.22E-03 | 6.22E-03 | 6.22E-03 | 1.19E-02 | 4.66E-03 | 4.66E-03 | 1.19E-02 | 4.66E-03 | 4.66E-03 | 1.19E-02 | 4.66E-03 | 4.66E-03 | 1.19E-02 | 4.66E-03 | 4.66E-03 | 4.66E-03 | 4.66E-03 |

(*) - Idle flow rates calculated by F-Factor; Intermediate, Military and Afterburner flow rates calculated by carbon balance.
 ND - Compound not detected at this detection limit. Compound may be present at a value less than the detection limit.

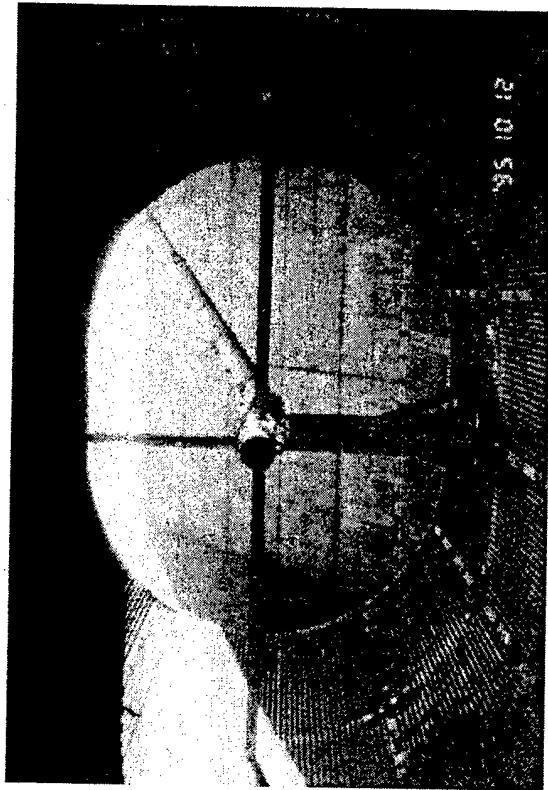

Figure 5-2. Augmenter Tube Side-Stream Extraction Tube and Gas Sampling

TABLE 5-13.
J85-GE-5M (Moody AFB)
SLIPSTREAM RAKE INTAKE
SAMPLE POINT DATA COMPARISON

| Sample Point | Idle CO (ppm) | Intermediate CO (ppm) | Military CO (ppm) |
|--------------|------------------|--------------------------|----------------------|
| 1 | 209 | 35.3 | 25.1 |
| 2 | 220 | 35.8 | 25.1 |
| 3 | 209 | 37.4 | 25.8 |
| 4 | 178 | 39.9 | 26.5 |
| 5 | 177 | 40.3 | 26.2 |
| 6 | 195 | 40.3 | 26.1 |
| 7 | 205 | 35.3 | 24.0 |
| 8 | 174 | 35.6 | 24.3 |
| 9 | 202 | 37.2 | 25.8 |
| 10 | 188 | 39.7 | 25.6 |
| 11 | 173 | 39.4 | 25.0 |
| 12 | 171 | 39.6 | 24.7 |
| Maximum | 220 | 40.3 | 26.5 |
| Minimum | 171 | 35.3 | 24.0 |

Note: Values are uncorrected averages for runs 1 and 2 of each condition.

Bold represents the maximum value at each condition.

Italics represent the minimum value(s) at each condition.

TABLE 5-14.
J85-GE-5M (MOODY AFB)
EMISSIONS FACTOR SUMMARY
PARTICULATE

| | Run Number | | | | | | | | | |
|---------------------------------|-------------------|-------|----------------------|-------|-------------------|-------|-------------------|-------|-------------------|-------|
| | 1 | | 2 | | 3 | | Composite | | Average | |
| | lbs/1000 lbs fuel | lb/hr | lbs/1000 lbs fuel | lb/hr | lbs/1000 lbs fuel | lb/hr | lbs/1000 lbs fuel | lb/hr | lbs/1000 lbs fuel | lb/hr |
| Flow Rate, dscfm ^(a) | 118,704 | | 118,704 | | 118,704 | | 118,704 | | 118,704 | |
| Fuel Flow, lbs/hr | 525 | | 525 | | 525 | | 525 | | 525 | |
| IDLE | | | | | | | | | | |
| Filterable | 1.61 | 0.86 | 1.64 | 1.26 | 2.39 | 0.73 | 1.39 | 0.95 | 1.80 | |
| Condensable ^(b) | 3.21 | 2.36 | 4.49 | 2.21 | 4.21 | 2.51 | 4.79 | 2.36 | 4.50 | |
| Total Particulate | 4.82 | 3.22 | 6.13 | 3.47 | 6.60 | 3.24 | 6.18 | 3.31 | 6.30 | |
| INTERMEDIATE | | | | | | | | | | |
| Flow Rate, dscfm ^(b) | 293,150 | | 293,150 | | 293,150 | | 293,150 | | 293,150 | |
| Fuel Flow, lbs/hr | 1,045 | | 1,045 | | 1,045 | | 1,045 | | 1,045 | |
| Filterable | 3.54 | 3.20 | 3.07 | 3.12 | 2.98 | 1.29 | 1.24 | 2.65 | 2.54 | |
| Condensable | 7.80 | 14.60 | 13.97 | 10.38 | 9.94 | 7.48 | 7.16 | 8.55 | 8.19 | |
| Total Particulate | 11.34 | 17.80 | 17.03 ^(c) | 13.50 | 12.92 | 8.77 | 8.40 | 11.20 | 10.72 | |
| MILITARY | | | | | | | | | | |
| Flow Rate, dscfm ^(b) | 544,312 | | 544,312 | | 544,312 | | 544,312 | | 544,312 | |
| Fuel Flow, lbs/hr | 2,550 | | 2,550 | | 2,550 | | 2,550 | | 2,550 | |
| Filterable | 9.11 | 9.16 | 3.59 | 8.18 | 3.21 | 4.57 | 1.79 | 7.30 | 2.86 | |
| Condensable | 6.30 | 2.47 | ND | ND | ND | 6.08 | 2.39 | 2.03 | 0.80 | |
| Total Particulate | 15.41 | 11.63 | 3.59 | 8.18 | 3.21 | 10.65 | 4.18 | 9.33 | 3.66 | |

(a) - Exhaust flow rate determined by F-factor
(b) - Exhaust flow rate determined by Carbon Balance
(c) - This run not included in averages.
(d) - Aqueous fraction only, see note below.

NOTE: Particulate measurements not made at Afterburner. It appears that hydrocarbons from unburned fuel are in the impinger solution at the idle and intermediate power settings. This accounts for the majority of the condensable fraction.

**TABLE 5-15.
PERCENTAGES OF CARBON PARTICLES IN VARIOUS
DIAMETER RANGES BY NUMBER OF PARTICLES**

| | Idle | Intermediate | Military | |
|--------------------------------|--------------|---------------------|-----------------|--------------|
| Filter Number | PC001 | PC002 | PC003 | Blank |
| Diameter Range (um) | | | | |
| .5-2.5 | 92.4% | 88.2% | 89.4% | NA* |
| 2.5-5.0 | 6.7% | 10.8% | 8.7% | |
| 5.0-7.5 | 1.0% | 1.0% | 1.0% | |
| 7.5-10 | 0.0% | 0.0% | 1.0% | |
| >10 | 0.0% | 0.0% | 0.0% | |

*NA - Insufficient particles for a valid statistical analysis

**PERCENTAGES OF CARBON PARTICLES IN VARIOUS
DIAMETER RANGES BY ESTIMATED MASS OF PARTICLES**

| | Idle | Intermediate | Military | |
|--------------------------------|--------------|---------------------|-----------------|--------------|
| Filter Number | PC001 | PC002 | PC003 | Blank |
| Diameter Range (um) | | | | |
| .5-2.5 | 34.8% | 26.9% | 18.4% | NA* |
| 2.5-5.0 | 39.2% | 51.4% | 27.9% | |
| 5.0-7.5 | 26.0% | 21.6% | 14.3% | |
| 7.5-10 | 0.0% | 0.0% | 39.3% | |
| >10 | 0.0% | 0.0% | 0.0% | |

*NA - Insufficient particles for a valid statistical analysis

The particulate sampling methodology was improved in several ways over past sampling campaigns in order to improve the detection limit in the exhaust stream. EQ and USAF personnel reviewed the historic sampling procedures and developed the following improvements:

- The sample run times were extended to 2 hours in length. This allowed for a larger sample volume and larger particle catch.
- A field balance was used to ensure that a positive mass gain on the filter was obtained. This allowed the field team to adjust the sample volume in the field as necessary.
- A Teflon filter frit without a gasket was used in the filter housing. This set-up prevented the filter from sticking to the frit.

The improvements made the particulate sampling much more representative of the engine emissions.

The filterable particulate emission results for this engine were higher than the historic data set. This is attributed to the improved particle collection during this program. The engine also noted a similar emission trend pattern. The filterable emission index was 1.8 lbs/1000 lbs fuel at idle, 2.5 lbs/1000 lbs fuel at intermediate, and 2.9 lbs/1000 lbs fuel at military. The condensable particulate matter was considerably higher than the past program indicated. It was noted in the field that the condensable fraction had a heavy yellow discoloration at idle, a murky yellow color at intermediate, and a cloudy consistency at military. It appeared that unburned fuel passed through the engine and into the exhaust stream. The organic fraction of the condensable particulate matter was removed from the results.

5.6.1 Particle Characterization

During one run at each setting, a particle sample was collected on a silver membrane filter for analysis via scanning electron microscopy to count the particles in each size range. The results of the particle counts are provided in Table 5-15. The analysis determined that the majority of particulate matter (>99%) was below 10 microns in size with >89% of the particles at a diameter <2.5 microns. The pore size of the filter was 0.5 micron; therefore, particles less than 0.5 micron in diameter may have passed through the filter. Additional analysis was performed to examine particles less than 0.5 micron by transmission electron microscopy (TEM) and elemental analysis of particles less than 10 microns by automated SEM.

Three types of material were detected on each of the filters. One type of material is composed of particles, primarily carbon in nature, greater than 0.5 Φ m. These particles make up approximately three-quarters of the larger particles. A second type of material is composed of non-carbon particles, primarily containing silicon, greater than 0.5 Φ m. The third type of material is composed of aggregated carbon particles generally smaller than 0.5 Φ m. The particles greater than 0.5 Φ m in all three samples generally have similar lengths and widths. The average aspect ratio (length to width) for the non-carbon particles is 1.8. Many of the particle aggregates are consistent with carbon soot. Others appear to be degraded soot aggregates.

5.7 EXHAUST FLOW DETERMINATION

The engine exhaust flow was determined using several methods in order to provide an opportunity to review data sets and disregard outliers. Carbon balance and F-factor were used to determine the exhaust flow rate. The F-Factor methodology provided the most representative exhaust flow data at the idle setting. Carbon balance provided the most representative trend for the remaining settings. As shown in Tables 5-3 and 5-5, the flow models provided representative data. The engine rake flow at Moody AFB (1 engine) was approximately half of the airflow directly behind the T-38C (2 engines) at Randolph. The idle results did not follow this trend. The engine's inefficiency tended to provide varying data which impacted the calculations. The afterburner flow at the engine rake at Moody AFB (Table 5-3) was calculated to be less than the military flow. During testing, the engine developed a malfunction that disabled operation at afterburner. Only a single 3-minute sample was collected, which did not allow for triplicate measurement. A longer sample time may have provided more representative results. The carbon balance and F-Factor flow calculation methods provided good correlation.

5.8 FUEL ANALYSIS

Fuel samples were collected during the emission test program from the fuel line feeding the engine. The fuel was analyzed to determine the presence of select metals and other physical parameters. In the sample, small quantities of selenium, zinc, silver, and thallium were present. The fuel analysis results are presented in Tables 5-16 and 5-17.

TABLE 5-16. JP-8 FUEL ANALYSIS

| Parameter | Analytical Method | Result |
|--------------|-------------------|---------------|
| Btu/lb | ASTM D-240 | 19,300 Btu/lb |
| Sulfur % | ASTM D-2622 | 0.0496% |
| Carbon % | ASTM D-5291 | 85.52% |
| Nitrogen % | ASTM 4629 | 0.0007% |
| Hydrogen % | ASTM D-5291 | 14.18% |
| Ash % | ASTM D482 | <0.001% |
| Naphthenes % | PONA Analysis | 45.6% |
| Aromatics % | PONA Analysis | 23.5% |
| Parafins % | PONA Analysis | 30.4% |
| Olefins % | PONA Analysis | 0.5% |

TABLE 5-17. SUMMARY OF SOURCE TARGET METALS FROM JP-8 FUEL ANALYSIS

| Metal | Analytical Method | Analytical Result (mg/kg) |
|------------|-------------------|---------------------------|
| Antimony | 6010 | <0.05 |
| Arsenic | 6010 | <0.063 |
| Barium | 6010 | <0.025 |
| Beryllium | 6010 | <0.0025 |
| Cadmium | 6010 | <0.013 |
| Chromium | 6010 | <0.013 |
| Cobalt | 6010 | <0.013 |
| Copper | 6010 | 0.025 (MDL = 0.025) |
| Lead | 6010 | <0.063 |
| Manganese | 6010 | 0.013 (MDL = 0.013) |
| Mercury | 7470 | <0.0005 |
| Nickel | 6010 | 0.038 |
| Phosphorus | 365.2 | 1.2 (MDL = 0.025) |
| Selenium | 6010 | 0.13 |
| Silver | 6010 | 0.013 |
| Thallium | 6010 | 0.075 |
| Zinc | 6010 | 0.025 |

Note: A sample and duplicate were submitted for analysis. The highest concentration is recorded in the table above.

5.9 ENGINE OPERATION

During the emission test program, specific engine parameters were monitored to note engine performance. Facility personnel were responsible for collecting and maintaining the operating data and for operating the engine in a safe manner. A summary of the engine operation is provided in Table 5-18.

**TABLE 5-18
ENGINE OPERATING DATA**

| Power Setting | Fuel Flow (lbs/hr) | | %RPM (Average) | | lb/Thrust (Average) | Cell Temperature (Average F) |
|--|--------------------|-------|----------------|-----|---------------------|------------------------------|
| J85-GE-5R (Moody AFB) | | | | | | |
| Idle | 525 | | 49.5 | | 55 | 83 |
| Intermediate | 1,045 | | 85.5 | | 808 | 86 |
| Military | 2,550 | | 99.7 | | 2,521 | 77 |
| Afterburner | 7,695 | | 99.8 | | 3,450 | 88 |
| T-38C with PMP Talon (Randolph AFB) | | | | | | |
| Engine | 1 | 2 | 1 | 2 | Not Recorded | |
| Idle | 520 | 520 | 50 | 49 | | |
| Intermediate | 980 | 1080 | 85 | 85 | | |
| Military | 2,200 | 2,240 | 100 | 100 | | |
| Afterburner | 7,695 | 7,695 | 100 | 100 | | |

APPENDIX A
EXAMPLE CALCULATIONS



EXAMPLE CALCULATIONS FOR POLLUTANT EMISSIONS

1. Volume of dry gas sampled corrected to standard conditions, ft³.

Note: Vm must be corrected for leakage if any leakage rates exceed La.

$$Vmstd = 17.647 \times Vm \times Y \left[\frac{Pbar + \frac{\Delta H}{13.6}}{TM, ^\circ R} \right]$$

2. Volume of water vapor at standard conditions, ft³.

$$Vwstd = 0.04707 \times Vlc$$

3. Moisture content in stack gas, dimensionless.

$$Bws = \frac{Vwstd}{Vwstd + Vmstd}$$

4. Dry molecular weight of stack gas, lb/lb-mole.

$$Md = 0.44 (\% \text{ CO}_2) + 0.32 (\% \text{ O}_2) + 0.28 (\% \text{ N}_2 + \% \text{ CO})$$

5. Molecular weight of stack gas, lb/lb-mole.

$$Ms = Md(1-Bws) + 18Bws$$

6. Stack velocity at stack conditions, f/s.

$$Vs = (85.49) (Cp) (avg \sqrt{\Delta P}) \sqrt{\frac{Ts, ^\circ R}{(Ps)(Ms)}}$$

7. Stack gas volumetric flow rate at stack conditions, cfm.

$$Qs = 60 \times Vs \times As$$

8. Dry stack gas volumetric flow rate at standard conditions, cfm.

$$Qsstd = (17.647) (Qs) \left(\frac{Ps}{Ts} \right) (1 - Bws)$$

EXAMPLE CALCULATIONS FOR POLLUTANT EMISSIONS (continued)

9. Concentration in gr/dscf.

$$C_s = (0.01543) \left(\frac{M_n}{V_{mstd}} \right)$$

10. Pollutant mass emission rate, lb/h.

$$\text{pmr, lb / hr} = \left(\frac{C_s}{7000} \right) \times Q_{sstd} \times 60$$

11. Pollutant mass emission rate, lb/MM Btu.

$$\text{pmr, lb / MM Btu} = \left(\frac{\text{pmr, lb/hr}}{\text{MM Btu/hr}} \right)$$

12. F-factor (F_d).

$$F_d = \frac{10^6 (3.64 \times \%H) + (1.53 \times \%C) + (0.57 \times \%S) + (0.14 \times \%N) - (0.46 \times \%O_2)}{GCV(\text{Btu/lb})}$$

13. F-factor, pollutant mass emission rate, lb/MM Btu (O₂-based).

$$= \frac{\text{lb / dscf} \times F \times 20.9}{(20.9 - \%O_2)}$$

14. Heat input, MM Btu/hr fuel.

$$= \frac{GVC(\text{Btu / lb}) * \text{Feed Rate}(\text{lb / hr})}{10^6}$$

15. Heat input, MM Btu/hr, F-factor.

$$= \frac{Q_{sstd}}{F_d} \times [(20.9 - \%O_2) + 20.9] \times 60$$



Environmental Quality Management, Inc.

NOMENCLATURE AND DIMENSIONS

- An = Cross-sectional area of sampling nozzle, sq.ft.
- As = Cross-sectional area of stack, sq.ft.
- Bws = Proportion by volume of water vapor in the gas stream, dimensionless
- Cp = Pitot tube coefficient, dimensionless
- Cs = Concentration of pollutant matter in stack gas – dry basis, grains per standard cubic foot (gr/dscf)
- % CO = Percent of carbon monoxide by volume, dry basis
- % CO₂ = Percent of carbon dioxide by volume, dry basis
- ▲H = Average pressure drop across the sampling meter flow orifice, inches of water (in.H₂O)
- GCV = Gross calorific value, Btu/lb
- I = Percent of isokinetic sampling
- La = Maximum acceptable leakage rate for either a pretest leak check or for a leak check following a component change; equal to 0.020 cubic foot per minute or 4% of the average sampling rate, whichever is less
- Md = Dry molecular weight, lb/lb-mole
- Mn = Total amount of pollutant matter collected, milligrams (mg)
- Ms = Molecular weight of stack gas (wet basis), lb/lb-mole
- % N₂ = Percent of nitrogen by volume, dry basis
- % O₂ = Percent of oxygen by volume, dry basis
- ▲P = Velocity head of stack gas, inches of water (in.H₂O)
- Pbar = Barometric pressure, inches of mercury (in.Hg)

NOMENCLATURE AND DIMENSIONS (continued)

- P_s = Absolute stack gas pressure, inches of mercury (in.Hg)
- P_{std} = Gas pressure at standard conditions, inches of mercury (29.92 in.Hg)
- p_{mr} = Pollutant matter emission rate, pounds per hour (lb/h)
- Q_s = Volumetric flow rate – wet basis at stack conditions, actual cubic feet per minute (acfm)
- Q_{std} = Volumetric flow rate – dry basis at standard conditions, dry standard cubic feet per minute (dscfm)
- T_m = Average temperature of dry gas meter, ER
- T_s = Average temperature of stack gas, ER
- T_{std} = Temperature at standard conditions, (528ER)
- V_{lc} = Total volume of liquid collected in impingers and silica gel, ml
- V_m = Volume of dry gas sampled at meter conditions, cu. ft.
- V_{mstd} = Volume of dry gas sampled at standard conditions, cu. ft.
- V_s = Average stack gas velocity at stack conditions, ft/s
- V_{wstd} = Volume of water vapor at standard conditions, scf
- Y = Dry gas meter calibration factor, dimensionless
- t = Total sampling time, minutes

NOTE: Standard condition = 68EF and 29.92 in. Hg

**CARBON BALANCE FLOW METHOD
EXAMPLE CALCULATIONS**

| | | | |
|-----------------|-----------|------------|---------|
| Client: | Moody AFB | Location: | Engine |
| Test Run No.: | 1 | Test Date: | 4/24/02 |
| Engine Type: | T38 | | |
| Test Condition: | Idle | | |

Inputs

| | | |
|--|-----|----------|
| Inlet Conc. CO ₂ , ppm | C2I | 0 |
| Inlet Conc. CO, ppm | CO1 | 0.00 |
| Inlet Conc. THC, ppmi | TC1 | 1.78 |
| Outlet Conc. THC, wet ppm | TCE | 179.8007 |
| Outlet Conc. O ₂ , dry percent | O2D | 19.96323 |
| Outlet Conc. CO ₂ , dry percent | C2D | 0.640847 |
| Outlet Conc. CO, dry ppm | COD | 688.5752 |
| Outlet Moisture, percent | BWE | 1.5 |
| Carbon Content of Fuel, wt fraction | FC | 0.8552 |
| Conversion Constant, percent/ppm | KC1 | 0.0001 |
| Conversion Constant, min/hour | KC2 | 0.016867 |
| Conversion Constant, dscm/dscf | KQM | 0.02831 |
| Mass rate Fuel Burn, lb/hr | MF | 525 |
| Inlet Moisture, percent | BWI | 1.5 |

Calculations

| | |
|---|---|
| Wet Mole Weight Exhaust, lb/lbmole | MWE = ((28)+(0.18*C2D)+(0.04*O2D)+(1-(BWE/100))+0.18*BWE) |
| | MWE = ((28)+(0.18*0.84)+(0.04*20.0))*(1-(1.5/100))+0.18*1.5 |
| | MWE = 28.73755 |
| Wet Mole Weight Inlet (Ambient), lb/lbmole | MWI = (28.84*(1-(BWI/100)))+(0.18*BWI) |
| | MWI = (28.84*(1-(1.5/100)))+(0.18*1.5) |
| | MWI = 28.6774 |
| Wet Conc. CO ₂ in Exhaust, wet % | C2E = C2D*(1-(BWE/100)) |
| | C2E = 0.64*(1-(1.5/100)) |
| | C2E = 0.631235 |
| Wet Conc. CO in Exhaust, wet % | COE = KC1*COD*(1-(BWE/100)) |
| | COE = 0.0001*689*(1-(1.5/100)) |
| | COE = 0.06881 |
| Weight Fraction Carbon in Exhaust | CE = (C2E+COE+(KC1*TCE))*12.01/MWE/100 |
| | CE = (0.631+0.0688+(0.0001*180))*12.01/28.74/100 |
| | CE = 0.003001 |
| Weight Fraction Carbon in Inlet | CI = KC1*(C2I+COI+TCI)*12.01/MWI/100 |
| | CI = 0.0001*(0+0+1.8)*12.01/28.68/100 |
| | CI = 7.47E-07 |
| Mass Rate Exhaust, lb/hr | ME = MF*(FC-CI)/(CE-CI) |
| | ME = 525*(0.8552-0.003)/(0.003-7.5E-07) |
| | ME = 149658.8 |
| Exhaust Wet Standard Flowrate, wscf/min | QCE _{1w} = KC2*ME*385.35/MWE |
| | QCE _{1w} = 0.016867*149,659*385.35/28.74 |
| | QCE _{1w} = 33447.62 |
| Exhaust Dry Standard Flowrate, dscf/min | QCE _{1d} = ((100-BWE)/100)*QCE _{1w} |
| | QCE _{1d} = ((100-1.5)/100)*33,448 |
| | QCE _{1d} = 32945.91 |
| Mass Rate Inlet, lb/hr | MI = MF*(FC-CE)/(CE-CI) |
| | MI = 525*(0.8552-0.003)/(0.003-7.5E-07) |
| | MI = 149133.8 |
| Inlet Wet Std. Vol. Flow, wscf/min | QCI _{1w} = KC2*MI*385.35/MWI |
| | QCI _{1w} = 0.016867*149,134*385.35/28.68 |
| | QCI _{1w} = 33400.2 |
| Inlet Dry Std. Vol. Flow, dscf/min | QCI _{1d} = ((100-BWI)/100)*QCI _{1w} |
| | QCI _{1d} = ((100-1.5)/100)*33,400 |
| | QCI _{1d} = 32898.2 |

**CARBON BALANCE FLOW METHOD
EXAMPLE CALCULATIONS**

| | | | |
|-----------------|-----------|------------|------------|
| Client: | Moody AFB | Location: | Slipstream |
| Test Run No.: | 1 | Test Date: | 4/24/02 |
| Engine Type: | T38 | | |
| Test Condition: | Idle | | |

Inputs

| | | |
|--|-----|----------|
| Inlet Conc. CO ₂ , ppm | C2I | 0 |
| Inlet Conc. CO, ppm | COI | 0 |
| Inlet Conc. THC, ppm | TCI | 1.783333 |
| Outlet Conc. THC, wet ppm | TCE | 41.36188 |
| Outlet Conc. O ₂ , dry percent | O2D | 20.69613 |
| Outlet Conc. CO ₂ , dry percent | C2D | 0.230523 |
| Outlet Conc. CO, dry ppm | COD | 212.1769 |
| Outlet Moisture, percent | BWE | 1.5 |
| Carbon Content of Fuel, wt fraction | FC | 0.8552 |
| Conversion Constant, percent/ppm | KC1 | 0.0001 |
| Conversion Constant, min/hour | KC2 | 0.016667 |
| Conversion Constant, dscm/dscf | KQM | 0.02831 |
| Mass rate Fuel Burn, lb/hr | MF | 525 |
| Inlet Moisture, percent | BWI | 1.5 |

Calculations

| | | |
|---|---------------------|--|
| Wet Mole. Weight Exhaust, lb/lbmole | MWE = | $\{(28)+(0.16 \cdot C2D)+(0.04 \cdot O2D)\}+(1-(BWE/100))+0.18 \cdot BW$ |
| | MWE = | 28.70176 |
| Wet Mole. Weight Inlet (Ambient), lb/lbmole | MWI = | $(28.84 \cdot (1-(BWI/100)))+(0.18 \cdot BWI)$ |
| | MWI = | 28.6774 |
| Wet Conc. CO ₂ in Exhaust, wet % | C2E = | $C2D \cdot (1-(BWE/100))$ |
| | C2E = | 0.227065 |
| Wet Conc. CO in Exhaust, wet % | COE = | $KC1 \cdot COD \cdot (1-(BWE/100))$ |
| | COE = | 0.020899 |
| Weight Fraction Carbon in Exhaust | CE = | $(C2E+COE+(KC1 \cdot TCE)) \cdot 12.01/MWE/100$ |
| | CE = | 0.001055 |
| Weight Fraction Carbon in Inlet | CI = | $KC1 \cdot (C2I+COI+TCI) \cdot 12.01/MWI/100$ |
| | CI = | 7.47E-07 |
| Mass Rate Exhaust, lb/hr | ME = | $MF \cdot (FC-CI)/(CE-CI)$ |
| | ME = | 425917.3 |
| Exhaust Wet Standard Flowrate, wscf/min | QCE _{1w} = | $KC2 \cdot ME \cdot 385.35/MWE$ |
| | QCE _{1w} = | 95308.05 |
| Exhaust Dry Standard Flowrate, dscf/min | QCE _{1d} = | $((100-BWE)/100) \cdot QCE_{1w}$ |
| | QCE _{1d} = | 93878.43 |
| Mass Rate Inlet, lb/hr | MI = | $MF \cdot (FC-CE)/(CE-CI)$ |
| | MI = | 425392.3 |
| Inlet Wet Std. Vol. Flow, wscf/min | QCI _{1w} = | $KC2 \cdot MI \cdot 385.35/MWI$ |
| | QCI _{1w} = | 95271.42 |
| Inlet Dry Std. Vol. Flow, dscf/min | QCI _{1d} = | $((100-BWI)/100) \cdot QCI_{1w}$ |
| | QCI _{1d} = | 93842.36 |

**CARBON BALANCE FLOW METHOD
EXAMPLE CALCULATIONS**

| | | | |
|-----------------|-----------|------------|---------|
| Client: | Moody AFB | Location: | Engine |
| Test Run No: | 2 | Test Date: | 4/24/02 |
| Engine Type: | T38 | | |
| Test Condition: | Idle | | |

Inputs

| | | |
|--|-----|----------|
| Inlet Conc. CO ₂ , ppm | C2I | 0.040126 |
| Inlet Conc. CO, ppm | COI | 0.00 |
| Inlet Conc. THC, ppm | TCI | -4.72 |
| Outlet Conc. THC, wet ppm | TCE | 155.5184 |
| Outlet Conc. O ₂ , dry percent | O2D | 19.91824 |
| Outlet Conc. CO ₂ , dry percent | C2D | 0.710671 |
| Outlet Conc. CO, dry ppm | COD | 691.9983 |
| Outlet Moisture, percent | BWE | 1.5 |
| Carbon Content of Fuel, wt fractio | FC | 0.8552 |
| Conversion Constant, percent/ppr | KC1 | 0.0001 |
| Conversion Constant, min/hour | KC2 | 0.016667 |
| Conversion Constant, dscm/dscf | KQM | 0.02831 |
| Mass rate Fuel Burn, lb/hr | MF | 525 |
| Inlet Moisture, percent | BWI | 1.5 |

Calculations

| | | |
|---|---------------------|--|
| Wet Mole Weight Exhaust, lb/lbmole | MWE = | $((28)+(0.16*C2D)+(0.04*O2D))+(1-(BWE/100))+0.18*BW$ |
| | MWE = | 28.74678 |
| Wet Mole Weight Inlet (Ambient), lb/lbmole | MWI = | $(28.84*(1-(BWI/100)))+(0.18*BWI)$ |
| | MWI = | 28.6774 |
| Wet Conc. CO ₂ in Exhaust, wet % | C2E = | $C2D*(1-(BWE/100))$ |
| | C2E = | 0.700011 |
| Wet Conc. CO in Exhaust, wet % | COE = | $KC1*COD*(1-(BWE/100))$ |
| | COE = | 0.068162 |
| Weight Fraction Carbon in Exhaust | CE = | $(C2E+COE+(KC1*TCE))*12.01/MWE/100$ |
| | CE = | 0.003274 |
| Weight Fraction Carbon in Inlet | CI = | $KC1*(C2I+COI+TCI)*12.01/MWI/100$ |
| | CI = | -2E-06 |
| Mass Rate Exhaust, lb/hr | ME = | $MF*(FC-CI)/(CE-CI)$ |
| | ME = | 137041.2 |
| Exhaust Wet Standard Flowrate, wscf/min | QCE _{1w} = | $KC2*ME*385.35/MWE$ |
| | QCE _{1w} = | 30617.85 |
| Exhaust Dry Standard Flowrate, dscf/min | QCE _{1d} = | $((100-BWE)/100)*QCE_{1w}$ |
| | QCE _{1d} = | 30158.58 |
| Mass Rate Inlet, lb/hr | MI = | $MF*(FC-CE)/(CE-CI)$ |
| | MI = | 136516.2 |
| Inlet Wet Std. Vol. Flow, wscf/min | QCI _{1w} = | $KC2*MI*385.35/MWI$ |
| | QCI _{1w} = | 30574.34 |
| Inlet Dry Std. Vol. Flow, dscf/min | QCI _{1d} = | $((100-BWI)/100)*QCI_{1w}$ |
| | QCI _{1d} = | 30115.73 |

**CARBON BALANCE FLOW METHOD
EXAMPLE CALCULATIONS**

| | | | |
|-----------------|-----------|------------|------------|
| Client: | Moody AFB | Location: | Slipstream |
| Test Run No.: | 2 | Test Date: | 4/24/02 |
| Engine Type: | T38 | | |
| Test Condition: | Idle | | |

Inputs

| | | |
|--|-----|----------|
| Inlet Conc. CO ₂ , ppm | C2I | 0.040126 |
| Inlet Conc. CO, ppm | COI | 0.00 |
| Inlet Conc. THC, ppm | TCI | -4.72 |
| Outlet Conc. THC, wet ppm | TCE | 35.56174 |
| Outlet Conc. O ₂ , dry percent | O2D | 20.65843 |
| Outlet Conc. CO ₂ , dry percent | C2D | 0.2309 |
| Outlet Conc. CO, dry ppm | COD | 186.8948 |
| Outlet Moisture, percent | BWE | 1.5 |
| Carbon Content of Fuel, wt fractio | FC | 0.8562 |
| Conversion Constant, percent/ppr | KC1 | 0.0001 |
| Conversion Constant, min/hour | KC2 | 0.016667 |
| Conversion Constant, dscm/dscf | KQM | 0.02831 |
| Mass rate Fuel Burn, lb/hr | MF | 525 |
| Inlet Moisture, percent | BWI | 1.5 |

Calculations

| | | |
|---|--------------------|--|
| Wet Mole. Weight Exhaust, lb/lbmole | MWE = | $((28)+(0.16*C2D)+(0.04*O2D))+(1-(BWE/100))+0.18*BW$ |
| | MWE = | 28.70033 |
| Wet Mole. Weight Inlet (Ambient), lb/lbmole | MWI = | $(28.84*(1-(BWI/100)))+(0.18*BWI)$ |
| | MWI = | 28.6774 |
| Wet Conc. CO ₂ In Exhaust, wet % | C2E = | $C2D*(1-(BWE/100))$ |
| | C2E = | 0.227436 |
| Wet Conc. CO In Exhaust, wet % | COE = | $KC1*COD*(1-(BWE/100))$ |
| | COE = | 0.018409 |
| Weight Fraction Carbon in Exhaust | CE = | $(C2E+COE+(KC1*TCE))*12.01/MWE/100$ |
| | CE = | 0.001044 |
| Weight Fraction Carbon in Inlet | CI = | $KC1*(C2I-COI+TCI)*12.01/MWI/100$ |
| | CI = | -2E-06 |
| Mass Rate Exhaust, lb/hr | ME = | $MF*(FC-CI)/(CE-CI)$ |
| | ME = | 429396.2 |
| Exhaust Wet Standard Flowrate, wscf/min | QCE _w = | $KC2*ME*385.35/MWE$ |
| | QCE _w = | 96091.3 |
| Exhaust Dry Standard Flowrate, dscf/min | QCE _d = | $((100-BWE)/100)*QCE_w$ |
| | QCE _d = | 94649.93 |
| Mass Rate Inlet, lb/hr | MI = | $MF*(FC-CE)/(CE-CI)$ |
| | MI = | 428871.2 |
| Inlet Wet Std. Vol. Flow, wscf/min | QCI _w = | $KC2*MI*385.35/MWI$ |
| | QCI _w = | 96050.56 |
| Inlet Dry Std. Vol. Flow, dscf/min | QCI _d = | $((100-BWI)/100)*QCI_w$ |
| | QCI _d = | 94609.8 |

**CARBON BALANCE FLOW METHOD
EXAMPLE CALCULATIONS**

| | | | |
|-----------------|-----------|------------|---------|
| Client: | Moody AFB | Location: | Engine |
| Test Run No.: | 3 | Test Date: | 4/24/02 |
| Engine Type: | T38 | | |
| Test Condition: | Idle | | |

Inputs

| | | |
|--|-----|----------|
| Inlet Conc. CO ₂ , ppm | C2I | 0.058618 |
| Inlet Conc. CO, ppm | CO1 | 0.10 |
| Inlet Conc. THC, ppm | TC1 | -9.91 |
| Outlet Conc. THC, wet ppm | TCE | 141.55 |
| Outlet Conc. O ₂ , dry percent | O2D | 19.91144 |
| Outlet Conc. CO ₂ , dry percent | C2D | 0.746357 |
| Outlet Conc. CO, dry ppm | COD | 688.438 |
| Outlet Moisture, percent | BWE | 1.5 |
| Carbon Content of Fuel, wt fraction | FC | 0.8552 |
| Conversion Constant, percent/ppm | KC1 | 0.0001 |
| Conversion Constant, min/hour | KC2 | 0.016667 |
| Conversion Constant, dscm/dscf | KQM | 0.02831 |
| Mass rate Fuel Burn, lb/hr | MF | 525 |
| Inlet Moisture, percent | BWI | 1.5 |

Calculations

| | | |
|---|---------------------|--|
| Wet Mole. Weight Exhaust, lb/lbmole | MWE = | $((28)+(0.16*C2D)+(0.04*O2D))+(1-(BWE/100))+0.18*BW$ |
| | MWE = | 28.75214 |
| Wet Mole. Weight Inlet (Ambient), lb/lbmole | MWI = | $(28.84*(1-(BWI/100)))+(0.18*BWI)$ |
| | MWI = | 28.6774 |
| Wet Conc. CO ₂ In Exhaust, wet % | C2E = | $C2D*(1-(BWE/100))$ |
| | C2E = | 0.735162 |
| Wet Conc. CO In Exhaust, wet % | COE = | $KC1*COD*(1-(BWE/100))$ |
| | COE = | 0.067811 |
| Weight Fraction Carbon In Exhaust | CE = | $(C2E+COE+(KC1*TCE))*12.01/MWE/100$ |
| | CE = | 0.003413 |
| Weight Fraction Carbon In Inlet | CI = | $KC1*(C2I+COI+TCI)*12.01/MWI/100$ |
| | CI = | -4.1E-06 |
| Mass Rate Exhaust, lb/hr | ME = | $MF*(FC-CI)/(CE-CI)$ |
| | ME = | 131385.2 |
| Exhaust Wet Standard Flowrate, wscf/min | QCE _{1w} = | $KC2*ME*385.35/MWE$ |
| | QCE _{1w} = | 29348.73 |
| Exhaust Dry Standard Flowrate, dscf/min | QCE _{1d} = | $((100-BWE)/100)*QCE1w$ |
| | QCE _{1d} = | 28908.5 |
| Mass Rate Inlet, lb/hr | MI = | $MF*(FC-CE)/(CE-CI)$ |
| | MI = | 130860.2 |
| Inlet Wet Std. Vol. Flow, wscf/min | QCI _{1w} = | $KC2*MI*385.35/MWI$ |
| | QCI _{1w} = | 29307.63 |
| Inlet Dry Std. Vol. Flow, dscf/min | QCI _{1d} = | $((100-BWI)/100)*QCI1w$ |
| | QCI _{1d} = | 28868.02 |

**CARBON BALANCE FLOW METHOD
EXAMPLE CALCULATIONS**

| | | | |
|-----------------|-----------|------------|------------|
| Client: | Moody AFB | Location: | Slipstream |
| Test Run No.: | 3 | Test Date: | 4/24/02 |
| Engine Type: | T38 | | |
| Test Condition: | Idle | | |

Inputs

| | | |
|--|-----|----------|
| Inlet Conc. CO ₂ , ppm | C2I | 0.058618 |
| Inlet Conc. CO, ppm | CO1 | 0.099488 |
| Inlet Conc. THC, ppm | TC1 | -9.91333 |
| Outlet Conc. THC, wet ppm | TCE | 28.30817 |
| Outlet Conc. O ₂ , dry percent | O2D | 20.41542 |
| Outlet Conc. CO ₂ , dry percent | C2D | 0.206798 |
| Outlet Conc. CO, dry ppm | COD | 166.6191 |
| Outlet Moisture, percent | BWE | 1.5 |
| Carbon Content of Fuel, wt fractio | FC | 0.8552 |
| Conversion Constant, percent/ppr | KC1 | 0.0001 |
| Conversion Constant, min/hour | KC2 | 0.016667 |
| Conversion Constant, dscm/dscf | KQM | 0.02831 |
| Mass rate Fuel Burn, lb/hr | MF | 525 |
| Inlet Moisture, percent | BWI | 1.5 |

Calculations

| | | |
|---|---------------------|--|
| Wet Mole. Weight Exhaust, lb/lbmole | MWE = | $((28)+(0.16*C2D)+(0.04*O2D))+(1-(BWE/100))+0.18*BW$ |
| | MWE = | 28.68696 |
| Wet Mole. Weight Inlet (Ambient), lb/lbmole | MWI = | $(28.84*(1-(BWI/100)))+(0.18*BWI)$ |
| | MWI = | 28.6774 |
| Wet Conc. CO ₂ in Exhaust, wet % | C2E = | $C2D*(1-(BWE/100))$ |
| | C2E = | 0.203696 |
| Wet Conc. CO in Exhaust, wet % | COE = | $KC1*COD*(1-(BWE/100))$ |
| | COE = | 0.016412 |
| Weight Fraction Carbon in Exhaust | CE = | $(C2E+COE+(KC1*TCE))*12.01/MWE/100$ |
| | CE = | 0.000933 |
| Weight Fraction Carbon in Inlet | CI = | $KC1*(C2I+COI+TCI)*12.01/MWI/100$ |
| | CI = | -4.1E-06 |
| Mass Rate Exhaust, lb/hr | ME = | $MF*(FC-CI)/(CE-CI)$ |
| | ME = | 478947.6 |
| Exhaust Wet Standard Flowrate, wscf/min | QCE _{1w} = | $KC2*ME*385.35/MWE$ |
| | QCE _{1w} = | 107230 |
| Exhaust Dry Standard Flowrate, dscf/min | QCE _{1d} = | $((100-BWE)/100)*QCE_{1w}$ |
| | QCE _{1d} = | 105621.5 |
| Mass Rate Inlet, lb/hr | MI = | $MF*(FC-CE)/(CE-CI)$ |
| | MI = | 478422.6 |
| Inlet Wet Std. Vol. Flow, wscf/min | QCI _{1w} = | $KC2*MI*385.35/MWI$ |
| | QCI _{1w} = | 107148.2 |
| Inlet Dry Std. Vol. Flow, dscf/min | QCI _{1d} = | $((100-BWI)/100)*QCI_{1w}$ |
| | QCI _{1d} = | 105540.9 |

F-FACTOR METHOD
EXAMPLE CALCULATIONS

Client: Mccoy AFB
Test Run No.: 1
Engine Type: T38
Test Condition: Idle

Location: Engine
Test Date: 4/24/02

| | | |
|--|------------------|-------------|
| Inputs | | |
| Outlet Conc. THC, wet ppm | TCE | 179.8007143 |
| Outlet Conc. O ₂ , dry percent | O ₂ D | 19.96323397 |
| Outlet Conc. CO ₂ , dry percent | C ₂ D | 0.840947449 |
| Outlet Conc. CO, dry ppm | COD | 698.5751987 |
| Outlet Moisture, percent | BWE | 2 |
| Carbon Content of Fuel, wt fraction | FC | 0.8552 |
| Hydrogen Content of Fuel, % by wt | FH | 14.18 |
| Sulfur Content of Fuel, % by wt | FS | 0.0498 |
| Nitrogen Content of Fuel, % by wt | FN | 0.0007 |
| Oxygen Content of Fuel, % by wt | FO | 0.2199 |
| | | |
| Conversion Constant, %/ppm | KC ₁ | 0.0001 |
| Calc. Constant min/hour | KC ₂ | 0.01666667 |
| | | |
| Mass rate Fuel Burn, LB/HR | MF | 525 |
| Inlet Moisture | BWI | 0.6335 |

| | | |
|---|-------|--|
| Calculations | | |
| F FACTOR FOR FUEL, scf/lb Fuel | FMD = | $(3.84 * FH) + (1.53 * FC * 100) + (0.57 * FS) + (0.14 * FN) - (0.46 * FO)$ |
| | FMD = | $(3.84 * 14.18) + (1.53 * 0.8552 * 100) + (0.57 * 0.0498) + (0.14 * 0.0007) - (0.46 * 0.2199)$ |
| | FMD = | 182.39 |
| | | |
| EXCESS AIR IN EXHAUST, dimensionless fraction | EAF = | $(O_{2D} - (0.00005 * COD)) / (20.9 - (O_{2D} - (0.00005 * COD)))$ |
| | EAF = | $(20.0 - (0.00005 * 699)) / (20.9 - (20.0 - (0.00005 * 699)))$ |
| | EAF = | 20.51 |
| | | |
| STOICHIOMETRIC AIR REQUIRED, scf/min | QS = | MF * FMD * KC ₂ |
| | QS = | 525 * 182.39 * 0.016667 |
| | QS = | 1,596 |
| | | |
| EXHAUST DRY STANDARD FLOWRATE, dscf/min | QFE = | QS * (1 + EAF) |
| | QFE = | 1,596 * (1 + 20.51) |
| | QFE = | 34,326 |
| | | |
| EXHAUST WET STANDARD FLOWRATE, wscf/min | QWE = | QFE / (1 - BWE / 100) |
| | QWE = | 34,326 / (1 - 2 / 100) |
| | QWE = | 35,026 |
| | | |
| NITROGEN IN EXHAUST, % dry basis | ND = | $100 * (O_{2D} + C_{2D} + (COD * KC_1) + (TCE * KC_1 * (1 - (BWE / 100))))$ |
| | ND = | $100 * (20.0 + 0.84 + (699 * 0.0001) + (180 * 0.0001 * (1 - (2 / 100))))$ |
| | ND = | 79.31 |
| | | |
| INLET DRY STANDARD VOLUMETRIC FLOW, dsct/min | QFI = | QFE * ((ND / 100) * (1 - (20.9 / 100))) |
| | QFI = | 34,326 * ((79.31 / 100) * (1 - (20.9 / 100))) |
| | QFI = | 34,416 |
| | | |
| INLET WET STANDARD VOLUMETRIC FLOW, wscf/min | QWI = | QFI / (1 - BWI / 100) |
| | QWI = | 34,416 / (1 - 0.6335 / 100) |
| | QWI = | 34,636 |

**F-FACTOR METHOD
EXAMPLE CALCULATIONS**

Client: **Moody AFB**
 Test Run No.: **1**
 Engine Type: **T38**
 Test Condition: **Idle**

Location: **Siprasam**
 Test Date: **4/24/02**

| | | |
|-------------------------------------|-----------------|-------------|
| Inputs | | |
| Outlet Conc. THC, wet ppm | TCE | 41.961575 |
| Outlet Conc. O2, dry percent | O2D | 20.99813061 |
| Outlet Conc. CO2, dry percent | C2D | 0.230523148 |
| Outlet Conc. CO, dry ppm | COD | 212.1768622 |
| Outlet Moisture, percent | BWE | 2 |
| Carbon Content of Fuel, wt fraction | FC | 0.8662 |
| Hydrogen Content of Fuel, % by wt | FH | 14.18 |
| Sulfur Content of Fuel, % by wt | FS | 0.0486 |
| Nitrogen Content of Fuel, % by wt | FN | 0.0007 |
| Oxygen Content of Fuel, % by wt | FO | 0.2199 |
| Conversion Constant, %/ppm | KC ₁ | 0.0001 |
| Calc. Constant min/hour | KC ₂ | 0.01668667 |
| Mass rate Fuel Burn, LB/Hr | MF | 625 |
| Inlet Moisture | BWI | 0.6336 |

| | | |
|---|--------------------|---|
| Calculations | | |
| F FACTOR FOR FUEL, sc/lb Fuel | FMD = | $(3.84*FH)+(1.53*FC*100)+(0.57*FS)+(0.14*FN)-(0.46*FO)$ |
| | FMD = | 182.39 |
| EXCESS AIR IN EXHAUST, dimensionless fraction | EAF = | $(O2D-(0.00005*COD))/(20.9-(O2D-(0.00005*COD)))$ |
| | EAF = | 96.46 |
| STOICHIOMETRIC AIR REQUIRED, sc/min | QS = | $MF*FMD*KC_2$ |
| | QS = | 1.686 |
| EXHAUST DRY STANDARD FLOWRATE, dsc/min | QFE ₁ = | $QS*(1+EAF)$ |
| | QFE ₁ = | 155.513 |
| EXHAUST WET STANDARD FLOWRATE, wsc/min | QWE ₁ = | $QFE_1*(1-BWE/100)$ |
| | QWE ₁ = | 152.687 |
| NITROGEN IN EXHAUST, % dry basis | ND = | $100-(O2D+C2D+(COD*KC_1)+(TCE*KC_1*(1-(BWE/100))))$ |
| | ND = | 79.05 |
| INLET DRY STANDARD VOLUMETRIC FLOW, dsc/min | QF ₁ = | $QFE_1*(ND/100)*(1-(20.9/100))$ |
| | QF ₁ = | 155.411 |
| INLET WET STANDARD VOLUMETRIC FLOW, wsc/min | QW ₁ = | $QF_1*(1-BWI/100)$ |
| | QW ₁ = | 156.402 |

**F-FACTOR METHOD
EXAMPLE CALCULATIONS**

Client: Moody AFB
 Test Run No.: 2
 Engine Type: T38
 Test Condition: Idle

Location: Engine
 Test Date: 4/24/02

Inputs

| | | |
|-------------------------------------|-----------------|----------|
| Outlet Conc. THC, wet ppm | TCE | 155.5164 |
| Outlet Conc. O2, dry percent | O2D | 19.91824 |
| Outlet Conc. CO2, dry percent | C2D | 0.710671 |
| Outlet Conc. CO, dry ppm | COD | 691.9983 |
| Outlet Moisture, percent | BWE | 2 |
| Carbon Content of Fuel, wt fraction | FC | 0.8552 |
| Hydrogen Content of Fuel, % by wt | FH | 14.18 |
| Sulfur Content of Fuel, % by wt | FS | 0.0498 |
| Nitrogen Content of Fuel, % by wt | FN | 0.0007 |
| Oxygen Content of Fuel, % by wt | FO | 0.2199 |
| | | |
| Conversion Constant, %/ppm | KC ₁ | 0.0001 |
| Calc. Constant min/hour | KC ₂ | 0.016667 |
| | | |
| Mass rate Fuel Burn, LB/HR | MF | 625 |
| Inlet Moisture | BWI | 0.6335 |

Calculations

| | | |
|---|--------------------|---|
| F FACTOR FOR FUEL, scf/lb Fuel | FMD = | $(3.64 * FH) + (1.53 * FC * 100) + (0.57 * FS) + (0.14 * FN) - (0.46 * FO)$ |
| | FMD = | 182.38 |
| | | |
| EXCESS AIR IN EXHAUST, dimensionless fraction | EAF = | $(O2D - (0.00005 * COD)) / (20.9 - (O2D - (0.00005 * COD)))$ |
| | EAF = | 19.58 |
| | | |
| STOICHIOMETRIC AIR REQUIRED, scf/min | QS = | $MF * FMD * KC_2$ |
| | QS = | 1,596 |
| | | |
| EXHAUST DRY STANDARD FLOWRATE, dscf/min | QFE ₁ = | $QS * (1 + EAF)$ |
| | QFE ₁ = | 32,817 |
| | | |
| EXHAUST WET STANDARD FLOWRATE, wscf/min | QWE ₁ = | $QFE_1 * (1 - BWE/100)$ |
| | QWE ₁ = | 33,487 |
| | | |
| NITROGEN IN EXHAUST, % dry basis | ND = | $100 - (O2D + C2D + (COD * KC_1) + (TCE * KC_1 * (1 - (BWE/100))))$ |
| | ND = | 79.29 |
| | | |
| INLET DRY STANDARD VOLUMETRIC FLOW, dscf/min | QFI ₁ = | $QFE_1 * ((ND/100) / (1 - (20.9/100)))$ |
| | QFI ₁ = | 32,895 |
| | | |
| INLET WET STANDARD VOLUMETRIC FLOW, wscf/min | QWI ₁ = | $QFI_1 * (1 - BWI/100)$ |
| | QWI ₁ = | 33,104 |

**F-FACTOR METHOD
EXAMPLE CALCULATIONS**

Client: **Moody AFB**
 Test Run No.: **2**
 Engine Type: **T38**
 Test Condition: **Idle**

Location: **Slipstream**
 Test Date: **4/24/02**

| | | |
|-------------------------------------|-----------------|------------|
| Inputs | | |
| Outlet Conc. THC, wet ppm | TCE | 35.5617981 |
| Outlet Conc. O2, dry percent | O2D | 20.6584326 |
| Outlet Conc. CO2, dry percent | C2D | 0.22069659 |
| Outlet Conc. CO, dry ppm | COD | 186.894804 |
| Outlet Moisture, percent | BWE | 2 |
| Carbon Content of Fuel, wt fraction | FC | 0.8552 |
| Hydrogen Content of Fuel, % by wt | FH | 14.18 |
| Sulfur Content of Fuel, % by wt | FS | 0.0486 |
| Nitrogen Content of Fuel, % by wt | FN | 0.0007 |
| Oxygen Content of Fuel, % by wt | FO | 0.2188 |
| Conversion Constant, %/ppm | KC ₁ | 0.0001 |
| Calc. Constant min/hour | KC ₂ | 0.01666667 |
| Mass rate Fuel Burn, LB/HR | MF | 625 |
| Inlet Moisture | BW1 | 0.6335 |

| | | |
|---|--------------------|---|
| Calculations | | |
| F FACTOR FOR FUEL, acf/lb Fuel | FMD = | $(3.64 * FH) + (1.53 * FC * 100) + (0.57 * FS) + (0.14 * FN) - (0.48 * FO)$ |
| | FMD = | 182.59 |
| EXCESS AIR IN EXHAUST, dimensionless fraction | EAF = | $(O2D - (0.00005 * COD)) / (20.9 - (O2D - (0.00005 * COD)))$ |
| | EAF = | 82.30 |
| STOICHIOMETRIC AIR REQUIRED, acf/min | QS = | $MF * FMD * KC_1$ |
| | QS = | 1,586 |
| EXHAUST DRY STANDARD FLOWRATE, dscf/min | QFE ₁ = | $QS * (1 + EAF)$ |
| | QFE ₁ = | 132,832 |
| EXHAUST WET STANDARD FLOWRATE, wscf/min | QWE ₁ = | $QFE_1 / (1 - BWE/100)$ |
| | QWE ₁ = | 136,645 |
| NITROGEN IN EXHAUST, % dry basis | ND = | $100 * (O2D + C2D + (COD * KC_1) + (TCE * KC_1 * (1 - (BWE/100))))$ |
| | ND = | 79.09 |
| INLET DRY STANDARD VOLUMETRIC FLOW, dscf/min | QFI ₁ = | $QFE_1 * ((ND/100) / (1 - (20.9/100)))$ |
| | QFI ₁ = | 132,912 |
| INLET WET STANDARD VOLUMETRIC FLOW, wscf/min | QWI ₁ = | $QFI_1 / (1 - BW1/100)$ |
| | QWI ₁ = | 133,780 |

**F-FACTOR METHOD
EXAMPLE CALCULATIONS**

Client: Moody AFB
 Test Run No.: 3
 Engine Type: T38
 Test Condition: Idle

Location: Engine
 Test Date: 4/24/02

Inputs

| | | |
|--|------------------|----------|
| Outlet Conc. THC, wet ppm | TCE | 141.55 |
| Outlet Conc. O ₂ , dry percent | O ₂ D | 19.91144 |
| Outlet Conc. CO ₂ , dry percent | C ₂ D | 0.746357 |
| Outlet Conc. CO, dry ppm | COD | 898.438 |
| Outlet Moisture, percent | BWE | 2 |
| Carbon Content of Fuel, wt fraction | FC | 0.8552 |
| Hydrogen Content of Fuel, % by wt | FH | 14.18 |
| Sulfur Content of Fuel, % by wt | FS | 0.0486 |
| Nitrogen Content of Fuel, % by wt | FN | 0.0007 |
| Oxygen Content of Fuel, % by wt | FO | 0.2199 |
| Conversion Constant, %/ppm | KC ₁ | 0.0001 |
| Calc. Constant min/hour | KC ₂ | 0.018667 |
| Mass rate Fuel Burn, LB/HR | MF | 525 |
| Inlet Moisture | BWI | 0.6335 |

Calculations

| | | |
|---|--------------------|---|
| F FACTOR FOR FUEL, scf/lb Fuel | FMD = | $(3.64 \cdot FH) + (1.53 \cdot FC \cdot 100) + (0.57 \cdot FS) + (0.14 \cdot FN) - (0.46 \cdot FO)$ |
| | FMD = | 182.38 |
| EXCESS AIR IN EXHAUST, dimensionless fraction | EAF = | $(O_2D - (0.00005 \cdot COD)) / (20.9 - (O_2D - (0.00005 \cdot COD)))$ |
| | EAF = | 19.43 |
| STOICHIOMETRIC AIR REQUIRED, scf/min | QS = | $MF \cdot FMD \cdot KC_2$ |
| | QS = | 1.596 |
| EXHAUST DRY STANDARD FLOWRATE, dsd/min | QFE ₁ = | $QS \cdot (1 + EAF)$ |
| | QFE ₁ = | 32.805 |
| EXHAUST WET STANDARD FLOWRATE, wscf/min | QWE ₁ = | $QFE_1 / (1 - BWE/100)$ |
| | QWE ₁ = | 33.270 |
| NITROGEN IN EXHAUST, % dry basis | ND = | $100 \cdot (O_2D + C_2D + (COD \cdot KC_1) + (TCE \cdot KC_1 \cdot (1 - (BWE/100))))$ |
| | ND = | 79.26 |
| INLET DRY STANDARD VOLUMETRIC FLOW, dsd/min | QFI ₁ = | $QFE_1 \cdot ((ND/100) / (1 - (20.9/100)))$ |
| | QFI ₁ = | 32.671 |
| INLET WET STANDARD VOLUMETRIC FLOW, wscf/min | QWI ₁ = | $QFI_1 / (1 - BWI/100)$ |
| | QWI ₁ = | 32.679 |

**F-FACTOR METHOD
EXAMPLE CALCULATIONS**

Client: Moody AFB
 Test Run No.: 3
 Engine Type: T38
 Test Condition: Idle

Location: Stipstream
 Test Date: 4/24/02

Inputs

| | | |
|--|------------------|-------------|
| Outlet Conc. THC, wet ppm | TCE | 28.30816667 |
| Outlet Conc. O ₂ , dry percent | O ₂ D | 20.41541637 |
| Outlet Conc. CO ₂ , dry percent | C ₂ D | 0.206798018 |
| Outlet Conc. CO, dry ppm | CO _D | 188.8190633 |
| Outlet Moisture, percent | BWE | 2 |
| Carbon Content of Fuel, wt fraction | FC | 0.8552 |
| Hydrogen Content of Fuel, % by wt | FH | 14.18 |
| Sulfur Content of Fuel, % by wt | FS | 0.0496 |
| Nitrogen Content of Fuel, % by wt | FN | 0.0007 |
| Oxygen Content of Fuel, % by wt | FO | 0.2189 |
| Conversion Constant, %/ppm | KC ₁ | 0.0001 |
| Calc. Constant min/hour | KC ₂ | 0.018666667 |
| Mass rate Fuel Burn, LB/HR | MF | 525 |
| Inlet Moisture | BWI | 0.6335 |

Calculations

| | | |
|--|--------------------|---|
| F FACTOR FOR FUEL, scf/lb Fuel | FMD = | $(3.64 \cdot FH) + (1.53 \cdot FC \cdot 100) + (0.57 \cdot FS) + (0.14 \cdot FN) - (0.46 \cdot FO)$ |
| | FMD = | 182.39 |
| EXCESS AIR IN EXHAUST, dimensionless fraction | EAF = | $(O_2D - (0.00005 \cdot CO_2D)) / (20.9 - (O_2D - (0.00005 \cdot CO_2D)))$ |
| | EAF = | 41.40 |
| STOICHIOMETRIC AIR REQUIRED, scf/min | QS = | $MF \cdot FMD \cdot KC_2$ |
| | QS = | 1,598 |
| EXHAUST DRY STANDARD FLOWRATE, dscf/min | QFE _d = | $QS \cdot (1 + EAF)$ |
| | QFE _d = | 67,568 |
| EXHAUST WET STANDARD FLOWRATE, wscf/min | QWE _d = | $QFE_d / (1 - BWE/100)$ |
| | QWE _d = | 69,049 |
| NITROGEN IN EXHAUST, % dry basis | ND = | $100 \cdot (O_2D + C_2D + (CO_2D \cdot KC_1) + (TCE \cdot KC_1 \cdot (1 - (BWE/100))))$ |
| | ND = | 79.36 |
| INLET DRY STANDARD VOLUMETRIC FLOW, dscf/min | QFI _d = | $QFE_d \cdot ((ND/100) / (1 - (20.9/100)))$ |
| | QFI _d = | 67,889 |
| INLET WET STANDARD VOLUMETRIC FLOW, wscf/min | QWI _d = | $QFI_d / (1 - BWI/100)$ |
| | QWI _d = | 68,322 |

Summary of Stack Gas Parameters and Test Results

030197.0002.5

Moody AFB - Valdosta, Georgia

US EPA Test Method 5 - Particulate Matter

Slipstream - T38 Idle

Page 1 of 2

| RUN NUMBER | M5-ID-1 | M5-ID-2 | M5-ID-3 | M5-ID-Comp | Average | |
|------------------------|---|----------------|----------------|-------------------|----------------|----------|
| RUN DATE | 04/24/2002 | 04/24/2002 | 04/24/2002 | 04/24/2002 | | |
| RUN TIME | 0751-1052 | 1110-1413 | 1455-1757 | 0751-1653 | | |
| MEASURED DATA | | | | | | |
| P_{static} | Stack Static Pressure, inches H ₂ O | 0.00 | 0.00 | 0.00 | 0.00 | |
| y | Meter Box Correction Factor | 1.001 | 1.001 | 1.001 | 1.006 | |
| P_{bar} | Barometric Pressure, inches Hg | 30.70 | 30.70 | 30.70 | 30.70 | |
| V_m | Sample Volume, ft ³ | 114.002 | 131.350 | 134.675 | 308.945 | 172.243 |
| $Dp^{1/2}$ | Average Square Root Dp, (in. H ₂ O) ^{1/2} | 0.0190 | 0.0224 | 0.0224 | 0.0212 | 0.0213 |
| DH | Avg Meter Orifice Pressure, in. H ₂ O | 1.23 | 1.69 | 1.70 | 0.95 | 1.39 |
| T_m | Average Meter Temperature, °F | 77 | 91 | 101 | 89 | 90 |
| T_s | Average Stack Temperature, °F | 130 | 148 | 150 | 139 | 142 |
| V_{ic} | Condensate Collected, ml | 36.5 | 35.5 | 38.1 | 95.1 | 51.3 |
| CO ₂ | Carbon Dioxide content, % by volume | 0.0 | 0.0 | 0.0 | 0.0 | 0.0 |
| O ₂ | Oxygen content, % by volume | 21.0 | 21.0 | 21.0 | 21.0 | 21.0 |
| N ₂ | Nitrogen content, % by volume | 79.0 | 79.0 | 79.0 | 79.0 | 79.0 |
| C_p | Pitot Tube Coefficient | 0.84 | 0.84 | 0.84 | 0.84 | 0.84 |
| | Circular Stack? 1=Y,0=N: | 0 | 0 | 0 | 0 | |
| A_s | Diameter or Dimensions, inches: | 576.00 | 576.00 | 576.00 | 576.00 | 576.00 |
| Q | Sample Run Duration, minutes | 180 | 180 | 180 | 540 | 270 |
| D_n | Nozzle Diameter, inches | 1.370 | 1.370 | 1.370 | 1.230 | 1.335 |
| CALCULATED DATA | | | | | | |
| A_n | Nozzle Area, ft ² | 0.010236 | 0.010236 | 0.010236 | 0.008251 | 0.009740 |
| $V_{m(Std)}$ | Standard Meter Volume, ft ³ | 115.422 | 129.749 | 130.665 | 311.859 | 171.924 |
| $V_{m(Std)}$ | Standard Meter Volume, m ³ | 3.268 | 3.674 | 3.700 | 8.831 | 4.868 |
| Q_m | Average Sampling Rate, dscfm | 0.641 | 0.721 | 0.726 | 0.578 | 0.666 |
| P_s | Stack Pressure, inches Hg | 30.70 | 30.70 | 30.70 | 30.70 | 30.70 |
| B_{ws} | Moisture, % by volume | 1.5 | 1.3 | 1.4 | 1.4 | 1.4 |
| $B_{ws(Std)}$ | Moisture (at saturation), % by volume | 14.7 | 23.4 | 24.6 | 18.6 | 20.3 |
| V_{wStd} | Standard Water Vapor Volume, ft ³ | 1.718 | 1.671 | 1.793 | 4.476 | 2.415 |
| 1- B_{ws} | Dry Mole Fraction | 0.985 | 0.987 | 0.986 | 0.986 | 0.986 |
| M_d | Molecular Weight (d.b.), lb/lb-mole | 28.84 | 28.84 | 28.84 | 28.84 | 28.84 |
| M_s | Molecular Weight (w.b.), lb/lb-mole | 28.68 | 28.70 | 28.89 | 28.69 | 28.69 |
| V_s | Stack Gas Velocity, ft/s | 1.1 | 1.3 | 1.3 | 1.3 | 1.3 |
| A | Stack Area, ft ² | 4.0 | 4.0 | 4.0 | 4.0 | 4.00 |
| Q_a | Stack Gas Volumetric flow, acfm | 268 | 321 | 321 | 301 | 303 |
| Q_s | Stack Gas Volumetric flow, dscfm | 118,704 | 118,704 | 118,704 | 118,704 | 118,704 |
| Q_b | Stack Gas Volumetric flow, dscmm | 3,361 | 3,361 | 3,361 | 3,361 | 3,361 |
| I | Isokinetic Sampling Ratio, % | 103.4 | 99.9 | 100.8 | 104.3 | 102.1 |

Summary of Stack Gas Parameters and Test Results

030197.0002.5

Moody AFB - Valdosta, Georgia

US EPA Test Method 5 - Particulate Matter

Slipstream - T38 Idle

Page 2 of 2

| RUN NUMBER | M5-ID-1 | M5-ID-2 | M5-ID-3 | M5-ID-Comp | | |
|---------------------------------|--------------------------------|----------------|----------------|-------------------|----------------|----------|
| RUN DATE | 04/24/2002 | 04/24/2002 | 04/24/2002 | 04/24/2002 | Average | |
| RUN TIME | 0751-1052 | 1110-1413 | 1455-1757 | 0751-1653 | | |
| EMISSIONS DATA | | | | | | |
| <u>Particulate Matter</u> | | | | | | |
| PM | Filter Weight Gain, mg | 4.7 | 2.35 | 4.45 | 8.2 | |
| PM | Beaker Weight Gain, mg | 7.1 | 4.75 | 6 | 6.3 | |
| PM | Total Catch, g | 0.0118 | 0.0071 | 0.0105 | 0.0145 | 0.0110 |
| CPM | Concentration, gr/dscf | 1.58E-03 | 8.44E-04 | 1.23E-03 | 7.18E-04 | 1.09E-03 |
| CPM | Concentration, lb/dscf | 2.25E-07 | 1.21E-07 | 1.76E-07 | 1.03E-07 | 1.56E-07 |
| EPM | Emission Rate, lb/hr | 1.61E+00 | 8.59E-01 | 1.26E+00 | 7.30E-01 | 1.11E+00 |
| EPM | Emission Rate, lb/1000 lb Fuel | 3.06E+00 | 1.64E+00 | 2.39E+00 | 1.39E+00 | 2.12E+00 |
| <u>Condensible Matter</u> | | | | | | |
| PM | Organic Gain, mg | | | | | |
| PM | Aqueous Gain, mg | 23.6 | 19.5 | 18.4 | 49.9 | |
| PM | Total Catch, g | 0.0236 | 0.0195 | 0.0184 | 0.0499 | 0.0279 |
| CPM | Concentration, gr/dscf | 3.16E-03 | 2.32E-03 | 2.17E-03 | 2.47E-03 | 2.53E-03 |
| CPM | Concentration, lb/dscf | 4.51E-07 | 3.31E-07 | 3.10E-07 | 3.53E-07 | 3.61E-07 |
| EPM | Emission Rate, lb/hr | 3.21E+00 | 2.36E+00 | 2.21E+00 | 2.51E+00 | 2.57E+00 |
| EPM | Emission Rate, lb/1000 lb Fuel | 6.12E+00 | 4.49E+00 | 4.21E+00 | 4.79E+00 | 4.90E+00 |
| <u>Total Particulate Matter</u> | | | | | | |
| PM | Total Catch, g | 3.54E-02 | 2.66E-02 | 2.89E-02 | 6.44E-02 | 3.88E-02 |
| CPM | Concentration, gr/dscf | 4.73E-03 | 3.16E-03 | 3.41E-03 | 3.19E-03 | 3.62E-03 |
| CPM | Concentration, lb/dscf | 6.76E-07 | 4.52E-07 | 4.87E-07 | 4.55E-07 | 5.18E-07 |
| EPM | Emission Rate, lb/hr | 4.82E+00 | 3.22E+00 | 3.47E+00 | 3.24E+00 | 3.69E+00 |
| EPM | Emission Rate, lb/1000 lb Fuel | 9.17E+00 | 6.13E+00 | 6.60E+00 | 6.18E+00 | 7.02E+00 |
| F | Fuel Flow, lb/hr | 525.000 | 525.000 | 525.000 | 525.000 | |

Summary of Stack Gas Parameters and Test Results

030197.0002.5

Moody AFB - Valdosta, Georgia

US EPA Test Method 5 - Particulate Matter

Slipstream - T38 Intermediate

Page 1 of 2

| RUN NUMBER | M5-INT-1 | M5-INT-2 | M5-INT-3 | M5-INT-Comp | | |
|------------------------|---|-------------------|-------------------|--------------------|----------------|----------|
| RUN DATE | 04/25/2002 | 04/25/2002 | 04/25/2002 | 04/25/2002 | Average | |
| RUN TIME | 0830-1030 | 1105-1205 | 1230-1430 | 0830-1434 | | |
| MEASURED DATA | | | | | | |
| P _{static} | Stack Static Pressure, Inches H ₂ O | 0.00 | 0.00 | 0.00 | 0.00 | 0.00 |
| y | Meter Box Correction Factor | 1.001 | 1.001 | 1.001 | 1.021 | 1.006 |
| P _{bar} | Barometric Pressure, inches Hg | 30.70 | 30.70 | 30.70 | 30.70 | 30.70 |
| V _m | Sample Volume, ft ³ | 118.244 | 56.792 | 120.297 | 347.322 | 160.664 |
| Dp ^{1/2} | Average Square Root Dp, (in. H ₂ O) ^{1/2} | 0.1000 | 0.1000 | 0.1000 | 0.1000 | 0.1000 |
| DH | Avg Meter Orifice Pressure, in. H ₂ O | 3.10 | 3.10 | 3.10 | 2.90 | 3.05 |
| T _m | Average Meter Temperature, °F | 88 | 97 | 102 | 101 | 97 |
| T _s | Average Stack Temperature, °F | 121 | 126 | 130 | 125 | 126 |
| V _{lc} | Condensate Collected, ml | 54.5 | 21.9 | 41.3 | 131.5 | 62.3 |
| CO ₂ | Carbon Dioxide content, % by volume | 0.0 | 0.0 | 0.0 | 0.0 | 0.0 |
| O ₂ | Oxygen content, % by volume | 21.0 | 21.0 | 21.0 | 21.0 | 21.0 |
| N ₂ | Nitrogen content, % by volume | 79.0 | 79.0 | 79.0 | 79.0 | 79.0 |
| C _p | Pitot Tube Coefficient | 0.84 | 0.84 | 0.84 | 0.84 | 0.84 |
| | Circular Stack? 1=Y,0=N: | 0 | 0 | 0 | 0 | |
| As | Diameter or Dimensions, inches: | 576.00 | 576.00 | 576.00 | 576.00 | 576.00 |
| Q | Sample Run Duration, minutes | 120 | 60 | 120 | 360 | 165 |
| D _n | Nozzle Diameter, inches | 0.750 | 0.750 | 0.750 | 0.745 | 0.749 |
| CALCULATED DATA | | | | | | |
| A _n | Nozzle Area, ft ² | 0.003068 | 0.003068 | 0.003068 | 0.003027 | 0.003058 |
| V _{m(std)} | Standard Meter Volume, ft ³ | 117.837 | 55.682 | 116.897 | 344.698 | 168.778 |
| V _{m(std)} | Standard Meter Volume, m ³ | 3.337 | 1.577 | 3.310 | 9.761 | 4.496 |
| Q _m | Average Sampling Rate, dscfm | 0.982 | 0.928 | 0.974 | 0.957 | 0.960 |
| P _s | Stack Pressure, inches Hg | 30.70 | 30.70 | 30.70 | 30.70 | 30.70 |
| B _{ws} | Moisture, % by volume | 2.1 | 1.8 | 1.6 | 1.8 | 1.8 |
| B _{ws(std)} | Moisture (at saturation), % by volume | 11.5 | 13.2 | 14.7 | 12.9 | 13.1 |
| V _{wstd} | Standard Water Vapor Volume, ft ³ | 2.565 | 1.031 | 1.944 | 6.190 | 2.932 |
| 1-B _{wstd} | Dry Mole Fraction | 0.979 | 0.982 | 0.984 | 0.982 | 0.982 |
| M _d | Molecular Weight (d.b.), lb/lb-mole | 28.84 | 28.84 | 28.84 | 28.84 | 28.84 |
| M _s | Molecular Weight (w.b.), lb/lb-mole | 28.61 | 28.64 | 28.66 | 28.65 | 28.64 |
| V _s | Stack Gas Velocity, ft/s | 5.8 | 5.9 | 5.9 | 5.9 | 5.9 |
| A | Stack Area, ft ² | 4.0 | 4.0 | 4.0 | 4.0 | 4.00 |
| Q _s | Stack Gas Volumetric flow, acfm | 1,402 | 1,407 | 1,411 | 1,406 | 1,406 |
| Q _s | Stack Gas Volumetric flow, dscfm | 293,150 | 293,150 | 293,150 | 293,150 | 293,150 |
| Q _s | Stack Gas Volumetric flow, dscmm | 8,301 | 8,301 | 8,301 | 8,301 | 8,301 |
| I | Isokinetic Sampling Ratio, % | 100.1 | 94.8 | 99.7 | 99.0 | 98.4 |

Summary of Stack Gas Parameters and Test Results

030197.0002.5

Moody AFB - Valdosta, Georgia

US EPA Test Method 5 - Particulate Matter

Slipstream - T38 Intermediate

Page 2 of 2

| RUN NUMBER | M5-INT-1 | M5-INT-2 | M5-INT-3 | M5-INT-Comp | | |
|---------------------------------|--------------------------------|-----------------|-----------------|--------------------|----------------|----------|
| RUN DATE | 04/25/2002 | 04/25/2002 | 04/25/2002 | 04/25/2002 | Average | |
| RUN TIME | 0830-1030 | 1105-1205 | 1230-1430 | 0830-1434 | | |
| EMISSIONS DATA | | | | | | |
| <u>Particulate Matter</u> | | | | | | |
| PM | Filter Weight Gain, mg | 2.75 | 0.35 | 2.2 | 5.25 | |
| PM | Beaker Weight Gain, mg | 8 | 4.25 | 7.2 | 6.25 | |
| PM | Total Catch, g | 0.0108 | 0.0046 | 0.0094 | 0.0115 | 0.0091 |
| C _{PM} | Concentration, gr/dscf | 1.41E-03 | 1.27E-03 | 1.24E-03 | 5.15E-04 | 1.11E-03 |
| C _{PM} | Concentration, lb/dscf | 2.01E-07 | 1.82E-07 | 1.77E-07 | 7.36E-08 | 1.59E-07 |
| E _{PM} | Emission Rate, lb/hr | 3.54E+00 | 3.20E+00 | 3.12E+00 | 1.29E+00 | 2.79E+00 |
| E _{PM} | Emission Rate, lb/1000 lb fuel | 3.39E+00 | 3.07E+00 | 2.98E+00 | 1.24E+00 | 2.67E+00 |
| <u>Condensible Matter</u> | | | | | | |
| PM | Organic Gain, mg | | | | | |
| PM | Aqueous Gain, mg | 23.7 | 20.9 | 31.3 | 66.5 | |
| PM | Total Catch, g | 0.0237 | 0.0209 | 0.0313 | 0.0665 | 0.0356 |
| C _{PM} | Concentration, gr/dscf | 3.10E-03 | 5.79E-03 | 4.13E-03 | 2.98E-03 | 4.00E-03 |
| C _{PM} | Concentration, lb/dscf | 4.43E-07 | 8.27E-07 | 5.90E-07 | 4.25E-07 | 5.72E-07 |
| E _{PM} | Emission Rate, lb/hr | 7.80E+00 | 1.46E+01 | 1.04E+01 | 7.48E+00 | 1.01E+01 |
| E _{PM} | Emission Rate, lb/1000 lb fuel | 7.46E+00 | 1.39E+01 | 9.94E+00 | 7.16E+00 | 9.62E+00 |
| <u>Total Particulate Matter</u> | | | | | | |
| PM | Total Catch, g | 3.45E-02 | 2.55E-02 | 4.07E-02 | 7.80E-02 | 4.47E-02 |
| C _{PM} | Concentration, gr/dscf | 4.51E-03 | 7.07E-03 | 5.37E-03 | 3.49E-03 | 5.11E-03 |
| C _{PM} | Concentration, lb/dscf | 6.45E-07 | 1.01E-06 | 7.68E-07 | 4.99E-07 | 7.30E-07 |
| E _{PM} | Emission Rate, lb/hr | 1.13E+01 | 1.78E+01 | 1.35E+01 | 8.77E+00 | 1.28E+01 |
| E _{PM} | Emission Rate, lb/1000 lb fuel | 1.08E+01 | 1.70E+01 | 1.29E+01 | 8.40E+00 | 1.23E+01 |
| F | Fuel Flow, lb/hr | 1045 | 1045 | 1045 | 1045 | |

Summary of Stack Gas Parameters and Test Results

030197.0002.5

Moody AFB - Valdosta, Georgia

US EPA Test Method 5 - Particulate Matter

Slipstream - T38 Military

Page 1 of 2

| <i>RUN NUMBER</i> | <i>M5-MIL-1</i> | <i>M5-MIL-2</i> | <i>M5-MIL-3</i> | <i>M5-MIL-Comp</i> | <i>Average</i> |
|------------------------|---|-----------------|-----------------|--------------------|----------------|
| <i>RUN DATE</i> | 04/26/2002 | 04/26/2002 | 04/26/2002 | 04/26/2002 | |
| <i>RUN TIME</i> | 0753-1008 | 1033-1159 | 1222-1450 | 0753-1450 | |
| MEASURED DATA | | | | | |
| P _{static} | Stack Static Pressure, inches H ₂ O | 0.00 | 0.00 | 0.00 | 0.00 |
| y | Meter Box Correction Factor | 1.001 | 1.001 | 1.001 | 1.006 |
| P _{bar} | Barometric Pressure, inches Hg | 30.72 | 30.72 | 30.72 | 30.72 |
| V _m | Sample Volume, ft ³ | 82.937 | 52.751 | 63.251 | 234.937 |
| Dp ^{1/2} | Average Square Root Dp, (in. H ₂ O) ^{1/2} | 0.2236 | 0.2236 | 0.2236 | 0.2236 |
| DH | Avg Meter Orifice Pressure, in. H ₂ O | 1.50 | 1.50 | 1.50 | 1.50 |
| T _m | Average Meter Temperature, °F | 74 | 81 | 87 | 81 |
| T _s | Average Stack Temperature, °F | 130 | 138 | 142 | 137 |
| V _{lc} | Condensate Collected, ml | 15.9 | 8.1 | 20.5 | 61.2 |
| CO ₂ | Carbon Dioxide content, % by volume | 0.0 | 0.0 | 0.0 | 0.0 |
| O ₂ | Oxygen content, % by volume | 21.0 | 21.0 | 21.0 | 21.0 |
| N ₂ | Nitrogen content, % by volume | 79.0 | 79.0 | 79.0 | 79.0 |
| C _p | Pitot Tube Coefficient | 0.84 | 0.84 | 0.84 | 0.84 |
| | Circular Stack? 1=Y,0=N: | 0 | 0 | 0 | 0 |
| AS | Diameter or Dimensions, inches: | 576.00 | 576.00 | 576.00 | 576.00 |
| Q | Sample Run Duration, minutes | 120 | 80 | 90 | 330 |
| D _n | Nozzle Diameter, inches | 0.420 | 0.420 | 0.420 | 0.430 |
| CALCULATED DATA | | | | | |
| A _n | Nozzle Area, ft ² | 0.000962 | 0.000962 | 0.000962 | 0.001008 |
| V _{m(Std)} | Standard Meter Volume, ft ³ | 84.551 | 53.082 | 62.949 | 240.245 |
| V _{m(Std)} | Standard Meter Volume, m ³ | 2.394 | 1.503 | 1.783 | 6.803 |
| Q _m | Average Sampling Rate, dscfm | 0.705 | 0.664 | 0.699 | 0.728 |
| P _s | Stack Pressure, inches Hg | 30.72 | 30.72 | 30.72 | 30.72 |
| B _{ws} | Moisture, % by volume | 0.9 | 0.7 | 1.5 | 1.2 |
| B _{ws(sat)} | Moisture (at saturation), % by volume | 14.7 | 18.1 | 20.1 | 17.7 |
| V _{wStd} | Standard Water Vapor Volume, ft ³ | 0.748 | 0.381 | 0.965 | 2.881 |
| 1-B _{ws} | Dry Mole Fraction | 0.991 | 0.993 | 0.985 | 0.988 |
| M _d | Molecular Weight (d.b.), lb/lb-mole | 28.84 | 28.84 | 28.84 | 28.84 |
| M _s | Molecular Weight (w.b.), lb/lb-mole | 28.74 | 28.76 | 28.68 | 28.71 |
| V _s | Stack Gas Velocity, ft/s | 13.1 | 13.2 | 13.3 | 13.2 |
| A | Stack Area, ft ² | 4.0 | 4.0 | 4.0 | 4.0 |
| Q _s | Stack Gas Volumetric flow, acfm | 3,150 | 3,170 | 3,186 | 3,170 |
| Q _s | Stack Gas Volumetric flow, dscfm | 544,313 | 544,313 | 544,313 | 544,313 |
| Q _s | Stack Gas Volumetric flow, dscmm | 15,413 | 15,413 | 15,413 | 15,413 |
| I | Isokinetic Sampling Ratio, % | 102.2 | 96.7 | 103.0 | 101.6 |

Summary of Stack Gas Parameters and Test Results

030197.0002.5

Moody AFB - Valdosta, Georgia

US EPA Test Method 5 - Particulate Matter

Slipstream - T38 Military

Page 2 of 2

| RUN NUMBER | M5-MIL-1 | M5-MIL-2 | M5-MIL-3 | M5-MIL-Comp | | |
|---------------------------------|--------------------------------|-----------------|-----------------|--------------------|----------------|----------|
| RUN DATE | 04/26/2002 | 04/26/2002 | 04/26/2002 | 04/26/2002 | Average | |
| RUN TIME | 0753-1008 | 1033-1159 | 1222-1450 | 0753-1450 | | |
| EMISSIONS DATA | | | | | | |
| <u>Particulate Matter</u> | | | | | | |
| PM | Filter Weight Gain, mg | 3.45 | 1.05 | 2.6 | 8.65 | |
| PM | Beaker Weight Gain, mg | 7.25 | 5.7 | 4.55 | 6.6 | |
| PM | Total Catch, g | 0.0107 | 0.0068 | 0.0072 | 0.0153 | 0.0100 |
| C _{PM} | Concentration, gr/dscf | 1.95E-03 | 1.96E-03 | 1.75E-03 | 9.80E-04 | 1.66E-03 |
| C _{PM} | Concentration, lb/dscf | 2.79E-07 | 2.80E-07 | 2.50E-07 | 1.40E-07 | 2.37E-07 |
| E _{PM} | Emission Rate, lb/hr | 9.11E+00 | 9.16E+00 | 8.18E+00 | 4.57E+00 | 7.75E+00 |
| E _{PM} | Emission Rate, lb/1000 lb fuel | 3.57E+00 | 3.59E+00 | 3.21E+00 | 1.79E+00 | 3.04E+00 |
| <u>Condensable Matter</u> | | | | | | |
| PM | Organic Gain, mg | | | | | |
| PM | Aqueous Gain, mg | 7.4 | 0 | 0 | 20.3 | |
| PM | Total Catch, g | 0.0074 | 0.0000 | 0.0000 | 0.0203 | 0.0069 |
| C _{PM} | Concentration, gr/dscf | 1.35E-03 | 0.00E+00 | 0.00E+00 | 1.30E-03 | 6.64E-04 |
| C _{PM} | Concentration, lb/dscf | 1.93E-07 | 0.00E+00 | 0.00E+00 | 1.86E-07 | 9.48E-08 |
| E _{PM} | Emission Rate, lb/hr | 6.30E+00 | 0.00E+00 | 0.00E+00 | 6.08E+00 | 3.10E+00 |
| E _{PM} | Emission Rate, lb/1000 lb fuel | 2.47E+00 | 0.00E+00 | 0.00E+00 | 2.39E+00 | 1.21E+00 |
| <u>Total Particulate Matter</u> | | | | | | |
| PM | Total Catch, g | 1.81E-02 | 6.75E-03 | 7.15E-03 | 3.56E-02 | 1.69E-02 |
| C _{PM} | Concentration, gr/dscf | 3.30E-03 | 1.96E-03 | 1.75E-03 | 2.28E-03 | 2.33E-03 |
| C _{PM} | Concentration, lb/dscf | 4.72E-07 | 2.80E-07 | 2.50E-07 | 3.26E-07 | 3.32E-07 |
| E _{PM} | Emission Rate, lb/hr | 1.54E+01 | 9.16E+00 | 8.18E+00 | 1.07E+01 | 1.09E+01 |
| E _{PM} | Emission Rate, lb/1000 lb fuel | 6.04E+00 | 3.59E+00 | 3.21E+00 | 4.18E+00 | 4.25E+00 |
| F | Fuel Flow, lb/hr | 2550 | 2550 | 2550 | 2550 | |

Summary of Stack Gas Parameters and Test Results

030197.0002.5

Moody AFB - Valdosta, Georgia

Test Method 0011 - Aldehyde/Ketones

Slipstream - T38 - All Conditions

Page 1 of 3

| <i>RUN NUMBER</i> | | <i>0011-ID</i> | <i>0011-INT</i> | <i>0011-MIL</i> | |
|--------------------------|---|--------------------------|--------------------------|--------------------------|-----------------------|
| <i>RUN DATE</i> | | <i>04/24/2002</i> | <i>04/25/2002</i> | <i>04/26/2002</i> | <i>Average</i> |
| <i>RUN TIME</i> | | <i>0751-1154</i> | <i>0830-1433</i> | <i>0753-1450</i> | |
| MEASURED DATA | | | | | |
| P _{static} | Stack Static Pressure, inches H ₂ O | 0.00 | 0.00 | 0.00 | 0.00 |
| y | Meter Box Correction Factor | 1.000 | 1.000 | 1.000 | 1.000 |
| P _{bar} | Barometric Pressure, inches Hg | 30.70 | 30.70 | 30.72 | 30.71 |
| V _m | Sample Volume, ft ³ | 171.250 | 163.722 | 236.070 | 190.347 |
| Dp ^{1/2} | Average Square Root Dp, (in. H ₂ O) ^{1/2} | 0.0198 | 0.1000 | 0.2236 | 0.1145 |
| DH | Avg Meter Orifice Pressure, in. H ₂ O | 1.60 | 0.56 | 1.60 | 1.25 |
| T _m | Average Meter Temperature, °F | 83 | 97 | 84 | 88 |
| T _s | Average Stack Temperature, °F | 126 | 125 | 134 | 128 |
| V _{ic} | Condensate Collected, ml | 58.8 | 70.9 | 68.9 | 66.2 |
| CO ₂ | Carbon Dioxide content, % by volume | 0.0 | 0.0 | 0.0 | 0.0 |
| O ₂ | Oxygen content, % by volume | 21.0 | 21.0 | 21.0 | 21.0 |
| N ₂ | Nitrogen content, % by volume | 79.0 | 79.0 | 79.0 | 79.0 |
| C _p | Pitot Tube Coefficient | 0.84 | 0.84 | 0.84 | 0.84 |
| | Circular Stack? 1=Y,0=N: | 0 | 0 | 0 | |
| A _s | Diameter or Dimensions, inches: | 576.00 | 576.00 | 576.00 | 576.00 |
| F | Fuel Flow, lb/hr | 525 | 1045 | 2550 | |
| Q | Sample Run Duration, minutes | 240 | 360 | 330 | 310 |
| D _n | Nozzle Diameter, inches | 1.450 | 0.495 | 0.435 | 0.793 |
| CALCULATED DATA | | | | | |
| A _n | Nozzle Area, ft ² | 0.011467 | 0.001336 | 0.001032 | 0.004612 |
| V _{m(std)} | Standard Meter Volume, ft ³ | 171.447 | 159.394 | 236.060 | 188.967 |
| V _{m(std)} | Standard Meter Volume, m ³ | 4.855 | 4.514 | 6.684 | 5.351 |
| Q _m | Average Sampling Rate, dscfm | 0.714 | 0.443 | 0.715 | 0.624 |
| P _s | Stack Pressure, inches Hg | 30.70 | 30.70 | 30.72 | 30.71 |
| B _{ws} | Moisture, % by volume | 1.6 | 2.1 | 1.4 | 1.7 |
| B _{ws(sat)} | Moisture (at saturation), % by volume | 13.2 | 12.9 | 16.3 | 14.1 |
| V _{wsld} | Standard Water Vapor Volume, ft ³ | 2.768 | 3.337 | 3.243 | 3.116 |
| 1-B _{ws} | Dry Mole Fraction | 0.984 | 0.979 | 0.986 | 0.983 |
| M _d | Molecular Weight (d.b.), lb/lb•mole | 28.84 | 28.84 | 28.84 | 28.84 |
| M _s | Molecular Weight (w.b.), lb/lb•mole | 28.67 | 28.62 | 28.69 | 28.66 |
| V _s | Stack Gas Velocity, ft/s | 1.2 | 5.9 | 13.2 | 6.7 |
| A | Stack Area, ft ² | 4.0 | 4.0 | 4.0 | 4.00 |
| Q _a | Stack Gas Volumetric flow, acfm | 279 | 1,406 | 3,164 | 1,616 |
| Q _s | Stack Gas Volumetric flow, dscfm | 118,704 | 293,150 | 544,313 | 318,722 |
| Q _s | Stack Gas Volumetric flow, dscmm | 3,361 | 8,301 | 15,413 | 9,025 |
| I | Isokinetic Sampling Ratio, % | 98.2 | 103.9 | 97.4 | 99.9 |

Summary of Stack Gas Parameters and Test Results

030197.0002.5

Moody AFB - Valdosta, Georgia

Test Method 0011 - Aldehyde/Keytones

Slipstream - T38 - All Conditions

Page 2 of 3

| <i>RUN NUMBER</i> | <i>0011-ID</i> | <i>0011-JNT</i> | <i>0011-MIL</i> | |
|---|---|-------------------|-------------------|----------------|
| <i>RUN DATE</i> | <i>04/24/2002</i> | <i>04/25/2002</i> | <i>04/26/2002</i> | <i>Average</i> |
| <i>RUN TIME</i> | <i>0751-1450</i> | <i>0830-1433</i> | <i>0753-1450</i> | |
| EMISSIONS DATA | | | | |
| HCHO | <u>Formaldehyde</u> | | | |
| Target Catch, µg | 13000.0 | 1500.0 | 200.0 | 4900.0 |
| Concentration, µg/dscm | 2677.75 | 332.33 | 29.92 | 1013.33 |
| Emission Rate, lb/hr | 1.188 | 0.364 | 0.061 | 0.538 |
| Emission Rate, lb/1000 lb fuel | 2.26E+00 | 3.48E-01 | 2.39E-02 | 8.78E-01 |
| CH₃CHO | <u>Acetaldehyde</u> | | | |
| Target Catch, µg | 1400.0 | 83.0 | 13.0 | 498.7 |
| Concentration, µg/dscm | 288.37 | 18.39 | 1.94 | 102.90 |
| Emission Rate, lb/hr | 0.128 | 0.020 | 0.004 | 0.051 |
| Emission Rate, lb/1000 lb fuel | 2.44E-01 | 1.93E-02 | 1.55E-03 | 8.82E-02 |
| CH₂CHCHO | <u>Acrolein</u> | | | |
| Target Catch, µg | 1800.00 | 55.00 | 11.00 | 622.00 |
| Concentration, µg/dscm | 370.77 | 12.19 | 1.65 | 128.20 |
| Emission Rate, lb/hr | 0.165 | 0.013 | 0.003 | 0.0604 |
| Emission Rate, lb/1000 lb fuel | 3.13E-01 | 1.28E-02 | 1.31E-03 | 1.09E-01 |
| CH₃CH₂CH₂OH | <u>Propanol</u> | | | |
| Target Catch, µg | 450.0 | 55.0 | 11.0 | 172.0 |
| Concentration, µg/dscm | 92.7 | 12.2 | 1.6 | 35.5 |
| Emission Rate, lb/hr | 0.041 | 0.013 | 0.003 | 0.019 |
| Emission Rate, lb/1000 lb fuel | 7.83E-02 | 1.28E-02 | 1.31E-03 | 3.08E-02 |
| CH₃CHCHCHO | <u>Crotonaldehyde</u> | | | |
| Target Catch, µg | 680.00 | 55.0 | 11.00 | 248.67 |
| Concentration, µg/dscm | 140.07 | 12.19 | 1.65 | 51.30 |
| Emission Rate, lb/hr | 0.062 | 0.013 | 0.003 | 0.0263 |
| Emission Rate, lb/1000 lb fuel | 1.18E-01 | 1.28E-02 | 1.31E-03 | 4.42E-02 |
| CH₃COC₅H₁₁ | <u>Methyl Ethyl Ketone/Butyraldehydes</u> | | | |
| Target Catch, µg | 450.0 | 55.0 | 11.0 | 172.0 |
| Concentration, µg/dscm | 92.7 | 12.2 | 1.65 | 35.5 |
| Emission Rate, lb/hr | 0.041 | 0.013 | 0.003 | 0.019 |
| Emission Rate, lb/1000 lb fuel | 7.83E-02 | 1.28E-02 | 1.31E-03 | 3.08E-02 |
| C₆H₅CHO | <u>Benzaldehyde</u> | | | |
| Target Catch, µg | 450.0 | 55.0 | 11.0 | 172.0 |
| Concentration, µg/dscm | 92.7 | 12.2 | 1.65 | 35.5 |
| Emission Rate, lb/hr | 0.041 | 0.013 | 0.003 | 0.019 |
| Emission Rate, lb/1000 lb fuel | 7.83E-02 | 1.28E-02 | 1.31E-03 | 3.08E-02 |
| CH₃)₂CHCH₂CHC | <u>Isopentanal</u> | | | |
| Target Catch, µg | 450.0 | 55.0 | 11.0 | 172.0 |
| Concentration, µg/dscm | 92.7 | 12.2 | 1.65 | 35.5 |
| Emission Rate, lb/hr | 0.041 | 0.013 | 0.003 | 0.019 |
| Emission Rate, lb/1000 lb fuel | 7.83E-02 | 1.28E-02 | 1.31E-03 | 3.08E-02 |

Summary of Stack Gas Parameters and Test Results

030197.0002.5

Moody AFB - Valdosta, Georgia

Test Method 0011 - Aldehyde/Keytones

Slipstream - T38 - All Conditions

Page 3 of 3

| <i>RUN NUMBER</i> | <i>0011-ID</i> | <i>0011-INT</i> | <i>0011-MIL</i> | |
|---|-----------------------|-------------------|-------------------|----------------|
| <i>RUN DATE</i> | <i>04/24/2002</i> | <i>04/25/2002</i> | <i>04/26/2002</i> | <i>Average</i> |
| <i>RUN TIME</i> | <i>0751-1154</i> | <i>0830-1433</i> | <i>0753-1450</i> | |
| EMISSIONS DATA - Continued | | | | |
| $\text{CH}_3(\text{CH}_2)_3\text{CHO}$ | <u>Pentanal</u> | | | |
| Target Catch, μg | 1400.0 | 55.0 | 11.0 | 488.7 |
| Concentration, $\mu\text{g}/\text{dscm}$ | 288.4 | 12.2 | 1.6 | 100.7 |
| Emission Rate, lb/hr | 0.128 | 0.013 | 0.003 | 0.048 |
| Emission Rate, lb/1000 lb fuel | 2.44E-01 | 1.28E-02 | 1.31E-03 | 8.59E-02 |
| $\text{C}_6\text{H}_4\text{CH}_3\text{CHO}$ | <u>o-Tolualdehyde</u> | | | |
| Target Catch, μg | 540.0 | 55 | 11.0 | 202.0 |
| Concentration, $\mu\text{g}/\text{dscm}$ | 111.2 | 12.2 | 1.6 | 41.7 |
| Emission Rate, lb/hr | 0.049 | 0.013 | 0.003 | 0.022 |
| Emission Rate, lb/1000 lb fuel | 9.40E-02 | 1.28E-02 | 1.31E-03 | 3.60E-02 |
| $\text{CH}_3(\text{CH}_2)_4\text{CHO}$ | <u>Hexanal</u> | | | |
| Target Catch, μg | 450.0 | 55 | 11.0 | 172 |
| Concentration, $\mu\text{g}/\text{dscm}$ | 92.7 | 12.2 | 1.6 | 35.5 |
| Emission Rate, lb/hr | 0.041 | 0.013 | 0.003 | 0.02 |
| Emission Rate, lb/1000 lb fuel | 7.83E-02 | 1.28E-02 | 1.31E-03 | 3.08E-02 |

Run #0011-ID had a Rpt. Limit of 450

Run #0011-INT had a Rpt. Limit of 55

Run #0011-MIL had a Rpt. Limit of 11

Summary of Stack Gas Parameters and Test Results

030197.0002.5

Moody AFB - Valdosta, Georgia

PAH

Slipstream - T38 - All Conditions

Page 1 of 4

| <i>RUN NUMBER</i> | <i>PAH-ID</i> | <i>PAH-INT</i> | <i>PAH-MIL</i> | | |
|------------------------|---|-------------------|-------------------|----------------|----------|
| <i>RUN DATE</i> | <i>04/24/2002</i> | <i>04/25/2002</i> | <i>04/26/2002</i> | <i>Average</i> | |
| <i>RUN TIME</i> | <i>0856-1156</i> | <i>0833-1440</i> | <i>0753-1447</i> | | |
| MEASURED DATA | | | | | |
| P _{static} | Stack Static Pressure, inches H ₂ O | 0.00 | 0.00 | 0.00 | 0.00 |
| y | Meter Box Correction Factor | 1.038 | 1.038 | 1.038 | 1.038 |
| P _{bar} | Barometric Pressure, inches Hg | 30.70 | 30.70 | 30.72 | 30.71 |
| V _m | Sample Volume, L ³ | 180.130 | 353.980 | 332.250 | 288.787 |
| Dp ^{1/2} | Average Square Root Dp, (in. H ₂ O) ^{1/2} | 0.0207 | 0.1000 | 0.2236 | 0.1148 |
| T _m | Average Meter Temperature, °F | 84 | 94 | 80 | 86 |
| T _s | Average Stack Temperature, °F | 139 | 126 | 137 | 134 |
| CO ₂ | Carbon Dioxide content, % by volume | 0.0 | 0.0 | 0.0 | 0.0 |
| O ₂ | Oxygen content, % by volume | 21.0 | 21.0 | 21.0 | 21.0 |
| N ₂ | Nitrogen content, % by volume | 79.0 | 79.0 | 79.0 | 79.0 |
| C _p | Pitot Tube Coefficient | 0.84 | 0.84 | 0.84 | 0.84 |
| | Circular Stack? 1=Y,0=N: | 0 | 0 | 0 | |
| As | Diameter or Dimensions, inches: | 576.00 | 576.00 | 576.00 | 576.00 |
| F | Fuel Flow, lb/hr | 525.00 | 1045.00 | 2550.00 | |
| Q | Sample Run Duration, minutes | 180 | 360 | 325 | 288 |
| CALCULATED DATA | | | | | |
| V _{m(std)} | Standard Meter Volume, L ³ | 186.134 | 359.177 | 346.093 | 297.135 |
| V _{m(std)} | Standard Meter Volume, ft ³ | 6.573 | 12.683 | 12.221 | 10.492 |
| P _s | Stack Pressure, inches Hg | 30.70 | 30.70 | 30.72 | 30.71 |
| B _{ws} | Moisture, % by volume | 1.4 | 1.9 | 1.1 | 1.5 |
| 1-B _{ws} | Dry Mole Fraction | 0.986 | 0.981 | 0.989 | 0.985 |
| M _d | Molecular Weight (d.b.), lb/lb•mole | 28.84 | 28.84 | 28.84 | 28.84 |
| M _s | Molecular Weight (w.b.), lb/lb•mole | 28.69 | 28.63 | 28.72 | 28.68 |
| V _s | Stack Gas Velocity, ft/s | 1.2 | 5.9 | 13.2 | 6.8 |
| A | Stack Area, ft ² | 4.0 | 4.0 | 4.0 | 4.00 |
| Q _a | Stack Gas Volumetric flow, acfm | 294 | 1,407 | 3,170 | 1,624 |
| Q _s | Stack Gas Volumetric flow, dscfm | 118,704 | 293,150 | 544,313 | 318,722 |
| Q _s | Stack Gas Volumetric flow, dscmm | 3,361 | 8,301 | 15,413 | 9,025 |
| Napthalene | | | | | |
| | Analysis, ug/sample | 18.0 | 2.0 | 2.0 | 7.3 |
| | Molecular Weight, MW | 128.2 | 128.2 | 128.2 | 128.2 |
| | Concentration, lb/dscf | 6.03E-09 | 3.47E-10 | 3.60E-10 | 0.0 |
| ppmdv | Parts Per Million, Wet Basis | 1.81E-02 | 1.04E-03 | 1.08E-03 | 6.74E-03 |
| | Parts Per Million, Dry Basis | 1.84E-02 | 1.06E-03 | 1.09E-03 | 6.84E-03 |
| | Emission Rate, lb/hr | 4.35E-02 | 6.22E-03 | 1.19E-02 | 2.05E-02 |
| | Emission Rate, lb/1000 lb fuel | 8.29E-02 | 5.95E-03 | 4.66E-03 | 3.12E-02 |

| | | | | | |
|-------|--------------------------------|----------|----------|----------|----------|
| | 2-Methylnapthalene | | | | |
| | Analysis, ug/sample | 28.0 | 2.0 | 2.0 | 10.7 |
| | Molecular Weight, MW | 142.2 | 142.2 | 142.2 | 142.2 |
| | Concentration, lb/dscf | 9.37E-09 | 3.47E-10 | 3.60E-10 | 0.0 |
| ppmdv | Parts Per Million, Dry Basis | 2.54E-02 | 9.40E-04 | 9.76E-04 | 9.10E-03 |
| | Parts Per Million, Dry Basis | 2.58E-02 | 9.58E-04 | 9.86E-04 | 9.23E-03 |
| | Emission Rate, lb/hr | 6.77E-02 | 6.22E-03 | 1.19E-02 | 2.86E-02 |
| | Emission Rate, lb/1000 lb fuel | 1.29E-01 | 5.95E-03 | 4.66E-03 | 4.65E-02 |
| | 2-Chloronapthalene | | | | |
| | Analysis, ug/sample | 2.0 | 2.0 | 2.0 | 2.0 |
| | Molecular Weight, MW | 162.6 | 162.6 | 162.6 | 162.6 |
| | Concentration, lb/dscf | 6.69E-10 | 3.47E-10 | 3.60E-10 | 0.0 |
| ppmdv | Parts Per Million, Wet Basis | 1.59E-03 | 8.22E-04 | 8.53E-04 | 1.09E-03 |
| | Parts Per Million, Dry Basis | 1.61E-03 | 8.38E-04 | 8.63E-04 | 1.10E-03 |
| | Emission Rate, lb/hr | 4.84E-03 | 6.22E-03 | 1.19E-02 | 7.65E-03 |
| | Emission Rate, lb/1000 lb fuel | 9.21E-03 | 5.95E-03 | 4.66E-03 | 6.61E-03 |
| | Acenaphthene | | | | |
| | Analysis, ug/sample | 2.0 | 2.0 | 2.0 | 2.0 |
| | Molecular Weight, MW | 154.2 | 154.2 | 154.2 | 154.2 |
| | Concentration, lb/dscf | 6.69E-10 | 3.47E-10 | 3.60E-10 | 0.0 |
| ppmdv | Parts Per Million, Dry Basis | 1.67E-03 | 8.67E-04 | 9.00E-04 | 1.15E-03 |
| | Parts Per Million, Dry Basis | 1.70E-03 | 8.84E-04 | 9.10E-04 | 1.16E-03 |
| | Emission Rate, lb/hr | 4.84E-03 | 6.22E-03 | 1.19E-02 | 7.65E-03 |
| | Emission Rate, lb/1000 lb fuel | 9.21E-03 | 5.95E-03 | 4.66E-03 | 6.61E-03 |
| | Acenaphthylene | | | | |
| | Analysis, ug/sample | 2.0 | 2.0 | 2.0 | 2.0 |
| | Molecular Weight, MW | 152.2 | 152.2 | 152.2 | 152.2 |
| | Concentration, lb/dscf | 6.69E-10 | 3.47E-10 | 3.60E-10 | 0.0 |
| ppmdv | Parts Per Million, Wet Basis | 1.69E-03 | 8.78E-04 | 9.11E-04 | 1.16E-03 |
| | Parts Per Million, Dry Basis | 1.72E-03 | 8.95E-04 | 9.22E-04 | 1.18E-03 |
| | Emission Rate, lb/hr | 4.84E-03 | 6.22E-03 | 1.19E-02 | 7.65E-03 |
| | Emission Rate, lb/1000 lb fuel | 9.21E-03 | 5.95E-03 | 4.66E-03 | 6.61E-03 |
| | Fluorene | | | | |
| | Analysis, ug/sample | 2.0 | 2.0 | 2.0 | 2.0 |
| | Molecular Weight, MW | 166.2 | 166.2 | 166.2 | 166.2 |
| | Concentration, lb/dscf | 6.69E-10 | 3.47E-10 | 3.60E-10 | 0.0 |
| ppmdv | Parts Per Million, Dry Basis | 1.55E-03 | 8.04E-04 | 8.35E-04 | 1.06E-03 |
| | Parts Per Million, Dry Basis | 1.57E-03 | 8.20E-04 | 8.44E-04 | 1.08E-03 |
| | Emission Rate, lb/hr | 4.84E-03 | 6.22E-03 | 1.19E-02 | 7.65E-03 |
| | Emission Rate, lb/1000 lb fuel | 9.21E-03 | 5.95E-03 | 4.66E-03 | 6.61E-03 |
| | Phenanthrene | | | | |
| | Analysis, ug/sample | 2.0 | 2.0 | 2.0 | 2.0 |
| | Molecular Weight, MW | 178.0 | 178.0 | 178.0 | 178.0 |
| | Concentration, lb/dscf | 6.69E-10 | 3.47E-10 | 3.60E-10 | 0.0 |
| ppmdv | Parts Per Million, Dry Basis | 1.45E-03 | 7.51E-04 | 7.79E-04 | 9.93E-04 |
| | Parts Per Million, Dry Basis | 1.47E-03 | 7.66E-04 | 7.88E-04 | 1.01E-03 |
| | Emission Rate, lb/hr | 4.84E-03 | 6.22E-03 | 1.19E-02 | 7.65E-03 |
| | Emission Rate, lb/1000 lb fuel | 9.21E-03 | 5.95E-03 | 4.66E-03 | 6.61E-03 |

| | | | | | |
|-------|--------------------------------|----------|----------|----------|----------|
| | 2-Methylnapthalene | | | | |
| | Analysis, ug/sample | 28.0 | 2.0 | 2.0 | 10.7 |
| | Molecular Weight, MW | 142.2 | 142.2 | 142.2 | 142.2 |
| | Concentration, lb/dscf | 9.37E-09 | 3.47E-10 | 3.60E-10 | 0.0 |
| ppmdv | Parts Per Million, Dry Basis | 2.54E-02 | 9.40E-04 | 9.76E-04 | 9.10E-03 |
| | Parts Per Million, Dry Basis | 2.58E-02 | 9.58E-04 | 9.86E-04 | 9.23E-03 |
| | Emission Rate, lb/hr | 6.77E-02 | 6.22E-03 | 1.19E-02 | 2.86E-02 |
| | Emission Rate, lb/1000 lb fuel | 1.29E-01 | 5.95E-03 | 4.66E-03 | 4.65E-02 |
| | 2-Chloronapthalene | | | | |
| | Analysis, ug/sample | 2.0 | 2.0 | 2.0 | 2.0 |
| | Molecular Weight, MW | 162.6 | 162.6 | 162.6 | 162.6 |
| | Concentration, lb/dscf | 6.69E-10 | 3.47E-10 | 3.60E-10 | 0.0 |
| ppmdv | Parts Per Million, Wet Basis | 1.59E-03 | 8.22E-04 | 8.53E-04 | 1.09E-03 |
| | Parts Per Million, Dry Basis | 1.61E-03 | 8.38E-04 | 8.63E-04 | 1.10E-03 |
| | Emission Rate, lb/hr | 4.84E-03 | 6.22E-03 | 1.19E-02 | 7.65E-03 |
| | Emission Rate, lb/1000 lb fuel | 9.21E-03 | 5.95E-03 | 4.66E-03 | 6.61E-03 |
| | Acenaphthene | | | | |
| | Analysis, ug/sample | 2.0 | 2.0 | 2.0 | 2.0 |
| | Molecular Weight, MW | 154.2 | 154.2 | 154.2 | 154.2 |
| | Concentration, lb/dscf | 6.69E-10 | 3.47E-10 | 3.60E-10 | 0.0 |
| ppmdv | Parts Per Million, Dry Basis | 1.67E-03 | 8.67E-04 | 9.00E-04 | 1.15E-03 |
| | Parts Per Million, Dry Basis | 1.70E-03 | 8.84E-04 | 9.10E-04 | 1.16E-03 |
| | Emission Rate, lb/hr | 4.84E-03 | 6.22E-03 | 1.19E-02 | 7.65E-03 |
| | Emission Rate, lb/1000 lb fuel | 9.21E-03 | 5.95E-03 | 4.66E-03 | 6.61E-03 |
| | Acenaphthylene | | | | |
| | Analysis, ug/sample | 2.0 | 2.0 | 2.0 | 2.0 |
| | Molecular Weight, MW | 152.2 | 152.2 | 152.2 | 152.2 |
| | Concentration, lb/dscf | 6.69E-10 | 3.47E-10 | 3.60E-10 | 0.0 |
| ppmdv | Parts Per Million, Wet Basis | 1.69E-03 | 8.78E-04 | 9.11E-04 | 1.16E-03 |
| | Parts Per Million, Dry Basis | 1.72E-03 | 8.95E-04 | 9.22E-04 | 1.18E-03 |
| | Emission Rate, lb/hr | 4.84E-03 | 6.22E-03 | 1.19E-02 | 7.65E-03 |
| | Emission Rate, lb/1000 lb fuel | 9.21E-03 | 5.95E-03 | 4.66E-03 | 6.61E-03 |
| | Fluorene | | | | |
| | Analysis, ug/sample | 2.0 | 2.0 | 2.0 | 2.0 |
| | Molecular Weight, MW | 166.2 | 166.2 | 166.2 | 166.2 |
| | Concentration, lb/dscf | 6.69E-10 | 3.47E-10 | 3.60E-10 | 0.0 |
| ppmdv | Parts Per Million, Dry Basis | 1.55E-03 | 8.04E-04 | 8.35E-04 | 1.06E-03 |
| | Parts Per Million, Dry Basis | 1.57E-03 | 8.20E-04 | 8.44E-04 | 1.08E-03 |
| | Emission Rate, lb/hr | 4.84E-03 | 6.22E-03 | 1.19E-02 | 7.65E-03 |
| | Emission Rate, lb/1000 lb fuel | 9.21E-03 | 5.95E-03 | 4.66E-03 | 6.61E-03 |
| | Phenanthrene | | | | |
| | Analysis, ug/sample | 2.0 | 2.0 | 2.0 | 2.0 |
| | Molecular Weight, MW | 178.0 | 178.0 | 178.0 | 178.0 |
| | Concentration, lb/dscf | 6.69E-10 | 3.47E-10 | 3.60E-10 | 0.0 |
| ppmdv | Parts Per Million, Dry Basis | 1.45E-03 | 7.51E-04 | 7.79E-04 | 9.93E-04 |
| | Parts Per Million, Dry Basis | 1.47E-03 | 7.66E-04 | 7.88E-04 | 1.01E-03 |
| | Emission Rate, lb/hr | 4.84E-03 | 6.22E-03 | 1.19E-02 | 7.65E-03 |
| | Emission Rate, lb/1000 lb fuel | 9.21E-03 | 5.95E-03 | 4.66E-03 | 6.61E-03 |

| | | | | | |
|-------|--------------------------------|----------|----------|----------|----------|
| | Benzo(k)fluoranthene | | | | |
| | Analysis, ug/sample | 2.0 | 2.0 | 2.0 | 2.0 |
| | Molecular Weight, MW | 252.3 | 252.3 | 252.3 | 252.3 |
| | Concentration, lb/dscf | 6.69E-10 | 3.47E-10 | 3.60E-10 | 0.0 |
| ppmdv | Parts Per Million, Dry Basis | 1.02E-03 | 5.30E-04 | 5.50E-04 | 7.01E-04 |
| | Parts Per Million, Dry Basis | 1.04E-03 | 5.40E-04 | 5.56E-04 | 7.11E-04 |
| | Emission Rate, lb/hr | 4.84E-03 | 6.22E-03 | 1.19E-02 | 7.65E-03 |
| | Emission Rate, lb/1000 lb fuel | 9.21E-03 | 5.95E-03 | 4.66E-03 | 6.61E-03 |
| | Benzo(a)pyrene | | | | |
| | Analysis, ug/sample | 2.0 | 2.0 | 2.0 | 2.0 |
| | Molecular Weight, MW | 252.3 | 252.3 | 252.3 | 252.3 |
| | Concentration, lb/dscf | 6.69E-10 | 3.47E-10 | 3.60E-10 | 0.0 |
| ppmdv | Parts Per Million, Dry Basis | 1.02E-03 | 5.30E-04 | 5.50E-04 | 7.01E-04 |
| | Parts Per Million, Dry Basis | 1.04E-03 | 5.40E-04 | 5.56E-04 | 7.11E-04 |
| | Emission Rate, lb/hr | 4.84E-03 | 6.22E-03 | 1.19E-02 | 7.65E-03 |
| | Emission Rate, lb/1000 lb fuel | 9.21E-03 | 5.95E-03 | 4.66E-03 | 6.61E-03 |
| | Indeno(1,2,3-c,d)pyrene | | | | |
| | Analysis, ug/sample | 2.0 | 2.0 | 2.0 | 2.0 |
| | Molecular Weight, MW | 276.3 | 276.3 | 276.3 | 276.3 |
| | Concentration, lb/dscf | 6.69E-10 | 3.47E-10 | 3.60E-10 | 0.0 |
| ppmdv | Parts Per Million, Dry Basis | 9.34E-04 | 4.84E-04 | 5.02E-04 | 6.40E-04 |
| | Parts Per Million, Dry Basis | 9.47E-04 | 4.93E-04 | 5.08E-04 | 6.49E-04 |
| | Emission Rate, lb/hr | 4.84E-03 | 6.22E-03 | 1.19E-02 | 7.65E-03 |
| | Emission Rate, lb/1000 lb fuel | 9.21E-03 | 5.95E-03 | 4.66E-03 | 6.61E-03 |
| | Dibenz(a,h)anthracene | | | | |
| | Analysis, ug/sample | 2.0 | 2.0 | 2.0 | 2.0 |
| | Molecular Weight, MW | 278.4 | 278.4 | 278.4 | 278.4 |
| | Concentration, lb/dscf | 6.69E-10 | 3.47E-10 | 3.60E-10 | 0.0 |
| ppmdv | Parts Per Million, Dry Basis | 9.27E-04 | 4.80E-04 | 4.98E-04 | 6.35E-04 |
| | Parts Per Million, Dry Basis | 9.40E-04 | 4.89E-04 | 5.04E-04 | 6.44E-04 |
| | Emission Rate, lb/hr | 4.84E-03 | 6.22E-03 | 1.19E-02 | 7.65E-03 |
| | Emission Rate, lb/1000 lb fuel | 9.21E-03 | 5.95E-03 | 4.66E-03 | 6.61E-03 |
| | Benzo(g,h,i,perylene) | | | | |
| | Analysis, ug/sample | 2.0 | 2.0 | 2.0 | 2.0 |
| | Molecular Weight, MW | 276.3 | 276.3 | 276.3 | 276.3 |
| | Concentration, lb/dscf | 6.69E-10 | 3.47E-10 | 3.60E-10 | 0.0 |
| ppmdv | Parts Per Million, Dry Basis | 9.34E-04 | 4.84E-04 | 5.02E-04 | 6.40E-04 |
| | Parts Per Million, Dry Basis | 9.47E-04 | 4.93E-04 | 5.08E-04 | 6.49E-04 |
| | Emission Rate, lb/hr | 4.84E-03 | 6.22E-03 | 1.19E-02 | 7.65E-03 |
| | Emission Rate, lb/1000 lb fuel | 9.21E-03 | 5.95E-03 | 4.66E-03 | 6.61E-03 |

APPENDIX B

EMISSION SAMPLING METHODS

EPA METHOD 5 AND EPA METHOD 202

Particulate

The test train utilized to perform the particulate and condensable particulate sampling will conform to U.S. EPA Methods 5 and 202 (M5/M202).

The impingers will be charged as indicated below (Figure 1):

- Impingers 1 through 3: 100 ml deionized water.
- Impinger 4: 300 g of silica gel.

The particulate train will consist of the following compounds:

- A borosilicate or stainless-steel nozzle with an inside diameter sized to sample the amount of exhaust specified in Method 5.
- A heated, borosilicate-lined probe equipped with a calibrated thermocouple to measure flue gas temperature and an S-type pitot tube to measure the flue gas velocity pressure.
- A heated oven containing a borosilicate connector and filter holder with a Soxhlet-extracted glass-fiber filter.
- A rigid borosilicate connector to join the outlet of the filter holder to the inlet of the impinger train.
- Greenburg-Smith impingers plus a thermocouple to detect sample gas exit temperature.
- A vacuum line (umbilical cord) with adapter to connect the outlet of the impinger train to a control module.
- A control module containing a 3-cfm carbon-vane vacuum pump (sample gas mover), a calibrated dry gas meter (sample gas volume measurement device), a calibrated orifice (sample gas flow rate monitor), and inclined manometers (orifice and gas stream pressure indicators).

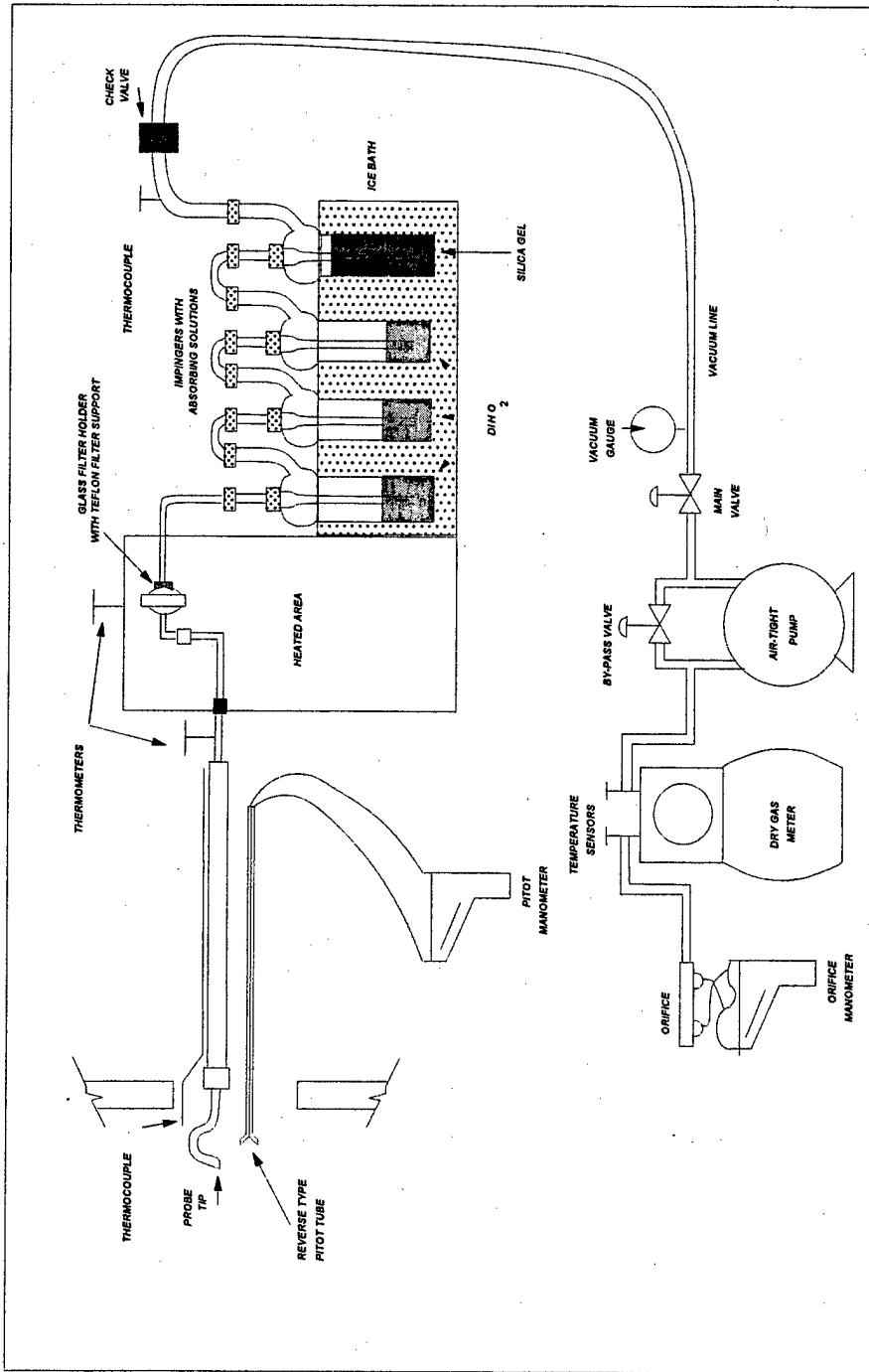

FIGURE 1
PARTICULATE (front and backhalf) SAMPLING TRAIN
EPA METHOD 5 AND METHOD 202

- A switchable, calibrated, digital pyrometer to monitor flue and sample gas temperatures.

The M5/M202 train will be calibrated to satisfy U.S. EPA requirements. Sample collection will follow U.S. EPA M5/M202 procedures. Prior to sampling, the number of traverse points and their locations will be calculated using U.S. EPA Method 1.

Figures 2, 3, and 4 illustrate the procedures that will be used to prepare the particulate sampling trains prior to each test, the procedures used to sample the stack flue gases, and the procedures used to recover the samples from the train, respectively. Each test will be ³ 60 minutes in length, ³ 50 ft³ in sample volume, and isokinetic \pm 10%.

Particulate Matter Analysis (M5/M202)

The M5 probe/front-half acetone wash and filter fractions and back-half condensate from all test runs will be analyzed gravimetrically for particulates according to U.S. EPA M5/M202. The front-half particulate analysis will be performed according to the procedures established in U.S. EPA Reference Method 5 (40 CFR 60, Appendix A). As specified by the method, quartz filters exhibiting >99.5 % efficiency on 0.3-micron dioctyl phthalate smoke particles will be used. Particulate analysis of the filter will be performed by oven-drying the filter. The filter will be oven-dried for 2 to 3 hours at 105°C (220°F) and cooled in a desiccator. The filter will be weighed to a constant weight.

Constant weight means a difference of no more than 0.5 mg or 1% of total weight less tare weight, whichever is greater, between two consecutive weighings.

The acetone probe rinse will be checked for any leakage during transport. The liquid will be measured volumetrically to the nearest \pm 1 ml. The contents will be transferred to a tared 250-ml beaker. The probe rinse will be evaporated to dryness at ambient temperature and pressure. The beaker will be weighed to a constant weight and the results reported to the nearest 0.1 mg.

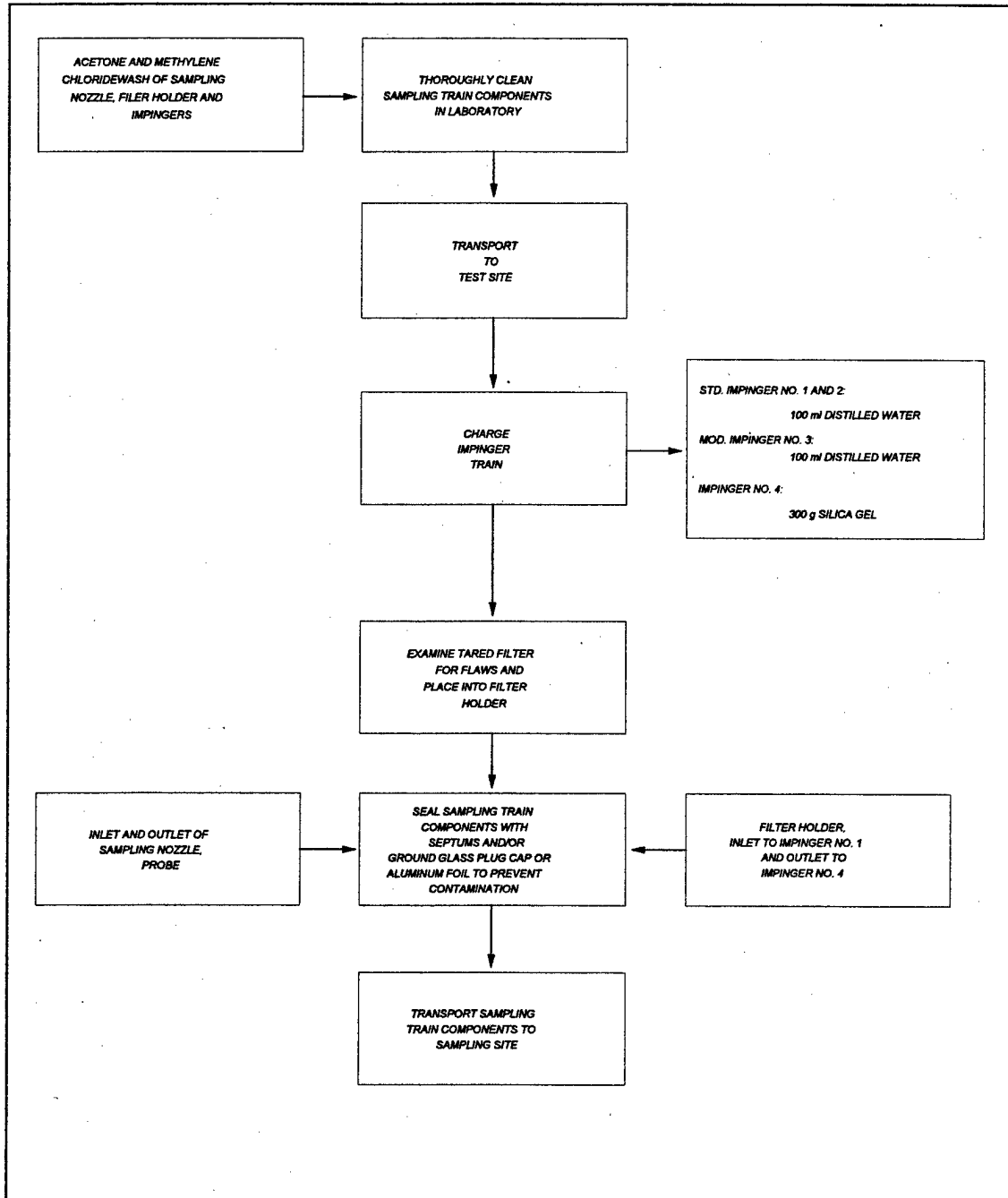

**FIGURE 2
PREPARATION PROCEDURES FOR PARTICULATE (M5/M202)
SAMPLING TRAIN**

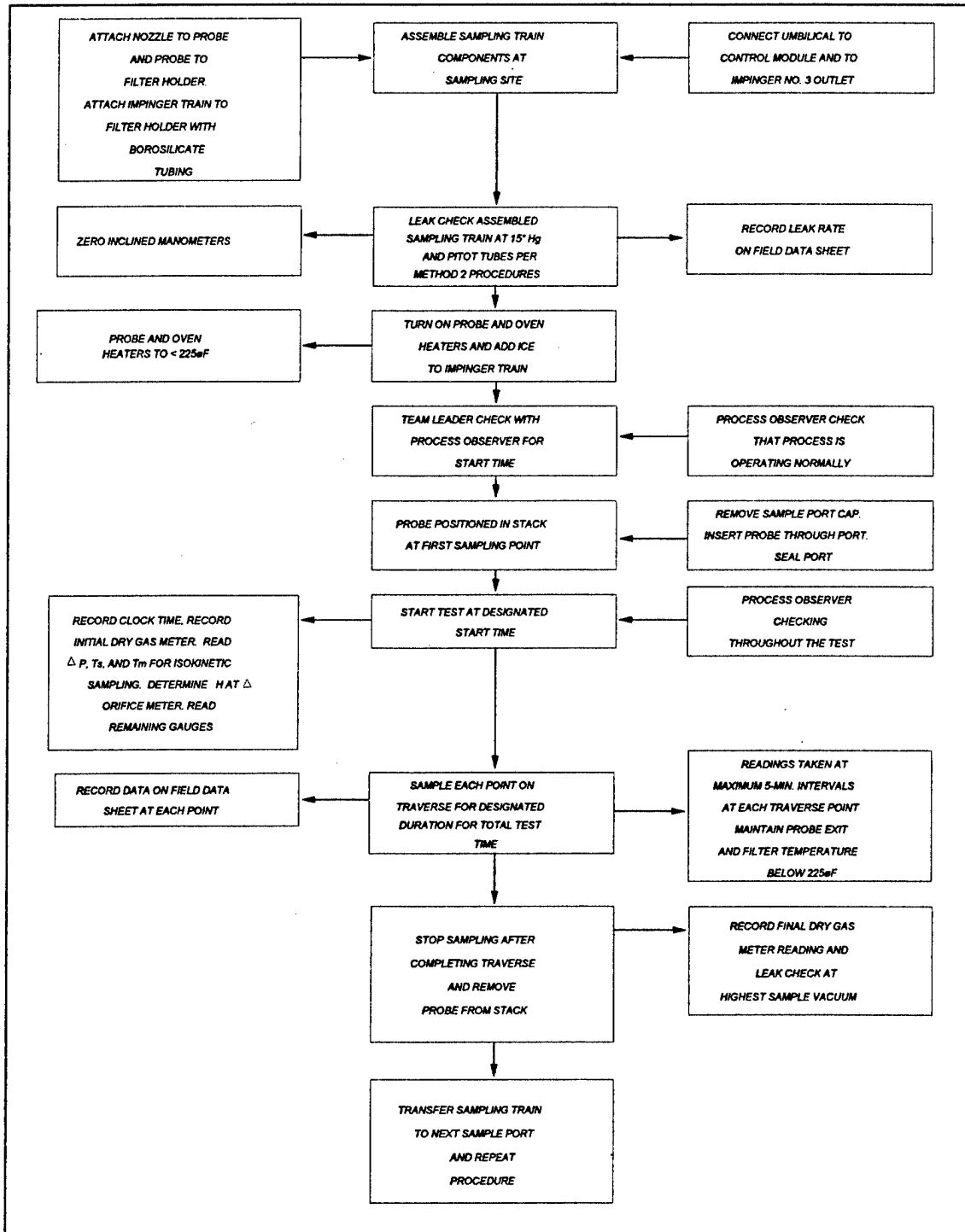

FIGURE 3
TEST PROCEDURES FOR PARTICULATES (M5/M202)

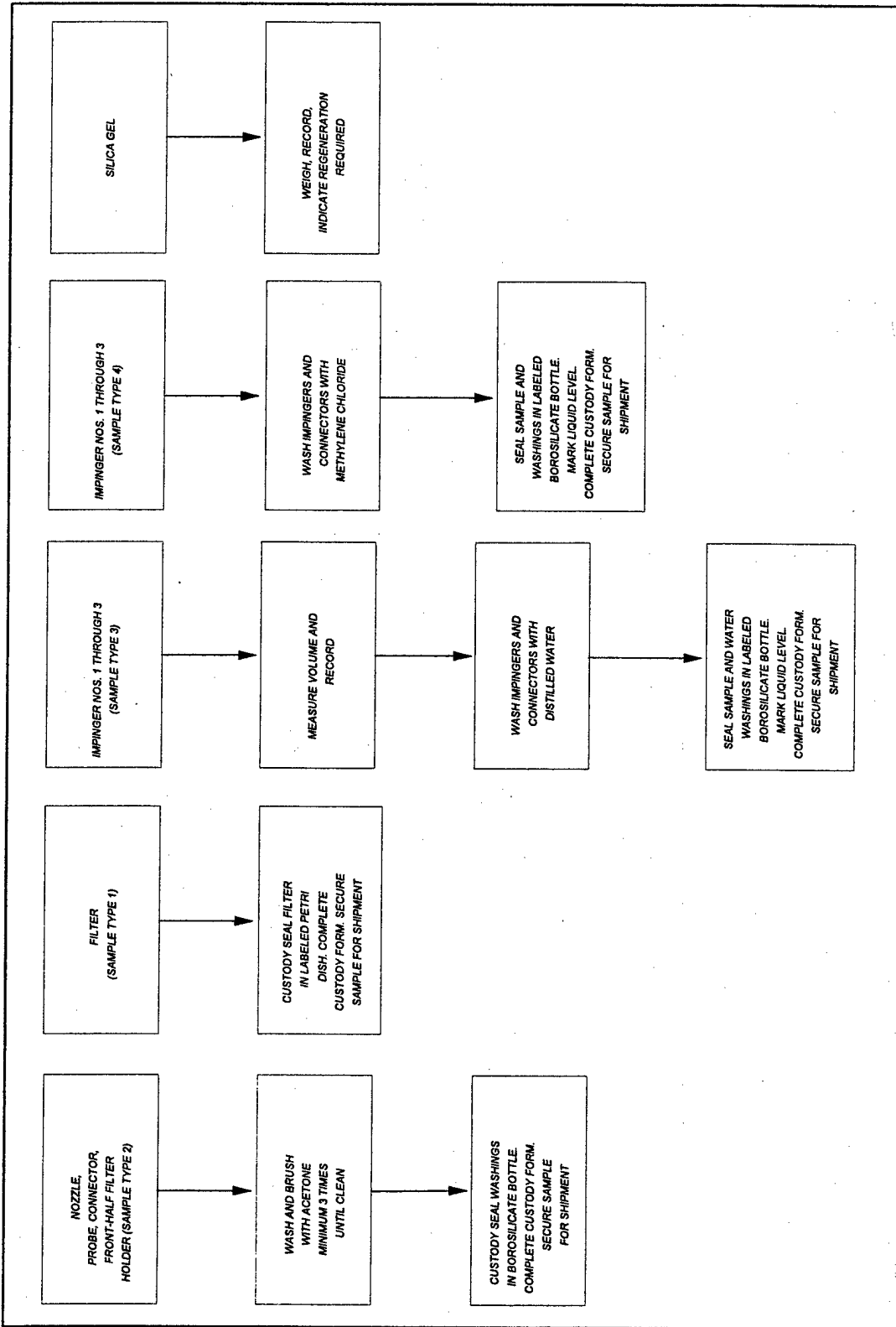

FIGURE 4
SAMPLE RECOVERY PROCEDURES FOR PARTICULATE (M5/M202) SAMPLING TRAIN

The back-half condensable particulate fraction analysis will be performed according to procedures established in U.S. EPA Reference Method 202 (40 CFR 60, Appendix A). The back-half water and wash samples will be combined in a separator funnel to separate aqueous and organic phases. The organic-phase extract will be placed in a tared beaker and evaporated to dryness at ambient temperature and pressure, then desiccated to a constant 0.1-mg weight. A methylene chloride extraction will be performed on the distilled water blank sampling to obtain a blank correction value.

The extracted water sample and extracted distilled water sample blank will be poured into tared beakers, evaporated to dryness at 220 to 230°F, then desiccated at ambient temperature and pressure to a constant 0.1-mg weight. The residue weight of the dried distilled water samples will be adjusted based on the water blank sample correction factor.

Particulate QC Sampling Procedures

The sampling QC procedures that will be used to ensure representative measurements of particulates are the following:

- The sample rate must be within 10 % of the true isokinetic (100 %) rate.
- All sampling nozzles will be manufactured and calibrated according to U.S. EPA standards.
- Particulate filters will be pre-test and post-test weighed (following 24 hours of desiccation) to the nearest 0.1 mg to a constant (± 0.5 mg) value.
- Recovery procedures will be completed in a clean environment.
- Sample containers for liquids will be constructed of borosilicate with Teflon[®]-lined lids. Filters will be stored in plastic or borosilicate petri dishes.

EPA METHOD 0011-FORMALDEHYDE SAMPLING TRAIN

The formaldehyde in the stack gas emission stream will be determined by U.S. EPA Method 0011. The sampling train (see Figure 1) will consist of the following components connected in a series:

- A calibrated borosilicate nozzle attached to a heated borosilicate probe.
- A rigid borosilicate connector to join the outlet of the sampling probe to the inlet of the impinger train.
- An impinger train consisting of four impingers. The first, second, and third impingers will each contain 100 ml of cleaned 2,4-dinitrophenylhydrazine (DNPH) solution. The fourth impinger will contain 300 grams of dry preweighed silica gel. The second impinger will be a Greenburg-Smith type; all other impingers will be of a modified design. All impingers will be maintained in a crushed ice bath.
- A vacuum line (umbilical cord with adapter) to connect the outlet of the fourth impinger train to a control module.
- A control module containing a 3-cfm carbon-vane vacuum pump (sample gas mover), a calibrated dry gas meter (sample gas volume measurement device), a calibrated orifice (sample gas flow rate monitor), and inclined manometers (orifice and gas stream pressure indicators).

Figures 2, 3, and 4 outline the preparation, sampling, and recovery procedures that will be used to determine the formaldehyde at the stack location.

Formaldehyde Analysis Procedures

The analytical procedures for the quantification of formaldehyde will be performed as specified in U.S. EPA Methods 0011 and 0011A utilizing high-performance liquid chromatography (HPLC).

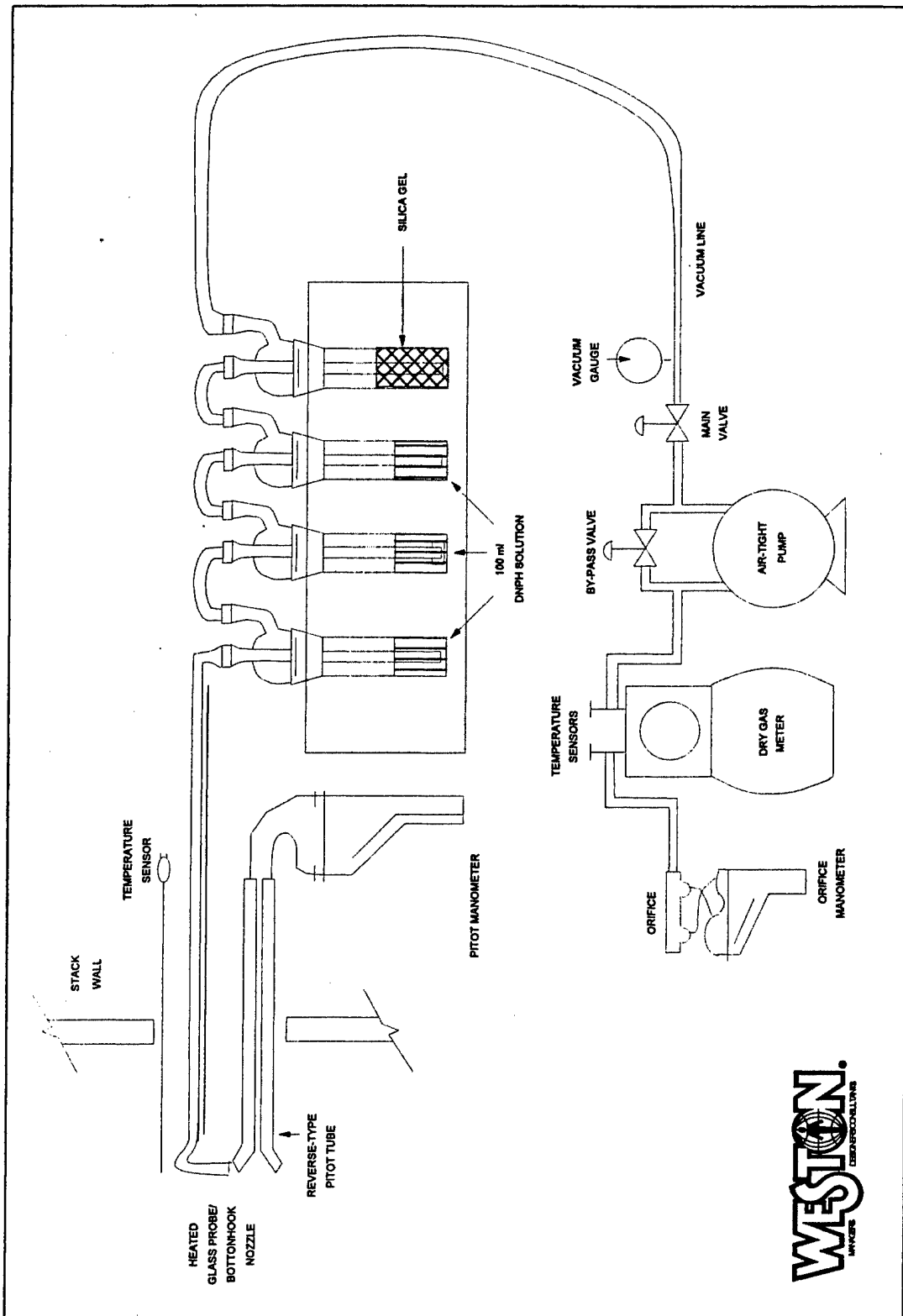
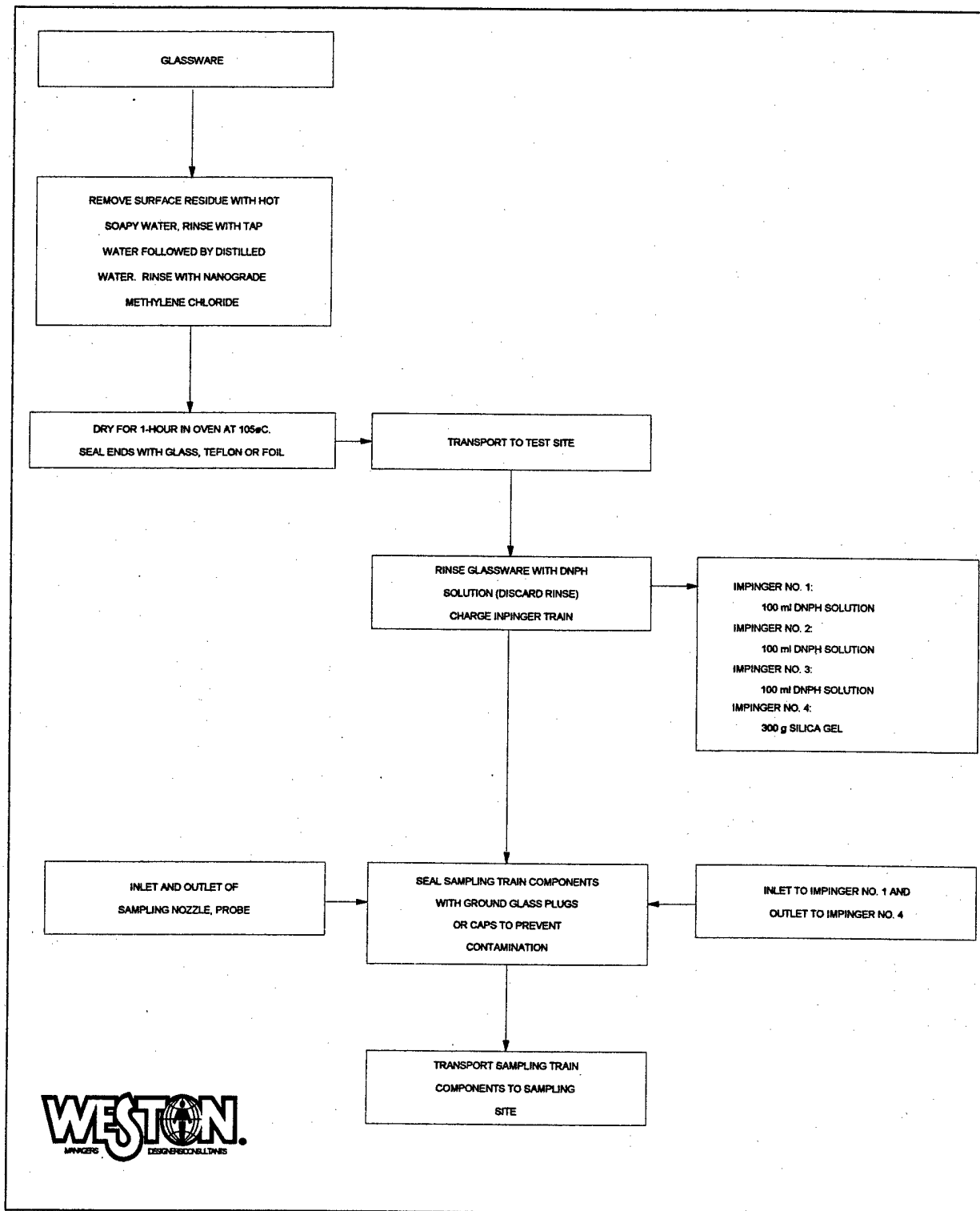
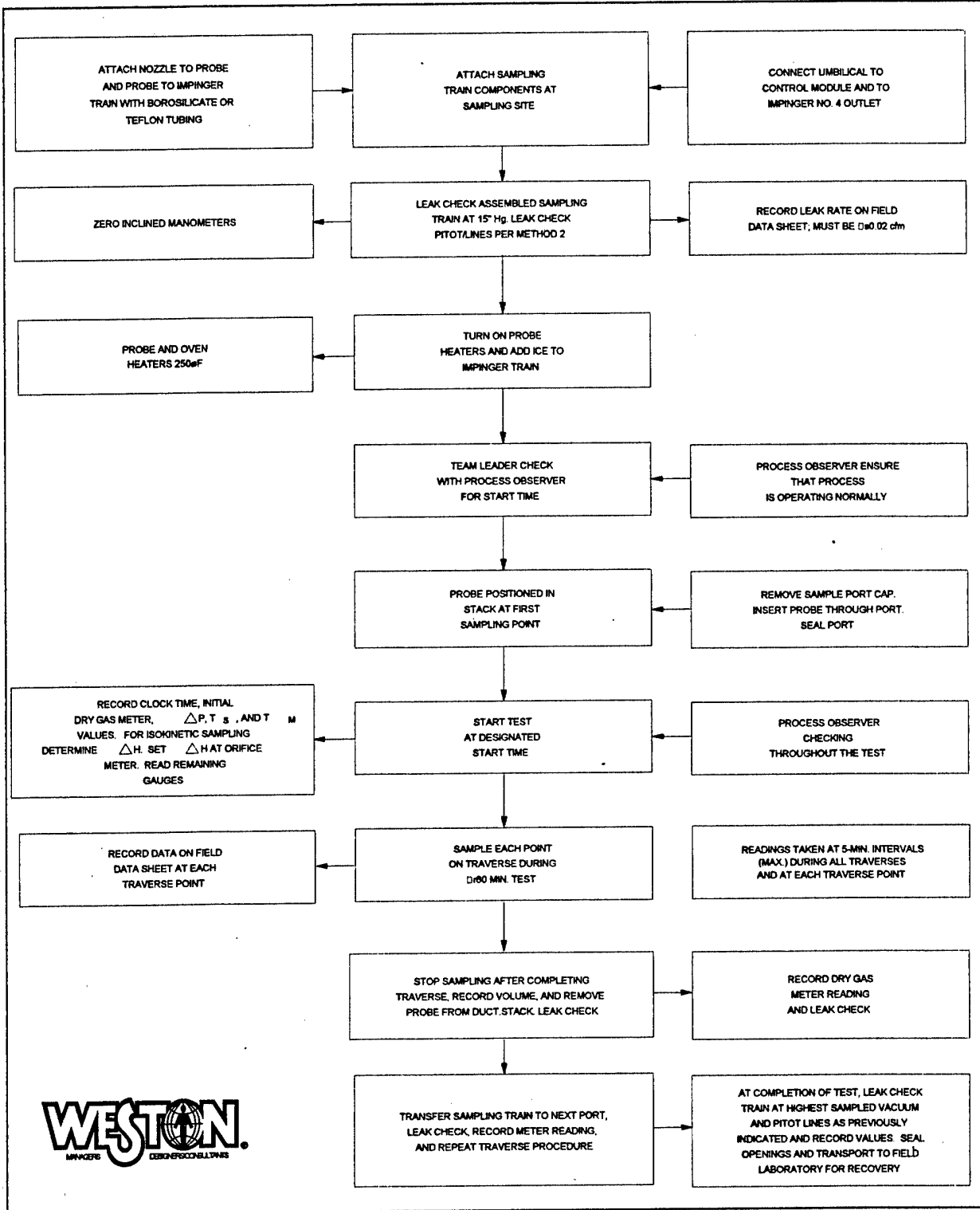

FIGURE 1
EPA METHOD 0011 - FORMALDEHYDE SAMPLING TRAIN



**FIGURE 2
PREPARATION PROCEDURES FOR FORMALDEHYDE SAMPLING TRAIN**



**FIGURE 3
SAMPLING PROCEDURES FOR FORMALDEHYDE**

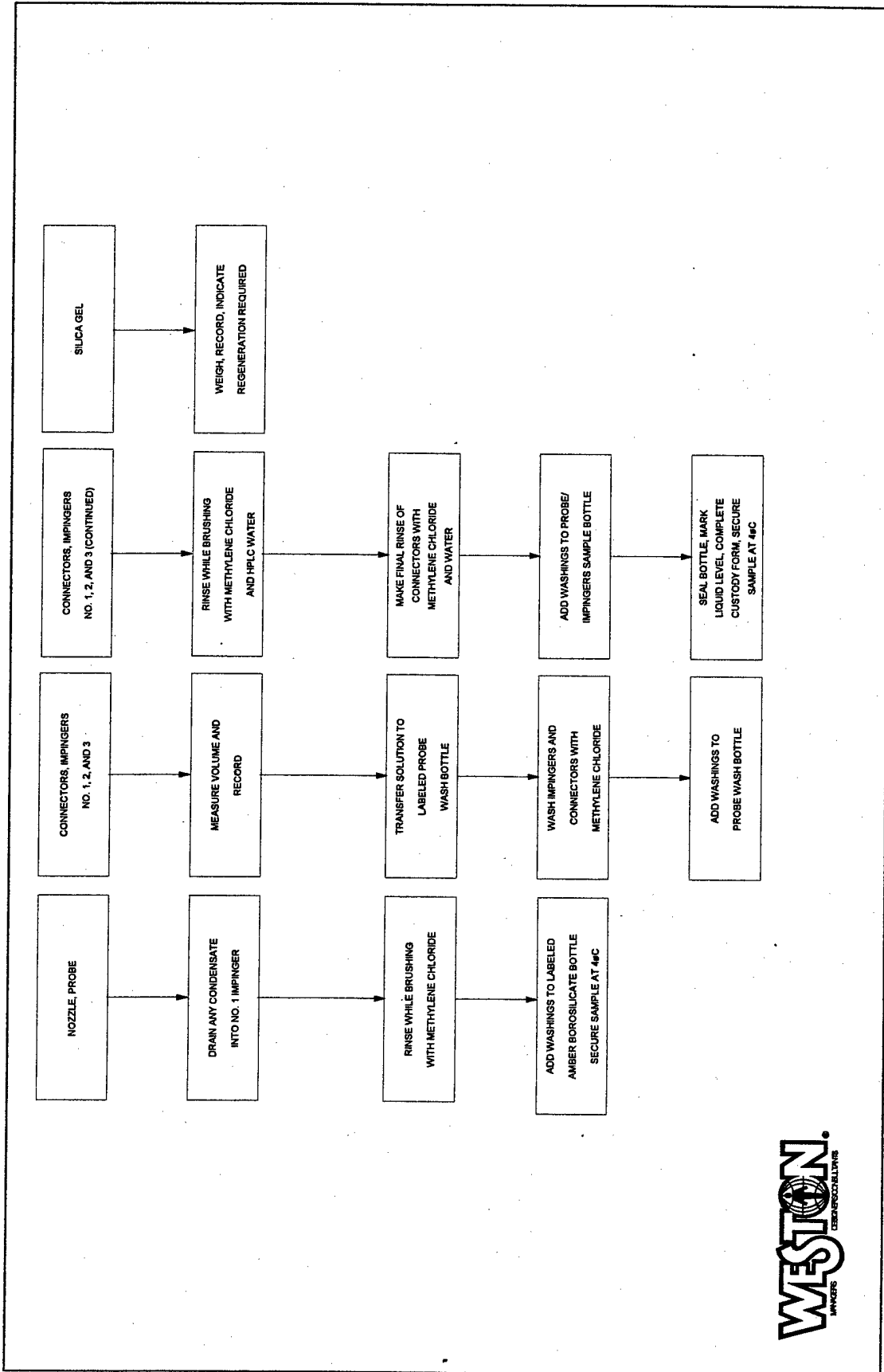

FIGURE 4
SAMPLE RECOVERY PROCEDURES FOR FORMALDEHYDE SAMPLING TRAIN

Each of the three DNPH impingers will be recovered, composited, and analyzed as one sample. The samples must be chilled immediately to stabilize the DNPH-carbonyl derivatives.

The HPLC will be calibrated prior to use each day. Calibration standard mixtures will be prepared from appropriate reference materials and will contain analytes appropriate for the method of analysis.

If a correlation of 0.996 cannot be obtained, additional standards must be analyzed to define the calibration curve. A midpoint calibration check standard will be analyzed each shift to confirm the validity of the initial calibration curve. The check standard must be within 20% of the initial response curve to demonstrate that the initial calibration curve is still valid.

Calibration data, including the correlation coefficient, will be retained in laboratory notebooks to maintain a permanent record of instrument performance.

At least one method blank and two method spikes will be included in each laboratory lot of samples. The method spikes and blanks will be in aqueous media. Method spikes will be examined to determine if contamination is being introduced in the laboratory.

The spikes will be examined to determine both precision and accuracy. Accuracy will be measured by the percent recovery of the spikes; precision will be measured by the reproducibility of both method spikes.

Formaldehyde QC Sampling Procedures

The following QC procedures will ensure representative formaldehyde data are taken:

- Reagents will be used that meet method criteria. A supply of the DNPH reagent will be extracted the day before shipping to the test site. Two aliquots from each lot of DNPH prepared will be reserved for blank analysis per U.S. EPA Method 0011.
- The formaldehyde trains will be assembled and recovered in an environment free from uncontrolled dust and contaminated organics, and will be performed in an area away from other test train recovery activities to minimize contamination. The train will be prerinsed with DNPH to eliminate any acetone residue prior to charging.
- DNPH will be stored in a cool environment and away from other solvents.

EPA METHOD 0030 (VOST)

Volatile Organic Compounds

The volatile organics in the stack gas emission stream will be determined by U.S. EPA Method 0030 (VOST). This sampling train (see Figure 1) will consist of the following components connected in series:

- A heated borosilicate or quartz probe containing a glass wool particulate filter.
- An ice-water-cooled condenser connected to the probe, followed by a temperature sensor, an adsorption cartridge containing 1.6 grams of Tenax, and a condensate trap.
- A section of Teflon tubing used to connect the outlet of the condensate trap to a second condenser, which will be followed by a backup sorbent trap containing 1 gram of Tenax and 1 gram of activated charcoal, a second condensate collector, and a borosilicate tube containing an unweighed amount of dry silica gel.
- A tube of silica gel connected via an umbilical cable to a control console containing flow controllers, a calibrated 1-liter-per-minute dry gas meter, a sample pump, a temperature indicator, and other components.

A total of one VOST tube pairs will be collected during each test period. The volatile organics will be determined by analyzing the tube pairs by purge-trap-desorb GC/MS.

Figures 2, 3 and 4 outline the preparation, sampling, and recovery procedures that will be used to determine the volatile organics at the stack location.

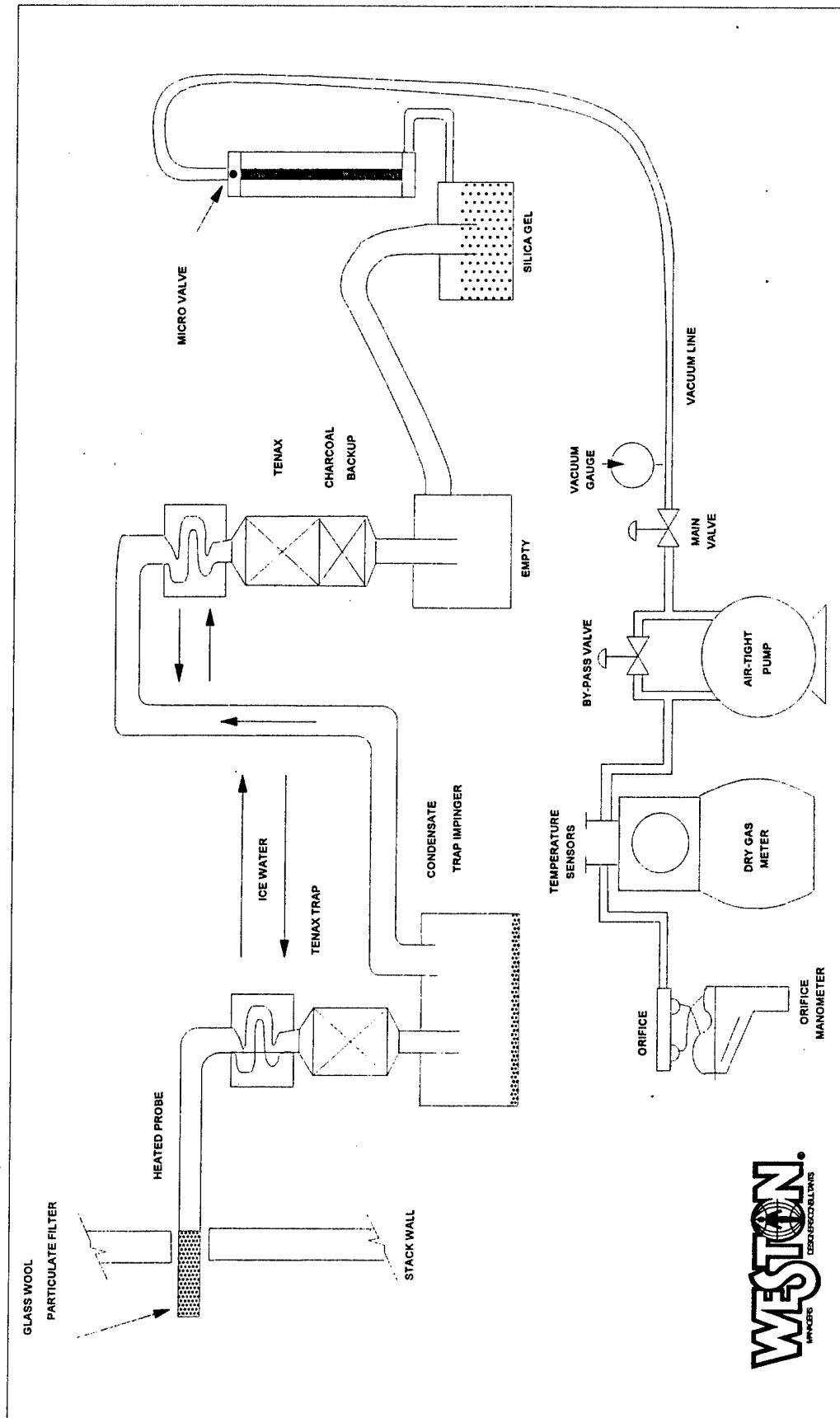
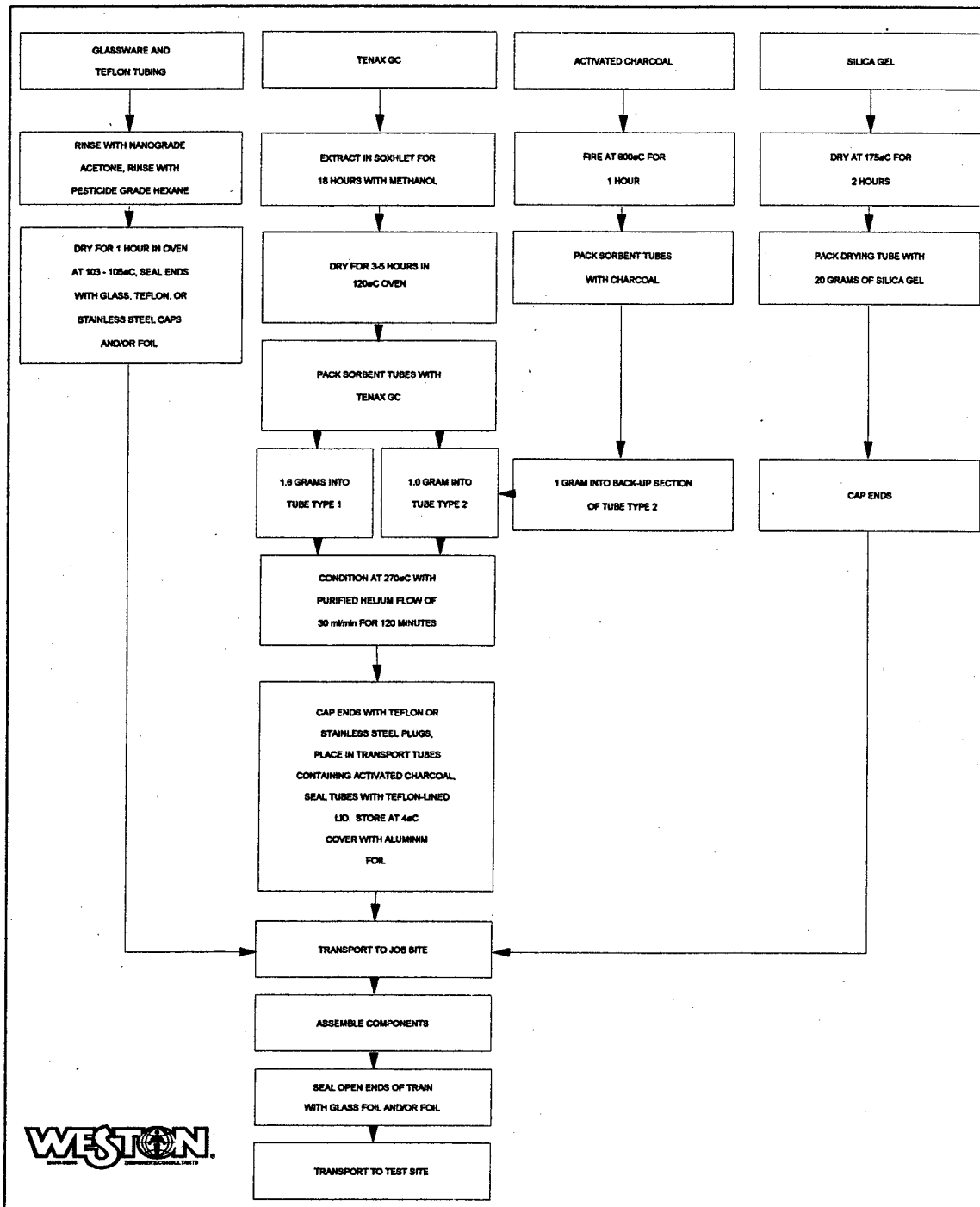
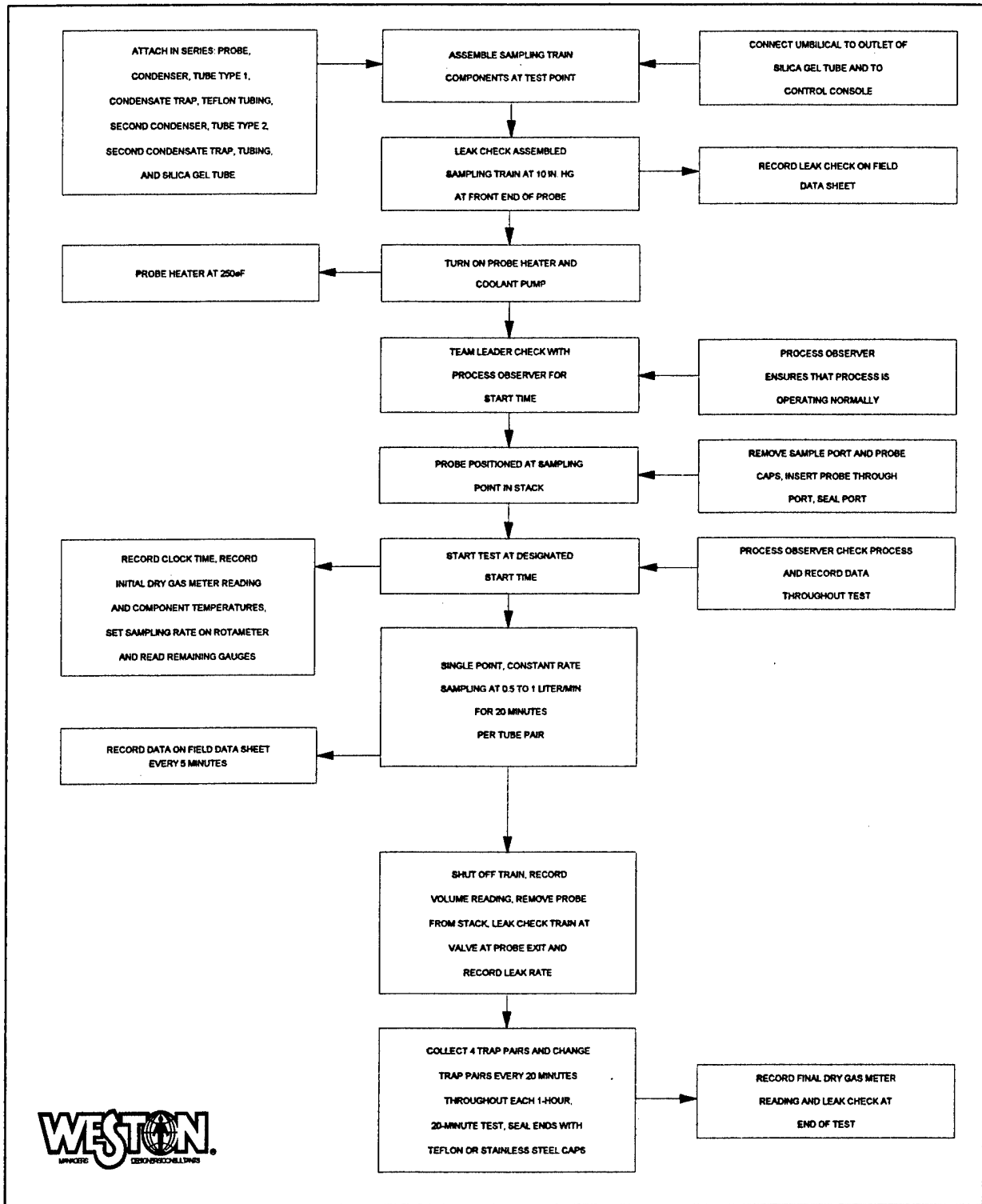

FIGURE 1
EPA METHOD 0030 - VOLATILE ORGANIC SAMPLING TRAIN (VOST)



**FIGURE 2
PREPARATION PROCEDURES FOR VOLATILE
ORGANICS SAMPLING TRAIN**



**FIGURE 3
SAMPLING PROCEDURES FOR VOLATILE ORGANICS**

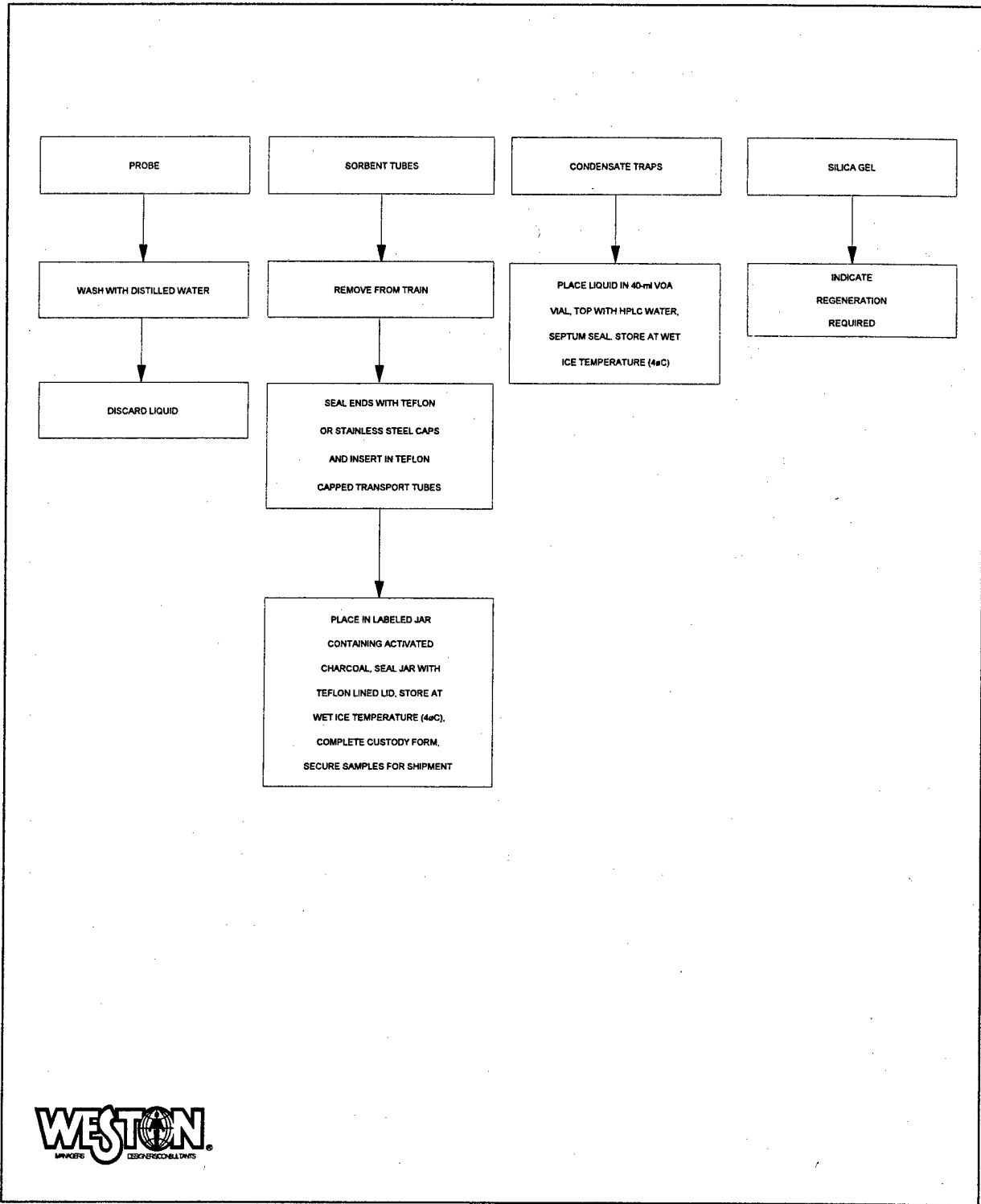

**FIGURE 4
RECOVERY PROCEDURES FOR VOLATILE ORGANICS**

Volatile Organics Analysis

The VOST samples will be placed in cold storage (<4°C) upon receipt in the laboratory. The samples have a recommended 14-day holding time from collection to analysis. The samples will require no additional preparation for analysis, except additions of the internal standard and the surrogate (D₈-toluene).

Volatile organics present in stack gases will be collected on Tenax and Tenax/charcoal sorbent cartridges using a VOST. Method 5040 (SW-846, third edition) describes in detail the procedural steps required to desorb VOST cartridges and analyze the effluent gas stream for VOCs. Additionally, if peaks of other compounds appear in the total ionization chromatogram (up to 10), they will be tentatively identified using a forward library search against the U.S. EPA/National Institutes of Health (NIH) mass spectral library and semiquantified relative to an internal standard spiked into the traps prior to analysis.

Methanolic solutions of internal standards compounds will be spiked onto each set of tubes prior to thermal desorption and analysis.

After spiking, the contents of the sorbent cartridges will be desorbed thermally for approximately 10 minutes at 180°C with organic-free nitrogen or helium gas, and bubbled through a tower to impinge water desorbed from the cartridges. Target analytes will be trapped on an analytical adsorbent trap. After the 10-minute desorption, the analytical adsorbent trap will be heated rapidly to 180°C with the carrier gas flow reversed. VOCs will be desorbed from the analytical trap and vented directly to a megabore column in the GC. The VOCs will be separated by temperature-programmed GC and detected by low-resolution MS. Concentrations of VOCs will be calculated using the internal standard technique.

VOST QC

The QC procedures that will ensure representative volatile organics data are the following:

- All sample and recovery glassware will be precleaned as per the procedure outlined in U.S. EPA Method 0030.
- The distilled water used for recovery of the condensate sample will be HPLC grade.
- Blanks of distilled water and unused tube pairs will be retained for blank analysis.

- All condensate and tube pair samples will be maintained at 4°C following collection and prior to analysis.
- VOST train preparation and recovery will be conducted in an area away from other test train recovery activities to avoid solvent contamination.

CONTINUOUS EMISSION MONITORING METHODS

The continuous emission monitoring system (CEMS) will be utilized to monitor gaseous emissions from stationary sources. The CEMS will monitor one or more of the following analytes: oxygen (O₂), carbon dioxide (CO₂), carbon monoxide (CO), sulfur dioxide (SO₂), nitrogen oxides (NO_x), and total hydrocarbons (THCs). These measurements will satisfy the requirements of the following U.S. EPA Reference Methods:

- Method 3A — Determination of Oxygen and Carbon Dioxide Concentrations in Emissions from Stationary Sources.
- Method 6C — Determination of Sulfur Dioxide Emissions from Stationary Sources.
- Method 7E — Determination of Nitrogen Oxide Emissions from Stationary Sources.
- Method 10 — Determination of Carbon Monoxide Emissions from Stationary Sources.
- Method 25A — Determination of Total Gaseous Organic Concentration Using a Flame Ionization Analyzer.

The CEMS consists of the sampling interface, the analyzers, and the data collection system. The sample interface will begin at the sample probe and extract the sample from the source, transport the samples to the analyzers, and filter the samples. For most of the analytes the moisture in the sample will be removed in the sample interface prior to analysis. Only the flame ionization analyzer sample will be analyzed on a wet basis. The sample interface will allow calibration gas to be introduced at the analyzer and at the sample probe. The analyzers will provide the next component of the CEMS. The analyzers must meet specific calibration requirements. The data collection system will record the raw voltage signal output from the analyzers, convert the signal to represent the analyte concentration, and store these concentrations as discrete averages (usually 1-minute averages). At the end of any test run, the data collection system will correct the test results for calibration drift and bias as required in the EPA methods.

The CEMS can be operated to monitor one or all of the analytes. The sampling interface will be modified to suit the source characteristics and the desired analytes.

Sample Interface

The hot, wet sample interface (see Figure 1) must be used if THCs are being measured. The sample will be extracted through a heated probe, filter, and sample line to prevent condensation. The sample interface components that are outside the stack will be maintained at or above 250 °F. The hot, wet sample interface will consist of the following components:

- An unheated inner stainless-steel probe extension, which will be maintained at stack temperature.
- A heated probe section (at least 250 °F) which penetrates the stack wall and connects the inner probe to the heated filter box.
- A heated filter box (at least 250 °F) which contains calibration gas injection ports and an in-line stainless-steel filter.
- A heated sample line (at least 250 °F) to transport the sample from the filter box to the analyzer manifold.
- A heated manifold, which will split the sample between the heated and unheated analyzers.
- A VIA MAK II low contact refrigerated condenser to remove water.
- A flow distribution manifold to maintain the required sample flow to each analyzer.

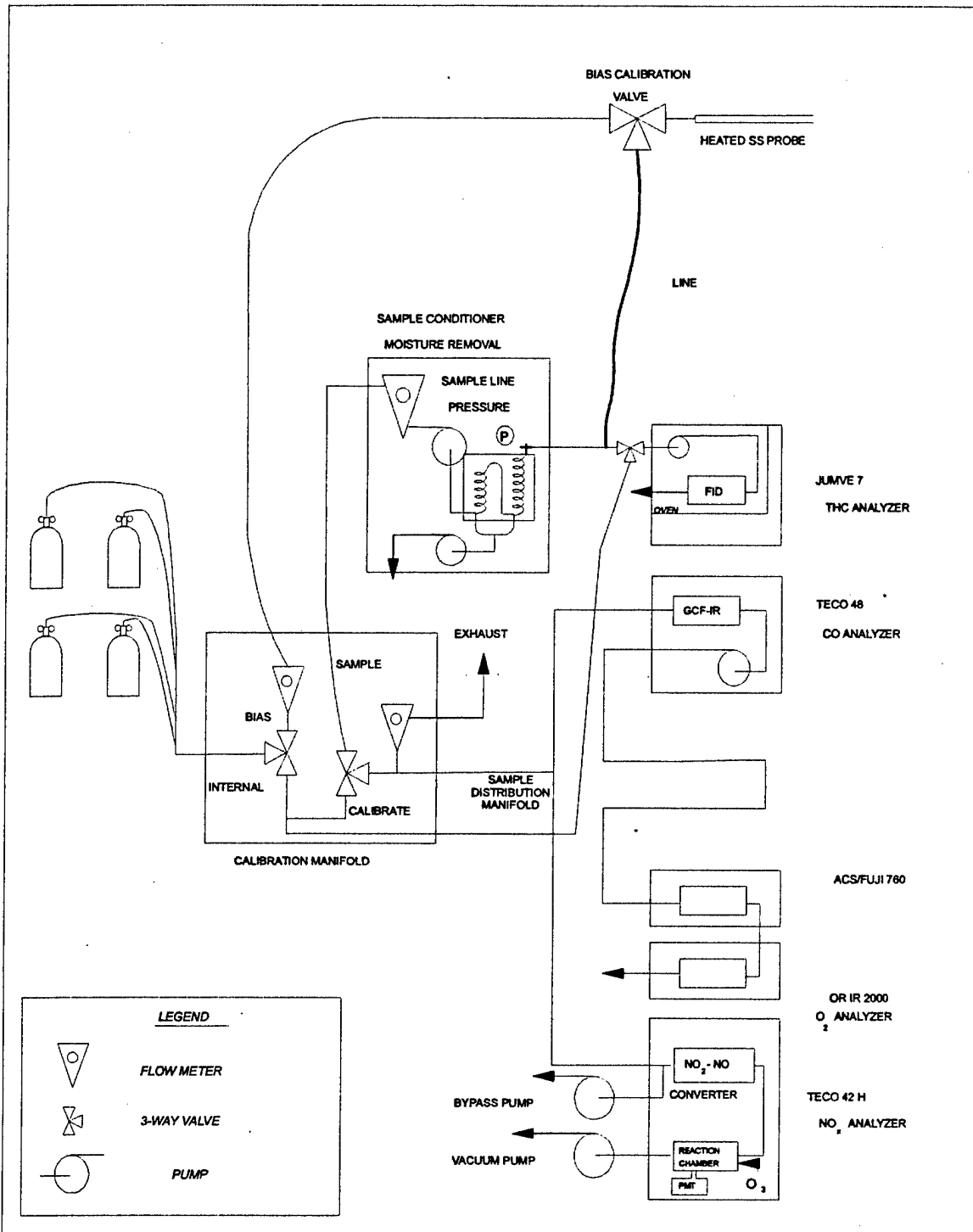

Figure 1
Continuous Emissions Monitoring System

One fraction of the sample will be transported by a short heated line to the hydrocarbon analyzer. The remaining sample will be sent to a VIA MAK II low-contact refrigerated condenser to remove water. The condenser will be maintained at 38 °F, and condensed moisture will be removed continuously from the bottom of the condenser through a peristaltic pump. The dried sample will pass through a pump and control valve, and will be distributed to the various analyzers by a distribution manifold. The critical flow parameter for each analyzer will be monitored with a rotameter as described below. The sample control valve will be adjusted to ensure that the sample gas always will be provided in excess, and that the excess sample will be released to the atmosphere.

Calibration

Calibration of the CEMS is always conducted in two steps: internal (direct to the instrument) and bias (direct to the probe end in the heated filter box). The internal calibration always is conducted first to verify instrument response. The internal calibration is conducted by introducing a calibration standard through the flow distribution manifold.

The instrument response will be adjusted initially by observing the front display of the analyzer. All final calibration response data **must be collected from the datalogger display**. Typically, there will be a slight difference between the analyzer front panel display and the data logger display, and the calibration data must be consistent with the recorded test data.

The bias calibration will be conducted prior to the start of the test run. This calibration will be conducted by introducing the calibration gas standard to a tee on the end of the probe in the heated filter box. The calibration gas will be supplied in excess and the surplus gas will flow out of the open end of the probe into the stack. This will ensure that bias calibrations are conducted at stack pressure.

The calibration drift will be measured at the end of the test run by repeating the bias calibration for zero and one or more calibration standards. The difference between the pretest and posttest CEMS response will be the calibration drift.

Analyzers

The following analyzers may be used in the CEMS:

- Total hydrocarbons:

JUM Model VE- 7
Flame ionization analyzer
Range: 0 to 100, 0 to 10,000 ppm as carbon equivalent.
- Sulfur dioxide:

Bovar Corporation Model 721, version AT or M
Nondispersive infrared adsorption
Range: 0 to 500, 0 to 5000 ppm as SO₂.
- Nitrogen oxides:

Thermo Environmental Company (TECO) Model 42H
Chemiluminescence
Range: Between 0 to 25 and 0 to 5000 ppm as NO or as NO_x; NO₂ by difference.

API Model 200
Chemiluminescence
Range: Between 0 to 100 and 0 to 10,000 ppm as NO or NO_x; NO₂ by difference.
- Carbon monoxide:

TECO Model 48 or 48H
Gas correlation nondispersive infrared
Range: 0 to 10 and 0 to 1,000 ppm (Model 48) and 0 to 10,000 ppm (Model 48H).

API Model 100
Gas correlation nondispersive infrared
Range: 0 to 100 and 0 to 1,000 ppm.
- Carbon dioxide:

Fugi/ACS Model 760
Nondispersive infrared
Range: 0 to 1000 ppm, 0 to 1%, and 0 to 5%.

- Oxygen:
 - Siemens Oxymat 5E
 - Paramagnetic
 - Range: 0 to 25 %.

 - Servomex 1400
 - Paramagnetic
 - Range: 0 to 25 %.

EPA Reference Methods

The performance parameters for the EPA Reference Methods are presented in Table 1.

The universal WESTON calibration performance requirements, applicable to all parameters, are the following:

- Calibration error: ± 2%
- Calibration bias: ± 2%
- Calibration drift: ± 3%

All parameters will be calibrated using zero plus three upscale gas standards. All sample data will be corrected using the EPA method 6C bias correction.

$$C_{\text{corrected}} = \frac{(C_{\text{raw}} - Z_b)}{(S_b - Z_b)} \times S_{\text{std}}$$

Where:

- $C_{\text{corrected}}$ = Run average concentration corrected for instrument bias and drift.
- C_{raw} = Raw run average concentration before correction.
- Z_b = Average pre- and posttest zero bias response.
- S_b = Average pre and posttest upscale bias response.
- S_{std} = True value of upscale bias standard.

TABLE 1. PERFORMANCE PARAMETERS FOR EPA REFERENCE METHODS

| Parameter | Method | Calibration Gas (% F _s) ^(a) | Calibration Error (% F _s) ^(b) | Calibration Bias (% F _s) ^(c) | Calibration Drift (% F _s) | Interference Check | Calibration Bias Drift Correction | Other Requirements |
|-----------------|--------|--|--|---|---------------------------------------|--|---|---|
| O ₂ | 3A | Zero - 0 | ± 2 % F _s | ± 5 % F _s | ± 3 % F _s /run | Per Method 20 ^(d) | Per Method 6C | |
| | | Low - N/R | | | | | | |
| | | Mid - 40 to 60 High - 80 to 100 | | | | | | |
| CO ₂ | 3A | Zero - 0 | ± 2 % F _s | ± 5 % F _s | ± 3 % F _s /run | Per Method 20 ^(d) | Per Method 6C | |
| | | Low - N/R | | | | | | |
| | | Mid - 40 to 60 High - 80 to 100 | | | | | | |
| SO ₂ | 6C | Zero - 0 | ± 2 % F _s | ± 5 % F _s | ± 3 % F _s /run | 7% of Method 6C ^(e) | Linear correction for average bias response | |
| | | Low - N/R | | | | | | |
| | | Mid - 40 to 60 High - 80 to 100 | | | | | | |
| CO | 10 | Zero - 0 | ± 2 % F _s ^(f) | ± 2 % F _s ^(f) | ± 10 % F _s /8 hrs | For CO ₂ and H ₂ O | Per Method 6C ^(g) | |
| | | Low - N/R | | | | | | |
| | | Mid - Approx. 30 High - Approx. 60 | | | | | | |
| NO _x | 7E | Zero - 0 | ± 2 % F _s | ± 5 % F _s | ± 3 % F _s /run | Per Method 20 | Per Method 6C | NO ₂ /NO converter efficiency 98% minimum. |
| | | Low - N/R | | | | | | |
| | | Mid - 40 to 60 High - 80 to 100 | | | | | | |
| THC | 25A | Zero - 0 | ± 5 % C _g ^(h) | ± 5 % C _g ^(h) | ± 3 % F _s /run | N/R | Per Method 6C ^(g) | Pretest calibration required within 2 hours of start of test run. |
| | | Low 25 to 35 | | | | | | |
| | | Mid - 40 to 60 High - 80 to 90 | | | | | | |

N/R = Not required by method.

F_s = Instrument full scale or span value.

C_g = Calibration gas value

a % F_s = Percent full scale of calibration range.

b Calibration error = difference between known calibration value and instrument response when injected directly into instrument.

c Calibration bias = difference between instrument response when calibration gas is injected directly into the instrument and when calibration gas is injected at the sample probe.

d Substitute 500-ppm NO for oxygen or carbon dioxide during interference check.

e Required for first use at a source category only.

f Difference between calibration error and calibration bias is not specified in method; CO accuracy requirement is applied to both.

g Not specific method, but required as WESTON basic operating procedure.

h According to method, all calibrations are conducted from probe.

Stack CEM QC Sampling Procedures

The following QC procedures will be applied to ensure collection of representative CEM data.

- CEMs (probe to sample conditioner) will be leak-checked prior to the testing.
- All CEMs will be calibrated prior to testing to ensure precise and accurate data. Cylinder gases with a certified accuracy of $\pm 2\%$ or Protocol One standards will be used to calibrate each of the analyzers. Each analyzer will be calibrated at four points (zero, low, mid, and high range). Nitrogen or hydrocarbon-free air will be used to set the instrument zero. The three calibration standards will be approximately 20 to 30, 45 to 55, and 80 to 100 % of span.
- Pre- and posttest calibration bias tests will be performed for each test run. The bias check will be performed with the calibration standard that is closest to the observed concentration in the sample gas. The average pretest/posttest bias drift will not exceed 3 % of full scale.
- A permanent data record of CEM analyzer responses will be made on a strip chart data logger and on the sampling data sheets.

THIS PAGE INTENTIONALLY LEFT BLANK

APPENDIX C

FIELD DATA

CEM Data Correction Data Sheet

| | |
|--------------------|---------------|
| Plant Name: | Moody AFB |
| Sampling Location: | Engine - Idle |
| Date: | 4/24/02 |
| Project Number: | 030197.0002.5 |
| CEM Operator: | Doug Allen |
| Pollutant: | CO |
| Molecular Weight: | 28.01 |

| Run No. | Start-Stop Time | Raw Data (ppm) | Calibration Data | | | Source Information | | Calibration Corrected Data (% or ppm) | Mass Emission Rate (lb/hr) | Mass Emission Rate (lb/1000 lb fuel) |
|---------|-----------------|----------------|------------------|------|-------|--------------------|-------------------|---------------------------------------|----------------------------|--------------------------------------|
| | | | Cma | Co | Cm | Stack Flow (dscfm) | Fuel Flow (lb/hr) | | | |
| 1 | 08:27-10:48 | 688.6 | 902.8 | -0.3 | 890.0 | 32,899 | 525 | 698.6 | 100.25 | 190.9433 |
| 2 | 12:00-14:19 | 674.3 | 447.8 | 0.5 | 436.5 | 30,116 | 525 | 692.0 | 80.90 | 173.1428 |
| 3 | 15:55-18:54 | 668.3 | 447.8 | -0.6 | 434.5 | 28,868 | 525 | 688.4 | 88.69 | 165.1155 |
| Average | | | | | | | | 693.0 | 92.61 | 176.4006 |

Calibration Error Correction

$C_{gas} = (C_{obs} - C_o) * (C_{ma} / (C_m - C_o))$
Mass Emission Rate (lb/hr)
 $E(lb/hr) = C_{gas} * MW_{gas} * Q_s(dscfm) * 60 / 385300000$
 $E(lb/hr)(Run 1) = 698.6 * 28.01 * 32,899 * 60 / 385300000 = 100.3$
Mass Emission Rate (lb/1000 lb fuel)
 $E(lb/MMBtu) = E(lb/hr) / Fuel\ flow * 1000$

| Pollutant | MWgas |
|-----------|-------|
| CO | 28.01 |
| Methane | 18.00 |
| NOx | 46.01 |
| SO2 | 64.08 |

CEM Data Correction Data Sheet

| | |
|--------------------|-------------------|
| Plant Name: | Moody AFB |
| Sampling Location: | Shipstream - Idle |
| Date: | 4/24/02 |
| Project Number: | 030197.0002.5 |
| CEM Operator: | Doug Allen |
| Pollutant: | CO |
| Molecular Weight: | 28.01 |

| Run No. | Start-Stop Time | Raw Data (ppm) | Calibration Data | | | Source Information | | Calibration Corrected Data (% or ppm) | Mass Emission Rate (lb/hr) | Mass Emission Rate (lb/1000 lb fuel) |
|---------|-----------------|----------------|------------------|------|-------|--------------------|-------------------|---------------------------------------|----------------------------|--------------------------------------|
| | | | Cma | Co | Cm | Stack Flow (dscfm) | Fuel Flow (lb/hr) | | | |
| 1 | 07:52-10:48 | 202.6 | 300.9 | -4.0 | 289.0 | 93,842 | 525 | 212.2 | 86.85 | 165.4257 |
| 2 | 11:26-14:21 | 179.9 | 300.9 | -4.0 | 292.0 | 94,610 | 525 | 186.9 | 77.13 | 146.9060 |
| 3 | 15:55-18:54 | 161.8 | 300.9 | -4.0 | 295.5 | 105,541 | 525 | 166.6 | 76.70 | 146.1005 |
| Average | | | | | | | | 188.6 | 80.23 | 152.8107 |

Calibration Error Correction

$C_{gas} = (C_{obs} - C_o) * (C_{ma} / (C_m - C_o))$
Mass Emission Rate (lb/hr)
 $E(lb/hr) = C_{gas} * MW_{gas} * Q_s(dscfm) * 60 / 385300000$
Mass Emission Rate (lb/1000 lb fuel)
 $E(lb/MMBtu) = E(lb/hr) / Fuel\ flow * 1000$

| Pollutant | MWgas |
|-----------|-------|
| CO | 28.01 |
| Methane | 18.00 |
| NOx | 46.01 |
| SO2 | 64.08 |

CEM Data Correction Data Sheet

| | |
|--------------------|---------------|
| Plant Name: | Moody AFB |
| Sampling Location: | Ambient |
| Date: | 4/24/02 |
| Project Number: | 030197.0002.5 |
| CEM Operator: | Doug Allen |
| Pollutant: | CO |
| Molecular Weight: | 0 |

| Run No. | Start-Stop Time | Raw Data (ppm) | Calibration Data | | | Calibration Corrected Data (% or ppm) |
|---------|-----------------|----------------|------------------|------|-------|---------------------------------------|
| | | | Cma | Co | Cm | |
| 1 | 07:52-08:21 | -0.3 | 902.8 | -0.3 | 890.0 | 0.00 |
| 2 | 11:26-11:55 | -0.3 | 447.8 | 0.5 | 436.5 | 0.00 |
| 3 | 15:20-15:49 | -0.5 | 447.8 | -0.6 | 434.5 | 0.10 |
| Average | | | | | | 0.03 |

Calibration Error Correction

$C_{gas} = (C_{obs} - C_o) * (C_{ma} / (C_m - C_o))$

CEM Data Correction Data Sheet

| | |
|--------------------|---------------|
| Plant Name: | Moody AFB |
| Sampling Location: | Engine - Idle |
| Date: | 4/24/02 |
| Project Number: | 030197.0002.5 |
| CEM Operator: | Doug Allen |
| Pollutant: | CO2 |
| Molecular Weight: | |

| Run No. | Start-Stop Time | Raw Data (% or ppm) | Calibration Data | | | Calibration Corrected Data (% or ppm) |
|---------|-----------------|---------------------|------------------|------|-----|---------------------------------------|
| | | | Cma | Co | Cm | |
| 1 | 08:27-10:46 | 0.6 | 9.9 | 0.0 | 9.8 | 0.6 |
| 2 | 12:00-14:19 | 0.6 | 9.9 | -0.1 | 9.9 | 0.7 |
| 3 | 15:55-16:54 | 0.6 | 9.9 | -0.2 | 9.9 | 0.7 |
| Average | | | | | | 0.7 |

Calibration Error Correction
 $C_{gas} = (C_{obs} - C_o) * (C_{ma} / (C_m - C_o))$

CEM Data Correction Data Sheet

| | |
|--------------------|-------------------|
| Plant Name: | Moody AFB |
| Sampling Location: | Slipstream - Idle |
| Date: | 4/24/02 |
| Project Number: | 030197.0002.5 |
| CEM Operator: | Doug Allen |
| Pollutant: | CO2 |
| Molecular Weight: | |

| Run No. | Start-Stop Time | Raw Data (% or ppm) | Calibration Data | | | Calibration Corrected Data (% or ppm) |
|---------|-----------------|---------------------|------------------|-------|------|---------------------------------------|
| | | | Cma | Co | Cm | |
| 1 | 07:52-10:48 | 0.204 | 1.01 | -0.03 | 0.98 | 0.231 |
| 2 | 11:26-14:21 | 0.203 | 1.01 | -0.03 | 0.98 | 0.231 |
| 3 | 15:55-18:54 | 0.181 | 1.01 | -0.02 | 0.98 | 0.207 |
| Average | | | | | | 0.223 |

Calibration Error Correction
 $C_{gas} = (C_{obs} - C_o) * (C_{ma} / (C_m - C_o))$

CEM Data Correction Data Sheet

| | |
|--------------------|---------------|
| Plant Name: | Moody AFB |
| Sampling Location: | Ambient |
| Date: | 4/24/02 |
| Project Number: | 030197.0002.5 |
| CEM Operator: | Doug Allen |
| Pollutant: | CO2 |
| Molecular Weight: | |

| Run No. | Start-Stop Time | Raw Data (% or ppm) | Calibration Data | | | Calibration Corrected Data (% or ppm) |
|---------|-----------------|---------------------|------------------|-------|------|---------------------------------------|
| | | | Cma | Co | Cm | |
| 1 | 07:52-08:21 | -0.03 | 9.94 | 0.00 | 9.80 | 0.000 |
| 2 | 11:26-11:55 | -0.06 | 9.94 | -0.10 | 9.85 | 0.040 |
| 3 | 15:20-15:49 | -0.09 | 9.94 | -0.15 | 9.90 | 0.059 |
| Average | | | | | | 0.033 |

Calibration Error Correction
 $C_{gas} = (C_{obs} - C_o) * (C_{ma} / (C_m - C_o))$

CEM Data Correction Data Sheet

| | |
|--------------------|---------------|
| Plant Name: | Moody AFB |
| Sampling Location: | Engine - Idle |
| Date: | 4/24/02 |
| Project Number: | 030197.0002.5 |
| CEM Operator: | Doug Allen |
| Pollutant: | O2 |
| Molecular Weight: | |

| Run No. | Start-Stop Time | Raw Data (% or ppm) | Calibration Data | | | Calibration Corrected Data (% or ppm) |
|---------|-----------------|---------------------|------------------|-----|------|---------------------------------------|
| | | | Cma | Co | Cm | |
| 1 | 08:27-10:46 | 19.9 | 20.0 | 0.1 | 19.9 | 20.0 |
| 2 | 12:00-14:19 | 19.8 | 20.0 | 0.1 | 19.9 | 19.9 |
| 3 | 15:55-16:54 | 19.7 | 20.0 | 0.1 | 19.8 | 19.9 |
| Average | | | | | | 19.9 |

Calibration Error Correction

$$C_{gas} = (C_{obs} - C_o) * (C_{ma} / (C_m - C_o))$$

CEM Data Correction Data Sheet

| | |
|--------------------|-------------------|
| Plant Name: | Moody AFB |
| Sampling Location: | Slipstream - Idle |
| Date: | 4/24/02 |
| Project Number: | 030197.0002.5 |
| CEM Operator: | Doug Allen |
| Pollutant: | O2 |
| Molecular Weight: | |

| Run No. | Start-Stop Time | Raw Data (% or ppm) | Calibration Data | | | Calibration Corrected Data (% or ppm) |
|---------|-----------------|---------------------|------------------|------|------|---------------------------------------|
| | | | Cma | Co | Cm | |
| 1 | 07:52-10:48 | 20.8 | 20.0 | -0.3 | 20.1 | 20.7 |
| 2 | 11:26-14:21 | 20.8 | 20.0 | -0.4 | 20.1 | 20.7 |
| 3 | 15:55-16:54 | 20.2 | 20.0 | -0.5 | 19.8 | 20.4 |
| Average | | | | | | 20.6 |

Calibration Error Correction

$$C_{gas} = (C_{obs} - C_o) * (C_{ma} / (C_m - C_o))$$

CEM Data Correction Data Sheet

| | |
|--------------------|---------------|
| Plant Name: | Moody AFB |
| Sampling Location: | Ambient |
| Date: | 4/24/02 |
| Project Number: | 030197.0002.5 |
| CEM Operator: | Doug Allen |
| Pollutant: | O2 |
| Molecular Weight: | |

| Run No. | Start-Stop Time | Raw Data (% or ppm) | Calibration Data | | | Calibration Corrected Data (% or ppm) |
|---------|-----------------|---------------------|------------------|-----|------|---------------------------------------|
| | | | Cma | Co | Cm | |
| 1 | 07:52-08:21 | 20.9 | 20.0 | 0.1 | 19.9 | 21.0 |
| 2 | 11:26-11:55 | 20.9 | 20.0 | 0.1 | 19.9 | 21.0 |
| 3 | 15:20-15:49 | 20.8 | 20.0 | 0.1 | 19.8 | 21.0 |
| Average | | | | | | 21.0 |

Calibration Error Correction

$$C_{gas} = (C_{obs} - C_o) * (C_{ma} / (C_m - C_o))$$

Total Hydrocarbon Data Correction

| | |
|--------------------|---------------|
| Plant Name: | Moody AFB |
| Sampling Location: | Engine - Idle |
| Date: | 4/24/02 |
| Project Number: | 030197.0002.5 |
| CEM Operator: | Doug Allen |
| Pollutant: | THC |
| Molecular Weight: | 16.00 |

| Run No. | Start-Stop Time | Raw Data (ppm) | Source Information | | Corrected Data Dry Basis (ppm) | Mass Emission Rate (lb/hr) | Mass Emission Rate (lb/1000 lb fuel) |
|---------|-----------------|----------------|--------------------|--------------------|--------------------------------|----------------------------|--------------------------------------|
| | | | Stack Flow (dscfm) | Stack Moisture (%) | | | |
| 1 | 08:27-10:46 | 179.8 | 34,326 | 2.00 | 183.5 | 15.69 | 29.8881 |
| 2 | 12:00-14:19 | 155.5 | 32,817 | 2.00 | 158.7 | 12.98 | 24.7153 |
| 3 | 15:55-16:54 | 141.6 | 32,605 | 2.00 | 144.4 | 11.73 | 22.3502 |
| Average | | | | | 162.2 | 13.47 | 25.65 |

Moisture Correction

$$C_{gas(dry)} = C_{gas(wet)} / (1 - (\% \text{ moisture} / 100))$$

Mass Emission Rate (lb/hr)

$$E(\text{lb/hr}) = C_{gas(dry)} * MW_{gas} * Q_s(\text{dscfm}) * 60 / 385300000$$

Total Hydrocarbon Data Correction

| | |
|--------------------|-------------------|
| Plant Name: | Moody AFB |
| Sampling Location: | Slipstream - Idle |
| Date: | 4/24/02 |
| Project Number: | 030197.0002.5 |
| CEM Operator: | Doug Allen |
| Pollutant: | THC |
| Molecular Weight: | 16.00 |

| Run No. | Start-Stop Time | Raw Data (ppm) | Source Information | | Corrected Data Dry Basis (ppm) | Mass Emission Rate (lb/hr) | Mass Emission Rate (lb/1000 lb fuel) |
|---------|-----------------|----------------|--------------------|--------------------|--------------------------------|----------------------------|--------------------------------------|
| | | | Stack Flow (dscfm) | Stack Moisture (%) | | | |
| 1 | 07:52-10:48 | 41.4 | 155,513 | 2.00 | 42.2 | 16.35 | 31.1497 |
| 2 | 11:26-14:21 | 35.8 | 132,932 | 2.00 | 36.3 | 12.02 | 22.8928 |
| 3 | 15:55-16:54 | 28.3 | 67,668 | 2.00 | 28.9 | 4.87 | 9.2764 |
| Average | | | | | 35.8 | 11.08 | 21.11 |

Moisture Correction

$$C_{gas(dry)} = C_{gas(wet)} / (1 - (\% \text{ moisture} / 100))$$

Mass Emission Rate (lb/hr)

$$E(\text{lb/hr}) = C_{gas(dry)} * MW_{gas} * Q_s(\text{dscfm}) * 60 / 385300000$$

Total Hydrocarbon Data Correction

| | |
|--------------------|---------|
| Plant Name: | 0 |
| Sampling Location: | 0 |
| Date: | 4/24/02 |
| Project Number: | 0 |
| CEM Operator: | 0 |
| Pollutant: | THC |
| Molecular Weight: | 16.00 |

| Run No. | Start-Stop Time | Raw Data (ppm) |
|---------|-----------------|----------------|
| 1 | 0000 | 0.00 |
| 2 | 0000 | 0.00 |
| 3 | 0000 | 0.00 |

CEM Data Correction Data Sheet

| | |
|--------------------|---------------|
| Plant Name: | Moody AFB |
| Sampling Location: | Engine - Idle |
| Date: | 4/24/02 |
| Project Number: | 030197.0002.5 |
| CEM Operator: | Doug Allen |
| Pollutant: | NOx |
| Molecular Weight: | 46.01 |

| Run No. | Start-Stop Time | Raw Data (% or ppm) | Calibration Data | | | Source Information | | Calibration Corrected Data (% or ppm) | Mass Emission Rate (lb/hr) | Mass Emission Rate (lb/1000 lb fuel) |
|---------|-----------------|---------------------|------------------|-----|------|--------------------|-------------------|---------------------------------------|----------------------------|--------------------------------------|
| | | | Cma | Co | Cm | Stack Flow (dscfm) | Fuel Flow (lb/hr) | | | |
| 1 | 08:27-10:46 | 3.5 | 19.9 | 0.2 | 19.9 | 32,899 | 525 | 3.4 | 0.80 | 1.5198 |
| 2 | 12:00-14:19 | 3.8 | 19.9 | 0.3 | 19.4 | 30,118 | 525 | 3.7 | 0.79 | 1.5076 |
| 3 | 15:55-16:54 | 3.7 | 19.9 | 0.2 | 18.8 | 28,868 | 525 | 3.7 | 0.77 | 1.4751 |
| Average | | | | | | | | 3.6 | 0.79 | 1.5009 |

Calibration Error Correction

$C_{gas} = (C_{obs} - C_o) * (C_{ma} / (C_m - C_o))$

Mass Emission Rate (lb/hr)

$E(lb/hr) = C_{gas} * MW_{gas} * Q_s(dscfm) * 60 / 385300000$

Mass Emission Rate (lb/1000 lb fuel)

$E(lb/MMBtu) = E(lb/hr) / Fuel\ flow * 1000$

| Pollutant | MWgas |
|-----------|-------|
| CO | 28.01 |
| Methane | 16.00 |
| NOx | 46.01 |
| SO2 | 64.06 |

CEM Data Correction Data Sheet

| | |
|--------------------|-------------------|
| Plant Name: | Moody AFB |
| Sampling Location: | Slipstream - Idle |
| Date: | 4/24/02 |
| Project Number: | 030197.0002.5 |
| CEM Operator: | Doug Allen |
| Pollutant: | NOx |
| Molecular Weight: | 46.01 |

| Run No. | Start-Stop Time | Raw Data (% or ppm) | Calibration Data | | | Source Information | | Calibration Corrected Data (% or ppm) | Mass Emission Rate (lb/hr) | Mass Emission Rate (lb/1000 lb fuel) |
|---------|-----------------|---------------------|------------------|------|-----|--------------------|-------------------|---------------------------------------|----------------------------|--------------------------------------|
| | | | Cma | Co | Cm | Stack Flow (dscfm) | Fuel Flow (lb/hr) | | | |
| 1 | 07:52-10:48 | 0.40 | 10.1 | -0.2 | 9.6 | 83,735 | 525 | 0.6 | 0.38 | 0.7252 |
| 2 | 11:26-14:21 | 0.40 | 10.1 | -0.1 | 9.8 | 84,495 | 525 | 0.5 | 0.31 | 0.5921 |
| 3 | 15:55-16:54 | 0.40 | 10.1 | 0.1 | 9.8 | 105,389 | 525 | 0.4 | 0.27 | 0.5216 |
| Average | | | | | | | | 0.5 | 0.32 | 0.6130 |

Calibration Error Correction

$C_{gas} = (C_{obs} - C_o) * (C_{ma} / (C_m - C_o))$

Mass Emission Rate (lb/hr)

$E(lb/hr) = C_{gas} * MW_{gas} * Q_s(dscfm) * 60 / 385300000$

Mass Emission Rate (lb/1000 lb fuel)

$E(lb/MMBtu) = E(lb/hr) / Fuel\ flow * 1000$

| Pollutant | MWgas |
|-----------|-------|
| CO | 28.01 |
| Methane | 16.00 |
| NOx | 46.01 |
| SO2 | 64.06 |

CEM Data Correction Data Sheet

| | |
|--------------------|---------------|
| Plant Name: | Moody AFB |
| Sampling Location: | Ambient |
| Date: | 4/24/02 |
| Project Number: | 030197.0002.5 |
| CEM Operator: | Doug Allen |
| Pollutant: | NOx |
| Molecular Weight: | #REF! |

| Run No. | Start-Stop Time | Raw Data (% or ppm) | Calibration Data | | | Calibration Corrected Data (% or ppm) |
|---------|-----------------|---------------------|------------------|-----|------|---------------------------------------|
| | | | Cma | Co | Cm | |
| 1 | 07:52-08:21 | -0.05 | 19.9 | 0.2 | 19.9 | 0.00 |
| 2 | 11:26-11:55 | 0.00 | 19.9 | 0.3 | 19.4 | 0.00 |
| 3 | 15:26-15:49 | -0.04 | 19.9 | 0.2 | 18.8 | 0.00 |
| Average | | | | | | 0.00 |

Calibration Error Correction

$C_{gas} = (C_{obs} - C_o) * (C_{ma} / (C_m - C_o))$

CEM Data Correction Data Sheet

| | |
|--------------------|-----------------------|
| Plant Name: | Moody AFB |
| Sampling Location: | Engine - Intermediate |
| Date: | 4/25/02 |
| Project Number: | 030197.0002.5 |
| CEM Operator: | Doug Allen |
| Pollutant: | CO |
| Molecular Weight: | 28.01 |

| Run No. | Start-Stop Time | Raw Data (ppm) | Calibration Data | | | Source Information | | Calibration Corrected Data (% or ppm) | Mass Emission Rate (lb/hr) | Mass Emission Rate (lb/1000 lb fuel) |
|---------|-----------------|----------------|------------------|------|-------|--------------------|-------------------|---------------------------------------|----------------------------|--------------------------------------|
| | | | Cma | Co | Cm | Stack Flow (dscfm) | Fuel Flow (lb/hr) | | | |
| 1 | 09:10-10:29 | 202.4 | 447.8 | -4.0 | 420.5 | 61,513 | 1,045 | 217.7 | 58.42 | 55.9077 |
| 2 | 11:35-13:04 | 194.5 | 447.8 | -4.0 | 418.5 | 55,855 | 1,045 | 210.4 | 51.06 | 48.8648 |
| 3 | 13:25-14:24 | 190.7 | 447.8 | -4.5 | 418.5 | 53,421 | 1,045 | 206.7 | 48.16 | 46.0849 |
| Average | | | | | | | | 211.6 | 52.55 | 50.2858 |

Calibration Error Correction

$$C_{gas} = (C_{obs} - C_o) * (C_{ma} / (C_m - C_o))$$

$$\text{Mass Emission Rate (lb/hr)}$$

$$E(\text{lb/hr}) = C_{gas} * MW_{gas} * Q_s(\text{dscfm}) * 60 / 385300000$$

$$\text{Mass Emission Rate (lb/1000 lb fuel)}$$

$$E(\text{lb/MMBtu}) = E(\text{lb/hr}) / \text{Fuel flow} * 1000$$

| Pollutant | MWgas |
|-----------|-------|
| CO | 28.01 |
| Methane | 18.00 |
| NOx | 46.01 |
| SO2 | 64.06 |

CEM Data Correction Data Sheet

| | |
|--------------------|---------------------------|
| Plant Name: | Moody AFB |
| Sampling Location: | Slipstream - Intermediate |
| Date: | 4/25/02 |
| Project Number: | 030197.0002.5 |
| CEM Operator: | Doug Allen |
| Pollutant: | CO |
| Molecular Weight: | 28.01 |

| Run No. | Start-Stop Time | Raw Data (ppm) | Calibration Data | | | Source Information | | Calibration Corrected Data (% or ppm) | Mass Emission Rate (lb/hr) | Mass Emission Rate (lb/1000 lb fuel) |
|---------|-----------------|----------------|------------------|------|------|--------------------|-------------------|---------------------------------------|----------------------------|--------------------------------------|
| | | | Cma | Co | Cm | Stack Flow (dscfm) | Fuel Flow (lb/hr) | | | |
| 1 | 08:36-10:32 | 39.0 | 59.4 | -1.2 | 57.0 | 292,603 | 1,045 | 41.0 | 52.36 | 50.1013 |
| 2 | 11:10-13:07 | 37.0 | 59.4 | -1.2 | 55.9 | 292,063 | 1,045 | 39.7 | 50.62 | 48.4428 |
| 3 | 13:25-14:24 | 35.7 | 59.4 | -1.3 | 54.8 | 294,783 | 1,045 | 39.1 | 50.34 | 48.1688 |
| Average | | | | | | | | 40.0 | 51.11 | 48.9043 |

Calibration Error Correction

$$C_{gas} = (C_{obs} - C_o) * (C_{ma} / (C_m - C_o))$$

$$\text{Mass Emission Rate (lb/hr)}$$

$$E(\text{lb/hr}) = C_{gas} * MW_{gas} * Q_s(\text{dscfm}) * 60 / 385300000$$

$$\text{Mass Emission Rate (lb/1000 lb fuel)}$$

$$E(\text{lb/MMBtu}) = E(\text{lb/hr}) / \text{Fuel flow} * 1000$$

| Pollutant | MWgas |
|-----------|-------|
| CO | 28.01 |
| Methane | 18.00 |
| NOx | 46.01 |
| SO2 | 64.06 |

CEM Data Correction Data Sheet

| | |
|--------------------|---------------|
| Plant Name: | Moody AFB |
| Sampling Location: | Ambient |
| Date: | 4/25/02 |
| Project Number: | 030197.0002.5 |
| CEM Operator: | Doug Allen |
| Pollutant: | CO |
| Molecular Weight: | 0 |

| Run No. | Start-Stop Time | Raw Data (ppm) | Calibration Data | | | Calibration Corrected Data (% or ppm) |
|---------|-----------------|----------------|------------------|------|-------|---------------------------------------|
| | | | Cma | Co | Cm | |
| 1 | 08:36-09:05 | -4.1 | 447.8 | -4.0 | 420.5 | 0.00 |
| 2 | 11:01-11:30 | -4.1 | 447.8 | -4.0 | 418.5 | 0.00 |
| 3 | 14:30-14:59 | -4.5 | 447.8 | -4.5 | 418.5 | 0.00 |
| Average | | | | | | 0.00 |

Calibration Error Correction

$$C_{gas} = (C_{obs} - C_o) * (C_{ma} / (C_m - C_o))$$

CEM Data Correction Data Sheet

| | |
|--------------------|-----------------------|
| Plant Name: | Moody AFB |
| Sampling Location: | Engine - Intermediate |
| Date: | 4/25/02 |
| Project Number: | 030197.0002.5 |
| CEM Operator: | Doug Allen |
| Pollutant: | CO2 |
| Molecular Weight: | |

| Run No. | Start-Stop Time | Raw Data (% or ppm) | Calibration Data | | | Calibration Corrected Data (% or ppm) |
|---------|-----------------|---------------------|------------------|------|------|---------------------------------------|
| | | | Cma | Co | Cm | |
| 1 | 09:10-10:28 | 0.6 | 9.9 | -0.2 | 10.1 | 0.8 |
| 2 | 11:35-13:04 | 0.6 | 9.9 | -0.3 | 10.0 | 0.8 |
| 3 | 13:25-14:24 | 0.6 | 9.9 | -0.3 | 10.0 | 0.9 |
| Average | | | | | | 0.8 |

Calibration Error Correction

$$C_{gas} = (C_{obs} - C_o) * (C_{ma} / (C_m - C_o))$$

CEM Data Correction Data Sheet

| | |
|--------------------|---------------------------|
| Plant Name: | Moody AFB |
| Sampling Location: | Stipstream - Intermediate |
| Date: | 4/25/02 |
| Project Number: | 030197.0002.5 |
| CEM Operator: | Doug Allen |
| Pollutant: | CO2 |
| Molecular Weight: | |

| Run No. | Start-Stop Time | Raw Data (% or ppm) | Calibration Data | | | Calibration Corrected Data (% or ppm) |
|---------|-----------------|---------------------|------------------|-------|------|---------------------------------------|
| | | | Cma | Co | Cm | |
| 1 | 08:36-10:32 | 0.132 | 1.01 | -0.03 | 0.98 | 0.159 |
| 2 | 11:10-13:07 | 0.134 | 1.01 | -0.02 | 0.97 | 0.159 |
| 3 | 13:25-14:24 | 0.135 | 1.01 | -0.02 | 0.97 | 0.158 |
| Average | | | | | | 0.159 |

Calibration Error Correction

$$C_{gas} = (C_{obs} - C_o) * (C_{ma} / (C_m - C_o))$$

CEM Data Correction Data Sheet

| | |
|--------------------|---------------|
| Plant Name: | Moody AFB |
| Sampling Location: | Ambient |
| Date: | 4/25/02 |
| Project Number: | 030197.0002.5 |
| CEM Operator: | Doug Allen |
| Pollutant: | CO2 |
| Molecular Weight: | |

| Run No. | Start-Stop Time | Raw Data (% or ppm) | Calibration Data | | | Calibration Corrected Data (% or ppm) |
|---------|-----------------|---------------------|------------------|-------|-------|---------------------------------------|
| | | | Cma | Co | Cm | |
| 1 | 08:36-09:05 | -0.03 | 9.94 | -0.15 | 10.05 | 0.112 |
| 2 | 11:01-11:30 | -0.07 | 9.94 | -0.25 | 10.00 | 0.179 |
| 3 | 14:30-14:59 | -0.09 | 9.94 | -0.30 | 10.00 | 0.203 |
| Average | | | | | | 0.165 |

Calibration Error Correction

$$C_{gas} = (C_{obs} - C_o) * (C_{ma} / (C_m - C_o))$$

CEM Data Correction Data Sheet

| | |
|--------------------|-----------------------|
| Plant Name: | Moody AFB |
| Sampling Location: | Engine - Intermediate |
| Date: | 4/25/02 |
| Project Number: | 030197.0002.5 |
| CEM Operator: | Doug Allen |
| Pollutant: | O2 |
| Molecular Weight: | |

| Run No. | Start-Stop Time | Raw Data (% or ppm) | Calibration Data | | | Calibration Corrected Data (% or ppm) |
|---------|-----------------|---------------------|------------------|-----|------|---------------------------------------|
| | | | Cma | Co | Cm | |
| 1 | 09:10-10:29 | 19.9 | 20.0 | 0.1 | 19.8 | 20.1 |
| 2 | 11:35-13:04 | 19.8 | 20.0 | 0.1 | 19.8 | 20.0 |
| 3 | 13:25-14:24 | 19.8 | 20.0 | 0.1 | 19.8 | 20.0 |
| Average | | | | | | 20.0 |

Calibration Error Correction

$$C_{gas} = (C_{obs} - C_o) * (C_{ma} / (C_m - C_o))$$

CEM Data Correction Data Sheet

| | |
|--------------------|---------------------------|
| Plant Name: | Moody AFB |
| Sampling Location: | Slipstream - Intermediate |
| Date: | 4/25/02 |
| Project Number: | 030197.0002.5 |
| CEM Operator: | Doug Allen |
| Pollutant: | O2 |
| Molecular Weight: | |

| Run No. | Start-Stop Time | Raw Data (% or ppm) | Calibration Data | | | Calibration Corrected Data (% or ppm) |
|---------|-----------------|---------------------|------------------|------|------|---------------------------------------|
| | | | Cma | Co | Cm | |
| 1 | 08:36-10:32 | 21.1 | 20.0 | -0.5 | 21.0 | 20.1 |
| 2 | 11:10-13:07 | 20.8 | 20.0 | -0.5 | 20.8 | 20.0 |
| 3 | 13:25-14:24 | 20.6 | 20.0 | -0.5 | 20.5 | 20.2 |
| Average | | | | | | 20.1 |

Calibration Error Correction

$$C_{gas} = (C_{obs} - C_o) * (C_{ma} / (C_m - C_o))$$

CEM Data Correction Data Sheet

| | |
|--------------------|---------------|
| Plant Name: | Moody AFB |
| Sampling Location: | Ambient |
| Date: | 4/25/02 |
| Project Number: | 030197.0002.5 |
| CEM Operator: | Doug Allen |
| Pollutant: | O2 |
| Molecular Weight: | |

| Run No. | Start-Stop Time | Raw Data (% or ppm) | Calibration Data | | | Calibration Corrected Data (% or ppm) |
|---------|-----------------|---------------------|------------------|-----|------|---------------------------------------|
| | | | Cma | Co | Cm | |
| 1 | 08:36-09:05 | 20.9 | 20.0 | 0.1 | 19.8 | 21.1 |
| 2 | 11:01-11:30 | 20.9 | 20.0 | 0.1 | 19.8 | 21.1 |
| 3 | 14:30-14:59 | 20.8 | 20.0 | 0.1 | 19.8 | 21.0 |
| Average | | | | | | 21.1 |

Calibration Error Correction

$$C_{gas} = (C_{obs} - C_o) * (C_{ma} / (C_m - C_o))$$

Total Hydrocarbon Data Correction

| | |
|--------------------|-----------------------|
| Plant Name: | Moody AFB |
| Sampling Location: | Engine - Intermediate |
| Date: | 4/25/02 |
| Project Number: | 030197.0002.5 |
| CEM Operator: | Doug Allen |
| Pollutant: | THC |
| Molecular Weight: | 16.00 |

| Run No. | Start-Stop Time | Raw Data (ppm) | Source Information | | Corrected Data Dry Basis (ppm) | Mass Emission Rate (lb/hr) | Mass Emission Rate (lb/1000 lb fuel) |
|---------|-----------------|----------------|--------------------|--------------------|--------------------------------|----------------------------|--------------------------------------|
| | | | Stack Flow (dscfm) | Stack Moisture (%) | | | |
| 1 | 09:10-10:29 | 12.1 | 61,513 | 1.50 | 12.3 | 1.89 | 1.8070 |
| 2 | 11:35-13:04 | 9.1 | 55,655 | 1.50 | 9.2 | 1.28 | 1.2242 |
| 3 | 13:25-14:24 | 7.6 | 53,421 | 1.50 | 7.7 | 1.02 | 0.9795 |
| Average | | | | | 9.7 | 1.40 | 1.34 |

Moisture Correction

$$C_{gas(dry)} = C_{gas(wet)} / (1 - (\% \text{ moisture}/100))$$

$$\text{Mass Emission Rate (lb/hr)}$$

$$E(\text{lb/hr}) = C_{gas(dry)} * MW_{gas} * Q_s(\text{dscfm}) * 60/385300000$$

Total Hydrocarbon Data Correction

| | |
|--------------------|---------------------------|
| Plant Name: | Moody AFB |
| Sampling Location: | Slipstream - Intermediate |
| Date: | 4/25/02 |
| Project Number: | 030197.0002.5 |
| CEM Operator: | Doug Allen |
| Pollutant: | THC |
| Molecular Weight: | 16.00 |

| Run No. | Start-Stop Time | Raw Data (ppm) | Source Information | | Corrected Data Dry Basis (ppm) | Mass Emission Rate (lb/hr) | Mass Emission Rate (lb/1000 lb fuel) |
|---------|-----------------|----------------|--------------------|--------------------|--------------------------------|----------------------------|--------------------------------------|
| | | | Stack Flow (dscfm) | Stack Moisture (%) | | | |
| 1 | 08:38-10:32 | 3.1 | 292,803 | 1.50 | 3.1 | 2.29 | 2.1904 |
| 2 | 11:10-13:07 | 2.2 | 292,083 | 1.50 | 2.2 | 1.62 | 1.5549 |
| 3 | 13:25-14:24 | 1.5 | 294,783 | 1.50 | 1.6 | 1.16 | 1.1031 |
| Average | | | | | 2.3 | 1.69 | 1.62 |

Moisture Correction

$$C_{gas(dry)} = C_{gas(wet)} / (1 - (\% \text{ moisture}/100))$$

$$\text{Mass Emission Rate (lb/hr)}$$

$$E(\text{lb/hr}) = C_{gas(dry)} * MW_{gas} * Q_s(\text{dscfm}) * 60/385300000$$

Total Hydrocarbon Data Correction

| | |
|--------------------|---------------|
| Plant Name: | Moody AFB |
| Sampling Location: | Ambient |
| Date: | 4/25/02 |
| Project Number: | 030197.0002.5 |
| CEM Operator: | Doug Allen |
| Pollutant: | THC |
| Molecular Weight: | 16.00 |

| Run No. | Start-Stop Time | Raw Data (ppm) |
|---------|-----------------|----------------|
| 1 | 08:36-09:05 | -0.45 |
| 2 | 11:01-11:30 | -0.48 |
| 3 | 14:30-14:59 | -0.20 |

CEM Data Correction Data Sheet

| | |
|--------------------|-----------------------|
| Plant Name: | Moody AFB |
| Sampling Location: | Engine - Intermediate |
| Date: | 4/25/02 |
| Project Number: | 030197.0002.5 |
| CEM Operator: | Doug Allen |
| Pollutant: | NOx |
| Molecular Weight: | 46.01 |

| Run No. | Start-Stop Time | Raw Data (% or ppm) | Calibration Data | | | Source Information | | Calibration Corrected Data (% or ppm) | Mass Emission Rate (lb/hr) | Mass Emission Rate (lb/1000 lb fuel) |
|---------|-----------------|---------------------|------------------|-----|------|--------------------|-------------------|---------------------------------------|----------------------------|--------------------------------------|
| | | | Cma | Co | Cm | Stack Flow (dscfm) | Fuel Flow (lb/hr) | | | |
| 1 | 09:10-10:29 | 5.5 | 19.9 | 0.2 | 19.5 | 61,513 | 1,045 | 5.5 | 2.44 | 2.3380 |
| 2 | 11:35-13:04 | 5.6 | 19.9 | 0.5 | 18.9 | 55,655 | 1,045 | 5.6 | 2.22 | 2.1263 |
| 3 | 13:25-14:24 | 5.7 | 19.9 | 0.3 | 18.3 | 53,421 | 1,045 | 6.0 | 2.29 | 2.1687 |
| Average | | | | | | | | 5.7 | 2.32 | 2.2177 |

Calibration Error Correction

$C_{gas} = (C_{obs} - C_o) * (C_{ma} / (C_m - C_o))$
 Mass Emission Rate (lb/hr)
 $E (lb/hr) = C_{gas} * MW_{gas} * Q_s (dscfm) * 60 / 385300000$
 Mass Emission Rate (lb/1000 lb fuel)
 $E (lb/MMBtu) = E (lb/hr) / Fuel\ flow * 1000$

| Pollutant | MWgas |
|-----------|-------|
| CO | 28.01 |
| Methane | 16.00 |
| NOx | 46.01 |
| SO2 | 64.06 |

CEM Data Correction Data Sheet

| | |
|--------------------|---------------------------|
| Plant Name: | Moody AFB |
| Sampling Location: | Slipstream - Intermediate |
| Date: | 4/25/02 |
| Project Number: | 030197.0002.5 |
| CEM Operator: | Doug Allen |
| Pollutant: | NOx |
| Molecular Weight: | 46.01 |

| Run No. | Start-Stop Time | Raw Data (% or ppm) | Calibration Data | | | Source Information | | Calibration Corrected Data (% or ppm) | Mass Emission Rate (lb/hr) | Mass Emission Rate (lb/1000 lb fuel) |
|---------|-----------------|---------------------|------------------|------|------|--------------------|-------------------|---------------------------------------|----------------------------|--------------------------------------|
| | | | Cma | Co | Cm | Stack Flow (dscfm) | Fuel Flow (lb/hr) | | | |
| 1 | 08:36-10:32 | 0.80 | 10.1 | -0.2 | 10.2 | 292,603 | 1,045 | 1.0 | 2.03 | 1.9386 |
| 2 | 11:10-13:07 | 0.80 | 10.1 | -0.2 | 10.3 | 292,063 | 1,045 | 0.9 | 1.91 | 1.8295 |
| 3 | 13:25-14:24 | 0.80 | 10.1 | -0.1 | 10.9 | 294,783 | 1,045 | 0.8 | 1.74 | 1.6695 |
| Average | | | | | | | | 0.9 | 1.89 | 1.8126 |

Calibration Error Correction

$C_{gas} = (C_{obs} - C_o) * (C_{ma} / (C_m - C_o))$
 Mass Emission Rate (lb/hr)
 $E (lb/hr) = C_{gas} * MW_{gas} * Q_s (dscfm) * 60 / 385300000$
 Mass Emission Rate (lb/1000 lb fuel)
 $E (lb/MMBtu) = E (lb/hr) / Fuel\ flow * 1000$

| Pollutant | MWgas |
|-----------|-------|
| CO | 28.01 |
| Methane | 16.00 |
| NOx | 46.01 |
| SO2 | 64.06 |

CEM Data Correction Data Sheet

| | |
|--------------------|---------------|
| Plant Name: | Moody AFB |
| Sampling Location: | Ambient |
| Date: | 4/25/02 |
| Project Number: | 030197.0002.5 |
| CEM Operator: | Doug Allen |
| Pollutant: | NOx |
| Molecular Weight: | #REF! |

| Run No. | Start-Stop Time | Raw Data (% or ppm) | Calibration Data | | | Calibration Corrected Data (% or ppm) |
|---------|-----------------|---------------------|------------------|-----|------|---------------------------------------|
| | | | Cma | Co | Cm | |
| 1 | 08:36-09:05 | -0.04 | 19.9 | 0.2 | 19.5 | 0.00 |
| 2 | 11:01-11:30 | -0.04 | 19.9 | 0.5 | 18.9 | 0.00 |
| 3 | 14:30-14:59 | -0.08 | 19.9 | 0.3 | 18.3 | 0.00 |
| Average | | | | | | 0.00 |

Calibration Error Correction

$C_{gas} = (C_{obs} - C_o) * (C_{ma} / (C_m - C_o))$

CEM Data Correction Data Sheet

| | |
|--------------------|-------------------|
| Plant Name: | Moody AFB |
| Sampling Location: | Engine - Military |
| Date: | 4/26/02 |
| Project Number: | 030197.0002.5 |
| CEM Operator: | Doug Allen |
| Pollutant: | CO |
| Molecular Weight: | 28.01 |

| Run No. | Start-Stop Time | Raw Data (ppm) | Calibration Data | | | Source Information | | Calibration Corrected Data (% or ppm) | Mass Emission Rate (lb/hr) | Mass Emission Rate (lb/1000 lb fuel) |
|-----------------|-----------------|----------------|------------------|------|-------|--------------------|-------------------|---------------------------------------|----------------------------|--------------------------------------|
| | | | Cma | Co | Cm | Stack Flow (dscfm) | Fuel Flow (lb/hr) | | | |
| 1 | 08:30-09:54 | 177.4 | 300.9 | -4.0 | 282.5 | 87,364 | 2,550 | 190.5 | 72.59 | 28.4857 |
| 2 | 11:02-12:27 | 170.9 | 300.9 | -4.0 | 282.5 | 83,385 | 2,550 | 183.7 | 66.80 | 26.1955 |
| 3 | 12:41-12:57 | 172.0 | 300.9 | -4.0 | 279.5 | 82,048 | 2,550 | 186.8 | 66.86 | 26.2187 |
| Average | | | | | | | | 187.0 | 68.75 | 26.9600 |
| A/B 15:35-15:38 | | 156.7 | 300.9 | -4.0 | 279.5 | 21,314 | 2,230 | 170.5 | 15.65 | 7.1085 |

Calibration Error Correction
 $C_{gas} = (C_{obs} - C_o) * (C_{ma} / (C_m - C_o))$

Mass Emission Rate (lb/hr)

$E (lb/hr) = C_{gas} * MW_{gas} * Q_s (dscfm) * 60 / 385300000$

Mass Emission Rate (lb/1000 lb fuel)

$E (lb/MMBtu) = E (lb/hr) / Fuel\ flow * 1000$

| Pollutant | MW _{gas} |
|-----------|-------------------|
| CO | 28.01 |
| Methane | 16.00 |
| NOx | 46.01 |
| SO2 | 64.06 |

CEM Data Correction Data Sheet

| | |
|--------------------|-----------------------|
| Plant Name: | Moody AFB |
| Sampling Location: | Slipstream - Military |
| Date: | 4/26/02 |
| Project Number: | 030197.0002.5 |
| CEM Operator: | Doug Allen |
| Pollutant: | CO |
| Molecular Weight: | 28.01 |

| Run No. | Start-Stop Time | Raw Data (ppm) | Calibration Data | | | Source Information | | Calibration Corrected Data (% or ppm) | Mass Emission Rate (lb/hr) | Mass Emission Rate (lb/1000 lb fuel) |
|-----------------|-----------------|----------------|------------------|------|------|--------------------|-------------------|---------------------------------------|----------------------------|--------------------------------------|
| | | | Cma | Co | Cm | Stack Flow (dscfm) | Fuel Flow (lb/hr) | | | |
| 1 | 07:54-09:54 | 26.9 | 59.4 | -1.1 | 57.4 | 554,869 | 2,550 | 28.4 | 68.65 | 26.9227 |
| 2 | 10:33-12:27 | 25.0 | 59.4 | -1.0 | 57.3 | 547,724 | 2,550 | 28.6 | 63.26 | 24.8067 |
| 3 | 12:41-14:18 | 24.9 | 59.4 | -1.1 | 56.6 | 530,345 | 2,550 | 26.8 | 61.99 | 24.3085 |
| Average | | | | | | | | 27.2 | 64.63 | 25.3459 |
| A/B 15:35-15:38 | | 27.4 | 59.4 | -1.1 | 56.6 | 177,277 | 2,230 | 29.4 | 22.71 | 10.1850 |

Calibration Error Correction

$C_{gas} = (C_{obs} - C_o) * (C_{ma} / (C_m - C_o))$

Mass Emission Rate (lb/hr)

$E (lb/hr) = C_{gas} * MW_{gas} * Q_s (dscfm) * 60 / 385300000$

Mass Emission Rate (lb/1000 lb fuel)

$E (lb/MMBtu) = E (lb/hr) / Fuel\ flow * 1000$

| Pollutant | MW _{gas} |
|-----------|-------------------|
| CO | 28.01 |
| Methane | 16.00 |
| NOx | 46.01 |
| SO2 | 64.06 |

CEM Data Correction Data Sheet

| | |
|--------------------|---------------|
| Plant Name: | Moody AFB |
| Sampling Location: | Ambient |
| Date: | 4/26/02 |
| Project Number: | 030197.0002.5 |
| CEM Operator: | Doug Allen |
| Pollutant: | CO |
| Molecular Weight: | 0 |

| Run No. | Start-Stop Time | Raw Data (ppm) | Calibration Data | | | Calibration Corrected Data (% or ppm) |
|---------|-----------------|----------------|------------------|------|-------|---------------------------------------|
| | | | Cma | Co | Cm | |
| 1 | 07:53-08:22 | -4.1 | 300.9 | -4.0 | 282.5 | 0.00 |
| 2 | 10:25-10:54 | -4.1 | 300.9 | -4.0 | 282.5 | 0.00 |
| 3 | 14:25-14:54 | -4.1 | 300.9 | -4.0 | 279.5 | 0.00 |
| Average | | | | | | 0.00 |

Calibration Error Correction

$C_{gas} = (C_{obs} - C_o) * (C_{ma} / (C_m - C_o))$

CEM Data Correction Data Sheet

| | |
|--------------------|-------------------|
| Plant Name: | Moody AFB |
| Sampling Location: | Engine - Military |
| Date: | 4/26/02 |
| Project Number: | 030197.0002.5 |
| CEM Operator: | Doug Allen |
| Pollutant: | CO2 |
| Molecular Weight: | |

| Run No. | Start-Stop Time | Raw Data (% or ppm) | Calibration Data | | | Calibration Corrected Data (% or ppm) |
|---------|-----------------|---------------------|------------------|------|------|---------------------------------------|
| | | | Cma | Co | Cm | |
| 1 | 08:30-09:54 | 1.3 | 9.9 | 0.0 | 9.9 | 1.3 |
| 2 | 11:02-12:27 | 1.3 | 9.9 | -0.1 | 10.0 | 1.4 |
| 3 | 12:41-12:57 | 1.3 | 9.9 | -0.1 | 9.8 | 1.4 |
| Average | | | | | | 1.4 |

| | | | | | | |
|-----|-------------|-----|-----|------|-----|-----|
| A/B | 15:35-15:38 | 4.6 | 9.9 | -0.1 | 9.8 | 4.8 |
|-----|-------------|-----|-----|------|-----|-----|

Calibration Error Correction

$$C_{gas} = (C_{obs} - C_o) * (C_{ma} / (C_m - C_o))$$

CEM Data Correction Data Sheet

| | |
|--------------------|-----------------------|
| Plant Name: | Moody AFB |
| Sampling Location: | Slipstream - Military |
| Date: | 4/26/02 |
| Project Number: | 030197.0002.5 |
| CEM Operator: | Doug Allen |
| Pollutant: | CO2 |
| Molecular Weight: | |

| Run No. | Start-Stop Time | Raw Data (% or ppm) | Calibration Data | | | Calibration Corrected Data (% or ppm) |
|---------|-----------------|---------------------|------------------|-------|------|---------------------------------------|
| | | | Cma | Co | Cm | |
| 1 | 07:54-09:54 | 0.187 | 1.01 | -0.02 | 1.00 | 0.207 |
| 2 | 10:33-12:27 | 0.187 | 1.01 | -0.02 | 0.99 | 0.210 |
| 3 | 12:41-14:18 | 0.181 | 1.01 | -0.02 | 0.98 | 0.217 |
| Average | | | | | | 0.212 |

| | | | | | | |
|-----|-------------|-----|-----|-----|-----|-----|
| A/B | 15:35-15:38 | 0.5 | 1.0 | 0.0 | 1.0 | 0.6 |
|-----|-------------|-----|-----|-----|-----|-----|

Calibration Error Correction

$$C_{gas} = (C_{obs} - C_o) * (C_{ma} / (C_m - C_o))$$

CEM Data Correction Data Sheet

| | |
|--------------------|---------------|
| Plant Name: | Moody AFB |
| Sampling Location: | Ambient |
| Date: | 4/26/02 |
| Project Number: | 030197.0002.5 |
| CEM Operator: | Doug Allen |
| Pollutant: | CO2 |
| Molecular Weight: | |

| Run No. | Start-Stop Time | Raw Data (% or ppm) | Calibration Data | | | Calibration Corrected Data (% or ppm) |
|---------|-----------------|---------------------|------------------|-------|------|---------------------------------------|
| | | | Cma | Co | Cm | |
| 1 | 07:53-08:22 | 0.00 | 9.94 | 0.00 | 9.85 | 0.000 |
| 2 | 10:25-10:54 | 0.00 | 9.94 | -0.10 | 9.95 | 0.101 |
| 3 | 14:25-14:54 | -0.03 | 9.94 | -0.10 | 9.80 | 0.068 |
| Average | | | | | | 0.055 |

Calibration Error Correction

$$C_{gas} = (C_{obs} - C_o) * (C_{ma} / (C_m - C_o))$$

CEM Data Correction Data Sheet

| | |
|--------------------|-------------------|
| Plant Name: | Moody AFB |
| Sampling Location: | Engine - Military |
| Date: | 4/26/02 |
| Project Number: | 030197.0002.5 |
| CEM Operator: | Doug Allen |
| Pollutant: | O2 |
| Molecular Weight: | |

| Run No. | Start-Stop Time | Raw Data (% or ppm) | Calibration Data | | | Calibration Corrected Data (% or ppm) |
|---------|-----------------|---------------------|------------------|-----|------|---------------------------------------|
| | | | Cma | Co | Cm | |
| 1 | 08:30-09:54 | 19.2 | 20.0 | 0.1 | 20.0 | 19.2 |
| 2 | 11:02-12:27 | 19.2 | 20.0 | 0.1 | 20.0 | 19.2 |
| 3 | 12:41-12:57 | 19.1 | 20.0 | 0.6 | 20.0 | 19.2 |
| Average | | | | | | 19.2 |

| | | | | | | |
|-----|-------------|------|------|-----|------|------|
| A/B | 15:35-15:38 | 14.4 | 20.0 | 0.6 | 20.0 | 14.3 |
|-----|-------------|------|------|-----|------|------|

Calibration Error Correction

$$C_{gas} = (C_{obs} - Co) * (Cma / (Cm - Co))$$

CEM Data Correction Data Sheet

| | |
|--------------------|-----------------------|
| Plant Name: | Moody AFB |
| Sampling Location: | Slipstream - Military |
| Date: | 4/26/02 |
| Project Number: | 030197.0002.5 |
| CEM Operator: | Doug Allen |
| Pollutant: | O2 |
| Molecular Weight: | |

| Run No. | Start-Stop Time | Raw Data (% or ppm) | Calibration Data | | | Calibration Corrected Data (% or ppm) |
|---------|-----------------|---------------------|------------------|------|------|---------------------------------------|
| | | | Cma | Co | Cm | |
| 1 | 07:54-09:54 | 20.8 | 20.0 | -0.5 | 20.4 | 20.6 |
| 2 | 10:33-12:27 | 20.9 | 20.0 | -0.5 | 20.4 | 20.5 |
| 3 | 12:41-14:18 | 20.7 | 20.0 | -0.5 | 20.0 | 20.8 |
| Average | | | | | | 20.6 |

| | | | | | | |
|-----|-------------|------|------|------|------|------|
| A/B | 15:35-15:38 | 20.0 | 20.0 | -0.5 | 20.0 | 20.1 |
|-----|-------------|------|------|------|------|------|

Calibration Error Correction

$$C_{gas} = (C_{obs} - Co) * (Cma / (Cm - Co))$$

CEM Data Correction Data Sheet

| | |
|--------------------|---------------|
| Plant Name: | Moody AFB |
| Sampling Location: | Ambient |
| Date: | 4/26/02 |
| Project Number: | 030197.0002.5 |
| CEM Operator: | Doug Allen |
| Pollutant: | O2 |
| Molecular Weight: | |

| Run No. | Start-Stop Time | Raw Data (% or ppm) | Calibration Data | | | Calibration Corrected Data (% or ppm) |
|---------|-----------------|---------------------|------------------|-----|------|---------------------------------------|
| | | | Cma | Co | Cm | |
| 1 | 07:53-08:22 | 20.9 | 20.0 | 0.1 | 20.0 | 21.0 |
| 2 | 10:25-10:54 | 20.9 | 20.0 | 0.1 | 20.0 | 20.9 |
| 3 | 14:25-14:54 | 20.9 | 20.0 | 0.6 | 20.0 | 21.0 |
| Average | | | | | | 21.0 |

Calibration Error Correction

$$C_{gas} = (C_{obs} - Co) * (Cma / (Cm - Co))$$

Total Hydrocarbon Data Correction

| | |
|--------------------|-------------------|
| Plant Name: | Moody AFB |
| Sampling Location: | Engine - Military |
| Date: | 4/26/02 |
| Project Number: | 030197.0002.5 |
| CEM Operator: | Doug Allen |
| Pollutant: | THC |
| Molecular Weight: | 16.00 |

| Run No. | Start-Stop Time | Raw Data (ppm) | Source Information | | Corrected Data Dry Basis (ppm) | Mass Emission Rate (lb/hr) | Mass Emission Rate (lb/1000 lb fuel) |
|---------|-----------------|----------------|--------------------|--------------------|--------------------------------|----------------------------|--------------------------------------|
| | | | Stack Flow (dscfm) | Stack Moisture (%) | | | |
| 1 | 08:30-09:54 | 2.0 | 87,364 | 1.50 | 2.0 | 0.44 | 0.1733 |
| 2 | 11:02-12:27 | 2.0 | 83,385 | 1.50 | 2.0 | 0.42 | 0.1654 |
| 3 | 12:41-12:57 | 2.0 | 82,049 | 1.50 | 2.0 | 0.42 | 0.1628 |
| Average | | | | | 2.0 | 0.43 | 0.17 |

| | | | | | | | |
|-----|-------------|-----|--------|------|-----|------|--------|
| A/B | 15:35-15:38 | 9.1 | 21,314 | 1.50 | 9.2 | 0.49 | 0.2190 |
|-----|-------------|-----|--------|------|-----|------|--------|

Moisture Correction

$$C_{gas(dry)} = C_{gas(wet)} / (1 - (\% \text{ moisture}/100))$$

$$\text{Mass Emission Rate (lb/hr)}$$

$$E(\text{lb/hr}) = C_{gas(dry)} * MW_{gas} * Q_s(\text{dscfm}) * 60 / 385300000$$

Total Hydrocarbon Data Correction

| | |
|--------------------|-----------------------|
| Plant Name: | Moody AFB |
| Sampling Location: | Slipstream - Military |
| Date: | 4/26/02 |
| Project Number: | 030197.0002.5 |
| CEM Operator: | Doug Allen |
| Pollutant: | THC |
| Molecular Weight: | 16.00 |

| Run No. | Start-Stop Time | Raw Data (ppm) | Source Information | | Corrected Data Dry Basis (ppm) | Mass Emission Rate (lb/hr) | Mass Emission Rate (lb/1000 lb fuel) |
|---------|-----------------|----------------|--------------------|--------------------|--------------------------------|----------------------------|--------------------------------------|
| | | | Stack Flow (dscfm) | Stack Moisture (%) | | | |
| 1 | 07:54-09:54 | 1.3 | 554,869 | 1.50 | 1.3 | 1.79 | 0.7009 |
| 2 | 10:33-12:27 | 0.7 | 547,724 | 1.50 | 0.7 | 0.96 | 0.3769 |
| 3 | 12:41-14:18 | 0.5 | 530,345 | 1.50 | 0.5 | 0.72 | 0.2835 |
| Average | | | | | 0.8 | 1.16 | 0.45 |

| | | | | | | | |
|-----|-------------|-----|---------|------|-----|------|--------|
| A/B | 14:25-14:54 | 3.2 | 177,277 | 1.50 | 3.3 | 1.45 | 0.6520 |
|-----|-------------|-----|---------|------|-----|------|--------|

Moisture Correction

$$C_{gas(dry)} = C_{gas(wet)} / (1 - (\% \text{ moisture}/100))$$

$$\text{Mass Emission Rate (lb/hr)}$$

$$E(\text{lb/hr}) = C_{gas(dry)} * MW_{gas} * Q_s(\text{dscfm}) * 60 / 385300000$$

Total Hydrocarbon Data Correction

| | |
|--------------------|---------------|
| Plant Name: | Moody AFB |
| Sampling Location: | Ambient |
| Date: | 4/26/02 |
| Project Number: | 030197.0002.5 |
| CEM Operator: | Doug Allen |
| Pollutant: | THC |
| Molecular Weight: | 16.00 |

| Run No. | Start-Stop Time | Raw Data (ppm) |
|---------|-----------------|----------------|
| 1 | 07:53-08:22 | 0.68 |
| 2 | 10:25-10:54 | 0.64 |
| 3 | 14:25-14:54 | 0.79 |

CEM Data Correction Data Sheet

| | |
|--------------------|-------------------|
| Plant Name: | Moody AFB |
| Sampling Location: | Engine - Military |
| Date: | 4/26/02 |
| Project Number: | 030197.0002.5 |
| CEM Operator: | Doug Allen |
| Pollutant: | NOx |
| Molecular Weight: | 46.01 |

| Run No. | Start-Stop Time | Raw Data (% or ppm) | Calibration Data | | | Source Information | | Calibration Corrected Data (% or ppm) | Mass Emission Rate (lb/hr) | Mass Emission Rate (lb/1000 lb fuel) | | | | | | | | | | | |
|---|-----------------|---------------------|------------------|-----|------|--------------------|-------------------|---------------------------------------|----------------------------|--------------------------------------|-----|-------------|------|------|-----|------|--------|-------|------|------|--------|
| | | | Cms | Co | Cm | Stack Flow (dscfm) | Fuel Flow (lb/hr) | | | | | | | | | | | | | | |
| 1 | 08:30-09:54 | 15.6 | 19.9 | 0.2 | 18.8 | 87,364 | 2,550 | 16.8 | 10.36 | 4.0633 | | | | | | | | | | | |
| 2 | 11:02-12:27 | 15.3 | 19.9 | 0.3 | 19.1 | 83,985 | 2,550 | 15.9 | 9.49 | 3.7198 | | | | | | | | | | | |
| 3 | 12:41-12:57 | 15.6 | 19.9 | 0.1 | 20.1 | 82,049 | 2,550 | 15.5 | 9.12 | 3.5765 | | | | | | | | | | | |
| Average | | | | | | | | 16.0 | 9.66 | 3.7865 | | | | | | | | | | | |
| <table border="1" style="width: 100%;"> <tr> <td>A/B</td> <td>15:35-15:38</td> <td>41.2</td> <td>19.9</td> <td>0.1</td> <td>20.1</td> <td>21,314</td> <td>2,230</td> <td>41.0</td> <td>6.26</td> <td>2.8090</td> </tr> </table> | | | | | | | | | | | A/B | 15:35-15:38 | 41.2 | 19.9 | 0.1 | 20.1 | 21,314 | 2,230 | 41.0 | 6.26 | 2.8090 |
| A/B | 15:35-15:38 | 41.2 | 19.9 | 0.1 | 20.1 | 21,314 | 2,230 | 41.0 | 6.26 | 2.8090 | | | | | | | | | | | |

Calibration Error Correction

$C_{gas} = (C_{obs} - C_o) * (C_{ms} / (C_m - C_o))$
 Mass Emission Rate (lb/hr)
 $E (lb/hr) = C_{gas} * MW_{gas} * Q_s (dscfm) * 60 / 385300000$
 Mass Emission Rate (lb/1000 lb fuel)
 $E (lb/MMBtu) = E (lb/hr) / Fuel\ flow * 1000$

| Pollutant | MWgas |
|-----------|-------|
| CO | 28.01 |
| Methane | 16.00 |
| NOx | 46.01 |
| SO2 | 64.06 |

CEM Data Correction Data Sheet

| | |
|--------------------|-----------------------|
| Plant Name: | Moody AFB |
| Sampling Location: | Stipstream - Military |
| Date: | 4/26/02 |
| Project Number: | 030197.0002.5 |
| CEM Operator: | Doug Allen |
| Pollutant: | NOx |
| Molecular Weight: | 46.01 |

| Run No. | Start-Stop Time | Raw Data (% or ppm) | Calibration Data | | | Source Information | | Calibration Corrected Data (% or ppm) | Mass Emission Rate (lb/hr) | Mass Emission Rate (lb/1000 lb fuel) | | | | | | | | | | | |
|--|-----------------|---------------------|------------------|------|------|--------------------|-------------------|---------------------------------------|----------------------------|--------------------------------------|-----|-------------|-----|------|------|-----|---------|-------|-----|------|--------|
| | | | Cms | Co | Cm | Stack Flow (dscfm) | Fuel Flow (lb/hr) | | | | | | | | | | | | | | |
| 1 | 07:54-09:54 | 0.97 | 10.1 | -0.1 | 10.2 | 654,869 | 2,550 | 1.1 | 4.31 | 1.8919 | | | | | | | | | | | |
| 2 | 10:33-12:27 | 0.92 | 10.1 | -0.1 | 9.6 | 547,724 | 2,550 | 1.1 | 4.25 | 1.6670 | | | | | | | | | | | |
| 3 | 12:41-14:18 | 0.88 | 10.1 | -0.1 | 9.2 | 530,345 | 2,550 | 1.1 | 4.09 | 1.6055 | | | | | | | | | | | |
| Average | | | | | | | | 1.1 | 4.22 | 1.6548 | | | | | | | | | | | |
| <table border="1" style="width: 100%;"> <tr> <td>A/B</td> <td>15:35-15:38</td> <td>1.9</td> <td>10.1</td> <td>-0.1</td> <td>9.2</td> <td>177,277</td> <td>2,230</td> <td>2.1</td> <td>2.70</td> <td>1.2120</td> </tr> </table> | | | | | | | | | | | A/B | 15:35-15:38 | 1.9 | 10.1 | -0.1 | 9.2 | 177,277 | 2,230 | 2.1 | 2.70 | 1.2120 |
| A/B | 15:35-15:38 | 1.9 | 10.1 | -0.1 | 9.2 | 177,277 | 2,230 | 2.1 | 2.70 | 1.2120 | | | | | | | | | | | |

Calibration Error Correction

$C_{gas} = (C_{obs} - C_o) * (C_{ms} / (C_m - C_o))$
 Mass Emission Rate (lb/hr)
 $E (lb/hr) = C_{gas} * MW_{gas} * Q_s (dscfm) * 60 / 385300000$
 Mass Emission Rate (lb/1000 lb fuel)
 $E (lb/MMBtu) = E (lb/hr) / Fuel\ flow * 1000$

| Pollutant | MWgas |
|-----------|-------|
| CO | 28.01 |
| Methane | 16.00 |
| NOx | 46.01 |
| SO2 | 64.06 |

CEM Data Correction Data Sheet

| | |
|--------------------|---------------|
| Plant Name: | Moody AFB |
| Sampling Location: | Ambient |
| Date: | 4/26/02 |
| Project Number: | 030197.0002.5 |
| CEM Operator: | Doug Allen |
| Pollutant: | NOx |
| Molecular Weight: | #REF! |

| Run No. | Start-Stop Time | Raw Data (% or ppm) | Calibration Data | | | Calibration Corrected Data (% or ppm) |
|---------|-----------------|---------------------|------------------|-----|------|---------------------------------------|
| | | | Cms | Co | Cm | |
| 1 | 07:53-08:22 | -0.09 | 19.9 | 0.2 | 18.8 | 0.00 |
| 2 | 10:25-10:54 | -0.09 | 19.9 | 0.3 | 19.1 | 0.00 |
| 3 | 14:25-14:54 | -0.12 | 19.9 | 0.1 | 20.1 | 0.00 |
| Average | | | | | | 0.00 |

Calibration Error Correction

$C_{gas} = (C_{obs} - C_o) * (C_{ms} / (C_m - C_o))$

CEM Data Correction Data Sheet

| | |
|--------------------|---------------|
| Plant Name: | Moody AFB |
| Sampling Location: | Engine - Idle |
| Date: | 4/24/02 |
| Project Number: | 030197.0002.5 |
| CEM Operator: | Doug Allen |
| Pollutant: | CO |
| Molecular Weight: | 28.01 |

| Run No. | Start-Stop Time | Raw Data (ppm) | Calibration Data | | | Source Information | | Calibration Corrected Data (% or ppm) | Mass Emission Rate (lb/hr) | Mass Emission Rate (lb/1000 lb fuel) |
|---------|-----------------|----------------|------------------|------|-------|--------------------|-------------------|---------------------------------------|----------------------------|--------------------------------------|
| | | | Cma | Co | Cm | Stack Flow (dscfm) | Fuel Flow (lb/hr) | | | |
| 1 | 08:27-10:46 | 688.6 | 902.8 | -0.3 | 890.0 | 34,326 | 525 | 698.6 | 104.59 | 199.2232 |
| 2 | 12:00-14:19 | 674.3 | 447.8 | 0.5 | 436.5 | 32,817 | 525 | 692.0 | 99.05 | 188.6746 |
| 3 | 15:55-16:54 | 668.3 | 447.8 | -0.6 | 434.5 | 32,805 | 525 | 688.4 | 97.91 | 186.4898 |
| Average | | | | | | | | 693.0 | 100.52 | 191.4626 |

Calibration Error Correction

$C_{gas} = (C_{obs} - C_o) * (C_{ma} / (C_m - C_o))$

Mass Emission Rate (lb/hr)

$E (lb/hr) = C_{gas} * MW_{gas} * Q_s (dscfm) * 60 / 385300000$

Mass Emission Rate (lb/1000 lb fuel)

$E (lb/MMBtu) = E (lb/hr) / Fuel\ flow * 1000$

| Pollutant | MW _{gas} |
|-----------|-------------------|
| CO | 28.01 |
| Methane | 16.00 |
| NOx | 46.01 |
| SO2 | 64.06 |

CEM Data Correction Data Sheet

| | |
|--------------------|-------------------|
| Plant Name: | Moody AFB |
| Sampling Location: | Slipstream - Idle |
| Date: | 4/24/02 |
| Project Number: | 030197.0002.5 |
| CEM Operator: | Doug Allen |
| Pollutant: | CO |
| Molecular Weight: | 28.01 |

| Run No. | Start-Stop Time | Raw Data (ppm) | Calibration Data | | | Source Information | | Calibration Corrected Data (% or ppm) | Mass Emission Rate (lb/hr) | Mass Emission Rate (lb/1000 lb fuel) |
|---------|-----------------|----------------|------------------|------|-------|--------------------|-------------------|---------------------------------------|----------------------------|--------------------------------------|
| | | | Cma | Co | Cm | Stack Flow (dscfm) | Fuel Flow (lb/hr) | | | |
| 1 | 07:52-10:48 | 202.8 | 300.9 | -4.0 | 289.0 | 155,513 | 525 | 212.2 | 143.92 | 274.1393 |
| 2 | 11:26-14:21 | 179.9 | 300.9 | -4.0 | 292.0 | 132,932 | 525 | 188.9 | 108.37 | 206.4107 |
| 3 | 15:55-16:54 | 161.8 | 300.9 | -4.0 | 295.5 | 67,668 | 525 | 166.6 | 49.18 | 93.6728 |
| Average | | | | | | | | 188.6 | 100.49 | 191.4075 |

Calibration Error Correction

$C_{gas} = (C_{obs} - C_o) * (C_{ma} / (C_m - C_o))$

Mass Emission Rate (lb/hr)

$E (lb/hr) = C_{gas} * MW_{gas} * Q_s (dscfm) * 60 / 385300000$

Mass Emission Rate (lb/1000 lb fuel)

$E (lb/MMBtu) = E (lb/hr) / Fuel\ flow * 1000$

| Pollutant | MW _{gas} |
|-----------|-------------------|
| CO | 28.01 |
| Methane | 16.00 |
| NOx | 46.01 |
| SO2 | 64.06 |

CEM Data Correction Data Sheet

| | |
|--------------------|---------|
| Plant Name: | 0 |
| Sampling Location: | 0 |
| Date: | 4/24/02 |
| Project Number: | 0 |
| CEM Operator: | 0 |
| Pollutant: | CO |
| Molecular Weight: | 0 |

| Run No. | Start-Stop Time | Raw Data (ppm) | Calibration Data | | | Calibration Corrected Data (% or ppm) |
|---------|-----------------|----------------|------------------|------|-------|---------------------------------------|
| | | | Cma | Co | Cm | |
| 1 | 0000 | 0.0 | 902.8 | -0.3 | 890.0 | 0.30 |
| 2 | 0000 | 0.0 | 447.8 | 0.5 | 436.5 | 0.00 |
| 3 | 0000 | 0.0 | 447.8 | -0.6 | 434.5 | 0.62 |
| Average | | | | | | 0.31 |

Calibration Error Correction

$C_{gas} = (C_{obs} - C_o) * (C_{ma} / (C_m - C_o))$

CEM Data Correction Data Sheet

| | |
|--------------------|---------------|
| Plant Name: | Moody AFB |
| Sampling Location: | Engine - Idle |
| Date: | 4/24/02 |
| Project Number: | 030197.0002.5 |
| CEM Operator: | Doug Allen |
| Pollutant: | CO2 |
| Molecular Weight: | |

| Run No. | Start-Stop Time | Raw Data (% or ppm) | Calibration Data | | | Calibration Corrected Data (% or ppm) |
|---------|-----------------|---------------------|------------------|------|-----|---------------------------------------|
| | | | Cma | Co | Cm | |
| 1 | 08:27-10:46 | 0.6 | 9.9 | 0.0 | 9.8 | 0.6 |
| 2 | 12:00-14:19 | 0.6 | 9.9 | -0.1 | 9.9 | 0.7 |
| 3 | 15:55-16:54 | 0.6 | 9.9 | -0.2 | 9.9 | 0.7 |
| Average | | | | | | 0.7 |

Calibration Error Correction

$$C_{gas} = (C_{obs} - C_o) * (C_{ma} / (C_m - C_o))$$

CEM Data Correction Data Sheet

| | |
|--------------------|-------------------|
| Plant Name: | Moody AFB |
| Sampling Location: | Slipstream - Idle |
| Date: | 4/24/02 |
| Project Number: | 030197.0002.5 |
| CEM Operator: | Doug Allen |
| Pollutant: | CO2 |
| Molecular Weight: | |

| Run No. | Start-Stop Time | Raw Data (% or ppm) | Calibration Data | | | Calibration Corrected Data (% or ppm) |
|---------|-----------------|---------------------|------------------|-------|------|---------------------------------------|
| | | | Cma | Co | Cm | |
| 1 | 07:52-10:48 | 0.204 | 1.01 | -0.03 | 0.98 | 0.231 |
| 2 | 11:26-14:21 | 0.203 | 1.01 | -0.03 | 0.98 | 0.231 |
| 3 | 15:55-16:54 | 0.181 | 1.01 | -0.02 | 0.98 | 0.207 |
| Average | | | | | | 0.223 |

Calibration Error Correction

$$C_{gas} = (C_{obs} - C_o) * (C_{ma} / (C_m - C_o))$$

CEM Data Correction Data Sheet

| | |
|--------------------|---------|
| Plant Name: | 0 |
| Sampling Location: | 0 |
| Date: | 4/24/02 |
| Project Number: | 0 |
| CEM Operator: | 0 |
| Pollutant: | CO2 |
| Molecular Weight: | |

| Run No. | Start-Stop Time | Raw Data (% or ppm) | Calibration Data | | | Calibration Corrected Data (% or ppm) |
|---------|-----------------|---------------------|------------------|-------|------|---------------------------------------|
| | | | Cma | Co | Cm | |
| 1 | 0000 | 0.00 | 9.94 | 0.00 | 9.80 | 0.000 |
| 2 | 0000 | 0.00 | 9.94 | -0.10 | 9.85 | 0.100 |
| 3 | 0000 | 0.00 | 9.94 | -0.15 | 9.90 | 0.148 |
| Average | | | | | | 0.083 |

Calibration Error Correction

$$C_{gas} = (C_{obs} - C_o) * (C_{ma} / (C_m - C_o))$$

CEM Data Correction Data Sheet

| | |
|--------------------|---------------|
| Plant Name: | Moody AFB |
| Sampling Location: | Engine - Idle |
| Date: | 4/24/02 |
| Project Number: | 030197.0002.5 |
| CEM Operator: | Doug Allen |
| Pollutant: | O2 |
| Molecular Weight: | |

| Run No. | Start-Stop Time | Raw Data (% or ppm) | Calibration Data | | | Calibration Corrected Data (% or ppm) |
|---------|-----------------|---------------------|------------------|-----|------|---------------------------------------|
| | | | Cma | Co | Cm | |
| 1 | 08:27-10:46 | 19.9 | 20.0 | 0.1 | 19.9 | 20.0 |
| 2 | 12:00-14:19 | 19.8 | 20.0 | 0.1 | 19.9 | 19.9 |
| 3 | 15:55-16:54 | 19.7 | 20.0 | 0.1 | 19.8 | 19.9 |
| Average | | | | | | 19.9 |

Calibration Error Correction
 $C_{gas} = (C_{obs} - C_o) * (C_{ma} / (C_m - C_o))$

CEM Data Correction Data Sheet

| | |
|--------------------|-------------------|
| Plant Name: | Moody AFB |
| Sampling Location: | Slipstream - Idle |
| Date: | 4/24/02 |
| Project Number: | 030197.0002.5 |
| CEM Operator: | Doug Allen |
| Pollutant: | O2 |
| Molecular Weight: | |

| Run No. | Start-Stop Time | Raw Data (% or ppm) | Calibration Data | | | Calibration Corrected Data (% or ppm) |
|---------|-----------------|---------------------|------------------|------|------|---------------------------------------|
| | | | Cma | Co | Cm | |
| 1 | 07:52-10:48 | 20.8 | 20.0 | -0.3 | 20.1 | 20.7 |
| 2 | 11:26-14:21 | 20.8 | 20.0 | -0.4 | 20.1 | 20.7 |
| 3 | 15:55-16:54 | 20.2 | 20.0 | -0.5 | 19.8 | 20.4 |
| Average | | | | | | 20.6 |

Calibration Error Correction
 $C_{gas} = (C_{obs} - C_o) * (C_{ma} / (C_m - C_o))$

CEM Data Correction Data Sheet

| | |
|--------------------|---------|
| Plant Name: | 0 |
| Sampling Location: | 0 |
| Date: | 4/24/02 |
| Project Number: | 0 |
| CEM Operator: | 0 |
| Pollutant: | O2 |
| Molecular Weight: | |

| Run No. | Start-Stop Time | Raw Data (% or ppm) | Calibration Data | | | Calibration Corrected Data (% or ppm) |
|---------|-----------------|---------------------|------------------|-----|------|---------------------------------------|
| | | | Cma | Co | Cm | |
| 1 | 0000 | 0.0 | 20.0 | 0.1 | 19.9 | 0.0 |
| 2 | 0000 | 0.0 | 20.0 | 0.1 | 19.9 | 0.0 |
| 3 | 0000 | 0.0 | 20.0 | 0.1 | 19.8 | 0.0 |
| Average | | | | | | 0.0 |

Calibration Error Correction
 $C_{gas} = (C_{obs} - C_o) * (C_{ma} / (C_m - C_o))$

Total Hydrocarbon Data Correction

| | |
|--------------------|---------------|
| Plant Name: | Moody AFB |
| Sampling Location: | Engine - Idle |
| Date: | 4/24/02 |
| Project Number: | 030197.0002.5 |
| CEM Operator: | Doug Allen |
| Pollutant: | THC |
| Molecular Weight: | 16.00 |

| Run No. | Start-Stop Time | Raw Data (ppm) | Source Information | | Corrected Data Dry Basis (ppm) | Mass Emission Rate (lb/hr) | Mass Emission Rate (lb/1000 lb fuel) |
|---------|-----------------|----------------|--------------------|--------------------|--------------------------------|----------------------------|--------------------------------------|
| | | | Stack Flow (dscfm) | Stack Moisture (%) | | | |
| 1 | 08:27-10:46 | 179.8 | 32,899 | 1.50 | 182.5 | 14.96 | 26.5006 |
| 2 | 12:00-14:19 | 155.5 | 30,118 | 1.50 | 157.9 | 11.85 | 22.5656 |
| 3 | 15:55-16:54 | 141.8 | 28,868 | 1.50 | 143.7 | 10.34 | 19.6881 |
| Average | | | | | 161.4 | 12.38 | 23.58 |

Moisture Correction

$$C_{gas(dry)} = C_{gas(wet)} / (1 - (\% \text{ moisture} / 100))$$

Mass Emission Rate (lb/hr)

$$E(\text{lb/hr}) = C_{gas(dry)} * MW_{gas} * Q_s(\text{dscfm}) * 60 / 385300000$$

Total Hydrocarbon Data Correction

| | |
|--------------------|-------------------|
| Plant Name: | Moody AFB |
| Sampling Location: | Slipstream - Idle |
| Date: | 4/24/02 |
| Project Number: | 030197.0002.5 |
| CEM Operator: | Doug Allen |
| Pollutant: | THC |
| Molecular Weight: | 16.00 |

| Run No. | Start-Stop Time | Raw Data (ppm) | Source Information | | Corrected Data Dry Basis (ppm) | Mass Emission Rate (lb/hr) | Mass Emission Rate (lb/1000 lb fuel) |
|---------|-----------------|----------------|--------------------|--------------------|--------------------------------|----------------------------|--------------------------------------|
| | | | Stack Flow (dscfm) | Stack Moisture (%) | | | |
| 1 | 07:52-10:48 | 41.4 | 93,842 | 1.50 | 42.0 | 9.82 | 18.7015 |
| 2 | 11:26-14:21 | 35.6 | 94,610 | 1.50 | 36.1 | 8.51 | 16.2105 |
| 3 | 15:55-16:54 | 28.3 | 105,541 | 1.50 | 28.7 | 7.56 | 14.3949 |
| Average | | | | | 35.6 | 8.63 | 16.44 |

Moisture Correction

$$C_{gas(dry)} = C_{gas(wet)} / (1 - (\% \text{ moisture} / 100))$$

Mass Emission Rate (lb/hr)

$$E(\text{lb/hr}) = C_{gas(dry)} * MW_{gas} * Q_s(\text{dscfm}) * 60 / 385300000$$

Total Hydrocarbon Data Correction

| | |
|--------------------|---------------|
| Plant Name: | Moody AFB |
| Sampling Location: | Ambient |
| Date: | 4/24/02 |
| Project Number: | 030197.0002.5 |
| CEM Operator: | Doug Allen |
| Pollutant: | THC |
| Molecular Weight: | 16.00 |

| Run No. | Start-Stop Time | Raw Data (ppm) |
|---------|-----------------|----------------|
| 1 | 07:52-08:21 | 1.78 |
| 2 | 11:26-11:55 | -4.72 |
| 3 | 15:20-15:49 | -9.91 |

CEM Data Correction Data Sheet

| | |
|--------------------|---------------|
| Plant Name: | Moody AFB |
| Sampling Location: | Engine - Idle |
| Date: | 4/24/02 |
| Project Number: | 030197.0002.5 |
| CEM Operator: | Doug Allen |
| Pollutant: | NOx |
| Molecular Weight: | 46.01 |

| Run No. | Start-Stop Time | Raw Data (% or ppm) | Calibration Data | | | Source Information | | Calibration Corrected Data (% or ppm) | Mass Emission Rate (lb/hr) | Mass Emission Rate (lb/1000 lb fuel) |
|---------|-----------------|---------------------|------------------|-----|------|--------------------|-------------------|---------------------------------------|----------------------------|--------------------------------------|
| | | | Cma | Co | Cm | Stack Flow (dscfm) | Fuel Flow (lb/hr) | | | |
| 1 | 08:27-10:46 | 3.5 | 19.9 | 0.2 | 19.9 | 34,326 | 525 | 3.4 | 0.83 | 1.5858 |
| 2 | 12:00-14:19 | 3.8 | 19.9 | 0.3 | 19.4 | 32,817 | 525 | 3.7 | 0.86 | 1.6428 |
| 3 | 15:55-16:54 | 3.7 | 19.9 | 0.2 | 18.8 | 32,605 | 525 | 3.7 | 0.87 | 1.6661 |
| Average | | | | | | | | 3.6 | 0.86 | 1.6315 |

Calibration Error Correction

$$C_{gas} = (C_{obs} - C_o) * (C_{ma} / (C_m - C_o))$$

Mass Emission Rate (lb/hr)

$$E (lb/hr) = C_{gas} * MW_{gas} * Q_s (dscfm) * 60 / 385300000$$

Mass Emission Rate (lb/1000 lb fuel)

$$E (lb/MMBtu) = E (lb/hr) / \text{Fuel flow} * 1000$$

| Pollutant | MW _{gas} |
|-----------|-------------------|
| CO | 28.01 |
| Methane | 16.00 |
| NOx | 46.01 |
| SO2 | 64.06 |

CEM Data Correction Data Sheet

| | |
|--------------------|-------------------|
| Plant Name: | Moody AFB |
| Sampling Location: | Slipstream - Idle |
| Date: | 4/24/02 |
| Project Number: | 030197.0002.5 |
| CEM Operator: | Doug Allen |
| Pollutant: | NOx |
| Molecular Weight: | 46.01 |

| Run No. | Start-Stop Time | Raw Data (% or ppm) | Calibration Data | | | Source Information | | Calibration Corrected Data (% or ppm) | Mass Emission Rate (lb/hr) | Mass Emission Rate (lb/1000 lb fuel) |
|---------|-----------------|---------------------|------------------|------|-----|--------------------|-------------------|---------------------------------------|----------------------------|--------------------------------------|
| | | | Cma | Co | Cm | Stack Flow (dscfm) | Fuel Flow (lb/hr) | | | |
| 1 | 07:52-10:48 | 0.40 | 10.1 | -0.2 | 9.8 | 155,513 | 525 | 0.6 | 0.63 | 1.2032 |
| 2 | 11:28-14:21 | 0.40 | 10.1 | -0.1 | 9.8 | 132,932 | 525 | 0.5 | 0.44 | 0.8329 |
| 3 | 15:55-16:54 | 0.40 | 10.1 | 0.1 | 9.8 | 67,668 | 525 | 0.4 | 0.18 | 0.3349 |
| Average | | | | | | | | 0.5 | 0.41 | 0.7903 |

Calibration Error Correction

$$C_{gas} = (C_{obs} - C_o) * (C_{ma} / (C_m - C_o))$$

Mass Emission Rate (lb/hr)

$$E (lb/hr) = C_{gas} * MW_{gas} * Q_s (dscfm) * 60 / 385300000$$

Mass Emission Rate (lb/1000 lb fuel)

$$E (lb/MMBtu) = E (lb/hr) / \text{Fuel flow} * 1000$$

| Pollutant | MW _{gas} |
|-----------|-------------------|
| CO | 28.01 |
| Methane | 16.00 |
| NOx | 46.01 |
| SO2 | 64.06 |

CEM Data Correction Data Sheet

| | |
|--------------------|---------|
| Plant Name: | 0 |
| Sampling Location: | 0 |
| Date: | 4/24/02 |
| Project Number: | 0 |
| CEM Operator: | 0 |
| Pollutant: | NOx |
| Molecular Weight: | #REF! |

| Run No. | Start-Stop Time | Raw Data (% or ppm) | Calibration Data | | | Calibration Corrected Data (% or ppm) |
|---------|-----------------|---------------------|------------------|-----|------|---------------------------------------|
| | | | Cma | Co | Cm | |
| 1 | 0000 | 0.00 | 19.9 | 0.2 | 19.9 | 0.00 |
| 2 | 0000 | 0.00 | 19.9 | 0.3 | 19.4 | 0.00 |
| 3 | 0000 | 0.00 | 19.9 | 0.2 | 18.8 | 0.00 |
| Average | | | | | | 0.00 |

Calibration Error Correction

$$C_{gas} = (C_{obs} - C_o) * (C_{ma} / (C_m - C_o))$$

CEM Data Correction Data Sheet

| | |
|--------------------|-----------------------|
| Plant Name: | Moody AFB |
| Sampling Location: | Engine - Intermediate |
| Date: | 4/25/02 |
| Project Number: | 030197.0002.5 |
| CEM Operator: | Doug Allen |
| Pollutant: | CO |
| Molecular Weight: | 28.01 |

| Run No. | Start-Stop Time | Raw Data (ppm) | Calibration Data | | | Source Information | | Calibration Corrected Data (% or ppm) | Mass Emission Rate (lb/hr) | Mass Emission Rate (lb/1000 lb fuel) |
|---------|-----------------|----------------|------------------|------|-------|--------------------|-------------------|---------------------------------------|----------------------------|--------------------------------------|
| | | | Cma | Co | Cm | Stack Flow (dscfm) | Fuel Flow (lb/hr) | | | |
| 1 | 09:10-10:29 | 202.4 | 447.8 | -4.0 | 420.5 | 78,902 | 1,045 | 217.7 | 74.94 | 71.7121 |
| 2 | 11:35-13:04 | 194.5 | 447.8 | -4.0 | 418.5 | 76,060 | 1,045 | 210.4 | 69.79 | 66.7804 |
| 3 | 13:25-14:24 | 190.7 | 447.8 | -4.5 | 418.5 | 74,072 | 1,045 | 206.7 | 66.77 | 63.8993 |
| Average | | | | | | | | 211.6 | 70.50 | 67.4640 |

Calibration Error Correction

$C_{gas} = (C_{obs} - C_o) * (C_{ma} / (C_m - C_o))$
 Mass Emission Rate (lb/hr)
 $E (lb/hr) = C_{gas} * MW_{gas} * Q_s (dscfm) * 60 / 385300000$
 Mass Emission Rate (lb/1000 lb fuel)
 $E (lb/MMBtu) = E (lb/hr) / \text{Fuel flow} * 1000$

| Pollutant | MWgas |
|-----------|-------|
| CO | 28.01 |
| Methane | 18.00 |
| NOx | 46.01 |
| SO2 | 64.06 |

CEM Data Correction Data Sheet

| | |
|--------------------|---------------------------|
| Plant Name: | Moody AFB |
| Sampling Location: | Slipstream - Intermediate |
| Date: | 4/25/02 |
| Project Number: | 030197.0002.5 |
| CEM Operator: | Doug Allen |
| Pollutant: | CO |
| Molecular Weight: | 28.01 |

| Run No. | Start-Stop Time | Raw Data (ppm) | Calibration Data | | | Source Information | | Calibration Corrected Data (% or ppm) | Mass Emission Rate (lb/hr) | Mass Emission Rate (lb/1000 lb fuel) |
|---------|-----------------|----------------|------------------|------|------|--------------------|-------------------|---------------------------------------|----------------------------|--------------------------------------|
| | | | Cma | Co | Cm | Stack Flow (dscfm) | Fuel Flow (lb/hr) | | | |
| 1 | 08:36-10:32 | 39.0 | 59.4 | -1.2 | 57.0 | 328,584 | 1,045 | 41.0 | 58.79 | 56.2623 |
| 2 | 11:10-13:07 | 37.0 | 59.4 | -1.2 | 55.9 | 328,688 | 1,045 | 39.7 | 56.97 | 54.5176 |
| 3 | 13:25-14:24 | 35.7 | 59.4 | -1.3 | 54.8 | 328,736 | 1,045 | 39.1 | 56.13 | 53.7170 |
| Average | | | | | | | | 40.0 | 57.30 | 54.8323 |

Calibration Error Correction

$C_{gas} = (C_{obs} - C_o) * (C_{ma} / (C_m - C_o))$
 Mass Emission Rate (lb/hr)
 $E (lb/hr) = C_{gas} * MW_{gas} * Q_s (dscfm) * 60 / 385300000$
 Mass Emission Rate (lb/1000 lb fuel)
 $E (lb/MMBtu) = E (lb/hr) / \text{Fuel flow} * 1000$

| Pollutant | MWgas |
|-----------|-------|
| CO | 28.01 |
| Methane | 18.00 |
| NOx | 46.01 |
| SO2 | 64.06 |

CEM Data Correction Data Sheet

| | |
|--------------------|---------------|
| Plant Name: | Moody AFB |
| Sampling Location: | Ambient |
| Date: | 4/25/02 |
| Project Number: | 030197.0002.5 |
| CEM Operator: | Doug Allen |
| Pollutant: | CO |
| Molecular Weight: | 0 |

| Run No. | Start-Stop Time | Raw Data (ppm) | Calibration Data | | | Calibration Corrected Data (% or ppm) |
|---------|-----------------|----------------|------------------|------|-------|---------------------------------------|
| | | | Cma | Co | Cm | |
| 1 | 08:36-09:05 | -4.1 | 447.8 | -4.0 | 420.5 | 0.00 |
| 2 | 11:01-11:30 | -4.1 | 447.8 | -4.0 | 418.5 | 0.00 |
| 3 | 14:30-14:59 | -4.5 | 447.8 | -4.5 | 418.5 | 0.00 |
| Average | | | | | | 0.00 |

Calibration Error Correction

$C_{gas} = (C_{obs} - C_o) * (C_{ma} / (C_m - C_o))$

CEM Data Correction Data Sheet

| | |
|--------------------|-----------------------|
| Plant Name: | Moody AFB |
| Sampling Location: | Engine - Intermediate |
| Date: | 4/25/02 |
| Project Number: | 030197.0002.5 |
| CEM Operator: | Doug Allen |
| Pollutant: | CO2 |
| Molecular Weight: | |

| Run No. | Start-Stop Time | Raw Data (% or ppm) | Calibration Data | | | Calibration Corrected Data (% or ppm) |
|---------|-----------------|---------------------|------------------|------|------|---------------------------------------|
| | | | Cma | Co | Cm | |
| 1 | 09:10-10:29 | 0.6 | 9.9 | -0.2 | 10.1 | 0.8 |
| 2 | 11:35-13:04 | 0.6 | 9.9 | -0.3 | 10.0 | 0.8 |
| 3 | 13:25-14:24 | 0.6 | 9.9 | -0.3 | 10.0 | 0.9 |
| Average | | | | | | 0.8 |

Calibration Error Correction
 $C_{gas} = (C_{obs} - C_o) * (C_{ma} / (C_m - C_o))$

CEM Data Correction Data Sheet

| | |
|--------------------|---------------------------|
| Plant Name: | Moody AFB |
| Sampling Location: | Slipstream - Intermediate |
| Date: | 4/25/02 |
| Project Number: | 030197.0002.5 |
| CEM Operator: | Doug Allen |
| Pollutant: | CO2 |
| Molecular Weight: | |

| Run No. | Start-Stop Time | Raw Data (% or ppm) | Calibration Data | | | Calibration Corrected Data (% or ppm) |
|---------|-----------------|---------------------|------------------|-------|------|---------------------------------------|
| | | | Cma | Co | Cm | |
| 1 | 08:36-10:32 | 0.132 | 1.01 | -0.03 | 0.98 | 0.159 |
| 2 | 11:10-13:07 | 0.134 | 1.01 | -0.02 | 0.97 | 0.159 |
| 3 | 13:25-14:24 | 0.135 | 1.01 | -0.02 | 0.97 | 0.158 |
| Average | | | | | | 0.159 |

Calibration Error Correction
 $C_{gas} = (C_{obs} - C_o) * (C_{ma} / (C_m - C_o))$

CEM Data Correction Data Sheet

| | |
|--------------------|---------------|
| Plant Name: | Moody AFB |
| Sampling Location: | Ambient |
| Date: | 4/25/02 |
| Project Number: | 030197.0002.5 |
| CEM Operator: | Doug Allen |
| Pollutant: | CO2 |
| Molecular Weight: | |

| Run No. | Start-Stop Time | Raw Data (% or ppm) | Calibration Data | | | Calibration Corrected Data (% or ppm) |
|---------|-----------------|---------------------|------------------|-------|-------|---------------------------------------|
| | | | Cma | Co | Cm | |
| 1 | 08:36-09:05 | -0.03 | 9.94 | -0.15 | 10.05 | 0.112 |
| 2 | 11:01-11:30 | -0.07 | 9.94 | -0.25 | 10.00 | 0.179 |
| 3 | 14:30-14:59 | -0.09 | 9.94 | -0.30 | 10.00 | 0.203 |
| Average | | | | | | 0.165 |

Calibration Error Correction
 $C_{gas} = (C_{obs} - C_o) * (C_{ma} / (C_m - C_o))$

CEM Data Correction Data Sheet

| | |
|--------------------|-----------------------|
| Plant Name: | Moody AFB |
| Sampling Location: | Engine - Intermediate |
| Date: | 4/25/02 |
| Project Number: | 030197.0002.5 |
| CEM Operator: | Doug Allen |
| Pollutant: | O2 |
| Molecular Weight: | |

| Run No. | Start-Stop Time | Raw Data (% or ppm) | Calibration Data | | | Calibration Corrected Data (% or ppm) |
|---------|-----------------|---------------------|------------------|-----|------|---------------------------------------|
| | | | Cma | Co | Cm | |
| 1 | 09:10-10:29 | 19.9 | 20.0 | 0.1 | 19.8 | 20.1 |
| 2 | 11:35-13:04 | 19.8 | 20.0 | 0.1 | 19.8 | 20.0 |
| 3 | 13:25-14:24 | 19.8 | 20.0 | 0.1 | 19.8 | 20.0 |
| Average | | | | | | 20.0 |

Calibration Error Correction

$$C_{gas} = (C_{obs} - C_o) * (C_{ma} / (C_m - C_o))$$

CEM Data Correction Data Sheet

| | |
|--------------------|---------------------------|
| Plant Name: | Moody AFB |
| Sampling Location: | Slipstream - Intermediate |
| Date: | 4/25/02 |
| Project Number: | 030197.0002.5 |
| CEM Operator: | Doug Allen |
| Pollutant: | O2 |
| Molecular Weight: | |

| Run No. | Start-Stop Time | Raw Data (% or ppm) | Calibration Data | | | Calibration Corrected Data (% or ppm) |
|---------|-----------------|---------------------|------------------|------|------|---------------------------------------|
| | | | Cma | Co | Cm | |
| 1 | 08:36-10:32 | 21.1 | 20.0 | -0.5 | 21.0 | 20.1 |
| 2 | 11:10-13:07 | 20.8 | 20.0 | -0.5 | 20.8 | 20.0 |
| 3 | 13:25-14:24 | 20.6 | 20.0 | -0.5 | 20.5 | 20.2 |
| Average | | | | | | 20.1 |

Calibration Error Correction

$$C_{gas} = (C_{obs} - C_o) * (C_{ma} / (C_m - C_o))$$

CEM Data Correction Data Sheet

| | |
|--------------------|---------------|
| Plant Name: | Moody AFB |
| Sampling Location: | Ambient |
| Date: | 4/25/02 |
| Project Number: | 030197.0002.5 |
| CEM Operator: | Doug Allen |
| Pollutant: | O2 |
| Molecular Weight: | |

| Run No. | Start-Stop Time | Raw Data (% or ppm) | Calibration Data | | | Calibration Corrected Data (% or ppm) |
|---------|-----------------|---------------------|------------------|-----|------|---------------------------------------|
| | | | Cma | Co | Cm | |
| 1 | 08:36-09:05 | 20.9 | 20.0 | 0.1 | 19.8 | 21.1 |
| 2 | 11:01-11:30 | 20.9 | 20.0 | 0.1 | 19.8 | 21.1 |
| 3 | 14:30-14:59 | 20.8 | 20.0 | 0.1 | 19.8 | 21.0 |
| Average | | | | | | 21.1 |

Calibration Error Correction

$$C_{gas} = (C_{obs} - C_o) * (C_{ma} / (C_m - C_o))$$

Total Hydrocarbon Data Correction

| | |
|--------------------|-----------------------|
| Plant Name: | Moody AFB |
| Sampling Location: | Engine - Intermediate |
| Date: | 4/25/02 |
| Project Number: | 030197.0002.5 |
| CEM Operator: | Doug Allen |
| Pollutant: | THC |
| Molecular Weight: | 16.00 |

| Run No. | Start-Stop Time | Raw Data (ppm) | Source Information | | Corrected Data Dry Basis (ppm) | Mass Emission Rate (lb/hr) | Mass Emission Rate (lb/1000 lb fuel) |
|---------|-----------------|----------------|--------------------|--------------------|--------------------------------|----------------------------|--------------------------------------|
| | | | Stack Flow (dscfm) | Stack Moisture (%) | | | |
| 1 | 09:10-10:29 | 12.1 | 78,902 | 2.00 | 12.4 | 2.43 | 2.3297 |
| 2 | 11:35-13:04 | 9.1 | 76,080 | 2.00 | 9.3 | 1.76 | 1.6816 |
| 3 | 13:25-14:24 | 7.6 | 74,072 | 2.00 | 7.7 | 1.43 | 1.3651 |
| Average | | | | | 9.8 | 1.87 | 1.79 |

Moisture Correction

$$C_{gas(dry)} = C_{gas(wet)} / (1 - (\% \text{ moisture} / 100))$$

Mass Emission Rate (lb/hr)

$$E(\text{lb/hr}) = C_{gas(dry)} * MW_{gas} * Q_s(\text{dscfm}) * 60 / 385300000$$

Total Hydrocarbon Data Correction

| | |
|--------------------|---------------------------|
| Plant Name: | Moody AFB |
| Sampling Location: | Slipstream - Intermediate |
| Date: | 4/25/02 |
| Project Number: | 030197.0002.5 |
| CEM Operator: | Doug Allen |
| Pollutant: | THC |
| Molecular Weight: | 16.00 |

| Run No. | Start-Stop Time | Raw Data (ppm) | Source Information | | Corrected Data Dry Basis (ppm) | Mass Emission Rate (lb/hr) | Mass Emission Rate (lb/1000 lb fuel) |
|---------|-----------------|----------------|--------------------|--------------------|--------------------------------|----------------------------|--------------------------------------|
| | | | Stack Flow (dscfm) | Stack Moisture (%) | | | |
| 1 | 08:36-10:32 | 3.1 | 328,584 | 2.00 | 3.2 | 2.58 | 2.4723 |
| 2 | 11:10-13:07 | 2.2 | 328,688 | 2.00 | 2.2 | 1.84 | 1.7588 |
| 3 | 13:25-14:24 | 1.5 | 328,736 | 2.00 | 1.6 | 1.29 | 1.2365 |
| Average | | | | | 2.3 | 1.90 | 1.82 |

Moisture Correction

$$C_{gas(dry)} = C_{gas(wet)} / (1 - (\% \text{ moisture} / 100))$$

Mass Emission Rate (lb/hr)

$$E(\text{lb/hr}) = C_{gas(dry)} * MW_{gas} * Q_s(\text{dscfm}) * 60 / 385300000$$

Total Hydrocarbon Data Correction

| | |
|--------------------|---------------|
| Plant Name: | Moody AFB |
| Sampling Location: | Ambient |
| Date: | 4/25/02 |
| Project Number: | 030197.0002.5 |
| CEM Operator: | Doug Allen |
| Pollutant: | THC |
| Molecular Weight: | 16.00 |

| Run No. | Start-Stop Time | Raw Data (ppm) |
|---------|-----------------|----------------|
| 1 | 08:36-09:05 | -0.45 |
| 2 | 11:01-11:30 | -0.48 |
| 3 | 14:30-14:59 | -0.20 |

CEM Data Correction Data Sheet

| | |
|--------------------|-----------------------|
| Plant Name: | Moody AFB |
| Sampling Location: | Engine - Intermediate |
| Date: | 4/25/02 |
| Project Number: | 030197.0002.5 |
| CEM Operator: | Doug Allen |
| Pollutant: | NOx |
| Molecular Weight: | 46.01 |

| Run No. | Start-Stop Time | Raw Data (% or ppm) | Calibration Data | | | Stack Flow (dscfm) | Fuel Flow (lb/hr) | Calibration Corrected Data (% or ppm) | Mass Emission Rate (lb/hr) | Mass Emission Rate (lb/1000 lb fuel) |
|---------|-----------------|---------------------|------------------|-----|------|--------------------|-------------------|---------------------------------------|----------------------------|--------------------------------------|
| | | | Cma | Co | Cm | | | | | |
| 1 | 09:10-10:29 | 5.5 | 19.9 | 0.2 | 19.5 | 78,902 | 1,045 | 5.6 | 3.13 | 2.9989 |
| 2 | 11:35-13:04 | 5.6 | 19.9 | 0.5 | 18.9 | 76,060 | 1,045 | 5.6 | 3.04 | 2.9059 |
| 3 | 13:25-14:24 | 5.7 | 19.9 | 0.3 | 18.3 | 74,072 | 1,045 | 6.0 | 3.17 | 3.0348 |
| Average | | | | | | | | 5.7 | 3.11 | 2.9798 |

Calibration Error Correction

$C_{gas} = (C_{obs} - C_o) * (C_{ma} / (C_m - C_o))$

Mass Emission Rate (lb/hr)

$E (lb/hr) = C_{gas} * MW_{gas} * Q_s (dscfm) * 60 / 385300000$

Mass Emission Rate (lb/1000 lb fuel)

$E (lb/MMBtu) = E (lb/hr) / \text{Fuel flow} * 1000$

| Pollutant | MWgas |
|-----------|-------|
| CO | 28.01 |
| Methane | 16.00 |
| NOx | 46.01 |
| SO2 | 64.06 |

CEM Data Correction Data Sheet

| | |
|--------------------|---------------------------|
| Plant Name: | Moody AFB |
| Sampling Location: | Slipstream - Intermediate |
| Date: | 4/25/02 |
| Project Number: | 030197.0002.5 |
| CEM Operator: | Doug Allen |
| Pollutant: | NOx |
| Molecular Weight: | 46.01 |

| Run No. | Start-Stop Time | Raw Data (% or ppm) | Calibration Data | | | Stack Flow (dscfm) | Fuel Flow (lb/hr) | Calibration Corrected Data (% or ppm) | Mass Emission Rate (lb/hr) | Mass Emission Rate (lb/1000 lb fuel) |
|---------|-----------------|---------------------|------------------|------|------|--------------------|-------------------|---------------------------------------|----------------------------|--------------------------------------|
| | | | Cma | Co | Cm | | | | | |
| 1 | 08:36-10:32 | 0.80 | 10.1 | -0.2 | 10.2 | 328,584 | 1,045 | 1.0 | 2.28 | 2.1770 |
| 2 | 11:10-13:07 | 0.80 | 10.1 | -0.2 | 10.3 | 328,688 | 1,045 | 0.9 | 2.15 | 2.0590 |
| 3 | 13:25-14:24 | 0.80 | 10.1 | -0.1 | 10.9 | 328,736 | 1,045 | 0.8 | 1.95 | 1.8618 |
| Average | | | | | | | | 0.9 | 2.12 | 2.0326 |

Calibration Error Correction

$C_{gas} = (C_{obs} - C_o) * (C_{ma} / (C_m - C_o))$

Mass Emission Rate (lb/hr)

$E (lb/hr) = C_{gas} * MW_{gas} * Q_s (dscfm) * 60 / 385300000$

Mass Emission Rate (lb/1000 lb fuel)

$E (lb/MMBtu) = E (lb/hr) / \text{Fuel flow} * 1000$

| Pollutant | MWgas |
|-----------|-------|
| CO | 28.01 |
| Methane | 16.00 |
| NOx | 46.01 |
| SO2 | 64.06 |

CEM Data Correction Data Sheet

| | |
|--------------------|---------------|
| Plant Name: | Moody AFB |
| Sampling Location: | Ambient |
| Date: | 4/25/02 |
| Project Number: | 030197.0002.5 |
| CEM Operator: | Doug Allen |
| Pollutant: | NOx |
| Molecular Weight: | 46.01 |

| Run No. | Start-Stop Time | Raw Data (% or ppm) | Calibration Data | | | Calibration Corrected Data (% or ppm) |
|---------|-----------------|---------------------|------------------|-----|------|---------------------------------------|
| | | | Cma | Co | Cm | |
| 1 | 08:36-09:05 | -0.04 | 19.9 | 0.2 | 19.5 | 0.00 |
| 2 | 11:01-11:30 | -0.04 | 19.9 | 0.5 | 18.9 | 0.00 |
| 3 | 14:30-14:59 | -0.08 | 19.9 | 0.3 | 18.3 | 0.00 |
| Average | | | | | | 0.00 |

Calibration Error Correction

$C_{gas} = (C_{obs} - C_o) * (C_{ma} / (C_m - C_o))$

CEM Data Correction Data Sheet

| | |
|--------------------|-------------------|
| Plant Name: | Moody AFB |
| Sampling Location: | Engine - Military |
| Date: | 4/26/02 |
| Project Number: | 030197.0002.5 |
| CEM Operator: | Doug Allen |
| Pollutant: | CO |
| Molecular Weight: | 28.01 |

| Run No. | Start-Stop Time | Raw Data (ppm) | Calibration Data | | | Source Information | | Calibration Corrected Data (% or ppm) | Mass Emission Rate (lb/hr) | Mass Emission Rate (lb/1000 lb fuel) |
|---------|-----------------|----------------|------------------|------|-------|--------------------|-------------------|---------------------------------------|----------------------------|--------------------------------------|
| | | | Cma | Co | Cm | Stack Flow (dscfm) | Fuel Flow (lb/hr) | | | |
| 1 | 08:30-09:54 | 177.4 | 300.9 | -4.0 | 282.5 | 94,623 | 2,550 | 180.5 | 78.62 | 30.8311 |
| 2 | 11:02-12:27 | 170.9 | 300.9 | -4.0 | 282.5 | 92,198 | 2,550 | 183.7 | 73.86 | 28.9641 |
| 3 | 12:41-12:57 | 172.0 | 300.9 | -4.0 | 279.5 | 92,391 | 2,550 | 186.8 | 75.28 | 29.5233 |
| Average | | | | | | | | 187.0 | 75.92 | 29.7728 |
| A/B | 15:35-15:38 | 156.7 | 300.9 | -4.0 | 279.5 | 24,493 | 2,230 | 170.5 | 18.22 | 8.1687 |

Calibration Error Correction

$C_{gas} = (C_{obs} - C_o) * (C_{ma} / (C_m - C_o))$
 Mass Emission Rate (lb/hr)
 $E (lb/hr) = C_{gas} * MW_{gas} * Q_s (dscfm) / 60 / 385300000$
 Mass Emission Rate (lb/1000 lb fuel)
 $E (lb/MMBtu) = E (lb/hr) / Fuel flow * 1000$

| Pollutant | MWgas |
|-----------|-------|
| CO | 28.01 |
| Methane | 16.00 |
| NOx | 46.01 |
| SO2 | 64.06 |

CEM Data Correction Data Sheet

| | |
|--------------------|-----------------------|
| Plant Name: | Moody AFB |
| Sampling Location: | Slipstream - Military |
| Date: | 4/26/02 |
| Project Number: | 030197.0002.5 |
| CEM Operator: | Doug Allen |
| Pollutant: | CO |
| Molecular Weight: | 28.01 |

| Run No. | Start-Stop Time | Raw Data (ppm) | Calibration Data | | | Source Information | | Calibration Corrected Data (% or ppm) | Mass Emission Rate (lb/hr) | Mass Emission Rate (lb/1000 lb fuel) |
|---------|-----------------|----------------|------------------|------|------|--------------------|-------------------|---------------------------------------|----------------------------|--------------------------------------|
| | | | Cma | Co | Cm | Stack Flow (dscfm) | Fuel Flow (lb/hr) | | | |
| 1 | 07:54-09:54 | 28.9 | 59.4 | -1.1 | 57.4 | 364,726 | 2,550 | 28.4 | 45.13 | 17.6968 |
| 2 | 10:33-12:27 | 25.0 | 59.4 | -1.0 | 57.3 | 389,257 | 2,550 | 26.5 | 44.96 | 17.6296 |
| 3 | 12:41-14:18 | 24.9 | 59.4 | -1.1 | 56.6 | 1,151,554 | 2,550 | 26.8 | 134.59 | 62.7817 |
| Average | | | | | | | | 27.2 | 74.89 | 29.3694 |
| A/B | 15:35-15:38 | 27.4 | 59.4 | -1.1 | 56.6 | 193,402 | 2,230 | 29.4 | 24.78 | 11.1113 |

Calibration Error Correction

$C_{gas} = (C_{obs} - C_o) * (C_{ma} / (C_m - C_o))$
 Mass Emission Rate (lb/hr)
 $E (lb/hr) = C_{gas} * MW_{gas} * Q_s (dscfm) / 60 / 385300000$
 Mass Emission Rate (lb/1000 lb fuel)
 $E (lb/MMBtu) = E (lb/hr) / Fuel flow * 1000$

| Pollutant | MWgas |
|-----------|-------|
| CO | 28.01 |
| Methane | 16.00 |
| NOx | 46.01 |
| SO2 | 64.06 |

CEM Data Correction Data Sheet

| | |
|--------------------|---------------|
| Plant Name: | Moody AFB |
| Sampling Location: | Ambient |
| Date: | 4/26/02 |
| Project Number: | 030197.0002.5 |
| CEM Operator: | Doug Allen |
| Pollutant: | CO |
| Molecular Weight: | 0 |

| Run No. | Start-Stop Time | Raw Data (ppm) | Calibration Data | | | Calibration Corrected Data (% or ppm) |
|---------|-----------------|----------------|------------------|------|-------|---------------------------------------|
| | | | Cma | Co | Cm | |
| 1 | 07:53-08:22 | -4.1 | 300.9 | -4.0 | 282.5 | 0.00 |
| 2 | 10:25-10:54 | -4.1 | 300.9 | -4.0 | 282.5 | 0.00 |
| 3 | 14:25-14:54 | -4.1 | 300.9 | -4.0 | 279.5 | 0.00 |
| Average | | | | | | 0.00 |

Calibration Error Correction

$C_{gas} = (C_{obs} - C_o) * (C_{ma} / (C_m - C_o))$

CEM Data Correction Data Sheet

| | |
|--------------------|-------------------|
| Plant Name: | Moody AFB |
| Sampling Location: | Engine - Military |
| Date: | 4/26/02 |
| Project Number: | 030197.0002.5 |
| CEM Operator: | Doug Allen |
| Pollutant: | CO2 |
| Molecular Weight: | |

| Run No. | Start-Stop Time | Raw Data (% or ppm) | Calibration Data | | | Calibration Corrected Data (% or ppm) |
|---------|-----------------|---------------------|------------------|------|------|---------------------------------------|
| | | | Cma | Co | Cm | |
| 1 | 08:30-09:54 | 1.3 | 9.9 | 0.0 | 9.9 | 1.3 |
| 2 | 11:02-12:27 | 1.3 | 9.9 | -0.1 | 10.0 | 1.4 |
| 3 | 12:41-12:57 | 1.3 | 9.9 | -0.1 | 9.8 | 1.4 |
| Average | | | | | | 1.4 |

| | | | | | | |
|-----|-------------|-----|-----|------|-----|-----|
| A/B | 15:35-15:38 | 4.6 | 9.9 | -0.1 | 9.8 | 4.8 |
|-----|-------------|-----|-----|------|-----|-----|

Calibration Error Correction
 $C_{gas} = (C_{obs} - Co) * (Cma / (Cm - Co))$

CEM Data Correction Data Sheet

| | |
|--------------------|-----------------------|
| Plant Name: | Moody AFB |
| Sampling Location: | Slipstream - Military |
| Date: | 4/26/02 |
| Project Number: | 030197.0002.5 |
| CEM Operator: | Doug Allen |
| Pollutant: | CO2 |
| Molecular Weight: | |

| Run No. | Start-Stop Time | Raw Data (% or ppm) | Calibration Data | | | Calibration Corrected Data (% or ppm) |
|---------|-----------------|---------------------|------------------|-------|------|---------------------------------------|
| | | | Cma | Co | Cm | |
| 1 | 07:54-09:54 | 0.187 | 1.01 | -0.02 | 1.00 | 0.207 |
| 2 | 10:33-12:27 | 0.187 | 1.01 | -0.02 | 0.99 | 0.210 |
| 3 | 12:41-14:18 | 0.181 | 1.01 | -0.02 | 0.98 | 0.217 |
| Average | | | | | | 0.212 |

| | | | | | | |
|-----|-------------|-----|-----|-----|-----|-----|
| A/B | 15:35-15:38 | 0.5 | 1.0 | 0.0 | 1.0 | 0.6 |
|-----|-------------|-----|-----|-----|-----|-----|

Calibration Error Correction
 $C_{gas} = (C_{obs} - Co) * (Cma / (Cm - Co))$

CEM Data Correction Data Sheet

| | |
|--------------------|---------------|
| Plant Name: | Moody AFB |
| Sampling Location: | Ambient |
| Date: | 4/26/02 |
| Project Number: | 030197.0002.5 |
| CEM Operator: | Doug Allen |
| Pollutant: | CO2 |
| Molecular Weight: | |

| Run No. | Start-Stop Time | Raw Data (% or ppm) | Calibration Data | | | Calibration Corrected Data (% or ppm) |
|---------|-----------------|---------------------|------------------|-------|------|---------------------------------------|
| | | | Cma | Co | Cm | |
| 1 | 07:53-08:22 | 0.00 | 9.94 | 0.00 | 9.85 | 0.000 |
| 2 | 10:25-10:54 | 0.00 | 9.94 | -0.10 | 9.95 | 0.101 |
| 3 | 14:25-14:54 | -0.03 | 9.94 | -0.10 | 9.90 | 0.066 |
| Average | | | | | | 0.055 |

Calibration Error Correction
 $C_{gas} = (C_{obs} - Co) * (Cma / (Cm - Co))$

CEM Data Correction Data Sheet

| | |
|--------------------|-------------------|
| Plant Name: | Moody AFB |
| Sampling Location: | Engine - Military |
| Date: | 4/26/02 |
| Project Number: | 030197.0002.5 |
| CEM Operator: | Doug Allen |
| Pollutant: | O2 |
| Molecular Weight: | |

| Run No. | Start-Stop Time | Raw Data (% or ppm) | Calibration Data | | | Calibration Corrected Data (% or ppm) |
|---------|-----------------|---------------------|------------------|-----|------|---------------------------------------|
| | | | Cma | Co | Cm | |
| 1 | 08:30-09:54 | 19.2 | 20.0 | 0.1 | 20.0 | 19.2 |
| 2 | 11:02-12:27 | 19.2 | 20.0 | 0.1 | 20.0 | 19.2 |
| 3 | 12:41-12:57 | 19.1 | 20.0 | 0.6 | 20.0 | 19.2 |
| Average | | | | | | 19.2 |

| | | | | | | |
|-----|-------------|------|------|-----|------|------|
| A/B | 15:35-15:38 | 14.4 | 20.0 | 0.6 | 20.0 | 14.3 |
|-----|-------------|------|------|-----|------|------|

Calibration Error Correction
 $C_{gas} = (C_{obs} - C_o) * (C_{ma} / (C_m - C_o))$

CEM Data Correction Data Sheet

| | |
|--------------------|-----------------------|
| Plant Name: | Moody AFB |
| Sampling Location: | Slipstream - Military |
| Date: | 4/26/02 |
| Project Number: | 030197.0002.5 |
| CEM Operator: | Doug Allen |
| Pollutant: | O2 |
| Molecular Weight: | |

| Run No. | Start-Stop Time | Raw Data (% or ppm) | Calibration Data | | | Calibration Corrected Data (% or ppm) |
|---------|-----------------|---------------------|------------------|------|------|---------------------------------------|
| | | | Cma | Co | Cm | |
| 1 | 07:54-09:54 | 20.8 | 20.0 | -0.5 | 20.4 | 20.5 |
| 2 | 10:33-12:27 | 20.9 | 20.0 | -0.5 | 20.4 | 20.5 |
| 3 | 12:41-14:18 | 20.7 | 20.0 | -0.5 | 20.0 | 20.8 |
| Average | | | | | | 20.6 |

| | | | | | | |
|-----|-------------|------|------|------|------|------|
| A/B | 15:35-15:38 | 20.0 | 20.0 | -0.5 | 20.0 | 20.1 |
|-----|-------------|------|------|------|------|------|

Calibration Error Correction
 $C_{gas} = (C_{obs} - C_o) * (C_{ma} / (C_m - C_o))$

CEM Data Correction Data Sheet

| | |
|--------------------|---------------|
| Plant Name: | Moody AFB |
| Sampling Location: | Ambient |
| Date: | 4/26/02 |
| Project Number: | 030197.0002.5 |
| CEM Operator: | Doug Allen |
| Pollutant: | O2 |
| Molecular Weight: | |

| Run No. | Start-Stop Time | Raw Data (% or ppm) | Calibration Data | | | Calibration Corrected Data (% or ppm) |
|---------|-----------------|---------------------|------------------|-----|------|---------------------------------------|
| | | | Cma | Co | Cm | |
| 1 | 07:53-08:22 | 20.9 | 20.0 | 0.1 | 20.0 | 21.0 |
| 2 | 10:25-10:54 | 20.9 | 20.0 | 0.1 | 20.0 | 20.9 |
| 3 | 14:25-14:54 | 20.9 | 20.0 | 0.6 | 20.0 | 21.0 |
| Average | | | | | | 21.0 |

Calibration Error Correction
 $C_{gas} = (C_{obs} - C_o) * (C_{ma} / (C_m - C_o))$

Total Hydrocarbon Data Correction

| | |
|--------------------|-------------------|
| Plant Name: | Moody AFB |
| Sampling Location: | Engine - Military |
| Date: | 4/26/02 |
| Project Number: | 030197.0002.5 |
| CEM Operator: | Doug Allen |
| Pollutant: | THC |
| Molecular Weight: | 16.00 |

| Run No. | Start-Stop Time | Raw Data (ppm) | Source Information | | Corrected Data Dry Basis (ppm) | Mass Emission Rate (lb/hr) | Mass Emission Rate (lb/1000 lb fuel) |
|---------|-----------------|----------------|--------------------|--------------------|--------------------------------|----------------------------|--------------------------------------|
| | | | Stack Flow (dscfm) | Stack Moisture (%) | | | |
| 1 | 08:30-09:54 | 2.0 | 94,623 | 4.96 | 2.1 | 0.50 | 0.1946 |
| 2 | 11:02-12:27 | 2.0 | 92,198 | 4.96 | 2.1 | 0.48 | 0.1898 |
| 3 | 12:41-12:57 | 2.0 | 92,391 | 4.96 | 2.1 | 0.48 | 0.1900 |
| Average | | | | | 2.1 | 0.49 | 0.19 |

| | | | | | | | |
|-----|-------------|-----|--------|------|-----|------|--------|
| A/B | 15:35-15:38 | 9.1 | 24,493 | 2.00 | 9.2 | 0.56 | 0.2529 |
|-----|-------------|-----|--------|------|-----|------|--------|

Moisture Correction

$$C_{gas(dry)} = C_{gas(wet)} \cdot (1 - (\% \text{ moisture}/100))$$

Mass Emission Rate (lb/hr)

$$E(\text{lb/hr}) = C_{gas(dry)} \cdot MW_{gas} \cdot Q_s(\text{dscfm}) \cdot 60/385300000$$

Total Hydrocarbon Data Correction

| | |
|--------------------|-----------------------|
| Plant Name: | Moody AFB |
| Sampling Location: | Slipstream - Military |
| Date: | 4/26/02 |
| Project Number: | 030197.0002.5 |
| CEM Operator: | Doug Allen |
| Pollutant: | THC |
| Molecular Weight: | 16.00 |

| Run No. | Start-Stop Time | Raw Data (ppm) | Source Information | | Corrected Data Dry Basis (ppm) | Mass Emission Rate (lb/hr) | Mass Emission Rate (lb/1000 lb fuel) |
|---------|-----------------|----------------|--------------------|--------------------|--------------------------------|----------------------------|--------------------------------------|
| | | | Stack Flow (dscfm) | Stack Moisture (%) | | | |
| 1 | 07:54-09:54 | 1.3 | 384,728 | 4.96 | 1.3 | 1.22 | 0.4775 |
| 2 | 10:33-12:27 | 0.7 | 389,257 | 4.96 | 0.7 | 0.71 | 0.2776 |
| 3 | 12:41-14:18 | 0.5 | 1,151,554 | 4.96 | 0.6 | 1.63 | 0.6360 |
| Average | | | | | 0.9 | 1.18 | 0.46 |

| | | | | | | | |
|-----|-------------|-----|---------|------|-----|------|--------|
| A/B | 15:35-15:38 | 3.2 | 193,402 | 2.00 | 3.3 | 1.59 | 0.7159 |
|-----|-------------|-----|---------|------|-----|------|--------|

Moisture Correction

$$C_{gas(dry)} = C_{gas(wet)} \cdot (1 - (\% \text{ moisture}/100))$$

Mass Emission Rate (lb/hr)

$$E(\text{lb/hr}) = C_{gas(dry)} \cdot MW_{gas} \cdot Q_s(\text{dscfm}) \cdot 60/385300000$$

Total Hydrocarbon Data Correction

| | |
|--------------------|---------------|
| Plant Name: | Moody AFB |
| Sampling Location: | Ambient |
| Date: | 4/26/02 |
| Project Number: | 030197.0002.5 |
| CEM Operator: | Doug Allen |
| Pollutant: | THC |
| Molecular Weight: | 16.00 |

| Run No. | Start-Stop Time | Raw Data (ppm) |
|---------|-----------------|----------------|
| 1 | 07:53-08:22 | 0.88 |
| 2 | 10:25-10:54 | 0.84 |
| 3 | 14:25-14:54 | 0.79 |

CEM Data Correction Data Sheet

| | |
|--------------------|-------------------|
| Plant Name: | Moody AFB |
| Sampling Location: | Engine - Military |
| Date: | 4/26/02 |
| Project Number: | 030197.0002.5 |
| CEM Operator: | Doug Allen |
| Pollutant: | NOx |
| Molecular Weight: | 46.01 |

| Run No. | Start-Stop Time | Raw Data (% or ppm) | Calibration Data | | | Source Information | | Calibration Corrected Data (% or ppm) | Mass Emission Rate (lb/hr) | Mass Emission Rate (lb/1000 lb fuel) |
|---------|-----------------|---------------------|------------------|-----|------|--------------------|-------------------|---------------------------------------|----------------------------|--------------------------------------|
| | | | Cma | Co | Cm | Stack Flow (dscfm) | Fuel Flow (lb/hr) | | | |
| 1 | 08:30-09:54 | 15.6 | 19.9 | 0.2 | 18.8 | 94,623 | 2,550 | 16.6 | 11.22 | 4.4009 |
| 2 | 11:02-12:27 | 15.3 | 19.9 | 0.3 | 19.1 | 92,198 | 2,550 | 15.9 | 10.49 | 4.1130 |
| 3 | 12:41-12:57 | 15.6 | 19.9 | 0.1 | 20.1 | 92,391 | 2,550 | 15.5 | 10.27 | 4.0273 |
| Average | | | | | | | | 15.0 | 10.66 | 4.1604 |

| | | | | | | | | | | |
|-----|-------------|------|------|-----|------|--------|-------|------|------|--------|
| A/B | 15:35-15:38 | 41.2 | 19.9 | 0.1 | 20.1 | 24,493 | 2,230 | 41.0 | 7.20 | 3.2280 |
|-----|-------------|------|------|-----|------|--------|-------|------|------|--------|

Calibration Error Correction

$C_{gas} = (C_{obs} - C_o) * (C_{ma} / (C_m - C_o))$

Mass Emission Rate (lb/hr)

$E (lb/hr) = C_{gas} * MW_{gas} * Q_s (dscfm) * 60 / 385300000$

Mass Emission Rate (lb/1000 lb fuel)

$E (lb/MMBtu) = E (lb/hr) / \text{Fuel flow} * 1000$

| Pollutant | MWgas |
|-----------|-------|
| CO | 28.01 |
| Methane | 16.00 |
| NOx | 46.01 |
| SO2 | 64.06 |

CEM Data Correction Data Sheet

| | |
|--------------------|-----------------------|
| Plant Name: | Moody AFB |
| Sampling Location: | Slipstream - Military |
| Date: | 4/26/02 |
| Project Number: | 030197.0002.5 |
| CEM Operator: | Doug Allen |
| Pollutant: | NOx |
| Molecular Weight: | 46.01 |

| Run No. | Start-Stop Time | Raw Data (% or ppm) | Calibration Data | | | Source Information | | Calibration Corrected Data (% or ppm) | Mass Emission Rate (lb/hr) | Mass Emission Rate (lb/1000 lb fuel) |
|---------|-----------------|---------------------|------------------|------|------|--------------------|-------------------|---------------------------------------|----------------------------|--------------------------------------|
| | | | Cma | Co | Cm | Stack Flow (dscfm) | Fuel Flow (lb/hr) | | | |
| 1 | 07:54-09:54 | 0.97 | 10.1 | -0.1 | 10.2 | 384,726 | 2,550 | 1.1 | 2.84 | 1.1121 |
| 2 | 10:33-12:27 | 0.92 | 10.1 | -0.1 | 9.6 | 389,257 | 2,550 | 1.1 | 3.02 | 1.1847 |
| 3 | 12:41-14:18 | 0.88 | 10.1 | -0.1 | 9.2 | 1,151,554 | 2,550 | 1.1 | 8.89 | 3.4860 |
| Average | | | | | | | | 1.1 | 4.92 | 1.9276 |

| | | | | | | | | | | |
|-----|-------------|-----|------|------|-----|---------|-------|-----|------|--------|
| A/B | 15:35-15:38 | 1.9 | 10.1 | -0.1 | 9.2 | 193,402 | 2,230 | 2.1 | 2.95 | 1.3222 |
|-----|-------------|-----|------|------|-----|---------|-------|-----|------|--------|

Calibration Error Correction

$C_{gas} = (C_{obs} - C_o) * (C_{ma} / (C_m - C_o))$

Mass Emission Rate (lb/hr)

$E (lb/hr) = C_{gas} * MW_{gas} * Q_s (dscfm) * 60 / 385300000$

Mass Emission Rate (lb/1000 lb fuel)

$E (lb/MMBtu) = E (lb/hr) / \text{Fuel flow} * 1000$

| Pollutant | MWgas |
|-----------|-------|
| CO | 28.01 |
| Methane | 16.00 |
| NOx | 46.01 |
| SO2 | 64.06 |

CEM Data Correction Data Sheet

| | |
|--------------------|---------------|
| Plant Name: | Moody AFB |
| Sampling Location: | Ambient |
| Date: | 4/26/02 |
| Project Number: | 030197.0002.5 |
| CEM Operator: | Doug Allen |
| Pollutant: | NOx |
| Molecular Weight: | #REF! |

| Run No. | Start-Stop Time | Raw Data (% or ppm) | Calibration Data | | | Calibration Corrected Data (% or ppm) |
|---------|-----------------|---------------------|------------------|------|------|---------------------------------------|
| | | | Cma | Co | Cm | |
| 1 | 07:53-08:22 | -0.09 | 19.9 | -0.2 | 18.8 | 0.00 |
| 2 | 10:25-10:54 | -0.09 | 19.9 | 0.3 | 19.1 | 0.00 |
| 3 | 14:25-14:54 | -0.12 | 19.9 | 0.1 | 20.1 | 0.00 |
| Average | | | | | | 0.00 |

Calibration Error Correction

$C_{gas} = (C_{obs} - C_o) * (C_{ma} / (C_m - C_o))$

CEM Data Correction Data Sheet

| | |
|--------------------|---------------|
| Plant Name: | Randolph AFB |
| Sampling Location: | Engine |
| Date: | 5/1/02 |
| Project Number: | 030197.0002.5 |
| CEM Operator: | Doug Allen |
| Pollutant: | CO |
| Molecular Weight: | 28.01 |

| Condition | Start-Stop Time | Raw Data (ppm) | Calibration Data | | | Source Information | | Calibration Corrected Data (% or ppm) | Mass Emission Rate (lb/hr) | Mass Emission Rate (lb/1000 lb fuel) |
|--------------|-----------------|----------------|------------------|------|-------|--------------------|-------------------|---------------------------------------|----------------------------|--------------------------------------|
| | | | Cma | Co | Cm | Stack Flow (dscfm) | Fuel Flow (lb/hr) | | | |
| Idle | 14:18-14:27 | 1650.0 | 447.8 | -1.2 | 437.5 | 24,956 | 1,040 | 1685.6 | 183.48 | 176.4244 |
| Intermediate | 14:35-14:43 | 384.9 | 447.8 | -1.2 | 437.5 | 82,241 | 2,060 | 373.7 | 134.04 | 65.0702 |
| Military | 14:46-14:53 | 255.2 | 447.8 | -1.2 | 437.5 | 120,532 | 4,440 | 261.7 | 137.60 | 30.9904 |
| Afterburner | 14:55-14:56 | 1300.0 | 447.8 | -1.2 | 437.5 | 17,130 | 4,460 | 1328.3 | 99.25 | 22.2523 |
| Average | | | | | | | | 912.3 | 138.59 | 73.6843 |

Calibration Error Correction

$C_{gas} = (C_{obs} - C_o) * (C_{ma} / (C_m - C_o))$

Mass Emission Rate (lb/hr)

$E (lb/hr) = C_{gas} * MW_{gas} * Q_s (dscfm) * 60 / 385300000$

Mass Emission Rate (lb/1000 lb fuel)

$E (lb/MMBtu) = E (lb/hr) / \text{Fuel flow} * 1000$

| Pollutant | MW _{gas} |
|-----------|-------------------|
| CO | 28.01 |
| Methane | 16.00 |
| NOx | 46.01 |
| SO2 | 64.06 |

CEM Data Correction Data Sheet

| | |
|--------------------|---------------|
| Plant Name: | Randolph AFB |
| Sampling Location: | Engine |
| Date: | 5/1/02 |
| Project Number: | 030197.0002.5 |
| CEM Operator: | Doug Allen |
| Pollutant: | CO |
| Molecular Weight: | 28.01 |

| Condition | Start-Stop Time | Raw Data (ppm) | Calibration Data | | | Calibration Corrected Data (% or ppm) |
|-----------|-----------------|----------------|------------------|------|-------|---------------------------------------|
| | | | Cma | Co | Cm | |
| Ambient | 1345-1352 | -1.1 | 447.8 | -1.2 | 437.5 | 0.03 |
| Average | | | | | | 0.01 |

Calibration Error Correction

$C_{gas} = (C_{obs} - C_o) * (C_{ma} / (C_m - C_o))$

CEM Data Correction Data Sheet

| | |
|--------------------|---------------|
| Plant Name: | Randolph AFB |
| Sampling Location: | Engine |
| Date: | 5/1/02 |
| Project Number: | 030197.0002.5 |
| CEM Operator: | Doug Allen |
| Pollutant: | CO2 |
| Molecular Weight: | |

| Condition | Start-Stop Time | Raw Data (% or ppm) | Calibration Data | | | Calibration Corrected Data (% or ppm) |
|--------------|-----------------|---------------------|------------------|-----|-----|---------------------------------------|
| | | | Cma | Co | Cm | |
| Idle | 14:18-14:27 | 1.7 | 2.0 | 0.0 | 2.0 | 1.7 |
| Intermediate | 14:35-14:43 | 1.1 | 2.0 | 0.0 | 2.0 | 1.1 |
| Military | 14:46-14:53 | 1.6 | 2.0 | 0.0 | 2.0 | 1.7 |
| Afterburner | 14:55-14:56 | 11.5 | 2.0 | 0.0 | 2.0 | 11.7 |
| Average | | | | | | 4.1 |

Calibration Error Correction

$$C_{gas} = (C_{obs} - C_o) * (C_{ma} / (C_m - C_o))$$

CEM Data Correction Data Sheet

| | |
|--------------------|---------------|
| Plant Name: | Randolph AFB |
| Sampling Location: | Engine |
| Date: | 5/1/02 |
| Project Number: | 030197.0002.5 |
| CEM Operator: | Doug Allen |
| Pollutant: | CO2 |
| Molecular Weight: | |

| Condition | Start-Stop Time | Raw Data (% or ppm) | Calibration Data | | | Calibration Corrected Data (% or ppm) |
|-----------|-----------------|---------------------|------------------|------|------|---------------------------------------|
| | | | Cma | Co | Cm | |
| Ambient | 1345-1352 | 0.02 | 2.00 | 0.00 | 1.96 | 0.015 |
| Average | | | | | | 0.004 |

Calibration Error Correction

$$C_{gas} = (C_{obs} - C_o) * (C_{ma} / (C_m - C_o))$$

CEM Data Correction Data Sheet

| | |
|--------------------|---------------|
| Plant Name: | Randolph AFB |
| Sampling Location: | Engine |
| Date: | 5/1/02 |
| Project Number: | 030197.0002.5 |
| CEM Operator: | Doug Allen |
| Pollutant: | O2 |
| Molecular Weight: | |

| Condition | Start-Stop Time | Raw Data (% or ppm) | Calibration Data | | | Calibration Corrected Data (% or ppm) |
|--------------|-----------------|---------------------|------------------|------|------|---------------------------------------|
| | | | Cma | Co | Cm | |
| Idle | 14:18-14:27 | 18.2 | 10.6 | -0.1 | 10.5 | 18.4 |
| Intermediate | 14:35-14:43 | 19.5 | 10.6 | -0.1 | 10.5 | 19.6 |
| Military | 14:46-14:53 | 18.8 | 10.6 | -0.1 | 10.5 | 18.9 |
| Afterburner | 14:55-14:56 | 5.5 | 10.6 | -0.1 | 10.5 | 5.6 |
| Average | | | | | | 15.6 |

Calibration Error Correction

$$C_{gas} = (C_{obs} - C_o) * (C_{ma} / (C_m - C_o))$$

CEM Data Correction Data Sheet

| | |
|--------------------|---------------|
| Plant Name: | Randolph AFB |
| Sampling Location: | Engine |
| Date: | 5/1/02 |
| Project Number: | 030197.0002.5 |
| CEM Operator: | Doug Allen |
| Pollutant: | O2 |
| Molecular Weight: | |

| Condition | Start-Stop Time | Raw Data (% or ppm) | Calibration Data | | | Calibration Corrected Data (% or ppm) |
|-----------|-----------------|---------------------|------------------|------|------|---------------------------------------|
| | | | Cma | Co | Cm | |
| Ambient | 13:45-13:52 | 20.8 | 10.6 | -0.1 | 10.5 | 21.0 |
| Average | | | | | | 5.2 |

Calibration Error Correction

$$C_{gas} = (C_{obs} - C_o) * (C_{ma} / (C_m - C_o))$$

Total Hydrocarbon Data Correction

| | |
|--------------------|---------------|
| Plant Name: | Randolph AFB |
| Sampling Location: | Engine |
| Date: | 5/1/02 |
| Project Number: | 030197.0002.5 |
| CEM Operator: | Doug Allen |
| Pollutant: | THC |
| Molecular Weight: | 16.00 |

| Condition | Start-Stop Time | Raw Data (ppm) | Source Information | | Corrected Data Dry Basis (ppm) | Mass Emission Rate (lb/hr) | Mass Emission Rate (lb/1000 lb fuel) |
|--------------|-----------------|----------------|--------------------|--------------------|--------------------------------|----------------------------|--------------------------------------|
| | | | Stack Flow (dscfm) | Stack Moisture (%) | | | |
| Idle | 14:18-14:27 | 208.4 | 24,956 | 1.50 | 211.6 | 13.16 | 12.6519 |
| Intermediate | 14:35-14:43 | 24.0 | 82,241 | 1.50 | 24.3 | 4.99 | 2.4200 |
| Military | 14:46-14:53 | 9.5 | 120,532 | 1.50 | 9.7 | 2.91 | 0.6548 |
| Afterburner | 1455-1456 | 260.0 | 17,130 | 1.50 | 264.0 | 11.27 | 2.5260 |
| Average | | | | | 127.4 | 8.08 | 4.56 |

Moisture Correction

$$C_{gas(dry)} = C_{gas(wet)} / (1 - (\% \text{ moisture} / 100))$$

Mass Emission Rate (lb/hr)

$$E(\text{lb/hr}) = C_{gas(dry)} * MW_{gas} * Q_s(\text{dscfm}) * 60 / 385300000$$

Total Hydrocarbon Data Correction

| | |
|--------------------|---------------|
| Plant Name: | Randolph AFB |
| Sampling Location: | Engine |
| Date: | 5/1/02 |
| Project Number: | 030197.0002.5 |
| CEM Operator: | Doug Allen |
| Pollutant: | THC |
| Molecular Weight: | 16.00 |

| Condition | Start-Stop Time | Raw Data (ppm) |
|-----------|-----------------|----------------|
| Ambient | 1345-1352 | 2.51 |

CEM Data Correction Data Sheet

| | |
|--------------------|---------------|
| Plant Name: | Randolph AFB |
| Sampling Location: | Engine |
| Date: | 5/1/02 |
| Project Number: | 030197.0002.5 |
| CEM Operator: | Doug Allen |
| Pollutant: | NOx |
| Molecular Weight: | 46.01 |

| Condition | Start-Stop Time | Raw Data (% or ppm) | Calibration Data | | | Source Information | | Calibration Corrected Data (% or ppm) | Mass Emission Rate (lb/hr) | Mass Emission Rate (lb/1000 lb fuel) |
|--------------|-----------------|---------------------|------------------|-----|------|--------------------|-------------------|---------------------------------------|----------------------------|--------------------------------------|
| | | | Cma | Co | Cm | Stack Flow (dscfm) | Fuel Flow (lb/hr) | | | |
| Idle | 14:18-14:27 | 7.0 | 19.9 | 0.4 | 21.5 | 24,956 | 1,040 | 6.3 | 1.12 | 1.0750 |
| Intermediate | 14:35-14:43 | 3.0 | 19.9 | 0.4 | 21.5 | 82,241 | 2,060 | 2.4 | 1.44 | 0.7006 |
| Military | 14:46-14:53 | 10.8 | 19.9 | 0.4 | 21.5 | 120,532 | 4,440 | 9.9 | 8.53 | 1.9207 |
| Afterburner | 1455-1456 | 100.0 | 19.9 | 0.4 | 21.5 | 17,130 | 4,460 | 94.3 | 11.58 | 2.5963 |
| Average | | | | | | | | 28.2 | 5.67 | 1.5731 |

Calibration Error Correction

$C_{gas} = (C_{obs} - C_o) * (C_{ma} / (C_m - C_o))$

Mass Emission Rate (lb/hr)

$E(lb/hr) = C_{gas} * MW_{gas} * Q_s(dscfm) * 60 / 385300000$

Mass Emission Rate (lb/1000 lb fuel)

$E(lb/MMBtu) = E(lb/hr) / \text{Fuel flow} * 1000$

| Pollutant | MWgas |
|-----------|-------|
| CO | 28.01 |
| Methane | 16.00 |
| NOx | 46.01 |
| SO2 | 64.06 |

CEM Data Correction Data Sheet

| | |
|--------------------|---------------|
| Plant Name: | Randolph AFB |
| Sampling Location: | Engine |
| Date: | 5/1/02 |
| Project Number: | 030197.0002.5 |
| CEM Operator: | Doug Allen |
| Pollutant: | NOx |
| Molecular Weight: | 46.01 |

| Condition | Start-Stop Time | Raw Data (% or ppm) | Calibration Data | | | Calibration Corrected Data (% or ppm) |
|-----------|-----------------|---------------------|------------------|-----|------|---------------------------------------|
| | | | Cma | Co | Cm | |
| Ambient | 1345-1352 | -0.04 | 19.9 | 0.4 | 21.5 | 0.00 |
| Average | | | | | | 0.00 |

Calibration Error Correction

$C_{gas} = (C_{obs} - C_o) * (C_{ma} / (C_m - C_o))$

CEM Data Correction Data Sheet

| | |
|--------------------|---------------|
| Plant Name: | Randolph AFB |
| Sampling Location: | Engine |
| Date: | 5/1/02 |
| Project Number: | 030197.0002.5 |
| CEM Operator: | Doug Allen |
| Pollutant: | CO |
| Molecular Weight: | 28.01 |

| Condition | Start-Stop Time | Raw Data (ppm) | Calibration Data | | | Source Information | | Calibration Corrected Data (% or ppm) | Mass Emission Rate (lb/hr) | Mass Emission Rate (lb/1000 lb fuel) |
|--------------|-----------------|----------------|------------------|------|-------|--------------------|-------------------|---------------------------------------|----------------------------|--------------------------------------|
| | | | Cma | Co | Cm | Stack Flow (dscfm) | Fuel Flow (lb/hr) | | | |
| Idle | 14:18-14:27 | 1650.0 | 447.8 | -1.2 | 437.5 | 25,101 | 1,040 | 1685.6 | 184.55 | 177.4490 |
| Intermediate | 14:35-14:43 | 364.9 | 447.8 | -1.2 | 437.5 | 97,837 | 2,060 | 373.7 | 159.46 | 77.4091 |
| Military | 14:46-14:53 | 255.2 | 447.8 | -1.2 | 437.5 | 138,865 | 4,440 | 261.7 | 158.53 | 35.7041 |
| Afterburner | 1455-1456 | 1300.0 | 447.8 | -1.2 | 437.5 | 18,446 | 4,460 | 1326.3 | 106.87 | 23.9622 |
| Average | | | | | | | | 912.3 | 152.35 | 78.6311 |

Calibration Error Correction

$C_{gas} = (C_{obs} - C_o) * (C_{ma} / (C_m - C_o))$

Mass Emission Rate (lb/hr)

$E (lb/hr) = C_{gas} * MW_{gas} * Q_s (dscfm) * 60 / 385300000$

Mass Emission Rate (lb/1000 lb fuel)

$E (lb/MMBtu) = E (lb/hr) / Fuel\ flow * 1000$

| Pollutant | MW _{gas} |
|-----------|-------------------|
| CO | 28.01 |
| Methane | 16.00 |
| NOx | 46.01 |
| SO2 | 64.06 |

CEM Data Correction Data Sheet

| | |
|--------------------|---------------|
| Plant Name: | Randolph AFB |
| Sampling Location: | Engine |
| Date: | 5/1/02 |
| Project Number: | 030197.0002.5 |
| CEM Operator: | Doug Allen |
| Pollutant: | CO |
| Molecular Weight: | 28.01 |

| Condition | Start-Stop Time | Raw Data (ppm) | Calibration Data | | | Calibration Corrected Data (% or ppm) |
|-----------|-----------------|----------------|------------------|------|-------|---------------------------------------|
| | | | Cma | Co | Cm | |
| Ambient | 1345-1352 | -1.1 | 447.8 | -1.2 | 437.5 | 0.03 |
| Average | | | | | | 0.01 |

Calibration Error Correction

$C_{gas} = (C_{obs} - C_o) * (C_{ma} / (C_m - C_o))$

CEM Data Correction Data Sheet

| | |
|--------------------|---------------|
| Plant Name: | Randolph AFB |
| Sampling Location: | Engine |
| Date: | 5/1/02 |
| Project Number: | 030197.0002.5 |
| CEM Operator: | Doug Allen |
| Pollutant: | CO2 |
| Molecular Weight: | |

| Condition | Start-Stop Time | Raw Data (% or ppm) | Calibration Data | | | Calibration Corrected Data (% or ppm) |
|--------------|-----------------|---------------------|------------------|-----|-----|---------------------------------------|
| | | | Cma | Co | Cm | |
| Idle | 14:18-14:27 | 1.7 | 2.0 | 0.0 | 2.0 | 1.7 |
| Intermediate | 14:35-14:43 | 1.1 | 2.0 | 0.0 | 2.0 | 1.1 |
| Military | 14:46-14:53 | 1.6 | 2.0 | 0.0 | 2.0 | 1.7 |
| Afterburner | 1455-1456 | 11.5 | 2.0 | 0.0 | 2.0 | 11.7 |
| Average | | | | | | 4.1 |

Calibration Error Correction

$$C_{gas} = (C_{obs} - C_o) * (C_{ma} / (C_m - C_o))$$

CEM Data Correction Data Sheet

| | |
|--------------------|---------------|
| Plant Name: | Randolph AFB |
| Sampling Location: | Engine |
| Date: | 5/1/02 |
| Project Number: | 030197.0002.5 |
| CEM Operator: | Doug Allen |
| Pollutant: | CO2 |
| Molecular Weight: | |

| Condition | Start-Stop Time | Raw Data (% or ppm) | Calibration Data | | | Calibration Corrected Data (% or ppm) |
|-----------|-----------------|---------------------|------------------|------|------|---------------------------------------|
| | | | Cma | Co | Cm | |
| Ambient | 1345-1352 | 0.02 | 2.00 | 0.00 | 1.96 | 0.015 |
| Average | | | | | | 0.004 |

Calibration Error Correction

$$C_{gas} = (C_{obs} - C_o) * (C_{ma} / (C_m - C_o))$$

CEM Data Correction Data Sheet

| | |
|--------------------|---------------|
| Plant Name: | Randolph AFB |
| Sampling Location: | Engine |
| Date: | 5/1/02 |
| Project Number: | 030197.0002.5 |
| CEM Operator: | Doug Allen |
| Pollutant: | O2 |
| Molecular Weight: | |

| Condition | Start-Stop Time | Raw Data (% or ppm) | Calibration Data | | | Calibration Corrected Data (% or ppm) |
|--------------|-----------------|---------------------|------------------|------|------|---------------------------------------|
| | | | Cma | Co | Cm | |
| Idle | 14:18-14:27 | 18.2 | 10.6 | -0.1 | 10.5 | 18.4 |
| Intermediate | 14:35-14:43 | 19.5 | 10.6 | -0.1 | 10.5 | 19.6 |
| Military | 14:46-14:53 | 18.8 | 10.6 | -0.1 | 10.5 | 18.9 |
| Afterburner | 1455-1456 | 5.5 | 10.6 | -0.1 | 10.5 | 5.6 |
| Average | | | | | | 15.6 |

Calibration Error Correction

$$C_{gas} = (C_{obs} - C_o) * (C_{ma} / (C_m - C_o))$$

CEM Data Correction Data Sheet

| | |
|--------------------|---------------|
| Plant Name: | Randolph AFB |
| Sampling Location: | Engine |
| Date: | 5/1/02 |
| Project Number: | 030197.0002.5 |
| CEM Operator: | Doug Allen |
| Pollutant: | O2 |
| Molecular Weight: | |

| Condition | Start-Stop Time | Raw Data (% or ppm) | Calibration Data | | | Calibration Corrected Data (% or ppm) |
|-----------|-----------------|---------------------|------------------|------|------|---------------------------------------|
| | | | Cma | Co | Cm | |
| Ambient | 1345-1352 | 20.8 | 10.6 | -0.1 | 10.5 | 21.0 |
| Average | | | | | | 5.2 |

Calibration Error Correction

$$C_{gas} = (C_{obs} - C_o) * (C_{ma} / (C_m - C_o))$$

Total Hydrocarbon Data Correction

| | |
|--------------------|---------------|
| Plant Name: | Randolph AFB |
| Sampling Location: | Engine |
| Date: | 5/1/02 |
| Project Number: | 030197.0002.5 |
| CEM Operator: | Doug Allen |
| Pollutant: | THC |
| Molecular Weight: | 16.00 |

| Condition | Start-Stop Time | Raw Data (ppm) | Source Information | | Corrected Data Dry Basis (ppm) | Mass Emission Rate (lb/hr) | Mass Emission Rate (lb/1000 lb fuel) |
|--------------|-----------------|----------------|--------------------|--------------------|--------------------------------|----------------------------|--------------------------------------|
| | | | Stack Flow (dscfm) | Stack Moisture (%) | | | |
| Idle | 14:18-14:27 | 208.4 | 25,101 | 14.18 | 242.9 | 15.19 | 14.6056 |
| Intermediate | 14:35-14:43 | 24.0 | 97,837 | 14.18 | 27.9 | 6.81 | 3.3042 |
| Military | 14:46-14:53 | 9.5 | 138,865 | 14.18 | 11.1 | 3.84 | 0.8659 |
| Afterburner | 1455-1456 | 260.0 | 18,446 | 14.18 | 303.0 | 13.92 | 3.1219 |
| Average | | | | | 146.2 | 9.94 | 5.47 |

Moisture Correction

$$C_{\text{gas(dry)}} = C_{\text{gas(wet)}} / (1 - (\% \text{ moisture} / 100))$$

Mass Emission Rate (lb/hr)

$$E \text{ (lb/hr)} = C_{\text{gas(dry)}} * MW_{\text{gas}} * Q_s \text{ (dscfm)} * 60 / 385300000$$

Total Hydrocarbon Data Correction

| | |
|--------------------|---------------|
| Plant Name: | Randolph AFB |
| Sampling Location: | Engine |
| Date: | 5/1/02 |
| Project Number: | 030197.0002.5 |
| CEM Operator: | Doug Allen |
| Pollutant: | THC |
| Molecular Weight: | 16.00 |

| Condition | Start-Stop Time | Raw Data (ppm) |
|-----------|-----------------|----------------|
| Ambient | 1345-1352 | 2.51 |

CEM Data Correction Data Sheet

| | |
|--------------------|---------------|
| Plant Name: | Randolph AFB |
| Sampling Location: | Engine |
| Date: | 5/1/02 |
| Project Number: | 030197.0002.5 |
| CEM Operator: | Doug Allen |
| Pollutant: | NOx |
| Molecular Weight: | 46.01 |

| Condition | Start-Stop Time | Raw Data (% or ppm) | Calibration Data | | | Source Information | | Calibration Corrected Data (% or ppm) | Mass Emission Rate (lb/hr) | Mass Emission Rate (lb/1000 lb fuel) |
|--------------|-----------------|---------------------|------------------|-----|------|--------------------|-------------------|---------------------------------------|----------------------------|--------------------------------------|
| | | | Cma | Co | Cm | Stack Flow (dscfm) | Fuel Flow (lb/hr) | | | |
| Idle | 14:18-14:27 | 7.0 | 19.9 | 0.4 | 21.5 | 25,101 | 1,040 | 6.3 | 1.12 | 1.0813 |
| Intermediate | 14:35-14:43 | 3.0 | 19.9 | 0.4 | 21.5 | 97,837 | 2,060 | 2.4 | 1.72 | 0.8334 |
| Military | 14:46-14:53 | 10.8 | 19.9 | 0.4 | 21.5 | 138,865 | 4,440 | 9.9 | 9.82 | 2.2128 |
| Afterburner | 1455-1456 | 100.0 | 19.9 | 0.4 | 21.5 | 18,446 | 4,460 | 94.3 | 12.47 | 2.7958 |
| Average | | | | | | | | 28.2 | 6.28 | 1.7308 |

Calibration Error Correction

$C_{gas} = (C_{obs} - C_o) * (C_{ma} / (C_m - C_o))$

Mass Emission Rate (lb/hr)

$E(lb/hr) = C_{gas} * MW_{gas} * Q_s(dscfm) * 60 / 385300000$

Mass Emission Rate (lb/1000 lb fuel)

$E(lb/MMBtu) = E(lb/hr) / \text{Fuel flow} * 1000$

| Pollutant | MWgas |
|-----------|-------|
| CO | 28.01 |
| Methane | 16.00 |
| NOx | 46.01 |
| SO2 | 64.06 |

CEM Data Correction Data Sheet

| | |
|--------------------|---------------|
| Plant Name: | Randolph AFB |
| Sampling Location: | Engine |
| Date: | 5/1/02 |
| Project Number: | 030197.0002.5 |
| CEM Operator: | Doug Allen |
| Pollutant: | NOx |
| Molecular Weight: | 46.01 |

| Condition | Start-Stop Time | Raw Data (% or ppm) | Calibration Data | | | Calibration Corrected Data (% or ppm) |
|-----------|-----------------|---------------------|------------------|-----|------|---------------------------------------|
| | | | Cma | Co | Cm | |
| Ambient | 1345-1352 | -0.04 | 19.9 | 0.4 | 21.5 | 0.00 |
| Average | | | | | | 0.00 |

Calibration Error Correction

$C_{gas} = (C_{obs} - C_o) * (C_{ma} / (C_m - C_o))$

THIS PAGE INTENTIONALLY LEFT BLANK

APPENDIX D

QUALITY ASSURANCE/QUALITY CONTROL PROCEDURES

D.1 QUALITY CONTROL PROCEDURES

As part of the engine testing program, EQ will implement a quality assurance (QA) and quality control (QC) program. QA/QC are defined as follows:

- Quality Control - The overall system of activities whose purpose is to provide a quality product or service (e.g., the routine application of procedures for obtaining prescribed standards of performance in the monitoring and measurement process).
- Quality Assurance - A system of activities whose purpose is to provide assurance that the overall QC is being conducted effectively.

The Field Team Leaders for stack sampling will be responsible for implementation of field QA/QC procedures. Individual laboratory managers will be responsible for implementation of analytical QA/QC procedures. The overall Project Manager oversees all QA/QC procedures to ensure that sampling and analyses meet the QA/QC requirements and that accurate data results from the test program are obtained.

D.1.1 Field QC Sample Collection/Preparation Procedures

Table B-1 provides a summary of the numbers and types of field and analytical QA/QC samples by parameter. General field QC procedures are the following:

- Collect only the number of samples needed to represent the media being sampled.
- To the extent possible, determine the quantities and types of samples and sample locations prior to the actual field work.
- As few people as possible should handle samples.

TABLE D-1. SUMMARY OF ANALYTICAL QA/QC SAMPLES

| SAMPLE LOCATION | PARAMETER | NUMBER OF SAMPLES | TYPES OF QA/QC SAMPLES | | |
|----------------------------|----------------------------------|-------------------|------------------------|--------|---------|
| | | | FB | TB | MS |
| STACK GAS ⁽¹⁾ : | | | | | |
| | Particulate | 48 | -- | 1 | -- |
| | Volatile organics ⁽²⁾ | 48 | 1 pair | 1 pair | 12 pair |
| | Aldehydes and Ketones | 4 | 1 | 1 | -- |
| AMBIENT (BACKGROUND) | | | | | |
| | Particulate | 4 | 1 | -- | -- |
| | Volatile organics | 5 | 1 | -- | -- |

⁽¹⁾ Trip blanks for stack gas samples will consist of reagent blanks. See Subsection 6.1.2 for a description of stack gas blank samples.

⁽²⁾ Four VOST tubes per test run.

FB = Field Blank

TB = Trip Blank

MB = Method Blank or Preparation Blank

MS = Matrix Spike

- The field sampler is personally responsible for the care and control of the samples collected until they are property transferred or dispatched.
- Sample records must be completed for each sample, using black waterproof ink or other measures to ensure the legibility and integrity of sample identification.
- The Field Team Leader ensures that proper preservation, storage, and security procedures are followed during the field work and decides if additional samples are needed.
- Storage conditions of samples must be documented on the sample forms or project records.

D.1.1.1 QC Procedures for Stack Gas Sample Collection

This subsection provides a list of QC procedures to be employed during the field sampling effort. Method-specific QC procedures are detailed in the method descriptions contained in Appendix A. General QC checks that will apply to all methods include the following:

- Leak checks.
- Use of standardized forms, labels, and checklists.
- Ensure sample traceability.
- Collection of appropriate blanks.
- Use of calibrated instrumentation.
- Use of Protocol 1 and/or NIST-traceable calibration gases.
- Review of data sheets in the field to verify completeness.
- Use of validated spreadsheets for calculating results.

D.1.1.2 Velocity/Volumetric Flow Rate QC Procedures

Volumetric flow rates will be determined during the isokinetic stack gas tests. The following QC procedures will be followed during these tests:

- The S-type pitot tube will be inspected visually before sampling.
- Both legs of the pitot tube will be leak-checked before sampling.
- Proper orientation of the S-type pitot tube will be maintained while making measurements. The yaw and pitch axes of the S-type pitot tube will be maintained at 90° to the flow.

- The manometer oil will be leveled and zeroed before each run.
- Cyclonic or turbulent flow checks will be performed prior to testing the source.
- Pitot tube coefficients will be determined based on physical measurement techniques as delineated in EPA Method 2.

D.1.1.3 Moisture Content and Sample Volume QC Procedures

Gas stream moisture will be determined by EPA Method 4 as part of the isokinetic stack gas tests. The following QC procedures will be followed in determining the volume of moisture collected:

- The balance zero will be checked and rezeroed if necessary before each weighing.
- The balance will be leveled and placed in a clean, motionless environment for weighings.
- The indicating silica gel will be fresh for each run and will be inspected periodically and replaced during runs, if needed.

The QC procedures that will be followed to ensure accurate sample gas volume determination are the following:

- The dry gas meter will be fully calibrated annually using an EPA-approved intermediate standard device.
- Pretest, port-change, and posttest leakchecks will be completed (must be less than 0.02 cfm or 4 % of the average sample rate).
- The gas meter will be read to the thousandth of a cubic foot for all initial and final readings.
- Readings of the dry gas meter, meter orifice pressure (**Delta H**), and meter temperatures will be taken at every sampling point.
- Accurate barometric pressures will be recorded at least once per day.
- Pre- and posttest program dry gas meter checks will be completed to verify the accuracy of the meter calibration constant (Y).

The most critical operating parameter for ambient air-sampling equipment is the airflow rate during sampling, which determines the total volume of air sampled. Calibrations of the ambient air-sampling equipment will be performed to accurately determine the operating flow rates of the samplers, and to verify that all method-based flow-rate requirements are met.

All ambient air samplers will be calibrated upon installation to establish the means for determining operating flow rates, and as required throughout the monitoring program whenever field calibration checks or repairs require recalibration. All calibrations will be conducted according to standard operating procedures (SOP), using materials traceable to NIST reference materials. Calibrations will be conducted by qualified personnel thoroughly familiar with the sampling equipment. All calibration and audit results will be recorded in a field logbook and/or the calibration/audit data sheets. Other specific QA/QC for particulate, VOST, aldehydes and ketones, and CEMS are in Appendix B.

D.1.2 Exhaust Gas Blank Samples

Stack gas blank samples will consist primarily of reagent blanks collected in the on-site sample recovery area during the test program. Reagent blanks will include solvents used to recover stack samples, absorbing solutions, filters, and resins (Tenax, Tenax/charcoal). All reagent blanks will be collected by transferring directly from storage containers to sample jars, or labeling filters and resins as blank samples.

For the VOST Method 0030* sampling trains, additional blank samples will be taken in the field according to the following procedures. Blank Tenax and Tenax/charcoal cartridges will be taken to the sampling location and the end caps removed for a period of time equal to the time required to exchange one pair of VOST tubes on the VOST train. After this time period, the end caps will be replaced on the blank tubes and these tubes will be handled in a manner similar to the other VOST tube samples. This procedure is consistent with the *EPA Quality Assurance/Quality Control (QA/QC) Procedures for Hazardous Waste Incineration* (January 1990).

* 40 CFR 60 Appendix A

A blank Method 0011* (aldehydes and ketones) sample train will be taken to the stack sample location, leak checked, and then recovered in the same manner as the Method 0011* stack samples.

The sampling media may contain small amounts of the target compounds emitted from naturally occurring or anthropogenic emission sources. Contamination may be introduced to the sampling media during handling of the media in the laboratory, in the field, or during shipping. Blank samples will be used to quantify these sources of contamination. A blank sample consists of a complete set of sampling media (e.g., a PUF cartridge and a glass fiber filter, or a complete ADS sampling train) that has had no air drawn through it by the sampling equipment. Field blank samples will be collected during the monitoring program.

The field blanks will be used to identify contamination resulting from field sample handling procedures. A field blank will be handled in the same manner as an actual sample, undergoing the same preparation, installation in the sampler module, and recovery procedures.

The following stack sample blank corrections will be performed.

- Particulate — Acetone and methylene chloride blank.
- VOST — Field and trip blanks.
- Aldehydes and Ketones — Reagent blanks.

D.2 SAMPLING CONTAINERS, PRESERVATIVES, AND VOLUME REQUIREMENTS

Table B-2 lists the holding times, storage containers and preservation requirements to be used for routine storage and handling of samples.

D.3 DECONTAMINATION PROCEDURES

Stack-gas sampling equipment will be precleaned following standard source test method procedures. All stack-gas sampling equipment will be cleaned on site as part of individual sample recovery procedures.

Sample containers will be purchased from a vendor with a certificate indicating that each lot of bottles is free of contaminants.

All personnel associated with sample collection will use designated personal protective equipment (PPE). Personnel will follow standard PPE decontamination procedures for each level of PPE required.

All personnel have received the proper hazardous materials training as specified in 29 CFR 1910.

D.4 SAMPLING PACKAGING AND SHIPMENT

All samples will be packaged and shipped according to the specifications detailed in the Hazardous Materials Transportation Regulations published by the U.S. Department of Transportation (DOT) (49 CFR 171-180) for ground transportation and the International Air Transport Association (IATA) regulations for air shipment. These regulations contain detailed instructions on how hazardous materials must be identified, packaged, marked, labeled, documented, and placarded. All personnel involved with sample shipment are trained and certified for shipment of hazardous materials.

When transferring possession of samples, the individuals relinquishing and receiving those samples will sign, date, and note the time on the sample chain-of-custody record. This record documents sample transfer from the sampler, often through another person or commercial carrier, to the sample custodian or analyst.

The procedure for shipping samples will be as follows:

- A complete sample inventory form (chain-of-custody) will be enclosed with the samples being shipped, and a copy retained by the Field Team Leader.
- DOT and IATA regulations will be followed for shipping container requirements. The regulations require that the shipper make a reasonable determination whether the sample is classified as a hazardous material and, if so, that it is appropriately identified.
- Each package will be designed and constructed, and its contents limited, so that under normal transportation conditions there will be no significant release of materials to the environment and no potentially hazardous conditions.

TABLE D-2. RECOMMENDED SAMPLE CONTAINERS, PRESERVATION TECHNIQUES, AND HOLDING TIMES

| SAMPLE LOCATION | ANALYTE | MATRIX | CONTAINER TYPE AND SIZE | PRESERVATION | HOLDING TIME |
|-----------------|---|------------------------------------|------------------------------|----------------------|---|
| STACK GAS | Particulate Condensable particulate Volatile organics | Liquids, filters, and resins | AG/500 mL | NA | NA |
| | | | AG/1.0 L G/40 mL AG/1L | NA ≤4 °C ≤4 °C | NA 14 days 14 days to exit/40 days to analysis |
| AMBIENT | Aldehydes and Ketones | Liquid | AG/1.0 L | ≤4 °C | 14 days |
| | | | E | NA | NA |
| | | | S G/A | NA NA 4 ± 2°C | 30 days 7 days to exit/40 days to analysis |

Key:

- A = Aluminum Foil
- AG = Amberglass
- D = Denuder Tube
- E = Envelope/Folder
- G = Glass
- NA = Not Applicable
- P = Plastic
- S = Stainless Steel Canister.

- Samples will be placed inside a shipping container for transport back to the laboratory.
- Preservation of the samples (e.g., refrigerant packs, ice, chemical preservatives, etc.) will be performed as required by the test plan or analytical requirements and documented on the sample inventory record.
- All freight bills and shipping records will be retained as part of the permanent records by the Project Manager.

D.5 CUSTODY PROCEDURES

An overriding consideration for environmental measurement data is the ability to demonstrate that samples have been obtained from the locations stated using the prescribed methods and that they have reached the laboratory without alteration. Evidence of collection, shipment, laboratory receipt, and laboratory custody until disposal will be documented to accomplish this objective. Documentation will be accomplished through a chain-of-custody record that documents each sample and the individuals responsible for sample collection, shipment, and receipt. A sample will be considered "in custody " under the following conditions:

- It is in a person's actual possession.
- It is in view after being in physical possession.
- It is secured in a locked compartment so that no one can tamper with it after it has been in physical custody.
- It is in a secured area, restricted to authorized personnel.

D.5.1 Field Custody Procedures

Sample custody will be initiated by EQ during collection of the samples. Preformatted labels will be used at the time of collection. Documents prepared specifically for monitoring field sample collection and recovery will be used for recording pertinent information about the types and numbers of samples collected and shipped for analysis. The samples collected first will be assembled at an on-site location for batching and paperwork checks. This task includes matching similar sample types (e.g., solids, liquids) from all sampling locations. Sample packaging procedures will comply with all DOT and IATA requirements for shipment of environmental

samples. Establishing or maintaining sample integrity involves numerous steps or considerations in addition to custody documentation. For example, major concerns in programs of this nature are contamination, cross-contamination, and/or degradation of sample containers; absorbing and filtration media; recovery materials; and actual samples, as applicable. These problems will be avoided or minimized at all times by using the following procedure:

- The lid of each labeled jar will be secured with a strip of custody tape.
- Individual sample jars will then be sealed in plastic bags and placed in appropriate shipping containers.
- Volatile materials will be stored, handled, and transported apart from sorbent materials (e.g., store, handle, and ship VOST tubes apart from solvents [methylene chloride, acetone, toluene, etc.] used to recover the other sample trains).
- Volatile, organic, and aldehyde and ketone samples will be sealed and kept away from sources of solvents, gasoline, etc., during recovery, transportation, storage, and analysis (e.g., recovery of particulate samples where acetone is used will be performed remote from preparation, recovery, and storage of VOST and aldehyde and ketone samples).
- Vermiculite will be placed around the bags in the shipping container for protection from damage, if needed. Ice will be placed in the shipping container, if required.
- One chain-of-custody form will be completed for each shipping container, placed in a large plastic bag, and the bag taped to the inside lid of the shipping container.
- The container will be taped closed with tape and sealed with custody tape on two sides such that opening the container will break the custody tape.

Collected samples will be kept under lock and key or within sight at all times until their shipment to the laboratory. The field sampler will act as the sample custodian and the document control officer in order to monitor the location of collected samples and to record vital sample information in field logbooks.

A unique system for individual sample identification will be used and included on each sample label.

This naming convention allows every sample to be completely and consistently identified on the field data sheets, sample media labels, chain-of-custody forms, and laboratory reports. The naming convention is designed to provide redundant information that can be used in conjunction with laboratory media identification numbers to verify sample identity.

The final evidence file will include at a minimum the following:

- Field logbooks.
- Field data and data deliverables.
- Photographs.
- Drawings.
- Laboratory data deliverables.
- Data validation reports.
- Data assessment reports.
- Progress reports, QA reports, interim project reports, etc.
- All custody documentation (i.e., tags, forms, airbills, etc.).

D.6 DATA REDUCTION, VALIDATION, AND REPORTING

Data will be produced primarily from three sources, specifically the following:

- Engine operations during the test program.
- Field measurements data, including sampling records (volumes and duration), and observations.
- Sample analysis and characterization data.

All data generated by field activities or by the laboratory will be reduced and validated prior to reporting. Specific data reduction, validation and reporting procedures are described in the following subsections.

D.6.1 Data Reduction

D.6.1.1 Field Data Reduction Procedures

The stages of data confirmation will begin with an initial series of calculations completed on the same day as the sampling effort to establish that the pretest assumptions were correct and

that the test procedures completed to that point were performed in an acceptable manner. This enables the on-site test team to correct any faulty procedures, and provides a greater understanding of any immediate problems. The on-site data reduction and confirmation activities will be performed by an experienced data management specialist.

D.6.1.2 Office Calculations

All data averages will be "double-checked" to verify numerical accuracy by an experienced technician. Prior to utilization of the analytical data for calculation of test results, a check will be applied to ascertain any obvious "out-of-line" results for reanalysis.

All results of calculations will be examined by another individual as assigned by the Field Team Leader. Depending on the complexity of the work, this person will either spot-check certain calculations or repeat the entire effort as assigned by the Field Team Leader. When all data are summarized, a check will be made for test result correctness by the Field Team Leader and by the EQ Program Manager. The EQ QA Manager will conduct routine audits to document that the checks are being performed and documented (with checker's initials and date).

The initial field test data and resulting calculations will be performed on a portable PC at the end of each test day. In the office, final results and result tables will be developed on a microcomputer. Standard EPA method programs have been developed and validated for the computational systems to ensure that correct equations are utilized to generate results. The programs will list all entry items (for proofing purposes) and produce calculated results in hard copy form. Reference method equations will be used to calculate the concentration and/or mass rate of each measured parameter.

D.6.2 Analytical Data Validation Evaluation

All data will be compared to the acceptance criteria of the reference method. For example, particulate tests must be 100% isokinetic, $\pm 10\%$, to be acceptable. Laboratory data will be acceptable only if calibration standards fall within the established control limits.

TABLE D-3. ACTIVITY MATRIX FOR CALIBRATION OF EQUIPMENT^a

| APPARATUS | ACCEPTANCE LIMITS | FREQUENCY AND METHOD OF MEASUREMENT | ACTION IF REQUIREMENTS ARE NOT MET |
|--|--|---|---|
| Wet test meter | Capacity 3.4 m ³ /hr (120 ft ³ /hr); accuracy within ±1.0% | Calibrate initially, and then yearly by liquid displacement. | Adjust until specifications are met, or return to manufacturer. |
| Dry gas meter | $Y_1 = Y \pm 0.02 Y$ | Calibrate vs. wet test meter initially, and when posttest check exceeds $Y \pm 0.05 Y$ | Repair, or replace and then recalibrate. |
| Thermometers | Impinger thermometer ±1°C (2°F); dry gas meter thermometer ±3°C (5.4°F) over range; stack temperature sensor ±1.5% of absolute temperature | Calibrate each initially as a separate component against a mercury-in-glass thermometer. Then before each field trip compare each as part of the train with the mercury-in-glass thermometer. | Adjust to determine a constant correction factor, or reject. |
| Probe heating system | Capable of maintaining 120° ± 14°C (248° ± 25°F) at a flow rate of 20 l/min (0.71 ft ³ /min) | Calibrate component initially by APTD-0576(11) if constructed by APTD-0581(10), or use published calibration curves. | Repair or replace and then reverify the calibration. |
| Barometer | ±2.5 mm (0.1 in.) Hg of mercury-in-glass barometer | Calibrate initially vs. mercury-in-glass barometer; check before and after each field test. | Adjust to agree with a certified barometer. |
| Probe nozzle | Average of three ID measurements of nozzle; difference between high and low 0.1 mm (0.004 in.) | Use a micrometer to measure to nearest 0.025 mm (0.001 in.); check before field test. | Recalibrate, reshape, and sharpen when nozzle becomes nicked, dented, or corroded. |
| Type S pitot tube and/or probe assembly | All dimension specifications met, or calibrate according to Subsection 3.1.2, and mount in an interference-free manner | When purchased, use method in Subsections 3.1.1 and 3.1.2; visually inspect after each field test. | Do not use pitot tubes that do not meet face opening specifications; repair or replace as required. |
| Stack gas temperature measurement system | Capable of measuring within 1.5% of minimum absolute stack temperature | When purchased and after each field test, calibrate against ASTM thermometer. | Adjust to agree with Hg bulb thermometer, or construct a calibration curve to correct the readings. |
| Analytical balance | ±1 mg of Class-S weights | Check with Class-S weights upon receipt. | Adjust or repair. |

(continued)

TABLE D-3 (continued)

| APPARATUS | ACCEPTANCE LIMITS | FREQUENCY AND METHOD OF MEASUREMENT | ACTION IF REQUIREMENTS ARE NOT MET |
|--|---|--|--|
| Differential pressure gauge (does not include inclined manometers) | Agree within $\pm 5\%$ of incline manometers | Initially and after each field use. | Adjust to agree with inclined manometer or construct calibration curve to correct the readings. |
| Orsat analyzer | Average of three replicates should be $20.9 \pm 0.5\%$ (absolute) or known concentration ± 0.5 (absolute) | Upon receipt and before any test in which the analyzer has not been checked during the previous 3 mo; determine % O_2 in ambient air, or use a calibration gas with known CO , CO_2 , and O_2 concentrations | Check Orsat analyzer for leaking valves, spent absorbing reagent, and/or operator techniques. Repair or replace parts or absorbing solutions, and/or modify operator techniques. |
| Rotameter or rate meter | Smooth curve of rotameter actual flow rates with no evidence of error. $\pm 5\%$ of known flow rate. | Check with wet test meter or volume meter at 6-month intervals or at indication of erratic behavior. | Repeat calibration steps until limits are attained. |

^a EPA-600/9-76-005, *Quality Assurance Handbook for Air Pollution Measurement Systems - Volume III*, U. S. EPA, Office of Research and Development, Environmental Monitoring and Support Laboratory, Research Triangle Park, NC, January 1976, as revised.

Outliers will be treated on a case-by-case basis. All questionable data will be reviewed in an attempt to find a reason for rejection. All questionable data will be outlined in the scientific and technical report.

Unacceptable data will be appropriately qualified in the scientific and technical report. Case narratives will be prepared, which will include information concerning data that fell outside acceptance limits, and any other anomalous conditions encountered during sample analysis. After the Laboratory QA Officer approves these data, they will be considered ready for data validation.

D.6.2.1 Procedures Used To Evaluate Field Data

Procedures used to evaluate field data include posttest field instrument calibration checks, acceptable isokinetic sampling rates, and demonstration of acceptable posttest leak checks.

D.6.3 Data Reporting

Data reporting procedures will be performed for field operations as indicated in the following subsections.

D.6.3.1 Field Data Reporting

Field data reporting will be conducted principally through the generation of test data tables containing tabulated results of all measurements made in the field, and documentation of all field calibration activities.

D.7 PREVENTIVE MAINTENANCE REVIEW

Well-maintained equipment is an essential ingredient in ensuring the quality, completeness, and timeliness of the field and analytical data. This subsection reviews the schedules of preventive maintenance that must be performed to minimize the downtime for critical measurement systems for each contracting company. Also, lists of critical spare parts that must be available at the individual field and laboratory sites must be developed and reviewed. This subsection represents a review of the preventive maintenance items that are required for the field operations.

D.7.1 Field Instrument Preventative Maintenance

Field source testing equipment and instrumentation that require maintenance and/or calibration will be serviced immediately prior to conducting the test program.

Normal spare parts (e.g., control consoles, sample boxes, probes, glassware, sample bottles, etc.) as well as extra materials/supplies (e.g., filters, solutions, solvents, XAD traps, etc.) are scheduled to be available at the field site during testing.

Extra spare parts and equipment for process sample collection and compositing equipment, glassware, sample containers, etc. are scheduled to be available at the field site during testing. Extra materials/supplies (e.g., filters, solvents, etc.) required for the process sample collection will also be available at the field site during testing.

Sufficient volumes of protocol and calibration gases for the CEM monitoring, extra fittings, sample lines, pumps, heating tapes, and analyzer cells, along with sufficient materials/supplies (e.g., pump oil, filters, etc.) will be available at the field site during testing.

D.8 CORRECTIVE ACTION

Corrective action is the process of identifying, recommending, approving, and implementing measures to counter unacceptable procedures or procedures out of QC performance that can affect data quality. Corrective action can occur during field activities, laboratory analyses, data validation, and data assessment. All corrective actions proposed and implemented should be documented in the regular QA reports to management. Corrective action should be implemented only after approval by the EQ Project Manager or his designee. If immediate corrective action is required, approvals secured from the EQ Project Manager should be documented in an additional memorandum.

Depending on the nature of the problem, the corrective action may be formal or informal. In either case, occurrence of the problem, the corrective action performed, and verification that the problem has been resolved will be documented. Whenever a corrective action is required, documentation will be completed by the individual noting the problem and a copy will be filed with the EQ Project Manager.

The shared effort for implementing the corrective action will be the responsibility of the EQ Project Manager, the EQ QA Managers, and the Field Team Leaders.

Corrective actions will be initiated when data quality problems are determined during the program. These data quality problems will be flagged "out of control" if they are outside the predetermined limits specified above for internal, performance, system, and data audits. When discovered, prompt action toward a solution will be undertaken by the generator of the data. The corrective action will be conducted through the following six activities:

- Define the quality problem.
- Notify the designated individuals listed in the work plan.
- Determine the cause of the problem.
- Determine the corrective action.
- Implement the corrective action.
- Verify the solution to the problem.

Corrective action will be instituted immediately by the individual noting a problem in a measurement system. An unresolved problem will be reported to the EQ Project Manager and the EQ QA Managers for further action.

APPENDIX E
QA/QC – CALIBRATION DATA



Environmental Quality Management, Inc.

CALIBRATION PROCEDURES AND RESULTS

All of the equipment used is calibrated in accordance with the procedures outlined in the *Quality Assurance Handbook for Air Pollution Measurement Systems, Volume III (EPA 600/4-77-027b)*. The following pages describe these procedures and include the data sheets.

CALIBRATION PROCEDURES AND FREQUENCY

This subsection describes the calibration procedures and the frequency at which these procedures will be performed for both field and laboratory instruments.

B.6.1 Field Instrument Calibration

The following equipment items will be calibrated before and after field usage:

- Velocity measurement devices.
- Gas flow rate metering systems.
- Gas volume metering equipment.
- Gas composition measuring apparatus (Orsat).

The calibration records will include device numbers, calibration dates, methods, and data and results, and will be maintained on file at the EQ laboratory. Copies of applicable calibration records also will be available at the job site for review.

Acceptance limits are shown for each equipment item in Table B-4.



Environmental Quality Management, Inc.

DRY GAS METER AND ORIFICE METER

Dry gas meters and orifices are calibrated in accordance with Section 3.3.2 of the QA Handbook. This procedure involves direct comparison of the dry gas meter to a reference dry test meter. The reference dry test meter is routinely calibrated using a liquid displacement technique. Before its initial use in the field, the metering system is calibrated over the entire range of operation. After each field use, the metering system is calibrated at a single intermediate setting based on the previous field test. Acceptable tolerances for the initial and final gas meter factors and orifice calibration factors are ± 0.02 and ± 0.20 from average, respectively.

Pitot Tube Calibration

Each pitot tube used in sampling meets all requirements of EPA Method 2, Section 4.1.** Therefore, a baseline coefficient of 0.84 is assigned to each pitot tube. The following pages show the alignment requirements of Method 2 and the Pitot Tube Inspection Data Sheet(s) for each pitot tube used during the test program.

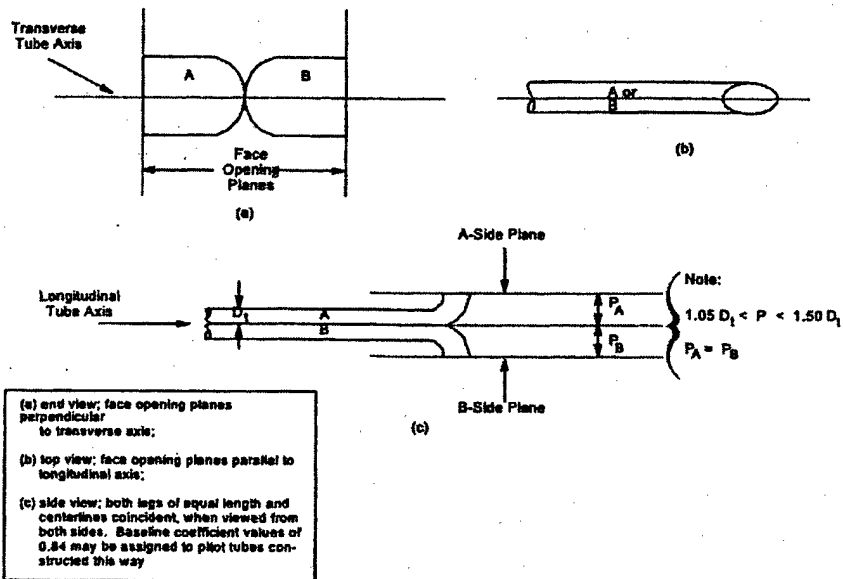

**40 CFR 60, Appendix A, July 1995

ENVIRONMENTAL QUALITY MANAGEMENT

PITOT TUBE CALIBRATIONS

| Pitot ID | Date Calibrated | α_1 | B_1 | α_2 | B_2 | Y | θ | A | z | w | P_a | P_f | D_1 | A/2/D ₁ | Accept/Reject |
|----------|-----------------|------------|-------|------------|-------|-----|----------|-------|-------|-------|-------|-------|-------|--------------------|---------------|
| P2-1P | 12/18/01 | 1.8 | 1.6 | 3.7 | 2.8 | 2 | 0.3 | 0.951 | 0.033 | 0.005 | 0.476 | 0.478 | 0.375 | 1.268 | ACCEPT |
| P2-2P | 12/18/01 | 1.3 | 0.4 | 3.0 | 0 | 0 | 0.2 | 0.945 | 0.007 | 0.003 | 0.473 | 0.473 | 0.375 | 1.260 | ACCEPT |
| P2-3 | 12/21/01 | 3.1 | 1.2 | 3.9 | 0.9 | 2.1 | 1.8 | 0.947 | 0.035 | 0.030 | 0.474 | 0.477 | 0.375 | 1.263 | ACCEPT |
| P3-1 | 12/21/01 | 1.3 | 2.5 | 1.8 | 2.8 | 1.6 | 1.3 | 0.941 | 0.028 | 0.021 | 0.475 | 0.475 | 0.375 | 1.255 | ACCEPT |
| P3-2 | 12/21/01 | 3.7 | 1.8 | 2.8 | 2.8 | 3.4 | 1.9 | 0.940 | 0.056 | 0.031 | 0.477 | 0.478 | 0.375 | 1.253 | ACCEPT |
| P3-3P | 12/18/01 | 1.7 | 1.2 | 0.2 | 1.7 | 0.8 | 1.2 | 0.941 | 0.013 | 0.020 | 0.538 | 0.539 | 0.375 | 1.256 | ACCEPT |
| P3-4P | 12/18/01 | 1.7 | 0.3 | 4.5 | 0.4 | 1.3 | 0.4 | 0.943 | 0.021 | 0.007 | 0.474 | 0.474 | 0.375 | 1.257 | ACCEPT |
| P4-1 | 12/21/01 | 0.6 | 1.4 | 1.8 | 1.5 | 2.3 | 1.3 | 0.955 | 0.038 | 0.022 | 0.477 | 0.477 | 0.375 | 1.273 | ACCEPT |
| P4-2 | 12/18/01 | 0.2 | 1.8 | 1.5 | 1.4 | 1.4 | 1.2 | 0.943 | 0.005 | 0.020 | 0.473 | 0.472 | 0.375 | 1.257 | ACCEPT |
| P4-3P | 12/21/01 | 1.1 | 1.2 | 0.8 | 0.4 | 1.8 | 0.5 | 0.995 | 0.028 | 0.008 | 0.472 | 0.473 | 0.375 | 1.193 | ACCEPT |
| P4-4P | 12/21/01 | 0.7 | 2.2 | 1.2 | 1.3 | 1.6 | 0.7 | 0.940 | 0.028 | 0.011 | 0.472 | 0.472 | 0.375 | 1.253 | ACCEPT |
| P4-6P | 12/21/01 | 3.6 | 2.1 | 3.6 | 1.2 | 0.8 | 0.5 | 0.930 | 0.013 | 0.008 | 0.472 | 0.472 | 0.375 | 1.240 | ACCEPT |
| T5-1 | 12/21/01 | 0.4 | 0.3 | 1.5 | 1.2 | 0.8 | 1.2 | 0.930 | 0.010 | 0.019 | 0.485 | 0.472 | 0.375 | 1.240 | ACCEPT |
| T5-2P | 12/21/01 | 0.3 | 2.0 | 0.4 | 1.0 | 0.8 | 1.2 | 0.975 | 0.014 | 0.020 | 0.488 | 0.472 | 0.375 | 1.300 | ACCEPT |
| T5-3 | 12/21/01 | 5.5 | 1.6 | 6.4 | 1.5 | 1.5 | 1.5 | 0.935 | 0.024 | 0.024 | 0.468 | 0.472 | 0.375 | 1.247 | ACCEPT |
| P6-1P | 12/21/01 | 4.2 | 0.8 | 3.2 | 0.5 | 0.2 | 0.9 | 0.955 | 0.003 | 0.015 | 0.478 | 0.475 | 0.375 | 1.273 | ACCEPT |
| P6-2 | 12/26/01 | 0.3 | 0.9 | 0.7 | 1.4 | 1.1 | 1.4 | 0.941 | 0.018 | 0.023 | 0.475 | 0.475 | 0.375 | 1.255 | ACCEPT |
| P6-3P | 12/26/01 | 3.0 | 1.2 | 2.9 | 0.7 | 1.1 | 0.4 | 0.910 | 0.017 | 0.006 | 0.461 | 0.461 | 0.375 | 1.213 | ACCEPT |
| P6-4P | 12/26/01 | 0.9 | 1.9 | 1.6 | 1.6 | 1.2 | 0.3 | 0.943 | 0.020 | 0.005 | 0.474 | 0.475 | 0.375 | 1.257 | ACCEPT |
| T7-1P | 12/26/01 | 0.1 | 0.5 | 2.3 | 0.8 | 0.4 | 0.2 | 0.928 | 0.006 | 0.003 | 0.474 | 0.475 | 0.375 | 1.237 | ACCEPT |
| P8-1 | 12/26/01 | 2.7 | 0.6 | 1.4 | 0.1 | 0.8 | 0.4 | 0.945 | 0.015 | 0.007 | 0.465 | 0.468 | 0.375 | 1.260 | ACCEPT |
| P8-2 | 12/26/01 | 0.8 | 1.5 | 2.6 | 0.8 | 0.9 | 0.3 | 0.939 | 0.015 | 0.005 | 0.486 | 0.488 | 0.375 | 1.252 | ACCEPT |
| P8-3P | 12/27/01 | 0.8 | 0.9 | 0.6 | 1.2 | 1.1 | 0.8 | 0.941 | 0.018 | 0.013 | 0.477 | 0.478 | 0.375 | 1.255 | ACCEPT |
| P8-4P | 12/27/01 | 0.3 | 0.6 | 0.7 | 0.1 | 0.7 | 0.6 | 0.941 | 0.011 | 0.008 | 0.473 | 0.473 | 0.375 | 1.255 | ACCEPT |
| P8-5 | 12/26/01 | 0.7 | 0.7 | 0.4 | 0.3 | 1.0 | 1.0 | 0.950 | 0.017 | 0.017 | 0.472 | 0.472 | 0.375 | 1.267 | ACCEPT |
| P8-1 | 12/26/01 | 1.2 | 0.5 | 1.2 | 0.3 | 0.4 | 0.6 | 0.939 | 0.007 | 0.010 | 0.472 | 0.472 | 0.375 | 1.252 | ACCEPT |
| P10-1P | 12/26/01 | 2.7 | 0.3 | 3.0 | 0.6 | 1.4 | 1.2 | 0.929 | 0.023 | 0.019 | 0.472 | 0.472 | 0.375 | 1.239 | ACCEPT |
| T11-1P | 12/26/01 | 1.0 | 0.3 | 0.1 | 0.3 | 1.1 | 0.5 | 0.965 | 0.019 | 0.008 | 0.472 | 0.472 | 0.375 | 1.287 | ACCEPT |

- 1P = Full Probe Assembly

- 1 = Pitot Alone



Environmental Quality Management, Inc.

DIGITAL INDICATORS FOR THERMOCOUPLE READOUT

A digital indicator is calibrated by feeding a series of millivolt signals to the input and comparing the indicator reading with the reading the signal should have generated. Errors did not exceed 0.5 percent when the temperatures were expressed in degrees Rankine. Calibration data are included in the following Thermocouple Digital Indicator Calibration Data Sheet(s).

ENVIRONMENTAL QUALITY MANAGEMENT

Box No.: MB-1 Bar. Press.(Pb): 29.60 in. Hg
 Date: December 26, 2001 Calibrated By: AH

| | | RUN 1 | RUN 2 | RUN 3 | RUN 4 | RUN 5 | RUN 6 |
|-----------------|------------------|---------|---------|---------|---------|---------|---------|
| DH | Delta H | 0.50 | 0.75 | 1.00 | 1.50 | 2.00 | 4.00 |
| in Hg | Vacuum | 10 | 10 | 10 | 10 | 10 | 10 |
| Vw ₁ | Initial RTM | 604.553 | 615.440 | 628.959 | 640.862 | 654.016 | 665.387 |
| Vw ₂ | Final RTM | 615.285 | 628.753 | 640.691 | 653.386 | 665.040 | 675.449 |
| Vd ₁ | Initial DGM | 726.766 | 737.820 | 751.557 | 763.679 | 777.103 | 788.723 |
| Vd ₂ | Final DGM | 737.552 | 751.344 | 763.494 | 776.465 | 788.354 | 798.958 |
| Tw | Ave. Temp RTM °F | 67 | 67 | 68 | 68 | 69 | 72 |
| Td | Ave. Temp DGM °F | 71 | 75 | 77 | 78 | 80 | 83 |
| t | Time (min.) | 25.0 | 26.0 | 20.0 | 18.0 | 14.0 | 9.0 |

| | | | | | | | |
|-----------------------------------|----------------|--------|--------|--------|--------|--------|--------|
| Vw ₂ - Vw ₁ | Net Volume RTM | 10.732 | 13.313 | 11.732 | 12.524 | 11.024 | 10.062 |
| Vd ₂ - Vd ₁ | Net Volume DGM | 10.786 | 13.524 | 11.937 | 12.786 | 11.251 | 10.235 |
| | Y | 1.001 | 0.997 | 0.997 | 0.994 | 0.995 | 0.994 |
| | dH⊙ | 1.520 | 1.590 | 1.616 | 1.720 | 1.790 | 1.786 |

| | | | | | | |
|---------------------|--------------|--|----|-------|--|---------------|
| AVERAGE Y = | 1.000 | (Reference meter correction factor of 1.004) | | | | ACCEPT |
| Average Y Range = | | 0.980 | TO | 1.020 | | |
| AVERAGE dH⊙ = | 1.670 | | | | | ACCEPT |
| Average dH⊙ Range = | | 1.470 | TO | 1.870 | | |

Calculations

$$Y = (Vw \cdot Pb \cdot (Td + 460)) / (Vd \cdot (Pb + (dHd / 13.6)) \cdot (Tw + 460))$$

$$dH\odot = 0.0317 \cdot dHd / (Pb (Td + 460)) \cdot (((Tw + 460) \cdot t) / Vw)^2$$

Initial Dry Gas Meter Calibration Form (English Units) 2002 Yearly Calibration

ENVIRONMENTAL QUALITY MANAGEMENT

Box No.: MB-1 Bar. Press.(Pb): 29.05 in. Hg
 Date: April 30, 2002 Pretest Gamma: 1.000
 Calibrated By JK Pretest dH@: 1.670
 Plant: Moody AFB GA

| | | RUN 1 | RUN 2 | RUN 3 |
|-----------------------------------|------------------|---------|---------|---------|
| DH | Delta H | 2.00 | 2.00 | 2.00 |
| in Hg | Vacuum | 1.00 | 1.00 | 1.00 |
| Vw ₁ | Initial RTM | 38.009 | 51.510 | 64.220 |
| Vw ₂ | Final RTM | 51.510 | 64.220 | 76.562 |
| Vd ₁ | Initial DGM | 286.005 | 299.485 | 312.335 |
| Vd ₂ | Final DGM | 299.485 | 312.335 | 324.901 |
| Tw | Ave. Temp RTM °F | 71.0 | 72.0 | 73.0 |
| Td | Ave. Temp DGM °F | 78.0 | 81.0 | 83.0 |
| t | Time (min.) | 16.0 | 16.0 | 16.0 |
| Vw ₂ - Vw ₁ | Net Volume RTM | 13.501 | 12.710 | 12.342 |
| Vd ₂ - Vd ₁ | Net Volume DGM | 13.480 | 12.850 | 12.566 |
| | Y | 1.010 | 1.001 | 0.996 |
| | dH@ | 1.606 | 1.809 | 1.919 |

AVERAGE Y = **0.993**

% Difference from Yearly Y = **-0.677**

ACCEPT

AVERAGE dH@ = **1.778**

Calculations

$$Y = (Vw * Pb * (Td + 460)) / (Vd * (Pb + (dHd / 13.6)) * (Tw + 460))$$

$$dH@ = 0.0317 * dHd / (Pb (Td + 460)) * (((Tw + 460) * time) / Vw)^2$$

Posttest Dry Gas Meter Calibration Form (English Units)

ENVIRONMENTAL QUALITY MANAGEMENT

**THERMOCOUPLE DIGITAL INDICATOR
CALIBRATION DATA SHEET**

DATE: 26-Dec-01 INDICATOR NO.: MB-1
 OPERATOR: AH SERIAL NO.: _____
 CALIBRATION DEVICE: Thermocouple Simulator MANUFACTURER: Omega

| TEST POINT NO. | MILLIVOLT SIGNAL | EQUIVALENT TEMP. °F | DIGITAL INDICATOR TEMP READING, °F | DIFFERENCE, % |
|----------------|------------------|---------------------|------------------------------------|---------------|
| 1 | -0.692 | 0 | -1 | 0.2 |
| 2 | 1.520 | 100 | 98 | 0.4 |
| 3 | 3.819 | 200 | 200 | 0.0 |
| 4 | 6.092 | 300 | 299 | 0.1 |
| 5 | 8.314 | 400 | 398 | 0.2 |
| 6 | 10.560 | 500 | 499 | 0.1 |
| 7 | 22.251 | 1000 | 1000 | 0.0 |
| 8 | 29.315 | 1300 | 1299 | 0.1 |
| 9 | 36.166 | 1600 | 1600 | 0.0 |
| 10 | 42.732 | 1900 | 1900 | 0.0 |

Percent difference must be less than or equal to 0.5 %

Percent difference:
$$\frac{(\text{Equivalent Temp. } ^\circ\text{R} - \text{Digital Indicator Temp. } ^\circ\text{R}) * (100)}{(\text{Equivalent Temp. } ^\circ\text{R})}$$

Where °R = °F + 460

ACCEPT

ENVIRONMENTAL QUALITY MANAGEMENT

Box No.: MB-7 Bar. Press.(Pb): 29.33 in. Hg
 Date: 3/13/02 Calibrated By: JK

| | | RUN 1 | RUN 2 | RUN 3 | RUN 4 | RUN 5 | RUN 6 | | |
|---|------------------|--|---------|---------|---------------|---------|---------------|--|--|
| DH | Delta H | 0.50 | 0.75 | 1.00 | 1.50 | 2.00 | 4.00 | | |
| In Hg | Vacuum | 10 | 10 | 10 | 10 | 10 | 10 | | |
| Vw ₁ | Initial RTM | 396.544 | 408.914 | 420.547 | 431.672 | 442.252 | 453.255 | | |
| Vw ₂ | Final RTM | 406.545 | 418.455 | 430.645 | 441.720 | 452.315 | 463.235 | | |
| Vd ₁ | Initial DGM | 51.398 | 63.784 | 75.535 | 86.782 | 97.489 | 108.599 | | |
| Vd ₂ | Final DGM | 61.398 | 73.885 | 85.675 | 96.815 | 107.525 | 118.627 | | |
| Tw | Ave. Temp RTM °F | 74 | 74 | 74 | 75 | 75 | 76 | | |
| Td | Ave. Temp DGM °F | 76 | 78 | 80 | 82 | 84 | 84 | | |
| t | Time (min.) | 24.0 | 20.0 | 17.5 | 14.5 | 12.5 | 9.0 | | |
| | | | | | | | | | |
| Vw ₂ - Vw ₁ | Net Volume RTM | 10.001 | 9.541 | 10.098 | 10.048 | 10.063 | 9.980 | | |
| Vd ₂ - Vd ₁ | Net Volume DGM | 10.000 | 10.101 | 10.140 | 10.033 | 10.036 | 10.028 | | |
| | Y | 1.003 | 0.950 | 1.005 | 1.011 | 1.014 | 1.000 | | |
| | dH@ | 1.656 | 1.888 | 1.710 | 1.783 | 1.755 | 1.857 | | |
| AVERAGE Y = 1.001 | | (Reference meter correction factor of 1.004) | | | | | ACCEPT | | |
| Average Y Range = | | 0.981 | TO | 1.021 | | | | | |
| AVERAGE dH@ = 1.775 | | | | | | | | | |
| Average dH@ Range = | | 1.575 | TO | 1.975 | ACCEPT | | | | |
| Calculations | | | | | | | | | |
| $Y = (Vw \cdot Pb \cdot (Td + 460)) / (Vd \cdot (Pb + (dHd / 13.6)) \cdot (Tw + 460))$ $dH@ = 0.0317 \cdot dHd / (Pb (Td + 460)) \cdot (((Tw + 460) \cdot t) / Vw)^2$ | | | | | | | | | |

Initial Dry Gas Meter Calibration Form (English Units) 2001 Yearly Calibration

ENVIRONMENTAL QUALITY MANAGEMENT

**THERMOCOUPLE DIGITAL INDICATOR
CALIBRATION DATA SHEET**

DATE: 13-Mar-02 INDICATOR NO.: MB-7
 OPERATOR: JK SERIAL NO.: 10285505
 CALIBRATION DEVICE: Thermocouple Simulator MANUFACTURER: Omega

| TEST POINT NO. | MILLIVOLT SIGNAL | EQUIVALENT TEMP, °F | DIGITAL INDICATOR TEMP READING, °F | DIFFERENCE, % |
|----------------|------------------|---------------------|------------------------------------|---------------|
| 1 | -0.692 | 0 | 0 | 0.0 |
| 2 | 1.520 | 200 | 200 | 0.0 |
| 3 | 3.819 | 400 | 396 | 0.5 |
| 4 | 6.092 | 600 | 600 | 0.0 |
| 5 | 8.314 | 800 | 801 | 0.1 |
| 6 | 10.560 | 1000 | 1000 | 0.0 |
| 7 | 22.251 | 1200 | 1199 | 0.1 |
| 8 | 29.315 | 1400 | 1397 | 0.2 |
| 9 | 36.166 | 1600 | 1601 | 0.0 |
| 10 | 42.732 | 1800 | 1800 | 0.0 |

Percent difference must be less than or equal to 0.5 %

Percent difference:
$$\frac{(\text{Equivalent Temp., } ^\circ\text{R} - \text{Digital Indicator Temp., } ^\circ\text{R}) * (100)}{(\text{Equivalent Temp., } ^\circ\text{R})}$$

Where $^\circ\text{R} = ^\circ\text{F} + 460$

ACCEPT

DIGITAL INDICATOR

2001 Yearly Calibration

ENVIRONMENTAL QUALITY MANAGEMENT

Box No.: MB7 Bar. Press.(Pb): 29.05 in. Hg
 Date: April 30, 2002 Pretest Gamma: 1.001
 Calibrated By JK Pretest dH@: 1.775
 Plant: Moody AFB GA

| | | RUN 1 | RUN 2 | RUN 3 |
|-----------------|------------------|---------|---------|---------|
| DH | Delta H | 3.00 | 3.00 | 3.00 |
| in Hg | Vacuum | 13.00 | 13.00 | 13.00 |
| Vw ₁ | Initial RTM | 144.665 | 159.910 | 174.225 |
| Vw ₂ | Final RTM | 159.910 | 174.225 | 190.064 |
| Vd ₁ | Initial DGM | 177.622 | 192.520 | 206.950 |
| Vd ₂ | Final DGM | 192.520 | 206.950 | 222.715 |
| Tw | Ave. Temp RTM °F | 71.0 | 72.0 | 73.0 |
| Td | Ave. Temp DGM °F | 77.0 | 79.0 | 81.0 |
| t | Time (min.) | 15.0 | 15.0 | 16.0 |

| | | | | |
|-----------------------------------|----------------|--------|--------|--------|
| Vw ₂ - Vw ₁ | Net Volume RTM | 15.245 | 14.315 | 15.839 |
| Vd ₂ - Vd ₁ | Net Volume DGM | 14.898 | 14.430 | 15.765 |
| | Y | 1.027 | 0.998 | 1.012 |
| | dH@ | 1.664 | 1.887 | 1.754 |

AVERAGE Y = 1.003

% Difference from Yearly Y = 0.236

ACCEPT

AVERAGE dH@ = 1.769

Calculations

$$Y = (Vw * Pb * (Td + 460)) / (Vd * (Pb + (dHd / 13.6)) * (Tw + 460))$$

$$dH@ = 0.0317 * dHd / (Pb (Td + 460)) * (((Tw + 460) * time) / Vw)^2$$

Posttest Dry Gas Meter Calibration Form (English Units)

ENVIRONMENTAL QUALITY MANAGEMENT

Box No.: MB-8 Bar. Press.(Pb): 29.33 in. Hg
 Date: 3/14/02 Calibrated By: JK

| | | RUN 1 | RUN 2 | RUN 3 | RUN 4 | RUN 5 | RUN 6 |
|-----------------|------------------|---------|---------|---------|---------|---------|---------|
| DH | Delta H | 0.50 | 0.75 | 1.00 | 1.50 | 2.00 | 4.00 |
| in Hg | Vacuum | 10 | 10 | 10 | 10 | 10 | 10 |
| Vw ₁ | Initial RTM | 473.842 | 484.796 | 496.125 | 507.315 | 518.706 | 530.618 |
| Vw ₂ | Final RTM | 483.975 | 495.235 | 506.445 | 517.490 | 529.335 | 540.815 |
| Vd ₁ | Initial DGM | 45.775 | 56.689 | 68.015 | 79.181 | 90.554 | 102.419 |
| Vd ₂ | Final DGM | 55.810 | 67.075 | 78.175 | 89.235 | 101.080 | 112.445 |
| Tw | Ave. Temp RTM °F | 76 | 77 | 77 | 77 | 76 | 76 |
| Td | Ave. Temp DGM °F | 79 | 81 | 82 | 82 | 82 | 83 |
| t | Time (min.) | 23.8 | 20.5 | 17.5 | 14.5 | 13.0 | 9.0 |

| | | | | | | | |
|--|----------------|--------------|--|--------|--------|---------------|--------|
| Vw ₂ - Vw ₁ | Net Volume RTM | 10.133 | 10.439 | 10.320 | 10.175 | 10.629 | 10.197 |
| Vd ₂ - Vd ₁ | Net Volume DGM | 10.035 | 10.386 | 10.160 | 10.054 | 10.526 | 10.026 |
| | Y | 1.014 | 1.011 | 1.023 | 1.018 | 1.016 | 1.020 |
| | dH ϕ | 1.582 | 1.666 | 1.650 | 1.752 | 1.714 | 1.782 |
| AVERAGE Y = | | 1.021 | (Reference meter correction factor of 1.004) | | | | |
| Average Y Range = | | | 1.001 | TO | 1.041 | ACCEPT | |
| AVERAGE dH ϕ = | | 1.691 | | | | | |
| Average dH ϕ Range = | | | 1.491 | TO | 1.891 | ACCEPT | |
| Calculations | | | | | | | |
| $Y = (Vw \cdot Pb \cdot (Td + 460)) / (Vd \cdot (Pb + (dHd / 13.6)) \cdot (Tw + 460))$ $dH\phi = 0.0317 \cdot dHd / (Pb (Td + 460)) \cdot (((Tw + 460) \cdot t) / Vw)^2$ | | | | | | | |

Initial Dry Gas Meter Calibration Form (English Units) 2001 Yearly Calibration

ENVIRONMENTAL QUALITY MANAGEMENT

**THERMOCOUPLE DIGITAL INDICATOR
CALIBRATION DATA SHEET**

DATE: 13-Mar-02 INDICATOR NO.: MB-8
 OPERATOR: JK SERIAL NO.: 10285505
 CALIBRATION DEVICE: Thermocouple Simulator MANUFACTURER: Omega

| TEST POINT NO. | MILLIVOLT SIGNAL | EQUIVALENT TEMP. °F | DIGITAL INDICATOR TEMP READING, °F | DIFFERENCE, % |
|----------------|------------------|---------------------|------------------------------------|---------------|
| 1 | | 0 | 0 | 0.0 |
| 2 | | 200 | 200 | 0.0 |
| 3 | | 400 | 397 | 0.3 |
| 4 | | 600 | 600 | 0.0 |
| 5 | | 800 | 801 | 0.1 |
| 6 | | 1000 | 1001 | 0.1 |
| 7 | | 1200 | 1199 | 0.1 |
| 8 | | 1400 | 1398 | 0.1 |
| 9 | | 1600 | 1602 | 0.1 |
| 10 | | 1800 | 1800 | 0.0 |

Percent difference must be less than or equal to 0.5 %

Percent difference:
$$\frac{(\text{Equivalent Temp. } ^\circ\text{R} - \text{Digital Indicator Temp. } ^\circ\text{R}) * (100)}{(\text{Equivalent Temp. } ^\circ\text{R})}$$

Where $^{\circ}\text{R} = ^\circ\text{F} + 460$

ACCEPT

DIGITAL INDICATOR

2001 Yearly Calibration

ENVIRONMENTAL QUALITY MANAGEMENT

Box No.: MB 8 Bar. Press.(Pb): 29.05 in. Hg
 Date: April 30, 2002 Pretest Gamma: 1.021
 Calibrated By: JK Pretest dH@: 1.691
 Plant: Moody AFB GA

| | | RUN 1 | RUN 2 | RUN 3 |
|-----------------|------------------|---------|---------|---------|
| DH | Delta H | 3.00 | 3.00 | 3.00 |
| in Hg | Vacuum | 5.00 | 5.00 | 5.00 |
| Vw ₁ | Initial RTM | 76.662 | 96.385 | 115.125 |
| Vw ₂ | Final RTM | 96.385 | 115.125 | 128.935 |
| Vd ₁ | Initial DGM | 523.826 | 543.115 | 561.825 |
| Vd ₂ | Final DGM | 543.115 | 561.825 | 575.785 |
| Tw | Ave. Temp RTM °F | 71.0 | 71.0 | 72.0 |
| Td | Ave. Temp DGM °F | 78.0 | 82.0 | 85.0 |
| t | Time (min.) | 19.0 | 19.0 | 14.0 |

| | | | | |
|-----------------------------------|----------------|--------|--------|--------|
| Vw ₂ - Vw ₁ | Net Volume RTM | 19.723 | 18.740 | 13.810 |
| Vd ₂ - Vd ₁ | Net Volume DGM | 19.289 | 18.710 | 13.960 |
| | Y | 1.028 | 1.015 | 1.006 |
| | dH@ | 1.592 | 1.751 | 1.747 |

AVERAGE Y = 1.007

% Difference from Yearly Y = -1.340

ACCEPT

AVERAGE dH@ = 1.697

Calculations

$$Y = (Vw \cdot Pb \cdot (Td + 460)) / (Vd \cdot (Pb + (dHd / 13.6)) \cdot (Tw + 460))$$

$$dH@ = 0.0317 \cdot dHd / (Pb (Td + 460)) \cdot (((Tw + 460) \cdot time) / Vw)^2$$

Posttest Dry Gas Meter Calibration Form (English Units)

ENVIRONMENTAL QUALITY MANAGEMENT

Date: 1/7/02 Flow Rate: 0.25 l/min
 Vost Box Number: VB-1 Rotameter Setting: 0.3
 Bubble Meter Temp.: 72

| Run 1 | | | |
|--------------|--------|----------------|---------|
| Bubble Meter | | Meter Box | |
| 1 | 256.2 | Initial Volume | 4579.00 |
| 2 | 256.3 | Final Volume | 4596.35 |
| 3 | 256.4 | Initial Temp. | 88 |
| 4 | 256.4 | Final Temp. | 90 |
| 5 | 256.8 | Average Temp. | 89 |
| 6 | 256.2 | Time: | 64 |
| 7 | 256.5 | QDGM= | 262.699 |
| Average: | 256.38 | Y= | 0.9760 |

| Run 2 | | | |
|--------------|--------|----------------|---------|
| Bubble Meter | | Meter Box | |
| 1 | 256.1 | Initial Volume | 4560.00 |
| 2 | 256.5 | Final Volume | 4577.48 |
| 3 | 256.3 | Initial Temp. | 85 |
| 4 | 256.5 | Final Temp. | 88 |
| 5 | 256.3 | Average Temp. | 86.5 |
| 6 | 256.6 | Time: | 64 |
| 7 | 256.3 | QDGM= | 265.878 |
| Average: | 256.37 | Y= | 0.9642 |

| Run 3 | | | |
|--------------|--------|----------------|---------|
| Bubble Meter | | Meter Box | |
| 1 | 256.4 | Initial Volume | 4597.00 |
| 2 | 256 | Final Volume | 4614.39 |
| 3 | 255.8 | Initial Temp. | 90 |
| 4 | 256.0 | Final Temp. | 88 |
| 5 | 256.4 | Average Temp. | 89 |
| 6 | 256.6 | Time: | 64 |
| 7 | 256.5 | QDGM= | 263.305 |
| Average: | 256.24 | Y= | 0.9732 |

$QDGM = ((V_{m2} - V_{m1}) * T_{Bm}^{\circ}R) / (T_{m}^{\circ}R * Time) * 1000$

$Y = Bm \text{ Average} / QDGM$

| | |
|------------|--------|
| Average Y= | 0.9711 |
|------------|--------|

ENVIRONMENTAL QUALITY MANAGEMENT

Date: 1/2/02 Flow Rate: 0.5 l/min
 Vost Box Number: VB-1 Rotameter Setting: 0.55
 Bubble Meter Temp. : 69

| Run 1 | | | |
|--------------|--------|----------------|---------|
| Bubble Meter | | Meter Box | |
| 1 | 488.9 | Initial Volume | 4281.00 |
| 2 | 488.8 | Final Volume | 4288.00 |
| 3 | 488.6 | Initial Temp. | 88 |
| 4 | 488 | Final Temp. | 89 |
| 5 | 488.1 | Average Temp. | 88.5 |
| 6 | 488.1 | Time: | 13.33 |
| 7 | 487.9 | QDGM= | 506.462 |
| Average: | 488.34 | Y= | 0.9642 |

| Run 2 | | | |
|--------------|--------|----------------|---------|
| Bubble Meter | | Meter Box | |
| 1 | 485.6 | Initial Volume | 4289.00 |
| 2 | 486.0 | Final Volume | 4295.00 |
| 3 | 485.8 | Initial Temp. | 89 |
| 4 | 486.3 | Final Temp. | 88 |
| 5 | 486 | Average Temp. | 88.5 |
| 6 | 486.1 | Time: | 11.54 |
| 7 | 486 | QDGM= | 501.446 |
| Average: | 485.97 | Y= | 0.9691 |

| Run 3 | | | |
|--------------|--------|----------------|---------|
| Bubble Meter | | Meter Box | |
| 1 | 484.9 | Initial Volume | 4296.00 |
| 2 | 484.9 | Final Volume | 4302.00 |
| 3 | 484.7 | Initial Temp. | 88 |
| 4 | 484.7 | Final Temp. | 88 |
| 5 | 486 | Average Temp. | 88 |
| 6 | 485.4 | Time: | 11.52 |
| 7 | 485.3 | QDGM= | 502.775 |
| Average: | 485.13 | Y= | 0.9649 |

$QDGM = (((V_{m_2} - V_{m_1}) * TBm^{\circ}R) / (Tm^{\circ}R * Time)) * 1000$

$Y = Bm \text{ Average} / QDGM$

Average Y= 0.9661

ENVIRONMENTAL QUALITY MANAGEMENT

Date: 1/2/02 Flow Rate: 1.0 l/min
Vost Box Number: VB-1 Rotameter Setting: 1
Bubble Meter Temp.: 68

| Run 1 | | | |
|--------------|--------|----------------|----------|
| Bubble Meter | | Meter Box | |
| 1 | 951.5 | Initial Volume | 4314.00 |
| 2 | 950.6 | Final Volume | 4326.00 |
| 3 | 948.9 | Initial Temp. | 88 |
| 4 | 949.4 | Final Temp. | 89 |
| 5 | 948.6 | Average Temp. | 88.5 |
| 6 | 948.9 | Time: | 11.51 |
| 7 | 949.1 | QDGM= | 1003.606 |
| Average: | 949.57 | Y= | 0.9462 |

| Run 2 | | | |
|--------------|--------|----------------|---------|
| Bubble Meter | | Meter Box | |
| 1 | 947.4 | Initial Volume | 4327.00 |
| 2 | 946.2 | Final Volume | 4337.00 |
| 3 | 947.7 | Initial Temp. | 89 |
| 4 | 946.5 | Final Temp. | 88 |
| 5 | 946.2 | Average Temp. | 88.5 |
| 6 | 947.1 | Time: | 9.54 |
| 7 | 945.9 | QDGM= | 880.897 |
| Average: | 946.71 | Y= | 1.0747 |

| Run 3 | | | |
|--------------|--------|----------------|---------|
| Bubble Meter | | Meter Box | |
| 1 | 949.7 | Initial Volume | 4338.00 |
| 2 | 948.6 | Final Volume | 4348.00 |
| 3 | 946.5 | Initial Temp. | 89 |
| 4 | 943.6 | Final Temp. | 89 |
| 5 | 944.2 | Average Temp. | 89 |
| 6 | 944.8 | Time: | 10 |
| 7 | 944.2 | QDGM= | 839.845 |
| Average: | 945.94 | Y= | 1.1263 |

$$QDGM = (((V_{m2} - V_{m1}) * TBm^{\circ}R) / (Tm^{\circ}R * Time)) * 1000$$

$$Y = Bm \text{ Average} / QDGM$$

| |
|-------------------|
| Average Y= 1.0491 |
|-------------------|

ENVIRONMENTAL QUALITY MANAGEMENT

**THERMOCOUPLE DIGITAL INDICATOR
CALIBRATION DATA SHEET**

DATE: 2-Jan-02 INDICATOR NO.: VB-1
 OPERATOR: AH SERIAL NO.: _____
 CALIBRATION DEVICE Thermocouple Simulator MANUFACTURER: Omega

| TEST POINT NO. | MILLIVOLT SIGNAL | EQUIVALENT TEMP. °F | DIGITAL INDICATOR TEMP READING, °F | DIFFERENCE, % |
|----------------|------------------|---------------------|------------------------------------|---------------|
| 1 | -0.692 | 0 | 0 | 0.0 |
| 2 | 1.520 | 100 | 100 | 0.0 |
| 3 | 3.819 | 200 | 202 | 0.3 |
| 4 | 6.092 | 300 | 301 | 0.1 |
| 5 | 8.314 | 400 | 400 | 0.0 |
| 6 | 10.560 | 500 | 501 | 0.1 |
| 7 | 22.251 | 1000 | 1002 | 0.1 |
| 8 | 29.315 | 1300 | 1302 | 0.1 |
| 9 | 36.166 | 1600 | 1603 | 0.1 |
| 10 | 42.732 | 1900 | 1903 | 0.1 |

Percent difference must be less than or equal to 0.5 %

Percent difference: $\frac{(\text{Equivalent Temp. } ^\circ\text{R} - \text{Digital Indicator Temp. } ^\circ\text{R})}{(\text{Equivalent Temp. } ^\circ\text{R})} \times (100\%)$

Where $^\circ\text{R} = ^\circ\text{F} + 460$

ACCEPT

ENVIRONMENTAL QUALITY MANAGEMENT

**THERMOCOUPLE DIGITAL INDICATOR
CALIBRATION DATA SHEET**

DATE: 2-Jan-02 INDICATOR NO.: VB-1
 OPERATOR: AH SERIAL NO.: _____
 CALIBRATION DEVICE Thermocouple Simulator MANUFACTURER: Omega

| TEST POINT NO. | MILLIVOLT SIGNAL | EQUIVALENT TEMP. °F | DIGITAL INDICATOR TEMP READING, °F | DIFFERENCE, % |
|----------------|------------------|---------------------|------------------------------------|---------------|
| 1 | -0.692 | 0 | 0 | 0.0 |
| 2 | 1.520 | 100 | 100 | 0.0 |
| 3 | 3.819 | 200 | 202 | 0.3 |
| 4 | 6.092 | 300 | 301 | 0.1 |
| 5 | 8.314 | 400 | 400 | 0.0 |
| 6 | 10.560 | 500 | 501 | 0.1 |
| 7 | 22.251 | 1000 | 1002 | 0.1 |
| 8 | 29.315 | 1300 | 1302 | 0.1 |
| 9 | 36.166 | 1600 | 1603 | 0.1 |
| 10 | 42.732 | 1900 | 1903 | 0.1 |

Percent difference must be less than or equal to 0.5 %

Percent difference:
$$\frac{(\text{Equivalent Temp. } ^\circ\text{R} - \text{Digital Indicator Temp. } ^\circ\text{R}) * (100\%)}{(\text{Equivalent Temp. } ^\circ\text{R})}$$

Where °R = °F + 460

ACCEPT

ENVIRONMENTAL QUALITY MANAGEMENT

Date: 3/20/01 Flow Rate: 0.5 l/min
 Vost Box Number: VB-2 Rotameter Setting: 0.6
 Bubble Meter Temp. : 72

| Run 1 | | | |
|--------------|--------|----------------|---------|
| Bubble Meter | | Meter Box | |
| 1 | 530.5 | Initial Volume | 4069.00 |
| 2 | 530.7 | Final Volume | 4074.00 |
| 3 | 511.4 | Initial Temp. | 84 |
| 4 | 512.2 | Final Temp. | 85 |
| 5 | 530.3 | Average Temp. | 84.5 |
| 6 | 527.3 | Time: | 10.07 |
| 7 | 530.3 | QDGM= | 485.126 |
| Average: | 524.67 | Y= | 1.0815 |

| Run 2 | | | |
|--------------|--------|----------------|---------|
| Bubble Meter | | Meter Box | |
| 1 | 520.1 | Initial Volume | 4075.00 |
| 2 | 526.7 | Final Volume | 4080.00 |
| 3 | 527.6 | Initial Temp. | 85 |
| 4 | 528.7 | Final Temp. | 86 |
| 5 | 537.7 | Average Temp. | 85.5 |
| 6 | 527.5 | Time: | 10.15 |
| 7 | 530.2 | QDGM= | 480.420 |
| Average: | 528.36 | Y= | 1.0998 |

| Run 3 | | | |
|--------------|--------|----------------|---------|
| Bubble Meter | | Meter Box | |
| 1 | 523.1 | Initial Volume | 4081.00 |
| 2 | 534 | Final Volume | 4086.00 |
| 3 | 507 | Initial Temp. | 86 |
| 4 | 533.8 | Final Temp. | 86 |
| 5 | 530.7 | Average Temp. | 86 |
| 6 | 504.1 | Time: | 10.1 |
| 7 | 502.7 | QDGM= | 482.356 |
| Average: | 519.34 | Y= | 1.0767 |

$$QDGM = (((V_{m2} - V_{m1}) * TBm^{\circ}R) / (Tm^{\circ}R * Time)) * 1000$$

$$Y = Bm \text{ Average} / QDGM$$

| | |
|------------|--------|
| Average Y= | 1.0860 |
|------------|--------|

ENVIRONMENTAL QUALITY MANAGEMENT

Date: 3/20/01 Flow Rate: 1.0 l/min
Vost Box Number: VB-2 Rotameter Setting: 1.1
Bubble Meter Temp. : 73

| Run 1 | | | |
|--------------|---------|----------------|---------|
| Bubble Meter | | Meter Box | |
| 1 | 998 | Initial Volume | 4087.00 |
| 2 | 1012.0 | Final Volume | 4097.00 |
| 3 | 1023 | Initial Temp. | 86 |
| 4 | 1013 | Final Temp. | 87 |
| 5 | 999 | Average Temp. | 86.5 |
| 6 | 1001 | Time: | 10.17 |
| 7 | 1011 | QDGM= | 958.994 |
| Average: | 1008.14 | Y= | 1.0512 |

| Run 2 | | | |
|--------------|---------|----------------|---------|
| Bubble Meter | | Meter Box | |
| 1 | 1030.0 | Initial Volume | 4100.00 |
| 2 | 996.0 | Final Volume | 4110.00 |
| 3 | 1009 | Initial Temp. | 87 |
| 4 | 1021 | Final Temp. | 87 |
| 5 | 1011 | Average Temp. | 87 |
| 6 | 1007 | Time: | 10.28 |
| 7 | 1008 | QDGM= | 947.866 |
| Average: | 1011.71 | Y= | 1.0674 |

| Run 3 | | | |
|--------------|---------|----------------|---------|
| Bubble Meter | | Meter Box | |
| 1 | 998.6 | Initial Volume | 4111.00 |
| 2 | 1017 | Final Volume | 4121.00 |
| 3 | 1015 | Initial Temp. | 87 |
| 4 | 1010.0 | Final Temp. | 88 |
| 5 | 1008 | Average Temp. | 87.5 |
| 6 | 1009 | Time: | 10.27 |
| 7 | 1012.0 | QDGM= | 947.922 |
| Average: | 1009.94 | Y= | 1.0654 |

$$QDGM = (((V_m2 - V_m1) \cdot TBm \cdot R) / (Tm \cdot R \cdot Time)) \cdot 1000$$

$$Y = Bm \text{ Average} / QDGM$$

| |
|-------------------|
| Average Y= 1.0613 |
|-------------------|

ENVIRONMENTAL QUALITY MANAGEMENT

**THERMOCOUPLE DIGITAL INDICATOR
CALIBRATION DATA SHEET**

DATE: 2-Jan-02 INDICATOR NO.: VB-2
 OPERATOR: AH SERIAL NO.: _____
 CALIBRATION DEVICE: Thermocouple Simulator MANUFACTURER: Omega

| TEST POINT NO. | MILLIVOLT SIGNAL | EQUIVALENT TEMP, °F | DIGITAL INDICATOR TEMP READING, °F | DIFFERENCE, % |
|----------------|------------------|---------------------|------------------------------------|---------------|
| 1 | -0.692 | 0 | 0 | 0.0 |
| 2 | 1.520 | 100 | 100 | 0.0 |
| 3 | 3.819 | 200 | 202 | 0.3 |
| 4 | 6.092 | 300 | 300 | 0.0 |
| 5 | 8.314 | 400 | 399 | 0.1 |
| 6 | 10.560 | 500 | 500 | 0.0 |
| 7 | 22.251 | 1000 | 1001 | 0.1 |
| 8 | 29.315 | 1300 | 1301 | 0.1 |
| 9 | 36.166 | 1600 | 1602 | 0.1 |
| 10 | 42.732 | 1900 | 1901 | 0.0 |

Percent difference must be less than or equal to 0.5 %

Percent difference:
$$\frac{(\text{Equivalent Temp., } ^\circ\text{R} - \text{Digital Indicator Temp., } ^\circ\text{R}) * (100\%)}{(\text{Equivalent Temp., } ^\circ\text{R})}$$

Where $^\circ\text{R} = ^\circ\text{F} + 460$

ACCEPT

DIGITAL INDICATOR

2002 Yearly Calibration



Environmental Quality Management, Inc.

DRY GAS THERMOCOUPLES AND IMPINGER THERMOCOUPLES

The dry gas thermocouples are calibrated by comparing them with an ASTM-3 thermometer at approximately 32°F, ambient temperature, and a higher temperature between approximately 100°F and 200°F. The thermocouples agreed within 5°F of the reference thermometer. The impinger thermocouples are checked in a similar manner at approximately 32°F and ambient temperature, and they agreed within 2°F. The thermocouples may be checked at ambient temperature prior to the test series to verify calibration. Calibration data are included in the following Dry Gas Thermometer and Impinger Thermocouple Calibration Data Sheet(s).

ENVIRONMENTAL QUALITY MANAGEMENT

**TEMPERATURE SENSOR CALIBRATION DATA FORM
FOR SAMPLE HEADS**

DATE: 26-Dec-01

| Reference point number | Source ^a (Specify) | Reference Thermometer Temperature, °F | Thermocouple Potentiometer Temperature, °F | Temperature Difference, °F ^b | |
|-----------------------------|----------------------------------|---------------------------------------|--|---|---------------|
| Sample Head No. 1 1 2 | Ambient Air Cold Bath | 68 37 | 69 37 | 1 0 | ACCEPT |
| Sample Head No. 2 1 2 | Ambient Air Cold Bath | 68 37 | 68 38 | 0 1 | |
| Sample Head No. 3 1 2 | Ambient Air Cold Bath | 68 36 | 69 36 | 1 0 | ACCEPT |
| Sample Head No. 4 1 2 | Ambient Air Cold Bath | 68 37 | 68 38 | 0 1 | |
| Sample Head No. 5 1 2 | Ambient Air Cold Bath | 68 37 | 69 37 | 1 0 | ACCEPT |
| Sample Head No. 6 1 2 | Ambient Air Cold Bath | 68 37 | 69 37 | 1 0 | |
| Sample Head No. 7 1 2 | Ambient Air Cold Bath | 68 37 | 68 38 | 0 1 | ACCEPT |
| Sample Head No. 8 1 2 | Ambient Air Cold Bath | 68 37 | 68 37 | 0 0 | |

^aType of calibration used.

Calibrated By: AH

^bAllowable tolerance $\pm 2^{\circ}\text{F}$

SAMPLE HEAD

2002 Yearly Calibration

ENVIRONMENTAL QUALITY MANAGEMENT

**TEMPERATURE SENSOR CALIBRATION DATA FORM
FOR METER BOX**

DATE: 26-Dec-01

THERMOCOUPLE NUMBER: MB-1

AMBIENT TEMPERATURE: 68 °F

BAROMETRIC PRES.(In.Hg): 29.60

CALIBRATOR: AH

| Reference point number | Source ^a (Specify) | Reference Thermometer Temperature, °F | Thermocouple Potentiometer Temperature, °F | Temperature Difference, °F ^b |
|------------------------|-------------------------------|---------------------------------------|--|---|
| Inlet | | | | |
| 1 | Ambient Air | 68 | 69 | 1 |
| 2 | Cold Bath | 36 | 36 | 0 |
| 3 | Hot Bath | 180 | 179 | 1 |
| Outlet | | | | |
| 1 | Ambient Air | 68 | 69 | 1 |
| 2 | Cold Bath | 36 | 35 | 1 |
| 3 | Hot Bath | 180 | 178 | 2 |

^aType of calibration used.

ACCEPT

^bAllowable tolerance $\pm 5^{\circ}\text{F}$

Comments:

METER BOX
THERMOCOUPLES

2002 Yearly Calibration

ENVIRONMENTAL QUALITY MANAGEMENT

**TEMPERATURE SENSOR CALIBRATION DATA FORM
FOR METER BOX**

DATE: 13-Mar-02 THERMOCOUPLE NUMBER: MB-7
 AMBIENT TEMPERATURE: 74 °F BAROMETRIC PRES.(In.Hg): 29.33
 CALIBRATOR: JK

| Reference point number | Source ^a (Specify) | Reference Thermometer Temperature, °F | Thermocouple Potentiometer Temperature, °F | Temperature Difference, °F ^b |
|------------------------|-------------------------------|---------------------------------------|--|---|
| Inlet | | | | |
| 1 | Ambient Air | 74 | 72 | 2 |
| 2 | Cold Bath | 40 | 39 | 1 |
| 3 | Hot Bath | 138 | 134 | 4 |
| Outlet | | | | |
| 1 | Ambient Air | 74 | 72 | 2 |
| 2 | Cold Bath | 40 | 39 | 1 |
| 3 | Hot Bath | 138 | 134 | 4 |

^aType of calibration used.

ACCEPT

^bAllowable tolerance ±5°F

Comments:

METER BOX
THERMOCOUPLES

2001 Yearly Calibration

ENVIRONMENTAL QUALITY MANAGEMENT

**TEMPERATURE SENSOR CALIBRATION DATA FORM
FOR METER BOX**

DATE: 13-Mar-02

THERMOCOUPLE NUMBER: MB-8

AMBIENT TEMPERATURE: 74 °F

BAROMETRIC PRES.(In.Hg): 29.33

CALIBRATOR: JK

| Reference point number | Source ^a (Specify) | Reference Thermometer Temperature, °F | Thermocouple Potentiometer Temperature, °F | Temperature Difference, °F |
|------------------------|-------------------------------|---------------------------------------|--|----------------------------|
| Inlet | | | | |
| 1 | Ambient Air | 74 | 71 | 3 |
| 2 | Cold Bath | 41 | 41 | 0 |
| 3 | Hot Bath | 138 | 134 | 4 |
| Outlet | | | | |
| 1 | Ambient Air | 74 | 71 | 3 |
| 2 | Cold Bath | 41 | 40 | 1 |
| 3 | Hot Bath | 138 | 136 | 2 |

^aType of calibration used.

ACCEPT

^aAllowable tolerance ±5°F

Comments:

METER BOX
THERMOCOUPLES

2001 Yearly Calibration

ENVIRONMENTAL QUALITY MANAGEMENT

**TEMPERATURE SENSOR CALIBRATION DATA FORM
FOR METER BOX**

DATE: 2-Jan-02 THERMOCOUPLE NUMBER: VB-1
 AMBIENT TEMPERATURE: 67 °F BAROMETRIC PRES.(In.Hg): 29.60
 CALIBRATOR: AH

| Reference point number | Source* (Specify) | Reference Thermometer Temperature, °F | Thermocouple Potentiometer Temperature, °F | Temperature Difference, °F ^b |
|------------------------|-------------------|---------------------------------------|--|---|
| Inlet | | | | |
| 1 | Ambient Air | 67 | 67 | 0 |
| 2 | Cold Bath | 36 | 36 | 0 |
| 3 | Hot Bath | 138 | 136 | 2 |
| Outlet | | | | |
| 1 | Ambient Air | 67 | 67 | 0 |
| 2 | Cold Bath | 37 | 37 | 0 |
| 3 | Hot Bath | 148 | 148 | 0 |

*Type of calibration used.

ACCEPT

^bAllowable tolerance ± 0.5 °F

Comments:

ENVIRONMENTAL QUALITY MANAGEMENT

TEMPERATURE SENSOR CALIBRATION DATA FORM
FOR METER BOX

DATE: 2-Jan-02

THERMOCOUPLE NUMBER: VB-2

AMBIENT TEMPERATURE: 67 °F

BAROMETRIC PRES.(In.Hg): 29.60

CALIBRATOR: AH

| Reference point number | Source ^a (Specify) | Reference Thermometer Temperature, °F | Thermocouple Potentiometer Temperature, °F | Temperature Difference, ^b °F |
|------------------------|-------------------------------|---------------------------------------|--|---|
| Inlet | | | | |
| 1 | Ambient Air | 67 | 66 | 1 |
| 2 | Cold Bath | 38 | 38 | 0 |
| 3 | Hot Bath | 130 | 130 | 0 |
| Outlet | | | | |
| 1 | Ambient Air | 67 | 67 | 0 |
| 2 | Cold Bath | 38 | 38 | 0 |
| 3 | Hot Bath | 132 | 131 | 1 |

^aType of calibration used.

ACCEPT

^bAllowable tolerance $\pm 5^\circ\text{F}$

Comments:

VOST Box
Thermocouples

2002 Yearly Calibrations



Environmental Quality Management, Inc.

STACK THERMOCOUPLES

Each thermocouple is calibrated by comparing it with an ASTM-3F thermometer at approximately 32°F, ambient temperature, 212°F, and 500°F. The thermocouple reads within 1.5 percent of the reference thermometer throughout the entire range when expressed in degrees Rankine. The thermocouples may be checked at ambient temperature at the test site to verify the calibration. Calibration data are included in the following Thermocouple Calibration Data Sheet(s).

ENVIRONMENTAL QUALITY MANAGEMENT
STACK THERMOCOUPLES

| Thermo. ID | Therm. | Date Calibrated | Ambient Air | Diff., % | Cold Bath | Diff., % | Hot Bath | Diff., % | Hot Oil | Diff., % | Accept/Reject |
|------------|-----------|-----------------|-------------|----------|-----------|----------|----------|----------|---------|----------|---------------|
| T2-1 | Reference | 12/27/01 | 67 | 0.19 | 38 | 0.40 | 162 | 0.48 | 442 | 0.22 | ACCEPT |
| | Pilot | | 68 | | 40 | | 159 | | 440 | | |
| T2-2 | Reference | 12/27/01 | 67 | 0.00 | 38 | 0.20 | 172 | 0.95 | 460 | 0.22 | ACCEPT |
| | Pilot | | 67 | | 39 | | 166 | | 458 | | |
| T2-3 | Reference | 12/27/01 | 67 | 0.19 | 38 | 0.20 | 180 | 0.78 | 460 | 0.65 | ACCEPT |
| | Pilot | | 68 | | 39 | | 175 | | 454 | | |
| T2-4 | Reference | 1/4/01 | 72 | 0.19 | 39 | 0.00 | 200 | 0.00 | 437 | 0.45 | ACCEPT |
| | Pilot | | 71 | | 39 | | 200 | | 439 | | |
| T2-5 | Reference | | | 0.00 | | 0.00 | | 0.00 | | 0.00 | ACCEPT |
| | Pilot | | | | | | | | | | |
| T2-6 | Reference | 12/26/01 | 66 | 0.00 | 36 | 0.20 | 184 | 0.31 | 458 | 0.98 | ACCEPT |
| | Pilot | | 68 | | 37 | | 182 | | 449 | | |
| T2-7 | Reference | 3/27/02 | 73 | 0.19 | 38 | 0.40 | 185 | 0.16 | 368 | 0.36 | ACCEPT |
| | Pilot | | 72 | | 36 | | 164 | | 366 | | |
| T3-1 | Reference | 12/27/01 | 67 | 0.19 | 39 | 0.00 | 156 | 0.49 | 460 | 0.76 | ACCEPT |
| | Pilot | | 68 | | 39 | | 153 | | 453 | | |
| T3-2 | Reference | 12/27/01 | 67 | 0.19 | 38 | 0.40 | 168 | 0.16 | 442 | 0.44 | ACCEPT |
| | Pilot | | 68 | | 40 | | 167 | | 438 | | |
| T3-3P | Reference | 12/28/01 | 69 | 0.19 | 40 | 0.40 | 172 | 0.63 | 460 | 0.43 | ACCEPT |
| | Pilot | | 67 | | 42 | | 188 | | 456 | | |
| T3-4P | Reference | 12/28/01 | 68 | 0.19 | 35 | 0.20 | 162 | 0.16 | 420 | 0.65 | ACCEPT |
| | Pilot | | 67 | | 37 | | 161 | | 454 | | |
| T3-5 | Reference | 12/26/01 | 68 | 0.19 | 38 | 0.20 | 188 | 0.62 | 458 | 0.11 | ACCEPT |
| | Pilot | | 67 | | 37 | | 184 | | 455 | | |
| T3-6 | Reference | 12/26/01 | 68 | 0.00 | 39 | 0.20 | 187 | 0.46 | 456 | 0.11 | ACCEPT |
| | Pilot | | 68 | | 39 | | 184 | | 455 | | |
| T4-1 | Reference | 12/28/01 | 66 | 0.19 | 39 | 0.20 | 177 | 0.16 | 460 | 0.22 | ACCEPT |
| | Pilot | | 67 | | 40 | | 176 | | 458 | | |
| T4-2 | Reference | 12/28/01 | 68 | 0.00 | 39 | 0.20 | 178 | 0.31 | 460 | 0.54 | ACCEPT |
| | Pilot | | 68 | | 40 | | 176 | | 455 | | |
| T4-3P | Reference | 12/28/01 | 68 | 0.00 | 36 | 0.00 | 184 | 0.31 | 436 | 0.00 | ACCEPT |
| | Pilot | | 68 | | 36 | | 186 | | 436 | | |
| T4-4P | Reference | 12/28/01 | 68 | 0.00 | 36 | 0.20 | 180 | 0.16 | 440 | 0.67 | ACCEPT |
| | Pilot | | 69 | | 37 | | 179 | | 434 | | |
| T4-5 | Reference | 12/28/01 | 68 | 0.00 | 35 | 0.81 | 152 | 0.16 | 460 | 0.65 | ACCEPT |
| | Pilot | | 68 | | 38 | | 151 | | 454 | | |
| T4-6 | Reference | 12/28/01 | 68 | 0.00 | 35 | 0.00 | 179 | 0.63 | 458 | 0.00 | ACCEPT |
| | Pilot | | 66 | | 35 | | 175 | | 458 | | |
| T4-7 | Reference | 12/28/01 | 66 | 0.00 | 36 | 0.40 | 176 | 0.47 | 458 | 0.11 | ACCEPT |
| | Pilot | | 68 | | 38 | | 175 | | 457 | | |
| T4-8 | Reference | 3/27/02 | 73 | 0.19 | 37 | 0.20 | 165 | 0.18 | 400 | 0.35 | ACCEPT |
| | Pilot | | 72 | | 36 | | 164 | | 397 | | |
| T5-1 | Reference | 12/28/01 | 68 | 0.00 | 36 | 0.20 | 181 | 0.00 | 450 | 0.11 | ACCEPT |
| | Pilot | | 68 | | 37 | | 181 | | 449 | | |
| T5-2P | Reference | 12/28/02 | 68 | 0.00 | 37 | 0.00 | 169 | 0.31 | 458 | 0.22 | ACCEPT |
| | Pilot | | 68 | | 37 | | 184 | | 456 | | |
| T5-3 | Reference | 12/28/01 | 68 | 0.00 | 38 | 0.20 | 178 | 0.16 | 450 | 0.22 | ACCEPT |
| | Pilot | | 68 | | 37 | | 177 | | 448 | | |
| T5-4 | Reference | 3/27/02 | 73 | 0.19 | 36 | 0.20 | 170 | 0.32 | 390 | 0.24 | ACCEPT |
| | Pilot | | 72 | | 35 | | 168 | | 388 | | |
| T5-5 | Reference | 3/27/02 | 73 | 0.19 | 36 | 0.20 | 170 | 0.32 | 400 | 0.35 | ACCEPT |
| | Pilot | | 72 | | 35 | | 168 | | 399 | | |
| T6-1 | Reference | 12/28/01 | 68 | 0.00 | 38 | 0.20 | 198 | 0.30 | 451 | 0.33 | ACCEPT |
| | Pilot | | 68 | | 39 | | 196 | | 448 | | |
| T6-2 | Reference | 12/28/01 | 68 | 0.00 | 38 | 0.20 | 199 | 0.15 | 451 | 0.11 | ACCEPT |
| | Pilot | | 68 | | 39 | | 199 | | 450 | | |
| T6-3P | Reference | 12/28/01 | 68 | 0.00 | 38 | 0.00 | 198 | 0.15 | 453 | 0.22 | ACCEPT |
| | Pilot | | 68 | | 38 | | 197 | | 451 | | |
| T6-4P | Reference | 12/28/01 | 68 | 0.00 | 37 | 0.00 | 200 | 0.15 | 454 | 0.11 | ACCEPT |
| | Pilot | | 68 | | 37 | | 199 | | 453 | | |
| T6-5 | Reference | 12/28/01 | 68 | 0.19 | 38 | 0.00 | 199 | 0.30 | 451 | 0.11 | ACCEPT |
| | Pilot | | 67 | | 38 | | 196 | | 450 | | |
| T7-1 | Reference | 12/28/01 | 69 | 0.19 | 37 | 0.40 | 180 | 0.31 | 450 | 0.55 | ACCEPT |
| | Pilot | | 69 | | 39 | | 178 | | 445 | | |
| T8-1 | Reference | 12/28/01 | 68 | 0.00 | 37 | 0.40 | 190 | 0.62 | 456 | 0.44 | ACCEPT |
| | Pilot | | 68 | | 39 | | 196 | | 452 | | |
| T8-2 | Reference | 12/28/01 | 68 | 0.19 | 37 | 0.20 | 200 | 0.30 | 440 | 0.11 | ACCEPT |
| | Pilot | | 69 | | 38 | | 198 | | 439 | | |
| T8-3P | Reference | 12/28/01 | 68 | 0.19 | 37 | 0.20 | 181 | 0.16 | 440 | 0.33 | ACCEPT |
| | Pilot | | 69 | | 38 | | 180 | | 437 | | |
| T8-4P | Reference | 12/28/01 | 68 | 0.00 | 37 | 0.00 | 181 | 0.16 | 440 | 0.44 | ACCEPT |
| | Pilot | | 65 | | 37 | | 180 | | 436 | | |
| T8-5 | Reference | 12/28/01 | 68 | 0.00 | 37 | 0.40 | 202 | 0.45 | 460 | 0.65 | ACCEPT |
| | Pilot | | 69 | | 39 | | 199 | | 454 | | |
| T9-1 | Reference | 12/28/01 | 68 | 0.00 | 38 | 0.20 | 183 | 0.16 | 440 | 0.00 | ACCEPT |
| | Pilot | | 68 | | 38 | | 182 | | 440 | | |
| T0-1 | Reference | 12/28/01 | 68 | 0.00 | 38 | 0.20 | 181 | 0.16 | 448 | 0.22 | ACCEPT |
| | Pilot | | 68 | | 38 | | 182 | | 446 | | |
| T11-1 | Reference | 12/28/01 | 68 | 0.00 | 39 | 0.00 | 160 | 0.31 | 448 | 0.55 | ACCEPT |
| | Pilot | | 68 | | 39 | | 178 | | 443 | | |

**ALIERA/DOBP (STINFO)
2513 KENNEDY CIRCLE
BROOKS CITY-BASE TX 78235-5116**

OFFICIAL BUSINESS