

REPORT DOCUMENTATION PAGE

AFRL-SR-AR-TR-03-

he
99
ntly

data needed, and completing and reviewing this collection of information. Send comments regarding this burden estimate or any other aspect of this burden to Department of Defense, Washington Headquarters Services, Directorate for Information Operations and Reports (0704-014302). Respondents should be aware that notwithstanding any other provision of law, no person shall be subject to any penalty for failing to provide information unless it is specifically required by statute. PLEASE DO NOT RETURN YOUR FORM TO THE ABOVE ADDRESS.

0026

1. REPORT DATE (DD-MM-YYYY) 05-02-2003		2. REPORT TYPE Final Technical		01-04-2001 - 03-31-2002	
4. TITLE AND SUBTITLE (U) (DURIP01) North Carolina Agricultural and Technical State University Jet Propulsion Laboratory				5a. CONTRACT NUMBER	
				5b. GRANT NUMBER F49620-01-1-0251	
				5c. PROGRAM ELEMENT NUMBER 61103D	
6. AUTHOR(S) Frederick Ferguson, Mark Schulz, and Mannur Sundaresan				5d. PROJECT NUMBER 3484	
				5e. TASK NUMBER US	
				5f. WORK UNIT NUMBER	
7. PERFORMING ORGANIZATION NAME(S) AND ADDRESS(ES) North Carolina Agricultural and Technical State University Greensboro NC 27411				8. PERFORMING ORGANIZATION REPORT NUMBER	
9. SPONSORING / MONITORING AGENCY NAME(S) AND ADDRESS(ES) AFOSR/NA 4015 Wilson Boulevard Room 713 Arlington VA 22203-1954				11. SPONSOR/MONITOR'S REPORT NUMBER(S)	
13. SUPPLEMENTARY NOTES					
14. ABSTRACT Defense University Research Instrumentation Program funding was used to acquire instrumentation. This instrumentation forms the basis of a Jet Propulsion Laboratory established in the Mechanical Engineering Department to support research and education projects for experimental and computational fluid dynamics.					
<div style="border: 1px solid black; border-radius: 15px; padding: 10px; display: inline-block; font-size: 2em; font-weight: bold;">20030305 098</div>					
15. SUBJECT TERMS defense university instrumentation fluid dynamics education					
16. SECURITY CLASSIFICATION OF:			17. LIMITATION OF ABSTRACT UL	18. NUMBER OF PAGES 29	19a. NAME OF RESPONSIBLE PERSON Julian M. Tishkoff
a. REPORT Unclassified	b. ABSTRACT Unclassified	c. THIS PAGE Unclassified			19b. TELEPHONE NUMBER (include area code) (703) 696-8478

A DOD Equipment Grant Final Report

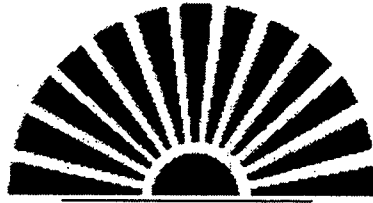

NCAT-CAR

Center for Aerospace Research

NCAT-CAR JET PROPULSION LABORATORY

AN EQUIPMENT GRANT

FINAL REPORT

Dr. Frederick Ferguson, Dr. Mark Schulz & Dr. Mannur Sundaresan
Mechanical Engineering Department

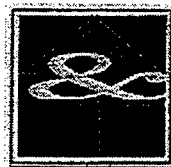

North Carolina

Agricultural and Technical
State University

NCAT JET PROPULSION LABORATORY

Executive Summary

The Center for Aerospace Research (CAR) was formed in 1992 at North Carolina A&T State University (NCAT) to foster interdisciplinary research. In fact, CAR's mission is to promote new science and technology concepts and to develop mechanisms for the increased participation by faculty and students in mainstream research. After 10 years of growth, CAR continues to provide services to NCAT that are needed to facilitate effective training at the baccalaureate, master's and doctoral program levels. This report describes CAR's effort to create a Jet Propulsion Laboratory in the Mechanical Engineering Department. With the use of the table below, all materials and equipment purchased with the funds provided by this grant are highlighted.

1 Mini-Lab Model Lx4000	41,483.00
1 Dell Computer Pentium Iii	1,783.00
1 Dynatup Impulse Windows 98/2000/Nt	8,503.73
1 Model 600 Pulser	650.00
1 Model Se25-P Dual Mode Pulsing Sensor	551.00
1 Alpha Series Emulator	70,000.00
1 Rankine Cyclor	20,339.00
4 Gateway Computers E-4650	12,480.00
1 Basic Tunnel 12x12 Test Section	17,225.00
1 Pressure System For 24 Model Pressures	5,646.00
1 Dell Computer Optiplex Gx240 Pentium 4	3,279.00
1 Glassman High Voltage	1,344.29
1 Computer 2 Optiplex Gx240 Pentium 4	2,124.00
TOTAL	185,408.02

The current equipment grant provided the equipment needed by the faculty and students to support the Experimental and Computation Fluid Dynamics research projects in the center. The Smart Structures and Structural Health Monitoring, the Control Systems and the Aerospace Systems groups also benefited from this laboratory. Thanks to the DOD equipment grant and the appropriate level of support it brought to the teaching programs, the College of Engineering and all its undergraduate engineering programs were recently re-accredited by ABET. Of greater importance is the fact that the NCAT-JPL is now the main teaching and research laboratory equipped to support the newly created Aerospace specialization in the Mechanical Engineering Department. The level of undergraduate support provided by this center is also document in this report. In terms of graduate research and training activities, the NCAT-JPL has provided leveraged support for two faculty members, one post doc, two PhD Students, and five MS students. A summary of their research activities is also presented in this report.

TABLE OF CONTENTS

	Abstract	ii
I:	Center For Aerospace Research	4
II:	Director	4
III:	Mission And Goals	5
IV:	Relevance To Institutional Mission	6
V:	2001-2002 Academic Year Performance Measures	7
	V.A: Funding Profile	7
	V.B: Publication & Proposal Profile	8
VI:	Student & Personnel Support	10
VII:	JPL Major Research Capability	12
VIII:	JPL Laboratory and Facilities	15
IX:	Research Activities	17
X:	Outreach Activities	22
XI:	Teaching Activities	25
XII:	Future Plans	26

I. NCAT-JPL LABORATORY

I.A. Name of Center

The Jet Propulsion Laboratory at North Carolina A&T State University is part of the Center for Aerospace Research (CAR). The legal name of CAR is North Carolina A&T State University Center for Aerospace Engineering as listed on our registration certification with the State of North Carolina. CAR is a university research center that is administered out of the College of Engineering, and is part of a non-profit organization.

I.B. Status

The NCAT-JPL laboratory was created in April 2001 as part of an equipment grant (of \$186K) from the Department of Defense (DOD). NCAT provided the laboratory space. CAR, on the other hand, was organized in 1992 through the use of the funds it received from the NASA University Research (URC) Program.

I.C. Year Authorized to Plan/Established

Even though CAR was established as a local center at NCAT in 1992, it was given formal approval to plan and establish in 1995 by the President of the UNC Board of Governors.

I.D. Internet Home Page URL

<http://www.ncat.edu/~nasacar>

II. DIRECTOR

II.A. Director

Dr. Frederick Ferguson

II.B. Faculty Rank, Department, School or College

Associate Professor
Department of Mechanical Engineering
College of Engineering

II.C. Address

North Carolina A&T State University
Edward B. Fort Building, IRC-301
1601 East Market Street
Greensboro, NC 27411

II.D. Phone: (336) 334-7254

Fax: (336) 334-7397

II.E. E-mail: fferguso@ncat.edu

III. MISSION AND GOALS

CAR seeks to serve as a national asset, contributing significantly to the accomplishment of aeronautics and astronautics technology research, education, and public service. The center mission rests with three permanent goals that guide its program, namely:

- Goal 1.** Recruit and train United States citizens for careers in the above mentioned areas, placing special emphasis on diversity by recruiting women, underrepresented minorities, and persons with disabilities.
- Goal 2.** Encourage collaborations among faculty, colleges, universities, businesses and Industry, and Federal and state governments, and continue to strengthen the national network of faculty, colleges and universities with interests and capabilities in aeronautics, astronautics, space science and technology.
- Goal 3.** Encourage interdisciplinary research programs that are relevant to the US Aerospace Industry and promote programs in aeronautics, astronautics, space science and technology research, education and public service.

The goals and objectives of CAR at NCA&TSU are as follows:

III. Goal.1: Increase the number of well-trained and diversified pool of professionals in aerospace engineering research, who will contribute to the national and global aerospace business environment.

Objectives:

- 1) Offer courses to advance students' proficiency in the skills required to understand and to participate in fundamental and applied aerospace engineering research.
- 2) Develop additional courses as needed to enhance the skills of our graduate students.
- 3) Recruit and offer financial incentives, such as scholarships, stipends and work-study to NCA&TSU predominantly diversified student body when enrolled in aerospace related disciplines.
- 4) Facilitate the university's effort in expanding existing Ph.D. programs to include Ph.D. programs in the Industrial Engineering Department.
- 5) Facilitate the university's effort to develop new graduate programs.

III. Goal.2: Develop collaborative and exchange programs involving North Carolina A&T State University faculty and students, the aerospace industry, other US universities and government laboratories and international agencies.

Objectives:

- 1) Form a network of partnerships with the aerospace industry, US Universities and related firms, their researchers and cooperating federal and state laboratories for the purpose of training and providing professional mentoring for students and faculty.
- 2) Establish partnerships with federal agencies and labs, international institutions, and aerospace industries to provide experiential learning to students and faculty in the fields of aerospace engineering and research.
- 3) Collaborate with the School of Technology, School of Business and Technology, Department of Arts and Sciences, Department of Mathematics, Physics, Chemistry, etc., in order to provide students a far-reaching background in Aerospace Engineering.

III. Goal.3: Contribute to the nation's base in aerospace engineering research by

providing new technologies, conduct collaborative research, encourage technology exchange and trained experts.

Objectives:

- 1) Obtain research programs in aerospace engineering and research for faculty and students. These programs may take the form of grants, cooperative agreements, contracts, etc.
- 2) Staff program with state-of-the-art faculty, as judged by their reputation and research productivity.
- 3) Produce 'top-notch' graduate students as judged by their marketability and their post-graduate performance.
- 4) Participate in targeted technology transfer by conducting applied research projects for small and disadvantaged businesses.
- 5) Collaborate with domestic and international institutions, laboratories and universities, through interdisciplinary aerospace research geared towards economic growth and development.

IV. RELEVANCE TO SPONSORS AND PARTNERS

One of the goals of NCAT is that its students attain a level of scientific literacy that will enable them to excel in the technological society of the twenty-first century. The CAR is one of many centers in the College of Engineering dedicated towards realizing this goal. CAR has facilitated innovative research break-through in the areas of Computational Fluid Dynamics (CFD), Autonomous Control Engineering (ACE), Structural Health Monitoring, (SHM) and Human Machine Systems Engineering (HMSE). CAR is providing leadership and inspiration to our students, our faculty and our community.

Presently, our scientists are conducting joint research with NASA field centers, such as, Lewis, LARC, Marshall and Dryden. CAR is also collaborating with private aerospace industries, such as Lockheed-Martin and Raytheon Systems. During the 2001-2002 academic year our researchers submitted and won research proposals to aerospace companies, such as, Rockwell International and Lockheed-Martin. Joint investigative proposals with universities, such as, Virginia Polytechnic Institute and NC State University were submitted to NSF, BMDO, ARO and Wright Patterson Airforce Base. All on going research projects received funding from NASA and associated industrial partners, and are carried out in accordance with the missions of the center.

The primary mission of CAR is to conduct high quality research in Aeronautics and Astronautics in a safe and cost-effective manner. CAR is one of the few NASA supported academic research centers that perform the critical research that contributes to the technology necessary to support the development of NASA's High Speed Civil Transport (HSCT) programs. Technology development geared towards the improvement of the Single and Two State to Orbit (SSTO, TSTO) missions is also conducted. Under development are research efforts geared towards the support of NASA's exploration of space, long term human presence in space, as well as to enhance life on earth by applying the resultant

advances in human knowledge and technology. Researchers at CAR are actively developing capabilities in the areas of space station design, space station project management and micro-gravity materials research.

V. 2001 – 2002 ACADEMIC YEAR PERFORMANCE MEASURES

V.A. Funding Profile

The data presented in Figure 1 illustrates the funding profile generated by CAR since its inception in 1992. Currently, NCAT receives over \$4 million in cumulative annual awards from the ongoing research activities in CAR laboratories.

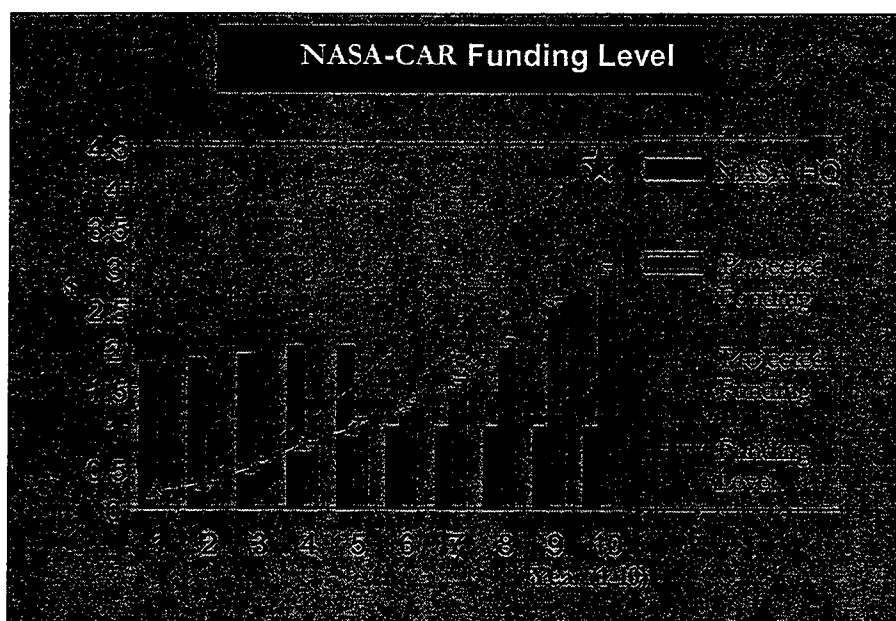

Figure 1: CAR Research Funding Profile (From 1992, 2002)

Table 1: A Summary of Accumulated 2001-2002 Support

Funding Category	Amount (FY-2000)
Direct State Appropriations	None
University Support (Overhead Return)	\$23K
External Support (Sponsor, NASA HQ)	\$1.0M
Estimated Support Derived from Grants & Contracts Awarded to Other University Units	None
External Support (Leveraged Support)	\$4.0M
Total Support	\$5.0M

The funding profile of NCAT-CAR over the last year is summarized in Table 1. It is from these resources that CAR is able to sustain its researchers and students in its education and research programs.

V.B. Publication and Proposal Profile

All refereed journal and conference publications, and technologies transfer initiatives are listed in this section.

Description	Outcome 2001	Outcome 2002	Predicted 2002	% Success
Faculty Participation	18	20	17	117.0%
Students Funded/Leveraged	65	67	65	103.0%
Degrees				
BS	16	14	16	87.0%
MS	7	9	7	129.0%
Ph.D.	0	0	0	100.0%
Graduated in all Fields	23	23	23	100.0%
Papers/Journals/Books /Book Chapters	51	50	51	98.0%

A list of recent funded projects generated by the PI and Co-PI of the current DOD Equipment grant are illustrated below:

Dr. Ferguson's Funding Profile

- 1 A Tool For The Design Of Safety Critical Space Crew Survival Systems, \$100K
NASA STTR/SBIR 01/01/02 - 12/31/02
- 2 Center For Aerospace Research-A NASA Center Of Research Excellence, \$200K
NASA LARC 01/01/01 - 12/31/01
- 3 Research For NASA High Speed Civil Transportation Phase I: Jet Noise Reduction
\$5.0K, N.C. STATE UNIVERSITY, 03/01/01 - 02/28/02
- 4 Research For Revolutionary Spacecraft Concepts - Phase I \$4.0K
NC STATE UNIVERSITY 03/01/01, - 02/28/02
- 5 NC A&T State University Jet Propulsion Laboratory , \$186K,
DOD/AIRFORCE/AFOSR 04/01/01 - 03/31/02
- 6 Lockheed Martin Astronautics Advanced Space Launch System Atlas Supplier
Development Program, PI/Co-PI: R. Westmoreland \$50K, Lockheed Martin
Corporation 09/15/99 - 12/31/01
- 7 Access To Space Through Research And Education \$200K, NASA LARC
08/01/99 - 12/31/01

- 8 Research For Revolutionary Spacecraft Concepts-Phase 1: Configuration Design, \$2.0K, NC STATE UNIVERSITY 03/01/00 - 02/28/01
- 9 Computational Fluid Dynamics Analysis Of Plume-Induced Flow Separation On The Atlas Liar Launch Vehicle, PI/Co-PI: S. Chandra, \$325K, Lockheed Martin Corporation 01/01/98 - 12/31/01

Dr. Mark Schulz's Funding Profile

- 1) Title: A Smart Sensor System for Structural Condition Monitoring of Wind Turbines, Agency: DoE, National Renewable Energy Laboratory, \$300,000, 2/01/00 to 1/31/05. PI/Co-PI: Mannur J. Sundaresan / Mark J. Schulz.
- 2) Title: A Smart Target for Supercavitating Projectiles, Agency: NUWC, \$100,000, 2/01/00 to 9/1/03.
- 3) Title: Neural Composite Materials, Agency: Army Research Office, \$180,000, 10/01/00 to 9/30/03. PI/Co-PI: Mark J. Schulz/Mannur J. Sundaresan/Anindya Ghoshal
- 4) Title: Distributed Sensors for Structural Health Monitoring, Agency: Sandia National Laboratory, \$15,000, 5-26-00 to 9-31-00. PI/Co-PI: Mark J. Schulz/P. Frank Pai
- 3) Title: Experimental Intelligent Structures, Agency: AFOSR, \$150,815 (Instrumentation Grant) 5-15-00 to 3-30-01. PI/Co-PI: Mark J. Schulz/Mannur J. Sundaresan/Anindya Ghoshal
- 4) Title: Structural Health Monitoring of Aerospace Vehicles Agency: NASA Marshall, \$200,000, 11-1-99 to 10-30-01. PI/Co-PI: Mark J. Schulz/P. Frank Pai
- 5) Title: Active Fiber Composites for Health Monitoring of Wind Turbine Blades, Agency: Sandia National Laboratory, \$15,000, 7-16-99 to 9-31-99, PI/Co-PI: Mark J. Schulz/P. Frank Pai
- 6) Title: Development and Testing of a Vibrometry Technique for Health Monitoring of Composite Material Structures, Agency: NASA Marshall, \$284,507, 11-1-96 to 10-30-99, PI/Co-PI: Mark J. Schulz/None
- 7) Title: Detecting Structural Damage Using Transmittance Functions, Agency: Sandia National Laboratory, \$19,600, 8-16-96 to 10-31-96. PI/Co-PI: Mark J. Schulz/P. Frank Pai
- 8) Title: Structural Damage Identification Research, Agency: College of Engineering, \$5,000, 6-1-95 to 5-30-96, PI/Co-PI: Mark J. Schulz/None
- 9) Title: New Techniques in Exp. Structural Dynamics using a Scanning Laser Vibrometer, Agency: AFOSR DURIP, \$195,497 (Instrumentation Grant), 3/15/97-3/14/98, PI/Co-PI: Mark J. Schulz/P. Frank Pai
- 10) Title: Health Monitoring of Helicopter Rotor Systems, Agency: Pennsylvania State University, 1-1-97 to 12-31-00, \$99,947, PI/Co-PI: M. J. Schulz/P.F. Pai
- 11) Title: New Techniques in Exp. Structural Dynamics using a Scanning Laser Vibrometer, Agency: Army Research Office DoD HBCU/MI Defense Infrastructure Support Program, \$135,947 (second part instrumentation grant), 5/1/97-4/30/98, PI/Co-PI: Mark J. Schulz/P. Frank Pai
- 12) Title: Measuring High Frequency Vibration Spectra using a Scanning Laser Vibrometer, Agency: United Technologies Research Corporation, CT, 12/15/97-5/31/98, \$30,000, PI/Co-PI: Mark J. Schulz/A. S. Naser
- 13) Title: Health Monitoring of Wind Turbine Rotors, Agency: Sandia National Laboratory, \$23,000, 8-2-98 to 10-31-98, PI/Co-PI: M. Schulz/K.Shivakumar/F. Pai

VI. STUDENT AND PERSONNEL SUPPORT

The Center of Aerospace Research is an organization within the College of Engineering that is made up of a group of faculty and students, working within one or more of five research laboratories. The faculty and students are drawn from the College of Engineering. Tables 3, 4 and 5 list the participants of CAR and indicate the level of support provided. The researchers who were directly supported by the activities in the NCAT-JPL are illustrated in Tables 3 and 4, where as Table 5 illustrates all of the students supported by the center.

Table 3: Student Researchers of NCAT-Jet Propulsion Laboratory

Name	Rank	% Support	Status/Employment
Mr. Geo Lee	PhD Student	100%	May 2003
Mr. Damon Jeffries	PhD Student	100%	May 2003/GE
Mr. Joshua Ampofo	MS. Student	100%	December 2002
Mr. Stephen Akawoba	MS. Student	100%	Planned, May 2003
Ms. Virginia Fluitt	MS. Student	100%	December 2002
Mr. Feras Darwish	MS. Student	100%	December 2002
Mr. Lester Jansen	MS. Student	100%	Joined Fall 2002
Mr. Terry Corbet	MS. Student	100%	Joined Fall 2002
Mr. Haile	MS. Student	100%	May 2003/GE
Ms. Nicole Bowden	MS. Student	100%	Joined Fall 2002
Mr. Mohammed Isse	MS. Student	100%	Planned, May 2003
Mr. Peter Ikome	MS. Student	100%	MS 2001/Duke Power
Ms. Monique Pryce	MS. Student	100%	MS 2001/Kodak

Table 4: Faculty Researchers of NCAT-Jet Propulsion Laboratory

Name	Rank	% Support
Dr. Frederick Ferguson	Associate Prof. & Dir.	50%
Dr. Suresh Chandra	Research Professor	25%
Dr. Ji Shen	Associate Professor	25%
Dr. Mark Kithcart	Research Associate	50%
Dr. Masoud Bagheri	Research Associate	50%
Ms. Peggy Brooks	Support Staff	100%
Mr. Rodney Westmoreland	Support Staff	50%

Table 5: History and Classification of Students Supported by CAR

STUDENTS NAME	LEVEL	STATUS	Ethnicity	Gender
Alexander, Mykia	UG	Graduated, 1999	A. American	F
Ampofo, Joshua	MS	Enrolled	Other	M
Bell, Melissa N.	UG	Graduated, 1999	A. American	F
Bouba Ali	MS	Enrolled	Other	M
Brown, Jr., Randy	UG	Graduated, 1999	A. American	M

Byrd, Keena	UG	Graduated, 2000	A. American	F
Daniels, Lenita	MS	Graduated, 2000	A. American	F
Dawson, Joshua L.	UG	Graduated, 1999	A. American	M
Dunnings, Johnson	MS	Graduated, 1999	A. American	F
Draper, Shamina M.	UG	Graduated, 1999	A. American	F
Kithcart, Mark	PhD	Graduation Pending	A. American	M
Griffin, Dorice	MS	No Longer Supported	A. American	F
Guthrie, Valenie	UG	Graduation Pending	A. American	F
Feras Darwish	MS	Enrolled	Other	M
Fluitt, Virginia	MS	Graduation Pending	A. American	F
Franceschini, Ricardo J.	MS	Graduated, 2000	Other	M
Harrison, Jeremy	UG	Graduated, 2000	A. American	M
Hawari, Hani	MS	Graduated, 1999	Other	F
Heath, Maurice L.	UG	Graduated	A. American	M
Hill, Jamaal	UG	Graduated, 2000	A. American	M
Hill, Stacie	MS	Graduated, 2000	A- American	F
Hughes, Derke	PhD	Graduation Pending	A. American	M
Ikome, Peter	MS	Graduation Pending	Other	M
Jeffries, Damon	PhD	Graduation Pending	A. American	M
Jolliff, Brian	UG	No longer Supported	A. American	M
Kaise Adams	MS	Enrolled	White	M
Karim, Timothy	MS	Graduated, 2000	A. American	M
Lee, Geo	PhD	Enrolled	Other	M
Lee, Ji	Ph. D	Enrolled	Other	F
Linen, Kevin	MS	Graduation Pending	A. American	M
Martin, William	PhD	Graduation Pending	A. American	M
Mayer, Een	MS	Graduated, 2000	Other	in
Mazaeva, Natalya	MS	Graduation Pending	Other	F
McRae, Jametta	MS	Graduated, 2000	A. American	F
Mickens, Travluss	MS	Graduated, 2000	A. American	M
Moore, Patrick R.	UG	Graduated, 2000	A. American	M
Onwualu, Che	MS	Graduation Pending	A. American	M
Pryce, Monique	MS	Graduation Pending	A. American	F
Raynor, Chavis	UG	Graduated, 2000	A. American	M
Rouland, Drew	MS	Graduation Pending	A. American	M
Seymour, Rodney	MS	Graduation Pending	A. American	M
Shen, Yaxi	PhD	Graduating pending	Other	F
Short, Brian	UG	Graduated, 1999	White	M
Stack, Brian	MS	Graduation Pending	White	M
Tillman, Reginald	MS	Graduated, 2000	A. American	M
Turrentine, David	MS	Graduation Pending	A. American	M
Waldron, Kenneth	MS	Graduation Pending	American	M
Walker, Kamilah	MS	Graduation Pending	A. American	M
Williams, Quincy	UG	Graduated, 2000	A. American	M
Wylie, Stuart	MS	Graduated, 2000	White	M

VII. NCAT-JPL MAJOR RESEARCH CAPABILITY

VIIA: NCAT Jet Propulsion Laboratory Hardware & Software Capabilities

The resources purchased through the use of the current equipment grant are listed in Table . Pictorial illustration of these resources are also given in Figures \$\$\$ through \$\$\$\$. However, the importance and usage of these resources are highlighted in the next section.

Item #	DESCRIPTION	AMOUNT
1	1 Mini-Lab Model Lx4000	41,483.00
2	1 Dell Computer Pentium Iii	1,783.00
3	1 Dynatup Impulse Windows 98/2000/Nt	8,503.73
4	1 Model 600 Pulser	650.00
5	1 Model Se25-P Dual Mode Pulsing Sensor	551.00
6	1 Alpha Series Emulator	70,000.00
7	1 Rankine Cyclor	20,339.00
8	4 Gateway Computers E-4650	12,480.00
9	1 Basic Tunnel 12x12 Test Section	17,225.00
10	1 Pressure System For 24 Model Pressures	5,646.00
11	1 Dell Computer Optiplex Gx240 Pentium 4	3,279.00
12	1 Glassman High Voltage	1,344.29
13	1 Computer 2 Optiplex Gx240 Pentium 4	2,124.00



Item #9: A 12X12 Test Section Windtunnel

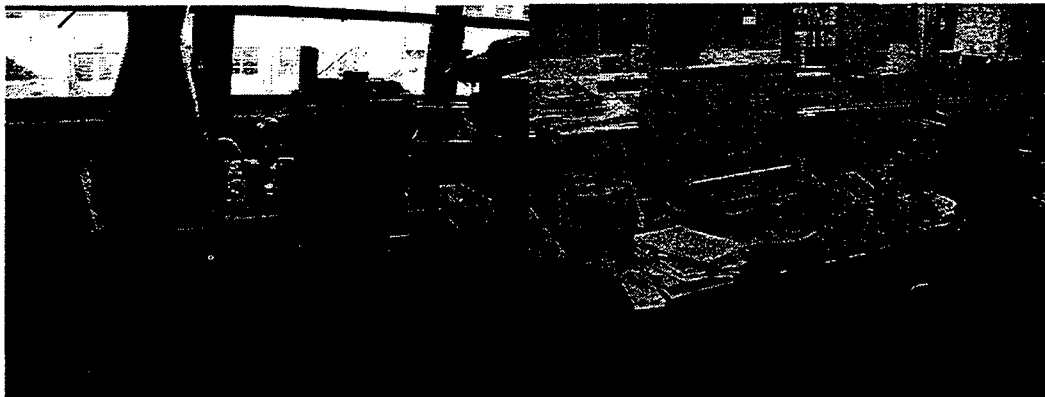

Items Numbers #7 and #11: A Rankine Turbine Laboratory Setup



Items Numbers #3 and #6: NCAT Re-configurable Computing Resources

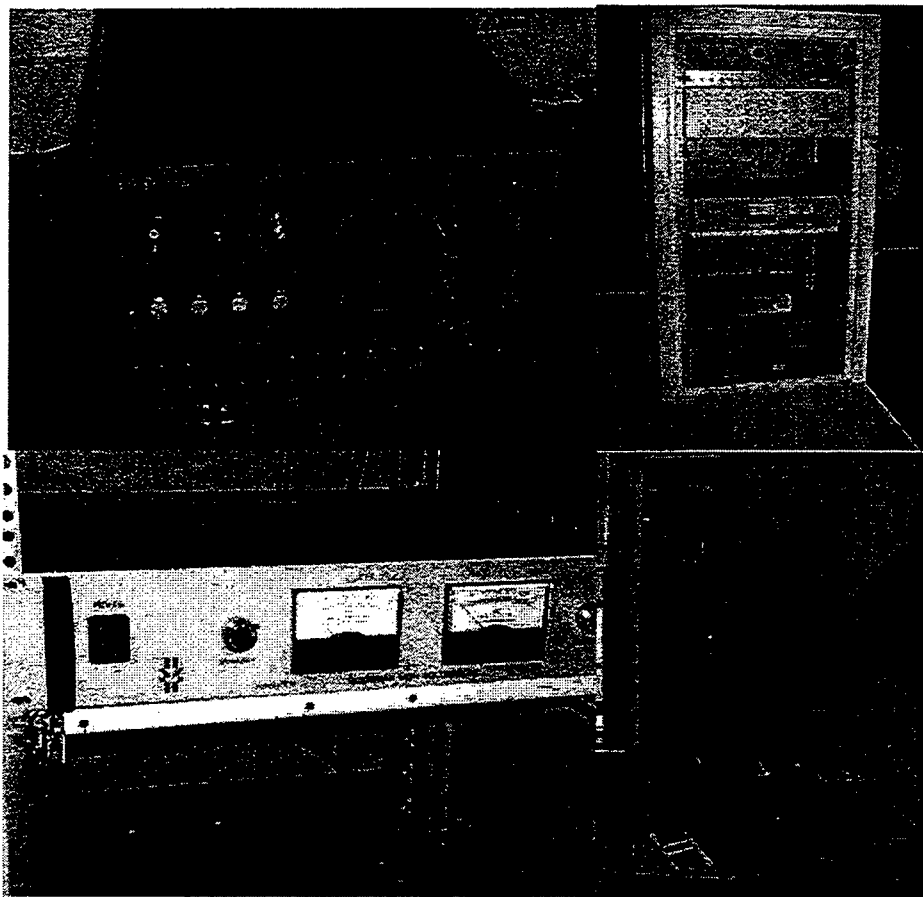

Items Numbers #4, #5, #12 and #13: NCAT JPL Supporting Hardware and Software

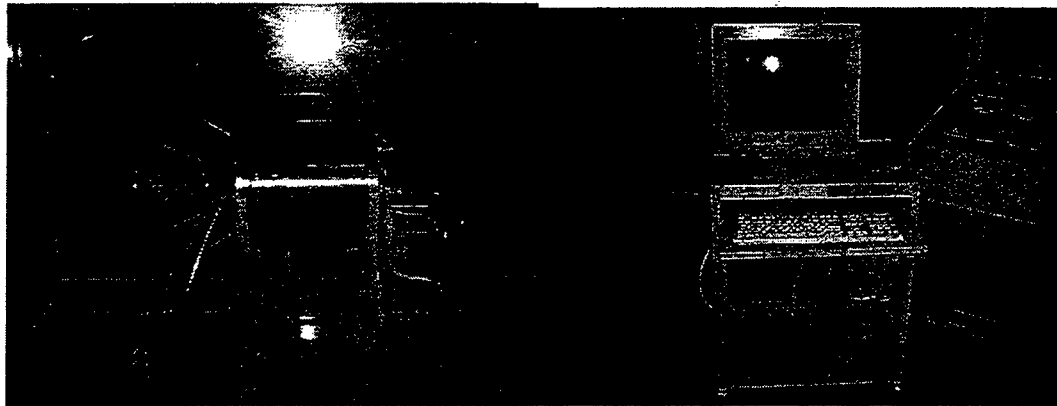

Items Numbers #1 and #2: A Mini-jet engine Laboratory Setup

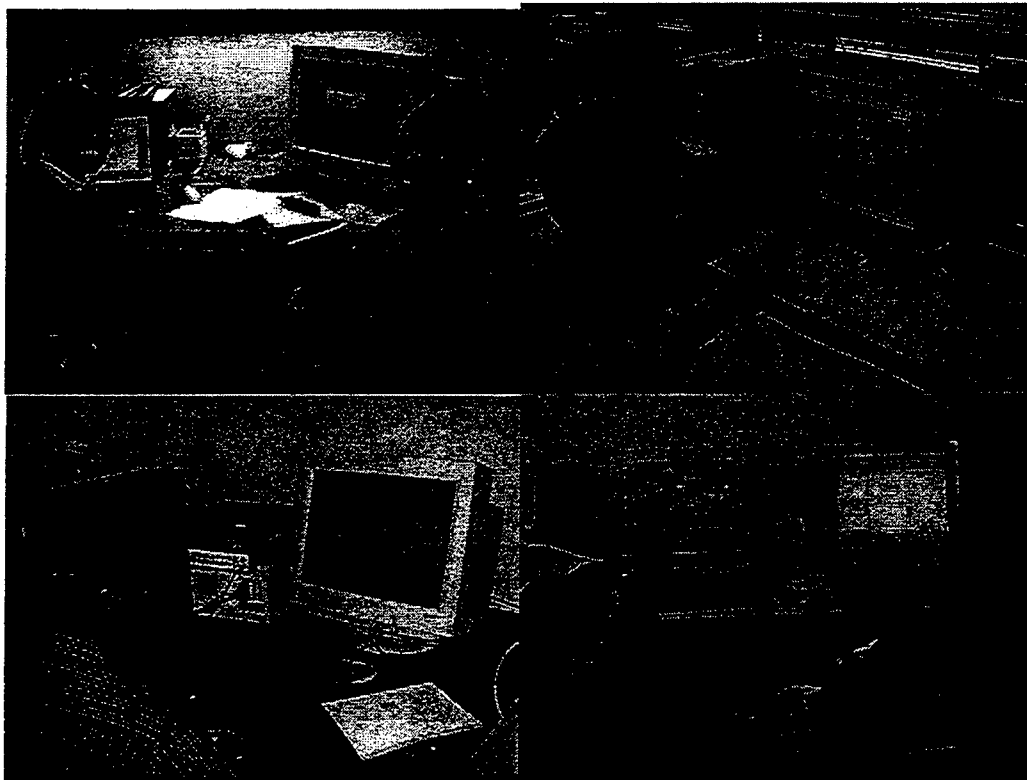

Students at Work with computer with NCAT JPL Grant

VII.B: Using Computation Fluid Dynamics to Develop Empirical Relations

Since fluid dynamics and heat transfer, are interlinked, FLUENT and TheroComp provide heat transfer evaluation with its CFD modules. The CFD component of NCAT-JPL codes solves the Navier-Stokes, temperature, and species equations in the inertial and rotating frames, using the finite element method. This module comes with its own drafting and sketching tools, so that third-party CAD packages are not involved in model preparation for a CFD project. Computed results include fluid velocities, temperature, pressure, heat flux (Nusselt number) distribution, and the transport of scalars and chemical species by fluid flow. There are at least seven turbulence models. NCAT-JPL CFD capabilities can

supplement proven engineering relations and empirical approaches. The researchers recognize that, while there are requirements for a front-end supercomputer to extract physics from engineering systems, often a quicker calculation is needed. Engineers also realize that, in the current state of CFD technology, the data needed for the design of many thermal/flow systems of industrial interest cannot be provided directly by CFD simulations. The flows of engineering interest are always turbulent and are not understood well enough to allow models of sufficient generality to be developed. Moreover, for engineering applications, the turbulence cannot be simulated directly on the computer because of inadequate computer speed and memory. Thus the engineer who actually does the design recognizes that CFD, although important, is often very limited. It must therefore be integrated with proven (usually empirical) engineering relations.

This is the philosophy of the Center for Aerospace Research: to integrate CFD, engineering empiricals, and other energy design tools in a single computing environment for the Jet propulsion system with an emphasis on system health monitoring and failure prediction. The overall package includes the set of boundary conditions, the variety of turbulence models, and automatic mesh generation. NCAT-JPL codes provide adiabatic thermal conditions, prescribed nodal values of velocities and temperatures, heat flux application on a portion of the domain, stress-free conditions, adiabatic thermal conditions film, and coefficient on a surface volumetric heat source.

VIII. NCAT-JET PROPULSION LABORATORY & FACILITIES

The Center for Aerospace Research (CAR) at North Carolina A&T State University developed a Jet Propulsion Laboratory (NCAT-JPL) as part of the \$186K equipment grant it received from the Department of Defense (DOD). This section describes the current status of the laboratory and the benefits the College of Engineering has derived from this laboratory thus far. At this time, the major research objective of the jet propulsion lab is to equip and instrument a jet engine model with smart sensors to study the relationship between fluid-structural interaction and engine failure, due to structural damage. The jet engine model, and all supporting materials, including personnel, resources, hardware and software, acquired as part of this effort are also presented in this section.

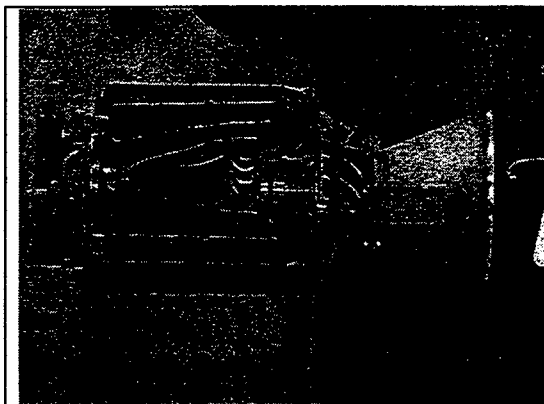

Figure 2: NCAT-JPL Mini-Jet Engine



Figure 3: Brainstorming sessions

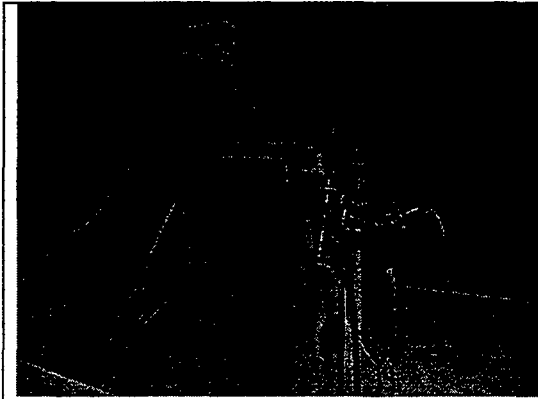

Figure 4: Jet engine with Sensors

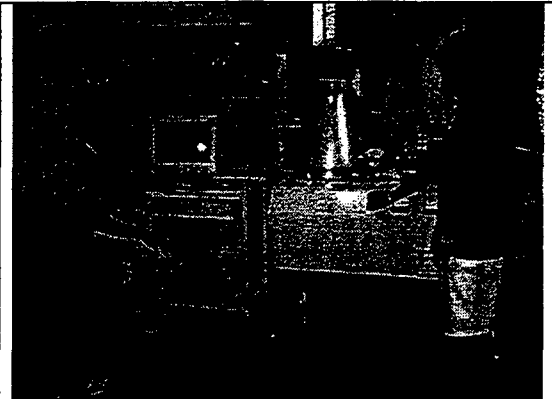

Figure 5: NCAT-JPL Turbine Experiment



Figure 6: NCAT-JPL Radiation Experiment



Figure 7: Propulsion Data Collection

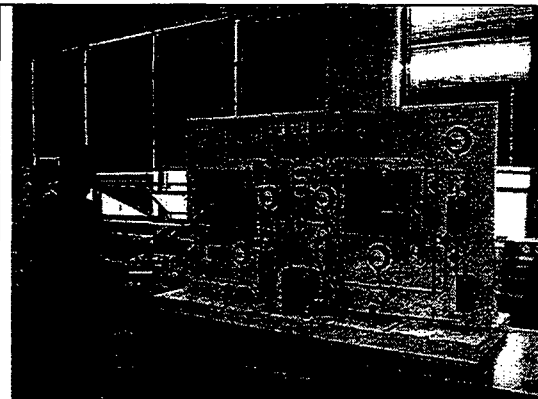

Figure 8: Fluid Heat Transfer Experiment

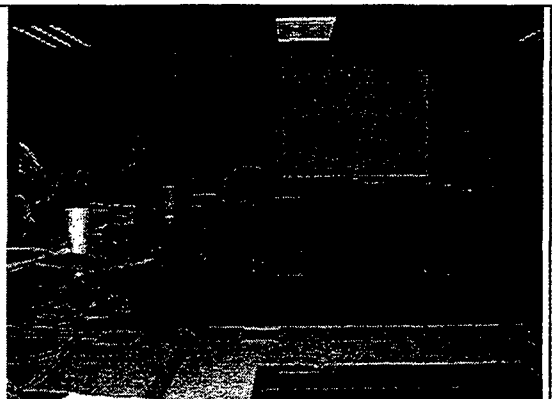

Figure 9: JPL Training Facility

IX. RESEARCH ACTIVITIES

IX.A Numerical Investigation of the Aerodynamic and Heat Transfer Characteristics of Surfaces with Concave Cavities

There is renewed interest on the part of the aero dynamists in the areas of heat transfer and aerodynamic resistance on dimpled surfaces. There is overwhelming evidence, derived from both numerical investigations and experimental studies, to suggest that a favorable relationship exists in terms of enhanced heat transfer rates and aerodynamic resistance for concave surfaces. In these studies, dimples are defined as holes with round off edges. In fact, on dimpled surfaces, the evidence tend to suggest that there is a much larger increase in the heat transfer coefficient when compared to that of the aerodynamic resistance. The net result is an overall increase in the rate of heat transfer for an established set of extraneous conditions. However, all the previous numerical studies in this area were confined to two-dimensional or limited three-Dimensional analysis.

The work described herein is based on the numerical analysis of a full three dimensional Navier-Stokes (NS) equations solver, developed by FLUENT. The NS solver can be operated with either the turbulent kinetic energy model or the large eddy simulation scheme. The preliminary results obtained from this study showed that the heat transfer coefficient increases at a rate greater than they can be attributed to the increasing surface area. Moreover, the increase heat transfer rate is due to the auto oscillations generated by the cavity under turbulent flowfield conditions. The regime of these auto oscillations is characterized by large scale, non-periodic transverse current oscillations and asymmetrical vortices within the cavity. The parameters of this regime are dependent upon the depth and radius of the dimple. A major objective of this study is the investigation of the relationship between the heat transfer coefficient and the aerodynamic resistance generated by the surface and the dimpled-characteristics of the surfaces themselves. Empirical relationships will be developed and the results compared to those generated by existing numerical and experimental data. Preliminary results from this study are illustrated in Figures 10 and 12.

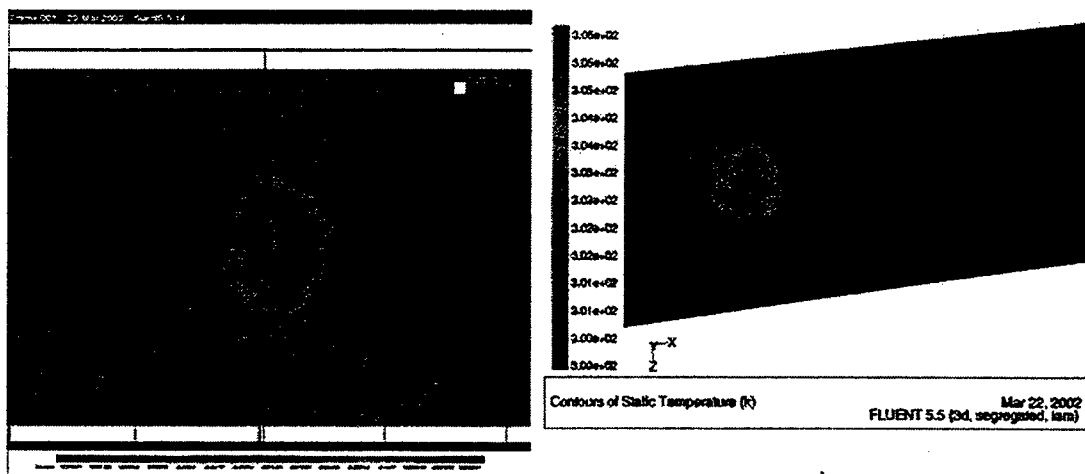

Figures 10: Contour plot of the pressure distribution on the cavity surface

IX.B: A Conceptual Design of an Autonomous Crew Escape System for the International Space Station

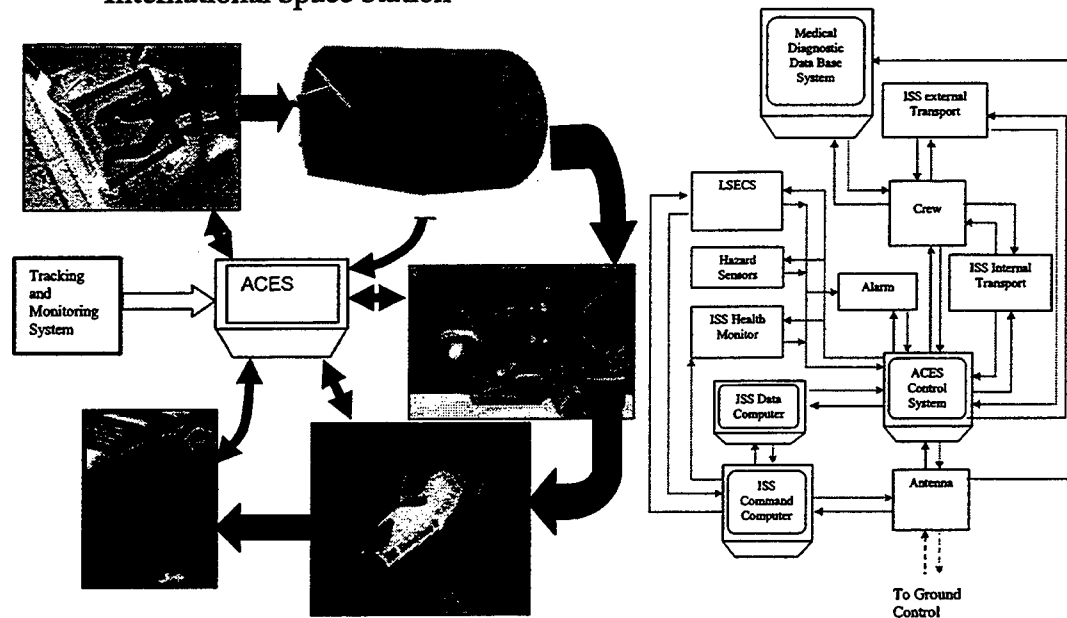

Figures 11: Frame work for ISS Crew Escape System

In this research effort, a multi-functional local and remote control crew emergency rescue/escape system for the International Space Station (ISS) is proposed. The frame work upon which the proposed system will be built are illustrated in Figure 11. It consists of discipline-oriented sub-systems, supervised by a crew and controlled by software that runs on a radio-link network of non-centralized computers located in modules, space vehicles and on the ground. The proposed concept would continuously co-operate with crew and ground control, and utilize sensors, industrial risks analysis techniques and software to identify threats, prioritize identified threats, stay ahead of threat, and adapt to changing situations to enhance rescue task execution capabilities, both providing alternatives for executing a task and by making task execution more robust. A new internal handcar that runs on rails is introduced. The integration of the handcar and rails allows for the automation of hatches, which drastically reduces ISS evacuation time.

IX.C: Activities in the Intelligent Structures and Mechanisms Laboratory

Three new desktop computers were purchased under this equipment grant for use in the Intelligent Structures and Mechanisms Laboratory of Mechanical Engineering Department. These computers are being used for data acquisition, numerical simulations, development of new embeddable instrumentation, as well as structural analysis. The main activities are briefly described below:

IX.C.1: Monitoring incipient buckling in bars: Most structural health monitoring analyses to date have focused on the determination of damage in the form of crack growth in metallic materials or delamination or other types of damage growth in composite materials. However, in many applications local instability in the form of local buckling can be the cause of unstable damage growth and collapse of the structure. Relatively few

investigations have addressed this type of damage initiation in structures. Recently, during the structural health monitoring of wind turbine blades, local buckling was identified as the cause for premature failure. Preliminary results from this investigation suggested that stress waves could be used for detecting the onset of local curvature that precedes the buckling type of failure in this structure.

The present investigation is to study the ability of stress waves to detect the onset of buckling under more controlled conditions. A composite bar 2 inches wide and 0.125 inch thick is instrumented with two PZT patches as shown in Figure 12. The instrumentation including the computer for data acquisition and analysis is shown in figure 13. This specimen is first supported in the straight unbuckled condition as shown in this figure. Later the bar was subjected to buckling that introduced increasing magnitudes of displacements at the midpoint. The feasibility of detecting the incipient buckling was investigated by pulse excitations ranging in frequencies starting from 50 Hz to about 15,000 Hz. The exciting pulse was applied to the PZT patch shown in the left side of the specimen. The magnitude of the specimen oscillations were measured using the PZT patch mounted on the right side of the specimen. The signals from the buckled and unbuckled configurations were compared for the various frequencies that were investigated. The result shown below corresponds to the first natural frequency of the beam that was 71Hz. The exciting pulse was a Gaussian sine pulse consisting of two complete cycles of sine waves created in an arbitrary function generator, and had amplitude of 9 volts. This pulse was amplified by a power amplifier by a factor of 20 before applying to PZT patch on the left side of the specimen. The signals from the patch on the right side of the specimen, corresponding to the amplitude of oscillations of the bar, was captured in a digital oscilloscope and then downloaded to a PC. The measurements were taken for central displacements of 0.2" (0.5 cm), 0.4" (1.0), 0.69" (1.75 cm), and 1.0" (2.5 cm). Finally, the bar was returned to its original unbuckled state, the vibration amplitude was again measured. Figure 13 shows a comparison of the waveforms corresponding to the unbuckled state and various buckled states. The magnitude of the oscillations undergoes a drastic reduction as the buckling displacement increases. These changes are apparent even at the early stages of buckling when the central displacement is of the order of 0.25". When the bar was returned to the unbuckled state, the signal amplitude returned to the initial unbuckled bar amplitude as seen from the figure 14, indicating that the changes in amplitude are indeed caused by the buckling deformation in the bar. A more detailed investigation is currently in progress.

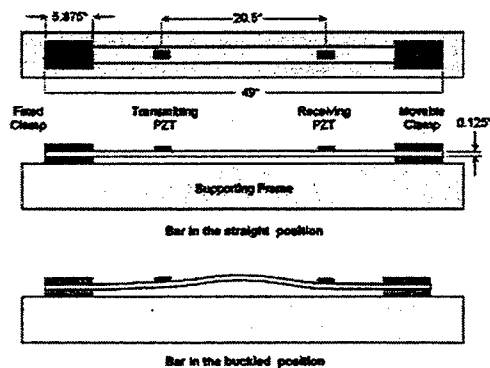

Figure 12 Specimen used for buckling

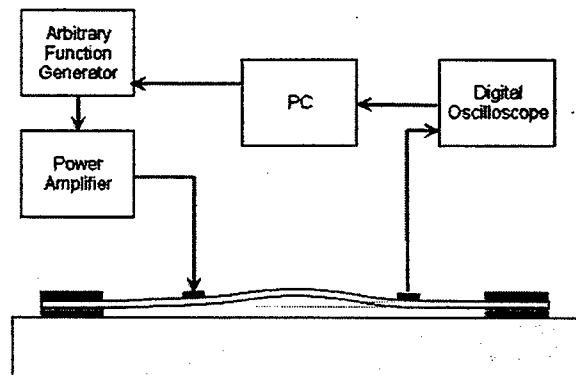
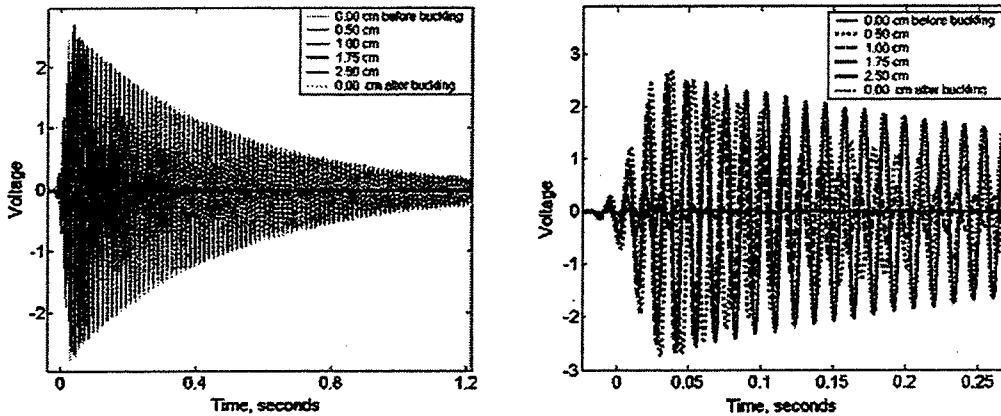

Figure 13. Instrumentation used in Experiment



Figures 3a & 3b: Waveforms obtained for unbuckled and buckled condition

IX.C.2. Development of a novel sensor system for the health monitoring of aerospace structures

Biological nervous systems found in living organisms have evolved over millennia and are optimized to their individual situations. A simplistic view of the neurons is illustrated in figure 4(a). It consists of a number of Dendrites, which are sensors, and the signals from the Dendrites feed into the cell body of the Soma. Soma integrates and interprets the signals. If it determines that the signal is of significance, it transmits the information digitally along the Axon. The system is exceedingly complex, with a large number of components and with an extremely large number of interactions

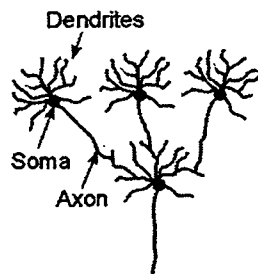

(a) Biological Neurons

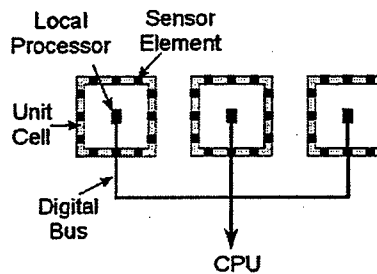

(b) Arrangement of continuous sensor & local processor

Figure 15. Comparison of biological neurons and the proposed biomimetic sensory system

In earlier studies the continuous sensor performance was studied and validated using simulated acoustic emission signals, namely that caused by pencil lead breaks. In the current work, the advantage of the continuous sensor configuration for monitoring actual acoustic emission signals generated by fatigue damage growth in a composite specimen is evaluated. A 610 mm long, 25 mm wide, and 3 mm thick fiberglass cloth laminate specimens were used. The central section of the specimen had two semicircular notches of 0.25-inch radii. The specimen was initially subjected to fatigue until a visible crack appeared at one

of the edges. The arrangement of sensors on the specimen is shown in figure 16. This specimen was instrumented with a surface bonded continuous sensor as shown in figure 16. The first node of the continuous sensor was at a distance of 0.625 inches from the fatigue damage site. In addition, two conventional sensors were also attached to the specimen. The sensors S1 and S2 were 0.25 inch damped ultrasonic sensors with a resonant frequency of 5 MHz. These sensors were chosen for their suitability in terms of wide band response non-resonant response needed for quantifying acoustic emission signals, based on an earlier study [23]. The specimen was subjected to a fatigue loading with a mean load of 750 lbs and amplitude of 500 lbs. The test setup is shown in figure 17.

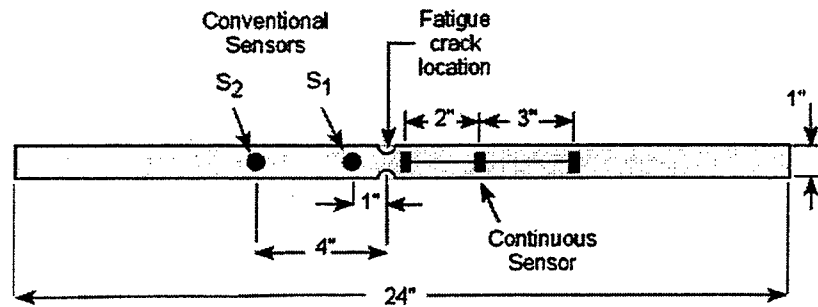

Figure 16: Composite specimen with fatigue damage

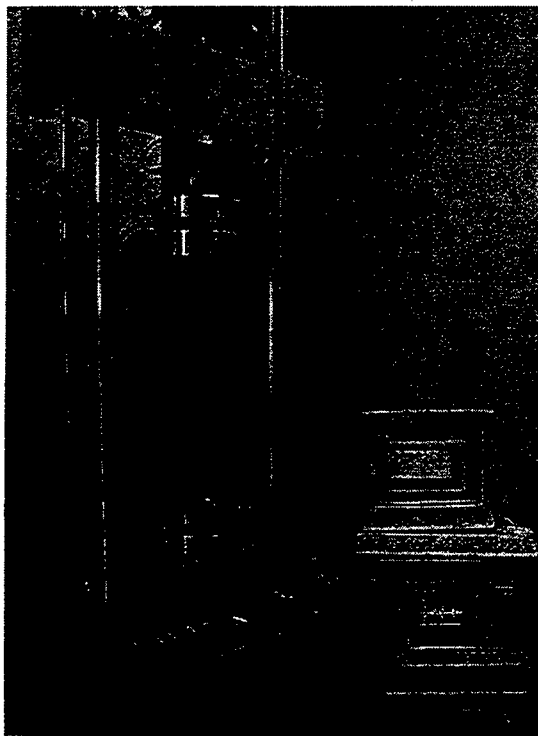

Figure 17: Expt. Test setup

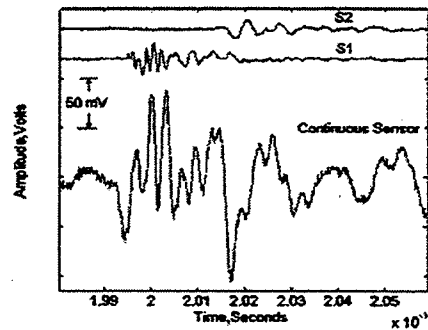
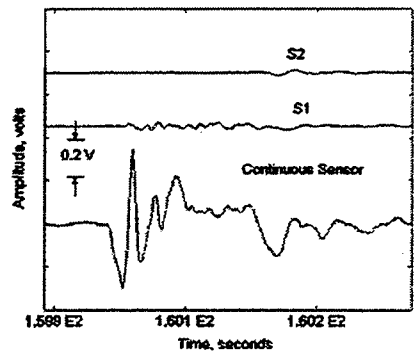

Figure 18: Acoustic Emission waveforms

Figure 18 shows the waveforms of the acoustic emission signals obtained during the fatigue loading. The signals from the continuous sensor were much larger than the conventional sensor. These differences can be attributed to the frequency responses of the two types of sensors, their relative sizes, and to the fact that surface bonded or embedded sensors are likely to be more sensitive to the acoustic emission signals compared to the conventional sensors. The acoustic emission signal sensed by the conventional sensors s_2 is much smaller in amplitude compared to that from an identical sensor s_1 , which is merely 3 inches closer to the damage site. Further, the high frequency components present in the signal from s_1 are absent in the signals from the sensor s_2 . This variation in the signal characteristics over as short a distance as 3 inches in composite media illustrates the need for multiple sensor nodes in critical regions for the accurate detection of damage magnitudes and rates.

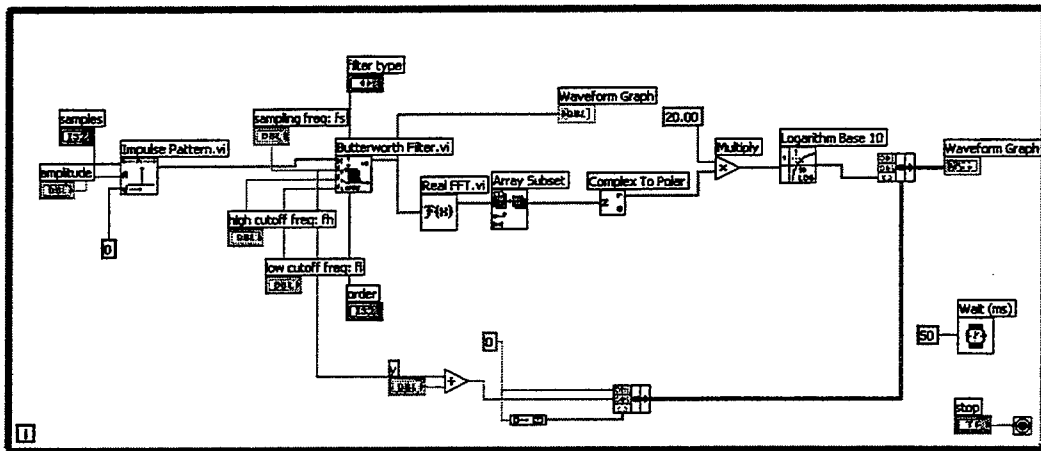

Figure 19: The VI diagram for the front end filter

IX.C.3. Development of an embeddable health monitoring processor chip

For the incorporation of the health monitoring scheme described above into critical structural elements such as an aircraft wing, a processor chip is under development in collaboration with industrial partners. The first step in this development is the emulation of the processor using software tools. LabView is currently being used for the design of the different components in the chip. Figure 19 describes the front end filters for the chip.

X: OUTREACH ACTIVITIES

X.A. A Summer Institute

North Carolina A&T State University's (NCAT) Center for Aerospace Research (CAR) in collaborations with Software Safety-Critical Systems, Inc (S3Inc) and the Mathematics and Science Education Network (MSEN) Pre-college program conducted a 3-day workshop for high school students at North Carolina A&T State University on June 17-20, 2002. The workshop entitled, 'A NASA Summer Education and Training Institute',

hosted 30 high school students who were selected from the Greensboro Area Mathematics and Science Education Center (GAMSEC) Pre-College Program (GAMSEC is a chapter of the MSEN program that is housed on campus at NCAT in Greensboro). Only students who satisfied the strict selection criteria (included in this report) were allowed to register for this workshop. Prior to the commencement of the 3-day workshop, all students were provided with a textbook and all other course materials. They also received lunch and evening snacks. The workshop provided an Integrated and Systemic Approach to NASA related technologies and its career development requirements. The S3Inc/NCAT-CAR/MSEN-GAMSEC summer institute was adapted especially for this high school audience. A major objective of this institute was to stimulate the interest of pre-college students in human space flight and to motivate them to continuously seek and pursue further experiences in this field. To this end an exit survey form was developed with the intention of student tracking and career impact studies. Figure 20 illustrates the participants and workshop in action.

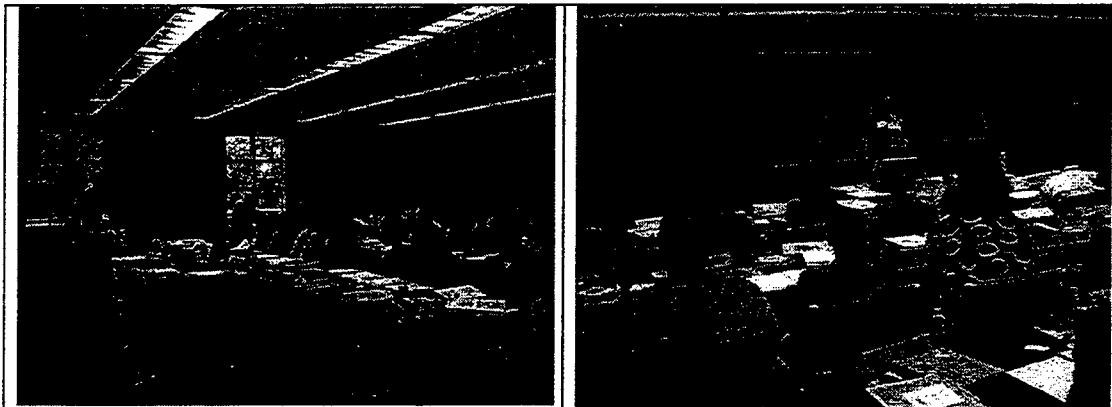

Figure 20: The students and their instructor at the commencement of Workshop

X.B. Re-configurable Computing Workshop

In the fall of 2002, NCAT hosted a Viva 2.0 Training session. The training class was an introductory course on the operation of Viva 2.0. This computer program was developed and is maintained by Starbridge Systems, Incorporated. When implemented with the proper hardware, it is used to configure Field Programmable Gate Arrays (FPGAs). This reconfigurable technology holds a great deal of potential to be the future of computing. This field is still immature yet due to efforts by companies such as Progress Forge, reconfigurable computing can become a powerful tool. Progress Forge's CEO, Tyler Reed, and Chief Gateway Engineer, David Callison, provided instruction for the class. These gentlemen provided top-notch training that gave all class participants an in depth explanation of Viva 2.0. Their structured course used various teaching methods such as PowerPoint presentations, demonstrations, and "hands-on" lab work. The class lasted 3 days, or approximately 24 hours. Training by Progress Forge extends beyond this 3 day window since they supply all students a temporary membership to their own ProgressTrack.net website. This website contains open forums for Viva users, such as NASA and USAF government employees. The site also contains extended libraries created by Progress Forge. Figure 21 illustrates the participants and Viva 2.0 workshop in action.

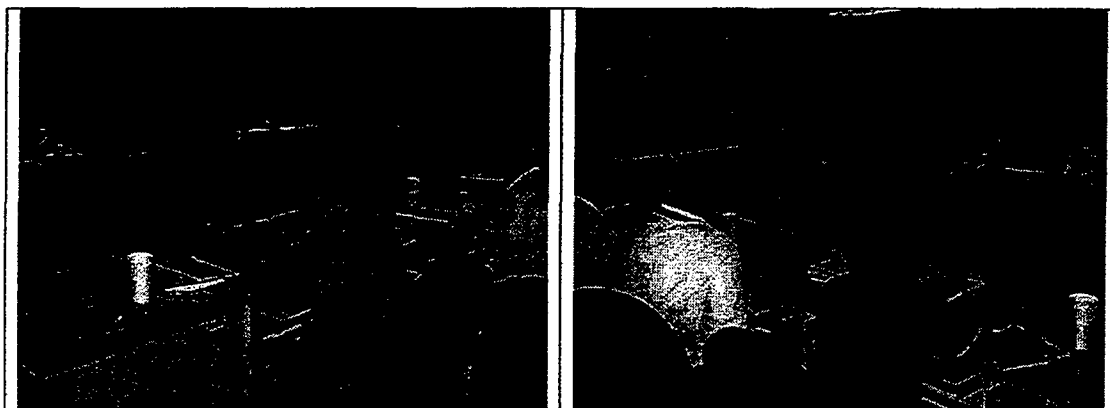

Figure 21: The students and their instructors at the Viva 2.0 Workshop

XI. TEACHING ACTIVITIES

With the use of Tables 6 and 7, this section illustrates how the Aerospace Specialization and the newly created NCAT-JPL laboratory integrate in the existing Mechanical Engineering Curriculum.

Table 6: Mechanical Engineering Curriculum

FALL			SPRING			
Freshman Year						
	Course	cr		Course	cr	
	GEEN 110	Colloquium I	0	GEEN 103	Computer Lab II	2
	GEEN 100	Engin. Design & Ethics	2	GEEN 120	Colloquium II	0
	MATH 131	Calculus I	4	ENGL 101/331	Technical Writing	3
	HIST	Elective	3	MATH 132	Calculus II	4
	ENGL 100	Ideas and Expression I	3	PHYS 241	Physics I	3
	CHEM 106	Chemistry	3	PHYS 251	Physics I Lab	1
	CHEM 116	Chemistry Lab	1	HIST	Elective	3
		Total	16		Total	16
Sophomore Year						
	MEEN 210	Numerical Methods in ME	3	MEEN 260	Materials Science	2
	MEEN 220	Mech Engr. Tools	3	MEEN 336	Strength of Materials	3
	MEEN 335	Mechanics I, Statics	3	INEN 260	Engineering Economics	2
	PHYS 242	General Physics II	3	SOC SCI	Elective	3
	PHYS 252	General Physics II Lab	1	MATH 431	Differential Equations	3
	MATH 231	Calculus III	4	ECON 200/201	Principle of Economics	3
		Total	17		Total	16
Junior Year						
	HUMANITIES	Elective	3	MEEN 400	Mech Engr Lab II	2
	MEEN 300	Mech. Eng. Lab I	2	MEEN 416	Fluid Mechanics	3*
	MEEN 337	Mechanics II, Dynamics	3	MEEN 440	System Dynamics	3
	MEEN 441	Fund of Thermodynamics	3	MEEN 442	Applied Thermodynamics	3*
	MEEN 446	Manufacturing Processes	3	MEEN 460	Engineering Materials	3
	ELEN 440	Electric Circuit Anal	3	MEEN 474	Engineering Design	3
		Total	17		Total	17
Senior Year						
	MEEN 501	Engineering Topics Review	1	MEEN 500	Mech Engr Lab III	2
	MEEN 562	Heat Transfer	3	MEEN 574	ME Senior Project II	3*
	MEEN 565	Comp. Aided Des. of Machines	3	MEEN 6XX	Technical Elective	3*
	MEEN 572	Senior Seminar	1	HUMANITIES	Elective	3
	MEEN 573	ME Senior Project I	3*	HEALTH/PE	Elective	2
	MEEN 6XX	Technical Elective	3*			
		Total	14		Total	13

(Total Credit Hours: 126)

*Note: Students following the Aerospace specialization should substitute MEEN 415-Aerodynamics for MEEN 416, MEEN 576-Propulsion for MEEN 442, and choose aerospace related technical electives and senior design project as approved by their advisor.

Table 7: Mechanical Engineering Technical Electives

Code	Course #	Course Description
MEEN	606	Mechanical Vibrations
MEEN	667	Environmental Control
MEEN	571	Turbo machinery
MEEN	612	Modern Composite Materials
MEEN	614	Engineering Modeling
MEEN	645	Aluminum Product Design and Manufacturing
MEEN	646	Advanced Manufacturing Processes
MEEN	647	Computer Integrated Mechanism Design
MEEN	650	Mechanical Properties and Structure of Solids
MEEN	651	Aero Vehicle Structures II
MEEN	652	Aero Vehicle Stability and Control
MEEN	653	Aero Vehicle Flight Dynamics
MEEN	654	Advanced Propulsion
MEEN	655	Computational Fluid Dynamics
MEEN	656	Boundary Layer Theory
MEEN	657	Design of Thermal Systems
MEEN	663	Energy Conversion System Design
MEEN	667	Environmental Control
MEEN	668	Gas Dynamics
MEEN	670	Internal Combustion Engines
MEEN	671	Turbo machinery
MEEN	675	Solar Energy Fundamentals and Design
GEEN	601	Industrial Automation
GEEN	602	Advanced Manufacturing Laboratory

All M.E majors are required to take two technical electives to be chosen from list below, or other courses approved by the student's academic advisor. Aerospace specialization students should choose aero related technical electives (MEEN-651 through MEEN-656), or other courses approved by their academic advisor. Other technical electives may be offered from time to time. Students should check with their academic advisor about the appropriateness of any course they are planning to take as a technical elective.

XII. FUTURE PLANS

XII.A. Inter-Institutional Cooperative Activities Involving the Center

New and creative collaborative activities have taken root in the Center for Aerospace Research, and these efforts will continue to expand over the next few years. Some of these funding activities take the form of student and faculty summer internships in government laboratories and in private aerospace industries. These activities are on going, and

will be expanded in the very near future. These activities have served to motivate our research staff, generate meaningful industrial contacts and prospective business partners, while generating summer salaries for CAR researchers and students.

The research infrastructure and expertise that CAR has acquired over the last four years provide the basis for its Inter-Institutional Cooperative Activities. To date, CAR has collaborated with a number of private and public agencies. Samples of these partnership agreements are provided in Appendix A. During the 2001-2002 academic year, CAR scientists conducted joint research with all of NASA field centers, the DOD and other federal agencies. Also, researchers of CAR have submitted a number of joint investigative proposals with aerospace companies that have developed into joint research programs with the University of Maryland, the University of Virginia, Virginia Polytechnic, and Georgia Tech to name a few.

XII.B. Technology Transfer Plans

The proper marketing and transfer of CAR's technology will lead to increasing revenue. CAR has and will continue to transfer its technology Small and Disadvantage businesses, and has successfully participated in the NASA SBIR/STTR program. Through preliminary business meetings and discussions with its aerospace industrial partners, CAR has learned of numerous opportunities, by which its laboratories, test equipment, experimental facilities, wind tunnel, and research scientists can be used for the generation of revenue and research opportunities.

CAR also plans to use its resources and research personnel in directly generating research funds through providing innovative solutions to problems in local industry and corporations in the field of structural health monitoring, fluids flows in pharmaceutical plants and transmission lines flutter suppression. Over the next four years, CAR plans to generate additional revenues by disseminating results of such research findings to interested parties through short courses and training sessions sponsored by private corporations.

XII.C. CAR Administrative Structure and Governance

The Center of Aerospace Research is an organization within the College of Engineering that is made up of a group of faculty and students, working within one or more of five research laboratories. The faculty and students are also drawn from the College of Engineering. Faculty and researchers use the services of CAR to enhance their academic experience, to generate opportunities for their students, to maintain and cultivate state-of-the-art aerospace research facility, and to attract research dollars to NCAT.

CAR is organized to cultivate interdisciplinary and multidisciplinary aerospace research activities. Research activities in CAR are conducted in three forms, designated by Levels I, II and III.

Level I: Research activities conducted by an individual professor and one or more students.

Level II: Interdisciplinary research activities conducted by a team of researchers in an individual group or laboratory of CAR. This type of activity involves the interactions of two or more professors along with one or more students.

Level III: Multidisciplinary research activities conducted by teams of researchers drawn from two or more of CAR laboratories along with one or more students.

A team of five research coordinators and a director manage the center. In addition, CAR's management team is guided by an External Advisory Board (EAB). The EAB consists of a team of highly qualified industrial, academic and government professionals and experts, who advise the management team in making appropriate decisions. CAR's management team consists of six people, as illustrated in Table 8. Their backgrounds consist of over fifteen years of research, management, teaching and marketing, with over ten years of corporate development within the Aerospace Industry. Five people within our management team have an average of over ten years of engineering and design experience. The Center of Aerospace Research laboratories are listed in Table 8. The leadership and alignment characteristics of CAR management team have resulted in the establishment of broad and flexible goals designed to meet the ever-changing demands of the quickly moving marketplace requiring our services. This is evident when the team responds to situations requiring new and innovative capabilities.

Table 8: CAR Laboratories

CAR LABORATORIES	LABORATORY COORDINATOR
Jet Propulsion Laboratory	Dr. Frederick Ferguson
Structural Health Monitoring Laboratory	Dr. Mannur Sundaresan
Manufacturing Laboratory	Dr. Samuel Owuzu-Ofori
Reconfigurable Computing Laboratory	Dr. Frederick Ferguson
Simulations and Control Laboratory	Dr. David Song
Computational Fluid Dynamics Laboratory	Dr. Suresh Chandra