

AD _____

Award Number: DAMD17-99-1-9232

TITLE: Development of Targeted Sindbis Virus Vectors for
Potential Application to Breast Cancer Therapy

PRINCIPAL INVESTIGATOR: Lesia K. Dropulic, M.D.

CONTRACTING ORGANIZATION: The Johns Hopkins University School of
Medicine
Baltimore, Maryland 21205-2196

REPORT DATE: September 2002

TYPE OF REPORT: Annual Summary

PREPARED FOR: U.S. Army Medical Research and Materiel Command
Fort Detrick, Maryland 21702-5012

DISTRIBUTION STATEMENT: Approved for Public Release;
Distribution Unlimited

The views, opinions and/or findings contained in this report are those of the author(s) and should not be construed as an official Department of the Army position, policy or decision unless so designated by other documentation.

20030313 105

REPORT DOCUMENTATION PAGE

Form Approved
OMB No. 074-0188

Public reporting burden for this collection of information is estimated to average 1 hour per response, including the time for reviewing instructions, searching existing data sources, gathering and maintaining the data needed, and completing and reviewing this collection of information. Send comments regarding this burden estimate or any other aspect of this collection of information, including suggestions for reducing this burden to Washington Headquarters Services, Directorate for Information Operations and Reports, 1215 Jefferson Davis Highway, Suite 1204, Arlington, VA 22202-4302, and to the Office of Management and Budget, Paperwork Reduction Project (0704-0188), Washington, DC 20503

1. AGENCY USE ONLY (Leave blank)		2. REPORT DATE September 2002	3. REPORT TYPE AND DATES COVERED Annual Summary (10 Aug 01 - 9 Aug 02)	
4. TITLE AND SUBTITLE Development of Targeted Sindbis Virus Vectors for Potential Application to Breast Cancer Therapy			5. FUNDING NUMBERS DAMD17-99-1-9232	
6. AUTHOR(S) Lesia K. Dropulic, M.D.				
7. PERFORMING ORGANIZATION NAME(S) AND ADDRESS(ES) The Johns Hopkins University School of Medicine Baltimore, Maryland 21205-2196 E-Mail: lesia@mail.jhmi.edu			8. PERFORMING ORGANIZATION REPORT NUMBER	
9. SPONSORING / MONITORING AGENCY NAME(S) AND ADDRESS(ES) U.S. Army Medical Research and Materiel Command Fort Detrick, Maryland 21702-5012			10. SPONSORING / MONITORING AGENCY REPORT NUMBER	
11. SUPPLEMENTARY NOTES				
12a. DISTRIBUTION / AVAILABILITY STATEMENT Approved for public release; distribution unlimited			12b. DISTRIBUTION CODE	
13. ABSTRACT (Maximum 200 Words) The purpose of the proposed research is to develop a propagation-competent alphavirus vector that is targeted specifically to receptors expressed on breast cancer cells or to receptors expressed on tumor-associated vasculature. We hypothesize that this type of targeted vector would provide a very efficient means of specifically killing a large number of malignant cells. Sindbis virus (SV), an alphavirus, containing a 200 basepair sequence encoding the epidermal-like growth factor domain of heregulin in place of a portion of its receptor-binding domain, is impaired in its ability to assemble and bud from transfected cells. However, a SV containing a 13 amino acid NGR-containing peptide motif is able to replicate and spread in infected cells. This NGR-containing SV exhibits an ability to more efficiently kill cells expressing the targeted CD13 receptor compared to parent virus-infected cells. Hence, we have demonstrated that it is possible to generate a propagation-competent SV containing a potential targeting ligand. However, the NGR-containing virus did not kill CD13 expressing cells more efficiently than non-CD13-expressing BHK-21 cells. The optimal location(s) for a targeting ligand within the receptor-binding domain of SV needs to be determined systematically.				
14. SUBJECT TERMS breast cancer, Sindbis virus, propagation-competent, targeted ErbB-2, heregulin, NGR-peptide, tumor associated vasculature			15. NUMBER OF PAGES 6	
			16. PRICE CODE	
17. SECURITY CLASSIFICATION OF REPORT Unclassified	18. SECURITY CLASSIFICATION OF THIS PAGE Unclassified	19. SECURITY CLASSIFICATION OF ABSTRACT Unclassified	20. LIMITATION OF ABSTRACT Unlimited	

NSN 7540-01-280-5500

Standard Form 298 (Rev. 2-89)
Prescribed by ANSI Std. Z39-18
298-102

Table of Contents

Cover.....	1
SF 298.....	2
Table of Contents.....	3
Introduction.....	4
Body.....	4-6
Key Research Accomplishments.....	6
Reportable Outcomes.....	6
Conclusions.....	6

I. Introduction.

Two main challenges of cancer gene therapy are the development of vectors targeted specifically to tumor cells and the efficient delivery of the therapeutic agent to all or to the majority of tumor cells. Addressing these two issues, we intend to develop Sindbis virus (SV), an alphavirus, into a novel vector for breast cancer gene therapy. The advantages of SV vectors include lack of serious disease caused by SV in humans, the ability of SV to infect nondividing and dividing cells, no risk of insertional mutagenesis because SV is an RNA virus, and the ability to produce high titer stocks and achieve high level of heterologous gene expression. Since SV kills cells by apoptosis, specific destruction of tumor cells will occur if the virus is targeted to tumor cells. Furthermore, use of a propagation-competent viral vector will provide a very efficient means of obtaining access to most or all of the tumor cell population. The long-term goal of this proposal is to develop target-specific SV vectors for application to breast cancer therapy by modifying the SV E2 envelope glycoprotein with ligands that recognize specific cell surface receptors on breast cancer tumors.

II. Body.

Task 1 of Statement of Work. Construct targeted viral vectors.

Over the past year, repeated difficulties were encountered with synthesizing SV RNA in sufficient quantities to perform additional experiments. Our baseline method of producing RNA involves synthesizing viral RNA in vitro using an SP6 DNA dependent RNA polymerase. We tried for 6 months to produce high quantities and quality of viral RNA, but were not successful despite trying to troubleshoot various parameters of the reaction. We were forced to devise an alternative method for producing SV.

SV can be produced by transfecting cells with SV genomic cDNA expressed from a pol II promoter. A strong pol II promoter, the CMV promoter, was cloned upstream of the 5'untranslated region (UTR) of the SV plasmid dsTE-EGFP (figure 1). The CMV promoter was cloned into dsTE-EGFP so that transcription initiates as close as possible to the authentic 5' end of the 5'UTR. A fragment that contains an intron and poly A signal was inserted downstream of the poly A stretches of dsTE-EGFP to increase the transport efficiency of the viral RNA genome from the nucleus to the cytoplasm.

PCMV-dsTE-GFP-InA DNA was electroporated into BHK-21 cells. Forty-eight hours after transfection, the amount of viral vector in supernatant fluids was determined by plaque titration on BHK-21 cells. Viral titers similar to those achieved after transfection of SV RNA (10^8 to 10^9 pfu/ml) were obtained.

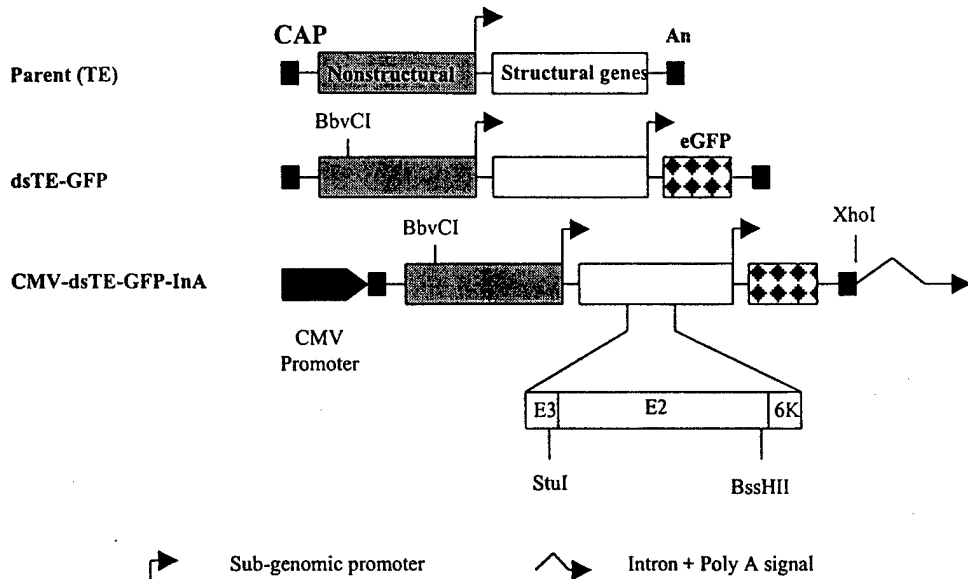

Figure 1. Schematic diagrams of the parental Sindbis virus genome (TE), the genome containing eGFP expressed from a duplicated sub-genomic promoter (dsTE-GFP), and the construct for making a molecularly "bred" E2 library (CMV-dsTE-GFP-InA). CMV-dsTE-GFP-InA contains the CMV IE promoter upstream of the 5' UTR and a fragment containing a synthetic intron and the late SV40 poly A signal at the 3' end of the genome. This diagram is not drawn to scale.

We have cloned the EGF-like domain of heregulin and the NGR (Asn-Gly-Arg)-containing peptide motif that binds to the CD13 receptor on tumor-associated vasculature in place of the E2 receptor-binding domains. We are in the process of trying to produce recombinant virus by transfecting the viral cDNA into cells:

Task 2 of Statement of Work: Test the targeted SV vectors for specificity of binding and specificity of infectivity of erbB-2-over-expressing breast cancer cells.

In our previous annual reports, we demonstrated that virus production was significantly decreased after modification of the putative E2 receptor-binding domains with an heterologous sequence. Additional experiments outlined in the statement of work were difficult to perform without the ability to produce a sufficient quantity of replication-competent virus.

The TE-NGR clone described previously was replication-competent and exhibited a similar ability to replicate in BHK-21 cells and SLK cells, which overexpress the CD13 receptor. Other cell lines were not available to test TE-NGR. Cells that have been transfected with the CD13 receptor tend to express the receptor only transiently in culture and then lose expression of the receptor (personal communication, R. Pasqualini). Ultimately, we would like to test a panel of cancerous and noncancerous cells that do or do not express the appropriate targeted receptors to determine the ability of the recombinant SV vectors to infect and kill breast cancer cells. Further experiments with viral RNA could not be performed because of our inability to produce sufficient quantities of viral RNA to perform experiments in various cell lines.

Task 3 of Statement of Work: Test the targeted SV vectors in a mouse model of breast cancer.

Unfortunately, this work was also placed on hold because of the inability to produce sufficient quantities of viral RNA or virus for injection into tumors.

III. Key Research Accomplishments.

- Modification of the putative receptor-binding domains of the E2 glycoprotein results in significant impairment of SV production and release.
- The SV clone containing the NGR-containing peptide motif did not preferentially infect SLK cells, which express the CD13 receptor.

IV. Reportable Outcomes.

- Abstract, DOD Era of Hope Meeting, Orlando, Florida, Sept. 2002.
Lesia K. Dropulic, J. Marie Hardwick, Boro Dropulic, Holly L. Hammond. Incorporation of the EGF-like Domain of Heregulin into the E2 Glycoprotein Modifies the Tropism of Sindbis Virus.
- Pilot Project Grant awarded by the Breast SPORE grant at the Sidney Kimmel Comprehensive Cancer Center at Johns Hopkins.
Cancer-specific replication-competent Sindbis virus.
- The technician partially funded by this award received the necessary training and experience to obtain a higher level job in a lentiviral vector laboratory that also works on breast cancer.

V. Conclusions. In our attempts to modify the E2 glycoprotein with ligands to try to target SV to specific receptors expressed on breast tumors, we have learned that this strategy can result in a significant decrease in virus production. This decrease in virus production has also been demonstrated by other investigators working on a similar strategy using other viral vectors, such as adenovirus (Era of Hope Meeting poster session, Orlando, Florida). The primary defect appears to occur at the level of trafficking of the modified glycoprotein through the secretory pathway. This can be further investigated by determining whether the modified glycoprotein is retained in a particular subcellular compartment. This obstacle will be difficult to overcome as one will need to find the optimal location in the viral glycoprotein for the optimal ligand that will not interfere with virus production. The structure of the SV E2 glycoprotein is not available for guidance in locating the optimal site for ligand placement.