

REPORT DOCUMENTATION PAGEForm Approved
OMB No. 0704-0188

Public reporting burden for this collection of information is estimated to average 1 hour per response, including the time for reviewing instructions, searching existing data sources, gathering and maintaining the data needed, and completing and reviewing this collection of information. Send comments regarding this burden estimate or any other aspect of this collection of information, including suggestions for reducing this burden to Department of Defense, Washington Headquarters Services, Directorate for Information Operations and Reports (0704-0188), 1215 Jefferson Davis Highway, Suite 1204, Arlington, VA 22202-4302. Respondents should be aware that notwithstanding any other provision of law, no person shall be subject to any penalty for failing to comply with a collection of information if it does not display a currently valid OMB control number. PLEASE DO NOT RETURN YOUR FORM TO THE ABOVE ADDRESS.

1. REPORT DATE (DD-MM-YYYY) 27-12-2002	2. REPORT TYPE Technical Paper	3. DATES COVERED (From - To)
---	-----------------------------------	------------------------------

4. TITLE AND SUBTITLE Heat Transfer and Deposition Behavior of Hydrocarbon Rocket Fuels	5a. CONTRACT NUMBER
	5b. GRANT NUMBER
	5c. PROGRAM ELEMENT NUMBER

6. AUTHOR(S) Ron Bates, Tim Edwards ¹ Michael L. Meyer ²	5d. PROJECT NUMBER 4847
	5e. TASK NUMBER 0244
	5f. WORK UNIT NUMBER

7. PERFORMING ORGANIZATION NAME(S) AND ADDRESS(ES)	8. PERFORMING ORGANIZATION REPORT NUMBER
--	--

¹ Air Force Research Laboratory (AFMC) AFRL/PRSA 10 E. Saturn Blvd. Edwards AFB, CA 93524-7680	² NASA Glenn Research Center Cleveland, OH	AFRL-PR-ED-TP-2002-320
--	--	------------------------

9. SPONSORING / MONITORING AGENCY NAME(S) AND ADDRESS(ES)	10. SPONSOR/MONITOR'S ACRONYM(S)
---	----------------------------------

Air Force Research Laboratory (AFMC) AFRL/PRS 5 Pollux Drive Edwards AFB CA 93524-7048	11. SPONSOR/MONITOR'S NUMBER(S) AFRL-PR-ED-TP-2002-320
---	---

12. DISTRIBUTION / AVAILABILITY STATEMENT Approved for public release; distribution unlimited.

13. SUPPLEMENTARY NOTES

14. ABSTRACT <div style="text-align: center; font-size: 2em; font-weight: bold;">20030227 128</div>
--

15. SUBJECT TERMS

16. SECURITY CLASSIFICATION OF:	17. LIMITATION OF ABSTRACT	18. NUMBER OF PAGES	19a. NAME OF RESPONSIBLE PERSON Leilani Richardson
a. REPORT Unclassified	b. ABSTRACT Unclassified	c. THIS PAGE Unclassified	A
			19b. TELEPHONE NUMBER (include area code) (661) 275-5015

48470244

MEMORANDUM FOR PRS (In-House Publication)

FROM: PROI (STINFO)

27 Dec 2002

SUBJECT: Authorization for Release of Technical Information, Control Number: **AFRL-PR-ED-TP-2002-320**
Ron Bates (PRSA) et al., "Heat Transfer and Deposition Behavior of Hydrocarbon Rocket Fuels"

Slide A

AIAA Aerospace Sciences Conference
(Reno, NV, 6-9 January 2003) (Deadline: 06 Jan 2003)

(Statement A)

Heat Transfer and Deposition Behavior of Hydrocarbon Rocket Fuels

Ron Bates, Tim Edwards

Air Force Research Laboratory, Propulsion Directorate
Edwards AFB, CA and Wright-Patterson AFB, OH

Michael L. Meyer

NASA Glenn Research Center
Cleveland, OH

Abstract

As the desire to increase the performance of hydrocarbon/liquid oxygen rocket engines naturally leads to increased combustion chamber pressures and higher energy hydrocarbon fuels, the combustion chamber and nozzle heat fluxes also increase. For engines regeneratively cooled with hydrocarbon fuel, this additional thermal stress must be effectively carried by the fuel without degradation of the cooling channel surfaces. A methodology for evaluation of the thermal performance (thermal stability and heat transfer characteristics) of hydrocarbon rocket fuels is suggested. As part of that methodology, an experimental research program to investigate the thermal performance of several new candidate hydrocarbon rocket fuels has been started. The experimental program utilizes a series of test rigs of increasing complexity and fidelity to successively screen identified fuels without the cost and complexity of a full engine system level test. Results of small-scale thermal decomposition experiments utilizing a System for Thermal Decomposition Studies (STDS) test rig provide an initial evaluation of the thermal stability performance of fuels from very small fuel samples. Measurements of heat transfer coefficient and the effect of wall temperature, flow velocity, and wetted-material on deposit formation in heated

test channels are obtained from larger rigs, such as the NASA/GRC Heated Tube Facility and the AFRL/PRS High Heat Flux Facility.

Introduction

Regenerative cooling of rocket thrust chambers, defined as cooling by flowing either fuel or oxidizer through passages in the walls of the chamber, was first postulated by Tsiolkovsky in 1903 [Salakhutdinov, 1990]. Thus, 2003 could be described as the "Centennial of Regenerative Cooling". In any case, access to space is dependent upon regenerative cooling of thrust chambers for boosters. This paper focuses on LOX/hydrocarbon thrust engines, as typified in Figure 1. In these chambers, temperatures can exceed 5000 F (3000 K), a temperature well in excess of known material limits. Thus, extended operation (e.g., boosters) requires thrust chamber cooling. Many approaches are available, including regenerative cooling, radiation cooling, film cooling etc. [Sutton et al, 1966]. A major issue in fuel cooling by hydrocarbons is deposit formation ("fouling", "coking"). As regeneratively-cooled engines evolved in the 1950s in the U.S., hydrocarbon propellants also evolved. Initial hydrocarbons used included gasoline, alcohol, and jet fuel (JP-4, JP-5), but these propellants had significant shortcomings. Ultimately, a hydrocarbon fuel was developed

specifically for this application, Rocket Propellant-1 (RP-1), which was a low sulfur, low aromatics kerosene distillate fuel (MIL-P-25576, 1956). This propellant is still in current use. Similar development efforts in the USSR produced a similar, slightly denser propellant known in the U.S. as RG-1 [Mehta et al, 1995] and in Russia as НАФТИЛ (variously “naphthyl” “naphtil” “naftin”).

The current issue is how (or if) regenerative cooling limits for hydrocarbons might be extended for high pressure engines. The final developmental F-1 LOX/RP-1 engines for the Saturn V approached 70 atm (1000 psia) in chamber pressure in the late 1960s. The current state-of-the-art in hydrocarbon engines, as exemplified by the RD-180, utilizes chamber

pressures in excess of 250 atm (3675 psia) [www.astronautix.com, www.Spaceandtech.com]. This increased pressure helps enable an increased Isp {311 sec (sea level) for the RD-180 vs 265 sec for the F-1}. As discussed below, engine heat flux is roughly proportional to chamber pressure, so this increased engine pressure comes at the expense of increased combustion heat flux delivered to the chamber wall and the fuel. An example of this is shown in Figure 2 [Wagner and Shoji, 1975], where the throat heat flux increases from 10 BTU/in²-sec (F-1) to about 70 BTU/in²-sec at 3750 psia. As shown in Figure 3 [Sutton et al, 1966], this increased heat flux may require augmentation of the regenerative cooling by film or transpiration cooling.

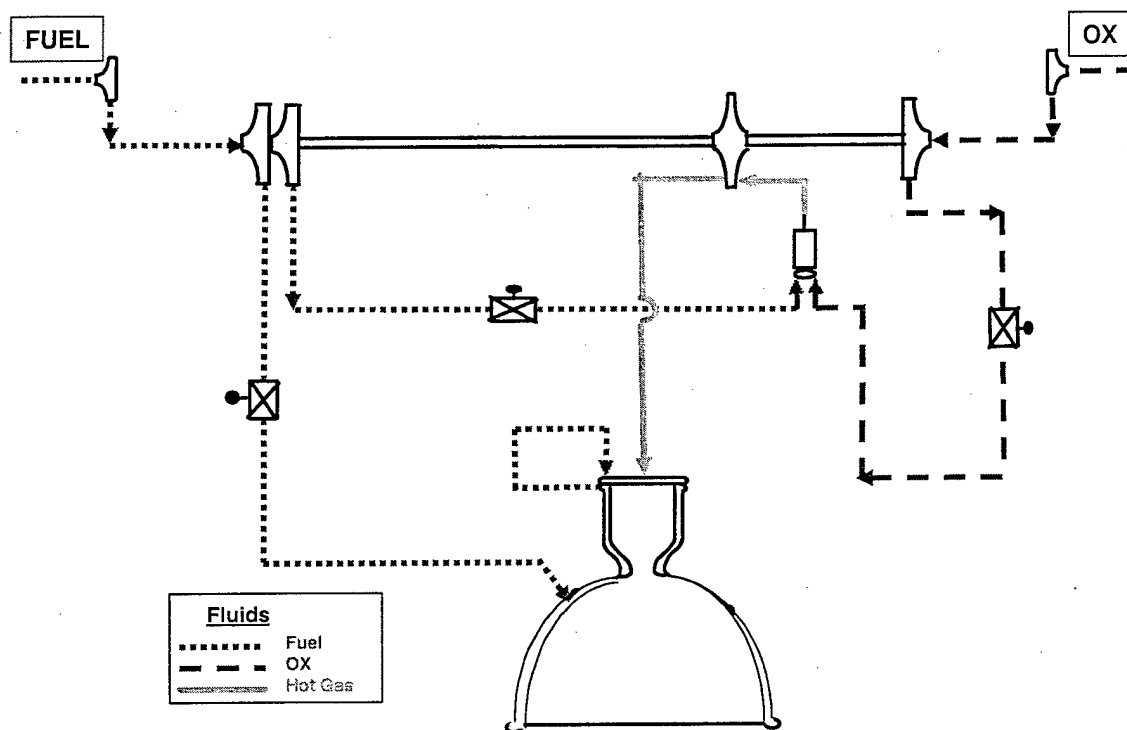

Figure 1. Rocket cycle schematic

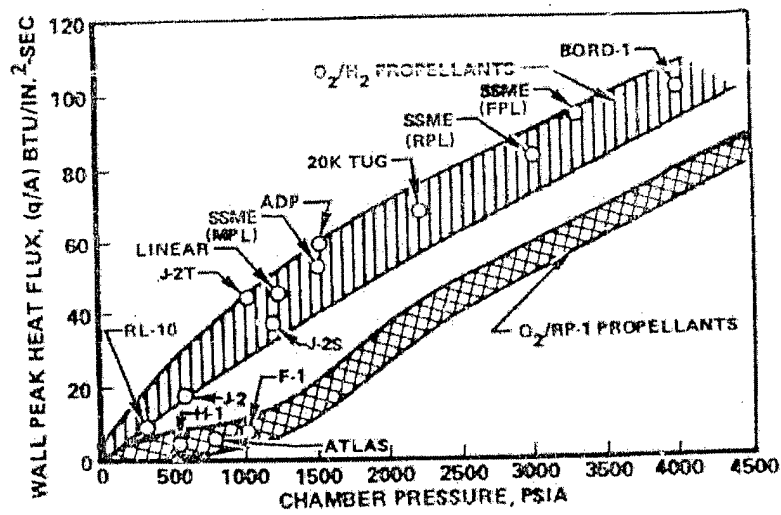

Figure 2. Effect of chamber pressure on nozzle heat flux [Wagner and Shoji, 1975].

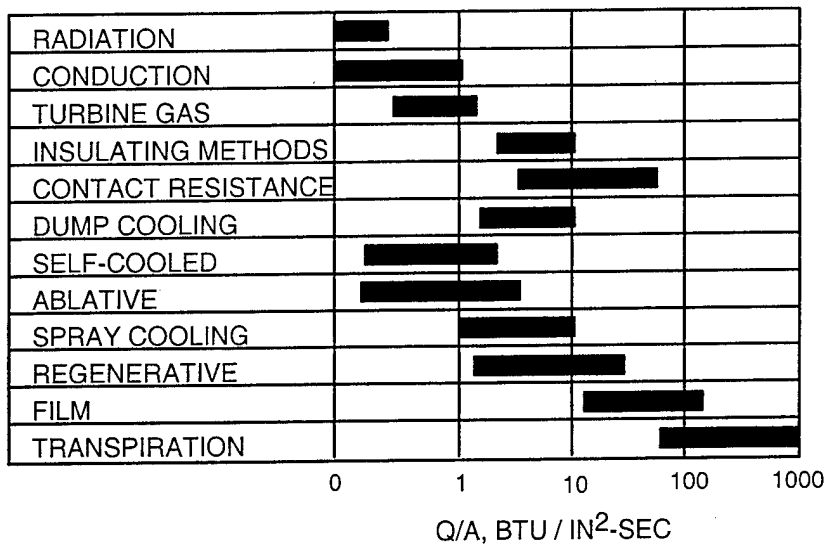

Figure 3. Types of thrust chamber cooling and applicable heat flux range [Sutton et al, 1966].

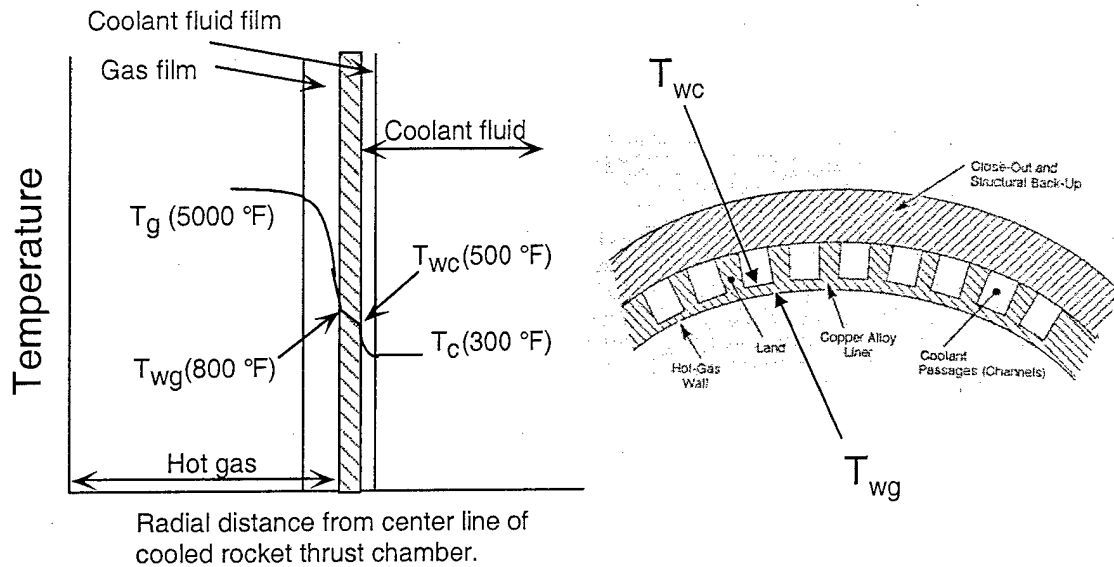

Figure 4. Regenerative cooling outline [Sutton, 1966; Huzel and Huang, 1992].

As shown in Figure 4, regenerative cooling is best expressed as a series of heat transfer processes. Combustion (hot-side) heat flux is calculated as

$$q \sim h_g (T_g - T_{wg})$$

where q is the heat flux (e.g., BTU/in²-s, h_g is the combustion side heat transfer coefficient, and the temperatures are as shown in Figure 4. Combustion-side heat transfer is beyond the scope of this paper, but a few comments are relevant.

1) $h_g \sim P^{0.8}$, so the trend of increasing chamber heat pressure increases wall heat flux [e.g., Wagner and Shoji, 1975].
 2) the heat flux absorbed by the propellant also increases as $P^{0.8}$, but the propellant mass flow increases as $P^{1.0}$, so the overall temperature rise in the propellant may decrease with pressure. In other words T_{wc} increases with pressure, but T_c at the coolant jacket exit may decrease.

3) Carbon deposition on hot-side chamber walls acts as a thermal

resistance and thus reduces heat flux [refs].

On the coolant side, heat flux is a strong function of propellant velocity through the Reynolds number ($\sim V$)

$$q = h_c (T_{wc} - T_c)$$

where

$$h_c \sim Re^{0.8} Pr^{0.33} (\mu/\mu_w)^{0.14} \text{ (Sieder-Tate)}$$

Fuel heat flux capability is increased by increasing flow velocity and/or careful cooling channel design. High heat fluxes can be absorbed by fluids undergoing nucleate boiling [Bartz, 1958], but current engine designs for hydrocarbons employ pressures well in excess of the critical pressure (~ 310 psia for RP-1), so this type of heat transfer is not an option. Note that any thermal resistance on the coolant side of the thrust chamber acts to increase T_{wc} for a given heat flux, which can lead to chamber failure ("burn through") if material temperature limits are

exceeded. Carbon deposition is the limiting factor for hydrocarbon propellant heat flux capability [Cook and Quentmeyer, 1980; Wagner and Shoji, 1975]. As shown in Table 1, the excellent insulating properties of "coke" deposits are evident. At the high velocities in regenerative cooling channels (which can exceed 100 ft/sec), carbon deposition can also create increased fuel system pressure drop and result in injection problems.

Table 1. Thermal conductivities of various materials relevant to regenerative cooling. Coke deposit data from [Hazlett, 1991].

Material	k, BTU/hr-ft-F (W/m-K)
Copper	210 (360)
Alumina	3.5 (6)
Superalloy	13 (22.5)
Coke deposit	0.07 (0.12)

Deposition is avoided by keeping the fuel temperature within a "coke limit", which is usually specified as a maximum coolant-side wall temperature (T_{wc} in Figure 4). However, this limiting T_{wc} is not universally agreed-upon or well-characterized in terms of its relationship to coolant velocity, system life, etc. As shown in Table 2, published values vary from 550-850 F.

Table 2. RP-1 Coking Wall Temperature Limit (T_{wc})

Reference	Upper Temperature Limit, °F
Ziebland and Parkinson, 1971	800
Van Huff, 1972	850
Wagner and Shoji, 1975	650 - 700

Wheeler, 1977	600
Cook and Quentmeyer, 1980	600
NASA CR-171712	550

Carbon deposition is often approximated as in Arrhenius form,

$$\text{Deposition rate} \sim \exp(-E/RT_{wc}),$$

yielding plots such as that shown in Figure 5 [Rosenberg et al, 1990]. Such a strong temperature dependence would be difficult to overcome in order to increase regenerative cooling capability of hydrocarbons by increasing T_{wc} . Note also the presence of a velocity-dependence of deposition. As coolant velocity increases at a constant T_{wc} , the boundary layer next to the wall thins and the coolant residence time decreases. Even so, the behavior of kerosene fuels in aircraft heat exchangers and fuel nozzles is much more complex than that shown in Figure 5. Typically, life is again roughly exponentially dependent upon temperature, yet above about 600 F (T_c), the dissolved oxygen in the jet kerosene is consumed and deposition ceases until roughly 900 F. Coking behavior in aircraft occurs under much different conditions than in rockets, as summarized in Table 3.

Several types of hydrocarbons are being examined as possible enhancements/alternatives to RP-1 [Edwards and Meyer, 2002]. Alternative kerosenes tend to focus on higher density, although lower H/C ratios often mitigate any net vehicle benefits [Mills, 2002]. Cryogenic hydrocarbons (e.g., propane) offer increased I_{sp} at the expense of reduced density. High energy (strained ring) hydrocarbons offer high I_{sp} and potentially increased

density, but are relatively uncharacterized and may have toxicity and cost concerns. Note, however, that RP-1 costs for current expendable launch vehicles (Atlas, Delta) are roughly 0.05% of the launch cost.

The rest of this paper describes ongoing efforts to characterize

regenerative cooling performance of alternative hydrocarbon propellants. Two major types of devices are used to obtain relevant high-heat-flux conditions: electrically heated tubes and heated copper blocks.

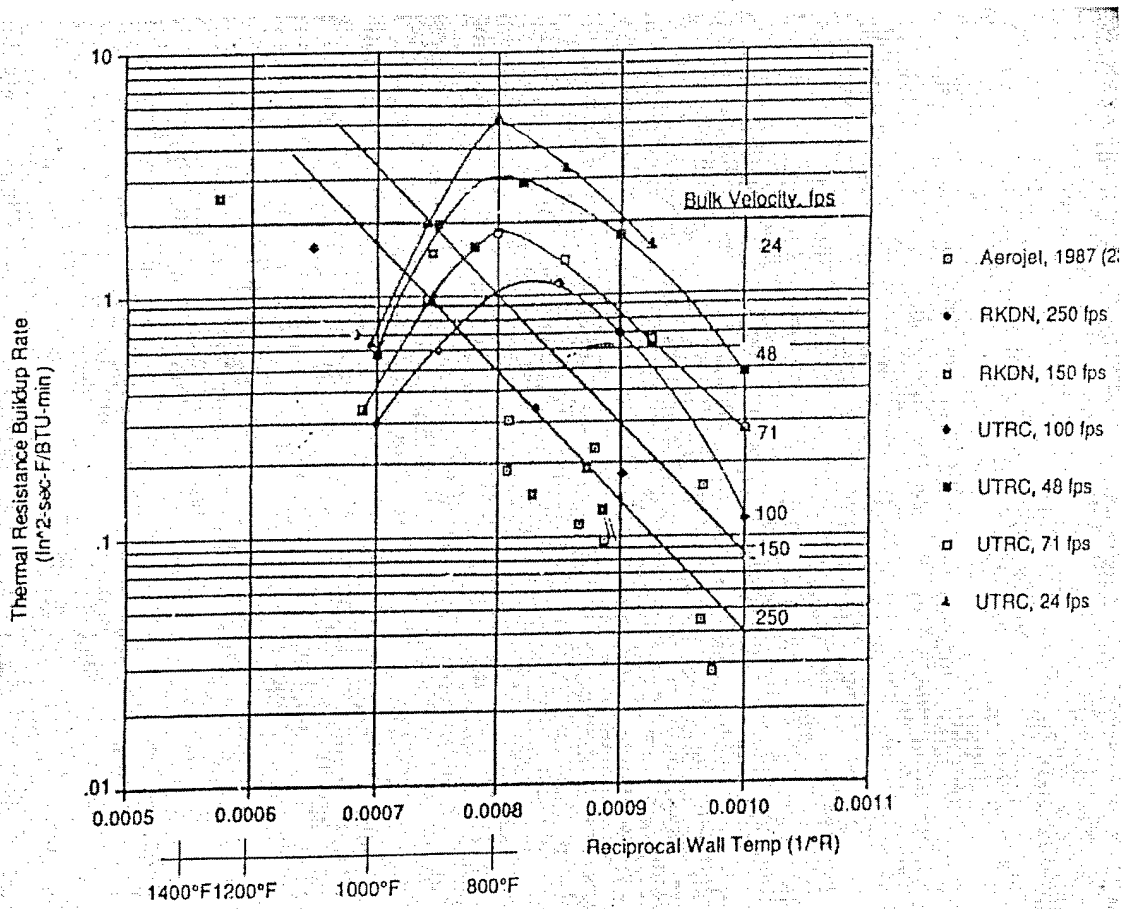

Figure 5 – Typical deposition (thermal resistance) behavior as a function of temperature [Rosenberg et al, 1970].

Table 3 – Comparison of aircraft and rocket cooling conditions

	Aircraft heat exchangers/fuel nozzles	Rocket regen cooling channels
Typical max heat flux, BTU/in ² -sec	1	100
Required lifetime	2000 hrs (min)	300 sec/mission X 50 missions = 4 hours
Materials	superalloys, perhaps coated	Cu alloys
Incompatible materials	Cu!! Cd, Zn, Pb	Cu incompatibility with S in fuel [Rosenberg et al, 1992]
Effect of dissolved oxygen	Oxygen removal below 1 ppm (from typ. 70 ppm) dramatically reduces deposition	Little effect? [Roback et al, 1983]
Maximum deposition rates	JP-8:JP-7~140:1	JP-8:RP-1:JP-7~1:1:1 [Stiegemeier et al, 2002]
Maximum allowable deposit thickness	0.001" (10% flow reduction in typical 0.020" ID passage)	1X10 ⁻⁶ " (est) to avoid burnthrough in copper at 100 BTU/in ² -sec
Deposition mechanism	300-600 F – molecular growth through hydroperoxide chain mechanism with acceleration by polar heteroatomic impurities; >900 F – pyrolytic fuel cracking leads to molecular growth through radical chain reactions	??
Specification thermal stability limits?	Yes – ASTM D3241	No

Experimental Measures of Regenerative Cooling Performance (Coking)

The ideal rig test for a propellant's thermal stability (coking tendency) would be:

1) Accurate simulations of the propellant environment in the cooling channels, in terms of heat flux, residence

time/velocity, geometry, temperatures, and materials

2) Low cost

3) Low fuel volume required (for developmental propellants that are high cost and/or scarce)

4) Adequately instrumented/analyzed to generate data from which to generate or anchor deposition and heat transfer models

It is quite difficult to fulfill all of these criteria in one test device. High heat flux requires expensive methods to generate the heat and high fuel flow velocities (and thus fuel consumption) to accept the heat. The most test device that generates the most realistic simulation would (of course) be an actual high-pressure, regeneratively-cooled engine, which is certainly not low cost or low fuel consumption. The following sections describe several current experimental efforts to generate fuel stability data under rocket conditions.

Electrically-heated tubes

These are the predominant devices used to obtain high heat flux cooling data, with notable literature references by UTRC [Roback et al, 1983; Giovanetti et al, 1985], Aerojet [Rousar et al, 1984; Rousar et al, 1998], and NASA/GRC [Green et al, 1995; Linne and Munsch, 1995, Stiegemeier et al, 2002]. Chinese work in this area has recently been summarized [Liang et al, 1998]. Currently, only the NASA/GRC rig is active. These types of devices generate heat by passing large amounts of current through a metal tube, which generates heat through electrical resistance. Many propellant studies have been done, notably:

- 1) Comparison of methane, propane, and RP-1 coolant temperature limits. Propane and RP-1 have roughly comparable limits, while methane exhibits a significantly higher limit.
- 2) Comparison of the effect of dissolved oxygen
- 3) Comparison of various kerosene fuels [Stiegemeier et al, 2002]

The NASA Glenn Research Center's Heated Tube Facility utilizes

resistively heated test sections to simulate cooling passages of advanced propulsion systems [Green et al, 1995]. The rig has been used in the recent past to investigate a number of heat transfer and fuel thermal stability issues for both liquid rocket engine and high-speed air breathing propulsion systems. The facility has recently been upgraded to better address current programmatic requirements: collection of data with both cryogenic fuels and exploratory HED fuels. The modifications to the facility center around a closely coupled fuel flow system that includes a 17-gallon liquid capacity fuel supply tank rated for 2400 psig. This tank has dual capability for both ambient temperature liquids and cryogenic liquid fuels.

A simplified view of the cryogenic configuration of this new fuel system is shown in Figure 6. The supply tank is filled by passing low-pressure gaseous fuel through a tube coil that is submerged in an open liquid nitrogen bath. As it passes through the coil, the fuel is condensed and thermally conditioned to the approximate temperature required for the test. The supply tank is also insulated and wrapped with a copper coil through which LN₂ flows to trim the temperature of the fuel in the tank. The fuel is pressurized with either gaseous nitrogen or helium brought through a diffuser into the ullage. The fuel is drawn from the tank through a dip tube and passes through a turbine flow meter which is interfaced to the flow control valve through a controller. The test section is contained in a vacuum chamber to reduce heat loss and for safety in the event of a hot fuel leak.

Conduction Heated Rigs

Conduction heated rigs, such as Aerojet's Carbothermal test rig developed under the Hydrocarbon-Fuel/Chamber-Liner Materials Compatibility Program in the late 1980's (NAS 3-25070), offer the advantage of significantly lower electrical power requirements to generate simulative, high heat flux test conditions in cooling

channels. Figure 7 shows schematically an example of the device. Unfortunately, the rig no longer exists. AFRL/PRS has undertaken design and construction of a new conduction heated, High Heat Flux Facility, based on the Carbothermal test rig and incorporating extension of maximum heat flux test capability to 100 BTU/in²-s.

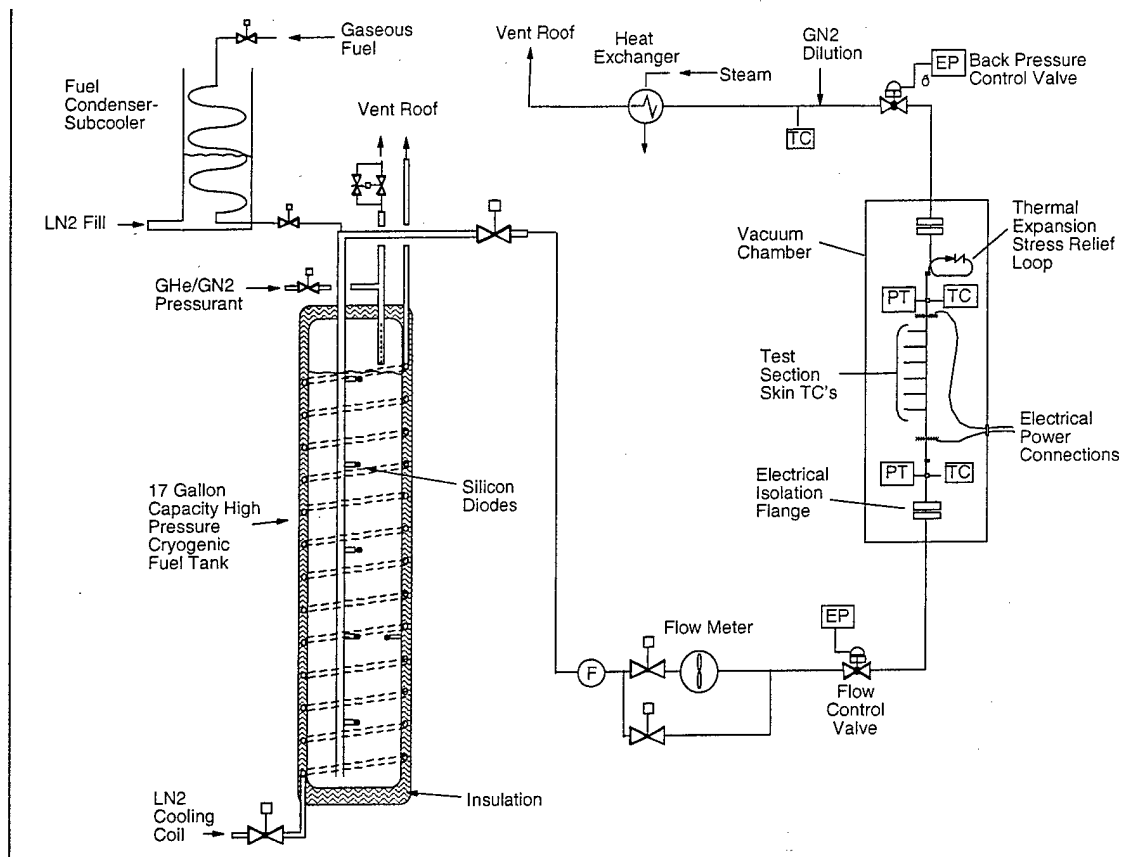

Figure 6. Simplified schematic of the NASA Glenn Research Center Heated Tube Facility's low volume fuel flow loop in cryogenic configuration.

Realistic simulation of engine cooling passages improves with asymmetric heating, three dimensional channel flow in materials and geometries found in high pressure hydrocarbon rocket engines. Pressure, velocity, mass flow

rate, bulk temperature, wall temperature, heat flux, axial and temporal heat profiles (spatial and temporal history of flowing fluid entering the test channel), may all be key factors in evaluating a particular fuel's cooling, corrosion, and

thermal stability characteristics. Using the CFD++ code, developed by Metacomp Technologies, Inc, which has the capability of simultaneously handling the conjugate heat transfer problem of 3-d heat conduction in the test device as well as fluid mechanically the flowing channel passage, the detailed behavior of the test channel and fluid can be examined for improved design of experiments. Initial evaluations using the code have reproduced qualitatively heat transfer coefficients within 10% from

measured values in experiments reported by Aerojet [Rosenberg et al, 1970]. Ongoing design and analysis activities at AFRL/PRS are addressing improvements in simulative test capability and are expected to yield a device capable of addressing the fundamental mechanisms of deposit formation and material corrosion under high heat fluxes expected in next generation reusable hydrocarbon engines.

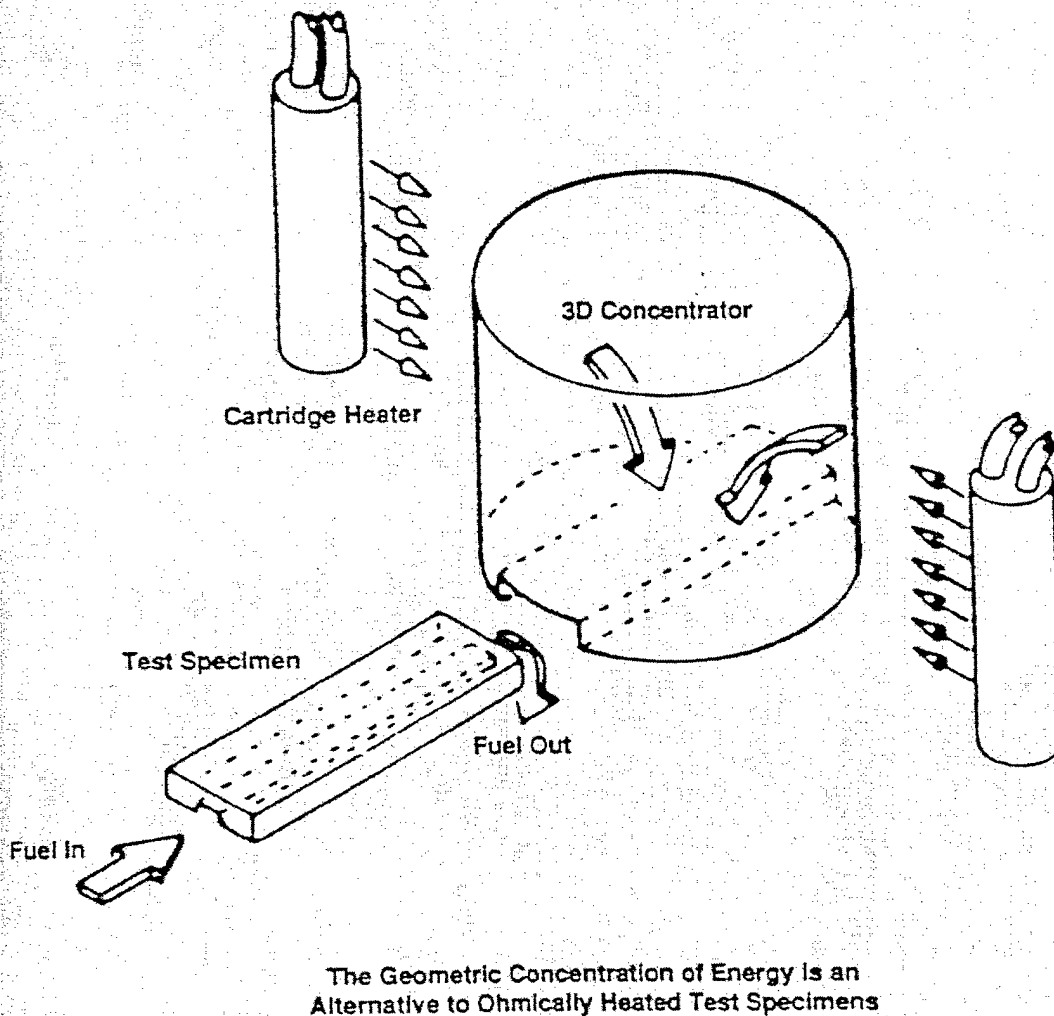

Figure 7 – Schematic of Aerojet’s Carbothermal Test Rig (a conduction heated device)

Summary

A methodology of thermal stability analysis incorporating an experimental research program to investigate the thermal performance of several new candidate hydrocarbon rocket fuels has been started. The experimental program utilizes a series of test rigs of increasing complexity and fidelity to successively screen identified fuels without the cost and complexity of a full engine system level test. Results of small-scale thermal decomposition experiments utilizing a System for Thermal Decomposition Studies (STDS) test rig provide an initial evaluation of the thermal stability performance of fuels from very small fuel samples. Measurements of heat transfer coefficient and the effect of wall temperature, flow velocity, and wetted-material on deposit formation in heated test channels are obtained from larger rigs, such as the NASA/GRC Heated Tube Facility and the AFRL/PRS High Heat Flux Facility.

References

- Bartz, D. R., "Factors Which Influence the Suitability of Liquid Propellants as Rocket Motor Regenerative Coolants," *Jet Propulsion*, pp. 46-53, Jan. 1958.
- Cook, R. T., Quentmeyer, R. J., "Advanced Cooling Techniques for High Pressure Hydrocarbon-Fueled Rocket Engines," AIAA-80-1266, 1980.
- Edwards, T., Meyer, M., Propellant Requirements for Future Aerospace Systems," AIAA 2002-3870, July 2002.
- Giovanetti, A. J., Spadaccini, L. J. and Szetela, E. J., "Deposit Formation and Heat-Transfer Characteristics of Hydrocarbon Rocket Fuels, J. Spacecraft, Vol. 22, No. 5, pp. 574-580, 1985. Also NASA CR 168277.
- Green, J. M., Pease, G. M., and Meyer, M. L., "A Heated Tube Facility for Rocket Coolant Channel Research," AIAA-95-2936, 1995.
- Hazlett, R. N., Thermal Oxidative Stability of Aviation Turbine Fuels, ASTM Monograph 1, ASTM, Philadelphia, PA, 1991.
- Huzel, D. K. and Huang, D.H., Modern Engineering for Design of Liquid-Propellant Rocket Engines, American Institute of Aeronautics and Astronautics, Washington, D.C., 1992.
- Liang, K. et al, "Investigation of Heat Transfer and Coking Characteristics of Hydrocarbon Fuels," *AIAA Journal of Propulsion and Power*, Vol. 14(5), pp. 789-796, 1998.
- Linne, D. L., Munsch, W. M., "Comparison of Coking and Heat Transfer Characteristics of Three Hydrocarbon Fuels in Heated Tubes," 32nd JANNAF Combustion Meeting, CPIA Publication 631, Vol. II, Oct. 1995, pp. 95-101.
- Mehta, G., Stone, W., Ingram, C., Bai, S. D., Sanders, T., "Comparative Testing of Russian Kerosene and RP-1," AIAA 95-2962, July 1995.
- Roback, R., Szetela, E. J. and Spadaccini, L. J., "Deposit Formation in Hydrocarbon Fuels," *Journal of Engineering for Power*, Vol. 105, pp. 59-65, 1983. Also NASA CR 165405.
- Rosenberg, S. D. and Gage, M. L., "Compatibility of Hydrocarbon Fuels with Booster Engine Combustion Chamber Liners," *Journal of Propulsion and Power*, Vol. 7(6), pp. 922-928, 1991.
- Rosenberg, S. D., Gage, M. L., Homer, G. D. and Franklin, J. E.,

- "Hydrocarbon-Fuel/ Copper
Combustion Chamber Liner
Compatibility, Corrosion Prevention,
and Refurbishment," Journal of
Propulsion and Power, Vol. 8(6), pp.
1200-1207, 1992. (AIAA-91-2213)
Also, NASA CR-185203 (April
1990)
- Rousar, D. C., Gross, R. S., Boyd, W.
C., "Supercritical Convection,
Critical Heat Flux, and Coking
Characteristics of Propane," AIAA-
84-1263.
- Rousar, D., Young, M., Ferrante, F.,
Greisen, D., "AS Proven Approach
for Correlating the Critical Heat Flux
of Coolants," IAF-98-S.3.02, Sept
1998.
- Salakhutdinov, G. M., "Development of
Methods of Cooling Liquid
Propellant Rocket Engines (ZhRDs),
1903-1970," Chapter 9 (pp. 115-122)
in History of Rocketry and
Astronautics, AAS History Series
Vol. 10, A. I. Skoog, ed., American
Astronautics Society, San Diego,
1990.
- Stiegemeier, B., Taghavi, R., Meyer, M.,
"A Thermal Stability and Heat
Transfer Investigation of Five
Hydrocarbon Fuels," AIAA 2002-
3873.
- Sutton, G.P., Rocket Propulsion
Elements, In Introduction to the
Engineering of Rockets, Fifth
Edition, John Wiley and Sons, Inc.,
New York, 1986.
- Sutton, G. P., Wagner, W. R., Seader, J.
D., "Advanced Cooling Techniques
for Rocket Engines," Astronautics
and Aeronautics, pp. 60-71, January
1966.
- Van Huff, N. E., "Liquid Rocket Engine
Fluid-Cooled Combustion
Chambers," NASA SP-8087, April
1972.
- Wagner, W. R., and Shoji, J. M.,
"Advanced Regenerative Cooling
Techniques for Future Space
Transportation Systems," AIAA 75-
1247, 1975.
- Wheeler, D. B., "Tripropellant Engine
Study," NASA CR-150444, 1977.
- Ziebland, H., Parkinson, R. C., "Heat
Transfer in Rocket Engines,"
AGARD-AG-148-71, 1971.