

Ladar-Acoustic Fused Sensor for Area Denial Application

Paul Kisatsky

ARDEC-Picatunny Arsenal

Dr. Gervasio Prado and Tom Brennan

Sentech, Inc.

Abstract

Area Denial concepts, as applied to the next generation of scatterable mines (NGSM), are oriented to the philosophy of greatly reducing the cost and logistics burden of the current family of scatterable mines (FASCAM) while maintaining or improving their effectiveness. By extending the sensing radius of the mines and employing some level of warhead mobility, each mine can protect a larger surrounding area, thus reducing the number of mines required per minefield. ARDEC is currently investigating short range, low cost, ladar-acoustic hybrid sensors, which would be capable of detecting, classifying, tracking, and selecting the optimal firing path to vehicular targets at various ranges from the sensor. In this concept, the strengths and weaknesses of each sensing mode are designed to complement each other, resulting in improved performance of the integrated product. Design concepts will be described and emphasis will be placed on techniques to detect and track targets despite near ground obstacle and terrain features, which can block line of sight. Experimental results, as available at the time of this paper, will also be presented.

Background: Area Denial at ARDEC

Current concepts of anti-armor minefields are well illustrated with the Family of Scatterable Mines (FASCAM) product currently in widespread use. In FASCAM, a section of the battlefield can be controlled and denied to enemy armor by virtue of classical minefield philosophy. When a vehicle encounters a mine, by literally running over it, the mine can register a "belly kill". The effectiveness of such a minefield is a direct function of the density of deposited mines over the protected area since the density directly controls the statistical probability that a vehicle will pass over the mine. In this sense, the classical mine is the original "unattended ground sensor", since it lays in wait until engaged.

A central goal of the current Area Denial concept is to greatly improve the cost-effectiveness efficiency of future FASCAM-like minefields by greatly reducing the density of required mines while maintaining the same (or better) effectiveness at same (or less) cost. The underlying premise of this concept is that a single mine node can protect an area of much larger radius, thus not required a vehicle to directly run over it. If the mine were capable of sensing a nearby passing vehicle, then engaging the vehicle with the proper warhead at a distance, the area of coverage per mine would be greatly extended. Even modest extension of the radius of protection results in dramatic savings. Figure 1 plots the savings in number of required mines (compared to a standard FASCAM minefield) as a function of the radius of protection per mine. The ability to sense and kill a vehicle at only a few meters can reduce the number of required mines to less than half, and if the radius of protection were on the order of 15 meters, an order of magnitude in savings could be realized!

The Area Denial Technology Base effort at ARDEC is investigating the feasibility of attaining and demonstrating the essential features of these goals with low cost, emerging technologies. The two pacing components of this concept are a sensing component and a mobility component. Wide varieties of mobility concepts, integratable with a variety of sensing components, are currently under investigation for performance and tradeoffs. Initially, each node will be sized and formed so as to be remotely launchable from a Volcano-like dispenser.

Report Documentation Page

Report Date 00 Oct 2000	Report Type N/A	Dates Covered (from... to) -
Title and Subtitle Ladar-Acoustic Fused Sensor for Area Denial Application	Contract Number	
	Grant Number	
	Program Element Number	
Author(s)	Project Number	
	Task Number	
	Work Unit Number	
Performing Organization Name(s) and Address(es) ARDEC Picatinny Arsenal, NJ 07806-5000	Performing Organization Report Number	
Sponsoring/Monitoring Agency Name(s) and Address(es) Department of the Army, CECOM RDEC Night Vision & Electronic Sensors Directorate AMSEL-RD-NV-D 10221 Burbeck Road Ft. Belvoir, VA 22060-5806	Sponsor/Monitor's Acronym(s)	
	Sponsor/Monitor's Report Number(s)	
Distribution/Availability Statement Approved for public release, distribution unlimited		
Supplementary Notes See also ADM201471, Papers from the Meeting of the MSS Specialty Group on Battlefield Acoustic and Seismic Sensing, Magnetic and Electric Field Sensors (2001) Held in Applied Physics Lab, Johns Hopkins Univ, Laurel, MD on 24-26 Oct 2001. Volume 2 (Also includes 1999 and 2000 Meetings), The original document contains color images.		
Abstract		
Subject Terms		
Report Classification unclassified	Classification of this page unclassified	
Classification of Abstract unclassified	Limitation of Abstract UU	
Number of Pages 7		

Potential Savings is Dramatic

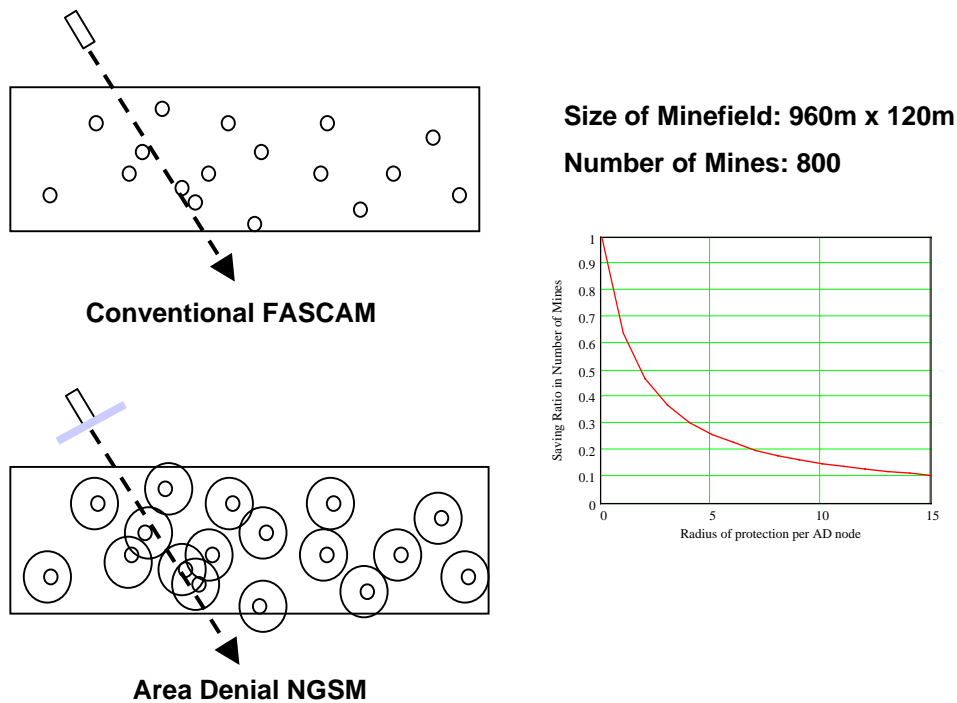

Figure 1

Sensor Challenges

Unlike most smart munition sensors, which reside on airborne platforms, a typical area denial node is a small, inexpensive package sitting directly on the ground. Although the range requirements for the target sensor are modest, generally less than 50 meters, the problem of local terrain obscuration is a major problem. The obscuration effects of even small local terrain features (i.e. grass, rocks, bushes, rolling terrain) become significant relative to observation points very near to the ground. Unless the sensor can be given some elevation, the probability of clear line of sight (PCLOS) can be low except for fairly clear, flat fields. If the sensor package is designed to provide some elevation, then there is concern with both visibility and vulnerability of the area denial node itself. An idealized sensor would be capable of detecting, classifying, tracking, and firing on approaching targets with as much resistance as possible to terrain obscuration. Additionally, the usual problems of avoiding clutter induced false alarms while operating in day-night, all weather environments, must also be considered.

Sensors for area denial applications can be divided into two categories: (a) Line of sight (LOS) sensors, which require a fairly clear line of sight to the target, (visible, IR, electro-optical, short wavelength EM) and (b) Non-line of sight (NLOS) sensors, which have the ability to sense targets despite obscuration. The latter class of sensors must rely on propagation phenomena which are capable of penetrating, directly or indirectly, through most obscuring media. Acoustic, seismic, long-wave EM, and magnetic propagation phenomena are in this category. At ARDEC we have placed a great deal of emphasis on acoustic and seismic sensing. Unfortunately, propagation phenomena that tend to be most absorbed and scattered by media are inherently high in spatial resolution, whereas phenomena that propagate well through and around objects are inherently low in spatial resolution. Because of recent advances in affordable, high sensitivity magnetic sensors, we are placing a significant effort on long-range magnetic detection and tracking. We are also studying small, low cost, wide-band radar, which might be able to offer some foliage penetration capability.

Description of an acoustic-ladar fused sensor:

This paper describes work we are doing to investigate the feasibility of a data-fused ladar-acoustic sensor for these applications. This concept combines two sensing technologies in a way that merges the complementary strengths and weaknesses of each sensing mode. It is also based on the observation that the ability to see targets close to the ground, at modest ranges, is not as bad as it might first seem. The premise is that, from an optical point of view, obscurants will frequently block some of the targets for some of the time from some of the viewing positions. However, for moving targets, it is difficult to block all of the target, for all of the time, from all viewpoints. As any hunter can testify, in all but the thickest of jungles, the moving target can usually be seen, tracked, and fired upon.

Figure 2 lists the strengths and weaknesses of both active ladar and passive acoustics. Clearly, the strengths of one sensing mode can offset the weaknesses of the other. In the concept described here, the sensor is initially in a low power, passive, listening mode. When a vehicle approaches the acoustic sensor (figure 3), the sound level can be easily detected and the vehicle can be at least partially classified based on characteristics of the temporal waveform from its acoustic emissions. A great deal of acoustics technology to detect and identify vehicular targets has already been conducted for programs such as the Hornet anti-tank munition. The advantage of using acoustics for initial detection and classification is that of relative immunity from LOS obscuration of nearby terrain objects. The physics of absorption, refraction, and diffraction due to near ground features work quite favorably in allowing the acoustic waveforms to penetrate these small distances with little or no distortion. A small array of three or more inexpensive microphonic transducers are adequate to detect the incident acoustic waveform with a high signal to noise ratio. By comparing the time or phase of arrivals at each of the microphones, it is quite conventional to be able to obtain an estimate of the angle of incidence of the wave. The vehicle is therefore not only detected, but also tracked in bearing angle with little or no interference from ground obscuring features. Being purely passive, the acoustic system is not capable of obtaining range information to the target. In general, a passive "point sensor" can only measure strength of signal. Since strength of received signal is a function of many parameters, besides range, it is mathematically impossible to uniquely measure range from signal strength alone.

Acoustic-Ladar Dual Mode	
<i>A Complementary Combination</i>	
Acoustics (Passive, Temporal Signature)	Ladar (Active, Spatial Signature)
<u>Strengths</u>	<u>Weaknesses</u>
Not CLOS limited	CLOS limited
Low power cuer	High power consumption when ON
Passive, undetectable	Active, detectable
Target classification/recognition	
Bearing to target	
<u>Weaknesses</u>	<u>Strengths</u>
Cannot range to target	High range resolution
Poor lateral resolution	High lateral resolution
Cannot "see" obstacles	Can map terrain obstacles
Multi-target confusion	Precision aimpoint capability

Figure 2

In order to be able to fire upon, and hit the target, it is not only necessary to be able to estimate range to target, but it is also necessary to be able to know that an open firing corridor exists. One of the strengths of acoustic sensing, the ability to sense and track a target behind obstacles, is also its weakness from a fire control point of view. Side-shooting at an acoustic signal alone might well cause the line of fire to terminate in a tree trunk. We not only want to detect and sense the target when it is invisible to LOS, but we also wish to determine when we do have LOS in order to assure a clear firing path.

When the target is acoustically sensed, classified, and coarsely tracked the cue is passed on to the active ladar sensor. In one version of this concept, this causes the sensing head of the ladar to rise up, on the order of a meter or less, to clear local features such as grass. The ladar can turn on while the target is still

Typical Area Denial Scenario

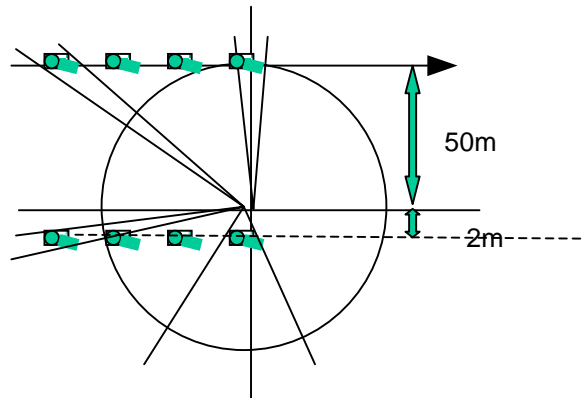

Target is initially detected, classified, bearing tracked and CPA is estimated with the acoustic sensor

Figure 3

a fairly large distance away. The ladar is capable of conducting a one or two-dimensional local scan of the sector suspected of containing the approaching target. The ladar is capable of measuring the local range to the nearest obscuring point. In a quick local scan, the ladar is able to map the local range clutter and place this information in memory. In the process of doing this, the ladar can also make note of the relatively open firing corridors available to the system, by finding the regions of relatively long range compared to the very near obscurants. Since the ladar can be cued to interrogate the suspected target region, the target may be sensed by the ladar as long as at least a portion of the target is visible to the ladar through "holes" in the local foliage and range clutter. The obscurant clutter will remain relatively constant in time and space. The target should be the only component in the scene that continuously moves in a particular direction and at a relatively uniform speed. Unless the local obscuration is very opaque, it is expected that there will be a high probability that in most scenes, portions of the target will be visible at least part of the time.

The acoustic-bearing track, as a function of time, can be correlated with the ladar-bearing track over the periods during which the target is partially visible to the ladar. The combined data of acoustic bearing, combined with optical bearing and range, provide a unique and high-resolution spatial pattern with which to identify, follow, and predict the future location of a moving target.

Because the firing corridors can be pre-mapped, the ideal firing location can be predicted. The system will be capable of combining the acoustic and optical data to predict a best estimate for an optimal firing point. Both distance to target as well as clearness of the firing line should be estimable. Since the ladar will be capable of providing a high spatial resolution profile of the target (even if it is composited, piecemeal), it should also be possible to pick the ideal firing point to hit a vulnerable point on the target.

Description of Experimental Apparatus:

An acoustic detection and tracking system was assembled using an array of five KNOWLES ceramic microphones. They were arranged in a spatial array with a 5-inch base diameter. The acoustic bandwidth of this system is approximately 400 Hz.

A commercial grade, inexpensive diode laser rangefinder was obtained and assembled onto a pan-tilt remotely controllable head. The ladar is the same type as that found in common, off the shelf, ranging binoculars. The system can range to 400 meters, far more than is required for this application. The current optics provides a beam width of 2.5 mr and the ranger is capable of measuring range to a resolution of .5 meters. It operates at a pulse rate of 1000 Hz and is sufficiently low in power to be rated "eye-safe" at distance greater than 25 meters.

Both the acoustic tracker and the ladar were assembled and co-aligned with a common video camera to provide continuous common visible imagery of the scene being tracked and ranged.

Some initial results:

The experimental test platform described above is currently used as a testbed to detect, classify, track, and range a variety of targets in a variety of near ground clutter scenarios. The objective of this investigation is to experimentally estimate the probability that an acoustic-ladar sensor will be able to find and direct fire to a nearby target as a function of random environmental terrains into which it can be immersed. Some early examples of data are shown in Figures 4 and 5

The top scene in figure 4 is the visible camera view of a common suburban lawn area, containing grass, local bushes and trees, with houses in the distance. Figure 5 is the ladar scan of the same scene. In this figure the range to each pixel is measured and displayed here in pseudo-gray scale. The horizontal scale is in milliradians. The trees are clearly visible, along with the distant open corridors.



Figure 4

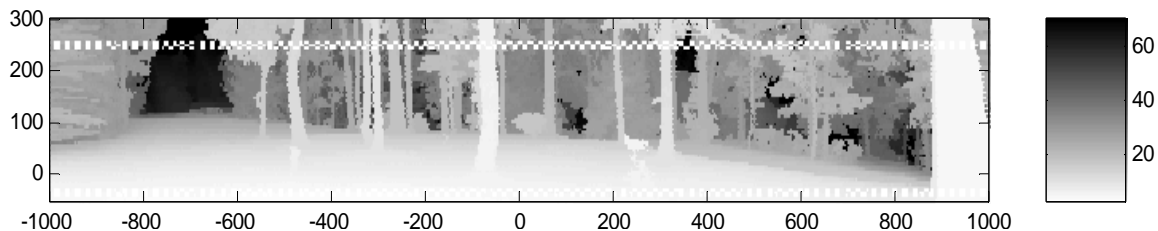

Figure 5

In Figure 6, an automobile (with trunk raised) is parked partially behind two trees of the scene. The auto is clearly visible in silhouette.

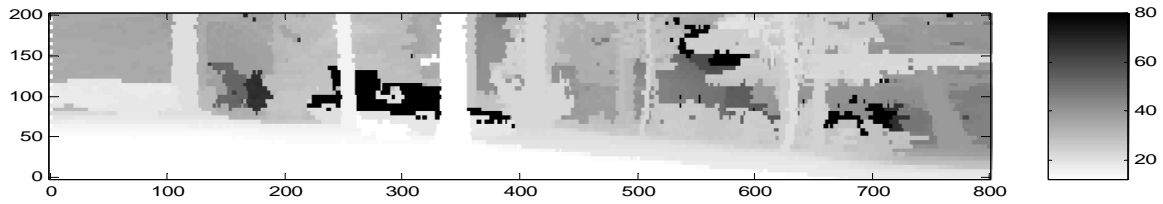

Figure 6

In figure 7, a small garden tractor was introduced into the scene. As the tractor moved left and right across the scene, the acoustic signal was both detected and tracked. This figure also shows the tracking angle as a function of time along with a measure of the received acoustic intensity. The resulting saw tooth like traces represented the vehicle as it proceeded back and forth across the lawn. From this data, along with the ladar obtained range data, the two tracks do correlate and it is possible to make a reasonable accurate measure of the velocity of the traveling vehicle.

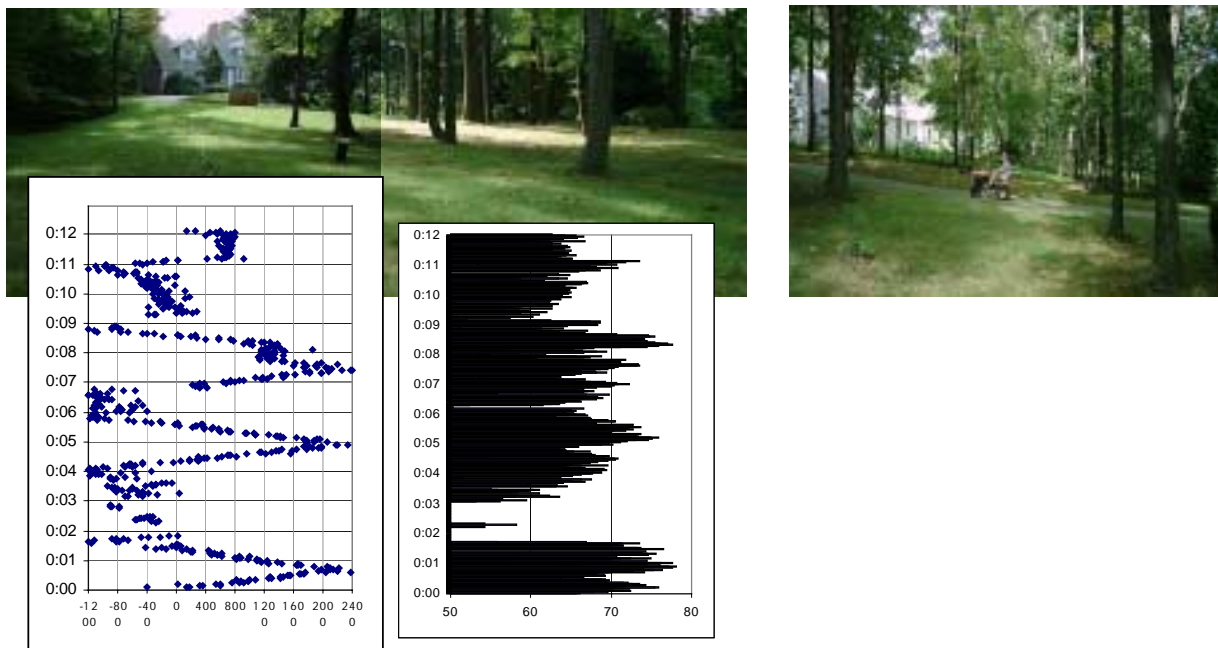

Figure 7

Conclusions and discussion:

We expect to employ the testbed described here to collect data, detecting, tracking, and ranging vehicles in a wide variety of near ground obscurant clutter conditions. We plan to gradually increase the severity and complexity of the background obscuration clutter until it is impossible to obtain ladar tracks of the target. We expect that in most scenes, the vehicle will be detectable and range-able, especially at the close distances required for this area denial application. We expect to develop algorithmic processes to enhance our ability to detect, track, and range the moving target by extracting it from the partially obscured background clutter. It will be especially important to be able to use this data to predict ideal firing corridors to allow an effective kill of the target. Our near term objective will address stand-alone sensing nodes. In the longer term, we intend to investigate the benefits gained from allowing the nodes to “communicate” with each other so as to share data on the targets they see. As mentioned earlier in this paper...no single sensor will be able to see the target all of the time. Nevertheless, many sensors should be able to see some of the targets, some of the time despite heavily wooded and obscured environments. The ability to piece together the jigsaw puzzle of space and time views taken from acoustic and optical data slices may bring a new perspective to the capability of using optical sensors to see otherwise obscured targets.