

## UNITED STATES AIR FORCE RESEARCH LABORATORY

### CIVILIAN AMERICAN AND EUROPEAN SURFACE ANTHROPOMETRY RESOURCE (CAESAR), FINAL REPORT, VOLUME II: DESCRIPTIONS

**Sherri Blackwell**

SYTRONICS, INC.

4433 DAYTON-XENIA RD

DAYTON, OHIO 45432

**Kathleen M. Robinette**

HUMAN EFFECTIVENESS DIRECTORATE

CREW SYSTEM INTERFACE DIVISION

WRIGHT-PATTERSON AFB, OHIO 45433-7022

**Mark Boehmer**

**Scott Fleming**

**Sara Kelly**

**Tina Brill**

**David Hoeflerlin**

**Dennis Burnsides**

SYTRONICS, INC.

4433 DAYTON-XENIA RD

DAYTON, OHIO 45432

**Hein Daanen**

TNO HUMAN FACTORS INSTITUTE

SOESTERBERG, THE NETHERLANDS

Project accomplished under a  
Cooperative Research Agreement with



400 COMMONWEALTH DR

WARRENDALE, PA 15096

20021212 038

JUNE 2002

INTERIM REPORT FOR THE PERIOD DECEMBER 1997 TO JUNE 2002

*Approved for public release; distribution is unlimited.*

Human Effectiveness Directorate

Crew System Interface Division

2255 H Street

Wright-Patterson AFB OH 45433-7022

## NOTICES

When US Government drawings, specifications, or other data are used for any purpose other than a definitely related Government procurement operation, the Government thereby incurs no responsibility nor any obligation whatsoever, and the fact that the Government may have formulated, furnished, or in any way supplied the said drawings, specifications, or other data, is not to be regarded by implication or otherwise, as in any manner licensing the holder or any other person or corporation, or conveying any rights or permission to manufacture, use, or sell any patented invention that may in any way be related thereto.

Please do not request copies of this report from the Air Force Research Laboratory. Additional copies may be purchased from:

National Technical Information Service  
5285 Port Royal Road  
Springfield, Virginia 22161

Federal Government agencies and their contractors registered with the Defense Technical Information Center should direct requests for copies of this report to:

Defense Technical Information Center  
8725 John J. Kingman Road, Suite 0944  
Ft. Belvoir, Virginia 22060-6218

## TECHNICAL REVIEW AND APPROVAL

AFRL-HE-WP-TR-2002-0173

This report has been reviewed by the Office of Public Affairs (PA) and is releasable to the National Technical Information Service (NTIS). At NTIS, it will be available to the general public.

The voluntary informed consent of the subjects used in this research was obtained as required by Air Force Instruction 40-402.

This technical report has been reviewed and is approved for publication.

### FOR THE COMMANDER

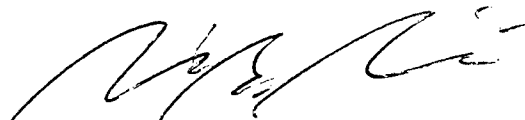

MARIS M. VIKMANIS  
Chief, Crew System Interface Division  
Air Force Research Laboratory

# REPORT DOCUMENTATION PAGE

Form Approved  
OMB No. 0704-0188

Public reporting burden for this collection of information is estimated to average 1 hour per response, including the time for reviewing instructions, searching existing data sources, gathering and maintaining the data needed, and completing and reviewing the collection of information. Send comments regarding this burden estimate or any other aspect of this collection of information, including suggestions for reducing this burden, to Washington Headquarters Services, Directorate for Information Operations and Reports, 1215 Jefferson Davis Highway, Suite 1204, Arlington, VA 22202-4302, and to the Office of Management and Budget, Paperwork Reduction Project (0704-0188), Washington, DC 20503.

1. AGENCY USE ONLY (Leave blank)	2. REPORT DATE June 2002	3. REPORT TYPE AND DATES COVERED Interim Report, December 1997 - June 2002	
4. TITLE AND SUBTITLE  Civilian American and European Surface Anthropometry Resource (CAESAR), Final Report, Volume II: Descriptions		5. FUNDING NUMBERS  C: F41624-93-C-6001 PE: 62202F  PR: 7184 TA: 08 WU: 46 and 61	
6. AUTHOR(S)  *Sherri Blackwell Kathleen M. Robinette *Mark Boehmer *Scott Fleming *Sara Kelly *Tina Brill * David Hoeflerlin *Dennis Burnsidess **Hein Daanen		8. PERFORMING ORGANIZATION	
7. PERFORMING ORGANIZATION NAME(S) AND ADDRESS(ES)  * Sytronics, Inc. 4433 Dayton-Xenia Road Dayton OH 45432  ** TNO Human Factors Institute PO Box 23 3769 ZG Soesterberg The Netherlands		9. SPONSORING/MONITORING AGENCY NAME(S) AND ADDRESS(ES)  Air Force Research Laboratory Human Effectiveness Directorate Crew System Interface Division Air Force Materiel Command Wright-Patterson AFB OH 45433-7022	
11. SUPPLEMENTARY NOTES		10. SPONSORING/MONITORING  AFRL-HE-WP-TR-2002-0173	
12a. DISTRIBUTION/AVAILABILITY STATEMENT  Approved for public release; distribution is unlimited.		12b. DISTRIBUTION CODE	
13. ABSTRACT (Maximum 200 words)  The Civilian American and European Surface Anthropometry Resource (CAESAR) project was a survey of the civilian populations of three countries representing the North Atlantic Treaty Organization (NATO) countries; the United States of America (USA), The Netherlands, and Italy (Robinette et al. 1999, Robinette 2000). One site in Ottawa, Canada was added to the USA sample and it is henceforth referred to as the North American sample. The survey was carried out by the US Air Force, with the help of 1) the contractor, Sytronics, Inc., 2) The Netherlands Organization for Applied Scientific Research (TNO), and 3) a consortium of companies under the umbrella of the Society of Automotive Engineers (SAE). The purpose of this document is to provide a general description which contains descriptions of the methods used for the demographics, the measurements (both 3-D and 1-D), and the landmarks. It has a companion document, Volume I: Summary, by Robinette et al. 2002.			
14. SUBJECT TERMS  Anthropometry, 3-D, Scanning, Measurement, Demographic		15. NUMBER OF PAGES 190	
17. SECURITY CLASSIFICATION OF REPORT Unclassified		16. PRICE CODE	
18. SECURITY CLASSIFICATION OF THIS PAGE Unclassified		20. LIMITATION OF ABSTRACT Unlimited	
19. SECURITY CLASSIFICATION OF ABSTRACT Unclassified		21. LIMITATION OF ABSTRACT	

THIS PAGE IS INTENTIONALLY LEFT BLANK

## PREFACE

The authors would like to thank the other members of the data collection teams whose hard work contributed to this study, especially Dennis Allen, Bridget Bailey, Teresa Crase, Patrick Files, Anna Riley, Steve Trimble; Italian team members Roberta Borghesi, Valeria Brusco, Samantha Castello, Catia Di Ceglia, Giorgia Latini, and Silvia Penna; Dutch team members Evie Sipkes, Claudia Nolte, Lotta de Beus, Joyce Schram, Marietta Brongers, Petra van Wierst, Miranda Senden, Angela Wit, Carla Dekker, and Elise Duinker; and Georgia Institute of Technology team members Beth Bryant McCrary and Sarah Endicott. We would also like to thank all of the people from the partner companies who contributed time and effort. In particular we would like to thank Kim Bennett of *Jantzen* and Laura Blalock from *Sara Lee Knitwear* for design and manufacture of scan garments. We would like to thank Italian coordinators Stefano Carosio and Massimiliano Marcellino, *Herman Miller* for cash incentives, and all those who arranged for data collection sites at their companies, including: Joe Koncelik of the *Georgia Institute of Technology*, George Rodriguez and Janice Pressley, of *Mervyn's California*, Clay Funkhouser and Kim Bennett of *Jantzen*, James Maida and Mel Buderer, of the *Johnson Space Center*, Carol Mager of *Dayton-Hudson Corporation*, Marc Rioux of the *National Research Council Canada*, Tom Wolfe and Kurt Stroemel of *Film East, LLC.*, Dr. Celestine Ntuen and Dr. Daniel Mountjoy of *North Carolina Agricultural & Technical State University*, Jerry Duncan of *Deere & Company*, Mari Milosic of *Magna Interiors*, and especially Linda Urette of *Nissan North America*, who provided our first North American data collection site. Thank you to all the partners who provided incentives to help encourage participation in the project. The authors would especially like to thank Gary Pollak at the Society of Automotive Engineers who arranged all of the industry partnerships and organized our biannual partner meetings. This effort was completed under contract number F33615-C-93-0001 with Sytronics, Inc. and for which Kathleen Robinette was the contract engineer.

## Table of Contents

Chapter I: Introduction.....	1
Chapter II: Demography: Description of Demographic Variables .....	2
Chapter III: Anthropometry .....	8
Anatomical Landmark Descriptions .....	8
Part I: the traditional Landmarks .....	9
Part II: -D Landmarks.....	18
Part III: Miscellaneous Landmarks .....	38
Traditional-Style Measurement Descriptions .....	39
Scan Measurement Descriptions.....	67
Part I: Caesar Scanning Postures.....	67
Part II: Scan Extracted Dimensions: Standing Dimensions .....	71
Part III: Scan Extracted Dimensions: Seated Dimensions.....	93
Chapter IV: Scan Extracted Measurements Calculated Methods .....	101
Calculation Types .....	104
Functional Butt Block Landmark.....	104
Determination of Scan Platform Level .....	104
Chapter V: Landmark Selection Rationale.....	106
Chapter VI: Landmark Point Picking Order .....	108
References.....	110
Appendix A: Demographic data Forms [North America, Dutch, Italian].....	111
Appendix B: anthropometry Data Forms [North American, Dutch, Italian] .....	124
Appendix C: glossary.....	128
Appendix D: Visual Index .....	137
Part I: Anatomical Landmarks for Traditional Anthropometry .....	138
Part II: anatomical Landmarks for Three-dimensional anthropometry.....	142
Part III: Traditional Anthropometry.....	155
Part IV: Three-dimensional Scan anthropometry .....	160
Appendix E: Demographic Variables and Responses.....	167
Index.....	185

## List of Tables

Table 1. Demographic Station Tasks .....	2
Table 2. Demographic Variables.....	3
Table 3. CAESAR Standing Extracted Measurements .....	101
Table 4. CAESAR Seated Extracted Measurements.....	103
Table 5. Platform Levels .....	105

## List of Figures

Figure 1. Footprints.....	67
Figure 2. Standing Posture .....	68
Figure 3. Seated Comfortable Working Posture .....	69
Figure 4. Seated Coverage Posture .....	70
Figure 5. The Butt Block Landmark Included in the 3-D Landmark Files .....	104

THIS PAGE IS INTENTIONALLY LEFT BLANK



## CHAPTER I: INTRODUCTION

The Civilian American and European Surface Anthropometry Resource (CAESAR) project was a survey of the civilian populations of three countries representing the North Atlantic Treaty Organization (NATO) countries: the United States of America (U.S.A.), The Netherlands, and Italy (Robinette et al. 1999, Robinette 2000). One site in Ottawa, Canada was added to the U.S.A. sample, and as a result, the U.S.A. sample became the North American sample. The survey was carried out by the U.S. Air Force, with the help of 1) the contractor, Sytronics Inc., 2) The Netherlands Organization for Applied Scientific Research (TNO) and 3) a consortium of companies under the umbrella of the Society of Automotive Engineers (SAE).

Typically the principal product from an anthropometric survey has been a document with summary statistics for a population, and often this included only means, standard deviations and percentiles. For engineering applications this information is generally not suitable nor sufficient. The population of interest is often a subset of the survey population, such as a particular age group. Also, the measurement of interest for a design may be different from those reported. For example, the stomach depth seated might be of interest for an automobile, but it isn't in the list of dimensions extracted. These things can be obtained from the raw data but not the summary statistics. This is particularly true for 3-D data which cannot be summarized into anything meaningful using means, standard deviations and percentiles. Therefore, the product of this survey is the raw data, including for the first time ever complete 3-D models of all subjects.

The development of a plan was an iterative process which was initiated with the formation of a NATO working group in 1993, the Advisory Group for Aerospace Research and Development (AGARD), Working Group 20: 3-D Surface Anthropometry. This group, consisting of representatives from six countries with a variety of technical expertise from physics to medicine, explored the use of the new technology for the purpose of conducting a NATO survey. NATO has a long history of anthropometric surveys of military populations (Hertzberg et al. 1963). However, unlike the previous surveys, CAESAR would be the first NATO survey of civilians and the first 3-D whole body surface anthropometry survey. The working group reviewed the 3-D Surface Anthropometry technology (Robinette et al. 1997) and developed a draft plan that became the starting point for the CAESAR project.

At the same time, two industry organizations were also making plans to conduct traditional type anthropometric surveys, the Society of Automotive Engineers' (SAE) G-13 Committee and the American Society of Testing and Materials (ASTM) D-13 Committee. The former consisted of representatives for the automotive and aerospace industries and the latter for the apparel industry. These groups had formed a list of critical variables for their needs and had begun to discuss working together on such an effort. CAESAR brought all of these groups together under one umbrella.

The purpose of this document, Volume II in a series of two, is to describe in detail the demography and anthropometry of the CAESAR survey.

## CHAPTER II – DEMOGRAPHY:

### Description of the Demographic Variables

The final list of demographic variables was the result of an iterative negotiation between the automotive and apparel factions within the CAESAR partnership. Although the partners ideally would have included an exhaustive list of questions to fine-tune the demographic database of their existing and potential customer bases, realistically, the list had to be kept to a reasonable minimum. Because data collection was a three-stage process (In-Processing/Demographics, Traditional Measuring, and Scanning stations), the amount of time each volunteer spent at a given station had to be equivalent to the time spent at each of the other stations for continuous, maximum subject throughput. The time required to process a subject through the traditional measuring and scanning station was 20 minutes each, which meant that the time to in-process the subject (which included completion of the demographic questionnaire at the demographic station) must also be 20 minutes. The tasks of the Demographics station are listed in Table 1.

Table 1. Demographic Station Tasks

At the Demographic station, the Greeter will:

- Greet the volunteer and cross their name off the schedule
- In the *Subject Log*, record the date, subject number, volunteer name, and arrival time
- Brief volunteer on CAESAR project and their role as a participant
- Have volunteer sign and date the *Informed Consent* form
- Assign a volunteer number, and hand out the *Demographic Questionnaire*, the *Traditional Measurement Data* form, and accompanying 3.5" floppy disk
- Confirm that volunteer has correctly completed the paperwork (the demographic questionnaire and the top section of the measurement data form)
- Select the appropriate size of shorts (and top also for a female volunteer), based on (1) the specifications of the size selection charts, and (2) the judgment of the Demographic Station team member.
- Hand shorts (and top, if applicable) to the each volunteer, along with a white lab coat. Instruct each volunteer to don the lab coat before walking from one data collection station to another.
- Provide the volunteer a rubber tub and lid, for the discreet containment of personal belongings.
- Escort volunteers to unoccupied changing rooms
- Input data from the completed demographic data form into the demographic database while the volunteer changes from street clothes to the CAESAR garments
- Escort volunteers from changing room to traditional anthropometry measuring station to begin the data collection process
- Collect data forms and floppy disks from volunteers who have completed the data collection process ("Departing Subjects")
- Hand appropriate rubber tubs to Departing Subjects; direct Departing Subjects to unoccupied changing rooms to change back into street clothes
- Collect used lab coats, scanning garments, and rubber tubs from Departing Subjects
- Record departure time for each volunteer in the *Subject Log*

The demographic questionnaire to was limited to 25 questions in order to keep it within the desired time frame, and time trials confirmed that 25 questions was a realistic maximum for the demographic questionnaire. While most questions were typical anthropometric survey questions, a few additional questions (such as car make and model) were included at the request of the partners. The final list of demographic questions, as approved by the CAESAR partnership, is shown in Appendix A. Table 2 shows the resulting demographic variables.

Table 2. Demographic Variables

<b>Data Form Name</b>	<b>Data File Name</b>
Subject Number	Subject Number
NL Subject (Netherlands)	NL Subject
Country of data collection	Country
Site of data collection	Site
Date of data collection (computer-generated)	Date
Time of day of data collection (computer-generated)	Time
Civilian or Military	Civilian
Date of Birth	Date of Birth
Age in years (computer-generated)	Age (years)
Birth State (U.S.)	Birth State
Birth Province (Netherlands)	
Birth Region (born in Italy)	
State (Netherlands)	State
Occupation	Occupation
Education Level	Education
Number of Children	Number of Children
Fitness Level	Fitness
Car Make	Car Make
Car Year	Car Year
Car Model	Car Model
Gender	Gender
Race	Race
Reported Height	Reported Height
Reported Weight	Reported Weight
Subgroup Number	Subgroup Number
Marital Status	Marital Status
Family Income	Family Income
Family Income (Italy)	Family Income IT
Salary (Netherlands)	Salary NL
Shoe Size	Shoe Size
Shoe Size (Italy)	Shoe Size IT
Shoe Size (Netherlands)	Shoe Size EU
Jacket Size	Jacket Size
Jacket Size (Italy)	Jacket Size IT
Pants Size Waist Circumference Pants Circumference (Netherlands) Waist Size (Italy)	Pants Size Waist
Pants Length Inseam Pants Length (Netherlands)	
Pants Length Inseam (Italy)	
Blouse Size (U.S., Netherlands); Blouse or Top Size (Italy)	Blouse Size
Pants Size Woman	

<b>Data Form Name</b>	<b>Data File Name</b>
Pants Size Woman (Italy)	Pants Size Woman IT
Bra Size (U.S., Italy)	Bra Size
Father's Birthplace (Netherlands)	Father Born
Mother's Birthplace (Netherlands)	Mother Born
Work Posture (Netherlands)	Work Posture
Work Hours (Netherlands)	Work Hours
(Bra) Cup Size (Netherlands)	Cup Size
Chest Circumference Under Bust (Netherlands)	Bra Size NL
Size Underwear (Netherlands)	Size Underwear
Weight Gain (Netherlands)	Weight Gain

The demographic questionnaire was filled out by the subject and the data entered by a CAESAR team member who asked the subject to clarify any apparent errors or inconsistencies in their questionnaire responses. A description of each demographic variable is included below. For the demographic questions that were presented with a list of possible responses, those responses are listed in Appendix E.

1. Age (years) – This is the subject's age. The value is calculated by subtracting the date of birth ("Date of Birth") from the date of the data collection ("Date").
2. Birth State – In the United States, this is the state where the subject was born. In the Netherlands, this is the province where the subject was born. In Italy, this is the region of Italy where the subject was born.
3. Blouse Size – In the United States and the Netherlands, this represents the numeric blouse size for women. In Italy, the blouse size for women is reported as small, medium, large, x-large, and xx-large. For the United States and Italy, the possible responses are shown in Appendix E. In the Netherlands the subject entered a number between 34 and 62.
4. Bra Size – In the United States and Italy, this represents the bra size.
5. Bra Size NL – In the Netherlands, this represents the subject's chest circumference (in centimeters) under the bust for Women.
6. Car Make – This represents the manufacturer of the subject's primary vehicle.
7. Car Model – This represents the model of the subject's primary vehicle.
8. Car Year – This represents the year of manufacture of the subject's primary vehicle.
9. Civilian – Whether or not the volunteer is currently an active member of the armed forces is also recorded. If the subject is not in the military the value is "Yes." If the subject is in the military the value is "No."
10. Country – This is the country where the data was collected. It was presumed that the data collection location and the volunteer's country of residence were synonymous. Much effort was made to ensure this, but it is possible that in rare, undocumented cases, this assertion may not be correct. Possible responses for "Country" are United States, Netherlands, and Italy. The "United States" category includes one data collection site in Ottawa, Ontario, Canada.
11. Cup Size – In the Netherlands, this represents the subject's cup size (bra) for women.

12. Date – This is the date when the data for a given subject was collected. A computer saved the current date when the data was entered.
13. Date of Birth – This is the subject’s date of birth as entered on the demographic questionnaire.
14. Education Level – The highest level of education completed is selected from a list of choices ranging from elementary school to post-doctoral studies.
15. Family Income – Net family income is selected from a list of choices. In the United States, this represents the subject’s family income. At the Ottawa site, subjects were instructed to report family income in Canadian dollars. Family income is divided into nine categories that range from less than \$10,000 US to more than \$100,000 US annually (from less than \$10,000 Canadian to more than \$100,000 Canadian).
16. Family Income IT – In Italy, this represents the subject’s family income in millions of Italian Lira. The range covers 10 categories and is given as less than 10M lire to greater than 150M lire.
17. Father Born – In the Netherlands, this represents the country where the subject’s father was born.
18. Fitness Level – “Hours per week in structured exercise” is selected from a list of choices as a measure of physical fitness. Hours of structured exercise range from 0 to more than 10 hours per week.
19. Gender – This represents the subject’s gender.
20. Jacket Size – In the United States and the Netherlands, this represents the subject’s jacket size for males only. For the United States, the possible responses are listed in Appendix E. For the Netherlands, the subject entered a value between 34 and 62.
21. Jacket Size IT – In Italy, this represents the subject’s jacket size for males, which ranges from 46 or smaller to 58 or larger.
22. Marital Status – Marital status is recorded by circling the appropriate choice.
23. Mother Born – In the Netherlands, this represents the country where the subject’s mother was born.
24. NL Subject – This is the original subject identifier for the Dutch subjects. This identifier is in the form of nl\_xxxx, where xxxx is the original 4 digit subject number.
25. Number of Children – This represents the number of children the subject has. Answers range from “0” to “7 or more.”
26. Occupation – The subject chooses his or her current occupation from a list of occupations. Both “Retired” and “Student” responses were included in the list. Although an “Other” response was provided, some subjects wrote in an alternative occupation. These additional occupations were included in the electronic data.
27. Pants Length Inseam – This represents the subject’s pants length (inseam). For the United States, the possible responses are listed in Appendix E. For the Netherlands, the subject entered a value between 28 and 40.

28. Pants Length Inseam IT – In Italy, this represents the subject's pants length (inseam) for males. It is customary in Italy to purchase pants with unfinished legs. A tailor then adjusts the length. Inseam lengths were estimated in centimeters.
29. Pants Size Waist – This represents the subject's pants size (waist). For the United States the possible responses are listed in Appendix E. For the Netherlands, the subjects entered a value between 28 and 46.
30. Pants Size Waist IT – In Italy, this represents the subject's pants size (waist) in centimeters.
31. Pants Size Woman – In the United States, this represents the pants size for women.
32. Pants Size Woman IT – In Italy, this represents the pants size for women.
33. Race – This represents the subject's race. Race classifications are listed, with more specific classifications following in parenthesis. Included for the U.S. and Canada are *African-American* or *Black*, *Caucasian* or *White*, *Native American* or *Native Alaskan*, *Spanish/Hispanic* (Cuban, Mexican-American, Puerto Rican, Other), *Asian/Pacific Islander* (Asian Indian, Chinese, Filipino, Guamanian or Chamorro, Japanese, Korean, Native Hawaiian, Samoan, Vietnamese, Other), and *Mixed Race* (Not Listed Above, No Response). For Italy, the race is listed as Italian or Other. For the Netherlands, the race is listed as Dutch or Other.
34. Reported Height – This represents the subject's height as reported on the demographic questionnaire.
35. Reported Weight – This represents the subject's weight as reported on the demographic questionnaire.
36. Salary NL – In the Netherlands, this represents the subject's salary in thousands of guilders.
37. Shoe Size – In the United States, this represents the subject's shoe size using U.S. shoe sizes.
38. Shoe Size IT – In Italy, this represents the subject's shoe size using Italian shoe sizes.
39. Shoe Size NL – In the Netherlands, this represents the subject's shoe size using European shoe sizes.
40. Site – This refers to the location of the data collection. It is recorded as the city where data was collected and includes cities within the United States, Canada, The Netherlands, and Italy. U.S. cities include Los Angeles, California; Detroit, Michigan; Dayton, Ohio; Ames, Iowa; Greensboro, North Carolina; Marlton, New Jersey; Minneapolis, Minnesota; Houston, Texas; Portland, Oregon; San Francisco, California; and Atlanta, Georgia. The Canadian site location is Ottawa, Ontario. The Dutch site location is Soesterberg, The Netherlands; and the Italian site location is Genova, Liguria.
- The scanner was recalibrated each time the scanner was moved from one site to another. Data was collected twice in Dayton, Ohio and twice in Genoa, Italy. Because the scanner was moved and recalibrated, these are considered different data collection sites.
41. Size Underwear – In the Netherlands, this represents the subject's underwear size. The response may be a size such as Small (S), Medium (M), Large (L), or a numeric size.
42. State – In the Netherlands, this is the State (or Province) where the subject resides.
43. Subgroup Number – This variable was not used.

44. Subject Number – Each subject was assigned a unique number. The North American subjects are numbered from 1 to 3128. There are some gaps in the subject numbers, particularly in the first three or four North American data collection sites. The Italian subjects are numbered 4000 to 4800. Due to the subject recruitment methods used for the Dutch data collection, the Dutch subjects were numbered 1001 to 7079 and are not sequential. To allow the Dutch subjects to be stored in the same database without conflicts, 10000 was added to the Dutch subject numbers. This results in the Dutch subject numbers ranging from 11001 to 17079.

45. Time – This is the time of day when the data for a given subject was collected. A computer saved the current time when the data was entered.

46. Weight Gain – In the Netherlands, this represents whether the subject has recently experienced any significant weight gain or loss.

47. Work Hours – In the Netherlands, this represents the amount of time per week the subject spent working. The subject entered a value between 1 and 80.

48. Work Posture – In the Netherlands, this represents the posture the subject usually maintains at work.

## CHAPTER III – ANTHROPOMETRY:

### Anatomical Landmark Descriptions

This chapter is divided into two sections: the traditional measuring landmarks, and the scan landmarks. All landmarks used in each activity are described in that section. The landmarks are listed in alphabetical order. Whenever possible, landmarks are cross-referenced using ISO 7250 nomenclature.

The CAESAR landmarks were assigned “CAESAR” landmark names based on *Landmark Name* (or, *Body Segment*), *Relative Location*, *Direction*, and *Posture*. For example, landmark name and direction are needed to distinguish the “Acromion, Right” and “Acromion, Left” landmarks. Malleolus, on the other hand, requires landmark name, direction, and relative location, since both lateral and medial points are marked on the left and on the right malleolus. Therefore, malleolus (landmark), medial or lateral (relative position), and left or right (direction), must all be used to distinguish between the four different malleoli landmarks.

A Visual Index containing all of the traditional anatomical landmarks is included as Appendix D. The Visual Index for the 3-D landmarks is also included in Appendix D.



Part I. The Traditional Landmarks

**CAESAR Name:** ACROMION, RIGHT  
**ISO Definition No.** 2.2.1  
**ISO Name:** Acromion

**Description:** Most lateral point of the lateral edge of the acromial process of the scapula.

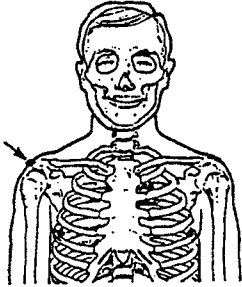

**CAESAR Name:** CERVICALE  
**ISO Definition No.** 2.2.5  
**ISO Name:** Cervicale

**Description:** Most prominent point of the spinous process of the seventh cervical vertebra (prominent bone at the base of the back of the neck).

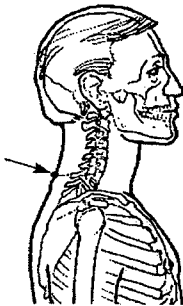

**CAESAR Name:** GLABELLA  
**ISO Definition No.** 2.2.9  
**ISO Name:** Glabella

**Description:** Most anterior point of the forehead between the brow ridges in the midsagittal plane.

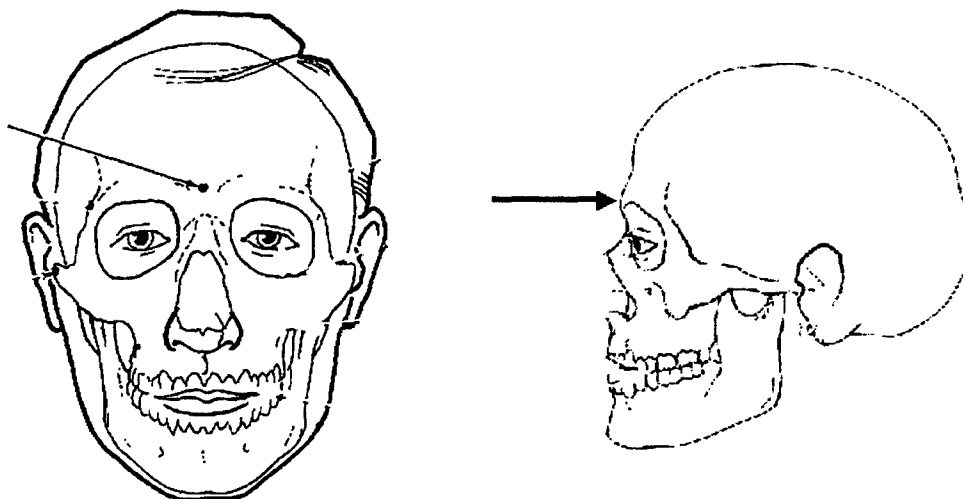

**CAESAR Name:** INFRAORBITALE, RIGHT  
**ISO Definition No.** N/A  
**ISO Name:**

**Description:** Lowest point on the inferior margin of the orbit (the bony eye socket), marked directly inferior to pupil.

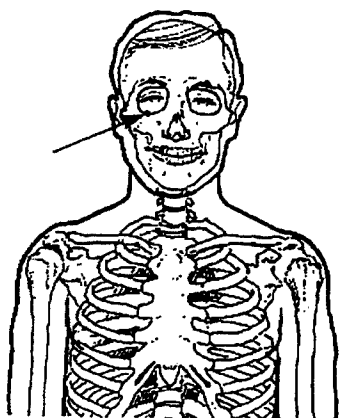

**CAESAR Name:** MALLEOLUS, LATERAL; RIGHT  
**ISO Definition No.** N/A  
**ISO Name:**

**Description:** Lateral point on the distal fibular protrusion of the ankle.

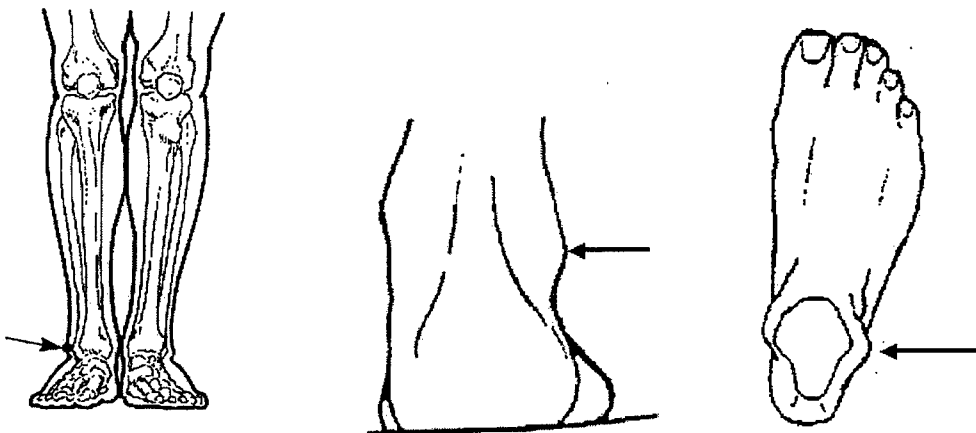

**CAESAR Name:** MALLEOLUS, MEDIAL; RIGHT  
**ISO Definition No.** N/A  
**ISO Name:**

**Description:** Medial point on the distal tibial protrusion of the ankle.

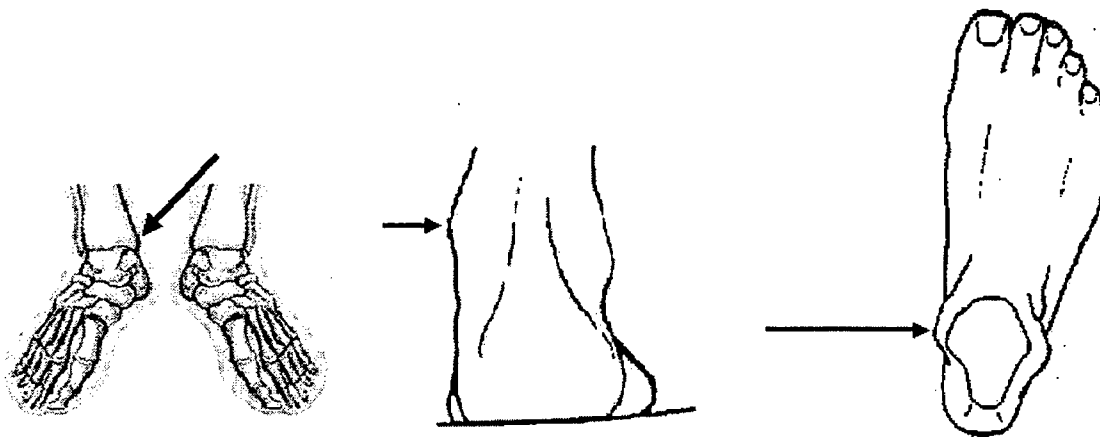

**CAESAR Name:** MENTON  
**ISO Definition No.** 2.2.16  
**ISO Name:** Menton; Gnathion

**Description:** Lowest point of the tip of the chin in the midsagittal plane.

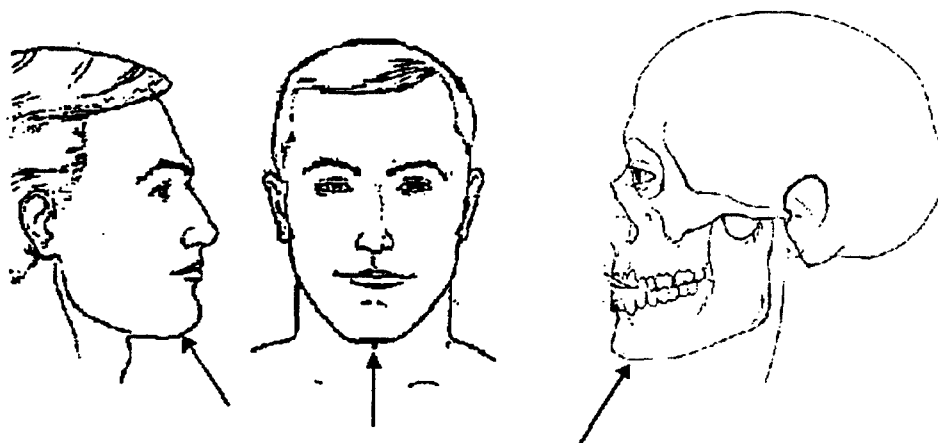

**CAESAR Name:** METACARPAL-PHALANGEAL II, RIGHT  
**ISO Definition No.** N/A  
**ISO Name:**

**Description:** Prominent point on the lateral surface of the second metacarpal-phalangeal joint.

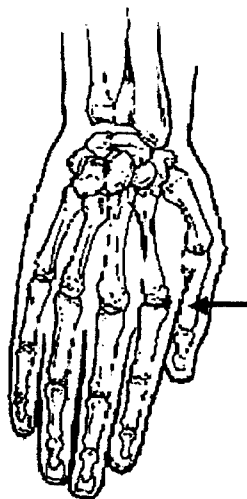

**CAESAR Name:** METACARPAL-PHALANGEAL V, RIGHT  
**ISO Definition No.** N/A  
**ISO Name:**

**Description:** Prominent point on the lateral surface of the fifth metacarpal-phalangeal joint.

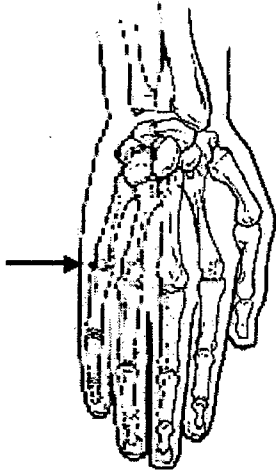

**CAESAR Name:** OLECRANON, RIGHT  
**ISO Definition No.** N/A  
**ISO Name:**

**Description:** Posterior point on the olecranon process of the ulna, marked with the elbow bent 90 degrees.



**CAESAR Name:** RADIAL STYLOID, RIGHT  
**ISO Definition No.** N/A  
**ISO Name:**

**Description:** Distal tip of the radius.

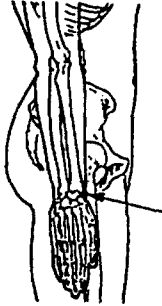

**CAESAR Name:** RADIALE, RIGHT  
**ISO Definition No.** N/A  
**ISO Name:**

**Description:** Proximal point on the head of the radius, near the midpoint of the elbow on the lateral aspect of the arm.

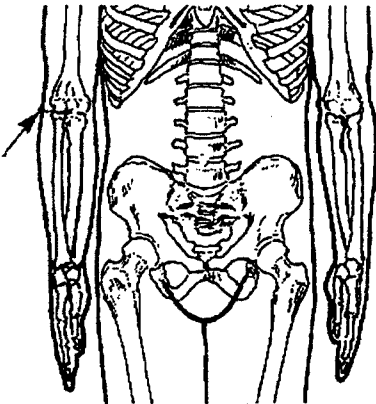

**CAESAR Name:** SELLION  
**ISO Definition No.** 2.2.19  
**ISO Name:** Nasion; Sellion

**Description:** Point of greatest indentation of the nasal root depression.

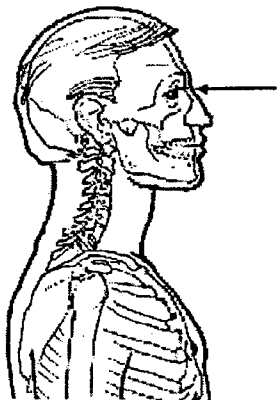

**CAESAR Name:** SUPRAPATELLA  
**ISO Definition No.** N/A  
**ISO Name:**

**Description:** Top of the right kneecap; the superior point on the patella while it is in the relaxed (loose) position.

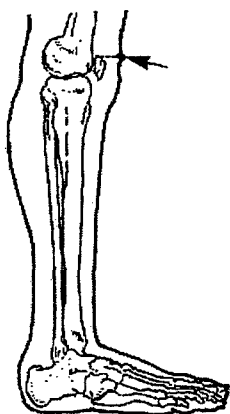

**CAESAR Name:** THELION/BUSTPOINT, LEFT AND RIGHT  
**Definition No.** N/A  
**ISO Name:**

**Description:** Most anterior protrusion of the bra cup on women. Center of the nipple on men.

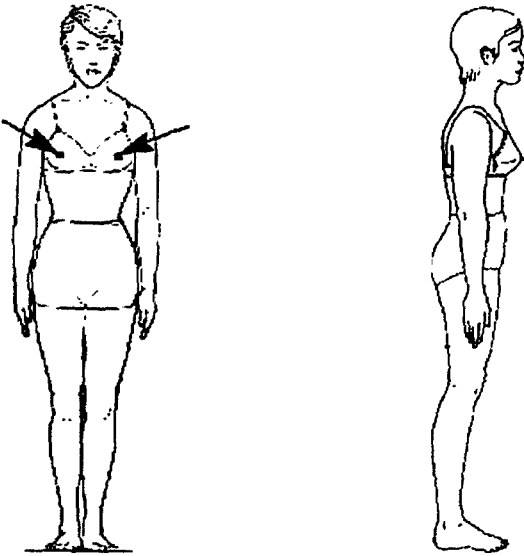

**CAESAR Name:** TRAGION, RIGHT  
**ISO Definition No.** 2.2.30  
**ISO Name:** Tragion

**Description:** Notch just above the tragus (the small cartilaginous flap in front of the ear hole).

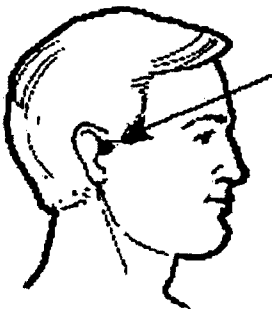



**CAESAR Name:** ULNAR STYLOID, RIGHT  
**ISO Definition No.** N/A  
**ISO Name:**

**Description:** Distal point of the ulna.

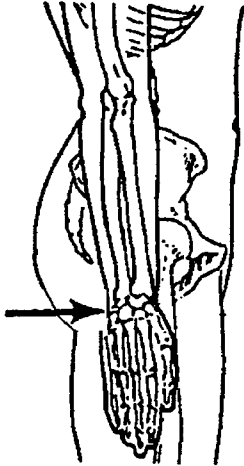

**CAESAR Name:** WAIST, PREFERRED, LATERAL  
**ISO Definition No.** N/A  
**ISO Name:**

**Description:** Level of the waist as marked on the subject's right side in the midlateral line.

*Note: Level of the waist is established by the subject placing an elastic band where he or she would prefer to wear the waist of their pants.*

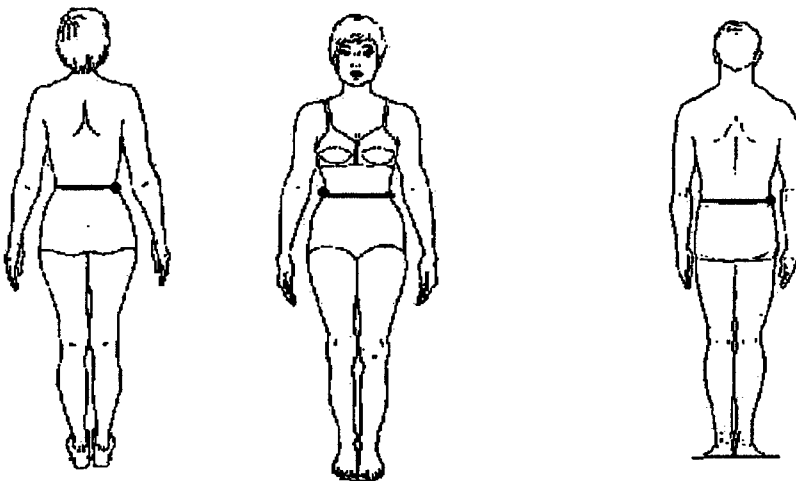

Part II. 3-D Landmarks

**CAESAR Name:** ACROMION, LEFT AND RIGHT  
**ISO Definition No.** 2.2.1  
**ISO Name:** Acromion

**Description:** Most lateral point of the lateral edge of the acromial process of the scapula.

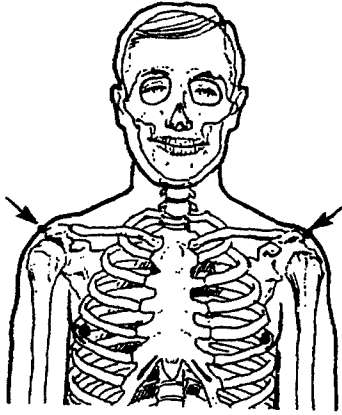

**CAESAR Name:** AXILLA POINT, ANTERIOR; LEFT AND RIGHT  
**ISO Definition No.** N/A  
**ISO Name:**

**Description:** Lowest point on the anterior axillary fold (armpit).

*Note: For scans, one adhesive dot is placed on the arm at the level of the lowest point on the axillary fold.*

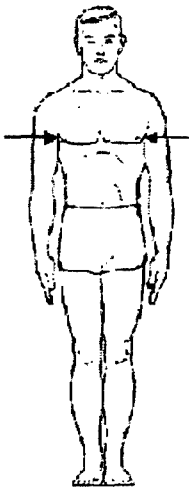

**CAESAR Name:** AXILLA POINT, POSTERIOR; LEFT AND RIGHT  
**ISO Definition No.** N/A  
**ISO Name:**

**Description:** Lowest point on the posterior axillary fold (armpit).

*Note: For scans, one adhesive dot is placed on the arm at the level of the lowest point on the axillary fold.*

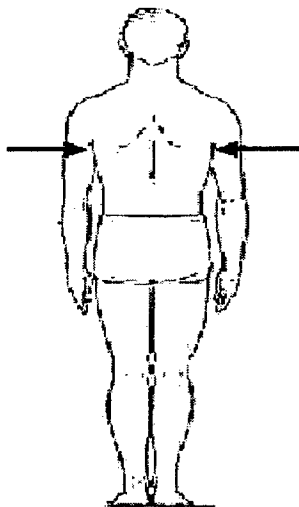

**CAESAR Name:** CALCANEUS, POSTERIOR; LEFT AND RIGHT  
**ISO Definition No.** N/A  
**ISO Name:**

**Description:** Most prominent posterior point of the heel.

*Note: The most prominent point on the heel may be on the tissue rather than on the Calcaneus bone.*

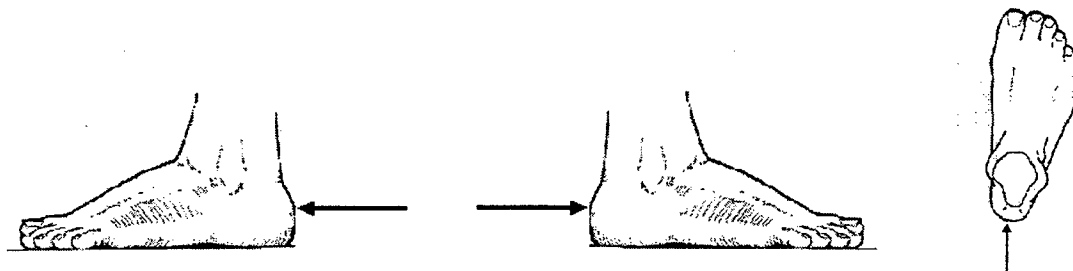

**CAESAR Name:** CERVICALE  
**ISO Definition No.** 2.2.5  
**ISO Name:** Cervicale

**Description:** Most prominent point of the spinous process of the seventh cervical vertebra (prominent bone at the base of the back of the neck).

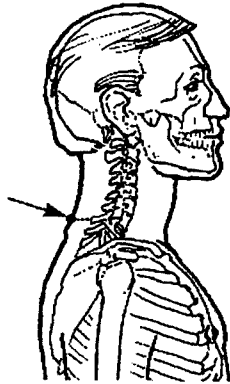

**CAESAR Name:** CLAVICALE, LEFT AND RIGHT  
**ISO Definition No.** N/A  
**ISO Name:**

**Description:** Most prominent point of the superior aspect of the medial end of the clavical at the sternoclavicular junction.

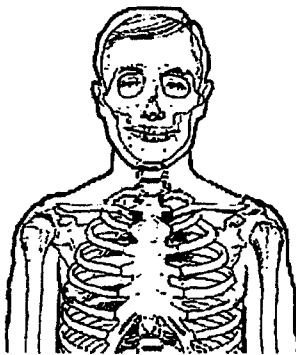

**CAESAR Name:** DACTYLION, LEFT AND RIGHT  
**ISO Definition No.** N/A  
**ISO Name:**

**Description:** Tip of the middle finger.

*Note: For scans, an adhesive dot is placed on the fingernail with the center of the dot corresponding to the tip of the finger.*

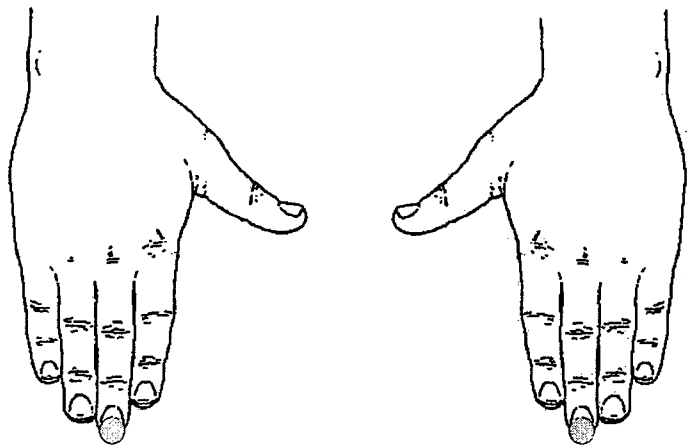

**CAESAR Name:** DIGIT II, LEFT AND RIGHT  
**ISO Definition No.** N/A  
**ISO Name:**

**Description:** Tip of the second toe.

*Note: For scans, an adhesive dot is placed on the tip of the toe, not on the toenail.*

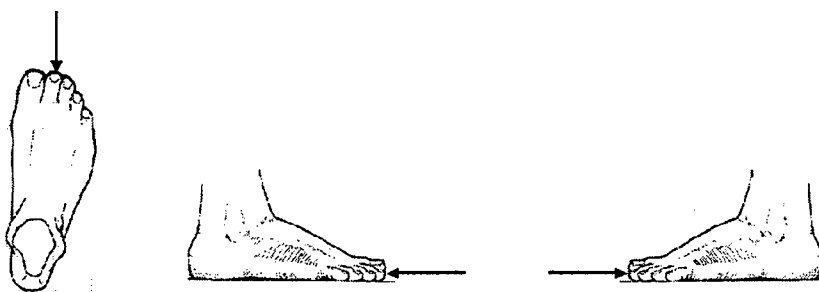

**CAESAR Name:** FEMORAL EPICONDYLE, LATERAL; LEFT AND RIGHT  
**ISO Definition No.** N/A  
**ISO Name:**

**Description:** Lateral point on the lateral epicondyle of the femur.

*Note: Femoral epicondyles are marked while the subject is standing.*

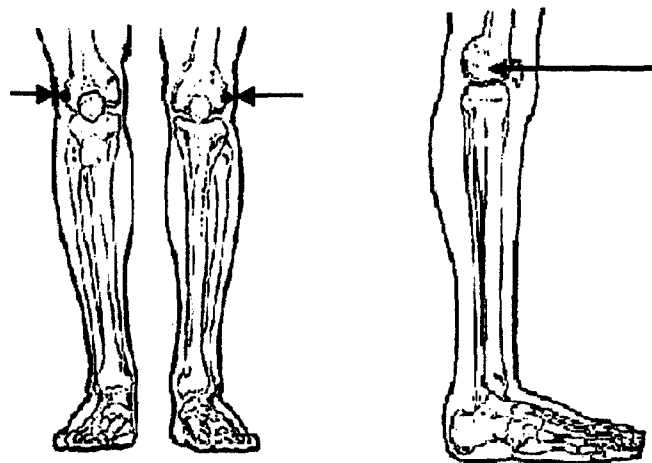

**CAESAR Name:** FEMORAL EPICONDYLE, MEDIAL; LEFT AND RIGHT  
**ISO Definition No.** N/A  
**ISO Name:**

**Description:** Medial point on the medial epicondyle of the femur.

*Note: Femoral epicondyles are marked while the subject is standing.*

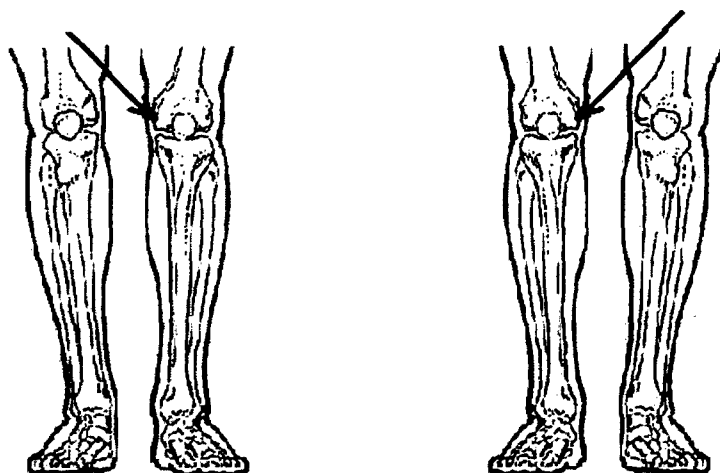

**CAESAR Name:** GONION, LEFT AND RIGHT  
**ISO Definition No.** N/A  
**ISO Name:**

**Description:** Inferior, posterior tip of the gonial angle (the posterior point on the angle of the mandible, or jawbone).

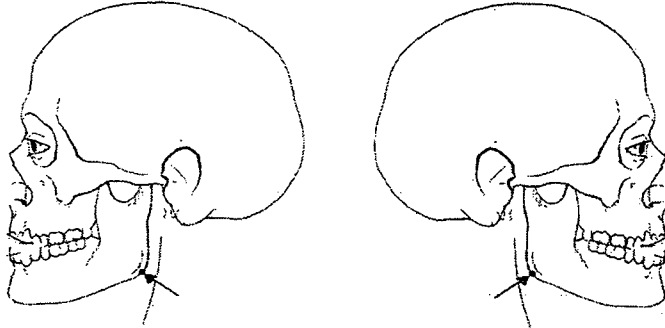

**CAESAR Name:** HUMERAL EPICONDYLE, LATERAL; LEFT AND RIGHT  
**ISO Definition No.** N/A  
**ISO Name:**

**Description:** Lateral point on the lateral epicondyle of the humerus, when the palm is facing the side of the body.

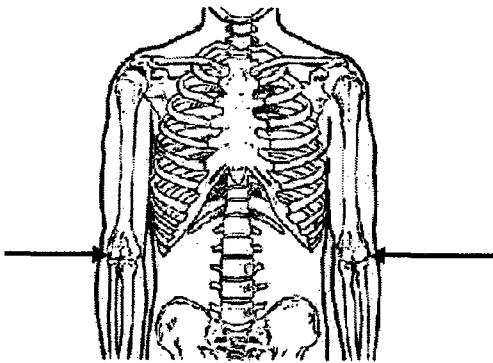

**CAESAR Name:** HUMERAL EPICONDYLE, MEDIAL; LEFT AND RIGHT  
**ISO Definition No.** N/A  
**ISO Name:**

**Description:** Medial point on the medial epicondyle of the humerus, when the palm is facing the side of the body.

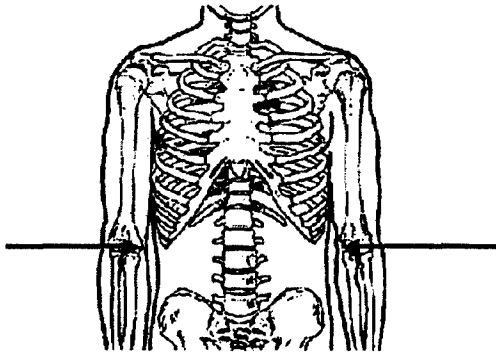

**CAESAR Name:** ILIAC SPINE, ANTERIOR, SUPERIOR; LEFT AND RIGHT  
**ISO Definition No.** N/A  
**ISO Name:**

**Description:** Prominent, anterior point on the anterior rim of the ilia.

*Note: The ilia are one of the three pair of bones that comprise the bony pelvis.*

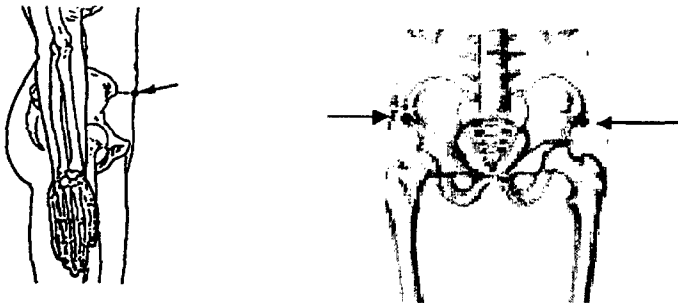



**CAESAR Name:** ILIAC SPINE, POSTERIOR, SUPERIOR; LEFT AND RIGHT  
**ISO Definition No.** N/A  
**ISO Name:**

**Description:** Prominent point on the posterior superior spine of the ilium; a dimple often overlies this point.

*Note: The ilia are one of the three pair of bones that comprise the bony pelvis.*

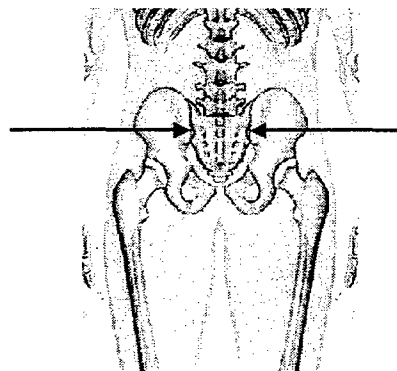

**CAESAR Name:** ILIOCRISTALE, LEFT AND RIGHT  
**ISO Definition No.** N/A  
**ISO Name:**

**Description:** Highest palpable point of the superior rim of the ilium in the mid-lateral line.

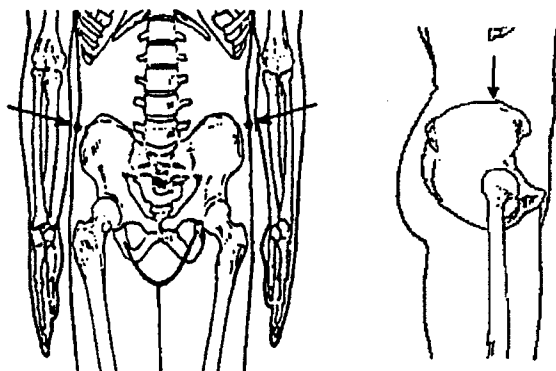

**CAESAR Name:** INFRAORBITALE, LEFT AND RIGHT

**ISO Definition No.** N/A

**ISO Name:**

**Description:** Lowest point on the inferior margin of the orbit (the bony eye socket), marked directly inferior to pupil.

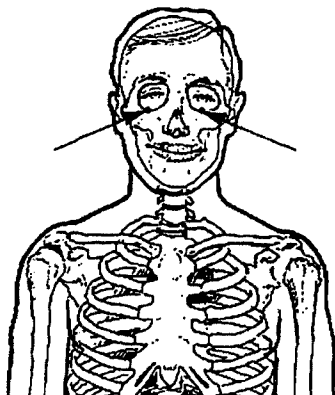

**CAESAR Name:** KNEE CREASE, LEFT AND RIGHT

**ISO Definition No.** N/A

**ISO Name:**

**Description:** Midpoint of the crease that runs medial to lateral on the posterior side of the knee.

*Note: Knee crease is marked while the subject is standing.*

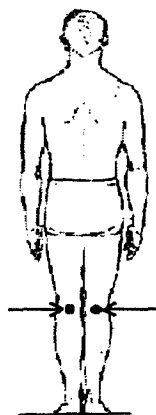

**CAESAR Name:** MALLEOLUS, LATERAL; LEFT AND RIGHT  
**ISO Definition No.** N/A  
**ISO Name:**

**Description:** Lateral point on the distal fibular protrusion of the ankle.

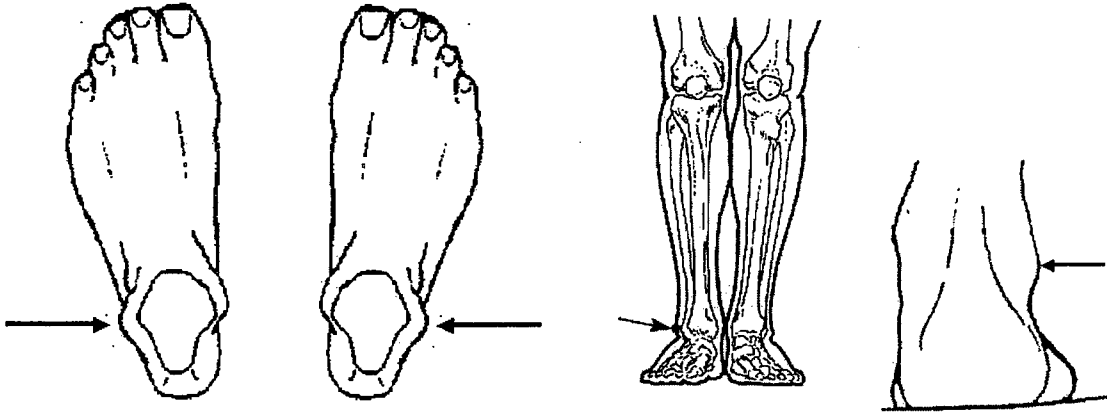

**CAESAR Name:** MALLEOLUS, MEDIAL; LEFT AND RIGHT  
**ISO Definition No.** N/A  
**ISO Name:**

**Description:** Medial point on the distal tibial protrusion of the ankle.

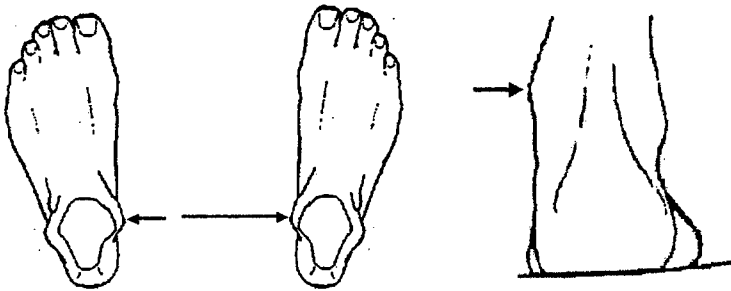

**CAESAR Name:** METACARPAL-PHALANGEAL II, LEFT AND RIGHT  
**ISO Definition No.** N/A  
**ISO Name:**

**Description:** Prominent point on the lateral surface of the second metacarpal-phalangeal joint.

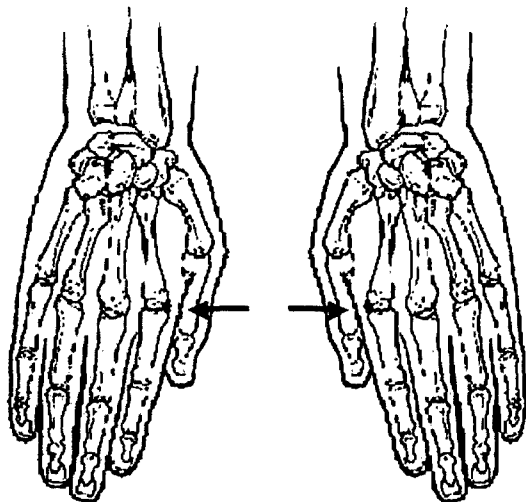

**CAESAR Name:** METACARPAL-PHALANGEAL V, LEFT AND RIGHT  
**ISO Definition No.** N/A  
**ISO Name:**

**Description:** Prominent point on the lateral surface of the fifth metacarpal-phalangeal joint.

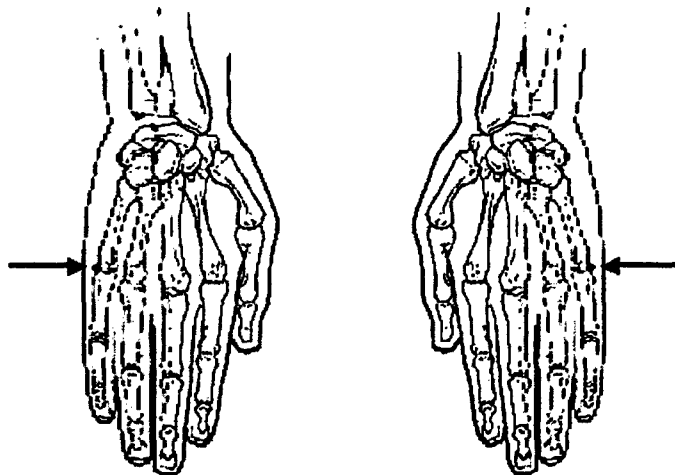

**CAESAR Name:** METATARSAL-PHALANGEAL I, LEFT AND RIGHT  
**ISO Definition No.** N/A  
**ISO Name:**

**Description:** Maximum protrusion of the inside of the foot at the head of Metatarsus I.

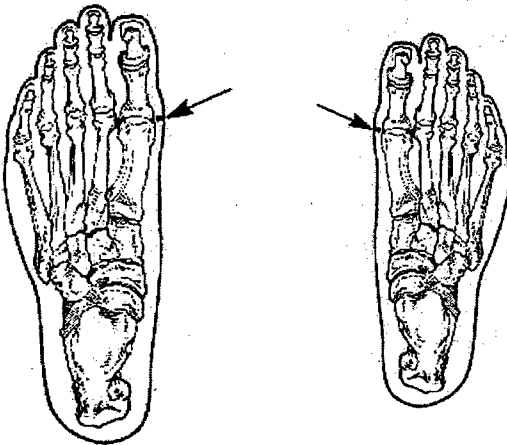

**CAESAR Name:** METATARSAL-PHALANGEAL V, LEFT AND RIGHT  
**ISO Definition No.** N/A  
**ISO Name:**

**Description:** Maximum protrusion of the outside of the foot at the head of Metatarsus V.

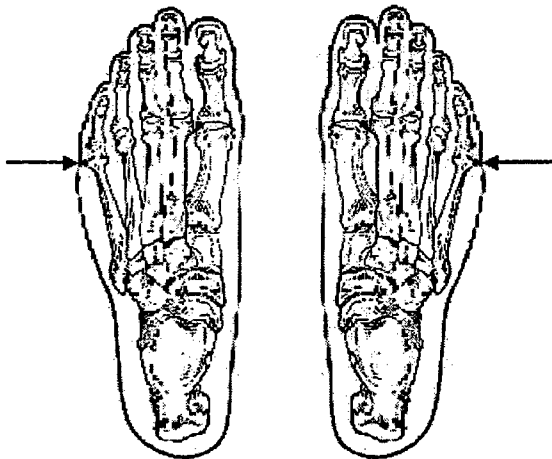

**CAESAR Name:** NUCHALE  
**ISO Definition No.** N/A  
**ISO Name:**

**Description:** Lowest point of the occiput that can be palpated among the nuchal muscles.

*Note: This point is often obscured by the hair and cap. It is marked in the midsagittal plane.*

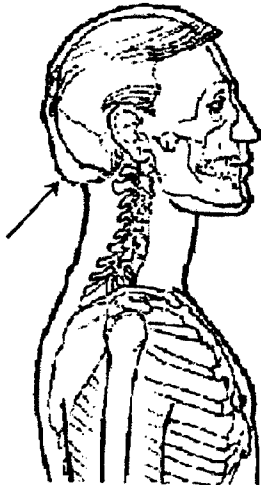

**CAESAR Name:** OLECRANON, LEFT AND RIGHT  
**ISO Definition No.** N/A  
**ISO Name:**

**Description:** Posterior point on the olecranon process of the ulna, marked with the elbow bent 90 degrees.

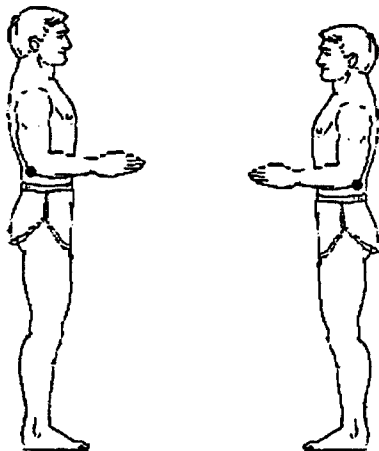

**CAESAR Name:** RADIAL STYLOID, LEFT AND RIGHT  
**ISO Definition No.** N/A  
**ISO Name:**

**Description:** Distal tip of the radius.

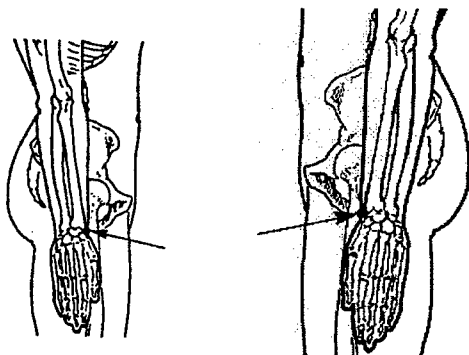

**CAESAR Name:** RADIALE, LEFT AND RIGHT  
**ISO Definition No.** N/A  
**ISO Name:**

**Description:** Proximal point on the head of the radius, near the midpoint of the elbow on the lateral aspect of the arm.

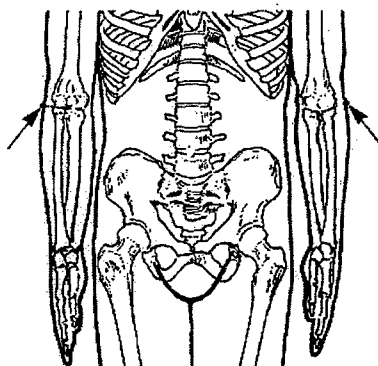

**CAESAR Name:** SELLION  
**ISO Definition No.** 2.2.19  
**ISO Name:** Nasion; Sellion

**Description:** Point of greatest indentation of the nasal root depression.

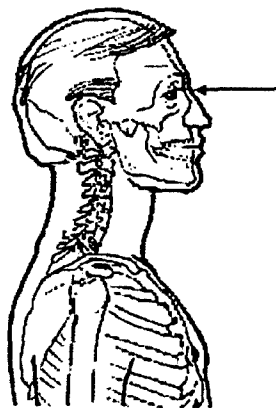

**CAESAR Name:** SPHYRION, LEFT AND RIGHT  
**ISO Definition No.** N/A  
**ISO Name:**

**Description:** Distal point on the medial side of the tibia.

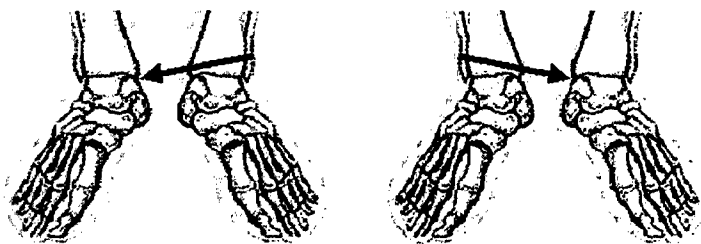



**CAESAR Name:** SUBSTERNALE  
**ISO Definition No.** N/A  
**ISO Name:**

**Description:** Lowest palpable point on the sternum (breastbone).

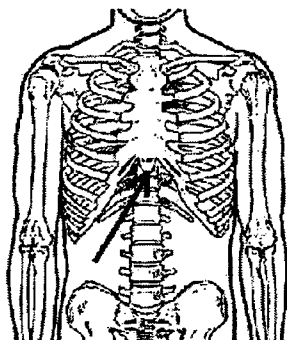

**CAESAR Name:** SUPRAMENTON  
**ISO Definition No.** N/A  
**ISO Name:**

**Description:** Point of greatest indentation of the mandibular symphysis, marked in the midsagittal plane.

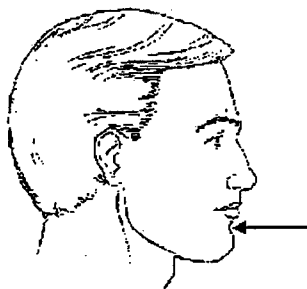

**CAESAR Name:** SUPRASTERNALE  
**ISO Definition No.** N/A  
**ISO Name:**

**Description:** Highest palpable point on the sternum (breastbone).

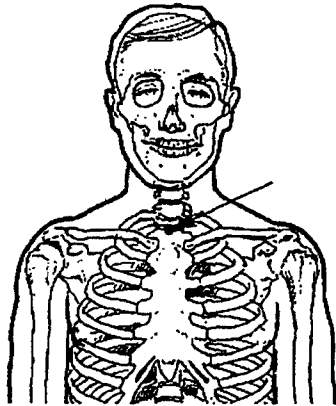

**CAESAR Name:** TENTH RIB, LEFT AND RIGHT  
**ISO Definition No.** N/A  
**ISO Name:**

**Description:** Lowest palpable point on the inferior border of the Tenth Rib at the bottom of the rib cage.

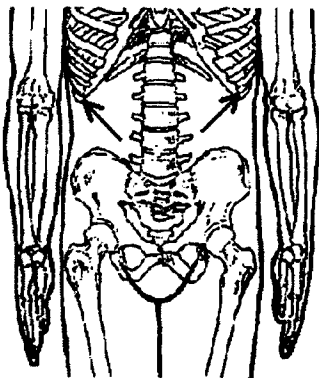

**CAESAR Name:** TENTH RIB, MIDSPINE  
**ISO Definition No.** N/A  
**ISO Name:**

**Description:** Level of the right tenth rib (landmark), marked on the spine.

*Note: The anthropometer is used to mark the height of the landmark at midspine (on the spine in the midsagittal plane).*

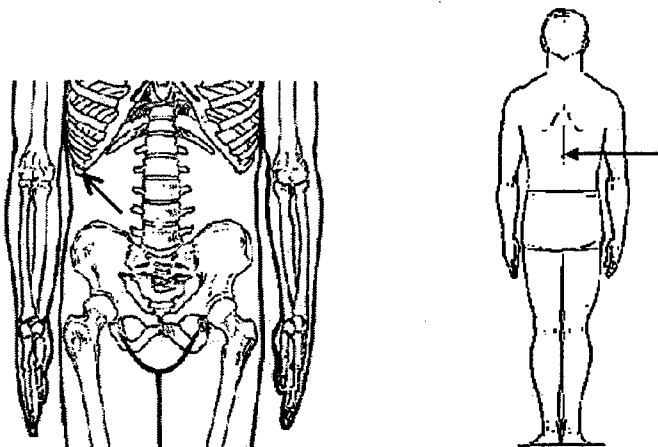

**CAESAR Name:** THELION/BUSTPOINT, LEFT AND RIGHT  
**ISO Definition No.** N/A  
**ISO Name:**

**Description:** Most anterior protrusion of the bra cup on women. Center of the nipple on men.

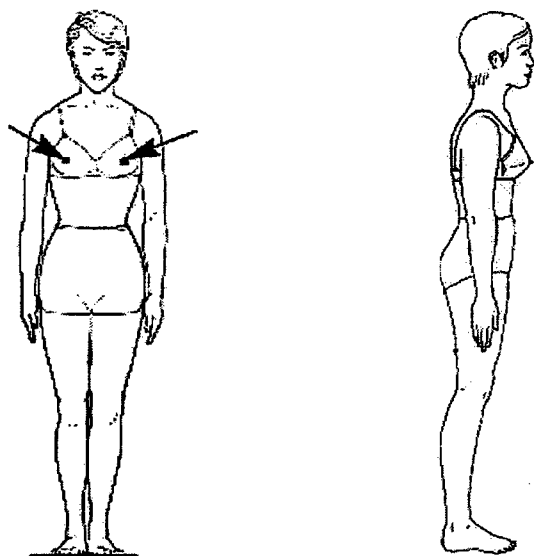

**CAESAR Name:** TRAGION, LEFT AND RIGHT  
**ISO Definition No.** 2.2.30  
**ISO Name:** Tragion

**Description:** Notch just above the tragus (the small cartilaginous flap in front of the ear hole).

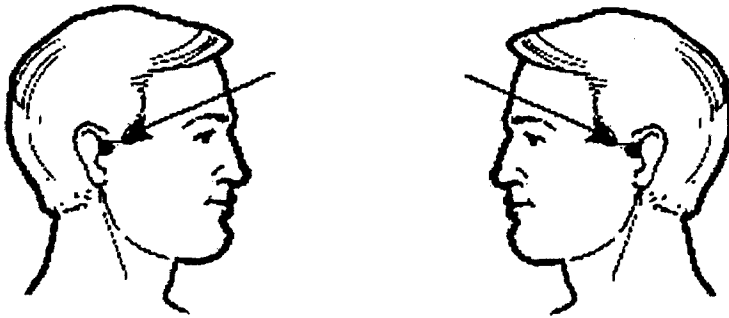

**CAESAR Name:** TROCHANTERION, LEFT AND RIGHT  
**ISO Definition No.** N/A  
**ISO Name:**

**Description:** Top of the bony lateral protrusion of the proximal end of the femur.

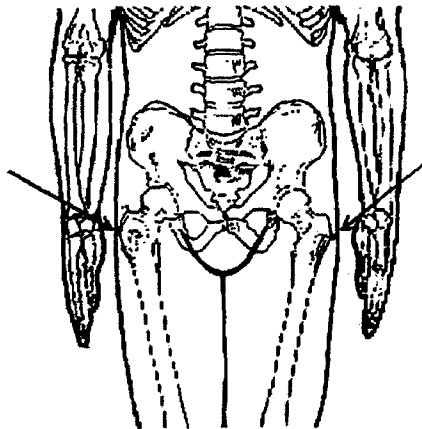

**CAESAR Name:** ULNAR STYLOID, LEFT AND RIGHT  
**ISO Definition No.** N/A  
**ISO Name:**

**Description:** Distal point of the ulna.

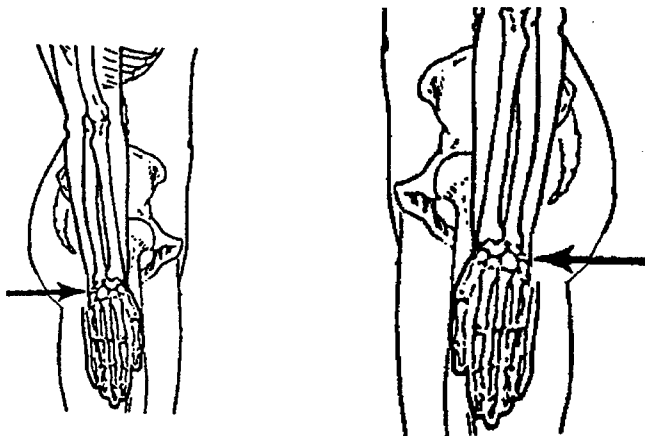

**CAESAR Name:** WAIST, PREFERRED, POSTERIOR  
**ISO Definition No.** N/A  
**ISO Name:**

**Description:** Level of the waist as marked on the subject's back in the midsagittal plane.

*Note: Level of the waist is established by the subject placing an elastic band where he or she would prefer to wear the waist of their pants. Before the elastic band is removed, a mark is placed at the preferred waist level on the subject's back in the midsagittal plane.*

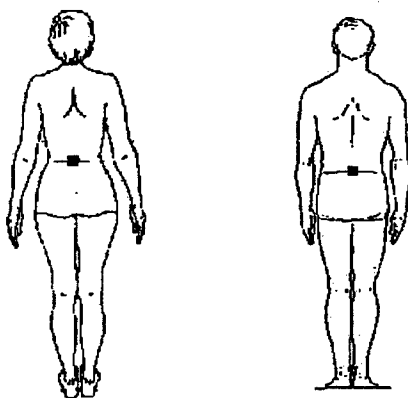

### Part III. Miscellaneous Landmarks

**CAESAR Name:** BUTT BLOCK  
**ISO Definition No.** N/A  
**ISO Name:**

**Description:** A small wooden block used for seated scans. The block is placed behind the subject on the flat seat surface (i.e., at the surface level), in light contact with the center of the subject's buttocks. The block is marked with a reference landmark.

*Note: In the scan-extracted measurement calculation another butt block point is used. This is described in Chapter IV.*

Butt Block used in North American and Italian  
Caesar Data Collection

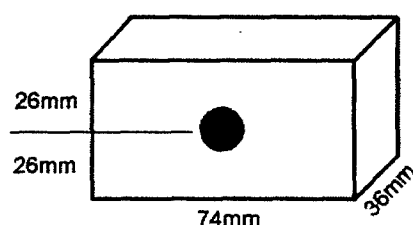

Not to scale!

**CAESAR Name:** CROTCH  
**ISO Definition No.** N/A  
**ISO Name:**

**Description:** Point calculated midway between the right and left trochanterion landmarks at the level of Crotch Height as measured with the anthropometer.

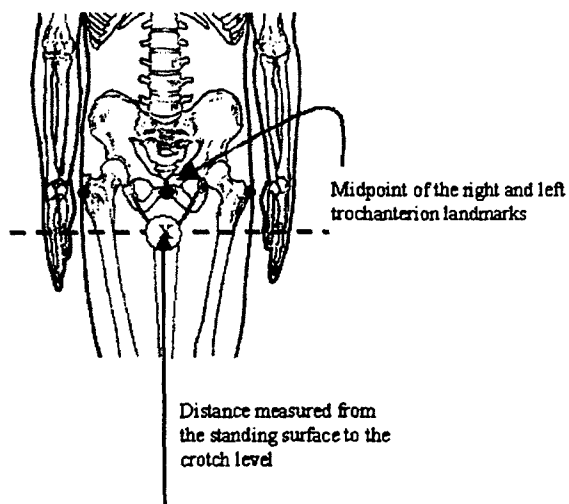

## Traditional-Style Measurement Descriptions

The CAESAR dimension descriptions are provided on the next few pages. The Dimension descriptions provide (1) the CAESAR measurement name, (2) the ISO 7250 reference number, if applicable, and (3) the corresponding ISO measurement name, if applicable.

Ideally, the CAESAR dimensions would have been assigned the ISO names; however, this was not possible because CAESAR has many left/right pairs of landmarks and several measures that are taken on both the left and right sides of the body. Because the ISO naming convention does not distinguish between left and right, it was therefore necessary to come up with a naming convention suitable for all the landmark and dimensions included in the survey. The CAESAR dimension names were derived based on the following:

Name of the **Landmark** or **Body Segment** involved in the measure. Examples include "Acromion," or "Arm."

**Measurement Type** (Length, Breadth, Height, Circumference, Reach, or Skinfold),

**Relative Position** (if applicable). Examples include anterior, posterior, lateral, medial, superior and inferior.

**Side of the body** (Left or Right, if applicable), and

**Posture** (standing/sitting).

Posture is included in the measurement name for all dimensions that (1) are measured in both the sitting and standing postures, or (2) are measured in a non-traditional posture. For example, *sitting (comfortable)* is used to emphasize that the seated CAESAR posture is different than the standard, anthropometric sitting posture.

The traditional-style dimensions are measured on the right side of the body for the following body parts or segments: acromion or shoulder, ankle, arm, buttock, elbow, eye, foot, hand, knee, thigh, wrist, and scapular and triceps skinfolds.

The traditional-style dimensions are described in detail, complete with photographic images and illustrations, on the following pages. They are separated listed in alphabetical order, and ISO 7250 names are referenced where applicable.

Descriptions of the Scan Extracted Measures are provided in this chapter under Scan Measurement Descriptions.

**1. CAESAR Name:** ACROMIAL HEIGHT, SITTING  
**ISO Reference No.** 4.2.4  
**ISO Name:** Shoulder Height, Sitting

**Description:** Vertical distance from a horizontal sitting surface to acromion.

**Method:** Subject sits erect on a flat surface, looking straight ahead. Knees are bent at right angles and the feet are supported. Thighs are parallel to each other, the feet are in line with the thighs, and the knees are bent 90°. Upper arms hang freely downwards and forearms are horizontal.

**Instrument:** Anthropometer.

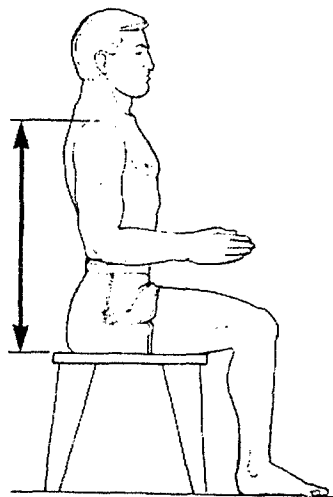

**2. CAESAR Name:** ANKLE CIRCUMFERENCE  
**ISO Reference No.** N/A  
**ISO Name:**

**Description:** Circumference of the ankle measured across the malleoli.

**Method:** Subject stands erect with the weight distributed equally on both feet.

**Instrument:** Steel tape measure.



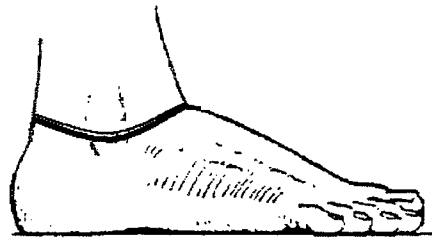

**3. CAESAR Name:** ARM LENGTH (SHOULDER-ELBOW)  
**ISO Reference No.** N/A  
**ISO Name:**

**Description:** Calculated by subtracting the Spine-Shoulder Length measurement from the Spine-Elbow Length measurement.

**Method:** Subject stands erect with the arm bent and fist placed on the hip. Distances from cervicale to the shoulder (Spine-Shoulder Length), from cervicale to the elbow (Spine-Elbow Length), and from cervicale to the wrist (Spine-Wrist Length) are measured in one continuous motion.

**Instrument:** Steel tape measure.

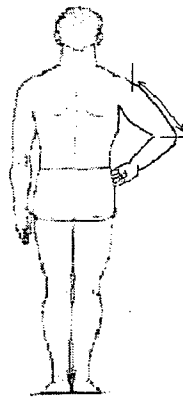

**4. CAESAR Name:** ARM LENGTH (SHOULDER-WRIST)  
**ISO Reference No.** N/A  
**ISO Name:**

**Description:** Calculated by subtracting Spine-Shoulder Length measurement from Spine-Wrist Length measurement.

**Method:** Subject stands erect with the arm bent and fist placed on the hip. Distances from cervicale to the shoulder (Spine-Shoulder Length), from cervicale to the elbow (Spine-Elbow Length), and from cervicale to the wrist (Spine-Wrist Length) are measured in one continuous motion.

**Instrument:** Steel tape measure.

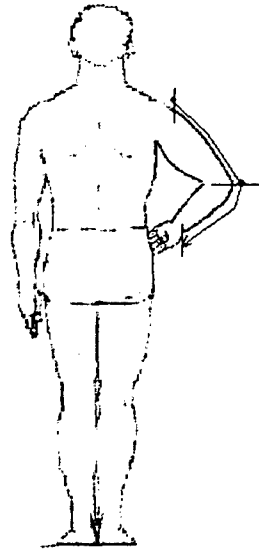

**5. CAESAR Name:** ARM LENGTH (SPINE-WRIST)  
**ISO Reference No.** N/A  
**ISO Name:**

**Description:** Surface distance measured from cervicale through acromion to a wrist band placed at the ulnar styloid landmark.

**Method:** Subject stands erect with the arm bent and fist placed on the hip.

**Instrument:** Steel tape measure.

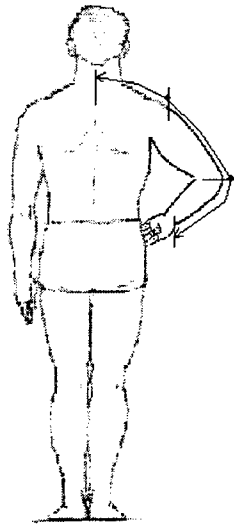
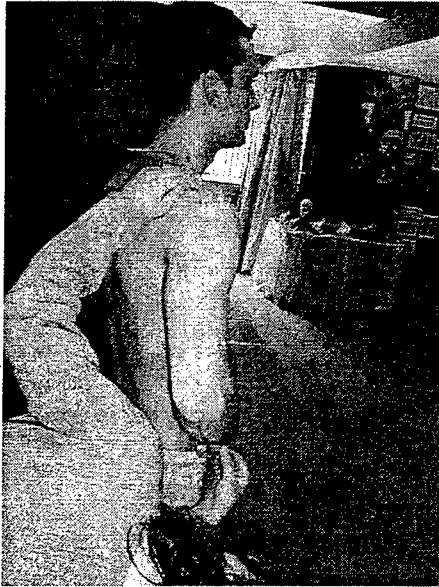

**6. CAESAR Name:** ARMSCYE CIRCUMFERENCE (SCYE CIRCUMFERENCE OVER ACROMION)

**ISO Reference No.** N/A

**ISO Name:**

**Description:** Distance from acromion through the armpit, and back to acromion.

**Method:** Subject stands erect with arm bent and fist placed on hip. Tape is placed through armpit, then subject relaxes the arm at the side so arm hangs freely downward. Dimension is measured from acromion, through the front-break point<sup>1</sup>, through the armpit, through the back-break point<sup>2</sup>, to acromion.

**Instrument:** Steel tape measure.

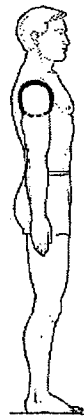
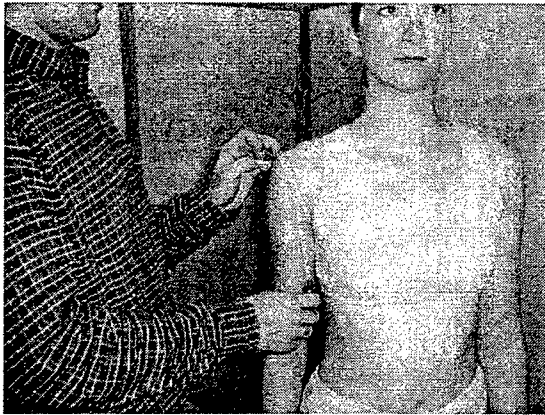

<sup>1</sup> Front-break point is the location on the front of the body where the arm separates from the body.

<sup>2</sup> Back-break point is location on the back of the body where the arm separates from the body.

**7. CAESAR Name:** BIZYGOMATIC BREADTH  
**ISO Reference No.** N/A  
**ISO Name:**

**Description:** Maximum horizontal distance is measured across the face between the zygomatic arches (cheekbones).

**Method:** Subject faces straight ahead with teeth lightly closed but not clenched.

**Instrument:** Spreading caliper.

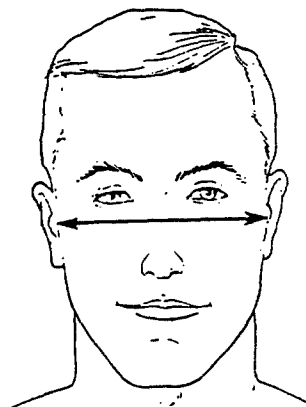
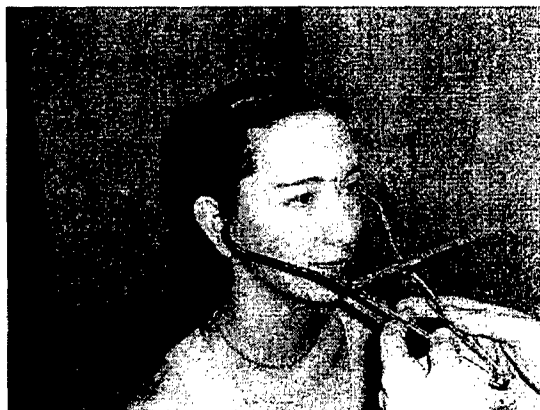

**8. CAESAR Name:** BUST/CHEST CIRCUMFERENCE  
**ISO Reference No.** 4.4.9  
**ISO Name:** Chest Circumference

**Description:** Circumference of the torso measured at nipple level.

**Method:** Subject stands fully erect with the weight distributed equally on both feet and the arms hanging freely downwards. Subject's feet are placed in footprints adhered to the standing surface (footprints are positioned approximately 10 cm apart at the heels and rotated 33° at the toes).

**Note:** *Males are measured shirtless; females wear their usual brassiere under the CAESAR top.*

**Instrument:** Steel tape measure.

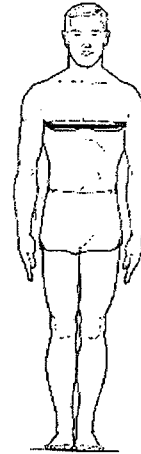
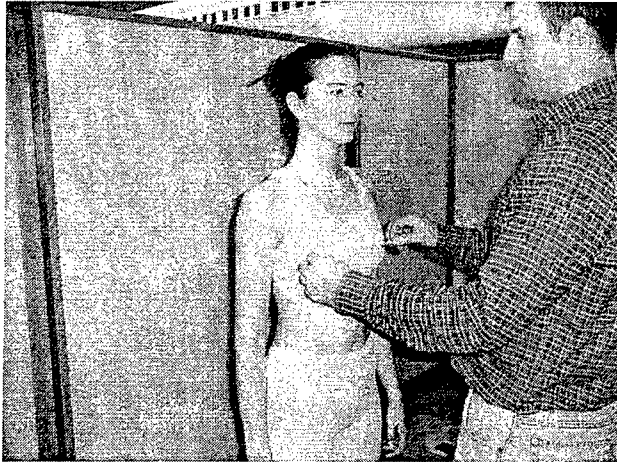

**9. CAESAR Name:** BUST/CHEST CIRCUMFERENCE UNDER BUST  
**ISO Reference No.** N/A  
**ISO Name:**

**Description:** Horizontal circumference of the torso is measured on female subjects just below the cups of the bra.

**Method:** Subject stands fully erect with the weight distributed equally on both feet and the arms hanging freely downwards. Subject's feet are placed in footprints adhered to the standing surface (footprints are positioned approximately 10 cm apart at the heels and rotated 33° at the toes). Circumference is measured parallel to the standing surface and is taken at the maximum point of quiet respiration.

**Instrument:** Steel tape measure.

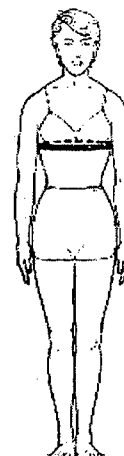
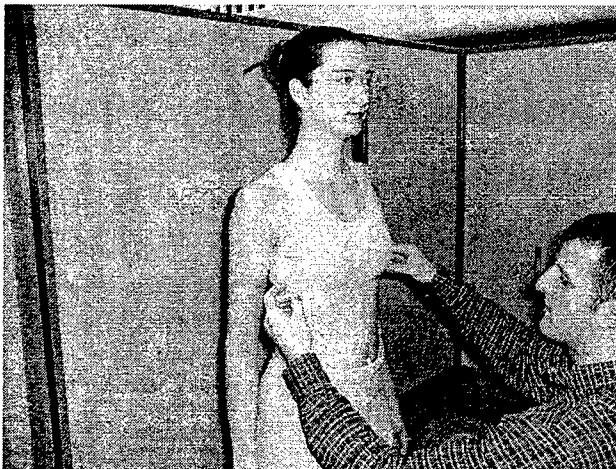

**10. CAESAR Name:** BUTTOCK-KNEE LENGTH, RIGHT  
**ISO Reference No.** 4.4.7  
**ISO Name:** Buttock-Knee Length

**Description:** Horizontal distance from the foremost point of the kneecap to the rearmost point of the buttock.

**Method:** Subject sits erect on a flat surface, looking straight ahead. Knees are bent at right angles and the feet are supported. Thighs are parallel to each other, the feet are in line with the thighs, and knees are bent 90°. Upper arms hang freely downwards and forearms are horizontal.

**Instrument:** Anthropometer (large spreading caliper).

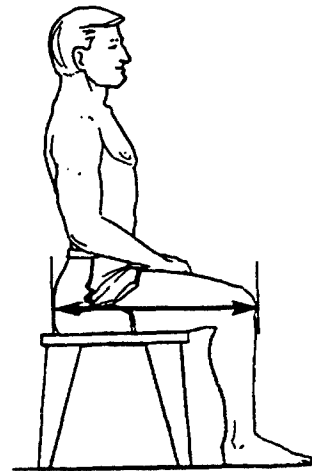
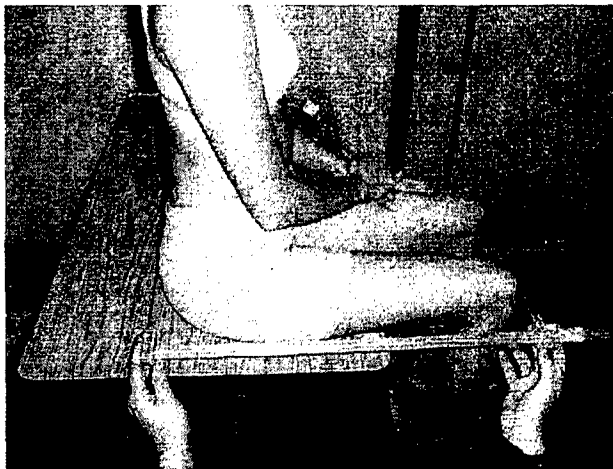

**11. CAESAR Name:** CHEST GIRTH (CHEST CIRCUMFERENCE AT SCYE)  
**ISO Reference No.** N/A  
**ISO Name:**

**Description:** Maximum circumference of the body is measured over the shoulder blades, under the arms, and across the upper chest.

**Method:** Subject stands fully erect with the weight distributed equally on both feet and the arms hanging freely downwards. Circumference is measured parallel to the standing surface and is taken at the maximum point of quiet respiration.

**Instrument:** Steel tape measure.

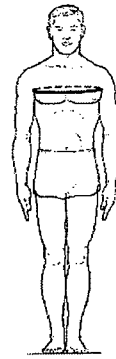
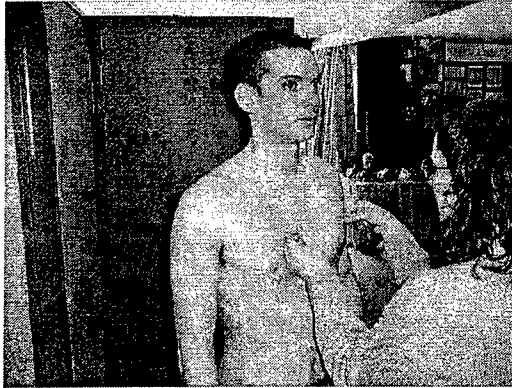

**12. CAESAR Name:** CROTCH HEIGHT  
**ISO Reference No.** 4.1.7  
**ISO Name:** Crotch Height

**Description:** Vertical distance from the standing surface to the crotch. The anthropometer bar is placed between the thighs and raised by the subject to the point where it comfortably touches the highest point of the crotch.

**Method:** Subject stands fully erect with the weight distributed equally on both feet and the arms hanging freely. Subject's feet are placed in footprints adhered to the standing surface (the footprints are positioned approximately 10 cm apart at the heels and rotated 33° at the toes).

**Instrument:** Anthropometer.

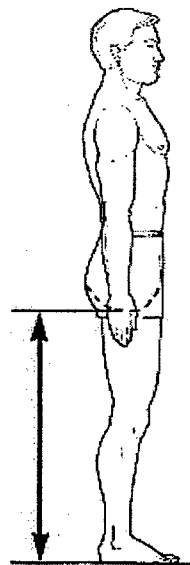
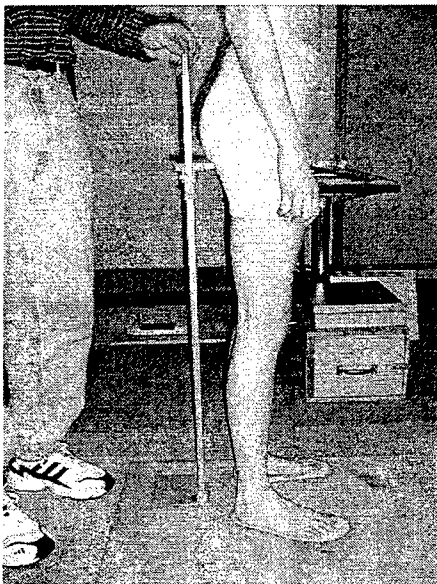

**13. CAESAR Name:** ELBOW HEIGHT, SITTING, RIGHT  
**ISO Reference No.** 4.2.5  
**ISO Name:** Elbow Height, Sitting

**Description:** Vertical distance from a horizontal sitting surface to the lowest bony point of the elbow bent at a right angle with the forearm horizontal.

**Method:** Subject sits erect on a flat surface, looking straight ahead. Knees are bent at right angles and feet are supported. Thighs are parallel to each other, feet are in line with the thighs, and knees are bent 90°. Upper arms hang freely downwards and forearms are horizontal.

**Instrument:** Anthropometer.

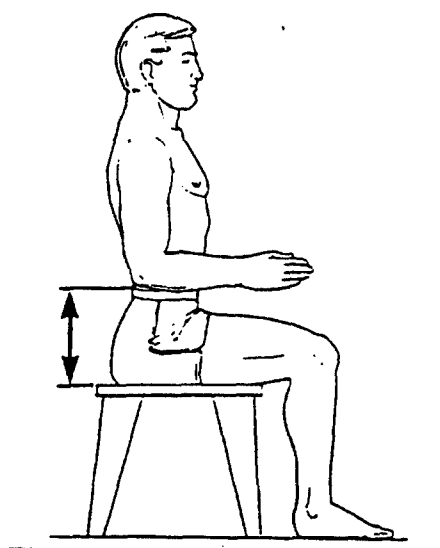

**14. CAESAR Name:** EYE HEIGHT, SITTING, RIGHT  
**ISO Reference No.** 4.2.2  
**ISO Name:** Eye Height, Sitting

**Description:** Vertical distance from a horizontal sitting surface to the outer corner of the eye.

**Method:** Subject sits erect on a flat surface, looking straight ahead. Knees are bent at right angles and feet are supported. Thighs are parallel to each other, feet are in line with the thighs, and knees are bent 90°. Upper arms hang freely downwards and forearms are horizontal.

**Instrument:** Anthropometer.



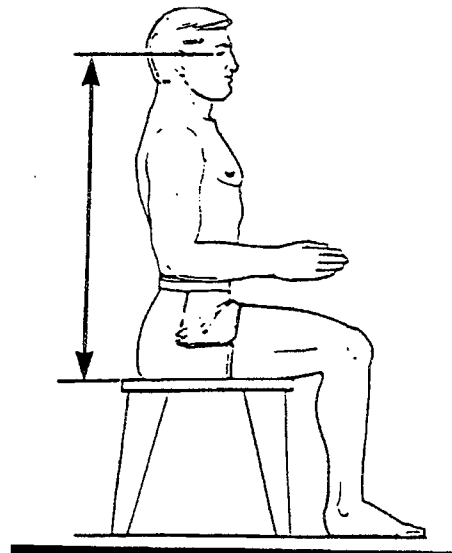

**15. CAESAR Name:** FACE LENGTH (MENTON-SELLION LENGTH)  
**ISO Reference No.** 4.3.11  
**ISO Name:** Face Length (Nasion-Menton)

**Description:** Distance between nasion and menton.

**Method:** Subject keeps mouth closed. Subject looks straight ahead.

**Instrument:** Sliding caliper.

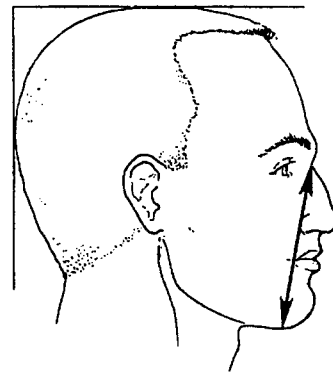
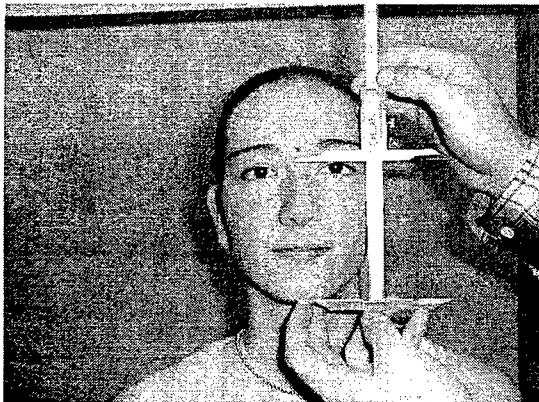

**16. CAESAR Name:** FOOT LENGTH, RIGHT  
**ISO Reference No.** 4.3.7  
**ISO Name:** Foot Length

**Description:** Maximum distance from the rear of the heel to the tip the longest (first or second) toe, measured parallel to the longitudinal axis of the foot.

**Method:** Subject stands with weight equally distributed on both feet.

**Instrument:** Anthropometer.

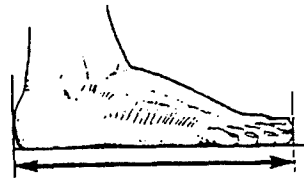
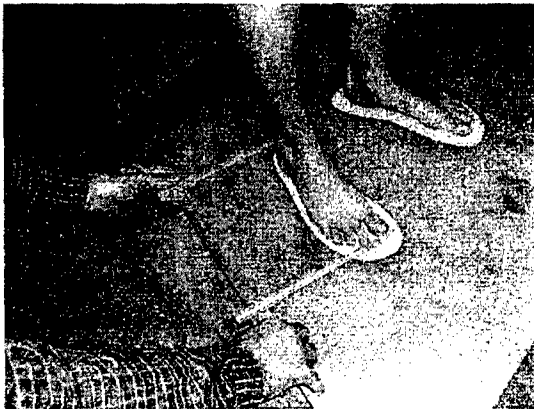

**17. CAESAR Name:** HAND CIRCUMFERENCE, RIGHT  
**ISO Reference No.** N/A  
**ISO Name:**

**Description:** Circumference of the hand is measured across knuckles of the index and little ("pinky") fingers at the point of each knuckle's greatest protrusion.

**Method:** Hand is held palm down with the fingers together and straight, and with thumb held away from the side of the hand.

**Instrument:** Steel tape measure.

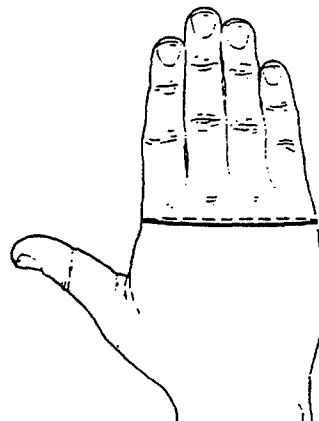

**18. CAESAR Name:** HAND LENGTH, RIGHT  
**ISO Reference No.** 4.3.1  
**ISO Name:** Hand Length

**Description:** Perpendicular distance from the elastic band that passes over the styloid process to the tip of the middle finger.

**Method:** Subject holds the forearm horizontal with hand stretched out flat, palm up.

**Instrument:** Sliding caliper.

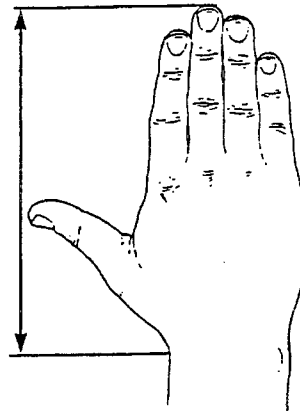
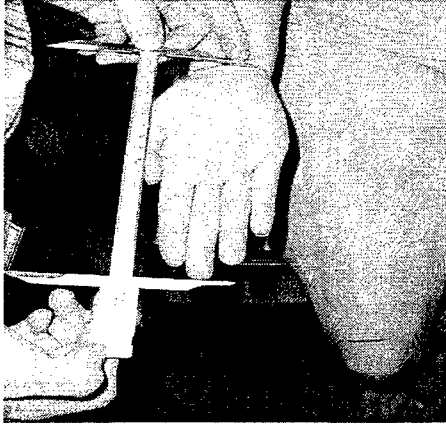

**19. CAESAR Name:** HEAD BREADTH  
**ISO Reference No.** 4.3.10  
**ISO Name:** Head Breadth

**Description:** Maximum breadth of head above the ears [measured perpendicular to the midsagittal plane.]

**Method:** Position of head has no influence on the measurement.

**Instrument:** Spreading caliper.

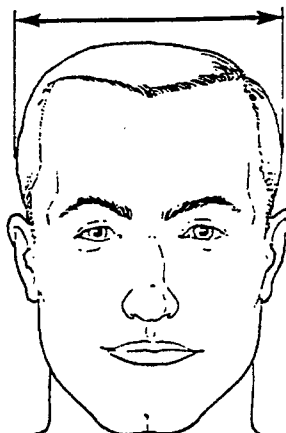

**20. CAESAR Name:** HEAD CIRCUMFERENCE  
**ISO Reference No.** 4.3.12  
**ISO Name:** Head Circumference

**Description:** Maximum, approximately horizontal circumference of head measured above the glabella and crossing the rearmost point of the skull.

**Method:** Tape measure is held on the glabella and led around the head so as to pass over the rearmost point of the skull. Hair shall be included in the measurement.

**Instrument:** Steel tape measure.

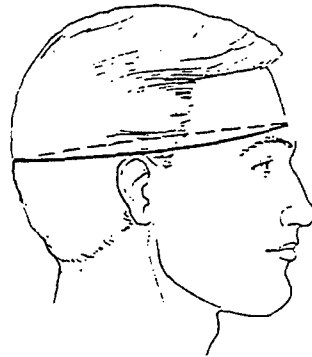

**21. CAESAR Name:** HEAD LENGTH  
**ISO Reference No.** 4.3.9  
**ISO Name:** Head Length

**Description:** Distance along a straight line between the glabella and the rearmost point of the skull.

**Method:** Position of head has no influence on the measurement.

**Instrument:** Spreading caliper.

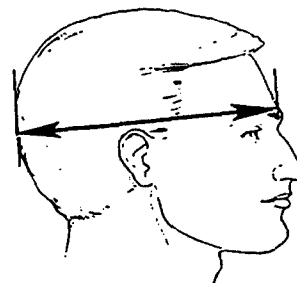

**22. CAESAR Name:** HIP BREADTH, SITTING  
**ISO Reference No.** 4.2.11  
**ISO Name:** Hip Breadth, Sitting

**Description:** Breadth of the body measured across the widest portion of the hips.

**Method:** Subject sits erect on a flat surface, looking straight ahead. Knees are bent at right angles and the feet are supported. Thighs, knees, and feet are kept together (touching). Knees are bent 90°. Measurement is taken without pressing into the flesh of the hips.

**Instrument:** Anthropometer (large spreading caliper).

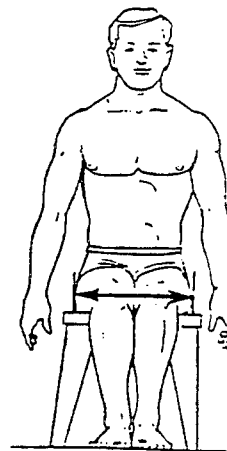
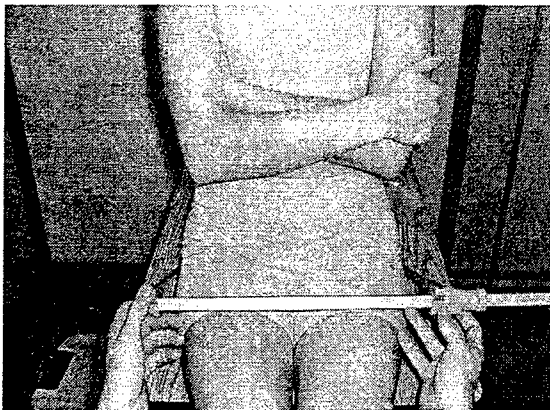

**23. CAESAR Name:** HIP CIRCUMFERENCE, MAXIMUM  
**ISO Reference No.** N/A  
**ISO Name:**

**Description:** Maximum hip circumference is measured parallel to the standing surface.

**Method:** Subject stands erect, looking straight ahead. Subject's feet are placed in footprints adhered to the standing surface (the footprints are positioned approximately 10 cm apart at the heels and rotated 33° at the toes).

*Note: The measurer and recorder take this measurement as a team. The tape is placed around the subject's torso approximately 2 cm above the maximum protrusion of the buttocks (visual inspection will often suggest the approximate area of the maximum circumference). The measurer and recorder use each other to establish that the plane of the tape is horizontal at all times. The tape is moved up and down from the starting point at approximately 1 cm intervals as directed by the measurer, who reads the tape and tracks each measurement until the maximum circumference is located. (The measurements will increase approaching the maximum circumference, and decrease as you move away from the maximum, so the measurer makes a mental note of each of the values until the circumferences begin to decrease and each successive measurement is smaller than the last.) The measurer and recorder return to the level of the maximum value, where the measurement is made and recorded.*

In some cases, the maximum circumference will occur over a fairly broad area of the torso. In such cases, the level is defined as the midpoint of the area at which the maximum circumference occurs. Also, occasionally a subject's waist may be larger than his or her hip. In these instances the maximum hip circumference is defined as the maximum circumference which also is below the top of the pelvis (below the iliac crest).

**Instrument:** Steel tape measure.

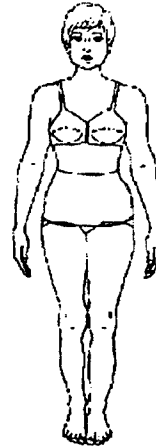
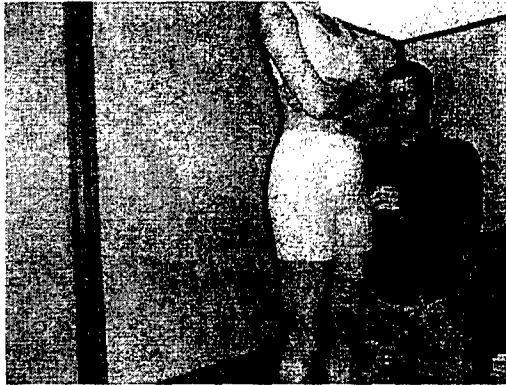

**24. CAESAR Name:** HIP CIRCUMFERENCE, MAXIMUM, HEIGHT  
**ISO Reference No.** N/A  
**ISO Name:**

**Description:** Vertical distance from the standing surface to the level of the maximum Hip Circumference.

**Method:** Subject stands erect, looking straight ahead with the weight distributed equally on both feet. Subject's feet are placed in footprints adhered to the standing surface (the footprints are positioned approximately 10 cm apart at the heels and rotated 33° at the toes). The height is measured to the level of the maximum hip circumference in the right mid-lateral line, before the tape is removed after taking the circumference.

**Instrument:** Anthropometer.

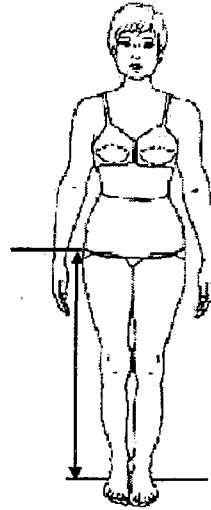

**25. CAESAR Name:** KNEE HEIGHT, SITTING, RIGHT  
**ISO Reference No.** 4.2.14  
**ISO Name:** Knee Height

**Description:** Vertical distance from the foot support surface to the highest point of the border of the patella.

**Method:** Subject sits erect on a flat surface with knees bent at right angles and the feet supported.

**Instrument:** Anthropometer.

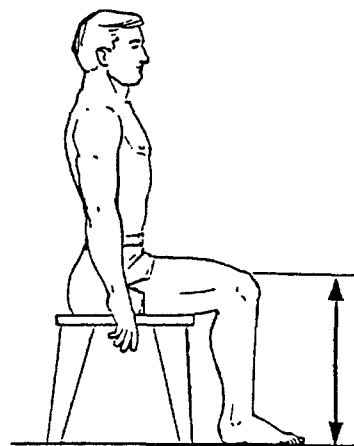
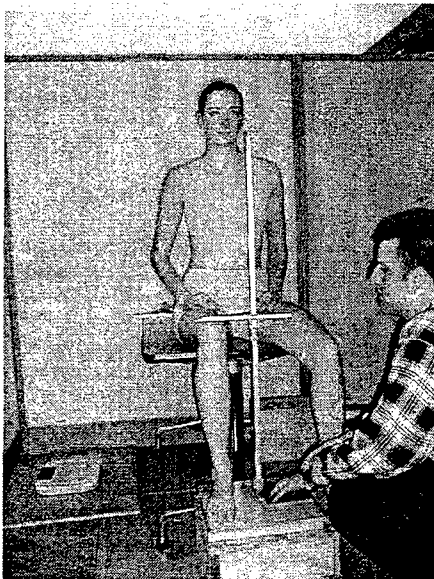

**26. CAESAR Name:** NECK BASE CIRCUMFERENCE  
**ISO Reference No.** N/A  
**ISO Name:**

**Description:** Circumference of the base of the neck is measured across the cervicale landmark at the juncture of the neck and the shoulders.

**Method:** Subject sits erect on a flat surface, looking straight ahead. This measurement is taken with a beaded chain with an alligator clip at one end. The chain is placed and clipped together so it lies at the base of the neck and falls over the cervicale landmark. The length of chain to the bead where it is clipped is measured.

**Instrument:** Steel tape measure.

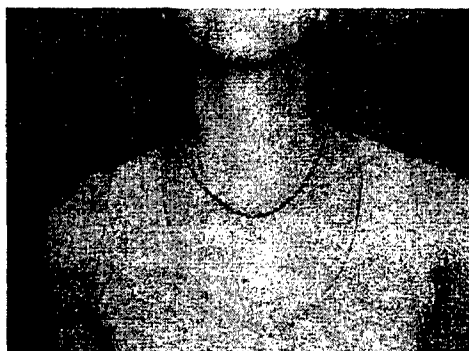

*NOTE: this picture is used solely to illustrate the neck chain. It does NOT reflect the accurate placement of the chain on a subject's neck.*

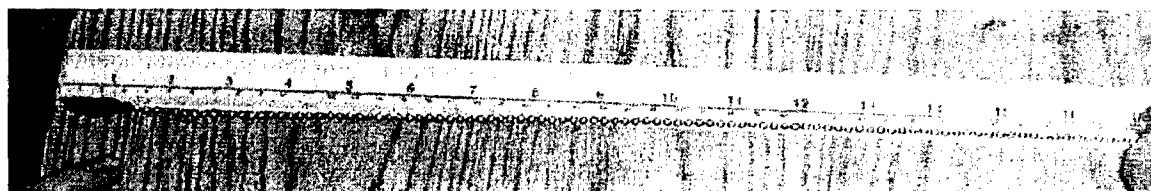

**27. CAESAR Name:** SHOULDER BREADTH, (BIDELTOID)  
**ISO Reference No.** 4.2.9  
**ISO Name:** Shoulder (Bideltoid) Breadth

**Description:** Distance across the maximum protrusions of the right and left deltoid muscles.

**Method:** Subjects stands fully erect with shoulders relaxed.

**Instrument:** Anthropometer (large spreading caliper).



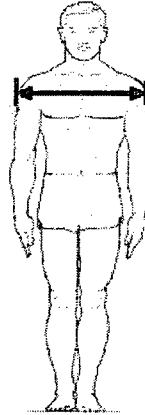

**28. CAESAR Name:** SITTING HEIGHT  
**ISO Reference No.** 4.2.1  
**ISO Name:** Sitting Height (Erect)

**Description:** Vertical distance from a horizontal sitting surface to the highest point of the head (vertex).

**Method:** Subject sits erect on a flat surface, looking straight ahead. Knees are bent at right angles and the feet are supported. Thighs are parallel to each other, the feet are in line with the thighs, and the knees are bent 90°. Upper arms hang freely downwards and forearms are horizontal.

**Instrument:** Anthropometer.

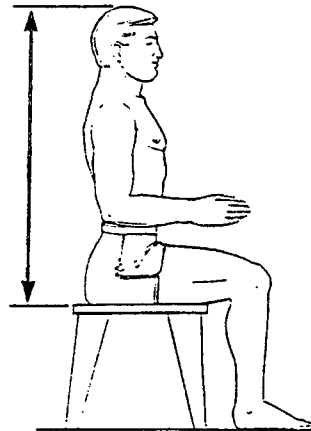

**29. CAESAR Name:** STATURE  
**ISO Reference No.** 4.1.2  
**ISO Name:** Stature (Body Height)

**Description:** Vertical distance from the standing surface to the highest point of the head (vertex).

**Method:** Subject stands fully erect with the weight distributed equally on both feet and the arms hanging freely downwards. The subject's feet are placed in footprints adhered to the standing surface (the footprints are positioned approximately 10 cm apart at the heels and rotated 33° at the toes).

**Instrument:** Anthropometer.

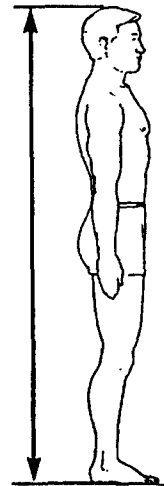

**30. CAESAR Name:** SUBSCAPULAR SKINFOLD, RIGHT  
**ISO Reference No.** N/A  
**ISO Name:**

**Description:** Thickness of skinfold overlying the shoulder blade.

**Method:** Subject stands with the shoulders and arms relaxed. Dimension is measured on the diagonal fold of skin and tissue (fat) at the tip of the right scapula.

**Instrument:** Lange skinfold caliper.

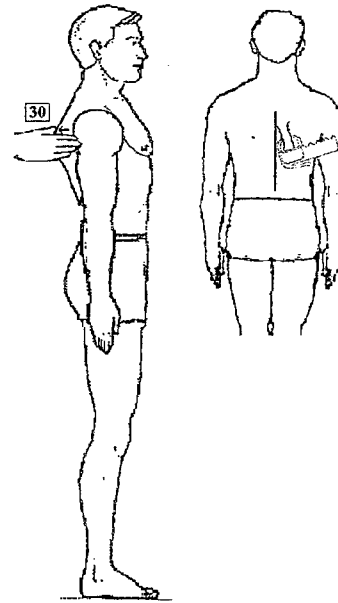
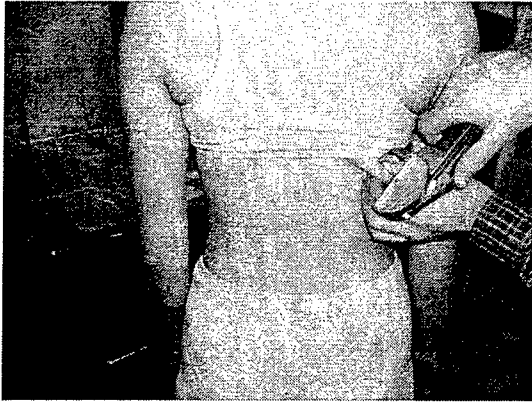

**31. CAESAR Name:** THIGH CIRCUMFERENCE, MAXIMUM, RIGHT  
**ISO Reference No.** N/A  
**ISO Name:**

**Description:** Maximum circumference of the thigh.

**Method:** Subject stands fully erect with the weight distributed equally on both feet and the arms hanging freely downwards. Maximum is established by placing the tape measure around the thigh at its proximal end (at the thigh/buttock juncture) and moving the tape measure down the thigh in one-centimeter increments until the maximum circumference is reached.

*Note: Maximum circumference is not necessarily located immediately below the gluteal furrow (at the thigh/buttock juncture).*

**Instrument:** Steel tape measure.

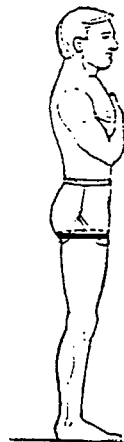

**32. CAESAR Name:** THIGH CIRCUMFERENCE, MAXIMUM, SITTING, RIGHT  
**ISO Reference No.** N/A  
**ISO Name:**

**Description:** Maximum circumference of the right thigh is measured on a seated subject.

**Method:** Subject sits erect on a flat surface with the entire upper leg resting on the flat surface and the lower leg dangling. Maximum circumference is established by placing the tape measure around the flattened thigh at its proximal end (at the thigh/buttock juncture) with the tape measure held perpendicular to the sitting surface. Maximum circumference is established by moving the tape measure down the thigh in one-centimeter increments until the maximum thigh circumference is found.

*NOTE: Maximum circumference may exist at the thigh/buttock juncture; however, on some subjects the tape measure may not be perpendicular to the sitting surface in this case the initial circumference would be more distal than the thigh/buttock juncture.*

**Instrument:** Steel tape measure.

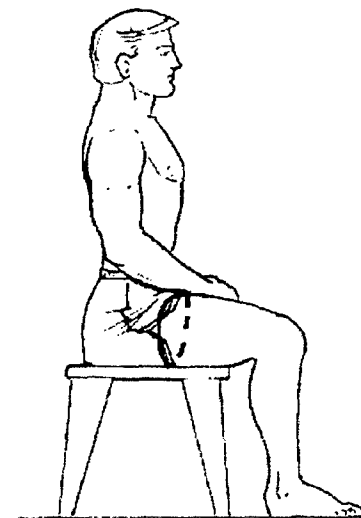
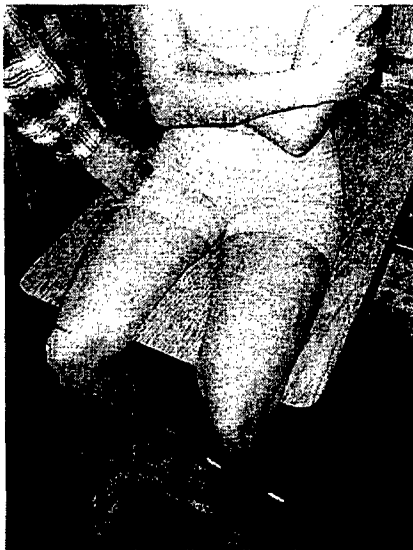

**33. CAESAR Name:** THUMB TIP REACH, RIGHT  
**ISO Reference No.** N/A  
**ISO Name:**

**Description:** Maximum horizontal reach measured from the back (the wall surface) to the juncture of the index finger and thumb.

**Method:** Subject stands with shoulders and back against a wall. Heels are 10 centimeters from the wall, approximately shoulder-width apart. Arm is extended forward with the index finger and thumb touching. Arm is held perpendicular to the wall (horizontal).

**Instrument:** Anthropometer.

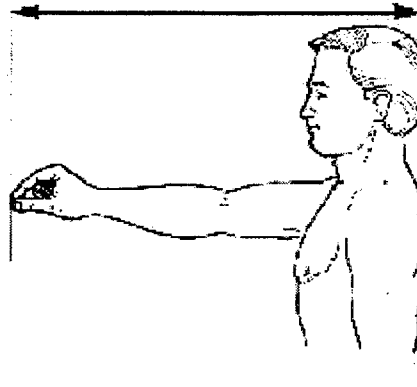

**34. CAESAR Name:** TOTAL CROTCH LENGTH  
**ISO Reference No.** N/A  
**ISO Name:**

**Description:** Surface distance measured from the front to the back of the waist with the tape passing through the crotch.

**Method:** Subject stands fully erect with the weight distributed equally on both feet and the arms hanging freely downwards. Subject's feet are placed in footprints adhered to the standing surface (the footprints are positioned approximately 10 cm apart at the heels and rotated 33° at the toes). An elastic band is used to mark the preferred waist level. Anterior preferred waist is a point on the subject's abdomen at the level of preferred waist in the midsagittal plane. Measurement is taken from the anterior preferred waist through the crotch to the *Preferred Waist, Posterior* landmark.

**Instrument:** Steel tape measure.

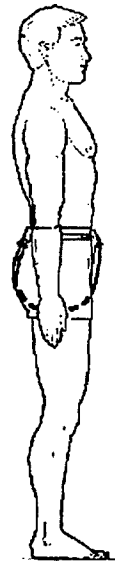
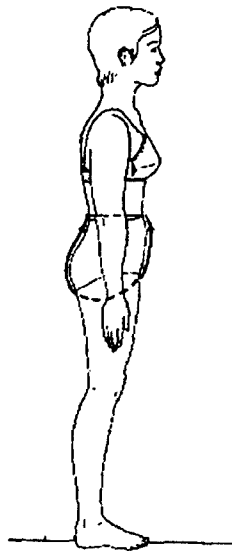
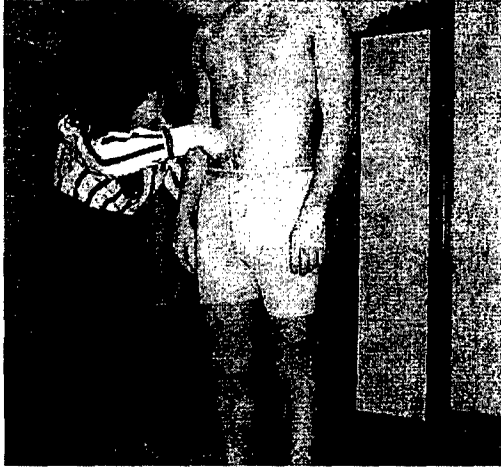

**35. CAESAR Name:** TRICEPS SKINFOLD

**ISO Reference No.** N/A

**ISO Name:**

**Description:** Thickness of the skinfold overlying the triceps muscle.

**Method:** Thickness of a vertical fold of skin and tissue (fat) is measured on the back of upper arm between the tip of the shoulder and the elbow while subject's arm is bent 90°.

**Instrument:** Lange skinfold caliper.

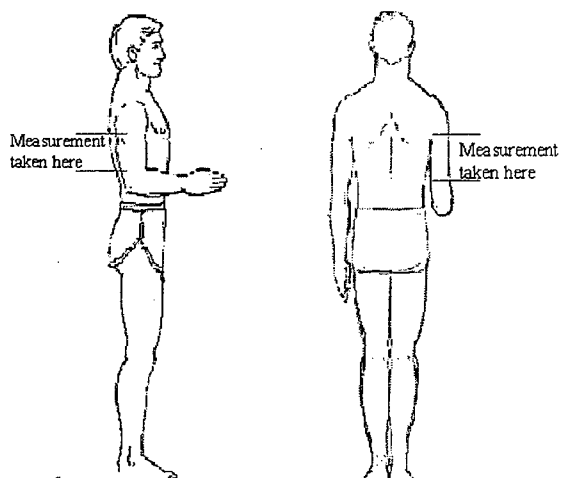
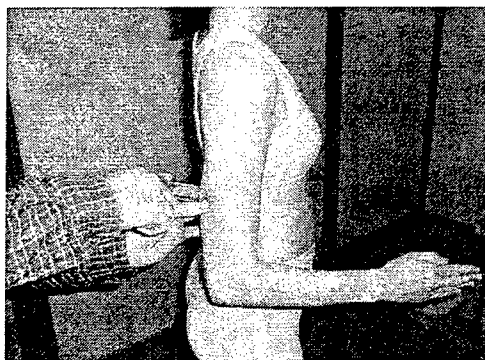

**36. CAESAR Name:** VERTICAL TRUNK CIRCUMFERENCE, RIGHT  
**ISO Reference No.** N/A  
**ISO Name:**

**Description:** Vertical circumference of the torso is measured from the shoulder, through the crotch, and back to the shoulder.

**Method:** Subject stands fully erect with the weight distributed equally on both feet and the arms hanging freely downwards. Subject's feet are placed in footprints adhered to the standing surface (the footprints are positioned approximately 10 cm apart at the heels and rotated 33° at the toes). Distance measured from a point on the right shoulder midway between the neck base and the shoulder joint, down the back, through the crotch, across the right bust point or thelion landmark, to the starting point. The measurer gently holds the tape against the skin in the small of the back.

*NOTE: Care must be taken to avoid constriction in the crotch.*

**Instrument:** Steel tape measure.

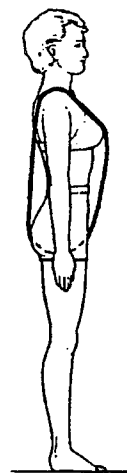

**37. CAESAR Name:** WAIST CIRCUMFERENCE, PREFERRED  
**ISO Reference No.** N/A  
**ISO Name:**

**Description:** Maximum circumference of the waist at the subject's "preferred" waist level.

**Method:** Subject stands fully erect with the weight distributed equally on both feet and the arms hanging freely downwards. The subject's feet are placed in footprints adhered to the standing surface (the footprints are positioned approximately 10 cm apart at the heels and rotated 33° at the toes). The subject's preferred waist level is marked using an elastic band.

*NOTE: Preferred waist level is established by the subject, who places an elastic band at the level he or she would prefer to wear the waist of their pants.*

**Instrument:** Steel tape measure.

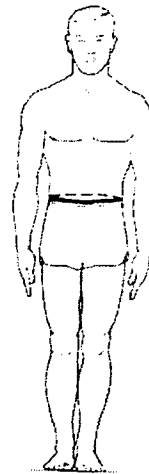
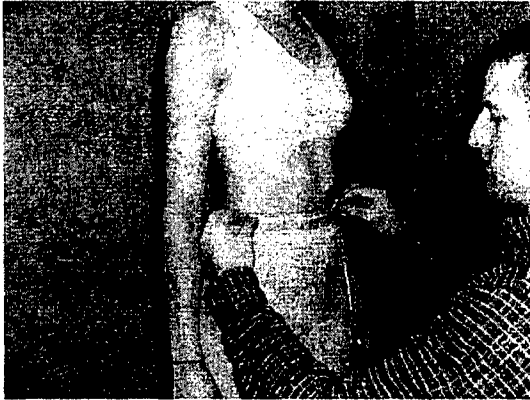

**38. CAESAR Name:** WAIST FRONT LENGTH  
**ISO Reference No.** N/A  
**ISO Name:**

**Description:** Surface distance from a point on the front neck base (in the midsagittal plane) is measured to the anterior preferred waist.

**Method:** Subject stands fully erect with the weight distributed equally on both feet and the arms hanging freely downwards. The subject's feet are placed in footprints adhered to the standing surface (the footprints are positioned approximately 10 cm apart at the heels and rotated 33° at the toes). Measurement is taken from the Neck Base point to the anterior preferred waist at the center of the elastic *Preferred Waist* band.

*NOTE: (1) A chain is placed around the neck to approximate a shirt collar. The anterior point on the chain serves as a neck base landmark. (2) Preferred waist level is established by the subject, who places an elastic band at the level he or she would prefer to wear the waist of their pants.*



**Instrument:** Steel tape measure.

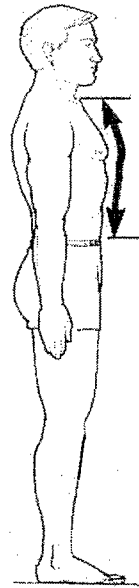
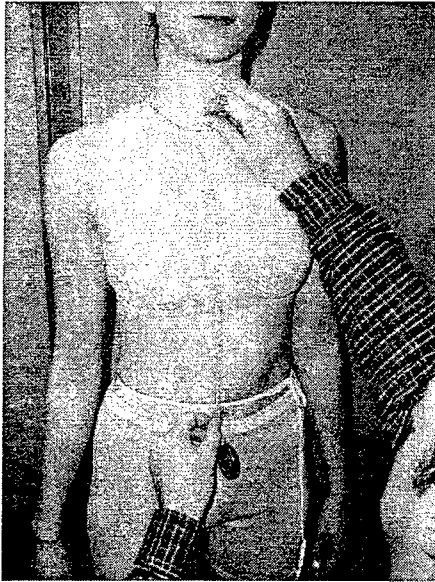

**39. CAESAR Name:** WAIST HEIGHT, PREFERRED

**ISO Reference No.** N/A

**ISO Name:**

**Description:** Vertical distance from the standing surface to the level of the preferred waist.

**Method:** Subject stands fully erect with the weight distributed equally on both feet and the arms hanging freely downwards. Subject's feet are placed in footprints adhered to the standing surface (footprints are positioned approximately 10 cm apart at the heels and rotated 33° at the toes). Distance is measured on subject's right side, from the standing surface to the center of the elastic *Preferred Waist* band.

*NOTE: Preferred waist level is established by the subject, who places an elastic band at the level he or she would prefer to wear the waist of their pants.*

**Instrument:** Anthropometer.

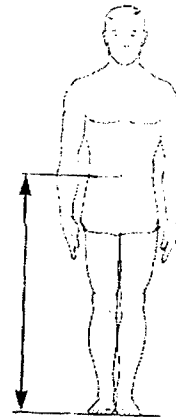
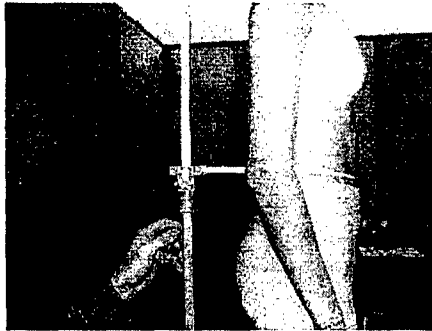

**40. CAESAR Name:** WEIGHT (MASS)

**ISO Reference No.** N/A

**ISO Name:**

**Description:** Weight of the subject.

**Method:** Subject stands on the scale fully erect with the weight distributed equally on both feet. Weight is measured with subject clad in CAESAR garments only.

**Instrument:** Scale

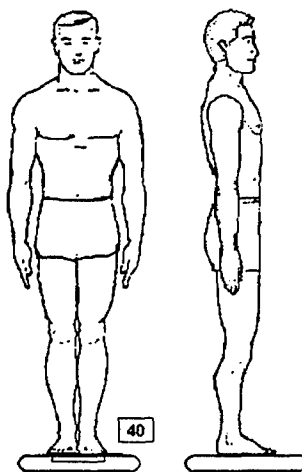

## Scan Measurement Descriptions

Three-dimensional (3-D) scans of the subjects were taken in three different poses. Pose A is a standing posture. Pose B is a seated posture in which the subject assumes a “comfortable working posture,” and Pose C is a second seated posture in which the subject raises his or her arms and head to provide the greatest possible scan coverage. The poses are described in more detail below.

Three-dimensional (3-D) measurements were taken from two of the three subject scans. These measurements consist of approximately 300,000 points on the body surface. In addition a series of one-dimensional measurements are extracted from the 3-D scans. These scan-extracted measurements are also described below.

### Part I: CAESAR Scanning Postures

#### Pose A: Standing Posture

The subject placed his or her feet on foot outlines positioned approximately ten centimeters apart (10.7 cm) at the inside of the heel. The subject's heel was lined up with the back of the foot outline and the second toe lined up with the line drawn through the long axis of the foot on the foot outlines. The footprints were positioned on the scanner platform at a 30° angle (see Figure 1). The investigator instructed the subject to stand up straight and look straight ahead. The investigator then used a dowel (20 centimeters in length) to adjust the subject's arm position so the hands were 20 centimeters away from the lateral-most point of the hip/thigh area. For individuals with “hips,” the dowel was placed at the widest protrusion of the hips (as viewed from the front). For individuals without a pronounced hip (more commonly males than females), the dowel was placed at the wrist. The arms and wrists were kept straight and the palms of the hands faced the body, with the fingers spread.

Pose A is shown in Figure 2.

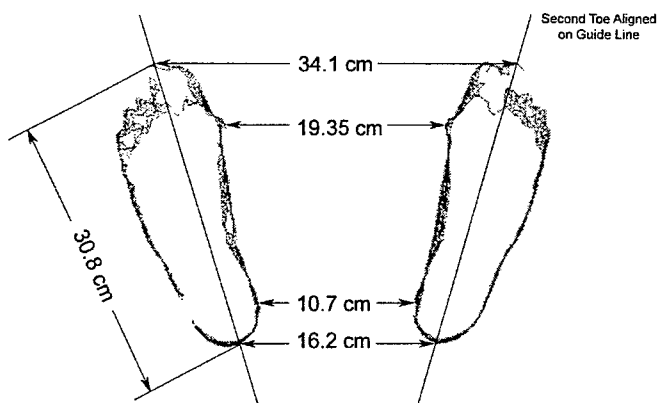

Foot Placement Guides for Whole Body Scans

Figure 1: Footprints

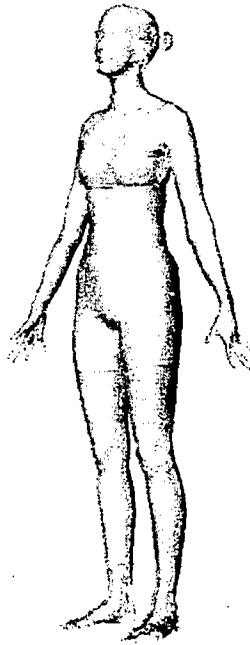

Figure 2: Standing Posture

#### Pose B: Seated Comfortable Working Posture

The goal of the seated comfortable working posture was to capture the natural, comfortable, seated working position. The subject sat on a modified stool that had a flat surface and a pneumatic height adjustment, with a seat height that adjusts from 15.5 to 20.5 inches. The stool was created using a standard swivel multitask chair (formerly referred to as a stenographer's or typist's stool). The back was removed and discarded. The seat was removed from the seat support and discarded. A piece of wood measuring 18 x 21 inches, with a thickness of 5/8 of an inch replaced the seat. The corners of the wooden seat are rounded with a 1-inch radius. The stool rests on five feet with casters.

The investigator adjusted the seat to a height that provided a comfortable working position as indicated by the subject. The subject was allowed to sit anywhere on the seat; however, both feet had to be flat on the platform. The investigator asked the subject to sit up straight, look straight ahead, and place the hands on the thighs. Next, the investigator asked the subject to keep the hands on the thighs and relax the postural rigidity until the subject had assumed a comfortable working position. The hands were placed at mid-thigh to prevent the medial and lateral femoral epicondyles from being blocked by the hands and fingers in the scan. The investigator placed a small block, marked with a reference landmark, behind the subject on the flat seat surface (at the surface level), in contact with the center of the subject's buttocks.

Pose B is shown in Figure 3.

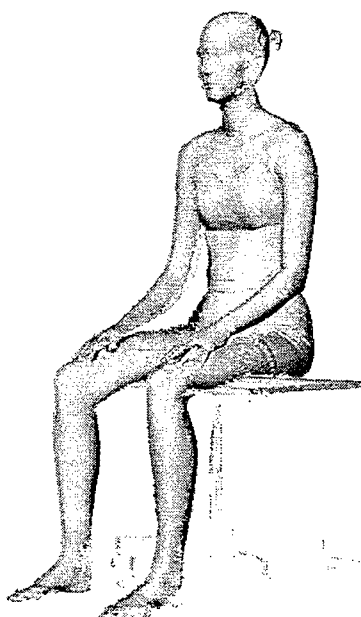

Figure 3: Seated Comfortable Working Posture

#### Pose C: Seated Coverage Posture

The seated coverage posture was designed to expose hard-to-see areas underneath the arms, between the thighs, and under the chin (Figure 4). The subject placed his or her feet on foot outlines positioned on the scanner platform for this seated posture. The investigator instructed the subject to sit up straight and look straight ahead. The subject sat on a modified stool that had a flat surface and a pneumatic height adjustment. The investigator adjusted the seat to a height until the knee angle was slightly greater than  $90^\circ$  with the calf almost perpendicular to the scanner platform.

For the coverage posture, a second set of footprints was adhered to the platform. The footprints follow the foot placement guide presented in Figure 1 but are placed further forward on the scan platform than the standing footprints. The subject keeps the feet on the seated foot outlines, the legs were spread slightly to allow coverage between the thighs. The subject held his or her hands over the head in the coronal plane and the subject's shoulders and elbows form right angles. The subject closes his or her right hand around a one-inch diameter dowel and spread the fingers of the left hand. The left hand was in line with the arm, with the hand flat and palm facing forward (away from the body). The head was tilted backward slightly so the chin/neck angle was greater than  $90^\circ$  to expose the shaded area under the chin. The investigator placed a small block, marked with a reference landmark, behind the subject on the flat seat surface (at the surface level), in contact with the center of the subject's buttocks.

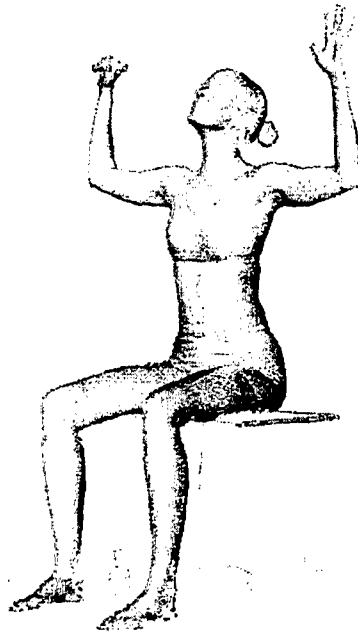

Figure 4: Seated Coverage Posture

Poses A and B were used for the scan-extracted measurements. Detailed descriptions of the calculations are included in Chapter IV.

The scan extracted measurements were named using the same naming conventions described at the beginning of Chapter III.

Whenever possible, dimensions were cross-referenced with ISO 7250.

Part II. Scan-Extracted Dimensions: Standing Dimensions

**41. CAESAR Name:** ACROMIAL HEIGHT, STANDING, LEFT  
**ISO Reference No.** 4.1.4  
**ISO Name:** Shoulder Height

**Description:** Vertical distance from the standing surface to the left acromion landmark.

**Method:** Calculated point-to-surface distance.

**Instrument:** Whole-body scanner

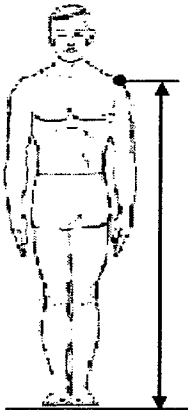

**42. CAESAR Name:** ACROMIAL HEIGHT, STANDING, RIGHT  
**ISO Reference No.** 4.1.4  
**ISO Name:** Shoulder Height

**Description:** Vertical distance from the standing surface to the right acromion landmark.

**Method:** Calculated point-to-surface distance.

**Instrument:** Whole-body scanner

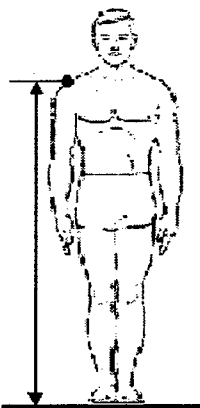

**43. CAESAR Name:** ACROMION-RADIALE LENGTH, LEFT  
**ISO Reference No.** 4.2.6  
**ISO Name:** Shoulder-Elbow Length

**Description:** Vertical distance from left acromion to the left lateral humeral epicondyle landmarks.

**Method:** Calculated point-to-surface distance.

**Instrument:** Whole-body scanner

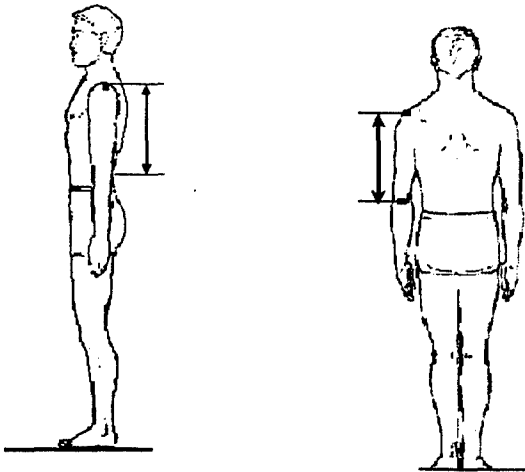

**44. CAESAR Name:** ACROMION-RADIALE LENGTH, RIGHT  
**ISO Reference No.** 4.2.6  
**ISO Name:** Shoulder-Elbow Length

**Description:** Vertical distance from right acromion landmark to the right lateral humeral epicondyle landmarks.

**Method:** Calculated point-to-point distance.

**Instrument:** Whole-body scanner

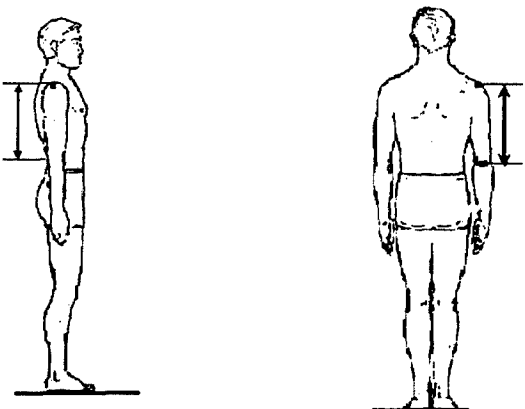



**45. CAESAR Name:** ARM INSEAM, LEFT  
**ISO Reference No.** N/A  
**ISO Name:**

**Description:** Distance from left anterior axilla landmark to left radial styloid landmark.

**Method:** Calculated point-to-point distance.

**Instrument:** Whole-body scanner



**46. CAESAR Name:** ARM INSEAM, RIGHT  
**ISO Reference No.** N/A  
**ISO Name:**

**Description:** Distance from right anterior axilla landmark to right radial styloid landmark.

**Method:** Calculated point-to-point distance.

**Instrument:** Whole-body scanner

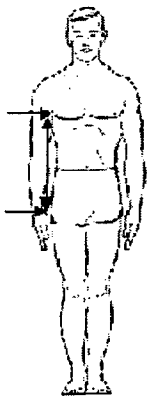

**47. CAESAR Name:** AXILLA HEIGHT, LEFT  
**ISO Reference No.** N/A  
**ISO Name:**

**Description:** Vertical distance from the standing surface to left anterior axilla point landmark.

**Method:** Calculated point-to-surface distance.

**Instrument:** Whole-body scanner

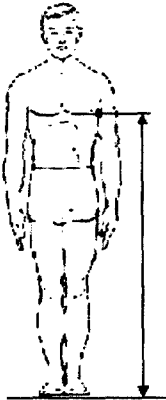

**48. CAESAR Name:** AXILLA HEIGHT, RIGHT  
**ISO Reference No.** N/A  
**ISO Name:**

**Description:** Vertical distance from the standing surface to right anterior axilla point landmark.

**Method:** Calculated point-to-surface distance.

**Instrument:** Whole-body scanner

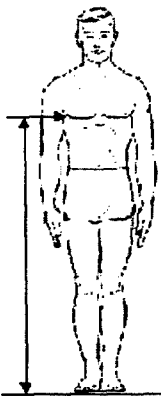

**49. CAESAR Name:** BIACROMIAL BREADTH  
**ISO Reference No.** 4.2.8  
**ISO Name:** Shoulder (Biacromial) Breadth

**Description:** Distance along a straight line from the left acromion to the right acromion landmarks.

**Method:** Calculated point-to-point distance.

**Instrument:** Whole-body scanner

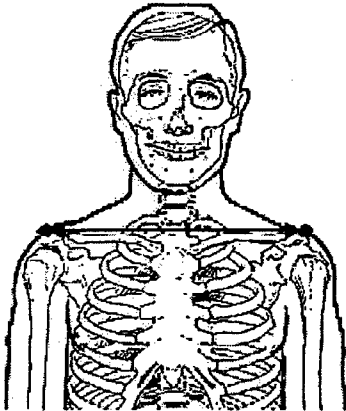

**50. CAESAR Name:** BI-CRISTALE BREADTH  
**ISO Reference No.** N/A  
**ISO Name:**

**Description:** Distance from left iliocristale to right iliocristale landmarks.

**Method:** Calculated point-to-point distance.

**Instrument:** Whole-body scanner

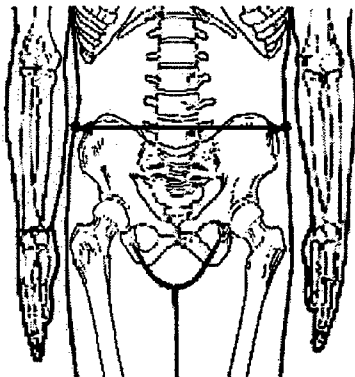

**51. CAESAR Name:** BI-SPINOUS BREADTH  
**ISO Reference No.** N/A  
**ISO Name:**

**Description:** Distance from left anterosuperior iliac spine to right anterosuperior iliac spine.

**Method:** Calculated point-to-point distance.

**Instrument:** Whole-body scanner

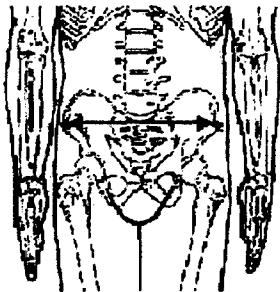

**52. CAESAR Name:** BIGONIAL BREADTH  
**ISO Reference No.** N/A  
**ISO Name:**

**Description:** Distance from left gonion to right gonion landmarks.

**Method:** Calculated point-to-point distance.

**Instrument:** Whole-body scanner

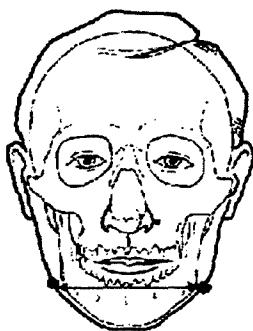

**53. CAESAR Name:** BITRAGION BREADTH  
**ISO Reference No.** N/A  
**ISO Name:**

**Description:** Distance from left tragion to right tragion landmarks.

**Method:** Calculated point-to-point distance.

**Instrument:** Whole-body scanner

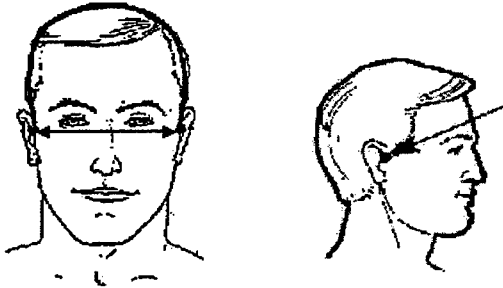

**54. CAESAR Name:** BI-TROCHANTERIC BREADTH, STANDING  
**ISO Reference No.** N/A  
**ISO Name:**

**Description:** Distance from left trochanterion to right trochanterion landmarks.

**Method:** Calculated point-to-point distance.

**Instrument:** Whole-body scanner

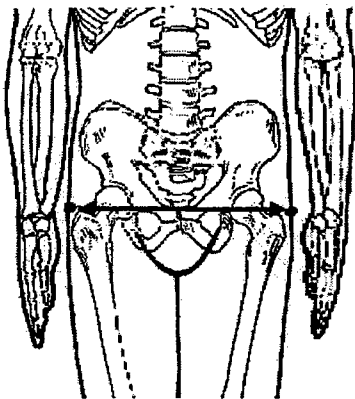

**55. CAESAR Name:** BUSTPOINT-BUSTPOINT BREADTH  
**ISO Reference No.** N/A  
**ISO Name:**

**Description:** Distance from left bustpoint to right bustpoint on women or left thelion to right thelion on men.

**Method:** Calculated point-to-point distance.

**Instrument:** Whole-body scanner



**56. CAESAR Name:** CERVICALE HEIGHT  
**ISO Reference No.** N/A  
**ISO Name:**

**Description:** Distance from the standing surface to the cervicale landmark.

**Method:** Calculated point-to-surface distance.

**Instrument:** Whole-body scanner

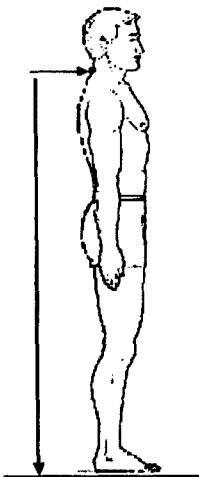

**57. CAESAR Name:** CHEST HEIGHT  
**ISO Reference No.** N/A  
**ISO Name:**

**Description:** Vertical distance from the standing surface to right bustpoint landmark on women or to right thelion landmark on men.

**Method:** Calculated point-to-surface distance.

**Instrument:** Whole-body scanner

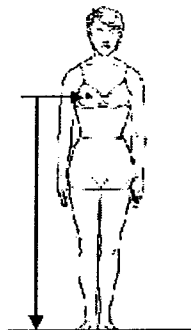

**58. CAESAR Name:** ELBOW HEIGHT, STANDING, LEFT  
**ISO Reference No.** 4.1.5  
**ISO Name:** Elbow Height

**Description:** Vertical distance from the standing surface to the olecranon landmark.

**Method:** Calculated point-to-surface distance.

**Instrument:** Whole-body scanner

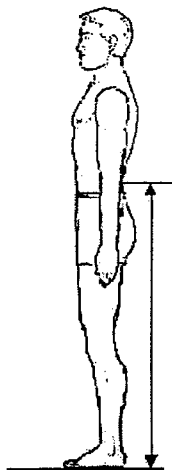

**59. CAESAR Name:** ELBOW HEIGHT, STANDING, RIGHT  
**ISO Reference No.** 4.1.5  
**ISO Name:** Elbow Height

**Description:** Vertical distance from the standing surface to the olecranon landmark.

**Method:** Calculated point-to-surface distance.

**Instrument:** Whole-body scanner

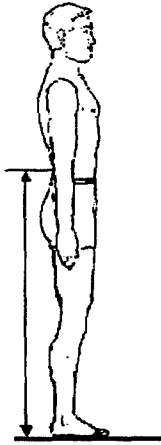

**60. CAESAR Name:** FOOT BREADTH, LEFT  
**ISO Reference No.** 4.3.8  
**ISO Name:** Foot Breadth

**Description:** Distance between the left Metatarsal-Phalangeal I and left Metatarsal-Phalangeal V landmarks.

**Method:** Calculated point-to-point distance.

**Instrument:** Whole-body scanner





**61. CAESAR Name:** FOOT BREADTH, RIGHT  
**ISO Reference No.** 4.3.8  
**ISO Name:** Foot Breadth

**Description:** Distance between the right Metatarsal-Phalangeal I and right Metatarsal-Phalangeal V landmarks.

**Method:** Calculated point-to-point distance.

**Instrument:** Whole-body scanner



**62. CAESAR Name:** INFRAORBITALE HEIGHT, STANDING, LEFT  
**ISO Reference No.** N/A  
**ISO Name:**

**Description:** Vertical distance from the standing surface to left infraorbitale landmark.

**Method:** Calculated point-to-surface distance.

**Instrument:** Whole-body scanner

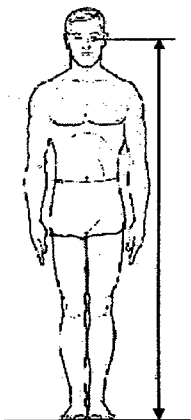

**63. CAESAR Name:** INFRAORBITALE HEIGHT, STANDING, RIGHT  
**ISO Reference No.** N/A  
**ISO Name:**

**Description:** Vertical distance from the standing surface to right infraorbitale landmark.

**Method:** Calculated point-to-surface distance.

**Instrument:** Whole-body scanner

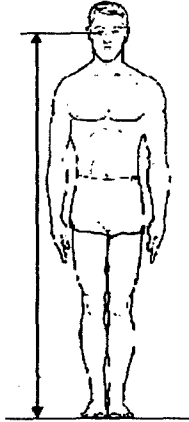

**64. CAESAR Name:** INTER-PUPILLARY DISTANCE  
**ISO Reference No.** N/A  
**ISO Name:**

**Description:** Distance from the center of left pupil to the center of right pupil.

**Method:** Calculated point-to-point distance.

*Note: This distance is calculated using the infraorbitale landmarks which are placed directly below the pupils.*

**Instrument:** Whole-body scanner

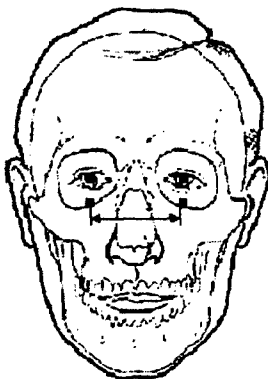

**65. CAESAR Name:** INTERSCYE DISTANCE  
**ISO Reference No.** N/A  
**ISO Name:**

**Description:** Distance across the back from left posterior axilla point to right posterior axilla point landmarks.

**Method:** Calculated point-to-point distance.

**Instrument:** Whole-body scanner

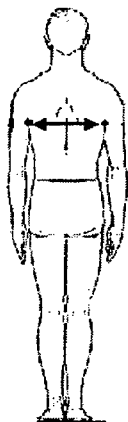

**66. CAESAR Name:** KNEE HEIGHT, STANDING, LEFT  
**ISO Reference No.** N/A  
**ISO Name:**

**Description:** Vertical distance from the standing surface to left knee crease landmark.

**Method:** Calculated point-to-surface distance.

**Instrument:** Whole-body scanner

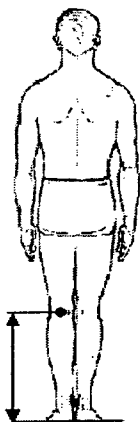

**67. CAESAR Name:** KNEE HEIGHT, STANDING, RIGHT  
**ISO Reference No.** N/A  
**ISO Name:**

**Description:** Vertical distance from the standing surface to right knee crease landmark.

**Method:** Calculated point-to-surface distance.

**Instrument:** Whole-body scanner

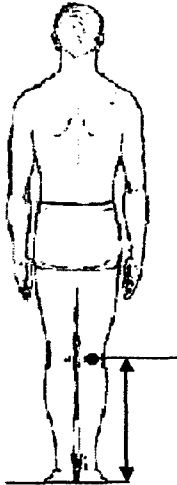

**68. CAESAR Name:** MALLEOLUS HEIGHT, LATERAL, LEFT  
**ISO Reference No.** N/A  
**ISO Name:**

**Description:** Vertical distance from the standing surface to a point picked on left lateral malleolus landmark.

**Method:** Calculated point-to-surface distance.

**Instrument:** Whole-body scanner

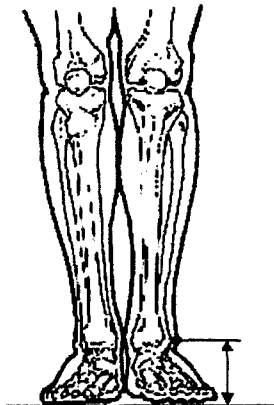

**69. CAESAR Name:** MALLEOLUS HEIGHT, LATERAL, RIGHT  
**ISO Reference No.** N/A  
**ISO Name:**

**Description:** Vertical distance from the standing surface to a point picked on right lateral malleolus landmark.

**Method:** Calculated point-to-surface distance.

**Instrument:** Whole-body scanner

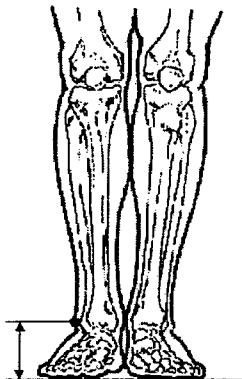

**70. CAESAR Name:** MALLEOLUS HEIGHT, MEDIAL, LEFT  
**ISO Reference No.** N/A  
**ISO Name:**

**Description:** Vertical distance from the standing surface to a point picked on left medial malleolus landmark.

**Method:** Calculated point-to-surface distance.

**Instrument:** Whole-body scanner

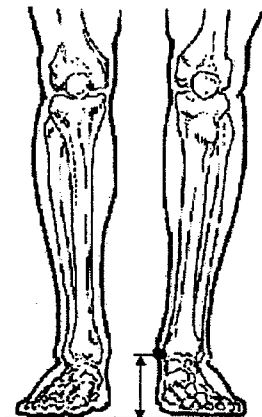

**71. CAESAR Name:** MALLEOLUS HEIGHT, MEDIAL, RIGHT  
**ISO Reference No.** N/A  
**ISO Name:**

**Description:** Vertical distance from the standing surface to a point picked on right medial malleolus landmark.

**Method:** Calculated point-to-surface distance.

**Instrument:** Whole-body scanner

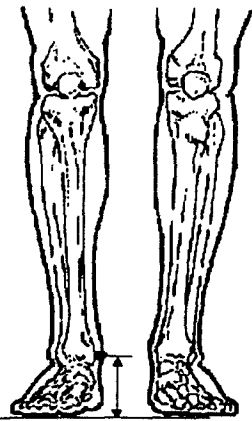

**72. CAESAR Name:** NECK HEIGHT  
**ISO Reference No.** N/A  
**ISO Name:**

**Description:** Distance from cervicale landmark to nuchale landmark.

**Method:** Calculated point-to-point distance.

**Instrument:** Whole-body scanner

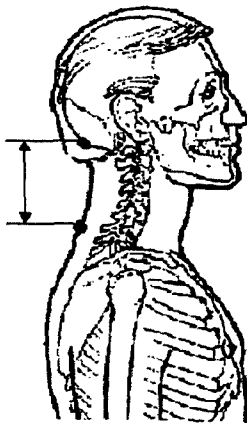

**73. CAESAR Name:** RADIALE-STYLION LENGTH, LEFT  
**ISO Reference No.:** N/A  
**ISO Name:**

**Description:** Distance from left radiale to left ulnar styloid landmark.

**Method:** Calculated point-to-point distance.

**Instrument:** Whole-body scanner

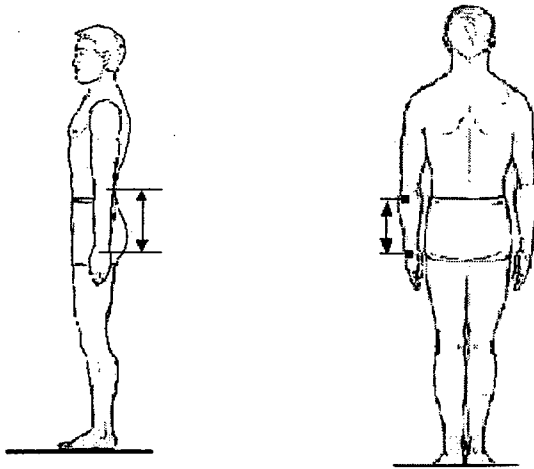

**74. CAESAR Name:** RADIALE-STYLION LENGTH, RIGHT  
**ISO Reference No.:** N/A  
**ISO Name:**

**Description:** Distance from right radiale to right ulnar styloid landmark.

**Method:** Calculated point-to-point distance.

**Instrument:** Whole-body scanner

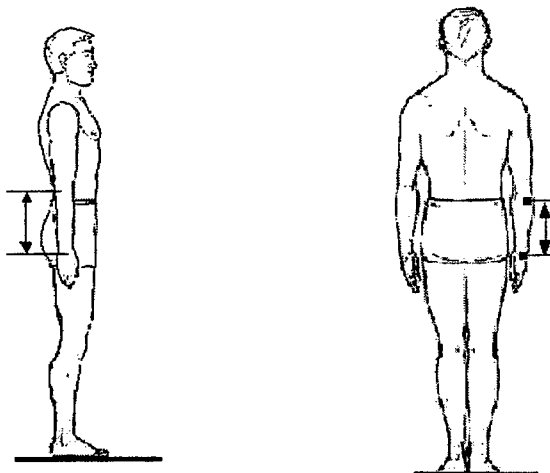

**75. CAESAR Name:** SELLION-SUPRAMENTON LENGTH  
**ISO Reference No.** N/A  
**ISO Name:**

**Description:** Distance from the supramenton to the sellion landmark.

**Method:** Calculated point-to-point distance.

**Instrument:** Whole-body scanner

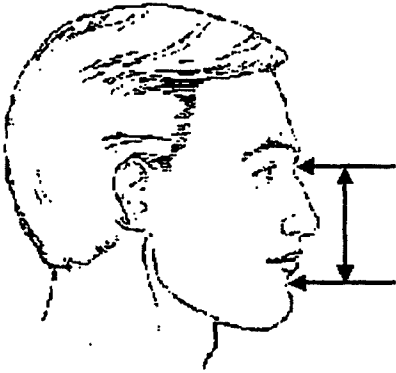

**76. CAESAR Name:** SLEEVE OUTSEAM LENGTH, LEFT  
**ISO Reference No.** N/A  
**ISO Name:**

**Description:** Distance from left acromion to left ulnar styloid landmarks.

**Method:** Calculated point-to-point distance.

**Instrument:** Whole-body scanner

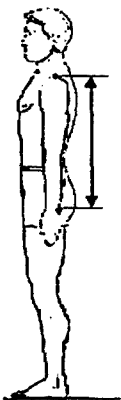



**77. CAESAR Name:** SLEEVE OUTSEAM LENGTH, RIGHT  
**ISO Reference No.** N/A  
**ISO Name:**

**Description:** Distance from right acromion to right ulnar styloid landmarks.

**Method:** Calculated point-to-point distance.

**Instrument:** Whole-body scanner

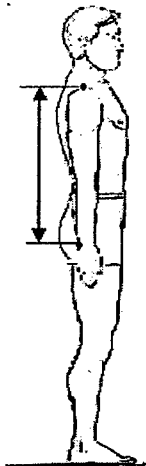

**78. CAESAR Name:** SPHYRION HEIGHT, LEFT  
**ISO Reference No.** N/A  
**ISO Name:**

**Description:** Distance from the standing surface to the left sphyrion landmark.

**Method:** Calculated point-to-surface distance.

**Instrument:** Whole-body scanner

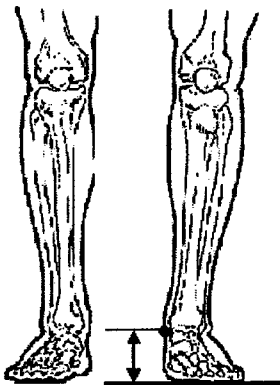

**79. CAESAR Name:** SPHYRION HEIGHT, RIGHT  
**ISO Reference No.** N/A  
**ISO Name:**

**Description:** Distance from the standing surface to the rightsphyrion landmark.

**Method:** Calculated point-to-surface distance.

**Instrument:** Whole-body scanner

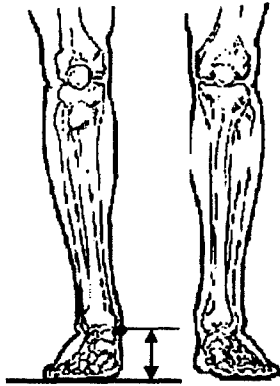

**80. CAESAR Name:** SUPRASTERNALE HEIGHT  
**ISO Reference No.** N/A  
**ISO Name:**

**Description:** Vertical distance from the standing surface to the suprasternale landmark.

**Method:** Calculated point-to-surface distance.

**Instrument:** Whole-body scanner

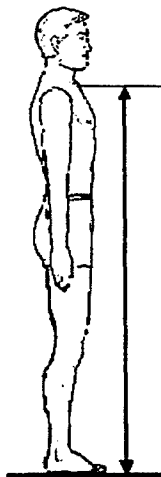

**81. CAESAR Name:** TROCHANTER HEIGHT, LEFT  
**ISO Reference No.** N/A  
**ISO Name:**

**Description:** Vertical distance from the standing surface to the left trochanterion landmark.

**Method:** Calculated point-to-surface distance.

**Instrument:** Whole-body scanner

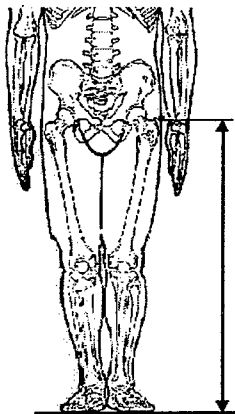

**82. CAESAR Name:** TROCHANTER HEIGHT, RIGHT  
**ISO Reference No.** N/A  
**ISO Name:**

**Description:** Vertical distance from the standing surface to the right trochanterion landmark.

**Method:** Calculated point-to-surface distance.

**Instrument:** Whole-body scanner

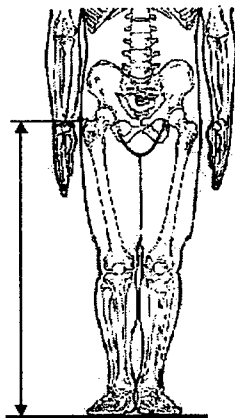

**83. CAESAR Name:** WAIST BACK (CERVICALE TO WAIST) LENGTH  
**ISO Reference No.** N/A  
**ISO Name:**

**Description:** Distance from cervicale landmark to the posterior waist preferred landmark.

**Method:** Calculated point-to-point distance.

**Instrument:** Whole-body scanner

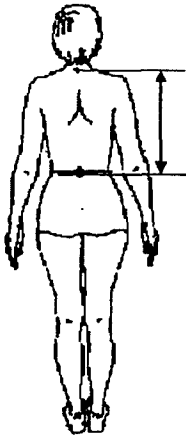

Part III: Scan-Extracted Dimensions: Seated Dimensions

**84. CAESAR Name:** ACROMIAL HEIGHT, SITTING (COMFORTABLE), LEFT  
**ISO Reference No.** N/A  
**ISO Name:**

**Description:** Vertical distance from the horizontal sitting surface to the left acromion landmark.

**Method:** Calculated point-to-surface distance.

**Instrument:** Whole-body scanner

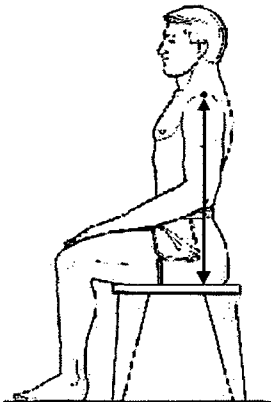

**85. CAESAR Name:** ACROMIAL HEIGHT, SITTING (COMFORTABLE), RIGHT  
**ISO Reference No.** N/A  
**ISO Name:**

**Description:** Vertical distance from the horizontal sitting surface to the right acromion landmark.

**Method:** Calculated point-to-surface distance.

**Instrument:** Whole-body scanner

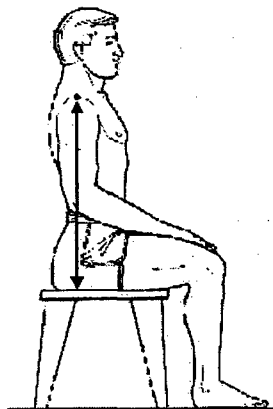

**86. CAESAR Name:** BI-LATERAL FEMORAL EPICONDYLE BREADTH, SITTING (COMFORTABLE)

**ISO Reference No.** N/A

**ISO Name:**

**Description:** Distance from left lateral femoral epicondyle to right lateral femoral epicondyle landmarks.

**Method:** Calculated point-to-point distance.

**Instrument:** Whole-body scanner

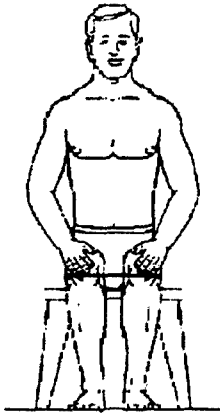

**87. CAESAR Name:** BI-LATERAL HUMERAL EPICONDYLE BREADTH, SITTING (COMFORTABLE)

**ISO Reference No.** N/A

**ISO Name:**

**Description:** Distance from left lateral humeral epicondyle to right lateral humeral epicondyle landmarks.

**Method:** Calculated point-to-point distance.

**Instrument:** Whole-body scanner

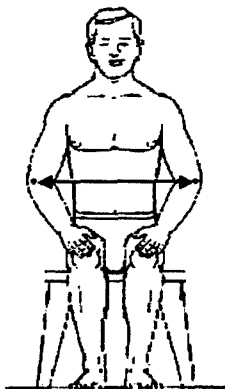

**88. CAESAR Name:** BI-TROCHANTERIC BREADTH, SITTING (COMFORTABLE)  
**ISO Reference No.** N/A  
**ISO Name:**

**Description:** Distance from left trochanterion to right trochanterion landmarks.

**Method:** Calculated point-to-point distance.

**Instrument:** Whole-body scanner

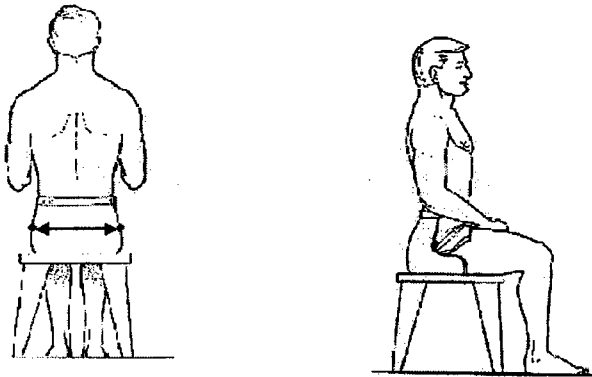

**89. CAESAR Name:** BUTTOCK TO TROCHANTER LENGTH (COMFORTABLE)  
**ISO Reference No.** N/A  
**ISO Name:**

**Description:** Distance from the functional buttock landmark to the line connecting the right and left trochanterion landmarks. The functional buttock landmark is calculated as the inferior point of the center longitude of the anterior surface of the butt block. The functional buttock landmark is calculated using the butt block point as described in Chapter 3.

**Method:** Calculated point-to-line distance.

**Instrument:** Whole-body scanner

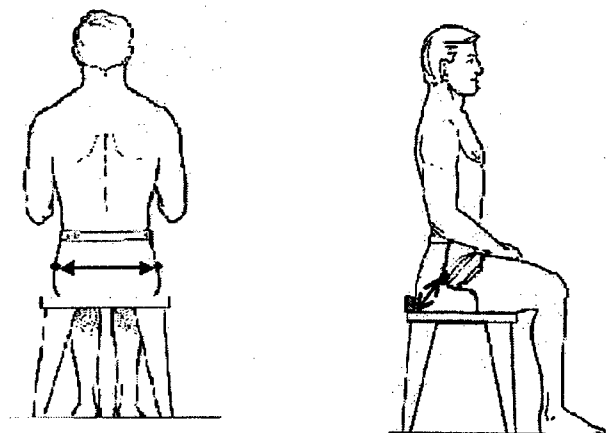

**90. CAESAR Name:** ELBOW HEIGHT, SITTING (COMFORTABLE), LEFT  
**ISO Reference No.** N/A  
**ISO Name:**

**Description:** Vertical distance from a horizontal sitting surface to the left lateral humeral epicondyle landmark.

**Method:** Calculated point-to-surface distance.

**Instrument:** Whole-body scanner

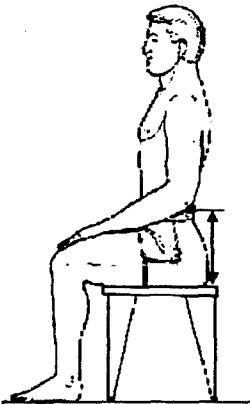

**91. CAESAR Name:** ELBOW HEIGHT, SITTING (COMFORTABLE), RIGHT  
**ISO Reference No.** N/A  
**ISO Name:**

**Description:** Vertical distance from a horizontal sitting surface to the right lateral humeral epicondyle landmark.

**Method:** Calculated point-to-surface distance.

**Instrument:** Whole-body scanner

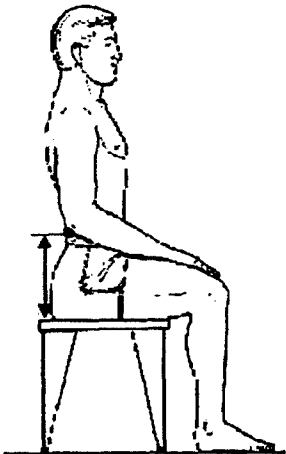



**92. CAESAR Name:** FEMORAL EPICONDYLE, LATERAL, LEFT TO MALLEOLUS, LATERAL, (COMFORTABLE) LEFT

**ISO Reference No.** N/A

**ISO Name:**

**Description:** Distance is measured from left lateral femoral epicondyle to left lateral malleolus landmark.

**Method:** Calculated point-to-point distance.

**Instrument:** Whole-body scanner

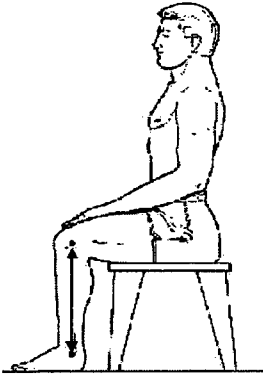

**93. CAESAR Name:** FEMORAL EPICONDYLE, LATERAL, RIGHT TO MALLEOLUS, LATERAL (COMFORTABLE), RIGHT

**ISO Reference No.** N/A

**ISO Name:**

**Description:** Distance is measured from right lateral femoral epicondyle to right lateral malleolus landmark.

**Method:** Calculated point-to-point distance.

**Instrument:** Whole-body scanner

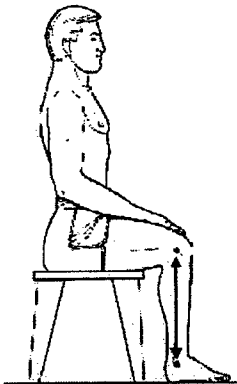

**94. CAESAR Name:** INFRAORBITALE HEIGHT, SITTING (COMFORTABLE), LEFT  
**ISO Reference No.** N/A  
**ISO Name:**

**Description:** Vertical distance from a horizontal sitting surface to the left infraorbitale landmark.

**Method:** Calculated point-to-surface distance.

**Instrument:** Whole-body scanner

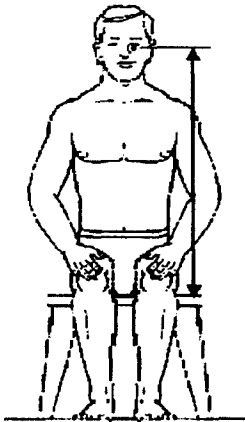

**95. CAESAR Name:** INFRAORBITALE HEIGHT, SITTING (COMFORTABLE), RIGHT  
**ISO Reference No.** N/A  
**ISO Name:**

**Description:** Vertical distance from a horizontal sitting surface to the right infraorbitale landmark.

**Method:** Calculated point-to-surface distance.

**Instrument:** Whole-body scanner

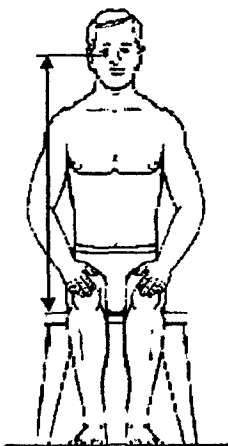

**96. CAESAR Name:** TROCHANTER TO FEMORAL EPICONDYLE, LATERAL (COMFORTABLE), LEFT

**ISO Reference No.** N/A

**ISO Name:**

**Description:** Distance from left trochanterion to left lateral femoral epicondyle landmarks.

**Method:** Calculated point-to-point distance.

**Instrument:** Whole-body scanner

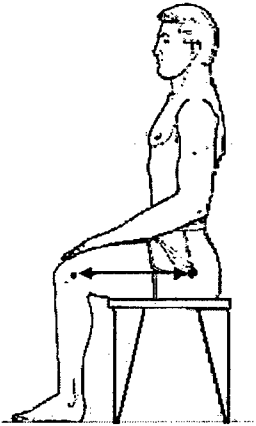

**97. CAESAR Name:** TROCHANTER TO FEMORAL EPICONDYLE, LATERAL (COMFORTABLE), RIGHT

**ISO Reference No.** N/A

**ISO Name:**

**Description:** Distance from right trochanterion to right lateral femoral epicondyle landmarks.

**Method:** Calculated point-to-point distance.

**Instrument:** Whole-body scanner

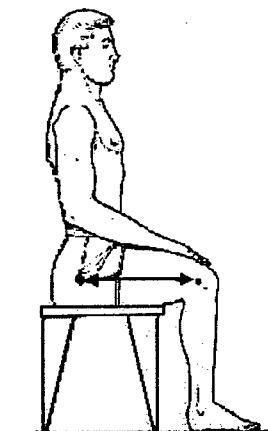

**98. CAESAR Name:** TROCHANTER TO SEATED SURFACE (COMFORTABLE), LEFT  
**ISO Reference No.** N/A  
**ISO Name:**

**Description:** Vertical distance from the horizontal sitting surface to the left trochanterion landmark.

**Method:** Calculated point-to-surface distance.

**Instrument:** Whole-body scanner

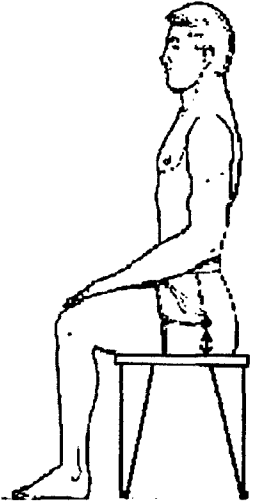

**99. CAESAR Name:** TROCHANTER TO SEATED SURFACE (COMFORTABLE), RIGHT  
**ISO Reference No.** N/A  
**ISO Name:**

**Description:** Vertical distance from the horizontal sitting surface to the right trochanterion landmark.

**Method:** Calculated point-to-surface distance.

**Instrument:** Whole-body scanner

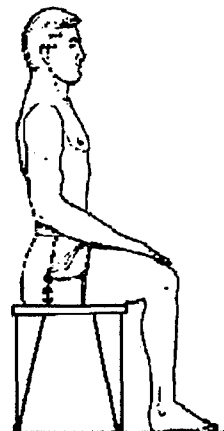

## CHAPTER IV: SCAN EXTRACTED MEASUREMENTS CALCULATION METHOD

Three-dimensional scans of the subjects were taken in three different poses, and 3-D measurements were taken from the standing scan (Pose A) and the seated comfortable working posture (Pose B). Table 3 outlines the measures extracted from the standing scans, and Table 4 outlines those extracted from the seated extracted scans.

Table 3. CAESAR Standing Extracted Measurements

Data File Name	Calculation Type	Landmarks Used	Data File Landmark Name
Acromial Ht Stand Lt	Ht	Acromion, Left	Lt. Acromion
Acromial Ht Stand Rt	Ht	Acromion, Right	Rt. Acromion
Acromion-Radiale Len Lt	Dist	Acromion, Left <i>and</i> Radiale, Left	Lt. Acromion; Lt. Radiale
Acromion-Radiale Len Rt	Dist	Acromion, Right <i>and</i> Radiale, Right	Rt. Acromion; Rt. Radiale
Ankle Ht Lt (Malleolus, Lateral)	Ht	Malleolus, Lateral; Left	Lt. Lateral Malleolus
Ankle Ht Rt (Malleolus, Lateral)	Ht	Malleolus, Lateral; Right	Rt. Lateral Malleolus
Arm Inseam Lt	Dist	Axilla Point, Anterior; Left <i>and</i> Radial Styloid, Left	Lt. Axilla, Ant; Lt. Radial Styloid
Arm Inseam Rt	Dist	Axilla Point, Anterior; Right <i>and</i> Radial Styloid, Right	Rt. Axilla, Ant; Rt. Radial Styloid
Axilla Ht Lt	Ht	Axilla Point, Anterior; Left	Lt. Axilla, Ant
Axilla Ht Rt	Ht	Axilla Point, Anterior; Right	Rt. Axilla, Ant
Biacromial Brth	Dist	Acromion, Left <i>and</i> Acromion, Right	Lt. Acromion; Rt. Acromion
Bicristale Brth	Dist	Iliocristale, Left <i>and</i> Iliocristale, Right	Lt. Iliocristale; Rt. Iliocristale
Bigonial Brth	Dist	Gonion, Left <i>and</i> Gonion, Right	Lt. Gonion Rt. Gonion
Bispinous Brth	Dist	ASIS, Left <i>and</i> ASIS, Right	Lt. ASIS Rt. ASIS
Bitragion Brth	Dist	Tragion, Left <i>and</i> Tragion, Right	Lt. Tragion Rt. Tragion
Bitrochanteric Brth Stand	Dist	Trochanterion, Left <i>and</i> Trochanterion, Right	Lt. Trochanterion Rt. Trochanterion
Bustpoint Brth	Dist	Thelion/Bustpoint, Left <i>and</i> Thelion/Bustpoint, Right	Lt. Thelion/Bustpoint; Rt. Thelion/Bustpoint
Cervicale Ht	Ht	Cervicale	Cervicale
Chest Ht Stand	Ht	Thelion/Bustpoint, Right	Rt. Thelion/Bustpoint
Elbow Ht Stand Lt	Ht	Olecranon, Left	Lt. Olecranon
Elbow Ht Stand Rt	Ht	Olecranon, Right	Rt. Olecranon

<b>Data File Name</b>	<b>Calculation Type</b>	<b>Landmarks Used</b>	<b>Data File Landmark Name</b>
Foot Brth Lt	Dist	Metatarsal-Phalangeal I, Left <i>and</i> Metatarsal-Phalangeal V, Left	Lt. Metatarsal-Phal. I Lt. Metatarsal-Phal. V
Foot Brth Rt	Dist	Metatarsal-Phalangeal I, Right <i>and</i> Metatarsal-Phalangeal V, Right	Rt. Metatarsal-Phal. I Rt. Metatarsal-Phal. V
Infraorbitale Ht Lt Stand	Ht	Infraorbitale, Left	Lt. Infraorbitale
Infraorbitale Ht Rt Stand	Rt	Infraorbitale, Right	Rt. Infraorbitale
Inter-pupillary Dst	Dist	Infraorbitale, Left Infraorbitale, Right	Lt. Infraorbitale; Rt. Infraorbitale
Interscye Dst Stand	Dist	Axilla Point, Anterior; Left <i>and</i> Axilla Point, Anterior; Right	Lt. Axilla, Post. Rt. Axilla, Post.
Knee Ht Stand Lt	Ht	Knee Crease, Left	Lt. Knee Crease
Knee Ht Stand Rt	Ht	Knee Crease, Right	Rt. Knee Crease
Malleolus Med Lt	Ht	Malleolus, Medial; Left	Lt. Medial Malleolus
Malleolus Med Rt	Ht	Malleolus, Medial; Right	Rt. Medial Malleolus
Neck Ht	Dist	Cervicale <i>and</i> Nuchale	Cervicale; Nuchale
Radiale-Styilion Len Lt	Dist	Radiale; Left <i>and</i> Radial Styloid, Left	Lt. Radiale; Lt. Radial Styloid
Radiale-Styilion Len Rt	Dist	Radiale; Right <i>and</i> Radial Styloid, Right	Rt. Radiale; Rt. Radial Styloid
Sellion Supramenton	Dist	Sellion <i>and</i> Supramenton	Sellion; Supramenton
Sleeve Outseam Len Lt	Dist	Acromion, Left <i>and</i> Ulnar Styloid; Left	Lt. Acromion; Lt. Ulnar Styloid
Sleeve Outseam Len Rt	Dist	Acromion, Right <i>and</i> Ulnar Styloid; Right	Rt. Acromion; Rt. Ulnar Styloid
Sphyrion Ht Lt	Ht	Sphyrion, Left	Lt. Sphyrion
Sphyrion Ht Rt	Ht	Sphyrion, Right	Rt. Sphyrion
Suprasternale Ht	Ht	Suprasternale	Suprasternale
Trochanterion Ht Lt	Ht	Trochanterion, Left	Lt. Trochanterion
Trochanterion Ht Rt	Ht	Trochanterion, Right	Rt. Trochanterion
Waist Back	Dist	Cervicale <i>and</i> Waist, Preferred, Posterior	Cervicale; Waist, Preferred, Post.

Table 4. CAESAR Seated Extracted Measurements

Measurement Name	Calculation Type	Landmarks Used	Data File Landmark Name
Acromial Ht Sit Lt	Zdelta	Acromion, Left <i>and</i> Functional Butt Block	Lt. Humeral Lateral Epicondyle; Functional Butt Block
Acromial Ht Sit Rt	Zdelta	Acromion, Right <i>and</i> Functional Butt Block	Rt. Humeral Lateral Epicondyle; Functional Butt Block
Bi-lateral Femoral Epicondyle Brth Sit	Dist	Lt. Femoral Lateral Epicondyle <i>and</i> Rt. Femoral Lateral Epicondyle	Lt. Femoral Lateral Epicondyle; Lt. Lateral Malleolus
Bi-lateral Humeral Epicondyle Brth Sit	Dist	Lt. Humeral Lateral Epicondyle <i>and</i> Rt. Humeral Lateral Epicondyle	Rt. Femoral Lateral Epicondyle; Rt. Lateral Malleolus
Bitrochanteric Brth Sit	Dist	Trochanterion, Left <i>and</i> Trochanterion, Right	Lt. Infraorbitale; Functional Butt Block
Buttock to Trochanter Lth	Point To Line	Functional Butt Block, Trochanterion, Left <i>and</i> Trochanterion, Right	Rt. Infraorbitale; Functional Butt Block
Elbow Ht Sit Lt	Zdelta	Lt. Humeral Lateral Epicondyle <i>and</i> Functional Butt Block	Lt. Trochanterion; Lt. Femoral Lateral Epicondyle
Elbow Ht Sit Rt	Zdelta	Rt. Humeral Lateral Epicondyle <i>and</i> Functional Butt Block	Rt. Trochanterion; Rt. Femoral Lateral Epicondyle
Femoral Epicondyle Lat to Malleolus Lat Lt	Dist	Lt. Femoral Lateral Epicondyle <i>and</i> Lt. Lateral Malleolus	Lt. Trochanterion; Functional Butt Block
Femoral Epicondyle Lat to Malleolus Lat Rt	Dist	Rt. Femoral Lateral Epicondyle <i>and</i> Rt. Lateral Malleolus	Rt. Trochanterion; Functional Butt Block
Infraorbitale Ht Sit Lt	Zdelta	Infraorbitale, Left <i>and</i> Functional Butt Block	Lt. Humeral Lateral Epicondyle; Functional Butt Block
Infraorbitale Ht Sit Rt	Zdelta	Infraorbitale, Right <i>and</i> Functional Butt Block	Rt. Humeral Lateral Epicondyle; Functional Butt Block
Trochanter to Femoral Epicondyle Lat Lt	Dist	Trochanterion, Left <i>and</i> Femoral Epicondyle, Lateral; Left	Lt. Femoral Lateral Epicondyle; Lt. Lateral Malleolus
Trochanter to Femoral Epicondyle Lat Rt	Dist	Trochanterion, Right <i>and</i> Rt. Femoral Lateral Epicondyle	Rt. Femoral Lateral Epicondyle; Rt. Lateral Malleolus
Trochanter to Seated Surface Lt	Zdelta	Trochanterion, Left <i>and</i> Functional Butt Block	Lt. Infraorbitale; Functional Butt Block
Trochanter to Seated Surface Rt	Zdelta	Trochanterion, Right <i>and</i> Functional Butt Block	Rt. Infraorbitale; Functional Butt Block

## Calculation Types

There are four different types of scan-extracted measures. Those types are listed below:

**Dist** = three dimensional point to point distance

**Ht** = height (Difference in z coordinates) from scan platform

**Zdelta** = vertical distance (difference in z coordinates) between two landmarks

**Point to Line** = perpendicular distance from point (first landmark) to the line defined by the second and third landmark

### Functional Butt Block Landmark

In the seated scanning postures, a small block of wood was placed on the scanning chair such that it rested against the subject's buttocks. The block has a landmark sticker centered on the vertical surface of the block that faces away from the subject. This is shown in the figure below. This is the 3-D landmark extracted from the scans that is described in Chapter III.

#### Butt Block used in North American and Italian Caesar Data Collection

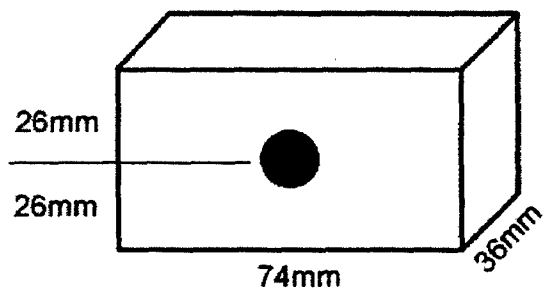

Not to scale!

However, in the extracted measurements above, another landmark is calculated to account for the height and thickness of the block. This new landmark is called the functional butt block landmark. During the calculation, the butt block landmark is moved 26mm down (to the bottom of the block and top of the seat) and 36mm toward the subject (to the anterior side of the block). Thus the functional butt block landmark is the point that marks the back of the buttocks rather than the back of the block. It also indicates the level of the seat.

Figure 5. The Butt Block Landmark included in the 3-D Landmark Files.

### Determination of Scan Platform Level

The level of the scan platform was determined from the scan data from each data collection site. A representative scan was chosen for each site. The scan platform level was determined by finding the lowest horizontal slice of data that contained data from the subject's foot. Due to re-calibration at each site, this value varies slightly for different data collection sites.

Platform Levels



The table below shows the scan platform levels for each of the data collection sites. Adding the appropriate value from the table below to the z-coordinate of a landmark will make the z-coordinate relative to the scan platform (i.e., scan platform at  $z = 0$ ).

The scanner used in the Netherlands did not capture the platform in the scan data. To determine the platform level of the scanner used in the Netherlands, scans of the same subject in identical postures were taken from both the Cyberware WB4 scanner and the Vitronic Vitus Pro scanner. The Cyberware scan included the foot of the subject and the top of the platform. The two scans were aligned and the platform position for the Vitronic scanner was extrapolated from the data in the Cyberware scan.

Table 5. Platform Levels

Data Collection Site	Subject Numbers	Platform Offset (mm)
1. Los Angeles, CA	0001-0321	1000
2. Detroit, MI	0324-0671	992
3. Ames, IA	1031-1173	998
4. WPAFB1, OH	1174-1261	994
5. Greensboro, NC	1262-1346	998
6. Marlton, NJ	1350-1480	1000
7. Ottawa, Ontario, Canada	1481-1713	1000
8. Minneapolis, MN	1715-2119	998
9. Houston, TX	2120-2343	998
10. Portland, OR	2344-2592	998
11. WPAFB2, OH	2593-2618	996
12. San Francisco, CA	2619-2788	998
13. Atlanta, GA	2789-3028	998
14. Genoa1, Italy	4000-4394	1000
15. Genoa2, Italy	4395-4800	1000
16. Soesterberg, Netherlands	11001-17079	993.1

## CHAPTER V: LANDMARK SELECTION RATIONALE

With each landmark name we had to figure out each rationale that was required. We came up with a list of five requirements (joint centers, segment-based coordinate systems, traditional anthropometry, segmentation, and scanned anthropometry). The table below gives the landmark name and summarizes the rationale for the landmark's inclusion in the CAESAR effort.

Codes: **A** Required for scanned Anthropometry  
**C** Required for segment-based Coordinate systems  
**J** Required for estimating Joint centers  
**S** Required for Segmentation  
**T** Required for Traditional anthropometry

	Landmark Name	Required		Landmark Name	Required
1	Sellion	A,C,T	41	Lateral Malleolus (L)	A,C,J
2	Infraorbitale (L)	C	42	Sphyrion (L)	A,C,S
3	Tragion (L)	C,J	43	Lateral Malleolus (R)	A,C,J
4	Gonion (L)	S	44	Medial Malleolus (R)	J
5	Infraorbitale (R)	C	45	Sphyrion (R)	A,C,S
6	Tragion (R)	C,J	46	Metatarsal-Phalangeal I (L)	A,C
7	Gonion (R)	S	47	Metatarsal-Phalangeal V (L)	A,C
8	Supramenton	A	48	Digit II (L)	C
9	Cervicale	A,C,J,S,T	49	Calcaneous (L)	C
10	Suprasternale	A,C	50	Metatarsal-Phalangeal I (R)	A,C,T
11	Substernale	C	51	Metatarsal-Phalangeal V (R)	A,C,T
12	Clavicale (L)	C,S	52	Digit II (R)	C
13	Acromion (L)	A,C,J,S	53	Calcaneous (R)	C
14	Anterior Axilla Ref. Pt. (L)	A,S	54	Medial Humeral Epicondyle (L)	C,J,S
15	Posterior Axilla Ref. Pt. (L)	A,S	55	Lateral Humeral Epicon. (L)	C,J,S
16	Clavicale (R)	C,S	56	Olecranon (L)	S
17	Acromion (R)	A,C,J,S,T	57	Lateral Humeral Epicondyle (R)	C,J,S
18	Anterior Axilla Ref. Pt. (R)	A,S	58	Medial Humeral Epicon. (R)	C,J,S
19	Posterior Axilla Ref. Pt. (R)	A,S	59	Olecranon (R)	S
20	Tenth Rib Midspine	J,S	60	Radiale (L)	A,C
21	Preferred Waist, Posterior	A,T	61	Ulnar Styloid (L)	C,J,S
22	Tenth Rib (L)	C,J	62	Radial Stylion (L)	A,C,J,S
23	Thelion/Bustpoint (L)	A,T	63	Radiale (R)	A,C
24	Tenth Rib (R)	C,J	64	Ulnar Styloid (R)	C,J,S,T
25	Thelion/Bustpoint (R)	A,T	65	Radial Stylion (R)	A,C,J,S
26	Iliocristale (L)	S	66	Metacarpal-Phalangeal II (L)	C
27	ASIS (L)	S	67	Metacarpal-Phalangeal V (L)	C
28	PSIS (L)	C,J	68	Dactylion (L)	C
29	Iliocristale (R)	S	69	Metacarpal-Phalangeal II (R)	C
30	ASIS (R)	S	70	Metacarpal-Phalangeal V (R)	C
31	PSIS (R)	C,J	71	Dactylion (R)	C
32	Medial Femoral Epicondyle (L)	C,J	72	Nuchale	A
33	Lateral Femoral Epicondyle (L)	C,J,S			
34	Knee Crease (L)	A			
35	Trochanterion (L)	A,C,J,S			
36	Medial Femoral Epicondyle (R)	C,J			

	Landmark Name	Required		Landmark Name	Required
37	Lateral Femoral Epicon. (R)	<b>C,J,S</b>		UNMARKED LANDMARKS	
38	Knee Crease (R)	<b>A</b>	1	Crotch	<b>S</b>
39	Trochanterion (R)	<b>A,C,J,S</b>			
40	Medial Malleolus (L)	<b>J</b>			

## CHAPTER VI: LANDMARK POINT PICKING ORDER

While we processed each scan the individual gave each landmark a coded variable (Z1-Z74). The table below shows the list of landmarks in the order that they were picked during processing and the point picking variable

### 3-D LANDMARKS (Arranged in point-picking order)

	CAESAR Name	Data File Name
Z1	SELLION	Sellion
Z2	INFRAORBITALE, RIGHT	Rt. Infraorbitale
Z3	INFRAORBITALE, LEFT	Lt. Infraorbitale
Z4	SUPRAMENTON	Supramenton
Z5	TRAGION, RIGHT	Rt. Tragion
Z6	GONION, RIGHT	Rt. Gonion
Z7	TRAGION, LEFT	Lt. Tragion
Z8	GONION, LEFT	Lt. Gonion
Z9	NUCHALE	Nuchale
Z10	CLAVICALE, RIGHT	Rt. Clavicale
Z11	SUPRASTERNALE	Suprasternale
Z12	CLAVICALE, LEFT	Lt. Clavicale
Z13	THELION/BUSTPOINT, RIGHT	Rt. Thelion/Bustpoint
Z14	THELION/BUSTPOINT, LEFT	Lt. Thelion/Bustpoint
Z15	SUBSTERNALE	Substernale
Z16	TENTH RIB, RIGHT	Rt. 10th Rib
Z17	ILIAC SPINE, ANTERIOR, SUPERIOR; RIGHT	Rt. ASIS
Z18	TENTH RIB, LEFT	Lt. 10th Rib
Z19	ILIAC SPINE, ANTERIOR, SUPERIOR; LEFT	Lt. ASIS
Z20	ILIOCRISTALE, RIGHT	Rt. Iliocristale
Z21	TROCHANTERION, RIGHT	Rt. Trochanterion
Z22	ILIOCRISTALE, LEFT	Lt. Iliocristale
Z23	TROCHANTERION, LEFT	Lt. Trochanterion
Z24	CERVICALE	Cervicale
Z25	TENTH RIB, MIDSPINE	10th Rib Midspine
Z26	ILIAC SPINE, POSTERIOR, SUPERIOR; RIGHT	Rt. PSIS
Z27	ILIAC SPINE, POSTERIOR, SUPERIOR; LEFT	Lt. PSIS
Z28	WAIST, PREFERRED, POSTERIOR	Waist, Preferred, Post.
Z29	ACROMION, RIGHT	Rt. Acromion
Z30	AXILLA POINT, ANTERIOR; RIGHT	Rt. Axilla, Ant
Z31	RADIAL STYLOID, RIGHT	Rt. Radial Styloid
Z32	AXILLA POINT, POSTERIOR; RIGHT	Rt. Axilla, Post.
Z33	OLECRANON, RIGHT	Rt. Olecranon
Z34	HUMERAL EPICONDYLE, LATERAL; RIGHT	Rt. Humeral Lateral Epicon
Z35	HUMERAL EPICONDYLE, MEDIAL; RIGHT	Rt. Humeral Medial Epicon
Z36	RADIALE, RIGHT	Rt. Radiale
Z37	METACARPAL-PHALANGEAL II, RIGHT	Rt. Metacarpal Phal. II
Z38	DACTYLION, RIGHT	Rt. Dactylion
Z39	ULNAR STYLOID, RIGHT	Rt. Ulnar Styloid

	<b>CAESAR Name</b>	<b>Data File Name</b>
Z40	METACARPAL-PHALANGEAL V, RIGHT	Rt. Metacarpal-Phal. V
Z41	ACROMION, LEFT	Lt. Acromion
Z42	AXILLA POINT, ANTERIOR; LEFT	Lt. Axilla, Ant
Z43	RADIAL STYLOID, LEFT	Lt. Radial Styloid
Z44	AXILLA POINT, POSTERIOR; LEFT	Lt. Axilla, Post.
Z45	OLECRANON, LEFT	Lt. Olecranon
Z46	HUMERAL EPICONDYLE, LATERAL; LEFT	Lt. Humeral Lateral Epicon
Z47	HUMERAL EPICONDYLE, MEDIAL; LEFT	Lt. Humeral Medial Epicon
Z48	RADIALE, LEFT	Lt. Radiale
Z49	METACARPAL-PHALANGEAL II, LEFT	Lt. Metacarpal-Phal. II
Z50	DACTYLION, LEFT	Lt. Dactylion
Z51	ULNAR STYLOID, LEFT	Lt. Ulnar Styloid
Z52	METACARPAL-PHALANGEAL V, LEFT	Lt. Metacarpal-Phal. V
Z53	KNEE CREASE, RIGHT	Rt. Knee Crease
Z54	FEMORAL EPICONDYLE, LATERAL; RIGHT	Rt. Femoral Lateral Epicon
Z55	FEMORAL EPICONDYLE, MEDIAL; RIGHT	Rt. Femoral Medial Epicon
Z56	METATARSAL-PHALANGEAL V, RIGHT	Rt. Metatarsal-Phal. V
Z57	MALLEOLUS, LATERAL; RIGHT	Rt. Lateral Malleolus
Z58	MALLEOLUS, MEDIAL; RIGHT	Rt. Medial Malleolus
Z59	SPHYRION, RIGHT	Rt. Sphyrion
Z60	METATARSAL-PHALANGEAL I, RIGHT	Rt. Metatarsal-Phal. I
Z61	CALCANEUS, POSTERIOR; RIGHT	Rt. Calcaneous, Post.
Z62	DIGIT II, RIGHT	Rt. Digit II
Z63	KNEE CREASE, LEFT	Lt. Knee Crease
Z64	FEMORAL EPICONDYLE, LATERAL; LEFT	Lt. Femoral Lateral Epicon
Z65	FEMORAL EPICONDYLE, MEDIAL; LEFT	Lt. Femoral Medial Epicon
Z66	METATARSAL-PHALANGEAL V, LEFT	Lt. Metatarsal-Phal. V
Z67	MALLEOLUS, LATERAL; LEFT	Lt. Lateral Malleolus
Z68	MALLEOLUS, MEDIAL; LEFT	Lt. Medial Malleolus
Z69	SPHYRION, LEFT	Lt. Sphyrion
Z70	METATARSAL-PHALANGEAL I, LEFT	Lt. Metatarsal-Phal. I
Z71	CALCANEUS, POSTERIOR; LEFT	Lt. Calcaneous, Post.
Z72	DIGIT II, LEFT	Lt. Digit II
Z73	CROTCH ( <i>Calculated Point only</i> )	Crotch
Z74	BUTT BLOCK	Functional Butt Block

## REFERENCE

Anonymous (1996) *Basic Human Body Measurements for Technological Design*; Technical Committee ISO/TC 159, Ergonomics, Subcommittee SC 3, Anthropometry and biomechanics prepared the International Standard ISO 7250. International Standard, ISO 7250; First Edition 1996-07-15, Reference number ISO 7250:1996(E)

Hertzberg, H.T. E., Churchill, E., Dupertius, C. W., White, R. M., and Damon, A., *Anthropometric Survey of Turkey, Greece, and Italy*. AGARDograph 73. Pergamon Press, Oxford. 1963.

Robinette, K.M. (2000) CAESAR Measures Up, in *Ergonomics in Design*, Vol. 8, No.3, pgs 17-23, Human Factors and Ergonomics Society, Santa Monica, CA

Robinette, K. M., Daanen, H., Paquet, E., And Rioux, M., (1999) The CAESAR Project: A 3-D Surface Anthropometry Survey, in *Proceedings of the 5<sup>th</sup> International Conference "High-Tech Cars and Engines*, Modena Italy, 3 June 1999.

Robinette, K.M., Vannier, M.W., Rioux, M., and Jones, P.R.M. (1997) *3-D Surface Anthropometry: Review of Technologies*, AGARD Advisory Report No. 329, Advisory Group for Aerospace Research and Development, 7 Rue Ancelle, 92200 Neuilly-Sur-Seine, France.

**APPENDIX A: THE DEMOGRAPHIC QUESTIONNAIRE**

**DEMOGRAPHIC QUESTIONS**  
(North American)

**SITE INFORMATION**

What is the data collection site (circle answer):

U.S.A.   Netherlands   Italy

Please circle the U.S. data collection site:

Los Angeles, CA	Detroit, MI	Dayton, OH	Ames, IA	Greensboro, NC
Marlton, NJ	Ottawa, Ontario	Minneapolis, MN	Houston, TX	Portland, OR
San Francisco, CA	Atlanta, GA			

**SAMPLING CRITERIA**

What is your gender (circle one):

Male   Female

What is your height without shoes?

\_\_\_\_\_ in.

What is your weight without clothes on?

\_\_\_\_\_ lbs.

**MONITORED SAMPLING**

What is your date of birth (MM/DD/YR):

\_\_\_\_/\_\_\_\_/\_\_\_\_

What is your race?

*Black or African American*      *Caucasian or White*      *Native American or Native Alaskan*

Spanish/Hispanic

Cuban

Mexican American

Puerto Rican

Other

*Asian/Pacific Islander*

Asian Indian

Chinese

Filipino

Guamian or Chamorro

Japanese

Korean

Native Hawaiian

Samoan

Vietnamese

Other

*Other*

Mixed Race

Not Listed Above

No Response

**PERSONAL INFORMATION**

Are you an active member of the Armed Forces?

No    Yes



**PERSONAL INFORMATION (Continued)**

What is your current occupation?

Administrative Support	Health Diagnosing Occupation	Sales/Marketing
Administrator	Health Non-Diagnosing Occupation	Scientist
Armed Services	Homemaker	Service Occupation
Attorney or Judge	Machine Operator	Student
Classroom Teacher	Management	Supervisor
Computer Programmer/Software Engineer	Material Handler	Technician
Construction	Mechanic	Training/Continuing Education
Degreed Engineer	Other Legal/Judicial Occupation	Transportation Occupation
Farm Occupation	Other Specialty Occupation	Unemployed
Forestry or Fishing Occupation	Retired	No Response

What is your marital status (circle one)?

Single      Married      Divorced      Widowed      No Response

How many hours per week do you engage in some form of structured exercise?

0-1      2-3      4-6      6-10      More than 10      No Response

What is the highest level of education you have completed?

High School	Some College	Technical Training	Associates
Bachelor	Masters	Doctorate/PhD	Post-Doctoral Studies
None of the above	No Response		

Where were you born?

If in the United States:

Alabama	Alaska	Arizona	Arkansas	California
Colorado	Connecticut	Delaware	Florida	Georgia
Hawaii	Idaho	Illinois	Indiana	Iowa
Kansas	Kentucky	Louisiana	Maine	Maryland
Massachusetts	Michigan	Minnesota	Mississippi	Missouri
Montana	Nebraska	Nevada	New Hampshire	New Jersey
New Mexico	New York	North Carolina	North Dakota	Ohio
Oklahoma	Oregon	Pennsylvania	Rhode Island	South Carolina
South Dakota	Tennessee	Texas	Utah	Vermont
Virginia	Washington	Washington DC	West Virginia	Wisconsin
Wyoming	U.S. Territory	Not born in the U.S.	Do not know	No Response

**PERSONAL INFORMATION (Continued)**

If Netherlands, what area of the country => North South

If Italy, what area of the country => North South

What is your net family income?

Less than 10,000    10,000-14,999    15,000-19,999    20,000-29,999    30,000-44,999  
45,000-59,999    60,000-79,999    80,000-100,000    Over 100,000    Do Not Know

No Response

How many children do you have?

0    1    2    3    4    5    6    7 or more    No Response

**CAR INFORMATION**

What is the model year of the car you drive most?

19\_\_

What is the make of your car (circle one)?

Acura	Audi	BMW	Buick	Cadillac	Chevrolet
Chrysler	Dodge	Eagle	Ford	GMC	Honda
Hyundai	Infiniti	Isuzu	Jeep	Lexus	Lincoln
Mazda	Mercedes-Benz	Mercury	Mitsubishi	Nissan	Oldsmobile
Plymouth	Pontiac	Porsche	Saab	Saturn	Subaru
Suzuki	Toyota	Volkswagen	Volvo	Other	Do Not Know

No Response

What is your car's model type (circle one)?

Economy	Compact	Intermediate	Full size 2-Dr	Full size 4-Dr	Luxury	Minivan
Van	Sports Car	Station Wagon	SUV	Truck	Other	Do Not Know

No Response

**SIZING INFORMATION**

What is your most common shoe size?

5 or Smaller    5.5    6    6.5    7    7.5    8    8.5    9    9.5    10    10.5  
11    11.5    12    12.5    13    13.5    14 or Larger    Do Not Know    No Response

**SIZING INFORMATION (Continued)**

What is your most common waist size of your pants (in inches)? (*MALES ONLY*)

28 or Smaller 29 30 31 32 33 34 36 38 40 42 44  
 46 or Larger Do Not Know No Response

What is your most common inseam of your pants (in inches)? (*MALES ONLY*)

28 or Smaller 29 30 31 32 33 34 36 38 40 or Larger  
 Do Not Know No Response

What is your most common jacket size? (*MALES ONLY*)

30 or Smaller 32 34 36 38 40 42 44 46 48 or Larger  
 Do Not Know No Response

What is your most common blouse size? (*FEMALES ONLY*)

4 or Smaller 6 7 8 9 10 11 12 13 14 15 16  
 18 20 22 or Larger Do Not Know No Response

What is your most common bra size? (*FEMALES ONLY*)

30 or Smaller 32 a b c d 34 a b c d 36 a b c d dd 38 a b c d dd 40 a b c d dd  
 42 a b c d dd 44 a b c d dd 46 a b c d dd 48 or Larger Do Not Know No Response

What is your most common pants size? (*FEMALES ONLY*)

2 or Smaller 4 5 6 7 8 9 10 11 12 13 14  
 15 16 18 20 or Larger Do Not Know No Response

**INFORMAZIONI DEMOGRAFICHE**  
(Italian)

**INFORMAZIONI SUL LUOGO**

In quale nazione e' il punto della collezione dei dati? (mettere un cerchio):

U.S.A.   Netherlands   Italy

Per favore, indicare il posto di collezione:

Los Angeles, CA	Detroit, MI	Dayton, OH	Ames, IA	Greensboro, NC
Marlton, NJ	Ottawa, Ontario	Minneapolis, MN	Houston, TX	Portland, OR
San Francisco, CA	Atlanta, GA	Genova, Italia		

**DATI DEI VOLONTARI**

Sesso :

Maschio      Femmina

Altezza senza scarpe :

\_\_\_\_\_ cm.

Peso senza vestiario

\_\_\_\_\_ kg.

**CONTROLLO DEI DATI**

Data di nascita (mese - giorno - anno):

\_\_\_\_/\_\_\_\_/\_\_\_\_

Razza:

Italiana      Altra      Non risponde

**INFORMAZIONI GENERALI**

Siete arruolati nelle Forze Armate?

NO              SI

## INFORMAZIONI PERSONALI (CONTINUA)

### LA PROFESSIONE ATTUALE:

Impiegato/a	Infermiere/a	Vendita/Marketing
Amministratore	Aiuto infermiera o simile	Scienziato
Servizi Leva	Casalinga	Servizi pubblici
Avvocato/Giudice	Operatore macchine	Studente
Insegnante	Direttore aziendale	Capo reparto
Programmatore computer/software	Portatore di materiale industriale	Tecnico
Costruttore edile	Meccanico	Tirocinio/Istituto professionale
Ingegnere	Altro lavoro legale/giudiziario	Trasportatore
Contadino	Altra specializzazione	Disoccupato
Guardia forestale o pescatore	Pensionato	Non risponde

### STATO CIVILE:

Celibe      Sposato/a      Divorziato/a      Vedovo/a      Non risponde

### Quante ore settimanali dedica a un esercizio fisico strutturato?

0-1      2-3      4-6      6-10      Piu' di 10      Non risponde

### QUAL'E' IL LIVELLO SCOLASTICO PIU' ALTO CHE HA OTTENUTO?

Scuola superiore	Iscritto all'universita'	Scuole tecniche	Mini laurea
Bachelor	Masters	Dottorato/PhD	Studi post-dottorato
Scuola elementare	Scuola media	Nessuna	Non risponde

### E'IN QUALE REGIONE E' NATO?

Abruzzo	Puglie	Basilicata	Calabria	Campania
Emilia Romagna	Friuli-Venezia Giulia	Lazio	Liguria	Lombardia
Marche	Molise	Piemonte	Sardegna	Sicilia
Trentino-Alto Adige	Toscana	Umbria	Val D'aosta	Veneto
Non so	Non risponde			

### QUAL'E' IL REDDITO NETTO ANNUALE DELLA FAMIGLIA?

Meno di 10 milioni	Da 10 a 14,9	Da 15 a 19,9	Da 20 a 29,9	Da 30 a 44,9
Da 45 a 59,9	Da 60 a 79,9	Da 80 a 99,9	Da 100 a 150	Piu' di 150
Non so	Non risponde			

## INFORMAZIONI PERSONALI (CONTINUA)

QUANTI SONO I FIGLI ?

0 1 2 3 4 5 6 7 o piu' Non risponde

## INFORMAZIONI SU AUTOMOBILI:

DI CHE ANNO E' LA SUA AUTO ?

Del 19\_\_ or 20\_\_

DI CHE MARCA E' LA SUA AUTO?

Acura	Audi	BMW	Buick	Cadillac	Chevrolet
Chrysler	Dodge	Eagle	Ford	GMC	Honda
Hyundai	Infiniti	Isuzu	Jeep	Lexus	Lincoln
Mazda	Mercedes-Benz	Mercury	Mitsubishi	Nissan	Oldsmobile
Plymouth	Pontiac	Porsche	Saab	Saturn	Subaru
Suzuki	Toyota	Volkswagen	Volvo	Altra	Non so
Non risponde	Fiat	Alfa Romeo	Lancia	Ferrari	Maserati

DI CHE MODELLO E' LA VOSTRA AUTO?

Economica	Compact	Intermediata	Full size 2-prt	Full size 4-prt	Lusso	Minivan
Van	Sportiva	Station Wagon	SUV	Camion	Motorino/scooter	Altra
Non so	Non risponde					

## INFORMAZIONI SULLE TAGLIE

### TAGLIE/MISURE

Qual'e' la misura piu' abituale delle vostre calzature?

35 o meno 35.5 36 36.5 37 37.5 38 38.5 39 39.5 40 40.5  
41 41.5 42 42.5 43 43.5 44 o piu' Non so Non risponde

**SOLO UOMINI** : Qual'e' la circonferenza di vita piu' abituale, in centimetri ?

75 o menor 80 85 90 95 100 105 110 115 120 125  
130 135 140 145 150 155 160 o piu'  
Non so Non risponde

**INFORMAZIONI SULLE TAGLIE (CONTINUA)**

**SOLO UOMINI :** Qual'e' la lunghezza dei pantaloni piu' abituale ?

66 o meno    68.5    71    73.5    76    78.5    81    83.5    86    88.5    91  
93.5    96 o piu'    Non so    Non risponde

**SOLO UOMINI :** Qual'e' la taglia piu' abituale della giacca (da abito) ?

46 o menor    48    50    52    54    56    58 o piu'  
Non so    Non risponde

**SOLO DONNE:** Che taglia porta di camicetta o top?

XSMALL    SM    MED    LG    XL    XXL  
Non so    Non risponde

**SOLO DONNE:** Qual'e' la misura del reggiseno?

30 o meno    32 a b c d    34 a b c d    36 a b c d dd    38 a b c d dd    40 a b c d dd  
42 a b c d dd    44 a b c d dd    46 a b c d dd    48 o piu'    Non so    Non risponde

**SOLO DONNE:** Che taglia porta di pantaloni ?

36 o meno    38    40    42    44    46    48    50    52    54    56    58  
60 o piu'    Non so    Non risponde

**Questionnaire – answer options**  
(Netherlands)

**State or Birth Province (see map)**

GR - Groningen  
FR - Friesland  
DR - Drente  
OV - Overijssel  
GL - Gelderland  
UT - Utrecht  
NH – Noord Holland  
ZH – Zuid Holland  
ZE - Zeeland  
NB – Noord Brabant  
LI - Limburg  
FL - Flevoland

Other codes are ISO country codes

**Sex**

M - Male  
V – Femaile

**Education (highest achieved)**

Geen - None  
BO - only primary school  
MO - only high school  
LBO - lower school for profession (e.g. carpenter)  
MBO - intermediate school for profession (e.g. administration)  
HBO - higher school for profession (e.g. physiotherapist)  
UNIV - university

**Father born/Mother born**

ISO country code for country where father/mother is born (see Appendix E)

**Sector (in which the subject is working)**

landbouw/visserij - agriculture and fishery  
defensie - defense  
industrie - industry  
vervoer - opslag en communicatie - transport, storage and communcation  
onderwijs - education  
bouwnijverheid - construction  
horeca - hotels and restaurants  
financiële instellingen - financial institutions  
gezondheidszorg en welzijnszorg - health and wellbeing  
handel - trade  
delfstofwinning - mining  
openbare voorzienings bedrijven - public service  
zakelijke dienstverlening - business support  
openbaar bestuur - government  
cultuur en recreatie - culture and recreation



**Sector (in which the subject is working) (cont)**

in dienst van huishouden	- in service of family
zonder werk	- no work
overig	- other
geen antwoord	- no answer

**Work posture**

meest zittend	- predominantly sitting
merendeels staand	- predominantly standing
meest lopen of fietsen	- predominantly walking or cycling
sjouwen en tillen	- carrying and lifting
Geen antwoord	- no answer

**Work hours**

1 – 80	- number of hours of work
Onbekend	- unknown
Geen antwoord	- no answer

**Car make**

Alfa Romeo	Audi	BMW	Chevrolet
Chrysler	Citroen	Daewoo	Daf
Daihatsu	Fiat	Ford	FSO
Honda	Hyundai	Iveco	Man
Mazda	Mercedes	Mitsubishi	Nissan
Opel	Peugeot	Renault	Rover
Saab	Scania	Seat	Skoda
Subaru	Suzuki	Toyota	Volkswagen
Volvo			
Overig		- other	
Onbekend		- unknown	
Geen antwoord		- no answer	

**Car year**

1930 – 2000	- year of car manufacturing
Onbekend	- unknown
Geen antwoord	- no answer

**Car type**

Personenauto klein	- compact car
Personenauto middenklasse	- middle class car
Personenauto luxe	- luxury car
Sportauto	- sports car
Stationwagen	- station car
Minivan – busje	- minivan
Vrachtauto	- truck
Terreinwagen	- off-road
MPV	- multi-purpose van
Bus	- bus
Bestelauto	- small truck
Pick-up	- pick-up

**Car type (cont)**

Overig - other  
Onbekend - unknown  
Geen antwoord - no answer

**Shoe size**

30 – 49 - shoe size  
onbekend - unknown  
geen antwoord - no answer

**Pants (waist) circumference**

28 – 46 - waist circumference  
Onbekend - unknown  
Geen antwoord - no answer

**Pants length**

28 – 40 - pants length  
Onbekend - unknown  
Geen antwoord - no answer

**Jacket size (only men)**

34 – 62 - jacket size  
Onbekend - unknown  
Geen antwoord - no answer

**Blouse size (only women)**

34 – 62 - blouse size  
Onbekend - unknown  
Geen antwoord - no answer

**Cup size**

AA  
A  
B  
C  
D  
E(=DD)  
Onbekend - unknown  
Geen antwoord - no answer

**Chest circumference under bust**

50 – 100 - chest circumference under bust  
onbekend - unknown  
geen antwoord - no answer

**Size underwear**

Free entry (number or S, M, L, etc) - size  
Onbekend - unknown  
geen antwoord - no answer

**Marital status**

Alleenstaand	- single
Verloofd	- engaged
Gehuwd	- married
Gescheiden	- divorced
weduwe of weduwnaar	- widow(er)
samenwonend	- living together
gereg. partner.	- registered partnership
geen antwoord	- no answer

**Exercise (number of hours a week)**

0 - 1	
2 - 3	
4 - 6	
6 - 10	
meer dan 10	- over 10
geen antwoord	- no answer

**Salary (before tax) in thousand guilders**

< 20	
20 - 30	
30 - 40	
40 - 60	
60 - 90	
90 - 120	
120 - 160	
160 - 200	
> 200	
onbekend	- unknown
geen antwoord	- no answer

**Children (number of)**

0	
1	
2	
3	
4	
5	
6	
7 of meer	- 7 or more
geen antwoord	- no answer

**Weight gain**

sterk afgenomen	- strong decrease
ongeveer gelijk gebleven	- about the same
sterk toegenomen	- strong increase

**APPENDIX B: ANTHROPOMETRY DATA FORMS**

North American

NAME \_\_\_\_\_

DATE \_\_\_\_/\_\_\_\_/\_\_\_\_

MALE \_\_\_\_ FEMALE \_\_\_\_

(Measurement Values in cm)

	Dimension	Value		Dimension	Value
1	Weight (Mass)		21	Thigh Circ. Max.	
2	Stature		22	Ankle Circ.	
3	Crotch Height		23	Foot Length	
4	Thumb Tip Reach - 1		24	Shoulder (Bideloid) Breadth	
	Thumb Tip Reach - 2				
	Thumb Tip Reach - 3		25	Sitting Height	
5	Subscapular Skinfold	mm	26	Eye Height Sitting	
6	Triceps Skinfold	mm	27	Acromial Ht. Sitting	
7	Arm Length (Spine-Shoulder)		28	Elbow Height, Sitting (Rt.)	
8	Arm Length (Spine-Elbow)		29	Knee Height Sitting	
9	Arm Length (Spine-Wrist)		30	Thigh Circ. Max Sitting	
10	Armscye Circ (Scye Circ/Acrom.)		31	Hand Circ.	
11	Chest Girth (Chest Circ at Scye)		32	Head Circ.	
12	Bust/Chest Circ.		33	Head Length	
13	Bust/Chest Circ. Under Bust		34	Bizygomatic Breadth	
14	Waist Circ., Preferred		35	Head Breadth	
15	Waist Height, Preferred (Rt)		36	Hip Breadth Sitting	
16	Waist Front Length		37	Buttock-Knee Length	
17	Total Crotch Length		38	Face Length	
18	Vertical Trunk Circ.		39	Hand Length	
19	Hip Circ., Maximum		40	Neck Base Circ.	
20	Hip Circ., Maximum Ht.				

Italian

NOME \_\_\_\_\_  
 MASCHIO \_\_\_\_ FEMMINA \_\_\_\_

DATA \_\_\_\_/\_\_\_\_/\_\_\_\_

(Misure in CM)

	Dimensioni	Misura		Dimensioni	Misura
1	Peso				
			21	Circ. Max. Coscia	
2	Statura				
			22	Circ. Caviglia	
3	Alt. Cavallo				
			23	Lung. Piede	
4	Portata Di Mano - 1				
	Portata Di Mano - 2		24	Larg. Spalle (Bideltoide)	
	Portata Di Mano - 3				
			25	Statura Da Seduti	
5	Calcolo Grasso Sottoscapolare	mm			
			26	Alt. Occhi, Seduti	
6	Calcolo Grasso Tricipide	mm			
			27	Alt. Spalla (Acromio), Seduti	
7	Lung. Braccio (Spina Dorsale-Spalla)				
			28	Alt. Gomito, Seduti (Destra)	
8	L.B. (Spina Dorsale-Gomito)				
			29	Alt. Ginocchio, Seduti	
9	L.B. (Spina Dorsale-Polso)				
			30	Max. Circ. Coscia, Seduti	
10	Circ. Manica (Acromio)				
			31	Circ. Mano	
11	Circ. Busto (Sotto Ascelle)				
			32	Circ. Testa	
12	Circ. Petto				
			33	Lung. Testa	
13	Circ. Sotto-Seno (Donne)				
			34	Larg. Zigomi	
14	Circ. Vita Preferita				
			35	Larg. Testa	
15	Alt. Circ. Vita Pref. (Destra)				
			36	Larg. Fianchi, Seduti	
16	Lung. Vita Davanti				
			37	Lung. Natica-Ginocchio	
17	Lung. Totale Cavallo				
			38	Lung. Viso	
18	Circ. Torso Verticale				
			39	Lung. Mano	
19	Circ. Max. Fianchi				
			40	Circ. Base Collo	
20	Alt. Max. Circ. Fianchi				

Dutch

Meetgegevens handmetingen

Nummer (Subject Number): \_\_\_\_\_

Datum (Date): \_\_\_\_\_

Gemeten door: \_\_\_\_\_

(Measurement Values in cm)

	Dimension (Dutch)		Dimension (North American/Italy)	Value
1	Lichaamslengte	2	Stature	
2	Hoofdomvang	32	Head Circ.	
3	Armlengte wervel-schouder	7	Arm Length [Spine-Shoulder]	
4	Armlengte wervel-elleboog	8	Arm Length [Spine-Elbow]	
5	Armlengte wervel-pols	9	Arm Length [Spine-Wrist]	
6	Handomvang	31	Hand Circ.	
7	Armomvang bij oksel	10	Armscye Circ. [Scye Circ./Acrom.]	
8	Borstomvang bij oksel	11	Chest Girth [Chest Circ. At Scye]	
9	Borstomvang	12	Bust/Chest Circ.	
10	Onderbusteomvang	13	Bust/Chest Circ. Under Bust	
11	Tailleomvang	14	Waist Circ., Preferred	
12	Romplengte voor	16	Waist Front Lengt	
13	Onderlichaamomvang	17	Total Crotch Length	
14	Rompomvang	18	Vertical Trunk Circ.	
15	Heupomvang	19	Hip Circ. Maximum	
16	Dijbeenomvang	21	Thigh Circ. Maximum	
17	Enkelomvang	22	Ankle Circ.	
18	Halsomvang	40	Neck Base Circ.	
19	Jukbeenbreedte	34	Bizygomatic Breadth	
20	Gezichtsleugte	38	Face Length	
21	Hoofdlengte	33	Head Length	
22	Dijbeenomvang zittend	30	Thigh Circ., Max., Sitting	
23	Heupbreedte zittend	36	Hip Breadth, Sitting	
24	Hoofdbreedte	35	Head Breadth	
25	Schouderbreedte (delt)	24	Shoulder [Bideloid] Breadth	
26	Handlengte	39	Hand Length	
27	Voetlengte	23	Foot Length	
28	Huidplooi schouderblad	5	Subscapular Skinfold	
29	Huidplooi triceps	6	Triceps Skinfold	
30	Taillehoogte	15	Waist Height, Preferred	
31	Heuphoogte	20	Hip Circ., Maximum Height	
32	Zithoogte	25	Sitting Height	
33	Ooghoogte zittend	26	Eye Height Sitting	
34	Acromionhoogte zittend	27	Acromial Height, Sitting	
35	Ellebooghoogte zittend	28	Elbow Height, Sitting	
36	Duim-reikafstand 1	4	Thumb Tip Reach - 1	
	Duim-reikafstand 2		Thumb Tip Reach - 2	
	Duim-reikafstand 3		Thumb Tip Reach - 3	
37	Kniehoogte zittend	29	Knee Height, Sitting	
38	Bil-knieschijf diepte	37	Buttock-Knee Length	
39	Binnenbeenlengte	3	Crotch Height	
40	Gewicht	1	Weight	

## APPENDIX C: GLOSSARY



## A

**ABDOMINAL:** Pertaining to the abdomen, particularly the region below the rib cage and above the pelvis.

**ABDUCT (ABDUCTION):** To move away from a position near (or parallel) to the axis of the body or one of its parts.

**ACROMIAL:** Pertaining to the acromial process of the scapula (shoulder blade).

**ACROMION:** Landmark title.

**ADDUCT (ADDITION):** To move toward a position closer (or more nearly parallel) to the axis of the body or of a body part.

**AGE:** The age in years of the subject at his or her last birthday.

**ANKLE (LANDMARK):** The level of the circumference of the ankle measured at the lateral and medial malleoli (rounded bony prominences on either side of the ankle).

**ANTERIOR:** Pertaining to the front (ventral) part of the body.

**ANTERO:** A prefix meaning anterior, or toward the front.

**ANTHROPOMETRY:** The study of human body measurements especially on a comparative basis.

**ARM:** The segment of the upper limb between the gleno-humeral joint (shoulder) and the elbow; commonly referred to as the upper arm.

**AURICLE:** The largely cartilaginous external ear (pinna).

**AURICULAR:** Referring to the auricle.

**AXILLA:** The armpit; refers also to the crease which forms on the front of the body at the armpit when the upper arm is relaxed against the chest.

**AXILLARY:** Referring to the axilla (the armpit region).

## B

**BI:** A prefix relating to each of two symmetrically paired points.

**BICEPS:** The large muscle on the anterior aspect of the arm.

**BICEPS (LANDMARK):** The level of the maximum bulge of the tensed biceps when the arm is bent to a right angle.

**BICEPS-FEMORIS:** A large posterior muscle of the thigh.

**BIVARIATE:** Of, relating to, or involving two variables.

**BREADTH:** The distance from side to side; width.

**BROW-RIDGE:** The ridge of bone known as the eyebrow; the bony ridge of the anterior forehead which lies above the orbit of each eye.

**BUSTPOINT:** The most anterior protrusion of the right bra cup.

**BUTTOCK (LANDMARK):** The maximum posterior protrusion of the right buttock.

**BUTTOCK-PROTRUSION:** The maximum posterior protrusion of the right buttock.

## C

**CALCANEUS:** The heel bone.

**CANTHUS (PLURAL-CANTHI):** The corners of the eyes.

**CARPUS:** The wrist bones, collectively.

**CERVICALE:** Landmark title.

**CHEILION:** The corners of the mouth formed by the juncture of the lips.

**CLAVICLE:** The bone connecting the sternum (breastbone) to the scapula (shoulder blade).

**CORONAL-PLANE:** The vertical (frontal) yz plane.

**COSTAL:** A part that resembles the rib.

**CRANIUM:** The upper part of the skull; it is bounded by the brow ridges, external auditory meatus and the occiput.

**CRINION (LANDMARK):** A title for the point in the midsagittal (xz) plane of the forehead at the hairline.

**CUTANEOUS-LIP:** The area between the upper lip and the nose.

## D

**DACTYLION:** Landmark title.

**DELTOID:** Designating or of a large, triangular muscle of the shoulder, which raises the arm away from the side.

**DELTOID-MUSCLE:** The triangular mass of muscle covering the point of the shoulder, originating from the clavicle, acromion and scapula and inserting onto the shaft of the humerus.

**DEPTH:** The distance from front to back.

**DIGIT:** A finger or toe; for CAESAR, it is used for the toe only (Digit II).

**DISTAL:** The end of a body segment farthest from the head; away from a point of origin; away from the head or torso; opposite of proximal.

**DORSAL:** Situated near or on the back.

## E

**ECTOCANTHUS:** The outer corners of the eyes; the lateral canthus

**ENDOCANTHUS:** The inner corners of the eyes; the medial canthus

**EPICONDYLE:** Immediately adjacent (toward the midsection of the bone involved) to the condyle or articular surface of a joint; bony eminence at the distal end of the humerus and femur.

**EXTEND:** To move adjacent segments so that the angle between them is increased, as when the leg is straightened, opposite of flex.

**EXTERNAL:** Farther away (relatively) from the center or central axis of the body or body segment.

## F

**FEMORIS-MUSCLE:** One of the muscles anterior to the femur.

**FEMUR:** The long bone of the thigh; the thigh bone.

**FIBULA:** The most lateral of the two long bones of the leg.

**FLEX:** To move a joint in such a direction as to bring together the two parts which it connects, as when the elbow is bent, as opposed to extended.

**FRANKFORT-PLANE:** A standard plane of orientation of the head, realized when the lowest point in the margin of the left eye socket (orbit) and the left tracion (superior margin of the external auditory meatus) are in a common horizontal plane.

**FRONTAL-PLANE:** The vertical (coronal) YZ plane.

## G

**GASTROCNEMIUS:** The largest muscle in the calf of the leg.

**GLABELLA:** Landmark title.

**GONION:** A corner of the jaw; the lateral point of the corner of the mandible (jaw bone).

## H

HUMERAL EPICONDYLE, LATERAL: Landmark title.

HUMERAL EPICONDYLE, MEDIAL: Landmark title.

HUMERUS: The long-bone of the (upper) arm.

HYPEREXTEND: To overextend a limb or other part of the body.

## I

ILIAC: Of, relating to, or located near the ilium.

ILIAC-CREST: The superior rim of the ilium or pelvic bone.

ILIOCRISTALE (LANDMARK): Landmark title.

INFERIOR: Below, in relation to another structure; lower, nearer to the feet.

INFRAORBITALE: Landmark title.

## J

## K

KNUCKLE: The joint formed by the meeting of a finger bone (phalanx) with a palm bone (metacarpal).

## L

LATERAL: Lying near or toward the sides of the body; to the right or left of the vertical fore-and-aft mid-line mid-sagittal plane of a bilaterally symmetrical body: orthogonal to the plane of symmetry. (The opposite of lateral is medial.)

LEG: The segment of the lower limb between the knee and the ankle: the shank.

LONGITUDINAL: Lengthwise

## M

MALLEOLUS: The projecting distal heads of the fibula (laterally) and of the tibia (medially) at the ankle.

MEDIAL: Lying near or towards the midline of the body; toward the midsagittal plane; opposite of lateral.

MENTON (LANDMARK): Landmark title.

METACARPAL-PHALANGEAL-JOINT: Any of the five joints of the hand between the metacarpal bones of the palm and the first phalanges of the fingers and thumb.

METATARSALS: The bones of the hind feet between the ankle and the toes; pertaining to these bones.

MIDAXILLARY-LINE: The vertical line which originates at the apex of the axilla (armpit).

MIDSAGITTAL-PLANE: The ventral plane which divides the body into right and left halves.

MIDSHOULDER: A point one-half the distance between the neck (right trapezius point) and the right acromion landmark.

MULTIVARIATE: Involving a number of individual variables.

## N

NUCHALE: Landmark title.

## O

OCCIPITAL-BONE: A curved bone forming the back and part of the base of the skull.

OCCIPUT: The most posterior portion (prominence) of the occipital bone, at the back of the head; the bone forming the posterior base of the skull.

OMPHALION: Landmark title referring to the navel, or umbilicus.

ORBIT: The eye socket.

ORBITAL-MARGIN: The rim of the hollow of the eye formed by the frontal, zygomatic, and maxillary bones.

ORTHOGONAL: Intersecting or lying at right angles.

## P

PALPATE: To examine by touch

PATELLA: The kneecap.

PHALANGEAL: Referring to a phalanx or to the phalanges, the long bones of the fingers and toes.

PHALANGES: The bones of the fingers and toes (singular, phalanx).

PHALANX (PLURAL-PHALANGES): A bone of the fingers or toes.

**PHILTRUM:** The shallow groove running from the upper membranous lip to the base of the nasal septum.

**PINNA:** The primarily cartilaginous external ear.

**PLANTAR:** Pertaining to the sole of the foot.

**POPLITEAL:** Pertaining to the area of the back of the leg directly behind the knee.

**POSTERIOR:** Pertaining to the back of the body, opposed to anterior.

**PROMENTON:** Landmark title

**PRONASALE:** Landmark title.

**PROXIMAL:** The end of a body segment nearest to the head; nearest a point of origin; nearest the head or torso; opposite of distal.

**PUPIL:** The center of the contractile (usually round) aperture in the iris of the eye; the center of the pupil.

## **Q**

## **R**

**RADIALE:** Landmark title.

**RADIUS:** One of the two long bones of the forearm on the thumb side.

## **S**

**SAGITTAL:** A vertical plane parallel to the coincident with the mid-sagittal plane.

**SCAPULA:** The large flat triangular bone forming the back of the shoulder; the shoulder blade.

**SCYE:** A tailoring term to designate the armhole or shirt sleeve hole of a garment; often refers to the landmarks which approximate the lower level of the axilla.

**SELLION:** Landmark title.

**SPHYRION:** Landmark title.

**SPINE (SPINAL PROCESS):** The posterior prominences of the vertebrae.

**STERNUM:** The breastbone.

**STYLOID-PROCESS:** A bony protuberance resembling a stylus. On the radius and ulna, this occurs at the distal end of the bone.

STYLION: Landmark title for the tip of the styloid process of the radius.

SUB: A prefix designating below or under.

SUBMANDIBULAR: Landmark title.

SUBNASALE: Landmark title.

SUBSTERNALE: Landmark title.

SUPERIOR: Higher, nearer to the head, as opposed to inferior.

SUPINE (SUPINATION): Lying on the back, face or ventral (anterior) surface upward.

SUPRA: A prefix denoting above or superior to.

SUPRAMENTON: Landmark title.

SUPRAMENTON-SELLION LENGTH: The vertical distance is measured between the point of greatest indentation of the mandibular symphysis in the midline of the face and the point of greatest indentation of the nasal root depression. (The point of greatest indentation where the bridge of the nose meets the forehead.)

SUPRAPATELLA: Landmark title.

SUPRASTERNALE: Landmark title

SYMMETRY: The correspondence in size, shape, and relative position of parts on opposite sides of a dividing line.

SYMPHESION (FEMALES): The anterior point in the midsagittal plane on the notch of the superior border of the pubic symphysis; the anterior juncture of the pelvis bones.

SYMPHESION (MALES): The lowest point on the superior border of the pubic symphysis; the anterior juncture of the pelvis bones.

## T

TARSUS: The collection of bones in the ankle joint, at the distal end of the tibia.

TEMPORAL-CREST: A narrow bony ridge along the side of the head above the ear level that serves as a point of attachment for the temporal muscles.

TEMPORAL-MUSCLES: The muscles of the temple region.

TENTH RIB: The inferior point on the inferior border of the lowest of the two tenth ribs.

TENTH RIB (LANDMARK): Landmark title.

THELION: Landmark title.

**TIBIA:** The inner and usually larger of the two bones between the knee and the ankle.

**TORSO:** The human trunk.

**TRAGION:** Landmark title.

**TRAGUS:** The small cartilaginous flap in front of the ear hole.

**TRAPEZIUS-MUSCLE:** The large muscle on each side of the back of the neck and shoulders, the action of which moves the shoulders.

**TRICEPS-MUSCLE:** The large muscle on the back of the upper arm.

**TROCHANTER:** A rough prominence at the upper part of the femur.

**TROCHANTERION:** Landmark title.

## U

**ULNA:** One of the two long bones of the forearm on the little finger side of the forearm.

**ULNAR:** Referring to the ulna.

**ULNAR STYLOID:** Landmark location and title.

**UMBILICUS:** The navel.

## V

**VENTRAL:** Located near the anterior surface opposite the back.

## W

**WRIST (LANDMARK):** The wrist as established by placing a band at the level of the ulnar and radial styloid.

## X

**XIPHOID-PROCESS:** The inferior segment of the sternum.

## Y Z

**ZYGOMATIC-ARCH:** The bony arch running along the side of the cheek to the ear, formed by the zygomatic process (zygoma) of the temporal and the zygomatic bones of the skull.



APPENDIX D: VISUAL INDEX

## Anatomical Landmarks for Traditional Anthropometry

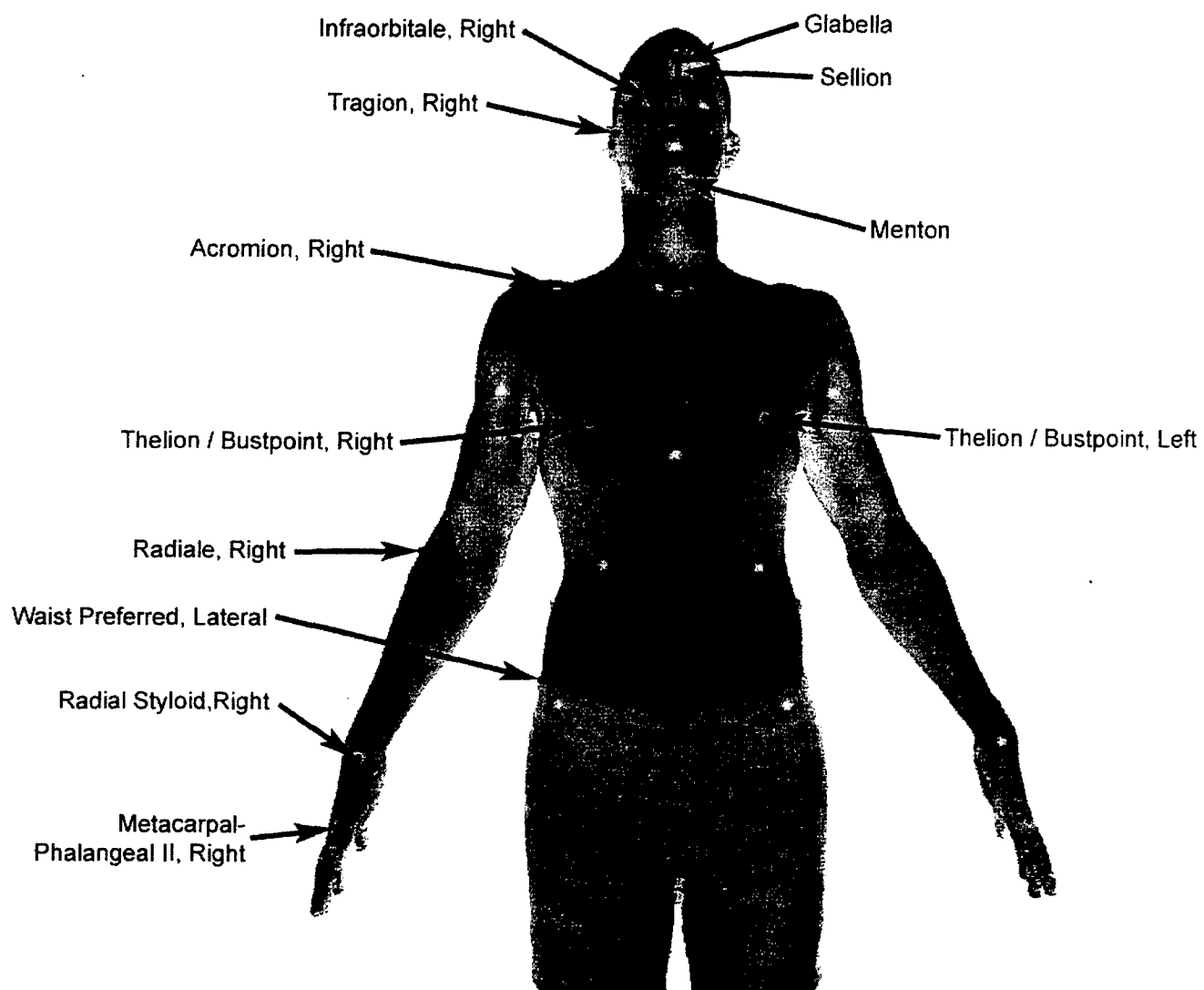

# Anatomical Landmarks for Traditional Anthropometry

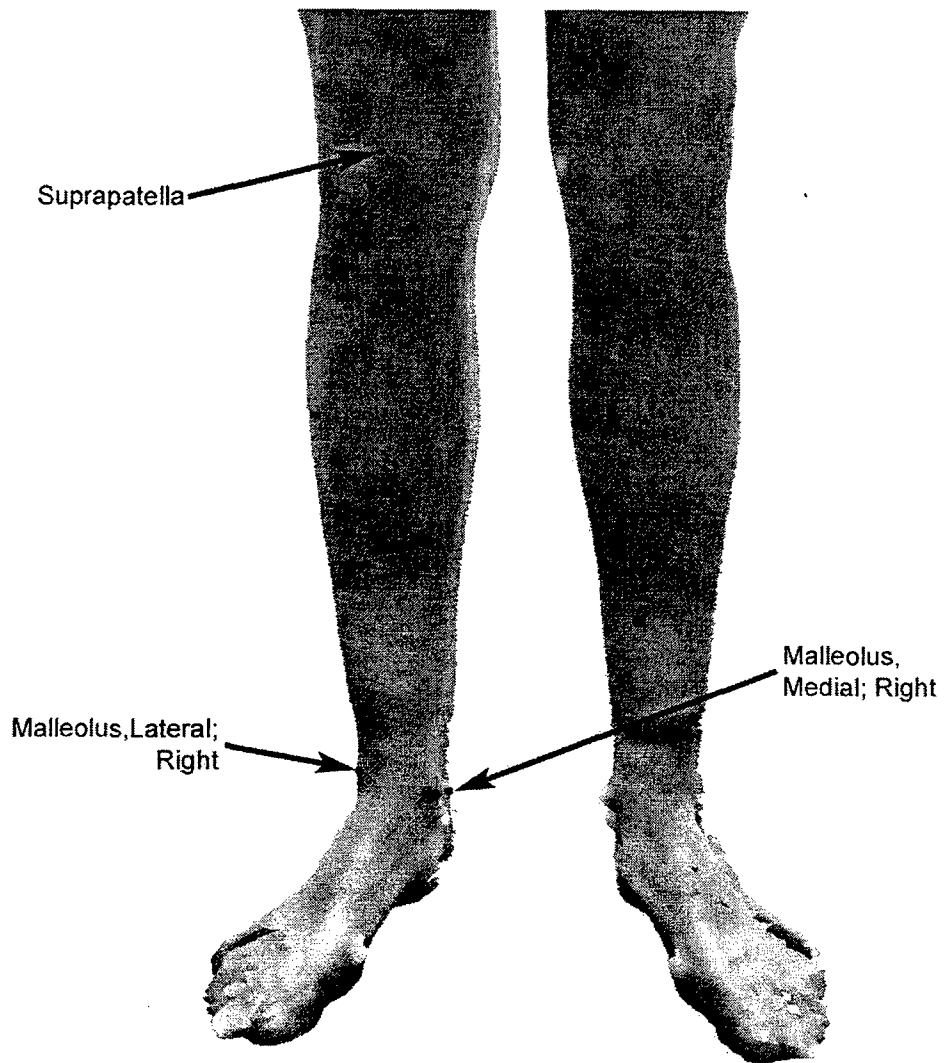

# Anatomical Landmarks for Traditional Anthropometry

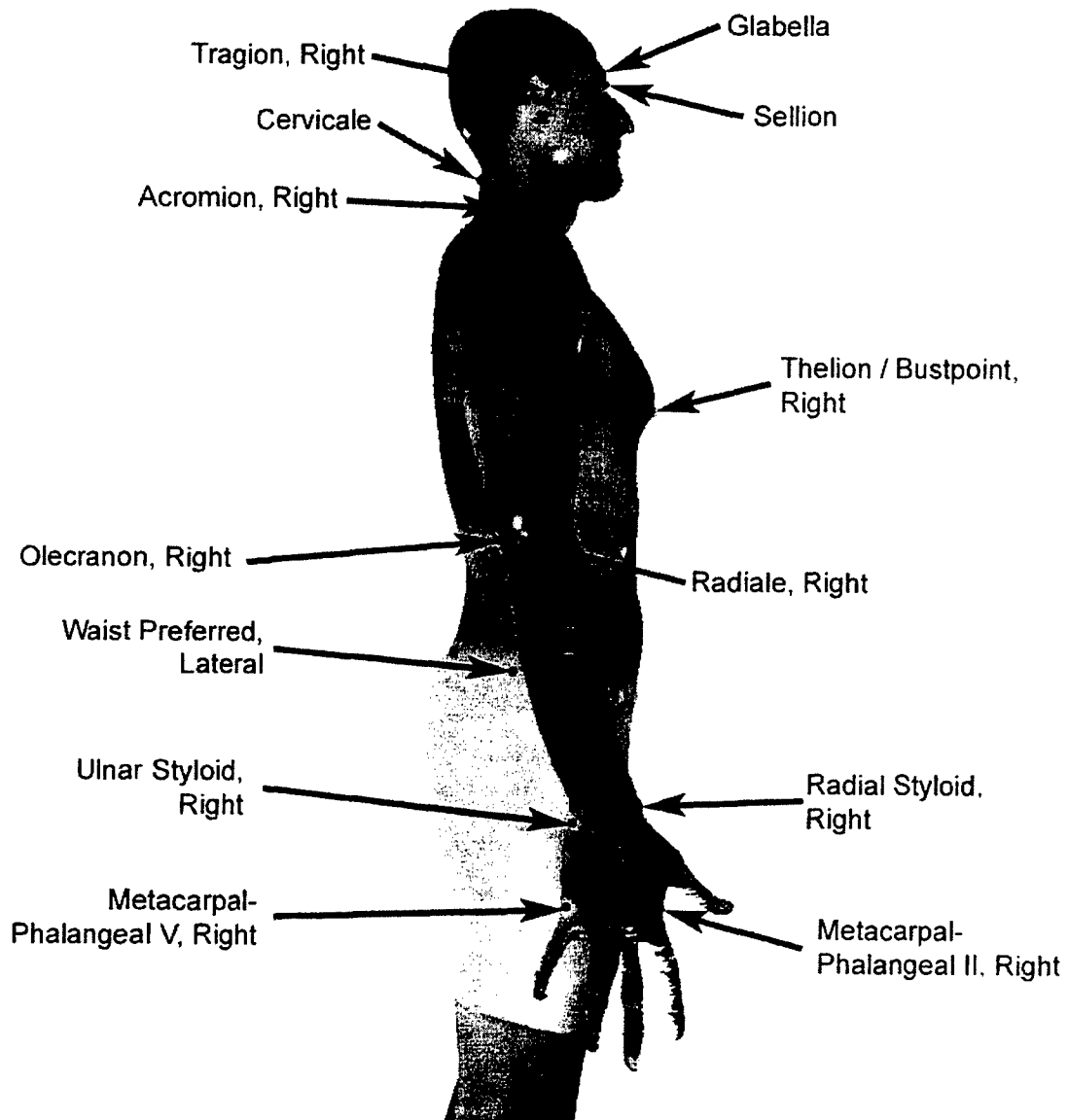

# Anatomical Landmarks for Traditional Anthropometry

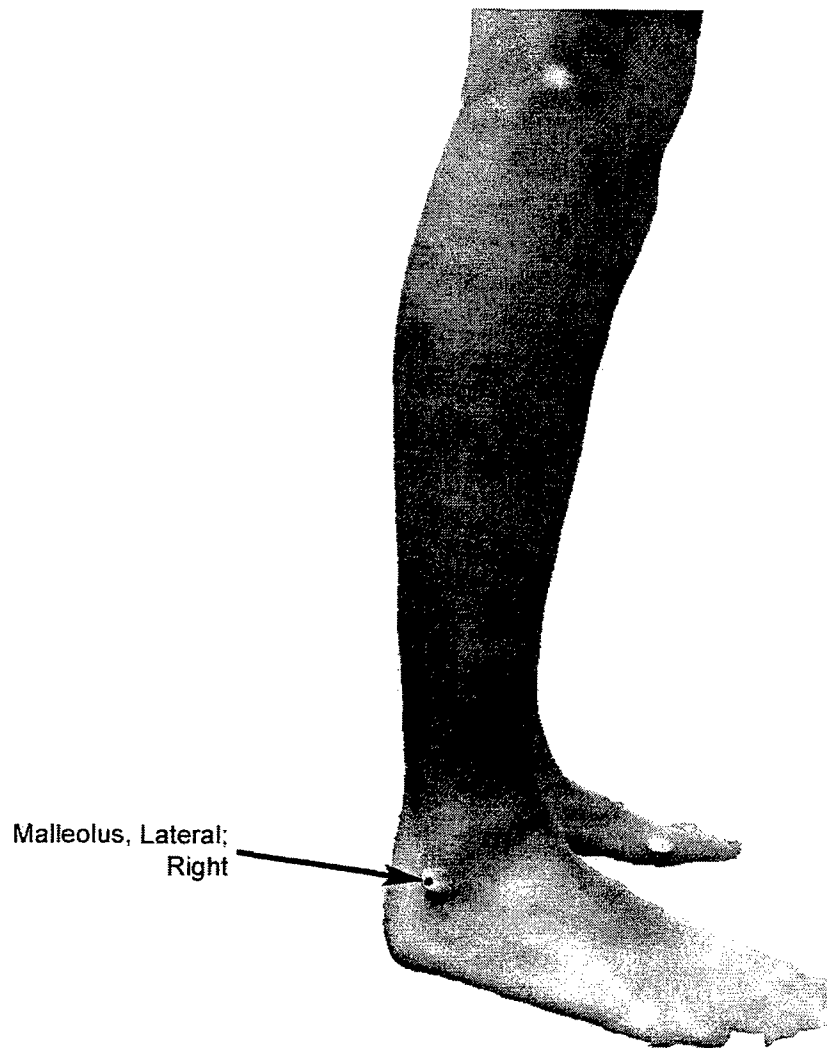

# Anatomical Landmarks for Three-dimensional Scan Anthropometry

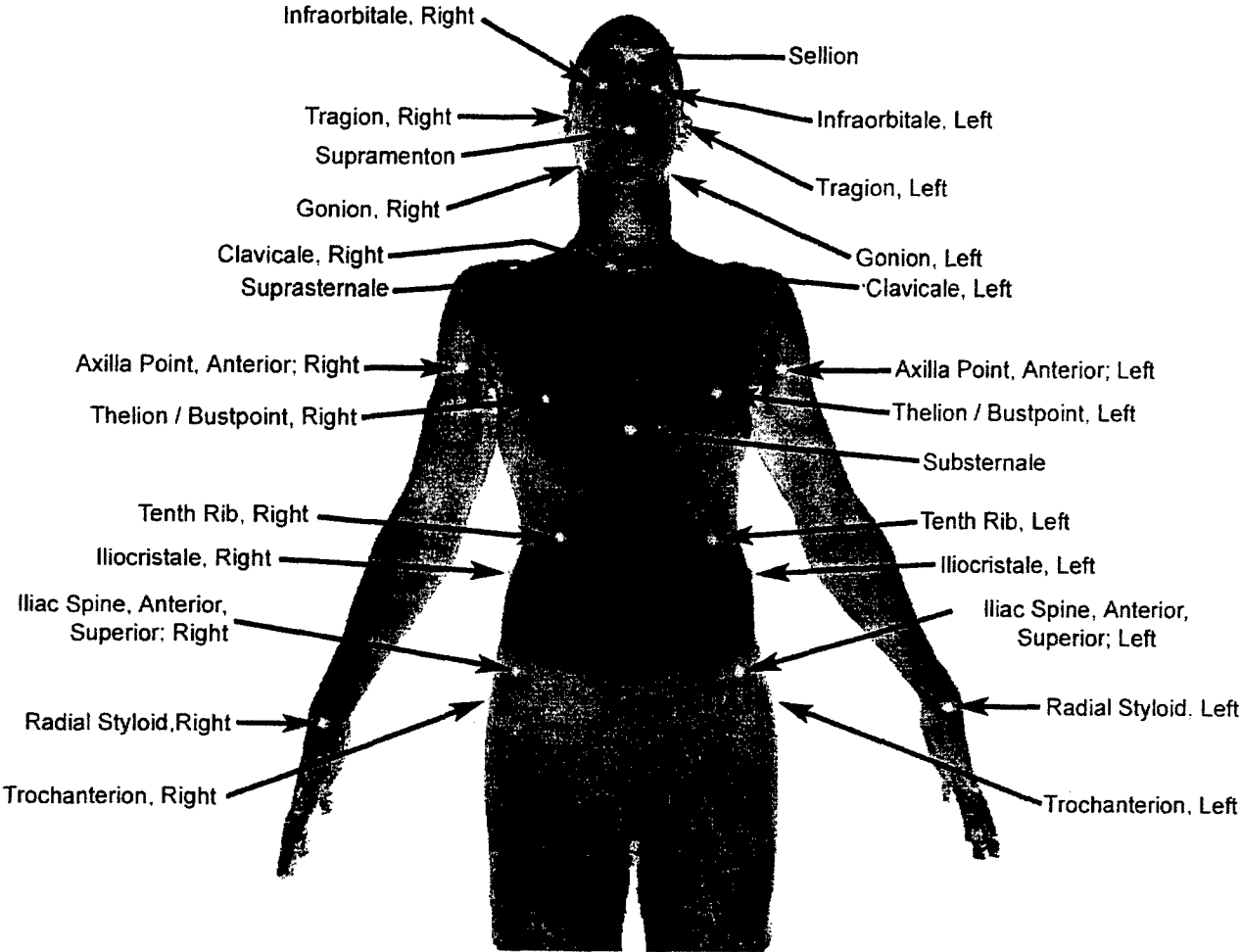

# Anatomical Landmarks for Three-dimensional Scan Anthropometry

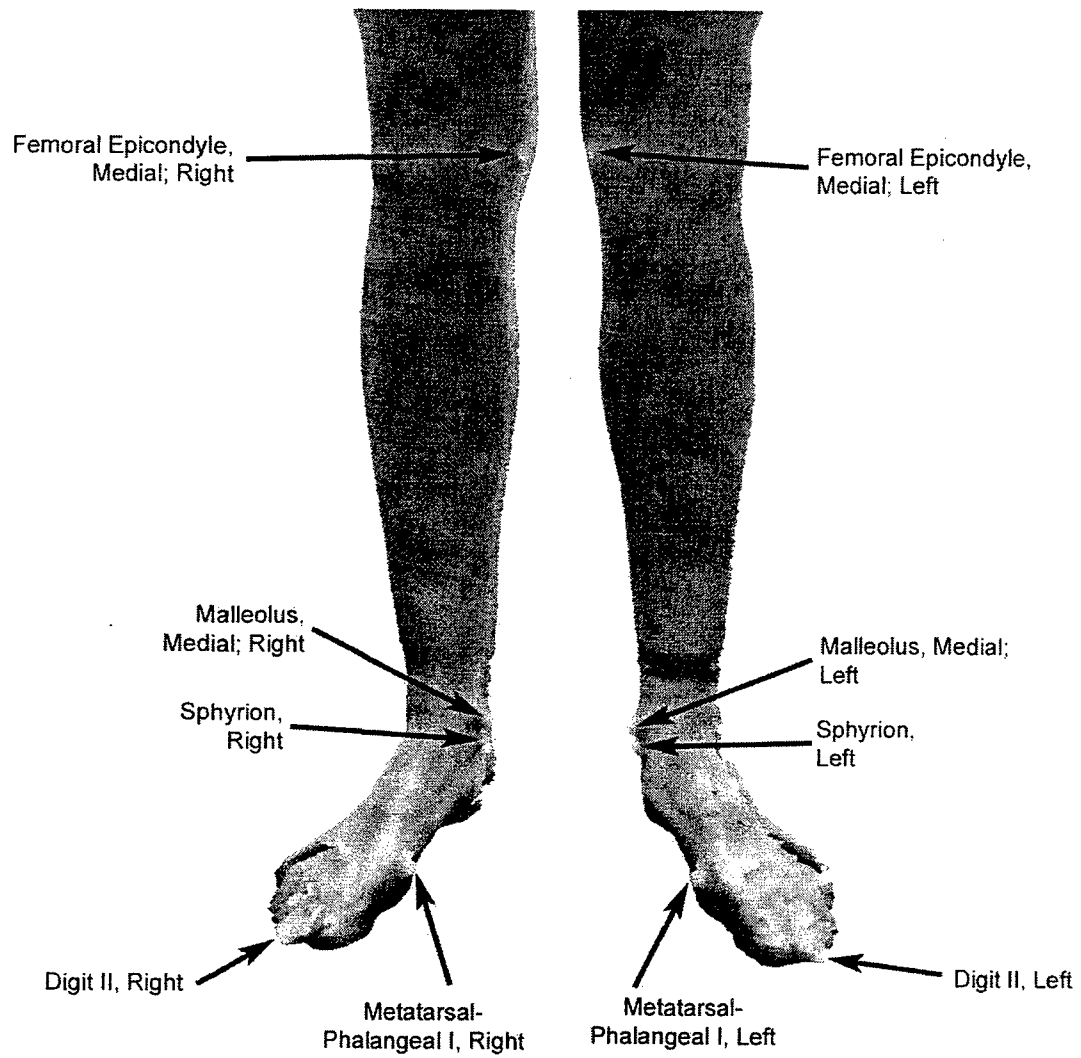

# Anatomical Landmarks for Three-dimensional Scan Anthropometry

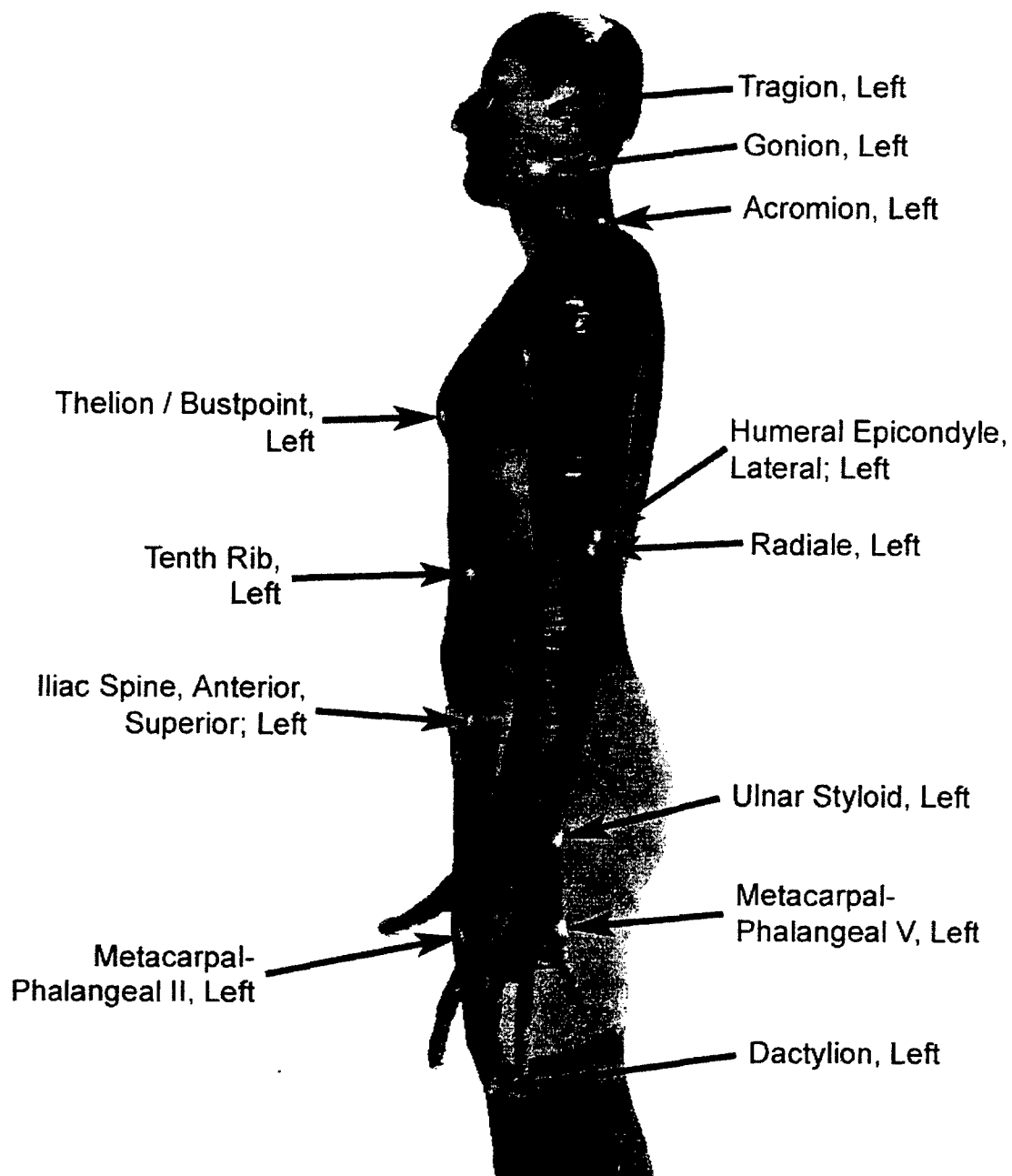



# Anatomical Landmarks for Three-dimensional Scan Anthropometry

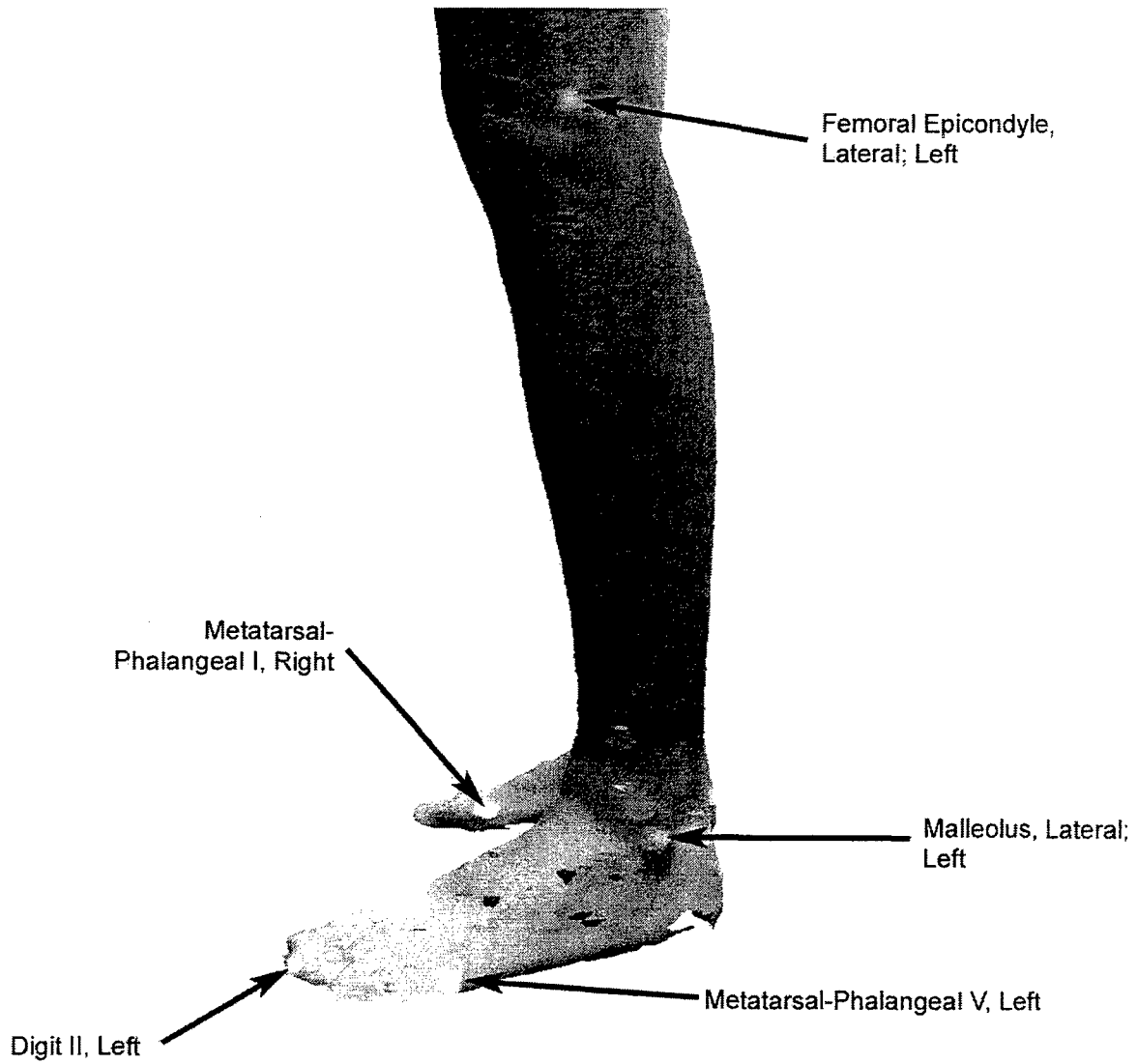

# Anatomical Landmarks for Three-dimensional Scan Anthropometry

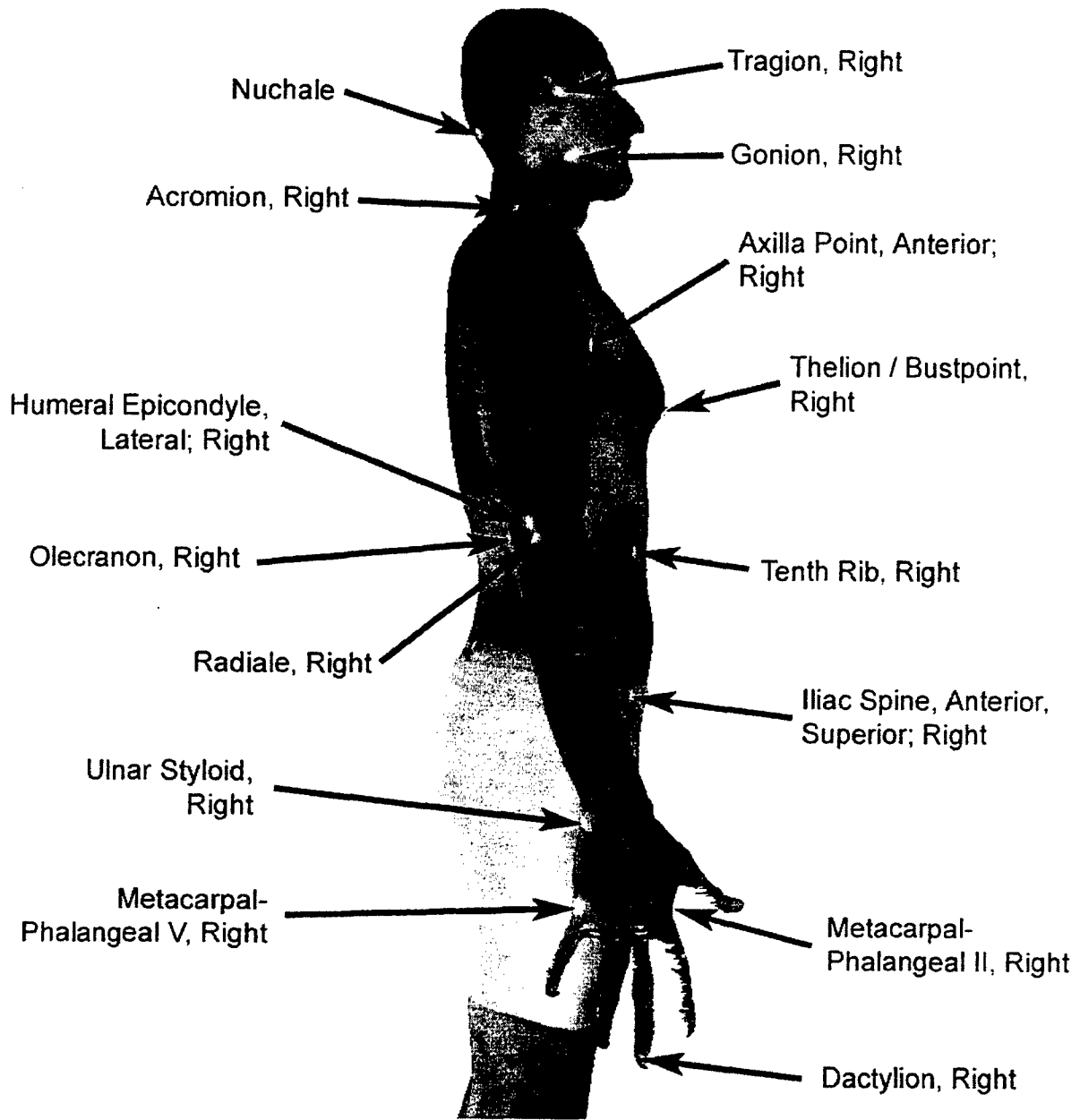

# Anatomical Landmarks for Three-dimensional Scan Anthropometry

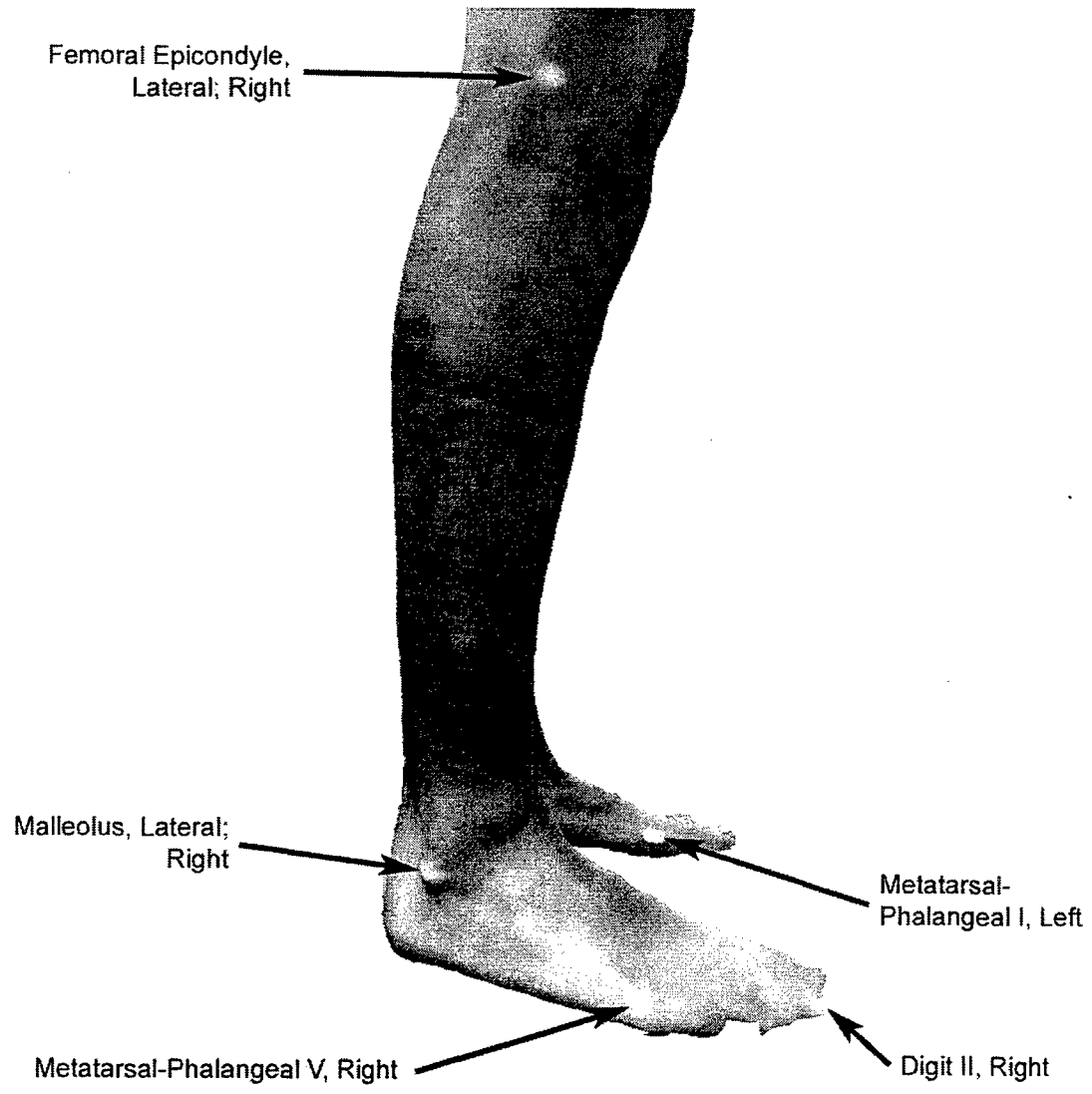

# Anatomical Landmarks for Three-dimensional Scan Anthropometry

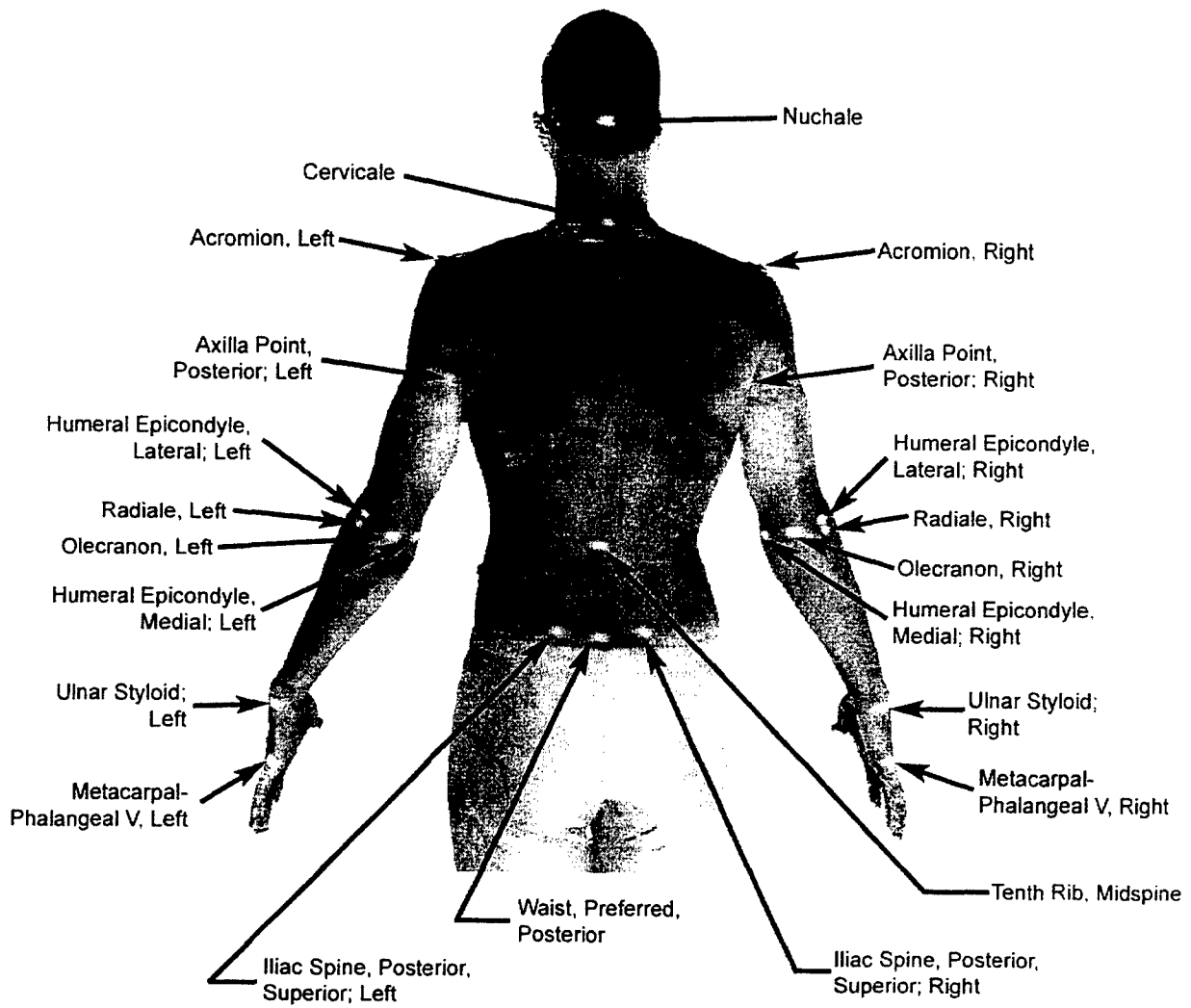

# Anatomical Landmarks for Three-dimensional Scan Anthropometry

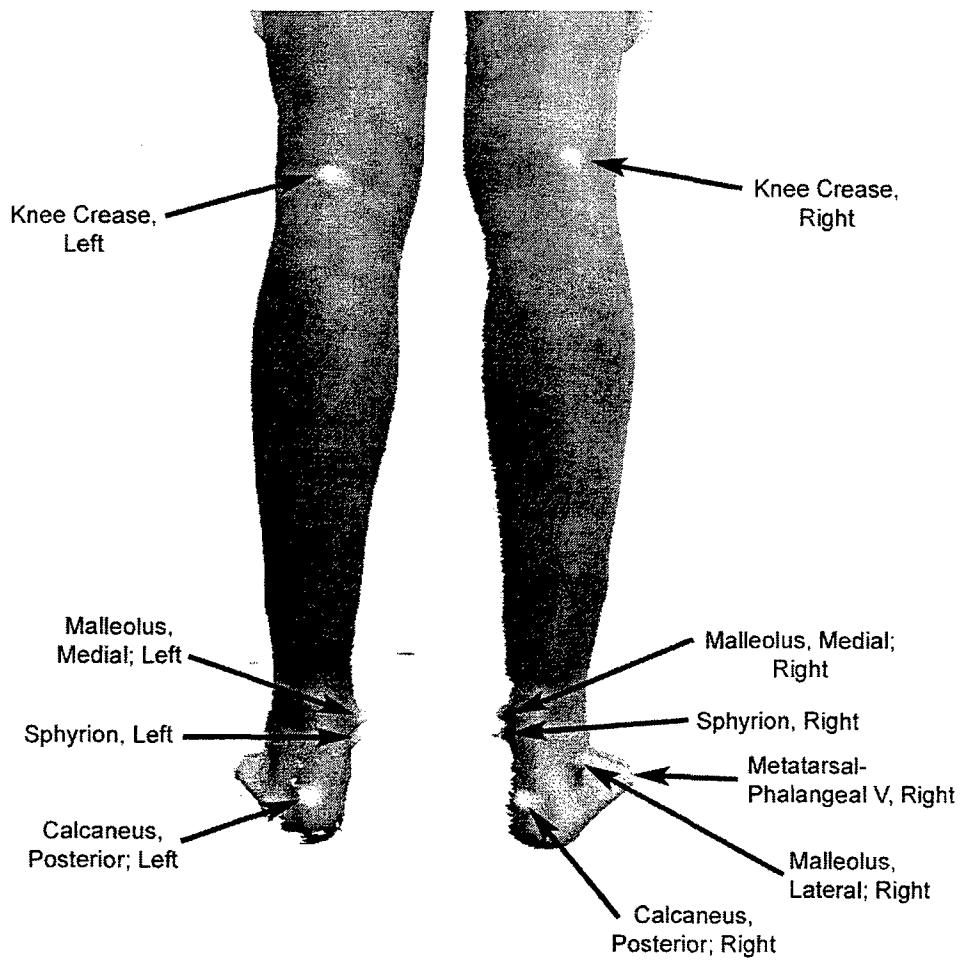

# Anatomical Landmarks for Three-dimensional Scan Anthropometry

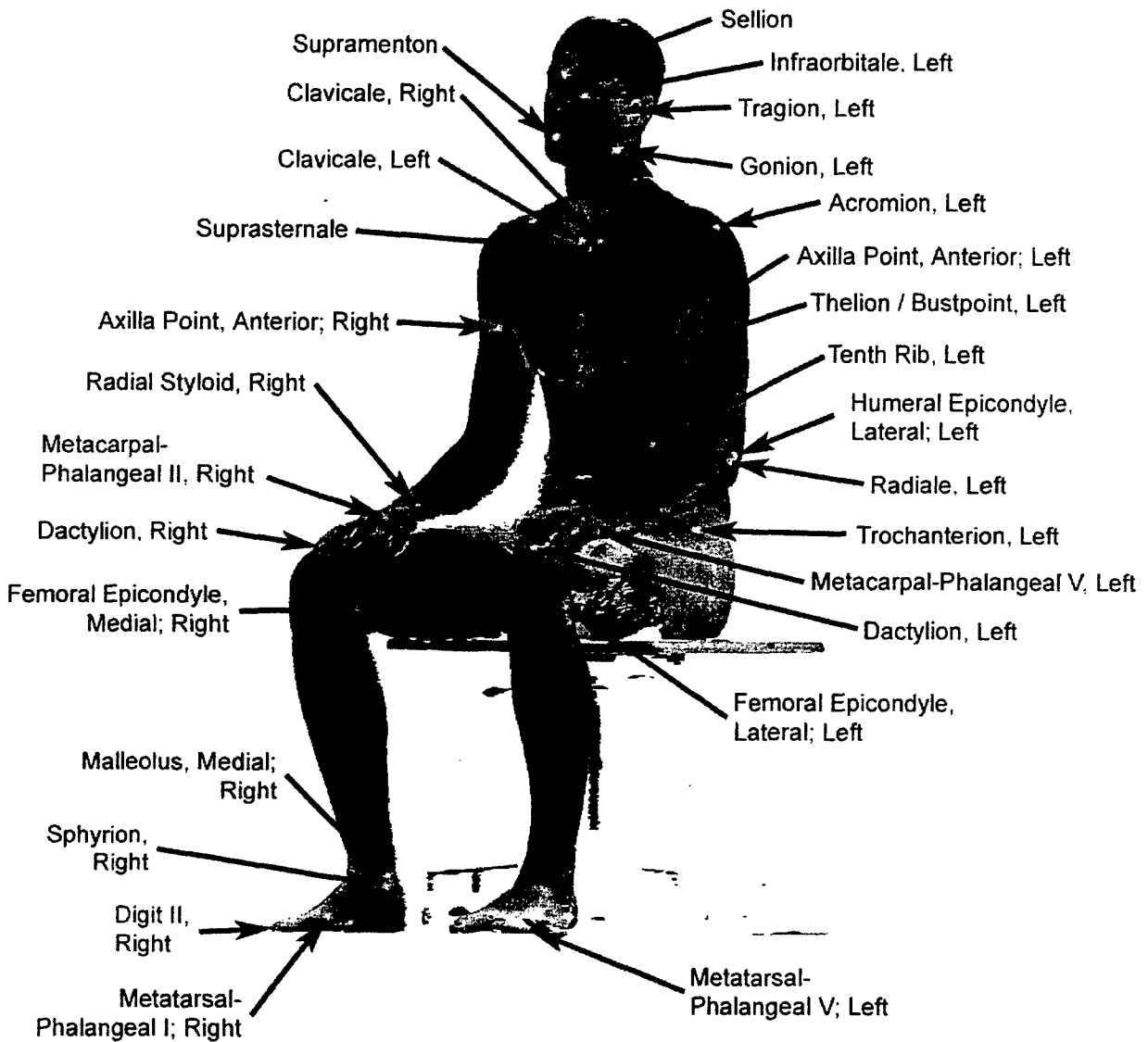

# Anatomical Landmarks for Three-dimensional Scan Anthropometry

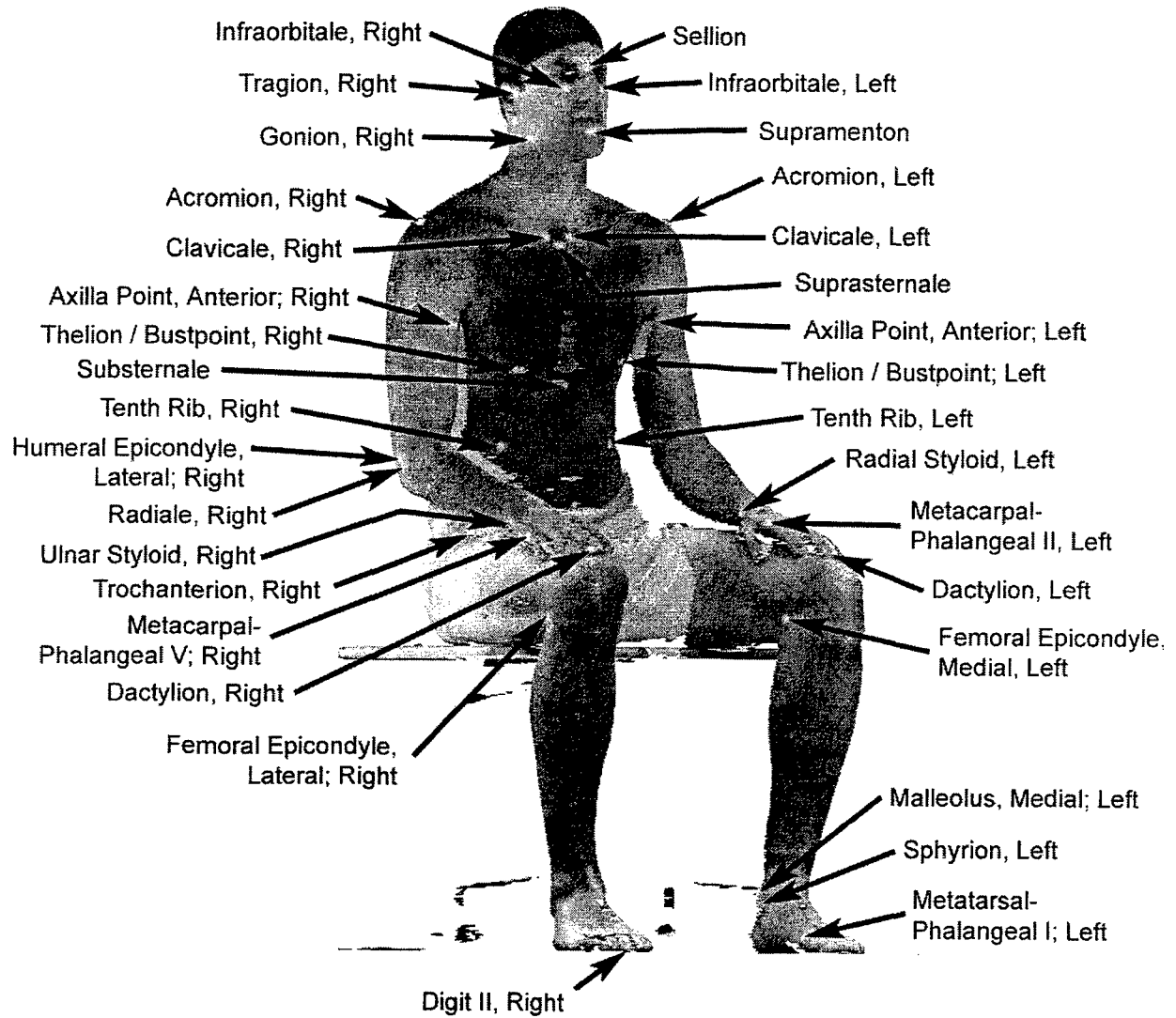

# Anatomical Landmarks for Three-dimensional Scan Anthropometry

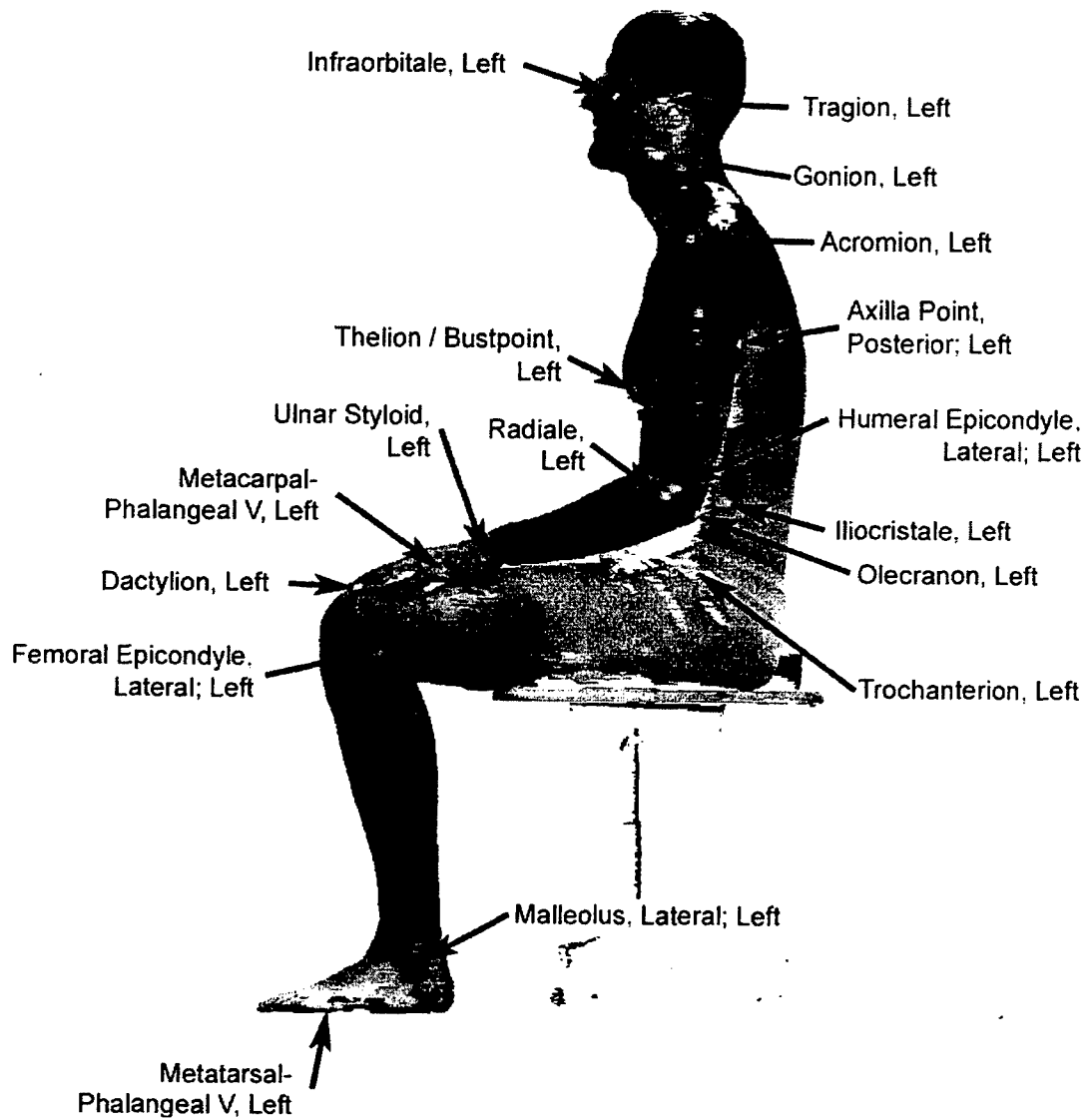



# Anatomical Landmarks for Three-dimensional Scan Anthropometry

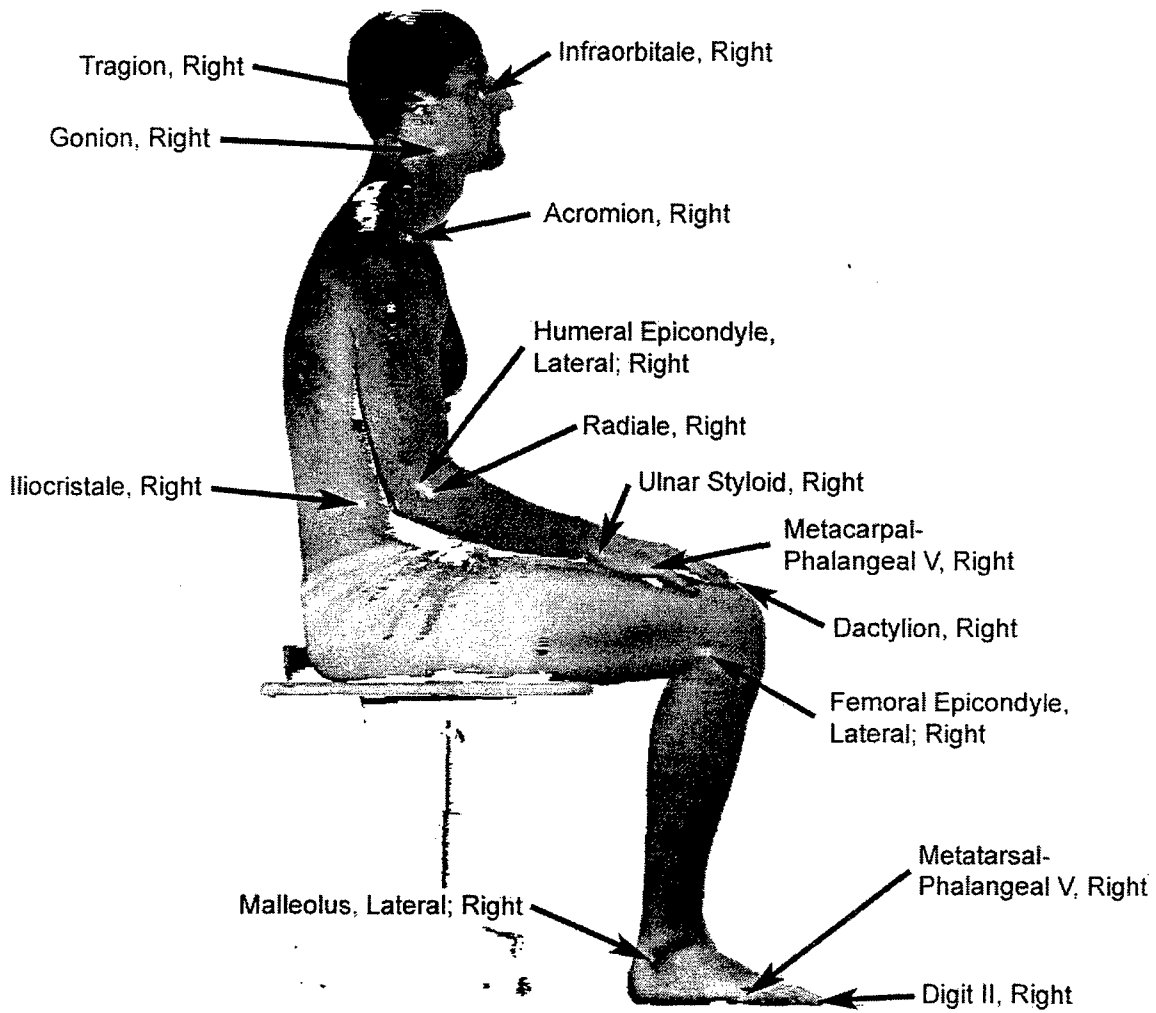

# Anatomical Landmarks for Three-dimensional Scan Anthropometry

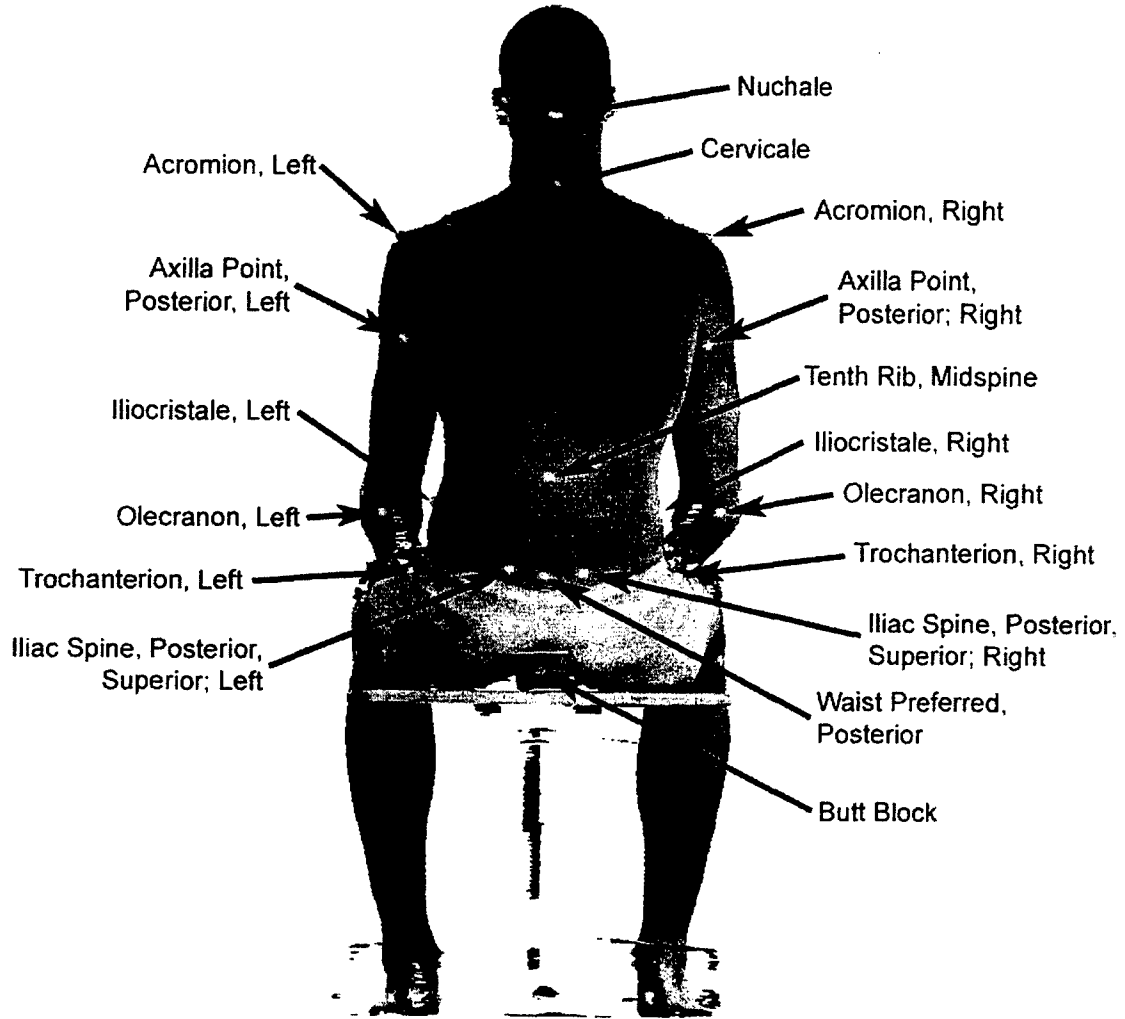

## Traditional Anthropometry

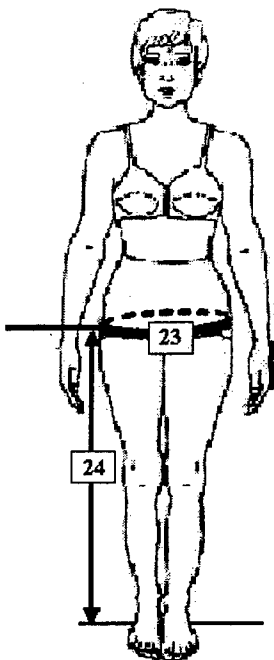
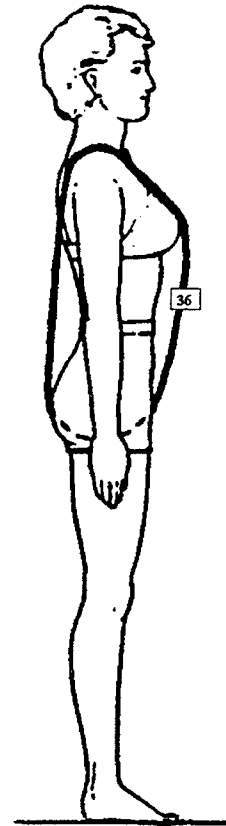
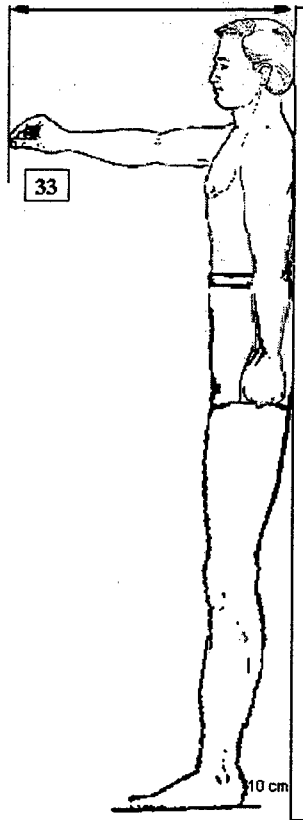
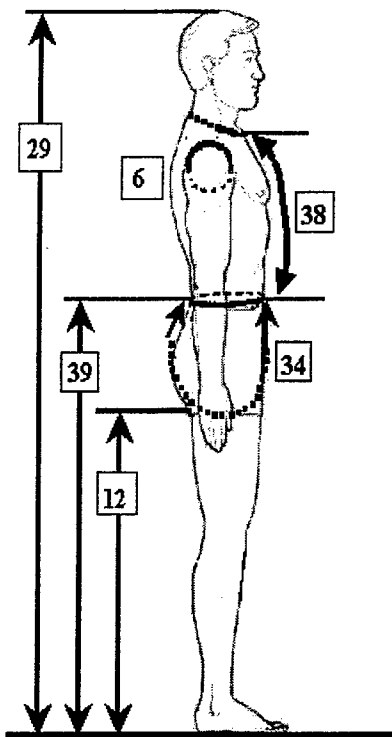

- 6. Armscye Circumference (Scye Circumference over Acromion)
- 12. Crotch Height
- 23. Hip Circumference, Maximum
- 24. Hip Circumference, Maximum, Height
- 29. Stature (Body Height)
- 33. Thumb Tip Reach, Right
- 34. Total Crotch Length
- 36. Vertical Trunk Circumference, Right
- 38. Waist Front Length
- 39. Waist Height, Preferred

# Traditional Anthropometry

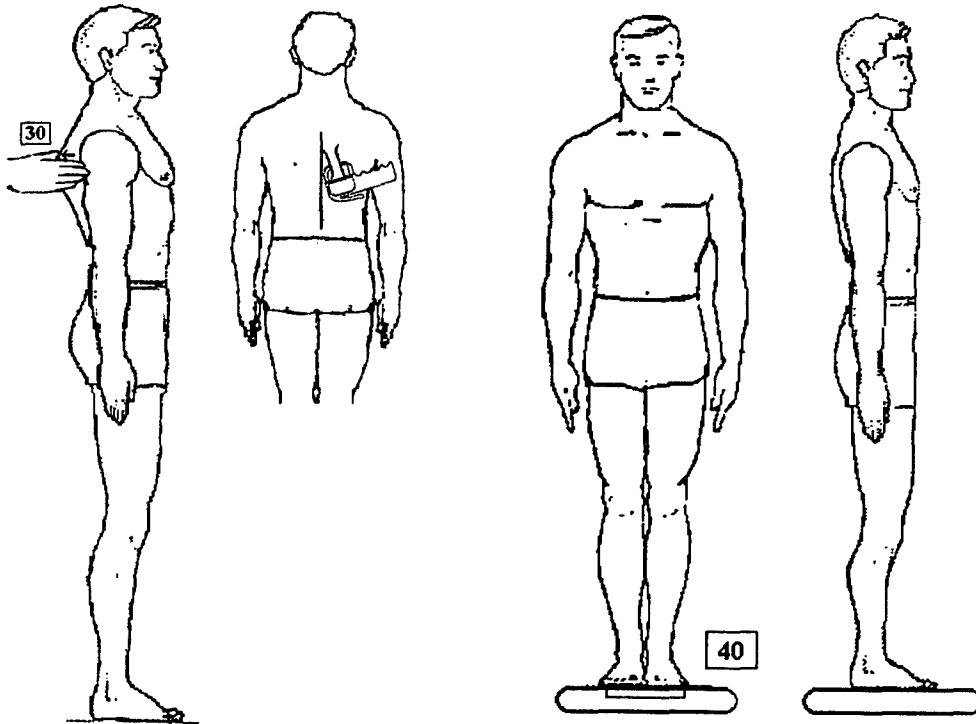

30. Subscapular Skinfold, Right

35. Triceps Skinfold

40. Weight (Mass)

## Traditional Anthropometry

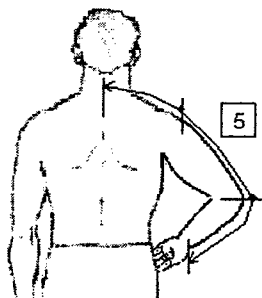
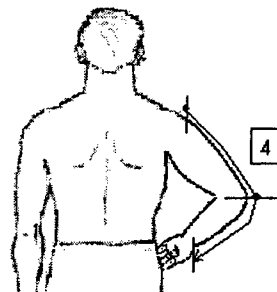
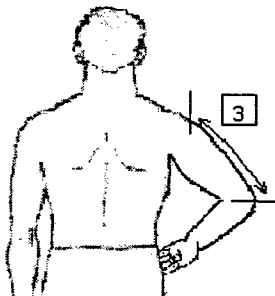
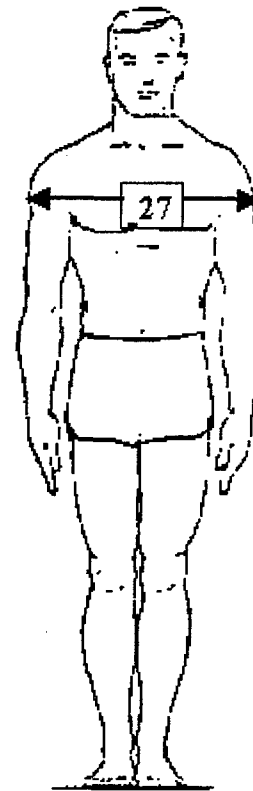
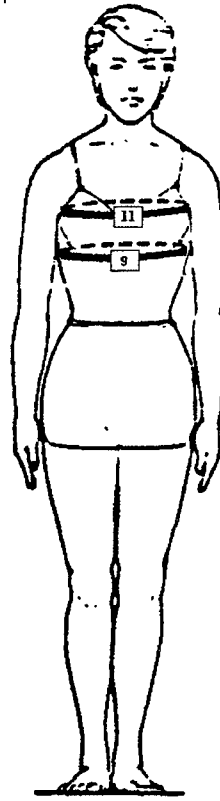
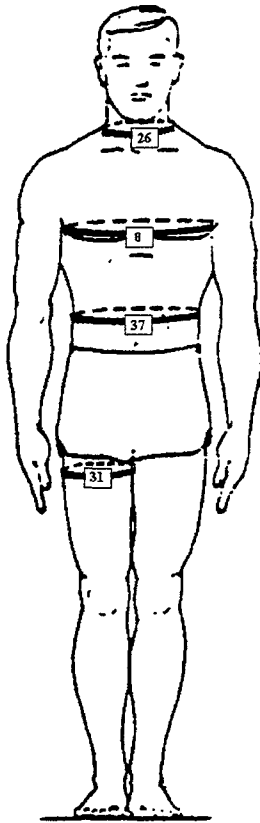

3. Arm Length (Shoulder-Elbow)
4. Arm Length (Shoulder-Wrist)
5. Arm Length (Spine-Wrist)
8. Bust/Chest Circumference
9. Bust/Chest Circumference Under Bust
11. Chest Girth (Chest Circumference at Scye)
26. Neck Base Circumference
27. Shoulder Breadth (Bideltoid)
31. Thigh Circumference, Maximum, Right
37. Waist Circumference, Preferred

## Traditional Anthropometry

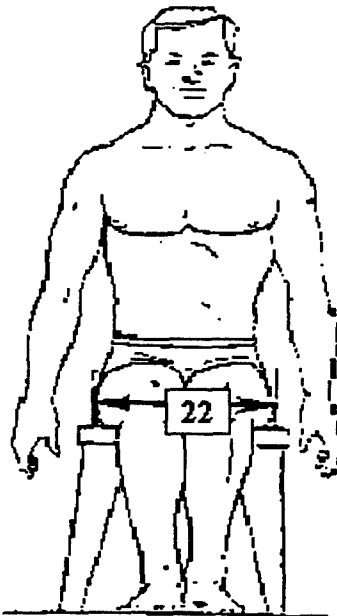
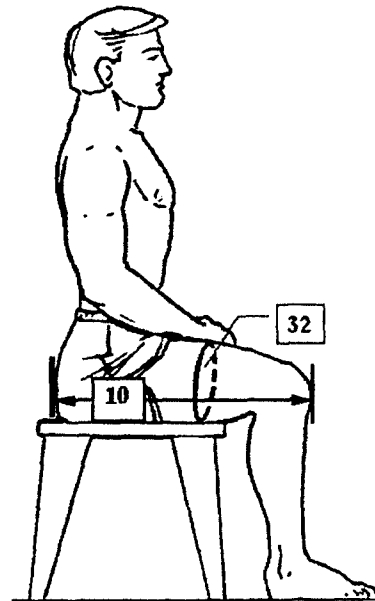
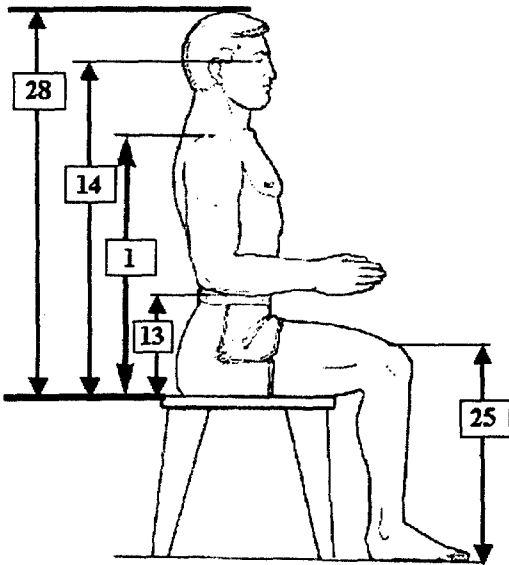

1. Acromial Height, Sitting
10. Buttock-Knee Length, Right
13. Elbow Height, Sitting, Right
14. Eye Height, Sitting, Right
22. Hip Breadth, Sitting
25. Knee Height, Sitting, Right
28. Sitting Height
32. Thigh Circumference, Maximum, Sitting, Right

## Traditional Anthropometry

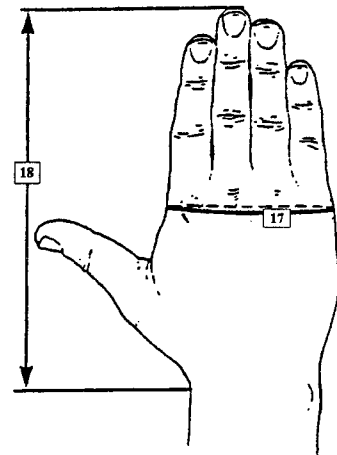
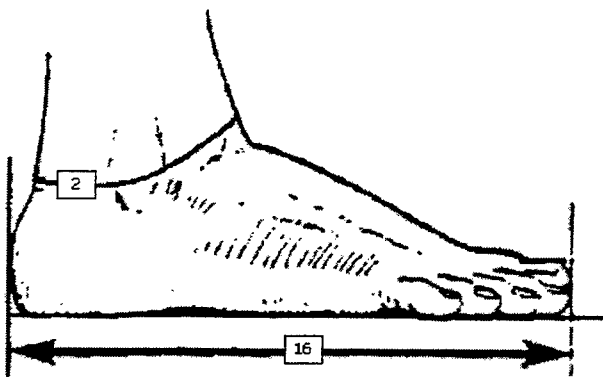
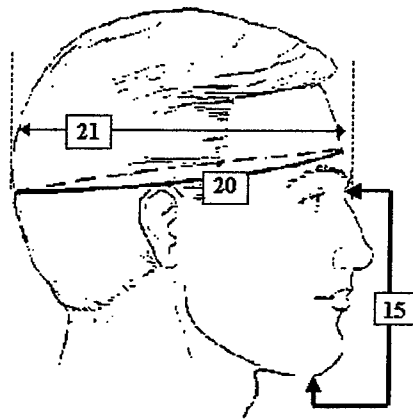
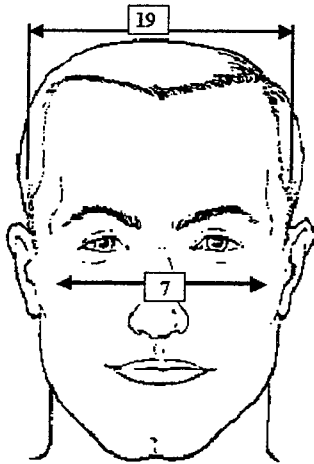

- 2. Ankle Circumference
- 7. Bizygomatic Breadth
- 15. Face Length (Menton-Sellion Length)
- 16. Foot Length, Right
- 17. Hand Circumference, Right
- 18. Hand Length, Right
- 19. Head Breadth
- 20. Head Circumference
- 21. Head Length

## Three-dimensional Scan Anthropometry

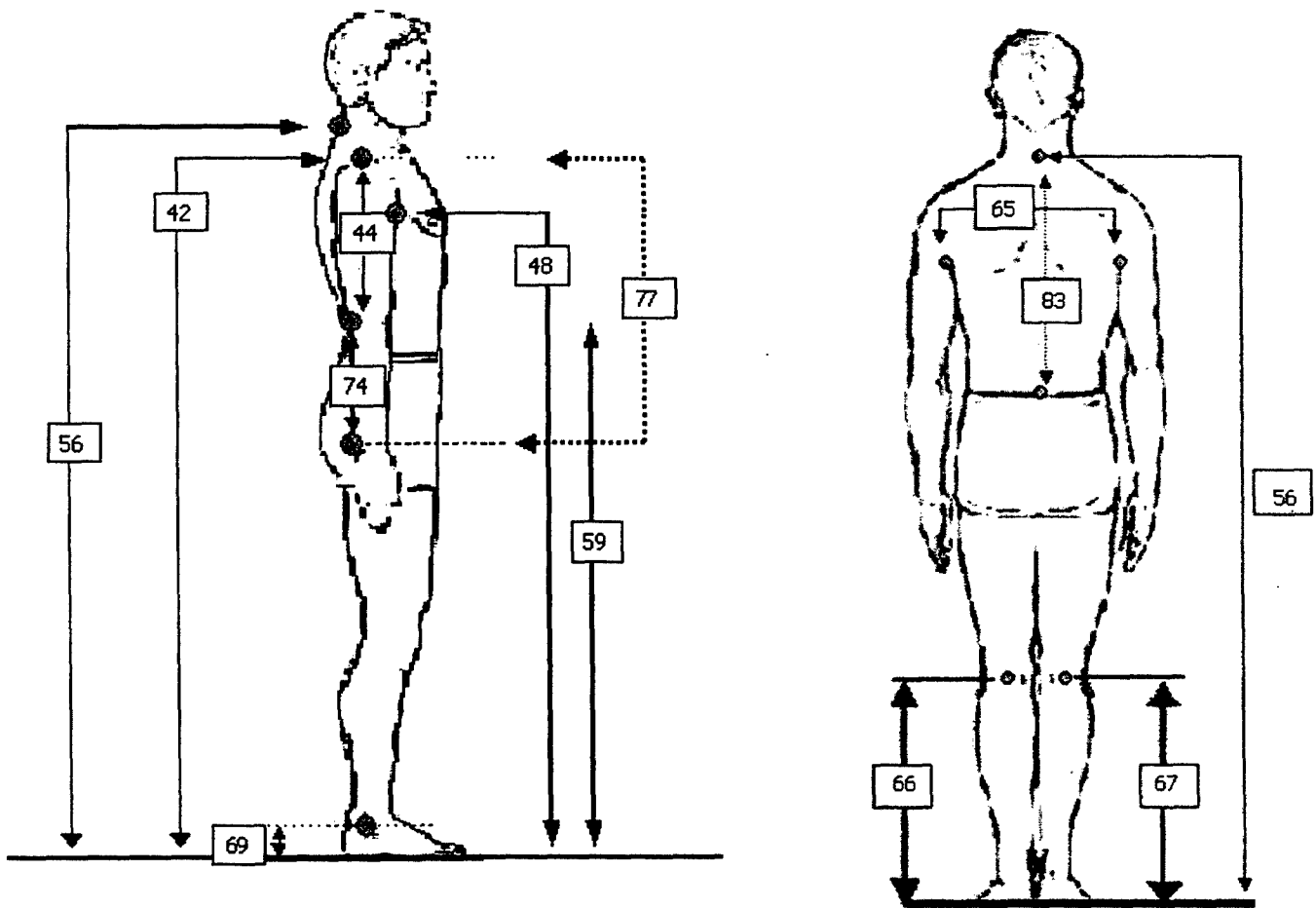

- 42. Acromial Height, Standing, Right
- 44. Acromion-Radiale Length, Right
- 48. Axilla Height, Right
- 56. Cervicale Height
- 59. Elbow Height, Standing, Right
- 69. Malleolus Height, Lateral, Right
- 74. Radiale-Styilion Length, Right
- 77. Sleeve Outseam Length, Right

- 56. Cervicale Height
- 65. Interscye Distance
- 66. Knee Height, Standing, Left
- 67. Knee Height, Standing, Right
- 83. Waist Back (Cervicale to Waist) Length



## Three-dimensional Scan Anthropometry

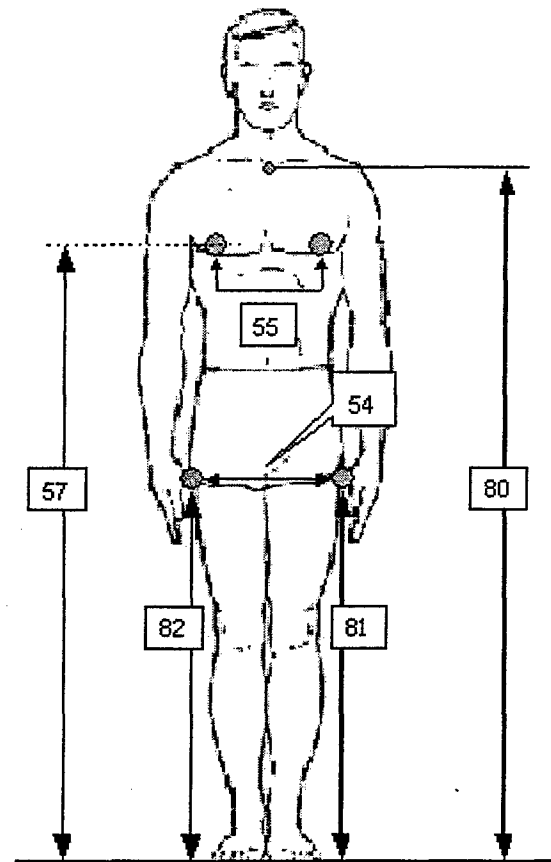
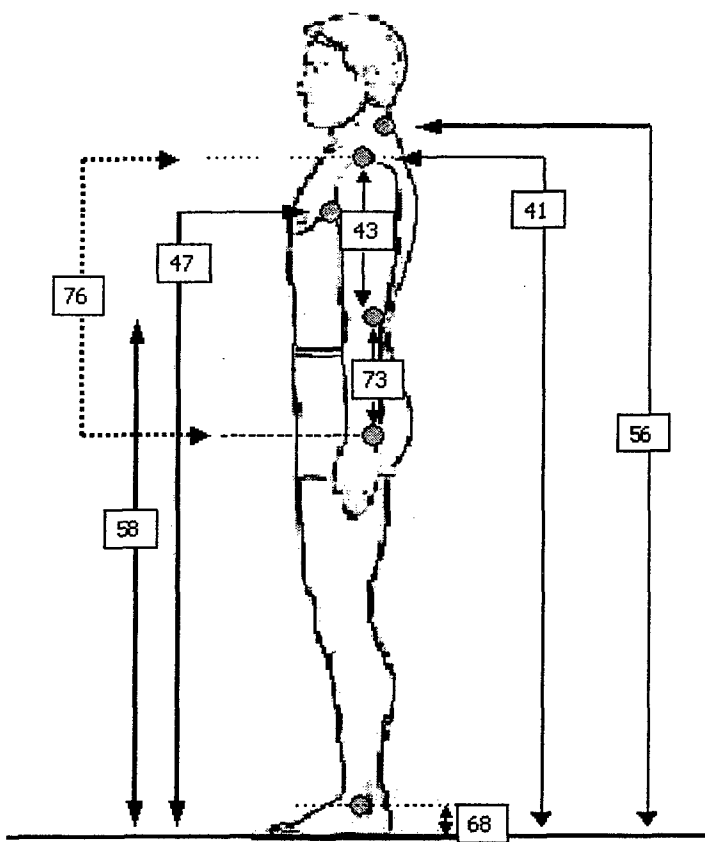

- 41. Acromial Height, Standing, Left
- 43. Acromion-Radiale Length, Left
- 47. Axilla Height, Left
- 56. Cervicale Height
- 58. Elbow Height, Standing, Left
- 68. Malleolus Height, Lateral, Left
- 73. Radiale-Stylion Length, Left
- 76. Sleeve Outseam Length, Left

- 54. Bi-Trochanteric Breadth, Standing
- 55. Bustpoint-Bustpoint Breadth
- 57. Chest Height
- 80. Suprasternale Height
- 81. Trochanter Height, Left
- 82. Trochanter Height, Right

## Three-dimensional Scan Anthropometry

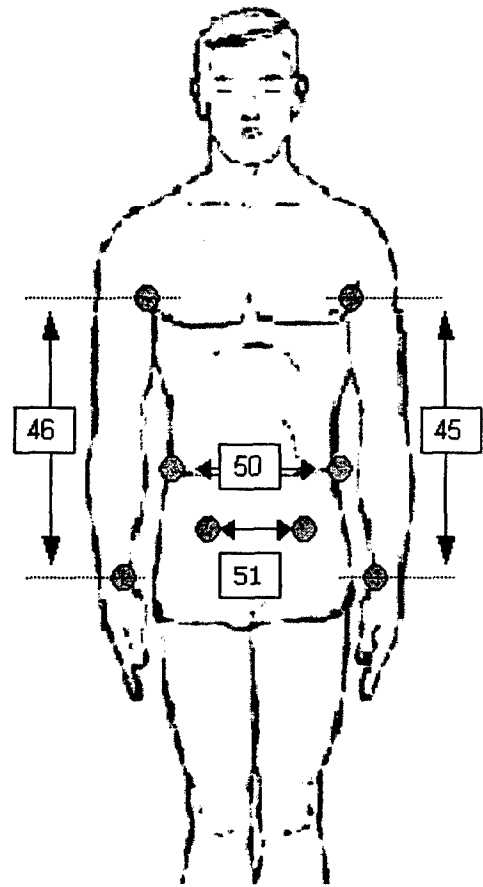
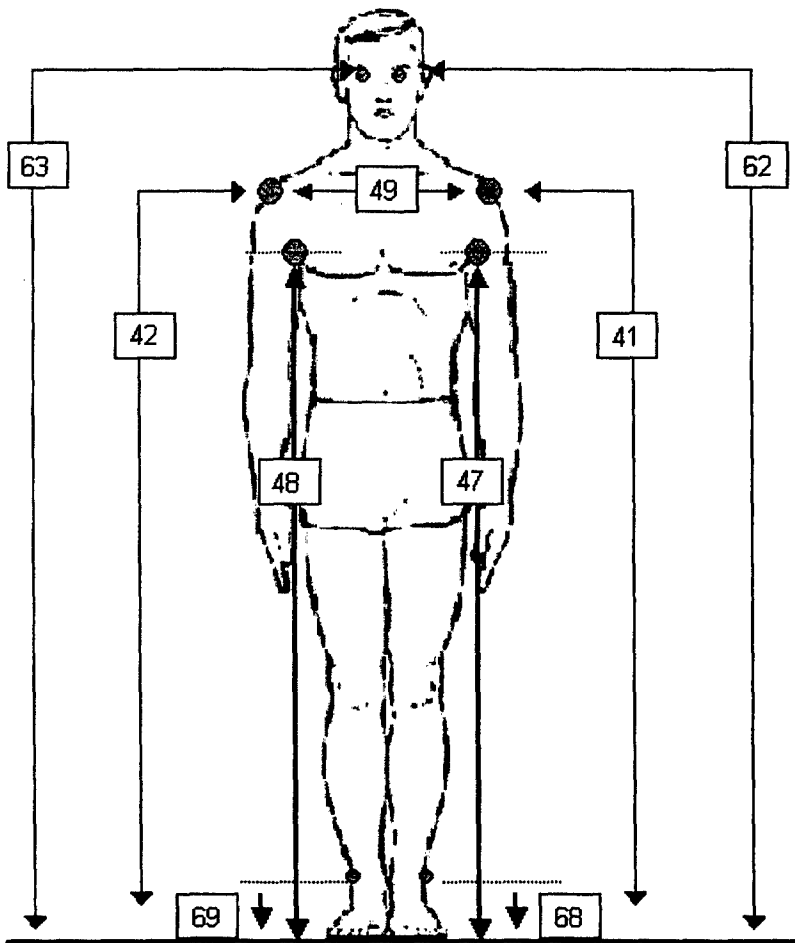

- 41. Acromial Height, Standing, Left
- 42. Acromial Height, Standing, Right
- 47. Axilla Height, Left
- 48. Axilla Height, Right
- 49. Biacromial Breadth
- 62. Infraorbitale Height, Standing, Left
- 63. Infraorbitale Height, Standing, Right
- 68. Malleolus Height, Lateral, Left
- 69. Malleolus Height, Lateral, Right

- 45. Arm Inseam, Left
- 46. Arm Inseam, Right
- 50. Bi-Cristale Breadth
- 51. Bi-Spinous Breadth

## Three-dimensional Scan Anthropometry

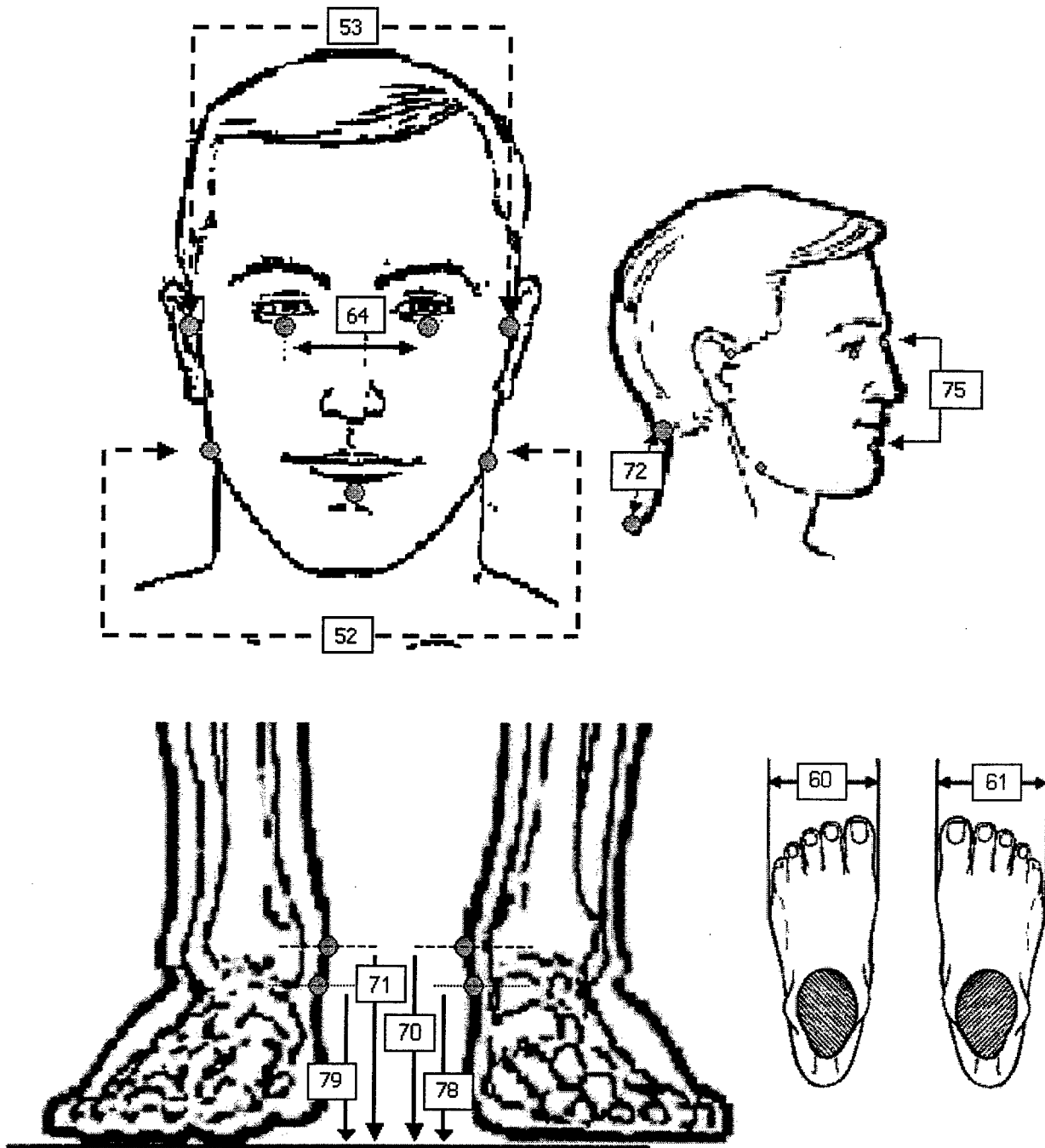

52. Bigonial Breadth

53. Bitragion Breadth

60. Foot Breadth, Left

61. Foot Breadth, Right

64. Inter-pupillary Distance

70. Malleolus Height, Medial, Left

71. Malleolus Height, Medial, Right

72. Neck Height

75. Sellion-Supramentum Length

78. Sphyrion Height, Left

79. Sphyrion Height, Right

## Three-dimensional Scan Anthropometry

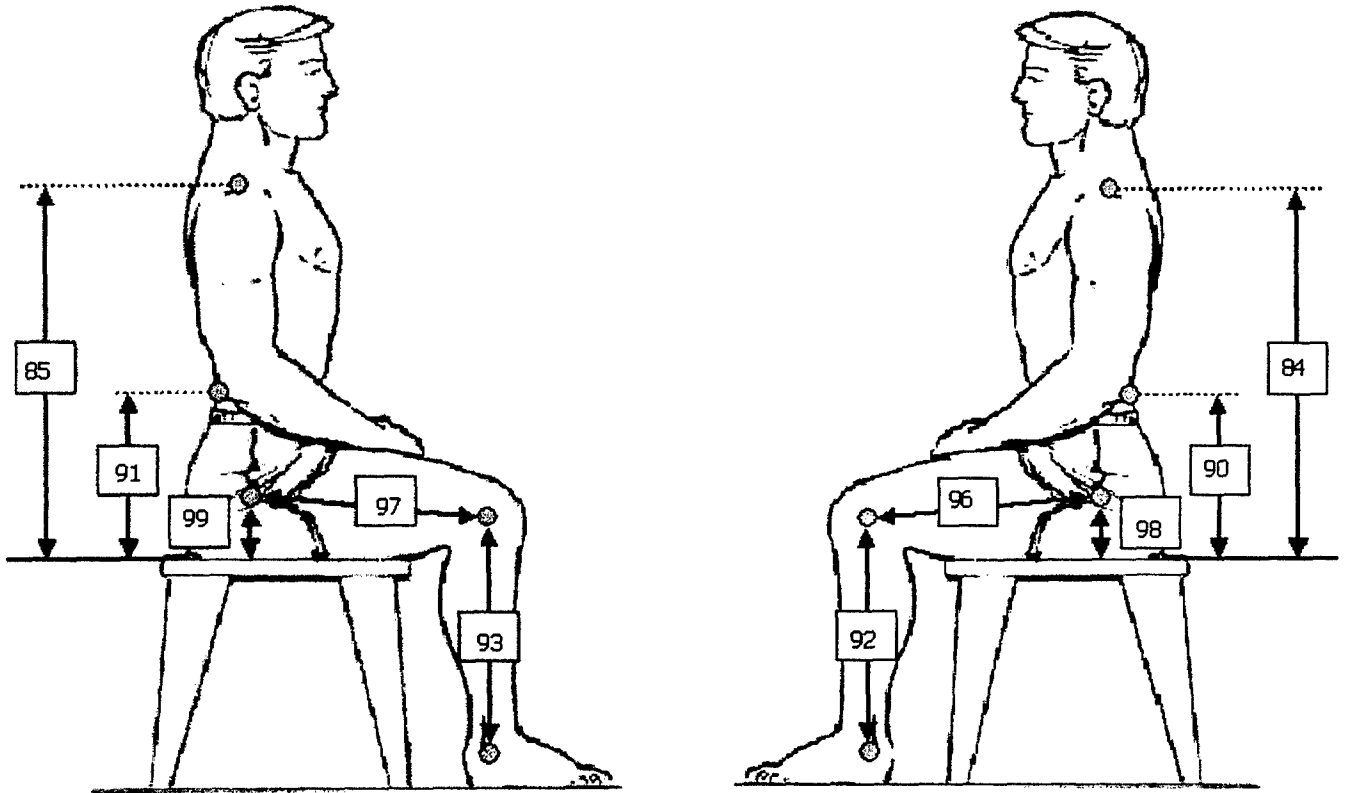

- 84. Acromial Height, Sitting (Comfortable), Left
- 85. Acromial Height, Sitting (Comfortable), Right
- 90. Elbow Height, Sitting (Comfortable), Left
- 91. Elbow Height, Sitting (Comfortable), Right
- 92. Femoral Epicondyle, Lateral, Left to Malleolus, Lateral (Comfortable), Left
- 93. Femoral Epicondyle, Lateral, Right to Malleolus, Lateral (Comfortable), Right
- 96. Trochanter to Femoral Epicondyle, Lateral (Comfortable), Left
- 97. Trochanter to Femoral Epicondyle, Lateral (Comfortable), Right
- 98. Trochanter to Seated Surface (Comfortable), Left
- 99. Trochanter to Seated Surface (Comfortable), Right

## Three-dimensional Scan Anthropometry

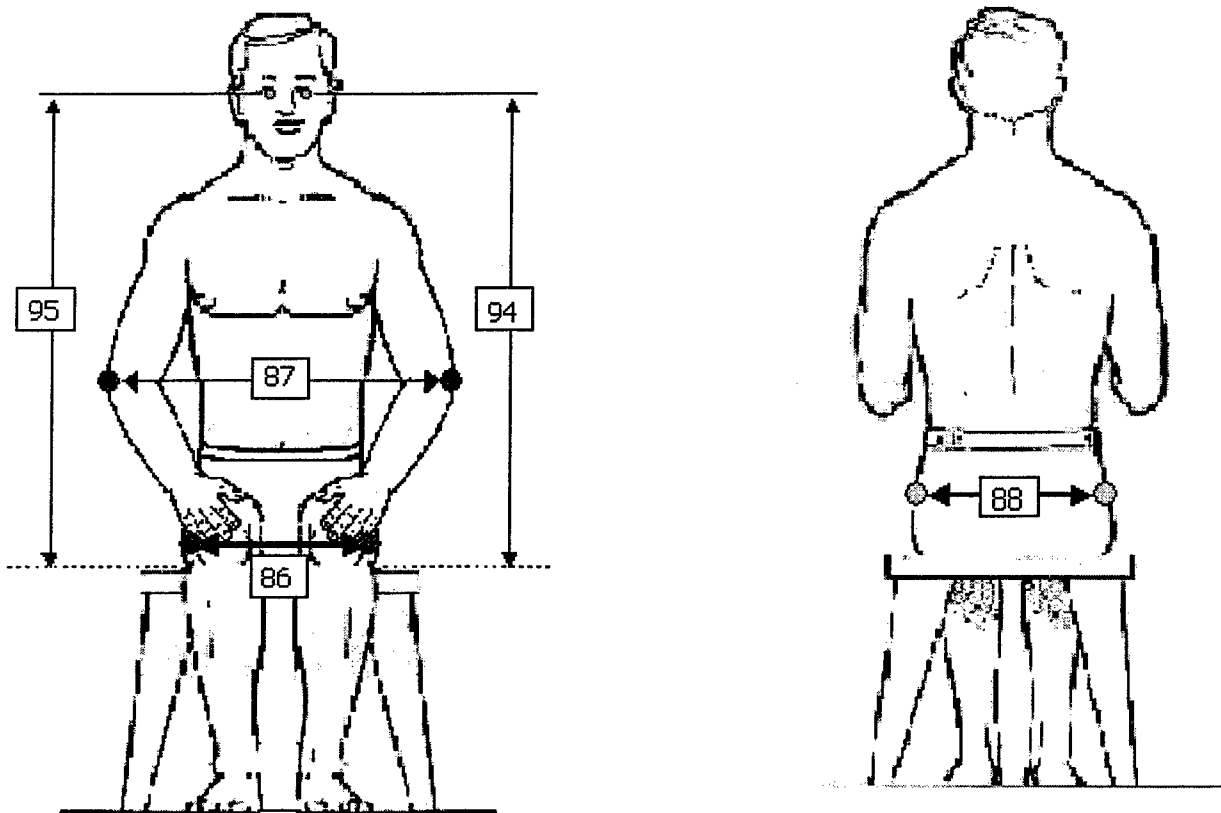

- 86. Bi-lateral Femoral Epicondyle Breadth, Sitting (Comfortable)
- 87. Bi-lateral Humeral Epicondyle Breadth, Sitting (Comfortable)
- 88. Bi-Trochanteric Breadth, Sitting (Comfortable)
- 94. Infraorbitale Height, Sitting (Comfortable), Left
- 95. Infraorbitale Height, Sitting (Comfortable), Right

## Three-dimensional Scan Anthropometry

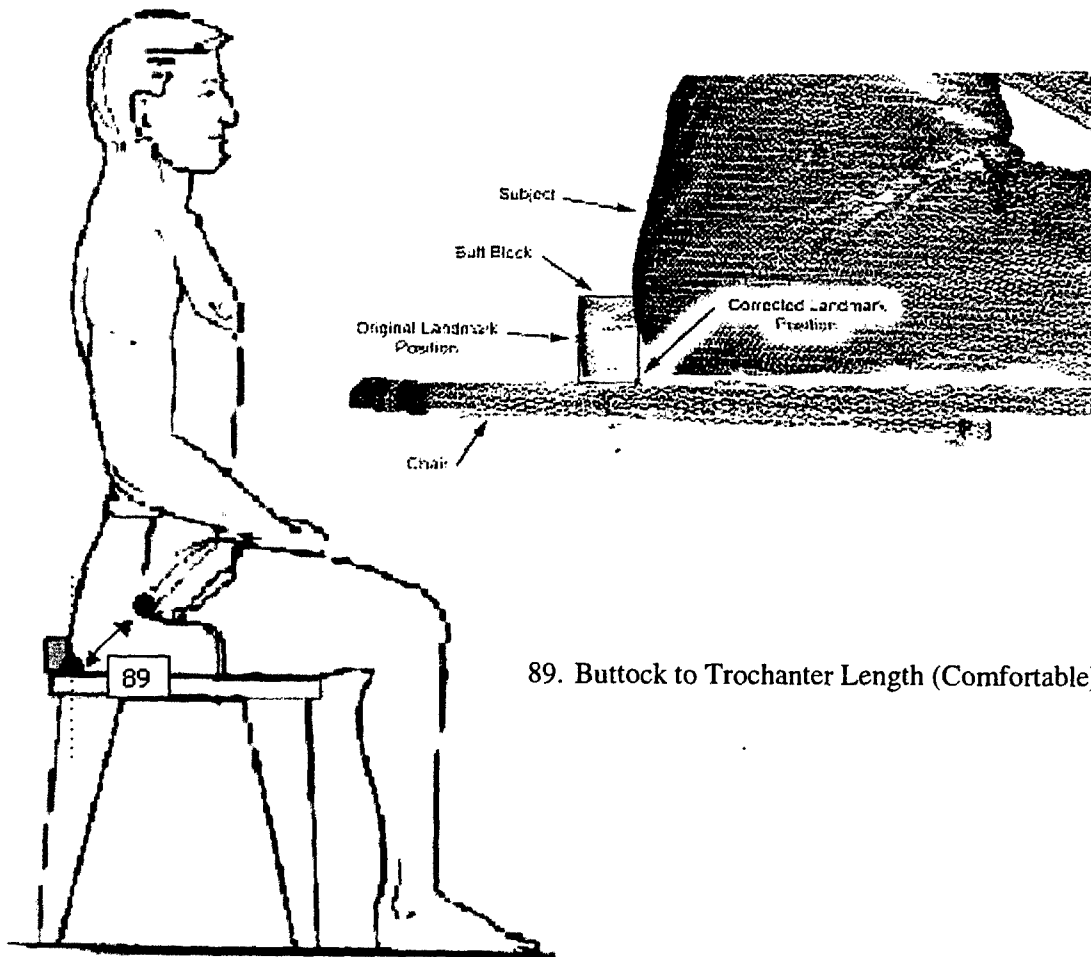

89. Buttock to Trochanter Length (Comfortable)

APPENDIX E: DEMOGRAPHICS VARIABLES AND RESPONSES

Variable	North American Responses	Italian Responses	Dutch Responses	Code
Birth State				
	Alabama			1
	Alaska			2
	Arizona			3
	Arkansas			4
	California			5
	Colorado			6
	Connecticut			7
	Delaware			8
	Florida			9
	Georgia			10
	Hawaii			11
	Idaho			12
	Illinois			13
	Indiana			14
	Iowa			15
	Kansas			16
	Kentucky			17
	Louisiana			18
	Maine			19
	Maryland			20
	Massachusetts			21
	Michigan			22
	Minnesota			23
	Mississippi			24
	Missouri			25
	Montana			26
	Nebraska			27
	Nevada			28
	Nebraska*			29
	New Hampshire			30
	New Jersey			31
	New Mexico			32
	New York			33
	North Carolina			34
	North Dakota			35
	Ohio			36
	Oklahoma			37
	Oregon			38
	Pennsylvania			39
	Rhode Island			40
	South Carolina			41
	South Dakota			42
	Tennessee			43
	Texas			44
	Utah			45



Variable	North American Responses	Italian Responses	Dutch Responses	Code
	Vermont			46
	Virginia			47
	Washington			48
	Washington DC			49
	West Virginia			50
	Wisconsin			51
	Wyoming			52
	US Territory			53
	Not Born in the US			54
	Don't Know	Don't Know		55
	No Response	No Response		56
		Abruzzo		57
		Basilicata		58
		Calabria		59
		Campania		60
		Emilia Romagna		61
		Friuli-Venezia Giulia		62
		Lazio		63
		Liguria		64
		Lombardia		65
		Marche		66
		Molise		67
		Piemonta		68
		Puglie		69
		Sardegna		70
		Sicilia		71
		Trentino-Alto Adige		72
		Toscana		73
		Umbria		74
		Val D'Aosta		75
		Veneto		76
		Not Born in Italy		77
State Mother Born Father Born				
			Groningen	78
			Friesland	79
			Drenthe	80
			Overijssel	81
			Gelderland	82
			Utrecht	83
			Noord Holland	84
			Zuid Holland	85
			Zeeland	86
			Noord Brabant	87
			Limburg	88
			Flevoland	89

Variable	North American Responses	Italian Responses	Dutch Responses	Code
			Aruba	90
			Afghanistan	91
			Angola	92
			Netherlands Antilles	93
			Australia	94
			Austria	95
			Belgium	96
			Brazil	97
			Brunei	98
			Canada	99
			Chile	100
			Colombia	101
			Czech Republic	102
			Germany	103
			Denmark	104
			Algeria	105
			Egypt	106
			Spain	107
			France	108
			United Kingdom	109
			Georgia	110
			Ghana	111
			Greece	112
			Croatia	113
			Hungary	114
			Indonesia	115
			India	116
			Iraq	117
			Italy	118
			Republic of Korea	119
			Lebanon	120
			Morocco	121
			Nigeria	122
			Netherlands	123
			New Zealand	124
			Peru	125
			Philippines	126
			Papua New Guinea	127
			Poland	128
			Portugal	129
			Singapore	130
			Suriname	131
			Slovakia	132
			Slovenia	133
			Sweden	134
			Swaziland	135
			Turkey	136

Variable	North American Responses	Italian Responses	Dutch Responses	Code
			United States	137
			Yugoslavia	138
			South Africa	139
			Other	140
			Zambia	141
			Democratic People's Republic of Korea	142
			Tsjech Republic	143
			Argentina	144
Blouse Size				
	4 or Smaller			1
	6			2
	8			3
	10			4
	12			5
	14			6
	16			7
	18			8
	20			9
	22 or Larger			10
	Don't Know	Don't Know		11
	No Response	No Response		12
	7			13
	9			14
	11			15
	13			16
	15			17
		X-Small		18
		Sm		19
		Med		20
		Lg		21
		XL		22
		XXL		23
Bra Size				
	30 or Smaller	30 or Smaller		1
	32a	32a		2
	32b	32b		3
	32c	32c		4
	32d	32d		5
	34a	34a		6
	34b	34b		7
	34c	34c		8
	34d	34d		9
	36a	36a		10
	36b	36b		11
	36c	36c		12
	36d	36d		13

Variable	North American Responses	Italian Responses	Dutch Responses	Code
	38a	38a		14
	38b	38b		15
	38c	38c		16
	38d	38d		17
	40a	40a		18
	40b	40b		19
	40c	40c		20
	40d	40d		21
	48 or Larger	48 or Larger		22
	Don't Know	Don't Know		23
	No Response	No Response		24
	42a	42a		25
	42b	42b		26
	42c	42c		27
	42d	42d		28
	42dd	42dd		29
	44a	44a		30
	44b	44b		31
	44c	44c		32
	44d	44d		33
	44dd	44dd		34
	46a	46a		35
	46b	46b		36
	46c	46c		37
	46d	46d		38
	46dd	46dd		39
	32	32		40
	34	34		41
	36	36		42
	38	38		43
	40	40		44
	42	42		45
	44	44		46
	46	46		47
	36dd	36dd		48
	38dd	38dd		49
	40dd	40dd		50
	34dd	34dd		51
	32dd	32dd		52
	40ddd	40ddd		53
	38ddd	38ddd		54
	34ddd	34ddd		55
	42ddd	42ddd		56
Car Make				
	Acura	Acura		1
	Audi	Audi	Audi	2
	BMW	BMW	BMW	3

Variable	North American Responses	Italian Responses	Dutch Responses	Code
	Buick	Buick		4
	Cadillac	Cadillac		5
	Chevrolet	Chevrolet	Chevrolet	6
	Chrysler	Chrysler	Chrysler	7
	Dodge	Dodge		8
	Eagle	Eagle		9
	Ford	Ford	Ford	10
	GM	GM		11
	GMC	GMC		12
	Honda	Honda	Honda	13
	Infiniti	Infiniti		14
	Isuzu	Isuzu		15
	Jeep	Jeep		16
	Lexus	Lexus		17
	Lincoln	Lincoln		18
	Mazda	Mazda	Mazda	19
	Mercedes-Benz	Mercedes-Benz	Mercedes-Benz	20
	Mercury	Mercury		21
	Mitsubishi	Mitsubishi	Mitsubishi	22
	Nissan	Nissan	Nissan	23
	Oldsmobile	Oldsmobile		24
	Plymouth	Plymouth		25
	Pontiac	Pontiac		26
	Porsche	Porsche		27
	Saab	Saab	Saab	28
	Saturn	Saturn		29
	Subaru	Subaru	Subaru	30
	Suzuki	Suzuki	Suzuki	31
	Toyota	Toyota	Toyota	32
	Volkswagen	Volkswagen	Volkswagen	33
	Volvo	Volvo	Volvo	34
	Other	Other	Other	35
	Don't Know	Don't Know	Don't Know	36
	No Response	No Response	No Response	37
	Hyundai	Hyundai	Hyundai	38
	Fiat	Fiat	Fiat	39
	Alfa Romeo	Alfa Romeo	Alfa Romeo	40
	Lancia	Lancia		41
	Ferrari	Ferrari		42
	Maserati	Maserati		43
			Daihatsu	44
			Opel	45
			Citroen	46
			Daewoo	47
			Daf	48
			FSO	49
			Iveco	50

Variable	North American Responses	Italian Responses	Dutch Responses	Code
			Man	51
			Peugeot	52
			Renault	53
			Rover	54
			Scania	55
			Seat	56
			Skoda	57
			Kia	58
Car Model				
	Economy	Economy		1
	Compact	Compact	Compact	2
	Intermediate	Intermediate	Intermediate	3
	Full Size 2-Dr	Full Size 2-Dr		4
	Full Size 4-Dr	Full Size 4-Dr		5
	Luxury	Luxury	Luxury	6
	Minivan	Minivan	Minivan	7
	Van	Van		8
	Sports Car	Sports Car	Sports Car	9
	SUV	SUV		10
	Truck	Truck	Truck	11
	Station Wagon	Station Wagon	Station Wagon	12
	Other	Other	Other	13
	Don't Know	Don't Know	Don't Know	14
	No Response	No Response	No Response	15
		Scooter		16
			Off-Road	17
			Multi-purpose Van	18
			Bus	19
			Small Truck	20
			Pick-up	21
Civilian				
	No	No		0
	Yes	Yes		1
Country				
	United States	United States		1
	Netherlands	Netherlands		2
	Italy	Italy		3
Cup Size			AA	1
			A	2
			B	3
			C	4
			D	5
			E	6
			F	7
Education				
	High School	High School	High School	1
	Technical Training	Technical Training		2

Variable	North American Responses	Italian Responses	Dutch Responses	Code
	Associates	Associates		3
	Bachelors	Bachelors	Bachelors	4
	Masters	Masters		5
	Doctorate	Doctorate		6
	Post-Doctoral Studies	Post-Doctoral Studies		7
	None of the above	None of the above		8
	No Response	No Response		9
	Some College	Some College		10
	Elementary School	Elementary School	Elementary School	11
	Middle School	Middle School		12
			None	13
			Lower Level Education for Profession	14
			Middle Level Education for Profession	15
			University	16
Family Income				
	Less than 10k\$			1
	10k\$ - 14.9k\$			2
	15k\$ - 19.9k\$			3
	20k\$ - 29.9k\$			4
	30k\$ - 44.9k\$			5
	45k\$ - 59.9k\$			6
	60k\$ - 79.9k\$			7
	80k\$ - 99.9k\$			8
	Over 100k\$			9
	Don't Know			10
	No Response			11
Family Income IT				
		Less than 10M Lira		1
		10M Lira - 14.9M Lira		2
		15M Lira - 29.9M Lira		3
		20M Lira - 29.9M Lira		4
		30M Lira - 44.9M Lira		5
		45M Lira - 59.5M Lira		6
		60M Lira - 79.9M Lira		7
		80M Lira - 99.9M Lira		8
		Unused		9
		Don't Know		10
		No Response		11
		100M Lira - 150M Lira		12
		Over 150M Lira		13
Salary NL			Less than 20k	1

Variable	North American Responses	Italian Responses	Dutch Responses	Code
			Guilders	
			20k – 30k Guilders	2
			30k – 40k Guilders	3
			40k – 60k Guilders	4
			60k – 90k Guilders	5
			90k – 120k Guilders	6
			120k – 160k Guilders	7
			160k – 200k Guilders	8
			Over 200k Guilders	9
			Don't Know	10
			No Response	11
<b>Fitness</b>				
	0-1	0-1	0-1	1
	2-3	2-3	2-3	2
	4-6	4-6	4-6	3
	6-10	6-10	6-10	4
	More than 10	More than 10	More than 10	5
	No Response	No Response	No Response	6
<b>Gender</b>				
	Male	Male	Male	1
	Female	Female	Female	2
<b>Head Hair Color</b>				
	Blond	Blond		1
	Brunet	Brunet		2
	Black	Black		3
	Red	Red		4
	Gray	Gray		5
	Salt-n-Pepper	Salt-n-Pepper		6
	N/A	N/A		7
<b>Head Hair Length</b>				
	Bald	Bald		1
	Buzzed	Buzzed		2
	Short	Short		3
	Medium	Medium		4
	Shoulder Length	Shoulder Length		5
	Long	Long		6
<b>Head Hair Style</b>				
	Curly	Curly		1
	Straight	Straight		2
	Bald	Bald		3
	Thinning	Thinning		4
<b>Jacket Size</b>				
	30 or Smaller			1
	32			2
	34			3



Variable	North American Responses	Italian Responses	Dutch Responses	Code
	36			4
	38			5
	40			6
	42			7
	44			8
	46			9
	48 or Larger			10
	Don't Know	Don't Know		11
	No Response	No Response		12
		46 or Smaller		13
		48		14
		50		15
		52		16
		54		17
		56		18
		58 or Larger		19
Marital Status				
	Single	Single	Single	1
	Engaged	Engaged	Engaged	2
	Married	Married	Married	3
	Divorced	Divorced	Divorced	4
	Widowed	Widowed	Widowed	5
	No Response	No Response	No Response	6
			Living Together	7
			Registered Partnership	8
Number of Children				
	0	0	0	1
	1	1	1	2
	2	2	2	3
	3	3	3	4
	4	4	4	5
	5	5	5	6
	6	6	6	7
	7 or more	7 or more	7 or more	8
	No Response	No Response	No Response	9
Occupation				
	Administrator	Administrator		1
	Management	Management		2
	Degreed Engineer	Degreed Engineer		3
	Scientist	Scientist		4
	Health Diagnosing Occupation	Health Diagnosing Occupation		5
	Classroom Teacher	Classroom Teacher		6
	Attorney or Judge	Attorney or Judge		7
	Other Specialty Occupation	Other Specialty Occupation	Other Specialty Occupation	8

Variable	North American Responses	Italian Responses	Dutch Responses	Code
	Technician	Technician		9
	Supervisor	Supervisor		10
	Sales/Marketing	Sales/Marketing		11
	Administrative Support	Administrative Support	Administrative Support	12
	Service Occupation	Service Occupation	Service Occupation	13
	Mechanic	Mechanic		14
	Construction	Construction	Construction	15
	Machine Operator	Machine Operator		16
	Transportation Occupation	Transportation Occupation		17
	Material Handler	Material Handler		18
	Farm Occupation	Farm Occupation		19
	Farm Related Occupation	Farm Related Occupation		20
	Forestry or Fishing Occupation	Forestry or Fishing Occupation		21
	Armed Services	Armed Services	Armed Services	22
	Unemployed	Unemployed	Unemployed	23
	Student	Student	Student	24
	Homemaker	Homemaker	Homemaker	25
	Retired	Retired		26
	Computer Programmer/Software Engineer	Computer Programmer/Software Engineer		27
	No Response	No Response	No Response	28
	Other Legal/Judicial Occupation	Other Legal/Judicial Occupation		29
	Training/Continuing Education	Training/Continuing Education		30
	Health Non-Diagnosing Occupation	Health Non-Diagnosing Occupation		31
			Agriculture and Fishery	32
			Industry	33
			Transport Storage and Communication	34
			Education	35
			Hotels and Restaurants	36
			Financial Institutions	37
			Health and Well-being	38
			Trade	39
			Mining	40
			Government	41
			Culture and	42

Variable	North American Responses	Italian Responses	Dutch Responses	Code
			Recreation	
			Chemical Industry	43
			Information and Communication Technology	44
Pants Size Inseam				
	28 or Smaller			1
	29			2
	30			3
	31			4
	32			5
	33			6
	34			7
	36			8
	38			9
	40 or Larger			10
	Don't Know	Don't Know		11
	No Response	No Response		12
		66 or Smaller		13
		68.5		14
		71		15
		73.5		16
		76		17
		78.5		18
		81		19
		83.5		20
		86		21
		88.5		22
		91		23
		93.5		24
		96 or Larger		25
Pants Size Waist				
	28 or Smaller			1
	29			2
	30			3
	31			4
	32			5
	33			6
	34			7
	36			8
	38			9
	40			10
	42			11
	44			12
	46 or Larger			13
	Don't Know			14

Variable	North American Responses	Italian Responses	Dutch Responses	Code
	No Response			15
	35			16
		75 or Smaller		17
		80		18
		85		19
		90		20
		95		21
		100		22
		105		23
		110		24
		115		25
		120		26
		125		27
		130		28
		135		29
		140		30
		145		31
		150		32
		155		33
		160 or Larger		34
Pants Size Woman				
	2 or Smaller			1
	4			2
	5			3
	6			4
	7			5
	8			6
	9			7
	10			8
	11			9
	12			10
	13			11
	14			12
	15			13
	16			14
	unused			15
	18			16
	20 or Larger			17
	Don't Know	Don't Know		18
	No Response	No Response		19
		36 or Smaller		20
		38		21
		40		22
		42		23
		44		24
		46		25

Variable	North American Responses	Italian Responses	Dutch Responses	Code
		48		26
		50		27
		52		28
		54		29
		56		30
		58		31
		60 or Larger		32
Race				
	White			1
	African American			2
	Native American/Alaskan			3
	Spanish/Hispanic Mexican American			4
	Spanish/Hispanic Puerto Rican			5
	Spanish/Hispanic Cuban			6
	Asian/Pacific Islander Native Hawaiian			7
	Asian/Pacific Islander Asian Indian			8
	Asian/Pacific Islander Chinese			9
	Asian/Pacific Islander Filipino			10
	Asian/Pacific Islander Guamanian or Chamorro			11
	Asian/Pacific Islander Japanese			12
	Asian/Pacific Islander Korean			13
	Asian/Pacific Islander Samoan			14
	Asian/Pacific Islander Vietnamese			15
	Other Not Listed Above			16
	No Response			17
	Other Mixed Race			18
	Asian/Pacific Islander Other			19
	Spanish/Hispanic Other			20
		Italy/Italian		21

Variable	North American Responses	Italian Responses	Dutch Responses	Code
		Italy/Other		22
			Netherlands/Dutch	23
			Netherlands/Other	24
Shoe Size				
	5 or Smaller			1
	5.5			2
	6			3
	6.5			4
	7			5
	7.5			6
	8			7
	8.5			8
	9			9
	9.5			10
	10			11
	10.5			12
	11			13
	11.5			14
	12			15
	12.5			16
	13			17
	13.5			18
	14 or Larger			19
	Don't Know			20
	No Response			21
Shoe Size IT				
		35 or Smaller		1
		35.5		2
		36		3
		36.5		4
		37		5
		37.5		6
		38		7
		38.5		8
		39		9
		39.5		10
		40		11
		40.5		12
		41		13
		41.5		14
		42		15
		42.5		16
		43		17
		43.5		18
		44 or Larger		19
		Don't Know		20
		No Response		21

Variable	North American Responses	Italian Responses	Dutch Responses	Code
Site				
	WPAFB1 OH			1
	Monterey CA			2
	Los Angles CA			3
	Detroit MI			4
	Ames IA			5
	Greensboro NC			6
	Marlton NJ			7
	Ottawa Ontario CA			8
	Minneapolis MN			9
	Houston TX			10
	Portland OR			11
	San Francisco CA			12
	Atlanta GA			13
	WPAFB2 OH			14
		Genova1 Italy		15
		Genova2 Italy		16
			Soesterberg, Netherlands	17
Team Members				
	Cindy Hunter	Cindy Hunter		1
	Chris Lafferty	Chris Lafferty		2
	Mary Lou Rizzotte	Mary Lou Rizzotte		3
	Scott Fleming	Scott Fleming		4
	Mark Boehmer	Mark Boehmer		5
	Sara Kelly	Sara Kelly		6
	Sherri Blackwell	Sherri Blackwell		7
	Patrick Files	Patrick Files		8
	Stacie Taylor	Stacie Taylor		9
	Tina Brill	Tina Brill		10
	Teresa Perkins	Teresa Perkins		11
	Bill Barnett	Bill Barnett		12
	David Hoferlin	David Hoferlin		13
	Kathy Robinette	Kathy Robinette		14
	Beth Sorrell	Beth Sorrell		15
	Bridget Bailey	Bridget Bailey		16
	Steve Trimble	Steve Trimble		17
	Dennis Allen	Dennis Allen		18
	Sara Endicott	Sara Endicott		19
	Beth McCrary	Beth McCrary		20
	Anna Riley	Anna Riley		21
	Silvia Penna	Silvia Penna		22
	Roberta Borghesi	Roberta Borghesi		23
	Catia Di Ceglia	Catia Di Ceglia		24
	Barbara Christopher	Barbara Christopher		25
	Terri Lauren	Terri Lauren		26
	Noah McNeely	Noah McNeely		27

<b>Variable</b>	<b>North American Responses</b>	<b>Italian Responses</b>	<b>Dutch Responses</b>	<b>Code</b>
	Rob Roy	Rob Roy		28
<b>Work Posture</b>				
			Predominantly Sitting	1
			Predominantly Standing	2
			Predominantly Walking or Cycling	3
			Carrying and Lifting	4
			No Response	5
<b>Weight Gain</b>			Strong Decrease	1
			About the Same	2
			Strong Increase	3
			No Response	4

\* Nebraska was inadvertently listed twice in the initial version of the data entry program used during data collection. Both instances were retained in the coded variable list to avoid reuse.