



Laboratory Simulation of the Deperm Process

T.M. Baynes, G.J. Russell and
A. Bailey

DSTO-TR-1340

DISTRIBUTION STATEMENT A
Approved for Public Release
Distribution Unlimited



Laboratory Simulation of the Deperm Process

T.M.Baynes[#], G.J.Russell[#] and A.Bailey^{}*

[#]School of Physics, University of NSW

**^{*}Maritime Operations Division
Systems Sciences Laboratory**

DSTO-TR-1340

ABSTRACT

The practise of demagnetising or "deperming" ships and submarines in order to evade magnetic detection has been around since World War II. The methods used rely somewhat on empirical knowledge and little research has been done to analyse the magnetostatic processes occurring during a deperm. We have constructed a scale model of a possible magnetic treatment facility for performing deperms on small (< 1 m) steel samples and measuring magnetostatic quantities that relate to the deperm procedure. The apparatus was found to be capable of measuring fundamental magnetostatic quantities remotely, with a comparable accuracy to direct magnetometric equipment. Additionally, a favourable comparison with deperm data from real naval vessels confirms that the scaled apparatus permits a valid simulation of conditions during an actual deperm. The system of measurement presented can thus be employed to investigate the magnetostatics of the current deperm method and possible alternatives. Important qualitative differences between the deperm results for ships and those for submarines were noted though it was still possible to achieve effective simulation of both of these in the scaled deperm apparatus.

RELEASE LIMITATION

Approved for public release

20021118 041

AQ F03-02-0371

Published by

*DSTO Systems Sciences Laboratory
PO Box 1500
Edinburgh South Australia 5111 Australia*

*Telephone: (08) 8259 5555
Fax: (08) 8259 6567*

*© Commonwealth of Australia 2002
AR-012-438
August, 2002*

APPROVED FOR PUBLIC RELEASE

Laboratory Simulation of the Deperm Process

Executive Summary

In 1994 the RAN Magnetic Treatment Facility (MTF) was commissioned into service following the successful deperm of the Oberon Submarine HMAS Orion. Since then the MTF has been used to successfully deperm several other classes of vessels including a Collins Class submarine, ANZAC Frigate, Fremantle class Patrol boat and a decommissioned Hydrographic ship. Deperming is a one-off treatment, performed perhaps on an annual basis that involves altering the permanent magnetism in ships or submarines. The aim of deperming is to erase any magnetic history, minimise permanent longitudinal (bow to stern) magnetisation (PLM) and to optimise permanent vertical magnetisation (PVM) for the anticipated region of operation. The latter objective involves donating a specific PVM that is designed to counteract the induced vertical magnetisation (IVM) in the relevant magnetic zone of the Earth's magnetic field. This will aid those degaussing coils concerned with minimising vertical magnetisation, and consequently reduce the amount of power required by them.

Despite the proven capability of the MTF, it was obvious that the whole deperm procedure had been formulated over the years by an empirical process with little knowledge of the underlying physics behind the procedure. In fact the procedure of deperming is still considered to be a "Black art". In practice, there was often little confidence at the start of each deperm that the final signature of the vessel would match the desired criteria to any degree of accuracy. This was especially so for the initial treatment of a 'First of Class' ship or submarine. In practice, past experience was used to estimate the necessary treatment schedule for each new class of vessel and if the resultant signature was not of an adequate nature, then adjustments were made to a few parameters based on the results of the previous treatment. Although this does seem to be quite unsatisfactory, it normally would only take two treatments for each new class of vessel to reduce the magnetic signature to a level that was at least 70% lower than that of the untreated value. Despite the obvious success of the MTF, there was an obvious requirement to set up a program of work to look at the whole deperm procedure on a fundamental basis and hopefully gain some insight into the physics of the process with the ultimate aim of developing a more reliable, predictable deperm procedure. To this end a scholarship was set up with the University of NSW where a suitable student would study deperming on a laboratory scale leading to the production of a PhD thesis.

In this report, a detailed description will be given of the set up of the laboratory MTF that was designed to simulate accurately the layout and procedure of the RAN MTF but on a much smaller scale (<1m). Initially, it was important to establish that the apparatus was capable of measuring fundamental magnetostatic quantities remotely, with a comparable accuracy to direct magnetometric equipment. Additionally, a favourable comparison with deperm data from real naval vessels confirmed that the scaled apparatus permits a valid simulation of conditions during an actual deperm. The system of measurement presented can thus be employed to investigate the magnetostatics of the current deperm method and possible alternatives. Important qualitative differences between the deperm results for

ships and those for submarines were noted though it was still possible to achieve effective simulation of both of these in the scaled deperm apparatus.

Authors

Timothy Baynes

**University of New South Wales, Sydney NSW 2052
Australia**

Tim Baynes has worked in a diverse range of applied science areas including neuroscience, radiotherapy, biophysics and most recently in a project looking at magnetic treatment of naval vessels. He received a BSc (hons) majoring in medical physics in 1995 and May 2002 he was awarded his PhD from UNSW for work on the demagnetisation process and its application to deperming. Tim has worked in collaboration with the signature Management group at DSTO Sydney for the last 4 years.

Graeme Russell

**University of New South Wales, Sydney NSW 2052
Australia**

Associate Professor Graeme Russell is a visiting academic at the University of New South Wales where for many years he was the director of first year studies in the School of Physics. He has published widely in the field of high temperature superconductivity and has also been the Director of the Advanced Electronics Materials Laboratory at UNSW. He is a member of both the British and Australian Institute of Physics.

Andrew Bailey

Maritime Operations Division

Andrew Bailey was awarded a PhD from the University of NSW in 1993 for his work on new high temperature superconductors. Since joining DSTO in 1992, he has worked in the area of magnetic signature reduction for RAN vessels specialising in closed loop degaussing and deperming. After a 2 year posting in Canberra as Staff Officer Science & Technology in the Capability Systems branch, he returned to MOD to lead a small group that is looking at the new concept of Mine jamming and Mine warfare Operations.

Contents

1. INTRODUCTION	1
2. EXPERIMENTAL.....	2
2.1 Equipment.....	2
2.2 Basic Magnetic Measurements.....	5
2.3 Model submarine construction and deperm	6
3. RESULTS AND DISCUSSION.....	7
4. CONCLUSION	13
5. REFERENCES.....	14
APPENDIX A: - MATERIAL SPECIFICATIONS.....	15
APPENDIX B: DIRECT MAGNETIC MEASUREMENT CALCULATIONS	17

1. Introduction

Ships and submarines are generally made from ferromagnetic materials and a considerable induced magnetisation arises in these components due to the Earth's background field (EBF). The local concentration of magnetic field through the vessel's structure makes it particularly susceptible to devices such as magnetic anomaly detectors (MADs) and magnetic mines. To combat this magnetic induction, and magnetisation of the ship in general, a number of tactics have been used with military vessels in order to evade magnetic detection [1]. It is common practice to use degaussing in concert with a deperming technique.

Degaussing involves on-board coils that are given a current of a specific magnitude and direction so as to generate fields opposing the permanent and induced magnetisation of the vessel. The degaussing coils are operated with a continuous supply of d.c. current in order to attenuate the vessel's magnetic presence. However, this represents an energy cost to the running of a vessel, especially at high latitudes. In addition, if the permanent magnetisation of the vessel is too large, the degaussing system will not have enough capacity to minimise the signature. To make the task of the degaussing coils easier, and to generally reduce the permanent magnetism of a ship or submarine, the Royal Australian Navy (RAN) uses a deperm procedure.

Deperming is a one-off treatment, performed perhaps once or twice a year, that involves altering the permanent magnetism in ships, submarines or other military vehicles (the United States Army also uses deperming on tanks and other armoured vehicles as a defence against magnetic sensing land mines [2]). The aim of deperming a military vessel is to erase any magnetic history, minimise permanent longitudinal (bow to stern) magnetisation (PLM) and to optimise permanent vertical magnetisation (PVM) for the anticipated region of operation. The latter objective involves donating a specific PVM that is designed to counteract the induced vertical magnetisation (IVM) in the relevant magnetic zone of the Earth's magnetic field. This will aid those degaussing coils concerned with minimising vertical magnetisation, and consequently reduce the amount of power required by them.

There has been some recent research applying finite element analysis to the practice of degaussing [3, 4]. By contrast, research on deperming has languished: the protocol still used by the R.A. N. [5] would be familiar to deperm practitioners of World War II though there have been some advances from empirical investigations [6]. The present work is part of a continuing investigation undertaken by DSTO in collaboration with the University of New South Wales. The project seeks to examine the incumbent deperm process and possibly derive a more accurate or reliable technique that can be applied to ships and submarines of the RAN. Much of this work focuses on the magnetostatics of deperming vessels as a whole. The magnetic properties of materials used to construct parts such as the hull or engine block, have been investigated previously [7].

The rarity of gaining access to military vessels for repeated experiments, and the technical difficulty in performing deperms on the large scale, suggest that an alternative form of experimentation should be found other than directly on ships and submarines. Here we are concerned with establishing a small scaled model as an effective tool, not only to simulate deperms, but also for measuring basic magnetic

properties such as initial magnetisation curves. It's important to be certain of both of these capabilities so that the outcomes of deperms performed in the laboratory have relevance to deperms on ships and submarines, and so that a rigorous physical analysis can be applied to the results.

A scaled model of a possible magnetic treatment facility (MTF) was used to observe what happens to the magnetic state of a steel specimen during deperming. The steel specimen itself was chosen to approximate the shape of a submarine.

2. Experimental

2.1 Equipment

The laboratory MTF was designed to be roughly in proportion to the dimensions of a real MTF in order to better replicate actual deperm conditions. The MTF at HMAS Stirling is shown in Figure 1(a). The offshore berth is constructed from a series of floating pontoons that are connected to form a large rectangle with a removable back section that allows vessels to enter. There are two cable bundles permanently attached to the pontoons: one is just below the water line and the other is 5 m below that (see Figure 1(b)). There are 5 turns of cable in each bundle and together these compose the "Z Coil" used to control the applied vertical fields. The vessel is wrapped with a third cable in a helical fashion that forms the rough solenoid that is called the "X Coil". This is responsible for applied longitudinal fields. The whole berth is orientated on a magnetic North-South heading to minimise any induced magnetisation athwartships. For the sake of clarity, any following reference to "MTF" concerns the facility at HMAS Stirling, unless otherwise specified as the "laboratory MTF".

Our scaled model has dimensions that imitate the MTF (see Figure 2(a)) with the following exceptions. The coils used at the real MTF are designed to carry thousands of amps in current and the gauge of the cables used is large (~10 cm). There are only a few turns (approximately 0.4 turns/metre) along the X Coil and only 10 turns in total in the Z Coil. To generate the same fields in the laboratory MTF we used much smaller currents and smaller gauge copper wire. Consequently we required many more turns/meter in both the X and Z coils. Refer to Table 1 for details.

Measurements at the MTF are made remotely using a linear array of 16 magnetometers aligned along a magnetic North-South heading, approximately 10m under the keel line of the vessel. These magnetometers take readings simultaneously but in the scaled model we used a single magnetometer (Bartington MAG-03 MC

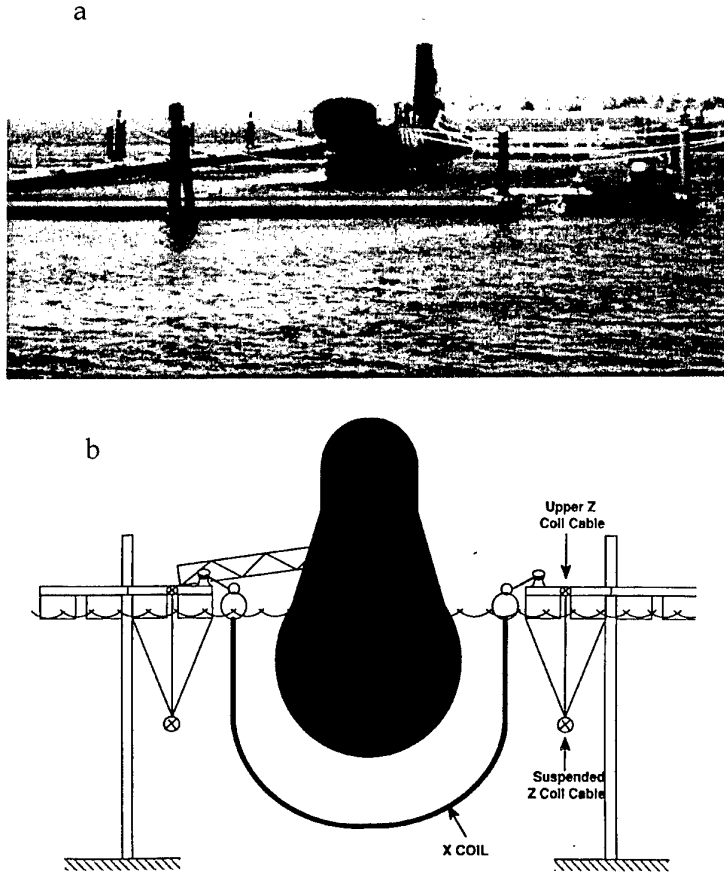

Figure 1. (a) Submarine in the MTF at HMAS Stirling. Note the cable wrapped around the sub that forms the X Coil (b) Cross section view of submarine in MTF berth (Z Coil) before being wrapped with X Coil.

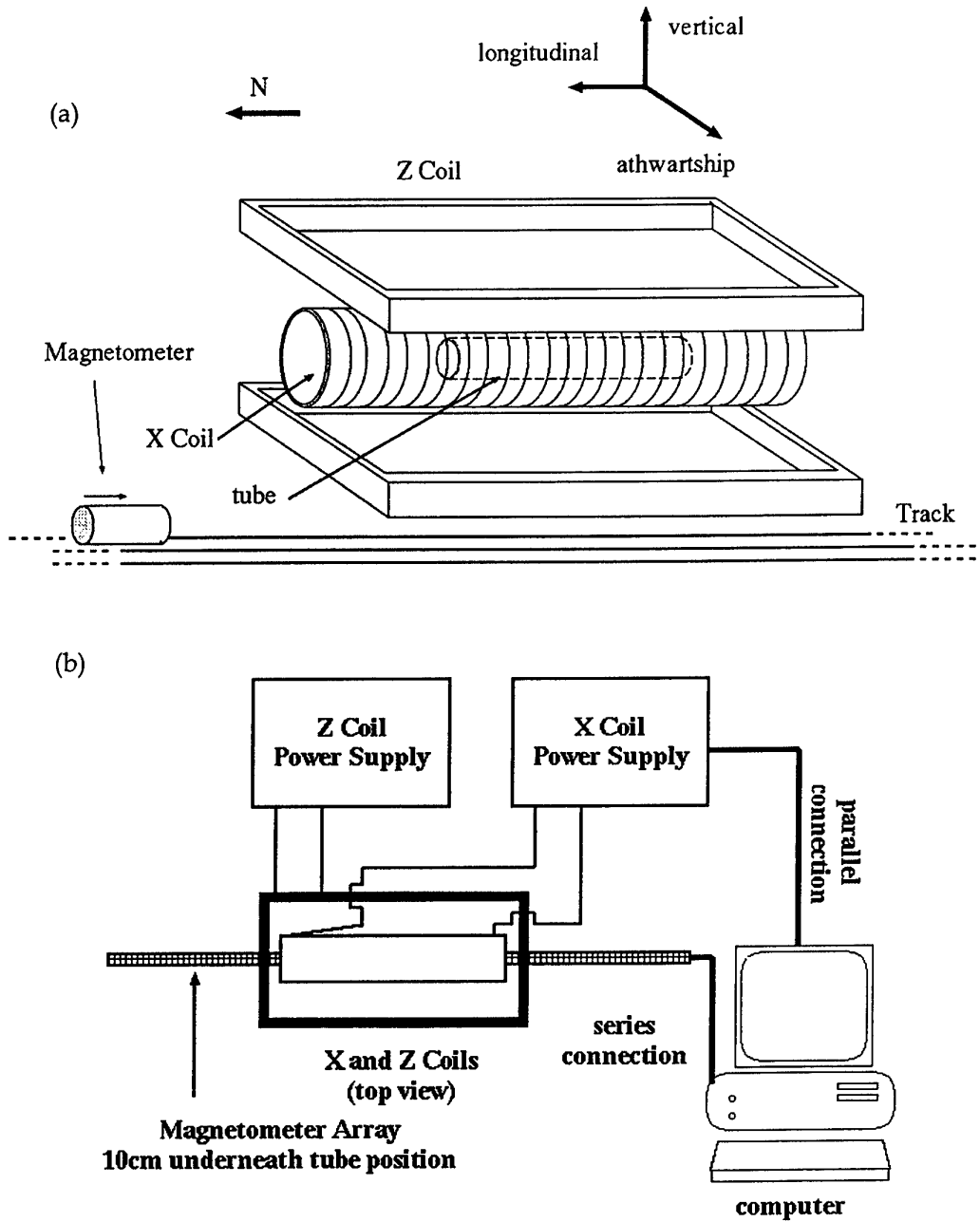

Figure 2. Laboratory MTF (a) showing direction of longitudinal, athwartships and vertical axes and position relative to magnetic north in the lab. (b) Schematic diagram of measurement and control system.

three axis magnetic field sensor, range $\pm 250\mu\text{T}$; sensitivity $\pm 7.5\text{nT}$) that was optically switched to record the magnetic field sequentially at 2cm intervals along a 1.4m track. The track was aligned along a magnetic North South direction and positioned approximately 10 cm directly underneath the model object to be depermed.

Similar software was used to acquire and process data in the laboratory MTF as in the MTF at HMAS Stirling. Numerical modelling of raw data was used to deduce the magnetic moments of the model vessel in three orthogonal directions. By dividing results for magnetic moment by the volume of the model vessel, we deduced values for magnetisation. Details of this numerical modelling used may be found in [8]. The fields applied during deperms in both systems were controlled by computer software. A schematic diagram of the control and data acquisition system for the laboratory MTF is shown in Figure 2(b).

Table 1. Dimensions of the MTF and laboratory MTF. Note that the magnetometer depth can vary with tidal levels at the MTF and, in the laboratory MTF, with the dimensions of the object to be depermed.

<u>Component</u>	<u>Real MTF</u>	<u>MTF in the lab</u>
Z Coil dimensions	~150 × 30 × 5 m	0.66 × 0.25 × 0.12 m
Z Coil turns/metre	5 in each stage	250 in each stage
X Coil length	40 - 120 m	0.5 m
X Coil turns/metre	0.5	200
Magnetometers	16	70*
Length of array	153 m	1.4 m
Magnetometer depth	~10 m	~0.1 m
Separation	9 m or 18 m	0.02 m
Length of vessel	40 - 120 m	0.3 - 0.4 m

*One magnetometer is used to make 70 measurements at different points: effectively this is a linear array of 70 magnetometers.

2.2 Basic Magnetic Measurements

It was important to confirm that the laboratory MTF (and the numerical modelling) was capable of measuring magnetic quantities with the same reliability as direct magnetometric equipment. We obtained the initial magnetisation curve for a thin bar shaped sample of CU200T-G steel using the remote method of the laboratory MTF and a direct measurement method involving coils wrapped around the bar. The latter is similar to procedures found in [9] and [13]. The dimensions of the steel bar were 1.6 × 15.5 × 98.4 mm. More detailed information on the composition of CU200T-G steel may be found in the Appendices.

The direct measurement technique had the bar wrapped, like a solenoid, with two coils of 1 amp wire around the longest axis. Each coil had 250 turns. One coil applied the magnetic field (primary) and another measured induction (secondary). This solenoid was then connected to the circuit shown in Figure 3. From the current through R_1 and the Biot-Savart Law we determined the applied field. Induction was calculated from the integrating circuit connected to the secondary coil by the following formula (see Appendices for derivation):

$$B = \frac{V_c R_2 C}{n_s A} \quad (1.)$$

Where n_s was the number of turns in the secondary coil, V_c was the voltage across

the capacitor and A was the cross sectional area of the bar. Using a 12V 50Hz a.c. power supply and an oscilloscope (CRO), we observed hysteresis loops noting the induction maxima occurring at peak field magnitudes from 0-10 000 A/m. According to Bozorth [10] the initial magnetisation curve can be formed from the positive induction maxima. We subtracted the contribution to induction from the peak field alone to determine the corresponding magnetisation in the bar at that peak field.

The same bar was fixed inside the X Coil of the laboratory MTF 8.3cm directly above the path of the magnetometer. Its longitudinal axis was aligned along magnetic North-South and the bar lay so its breadth was aligned East-West. Applied fields of 0-7000 A/m were generated by a d.c. current in the X Coil and calculated using the Biot-Savart Law (these calculations were also independently checked with measurements from a Bell 600 Gaussmeter). For a given applied field, 70 readings were taken by the magnetometer at 2cm intervals along a path underneath the bar. The mathematical modelling of this raw data produced values for the longitudinal, vertical and athwartships magnetic moments of the bar. By then dividing the values for the longitudinal moment by the volume of the bar, we deduced the magnetisation in that direction. This longitudinal magnetisation was compared with the longitudinal magnetisation results from the direct measurement technique.

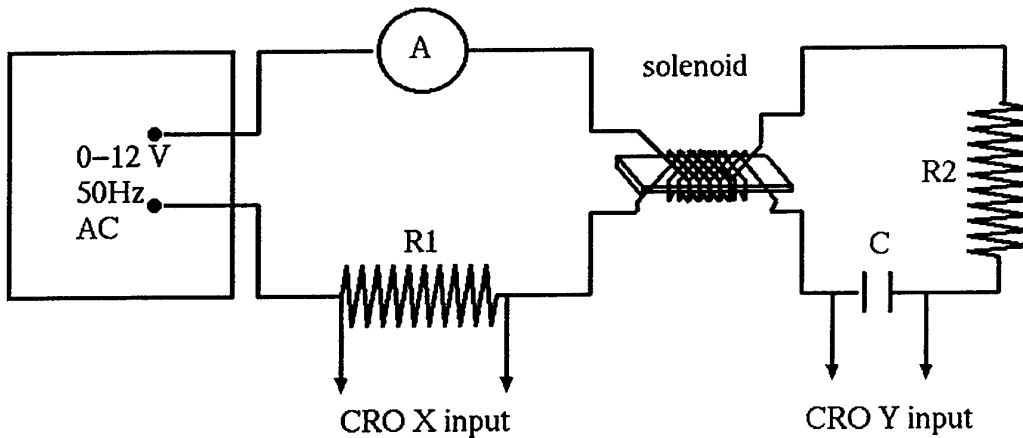

Figure 3. Circuit diagram for direct method of measuring hysteresis loops in the CU200 steel bar.

2.3 Model submarine construction and deperm

Steel tubes were chosen as the small-scale models for a submarine. An exact scale replica would be a premium way to model ships or submarines, but steel tube takes far less time to construct and its symmetry allows much greater flexibility in regards to positioning and aligning the model in the deperm apparatus. There is also the advantage that with a simpler system you restrict the number of possible variables in the experiment. We sought the simplest model for which the deperm results would simulate those of a real vessel. If this were possible with steel tubes it would permit the laboratory MTF to be used as a deperm simulator for future investigations on alternative deperm protocols.

The first tube tested was made from 1020 grade steel bar. The original solid bar (300mm long, diameter = 50mm) was turned into a cylinder and hollowed out so that the tube wall thickness was 0.7 mm. The second tube used was made from 0.54mm thick CA2S-E sheet steel, rolled and welded to make a hollow cylinder. It should be mentioned that this method of construction is closer to that used in the actual construction of a submarine pressure hull. Dimensions of the tubes are shown in Table 2; material specifications are shown in the Appendices. The only general requirement in the choice of a steel tube was to have the wall thickness approximately 1/100th that of the outer diameter. This is close to the proportions of a real submarine hull.

Table 2. Dimensions of the steel tubes used in deperm simulations.

	Length	Inside Ø	Outside Ø
1020 tube	0.299 m	44 mm	45.4 mm
CA2S-E tube	0.38 m	50 mm	51.08 mm

The deperm technique utilised at the MTF is known as the Flash-D method. It involves applied fields in the vertical direction through d.c. currents in the Z Coil and alternating longitudinal fields generated by pulses of d.c. current in the X Coil called "shots". The procedure has three stages: Stage 1 has a series of alternating shots that decrease from an initial maximum by a set decrement. These are concurrent with the application of a vertical field oppositely directed to the ambient vertical field. Stage 2 starts with two pre-set pairs of opposing shots but subsequent shots are defined using a recursive algorithm that considers previous applied fields and the resulting changes in magnetisation. Stage 3 begins with the same shot as the end of Stage 2 and decreases in the manner of Stage 1 with a smaller decrement value. For more details refer to [6].

Deperms were carried out on TSM Ovens during April 1996, and on HMAS Geraldton in September 1997. A similar treatment protocol to that used in those deperms was repeated with the laboratory MTF on both steel tubes. All measurements and applied fields compensated for the effect of the Earth's background field (EBF) so that no deperm outcomes for submarine, ship or tube were influenced by the ambient field.

3. Results and Discussion

It has been demonstrated that the laboratory MTF was a valid way of making fundamental magnetostatic measurements. The initial magnetisation curve was determined for a bar-shaped sample of CU200T-G steel, using both the direct measurement arrangement and the laboratory MTF (see Figure 4). There was excellent agreement between the two measurement methods over the range of applied fields tested. Therefore it can be said with confidence that the laboratory MTF is able to determine magnetic properties of steel samples, with the same accuracy as a direct measurement method similar to standard techniques found in [9, 13]. The error bars shown, for data from the direct measurement technique, are

derived from the reading error on the CRO. For the laboratory MTF the error is estimated from the fit of the computer modelling to the raw data.

Steel tubes formed by different methods of fabrication were tested to find a simple but effective model for ships and submarines in the deperm apparatus. A comparison of the results from a deperm on CA2S-E and 1020 grade steel tubes is shown in Figure 5. There is a clear difference in the response of the two types of tubes to the same deperm protocol. Data for the 1020 tube lacks the predictable form of results for the CA2S-E tube, and there is a significantly higher end-of-Stage 1 vertical magnetisation for the CA2S-E tube than for the 1020 tube. This is usually a good indicator of the quality of a deperm; with a larger end-of-Stage 1 vertical magnetisation you have more control in reducing the vertical magnetisation in Stage 2. This often translates into a more stable final magnetic state.

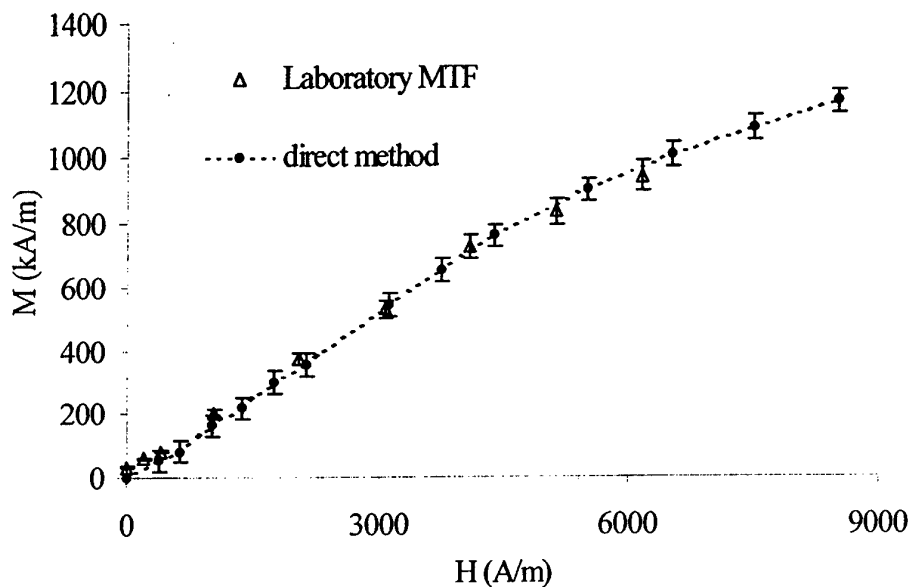

Figure 4. Initial magnetisation curve as measured by the direct measurement method (shown by dotted line) compared with the results, for the same CU200 steel bar, as measured using the laboratory MTF.

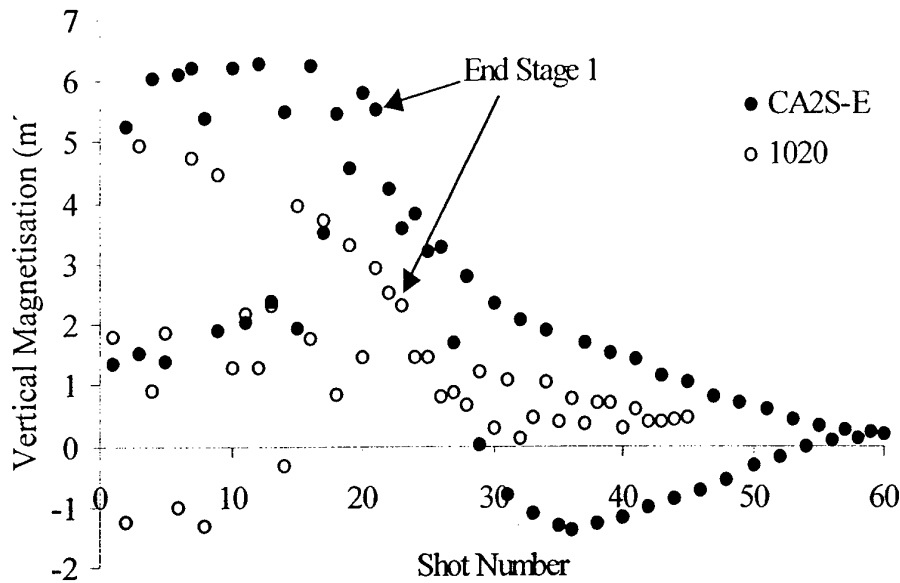

Figure 5. Comparison of vertical magnetisation during deperms on the CA2S-E and 1020 grade steel tubes. The end-of-Stage 1 vertical magnetisation for the 1020 tube is half that for the CA2S-E. The brevity of the deperm on the 1020 is a direct consequence of this.

It is suggested that this result is due to the magnetic texture or "anisotropy" of the steels being used rather than the composition. The chemistry of both grades is quite similar as can be seen in the table in the Appendices. We believe the important difference lies in the construction of the tubes: the CA2S-E was rolled into sheet and then rolled again to an open tubular shape before being TIG welded. It has been found [10] that (in silicon sheet steel) cold rolling produces a favourable magnetic anisotropy in two orthogonal directions. It's possible for the rolled CA2S-E tube to have easy directions of magnetisation both longitudinally and around the circumference. By contrast the 1020 grade tube, being made straight from bar steel, would have only one easy axis of magnetisation: in the longitudinal direction. This means the vertical direction would be a hard axis of magnetisation. Since the construction of the tube model was such an important factor in simulating a deperm, all the following data comparing "tube deperms" to those of naval vessels, refers specifically to the CA2S-E steel tube.

Shown in Figure 6 are the data for longitudinal and vertical remanent magnetisation measured after each shot in deperms on the CA2S-E tube and HMAS Geraldton. All measurements were taken after any applied fields had been removed. Figure 7 compares the same data from the tube with a deperm on the decommissioned submarine TSM Ovens.

In both figures the progress of a vessel's magnetisation through a deperm shows how the magnitude of the PLM started at a maximum for the first couple of shots in Stage 1, reducing with each step to a temporary minimum before Stage 2 (refer to Figure 6(a)). The shot pairs in Stage 2 had an absolute magnitude that increased with each pair and so, by the start of Stage 3, both vessels actually gained a longitudinal

magnetisation. In Stage 3 the decrement in magnitude between longitudinal shots was much finer than in Stage 1 and consequently the decrease in longitudinal magnetisation was more gradual.

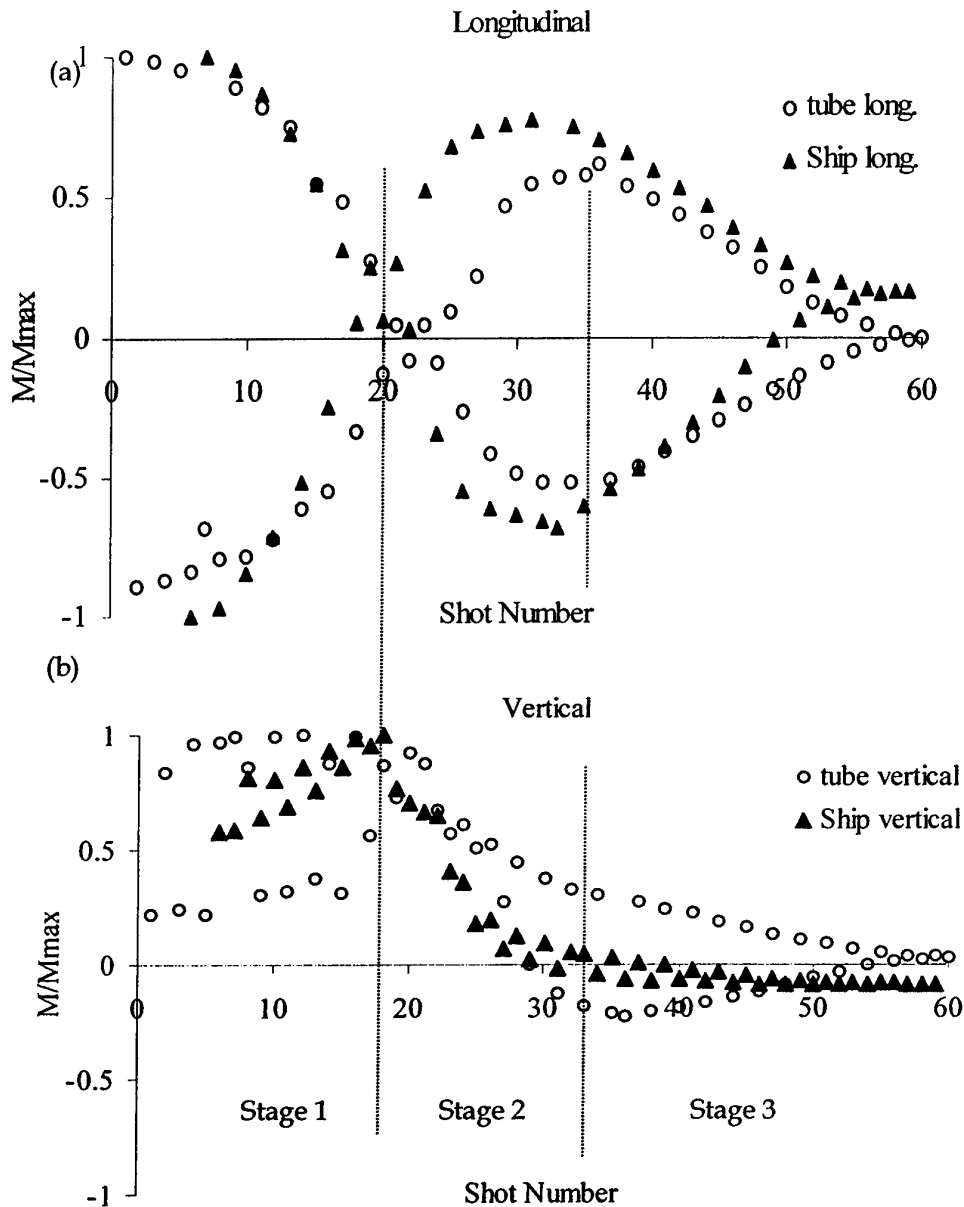

Figure 6. Comparison of reduced (a) longitudinal and (b) vertical magnetisation throughout deperm for the CA2S-E steel tube and HMAS Geraldton. Note that the raw data has been divided by the largest absolute magnetisation measured during the respective deperms for a given direction. The starting shot number for the HMAS Geraldton has been adjusted so that magnetisation data corresponds approximately to the same applied fields.

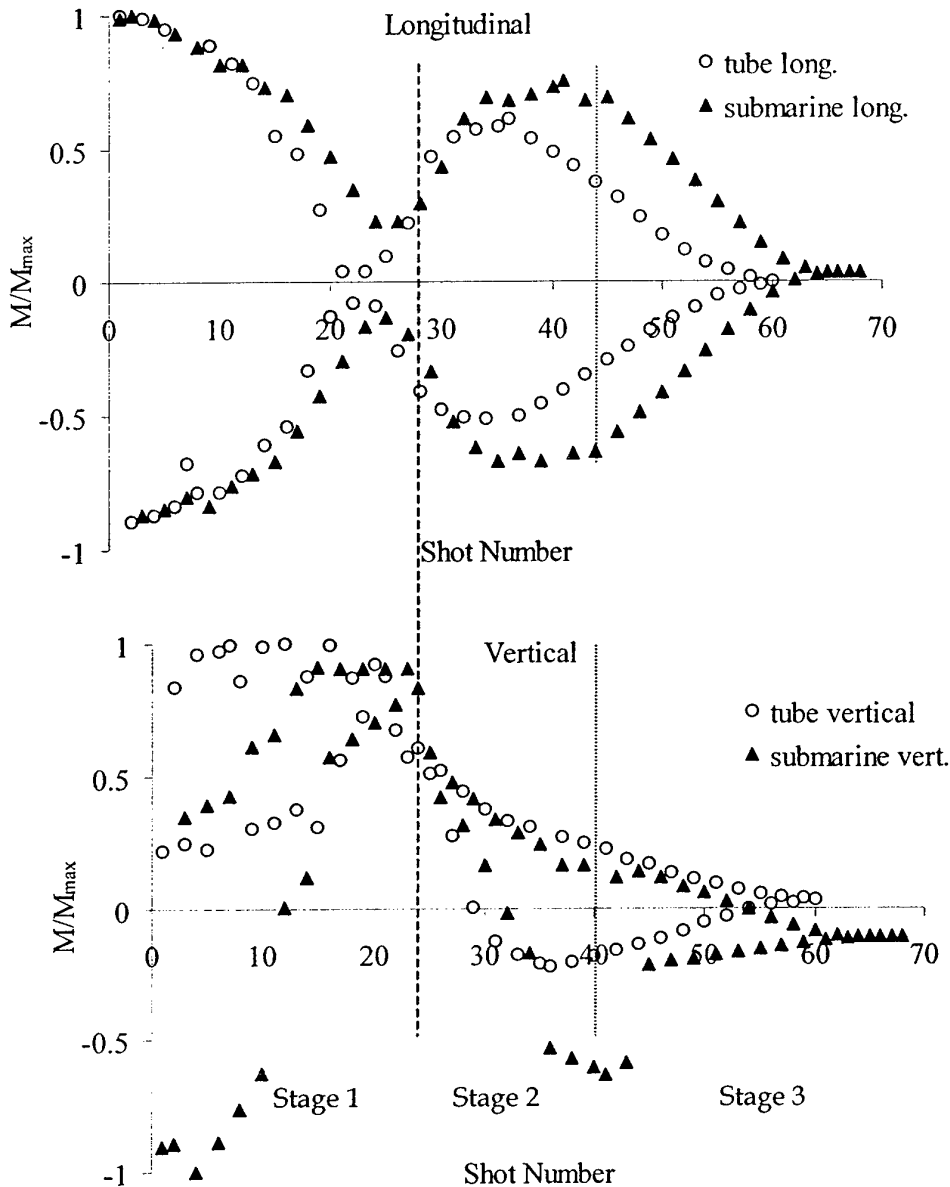

Figure 7. Comparison of reduced (a) longitudinal and (b) vertical magnetisation throughout deperm for the CA2S-E steel tube and TSM Ovens. As in Figure 6, the raw data was divided by the largest absolute magnetisation measured during the respective deperms for a given direction.

It can also be seen from Figure 6(a) and Figure 7(a) that the results for the tube possess the same features of longitudinal magnetisation changes at the same stages throughout a deperm. Though the tube data is not an exact match with that from the vessels, we can say the tube provides (qualitatively at least) a valid simulation of the response of both the ship and submarine to deperming.

The ultimate aim is to achieve zero PLM at the end of the deperm. In the MTF the outcome may be influenced by the irregular placement of the X Coil cables and

movement of the vessel in the berth during the deperm. These factors are not a significant consideration in the laboratory MTF but there is the common problem of correctly accounting for ILM in each longitudinal shot. Any systematic error in compensating for ILM would result in a biased PLM. Though we do not quantify this here, we believe that it is the cause of the non-zero final longitudinal magnetisation in the laboratory MTF.

It is encouraging to note the shape of the decrease in longitudinal magnetisation during Stage 1. The datum for each shot represents the PLM after the applied field of that shot and we can plot this data as a function of applied field (H), as in Figure 8. The initial remanent longitudinal magnetisation curve, for the same tube, is also shown for comparison. The latter was also measured using the laboratory MTF. Each point on the remanent curve was obtained by first demagnetising the tube, then applying a known field, and measuring magnetisation after the field was returned to 0 A/m. This is not strictly a proper comparison since no data from Stage 1 in the deperm follows a demagnetised state. Despite this, it is interesting to note how closely the Stage 1 data does seem to follow the initial remanent curve. Note also that remnant longitudinal magnetisation starts to saturate at field values above 2000 A/m. More thorough deperms on the tube might begin with larger applied fields but such deperms would profit relatively little by having starting fields > 2000 A/m.

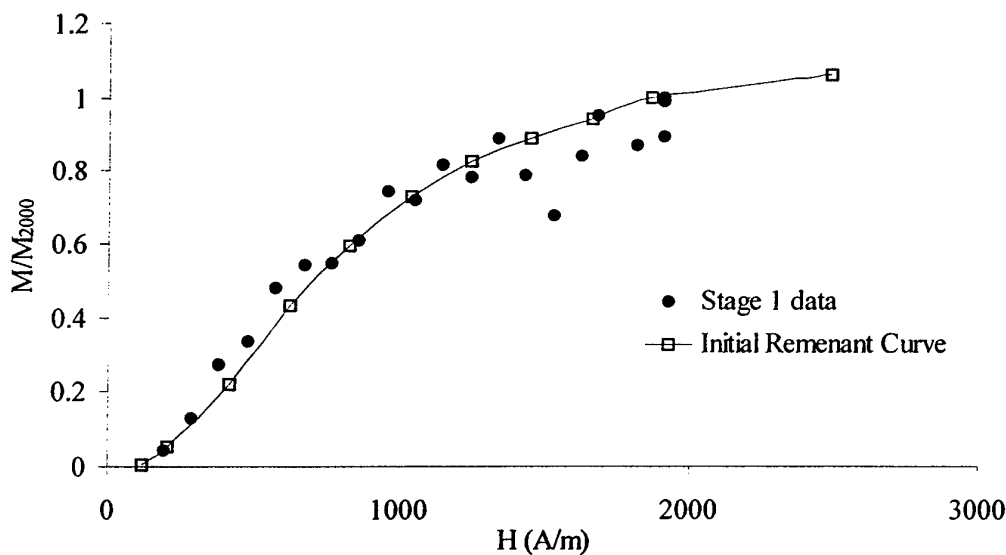

Figure 8. Initial remanent magnetisation for the CA2S-E tube in the longitudinal direction (shown by the line) and raw data from Stage 1 of the deperm on the same tube. Magnetisation data has been divided by the magnetisation measured at 2000 A/m, M_{2000} . The Stage 1 data is just the magnitude values for magnetisation measured after shots of applied field, H .

The progress of the remanent vertical magnetisation through the deperm process is more complex. It might be expected that vertical magnetisation would increase with each step in Stage 1 and this is indeed what is observed (see Figure 6(b) and Figure 7(b)). There is, however, the commonly observed phenomenon, in both the small and large scale, that some change in measured vertical magnetisation is effected by a

change in longitudinal magnetisation. On further inspection of Figure 6(b) and Figure 7(b) the change appears to be proportional to, and directed by, changes in longitudinal magnetisation. That is, if the longitudinal magnetisation moves from magnetic south to north, the change in the direction of vertical magnetisation is from up to down. This curious occurrence had previously been explained as a measurement anomaly but we believe it to be too regular and suggest a possible alternative. In both the real MTF and the laboratory MTF it is a necessary condition for the mathematical modelling that the magnetic centre of the depermed object be known. If the object was magnetised as a longitudinal dipole then this centre would coincide with the geometric middle of the dipole. The way in which the geometric centre is determined prior to a deperm is by measuring the physical dimensions of the vessel or, in the laboratory, the tube. The geometrical midpoint of the depermed object may not, however, be the midpoint of magnetic material distributed in that object. We believe the phenomenon mentioned above is an artefact that arises when there is a horizontal offset of the magnetic centre from what is anticipated by geometrical calculations.

Again there are common traits in the form of vertical magnetisation results for the tube and for naval vessels. The simulation is not as close as that for longitudinal magnetisation but it's important to note the significant difference between the ship and submarine data, particularly during Stage 1. We suggest that this is due to the construction of the hulls of the respective vessels: the submarine being a can made from rolled steel; the ship being more of a hollow triangular prism bounded by the port and starboard sides of the hull and the deck. Consequently it would be expected that no single model could imitate both of these vessels during deperm. The tube best simulates the results from the submarine and a model hollow triangular prism is proposed for future investigations on simulating ship deperms.

4. Conclusion

The laboratory MTF can be used to obtain fundamental magnetic information about a ferromagnetic object with the equivalent accuracy of direct magnetometric equipment. The same system can be used to effectively model the magnetic changes that occur during a real deperm process on a large ferromagnetic object such as a naval vessel.

A steel tube was selected as a convenient scale representation of a hollow vessel, though a condition for choosing any future model vessel should be that it share a similar magnetic anisotropy with the ship or submarine being modelled. It was found that constructing even a simple tube from steel with a uniaxial magnetic texture predisposed the tube to magnetisation in one direction at the expense of any other. This is certainly a disadvantage because any effective deperm simulation involves both vertical and longitudinal magnetisation.

The results from a deperm of a 38 cm CA2S-E steel tube were shown to have a good qualitative similarity to results from deperms on HMAS Geraldton and TSM Ovens. Of course the magnitude of the tube's magnetisation was many times less than that for the ship or submarine and some differences occur in the manner of vertical magnetisation. However, we believe that the steel tube provides a good simulation

for further investigations of the deperm process. A conclusion from a deperm on this type of steel tube in the laboratory MTF would find application in deperms of naval vessels. Indeed, results from preliminary experiments on alternative deperm protocols indicate that more effective techniques are practicable on the tube model and are therefore a consideration for future deperms on ships or submarines. The laboratory MTF is a unique facility that permits such tests with the knowledge that any results are based on sound magnetostatic measurements, but without the need to perform expensive and time consuming experiments on real naval vessels.

5. References

1. Gordon R., *Electronics and Power* June (1984) pp473-476
2. MacBain J. A., *IEEE Trans. Mag.* 29, 1 (1993) pp159-165
3. Le Dorze F. *et al*, *IEEE Trans. Magn.*, Vol. 34, 5 (1998) pp2477-2480
4. Xu X. B. and Zeng. L, J. *Electromagnetic Waves and Applications*, Vol. 12 (1998) pp1039-1051
5. "Degaussing by Magnetic Treatment, Section 4: Deperming and Magnetic Theory," British Standard BR 825, (U.K Ministry of Defence, Jan. 1975).
6. Bailey A., "Review of the RAN Magnetic Treatment Facility", DSTO Technical Report to be published (2002).
7. Robertson I. M., "Further Investigation of the Magneto-elastic behaviour of BIS 812 EMA submarine hull steel (u)", DSTO Research Report (MRL-RR-4-91) (1991 - Confidential).
8. Theobald A.G., "On the numerical modelling of a magnetic source" ARE TR 86113 Accession Number 73823, (July 1986).
9. "Direct-Current Magnetic Measurements for Soft Magnetic Materials STP 371 S1", American Society for Testing and Materials (Philadelphia 1970).
- 10.. Bozorth R. M., *Ferromagnetism*, IEEE Press (New Jersey 1993).
- 11.. "BHP Australia - Product Data Manual for Cold Rolled Steel", BHP Ltd. (1995).
- 12.. "<http://www.globalmetals.com.au/htdocs/products/mildtable.html>", Global Metals Pty Ltd. Product Catalogue 2001.
13. "Direct-Current Magnetic Hysteresisgraphs STP 526", American Society for Testing and Materials (Philadelphia 1973).

Appendix A: - Material specifications

CU200T-G cold-rolled or temper-rolled steel is suitable for general fabrication and welding. Typical applications include tubing and pressing (Australian Standard AS1365)[11]. CA2S-E is cold-rolled steel for moderate forming and pressing. Typical applications include tubing and pressing (Australian Standard AS1595) [11]. 1020 grade steel is cold finished mild steel used for machined parts [12].

Table A1 Mechanical Properties

<u>Grade</u>	<u>Transverse tensile yield strength</u>	<u>Elongation</u>	<u>Hardness (HRB)</u>
CU200T-G	200Mpa	28% (on 80mm)	65
CA2S-E	160Mpa	33% (on 80mm)	55
1020	380Mpa	13% (on 56mm)	-

Table A2 Chemical Composition

	CU200T-G	CA2S-E	1020
Carbon	0.15%	0.10%	0.23%
Phosphorous	0.04%	0.025%	0.04%
Manganese	0.6%	0.45%	0.6%
Sulphur	0.04%	0.03%	0.04%
Silicon	0.005-0.010%	0.005-0.010%	0.030%
Aluminium	0.03-0.05%	0.03-0.05%	-
Nitrogen	0.001-0.005%	0.001-0.005%	-

Appendix B: Direct magnetic measurement calculations

(refer to Figure 3).

The voltage measured across R_1 is directly proportional to the current in the primary coil and, using the Biot-Savart law, we gained a measure of the applied field. The change in flux through the secondary coil produces a voltage across that coil given by

$$V_s = n_s A \frac{dB}{dt} \quad (A1)$$

Where n_s is the number of turns = 250 and A is the cross sectional area = $1.6\text{mm} \times 15.5\text{mm} = 24.8\mu\text{m}^2$. Thus to determine induction in the steel bar with the secondary coil, we need to integrate V_s over time. This is an inherent problem with any measurement hystereograph [13] and in our case the integration is effectively achieved through the circuit connected to the secondary coil (see Figure 3). The voltage across the capacitor, V_C is:

$$V_C = \frac{1}{C} \int I dt \quad (A2)$$

Where C is the capacitance and I is the current in the secondary circuit. If ω is the frequency and $1/\omega C \ll R_2$, we can use the approximation that:

$$V_C = \frac{1}{(R_2)C} \int V_s dt. \quad (A3)$$

The values used in the experiment were: $\omega = 100\pi$ Hz and $C = 9.39\mu\text{F}$. Hence $1/\omega C = 339\Omega$ and, with $R_2 = 22\text{K}\Omega$, the above approximation is valid. Combining (A1) and (A3) we determined the induction using the voltage measured across the capacitor.

$$B = \frac{V_C R_2 C}{n_s A} \quad (A4)$$

DISTRIBUTION LIST

Laboratory Simulation of the Deperm Process

T.M.Baynes, G.J.Russell and A.Bailey

AUSTRALIA

DEFENCE ORGANISATION

Task Sponsor

DGMD Attention DDMWCD

S&T Program

Chief Defence Scientist
FAS Science Policy
AS Science Corporate Management
Director General Science Policy Development
Counsellor Defence Science, London (Doc Data Sheet)
Counsellor Defence Science, Washington (Doc Data Sheet)
Scientific Adviser to MRDC Thailand (Doc Data Sheet)
Scientific Adviser Joint
Navy Scientific Adviser
Scientific Adviser - Army (Doc Data Sheet and distribution list only)
Air Force Scientific Adviser
Director Trials

} Shared Copy

Systems Sciences Laboratory

CMOD
RLMW
Dr Bryan Jessup
Dr Jim Smelt
Mr Andrew Munyard
Mr Paul Sheehan
Dr Andrew Bailey (3 copies)

DSTO Library and Archives

LibraryEdinburgh
Australian Archives
Library, MOD

Capability Systems Staff

Director General Maritime Development
Director General Aerospace Development (Doc Data Sheet only)

Knowledge Staff

Director General Command, Control, Communications and Computers (DGC4)
(Doc Data Sheet only)

Navy

SO (SCIENCE), COMAUSNAVSURFGRP, NSW (Doc Data Sheet and distribution list only)

Army

ABCA National Standardisation Officer, Land Warfare Development Sector,
Puckapunyal (4 copies)
SO (Science), Deployable Joint Force Headquarters (DJFHQ) (L), Enoggera QLD
(Doc Data Sheet only)

Intelligence Program

DGSTA Defence Intelligence Organisation
Manager, Information Centre, Defence Intelligence Organisation

Defence Libraries

Library Manager, DLS-Canberra
Library Manager, DLS - Sydney West (Doc Data Sheet Only)

OTHER ORGANISATIONS

National Library of Australia
NASA (Canberra)
AusInfo

OUTSIDE AUSTRALIA**INTERNATIONAL DEFENCE INFORMATION CENTRES**

US Defense Technical Information Center, 2 copies
UK Defence Research Information Centre, 2 copies
Canada Defence Scientific Information Service, 1 copy
NZ Defence Information Centre, 1 copy

UNIVERSITIES AND COLLEGES

Australian Defence Force Academy Library
Head of Aerospace and Mechanical Engineering
Serials Section (M list), Deakin University Library, Geelong, 3217
Hargrave Library, Monash University (Doc Data Sheet only)
Librarian, Flinders University

ABSTRACTING AND INFORMATION ORGANISATIONS

Library, Chemical Abstracts Reference Service
Engineering Societies Library, US
Materials Information, Cambridge Scientific Abstracts, US
Documents Librarian, The Center for Research Libraries, US

INFORMATION EXCHANGE AGREEMENT PARTNERS

Acquisitions Unit, Science Reference and Information Service, UK
Library - Exchange Desk, National Institute of Standards and Technology, US

SPARES (5 copies)

Total number of copies: 50

DEFENCE SCIENCE AND TECHNOLOGY ORGANISATION DOCUMENT CONTROL DATA				1. PRIVACY MARKING/CAVEAT (OF DOCUMENT)			
				2. TITLE Laboratory Simulation of the Deperm Process		3. SECURITY CLASSIFICATION (FOR UNCLASSIFIED REPORTS THAT ARE LIMITED RELEASE USE (L) NEXT TO DOCUMENT CLASSIFICATION) Document (U) Title (U) Abstract (U)	
4. AUTHOR(S) T.M.Baynes, G.J.Russell and A.Bailey				5. CORPORATE AUTHOR Systems Sciences Laboratory PO Box 1500 Edinburgh South Australia 5111 Australia			
6a. DSTO NUMBER DSTO-TR-1340		6b. AR NUMBER AR-012-438		6c. TYPE OF REPORT Technical Report		7. DOCUMENT DATE August, 2002	
8. FILE NUMBER 490/6/124		9. TASK NUMBER NAV 00/039		10. TASK SPONSOR DGMD		11. NO. OF PAGES 18	
						12. NO. OF REFERENCES 13	
13. URL on the World Wide Web http://www.dsto.defence.gov.au/corporate/reports/DSTO-TR-1340.pdf				14. RELEASE AUTHORITY Chief, Maritime Operations Division			
15. SECONDARY RELEASE STATEMENT OF THIS DOCUMENT <i>Approved for public release</i>							
OVERSEAS ENQUIRIES OUTSIDE STATED LIMITATIONS SHOULD BE REFERRED THROUGH DOCUMENT EXCHANGE, PO BOX 1500, EDINBURGH, SA 5111							
16. DELIBERATE ANNOUNCEMENT No Limitations							
17. CITATION IN OTHER DOCUMENTS				Yes			
18. DEFTEST DESCRIPTORS Mine countermeasures, naval mine warfare, magnetic signatures							
19. ABSTRACT The practise of demagnetising or "deperming" ships and submarines in order to evade magnetic detection has been around since World War II. The methods used rely somewhat on empirical knowledge and little research has been done to analyse the magnetostatic processes occurring during a deperm. We have constructed a scale model of a possible magnetic treatment facility for performing deperms on small (< 1 m) steel samples and measuring magnetostatic quantities that relate to the deperm procedure. The apparatus was found to be capable of measuring fundamental magnetostatic quantities remotely, with a comparable accuracy to direct magnetometric equipment. Additionally, a favourable comparison with deperm data from real naval vessels confirms that the scaled apparatus permits a valid simulation of conditions during an actual deperm. The system of measurement presented can thus be employed to investigate the magnetostatics of the current deperm method and possible alternatives. Important qualitative differences between the deperm results for ships and those for submarines were noted though it was still possible to achieve effective simulation of both of these in the scaled deperm apparatus.							